

SIR OLIVER LODGE WRITES IN THIS ISSUE

PRACTICAL TIPS FOR ALL

P.W.'s SPECIAL
TELEVISION
SURVEY

By
G. P. KENDALL,
B.Sc.

(See page 953)

Popular Wireless

No. 809.
Vol. XXIV.
February 3rd,
1934.

EVERY WEDNESDAY
PRICE 3^d

ON THE AIR
with the
**NATIONAL
ECKERSLEY**
3

ALSO
**THE CHIEF
ENGINEER
OF THE B.B.C**
on
BROADCASTING QUALITY

UNIQUE MICROLODE MATCHING
FOR EVEN BALANCE OF REPRODUCTION

FOR AMAZING SENSITIVITY

UNIQUE MANSFIELD MAGNETIC SYSTEM

EFFICIENCY UNIFORMITY LONG LIFE



KINGS OF THE AIR



NEW STATION CHART

Get one of the new Cossor Station Charts which gives the revised wavelengths, etc., of over 80 foreign stations and has space for entering your own dial readings, price 2d. from your Dealer or write to A. C. Cossor Ltd, Melody Dept., Highbury Grove, London, N.5, enclosing 2d. stamp.

To A. C. COSSOR LTD., Melody Dept., Highbury Grove, London, N.5.

Please send me free of charge, a copy of the Cossor 72-page Wireless Book.

Name

Address

Variation of characteristics or of efficiency is definitely prevented in Cossor Mains Valves by the use of the famous Mica Bridge. This well-tried method of construction permits a degree of accuracy in assembly that ensures strict adherence to characteristics, uniform efficiency and, due to the great mechanical strength it imparts to the electrode assembly, long and dependable service. Your dealer will be glad to help you choose the correct types for your Receiver.

COSSOR A.C. and D.C. MAINS VALVES

COSSOR A.C. MAINS VALVES (4 Volt Indirectly Heated Cathodes)

Type	Purpose	Impedance	Amp. Factor	Mut. Con. m.a.v.	Price
*M.S.G.-H.A.	Super H.F. Amp'n	500,000	1,000	2.0	17/6
*41 M.S.G.	Super H.F. Amp'n	400,000	1,000	2.5	17/6
*M.S.G.-L.A.	Super H.F. Amp'n	200,000	750	3.75	17/6
**M.V.S.G.	Variable-Mu S.G.	200,000	—	2.5	17/6
*M.S./PEN.-A	H.F. Pentode	—	—	4.0	17/6
*M.S./PEN.	H.F. Pentode	—	—	2.8	17/6
*M.V.S./PEN.	Variable-Mu H.F. Pentode	—	—	2.2	17/6
*41 M.D.G.	Bigrid	40,000	10	.25	19/-
**D.D./PEN.	A.V.C. (Detector and L.F. Amp.)	—	—	2.7	20/-
**D.D.T.	A.V.C. (do)	17,000	41	2.4	15/6
41 M.R.C.	R.C.C. or Det.	19,500	50	2.6	14/-
*41 M.H.	Detector	18,000	72	4.0	13/6
41 M.H.F.	H.F. or Det.	14,500	41	2.8	14/-
*41 M.H.L.	Det. or H.F.	11,500	52	4.5	13/6
41 M.L.F.	Low Frequency	7,900	35	1.9	14/-
41 M.P.	Normal Power	2,500	18.7	7.5	14/-
41 M.X.P.	Extra Power	1,500	11.2	7.5	16/6
M.P./PEN.	Pen. Power Output	—	—	3.5	18/6
‡P.T. 41B	Pen. Power Output	—	—	2.25	22/6
‡P.T. 41	Pen. Power Output	—	—	3.0	18/6

* Supplied with Plain or Metallised Bulbs. ** Stocked with Metallised Bulb only. † Characteristics measured at -1.5 Grid Volts. ‡ Directly heated filaments.

COSSOR D.C. MAINS VALVES (16 Volt 0.25 amp. Indirectly Heated Cathodes)

Type	Purpose	Impedance	Amp. Factor	Mut. Con. m.a.v.	Price
†D.V.S.G.	Variable-Mu S.G.	—	—	2.5	17/6
*D.H.L.	Detector	13,000	58	4.5	13/6
D.P.	Power Output	2,800	17	6.0	14/-
D.P./PEN.	Power Pentode	—	—	3.5	18/6
*D.S./PEN.	H.F. Pentode	—	—	3.0	17/6
†D.V.S./PEN.	Variable-Mu H.F. Pentode	—	—	3.0	17/6
**D.D.T.16	Double Diode Triode (A.V.C.)	16,000	40	2.5	15/6

* Supplied with Plain or Metallised Bulbs. ** Stocked with Metallised Bulb only. † Characteristics measured at -1.5 Grid Volts.

Prices in this List do not apply in I.F.S.

POPULAR WIRELESS

THE FIRST AND FOREMOST RADIO WEEKLY FOR THE CONSTRUCTOR & AMATEUR EXPERIMENTER

Scientific Adviser: SIR OLIVER LODGE, F.R.S.
 Technical Editor: G. V. DOWDING, Associate, I.E.E.
 Assistant Editor: P. ROBERT BIRD.

Managing Editor:
 N. F. EDWARDS.

Chief Radio Consultant: P. P. ECKERSLEY.
 Assistant Editor: A. JOHNSON-RANDALL.
 Chief of Research: K. D. ROGERS.

A PEA SOUP RECORD
 SIR EDWARD ELGAR
 RUSSIAN TOPICS
 U.S.A. RECEPTION

RADIO NOTES & NEWS

POETRY READINGS
 TUNING BY FEEL
 A "FOUR-YEAR PLAN"
 FROSTY RECEPTION

What is "News"?

CONSIDERING the enormous importance of the broadcast news bulletins to many listeners, one cannot refrain from wishing that those responsible for them were better qualified for their job.

While I was reading a letter from a Rhodesian to the "Spectator," pointing out that the sole item of news from America on November 30th, sent by the Empire Service, was that the record for drinking pea soup had been broken, I heard the National "news" open with a boost of the Department of Scientific and Industrial Research and its latest report.

Years ago I suggested Cochran for entertainment; I now suggest Tom Clarke, or some "live wire" like him, for the news.

The New Elgar Symphony.

SIR EDWARD ELGAR, the greatest living British composer, as many think, has not been in the news for some time, although he is, unfortunately, still in a nursing home at the time of my writing.

I learn, however, that it is hoped he will soon be well enough to continue work on his new symphony, which he has dedicated to the B.B.C., and I am sure that, highbrows or not, we all heartily concur in that hope.

Matter of Opinion?

IN one of the B.B.C. announcements relating to a programme of "music of the oppressed" I read: "... and the music of the two Russias—that of Czarist times (when the Nihilists and such like were oppressed) and that of the U.S.S.R., in which a totally different oppressed class has appeared."

Programme notes are not the proper vehicle for an expression of a B.B.C.'s employee's views on the state of Soviet society; moreover, what is the authority for the statement?

Lots of people have come back from Russia declaring that it is the home of the freed, and lots of others have returned so hastily that their coat-tails were obscured

by clouds of dust. Does the B.B.C. want to have Mr. Maxton after it?

America With One Valve.

THANKS to all readers who have answered my query. Apparently the U.S.A. is regularly received on medium waves by many of you. D. P. (Chesterfield) claims W G Y, W A B C and W G I C on a one-valver, at about midnight.

Constructor" each month is an event of great interest and importance in our world of radio. Whether you follow J. S. T. in his technical vein or chuckle at his arm-chair chatter, you are mixing with the best of wireless society.

As a matter of fact, you are really very lucky people, for with P. P. E. in "P.W." and J. S. T. in the "Constructor" you have cornered a couple of the hottest radio men since Marconi was a lad.

Of special interest in the February "Constructor" is the "Ferro-Power" Five, by our very own K. D. Rogers, Chief of "P.W." Research.

Poetry to Invade The Midlands.

I AM glad to observe that in confessing that it is going to start poetry readings in the Midland Regional programmes, the B.B.C. goes all out and admits, with a sob in its Roneo, that lyrics are, "unfortunately," read in a melancholy or wistful style.

If we must have poetry readings I should welcome Masefield reading some of his early work about sea and ships and sailormen. And so would you.

A Projectionist's Plea.

L. H. D. (Derby), a "projectionist" in a "talkie" cinema, sees great possibilities for television in talking pictures, and asks every "P.W." reader to study our articles

on the subject. By the way, I have had a gratifying bundle of letters about those articles, which are, say the writers, making television matters quite simple to them.

Well, L. H. D. foresees future cinemas installed with radio television receivers instead of the present apparatus, and a huge saving in the costs, eliminating copying the films and distribution. Quite Wellsian—but some way off yet, I suggest.

That Feels Like K D K A.

I HEAR that the latest idea in American radio, apart from two-valve mains sets at £2 8s. each, is a system of

(Continued on next page.)

THE NATIONAL ECKERSLEY THREE "Definitely Worth its Weight in Gold"

From G. Burgess, 88, Newby Street, Walton, Liverpool.

I am wondering if this is the first correspondence to reach you regarding your "National Eckersley Three." I completed this set on the Friday evening, and must first congratulate you on such an overwhelming success.

I have been a regular reader of "P.W." since No. 1 and this is the first time I have ever written to you. However, this time I feel I must, as I have never come anywhere near a set that could be compared with this marvel.

It is extremely powerful, selective and sensitive, and attains everything you claim it will do, to say the least of it. It is definitely worth its weight in gold.

I have not yet been able to log the number of stations received, but have a log of 85 stations on my old set, and I know I shall beat it with the "National Eckersley Three," this being a certainty. I have already received several American transmissions at wonderful volume, on an A.C. energised moving-coil speaker, this alone being sufficient to prove the set's capabilities.

Wishing "P.W." every success in the future.

Europe on Medium Waves.

IN this connection I was very interested to learn from a letter written by W. B. T., of Sitiawan, Federated Malay States, that on his six-valve superhet it is possible to hear quite a number of British and Continental medium-waves.

Of course, "conditions" are more important factors in reception in the F.M.S. than in Great Britain, and results are apt to be variable: However, at about 6.30 a.m. (his time) several Regionals are audible, and the new Western Regional sometimes attains R.4 loudspeaker strength.

A Monthly Treat.

I SUPPOSE that you all agree with me that the advent of "The Wireless

A VACUUM FURNACE AS HOT AS THE SUN

tuning by feel. A few stations, chosen beforehand by the makers, can be tuned in by some mechanical means without reference to a dial.

That is useful for the blind, perhaps, though even they could tune in by ear, which is the best method. Unless there is some useful feature of the new design of which I am ignorant, I must regard it as a symptom of sterile inventiveness.

Light in Dark Places.

I UNDERSTAND that the Egyptian Government intends to broadcast official lectures on social, agricultural and sanitary problems to villagers, and in this connection is considering a "four-year plan" for the installation of receiving equipment in two thousand villages.



I should think that the amount of "servicing" which will be required to keep the scheme working will be enormous.

And precisely what will go on in the minds of the villagers when the lectures on "problems" begin is worthy of a bit of speculative writing by H. G. Wells.

A Singer by Chance.

THAT title seems to me to fit very happily the instance of Mr. Franklyn Kelsey, and, as you will see, in no way belittles his talent. Before the war he worked in Canada as farmer, cowboy, book-keeper, estate salesman, homesteader, railway constructor, waiter, miner, hunter, trapper and mining engineer.

Whilst convalescent at Hastings after a war wound he won the gold medal at the Hastings Musical Festival, and thereafter trained under Marcel Journet.

The other chance is that his throat is unique, one vocal cord being shorter than the other, which probably accounts for the special qualities of his voice.

Domestic Drama.

JONES—I'll call him that—looked rather fed up as he boarded our train to-day, so I asked him: "How come?" "Had to stay late in town last night and left wife by herself all evening. Frightfully frosty exception when I got home."



"She had desired to hear the news bulletin and had monkeyed with the radio set, receiving nine speeches, a bit of opera (unknown) from (unknown) and some excellent Morse."

He added: "I simply can not drive into her head the idea that my set is not a private wire direct from the London National studio." "I know," I said, pressing his hand!

"Now I Heard Perhaps."

LETTER received by the B.B.C. this year: "Sir, I wouldn't you ask how much that radio cost in Dutch money. And can this radio also good to play we to live in one street where one tram rides.

"Can I now with that radio also here in Rotterdam good America—England and Europa to get. Wouldn't you my now the price and the one and other to let to answer.

"But good to play and America also good to hear from out Rotterdam. Now I heard perhaps. What from you."

This Week's English Lesson.

HEADLINE from "Variety," an American newspaper: "Hamlet Exhibs Kick on Oxford Accents in American Pix." That, gentlemen, does not refer to

SHORT WAVES

"What is the best method of silencing distortions in a loudspeaker?" asks a correspondent in a contemporary. Has he tried a coal-bammer?—"Punch."

"Apparatus for automobile reception of SOS signals is being fitted to British ships carrying only one radio operator," writes an American paper.

It would be interesting to know whether signals come in best on a Ford or a Rolls-Royce.

"Tin Can Jazz," runs a headline in the "Daily Mirror." That's queer; we didn't know it could even walk.

A cow once lived in a wooden shed, Both plainly housed and plainly fed; Her mind was just as dull as mud While all day long she chewed the end.

But scientists said: "That old cow Would be much happier than now If she could hear some simpler air Of music as she sits in there." And so they brought a gramophone, Which seemed to please her with its tone.

And, for a time, her milk increased, Then suddenly it almost ceased. The cow said: "No more do you get Until I have a wireless set." "Answers."

"the melancholy Dane" or to a well-known proprietary radio adjunct.

It means that exhibitors, of "talking" cinema films in small towns object to the accents of English film artistes. I am reminded that English is of little use to Americans by seeing in the programmes a Jewish Half-Hour (in Yiddish), "La Tribuna" Hour (in Italian) and a Polish programme (in Polish).

B.B.C. Programmes Analysed.

WHEN we imagine that because an evening has been stodgy all the B.B.C. programmes are similar a dose of the facts may be salutary. During 1933 the National broadcast 62.4 per cent music, of which Light was 25.9 per cent and Serious 16.5 per cent. Dance Bands occupied 9.6 per cent, records 7.2 per cent and Variety 3.1 per cent.

The Regionals put out 78.7 per cent of music, made up of 17.8 per cent Serious, 38.1 per cent Light, 11.3 per cent Dance Bands, records 7.9 per cent and Variety 3.3 per cent.

The Snag in Television.

IN view of the fact that we are looking forward so eagerly to being able to see as well as hear our pet broadcasters, it is just as well to ponder on the cold douche which a charming artiste received after singing at the U.S.A. Passaic television station.



One admirer wrote to her, saying: "I like the television broadcast very much. When you sing I like to close my eyes and dream." (My italics!)

A Call to the R.M.A.

FROM the direction of Scotland I have heard shouts of "sweating" in connection with the radio industry. Although I cannot know what goes on in the back alleys of the business, I do know, either personally or by reputation, a number of the leading men in commercial radio, and I flatly decline to believe that they would countenance "sweating."

Some of the firms are old and of established good repute, and most are new and have begun by observing the principle that healthy and happy workpeople are a good investment. Will not the R.M.A. scotch this lie before it swells with its own gas?

Take It or Leave It.

FROM an American weekly devoted mainly to telegraph and telephone matters I learn that the latest use of the vacuum tube is as a furnace. The device has three electrodes, and the fuel used is hydrogen at low pressure.



Now comes the desert! The report says that the heat generated in the hottest spots of the "furnace" is equal to that of the sun.

On reference to the works of Sir James Jeans I find that the temperature at the centre of the sun is 50 million degrees; hence, if the report is accurate, the tube, the inventor and, say, 3,076.04 square yards of the surrounding territory must have been singed pretty badly.

A Blind Radio Transmitter.

UNTIL I heard about Mr. F. H. Bridgewater I thought that there was no blind person who is a "working" radio fan, complete with transmitter. Mr. Bridgewater owns and operates VK2ZO in Sydney, Australia.

With his twelve watts he transmits on the short and broadcast bands; telephony on about 220 metres. I congratulate him on his pluck in sticking to radio after losing his sight, and trust that his hobby will never fail him.

ARIEL.

BROADCASTING QUALITY

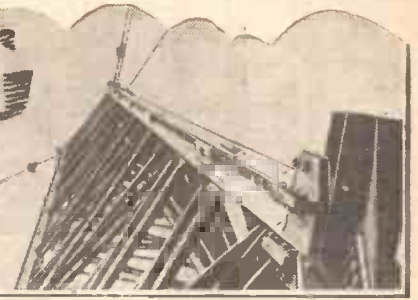

In view of the launching of the Lucerne Plan last month, this special article by Noel Ashbridge, B.Sc., M.I.E.E., Chief Engineer of the B.B.C., is particularly timely. The question of interference due to the crowded condition of the ether is dealt with and the problems of the broadcasting engineer are lucidly explained.

IF we consider the quality which it is possible for a broadcasting receiver to reproduce when situated in the outer regions of the service area of any transmitter we arrive at the conclusion that this will depend on the channel width which is available; in other words, the distance between the wanted and unwanted stations on either side, expressed in kilocycles.

Thus, even when we start out to discuss "quality," we find that we are not free from international complications. It is indeed unfortunate that, in addition to limiting the number of wavelengths which we may use, these difficulties should affect the quality which can be reproduced.

Separation of Less than 9 Kilocycles.

However, the fact remains that a listener situated in a district where the field strength from the wanted station is less than, say, 10 millivolts per metre cannot obtain really first-class reproduction at night, whatever receiver he uses and whatever efforts the B.B.C. makes to this end at the transmitter.

Although in some cases the Lucerne Plan shows a separation of 10 kilocycles between stations, in general there is a standard separation of 9 kilocycles. In a few cases there are separations of even less than 9 kilocycles. If, therefore, we consider the case where a listener is receiving one of the B.B.C. Regional transmitters in an area where the field strength from it is, say, 5 millivolts per metre, during the winter nights one may expect frequent peaks of "indirect rays" from the neighbour stations of about the same strength.

In Practice it is Impossible.

Let us assume for the moment that every transmitter limited its side-band frequencies to plus or minus 4,500 cycles per second on each side of the carrier frequency. In these circumstances, in order to be certain of not being interfered with by the neighbour stations, the listener who is situated as above must not receive any side-band frequencies beyond 4,500 cycles per second. Since in practice it is impossible to receive the carrier frequency plus or minus 4,499 cycles per second and reject plus or minus 4,500 cycles per second, we should have to allow a margin.

At the very best, therefore, all he could do would be to arrange his circuits so that they cut off sharply at about 4,000 cycles per second. In these circumstances he would be free from jamming from the neighbour stations, but most unfortunately he would also be free from all musical frequencies above 4,000 cycles radiated from the wanted station.

Although transmitters do not restrict their side-bands to 4,500 cycles per second, the above conditions do actually apply in practice in a general way, because the modulation or side-band frequencies above 4,500 cycles per second are relatively weak in volume.

Looked at in this way, the situation looks rather depressing from the point of view of the listener who is really anxious to get a high degree of musical quality. In practice,

NOEL ASHBRIDGE



A recent photograph of the B.B.C.'s Chief Engineer, on whom devolves the gigantic task of guaranteeing first-class quality of radio transmission to millions of British and Colonial listeners.

however, the situation is not quite so serious as appears at first sight, because, taking again the case of any of the existing Regional stations, there are millions of the population living in areas where the field strength from the Regional transmitter is considerably more than 10 millivolts per metre.

In the case of the North Regional transmitter we find that the whole of Manchester, Leeds, Bradford and Sheffield, in addition to other highly populated areas, are so situated, and in the case of the

London Region there is, of course, the whole of London and the suburbs. It is partly for this reason that the B.B.C. continues to radiate as large a band of musical frequencies as possible, and does not cut off in the transmitter at, say, some frequency such as 5,000 cycles per second.

The Higher Frequencies are Weak.

It might be said: Would it not be better if all transmitters did cut off at such a frequency in order to prevent mutual interference? It has been already mentioned, however, that the higher musical frequencies are relatively weak and do not cause bad jamming. The "splashing" or "grasshopper noises," which are due to the heterodyning of the carrier of the wanted station with the side-bands of the unwanted stations on either side, are due mainly to the modulation frequencies which contain considerable energy—those between, say, 300 and 3,000 cycles per second. This has been proved by experiment.

Cutting off in the transmitter might reduce mutual interference to a small extent, but it would not by any means eliminate it, and there would be the disadvantage of depriving—in this country, at any rate—several millions of listeners of the possibility of first-class reproduction.

The question now arises: Are listeners who enjoy a strong field strength in possession of apparatus which will give really good quality? The answer is that in many cases they are, but in too many cases they are not, and the latter applies not infrequently to those with new sets. There are in these days a very large number of superheterodyne receivers in use, and the growth of this type of receiver is due to the state of affairs which has been described in the first few sentences of this article.

No Argument Against Superhets.

A high degree of selectivity is essential to cut out interference to the maximum extent, and the superheterodyne circuit offers at least one very practical and satisfactory means of attaining this result. Unfortunately, however, in many cases this selectivity is obtained by means of what amount to fixed band-pass filters in the intermediate circuits, and the selectivity of the latter is the same whatever strength may be available from the station which is being received. Naturally, in these circumstances, the degree of selectivity is set for the worst conditions—that is, where the available field is very weak.

It must be emphasised that this must not be taken as an argument against:

(Continued on page 966.)

Short Wave Notes

News and comments on short-wave topics are this week put into the form of answers to correspondents by our contributor—Britain's leading short-wave expert.

I SAT down to write these notes with the idea of clearing off some of the "general-interest" correspondence in my post-basket, and with an idea that I *might* be able to clear it right out. But for some reason or other there has been a steady increase in the volume of correspondence lately, and I cannot hope to keep up to date just at present.

Will those who have written to me, therefore, please be patient if my replies to their queries do not reach them or appear in print at once? The man I really admire, of course, is the reader who sends me a short, concise, but "newsy" letter; who does not enclose a stamped, addressed envelope, thereby saving me those twinges of conscience that sometimes arise if such a letter is delayed; and who repeats the dose frequently!

"Now for the Postbag."

But that is pure selfishness on my part. Readers *must* ask questions—and, after all, why shouldn't they? But *please* try to be concise and, above all, legible. Thank you. Now for the post-bag.

F. G. (Lenton) finds W 8 X K on 19.72 metres occasionally coming over as late as 7 p.m. "Fade-out time" is apparently becoming much later; last time I listened specifically for W 8 X K he had gone by 5.30.

L. H. S. (S.E.1) and others ask me to make it quite clear that the International DX-ers' Alliance is primarily a broadcast-wave concern. I am sorry if I failed to do this before; but they run quite a number of tests from short-wave stations which should be interesting, whether one is a member or not.

L. J. W. (Cambridge) picked up a station that he thinks was O A 4 B (Peru), at 5 a.m. one cold morning. He picked up some American phone, afterwards finding that his set worked rather better when the aerial was connected to it! He also asks me to mention that W 8 X K on 13.92 metres, his shortest wave, is quite good nowadays in the afternoons.

An Indefatigable Enthusiast.

The indefatigable J. B. M. (Glasgow) has broken into the realms of amateur DX, having logged W 2 G O Q on the 20-metre band (on telephony, of course). He also reports L S L, Buenos Aires, on about 29 metres; Berlin on 49 metres; a station in Trinidad on 40 metres; and somebody announcing "Madagascar" on about 42.5. Can anyone trace the last mentioned?

He has also been amusing himself with my one-valver on the medium waves, and has already bagged an American on it.

A gentleman signing himself Y. Z. (Callington)—I can't believe that those are his real initials—sends in a long list of stations that is interesting chiefly because of the number of transmissions above 40 metres that he has identified. Most of us rather neglect the "over-40's," but look at this—Bandoeng (58.03), Kharbarovsk (70.2), Long Island (62.5), Quito (47), Jeloy (42.92), the usual Americans and, of course, the locals like Zeesen, Vatican and Moscow.

Personally, I very seldom listen above 40 metres with any idea of finding much

TO PROTECT AIRCRAFT



The erection of a neon danger beacon at the Rugby wireless station was begun only a few days before the Imperial Airways liner Apollo flew into a radio pylon at Ruysseide. The Rugby beacon will be visible over a radius of fifty miles.

beyond the "Yanks" and Nairobi. I am mending my ways forthwith.

W. W. (Exeter) sends me Nairobi's latest schedule, as follows: Monday to Friday inclusive, 4-7 p.m.; Saturday, 4-8 p.m.; Sunday, 4-7 p.m.; and earlier transmissions on weekdays which are not likely to get here. The times are G.M.T. The said W.W. is one of the select few who can claim to have received CP 5 (La Paz, Bolivia) in this country. W.H.R. (Plymouth) is another, and so is E.G.A. (Oxford), who logged him as far back as October 26th.

The latter wants identification of the amateur stations EA 1 B B, EA 1 A M and Y R 5 A A. The "EA's" are the Spaniards with their new call-signs: I heard a little while back that they were dropping their dreadful "EA R 1975" affairs, and they have now changed over. "Y R" is given in my latest call-book as the new prefix for Roumania.

New Amateur Prefixes.

While we are on the subject I may as well mention that other new amateur prefixes now in use are U for the U.S.S.R. (instead of EU), Y U for Jugo-Slavia (instead of U N) and L Y in place of the previous R Y for Lithuania.

I want to remind readers of the special I.D.A. broadcast from CR 7 A A (Mozambique) on February 4th, 2-4 a.m. G.M.T. This is the second, the first being on January 21st. No news of it will be available just yet. This station is in quite a new corner of the world, and should be worth getting up (or staying up) for, even if it's a cold night.

P. C. M. (South Nutfield) has been lucky enough to find VK 2 M E (Sydney) at quite good strength on a Sunday afternoon—3.25 p.m., to be precise. Very few readers seem to hear him at that time of day (or, if they do, they don't write and tell me so). Thanks for your good wishes, P.C.M., and reciprocations!

Some Interesting Cuttings.

An Australian reader has sent me a whole bundle of short-wave cuttings from "Australian Radio News," which seems a very interesting and bright paper. They certainly give me the impression that there is much more enthusiasm over short-wave work "down-under" than is the case back here at home.

Five-metre work is all the rage amongst the "hams" of Sydney, and very good work they appear to be doing, too. Applications on which they are working are the control of planes from ground stations, and, of all the strange things, the controlling of the competing cars at speedway meetings! If the driver of a car on the speedway has the time and ears to listen to "orders" on 5 metres the equipment must be pretty reliable.

Incidentally, Mr. Don Knock (V K 2 N O), who is responsible for most of the short-wave matter in the "Australian Radio News," used to be an active amateur in North London, with the call G 6 X G. I wonder if any of my present readers remember him by any chance.

A Request to Readers.

Now I am going to ask a favour. Will some kind reader in South Africa, or Canada, or India please forward to me anything of short-wave interest that appears in his local radio publication? I found the Australian stuff such interesting reading that I have developed quite a craving for more. Besides, one can learn such a lot from other people's opinions, and one doesn't hear nearly enough of what the overseas folk are working at.

Occasionally I get letters from regular readers of "P.W." who are situated in the most unbelievable places. I must pass some of them on to friend "Ariel," who will almost certainly wax poetic about them.

W. L. S.



RADIO STEP-BY-STEP

OUR SPECIAL
SUPPLEMENT for
BEGINNERS

ELECTRODE.

An integral part of a valve or of a battery. In a valve the filament, grid and anode are electrodes, as also are the plates of an accumulator.

ELECTRO MAGNET.

A magnet produced by passing current through a winding having a core of soft iron. There is negligible magnetism when there is no current, and the strength of the magnet is directly proportional to the amount of current.

ELECTRO-MOTIVE FORCE (E.M.F.).

Electrical pressure or voltage.

ELECTRON.

This is presumed to be the smallest particle of any substance which can have a separate existence. An atom consists of a nucleus and a certain number of electrons. Electrical current is a flow of electrons from one point to another.

ELIMINATOR.

A device which eliminates the need for one or more batteries by rendering mains current suitable for the purpose. This term has now largely been replaced by "mains unit."

EMISSION.

The electrons given off by the cathode (filament) of a thermionic valve. A direct index of the emission of a valve is

SINGLE CIRCUIT

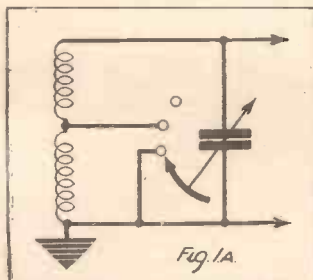

This diagram shows a single tuning circuit employing an extenser. Note the symbol employed in the circuit diagram.

given by the anode current which flows. Due either to long usage or an accidental application of H.T. without grid bias (in the case of a power valve), a valve may lose its emission or, at least, its emission may seriously depreciate.

This results in great loss of volume, accompanied often by distortion. A satisfactory test for a valve's emission is to place a milliammeter in its plate circuit. If there is less current flow than is anticipated with the amount of H.T. and G.B. used a decaying emission is indicated and the valve needs to be replaced.

ETHER.

A hypothetical medium which is supposed to pervade all space, but which possesses no ordinary physical properties except great elasticity. Its existence is presumed in order to supply a

RADIO TERMS

BY G.V. DOWDING ASSOCIATE I.E.E.

wave-motion theory for light, heat and radio analogous to sound waves in air. The ether theory is not universally accepted, and there are alternative theories to explain the mysteries of radio transmission and reception, but we consider that the ether conception still remains as the most generally satisfying.

EXTENSER.

A wireless component comprising the combination of a tuning condenser and wavechange mechanism (Fig. 1). In general form it is similar to an ordinary variable condenser, but the moving vanes (and dial) rotate through 360°. The dial is marked 0-100 and 101-200 in the successive halves.

The 0-100 is used for medium-wave tuning, and the long waves are represented by the 101-200 marking.

The switch-over from the one waveband to the other is accomplished automatically by mechanism operated by the spindle of the device.

A simple extenser tuning circuit is shown at Fig. 1a.

FULL ROTATION

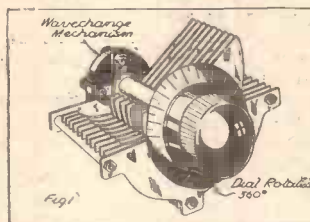

The dial of an extenser rotates through 360°. While the dial is being turned through the first half of its rotation it tunes in the medium waveband. The coil is then automatically switched and the rest of the dial's rotation covers the long waveband.

FADER.

A control which smoothly changes a set over from radio to record operation, at the same time acting as a volume control.

A centre-tapped potentiometer is employed, and is wired in the grid circuit of an L.F. valve as at Fig. 2. It should be noted that the arrangement cannot easily be applied to a detector valve.

When the slider of the potentiometer rests at a position corresponding to the centre tap, nothing comes through. A movement of the control brings in either radio or records with increasing volume as desired.

As will be seen, the change

over from the one to the other is a "fade out," followed by a "fade in," and it is this which gives the method its name.

FARAD.

The unit of capacity. But it is too large for practical purposes, so the microfarad (one millionth of a farad) is used.

FEED-BACK.

The passing back of energy from one point in a set to a preceding point where it can again be amplified by a valve or valves. Reaction is controlled feed-back, and this enables the sensitivity of a set considerably to be increased.

Uncontrolled feed-back (the distinction is our own, but one we feel is fully justified by present uses of the term) may lead to instability and howling. It occurs through undesired coupling effects set up in batteries, between components and wiring, etc.. Strictly speaking, this, too, is reaction, but we prefer to confine the use of this term to that deliberate form of feed-back utilised for purposes of improving the performance of a set.

FIELD STRENGTH.

The intensity of the magnetic and electric fields set up at a given point by a wireless transmission. It is expressed in millivolts per metre, and is thus the voltage induced in an aerial having the effective height of one metre.

FIELD WINDING.

A coil having an iron core designed to create a powerful electro-magnetic field when current is passed through it. A field winding often replaces the permanent magnet of a moving-coil loudspeaker in a mains set.

In such a case the field winding can also be made to function as a smoothing choke.

In the case of an A.C. mains supply the field winding of a "mains-driven" moving-coil loudspeaker must receive rectified current; it cannot be operated by "raw" A.C.

FILAMENT.

One of the electrodes of the valve. It is a thin wire which is heated by having current passed through it, and this causes it to emit electrons. The heating of the metal is due to electrons moving rapidly about, and in a filament of tungsten, when an electron reaches a speed of about 600 miles per second, it is able to break through the surface tension of the filament.

RADIO TO RECORD

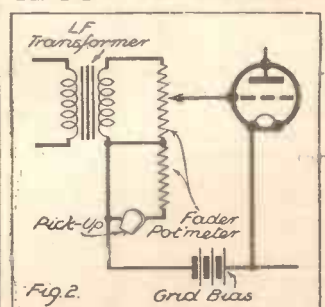

The arrangement which allows a receiver to be changed over smoothly from radio to record operation while applying control to volume.

In the indirectly-heated valve the electron-emitting filament is replaced by a cylinder of electron-emitting material, which is heated by a heater element running through its centre.

(Continued on next page.)

Special Beginners' Supplement—Page 2.

FILTER.

A circuit composed of inductances and capacities designed to prevent passing or to pass certain frequencies.

A simple example is shown at Fig. 3. The filter circuit L—C,

CYCLES PER SECOND

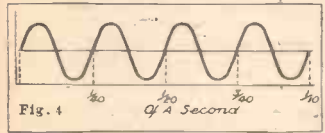

composed of a coil and condenser, has its characteristics adjusted by the condenser C, so that it offers an easy path to the frequency of a powerful station which would otherwise interfere with reception.

Several other forms of filter will be encountered in this summary of terms; several also of an H.F. type were discussed under the heading of "Band-pass," these being designed to offer barriers to all other frequencies except certain desired bands.

FLUX DENSITY.

This is a measure of the intensity of an electric or magnetic field. It is given as the number of lines of force existing

in a unit area of cross-section of the field.

An indication of the efficiency of the magnetic system of a moving-coil loudspeaker is the number of lines of magnetic force which exist per square inch in the gap in which the speed coil moves.

FIXED CONDENSER.

As its name implies, this is a condenser of fixed capacity.

FOUR-ELECTRODE VALVE.

Another name for this is tetrode. It is a valve having two grids in addition to an anode and a filament. The most widely used four-electrode

A WAVETRAP

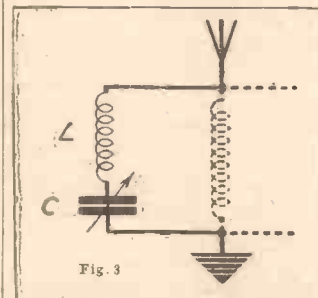

Removing interference by means of a tuned filter across the aerial circuit, which allows an easy path at the frequency of a powerful station which would otherwise spoil reception.

valve is the "S.G." In this the extra grid is the screening grid, and later on we shall have quite a deal to say about this.

FREQUENCY.

The number of cycles an alternating current passes through in a second. Fig. 4 shows four cycles of a current having a frequency of 40—i.e. there are 40 cycles per second.

RECTIFICATION

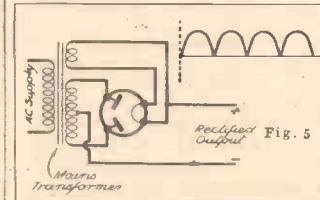

This diagram illustrates how full-wave rectification provides one unidirectional impulse for each half cycle of A.C.

Obviously, then, one cycle, which is a complete rise from and fall to zero in both directions, will take 1/40 second, two cycles 1/20 second, four cycles 1/10 second and so on. The time occupied by half a cycle will be 1/80 second.

This last is important to remember, for if you examine the diagram illustrating Full-Wave Rectification (Fig. 5) you will see that there is, after full-wave rectification, one unidirectional pulsation for each half cycle.

FREQUENCY DISTORTION.

Given a constant input amplitude, if there is a variation in response at different frequencies, then there is Frequency Distortion. Glance at Fig. 6. This might be a pictorial illustration (response or frequency characteristic) of the performance of an L.F. amplifier.

For perfect results the amplifier would have to give "straight-line amplification"—that is to say, exactly the same degree of amplification must be given to every frequency. The dotted line is much more like the results we generally encounter!

As will be noted, a 100-cycle note receives only half the amplification of a 400-cycle note, while a 50-cycle note is barely amplified at all. Similarly, above about 2,000 cycles there is a serious "falling off," and successively higher notes receive less and less amplification.

In short, there is considerable Frequency Distortion.

AVERAGE OUTPUT

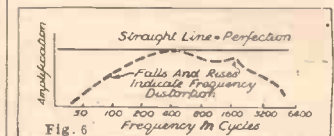

The average set usually has a response curve something like that shown by the dotted line.

WE saw last week that the "resistance" offered by a length of wire, or, in fact, any electrical circuit, to the flow of alternating current was somewhat different from that of a similar length of wire or circuit in which a direct current was flowing.

The direct current has to contend only with a simple form of resistance (R) which, as we have already seen, is analogous to friction in a pipe.

Capacity and Inductance.

But an alternating current, because of its constant variations in strength and direction, is faced with something more than this simple resistance. Two other factors have to be taken into consideration. These are inductance and capacity.

In discussing "A.C. resistance" we showed how the "resistive effect" or reactance of a circuit possessing inductance or capacity (or both) could be conveniently denoted by the letter X and the total impedance (A.C. resistance) to the flow of alternating current by the letter Z. The impedance, of course, is simply the result of combining the ordinary direct-current resistance (R) and the reactance (X).

We also mentioned that the reactance due to capacity could be called Xc and that produced by inductance XL.

But before we express

HOW YOU WORK IT OUT
Explaining further interesting figures and formulæ used in radio.

Xc or XL as numbers, as we have to, if we want to find the reactance in practice, we must write them down in another form.

XL can be written $2\pi fL$, the letter f being the frequency of the alternating-current supply in cycles per second and L the inductance of the circuit in henries. The Greek letter π (pronounced pi) is nothing more than a number which is always constant. It is equal to 3.14. Hence, whenever you see this particular symbol, you will know that it is merely a convenient way of writing the number 3.14 (or, more exactly, 3.14159).

Saving Trouble.

Since 2π is 6.28 (twice 3.14), the expression $2\pi fL$ is therefore 6.28 times the frequency times the inductance.

Also Xc is equal to $\frac{I}{2\pi fC}$

where 2π and f are the same as before and C is the capacity in farads.

Sometimes the Greek letter ω (omega) is used to represent $2\pi f$. We could, if we wished,

write $2\pi fL$ as ωL , or $\frac{I}{2\pi fC}$ as

$\frac{I}{\omega C}$. So you see these mysteri-

ous-looking symbols are employed simply for convenience, and you must agree that they do save time and trouble.

Inductive Reactance.

Now, suppose we had a circuit with an inductance of 2 henries and in which the alternating-current supply had a frequency of 50 cycles. What would be the inductive reactance XL?

This is very simple to work out. We know that XL is equal to $2\pi fL$, and that in the case in point f is 50 and L is 2.

Hence $2\pi fL = 6.28$ times 50 times 2 = 628. Therefore XL is 628 ohms.

Next we can take a circuit in which the capacity is .5 farad and the frequency 50.

Here C = .5 and f = 50, as before.

Xc, the capacity reactance, is equal to $\frac{I}{2\pi fC}$, i.e. $2\pi fC$ divided into one.

$2\pi fC$ in this case is 6.28 times 50 times .5, which is equal to 157. But to get the correct answer we have got to divide this figure into one, and working this out by simple division of decimals, the result is .006.

$$\text{Thus } Xc = \frac{I}{2\pi fC} =$$

$$\frac{I}{6.28 \times 50 \times .5} = \frac{I}{157} = .006$$

ohm. But what of our Ohm's Law formula? Well, we know from last week's article that

$$Z \text{ (the impedance)} = \sqrt{R^2 + X^2}$$

Now, if the circuit contains only inductive reactance and no capacity reactance, the expression is $Z = \sqrt{R^2 + Xl^2}$.

The Final Formula.

On the other hand, if the circuit contains capacity but no inductive reactance the expression becomes $Z = \sqrt{R^2 + Xc^2}$.

And finally, if the circuit has both inductance and capacity, the impedance

$$Z = \sqrt{R^2 + (Xl - Xc)^2}$$

Next week we will take a practical example and work it out fully, and then you will see how easy these fearsome formulae are.



By P. P. ECKERSLEY

"GIVEN A PROPER AERIAL, THE NATIONAL ECKERSLEY THREE GETS EVERYTHING THAT IS WORTH GETTING." That is how our distinguished contributor sums up the remarkable powers of the set he specially designed for "P.W."

"IT ISN'T A KNOB-TWISTER'S SET. IT'S AN HONEST, WORKMANLIKE JOB FOR ENTERTAINMENT IN THE NATION'S LIVING-ROOM." And the easy operation for local and for long-distance reception is described in detail in this article.

I CAN'T think what to say! After all, I have insisted all along that this is a simple set. And my preaching has been on the text that the product improves as it is simpler to handle.

Everything goes that way. The machine is meant to be our slave. One doesn't want to be always shouting at slaves. The best slaves are smooth, efficient things which almost anticipate one's wants.

The perfect vacuum cleaner goes phoop all by itself while you lie in bed, shows you the dust it has collected, puts it in a bin (all of it) and then you can get up.

The perfect wireless set is an arrangement which has a ground-glass screen with numbers on one side and the headlines of programmes available on the other.

The Ideal Method.

No. 4 is America's running commentary on a European disarmament conference; No. 8 the 15th Symphony; No. 1 a debate; No. 7—well, so on and so forth. Then you press a button marked with the number you want and there it is.

And when the programme changes, there it is all written out on the screen. No "Radio Times" and searching and North National or London Regional.

But that, to-day, would cost you a lot of money. It costs you more and more money to have better

and better machines to minister to you, to bring you leisure and time to think about things which amuse you.

The Eckersley Three was designed to a specification. The nation is not so rich as to be able to afford all the luxuries. But the National Set was designed so that the user could get laziness for his money.

"You Get a Lot of Stations."

It isn't a knob-twister's set. It's an honest, workmanlike job for the honest purpose of reproducing radio entertainment in the nation's living-room.

So there's a switch. That switches it on or off. On, and there's a noise; off, and there's peace—well, no noise.

Then there's the tuning knob. Turn that round and round and you get a lot of stations, some worth hearing, some not.

Some which fade because fading is inevitable; some which will be jammed by atmospherics because atmospherics are inevitable; some which are too faint to enjoy, but which, if magnified any more, would be too noisy to enjoy.

Given a proper aerial, the National Eckersley Three gets everything that is worth getting.

And there's the retroaction (or reaction) control. Now, if the set could have been a little more expensive, could have carried just a few more components, there would not have been any retroaction under the user's control. As it is, we have to have it because the set could not be sensitive and selective enough in many cases without it.

Retroaction Effects.

Now, retroaction does four things:

(1) It reduces the damping in the tuned circuit connected to the detector and so makes up for the losses which are introduced by the detector-grid-current load.

(2) It raises the sensitivity of the high-frequency valve because it raises the dynamic impedance of the circuit effectively in the anode circuit of that valve.

(3) It increases the selectivity of the last circuit (and hence the whole set) because it reduces the effective resistance of the circuit.

(Continued on next page.)

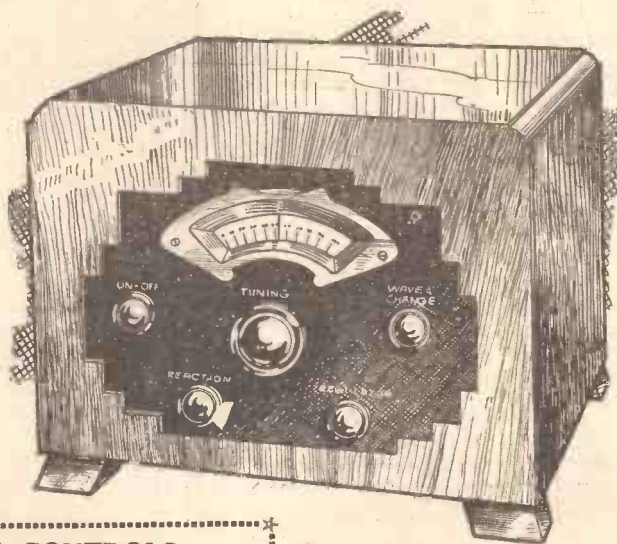

ALL ABOUT THE CONTROLS

The whole of the tuning is actuated by the large central knob, which swings a pointer across the clear, open-reading scale, reading from 0 to 100. To the left of this is the on-off switch, and in the corresponding position to the right is the wavechange control, for placing the tuning on medium or long waves, as desired.

Of the two controls at the bottom of the panel, that on the left governs reaction—or retroaction, as P. P. Eckersley generally calls it; whilst the adjustment of the right-hand knob is the all-important Regulator, for ohmic control.

This is an entirely novel feature, never fitted before to any other set. It performs the two important functions of regulating the selectivity and controlling the volume.

CORRECT VALVES FOR THE THREE STAGES

Make	S.G.	Detector	Output
Cossor	220S.G.	210H.F.	220H.P.T.
Mullard	F.M.12A.	P.M.1 H.L.	P.M.22A.
Mazda	S.215A.	H.L.2	Pen.220
Marconi	S.24	H.L.2	P.T.2
Osram	S.24	H.L.2	P.T.2

THE ACCESSORIES WE CAN CONFIDENTLY RECOMMEND

LOUDSPEAKER.—Celestion, W.B., Rola, Blue Spot, R. & A., Ferranti, H.M.V., Amplion, Marconiphone, Cossor, G.E.C.
 BATTERIES.—H.T. 120 volts: Lissen, G.E.C., Ever Ready, Siemens, Pertrix, Ediswan, Drydex, Marconiphone, Grosvenor, Hellesens or Block H.T. accumulators.
 L.T. 2 volts: Block, Lissen, Pertrix, G.E.C., Ediswan, Exide, Oldham.

AERIAL AND EARTH EQUIPMENT.—Electron "Superial," Goltone "Akrite," British Radiophone "Receptru" down-lead, Bulgin Lightning switch, Graham Farish "Filt" earthing device.

ON THE AIR WITH THE NATIONAL ECKERSLEY THREE

(Continued from previous page.)

(4) If pushed too far it sets up a howling noise unpleasant to listen to but terribly convenient as a means to search for stations.

(While it is true that the screened valves minimise the interference caused to other listeners by set oscillation, some "noise" is radiated, and the P.M.G. tells you, on the back of your licence, that you mustn't do it.)

Now, I am not going to tell you how to use retroaction until I tell you how to use the regulator or coupling resistance, because the two are interdependent.

The regulator or coupling resistance is

Now let us see what to do in different circumstances.

First, local stations: strong volume. Put retroaction to minimum. That is, if you turn one way the set squeals and is more sensitive; if you turn the other it is less sensitive. That's where I want it: least sensitive. Now, simply regulate volume by the regulator.

For Distant Stations.

Second, distant station. Put regulator to full—i.e. all resistance in, i.e. most sensitive. Then bring up retroaction until you have too much volume, then reduce by regulator. All other stations intermediately.

I cannot go into the whole thing now, but by doing what I have asked you to do you keep the selectivity constant for all stations, distant or local.

This is right, because it means that you get the same quality for all. The rising pentode characteristic tends to offset the

special mention. The grid-bias connections, for instance.

What you have to do with these is to connect G.B. + to the positive socket of the G.B. battery, and G.B. - 1 to 1½ volts negative. G.B. - 2 must be connected to the negative tapping which is the highest possible without causing distortion.

Generally, this will be about 15 volts. The higher the voltage applied here the lower the anode current.

The pick-up leads are passed through a hole in the chassis and connected to the terminals (indicated in the diagram) of the combined 50,000-ohm potentiometer and radiogram switch.

Trimming the Tuning.

Trimming the ganged tuning condenser must be done before the set is placed in the cabinet. This is carried out in the same way as was described for the National set in last week's issue. The difference is

THE PARTS AND RECOMMENDED MAKES FOR

- 1 British Radiophone 3-gang 0005-mfd. tuning condenser, type 604.
- 1 British Radiophone slow-motion drive for above, type 711.
- 1 Set 3 Telsen matched screened coils, type W288, or Colvern K.G.O., K.G.O., K.G.R.
- 3 W.B. large type 5-pin valve holders, or Benjamin, Telsen, Lissen, Graham Farish.
- 1 Lissen Hypernik L.F. transformer, or Telsen, type GS5, Varley, R.I.
- 1 Graham Farish screened H.F. choke, type H.M.S., or Telsen, Bulgin, Wearite.
- 1 Graham Farish 0003-mfd. differential reaction condenser, or Polar, Telsen, J.B., British Radiogram.
- 1 Graham Farish 2-mfd. fixed condenser, or T.C.C., Telsen.
- 2 T.C.C. 2-mfd. fixed condensers, type 50, or Graham Farish, Telsen.
- 1 Igranic 20-ohm. variable resistance, type WYPAD.
- 1 Dubilier 100-ohm resistance, 1-watt type, or Graham Farish, Bulgin (with wire ends or terminals).
- 1 Graham Farish 100,000-ohm 1½-watt type Ohmite resistance with horizontal holder, or Ferranti.
- 1 Graham Farish 30,000-ohm 1½-watt type Ohmite resistance with horizontal holder, or Ferranti.
- 1 Graham Farish 5,000-ohm 1½-watt type

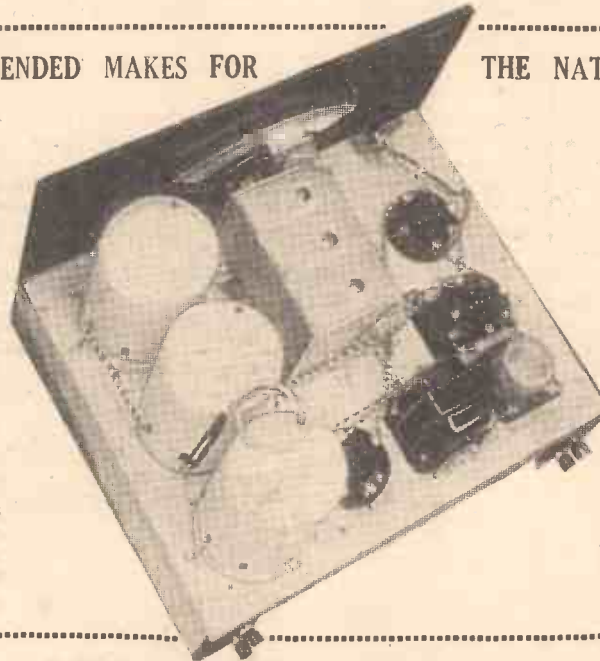

THE NATIONAL ECKERSLEY THREE

- Ohmite resistance with horizontal holder or Ferranti.
- 1 Graham Farish 300-ohm 1½-watt type Ohmite resistance with horizontal holder.
- 1 Lissen 1-meg. grid leak with wire ends, or Varley, Dubilier, Bulgin.
- 1 Dubilier 1-mfd. tubular fixed condenser, type 4404, or T.C.C., Graham Farish.
- 1 Dubilier 0002-mfd. fixed condenser, type 620, or T.C.C., Lissen, Graham Farish, Telsen.
- 1 British Radiogram rotary QMB on-off switch, type No. 51, or Bulgin.
- 1 Clix S.G. anode connector, or Belling-Lee, Bulgin.
- 4 Clix indicating terminals or Bulgin, Belling-Lee, Igranic.
- 2 Belling-Lee wander-plugs, or Igranic, Clix, Bulgin.
- 1 Belling-Lee wander-fuse.
- 2 Clix accumulator spades, or Belling-Lee, Eelox.
- 1 Peto-Scott Metaplex chassis, 12 in. x 10 in. x 2½ in., with terminal strips.
- 1 Peto-Scott ebonite panel, 12 in. x 8 in., or Goltone, Permcoc, Wearite.
- 1 Set British Radiogram matched knobs.
- 2 Coils British Radiophone "push-back" wire.
- 1 Peto-Scott cabinet.
- Screened wire, flex, screws, etc. (Peto-Scott).

novel. It has never been fitted before to any other set. It has two functions: (a) to regulate the selectivity of the set; (b) to regulate volume.

You cannot, by means of the regulator, increase selectivity beyond a certain amount. But you can decrease volume to zero.

falling characteristic of the high-frequency circuits.

The conventional circuits, which use only retroaction to get selectivity, are bound to give different quality performances on different retroaction settings. If you will operate the set as I have asked you to you will be making full use of the invention of resistance coupling which I have put at your disposal.

If I had more money of yours to spend I should have made a self-compensating arrangement between retroaction and the coupling resistance. It would have meant special components, too, which is all outside the specification.

So I leave you with the facility to get something quite new and original—constant quality whatever the medium-wave station.

The National Eckersley Radiogram.

To those readers who favour the Radiogram version of the "National Eckersley Three" I need not address a special article on operation, because the controls are identical on both sets. So what I have said for the one holds good for the other.

But there are nevertheless one or two points about the Radiogram that deserve

that the trimmers are on the side of the tuning condenser in the Radiogram, but the process of trimming is identical.

The on-off switch for the Radiogram has three positions. The central position is "off." Turn to the left for gramophone

(Continued on page 966.)



OHMIC CONTROL

The Regulator in position on the panel.



CANNED EFFICIENCY

A close-up of the S.G.—detector coupling unit.

The NATIONAL SET for D.C. MAINS

BY P.P. ECKERSLEY

SOME have D.C. mains. A few will have D.C. mains for a long time yet. Others now enjoying the benefits of D.C. could do well to find out from the local authority how long it will be before the D.C. will be changed to A.C. Because, if it's only a short time before that happy change-over takes place, it's no good making D.C. sets and then having to scrap them.

But if your D.C. is likely to persist it is maddening to have all that electric power and not be able to use it.

When I had D.C. I used it as H.T. direct, and had a rotary converter to charge my accumulators. But the B.B.C. were kind enough to arrange all that for me, and it was an expensive arrangement. So, unless you feel particularly like spending from five to ten pounds, I do not advise it.

The National Eckersley Three, which was fully described in our January 20th number, can easily be converted to operate from D.C. mains. On this and succeeding pages our famous contributor tells you exactly how the simple change-over is made. So in this case we have a converted set and a new mains unit.

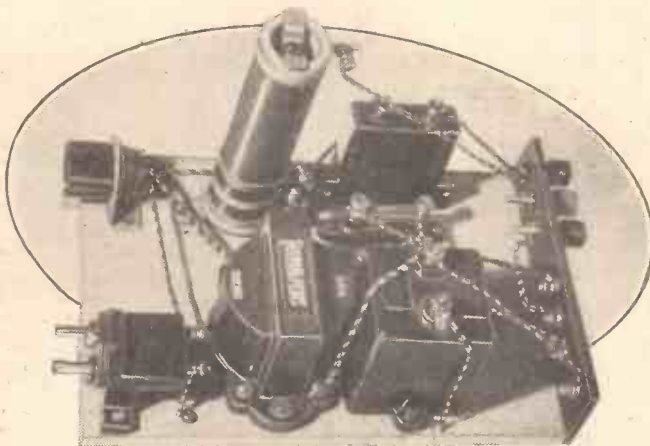

I assume you have read all the dope on the battery model, and that this will serve as notes on a conversion.

You want extra components as follows: One combined 5,000-ohm potential divider (or wrongly called "potentiometer") and on/off switch.

One 100-ohm fixed resistance and one 0.1-mfd. fixed condenser.

Let us look at the top of the chassis first, then proceed to:

Remove the lead joining the switch to the filament terminal of V_2 which is nearer the panel.

Remove the L.T. negative lead from the switch and connect it to the aforementioned filament terminal of V_2 .

Very Little Alteration.

Also remove the leads joining this same filament terminal of V_2 to the chassis and to the right-hand filament terminal of V_3 (looking from the back of the set).

Then remove lead joining filament terminal to cathode terminal of V_2 and connect cathode terminal to chassis.

Also remove lead joining filament terminal, farther from panel, of V_1 to filament terminal, farther from panel, of V_2 .

Finally, removed lead joining cathode of V_3 through the baseboard to a 2-mfd. condenser on the underside of the chassis.

Now you have finished with the top of the chassis, and so to the underside.

Connect a short length of single flex to (Continued on page 952.)

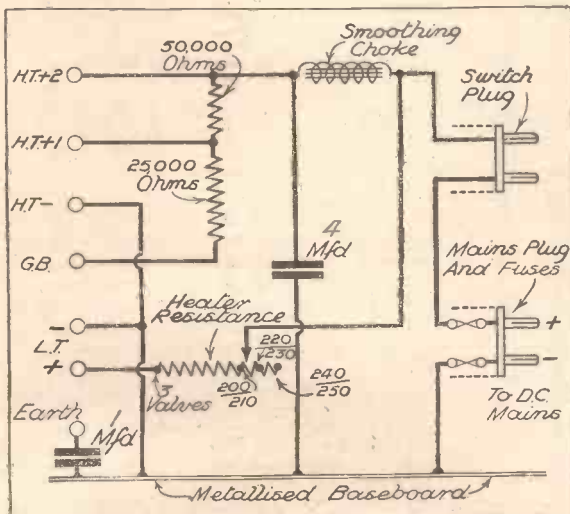

EXTREMELY EASY

A D.C. mains unit supplies the L.T. and H.T. requirements of the set, and its simple construction is well illustrated by the view above.

★ ★

To the right is a close-up of part of the set, showing how the filament wiring, etc., are altered for D.C. working. The necessary alterations in the connections to change the receiver from battery to D.C. working can be carried out in a few minutes.

★ ★

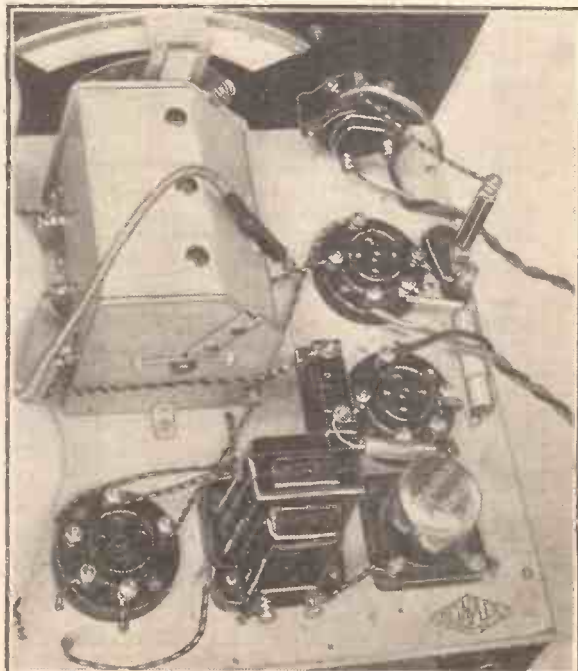

FEW PARTS AND STRAIGHTFORWARD CONSTRUCTION

Above is the circuit diagram of the simple D.C. unit for the National Eckersley Three, showing the values of the resistances and condensers employed. (This same unit is employed for the Radiogram version, the D.C. conversion of which will be described shortly.)

WHICH D.C. MAINS VALVES TO USE

Make	S.G.	Detector	Output
Marconi	VDSE	DH	DPT
Ostram	VDSE	DH	DPT
Cossor	DVSG	DHL	—

The above-baseboard layout and wiring of the National Eckersley Three for D.C., showing the modifications that have to be made to the battery model.

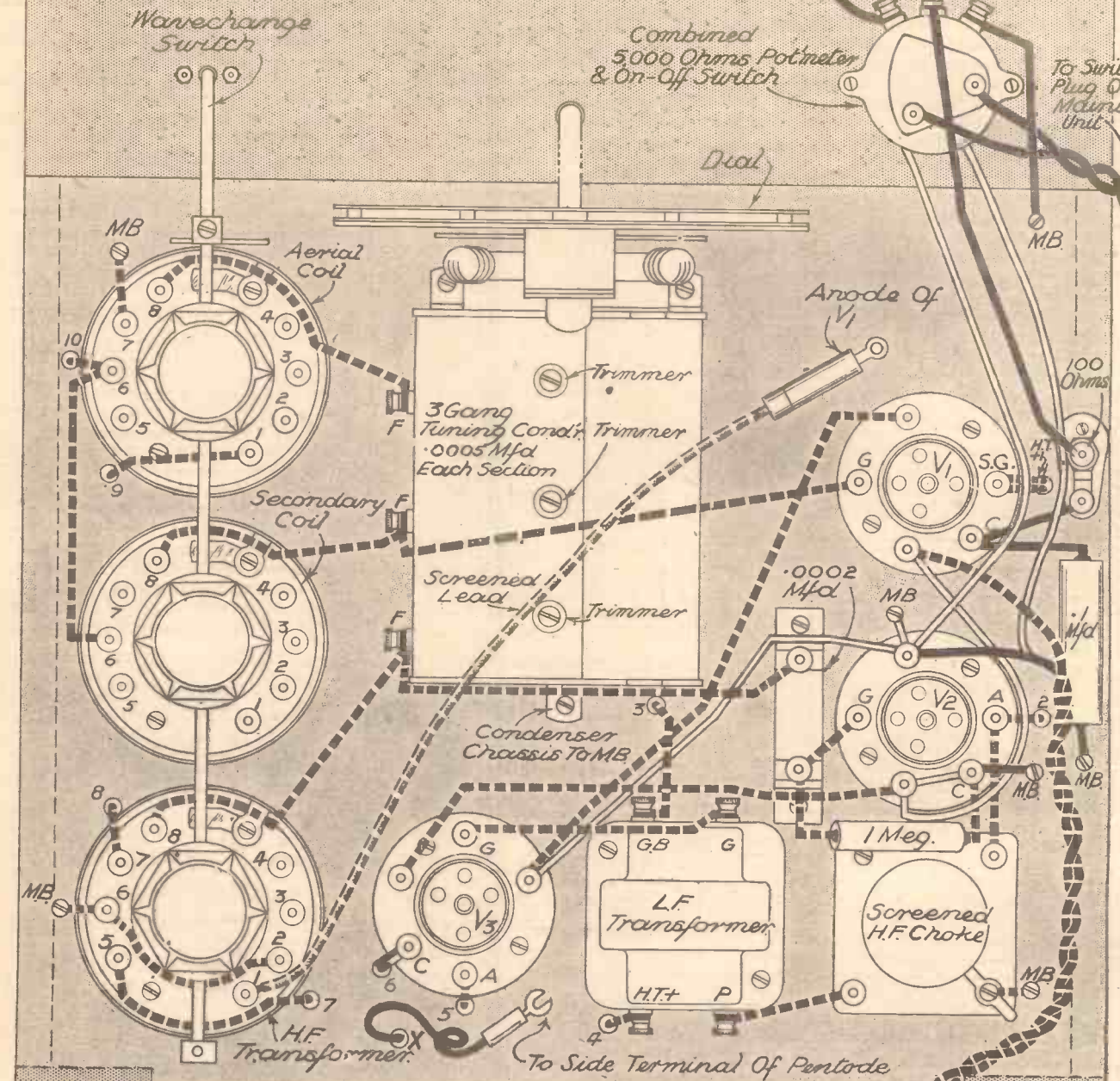
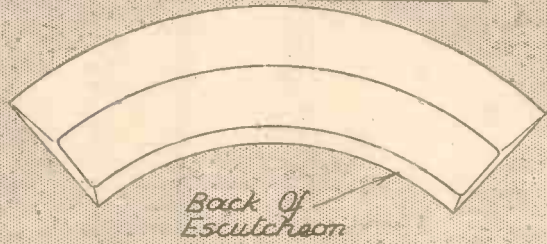

Note:
Leads To 'MB' Go
To Metallised
Baseboard.



Aerial

LS-

Converting the National Eckersley Three to D.C.

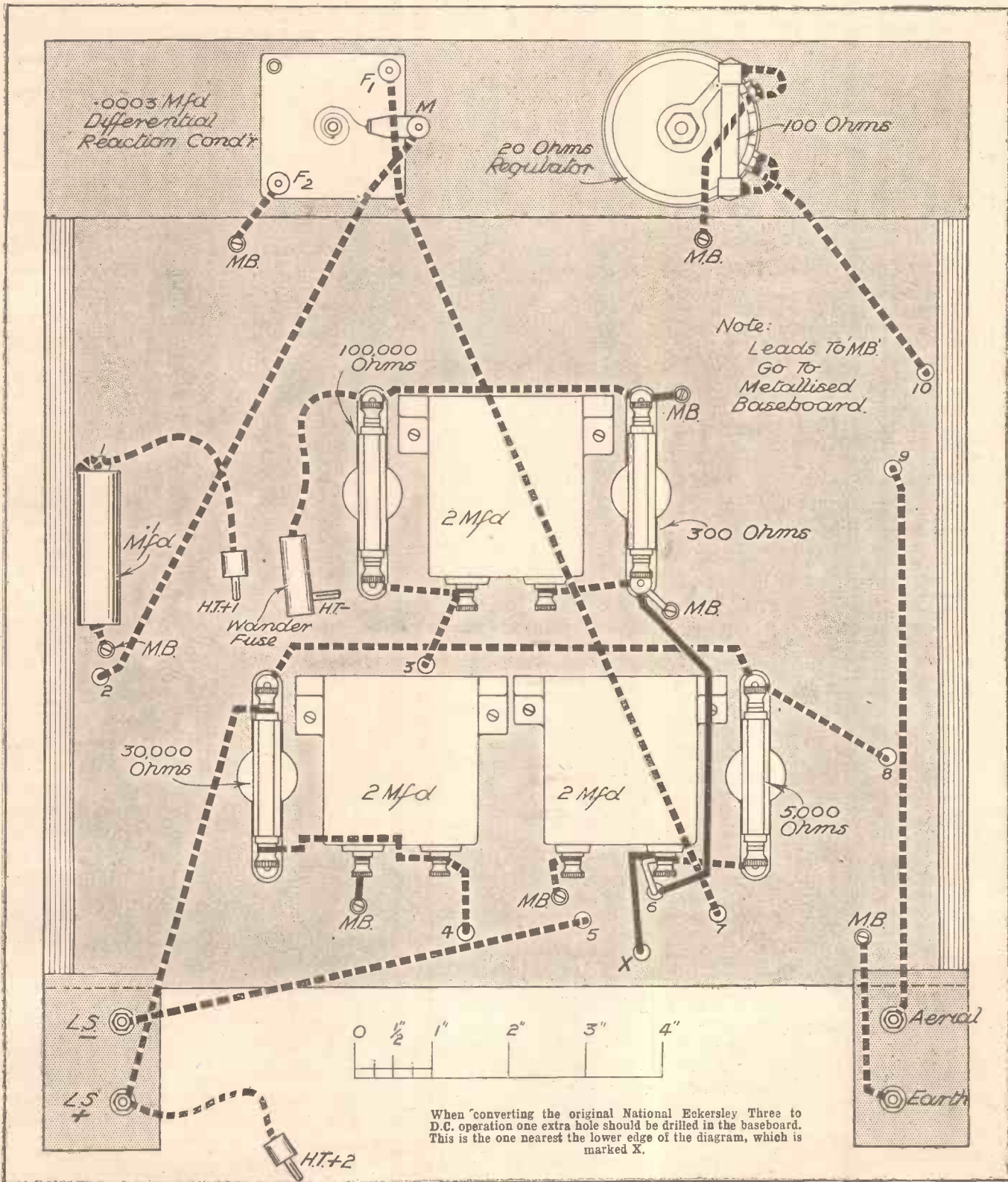

On this page we show the alterations to the wiring below the baseboard, whilst the preceding page illustrates the above-baseboard wiring when the set is converted to run from D.C. mains. On both, the heavy dotted lines show the original wiring which remains unaltered. The few new wires required are shown in solid black. Wires which must be removed from the original set are shown "hollow," and examples of all three classes of leads will be seen connected to the lower terminals of the 300-ohm resistance near the centre of this page.

THE NATIONAL SET FOR D.C. MAINS

(Continued from page 949.)

the same terminal of the 2-mfd. condenser just mentioned. Drill a hole in the chassis and pass the flex through it. (This will be connected to the side terminal of the pentode output valve.)

Remove lead joining the 300-ohm resistance to the chassis and connect the same terminal of this resistance through hole 6 to the cathode of V_3 . Connect the other terminal of this resistance to chassis.

Go back once more to the top of the chassis and remove the on/off switch and replace by the combined potentiometer and switch. Mount the .1-mfd. fixed condenser, and also the 100-ohm resistance in vertical holder.

The cathode terminal of V_1 must be connected to the terminal on the resistance connected to the chassis and also to one wire end of the .1-mfd. condenser. The other wire end of the condenser is connected to the chassis.

The top terminal of the resistance is connected to the centre terminal of the potentiometer. Connect the latter's right-hand terminal to the chassis and the left-hand terminal to a length of single flex about eighteen inches long.

Connecting the Earth.

Also connect a length of twin flex about the same length to the switch terminals of the potentiometer.

The socket which connects to the switch plug on the mains unit is attached to the other end of this twin lead. The mains leads must be connected to the socket portion of the mains plug and fuses.

The receiver is now ready to be connected to the mains unit. The position, function, etc., of the L.T. and H.T. leads are obvious. The single-flex lead from the potentiometer has a wander-plug attached to it and is plugged into the socket on the mains unit marked "G.B." The twin-flex lead from the switch is attached to the switch plug by means of the socket.

Do not connect the earth lead to the earth terminal of the receiver, but to the earth terminal of the mains unit.

Now it is necessary to make up the D.C. mains unit.

The baseboard is made of Metaplex, and measures 8½ in. by 6 in. Several connections are made direct to the conducting baseboard, thus making the already simple wiring simpler.

(Continued on page 970.)

WHAT YOU REQUIRE FOR THE D.C. MAINS UNIT

- 1 Igranic smoothing choke, type C.H.4, or R.I.
- 1 Dubilier 4-mfd. fixed condenser, type BB, or T.C.C., Igranic.
- 1 Bulgin combined mains plug and fuses, type F.15.
- 1 Bulgin mains plug, type P.21, or Belling-Lee, Goltone.
- 1 Bulgin heater resistance, type M.R.8.
- 1 T.C.C. 1-mfd. fixed condenser, type 50, or Dubilier, Graham Farish, Telsen, Lissen, British Radiogram.
- 1 Ferranti synthetic resistance, 50,000-ohms, in horizontal holder, or Graham Farish.
- 1 Ferranti synthetic resistance, 25,000-ohms, in horizontal holder, or Graham Farish.
- 3 Clix indicating terminals, type B, or Bulgin, Belling-Lee, Igranic, Eelex.
- 4 Clix sockets with engraved shoulders, or Igranic, Belling-Lee, Eelex.
- 1 Peto-Scott Metaplex baseboard, 8½ in. x 6 in.
- 1 Peto-Scott terminal strip, 6 in. x 1½ in., or Goltone, Permcol, Becol.
- 1 Coil of British Radiophone "push-back" wire.
- 1 Peto-Scott metal cover.
- Screws, etc. (Peto-Scott).

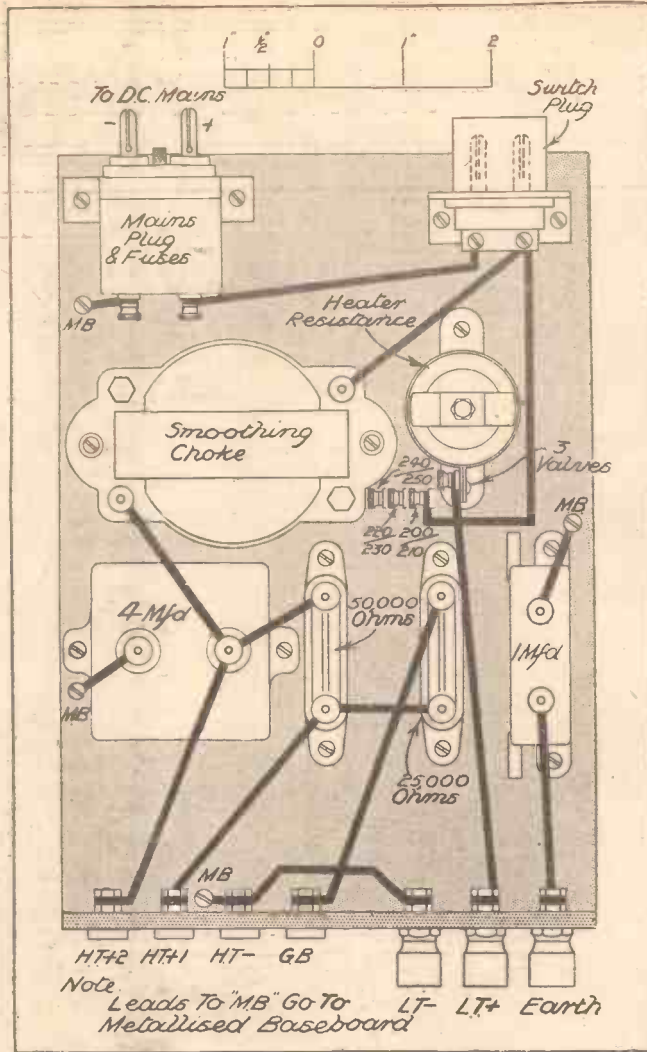

THE EXTRA PARTS NEEDED

to
CONVERT
THE SET
TO D.C.

- 1 Bulgin 5,000-ohm potentiometer with on/off switch, type V.S.29, or Lewcos.
- 1 T.C.C. 1-mfd. fixed condenser, type 250, or Dubilier.
- 1 Graham Farish 100-ohm 1½-watt, type "Ohmite," resistance in vertical holder.

★ ★ ★

These two illustrations make perfectly clear the simple construction of the mains unit for D.C., using the components listed below. (This same mains unit is applicable to the National Eckersley Radiogram, so keep these particulars if you are building that model.)

★ ★ ★

RECOMMENDED ACCESSORIES

- LOUDSPEAKER.**—Celestion, W.B., Rola, Blue Spot, R.&A., Ferranti, H.M.V., Amphon, Marconiophone, Cossor, G.E.C.
- AERIAL AND EARTH EQUIPMENT.**—Electron "Superial," Goltone "Akrite," British Radiophone "Receptru" down-lead, Bulgin Lightning switch, Graham Farish "Filt" earthing device.

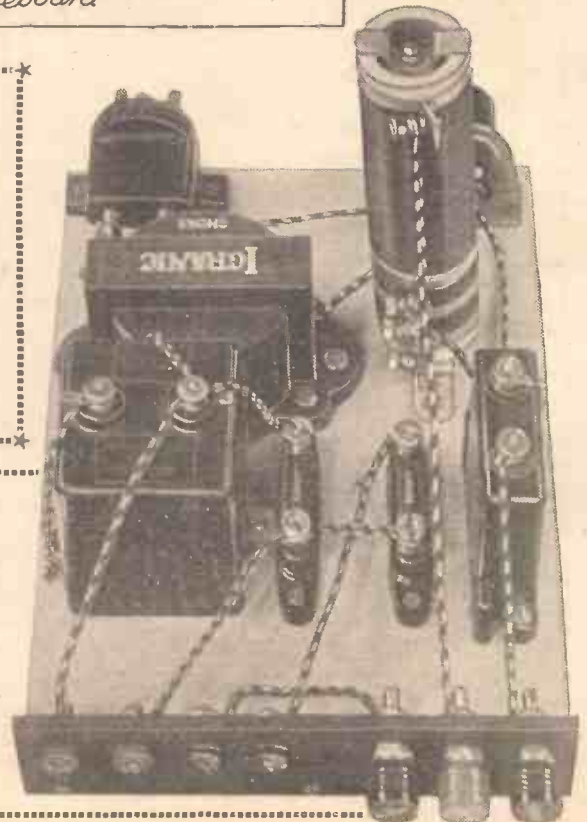

TELEVISION

KEEPING IN STEP

BY G.P. KENDALL B.Sc.

WE have now got a pretty good general idea of the way a television image is transmitted in little pieces, and how those pieces are reassembled on the receiving screen. We have seen how each fragment of the picture can be placed in the right spot on the screen by means of a scanning disc, and how the correct light-and-shade effect can be achieved with the aid of light-control methods.

In the course of all this we discovered

Every movement on a television screen must take place at precisely the same time as the original, so obviously the transmitter and receiver must keep exactly in step with one another. How this is done is interestingly described in this article.

that the success of the whole process depends upon some arrangement being made to ensure that the moving spot of light which is scanning the receiving screen is, at any particular instant, in a position exactly corresponding to the little bit of the picture which is being broken up at the transmitting end.

This means that the receiving scanning process must be kept in exact step with the equivalent operation at the transmitter, and here we meet one of the fundamental problems of television: synchronism!

A Difficult Problem.

More promising systems have been wrecked on this rock than any other single difficulty which the inventor encounters. The point is that until the receiver has been brought into step with the transmitter no sort of picture at all can be seen; consequently it is necessary to provide some means of achieving synchronism before experiments can be made upon any other detail.

Evidently, then, it is advisable to spend a little time on the subject and make sure that we understand its main principles.

First, we must realise clearly that the problem is one of keeping the receiver in exact step with the transmitter, and not merely running the former at some fixed constant speed; the speed of the scanning process at the transmitter may vary a trifle, and we have to see that there is instantly a corresponding variation at the receiver.



In the early days they used to use what may be called "hand" methods of synchronising, which were probably responsible for more naughty words than anything else in the whole field of television. Unless you have tried it you cannot imagine the state of helpless exasperation to which these methods can reduce even the most placid person after half an hour's



THE ADVANTAGE OF THE CATHODE RAY

One striking feature of the cathode ray for television is that it involves no revolving mechanism for synchronising, the process being entirely electrical for this class of receiver.

struggle, in the course of which he has probably had half a dozen fleeting glimpses of the picture, but has never been able to hold it for more than a few seconds.

They usually worked by the use of a variable resistance in the circuit of the motor driving the scanning disc, and the difficulty was, first, that you had to wait some time for the motor to settle down to its new speed after every adjustment and before you could try another; and, secondly, even when great care and patience resulted in synchronism, a very slight variation at the transmitter caused you to lose it again.

Among the appreciative letters about this Special Television Survey we constantly get references to the fact that Mr. Kendall makes it all seem comparatively simple. Television is not that, by any means, but the statements are a remarkable tribute to the lucidity of our contributor's style.

I mention this crude scheme because it enables us to see in somewhat greater detail what we want an automatic synchronising device to do.

If we could in some way cause the incoming signals themselves to operate the resistance which controls the speed of the motor we should achieve our object.

Regular Impulses.

To be able to do this we should have to see that the signals contained some sort of regular impulses which could be used for timing purposes, and then we should have to devise something which would speed up or slow down the motor whenever it found itself getting out of step with them.

That is almost exactly how it is usually done in practice. There is actually a regular "timing" frequency in the transmission, which goes on the whole time and acts as a sort of electrical gear wheel with which we can engage our synchronising device and so cause it to be held in step.

This is really the best way of looking at the action of an automatic synchroniser of the type mostly used in this country. It does not function by varying a resistance in the motor circuit, like the imaginary system with which we started, but may best be compared with an electrical gearing of the receiver to the transmitter.

Just as would be the case with mechanical gearing, the "teeth" cannot be slid into mesh (Continued on next page.)

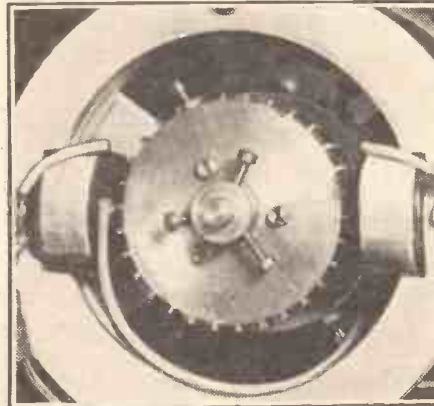
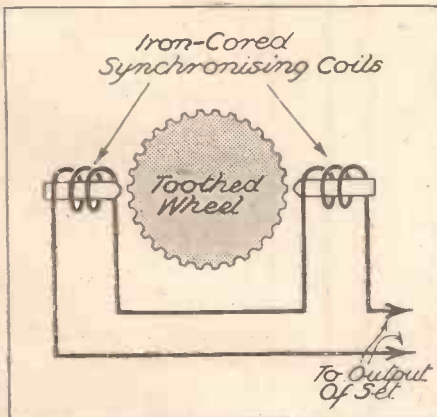

RUNNING THE DISCS AT CONSTANT SPEED—IN THEORY AND PRACTICE

To the left is the scheme of connections of a synchronised disc, the speed of which is affected as explained on the next page. The picture to the right shows an example of the practical form the apparatus takes, being a close-up of the synchronising device fitted to a Baird Televisor.

KEEPING IN STEP

(Continued from previous page.)

unless the two "gear wheels" are first made to run at the correct speeds. Once the teeth have been engaged, of course, one wheel is driven by the other and so kept in "synchronism."

What this means in practice is that the television synchroniser of the usual type is not capable of dragging the receiving scanner into step in the first place unless it happens to be running very nearly at the correct speed. Consequently, there is usually a hand control with which one varies the



A FRENCH PIONEER.

M. Belin, who has done much in France to develop the transmission of pictures and television technique.

motor speed a little one way or another until one hits upon something like the right rate, whereupon the automatic synchroniser takes charge and brings it to the exact speed of the transmitter.

Where the comparison with gear wheels is not good, and may mislead us if we are not careful, is in the matter of the actual driving of the scanner. In the case of real mechanical gears everything would be simple; the wheels which provided the synchronising effect would also do the driving.

The "Timing Signal."

With electrical "gearing," however, there is not sufficient power available for this to be possible, and so we have to arrange matters rather differently. We must provide a motor to do the hard work, and only expect our electrical gearing with the transmitter to give enough power to control the speed.

The actual power available naturally depends upon the nature of the radio receiver which is used, but it will only be of the order of a few watts, whereas it may take perhaps 50 watts to drive the scanner properly. Our problem, then, is to see how a few watts of "timing signal" can be made to control the speed of a motor taking 50 watts.

The timing signal is in the form of a continuous note which is sometimes called the scanning note, and gives the characteristic sound which you hear at the beginning of a television transmission before any actual image is going out. Once the transmission of a picture begins, of course, the scanning note sounds blurred and

obscured to some extent by the various impulses representing the image.

In the case of the present B.B.C. transmission the scanning frequency is 375 per second, which is the number of times that the scanning spot crosses the image in each second. (A thirty-line picture, repeated $12\frac{1}{2}$ times per second, obviously means $12\frac{1}{2} \times 30$ sweeps of the spot in each second.)

This, it should be noted, is a rather general explanation of the nature of a television transmission, but it will serve our purpose for the time being.

Automatic Control.

This is how we use the scanning frequency to govern the speed of the receiving scanner: first, we adjust the speed to nearly the right figure by means of a resistance in the motor circuit. It so happens that a motor running under these conditions of light load and limited speed is very sensitive to the effects of control. A very small braking force slows it down considerably, and a little assistance will make it speed up to a similar extent.

On the shaft of the motor is mounted a toothed wheel made of iron, and almost touching the teeth at each side are electro-magnet coils, the arrangement being shown in the sketch on the previous page. The synchronising signals are fed into the coils, and the whole device then becomes what is called an "induction motor" of almost the simplest possible type.

Such a motor will normally run at one speed only, which is fixed by the number of teeth on the wheel and the frequency of the current which supplies it. Force

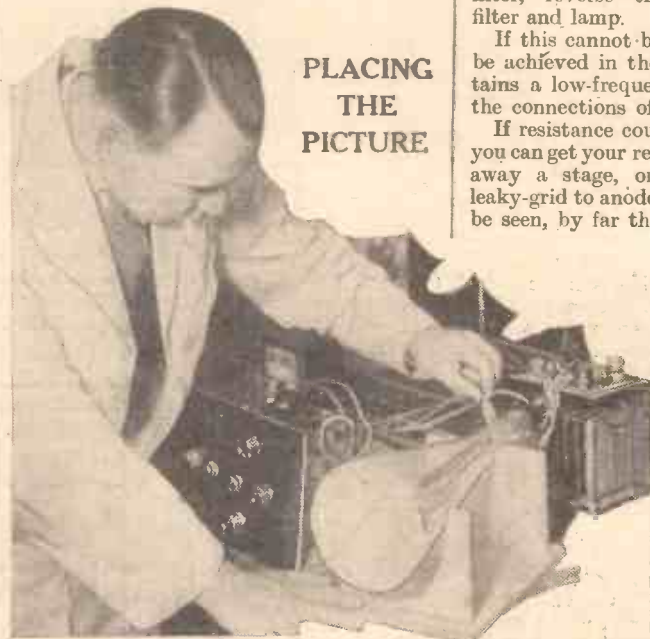

Mr. K. D. Rogers, Chief of "P.W.'s" Research Department, adjusting the connections to the deflectors of a cathode-ray television receiver. It was fully described in this journal, being the first practical model produced for the benefit of the home-constructor.

must be applied to it to make it run either slower or faster, and here we see how synchronism can be maintained when once it is achieved.

Any tendency to wandering by the driving motor will be firmly resisted by the toothed wheel, which insists on running at the speed fixed by the frequency of the scanning signal. Any little variation in the

frequency of the incoming signal will cause the toothed wheel to speed up or slow down the driving motor, and so keep the receiving scanner in perfect step.

This is only one method of using the synchronising signal, but it is one of the most popular and effective.

REVERSED IMAGES

Some practical points about two puzzling phenomena.

IN television experimental work one sometimes gets an image which is "reversed" in one or other of two ways. Much the most common of these is the reversal of light and dark which occurs with the neon lamp type of receiver.

To use a photographic term, the image is a "negative" instead of a "positive," and the effect is apt to be puzzling the first time that it is seen. If something queer seems to be wrong, therefore, just look carefully at the face of anyone who may appear in the viewer and note whether it seems to have white eyes, mouth and hair. If it has you are most likely getting a negative.

The technical remedy is to reverse the polarity of the signal impulses to the lamp in relation to the steady D.C. polarising voltage. If the lamp is fed from an output filter, reverse the connections between filter and lamp.

If this cannot be done the reversal must be achieved in the amplifier. If this contains a low-frequency transformer, reverse the connections of the secondary.

If resistance coupling is used throughout you can get your reversal by adding or taking away a stage, or by changing over from leaky-grid to anode-bend detection. As will be seen, by far the easiest method is with the aid of an output filter.

The "Mirror Effect."

The other form of reversal is, sometimes experienced with receivers of the mirror-drum type, and takes the form of a picture in which right and left are interchanged. This is usually the result of an incorrect arrangement of the various supplementary mirrors which carry the beam of light to and from the drum.

Think what happens when you look at yourself in a looking-glass, and you will get

an idea what can go wrong. If you look at yourself with the aid of two mirrors, remember, right and left are not reversed.

In general, if you avoid any system of mirrors which results in the beam being turned so that it runs for some part of its journey parallel to the driving shaft of the drum you are not likely to get a reversal.

G. P. K.

Meet Your Favourite RADIO STARS

One of the curious things about radio is that it puts you on friendly terms, as it were, with a host of clever folk whom you have never seen—whom you possibly never will see.

You have listened to their voices so very often during the eleven or so years of broadcasting that you cannot but feel that you know them well. And yet—what are they like? You must often have wondered.

No need to wonder any longer. Here they are—over three hundred of them—assembled to meet you in the pages of WHO'S WHO ON THE WIRELESS. Dance Band Leaders, Comedians, Singers, Entertainers, Critics, Commentators—the whole team are lined up to say "How do!" Now you can see how near you got with those mental pictures you formed to fit the voices that come over the air. Here are

Over 300 BIOGRAPHIES and Numerous Portraits of Famous Broadcasting Stars

This is a book which contains the stories of a host of your old friends. It's a book to dip into when you've switched on the radio—a book to keep because it will be always topical—always attractive. Don't miss it.



At all Newsagents - - - - 6d.

EXPERT Fault - Detection WITH EASE!

TEN
TESTING INSTRUMENTS
in **ONE**

—PROVIDING
a sure way
to better results.

MILLIAMPS

0-6 milliamps.
0-30 "
0-120 "

VOLTS

0-6 volts.
0-120 "
0-300 "

OHMS

0-10,000 ohms.
0-60,000 "
0-1,200,000 "
0-3 megohms.



WITH the Avominor you can be sure of results that it previously took an expert to obtain. You can trace every source of trouble and detect every fault that mars the concert pitch performance of your set. You can test circuits, valves, components, batteries and power units, and test them ACCURATELY. The Avominor is an accurate moving coil combination instrument. It gives TEN different ranges of readings in milliamps, volts and ohms. It has a total resistance of 100,000 ohms, and full scale deflection is obtained with only 3 milliamps. No similar instrument makes so many tests with such dependable accuracy.

40/-
Deferred Terms
if desired.

The **AVOMINOR** TRADE MARK
TELLS THE WHOLE TRUTH!

BRITISH MADE Dimensions: 4" x 3" x 1 1/2". Complete in handsome case with pair of leads, interchangeable crocodile clips and testing prods.

WRITE FOR FULLY DESCRIPTIVE FOLDER

THE AUTOMATIC COIL WINDER & ELECTRICAL EQUIPMENT CO. LTD.
WINDER HOUSE, DOUGLAS STREET, LONDON, S.W.1.
Telephone: Victoria 3405-6-7.



"If I were king . . .," says P. P. Eckersley: and proceeds to explain how the question of international broadcasting wavelengths might yet be solved by a man with courage, foresight and unlimited powers. No fairer or more trenchant comment has been yet made on the Lucerne Plan than that which our Chief Radio Consultant offers in this article.

THE wavelength change-over! If it wasn't so tragic one might laugh. Particularly interesting are the comments of the correspondents—nearly all of them "special"—in the daily Press. One of them assured us that this wavelength changing was not very difficult—just changing the capacity and inductance of the station.

Those Minor Peccadilloes.

Don't think I am sneering at people who know nothing of technicalities—I am really admiring their courage. It requires pluck to dash in and spread your opinions about subjects of which you are ignorant. I would be equally foolish if I wrote about the petty scandals of artistes and the minor peccadilloes of Broadcasting House, of which I know nothing.

I see someone measured things in metres and millimetres. Field strengths were measured in these units, and somewhere something, as much as five hundred kilocycles out, was kept in an oven.

The "Emperor of the Ether" wasn't a bad, if a somewhat soporific, title for M. Braillard.

Then the Leipzig mast had headlines as high as its lattice work. Of course, incendiarism was hinted at. The station was burnt down before one started to read—it was still transmitting at the bottom of the paragraphs.

* * *

But, of course, this wavelength chaos is a bit serious, however much people may attempt to disguise the fact. The B.B.C. has been perfectly honest about it all. Daventry 5 X X is just jammed right away by the Eiffel Tower.

And I read that really the French are terribly worried about it, but they cannot see how to change the wavelength of the station. It's got stuck to its present frequency. Evidently it's not so simple to change French inductance and capacity—very hard stuff—and there, in the heart of Paris, the Camelots du Roi are counting the cycles, crying, "We will not budge."

Selectivity up Their Sleeves.

Then some of the more enterprising radio manufacturers are not afraid of all this. They have selectivity up their sleeves—they can shake off the offending kilocycles without any detriment to the robust character of the result.

What a sham it all is! What foolish, foolish rot!

To think that the many members of the old technical committee of the Union, those of us who pioneered the European wireless rapprochement, are disbanded and our work all brought to futility! "Nation unto nation shall speak peace." Not even in wireless do we observe commonsense. Not even in the realm of technicalities can we find sense. The people who are supposed to serve the European listener have let us down.

There is a solution to it all. But it will be years before anyone will adopt the solution. The vested interests of bureaucracy and commerce are, for a while, too strong to allow you to get the enjoyment you might. However, no one cares, or, if they care, the results are invisible.

* * *
If I were king . . . !

But what of the wireless services for ships and aeroplanes?

I agree that these are terribly important, but, given good will, the use of wavelengths above 3,000 and below 300 metres would suffice for all their work. Three hundred and fifty million people listen to broadcasting. It's an important little activity.

And to give variety of choice of programme we should use the wire for our urban entertainment.

Their Job is Not to Listen.

One day a blast of common sense may blow over the desks of our administrators and they will have nothing to do but to sit back and think. They would then see that their job is not to listen to conflicting voices and then make a compromise decision, but rather to see clearly what is best to do for the thing they administer.

For instance, it should be decided once and for all never to use wireless if the wire will serve. Thousands of interests would object to the implementing of such a rule. But you think it out and see what would happen. For one thing, you would get a decent wireless service.

Apparently, the Lucerne Plan has brought about revolutionary changes. I read from an informed source—headlined on a front page as "B.B.C. Giant Can Jam"—that the new Droitwich transmitter has "an aerial strength up to 200 kilometres."

So evidently we are now to measure aerial strength in terms of the distance we can throw our transmissions into another country. This seems only a fair and right definition, considering the state of the ether.

This talk about "jamming other stations" on purpose to stop their propaganda seems unnecessary, when by official agreement they are now all jamming each other quite efficiently. I prophesy that things will get better—because the summer is coming and there will be less night-ray interference.

Fortunate Brighton!

But wait until North National shares with Jerusalem as Daventry 5 X X now shares with Paris And when nearly all our Regional stations start sharing well, we shall be thankful for "the 200-kilometre aerial strength available by the new transmitter."

It will just reach Brighton!

THE MAN WHO CHANGED THE WAVES



M. Braillard, on whose shoulders as "Chief Commissioner of the Ether Police" fell the burden of seeing that the changes under the Lucerne Wavelength Plan were carried out on January 15th.

There can be no doubt about what ought to be done.

First, the wavelengths allotted to broadcasting should number about 30. They should occupy the band from 3,000 metres to 300. There should be more than a 20-kc. separation between each and they should use unlimited power. This would give every person in any continent anywhere the service of at least one good-strength national programme.

In many cases the transmissions from foreign countries could be well and truly heard. The length of wave could be allocated according to the character of the ground over which the waves travelled and the area of the nation to be served.

ALL ABOUT SOUND *and* RADIO WAVES

In his previous article our distinguished contributor dealt principally with wave-form in general and with sound waves in particular, with numerous practical analogies.

LET a cord be hanging from a high ceiling; it may be a rope or a chain. Take the bottom of the rope in your hand and then waggle the hand to and fro. Pulses are seen travelling up the rope as waves.

Each pulse as it reaches the top is reflected at the hook, and comes down again; so that presently, by timing the hand properly, you get the whole rope into a steady state of vibration, divided up into vibrating segments with nodes between.

The waves now cease to progress and are stationary. They are called stationary waves, being produced by the interference of direct and reflected pulses.

Wave Reflection.

But reflection depends on the hook at the top: if the rope were of infinite length there would be no stationary waves; there would be no reflection, and the waves would continue to the end, all travelling along, alternately a hump and a hollow, following one another at a rate depending on the tension and the linear density of the cord, not depending on the frequency of the oscillation.

In practice you always have a finite length of cord, there must be reflection sooner or later, and so the whole is sooner or later cut up into stationary waves, behaving like a string from a musical instrument sounding one of its harmonics.

Now let us make an experiment upon the ether. We must have the means of producing an oscillation in the ether. The easiest way to do that is to take an electrical charged body or a magnetic pole and wave it about.

The charged body has electric lines of force radiating out in all directions, which represent lines of strain in the ether. These, when the body is moved, follow it very rapidly, so that at all ordinary speeds of oscillation they remain straight.

But otherwise we can picture a line of force as analogous to the cord just considered, and allow any number of cords in every direction; the velocity with which the pulse travels along them is enormous: so that if the oscillations are made as rapidly as possible by the hand, say ten a second, the first pulse will have travelled a distance along the line of force nearly 20,000 miles before it is followed by a second; the velocity with which the ether transfers pulses being denoted by 3×10^{10} centimetres per second.

Mechanical Methods Too Slow.

Hence to produce any perceptible kinks in the line of force, the vibration rate must be very great: even a thousand a second will not suffice, though it would give a high note in acoustics. No known mechanical device would suffice to give the fre-

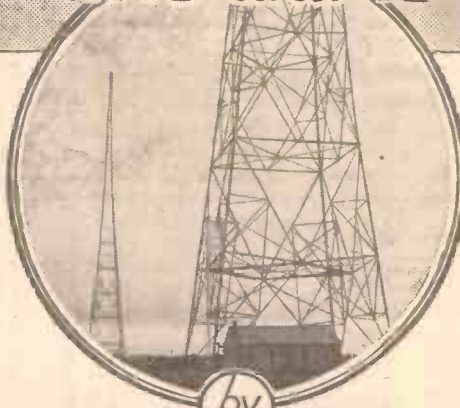

by
SIR OLIVER LODGE
F.R.S.

quency needed for any moderate wavelength.

But by electrical methods, i.e. using the properties of the ether, it is possible to vibrate a charge at a rate of a million a second, in which case the wavelength or distance the first pulse has had time to travel before the second occurred would be 1,000 ft; a considerable wavelength, but still one that can be dealt with.

The First Radio.

Oscillations of this kind were produced by Professor Hertz at Carlsruhe in 1887, and were detected at a distance by arranging two pieces of metal close together, the charges on which when oscillations fell upon them were perturbed and surged in sympathy, giving a little spark between the two. The intensity of radiation was very great, greater than had been anticipated: it had not been thought likely that it would produce sparks in a metal.

EARLY APPARATUS

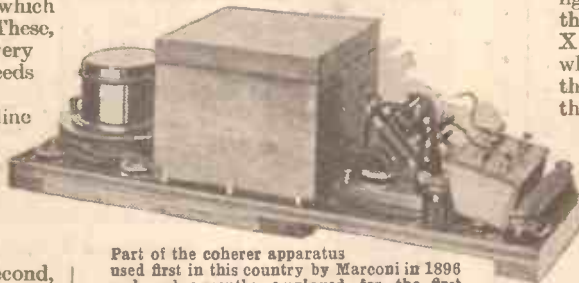

Part of the coherer apparatus used first in this country by Marconi in 1896 and subsequently employed for the first wireless telegraphy signals between England and America in 1901.

Later another plan was adopted. A battery circuit containing an electric bell was nearly but not quite closed by laying its two terminals on each other, touching in very light contact, so that the current transmitted by the circuit was enough to ring the bell and was very feeble.

When waves arrived at the circuit an excessively small spark occurred at the imperfect junction and welded two metals together: thereafter conduction was perfect

This week, ether waves and the means of producing an oscillation in the ether form the basis for another of Sir Oliver Lodge's erudite yet understandable explanations.

and the bell continued to ring. A slight tap freed the metals again, broke the connection, and set the thing free for another signal.

This arrangement was called a coherer. It was applied to telegraphy, and it was shown that it could be used for telegraphy in 1894. We are not here concerned with the practical use of the device, which was brought to this country by Marconi in 1896, and treated as a novelty by Sir William Preece, head of the Telegraph Department; but we are chiefly interested in the properties of the ether, which enable the pulses to be generated and travel to a distance with immense speed.

Uniform Speed of Travel.

In dealing with the ether one has to do with a substance of remarkable properties and of very simple construction. The wave velocity in a medium depends upon a variety of causes which are responsible; and the simpler these are kept, the more uniform is the velocity with which the waves go. In the case of sound all waves go at the same rate, because they are transmitted by the air—one simple medium.

In the case of the ether the same thing happens. Whether those vibrations are fast or slow, the waves generated by them travel at the same rate.

They are produced by oscillations of an electric charge, that is, by an alternating current, and whether the alternations occur at the rate of fifty a second (which they do in an ordinary electric supply), or at the rate of a million a second (which they may do in the discharge of a leyden jar), or at the rate of five hundred-million-million a second (which is the case of ordinary visible light), or at a rate a thousand times greater than that (which may be reached by some X or gamma rays, or by the cosmic rays which have recently attracted attention), the ether transmits every kind of wave at the same pace.

Analogous to Elasticity.

The velocity of wave transmission in the ether is a constant term c , whose value is 3×10^{10} centimetres per second, and, as is the case in an organ-pipe, the oscillating column which starts the vibrations and the waves, are of the same material as that which transmits them.

We may follow the details of the process by which an oscillation is set up by considering an electron with its lines of force in every direction shifted from its position of equilibrium and let go. The restoring force is something analogous to elasticity, and would be represented by a bending of those lines, which may be thought of as elastic threads, and which when stretched give the phenomenon called electric charge.

(Continued on page 968.)

IT looks as though the new high-power station at Droitwich; replacing the stations at Daventry, will be ready to open towards the end of July. It would be appropriate to date the inauguration for July 25th, which would be the ninth anniversary of the opening of Daventry 5 X X. The latter was the greatest occasion of its kind in the history of the B.B.C.

The special train that went from London carried a distinguished gathering, headed by Sir William Mitchell Thompson (now Lord Rankeillour), the then Postmaster-General, Lord Wolmer, his assistant, Lord Gainford, Chairman of the B.B.C., Sir William Bull, Major Basil Binyon and other B.B.C. directors.

This year an even more ambitious programme for the opening is being planned. It has been suggested that Royalty may be represented, and it is on the cards that, engagements permitting, the Prime Minister may preside.

Testing the Organisation.

Apparently the Governors of the B.B.C. do not intend to be caught napping by any unexpectedly early Parliamentary inquiry into broadcasting. One point on which critics may fasten is the method of recruiting staff and arranging promotion.

So the B.B.C. Board has set up an independent panel of investigators to examine and report upon this particular aspect of the organisation at Broadcasting House.

WE do hear some talks badly delivered. But, as this is probably the exception rather than the rule, I lend no support to the movement for brightening up the broadcast talks. I have listened lately to a number of talks—and critically, too—with a view to ascertaining in what way they could be brightened up if needs be.

I wonder when people complain of the dullness of talks if they refer to the speaker's delivery or to his subject-matter. The thing that struck me most during this course of critical listening was the surprisingly great variety of deliveries that were to be heard.

For sheer brightness I would award the palm to Lady Hosie, whose talk on the Cities of China must have brought into use every note of a treble-clef scale. She spoke for a quarter of an hour, and her style suited her subject-matter perfectly.

I tried to visualise the weekly talk on New Books being given in the same way. It couldn't be done. In spite of his dull monotone and solemnity, Mr. Desmond MacCarthy is infinitely to be preferred. I thought, too, of G. K. Chesterton's Book Talks, and, before these, of Miss Sackville West's, and though these again were different from one another, they, like Desmond MacCarthy's, were ideal book talks.

When Oliver Baldwin talks about films, Stephen King-Hall about economics, Vernon Bartlett about foreign affairs, they have styles of discourse characteristic of themselves and of their subjects. One could go through the complete list of present-day broadcast speakers, including the several language teachers, and one would find similar differences of style. Surely it is because of this rich variety of

THE MIRROR OF THE B.B.C.

OPENING THE DROITWICH STATION

Inquiry into Staff Appointments—The Future of Television—More Comedy Required—Pancake Day Street Football.

REFLECTIONS BY O. H. M.

Television Moves.

The rivalry between the Ostrer group (through the Baird Co.) and the H.M.V. group (through Electrical and Musical Industries) gets more and more acute as

The B.B.C. Report.

The annual report of the B.B.C., dealing with operations for 1933, was delivered to the Postmaster-General just a fortnight after the beginning of the New Year. This represented a brilliant piece of organisation, and was made possible by the completion of the financial statement in the first week of the New Year.

It has been the custom in the past for the P.M.G. to defer publication of the B.B.C. report until he is ready to present it to Parliament in the form of a White Paper. It looks as though this year the former procedure will have to be expedited.

Searching for Comedy.

The B.B.C. is anxious to find new material for broadcast comedy. This applies both to personnel and to scripts. The new search is overdue, because staleness has been obvious for some time.

(Continued on page 968.)

A NEW DANCE BAND COMES TO THE MICROPHONE



Some years ago an attempt was made to form a permanent dance band of players drawn from various public schools. The idea was only partly successful, but now Mr. Dave Lea is running a band composed entirely of ex-public schoolboys and meeting with great success. The band has already broadcast on more than one occasion, and is here seen playing at the Park Lane Hotel.

the time approaches for the vital decision by the B.B.C.

Before Christmas the ultra-short wave apparatus of the Baird Company was tested at Broadcasting House; now the rival apparatus is having its turn. There may

voices that broadcast talks make so great an appeal. Supposing all speakers were trained in the same school, and so cultivated the same manner, bright though that manner might be, what a bore broadcast talks would be!

Ion Swinley was a tremendous success in that new Sunday evening feature, "Pilgrim's Way." He read poetry just as it should be read and the Bible as few parsons could. Yet I wouldn't care for every talk to be done *à la* Ion Swinley.

For instance, I don't think the style would suit the Industrial Britain series. Though there were some imperfections in Professor John Hilton's

beginning and end of every lecture. We've already something of the sort in those few bars of storm-music that begin Mr. Watson Watt's Weather House talks.

Personally, I think this sort of thing is childish. No amount of storm-music will induce listeners to listen to the Weather House talks if they aren't interested in the subject. On the other hand, people genuinely interested in the weather need no storm-music to get them to listen to a discussion on it.

And this, I think, is the explanation of the complaints we hear about dull talks. When we aren't interested in the subject-matter of a series we are wont to criticise the speaker and say he is dull. When we are interested we are often too engrossed in what we are hearing to observe the speaker's imperfections.

But I cannot agree that our radio speakers are in the main dull. Nor would I have them moulded to one pattern whose chief feature was brightness. If they were they would lose all that individuality which is the very life-blood of radio talks. Furthermore, those differences of manner that characterise the different speakers is as good as a rest.

While the public generally is persuaded into believing that the high-light of recent light music was "Songs From the Shows," I shall express a preference for that little operetta, "Away to the Hills." Quite a good little story was told in a lively libretto: the humour was excellent, Miss Agatha, played by Phoebe Hodgson, being a very amusing character. Then there was Mark Lubbock's music, much above the average for this kind of production. Unfortunately, we may never hear it again. We seldom have these operettas repeated. C. B.

THE LISTENER'S NOTEBOOK

Frank comments on recent B.B.C. programmes.

manner (he would drop his voice so, giving one the impression his talk was packed with asides), he was essentially alive. Such a style couldn't be called dull or unsuitable for a talk on Britishers at work.

Another lively talk, if speed is indicative of liveliness, was Mr. Theodore Besterman's "Psychical Research." He was really too lively, for he hardly gave himself time to form his words.

It may be, perhaps, that these brighter-talks folk want to see some showmanship introduced into the discourses, say with a big fanfare of trumpets at the

FOR EVERY SET — there's a PILOT. AUTHOR KIT

CASH — C.O.D. — or H.P.

IMPORTANT.—Miscellaneous Components, Parts, Kits, Finished Receivers or Accessories for Cash, C.O.D. or H.P. on our own system of Easy Payments on orders over £2. Send us a list of your wants. We will quote you by return. C.O.D. orders value over 10/- sent carriage and post charges paid Great Britain only. **OVERSEAS CUSTOMERS CAN SEND TO US WITH CONFIDENCE.** We carry a special export staff and save all delay. We pay half carriage—packed free. Send full value plus sufficient for half carriage. Any surplus will be refunded immediately. Hire Purchase Terms are NOT available to IRISH or OVERSEAS-customers.

EXCLUSIVELY SPECIFIED PETO-SCOTT RADIOGRAM CABINET

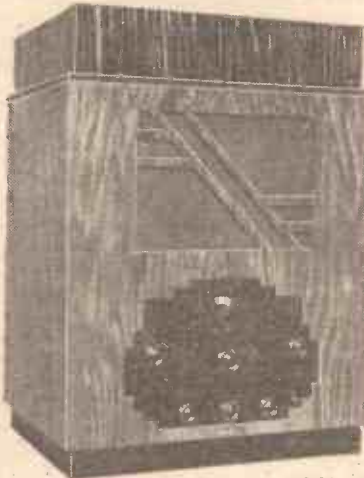

See "Tested and Pounded" Popular Wireless, January 29th, 1934, Page 302.

Another exclusive and delightful cabinet by PETO-SCOTT, also specially designed at the request of "Popular Wireless" for the Eckersley National Radiogram. The beautiful walnut finish and handsome contrasting macassar veneer set the seal of perfection in cabinet design on this latest Peto-Scott production. Cash or C.O.D. **47/6**

Packing and Carriage, 2/6 extra.

H.P. 7/6 Deposit and 9 monthly payments of 5/3. Loudspeaker Baffle Baseboard Assembly if required, 3/6 extra. State size of hole required when ordering.

TABLE MODEL, as specified.

This handsome walnut-polished cabinet was specially designed by PETO-SCOTT at the request of "Popular Wireless" to house the Eckersley National 3. Constructed throughout in first-quality material and beautifully finished by hand french-polishing macassar veneer set the seal of the piano trade. Cash or C.O.D. **17/6**

Packing and Carriage, 2/6 extra.

SEND FOR NEW CABINET CATALOGUE.

ECKERSLEY NATIONAL 3

MAINS UNITS

A.C. KIT "A." Complete Author's Kit as specified, excluding Rectifier Valve and Aluminium Cover. Cash or C.O.D. Carriage Paid.

£3-12-6 or 12 monthly payments of **6/9**

ACCESSORIES:

- 1 Mullard I.W.2 rectifier valve ... £ s. d. 12 6
- 1 Peto-Scott cover to specification ... 10 6

KIT "B." As Kit "A." but complete with rectifier valve and Peto-Scott cover. Or 12 monthly payments of 8/9. **4 15 6**

D.C. KIT "A." Complete Author's Kit as specified, excluding Aluminium Cover. Cash or C.O.D. Carriage Paid.

£1-15-0 or 7 monthly payments of **5/6**

KIT "B." As Kit "A." but with Peto-Scott aluminium cover. Cash or C.O.D. Carriage Paid, £2-5 6, or 8 monthly payments of 6/-.

ECKERSLEY NATIONAL 3

KIT "A" Author's Kit of first specified parts including **READY-DRILLED** PANEL and **METAPLEX** chassis assembly, but less valves and cabinet, Cash or C.O.D. **£5:10:0** Carriage Paid

or 12 monthly payments of 10/-

KIT "B"

As Kit "A," but including set of specified valves, but less cabinet. Cash or C.O.D. Carriage Paid.

£7:9:0

or 12 monthly payments of 13/9

KIT "C"

As Kit "A," but including valves and Table cabinet. Cash or C.O.D. Carriage Paid.

£8:6:6

or 12 monthly payments of 15/3

KIT-BITS You pay the Postman. We pay post charges on all orders over 10/- GT. BRITAIN ONLY.

- 1 British Radiophone 3-gang, type 604 ... £ s. d. 1 0 0
- 1 British Radiophone 3.M. drive, type 711 ... 8 6
- 1 Set of Telsen screened coils, type W.288 ... 1 1 6
- 1 Lissen Hypernik L.F. transformer ... 12 6
- 2 T.C.C. 2-mid. fixed condensers, type 50 ... 7 0
- 3 Mullard valves as specified ... 1 19 0
- 1 Peto-Scott table cabinet (Carr. 2/6 extra) ... 19 6

ECKERSLEY NATIONAL RADIOGRAM

KIT "A" Author's Kit of first specified parts including **READY-DRILLED** PANEL and **METAPLEX** chassis assembly, but less valves, cabinet, speaker and gramophone equipment. Cash or C.O.D. Carriage Paid, **£6:10:0** or 12 monthly payments of 12/-

KIT "B"

As Kit "A," including valves, but less speaker, cabinet and gramophone equipment. Cash or C.O.D. Carriage Paid.

£8:9:0

or 12 monthly payments of 15/6.

KIT "C"

As Kit "A," including valves, radiogram cabinet and PETO-SCOTT gramophone equipment but less speaker. Cash or C.O.D. Carriage Paid.

£12:14:6

or 12 monthly payments of 23/3.

With Peto-Scott Permanent Magnet Moving-coil Speaker, if required, add 13/6 to Cash Price or 1/9 to each monthly payment.

KIT-BITS You pay the Postman. We pay all post charges on orders over 10/- GT. BRITAIN ONLY.

- 1 J.B. tuning condenser, Nugang A ... £ s. d. 1 2 6
- 1 Golvorn 3-gang coil, K.G.O., K.G.O., K.G.R. ... 1 8 6
- 1 Graham Farish Booster unit ... 7 6
- 1 Westinghouse Westector, type W.4 ... 7 6
- 1 British Radiogram pick-up ... 17 6
- 1 Edison Bell double spring motor, 7" handle ... 17 0

S.T. 500

KIT "A" Comprising Mr. John Scott-Taggart's Kit of **FIRST SPECIFIED** Components, including Telsen "Class B," Output Choke, Peto-Scott "Metaplex" Baseboard and Ready-drilled Panel and Terminal Strip. Less Valves and Cabinet. With **FULL-SIZE** Blue Print and copy "Popular Wireless," Oct. 21st. Cash or C.O.D. Carriage Paid. **£5-5-0**

or 12 monthly payments of 9/6.

KIT "B"

As Kit "A," but including 4 Specified Valves. Cash or C.O.D. Carriage Paid, **£7-10-3**

or 12 monthly payments of 13/9.

KIT "OT"

As Kit "B," but including Peto-Scott Specified Walnut Table Cabinet. Cash or C.O.D. Carriage Paid, **£8-9-9**

or 12 monthly payments of 15/6.

KIT "CC" As Kit "B," including Peto-Scott Specified Walnut Console Cabinet. Complete with Baffle Baseboard Assembly, but less Speaker. Cash or C.O.D. Carriage Paid ... **£8-18-9**

Or 12 monthly payments of 16/3.

If Peto-Scott Permanent Magnet Speaker required add 19/6 to Cash Price or add 1/9 to each monthly payment.

CONVERT YOUR S.T.400 to S.T.500

Peto-Scott S.T.500 Conversion Kit comprises all **FIRST SPECIFIED** parts required to convert your S.T.400 to the new S.T.500, including output choke, but less valve. Balance in 8 monthly payments of 5/3.

YOURS FOR 5/-
Complete Kit with Valve. Cash or C.O.D. Carriage Paid, £2 16 0 or 12 monthly payments of 5/3.

PETO-SCOTT S.T.500 WALNUT CONSOLETTTE



Regd. Design No. 787,010

An outstanding example of cabinet craftsmanship. Hand French polished. Veneered Macassar and Walnut finish by experts. Cash or C.O.D., 25/-, Carr. and Packing, 2/6 extra, or 6/- Deposit and 4 monthly payments of 6/- (including carriage and packing) Baffle-Baseboard Assembly, 3/6 extra. Specified PETO-SCOTT TABLE CABINET, CASH or C.O.D., 15/6, or 6/- Deposit and 3 monthly payments of 6/- (including carriage and packing).

PETO-SCOTT Co. Ltd., 77, City Rd., London, E.C.1

Telephone: Clerkenwell 9406/7.

West End Showrooms: 62, High Holborn, London, W.C.1. Telephone: Holborn 3248.

Dear Sirs,
(a) Please send me.....
(b) I enclose Cash/Deposit.....
NAME.....
ADDRESS.....
P.W., 3/2/34.

ANY ITEM SUPPLIED SEPARATELY—ORDERS OVER 10/- SENT C.O.D. CARRIAGE AND POST CHARGES PAID

STATIONS WORTH HEARING

A review of recent conditions on the "broadcast" bands, including details of stations that are coming in well, and other information that will help you to get the best results when searching for foreigners.

By R. W. HALLOWS, M.A.

TAKING it all round, the old Prague Plan worked remarkably well. There were heterodynes, of course, here and there, but these are only to be expected when more stations than there is really room for have to be crammed into both the long- and medium-wave bands. The Prague Plan would have continued to allow us to receive from twenty to thirty foreign stations clear of interference on any night had stations remained as they were six months ago.

More Changes Pending.

But big changes have been made since then, and many more are pending. One of the chief reasons why a new plan became an urgent necessity was that so many stations contemplated huge increases in their output power.

Some of these are already at work as I write. Kalundborg, which up to the beginning of the year was using only 15 kilowatts, is now radiating with its full 30. Budapest and Vienna are now in full operation with transmitters rated respectively at 120 and 100 kilowatts. Stuttgart and Munich have increased their powers from 60 to 100 kilowatts, whilst the medium-wave Berlin station has gone up from 4 to 100 kilowatts.

Many other increases will take place between now and next summer. The two Brussels stations will multiply their present powers five-fold by advancing from 15 to 75 kilowatts, whilst French Government or "P.T.T." stations now in process of construction at Nice, Lyons and Toulouse will all be rated at from 75 to 100 kilowatts.

Other big augmentations of output power will take place in Sweden, Spain, Italy, Greece, Turkey and some of the Balkan States.

Experimental Transmissions.

The long-distance enthusiast will therefore have plenty of new stations to look out for during the coming months. Some of them may be expected to begin experimental transmissions outside normal programme hours quite shortly.

A good deal of nonsense was written before the Lucerne Plan came into operation about its possible dire effects upon reception, and when things were not too good on the long waves during the first day of the Plan's existence some of those who should have known better leaped to the scare-headline conclusion that it was an utter failure.

The position on the long waves is not yet completely cleared up, though it is distinctly improving.

Huizen continues to use its old wavelength of 1,875 metres, and suffers in consequence from a considerable background of interference of Russian origin. Radio-Paris is clear, and Zeesen is generally well received. Warsaw comes in strongly and well, but Motala, Kalundborg and Oslo are

all troubled—at times, at any rate—by heterodynes.

On the medium waveband there were also difficulties of no small magnitude. Few stations actually stood outside the Plan; the main difficulty was for transmitters to keep precisely to their allotted frequencies.

Under the provisions of the Lucerne Plan the maximum deviation allowed to stations with individual channels is 50 cycles, or .05 kilocycle; stations on one kind of common waves may not deviate by more than 50 cycles, whilst on another kind the maximum permissible deviation is but 10 cycles.

KEEPS THE VALVES COOL

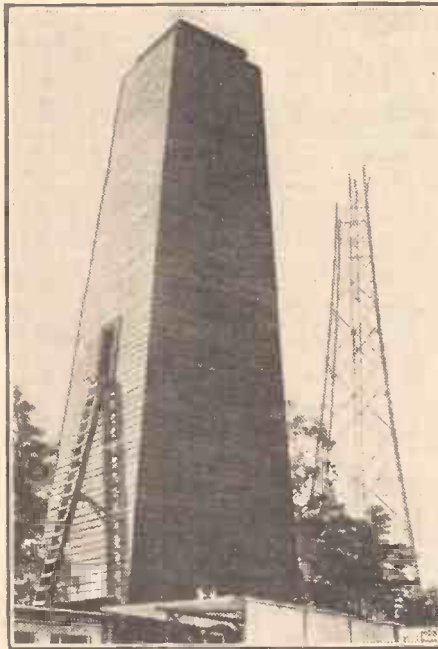

This is the water tower which is used in conjunction with the valve-cooling apparatus at Tegal, the new German broadcasting station near Berlin. In the background can be seen one of the giant aerial masts in course of erection.

It is doubtful whether on January 15th there were many stations outside Great Britain, the Irish Free State, Germany, Italy and Scandinavia that were capable of keeping within anything like such narrow limits.

When measurements were made by the Brussels checking station during the great change-over that took place on the night of January-14th-15th, deviations of from 300 to 500 cycles were frequent, whilst amongst Russian stations the average error was little short of 2 kilocycles.

To work the Plan properly every station must instal either crystal or tuning-fork control of very special and delicate kinds. It may be some little time before all stations are so equipped, but in the meantime,

despite all difficulties, reception on the medium waveband is remarkably good.

I was bold enough to predict in my last report that the number of medium-wave stations receivable when the new Plan had been in operation for a few days would certainly not be less than it had been under the Prague Plan. This prophecy has been amply borne out since.

In order that I may not be accused of seeing the reception conditions of the moment through rose-tinted spectacles by using an ultra-selective modern receiving set of the superheterodyne type, I have just made a survey of the broadcast band with a 1930 set of well-known make. This set contains two screen-grid stages, a grid-leak-and-condenser detector and a transformer-coupled output stage.

Round the Medium Band.

It is exactly as it was originally issued without any alteration whatsoever. I should mention, though, that it was worked from an indoor aerial consisting of forty feet of cabled wire suspended across an attic, the down-lead being about eighteen feet in length.

Here is the result of a trip round the medium waveband: Budapest, Beromünster and Athlone are all now good and clear, though during the first few days of the new order of things there was a heterodyne on Beromünster. Stuttgart and Vienna are both well heard, but Florence has a background, as one would expect, considering that it shares a wavelength. Brussels No. 1 is sometimes heterodyned, probably by a Russian station. Prague is heterodyned, the interference being again of Russian origin.

Next come Langenberg, the North Regional and Söttens, all of which are excellent. Stockholm was heterodyned at first, but is now clear, as are Paris P.T.T. and Rome.

Munich gives fine reproduction, but Katowice is not quite up to form. There is a little background interference on the Midland Regional.

Berlin Coming Over Well.

The Russian station Stalino seems to be somewhat off its wavelength and is interfering with both Toulouse P.T.T. and Leipzig. The Scottish Regional is free from interference, but Milan is slightly heterodyned by Moscow IV.

The new Berlin station is coming in excellently. The London Regional has no troubles. Radio Toulouse and Hamburg are both as good as one could wish.

Brno is an uncertain kind of station that one hears only occasionally at good strength. Whenever I have found this station lately it has come in without interference. Brussels No. 2 is not clear and Göteborg is sharing a wavelength.

Breslau and the Poste Parisien both provide excellent reception. The West Regional is clear, Hilversum is well received and the North National is quite reliable.

Frankfurt, though sharing a wavelength with two smaller German stations, is generally well heard. Gleiwitz is also often receivable without interference, though, again, it has wavelength partners.

Apparently some of the German common-wavelength stations are using the 240-2 metres allotted to Luxembourg. Lower down the band conditions are not too good.

Recommended WRINKLES

SIMPLE EARTHING.

GETTING a good earth connection without damage to a waterpipe is really quite easy. After cleaning the waterpipe with a very light scrape, obtain some thick copper wire and make it bright with emery cloth. Whip one end round the pipe, and continue winding round for about two inches, making each turn close up. Again whip the wire for the last few turns, leaving a loop at the end. This method strengthens the pipe rather than weakens it, and the turns being close together keeps the contact bright. After the end of the earth lead has been soldered to the loop, the wire can be covered over with a piece of rubber sheet tied in position. By doing this the joint will need no attention for years.

CONTROLS ON SLOPING CABINETS.

WHERE cabinets are employed with a pronounced slope from top to bottom, and it is desired to place a wavechange switch or other control at the side, difficulty is often experienced in keeping the control straight. This can be overcome by counter-sinking a hole in the side of the cabinet, a little deeper than the fixing nut, and either making the side of this perpen-

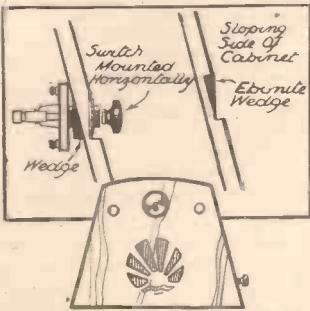

An unusual problem is here solved in an efficient and practical manner.

dicular or inserting a small wedge of ebonite which is thicker at one end than the other.

THE CARE OF HYDROMETERS.

OCCASIONALLY I used to damage hydrometers when testing an accumulator, owing to the instrument rolling on to the floor. This often meant a new hydrometer, as the parts were not obtainable.

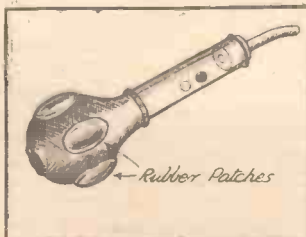

The rubber patches on the bulb prevent the hydrometer from rolling off the table.

To prevent this I fixed several pieces of rubber, cut oval shape, to the rubber bulb, as shown. The hydrometer could then be placed on the table without fear of it falling off.

FIXING BALL CATCHES.

IT is a good plan when fitting ball catches to a cabinet door to put a spot of ink on the ball and to close the



Marking the exact position of a hole to take a ball catch.

door to the correct position. On opening the door again a line will be found, the end of which is the centre of the hole to be sunk to receive the ball catch.

ONE GUINEA FOR THE BEST WRINKLE!

Readers are invited to send a short description, with sketch, of any original and practical radio idea. Each week £1 is. will be paid for the best Wrinkle from a reader, and others published will be paid for at our usual rates.

Each hint must be on a separate sheet of paper, written on one side of the page only. Address your hints to the Technical Editor, "Popular Wireless," Tallis House, Tallis Street, E.C.4., marking the envelope "Recommended Wrinkles."

Will readers please note that the Editor cannot, in any circumstances, guarantee to return rejected Wrinkles, and that payment for published hints is not made until ten days after they appear?

The best Wrinkle in the January 13th issue was sent by Mr. A. J. Symons, of "Colong," Beaumont Avenue, West Ryde, N.S.W., Australia, to whom a guinea is being awarded.

LOCAL-DISTANCE SWITCHING.

WHEN a simple type of radio receiver is located close to a comparatively powerful broadcasting station it is sometimes difficult to reduce the volume to reasonable limits. Even if a volume control is provided it is not always possible to reduce it sufficiently by this means.

A very good auxiliary control can be obtained by arranging a resistance of about 50 ohms so that it can be connected between the aerial and earth terminals of the set by means of a switch. If 50 ohms reduces the volume too much a larger value, say 100 ohms, could be tried.

CONNECTING FOR RECORDS.

FOR radiogram switching the simplest type of switch is the single-pole double-throw type, particularly the rotary operated kind.

It is usual to join the moving arm to the grid of the valve and the remaining two terminals to the grid condenser and leak, and to one pick-up terminal respectively.

In some cases it may be found that radio signals break through and are heard on the loudspeaker, although the switch is set for gramophone record reproduction.

This is due to capacity between the switch contacts, and, of course, could best be remedied by replacing the

switch by one having a smaller self-capacity.

The simpler way, however, is to remember to set one of the wavechange switches to "long" and the other to "short" when switching to gramophone, and this will prevent such interference.

Where only one tuned circuit is used the tuning condenser may be de-tuned, or if necessary the aerial disconnected from the aerial terminal.

WIDER VOLUME CONTROL.

WHEN operating a battery set having one or more variable-mu valves at some distance from a powerful station it is frequently found that the volume-control movement is small for full control.

That is, by turning the volume control only about a quarter of the travel, volume is reduced to zero. In this case it is best to reduce the grid-bias voltage of the variable-mu valves.

The best way to effect this is to tune in the most powerful station received. Then turn the volume control about three-quarters back. The variable-mu grid bias should then be altered so as

AN ADJUSTABLE LIGHT.

TAKE an old comb, as shown in the drawing, and break out a couple of teeth at two points close to one another.

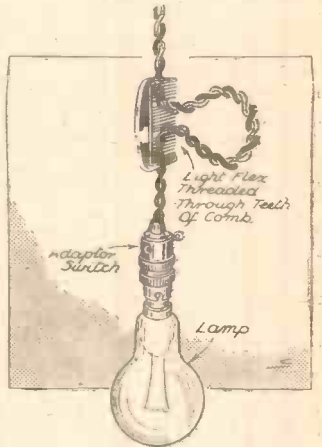

Adjusting the height of a lamp without tying knots or loops in the flex is an easy matter.

Then, by threading the wire through these gaps, the bulb can be placed at any height within the scope of the cord.

STRENGTHENING YOUR AERIAL.

I WAS once "let down" by a break in my aerial, where I had soldered my lead-in to the horizontal portion.

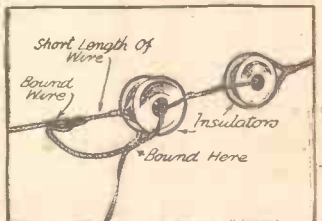

By connecting the lead-in in this way the strain comes on the insulators and stays instead of on the aerial itself.

The strain after a while broke this joint away.

Now, whenever I erect an aerial of continuous length, or with a soldered lead-in, I adopt the idea given in the accompanying sketch, leaving a loop of about 6 inches. This throws the lead-in strain on the insulator instead of the aerial wire.

BAD CONTACTS.

CRACKLINGS and weak reception are not infrequently caused by faulty contact in the low-tension switch. When the latter is of the two-spring-and-plunger type it can easily be inspected.

Unfortunately the same cannot be said of the enclosed type. Nevertheless, it is a simple matter to check such a switch by shorting with a length of flex across its two terminals.

to be the smallest voltage which will give weak signals.

It will then be found that the full travel of the volume-control knob is used, so giving a satisfactory smooth reduction or increase of volume.

MOVING YOUR MAST.

WHEN erecting a wireless pole it is rather disappointing sometimes to find that the pole has worked round, with the pulley facing away from the house. Instead of taking it out again, get a stake or any suitable piece of wood and lash it to the pole, as illustrated, with a chain, and it will be found quite simple to twist it to the required position.

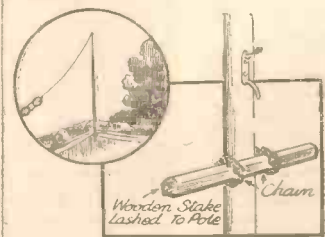

If you find that the pulley faces the wrong way after you have erected a new aerial mast, try this method of turning it.

TESTED AND FOUND?

Being leaves from the Technical Editor's Notebook

A NEW WEARITE COIL

A FEW months ago we had occasion to make a close investigation into the waverange coverages of commercial coils. Some illuminating facts and figures resulted, as "P.W." readers may remember. Among other things we discovered that numerous coils would not tune below about 230 metres. The minimum of some was even higher.

And just as deplorable results were evinced at maximum wavelength limits. Of course, there were noted exceptions, but restriction of a serious character was not rare, by any means.

How the sets in which the less effective coils figure will get on now that the European ether has been remanifested hardly bears contemplation!

But it is at this opportune moment that Messrs. Wright and Weaire, of 740, High Road, Tottenham, London, N.17, have produced a new dual-range coil.

As a matter of fact, this Wearite Universal Dual-Range Coil has been specially designed to meet the requirements of these new conditions.

The medium-wave tuning range, using an average .0005-mfd. variable condenser, is from 150 to just above 550 metres, while the long-wave coverage is equally extensive and useful, i.e. 750 to 1,950 metres.



The coil is also made to a high standard of repetition accuracy so that it can be used in gang formations.

A further feature is that extremely simple wavechanging is possible.

The design of the coil is such that it can figure in any of the conventional circuit positions as an aerial unit or as a tuned grid or H.F. transformer interstage coupler.

It is completely screened, and the terminals are exterior to the screen and placed for easy and efficient wiring.

It is a good coil, and I can recommend it to the attention of constructors.

IGRANIC FIXED CONDENSERS

It may appear to some that a little too much emphasis is given to test voltages of fixed condensers and too little to other factors such as insulation resistances.

A year or two ago I would have agreed, for the average high-capacity condenser was a poor charge holder. The one which would hold a charge for hours was, in my experience, a rarity. But that is not the case to-day.

The majority of fixed condensers which come my way exhibit pretty good insulation resistances, but I still encounter too many which break down at what must be voltages well below double the rating of the condensers.

Therefore, when I note that the 1, 2 and 4-mfd. Igranic fixed condensers are tested at a voltage nearly three times their rated working voltages, I feel that this is testing that is carried out to the letter under proper conditions.

This either cannot apply to some others or the material of which they are made is not up to the standard set by Igranic. This is not mere eulogy, because it happens to be quite true that I have not met a "dud" Igranic, whereas I have only this very week of writing encountered two condenser breakdowns which, according to their respective books, should not have occurred.

(I expect my friend Dr. Roberts feels quite as keenly about this matter as I do, for he encountered a bad condenser breakdown—which led to the damage of other components—in his own home outfit only about a month ago!)

Of course, condensers age, but all the above can claim no excuses on that account. In addition to these Igranics being "700-volt D.C. test, 250 working," they are of non-inductive construction—a point to remember when you are working at the H.F. end of your set.



The Igranic Electric Co., Ltd., of 149, Queen Victoria St., E.C.4, is responsible for these new non-inductive fixed condensers.

They retail at the reasonable prices of 2s. 6d., 3s. and 5s. for the 1, 2 and 4-mfd. respectively, and they are obtainable in either bakelite or metal cases.

By the way, I seem to have been saying a lot of nice things about Igranic lately, but I shall have to continue in that vein while they, on their part, continue to produce such obviously sound and attractive components.

THE UNIVERSAL AVOMETER

A few weeks ago I described the AvoMinor, and concluded my review of this new product of Messrs. Automatic Coil Winder and Electrical Equipment Co., Ltd. (whose address, by the way, is Winder House, Douglas Street, S.W.1), by saying that I would devote a separate report to the new 34-Range Universal Avometer, which had also been sent me for test.

Well, even though I have reserved approximately a third of this week's article for the purpose, I still feel cramped for space. I have never before felt so much like really spreading myself as I do about this Avometer!

It is far and away the best thing of its kind that has come my way. Just let me as briefly as possible show you what it can do. If I get nothing else in I shall have gone a good way towards "getting over" something of its wonder.

Without using any sort of external shunt, multiplier or transformer, this Universal Avometer provides no less than 34 ranges of readings.

The D.C. ranges are as follows: Current: 0-12 amps., 0-6 amps., 0-1-2 amps., 0-600 milliamps, 0-120 milliamps, 0-60 milliamps, 0-12 milliamps, 0-6 milliamps.

Voltage: 0-1,200 volts, 0-600 volts, 0-120 volts, 0-60 volts, 0-12 volts, 0-6 volts, 0-1-2 volts, 0-600 millivolts, 0-120 millivolts, 0-60 millivolts.

Resistance: 0-1 megohm, 0-100,000 ohms, 0-10,000 ohms, 0-1,000 ohms.

And here are the A.C. ranges, and it should be noted that the instrument conforms to First Grade B.S. standards from 25 to 100 cycles, and that the total resistance is 200,000 ohms. On A.C., then: Current: 0-12 amps., 0-6 amps., 0-1-2 amps., 0-600 milliamps, 0-120 milliamps, 0-60 milliamps.

Voltage: 0-1,200 volts, 0-600 volts, 0-120 volts, 0-60 volts, 0-12 volts, 0-6 volts.

The readings covered are: D.C.: 50 microamps to 12 amps., 500 microvolts to 1,200 volts, 0-1 ohm to 1 megohm. A.C.: 500 microamps to 12 amps. and 50 millivolts to 1,200 volts.

There is a five-inch scale, and the needle is absolutely dead beat. It swings right over to the reading and

stays there without a quiver. And it is extremely alert, too—two virtues which rarely go together.

And if you think that the Universal Avometer needs a scientist to operate it you are quite wrong. Directions for use are concisely given on a metal plate at the back of the instrument, and all the ranges are immediately available by operating a couple of switches.

It is simplicity itself to operate—just the thing, in fact, for the lower as well as higher grades of factory worker and for the service-man. Also, I must add, for the radio experimenter, too, because here in one compact article is the equivalent of a whole collection of first-class A.C. and D.C. meters. We've got a fairly good bunch of meters in our Research Department, but I notice that it is this new Universal Avometer which does most of the jobs these days!

Its accuracy is almost uncanny, and in many respects is equal to some of our best hand-calibrated instruments. And this mark you, in 34 ranges at twelve guineas!

It may cost more than some constructors feel they can afford for a meter, however universal, but it is certainly an instrument that every experimenter and service-man should aspire to.



Thirty-four ranges of readings are obtainable from this Universal Avometer.



Weekly jottings of interest to all buyers.

By G. T. KELSEY.

THE Class B output scheme for battery sets superseded Q.P.P. because, in general, it was so much more satisfactory. But do not misunderstand me. Judged on technical merits alone, the difference between the two methods was not great, and probably the only reason why Class B swept Q.P.P. into comparative insignificance was because it was so much more practical from the point of view of the man in the street. On the score of cost there was not much in it.

A New Q.P.P. Valve.

But now the difficulties associated with Q.P.P. have been overcome, as described in "Popular Wireless" last week, by the introduction of a new valve in the Marconi and Osram ranges, and, frankly, I think it is likely to influence the design of battery sets in the future quite considerably.

Constant-Slope Push-Pull, which is the name applied to the new scheme, is achieved by the new Marconi and Osram Q.P.21 valve, which is really two valves in one.

One of the main difficulties with Q.P.P. in the past has been the necessity for careful adjustment of screen voltages, it being held that by this means the anode currents of the two pentode valves could be matched and the best output obtained.

In the Q.P. 21 there is only one screen connection which is common to both halves

(Continued on page 966.)

"NATION SHALL SPEAK PEACE UNTO NATION"

By the **VISCOUNTESS SNOWDEN J.P.**

NEARLY seven years ago, in the stuffy little board room of the British Broadcasting Corporation at Savoy Hill, the first five Governors of the B.B.C. met to discuss, amongst other matters, the question of a motto for the newly formed Public Service.

The Chairman was the Earl of Clarendon, now Governor-General of South Africa, keen sportsman, fine amateur musician and full of the charm of old-world courtesy.

The Vice-Chairman was Lord Gainford, a one-time Postmaster-General, chosen for this new office by reason of his proved business ability and for his vision and courage in helping the infant radio industry.

The Best Traditions.

Dr. Montague Rendall, scholar and educator, represented on the first Board the best traditions of our public schools and ornamented with a fine culture the office of Governor. Sir Gordon Nairne, whose name once appeared on our banknotes and whose fine integrity shone from his every word and deed, was the fourth Governor, and myself the fifth.

These appointments were not political, nor should they have been. To the end of our term of office I remained ignorant of the politics of two of my colleagues. Doubtless we represented several schools of political thought, yet there was immediate and unanimous acceptance of the suggestion that we should have for our motto, to be printed on all our publications, the words: **NATION SHALL SPEAK PEACE UNTO NATION.**

These words have a biblical flavour about them, but I am not sure that they actually appear in the Bible. I have been carefully through every reference in my Concordance to make quite sure, but nowhere have I found these exact words.

A Command to be Obeyed.

There is in the fourth chapter of the prophet Micah a sentence of similar content: "Nation shall not lift up a sword against nation, neither shall they learn war any more"; but this is of the nature of a prophecy, whereas the words of the B.B.C. motto indicate, and were meant to indicate, something of the nature of a command to be obeyed.

Clearly, however, no command from the

The full story of how the first five Governors of the B.B.C. chose a motto for the new public service of Broadcasting and how they were criticised for pacifist propaganda. An exclusive article by one of those Governors who were present in the Board Room at Savoy Hill on that occasion.

first Board of Governors could be laid upon any nation with any expectation of its being obeyed. The writ of the B.B.C. does not run beyond the bounds of its own territory; but the first Governors were full of a sense of responsibility, and from the first moment in office they wished to direct broadcasting towards a lofty national and international purpose.

Might be Misconstrued.

There were those who thought that our intention was to dedicate the B.B.C. to pacifism. Others feared that foreign nations, in the persistent but mistaken belief that the British Government dictates the policy of the Broadcasting Corporation, might misconstrue the will and the spirit of our people to our detriment in the light of a motto not internationally accepted. A small minority would have been better pleased had the words, "My country, right or wrong," disfigured the front page of the

"Radio Times."

No such idea as that of labelling the B.B.C. pacifist entered the head of any one of us. The B.B.C. can have no opinions of any sort whatever. There is no B.B.C. creed, no B.B.C. party. The B.B.C. is not a soul: it is an instrument. It is not a personality; it is a medium. It is the channel through which those persons who have principles and opinions can expound them, and broadcasting is legitimately used in proportion as it is at the service of every shade of thought-out opinion.

The moment that the Broadcasting Corporation becomes the slave of one creed, whether religious or political, whether pacifist or militarist, communist or conservative, socialist or fascist, Protestant or Catholic, it departs from its proper uses and becomes a danger and a menace.

This New Thing in Their Midst.

The first five Governors believed this with all their hearts, and believed that any serious departure from this would mean strife, and might ultimately mean war. They were exceedingly anxious to find some words which would be a guide to listeners at home and an indication to listeners abroad as to the purpose which should consecrate this new thing in their midst.

(Continued on next page.)



Above is a photograph of the historic occasion of the opening of Radio City, the new home of the National Broadcasting Company of America. The presence of Sir John Reith, who is seen in the left of the picture next to Mr. Owen D. Young, helped further to strengthen the bonds of friendship between the two countries. Below is another use of radio—a Fascist meeting in Italy, with a rousing speech being broadcast throughout the country.



"NATION SHALL SPEAK PEACE UNTO NATION"

(Continued from previous page.)

From time immemorial the soil has been soaked in human blood because of human quarrels. Ships have gone down into the depths of the sea with the bodies of men mangled in battle. For twenty years men have ridden one another to death in the air and dropped bombs on defenceless cities.

Earth, sea and sky have been prostituted to the base uses of war. Shall the ether, we asked each other, be used in the same way? We fervently hoped not, and we thought to direct the attention of the nation to its responsibility for the right use of the ether by choosing for our motto the words: *Nation Shall Speak Peace Unto Nation.*

Other broadcasting systems have accepted in part this idea. The various international radio conferences have agreed that their members shall bind themselves not to attack the political policies of their respective Governments or do propaganda for the opposition parties of the various countries represented.

It is a Good Rule.

Individual speakers may, within the limits of courtesy and goodwill, express their views or recount their experience of foreign affairs, but this rule forbids official attacks through the ether; and it is a good rule.

The B.B.C. strives to obey this rule, remembering that it has no opinions of its own, and that provocation, however reasonable, and retaliation, however just, is no part of its business.

But the extent to which the opposite

line of conduct creates ill-feeling and tempts to retaliation is illustrated in the Russian practice of broadcasting Communist propaganda speeches in English in defiance of good taste and the expressed wishes of the Radio Alliance. These speeches are meant for people in this country who are inclined to listen; but they dispose many people to ask for retaliatory measures, which would inform the Russians, through Russian speakers in this country, that the working people of England under Capitalism are better off than the Russian starving peasants and underpaid artisans under Communism.

The right line of radio policy is, of course,

to avoid propaganda of every kind, since propaganda means the presentation of selected facts and chosen arguments in order to make a weak case strong, and is not concerned with the truth. For a strong case the truth is always sufficient.

Wide Dissemination of Culture.

The first Governors of the B.B.C. were never pacifist in the sense that they would have favoured a policy which left their country naked to her enemies or would have denied her adequate help in dire extremity; but they dared to hope and believe that the wide dissemination of culture implicit in the use of the microphone would so fill the minds of people with "the things that are more excellent" that there would be no room in their hearts for war.

No Vain Hope.

Beautiful music in its many forms, fine drama, poetry, interesting books, sport, the spirit of the dance, news gathered from the four corners of the earth—with all these interests increasingly filling the lives of men and women the world over, is it a vain hope that some day, brought nearer to us through the advent of broadcasting, nation will speak peace unto nation, neither will they learn war any more?

LITTLE COMRADES OF THE U.S.S.R.



An example of the political propaganda to which Lady Snowden refers. Members of a Russian Youth Association listening to the latest political news.

CONDENSERS which CORRODE

Although condensers of reputable manufacture are never likely to give trouble in this way, there are components which corrode or "grow whiskers." Our correspondent tells you all about them here.

TO discover that your set's condenser is slowly but surely corroding away is, to say the least, a startling fact to come across during the overhauling of the receiver.

The trouble, of course, could hardly occur with modern makes of condensers, for I know that the makers of these precision instruments take adequate precautions to prevent inferior metal from being used in their products.

A Peculiar and Interesting Trouble.

You do come across sets, however, whose components are shoddy and inferior indeed. It is in these sets that the peculiar and interesting condenser trouble of which I am writing occasionally crops up.

Condenser corrosion manifests itself in one or two ways. You may find that a certain condenser slowly becomes more and more inefficient. Examination shows

faulty vane contacts. The aluminium vanes have become covered with a whitish film, which can be powdered away with the tips of the fingers.

At other times the condensers may "grow whiskers." That is to say, thin white filaments may actually grow upon the condenser vanes and so bridge the gaps between them. You may clear away these "whiskers," but the chances are that they will recur.

The cause of troubles of this nature is obvious: faulty metal. Condenser vanes are generally composed of aluminium, or, rather, of aluminium alloys, which appear to vary in composition with the different makes of condensers.

More Chemically Stable.

Crude aluminium resists corrosion very badly indeed. Good-quality commercial aluminium, however, approximates to about a 99.6 per cent purity, and this grade of metal resists atmospheric corrosion much better.

Still, for many purposes pure aluminium is too easily oxidisable a metal. Consequently, attempts have been made to find aluminium alloys which are more chemically stable than the pure metal.

Several of these alloys have been worked out, and they have been employed for the making of radio condensers, photographic lenses, camera mechanisms and for other purposes in increasing amounts.

Still, there are quite a number of conden-

sers whose vanes consist of nothing else but pure aluminium, and which are found to be perfectly satisfactory in actual practice.

When, therefore, you come across a case of condenser corrosion—that is, of course, providing acid hasn't been spilt over the condenser, or providing that some similar mishap has not occurred to it—you may always be sure that the cause is due to the use of bad and impure crude metal in the manufacture of the vanes.

No Cure for Faulty Metal.

In such instances the only "cure" consists in the entire scrapping of the condenser. Faulty metal will never be anything else but faulty.

You can, of course, effect some sort of a cure to diseased metalwork of this description by rubbing away all the powdery deposit on the condenser vanes and then by varnishing the metalwork. But, in doing so, you have to bear in mind that the interposition of films of varnish between the metal vanes upsets the capacity of the condenser.

The increase in capacity is, of course, not serious, but care should be taken that the varnish (shellac) is applied evenly, especially in cases of gang condensers, if inequalities in tuning are not to be experienced.

Aluminium exposed to sea air is likely to show more signs of corrosion than that used inland.

O. L.

RADIOTORIAL

The Editor will be pleased to consider articles and photographs dealing with all radio subjects, but cannot accept responsibility for manuscripts or photos. Every care will be taken to return MSS. not accepted for publication. A stamped and addressed envelope must be sent with every article.

All Editorial communications should be addressed to the Editor, POPULAR WIRELESS, Tallis House, Tallis Street, London, E.C.4.

All inquiries concerning advertising rates, etc., to be addressed to the Advertisement Offices, John Carpenter House, John Carpenter Street, London, E.C.4.
The constructional articles which appear from time to time in this journal are the outcome of research and experimental work carried out with a view to improving the technique of wireless reception. As much of the information given in the columns of this paper concerns the most recent developments in the radio world, some of the arrangements and specialities described may be the subjects of Letters Patent, and the amateur and the trader would be well advised to obtain permission of the patentees to use the patents before doing so.

QUESTIONS AND ANSWERS

GETTING FULL VALUE FROM THE "DOUBLE X THREE."

"I like your 'Double X Three' immensely," says L. N., of Colwyn Bay, "but I am not sure that it likes me!

"Not being a regular set-making fiend, I have to choose rather carefully," he explains, "to make sure I get something within my capabilities. And, somehow, the 'Double-X' tickled my fancy right off, and it all looked perfectly clear, so I got it going over Christmas.

"Right from the start it went fine, but it seem'd to have several peculiarities of its own. I thought at first I should overcome these, but after three weeks or so I am still a bit in the dark, so I propose to tell you about them and see what you suggest.

"First, the H.T. +1 lead. I can take this right out of the battery sometimes without making any difference that I can hear. Surely this is a bit of double-crossing on 'Double-X's' part?

"I know it's a Good Set."

"Another time, after putting in the S.G. valve, I forgot to connect up the lead from the No. 6 terminal on the H.F. transformer (the one marked to anode of V1), but it went quite O.K. for a time like that. What do you know about that?

"I expect it's something I am doing wrong. Reaction puzzles me, but the set is as lively as Test Match cricket, in spite of these (to me) incomprehensibilities. So if you can clear up these mysteries and give me some advice about using the combined volume control and switch I shall lap it up.

"I know it's a good set, but I've got the feeling that if I could sort of make friends and get to understand it a bit it would be better still."

You certainly appear to have got yourself rather tied up, L. N.! And probably this is because the "Double X" was a very novel set in its way, for all its fundamental simplicity.

The "incomprehensibilities" you have referred to are all easily explained when you remember that the set works either as a two-valver or a three-valver, according to the position of the combined volume control and on-off switch (left of panel).

Naturally enough, if you adjust this control to convert the set into a "two" (detector and L.F.), the results are not going to be affected by anything you do to the H.F. (S.G.) valve, because it is automatically switched off. So it is not surprising that H.T. +1 then has no effect, is it?

Learning to Handle Reaction.

But you are quite right in suggesting that if you can sort of "get friendly" with the set you will get much better results from it. And the first thing to do is to learn how to handle reaction properly.

For this it is better to practise with only two valves in action. So turn the combined volume control and switch right over to the left, anti-

clockwise, and then adjust both tuning and reaction simultaneously.

It will be the right-hand tuning dial only, because the other valve is now out of action. And you will find that if you tune in a rather weak station, and then slowly increase reaction, this will result in improved strength.

But only a slow reaction increase must be made



THE WESTECTOR
—a metal rectifier
for H.F.

must be numbered the
H.F. work.

Known as the "Westector," this device is only about the size of a grid leak. It acts like a diode detector, with pronounced advantages as regards distortionless reproduction.

It is particularly useful as second detector in a superhet, as it will handle a large input without overloading. Unlike a triode detector, however, it does not act as an L.F. amplifier as well.

because it is easy to overdo it. What happens when this occurs is that, although at first, as you increase reaction, results get better and better, there comes a point where the loudspeaker gives a sort of "pop" (you'll hear it if you listen carefully), and then you get distorted reception.

Sometimes there is a whistle as well, and the whole tuning seems too lively; but these troubles will disappear if you immediately slack off the reaction a little. The extra liveliness, whistles, poor quality, etc., are all due to the fact that too much reaction has made the set "oscillate."

Don't let it do this. It spoils your own reception and possibly other people's as well, so always keep reaction adjusted below the oscillation point—that is, below the setting where the "pop" is heard.

P.W. PANELS, No. 155.—SAN SEBASTIAN, SPAIN.

Under the recently introduced Lucerne Plan, San Sebastian has been allotted a wavelength of 238.5 metres, sharing this with Riga and Rome II.

It is too early to say whether this sharing will generally prevent reception in this country, but it seems likely, because Riga uses 15 kilowatts, which is five times the power of San Sebastian.

As Riga closes comparatively early, however, the San Sebastian close-down may be heard, the announcer saying good-night in the form of "Buenas Noches, Senores; hasta mañana."

The call sign is E A J 8, and sometimes the location of the station, Monte Igeldo, is mentioned. To English ears this sounds like "Iggeldo." (Distance from London, 569 miles.)

You will find that this oscillation point on the reaction dial is not always at the same dial-reading, because it depends partly on the tuning. And you will notice that you require more reaction when the tuning-dial reading is high than when tuned to a low wavelength station (one with a low dial-reading).

Practise a little with reaction control until you have the hang of it. And be sure to do this outside broadcasting hours, or you may interfere with your neighbours' reception. (Once you get accustomed to keeping below the oscillation point this possibility of interference with others will disappear.)

When you are able to handle reaction and tuning together properly you will find that even on the two valves you can pick up plenty of foreign programmes.

Get this good feeling first by sticking to the two valves until you get really good results from them. And then turn that control over to the right, and by thus bringing in the third valve see what the set really can do. It will surprise you!

But remember this important point: The correct operation of the two tuning controls is now much more important than the reaction control which you have been learning.

Keep the Dials in Step.

So for the three valves this is how you proceed: First turn the reaction right off, to its minimum-effect position.

It can be left there for all but the very weak stations, because you can now afford to do without it. What you do instead is to put one hand on one tuning dial and the other hand on the other tuning dial, and then keep these two "in step."

That is to say, you first turn the left-hand tuning till you hear some trace of a station, and then, holding that dial still for a time, you bring up the left-hand tuning dial slowly, to somewhere near the same dial-reading. And suddenly you will find it gets in tune (or "in step," as we generally say), and there is a great advance in strength of reception.

After you have got both tuning dials right in this way, you can, if you like, turn your attention to reaction for a moment and increase the strength still further—but not, of course, by passing the oscillation point. But the great thing to remember is that reaction is only a side issue when you have two tuning dials to handle, and the main principle is then to keep the two in step, as explained above.

We are afraid you have tempted us to go into a lot of detail, but good handling makes such a lot of difference to any set that you will be more than repaid for any trouble you take.

MORE CURIOUS FAULTS REPORTED BY READERS.

We should like this week to thank the many readers who have sent in details of curious faults which have occurred within their experience. These are always interesting, and often valuable to other readers suffering from similar symptoms, so we greatly appreciate the kindly thought of those who send in such reports.

Mr. A. A. Payton, of 43, Burnaby Gardens, Chiswick, tells of an unusual trouble with the "Apex," which produced all the symptoms reported recently by another reader (D. F., Liverpool. See "Radiatorial" in "P.W.," dated December 23rd, 1933). After "any amount of trouble" A. A. P. found that under the base of the H.F. coil (T.D. type) the metal strip had developed a very high resistance where it connected to the screw socket, and when this fault was removed the troubles disappeared.

Another interesting letter is reproduced below. It is from Mr. J. Irving, of s.s. Camillo, lying at Tier No 8, West Dunton-on-Tyne.

Mr. Irving says:

"Thanks for your aid in trying to find the fault. I said in my previous letter that when the set was working on long waves the right-hand switch (facing the panel) could be pushed in and out with no effect on receiving, say, Daventry 5 X X."

"Glad to say my troubles are over now. I've found the fault.

"It was the aerial coil. . . On being screwed down the tin-foil on the baseboard buckled up, and so shorted the wires! I had had that coil off and on in place three times!

"P.S.—The set now works beautifully."

AN AMAZING VALVE BOOK

Details of the latest Mazda catalogue of receiving valves.

SEVENTY-SEVEN pages crammed with valuable information about Mazda valves! Such is the contents of one of the finest valve books yet produced. With its neat black cover and green lettering the Mazda valve book is attractive and pleasingly unconventional in appearance.

With Invaluable Index.

The index at the end is invaluable, for the book is wonderfully complete, ranging from descriptions and technical data of the full range of Mazda battery valves to the most recent mains pentodes. In addition, a great deal of useful information on the use of the valves, data of replacement types, diode detection and A.V.C., and valve-base connections are given, making the whole book invaluable to keen home constructor and research engineer alike. There are also many useful circuits, together with the necessary component values, indicating how various valves are used in receiver designs.

And it is free. Just a postcard to the Mazda Valve Dept., The Edison Swan Electric Co., Ltd., Radio Division, 155, Charing-Cross Road, London, W.C.2, will bring you a copy. And you will be well pleased with it.

ON THE AIR WITH THE NATIONAL ECKERSLEY 3

(Continued from page 948.)

and to the right for radio. For radio reception the bottom central knob, which controls the combined gramophone volume control and radiogram switch, must be turned to the left until the switch snaps over. When you turn this knob to the right the switch snaps back again, the pick-up is in circuit and the volume control functions in the normal way. As already stated, the selectivity control acts as a volume control on the radio side, and if you turn it to the right volume is decreased.

On the Long Waves.

One last point about the operation. On both the National Eckersley Three and the Radiogram always keep the regulator at maximum for long-wave stations and when receiving weak stations use retroaction for greater sensitivity. You would only need the regulator on very strong local long-wave stations—perhaps when Droitwich gets going.

If you desire to use Telsen coils instead of Colvern, in the National Eckersley Radiogram, the holes for the wavechange spindle and on-off switch are drilled 3 3/4 in. from the bottom of the panel instead of 4 1-16th in.

The Telsen coil connections are as follows: Coil nearer panel—Terminal 6 to terminal nearer chassis of 20-ohm variable resistance, and also to 6 on middle coil; 7 to chassis; 8 to fixed vanes of front section of ganged tuning condenser; 1 to aerial terminal.

The remaining connection of middle coil is: 8 to fixed vanes of middle section of ganged tuning condenser.

Rear-coil connections—8 to fixed vanes of rear section of ganged tuning condenser; 7 to one tag of .25-mfd. fixed condenser, and also to rear terminal of 1,000-ohm resistance under chassis; 6 to chassis, and also to 2; 5 to F.I. of differential reaction condenser, and terminal 1 to anode of S.G. valve.

Connect the front terminal of the .0002-mfd. grid condenser to the fixed vanes of the rear section of ganged tuning condenser. (Omit flex lead on .0002-mfd. condenser.)

THE LINK BETWEEN

(Continued from page 962.)

of the valve; thus the initial difficulties of adjustment are virtually overcome.

There are, of course, other incidental advantages of having the two valves in one bulb. There is, for instance, the question of matching, for it is obvious that any slight drift in characteristics will normally apply equally to both halves of the valve. In addition, although the price of the Q.P.21 has not yet been definitely fixed, it is hoped that it will be considerably less than the cost of two separate valves.

In my opinion, there is every likelihood that the system of Constant-Slope Push-Pull amplification with this new double valve will become tremendously

MAKING PORTADYNE SETS



A view of one of the busy workshops where Portadyne receivers are constructed and tested.

popular. I am not certain whether descriptive literature is yet available, but if readers who would care for further details will kindly let me have the usual postcard, I shall be happy to make the necessary arrangements for information to be sent off at the earliest opportunity. (No. 74)

Here and There.

Mancunians and others concerned, kindly note that the Manchester address of the Fuller Accumulator Co. (1926), Ltd., has recently been changed. Henceforth all inquiries, etc., should be addressed to 53, Back George Street, Princess Street, Manchester. Telephone number, Central 6356.

Columbia's announce the introduction of a new battery receiver at the remarkably low inclusive price of 4 guineas. The instrument is completely self-contained in a neat cabinet of two shades of oak, and it is only 1/4 of a cubic foot in size. Next week I hope to be able to give you further details.

Users of Marconiphone sets will be interested to learn that the manufacturers have just produced a most helpful station list to overcome any difficulties which may arise in consequence of the wavelength readjustments. It is available from your local Marconiphone dealer, or direct from The Marconiphone Co. Ltd., 210/212, Tottenham Court Road, London, W.1.

Ekco's have just patented and produced an entirely new and ingenious wavelength scale on which the station names are instantly changeable. This, surely, is the one complete answer to the problems set by the changes in broadcast wavelengths. The new scale is primarily intended for Ekco models A.C.74, D.C.74 and B. 74, and it can be obtained from all Ekco dealers at the price, of 2s. 9d. Next week I shall be giving you further details.

A copy of the latest Ferranti Receiver Catalogue which has recently come to hand reveals the interesting news that four new models have been added to their "ady outstanding range. The "Lancaster Radiogram," the "Arcadia Magna Consolette," the "Arcadia Console" and the "Arcadia Radiogram" are the models in question, and these together with all the other sets in the Ferranti range, are included in a catalogue which can be obtained through the medium of our postcard (No. 75) literature service.

One of the best station identification charts for the new conditions that I have yet seen has just come to hand from Messrs. A. C. Cossor. Like all Cossor productions, it is exceptionally well prepared, and in addition to giving the wavelengths, frequencies and powers of practically every worth-while station in Europe, it contains a list of call-signs invaluable for identification purposes. Apply to Messrs A. C. Cossor, Ltd., Highbury Grove, London N.5, mentioning "P.W." and enclosing a 2d. stamp for postage and a copy will be sent free of charge.

In a recent Siemens advertisement in "P.W." announcing price reductions to the "Full o' Power" range of triple-capacity batteries, the type number of the 108-volt battery was given as V6. The makers now advise us that this should have been V7 so will interested readers kindly note?

Last year H.M.V.'s announced that henceforth they would work to an all-the-year-round production policy, a policy on which I warmly commended them as being the only logical way of putting radio manufacture on a really stable basis.

Now, in pursuance of that policy which I understand, has worked extremely well, H.M.V. announces the release of two new models, two models incidentally, which are likely to create a big sensation in the radio world. In a short while, possibly by next week, I shall be in a position to give you full details.

Readers will be interested to learn that the Technical and Commercial Radio College has recently moved to more centrally situated premises. Henceforth the address is Cromwell House, High Holborn, London.

OUR POSTCARD SERVICE

Applications for trade literature mentioned in these columns can be made through "P.W." by quoting the reference number given at the end of the paragraph. Just send a postcard to G. T. Kelsey, at Tallis House, Tallis Street, E.C.4. Any literature described during the past few weeks may be applied for in this way—just quote the number or numbers.

BROADCASTING QUALITY

(Continued from page 943.)

super-heterodyne receivers. They are excellent, and I use one myself. Whatever type of receiver is used, the obvious solution of the difficulty is to make the selectivity of the high-frequency circuits variable, so that if the detector and low-frequency circuits are well designed and a good loudspeaker is being used, the stronger the field strength the better the quality of reception from the frequency-spectrum point of view.

No Variation of Selectivity.

Many receivers do this, some of them automatically varying the selectivity of the high-frequency circuits with the volume control. In some cases, perhaps, this has come about accidentally; in others, of course, it has been carefully thought out. Quite a number, however, have practically no variation of selectivity, and one still hears a good deal of bass heavy quality from receivers operating with a field strength of 30 or 40 millivolts per metre. Of course, this is due sometimes to box resonance in the loudspeaker container and not to the cutting off of high frequencies; but that is altogether another matter.

[Mr. Ashbridge will continue his talk about quality in a concluding article, where he will discuss the question of long-wave reception and the reason for its apparently inferior quality compared with that obtained on the medium waves.—EDITOR.]

3 TYPICAL USES FOR WESTECTORS

AUTOMATIC VOLUME CONTROL

Usually the introduction of Automatic Volume Control necessitates complicated alterations. But even delayed A.V.C. may be obtained in a simple manner with the Westector.

Used as a battery economiser, the Westector enables a large output to be obtained from a battery set without using special equipment, and is applicable to any type of receiver.

BATTERY ECONOMY

HIGH-QUALITY DETECTION

When used as the second detector in a Super-heterodyne the Westector gives straight line rectification with distortionless detection, and it is almost impossible to overload it.

You will want to know more about this useful component. A development of the permanent Westinghouse Metal Rectifier, the Westector retains all the qualities of long life, reliability, etc. A 3d. stamp, to Dept. P.W., will bring you a copy of our booklet "The All Metal Way, 1934."

THE WESTINGHOUSE BRAKE & SAXBY SIGNAL CO., LTD.,
82 York Road, King's Cross, London, N.1.



A delightfully cool sweet smoke, burning free and evenly... an Empire Blend of the highest quality.

PLAYER'S AIRMAN MIXTURE

ALSO AIRMAN NAVY CUT AND FLAKE - 10⁰/₂ NAVY CUT DE-LUXE 11⁰/₂



10^D PER OZ



BIG Double GIFT

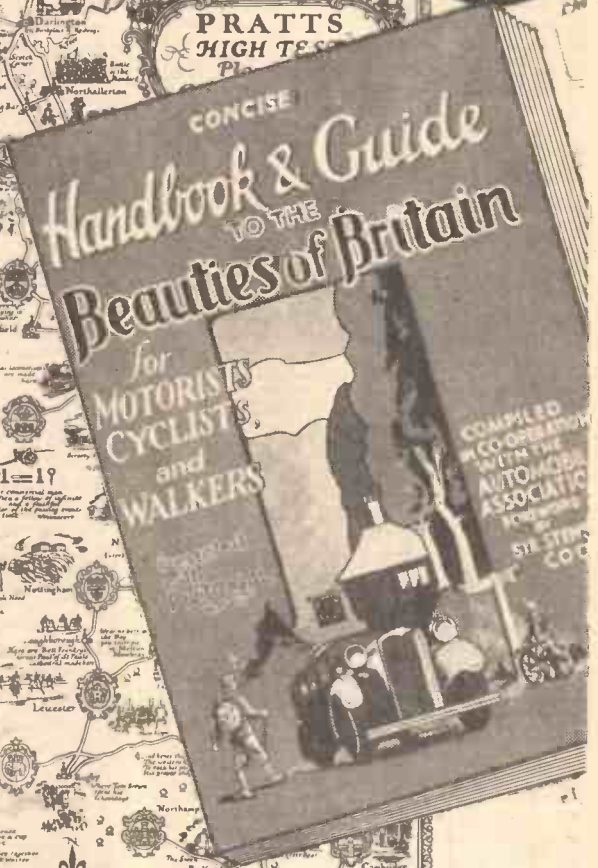

FREE

44 Page Handbook and Guide to the BEAUTIES OF BRITAIN, and PICTURE ROAD MAP in Full Colours!

Unquestionably, these are the finest gifts ever presented by a weekly paper to its readers. You can only make certain of them by getting the big, Double-Gift issue of—

PICTORIAL WEEKLY 2d.
On Sale Friday, Feb. 2nd.

EASY TERMS

Everything radio supplied on convenient terms. For real prompt delivery entrust your order to us. Goods ordered cash or C.O.D. despatched same day. Strict privacy. Carriage paid. Price List FREE.

SET OF THREE VALVES—Cossor, Mullard or Mazda. 1 Screen Grid, 1 Detector, 1 Power. Cash or C.O.D. £1-11-3, or 5/- with order and 6 monthly payments of 5/-.

All types of A.C. valves also supplied.
ATLAS MODEL CA25 H.T. ELIMINATOR. Output 25 milliamps. 4 Tappings. Cash price £2-19-6, or 5/- with order and 11 monthly payments of 5/6.

BLUE SPOT MOVING-COIL CHASSIS
45PM 5/- with order & 9 month payments of 5/-
99PM 5/- 11 5/6

Send list of goods you are interested in and a quotation will be sent by return of post. No obligation.

To avoid delay, will customers kindly send first payment with order!

Estd. 1925 THE National 1977

LONDON RADIO SUPPLY COMPANY

11, OAT LANE-NOBLE STREET, LONDON, E.C.2

YOU ARE WANTED ON THE SHORT WAVES

Short-wave reception with any receiver with the new remarkable UNIT RADIO short-wave unit. IDEAL for use with the ST.500. Complete unit sent for 5/- down. Send for illustrated leaflet. Cash or C.O.D. 37/6
UNIT RADIO, 12, Pulteney St., London, N.1.

Add 50/- WEEKLY to your earnings

by charging accumulators in your spare time. Complete Plant incorporating Westinghouse Rectifiers, to charge 105 cells weekly. Trade Price £4:4:0 or 8/- monthly A.O. Mains only. Send for descriptive booklet.



M.P.R. Ltd ROMFORD, ESSEX.

LOUD SPEAKERS REPAIRED. 4/-

(Blue Spot a Speciality, 5/-.)
Transformers and Headphones, 4/-, Eliminators, Mains Transformers and Moving Coils quoted for. 24-Hour Service. Trade Discount. Clerkenwell 9069.
E. MASON, 44, EAST ROAD (nr. Old Street Tube Station), LONDON, N.1.

ABUNDANT H.T.

YEAR IN—YEAR OUT!



Let the wonderful Standard Leclanche Battery give you pure steady power—year in, year out—at half the cost of dry batteries. Always up to strength—cells are regenerative. Annual replenishment at small cost all that is necessary. A.R., of Aberdeen, writes: "Have given every satisfaction; no trouble, no worry; just a look over when I remember."

120-v., 12,500 m.a. £2 complete, earr. paid. Write for details. All Standard Battery Spares supplied.

WATES METER 4 in 1

This famous precision instrument now gives 4 readings—0-30 m.a., 0-180-v., 0-5-v., 0-15-v., 2/3 post free.
Wates Glass Accumulator, 2-v. 40 amp. hrs., 7/1-



THE WET H.T. BATTERY CO. (P.W.), Gerrard 6121. 26, Mile Street, London, W.C.2.

RADIO SUPPLIES

Send your list of Radio needs for our quotation Kils, Paris. Sets, etc. Everything in Radio stocked, prompt delivery. 7 days' approval. Catalogue free. Taylex & Standard Wet H.T. replacements stocked.
P. TAYLOR, 9, GROVE ROAD, BALHAM, S.W.12

OPENINGS for ENGINEERS

ENGINEERING OPPORTUNITIES
250 PAGES free

Never before has engineering offered such magnificent chances. With the rise of the depression, the industry is literally teeming with first-class opportunities. Our 250-page Hand-book, "ENGINEERING OPPORTUNITIES" shows where the opportunities lie, and the easiest way to prepare for them. The Hand-book gives details of A.M.I.Mech.E., A.M.I.E.E., A.M.I.C.E., G.P.O., etc. Exams., outlines Home-Study Courses in all branches of Civil, Mech., Elec., Motor, Radio and "Talkie" Engineering, Building, etc., and explains our unique Employment Dept. Send for this valuable Hand-book to-day—FREE! British Institute of Engineering Technology, 101, Shakespeare House, 29, Oxford St., London, W.1

THE MIRROR OF THE B.B.C.

(Continued from page 958.)

"Street" Football.

Running commentaries upon and eye-witness' accounts of something new are so rare in these days that a Shrove Tuesday (February 13th) broadcast, arranged by the Midland Regional programme builders, stands out like an oasis in the desert.

That evening we are to hear an eye-witness' account of the street football match which is to be played that day in the main thoroughfare of Atherstone, a Warwick village close to the Leicester border.

Any number of players can take part in this annual Pancake Day tussle, and there will certainly be no shortage of contestants now that it has been announced that the B.B.C. is interested.

"Forty Years Off."

Two new series of talks for North Regional listeners, which begin in mid-February, are somewhat out of the ordinary. In one, entitled "Forty Years Off," a number of North Country men and women, all of them sixty years of age, and some much older, will come to the microphone to describe their youthful experiences, and to compare conditions in the eighties and nineties with life to-day.

Battersea Power Relay.

For whatever useful purpose it may serve, the Outside Broadcast Department of the B.B.C. is hoping to arrange a relay from the super-electrical generating station on the banks of the Thames at Battersea on Friday, February 23rd.

With its colossal output of 100,000 kilowatts, there is no doubt a good deal of general interest in the working of this giant power-house, but how much listeners will enjoy the noise remains to be seen.

The broadcast is to take the form of a tour of the station, and the relay is said to be one of the most difficult ever attempted, because of the problem of screening the broadcasting apparatus in order to secure effective transmission.

The engineers are now very busy making tests and experiments—which will doubtless cost far more than the programme value which London Regional listeners are likely to derive from the broadcast.

ALL ABOUT SOUND AND RADIO WAVES

(Continued from page 957.)

But the charge is not in equilibrium; it has been forced out of that position by an electromotive force; and when that is relaxed it rushes back, the motion of the charge through the ether producing a disturbance which is called a magnetic field, and which has the property of prolonging the motion of the charge beyond its position of equilibrium, so that it overshoots its mark in the opposite direction, and then is brought back by the strained elastic filaments with a reversed magnetic field which prolongs the return journey, until it once more surpasses its starting-point.

The field is thus alternately electric and magnetic in the course of an oscillation, the electric field being a maximum at the

extremities when the particle is at rest for an instant; and the magnetic field being the maximum at the middle of the swing when the particle has its maximum velocity.

Therefore, in an oscillation the electric and magnetic disturbances are not of the same phase; they differ by a quarter period. But within a quarter wavelength of the source they have caught each other up, and thereafter they agree in phase and in every other particular. But they are at right angles to each other, and they travel at a speed depending on the electrostatic and magnetic constants of the ether.

The constant which regulates the charge is called K: this is responsible for the elasticity of recoil. The constant which permits the continuance of the vibration, that is, the overshooting the mark and the consequent return, is analogous to inertia, it represents the magnetic properties and is called μ .

The frequency of oscillation depends on the product of these two quantities, combined with some geometrical considerations respecting the shape and size of the circuit. Whereas the velocity of propagation of the waves depends on the two constants alone, being independent of everything else. And the measure of that speed gives the product of the two constants, in accordance with Maxwell's theory.

The Etheric Constants.

The value of neither constant is at present known; but there is every reason to suppose that the electrostatic constant K is a measure of the elasticity of the ether: and similarly the magnetic one μ is a measure of the density. And a natural assumption is that the etheric elasticity equals $\frac{4\pi}{K}$ and that the etheric density is $4\pi\mu$.

The ratio of elasticity to density gives the square of the velocity of light, as Newton proved in the Second Book of the "Principia," though he only actually proved it in the case of sound and in the case of waves of condensation and rarefaction. But the same is true for any waves, even transverse waves, if the right kind of elasticity is employed. Maxwell's theory makes the waves travel at a rate $\frac{1}{\sqrt{K\mu}}$, and this is equal to the square root of the elasticity divided by the density.

Recently it has been the fashion in physics to deny or ignore the existence of the ether, and therefore not to attend to the two ether constants K and μ . This is a temporary phase, which will come to an end directly we have the means of determining the value of one of these two etheric constants.

THE "NO-MAST" AERIAL

MESSRS. "No-Mast" Radio Developments, of 110, Singleton Avenue, Birkenhead, inform us that they have had many enquiries regarding their "No-mast" Patent Aerial, Patent No. 337866, and that they would be willing to extend permission to any genuine amateur who is a reader of POPULAR WIRELESS to make such an aerial for his own experimental uses. Readers who are interested should apply to Messrs. "No-Mast" Radio Developments to obtain the necessary permission.

**LISTEN TO THESE
NEXT WEEK**

Outstanding items selected from the B.B.C. programmes for the week ending February 10th.

Sunday February 4

National: Orchestral concert from Eastbourne. Tom Jones and his Orchestra are always a popular Sunday evening feature.

Monday February 5

National: "Charlot's Hour." Uncle André back again in the studio in one of the programmes which he has made so famous since 1928. "Have You Forgotten?" will be the theme of this "old favourite's" hour (to be repeated on the Regional wave on Tuesday).
North Region: Microphone Tour No. 3. Surprise is the keynote of these feature programmes, but we would point out that Yorkshire has yet to be visited by the travelling microphone.

Tuesday February 6

National: "Whither Britain?" Mr. George Bernard Shaw makes a welcome appearance in this series. Not many sets will be silent this evening.
Midland Region: Military Band Concert. A bright programme of the kind which listeners never fail to enjoy.

Wednesday February 7

Regional: "Song Writers on Parade." A new type of light entertainment in which such people as Noel Gay, Ray Noble, Ivy St. Helier and Ivor Novello will perform their own popular compositions. "Keep the Home Fires Burning," "Coal Black Mammy" and "The King's Horses" will be among the numbers performed.

Thursday February 8

Midland Region: "Ring o' Roses." A jazz operetta—already broadcast last year in the London programme with outstanding success—will add to the first-class productions which Martyn Webster has given the Midlands since October last.

Friday February 9

National: "Emil and the Detectives." A play for the microphone translated from the German. If you saw the film—or if you did not—you will enjoy this play, which is one of the Production Director's "high-spots" for the year.
West Region: "Hurdy Gurdy." A selection from songs from stage, screen and drawing-room.

Saturday February 10

National: "Music Hall." A variety programme, including Tod Slaughter, hero of melodrama through three generations.

**THE PEOPLES
OF THE WORLD**

EVERYONE to-day wants to know something about foreign peoples and their ways, and certainly all those interested in wireless, who make a point of listening-in to foreign stations, will welcome a very valuable book which will be published in about 60 weekly parts at sixpence each.

The book in question is called *PEOPLES OF ALL NATIONS*, and it is edited by Sir John Hammerton. It is the most encyclopedic work of its kind ever produced. All peoples are dealt with, and the book is profusely illustrated with 3,500 magnificent photographs of national types from scores of countries.

There are in addition over 120 plates in full colour, making the book one of the most sumptuous as well as one of the most informative works on the world's inhabitants ever published.

The first part is now on sale, and if you get it you will certainly thoroughly appreciate the work.

PETO-SCOTT

EVERYTHING RADIO — CASH — C.O.D. — or H.P.

IMPORTANT—Parts, Kits, Miscellaneous Components, Finished Receivers or Accessories for Cash, C.O.D., or H.P. on our own System of Easy Payments. Send us a list of your wants. We will quote you by return. Easy Terms on orders over £2. CASH or C.O.D. orders value over 10/- sent Carriage and Post Charges Paid. **GREAT BRITAIN ONLY.** H.P. Terms are NOT available to IRISH or OVERSEAS Customers.

- BLUE SPOT 99 P.M. PERMANENT MAGNET MOVING-COIL SPEAKER.** Complete with tapped Input Transformer. Cash or C.O.D. Carriage Paid, £2/19/6. Balance in 10 monthly payments of 6/-.
- NEW W.B. P.M.4A. MICROLODE PERMANENT MAGNET SPEAKER,** complete with switch-controlled multi-ratio input transformer. Cash or C.O.D. Carriage Paid, £2/2/0. Balance in 7 monthly payments of 5/9.
- NEW LISSEN SKYSCRAPER FOUR ALL-WAVE CHASSIS MODEL.** Complete Kit comprises all components, including set of Lissen Valves. Cash or C.O.D. Carriage Paid, £5/12/6. Balance in 11 monthly payments of 10/3.
- ROLA F6P.M. PERMANENT MAGNET MOVING-COIL SPEAKER,** with input transformer. Cash or C.O.D. Carriage Paid, £2/9/6. Balance in 8 monthly payments of 6/-.
- NEW GARRARD MODEL 202A.** 12-in. Turntable. Electric Motor for A.C. mains. Cash or C.O.D. Carriage Paid, £2/10/0. Balance in 8 monthly payments of 6/-.
- ATLAS C.A.25 for A.C. mains,** Class B and Q.P.P. Four tappings; 60/80, 50/90, 120, 150 volts., 25 m.a. Cash or C.O.D. Carriage Paid, £2/19/6. Balance in 10 monthly payments of 6/-.

1934 WALNUT ADAPTAGRAM

38 in. high, 22 in. wide, 15 1/2 in. deep. Speaker 17 in. by 14 in. by 19 in. by 14 in. **YOURS FOR 8/3**

CONVERT YOUR EXISTING SET INTO A MODERN RADIOGRAM

with this beautiful Cabinet. Direct from Factory. NO MIDDLEMAN'S PROFITS. Built by master-craftsmen of the piano trade. Real inlaid walnut, mortised, tenoned. French polished. With motor-board ready to take your set, speaker and power equipment. Plain front or vignette for panels. 17 in. by 7 in., 16 in. by 7 in., 18 in. by 8 in. Baffle-board, 3/6 extra.

Special Drillings or other special cut-out designs, add 3/- to Cash Price or 3d. to each monthly payment. SEND FOR NEW CABINET CATALOGUE.

As illustrated. **63/-** Cash or C.O.D. Carriage 2/6 extra.

Or 8/3 Deposit and 11 monthly payments of 5/9 (Carriage paid).

IN OAK OR MAHOAGANY NO EXTRA.

ALL THE RAGE — PILOT CLASS B SPEAKER AMPLIFIER

Without Class B amplification your present Battery Set is obsolete. Realising this, we have produced this marvelous self-contained Unit, comprising guaranteed Peto-Scott Class B Moving-Coil Speaker, Class B Transformer and Output Choke, B.V.A. Class B Valve. Gives 7 times the volume with mains quality and power. Low H.T. consumption. Connected to your set in a moment. JUST PLUG IN the amazing 5-WAY Automatic Connector.

5/- DOWN. Balance payable in 11 monthly payments of 5/6. Carriage Paid to your door. Cash or C.O.D. Carriage paid. **59/6**

TELSEN 323 3-VALVE KIT with set of three Valves. Cash or C.O.D. Carriage Paid, £2/15/6. Balance in 9 monthly payments of 6/- only

RADIO In Every Room!

PETO-SCOTT Permanent Magnet Moving-Coil 1934 EXTENSION SPEAKER

30 RATIOS

With inclined baffle, supported on felt cushions. Free from all resonance and boom—enhancing the already perfect tonal balance. Complete with Combined Volume Control and Switch. In beautiful walnut cabinet. Suitable for any type of set. Direct only from PETO-SCOTT.

5/- DOWN Balance in 7 monthly payments of 5/6. Cash or C.O.D. Carriage Paid, 39/6.

BARGAIN PHILCO 5-VALVE BALANCED SUPER-HETERODYNE

LOWBOY (CONSOLE) MODEL 56.

All Electric; seven tuned circuits with single dial control. Gives amazing performance with new economy in operating costs. Duo wavelengths; no leak between bands. Illuminated dial, no reaction; chassis and tuning condenser floating on rubber. Oversize, energised M.O. Speaker with large baffle-board gives exquisite, full tone. Beautiful cabinet in rich inlays. Height, 39".

22 GNS. OUR PRICE **12 GNS.** Or 18 Monthly payments of 16/6.

PETO-SCOTT PERMANENT MAGNET MOVING-COIL SPEAKER

Complete with input transformer for power or pentode output. Cash or C.O.D. Carr. Paid, only 19/6. Balance in 5 monthly payments of 4/-.

CLASS B type. Cash or C.O.D. Carriage Paid, 22/6, or send 2/6, balance in 6 monthly payments of 4/-.

Pilot Class 'B' Conversion Kit

Converts your present Battery Set to Class B Amplification. Complete with all necessary components, including driver transformer, Class B output choke, W.B. 7-pin valve holder, B.V.A. 240B valve, wire and screws, etc. Full size Blueprint, assembly instructions and diagrams. Cash or C.O.D. 37/6. Balance in 7 monthly payments of 5/6. only

5/-

PETO-SCOTT CO. LTD., 77, City Road, London, E.C.1. Phone: Clerkenwell 9406/7. West End Showrooms: 62, High Holborn, London, W.C.1. Telephone: Holborn 3248.

Dear Sirs,
Please send me CASH/C.O.D./H.P.

for which I enclose £.....d.
CASH/H.P. DEPOSIT.

NAME.....
ADDRESS..... P.W., 3/21/34.

Buy by Post — it's Quicker

THE NATIONAL SET FOR D.C. MAINS

(Continued from page 952.)

The fixed condensers must be rated to work at a voltage which is not less than that specified for the original unit, otherwise there is a risk of breakdown and serious trouble.

If you want to use a choke which is not specified in our list of components, do be sure that it will both carry the required current and still keep its inductance value. (This is important.)

The Heater Resistance.

The combination of mains plug and fuse is a further act of compression and saving baseboard space.

The other mains-type plug, marked "switch plug" in the diagram, is a neat way of connecting the on/off switch on the set to the mains unit, and enables one pole of the mains to be broken when switching off.

In order that no mistake can be made when connecting the set to the unit the L.T. connections are terminals whilst the H.T. connections are sockets. The connection for "G.B." is also a socket.

Make absolutely certain that you obtain the correct type of heater resistance, as there are several types made for different numbers of valves and also different types of valves.

Particular care should be taken in mounting the mains plug and switch plug. Their centres must be exactly 1 in. from the respective sides of the baseboard, otherwise they will be fouled by the metal cover.

The terminal strip is drilled as follows: All the holes are $\frac{1}{2}$ in. from the top of the strip. The hole for the end socket is $\frac{1}{4}$ in. from the end of the strip, the holes for the other three sockets being spaced at intervals of $\frac{1}{4}$ in.

Connecting the Mains.

The hole for the end terminal is $\frac{1}{2}$ in. from the other end of the strip, the remaining terminals being spaced by $\frac{1}{4}$ in.

Mains voltages vary. The unit must be adapted to the proper mains voltage.

There are four terminals on the heater resistance, three being near the bottom and one at the top of this component. The L.T. + is always connected to the top terminal.

The bottom terminals are marked 200/210, 220/230 and 240/250. The lead from the switch plug connects to the appropriately labelled terminal, and the label obviously refers to the existing mains voltage.

If your voltage is in the 200/210 range, use that terminal labelled 200/210; if 240/250, the terminal so labelled, etc., etc.

Don't Forget the Earth.

Insulation is very important. You are not making a toy. The mains have power behind them. Be careful. And be sure that the wires used are well and truly insulated.

And once more, and positively, be sure that, when connecting the unit to the set, the earth lead is removed from the set and connected instead to the earth terminal on the mains unit. If you forget this your fuses will remember, and your family won't be pleased when the lights go out.

TECHNICAL NOTES

Some diverse and informative jottings about interesting aspects of radio.

By Dr. J. H. T. ROBERTS, F.Inst.P.

Simplifying the Superhet.

TO the multitude of new valves which we have had lately there is another one, which hails from America and which goes one better than the pentode in that it has six electrodes instead of five. This valve may be used in a superhet circuit, and one grid takes the intermediate frequency, whilst another takes the rectified low-frequency current.

In order to keep these two frequencies apart and prevent any "mutual modulation," special filter circuits are inserted. Thus this six-electrode valve can be used for three different frequencies, for, in addition to the two which I have already mentioned, it handles, of course, the incoming signal frequency.

With all these developments in multi-grid and multi-purpose valves it looks as though the superhet of the immediate future will be no more than a waistcoat-pocket edition of the affair of six or seven years ago.

High-Note Cut Off.

I am frequently asked whether there is any simple way to cut out needle scratch or "surface noise" when using a pick-up for electrical reproduction of records.

Surface noise is due to the minute irregularities, dust particles, grit and so on in the record track, and inasmuch as these irregularities are in general small compared to the "sound waves" on the record it follows that the scratch may be expected to be of considerably higher average pitch than the regular reproduced sound. I say "average pitch" because clearly it is a noise and not a musical sound, and therefore cannot be said to be of any definite regular frequency.

A Useful Accident.

The fact that this average pitch is fairly well removed from the pitch of the sound we want to reproduce is a fortunate accident, because it enables us to introduce selective filtering arrangements which suppress the scratch without appreciably interfering with the desired tones. A fair average for the cut-off position is about 4,000 to 5,000 cycles. If we make it much lower than this the upper notes of the required sound are interfered with, whilst if we make it much higher the scratch is not properly cut out.

"Selective Suppressor."

If we use some form of variable impedance this will act as a "selective suppressor," as it were, and give us the control we want. A simple way of doing this is to take a suitable variable resistance and a small condenser in series with it, and then connect the combination across the pick-up.

For the resistance a maximum value of 50,000 ohms is generally suitable, whilst for the condenser you may start with a fixed value of .01 microfarad, but you will

(Continued on next page.)

MAKE YOUR HOBBY PAY

You can qualify for well-paid employment

Thousands of men who started radio as a hobby are now in well-paid regular employment. Research and Laboratory work, Designing, Testing, Servicing, Installing, Demonstrating and Selling, Technical Correspondence, and many other interesting jobs at good pay are available for trained men, whilst many other industries outside radio also require men with radio knowledge. We train students of all ages. We can train you and give you the sort of training that employers demand. Every student is guaranteed introductions to leading employers, and is given valuable assistance in obtaining the sort of work he wants.

EARN £5 A WEEK IN YOUR SPARE TIME

One of our students has just informed us that he is now averaging £5 a week from spare-time servicing and set building. As a result of his work he has been offered two full-time jobs at good pay.

You can do the same, and we can give you the sort of training which will enable you to earn good money in your spare time without interfering with your ordinary occupation.

We specialise in radio, and the College is conducted by well-known radio experts. (Chief Technical Contributor: G. P. Kendall, B.Sc., Principal: R. H. Bradley.) We do not use foreign text books, or waste your time with obsolete theory. T.C.R.C. Correspondence Training is thorough, up-to-date and individual. Every modern development is clearly explained. The inclusive fees are very reasonable, and can be paid by easy instalments if desired.

ACT NOW, SUCCESS AWAITS YOU. Post coupon now for our Prospectus. It is free for your asking. We will place you under no obligation. You will not be pestered to enrol.

RECOMMENDED BY LEADING RADIO MEN

W. S. Verrells, Esq., Managing Director of EKCO Radio, writes: "There is a great future in radio, and the men who take the trouble to study and specialise will find their progress assured."

Leslie McMichael, Esq., of McMichael Radio Ltd., writes: "The need for good and well-trained service men is a very urgent one, and jobs are undoubtedly available for this class of man."

Other manufacturers and the Technical Press also praise T.C.R.C. trainings.

TECHNICAL & COMMERCIAL RADIO COLLEGE

Please note new address:

CROMWELL HOUSE, HIGH HOLBORN, LONDON, W.C.1

To Technical & Commercial Radio College, Cromwell House, High Holborn, London, W.C.1. Please send me a free copy of your Prospectus.

(Id. stamp if posted in unsealed envelope.) Name.....

P.W.4.

Address.....

TECHNICAL NOTES

(Continued from previous page.)

possibly find that a somewhat larger value than this gives better results. If you have a number of fixed condensers on hand you can try different values until you get the one which gives the best results.

Ether Congestion.

There have been, as you know, all kinds of suggestions as to how the congestion in the ether can be minimised. One very ingenious scheme, which is at present being tried out on the Continent, is to take advantage of what is known as "polarisation" of the waves. I dare say you know that electro-magnetic waves, such as light waves, can by suitable means be brought to vibrate in definite planes instead of being scattered, as it were, in an infinite number

IMPROVING SELECTIVITY

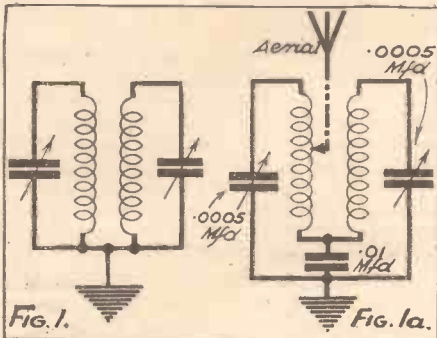

A simple and very effective way to increase aerial selectivity is to use a bandpass coil arrangement. Fig. 1 shows a simple scheme by which two plug-in coils can be used to form a loose-coupled band-pass circuit. Fig. 1a is a somewhat similar arrangement except that the two circuits are in series, with a fixed condenser of .01 microfarad connected across the mid-points of the coils and the variable condensers, and also the aerial is brought to a tapping on one of the coils. These two coils, by the way, may conveniently be about No. 60, whilst a screen should be placed between the coils and their corresponding condensers.

of different planes. With radio waves, owing to the different method of production and propagation, the separation into two planes (in this case one vertical and the other horizontal) is a relatively simple matter.

Using Polarised Waves.

If you were told that two different programmes were being radiated on the same wavelength you would wonder by what possible means a receiving set could separate the one from the other; but when it is explained that, although the wavelength is the same, the one programme is sent out on one polarised wave and the other programme on the other polarised wave, you will readily see that, provided the receiver can be adjusted to receive one polarised wave and to reject the other, you will be able to select either of the two programmes.

It all sounds very simple on paper, but, of course, is not quite so simple in practice. At any rate, this is the basis of the scheme which is being tried out, and, in view of the congested state of the ether, if it "makes two blades of grass grow where only one grew before" it should be worthy of serious attention.

Cutting Out Clicks.

A little while back I was talking about interference suppressors: devices for cutting out those awful clicks when somebody in another part of the house switches the electric light on or off, and also the noise of the lift motor and the crackling due to nearby neon signs.

I mentioned that it was generally better to install such a suppressor close to the electricity meter rather than close to the receiver itself, and several readers want to know why this is so. The general idea seems to be that either the suppressor cuts out the interference or else it *doesn't*, and that therefore its position in the electric supply must be immaterial.

Indoor Radiation.

At first sight this might seem to be the case, but in point of fact it is not, because it has been found that the electric wiring system of the house may itself act as an efficient transmitting aerial, throwing off the disturbances which cause so much trouble in the set.

If you think of the electric wiring as an aerial you will soon see why it is so much more important to cut out the interference at the source, as it were—if not at the true source, at any rate at the place where it enters the house, which is the source so far as the house is concerned—rather than to put the suppressor near the set and try to prevent the interference from entering the set direct.

Aerial Pick-up.

If you assume that the interference is picked up on the aerial it is quite evident why the suppressor should be near the meter, because in that position it helps to damp out the house wiring as a radiator. On the other hand, if you assume that the interference enters the receiver via the mains wiring (in the case of an all-mains set), then it would seem to be immaterial where the suppressor was placed. The fact that in practice it is found to be much better to put it near the meter goes to show that the radiation from the wiring plays an important part in the disturbances.

Post-Office Tests.

I should say, however, that practically no two cases are exactly alike, and it is very difficult indeed to lay down any hard-and-fast rule about this suppression of interference. You really should try different arrangements for yourself until you get the one which suits your particular case best. A comprehensive investigation was made recently by Post Office engineers on this subject, and they found that in a large percentage of cases interference was due to high frequency brought in by the electric mains and radiated by the electric wiring of the house, being then picked up upon the aerial system of the set.

Iron-Core Coils.

Since the advent, or rather the revival, of iron-core coils we seem to be having as many new coils as new valves, and that's saying something. I say this, however, not in any carping spirit, because undoubtedly the most extraordinary improvements have lately been made in coils, and increases in efficiency have been really extraordinary.

(Continued on next page.)

Easy Terms

Strict Privacy Guaranteed

—we deal with you direct

N.T.S. CLASS 'B' SPEAKER-AMPLIFIER

SEND FOR IT ON 7 DAYS' TRIAL
GIVES SEVEN TIMES THE VOLUME, READY ASSEMBLED WITH CLASS B VALVE.

5/- DOWN

Send only 5/- for 7 days' trial. If approved, balance in 11 monthly payments of 5/6. Cash or C.O.D., Carriage Paid, £2/19/6.



N.T.S. CLASS 'B' SPEAKER

SEND FOR IT ON 7 DAYS' TRIAL

Complete with Input Transformer, Power or Pentode. Send only 2/6 for 7 days' trial. If approved, balance in 5 monthly payments of 4/6. Cash or C.O.D., Carriage Paid, £1/2/6. Power or Pentode Model. Same Price and Terms. When ordering, state which type required.

W.B.P.M. 4 MICROLODE MOVING-COIL SPEAKER

SEND FOR IT ON 7 DAYS' TRIAL

With switch-controlled multi-ratio Input Transformer. Send only 5/- for 7 days' trial. If approved, balance in 8 monthly payments of 5/3. Cash or C.O.D., Carriage Paid, £2/2/0. W.B.P.M.6. Send only 2/6, balance in 8 monthly payments of 4/3. Cash or C.O.D., Carr. Paid, £1/12/6.

ROLAF 6 PERMANENT MAGNET M.C. SPEAKER

SEND FOR IT ON 7 DAYS' TRIAL

A popular standard P.M. Moving-Coil Speaker. Send only 5/- for 7 days' trial. If approved, balance in 11 monthly payments of 4/6. Cash or C.O.D., Carriage Paid, £2/9/6.

NEW BLUE SPOT CLASS 'B' OUTPUT STAGE

SEND FOR IT ON 7 DAYS' TRIAL

With Class B Output Valve (less Speaker). Send only 2/6 for 7 days' trial. If approved, send further 1/6. Balance in 11 monthly payments of 4/-. Cash or C.O.D., Carriage Paid, £2/3/6.

Any items advertised in this journal CASH, C.O.D., H.P. Send for quotation by return.

New Times Sales Co.

56, LUDGATE HILL, LONDON, E.C.4.

Dear Sirs:
 (a) Please send me.....
 (b) I enclose Cash Deposit.....
 NAME.....
 ADDRESS.....
 P.W., 3/2/34.

TECHNICAL NOTES

(Continued from previous page.)

Impedance Tuning.

One of the latest newcomers is the Micron, by the R.I. people, which they describe not as permeability tuning but "impedance" tuning. The core of the coil is of iron particles and the inductance is adjustable by means of a micrometer screw. At the end of the coil former, opposite to this screw—that is, the closed end—a resilient buffer is provided so that the dust-iron core can be forced by the adjusting screw against this buffer. In the complete coil unit two separate coils are provided, one for the medium wave-band and the other for the long wave-band, these coils independently mounted and at right angles to one another.

Readily Adapted.

The Micron coil can in most cases be substituted for the existing coils and is claimed to give a great increase in selectivity and range.

EASY TERMS PROMPT DELIVERY

Any Amplion, Blue Spot, Baker, Celestion, Epoch, Ferranti, Gramplan, Igranic, Lamplugh, Magnavox, Ormond, R & A, Rola, Sonochorde or W.B. Speaker supplied.

Send 5/- only

and pay balance by monthly instalments. No references. Entirely private and confidential.

KITS, PARTS, VALVES ELECTRIC CLOCKS ON EASY TERMS.

Send for List of 83 Speakers and state requirements
TURNADGE & PARTNERS, LTD.,
107, Fleet Street, London, E.C.4.

Telephone: Central 1903.

Write for Illustrated Catalogue of RADIO-GRAM-O-PHONE CABINETS of exclusive modern design, made by craftsmen in highly figured Oak, Walnut, or Mahogany, post free.

REMARKABLE VALUE Cabinets made to order a speciality.

Maker under licence, of the HOWE BOX BAFFLE

Recommended by the B.B.C. Full details on request.

GILBERT SWINDON
Cabinet Maker, Estd. 1866.

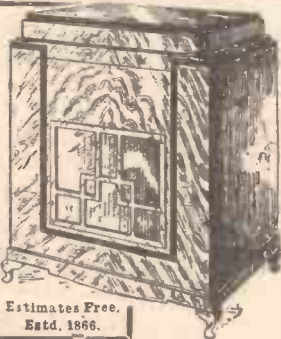

Estimates Free. Estd. 1866.

Those of you who have sets with dual-range coils should look into this question of the Micron, as it is particularly adaptable to sets of that type. The manufacturers' slogan is that you can get "superhet efficiency" by merely changing over to these new coils.

L.F. Choke Coupling.

When you are using low-frequency choke coupling it is sometimes a little difficult to decide on the correct values of grid leak and condenser, but, generally speaking, if you assume that the value of the grid leak is in the region of ten times the value of the valve impedance you will not be so very far wrong. Of course, in some

If you go into the figures for the theoretical gain at each stage you will get some surprising results. You can take the maximum grid swing of the detector and then multiply this up by the amplification factor of the valve and the ratio of the transformer which follows, and this will give you the volts delivered to the grid of the next valve.

If you do the same thing again, multiplying by the amplification factor and then the ratio of the next transformer, you will very quickly find that—theoretically, at any rate—you get an enormous voltage in the anode circuit of the output valve.

In actual practice you would never get anything approaching the theoretical value;

NEXT WEEK

Read in "P.W." about the Triumphant Success of
THE NATIONAL ECKERSLEY THREE

ALSO

THE ECKERSLEY A.C. RADIOGRAM

Full details for converting a great set for use with records

Wednesday — POPULAR WIRELESS — Threepence

cases this value may be too high, and you will get better results by using a grid leak of, say, five to eight times the valve impedance.

How Many Amplifying Stages?

During the last two or three years the habit of using several low-frequency stages has been rather dying out.

Output valves have increased so much in efficiency that in quite a large proportion of sets only one low-frequency stage is used. Of course, if there is no high-frequency amplification before the detector valve, then it may be an advantage to use an intermediate low-frequency stage between the detector and output.

Overloading.

If, however, you do use two low-frequency stages after the detector you must take great care that amplification is not increased too much at each stage, otherwise you will get bad overloading and distortion.

but at the same time a little investigation of this sort will serve to show you how easy it is, especially when using two stages of L.F., to overload the poor old output stage out of all recognition.

An ordinary power valve used in the output stage cannot be expected to handle more than about 25 to 30 volts in the anode circuit, whereas, according to theoretical considerations, the voltage developed may run into several hundreds with the arrangement mentioned above.

Class B an Exception.

Although it is often difficult to get amateurs to believe it, the fact remains that much better results can generally be obtained with an efficient detector and a single low-frequency stage, except in the case of Class B when it is, of course, necessary to use a driver stage to operate the Class B valve. With Class B the output stage is power and not voltage operated.

OSTAR-GANZ

"UNIVERSAL" HIGH VOLTAGE MAINS VALVES

EASILY CONVERT YOUR BATTERY SET TO ALL-MAINS, and enable anyone to build a splendid "Universal" A.C. D.C. set. Highly efficient and most economical in every way. NO TRANSFORMERS, NO RESISTANCES, NO BARRETTERS needed. Astounding results guaranteed by our technical staff.

"UNIVERSAL" KITS also supplied. Blue Print with each kit. 3, 4, 5, and 7 Valve Receivers. 3 and 4 Valve Radiograms. 2 and 3 Valve Amplifiers. Complete List "P" and all details of the full range of Ostar-Ganz High Voltage Mains Valves, Free on request.

Remember too that Ostar-Ganz "Universal" High Voltage Mains Valves work equally as well on either D.C. or A.C., so there's never any need to scrap them because your electric supply is changed.

EUGEN FORBAT, 28-29 Southampton Street, Strand, London, W.C.2. Phone: Temple Bar 8608.

UNIVERSAL MODEL SETS

The most economical sets to buy and use. They work off either A.C. or D.C. supply without alteration. Remarkably free from mains hum. Reproduction is superb. Full range available, including the—

"HIGHMU 3" UNIVERSAL MODEL SET. Employs a highly selective circuit with Ferrocast nickel iron coils, Highmu detector D.130, and multigrad output Pt. 3, capable of an undistorted output of 2.6 watts. Indirectly heated rectification system is utilized by the EG.50 rectifier valve, so giving hum-free reception. Fitted with latest type mains energised moving-coil speaker in walnut cabinet, ready for use.

Price £9 9s. 0d.

A postcard will bring you full details and prices. The greatest value obtainable in all-mains sets. Write now.

"S.T."
MANUAL
TOKEN 3

Printed and published every Wednesday by the Proprietors, THE AMALGAMATED PRESS, LTD., The Fleetway House, Farringdon Street, London, E.C.4. Advertisement Offices: John Carpenter House, John Carpenter Street, London, E.C.4. Registered for transmission by Canadian Magazine Post. Subscription rates: Inland and Canada, 17/6 per annum. Abroad (except Canada), 19/6 per annum. Sole Agents for Australia and New Zealand: Messrs. Gordon & Gotch, Ltd.; and for South Africa: Central News Agency, Ltd. Saturday, February 3rd, 1934. S.S.

POPULAR WIRELESS

THE FIRST AND FOREMOST RADIO WEEKLY FOR THE CONSTRUCTOR & AMATEUR EXPERIMENTER

Scientific Adviser: SIR OLIVER LODGE, F.R.S.
 Technical Editor: G. V. DOWDING, Associate, I.E.E.
 Assistant Editor: P. ROBERT BIRD.

Managing Editor:
 N. F. EDWARDS.

Chief Radio Consultant: P. P. ECKERSLEY.
 Assistant Editor: A. JOHNSON-RANDALL.
 Chief of Research: K. D. ROGERS.

TEACHING TELEVISION
 "DOUBLE" LECTURE
 A SWEDISH CONTRACT
 SOCIETY NEWS

RADIO NOTES & NEWS

GERMAN MUSIC
 MORE "HOWLERS"
 HITTING THE OZONE
 CIGARS AND GUITARS

Santa Claus in Danger?

SO the B.B.C. has, apparently, joined the ranks of the "de-bunkers," those who try to prove that Shakespeare, Napoleon, the Cock Lane ghost, etc., never existed! But the Ancient Order of Foresters laughs lightly at the B.B.C.'s notion that Robin Hood and Little John are merely survivals of folk-lore.

Why, if the graves of those worthies are at Hathersage, what more proof does one require? This latest attempt at rationalising romance seems to me to come perilously near Santa Claus, and if the B.B.C. dares to lay sacrilegious hands on *him*—look out for "squalls" from Britain's babies!

The Great "Stooge" Mystery.

MY valued New York correspondent informs me that "stooge" is rumoured to be a corrupted abbreviation of "stud(g)ent," and refers to an accomplice who is "planted" in the audience by a performer. I dare say that is about right, but what are we to make of my latest find, "stooge author"?

From the available evidence this official is a sort of salaried hack writer of jokes and patter for the use of the popular comedians who "put the stuff over," enhanced in value by their "poisonalities," as New Yorkers would say.

Go-ahead Methods.

PERHAPS because they have learned that salesmen who handle radio apparatus must be able to talk about it correctly, some of the big London stores are having certain members of their staffs trained in the mysteries of television at the Borough Polytechnic.

This may not presuppose the early coming of cheap television receivers and regular broadcasts, but it is certainly an instance of the vitality of our business men, as it is tantamount to taking Time by the forelock almost before it has sprouted.

Advancing Towards Television.

MR. H. M. DOWSETT not long ago demonstrated television pictures five feet square at the Marconi Works. He said that television was undoubtedly coming, and as he is a man who has seen wireless grow up—he was in South Africa

during the last Boer war, with wireless apparatus and kite aeriels—I think that his judgment merits respect.

But I gather that he does not expect it this year, for he remarked that 1934 would be devoted to the testing of various systems.

A Great Success.

SIR AMBROSE FLEMING'S lecture at the Imperial College of Science and Technology was, as I expected, crowded out. In fact, so great was the demand for admission that a "second

ON OTHER PAGES

"I saw a voltmeter in a bath of water, and it worked. I think it was a very good voltmeter."

P. P. ECKERSLEY, on page 993.

"When we come to Daventry 5XX, the quality is very much inferior to the Regional stations."

NOEL ASHBRIDGE, on page 991.

"Television presents difficulties of its own, which really arise from the fact that the eye is far less tolerant of errors than the ear."

G. P. KENDALL, on page 983.

"A friend of mine once received a postcard addressed to 'British Radio Station G2, Italy, Canada!'"

W. L. S., on page 980.

house" was arranged and the lecture was read by a deputy. I have never heard of such a thing being done before in the case of a scientific lecture.

By the way, Sir Ambrose let out that he is working at telephone problems, adding: "At present the telephone is only half invented." Yes, but then the rental is twice what it should be.

Safety at Sea.

BECAUSE broadcasting has become an everyday matter we are, I think, apt to forget what a great part wireless takes in the world's work. There is no doubt whatever that the loss of life and

property at sea has been very greatly reduced by the use of wireless.

As an illustration of this I may say, on the authority of Sir Percy Mackinnon, that whereas in former times as many as sixty-five ships used to be posted at Lloyd's every year as "Missing," during 1933 only three were so posted, they being Newfoundland coastal vessels.

The New Motala.

IT is good to learn that the Swedish Government has given the order for Motala's great new broadcasting station to a British firm here. The station will have an unmodulated aerial input of 150 kilowatts, and is so designed that this can be increased to 220 kilowatts.

As this station will be so powerful it is just as well that the constancy of its frequency will be one in one million—crystal control, of course.

An unusual feature of the transmitter is that it will be capable of operation as a high-speed telegraph transmitter, with a power of 100 kilowatts.

Club Jottings.

THE Bolton Radio Club is now affiliated with the Anglo-American Radio and Television Society, thus being able to offer its members a more attractive programme. Assist. Sec., J. E. Crompton, 125, Deansgate, Bolton, Lanes.

The Derby Wireless Club (founded 1911) is still active and healthy. For details, apply to Hon. Sec., R. H. Hodgkinson, Field House, Allestree, near Derby.

The Horsham Radio Club, now four months old, reports satisfactory progress, but requires more members. Lectures, demonstrations, beginners' section and Morse class. Hon. Gen. Sec., J. R. H. Cade, 24, Hurst Avenue, Horsham, Sussex.

A President's Private Haul.

LESLIE W. ORTON, Hon. Pres. Anglo-American Radio and Television Society, tells me that his best catch recently was W A A T (Jersey City), on 319 metres, using 300 watts; L.S. reception. He adds that when the North National closes down he receives W B Z very well,

(Continued on next page.)

THE LISTENER WITH THE PERFECT FAMILY

though at 11.30 p.m. L R 4 (Buenos Aires) interferes with it.

Leslie is hugging to his bosom the fact that he got H H K (Hayti)—or, I should say, Port au Prince—on 325.4 metres, 1,000 watts. Join his society and learn how to do jobs like those!

Pity the Poor Germans!

RADIO broadcasting in Germany looks like going to pieces, so far as the ordinary listener is concerned. The authorities have banned radio advertising by individual firms—which is all to the good—but, on the other hand, have let it be known that in future German broadcasting is to be regarded “as a public instrument for propaganda to serve only the nation as a whole.”

It is lucky, therefore, that the people who do not like propaganda as an entertainment can get plenty of German music from the B.B.C. stations.

Antipodean “Howlers.”

WHILST analysing the Sydney “Wireless Weekly” I came upon some glorious announcers’ “howlers,” of which I make a small selection: “This is the last ball of Morgan’s next over;”



“Ladies, fix your dial at 7 o’clock in the morning and there’s no need to change it until midnight;” “As she let himself in.”

“The time for the race was one minute two and a half furlongs;” “7 a.m. till midnight, seven days a week, including Sunday;” “2 U W, the personality station, never off the air. We are closing down for a few minutes.”

Nothing Like Variety!

GROWING tired of calling the ether by its right name, journalists have tried—and got away with!—“air”; “On the air” will probably stick. But America must always be improving things, and so now I am able to read “hitting the ozone”—which means “broadcasting.”

I’ll give the American paragraphists a tip. Let them recollect that air is composed of oxygen, nitrogen, with small percentages of helium, neon, argon and sometimes traces of nitric acid, sulphur, etc. Hence, why not say: “Electrocuting the gasworks”?

Australia has the Right Idea.

VERY pleasant to receive a booklet about 6 I X and 6 M L (W. Australia) from “a Lancashire lad.” I return his compliments with best wishes. But I was momentarily stunned to read that “the vital object of every radio programme is to entertain.” Vital object, mark you.

Well, all I say is, let’s import a couple of dozen of those I X and M L chaps, for they have the right idea. Folk say to me; “You are a sober and studious man. So why don’t you agree with the B.B.C.’s

educational policy?” It would take too long to explain here.

Real Courage.

I CONGRATULATE G. D. (Co. Durham) on two heads—to wit his luck in receiving American stations and his perfect family. As to the first, his “bags”



after midnight both surprise and delight him, and he recommends the sport to all other-searchers.

As to the second, he tells how, when he got W B Z A after 3 a.m. at excellent L.S. strength, the rest of the household were in bed and were awakened by the din. “So they came down to hear the cause, and were delighted by the reception.” Real “three-o’clock-in-the-

SHORT WAVES

A loudspeaker, with a radius of over four miles, has been constructed. This should give an added impetus to attempts to establish a new high-flying record.—“Hamorist.”

A WIRELESS RECORD.

There seems to have been a little sensation over a broadcast of the bagpipes. The number of people who took their sets to pieces in the endeavour to locate the trouble approaches a record.—“World’s Pic. News.”

“The set consisted of three valves—one H.F., one detector and one L.F., the latter being fitted with variable-grid bonus,” we read in a provincial newspaper.

A sort of “Sliding Scale,” we presume.

One of our readers recently telephoned and asked us for the address of Spaghetti Resistances.

We’re afraid we don’t know the address, but we have heard that there are about fifty-seven varieties—all preserved in bottles.

A wireless enthusiast says that on a recent occasion he heard double.

Perhaps his headphones were tight.—“London Opinion.”

morning” courage indeed! Again I say, what a family! They were not only non-violent, but delighted!

Kilocycles from Bicycles.

IT has been widely reported in the Press that patrol officers in New Guinea are to adopt a wireless transmitter whose power is derived from a generator which is driven by pedal power, the operator sitting on a bicycle-like affair and pedalling like mad, though achieving no mileage.

So far so good. But when the published reports go on to refer to “the new apparatus” I am bound to say that it is very old, this principle having been used by Marconi’s for a long time. Indeed,

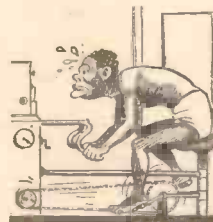

the Press itself made quite a “feature” in 1933 of a picture of African natives operating the bicycle part of such wireless sets.

News from Nowhere.

ALL the philatelists in the office agree that “there ain’t no sich animile” as the stamp, which is dirty grey and appears to depict a dead cow lying on the roof of a labour exchange. The postmark is blurred except for the letters “O T,” and no address is given.

Here we go: “Steamed sir, please regard we herein reads yor nots news like the residue of Populer Wireless so interesting or usefule. Making to like that to know how we herein getting our Hands on essential members for comets, of course no shop by or near herein. Henceforth, hows the job concluded.”

What he wants to know is how to get components for “P.W.” Comet sets of blessed memory!

How They Line Up.

A REPORT by the U.S.A. Department of Commerce on the world’s broadcasting stations contains some surprising figures. America tops the list for number, possessing 585 stations; Russia is second with 73; and Canada, with 63, is third.

Now, consider the size and importance of Russia, and then learn that Cuba has 57 stations. Looks to me like a precious bit of American “dumping,” for the Cubans cannot need all that broadcast when they have those cigars and guitars, can they?



Engineers Do See Life!

THERE is no doubt that wireless engineering enables its votaries to see life and the world. Only to-day I had a telephone call and a voice said that its owner had just returned from eighteen months in Arabia, hundreds of miles from civilisation. This man has been mixed up with sheiks, camels, wireless sets, wells, sand and dates for a year and a half.

He told me that he has had to drink water which sported all the colours of the spectrum, fight mad camels, and keep Arab workmen from murdering him. He added that he never wants to see another date and that sherbet is not what it is cracked up to be.

Public Radio Performances.

PROGRESS has been made in the matter of the fees to be charged by the Performing Right Society to public-houses, cafés, etc., in respect of the public performance of music by means of gramophones or loudspeakers operated by radio.

The average annual fee will be between two and three guineas, depending on the rateable value of the premises concerned.

The P.R.S. scale of fees was drawn up in consultation with the representative bodies concerned.

ARIEL.

ECKERSLEY'S NATIONAL THREE — A TRIUMPHANT SUCCESS

Backed by the absolutely unique reputation of its designer, and with its attractive simplicity of construction, the "National Eckersley Three" is everywhere proving an immediate and an amazing success. Tuned by a single knob, and with nothing lacking nor superfluous, this outstanding 1934 receiver has astounded readers who have tried it.

SUPERB POWER — QUALITY — PHENOMENAL RANGE.

It was on January 17th that the bookstalls and newspaper shops displayed the special number of POPULAR WIRELESS in which appeared the details for making the "National Eckersley Three." And already it has scored a spectacular success with the public.

Many thousands of our regular readers, keen connoisseurs in construction, at once "spotted the set for a winner" (to borrow the phrase of one of them) and got busy on the building of it right away. In their hands, all over the country, it has evoked unbounded enthusiasm.

Thousands of New Readers.

We are not surprised at this, for it was a result that could have been predicted almost with certainty. But what has been surprising is the attitude of the thousands and thousands of new readers who also decided to build the set—in spite of the fact that home construction was something of a novelty to them, and decidedly an adventure.

This popularity with a vast public of new readers was, frankly, unexpected, for most people thought that the days when the general public eagerly cleared the kitchen table and seized the screwdriver and pliers to construct their own wireless sets had passed away.

But for some reason or other the "National Eckersley Three" "caught on" all over the country with epidemic suddenness, and its popularity is still spreading day by day. The Query Department, always alert to readers' demands, has had a busy time—and overtime—in dealing with the "Eckersley" letters, and the wisdom of the designer in choosing all-standard components becomes more and more apparent. (For there is nothing more disappointing to a would-be constructor than to find that the set is hung up, on delivery of some essential part, because the sole manufacturers cannot cope with the demand.)

"Proved by the Public."

That the set must use only standard components, procurable by the ordinary buyer, was one of the guiding principles of design. And this important principle having been justified by results, we can examine the excellence of its other features, as proved by the public.

First, a word or two about the quality of the reproduction. This appears to have aroused unusual enthusiasm:

A large proportion of the reports pay special tribute to the "top" obtained—speech, they say, is so natural—whilst all the high-note musical stuff is crisp and clean. As one enthusiast puts it: "The violin is a violin, with a straight-from-the-strings appeal to critical ears."

As practically every report contains a reference to this crispness and clarity of the reproduction we may say, in passing, that it all follows from the fact that the pentode compensates for the falling characteristics of the high-frequency circuits.

P. P. Eckersley has already explained that it is impossible to get the necessary

this feature can be obtained in any ready-made receiver now on the market must be answered in the negative. So far as we are aware, there is nothing like it available elsewhere at any price.)

Amazing Quality.

Another point about the quality obtainable with this set is, curiously enough, the unusually good low-note response. Many owners are already finding a new delight in the beat of drums and in the rumble of low organ notes, which, of course, are all the more noticeable in conjunction with the good reproduction of "top" already referred to.

There is nothing inconsistent about this. A good set should be able to bring out the low notes with convincing power, whilst at the same time rendering the high notes clearly: and, as it were, *separately*, just as though the two entirely different instruments were being heard together, each retaining its individuality of quality.

But remember that quality largely depends upon the loudspeaker, and these instruments differ greatly among themselves. The designer himself has referred to this in a preceding article about the "National Eckersley Three," so there is no need to enlarge upon this point again.

Sensitivity and Selectivity.

The above references to the quality obtainable with this set will be grudged first mention by many of the builders because, in their experience, the most noteworthy feature is the remarkable range. It has revolutionised their ideas

of the entertainment value of foreign stations' programmes.

We have here two interdependent factors to explain: the *Sensitivity*, which makes the most of the feeble currents flowing in the aerial; and *Selectivity*, which enables the owner to disentangle one programme from another on an adjacent wavelength.

Obviously, the sensitivity is a huge advantage in freeing one to choose many stations instead of from just a few. But it is useless to be able to pick up a foreign station if one's enjoyment of its programme is continually marred by the chortles and

(Continued on next page.)

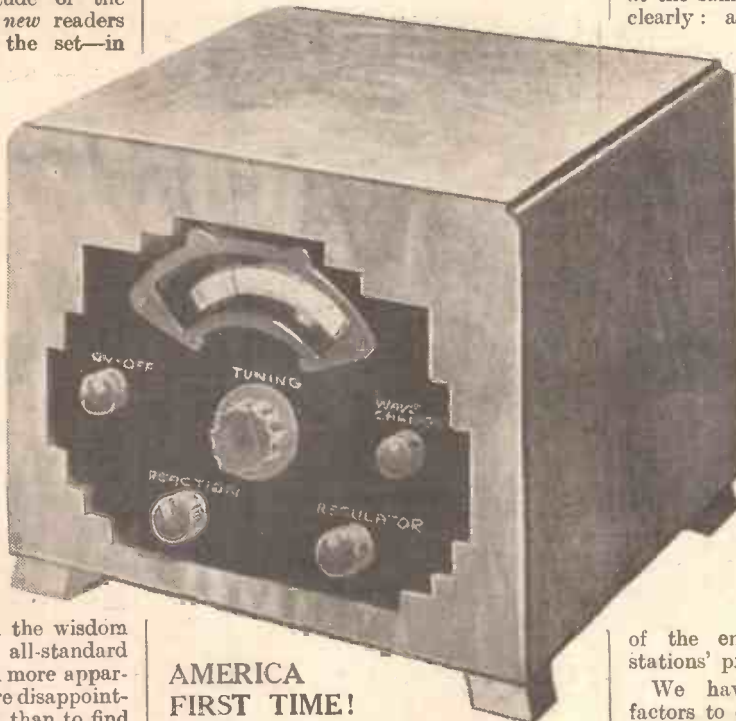

AMERICA FIRST TIME!

One of the very earliest reports was from a Liverpool reader, who said: "I have already received several American transmissions at wonderful volume." This is a remarkable tribute to a one-knob-tuning receiver designed for easy handling and suitable for operation by any member of the family.

overall constancy of characteristic if band-pass and pentode are used in conjunction, so instead of the former we have the ingenious resistance-coupled arrangement which this set introduces to an appreciative public. (Incidentally, inquiries as to whether

**ECKERSLEY'S NATIONAL
THREE—A
TRIUMPHANT SUCCESS**

(Continued from previous page.)

chattering of a B. ð.C. programme from the too-insistent local station.

Both sensitivity and selectivity call for careful control if the advantages of both are to be achieved. Everyone knows that this can be done by complicated circuit design, but the "National Eckersley Three" is daily demonstrating that complications are not essential.

Long-Distance Reception.

In fact, complications often result in the loss of the very feature they are intended to introduce! They provide for so many possibilities that the set owner becomes bewildered by the multiplicity of choice and fails to obtain the full benefits of any of them.

Deplorable, of course! But definitely a danger which the designer has to face. And a danger which is entirely absent in this design.

That is why we are getting so many tributes to the long range of this receiver. It produces the programmes from distant transmitters clear and convincing, even in the hands of the inexpert owner.

The designer, P. P. Eckersley himself, would be the last to claim that there is anything in the way of a super-circuit for long-distance reception about this receiver. But, nevertheless, it is a first-class long-range set, because that is how it behaves in use.

Clear-Cut Tuning.

As you turn the tuning dial, station after station presents itself from the loud-speaker. The tuning is clear-cut, individual—stop where you like and listen to what you like.

If you then adjust reaction to bring up

the strength still further, you do not find that the station disappears and has to be retuned. Once tuned in it "stays put" until tuning is altered.

On the other hand, if you are receiving a station whose programme is too powerful for comfort, you can reduce volume, by means of the Regulator, to any desired degree without upsetting either reaction or tuning one iota.

So the result is that what you have you hold. The different controls can be used with confidence, because the effect of each is independent and immediately apparent.

There are only five knobs to "operate" in all, and each is, from the first, a friend whom you can trust. This one puts the set on or off. That one gives long or

Department reports that, in proportion to the great volume of correspondence about the set, there are remarkably few technical queries to answer.)

The remaining control is the Regulator (bottom right-hand of panel), and as this is a completely novel adjustment, never before fitted to a home-constructor's set, it may be useful to remind readers how it acts.

Varying the Coupling.

When the knob is turned fully to the right the set is in its most sensitive condition for searching, because the coupling between the first two circuits is at a maximum.

By turning the knob to the full-left position the opposite condition is achieved—namely, minimum coupling between the

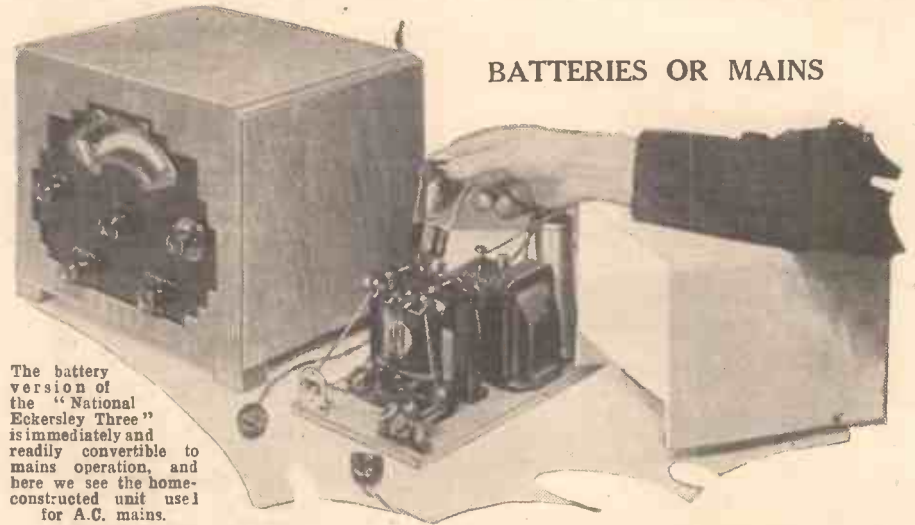

The battery version of the "National Eckersley Three" is immediately and readily convertible to mains operation, and here we see the home-constructed unit used for A.C. mains.

BATTERIES OR MAINS

medium wavelengths. And all the tuning is done on the central control.

The two other knobs, at the lower level of the panel, are equally straightforward in purpose and decisive in action. That on the left governs reaction, and is so easily handled that so far we have not had a single inquiry asking how it should be manipulated for best results. (Indeed, our Query

circuits and consequently sharpest tuning. Intermediate positions of the control knob give the corresponding intermediate results.

So simple is the whole thing that a very little practice "on the air" suffices to give the owner complete control and confidence that he is working the set as it should be worked. And this effect is enhanced by the fact that when the Regulator is round towards the left, for local-station selectivity, it automatically comes into use as a volume control.

Built in no Time.

This Regulator control of volume is adequate for all ordinary conditions, but it was foreseen that those readers who lived quite close to a powerful station would be best served by using a multi-mu type of S.G. valve and separate volume control. It is a very easy matter to fit the necessary grid bias, etc., for this, and details will follow in an article in the near future.

Over and above the outstanding simplicity and tractability of the controls there is another factor contributing to the success of this set in the hands of the general public. We refer to its remarkable ease of construction.

For a powerful set it is surely one of the simplest ever designed, calling for no previous experience on the part of the constructor. Anybody who can handle a screwdriver and a pair of pliers is fully qualified to build it; and every builder is entitled to expect complete mastery of its controls within an hour of switching on.

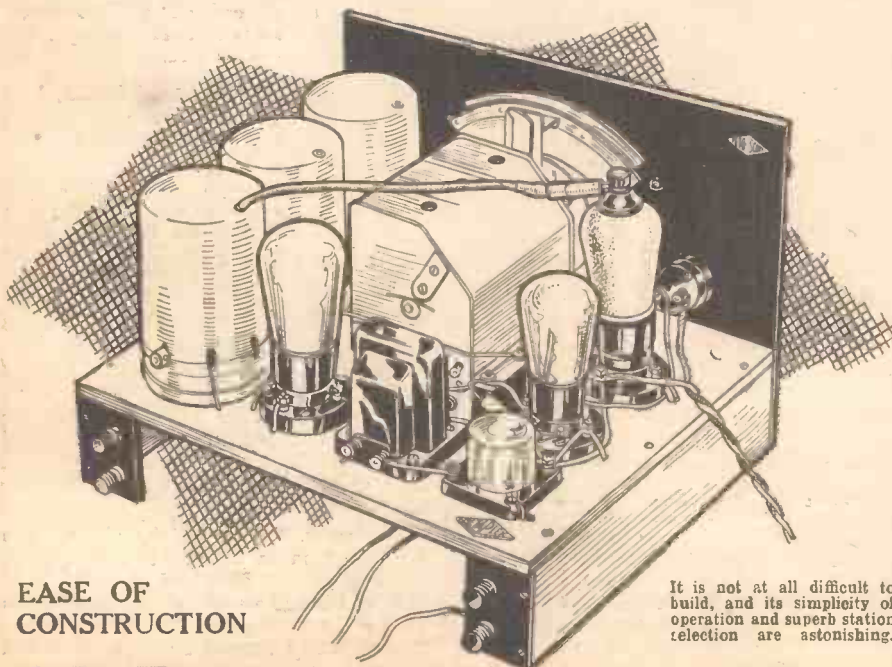

**EASE OF
CONSTRUCTION**

It is not at all difficult to build, and its simplicity of operation and superb station selection are astonishing.

THE ECKERSLEY A.C. RADIOGRAM



When introducing the National Eckersley Radiogram in our January 20th number it was stated that conversion to mains operation was easily arranged.

Below are the full details for a change-over to A.C., and it will be seen that the alterations to the set are of a minor character, involving but few extra parts.

The necessary modifications are fully described below

By P. P. ECKERSLEY

THE star turn in sets is the radiogram. The star method to use the radiogram is to use mains (which you can only use when you've got them). The star mains are those supplying ripple-proof, pure, steady frequency, stabilised farthing-a-unit alternating current electrical energy.

One feels that the A.C. Radiogram, to be fed from such a pure source, has got to be terribly careful of its p's and q's. Well, the "National Three" won't, within the limits of its specification, do so badly.

The New Parts.

So, assuming you have learned all the basic things about the set and the radiogram version of the set, I will proceed to give you in bald but convincing narrative how to convert the battery radiogram into the A.C. Radiogram.

First of all, extra components.

(1) Combined 5,000 potential divider (all right, potentiometer!) and on-off switch. The potential divider is used to control the potential of the multi- μ valve, and so acts as a volume-control device.

The switch, as is implied in its succinct title, switches the power on or off. It is connected by a twin-flex lead to the mains unit and is in series with the mains.

(2) A 100-ohm fixed resistance. This limits the minimum bias which can be put on the multi- μ valve grid, and so ensures stability at all settings of the volume control.

Automatic Bias.

(3) A 0.1-mfd. fixed condenser to hold the cathode at (H.F.) earth potential. It connects from cathode to chassis.

(4) A 2-mfd. fixed condenser and a 500-ohm resistance, connected, in parallel, between the cathode of V_2 and chassis, to provide the grid bias (automatically) for this valve when it changes from a detector

into the first-note magnifier for the gramophone input.

(5) A 2-mfd. fixed condenser and resistance, used much as in (4), to provide automatically the grid bias for the pentode valve.

The resistance value depends upon the make of valve, so find out from the literature supplied with the valve what it should be. (Look under "Automatic Grid Bias" or "Free Grid Bias.")

(6) A 0.25-megohm grid leak to replace the 1.0-megohm grid leak used in the battery set. This substitution is necessary to minimise reproduced mains hum in the A.C. version.

Step-by-Step Details.

The combined gramophone volume control and radiogram switch is replaced by a similar component, the resistance value of which is, however, 10,000 ohms. This will reduce the higher audio-frequencies, which would otherwise be too pronounced.

Now we get on with the actual alterations.

The H.T. economiser unit is, of course, no longer required, and is removed, together with its associated leads. Remove lead joining filament terminal (the one nearer panel) of V_2 to chassis.

Remove L.T. negative lead from switch and connect it to the above-mentioned filament terminal of V_2 .

(Continued on next page.)

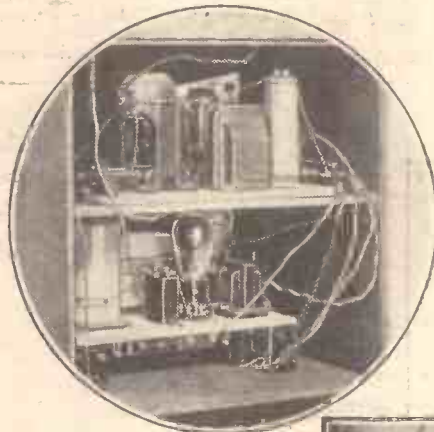

ON SEPARATE SHELVES

The general arrangement is shown in the circle above, which depicts the set from the back, with the cover removed.

On the upper shelf the A.C. mains unit is placed where it is completely covered in use, but readily accessible if wanted.

To the right is a close-up of the altered "filament" wiring and of the combined 5,000-ohm potentiometer and on-off switch that is mounted on the panel.

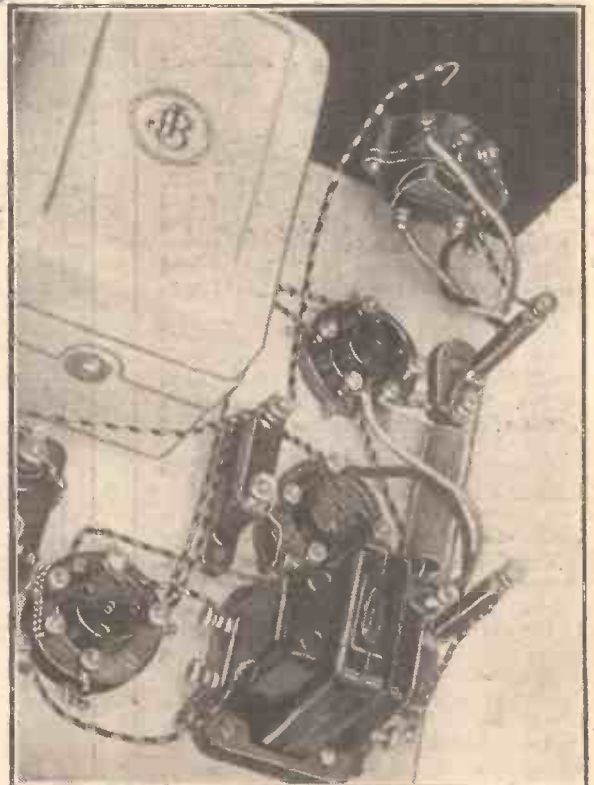

EXTRA RADIOGRAM COMPONENTS FOR A.C. WORKING

- 1 Dubilier 2-mfd. fixed condenser, type BB, or T.C.C., Graham Farish, Telsen, Iganic.
- 1 T.C.C. 2-mfd fixed condenser, type 50, or Graham Farish, Telsen.
- 1 Dubilier 1-watt type resistance (output-valve bias; for value see text), or Graham Farish, Bulgin, Varley.
- 1 Graham Farish 500-ohm 1½-watt type "Ohmite" resistance in vertical holder.
- 1 Graham Farish 100-ohm 1½-watt type "Ohmite" resistance in vertical holder.
- 1 Dubilier 1-mfd. fixed condenser, type 4404, or T.C.C.
- 1 Bulgin 5,000-ohm potentiometer with on-off switch, type VS29, or Lewcos.
- 1 Lissen 1-meg. grid-leak with wire ends, or Varley, Dubilier, Bulgin, Goltone, Erie.
- 1 Garrard A.C. electric gramophone motor, type A.C.4.
- 1 Bulgin combined 10,000-ohm potentiometer and 3-pt. change-over switch, type V.S.32.
- 1 yd. Goltone single-screened flex, type R43/96.

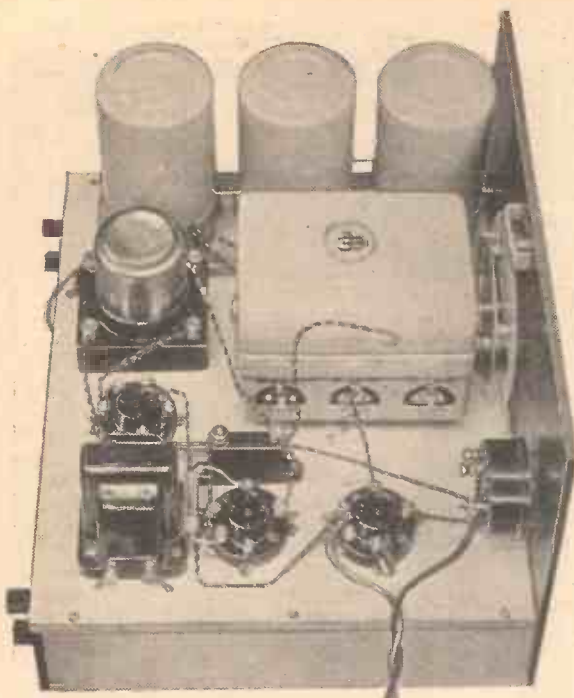

The set in its original form is shown above, whilst to the right is a diagram of the above-baseboard alterations. The dotted black lines on this show the original wiring which remains unaltered. The full black lines show new wires, whilst "hollow" lines show the old wiring which is removed. (To the nearer-panel filament terminal of V_1 examples of all these are seen.)

(Continued from previous page.)

Remove lead joining filament terminal (the one nearer panel) of V_1 to bottom right-hand terminal of switch.

A lead joins the right-hand filament terminal of V_3 to the bottom centre terminal of the switch. Remove this lead from the switch and connect it to that filament terminal of V_1 which is nearer panel.

Replacing the Switch.

Remove the switch from the panel and replace it by the combined 5,000-ohm potentiometer and on-off switch.

Mount the holder for the 100-ohm resistance. Connect the terminal on this holder and also one wire end of the .1-mfd. fixed condenser to the cathode terminal of V_1 . Connect the other end of the condenser to the chassis.

Insert the resistance in its holder and connect its top terminal to the centre terminal of the potentiometer.

To the left-hand terminal of potentiometer connect a single-flex lead about 2 feet long, and the right-hand one connect to chassis. To the two switch terminals a length of twin flex is connected, about 2 feet.

Remove lead from filament terminal to cathode terminal of V_2 .

The 500-ohm Resistance.

Mount the holder of the 500-ohm resistance to the right of V_2 .

Also connect the terminal on the holder to the cathode of V_2 , and also, through a hole in the chassis, to one terminal of a 2-mfd. condenser which must be mounted under the chassis. The other terminal of this condenser is connected to the chassis.

Insert the 500-ohm resistance in holder and connect its top terminal to chassis.

Remove the 1-meg. grid leak connected between grid and cathode of V_2 and replace by one of $\frac{1}{2}$ meg.

Mount 2-mfd. condenser next to V_3 and connect across it the biasing resistance (the value of which will depend upon the valve used). Connect the rear terminal of this condenser to the cathode terminal of V_3 and the other terminal to the chassis.

Remove the lead joining the cathode terminal of V_3 through the chassis, to a 2-mfd. condenser under the chassis. To the same terminal of this condenser connect a flex lead.

Removing G.B. Leads.

This passes through the same hole in the chassis and will connect to the side terminal of pentode output valve. Also remove the G.B. positive lead.

Remove G.B. -1 lead from terminal on potentiometer under chassis. Connect this

THE A.C. VALVES TO USE

Make	S.G.	Detector	Output
Cossor	M.V.S.G.	41M.H.L.	M.P./Pen.
Mullard	M.M.4V.	354V.	Pen.4V.
Mazda	A.C./S.I.V.M.	A.C./H.L.	A.C./Pen.
Osram	V.M.S.4B.	M.H.4	M.P.T.4
Marconi	V.M.S.4B	M.H.4	M.P.T.4

RECOMMENDED AERIAL AND EARTH EQUIPMENT

Electron "Superial," Goltone "Akrite," British Radiophone "Receptur" down-lead Bulgin lightning switch, Graham Farish "Fit" earthing device.

LOUDSPEAKER

1 W.B. Microlode loudspeaker chassis, type P.M.4a, or suitably sized R. & A., Rola, Blue Spot, Celestion, Amplion.

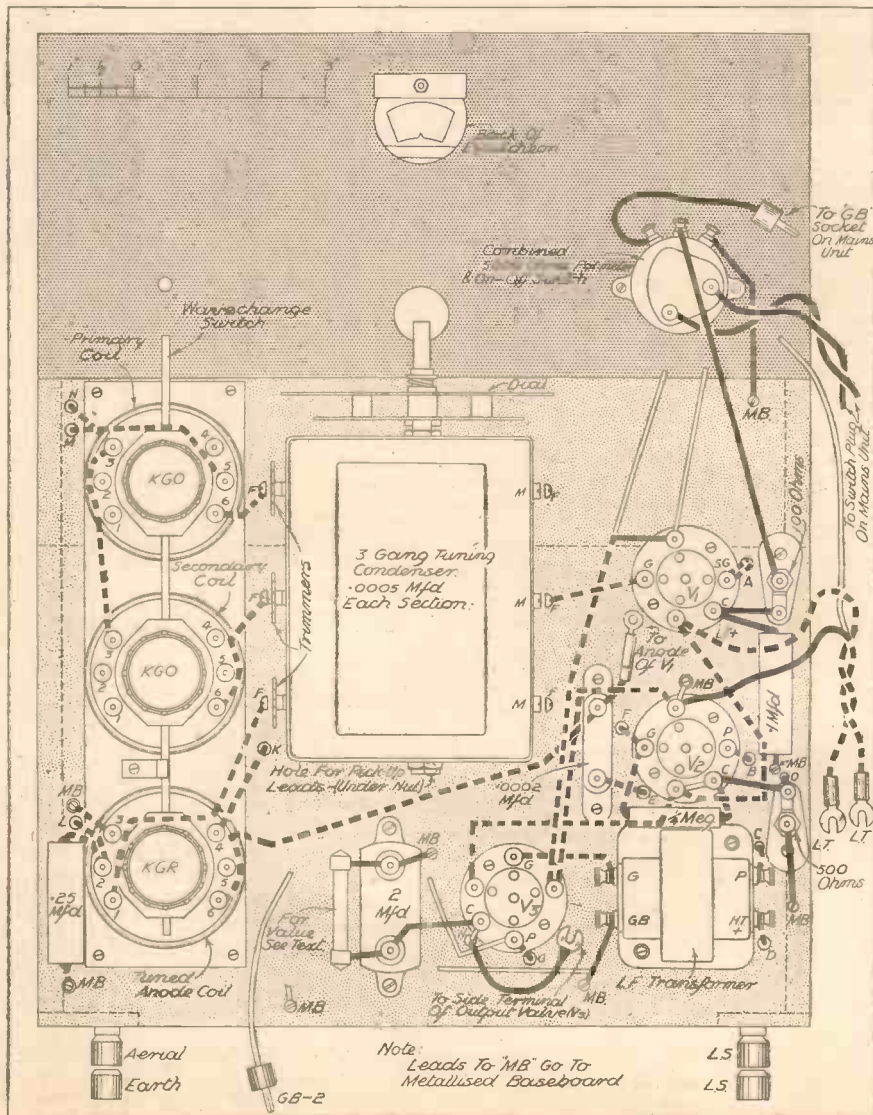

terminal of potentiometer to chassis. Connect G.B. terminal on L.F. transformer to chassis.

Attach a wander-plug to the single-flex lead connected to the combined 5,000-ohm potentiometer and on-off switch.

Attach the necessary socket to the twin-flex lead from the switch terminals, for connection to the switch plug on mains unit.

The actual receiver is now completely converted, and all that remains to be done is to fit the A.C. turntable to the motor-board and to connect up the pick-up.

The template, supplied with the A.C. electric gramophone motor, is placed on the

motor-board so that the centre of the hole for the main spindle is 7 in. from the front and 6½ in. from the left-hand side of the motor-board.

The hole to be cut out is indicated by a dotted line. The flat of this hole must be parallel to the back of the motor-board.

Mark out this hole on the motor-board, and cut out by means of a fret saw or key-hole saw.

Before screwing the motor

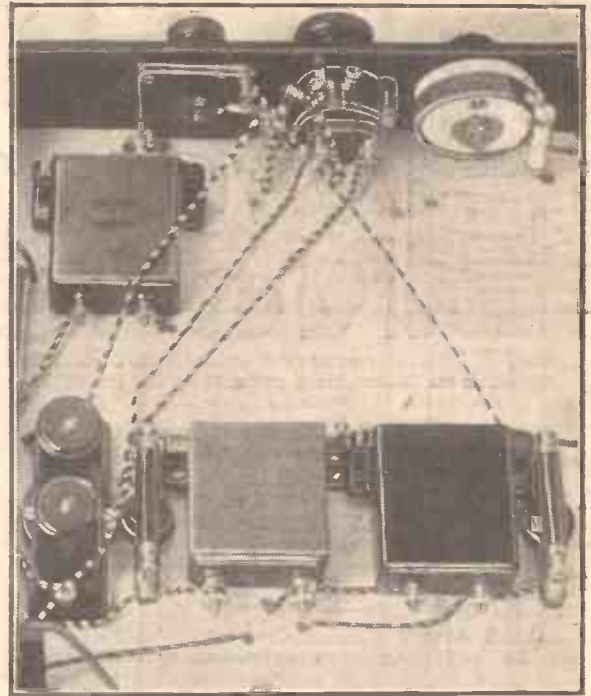

A comparison of this picture with the diagram below will clearly show how this part of the wiring is carried out.

COMPONENTS FOR THE A.C. UNIT

- 1 R.I. mains transformer, type E.Y.30.
- 1 Lissen smoothing choke; type L.N.5301, or Wearite, type H.T.12.
- 1 T.C.C. 4-mfd. fixed condenser, type 80, or Dubilier.
- 1 Dubilier 4-mfd. fixed condenser, type 9200/9202.
- 1 Benjamin 4-pin valve holder, "Vibrolder" type, or W.B., Telsen, Lissen.
- 1 Graham Farish 30,000-ohm 1½-watt "Ohmite" resistance in vertical holder.
- 1 Graham Farish 15,000 ohm 1½-watt "Ohmite" resistance in vertical holder.
- 4 Igranic "Indigraph" sockets, or Clix, Bulgin, Belling-Lee.
- 2 Igranic "Indigraph" terminals, or Belling-Lee, Bulgin, Clix.
- 1 Bulgin combined mains plug and fuses, type F.15.
- 1 Belling-Lee mains plug, type 1042, or Bulgin, Goltone.
- 1 Peto-Scott "Metaplex" baseboard, 12 in. x 6 in.
- 1 Peto-Scott terminal strip, 6 in. x 1½ in.
- 1 Coil of British Radiophone "Push-back" wire.

RECTIFIER VALVE : 1 Mullard I.W.2, or Mazda U.U.60/250.

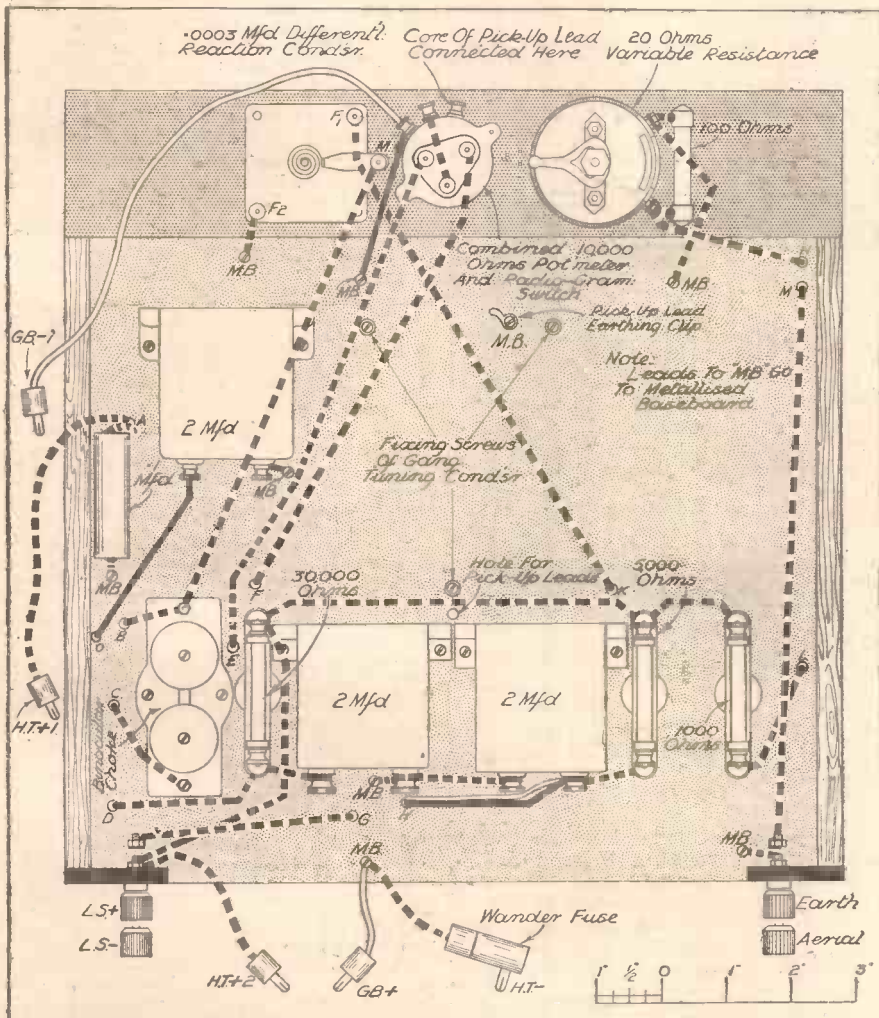

Here we have the below-baseboard wiring when the set is altered for A.C. operation. Wires which are unaltered, and those which are to be removed or inserted, are indicated respectively by dotted "hollow" or full black lines, as explained in the above-baseboard diagram on the opposite page. Note that a Goltone screened pick-up lead has its core fixed to one terminal of the combined potentiometer and Radiogram switch and its outer covering joined to the metal baseboard by a metal clip and screw, as shown at the top of the diagram.

into position connect a twin-flex lead to its mains terminals. The other ends of this lead will be connected to the mains input terminals of the transformer in the main unit.

Mounting the Motor

Instructions for setting the automatic switch are supplied with the motor, and it is unnecessary to repeat them here. Unless the motor is mounted exactly as described, it may foul the loudspeaker or the lid stay. So make sure that it is in the correct position.

Of course, there is a certain amount of latitude, since the motor fits easily into the hole in the motor-board. In fact, there is space all round it.

The pick-up is mounted with the aid of the template supplied with same.

Cut the pick-up lead so that only about 3 in. remain. Take a length of single-screened flex and connect one wire of the pick-up lead to the screening and the other to its core.

Pick-up Connections

Pass the other end of the screened flex through the chassis and connect the screening to the chassis and the core to the free terminal of the 10,000-ohm potentiometer. The set can now be placed in position and connected up to the mains unit, which was fully described in the January 27th number of "Popular Wireless" for the "National Three" for A.C. (The same connections are employed for the Radiogram as for the original "National Three," but as the Radiogram uses an all-in cabinet no lid is necessary for the Radiogram version of this unit.)

And there you have an A.C. radiogram, and I hope it plays and behaves nicely as it ought to do.

Next week I shall deal with a D.C. version of the National Eckersley Radiogram for those with this type of mains supply.

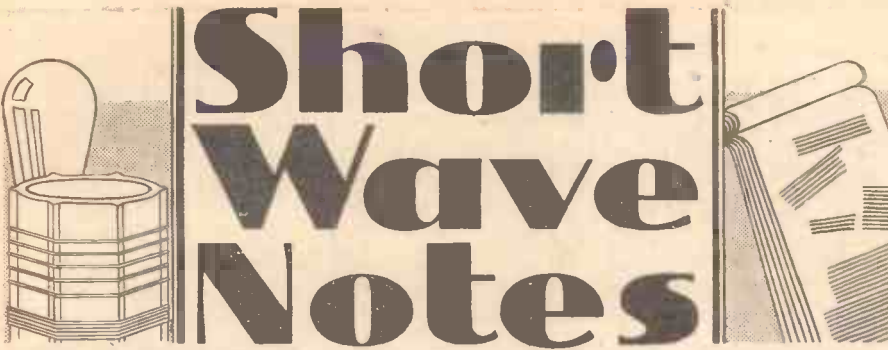

Short Wave Notes

Notes of interest concerning stations and conditions on the short-wave band, written in an entertaining manner by the foremost expert in short-wave practice.

SPRING is coming! Already I am receiving reports of the reception of the 19-metre broadcasting stations as late as 8 p.m., which, compared with the 5.30 p.m. fade-out at Christmas, seems distinctly hopeful. Console yourselves with this cheerful thought on these frosty, foggy mornings.

By the time this appears in print the R.S.G.B.'s annual "B.E.R.U. Contest" will be half over. The extraordinary number of really D X amateur signals that one hears on the air during events of this kind always prompts me to a sneaking feeling that the periods that we call "bad conditions" are really due to sleepy operators!

Signals From All Over the World.

It is perfectly true that a big contest generally succeeds in filling up our bands with signals from all over the world, whatever conditions may have been like just before its commencement.

The International Short-Wave Club asks me to announce that the Dutch station PA-0ASD is giving them a special broadcast on February 25th. This will take place between 3 and 5 a.m. on 79.57 metres, and will consist of a musical programme interspersed with messages for listeners in all parts of the world. There will be a bugle call, by way of identification, between the items.

Will W. S. C. (King's Lynn), who wrote to me a little while ago, kindly make himself known to E. W. B.? The latter's address is E. W. Burgis, St. Ann's House, King's Lynn. Unfortunately, I have not kept W. S. C.'s letter, and therefore don't know his address.

W. H. (Tottenham) mentions a certain little trouble with the "H.A.C. Three-Valver" that I seem to remember meeting before. Users of any other sets who are similarly worried might do well to note this. He finds that below 25 metres, with a "4" coil in the grid circuit, the set will not stop oscillating with a "6" reaction coil; it won't even begin with a "2." With the "6," even with the reaction condenser at zero, the set oscillates hard.

Try a Different Reaction Condenser.

Now, from the face of it it seems obvious that the reaction condenser has a higher minimum than it ought to have. Alternatively the H.F. choke is no good, and the self-capacity of the transformer winding is sufficient to keep the set in an oscillating state.

The best way of curing the trouble (assuming that the choke is above reproach)

is to try a different reaction condenser. Failing this, use another "4" coil as reaction, which ought to make things just right. Personally, I always find it a great convenience to have two "4's" and two "6's" available.

Five-Metre Work in Yorkshire.

In sets with a tuned H.F. stage, where there is already a second "4" in use as aerial coil, try that as a temporary expedient for the reaction coil, and see whether you can't bring the aerial circuit into tune with a "6."

W. H. apparently hasn't tried separating the coils by an extra inch, but I quite realise that in modern sets the fixed-coupling idea is so general that we designers don't leave much spare room!

THE KING'S BROADCAST



A permanent record of the King's Christmas message to his Empire—broadcast on December 25th last through the Empire short-wave Station at Daventry—has been made by the Gramophone Company, and the factory girl in the picture is preparing an H.M.V. disc for his Majesty's personal use.

When writing last year about the peculiarities of 5-metre work in East Yorkshire, with particular reference to the Bridlington area, I queried whether there was anything abnormal about the geological formation in that part of the world.

An interesting letter and sketch from C. J. P. (Plumstead) throws a certain amount of light on the subject. What interests me more, however, is his statement that mist or fog has been proved to have a marked effect upon the transmission of 5-metre signals. It seems quite possible that

a dense stratum of moist air could act as an inefficient kind of reflector. Its conductivity isn't particularly high, but is certainly much higher than that of dry air.

I am awaiting evidence that clouds play a part in 5-metre "freak" long-distance working. Our 200-mile range from the Crystal Palace last year certainly didn't come under the heading of optical, or even "quasi-optical," working!

Strong "Jekyll and Hyde" Flavour.

Incidentally, C. J. P., your guess at my identity is quite misplaced. How could I be Mr. Walters when he was up in the plane, talking to me on the top of the Tower? There's a strong Jekyll-and-Hyde flavour about such a suggestion.

P. McD. (Dublin) asks about the Amateur Call-Book and where it can be obtained. Since the death of Mr. Carter I am not quite clear about that, but it can always be had from the R.S.G.B. at 53, Victoria Street, London, S.W.1.

J. B. M. (Glasgow) protests against the common habit of using place-names for call-sign identification, which, I agree, is very misleading. I have heard F 8 C V announcing himself as "Huit Canada Victoria," which, to the uninitiated, might mean almost anything. A friend of mine at Folkestone, G 2 I C, once announced himself as "G Two Italy Canada," and received a postcard addressed to "British Radio Station G 2, Italy, Canada"! Luckily, the omniscient G.P.O. didn't trouble to send it all the way to Canada, probably knowing that they wouldn't find Italy when they got there. As it came from the same road it was delivered straight to his door!

What's wrong with the old "Ack-Beer-Cork-Don"?

W.L.S.

REALISTIC REPRODUCTION.

A Reader's Opinion.

The Editor, POPULAR WIRELESS.

Dear Sir—As Mr. Scroggie remarks in POPULAR WIRELESS issued on Dec. 9th, musical reproduction certainly involves the "human element." I should be more inclined to apply the term "personal element," and maintain that a response such as he suggests would be a purely personal one, but not scientifically founded.

Reverting to the question once more, our aim is to reproduce the original, and in my mind straight-line response would achieve this. Certainly we must have the correct volume, but surely that does not mean that if we intend to listen to an orchestral item the speaker must reproduce at the original orchestral volume.

On the contrary, it should be required to reproduce the music at a volume depending upon the dimensions of the room in which it is placed—that such, to a listener in that room, it would appear to be the same volume as the original would appear to another listener situated in the hall itself.

Then, neglecting the effects of the differences in acoustic properties, with straight-line response throughout, the total balance would be a replica of the original. With decreased volume the bass and treble would certainly become less audible, but so it would also if the original were heard at lesser volume.

In short, any curve other than a straight line cannot reproduce the original at any volume whatsoever. I am not disputing that the music might sound more pleasing with a response curve such as Mr. Scroggie suggests, but it is not a curve that can be attained by scientific reason.

And if our aim is to be reproduction in the actual sense of the word, straight-line response stands undisputed as the ideal. Mr. Scroggie's arguments are negligent of the fact that his "human-element" curves apply to the original as well as to the reproduced music.

I am,

Yours faithfully,

A. M. STURROCK, B.Sc.

16, Townfield Road, Hayes, Middlesex.



RADIO STEP-BY-STEP

OUR SPECIAL
SUPPLEMENT for
BEGINNERS

FUSE.

A protective device designed to prevent more than a given amount of current flowing in a circuit. The commonest form of fuse in general use is a wire which will melt when the current increases above a certain value.

In wireless sets tiny electric bulbs similar to those employed in flashlamps are often used.

Fuses should always be chosen carefully, and the current value at which they will "blow" (burn out) must not be greatly in excess of the average current normally flowing in the circuit in which it is used.

Complete protection against excessive H.T. current is not necessarily given by one fuse inserted in the negative H.T. lead. Considerable voltages may exist between different positive tapplings.

When a large grid-bias battery is employed it may be considered desirable to have a fuse in series with it.

Sometimes it is not easy to see if a fuse has actually been burned out, in which case a continuity test through it is necessary. This can be done with a small battery, a limiting resistance, and a milliammeter, or with a voltmeter and battery.

GRID.

The valve electrode which controls the electron stream and to which, therefore, the input energy is generally fed is now

APPLYING POTENTIAL

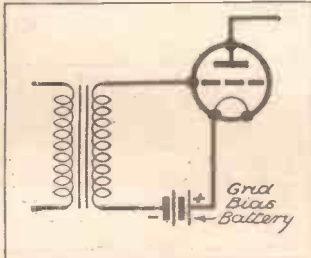

Fig. 1. Illustrating the application of grid bias to an L.F. amplifying valve. Grid bias (in the usual 2-volt battery L.F. valves) may vary between 1½ and 18 volts.

usually known as the Control Grid. Additional grids for screening this control grid are to be found in "S.G." and Pentode valves.

The Control Grid is a mesh of wire situated between the fila-

ment and plate. And as it is nearer the filament than the plate a small positive potential on it will have the same effect as a larger potential on the plate.

If the grid is made negative a relatively small voltage on it will counteract a large positive plate potential. Obviously, therefore, if this grid voltage is varied the anode current flow is controlled accordingly.

It is the relation between such plate-current variations due to grid-voltage fluctuations and the plate voltage which determines the amplification factor of a valve.

GRID BIAS.

The application to the grid of a valve of an initial potential in order to bring the valve to a required operating condition.

This can be done with a small battery of suitable voltage as at Fig. 1. In this case an L.F. amplifying valve is being given a negative Grid Bias in order that the anode current is adjusted to such a value that negative and positive impulses

For example, if the anode current is 10 milliamperes and the bias resistance is 1,000 ohms, there will be a 10-volt negative bias on the grid.

Obviously, it is a simple matter to determine the resistance needed to produce any desired grid bias; all that has to be done is to divide the voltages required (in volts) by the current which will be passed through it (in amperes).

Automatic Grid Bias in a mains set is just as easy to understand (the calculations are the same) if the fundamental principle explained by Fig. 3 is fully grasped.

A simple arrangement for an indirectly-heated valve is shown at Fig. 4. The cathode is "raised" from the earth line by a bias resistance R_1 across which is a bypass condenser C . This is exactly the same in principle as the Fig. 2 circuit, as a moment's thought will show.

GRID CIRCUIT.

This is the circuit connected between the control grid and

and so called because one of its main purposes is to enable charges on the grid to "leak" back to the filament.

GRID CONDENSER.

Usually a fixed-capacity condenser joined directly in series with the control grid. In the case of a grid-rectifying (detector) valve the capacity of the grid condenser is chosen in relation to the resistance of grid leak.

A grid condenser employed in resistance or choke coupling needs to be of efficient construc-

AUTOMATIC BIAS

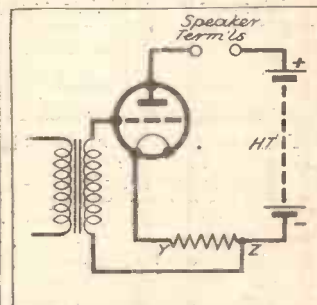

Fig. 2. Automatic grid bias is obtained by inserting a suitable resistance in the position (YZ) shown above, and the value of the resistance is obtained by the method given in the text this week.

RADIO TERMS

BY G.V. DOWDING Associate I.E.E.

fed to the grid by the transformer provide equal decreases and increases of anode current. This is essential in this type of amplifier if distortionless amplification is to be obtained.

The battery can be dispensed with and the bias obtained by inserting a suitable resistance in the anode circuit (Fig. 2).

To understand how this method functions reference should be made to Fig. 3, where a resistance symbol replaces the valve and loudspeaker.

It will be seen that the bias resistance and the resistance due to the valve and speaker constitute a potentiometer, and that the grid's connection is taken to the negative end and the filament to an intermediate point.

Clearly the filament is positive in regard to the grid, or, in other words, the grid is negative in respect to the filament.

The actual potential difference between these two points depends upon the value of the bias resistance and the current flowing through it as per Ohm's Law.

filament of a valve. A break in a grid circuit generally evinces itself as a howl. Such a break may take the form of a faulty connection or the failure of a grid leak.

Other frequently encountered causes are the breakdown of the secondary winding of an L.F. transformer or of a tuning coil or the decay of a grid-bias battery.

Almost invariably there must exist a direct electrical path for D.C. between the grid and filament of a valve.

GRID CURRENT.

If the grid is made positive in respect to the filament it will attract electrons to it that will return to the filament via the grid circuit. Considerable grid current flows in this way in Class B amplification, but grid current is to be avoided with ordinary (Class A) amplifiers.

GRID LEAK.

A resistance joined between the grid and filament of a valve,

tion, for if it were to break down H.T. voltage might be impressed on the grid.

GRID RECTIFICATION.

This is alternatively termed "cumulative-grid rectification," "grid-circuit rectification or detection," "leaky-grid detection" and various other similar combinations.

We prefer "grid-circuit detection" as being more closely descriptive than the majority of other terms of what happens.

Indeed, we should like the terms "rectification" and "rectifier" to be confined to mains apparatus in connection with the "rectifying" of A.C.; and "detection" and "detector" employed for the "detecting" of radio speech and music, for at present the words quite haphazardly alternate in radio literature. However, the processes to which they are applied have much in common, and, given clear context, no confusion should arise.

Grid detection or rectification
(Continued on next page.)

Special Beginners' Supplement—Page 2.

(remember, the terms are synonymous) comprises the detection of the radio energy in the grid circuit and its subsequent amplification by the valve at low frequency.

In anode-bend detection the detection takes place in the anode circuit.

A knowledge of the manner

BASIC PRINCIPLES

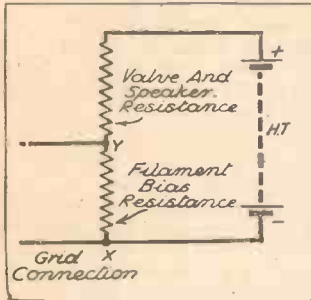

Fig. 3. Illustrating the fundamentals of automatic bias. The upper resistance represents the valve and speaker in Fig. 2, while the lower resistance provides the bias.

in which an anode-bend detector operates makes it fairly easy to understand the grid-circuit method.

A small current (of the order

of a few micro-amperes) flows from the grid of the valve (Fig. 1) through the grid leak back to the filament.

The value of this current is altered by the input energy. Positive impulses cause it to increase and negative impulses to decrease.

But the decreases are not so great as the increases, for the grid-volts-grid-current curve is not straight. It follows, therefore, that the grid current is made to rise above its average to degrees in proportion with the L.F. modulations of the H.F. energy.

We now have L.F. impulses in the grid circuit, and these will affect the grid of the valve and cause variations in the anode

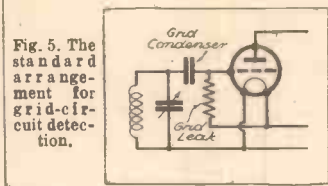

Fig. 5. The standard arrangement for grid-circuit detection.

current, the valve acting as an L.F. amplifier.

It should be noted that the increases of grid current corresponding with the L.F. fluctuations make the grid more or

less negative, although they are actually due to the positive impulses of the H.F. energy.

In other words, the greater the grid current becomes the higher the negative potential on the grid.

A simple way to grasp this is to remember that electricity

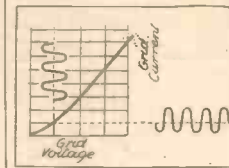

Fig. 6. How the grid current varies with grid voltage.

always flows from a negative point. The grid current flows from the grid through the grid leak back to the filament (always). The greater the current flow the greater must be the potential difference between the two ends of the grid leak (Ohm's Law), and that means the greater must be the negative potential on the grid.

The grid condenser is necessary because in its absence the tuning coil would short-circuit the grid leak because of its, the coil's, much lower ohmic resistance.

If the grid condenser is too small it will offer an unreason-

ably high impedance to the H.F. energy. If it is too large it will, in association with the tuning coil, tend to short-circuit the grid leak in so far as the L.F. fluctuations across it are concerned.

The value of the grid leak affects the operating point on the grid-volts-grid-current curve.

But its value is not critical, and 2 megohms in combination with a grid condenser of .0003-mfd. capacity are often chosen.

MAINS OPERATION

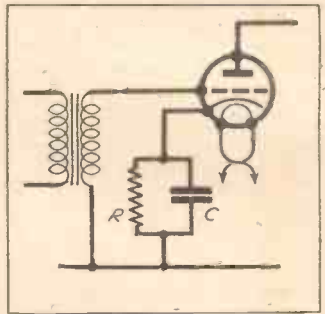

Fig. 4. Note how, with an indirectly-heated valve, the resistance is inserted, together with a by-pass condenser, between cathode and earth. Compare this diagram with Fig. 2 on the previous page.

BY this time you will no doubt agree that the various symbols used by mathematicians are not turning out to be so mystifying as they appear at first sight. Remember that a symbol is simply a convenient way of writing down a number which can be substituted for the symbol when necessary.

Thus, if we have two numbers, say 3 and 4, and call the first X and the second Y, we know that the expression XY is the same thing as 3 x 4, i.e. 12.

Similarly X + Y would be 3 + 4, i.e. three and four added together, giving an answer of seven. Y - X is 4 minus 3, i.e. three subtracted from four.

Suppose we take a few more practical examples. Here is one: $\frac{X}{Y}$ viz. X divided by Y, giving an answer of $\frac{3}{4}$, or .75.

Squares and Square Roots.

Here is another: $X^2 + Y^2$. This is three squared plus four squared, or 9 added to 16, which equals 25. Or we can find the square root of the expression by

writing it as $\sqrt{X^2 + Y^2}$. In this case $X^2 = 9$ and $Y^2 = 16$. Adding them both together results in an answer of 25, and the expression then becomes $\sqrt{25}$, which equals 5.

You will remember that in a previous article we dealt with square roots and said that it was that number which, when multiplied by itself, gave the given number.

The given number here is 25,

SIMPLIFYING RADIO SUMS

Further facts and figures which help you to a better understanding of wireless technique.

and it is easy to see that it is equal to 5 multiplied by 5. Suppose we tackle our impedance formula—explained last week.

We learnt that XL was merely a shorthand representation of $2\pi fL$, and Xc an alternative way of putting down $\frac{I}{2\pi fC}$.

Also we found that Z (the impedance) was equal to

$$\sqrt{R^2 + (X_L - X_C)^2}$$

Now,
$$\sqrt{R^2 + (X_L - X_C)^2}$$

is just the same as
$$\sqrt{R^2 + \left(2\pi fL - \frac{I}{2\pi fC}\right)^2}$$

and it is quite easy to find out what Z is, provided the resistance R, inductance L, capacity C and frequency f are known.

Somewhat Cumbersome.

The only trouble with an expression like this is that it is somewhat cumbersome. You can't solve it by mental arithmetic because the processes have to be worked out step by step. Let's take an example and see how it's done.

Suppose we have a 100-volt A.C. supply with a frequency of

50 cycles connected to a circuit having a resistance of 10 ohms, an inductance of .05 henries and a capacity of .002 farad.

Now, in this case R is 10, L is .05 and C is .002. f, the frequency, is equal to 50.

It is best to work out each item in the impedance expression separately.

So, taking the resistance first, we have $R^2 = 10$ times $10 = 100$; $2\pi fL = 6.28 \times 50 \times .05 = 15.7$; also $2\pi fC = 6.28 \times 50 \times .002 = 628$;

and $\frac{I}{2\pi fC} = \frac{I}{628} = 1.6$ (by dividing 628 into one).

The next procedure is to finish working out the expression in the brackets and then to square it.

The bracketed portion is
$$\left(2\pi fL - \frac{I}{2\pi fC}\right)$$

Substituting the numbers already worked out, we have

$$\left(2\pi fL - \frac{I}{2\pi fC}\right) = (15.7 - 1.6);$$

15.7 minus 1.6, or 1.6 subtracted from 15.7, is equal to 14.1.

Next we have got to square 14.1. Thus:

$$\left(2\pi fL - \frac{I}{2\pi fC}\right)^2 = (14.1)^2 = 141$$

$\times 14.1 = 198.8$.

Now we can go a little farther by adding the resistance part of the expression.

We know that $R^2 = 100$.

Therefore

$$R^2 + \left(2\pi fL - \frac{I}{2\pi fC}\right)^2 = 100 + 198.8 = 298.8$$

That really was simple!

The Last Stage.

And now for the last part, viz. getting the square root. There are three methods to use. One is to look up the square root in some tables (you can buy them for a few pence). Or you can work out the root by arithmetic or by logarithms. We shall have something to say about logs. in a later article.

But, going back to the expression for impedance, we have

$$Z = \sqrt{R^2 + \left(2\pi fL - \frac{I}{2\pi fC}\right)^2} = \sqrt{298.8}$$

The square root of 298.8 is 17.3 approximately. If you multiply 17.3 by itself you will find that it is 299.3, sufficiently near 298.8 for our purpose.

Hence $Z = 17.3$ ohms.

To find the current flowing we can apply Ohm's Law, viz. I (the current in amps.) =

$$\frac{E \text{ (volts)}}{Z \text{ (impedance)}}$$

The voltage of the supply is 100; thus $E = 100$.

Hence $I = \frac{100}{17.3} = 5.8$ amps.

TELEVISION CIRCUITS

by G.P. Kendall
B.Sc.



WE have now got some general idea of the way the actual television apparatus functions, and here I think we had better pause a while and have a look at the radio side of the process.

On the face of it there is no special problem involved, since we are already familiar with the operations concerned in the transmission and reception of the wide range of frequencies required in sound broadcasting. We shall find, however, that television presents difficulties of its own, which really arise in the first place from the fact that the eye is far less tolerant of errors than the ear.

High Modulation Frequencies.

This may seem rather a startling statement, and I know it is customary to wrap it up a bit, but I fail to see why we should not face it right away. It is usual to speak mysteriously of the enormously high modulation frequencies involved in television transmission, as though that explained the whole thing, but the fundamental fact is far simpler.

To get really fine detail in the picture it is true that we do indeed require to handle extremely high frequencies; but as things stand, with our main source of pictures a transmission on the ordinary broadcast waves, the importance of this factor can easily be over-estimated. On these waves it is not practicable to radiate such ultra-high frequencies at the strength required for extreme detail pictures, a point which is conveniently forgotten by the mystery merchants.

In actual fact we are concerned with a moderate range of frequencies, quite comparable with those involved in sound transmission, and the matter would be simple enough were it not for the extremely critical power of our sense of sight.

"Side-band" Cutting.

This is the point: good detail in a picture does actually depend upon the correct handling at full strength of the highest frequencies in the transmission, and the least falling off here is at once apparent to the eye. A similar weakening of the "top stuff" in a sound transmission merely makes us say that it seems a bit "dull" or "round." In some cases we may even call it "mellow," and like it!

Evidently, then, the first requirement in a circuit for the reception of television is that very strict attention must be paid to the preservation of the highest possible modulation frequencies. In practice this means that we must start with our tuning circuits and see that they are not doing any harmful

An informative and interesting survey of the radio side of television, packed with practical hints on the different hook-ups and details of how to get the best results from them.

"side-band" cutting, especially if they are of the highly selective, single-tuned type.

If the circuit is of the band-pass type particular care must be taken to see that the top of the resonance curve is not too narrow.

I'm afraid that sounds rather vague, but in practice it is chiefly a matter of seeing that the ganging is done as accurately as may be, and, if possible, trying a "tighter" coupling between the two circuits.

In those cases where the coupling is done by means of a fixed condenser it can often be tightened by substituting one of rather smaller capacity, with good effect on the image. General broadcast results, of course, will probably not be improved, because selectivity will most likely suffer a little.

The L.F. side of the set is the most important, of

course, and great care should be taken to avoid anything likely to lead to loss of the vital higher frequencies. Large fixed condensers from the detector-plate circuit down to earth should be avoided, and similar by-passes in the L.F. stages must be left out altogether. (They are not really desirable in any normal set.)

One of the circuits on these pages shows how the detector-plate circuit may be arranged with the minimum of by-pass capacity. Note that the actual capacity shown is only .00005 mfd., also that a resistance of 3,000 ohms is suggested instead of a choke.

Resistance Coupling Best.

The reaction circuit is not shown, because it will naturally depend upon the particular type of coil used; but here again you should try to use as little capacity as possible. (A high plate voltage helps in this.)

Observe that I show resistance coupling throughout. I don't want to be dogmatic about it, but I must say that I have found it decidedly easier to get the desired results in this way. Note the comparatively low value of the anode resistances, the carefully chosen leak and condenser values and the use of a 4-mfd. output condenser: all points of considerable importance.

In connection with the L.F. side I should mention a scheme which is favoured for the more elaborate type of television receiver, wherein two separate output valves are used, one to feed the synchronising device and the other to supply the picture impulses to the light valve.

A Split Output.

The scheme is shown in "skeleton" form in one of my diagrams, and it will be seen that the valve which handles only the synchronising signal is fed by a special intervalve coupling which is tuned to the 375-cycles-per-second frequency of those signals. The arrangement is of some help in getting an adequate output from valves of moderate size.

In general it is wise to standardise upon filter output, for it simplifies many problems.

It presents an apparent difficulty in the case of the neon lamp, when we want to use the H.T. voltage to polarise the tube. The arrangement shown in another of my sketches shows how the difficulty may be overcome in a very simple way.

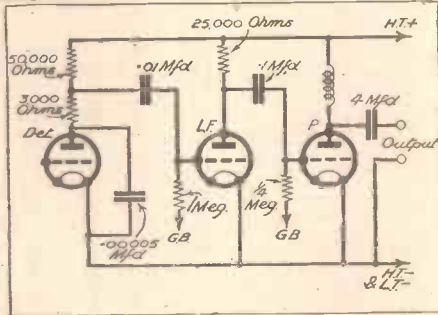
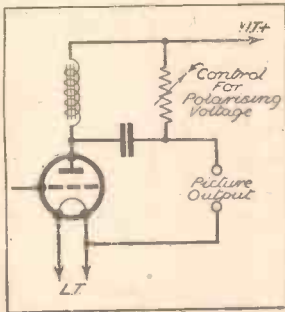

AT THE L.F. END

The smaller diagram illustrates a circuit for a neon-tube reproducer, and shows how a limited amount of H.T. is used for polarising.

Vital points in securing good detail are shown in the centre diagram, the special values in the detector plate circuit being intended to avoid high-frequency loss, whilst those in the succeeding grid circuit preserve the lower frequencies.

A de-luxe scheme is shown in simplified form to the right, in which one valve handles the picture output and the other the synchronising.

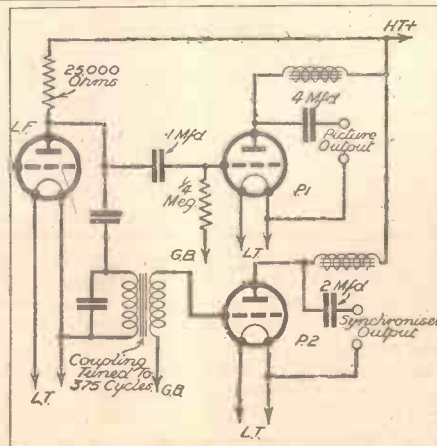

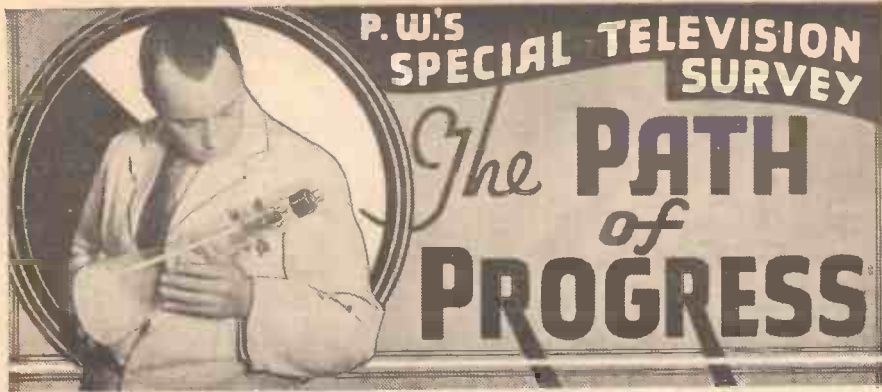

THE present position of the cathode-ray tube and its rivals in television may be compared with that of the three-electrode valve in the early days of broadcasting. One could, of course, listen-in on a crystal set so long as one was content to accept its limitations. But the results obtained were poor, compared with those given by the valve, which held the key to the future, because it made use of an electron stream to amplify the received signals.

To follow the argument a step farther, one has only to compare the performance of the old bright-emitter valve with that of the modern S.G. or Pentode. What intensive development has done for the thermionic amplifier it will do for the cathode-ray tube and for the future of television.

Detail Difficulties.

Designers are, in fact, already busy attacking what may be called the "detail" difficulties of cathode-ray working—those unexpected snags which so often stand in the way of complete success after the major problems have been solved. Quite a number of these concern the fluorescent screen upon which the received picture is projected inside the tube.

The size of the picture is, in the first place, determined by the size of the screen; and since a large screen necessarily involves a large—and more expensive—tube, there is obviously room for any improvement which will throw the picture outside the tube and so enable it to be seen on a larger scale.

One obvious expedient is, of course, to view the screen through a magnifying lens; but a more ingenious suggestion is to replace the fluorescent screen by a relatively small anode, which generates X-rays of varying intensity as the cathode ray strikes against it. The X-rays pass freely through the glass wall of the tube, and, after being focused by a pin-hole shutter, can be used to reproduce the picture upon a larger fluorescent screen situated completely outside the tube.

The Colour Problem.

Another idea is to divide the tube into two parts by a thin partition of oxide-coated glass. This separates the narrow part of the cathode-ray tube from an enlarged gas-filled portion which contains the viewing screen proper. As the electron stream strikes against the coated-glass partition the gas-filled outer chamber "glows" momentarily and so projects an enlarged picture on to the end screen.

All over the world scientists are attacking the problems of Television, and on this page J. C. JEVONS discloses some very promising recent developments in cathode-ray methods.

A second minor problem arises from the peculiar "greenish" colour of the picture reproduced on an ordinary fluorescent screen. This is not so pleasing to the eye as the more natural black-and-white shading. Designers have now succeeded in

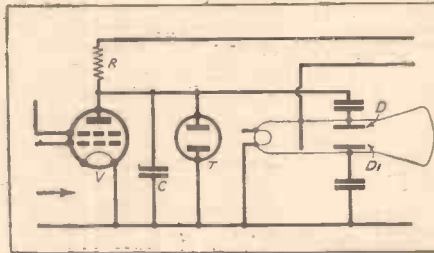

PREVENTING BURN-OUT

If the electron beam is allowed to stay at rest on the screen it may burn a hole there, so, as explained in the article, the above ingenious circuit has been devised to prevent this. The resistance R has the effect of keeping the beam swinging, even when the synchronising signals have ceased.

ILLUMINATING!

A quarter of a million candle-power is claimed for the tube shown to the right, its special feature being the easy control possible at the receiving end when it is harnessed to the incoming television impulses. The photograph shows how small the tube is, making it a convenient fitting for television receivers.



getting rid of the objectionable yellow-green hue by directing on to the screen, at the same time as the picture, a ray of a complementary colour supplied from a small auxiliary lamp screened off from the direct view of the observer.

It is known that the ordinary fluorescent screen tends to lose sensitivity after prolonged use, so that the brightness of the picture begins to fall off. Von Ardenne has discovered that this defect can be remedied by mixing the fluorescent sulphide or tungstate compound with potassium water-

glass, which serves not only as a "binder," but also as a recuperating agent.

Some curious effects also occur in the electron stream itself. The spot of light produced by the impact of the stream against the fluorescent screen is naturally brightest at the centre, though it is also surrounded by a small area of less intensity. In the ordinary way the speed at which the spot travels over the screen prevents the outer edges of the spot from producing any overlapping effect. In certain cases however, it is advantageous to adopt special means for preventing undue "spreading" of the ray.

One method of doing this is to introduce a certain quantity of free ions into the tube, either by deliberately ionising some of the contained gas or by inserting a small quantity of radio-active material in the tube.

Safeguarding the Screen.

The effect of the free ions is rather remarkable. Being positively charged, they form a focus about which the individual electrons concentrate in their passage from the cathode to the screen. In this way the electron stream is confined to a narrow "pencil," which produces a sharply defined spot on the screen.

One other possible source of trouble is a screen "burn-out."

The electron beam is quite strong enough to burn a hole through the material of the screen if it is held stationary on any given spot for even a short space of time. This might occur, for instance, on a stoppage or failure of the synchronising signals controlling the scanning movement.

The circuit shows one arrangement designed to prevent damage from being done in this way.

The scanning potentials for the deflecting plate D, D1 of the cathode-ray tube are produced across a condenser C, which is

charged through a resistance R and discharged by a valve V as soon as the latter is rendered conductive by the application of a positive synchronising signal to its control grid. Should the synchronising signal fail, the potential across the resistance R continues to build up until it reaches the flashing point of a neon tube T. It is then discharged through the "safety" tube T, which, with the condenser C, forms a pulsating circuit which keeps the cathode ray in motion over the screen in spite of the absence of synchronising signals.

THE NEW HUIZEN

Scheduled under the Lucerne Plan to work on 1,345 metres, and designed to replace the old 7-kw. station, Radio Kootwijk is at present testing on Huizen's old wavelength of 1,875, from which the Dutch long-waver seems loth to depart.

HUIZEN is almost as famous a transmitting centre as our own Daventry.

In fact, there is great similarity between the two: for while Daventry is now the home of the short-wave Empire broadcasters as well as the famous long-wave station, Huizen is also the locality of a short-wave broadcaster for the Dutch East and West Indies, in addition to the famous Huizen broadcast-band transmitter.

You must bear in mind that this is the

TYPICALLY MODERN STYLE



The small emergency studio situated in the station building for use should any land-line breakdown occur.

new Huizen broadcasting station. It is owned by the N.D.O. (Nederlandsche Drazlurze Omroep), and is used alternatively by the two main religious societies in Holland, the K.R.O. (Roman Catholic Broadcasting Society) and the N.C.R.V. (Protestant Broadcasting Society).

This part of Holland is typically flat, and is about a couple of miles from the main railway station. You don't need a guide to direct you to the N.D.O. building, for the two aerial masts are nearly two hundred feet high and are about 750 feet apart.

An Up-to-date Transmitter.

The transmitter building is new, quite small and very modern in style. At the back is a concrete cooling pond, in which the water is carried for cooling the anodes of the main rectifier and transmitting valves. It is in two sections, a high ridge of concrete being carried across the cooling pond to separate the water-cooling circuits.

There is a small ante-room facing the main transmitter where the two operators sit

while the long-waver is working. There is no control desk—at least, not of the conventional type—as the station operator can walk round all the open racks on which the valves and tuning circuits are carried. A sloping panel carries meters showing the peak volts and the depth of modulation, while simple side-tone checks can be carried out at the touch of a two-way switch.

Racks made of bent tubing carry the main components of the transmitter. This tubing is so arranged that it does not come immediately within the field of the tuning circuit. The air-spaced coils are arranged with their fields at right angles to the supporting tube, and, in addition, wooden frames support many of the H.F. components.

All the racks are open, and the high-voltage meters are carried mainly on the bent tubing. There is no panel front, nor any protection for the operator from the high-voltage side.

Unusual Tuning.

Tuning is carried out in rather an unusual manner for a big transmitter. The aerial and feeder condensers are not adjustable, but consist of widely spaced plates carried horizontally. There are variable tap-

ings to the turns of the air-spaced coils, and the feedback coils in the master oscillator are arranged somewhat like the variometers we had in the early days. The feedback coils are adjustable by means of a short lever, which enables the operator to control the feedback without getting too close to the field of the main oscillator coil.

All the power comes from the local alternating current cables. A four-section mains switchboard is used to control the power supplied to the rectifier, and this carries rapid make-and-break switches and four safety indicator lights.

I was interested to see that at the side of the mains



switchboard are two meters of the recording type, carrying small cardboard discs on which is printed automatically a record of the power consumed by the Huizen broadcaster.

This enables the engineers to check up the power output in conjunction with the total power taken from the alternating current mains. The same type of meter is in use at most of the Swiss broadcasting stations.

The Stand-by Studio.

The programmes for the Huizen broadcaster are provided by the Roman Catholic and Protestant Broadcasting Societies, but at the transmitter buildings there is a small emergency studio, with one microphone, which is used if the land lines to the studio break down entirely. This studio, as you can see from one of the accompanying photographs, is decorated in a scheme typical of modern Holland. A. A. S.

WATCHING THE WATTS

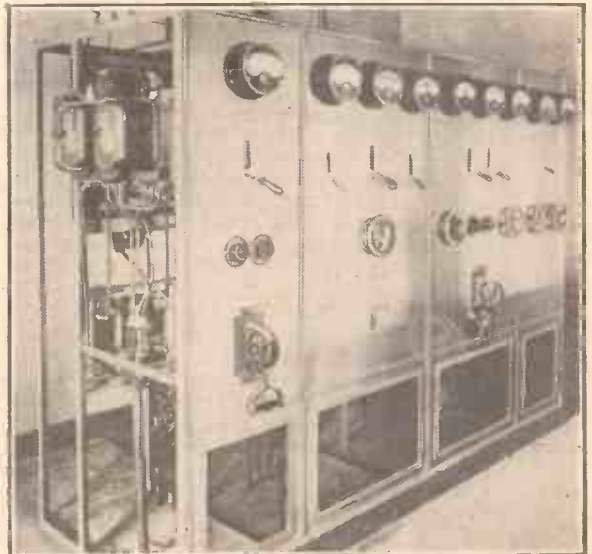

At the side of the main panels are two input power meters which check up the total amount of electricity consumed by the transmitter. Thus the efficiency of the installation can be readily calculated.

ACROSS THE CHANNEL

First details of a new system of radio communication, utilising the recently developed micro-ray, which is likely to have far-reaching results in ensuring the safety of aircraft.

A DEFINITE landmark in the history of radio communication was reached on January 26th, when the Rt. Hon. Sir Philip Sassoon, the Under Secretary of State for Air, officially inaugurated the new micro-ray service connecting the aerodromes at Lympne and St. Inglevert. This link has been established through the co-operation of the British and French Air Ministries, and will be used for notifying the arrival and departure of aircraft crossing the Channel.

The Shortest Commercial Wave.

The equipment has been designed and manufactured by Standard Telephones & Cables, Ltd., and is a direct outcome of the successful tests in March, 1931, of two-way telephony between Dover and Calais on a wavelength of 18 cm.

RAPID COMMUNICATION



One of the teleprinters installed at the Lympne terminal of the new trans-Channel micro-ray link.

This demonstration has, up to the present, remained the only instance of a duplex telephone circuit that has been shown to be capable of operating on a commercial basis on such a minute wavelength, and the name micro-ray was given at that time to the system employed.

The new link between Lympne and St. Inglevert operates on a shorter wavelength than that used on any other commercial service in the world, and may be considered as heralding an era in which the practical advantages of micro-ray communication—privacy, efficiency and reliability—will be fully exploited.

Simplex or Duplex Working.

Rapid notification of the arrival and departure of cross-Channel aircraft is an essential part of the Air Ministry's plans for the safety of civil aviation, particularly in the case of private owners, whose machines are not normally equipped with radio, and who cannot, therefore, summon help in the event of a forced descent.

This new link, operating on a waveband where there is no congestion, provides direct and uninterrupted communication free from the possibility of interference and

atmospherics. Communication will normally be carried on between the two stations by means of simplex teleprinter working—that is, alternate transmission and reception—but duplex working (simultaneous transmission and reception) can also be carried out if the traffic density renders this desirable. Alternatively, a duplex telephone service can be operated.

When compared with radiations of the more usual wavelengths, the micro-rays present many striking features. For example, their extremely short wavelength permits the use of electro-optical devices more usually associated with light, such as reflectors, in addition to diminutive aerial systems.

A further similarity between these radiations and light is that, although fog, rain and such-like climatic effects—as well as day and night—do not materially interfere with the propagation of the waves, it is necessary to have virtual optical visibility between transmitter and receiver.

Radio Path Clear of Obstacles.

The distance between the two terminal stations at Lympne and St. Inglevert is 56 kilometres, and the sites have been chosen so that the path between them is clear of obstacles, the electro-optical equipment being installed on the roof of a hangar 43 ft. above ground in the case of Lympne, and on 66-ft. steel towers at St. Inglevert. The stations are in essentials identical.

The stations operate on wavelengths which are both in the neighbourhood of 17.5 cm., but are sufficiently different to permit simultaneous working without giving rise to local interference and cross-talk troubles.

For generating the 17.5 cm. oscillations use is made of a specially designed valve, known as a micro-radiation valve, fitted with a double-ended helical grid and a normal cylindrical plate electrode. The double-ended grid, in addition to being biased positively, is included as a tuning element in the main oscillatory circuit.

As is usual in all classes of "electronic" oscillator, i.e. those in which the frequency depends upon the rate of travel of electrons from the filament, the wavelength is dependent on valve geometry, the output circuit and the electrode voltages. These must, therefore, be considered as tuning elements, and the power supplies are accordingly designed to give the necessary stability.

It must be noted that in this system the normal control function of the grid is not used, and it is customary to refer to the grid in terms of its function as the "oscillating electrode," while the outer electrode,

or "plate," is correspondingly referred to as the "reflecting electrode."

The latter is biased negatively, and there is no plate current: the grid, or oscillating electrode, is biased positively, and in many respects must be regarded as replacing the anode of a normal valve. For example, it is this grid which dissipates the power lost in the valve.

The aerial and reflector assemblies for transmitter and receiver are similar in construction. The main reflector is paraboloidal—10 ft. 6 in. diameter—and is spun out of an aluminium sheet about 5 mm. thick. A spherical reflector, 3 wavelengths in diameter, faces the large reflector, to which it is attached by three radial wooden members.

A Gain of 31 Decibels.

The aerial, which is of the half wavelength type, is placed at the focus of the paraboloidal reflector, which coincides with the centre of the spherical reflector.

The focus of the paraboloidal reflector is situated in the aperture plane of the spherical reflector, and the radiation emitted from the aerial on the transmitting side is concentrated into a very sharp beam by means of the main paraboloidal reflector.

The spherical reflector is used to reflect the direct forward radiation of the antenna back to the paraboloidal reflector, thus increasing the gain of the total electro-optical system.

The gain of the paraboloidal reflector alone is of the order of 28 decibels, which rises to 31 decibels when the spherical reflector is added to the system. The same gain is obtained on the receiving side, where the electro-optical system concentrates the incoming wave towards the receiving aerial.

The valve is mounted in a socket of the conventional bayonet pattern, but the two

AN UNINTERRUPTED BEAM



The reflector assemblies and the valve housing are installed on platforms supported by steel towers above the hangars.

lead-in wires to the oscillating grid electrode of the valve are adjustable in relation to the transmitting line.

The oscillatory circuit is connected to the tubular transmission line through small H.F. condensers to avoid the application of any D.C. voltage to the transmission line and aerial.

THE B.B.C. Police Station

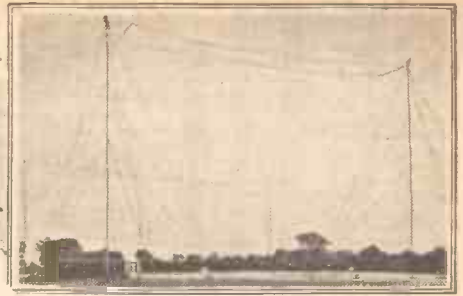

As you sit by your fireside these cold winter nights tuning in station after station, give a thought to the B.B.C. men who are "policing" the ether. Up on the hills in the lonely Tatsfield Listening Post they are hard at work every night, twiddling knobs and taking delicate measurements as they check wavelengths and generally keep an eye on receiving conditions on the broadcast wavebands.

It is an unusual job, and, but for the continual sound of voices and music from the loudspeaker, it would be dull and cheerless. But the B.B.C. engineers are too engrossed in their work—and just now far too busy to experience monotony.

The Full Fury of the Weather.

Tatsfield is a little village in Surrey on the Kent border. The actual receiving station is about half a mile away in a field close to the main road over Titsey Hill. The small brick houses are built at a height of more than 800 feet above sea-level, leaving them exposed to the full fury of the weather, but ideally situated for long-distance reception free from electrical interference.

The Croydon-Paris air route lies almost directly over Tatsfield, so the tall aerial masts bear bright red beacons, which glow at night and can be seen for miles around, both from the air and the ground. The engineers work there at all times of the day, but more particularly at night, when the world is listening.

I called on them one evening recently—having first obtained permission from the B.B.C.—and found them hard at work checking a transmission from Rome.

A Conventional Three-Valver.

If anyone imagines that the B.B.C. fits its listening post with luxurious radio-gramophones, consolettes and other drawing-room receiving apparatus he will be sadly disappointed.

I found the interior essentially a laboratory, a business-like machine-room. Most of the receiving apparatus is built on the panel system, fastened on to upright steel frames.

True, this panel extended along the whole length of one wall for about eight or ten feet and stood six feet high; but the actual set in use at the moment was a three-valver, with a quite conventional circuit such as millions of listeners use. The great selectivity of the set was very largely due to the use of directional aerials.

For short-wave work and on special occasions a multi-stage superheterodyne receiver is used. The outputs of all the receivers can be plugged through to the telephone switchboard, which is linked directly to Broadcasting House.

"Our receiving work comes under two

categories," explained the engineer-in-charge. "First, there are the relays from the Continent and from the U.S.A. The requirements here are a good-quality steady signal, so we have very carefully designed receivers with automatic volume control and adequate selectivity.

★.....★

The Tatsfield station of the British Broadcasting Corporation is not a transmitter; it confines itself entirely to reception. But the receiving apparatus is of a very scientific nature, since it is the purpose of the station to check up the frequencies of the B.B.C. and continental transmitters, as described by our Special Correspondent.

★.....★

"Secondly, there are measurements to be made, the most outstanding of which are wavelength measurements. For slipping quickly from station to station to obtain a check on the wavelength of each we need a simple receiver such as the one we are using now.

Each Thursday evening, as a matter of routine, we record the wavelength of every

We use the direction finder to see where it lies; listen for announcements; check its programmes and so on. We usually have them all 'taped' by the end of the evening."

As a matter of fact, these B.B.C. men gave me the impression that they were capable of dealing with a dozen Lucerne Plans. The work they get through is really amazing. Apart from these wavelength measurements there are the real super-accurate laboratory comparisons to be made on the wavelengths of the B.B.C.'s own stations.

The B.B.C. takes great pride in the accuracy of its wavelengths. The success attained in this direction is very largely due to the work at Tatsfield, where the engineers "keep an eye" on all B.B.C. stations at frequent intervals each evening.

Thermostatically Controlled Radiators.

The standard wavemeter used for this job has a room apart. The master tuning fork hums away to itself in a constant-temperature oven, and the room itself is kept at an even temperature by the use of thermostatically controlled radiators.

"The only difficulty worth mentioning, so far as our own wavelengths are concerned," explained the engineer-in-charge, "occurs on the common waves.

"As most people know, two stations are kept synchronised on a common frequency by the use of tuning forks or crystal control. Even such accurate apparatus as this sometimes may allow a station to wander a few cycles off the wavelength, and this wandering, if serious, may cause a low wail in listeners' sets. As soon as we, here at Tatsfield, notice it we telephone through to the engineer in charge of the station concerned and ask him to correct the wavelength of his transmitter.

Everything is All Right.

"This is all very well, but the poor fellow at the other end of the telephone would find it very difficult to correct his wavelength so absolutely accurately. How does he do it, then? Well, we listen to the beat note and put it 'down' the telephone line to him so that he can hear the trouble for himself. He then adjusts his apparatus, and when the beat note disappears he knows that everything is all right. However, this wandering is quite infrequent with present-day tuning-fork or crystal drives."

Over on a shelf at the end of the main laboratory I noticed a queer machine—a machine that strangely reminded me of a barograph.

"What is that?" I asked.

(Continued on next page.)

CHECKING WAVES AT TATSFIELD



The telephone switchboard at Tatsfield, which is directly linked with Broadcasting House, and to which any of the outputs of the various receivers at Tatsfield can be connected.

station we can hear—which is practically every station in Europe. It is no light task to sort them all out one after the other and identify them in one evening. Sometimes we tune in a station and take quite a long while identifying it. That's where the fun comes in.

THE B.B.C.'s POLICE STATION

(Continued from previous page.)

The engineer explained to me that this was the apparatus on which the depth of modulation is recorded. He went into a long technical explanation as to why over-modulation causes interference and distortion, and why under-modulation results in weak signals. Briefly, it appears that the B.B.C. sets a standard for depth of modulation of all its stations, and Tatsfield has the job of checking up on each station to see that it is keeping within the required limits.

How Over-Modulation is Avoided.

The depth of modulation is recorded on a strip of paper that comes from this machine as a thin, wiggly line which must not travel above a certain mark on the paper if over-modulation is being avoided.

Very rarely does the "peak" rise above this "safety level." Whenever it does the station concerned "hears of it."

I thought of some of my own recent listening experiences since the Lucerne Plan came into operation, when certain of the British stations were badly interfered with by foreigners. I determined to clear up a question which has probably been interesting you as well.

And what do you do if you find some

station interfering with London, for instance?" I inquired.

"Well, we first of all try to identify the interference," explained the engineer-in-charge.

"This may or may not be simple. Then we send a report to headquarters,

and see that the interfering station is advised of the trouble it is causing.

"Sometimes the trouble is due to an increase in power at the other transmitting station. In this case we measure its field strength on that instrument over there."

WHO IS THAT HETERODYNING LONDON?

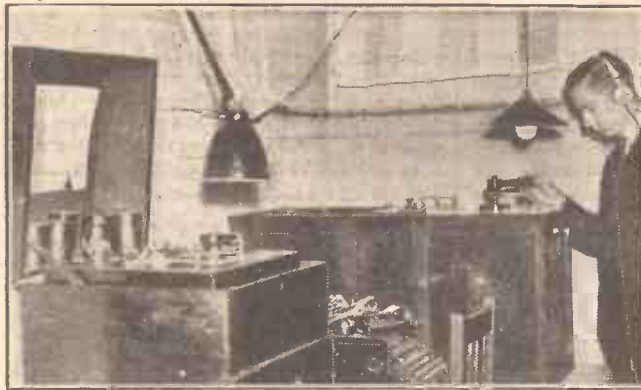

One of the duties of the B.B.C. engineers at Tatsfield is tracing the source of interference which arises on any of the British stations, and very accurate wavemeters and careful adjustments are needed. One of the biggest tasks with which the engineers at Tatsfield have had to contend was the wavelength change-over on January 15th. On this occasion practically every European wavelength was accurately checked.

and what they do with it there is no concern of ours, although, as a matter of fact, they communicate with the International Broadcasting Union in Geneva

"Exactly," replied my guide. "And that, no doubt, together with other similes, is why the newspapers call us 'The Policemen of the Ether.'"

Scientific Logic.

He pointed to a portable receiver which is used for very exact measurements of the strength at which a station is received.

"If we can say definitely that such and such a station is being received at twice the strength it was two nights ago, we can argue with a certain amount of scientific logic on our side."

"Just as policemen measure skid marks with a tape measure when there has been an accident, and argue from this that your brakes were faulty, I suppose?"

AUTOMATIC RECORD PLAYING

Details of a new and fascinating record player.

I AM always attracted by robot mechanisms, and as we are rapidly approaching the "robot age" the number of automatic gadgets I see in the course of my work is rapidly increasing.

One of the most fascinating I have examined for a long time, however, is the Collaro Automatic Record Player. It is not a record changer, in that it deals with only one record at a time and has no feed magazine, but it is ingenious in the extreme.

As the illustration shows, an attractive cabinet has in front a slit, like a large letter-box. Into that slit you place a record, 9, 10 or 12 inch—it does not matter which. Assuming the unit is attached to a radio receiver, in the same way as an ordinary record player is attached, it will take that record in mechanical "hands," place it on the turntable, play it and pass it back to you on completion. Incidentally, the electric motor is switched on and off at the beginning and end of each cycle of events.

If you don't like

the record it can be rejected and handed back at any time during the playing. Quite uncanny, isn't it? And the gentleness of the "hands" is surprising—there is no danger of the discs being knocked about or maltreated in any way.

No Pick-up Manipulation.

There is no pick-up manipulation to carry out—simply needle changing on occasion when the permanent needle requires replacing. I like the scheme very much, and sold in Table or Lowboy form, with space for the radio set to be placed above it, the Collaro Player is ideal.

R. K.

A
RECORD
POST!



A new photograph of the Collaro automatic record player in use.

AN APPRECIATION AND A SUGGESTION

Both from readers of "P.W."

THE "DOUBLE-X" THREE.

To the Editor, POPULAR WIRELESS.

Dear Sir,—I now take the opportunity of thanking you for the information regarding the "Double X" Three. I have made up a few sets, and must admit I have never had such good results.

Even during the daytime I get a good selection of foreigners, and at night, "Oh!" the dial is absolutely alive with stations, and they all come in with ease, and at good loudspeaker strength, too.

It might interest other readers to know that the volume received on two valves is equal to a three-valve on the National and Regional stations. It also works very well as a radiogram.

These are all its good points, but I must admit I had one set-back, and it took me a day to find out the trouble.

After everything was ready for testing, and I full of expectations, I switched on, and "Oh!" not a sound or a reaction whistle. I tested every part, but still nothing. I then had a brain-wave and took out the screw that was earthing the H.F. choke, and lifted the choke off the baseboard, and that was the cause of all the trouble.

The set is a marvel. Those who want all-electric sets to get foreign stations will have a job to beat the performance of the "Double X" Three. So thanking you for publishing such an efficient set,

Yours truly,

D. J. BANNISTER.

260, Blandford Road,
Beckenham, S.E.

A SIMPLE MICROPHONE.

To the Editor, POPULAR WIRELESS.

Dear Sir,—In a recent issue of "P.W." a reader described what he called "a simple and effective microphone," made from an old earphone.

May I suggest that those readers of "P.W." who provision for gramophone pick-up on their sets will find it far simpler and, I think, just as effective merely to plug the headphone leads straight into the pick-up sockets and speak into one of the earphones? For convenience one 'phone may be disconnected and the leads shorted.

Yours faithfully,

J. A. G. BALDWIN.

"St. Helen's,"

37, St. Barnabas Road, Cambridge.

FOR EVERY SET — there's a PILOT AUTHOR KIT

CASH — C.O.D — or H.P.

S.T. 500

KIT "A" Comprising Mr. John Scott-Taggart's Kit of FIRST SPECIFIED Components, including Telsen "Class B" Output Choke, Peto-Scott "Metaplex" Baseboard and Ready-drilled Panel and Terminal Strip. Less Valves and Cabinet. With FULL-SIZE Blue Print and copy "Popular Wireless," Oct. **£5-5-0** 21st. Cash or C.O.D. Carriage Paid. **£5-5-0** or 12 monthly payments of 9/6.

KIT "B" As Kit "A," but including 4 Specified Valves. Cash or C.O.D. Carriage Paid, **£7-10-3** or 12 monthly payments of 13/9.

KIT "OT" As Kit "B" but including Peto-Scott Specified Walnut Table Cabinet. Cash or C.O.D. Carriage Paid, **£8-9-9** or 12 monthly payments of 15/6.

KIT "CC" As Kit "B" including Peto-Scott Specified Walnut Console Cabinet. Complete with Baffle Baseboard Assembly, but less Speaker. Cash or C.O.D. Carriage Paid, **£8-18-9** Or 12 monthly payments of 16/3. If Peto-Scott Permanent Magnet Speaker required add 19/6 to Cash Price or add 1/9 to each monthly payment.

NEW W.B. P.M.4A. MICROLODE PERMANENT MAGNET SPEAKER, complete with switch-controlled multi-ratio input transformer. Cash or C.O.D. Carriage Paid, **£2/2/0**. Balance in 7 monthly payments of 5/9.

NEW BLUE SPOT 29 P.M. PERMANENT MAGNET MOVING-COIL SPEAKER. With input transformer. Cash or C.O.D. Carriage Paid, **£1/12/6**. Balance in 6 monthly payments of 5/-.

ROLA F.R.6 P.M.23 CLASS "B" SPEAKER, with input transformer. Cash or C.O.D. Carriage Paid, **£1/19/6**. Balance in 9 monthly payments of 4/6.

NEW LISSEN SKYSCRAPER FOUR ALL-WAVE CHASSIS MODEL, complete kit comprising all components, including set of Lissen Valves. Cash or C.O.D. Carriage Paid, **£5/12/6**. Balance in 11 monthly payments of 10/3.

TELSEN 323 KIT, with set of 3 Valves. Cash or C.O.D. Carriage Paid, **£2/15/6**. Balance in 9 monthly payments of 6/-.

TELSEN 8.G.3, less Valves. Cash or C.O.D. Carriage Paid, **£1/19/6**. Balance in 9 monthly payments of 4/3. If Valves required, add £1/19/0 to cash price. H.P. 12 monthly payments of 7/3.

ATLAS C.A.25, for Mains, Class "B" and Q.P.P., four tappings: 60/80, 50/90, 120, 150, 25 m/A. Cash or C.O.D. Carriage Paid, **£2/19/6**. Balance in 10 monthly payments of 6/-.

TELSEN D.C. MAINS UNIT, No. W.348. 200-250 volts. 28 m/A at 150 volts. 3 tappings. Cash or C.O.D. Carriage Paid, **£1/15/0**. Balance in 7 monthly payments of 5/-.

PETO-SCOTT PERMANENT MAGNET MOVING-COIL SPEAKER



Power or Pentode Complete with input transformer. **19/6** Cash or C.O.D. Carriage Paid.

Send only 2/6, balance in 5 monthly payments of 4/-.

Class "B" Model, Cash or C.O.D., Carriage Paid **£1/2/6** or 2/6 down and 6 monthly payments of 4/-.

2/6 DOWN.

ECKERSLEY A.C. RADIOGRAM

KIT "A" CASH or COD **£7-15-0** Or 12 monthly payments of **14/-**

EXCLUSIVELY SPECIFIED
PETO-SCOTT
RADIOGRAM CABINET

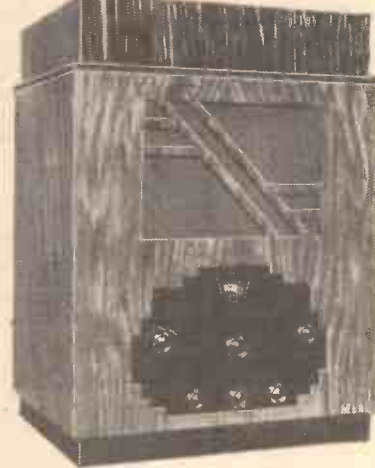

Another exclusive and delightful cabinet by PETO-SCOTT, also specially designed at the request of "Popular Wireless" for the Eckersley National Radiogram. The beautiful walnut finish and handsome contrasting macassar veneer set the seal of perfection in cabinet design on this latest Peto-Scott production. Cash or C.O.D. **47/6** Packing and Carriage 2/6 extra. **SEND FOR NEW CABINET CATALOGUE.**

KIT "A" Author's kit of first specified components for the Receiver Portion, including PETO-SCOTT ready-drilled panel, and METAPLEX chassis, but less valves and cabinet. Cash or C.O.D. Carriage Paid, **£7/15/0**, or 12 monthly payments of 14/-.

POWER PACK Kit of parts for building the Power Pack, including PETO-SCOTT cover, but less rectifier. Cash or C.O.D. Carriage Paid, **£4/3/0**, or 12 monthly payments of 7/6.

COMPLETE KIT As for Receiver and Power Pack, including A.C. valves, together with rectifier valve, Garrard A.C.4 motor, British Radiogram pick-up and Cabinet, but less speaker. Cash or C.O.D. Carriage Paid, **£20/7/6**. Deposit **£5/7/6**; balance in 11 monthly payments of **£2/10/0**.

With PETO-SCOTT Permanent-Magnet Moving-Coil Speaker, if required, add 19/6 to Cash Price or 1/9 to each monthly payment.

KIT-BITS You pay the Postman. We pay post charges on all orders over 10/-. **GREAT BRITAIN ONLY.**

- I J.B. Nugang type A. tuning Condenser .. 1 2 6
- I Set of Colvern 3-coil Unit as specified .. 1 8 6
- I Lissen Hypernik Transformer .. 12 6
- I Graham Farish Booster Unit .. 7 6
- I Peto-Scott METAPLEX Chassis .. 3 6
- I Set of Specified Valves for Receiver Portion .. 2 9 6
- I Rectifier Valve (for Power Pack) .. 12 6
- I Garrard A.C. Electric Gramophone A.C.4. Motor .. 2 2 6
- I British Radiogram Pick-Up .. 17 6
- I Peto-Scott Radiogram Cabinet .. 2 7 6

ECKERSLEY NATIONAL 3

KIT "A" Author's Kit of first specified parts including READY-DRILLED PANEL and METAPLEX chassis assembly, but less valves and cabinet, Cash or C.O.D. **£5:10:0** Carriage Paid or 12 monthly payments of 10/-

KIT "B" As Kit "A," but including set of specified valves, but less cabinet. Cash or C.O.D. Carriage Paid, **£7:9:0** or 12 monthly payments of 13/9

KIT "C" As Kit "A," but including valves and Table cabinet. Cash or C.O.D. Carriage Paid, **£8:6:6** or 12 monthly payments of 15/3

Exclusively Specified PETO-SCOTT Cabinets: TABLE MODEL 17/6; RADIOGRAM MODEL (as illustrated above) 47/6. FOR FULL DETAILS SEE PREVIOUS ISSUES OF "POPULAR WIRELESS."

IMPORTANT Miscellaneous Components, Parts, Kits, Finished Receivers, or Accessories for Cash, C.O.D. or H.P. on our own system of Easy Payments. Send us a list of your wants. We will quote you by return. C.O.D. orders value over 10/- sent carriage and post charges paid (GREAT BRITAIN ONLY). OVERSEAS CUSTOMERS CAN SEND TO US WITH CONFIDENCE. We carry a special export staff and save all delay. We pay half carriage—packed free. Send full value plus sufficient for half carriage. Any surplus returned immediately. Hire Purchase Terms are NOT available to Irish or Overseas customers.

ECKERSLEY NATIONAL 3 MAINS UNITS

A.C. **KIT "A,"** Complete Author's Kit as specified, excluding Rectifier Valve and Aluminium Cover. Cash or C.O.D. Carriage Paid.

£3-12-6 or 12 monthly payments of **6/9**
KIT "B," As Kit "A," but complete with rectifier valve and Peto-Scott cover. **£4/15/6**. Or 12 monthly payments of 8/9.

D.C. **KIT "A,"** Complete Author's Kit as specified, excluding Aluminium Cover. Cash or C.O.D. Carriage Paid.

£1-15-0 or 7 monthly payments of **5/6**

KIT "B," As Kit "A," but with Peto-Scott aluminium cover. Cash or C.O.D. Carriage Paid. **£2/5/6**, or 8 monthly payments of 6/-.

PETO-SCOTT Co. Ltd. 77, City Rd. London, E.C.1
Telephone: Clerkenwell 9406/7.
West End Showrooms: 62, High Holborn, London, W.C.1. Telephone: Holborn 3248.

Dear Sirs,

(a) Please send me.....

(b) I enclose Cash/Deposit.....

NAME.....

ADDRESS.....

P.W., 10/2/34.

THE MIRROR OF THE B.B.C.

A NEW STATION FOR SCOTLAND

Thirty-line Transmissions to be Resumed—Dealing with the Wavelength Situation—The Radio Trade and Broadcasting—A Devonshire Comedy

REFLECTIONS BY O. H. M.

IT is practically decided that the new transmitter for the North of Scotland will be built at Elgin and will be ready to radiate about the middle of 1935. It remains to be seen whether the service from this station will cover the Highlands. If it does not, then Provost Murray, of Dingwall, can be depended on to lead out the clans again.

Broadcasting Salaries.

This is the time of year when the salaries of officials at Broadcasting House are overhauled. The extreme secrecy with which the facts of salaries are kept gives rise to a good deal of speculation and guess work. A jumping-off point for a good deal of this is the statement made in a popular work of reference five or six years ago that Sir John Reith, the Director-General, received £6,000 a year.

There are rumours that this figure is now considerably more. Not that any reasonable person would object to a really high salary for such an important and highly specialised job. What the other people get is not stated, but it is felt that there is unevenness in the pay of the actual programme builders.

Another effort is to be made in Parliament to get more details. The B.B.C. should anticipate this pressure.

Television News.

The present break in the regular thirty-line television transmissions of the B.B.C. is due to the move of the studio and other equipment from the basement of Broadcasting House to Number 16, Portland Place. Transmissions will be resumed in a few days on the same basis as before, and will run on until the end of March, when they "fade out" as a programme service.

Another International Conference.

The International Union of Broadcasters has assembled an International Technical Conference in Brussels to try to sort out some of the snags which the first weeks of working the Lucerne Plan have revealed. Mr. Noel Ashbridge, Chief Engineer of the B.B.C., is not optimistic of any early improvements. The process of putting down the "pirates" is going to be a long one.

The B.B.C. Aroused.

I have already referred to the fact that the B.B.C. has become the subject of public debate and interest in the United States as the result of nation-wide discussions on the desirability or otherwise of applying in that country the B.B.C. system of radio control and management.

Apparently the American broadcasters had to take recourse to such extreme methods in self-defence that their attacks on the B.B.C. have stirred up Broadcasting House to launch a counter-attack. This, I believe, is the first time the B.B.C. has undertaken an elaborate vindication of itself. The Americans, nothing daunted, are returning the compliment, and a pretty controversy is developing.

Mr. Bate, the N.B.C. representative in Europe, has just been recalled suddenly



Roy Fox's long association with broadcasting is unlikely to be broken when he leaves his present home—the Kit-Bar—at the beginning of next month. It is probable that the B.B.C. will make arrangements to relay his band from its new London abode.

ON WITH THE DANCE

to New York, where he is now in consultation with his chiefs on various subjects of which the most important is believed to be the row with the B.B.C. Despite protestations on both sides, there is no doubt that the relations of the B.B.C. with N.B.C. and Columbia are seriously strained.

I WAS asked the other day, "Do you think that Ann Penn, now that she has turned a pukka Lancashire comedienne, threatens Gracie Fields' supremacy?" My answer was, "No!" She will never outclass Gracie at this game, though she may ultimately come near her. At the moment Ann has a long way to go.

I'm not so sure that she has acted wisely in chucking up the impersonating business. Good impersonators like Ann Penn are few and far between, and they are always worth listening to. I should have thought it would have paid Ann better to carry on as she was, for, after all, she held a high position in her particular line.

I don't think Gracie need fear any rival. Her position is an enviable one. I'm sure that she could, even as a straight singer, command as great a following as she does as a comedienne. I once heard a musical Johnnie say he thought that Gracie oughtn't to be maltreating a voice as beautiful as hers by doing that comic stuff.

A voice that fascinates me rather these days is that owned by the little lady (I can't recall her name) who assists Sir Walford Davies in his broadcasts to schools. She sings with marvellous ease. There's no suggestion of affectation and you hear every word she sings. Her rendering of Schubert's Brook Song the

A New Policy.

The wireless trade as a whole is adopting a new policy towards the B.B.C. In recent years the tendency of the trade through its various organisations has been to leave the B.B.C. pretty much to itself. There has been contact, but not of a very definite kind.

The trade is now determined to make its influence felt in the matter of programmes. If the B.B.C. is amenable and welcomes the more definite help that is offered there is no reason why amicable relations should not only continue, but be strengthened. There are signs, however, that the B.B.C. may not welcome this new attitude on the part of the trade. In this event the trade is ready to take independent action to secure its ends both inside and outside Parliament.

"The Farmer's Wife."

So many people, both in London and the provinces, have seen "The Farmer's Wife" that it should be pointed out there may be considerable disappointment among listeners with the broadcast version of Eden Phillpott's famous Devonshire comedy when it is included in the Regional and National programmes on Monday and Tuesday, February 12th and 13th respectively.

The play is being produced in the West Regional studios, and it will differ from the stage version by being given as a comedy rather than as a farce. In the adaptation for the microphone most of the amusing "business," particularly in the part of "Churdles Ash," has been eliminated, and since this "business," more than the lines of the author, is remembered better by those who saw it, the whole perspective of the play will be different.

Birmingham Repertory Theatre.

The studio at the Birmingham Repertory Theatre has turned out to be of almost incalculable value to broadcasting, not only for British listeners, but also to the Empire service, which has taken

(Continued on page 996.)

THE LISTENER'S NOTEBOOK

Being frank comment on recent B.B.C. programmes and on radio personalities.

other afternoon was a revelation. Would all vocalists copy, please?

It is a joy to hear the words of a song. I think it was mainly because I could do so that I enjoyed Act. I of "Tosca," relayed from Sadler's Wells, so much. In fact, I think this performance was unique in this respect. It stands to the credit of crooners and dance-band vocalists (I think the two should be differentiated now) that they always get their words over.

Is it because they haven't to pay such great attention to tone? This shaping the mouth for tone must be responsible for a lot of the wolf-woof that so often appears to be set to music.

Radio drama went up many points with the presentation of "Trent's Last Case." I frankly confess I gave Ibsen's "Ghosts" a miss, if only as a protest against yet another production of the play of the horror type. I've said before how the B.B.C. excels in this sort of thing, but it mustn't be allowed to think that this is the only thing it can succeed in.

"Trent's Last Case" made it evident that the detective play makes good broadcasting. The detective novel is universally read and enjoyed, so why shouldn't the detective play have a similar popularity on the air? It has been said that the broadcast

(Continued on page 996.)

BROADCASTING QUALITY

By
NOEL ASHBRIDGE
B.Sc.,
M.I.E.E.



THE first part of this article explained how it came about that international wavelength agreements determined the quality of reproduction which could be obtained in areas where the strength of the "wanted" station was small.

It was stated that the need for high selectivity in such areas seemed to be having an effect on the design of broadcasting receivers, and that in some cases the selectivity was not variable, with the result that there was still a severe loss of the higher musical frequencies, even when receiving a very strong station.

Peculiar "Loudspeaker Music."

The unfortunate part of all this is that there is gradually coming into existence a kind of peculiar loudspeaker music to which the ear of the public is gradually becoming accustomed, and which is not the same thing, or even approaching the same thing, as the music heard in the studio or concert-hall.

I was very much struck by this recently when listening to a highly elaborate loudspeaker which had been designed with the object of including practically all audible frequencies. An apparent preponderance of "top" was very obvious, and I must say that for the first quarter of an hour or so I did not like the quality at all, in spite of being accustomed to listening to loudspeakers in Broadcasting House which are frequently connected directly to the low-frequency microphone circuits and therefore reproduce more high frequencies than the average receiver.

However, if what may be called the more correct type of music is listened to for a few days, then one does not like returning to what has already been described as "loudspeaker music."

The conclusion we arrive at, therefore, is that there is still plenty of scope for receivers and loudspeakers giving really excellent reproduction, so far as a large percentage of the total number of listeners is concerned. The question is: "Why can this not apply to every listener?"

Can Anything Be Done?

The answer is that, in order to meet the insistent demands of the many European nations interested in broadcasting, places have to be found for more stations than is technically admissible, assuming, of course, that a high degree of quality is considered necessary. One can only say in this connection that it is better to have an agreed plan on a basis of a general separation of 9 kilocycles between stations than a state of semi-chaos.

It is interesting, however, to note that the various countries concerned with broadcasting in North America recently met together to attempt to carry out similar work to that which was done at Lucerne

by European countries, and in this case the existing separation in North America—namely, 10 kilocycles—was reaffirmed. However, it should be added that this conference did not arrive at as great a measure of agreement as was obtained at Lucerne.

The question is: "Can anything be done to improve the quality usually obtained on an average set when receiving in a comparatively weak field?" Perhaps there is one small thing which might help, but which is not usually done.

If a receiver is working under conditions

This special article by the Chief Engineer of the B.B.C. explains the important part played by the receiver in the quality of radio programmes. Last week our distinguished contributor dealt with the limitations that the present distribution of stations places on perfect reproduction.

of high selectivity which make it cut off at, say, 4,000 cycles per second or less, a more agreeable quality is often obtained if the bass frequencies are somewhat reduced. Obviously, this has to be adjustable. But it is certainly not a fundamental solution; it is merely a possibility of doctoring the receiver to make it sound a little more natural.

Medium versus Long.

There is another aspect of broadcasting quality which it might be interesting to discuss briefly—namely, the quality given by transmitters working on "medium" waves as compared with those working on "long" waves. All the medium wavelength transmitters at the B.B.C. Regional stations, including the Midland Regional, 5 GB, are capable of giving what can be called high quality—that is to say, not more than about 3 decibels down, and in most cases less, at

First-class quality is not quite so easily achieved on long waves as on medium. But when the Droitwich station (one of the masts of which is here seen in course of erection) is completed, the long-wave B.B.C. transmissions should be every bit as good as those radiated on the lower frequencies.

8,000 cycles per second.

The actual quality which is emitted, however, depends very much on the programme and on the telephone lines which are involved. The music circuits in the main buried cable routes linking the stations together are all excellent, some giving up to 8,000 cycles per second with a small loss; but sometimes, of course, there are outside broadcast lines which are of a temporary nature, and therefore such excellence is not obtainable.

The New Droitwich Station.

However, when we come to Daventry 5 X X the quality is very much inferior to the Regional stations. This station was designed nine years ago, and at the time it was an excellent station. Still, the cut-off, even at 5,000 cycles per second, is serious, largely due to side-band cut-off in the aerial circuits.

On top of this, in most ordinary receivers, the response of the radio-frequency circuits to the higher side-band frequencies is far worse on "long" waves than on "medium" waves. The result is that we get indifferent quality from the transmitter, made worse by indifferent reception conditions.

In the case of the Droitwich transmitter the frequency characteristic will be practically on a line with that given by the "medium" wave Regional transmitters, and the aerial will be so designed as to be capable of radiating side-band frequencies up to 7,000 cycles per second at approximately their correct strength.

(Continued on page 996.)



TESTED AND FOUND

Being leaves from the Technical Editor's Notebook

W.B. "MICROLODE" SPEAKERS

SPEAKER matching—does it make a difference? I expect quite a number of readers are of the opinion that this would make a fruitful topic for controversy.

In actual fact there can be no argument so long as the principle is properly applied. I can well imagine that numerous constructors having loudspeakers fitted with multi-ratio transformers play about with the ratios and fail to notice much difference.

But there will be definite reasons for this. At the extreme there may be so much distortion occurring before the output of the set is reached that, whatever is done at that point, there is little noticeable change!

Even given a good output the speaker and/or its transformer can be so bad that transformer ratio changes move you from one kind of distortion to another. Yes, there still are loudspeakers like that about, though fortunately in decreasing numbers.

However, provided the conditions are right (and there is no reason why they should not be), loud-speaker matching is of prime importance and is the final link in the chain of good reception.

First, obviously, the set must be up to scratch, and then an efficient loudspeaker fitted with a satisfactory transformer is needed. Of course, a good speaker will make a bad set better. But what a waste of a good speaker!

Matching Made Easy.

In the W.B. P.M.6 Microlode matching is reduced to a marvellously simple business. The ratio of the transformer fitted to this outstanding production is adjustable by means of a double switch at the back of the instrument. It can plainly be seen in the accompanying photo.

There are no terminal connections to juggle with and the ratio can at once be changed while the speaker is actually working, if that should ever be necessary.

The switch positions are indicated by letters, and clear instructions are provided showing how any ratio from 7.5 to 100 to 1 through a wide range of intermediate values can be obtained.

It will be clear from this that the W.B. Microlode is a very adaptable speaker. Actually it can be matched readily to any type of output, including both power and pentode stages. There is a centre tap on the transformer, and push-pull, Class B and Q.P.P. can all be catered for.

The advantages of purchasing an instrument of this nature are plain to be seen, and one can sympathise with those whose speakers, with their present



The W.B. P.M.6 Microlode speaker can be matched to any type of output—and the price is only 32s. 6d.

transformers, limit them to definite types of outputs in these days of changing circuit conditions.

As for the P.M.6 Microlode itself, this is a very clean little production from every point of view. It is, of course, of the permanent-magnet moving-coil type, and, despite its compact dimensions, it achieves an excellent sensitivity through the introduction of a special cobalt-steel magnetic system.

The retail price is only 32s. 6d., and Messrs. Whiteley

Electrical Radio Co., of Radio Works, Mansfield, Notts, who are the makers, have a new folder about this interesting and most attractive loud-speaker which they are distributing free to all who write for it.

A CLIX CONTINENTAL VALVE HOLDER

It will be a great day for radio when at long last there is an international standardisation of component parts and accessories. At the present

moment, however, we are only at just the beginnings of standardisation in this country.

Not that any particular interest or group of interests can be criticised for this, for the problems involved are numerous and difficult, as anyone who has sat on a standardisation committee will know.

But the unfortunate fact remains that while some radio components and accessories are quite interchangeable all over the world, this is decidedly not the case with many others. For example, an American valve will not go into a British valve holder, and even if it did it is unlikely that its characteristics would be suitable for the particular set in which the valve holder figured.

When, with the introduction of the Class B and other special valves, it became necessary to have seven-pin valve holders, it might be thought that it was at least possible to arrange an international pattern of pins and sockets.

But no; we have "British" and "Continental" types, not much different, but quite different enough to make it impossible for them to be interchangeable.

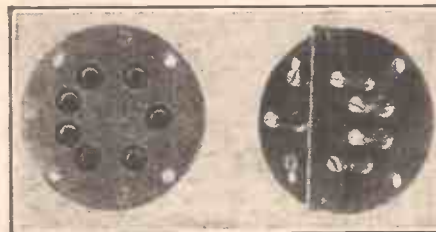

The unfortunate position in which constructors find themselves over 7-pin valves in British and Continental types has been overcome by "Clix," who have now added a Continental type valve holder to their range.

Lectro Linx, of 79a, Rochester Row, London, S.W.1, whose chassis-mounting valve holders will be well known to constructors, have produced a "Clix" Continental valve holder in two models, and there will be many to say that if we must have non-standardisation, then it is at least satisfactory to learn that the different patterns are to be made by such firms as Lectro Linx.

The "Clix" Continental type is similar in general design and construction to the British type which I have already favourably reviewed. There is an unscreened model and one that is screened for use with Ostar-Ganz valves.

THE VARLEY A.V.C. UNIT

There is no doubt about the popularity of automatic volume control, and there is even less doubt

QUITE a lot of trade news this week comes from the commercial-set makers. No doubt this sudden burst of activity is the logical aftermath of the recent great wavelength shuffle, for already new models are appearing which have been specially designed to meet the new conditions. Who says that British manufacturers are not enterprising?

First of all, some more detailed information of an important innovation to which I made a brief reference in the last issue. It concerns H.M.V. Getting on for 12 months ago this enterprising organisation embarked upon a policy which, while not exactly hazardous, was at least a complete breakaway from the stereotyped procedure which manufacturers in general have followed almost since broadcasting commenced.

Achieving Greater Efficiency.

Instead of putting on the soft pedal during the

about its value. Fading is the biggest fly in the ointment of distant listening.

I don't think there can be anything more annoying

than to have a nice programme nicely tuned in and free from interference, and then periodically nearly to lose it altogether because of the pranks of Heavyside's wretched layer.

True, at the moment of writing, nice programmes from abroad free from interference are hard to find, but it is to be hoped that the Lucerne Plan will not be a Five-Year Plan, but will do all that it is hoped that it will do—and very shortly, too.

Now, I have suggested that A.V.C. is popular, but nevertheless it hasn't yet achieved the popularity of wide usage in home-constructor sets, mainly because the principle has so far been coupled with somewhat intricate valves and rather complicated circuits.

But now Varley, of Kingsway House, 103, Kingsway, London, W.C.2, have produced an A.V.C. unit which enables automatic volume control to be fitted to practically any kind of set.

It makes use of the ubiquitous Westector, and there are many of the opinion that this method is superior to that necessitating valves.

The Varley Nicore automatic volume control unit, to give it its full name, is a small article, and is, in fact, no larger than the average H.F. choke.

But it is absolutely complete and all ready to wire into circuit. It is connected in place of the detector H.F. choke (if one is used), and there are only four connections to be made.

It will operate with either an anode bend or grid-circuit detector, and the set can be either battery or mains operated.

Further, the unit can be worked in accordance with either the simple or delayed system.

Detailed Instructions Supplied.

Most detailed instructions for using the unit are supplied with it, and there are many diagrams illustrating its application to various circuits. And, as far as I can see, every eventual, likely and unlikely, is admirably covered, thus ensuring that all who buy this worthwhile device will receive the fullest satisfaction from it.

I often wonder more firms do not issue comprehensive instruction sheets with their components instead of, as is more usual, abbreviated price lists.

But, of course, instructional sheets such as Varley produce need very careful and very skilful preparation, and first-class technicians are required for the work.

However, the time and trouble involved must surely be amply repaid, for how else could a constructor think of the firm that provides him with an illustrated article on the use of its component than in the most friendly of terms?

But to revert to the Nicore A.V.C. unit. This is definitely efficient and effective in use. I added my sample to a two-H.F. set of quite an ordinary kind, and the result was most successful. Eliminating one H.F. stage and thereby reducing the set to normal H.F., det., and L.F. proportions, the control was still completely satisfactory.

I can recommend the unit to all constructors. Properly used in practically any set, distant listening becomes an entirely different proposition.



The Varley Nicore A.V.C. unit can be successfully fitted to almost any type of set.



Weekly jottings of interest to all buyers.

By G. T. KELSEY.

summer months and then rising up to "double-forte" in time to launch dozens of new models for "Show" time. H.M.V. decided to release their new models at various times throughout the year. Result: elimination of production "peaks," all-the-year-round employment for its thousands of skilled workers, and adequate time for concentration upon the design of every instrument produced, instead of having to rush through a whole range by a given date.

A noble ideal; but the gratifying part of it is that not only has it worked out in practice beyond all expectations: it has so

revolutionised the processes of manufacture that H.M.V. are now able to offer an all-electric superhet in a handsome walnut cabinet at the astonishingly low price of 12 guineas complete, which is without doubt a noteworthy achievement.

(Continued on page 997.)



A visit to the recent Physical Society's Exhibition in London has provided our Chief Radio Consultant with plenty of material for a talk in his usual amusing yet pointed style. His only regret is that he was unable to buy some of the scientific "toys" about which he tells you this week.

PERHAPS the title is misleading, standing as it does directly above what is to follow. But Eckersley explains that he is amazed with the particular *chi-chi* which appears to attack our manufacturers every time they produce a catalogue.

You can make a definite division between manufacturers who are proud of the price of their products and those who are ashamed. But those who are proud of the price seem ashamed to describe the product, and those who are proud of the product are ashamed to tell you its price.

What Lovely Things!

I went to the Physical Society's Exhibition. I have seen all the wonders. As a possible buyer, however, I have to whisper rather shamefacedly about the price.

On the other hand, what lovely things! You know that the B.B.C. record some events, speeches, etc., with the idea to rebroadcast the events recorded at some later date.

Also, I believe, they use their recording apparatus in order to give their would-be talkers an inferiority complex. You have to talk, so they say, in a special way for broadcasting.

They must have got the idea from listening to the English talkies, where everyone is perfectly unnatural in order to please the microphone. But that's all by the way.

The point is, I saw the type of steel wire recorder they use at the B.B.C. The principle of its action is fairly easy to understand; to get the machine to make nice, pretty noises is, I expect, more difficult.

Talking Backwards.

You have a piece of steel running through a magnetic field, and the intensity of the magnetic field is altered according to the intensity of the sounds you wish to record. So the wire is magnetised at different intensities along its length and, if you run it the right way through a coil of wire, it gives up its magnetism in the form of electric currents in the coil of wire.

These currents, of course, copy the wire's magnetic state, which, in turn, has been copied from the sound intensities recorded.

The amusing thing is that if you run the

wire through the coil the wrong way you get reversed speech or music. So you can . . . No, you can't; but someone demonstrating the thing can . . . speak backwards speech into the recorder, play the backwards speech backwards and get intelligible speech!

To make this clearer: suppose I record the words "it's a fine day" on the steel strip, I can run it backwards and the loud-speaker says, "yad nf ya sits," or sounds to that effect.

So if I then learn to make those sounds, "yad nf ya sits," and say them into the recorder and then play the recorder backwards, the recorder tells me, in somewhat broken English, that "it's a fine day." I think that's rather fun.

I saw a voltmeter in a bath of water,

"... TAKEN DOWN IN EVIDENCE ..."



A Blatnerphone was used during a case in the Manchester City Police Court for recording the evidence. Above we see members of the bench listening to the sounds on the steel strip during an interval in the case.

and it worked. As there is no water in the country this doesn't matter. But I think it was a very good voltmeter.

I saw some wireless sets, too; but, thanks to some humane regulation, they were not playing. But their scales showed that they could "get" practically every station in Europe—if you could read the letters on the scale.

I saw a beautiful little set producing

waves two metres long. That's a frequency of one hundred and fifty million vibrations in every second. You watch . . . but don't be silly—these rocking currents lighted a lamp. They are intended to penetrate your pinny and warm you up in the sub-skin regions, and that warming cures you. Or so some people think it might. The waves are produced by a dynatron valve.

A World of Thought.

It may all seem remote to you—it may look as if these were merely priceless things about which dreamy-looking enthusiasts will talk for over-burdened hours. And yet it was just such people, working away for the love of the thing, working in an abstraction, a world of thought, who have given you your double-diode triodes, and your loudspeakers, and your superhets, and your batteries. . . . They are worth while.

I only wish their spirit were more manifest in the catalogues of commerce, and that their catalogues would be less of a dreamy abstraction. I wanted to buy some of those toys.

THE LAW SPEAKS

A Novel Public Address System.

A NEW horror has been added to the once gangster-ridden populace of Chicago in the form of a mobile loudspeaking police "truck." The idea is this: The van is normally employed in patrolling the city on the look-out for lawbreakers, of various kinds.

On the van are mounted a powerful amplifier and loud-speaker, with a microphone hanging down beside the driver, so that whatever he cares to announce is boomed out to the surrounding district.

Persons attempting to cross the road contrary to traffic regulations, commercial drivers and private-car owners parking in the wrong places or carrying out a risky manoeuvre are apt to hear a stentorian voice drawing their, and everybody else's attention to the "crime" being committed as the driver of the patrol spots the offender "in the act." It is stated that the effects are "most salutary."

RADIO EDITORIAL

The Editor will be pleased to consider articles and photographs dealing with all radio subjects, but cannot accept responsibility for manuscripts or photos. Every care will be taken to return MSS. not accepted for publication. A stamped and addressed envelope must be sent with every article.

All Editorial communications should be addressed to the Editor, POPULAR WIRELESS, Tallis House, Tallis Street, London, E.C.4.

All inquiries concerning advertising rates, etc., to be addressed to the Advertisement Offices, John Carpenter House, John Carpenter Street, London, E.C.4.
The constructional articles which appear from time to time in this journal are the outcome of research and experimental work carried out with a view to improving the technique of wireless reception. As much of the information given in the columns of this paper concerns the most recent developments in the radio world, some of the arrangements and specialities described may be the subjects of Letters Patent, and the amateur and the trader should be well advised to obtain permission of the patentees to use the patents before doing so.

QUESTIONS AND ANSWERS

HOW A CHOKE'S REACTANCE VARIES WITH FREQUENCY.

W. R. (Tunbridge Wells).—"In one of the 'Eckersley Explains' articles of last year I got interested in a statement about values of output chokes, etc., and I am trying to work this out for my own case.

"I won't submit the complete problem to you, because, to be candid, I am enjoying the mental exercise of doing it myself along the lines stated in 'P.W.' But I do want a bit more information than I have at present about the reactance of a choke at various frequencies.

"So can you tell me how the reactance of a choke of 20 henries varies for the following frequencies: 100, 200, 300, 400, 500, 600, 700, 800, 900 and 1,000?"

The table below gives the required information.

Frequency	Reactance (ohms)
100	12,560 (approx.)
200	25,120
300	37,680
400	50,240
500	62,800
600	75,360
700	87,920
800	100,480
900	113,040
1,000	125,600

THE NEW WAVELENGTHS ON A 180-DEGREES DIAL.

Writing from 11, Britannia Avenue, Liverpool, "W. B." says:

"Here's the best of luck to all your staff! But why have you been so unkind as to leave all the 'S.T.300,' 'S.T.400' and 'S.T.500' gang stone cold by not showing alterations on 180 dials?"

"You have simply mentioned 100 dials in January 6th 'P.W.' So be a lot of good scouts and give us new places on 180 dial next week.

"My 'S.T.300' beats any for purity. And you can tell the world."

There are one or two points about this wavelength change that we should like to refer to, and W. B.'s cheery letter gives us an excellent opportunity.

First, this question of the dial-readings on a 180-degrees dial. We know the new wavelengths (which have been generally agreed to), and therefore we know the order in which the stations should appear on the dial now the change has taken place.

This wavelength order in which the stations are arranged is the all-important factor in deciding their new dial positions.

And a long list, showing this new order, will be found on pages 796 and 797 of our January 6th issue.

On 203.5 metres (right at the bottom of the medium-wave dial) we have Bournemouth and Plymouth, and then all the principal stations are given in order of ascending wavelengths, right up to 569.3 metres (top of the dial), where we find Ljubljana is located.

Similarly, for long waves, Moscow No. 2 is the bottom station and Brasov is the top one. (But as Brasov is a Romanian station he is seldom

receivable in this country, so in practice his nearest neighbour, Radio Paris, will be your top station.) The point to notice is that, no matter what kind of dial is employed, this relative order of the stations remains the same. So if you pick up any particular programme you can tell, by reference to the list, which station should occupy the readings above and below this.



FOR BETTER RADIO

Originally valves were decidedly delicate, and easily harmed by accident or carelessness, but as they were improved in characteristics they were also made much more robust.

CARE OF THE VALVE

Within the last year or two, however, many multi-electrode types have become popular, and these are generally more easily damaged than the simpler types. So care should be taken in handling them, and they should not be subjected to knocks, etc.

Remember that when pulling a valve out of its holder it should be held at the base, as illustrated, and if packed away it should be repacked in its box, to protect it.

Thus, for instance, if you know exactly where Brussels No. 1 (433.9 metres) comes on the dial, you know from the list that just below it will be Prague; just below that, Lyons; just below that, Langenberg; and just below that, North Regional. And so on.

On page 791 of the same issue of "P.W." we gave a "dial" showing the approximate positions of most of the medium-wave stations. The dial, in that instance, was marked 0 to 100 (because most dials are like that to-day), but it is very easily transferred to the 0 to 180 readings as follows:

Place a piece of semi-transparent paper over the "1934" sketch, and copy it through, except for the figures on the scale at the bottom of the sketch. Then divide this scale equally into 0 to 180 divisions, i.e., 0 at the bottom, 180 at the top, 90 half-way, 45 a quarter of the way round (midway between 0 and 90), etc.

This new scale, instead of the old one, will give the required information, with quite a high degree of accuracy. But, of course, on each set the dial-

reading varies a little owing to individual peculiarities.

Actually, the best way to plot the dial-readings accurately and fully is to draw a curve on proper graph ("squared") paper, as explained below in this column.

Finally, it must be remembered that at first the new wavelengths are being tried experimentally. And although they will, in general, remain in force, there will doubtless be minor modifications when the scheme has been in use some time.

DRAWING UP A TUNING CHART FOR THE PRESENT STATION POSITIONS.

J. M. (Montrose).—"I want to draw up for my set one of those tuning charts showing the wavelengths against the various dial-readings, but am not sure of the right way to go about it. I already have a large sheet of paper lined with squares, every tenth line being thickened, so that each 100 squares is enclosed by the thicker border.

"Please describe how this paper is converted into a chart for showing wavelengths against dial-readings."

For a start we should use only a portion of the paper, say a piece approximately a foot or 18-in. square.

The idea is to rule along the bottom of this a line (along one of the thickened lines), the vertical divisions on which will correspond with your dial-readings.

If, for example, your dial is marked 0 to 100, by ruling along ten of the larger squares you will have 100 divisions, one for each degree on the dial.

(More accurate results can be achieved by the use of larger paper and, say, two divisions for each degree; but at first a smaller chart is preferable. The larger one can be made later, when you are familiar with the method.)

THE VERTICAL LINE.

When the degrees on the dial are all represented by numbers on the bottom of the chart, draw a line up the left side, at right angles, to represent the wavelengths which are under consideration.

If, for instance, it is a long-wave chart, you will need from say 1,000 to 2,000 metres, represented by equal divisions on the chart. So start with 1,000 at the bottom, place 2,000 at the top and divide off equally, with 1,500 halfway, etc.

This completes the groundwork. You now have upright lines representing all the degrees on the dial and horizontal lines corresponding to all the wavelengths.

Your next step is to transfer all the known dial-readings on your set to the chart. If, for instance, Daventry 5 X X comes in exactly at 50 degrees, put a dot representing 5 X X on the 50 line. And put it exactly on the line representing Daventry's wavelength (1,500 metres).

Thus this dot will show two things about 5 X X. The left-to-right line on which it is placed shows that its wavelength is 1,500 metres, and the up-and-down line shows its dial-reading is 50.

Do the same for all the other stations that you can tune in accurately. The exact wavelengths are obtainable from a wavelength list, such as that published in "P.W." January 6th issue, and the dial-readings you can fill in from careful observation.

DRAWING THE CURVE.

When you have done this for a number of stations you will notice that the dots representing the stations have spread themselves out into a diagonal line across the chart. Not, perhaps, a perfectly straight line, but one without any pronounced irregularities.

This is the important part of the business. So take a pencil and lightly and carefully join all the dots together, in one long sweep right across the chart.

When the line is drawn in you can see at a glance the dial-reading for any of the wavelengths covered.

If, for example, you wanted to find the whereabouts of Kalundborg on his new wavelength, you first ascertain from the list that this latter is now 1,261 metres.

To find the appropriate dial-reading, look along the line representing 1,261 metres to the point where it is cut by the curve, and then follow that upright line down from there to the bottom of the page where it will denote the new Kalundborg dial-reading.

(Continued on next page.)

"P.W." PANELS No. 156.— SCHWEIZERISCHER LANDESENDER (BEROMÜNSTER)

Situated at Beromünster (Switzerland) and often called by that name, Schweizerischer Landessender is the Regional Station which serves German-speaking Switzerland. All the announcements are in German.

Under the Lucerne Plan Schweizerischer Landessender (or "Beromünster") was allotted the wavelength of 539.6 metres, and at the time of writing it is operating there on a power of 60 kilowatts.

The programmes are provided from studios at Basle, Berne and Zurich, so one of these names is generally heard in the announcements. Distance (from London), 478 miles.

RADIOTORIAL QUESTIONS AND ANSWERS

(Continued from previous page.)

The same applies to any other station, of course. And you thus know definitely exactly where to look for any desired programme.

Moreover, all unknown stations can be identified in a moment by reversing the process.

Thus, if you had a programme which you did not recognise coming in at 57 on the dial, you can use the chart to see whose programme it is. All you do, of course, is to follow up the line representing 57 to the point on the chart where it cuts across the curve. Then read to the left to see what wavelength it corresponds with.

It might, for example, be a fraction above the 1,570 metres, in which case your wavelength list tells you it is Deutschlandsender (Königswusterhausen), the long-wave Berlin station. Any other unknown station can be identified in the same way, for once you have a good chart made you can definitely "place" every programme that you hear.

But don't forget that owing to the recently adopted wavelength plan there may be a bit of shuffling of wavelengths going on for a time, which is one reason why we recommend that the making of your final chart should not be done, to begin with.

USING A METAL WINDOW FRAME AS AN "INDOOR" AERIAL.

C. G. (Windsor).—"We are moving into a new house in March, and instead of the old-fashioned wooden type of window it has Crittall (metal) window-frames. One of these is about 4 ft. 6 in. long and 3 ft. high, and I am hoping to use it as an 'indoor' aerial."

"I remember seeing in 'P.W.' that there is a way of doing this, but I have forgotten what was said about it and cannot find the back number where it was given."

"Please say how it should be wired up and whether there are any special points to watch about this method of reception."

"Also, is it as good as an aerial in the roof?"

A large metal window-frame like the one you mention can often be employed successfully as an

"indoor" aerial, especially when the house is in an open situation and there are no facing buildings.

But in any given instance there is no saying whether it will be a success or not. The only way is to try it.

In general, upstairs windows seem better than those on the ground floor. And also, generally speaking, a large window-frame is necessary to get good results.

To try the method, all you have to do is to run the lead-in wire to the window-frame in question and make a good contact with it. Usually it is necessary to scrape off the paint so as to expose a clean metal surface.

But sometimes one of the metal screws can be loosened, the bare wire slipped under it, and then the

IS YOUR SET BEHAVING ITSELF?

Perhaps your switching doesn't work properly? Or some mysterious noise has appeared and is spoiling your radio reception? Or one of the batteries seems to run down much faster than formerly?

Whatever your radio problem may be, remember that the Technical Query Department is thoroughly equipped to assist our readers, and offers its unrivalled service.

Full details, including scale of charges, can be obtained direct from the Technical Query Dept., POPULAR WIRELESS, The Fleetway House, Farringdon Street, London, E.C.4.

A postcard will do. On receipt of this an Application Form will be sent to you post free immediately. This application will place you under no obligation whatever, but, having the form, you will know exactly what information we require to have before us in order to solve your problems.

LONDON READERS, PLEASE NOTE: Inquiries should NOT be made by phone or in person at Fleetway House or Tallis House.

tightening of the screw will ensure good contact with the wire.

If the window-frame proves to be a good collector of energy it is an easy matter to drill a hole through the frame and insert a terminal shank, to enable good permanent contact to be made.

Before doing this, try it out experimentally, as you may find the whole thing a wash-out and quite

incapable of providing your set with sufficient strength.

It is difficult to make comparisons with indoor aerials, as these vary greatly; but, generally speaking, the metal window-frame aerial is not as good as a well-placed roof aerial, owing to the fact that the latter covers a much greater area and so picks up more energy.

Nevertheless, window-frame aerials can be unexpectedly good, and as they are so easily tried it is always worth while to experiment with one if an indoor aerial is to be employed.

A SET WHICH COVERS ALL THE SHORT WAVELENGTHS.

D. E. W. (Willenhall).—"On a visit to London last November I saw a particularly neat short-wave set in the Science Museum at South Kensington. It covered all the short waves from 16 metres up, and I understood it was to be described in 'Popular Wireless.'"

"If the details for making it have been given, please say in which edition they appeared and how this can be obtained."

The "All-Band Short-Wave Receiver" was described fully in "P.W." dated November 18th, 1933. If difficulty is experienced in obtaining through a newsagent, write direct to the publishers, Amalgamated Press, Ltd., Bear Alley, Farringdon Street, E.C.4. The price of "P.W." back numbers is 4d. per copy, including postage.

MAINS H.T. FOR THE "ECONOMY THREE."

F. Y. (Gateshead).—"When you called it the 'Economy' you said it! And even now I don't want to change it. But I do want to get away from battery H.T. if you say it can be run from an H.T. eliminator."

"Can it? And do I have to alter the wiring?"

No modification whatever will be necessary, providing the mains unit is suitably decoupled, which will be the case with any make of good repute.

A 20- or 25-milliamp unit is suitable, although if a small type of output valve is used a smaller mains unit could be employed.

The makers will be pleased to advise you as to their most suitable model if you tell them what valves you are using.

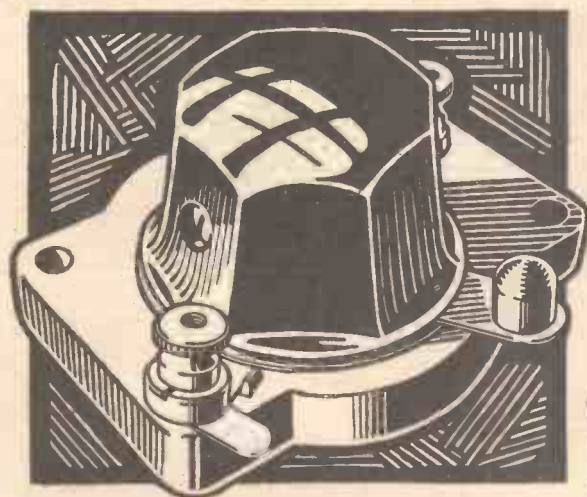

SORT OUT THE NEW WAVELENGTHS WITH SLOT AERIAL FILTER

FREE
Tuning Chart
showing all the
New Wave-
lengths given
Free with every
SLOT

The new Wavelengths mean new problems to thousands of Set owners. Stations difficult to separate; many quite unobtainable, especially on the lower broadcast waves. Don't put up with this—PUT MATTERS RIGHT WITH SLOT. Fix SLOT on or near your Receiver—connect to the Aerial lead-in and adjust the knob. Notice how sharply the Stations come in, interference conquered, Selectivity improved! SLOT masters the new Wavelengths. SLOT improves reception for good.

Obtainable from all Dealers or post free from Sole Makers.

2!

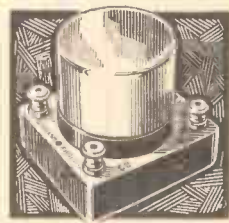

BOOSTER UNIT 7/6

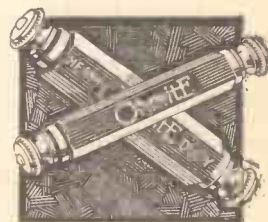

OHMITE RESISTANCES, 1½ watts 1/6
3 watts 2/3



NON-INDUCTIVE CONDENSERS
½ mfd., 1/6 1 mfd., 2/-
1 mfd., 1/9 2 mfd., 3/-

BROADCASTING QUALITY

(Continued from page 991.)

This means that although the quality may be, on paper, a little inferior to that given by the Regional transmitters, the difference will be undetectable even on a receiver capable of considerably better reproduction than the average.

It is hoped that everything will be done, therefore, in the future to provide receivers giving really good quality on the "long" waves, because the Droitwich station is going to be the most important station in the whole system, giving the National programme to the greater part of the United Kingdom.

Finally, having regard to the title of this article, we ought to add a few words about quality from other points of view than

frequency response. I am not proposing to go into the complicated considerations of straight-line and square-law detection, the effect of transients and so on. But there are one or two much simpler matters which are worth mentioning.

Too Much Mains Hum.

In these days many receivers which work off the mains produce too much hum. Usually this is not merely due to insufficient smoothing condensers and chokes, but to some induction effect between the various circuits and the mains transformer or incoming leads within the receiver; in others words, the smoothing circuit becomes, so to speak, bridged over.

Hum in itself is highly objectionable during the quieter passages in any type of programme, particularly dramatic programmes, where it is desired to get effect by

pauses of silence. In addition to this, however, there are various unpleasant beat effects caused by interference between the hum frequencies and the wanted modulation frequencies.

In this case the distortion is most noticeable during music of certain types, such as organ music. Distortion of this variety is of a complicated nature, because the hum is usually not made up merely of one single frequency.

Then, again, some of the new superheterodyne receivers seem to me to make more hiss than they need, and this hiss on the reception of weak stations is definitely obtrusive. The fact that all superheterodynes do not do this to an equal degree looks as though the fault is by no means an essential one.

Of course, these smaller troubles are difficult to eliminate in cheap receivers; but there is no doubt that a silent background does increase the pleasure of listening and is almost as important as good reproduction.

THE MIRROR OF THE B.B.C.

(Continued from page 990.)

two relays from it during the last month.

On Friday, February 16th, two one-act plays will be performed there for inclusion in the Midland programme: "Sir Herbert is Deeply Touched," by H. C. G. Stevens, and "On Dartmoor," by Neil Grant.

The play by Mr. Stevens, who, incidentally, as a theatrical publicist did the B.B.C. many good turns in the early days of broadcasting, when some managers were inclined to be "difficult," has a distinguished actor (to be played by Hugh Millar) as its chief character.

"On Dartmoor" is the story of how a convict and several warders visit (but not together, so far as they know) a bungalow not far from the "big house" which has been so much in the public eye during the last few years.

THE LISTENER'S NOTEBOOK

(Continued from page 990.)

version of "Trent's Last Case" wasn't a patch on the book.

I won't go so far as to say that. It was abbreviated very considerably, of course, but none of the essentials were omitted. The story wasn't so long in unfolding itself as it is in the novel. But who wanted it to be? To hear the book read in *toto* at one sitting would call for a superhuman effort on the listener's part.

No! I thought the adaptation was very cleverly done, and never was the solution to the mystery too obvious for one to lose interest. The cast, as usual, was good, premier honours going to Trent himself and the inspector.

Another detective play in the near future won't come amiss. There are quite a number of these to choose from, but they mustn't be thought too involved for easy entertainment as broadcast plays. I think the B.B.C. rather underestimates the average listener's listening powers. There was a time when, as inexperienced listeners, we did find it difficult to follow a complicated plot. But things are different now.

Saturday evening programmes are striking exactly the right note at the moment. Beginning with a Pewter episode, always full of sound common sense and amiability, every succeeding item seems to be rivalling its predecessor for the privilege of topping the bill.

"In Town To-night" is improved by the omission of the sort of entertainment that one is likely to hear any night. It has variety, too. There was rich variety, for instance, in the eleventh of the series which introduced Mrs. Wilson, the theatrical dresser, in conversation with Hermlone Gingold on the good old days of the theatre.

(Continued on next page.)

MICROLODE MATCHING FOR PERFECT BALANCE

Seventeen ratios for power or pentode valves, and four for Class B, Q.P.P., or push pull all on the one speaker. Accurate adjustment of load impedance by the simple setting of a switch.

By introducing this unique feature V.V.B. engineers make possible an accuracy of adjustment which must improve performance.

Nearly every leading technician has signified wholehearted approval of this new and extraordinarily efficient range of speakers. Users everywhere write in enthusiastic terms of the improvement a Microlode has brought to their sets.

Since last autumn Microlode speakers have been specified as first or sole choice in practically every published constructor receiver. Hear one on your set to-day. You will be amazed at its performance.

30% stronger than a good cobalt steel magnet of equal weight. The crisp attack, excellent sensitivity, and surprising freedom from resonance are directly due to the unique properties of this exclusive W.B. magnetic system.

PM6 32'6 - PM2A 79'6
PM4A 42' - PM1A 120'.

MANSFIELD MAGNET FOR GREATER SENSITIVITY.



Write now for new folder
Whiteley Electrical Radio Co., Ltd.,
Dept. P., Radio Works, Mansfield, Notts.

Sole Agents in Scotland: Radiovision Ltd., 233, St. Vincent St., Glasgow, C.2.

Sole Agents in I.F.S.: Kelly and Shiel, Ltd., 47, Fleet St., Dublin.

THE LISTENER'S NOTEBOOK

(Continued from previous page.)

The thirteen-year-old prodigy—the Bombay boy and a Caruso in the making—was quite a unique turn, while Edgar K. Bruce, the actor, on the immortal melodrama "East Lynn," shared with James Whale, the film director (how fond the B.B.C. is of introducing film directors to us!), the rest of the time in boosting respectively the said melodrama and H. G. Wells' book, recently filmed, "The Invisible Man." Both were interesting.

"Musie Hall" is continuing its bid for premier place in radio entertainment. Sutherland Felce has set a new fashion for comères by making himself an essential part of the programme to a degree hitherto unknown. He told stories galore.

THE LINK BETWEEN

(Continued from page 992.)

A Superb Instrument.

The H.M.V. "Superhet Four Forty" is a winner, and so also is the radio-gramophone which has been released with it. The "Superhet Five Forty Radiogram," which, on the radio side, is twin brother to the "Superhet Four Forty," is a superb-looking instrument, and again the lowness of the price is an astonishing feature, for it is to sell complete for 20 guineas.

There is little doubt that these two fine sets, which, while highly competitive in price, are every bit up to the high standard for which the name of H.M.V. is justly famed, will create a big sensation in the radio world, and if there are any readers of "P.W." who would care for further details to be sent to them I shall be pleased to make the necessary arrangements through the medium of our postcard (No. 76) literature service.

"Lucerne Specials."

Marconiphone is another firm which has been particularly active during the past month or so. The activities of this company have all been directed towards the design and production of two new receivers to meet the somewhat exacting conditions imposed by the Lucerne Plan.

The point of view which they put forward (and in many respects it is a very sound one) is that, although as a result of the recent shuffle the expected broadcasting millennium has not exactly materialised, a lot of the selectivity troubles which are at present being experienced are due not to the ineffectiveness of the Plan so much as to the inadequacy of certain types of sets for the new conditions.

That is true to a point, but it should not be assumed that all interference troubles under the new Plan are due to failings in the design of existing sets. A lot of work has yet to be done by Europe's "ether policemen" before finality is reached, and, meanwhile, the few irregularities which have made themselves manifest will still be present even with the most selective of sets.

However, that does not detract in the slightest degree from the credit due to the Marconiphone Company for the enterprising efforts they have made in dealing with the reception side of the problem.

In the design of the two new Marconiphone "Lucerne Specials"—as they are called—every possible attention has been given to what is probably the most urgent radio need of the day, and it is the makers' claim that they fulfil in every particular the selectivity requirements of 1934.

These two new instruments consist of an all-ruins table model superhet, Model "262," at 12 guineas, and a superb all-electric radiogram, Model "296" (also a superhet), at 20 guineas. D.C. models are available in both cases for an extra cost of one guinea.

Full technical details are available to "P.W." readers through our free literature (No. 77) service.

A Brilliant Idea.

While on the subject of commercial sets, a word or two more about the new and ingenious Ekco dial to which I made a brief reference in the last issue.

I may as well come out into the open and admit that I think it a brilliant idea.

The dial itself, which is made from the usual ivory material, is calibrated only in wavelengths, but the station names are engraved on a transparent celluloid strip which fits into position over the top of the wavelength scale and which is instantly removable from the front of the set. Simple, my dear Watson, isn't it? And to think that nobody thought of it before!

OUR POSTCARD SERVICE

Applications for trade literature mentioned in these columns can be made through "P.W." by quoting the reference number given at the end of the paragraph. Just send a postcard to G. T. Kelsey, at Tallis House, Tallis Street, E.C.4. Any literature described during the past four weeks may be applied for in this way—just quote the number or numbers.

H.F. Chokes

SUPERIORITY

FEW people realise the importance of using only the most efficient H.F. chokes. But set designers know; that is why "Bulgin" is so continually specified. Follow the lead; the best is cheapest.

SCREENED SUPER H.F. CHOKE

Inductance 500,000 μ H, self-capacity 1.5 μ F. approx. Chokes smoothly 99.9% at 180-2,000m. 500 Ω D.C. approx. **5/6**
List No. H.F.10 - - - EACH

SCREENED STANDARD H.F. CHOKE

Inductance 250,000 μ H, self-capacity 2.5 μ F. approx. Chokes smoothly 97% approx. at 200-1,800m. 400 Ω D.C. approx. **3/6**
List No. H.F.9. - - - EACH

SCREENED MIDGET H.F. CHOKE

Inductance 198,000 μ H. Self-capacity 3.5 μ F. approx. Chokes smoothly 98% at 200-1,750m. 380 Ω D.C. approx. **2/3**
List No. H.F.8 - - - EACH



Telephone: Grange Road 3266-3267.
A. F. BULGIN & CO. LTD., BARKING, ESSEX



H.F.10



H.F.9



H.F.8

Cut here

Please send the New 80-page Catalogue 153 "P" and Bulgin literature to:—

NAME

ADDRESS

Enclose 2d. Postage. (Block Letters Please.)

MICROLODE

SPECIFIED FOR THE NATIONAL
ECKERSLEY RADIO-GRAM

SEND ONLY

2/6

BALANCE MONTHLY

Are you building the "National Eckerley Radio-gram"?

Then send for the W. B. "MICROLODE" model M/4a the Speaker officially specified and which will give you maximum results. With ANY set this Speaker will give amazing sensitivity and volume because it incorporates the famous "Microlode" Unit, which, by a simple switch adjustment, assures perfectly true matching.

SEND ONLY 2/6

for 7 days' Trial. If satisfied, pay further 2/6 at once, then 8 monthly payments of 5/- (Cash, in 7 days, 42/-)

British-made WATES UNIVERSAL METER. The only popular priced instrument for testing resistances as well as batteries, valves, circuits and all components. SEND ONLY 1/6 for 7 days' Trial. If satisfied, balance by five monthly payments of 2/6. (Cash, in 7 days, 12/6.)

ONLY 1/6 DOWN

E. J. HERAUD, Ltd. (Dept. P.W.29)
NUMBER ONE, EDMONTON, LONDON, N.18
Phone: Tottenham 2256. Estab'd. 34 Years.

Branches: 78/82, Fore St., Edmonton; 77, West Green Rd., Tottenham; 34, St. James' St., Walthamstow; and 139, Hertford Rd., Enfield, Wash.

"We're Fluxite and Solder—the reliable pair; Famous for Soldering—known everywhere!"

The SET may look lovely—it may have cost much! To make SURE it is PERFECT—add this finishing touch!"

See that Fluxite and Solder are always by you in the house—garage—workshop—anywhere where simple, speedy Soldering is needed.

ALL MECHANICS WILL HAVE

FLUXITE

IT SIMPLIFIES ALL SOLDERING

All Ironmongers sell Fluxite in tins: 4d., 8d., 1s. 4d., and 2s. 8d. Ask to see the FLUXITE POCKET SOLDERING SET—complete with full instructions—7s. 6d. Ask also for our leaflet on HARDENING STEEL with Fluxite.

FLUXITE LTD. (Dept. 324), Rotherhithe, S.E.16

FOR ALL REPAIRS!

Continued from previous page.

EASY TERMS

Everything radio supplied on convenient terms. For really prompt delivery entrust your order to us. Goods ordered cash or C.O.D. despatched same day. Strict privacy. Carriage Paid. Price List FREE.

PERMANENT MAGNET M.C. LOUD-SPEAKER UNITS.

	Cash with Price	Order	No. Monthly Instal- Months	ments
Blue Spot 99 PM (Still the best unit)	59/6	5/-	11	5/6
Blue Spot 45 PM	45/-	5/-	9	5/-

H.T. ELIMINATORS.

Atlas, with trickle charger T.25	90/-	8/3	11	8/3
Atlas CA.25	58/6	5/-	11	5/6
Atlas DC 15.25	39/6	5/-	7	5/6

VALVES (battery)

Set of 3, 1 S.G., 1 Det., 1 Power (all makes) 31/3 5/- 6 5/-
All types of A.C. and D.C. Valves also supplied.

To avoid delay, will customers kindly send first payment with order!

Estd. 1925 **THE LONDON RADIO SUPPLY COMPANY** Phone: National 1977
11, OAT LANE, NOBLE STREET, LONDON, E.C.2

H.T. THAT LASTS YEARS

Dead "silent" background. When you install a dry battery your set is full of life and power. But all too soon it falters, and so does reception. Install a Standard Leclanche Battery, and end the problem for good. Gives you full, abundant power year-in-year-out at half cost of dry batteries. Annual replenishment all that is necessary. Purest form of current known. Beautiful tone and permanent freedom from H.T. worries. 120 v., 12,500 m.a., £2 complete, carriage paid. All Standard Battery Spares Supplied. The well-known

Any voltage supplied. **WATES METER 4 in 1**
This famous precision instrument now gives 4 readings—0-30 m.a., 0-180 v., 0-6 v., 0-15 v. 8/6 post free. No listener should be without it. Wates' Glass Accumulator, 2-v. 40 amp. hrs., 7/-.

THE WET H.T. BATTERY CO. (P.W.), 26, Lisle Street, London, W.C.2. Gerrard 6121.

LOUD SPEAKERS REPAIRED 4/-

(Blue Spot a Speciality, 5/-.) Transformers and Headphones, 4/-, Eliminators, Mains Transformers and Moving Coils quoted for 24-Hour Service. Trade Discount. Clerkwell 9069. E. MASON, 44, EAST ROAD (nr. Old Street Tube Station), LONDON, N.1.

EASY TERMS PROMPT DELIVERY

Any Amplion, Blue Spot, Baker, Celestion, Epoch, Ferranti, Gramplan, Igranic, Lamplugh, Magnavox, Ormond, R & A, Rola, Sonochorde or W.B. Speaker supplied.

Send 5/- only and pay balance by monthly instalments. No references. Entirely private and confidential.

KITS, PARTS, VALVES, ELECTRIC CLOCKS ON EASY TERMS.

Send for List of 83 Speakers and state requirements. **TURNADGE & PARTNERS, LTD.,** 107, Fleet Street, London, E.C.4. Telephone: Central 1903.

RADIO GRAM CABINETS

as supplied to B.B.C.
65/- Polished Cabinet for 35/- No Middle Posts!
Famous maker offers finest Radio Furniture. As Supplied to B.B.C. A Quality and Value impossible to better. Beautifully hand polished! GUARANTEED Piano Tone Acoustically.

Trial Will Delight You! (Cash or 10/- Monthly.) LIST FREE! From Makers—

PICKETT'S Piano Tone Cabinet (P.W.) Works, Albion Rd., Bezeleyheath, Nr. London

LISTEN TO THESE NEXT WEEK

Outstanding items selected from the B.B.C. programmes for the week ending February 17th.

Sunday February 11

National: "Antony and Cleopatra." An abridged version for broadcasting of Shakespeare's tragedy.

Monday February 12

National: "Love Needs a Waltz." A modern fairy tale by James Drydenforth, who will also act. Natalie Hall will play the leading rôle, supported by Bruce Carfax, and there are four tunes at least in this show which will create wide interest. (To be repeated on the Regional wave on Tuesday.)
Regional: "The Farmer's Wife," Eden Phillpotts' Devonshire comedy played (in a microphone version) from the West Regional studios in Devon dialect. Don't miss this. (To be repeated on the National wave on Tuesday.)

Tuesday February 13

National: "The Farmer's Wife." (See "Regional: Monday.")
Regional: "Love Needs a Waltz." (See "National: Monday.")
Midland Region: Edwardian Memories. A choral and instrumental concert of a kind which listeners enjoy.

Wednesday February 14

Regional: "The Bo's'n's Mate." Dame Ethel Smyth's opera, based on the story by W. W. Jacobs, will form the relay from Sadler's Wells, an almost ideal broadcasting theatre. Those who do not as a rule listen to opera will enjoy this one.
Midland Region: "The Regional Revellers." A local concert party of regular broadcasters which has achieved national popularity.
Belfast: A relay of variety from the Empire Theatre.

Thursday February 15

Midland Region: "Strange Music." A programme of gramophone records which will be followed, later in the month, by a direct programme of curious instruments from the studio.
North Region: Hallé concert relayed from the Free Trade Hall at Manchester.

Friday February 16

Midland Region: Two short plays: "Sir Herbert is Deeply Touched" and "On Dartmoor." Both these plays are comedies, and both will be relayed from the studio at the Birmingham Repertory Theatre.

Saturday February 17

Regional: "Rugby Calls the World." The microphone is taken on a visit to the Rugby Radio Station.
Scottish Region: "Green Grass Widow." A tale of the Scottish Tinklers between 1914 and 1919.

TWO POPULAR SETS

Readers' Reports

A "NO-GAP" THREE TIP.

The Editor, POPULAR WIRELESS.
Dear Sir,—I built the "No-Gap" Three and was delighted with the set, but I must register a criticism. The coils have a triple range, and yet the manufacturers did not even bother to put an arrow on the knobs of the switch rods nor to supply an indicator, so how is one to know which range is in use?

My own way out of the difficulty may be of interest to you. I obtained a pair of Telsen switch knobs, complete with plate showing ranges, and arranged them so that the knob indicates medium and long waves, and when the short range is in use the pointer is at the space below the medium-wave range.

I should like to take this opportunity of thanking the Technical Staff for this and many other very excellent sets, from the "Magic Three" onwards.

Yours faithfully,
North Wembley, R. MERVYN LEE.

THE "AIRSPRITE" TWO.

The Editor, POPULAR WIRELESS.
Dear Sir,—I have lately constructed your "Air-sprite" two-valve set, and I am so pleased with its performance that I am writing to express my appreciation.

Your A.T.B. gives to a two-valve the tone and volume of a three-valve set, and up to the date of writing to you I have logged twenty-three stations at full loudspeaker strength.

Yours truly,
5, Robin Hood Croft, EDWARD MORSE.
Hall Green, Birmingham.

The TERMINAL for the "NATIONAL ECKERSLEY THREE"

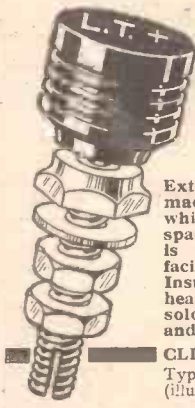

Extremely robust and soundly made. Hexagonal shoulder, which, by being held with a spanner while the nut behind is made tight, greatly facilitates mounting. Insulated and non-removable head. Provision for secure, solderless connection. Clear and easily read markings.

CLIX PANEL TERMINAL Type B 4d. Type A 2 1/2d. (illustrated)

THE DESIGNER ALSO SPECIFIES

CLIX SPADE TERMINALS

Positive metal-to-metal wiring is fully protected from creeping acid by a specially designed collar. Corrosion is impossible. Contact is perfect. Large size, Nickel-plated or lead-coating 2d. Small size, Nickel plated 1 1/2d. Latest Leaflet "P" sent on request.



LECTRO LINX Ltd., 79a Rochester Row, S.W.1

ELECTRADIX HOME RADIO BROADCASTERS

SOLO MIKE No. 11 in fine bakelite case, with terminals, front metal grille. New and 5/6 finely finished. Only P.W.11 TABLE TYPE with high ratio Transformer and Plug Switches 10/6

MICROPHONE PARTS for all purposes, complete Buttons, 1/-.

Volume Controls, 6d. Microphone Carbon Granules, enough for four buttons: Grade No. 1, 8d.; No. 2, Medium, 1/-; No. 3, Fine, 1/6; Carbon, solid back, blocks, 3d. Mouthpieces, curved or straight, 10d. Carbon diaphragm, 5s/m.m. 4d. Panel Brackets, pivoted, 5/-. Reed Receiver Unit for Amplifier P.W.11, making, 3/-. Headphones, 2/9 pair. Veeder 10,000 Counters, 1/3. Mike leaflet, with diagrams, free if stamped envelope sent.

PARCELS of experimental odd coils, magnets, wire, chokes, condensers, switches, terminals, etc., post free. 10 lbs., 7/7; 7 lbs., 5/-. 1,000 other Bargains in Feb. Sale List.

ELECTRADIX RADIOS, 218, UPPER THAMES ST., LONDON, E.C.4. Telephone: Central 4611.

RADIO SUPPLIES

Send your list of Radio needs for our quotation. Kits, Parts, Sets, etc. Everything in Radio stocked, prompt delivery. 7 days' approval. Catalogue free. Taylor & Standard Wet H.T. replacements stocked. P. TAYLOR, 9, GROVE ROAD, BALHAM, S.W.12

Micromesh THE MODERN VALVE

Literature and prices on request. Standard Telephones & Cables Ltd., St. Chad's Place, 364, Gray's Inn Rd., W.C.1. Terminus 6255

PLEASE be sure to mention "Popular Wireless" when communicating with Advertisers. Thanks!

TECHNICAL NOTES

Some diverse and informative jottings about interesting aspects of radio.

By Dr. J. H. T. ROBERTS, F.Inst.P.

Back Coupling.

I HAVE mentioned recently how the high-tension battery or other high-tension source can cause coupling, and several readers have asked me why this should be so. Well, if you think about it for a moment the reason is really quite clear, because you have the anodes connected to different positive points on the H.T. source, and therefore there is a common span (which generally comprises the major part of the high-tension voltage) between theseappings and the H.T. negative.

Motor-Boating.

This part of the battery or other source is obviously common to all the circuits which are connected, and therefore the H.T. sides of all of the components in the anode circuit are joined together directly or indirectly.

Now, any stray currents which may be present in any of the anode circuits can by this means be distributed to other circuits, where they will cause motor-boating, oscillation or other form of instability. I should perhaps mention that with an H.T. mains unit, since theappings, as you know, are obtained from the main maximum voltage by means of voltage-dropping resistances, the likelihood of this redistribution of stray currents, and therefore of oscillation, is still greater.

Overcoming the Trouble.

If these stray currents, or, in fact, any currents except those supplied by the battery or the unit, are given a path to H.T. minus, this will help to get over the trouble, and at the same time the anodes should be separated from one another by means of a condenser and a resistance or choke.

If the high-tension current is particularly large it may be better to use a choke for this purpose, but generally the resistance is used. In the output stage, however, a choke is used to feed the loudspeaker and to cause the speech currents to pass through the loudspeaker coils and to earth.

Decoupling Pointers.

This separating of the anodes and the provision of a path to H.T. minus for the stray currents is classed under the general name of decoupling. Decoupling is most important in connection with the detector.

If too large a value of decoupling resistance is used with the detector it means that the high-tension voltage actually applied will be too low, which may be a disadvantage.

One simple rule which is sometimes used is that the product of the resistance in ohms and the capacity of the condenser in microfarads should exceed 40,000. You may, for instance, use a 1-microfarad condenser with a 50,000-ohm resistance or a 2-microfarad condenser with a 20,000-ohm resistance and so on.

Decoupling is very simply carried out and makes more than anything else for the stability of the set. I am continually

coming across receivers, especially home-constructed ones, which suffer from a lack of sufficient decoupling.

Parallel Power Valves.

Talking about decoupling, by the way, the same sort of thing applies when you are using a pair of power valves in parallel for the output stage. This is sometimes done—though not so often nowadays, since the push-pull arrangements and its variations are much more popular.

In using valves in parallel in the output stage you must be certain that the high-tension and low-tension supplies can cope with the demands which will now be made upon them. Another point to remember is that if the loudspeaker is connected directly in the output circuit it will have a much larger current passing through its windings.

This larger current may have the effect of saturating the core, or so nearly saturating it magnetically that the loudspeaker will not function properly. This trouble can be overcome by the use of an output filter circuit; but here again you must be sure to use a choke or transformer which is adequately proportioned, or you will have the same trouble with the core of that component itself.

Use Stopping Resistances.

To use two valves in parallel in the output circuit it is important to have them as nearly as possible identical with one another, and—to come to the point which I mentioned about decoupling—it is an advantage to decouple by means of stopping resistances in the grid circuit of each valve. These stopping resistances, by the way, can be from 50,000 to 100,000 ohms each.

A more popular arrangement for increasing volume and power is the push-pull arrangement of two valves in the output stage. This has several advantages, one very practical advantage being that the high-tension voltage necessary for operating the push-pull arrangement efficiently need not be so high as when the ordinary arrangement is used.

Putting this in another way, it means that the push-pull arrangement makes more efficient use, as it were, of the high-tension voltage available. With the push-pull arrangement you will want an input and an output transformer, the input transformer having its output winding centre tapped and the output transformer having its input winding centre tapped.

The Push-Pull Arrangement.

The two ends of the secondary of the first transformer are connected to the grids of the two output valves, a stopping resistance of, say, 50,000 to 100,000 ohms being included in each grid circuit.

The centre tap on the first transformer is connected to grid-bias negative, whilst the centre tap of the primary of the second transformer is connected to H.T. plus.

(Continued on next page.)

DUBILIER

CONDENSERS

*Unfailing
reliability—
Superlative
performance—
characteristic
of Dubilier
Condensers*

HIGH VOLTAGE DRY
ELECTROLYTIC CONDENSERS

4 mfd 4/6



6 mfd 5/-
8 mfd 5/6

Condensers designed for a maximum peak of 500 D.C.

*Follow the
leading radio
designers
and insist on*

Dubilier

DUBILIER

CONDENSERS

DUBILIER CONDENSER CO. (1925) LTD.
Ducon Works, Victoria Rd., North Acton, London. W.3



HERE'S YOUR 1934 RADIO GUIDE!

Have you got the Heayberd 1934 Handbook?—if not, get it NOW. Contains all useful information on how to run your radio

from the mains. Fifteen blueprints showing how to build your own mains unit or battery charger, etc. Two pages of helpful radio hints for all amateurs. The third edition, published in February, contains SPECIAL TELEVISION SUPPLEMENT.

Cut out this advertisement, write your name in the margin, and send with 3d. in stamps for your copy.

F. C. HEAYBERD & CO.,
10, FINSBURY STREET, E.C.2. P.W.

MAKE YOUR SET SUPER SELECTIVE



VARIAL

gives aeriels every desired degree of selectivity, cutting out interference from other stations. Fixed in a moment on any set on any aerial with no alterations. Can also be supplied already attached to a coil of Superial.

The only self-contained variable aerial.
100 ft. 75 ft. 50 ft. The world's most selective aerial.
4/6 3/6 2/9

INVISIBLE AERIALS

Run Superial through ELECTRON INSULATOR PINS and have the ONLY efficient indoor or invisible aerial. OAK, MAHOGANY, BLACK. Six in a box. **6d.**

THE NEW LONDON ELECTRON WORKS, LTD.,
19, East Ham, E.6.

EASY PAYMENTS

"There's no place like HOLMES."

The first firm to supply Wireless parts on easy payments. Nine years advertiser in "Popular Wireless." Thousands of satisfied customers.

We recommend

EPOCH SPEAKERS

	De. posit	Monthly Payments
SUPER DWARF P.M. ...	23/6	4/4 5 of 4/4
20th CENTURY P.M. ...	35/-	4/10 7 of 4/10
11-in. SUPER P.M. ...	45/-	4/11 9 of 4/11
B5 P.M. ...	84/-	7/8 11 of 7/8

LISSEN Skyscraper 4 Kit	112/6	10/-	11 of 10/3
TELSEN 325 Star Kit ...	39/6	5/5	7 of 5/5
EXIDE H.T. Accu. 120-v.	60/-	6/-	9 of 6/8
ATLAS Eliminator C.A.25	59/6	5/-	11 of 5/6
BLUE SPOT 29P.M. ...	35/-	4/10	7 of 4/10
B.T.H. Pick-up Vol. Con.	25/-	4/8	5 of 4/8

Parts for any Kit Set. Any make of Speaker. New Goods Obtained for Every Order.

Send us a list of the parts you require and the payments that will suit your convenience, and we will send you a definite quotation. Anything Wireless.

H. W. HOLMES, 29, FOLLEY STREET,
Great Portland Street, London, W.1.
Phone: Museum 1414.

TECHNICAL NOTES

(Continued from previous page.)

The secondary of the output transformer is, of course, connected to the loudspeaker. The two stopping or decoupling resistances in the two grid circuits are for stabilising the stage, as already mentioned.

With the push-pull arrangement the positive half-cycle of a wave goes to the grid of one valve and the negative half-cycle to the other. At any moment one valve pushes, as it were, whilst the other one pulls, and it is for this reason that the arrangement gets its name of "push-pull."

Before leaving this point I should mention that just as when you are using two power valves in parallel, so in push-pull it is very desirable to have the valves as nearly as possible identical.

NEXT WEEK

Two fine constructional articles

A TELEVIEWER FOR 10/-

AND

THE ECKERSLEY RADIOGRAM FOR D.C. MAINS

Wednesday. Price 3d.

Non-Inductive Resistances.

Metallised resistances are now very popular, as indeed they deserve to be in view of their great convenience. I mean the type in which a fine column of partly conducting material is encased in a porcelain or other insulating tube, with metal end caps for contact.

These resistances are very small and compact, and are virtually non-inductive. By the way, we often speak of components being "non-inductive," but, strictly, it is impossible for any conductor to be absolutely non-inductive: even a perfectly straight wire, carrying current, is surrounded by a magnetic field. When we say a component is non-inductive, what we really mean is that its inductance is reduced to near the minimum. But this is just in passing.

Methods of Mounting.

In some cases these metallised resistances are provided with a short length of wire at each end, in addition to the metal end caps, so that they can be connected into the circuit by the wires without the use of a spring-clip holder at all. You are sometimes advised to lengthen these wires, if they are not long enough, by soldering extension wires to them, but personally I do not recommend this, and I will tell you why.

If the short wires already attached to the resistance are not long enough and you have to lengthen them it means that the resistance is going to be a long way from

the components to which it is connected and may then be floating about in mid-air, so to speak. The wires already connected to the resistances are short and fairly stiff, and if connected directly by these wires the resistance will be held fairly rigidly, as it is intended to be.

Hanging By Its Tail.

But if these wires will not bridge the gap, then it is much better practice to fit a spring-clip holder and secure the resistances that way. I think it is rather shoddy to use long extensions to the resistance and leave it "hanging on by its tail."

These resistances are generally rated in powers from 1 to 10 watts. The wattage, of course, means current passing through the resistance multiplied by the voltage at its ends, the current being in amps.

ENJOY MAINS VOLUME FROM YOUR BATTERY SET

at very low use of H.T. current.

SEND ONLY 2/6 BALANCE MONTHLY

The New ROLA CLASS "B" SPEAKER-UNIT combines the latest type Rola P.M. Moving-Coil Speaker and a complete, properly matched Class "B" Unit. Simply connect to your battery set and you obtain mains volume equal to an expensive all-electric set. SEND ONLY 2/6 for 7 days trial, if satisfied pay further 2/6 at once, then 10 monthly payments of 7/6. (Cash, in 7 days, £3 11). Complete with Class "B" Valve.

SPECIAL OFFER OF "LIMIT" PICK-UP with Free Gift of British made Double-Reading Volt Meter (worth 6/-). SEND ONLY 2/-, if satisfied balance by 3 monthly payments of 5/-. (Cash, in 7 days, 15/6.)

E. J. HERAUD, Ltd. (Dep. P.W.30)
NUMBER ONE, EDMONTON, LONDON, N.18
Branches: 78/82, Fore St., Edmonton; 77, West Green Rd., Tottenham; 34, St. James St., Walthamstow; and 139, Hertford Rd., Enfield Wash.

ENGINEERS!

ARE YOU EARNING LESS THAN £10 PER WEEK?

If so, you cannot afford to carry on without reading our 256-page Handbook. The book explains clearly and definitely many ways of carving out a successful career. Among other things it explains the Services of our unique Appointments Department, outlines Home-Study Courses in all branches of Civil, Mechanical, Electrical, Motor, Aero, Wireless, "Talkie," Eng., Building, etc., and gives details of B.Sc., A.M.I.C.E., A.M.I.A.E., G.P.O. MATRIC., and all Exams. We alone Guarantee—"No Pass—No Fee." Whether you be an old hand or a budding apprentice get this book to-day—FREE AND POST FREE. British Institute of Engineering Technology, 101, Shakespeare House, 29/31, Oxford Street, London, W.1.

256 PAGES FREE!

"S.T." MANUAL 4 TOKEN

Printed and published every Wednesday by the Proprietors, THE AMALGAMATED PRESS, LTD., The Fleetway House, Farringdon Street, London, E.C.4. Advertisement Offices: John Carpenter House, John Carpenter Street, London, E.C.4. Registered for transmission by Canadian Magazine Post. Subscription rates: Inland and Canada, 17/4 per annum. Abroad (except Canada), 19/6 per annum. Sole Agents for Australia and New Zealand: Messrs. Gordon & Gotch Ltd.; and for South Africa: Central News Agency, Ltd. Saturday, February 10th, 1934. S.S.

RADIO STEP-BY-STEP

Popular Wireless

No. 611.
Vol. XXIV,
February 17th,
1934.

THE
ECKERSLEY
RADIOGRAM
FOR
D.C. MAINS

EVERY WEDNESDAY PRICE 3^D

A TELEVIEWER



FOR

10/-

Full
CONSTRUCTIONAL
DETAILS INSIDE

ROLA

the World's Finest Reproducers

sell the Most Speakers
because they Make the Best Speakers

and one of the very best is the Rola Class B Speaker Amplifier Unit which takes 5 secs. to fit to your battery set and increases volume at least five times. Price 57. Ask your dealer or write to-day for folder.

THE BRITISH ROLA Co. Ltd., MINERVA ROAD, PARK ROYAL, N.W.10



ADVT.

UNIFORMITY EFFICIENCY RELIABILITY

BETTER RADIO RECEPTION

Be a critic for once. Switch on your Set and listen—listen critically. Is the bass rich and full—is the treble brilliant, clear cut? Can you get the volume you want? And will it bring in the stations it used to?

It's a simple matter to make your Set like new again. You can easily give it a new lease of life. With the right types of Cossor Valves (your dealer knows them) you can improve its performance out of all recognition—it's surprising what a difference they make.

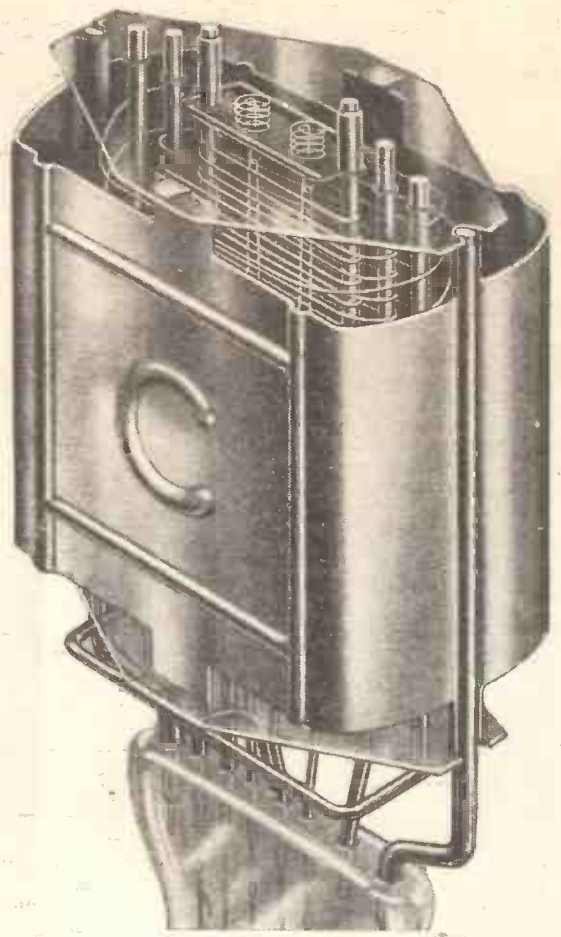

NEW STATION CHART!

Get one of the new Cossor Station Charts which gives the revised wavelengths, etc., of over 80 foreign stations and has space for entering your own dial readings, price 2d., from your Dealer or write to A. C. Cossor Ltd., Melody Dept., Highbury Grove, London, N.5. enclosing 2d. stamp.

FREE!

72-page WIRELESS BOOK

From cover to cover this new Cossor 72-page Wireless Book is packed full of useful and interesting information—latest circuits—explanations of technical terms—list of broadcasting stations, etc. Send at once for free copy. Please use the coupon.

To **A. C. COSSOR LTD.**, Melody Dept., Highbury Grove, London, N.5
Please send me, free of charge, a copy of the Cossor 72-page Wireless Book.

Name.....

Address.....

B.V.33 P.W. 17/2/34.....

COSSOR VALVES



KINGS OF THE AIR

A. C. Cossor Ltd., Highbury Grove, London, N.5. Depots at Birmingham, Bristol, Glasgow, Leeds, Liverpool, Manchester, Newcastle, Sheffield, Belfast, Cardiff and Dublin.

POPULAR WIRELESS

THE FIRST AND FOREMOST RADIO WEEKLY FOR THE CONSTRUCTOR & AMATEUR EXPERIMENTER

Scientific Adviser: SIR OLIVER LODGE, F.R.S.
Technical Editor: G. V. DOWDING, Associate, I.E.E.
Assistant Editor: P. ROBERT BIRD.

Managing Editor:
N. F. EDWARDS.

Chief Radio Consultant: P. P. ECKERSLEY
Assistant Editor: A. JOHNSON-RANDALL.
Chief of Research: K. D. ROGERS.

"WITHER BRITAIN?"

WHAT IS A STAR?

THE IMMORTAL SHIRT RADIO LESSONS

RADIO NOTES & NEWS

THE B.B.C. BEST
HAYDN'S "TOY
SYMPHONY"
ROBOT RECEPTION
THE "ELEPHANT'S TAIL"

The Great Wavelength Shuffle.

TO the ordinary listener the consummation of the Lucerne Plan meant little more than the noting of a few new dial readings; but to the white-hot guardian of the ether, that faithful shepherd whose crook knew every station from Archangel to Tetuan by name—said he, mixing the metaphor with a skilled hand—and who used to see them all in their proper places each night, the ordeal was almost as painful as spring cleaning.

My own pet "fan" said: "This wavelength shuffle was the bad place with the bars off. Believe me, I sweated like a cheese at a fire—and my wavemeter has gone all googly."

How the Others Took It.

"GASPER GERT," our domestic assistant, heard of some change which was to interfere with her auxiliary postman's radio set. "My Erb," quoth she, "says he reckons it's all a plot to stop them Bolshies from mucking up the Lucerne Pact."

My own ladies anxiously inquired whether (a) they had now to tune in to Lucerne, (b) all the long waves were short and the short medium, and (c), if so, what happened to the mediums and where is Rome; is it near the "nought" end of that thing when they have this switch so, or is that where Radio-Paris used to be when the switch was the other side? And, in particular, is there any alteration in the length of the programmes!

A Veteran Reappears.

I WAS glad to note, not long since, that Stanton Jefferies was conducting the B.B.C. orchestra on one of its big nights. This veteran, not very ancient in years, was the first musical expert engaged by the B.B. Company on its regular staff.

He certainly made his mark on broadcasting in those days and did his fair share of "uncle-ing" with the rest of the old gang,

Rex and so on. I have sometimes felt that he had been side-tracked, although I know that he has been doing vital work in connection with "control," and I hope that we shall see his name in the programmes more frequently.

Wells as Heard in America.

ADMIRATION of Mr. Wells' subject matter was amusingly mingled with criticisms of his performance as a broadcaster in the American Press notices of his contribution to the "Whither

A little mixed, stranger; it's not quite like that. The British idea of a sponsored programme is the sale of "ether time" to parties who use it for advertising their business. And that's what it is!

Must Radio Have "Stars"?

I SUPPOSE that the tendency to siderealise (that's a good one, yes?) popular broadcasters is natural, and as legitimate as the same process applied to film artistes; yet sometimes I deplore it. The implied superiority of one particular artiste to the rest is a little unkind and not at all encouraging to the strugglers.

What characterises a star, anyway? Its scintillation? I could name some very pleasing and popular radio personalities who do not scintillate.

Its remoteness? Why, bless me, as a general rule the performers and speakers we love most are those who come close home to hearth and heart! I do trust that this "star" business will not reach the absurd state of exaltation found in Hollywood.

Ariel's Preferences.

IT would be preferable to glorify some of the B.B.C.'s outstanding successes: impersonal things. Thus I would elevate to the empyrean the "Kentucky Minstrels," "In Town To-night," "Songs from the Shows," various series of talks, such as "Escape" and "Anywhere for a News Story," and the theatre and symphony orchestras.

Also the section of the staff which tries to protect us from music "never before performed in this country" and the engineers who supply the carrier-wave so unflinchingly.

Also the announcer who immortalised the crackling of his shirt-front: for those crackles are still rippling down the arches of the years and into infinity of space, troubling the ether in the cores of celestial bodies!

(Continued on next page.)

ON OTHER PAGES THIS WEEK.

- "... I believe the maximum enjoyment that you can get out of a certain number of valves depends upon their being used alternatively for radio or for gramophone . . ." page 1003
- "... Jeloy is a conspicuous example of the art of making one kilowatt go a long way . . ." page 1006
- "... The television unit described herein has, in practice, provided many hours of 'looking-in' at an inclusive initial cost of less than ten shillings . . ." page 1015
- "... Surely it wasn't the wish of the artistes that they should remain anonymous. I thought all artistes craved for publicity . . ." page 1008

Britain?" series—or "Wither Britain," as one wise-cracker put it.

It was stated that within half an hour listeners on that side could "time his bronchial whoops." However, there was a good measure of appreciation, the most being expressions of wonder at his simple style in handling big ideas.

What is a "Sponsored" Programme?

SOMEONE who signs himself "Americus," but forgets to give his address, writes, presumably as an American—though his letter has not the genuine U.S.A. flavour—to ask what is the British idea of a "sponsored" programme. He asserts that gramophone records, cinemas, dance bands, hotels and even Devonshire cream and cider receive much valuable publicity from the B.B.C.: "the listeners foot the bill and the Government gets all the profit."

WHEN ARIEL PLAYED THE BIG DRUM

Chicago Station Learns Politics.

I HAVE a very interesting batch of news items from America, the most enlightening of which concerns a broadcast of something which Mr. De Valera had to say.



At the last minute the Chicago station in question decided to give Eamon the go-by and to substitute a profitable commercial broadcast, with the result that its telephone was occupied for half an hour with indignant screeches from listeners. Considering that Ireland invented crooning and supplies the U.S.A. with its police, no wonder it is popular over there!

Radio—the Kids' Enemy.

OF all the mean, low-down sneaks tricks! Well! In America there is a place called Des Moines (which sounds like 100 per cent. French), and its schools were closed for an extra week at the New Year holiday-time for repairs.

The kids naturally considered this to be a piece of pure "bunce." But oh! the soulless robots who preside over the Des Moines schools considered otherwise, and shot out lessons per radio twice daily.

Could the nippers play truant? Oh, nary a one! The coyotes in charge of the minds of those miserable co-eds announced that examinations on the radio lessons would be held. There's no justice in this world!

The British v. The American Method.

FOR a year past U.S.A. high schools have been debating, "Resolved: that the United States should adopt the essential features of the British system of radio control and operation." The audience of these debates are said to have amounted to several millions. I do not know how the voting went, but I can give you a summary of the arguments for and against.

In favour: Radio ads. cost consumer 1.5 dollar a year; Federal Radio Commission is a political device to disguise a monopoly; minority has no voice in

tax is a nuisance and hard to collect; conflicting opinions are not broadcast here; no freedom of speech before "mike" here; American system much more sensitive to public criticism.

I am afraid that the pro-American debaters were not very well informed on the second, third and fourth points. As to the silences, good heavens! are we to listen to radio all our waking hours?

Freedom of speech—hum! It's one thing to allow it in Hyde Park, but quite another matter to give an unknown quantity *carte blanche* of millions of ears. Last point is correct.

The Oddments Orchestra.

AT the age of six I publicly performed on the drum in Haydn's "Toy Symphony"—grandpa conducting. I played on the simple principle of giving the drum a wallop for every dot I saw on my score, with a few extra each time grandpa shoved his baton in my direction. I was a huge success, but was not broadcast.

All this comes back vividly to me when I read how Radio Colonial broadcast "music" produced by twenty-one children from bottles of water, hat boxes, wrapping paper, iron pipes, stones and zinc bath-tubs. Just the sort of band for brother Honegger to compose for.



An Unnecessary Complication?

I HAVE heard, with scant enthusiasm, that W A B C engineers are working on a gadget which is intended to ring a bell or light a lamp or even switch on the radio set itself when a broadcast item of a certain selected type is about to be broadcast.



The idea is that the bone-idle listener pushes a button on his set under a label

marked, say, "News" or "Variety" or "Who was which?" and goes to sleep until something comes through. What's wrong, or difficult, about consulting the published programmes?

I suggest the construction of a robot to listen for us and then tell us about it briefly.

Listening for the Byrd Expedition.

ARE you all set for picking up signals direct from Antarctica? When Byrd reaches his old base the broadcasting station which is now aboard his ship will be landed and will use the call-letters K F Z.

Transmissions will be effected on one or other of fifteen short wavelengths in the bands of 3,000, 5,000, 8,000, 13,000 and 16,000 kilocycles. The transmitter is a 1,000-watter and will be directional on Buenos Aires.

Another station of 200 watts, K F Y, is to be erected four hundred miles from the

Pole, to maintain telephone communication with Byrd's aeroplane during its polar flight. Good hunting all!

A Preliminary Show Note.

ALWAYS red hot with the news, we hasten to announce that there will be the usual radio shows this year. The dates proposed for the Glasgow Kelvin Hall are Aug. 31st to Sept. 8th, and for

BRIGHTER BROADCASTS

PROOF POSITIVE.

"This is Barcelona!" exclaimed the wireless enthusiast.
"Oh, yes," said his grandmother. "I can hear them cracking nuts."—"Tit-Bits."

We wonder whether the dance-band crooner who sang "Close Your Eyes" the other night thought it was a television transmission.

"Would you lend me your portable set for a day or two?"

"Certainly. Can you work it?"

"No—but neither can you while I've got it."

Manchester City Hall, Sept. 14th to Sept. 22nd.

The details of the Olympia show are not yet known to me; but, as the R.M.A. tenancy period is from Aug. 13th to Sept. 2nd, I suppose that one may tentatively count on those dates. "Colour scheme" not yet made public!

Peebles in Equilibrium.

HERE'S a curious fact: During December last every blessed county in Great Britain and Northern Ireland, *except Peebles*, increased its total of radio licences. But Peebles did not show a reduction—oh no! It just stayed as it was in November.

What is there about Peebles that not one single . . . ? A cynical friend suggests that, as December was next door to the New Year, Peebles was "saturated."

Another man, thinking of nothing like that, said: "They were just full up." Yes—saturation; same thing. I think, however, that the real reason is that the crystal broke, so that the set could not very well be passed on.

More Cantor "Cracks."

EDDIE CANTOR, continuing his campaign against studio audiences, says that, with a visible audience, the radio performer is "tempted to play to the elephant's tail." Good!

Eddie says also of radio: "Its paramount needs at the present time are writers with originality and, of more importance, showmen. Radio is show business, and you cannot run show business without showmen."

Goldarn it! I've said that for years—but the B.B.C. thinks that 'Varsity men ought to be able to run anything.



SHORT WAVES

WELL CAST!

He thought he could act,

But he had no tact;

At trying his stuff he was tireless.

No rebuff would save him,

So one day they gave him

A non-speaking part on the wireless.

* * * * * "Answers."

She: "Do you get much on your radio receiver?"
He (absentmindedly): "Well, I only got five pounds last time."

programmes; 30 nations besides Britain operate on non-advertising basis; many advertised products are worthless; American system threatens the Press, music and theatre business.

The Other Point of View.

ON the other hand, it was argued that: the B.B.C. has long, silent periods; public tastes are neglected here; the

The ECKERSLEY RADIOGRAM for D.C. MAINS

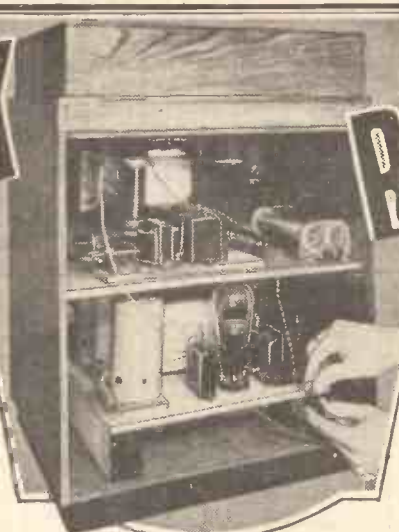

CERTAIN electric current supply authorities have not yet changed their systems from D.C. to A.C.

In many cases it will be a long time before such a change takes place. It is most likely that D.C. will continue to exist in those areas which use electricity for industrial machinery, for arc lighting and so on.

By means of a few simple modifications the National Eckersley Radiogram—which was introduced in our January 20th issue—can be adapted to obtain its H.T. and L.T. from D.C. mains instead of from batteries. The full particulars for the change-over are given here.

I use a laboratory in the heart of London (or should I say in the heart of the theatre district?), and I am told that it will be a long time before we get A.C. through because the theatre apparatus would be very expensive to change to A.C. operation.

In our laboratories we have to take the most elaborate precautions to get interference-free reception even on the local stations, and so I should say that if I had D.C. supply I should be more likely to want to use records.

Moreover, I have noticed that the word "pick-up" can often be applied in a double sense, because not only does it give one the music from the record, but also a nice bass note of 50 cycles/sec. where it "picks up" from the A.C. mains transformer! This trouble should not be noticed with D.C., because D.C. ripples; it doesn't hum.

Maximum Enjoyment.

I have said before, and I say again, that I believe the maximum enjoyment that you can get out of a certain number of valves depends upon their being used alternatively for radio or for records. The Lucerne Plan, the D.C. noise and the grand traditions which underlie the monotony of the local programme, all make the gramophone a means to escape dullness or noise.

You will need extra components to convert the National Eckersley Radiogram to D.C. mains. The 5,000 potentiometer with an on-off switch is needed to control the negative bias on the grid of the variable- μ on the S.G. valve. This will therefore act as a volume control.

By P. P. ECKERSLEY

The switch breaks one lead of the mains, and thus acts as the on-off switch.

You will want a 1-mfd. fixed condenser, which is to be connected between the cathode of V.1 and the earth line—that is, H.T.—which is common to the chassis.

You will need a 100-ohm resistance to limit the minimum negative bias to V.1. Further, a 2-mfd. fixed condenser and a 500-ohm fixed resistance are connected in the cathode circuit of V.2, and provide automatic negative bias to the grid of this valve when it is used as an amplifier for gramophone records.

The whole essence, of course, of a radiogramophone consists, in one case, of using a detector valve as a detector, and, in the other, of putting negative on its grid and using it as an L.F. amplifier.

You will require another 2-mfd. fixed condenser and 250-ohm fixed resistance. This, again, forms the circuit for providing

Enabling one to choose either radio or gramophone records at will, and dispensing altogether with the bothers of battery renewal, this magnificent outfit provides everyone with 200-250 volt D.C. mains with a constant and trouble-free source of first-class entertainment.

the usual biasing arrangement for V.3, the output valve.

It is necessary to change the value of the detector's grid leak from its value as originally specified. We had a 1-meg. grid leak in the battery set, but in mains-operated sets a $\frac{1}{2}$ meg. is sufficient; in fact, it is limited to this value, for otherwise a mains ripple will be reproduced.

The combined 50,000-ohms potentiometer and 3-point change-over switch on the underside of the chassis is replaced by a similar component having a resistance value of 10,000 ohms. The object of this change is to balance the level of reproduction of the audio-frequencies to suit the new circuit conditions.

How to Convert.

In other words, using the components we have to for a given performance in radio, where the high audio-frequencies are cut down by the H.F. circuits, it is necessary to compensate for this when using gramophone records.

Now you will have to do some grave and concentrated reading, and I have to write down in a steady stream all the instructions to tell you what to do to convert the set to a D.C. Radio Gramophone.

First of all, remove the H.T. economiser and all the leads associated with it.

This leaves the G.B. terminal of the L.F. transformer free. It is then connected to the chassis. Remove the lead joining the filament terminal, nearer the panel, of V.2 to chassis.

(Continued on next page.)

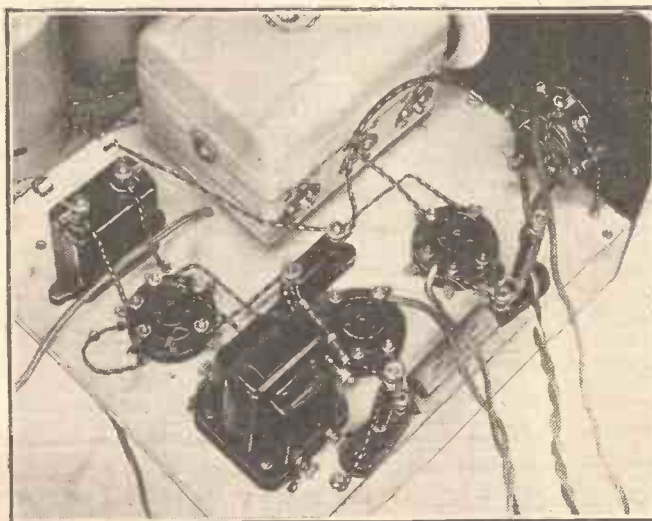

Nearly all the alterations to the wiring are clearly shown in the picture above, and on following pages the modifications are given in detail, in diagrammatic form.

THE EXTRA PARTS YOU WILL REQUIRE

- 1 Dubilier 2-mfd. fixed condenser, type BB, or T.C.C., Graham Farish, Lissen, British Radiogram.
- 1 T.C.C. 2-mfd. fixed condenser, type 50, or Graham Farish, Telsen.
- 1 Dubilier 1-mfd. fixed condenser, type 4404, or T.C.C.
- 1 Graham Farish 100-ohm $\frac{1}{4}$ -watt type "Ohmite" resistance in vertical holder.
- 1 Dubilier 250-ohm. 1 watt Resistance.
- 1 Graham Farish 500-ohm $\frac{1}{4}$ -watt type "Ohmite" resistance in vertical holder.
- 1 Bulgin combined 5,000-ohm potentiometer and on-off switch, type V.S.29, or Lewcos.
- 1 Bulgin combined 10,000-ohm potentiometer and 3-point change-over switch, type V.S.32.
- 1 Lissen $\frac{1}{2}$ -meg. grid leak with wire ends, or Varley, Dubilier, Bulgin, Goltone.
- 1 Garrard Universal gramophone motor for D.C. with slider resistance. 2 ft. Goltone single screened flex R 43/96

MORE than once recently I have been mildly slated for ignoring the amateur transmitter. Let me assure the "slaters" that I should find it quite impossible to do such a thing; on the other hand, I am always only too conscious of him, being one of the fraternity myself!

The fact remains, however, that I must keep to subjects that prove interesting to the greatest number of readers; and the amateur transmitter, though his own circle is the essence of keenness and enthusiasm, doesn't seem to appeal to the casual short-wave listener as much as he might.

A Body to be Reckoned With.

Just at the moment we are in the middle of the biggest series of short-wave tests ever organised. I refer to the R.S.G.B.'s annual "B.E.R.U. Contest." The British Empire Radio Union has grown out of the R.S.G.B., just as the R.S.G.B. grew out of the Wireless Society of London, and I can assure anyone who doubts it that the B.E.R.U. is a body to be reckoned with.

A society linked together by the common enthusiasm of its members for short-wave radio, purely as an amateur hobby, and embracing the five continents of the world, as well as lots of little places that can't be classified under any of them, is unique.

More unique still, though, is the very thought that the members of such a society, spread over the whole Empire, should be able to keep in regular and

Short Wave Notes

News and comment by radio's foremost short-wave expert.

personal touch with one another. An amateur at home here, with quite simple gear, can talk to fellow-members of his society in Canada, South Africa, India and Australia, all within a few hours.

Doesn't that thought, alone, stir up a desire to know more about this amateur-transmission business? My advice to any reader of these notes who is, at present, not interested, but feels that he would like to be, is to get into touch with the nearest amateur and ask him all about it.

Conditions Are Better Than Ever.

I have been listening a lot on the amateur bands of late—chiefly as a test of a new receiver—and have accumulated some interesting data on the subject of variable conditions.

Two days ago, for instance, the 20-metre band in the afternoon was crowded with very strong American signals, and, lower down, W 2 X A D on 19.56 metres was exceptionally good. Yesterday, at 3 p.m., there was only one American

amateur to be heard, and W 2 X A D was just about audible.

To-day, just before writing this, I listened again, and found conditions better than ever. For a few minutes it sounded quite like the good old days of 1928, when a "band-full of Yanks" was a commonplace for weeks and months on end.

Forty metres doesn't vary quite so much. One can generally count on hearing something from outside Europe every evening; and when conditions are good one can log Australia, New Zealand, South Africa, U.S.A. and, of course, Europe (far too much of it!) every evening between tea and supper.

The Popularity of the 49-Metre Band.

This accounts, I suppose, for the popularity of the 49-metre broadcast band among those listeners who confine themselves to short-wave broadcasting. On a good day it is not so good as 19 metres, but on a bad day it is far better.

Many thanks to all the readers who have sent me full particulars of Jeloy (Norway) on 42.92 metres. He is certainly the easiest short-wave broadcast station for a novice to find nowadays, and is usually at least as strong as Moscow, if not even stronger. The purpose of the station is to relay Oslo's long-wave programmes to the north of Norway.

Jeloy is a conspicuous example of the art of making 1 kw. go a long way, although, of course, his distance isn't very great.

W. L. S.

THE whole of the gramophone world seems to be going psychic, for from disc after disc comes the plaintive inquiry whether I have "Ever seen a dream walking." Judging by the numbers of crooners—and singers (I differentiate advisedly)—who have received this wonderful revelation, I must be a very ordinary and material person.

All the latest lists include this hit from the film *Sitting Pretty*, and we therefore have a wonderful variety. Bing Crosby on Brunswick, Elsie Carlisle on Decca, Joseph Wagstaff and also The Three Ginx on Imperial and Rex, are only a few of the first vocal numbers to reach me. Full dance-band renderings also are now available, and others are still to come.

The Bing Crosby and Elsie Carlisle interpretations I like best, though The Three Ginx are wonderfully neat.

Who is Mae Marion?

Another, smaller, hit is the ridiculous but pleasing "Annie doesn't live here any more." Here I am going to give you a tip—try the Brunswick Guy Lombardo and his orchestra, and Leslie Holmes singing it on Rex.

From the film *Going Hollywood*, featuring the "world's dandiest songster"—Bing Crosby—we have five numbers sung on Brunswick by the famous crooner. They are all accompanied by the orchestra used in the film, and provide a wide variety. A sixth number—"Lazy Day"—takes up the sixth side of the three discs. You should hear them all.

For light-hearted fun I recommend The Three Radio Rogues in "A Radio Party" (Brunswick), which contains a wide variety of mimicry from Kate Smith to Rudy Vallee during an impressionistic sketch of American radio programmes.

I haven't heard or seen Mae West in her notorious *I'm No Angel* film, but she has recorded numbers of it on Brunswick, I understand. Mae Marion, on the other hand, I have heard in "Come Up and See Me Sometimes," from the film *Take a Chance*, on Rex, and she is really excellent. If you like the "hotcha" type of number you'll thoroughly enjoy it. "Mae Marion," by the way, sounds very much like Eve Becke, especially in the second number on the disc, "The Girl on the Scooter."

Britain's Best Dance Vocalist.

Jack Hylton still wears the crown of British stage bands, so you must hear him on Decca playing "Honey-moon Hotel"—full of pep and truly Hyltonian.

I am a little disappointed in the recording of the Eight-Piano Symphony on Decca this month. The pianos "swing" a bit, and thus spoil the sustained passages. Otherwise, "My Song Goes Round the World" and "By a Waterfall" are noteworthy achievements.

Another piano record worth close attention is the Peggy Cochrane Selections from "Too Much Harmony" and "Moonlight and Melody" on Broadcast. They are both very good and well arranged,



ROUND the RECORDS

Selections and recommendations from the latest gramophone lists
By K. D. ROGERS.

Probably Britain's best dance vocalist (he is not really a crooner, but a singer) is Maurice Elwin, and he is to be heard—minus the Savoy Hotel Orpheans—on Imperial. He has made two discs, both good, and the choice of numbers is "At the End of the Day" with "Lullaby Lady," and "Just a Year Ago To-night" with "Good-night" (Athlone's famous signature tune).

I am often asked by friends what is the "best H.M.V. of the month" or the "prettiest Columbia," and so forth. A question impossible to answer, of course, without a host of explanations and qualifications.

H.M.V. are not so dubious, I find, for they have definitely decided that their best record for February is that of Benjamin Gigli, the famous tenor, singing "Mamma mia, che vo sape" (Nutile) and "Musica Proibita" (Gestaldon) on DB1585. It's good, too!

Another Broadcasting Discovery.

Another famous tenor, John McCormack, is to be heard again on H.M.V. this month. "South Winds" and "Vespers" are the two songs (DA1343), the former being a composition by request of McCormack, written by his accompanist, Percy Kahn, subsequent to a drive the two took recently through some of the beauty spots of Berkshire.

Yet a third tenor figure in the list—Walter Glynn—who on B8040 gives us "I passed by your window," a never-dying ballad, and "There is a flower that bloometh."

The B.B.C. organ, a much-discussed instrument, is the star of B8094, in the able control of Thalben-Ball, organist of the Temple Church. And he shows what that organ can do with Mendelssohn's "Wedding March" and the time-honoured "War March of the Priests." I understand that the record has been made at the express request of many churches which are not equipped with full-blooded organs and want to provide music by electrically amplified gramophone for their wedding services.

Another mimic has come to the fore in the gramophone world—Beryl Orde. She is a broadcasting discovery and is only nineteen. Her "Jazz Justice" (B8104) is amusing, though the situation is rather too unreal, and features the "synthetic" personalities of Mrs. Buggins and Grandma, Zasu Pitts (always a favourite of impersonators), Billy and

Rene Houston, Greta Garbo (another well-worked name), Tallulah Bankhead, Wee Georgie Wood (excellently done) and Gracie Fields (not so good).

Greta Garbo was particularly good, and on this impersonation there hangs a tale, said to be true. It is said that when Garbo was reported to be in England some months ago a great crowd collected in one of the London teashops near a customer whose voice was undoubtedly that of the famous Swedish star. Actually it was Beryl Orde, who, I am told, believes in using in everyday life the voices of the people she imitates. On this occasion Garbo was the chosen one as Miss Orde sat talking to a friend over a dish o' tea.

An Uninteresting Collection of Discords.

It is said that Duke Ellington has dedicated his latest horror in the realms of cacophony to Mrs. Constant Lambert, wife of the composer-conductor. It appears that Mrs. Lambert met Ellington when he was over here last year, and remarked that she always called his famous "Mood Indigo" by the nickname of "Rude Interlude."

Ellington decided that it was a good title for a new number, and promptly perpetrated one of his most uninteresting collection of discords, called it "Rude Interlude," and dedicated it to Mrs. Lambert.

The name, perhaps, is well chosen, though a prefix C would make it better still, but the dedication is surely not a compliment. And yet there are some who will like it. It's a strange world!

Hail Columbia! Arrived late, but in time for a few brief comments as we go to press. More next time.

Here goes. Stanley Holloway, in popular "Sam" style, telling about "Gunner Joe" and "Runcorn Ferry" (per tuppence per person per trip). Excellent fare. (DX559.) Self-appointed Guardian—John Tilley—discourses on "The Loch Ness Monster." Very funny! (DB1265.)

A Dainty and Delightful Record.

Band of the Salvation—no! the thud of the big drum (or is it the double bass?) has misled me. It's the B.B.C. Dance Orchestra playing "On a Steamer Coming Over" and "Have you ever seen a dream walking?" Should not think they have if they make so much noise. Wants to be much more delicate. Too heavy and monotonous for indoors.

Dainty and delightful piano record—Carroll Gibbons and John W. Green (composer of "I Covered the Waterfront" and lately returned to America), playing "Close Your Eyes" and "You've Got Everything." So have they. Let's have some more. (DB1263.)

More serious, but just as pleasing—the Ivory Keys Piano Orchestra playing "Hungarian Dances" (Brahms) and "Ride of the Valkyries." Prefer the former; latter needs strings. A fine record, though. (DB1260.)

RECEIVERS of RENOWN

THE manufacture of modern radio sets calls more than ever for the services of highly skilled operatives if anything approaching mass production is to be achieved. It is practically impossible to take on additional workers at the peak season of the year and to trust to luck that they will be able to do the job. Each and every one of them has to be trained, and the training costs money—money which has got to be paid by someone, and that someone is *you!* Your contribution is included in the price that you pay for your set.

Delicate Processes in Manufacture.

Yes, you may argue, but what is it compared with all the other costs which are incurred in the production of a set? Perhaps the best answer is to tell you that for some years past the training of operatives to carry out the delicate processes in the manufacture of their sets has involved H.M.V. in an annual outlay of £25,000!

Twenty-five thousand pounds! But it is an expenditure which will be incurred no longer in the production of H.M.V. sets, for by the introduction of a spread-over system which provides all-the-year-round employment for their workers the expenses which would ordinarily be incurred in the training of fresh hands are practically eliminated.

And the first fruits of this go-ahead innovation? An honest-to-goodness right-up-to-the-mark all-electric superhet for 12 guineas! A set that is honestly worth 15 or 16 guineas of anybody's money; a set that definitely sets a standard for 1934.

If it Passes our Tests—It's Good.

Of course, it's easy to be eulogistic in print; in fact, somebody asked us recently why it was that *all* our test reports on commercial sets were good. The plain truth is that unless a set submitted for test comes up to the standards that we set for it, then we obviously cannot include it under the heading of a "Receiver of Renown." If it does appear as a receiver of renown, then it has passed our tests and it is good.

But sometimes, in the course of our many tests, we come across a receiver that is outstandingly good, and such a set, without a doubt, is the new H.M.V. "Superhet Four Forty." Naturally, in judging performance, we are not able to neglect price, for it is true the whole world over that you cannot get a quart from a pint pot. But you *can* get a "pint" of quality, and it's a jolly good pint that you get from the "Superhet Four Forty."

Appreciating the Value.

Bear in mind the price, and then, as we tell you more about it, you will appreciate to the full the value that is offered in this remarkable new set.

The A.C. model, which was the one submitted to us for test, can be operated in any room, if necessary, without the use of external aerial and earth. No more "haven't-an-aerial; couldn't-use-it-if-I-had-



THE NEW H.M.V. "SUPERHET FOUR FORTY"

SPECIAL FEATURES OF AN OUTSTANDING DESIGN.

1. No external aerial or earth needed.
2. Whistle suppressor ensures particularly clear reception.
3. Single-knob, ball-bearing main tuning.
4. No-loss of quality when controlling volume.
5. New type moving-coil speaker with "secret process" cone.
6. Undistorted output of 1½ watts.
7. Voltage range from 200-250 : Consumption approximately 60 watts.

Models for A.C. or D.C. mains are available at 12 guineas and 13 guineas respectively.



A back view of the new H.M.V. receiver shows that the high quality of workmanship which one associates with H.M.V. productions has not been sacrificed to the extremely moderate price of the instrument.

it" complaints. This is a set that can be used by anyone whose home is wired for A.C.

No "Disconcerting Bursts."

Point number two: it is a superhet; but it does *not* cause interference with nearby sets, it does *not* suffer from "images" and it does *not* give a disconcerting burst whilst tuning past the local station. So much for the "does nots," and now, more to the point, for the "what it does do's"!

First, it gives particularly clear reception, due to the duplex action whistle suppressor which is incorporated. Those of you who have had the pluck to search round Europe since the Lucerne Plan came into force might well want a "whistle suppressor" also on hearing that. It's enough to make anybody ejaculate a whistle! Yet our tests tend to show that it is in fact the case that a lot of Europe's cacophony at the present time is lost to the user of the "Superhet Four Forty." Reception is definitely clearer.

Station after Station—One Control.

Then, again, the wide balance of reproduction, i.e. true top as distinct from second-harmonic top, was a most noticeable feature in the tests which we conducted. Most noticeable, too, was the extreme ease with which the set could be operated.

Station after station—literally dozens of them—could be heard simply by rotating the one main tuning control, and the provision of a graduated volume control enabled the level of sound to be adjusted *without loss of quality on low volume*. That is a most important point to bear in mind. As for tone—well, most of us seem to have different ideas on the subject, and the provision in the design of the "Superhet Four Forty" of a tone control is, in our submission, a most welcome feature.

This Set will Achieve Popularity.

As is only to be expected of a really modern design such as this, provision is also made for the connection of a gramophone pick-up. The total undistorted output on radio or gramophone is 1½ watts, a figure more than adequate for all normal domestic requirements, and the loudspeaker is a moving coil of the energised type.

The cabinet is a fine piece of work. It is of cross-grained walnut marquetry standing on ebonised feet, and particular attention has been paid in its design to the elimination of "boom." There is no wooden fret in front of the loudspeaker cone and an unobstructed path is thus provided for the sound waves.

All things considered, there is little doubt that this set will achieve widespread popularity. The price at which it is offered, coupled with the high esteem in which all H.M.V. products are held, will be good enough recommendation for most people; and as for the "doubting Thomases," if any—well, our word is good enough, isn't it? It is certain that you will not find better value anywhere.

THERE has just been a sort of panic at Broadcasting House among the programme staff. This seems to have started with a rumour that the Board of Governors had ordered a sudden and drastic reduction of expenditure on programmes. There were hurried meetings and conferences and much attention paid to various alternative systems of "cuts," each of which seemed seriously to lower programme standards.

And then it turned out that the anxiety and effort were not as necessary as imagined. No order of the kind had been given. What was done was to ask programme staffs to review their commitments and plans in order to see if the summer period could be carried on a somewhat lighter budget than the winter.

From the all-too-obvious effect on the morale of my friends in the programme departments I think it is not too much to ask of the B.B.C. administration that they take steps to prevent the recurrence of any such panic. The programme end of broadcasting should get all the support and resources available, and it should be recognised that this is a matter of permanent policy.

The B.B.C. in Balham.

The B.B.C. is to be congratulated on getting hold of the new property in Nightingale Square, Balham, at such favourable terms. This transaction is regarded as a special feather in the caps of Mr. Ashbridge, the Chief Engineer, and Mr. Tudsbury, the Civil Engineer to the Corporation. I understand about seven acres are involved, and that the deal has been put through by Messrs. Salter, Rex & Co. for a figure of about £13,000. It includes the Convent of the Perpetual Adoration, the chapel of which is being converted for sound experiments.

The new property is badly needed by the technical research officials of the B.B.C., who will be able to get straight on with micro-wave, television and other new work.

Bother in the West.

The B.B.C. is having a rough passage in Devon and Cornwall. I have already reported the meetings of protesting mayors

THE MIRROR OF THE B.B.C.

A PROGRAMME PANIC

**New Quarters for Research—
The Mayors' Protest—Opera in
1934—Close Co-operation with
Film Studios.**

REFLECTIONS BY O. H. M.

in Plymouth. The immediate grievance was the threatened disappearance of the Plymouth station. The B.B.C., however, has agreed to keep an "open microphone" at Plymouth, so that all local features that deserve broadcasting can be put on the air from there.

"STAINLESS" TAKES A LESSON



Reginald New explains to Stainless Stephen the mysteries of the organ at the Blackpool Tower. "Brainless" (exclamation mark) wants to know what would happen if he tried to operate all the "gadgets" at once (full stop).

The other and chief grievance is that Wales is getting undue attention in the West Regional arrangements. There is also disappointment that Daventry 5 X X cannot be received on simple sets in Cornwall.

Representations on these and other subjects are to be made to the B.B.C.

and the P.M.G., and it is likely that West Country M.P.'s will raise the matter in the Commons.

Broadcasting and Covent Garden.

Great secrecy surrounds the negotiations and arrangements made for this year between the B.B.C. and the new management of Covent Garden opera. I believe the negotiations have been handled by Mr. Roger Eckersley for the B.B.C. and Sir Thomas Beecham for the opera syndicate.

It is known that arrangements have been made for three relays a week for the eight weeks of the "grand season," and that the B.B.C. will pay something like £2,000 for this series. To what extent the B.B.C. has undertaken to "carry the baby" further is a closely guarded secret, but circles in close touch with the principals speak confidently of the continuance of the subsidy in some form.

No doubt the P.M.G. will give the figure when he introduces the B.B.C. accounts in the House of Commons.

Links with the Films.

Having made peace with the variety theatre interests, the B.B.C. is losing no time in getting a closer working arrangement with the big film companies. Through the good offices of Mr. George Grossmith, London Film Productions are to provide a feature programme of an hour of their stars, and this, no doubt, will be followed by similar programmes from other cinema organisations.

A "Roman Roads" Series.

Among the proposals made by the Executive Committee for the meeting on March 21st of the Central Council for Broadcast Adult Education is one that the summer talks programme should include a series of six talks based on the re-exploration by the speakers of the Roman roads of Britain.

"Light" Features.

Gwen Farrar, the well-known music-hall star, is taking part in a broadcast programme on Wednesday, February 21st, after an absence of five years from the
(Continued on page 1026.)

THAT fascinating story of the trial of Charles I recently broadcast raises a certain question of radio technique. I refer to the employment of two narrators to tell the story in the Marco-Giuseppe manner, immortalised in that famous song in the "Gondoliers," "United we sing as one individual." The idea isn't a new one, for it has become the B.B.C.'s practice to use it in their big broadcast on Christmas Day.

Candidly, I don't think the device is the best one for the job, especially as the narrators are wont to assume too great an air of importance. In the Christmas Day broadcast this air of importance is accentuated to an absurd degree. In the "Trial," however, it wasn't quite so marked, and it didn't strike one as being so absurd.

After all, the narrators are there only in a subordinate position. They couldn't be otherwise if they are to justify the presence of the actors and actresses to perform the scenes and incidents they recount. As it is, the narrators tend to steal the artists' limelight by the suggestion that they are the greater part of the whole.

We sometimes have similar items in the Children's Hour. But here there is only one narrator who does his job quietly and unobtrusively, but no less effectively. I much prefer the quieter method, as

it brings into greater relief the performance which is the real purpose of the broadcast.

This imperfection, however, didn't interfere with my enjoyment of the "Trial." The fact that after it I felt I must read more of the interesting period

rapidity with which people and things are made to move. Such a distortion is not uncommon on the films, and as both media experience the same difficulties in production it might conceivably happen on the air.

I haven't read any reason for not divulging the names of the cast that played the "Trial." Surely it wasn't the wish of the artists that they remain anonymous. I thought all artists craved for publicity. Whose inspiration was it, then? Was it just one of those inexplicable things the B.B.C. does every now and again?

Broadcasting has taught us to appreciate the virtues of a nice speaking-voice. In fact, it is by their voices that we judge broadcasters. Some players in the "Trial" possessed good voices, while others did not. I thought the actor who played the king was delightful and contributed as much as anyone to the success of the performance. He spoke with such dignity and modulated his voice so that he could never become monotonous. He made his judges sound second-rate.

As orthodoxy seems to be the underlying principle of programme building, an unusual item has a greater chance of scoring. This is why I liked "Flordora." This musical comedy was nearly as successful
(Continued on page 1026.)

THE LISTENER'S NOTEBOOK

Comment and criticism on recent radio programmes.

in history is proof enough that the time spent in listening to the broadcast wasn't wasted.

One incident—the public branding of Lady Fairfax, whose loyalty to the king urged her to utter words of protest during the court proceedings and the agonising shriek that followed the branding—made me wonder whether this was historically correct. I had never read or heard of it before. I wondered whether the author introduced it just to heighten the drama.

Though I wouldn't doubt Mr. Peter Creswell's knowledge of the facts, it is true that history can easily be distorted in a modern presentation. For instance, history is sometimes distorted by the

OUR SPECIAL
SUPPLEMENT for
BEGINNERS

RADIO STEP-BY-STEP



THERE are three basic qualities which every good radio set must possess. The first of these is the ability to separate one programme from another so that the *wanted* station shall be available free from interference from *unwanted* stations. This quality is called *selectivity*.

The Second Essential.

The second essential is range of reception or *sensitivity*. When a set is capable of receiving a variety of distant programmes it is said to have high sensitivity. If, on the other hand, the range is restricted to the local Regional and National transmissions, with perhaps an occasional item from

Our aim in this article is to deal with the question of selectivity, but owing to the relationship already mentioned it is impossible to discuss the one property without due consideration of the other two.

High selectivity only becomes necessary when the sensitivity

With the increase in the efficiency of modern valves and components it can be said, without fear of contradiction, that any properly designed receiver utilising three valves or more possesses high sensitivity. This means that the receiver will pick up every major British and

your tuning control to, say, London National with the knowledge that you will not get Turin's programme butting in just when you are listening to some item that you particularly wish to hear.

The greater the sensitivity of of the set the greater must be its selectivity.

WHY WE NEED HIGH SELECTIVITY

is also high. To put it another way, if the set is incapable of receiving a number of programmes the need for selectivity doesn't arise.

In the early days of broadcasting there were few stations. Consequently the receivers in use at that time did not require a very high degree of selectivity because the problem of interference did not exist.

Many More Stations.

Since then there has been a steady increase in the number of broadcasting stations occupying the band of wavelengths between 200 and 550 metres. In order to fit all these stations into this band of wavelengths it has been necessary to space them close together so that the various programmes are virtually on top of each other.

Moreover, many of these stations are using considerable power, a factor that adds further difficulties to the attainment of adequate selectivity.

Continental transmission, and also many of the lower-powered stations when conditions are favourable (as at night).

Suppose we have a set of this type with low degree of selectivity. What would happen? A practical test would soon reveal the fact that every programme tuned in would be accompanied by a background of interference from another station on a neighbouring wavelength.

Such a state of affairs would be intolerable, because the entertainment value of the receiver would be nil.

Jumbled Together.

What is the use of having a sensitive set when all that it will give is a hopeless jumble of two or three programmes *together*?

But if you have a receiver with high sensitivity and also high selectivity you have both range and the ability to choose your programme at will.

You can, for example, adjust

Several Tuned Circuits.

But selectivity of a high order can only be obtained by employing two or more tuning circuits. In practice this generally entails the use of several tuned circuits or the superheterodyne principle. It is impossible to deal with the various methods

REDUCED "SPREAD"

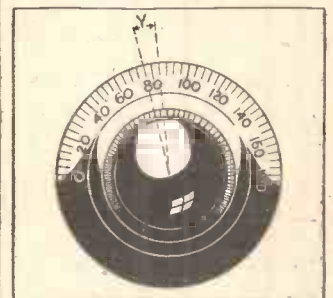

In this case the number of degrees (Y) covered by the received programme is reduced to eight, and the enhanced selectivity thus renders the reception of stations on nearby wavelengths practicable.

of meeting present-day selectivity requirements at this stage. These we must leave for a further article.

The Fidelity is Affected.

But the following facts concerning selectivity in general are of special interest:

While a high degree of selectivity is absolutely essential for a reception other than that of the local broadcasting station, it is an unfortunate fact that the ability to separate one station from another has a detrimental effect upon the fidelity.

The result of high selectivity is to reduce the higher musical notes so that, unless some correction is made elsewhere in the receiver, the reproduction tends to lose its crispness and to become too "mellow." In the modern receiver it is now quite usual to allow for this high-note loss by applying the necessary correction elsewhere in the circuit.

A BAD CASE

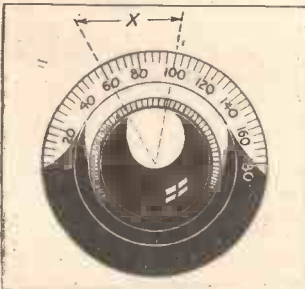

This is what would happen with a receiver possessing poor selectivity. The programme tuned in spreads over 40 degrees (X) of the tuning dial, and makes it impossible to get stations at, say, 62 or 98 degrees.

one of the more powerful continental stations, the sensitivity is said to be poor.

Question of Reproduction.

Thirdly, there is the question of reproduction. Every spoken word or musical note should be a faithful copy of the original. In the perfect receiver there would be no difference between the sounds emanating from the loudspeaker and those picked up by the microphone in the broadcasting studio. But perfection such as this does not yet exist. The good receiver possesses no noticeable distortion. That which is lacking in its reproduction must not be sufficiently marked to be audible to the average ear. In other words, a good receiver is one with a high degree of *fidelity*.

Now, although these three basic qualities—selectivity, sensitivity and fidelity—are widely different in their applications, they are, nevertheless, very closely related.

H.F. STAGES PROVIDE SHARP TUNING

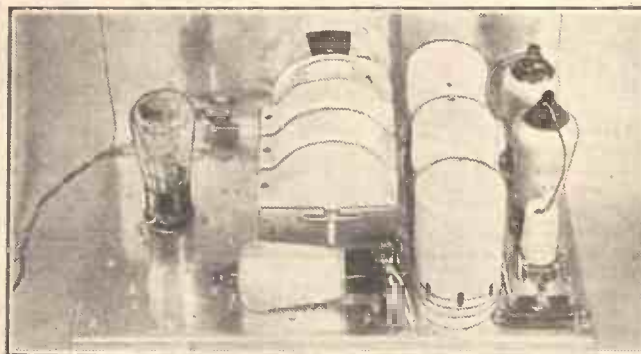

The multi-stage H.F. receiver and the superheterodyne are excellent examples of high selectivity combined with sensitivity. They usually employ band-pass tuning throughout and enable stations to be separated with ease.

Special Beginners' Supplement, Page 2

GANGED CONTROL.

THE linking of two or more adjustments so that they can be operated simultaneously by means of a single control. Common examples of "ganging" are the coupling of potentiometer and switches, the linking of wavechange switches and, most familiar of all, variable condensers.

A "two-gang" condenser is a pair of tuning condensers operated by a common control.

There can be serious losses of efficiency in a ganged condenser tuning system if (a) the separate condensers in the unit are not accurately matched, and (b) the coils used with the device also are not accurately matched.

It is not only necessary that the maximum capacities of the condensers should be identical, but that at any given setting made with the common control the same precision of matching should be achieved.

The various stray capacities in the attendant wiring and associated apparatus are compensated for by "trimmers," and these are small condensers

A ONE-WAY PATH

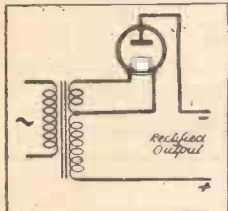

Fig. 1. The valve in this half-wave rectifier circuit passes current in one direction only.

joined in parallel and integral with the construction of the ganged unit.

Sometimes the adjustment of one of the trimmers is made by means of a small knob concentric with the main tuning control. With this ganging, deficiencies which may occur at various points in the tuning range can be compensated for, and the performance of the set that is being tuned may materially benefit.

Robust Construction.

A ganged condenser needs to be very robustly constructed, for any mechanical weakness will probably react very undesirably on its electrical effectiveness.

Complete metal screening for such a component is often highly desirable.

It should be noted that there are definite standards laid down for ganged condensers, and when these are worked to and the condenser is properly used with suitable coils, ganged tuning can be very satisfactory.

GRAMOPHONE MOTOR.

A clockwork gramophone motor needs periodic oiling, and a high-grade, fine oil should be used for the various bearings and the brake pad, and grease for the gears.

Sparking at the commutator, and even irregular running in a D.C. motor, indicate that either the brushes need adjustment or, more likely, the commutator needs cleaning. Use fine glass paper for this.

Harmonics are not usually desired in wireless transmission, for a station obviously does not want its fundamental frequency to be accompanied by radiations on other wavelengths; but harmonics are very important in speech and music, for it is these which give characteristic tone or timbre.

It is the harmonics which enable one to differentiate between the same notes struck on different instruments, for instance.

travel to the layers and be reflected back as "echoes."

HENRY.

The unit of inductance.

HETERODYNE INTERFERENCE.

This is usually heard as a continuous, high-pitched whistle. It is caused by the "carrier" of an unwanted station beating with that of the required station. The frequency of the beat note is the difference between the frequencies of the two stations.

The station causing the interference may be hundreds of miles away.

A very high-pitched heterodyne interference can be eliminated with a "heterodyne whistle filter" comprising a choke and condenser designed to absorb at the frequency of the heterodyne. Or tone control of a conventional kind can be applied to reduce the high notes, though in the process speech and music must, of course, suffer to some extent.

HIGH FREQUENCY.

Any frequency above about 20,000 cycles. Also referred to as a radio or supersonic frequency.

WHAT IT DOES

Fig. 1a. Showing the effect of half-wave rectification.

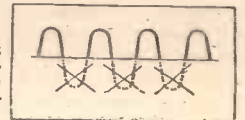

HIGH TENSION.

The voltage applied to the plate of a valve.

HYDROMETER.

A device for measuring the specific gravity of fluids. Several types are made, but the one most usually employed for testing accumulator acid solutions consists of a small glass container, into which the solution is drawn with the aid of a rubber bulb having coloured beads in it designed to float or sink at certain specific gravities.

HYSTERESIS.

This is a lagging of the magnetic effect in iron which occurs when the magnetising force is increased or decreased.

Change the current flow in the winding of an electro-magnet and the resulting magnetism (flux density) does not keep quite in step, but lags behind. The energy dissipated in this way is known as hysteresis loss.

There is very little hysteresis loss in the modern cobalt- and nickel-iron alloys used in radio apparatus.

RADIO TERMS

A PRACTICAL REVIEW

BY C.V. DOWDING, ASSOCIATE I.E.E.

The inductive type of A.C. motor is probably the most trouble-free type.

HALF-WAVE RECTIFICATION.

We have seen that in full-wave rectification both the positive and negative half-cycles of the A.C. mains supply are made use of, but in half-wave rectification only alternate half-cycles are employed.

The action of a half-wave rectifier is to suppress the one half of each cycle (Fig. 1a).

A simple half-wave (or single wave, as it is sometimes called) rectifying circuit is shown at Fig. 1. A two-electrode valve is illustrated, although a metal rectifier can be employed.

HARD VALVE.

A valve in which very little gas indeed is left. A perfect vacuum is impossible, but a hard valve is one of the closest approximations to the ideal that can in practice be attained.

A soft valve, i.e. one in which there is a higher residue of gas particles, develops "blue glow" owing to the ionisation of the atoms of gas resulting from collisions between them and the electrons.

HARMONICS.

Frequencies that are multiples of another frequency which is known as the fundamental. A frequency twice as great as the fundamental is styled the second harmonic, one three times as great the third harmonic, and so on.

This feature is not merely a glossary of technical terms, but a compact yet comprehensive survey of modern radio technique presented in a particularly readable and practical manner. It forms a perfect accompaniment to the other articles in the Supplement.

The harmonics, or "over-tones" or "partials," extend into the higher frequencies. A middle "C" has the fundamental frequency of 256 cycles and harmonics of 512, 768, 1,024, 1,280, 1,536 cycles, etc.,

in varying degrees of strength in accordance with the character of the instrument from which it originates.

Therefore, to preserve full tones, it is essential that the set and loudspeaker should be able to reproduce the higher frequencies adequately.

HEAVISIDE LAYER.

The credit for discovering this fascinating air stratum is now shared between Kennelly and Heaviside, and so it is referred to as the Kennelly-Heaviside Layer.

The layer is a belt of air that has become ionised by the rays of the sun, and it is believed that it reflects long waves and so enables them to follow the curvature of the earth.

Short waves are presumed to penetrate this layer, but are reflected by an upper layer discovered by Professor Appleton.

RADIO REFLECTORS

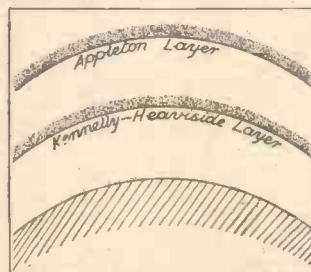

These two layers exist above the atmosphere and reflect radio waves back to the earth.

These layers are held to be the cause of fading by their frequently varying reflective properties.

The Kennelly-Heaviside Layer is some sixty-two miles above the surface of the earth, and the Appleton Layer one hundred and forty or so. These heights have been measured by noting the time taken for signals to

G.P. KENDALL

ON TELEVISION

TRANSMISSION METHODS

SO far we have kept closely to the receiving side of the question, and as far as practical work is concerned this is all that we need to study. However, I imagine that the reader who is taking a real interest in the subject will not be content with such a one-sided knowledge.

Just a general idea of the transmitting methods now in use will provide him with a considerably increased interest in the subject, and perhaps help him, too, in understanding certain special schemes for transmitting both sound and picture on the same wavelength which he may want to study later on.

Sound and Vision Broadcasting.

This week, therefore, I propose to devote my article to a general explanation of the methods used in transmission in so far as they differ from those of ordinary sound broadcasting. I put it this way, by the by, because I want to emphasise from the first that there is not a tremendous deal of difference between sound and vision broadcasting.

If we realise this fact from the start we shall find the subject will become much easier to understand. Let us get it quite clear in our minds before we go any farther.

In sound broadcasting the radiation of the transmitter is modulated at the right frequencies by applying to it speech and music currents derived from the microphone. These microphone currents are the exact electrical equivalents of the sounds which produced them in the first place, so when they are made to modulate the high-frequency radiation of the transmitter the result is something from which we can recreate the original sounds with suitable receiving gear.

The "Electric" Eye.

Once we have got our microphone currents everything is simple, as far as general principles are concerned. Evidently, it all depends on the microphone.

If this means of producing currents from sounds had never been invented broadcasting would have been impossible, no matter how great our knowledge of valves, circuits and all the other paraphernalia of radio transmission and reception.

In television we have a very similar position. The general arrangement of the transmitting apparatus will be just the same as for



In ordinary broadcasting we depend upon the microphone—an "electric ear"—but television transmission requires instead an "electric eye." The action of the photo-electric cell provides us with this, and our contributor deals below with the absorbingly interesting principles on which it works, and with its applications to television.

telephony, but we must now modulate with currents which shall be the electrical equivalents of the light-and-shade detail of each little bit of the picture being transmitted.

Where for sound we use a device which can be described as an electric ear, for television we want an electric eye, to give

USED BY THE B.B.C.
 These two photographs show some of the Baird television transmitting apparatus installed by the B.B.C. An engineer is seen making adjustments in the picture to the left. Note that the whole "camera" swivels round on a turntable.



SCANNING THE SUBJECT.

The cover has been removed from the apparatus in the right-hand picture, disclosing the interior of the camera-like structure and showing its relative simplicity. Note how the instrument is arranged to fit in a "window" which communicates with the television studio.

us the picture currents for the modulation of the transmitter.

The basis of the electric eye is nowadays almost always a device called a photo-electric cell, which is, in its usual form, the exact equivalent of the microphone. Whereas, however, the latter produces currents which vary according to the sound waves which fall upon it, the photo-electric cell produces currents varying in accordance with the light waves striking it.

Very Small Output.

Thus, when a bright light falls upon a cell it passes a relatively large current, while a weak light produces only a small current. With a good cell the current produced is exactly proportional to the brightness of the light which strikes it.

By the way, don't be misled by my reference to a "relatively large current." The actual output of the average cell is extremely small, and requires a great deal of amplification to bring it up even to the level of the output of a microphone of one of the more commonly used types.

In appearance the photo-electric cell generally resembles a small electric lamp, since the parts are enclosed in a glass bulb fitted with a cap carrying the contacts which enable connection to be made to the elements within.

The "Flying Spot" Method.

So far so good. We have here a device which will produce currents equivalent to light variations, but that alone is not quite enough. As it stands it would merely produce currents proportional to the light reflected to it by the scene or picture as a whole.

What we want it to do is to give us currents equivalent to the light reflected to it by one tiny piece of the scene at a time, so that

we can cover the whole by a scanning process similar to that in the receiver.

The simplest way to understand how this can be done, I think, is to take the system used in the present B.B.C. transmissions and see how this works. It is one of the simplest of all, yet it demonstrates the general principle so clearly that if the student once understands it he will find little difficulty in following other systems.

The name of the system I am going to

(Continued on next page.)



TELEVISION TRANSMISSION METHODS

(Continued from previous page.)

describe tells us a good deal about its working: it is called the "Flying Spot" method, and it makes use of a single brilliant spot of light flying about over the scene which is being transmitted.

The spot travels in a methodical manner, and covers the whole scene in a series of sweeps, scanning it in exactly the same fashion as that in which the receiving spot covers the viewing screen. Since, as we already know, the two operations are synchronised, the transmitting spot must scan at the same rate; it must cover the scene $12\frac{1}{2}$ times a second.

A Weird Effect.

Apart from the flying spot, the scene is usually kept in darkness, so it may well be imagined that a television studio working on this system is rather a strange place when transmission is going on, with nothing but the eerie, flickering light of the spot.

The photo-electric cell is set up facing the scene, and it will readily be understood that the only light

them joined up so that their currents are all added together before they go to the amplifiers.

I'm afraid my space will not permit me to explain in detail how the flying spot is produced, but in conclusion I can just give you a hint as to how it is done. A sort of overgrown scanning device is used, and on to this a very powerful concentrated light is focused, the usual form being an arc of the type used in large cinema projectors.

The light of the arc is directed on to the subject as the scanning device rotates, and the result is a super-powerful scanning spot.



Ulysses A. Sanabria is one of the youngest inventors prominent in the television field, and below are given some very interesting details concerning the noteworthy results recently obtained by him.



AFTER ELEVEN O'CLOCK.

Fred Douglas is the gentleman with striking garb and make-up in the picture to the left, which was taken on the occasion of the first B.B.C. television broadcast. It will be seen that he is standing on the other side of the "window" illustrated on a preceding page.

Above is another view taken during a television broadcast. This shows one of the engineers behind the scenes at Broadcasting House, making adjustments on the control panel.



falling upon it will be that reflected back from that piece of the scene upon which the spot happens to be at any given instant.

The brightness of the reflected light will obviously depend upon the light or dark nature of that particular part of the scene, and so we see how the output of the cell will vary in accordance with the nature of the various parts of the scene covered.

There you have the main principle of the method, and if you think it over I expect you will be able to visualise the way the output of the cell is continually varying in exact sympathy with the detail of light and shade of the subject which is being scanned by the flying spot.

How it is Done.

What this means is that the output of the cell is the exact electrical equivalent of the varying light-reflecting power of the parts of the scene covered by each sweep of the spot, and so there is generated the series of picture impulses which operate our television receivers.

As a practical point it may be noted that, as the output from a single cell is so small, it is customary to employ a "bank" of

MORE LIGHT!

The advance towards attaining bigger and brighter television scenes.

A PART from such questions as the need for more accurate light-control methods and greater detail, one of the most important problems in television to-day concerns the provision of more light for the illumination of the receiving screen.

Bigger and brighter pictures are badly wanted in order that we may take full advantage of the entertainment value of the programmes, and that means that a more powerful source of light at the receiver would be a great help.

This may seem strange to those with experience of ordinary lantern or home-movie projection, when it is remembered that a lamp of 100 watts may be used in a

mirror-drum televiewer. Such a lamp in a movie projector would give a brilliant picture of some two or three feet wide, but it has to be borne in mind that in this case quite a large proportion of the total light output of the lamp is actually brought to bear upon the screen.

Matters are far otherwise in the case of even the most efficient of the present television receivers. Here only a very small fraction of the total amount of light is actually put upon the screen.

Directly Modulated Source.

It is therefore very interesting to note the number of reports from different quarters which indicate that many television experimenters are working on the problem of a more intense source of light.

In some cases it appears that they are renewing the old struggle to produce a source of light which is not merely powerful but is also what may be termed self-modulating, so that it requires no separate light-control apparatus. This means in effect that they are seeking to produce a source of light which can be varied in strength by the direct application of the picture impulses, as is done in the case of the neon tube, but is of much greater intensity than this type of lamp.

In general such attempts have not seemed very promising in the past, but some interesting details which are beginning to arrive concerning the results obtained by one Ulysses A. Sanabria, of Chicago, appear to show that he has achieved something noteworthy on these lines.

The Latest Development.

It was learned last autumn that he had been concerned in giving a demonstration at a large New York "department store" in which a brilliant image, *five feet wide*, was shown. Details are still rather scanty, but it is known that he used a new light source which he has developed in co-operation with two other experimenters, and which is largely responsible for the results.

I gather that the new lamp is not merely of tremendous intensity, but is also fully self-modulating. It consists of a form of an arc burning in an atmosphere of carbon-dioxide gas, and the method of control would seem to be an electro-magnetic one.

G. P. K.

Peerless Quality

What better symbol of quality than the famous Rolls-Royce radiator? At the risk of being accused of plagiarising, we might claim Dubilier to be "the Rolls-Royce of Condensers & Resistances." Dubilier Condensers & Resistances are justly famed for reliability and steadfast trouble-free service in every type of set, however severe the conditions under which they operate. Dubilier's technical advisers, who are in the forefront of modern condenser and resistance design, are at the service of any radio manufacturer — entirely without obligation.

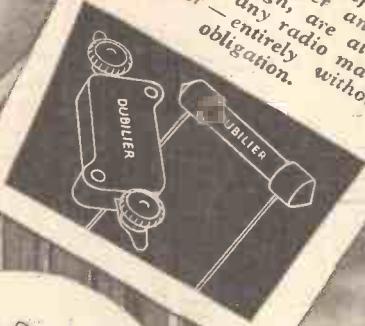

DUBILIER
CONDENSERS & RESISTANCES

7407

DUBILIER CONDENSER CO. (1925) LTD., DUCON WORKS, VICTORIA ROAD, NORTH ACTON, LONDON, W. 3.

STATIONS WORTH HEARING

A review of recent conditions on the "broadcast" bands, including details of stations that are coming in well and other information that will help you to get the best results when searching for foreigners.

By R. W. HALLOWS, M.A.

IN my last report I covered the very early days of the Lucerne Plan's working; we have now reached a particularly interesting time when the Plan is really settling into its stride—so far, at any rate, as the medium waves are concerned.

On the long waves there is still a good deal of trouble. This arises from the fact that of twenty-one stations involved thirteen stations are working according to the Plan, whilst eight are not. Huizen, or rather Kootwijk, is still trying to work on 1,875 metres, though programmes are generally ruined by a powerful Moscow station. Warsaw declined to work the Plan, and its channel was promptly grabbed by Luxembourg. Though the French had undertaken to close down the Eiffel Tower on January 15th, it remains at work, using a wavelength of about 1,400 metres.

The Eiffel Tower Trouble.

Radio-Paris (1,796 metres) is badly heterodyned, and the French say that they will not close down the Eiffel Tower until Radio-Paris is clear of interference. To this the U.I.R. reply that Radio-Paris cannot be cleared so long as the Eiffel Tower butts in and adds to the overcrowding of the long waveband. At present the problem is something like that of the irresistible force and the immovable mass.

Still, though things are by no means what they should be on the long waves, the number of stations that can be received well is not too bad. Good reception is generally obtainable from Königswusterhausen (1,571 metres), Warsaw (1,415 metres), Luxembourg, and Oslo (1,186 metres) and sometimes from Kalundborg (1,261 metres).

Luxembourg continues to defy Europe by using both a power of 200 kws. and a long-wave channel (1,304 metres). Strong official representations are, I believe, to be made to the Luxembourg Government, and if these produce no effect there is talk of deliberate mass heterodyning of the station until it is forced to adopt the wavelength assigned to it.

Long-Wave Conference.

I don't think that anything of the kind will be done; I believe that there will shortly be another conference between representatives of countries which have long-wave stations, and that eventually some satisfactory working arrangement will be reached.

On the medium waveband much better conditions prevail. About twenty medium-wave stations are received without interference on most evenings, and the number is steadily increasing. We lose a few old friends such as Strasbourg, Genoa, Heilsberg, Frankfurt and Gleiwitz, which no longer have wavelengths of their own and are therefore usually interfered with by those with whom they share channels. On the other hand, we gain a good many valuable stations which are freed from the

heterodynes that marred their transmissions before the coming into force of the Lucerne Plan.

A good example is Beromünster, now working on 539.6 metres. Up to January 15th this station was rarely heard well, but it now comes through with splendid quality and strength night after night. Mühlacker, again, could not be received by most people when it was the London Regional's next-door neighbour, but now that it is working on 522.6 metres it is amongst the best of Continental stations.

Another Fine Transmission.

Söttens (443.1 metres) some readers may find "blanketed" by the North Regional, but when a selective receiving set is used this second Swiss high-power station is well heard. Other big additions on the gain side of the account are Paris P T T on 431.7 metres, Berlin on 356.7 metres, Hamburg on 331.9 metres and Bari on 283.3 metres.

To these we shall shortly be able to add Belgrade on 437.3 metres, Marseilles on 400.5 metres, Bucharest on 364.5 metres and Kosice on 269.5 metres when their new high-powered transmitting plants are completed.

HELD DOWN BY STEEL CABLES



This station, situated at Summit, California, is 7,200 feet above the sea level. It is employed for communication with American air liners, and on account of the heavy winds at this high altitude the building is anchored by steel cables.

Up at the top of the waveband Budapest, Beromünster and Athlone are magnificently heard evening after evening. Mühlacker is generally good, though on certain recent days it has been jammed, apparently by Madona, working off its wavelength. Vienna on 506.8 metres is completely reliable, and Florence (491.8 metres), though officially sharing a channel with Murmansk, always comes in well. Brussels No. 1 is not yet to be relied upon. On some evenings it is splendidly received; on others it is heterodyned, apparently by Trondheim (476.9 metres).

Prague (470.2 metres) is free from interference as a rule, but does not appear to be always using full power at present. Lyons P T T (463 metres) is generally clear of interference and provides excellent

reception. Langenberg on 455.9 metres is always good, and Söttens is generally to be found. Paris P T T, Stockholm and Rome are clear and good. Munich (405.4 metres) is strong and interfered with only on rare occasions. Marseilles (400.5 m) though seldom very strong, is not often interfered with.

A Permanent Heterodyne.

Leipzig (382.2 metres), unfortunately, has developed what appears to be a permanent heterodyne caused by a station that may be Lwow working off its wavelength. Milan is also frequently heterodyned, the offender seeming to be Moscow IV, which ought to be working eight metres away, but does not always do so. The 100-kw. Berlin station on 356.7 metres is as good as one could desire. Strasbourg, as already mentioned, shares with Simferopol, but is occasionally quite well heard. Radio Toulouse has its good nights, though there are others when there is a heterodyne. This station shares with Helsinki. When both are exactly on the same wavelength the French station can be heard without a whistle and often without the slightest background. But if either station wanders a little a heterodyne results.

Two Causes of Interference.

Hamburg is often clear; when a heterodyne does occur it appears to be due to Dniepropetrovsk. Brussels No. 2, working on 321.9 metres, often comes in well. Breslau and the Poste-Parisien suffer only on the rarest occasions from heterodyning, but Hilversum has been rather badly jammed of late, probably by Cracow. Bratislava is not yet coming in well, but Bordeaux P T T is magnificent.

When the heterodynes that occur are analysed they are due mostly to one of two causes. Some are brought about by smallish stations on group wavelengths which either cannot or will not keep exactly to their allotted frequencies. For others some of the Russian stations seem to be responsible. When the great wavelength change-over was made on the night of January 14th-15th many of the Russian stations did not submit themselves for wavelength measurement by the Brussels Laboratory and others were not within miles of their proper frequencies. Improvements in wavelength keeping are being made steadily, but it must be some time before all stations have up-to-date frequency-control apparatus.

Which Are Really Fit?

Since the balance of the Lucerne Plan is so delicate perfect working is not to be looked for until such control apparatus is in use by every station in Europe.

When it appears the report of the Brussels Laboratory on the doings of stations during the present month will make interesting reading. It will show us how many of them are really fit to be in use under modern conditions.

TELEVISION FOR YOU



HOW TO MAKE AN ASTOUNDINGLY SIMPLE AND CHEAP VIEWER

TO those of you who think of television in terms of fifty-guinea equipment and huge power output the title of this article may invite scepticism. But the proof of the pudding is in the eating, and it is sufficient to say that the television unit described herein has, in practice, provided many hours of "looking-in" at an inclusive initial cost of less than ten shillings for the additional equipment added to a perfectly ordinary home-built radio-gramophone.

Ownership of or access to a radio-gramophone is essential, for it is intended that the electrically driven turntable of the dual instrument should serve a second purpose in driving the scanning disc of the televiewer. Removal of the unit is a matter of seconds when the radiogram is required for use with records.

Variable Speed Essential.

The unit described was designed for the particular type of radiogram cabinet which has a flush-fitting motor-board, which would appear to be the most popular type for home construction. For cabinets with a sunk motor-board certain modifications will be necessary, which will be described later.

Another important point is that a variable-speed motor is essential. This rules out the use of the unit on radiograms fitted with the particular type of motor which has to be "flicked" round to start. This type is designed to run at one definite speed—i.e. synchronously with the frequency of the supply—and is obviously unsuitable, as fine adjustment of speed of the rotating scanning discs is absolutely essential.

One more point to bear in mind is that, when the radiogram is "hooked up" for reproduction of the television image, it will not be available also for sound—i.e. if the sound accompaniment to the television transmission is required it will be necessary

to be made alternatively in sheet aluminium of heavy gauge, as sold for making up the chassis of radio receivers, or of plywood if no sheet-metal working tools are available.

If made of wood it would be advisable to line it with thin aluminium foil to give reflective surroundings to the neon lamp and to increase its effective brilliance through the image aperture. The lamp-house is completed by a simple wooden top-piece (there is no need to make provision for ventilation, as the

Though phenomenally low in cost, this easily constructed apparatus enables any listener to experience the thrills of looking-in to the television broadcasts regularly transmitted by the B.B.C. Its assembly and operation are fully described in an extremely lucid manner

By JAMES PEERS.

to beg, borrow or steal another receiver capable of receiving the Midland Regional (391.1 m.) programme through which the sound accompaniment is put on the air.

The neon lamp-house forms the basis of the whole unit, and its general appearance is apparent from Fig. 8. The original unit was made from tin-plate, cut out to the template given in Fig. 1, although it might

heat developed is negligible), and a false wooden bottom carries the lamp-holder, which is an ordinary batten-holder, from which the flexible lead passes out through a hole in the side, bushed, in the case of the metal housing, by a suitable insulating bush, such as the composition top of a wander-plug.

Building the Lamp-House.

The front edges of the lamp-house are flanged over to provide a light-tight joint with the front cover. This consists simply of a piece of plywood cut to the dimensions shown in Fig. 2, with a piece of thin ground glass stuck over the aperture at the back to diffuse the light from the neon and eliminate the direct view of the "bee-hive," which will otherwise be observable. The right-hand flange (viewed from the front) also carries a spacing piece consisting of a length of smooth planed wood about 1 in. by 1/2 in., to the front of which is fixed the front aperture light-shield made from plywood, as shown in Fig. 3.

An additional refinement which can be added is the extended hood of

(Continued on next page.)

THE COMPLETE UNIT



This view of the fully assembled apparatus emphasises its inherent simplicity of design. The scanning disc is very easy to pierce, since it is cut from cardboard.

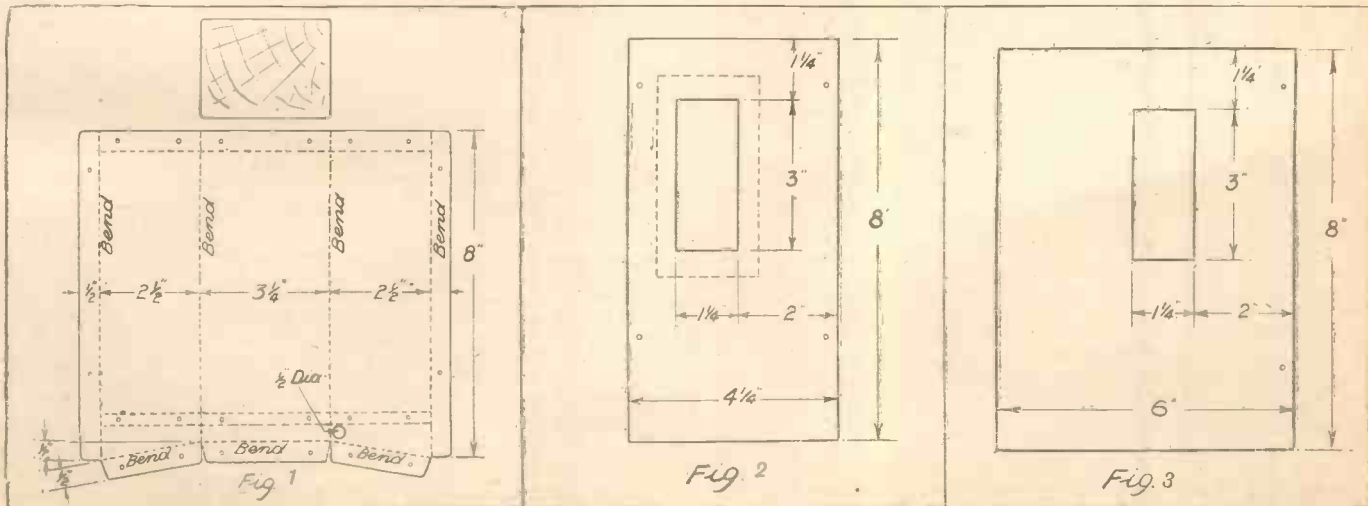

The construction of the metal- and-wood housing for the neon lamp and the aperture plate is illustrated in these three diagrams, which show how the material is cut and bent.

TELEVISION FOR 10s.

(Continued from previous page.)

cardboard, stuck to the front of the light-shield with Seccotine, and painted dull black inside and out. It adds to the brilliancy of the image by cutting off stray light in the room if it is necessary to keep the lights on, although it will be realised that, in view of the minute light actually available in the image, it is preferable to keep the room in complete darkness for effective results.

Sound to Vision Switch.

A base of 3-ply wood, to which the lamp-house is screwed, completes the unit. The dimensions and shape of the base will be governed by the space available on the motor-board to mount the unit without fouling any controls, speed regulator, pick-up arm rest, etc., but it is an advantage to have an inch of width available on the right-hand side on which to mount a single-pole change-over switch to change from loudspeaker to neon.

If the switch is connected, as shown

HOW YOUR MONEY IS SPENT

Part	Meccano Part No.	Price s. d.
A Back bearing	178	0 8
B Friction wheel, small, 1/2 in.	23a	0 3
or medium, 1 1/2 in.	20 rubber	0 1
or large, 1 1/2 in.	21 ring	
C & H Drive shaft	13 & 14	0 3
D Coupling for shaft	63	0 6
E Front bearing	177	1 0
F Clamping wheel—back	19b	0 7
G Clamping wheel—front	20	0 5
Nuts and bolts, 1 doz.		0 3
Neon lamp, Osgrim 5 w., Beehive		3 1
Lampholder		0 6
Tinplate		1 0
Plywood		0 5
Ground glass		0 3
Cork plate mat for friction drive to record		0 3
Cardboard		0 3
Picture plates and screws		0 3
Total		10 0

(Fig. 5), as a short-circuiting switch, it makes it possible to have loudspeaker only, neon only, or loudspeaker and neon together in series. The baseboard is provided with a convenient number of small brass attachment pieces, such as are sold for fixing mirrors, and these are arranged to slip over terminals screwed at convenient points into the motor-board, so that the unit can be attached or detached in a few seconds. If the baseboard is covered underneath with a piece of thick sheet rubber—e.g. a portion of an old motor-car inner tube glued on—it will obviate any undue marring of the motor-board and also reduce vibration.

Setting the Position.

The front bearer arm is attached by small nuts and bolts to the metal lamp-house, or by wood screws for the plywood construction, and a small strip of rubber is inserted to prevent any vibration from being passed to the neon. The position of this front bearing arm is dependent on the position of the lamp-house unit on the motor-board, the height of the turntable

surface from the board and the size of the turntable.

Actually the best method of setting the position, perhaps, is to fix the back bearing (A, Fig. 7; see also Fig. 9) to the motor-board at the back of the turntable, assemble the drive spindle C D H, and friction wheel B, and set the position of the bearing arm E so that the drive runs smoothly and the disc will run as nearly as possible parallel with the face of the aperture plates and centrally in the gap between them. It is very important that the drive should run smoothly and without

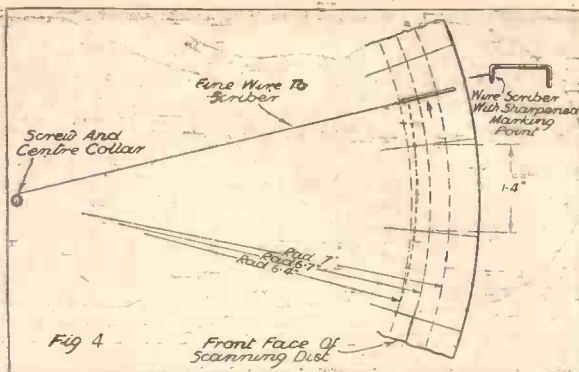

An ingenious method of marking out the spiral on the scanning disc is adopted, and is illustrated by this figure and described in the text.

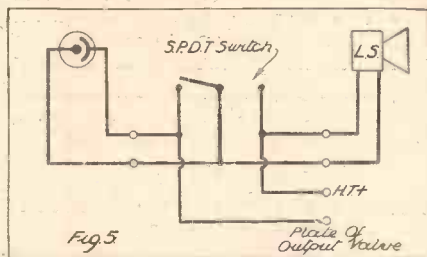

By means of a change-over switch, connected as shown here, either the television viewer or loudspeaker can be joined to the set's output.

undue friction, because the turntable motor is being loaded with a gear with a step-up ratio of about ten to one, and any undue friction on the high-speed spindle will slow the motor to such an extent as to make the requisite speed of 750 r.p.m. unattainable.

The bearings should receive a drop of light oil after final assembly, but care should be taken to keep the oil from the rubber-tyred friction wheel B. The size of this friction wheel will have to be decided by experiment, but there are several sizes of Meccano wheels available, giving diameters from 1/2 in. to 1 1/2 in., for which rubber tyres in the form of umbrella rings from the local ironmonger can be easily obtained, and the final adjustment of the gear ratio can be made by moving the friction wheel closer to the edge of the turntable, thus increasing the gear ratio, or closer to the turntable centre, and so reducing the ratio.

non-slip contact with the rubber tyre of the friction wheel, and if all the components of the friction drive are correctly and carefully assembled no difficulty should be experienced in obtaining a smooth positive drive.

The scanning disc, which is 15-in. to 16-in. diameter, will overhang the edge of the motor-board when the unit is mounted flush with the edge of a radiogram having a flat top motor-board. Where a sunk motor-board is used it will be necessary to arrange the unit inside, mounted on the motor-board, with the spindle H suitably extended and a small cardboard tunnel T (Fig. 6) fixed to the back aperture plate and the front aperture mounted on extended spacing pieces. Or, alternatively, the whole unit can be mounted out in front of the cabinet, supported on a pair of panel brackets.

The Final Steps.

SCANNING DISC.—It was found during experimental work on the "Ten-Shilling Radiovisor" that the average turntable motor could not be depended upon to drive a disc larger than about 15-in. to 16-in. diameter without overloading the motor to such an extent as to make it impossible to obtain the requisite speed of 750 r.p.m. In the unit as described here the viewing aperture is made larger than the actual size of the image "frame" to allow of various sizes of discs being used, the actual "frame" being decided as to size and position by using a cardboard mask,

1.4 in. by .6 in., which is just slipped inside the viewing hood against the aperture and gummed in place.

Adequately satisfactory scanning discs can be made from cardboard, which can be bought in sheets

(Continued on page 1018.)

ALTERNATIVE METHODS OF MOUNTING

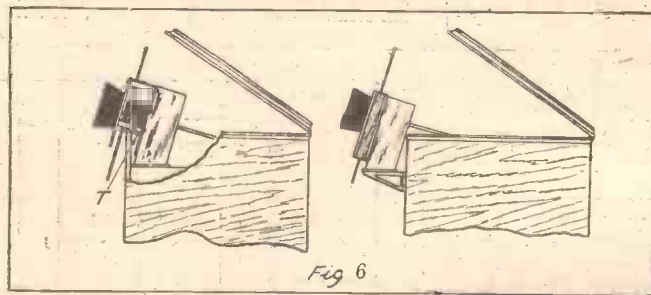

Alternative mountings for the "sunk" styles of radiogram cabinets. The photograph shows how the unit is fixed on a cabinet with a "flush" motor board.

The drive is taken from a discarded 12-in. record, which is mounted on the turntable, with a cork disc K (actually a 3d. Woolworth cork dish mat) between to eliminate slipping and to ensure a positive drive. The use of a 12-in. record will provide the full diameter which may be necessary to give the required gear ratio. The grooved surface also provides a positive



PETO-SCOTT

EVERYTHING RADIO - CASH C.O.D. or EASY TERMS

IMPORTANT. Parts, Kits, Miscellaneous Components, Finished Receivers, or Accessories for Cash, C.O.D. or H.P. on our own System of Easy Payments. Send us a list of your wants. We will quote you by return. C.O.D. orders value over 10/- sent Carriage and Post Charges Paid. **GREAT BRITAIN ONLY.** Irish orders executed for Cash only.

BARGAIN
PHILCO 5 VALVE BALANCED SUPER-HETERODYNE LOWBOY CONSOLE MODEL 5/6.
 All Electric; seven tuned circuits with single dial control. Gives amazing performance with new economy in operating costs. Duo wavelengths; no leak between bands. Illuminated dial, no reaction; chassis and tuning condenser floating on rubber. Oversize, energised M.C. Speaker with large baffle-board gives crisp, full tone. Beautiful cabinet in Walnut and Oriental woods with rich inlays. Height, 39½ in.
LIST PRICE 22^{GN} OUR PRICE 12^{GN}
 Or 18 Monthly payments of 16/6.

CONVERT YOUR SET TO CLASS "B"
Pilot Class "B" Conversion Kit
 Converts your present Battery Set to Class B Amplification. Complete with all necessary components, including driver transformer, Class B output choke, W.B. 7-pin valve holder, B.Y.A. 240B. valve, wire and screws, etc. Full-size blue print assembly instructions and diagrams. Cash or C.O.D. Carriage Paid, 37/6.
5/- only
 Balance in 7 monthly payments of 5/6.

BRITISH RADIOPHONE MATCHED PERFECTION 7. Complete Kit, less Valves. Cash or C.O.D. Carriage Paid, 28/5/0.
15/3 only
 Balance in 11 monthly payments of 15/3.
GUARDIAN P.P.P. 4-VALVE KIT, less Valves. Cash or C.O.D. Carriage Paid, 22/19/6.
5/6 only
 Balance in 11 monthly payments of 5/6.
TELSEN CLASS "B" 3 KIT. Complete kit of Parts, less Valves. Cash or C.O.D. Carriage Paid, 23/14/0.
5/- only
 Balance in 11 monthly payments of 7/-.
NEW BLUE SPOT PERMANENT MAGNET MOVING-COIL SPEAKER 45 P.M. With input transformer. Cash or C.O.D. Carriage Paid, 22/5/0.
6/- only
 Balance in 7 monthly payments of 6/-.
NEW ROLA CLASS "B" PERMANENT MAGNET MOVING-COIL SPEAKER AND AMPLIFIER. Complete with valve and input transformer. Two models: "A" for P.M.2B, P.D.220 and 220B; "B" for 240B and H.P.2 (state which when ordering). Cash or C.O.D. Carriage Paid, 23/11/0.
6/6 only
 Balance in 11 monthly payments of 6/6.

W.B. P.M.4A. MICROLODE PERMANENT MAGNET SPEAKER
 complete with switch-controlled multi-ratio input transformer. Cash or C.O.D. Carriage Paid, 22/2/0.
5/9 only
 Balance in 7 monthly payments of 5/9.

GARRARD AUTOMATIC RECORD CHANGER for A.C. mains. Mounted on unit plate, complete, ready for fitting in position, including Garrard Pick-up and Tone Arm. Cash Price, 110/10/0. Carriage Paid.
18/6 only
 Balance in 11 monthly payments of 18/6.
B.T.H. MINOR PICK-UP AND TONE ARM. Cash or C.O.D. Carriage Paid, 21/1/0.
4/6 only
 Balance in 4 monthly payments of 4/6.
W.B. EQUILODE EXTENSION SPEAKER with adjustable Switch, Chassis and Equilode Unit for perfect matching. Cash or C.O.D. Carriage Paid, 21/13/6.
4/6 only
 Balance in 7 monthly payments of 4/6.
R. & A. MULTIX EXTENSION SPEAKER for Commercial or Home-Built Receivers, past or present, no matter what the circuit. Chassis Model. Cash or C.O.D. Carriage Paid, 21/10/0.
4/- only
 Balance in 7 monthly payments of 4/0.

PETO-SCOTT 30 Ratio EXTENSION SPEAKER
 Suitable for 1001 Receivers, including CLASS B, Q.P.P., Super Power and Pentode outputs. Instantly adjustable ratios. Cash or C.O.D. Carriage Paid, 29/6.
2/6 DOWN.
 Yours for 2/6; balance in 6 monthly payments of 4/9.

ECKERSLEY D.C. RADIOGRAM YOURS FOR 18/-

and 11 monthly payments of 18/-
KIT "A" Author's Kit of First Specified Parts, including Receiver and Power Unit, but less Valves and Cabinet. Cash or C.O.D. Carriage Paid, 29/18/0, or 12 monthly payments of 18/-.
KIT "B" As for Kit "A" but with Valves only. Cash or C.O.D. Carriage Paid, 22/7/6, or deposit 22/7/6 and 11 monthly payments of 21.
KIT "C" As for Kit "A" but with Valves and PETO-SCOTT D.C. Radiogram Cabinet as illustrated, less Gramophone Equipment and Speaker. Cash or C.O.D. Carriage Paid, 21/10/0, or deposit 21/10/0, and 11 monthly payments of 21/10/0.

RECOMMENDED ACCESSORIES
 1 Garrard Universal Gramophone Motor for D.C. complete with Slider Resistance. Cash or C.O.D. Carriage Paid, 25/5/0, or 12 monthly payments of 9/6.
 1 B.R.G. Pick-up, Cash or C.O.D. Carriage Paid, 17/6.
 If Peto-Scott Permanent Magnet Moving-Coil Speaker required, add 19/6 to cash price, or 1/9 to each monthly payment.

EXCLUSIVELY SPECIFIED PETO-SCOTT RADIOGRAM CABINET



Another exclusive and delightful cabinet by PETO SCOTT, also specially designed at the request of "Popular Wireless" for the Eckersley National Radiogram. The beautiful walnut finish and handsome contrasting macassar veneer set the seal of perfection in cabinet design on this latest Peto-Scott production. Cash or C.O.D. Carriage Paid, 47/6. Or deposit 7/6 and 9 monthly payments of 5/3, Carriage Paid, Baffle-baseboard assembly 3/6 extra. Packing and Carriage, 2/6 extra.

SEND FOR NEW CABINET CATALOGUE.

SEVEN TIMES THE VOLUME PILOT CLASS "B" SPEAKER-AMPLIFIER KIT

Assemble this amazing Unit yourself in less than half an hour. Gives seven times the volume with mains quality from your existing battery set. Complete Kit comprises B.V.A. Class "B" Valve, Peto-Scott Permanent Magnet Moving-Coil Speaker, B.R.G. Driver Transformer and Input Choke, seven-pin Valveholder. Peto-Scott Baffle and Baseboard Assembly, all necessary Wires, Screws, and plug-in Valve Adapter, with full-size Diagrams and Assembly instructions.
SUITABLE FOR ANY BATTERY SET



Complete with Speaker Cash or C.O.D. 55/- Carriage Paid.
 Or Send Only 6/-
 Balance in 11 monthly payments of 5/-.

ECKERSLEY NATIONAL 3

KIT "A" Author's Kit of first specified parts, including READY-DRILLED PANEL and METAPLEX chassis assembly, but less valves and cabinet. Cash or C.O.D. 25:10:0
 Carriage Paid or 12 monthly payments of 10/-

"KIT B" As Kit "A" but including set of specified valves, but less cabinet. Cash or C.O.D. Carriage Paid, 27/9/0, or 12 monthly payments of 13/9.
"KIT C" As Kit "A" but including valve and Table cabinet. Cash or C.O.D. Carriage Paid, 28/6/6, or 12 monthly payments of 15/3.
 Exclusively Specified PETO-SCOTT Cabinets. TABLE MODEL 17/6. RADIOGRAM MODEL (as illustrated) 47/6. FOR FULL DETAILS SEE PREVIOUS ISSUES OF "POPULAR WIRELESS."

S.T. 500

KIT "A" Comprising M. Jona Scott Taggart's Kit of FIRST SPECIFIED Components, including Tolsen "Class B" Output Choke, Peto-Scott "Metaplex" Baseboard and Ready-drilled Panel and Terminal Strip. Less Valves and Cabinet. With FULL-SIZE Blue Print and copy "Popular Wireless," Oct. 21st. Cash or C.O.D. Carriage Paid, 25-5-0
 or 12 monthly payments of 9/6.

KIT "B" As Kit "A" but including 4 Specified Valves. Cash or C.O.D. Carriage Paid, 27-10-3
 or 12 monthly payments of 13/9.
KIT "CT" As Kit "B" but including Peto-Scott Specified Walnut Table Cabinet. Cash or C.O.D. Carriage Paid, 28-9-9
 or 12 monthly payments of 15/6.

KIT "CC" As Kit "B" including Peto-Scott Specified Walnut Console Cabinet. Complete with Baffle Baseboard Assembly but less Speaker. Cash or C.O.D. Carriage Paid ... 28-18-9
 Or 12 monthly payments of 16/3.
 If Peto-Scott Permanent Magnet Speaker required add 19/6 to Cash Price or add 1/9 to each monthly payment.

S.T. 500 CONSOLETTTE

An outstanding example of cabinet craftsmanship. Hand French polished. Veneered Macassar and Walnut finish by experts.



Panel size: 16" x 7" Baseboard. Size: 16" x 12". Top Loud Speaker and Battery Compartment, size, 16" x 10" high x 12" front to back.

Cash or C.O.D., 25/- Carriage and Packing, 2/6 extra. Or 6/- Deposit and 4 monthly payments of 6/- (including carriage and packing). Baffle-Baseboard Assembly, 3/6 extra.

PETO-SCOTT Co. Ltd. 77, City Rd. London, E.C.1
 Telephone: Clerkenwell 940677.
 West End Showrooms: 62, High Holborn, London, W.C.1. Telephone: Holborn 3248.
 Dear Sirs,
 (a) Please send me.....
 (b) I enclose Cash/Deposit.....
 NAME.....
 ADDRESS.....
 P.W. 17/2/34

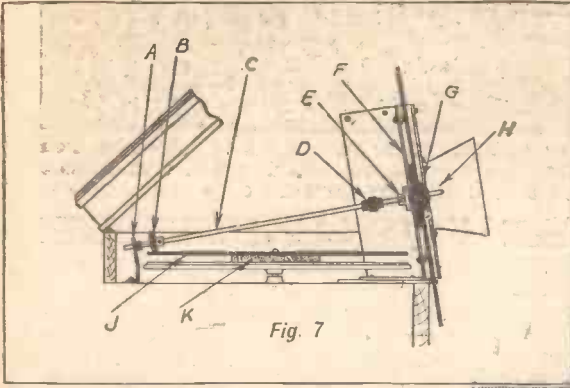

In the diagram above and photograph to the right the television is shown fitted to the motor turntable.

(Continued from page 1016.)

having a smooth white surface (ask your stationer for "three-sheet white paste-board") on which accurate measurements can be made. For the making of the scanning disc you will require a straight ruler, a pair of compasses, a good-quality celluloid protractor with clear and accurate spacings, a pencil with a long, fine point, a comfortable table to work on and a clear light to work with, as upon the accuracy with which you make your disc will depend the quality of your results.

Piercing the Disc.

The size of the aperture is 1/4 in. high by 6 in. wide, which will agree with the B.B.C. ratio of 7:3 between image height and width. 1.4 multiplied by 30 gives us a required circumference of 42 in., so that, dividing by "pi" 3.14, we arrive at the diameter 13.4 in. For our requirements 13.4 in. will be precise enough, so that, after a 15-in. circle has been cut from the cardboard, a circle with a radius 6.7 in. should be drawn and divided by thirty exact radial lines spaced 1.4 in. on this circumference. This should be stepped out very carefully around the circumference to make sure that it is exact, as any error in marking out will result in distortion in the image.

A circle 6.4-in. radius and another 7-in. radius are now drawn, the annular space between of .6 in. representing the total width of our image. The spiral of scanning holes has now to be marked off between these two circles, each hole being $.6 \div 30$, i.e. .02-in. diameter, and the holes being spaced the same distance apart.

It is not possible with ease to mark off from a ruler to such close limits of accuracy, so an alternative method is used

which gives the exact marking of the spiral. This is accomplished by fixing the disc down to the table, front face uppermost, with a screw carrying a collar (such as a terminal cap, condenser-spacing collar or mains-plug socket), which has a diameter of 1/5 in. A length of fine wire—e.g. fuse wire—is then fixed to the

will be seen that there are black lines due to the holes not being large enough to cover their respective scanning paths completely.

Enlarging the Holes.

The holes are therefore enlarged a little at a time by pricking through with a loud-tone gramophone needle, with a collar and set-screw (taken from an old discarded porcelain connector) slipped on to limit the distance the needle goes in along its taper and the resultant size of the hole. If this is done skilfully, taking the collar back carefully along the needle about a millimetre between each "pricking out" and testing between each operation, the black lines can be almost eliminated, and the disc is then ready for use.

The neon used is a standard Osglim 5-watt 240-volt neon, as used for domestic lighting in passages, etc. It requires

READY FOR VIEWING



centre boss so formed, and about two turns of wire are taken around its circumference (Fig. 4).

A small pair of dividers or a stout piece of wire bent up, with one end sharpened to a marking point, is then attached to the outer end, and, with the wire pulled firmly, *without stretching*, the marking point is worked round so that the wire is unwound as the marker moves in an anti-clockwise direction, starting from the inner circle. (A slight variation from 1/5 in. can be tolerated. If the centre-bush diameter is too large the holes will be slightly over-spaced, and the resultant images will be rather fatter than they should be, and conversely for a small bush.)

Having thus found the exact position of

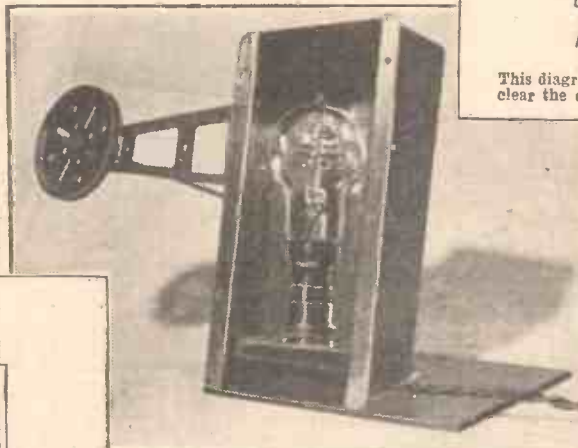
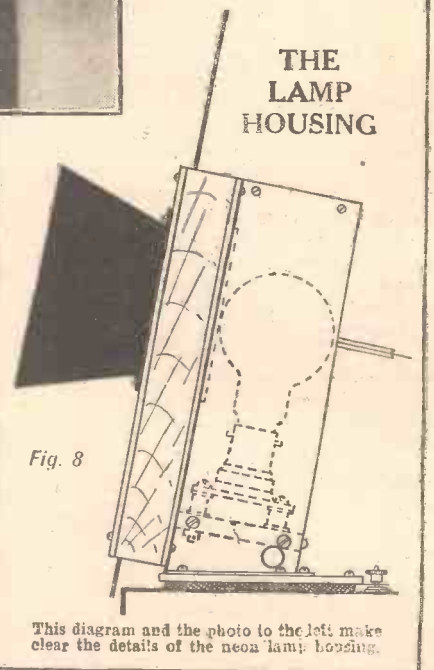

Fig. 8

This diagram and the photo to the left make clear the details of the neon lamp housing.

THE LAMP HOUSING



about 170 volts to strike and takes about 10 milliamperes minimum for effective television operation, with the resistance removed. This ballast resistance is concealed in the base of the lamp, and the base can either be sawn round close to the glass or heated gently to loosen the cement.

The Lamp Connection.

After the resistance has been taken out new insulated leads are soldered on inside and resoldered through holes drilled in the solder pips in the lamp base. (Alternatively, if you are dubious about carrying out this rather delicate piece of lamp surgery you can obtain the lamp without the resistance by ordering specially from the G.E.C. through your local dealer.)

The simplest method of connection is to insert the lamp directly in the plate circuit

each hole, the intersection of each radius and the spiral are pierced very carefully with a thick needle and the whole unit is ready for testing.

The complete unit should be assembled and the motor started with the neon light (or an ordinary incandescent lamp) alight in the lamp-house. As the disc rotates it

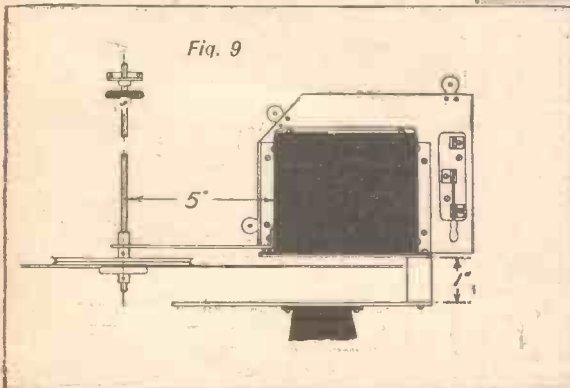

A plan view of the complete television viewer which shows clearly how the various parts are relatively disposed.

(Continued on page 1026.)

A NEW SHORT-WAVE CIRCUIT

PERHAPS you've been unimpressed by the push-pull detector circuits you have seen in the past. Their merits in theory may have been undoubted, but handicapped in practice by such obvious snags as centre-tapped coils, cumbersome reaction control and hand-capacity defects. I hope to show how these difficulties can be smoothed out, leading to a new type of push-pull detector particularly attractive for short-wave reception.

Common Output Coupling.

There is no better way of demonstrating how the push-pull detector scores over the ordinary grid detector, and how to put this theoretical superiority to the best practical advantage, than by considering a simple push-pull circuit such as that of Fig. 1.

In this detector scheme, as in all push-pull circuits, the H.F. potentials applied to each grid when a station is tuned in are exactly opposite (180° out of phase). The process of grid rectification in each valve, however, results in the rectified L.F. currents being exactly in phase, so that the two anodes can be joined together and a common output coupling used.

Although the L.F. outputs can thus be added together, the net result is not an increase in signal strength as compared with the result from one valve, because only half the input H.F. voltage is applied to each detector.

Increased Efficiency.

In spite of this you do get an increased efficiency from the push-pull detector which more than compensates for the use of two valves. Firstly, the H.F. components of

THE FIRST STEP

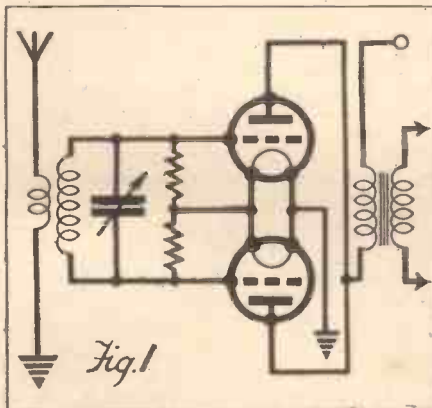

A simple form of push-pull detector which does away with the need for grid condensers.

the two anode currents are, like the grid potentials, 180° out of phase, thus cancelling one another at the common output connection. Without complicated by-passing we have thus eliminated one of the

A novel application of push-pull rectification, with reaction, to circuits designed for operation below 50 metres.

By J. ENGLISH.

chief causes of detector inefficiency—unwanted H.F. energy in the anode circuit.

Consequently, in the detector of Fig. 1 there is an absence of instability and undesirable capacity effects, and, more important still, the elimination of the heavy damping which is reflected into the input circuit by the normal grid detector.

It follows that the push-pull detector is

SIMPLE REACTION

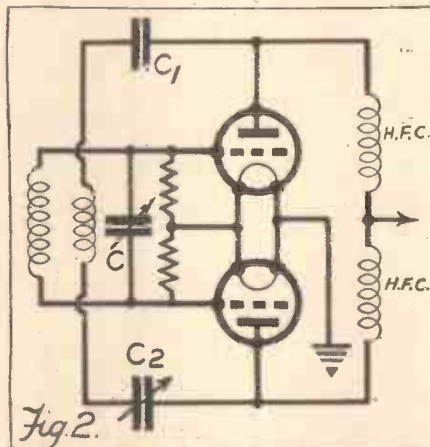

The method of reaction found most convenient by the author, and obviating the need for a centre-tapped reaction coil.

more selective and more sensitive than the single-valve detector.

Thus far we have considered the detector of Fig. 1 without reaction, which, although interesting enough in theory, is pretty hopeless for short-wave reception. Unfortunately, the fact that the two H.F. currents cancel out in the output circuit makes the ordinary reaction circuits quite useless here.

A Symmetrical Design.

Numerous reaction ideas were tried out on paper, after which experiment led to the final development shown in Fig. 2.

As far as I am aware, this scheme for a reactive push-pull detector has not previously been described, but in any case there is no doubt about its effectiveness. In fact, this circuit goes a long way towards realising the full advantages of push-pull detection in the simplest practical manner with ordinary components.

A glance at Fig. 2 reveals that the reaction circuit is quite symmetrical, which accounts for one of its most valuable features—the negligible effect on tuning of reaction adjustments. In addition, large variations of the control are unnecessary over a wide band of wavelengths. The detector oscillates quite easily down to 15 metres, the limit of present experiment, without backlash or threshold howl. The circuit also promises well for ultra-short-wave work.

The H.F. Chokes.

The degree of reaction is controlled by one of the condensers, C_1 or C_2 , as increasing the capacity of either increases reaction. Thus if C_2 is made the variable control, C_1 can be a semi-variable giving a subsidiary form of control. The main purpose of C_1 is to prevent short-circuiting the H.T. supply by the accidental contact of bare coils.

One objection that you may have to this reaction scheme is the possibility of hand-capacity trouble with C_2 . If this is mounted some little way behind the panel with an extended spindle this trouble is easily avoided.

It rather looks from Fig. 2 as if a centre-tapped H.F. choke were necessary, but two separate and similar H.F. chokes are all that are required. I have used with every satisfaction an ordinary binocular choke connecting the common anode lead to the wire joint between the two halves. Incidentally, it is only by using a symmetrical reaction circuit such as this that you can get an almost complete elimination of H.F. energy from the detector output.

You can get a nearly perfect balance of the grid circuit by using a ganged condenser or one of those special double short-wave condensers (Fig. 3). It matters little if the

THE FINAL ARRANGEMENT

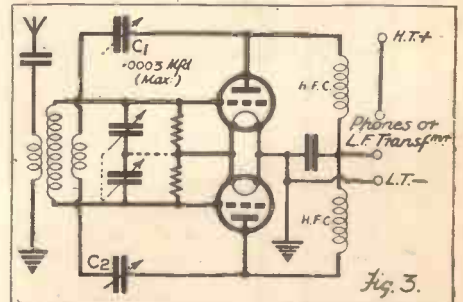

A series-gap tuning condenser is ideal for the practical application of the final circuit shown above.

max. capacity of each section is as high as $\cdot 0005$ mfd., as the effective capacity will then be $\cdot 00025$ mfd. For easy tuning two sections of $\cdot 0003$ mfd. are rather more preferable.



"Quality on musical broadcasts" has for long been the cry of our Chief Radio Consultant. This week P. P. Eckersley explains why he opposed the scheme of an Empire transmitter when he was Chief Engineer of the B.B.C.

I EXPECT you've heard me, once or twice, talking about quality. I have consistently maintained that, in the bitter end, the enduring appeal of radio lies in the spoken word and the good reproduction of music.

It is true to say that the perfection of quality is not necessary in order to understand what the broadcaster is saying. And if, by a rare chance, he is saying something interesting, then that something is the interesting thing; one is not intrigued particularly by a gain in "S" sounds or a loss of chest notes.

The most interesting broadcasts that I heard last year were, first, President Roosevelt's inauguration speech and, secondly, the Christmas-round-the-Empire stunt. The quality was in both cases, relatively speaking, poor. But the broadcasts were in both cases interesting—in one case thrilling.

But when it comes to music one is not interested in compromise quality. I loathe reproduced music. More and more and more I loathe it. Such a meretricious sham—such an ear-piercing quality!

Something Rather Extraordinary.

However, that's only *me*; I know a lot of people, particularly those called musicians, like it very much. Sir Walford Davies was quoted as saying that a reproduction he heard was—well, I forget the exact superlative. Mr. Percy Scholes once told me that his set—in 1925 or thereabouts—was perfect. As transmission was, and is, imperfect, the set must have been something rather extraordinary.

But musicians can extrapolate from their knowledge of the music the sounds that are really missing; inexpert people like myself, who enjoy certain types of music, must have all or nothing for our enjoyment.

I opposed the Empire station scheme when I was in charge of our broadcasting service. I received a great deal of criticism from people who quite honestly thought I was being reactionary and against progress, or who imagined I had some grudge against our "Dominions, Crown Colonies and Protectorates."

Now people down-under and up-over and east of Suez and all that are beginning to complain about the Empire service. They complain on two counts: first, that the programmes are not very interesting when they can hear them; and, secondly, that they seldom hear them satisfactorily enough really to understand why they dislike them so.

What I felt, and feel still, about the Empire service is bound up in the reasoning I set out at the beginning of this little diatribe.

The interesting thing about the Empire station to those in the Dominions and Colonies would be the spoken word. As to music, it's absurd to imagine that the "X"-ridden, swishing and fading noises can constitute a permanent cultural appeal. But the spoken word might. But we do not seem to be very inspired about the arrangement and content of our Empire programmes. At least, so the people of the Empire appear to think.

IN SEARCH OF QUALITY



Testing a loudspeaker in the G.P.O. Research Laboratories at Dollis Hill, London, where many problems of quality reception are solved.

It is, furthermore, unlikely or impossible that there should be a supply of that kind of continual feast of fun enjoyed by those to whom the transmissions are addressed. There might be a first approximation to suitability if Empire advertisers were allowed a shot at sponsoring programmes; but even then

Feeling Grand About Big Ben.

My own feeling was, and is, that the way to link up the Empire and, more important, the world is to use the overseas short-wave telephone link to interconnect the National or Continental broadcasting systems.

Let us suppose some important event or speech is to be given in London or Sydney, in Ottawa or Bombay or Cape Town: then it would be possible to interlink all these places by hiring the overseas telephone. At least, the majority could be interlinked.

Then the local stations could rebroadcast the event, and far more people would be

able to listen to it satisfactorily than if the broadcasting—as contrasted with the beam—stations were used.

People right away in the wilds of Australia, for example, get a better technical service from their—for want of a better word—local stations than from the Empire short-wave station.

If people want to feel grand about Big Ben, if it is a thrill to link up with the Mother Country, if the demand for that thrill is continuous and widespread, why not use the overseas telephone? It can give a much better service than the short-wave Daventry station, because the receivers of the overseas telephone, the beam receivers, are costly and expertly managed affairs, not just a det. and 2 L.F., with a piece of damp tropical creeper for an aerial.

We Must Cater for Majorities.

No! The interest in the spoken word and quality are the two recommendations of a good broadcasting service. Neither facility is supplied by the Empire station. One defect might be remedied, but the most intelligent could hardly supply a continuous service of interesting matter to be broadcast.

Thus, rather than dragging up all sorts of stuff and shooting it out, echoing between Earth and Heavenside, over a bored and empty world, wait the event and then supply the experts.

I think I was right then. I am sure I am right now!

And, finally, remember, while radio is a happy hobby for you and hundreds of thousands of others, it is just entertainment to millions. And an engineer must recognise this and cater for majorities.

"A TRULY MARVELLOUS CIRCUIT"

A "P.W." Reader Logs 39 Stations on the Loudspeaker

The Editor POPULAR WIRELESS.

Dear Sir,—Reading the article about the "Unity Two," I came across the sentence, "It is surprising what can be done with a good 'Two,'" which prompted me to write you regarding my experiences with a "P.W." Two.

A friend of mine asked me to build him a two-valver, so I looked through my "P.W.'s" and found that the "Airsprite" Two was the latest. I used everything of the best, including a fine moving-coil speaker, and I was absolutely astounded at the results.

Before I handed the set over to my friend I had logged 33 stations at good I.S. volume, and since receiving it he has brought that up to 39 on I.S.

I never expected such results from a two-valver. Thanks very much for a truly marvellous circuit.

Yours faithfully,

P. A. SALE.

124, Clare Road, Tankerton, Whitstable, Kent.

3 TYPICAL USES FOR WESTECTORS

AUTOMATIC VOLUME CONTROL

Usually the introduction of Automatic Volume Control necessitates complicated alterations. But even delayed A.V.C. may be obtained in a simple manner with the Westector.

Used as a battery economiser, the Westector enables a large output to be obtained from a battery set without using special equipment, and is applicable to any type of receiver.

BATTERY ECONOMY

HIGH-QUALITY DETECTION

When used as the second detector in a Super-heterodyne the Westector gives straight line rectification with distortionless detection, and it is almost impossible to overload it.

You will want to know more about this useful component. A development of the permanent Westinghouse Metal Rectifier, the Westector retains all the 'qualities of long life, reliability, etc.' A 3d. stamp to Dept. P.W. will bring you a copy of our booklet 'The All Metal Way 1934.'

THE WESTINGHOUSE BRAKE & SAXBY SIGNAL CO., LTD.,
82 York Road, King's Cross, London, N.1.

WHAT SET IS YOURS?

FOR EVERY SET ON THE MARKET THERE IS A SUPER-LIFE GROSVENOR BATTERY.

For instance, is yours a **PYE**

There is a Super-Life Grosvenor for every Pye Model. Ask your dealer.

Whatever the make, you would get the *most* out of your set with a Grosvenor Battery. A Grosvenor would give it just the silent super-abundant power it needs—and lasts far longer than any battery you have ever had. The Grosvenor MERCURY process is the secret; guarding against corrosion and enabling the cells to be hydraulically crammed with *extra* chemicals. Next time, insist on a Grosvenor. There is one made for *your* set!

or, if yours is a **McMICHAEL** your dealer has a Super-Life Grosvenor made specially for your set.

- PYE G.B.1. Ask for Grosvenor DBA. 475 (159 + 9 v.) 17/6
- PYE P.B. Ask for Grosvenor SR. 590 (130½ + 4½ v.) 17/6
- McMICHAEL Duplex 4. Ask for Grosvenor DBA. 395 (120 v.) 14/-
- McMICHAEL Class B.5. Ask for Grosvenor SR. 490 (99 + 7½ v.) 16/-

Mercury-protected cells make it The Longest-Lived Battery in the World

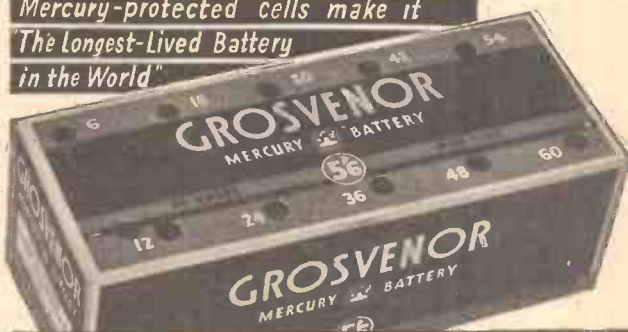

GROSVENOR ELECTRIC BATTERIES LTD., 2-3, White St., E.C.2.
Works: Watford, Herts. Telephone: METropolitan 6866 (3 lines)



Meet your Favourite RADIO STARS

One of the curious things about radio is that it puts you on friendly terms with a host of clever folk whom you have never seen—whom you possibly never will see.

You have listened to their voices so very often during the eleven or so years of broadcasting that you cannot but feel that you know them well. And yet—what are they like? You must often have wondered. No need to wonder any longer. Here they are assembled to meet you in the pages of WHO'S WHO ON THE WIRELESS, Dance Band Leaders, Comedians, Singers, Entertainers, are lined up to say "How do!"

This is a book which contains the stories of a host of your old friends. It's a book to dip into when you've switched on the radio—a book to keep because it will be always topical—always attractive. Don't miss it.

Over 300 Biographies
and Numerous Portraits
of Broadcasting Stars

WHO'S WHO ON THE WIRELESS

ON SALE AT ALL NEWSAGENTS AND BOOKSTALLS

6d.

TESTED AND FOUND?

Being leaves from the Technical Editor's Notebook

ELECTRICAL INTERFERENCE

SOME months ago a committee was formed to investigate the subject of electrical interference. Is it still sitting? I suppose it is, but news of its activities is becoming rarer and sifts through in dribbles at wider and wider spaced intervals of time.

It seems always to be like this with official or semi-official commissions and committees. They start off with great trumpet-blowing and much discussion, and then, to the man in the street, appear to fade away. A year later, or it may be two or three years later, voluminous reports suddenly appear from the void. Almost invariably there are "majority" and "minority" recommendations, for unanimity of agreement is a *rara avis* with commissions.

Everybody observes: "Oh yes, we'd forgotten all about that jolly old commission; let's see what it's got to say." The report is read, someone says a bit about it in Parliament, and that is that.

Let us hope that something more definite will result from radio's own commission, and that, too, before we have completely forgotten about it!

SILENT LISTENING

The T.C.C. Anti-Interference Unit makes no extravagant claims to be "a cure for all ills." It is scientifically made in accordance with Post Office recommendations, to deal with mains and other electrical sources of interference.



In the meantime, electrical interference continues, but is not being forgotten by enterprising concerns of the radio industry.

For example, I have recently received a T.C.C. Anti-Interference Unit. And first I must congratulate T.C.C. on the most explicit instructions which they have drawn up for its use.

Secondly, it should be pointed out that this T.C.C. device is not a "patent nostrum" of dubious character. But perhaps I ought not to have said that in view of the high standing of the manufacturers concerned; for in the circumstances it goes without saying.

Actually the unit is constructed in strict accordance with Post Office specifications and recommendations. And it embodies that well-known and well-tried two-condenser centre-point earthing system.

Simple though this is, it is remarkably efficacious in a large number of cases. We know that there are two ways in which electrical interference can reach our sets. One is via the mains themselves. And such a unit as this T.C.C. device can deal very thoroughly with that.

Connected in the mains circuit, it by-passes the disturbing irregularities to earth.

The other manner of arrival of interference is through the ether, and this—at least, that which is "man-made"—can be dealt with at the source just as successfully with the T.C.C. unit. Flashing signs, fan-motors, refrigerators, vacuum cleaners and so on can all be subdued.

We have a fan in our research department which sparks viciously at its brushes and creates havoc in the adjoining ether—unless a T.C.C. unit or similar device is applied to it.

This T.C.C. Anti-Interference Unit is fitted with fuses, and at 10s. 6d. complete provides an inexpensive cure for the majority of cases of electrical interference.

THE SILTIT EARTH CARTRIDGE

There is no doubt at all but that the direct buried earth is more efficient than any other. Nevertheless, a mere contact with the ground is not enough. You might almost as well have no earth at all as a small metal stake driven into dry, powdery soil underneath a sheltering wall.

Bone-dry soil is no medium for an earth connection—it is generally an efficient insulator!

Moisture is essential; it is the electrical binding link as it were. Very often, especially in the summer, you have to go down fairly deeply before you arrive at a sufficiently moist layer to make a first-class connection, and even so, exceptional adverse conditions may follow you down.

How, then, can a satisfactory contact be maintained? The answer is to be found in "Siltit," which is made by No-Mast Radio Developments of 110, Singleton Avenue, Birkenhead.

The Siltit Earth Cartridge contains a metallic compound of a highly hygroscopic nature. That is to say, it attracts moisture to it, condensing it out of the very atmosphere itself, in addition to pulling it in from the surrounding and lower soil.

Oh, yes, it really does do this, I can assure you, for I have not only had the contents of a Siltit analysed, but have also given it practical tests myself.

The manner in which some devices are advertised may lead the more knowledgeable of my readers into the error of imagining that a chemical earth of the nature of Siltit is a member of the same species. But it certainly isn't.

Siltit is based on a sound scientific principle, and cannot fail to be of value in making a good earth better or rendering it possible to make an efficient contact with otherwise quite unsuitable soil.

Siltit also includes no terminal or other such junction to be eaten away by a corrosive or electrolytic action, for the stranded connecting wire is carried right down to the lowest point where it spreads out.

A most commendable feature, this, and one which adds reliability to an intrinsically sound idea.

Siltit costs 3s. 6d., which is not much to pay for a sound earth. Owing to its special character it does not necessarily have to be buried at any fantastic depth, and so can be installed with a minimum of time and trouble.

A UTILITY FLAT SWITCH

The problem of multi-pole change-over switching is a nasty one, especially in H.F. circuits. Generally, in order to ensure noiseless contacts, large surfaces and a bulky construction seem almost inevitable.

Even given that, there remains the capacity question, with its implications of unwanted coupling effects to be settled.

However, in characteristic manner, a well-known firm of condenser makers have turned their attention to the matter, and with sound engineering, great ingenuity and a full knowledge of everything connected with noise-free contacts and low losses have produced what is, in its way, quite a masterpiece.

This is the Utility Flat Switch, made by Messrs. Wilkins and Wright, Ltd., of Utility Works, Holyhead Road, Birmingham.

MULTI-POLE CHANGEOVER

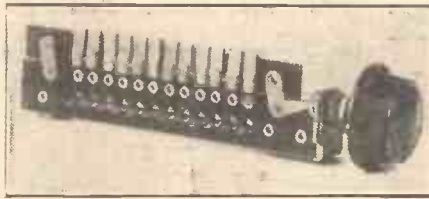

The photograph above is of the "Utility" four-pole double-throw switch, which can be mounted through only one hole on the panel, takes up virtually no room and is very moderately priced.

"Flat" is an apt name, for, as they themselves say, "Here is a new type of switch which occupies virtually no space at all!"

The action is quite novel and most effective. The easily rotating knob works a small lever which pushes the top section of the device backwards and forwards.

This slides the moving contacts to and fro, and they make contact each with one of the springs and either of its neighbours. Thus you will see that it is a self-cleaning action; and as the springs are highly resilient and of German silver and the moving pieces of silver, the switching is perfect in every way.

And owing to this special form of design the inter-contact capacity is absolutely negligible.

My sample of a 4-pole double-throw Utility Flat Switch has been operated scores of times, both for test purposes and merely for the pleasure of handling a first-class piece of work, and it has not evinced the tiniest flaw of any kind.

The Utility Flat Switch is not confined to large numbers of contacts. It can be obtained at the low price of 1s. 6d. as a 3-pole single-throw or at 2s. as a 3-pole change-over. In fact, the whole range is adequately covered.

And it should be noted that it can be mounted by means of only one hole on the panel.



Weekly jottings of interest to all buyers.

I AM afraid I rather loathe being in the position of "knowing something" which, for the time being, at any rate, I am not in a position to divulge. It mightn't be so bad if I wasn't so tremendously excited about it myself; but there it is: "orders is orders," and just for a little while longer I am afraid you must be patient and contain your curiosity.

Why have I taken the trouble to mention it at all? Simple, my dear Watson! What would you all think of uncle if, through failure to give you adequate warning, you happened just to miss a certain forthcoming issue of "P.W." in which will be given the very first and absolutely exclusive details of a development that will startle the world? Well, well, the rest is up to you.

Just watch "P.W." particularly carefully for the next few weeks, and you have my word for it that you will not be disappointed.

Historical Note.

There must surely be few firms in this twentieth century industry of ours that can make the proud boast of having just held a twentieth annual staff dinner.

It was the auspicious occasion of Ferranti's "twentieth annual" that directed my steps northwards recently, and, like everything else that this enterprising firm tackles, the effort was a brilliant success. The "electric" personality of its distinguished chief, Mr. V. Z. de Ferranti, saw to that.

I wonder how many people realise that the firm of Ferranti was founded as electrical engineers over half a century ago in Charterhouse Square, London. I have often wondered why they eventually established their home in the Manchester district, but, as a result of my recent visit, I have a shrewd suspicion that I now know.

I believe it is sound business procedure to establish one's factory in the locality where the demand is greatest. Mind you, it's purely an assumption, but while I was in Manchester it was pitch dark from the moment I arrived until the time of my departure! What would our northern friends do without electricity and Ferranti's?

"Crikey!"

Like the Loch Ness monster in a recent amusing petrol advertisement, I'm prompted to say "crikey"! So will you, I fancy, when you have read this.

It appears that in a recent advertisement in these columns our old friends J.B. announced that a blue print and constructional chart of their famous "Linacore" set would be sent free to all "P.W." readers who cared to send a twopenny stamp to cover postage.

To say that the response was amazing is to put it mildly. From the day the issue in question was published up to the time of writing these notes J.B. have been literally deluged with applications, and all existing stocks of the chart were cleared out in no time.

(Continued on page 1025.)

?

**WHAT
IS IT**

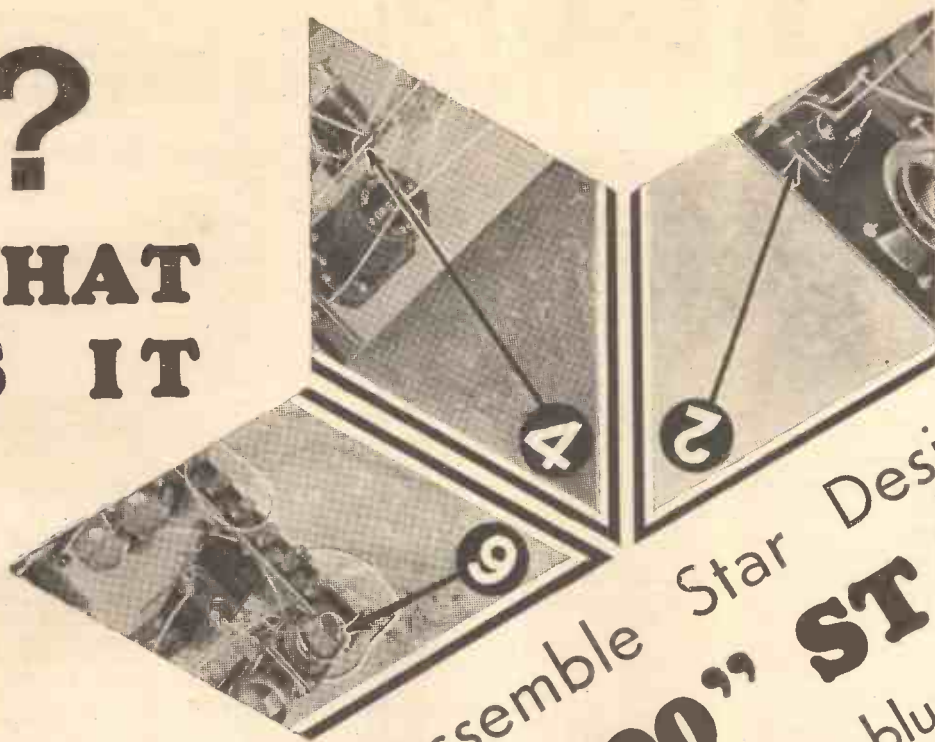

An Easy-to-Assemble Star Design
The "S.T.300" STAR
 fully described—with full-size blueprint—
 by **JOHN SCOTT-TAGGART**

in the MARCH

WIRELESS CONSTRUCTOR
 on sale this week
 SIXPENCE

CUT THEM OUT!

Cut out the six diamond shapes on this page—numbered 1 to 6—and fit them together to form a six-pointed star.

You will then have a photograph showing the salient features of John Scott-Taggart's latest triumph—the receiver you can build from THE WIRELESS CONSTRUCTOR on sale this week.



RADIO EDITORIAL

The Editor will be pleased to consider articles and photographs dealing with all radio subjects, but cannot accept responsibility for manuscripts or photos. Every care will be taken to return MSS. not accepted for publication. A stamped and addressed envelope must be sent with every article.

All Editorial communications should be addressed to the Editor, POPULAR WIRELESS, Tallis House, Tallis Street, London, E.C.4.

All inquiries concerning advertising rates, etc., to be addressed to the Advertisement Offices, John Carpenter House, John Carpenter Street, London, E.C.4.

The constructional articles which appear from time to time in this journal are the outcome of research and experimental work carried out with a view to improving the technique of wireless reception. As much of the information given in the columns of this paper concerns the most recent developments in the radio world, some of the arguments and specialties described may be the subjects of Letters Patent, and the amateur and the trader would be well advised to obtain permission of the patentees to use the patents before doing so.

QUESTIONS AND ANSWERS

TROUBLE FROM THE GRID-BIAS BATTERY.

Writing from 7, Canning Place Mews, London, W.8, Mr. E. Barrow tells amusingly of a disconcerting experience he had with a new valve recently.

"Returning home," he says, "with three new valves (det., L.F. and power), I took them out of their boxes, read the charts about G.B., etc., took out the old valves in the set, placed the new ones in, switched on.

"Well, the tone and volume was a gift from heaven. But it didn't last long, for after twenty minutes it went soft.

"I looked at the set and, to my surprise, the power valve was giving a bright light!

"I switched off at once, but that made no difference—it still kept bright.

"I pulled out the H.T.—, but that made no difference. Then I pulled out the power valve; it then, of course, went out.

"Being an old hand, I rumbled what was wrong. It had been getting current from the G.B. battery through the grid touching the filament, as the G.B.+ is joined to the L.T.—; via the G.B.— to G. of valve.

"If that happens again I shall pull out the valve at once. But thank goodness I only had 4½ G.B. on the power valve, as my H.T. had got down to seventy volts, and it did not blow the filament.

"Thanking you for your quick work in answering about the R.C. units. Now will you please tell me the best place to put the G.B.+ lead? Is it before the H.T.— fuse or after? Some put it one way and some the other, but I have got mine after the fuse."

To deal first with the position of the fuse:

When low grid-bias values are employed there is generally no point in having a G.B. fuse, but it may save damage in the case of the 16½-volt, or more, G.B. batteries.

As fuses are very cheap there is little to be said for trying to use the H.T. fuse for G.B. as well, a much better plan being to have a separate fuse in the G.B.+ lead.

If, however, it is desired to use the fuse in both H.T. and G.B. circuits, and the leads can be kept short, the connections should be arranged so that the G.B.+ lead does not go direct to the filament wiring, as usual; but G.B.+ should instead be taken to the H.T. battery side of the H.T.— fuse.

As regards the glow from the valve in this particular instance, it seems possible that some other factor was at work unsuspected by Mr. Barrow. But he certainly did the right thing in pulling out the valve!

HIGH-PITCHED HOWL WHEN USING A MAINS SET.

G. M. (Rugby).—"I never had any trouble worth mentioning until I put in the H.T. mains unit, and now it is only sometimes.

"I mean, the strength I get with the unit is much better than when I had the battery, but now I get this high-pitched howl some nights.

"It increases in volume until it gets unbearable, and nobody can stand it. So I have to switch off.

"When I had the battery in it used to ring a bit sometimes, but never this unbearable row until I turned over to the mains. No



CLIP CONTACTS.

contact of the clip itself is less likely to be the cause of this than a fault in the flex lead.

Often the continual shifting of the clip causes a break of some or all of the strands of covered wire, giving rise to weak reception, crackling, etc.

Another often overlooked trouble is the shorting of "whiskers" on to metal cans, etc. And it must be remembered that the clip should be placed on a clean bare metal surface, and not on a lacquered or dirty one, as sometimes happens.

alterations have been made to the set since fitting the unit. So what can I do?"

A howl which builds up in strength in the manner you describe is usually due to the use of a microphonic valve.

Generally it is the detector that gives the trouble, but sometimes it occurs through a microphonic valve in one of the other stages.

Probably you will easily be able to trace the culprit, because the effect can be produced artificially by tapping each valve in turn when the set is working.

If the valve is not microphonic the tapping has no noticeable effect; but when you try it on the guilty valve you will find the howl starts to build up as you describe, and the set has to be switched off to stop it.

In ordinary use it is the sound waves from the loudspeaker which are responsible for the trouble, because they cause the valve to vibrate mechanically. This vibration causes an electrical effect, which is amplified by the set and reproduced in the loudspeaker. It causes a howl, and this gives rise to

P.W. PANELS, No. 157.—STOCKHOLM, SWEDEN.

Before the Lucerne Plan came into operation last month Stockholm's wavelength was 438 metres. It is now working on 426.1 metres, immediately above the Rome dial-reading and below that of Paris P.T.T.

The power employed is 55 kilowatts, which definitely places Stockholm as a high-power station. It is well received in many parts of this country, and the same programme is usually radiated by Motala on long waves, so this should be remembered if the medium wavelength proves unreliable for reception at any time.

The call is generally given as "Stockholm—Motala," and the closing words are "God-natt, God-natt" (Swedish for "Good-night").

further shaking of the valve, which thus emphasises the trouble and causes the build-up to continue until it becomes intolerable.

The trouble can be overcome by preventing the vibrations of the valve in question.

This can best be done by surrounding it with a covering of cotton wool, felt, or similar substance, which prevent the sound waves from affecting it. But remember that a rigid valve holder must not be used, or the vibrations may be communicated to the valve via its supports.

If the valve is rather inaccessible it is sometimes sufficient to alter its vibration period by loading it with a piece of metal (or a few lead shots), embedded in "Plasticine" or chewing gum, stuck on to the top of the bulb.

(Probably the reason you did not notice the trouble much with batteries in use was because the volume then obtained was insufficient to cause the fault.)

ACCURATELY MEASURING THE VOLTAGE ON THE PLATE OF A VALVE.

E. B. J. (Forest Gate).—"Can you tell me why it is that if the voltages are measured with a reasonably good voltmeter there is often a misleading result? But an equally 'good' milliammeter is supposed to be able to tell what the actual voltage is quite satisfactorily.

"As the two instruments work on the same fundamental principle of needle deflection, why should one method give better results than the other?"

"I know it is generally supposed to do so, because people go to the trouble of working out voltage from Ohm's Law rather than trust the direct reading which the voltmeter gives. But why is the voltmeter inferior to the milliammeter method?"

The point is not that the milliammeter is superior to the voltmeter, but that the conditions under which a milliammeter is used are far better for accuracy than the conditions prevailing when a voltmeter is used.

In practice it amounts to this: If you put the average voltmeter across filament and plate to measure the voltage between these points, the mere connecting of the instrument alters the voltage which it is desired to measure.

There is often an appreciable voltage drop as soon as the connections are made, owing to the fact that a comparatively large current is passed through the voltmeter.

But when the milliammeter is used it is in conjunction with a high resistance, which limits the amount of current passing through the measuring instrument. And therefore, although there is inevitably some alteration of the voltage it is desired to measure, this is quite small in the case of the properly arranged milliammeter method, and results are reasonably accurate.

Actually, by using a really high-resistance voltmeter one can obtain the same accuracy with a voltmeter as with a milliammeter. But sensitive milliammeters are commoner than high-resistance voltmeters, so we often find the former preferred in practice.

HOW MANY OHMS?

H. A. (Weymouth, Dorset).—"I have an Igranic potentiometer which is marked '0.5 meg.', which a friend of mine tells me is the equivalent of 100,000 ohms (one hundred thousand).

"I queried him. Is he right? If not, will you please give the correct value in ohms?"

"And, in concluding, may I say that the 'Airsprite Three' was a topper, thanks to A.T.B.?"

The value of a resistance of 0.5 meg. is 50,000 ohms. As many resistances are marked in decimal fractions of a megohm it may be as well, perhaps, to again explain the principle underlying the method.

The prefix "meg." (or mega) stands for a million. So a meg-ohm means a million ohms, a mega-cycle means a million cycles, and so on.

(Continued on next page.)

RADIOTORIAL QUESTIONS AND ANSWERS

(Continued from previous page.)

Thus the value of a typical grid leak might be stated as two million ohms (2,000,000 ohms) or as two meg-ohms. They mean the same thing.

And obviously it is easier and more convenient to express big values in the latter way rather than as plain numbers.

The same applies to fractions of a million. For instance, 500,000 is half 1,000,000, so we can say it is half a meg-ohm. And 250,000 is a quarter of a million, so a 250,000-ohms resistance can be described as a 1/4-meg. resistance.

Or, alternatively, decimal fractions may be employed, as in the case referred to. The following are some representative values expressed in this way:

3,500,000 ohms = 3.5 meg., 750,000 ohms = .75 meg., 500,000 ohms = .5 meg., 50,000 ohms = .05 meg., 10,000 ohms = .01 meg., and so on.

FAULT FINDING

If you are up against a radio problem remember that our Technical Query Department is thoroughly equipped to assist our readers, and offers you its unrivalled service.

Full details, including scale of charges, can be obtained direct from the Technical Query Dept., POPULAR WIRELESS, The Fleetway House, Farringdon Street, London, E.C.4.

A postcard will do. On receipt of this an Application Form will be sent to you post free immediately. This application will place you under no obligation whatever, but, having the form, you will know exactly what information we require to have before us in order to solve your problems.

LONDON READERS PLEASE NOTE: Inquiries should NOT be made by phone or in person at Fleetway House or Tallis House.

"ANOTHER DELUSION—AUTOMATIC VOLUME CONTROL."

"DISGRUNTLED" (Pershore).—"All these new things come along, with a big noise and fuss, but what do they amount to? Ballyhoo, half the time.

"Take this Automatic Volume Control, for instance. And tell me this:

"If it is so good in keeping a station at steady strength. . . . If it really does overcome the effects of fading and strengthen the weak periods or tone down the too-strong periods. . . . If it does automatically control the volume, as it is supposed to be able to do, why do the manufacturers fit an ordinary hand-control of volume on the panel as well?"

"It's a simple question, but can you answer it in print? Plenty of us wonder about these things, but nobody explains them.

"I could give you plenty of other instances, but this is a perfect example of the sort of thing that we are expected to believe. It is hailed as a great invention, and supposed to enable the owner of the set to sit back and enjoy it without having to increase or decrease the loudness of the programme. And yet they put a volume control knob on the panel! Why?"

"Another delusion—automatic volume control, my foot!"

Just A Simple Question.

Cheer up, "Disgruntled," cheer up! We'll gladly answer your "simple" question, by asking you another, equally simple. It is this:

Suppose you had a fine set which always and truly controlled the volume automatically; and it worked beautifully, compensating for fading, etc., so that once a programme was tuned in you held it at the same strength all the time. However much you enjoyed it, would you want it at full strength all the time?

Surely there would be evenings when you wanted soft music as a background rather than "full band" strength. And surely you don't want to hear the news read out as powerfully as an orchestral finale?

That is why the manufacturers provide hand control—to enable you to choose the desired strength, and the A.V.C. holds that strength automatically.

WHERE IS RADIO-NORMANDIE NOWADAYS?

E. L. (Ripley, Surrey).—"Since the revision of the wavelengths I cannot get Fécamp or Radio-Normandie. Would you be kind enough to tell me what I can do to get it as before?"

This is a typical query arising from the experiences of readers since the wavelength re-shuffle, and we hope that the following answer will settle many doubts about the matter, and dispel the many unfounded suspicions about the sets' "falling-off" which have been entertained by readers unaware of the true cause of this reduced reception.

The cause of the fall-off is not the set, but the fact that Radio-Normandie is now using reduced power.

This being so, nothing can be done by the listener to improve matters, unless, of course, he is able to use a much more powerful set. And even with a powerful superhet, the daylight strength obtainable in Surrey is only a small fraction of what it was on a four-valver before the reduction in power took place.

THOSE U.S.A. STATIONS ARE STILL COMING OVER.

We continue to receive a great deal of correspondence about the excellent results given by the American broadcasting stations after midnight, on ordinary wavelengths. In fact, some readers get America better on the medium waveband than they can on short-wave sets, with the special 2-, 4- and 6-turn coils!

One specially interesting letter was from Mr. H. Squires, of 29, Bracewell Drive, Halifax, who says:

"I have taken your paper about five years, and the first set I ever made was the 'Magic Three.' From that time I have tried almost every circuit you have published.

"The first time I heard an American station was on January 23rd, 1932. The station was W B Z.

"I wrote for confirmation, which was duly received by me on 17/2/32. The set I was using at that time was your "Maxi-Power Four." I had dug this out because it was such a good set.

"I Am Now Using . . ."

"The best set I used till just recently was your '1933 Four.' I am now using a compromise set, using Mr. Scott-Taggart's 'S.T.500' aerial and anode circuits, but with ordinary L.F. transformer coupling, using a super-power valve operating an R. & A. Victor M.C. speaker.

"I listen every week-end for the U.S.A. stations, my latest bag being W B Z, WCA U and WTIC, the latter station coming through so strongly that it woke my wife.

"I usually get these stations any time after 12.5 a.m. at this time of the year.

"Reception is usually best when the moon is full, or thereabouts.

"Mr. Scott-Taggart's aerial reaction makes daylight reception of foreign stations a pleasure.

"My power unit is an eliminator I made from a circuit in POPULAR WIRELESS.

"(I wish to thank you for the Manual of Modern Radio—a magnificent gift.)"

THE LINK BETWEEN

(Continued from page 1022.)

So J.B. have asked me to crave your indulgence if your application happens to have been subjected to delay, and to tell you that the reprint edition is going out just as fast as they can dispatch it. From my personal knowledge of the set, you have my assurance that even if your application has been subjected to delay it's well worth waiting for.

Here and There.

Owners of the famous Marconiphone Model "269" portable receiver will be interested to learn that a special canvas cover is now available from the makers. The retail price of the cover is 25s., and, judging by the thorough way in which it is made, I am of opinion that it is worth every penny of the price.

To obviate false representation, all H.M.V. service engineers will in future carry an identification card bearing the photograph of the individual. These new "passports," which are about the size of a driving licence, will be presented whenever an H.M.V. engineer makes a call.

Easy Terms

Strict Privacy Guaranteed —we deal with you direct

ROLA CLASS 'B' SPEAKER-AMPLIFIER

SENT ON 7 DAYS' TRIAL

Complete Class B Amplifying Unit, with Valve and Rola P.M. Marine-coil Speaker. Send only 5/- for 7 days' trial. If approved, balance in 11 monthly payments of 5/6. Cash or C.O.D. Carriage Paid, £3/11/0.

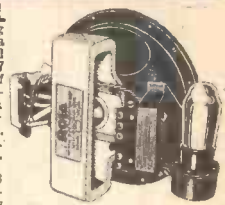

ROLA P.M. Marine-coil Speaker. Send only 5/-, balance in 8 monthly payments of 4/9. Cash or C.O.D. Carriage Paid, £1/19/6.

N.T.S. CLASS 'B' SPEAKER

SENT ON 7 DAYS' TRIAL

Complete with Input Transformer. Power or Pentode. Send only 2/6 for 7 days' trial. If approved, balance in 5 monthly payments of 4/6. Cash or C.O.D. Carriage Paid, £1/2/6. CLASS B Model, same Price and Terms. When ordering, state which type required.

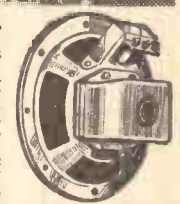

CELESTION P.P.M. 19 MOVING-COIL SPEAKER

SEND FOR IT ON 7 DAYS' TRIAL

With Standard or Pentode Transformer. Send only 5/- for 7 days' trial. If approved, balance in 11 monthly payments of 4/3. Cash or C.O.D. Carriage Paid, 47/6.



TELSEN CLASS 'B' 3 KIT

Described in the Telsen Model Radio Engineer

Complete Kit of parts, less Valves. Send only 5/-, balance payable in 11 monthly payments of 7/-. Cash or C.O.D. Carriage Paid £3/14/0.

If valves required add 2/9 to deposit and each monthly payment of £1/9/9 to cash price.



N.T.S. ELIMINATOR

FOR A.C. MAINS. SENT ON 7 DAYS' TRIAL

25 m/a. 150 volts. 4 Tappings. Suitable for all outputs, including Class B and Q.P.P. Send only 5/- for 7 days' trial. If approved, balance in 8 monthly payments of 3/6. Cash or C.O.D. Carriage Paid £1/17/6.



D.C. MODEL. Cash or C.O.D. 15/- or 5/- down and 3 monthly payments of 3/9. Any items advertised in this journal CASH. C.O.D., H.P. Send for quotation by return.

New Times Sales Co.

56, LUDGATE HILL, LONDON, E.C.4.

Dear Sirs:

(a) Please send me.....

(b) I enclose Cash Deposit.....

NAME.....

ADDRESS.....

P.W. 17/2/34.

FOR THE NEW WAVE-LENGTHS

THIS WAY CLEAR Reception

NO MORE MASTS OR WIRES!



Use a selective aerial! Use an Airclipse. Get every station separately—free from mush, with reception amazingly improved by the Airclipse filtering incoming signals. Masts and wires are banished; lightning danger eliminated. Not another gadget—a new principle.

AN AIRCLIPSE 5! AUTO-INDUCTIVE AERIAL

With astonishing clarity and new selectivity, the Airclipse gives the efficiency of an outside aerial 50 ft. high. Get an Airclipse yourself—and hear the difference.

AIRCLIPSE Ltd., 182 Vauxhall Bridge Rd., London, S.W.1

H.T. THAT LASTS YEARS

Dead "silent" background.



Any voltage supplied.

Ends the H.T. problem for good. Gives you steady, pure current year-in year-out at half cost of dry batteries. Replenish it yourself at long intervals—that's all! A proved money-saving proposition. 120 v., 12.500 in. £2 complete, carriage paid. Write for details. All Standard Battery Spares Supplied.

The well-known

WATES METER 4 in 1

You cannot get the best from your set without a good testing instrument. The Wates Meter is ideal. 0-30 m.a., 0-180-v., 0-6-v., 0-15-v., 8/6 post free. Wates Glass Accumulator; 2-1/2, 40 amp. hrs.



THE WET H.T. BATTERY CO. (P.W.), 26, Lisle Street, London, W.C.2. Gerrard 6121.

ENGINEERS! ARE YOU EARNING LESS THAN £10 PER WEEK?

If so, you cannot afford to carry on without reading our 256-page handbook. The book explains clearly and definitely many ways of carving out a successful career. Among other things it explains the Services of our unique Appointments Department, outlines Home-Study Courses in all branches of Civil, Mechanical, Electrical, Motor, Aero, Wireless, Talkie, Eng., Building, etc., and gives details of B.S.C., A.M.I.E.E., A.M.I.A.E.G.P.O., M.A.T.I.C., and all Exams. We alone Guarantee—No Pass—No Fee.



Whether you be an old hand or a budding apprentice get this book to-day—FREE AND POST FREE. British Institute of Engineering Technology, 101, Shakespeare House, 29/31, Oxford Street, London, W.1.

FREE!

Write for Illustrated Catalogue of RADIO-GRAMOPHONE CABINETS of exclusive modern design, made by craftsmen in highly figured Oak, Walnut or Mahogany, post free. REMARKABLE VALUE Cabinets made to order a speciality. Maker, under licence, of the HOWE BOX BAFFLE Recommended by the B.B.C. Full details on request. GILBERT Cabinet Maker, Estimates Free. SWINDON Estd. 1866.

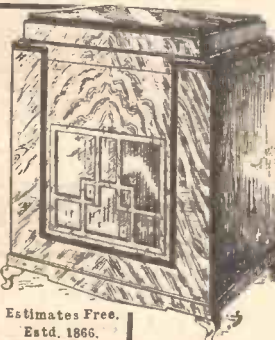

TELEVISION FOR 10/-

(Continued from page 1018.)

of the output valve, when it should strike and glow, with a light covering all the outer "bee-hive" if everything is in order. If it fails to strike, or if the glow covers only the centre disc, it should be reversed.

If you are still unsuccessful it may be due to the fact that an output filter circuit is used in the receiver, in which case a pair of leads should be brought out direct from the plate of the valve and the H.T. positive of the output choke, disconnecting the latter, and the lamp inserted. With this direct connection of the neon it is apparent that there will be a reduction of voltage on the plate of the output valve of about 160 volts, representing the voltage dropped across the lamp, so that the rectifier or eliminator should be capable of delivering about 260 volts at least, to avoid "starving" the plate of the output valve.

Automatic Speed Check.

If this voltage is not obtainable it is necessary to arrange for a separate exciting voltage supply for the neon from a battery or separate eliminator, and feed the modulated output of the last valve into the neon circuit either through a transformer or output circuit.

Having obtained satisfactory striking of the neon and noted that it fluctuates when any ordinary music or speech is tuned in, the unit should be assembled and the disc checked for speed. Users of A.C. 50-cycle mains can simply attach a small disc stroboscope on which eight arms are roughly marked, which will appear to stand still when viewed in the light of a lamp fed from the 50-cycle mains when it is running at precisely 750 r.p.m.

THE VIEWER ON TEST

THE familiar high-pitched whining told us that another television programme had started. A slight click, and we had switched over from loudspeaker to neon lamp, the red glow from which immediately suffused the viewing aperture.

Just a couple of seconds to adjust the speed of the motor, and there on the screen was the figure of a singer. And it stayed there, swinging up and down a trifle, but always completely in view.

I was witnessing a demonstration of the 10s. television just described. The most amazing part of the outfit was the simplicity of obtaining synchronisation and the ease with which it was maintained.

But don't get the impression that the test was being carried out under ideal conditions. Actually the set used was really below the average in results, thus making the demonstration even more convincing.

A detector and one L.F. circuit, driven from a 6-volt rectifier running on four volts, provided the output. And reaction had to be pushed to a noticeable extent.

Even so the head and shoulder views were perfectly clear, though the "full-stage" scannings were inclined to be lost. This, however, was no doubt largely due to the circuit conditions.

The "Good-night" card was absolutely clear, and proved beyond dispute that expensive apparatus is not necessary for practical television, experiments for the half-hour had gone all too quickly. A.S.C.

THE LISTENER'S NOTEBOOK

(Continued from page 1008.)

as "No, No, Nanette" was a short time ago. Thus there seems to be a big public for liting music. At the same time, we hear in certain quarters that dance music needs brightening up. An attempt has been made to do this by having two bands playing alternately, thus providing some entertaining contrasts. This popularity of old-time music coinciding with a decreasing enthusiasm for syncopation isn't without significance. Is this the first sign of the decline of jazz?

The success of Bruno Walter's radio version of "Il Seraglio," broadcast from the London studio, should encourage the B.B.C. to believe that this method of opera production is by no means a failure. Opera occupies a small place in broadcast programmes. There's no reason why it should.

It was a treat to hear John Hendrik, the German tenor, so soon after his appearance in the recent "Viennese" programme.

I don't think Harry Tate could have enjoyed himself much in that newspaper-office sketch written by Tom Webster. Nor could he blame his audience for being so wooden, as the sketch wasn't really up to much. Newspaper men may have seen something in it to laugh at, but to anybody else it was very dull.

Mario's always seem to achieve remarkable popularity with listeners. Mario de Pietro, of course, is quite an old-stager and a regular Children's Hour artiste. Mario Lorenzi, the harpist, is well on the way to becoming just as popular a state of affairs which his playing fully justifies.

It is to the credit of Elsie and Doris Waters that they are so consistently good. They never seem to have an off-night. I don't know whether I like them better in their songs or their cross-talk. They never do a thing to death and can always be relied on to give something fresh. Vive les seurs Waters!

It is a pity Hilaire Belloc hasn't a better voice, for he cannot do himself justice as a broadcaster. If he could I would agitate for a series of history talks by him. They would be immensely popular now that history seems to have caught the public fancy. Witness the number of historical plays now running on the stage and the films. C. B.

THE MIRROR OF THE B.B.C.

(Continued from page 1008.)

microphone. With her in the same variety bill will be Marion Harris, who is returning to England to fulfil a cabaret engagement after a year's absence in America. Other artistes in this programme are Dorothy McBlain (the Girl who Whistles in her Throat), Mrs. Pulplesure (violin solos) and John Tilley (otherwise the Mutterer). S. Kneale Kelley will be in charge of the Theatre Orchestra, as usual.

On the following evening another Old-time Music-hall programme will be presented by Mr. Willson Disher, who will recall famous nights at the old Palace. Yet another contrast will be provided on Friday, February 23rd, when southern listeners will be invited to participate in a microphone tour of some northern music-halls—the Argyle, Birkenhead; the Grand, Blackburn; the Empire, York; and the Empire, Middlesbrough.

Ernest Milton in "Loyalties."

There is no doubt that the B.B.C. is to be congratulated in having secured the services of Ernest Milton to take the part of De Levis in the broadcast of "Loyalties," by John Galsworthy, on Monday and Tuesday, February 19th and 20th respectively (National and Regional).

Mr. Milton gave a tremendous piece of characterisation when he played the part in the original production at St. Martin's Theatre, London, in 1922.

PLEASE be sure to mention "POPULAR WIRELESS" when communicating with Advertisers. THANKS!

TECHNICAL NOTES

Some diverse and informative jottings about interesting aspects of radio.

By Dr. J. H. T. ROBERTS, F.Inst.P.

That A.C. Hum.

ONE of the commonest troubles with a mains set, more particularly with a home-constructed one, is hum from the mains. I say more particularly home-constructed sets, although perhaps this is hardly fair, because I have tried many a home-constructed set which gave perfect results and in which the mains hum was virtually non-existent, while on the other hand I have had endless trouble sometimes with commercial mains sets, owing to hum and other forms of interference.

You would think that a manufacturer would have everything tried out once for all so that he knew definitely that the set would be free from hum when put on the market. I suppose this is true in a general way, but variations occur in the best regulated works, and perhaps some accidental flaw in a component, or other trifling cause, will lead to one set misbehaving itself.

Some of the Causes.

Broadly speaking, the cure for hum is plenty of smoothing chokes and condensers in the supply units and also the proper spacing and, if necessary, screening of the various components. This latter, by the way, is where trouble most frequently occurs.

The actual smoothing chokes and condensers provided, at any rate by the better manufacturers, are as a rule quite sufficient. Often, however, the mains leads into the set or radiogram will be of the twin-flex variety, and, in fact, it often happens that there are two or three other twin-flex conductors inside the set as well. Now these are apt to get shifted about, and you can easily see how trouble can arise if a bit of flex carrying A.C. gets into the wrong position.

In some sets the mains connection is made by means of a plug at the back of the cabinet, but in others a length of flex is provided, two or three yards long, terminating in an electric-light plug or twin plug, this flex passing through a hole in the back of the cabinet, with a loose part inside.

If the back of the cabinet has been removed for any reason, and on being replaced the flex gets pushed into the cabinet, so that it is lying about inside, you can easily see how this may give rise to A.C. pick-up.

'Ware A.C. Conductors.

If your set has been behaving normally and the A.C. hum has been negligible, or at any rate reasonably small, and then you suddenly find that it has become noticeable, the best thing is to go over the set and see whether by chance you haven't shifted some of the conductors about in the way I have just described. I have actually known this sort of thing to happen quite half a dozen times within my own experience.

Permeability Tuning.

We have heard a good deal lately about permeability tuning, and some people think

that this method of tuning is destined to replace the ordinary method of tuning with a fixed inductance coil and variable capacity. Several readers have asked me questions about variable tuning from time to time, so I may as well take the opportunity of saying a few words about it now.

Variable Inductance.

Perhaps, before going any farther, it may simplify matters if I say that whereas with ordinary tuning we have a fixed inductance and a variable capacity, on the other hand with permeability tuning we have a fixed capacity (or at least we may have a fixed capacity) and a variable inductance in the coil.

You may say at first that to vary the inductance for the purpose of tuning is nothing new, and, in fact, the old variometer, in which one coil was rotated in relation to another, depended upon precisely such principle.

Too Much H.F. Resistance.

It is perfectly true that tuning by means of variable inductance is as old as the hills, but the variometer tuning had certain disadvantages which caused it to fall into disuse. One of the principal disadvantages was that if the inductance was diminished the high-frequency resistance increased rapidly; the result of this was that on the lower wavelengths tuning became very broad.

Coil and Condenser Tuning.

With coil and condenser tuning this effect does not arise to any serious extent, although there is still the disadvantage that the capacity varies. It would be an advantage in some ways to keep the tuning capacity as small as possible, because this would improve the selectivity as well as the sensitivity. Inasmuch, however, as we depend upon the capacity for the tuning, this has to be varied.

With permeability tuning, on the other hand, we can at least use a fixed condenser of very small capacity and then alter the inductance so as to get our tuning range without altering this very small capacity. This may be expressed by saying that what we are after is to make the ratio of inductance to capacity as large as possible. There is, of course, still the question of the high-frequency resistance, which I mentioned above in connection with the variometer arrangement, although this is not very serious.

A Movable Iron Core.

In actual practice the arrangements for using permeability tuning are not quite so simple as they appear at first sight. As you probably know, the inductance of the coil is varied by means of a movable core, but this does not vary the inductance to anything like so great an extent as might be wished. For very large variations in the

(Continued on next page.)



Mains power volume from your H.T. BATTERY!

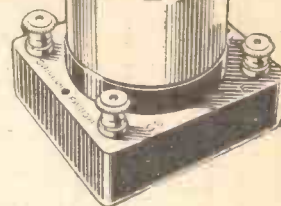

The Booster Unit enables super-power valves to be employed with an actual saving of H.T. current.

If your Receiver is extravagant of H.T. current follow the lead of eminent designers, fit a Booster—and get mains-power volume from your normal H.T. Battery.

A type for all receivers, 7-6.

Write for leaflet B.P.1 to Sole Manufacturers:

GRAHAM FARISH, LTD.,
MASONS HILL,
BROMLEY, KENT.

7/6



ELECTRADIX Home Broadcasting Microphones



No. 11, 5/6.

No. 11 Home Mike for Wireless. A complete solo microphone for hand or stand, in fine bakelite case with back terminals, front metal grille. **5/6** Only. Finely finished.

"P.W." TABLE No. 11 is a splendid little pedestal microphone for speech and music. The bakelite case containing a 2" mike and transformer is on a bronze pedestal. Switch and plug sockets are fitted on the case. It stands unrivalled for **10/6** quality and price.

CROONERS Lapel Mikes for Dance Bands. American **12/6** type model.

PARTS for Home Constructors. Microphone Carbon Granules, in glass capsule, for four buttons. Grade No. 1, 8d.; No. 2, Medium, 1/-; No. 3, Fine, 1/6; Carbon solid back blocks; 3d. Mountpieces, curved or straight, 10d. Carbon diaphragms, 55 in/m., 4d. Panel Brackets, pivoted, 5/-; Reed Receiver Unit for Amplifier making, 3/-; Headphones, 2/9. Leaflet with diagrams free. 1,000 other Bargains in our February Sale List "P."



"P.W." 11, 10/6.

ELECTRADIX RADIOS
218, Upper Thames Street, London, E.C.4.
Telephone: Central 4611.

RADIO SUPPLIES

Send your list of Radio needs for our quotation. Kits, Parts, Sets, etc. Everything in Radio stocked, prompt delivery, 7 days' approval. Catalogue free. Taylex & Standard Wet H.T. replacements stocked.

P. TAYLOR, 9, GROVE ROAD, BALHAM, S.W.12

WE invite readers to support our Advertisers—care being taken to accept only announcements of reputable firms!

EASY TERMS

Everything radio supplied on convenient terms. For really prompt delivery entrust your order to us. Goods ordered cash or C.O.D. despatched same day. Strict privacy. Garage Paid. Price List FREE. PERMANENT MAGNET M.C. LOUD-SPEAKER UNITS.

	Payment Cash with Price order	No. of Instal-ments	Monthly
Blue-Spot 59 PM (Still the best unit)	59/6	5/-	11 5/6
Blue Spot 45 PM	45/-	5/-	9 5/6
H.T. ELIMINATORS.			
Atlas, with trickie charger T.25	90/-	8/3	11 8/3
Atlas DC 15 25	39/6	5/-	7 5/6
VALVES (battery)			
Set of 3, 1 S.G. 1 Det. Power (all makes)	31/3	5/-	6 5/-
All types of A.C. and D.C. Valves also supplied.			
Avoninor testing meter	40/-	5/-	7 5/6

To avoid delay, will customers kindly send first payment with order!

Estd. 1925 THE National 1977

LONDON RADIO SUPPLY COMPANY

11, OAT LANE - NOBLE STREET - LONDON, E.C.2

LOUD SPEAKERS REPAIRED 4/-

(Blue Spot a Speciality, 5/-) Transformers and Headphones, 4/- Eliminators, Mains Transformers and Moving Coils quoted for 24-Hour Service. Trade Discount. Clerkenwell 9069. E. MASON, 44, EAST ROAD (nr. Old Street Tube Station), LONDON, N.1.

Add 50/- WEEKLY to your earnings

by charging accumulators in your spare time. Complete Plant incorporating Westinghouse Rectifiers, to charge 105 cells weekly. Trade Price £4:4:0 or 8/- monthly A.C. Mains only. Send for descriptive booklet.



M.P.R. Ltd. ROMFORD, ESSEX.

G.P.O. Engineering Dept. (No experience required). Commence £4 per week. Age 17-23. Excellent prospects. Free details of entrance Exam. from B.I.E.T. (Dept. 568), 31, Oxford Street, W.1.

EASY TERMS PROMPT DELIVERY

Any Amplion, Blue Spot, Baker, Celestion, Epoch, Ferranti, Gramplan, Igranie, Lamplugh, Magnavox, Ormond, R & A, Rola, Sonochorde or W.B. Speaker supplied.

Send 5/- only

and pay balance by monthly instalments. No references. Entirely private and confidential.

KITS, PARTS, VALVES, ELECTRIC CLOCKS ON EASY TERMS.

Send for List of 83 Speakers and state requirements **TURNADGE & PARTNERS, LTD., 107, Fleet Street, London, E.C.4.** Telephone: Central 1903.

MICROPHONES

Buy from the actual makers at rock bottom prices. Button capsules, complete for detectaphone and other experiments; only 1/- Transformers, 3/6. No. 11 Home Mike, bakelite body, 2" dia., unbreakable, 5/6. Table P.W. 11, a handsome announcer's model, 3" x 3" on brass stand—a self-contained Mike and Transformer with switch, 10/6. Tall Pedestal Broad-casting Model 12B, with Microphone hung in ring, 12" high, 18/6. Complete Deaf Aid Sets, 18/6. Special P.A. makes for Dance Bands and Public Address. All Parts in stock for Home Constructors, granules, blocks, etc. Write for Lists P. 1 and 2. **ELECTRADIX RADIOS, 218, Upper Thames Street, London, E.C.4.** Tele.: Central 4611.

All applications for Advertising Space in POPULAR WIRELESS should be addressed to the Advertising Department, John Carpenter House, John Carpenter Street, London, E.C.4.

*Phone: Central 8080.

TECHNICAL NOTES

(Continued from previous page.)

inductance we have to resort to other methods which involve the use of so-called high-frequency iron.

There are in practice other difficulties which have to be met, such as the ganging together of two or three circuits, and this depends for its success partly upon getting the iron core uniform and partly upon matching the turns of the coils.

Increased Selectivity.

I do not want to predict the future of permeability tuning either the one way or the other, and I can only give you my personal opinion. Personally, I think that permeability tuning has very great possibilities in the direction of increasing the selectivity and sensitivity of a receiver, and I think that the difficulties which I have mentioned, in regard to the accuracy of its adjustment and so on, will be overcome in due course.

Thin Foil Shielding.

Some people use very thin metal foil for shielding purposes, but I do not think this is worth while owing to the fact that the

more easily handled. By the way, if you buy ready-made screens you should examine these to see whether they are lacquered.

Sometimes these ready-made screens are lacquered over with cellulose or some other transparent lacquer in order to preserve the bright appearance of the aluminium. If this is the case and you want to make contact it will be necessary to scrape the part quite clean where you are going to make the contact.

Accumulator Acid Strength.

A reader wants to know why it is that battery acid should be of the particular strength of 1.12 gravity, which is always recommended, and whether it would not be preferable to use it stronger. This particular dilution of sulphuric acid, known as "battery acid," gives a very high electrical conductivity. You will understand this better, perhaps, if you remember that it is a mixture of two substances of very low conductivity.

We can regard the mixture as starting with a hundred per cent water and, as we increase the acid content, ending up as a hundred per cent acid, and being virtually an insulator at both ends of the scale. Somewhere in between these two concentrations there is a dilution which gives maximum conductivity.

It is from considerations of this sort that the particular dilution used for batteries has been arrived at, and it will be found to be the best for all-round use. At the same time there is nothing very critical about this dilution; in practice you may guess that the strength of battery acids varies very largely, with apparently no very serious effect on the performance of the batteries.

THE SET OF THE FUTURE

WHERE IS THE TREND OF RADIO LEADING US?

READ THE PROVOCATIVE ARTICLE
By Our Chief of Research

"THE FUTURE OF MULTI-PIN VALVES"

in

POPULAR WIRELESS

NEXT WEEK

ALSO IN THAT ISSUE

"SHARPENING THE SHORT WAVES"

OF SPECIAL INTEREST TO CONSTRUCTORS

WEDNESDAY - - PRICE 3d.

foil is so fragile and also owing to the liability of bad contacts and high resistance.

A Faulty Contact.

The high resistance is not so likely to occur in the actual body of the foil itself, but rather in the place where contact is made to it. There is always a great danger of breaking the foil at the place where contact is made, and probably the best method is to use a "pack" of three or four or even up to half a dozen little washers cut from the same foil itself, these being packed on each side of the foil and then the whole bolted together by means of a bolt with a nut on each side and an ordinary hard metal washer on top of the foil washers.

The foil washers act as a sort of spring washer and get a decent area of contact where the ordinary thick washer would only touch at one or two points and probably tear the foil.

Using Aluminium Screens.

Anyway, as I say, it is far better not to use foil at all, but to use thin aluminium sheet, which is quite cheap and much

20,000 LIFE STORIES

A splendid new work obtainable in fifty-two weekly parts.

WHATEVER our taste in literature may be, whether we prefer the newspaper or the novel, the serious book or the trivial, it remains a fact that with all of us the most satisfying reading matter is that which deals with actual persons, with men and women of all times and countries who have done something to make their presence felt in the world.

It is, therefore, with much interest that we announce the publication of a new standard work, containing no fewer than 20,000 life stories of famous persons, which can be obtained for the trifling outlay of 6d. a week.

CONCISE UNIVERSAL BIOGRAPHY is written in a common-sense, informative and yet attractive way. It is beautifully planned and illustrated and, moreover, is up-to-date and authoritative in every particular.

The weekly parts, 52 in all, can be bound into one volume in a new and improved self-binder, or one or two volumes by the usual methods of binding.

Part 1 of **CONCISE UNIVERSAL BIOGRAPHY** is now on sale, and succeeding parts will be published each Tuesday.

A Companion Work to the **CONCISE UNIVERSAL ENCYCLOPEDIA**

CONCISE UNIVERSAL BIOGRAPHY

Edited by **SIR JOHN HAMMERTON**

A Standard Work of Reading and Reference published in the convenient form of

6^o Weekly Parts

This is the most important popular work of reference published for many years; it is an essential complement to an encyclopedia, and is another welcome addition to the famous series of concise reference books prepared under the editorship of Sir John Hammerton.

CONCISE UNIVERSAL BIOGRAPHY is a tribute to Human Achievement, a temple of fame containing over 20,000 separate biographies of men and women famous in all walks of life, of all times and of all countries. It is a work that fulfils a long-felt need, providing in readable form a wealth of information concerning the vital personalities who have made their mark in the world since the world began.

Arranged alphabetically for easy reference, it offers to the intelligent man and woman a never-ending source of inspiration.

CONCISE UNIVERSAL BIOGRAPHY is *not* a collection of hard, dry facts; it is far otherwise. Great and varied human interest will be found in its pages, where bishops and bruisers jostle each other; actors and astronomers are placed almost literally cheek by jowl; poets and politicians, profligates and puritans, each in his place in the serried ranks of the great. Nor must the many women therein be forgotten, whether saints or sinners, rulers or writers, for the selection of them is as catholic and comprehensive as is the case with the men. It includes, for instance, all the noteworthy film stars of to-day.

CONCISE UNIVERSAL BIOGRAPHY draws its characters not from Great Britain alone, but from all nations, living and dead alike, and it is thus unique among modern biographical publications.

It is supremely well illustrated. Care has been taken to avoid the monotonous effect of assembling a large number of portraits of nearly equal size by illustrating in many cases places and things associated with the personalities described in the text. There are 5,000 illustrations in the work altogether.

CONCISE UNIVERSAL BIOGRAPHY is a publication for which the "Self-Binding" method is particularly suitable, as it is essentially a work of reference, although every page is made as attractive and readable as though it were a popular magazine. A new and improved Self-Binder is therefore being provided for those to whom that economical method of preserving the volume appeals.

PART 1
Now on Sale 6^d.

At all Newsagents and Bookstalls.

COMPLETE IN ONE VOLUME
FULLY ILLUSTRATED

20,000
Life Stories
of Famous
Persons of
all Times
and all
Countries

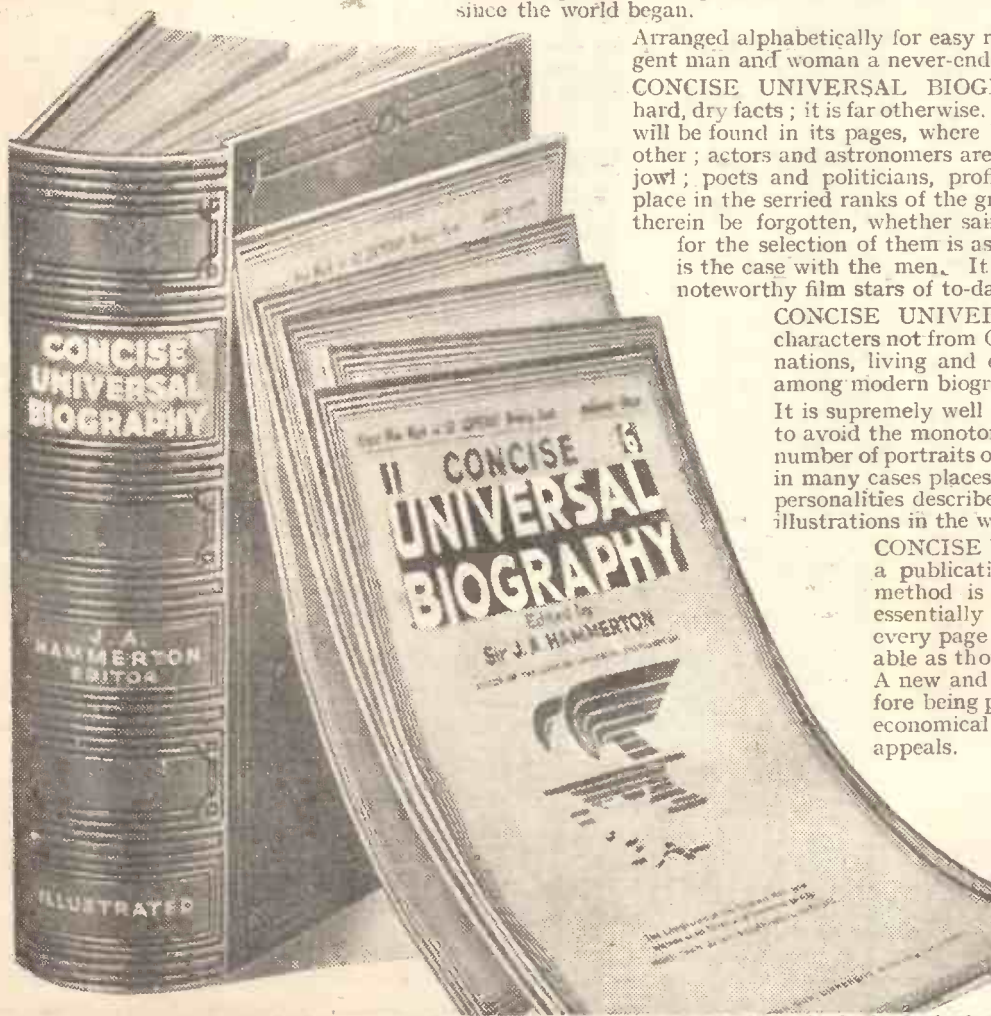

POPULAR WIRELESS

THE FIRST AND FOREMOST RADIO WEEKLY FOR THE CONSTRUCTOR & AMATEUR EXPERIMENTER

Scientific Adviser: SIR OLIVER LODGE, F.R.S.

Technical Editor: G. V. DOWDING, Associate, I.E.E.

Assistant Editor: P. ROBERT BIRD.

Managing Editor:

N. F. EDWARDS.

Chief Radio Consultant: P. P. ECKERSLEY

Assistant Editor: A. JOHNSON-RANDALL.

Chief of Research: K. D. ROGERS.

**SIMPLE RADIO
"ANTI-CRAMP" KNOBS
CURE, NOT DESTROY
RARE EDITIONS**

RADIO NOTES & NEWS

**THE RADIO AUCTION
DIDN'T WANT WIRELESS
ANOTHER LONG-WAVER
THE "SPEAKERINE"**

Fees by Instalments.

WHAT was pronounced as impracticable in Britain is in force in Australia—the payment of wireless licence fees by instalments. Cards divided into forty-eight squares are issued to licensees, who buy and dab on sixpenny stamps from time to time until twenty-four shillings have been paid to the Post Office, which then takes the card and issues or renews the licence.

I believe that something of this kind would be welcomed by poor folk in this country, and is really needed.

The First Airship "Sparks."

THE recent death of Wellman, the airship pioneer, who tried to fly (or drift) the North Atlantic in 1910, brings to mind Jack Irwin, who accompanied him as wireless operator and was the world's first Marconi airship officer.

The station on which I was serving was in touch with the airship *America* not long before she came down in the sea, and I well recall the gloom which descended on me when I lost her signals.

Simple Radio of Yesteryear.

THEY were, however, safely picked up by the *Trent* on a 100 to 1 chance, and the incident was rather amusing from the radio point of view, because when they were sighted Irwin had to Morse to them by flash-lamp to tell them that he could communicate by wireless.

And *such* wireless, too! All he had was a ten-inch spark coil worked from a 25-volt battery, a magnetic detector, a loose-coupled "jigger" (oscillation transformer) and one variable receiving condenser.

A Radio Society Branches Out.

I AM informed that the Golders Green and Hendon Radio Scientific Society, in response to an increasing interest in cinematography shown by many amateurs, are forming a subsection to develop that art as a hobby.

On March 1st, at 8.15 p.m., at the Hampstead Public Library, Finchley Road, a meeting will be held at which Mr. P. Harris will deal with the question of amateur cinematography.

Films taken by amateurs will be shown and a new piezo-electric loudspeaker will be demonstrated. Free tickets are available to "P.W." readers, who should apply to Lt.-Col. H. Ashley-Scarlett, D.S.O., 60, Pattison Road, N.W.2.

An Inexpensive Text-book.

IF you are building up a library of radio books you may be glad to know about Radio Research Special Report No. 13, issued by the Department of Scientific and

and is well illustrated by the new H.M.V. models.

This firm, determined that every single part of its sets shall be as excellent as science and skilled craftsmanship can render it, has turned its critical eye upon that humble component the knob, and is now fitting *anti-crimp knobs designed by anatomical experts*. I doubt whether thoroughness could go farther than that.

The "Death Ray" Again.

A LEICESTER lecturer on electrical subjects has been experimenting with high-frequency oscillations of the order of 3,000 million cycles, which the newspapers promptly referred to as the "death ray."

As a matter of fact, he did kill some flies, and then worked his way up to mice; but these innocents were sacrificed in the interests of his theory, not as the proof that he is on the right road to devising a new form of man-killer.

Now let me emphasise that he is reported to have said that what he really hopes to find is a ray which may cure rather than destroy. We could do with it.

A New Club Being Formed.

MR. HENRY DUFF, 90, Budhill Avenue, Shettleston, Glasgow, E.2, asks me to be a sport and announce that he will be glad if all those who are or would be interested in the formation of a radio club in his part of Glasgow will write to or call upon him.

Done—like the sport I am! No, H. D., you must guess again, for I am not the erstwhile owner of station 2 R J, but Ariel.

Collectors, Please Note.

A BUSINESS man, Mr. E. C. Bushell, of 151, High Street, Sandgate, Kent, begs to announce that he owns the first two dozen copies of "P.W." in good condition, except for two or three whose edges are slightly damaged. He will sell these rare editions if the matter can be arranged.

Now, collectors, don't waste any more time in looking for first folio Shakespeares, but secure these remarkable specimens of early radio literature now.

(Continued on next page.)

YOUR S.T. MANUAL IS WAITING FOR YOU

IF you have collected six of the gift tokens from "P.W." (No. 6 is on the last page of this week's issue), you should send in your completed gift Voucher at once.

BUT if you have only collected four or five tokens, you will have a chance to complete your set during the next two weeks.

REMEMBER that the sooner you send your Voucher, the sooner you will receive your copy of the MANUAL.

NOW TURN TO PAGE 1048

Industrial Research; one shilling, obtainable from H.M. Stationery Office. It is entitled "Valve Oscillators of Stable Frequency—a Critical Survey of Present Knowledge."

It is in two parts, the first of which amounts to a text-book on oscillators; the second contains abstracts of the most important work published on the subject, with notes.

Science in Industry.

THE degree of refinement to which the radio trade has brought the application of scientific principles into the manufacture of apparatus is astounding,

THE FRENCH HAVE A WORD FOR IT

Making a Hash of It.

BBROADCASTING in the U.S.A. progresses, like a nightmare, from horror to horror. But a tender story reaches me from Chicago to the effect that a certain chain restaurant broadcast an offer of a can of "corned beef hash" to anyone sending in his name.

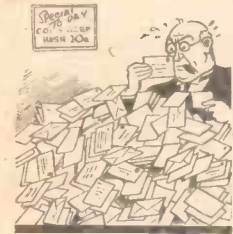

Such is the distress in Chicago that 12,000 requests were received. "I cannot dig, to bootleg I am ashamed, but watch me chase a can of C.B.H.!" So is the penury of a proud people relieved in an up-to-date, non-humiliating way.

Medium-Wave Results.

OF a large number of letters, for which I thank the writers, I select that of N. J. W. (Newbury, Berks), who with becoming modesty relates his experiences on four consecutive nights with a home-made two-valver.

His catch on medium waves included Boston, Hartford (Conn.), Philadelphia and, he believes, St. Paul (Minn.). All results on L.S., some perfect enough to be taken down in shorthand, and were obtained between midnight and one-thirty a.m. For a first shot I think this work is very creditable.

A Cry from Ireland.

IHAVE a letter from a short-wave "fan" in Ireland, the writer of which describes the evolution of his species and argues that "P.W." ought to devote much more space to short-wave radio and also some to the amateur transmitting side.

We should, of course, be only too happy to hit on the magic formula for pleasing everybody, but until we succeed we are bound to observe that well-known injunction: "Proportion, gentlemen, proportion."

At the present time, at any rate, "P.W." does not cater for transmitting amateurs, and it devotes a carefully calculated amount of space to S.W.—a growing amount, I think. But a threepenny paper—even "P.W."—cannot "cover the whole radio front," if I may thus parody the song.

Auction by Air.

AFTER radio weddings, the radio auction. A Seattle "department store," moving to new premises, held an auction of its old stock via radio from station K J R.

The ceremony occupied two 15-minute periods daily for two weeks. Unfortunately, the report does not explain how the bids were made or how the bidders knew what each had bid. Again, is it possible that the acute Seattlers were induced to make offers for "lots" unseen? Perhaps



some ingenious reader can suggest how the matter was managed.

A Gipsy's Viewpoint.

DURING one of my week-end rambles I smoked a pipe with an old gipsy on the step of his caravan, and asked him, amongst other things, whether he had ever thought of getting a radio set.

He indicated that he acquired all the knowledge which was useful to him by direct contact with realities; that he had an inexhaustible field of study in nature; that when he wanted music he could make it himself; and that nothing could make him happier, except perhaps a brisker trade in baskets and slightly less rheumatic pain in his shoulders. Interesting—but we cannot all live the simple life.

The Later the Worse.

HERE is a little anecdote which will tickle those who make a point of sitting up for the late dance music: A negro preacher named Solomon Lightfoot Michaux, who broadcasts sermons for the

SHORT WAVES

GETTING READY.

"There is talk that the next war will be fought with radio."
"Well, I'm in training. I've faced some terrible programmes."—*"Everybody's Weekly."*

Miss —, concluding a broadcast talk on cookery, said: "It takes one hour to cook and serve six people."

We had not heard that the Empire broadcasts were to be extended for the benefit of cannibals.

QUITE EASILY DONE.

They were listening with rapt attention to the opera broadcast when it was noticed that the fire needed attention. Someone reached for the poker.

"How can I poke the fire without disturbing the music?" he whispered.

"Between the bars," replied his neighbour.

Little girl (watching her father remove the inside of the wireless set): "Oh, daddy, now we shall be able to see the stations!"—*"Daily Mirror."*

Columbia chain in America, was asked whether he objected to going "on the air" an hour later. Said Sol: "No. All sinners stay up late. The later we go on the more sinners we'll hit." Bless us! What do all you white folk think of yourselves now?

Concerning "Howlers."

ALTHOUGH I am proud of my faithful pack of human sleuth-hounds, who never fail to bring to my notice my own slips (mind, I admit nothing!) and the grotesque statements sometimes found in the lay Press, I must give them a friendly warning not to be so exacting as to "pick a man up" over a commonly used phrase which may not be text-book truth.

For instance, a Glasgow reader sends me a clipping in which the "expert" says that a "fixed condenser" is used to "pass A.C." I take my friend's point, but I would ask him whether, if he thinks that a condenser cannot pass A.C., he believes that an electrical circuit can exist with a condenser in it. Surely the term "pass" is a legitimate description of the ultimate effect.

Is Your Set Dust-Proof?

YOU all know what an unspeakable nuisance that star dust is. One is for everlasting at the set with a brush.

But a well-known Californian scientist, tired of dusting and listening to the "frying" noises caused by cosmic dust, has developed a receiver which, together with its aerial, is shielded from the bombardment of the stars. He tells us, however, that his shielded set is not practical for everyday use. Ah, well, I can still manage to get London in spite of star chunks!



Still More Orders.

IHAVE the pleasant duty to report that, in addition to receiving the order for the new Motala station, Marconi's have been commissioned to build two stations for the Roumanian Broadcasting Company, one of 150-kw. aerial energy and another of 20 kw.

I understand that these contracts will provide employment for many months for a number of skilled workmen at Chelmsford. The 150-kw. station (Brasov) will transmit on a wavelength of 1,875 metres. That is, according to plan. At the moment Huizen is still occupying the wavelength.

Rubbing It In.

SOMETIMES the French do things very prettily. For instance, consider the result of M. Charles Colin's law suit, in which he alleged that the title of a piece of music which had been broadcast was his copyright, being the same as that of his opera. He won his case, and the court ordered notice of the judgment to be broadcast and followed by selections of the opera.

What a pity television lags! Were it here we might be able to see M. Colin kissing his counsel, the judges, gendarmes, etc., in the usual Gallic outburst of calm!

Think of a Word.

THE hunt for words to fit people and things to do with radio continues hotly. Words in various tongues to denote "listeners" and "radio fans" are

becoming more and more familiar, and now, I hear, the French have been tackling the one-word definition of a woman broadcaster in English.

I cannot say that I admire the result—"speakerine"; it reminds one of tangerine, margarine, etc. Considering that we have to do with a woman and with speaking, why not adopt the transatlantic word "speakeasy"? They do, you know! And then some.



ARIEL.

MULTI-MU CONTROL for the NATIONAL ECKERSLEY THREE

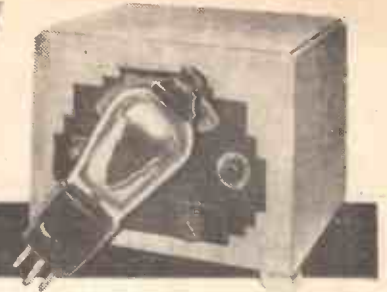

ONE of the most difficult problems in designing a wireless set is to get a smooth control of volume. It is perfectly easy to get a volume control which operates over a small range, but in practice you may want to cut down a local station which is a hundred times stronger than another distant station which the set can get when it is sensitive enough.

The stray capacities of the system prevent one effectively from using potential dividers, as one could if the currents were of low frequency.

The Regulator.

If you use a potential divider in the aerial circuit without precaution you will find that the local station is just as embarrassing loud whatever setting you use on the resistance. This is because the self-capacity of the unit has a less reactance than its resistance.

I got over this difficulty in the original "National Eckersley Three" design by using the regulator resistance, which is at a point in the circuit where the potentials and impedances are low, and therefore where stray reactances are negligible.

The method was extremely attractive because it regulated volume without, if the resistance was lower than a certain value, changing selectivity. Thus it was a splendid way to overcome the overpowering effects of a local station and yet to preserve that local station's quality.

For Adjustments of Volume.

I could, of course, have used a fixed resistance for the coupling of the two first circuits if I could have achieved volume control by using a variable-mu (or "multi-mu") valve.

There were two objections to this: first, that my regulator resistance, if fixed, would not control selectivity as it does; and, secondly, that many people do not possess variable-mu valves, and those who set me the problem of designing to a specification said that no components must be "special."

But variable-mu valves give, to those who possess them, a splendid way to get volume control, and also allow a more comprehensive use of the regulator resistance.

Really effective volume control when living close to a powerful broadcasting station calls for the use of a multi-mu S.G. valve. Below are the full details for fitting one of these efficient devices to the 'National Eckersley Three,' the wonderful receiver described a few weeks ago in this journal

By Our Chief Radio Consultant:
P. P. ECKERSLEY, M.I.E.E.

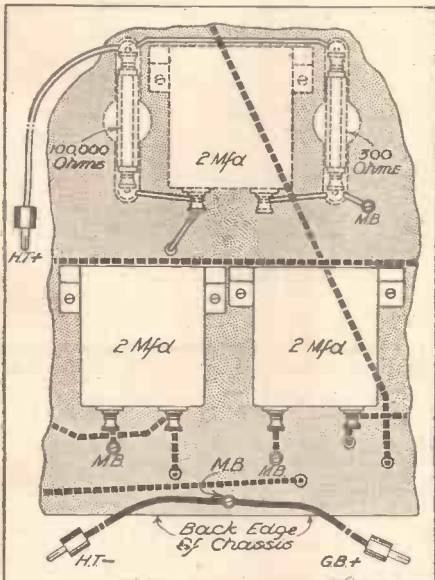

EASY TO ALTER

The components shown dotted are removed, as are the "hollow" wires attached to them. The dotted wires are unaffected, and new leads are fitted for H.T. and G.B. +.

UNDER-BASE WIRING

To the right is shown the arrangement of the principal components concerned after the alterations indicated above have been carried out.

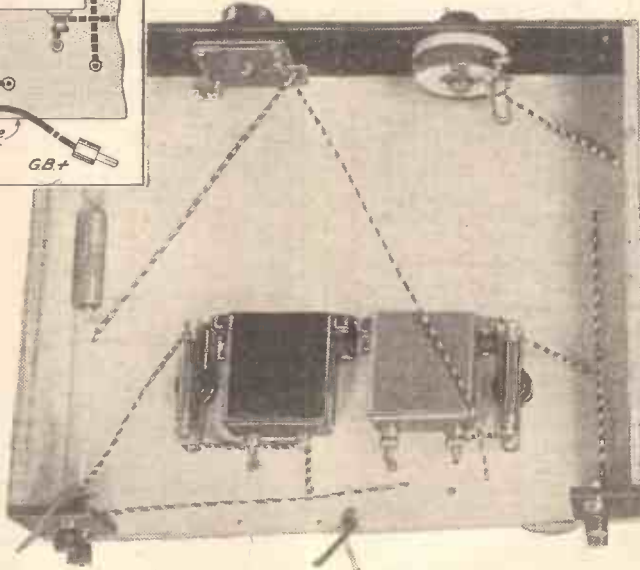

THE VALVES YOU WILL NEED

Make	Variable-mu	Detector	Output
Cossor	220V.S.	210H.F.	220H.P.T.
Mullard	P.M.12M.	P.M.1H.L.	P.M.22A.
Mazda	S.215V.M.	H.L.2	Pen.220
Osram	V.S.24	H.L.2	P.T.2
Marconi	V.S.24	H.L.2	P.T.2
Hivac	—	H.210	Y.220
Tungstam	—	H.R.210	—

NOTE.—The grid-bias battery required is one of the 9-volt type

All design is compromise, and probably, had it not been for the fact that not everybody possesses variable-mu valves, I would have put one in as part of the specification. With a variable-mu valve you can use the regulator resistance as a selectivity control pure and simple, and the variable-mu valve as volume control pure and simple.

It is better to have, if you are using battery power, the "short-base" variable-mu valve, because, of course, this requires fewer volts to operate it.

Varying Anode Current.

The total anode current taken by the set will vary as the bias of the variable-mu valve is altered. Thus it will be impossible to retain the automatic grid bias for the output valve. It is necessary, therefore, to use a bias battery for this valve in the normal way.

The valves which have been specified give a wide range of control if you use a 9-volt battery. I should say, in fact, that in using this value you can use them to control volume—even to cut out a "very local" station.

No alteration to the wiring of the coils is necessary if you apply the variable

bias through a grid leak. The actual alterations that have to be made to the set will now be set out in detail.

First of all, remove the 300-ohm and the 100,000-ohm resistances from the underside of the chassis, and also the 2-mfd. condenser from between them. Remove also all the leads with these components.

Connect the H.T. — lead to the chassis, and to the same point connect also another flex lead which will be joined to the positive terminal of the grid-bias battery. (It is marked G.B. + in the diagram.)

Connect a flex lead to the G.B. terminal of the L.F. transformer. This is marked G.B. — 2 in the diagram.

A lead connects the fixed vanes of the centre section of the tuning condenser to the grid terminal of V1. It is disconnected from the latter point and connected

(Continued on next page.)

MULTI-MU CONTROL FOR THE NATIONAL ECKERSLEY THREE

(Continued from previous page.)

to the rear terminal of the .0003-mfd. condenser which is mounted to the left of V1.

The other terminal of this condenser is connected to the grid of V1 and also to the 1-meg. grid leak. What to do with the other terminal is dealt with later.

Disconnect the leads to the on-off switch and remove the switch from the panel. Mount the combined 50,000-ohm potentiometer and 3-point switch in its place.

Connect the leads which were connected to the original switch to two terminals of the switch portion. The third terminal is connected to the right-hand potentiometer terminal, as shown in the diagram.

G.B. Plug Connections.

Join the remaining terminal of the 1-meg. grid leak to the centre terminal of the potentiometer, to the left-hand terminal of which connect a flex lead. (This lead is marked G.B. - 1 in the diagram.)

The three extra flex leads which have been added must have wander-plugs attached to their ends, to plug into the grid-bias battery.

That completes the alterations, and the set is now ready to be connected up.

Assuming that a 120-volt H.T. battery is used, G.B. - 1 will be connected to - 9 volts on the G.B. battery, and G.B. - 2 to - 3 or 4½ volts. G.B. + will, of course, be connected to + on the battery.

THE EXTRA COMPONENTS

- 1 50,000-ohm potentiometer with 3-point shorting switch, Bulglin V.S.36, or Lewcos.
- 1 1-meg. grid leak with terminals or wire ends, Graham Farish, 1½-watt "Ohmite," or Dubilier, Lissen, Bulglin.
- 1 .0003-mfd. fixed condenser, Dubilier, type 620, or T.C.C., Lissen, Telsen, Graham Farish.

The H.T. connections will be normal: H.T. - to negative on H.T. battery; H.T. + 1 to anything between 60 and 80 volts; and H.T. + 2 to 120 volts.

It will be seen that the potentiometer, which controls the bias on the variable-mu valve, has a 3-point shorting switch combined with it.

Apart from being an L.T. switch, it also serves to break the bias circuit when the set is switched off, and thus prevents the bias battery from being discharged through the potentiometer while the set is not in use.

The Use of the Regulator.

As I said before, the regulator resistance may now be used purely as a selectivity control, whilst the variable-mu control is used simply to adjust volume.

Maximum selectivity is obtained by turning the regulator resistance to the right, as far as it will go. For long-wave reception it will usually be necessary to turn it back to the left as far as possible.

For maximum sensitivity the variable-mu control is turned to the extreme right. This will be necessary only when receiving distant stations.

Remember that the farther to the left you can keep this control the better it is for the life of the H.T. battery. This is another of the many advantages of the variable-mu valve.

When listening to a local station—which generally means a large percentage of the time that the set is in use—it is possible to apply a large negative bias, and in consequence the H.T. current consumption of the valve is reduced to an almost negligibly low figure.

Whilst on the subject of H.T. consumption, just a word with regard to the voltage applied to the screening grid, H.T. + 1.

I have given this as 60 to 80 volts.

Remember that the lower the voltage applied the lower the current taken from the H.T. battery. So don't use 80 volts if 60 volts give equally good results.

Short-Base Valves.

The voltage required for optimum results will depend upon the particular valve used and is a matter for experiment.

I must remind you again that I used so-called short-base variable-mu valves, which require a maximum bias of 9 volts. If you should by any chance use a variable-mu valve other than one of those specified you will probably need a grid-bias battery of higher voltage in order to obtain adequate control. Some of the older types of valves require as much as 16½ volts.

PUTTING IN A "MULTI-MU"



The photograph shows the alterations in practical form whilst the diagram explains exactly how the wiring is affected. The heavy dotted lines show the original wires, which are unaltered and the full black lines depict new wires. One wire is removed altogether, so it is shown "hollow."

To Fixed Vanes
Of Middle Section
Of 3-Gang Tuning
Condenser.

To Fixed Vanes
Of Rear Sections
Of 3-Gang Tuning
Condenser.

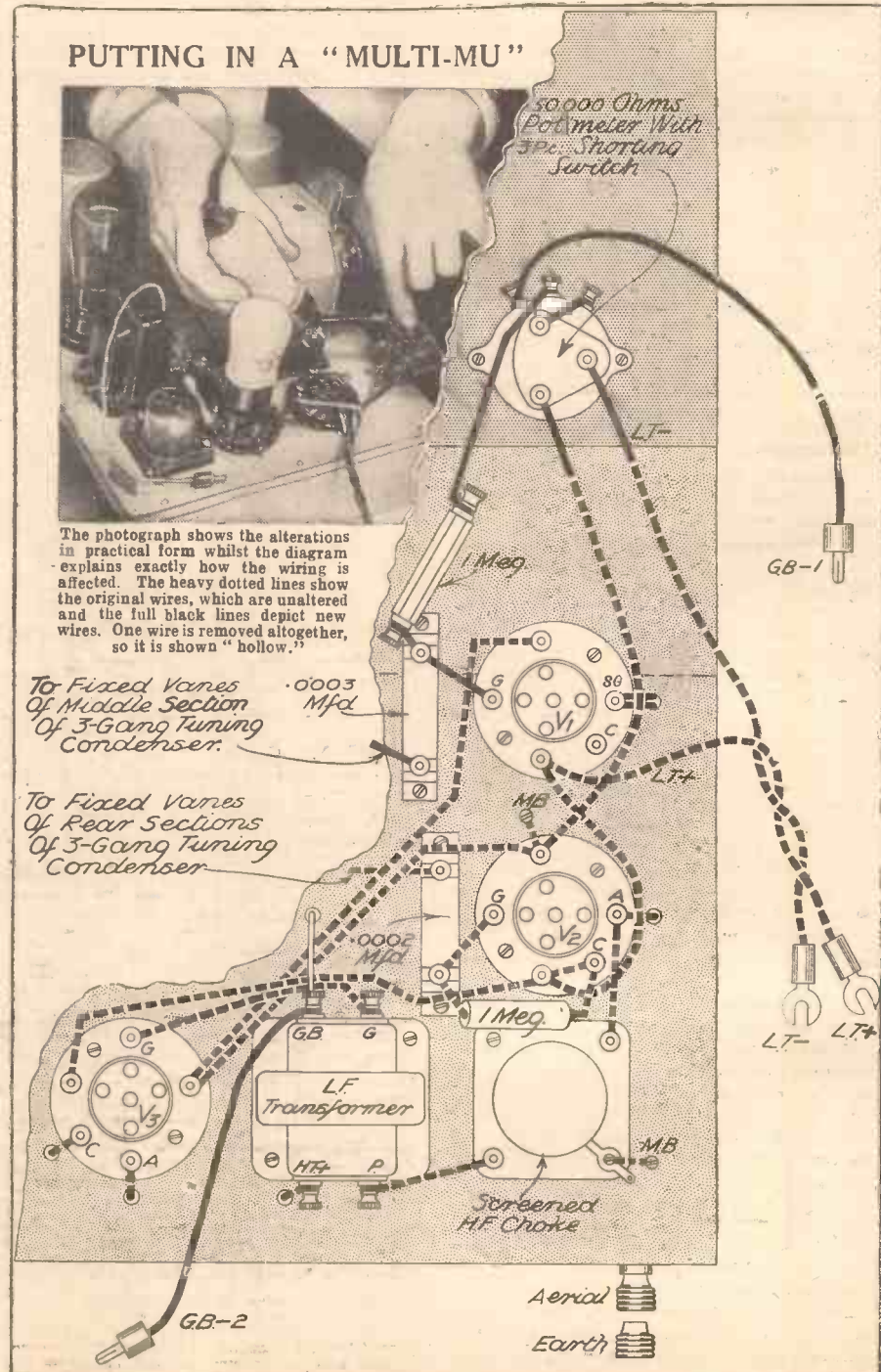



MIRROR DRUM TELEVISION

BY

G.P. KENDALL B.Sc.

THE reader must have noticed how often I have referred in this series to the need for more light, larger and more brilliant pictures and so forth.

As a matter of fact, this is one of the fundamental problems of the present systems of television, for almost all of them tend, in their simpler forms, to give a rather small picture which would be much improved by an increase in both size and brightness.

It is, therefore, only natural that experimenters should devote a great deal of energy to this particular detail, and that we should so often have to record progress in the same direction. Bit by bit, every detail of the receiving system is being overhauled by research workers, with the object of getting more and more light through to the screen, and some of the results we have already seen.

Disc Scanning Replaced.

Naturally, the scanning method has come in for a good deal of attention in the course of this work, and several noteworthy advances have been made on the early form of perforated disc. The improvements obtained with the later methods are actually so substantial that the simple disc is now quite definitely considered out of date, except where the utmost simplicity is of the first importance.

It is now regarded as almost the least efficient of all the many scanning devices, because it passes so little light through to the screen. This follows from the fact that it is not possible to focus or concentrate a large proportion of the light into the scanning spot, as can be done with some of the later systems.

All that can be done with the older form of disc is to allow the light to cover the whole surface of the screen, so that wherever one of the holes may be between light source and screen its spot may fall on the picture area.

In the newer methods it is possible to focus (by means of lenses) quite a large fraction of the total output of light into a slender but very intense pencil which is directed upon one tiny spot on the scanning device. From this point the scanning apparatus sends it on in varying directions to cover the screen in the usual series of sweeps.

A Concentrated Beam.

The essence of the superiority of these new systems is to be found in their ability to use a narrow, concentrated, and consequently intense beam of light, instead of diffusing to allow the light to spread out in a hazy beam capable of covering the whole screen area.

This concentrated beam is made to cover the screen by the mechanism itself, which may employ some such device as a rocking mirror to make the beam perform its proper function of scanning.

One of the most successful of these newer scanning systems is one called the "mirror-drum" method. This uses a revolving drum carrying a row of little reflectors on

reflect the light away again, so that it might next fall, say, on a screen, where it would make a bright spot.

That spot, it is to be noted, would sweep down the screen in a straight line, and as it went off the bottom edge another spot from the next mirror would appear at the top of the screen and chase down after the first one. In other words, we should get a stream of spots of light flowing down the screen in a steady stream.

To get each spot to appear at the top edge of the screen at the exact moment that the previous one was vanishing from the bottom would require a little careful arrangement, but this is not very difficult.

Granted that it can be done, it is evident that we have

here the beginning of a scanning system. It will not yet do quite what we want, however, because all the spots of light will pass across the screen on exactly the same line.

Getting the Correct Setting.

To get true scanning we require that each spot shall sweep down the screen on a line beside, but not overlapping, the path taken by the previous one. Further, this must go on until the whole area has been covered, whereupon the spots must begin again at the extreme edge of the screen and repeat the process.

To get this effect with a mirror-drum system is quite simple: all that is needed is to set each mirror at a slight angle to the previous one.

If we place, say, thirty mirrors on the drum, set in this way, we shall get our spots to trace out thirty lines on the screen at each revolution of the drum. After each revolution is complete, also, the first mirror will come round again and start a fresh "scan."

That, as a matter of fact, is precisely how things are arranged for the present thirty-line transmissions. We must have a mirror for every line of the transmission, and the drum must make one complete revolution for each complete "picture."

Accurate Speed Control.

Since there are 12½ pictures per second, it follows that this is the speed at which the standard drum must run: 12½ revolutions per second, which is, of course, the standard speed of 750 revs. per minute.

This speed is kept at both transmitting and receiving ends, hence the need I have already stated for accurate synchronisation of the motor at the receiving end.

And there I must leave the matter for the moment. Next week I hope to describe the practical use of the mirror drum in somewhat greater detail.

The old method of using a perforated disc for television scanning has been greatly improved upon, and one of the most promising devices is the mirror drum. How this functions, and where its superiority lies are outlined in this review by our contributor, who clearly sets out the fundamental facts underlying the practical application of the system.

its rim, driven at the correct speed by a small motor which is made to run in exact step with the transmission by means of one of the well-known synchronising devices.

Now, imagine that all the little mirrors were set quite flat on the outer surface of the drum, and that a fine pencil of light were to fall upon the drum as it revolves. As each mirror came into the beam it would

A RECENT IMPROVEMENT



Here is an ingenious German instrument in which the mirror-drum principle of rotating reflectors is applied by means of a "mirror screw" for television reception. It functions in much the same way as the drum, but with advantages of smaller diameter and better speed control.

THE MIRROR OF THE B.B.C.

PROGRAMME CHIEFS SAIL FOR U.S.A.

Pleasing Listeners in Wales—Another Capt. Wakelam Commentary—
A Factory Girl who "Croons"—Morris Dances from Oxford Festival—
Summer Plans.

REFLECTIONS BY O. H. M.

BY the middle of April a large proportion of B.B.C. programme chiefs will be on the other side of the Atlantic. Gerald Cock, the "Outside Broadcasts" Director, sails in a few days directly for San Francisco; Roger Eckersley, Director of Entertainment, and Charles Siepmann, Talks Director, leave in a fortnight for New York, and will tour North America and perhaps some of South America as well; Eric Maschwitz, alias Holt Marvell, Director of Variety and Vaudeville, is shortly slipping over to have a look at Radio City.

But I dare say the programmes will go on much as usual. Colonel Dawnay, the head of the Programme Division, has settled in and keeps a close watch on all parts of the work. His "right-hand men," in the absence of the others, will be Gerald Beadle and Arthur Rose-Troup, the former for entertainment and the latter for talks.

The Welsh Problem.

Sir John Reith is taking exceptional care to try to placate Welsh opinion. The advisory committee appointed by the University of Wales to represent the wishes of the Principality in matters of broadcasting receives the most attentive hearing at the "Big House." Recognising a committee of this kind is something of a departure in B.B.C. policy.

Although all its demands have not been met, the committee has already secured important concessions. There is to be a substantial increase in the purely Welsh parts of the West Regional transmissions, with probably an extension of the Welsh from Daventry 5XX. I wonder if the B.B.C. realises what trouble these concessions will stir up in Devon and Cornwall, where there is already acute dissatisfaction.

Economy Countered.

The attempt by the administrative side of the B.B.C. to effect large reductions in the money for programmes has been successfully resisted by Colonel Dawnay and his staff. The reason for the attempt has not been disclosed, but it is suspected that it may have been the desire to make an additional voluntary contribution to the Treasury. If so, the desire was singular. Already the resources of the B.B.C. are rather less than half the licence revenue; if there is to be a change it should be in the direction of more, not less.

An Enterprising Artist.

Elizabeth Scott, who is to take part in the London Regional programme on February 28th, traces her descent to the Greshams who built the Royal Exchange, London. She also had another ancestor, a highwayman uncle, who frequented the New Forest and stopped coaches "for the fun of doing so."

Elizabeth started her working life in a showroom, and was "discovered" by a well-known poster artist and writer of

children's books. She has sung in the United States, in London music-halls and in famous restaurants. Gardening and artistic design on American cloth are her hobbies, and she does not propose to get married for another ten years!

HIGH NOTE SUPPRESSION



The problem of recording high notes smoothly through the microphone is being tackled at the moment through the use of a cellophane "muting hood," a sample of which is being worn in our picture.

Navy v. Army.

Yet another to his long list of commentaries on Rugby matches, since

OF course I sat up for the running commentary on the Harvey-Gains fight: first for its own sake, and secondly because it came in a week when programmes fell a little below standard; or shall I say when the stereotyped plan, the arch enemy of expansion, seemed more prominent than ever in the programmes? In fact, one was made to wish that a few fresh brains could be imported into B.B.C. headquarters.

The Commentary was as entertaining as usual. The commentator appeared to be doing his job well until the result was announced. Then we felt we had been led astray. The account had all through been only what we, who had read the propheta of the previous days, expected it to be. So we weren't too hard on the commentator. The eye-witness reports (or some of them) that we read the next morning confirmed what the commentator had said of the fight. So all was well with him again.

This incident clearly shows the difficulties of a boxing-match commentary. The fact that the commentator doesn't decide the issue himself, or that the score isn't settled till the end, makes it imperative that the commentator misses nothing. His score must tally with the judges. If it doesn't, we are inclined to think he's a bad commentator. And I wouldn't say that Seccombe was that

1927 will be added by Captain H. B. T. Wakelam on Saturday, March 3rd, when he describes the Inter-Service match between the Royal Navy and the Army, which is to be played at Twickenham.

Leonard Henry in "The Arcadians."

The revived version of "The Arcadians," which is the principal item in the National and Regional programmes for the last two days of February, will provide Leonard Henry and Horace Kenney with ample scope to do their "funny stuff."

Leonard will be James Smith (of Smith & Co., caterers) and Simplicitas, while Horace is to play the part of Peter Doody, a jockey.

A Midland "High Light."

Midland Regional programmes for the week ending Saturday, March 3rd, will include an attractive broadcast in the concert to be relayed from Oxford, arranged by the Oxford and County Branch of the English Folk Dance and Song Society.

It is seldom that a Region goes outside its own area for such a relay, and although the City of Oxford is not inside the Midland Region, many of the folk songs and dances which are to be heard were collected in villages in North Oxfordshire, which are within the Region.

Oxfordshire may claim to rank with Gloucestershire as the chief home of the still-popular Morris Dances.

"Owt about Owt."

"Owt about Owt," which, in more understandable English to most of us, means "anything about anything," is the title of a new feature which starts for Northern listeners on Saturday, March 10th.

It will consist of light stories and short broadcast interviews served up in what has so often been described as, but is never quite like, a film news reel.

Manchester's Girl "Crooner."

Among a number of the attractive type of girls who are busy working in one of the large trading houses in Manchester is one who can "croon," and, what is more, can do it better than any other "crooner" the North Regional Outside Broadcast Director has ever heard.

(Continued on page 1052.)

THE LISTENER'S NOTEBOOK

Comment and criticism on B.B.C. programmes and artistes.

In Soccer and Rugby commentaries it's different. From start to finish we know how matters stand. Neither Allison nor Wakelam has to commit himself in any way. Like the eye-witnesses who write up the match for the next morning's papers, they can say that one side could do anything but get goals, or that the score didn't represent the general run of the play. But that's football! It isn't so with boxing, however, and we must not forget it when we judge a boxing commentator.

"Emil and the Detectives" was unusual radio fare. It was unusual for the array of juvenile artistes in the cast. The future of broadcasting seems assured for many years to come with so many stars in the making. Perhaps it is an injustice to call them stars in the making, for most of them played with the confidence of the oldest old hand. No sign of nerves or hysteria which, so we read, attacks the adult novitiate sometimes.

It is inevitable that we should compare the broadcast version with that of the film. The film version has the advantage over the broadcast because an appeal to the eyes is easier than it is to the ears. But Lance Sieveking is to be congratulated on the success of his attempt to reproduce in a sound picture

(Continued on page 1052.)

RECEIVERS of RENOWN

ONE of the dangers of fame in the world of radio—and one which is often forgotten—is that one's best work is so often taken for granted. An achievement which, taken by itself, might appear as a startling contribution to better radio becomes a matter of course when it is merely compared with other achievements from the same hand.

Telsen receivers are apt to suffer in this way when it is a question of writing a test report. For many years one has been accustomed to regard a Telsen product as the hall-mark of good reception within the reach of all. Because each new Telsen receiver has been a little better than its predecessors we have begun to take such progress as a natural thing, with the result that the intrinsic merits of a new design are apt to be overlooked.

It is just a penalty of fame!

Nevertheless, there seems to be no danger of the Telsen "474" being overlooked. It is a receiver which dares to be "different." That is not to say that it is in any way a freak. No experiments are being tried on the listener.

An Example of Skilful Design.

It has never been the policy of Telsen to think of a new idea and then "try it on the dog." Experiments are a matter of months, sometimes years of exhaustive work in the laboratory. So the "474" is the result of a combination of skilful design work and scientific research. No pains have been spared to make it thoroughly up to date in every respect.

Let us have a look at some of the special features.

The advantages of H.F. pentodes both in the high-frequency and the detector stages have been enumerated often enough in the pages of POPULAR WIRELESS. The extreme sensitivity and the almost uncanny selectivity of the "474" are to a great extent due to the use of these pentodes in the first two stages of the set.

Another important contribution to the ultimate solution of the wavelength chaos is the use throughout of iron-cored coils. Hard things have been said in certain quarters against iron-cored coils. Their justification might be found—if nowhere else—in the performance of this new Telsen receiver.

The undistorted pentode output is no less than 3 watts, and the use of a mains-energised moving-coil speaker has preserved quality as well as quantity.

Full of Fine Features.

But why go on? The features of this receiver might be continued almost indefinitely: from the single-knob, horizontal-scale tuning, through mains aerial and pick-up provision, to the hum adjuster and aerial volume control. Instead, we will be content to draw attention to but two further points.

The first may seem small in itself. Nevertheless, so far as we are aware, it is a complete innovation in the realm of



THE TELSEN "474" RECEIVER FOR A.C. MAINS OPERATION

OUTSTANDING FEATURES WHICH COMMEND AN UNIQUE RECEIVER

1. A pentode in every stage.
2. Single-knob, ganged tuning, operating a full-vision illuminated horizontal scale (calibrated in wavelengths).
3. Provision for outdoor, indoor or mains aerial, according to need.
4. Adjustments to enable receiver to be used on A.C. mains from 200 to 250 volts (40 to 100 cycles).
5. Hum minimiser to reduce any mains hum which may become noticeable on bad mains.
6. Provision for pick-up and extra loudspeaker.



Note in this photograph the extreme compactness of construction which is combined with immediate accessibility in all Telsen receivers. The pleasing design of the cabinet is illustrated in the heading photograph at the top of the page.

commercial receivers. On the back of the cabinet of the "474" there is attached an ivory plate bearing the warning:

FOR USE ON A.C. MAINS
ONLY.

REMOVE BACK AND READ INSTRUCTIONS.

A small point, maybe. But when the usual procedure is to hide such booklets behind the chassis, with no details as to where it may be found, all-important instructions are apt to be overlooked in the excitement of getting a new set to work for the first time. Congratulations to Telsen for another sensible innovation!

Secondly, the cabinet must come in for its own particular share of attention. Since the Radio Exhibition of 1933 cabinet work has assumed an importance which was never dreamed of before. Technical efficiency is no longer the strongest selling point of a new receiver.

The cabinet of the "474" is carried out in wood. But the actual design has all the detailed appearance of moulded bakelite.

Moderately Priced But Efficient.

And the "474" is moderately priced. A three-pentode, all-mains, self-contained instrument for 11 guineas is indeed going a long way towards ensuring that everyone with A.C. mains shall have the best in electric radio.

It is not very often that the tests of a new receiver provide pleasurable entertainment. There are certain tests for selectivity, quality and so on which have to be applied to every set, which makes it more or less of a routine job.

With the Telsen "474," however, it was quite a different matter.

As a first test it was decided to check up on the accuracy of the tuning scale—a scale which is calibrated in wavelengths, a great boon after the "ethereal earthquake" of Lucerne! The wavechange switch on the side of the cabinet was turned to "long waves" and the single tuning knob slowly rotated. No fewer than nine long-wave stations at the first attempt, and all within a fraction of their setting on the wavelength scale! On the medium waves the number of stations received was too large for recording in full, but the accuracy of the scale was even more marked here.

Remarkable Selectivity.

One is apt to make sweeping statements about selectivity whenever one finds a receiver which is able successfully to separate nearby stations. When, therefore, we say that the selectivity of the "474" is remarkable we mean that it has not been surpassed by anything we can remember having come across for a very long time. And that is saying something!

The quality of reproduction was good and in short, the tests of the "474," far from being in any way a routine, became a real pleasure.

Which, when you think of the number of receivers we test, is high praise indeed.

SHARPENING THE SHORT WAVES

For a long time it has been the prerogative of the medium and long-wave stations to be interfered with, and many plans have been devised to overcome the trouble. Now the short waves seem to be up against it, as explained in this practical article by W. L. S.

SHORT-WAVE listeners are rapidly being beset by a comparatively new trouble—that of interference from very high-powered short-wave commercial stations. Just why this has not cropped up before is not very clear. Probably it is partly due to the fact that "skip" seems to have changed during this autumn and winter in such a way that European stations are much stronger in this country than they have been during the past two or three years.

Interfering Commercial Stations.

Any listener who can read Morse must have said (or thought) uncomplimentary things about the Hungarian stations HAT2 and HAS2, who seem to be exceptionally broadly tuned and use I.C.W. notes of a particularly penetrating character.

The most logical way of increasing the selectivity of a short-wave set is to add a good stage of H.F. For the benefit of those who don't want to go so far as this I am suggesting one or two easier methods of "clearing up the dial."

My first piece of advice is to reduce the capacity of your aerial coupling condenser to a bare minimum. One would think that this was too obvious to mention; but

IMPROVES THE TUNING

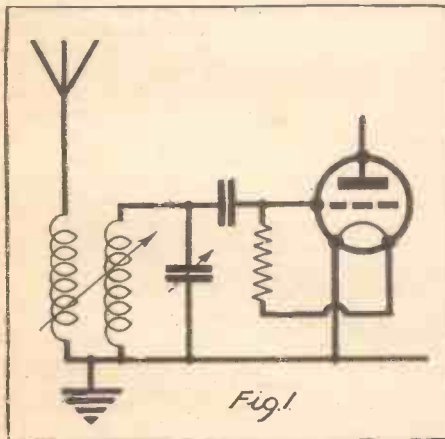

An aperiodic and variably-coupled aerial coil is better than a direct-capacity connection.

it is my experience that a surprising number of listeners keep that important component screwed well down so as to get the very maximum of signal strength out of the set. It's no good doing that nowadays.

Capacity-coupled aeriels are terrible

things if the coupling is too tight. If the interference is still bad with a very small degree of coupling, scrap the method altogether and use loose inductive coupling. An untuned coil of four turns, fairly tightly

FOR BETTER SELECTIVITY

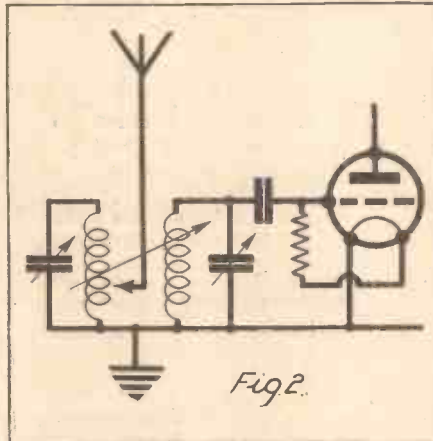

An efficient and selective method of connecting the aerial.

coupled to the grid coil, is quite efficient, while giving a much higher degree of selectivity than one can ever obtain from capacity coupling.

The coil mounting should be made "flexible" so that the best setting can be found experimentally. If the set is still unselective there is nothing for it but to tune the aerial circuit properly.

Use of Aperiodic Coupling.

Fig. 1 shows the aperiodic form of "tight coupling," while Fig. 2 shows the still more efficient "tuned loose coupling." It is most important, by the way, that the aerial should be tapped quite low down on the coil, or else its damping effect will flatten out the tuning to such an extent that no gain in selectivity will result.

It is even a good scheme sometimes to provide a tuned aerial circuit of this kind and to capacity-couple the aerial to the new circuit with a preset condenser. I have advocated this scheme in one or two really bad cases, and it has always been successful.

Don't overlook the fact that inadequate selectivity can be caused by an inefficient grid circuit, quite apart from the aerial. The use of a poor tuning condenser, a doubtful coil and one or two dirty, high-resistance joints in between the two can result in an incredibly high-loss circuit.

Wire the coil directly to the condenser that tunes it, with no imitations of Hampton Court Maze *en route*! Then, again, too large a grid condenser can cause funny effects: .0001 is generally large enough for all short-wave purposes; and don't screw a flat-type condenser straight down on a metal baseboard, or you are providing a nice high capacity across the coil right away.

As a matter of fact, the use of a "high-C" circuit—carried out in the proper way—is not a bad cure for inselectivity. It simply implies the use of fewer turns in the coil and a little more capacity to compensate for the difference.

Try a Smaller Aerial.

Unfortunately, we can't have it both ways, and this will usually result in a slight loss of sensitivity. This is not serious, however and, after all, it's not much use having a set that gives great strength of signals if it brings the whole lot in together!

Another obvious dodge is to use a smaller aerial. Surprising results are possible on short waves with quite a small indoor aerial, and if you can try a vertical one, so much the better.

It is a common habit for broadcast listeners to use a quite unnecessary length of aerial, grumbling the while because foreign and local stations are inextricably mixed up! I'm beginning to think that a good many short-wave enthusiasts are in the same boat.

I wonder how many of the people reading this article can receive the Spanish station on about 43 metres while "HAT2" is pumping out his interminable strings of "V's" on a nearby wavelength. I can't always do it myself, so I write with feeling.

The selectivity problem on the broadcast bands has created quite a new standard by which broadcast receivers are judged; and I am convinced that we short-wave folk will have to buck our ideas up before many months have passed.

Were it not for the great public demand for one- and two-valve sets I should prefer never to describe anything without a screened-grid stage. But while excellent

CAPACITY-FED INPUT

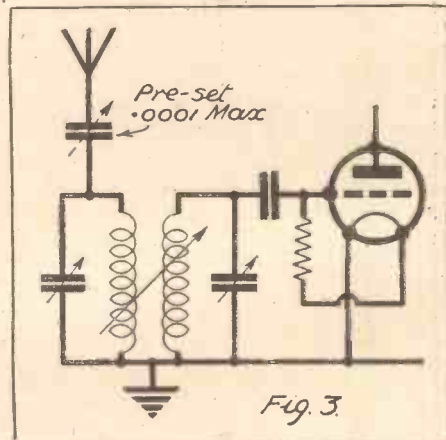

A method of improving on the circuit arrangement shown in Fig. 2.

results can still be obtained without one (as at present, fortunately), there is no necessity to lay down the law in that way.

Screened-grid units are easily made, and can be put to work in the really bad cases of interference.



RADIO STEP-BY-STEP

Our
**SPECIAL
SUPPLEMENT
FOR
BEGINNERS**

HIGH-FREQUENCY RESISTANCE.

RESISTANCE offered to high-frequency currents in a circuit or by a conductor. It is always higher than the ohmic resistance (i.e. the resistance offered to D.C.) owing to an equivalent resistance due to dielectric losses and eddy currents which is included.

IMPEDANCE.

This is often styled "A.C. resistance," for it is the opposition offered to alternating current by the resistance, inductance or capacity, or a combination of all three.

It varies as with the frequency of the A.C., except when there is only pure resistance present. Thus the impedance of a non-inductive resistance of, say, 50,000 ohms having negligible capacity will be 50,000 ohms, whether the frequency of the A.C. be 50 or 500 cycles.

Parallel capacity reduces the impedance of a circuit and series capacity increases it, as also does series inductance. (See below.) But when both capacity and inductance are present the circuit possesses a natural frequency at which it will resonate.

In this case the inductive reactance is neutralised by the capacitive reactance.

INDIRECTLY-HEATED CATHODE.

Figures in that type of mains valve where the electron-emitting element is heated by a filament (heater) not in electrical connection with it. The heat is conveyed to the cathode by radiation.

IMPEDANCE CHANGES

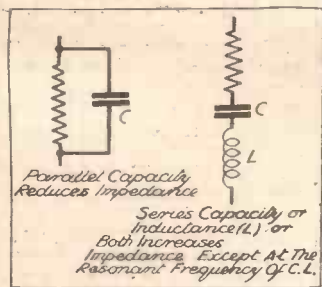

The heater can be heated by raw A.C. passing through it or by unsmoothed D.C. mains supply without the current variations causing undue hum.

INDIRECT RAY.

The waves from a transmitter reflected back to earth by the Heaviside or Appleton Layers.

INDUCTANCE.

Sometimes styled self-inductance, this can be likened to mechanical inertia, for it is that property of a circuit or conductor which tends to oppose current changes.

On the application of an E.M.F. to a circuit the current does not at once reach its

For example, a tuning coil is often referred to as an inductance, for its purpose is to provide a given measure of inductance in conjunction with a condenser-contributing capacity, so as to achieve a natural frequency corresponding with the frequency of a desired station.

The inductance of two or more inductances in series is the sum of the individual inductances, and that of inductances in parallel is calculated in

INERTIA.

The opposition of a body to any change in its state of rest or to its uniform motion.

INSULATION RESISTANCE.

The resistance between two circuits or conductors which are insulated from one another. The insulation resistance of a condenser must be high, or it may fail in its purpose.

That of a fixed condenser can be roughly tested by charging it up and then noting whether or not it holds its charge for a reasonable length of time. An efficient 2- or 4-mfd. condenser will produce a spark when its terminals are shorted some hours after it has been charged, thus demonstrating that the charge has not leaked away through a low insulation resistance.

INSULATOR.

A substance which offers a very high resistance to electrical current. Examples are ebonite, glass, mica, paper.

INTER-ELECTRODE CAPACITY.

The capacity existing between the electrodes of a valve. As the grid and anode are respectively in the input and output circuits of the usual H.F. valve amplifier, undue capacity between the grid and anode will cause an undesired coupling.

Special neutralising arrangements have been employed, but in modern circuits the screened-grid valve is used. This has an additional grid situated between the control grid and the anode

CURRENT FLOW

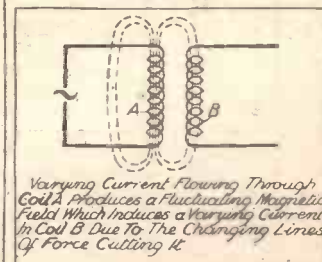

for the purpose of eliminating, or at least vastly reducing, the grid-anode capacity.

INTERMEDIATE FREQUENCY.

The beat frequency that is generated in a superheterodyne set.

RADIO TERMS

by
G.V. DOWDING
ASSOCIATE I.E.E.

Every aspect of radio practice presented in a readable manner for easy reference.

maximum value, but is held back while the magnetic field is being built up. When the E.M.F. is removed the collapse of the magnetic field induces an E.M.F. which tends to prolong the current flow.

Likewise an increase or decrease in the applied E.M.F. results, as the case may be, in a delay of current increase or a prolongation of current reduction.

Obviously, the intensity of the magnetic field bears a direct relation to the inductance of a conductor, for the more intense the field the greater will be the "electrical inertia," i.e. inductance.

Thus the inductance of a wire can be increased by coiling it up, and still further by then inserting an iron core.

The term inductance is applied to a coil designed to produce a relatively high degree of this factor.

accordance with the formula:

$$\frac{1}{L} = \frac{1}{L_1} + \frac{1}{L_2} + \frac{1}{L_3}, \text{ etc.}$$

(See diagram below).

But if the coils are in close proximity and are unshielded, then mutual inductance between them will exist and must be taken into account. No simple formula enables this condition to be calculated.

The unit of inductance is the henry.

METHODS OF JOINING

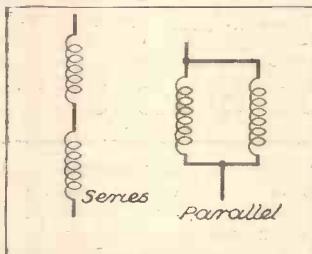

Inductances joined in series or in parallel follow the same rules as for resistance coupling (see text).

INDUCTIVE COUPLING.

When the lines of force of a magnetic field cut a conductor, current is induced in the conductor. Therefore, if a coil is placed in close proximity to another coil through which a varying current is passed, current will be induced in it because of the variations of the magnetic field thus set up (See right.) Two circuits arranged in accordance with this principle are said to be inductively coupled.

OTHER RADIO TERMS IN THIS SERIES

have appeared in previous issues of POPULAR WIRELESS, numbers 611, 610, 609, 608, 607, 606, 604, 603, 602, 601, 598 and 597.

Special Beginners' Supplement. Page 2.

IN an earlier article in this series ("P.W." No. 603) we explained in some detail what happens when we tune in a broadcasting station. In doing so we touched briefly upon the phenomenon of resonance, showing that when a circuit is tuned to the wavelength of the wanted station it will then give its maximum response to that particular station's programmes and a very much smaller—even negligible—response to programmes on other wavelengths.

A SWING ANALOGY

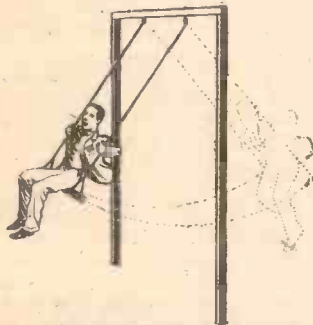

The ordinary garden swing is a good analogy for resonance, as explained on this page.

When the circuit is exactly in tune with the frequency of the wanted station it is said to be in resonance. It is upon this simple principle that both volume and selectivity largely depend.

The Term Defined.

Resonance is defined as the transference of energy—in our case, electrical energy—from one system to another in a series of waves or impulses which are timed to coincide with the natural rate of vibration of the second system.

This sounds rather academic, doesn't it? So suppose we take a simple analogy.

WHEN we considered the various steps of the impedance formula $Z = \sqrt{R^2 + X^2}$ we discovered that certain rather cumbersome multiplications and divisions were needed. These little arithmetical sums, although simple enough, took time. In fact, it can be truthfully stated that all multiplications and divisions by the ordinary "long-hand" arithmetical processes are cumbersome.

But engineers and mathematicians prefer to use some sort of shorthand method, whenever possible, for multiplying and deciding numbers. And the greatest time-saver of any is the common system of logarithms.

Logarithms make arithmetic much easier because, with the aid of tables already worked out, you can multiply, divide, and find the squares and square roots of numbers with the utmost simplicity.

Multiplication is changed into

The ordinary garden swing is a good example. You start the movement by giving a sharp push with your feet, and the swing moves backwards a certain distance. Then at the suspension (i.e. between the rope and the hooks).

This is an example of resonance or correct timing, and we can find many other cases in everyday life.

WHAT DO WE MEAN BY RESONANCE ?

moment it reaches its limit you throw your weight forward and the swing moves through an arc in the forward direction. As soon as it reaches its limit of travel in this direction you throw your weight backwards.

Now, if you think about this for a moment you will realise that the movements of the swing depend solely upon the way in which you shift your weight. In other words, you must time the backward and forward movements correctly, otherwise the swing will stop. This would happen if you threw your weight forward when the swing had only completed half of its travel backwards, and vice versa.

But, provided your timing is accurate, the travel of the swing will get greater and greater, the only limiting factor to the length of arc through which the swing travels being the resistances of gravity and the friction of the

RESISTANCE EFFECT

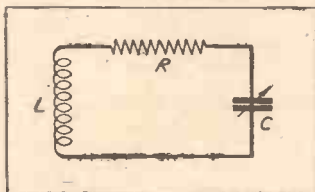

Every tuned circuit contains resistance, and this has a marked effect upon the voltage build-up due to resonance.

Let us apply the phenomenon once more to radio. The receiving aerial picks up a number of different programmes. It doesn't discriminate between any of them, and it is left to the tuning circuits to sort them out. And it is the principle of resonance that enables this sorting out to be achieved.

And, as we saw in the article on "Tuning Your Receiver,"

SERIES TUNING

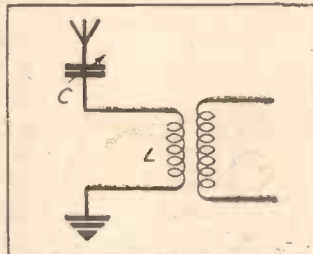

When a condenser C and an inductance L are joined in series for tuning, the arrangement is called a series-resonance circuit.

the greatest energy transference from the aerial to the tuning circuit occurs when the tuning circuit is adjusted to exactly the same wavelength as that of the wanted programme. When this adjustment is properly carried out the voltages across the ends of the tuning circuit reach their maximum for that particular programme.

But every resonant circuit has

losses, and it is these losses which limit the extent to which the voltages can develop. This is analogous to resistance in the case of the swing.

In a tuning circuit there is the resistance of the tuning coil as well as the losses in the condenser and its associated wiring to consider. These losses have a very marked effect upon the efficiency of the receiver. The resistance (high-frequency resistance) of the tuning coil is a very important factor, for upon

PARALLEL WIRING

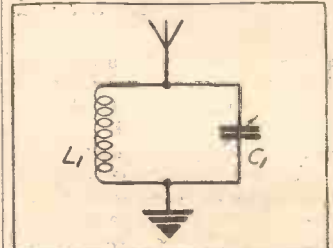

An arrangement consisting of an inductance L, and a condenser C, connected in the manner shown above, forms a parallel-resonance circuit.

this depends not only the voltages due to resonance, but also the selectivity of the set.

A selective circuit is one that responds sharply to one particular frequency or wavelength. But if a circuit has considerable resistance losses it does not do this. On the contrary, its ability to differentiate between one wavelength and another largely disappears, and the voltages due to the wanted programme are much less than they would be if the circuit had a low resistance.

Distinct Types.

There are two types of resonant circuit, viz. the series-resonant circuit and the parallel-resonant circuit. The latter is the type commonly used for tuning purposes in modern designs.

RADIO SUMS SIMPLIFIED

addition and division into subtraction and so on. But we mustn't go too fast. Let us first of all see what a logarithm really is.

We have already explained in previous articles that a number raised to the power of two is the same as saying that the number is squared. Thus 4^2 is four squared, i.e. four times four, or sixteen.

But we can also say that two is the logarithm of sixteen to the base four.

This would be written $\text{Log}_4 16 = 2$.

Similarly $2^3 = \text{two multiplied by two multiplied by two} = 8$. In logarithmic language we should say that $\text{Log}_2 8 = 3$, or the logarithm of 8 to the base two is equal to three.

Thus the logarithm of a

number to a given base is the index of the power to which the base must be raised to give the number.

Hence in the above example the index of the power is 3 and the base 2. Since 2 raised to the power of 3 is 8, 3 is therefore the logarithm to the base 2.

Now, the common system of logarithms, which practically everyone uses, has a base of 10. We know from our previous explanations that $10^2 = 100$, i.e. 10 times 10, or 10 to the power of two equals one hundred. The power merely indicates how many times 10 must be multiplied by itself to give the number.

Hence $10^1 = 10$, $10^2 = 100$ and $10^3 = 1,000$. The logarithm of ten to the base ten is therefore one, or $\text{Log}_{10} 10 = 1$. Similarly $\text{Log}_{10} 100 = 2$ and $\text{Log}_{10} 1,000 = 3$.

There is really no reason to indicate the base ten when using ordinary common logarithms, because this is assumed. It is only when some other base is employed that it becomes necessary to write it down. In the ordinary course of events we should just say that $\text{Log. } 100 = 2$ and $\text{Log. } 1,000 = 3$.

We can now see that the logarithm of numbers between 1 and 10 is less than one (the logarithm of 1 is 0) and of numbers from 10 to 100 is between 1 and 2.

Also the logarithm of numbers ranging from 100 to 1,000 is between 2 and 3.

If you have a set of log. tables to refer to you will see that the logarithm of 9 is .9542 and that the logarithm of 12 is 1.0792 (to four places of decimals).

But we will leave it at that for the moment and proceed a step further next week.



"Efficiency and good quality, sensitivity and stability do not go together" says our Chief Radio Consultant, as he shows how the desire for cheap receivers proves a serious set-back to the achievement of radio quality.

I HAVE been more and more struck, as certain work I am doing advances my knowledge, how the demands of commerce spoil results. I am talking, in this case, about wireless reception.

I am referring to the fact that the public want cheap receivers and the manufacturers give them what they want. They give them a cheap result, too. No blame attaches to anyone—the fact remains.

Now I am told, by everyone who knows commerce, that the public prefers a receiver which "gets" foreign stations, and all other stations, to one which is not sensitive but gives a good result on the local station.

A Really Good Receiver.

For fifteen guineas I think I could design a really good local-station receiver. It would never get anything unless the field strength available was of the order of 10 millivolts per meter. And I am told that no one would buy it. This is, of course, a fairly acute criticism of the B.B.C. programmes.

If, for a given cost, you have to design a receiver which gets all programmes badly you have to concentrate upon "efficiency." Now, the word efficiency used like that means instability, particularly in H.F. magnification.

The reason we have to use high-frequency magnification is that detectors, to work without giving distortion, must have "volts," not millivolts, of high-frequency signal applied to their input terminals.

If we connected the aerial circuit (through filters or tuners) directly to the detector we could only get millivolts of signal for all but the local station.

So high-frequency magnification is essential, apart from any consideration of efficiency, to get good quality when the incoming signal is weak or the aerial pick-up poor.

Reducing Back Coupling.

Now, the high-frequency valve is designed so that it minimises retroaction or back coupling. If we used an ordinary three-electrode valve for H.F. mag. we should find that the capacity between the electrodes would be enough to "couple" the input and output circuits, and the whole thing would oscillate.

Why, then, you may ask, do we ever use three-electrode valves for anything? Answer: we only use them when the

frequencies dealt with are low, e.g. audio-frequency.

By and large, this is true of receiver design, so we use screened electrode valves to prevent the electrodes coupling. Because of the screen construction the valve impedance becomes very high.

To get good magnification out of a valve the impedance in its anode circuit must be of the order of the impedance of the valve. So, for high-frequency magnification, using typical H.F. valves, we want impedances of

lowish impedance you wouldn't get more than a magnification of two or three per valve with R.C. coupling. "Efficiency" demands twenty or thirty.

The solution adopted is to use "tuned circuits" in the anode of the valve. This has several apparent advantages.

Firstly, the valve capacity, which shunts away the high-frequency signal in resistance- or choke-capacity magnification, is in parallel with a (large) condenser which "tunes" the inductance. It is thus absorbed, and, because it is part of a tuned circuit, has no effects except as part of that tuned circuit.

Selective and Sensitive.

Secondly, the tuned circuit, when its capacity and inductance reactances are equal and opposite, i.e. when the circuit is in tune to a given signal, has a high impedance which, so far as the valve is concerned, looks like a resistance. But at other frequencies, considerably different from the tuned frequency, the tuned circuit does not look like a high impedance; in fact, it looks to the valve like a low impedance, and so the valve does not magnify, and the arrangement is selective, AND it amplifies.

This looks grand until you work for efficiency! Because when you force things you depend for a good result (a) upon exactitude of tune which, with the best ganged condensers, you don't get; (b) upon there being no retroaction which, in spite of screening in the valve, you get; (c) upon no variation of circuit performance when, in a variable μ valve, you vary the μ , which you do get.

A "Lop-sided Response."

The result is lop-sided response in the circuit, and hence bad quality, instability and—well, efficiency.

This can all be cured, at the expense of sensitivity and selectivity for a given number of valves, by shunting every tuned circuit by resistances of the order of 20,000 to 50,000 ohms. Your set which, before so drastic an operation, could get hundreds of stations may then only get the local. But, with good L.F., it should get it, really well.

No! Efficiency and good quality, sensitivity and stability do not go together. But apparently the public are determined to have quantity. They may well be right: it's more fun to get the sparkle and amusement from some overseas stations than the too-often-repeated dreariness of the local.



QUANTITY, NOT QUALITY
"It's more fun to get the sparkle and amusement from some overseas stations than the too-often-repeated dreariness of the 'local,' however well reproduced," says P. P. E. Here you see part of the aerial system of Leipzig—a station well received in this country.

the order of hundreds of thousands of ohms. Why not, then, use resistance-capacity H.F. mag.? This could be stable and would not depend upon frequency. You could design a beautiful "tuner" before the currents entered the valve at all.

Alas! the valve electrodes have capacity to earth, even though they may have little or no inter-electrode capacity. And this capacity has an impedance of the order of tens of thousands of ohms at high frequencies. And so, if you tried to use resistance-capacity high-frequency magnification with modern screened-grid valves, you would just get no magnification.

Even with valves designed to have very small electrode-to-earth capacity and

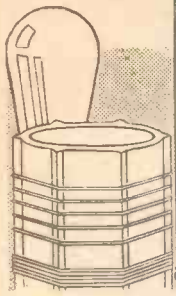

Short Wave Notes



Notes of interest concerning stations and conditions on the short-wave band, written in an entertaining manner by the foremost expert in short-wave practice.

IF the urge to "write to the papers about it" is in any way a fair measure of enthusiasm, then short waves are definitely going ahead. A check on my correspondence shows that in January, 1934, I received rather more than twice the number of letters that reached me in January, 1933. My correspondence basket is, in fact, becoming a little bit of a worry to me, because I can't possibly answer all the letters personally, and many of them are not of sufficient general interest to answer in print.

Amateur Telephony From America.

This week, however, something has got to be done about it, so here goes with some "potted replies" to the general-interest queries. First, fifteen different readers who want to know when a short-wave set is going to appear in "P.W.": The Editor has one of mine in hand, and will release it when he thinks fit.

Next, a whole bunch of readers who want "J. B. M.'s" address. I am sure he won't mind my publishing it. He is Mr. J. B. Morgan, of 21, Killoch Drive, Glasgow, W.3. Don't all write at once!

"E. G. W." and others report reception of an unlisted station at Bandoeng in the 31-metre band. I believe he is in the latest lists, but in any case it can be taken for granted that it is PLV, Bandoeng, Java, on 31.86 metres.

All those people who have logged "W2GOQ" on about 21 metres and think he is a new American broadcasting station might note that he is an amateur working in the 21-metre amateur telephony band. At my own station I find that he is easily the strongest American "ham" on telephony at present. Unfortunately, he is a comparatively new station and doesn't appear even in the latest call-book, but the A.R.R.L., 38, La Salle Road, West Hartford, Conn., would forward reports to him.

Was It a Re'ay?

"A. K." (Bristol) reports an American broadcaster on about 31.48 metres, apparently giving the call-sign WDN. I think it probable that this was a relay of a medium-wave station through W2XA-F, but someone might be able to confirm that.

"T. D. M." (Brierfield) reports some of the "Buffalo Blue Six" and "Buttercup" variety of call-signs on approximately 75 metres. These are R.A.F. stations and aeroplanes, and may be heard practically any day between 60 and 100 metres. (Incidentally, remember the "divulgence" clause in the licence when talking about these fellows!)

"W. P. McG." (Solihull) has heard music and announcements in Spanish on about 49.2 metres, and wonders whether the station concerned might possibly be the elusive CP5, La Paz, Bolivia. I should think it is more likely to be the better known YV1BC, Caracas, Venezuela, on 49.08, but one never knows!

Plenty of "Bits and Pieces."

"W. P. McG." also wants to know whether there is anything really interesting between 50 and 100 metres. The full list



Mr. H. D. Price, of Sydenham (station G6HP), tuning up his apparatus for the B.E.R.U. contest about which "W. L. S." spoke last week. In last year's contest Mr. Price made contact with over forty amateur stations in New Zealand and Australia.

of stations gives innumerable "bits and pieces" using these wavelengths, but there is very little in the way of regular broadcast. Two stations worth listening for, however, are RC V15, Khabarovsk, U.S.S.R., on 70.65, and HCJB, Quito, Ecuador, on 73.0 metres. The latter would be a good "bag."

Will readers please note that the various calls—"Oslo," "Vadso," etc.—heard on 42.92 metres all emanate from Jeloy, LCL? He relays the Oslo programmes as a rule, and is tremendously strong in the early evenings. This station has achieved more notoriety since he has been on the air than any other that I can remember.

"V. G. W." (Cardiff) has just started struggling with Morse, and inquires about the meaning of "TR" immediately before the call-sign of a station. I should imagine that he is misreading "DE"—meaning "from." It can easily be taken for "TR" when sent fast, when one is in the early days of Morse! The usual formula for commercials testing is "ABC ABC ABC de J N J J N J v v v v," and so on ad lib. The "v's" may number anything between three and thirty!

That Identification Difficulty.

"G. C. W. A." (Isle of Man) writes a long letter, full of news and queries. He has run up against the usual bugbear, hand-capacity troubles, but seems to have made a good shot at curing them without any external aid. Let me take this opportunity of confirming, in public, his supposition that the layout of parts has an enormous amount to do with instability and kindred troubles in short-wavers.

The said "G. C. W. A." picked up V W Y, Poona, India, on 17.1 metres. I don't remember one single report on this station except his. His next "bag" was X G R, Shanghai, China, on 26 metres at a strength of R 8! He, likewise, has got (or should I say "gotten"?) all tangled up among the American amateurs on the 20-metre band, and complains of the difficulty of logging that troublesome American letter "Zee" with certainty.

A Very Confusing Letter.

It certainly is a beastly letter to have in the alphabet, and I have never been able to understand why they have not adopted "Zed." "Zed" can't be confused with any other letter, but "Zee," from a weak station, might be B, C, D, G, P, T or V! American "hams," if any of them read this, please note. Say "Zebra" if you like. A definite international pronunciation code for amateurs, like that used by our Post Office, would do a great deal to clear up the confusion that exists.

Now I really must leave the correspondence—although there are about fifty interesting letters left—and get down to things. Does it surprise anyone to learn that there are now over a hundred regular or experimental broadcast stations below 60 metres?

They seem so very few and far between on account of the enormous "acreage" that one has to cover with a short-wave receiver, but there are the figures.

Over 20,000 in U.S.A.

Readers who are interested in the amateur transmitter, too, might note that according to the latest Call-book there are over 35,000 in the world, of whom rather more than 20,000 are located in the U.S.A. I can well believe this—I think they were all sitting on top of an Australian that I was trying to copy on 20 metres the other day.

Once again I have been bitten by the superhet craze: not for short-wave amateur work, but for broadcast and general short-wave telephony reception. I believe I'm on to something quite new. It is a superhet of really charming simplicity and economy which seems, at the moment, altogether too good to be true. As soon as the thing is workable and describable you will be hearing some more.

W. L. S.

Tone

That fidelity of reproduction which banishes all thought of mechanism between performer & listener is the outstanding feature of

TELSEN '470'

ALL - ELECTRIC RECEIVER
Designed to meet the most modern requirements — with Single Knob Tuning, full vision scale calibrated in wavelengths and Moving Coil Speaker.
PRICE - - **10 GNS.**

TELSEN '474'

ALL - ELECTRIC RECEIVER is similar but employs an additional tuned circuit for ultra selectivity.
PRICE - - **11 GNS.**

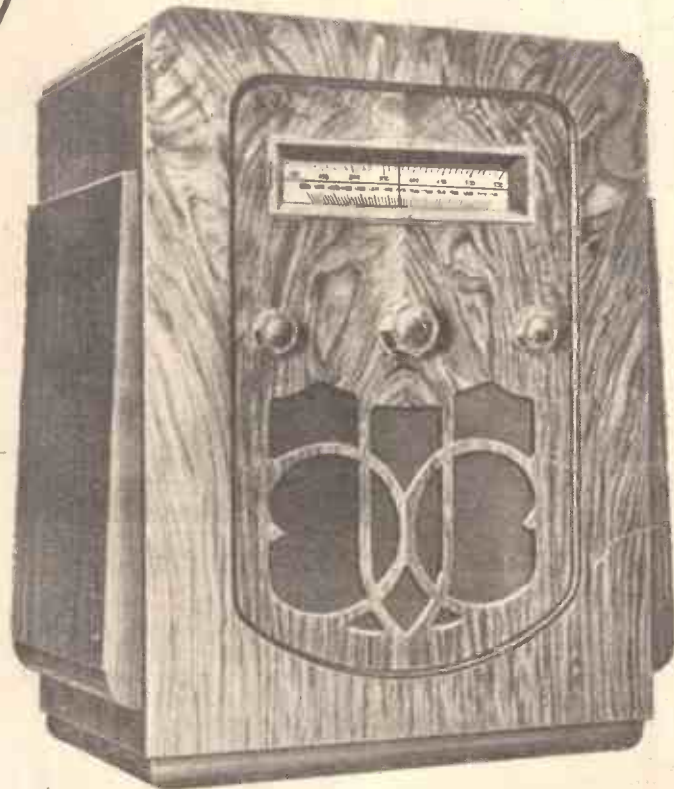

Announcement of Telsen Electric Co. Ltd., Aston, Birmingham.

THE FUTURE OF MULTI-PIN VALVES

So rapid are the changes taking place in the design of radio receiving valves that seemingly every few days we hear of new types that have arrived on the market or are promised in the near future. K. D. Rogers, "P.W.'s" Chief of Research, views with alarm the trend of radio development for the reasons set out below.

THE set of the future will probably have only one valve. Having steadily and somewhat laboriously graduated from the crystal receiver, through one, two, three valves and so forth, to superhets having as many as nine valves, the trend of development at the moment seems to be to cut down the number of valves again.

But our one-valver of the future will not be the simple receiver of the past. It will consist of one valve situated in the middle of a glorious concoction of coils and condensers, resistances and chokes.

"An Endless Delight to its Owner."

The set will have single-knob control, and will be designed to get practically any station worth hearing in Europe or America. Automatic volume control will be included, together with an electric clock and automatic tone control, while stations will come in at every degree of the tuning scale at the same quality and strength.

The receiver will be all-mains, of course, and will be capable of being used either as a radio set or for the reproduction of records. It will be an endless delight to its owner, a nightmare to its designer, and if it ever goes wrong it will have to be thrown away and a new one bought. There will be little hope of servicing it.

This sounds ridiculous and far fetched, doesn't it? But it is not nearly so fanciful as it appears, for it is founded not on mere imagination, but on a process of common deduction, mixed with a little foresight, and developed from fact.

If you review the past six years of radio development you will see that not only has progress become more and more rapid, but that the whole trend has been to make valves do more work.

More and More Amplification.

We started off with screen-grid valves and pentodes. They provided, respectively, more H.F. amplification and greater output power. Then followed H.F. pentodes, with further capabilities of amplification.

Somebody thought of automatic volume control, and this produced the double-diode triode—two valves in one. Hard on its heels came "hotter" valves of similar purpose—double-diode tetrodes and double-diode pentodes. All these do the work of two valves instead of one, so that we can save a valve in our set design.

Class B valves arrived, followed by one

that had the driver and the "B" valve in one glass envelope. Later came a double valve for Q.P.P., and this was followed by the production of a Heptode—seven electrodes—for superhet work.

Nine-pin Bases.

These valves necessitate a seven-pin base and special valve holders to take them. But more is to come. Not content with the Heptode and its method of acting as mixer and oscillator in one, we are to be treated to a nine-pin valve—a triode pentode, also for superhet mixer-cum-oscillator work.

MODERN RADIO RESEARCH



The chemist, as well as the electrical engineer, is brought into the science of radio. A scene at the new Post Office Research Station is depicted.

Its action is different from that of the Heptode, which provides "electronic" frequency changing, for the new nine-pin valve is virtually two completely separate valves, the triode section acting as oscillator and being screened from the pentode portion, which does the work of mixer or frequency changer.

Incidentally, a new double-diode plus L.F. pentode is also on the way, but I do not know how many pins it will have—probably nine.

I am expecting to see an eleven- or fifteen-pin valve arrive at any moment. Instead of getting down to the task of standardising the various types of valves and of perfecting their production so that the standard of tolerance of the impedance

need not be so big as at present, the valve makers are going all out on the development side. The search for a new "wangle"—improvement, if you like—seems to be paramount, and I seriously ask them and you: Is it worth it?

Is all the money being expended on research, new jigs, the training of staff each time a new valve has to be made going to have its due reward? I doubt it.

I am not an anti-progress fiend, deploring anything new. I welcome fresh developments; but the mad race that is now going on is not, I am sure, in the interests of good radio. Fresh ideas are not having time to be thoroughly tested and put into commercial practice in a proper manner before they are whisked away to make room for something new.

An Inevitable Effect.

And not only the valve makers are concerned; the coil designers and manufacturers are, willy-nilly, dragged into the maelstrom, with the result that the really tried and tested and commercially sound set is liable to give way to a "latest-things-in-radio" model that has not had a chance to be soundly developed. The consequence is inevitable: a far larger percentage of rejects in the factories—both of the valves and of complete sets—and a too high percentage of failure in the hands of the public.

Not that I say this is so now. But it will surely come unless the brake is put on this so-called "progress." It is a high ambition to aim at valves that will do more and more tasks, and will do them really efficiently; and the ideal of one valve doing everything, albeit it may have 27 pins, is a pretty one. But only if the set it contains is thoroughly efficient, inexpensive and reliable.

I would rather have a fifteen-guinea (the price allowing a good profit) seven-valve set that did its job with perfect reliability than a seventeen-guinea receiver (whose price has been cut to the bone) with only four valves, A.V.C., and D.D.P., which was also more often than not D.U.D.

I am not being rude to the manufacturers. Their sets are excellent. But they will have to go very warily if their reputations for reliability are not to be seriously tried in the future.

Reliability in a set means working to careful standards, and incidentally it means the possibility of easy replacement of any part that becomes faulty or wears out.

Standardisation of Types.

In the case of valves this means careful standardisation of types, and with the present rush such a standardisation is going to be next to impossible. Costs will remain higher than they need be, supplies will be difficult to obtain (owing to the large numbers of rejects), replacements of such tricky valves will not necessarily work as well as the originals, and the profits of the radio industry will inevitably suffer.

I have said nothing of the home constructor. He will, of course, be safely out of the great scramble while the set makers struggle among themselves for supremacy.

And while they struggle he will be getting good results, reliable reception, first-class quality from his three- and four-valvers, advancing steadily along a certain road of progress, assured of obtaining full advantage from new developments when, and if, they prove to be worth while.



"BRITISH BROADCASTING REORGANISED" BY OUR SPECIAL INVESTIGATOR

Although the Control Board lasted about six years, it did not satisfy either Sir John or the Board of Governors. It was felt that there were too many people for him to deal with, and that some of them needed more supervision than he could give. So there came into being the era of refinements of organisation and "safeguards." An Administrative Department was set up

The infection had gained such headway that its blandishments were irresistible. And certainly, on the face of it, there appeared to be arguments almost compelling. The work was rapidly growing. The programmes were becoming more specialised. Resources were at hand to

AFTER rather more than ten years it has not yet dawned on the B.B.C. that listeners and the public in general are very much interested in the "organisation" or "organisers" of broadcasting.

What the public wants are good varied programmes and plenty of them, well balanced and well presented. The public also likes to know something about the actual personalities behind the microphone. Only the personal habits, ambitions and theories of administrative chiefs leave the public literally cold.

Two-Thirds of the Task of Achievement.

But somehow or other the B.B.C. has contrived to put on an excellent if limited programme service, despite its "organisation" obsession.

It has managed, however, to defeat in large measure the desire of listeners to learn something about their microphone favourites—and this has been a bad thing for broadcasting.

Wherefore this organisation "obsession"? Behind it reposes a feeling that organisation is something miraculously meritorious in itself: that a scientifically prepared plan of the distribution of responsibility and "chains of direction" illustrated in grandiloquent charts is rather more than two-thirds of the task of achievement. The opposite method of approach—and to most plain people the simpler and certainly the common-sense one—is to organise round the function, not despite it.

The latter would regard broadcasting as a means to get lots of good programmes well received in every household throughout the land. Despite all its great achievements, the B.B.C., for the most part, is of the former attitude.

A Sort of Unofficial Committee.

In the early days of the B.B.C. there was naturally not much time for organisation diversions. Then Sir John Reith was, in fact, the dictator he is supposed to be still. He personally directed the whole business and gave it the wonderful start that has enabled it to survive so many subsequent organisation shocks. As time went on Sir John, at the instigation of his Board, decided to devolve increasingly on his departmental heads. He set up a sort of unofficial executive committee known as the Control Board, which met weekly for the purpose of dealing with the day-to-day business of the service.

After many weeks of patient toil, one of "P.W.'s" most valued contributors has succeeded in collecting definite and reliable information about the B.B.C.'s latest reorganisation epidemic. The B.B.C. is notoriously chary of letting "outsiders" explore the mysteries of the intricate machinery which enables the wheels to go round, so that our contributor had no little difficulty in collecting the information upon which this and succeeding articles are based; but patience, pertinacity and no small degree of courage have been rewarded, and "P.W." readers now have an opportunity of reading the first of a series of the most authoritative articles on the B.B.C. ever penned.—The Editor.

under Sir Charles Carpendale; numerous administrative "experts" appeared on the scene; the insidious infection of "Chartitis" got its grip. This was the state of affairs when the great overhaul of 1933 was reached.

When the Board of Governors examined the position in January, 1933, it was still possible for them to take either of two courses: the one to simplification; the other to complication. They chose the latter.

PROGRAMME CONTROLLER



"Programmes" were also transferred into a "Division." . . . Col. Dawnay, of the Imperial General Staff, became General Officer, commanding in chief the Programme Division."

explore new fields. How were conditions to be adapted satisfactorily?

It was represented that the creation of the Administrative Department had already done a lot to regularise procedure and keep "normal channels" clear. But the process had not gone far enough. On the one hand, the Director-General, the executive chief of the service, was still too much immersed in detail: had still to deal with too many individuals of different grades, and was, in fact, too close to his own organisation.

On the other hand, programme builders were taking excessive interest in the management of the business and of their own jobs to be able to give their main attention undivided to "creative" work.

No Irsome Details for Them.

So the Governors said: "This is fine! Let's have lots more organisation," and they set about it. The first step, of course, was to promote the Administrative Department to the exalted pinnacle of a full-blown "Division," to which was entrusted the whole of the executive, business and staff work of the B.B.C.

"Programmes" were also transformed into a "Division," but not quite at the same dizzy elevation in dignity or authority. Col. Dawnay, of the Imperial General Staff, became General Officer, commanding in chief the Programme Division, while the administrative brigades marched under the flag of Vice-Admiral Sir Charles Carpendale.

Theoretically, the programme staff were to have all the best of the change. In future no mundane or irksome business details for them! They would concentrate on creation, and, as each brain-wave was hatched, regiments of administrators were eagerly waiting to snatch the opportunity of pushing the idea through, with all the resources of the Corporation behind them.

The application of this development of organisation entailed allotting to each

Continued on next page.

BRITISH BROADCASTING "REORGANISED"

(Continued from previous page.)

considerable creator an equally considerable administrator, complete with staff. As they belonged to different Divisions they were equal in status. Both in London and in the Regions the new distribution of functions involved more staff. In the Regions this was particularly noticeable. There the Regional Director (creative) has a Director of Programmes (creative) and an equal Regional Executive (administrative), with appropriate specialist officials and retainues. This has left the Regional Directors themselves with very little to do. They have been, in fact, almost "helped" out of their jobs!

In London five months' working of the new organisation has not revealed any improved results, but has certainly slowed down the whole machinery of action.

This is the sort of thing that happens: A producer secures approval for an idea for a programme requiring certain artistes and a particular author. The producer sends for the author—perhaps a man or woman of literary eminence. Having discussed the idea with the author, the producer, being "creative," dare not, at the risk of losing his job, touch upon the mysterious subject of monetary reward. If the author should mention this material subject the producer is bound to say that, of course, he has no concern with the pay, that being a job of "another department."

With the interview leaving the matter pretty well in the air the author goes away to await the summons of the "other department."

A Long-Distance Paper Bombardment.

Meanwhile, "forms" of different kinds are moving efficiently enough in various directions at the Big House. The "executive" concerned with the work of the particular producer probably gets far enough down his tray to reach the relevant form in three or four days after the interview. The author is then sent for and asked what he wants to be paid. Whatever he says he is told it is excessive, and he is reminded of the honour of broadcasting and its publicity value to him.

After a long wrangle negotiations are probably suspended. When the producer hears that the executive has mucked up the interview on a question of fee, he is naturally upset and invokes the aid of the head of his department, who goes in turn,

probably a day or two later, to the head of his branch, who in due course requests the support of his divisional commander, Col. Dawnay. The last-mentioned, always ready to support his people, opens a heavy long-distance paper bombardment on the rival divisional commander, the gallant Admiral Sir Charles Cappendale. The admiral is bound to show fight, if only for the honour of the Division, so he repels the first attack without suggestion of possible compromise.

But he follows up the matter, down through the long chain of responsibility

seen the author, the original fee is agreed, and then it is found that the author, committed meanwhile to something much more profitable elsewhere, cannot entertain the idea, which is dropped.

Not a Gross Exaggeration.

The above may be a slight caricature, but it is certainly not a gross exaggeration. Apart from ridiculous complications of bureaucracy, the serious aspect of the matter is that the executive, who was theoretically supposed to be an aid or "service" to the programme builder,

becomes in practice a check and brake. It is the same sort of thing as prevails when a board of directors entrusts the handling of its business to two joint managing directors, instructing each privately to watch and report on the other.

Fortunately, British broadcasting is vital and flexible enough, and its programme builders are loyal and zealous enough, to manage somehow to continue high programme standards in face of these discouragements. But even they will be unable permanently to offset the effects of the "dead hand."

In the Old Days.

I am hopeful, however, that the problem will be solved before long. This may come about in several ways. The most likely is that Sir John Reith himself, awakening to what is going on, will wade in, as he did in the old days, and clear up the whole situation. If this does not happen, then the Parliamentary inquiry due next year is bound to deal with the subject.

Sir John Reith

"In the early days of broadcasting there was naturally not much time for organisation diversions. Then Sir John Reith was, in fact, the dictator he is supposed to be still."



Admiral Sir Charles Cappendale

"The gallant admiral is bound to show fight, if only for the honour of the Division, so he repels the first attack without suggestion of possible compromise."

that links him remotely with the programme producer who first got the idea agreed. By this time we are at the meeting stage. Conferences are held and "aides-memoir" are circulated. Finally, perhaps six or seven weeks after the producer had

HE was an expert.

That was quite obvious at a glance. And, anyhow, in spite of popular delusions to the contrary, Government departments don't send out boneheads on important jobs.

It was a pleasure to watch him handle the mass of gear which, when assembled, would comprise a small transmitting and receiving station for wireless telephony. Under his nimble fingers the components slid into place like the pieces of a well-practised jigsaw puzzle.

At his back stood the old linesman, proffering occasional snatches of advice, but for the most part dreaming blissfully of the days, long since past, when he tapped a coherer. A few swift tests and the transmitter was passed O.K.

The receiver was a beautiful piece of work, a superhet of the latest type, employing several variable-mus and a pentode output. The layout, even to amateur eyes, was a joy to behold.

The engineer screwed up a terminal, slipped

THE EXPERT

A radio story—with a moral.

the plugs into the battery and stood back reviewing his handiwork with pardonable pride.

"All O.K. now, 'Better try her out.'"

His hand toyed with the switch. "Sorr," came the voice of the linesman over his shoulder. But it was too late. Coinciding with the click of the switch came a flash. "Faith, sorr," gasped the linesman, pointing with agitated finger, "I was tryin' to tell ye."

I followed the line of his finger. Dangling from the receiver was a tiny strand of flex, slipped from its moorings. The youngster frowned.

"Bad luck, that," he observed. Then he turned to me with a bleakish grin. "No use getting all hot and bothered, eh? Anyone round here stock valves?" He was evidently a philosopher.

So next time you have a little mishap don't be discouraged. Even the best can stumble. Remember, he was an expert.

E. O. M.



ECKERSLEY NATIONAL

S.T. 500



PILOT AUTHOR KIT EXACT TO SPECIFICATION

The Pilot Kit SERVICE was founded in 1919.

See the PILOT on the carton. It's a real guarantee.

IMPORTANT Miscellaneous Components, Parts, Kits, Finished Receivers or Accessories for Cash, C.O.D. or H.P. on our own system of Easy Payments. Send us a list of your wants. We will quote you by return. C.O.D. orders value over 10/- sent carriage and post charges paid (GREAT BRITAIN ONLY). OVERSEAS CUSTOMERS CAN SEND TO US WITH CONFIDENCE. We carry a special export staff and save all delay. We pay half carriage—packed free. Send full value plus sufficient for half carriage. Any surplus refunded immediately. Hire Purchase Terms are NOT available to Irish or Overseas customers.

PILOT CLASS "B" FOUR KIT

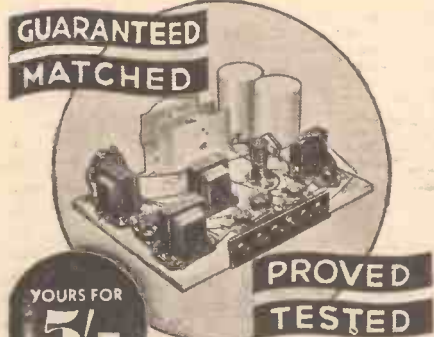

GUARANTEED MATCHED
PROVED TESTED
YOURS FOR **5/-**
Another PETO-SCOTT triumph—this latest Class B Battery 4 Kit at a popular price. Seven times the volume of an ordinary battery set, with outstanding performance equal to "mains" receiver. Kits supplied with detailed "Simple to build" instructions and assembly blue print. Matched and tested components. Guaranteed for 12 months by Peto-Scott. **KIT "A,"** less Valves and Cabinet. Cash or C.O.D. Carriage Paid, £3/10/0, or 5/- deposit, balance in 12 monthly payments of 6/-.

KIT "B"—As Kit "A," but including 4 PETO-SCOTT matched and tested Valves. Cash or C.O.D. Carriage Paid, £5/2/6, or 12 monthly payments of 9/6.
KIT "C"—As Kit "A," but including 4 PETO-SCOTT matched and tested Valves and Peto-Scott Console Cabinet. Cash or C.O.D. Carriage Paid, £5/15/0, or 12 monthly payments of 10/6.

Recommended PETO-SCOTT SPEAKER, if required, add 22/6 to Cash Prices or 2/- to each monthly payment.

CASH BARGAIN PETO-SCOTT MAINS UNITS

D.C. MODEL
A wonderful opportunity to possess a guaranteed PETO-SCOTT Eliminator 20 m/a output at 120 volts, 4 Tappings. Soudly constructed in metal case. As above, but with 25 m/a output. Cash or C.O.D. Carriage Paid... **15/-**
For A.C. Mains, 120-volts, 25 m/a, 4 Tappings. Cash or C.O.D. Carriage Paid... **37/6**

NEW W.B. P.M. 4A. MICROLODE PERMANENT MAGNET SPEAKER, complete with switch-controlled multi-ratio input transformer. Cash or C.O.D. Carriage Paid, £2/2/0. Balance in 7 monthly payments of 5/9.

10/- TELEVIEWER

READY-BUILT Lamp Housing. Complete on Base with viewing panel and Neon Lamp holder exactly as specified. (See "Popular Wireless," Feb. 17th, 1934. **10/-** Post Free Neon Lamp, if required 3/1 extra.

ECKERSLEY NATIONAL 3

KIT "A" Author's Kit of first specified parts, including **READY DRILLED PANEL and METAPLEX** chassis assembly, but less valves and cabinet. Cash or C.O.D. **£5:10:0** or 12 monthly payments of 10/-

"KIT B" As Kit "A," but including set of specified valves, but less cabinet. Cash or C.O.D. Carriage Paid, £7/9/0, or 12 monthly payments of 13/9.
"KIT C" As Kit "A," but including valves and Table cabinet. Cash or C.O.D. Carriage Paid, £8/6/6, or 12 monthly payments of 15/3.

Exclusively Specified PETO-SCOTT Cabinets: **TABLE MODEL 17/6; RADIOGRAM MODEL 47/6.** FOR FULL DETAILS SEE PREVIOUS ISSUES OF "POPULAR WIRELESS."

MULTI-MU COMPONENTS

- 1 Bulgin 50,000-ohms Potentiometer, with 3-pt. s. d. shorting switch, type V.S.36 **5:0**
- 1 Graham Farish Ohmite 1-meg. grid leak, with terminals **1:6**
- 1 Dubilier .0003 fixed condenser, type 620 **1:3**

ECKERSLEY D.C. RADIOGRAM

KIT "A" Author's Kit of First Specified Parts, including Receiver and Power Unit, but less Valves and Cabinet. Cash or C.O.D. Carriage Paid, £9/18/0, or 12 monthly payments of 18/-.

KIT "B." As for Kit "A," but with Valves only. Cash or C.O.D. Carriage Paid, £12/7/6, or deposit £2/7/6 and 11 monthly payments of £1.
KIT "C." As for Kit "A," but with Valves and PETO-SCOTT D.C. Radiogram Cabinet, less Gramophone Equipment and Speaker. Cash or C.O.D. Carriage Paid, £18/0/0, or deposit £3/0/0, and 11 monthly payments of £1/10/0.

RECOMMENDED ACCESSORIES

- 1 Garrard Universal Gramophone Motor for D.C., complete with Slider Resistance. Cash or C.O.D. Carriage Paid, £5/5/0, or 12 monthly payments of 9/6.
- 1 B.B.G. Pick-up. Cash or C.O.D. Carriage Paid, 17/6. If Peto-Scott Permanent Magnet Moving-Coil Speaker required, add 19/6 to cash price, or 1/9 to each monthly payment.

TELSEN

"MODERN RADIO ENGINEER" KITS
TELSEN 323 KIT. Less Valves. Cash Send **5/-** or C.O.D. Carriage Paid, 29/6. Balance in 5 monthly payments of 5/3.
TELSEN 323 KIT with set of 3 Valves Cash or C.O.D. only Send **6/-** Carriage Paid, £2/15/6. Balance in 9 monthly payments of 6/-.
TELSEN EXPERIMENTAL 3 KIT, less Valves. Cash or C.O.D. Carriage Paid, **5/9** £3/2/0. Balance in 11 monthly payments of 5/9.
TELSEN CLASS "B" 4 KIT. Less Valves. Cash or C.O.D. Carriage Paid, **8/3** £4/9/0. Balance in 11 monthly payments 8/3.
TELSEN S.G.3 KIT. Less Valves. Cash or C.O.D. Carriage Paid, **4/6** £1/19/6. Balance in 9 monthly payments of 4/6.
If valves required add £1/19/0 to Cash Price; H.P., 12 monthly payments of 7/3.

NEW GARRARD MODEL 202A. 12-in. Turntable Electric Motor for A.C. mains Cash or C.O.D. Carriage Paid, £2/10/0. Balance in 8 monthly payments of 6/-.

S.T. 500

KIT "A" Comprising Mr. John Scott-Taggart's Kit of **FIRST SPECIFIED** Components, including Telsen Class B Output Choke, Peto-Scott "Metaplex" Baseboard and Ready-drilled Panel and Terminal Strip, Less Valves and Cabinet. With **FULL-SIZE Blue Print** and copy of "Popular Wireless" **£5-5-0** Oct. 21st. Cash or C.O.D. Carriage Paid. or 12 monthly payments of 9/6

KIT "B" As Kit "A," but including 4 Specified Valves. Cash or C.O.D. Carriage Paid, **£7-10-3** or 12 monthly payments of 13/9.

KIT "CT" As Kit "B," but including Peto-Scott Specified Walnut Table Cabinet. Cash or C.O.D. Carriage Paid, **£8-9-9** or 12 monthly payments of 15/6.

KIT "CC" As Kit "B," including Specified Walnut Console Cabinet. Complete with Baffle Baseboard Assembly, but less Speaker. Cash or C.O.D. Carriage Paid **£8-19-9** Or 12 monthly payments of 16/3. If Peto-Scott Permanent Magnet Speaker required add 19/6 to ash Price or add 1/9 to each monthly payment.

PETO-SCOTT S.T.500 CABINET



Reqd. Design No. 78,011 EXCLUSIVELY SPECIFIED. **19/6**

TABLE MODEL, with veneered macassar and fine walnut finish. Hand French polished. Cash or C.O.D., 15/6. Carriage and packing, 2/6 extra. Or 6/- deposit and 3 monthly payments of 6/- (including carriage and packing).

CONVERT YOUR S.T.400 to S.T.500

With Free Copy of "POPULAR WIRELESS" and OFFICIAL BLUE PRINT
YOURS FOR 5/- BALANCE IN 8 MONTHLY PAYMENTS OF 5/3
Peto-Scott S.T.500 Conversion Kit comprises all **FIRST SPECIFIED** parts required to convert your S.T.400 to the new S.T.500, including output choke, but less valve. Cash or C.O.D. Carriage Paid, £2/- H.P. TERMS Complete Kit with Valve, 12 monthly payments of 5/3.

PETO-SCOTT Co. Ltd. 77 City Rd. London, E.C.1
Telephone: Clerkenwell 9406/7.
West End Showrooms: 62, High Holborn, London, W.C.1. Telephone: Holborn 3248.

Dear Sirs,
(a) Please send me.....
(b) I enclose Cash/Deposit.....
NAME.....
ADDRESS.....
P.W., 24 2/34.

SEND DIRECT to AVOID DELAY — CASH, C.O.D. or EASYWAY

TESTED AND FOUND-

Being leaves from the Technical Editor's Notebook

HYDRA CONDENSERS

IT might reasonably be thought that there is not much scope for a variety of quality in fixed condensers and that, given an adherence to a few basic principles, any concern equipped with the necessary machinery could turn out satisfactory specimens.

But this is very far from being the case. There are many problems concerned in the manufacture of condensers, and it is only of recent years that their solutions have been at all widely known.

Indeed, it is not so long ago that, passably efficient makes were distinct exceptions, and I well remember the warm welcome that was accorded to the Hydra when first it made its appearance on the market.

There were other good condensers, but so few of them that the arrival of the Hydras was a distinct event—in my experience, at least.

And almost at once one began to use them for important tasks, for their reliability soon became a by-word among radio engineers.

Unlike many others, they held their charges and nobly stood up against reasonable over-loads. For five years I had a whole bank of them in a certain piece of apparatus, which was in daily use, and not one of them failed to pass this exacting test.

As a matter of fact, it was only because the instrument in which they were solidly planted became obsolete that these early Hydras went on to the retired list. They each have probably many more years of useful life in them.

A Test Voltage of 2,000

A further fact, which ought to be recalled, is that they date from days when paper dielectric condensers particularly were regarded by many with suspicion, and justifiably so, in view of the standards of many.

Remembering all this, I regard it as good news that Hydra condensers are again to be available in quantity. This is made possible by the fact that they are to be manufactured in this country by the Telephone Manufacturing Co., Ltd., of Hollingsworth Works, West Dulwich, London, S.E.21.

In regard to reliability it should be noted that all T.M.C. Hydra condensers carry a twelve months' guarantee, and their values are also guaranteed to be within ten per cent of their nominal ratings.

A most comprehensive range has been produced. It includes five groups styled Types Nos. 25, 30, 40, 50 and 75 to indicate working voltages of 250, 300, 400, 500 and 750 respectively.

The test voltage for the 250 D.C. group (Type No. 25) is 500 volts, but it increases even above this double value with each group, and is nearly three times at 2,000 volts with the Type No. 75!

The capacities available range from .1 mfd. to 10 mfd. with the exception of the Type No. 75 group, where 6 mfd. is the maximum.



Hydra condensers, produced in a most comprehensive range of capacities, carry with them a twelve months' guarantee.

The prices are distinctly competitive, and render the Hydras exceptional value for money. I have tested numerous samples of the new British-made versions, and find them to be right up to the standard which the tradition behind the name would lead one to anticipate.

They are fine condensers, and will appeal the more to modern constructors because they are available with either soldering tags or terminals, at the same prices.

A CLIX PLUG

WHEN a small packet was laid on my desk bearing this inscription, "Clix Plug—will fit any 5-amp. socket," I very nearly cheered!

I think my house must have as many different sized power sockets in it as there are spikes on a porcupine.

Every time I transfer a radio or electrical appliance from one room to another I have to change the plug on it. A most annoying and unnecessary delay!

For years I have promised myself a complete overhaul and a standardisation of socket sizes. But every time the idea becomes practical politics the thought occurs that, even if all my sockets were of the same dimensions, where would be the guarantee that all the plugs on any odd pieces of apparatus subsequently introduced would be similar?

This "Clix" plug, though extremely simple in design, possesses the great advantage that it will fit any 5 amp. socket. Another great point in its favour is the fact that only one screw need be removed to give access to the connections.



However, here, any way, is a 5-amp. plug which is guaranteed to fit any 5-amp. socket, so with one or two of these handy the problem is pretty well solved!

This Clix Plug is of quite simple design, though completely effective. It has two split pins of a particularly resilient nature, and they do in fact slide gradually and efficiently into a very diverse collection of sockets, as I have proved to my entire satisfaction.

Another equally good point, in my view, is that it is only necessary to take out one screw in order to obtain access to the connections. Why one of my existing plugs should have no less than four is quite a mystery.

The plug is very well made, and that one screw holds the two parts together with perfect rigidity and no twisting action can loosen it.

But the screw—this one solitary screw—does another job. It holds the wires on to their terminals! No fiddling little nuts or screws have to be manoeuvred in this Clix Plug. To connect a lead to it, all that has to be done is to take the one screw out (whereupon the article falls into two halves) thread the wires through a channel, which removes the direct strain, and slip them into the ends of the split pins.

The replacement of the one screw holds the wires firmly and maintains the assembly of the plug. And if you think that an undue responsibility for one screw you don't know this Clix Plug!

It is a product of Messrs. Lectro Linx of 254, Vauxhall Bridge Road, S.W.1.

A NOVEL SELECTIVITY DEVICE

THERE must be tens of thousands of sets unable adequately to cope with modern ether conditions owing to an inherent lack of selectivity.

Why, even the outfit at one of our largest London hospitals, which has to supply programmes to hundreds of bed patients, operates with a constant overlapping background of another programme. I

know that because I have heard it—fortunately as a visitor.

Can anything short of complete reconstruction be done to clean up such a set? As a matter of fact, it is not difficult to improve the general selectivity of a set. I say "general selectivity," because an obvious way to remove an interfering programme is to employ a wave-trap.

But a wave-trap is limited in its application. At least, the majority are, and when a station is bracketed by powerful neighbours other steps have to be taken. And, after all, this is what usually happens these days.

The case of a simple local station swamping seldom occurs now, but even if this is all that happens, the alternative I have in mind can deal with it, and at less cost, too.

This alternative is the inclusion in the aerial circuit of the set of a series capacity adjuster. A vastly

Many alternative arrangements are available with this new selectivity device for which no extravagant claims are made. Listeners are thus enabled to experiment for themselves.



better method, by the way, than the physical shortening of the aerial, as has been amply proved.

And such a scheme can be applied very easily and simply by using a new device known as the "Tonastat," which is made by T. X. Products, of 32, Queensway, Ponders End, Middlesex.

This device is a quite inexpensive one, for it costs only 3s. 6d., or 3s. 9d. by post direct from the makers at the above address. I was particularly attracted to this device, because no sensational and baseless claims appear to be made for it.

In the past I have come across much less effective articles, selling at over three times the price, which were claimed to do all sorts of marvellous things.

The "Tonastat" is a most adaptable gadget. It is a neat, well-made little affair, that can quickly be connected externally to any set. There are six terminals and one adjusting knob.

By varying the connections to these terminals an extremely wide range of initial settings are obtainable, and almost any conceivable compromise between selectivity and power with any set obtained.

These six terminals connect to a small variable condenser and capacitive coils in the interior of the device, and full instructions are given for adapting the connections to any conditions.

And if the user cares to do so he can himself experiment with the couple of score or so arrangements available until just the right results are given.

I tested the "Tonastat" on a number of different sets and found it to be perfectly satisfactory. I would advise all those who desire to sharpen the tuning of their sets to give this effective little piece of apparatus their closest consideration.

THE LINK BETWEEN

Jottings of interest to buyers
By G. T. KELSEY.

THE precious secret—the secret to which I referred last week, and which, in my opinion, when it is finally divulged, will create the biggest sensation of the year in the radio world—is almost out. I am happy to be able to tell you that full and absolutely exclusive details of this great new development are to appear in our next issue.

The suspense of having to keep to myself all the details of the exciting experiences that I have had with this astonishing "something" is too much, even for me; hence the relief at being able officially to announce the release date.

A Big Step Forward.

As I write these notes I am musing as to what sort of guess you have made at this "something" which is in store. A new valve development or perhaps an L.F. coupling innovation? No, it's something far more important; a step that will probably go a long way towards obviating the desirability of still another European Wavelength Conference, and what, at the present time, could be more important than that?

But if I go on like this I shall be telling you what it is, and as I have had to keep it to myself for so long it's a pity now to spoil it. Next week you will know all about it, and if you take my tip you will make a special point of ordering or reserving a copy of "P.W." in advance, for inevitably the demand is bound to be a heavy one.

(Continued on page 1052.)

MODERN METHODS OF

By **A. S. CLARK**

VISUAL TUNING

ORDINARY tuning is entirely aural—that is to say, one decides when a certain station is tuned in completely by the volume of sound heard by the ear. Such tuning can be done as well with the eyes shut as open.

Visual tuning can be done, on the other hand, as well when the ears are "shut" (or the loudspeaker is disconnected) as when the reception is audible.

If any station is not tuned in exactly, interference may quite likely be aggravated

From the foregoing it is clear that maximum deflection of the needle means a station is properly tuned in. And the positions of the dials for maximum deflection will be sharply defined. With a grid-leak rectifier the current decreases with carrier strength, and with anode-bend detection it increases.

The Effect of A.V.C.

So far so good. Now let's consider what happens to the needle when A.V.C. is employed.

Since the object of A.V.C. is to keep the input to the detector constant after a certain value is reached by regulating the amount of amplification given by the multi-mu S.G. valve, there will be a tendency for the needle to stay stationary over a few degrees on the dial. Of course, the blurring of the tuning position is by no means so bad as it appears with aural tuning.

However, the problem of accurate tuning is completely solved by the latest type of visual indicator, the "Tunograph," made by the manufacturers of Micromesh valves—namely, Standard Telephones and Cables, Ltd., of St. Chad's Place, 364, Gray's Inn Road, London.

The "Tunograph" is actually a miniature cathode-ray tube whose design and connections are shown in Fig. 1. It is primarily intended for mains-operated circuits, but, since it will work with 180

volts, those who have ample H.T. can use it on a battery receiver.

The tube has a little rectangular plate on which a tiny green spot appears when it is connected up. This spot can be moved backwards and forwards by varying the potential difference existing across the deflecting plates. (It can also be deflected by the magnets of a moving-coil speaker! So it must be kept at least 6 in. to 12 in. away from such an instrument.)

.....
 One hears the term "visual tuning" with increasing frequency, and those unacquainted with its exact meaning might argue that surely all tuning is visual, since a dial of some sort is a universal fitting.
 The reply to that is definitely no, and this article explains why the answer to this question is in the negative.

and distortion may also exist. Unfortunately, the ear cannot differentiate between two sounds varying but slightly in strength, and consequently with aural tuning it can be difficult to decide on the exact tuning point of a station.

The modern wide use of automatic volume control renders tuning even more difficult because A.V.C. generally tends to make a powerful station provide an even intensity of sound over several degrees. Once a certain volume is reached, A.V.C. prevents a rise above this value, so a station may reach the maximum a number of degrees before its real tuning position.

Absolute Exactitude obtained

The eye is much more critical than the ear, and can tell with absolute exactitude when an indicator is showing maximum deviation, representing dead-right tuning. Hence the increasing popularity of visual tuning.

The most common form of visual-tuning indicator is a millimeter in the anode circuit of the detector valve. Briefly, the principle of its working is as follows:

The anode current of the valve carries high-frequency pulses of current in accordance with the frequency of the carrier-wave applied to its grid. Since the needle cannot move backwards and forwards at high frequency, it registers a mean-current variation which is proportional to the strength of the carrier (the latter is greatest when a station is fully tuned in).

The modulation on the H.F. has no effect, since it merely moves the strength of the H.F. above and below the mean, thus not altering it.

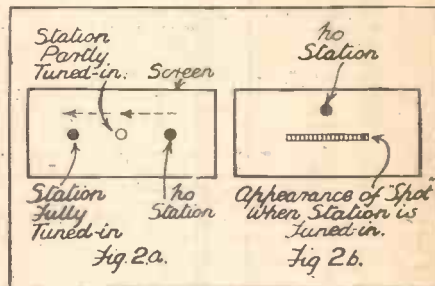

Illustrating two ways in which correct tuning can be indicated.

Fig. 1a shows the connections for an A.V.C. circuit. As the automatic control increases the negative bias on the grid of the multi-mu S.G., its anode current falls, and so also does the voltage across the resistance R. Since the deflectors are joined across this resistance, the voltage across them also drops and the green spot moves.

The spot goes on moving with alterations in tuning irrespective of what volume changes come from the speaker, and thus the tuning position is accurately indicated. Fig. 2a illustrates the movement of the spot.

From Spot to a Line

The connections of Fig. 1 are for an ordinary non-A.V.C. set. In this case the H.F. potentials across the tuned-anode coil are communicated to the deflectors.

Unlike the needle of a meter, the spot is able to follow the high frequency, and, as a station is tuned in and the high-frequency potentials increase, the spot changes into a line which gets longer and longer. This line will also indicate immediately when the set goes into oscillation, for the line is then at its longest and is, peculiarly, brighter at either end (Fig. 2b).

In a parallel-fed tuned-anode circuit the deflector P is connected via the condenser to the top end of the grid coil, but careful choice of condenser and resistance values are necessary to avoid an undesirably large decrease in strength of reception.

A NEW RAY SYSTEM

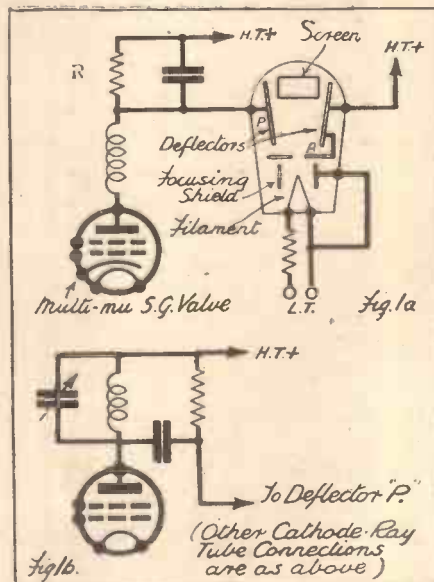

(Fig. 1) Showing connections for the latest visual-tuning indicator—a miniature cathode-ray tube.

RADIOTORIAL

The Editor will be pleased to consider articles and photographs dealing with all radio subjects, but cannot accept responsibility for manuscripts or photos. Every care will be taken to return MSS. not accepted for publication. A stamped and addressed envelope must be sent with every article.

All Editorial communications should be addressed to the Editor, POPULAR WIRELESS, Tallis House, Tallis Street, London, E.C.4.

All inquiries concerning advertising rates, etc., to be addressed to the Advertisement Offices, John Carpenter House, John Carpenter Street, London, E.C.4.

The constructional articles which appear from time to time in this journal are the outcome of research and experimental work carried out with a view to improving the technique of wireless reception. As much of the information given in the columns of this paper concerns the most recent developments in the radio world, some of the arrangements and specialities described may be the subjects of Letters Patent, and the amateur and the trader would be well advised to obtain permission of the patentees to use the patents before doing so.

QUESTIONS AND ANSWERS

IS THIS A RECORD ?

The letter in the February 10th issue of "P.W." from a Cambridge reader, suggesting the use of a set's radiogram terminals when connecting a simple microphone to it, has brought us many appreciative remarks.

Of special interest is the communication from Mr. Norman Blasebalk, of 59, Marchmont Road, Edinburgh, in which he says :

"I have read with interest the letter from J. A. G. Baldwin in this week's issue of 'P.W.', and I appreciate the value of his suggestion. I would, however, mention that I have tried this previously and the reception was rather poor.

"After experimenting, I tried the same method using an old speaker instead of the ear-phon. The results were perfect.

"The set I used was the 'National Eekersley' on which, by the way, I have logged 42 stations, including 12 Americans. Is this latter a record ?

"To conclude, let me express my gratitude for the many and varied hints in which 'P.W.' abounds."

If not a record, this reader's reception of 12 Americans on a three-valver is certainly extremely good work, and we take this opportunity of congratulating Mr. Blasebalk upon his results.

RECEIVING AMERICA DIRECT ON THE "1933 ECONOMY" THREE.

We are still receiving many inquiries about the possibilities of receiving American broadcasting stations direct upon the medium wavelengths after the majority of the European stations have closed down for the night.

At the time of writing this is still a comparatively easy matter, provided the set is one of the ordinarily-good-at-long-distance type. But sometimes one or two further attempts have to be made, as the times first chosen may not be good enough for transatlantic reception.

Although a well-handled one-valver is quite capable of such results, it is generally the three-valve-or-more type of set that scores, especially if one of the valves is of the S.G. (high-frequency-amplifier) class. The following letter from Mr. F. Craw, of 40, Lower Eldon Street, Swinton, Nottingham recounts a typical experience :

"I built your '1933 Economy' Three one day after it was published.

"Well, the programmes I have heard have urged me to thank you.

PROGRAMMES THAT WERE HEARD.

"On January 17th I sat up late and tried for a few foreigners. And the following came in at 55 on the Telsen vernier dial (0 to 100) :

"2.50 to 3.30 a.m. : Travellers' Insurance Co., Travellers' Hour, 'Wings of Song', 'Roll on, Silver Moon' (yodel), etc.

"3.30 a.m. : 'Smoke Domino Cigarettes' and a talk on Gold Standard and American Dollar.

"About 4 a.m. : Three gongs and W B I C, or W Zee I C (I'm not sure about this), 'Wear a Bulova Watch' and 'Harry Cosmis' Dance Band.'

"Also the same night I had Barcelona (I.B.C.) on 274 metres. All this was on a moving-coil loudspeaker and indoor aerial.

"I should very much like to know which American station I was receiving so well."

We regret that we cannot identify the station that Mr. Craw heard on this occasion from the particulars given, though it might have been W T I C, Hartford, Connecticut. But, falling further details, we cannot be sure.

Readers interested in reception of American broadcasts may like to be reminded that when unusually good results are achieved the American station will generally be pleased to confirm that it was their programme that was picked up if the items received, time wavelength (approximately), etc., are sent to

(Continued on page 1050.)

YOUR VOLUME OF MANUAL OF MODERN RADIO

Now Ready

Your volume is waiting. This week gift token No. 6 appears and readers who started collecting gift tokens from No. 1 will be able to complete their Gift Vouchers which, together with cash remittance, should be sent in immediately.

Readers who started with token No. 2 must wait one more week until they have collected six consecutive tokens in all.

Do not delay! Volumes will be sent out in strict rotation, and if you want yours quickly, you must send in that completed Gift Voucher the moment it is ready.

Send Voucher and remittance to :

The POPULAR WIRELESS Presentation Book Dept. (G.P.O. Box No. 184a), Cobb's Court, Broadway, London, E.C.4.





A delightfully cool sweet smoke, burning free and evenly.... an Empire Blend of the highest quality.

PLAYER'S AIRMAN MIXTURE

ALSO AIRMAN NAVY CUT AND FLAKE 10¹/₂oz NAVY CUT DE-LUXE 11¹/₂oz

10¹/₂ PER OZ
PA 37 C

S.T. 300

¶ In January, 1932, the famous S.T. 300 set was first published. ¶ There have been other S.T. sets since then, but no other three-valver—the S.T. 300 has remained for two years as the standard “S.G., Detector and Output” S.T. receiver. ¶ But now

John SCOTT-TAGGART has come to the conclusion that the time is ripe for constructors to be given the chance to build another S.T. three-valver. ¶ So he has designed the S.T. 300 STAR, complete details of which—together with a full-size blue print—appear in the March issue of

THE WIRELESS CONSTRUCTOR

ON ALL BOOKSTALLS . . . SIXPENCE

B.I. STATIC CONDENSERS

for ELIMINATION OF INTERFERENCE in RADIO RECEPTION

The causes of interference in Radio reception may be classified under three principal headings, as follows :

1. Atmosphèrics.
2. Supply Mains.
3. External.

Atmospheric troubles are usually static, and cannot be eliminated by means of condensers.

In the case of No. 2, trouble may be experienced through the interference being conveyed over the Supply Authorities' distribution system.

In the case of No. 3, external interference, this is caused by direct radiation, and originates in electric motors, vacuum cleaners, and any other electrical apparatus in which sparking takes place during operation: for example, violet-ray apparatus, or even when switching on or off any kind of electrical plant.

In attempting to overcome such interference it is necessary to try the application of the remedy at the source.

In many cases the use of condensers alone is sufficient to minimise very largely, and often entirely suppress, the interference.

The Condensers employed must be suitably designed for the working conditions, and should have a 5-ampere fuse inserted between the mains and the condensers.

Our type 212 Condensers, as illustrated, are designed with a liberal factor of safety for this duty. Write for Leaflet.



BRITISH INSULATED CABLES LTD.

CABLEMAKERS AND ELECTRICAL ENGINEERS

PRESCOT-LANCS.

Telephone No. : Prescot 6571.

London Office: **Surrey House, Embankment, W.C.2.**

Telephone Nos. : Temple Bar 4793, 4, 5 & 6.



THE HUSBAND NOTE

"Courage! All is solved! If D.C. is vital to your happiness, and A.C. to mine, we can still find greater strength and harmony than ever—in one of these Universal valves of Tungstram's!"

AC or DC at will!

Far better than ordinary D.C. valves—even better than ordinary A.C.! The astonishing Tungstram Universal—the valve that works on A.C. or D.C. at will!



No worry about possible changes in mains supply—any mains supply will serve for the Tungstram Universal valve! No need to scrap an existing set—with these new valves you can convert it in a moment! All types available from V/MU H.F. Pentode Heptode (Pentagrid) Mixers and Double Diode Pentodes to simple Multi-grid Valves. Write our Technical Department about your radio problems.

TUNGSTRAM
UNIVERSAL A.C./D.C. VALVES

Tungstram Electric Lamp Works (Gl. Brit.) Ltd., 72 Oxford St., W.1

TAS/Tu.40a

RADIOTORIAL QUESTIONS AND ANSWERS

(Continued from page 1048.)

the station director in a letter recounting the circumstances.

It is true that some of the larger American stations have received so many reports from this country that they may now be getting a little tired of replying to reports of reception. But at the lesser known or inland stations news of the fact that somebody was enjoying their programme in England will be likely to tickle them to death!

From an Irish Reader.

Very loud reception with three- and four-valves seems to be experienced quite frequently. (In fact, plenty of readers with only two-valve sets have succeeded beyond their expectations with transatlantic programmes.) We cannot quote many of the letters, but here are some extracts from a report by an Irish reader, Mr. A. Crossan, 53, Merriion Street, Belfast:

"From 11.30 p.m. to 3.30 a.m. from New Year's night I have logged the following stations, got their calls and heard their programmes: WTIC, WCAU, WPG, WGZ, WLWL, WABC, WBOO, WOR, WCB, WOAI, KDKA, WGY, LR3, WMBI, WLW, WTAM, WEA, F, WWO, WAA and WBZ.

"With regard to WBZ, there is another station with it, but I can always get WBZ clear, thanks to J. Scott-Taggart's wonderful aerial coupler. I think it's a South American station.

"On the night of January 24th, 1934, on WPG, I was listening to the Warwick Sisters, also to the Travellers' Hour on WTIC, at 12.30 a.m.

"The volume with all these stations is very strong—in fact, so strong that I had to put on a small speaker so that I would not waken the people living around me.

"I changed from the 'S.T.400' but I could not get near as many stations. I could get only about twelve, but since I went back to the 'S.T.400' I can get about thirty American stations."

U.S.A. on an Indoor Aerial.

Finally the experiences of a 15-year-old reader must be briefly summarised. He is Mr. L. F. Steel, of Charterhouse, Godalming, Surrey, and he says he became exceedingly interested in the medium-wave American stations through reading about them in "Radiatorial," with the following result:

"I also thought I would try my luck one night, as it is my custom on most nights to tour the ether, so to speak. I tuned to the wavelengths of several American stations, but only managed to get Rochester WHAM, 260.7 metres, which was received at good enough strength to be heard in the next room directly the London National was closed down (i.e. 10.30 to 10.45 p.m.).

"Seeing that I could get America, I decided to devote one of the following nights and early hours to listening in.

"Although I only use a picture-rail aerial and a gas-pipe earth, I received 18 Yanks worth listening to, as well as several others.

"WABC was the best, and could be heard all over our house. WHAM, WBZ (I was glad of your tip of Z being pronounced 'Zee'), KDKA and WTIC were all heard well.

"I also got a station just over 500 metres. At about 2.30 a.m. I was carefully feeling my

way about with the volume control at maximum when I was nearly blasted out of the room! I thought to myself, 'This is as loud as the local.' It was the local, testing on 342 metres, the new Lucerne wavelength.

"I dare say you can imagine the jump I got, especially when I say that the Brookmans Park masts are easily visible from my home near St. Albans. Daventry 5 X X, Brasov, and, I suppose, Budapest, well below 1,000 metres, were also testing."

REMARKABLE TWO-VALVE RECEPTION.

P. C. (Weymouth).—"I was reading what you said about very long distance reception on ordinary sets. Does this mean two-valves, or is it essential to have three or more valves to pick up stations thousands of miles away?"

We have indicated above that two-valves are quite capable of transatlantic reception. The best answer to this question happened to come by the same



H.F. GRID BIAS.

FOR BETTER RADIO

When a separate grid-bias battery is used for the H.F. valve, it is important not to forget that this battery "runs down" in

time, and should then be renewed.

Unless this replacement is made the quality may be impaired, and the drain on the H.T. Battery will certainly be increased.

If a single cell is used, its centre terminal (indicated in the photograph) is + and the zinc container is -. Such cells are quite inexpensive, and as they save more than they cost it is always an economy to keep the bias in good condition.

post as the question itself, in the form of a letter to the Editor from a reader in the Channel Islands.

For the benefit of others who have wondered about this point, we give below extracts from the letter in question showing what can be done on a good "two" when conditions are favourable:

(Perhaps some other builder of a "P.W." two-valve set can beat this experience, which is recounted by E. H. "A Satisfied Reader of 'P.W.'" (St. Clair Hill, St. Sampson's, Guernsey):

"This is the first time I have taken the opportunity of writing to you.

"I have built many of your sets, and they have all been as good as you said they would, and some time ago I built your 'Airsprite' Two.

"But last night, February 2nd, I happened to be up early in the morning, and at 3 a.m. I switched the good old 'two' on, turned the dial around and, to my surprise, I had dance music at good loud-speaker strength.

"I was still more surprised to hear an American announcing the names of the dance tunes. I continued to search and this is what I logged from 3 a.m. to 6 a.m.:

"WHAM, 260 metres 3.45, news; 4 a.m., songs.

"WLW 428 metres, 4.15, dance band; at 5.30 a.m. interference by a foreigner.

"WBT: One announcement was something about the Columbia Broadcasting Co.

"WTAM, 280 metres, and WTIC, 282 metres: Programme from the Grand Commodore Hotel, New York, where it was announced, Mary Pickford was staying.

(Continued on next page.)

P.W. PANELS, No. 158—STRASBOURG.

The best way to find Strasbourg is to remember that his dial-reading is about 2 degrees higher than that of London Regional. It is not an easy station to identify, as both men and women announcers are employed, and announcements are made in French and in German. The call in the former language is "Allé! Ici Radio Strasbourg."

The change in Strasbourg's wavelength under the Lucerne Plan was only the slight alteration from 345 to 349.2 metres. But whereas its old wavelength was an exclusive one, it now shares 349.2 metres with Simfropol, the U.S.S.R. station.

Strasbourg's power has recently been raised a little to 12 kilowatts. The distance from London is approximately 400 miles.

RADIOTORIAL QUESTIONS AND ANSWERS

(Continued from previous page.)

"W B Z, 303 metres: A great deal of interference from foreigners about 5.30 a.m."

All these were received at good loudspeaker strength. I am wondering if any other owner of an 'Airsprite' Two, also run on batteries, has had such good luck as I?"

THE METHOD OF CONNECTING AN ECONOMISER CIRCUIT.

J. D. D. (Windsor).—"Are the following the right connections, ohms, etc., for a battery economiser?"

"Plate of output valve to a .25-mfd. condenser. Other side of condenser to 100,000-ohms resistance.

"Other side of 100,000 ohms to + on Westector, and to two resistances, one 50,000 and one 250,000 ohms.

"Other side of the 50,000 to -G.B. and other side of Westector. Other side of 250,000 to G.B. on transformer and to a 1-mfd. condenser, the remaining side of which is joined to earth."

The connections you describe are those recommended for the Mazda Pen.220A, but note particularly that different values for the 100,000 resistance will be necessary in many cases where other types of output valves are used.

**★ LISTEN TO THESE !
NEXT WEEK ★**

Outstanding items selected from the B.B.C. programmes for the week ending March 3rd.

Sunday February 25

National: "Everyman." A 15th-century miracle play provides different (but not light) fare for another Sunday.

Monday February 26

Midland Region: "Cupid's Eclipse." The invention of an anti-love ray, and its operations upon a peace society, a newly married couple and so on, provides the theme for a new radio play along comedy lines.

Tuesday February 27

National: "The Arcadians." Leonard Henry, Wynne Ajello, Horace Kenney and Bernard Ansell will play in this latest revival of popular musical comedy. After the success of "Florodora," this should be listened to. (To be repeated on the Regional wave on Wednesday.)

Wednesday February 28

North Region: Variety Programme. Another of the excellent relays from the stage of the Grand Theatre, Blackburn.

Thursday March 1

National: "St. David's Day Programme." A pageant produced from the Cardiff Studio, commemorating Welsh history through the days of the Druids and Romans down to Mr. Lloyd George and the Welsh International Rugby team!

Regional: "Alibi from the Air." An entirely new kind of evidence heard in court is the chief thrill in a play of thrills, produced by Lance Sievking. (To be repeated on the National wave on Friday.)

Friday March 2

Midland Region: New Tunes by Midland composers. A programme of light music of the kind which Joseph Lewis made so popular.

Saturday March 3

National: Three Special Programmes:
(A) Royal Navy v. The Army: A running commentary from Twickenham on the inter-Services Rugby Football Match.

(B) "Tea Mixture": The variety staff presents the first of a new series of Saturday afternoon broadcasts in which artistes new to the microphone will appear with "old stagers."

(C) "Music Hall": Veterans of variety—Charles Coburn, Marie Kendall, Vesta Victoria, Joe O'Gorman and the rest—will come to the microphone, with John Southern in the chair, in an old-time programme.

THEY ALL USE T.C.C. ALL-BRITISH CONDENSERS

BUDAPEST

SOTTENS

WEST REGIONAL

KALUNDBORG

LONDON REGIONAL

EMPIRE BROADCASTER

BUCHAREST

MORE STATIONS USING
T.C.C. CONDENSERS

- MIDLAND REGIONAL
- NORTH REGIONAL
- SCOTTISH REGIONAL
- PRAGUE
- BUENOS AIRES
- MOTALA
- GOTHENBURG

THEY ALL MAKE SURE
—SO CAN YOU—

USE ONLY T.C.C.

THE TELEGRAPH CONDENSER CO. LTD., WALES FARM RD., N. ACTON, W.3.

Photos: B.B.C., Topical Press, Photopress, Kachmann, Gerber.

4561

THE LINK BETWEEN

(Continued from page 1046.)

Buy British.

It isn't often that I bring the "Buy British" slogan into these notes, for the very simple reason that the discriminating purchaser knows as well as I do that if he wants the best in radio at the most reasonable price there is no option about it.

Without giving away my political aspirations (yes, even radio folk have them!) I think we can all regard the imposition of tariffs on imported radio apparatus as a good thing, for, to put it bluntly, it does definitely prevent the possibility of uninitiated listeners being sold a pup, as they say.

If all imported sets were subjected to a "standard-of-quality" test before being allowed into the country it might be different, but even then there is the question of servicing in the event of breakdown. The extent of facilities for after-sales service is, in my opinion, a most important consideration, and yet it is the one that is most frequently overlooked. Bear in mind that however thoroughly a set may be tested before it is sent out from the works there is always the possibility of a fault developing, although, admittedly, with British sets that possibility is remote.

But it isn't the complete set aspect of the question with which I am concerned at the moment. The real reason for exhorting you to buy British is because it has been brought to my notice that there is a glut of cheap imported measuring instruments about at the present time, and although they are quite attractive to look at they are in many cases unsound technically.

With measuring instruments particularly, the purchase of an inferior article because it happens to be cheaper is very definitely a case of penny wise, pound foolish. If you want reliability and accuracy I strongly advise you to pay the extra shilling or two and to buy an instrument of repute. Again, if you stick to the British manufacturer, you will not go very far wrong.

But don't buy an unnamed foreign article just because the price happens to be low. If you do you can rest assured that its resistance, like the price, will also be low, and in those circumstances you might just as well not make the measurements!

A New Ever Ready Battery.

Users of the famous G.E.C. Class B Superhet Six, model B.C.3446, will be interested to learn that the Ever Ready Company has just introduced a new high-tension battery which has been specially designed for this set.

The new battery, with an E.M.F. of 140 volts, has a 9-volt grid-bias battery included in the case, and it measures 9 1/2 in. by 7 1/2 in. by 3 1/2 in. Ask for battery No. W.1250 when ordering. The list price is 14s.

Price of the New QP.21 Valve.

A week or two ago in these notes I told you all about the new two-in-one valve which has been produced by Marconi and Osram for Q.P.P. circuits. I can now tell you that the price has been fixed at 22s. 6d., which, of course, is appreciably less than the cost of two separate pentodes.

This interesting valve certainly seems to have created a stir, and already several new components for use in the new circuits have been placed on the market. For instance, I understand that both R.I. and Wearite have produced special output chokes.

MOULDING BAKE-LITE

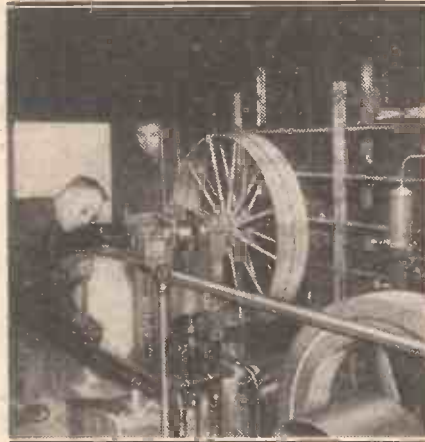

An increased output of nearly 50% is anticipated from the new hydraulic machinery installed for the production of bakelite mouldings by Messrs. Graham Farish of Bromley, Kent. It is interesting to note that, although the old plant was working 24 hours a day, it was impossible for Messrs. Graham Farish to keep pace with the demands from builders of "P.W." sets.

THE LISTENER'S NOTEBOOK

(Continued from page 1034.)

an effect that a photographer had already produced so cleverly on a film.

Take Emil's dream, for instance. This was very realistic. One was struck with the great similarity between the respective methods of producing, each in its own way, the same effect. The one used a towering figure; the other towering music. The clutching hand had its counterpart in something that couldn't be better described than clutching music. Lance Sievekink must have seen the film, and his conversion of light into sound was clever.

One feature of the production struck me as being very curious. Obviously an attempt was made to preserve the real German flavour of the play. Whenever the attempt was made it met with success. All the adult members of the cast spoke their English lines with a decided German accent. To all intents and purposes they were Germans.

But what about the children? No attempt was made to give them the appearance of being German. They spoke with the accent of a good-class English preparatory school, while the idiom they employed was a mixture of the prep. school, the East End and Hollywood.

If the children used the words of the translator, then all I can say is, the translation is a bad one. This defect made it impossible to regard the play, despite its setting as a purely German play.

We don't always want to hear the whole of a variety or music-hall bill. While it is generally possible to tell which of the turns will be the "last and not least," it isn't always so easy to place the rest. We are now familiar with most variety artists. We know their act. We know, too, whether it is likely to be the same as they did last time, and to such a turn we sometimes want to give a miss.

Under present arrangements we can't very well do this, because we aren't told the order of appearance of the different turns. What I'm getting at is this: It would be a great help if the "Radio Times" published, besides the bill, the time at which the different items are due to come on.

Take the other Saturday night, for instance. While I was pretty certain that Will Fyffe would come on last, I had no idea when to expect Bertha Willmott. And I particularly wanted to hear her. In my determination not to miss her I had to listen to practically the whole of the programme, which I hadn't really the time to do on this occasion. A bill with times would be a great boon.

And more particularly so when a variety bill comprises one big name and a number of undistinguished ones. The Gillie Potter bill is a case in point. By the way, I didn't think that Gillie Potter in this appearance was quite as lively and irresistible as usual, though on the whole his humour was characteristic of him.

In the 10 p.m. appearance two nights before, this restraint was even more marked. I thought he sadly needed an audience. He did not reach his "Olympian" heights on this occasion.

Lord Ponsonby maintained the high level set by his predecessors in the "Seven Days' Hard" series. 'Tis a great series, this. In fifteen minutes' musing he made out a great case for his convictions, and one readily believed he was sincere when he said: "I am a firm believer in the unquestionable importance of the small."

THE MIRROR OF THE B.B.C.

(Continued from page 1034.)

The girl was "discovered" by her boss, a friend of the "O.B." man, but so far she has not been identified from among her colleagues, all of whom sing at her work.

The trouble is that the office regulations cannot very well be disturbed with inquiries about "crooners" among the staff, but ways and means are being planned in secret to establish her identity. After that it should be plane sailing.

Summer Plans.

It is early days to write about summer relays from seaside resorts, but the B.B.C., as most listeners are aware, has to make its plans many months ahead, and the various Regions are already scheming out ideas for the light evenings' entertainment.

The Midland Region is not so fortunately situated with health resorts as the others, but this year it intends to make full use of the one popular seaside town within its boundaries—Skegness.

It seems curious that Skegness has not yet been directly represented in the programmes, but that omission will be amply repaired this summer. Braising news indeed!

20 Watt

POWER RESISTORS

SUPERIORITY again. It always counts. What do you ask of a resistor? Accuracy, permanency, reliability and high carrying capacity, as possessed by these resistors. Composed of finest nickel-chrome wire, asbestos, porcelain, etc. The terminal bands may be moved to adjust value, a useful feature.

Add "V" to list No. for vertical type (same prices.)

List No.	Ω	mA.	List No.	Ω	mA.
P.R.22	50	632	P.R.6	1,500	117
P.R.23	100	447	P.R.7	2,000	100
P.R.24	200	316	P.R.8	3,000	81
P.R.1	300	257	P.R.9	5,000	63
P.R.2	500	200	P.R.10	7,500	54
P.R.3	600	180	P.R.11	10,000	45
P.R.4	750	160	P.R.12	15,000	36
P.R.5	1,000	140	P.R.13	20,000	30

ALL ABOVE **2/6** EACH

List No.	Ω	mA.	List No.	Ω	mA.	Price	
P.R.14	25,000	28	2/6	P.R.18	60,000	20	3/6
P.R.15	30,000	26	3/-	P.R.19	75,000	17	3/6
P.R.16	40,000	24	3/-	P.R.20	80,000	15	4/-
P.R.17	50,000	22	3/-	P.R.21	100,000	11.5	4/6



Telephone: GRA.3266/7.
A. F. BULGIN & CO., LTD., BARKING, ESSEX

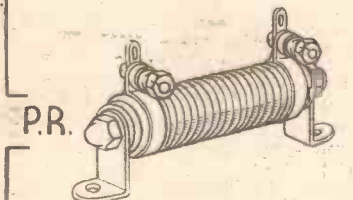
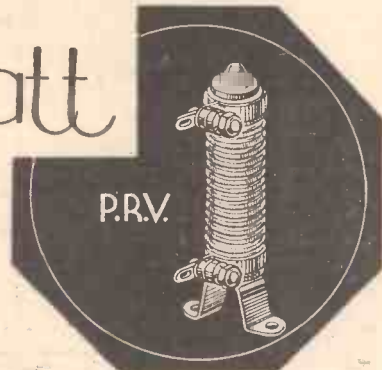

Please send the new 80-page Catalogue 153 "P" and Bulgin literature to:—

NAME

ADDRESS

Enclose 2d. Postage. (Block-letters please.)

TECHNICAL NOTES

Some diverse and informative jottings about interesting aspects of radio.

By Dr. J. H. T. ROBERTS, F.Inst.P.

High-Frequency Chokes.

HIGH-FREQUENCY chokes serve a variety of purposes, but the two principal uses to which they are put are first of all for the purposes of a coupling impedance, and secondly for choking back high-frequency currents in order to provide reaction.

For the purposes of reaction a choke need not have an inductance of more than 100,000 or 150,000 microhenries. It is very important, however, whether for reaction, or any other purpose, that its ohmic resistance should be as low as possible, and in a good make of choke this will not be more than, say, 500 ohms. At the same time it is equally important that the self-capacity should be very low, otherwise the choke, so to speak, "by-passes itself"—in other words, "leaks."

As a Coupled Impedance.

If the high-frequency choke is to be used as a coupling impedance its inductance should be somewhat higher, and 250,000 microhenries is a suitable value. The choke should preferably be wound in one of the various forms which prevent extraneous field—the binocular form is a well-known example of this—because if the field of the choke "wanders" to other components there is a liability to interaction and instability.

Simplified Soldering.

In addition to my experimental work in connection with radio I also have a good deal of other experimental work to do quite apart from wireless, and as this frequently involves soft soldering I have for a long time past used an electric soldering iron. I don't know how many of my readers use the electric iron and how many stick to the ordinary gas-heated soldering bit. At any rate, if you have much soldering to do (particularly small joints such as you meet with in wiring up the receiver) I strongly recommend you to consider an electric soldering iron. These can now be obtained very cheaply. The one I use is a Solon made by Henley's. It is ever so much more convenient than using the ordinary iron, which has to be heated in the fire or over a gas-ring or a Bunsen burner.

The electric iron maintains its heat and is always ready for use without having to keep putting it back on the gas and heating it up again. In my laboratory I used to heat the soldering irons in a special gas heater, but this makes a smell and is very unpleasant, particularly if the iron is accidentally left on too long and starts to burn.

You get none of this with the electric soldering iron, and I advise those of you who do not already use one to consider the point.

Some Variable-Mu Points.

With variable-mu valves, as you know, the anode current varies quite a lot when

(Continued on next page.)



*Have a Capstan!
—you'll like it better.*



10 FOR 6^D

20 FOR 11^D 1/2

Plain or
Cork-Tipped

THERE'S NO BETTER VALUE

Issued by The Imperial Tobacco Company (of Great Britain and Ireland), Ltd.

CC430 E.

Piano Tone RADIO GRAM CABINETS
As supplied to B.B.C.

65/- Polished Cabinet for 35/-
No Middle Profits!

Famous maker offers finest Radio Furniture. As Supplied to B.B.C. A Quality and Value impossible to better. Beautifully hand polished! GUARANTEED Piano Tone Acoustically.

Trial Will Delight You! (Cash or 10/- Monthly.)

LIST FREE! From Makers—

PICKETT'S
Piano Tone

Cabinet (P.W.) Works, Albion Rd., Bexleyheath, Nr. London

EASY TERMS PROMPT DELIVERY

Any Amplion, Blue Spot, Baker, Celestion, Epoch, Ferranti, Gramplan, Igranic, Lamplugh, Magnavox, Ormond, R & A, Rola, Sonochorde or W.B. Speaker supplied.

Send 5/- only

and pay balance by monthly instalments. No references. Entirely private and confidential.

KITS, PARTS, VALVES, ELECTRIC CLOCKS ON EASY TERMS.

Send for List of 83 Speakers and state requirements
TURNADGE & PARTNERS, LTD.,
107, Fleet Street, London, E.C.4.

Telephone: Central 1903.

★ PLEASE be sure to mention "Popular Wireless" when communicating with Advertisers. Thanks! ★

TONASTAT

SOLVES THE QUESTION

OF INCREASING SELECTIVITY WITHOUT APPRECIABLE LOSS OF SIGNAL STRENGTH, AND OF REDUCING VARIOUS FORMS OF INTERFERENCE

"Practical Wireless" says:

"We tested this device with a number of circuits and found it functioned admirably."
 "... It will not be found difficult to find a setting which will give not only a great improvement in selectivity, but which will, also, in cases where interference is experienced, reduce that nuisance without appreciably interfering with signal strength."

'TONASTAT' WILL SOLVE YOUR NEW WAVELENGTH TROUBLES

See "Popular Wireless" test report on page 1046

Simple to use. Easy to connect. A circuit to suit your set is shown on instruction leaflet "P" supplied with every "Tonastat."

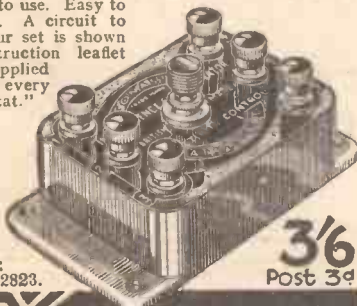

Phone: Enfield 2823.

PRODUCTS Co

32, QUEENSWAY, PONDER'S END, MDDLX.



TELEVISION IN THE NEW HEAYBERD HANDBOOK

The third edition of this Handbook contains **SPECIAL TELEVISION SUPPLEMENT**, and also

blueprints of kits of parts for all TELEVISION uses. Fifteen blueprints showing how to build your own mains unit or battery charger, etc. Two pages of technical hints and tips. No keen amateur can afford to be without a copy.

Cut out this ad. and send NOW for your copy.

F. C. HEAYBERD & CO.,
 10, Finsbury St., London, E.C.2

LOUD SPEAKERS REPAIRED 4/-

(Blue Spot a Speciality, 5/-)
 Transformers and Headphones, 4/-. Eliminators, Mains Transformers and Moving Coils quoted for 24 Hour Service. Trade Discount. Clerkewell 9069.
E. MASON, 44, EAST ROAD (nr. Old Street Tube Station), LONDON, N.1.

MICROPHONES

Buy from the actual makers at rock bottom prices. Button capsules, complete for detectaphone and other experiments, only 1/-. Transformers, 3/6. No. 11 Home Mike, bakelite body, 2" dia., unbreakable, 5/6. Table P.W.II, a handsome announcer's model, 3" x 3", on brass stand—a self-contained Mike and Transformer with switch, 10/6. Tall Pedestal Broadcasting Model 12B, with Microphone hung in ring, 12" high, 13/6. Complete Deaf Aid Sets, 15/6. Special P.A. makes for Dance Bands and Public Address. All Parts in stock for Home Constructors, granules, blocks, etc. Write for Lists P. 1 and 2.
ELECTRADIX RADIOS, 218, Upper Thames Street, London, E.C.4. Tel.: Central 4611.

PLEASE be sure to mention "Popular Wireless" when communicating with Advertisers. Thank!

TECHNICAL NOTES

(Continued from previous page.)

the grid bias is adjusted for the purposes of volume control. If the grid bias is increased and the anode current decreased, this means that there will be a rise in the voltage applied to the anode. This rise in voltage will, of course, depend upon the external resistance—that is to say, the resistance of the H.T. supply unit, whatever it may be.

The important point here is that if the resistance of this unit is large there will be quite considerable variations in the voltage actually applied to the anode of the variable-mu valve when the latter is in operation, owing to the variations in the anode current and to the consequent redistribution of the voltage between the external resistance and the valve.

High Anode Voltages.

Many people nowadays are going in for considerably higher anode voltages, more particularly for the purpose of operating super-power output valves, together with moving-coil speakers. As everybody knows, much better results can be obtained by using plenty of anode voltage, although often enough the extra expense acts as a deterrent. Voltages of the order of 300-400 volts for the anode supply can, of course, be obtained from batteries, but with these rather higher voltages it is more usual to employ a form of H.T. mains unit in which the transformer is designed to give the necessary step-up in voltage.

You will see that if you employ a unit having a maximum output of, say, 300 or 350 volts, this maximum voltage being intended for the output stage from the receiver, it will be necessary to use a good deal of resistance in the leads to the other valves in the set so as to bring down the voltage to the required amount for those valves.

A Separate Unit.

Now if the voltage to a variable-mu valve is supplied in this way—that is, by a much higher voltage which has been broken down by a resistance—you will get the effect which I mentioned above, a considerable variation in the voltage actually applied to the anode of the variable-mu valve when the anode current is varied.

If you wish to go in for high voltages for the output stage or stages it is worth while to have a separate unit to give you the lower voltages for the earlier stages rather than to break down the higher voltage. This gets over the need for any large resistances, and consequently the "regulation" (that is, the constancy of the voltage when the current varies) is greatly improved.

Transformer Response Curves.

Most good L.F. transformers nowadays are designed to give a fairly uniform response curve—that is to say, to give a reasonable level of response whether the reproduction be in the upper, middle or lower registers. Sometimes you hear of a transformer with a "rising characteristic"; this means that the characteristic curve rises as the audio-frequency rises, so that in the upper registers the transformer gives a greater response than in the lower ones.

At first sight you might think that this was definitely a disadvantage, but there

(Continued on next page.)



"We're Fluxite and Solder—the reliable pair; Famous for Soldering—known everywhere!"

The SET may look lovely—it may have cost much! To make SURE it is PERFECT—add this finishing touch!"

See that Fluxite and Solder are always by you in the house—garage—workshop—anywhere where simple, speedy Soldering is needed.

ALL MECHANICS WILL HAVE

FLUXITE

IT SIMPLIFIES ALL SOLDERING

All Ironmongers sell Fluxite in tins: 4d., 8d., 1s. 4d., and 2s. 8d. Ask to see the **FLUXITE POCKET SOLDERING SET**—complete with full instructions—7s. 6d. Ask also for our leaflet on **HARDENING STEEL** with Fluxite.

FLUXITE LTD. (Dept. 324), Rotherhithe, S.E.16

FOR ALL REPAIRS!



G.P.O. Engineering Dept. (No experience required). Commence £4 per week. Age 17-23. Excellent prospects. Free details of entrance Exam. from B.I.E.T. (Dept. 568), 31, Oxford Street, W.1.

EASY PAYMENTS

"There's no place like HOLMES."

The first firm to supply Wireless parts on easy payments. Nine years advertiser in "Popular Wireless." Thousands of satisfied customers.

	Monthly	Deposit payments
TELSEN Latest 323 Kit	£9/8	4/- 7 of 4/1
LISSEN Sky scraper 4K Kit	112/6	10/- 11 of 10/3
EXIDE H.T. Accu. 120-v.	60/-	8/- 9 of 6/8
ATLAS Eliminator C.A.25	59/8	5/- 11 of 5/8
BLUE SPOT 29P.M.	32/6	4/5 7 of 4/5
B.T.H. Pick-up Vol. Con.	21/-	3/10 5 of 3/10
EPOCH 20thC. M.C.	35/-	4/10 7 of 4/10

Parts for your Kit Set. Any make of Speaker.
 New Goods Obtained for Every Order.
 Send us a list of the parts you require and the payments that will suit your convenience, and we will send you a definite quotation. Anything Wireless.

H. W. HOLMES, 29, FOLEY ST.,
 Great Portland Street, London, W.1.

Phone: Museum 1414.

Literature and prices on request.

Micromesh

THE MODERN VALVE

Standard Telephones & Cables Ltd.,
 St. Chad's Place,
 364, Gray's Inn Rd., W.C.1
 Terminus 6255

WE invite readers to support our Advertisers—care being taken to accept only announcements of reputable firms!

TECHNICAL NOTES

(Continued from previous page.)

are some cases in which you actually require such a *rising* characteristic in order to compensate for the effect of some other component which is giving a *falling* characteristic.

The Detector Stage.

For example, the detector stage may, owing to reaction, reduce the strength in the upper register, and the low-frequency transformer, if it has a rising characteristic, will increase the strength in the same region, so that the two will tend to counter-balance.

This, however, depends upon the reaction, because we are assuming that it is owing to reaction that the detector stage causes the falling characteristic effect. Therefore the rising characteristic of the transformer will really only be able to compensate for the reaction effect at one particular reaction setting.

If the reaction is increased it will tend to cut down the high notes more than the L.F. transformer can make up for them, so that the overall tone will be lowered, whilst, on the other hand, if the reaction is reduced the loss of the high notes will not be so great, and this will be over-compensated by the rising characteristic of the transformer, so that the overall quality of reproduction will tend to become shrill. This effect can, however, be got over fairly simply by means of a condenser across the L.F. transformer primary.

Automatic Variation.

You will see that this condenser will reduce the high-note response, and, therefore, if the condenser is reduced in capacity or removed altogether the high-note response will be increased. If, then, the value of the condenser can be automatically varied it is obvious that the reduction of high-note response can be adjusted as desired.

This is done by means of a differential condenser, the two fixed sets of vanes being connected to the two ends of the reaction coil, whilst the moving set of vanes is connected to earth; one of the fixed sets of vanes is also connected, through a fixed condenser of 0.01 or 0.02 microfarad capacity, to the anode of the valve.

Class B and Q.P.P.

When you use a Class B valve the H.T. current, as you know, increases with the volume and diminishes, if the volume diminishes, the normal level, when no signals are being received, being relatively small. This, in fact, is one of the important advantages of this system, since H.T. current is not being wasted and is only called for to any great extent when signals come along. The same sort of argument applies to the quiescent push-pull output stage.

Current Consumption.

People often think that the high-tension current consumption of an ordinary set (that is, not using Q.P.P. or Class B) depends on the strength of signals, and I have often come across cases where people have deliberately turned down the volume in the belief that they were economising,

(Continued on next page.)

HIGH IN QUALITY



LOW IN PRICE

ECKERSLEY TELLS YOU the valves to use

HIVAC Y. 220 12'6
Multi-grid, low consumption.

HIVAC H. 210 4'6
Grid Det. or Oscillation in Super-hets.

FOR THE MULTI-MU CONTROL "NATIONAL ECKERSLEY THREE"

Results will be fully up to standard for those who use the Hivac valves recommended.

Your dealer can supply HIVAC. If slightest delay, order direct.

Write Dept. "P."

HIVAC THE SCIENTIFIC VALVE

British made by the **HIGH VACUUM VALVE CO., LTD.**
113-117, Farringdon Rd., London, E.C.1.
Telephone: Clerkenwell 7587.

ELECTRADIX Home Broadcasting Microphones

No. 11. Home Mike for Wireless. A complete solo Microphone for hand or stand in fine bakelite case with back terminals, front metal grille. **Finely finished. Only 5/6.**

GROONERS.—LAPEL MIKES for Dance Bands. American model, 12/6.

PARTS FOR HOME CONSTRUCTORS.—Microphone Carbon Granules. In glass capsule, enough for four buttons. Grade No. 1, 8d.; No. 2, Medium, 1/-; No. 3, Fine, 1/6; Carbon, solid back, blocks, 3d. Mouthpieces, curved or straight, 10d. Carbon diaphragm, 55 m/m., 4d. Panel Brackets, pivoted, 5/-; Reed Receiver Unit for Amplifier making, 3/-; Headphones, 2/9 pair. Leaflet with diagrams free. Send for Bargain List "P."

ELECTRADIX RADIOS,
218, Upper Thames St., E.C.4. Telephone: Central 4611.

RADIO SUPPLIES

Send your list of Radio needs for our quotation. Kits, Parts, Sets, etc. Everything in Radio stocked, prompt delivery. 7 days' approval. Catalogue free. Taylex & Standard Wet H.T. replacements stocked.

P. TAYLOR, 9, GROVE ROAD, BALHAM, S.W.12

High Tension for your Radio from the Mains at 1/- PER YEAR

"MPR" ELIMINATORS make this possible.

D.C. models 21/- or 3/- monthly.
A.C. models 39/6 or 5/7 monthly.
Write to Dept. C. for full particulars.



M.P.R. Ltd. ROMFORD, ESSEX

All applications for Advertising Space in **POPULAR WIRELESS** should be addressed to the Advertising Department, John Carpenter House, John Carpenter Street, London, E.C.4.

Easy Terms

Strict Privacy Guaranteed
—we deal with you direct

N.T.S. CLASS 'B' SPEAKER-AMPLIFIER

SEND FOR IT ON 7 DAYS' TRIAL
Gives Seven Times the Volume. Ready assembled with Class B Valve. Send only 5/- for 7 days' trial. If approved, balance in 11 monthly payments of 5/6. Cash or C.O.D. Carriage Paid, £21/19/6.

5/- DOWN

Simply plug-in to your existing battery set.



TELSEN "323" KIT

Complete Kit of Parts for new Telsen Straight 3. Send only 2/6; balance in 6 monthly payments of 5/-; Cash or C.O.D. Carriage Paid, £18/9/6.

2/6 DOWN

If valves required, add £1/6/0 to cash price or 6/- deposit and 9 monthly payments of 6/-.

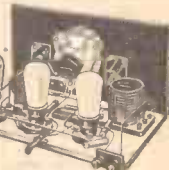

W.B.P.M. 4 MICROLODE MOVING-COIL SPEAKER

SENT ON 7 DAYS' TRIAL
With Switch Controlled multi-ratio input transformer. Send only 5/- for 7 days' trial. If approved, balance in 8 monthly payments of 5/3. Cash or C.O.D. Carriage Paid, £2/2/0.

5/- DOWN

W.B.P.M. 6. Send only 2/6. Balance in 8 monthly payments of 4/3. Cash or C.O.D. Carriage Paid £1/12/6.



TELSEN S.G.3 KIT

Complete kit of parts for building. Send only 4/6; balance in 9 monthly payments of 4/6. Cash or C.O.D. Carriage Paid, £1/19/6.

4/6 DOWN

If valves required, add £1/9/0 to Cash Price or 7/3 deposit and 11 monthly payments of 7/3.

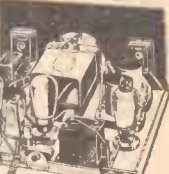

ATLAS ELIMINATOR

SEND FOR IT ON 7 DAYS' FREE TRIAL
Model C.A.25. Suitable for all outputs, including Class B and Q.P.P. Send only 3/6 for 7 days' trial. If approved, Balance payable in 11 monthly payments of 5/6 (or cash in 7 days) £2/19/6. Carriage Paid.

3/6 DOWN

D.C. Model 15/25. Cash or O.D. Carriage Paid £1/19/6, or 4/- down and 10 monthly payments of 4/-.

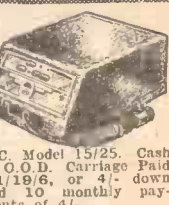

Any items advertised in this journal CASH, C.O.D., H.P. Send for quotation by return

New Times Sales Co.

56, LUDGATE HILL, LONDON, E.C.4.

Dear Sirs:
(1) Please send me.....
(2) I enclose Cash/Deposit.....
NAME.....
ADDRESS.....
P.W. 24/2/34.

READ WHAT THIS BIRMINGHAM USER THINKS OF THE EMET

Mr. Cyril Morris, Dentist, 78, Beaufort Road, Birmingham, writes:

"Your EMET Ground Aerial is a wonderful success. Perfect reception, NO interference. I had previously fitted suppressors (main), but no difference accrued. I am convinced no one would think of an outside aerial if they would only try your EMET"



PROV. PAT. 2247/34

EMET GROUND AERIAL

In the Great War, the Ground Wave system enabled signals to be heard clearly through static and enemy interference. The EMET ensures perfect reception through an earth connection only, free from interfering noises picked up by ordinary aerials. Specially adapted for All-Mains Sets. Sent post free, 5/- . Money refunded if not satisfied.

NO OUTSIDE AERIAL
REDUCES STATIC
IMPROVES
SELECTIVITY

FREE TRIAL OFFER

To THE EMET COMPANY, 6, Rutherford St., Newcastle-on-Tyne.

Please send me, without any obligation, full details of the EMET Ground Aerial and your FREE TRIAL offer.

NAME

ADDRESS

EASY TERMS

Everything radio supplied on convenient terms. For really prompt delivery entrust your order to us. Goods ordered cash or C.O.D. despatched same day. Strict privacy. Carriage Paid. Price List FREE.

	Cash Price	with order	No. Months	Monthly Instalments
Blue Spot 99 PM (Still the best unit) ..	59/6	5/-	11	5/6
Blue Spot 45 PM ..	45/-	5/-	9	5/-
Atlas CA 25 ..	59/6	5/-	11	5/6
Set of 3 Valves, 1 SG, 1 DET., 1 Power (All makes) ..	31/3	5/-	6	5/-
All types of A.C. and D.C. Valves also supplied.				
Avonmor Universal Testing Meter ..	40/-	5/-	7	5/-
Exide 120v H.T. Battery, 5000 ma/a	75/-	6/10	11	6/10

To avoid delay, will customers kindly send first payment with order!

Estd. 1925 THE LONDON RADIO SUPPLY COMPANY 1977

LONDON RADIO SUPPLY COMPANY

11 OAT LANE, NOBLE STREET, LONDON, E.C.2

ENGINEERS! ARE YOU EARNING LESS THAN £10 PER WEEK?

IF YOU cannot afford to carry on without reading our 256-page Handbook, The book explains clearly and definitely many ways of carrying out a successful career. Among other things it explains the Services of our unique Appointments Department, outlines Home-Study Courses in all branches of Civil, Mechanical, Electrical, Motor, Aero, Wireless, "Talkie," Eng., Building, etc., and gives details of B.Sc., A.M.I.C.E., A.M.I.A.E., G.P.O., PATENT, and all Exams. We alone Guarantee—"No Pass—No Fee." Whether you be an old hand or a budding apprentice get this book to-day—FREE AND POST FREE. British Institute of Engineering Technology, 101, Shakespeare House, 29/31, Oxford Street, London, W.1.

"S.T." MANUAL 6 TOKEN

Printed and published every Wednesday by the Proprietors, THE AMALGAMATED PRESS, LTD., The Fleetway House, Farringdon Street, London, E.C.4. Advertisement Offices: John Carpenter House, John Carpenter Street, London, E.C.4. Registered for transmission by Canadian Magazine Post. Subscription rates: Inland and Canada, 17/4 per annum. Abroad (except Canada), 19/6 per annum. Sole Agents for Australia and New Zealand: Messrs. Gordon & Gotch, Ltd.; and for South Africa: Central News Agency, Ltd. Saturday, February 24th, 1934. S.S.

TECHNICAL NOTES

(Continued from previous page.)

just as if they turned down the gas-fire. With an ordinary set this is not the case, because you have the practically steady level of H.T. and L.T. current flowing in the valves, and this is scarcely affected when the signals come through. Reducing the volume will usually be done by turning the reaction control, or it may be done by other forms of volume control.

Detector and Reaction.

In any case, however a reduction of volume may be achieved, it makes scarcely any difference to the H.T. or L.T. current consumption. Bear in mind always that I am talking about ordinary sets and not the more modern type referred to above.

As a matter of fact, about the only thing that happens that can be said to be appreciable is a slight change in the high-tension current consumed by the detector valve, assuming this is of the grid-leak-and-condenser variety; this slight change is in the direction opposite to what you might expect, since the current sometimes becomes slightly less when a strong signal is applied to it—for example, by increasing the reaction.

Output Valve Consumption.

While on this subject I should like to say something about the consumption of output valves, which is often raised by readers.

With an ordinary power valve, and using ordinary high-tension batteries, an H.T. current consumption up to about 10 milliamps is really quite as much as you can stand; if you want to go beyond this it means that you must go in for a heavy-duty H.T. battery or, on the other hand, you can use a mains unit, provided this gives sufficient current output.

The Input Question.

A good deal depends on whether you have a stage of low-frequency amplification between the detector and the output stage. If you have, then you want a power valve which is capable of handling a fairly large grid swing, whilst if the output stage immediately follows the detector the output valve need not be capable of handling so large a grid swing.

A fair average figure would be, say, 10-volts grid swing for the output where this is the second low-frequency stage and, say, 5-volts grid swing where the output immediately follows the detector.

The Use of Pentodes.

In this connection it is now very common practice to use a pentode as the combined single low-frequency and output stage following the detector, and some people think that a pentode valve must necessarily be rather heavy on H.T. current.

In the early days of pentodes this may have been true; but with the modern small pentode it is not true at all, and, if you use 100 volts on the screen and 120 volts or even more on the anode, you will probably not find a bigger H.T. current consumption than perhaps 5 to 7 milliamps (sometimes even less), which is very economical, considering the extraordinary results

you get from the pentode in proper conditions.

Allocating Wavelengths.

The Lucerne Plan for allocating wavelengths, which is so much in the public eye at the moment, depends on the accuracy with which the various wireless transmitters can be adjusted to their proper wavelengths and kept to them. This is known as "stability of frequency," and has been the subject of a good deal of recent research.

So far as the larger fixed stations are concerned—including broadcasting stations—the well-known method of quartz crystal or tuning-fork control has been found to give a very high degree of frequency stability, but these methods require a fixed wavelength of operation and involve rather elaborate equipment.

There are some cases where only relatively simple apparatus can be used, and where the same transmitter may have to send out several different wavelengths: these cases

AN IMPORTANT

ANNOUNCEMENT

FULL DETAILS OF AN
OUTSTANDING DEVELOPMENT

will be given in

POPULAR WIRELESS

NEXT WEEK

With far-reaching effects, this great Radio advancement is of vital importance to all readers.

DON'T MISS IT. NEXT WEDNESDAY.

occur, for instance, on shipboard and on aircraft, and this problem is at present being actively studied by the Radio Research Board.

Knobs that Shift.

Is there anything more annoying than a tuning knob—or any other control for that matter—that shifts on its spindle? On one of my regular sets I had a volume control knob that used to shift around, and it was quite impossible to fix it, so I had to fit a new knob. Remember, however, that the shifting is generally due to rough handling in the first instance. The knob is often held by a grub screw and you get a pretty good leverage against it when the knob is large. If the grub screw strips (or rather the ebonite or composition of the knob) there is nothing for it but a new knob. So go easy with the controls and never force them when they get to the end of their travel.