

**"P.W." BREAKS WORLD'S RECORD!** (See Page 386)

**BUILDING A CATHODE RAY TELEVISION VIEWER**

# Popular Wireless

**HAVE YOU TRIED "our RADIO PICS?"**

**EVERY WEDNESDAY PRICE 3<sup>d</sup>**

No. 574.  
Vol. XXIII.  
June 3rd,  
1933.

## 11 YEARS of PROGRESS

**DESCRIBED THIS WEEK**



*The*  
**CONQUEST**  
—A 1933 STAR DESIGN

# OUR SPECIAL BIRTHDAY NUMBER

ALSO INSIDE:—

**THE "DOUBLE-D PEN"**

introducing

**DUAL A. V. C.!**

Build your **CONQUEST** with a  
**PILOT AUTHOR KIT**

100% SUCCESS . . . exact to specification

**KIT "A"** Author's Kit of **FIRST SPECIFIED PARTS** with **READY DRILLED** Panel and Chassis, but excluding valves and cabinet. Cash or C.O.D. Carriage Paid. **£8.2.6.**

Set of 4 Specified Valves - - £2. 4. 6  
Oak Cabinet as specified - - £1. 15. 0

**PETO-SCOTT CO. LTD., 77, CITY RD., LONDON, E.C.1**  
Telephone: Clerkenwell 9406/7.

**SEND ONLY 15/-**

Balance in 11 monthly payments of 15/-.



## UNBREAKABLE CATKIN VALVES

If you are not already familiar with details of the new UNBREAKABLE CATKIN VALVES, please write to the Marconiphone Company Ltd., 210-212 Tottenham Court Road, London, W.1, for a fully descriptive leaflet.



# CONI



Types at present available are : §MS4B. High conductance S.G. . 19/- . §VMS4. Variable-Mu. S.G. . 19/- . §MH4. General Purpose triode . . . 13/6 . MPT4. Power Pentode . . . 20/-  
§With or without screening cover.





KINGS  
OF THE  
AIR

# WHEN SUMMER COMES

When Summer comes distant stations are more difficult to bring in. The strong ones get weaker—others "disappear"—and fading increases too.

It's quite simple to prevent this Summer "falling off." All you have to do is to increase the efficiency of your Set. You can easily do this by fitting a Cossor Screened Grid Valve.

Cossor Screened Grid Valves make a big difference to any S.G. Receiver. They definitely ensure a marked improvement in range and selectivity. The right type of Cossor S.G. Valve will make your Set like new again. Thousands of wireless users have already taken this simple step to better radio reception. Your dealer will tell you the type you need.

## COSSOR SCREENED GRID VALVES



To A. C. COSSOR LTD., Melody Department, Highbury Grove, London, N.5.

Please send me, free of charge, a copy of the 40-page Cossor Valve and Wireless Book B.17.

Name .....

Address .....

P.W. 3/6/33 .....

Send for a free copy of the 40-page Cossor Valve and Wireless Book which contains a wealth of interesting and useful information including Radio Definitions—Useful Circuits—List of Stations, etc. Please use the Coupon.

A. C. COSSOR LTD., Highbury Grove, London, N.5. Depots at Birmingham, Bristol, Glasgow, Leeds, Liverpool, Manchester, Newcastle, Sheffield, Belfast, Cardiff and Dublin.



# POPULAR WIRELESS

THE FIRST AND FOREMOST RADIO WEEKLY.

Scientific Adviser : SIR OLIVER LODGE, F.R.S. Chief Radio Consultant : P. P. ECKERSLEY, M.I.E.E.  
 Editor : N. F. EDWARDS.  
 Technical Editor : G. V. DOWDING, Associate I.E.E.  
 Assistant Editors : P. R. BIRD and A. JOHNSON-RANDALL.  
 Chief of Research Department : K. D. ROGERS.

The Paper that Made Wireless Popular

OUR BIRTHDAY  
 ACHIEVEMENT  
 COAL AND CRACKLES  
 WITHOUT TEARS

## RADIO NOTES & NEWS

RADIO SHOWS  
 NOW YOU KNOW  
 GILBERTIAN CRIME  
 RHYTHM AND ROMANCE

### Our Birthday.

WE are entering our twelfth year with this issue, and as a treat for this special occasion we hand ourselves a bouquet made of press clippings, "galley pulls" and paste-brushes. But what a life!

Eleven years of steady slogging at the task to which we set our hands in 1922—the popularisation of radio. It is good to look back over those years and to realise that we have deceived no man and hurt no man, on the road we have traversed.

### What We Have Done.

ON the contrary, we have helped hundreds of thousands of people to learn and enjoy the secrets of wireless and have instilled in them a love for the simple, healthy pleasures of handicraft. We have kept our readers fully informed about every new development of radio reception methods, and our advices thereon have been up-to-the-minute, precise and reliable.

Some of those developments have been contributed by "P.W." itself, thanks to its advisers, consultants, and excellent technical staff. "P.W." is not merely a weekly journal—it is a force in the amateur radio world. And now for the twelfth year!

### PAST

"POPULAR WIRELESS" began before broadcasting, ahead of all competitors, and secured for its readers the advisory services of the inventor of tuning, Sir Oliver Lodge, F.R.S.; the originator of Regional Broadcasting, P. P. Eckersley, M.I.E.E., and the finest permanent staff of technical journalists in the country.

### Dr. Appleton's New Laboratory.

IT was Lord Rutherford who opened the Halley Stewart Laboratory at Hampstead, which is to be devoted in particular to Professor E. V. Appleton's researches on the electrical properties of the upper atmosphere.

Professor Appleton, who is well known to radio men because of his researches in short-wave work, the Heaviside Layer, etc.,

described the work to be done, and suggested that the first survey of "electrical weather" would not be completed in less than eleven years because the electrification of the atmosphere varied with the sun-spot cycle of eleven years.

### A Fine Orchestra.

THE Bournemouth Municipal Orchestra, which broadcast last month, has completed forty years of unbroken service under Sir Dan Godfrey. It has given

### PRESENT

Still maintaining its position of acknowledged pre-eminence, "POPULAR WIRELESS" to-day triumphantly enters its twelfth year.

32,000 concerts, of which 2,600 were symphony concerts, 600 performances of Beethoven symphonies and 300 of Brahms' symphonies.

Ben Davies, who sang with the orchestra on May 21st, was with it in 1893. The first item the orchestra played in 1893 was the Festival March from Tannhauser. So sunny Bournemouth hath her musical tradition no less than London or Manchester.

### "Coal Causes Crackles."

MR. TURNER'S recent letter about the crackles heard in his loud-speaker when he rubbed a piece of coal in the fire with the poker has brought news of similar experiences by others. No doubt W. G. W. (Leicester) and others will be interested in T. H. S.'s (Denbigh) theory that these crackles were the result of tiny electric sparks caused by the imperfect contact of two different metals in the presence of heat.

The other metal besides the poker being some impurity in the coal.

There are a few points about this which make me unhappy, but until I hear a better explanation I will reserve them.

### Results on My Superhet.

SO far, my opinion is that the B.B.C. wins, except on Sundays and an occasional weekday evening. Continental humorous stuff is beyond and

above me. That wipes out a large part of the claims of foreign listening, to begin with. Next, foreign talks, which seem to be very copious, are useless to me. On the other hand, many of the B.B.C.'s "talks" are first-class, and not to be missed, especially those which are poked in as surprises—returned explorers, etc.

I see that my superhet is going to be just a Sunday stand-by. But the radiogram part of it is a positive joy. Some of my records seem almost "lifelike" when played upon it.

### Loss of B.B.C. Official.

BY the death of Mr. J. C. Stobart on May 11th, the B.B.C. and the cause of educational wireless have respectively lost a valued official and a staunch supporter.

As you may have observed in these Notes I did not see eye to eye with Mr. Stobart on the subject with which he was so deeply concerned, but I dare say that he backed the better horse. He was primarily an educational expert; he did his job with the B.B.C. as such. I will say this much—better let us have education by radio than puerile or sex-loaded material such as the "films" have been used for so largely.

### FUTURE

Plans for a future dwarfing all past achievements have been laid, and readers of "POPULAR WIRELESS"—The Journal which made Wireless Popular—will continue to receive the first news and finest service.

### Science Without Tears.

I AM now convinced, after certain profound researches, that a good many people are not very clear about alternating currents and oscillating currents.

Indeed, I have recently seen the statement in some newspaper that an oscillating current is not necessarily an alternating current and may be either alternating or uni-directional! Oh, no, no! Gentlemen, if a current changes its direction periodically it is either a low-frequency alternating

(Continued on next page.)



# ARIEL CONTINUES HIS RUNNING COMMENTARY ON RADIO

current or a high-frequency one; and if the frequency is of the order of many thousands or so per second, it is generally called an oscillating current.

## Seeing Round the World.

THAT'S like the R.A.F.'s inducement to would-be recruits, isn't it? But in this instance I refer to Sir F. Smith's Kelvin Lecture at the I.E.E. last month, in which he repeated Sir Ambrose Fleming's declaration, based on calculation, that if our atmosphere were of the gas Krypton, light waves would travel parallel to the earth's surface, so



that if there were no obstructions or absorption of energy we should be able to look right round the earth and see over our own backs.

"If 'ifs and ands' were pots and pans!" If the force of gravity were so much less than it is, and if our atmosphere were so much rarer, we should be able to jump like fleas!

## The Ironclads.

NO longer shall I be able to relate to you sad stories of maltreated valves which, despite all shocks, stood up and did their little bits. For as you know the ironclad tube has arrived bearing the beatific, botanical name "Catkin"—the food of the sparrow.

No longer will manufacturers be able to release steam-roller and Nasmyth hammer stories of valves! No, they will be reduced to advertising frantically for someone to step forward and depose that they actually saw a "Catkin" in good working order after being dropped in boiling nitric acid. Or will they offer a reward to any person who can really wound a "Catkin"?

## The Pit and the Pendulum.

HOW aptly this title of Poe's terrible story fits the career of Webster Gibbon, who was broadcast by the North Regional earlier in the month! He



worked in the Pit, at the coal face, for six years, and the Pendulum of time has brought him to fame, thanks to the help of Sir Daniel Stevenson, who heard him singing and sent him to

Milan to study singing.

What, after all, is more romantic than real life?

## The Showses are the Thingses.

THE Irish Radio Show is to be held at the Mansion House, Dublin, from September 18th to September 23rd. Details are obtainable from Mr. H. J. Duncan, 29, South Anne Street, Dublin.

There is, after all, a public radio exhibition to be held in New York, September 20th to 30th, but the American Radio

Manufacturers' Association has decided not to support it, though this does not mean that members of the R.M.A. may not exhibit. Set-piece of New York is a vision of the Rockefeller family paying off the artiste who tried to decorate some interior of Radio City with a picture of Lenin.

## So Now You Know.

HAVE you ever had the luck to get a seat in Broadcasting House during a vaudeville concert? I hope so—and I hope not.

For those audiences have been sized up by one of these so-called "radio critics" as "hysterical dead-heads."

Some dead-heads, I may remark, are not hysterical—only nonsensical.

This critic of studio audiences refers to them as a "scandal," and expresses doubt as to where they come from. When "radio

## SHORT WAVES

For a recent broadcast play, the B.B.C. was faced with the problem of creating a noise like a million rats.

They should have announced two hours' Chamber Music on Saturday night, and recorded listeners' comments. "Pictorial Weekly."

A Mitcham correspondent asks us to recommend the most suitable receiver for his locality. He adds: "I recently built a set whilst I was living with my mother-in-law. Now we have separated."

It must have been a VERY useful set.

"Engaging B.B.C. Artists," runs a headline in the "Star."

Some of them are—very.

## RADIO REGAINED.

The night is vibrant with a thousand tongues; Unseen sopranos exercise their lungs. Switch on, switch on! Does not the P.M.G. Possess ten bob that once belonged to me?

Again a fully-licensed listener-in, I crave my money's worth Of melody and mirth. Switch on, I say! Let the rich feast begin! "Punch."

criticism" reaches such a low level I begin to feel that there is room, and need for—a school of radio criticism.

## A Gilbertian Crime.

I CAN sympathise with any burglar who pinches a dentist's instruments of torture or a copper's truncheon, but when one of these call-by-night gentry goes and separates Mr. E. R. Appleton's house from his wireless receiver I think he goes too far.

As West Regional Director of the B.B.C., Mr. Appleton leads a blameless, Dartmoorish, Lorna Doone-ish sort of life; hence he is entitled to a little consideration, surely.

Can it be that the underworld object to his pronunciation of "zider"?

## "The Bottle Imp."

R. L. STEVENSON'S story, "The Bottle Imp," which was rendered in broadcast form recently, was written in 1889 or 1890 and was the very first of his Polynesian stories. He had landed at Apia (Samoa) about Christmas 1889, after a cruise in the most primitive of the South

Sea island groups, the Gilberts, and was staying with an American trader named Moors, and either there or in a nearby cottage this remarkable yarn was brought into being.

Small wonder that the Samoans named him "Tusitala," or the Teller of Tales.

## Rhythm and Romance.

THE composer of "Rhythm of the East," Clifford Hellier, whose work has been performed by Henry Hall's orchestra, got his impressions for this piece of music from a visit to

Algeria. Clifford, one is glad to know, is not of the long-haired, effeminate type of musical composer; he returned from Algeria with quite a different kind of impression, in the form of a scar, due to his having been mixed up with a romantic fracas in a cafe, the heroine being a damsel in distress.



## Not so "Dumb."

THE running commentary on the Open Hill Climb for racing and sports cars at Shelsley Walsh provided a good example of what broadcasting can do for "dumb acts"—though racing cars are not so very dumb in one respect. Shelsley is about twelve miles north-west of Worcester and from the foot to the summit of the hill is over a thousand yards. This contest is known all over the world and brings many foreign drivers to compete in it.

## A Passing Tribute.

BEAR with me while I pay tribute to the memory of Mr. G. E. Cox, of Leyton, who recently passed away aged 91. Mr. Cox was an enthusiastic "listener" and experimenter, and contributed to some of our earlier numbers. His interests were many, ranging from Darwinism to book-collecting and orchid-culture. He inspired in his associates a love of truth and beauty and I doubt whether a human being could do much better than that.

## Witty Wireless Dealers.

THE "trade" papers occasionally present a feeble sparkle to the eye of the uncommercial traveller through their pages. I am indebted to one for recording that a Watford dealer, disgusted with the slogans of the cheap-jacks, announced, to the astonished passers-by, "A fourteen-guinea set for fourteen guineas."

Another retailer who has been trying to sell some undisguised "junk" has amused his fellow citizens with tickets like, "Cabinet by Tate and Lyle; sound-box by accident." "Three and eleven or two bottles of lunch." I do not think that any other nation could produce such salesmen.







# Building a CATHODE RAY TELEVISION VIEWER

Continuing his description of the easily-made, inexpensive television viewer developed by "P.W.," Mr. K. D. Rogers this week deals with the double time-base which controls the electron stream.

**L**AST WEEK we gave a brief outline of the whys and wherefores of the Cathode Ray tube as applied to the reception of Television. Without going into deep technical details we are now going to describe the practical application of that tube so that you can go straight ahead on the construction of a really practical television viewer.

We should like to stress the practical aspect, for not only is the cost of the components quite moderate (especially as many readers will have many of the required parts already in their possession), but the possibilities of the system for future development are enormous.

### Resistance-coupled Set.

As a start we are going to describe the building of the double time-base unit, the section of the gear that causes the beam in the cathode tube to carry out even, and perfectly controlled, scanning. But before we do that we should like you to get a good grasp of what will be necessary in order to assemble the complete viewer.

We have mentioned the double time-base—the component list of which is given in this article—and the possession of a cathode ray tube, Ediswan type T, is a foregone conclusion.

In addition a small radio set is required. This can be a three- or four-valver of quite modest design, but to make it most effective for picture reception it should have resistance coupling, and a special, quite cheap filter output circuit.

This set can easily be knocked up out of components you have by you—you will want your ordinary set for the sound reception on another wavelength, so you cannot use that set for vision—but as a

guide we are going to publish details of a suitable battery set next week.

### The Power Supply.

All that remains is the power to operate the tube, the time-base and the radio receiver. This is going to sound a great deal, but it is not so much as it sounds, for it must be noted that the cathode ray tube, requiring as it does a rather high H.T.

Sundry other battery supplies are necessary, H.T. for the time-base and the receiver, and bias for the cathode tube shield (which is tapped off the accelerator H.T.), and for the deflectors. In all the reception of television can be carried out with a total voltage of 700 volts or so, split up into sections among the different parts of the apparatus.

But as the current taken from this supply is very small indeed, the wattage consumption is extremely small, and compares most favourably with the large wattage needed for the operation of the mechanical methods.

### No Danger.

There is no danger of serious shock with the cathode ray scheme if proper precautions are taken, for in the H.T. supply to the tube (350 volts or so—it can be increased to 700 if desired), a low-milliamp fuse can be inserted to prevent heavy current flow, or a resistance can be used in series for the same reason.

Moreover, in our finished design, as you will see, we have taken ample precautions to protect the operator from inadvertent shocks, not that they would be likely to be harmful if received, but because none of

(Continued on next page.)

## TRACING THE TELEVISION PICTURE

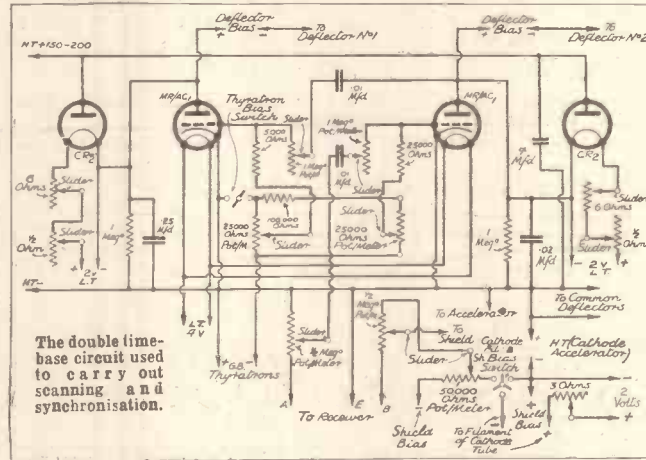

voltage (from 350 volts upwards) on its accelerator, does not consume any H.T. current worth talking about.

The current consumption is a mere 20-30 microamps. So the H.T. batteries, which can be of the smallest capacity dry type, have a life similar to their life in the hands of the radio dealer—i.e. their shelf life.

## ALL THAT IS REQUIRED FOR THE "P.W." CATHODE RAY TELEVISION VIEWER

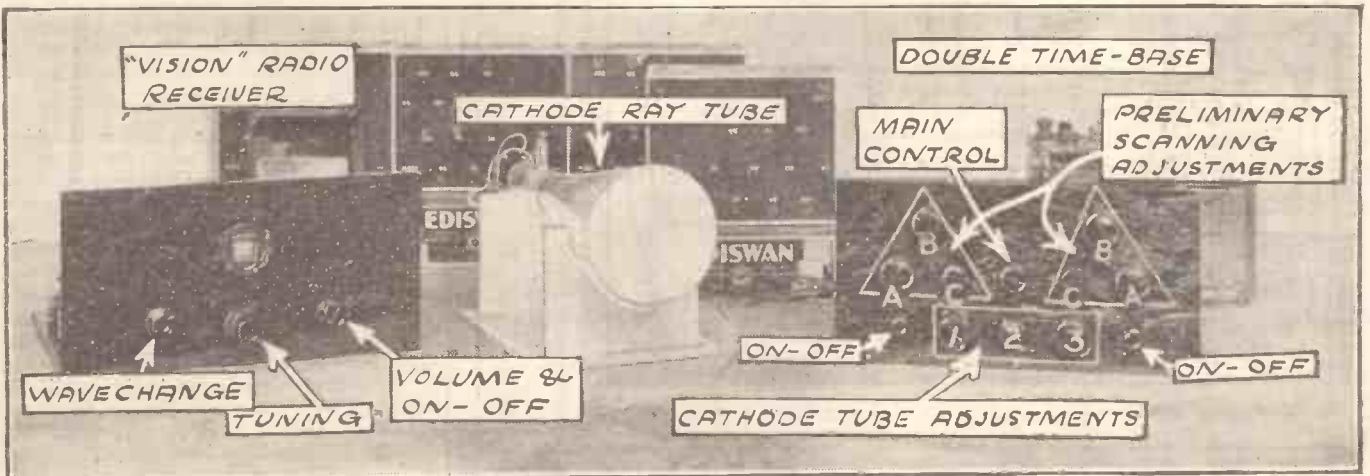





## BUILDING A CATHODE RAY TELEVISION VIEWER

(Continued from previous page.)

This week we give the theoretical and wiring diagrams for the four-valve piece of apparatus known as a double time-base. It is this device that is used to swing the cathode ray about to make it scan the screen.

Half the base causes the beam to run vertically up the screen, and the other half to move across from left to right. The result is 30 scannings vertically carried out 12½ times per second. That is what is required by the Baird process of television transmission.

Last week we saw that the scanning effect

### PHOTOGRAPHIC RECORDS

During the extensive research on cathode ray television reception carried out in the "P.W." Research Department, the camera was frequently called in to record results. The technical difficulties in obtaining quickly moving television images on the photographic plate are tremendous. The camera does not possess the persistence of vision which in the human eye is the basis of success of both television and the cinematograph. Typical of the results as recorded by the camera is that on the right, taken on May 16th, of one of the B.B.C. artistes during a comic item.



could be obtained with a resistance, condenser and glow-discharge tube. In practice this is more accurately obtained with a diode instead of the resistance, with the condenser as before, and a thyatron type of glow discharge tube.

By these means we get a complete control of the time taken for the scanning to be carried out, and the distance of travel of the cathode ray before it completes the scanning and is returned, instantaneously, by the discharge of the condenser by the glow tube.

The input voltage across the condenser is fixed, and the size of the condenser in each time-base section is fixed. The variation of the time taken for the condenser to charge up is obtained by controlling the filament heat of the diode valve, by means of an ordinary rheostat. Thus we can feed current into the condenser at a regular and predetermined rate.

#### Predetermined Flash Voltage.

By applying bias to the grids of the thyratrons, we can also predetermine the voltage at which they will flash over and discharge the condensers. Thus we have complete control over the time of the scanning of the beam. How this is used in practice we shall describe later.

If you study the circuit given this week (it differs slightly in some minor features from the one given last week) you will see that the two time-bases each contain a diode valve (Ediswan C.R.2) and a thyatron (Ediswan M.R./A.C.1). In addition, from anode to cathode of each thyatron is a condenser across which is a resistance.

These condensers are vital parts of the circuits, for they are the condensers that have to be charged and then suddenly discharged by the thyratrons.

#### Discharge Rates.

In one case the value of the condenser is .25 mfd., and in the other it is .02 mfd. This is because the first has to charge and discharge at a slower rate than the second, the actual rates being controlled as before mentioned, but being set by means of the natural characteristics of the circuit somewhere near the required figure.

Actually the .25-mfd. condenser has to charge and discharge at 12½ times a second, while the other has to work at 30 times that speed.

The resistances in series with the filaments of the diodes are for "coarse" and "fine" adjustments, and the 6-ohm "coarse" ones are situated on the base-board behind the panel, for after they are set there is no need to touch them again.

As a matter of fact, the same can be said of a number of the knobs on the panel, for many are of the once-set-left-alone type, though it is handy to have them on the panel in case any slight departure from adjustment of the apparatus is noticed.

The actual construction of the time-base is extremely simple and can be carried out in a very short time. Rather a lot of flex leads are used to connect the base to the batteries and the cathode ray tube, but these are considered more satisfactory than terminals, for flex leads can be made more secure to their sources if they are tightly fixed when the set is built than can leads taken to ordinary terminals.

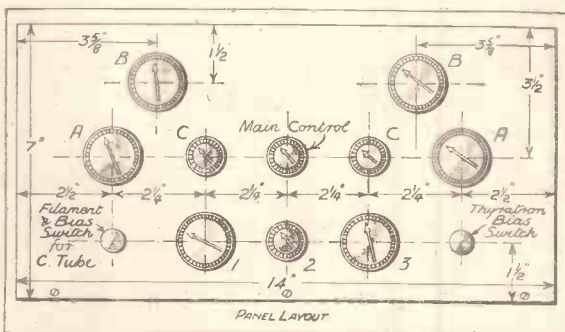

The significance of the various groups of controls A, B, C; C, B, A, and 1, 2, 3 are explained in the photograph on a preceding page.

on to their operation, and to the linking of the various parts together, and the full use of the diagram will be made in a later issue.

All parts used in the time-base should be of good, reliable manufacture, and constructors are strongly advised to keep to the makes specified in the list given on another page. The values, too, are critical and should not be altered on any account.

#### Indirectly-Heated Valves.

The thyratrons are indirectly-heated valves, and are operated by a common 4-volt L.T. supply. In the case of the diodes, which are of the directly-heated filament type, a separate 2-volt battery must be used for each.

The question of the battery controls for the thyratrons and the diodes will come up later when the whole assembly of the system is considered, for we suggest that a battery box, containing H.T. and L.T. compartments, be used with the requisite control switches on it.

The cathode tube can be controlled by the switch on the panel of the time-base, for as it is essential to provide the tube with a shield battery switch, it was considered best to kill two birds with one stone and to control the filament with the same switch.

#### Testing Base.

When the time-base has been built, it should be tested in part to see the filaments are correctly connected, and that the diode filaments can be controlled by the resistances. If you care to connect 150 to 200 volts to H.T. plus and minus, and to connect two 2-volt L.T. batteries to the diode inputs, and a 4-volt supply to the thyratrons you will be able to see the latter in action, flashing over at different intervals as the diode resistances are varied, and the rate of charge and discharge is controlled.

About 9-volts grid bias will be required on the thyratrons, and the potentiometers controlling this bias (marked B in the front of panel diagram and photograph) should be about central.

(Continued on page 410.)

### SYMMETRICALLY ARRANGED LAYOUT

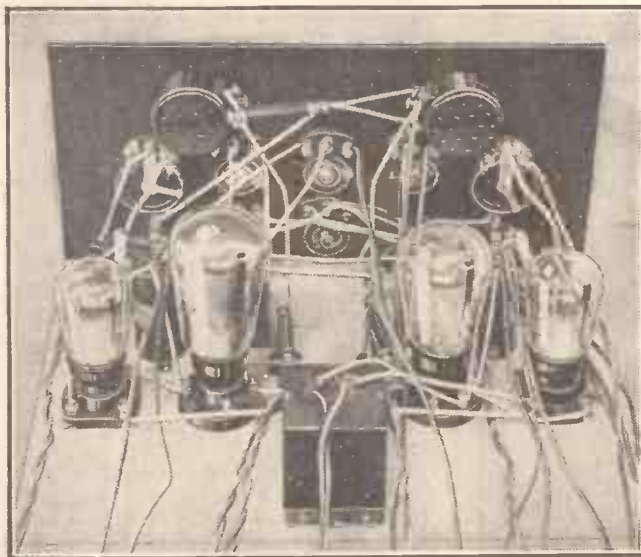

The two outside small valves are the diodes for regulating the current flow, the larger ones being the thyatron mercury-vapour discharge tubes.

In the diagram of the theoretical circuit we have given all the main connections to the base, and to the cathode ray tube as well. These show how the whole outfit is connected, including the output from the radio receiver, but we propose to complete the construction of every part before we go

THE MIRROR OF THE B.B.C.

By O.H.M.

## SPEECHES BY THE KING

Vernon Bartlett's Return—Tackling the Electrical Interference Problem—Seaside O.B.'s, etc.

Polish incident arising out of the New Year's Eve relay, so I suppose, in a way, one can hardly blame them for "going easy" on any subject that might offend the political susceptibilities of Central Europe—or of any other part of the world for that matter.

### Tackling Interference.

There is increasing alarm at Broadcasting House over the question of electrical interference, and I hear that plans are being considered for an intensive campaign to obtain legislation making it illegal to allow any electrical apparatus to radiate interfering noises.

This is a big step in which the B.B.C. have the full support of the Post Office, but before any definite move can be made it will be necessary to pave the way by a good deal of skilful propaganda. I suspect that when Major Gladstone Murray returns from Canada this will be one of the first problems to which he will be asked to devote attention, so prepare yourself to hear a great deal about electrical interference during the next few months.

The Post Office deals with more than 10,000 cases of electrical interference annually, but most of these are new cases and there are hundreds of thousands of listeners who have always suffered from it and will continue to suffer unless Parliament takes a hand and declares the right of every licence holder to receive the broadcast programmes free from clicks, buzzes, grunts and whirrs.

### Seaside O.B.'s.

Concert party entertainments are to be a big feature of the provincial programmes during the next few months, but for some reason or other the "O.B." department at Broadcasting House does not seem to have so marked an inclination to include this highly popular type of show in their part of the programmes.

As I have pointed out so many times, the holiday resorts from Yarmouth down the East Coast to Southend, around Kent and Sussex to Bournemouth, and even further West, abound with excellent concert party entertainers, and it does seem a great

(Continued on page 410.)

the High Commissioner for South Africa, will be heard towards the end of June.

### Vernon Bartlett's Return.

Mr. Vernon Bartlett, who is now a fully-fledged member of the B.B.C. staff, is back from his lightning tour of Europe full of ideas for his new series of talks on the Strong Men of Europe.

If he were given an absolutely free hand he could provide listeners with some amazingly good stories, but the powers that be at Broadcasting House have drawn his attention to various questions of policy which I fear will hamper him. Just now, in particular, all manner of questions of foreign policy are rampant at Broadcasting House, and it may be some consolation to Mr. Bartlett to learn that he is not the only one to suffer from restrictions which the B.B.C. are so keen on imposing on broadcast speakers.

The B.B.C. have not yet forgotten the

THE KING may be heard on the wireless twice during June, once at the opening of the World Economic Conference, and again when he performs the opening ceremony of South Africa House, Trafalgar Square.

Listeners are already familiar with the arrangements which have been made for broadcasting the World Economic Conference, but no announcement had been made regarding His Majesty's second broadcast because it was at first intended to be an Empire broadcast for the South African Zone only. Very naturally, however, South Africans were most anxious that the whole world should hear His Majesty honour their country.

### From South Africa House.

Various formalities have to be gone through before the nature of a Royal broadcast can be changed, but there is little doubt that the King and Mr. C. T. Walter,

## BROADCASTING THE DERBY

Scenes from the course on which the world's greatest race is run.



Above, commentators scanning the field from their observation post, and an engineer fixing the "mike." Right, a Derby finish.





From SIR JOHN REITH.

Dear Sir,—Eleven years is a long life for a magazine which deals with a medium of expression that came into existence so short a time ago. Yours must be one of the oldest magazines associated with the development of wireless, and once again I am happy to congratulate you on the occasion of your anniversary.



SIR JOHN REITH.

I am sure that "Popular Wireless" will long continue to enjoy the position among wireless listeners that it now occupies.

Yours sincerely,  
J. C. W. REITH.

From SIR OLIVER LODGE, F.R.S.

Dear Sir,— "Popular Wireless" has achieved another birthday, and I congratulate it on being able to retain the interest of its readers week by week. I attach a high importance to broadcasting as an agent for good in the exciting times in which we live; and I hope that "Popular Wireless" will long continue to keep its readers in touch with all sides of a fascinating subject.

OLIVER LODGE.

From SIR AMBROSE FLEMING, F.R.S.

Dear Sir,—I congratulate "Popular Wireless" on its birthday issue. Certainly the most wonderful industry in the world is the wireless industry and the most amazing side of that is the achievement of short-wave transmission with all its possibilities as regards television.

I wish "Popular Wireless" all possible success and prosperity in the coming years.

AMBROSE FLEMING.

From THE CHIEF ENGINEER OF THE B.B.C.

Dear Sir,—In wishing "Popular Wireless" many happy returns of its birthday, and every success for the future, I should like to emphasise its great value in promoting the maintenance of high quality broadcasting. The B.B.C. has always done its utmost to keep the quality of transmission on the highest possible plane consistent with reasonable economic limits, but high quality transmission is of little use without high quality reception.



SIR AMBROSE FLEMING, F.R.S.

By constant research on new receiving circuits and devices "Popular Wireless" has already rendered the most valuable assistance, and will, I feel confident, continue to do so in the future.

Yours sincerely,  
N. ASHBRIDGE.

From P. P. ECKERSLEY.

Dear Sir,—It was remarked by a writer in the "New Yorker" that in the war we were told to do

A selection from the large number of anniversary greetings received by "Popular Wireless" from eminent people who have all helped to further the science of radio.

our "bit," but now the "bit" has got to be quite a big boy and no one has told us to stop doing it. "P.W." is getting a big boy too, and while I have often said "Don't do it," I never applied this objection to a paper which so ably keeps alive an interest in wireless in general and the great hobby of set making in particular.

To wish a paper luck and happy returns is an impersonal kind of business, and so, with your permission, may I send our warmest greetings not only to the big boy but also to the keen, devoted and hard-working staff which keeps the boy growing!

P. P. ECKERSLEY.

From THE MARCONIPHONE COMPANY LIMITED. Dear Sir,—Please accept on behalf of "Popular Wireless" our very best wishes on the occasion of its birthday.

Every successive year the name of your interesting, progressive journal becomes more and more justified. "Popular Wireless" has surely contributed as much as any other journal to the ever-growing influence of wireless in the home.

Yours sincerely,  
G.-J. FRESHWATER.



SIR OLIVER LODGE, F.R.S.



NOEL ASHBRIDGE, B.Sc.

From PETO-SCOTT CO. LTD.

Dear Sir,—In wishing you birthday greetings on the occasion of yet another anniversary of your wonderful publication, may I congratulate you on successfully adding another eminently prosperous year to a decade gone all too swiftly but happily.

Judging by our own sales of "P.W." kits, your policy of keeping right up to date with all the latest developments in Radio is well rewarded, for to quote the words of one of our customers, "P.W." set designs are always in front of mass production sets."

In conclusion, I would say that the public and my Company are looking forward to many wonderful and new "P.W." developments during the coming year, which, I trust, will be as successful as the last.

Yours faithfully,  
W. SCOTT WORTHINGTON.

From LISSEN LTD.

Dear Sir,— "Popular Wireless" has this advantage over mankind—where the latter weakens under the weight of years the former strengthens with time.

To those of us who have been in the industry from the beginning "Popular Wireless" stands out as an original landmark and looms up to-day larger and better than ever. It has done much to help the Radio industry—influenced design—moulded trend—created a vast army of home constructors. The

public and the industry owe "P.W." a great deal. I add my congratulations to the many others you are likely to receive on this your eleventh anniversary.

Yours sincerely,  
T. N. COLE.



P. P. ECKERSLEY, M.I.E.E.

From RADIO INSTRUMENTS LIMITED

Dear Sir,—May I convey to you and your Staff my greetings on the 11th birthday of "Popular Wireless." This is specially interesting to me as I have previously pointed out that it coincides with the 11th birthday of R.I.

After this lengthy period it is remarkable to find that the interest amongst constructors is greater than ever. This I attribute to the striking

developments that are constantly occurring in this

fascinating industry. I am confident that with your usual enterprise readers of "Popular Wireless" may look forward to numbers which will be far more fascinating than anything previously published by you.

Yours faithfully,  
J. JOSEPH.

From VARLEY (OLIVER PELL CONTROL) LTD.

Dear Sir,—It is with many memories of happy associations that I write to wish "Popular Wireless" "Many Happy Returns."

In making the general public radio-minded, you have contributed very largely to the success of the wonderful industry you adorn and to which I belong.

Yours sincerely,  
J. M. G. REES.

From COLUMBIA GRAPHOPHONE CO., LTD.

Dear Sir,—Many happy returns to "Popular Wireless" on its birthday. Eleven years is a great age in radio journalism really, and you have the satisfaction of knowing that a very great deal that is both educative and entertaining has been given to thousands of homes.

"Popular Wireless" strikes a note of attractive

caholicity in its matter; there is something for everybody in its columns. Its technical side is able and lucid—its magazine features readable and informative. It is therefore a pleasure (almost a duty!) to wish it good luck for the future years.

Yours sincerely,  
W. O. TWELLS,  
Advertising Dept.



MARCHESE MARCONI.



# "P.W." BREAKS WORLD'S RECORD

Amazing success of our Ultra-Short-Wave Tests from the top of the Crystal Palace Tower! All ultra-short-wave records easily beaten in the first British big-scale experiment with quasi-optical waves!

ON Sunday, May 21st, a spectacular addition was made to the list of low-power records held by amateur transmitters, when portable station G 6 Q B, working from the Crystal Palace Tower, was heard 190 miles away in Yorkshire, and at "R9" in an aeroplane over the North Sea, 130 miles away, on 5 metres.

G 6 Q B was operated by three South London amateurs, in co-operation with the "P.W." Research Staff, and special permission had been obtained from the Postmaster-General.

Up to the present the longest distance covered on 5 metres in this country has been 50 or 60 miles. The special portable station at the Crystal Palace worked with practically every active station within this radius with the greatest of ease, but was also heard continuously by a special receiving station in an aeroplane, operated by Mr. P. D. Walters (G 5 CV) in conjunction with the "Daily Herald."

## Hardy Amateurs.

The history of the Crystal Palace tests will make amusing reading when we have all the data available. The three hardy amateurs who voluntarily cut themselves off from civilisation for a day were Mr. A. D. Gay (G 6 N F), who provided the transmitting gear; Mr. L. H. Thomas (G 6 Q B), who co-operated with "P.W." in the work of arranging the whole thing beforehand and provided one of the receivers; and Mr. H. D. Price (G 6 H P), who supplied some of the essential gear and did sterling work during his shifts as operator.

The "P.W." Research Staff (not forgetting W. L. S.!) also collaborated by supplying one of the receivers used on the tower station, and sending out another portable receiver in a car, which kept as nearly as possible to a compass course in a south-westerly direction. When all the reports from this and other portable receiving stations have been analysed, some valuable data should be available.

## "P.W.'s" Mobile Receiver.

Punctually at 10 a.m. the "P.W." car was dispatched from the Crystal Palace Parade, after a complicated series of handkerchief signals had been exchanged between the operators "down below" and those in charge of the transmitter up above on the tower.

From then onwards the car station was

called, at every half-hour, although those operating the transmitter had no idea until the end of the day about where their mobile station had got to!

In actual fact the signals appeared to be about the same strength at any un-screened

During the afternoon duplex telephony was worked with G 2 J U of Harrow, and tests were made until this duplex was just as reliable as a local call on the land-telephone.

Towards the end of the afternoon came the most successful two-way test of the day, when weak signals were picked up from G 5 S A, a small portable station operated by Mr. D. Price-Jones, at that time in the vicinity of Wendover. The distance was rather over 40 miles, and the signals from the Crystal Palace were received at the other end with the greatest of ease.

Probably owing to G 5 S A's location and the low power used, it was not possible to hear his telephony, but he reported G 6 Q B's telephony as perfect.

After the conclusion of the tests, all concerned were interested to receive Mr. Walters' report. The receiver in the 'plane had hardly lost the Crystal Palace transmission once, and when the 'plane was flying at 10,000 feet, somewhere north of the Wash, the transmission was described as "R 9 plus"!

## A Great Success.

These are the bare details of a very successful experiment, but next week we shall publish a full report and an analysis of all the results obtained, with a more technical description of the gear.

The transmitter used was not actually a "portable," as it was decided rather hurriedly to take advantage of the offer of Mr. A. D. Gay (G 6 N F), and to use his own "home" station. The A.C. mains at the top of the tower were used to supply the necessary input of 10 watts to the oscillator itself, although the total input to the gear was in the neighbourhood of 50 watts, including the modulator H.T. supply and the filaments.

A very interesting feature of the receiving side of the tests was that two receivers were installed, one on either side of the tower, and that these could be used together without serious interference. Thus it was possible to keep a continuous watch for signals from practically every direction.

The receivers were moved about from time to time, and some extraordinary "freaks," due to the screening effect of the tower, were noticed.

The reception by G 6 P L (Mr. F. J. Popplewell, of Hollinbank, Yorkshire) constitutes a world's record for 5 metres. More details of this will appear next week.

It is well known that the B.B.C. is now carrying out tests on 7 metres from Broadcasting House and that such ultra-short waves may revolutionise broadcasting technique. But commercial interest in these remarkable wavelengths has been limited because the range of transmission was believed to be extremely small. The remarkable "P.W." tests briefly described on this page throw an entirely new light on low-power possibilities, and prove that communication is possible at distances of almost 200 miles!

By a Member of the "P.W." RESEARCH DEPARTMENT.

point within the sixty-mile radius.

Unknown to us at the time, the "Daily Herald" aeroplane, with Mr. Walters and his receiver, was making wide circles round the tower, carrying out final adjustments prior to a long flight in a north-easterly direction.

For most of the morning, with the aerial on the tower pointing north-west, contact

## ON TOP OF THE TOWER



The "three hardy amateurs" with their transmitting and receiving gear installed at the top of the Crystal Palace tower. L. H. Thomas is wearing 'phones while A. D. Gay is using the "mike." The genial smile of H. D. Price seems to indicate another successful contact.

was maintained with other London stations and with amateurs as far out as Uxbridge and Harrow. G 6 U H, a portable station near Limpsfield, Surrey, was also contacted with the greatest of ease.

## Amazingly Reliable.

At 2 p.m. the gear and the aerial were shifted round to the south-west side of the tower in readiness for schedules with G 2 F X at Bexhill. Unfortunately the tests with this station were not productive of results.



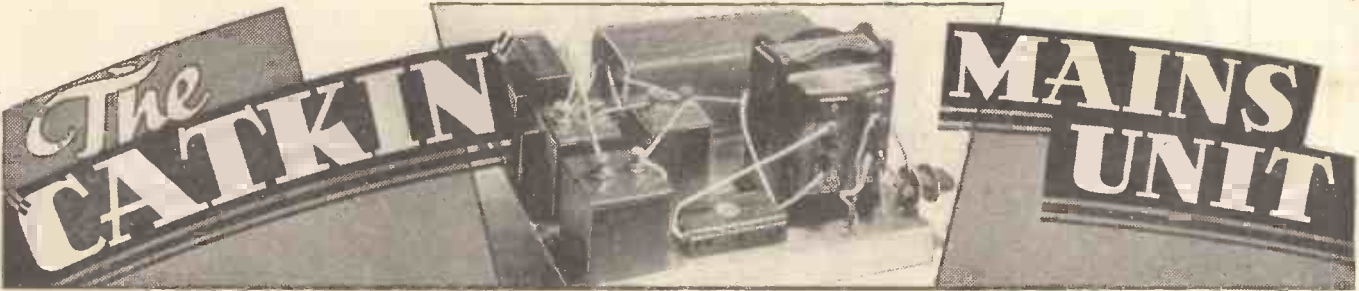

**T**HE mains unit, which has been designed for use with the "Catkin" Three—or with any other powerful mains set using indirectly-heated valves throughout—is of very simple design.

Its components, which are few in number, are mounted on a metal chassis, and rectification is carried out by a metal rectifier working on the voltage doubling system.

A very useful feature is a thermal delay switch, inserted between the high-tension output of the mains transformer and the A.C. input of the rectifier. This allows the valve cathodes to heat up before any high-tension voltage is applied to their anodes. It also prevents any voltage rise in the high-tension circuit, and consequent condenser breakdown.

**Choosing Components.**

There are only four output terminals—two for the valve heaters, and two for high-tension. (Arrangements for dropping voltage in various parts of the circuit are carried out in the receiver itself.)

It will be noticed that there are two "mains" plugs on this unit. One of these is for connection to the mains, and the other is connected to the mains switch on the receiver.

**PARTS USED IN "CATKIN" MAINS UNIT**

Component.	Used by Designer.	Alternatives of suitable specification recommended by Designer.
1 Chassis 12 in. x 11 in.	—	—
1 Metal rectifier	Westinghouse H.T.8	—
1 Delay switch	Varley	Bulgin
2 4-mfd. fixed condensers	T.C.C., type 61	Dubilier
1 4-mfd. fixed condenser	Dubilier L.S.B.	T.C.C.
1 mains transformer	Heaberd W.31	—
1 Smoothing choke	Ferranti B.10	R.I., Wearite, Varley
4 Terminals	Belling-Lee type B.	—
3 Insulating Washers	Belling-Lee	—
2 Mains connectors	Belling-Lee type 1042	—
2 yds. sleeving	Goltone	Wearite
3 yds. 18-gauge tinned copper wire	Goltone	Wearite

If components other than those specified are used, care should be taken in choosing them, so that their characteristics conform to the requirements of the design. The H.T. smoothing choke must be capable of carrying 60 m.a. whilst still maintaining an inductance of 20 to 30 henries. Whilst

Designed and Described by the "P.W." RESEARCH DEPARTMENT. This instrument is capable of providing a smoothed output of fifty milliamps, at 250 volts—just the thing for providing the H.T. for a powerful mains set. Employing a metal rectifier, it is specially suitable for use with the "Catkin" Three, described recently in "P.W."

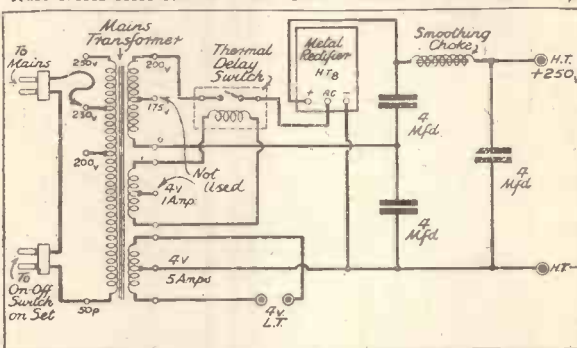

simplicity is a keynote of the circuit arrangement, but ample power is available.

in a vice. Having bent it over, place another block of wood over the bench, and beat down with a mallet. In this way a good square bend will result. This, of course, raises the base of the chassis 1 in.

**Mains Voltage Adjustments.**

The chassis is now ready to have the components mounted on it. It is unnecessary to make any remarks regarding this, as there are no difficulties to be overcome. There is only one point regarding the output terminals: these are all insulated from the chassis, except the H.T.—. The insulation washer is omitted on this one, as it is necessary that this terminal should make contact with the chassis.

When all the components have been mounted, the wiring may be commenced. There are four mains input terminals, respectively marked 50P.: 200 v., 230 v., and 250 v. Whatever the voltage of your mains, the terminal marked 50P will be connected as in diagram. The remaining mains lead will be connected to 200 v. for (Continued on next page.)

**THE LEADS THAT LINK TO SET**

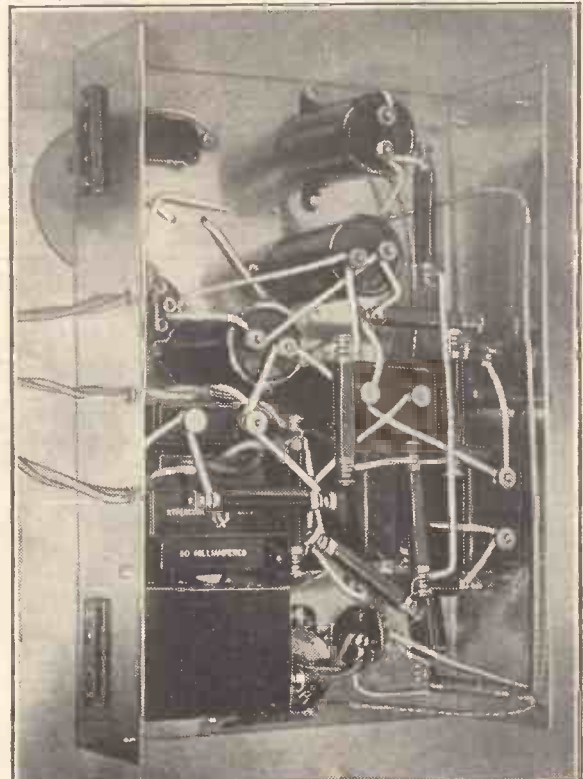

An under-chassis view of the "Catkin" Three. The three sets of flex leads on the left go to the mains unit; the top one for heaters, the centre one for mains, and the lower one for H.T.

the 4-mfd. condensers must have a working voltage at least as high as those specified.

Having described the general principles of its design, it now remains to describe the construction of the unit.

The metal chassis is made from a piece of aluminium 12 in. x 11 in. and of 16 gauge. Scribe a line parallel to and 1 in. from each of the shorter edges. Now place all the components in position within these lines. The only components outside these limits are the four terminals, which are mounted on the 1-in.-wide strip nearer the metal rectifier and smoothing choke. With the components in position, mark out the positions of the holes to be drilled for fixing them.

**Drilling the Chassis.**

When the holes are drilled, it will be found that a burr is left on the underside. This burr should not be removed, as it will prevent the nuts on the fixing bolts from working loose. Do not forget to drill the holes through which the heater leads pass to their terminals, and the H.T. + lead to its terminal.

Having drilled all the holes, the chassis may now be bent to shape. It is bent about the two lines which were scribed. This should be done between two blocks of wood clamped



## THE "CATKIN" MAINS UNIT

(Continued from previous page.)

mains voltages between 200 and 210 volts; to 230 v. for those between 220 and 230 volts; and to 250 v. for those between 240 and 250 volts.

Only two of the three H.T. terminals are used, those marked 0 and 200 v. The terminal marked 175 v. is not used.

Great care should be taken that the holes through which the leads to the heater terminals and H.T. + terminal pass have no sharp edges, otherwise they will cut through the insulation, and cause short circuits, with possible disastrous results to components.

### Avoiding Voltage Drop.

Heavy flex should be used to connect the 4-volt heater winding terminals on the mains transformer to the heater terminals on the chassis. If this is too thin there will be a voltage drop, and the valve heaters will not obtain the requisite 4 volts.

As the H.T. voltage is fairly high—250 volts—it is essential that the insulation of the lead running through the chassis to the H.T. + terminal should be adequate. A piece of single flex with a thick rubber covering is satisfactory. Ordinary insulating sleeving will not stand 250 volts across it without risk of breaking down.

It is for this reason that, where a positive H.T. lead must run near any negative points it should not actually touch, otherwise the insulation may break down and arcing take place.

Having finished the wiring, the unit is now ready to be connected to the receiver and the mains. First make certain that the mains on-off switch is in the off position.

### Delayed Action.

Connect the heater leads and high-tension leads from the receiver to their respective terminals on the unit, then plug in the switch leads and lastly the mains plug.

### A METAL RECTIFIER IS USED

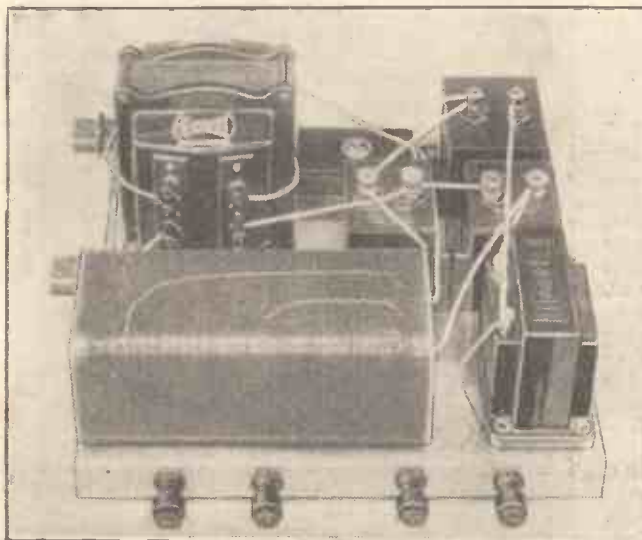

The component in the foreground with perforated cover is the rectifier. Below it are seen the terminals mounted on the chassis from which three of them have to be insulated with bushes. The H.T. - terminal does not require insulation.

If the receiver is now switched on, nothing will be heard until half a minute or so has elapsed, when a click in the loudspeaker will denote that the thermal delay switch has gone over, and the set is alive.

This unit has not been designed with a cover, as it is usual nowadays to house the

saturated solutions of potassium permanganate and ammonium sulphate respectively.

Anyone who has watched a borrough water cart "at work on a hot summer's day, deluging the road with its bright purple spray," to quote a minor poet, will at once realise that potassium permanganate is not one of the rare chemicals. As for ammonium sulphate, ask any farmer. He scatters it by the ton on pasture land to improve the grazing. In addition the cell was stated to be very economical in zinc.

The outlay was so trivial that we felt we must make it up. I am afraid its inventor, not wishing to let the child of his brain down with a bump, was a bit optimistic.

The voltage at 1.8 almost came up to specification. With a stated internal resistance of only half an ohm, its amperage should have been something wonderful.

### Peculiar Tactics.

In sober fact, it about equalled a Daniell cell. However, we would have forgiven it this minor lapse, but its peculiar tactics in an un-

expected direction put it right outside the pale.

One hesitates to accuse an honest-looking British battery of malingering, but our specimen gave what can only be described as an intermittent current. It would light a flash-lamp brightly for a few moments, and then fade away. Breaking contact brought it back to life immediately, and it appeared both anxious and capable of carrying on in this manner indefinitely.

### The Last Hope.

It was not polarisation, for substituting a fresh carbon made no difference; it just seemed a habit with the cell.

Anyone who has attempted to charge an accumulator making and breaking contact at the terminals ad nauseam, will agree that it is a very tiring business. We did think of rigging up an old watch to operate a very slow make and break, but the mechanical difficulties were appalling.

Perhaps, in the peaceful seclusion of the laboratory, these cells perform valiantly, but they seem much too delicate for the rough and tumble of this wicked world. As far as I can see, there is just one hope for them.

You all know those natty little light buoys that wink at you on the river: two minutes' rest, and then a blink. The cells would be right in their element here, and there's no getting away from the fact that they are jolly cheap.

### WIRED IN A FEW MINUTES

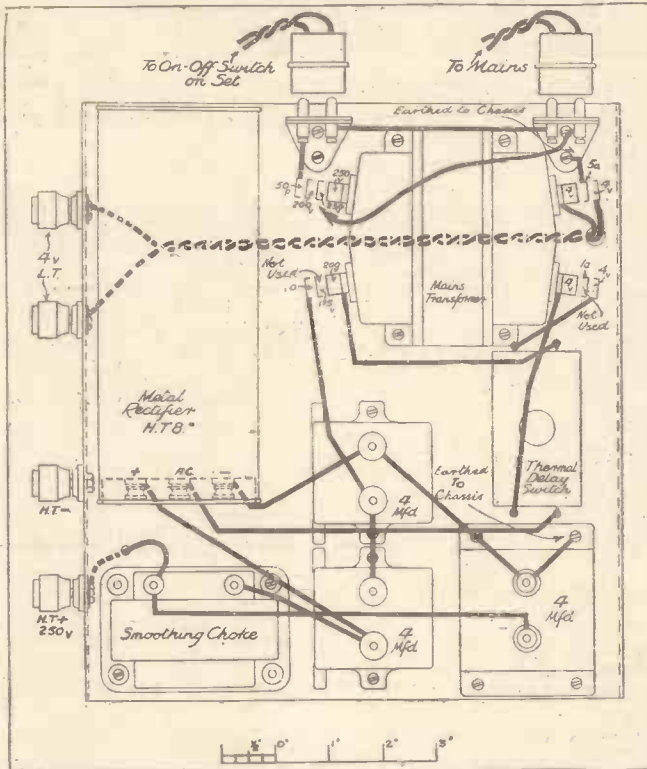

The few parts are quickly and easily wired up. No soldering is required, all components being supplied with terminals.

receiver and power unit in one cabinet. However, if it is desired to use it as a separate unit, a metal cover should be employed, and can easily be made to fit over it. A thinner gauge of metal than that from which the chassis is made should be used, simply because it is easier to work.

Alternatively, a wooden box could be made large enough to accommodate the whole unit with holes through which to pass the leads and perhaps one or two for ventilation purposes.

### SOMETHING FOR NOTHING!

**B**ROWSING through an old electrical journal the eye glimpsed what promised to be a highly attractive proposition.

To the connoisseur the ingredients of the cell described simply spelt cheapness all along the line. The electrolytes were



# ELEVEN YEARS OF PROGRESS

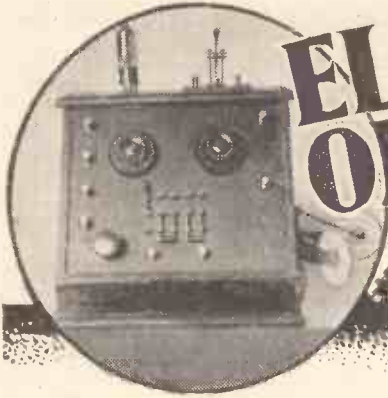

By THE EDITOR.

**ELEVEN** years is a very long time in the annals of wireless, so long indeed that the history of POPULAR WIRELESS might almost be styled "The Cavalcade of Radio." Alternatively, what about "From Catswhisker to 'Class B'?"

But although "P.W." is older than broadcasting, I don't think even our bitterest critic could accuse us of any diminution of virility! We appeared on June 3rd, 1922, and gave details of the first popular home-constructor set. 1933 sees us still maintaining the tradition of "P.W." pre-

## STARTED WORLD FASHION

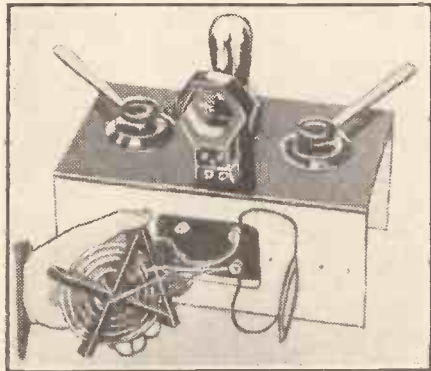

The "Antipodes Adaptor," described in "P.W.," was the first unit for providing short waves on an ordinary broadcast receiver and has been copied throughout the world.

eminence which was laid down by that notable radio event.

It is a great achievement, and I have no hesitation in saying so because it is as much due to the loyal support accorded to us by an immense band of enthusiastic readers as it is to our own efforts.

Of course, there has been a deal of really hard work, and there still is, but it has been thoroughly enjoyable work.

However, I do not propose to dwell at length on the past. At the same time I should say just a little about it because it has a vital bearing on our present position of pre-eminence in radio journalism.

For example, we've obtained an extremely wide experience of the desires and requirements of the home constructor. And we have been able to build up a compact and efficient organisation to serve him.

### In the Beginning.

When we started we had no proper laboratory facilities whatever, and all our research and constructional work had to be carried out in a small workshop. But it is amusing to recall that even this little room, staffed by a couple of mechanics, could

Little though some readers may realise it, "Popular Wireless" was designing sets for home constructors before broadcasting began. And it is this long experience, coupled with an unrivalled Research Department, which enables "P.W." to lead the way in producing designs embodying the very latest developments in radio.

unashamedly be styled a Research Dept. in those early days, such was the undeveloped condition of wireless in general and the radio industry in particular!

Our very able and enterprising Research Dept. of the present day may not be immense, if judged purely by its total floor area, but physical size alone does not determine the value of a laboratory.

### Experienced Investigators.

The personnel and the equipment are the things which matter. And I think I can safely say that nowhere in the country exists such an enthusiastic, reliable and experienced band of young radio investigators and mechanics as that which our cheery Mr. Rogers has gathered round him.

And practically all the gear has been specially developed and built by us for the special purposes for which it is employed.

Originality, speed and efficiency are the watchwords of the "P.W." Research and Construction Dept., and I presume it must be obvious to all that it faithfully observes them! Of one thing I am very

## LONG, MEDIUM AND SHORT

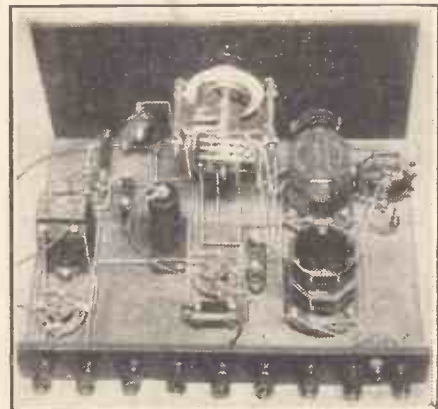

The importance of short waves has always been appreciated by "P.W." designers and the "Cosmic" Three, shown here, was one of the first sets to cover this band as well as the broadcast waves without coil changing.

certain, and that is—I'd hate exceedingly to be in competition with it! The mere thought produces a hollow feeling in the vicinity of my third waistcoat button!

It is also a fine thing to remember that we have been privileged to witness Sir Oliver Lodge, the inventor of tuning, P. P. Eckersley, originator of Regional broadcasting, and other eminent technicians experimenting in the "P.W." Research Dept.

I expect some of you are wondering when I am going to reveal the secrets of the

## FIRST "CATKIN" SET

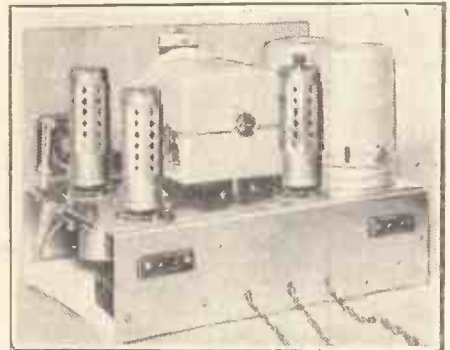

For eleven years it has been the policy of "Popular Wireless" to give the constructor the immediate benefit of anything new. The "Catkin" Three, recently described, shows how this policy is being carried out as rigorously as ever.

methods whereby we are able to give the first details of all the new developments. But actually there aren't any secrets. Our success is due entirely to the scientific system which we have built up during the past eleven years. We had a useful start in being the first popular radio journal, and we have maintained that lead. If we went to sleep for a few years others might catch us up—!

One curious thing emerges from a study of the general progress of radio, as recorded in the volumes of "P.W.," and that is that in the later years there has been a continuous, steady development along fairly clearly defined lines.

### The Oscillating Crystal.

There have been extremely few cul-de-sacs. The only one that really stands out concerns the crystal set. Very early on this arrived at a stage of development from which it appeared further advancement was impossible.

Then came the oscillating crystal detector, and it seemed that reaction and

(Continued on next page.)



## ELEVEN YEARS OF PROGRESS

(Continued from previous page.)

amplification were going to be possible and that the crystal might prove a formidable rival of the valve.

A multitude of different circuits for oscillating crystals was proposed and at first the results were excitingly promising. But nothing practical eventuated and the experiments, which had been feverishly carried out all over the world, suddenly came to a stop. Then the crystal began to lose favour with the public.

On the other hand, the valve went from strength to strength. Literally, for as its filament consuming costs went down, so did its operating effectiveness rise.

But for years no one seemed to be particularly dogmatic as to the usefulness of the valve as an H.F. amplifier. However, the introduction of the screened-grid type finally settled all the arguments centring around the controversy "Is H.F. Amplification Worth While?"

### Revolutionary Developments.

Curiously enough, it was only last year that people were saying that the L.F. end of the set had apparently reached finality. I say "curiously," because 1932 and 1933 have seen almost revolutionary upheavals in L.F. practice.

The ordinary pentode never attained the popularity of the S.G., but I think it very likely that the triode output valve, which has had such a long run, is now approaching the evening of its days.

"Class B" as we know it now may not be the ultimate output stage (no pun intended!), even for battery sets, but I think it highly probable that it foreshadows

### THE "DOUBLE D.T."



Double-diode-triode valves for automatic tone control are of recent production, but "Popular Wireless" was first with full details of how to build a receiver incorporating this new development.

the future trend of development and that it is destined to enjoy a pretty good life.

Although the pentode has hitherto had somewhat of a mixed reception, it is probable that it will meet with greater success in H.F. than it has had in L.F. stages.

In the "multi-mu" form for manual or automatic volume control it has certain very definite advantages.

From all this, it is obvious that "P.W.'s" eleventh birthday coincides with a most interesting phase of valve development and it will be clear to all that we are on the

threshold of a fascinatingly active period of development.

Almost every day brings news of new valves.

Now why is this? For years valve development has been slow but sure. Then, suddenly, a veritable flood of new ideas. And here I must disclaim the suggestion on the part of a very, very enthusiastic "P.W." reader that all these new valves must have originated in the "P.W." Research Laboratory for "P.W." to be so habitually first with news of them!

### Enterprising Valve Industry.

However, whatever may be the true reason, we can be grateful for the alert technicians and enterprising firms of the

### "CLASS B" AMPLIFICATION

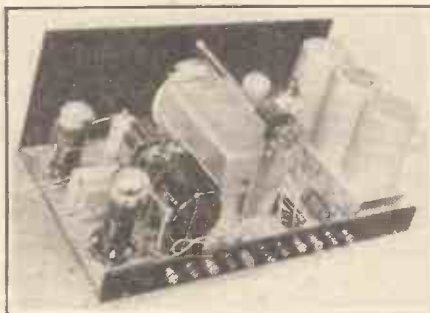

Just when everyone was deciding that L.F. amplification had reached finality, out came "P.W." with the "Class B" Four, employing an entirely new "double" L.F. valve.

valve industry for providing us with such a wealth of fascinatingly novel material. And if some constructors have been rather bewildered and have held their hands for fear of embarking on sets which might be rendered obsolete overnight many, many more have waded in and thoroughly enjoyed themselves.

Adding a few new essential components as required, they have been able to juggle about with new circuits in a way which would have turned the 1923 amateur green with envy.

And they have had the additional satisfaction of knowing that modern radio developments are under strict control. Indeed, it is possible to predict with considerable accuracy what a given hook-up will do merely by reference to its theoretical circuit.

### Steadily Advancing.

Not that the average constructor is able to do that, but the men responsible for placing them before him are able to base their designs on a secure foundation, and are able to rely upon a standard of component and accessory efficiency which at one time would have seemed an impossible ideal.

The most valuable practical result is that reception technique steadily advances.

## "P.W."

STARTED FIRST, IS FIRST & ALWAYS WILL BE FIRST

BECAUSE

Our Readers appreciate the Best and Most Practical Wireless Paper in this or any other Country.

And each new development is almost certain to be a definite step forward.

And here let me say that, in my opinion, "Class B," A.V.C., and so on, are not, as has been said, merely old schemes dug out of history and reclothed to provide stimulation for the radio industry. No doubt if some of the most prolific of our radio inventors had been able to divide themselves up into pieces and each piece had as energetically pursued the many different lines of thought hand in hand with an industry magnified tenfold, many of the new valves and circuits would have been perfected years ago.

It is so easy for an imaginative technician to stake his claim in posterity by throwing a wide net of conjecture. It is most successfully done in patent claims.

Actually, the success of such a thing as "Class B," for example, is not the practical expression of any one man's thought, but is the crystallisation of the efforts of countless workers, and the general experiences of a whole industry.

### Technical Requirements.

Consider the requirements of just this single development. First we must have a special valve manufactured with extreme precision, for it is really two valves perfectly matched and built into one bulb.

Then special transformers having special qualities are needed. But these would not have been possible were it not for the advances made by transformer designers and manufacturers. It makes one shudder to think of "Class B" with 1923 transformers—and 1923 loudspeakers!

No, these developments of 1933 are products of modern times, although inevitably they are linked with the past. But, if you take that theme to its extreme, nothing could ever be done of which it

### AN OLD FAVOURITE



The "Magic" Three was a highly successful Det., 2 L.F. set, a type which was once extremely popular.

could not be said that it was in some way directly or indirectly predicted (or wildly guessed at?) by the ancients!

I hope I have made my point clear. Those who are comparatively new to radio may find it difficult to distinguish between serious invention, discovery and progress and things which are purely "stunts."

But this is where our eleven years of experience enables us to give exceptional service to readers. We are able to separate the wheat from the chaff and, while others are thinking and wondering and doubting, we are acting!



# THE NEW MULLARD *Screened* PENTODE makes its bow in the first stage

**MORE POWER IN THE EARLY STAGE MEANS PENTODE POWER IN THE H-F STAGE**

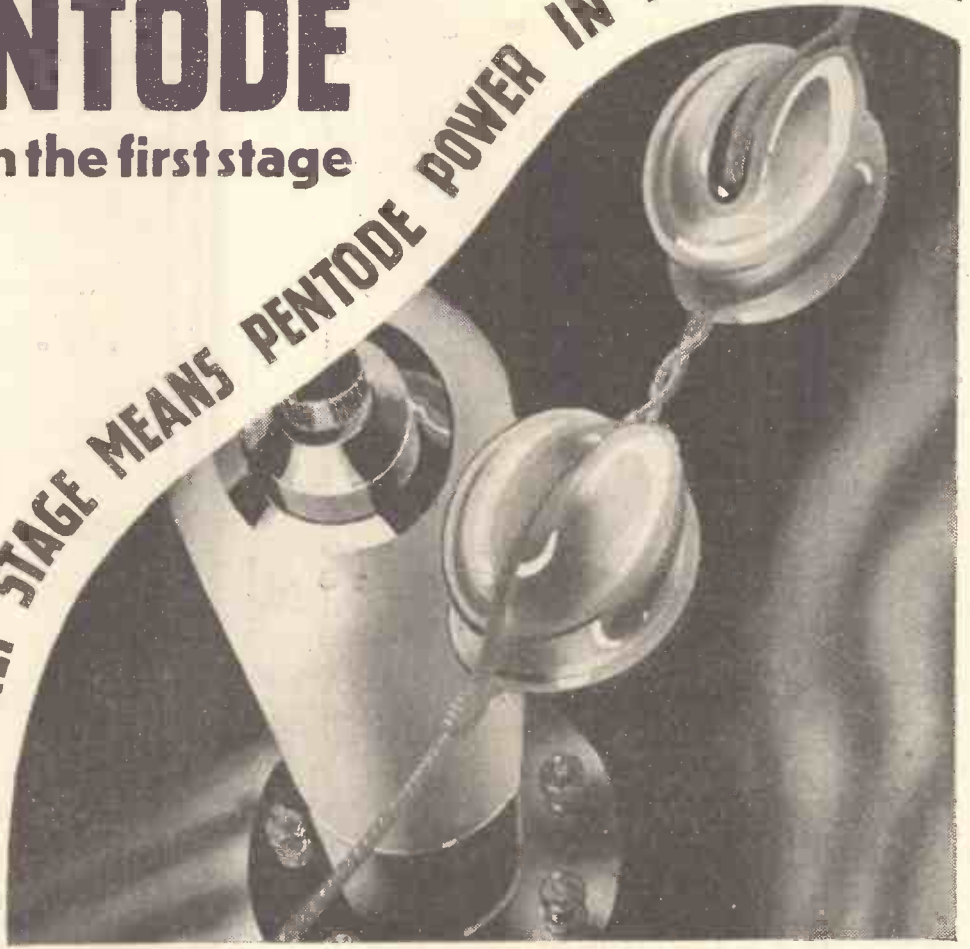

"More power in the first stage." What an idea! "Pentode Power in the H.F. stage." What an ideal! Radio users have never imagined it could be achieved. Radio scientists have been endeavouring to achieve it for years. And now, Mullards, always the pioneers in valve design (the originators of the Pentode), have at last perfected the new Screened Pentode for the H.F. Stage.

It will plug into *your* A.C. set. It will plug into *any* A.C. set. That is the wonder of it. No more worries about "my circuit isn't designed to take that valve." *The new Screened Pentode goes into any H.F. holder in any and every A.C. set.*

Ask your dealer about it. He'll give you all the glowing details. He'll tell you everything you want to know. And remember, Mullards first perfected the Pentode in the speaker stage—WHICH SPEAKS VOLUMES.

ASK T.S.D.—Whenever you want advice about your set or about your valves—ask T.S.D.—Mullard Technical Service Department—always at your service. You're under no obligation whatsoever. We help ourselves by helping you. When writing, whether your problem is big or small, give every detail, and address your envelope to T.S.D., Ref. C.F.1.

# V.P.4 Mullard

# S.P.4 THE MASTER VALVE

The Mullard Wireless Service Co., Ltd., Mullard House, Charing Cross Road, London, W.C.2

# SPECIAL SUMMER-SEASON OFFER

Limited Quantity Only

Buy now and take advantage of low prices prevailing. Radio will never be so cheap again.

## Direct Radio Battery Operated "159 B" Band-Pass Radiogram Chassis

Factory Built and tested ready for immediate use.

### SPECIFICATION

1. Band-Pass, Screened-Grid H.F. Stage separately tuned giving maximum selectivity.
2. High Power Detector with capacity reaction.
3. "Class B" Amplification giving super quality and volume equal to that expected from a high-powered A.C. mains-operated set.
4. 3 Stage Gramo Amplification for life-like reproduction.
5. Highest quality British components throughout.
6. Aerial tested and fully guaranteed.

**PRICE** Chassis only, Factory Wired £5 : 12 : 6  
and Tested  
or 12 monthly payments of 10/-  
Chassis as above with 4 latest type Mullard valves £7 : 17 : 6  
or 12 monthly payments of 15/-

Separate Quotation for cabinets to suit your particular requirements will be given on application

## "P.W.'s" Great Birthday Set "CONQUEST"

### THE SET OF THE SEASON

	£	s.	d.		£	s.	d.
1 "159" walnut table cabinet	1	1	0	1 T.C.C. .005-mfd. fixed condenser, type "M"	1	6	
1 Aluminium chassis bent to form baseboard	4	6		1 ReadRad H.F. choke	4	6	
1 J.B. .0005-mfd. triple-gang condenser with right-hand trimmers with disc drive	1	8	3	1 Kinva screened H.F. choke	2	9	
1 Set of Colvern Ferrocart type F.1, F.2 and F.3 canned coils	2	10	0	1 ReadRad L.F. transformer	8	6	
3 Clix 4-pin chassis mounting valve holders	2	0		1 R.I. "Driver" transformer, type D.Y.37	16	6	
1 Clix 7-pin chassis valve holder	1	0		2 Belling-Lee twin sockets, with plugs No. 1047	1	6	
1 ReadRad .0003-mfd. reaction condenser	2	3		4 Yards insulating sleeving	1	0	
1 Lewcos 50,000-ohm potentiometer, with three-pole switch	6	9		6 Yards 18-gauge tinned copper wire	6	6	
1 ReadRad Radiogram switch	2	9		2 Yards spiral screened sleeving	1	0	
1 Thermium 150,000-ohm resistance with horizontal holder	1	3		7 Belling-Lee battery plugs	1	0	
1 2-meg. resistance with horizontal holder	1	3		1 Belling-Lee Wanderluc No. 1028	1	0	
1 20,000-ohm resistance with horizontal holder	1	3		2 Belling-Lee accumulator spades Flex, screws, nuts and bolts, etc.	1	6	
2 1,000-ohm resistances with horizontal holders	2	6		4 Mullard valves: P.M.12M S.G. P.M.1.H.L. detector valve, 1 P.M.2.D.X. driver valve, 1 P.M.2B output valve	2	4	6
1 15,000-ohm resistance with horizontal holder	1	3					£11 7 0
1 T.C.C. 2-mfd. fixed condenser	3	6		<b>KIT 1</b> , without valves and cabinet, £8.1.6, or 12 monthly payments of 15/-.			
1 T.C.C. 2-mfd. fixed condenser, type 50	3	6		<b>KIT 2</b> , as above, with valves, less cabinet, £10.6.0, or 12 monthly payments of 19/-.			
1 Dubiller, 5-mfd. fixed condenser, type 9200	2	6		<b>KIT 3</b> , as above, with valves and cabinet, £11.7.0, or 12 monthly payments of 21/-.			
1 T.C.C. .25-mfd. fixed condenser	2	3		<b>KIT 4</b> , as above, with "159" Console cabinet, W.B. P.M.4 moving-coil speaker, and valves, £13.17.6, or 13 monthly payments of 25/6.			
1 T.C.C. .0003-mfd. fixed condenser, type "S"	1	3					
1 T.C.C. .0002-mfd. fixed condenser, type "S"	1	3					
1 T.C.C. .0002-mfd. fixed condenser, type 34	1	3					

# Direct Radio

To DIRECT RADIO, LTD., 159, Borough High St., London Bridge, "Phone: Hop 3000. Grams: "Dirrad, Sedist, London." S.H.A.

Please dispatch to me at once the following goods.....

for which (a) I enclose (b) I will pay on delivery (c) I enclose first deposit of  cross out line  not applicable £.....

NAME.....  
ADDRESS.....

(Pop. W. 5/6/33.)

## THE "WELLINGTON" CABINET-DE-LUXE



SPECIALLY DESIGNED FOR and EXCLUSIVELY SPECIFIED BY the Designer of the

## "P.W. CONQUEST"

We are in a position to supply all the Components specified for this Receiver at Manufacturers' List Prices. In anticipation of the phenomenal demand for these Components, we have acquired adequate stocks to ensure immediate delivery. By placing their orders direct with us, readers of "Popular Wireless" can rest assured of all orders being despatched the same day as receipt.

Once again a "C.A.C." Cabinet has been exclusively specified for this excellent Receiver. The above illustration cannot do justice to the handsome appearance of the Cabinet which is soundly constructed in selected Walnut, of dignified design and irreproachable finish. Special care has been taken to ensure that Cabinet resonances are eliminated.



PRICE, carriage paid **35/-**

DELIVERY BY RETURN.

TERMS: CASH WITH ORDER.

Showrooms: 4, Surrey Street, Strand, London, W.C.2.

Telephone: Temple Bar 8620.

Advt. of The City Accumulator Co. Ltd.

Office and Works: 7, Angel Court, 173, Strand, London, W.C.2.

Telegrams: Cityacco, Estrand, London.

# A SUPER AERIAL

## Lewcos

RECORDED

### BRAIDED AERIAL WIRE

Having a backing of over 50 years' wire-manufacturing experience behind it, Lewcos Braided Aerial Wire is the most efficient obtainable. This Aerial is moisture resisting and does not discolour wallpaper, woodwork, etc. Suitable for inside or outside use.

Ask your Dealer for it by name — "LEWCOS"!

Prices  
50ft - 1/6  
75ft - 2/2  
100ft - 2/9

The London Electric Wire Company and Smiths Limited  
Church Road Leyton  
London, E.10.

A 50,000-ohm Lewcos Potentiometer is specified by the designer for the "Conquest" described in this issue.

Stocked by all reputable Dealers.



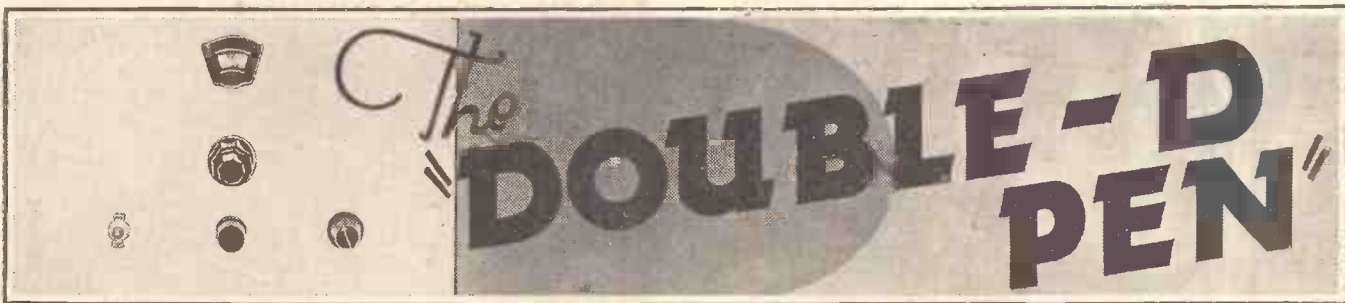

# The "DOUBLE-D PEN"

"P.W." presents exclusive details of another outstanding and up-to-the-minute design incorporating the very latest developments in valve technique.

A Dual Automatic Volume Control Receiver.—Designed and Described by the "P.W." RESEARCH DEPT.

Of late we have had a fair innings, one way and another, of automatic volume control and variable-mu screened-grid and H.F. pentode valves.

Set designers have become used to thinking in terms of pre-detector amplification control, and of ways and means of automatically achieving a steady input to the detector, no matter what the strength of the received "signal" might be.

Such automatic volume control is very useful for it helps to combat that most disagreeable phenomenon called fading, and it prevents overloading of a set to a remarkable and uncanny extent.

### Multi-Mu L.F. Amplification.

But it is found in practice that the volume control obtained by ordinary H.F. A.V.C. from, say, a diode rectifier, leaves something to be desired. Delayed A.V.C. is certainly a great help in achieving sensitivity as well as volume control, for by its means weak inputs to the set are allowed to build up in the H.F. stages before any amplification check is applied by the detector.

But even with delayed A.V.C. we have not obtained our ideal, for impulses from distant stations have to be built up to a tremendous amount if they are to be made anything like as powerful at the rectifier as local transmissions.

This means that the H.F. valves should have long grid bases if complete and accurate control of the "signal" strength is to be achieved, and this means a large variation of voltage on the diode.

With large variation of diode voltage we get large variation of L.F. voltage passed on to the L.F. valves and therefore the control of L.F. overloading (not being automatically variable) becomes no easy matter.

The ideal would be to have some form of variable-mu L.F. available so that the L.F. amplification could be varied conversely with the strength of the received impulses. By this means not nearly so much variation of H.F. amplification would be necessary and the task of the set designer would not only be easier but the efficiency of his sets would be greater.

### Solution to Major Problem

By virtue of a new arrival in the ranks of double-diode valves—the Cossor D.D. Pen.—variation of L.F. amplification in terms of the received "signal" can now be achieved, and the solution to one of the major problems of powerful set design is obtained.

The new valve is most ingenious, and is the result of a very great deal of research experiment on the part of the Cossor staff,

and it solves the problem beautifully. This you will be able to test to your own satisfaction in the "Double-D. Pen." receiver, of which this is Part I of the description.

The receiver is designed on normal chassis lines, and, taking advantage of the new valve caters for both H.F. and L.F. automatic volume control—a complete departure from previous set designs.

### THE FINAL DESIGN



Above we see a member of the "P.W." Research Staff at work on the chassis layout finally adopted. Two multi-mu S.G. valves are used in this receiver, and these precede a double-diode variable-mu pentode as shown in the basic circuit given below. The output valve is an indirectly-heated pentode capable of delivering over two watts of undistorted energy.

### NEW CIRCUIT WITH NEW PRINCIPLE

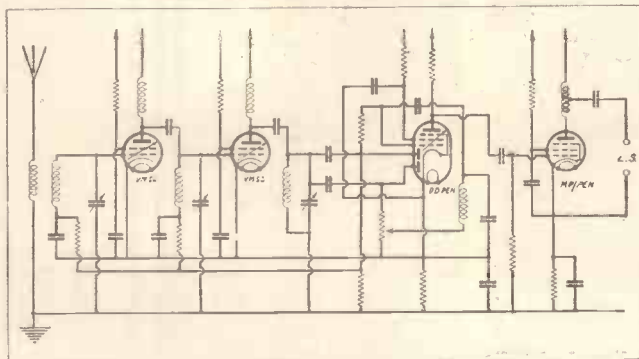

The result is that L.F. overloading is an impossibility, for as soon as the voltage applied to the diode becomes greater than that required to fully load the L.F. stage the amplification of the L.F. side is reduced.

### Tremendous Possibilities.

This is achieved in a most ingenious way, as will be seen from the simplified theoretical diagram of the set. In this diagram, in which the circuit has been shorn of its "frills," such as decoupling of anode circuits, power supply, and so forth, we see that the key valve (the "D.D. Pen.") is a double-diode variable-mu pentode.

We have had double-diode triodes, and rumours of double-diode tetrodes have reached us, but the accomplishment of a double-diode incorporating a variable-mu pentode is something of which we must all "sit up and take notice."

Combined in a circuit such as that of the "Double-D. Pen.," the new Cossor valve offers tremendous possibilities, for efficient delayed automatic volume control on the H.F. side can be combined with delayed A.V.C. on the L.F. side.

Thus overloading of the last valve becomes an impossibility, for a simple pre-set manual control enables the maximum volume to be set to a nicety, any fluctuations being catered for by the variable-mu pentode in the double-diode valve unit.

### Simple But Ingenious.

The manner in which this is achieved is simple but ingenious. The normal split diode scheme is used for rectification and delayed volume control of the H.F. side, but the A.V.C. voltage from the second diode is tapped off and applied to the grid of the pentode as well as to the grids of the H.F. variable-mu valves.

The result is that not only is the bias of the H.F. valves varied in accordance with the incoming "signal" strength, but the

bias of the pentode is also varied. As this is of the variable-mu type, we obtain automatic variation of its amplification powers.

Obviously, then, we need not set our H.F. side so critically and can use "steeper sloped" valves with the possibilities of greater available stage gain, for with the H.F. amplification control backed up with variation of L.F.

(Continued on page 409.)

# ECKERSLEY EXPLAINS-



I KNOW I have written about this before, but I cannot help being continually concerned. The aerial!

Now, the aerial is almost an anachronism. Have I not said, and do I not continually say that in time we shall do away with the aerial altogether?

People will take up wireless relay, others will use tinsel indoor aerials; frame sets and mains aerials will be used more and more. The wireless set of the future will be a box only a few inches cube, and it will emit pleasant sounds. Of course!

But in this year of grace 1933—and a fine Summer day, it is with all the birds oscillating and the earth making a fine contact and the sun a lovely phosphor bronze—I say, in this year of grace, money is not an anachronism. In spite of the fact that in the world of plenty many are half-starved, in spite of the fact that armament firms are declaring dividends over your potentially mangled body, still money is a factor.

And aerials save money—save it for the cinema and to be invested in armaments. Valves cost money—they must, they also create employment. The smaller the aerial the more for a given result the number of valves necessary to pull in those

## OVER 500 FT. HIGH

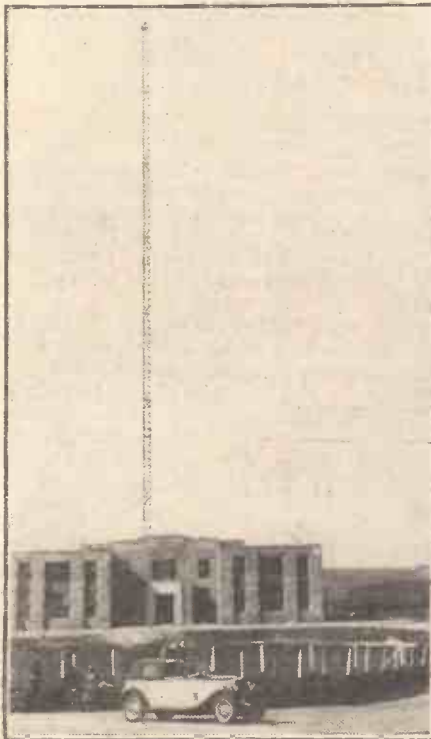

(Photo by E. M. Wright, Salisbury Sq. House, E.C.4. A view of the transmitting house and one of the masts at the West Regional station, near Minehead.

### ABOUT THE AERIAL.

"Aerials save money," says P. P. ECKERSLEY, "P.W.'s" Chief Radio Consultant, in this illuminative article, which is followed by his reply to a reader's question on the use of a safety gap.

ever delightful noises said to be Zphylvseyod in Czechoslovakia.

One valve will hear all Europe if one of its grids is tied on to M. Piccard's balloon and its filament knows something of the wet subsoil. So when R. W. (Maidenhead) says "that he has frequently found that in practically every case where an indoor aerial was used long-wave results were very poor." I agree with him. Why? says R. W., why so good on medium waves and so poor on long? Eckersley explains it this way.

#### Half the Wavelength

In general for really efficient reception the aerial height should approximate to half the wavelength. My room containing my aerial is not 800 metres high. So my aerial is inefficient on long waves. But my room is about 8 feet high and 8 is nearer 15 than 800, anyway.

So my aerial likes the waves to be shorter. So a big aerial pays—oh, but it PAYS. I know it's clumsy, I know it's an anachronism, I know all about that, and if I could buy a really good set I would have a tiny aerial. But I do not want a many-valved set because I cannot feel sure that all these valves are not distorting. I could if I had nursed them from babyhood, but I haven't, so the better the fewer.

I tried a little set the other day—one in which I am very interested. It gives lovely quality and, on a decent aerial, picked up all that was worth the picking. It was brought to my steel-framed flat to be connected to an aerial which has to sneak out of the window and wanders on to the (steel) roof.

I got the Londons all right and Poste Parisien, no long waves except Daventry, and that was that! No! it pays to have a big aerial because I shall have to add another valve to my little set if I want to be amused.

### PROTECTING THE SET BY A SAFETY GAP

P. G. G. (Glasgow).—"I have made up a lightning arrester consisting of two metal strips placed close together, the gap being about equal to the thickness of a visiting card.

"One side of the arrester is joined to the

aerial and the other to earth, as in my diagram (Fig. 1).

"If the aerial becomes charged and the gap sparks across, will this protect the set?"

The circuit you show might have more theoretical than practical value. Think what happens with lightning around. First, when there is a severe electrical storm in the neighbourhood it is possible, if an aerial is insulated, to store a charge in it, when an arrester gap will prevent the voltage of that charge rising above a certain amount. But in your case the aerial cannot become steadily charged because the inductance short circuits the aerial to earth.

On the other hand, when there are electrical storms around, there is frequently lightning. Nearby lightning induces a sudden pulse of voltage in the aerial and this will not be short-circuited to earth by the inductance because the very definition of inductance means that it resists sudden changes of current.

#### Dependent on Circuit

Therefore, this lightning induces a sudden surge in the aerial and raises it perhaps to enormous potentials when the arrester gap, not having inductance, will spark across.

It is common to use the circuit of Fig. 2, when an arrester gap, as shown, has the real purpose of protecting the series condenser C

### IS A GAP ADVISABLE?

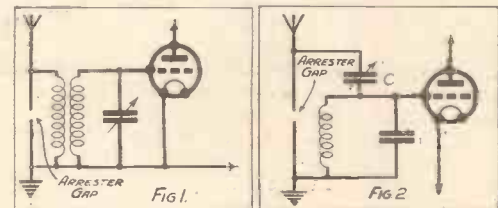

The two arrangements for the gap to which P. P. Eckersley refers above.

from sudden impulsive kicks, as well as from having a static charge established across it greater than a certain amount.

I think that I would not go to the trouble of putting an arrester gap in the circuit that you have shown, I would simply loosen the coupling between the inductances when a storm was about, but I would be inclined to use an arrester gap if I had the circuit shown in Diagram 2. — P. P. E.





# The P.W. CONQUEST

Featuring—  
**"CLASS B"**  
**FERROCART COILS**  
**SHORT-BASE**  
**MULTI-MU**  
**CONTROL**  
**BAND-PASS TUNING**

THIS set was designed specifically for "P.W.'s" anniversary number to symbolise the most modern aspects of present-day radio.

In this very easy-to-build and inexpensive receiver every applicable up-to-the-minute idea is incorporated. Indeed, its specification is most impressive and clearly indicates the great progress made in reception technique during the past year.

**Simple Operation.**

Let us examine its major points of design in detail:

There is band-pass tuning, in which Ferrocart coils figure, for great selectivity and keen ether-piercing qualities. Scores of medium and long-wave stations can be received clearly, and at really good loudspeaker strength.

And by means of a ganged tuning control the operation is considerably simplified.

The variable-mu S.G. valve enables the high amplification to be

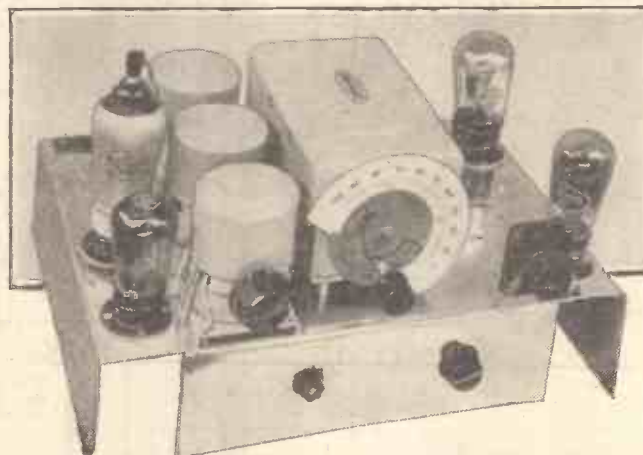
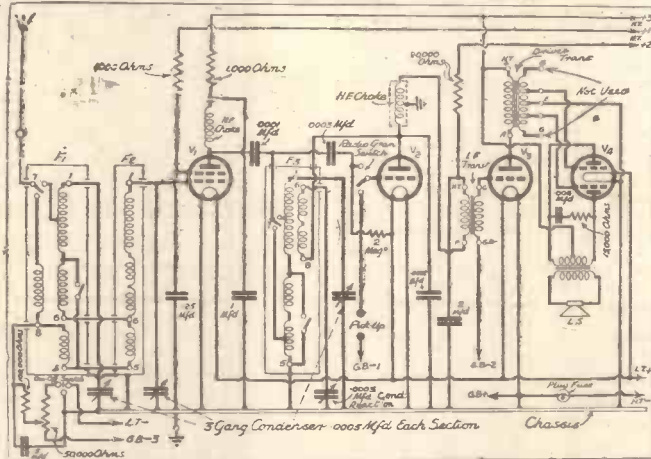

Many new developments are embodied in the circuit, but the completed design is pleasingly free from complication.

Designed and Described by  
**G. V. DOWDING, Assoc.I.E.E.**

Behind the design of this receiver lie eleven years of experience in producing sets for home constructors. For that reason the "P.W. Conquest" represents a real conquest over the difficulties of set-building. Its layout is straightforward, its assembly easy, its results magnificent.

brought under close control so that the volume is adjustable within wide limits.

The actual volume-control incorporates a switching action (a "P.W." idea) with which the set is switched on and off and the grid bias automatically disconnected when it is not needed.

There is a radiogram switch, and "Class B" amplification for a big output with economy, feeding into a moving-coil loudspeaker.

**Entirely Modern.**

Despite all these valuable features and ample decoupling, and so on, the circuit is extraordinarily free from complication.

In regard to the constructional design of the set, the entirely modern note is preserved.

It assumes the consolette form, and the cabinet provides accommodation for the loudspeaker and batteries. As will be observed from the photo, this specially devised cabinet is a very handsome

(Continued on next page.)

## THE SPECIFICATION AND MAKES OF ALL THE COMPONENTS YOU NEED

Component	Make used by designer	Alternative makes of suitable specification recommended by designer	Component	Make used by designer	Alternative makes of suitable specification recommended by designer
1 Cabinet	C.A.C. "Wellington"	—	2 1000-ohm resistances with horizontal holder	Graham Farish "Ohmite"	—
1 Sheet 18-gauge aluminium for chassis, 20 in. x 10 in. This is bent to form base-board 14 in. x 10 in.	—	—	1 15,000-ohm ditto	Graham Farish "Ohmite"	—
1 Sheet ditto 10 in. x 4 in. This is bent to form sub-panel 10 in. x 3 in.	—	—	1 2-mfd. fixed condenser	Dubilier BB	T.C.C., Telsen, Igranic
1 .0005-mfd. triple-gang condenser with right-hand trimmers, cover and disc drive	Radiophone	—	1 2-mfd. fixed condenser	T.C.C. type 50	Dubilier, Telsen, Igranic
1 Set of canned coils	Colvern Ferrocart F.1, F.2, and F.3 Clix	—	1 .5-mfd. fixed condenser	Dubilier 9200	T.C.C., Telsen, Igranic
3 4-pin chassis-mounting valve holders	—	W.B.	1 .25-mfd. fixed condenser	Dubilier type BB	T.C.C., Telsen
1 7-pin chassis valve holder	Clix	—	1 .0003-mfd. fixed condenser	Dubilier type S	Dubilier, Ferranti, Telsen
1 .0003-mfd. reaction condenser	Telsen	Polar, Graham Farish	1 .0001-mfd. fixed condenser	T.C.C. type S	Dubilier, Ferranti, Telsen
1 50,000-ohm potentiometer, with three-point switch	Lewcos	—	1 .0002-mfd. fixed condenser	Dubilier 620	T.C.C. upright
1 Radiogram switch	Bulgin S.86	—	1 .006-mfd. fixed condenser	T.C.C. "M"	Dubilier, Telsen
1 100,000-ohm resistance with horizontal holder	Graham Farish "Ohmite"	—	1 H.F. choke	R.I. "Quada-static"	Wearite, Keystone
1 2-meg. ditto	Graham Farish "Ohmite"	—	1 Screened H.F. choke	Graham Farish H.M.S.	Bulgin
1 20,000-ohm ditto	Graham Farish "Ohmite"	—	1 L.F. transformer	Igranic Midget	—
			1 "Driver" transformer	Varley D.P.40	R.I. D.Y.37
			2 Twin socket strips	Belling-Lee	Bulgin
			4 yds. insulating sleeving	Goltone	Wearite
			6 yds. 18-gauge tinned copper wire	Goltone	Wearite
			1 yd. spiral screened sleeving	Goltone	—
			7 Battery plugs	Clix	Belling-Lee, Igranic, Eelex
			1 Wanderfuse	Belling-Lee	Goltone
			2 Accumulator spades	Clix	Belling-Lee
			Flex, screws, nuts and bolts, etc.	—	—





# LORD KELVIN

It was in a badly lit, disused wine cellar that Kelvin first began his scientific research. Converted into a laboratory, it was here that he made many of his important discoveries, and delivered many of his famous lectures. Whilst still a young man, he enjoyed a reputation that was the envy of many a veteran

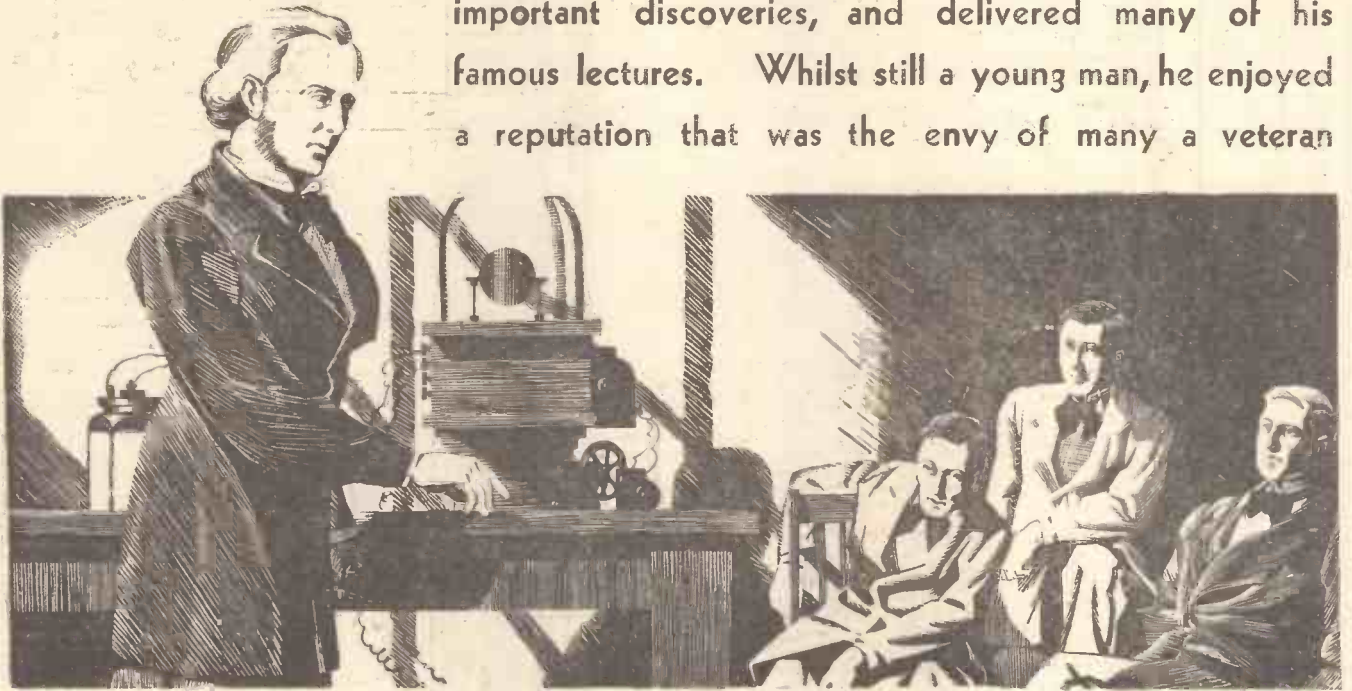

scientist, a reputation that was earned, not by reason of his intellectual gifts alone, but because of his amazing capacity for tireless research.

The same might also be said of the Dubilier Condenser Company. Their present prominent position is due not to resting on laurels won many years ago, but to consistent and untiring research through 21 years of successful trading. The result of this research is seen in the high standard of dependability for which Dubilier Condensers and Resistances are to-day famous the world over.



DUBILIER CONDENSER CO.  
(1925) LTD.,  
DUCON WORKS, VICTORIA RD.,  
NORTH ACTON, W.3

# DUBILIER

## CONDENSERS

# THE "P.W. CONQUEST"

(Continued from previous page.)

Those who do not care to tackle metal-work can, of course, obtain the complete drilled chassis ready for use from such firms as Peto Scott.

In mounting the components, care must be taken to ensure that none of their terminals or other "live" metal parts come into contact with the metal chassis.

The same thing applies to the wiring. But the set has been designed in that only a very few leads actually pass through the baseboard. Even so, all the leads must be adequately insulated.

Don't try to use ordinary cotton-covered wire.

Certain of the leads require to be shielded in addition and these are clearly indicated in the diagrams.

### Screened Wiring.

We are specifying a particular make of spiral screened wire for these because this is particularly easy to handle, especially in regard to its earthing to the points marked.

For the flexibles, employ a rubber-covered wire.

To locate the holes for the controls in the front of the cabinet, remove all the knobs and put a spot of ink on other black marking substance on the ends of the spindles.

Slide the chassis into the cabinet carefully and press it up against the front so that the spindles mark the places where the holes must be.

The reaction condenser can either be temporarily held in place with stiff wire to add to the support afforded by its leads, or its hole located by measurement.

### "Short-Base" Control.

The H.T.'s and G.B.'s will vary slightly with different valves. For example, the Mullard Vari-mu S.G. needs only 4½ volts G.B., while others need 9.

That is because the Mullard P.M.12M. is what is known as a "short base" variable-mu valve. The control of volume from the proverbial "whisper to a shout" is possible with a grid-bias battery no larger than the kind of battery used for pocket lamps.

As you will see, the L.T. and H.T. batteries are accommodated on the shelf,

while there will be plenty of room at the bottom of the cabinet for the grid-bias battery.

It will be advisable to stand the L.T. and H.T. batteries on thick cardboard, or several folds of blotting paper, so that any moisture which might exude from them is absorbed.

Needless to say, the battery leads should be carefully run. Not that there is any danger of instability in this

## NOTHING IS CRAMPED

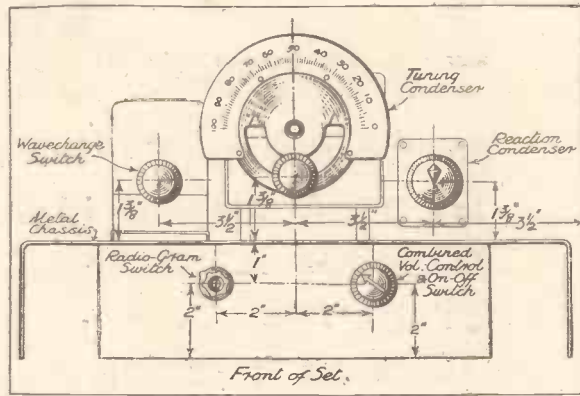
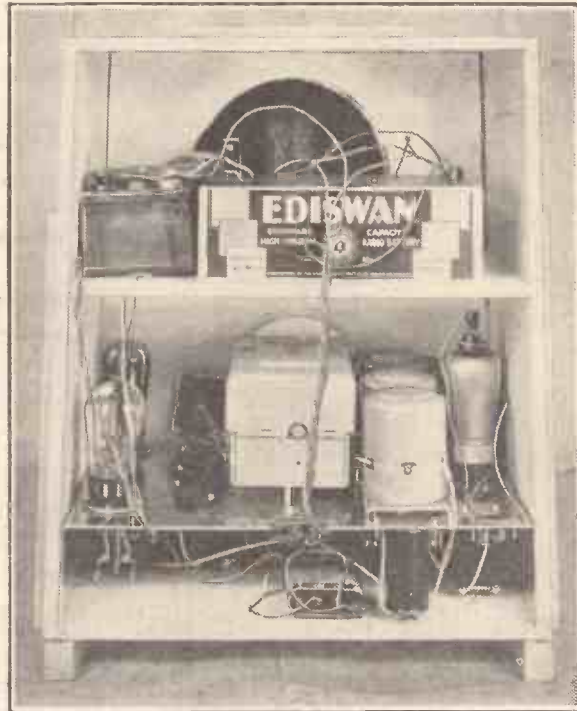

set, but obviously care must be taken that shorting cannot occur.

Don't finally connect up the batteries until the valves are in position; it is particularly important that the lead to the anode terminal of the S.G. valve is securely fixed, and never allowed to hang loose when the H.T. is joined up.

### H.T. and G.B. Values.

Now we have discussed the G.B. for the S.G. valve, and I think there will be just enough space for a brief reference to the other battery adjustments.

Usually 1½ volts for G.B.1 and 4½ volts for G.B.2 will be O.K. And, of course, the "Class B" valve will not need any G.B.

Use the full 120-volts H.T. for H.T. plus 3 and about 90 for H.T. plus 2, and 75 for H.T. plus 1.

You will find many invaluable hints and tips on the adjustment of the gang condenser and the general operation of this magnificent set in our Radiotorial columns.

The disposition of the controls on the front of the set, and the arrangement of the accessories inside the receiver are both seen on this page. The reference letters against holes in the chassis in the diagram below link up with those in the diagram on the previous page.

## ACCESSORIES TO USE

**LOUDSPEAKER.**—Rola "Class B." Type P5 to suit "Class B" valve used (see text).

**BATTERIES.**—120-volts H.T. Ediswan, Siemens, Lissen, Pertrix, Ever Ready, Drydex.

Grid Bias, 4.5 or 9 volts to suit S.G. valve used.—Siemens, Ever Ready, Lissen, Pertrix, Ediswan, Drydex.

L.T. 2 volts.—Exide, Ever Ready, Ediswan, Lissen, Pertrix, Block, Oldham.

**AERIAL AND EARTH EQUIPMENT.**—Goltone "Akrite," Electron "Superial," Radiophone "Receptru" screened down-lead, Graham Farish "Filt" earthing device.

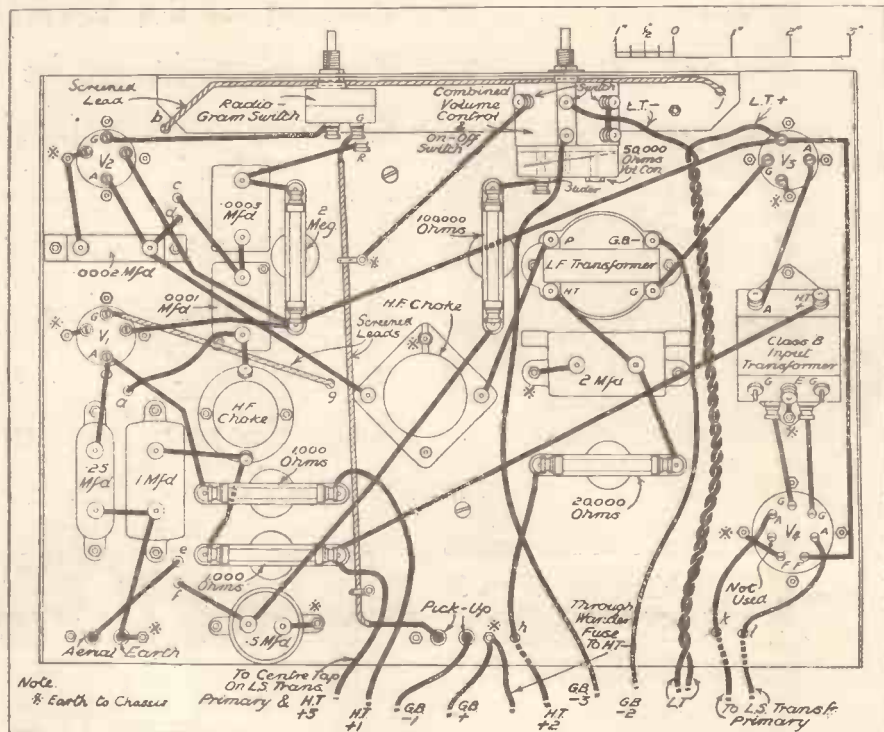



# THE OSRAM 'CATKIN' VALVE

IS A REVOLUTIONARY CHANGE  
IN THE TECHNIQUE OF VALVE  
DESIGN AND CONSTRUCTION.  
IT IS THE COMMENCEMENT OF  
A NEW ERA IN VALVE USAGE

## OSRAM (CATKIN) Valves

FOR A.C. MAINS RECEIVERS

### Metal instead of Glass

Made in England. Covered by World Patents

The characteristics of OSRAM 'CATKIN' VALVES are the same as the glass types they replace, so that they can be utilized in any existing mains sets employing equivalent glass valves. A better all-round performance, however is assured, due to unique features in the

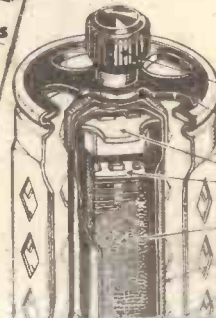

- ANODE TERMINAL DIRECTLY CONNECTED / LOOSE CAP IMPOSSIBLE
- INSULATION BETWEEN ANODE AND SHIELD
- PRECISION INSULATORS LOCKING ELECTRODES
- HEXAGONAL SCREEN GRID
- AIR COOLED ANODE
- CONTROL GRID STRAIGHT WIRE CONSTRUCTION
- METAL ANODE TO GLASS VACUUM TIGHT JOINT
- PRECISION INSULATOR LOCKING ELECTRODES
- FILAMENT CONNECTIONS THE ONLY WELDS IN THE ELECTRODE SUPPORT SYSTEM
- METAL CAPPING SHELL GIVING MINIMUM GRID - ANODE CAPACITY
- RUBBER MOUNTING ANTI - MICROPHONIC
- INSULATED STEEL CLAMP SUPERSEDING DELICATE PINCH OF GLASS VALVE
- GLASS CIRCULAR SEAL GIVING MAXIMUM INSULATION SPACING BETWEEN WIRES
- METAL SHIELD GIVING MECHANICAL PROTECTION AND ELECTRO STATIC SHIELDING

A complete breakaway from the usual method of making wireless valves with a glass bulb has been accomplished by the introduction of the OSRAM 'CATKIN' VALVE. Not only has metal been substituted for glass, but the electrodes have been greatly strengthened by a packed and rigid assembly. Special features of the OSRAM 'CATKIN' valve include

1. FAR GREATER STRENGTH.
2. GREATER UNIFORMITY IN CHARACTERISTICS.
3. FREEDOM FROM MICROPHONICITY.
4. SMALLER SIZE
5. PERFECT SCREENING

# TITUTION

**G**OOD diction, a subtle story and a picturesque setting are first-class ingredients for a rattling good play. But whether the mixture succeeds or fails as a play depends for the rest on its presentation. I don't know how much of the original story of "The Bottle Imp" was used, but I thought the play might have been longer without overshooting the hour mark.

It was woefully slow. It may be characteristic of Pacific Islanders to draw out their words, but is there any need for endless breaks in the continuity of the dialogue? This fault was made even more glaring by the Waikiki boys. There was much too much of them. They could have produced all the atmosphere the producer wanted with a tenth of the music that they would keep on playing.

Despite this drawback, "The Bottle Imp" was something different in the way of radio plays. This alone justified its being put on. I thought there was much to be said for it; judged on its own merits as a play.

It was clear there was to be no mistaken ideas about the reason for the Crook Dramatic Society's production, "A Dose of Physic."

"We represent," we were told in a preamble, "no particular school of dramatic art, nor do we make any contribution to radio drama."

But whatever the purpose (and wasn't it primarily for their own ends in various parts of the country that these Westmorland folk gave this little fragment of Westmorland life?) it was a courageous effort, spoken clearly and decisively, though, perhaps, a little monotonously.

The play opened perfectly, with a flock of sheep to provide the right atmosphere at once. What a pity the farmhouse door was closed so early—the noise they made was very telling. I'm all in favour of giving such opportunities as these to amateur dramatic societies. Go on with the good work, Mr. Filson Young. You never know what talent you may discover in your guest.

Neither of these plays, however, pleased me so

## THE LISTENER'S NOTEBOOK

Topical jottings on radio programmes and personalities.

much as "Tickets Please" did, although this was quite a different sort of thing.

A musical friend of mine who heard this broadcast confessed that although it was bad music, it was, nevertheless, good bad music. It is extraordinary how really musical folk refuse to see any virtue in this sort of stuff.

Well, it's good enough for me, particularly when the melody is good. And Mr. Hill can number me among his followers.

But the book was feeble. Leonard Henry hadn't a good line to say from start to finish. Yet he managed to be as fizzy as ever, and to make himself indispensable. The cast was adequate, although the policeman at times seemed on the point of petering out altogether. I couldn't quite "get" the interpretation of the part. By the way, it's funny how popular wayside railway stations are just now in radio sketches.

Mr. Cecil Lewis, though interesting, hasn't altogether fulfilled the promise he showed in his first talk on Picture-making. The fact is, he has become too technical.

His "Extract of a Script," for instance, was much too long. A writer for the pictures may have enjoyed it all, but the ordinary picture-goer would have been satisfied with a good deal less technical detail.

Though I always listen-in according to plan, two chance items have pleased me no end. Both were

meant for children, incidentally. I switched on one afternoon to hear a terrible moaning noise not usually associated with broadcasting. It proved to be M. Stéphan playing the part of a *vieu*—the cow's little one, as he called it afterwards.

Yes, M. Stéphan is a great actor! He sings, too. How children must love him! And what about little André, his assistant? Isn't he just sweet with his "Oui, monsieur" and his "Non, monsieur"?

The other turn was the children's half-hour at the Zoo. I should think the B.B.C. were very satisfied with this broadcast.

Everything came off. Not one of the animals or birds turned shy or obstinate. Without exception, they all did their bit with the confidence of an expert broadcaster.

The keepers, too, were good, especially the cockatoo's. I must say that bird does him credit. What a marvellous kiss of his that is! How well it came over the air!

I'm sure that Zoo broadcasts—if the same standard of excellence could be reached again—wouldn't disgrace an adult programme.

More than one listener will be pleased now that the White Coons have begun another series of concerts. I am certain that when they sing in their opening chorus, "We'll cheer you up and make your life worth living," they mean it.

Stanley Holloway, to mention but one of the party, is a real tonic, and his Buckingham Palace do is a rare treat. The White Coons are ideal for a Saturday night in spring, summer, autumn or winter.

Outside Broadcasts will soon be coming along fast and furious. The list, as usual, is a pretty long one, but I still think it could be longer.

The "transmission of actualities," as these outside broadcasts have been aptly called, is, to my mind, one of the biggest things broadcasting has achieved, because it satisfies a want inherent in every man alive.

## LAST WEEKS OF "RADIO-PICS"

ALL-CASH  
FIRST PRIZE!

£25

AND

50

WIRELESS  
"EXTRAS"  
For Runners-Up.

The Consolation Prizes will all be very useful to set builders as they include:  
Loudspeakers—Canged Condensers—Coil Units—"Class B" Transformers, etc.

£25 cash is the First Prize in this fascinating, free radio competition; while for runners-up there are fifty valuable wireless components.

All you have to do to enter and try for a prize is to solve six sets of easy puzzle-pictures—all of which denote the names of wireless stations at home and abroad. The first three sets have already appeared—but you can still obtain them if you ask your newsagent for the three previous issues of "P.W." (dated May 13th, 20th, and 27th) in which they appear. Here you have this week's puzzles—the Fourth Set to solve—each picture representing one station name. The answers are all quite easy to find, and, as a further guide, all Set-4 solutions are contained in the short "key" list below—thus it is merely a matter of fitting the right stations to the right pictures.

Write the answers IN INK (and in BLOCK LETTERS) in the spaces provided; then cut out the picture-set and keep it until next week, when we shall publish six more of these entertaining puzzles. Each set has its own "key" list, and in the Sixth and Final Week full sending-in directions will be given. The competition rules have already appeared and will be reprinted later.

### "RADIO-PICS"

#### SET 4

As for the purposes of the competition, wireless stations all over the world are being used, the following short guide list of names is given for reference with this week's pictures:

- WASHINGTON
- HAVANA
- KIEL
- GLASGOW
- BROOKLYN
- DAVENTRY
- LONG BEACH
- ATLANTIC CITY
- MONTREAL
- STUTTGART
- BUTTE
- ATHLONE
- PULLMAN
- BAY CITY
- SEVILLE

EASY COMPETITION—PRIZES MUST BE WON—NOTHING TO PAY!



# SHORT-WAVE NOTES

BY W. L. S.

All the interesting news and views of current short-wave practice.

ONE or two readers have written to me to say that though they have "qualified for H.A.C.," they have received no diploma! Let me make it clear that we are not (as yet) issuing certificates. There is no reward attached to the feat of "hearing all continents" except the pleasant glow of satisfaction that results from the achievement.

I am trying to think of a more up-to-date test of reasonable severity to take the place of this "H.A.C." business, which is far too easy nowadays. How many listeners, for instance, can claim to have heard short-wave broadcast from more than thirty different countries? For those who listen to amateur signals 100 countries is an easily possible figure. So far as I can calculate from my own log, I have heard "hams" in 132 countries to date.

### End of World Tour.

E. S. (Dundee) gladdens my heart with a letter commencing "I am writing these few lines to let you know the excellent conditions in our locality for short-wave reception." In these days, when four letters out of every five that I receive contain a moan about the poor locality in which the writer lives, such a letter as this is like an oasis in the dismal desert.

The "S.G. Four" that I alluded to recently as going on a world tour, has just about returned to this country by now.

## A WARNING LIGHT

A good many people use an indirectly-heated valve nowadays for a short-wave detector, and sometimes supply the filament current of 1 amp. from an accumulator. In this case it is often worth while to wire up a small pilot lamp on the panel; leaving a set running is not a serious matter with the ordinary dull-emitter, directly-heated valve, but a drain of 1 amp. on an accumulator for a whole night and perhaps the following day is apt to be expensive!

When an illuminated dial is used, this should always be arranged so that, instead of having a separate switch for the bulb, it acts as a "telltale" for the L.T.

### HOW TO WIRE IT

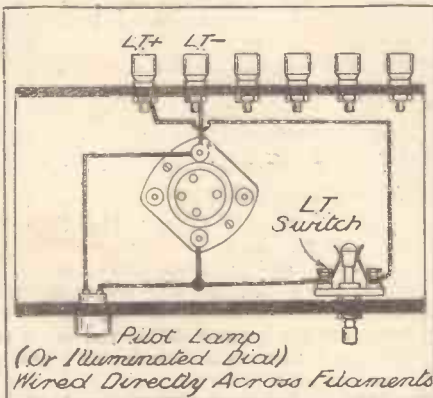

The easily-fitted wiring for the warning light, which W. L. S. recommends.

My last letter was from Monte Video, after the rounding of Cape Horn.

W. G. W., the operator, seems to have logged the various Empire stations in nearly every corner of the world. He heard the boat-rate commentary from the South African Zone transmission, while in the South Pacific (apparently after the "beam" had gone right across the South Pole!), and in the South Atlantic the West African broadcast has been good.

### Portable Short-Wavers.

These thrilling exploits put the thought into my head that not nearly enough is done with portable short-wavers. One can generally receive things out in the open country at better strength than in town; and it should be interesting to take a really portable set on a hike, even if one went no further than the Surrey hills or the Chilterns.

My own adventures with "Buzz" in North Wales last year were interesting, but it was not a really portable set, and could not be taken far off the roads. I am setting about the design of a vest-pocket single-valver forthwith!

Reverting to the "H.A.C." business, R. W. R. (Southport) remarks that he doesn't see how anyone with the least idea of how to manipulate a short-wave set can fail to hear 'em all within a very short time. Needless to say, he becomes a member himself.

### Our Crystal Palace Tests.

Well, the "Crystal Palace" tests are all over bar the shouting, and very fine business they appear to have been. All concerned in them agree that the whole affair was very thrilling—even the "hike" up 400 steep stairs, carrying various heavy and knobbly bits of gear!

130 miles strikes me as very good going for low power. It is definitely a world's record for 10 watts. Unfortunately, owing to lack of petrol, the plane had to turn back at that distance. The operator says he is certain that they could have gone on twice as far without much of a drop in signal strength.

### Future Developments.

These tests have shown conclusively that there is a commercial future for ultra-short waves as a means for plane-to-ground communication. Just watch for the next development!

## THE A.C. "AIRSPRITE" IS MARVELLOUS!

Enthusiastic praise from a reader who thanks "P.W." for a good design and helpful assistance.

The Editor, POPULAR WIRELESS.

Dear Sir.—I wrote to you concerning a few technical details re the A.C. "Airsprite," and the help you gave me was above all my expectations. And the results—Marvellous! Great! Powerful!

I called in a few of my radio friends, and were they stunned? Why, they were astonished.

A.T.B. and How. Listen! Perhaps I've gone too far with the bouquets, but I can't help it. Why couldn't you have christened it "H.A.C."?

Well, good luck to you, "P.W.," and your technical service—the father to all constructors.

Yours, Now a Regular Reader, C. SEARRY.

53, Kiekhams Road, Ichicore, Dublin, I.F.S.



Weekly jottings of interest to buyers.

OUT of fairness to all those readers who wrote in so promptly for their names to be entered on the "Catkin" radio literature waiting list, I feel compelled to announce a closing date. Any applications received after the first post on Monday morning, June 5th, will, therefore, be entered on a second list which I propose to open.

Meanwhile, there is still time for you to get your name on the first list if you send off a postcard without delay. Just mark it "Catkin" literature, and send it with your name and address to me at Tallis House, Tallis Street, London, E.C.4.

### Cossor and "Class B."

Well to the fore, as usual, Messrs. A. C. Cossor has just produced an artistic brochure on the subject of "Class B" amplification which does them credit.

It is easy enough for any technically-minded person to give an explanation of the new system in his own words, but to make it so that it can be understood by anyone is quite a different proposition! The technical staff of Messrs. Cossor seem

### OUR POSTCARD SERVICE

Applications for trade literature mentioned in these columns can be made through "P.W." by quoting the reference number given at the end of the paragraph. Just send a postcard to G. T. Kelsey at Tallis House, Tallis Street, E.C.4. Any literature described during the past four weeks may be applied for in this way—just quote the number or numbers.

to have acquired that happy knack of saying technical things without getting academical about it.

Believing that there are probably many readers of "P.W." who would like a copy of this new Cossor publication, I propose to make it available through our postcard service. The interest in "Class B" generally most definitely appears to be on the increase, and the Cossor brochure could not have been produced at a better time. (No. 38)

### Speakers of Merit.

"A good speaker should have no tone; that is to say it should reproduce the original, neither adding to it nor subtracting from it in any way."

I quote these words of wisdom from a booklet that has just reached me relative to the famous Ferranti range of moving-coil loudspeakers. And to think that there are still people—not in the ranks of "P.W.ites," thank goodness—who like a particular speaker because of its "nice mellow tone"! Gr-r-r-r!

The truth of the matter is that a year or, so ago, sets themselves were, comparatively

(Continued on page 410.)



# CHOOSING WAVELENGTHS AT THE LUCERNE CONFERENCE.

By A. A. GULLILAND.

Europe's wavelengths are being radically altered at Lucerne, and below is some first-hand information by P.W.'s Special Correspondent on the spot.

AS I sit writing this in my room looking out on to the sun-steeped lake of the four cantons at Lucerne, the great European wavelengths distribution has just begun.

A few hours ago I stood in the hall of the Hotel National and stopped delegates as they passed to and from meetings and asked them for their views on the conference. Readers, of course, will remember that the press, even the technical press, have been excluded from the meetings and also from gatherings not connected with the work.

The delegates therefore look on the journalist as a somewhat unknown quantity. They perhaps might like to say a lot, but there are the restrictions of the rules of the conference and so they kind of look over their shoulders to see if anyone is watching them talking to the journalist, hastily say a few words, and pass on.

Well, here is the result of my hours of vigil in the hall:

## Portuguese Difficulties.

M. Caillaux, chief delegate of France (after the departure yesterday of the doyen), said that the French delegation had come with the full intention of having everything finished by Whit Sunday.

"We have come," said M. Caillaux, "to arrive at a new wave-plan. At Madrid we discussed the general basic principles, here we want to put them into practice. We have the goodwill to co-operate with all the others."

Mr. Philipps, chief of the British delegation, shook his head and said: "If I were at home—but here we are bound by the rules of the conference."

Mr. Pirès, the head of the Portuguese delegates, pointed out to me the difficulties of countries in the same position as Portugal. "You see," he said, "we have only just passed the laws regulating broadcasting in our country.

"We have a twenty-kilowatt station under construction at Lisbon; this will be opened together with the new studio building on October 5th, 1933, the day of our National Fête. We have also a short-wave station under construction for broadcasting to our colonies and to the South American States speaking our language. This will be completed by January 1st, 1934.

## Satisfying the Listeners.

"Then we require a national station close to Oporto to satisfy the needs of our listeners. But this station is only about to be ordered.

"Here we are at Lucerne and have to defend our interests against those of countries which have had organised broadcasting services for the last ten years. We need radio just as much as they, but we are only just starting. We have well over 30,000 listeners, and already they clamour for a good service."

Mr. Ishan Cemal, the chief delegate of the Turkish delegation, told me that he was unable to tell me his hopes of the Lucerne conference. He pointed out that Turkey would shortly open a 100-kilowatt station at Ankara, the new capital of Turkey, and that the number of listeners in Turkey was at present estimated at 35,000. He was sure that the conference would be a success and expressed his delight at the hospitality of the Swiss government.

## Speaking the Same Language!

Ministerialdirektor Giess, head of the German delegation, said: "You see, we, engineers and technicians, have come here to discuss technical questions. We all speak the same language, that of curves and figures, which is a great help.

"I am the president of the committee which has the most difficult task—that of actually building the wave-plan. I have at least one consolation in that arduous task—politics are not with us here.

"We will discuss our difficulties openly as one man to another, and I sincerely hope that we will be able to terminate our work

## REPRESENTING GREAT BRITAIN



Mr. Noel Ashbridge (centre), the Chief Engineer of the B.B.C., is Britain's technical representative at Lucerne.

by Whit Sunday. It will mean hard work and long meetings, from morning till evening, but we are not afraid of that."

Professor Hirschfeld, the head of the Russian delegation, very kindly explained to me the difficulties of his position. "You see, we were not invited to Washington in 1927 and that was a great pity.

"We have loyally co-operated with the U.I.R. since 1927 or even earlier. We changed the wavelength of our station Leningrad from 1,000 metres to 857 metres just because this station was interfering with the air services of other countries.

## Willing to Co-operate.

"We realise that it is a difficult matter to fit our independent system of wave distribution into the system adopted at Washington and re-adopted at Madrid. We are willing to co-operate as much as

possible as we wish to live in peace with the world, and you can rest assured that we will do all in our power to unite our different technical basic principles with those of the rest of Europe."

## None Too Easy.

Mr. Keller, the vice-president of the conference, and the head of the Swiss radio department, the second in command of the Swiss delegation and general organiser of the conference, pointed out to me that the Swiss position was none too easy. Switzerland had three official languages, it therefore required at least three exclusive waves. He hoped that the conference would be short and successful.

Mr. Jaacques, of Luxembourg, the director of the postal services there, pointed out the very novelty of the suggestion made by his delegation: To arrange for an international station at Luxembourg. He hoped he and his colleagues would be successful.

## FOR THE STUDENT AND EXPERIMENTER

A REVISED "MORECROFT."

IF there is one thing that no radio experimenter or craftsman should be without, that is a comprehensive, authoritative and thoroughly up-to-date book covering all aspects of radio reception and transmission.

There are very few of these in existence, although there is no shortage of scrappy, inadequate works of a purely superficial character.

But these are not the serious works of reference such as the investigating amateur or the service man needs in his endeavours to further his knowledge of the laws and fundamentals of wireless.

Fortunately, there are a few books of

that calibre if you know where to look for them. And "Principles of Radio Communication," by J. H. Morecroft, assisted by A. Pinto and W. A. Curry, is a pre-eminent example.

The third edition, thoroughly revised, has just been published in this country by Chapman and Hall, and the price is 46/6.

## A Comprehensive Treatise.

A stiff price, certainly, but there are 1,084 pages illustrated by over a thousand diagrams and photos. That it is an American book in no way affects the great bulk of its contents so far as British students are concerned, for American and British technique is tending to grow less and less diversified.

And no American "fan" regards himself as completely equipped if he hasn't got a "Morecroft"!



# A GREAT STEP FORWARD AUTOMATIC VOLUME CONTROL

Inventor: F PLEW. Patent Pending No. 13651/33.

BATTERY & MAINS (A.C. & D.C.) USERS can now fit A.V.C. without the slightest difficulty to any existing set having one or more stages of H.F. or I.F.

## ELIMINATES FADING OVERLOADING & DISTORTION.

Brings in Home or Foreign Stations at the same volume.

## NO SPECIAL VALVE REQUIRED

SEND for complete UNIT, together with full explanatory and wiring diagrams.

**Price 10/-** Post Free U.K. and Northern Ireland.

*Cheques and Postal Orders should be crossed to*

### PHASODYNE RADIO Co.,

Radio Manufacturers,

22, George Street, Hanover Square, London, W.1.

Phone: MAYFAIR 5742.

*Trade Enquiries to:*

R. F. PAYNE-GALLWEY, 53, Haymarket, S.W.1. Whitehall 1922.

# IGRANIC MIDGET TRANSFORMER SPECIFIED FOR THE "CONQUEST"



## IGRANIC MIDGET TRANSFORMER

It is not surprising that the designer of the "Conquest" should have specified the Igranic Midget Transformer. Igranic have specialised in Transformer manufacture since radio began, and years of experience and research have led to the production of the "Midget" Transformer—unsurpassed for quality and performance. This wonderful Transformer renders the highest standard of tonal purity without a trace of "drumming." Its reproduction reaches a standard never previously attained by a Transformer of such reasonable price. Supplied in ratios 3-1 and 5-1. Price **10/6**



Write for fully illustrated Catalogue No. R.202 of Igranic Quality Components.

Igranic Electric Co., Ltd.,  
149, Queen Victoria St., E.C.4

## IGRANIC COMPONENTS WILL BE THE MAKING OF YOUR SET

Player's  
Please  
Everybody





# RADIO SIMPLIFIED

## A PRACTICAL OUTLINE for BEGINNERS

**I**N the article on Parallel-Feed in last week's issue we dealt with L.F., but the method can be applied to high-frequency as well as low-frequency circuits. In fact it is probably true to say that seventy-five per cent of the S.G. circuits in use at the present time are parallel-fed.

There are various methods of coupling H.F. circuits together. For example, one can employ untuned couplings, such as simply connecting a choke or resistance in the anode circuit of the S.G. valve and joining this direct to the grid of the succeeding valve via a small coupling condenser.

### H.F. Coupling.

An arrangement of this type is, however, unselective and incapable of giving sufficient amplification to make the use of the S.G. stage worth while. Then there are the two fundamental methods of tuned H.F. coupling.

The first of these is the tuned anode, in which the tuning coil and its condenser are connected directly in the anode circuit of the valve, both sides of the tuning condenser being sometimes at an H.F. potential to earth, and therefore capable of giving rise to hand-capacity effects.

Alternative methods of joining the tuning condenser have been adopted to overcome this and to enable the moving vanes to be connected to the "earth line" so that the spindle and metal frame of the condenser are at earth potential.

### Good Amplification.

From the point of view of amplification the tuned anode is the most satisfactory of all the schemes, but it has the drawback of requiring very careful screening and decoupling if full advantage is to be taken of this feature. The other

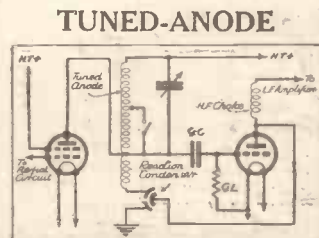

With the ordinary tuned-anode scheme, the moving vanes of the tuning condenser are not joined directly to the "earth line," and the steady anode current flows through the coil windings.

system, in which a tuned transformer is employed, is also a good one provided the transformer is designed for the job.

For instance, the primary winding must be properly proportioned so as to meet the amplifi-

cation and selectivity demands of the circuit arrangement. Used correctly, the tuned transformer has much in its favour.

There are, however, certain benefits to be derived from arranging the H.F. coupling circuit so that it is called upon to deal only with H.F., the D.C. from the high-tension supply being deflected from the tuning coil windings.

This method, known as parallel- or shunt-feed, makes use of an H.F. choke and a coupling condenser in addition to the tuning coil and its condenser.

The choke is connected in series between the anode of the S.G. valve and the H.T. supply, the steady anode current thus passing through the choke winding and maintaining the valve in its normal operating condition.

The choke, although readily permitting the flow of the steady anode current—provided its resistance is reasonably low—acts as a barrier to the amplified H.F. impulses at the S.G. anode, which are compelled to take an alternative path.

This path is via a coupling condenser to the tuning coil and its associated condenser, which thus have to deal only with the amplified H.F. impulses. It is, of course, unnecessary to explain that the steady anode current is unable to flow through

the coupling condenser, which, incidentally, must be of good quality since it has to resist the full H.T. voltage applied to the anode of the valve.

The value of the coupling condenser is not critical within the

limits of say, .0003 mfd. and .005 mfd. Too small a value will produce an appreciable loss of H.F. voltage and so weaken reception, although for short-wave work where the frequency is very high the value may be reduced considerably without detriment and often with advantage.

One point that needs care in all shunt-fed H.F. circuits is the type of H.F. choke employed.

This component must act as an effective barrier to H.F. over the whole of the band of wavelengths the set is designed to cover.

A high inductance value is a necessity and a low distributed capacity desirable. Moreover, a choke, since it is an inductive winding, has a magnetic field, and the modern tendency is to endeavour to keep this field down to a minimum. The binocular method of winding in which the choke is split into two sections, arranged so that their external fields nullify each other, is often used. Metal screening also has its adherents, but both schemes require more turns for a given inductance than a straight layer winding, and with the screened type great care must be taken to obviate losses due to eddy currents in the metal shield.

Avoiding "Shorts." Parallel-feed H.F. coupling can result in a definite loss of amplification when compared

with other efficient methods unless the choke is a really good one.

Provided this important component is up to its work shunt-feeding tends to simplify design and is stable.

A shunt-feed circuit has one advantage, and that is that an accidental "short" between the coil winding and the earthed "can" will not cause damage since, unlike the tuned anode, the coil is isolated from the H.T. supply.

### Output Filters

Reverting to the low-frequency side of the set, there is another type of parallel-feed circuit that we should mention, and that is the output filter.

In this case we have an iron-core choke connected in series between the anode of the output valve and the H.T. supply. Then between the anode of the valve and one terminal of the loudspeaker is joined a large condenser, the other loudspeaker terminal being connected to the "earth-line" of the set.

The steady anode current, therefore, flows through the choke winding, but the L.F. impulses are deflected and pass into the loudspeaker circuit via the large condenser.

### Suitable Values.

Hence the speaker is called upon to deal only with the actual speech and music impulses, and is not concerned with the steady anode current, a fact that is often of considerable importance from the standpoint of reproduction. Suitable values for the output choke and condenser are 20 henries and 2-mfd. respectively, although for pentodes the choke value may, with advantage, be increased.

## MORE ABOUT PARALLEL-FEED

and selectivity demands of the circuit arrangement. Used correctly, the tuned transformer has much in its favour.

There are, however, certain benefits to be derived from arranging the H.F. coupling circuit so that it is called upon to deal only with H.F., the D.C. from the high-tension supply being deflected from the tuning coil windings.

This method, known as parallel- or shunt-feed, makes use of an H.F. choke and a coupling condenser in addition to the tuning coil and its condenser.

The choke is connected in series between the anode of the S.G. valve and the H.T. supply, the steady anode current thus passing through the choke winding and maintaining the valve in its normal operating condition.

The choke, although readily permitting the flow of the steady anode current—provided its resistance is reasonably low—acts as a barrier to the amplified H.F. impulses at the S.G. anode, which are compelled to take an alternative path.

This path is via a coupling condenser to the tuning coil and its associated condenser, which thus have to deal only with the amplified H.F. impulses. It is, of course, unnecessary to explain that the steady anode current is unable to flow through

the coupling condenser, which, incidentally, must be of good quality since it has to resist the full H.T. voltage applied to the anode of the valve.

The value of the coupling condenser is not critical within the

limits of say, .0003 mfd. and .005 mfd. Too small a value will produce an appreciable loss of H.F. voltage and so weaken reception, although for short-wave work where the frequency is very high the value may be reduced considerably without detriment and often with advantage.

One point that needs care in all shunt-fed H.F. circuits is the type of H.F. choke employed. This component must act as an effective barrier to H.F. over the whole of the band of wavelengths the set is designed to cover. A high inductance value is a necessity and a low distributed capacity desirable. Moreover, a choke, since it is an inductive winding, has a magnetic field, and the modern tendency is to endeavour to keep this field down to a minimum. The binocular method of winding in which the choke is split into two sections, arranged so that their external fields nullify each other, is often used. Metal screening also has its adherents, but both schemes require more turns for a given inductance than a straight layer winding, and with the screened type great care must be taken to obviate losses due to eddy currents in the metal shield.

Avoiding "Shorts." Parallel-feed H.F. coupling can result in a definite loss of amplification when compared

### HOW IT WORKS

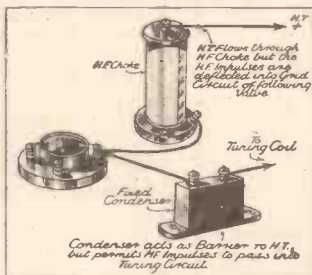

Here we see how the H.F. choke and coupling condensers are arranged so that the steady H.T. current does not flow through the tuning-coil windings. Only good mica dielectric condensers should be used in these circuits, a suitable value being .0003 mfd.

## PARALLEL-FEED

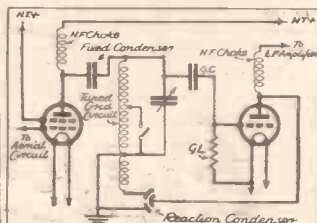

In this case the tuning coil is shunt fed and the moving vanes of the condenser go to earth. No H.T. can flow through the coil windings, since the fixed condenser will only permit H.F. impulses to pass.



# ROLA

*the World's Finest Reproducers*

The Following

**ROLA Speakers**

are Solely Recommended for the

"POPULAR WIRELESS"

**CONQUEST Class B Receiver**

CLASS B VALVE	ROLA MODEL
Mullard PM2B .. ..	F5-PM-12-Class B
Cossor 240B .. ..	F5-PM-14-Class B
B.T.H. PD220 .. ..	F5-PM-12-Class B

Price (All above Models) 32/6

Write to-day for the Rola Folder.

**THE BRITISH ROLA CO., LTD.,**  
Minerva Road, Park Royal, N.W.10

\*Phone: Willesden 4322-3-4-5

**ROLA SPEAKERS**  
for better Radio Reception

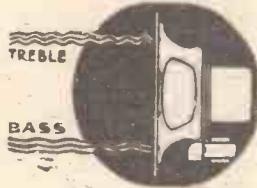

## RECEPTRU

eliminates

**CRACKLE, BACKGROUND, MUSH AND ALL MAN-MADE STATIC**

95% of so called "atmospherics" is actually caused by local electrical machinery such as vacuum cleaners, flashing signs, trains, trams, etc. RECEPTRU, the new screened low loss lead in cable, definitely eliminates all these unwanted noises. It traps them before reaching the receiver and drains them to earth. Reception is tremendously improved, selectivity and sensitivity increased. Any set user can fit Receptru in a few minutes. Get one to-day from your dealer. If any difficulty send P.O. for 10/- and we will supply post free by return.

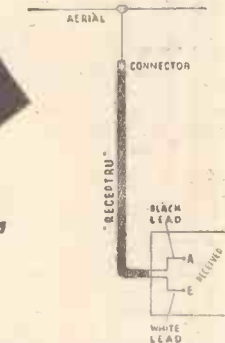

Price (15 feet length) **10/-**  
Longer sizes at proportionate prices.

Specified for F.W. "CONQUEST" Radiophone 3 gang condenser Type 344J with cover and disc drive. Price 33/-  
**RECEPTRU** screened lead in Price 10/-

## RECEPTRU FOR TRUE RECEPTION

BRITISH RADIOPHONE LTD.  
Aldwych House, Aldwych, London, W.C.2  
Telephone: Holborn, 6744.

# NICORE TUNING COILS



B.P. 30—Aerial or Tuned Grid with Reaction, 10/6  
B.P. 31—H.F. Inter-valve Transformer with Reaction, 10/6  
Set of 3 ganged together, 33/-

Varley again! Leaders in the new tuning technique as in the old. . . . The release of Varley NICORE Coils marks the biggest advance in radio tuning since the introduction of Square Peak Coils.

Consistency has been the great aim, and has been attained with an even greater efficiency than was thought possible. Selectivity, with these new Varley coils, is a maximum.

The use of powdered metal cores is not new to Varley. As far back as 1926 Varley produced some Constant Inductance Chokes with iron powdered cores. Varley NICORE Coils are an outstanding result of years of research.

# Varley

FOREMOST AS PIONEERS

Advt. of Oliver Pell Control Ltd., Kingsway House, 103, Kingsway, London, W.C.2.

Special Beginners' Supplement—Page 2.

WHEN discussing graphs in a recent article in this series, it was emphasised that they are not only easy to make, but they are really interesting and useful as well.

There is no better illustration of this than the construction—of "plotting"—of a tuning curve.

The object of this kind of graph is to show, in correct relationship, all the dial readings of the set and the wavelength to which each corresponds. The wavelengths of the various stations being known or easily ascertainable from a list of European stations, the set-owner who has made a curve of this kind knows definitely the whole truth about his set's tuning range.

**A Complete Key.**

From the lowest reading to the highest, the curve gives a complete key to the set's tuning adjustment. And every station that is tuned helps to identify any unknown stations which may be received from time to time.

**THE GROUNDWORK OF THE GRAPH**

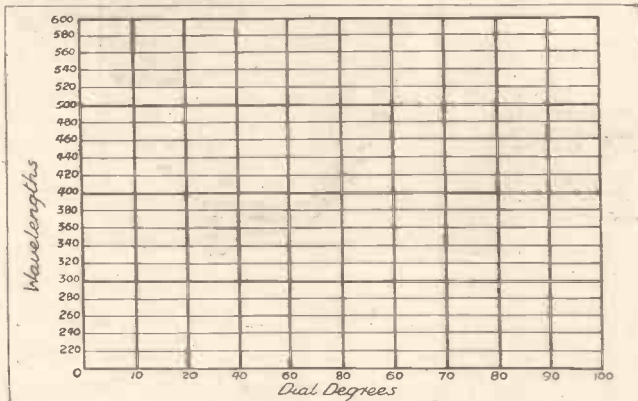

The first step is to mark two scales on squared paper, one showing dial degrees and the other the wavelengths, as shown. (The smaller lines of the squared paper are not reproduced, for the sake of clearness.)

As explained in the previous article, the two factors that are to be related in a graph are recorded on scales which are placed at right-angles to one another, and then the curve itself is made, traversing the common ground, and relating both scales simultaneously.

To make such a tuning chart we need a sheet or two of "squared" or "graph" paper, a pencil, rubber, ruler, and a list of stations showing their wavelengths. That is all.

**The First Step.**

Along the bottom of a piece of the graph paper we first rule off a scale representing the degrees on the tuning dial. In the example given we have assumed the scale to be one ranging from 0 to 100, but of course any other scale can be represented.

Note that for accuracy's sake it is better to draw a really big tuning curve at first, preferably

with one line of the graph paper for every degree of the dial. But if this is impracticable, a one-line division can stand for two degrees on the dial—in fact, so long as the scale is regular, it can be extended or compressed as necessary.

When the base line has been marked off to represent the number of degrees on the dial, a



vertical line is drawn, to the left, and this is marked off in wavelengths.

If we are making a long-wave curve the scale will be from 1,000 to 2,000 metres. If it is the medium waves we are plotting, the limits are between 200 and 600 metres. On many sets it is unnecessary to take the scale as low as 200 or as high as

are 239, 261.6, 288.5, 356, 398.9, and 480 metres.

Commencing with Nurnberg, its 10 degrees are related to its 239 metres by placing a dot on the 10 line a fraction below the 240-metre line, to represent 239. And so with the other stations, each dot being placed carefully at the intersection of the two lines appropriate to it.

Only half a dozen stations have been indicated on the diagram on this page, but it is advantageous to have as many dots as possible to guide in drawing in the curve, so if more than six accurately known dial-readings are available, they should all be dotted in.

When all the known stations have been represented in this way by accurately placed dots, these latter should be lightly joined together by a pencilled line, which is our tuning curve.

Its shape and slope will, of course, depend upon the position of the dots, and although it will not be perfectly straight, as if drawn by a ruler, it should nevertheless be without humps or kinks—a gentle, sweeping curve.

**Manifold Uses.**

If one of the stations does NOT lie in line with the others, we can be sure that something is wrong. Either it is working off its proper wavelength, or else the dial reading is inaccurate.

Once the line has been pencilled in its uses are manifold. If,

The Poste Parisien station works on 328.2 metres, so we can lightly mark the tuning curve at a point slightly above the 328-metre line; and looking down from that point we see this corresponds with a dial-reading of approximately 48 degrees.

By turning the dial to this reading we can be sure that the tuning dial is correctly adjusted for Poste Parisien.

**Easily Identified.**

Similarly, we can identify any unknown station which is picked up, merely by its dial-reading. If, for instance, we pick up a German programme at about 28 degrees on the dial, we may find on looking at the wavelength scale that this corresponds with 276.5 metres. As Heilsberg, the East Prussian Regional, works upon this wavelength, obviously our previously unknown German is proved to be Heilsberg.

It is, of course, important to place the dots accurately. And for this reason, it is generally better to choose the second dial of a two-dial set, in preference to the first, because the latter's readings are often affected slightly by selectivity adjustments, or are "flatter."

**Two at Once.**

If desired, two charts can be drawn upon the same piece of graph paper. For example, we could also have shown the wavelengths between 1,000 and 2,000 metres, at the right-hand side of the diagram and then have drawn in a second curve for long waves accordingly.

This and many other variations can be tried, and it is safe to say that virtually everyone who has drawn up a tuning

**LINKING STATIONS TO DIAL DEGREES**

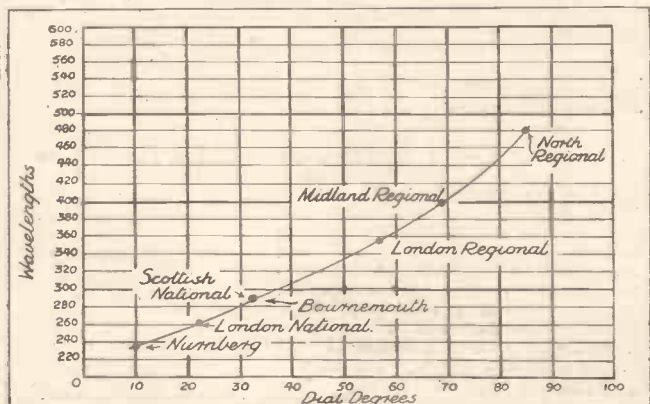

In this sketch some of the known stations have been dotted in on their dial readings and wavelengths, and then the curve—which relates all the other degrees and wavelengths—has been drawn through the dots.

for instance, we wish to try for a new station—say Poste Parisien—we can find the exact point on the dial where he should be received, because the curve relates dial-reading to wavelength.

curve will agree that preparing such graphs is not only a fascinating pastime, but is the most valuable aid to station-identification and the logging of foreign programmes that is possible to employ.



FROM THE TECHNICAL EDITOR'S NOTE BOOK

TESTED AND FOUND?

"CLASS B" COUPLING

THE various makes of "Class B" valves differ very considerably in their characteristics. Indeed, the differences can be said to be fundamental, for they impose widely varying operating conditions.

This is a pity, and is a move away from the general standardisation that we have all been hoping for. Transformer designers in particular must be far from pleased, for it makes their task a difficult one.

Benjamin Electric have effected a good compromise in giving their "Class B" input transformer a tapped primary enabling both 1 1/2 to 1 and 1 to 1 ratios to be obtained by the use of alternative terminals.

This Benjamin transformer has a cleanly pressed metal casing and thereby strikes a modern note. The design will be particularly apt when there is an all-metal "Class B" valve!

It is certainly a breakaway from the now almost universal bakelite casing which, by the way, does not impose the extra manufacturing cost that some appear to think. As a matter of fact, I have it on



The Benjamin "Class B" Transformer.

working. I have had it in use in a special test set, and find it perfectly satisfactory.

It retails at the attractively low price of 10/6.

SAVING THE BIAS BATTERY

If the grid bias is not switched off in a set employing the usual type of variable-mu H.F. control, a constant drain, though admittedly small, will be imposed on the grid bias battery.

"P.W." has long advocated a potentiometer combined with an on-off switch to overcome this, and so we can proffer both thanks and congratulations to Lewcos for producing such a component.

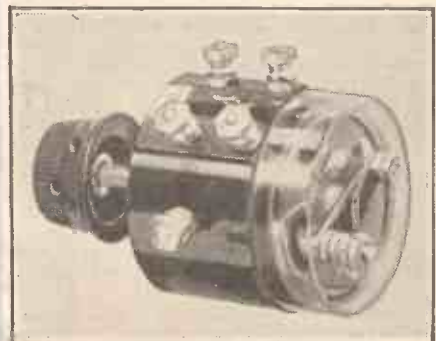

This is the Lewcos combined volume control and three-point on-off switch.

It embodies the standard Lewcos potentiometer and a quick acting three-point switch.

This latter can be wired to break both the L.T.

and grid bias circuit. It comes into action at the extreme anti-clockwise travel of the control knob and the switching is signalled by a distinct click. Thus there can be no doubt as to whether the set is in fact switched on or off.

It makes a very useful and effective combination control and, in my opinion, its advantages exceed those of a mere "knob reducing" device.

We must all have had experience of breaking in on a full strength programme; it is most disconcerting for the set to blare out like that, perhaps even with such volume that there is definite overloading, the moment it is switched on.

But that cannot possibly happen if you use one of these Lewcos controls.

You must start at minimum volume, and it is then up to you whether you at once and quickly run into maximum volume, or gently bring the sound up to the required intensity in the gentlemanly way in which the B.B.C. "fade-in" a new item.

FOR TIDY WIRING

I expect most constructors have at one time or another been faced with the problem of grouping leads originating at awkwardly different parts of a set.

For example, the leads joining a "power pack" section of the set which is in one part of a cabinet to the set itself.

The Wilburn Connector solves the problem neatly and effectively. It is, in effect, a small edition of those junction boxes used in heavy electrical engineering. It can be firmly screwed to the baseboard and all the leads terminated at it. Then a tidy cable can be joined up. It has its uses in battery sets as well, for it makes a fine junction for a battery cord and relieves all the strain individually and collectively imposed upon the various leads.



A handy gadget—the Wilburn Connector.

A FIRST-CLASS LOUDSPEAKER

Where possible I would always use a mains energised moving-coil speaker for I consider that it provides better value for money. For example, I have not encountered the permanent magnet equal of the Ferranti D.3T. for sensitivity, power handling and evenness of response at anything like its price of £2 10s.

Besides, its field winding can be used as a smoothing choke, for it is fitted with the necessary hum-reducing coil.

The Ferranti D.3T. is able to take 3 watts, and its performance is impressive.

The transformer with which it is fitted has 3 ratios, 10/1, 20/1 and 30/1, so that it can be matched with any ordinary power or pentode output valve.

It is certainly a fine production and I commend it to the attention of all constructors, who are so fortunate as to have access to mains supplies.

AN INSULATED LEAD-IN STRIP

Those whose houses are fitted with metal windows or who are for some other reason debarred from or disinclined to drill holes for the conventional lead-in

tube, should warmly welcome the Goltone Insulated Lead-In Strip.

This is flat and flexible, and can adapt itself to any shape. It is also tough and strong and efficient electrically. Stout terminals are fitted at each end.

It is supplied in 6-in., 9-in. and 12-in. or longer lengths if necessary, and the retail price of the 6-in. length is only 6d.

THE "TONIC" CHARGER

Mr. T. R. P. Williams, of Netherend, Bradley, Birmingham, has sent me one of his improved "Tonic" Trickle Charger Kits.

It comprises the parts for assembling a battery of four primary cells of a modified Daniell type. A special feature is that unusually massive zincs are supplied and this, of course, gives the battery a relatively long life.

All the individual parts are obtainable separately at reasonable prices. I have had the battery made up and it has successfully maintained a 20 ampere hour accumulator, subjected to an average discharge, in good condition.

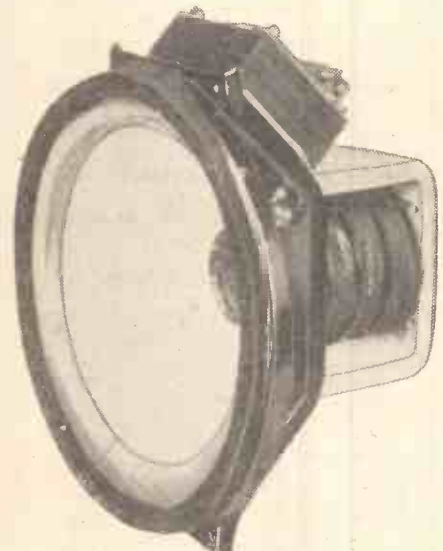

The Ferranti D.3T. Chassis.

I recommend the "Tonic" to the attention of all listeners living in remote parts of the country where charging facilities are non-existent.

TECHNICAL TOPICS

Some interesting items concerning the technicalities of your set.

Loose laminations in a mains transformer sometimes cause hum for which incomplete smoothing is blamed. It often pays to "cushion" the mains unit on a rubber pad or rubber mat, to prevent slight mechanical vibrations setting up hum.

An ordinary L.F. transformer is one good way of completely disconnecting a pick-up from the set with which it is used.

Instability in a set employing automatic grid bias is often due to failure to provide adequate bypassing across the automatic bias resistance.

When using home-made coils it is important to stick to the size and diameter specified, as a departure from this affects the wave-lengths covered and also the selectivity.

When a milliammeter connected in the plate circuit of the last valve kicks to a lower value on loud passages, it generally means that the grid-bias value is too low.

To discover the frequency of a station whose wavelength is known, all that is necessary is to divide the number of metres into 300,000.



# COLVERN FERROCART COILS

A DEFINITE advance in the design of radio frequency coils.... large diameter coils now unnecessary.... greater selectivity.... and higher efficiency attained with the compact Ferrocart Coils.

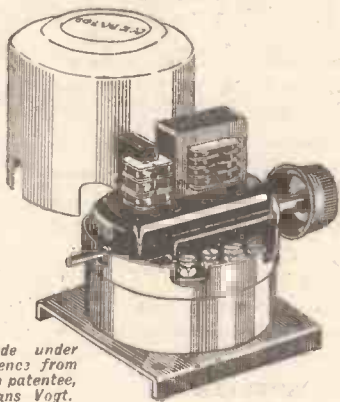

Made under  
license from  
the patentee,  
Hans Vogt.

FOR THE

## "P.W. CONQUEST"

Type F1, F2. Input Band-pass filter. Constant selectivity, ganging unaffected by variation in aerial reactance, symmetrical resonance curve.

Type F3. Auto transformer intervalve coupling with reaction, ganging perfectly maintained on both wave ranges by transfer of tapping point in correct turns ratio, practically constant reaction.

37/6 per set

# COLVERN

MAWNEYS ROAD, ROMFORD, ESSEX.

London Wholesale Depot, 150, King's Cross Rd., W.C.1

# RADIOTORIAL

The Editor will be pleased to consider articles and photographs dealing with all radio subjects, but cannot accept responsibility for manuscripts or photos.



Every care will be taken to return MSS. not accepted for publication. A stamped and addressed envelope must be sent with every article.

All Editorial communications should be addressed to the Editor, POPULAR WIRELESS, Tallis House, Tallis Street, London, E.C.4.

All inquiries concerning advertising rates, etc., to be addressed to the Sole Agents, Messrs. John H. Lile, Ltd., 4, Ludgate Circus, London, E.C.4.

The constructional articles which appear from time to time in this journal are the outcome of research and experimental work carried out with a view to improving the technique of wireless reception. As much of the information given in the columns of this paper concerns the most recent developments in the radio world, some of the arrangements and specialities described may be the subjects of Letters Patent, and the amateur and the trader would be well advised to obtain permission of the patentees to use the patents before doing so.

## QUESTIONS AND ANSWERS

### "OUT-OF-GANG" ON LONG WAVES.

S. B. L. (Petersfield).—"I have managed to get my ganging on medium waves very accurate indeed, but it then seems all wrong for long waves. Does this mean that the long-wave coils are not properly matched?"

"What happens is that after I get the trimmers 'all set' on medium and switch over, I find one trimmer has to be advanced from nearly minimum to maximum, to bring strength up. (On the others there is no noticeable difference in strength.)

"As a matter of fact, it seems as if the long-wave side would be better if I could put in more capacity than the trimmer will give. But if I try to add any I am afraid of throwing out ganging when the switch is over to medium, and as this is very well trimmed, I don't want to do that.

"It would be very difficult and inconvenient to take the whole coil unit out, and return to makers, so any suggestions that would get round the difficulty of bad ganging on long waves and constant readjustments will be thankfully received."

There seems no doubt about the bad "matching" of one of the long-wave coils, and although theoretically this should be put right by increasing its inductance—which you cannot do—there is a simple way out of the difficulty by using a loading capacity.

It will not perhaps be perfect, but should be a very great improvement on the present arrangement. The idea is to add a small capacity across the long-wave coil winding in question—a "neutrodyne" type of condenser, or even a twist of insulated wires will probably be sufficient.

The added capacity should be variable, and after first setting the ganging on medium waves you should go over to long waves and adjust the new capacity instead of the original trimmer until the circuits are all ganged properly on long waves.

Then when the switch is thrown over to medium again the new capacity will automatically be thrown out of action and your original trimming will thus hold good on medium waves, and on long waves as well.

### FIXING A BABY ALARM.

J. L. (Harrogate).—"The question I want to raise is an unusual one, but I remember seeing something of the sort dealt with in 'P.W.' last year, so I hope you can give me some assistance.

"What I want to know is how to fix an 'alarm' to the set so that if it is working we shall know via the loudspeaker when the baby cries upstairs? Naturally, the music in the ordinary way will drown a baby's cry, but I believe there is a stunt of using another loudspeaker as a microphone.

"I should like to try this, if you can give details of connections, as I have a sensitive cone speaker that I could stand close to the head of the cot. But I don't know how to wire up.

"I am told a microphone generally has a transformer, and I have an old 3½ to 1 ratio in good condition if that is any use.

"The set is a Det., 2 L.F. (both transformers), with volume control on first L.F. transformer. Any hints you can give would be welcome, as at present we have to keep switching off or else running upstairs, which completely spoils enjoyment of the programmes."

You can certainly try, with the apparatus on hand, and there seems to be no reason why it should not be a success. But keep the wiring as short as possible.

The circuit wiring will be as follows: The "microphone" loudspeaker, which will be placed close to the cot, should be wired across the primary terminals of an L.F. transformer; a sensitive cone loudspeaker should be O.K. for the purpose, and a 3 to 1 (or higher) ratio transformer will do.

To the secondary terminals attach two wires, and run these to the set by the shortest possible route. One must go to the detector's grid terminal and the other to the L.T. positive via a .05-mfd. fixed condenser. In other words the secondary, with the .05-mfd. condenser (this value is not critical) in series with it, will be wired across the detector's grid leak.

Probably you will find that this extra wiring will have little or no effect on the programme unless a noise is made near the upstairs loudspeaker, when a corresponding noise will be superimposed on the programme. It is certainly worth trying.

### TRIMMING AND OPERATING THE "P.W. CONQUEST."

The "trimming" of a ganged-condenser set should always be carried out with some care as it greatly affects the sensitivity of the set.

In the "P.W. Conquest" the on-off switch is combined with the variable- $\mu$  volume control, so to switch on all that is necessary is to start to turn the volume control knob to the right, when the switch will snap over. Continue turning till the control is full on, and then adjust the tuning to somewhere between 0 and 30 to 40 degrees, searching for a medium-wave station.

The coils are not marked as to the wavelength range positions, but it is of value to know that the coils are on "medium" when the wavechange switch is set with the flat of the spindle horizontal. (It may not be possible to see this at the switch knob but the rod is visible between the coil units).

A fairly strong station will do as a test at first, and after tuning it in the volume control should be reduced until the station is at quite low strength. Then slack off the three trimmers on the side of the condenser assembly.

Adjust the tuning of the station again, and reduce the volume to the minimum that will give loudspeaker audibility. Now screw up the trimmer nearest the panel till loudest results are obtained.

Again reduce volume by the volume control and adjust the middle trimmer, finally doing the same with the third.

(Continued on next page.)



## RADIOTORIAL QUESTIONS AND ANSWERS

(Continued from previous page.)

### Final Adjustments.

The test station will now be too strong for comfort, so it is best to tune in a weak foreign station, somewhere below 25 degrees on the dial if possible, and to repeat the trimming.

Quite sharp tuning points should be found for the trimmer nearest the panel, and for the middle one; while the third will probably be not quite so sharp. This will not, however, be "flat" in any way, so care must be taken that the trimming is done systematically and slowly.

The aim is always to use a minimum of added trimming capacity, otherwise the efficiency of the coils will be impaired, and the trimming over the whole of the two wavebands will not hold properly. Reaction is hardly necessary with this set, but is there if required. It is handy to sharpen tuning or to bring up the strength of any dead weak station you may become interested in.

With the trimming adjusted there is nothing else to be done except to adjust the bias for the "driver" valve to the greatest voltage that is consistent with good power output. Probably the voltage can be 6 volts or more with some of the small power valves, though 4½ volts is about right for the L.P.2. class.

The bias necessary for the variable-mu depends upon the type of valve you use, and also on the strength with which you receive the local station.

With a P.M. 12 M. valve only 4½ volts are necessary (unless you are very close indeed to the local station), but other variable-mu valves require a 9- or perhaps a 16-volt battery for the H.F. end.

Incidentally, the 15,000-ohm resistance and .006-mfd. fixed condenser which are given in the list of components and shown in the theoretical circuit are for tone control purposes. They are joined directly across the primary terminals of the loudspeaker input transformer, and are therefore not shown in the wiring diagram.

The actual handling of the "Conquest" needs no description, for once trimmed and adjusted properly the mere turning of the tuning adjustment brings in station after station, and the strength of each is under complete control by means of the variable-mu adjustment.

### A CURIOUS COUPLING EFFECT.

S. J. (Potters Bar).—"As you will see from my address, I live quite close to the Brookmans Park station, and as the aerial is a fair-sized one, I get both National and Regional programmes at big strength, and wide tuning. The latter trouble had been cured in the case of a friend's set by winding fifteen turns of wire into a coil, and joining its ends to aerial and earth, which were removed from the set's terminal for the purpose.

"Placing the new coil up against the old one, and fixing it there in the position which proved best for it, has sharpened up his tuning like that of a good valve set, so not a whisper of the programme that he is not listening for comes through.

"In my own set the cabinet is a small one, and I could not seem to get the coils well enough separated until I put the 15-turn new coil outside the cabinet, where it worked perfectly.

"So now the aerial and earth lead go to the small coil which is outside the set altogether, and the set works excellently, in spite of the fact that there is a wooden cabinet between the coil inside the set and the other coil to which the aerial is joined. Is this something new?"

No, it is a well-known effect to those who have experimented with coupling. The presence of a good insulating material between the coil acting as primary

(In your case the 15-turn coil is the primary) and the secondary has no noticeable effect, because it is only a variation of the normal method. The usual insulator in the space between the two coils is, of course, the air.

(It is not often stated in print that wood, etc., will not affect such a coupling to a noticeable extent, because this is only true if the wood is dry and free from a conductive coating.)

### ADDING DECOUPLING WITHOUT ALTERING THE SET'S WIRING.

P. L. J. (Beckenham).—"Ever since I fitted the new valves there has been a likelihood of howling when the battery was more than a month or six weeks old, especially if I attempt to work the set all the evening.

"I am told that decoupling will cure this, using a 1-mfd. condenser and 25,000-ohms resistance. But is it necessary to alter the wiring of the set inside, or can it be done without that?"

In the majority of cases there is no need to alter the internal wiring, because the lead supplying H.T. to the detector (which is the one we want to decouple) is separate from the other H.T. + leads.

If that is so in your set, all you need do is to undo the detector's lead from its H.T. + terminal, and insert the resistance there between battery and set; at the same time joining one side of the new condenser to this H.T. + terminal.

Then the other side of this condenser is joined to the H.T. - terminal of the set, and the alterations for decoupling are completed.

### THE "DOUBLE-D PEN"

(Continued from page 393.)

amplification we can more fully load the diode—with beneficial results—without calling upon it to supply a wide range of accurate A.V.C. to the S.G. valves. Incidentally we can have a far greater possible L.F. stage gain, to be fully used on weak stations.

This latter was impossible before due to the non-existence of L.F. A.V.C., and for this advance we must tender our thanks to the Cossor engineers for no small benefit given to radio reception.

One thing must be realised, however. That the volume control applied to the variable-mu pentode in the diode bulb is not applied as regards the L.F. modulation. It is dependent on the carrier (H.F.) strength applied to the diode, so that the proportions of loud and soft passages of music (L.F.) are retained. It is only the overall strength that is affected—by virtue of the variation of L.F. amplification.

### A Straightforward Receiver.

As will be seen, the whole set is quite straightforward. The two variable-mu S.G. valves are fed into the double-diode variable-mu pentode, which is resistance-coupled to an output pentode of the usual type. Delayed A.V.C. is obtained by applying an automatic static bias on the diode which is used for A.V.C. (the top one in the diagram), so that until the incoming "signal" is strong enough to overcome the initial bias no reduction of amplification at either H.F. or L.F. end is engendered.

About 3-volts static bias is applied to the diode anode—not to the H.F. and L.F. grids—so that 3 volts of "signal" are required on the diode before any automatic biasing takes place. This fixes the limit of amplification on both H.F. and L.F. sides of the set, and effectively prevents overloading, while maintaining sensibly even reproduction strength over very wide ranges of reception.

Next week we shall give further information concerning the "Double-D. Pen.," including details of construction and operation which will enable readers to take full advantage of this sensational development in valve technique.

**BEWARE LIGHTNING!**  
GRAHAM FARISH  
**GARD**  
WILL PROTECT YOUR AERIAL

Your set—your home itself, is at the mercy of Lightning if your aerial is unprotected. For a few pence a GARD gives permanent protection and makes it safe to listen-in during the worst thunder storms. Be sure to get the genuine Graham Farish GARD—the Lightning Arrester that protects a million homes. Every GARD carries £100 Guarantee.

**1/6 EACH**

**GET A GARD 1/6**

GRAHAM FARISH LTD., MASONS HILL, BROMLEY, KENT.

If you are troubled with a noisy background or mains hum fit a

### BACKGROUND SUPPRESSOR

2/9 post free. Obtainable only from:  
GOSPORT CENTRAL RADIO STORES, FORTON ROAD, GOSPORT

**INVENTORS.** Your ideas may be worth royalties apply for your PATENT first. Write for my FREE "INVENTORS' POCKET-BOOK," explaining how to patent inventions. Submit particulars in confidence for free expert advice. — EDWIN V. AXE, A.I.M.E., 27, Chancery Lane, London.

### LOUD SPEAKERS REPAIRED, 4/-

(Blue Spot a Speciality, 5/-)  
Transformers and Headphones, 4/-, Eliminators, Mains Transformers and Moving Coils quoted for 24-Hour Service. Trade Discount. Clerkenwell 9069  
E. MASON, 44, EAST ROAD (near Old Street Tube Station), LONDON N.1.

### IF YOUR RECEPTION IS BAD

**SUPERIAL**  
THE AERIAL WHICH MADE BROADCASTING POPULAR  
ELECTRON'S SUPER-AERIAL

### WILL IMPROVE IT!

Whether it is a bad set or a bad locality SUPERIAL will make your reception definitely better, because it is the most efficient and powerful aerial ever devised. The extra-heavy rubber insulation stops interference and noise, abolishes masts, insulators and separate leads-in, and increases the signal strength. The only efficient indoor or invisible aerial. Lightning proof, too. Get your 2/6 Free Insurance to-day. From all dealers.

100 ft 3/6 : 75 ft 2/6 : 50 ft 1/9 : 25 ft 1/6  
THE NEW LONDON ELECTRON WORKS LTD EAST HAM LONDON E.6



## MIRROR OF THE B.B.C.

(Continued from page 384.)

pity that as much notice is not taken of them as there would be if they were performing in the North.

Billy Merson is going to Clacton. The Roosters to the Isle of Man, the Isle of Wight, and then on to Guernsey and Jersey, while Leonard Henry will be off to Rhyl.

It is doubtful whether we shall hear very much of any of them on the wireless until they return to London, which does not seem to be quite as it should.

## Vignettes of Variety.

Many famous personalities of the music-hall stage, from the days of Charles Coburn to Harry Weldon, will be recalled in the next and sixth of the series of Vignettes of Variety programmes which Charles Brewer is presenting for Midland Regional listeners on Tuesday, June 13th.

Wilkie Bard, Chirgwin ("the White-eyed Kaffir"), R. G. Knowles, George Bastow, Gene Stratton and Charles Godfrey, Vesta Victoria, Jenny Hill, Flo Gallimore and Vesta Tilley—what memories these names will recall to listeners who knew the music-halls of London before the War. The programme, which is also to be broadcast as part of the Empire service to West and South Africa, will be presented by Evelyn Over, Sydney Lester, Ernest Shannon and the Midland Revue Chorus and Orchestra with Charles Brewer as the compère.

It is built upon suggestions from listeners who have thoroughly enjoyed hearing its predecessors in the same series.



"We're Fluxite and solder—the reliable pair; Famous for Soldering—known everywhere!"

We're HERE to remind you—whatever your set; If something goes wrong you'll be glad we met!

See that Fluxite and Solder are always by you—in the house—garage—workshop—anywhere where simple, speedy soldering is needed.

ALL MECHANICS WILL HAVE

# FLUXITE

IT SIMPLIFIES ALL SOLDERING

All Ironmongers sell Fluxite in tins; 4d., 8d., 1s. 4d. and 2s. 8d. Ask to see the **FLUXITE POCKET SOLDERING SET**—complete with full instructions—7s. 6d. Ask also for our leaflet on **HARDENING STEEL** with Fluxite.

FLUXITE LTD., (Dept. 324), Rotherhithe, S.E.16

FOR ALL REPAIRS!



## BUILDING A CATHODE RAY TELEVISION VIEWER

(Continued from page 383.)

Turn the right-hand (looking at it from front of panel) baseboard-mounted rheostat full on, and control the diode it refers to by the panel rheostat only (A on the right-hand side). The left-hand baseboard rheostat should be about  $\frac{2}{3}$  on, and control of its diode carried out by A on the left of the panel.

## Two Complete Sections.

Note in this case especially how the speed of the blue glow of the thyratron is varied. You will have seen that the time-base is divided into two complete, but linked, sections, the left-hand part (from front) being the  $12\frac{1}{2}$  and the right hand the 375 per sec.

You will find that at this stage none of the other controls make any difference, for they all refer to the actual scanning on the cathode tube, and their effects can only be seen when the tube is connected up.

But as a rough test of the time-base the foregoing is useful, especially if it is remembered that the right-hand thyratron will light up continuously (or so it seems, for the 375 flashes per second are not separately visible), while the left-hand one distinctly flashes at a very much slower rate, according to the diode control setting.

## Obtaining a "Tick Over."

If the base is working really well, and the diode control of the right-hand section is carefully set, it may be possible by judicious variation of the bias control (B) to make the 375 thyratron "tick over" slowly, or comparatively slowly. But this is not important, and it is not a sign that everything is O.K. unless the rapid flash giving apparently continuous discharge is alternatively obtainable.

If you cannot control the base suspect the .25- and .02-mfd. condensers, or the resistances across them. Leakage here, at a greater rate than required, due to faulty condensers or resistances, will completely upset the operation of the circuit.

So much for the construction and preliminary tests of the time-base for the cathode ray television viewer. Next week we shall describe the radio receiver for the system, and then go on to the actual linking up of the whole apparatus and its operation.

## THE LINK BETWEEN

(Continued from page 401.)

so inefficient, that one had to rely upon a certain amount of "faking" in the speaker to put back what the set had very kindly removed! The tragedy of it is that one's ears can so easily become attuned to a particular speaker that it is not at all easy to get used to the real thing.

Fortunately, the "mellow-toners" are rapidly becoming an extinct species, and it is not surprising when there are such speakers as Ferranti from which to choose.

While I do not propose to enter into an argument upon the question of what constitutes a good speaker, the prestige which Messrs. Ferranti have built up for themselves in connection with all aspects of L.F. amplification leaves no room for doubt concerning the excellence of their speakers. You can draw your own conclusions from the fact that Ferranti is included as one of the few speakers that I have selected for use in my own home. But keep that dark!

## Radio "History."

Way back in the good old days of 1925 (almost a lifetime in wireless history!) a certain Southend electrician constructed what he called a "power unit," the purpose of which was to enable a wireless receiver to be run from the ordinary electric light mains.

A mere eight years ago, and yet from that "early" experiment an organisation has been built up which to-day can justly be claimed to be Southend's main industrial undertaking. So much for the enterprise of Messrs. E. K. Cole.

As a matter of passing interest, the term "power unit," now the name for so many types of battery eliminators, was originated by Ekco, and they were the first British firm to produce them as a commercial proposition.

As is only to be expected, their present range includes models for almost every conceivable purpose, and I believe it to be one of the most comprehensive in the country.

If there are any readers who are contemplating a change over from batteries to mains eliminators, take my tip and first obtain a copy of the Ekco catalogue. It is available through "P.W.'s" postcard literature service, and arrangements will be made for it to be sent post free to all those making (No. 39) application in the usual way.

## Exide Price Reduction.

The Exide Drydex battery type H.1039, which is a replacement battery for Pye "Q" and similar portable receivers, has recently been reduced in price from 17s. 6d. to 15s. 6d.

Incidentally, while on the subject of replacements, it may be of interest to mention that the correct Drydex replacement battery for the Pye "G.B." receiver is the H.1062, the price of which is 17s. 6d.

## A Pat on the Back.

A special word of praise this week goes to the British Rola Company, Ltd., in connection with an invaluable leaflet that they have just produced.

Almost every commercial receiver these days is provided with terminals or sockets at the back for the connection of an external loudspeaker, but rarely is advice given by the set manufacturers as to the best type of speaker to use for the purpose.

The leaflet that has been prepared by the Rola people effectively overcomes any difficulties that are likely to arise in this respect, since it gives a list of almost every commercial receiver on the market, together with the appropriate Rola speaker to use for extension purposes.

I regard it as a particularly useful leaflet, and for that reason I think it is well worthy of inclusion in our free literature service. (No. 40)

We invite readers to support our Advertisers—care being taken to accept only announcements of reputable firms!

## WHY PAY EXORBITANT PRICES FOR VALVES?



SEND DIRECT TO THE MAKERS FOR BRITISH 362 VALVES (AS SPECIFIED FOR THE "CONQUEST" SET IN THIS ISSUE) FULLY GUARANTEED to have as high, or higher, characteristics as any valves (British or foreign). Equal to any, better than most. Non-microphonic. Buying direct by post from the makers SAVES YOU 50%. Post your order to-day.

Post Free from  
**3/6**

THE "CLASS B" 9/- Mains Volume NEW from a Battery set obtained at insignificant H.T. consumption.

R.C., H.F., L.F., and Detec. 3/6. Power 4/-. Super-Power 4/6. S.G. 7/6. Var-Mu. 7/6. "Class B" type 9/-. Pentode type 10/-. All in 2v., 4v., or 6v. Metallised 3d. extra. Delivery by return of post.

Cash with order. Cheques and P.O.'s must be crossed and made payable to—**THE 362 RADIO VALVE Co., Ltd.** (Dept. X.5), 415, Mare St., Hackney, London, E.8  
Monogram: —BCM/362, London. Easy to remember in case you forget our address.



# TECHNICAL NOTES

Some diverse and informative jottings about interesting aspects of radio technique.

By Dr. J. H. T. ROBERTS, F.Inst.P.

## Tuning.

PEOPLE often think that it is a good thing to be able to receive signals directly on the coils of the set. You know well enough that with a simple type of set you can often receive powerful signals, such as those from the local station, without any aerial at all. But this is not really an advantage, because the coils may occasionally pick up unwanted interference and programmes.

In point of fact, it is really better, especially if you require selectivity (as most of us do nowadays), not only *not* to rely upon any direct reception on the coils, but actually to take precautions to *prevent* any such direct reception—by screening the coils, for instance. If you have the coils properly screened, either with local screens or by the screening of the receiver as a whole, then you rely upon the signal energy picked up on the aerial and you have intimately more control over the selectivity and tuning.

With a short aerial, albeit the actual pick-up is smaller, the overall results are often much better, due to this very factor of tuning. A long or large aerial tends to flatten the tuning, owing to the damping.

## Cutting Out Interference.

People often take pride in the fact that they can receive signals on their set "without any aerial or earth," as though this were some sort of recommendation of the peculiar sensitivity of the receiver. But you will see from what I have just said above that this is not really an advantage, and, in fact, in present-day conditions is more generally something to be avoided.

By the way, I wonder how many of you have noticed that you can often get good signals, especially from local stations, by the use of an earth connection only, and better still if this earth lead is connected to the aerial terminal.

This arrangement sometimes has the advantage that it gets rid of the worst of atmospherics or other suchlike interference. It is not generally much good, however, for long-distance reception or weak signals, only for strong signals.

## The Valve Vacuum.

You have all heard of Dr. Irving Langmuir, the famous American Radio physicist, who was recently awarded the Nobel prize. Langmuir is known the world over for his inventions and discoveries in connection with radio valves, particularly the dull-mitter type of filament which was introduced a few years back.

Another of his special subjects is the production of high vacua, and recently a new 50-kilowatt station of the National Broadcasting Company was "christened" its opening, not with the customary bottle of champagne, but with a "bottle of nothing," broken in the Research laboratory at the General Electric Company at Schenectady.

This "bottle of nothing" was a glass bulb which had been exhausted to the maximum degree of nothingness commercially possible, the vacuum within the bulb being 99.99999 per cent complete. The explosion when the exhausted bottle was broken was broadcast over the entire National chain of stations.

## "Signal Energy."

It is interesting to note that with the latest method of vacuum pumping, not more than a hundredth-millionth of the air originally in the bulb remains after the pumping process is complete. This can be roughly compared to removing all the inhabitants from the whole of the area of the United States *except just one*.

A number of other interesting popular statistics are given in the account before me, of which the following is an example: A receiving set at a distance of a few hundred miles from a transmitting station of 50 kilowatts will receive about as much power as a fly would require to climb up a wall at the rate of two feet a minute, this being estimated as roughly a hundred-million-millionth of the power sent out by the broadcasting station.

## Interesting Experiments.

I mentioned some little time back some experimental arrangements for using a photo-electric cell with a power amplifier and a number of readers who are experi-

## THE PHOTO-ELECTRIC CELL

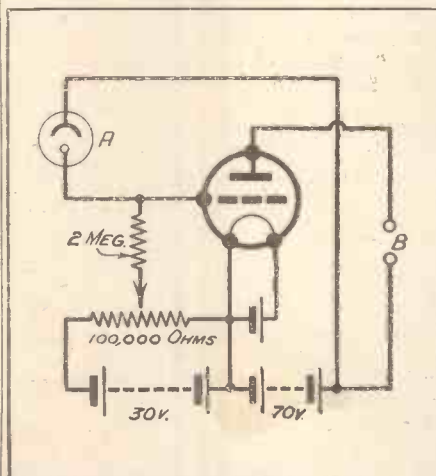

The symbol at A represents the photo-electric cell and B is the point where the relay or other device is inserted.

menting with these cells have asked for details.

The arrangement of the amplifier is very simple and is shown in the figure herewith. The cell is included at the position A, whilst the milliammeter or the relay, or whatever you wish to operate, is connected at B in the anode circuit.

(Continued on next page.)

## IN ALL THE BEST SETS!



## ROTARY SWITCHES

Chosen again by the designers of the 'CONQUEST' receiver, Bulgin switches undoubtedly take first place on account of their splendid action and reliability.

### ON-OFF TYPE

The finest snap action switch obtainable. Fitted with phosphor bronze cleaning action springs and bakelite indicating plate.

Black, Walnut or Mahogany finish. List No. S. 85. Price **1/6**

### RADIOGRAM TYPE

Quick action, single-pole change-over switch, with radiogram indicating plate.

Black, Walnut or Mahogany finish. List No. S. 88. Price **1/9**

80-page Catalogue "P." Send 2d. postage



**A. F. BULGIN & CO., LTD.,**  
Abbey Road, Barking, Essex.  
London Showrooms: 9, 10, 11, Corsitor Street  
Chancery Lane, E.C.4.

## EASY TERMS

Everything Wireless supplied on lowest terms. Prompt Delivery Guaranteed. Price List Free on request. With Order

**NEW BLUE SPOT 99 PERMANENT-MAGNET MOVING-COIL UNIT.** → **5/-**  
Cash Price £2/19/6  
And 11 monthly payments of 5/6.

Class "B" Kit, consisting of Multitone driver trans. and output matching choke, Coscor 240 B valve and special valve holder. Free instruction book with every order. Cash Price £1/15/3 or 6/- with order and 6 monthly payments of 5/6.

**12 EXIDE W.H. HIGH-TENSION AC-CUMULATORS** (120 volts, 5,000 M/a.) → **7/-**  
Cash Price £3/15/-  
And 11 monthly payments of 7/-.

**ATLAS ELIMINATOR A.C. 244** Three H.T. tapings. 20 M/a output. Cash Price £2/19/6. → **5/-**  
And 11 monthly payments of 5/6.

All Carriage Paid. Quotations by return. To avoid delay will customers kindly send first payment with order.

Dept. P.  
**THE LONDON RADIO SUPPLY CO.**  
11, Oat Lane, Noble Street, London, E.C.2  
Phone: NATIONAL 1977.

## engineers PUT US TO THE TEST

All we ask is the chance to prove that you can earn £300, £400, £500 per year and more. Other men are doing it and you can do the same.

The first thing to do is to send for our FREE Handbook, "ENGINEERING OPPORTUNITIES." This 250-page book contains details of B.Sc., A.M.I.C.E., A.M.I.Mech.E., I.E.E., A.M.I.A.E., M.I.M.P., G.P.O., etc. Exams; outlines Home-Study Courses in all branches of Civil Mech., Elec., Motor, Aero., Wireless and "Talking-Picture" Engineering, and explains the advantages of our unique Employment Dept. We urge you not to neglect our offer. Send for your copy of our Handbook to-day, FREE of any charge.

**BRITISH INSTITUTE OF ENGINEERING TECHNOLOGY.**  
101, Shakespeare House, 29/31, Oxford St., London, W.2





## CHOSEN for the CATKIN MAINS UNIT

Build the "Catkin" receiver—the new metal valves ensure a safe and reliable job. Build the "Catkin" Mains Unit—the Heayberd W31 Transformer ensures a safe, reliable and economical unit. Exclusively specified by the designer, this transformer is constructed from the finest British materials. Voltage regulation is extremely good, with negligible temperature rise.

RECTIFIED OUTPUTS: 200 or 250 v. at 60 ma. A.C. L.T. SUPPLY: 2 + 2 v. 5 amps. and 2 + 2 v. 1 amp. **30/-**

.....POST COUPON TO-DAY.....  
I enclose 3d. stamps for 36 page Handbook. Packed with hints, tips and diagrams.

Mr. .... P.W.

Address.....

If you have difficulty in obtaining Heayberd products locally—please write to us.

10, FINSBURY ST., LONDON, E.C.2.

(Minute from Moorgate Stn.)

# HEAYBERD

MONARCH OF THE MAINS.

### RADIO SUPPLIES

Send your list of Radio needs for our quotation; Kits, Parts, Sets, etc. Everything in Radio stocked, prompt delivery, 7 days' approval. Catalogue free. Taylex & Standard Wet H.T. replacements stocked.

P. TAYLOR, 57, Studley Rd., Stockwell, London

Of special interest to owners of Portables.

Are your Valves Microphonic?  
Do they "Sing," "Howl" or "Pong"  
with the slightest vibration?

If so—fit

## "NON-PONGS"

and enjoy better results.

ABSORBS VIBRATION. FITTED IN A JIFFY.

BATTERY VALVE TYPE 6d. set of 3

MAINS VALVE TYPE 1/- set of 3

P.O.'s only. Post free from—

"NON-PONGS," 90, Friargate,  
PRESTON.

## ELECTRADIX BARGAINS

NEW SALE LIST  
NOW OUT

Hundreds of Radio and  
Electrical Bargains. Send  
stamp for details.

ELECTRADIX RADIOS  
218, UPPER THAMES ST., E.C.4

PLEASE be sure to mention "Popular Wireless"  
when communicating with Advertisers. Thanks!

## TECHNICAL NOTES

(Continued from previous page.)

A two-megohm grid leak connects the grid to the slider of a 100,000-ohm potentiometer. A 100-volt H.T. battery serves the purpose quite well, the voltage to the anode being about 70 and the voltage across the potentiometer the other 30.

The current through the point B is initially kept at a low value by keeping the cell in darkness and adjusting the potentiometer. Sometimes a better effect is obtained by reversing the positions of the grid leak and the cell.

### Radio Transmission.

I have before me an interesting Report, sent by The Department of Scientific and Industrial Research, of the Kelvin Lecture of the Institution of Electrical Engineers, delivered by Sir Frank Smith. The lecturer dealt largely with the electrical layers in the atmosphere and their effect upon the transmission of radio waves.

Amongst other things, it was shown that bending by ordinary optical refraction due to the atmosphere could not account for the distant travel of wireless waves, and it was recalled that Sir Ambrose Fleming made calculations which showed that wireless waves could be bent so as to travel parallel to the earth's surface if the diameter of the earth were about five times its actual diameter.

### Bending the Waves.

If the atmosphere consisted entirely of very rare gas, the bending would be concentric with the earth. If light waves could be made to travel parallel to the surface of the earth, we should be able to look in one direction and see our own backs—assuming, of course, that there were no obstructions and no appreciable absorption of the energy.

As a matter of fact, so far as radio matters are concerned, we have already, in a sense, been able to "see our own backs," as radio signals have been detected after they have completely encircled the earth not once but several times.

### Thunderstorms.

Some interesting facts were brought out about thunderstorms which, so far as the lower layer of the atmosphere is concerned, are about the only phenomenon likely to affect wireless waves. "The thunder cloud," said the lecturer, "is the seat of a separation of electric charges on such a scale that there is probably a potential difference of a thousand million volts built up!

"A typical thundercloud may be taken as covering an area of a few square kilometres and as having its base a kilometre or so above ground. Its head may reach very nearly to the top of the troposphere, some 10 kilometres, or roughly 6½ miles, above ground.

"The importance of thunderstorms in relation to the travel of radio waves is likely to be manifested not at the actual place and level of the storm, but at great heights above, and spreading to great distances from, the thunder centre."

### Conducting Layers.

It was also shown that in certain circumstances charged electrical particles are projected from the sun and drawn by the

action of the earth's magnetic field to the earth particularly in the vicinity of the magnetic poles. The upper regions of the atmosphere are therefore bombarded by these charged particles and become conducting layers.

The result is that electro-magnetic waves may be reflected from them, while the directions of the forces in the waves may be altered. The region of the conducting layers of the atmosphere which affect wireless waves have recently been called the "ionosphere."

### Fading.

One of the most important parts of the lecture, so far as radio listeners are concerned, dealt with the fading of broadcast stations. After dealing with the travel of short waves, and showing that these were suited to long-distance communication, the lecturer dealt with the medium waves used for broadcasting, and explained that fading with these waves was produced by a portion of the energy (the ground ray) from the transmitting station, travelling along the ground, being at one moment augmented and at another moment wiped out at the receiver by energy arriving via the upper atmosphere (the space ray).

### Foreign Stations.

"The only cure for fading," he said, "lies in concentrating as much of the radiated energy as possible into the ground ray, so that not only is it stronger at any given distance, but the interfering down-coming space ray is relatively and actually

## NEXT WEEK

Further details of  
**THE "DOUBLE-D PEN"**

—the first set to use

**Dual Automatic Volume Control**

"P.W." Out on Wednesday 3d.

weaker." Special aerial arrangements are now available for this purpose and are proving themselves of substantial value.

One of the effects, however, of the use of such a device would be to reduce the scope of foreign listening on the medium wave-band (which is almost wholly effected by ionospheric rays), but most listeners will agree that this is not too high a price to pay for the reduction of fading troubles on home sets.

### Motor-boating Troubles.

I have more than once heard from readers about sets which, after working quite satisfactorily for long periods, months or even a year or more, have suddenly—or, in some cases gradually—developed motor-boating troubles. There are various causes which lead to this, one of which, and a very natural one, is that the valves are getting worn out either in the fullness of time or by excessive use or possibly by abuse. These are the cases where instability and a tendency to motor-boating will probably have been noticed over quite a period, getting gradually worse and worse. The remedy in such a case is obvious.



MODERN WIRELESS PRESENTS

# The FERRO B<sup>4</sup> Four

A FERROCART AND 'CLASS B' RECEIVER DE LUXE

Introduced by

**P.P. ECKERSLEY** M.I.E.E.

(CHIEF RADIO CONSULTANT TO MODERN WIRELESS)

CIRCUITAL DEVELOPMENT | LABORATORY CHECK AND CALIBRATION  
by **G.V. DOWDING** | by **A. JOHNSON RANDALL**  
ASSOCIATE I-E-E

Locality Tests by **D<sup>r</sup> J.H.T. ROBERTS**

First P  
CONSTRUCTIONAL DESIGN AND DESCRIPTION BY **K.D. ROGERS**

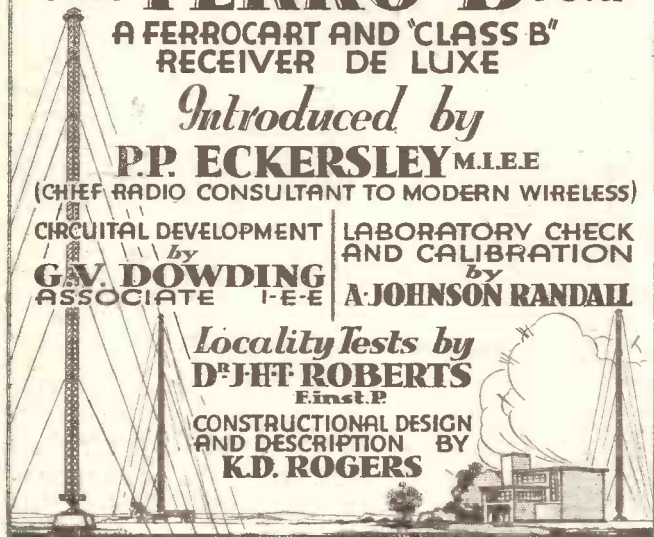

## MODERN WIRELESS

BRITAIN'S LEADING RADIO MAGAZINE

has an appeal for everyone who is interested in radio. The diversity of subjects covered includes Home-Construction, Recent Inventions and Developments, Radio in Other Countries, New Stations, Getting the Best from Your Receiver, Short-Wave Work, Programme Features, Long-Distance Reception, B.B.C. Activities, all the latest news, etc., etc., etc.

Items in

IN THE

THE JUNE ISSUE INCLUDE:—

### THE "A.T.B." THREE

An ideal receiver for adding foreigners to your alternative programmes.

THE

### WORLD'S PROGRAMMES

A special 18 - page section devoted entirely to distant stations and how to receive them.

### HOW TO OBTAIN BETTER RADIO

This supplement is intensely practical and contains hints and tips of interest to all set users.

THERE ARE ALSO ARTICLES ON:—

- Radio To-day in Germany
- Secrets of the High K/c's
- Faults I have Found
- The Future of Positive Drive
- Are Portables Worth While?
- etc., etc., etc.

OUT THIS WEEK—PRICE 1/-

## JUNE NUMBER

THERE IS SOMETHING FOR EVERYONE IN MODERN WIRELESS

OF



Are you taking full advantage of your electric light?



**Radio reception now costs only 1/- a year\***

*★Based on 3 hours daily use of an average 3-valve set. The equivalent cost of Batteries is 50/-!*

Do you still run your radio from batteries? If you do, you are behind the times—and paying a lot more than you need pay. Provided you have electric light you can reduce your set's costs to a negligible amount, and at the same time get constant unvarying power!

All you have to do is to connect the suitable EKCO Power Unit in place of the battery, plug into the electric light, and switch on—that's all! No alterations to set, valves or wiring. Consult your dealer or write for free illustrated literature.

**Prices from 39/6, or by Easy Payments.**

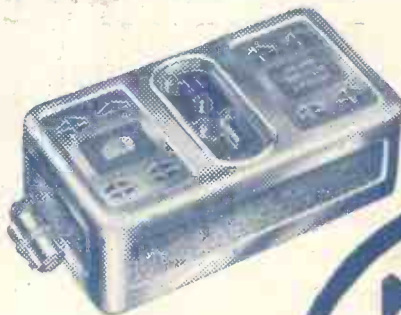

*Ekco Power Unit Model A.C.18.*

*All Ekco units are similar in size and design. Size 9 ins. x 5 ins. x 3 1/4 ins.*



**RADIO POWER UNITS**

To E. K. COLE, Ltd., Dept. A.6,  
Ekco Works, Southend-on-Sea.

Please send me free illustrated details of Ekco All-Electric Radio.

Name.....

Address.....





**POPULAR WIRELESS**

*The Paper that Made Wireless Popular*

**THE FIRST AND FOREMOST RADIO WEEKLY.**

Scientific Adviser : Chief Radio Consultant :  
 SIR OLIVER LODGE, F.R.S. P. P. ECKERSLEY, M.I.E.E.  
 Editor : N. F. EDWARDS.  
 Technical Editor : G. V. DOWDING, Associate, I.E.E.  
 Assistant Editors : P. R. BIRD and A. JOHNSON-RANDALL.  
 Chief of Research Department : K. D. ROGERS.

**LOOKING-IN  
 WORLD-WIDE SPEECH  
 THE SHOW  
 UNEARTHED!**

# RADIO NOTES & NEWS

**SAFELY BOUGHT  
 OCEAN TALKS  
 MOTHER'S JOB  
 HOMING PLANES**

**"P.W." and Television.**

**I**N presenting the amateur world of radio reception with the first cathode ray television viewer for home construction, "P.W." increases its lead with a spurt. We have hitherto taken a conservative view of the present possibilities of television as a home entertainment, even at the risk—nay, the certainty—of censure; but we have never "crabbed" it. Now we believe that so far as television is concerned, and probably the ultimate method of transmission, also, the electronic method offers a greater scope than the mechanical for the movement towards perfection of the art. Time will show.

**Interval Signals.**

**A**LTHOUGH, as I understand, they have no intervals in American broadcasting, Europe seems to spend much ingenuity in devising suitable interval signals, and to invest them with an importance which we in England do not think they merit.

When interval signals have to change because a new political party is in power, we may believe that broadcasting is in some instances an instrument which has been debased into a mere propagandist trumpet. Perhaps our own soulless "doomp" is not such a bad idea, after all. It expresses the passage of time, and nothing else.

**Another Royal Broadcast.**

**I**T is to be hoped that the broadcast of H.M. the King's speech when he opens the World Economic Conference this month will be world-wide. America is already agog to hear it, despite the average American's quiet humour in referring to monarchies. Quiet—sometimes! But it's only a pose, really, which every 100 per cent American considers himself obligated to maintain.

I believe that the B.B.C. and the Post Office—to which department more credit should be given—will accomplish a great achievement on this occasion.

**Licence Fees by Instalments.**

**T**HE proposal of Mr. J. Baldwin-Webb, M.P., that the Post Office should consider the possibility of allowing wireless licences to be paid for in quarterly

instalments in the instances of families whose wage-earner is unemployed presents serious difficulties of a practical kind, but, nevertheless, merits grave attention. I myself, a lover of the printed word, have never considered the B.B.C.'s fare as a necessity. But I am ready to agree that "listening" may be a necessity to those who are not natural-born readers—or gardeners, or what you will.

**This Journal places the widest possible interpretation on the word**

## SERVICE

Not content with the collection and first publication of all the vital radio news, "Popular Wireless" is itself in the forefront of radio research and development.

In conjunction with one of the most important Corporations in the industry it has instigated and is now presenting

### THE FIRST CATHODE RAY TELEVISION for CONSTRUCTORS

Another "Popular Wireless" development, which has evoked world-wide interest, was carried out recently at the Crystal Palace—as described this week on page 415—and won for Britain

## A WORLD'S RECORD

**Britain's Place.**

**I**T is regrettable to learn that, although the radio exports of the four chief exporting countries increased between 1928 and 1931 by some £15 million, that increase was contributed by our competitors alone. On the other hand, we may congratulate ourselves that whereas during 1932 the exports of Holland, U.S.A. and Germany slumped, ours rose slightly. From letters which I have received from many countries, both in and outside the Empire, it appears that our prices are too high.

**Radio Show News.**

**I** LEARN that for this year's Radio Show at Olympia there is projected a great entertainment centre which is to take up all the National Hall. If this fructifies, all the demonstration rooms will be omitted and arrangements made for the centre to benefit every exhibitor.

There will be no retail exhibitors this year. Considering that the U.S.A. is to have no official radio show, we have cause to be thankful that our 1933 event will be held, and is being organised with such zest.

**More Show Notes.**

**A**N international radio and gramophone exhibition will be held in Lyons from September 16th to 24th.

The Radio Manufacturers' Association are busily organising the Scottish Radio Exhibition in the Kelvin Hall, Glasgow, from September 1st to 9th. A special feature will be a "tea dance," that is, a large dance floor entirely surrounded by a café. It ought to be called a "coffee dance."

**Gathering of the Clans.**

**O**N May 11th, "Electra House," the new office which has been built on the Embankment site of the old School Board offices to house the various companies of the Marconi-Eastern Cable Merger, was opened officially. The Marconi Company and the Marconi International Marine Communication Company will migrate thereto from Marconi House, and the Empire's communications will thus come under a common roof.

**"Stars in Their Courses."**

**T**HE theme tune which has been used to introduce the performances in the "Stars in their Courses" series has evoked much curiosity; in fact, many people have gone to the length of writing or telephoning to the B.B.C. about it. Well, the chords were extracts from Gershwin's "Rhapsody in Blue," and a Paul Whiteman record was used.

One exception to this occurred on the Fay Compton evening, when the talk was introduced by incidental music from "Mary Rose."

*(Continued on next page.)*



# ARIEL CONTINUES HIS RUNNING COMMENTARY ON RADIO

## Reduce the Licence Fee.

THE Viscountess Snowden's article in "P.W." for May 13th is indeed bold and cogent. Nevertheless I would suggest that if it is correct that there is a cool million pounds to spare after paying income tax and the Post Office, and presenting £36,000 to the Treasury, then it is patent that the licence fee could be reduced to seven-and-sixpence—and should be.

## Dig Not Too Deep.

A NEWPORT (I. of W.) trader has experienced a thrill which is, luckily, denied to most of us. Whilst engaged in the peaceful art of digging preparatory to the erection of an aerial mast he came plump upon a human skull and bones.



What bygone tragedy he has uncovered is, I believe, still the subject of controversy

amongst the local ancients. Better luck next time; a hoard of golden coins or a Roman pavement.

The only other treasure I recall to have been brought to light during digging for radio purposes was the beautiful old pottery which was found during the building of a Marconi station in Greece before the war.

## New Use for Mr. "Mike."

AT the Eye Institute of the Presbyterian Hospital, New York, the main operating room is designed to allow the students to watch the operations through a glass dome by means of opera glasses. As the students look on at even the most delicate operations the surgeon quietly describes his work, his remarks being caught by a tiny microphone worn in his lapel.

The microphone conveys the matter to a public address system, and so the students get a lecture and a practical demonstration simultaneously.

## Safety First.

SOME of the radio manufacturers have introduced the "home safe" idea in connection with their hire-purchase system. It's a wise firm that looks after the instalments—as much as possible.



I am not advised of the particular design of the safes; they may be just common money-boxes, or those diabolical traps which open only

to a master-key in the possession of the legally interested party. However, I fear that these firms have but placed one more temptation to "burglary with violence" in the way of impecunious papas who have already filled the baby's saving's-bank with I.O.U.'s.

## Premier Inaugurates New Service.

ON April 20th, Mr. Ramsay MacDonald, who was aboard the *Berengaria*, several hundred miles from New York, inaugurated a radio-telephone service between that vessel and the U.S.A. He spoke to the British Ambassador at Washington, his voice being conveyed first by radio to Forked River, New Jersey, where it was transferred to the lines to Washington.

Telephone services from ships at sea are gradually increasing, and in ten years no escape from the tinkling bell will be possible.

## The "Children's Hour."

A. N. (Salisbury), who is interested in the "Children's Hour," is anxious to know the ages of the children for which the B.B.C. imagines it caters. Such

## SHORT WAVES

Sad News Item: "The island of Tonga-Tonga has no taxation, Parliament or wireless station."

Brilliant Idea: "Let's give them ours."—"Pictorial Weekly."

A Sydenham correspondent, who recently complained of trouble with his wireless set, now writes: "One morning last week there was a broadcast talk which my wife particularly wanted to hear, and she got so annoyed with the set, which still refused to function properly, that she struck it. And, lo! it became normal and has remained so ever since."

We hope this will be a lesson to it!

The "Providence Journal," of America, gives the following programme of radio entertainment: "9.35 p.m. Baseball scores, Luskv 40 MaHwpluh. EAL m m mwkwk." It doesn't seem much good trying to eliminate static when they're actually broadcasting it these days.

## ANSWERS TO CORRESPONDENTS.

Q.: What is a Henry?

A.: Second cousin to a Ham.

Q.: What advantage has an indoor aerial over an outdoor one?

A.: 10/- per annum.

## THE TRIO.

Brown: That's a fine-looking set you've built, old man.

Jones: Yes. I've called it the Trio Set.

Brown: Oh, why?

Jones: Because I get three stations at once on it.

words as "apprehensive," "epigram," "verbatim," and "subtleties" do seem to be above the heads of kiddies, even such sophisticated youngsters as we have nowadays.

My dear A.N., I have no doubt that the "Children's Hour" is organised by theorists—whereas it ought to be run by mothers.

## "The Piccardeers."

THIS is not the name of a new concert party, but the title—my title—for that band of experimenters who, stimulated by Prof. Piccard, and perhaps thinking of Jules Verne's "Five Weeks in a Balloon," shinned up the North Tower of the Crystal Palace and tickled the ether on five metres.

Their motto doubtless is "Per ardua, ad stratosphere." This is a new venture for radio journalism here, and is a true "P.W." touch.

## "Before Broadcasting Began."

I PROMISED to let you know where you might find my article on the habits and customs of early post-war amateurs, and I redeem that promise by stating that the article appears in this month's "Modern Wireless" under the heading given above. For reasons why you should buy that magazine I refer you to all the other features in it.

## Aircraft as Pigeons.

AIRCRAFT, like certain pigeons, practise "homing"; in the case of aircraft this means that the pilot can shape his course with the aid of a wireless station on his route, just as the mariner uses the coastal lights.

Developing this idea, Marconi's have produced an ingenious apparatus, including a "frame" aerial, which enables the pilot to tell by means of sounds in his telephones, whether the head of his plane is on the direct route towards the wireless station, or has veered to right or left of it.



## Radio Advertising.

AN aspect of the radio advertising method of operating broadcasting in the U.S.A. which is not properly appreciated over here is that its clientele is "seasonal." Listening tends to drop off during the summer, and accordingly so also do radio advertisements.

"Lucky Strike," the cigarette people, who bought over 1,800,000 dollars' worth of the N.B.C.'s time last year, has "gone off the air," certainly until the autumn. Who will fill up this hole in the N.B.C.'s revenue?

Not Beer, as had been hoped. That of all things needs no publicity at the moment.

## Kindness of a Power Company.

THE North Metropolitan Electric Power Supply Company has, out of the kindness of its heart, agreed with the Tottenham Urban District Council Housing Committee to allow tenants to use its electricity for mains-driven radio receivers for one penny per week each—for the privilege, not for the power. And the U.D.C. has to collect the pennies, retaining 5 per cent thereof for expenses.

No doubt it pains the Power Company deeply to be obliged to sell its power to householders, and therefore I commend this noble and unselfish gesture to your generous recognition.







## What they heard

# ON FIVE METRES

By L. H. THOMAS (G 6 Q B).

When all five-metre long-distance records were broken during the "P.W." Crystal Palace tests on Sunday, May 21st, short-wave enthusiasts were listening in all parts of the country. Mr. L. H. Thomas, who was in charge of the transmitter at the top of the tower, describes in detail the proceedings and achievements of this momentous day in the history of short-wave radio.

"CRYSTAL PALACE DAY"—May 21st, 1933—was confidently expected to be interesting, but the most optimistic of us hardly expected the amazing results that we obtained. Still the reports arrive (strange how long some people take to write a short letter!) and still more surprises are added to the day's total.

I have been asked to give a fuller description of the experiments than was possible in last week's "P. W." and cannot do better than quote from our station log for May 21st, together with some of the reports received since then.

### Transmitter Details.

First, however, a few words about the station itself. Although I am still basking in reflected glory, I cannot over-emphasise the fact that the actual transmitter used was the property of Mr. A. D. Gay (G 6 N F). I had an idea, beforehand, that his transmitter was rather more efficient than my own, and as we were all hazy, at that time, as to whether we should get anywhere at all, we decided to use the more efficient gear.

The transmitter used two six-volt power valves in push-pull, and the input was the merest fraction over 10 watts. The plate voltage was only 170, at a current of 60 milliamps—a power of 10.2 watts!

Two larger valves, in parallel, were used to modulate the transmitter, and as these two had an amplification factor of 12, no amplifier was used after the microphone, which fed directly into the modulator stage.

The aerial assembly was quite a Heath-Robinson affair, consisting of a nine-foot length of batten, which was poked out from the Tower à la fishing-rod. From an insulator on the end of this dangled eight feet of copper petrol-pipe, and two feeders of ordinary lighting flex came back along the sides of the pole to the transmitter.

### Severe Screening.

The erection of this was not made easier by the fact that the Tower gallery is surrounded by a kind of wire cage, intended as a foil to would-be suicides!

Two receivers were used, one belonging to G 6 N F and the other to W.L.S.—the now-famous receiver that was first described in "M.W." and in "P.W." three weeks ago. These were mounted on soap-boxes, with the H.T. and L.T. on the lower deck, and with lengths of wire that could just be dropped vertically through cracks in the floorboards to serve as aerials.

It was found to be invaluable to have these two receivers, on account of the severe screening effect of the Tower itself. They were moved round from time to time, and very interesting results were obtained.

The gear was taken up by lift on the previous day, but on the Sunday the operators had to trudge up 400 steep stairs, laden with the necessary food and drink to keep body and soul together for ten hours or so!

The day's work started in earnest at 9.45 a.m., when we had a chat with G 5 V Y of Tottenham, who reported our phone very strong indeed. A few minutes after this we spotted Mr. A. S. Clark of "P.W." in a car on the Parade, nearly three hundred feet below. In response to the request "Wave a handkerchief if you are getting us strongly," there was a fine flutter of white down below. This was qualified to "Very strongly," and the handkerchief appeared again.

## MAKING MOBILE TESTS



Mobile reception was successfully carried out by a member of the "P.W." technical staff during the Crystal Palace tests.

Finally we sent him off with the promise that we would call him at every hour and half-hour.

The two best contacts of the morning were with G 6 C J (Uxbridge) and G 6 U H (a portable at Limpsfield, Surrey). All this work was done with the aerial pointing north-west. Telegrams arrived from Mr. F. Briggs (also of "P.W.") to say that we were being received well at King's Langley.

According to schedule, at 2 p.m., we shifted the aerial round to the south-west side, and proceeded to work more locals, and also G 2 J U at Harrow, with whom we had no trouble in working "duplex." G 6 U H was worked again, and reported us as "R 99," which may be taken to mean something stronger than the ordinary run of signals! Both speech and "tone" were being used throughout these tests.

At 5.20 p.m. we did the best two-way work of the day, by getting into communication with G 5 S A, a portable near Wendover—nearly 50 miles away.

We noticed on G 2 J U (Harrow) that, though his speech was R7 with a receiver

on his side of the tower, he was absolutely inaudible on the far side. The shifting of our own transmitter didn't appear to make nearly as much difference as the shifting of the receiver.

Not too happy about the distance we had covered, we all descended, carrying unbelievably heavy loads of gear, at 7 p.m., to find, at the bottom, the cheering news that Mr. Douglas Walters (G 5 C V) had been listening to us from a plane, and had been as far away as 130 miles.

### All Records Broken!

G 5 C V told us that at a point north of Hunstanton (Norfolk), out over the North Sea, our speech was as loud and clear as when he had been flying round the North Tower in the morning. Only the fact that petrol was necessary made him turn back then.

Mr. Clark gave us some interesting data about the reception of our transmissions in distant parts of Surrey, and several more or less "local" stations rang up to tell us of their luck.

The postal reports, however, were productive of the greatest thrill of all, especially from G 6 P L of Hollin Bank, Yorkshire, who had been getting us at the almost incredible distance of 190 miles. This constitutes a world's record for 5 metres!

A complete analysis of these reports will probably be published shortly. Sufficient to say here that we were heard at Cranleigh, Surrey (right down behind Leith Hill from the Crystal Palace), Farnborough (Hants), Newbury (Berks), Leicester (about 95 miles), Ashdown Forest (Sussex), Winchester, Benfleet (Essex) and, of course, by innumerable Londoners. Nearly all reports gave us as "R9."

### Achieving The Impossible.

I have been sending out Q S L cards ever since to those who were good enough to report our transmissions:

When we publish the full results, they should make an interesting answer to those who still hold that 5 metres is no good for work over greater distances than a few miles. One gentleman of my acquaintance whose theory is well ahead of his practice assures me, in all solemnity, that we have "put a nought on somewhere." My answer to that is that an amateur can always achieve the impossible, provided that he doesn't know that it is impossible.

We should all like to convey our thanks to readers of "P.W.," many of whom made up W. L. S.'s 5-metre receiver in the course of two or three days, especially to listen for us. Good work all round!



# ECKERSLEY EXPLAINS-



When your results are distorted, do you always blame the receiver? That the quality of the broadcast is not invariably above suspicion is pointed out by our Radio Consultant-in-Chief, who this week deals with the general aspects of quality in relation to radio.

"I'VE gotter motter!" It is that quality counts. To — with all these nasty noises. What's the fun, anyway, in just picking up noises? And what a lovely subtle, impossible, almost insoluble problem it is, to get good quality—really good quality.

I do not want to be misunderstood. I am not getting at anyone. I know, better than anyone else perhaps in the wide world, the difficulties of maintaining a technically perfect system of broadcasting; but, nevertheless, I think that B.B.C. quality is not *always* up to that standard which should make us always suspicious of our receivers when poor quality results.

## An Hour Wasted.

Maybe there are reasons; maybe these reasons are perfectly good reasons; maybe it's better to have the programme flexibility brought about by using land lines coupled with variable quality than to be rigidly insistent upon as good as the best possible *always*.

The other day I was concerned in studying the problems of radio relay broadcasting. I was particularly interested in certain distortions introduced by the network. I was anxious to know if certain correctors were worth while, if the ordinary speaker noticed what existed.

And I spent an hour more than I need have done because the B.B.C. transmission (only *one* in the afternoons very often, and then not always that) was far from good. It lacked the "top" usually given.

I do not blame, I observe. I hear that the B.B.C. have been sending out "notes" of different frequency in order that the ordinary listener may judge his own set's performance.

## Records not Suitable.

That is all very well; might it, perhaps, not be advisable to put out the notes from the source of broadcasting? Evidently landline transmission has much to recommend it as a convenience for experimenters who must have a standard of quality. Gramophone records are no good in the final issue because they are deficient both in bass and top.

Perhaps the B.B.C. might announce or print or let us know somehow, when, in their opinion, transmission is inferior, due to one cause or another.

Then, again, I turn myself round and wonder if I were still responsible, what I should say to this implied criticism. Obviously day-time transmissions cannot be so well supervised as those given at night; far more people listen by night. Obviously it's better to have a poor P.O. line than no line at all.

Obviously to announce continually that such and such transmission was inferior creates a bad impression. Obviously the informed technician should know this and be careful not to set too much store by daytime and O.B. quality.

## Variable Transmission.

But, for what it's worth, I can assure those experimenting on "quality" that the standard on which they may be blindly relying is, in fact, a variable standard.

This fact is particularly well known by those who try to sell sets by demonstration. They pray for "a good transmission" as they call it.

Here, again, a friend of mine asked me

## WHEN A WOMAN WHISPERS

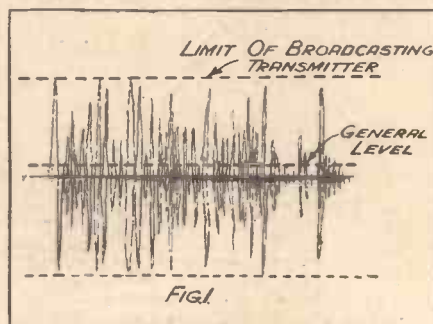

Although the peaks are very high for some parts of certain items, the general level of sound may yet be very small. A state of affairs clearly illustrated in this diagram.

why transmission was, apart from being so variable in quality, so variable in strength. Again, it's a question of the abilities and idiosyncracies of the man controlling; but, more than that, the acoustics of the place from which the broadcast is being given. Eastbourne! Well, it used to be a very poor land line, but it was always the most popular broadcast. Nor was Mr. Sandler entirely to blame for this. Mr. Acoustic accompanied Mr. Sandler.

You see sound has wave form. The momentary intensities may be as shown in my diagram 1 or 2, to take extreme cases.

## What is Loudness?

Now, in one the sound impinging upon the microphone is very "peaky," while the general "level" is very low. But for the same peaks (2) the general average level is much higher.

The condition 2 is approached when that cursed, filthy, anachronistic, mechanical, piercing (but entirely necessary, of course) tuning note comes on. Condition 1 occurs when a woman whispers in a padded cell, or when certain voices are transmitted from certain studios or when people shout in too heavily damped studios.

The loudness of the reproduction of the voice of a speaker at a public banquet and, in spite of that, the pleasingness of the reception has got to be heard to be believed. Contrast the voice of one who in the nature of things shouts a bit (radio drama), but is as so many say "too close to the microphone."

## Quality does Count.

A church organ can be reproduced in all its rounded mellowness (ugh!), but frequently a cinema organ is weaker. (In this case, to me, much more pleasant.)

So you see, the variables are pretty considerable. Land lines, acoustics, controller, receiver—and so on and so forth. I use a gramophone a whole lot because it is consistent in any case. Then I can turn on what I guess may be good B.B.C., and then if it sounds nice I know I've been clever.

In spite of everything, I still think that quality counts and that every endeavour should be made by designers of receivers to ensure that their products do justice to the best B.B.C.

Their job won't be easy. It is far simpler to pick up any sort of a noise from across Europe than to do full justice to Henry Hall.

## THE "TUNING-IN" NOTE

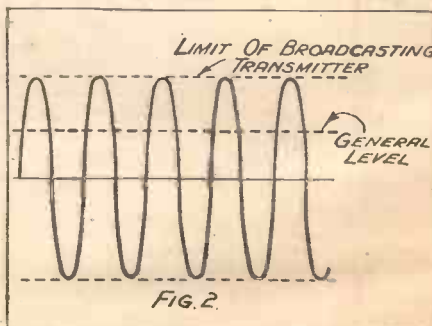

Although in this case the peaks are no greater than in Fig. 1, they are regular, and the general sound level is considerably higher.



# The WESTERN REGIONAL

DOWN "Zumerzet way," on the hills overlooking the Bristol Channel near Watchet, you will find two tall aerial masts and a little group of stone buildings. A rough drive runs up to the entrance of the largest building, and at the main gate a notice board tells you that it is B.B.C. property, and that no one is allowed there except on business.

This is just about all that one can see of the West Regional broadcasting station without trespassing. Fortunately, I was with no less a personage than the Chief Engineer of the B.B.C., Mr. Noel Ashbridge, so I was able, as it were, to have the run of the entire premises. Let me tell you what I saw.

### On the Coldest Morning.

In we go to the power-house, where four huge Diesel engines, each of 420 brake-horse-power tower above us. Mr. Ashbridge explains that even on the coldest of mornings the engines can be started up within half a minute or so. One of them is started up there and then. Swish! The big fly-wheel turns once under the pressure of compressed air and immediately it is off and roaring round at full normal speed. If necessary 245 kilowatts of electrical energy can be taken from the generator which is coupled up to it.

There are some big storage tanks just outside with sufficient oil fuel to run all four engines for three months. An ingenious device boils water round the exhaust pipes of the Diesels and this provides the central heating system for the whole station.

Then we walk into a small room where there is nothing but accumulators, which are chiefly used for lighting and emergency purposes. Well, we've all seen accumulators, even if these do happen to be outside ones, so let's get on.

### Grid Bias Generators.

The machine room. Rows of glittering monsters humming and buzzing like a gigantic hive of bees. There is something very impressive about them, and there are a lot of them, too. Here, for instance, are three low-tension generators, each giving an output of 1,300 amperes at 20 volts (which would be just about sufficient to fuse the water pipe you use as an earth!). Nearby are three high-tension generators, each having an output of 19 amperes at 12,000 volts. Your little grid-bias battery would look a bit silly beside the imposing row of grid-bias generators in this machine-room. There are three of them, supplying grid bias for the transmitting valves at 200, 500 and 2,000 volts respectively. In addition, there are small high-tension machines which supply the low-power oscillator and modulator stages of the transmitters.

The last of the B.B.C.'s Regional stations, now being put into service in Somerset, is described by E. JEFFRIES, our Special Correspondent, who visited Washford Cross with the Chief Engineer of the B.B.C.

Now we come to the transmitter hall itself, and Mr. Ashbridge shows me the elaborate safety devices which prevent the engineers receiving shocks. Nothing can be touched unless the current is first switched off, and even if the engineer forgets and opens the cage at the back of the transmitters, there is a little "click" on the main switchboard, a relay opens, and the whole unit closes down.

prevent them melting under the tremendous heat.

Perhaps the most tricky part of all is the tuning-fork drive which is to be used to synchronise the wavelength of the West National with the wavelength of London National, i.e. 261.6 metres. "We are going to try putting the two stations on the same wavelength as soon as may be practicable," said Mr. Ashbridge.

### Listeners Needn't Worry.

I asked whether any trouble was anticipated, and the answer, it seems, depends upon the tuning forks. If they keep the wavelengths accurate then there will be no trouble, but if the wavelengths are permitted to change, even slightly, then the whole scheme will be useless.

"Of course the two stations will only be really well received within their own service areas," explained Mr. Ashbridge. "In between, where the transmissions from both stations can be heard simultaneously on the same wavelength, there will be an area of mush. But this should not worry listeners, for they can always get the long-wave National."

### Little Studio.

Before leaving the station, we visit two or three little rooms leading out of the main transmitter hall. One of these is a test and check room. Another is where the telephone cables from the studios at Swansea, Cardiff

and Plymouth enter the building, and there is even a little studio which can be used in emergency.

The West Regional station, which is just off the main Minehead road, is raised somewhat above the level of the surrounding ground and therefore occupies a commanding site. The stone used for the station harmonises with the prevailing colour of the countryside, and, with the exception of a frontal office, the building is only one storey high.

I could have gone up to the top of one of the steel aerial masts, but when an engineer, who had made the ascent, described what it felt like, I decided that "P.W." readers would have to excuse me writing that part. If the truth be told I don't think Mr. Ashbridge was too keen on going up, either!

## THE CONTROL OF THE TWIN TRANSMITTERS



The main transmitter hall, showing the two control desks at which the engineers will sit whilst the twin stations are working.

The two transmitters—National and Regional—are arranged along either side of the hall, while the transmitter power switchboard occupies one end. In front of each is a control desk on which is mounted a number of meters showing how the transmitter is working.

### A Gallon a Second.

Engineers sit at these desks all day long, and keep a log book showing what the meters indicate at various times, and make various alterations to the controls so as to keep the transmissions at constant strength.

The transmitters themselves are shining displays of steel and aluminium with glass panelled doors. Behind the panels are the valves—about 20 in all. Several of them are water-cooled, and even then require sixty gallons of water a minute to



SOME NOTES ON THE

# DOUBLE-DIODE TRIODE

By A. S. RADFORD, D.I.C., B.Sc., A.R.C.S.

A valuable development in valve technique which has already created considerable interest and is assured of wide use in the near future; particularly in circuits of the A.V.C. type.

THE double-diode triode is a valve developed specially for use in Automatic Volume Control circuits. As its title implies, it consists of two diode rectifiers and a triode amplifier contained in the same bulb. Reference to the photograph of the new Marconi M.H.D.4 in Fig. 1 will show that in construction the upper portion is very similar to the normal indirectly-heated triode of the M.H.4 class.

Shielding the anode of this triode from the lower portion of the construction is a metal screen connected to the cathode, and beneath this are supported the two auxiliary anodes of the diodes. The function of the screen is to ensure that the capacity between these auxiliary anodes and the anode of the triode shall be as low as possible, so that the minimum amount of radio-frequency energy or high audio-frequency energy is passed on directly from the rectifier to the amplifier section of the valve.

## THE M.H.D.4.



Fig. 1.—This valve is developed especially for automatic volume control, and consists of one triode and two diode valves in one bulb.

Shielding the anode of this triode from the lower portion of the construction is a metal screen connected to the cathode, and beneath this are supported the two auxiliary anodes of the diodes. The function of the screen is to ensure that the capacity between these auxiliary anodes and the anode of the triode shall be as low as possible, so that the minimum amount of radio-frequency energy or high audio-frequency energy is passed on directly from the rectifier to the amplifier section of the valve.

### Connections.

Connection to the grid of the triode is made via the terminal at the top of the valve, while the disposition of the pins in the base and their connection to the other electrodes

is shown in Fig. 2.

For use in a simple A.V.C. circuit the double-diode triode may be connected so that full-wave rectification of the signal takes place between the two auxiliary anodes and the cathode. The rectifier voltage is then applied across the ends of a potentiometer from the slider of which connection is taken via a coupling condenser of about .01-mfd. to the grid of the triode. Thus the A.C. portion of the rectified signal is led off to be amplified, the potentiometer acting as a manual volume control.

### Low Damping.

Meanwhile, a D.C. voltage (due to the rectified carrier-wave) is developed in the resistance. This is a measure of the strength of the incoming signal, and may be applied as bias to variable- $\mu$  valves

in the preceding stages, whether used as radio-frequency or intermediate-frequency amplifiers.

Consideration of this arrangement will show the main advantages of the use of the double-diode triode.

Firstly, the damping effect of the rectifier on the preceding H.F. stage is low, due to the high input impedance of the diode. Actual measurements made on diodes under working condition show that the effective shunt damping impedances are of the order of  $\frac{1}{2}$  the value of the load resistance across which the rectified voltage is applied—i.e. between 100,000 and 250,000 ohms.

### Distortionless Rectification.

It is well known too, that diode rectification is one of the best methods of distortionless detection over a wide range of input voltages besides being between 80—100 per cent efficient.

A third advantage results from the separation of the rectifier and amplifier portion of the circuits. With the efficient screening between the diode anodes and

## ELECTRODE ARRANGEMENT

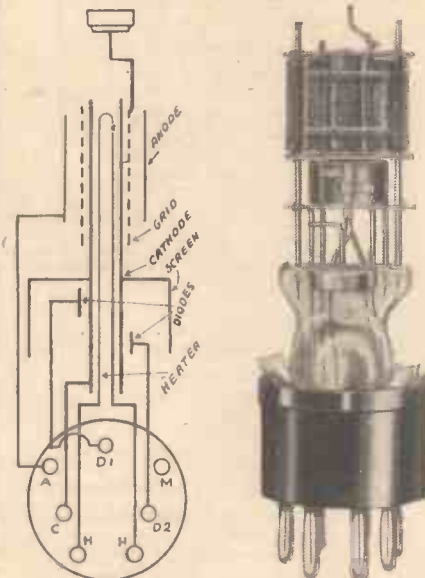

Fig. 2.—The relative positions of the electrodes are well illustrated in this diagram and photo. Note how the two diodes are screened from the triode by a shield connected to the cathode.

the grid and anode of the triode, the amount of L.F. signal available from the triode becomes independent of the depth to which the incoming signal is modulated.

The characteristics of the Marconi M.H.D.4 at zero grid bias with 100 volts on the anode are:

Amplification factor	.. 40
Impedance	.. 18,200 ohms
Mutual conductance	.. 2.2 m.a./v.

The double-diode triode may also be used effectively in circuits for Q.A.V.C., the one diode-anode circuit being used to provide half-wave rectification and simple A.V.C. and the other diode so as to provide bias volts, so that no signal is passed unless of more than a definite value. This predetermined voltage is set to be somewhat higher than the average voltage from music noises, etc., so that until this value is exceeded by the incidence of a signal the receiver remains quiet.

### Many Interesting Arrangements.

From the above it will be realised that many interesting arrangements may be made using the M.H.D.4. For example, one diode may be used to delay the action

## FULL-WAVE A.V.C. CIRCUIT

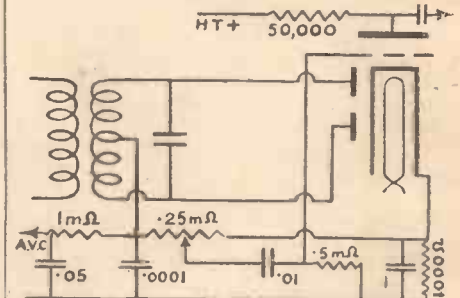

Fig. 3.—The connections for using a double-diode triode for full-wave rectification and automatic volume control.

of the A.V.C. operation of the other so that the control does not come on until the detector is about to be overloaded.

Several circuits have been developed, and it is hoped to follow this article with one on which the various arrangements and their applications are discussed.

## A READER'S EXPERIENCES WITH "P.W." SETS

The Editor, POPULAR WIRELESS.

Sir,—It is over two years since I last wrote to you, when you and the technical staff were so helpful in your assistance with my "Comet" Three.

I again thank you all for all the help I have received in the past from 1927, through the "Economy" Three, "Magic" Three and other Threes and Twos, short-wavers and adaptors, and above all for the assistance with my Super "Comet" Three which, though the receiver cost over £12 the money was well spent, as it has been no trouble, and to-day even against the latest "Threes" it is a winner.

In Aldershot there are five exact copies of the "Three," and they have cost only the upkeep of batteries since they have been made, which says a good word for your designs.

Now a word of praise for the "Airsprite," that I made up for a chum. It is all you claim.

I think I have helped all I can to make you and your sets known, for my advice to the people I know (and I am surrounded with them—uncles, aunts, nephews, etc., especially the latter) is, before they buy or make their receivers, etc., to obtain a second-hand set to give them an idea of circuits and handling, study their "P.W.," "M.W.," etc., and their booklets issued with "P.W." from time to time and then after a few months with an inferior set, make up one of your designs and settle down to real enjoyment and a trouble-free set. Then they will cease to wonder why we make up our own sets.

I also thank the various advertisers in your journals for the help I have received at various times, and my dealings either for goods or assistance has been expeditiously dealt with, especially Messrs. Ormond, Ferranti, Igranic, Fullers, Colvern and Mullard. I forgot to name in my above appreciations Messrs. Graham Farish.

Excuse the roughness of this letter, but it is late in the evening, time I had retired, and work has to be done to-morrow.

Again many thanks.

Yours sincerely,

W. RICHARDSON.

71, High Street, Aldershot.



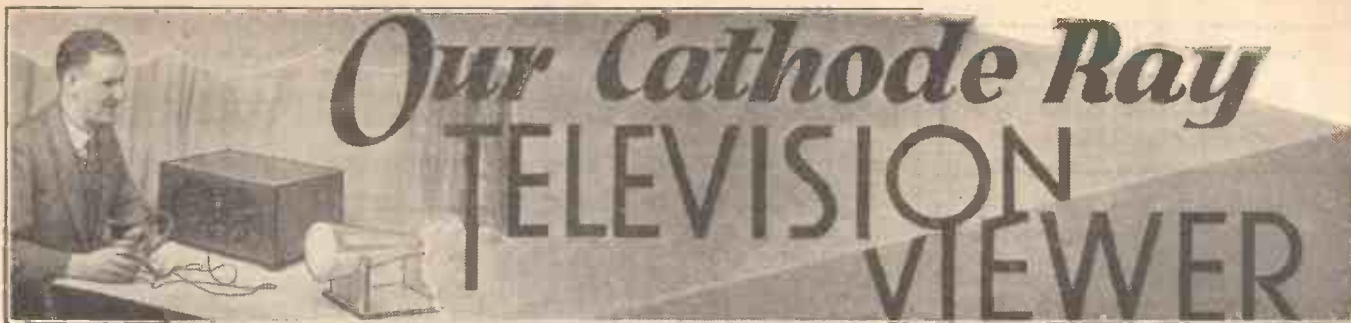

# Our Cathode Ray TELEVISION VIEWER

IN the last two issues of POPULAR WIRELESS I have dealt with the methods employed in our cathode ray television viewer for scanning and controlling the electron beam emitted by the tube. And the simple nature of the assembly of components required to do this has been made apparent.

It now remains to go into the matter of the radio receiver that is to pick up the broadcast pictures, and then to assemble the units of the viewer to form the composite instrument.

The radio receiver is extremely simple, and those who do not wish to build it *in toto* will be able to convert their existing receivers quite easily. But before I embark on the description of the actual set used in the Research Department in conjunction with the time-base already described, I should like to express my deep regret that the B.B.C. do not give more facilities to reception research by giving longer television broadcasts. Half-hour spasms four times a week are not much use to the research engineer, and longer periods would be most valuable.

### Important Discovery.

But, in spite of the restraint placed on research by the B.B.C., we have managed to carry out a considerable amount of investigation—largely in half-hour doses, of course, late at night—and the results so far

Continuing the description of our inexpensive and easy-to-make cathode ray television viewer, full details are given this week of a special set for the reception of "vision" broadcasts. This set is both economical to run and simple to operate. Designed and described by K. D. ROGERS.

### SPLIT OUTPUT IS EMPLOYED

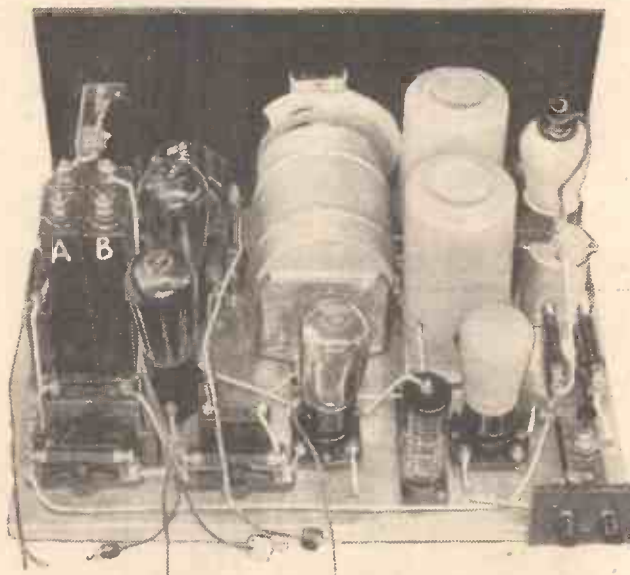

The receiver supplies the synchronising pulses as well as those for light modulation. And for this reason parallel output valves are used, each performing one of these duties.

attained we are presenting for your notice.

One of the most important things we have found out is that control of synchronisation in the cathode ray scheme can be carried out by impulses of a fraction of a volt, provided they are clear of extraneous potentials.

The main synchronising impulse is that which comes over at 375 times a second; that is the one that marks the commencement of each vertical scanning line, there being 30 lines  $12\frac{1}{2}$  times per second.

The other synchronising impulse, which controls the speed of the picture-change, i.e. the number of complete scannings per second is the  $12\frac{1}{2}$  per sec. impulse, and this is not nearly so important.

### Cumulative Effect.

To assist in the production of this latter impulse strongly enough the two thyatron of the double time-base described last week are linked. This is done in such a way that the thyatron flashing at 375 impulses per second passes the 375 per sec. flash impulses to the grid of the  $12\frac{1}{2}$  valve.

These impulses are not strong enough to upset the  $12\frac{1}{2}$  valve, but this valve is also receiving from the radio set a certain proportion of the  $12\frac{1}{2}$  synchronising impulse sent out. It may be weak, but when on it is

(Continued on next page.)

## USE THESE COMPONENTS TO PICK UP YOUR TELEVISION

Component	Make used by designer	Alternative makes of suitable specification recommended by designer.	Component	Make used by designer	Alternative makes of suitable specification recommended by designer.
1 Panel, 14 in. x 7 in.	Goltone	Feto-Scott, Becol.	1 25,000-ohm resistance	Graham Farish "Ohmite"	—
1 Baseboard, 14 in. x 10 in., foil covered	—	—	1 20,000-ohm resistance	Graham Farish "Ohmite"	—
1 .0005-mfd. double-gang variable condenser with cover.	Polar "Uniknob"	J.B. "Unitune"	2 10,000-ohm resistances	Graham Farish "Ohmite"	—
1 1-mfd. fixed condenser	Telsen	—	1 pair screened coils on base	Colvern K5	—
2 .5-mfd fixed condensers (high voltage)	Dubilier LSG	—	1 H.F. choke	Ready Radio	Lewco; "Super," R.I., Goltone "Super," Bulgin S.G., Varley
1 .25-mfd fixed condenser	T.C.C. OF	—	1 Screened H.F. choke	Bulgin HF19	—
1 .25-mfd fixed condenser	Telsen	T.C.C., Dubilier	4 Four-pin valve holders	Benjamin	W.B., Telsen, Lissen
1 .1-mfd fixed condenser	Telsen	T.C.C., Dubilier	1 .8-henry special choke	R.I.	—
1 .01-mfd. fixed condenser	Telsen	—	1 Terminal block	Sovereign	—
1 .0003-mfd. fixed condenser	Dubilier 67D	—	2 Indicating terminals	Belling-Les "R"	Goltone, Igranic
2 .00005-mfd. fixed condensers	T.C.C. type S	Dubilier 610	4 Wander plugs	Goltone	Belling-Lee, Clix, Igranic
1 .0003 max. pre-set condenser	Goltone	Telsen, Sovereign	1 Wandertuse	Belling-Les	—
1 50,000-ohm potentiometer with 3-point switch	Lewco	—	2 Accumulator tags	Ealex	Clix, Belling-Les
1 .5-meg. clip-in grid leak	Dubilier	Telsen, Lissen	1 Single closed-circuit jack and plug	Igranic P62	—
1 250,000-ohm resistance with vertical holder	Graham Farish "Ohmite"	—	4 Yards insulating sleeving	Goltone	Wearite
1 40,000-ohm resistance with horizontal holder	Graham Farish "Ohmite"	—	6 Yards 18-gauge tinned copper wire	Goltone	Wearite
			1 Anode connector	Belling-Les	—
			Flex, screws, etc.	—	—







# OUR CATHODE RAY TELEVISION VIEWER

(Continued from previous page.)

up horribly on the screen, much more than in the speaker when music is being reproduced—and the cathode ray is very sensitive to any form of modulation distortion. The diode type of rectifier has been chosen in our receiver as giving the best

## THE VALVES THAT YOU SHOULD USE

Make	S.G.	Det.	L.F.	Output(Pair)
Mullard	P.M.12M.	P.M.1H.L.	P.M.2D.X.	P.M.2A.
Marconi	V.S.2	H.L.2	L.210	L.P.2
Osram	V.S.2	H.L.2	L.210	L.P.2
Mazda	S.215V.M.	H.L.2	L.2	P.220
Cossor	220V.S.G.	210H.F.	210L.F.	220P.A.
Hivac	V.S.210	H.210	L.210	P.220

form of rectification, for it is free from the overloading bogey, and provides a wonderful distortionless output.

Following the diode is an L.F. stage resistance coupled to the split output stage already mentioned. To provide adequate input to the rectifier, and to arrange for satisfactory volume control of the radio receiver, a multi-mu H.F. stage is used.

The tuning is carried out by plain inductances so that the selectivity is sufficiently broad to prevent sideband cut off, with its deleterious effect on the picture reception, while it is sufficient to prevent interference from nearby stations.

### Avoiding Negative Pictures.

In the design of a television receiver care has to be taken that the right phase relationship is obtained, for it is just as easy to obtain a *negative* picture as it is to get a positive one.

This peculiarity is synonymous with the negative and positive as applied to photography, and a negative television picture reproduces the light portions as dark ones, and vice versa. To prevent this the number of L.F. stages must be correct, for each stage reverses the phase of the received impulses, so that we get alternately positive and negative pictures as we go from stage to stage through the receiver after the rectifier.

Here, too, the type of rectifier must be taken into account, for the leaky-grid type results in a negative picture, and the diode in a positive one. Therefore if leaky-grid rectification is used the set must have either one or three L.F. stages of amplification if a positive output is to be obtained, while the diode requires either two or four stages following for the same result.

### Low Power Requirements.

In the cathode ray system of reception the amplification required is not great, for, as previously stated, the cathode tube is a voltage-operated device, and so a mere few volts (about 5 volts R.M.S.) are required to modulate the tube fully.

In the case of the glow-lamp type of light supply quite a large power is required, a matter of watts A.C. output being necessary for good modulation of the light source, resulting in the need for great modulation and large valves.

This is a point that cannot be stressed too much, for whereas in the cathode ray system small battery-operated valves with a mere 120-volts H.T. give ample output, the mechanical method of reception necessitates mains valves and heavy anode power consumption if bright pictures are to be obtained.

The relative consumptions of the receivers for the two systems works out at something like 120 volts and 10 milliamps for cathode ray work, and 250 to 400 volts and round about 50 milliamps for satisfactory reception on other systems.

Obviously, then, the cathode ray scheme scores very heavily on this point, as it does on the other features that have already been brought to your notice.

The actual constructional facts of the cathode ray receiver are so simple that we need not go into them in detail. The photographs and diagrams show very

clearly how construction is carried out, and the set is obviously as easy to make as an ordinary small broadcast set.

It is built on normal baseboard lines, and offers no difficulties either in construction and operation. Single-dial tuning control with concentric trimming is employed for wavelength adjustment, and long waves have been incorporated, because although in this country all present television transmissions are carried out on the London National there are transmissions available from the long-wave Berlin station that will be of interest to experimenters.

### An Aid to Tuning.

No reaction is used, as this is a frequent source of distortion where vision reception is concerned, while a plug and jack break is inserted in the synchronising output circuit so that a pair of phones may be inserted while the set is being tuned in. This is a valuable feature, for it enables accurate aural tuning to be carried out without any interference with the modulation of the cathode tube.

The rigging up of the set will be discussed later, when the complete Television Viewer is assembled, but it can be seen from the foregoing that this is a very easy matter.

## SPECIAL OUTPUT FILTER WIRED INTO CIRCUIT

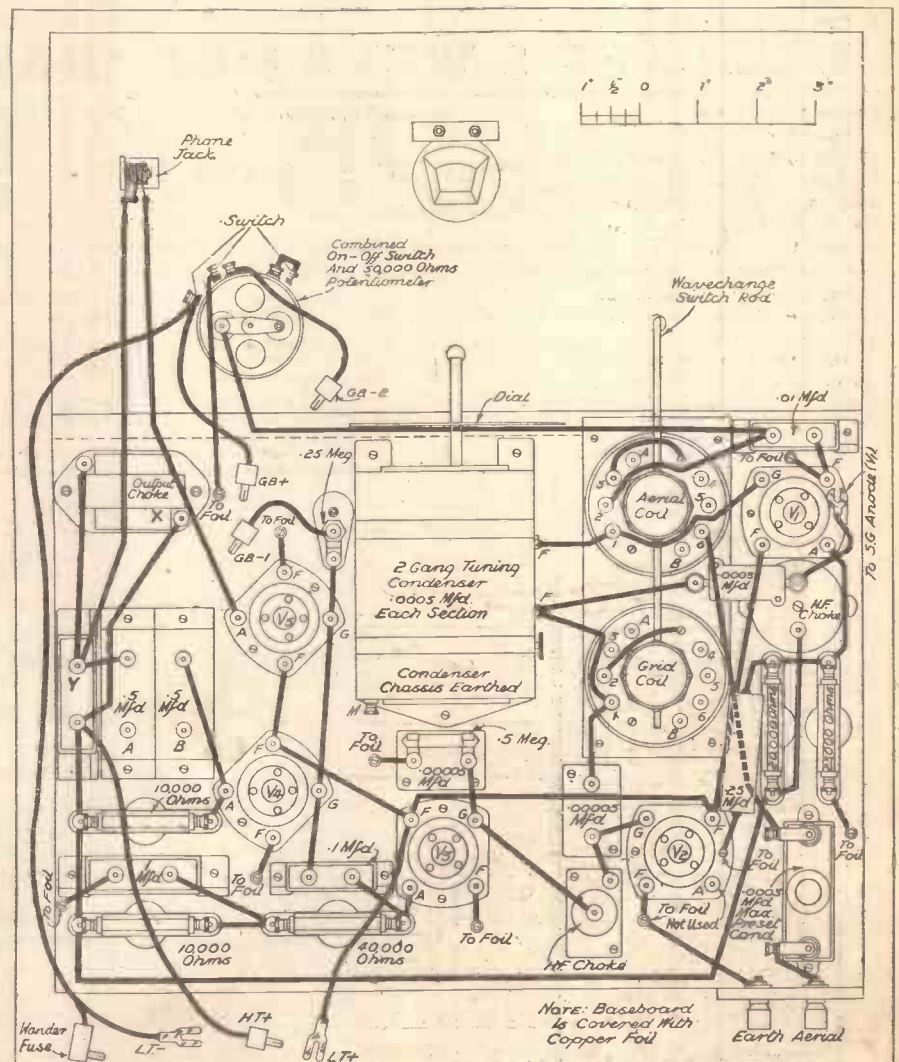

All the wiring is shown in this diagram, and the special tuned output filter for isolating the 375 synchronising pulse comprises the choke X and the condenser Y. Its object is to prevent strong modulation from upsetting the flash point of the two thyratron valves.



**D**ID you like "Aucassin and Nicolette"? I feel certain that it was intended to be an experiment in a new type of play. I am also certain that the experiment was just as exciting to some listeners as it was dull to others.

Literary folk must have revelled in it, while the rest would find it thoroughly bad entertainment.

It may not be known to everybody that "Aucassin and Nicolette" is something of a literary monument, and is considered one of the most charming romances in the world's literature. This alone makes the broadcasting of this mediæval story indeed an event of the greatest magnitude.

**Strange Literary Form.**

The unique mingling of prose and verse—the verse being sung to peculiarly monotonous music, sometimes approaching a wail—while it must have bored many listeners, did, I am sure, delight those who were already acquainted with the story and its strange literary form.

It may console some of you who were bored with it to know that the 13th century audience, when it listened to a recitation of "Aucassin and Nicolette," hadn't the same variety of music for the different verse sections as Robert Chignell wrote for the 20th century broadcast production. I believe that originally every verse section was sung to the same air.

Such a thing wouldn't be tolerated to-day, especially by the ordinary listener. Times have changed!

Literary people tell us that "Aucassin and Nicolette" was, in its own day, a failure. But though a failure some 500 years ago, it is considered now a success, at any rate in certain circles.

**A Matter For Conjecture.**

Whether broadcasting the play has enlarged those circles is a matter for conjecture. The B.B.C. is certain to receive many letters of appreciation or

**THE LISTENER'S NOTEBOOK**

Some points from the programmes, and comments on interesting items recently served up by the B.B.C.

otherwise. If appreciation is widespread, then we are certain to have broadcast in the future other mediæval romances of similar type.

There are, I know, several of them, but they are generally prose narratives rather than a mixture of prose and verse.

In the Empire Day celebration we were again treated to a long prose narrative, broken here and there by excerpts from the poets, snippets of music, or noises from the Effects Dept. Mr. E. A. Harding's Dramatic Bulletin had much to commend it.

There is little doubt that the B.B.C. is good at this sort of thing. The idea was good, too, just as was the way the broadcast was done.

All the sound-pictures were convincing. The only fault I could find with the production was that there was just a little too much geography.

I would have preferred a little more Home News, though, of course, to those of our breed living in remote parts of the Empire, even a geographical survey of the British Isles has an appeal that we at home can't appreciate to the same extent. I liked especially the small tributes paid here and there to the great men of the age and the ages.

A memorable broadcast, comparing favourably with the broadcast to the Empire last Christmas.

**Too Vigorous a Singer.**

I was interested to find Ronald Hill in a variety bill, particularly after hearing his music and lyrics in "Tickets, Please." There is a restraint about his singing that appeals to one immediately. But some of this appeal is lost when he sings with his partner. Mary Lee is much too vigorous a singer for him.

It will be a pity if this defect isn't corrected in the future. Balance is everything in their sort of turn.

Hugh E. Wright was a newcomer to me, but, provided he can change his stuff fairly frequently, I don't mind how often I have to listen to him. He is a raconteur of class.

I prefer his long rambling dissertations to his poetry. His style isn't nearly so funny.

I don't know whether the audience he referred to in one of his jokes was the "studio audience." It sounded rather like it. If so, I would remind him of his unseen audience. If not, then I pick up this hint with apologies.

**HOW THE MOON AFFECTS RADIO.**

The Editor, POPULAR WIRELESS.

Dear Sir,—I was interested to see Mr. H. A. C. Todd's remark in the May 20th issue of "P.W." concerning the variation of signal strength with the moon. I have often noticed a very marked increase in signal strength beginning about four or five days before full moon and peaking about three days after full moon, finally dying rapidly away to normal in about two days.

I usually find this taking place not only on the 49 m. band but also on 31 and 25 m. On 80 and 160 m. the effect seems very slight or entirely absent.

Although this variation of signal strength may be masked by other conditions, it seems by far the most regular of any "weather variations."

Has Mr. Todd noticed the greatly increased strength of the 13, 16 and 19 m. U.S.A. stations existing on fine cold afternoons? I found this very marked during the autumn of last year, more particularly on the two lower waves. On many occasions I have received W 3 X A L on 16 m. for a whole afternoon at R 7 on an 0-v-0 with hardly a fade, with weather conditions as mentioned above.

Yours faithfully,

R. T. WARD (BRS 958).

**LAST 2 WEEKS OF "RADIO-PICS"**

ALL-CASH FIRST PRIZE!

**£25 AND 50**

WIRELESS "EXTRAS" For Runners-Up.

The Consolation Prizes will all be very useful to set builders as they include: Loudspeakers—Ganged Condensers—Coil Units—"Class B" Transformers, etc.

IN this fascinating free competition, £25 in cash will be paid to the reader who solves the six sets of our "Radio-pics" puzzles correctly, or most nearly so. The fifty wireless "extras" will be awarded for the next-best entries.







The first four puzzle-sets have appeared already, while here you have Set 5 to solve. Each picture denotes the name of a wireless station at home or abroad. Can you find them? The puzzles are all perfectly easy and, as a further help, all this week's winning answers are in the guide list below: thus it is merely a matter of fitting the right stations to the right pictures. Each other set in the competition has its own "key" list, too.

Write the answers IN INK (and in BLOCK LETTERS) in the spaces provided; then cut out the picture-set and keep it until next week, when we shall publish the Sixth and Final Set, together with full sending-in directions. The competition rules have already appeared, and will be repeated next week, too.

**"RADIO-PICS" SET 5**

As for the purposes of the competition, wireless stations all over the world are being used, the following short guide list of names is given for reference with this week's pictures:

- FLORENCE
- ANCHORAGE
- FOREST HILLS
- MARSEILLES
- BUFFALO
- MADRID
- CAPE TOWN
- EDINBURGH
- TOULOUSE
- PORTLAND
- PLYMOUTH
- HOLLYWOOD
- BOSTON
- BRANDON
- WHITEHAVEN
- OSLO

<p>FP</p> 	<p>RD</p> 	<p>H</p> 
<p>25</p> 	<p>26</p> 	<p>27</p> 
<p>28</p>	<p>29</p>	<p>30</p>

EASY COMPETITION—PRIZES MUST BE WON—NOTHING TO PAY!



# THE NEW MULLARD *Screened* PENTODE

## V.P.4 S.P.4



**'BUT MY CIRCUIT IS MY OWN DESIGN' HE SAID**

"But even then," we told him, "the new Screened Pentode will plug into the H.F. holder."

He was surprised. He was gratified. This was something new. Pentode Power for the H.F. stage of his receiver, and yet none of these old troubles about redesigning the circuit—none of those old worries about new type valves not plugging into old-type circuits! And, as usual with valve developments, it is Mullards (the originators of the ordinary Pentode) who have come forward, after intensive scientific researches, with the new Screened Pentode for any H.F. holder in any and every A.C. circuit.

It is the greatest valve improvement of recent times. It affects you! Ask your dealer for details. He will be enthusiastic himself about the new Screened Pentodes — WHICH SPEAKS VOLUMES.

**TYPE V.P. 4 for HIGH FREQUENCY STAGES  
TYPE S.P.4 for the DETECTOR STAGE**

ASK T.S.D. Whenever you want advice about your set or about your valves—ask T.S.D. —Mullard Technical Service Department—always at your service. You're under no obligation whatsoever. We help ourselves by helping you. When writing, whether your problem is big or small, give every detail, and address your envelope to T.S.D., Ref. C.L.L.



# Mullard

**THE MASTER VALVE**

The Mullard Wireless Service Co., Ltd., Mullard House, Charing Cross Road, London, W.C.2.

Arhs

THE MIRROR OF THE B.B.C.

By O.H.M.

## NO SEASIDE PUBLICITY

Trouble with the New Organ—Producer's Holiday—Learning to Dance—Sheffield on the Air.

THE Governors of the B.B.C. view with apprehension the increasing demands from the mayors and local authorities of seaside resorts who are anxious to obtain broadcast publicity. Remarks passed at the Conference of Health and Pleasure Resorts showed quite plainly that there was a good deal of feeling on the question.

In these days of abundant pleasure cruises the holiday resorts find increasing difficulty in filling their hotels, and quite naturally they look to the B.B.C., as the organisation that did a great deal to popularise holiday cruises, to come to their aid and advise listeners to stay at "Tooting By Sea," or "Little Mudham," and so on.

The Governors realise that the B.B.C. has not a leg to stand on against the attacks of the local authorities, but vague explanations continue to flow from Broadcasting House with the result that nobody is satisfied. I advise the Governors to say straight out that they don't want to boost the holiday resorts because once such a policy is adopted there may be no end to it.

### The After-thought Organ.

There has been a lot of unnecessary reticence regarding the beautiful organ that has been built in the Concert Hall. The instrument is one of the finest of its type in the world—as listeners will appreciate when they hear it on June 16.

The finest organ-builders in the country have devoted every care upon it, and the famous organists who have played it are loud in its praise.

The trouble is that the B.B.C. decided to have an organ as an after-thought. The result is that they had to put the organ where there was room for it, and it was discovered too late that the deep notes penetrated into some of the studios.

Engineers and acoustical experts have suggested all sorts of devices to keep out the

noises, but the big boom of the mighty organ has so far beaten them all. I hear that a new scheme of soundproofing is to be adopted now, so let us hope that it will prove successful.

### "WAIT HERE, PLEASE"



On being shown into this B.B.C. waiting room at Leeds, you might easily imagine from the style of furnishing that you were in Broadcasting House, London.

If it isn't, the bass response will have to be taken out of the microphones in the adjoining studios whenever the organ is playing!

### John Watt's Return.

John Watt, the hardest worked of all the B.B.C. producers, will be back in London again soon bubbling over with bright ideas

after a well-earned holiday. He has been on a central-European tour—his first holiday in two years.

Sir John Reith almost forced him to go, and since he said he intended to hunt around for ideas (not for talent, as the Productions Department are anxious to explain) I understand that the Corporation willingly paid his expenses.

Watt really "made his name" with listeners over his "Songs From the Shows," although his work was very well known long before then. His is one of the really original minds on the light entertainment side at Broadcasting House, and I am not surprised to hear that outside interests are after his services and are ready to offer most attractive salaries.

Eric Maschwitz, the new variety chief, will see that he doesn't go.

### Dance Lessons in the Autumn.

Rumour says that Santos Casani may broadcast another series of dance lessons as part of the autumn programmes. Should he do so, they will, no doubt, be on similar lines to those which created so much interest some years ago.

Mr. Casani is owner of the club in Regent Street which bears his name, from which the late dance music will be relayed on June 13th, provided by Charlie Kunz and his Band.

### Methodist Conference Relays.

Methodists all over the country will look forward to hearing the relays from two services on Sunday, June 18th, in connection with the Methodist Conference which this year is being held in Belfast.

The first takes place in the Grosvenor Hall in the afternoon, and will be conducted by the Rev. John A. Duke, President of the Methodist Church in Ireland, when the singing will be led by a special choir of young people. The second service will be relayed from the Carlisle Memorial Church, and is to include an address by the Rev. Dr. J. Scott Lidgett, C.H., President of the Methodist Church.

Dr. Scott Lidgett was founder with the late Dr. Moulton in 1891 of the Bermondsey Settlement in London, of which he is Warden.

(Continued on page 433.)

### A LOUDSPEAKER HINT.

THAT hollow-sounding reproduction known as "boxiness" is not due to the loudspeaker itself. Many of the excellent permanent-magnet moving coils that are now enjoying a well-deserved popularity are spoiled by this "boxy" effect.

There is no reason why a speaker should not be built into the same cabinet as the

### HOW TO COVER THE BACK

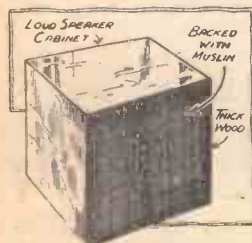

Muslin is usually preferable to a solid piece of wood for the back of a loudspeaker cabinet, as it permits sound waves to pass without opposition.

set, or into a special cabinet of its own. But the wood from which the cabinet is made must be substantial.

## FOR THE PRACTICAL MAN

How to avoid "boxiness" in your speaker, and a good substitute for proper fuses.

The thicker the wood the better. Much of the "boxiness," however, is caused by the use of a solid back to the cabinet.

It is true that some kind of back is desirable to keep the dust out, but this can easily consist of muslin or similar material stretched over a skeleton framework.

### Use Thick Wood.

Those who prefer plain flat baffles should employ wood at least  $\frac{3}{4}$  in. in thickness. If the thickness can be increased to 1 in., the effect of the baffle will be noticeably enhanced.

And don't use a baffle less than 2 ft. square if you wish to bring out the bass properly!

### AN IMPROVISED FUSE.

OCASIONS arise when we find we have blown the fuse or fuses in the leads of our mains equipment. On these occasions, if after things have been adjusted a doubt exists as to the effectiveness of the adjustment, and a spare fuse is not available, a temporary one can be made from a strip of cigarette carton tin foil.

If the fuse to be replaced is of the bulb type it is expedient to attach the foil between the two holder terminals on the

### WHEN THE FUSE BLOWS

A piece of ordinary tin foil laid along the side of a cartridge fuse will make an ideal temporary but safe circuit connection.



outside. For a cartridge fuse the foil should be supported on the old case, the ends of which should receive a binding of foil sufficient to make good contact with the holder clips.





More about the first set to embody Dual A.V.C.  
Automatic Control of both H.F. and L.F. Amplification.  
Designed and Described by the "P.W." RESEARCH DEPARTMENT.

**T**HIS week we continue the constructional details of that very latest thing in radio receivers, the "Double-D Pen." As will be remembered, the set is a four-valve A.C. chassis model employing the new Cossor double-diode multi- $\mu$  pentode, which enables automatic volume control to be applied to both H.F. and L.F. sections.

The result, of course, is very strongly applied A.V.C., for with control of both the multi- $\mu$  screened-grid valves and the multi- $\mu$  pentode L.F. amplifier the rectifying diodes can carry out their work most efficaciously.

A skeleton circuit arrangement of the "Double-D Pen" was published last week, and it remains for us but to go into the finer details of the circuit and to discuss its practical application.

**Achieving Short Connections.**

As can be seen, the circuit is not a complicated one, and the putting it into practice is well within the scope of the home constructor. We have chosen the chassis type of design as the most suitable for the set owing to the desirability of having short anode and grid leads and tuning connections at the H.F. end of the receiver.

By placing the ganged tuning coils below

the variable condenser very short connections can be obtained, and, moreover, the leads are almost completely screened throughout their lengths.

**EXCEPTIONALLY CLEAN DESIGN**

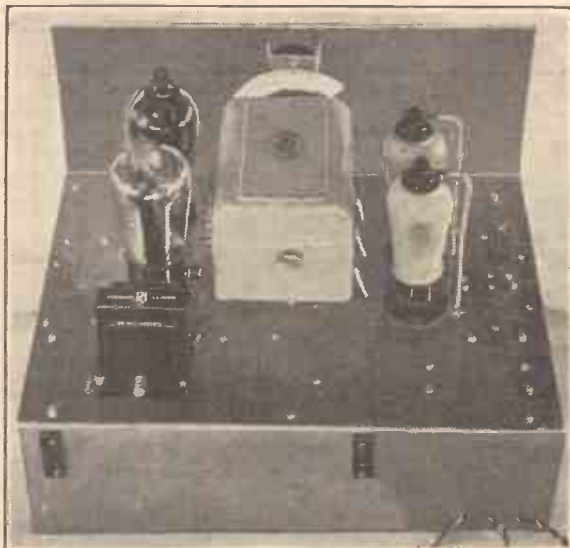

Apart from the four leads to terminals on the valves, there is practically no wiring above the chassis "baseboard," which gives the set a most attractive and business-like appearance.

Quite ordinary canned coils are used in the "Double-D Pen," H.F. transformer coupling being used in each stage. With the amplification with which a combination of valves of the types used is capable we can afford to go out for the maximum selectivity, and tuned H.F. transformer coupling is admittedly much more selective than the tuned-anode method.

**Circuit Details.**

The aerial is fed into the primary of the first H.F. transformer, the secondary of which forms the grid circuit of the first multi- $\mu$  screened-grid valve. This valve is transformer coupled to the second, and in turn this latter is transformer fed to the double-diode multi- $\mu$  pentode.

It will be noticed that earth ends of the tuning coil (Continued on next page.)

**THESE COMPONENTS ARE RECOMMENDED FOR THIS EXCLUSIVE "P.W." DESIGN**

Component	Make used by designer	Alternatives of suitable specification recommended by designer	Component	Make used by designer	Alternatives of suitable specification recommended by designer
1 Aluminium panel, 14 in. x 10 in.	Peto-Scott	—	21,000-ohm resistances with vertical holders	Graham Farish "Ohmite"	—
1 Base, 14 in. x 10½ in., turned down ¼ in.	Peto-Scott	—	2 8,000-ohm do.	Graham Farish "Ohmite"	—
1 Strip for back support of base 5½ in., turned down to give 4½ in. vertical	Peto-Scott	—	1 10,000-ohm do.	Graham Farish "Ohmite"	—
1 Three-gang .0005-mfd. variable condenser	J.B. "Unitune"	—	1 3,000-ohm do.	Graham Farish "Ohmite"	—
1 50-mfd. electrolytic fixed condenser	T.C.C. type 521	—	1 300-ohm do.	Graham Farish "Ohmite"	—
1 2-mfd. fixed condenser	T.C.C. type 80	—	1 15,000-ohm resistance with terminals	Graham Farish "Ohmite"	—
4 2-mfd. fixed condensers	T.C.C. type 50	Dubilier, Telsen	1 250-ohm do.	Graham Farish "Ohmite"	—
2 .25-mfd. fixed condensers	Telsen Miniature	—	1 .25-meg. potentiometer	Igranic "Megostat"	Bulgin
2 .1-mfd. fixed condensers	Telsen Miniature	—	3 Matched screened coils	Telsen 288	—
2 .01-mfd. fixed condensers	Telsen Miniature	T.C.C., Dubilier	1 H.F. screened choke	Bulgin "Superhet"	—
2 .01-mfd. fixed condensers	Dubilier 670	T.C.C.	3 5-pin valve holders for chassis mounting	Clix	—
3 .0001-mfd. fixed condensers	Dubilier 670	T.C.C., Ferranti, Telsen	1 7-pin do.	Clix	—
2 1-meg. resistances with vertical holders	Graham Farish "Ohmite"	—	1 On-off switch	Bulgin S.80	—
1 2-meg. do.	Graham Farish "Ohmite"	—	2 Pairs twin sockets	Belling-Lee	—
1 .25-meg. do.	Graham Farish "Ohmite"	—	1 Pentode output choke	R.I. "Hypercore," centre tapped	Lissen
1 .5-meg. do.	Graham Farish "Ohmite"	—	6 yds. insulating sleeving	Goltone	Wearite
1 80,000-ohm do.	Graham Farish "Ohmite"	—	2 yds. spiral screened sleeving	Goltone	—
2 20,000-ohm do.	Graham Farish "Ohmite"	—	10 yds. 18-gauge tinned copper wire	—	—
			Flex, screws, 6 B.A. nuts and bolts, etc.		



# THE "DOUBLE-D PEN"

(Continued from previous page.)

secondaries are not taken direct to earth, or the chassis, but are fed through decoupling resistances to one of the anodes of the diode section of the rectifying valve.

The H.F. circuit return is via the .01-mfd. condensers which are connected between the bottoms of the coils and the cathodes of the requisite valves. This arrangement is essential in order that the triple gang condenser can be used with its rotors "grounded." This is very important if hand capacity is to be completely obviated.

## Providing Better A.V.C.

A common bias resistance of 250 ohms is used for the two H.F. valves, and the pentode section of the "D-D Pen"

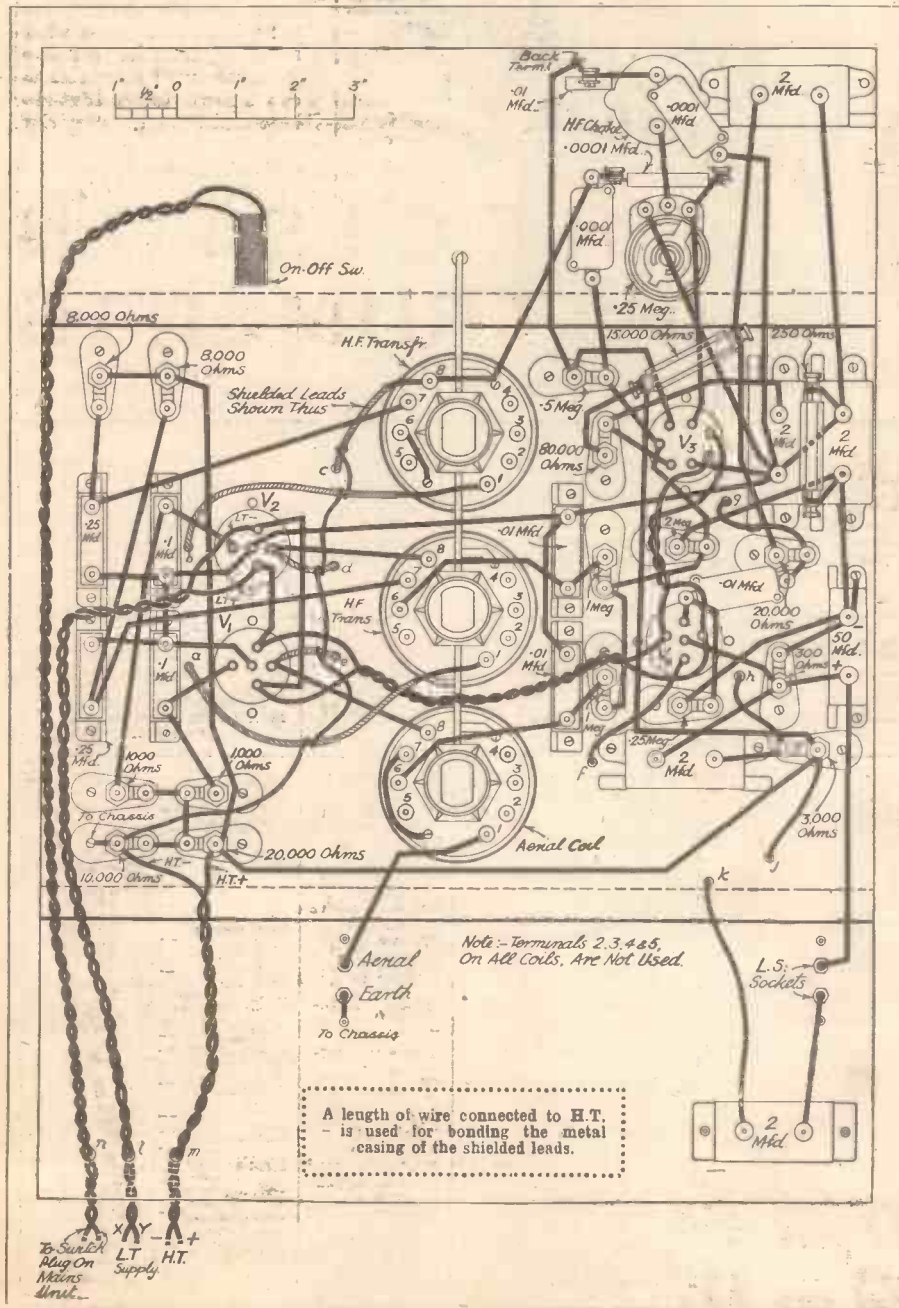
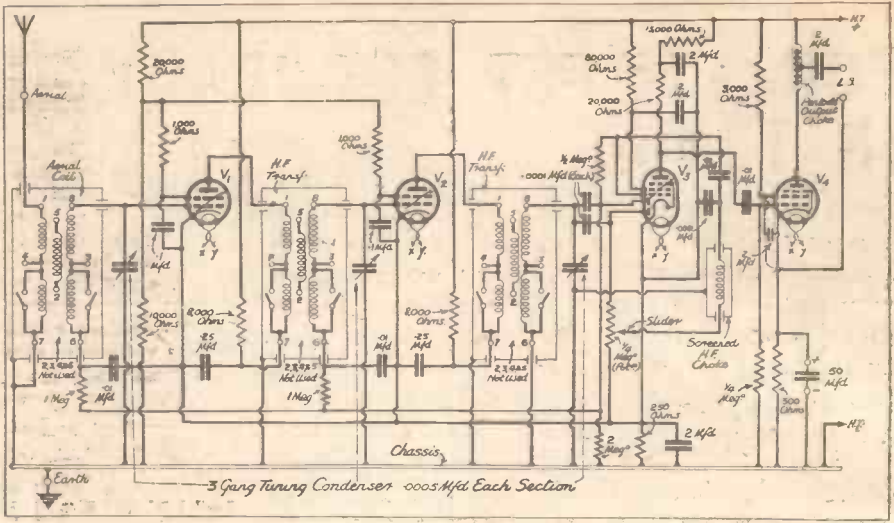

Two multi-mu screened-grid valves, the double-diode multi-mu pentode and the mains pentode output amplifier form an efficient and powerful team. Self-control of volume comes into operation only after a certain level of strength is reached, thus ensuring full volume from distant transmissions. The chassis, the underneath wiring of which is shown on the left, is constructed from three pieces of aluminum sheet, a straight panel 14 in. x 10 in., a "baseboard" which is bolted to the panel, and a back support which is fixed to the underside of the base.

This is an arrangement that provides somewhat better automatic volume control than the separate cathode resistance-bias method. It is, of course, necessary to decouple the S.G. valves thoroughly, and this is done, as previously mentioned, by the resistances in series with the tuning coils, and the .01-mfd. condensers.

These latter condensers and the resistances have a very definite effect upon the action of the automatic volume control. If the resistances are too high, or the condensers too large, the charging up of the condensers which occurs, especially on strong carrier swings, such as occur with fading stations, makes the A.V.C. lag—while the charge leaks away—with the result that the set does not return to normality as quickly as it should.

## THE D-D. PEN



## Effect of Atmospheric.

In such circumstances the strong swings are reduced, as they should be, but when the station fades quickly—as it does sometimes—the sensitivity of the set does not increase

This valve, which is the double-diode multi-mu pentode, forms the basis of our latest circuit development.

(Continued on page 428.)



# FOR UTMOST ACCURACY IN TUNING . . . . .

Gives extremely fine tuning. Similar in construction to the "NUGANG" Condensers, but the trimmer of front section is operated independently from the receiver panel by means of a second knob concentric with the main tuning knob, Rigid one-piece chassis, very robust construction. Trimmer to each stage. Heavy gauge wide spaced aluminium vanes. Special bearings to rotor ensure permanent accuracy. Capacity .0005. Matched to within 1/2 mmfd. plus 1/2 per cent. Complete with disc drive and bakelite escutcheon plate.

2 gang - 18/6

3 gang - 27/-

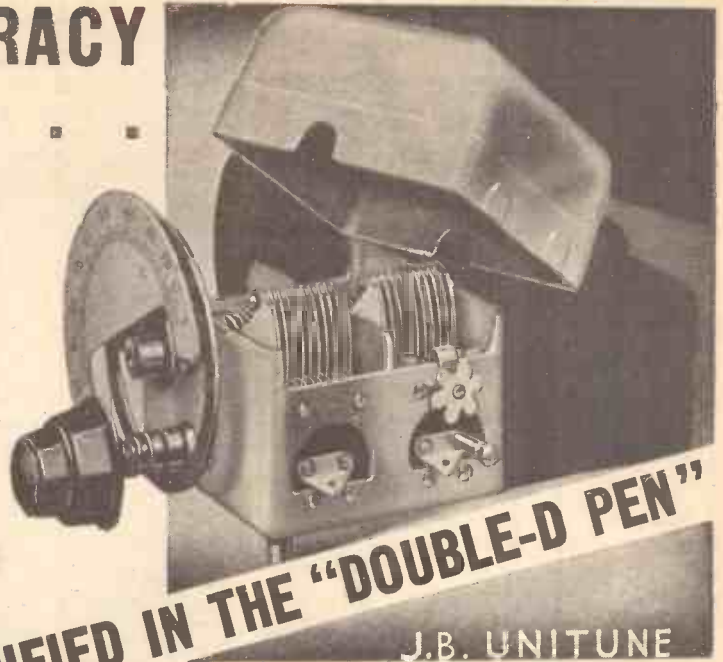

**SPECIFIED IN THE "DOUBLE-D PEN"**

J.B. UNITUNE

Write for FREE Catalogue

## PRECISION INSTRUMENTS



Advertisement of Jackson Bros. (London), Ltd., 72 St. Thomas' Street, London, S.E.1.

Telephone: Hop 1837.

**WILLS'S  
CAPSTAN  
ARE  
CAPITAL**



**10 FOR 6<sup>D</sup>  
20 FOR 11<sup>1</sup>/<sub>2</sub><sup>D</sup>**

# THE "DOUBLE-D PEN"

(Continued from page 426.)

rapidly enough and a fade out of the programme results.

This effect is also noticeable (if the condenser or resistances are too large), when a powerful atmospheric arises. In such an instance the set's amplification is, of course, checked, but instead of returning immediately the atmospheric comes it continues to be checked while the charges on the condensers leak away.

The best compromise for adequate decoupling of the S.G. grid circuits and speed of A.V.C. seems to be the values chosen, namely 1 megohm for the resistances and .01 mfd. for the condensers. These values, then, should be noted and adhered to by constructors.

## Feeding Two Diodes.

The feed from the "top" of the third coil secondary is split between the two diodes of the new Cossor valve. The top diode in the theoretical circuit rectifies the incoming H.F., and the resultant current (D.C., of course) flows through the 2-megohms resistance to earth.

This causes a potential to be developed across the resistance, the potential being varied automatically according to the strength of the incoming "signal." This

## EFFICIENT LAYOUT

The deep chassis allows the tuning coils, as well as most of the other components, to be fixed below the metal "baseboard." As you can see from the photo and diagram of the wiring, the coils are immediately below the gang condenser, which is connected up with screened leads.

varying potential is applied to the grids of the S.G. valves, and is the voltage which carries out the automatic volume control.

Not only is the potential applied to the grids of the H.F. valves, but it is also applied through the 1/2 megohm resistance to the control grid of the multi-mu pentode section of the Cossor valve. Thus, this too is automatically controlled in amplification powers by the variations of the input to the diode.

The second diode also carries out rectification and in this case the voltage is applied across the .25-meg. potentiometer, from whence a pre-determined proportion can be tapped to the grid of

## CONTROLS REDUCED TO A MINIMUM

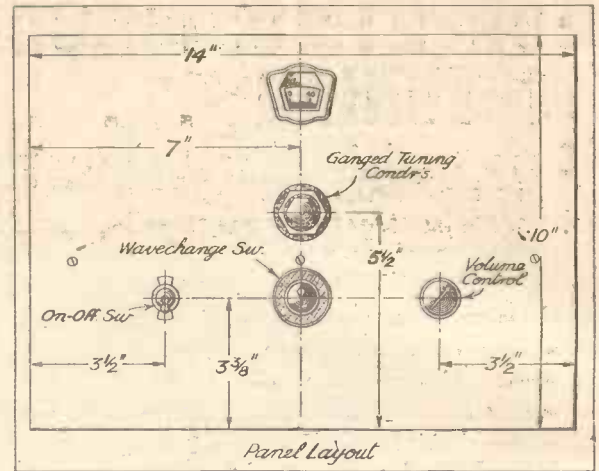

The receiver is virtually one-knob controlled, the volume adjustment being merely for preliminary setting of the maximum level.

the 15,000-ohms resistance and the 2-mfd condenser to earth.

A centre-tapped pentode output choke is used in the anode circuit of the last valve, the loudspeaker return being taken to the cathode of the valve in the usual way. It is interesting to note that a 50-mfd. condenser is used to by-

pass the 300-ohm cathode resistance which is employed to provide grid bias to the output valve.

## New Type Condenser.

The condenser is of the new dry electrolytic type, and its large value is particularly important, for it means it does have a definite by-passing effect right down to

## Perfectly Straightforward.

The screened H.F. choke is an essential part of the circuit, for it prevents any H.F. impulses being passed on to the grid of the pentode. Thus only A.C. variations are used from the second diode rectification.

From this point onwards the circuit is perfectly straightforward and usual. The anode circuit of the multi-mu pentode is resistance-capacity coupled to the output pentode, and is adequately decoupled by

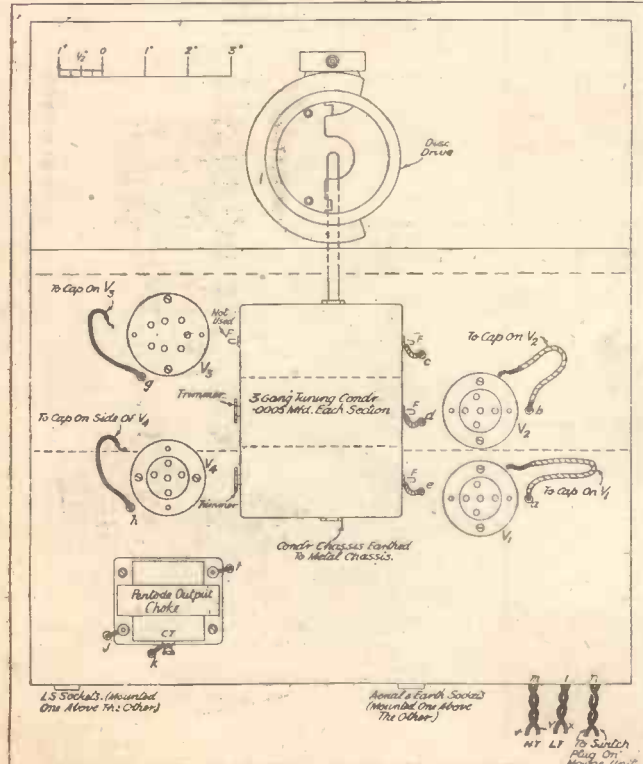

## VALVES AND ACCESSORIES

**VALVES.**—2 Cossor MVSG., 1 Cossor D.D. Pen., 1 Mullard Pen. 4V., or Cossor MP/Pen., Marconi and Osram M.P.T.4, Mazda A.C./Pen. Note.—If other than the output valve first mentioned is used, care should be taken to see that the bias resistance is of a value in accordance with the valve maker's advice.

**LOUDSPEAKERS.**—R. & A., Rola, Amplion, H.M.V., Marconiphone, Atlas, Ferranti, Epoch, Ormond, Blue Spot, G.E.C., B.T.H.

**MAINS UNIT.**—Suitable units are the Catkin unit, Heyberd M.W.L. or other units capable of giving 250 volts H.T. at 50 milliamps, and an L.T. supply of 4 volts 4 amps. Note.—Only H.T. pos., H.T. minus, and two L.T. feeds are required.

**AERIAL AND EARTH EQUIPMENT.**—Goltone "Akrite," Electron "Superial," Radiophone "Receptru" down lead, Graham Farish "Filt" earthing device.

50 cycles or less, the reactance of the 50 mfd. being a lower value than 300 ohms. As the condenser is of the electrolytic type, however, care must be taken that the

(Continued on page 434.)





**AN ADAPTOR LID.**

As so many home-made valve base adaptors are used to-day, here is a very efficient "lid" for them, which saves a lot of time and fumbling when inserting the adaptor. All that is required is a short piece of threaded brass (1) with two nuts to fit (2) and a knob off an old reaction condenser (one with arrow on top preferred). Most valve bases have a hole in the bottom through which the brass is

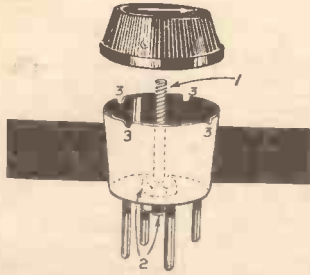

It saves a lot of fumbling.

fixed, as diagram. When fixing knob, see that the arrow is pointing in the direction of the leg marked P. The gaps (3) cut in the top of base are to allow the flex leads to come through. It is advisable to tie a knot in the flex just inside the gaps so as to prevent strain on the solder joint in the valve leg. If a black knob and base are used, the finished adaptor looks quite smart and unique.

**CURING MAINS CLICKS.**

OBJECTIONABLE electric noises and clicks occurs in mains sets when switches in the house are put on and off. This can be eliminated by a simple contrivance composed of four



Connections for a "double" mains filter.

1-mfd. condensers, two 3-in. by 1 1/2 formers, and some 20 or 22 gauge wire, as the accompanying sketch. It would be advisable to fit inside set or in a box outside.

**REPAIRING SPEAKER LEADS.**

MOST constructors know that a broken L.S. tag is sometimes a problem to repair owing to the difficulty of making a good joint with the flimsy tinsel wire usually employed.

Quite a serviceable repair may be made by stripping away the insulation and tightly wrapping the exposed wire with a strip of tinfoil; this should be

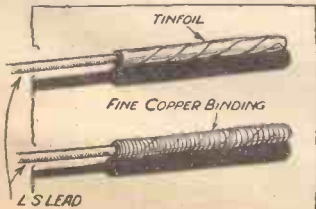

How to deal with tinsel leads.

twisted tightly with the finger and thumb and finished off with a layer of fine copper wire.

It will now be possible to make a good connection either by looping around terminal or attaching one of the numerous types of spade tags.

**A CHEAP CLEANING BRUSH.**

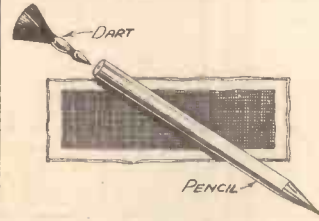

Serviceable brushes can be made from air-gun darts.

THE wireless constructor has many uses for a small brush. In fact, so varied are these jobs that new brushes are sometimes needed for two distinct, if trivial, purposes. For example, a brush which has been used for amyl acetate in doing an accumulator repair cannot well be used for, say, spirit varnish afterwards, unless considerable trouble is expended in cleaning it.

Small air-gun darts as sold at a few coppers per dozen will be found ad-

the baffle, as shown in the illustration. The flex is wound round these, and only sufficient let out, as required.

**AN ACCUMULATOR FOR 6d.**

MOST car accumulators are scrapped when one cell becomes faulty. I am using a 2-volt accumulator made from a 6-volt car battery, the end cell of which was dud. It gives me approximately 250 hours of perfect service, and cost 6d. Select a perfect cell: with a hacksaw blade cut down accumulator casing about 1/4 in. away from separating walls (see sketch) each side of cell.

Make wooden box 1/4 in. bigger than cell. Melt 1 lb. of pitch and pour in wooden box—put cell in before pitch hardens. Another 3 or 4 lbs. of pitch will have to be poured in to complete the job. When pitch is set it can be

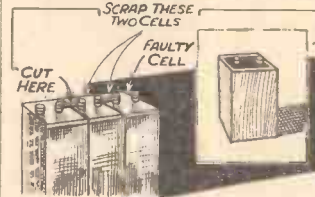

The faulty cells are scrapped, but the good one retained for use.

smoothed off to look like a professional article.

**ONE GUINEA FOR THE BEST WRINKLE!**

Readers are invited to send a short description, with sketch, of any original and practical radio idea. Each week £1 Is. will be paid for the best Wrinkle from a reader, and others will be paid for at our usual rates.

Each hint must be on a separate sheet of paper, written on one side of the page only. Address your hints to the Technical Editor, "Popular Wireless," Tallis House, Tallis Street, E.C.4, marking the envelope "Recommended Wrinkles."

Will readers please note that the Editor cannot, in any circumstances, guarantee to return rejected Wrinkles, and that payment for published hints is not made until ten days after they appear.

The best Wrinkle in the May 27th issue was sent by Mr. W. H. Grayling, 8, Milton Road, Cambridge, to whom a guinea has been awarded.

mirable for nearly all the jobs likely to be tackled in this connection.

The sharp end of the dart can be easily stuck into a piece of wood to serve as a handle; a pencil makes a very good handle. Should a wide brush be needed several darts may be stuck, side by side, in the end of a strip of wood of the necessary width. Being so cheap, the darts may be thrown away when the job is done.

**TIDY EXTENSION LEADS.**

IT is useful to have a long lead of flex attached to a moving-coil speaker, but this is likely to become tangled

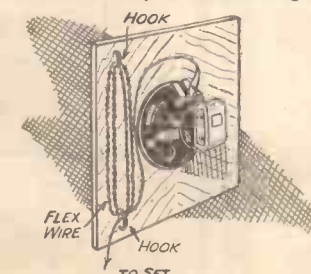

A means of "taking up" flex leads.

and get in the way when the speaker is placed near to the set.

To overcome this difficulty two brass hooks can be screwed to the back of

Drill lead plate ends to take terminals.

**HAIR-LINE TUNING.**

THE ordinary flat ebonite dial can be adapted for hairline tuning in the following way. Drill a 1/4-in. hole in the rim of the dial, about midway

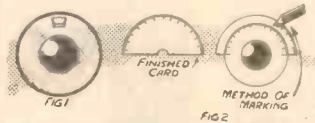

How to convert a plain dial for accurate reading.

between the finger grip and the edge, as shown in sketch, Fig. 1. Square out with a small square file or fretsaw. On the side that fits against the panel mark out a line running through the centre of the hole you have made. Cut a small slot on either side with an old penknife with a rather "sawy" edge. Insert a short length of a single strand of flex wire, taking care that it is perfectly straight, and cement in with a drop of hot pitch from an old battery, level off so that it lies flush with the dial. Next get a piece of stiff white paper, a postcard will do, and mark out a semicircle inside of which you make a smaller one, the diameter of the condenser spindle. The larger circle should be slightly less than the dial. To mark degrees on the card, place the

dial over the semi-circle and mark off from the actual ones on the dial. Now cut out the card as shown in Fig. 2 and glue on to the panel with the small cut-out resting on the spindle. Tighten up the condenser fixing nut and the card will be held firmly in place. All that remains now is to fix the dial on the spindle and the tuner is complete.

**STAND FOR LOUDSPEAKER.**

IT is sometimes difficult to find a suitable place for the single cabinet loudspeaker convenient for all to hear, especially if one is troubled with deafness. But if the loudspeaker is made and fixed on a stand as shown it can be placed in any part of the room or by the chair of the person whose hearing is not so good.

It is not difficult to make and looks well if made in mahogany and stained on the dark side and french polished. The body of the cabinet is 7/8 in. thick and dovetailed. The front and back edges are rabbeted to receive the fittings for the grille and the back of the cabinet.

A frame made of 1 1/2 x 3/4 in. mahogany as shown in the full-sized section is mitred and pinned or nailed together and then carefully fitted in the front rabbet and fixed with, say, 3-in. panel pins. In the groove formed at A is fixed a raised beading and glued, this can be varied with any of the ornamental beadings, etc., one can get at any of the shops which deal in this kind of material.

The grille of ply-wood is screwed to the back of the mitred frame with small screws, care being taken that the screws don't show through.

The centre of the loudspeaker is 2 ft. 10 in. in height from the floor. This is about the average height suitable when one is sitting in an easy chair.

On the top of the frame is fixed a

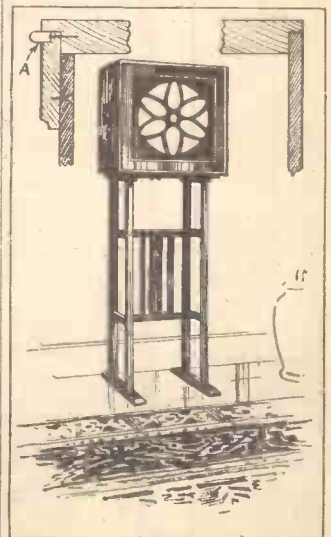

If you mount your speaker on a frame it can be placed in the most suitable part of the room.

flat piece about 5 in. x 3/4 in., with a 3-in. hole in the centre, a 3/8-in. hole is also bored in the centre of the bottom of the cabinet, and a 3-in. bolt with wing nut fixes both together.

The stand can be of any design to meet the skill of the maker.





# TESTED AND FOUND?

## A NEW ELECTROLYTIC CONDENSER

**H**ITHERTO the electrolytic principle has largely been applied to condensers of very high value. But it is now being employed more and more widely for the lower values, too.

And it is evident that it can prove a very desirable method. Note the dimensions of the 6-mfd. fixed condenser of the paper type and visualise the space required to accommodate two of them as well as one of 1-mfd. capacity.

Compare this with the four cubic inches or so which the Hellesens Dry Electrolytic Pack measures. The whole unit is no larger than an average 2-mfd., despite its total of 15 mfd.

It is built into a tough waxed casing and four flexible leads are taken off from it, one being a negative connection common to all these sections.

As we have indicated, two of these sections have a capacity of 6 mfd. each and one of 1 mfd. So practically all the smoothing capacity required for a simple mains set or unit is contained in the one small unit.



There are three condensers in this Hellesens compact dry electrolytic pack.

It can cope with peak voltages of 300, and we have found it perfectly satisfactory in every way.

## A FERRANTI MAINS TRANSFORMER

When one has seen enormous transformers for the National Grid System being built from virtually raw materials in the vast Hollinwood Factory, one realises how apt it is that Ferranti should also manufacture the comparatively small transformers for use in radio sets at the other end of the mains.

And one further appreciates how well fitted



The Ferranti type S.V.34 mains transformer.

Ferranti are to make such components, both in experience and equipment.

The efficiency and reliability of his radio mains apparatus means as much to the individual listener as does the efficiency and reliability of the mains gear which generates and distributes the power with which he feeds his outfit, at least, in so far as his radio is concerned.

And in this connection it is to be noted that Ferranti mains transformers are tested to 2,000-



On the left is the Ormond R.531, and on the right the R.531 C.T. transformer.

volts A.C. with an insulation resistance of not less than 200 megohms.

Also they are completely shrouded in sheet-steel cases.

We have recently given very practical tests to the Ferranti S.V.34 type, which is designed for a U.12 valve rectifier. It has an H.T. output of 350 volts at 70 m/a, while there is a rectifier 4 volts, 2.5 amps; and 5 amps 4 volts and 1 amp 4 volts L.T. windings centre tapped.

It is a fine component, and we have no hesitation in recommending its use to our readers.

## TWO ORMOND TRANSFORMERS

It would seem that the prejudices against the use of nickel iron cores in L.F. transformers is wearing down.

Of course, it is very comforting to have such a fat mass of iron that the component can be connected directly in almost any anode circuit without an inductance depreciation.

But the nickel transformer is smaller and, generally speaking, less expensive. And it offers distinct alternatives to the constructor.

He can employ a parallel feed, lose a little amplification and obtain almost incomparable results in point of quality, and he can risk a possible falling characteristic in a direct connection which might or might not operate disadvantageously. As a matter of fact, by chance it could even function to the betterment of his overall results!

Of course, there are transformers designed specifically for parallel-feed, which act extraordinarily well in that capacity but which are hopeless in the direct connection.

The Ormond R.531 is a general utility type which does not fall within that category. Directly connected, it can take up to about 24 milliamps (a good detector current, and still maintain a good performance.

Used with a parallel-feed it exhibits all the virtues of the high-class nickel-iron transformer.

It has a ratio of 1 to 3½ and it is built into a handsome walnut bakelite case.

The Ormond R.531 C.T. is of similar general design, but is given a 1 to 8 ratio, has a centre tap, and is for use in Q.P.P. circuits.

## A WELL-DESIGNED CONDENSER

F. E. Godfrey (Radio), Ltd., claim that their short-wave condenser is the only condenser of its class and type yet produced in this country, and that it "is not an ordinary reaction condenser, nor is it a converted broadcast-band condenser." And they produce no less than 14 points succinctly to uphold their claim.

These are so well brought out that I cannot refrain from reproducing them in full. Here they are:

1. The plates are designed to give S.L.F. law when the maximum condenser size is .0002-mfd. It should be pointed out that the plate shape for the .0002-mfd. condenser is different from that of the .0005-mfd. condenser designed to the same law. S.L.F. tuning separates the stations evenly around the dial.

2. The rotor revolves through 270 degrees, which provides 50 per cent more dial space in which to log stations.

3. The end plates, although normally both at the same potential, are insulated from each other, thus there is no short-circuited turn such as is usually found with U frames and their variants.

4. The back plate is only a support for the spindle end; it does not provide tension, as is usually the case. The back plate also acts as the contact for the rotor as it supports the soldering tag to which the non-inductive pigtail is attached.

5. The bearing for the rotor is entirely carried by the front plate. Before assembly the spindle is ground into the bush, this making for smooth working and assisting in the diminution of noise.

6. A positive stop to limit rotation of the rotor is provided also by the friction device.

7. A truly non-inductive pigtail is carried inside the spindle, being held in place at the forward end by a long grub screw which also forms a part of the top, whilst it is soldered to the contact tag on the back plate.

8. One-hole fixing is provided, with an extra nut so that the condenser can be kept back from a metal panel.

9. A standard ¼-in. diameter spindle of generous length is provided.

10. The stator plates are soldered together and to their supporting rods so that efficient electrical bonding is assured.

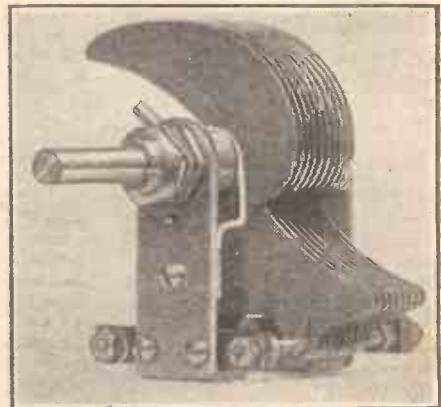

The Godfrey Radio short-wave condenser.

11. The minimum possible quantity of insulation—tropical grade paxolin—is used, and it is placed outside the electrostatic field.

12. The small size of the plates considerably reduces the field of the condenser as compared with that of an adapted broadcast-band condenser.

13. Brass is used throughout for the plates; spindles and bearings, not only on account of its greater strength, but because aluminium readily oxidises, particularly in humid climates, causing losses through developing high resistance.

14. The smaller sizes of these condensers, intended for the ultra short wave-band, are silver plated, thus reducing the resistance to high-frequency currents which, as is well known, do not penetrate far beneath the skin of the metal.

Well, I've closely examined my sample and it certainly "grades up" to the above. I should imagine that it is a component which will be enthusiastically received by short-wave experimenters.

## CONCERNING VOLTAGES

When a mains unit which is capable of supplying, say, 120 volts to four valves, is used on a two-valve set, the voltage will be much higher than that specified, because of the reduced load.

The difference between a paper condenser rated for, say, 250 volts, and a similar one rated for, say, 500 volts, lies chiefly in the paper employed as a dielectric.

Don't forget that results with an S.G. valve depend greatly upon the exact best voltages for grid bias and screen being applied, so it pays to readjust these if the batteries have dropped a little voltage.



**ANNOUNCERS** are born to the extent that they are endowed by nature with silvery voice tones, but for the rest they are practically made.

In the old days, when a broadcasting studio staff consisted in the main of enthusiastic experimenters of still earlier times, the men who sounded best over the telephone were chosen for the dirty work, and sometimes would be assisted by even the engineers. Those golden voices of yore to-day dictate letters, for their owners hold responsible executive jobs, and a new school of announcers have arisen who are fully trained.

**Choosing the Right Man.**

The lucky ones out of dozens of applicants who every year pester the B.B.C., have been selected first by the abilities apparent in their letters, and, secondly, by the results of a voice test which may have been extended over more than a week. And then they have been trained by a senior announcer in the correct pronunciation, in voice inflection, and the microphone manner.

They have followed this experienced "elder" from studio to studio, nuke to mike, and heard the news bulletins read over and over. Yes, all this before they have been drafted to provincial stations—real announcers!

They find their work far from simple. The many ways of saying the simplest words (in spite of the Advisory Committee on Pronunciation); the difficulty of repeating long proper names; the soothing of nervous artistes and newcomers to the studio, and the necessity of being polite to everyone is sometimes the essence of difficulty.

There is the story of the announcer who had to inform the Very Important Personage that he was addressing the microphone far too quickly, and who afterwards resigned because of what the Very Important Personage said.

Incidentally, it is often thought that all announcers have stentorian voices. This is not so.

**Advertising for Announcers.**

The reader of the News Bulletin may boom out of your loudspeaker, but this is the result of amplification on the part either of yourself or the B.B.C. engineers, and generally both. An announcer usually almost whispers to the microphone and his voice can scarcely be heard in the studio itself.

Only once has an advertisement for an announcer appeared in the newspapers. This resulted in such a number of applications that it was weeks before any choice could be made, and then there resulted one of the most extraordinary scenes in the history of the B.B.C.

Over thirty applicants turned up at the studios, some so wildly unsuitable that it

# SOME FACTS ABOUT ANNOUNCERS

You may imagine that just having to talk is one of the easiest jobs in the world. It certainly is not where radio announcers are concerned, as you will appreciate from these details of a job to which many aspire.

By HAROLD A. ALBERT.

seemed incredible they should have applied. A Scotsman who could speak only in the broadest Highland dialect believed he would do very well for a Northern station; a

**"HERE IS THE SECOND NEWS BULLETIN"**



You can easily visualise the announcer with his papers, sitting before the microphone in this studio giving out the news. To his left are turntables and pick-ups so that he may fill in an odd gap in the programme.

## THE "AIRSPRITE" TESTS

A letter of general interest from a reader who comments on a number of topics.

The Editor, POPULAR WIRELESS.

Dear Sir,—Although it is now some time since the occasion when I was privileged to view some tests on the "Airsprite" at Tallis House, I make this belated effort to thank you for a very interesting hour or so. The "bonhomie" and obvious keenness in their work displayed by Messrs. K. D. Rogers, A. Smith, and A. Johnson-Randall made it a real pleasure to meet them, and certainly "P.W." readers should appreciate the hard work these clever chaps put in to keep, as they do, ahead of the times.

Thanks to them also from myself for the numerous questions answered at the time I met them. Before concluding, I would like to refer to Mr. Cole's recent article in "P.W." re television. I am surprised to read his opinion that a 230-volt shock is sufficient to quench an enthusiast's keenness. I am a tester in a huge radio factory, and during the

scholarly gentleman of sixty-four told a pitiful tale of many dependents and very little money, and a youth who claimed in his letter to have been educated at Eton turned out to be a grocer's boy with much ambition and fantastic ideas about studio life—to say nothing of an actor with a very good voice but excessive joviality, a former telephone operator, and a talkie extra—

all these "arrived."

And eventually a well-spoken young man with an aptitude for exotic poetry took his place among the angels of Savoy Hill.

**A Life With Advantages.**

The supply of announcers, it will be seen, very much exceeds the demand.

For, although it may be difficult to report the defeat of your favourite footer team without any trace of bias, there is no doubt that an announcer's life has its advantages.

He hears the best artistes, the most famous people, and entertainment after entertainment free of charge. But perhaps it becomes boring after a time. Although a roadmender may usually spend Christmas at home, an announcer often may not. Besides, he is not a particularly highly-paid official!

**Where Women Fail.**

And this although he fills a post in a profession which few women will enter. Women announcers have been tried by the B.B.C., but never with any great success.

The feminine voice is not so suited to the microphone as are the full tones of a man.

Its pitch is a little too high, and its inflections not sufficiently varied.

Grumble at the B.B.C. though we may, it never inflicts the worst upon us!

course of a normal day's work get dozens of shocks varying from 50 to 500 and more volts when checking over the mains sets I have to test in the course of my work.

**Simply Asking For It.**

I, in common with other testers, often invite these shocks by deliberately bridging contacts with fingers, which contacts, provided the associated circuit part is O.K., are known to be at high potential to each other. As a matter of possible interest to readers of "P.W." I would add that my worst shocks have been 3,000 volts discharged from 2 8-mfd. condenser blocks.

These are pretty awful, and although I have never suffered ill-effects, I know of many who have been laid up for weeks and more, as these high voltages are capable, under some circumstances, of having fatal results.

Really, a tester's life is SHOCKING, but we like it.  
Yours sincerely,  
R. W. BRYANT.  
108, Eithorne Avenue,  
Hanwell, W.7.

P.S.—I would add that testers do not invite shocks because they like them, but in many cases it shows a great time-saving as against use of an "Avo," etc.

[ED. NOTE.—In spite of our contributor's assurance to the contrary, we still think that a "safety-first" policy is the best. Some people are seriously affected by 230 volts or less.]



# RADIOTORIAL

The Editor will be pleased to consider articles and photographs dealing with all radio subjects but cannot accept responsibility for manuscripts or photos.

Every care will be taken to return MSS. not accepted for publication. A stamped and addressed envelope must be sent with every article.

All Editorial communications should be addressed to the Editor, POPULAR WIRELESS, Tallis House, Tallis Street, London, E.C.4.

All inquiries concerning advertising rates, etc., to be addressed to the Sole Agents, Messrs. John H. Lite, Ltd., 4, Ludgate Circus, London, E.C.4.

The constructional articles which appear from time to time in this journal are the outcome of research and experimental work carried out with a view to improving the technique of wireless reception. As much of the information given in the columns of this paper concerns the most recent developments in the radio world, some of the arrangements and specialties described may be the subjects of Letters Patent, and the amateur and the trader would be well advised to obtain permission of the patentees to use the patents before doing so.

## QUESTIONS AND ANSWERS

### THE "AIRSPRITE" TWO.

C. B. W. (Haddington).—"I want to knock up a good two-valve set, using a dual-range coil of the 154 Telsen type, and I have been told that you gave an 'Airsprite' set in which this was used last winter. If so, please say date of the number.

"Also, can you tell me if there is a woman announcer at the Luxembourg long-wave station, as well as a man, as I cannot make out whether I hear one or two different stations on that wave setting?"

The "Airsprite" Two, for which the coil you mention is perfectly suitable, was described in the February 25th issue of "P.W." number 560.

NOTE.—If unobtainable locally, book numbers of "P.W." which are still in print can be obtained from the publishers direct. The address is: The Amalgamated Press, Ltd., Back Number Dept., Bear Alley, Farringdon Street, London, E.C.4. Price: 4d. per copy, post free.

Re Luxembourg. Yes, there is a woman announcer who often repeats the announcements of her colleague.

### CALCULATING THE AMPLIFICATION.

J. R. (Burton-on-Trent).—"I have been interested in trying to calculate the gain per stage of resistance coupling—or rather the hoped-for gain, if practice were the same as theory—by means of the formula:

$$\text{Amplification} = \mu \frac{R}{R + R_a}$$

where  $\mu$  is valve's amplification factor,  $R$  the anode resistance, and  $R_a$  impedance of the valve.

"Is there a similar formula for calculating the gain of an L.F. choke-coupled stage?"

For a choke-coupled stage the following formula can be employed:

$$\text{Amplification} = \mu \frac{X}{\sqrt{X^2 + R_a^2}}$$

where  $\mu$  and  $R_a$  have the same significance as before, and  $X$  = Reactance of choke.

This reactance will be equal to  $2\pi fL$ , i.e. approximately 6.28 times the frequency, multiplied by the number of henries.

### GUARDING AGAINST A SHOCK FROM D.C. MAINS.

"PRECAUTIONARY" (Liverpool).—"My brother and I were thinking of giving a wireless set to the old people, and he has his eye on one of the kind worked from the electric light, which I have heard going in another house, and which seems to be just the thing. My only doubt is in connection with shocks.

"I do not mean from the set, but I have heard of aeriels which were tingly to the touch when worked from direct current mains, as this set will be. And as my mother has to be

very careful, she could not stand a small shock which might be of no importance where people of ordinary health were concerned.

"We shall not get the set, of course, unless we find it is guaranteed safe. But if we do, what could be done to make sure that the aerial would also be incapable of giving a shock if touched accidentally?"

Although cases do occur in which aeriels become "alive" when worked from D.C. mains sets, there is no need for this to occur. It can very easily be prevented.

### FIXING A LOOSE BASE



If the glass bulb of one of your valves gets loose, a little seccotine run round the base will effect a reliable repair.

be "alive" from the mains voltage. It will also enable an ordinary earthing switch to be fitted to the outdoor portion of the aerial, which should then be kept earthed when not in use, and, of course, when thunderstorms are about. (Generally the usual natural signs of a thunderstorm will be augmented by crashes in the loudspeaker, so in addition to automatically spoiling the pro-

All that need be done is to break the lead close to the set's aerial terminal (preferably inside the set), and insert there a fixed condenser: its capacity should be of '005-mfd. or so—the value is not critical so long as it is not too low—but it is important that the fixed condenser should be of the mica type, and of good make.

The insertion of the condenser will not affect tuning or operation in any way, but it will ensure that the aerial will not

### DIRECTIONAL LOUDSPEAKERS.

E. A. L. (Kensington).—"I am specially keen on listening to the brass instruments and military band music, and in this connection I have often fancied that I get better and clearer response from my loudspeaker when sitting directly in front of it than when I sit with it in a sideways-on position.

"Is there anything which is likely to cause such an effect, or is it, perhaps, a matter of fancy on my part?"

It is quite possible that there is the difference in reproduction, because some loudspeakers have a more or less pronounced tendency to show a fall off in high notes as the angle of radiation increases outwards, from the central or straight ahead position.

You might, therefore, find it advantageous to keep the loudspeaker turned to face your chair.

### PICK-UP CONNECTIONS AFFECT TRIMMING.

H. H. (Morpeth).—"After fitting the pick-up wiring I noticed that the results on the distant stations when on the radio side did not seem quite so good, and finally I found that a slight decrease in the capacity of the trimming condenser for the detector's grid circuit put the matter right again.

"Is this usual? I am certain that the trimmer had not been moved during the other alterations, as it was firmly locked, so it seems that in some way the extra wiring must have thrown the trimming out."

It does sometimes happen that the additional wiring, by adding a small capacity, necessitates re-setting of the detector's trimmer. Generally such an alteration has a negligible effect, if it does throw the trimming out it is easily put right by re-trimming as you have found.

### WHICH SWITCH FIRST?

D. K. (West Croydon).—"With my other set high tension is taken from an A.C. mains eliminator, and the set has a separate on-off switch for L.T.; and in reply to my last letter you gave me the correct order for switching these on and off. The letter has been mislaid, and now there is an argument between us as to which switch you said should be first—L.T. or H.T.?"

"If you could give the reason for the order decided upon it would be a help in remembering the correct way in future."

To be candid, it does not seem to matter a lot in practice which order is observed in the switching of such a combination. But theoretically it is better to switch on the L.T. before the H.T., and then to switch off the H.T. before the L.T.

An easy (if ungrammatical) mnemonic is to think of L.T. as always being on Longes!

The reason for this order is that A.C. voltages are not steady ones, but attain high peak values unless a load is imposed on the output of the unit.

By switching on the low tension first you provide a load (through the lit valves) and this load should be on till the H.T. is switched off again. If the L.T. is not switched on first and off last there is no load across the unit, and therefore unnecessarily high voltages are developed, which theoretically are harmful to the valves and possibly to some of the apparatus, such as chokes and condensers.

### "PW." PANELS. No. 125. KOSICE, CZECHOSLOVAKIA.

The Kosice station is seldom heard direct in this country, though occasionally its items are relayed via the Czechoslovakian stations.

The wavelength, 293 metres, is shared between Kosice and Limoges, France, the former having a power of 2.5 kw.

Kosice has a man announcer, and the Hungarian, Slovak and German languages are all used. The closing words "Dobru Noc" mean "Good-night."

gramme a thunderstorm generally gives warning of its own approach, thus enabling the listener to switch off in ample time.

It is, of course, unwise to go near the aerial or any similar conductor or high object when a storm is in progress. But an earthed aerial is actually protective rather than dangerous.

You have, therefore, absolutely no cause to fear installing a set if proper precautions are taken.

And if it is a good set the maker will have seen to the other safeguards that are usually incorporated, and which take the form of a condenser of suitable type in the earth lead, a filtered output circuit, and the complete insulation of all control knobs from high potential.

### WHAT THE METER SHOWED.

"MILLI" (Ponders End, Middlesex).—"At the time the set was bought I was advised to make a memo of the H.T. taken by the valves (each valve and all the lot together). And the idea was that every month or so these readings were to be checked.

"At first they were. Lately, however, there has been more breach than observance, and the milliammeter aided and abetted this by

(Continued on next page.)



## RADIOTORIAL QUESTIONS AND ANSWERS

(Continued from previous page.)

continuing to show the same total H.T. current flowing in the negative H.T. lead.

"But quality fell off a bit, and the reaction seemed different, more being required to make the set oscillate, and the results being floppy instead of smooth reaction as before.

"In the end each valve was checked separately, and it was found that although the milliammeter showed the same total current, the detector was taking much less than when the set was new, and the other valves' increase was accounting for getting the same total H.T. reading on the milliammeter as originally. What is this a sign of?"

The readings give a clear indication that the detector valve is losing its emission, and needs replacing by a new one of the same type.

The fact that your total H.T. consumption remained unaltered was possibly a matter of "regulation" if you use an H.T. mains supply—or variation in G.B. But the new valve should put matters right.

### LOW-TENSION EXPERIMENTS.

P. P. M. (Southampton Row, W.C.1).—  
"Since experimenting with two or three different L.T. transformers which I borrowed for the purpose, I find my valves take longer to warm up than they did before, and also that

### HOW IS YOUR SET GOING NOW?

Perhaps your switching doesn't work properly? Or some mysterious noise has appeared and is spoiling your radio reception? Or one of the batteries seems to run down much faster than formerly?

Whatever your radio problem may be, remember that the Technical Queries Department is thoroughly equipped to assist our readers, and offers its unrivalled service.

Full details, including scales of charges, can be obtained direct from the Technical Queries Dept., POPULAR WIRELESS, The Fleetway House, Farringdon Street, London, E.C.4.

A postcard will do. On receipt of this an Application Form will be sent to you post free immediately. This application will place you under no obligation whatever, but, having the form, you will know exactly what information we require to have before us in order to solve your problems.

**LONDON READERS, PLEASE NOTE:**  
Inquiries should NOT be made by phone or in person at Fleetway House or Tallis House.

the set does not seem so frisky on the foreigners, even now I am back again with the original heater-wiring and transformer.

"Can you say what the reason of this state of affairs is?"

We rather suspect that your experiments caused a certain amount of damage, and that you have "over-run" the valves by applying excessive heater voltage. If possible test the valves for this, by substitution. (That is, by interchange with similar ones, known to be O.K., and comparing results.)

### CAPACITY OF THE DECOUPLING CONDENSER.

J. L. (Leith).—"In the component list it stated three 1-microfarad condensers, but owing to an error in ordering I got four of these, and enough of all the others mentioned, so I am left with one too many.

"Instead of just letting it stand aside I thought I might be able to use it to advantage in the set, but do not wish to try this unless there is a definite hope that it will do some good.

"Most of my friends to whom I have mentioned it are of the opinion that I should do best by putting it in parallel with the 1-mfd. decoupling condenser in the anode circuit. (joined between transformer primary, etc., and L.T.) of the detector.

"But one suggests that it would have far more effect on quality—a matter on which I am particular—if I wired it across the 2-mfd. condenser in the loudspeaker output filter circuit. What do you think?"

There is no absolute rule, for different sets even of the same circuit and components will differ enormously in the effect (if any) that such an alteration will have upon them.

But it is so very easily tried that we suggest you should leave enough room for it to go beside either, and then try it successively in each position, to decide which gives the better results.

If, however, you do not wish to do this, but would rather wire it up permanently to begin with, we should be inclined to favour its addition across the decoupling condenser rather than across the output filter condenser.

Not only is decoupling often susceptible to noticeable improvement as a result of increase of its capacity, but there is the additional advantage that your proportional increase will be bigger there; you can double the decoupling capacity, but can add only fifty per cent to the output filter's.

And the effect on quality of improved decoupling is likely to be just as marked as that resulting from an alteration to the output condenser.

### THE LOUDSPEAKER'S TRANSFORMER.

F. D. P. (Chepstow).—"Altogether I shall have an eighteen-foot run for my wires to the loudspeaker, there being another room to cross between the one where I keep the set and the one in which the loudspeaker will stand.

"Which is the best place to have the loudspeaker's transformer—at the loudspeaker itself, or at the set end?"

As a rough-and-ready guide it is generally considered better to have the loudspeaker's transformer at the set end; although the convenience of having speaker and transformer mounted together have led to it being placed at the loudspeaker end in most instances.

The fact that this rarely leads to noticeable trouble (even with leads as long as yours will be) is evidence that it is not a vitally important point. But on account of the advantage of keeping H.T. out of the L.S. leads, if for no other reason, we should as a general rule prefer to see the transformer placed close to the set, rather than at the loudspeaker end of the long wiring.

### MIRROR OF THE B.B.C.

(Continued from page 424.)

#### Sheffield's Civic Week.

When Sheffield lost its relay station soon after the inauguration of the Regional scheme, there were those who feared that such civic advantages as local broadcasting headquarters can confer upon a city would be lost for all time.

In this they were wrong because no local station and low-power transmitter could do as much for any city as will the North Regional station, with its giant transmitter at Moorside Edge, for Sheffield during its forth-coming Civic Week celebrations.

Practically every local organisation is co-operating with the Sheffield Junior Chamber of Commerce to make Civic Week a huge success as a display of the trade and resources of the city. The most interesting of all the arrangements will be opportunities for the public to visit the most important factories, and such municipal undertakings as the new electric station, the waterworks and other public services.

The Lord Mayor of London and his state coach will come to Sheffield during the Week, and there will also be floral displays, dances, exhibitions, lectures, swimming galas, window-dressing competitions, processions of cars and horses, fire brigade demonstrations, and lots of merrymaking.

The B.B.C. intends to do all in its power to mark the great occasion with several relays of the various events, of which no fewer than four will be taken from the City Hall, beginning with the Civic Service on Sunday, June 25th, in which representatives of all creeds and denominations will take part.

**BEWARE LIGHTNING!**  
GRAHAM FARISH  
**GARD**  
WILL PROTECT YOUR AERIAL

Your set—your home itself, is at the mercy of Lightning if your aerial is unprotected. For a few pence a GARD gives permanent protection and makes it safe to listen-in during the worst thunder storms. Be sure to get the genuine Graham Farish GARD—the Lightning Arrester that protects a million homes. Every GARD carries £100 Guarantee.

**1/6 EACH**

**GET A GARD 1/6**

GRAHAM FARISH LTD., MASONS HILL, BROMLEY, KENT.

**PATENTS, TRADE MARKS.**  
"Advice Handbook" and Consultations FREE.—B. T. KING, C.I.M.E., Regd. Patent Agent (G.B., U.S. and Canada), 146a, Queen Victoria Street, London, E.C.4. 47 years' experience. Phone: Cent. 0682.

**Famous Maker's Offer!** £5 Radio-Gram CABINET for 65/-  
**SEVEN DAYS' FREE TRIAL**  
(OR 10/- MONTHLY)  
Polished Oak 1 and Piano built! The acoustic Tone brings a fine thrill. Makers to Radio-Press, B.B.C., 3,000 clientele. MODELS FROM 35/- to £15. Photographs and List FREE. **PICKETTS** Piano-Tone Cabinets. P.W., Albion Road, Bexleyheath.

"D" £8-15-0

## COST OF H.T. CUT IN HALF

A free booklet describing the remarkable Standard battery will be sent by return post. H.T. current from this unique battery is extremely economical and definitely improves reception. It recharges itself overnight and lasts for years. There is no corrosive acid or fumes. Sold direct and fully guaranteed, no skill is required to fix and maintain. End your H.T. troubles by becoming a Standard enthusiast. Write now for free booklet.

The Popular Model H5 for average sets. 126 volts No. 3 cells, costs **37/8** (or on easy payment terms).  
**STANDARD BATTERY CO. (Dept. P.W.)**  
184-188 SHAFESBURY AVENUE, LONDON, W.C.2

## CHANGE OF ADDRESS

Application for Free Booklet should be made to  
**RADIO TRAINING INSTITUTE OF GREAT BRITAIN, 85, NEW OXFORD STREET, LONDON, W.C.1.**

We Specialise in home-study training for appointments in Radio and Talking Picture Engineering. Introductions guaranteed. Students awarded our "Certificate of Proficiency" may become Associate Members of the R.T.I. and assume the designation "A.M.R.T.I. (Gt. Br.)."

PLEASE be sure to mention "Popular Wireless" when communicating with Advertisers. Thanks!



# COLVERN FERROCART COILS

INCREASED sales... increased production facilities mean reduced costs.

Prices of Ferrocart coils reduced from 1st June, 1933.

Types F1, F2, F3 ganged on sub base with wave-change switches,

NOW 37/6 per set.

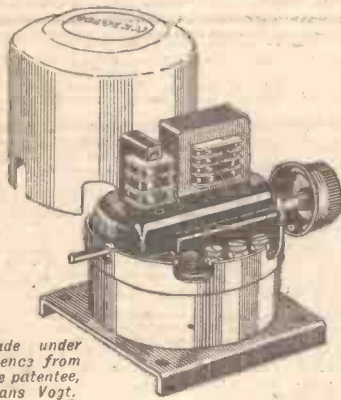

Made under licence from the patentee, Hans Vogt.

## FOR THE CATHODE RAY TELEVISION RECEIVER—

ONE PAIR COLVERN K5 COILS.

Ganged and mounted on an aluminium base.

19/- complete,

# COLVERN

MAWNEYS ROAD, ROMFORD, ESSEX.

London Wholesale Depot, 150, King's Cross Rd., W.C.1

## THE "DOUBLE-D PEN"

(Continued from page 428.)

polarity of the connections is duly observed.

The actual construction of the set is not difficult, all the parts being held on the chassis (above or below) by nuts and bolts, Size 6 B.A. being most convenient. The majority of the components are mounted on the underside, and as a matter of fact the valveholders (which protrude through the chassis), the variable condenser and the output choke are the only parts fixed "upstairs."

### Points for Constructors.

There are one or two precautions that must be taken with chassis sets. One is that no metal filings shall cause leakage or shorting of valve-holder legs, another that the wiring shall not be pressed too hard against the edges of the holes where it passes through the chassis.

This latter point is very important, and as a matter of fact we always smooth off the holes in the chassis by means of a rose bit before the wiring is carried out.

Finally, do not overlook the fact that the Graham Farish Ohmite vertical holders have screwheads underneath which are the ends of the terminal shank. These come very near to being flush with the bakelite moulding, and to prevent any possibility of the heads making contact with the chassis we always place a piece of thin card between each holder and the chassis when mounting. It is a tip well worth noting.

Certain grid and plate leads are run in screened sleeving, and this is an important part of the design, obviating instability. The screened sleeving should be bonded together with wire, and the wire taken to an earthed point.

As regards operation little need be said. The set connects up to the H.T. + and H.T. - of a 50-milliamp 250-volt mains unit, and to the L.T. output of that unit. The loudspeaker should be of the normal type, it should be suitable for ordinary super-power valves, not pentodes, as the necessary step-down ratio is obtained from the output choke on the set.

### Inserting the Valves.

With aerial and earth connected up, a couple of M.V.S.G. valves in  $V_1$  and  $V_2$ , the "D.-D. Pen." in  $V_3$  and a pentode in  $V_4$ , the power should be switched on and the set trimmed. The on-off switch is connected in series with one lead from the mains to the power unit.

To start with, set the trimmers on the variable condenser slacked off (before the set is switched on) and the volume control at  $\frac{1}{2}$  round to the right. Then trim in the normal way, on a low-wave medium-band station. Check trimming on a distant transmission and then tune to the nearest local.

This will possibly be too loud to be comfortable. Volume can be reduced to a predetermined maximum by the volume control and thereafter it need not be touched, for the set will automatically keep to that maximum.

For very distant reception you may like more L.F. amplification, and this can be obtained by turning the volume-control knob hard to the right. The knob is only a pre-set control, and after it has been set for any station, or series of stations, it need not be touched again.



Weekly jottings of interest to buyers.

TENNIS and the other forms of outdoor sports appear very definitely to be fighting a losing battle with radio this year. I do not think that I can remember a summer in the whole history of radio that is comparable with that of 1933 from the point of view of home-constructor activity.

A typical instance of the continued interest is to be found in the demand for Ferranti Constructors' charts, one of which—the Band-Pass Screened-Grid Three—has just reached the seventh edition, and I am given to understand that it will not be long before still another edition will become necessary. Stuff to give 'em!

By the way, I have just been examining a copy of this latest Band-Pass Three chart, and I note with interest that one or two slight improvements have been included in both the battery and the A.C. versions.

Readers desirous of obtaining a copy of the latest edition of this famous set chart

### OUR POSTCARD SERVICE

Applications for trade literature mentioned in these columns can be made through "P.W." by quoting the reference number given at the end of the paragraph. Just send a postcard to G. T. Kelsey at Tallis House, Tallis Street, E.C.4. Any literature described during the past four weeks may be applied for in this way—just quote the number or numbers.

can do so by sending a 1½d. stamp to Messrs. Ferranti at Hollinwood, Lancs.

### More "Class B" News.

That famous trade barometer of mine—my correspondence file—shows a distinct tendency this week to swing hard over to "Class B." I am very much afraid that if I were to attempt to deal with all the letters received I should require a specially enlarged issue of "P.W." all to myself!

Much as I regret, therefore, that I cannot possibly deal with them all, my notes, I feel, would not be complete without reference to at least the most important items of news.

First, then, comes the news that stocks of the eagerly awaited Mullard "Class B" valve—the P.M.2B.—are now available all over the country. Of particular interest in connection with this valve is the fact that a P.M.2D.X. can be used quite satisfactorily for the "driver," which, from the point of view of H.T. consumption, is a considerable improvement, since it takes only 1½ milliamps.

Several of the speaker manufacturers have produced models specially for "Class B" use, and the latest name to be added to the list is that of Baker's Selhurst Radio, who are responsible for two new models in their famous "Pernag" range.

From Sound Sales, Ltd., comes news of a self-contained "Class B" unit which can be used for the conversion of existing sets. The price is 35s., excluding valve.



# TECHNICAL NOTES

Some diverse and informative jottings about interesting aspects of radio technique.

By Dr. J. H. T. ROBERTS, F.Inst.P.

## Increasing Amplification.

**L**ISTENERS who use simple sets, such as a detector and one low-frequency amplifier, sometimes find that although they can receive a particular station the volume is not sufficient, and they often jump to the conclusion that an additional stage of either high-frequency or low-frequency amplification is necessary.

Before concluding that the set is not up to the work, however, it is better to go over it carefully and make sure that the last ounce of efficiency is being got out of it. One of the first points to look to is the reaction, because if the reaction is working properly it should give a considerable increase in the signal strength.

Oscillation should come on smoothly and gently and the set should not suddenly burst into a howl. If this happens, as it so often does, it usually indicates that the reaction coil is too large or that the H.T. voltage to the detector valve is too high.

It is a very simple matter to prove for yourself that increasing voltage on the detector intensifies the effect of the reaction. It is, of course, all to the good to increase the detector anode voltage, provided this is not done to excess.

On the other hand, you will sometimes find that the set cannot be brought into oscillation, even when the reaction is put to the maximum, and in such a case it is better to try a larger reaction coil.

## Reducing Damping.

Another point is that you may be using an unsuitable valve for the detector, so if you have tried the remedies already

## COMBINED COUPLING

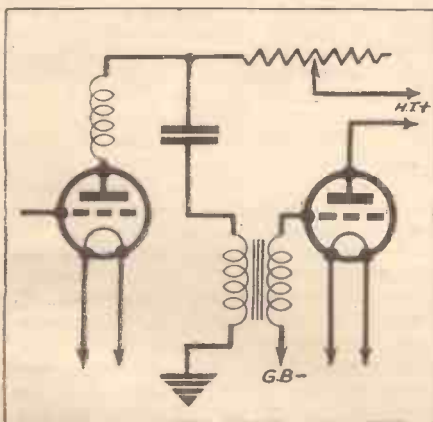

Resistance-capacity and transformer-coupling are combined in this scheme. The variable resistance enables a certain degree of "matching-up" with the valve to be achieved.

mentioned, it might be worth while to exchange the valve for another one—perhaps borrowed from a friend—to see whether this makes any difference. I should mention that if you use a small condenser in series with the aerial this will reduce the aerial damping and will consequently make the set oscillate more readily

than when the aerial is connected directly to the tuning coil.

## Adding an L.F. Stage.

If, however, you are satisfied that all the above-mentioned points have been attended to, and you still cannot get sufficient volume, then it may be necessary to add a stage of amplification. Theoretically, a stage of high-frequency is indicated (that is if the set is working loudly enough on a local station and you cannot receive a somewhat more distant one), but an extra high-frequency stage involves the use of another tuned circuit and, apart from this slight disadvantage, there may not be enough room in the cabinet for the extra components.

On the other hand, if the quality is good and it is only lack of volume which is the trouble, you will probably find it more convenient to add a stage of low-frequency rather than a stage of high-frequency amplification. This has the further advantage that if there is no room in the present cabinet to accommodate the stage it can be built up externally and connected to the receiver.

## Resistance-Fed Transformers.

Several readers have asked me from time to time about the use of a resistance-fed transformer. This type of transformer, which has come into a good deal of popularity lately, is in principle an arrangement for enabling resistance-capacity coupling and transformer coupling to be combined. As you know, each of these methods of inter-valve coupling has its own separate advantages and disadvantages, but this combination of the two is designed to eliminate the disadvantages as far as possible and to combine the advantages of both. To a large extent the arrangement succeeds in this object.

## Matching.

The resistance-fed transformer as at present available incorporates a high resistance (often about 50,000 ohms) and a condenser. This resistance forms part of the resistance-capacity coupling arrangement and is sometimes tapped at a point mid-way or rather higher so that either the full 50,000 ohms or some proportion of it may be put into the H.T. circuit; 30,000 ohms in such a case forms a convenient tapping. The anode of the detector, for instance, is then coupled to the grid of the next valve through the condenser and transformer, whilst the H.T. is supplied to the anode, as already mentioned, through the resistance.

The object of the tapping on the resistance is so that it may be roughly "matched up" with the valve.

## Scratch Filters.

When you add a scratch filter to a radio-gram you will most probably get rid of the greater part of the scratch, which seems to

(Continued on next page.)

**A SUN DRIED EARTH IS INEFFICIENT**

**BUT FILT KEEPS WET**

A damp earth all the year round is essential to good reception. Filt keeps wet without attention, giving better, clearer, crisper radio, no matter how hot the summer. It is significant that every paper exclusively recommends Filt for every set published. EVERY expert can't be wrong!

**2/6**

From all Dealers or post free from the Sole Makers.

GRAHAM FARISH Ltd., Masons Hill, Bromley, Kent

## RADIO SUPPLIES

Send your list of Radio needs for our quotation; Kits, Parts, Sets, etc. Everything in Radio stocked, prompt delivery, 7 days' approval. Catalogue free. Taylor & Standard Wet H.T. replacements stocked.

P. TAYLOR, 57, Studley Rd., Stockwell, London

## AMBITIOUS ENGINEERS WANTED

to apply for our free 250-page Hand-book. Gives details of A.M.I.Mech.E., I.E.E., A.M.I.A.E., G.P.O., etc., Exams., outlines latest Courses in Mech., Elec., Motor, Radio and Aero. Engineering, and shows clearly where first-class vacancies occur each year. Send P.C. for FREE Hand-book immediately to BRITISH INSTITUTE OF ENGINEERING TECHNOLOGY, 401, Shakespeare House, 29, Oxford Street, W.1.

## LOUD SPEAKERS REPAIRED, 4/-

(Blue Spot a Speciality, 5/-) Transformers and Headphones, 4/- Eliminator, Mains Transformers and Moving Coils quoted for. 24-Hour Service. Trade Discount. Clerkenwell 9069 E. MASON, 44, EAST ROAD (nr. Old Street Tube Station), LONDON, N.1.

## Again the designer's choice

because CLIX Contact Components definitely meet the requirements of receivers of advanced design.

## Specified for the "DOUBLE-D. PEN"

Chassis Mounting VALVE HOLDERS

3, 5-Pin, 9d. each (Standard Type)

1, 7-Pin, 1/- (Floating Type)

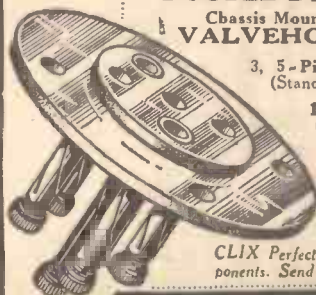

Folder 'P' gives full details of CLIX Perfect Contact components. Send for a copy now.



LECTRO LINX Ltd., 79a, Rochester Row, S.W.1



**YOU CAN TAKE IT FROM ME!**



**ELECTRADIX SUMMER SALE BARGAIN LIST**  
for June now Ready  
*Will save You Pounds*

Superseders for H.T. without Batteries, 37/6.  
Dix-Onometers, 60/- A.C. Mipantas, 19/6.

200 True-View Camerascopes, Brown's Double Lens.  
2/- For Set Builders: All-metal Base Chassis, fitted 2 valve holders, all drilled for Brownie components, 3/6. Loud Speaker Fret Silk, 12 ins. x 10 ins., 1/-, 24 ins. x 24 ins., 3/-. 35 gau. enamelled Bobbin Wire, 2/6 lb. Switches, panel push-pull for radio to gram, long to short or on and off, one hole, 9d.

Microphone Buttons for all purposes, 1/-. Booklet rec. Announcers' No. 11 Mikes, 5/6; diaphragm type, 5/6.

See June Sale List "P" for Aerials, Buzzers, Bells, Batteries, Edison; Condensers, Cable, Chokes, Chargers, Dynamos, Motors, Engines, Meters, Flashers, Neons, Mikes, Mipantas, Receivers, Transformers, Transmitters, Spark Sets, Testers, Valves, Wavemeters, Wire and Stampings, all in stock here.

PARCELS of experimental odd Coils, Magnets, Wire Chokes, Condensers, Switches, Terminals, etc., post free, 10 lb. 7/-; 7 lb. 5/-.



**ELECTRADIX RADIOS**  
218, Upper Thames Street, London, E.C.4

## A Whitsun Holiday Treat!

This week's issue of ANSWERS is a special, enlarged "Open Air" Number, containing a record budget of holiday reading, including the opening article of a series telling the story of an English girl's amazing lone walk from Coast to Coast of a vast country. It is entitled—

**"Hiking Across Canada"**

and

**"The Romance of the 'A.A.'"**

is another fascinating contribution in which Clifford Ince tells you the Automobile Association's remarkable story. There is a complete programme of "open road" features on pleasure cruising, cycling, hiking, seaside and country. The finest Holiday Programme of the Year—you'll find it all in to-day's Enlarged Whitsun Issue of

# ANSWERS

Britain's National Weekly  
Every Saturday - - 2d.

## TECHNICAL NOTES

(Continued from previous page.)

be very much magnified by certain types of pick-up, but on the other hand you may find that you lose on the high notes. This can, however, be got over by using a switch so that the filter can be put into or out of circuit at will.

With records which are chiefly concerned with the bass or lower register, such as a bass or baritone vocal selection, some types of band record and so on, the scratch filter may be used, whereas when you are playing records which are mainly in the higher register, such as certain types of violin record, the flute and so on, you can put the filter out of circuit.

This avoids any cutting down of the higher frequencies by the filter and furthermore you will find that the scratch is not so noticeable now because it does not contrast so strongly with the type of reproduction from the record.

### A Question of Frequency.

Scratch has been estimated to have a frequency around or above the 5,000 mark, so that in one sense it is really rather above the higher audio frequencies that one commonly reproduces. Nevertheless the estimate for the frequency of the scratch is largely guesswork and my own opinion is that the scratch covers quite a broad band of audio-frequencies, including frequencies much lower than is commonly suspected.

### Power-Grid Detection.

I receive letters from readers from time to time about the method of so-called power-grid detection. I mentioned this in these Notes some little time back and also wrote an article on the same subject in "P.W." several months ago.

Many readers seem to have the idea that you can change over to power-grid detection simply by altering the value of the grid condenser or grid-leak, or both.

In point of fact, whilst it is true that you do generally alter the two above-mentioned values, the important features of power-grid detection are a large anode current and strong signals applied to the valve. This means that a valve with an impedance of, perhaps, 15,000 to 25,000 ohms should be used.

The transformer also needs attention because, with the large current used, most ordinary low-frequency transformers will not stand up to the work. This can be got over, however, by using R.C. coupling or parallel feed.

### Importance of Conditions.

If R.C. coupling is used, there will be considerable loss of voltage in the resistance and therefore a relatively high initial H.T. voltage must be used whilst, owing to the heavier current, the source of the H.T. voltage must be an ample one, such as a main's unit with a voltage output sufficient to maintain a suitable anode voltage.

Power-grid detection is like several other devices in receiving circuits, in that it only works well when proper values are used and proper conditions provided; you cannot, however, just switch over to it by changing the values of grid leak and condenser without making certain that the other conditions in the circuit are suitable.

### Freak Effects.

People often tell me that they have got better results from a set by reversing the aerial and earth connections, the aerial lead-in being connected to the earth terminal and the aerial terminal of the set being connected to the earth.

This arrangement has the effect of altering the circuit conditions and may completely shift the tuning positions on the set for different stations. At the same time, this change in the wiring will generally mean weaker signals, although admittedly there are some cases where the set apparently works better this way than with the normal connections.

You can take it for granted, however, that when the set works better when the aerial and earth terminals are reversed, it is a sign that something is wrong with the set or the aerial or earth.

It is quite possible that the aerial has much too large a capacity or, on the other hand, it may be that the earth connection is a poor one. In the same way you will sometimes find that a set seems to work better, in the sense of being brighter and more lively, when the earth is disconnected.

### Dial Positions.

Anyway, it is always better to have a set working with the aerial and earth connections in their proper places, and any apparent advantages you get by disconnecting either of them or reversing them are

## NEXT WEEK.

Another long article on our  
Cathode Ray Television Viewer.

**ORDER YOUR COPY NOW**

only to be classed as "freak" effects and are due, as I say, to some abnormal condition in the set or in something connected to it.

Incidentally, you will sometimes go to your receiver and switch on and find that the stations have all shifted their positions on the dial. If this is the case you may be fairly sure that either the aerial has been disconnected, or something has happened to it, or the earth has become disconnected.

### Tell-Tale Earth.

I have one set in particular, a small mains set which uses an earth, and this set is in a room where it is not convenient to use any other earth than the tap of a gaspipe leading to a gasfire. The earth wire is connected to this by means of a crocodile clip (don't tell me that this breaks all the known rules for a good earth: I know it does), and every now and again an energetic maid knocks the crocodile clip off the gaspipe.

When I go to the set I can tell immediately, by the way the stations come in, whether there is anything wrong with the earth. Sure enough if I go to look at the crocodile clip connection I find that it is lying loose, but on replacing it everything is O.K.

Sometimes you will find a sort of "mis-tuning" effect will arise, where a switch is used to earth the aerial, if you happen to operate the set with only the earth connected and forget to un-earth the aerial.





**THE FIRST AND FOREMOST RADIO WEEKLY.**

Scientific Adviser : **SIR OLIVER LODGE, F.R.S.** Chief Radio Consultant : **P. P. ECKERSLEY, M.I.E.E.**  
 Editor : **N. F. EDWARDS.**  
 Technical Editor : **G. V. DOWDING, Associate I.E.E.**  
 Assistant Editors : **P. R. BIRD and A. JOHNSON-RANDALL.**  
 Chief of Research Department : **K. D. ROGERS.**

*The Paper that Made Wireless Popular*

**CONGRATULATIONS!  
 SCHOOL BROADCASTS  
 FOR PIGEON FANCIERS  
 ENGLAND'S WAY**

## RADIO NOTES & NEWS

**RADIO PLAYS  
 BETTER RESEARCH  
 HOUSE WIRING  
 NOT NOVEL**

### Our Eleventh Birthday.

**B**EFORE we begin the business of the day I should like to acknowledge with thanks, on behalf of the Editor and his crew, the numerous congratulatory letters from our readers who have in no half-hearted fashion expressed their appreciation of "the great radio weekly," as one fellow put it, meaning us. Be assured that we shall spare no efforts to keep you the best-informed body of radio enthusiasts in the country.

### Broadcasting for Schools.

**T**HE Central Council for School Broadcasting, whose chairman is Lord Eustace Percy, is now in its fifth year. Dr. W. W. Vaughan, M.V.O., is Vice-Chairman and Chairman of the Executive in place of Mr. F. Roscoe, who distinguished himself by being instrumental in securing the development of school broadcasting on lines adapted to the curriculum in elementary schools. I do not believe in this B.B.C. activity, and on this I am a die-hard. Elementary scholars need their teachers and lots of the three R's. All this broadcasting about newts and cuckoo-spit is sheer waste of their time.

### Pigeon-Fanciers Should Note.

**O**N June 26th, from the Midland, lovers of pigeons, especially of the kind which you take for a ride and then leave to fly home, are to have a talk on pigeon-flying by Mr. H. J. Sewell, Vice-President of the National Homing Union. It is not *my* pidgin, for to me a pigeon is only a voracious, highly sentimental bird which turns its pink toes inwards and cannot keep its neck rigid while it walks. P. pies were much esteemed by our ancestors, but, then, so also were rook pies. Ugh! We will talk about radio.

### A Battery Superhet.

**T**HE "Wireless Constructor" for June is notable for its design of a highly-efficient superhet circuit for battery-operated valves, which I should imagine is a heaven-sent affair for many country dwellers. Scott-Taggart's skill, experience, and personality are writ large over this issue, and his famous "Armchair" chat is the delight of the reader and the envy of the penny-a-liner of journalism.

### The English Way.

**O**N June 12th there was announced for the Regional wavelength an English singer, Sybit Crawley, who, failing to find honour or even recognition

## SERVICE

We are glad to note that we have set a style and standard in these occasional Editorial reminders of how "Popular Wireless" offers an unrivalled service to its readers.

This week we jog your memory once more by reminding you that in this journal you have, within the last few weeks, had the first opportunity of reading about some really important developments in radio—not developments concerned with "odds and ends and gadgets," but developments of paramount importance in radio technique.

For example, it was in "Popular Wireless" you could first read about :

1. A "Class B" set.
2. A home-constructor's Automatic Radiogram.
3. A Multi- $\mu$  Pentode set.
4. A "Class B" Portable.
5. A Double-Diode Triode set.
6. A "Cold Valve" Westector receiver.
7. A "Catkin" All-Metal Valve set.
8. A Low-Bias Multi- $\mu$  set.
9. A Triode "Class B" set.
10. A 4-Pentode receiver.
11. A Cathode-Ray Television Viewer for Constructors.
12. A Double-Diode Pentode set.

And, finally, the first National 5-metre tests, in which a world's record was secured for Britain by "P.W.'s" efforts.

Compare this list with lists published in other wireless papers when you advise your friends to purchase a first-rate radio journal.

in her own country, went abroad and found fame. She has just finished a season at Monte Carlo.

Perhaps we are a musical people, but perhaps we are not musical enough to recognise outstanding musical talent until

foreigners point it out to us. It's a controversial matter, anyhow, and perhaps Miss Crawley just struck a patch of bad luck here.

### Radio Plays.

**I** SEE the B.B.C. is to repeat twelve of the broadcast plays of the past ten years during twelve weeks beginning in October. Amongst these "repeats" I see "The White Chateau," "Carnival," "The Three Musketeers," and "The Path of Glory."

Surely the B.B.C. makes an error when it says, "These twelve are regarded as the most important plays transmitted by wireless in Great Britain." Are any of them more "important" than "Macbeth" or "Hamlet"?

### The Lady of Bengal.

**I**F you heard that talented lady, Miss Devika Rani (who "starred" in "Karma," the first all-Indian "talkie") when she broadcast and televised last month, you may be interested to add to your notes that she is a native of Bengal, is an experienced broadcaster, speaks fluent English, French, German, Italian, and Hindustani, besides Bengali.

She is the daughter of Lieut.-Col. M. N. Chadhuri, of the Indian Medical Service, and a great-niece of Sir Rabindranath Tagore, the Indian poet.

### Co-operation in Radio Research.

**T**HE wireless division of the National Physical Laboratory has been amalgamated with the Radio Research Station of the Department of Scientific Industrial Research, to form a new Radio Department of the National Physical Laboratory. The erstwhile superintendent of the Radio Research Station, Mr. R. A. Watson Watt, is the superintendent of the new Department.

### An American Ballot.

**T**HE University of Minnesota has inquired into the habits, likes, and dislikes of the radio listeners of Minneapolis; some of the results are interesting. The average listening time per person is 19.6 hours a week. I should

*(Continued on next page.)*



# ARIEL CONTINUES HIS RUNNING COMMENTARY ON RADIO

say that London listens more than that. The highest figure was 85 hours.

Housewives had the highest average. Classical music is more popular than jazz, and the bottom of the popularity list is "advertising, religious sermons, crooners, political speeches, jazz music."

So they do not like ads. and crooners! How English!

## Beware the House Wiring.

BY this time H. E. M. (Wallasey) will have learned, if he has read my Notes carefully, that the cause of my superhet's crackles have been traced to the house wiring, and corrected. Just like his! Nevertheless, I thank him for his letter.

He is certainly a master of the left-handed compliment, for after making my pulse race by saying that he reads my two pages first, he naively adds that this is because they are the first two pages, barring advertising matter.

What about our cover! We rather spread ourselves over our covers!

## A British Short-Wave Society.

THE Hon. Sec. of the Leicester Experimental Short-Wave Society asks me to inform the thousands of British short-wave workers that his address has been changed to 74, Stretton Road, Leicester. Why should not a great British Short-Wave Society be domiciled at the good old English town of Leicester? We really do need a British S.-W. Society, with all due respect to those of transatlantic origin. Rally round Leicester. "There's nothing like leather."

## Not Novel Noises.

I THINK that the B.B.C. sadly underestimates the intelligence of its patrons, and I refer in particular to its presentation, last month, of Big Ben, street



traffic, motor-horns, church bells and bands on piers. That sort of thing is on a par with the earliest cinema films depicting waterfalls, trains arriving at stations, and so forth.

Again, on June 3rd, the B.B.C. used the North Regional for the purpose of broadcasting the "turn-out" of a fire brigade! Why don't they hand the "stunt" programmes over to the office-boy and confess to the sterility of their imagination?

## Very Rùm.

IN all the history of crime—I am a detective story eater—I do not think that there has been a blacker case than that reported of a radio firm who, with that inhuman indifference to the rights of man which characterises the born criminal, allowed thieves to enter their premises

only to encounter a black bottle which did not contain rum or other sedative—but furniture polish! The bait, a paltry £10 and a few valves and electric torches, was not a fair reward for so dangerous an enterprise as was undertaken by the communistic gentry who desired only to scale down the firm's wealth. I did not suspect that radio dealers were so inhospitable!

## Another Society Paragraph.

MR. LESLIE W. ORTON, Hon. President of the Anglo-American Radio and Television Society, says that they have formed a South-London Branch whose Hon. Sec. is Mr. W. Cope, 7, St. Alphonsus Road, Clapham, S.W.4. This branch's season begins on September 1st,

## SHORT WAVES

"It is an interesting fact that the majority of hospitals are now fitted with wireless receiving sets," we read.

But it is very unkind to suggest that owing to the dullness of some of the B.B.C. programmes they might almost be used instead of anaesthetics.

"Literary people rarely commit crimes," says a writer. He evidently doesn't listen-in very much!

The young sons of a wireless announcer will broadcast soon. Then little boys will be heard and not seen.—"Punch."

A few suggestions for the further development of "Wireless": Why not wireless wire-haired terriers, wireless champagne corks, wireless wire fences, and wireless birdcaages? And what about wireless wire mattresses, and wireless wireworms?

## PRONUNCIATION.

Combat—this is pronounced "cumbat" though we shall still refer to certain undergarments as "combinations" and to the partner of the hairbrush as a "cohm" (not a "cum").

Pathos—this is to have a long a, but poor "patriot" only a short one.

Humour—the aspirate should be sounded—which will be a joke on those who mute it.

## UP TO DATE.

It was the schooner Hesperus  
That sailed the wintry sea;  
But the Skipper had a wireless set  
To keep him company.  
(So what cared he for the wintry sea?)

We hear that an amplifier has recently been put on the market which is so powerful that if it is turned full on it will break your windows. And if the amplifier doesn't actually do the trick, your neighbours probably will.

but meetings are already being held monthly. On the first Thursday in August there will be a demonstration of recordings, made by the Hon. President of American stations. In return for this notice I beg the Hon. President to spell "Ariel's" name aright!

## Any Stick Will Serve.

NO public body suffers more than the B.B.C. from the frivolous attacks of those who appear to think that it can do nothing right. Listen to this! Sir Thomas Beecham wanted chorus for two works to be performed at Covent Garden, and as he could not afford professionals he asked the B.B.C. to advise the B.B.C. chorus—who are amateurs—of the

situation, and he added the assurance that any volunteers would not be displacing professionals. Nevertheless, the B.B.C., having complied with Sir Thomas's request, was attacked for adopting a "policy of economy." "Policy" does not seem to enter into the matter. Only common courtesy.

## Henry, Beware.

FROM a usually reliable source I learn that H. Hall, dance orchestra conductor of the B.B.C., is going to America in the late summer of this year.

I hope he will not come home full of American notions of what dance music should be. Why America attracts so many people is beyond my comprehension.



I have been there several times too many. But for our own radio dance orchestra conductor to flutter at that flame bodes ill for our dance programmes, and more ill for us listeners.

Henry, for de Law's sake, go to—oh, well—Barcelona or Buenos Aires.

## The Piper Pipes as he Pleases.

ACCORDING to report, Sir John Reith said, on receiving the honorary degree of Doctor of Law of the Manchester University, that the silliest criticism of the B.B.C. is that he who pays the piper has the right to call the tune. If Sir John takes the old adage literally and refers to some barbaric custom of his countrymen—when the bawbees were flung upon the ground and the (bag) piper did his darndest—O.K. But if he means that the people of these islands are to contribute over 2½ million sterling and are not to "have a say" in regard to the programmes to be broadcast—then I regret to have to remind him that he has to deal with the people who are the salt of the earth and suffer no dictator. It's just a matter of time!

## Stand Up and—Listen.

AS one that has a lot to do with listening and listeners I was vastly amused to read that grasshoppers and crickets carry their ears on their shins; this on the

authority of Dr. R. T. Beatty of the Admiralty Research Laboratory.

What the Navy has to do with grasshoppers I leave to questions in Parliament. It is a mercy that humans are not equipped with acoustic shins, isn't it? Fancy having to sit with the legs away from the fire on a cold night!

On the other hand, it would be highly convenient in some ways, for instance, when the wife raves about a new hat. "Sorry, m'dear. I had my legs crossed. Couldn't hear a word!"







# The P.W. REFLEX

## An UP-TO-DATE DUAL-AMPLIFICATION DESIGN

Using a high-efficiency circuit capable of great volume and tremendous range, this is an economical receiver in which three valves do the work of four. Designed and Described by J. ENGLISH.

TAKE a census of all the home-constructed receivers in your immediate neighbourhood, and the betting is ten to one that you would find the majority were three-valvers of the S.G.-Det.-L.F. type.

There is no doubt about the popularity of this combination, which, for station-getting and economical running, is about the high-water mark of efficiency in three-valve receiver design. But when you have handled the controls of the receiver illustrated here I think you will change your ideas about that.

### A Practical Design.

The design we are presenting here is something new in three-valvers, the result of an endeavour to get more than three-

especially for summer-time reception. Consequently, I know that you will welcome any ideas that will add more punch and range to your own three-valves, and here they are.

First of all, for increased selectivity, the super-efficient Ferrocart coil which affords a real improvement in station separation, and, for higher sensitivity, a dual or reflex stage which makes one valve do the work of two!

The enhanced performance of this receiver is the result of the successful application of both of these ideas. The one which will probably interest you most is the revival of the reflex circuit which enjoyed such tremendous popularity in the earlier days of radio, as some may remember. If you experienced the excitement of working

those primitive dual receivers, you will not need to be reminded of their "howling" tendencies, nor of the inferior reproduction and poor selectivity as judged by modern standards.

"Why bother then to revive the reflex when we have so many new ideas in radio?" A sound question; but don't forget that some of these, the modern

reflex circuit with modern valves and components, and after I had put to experiment some of my own ideas thereon, that I myself realised how useful the reflex could be for the economical "gingering up" of the straight three-valver. The resulting receiver that you see here is as stable and

### BASIC PRINCIPLES

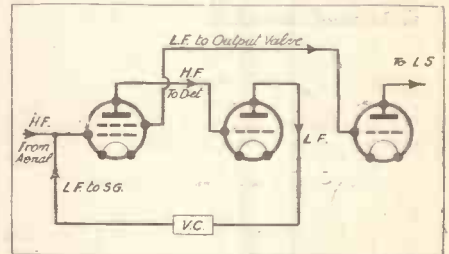

This skeleton diagram of the circuit illustrates the method of feeding back L.F. impulses to the S.G. valve, where they are again amplified.

efficient as the old reflex set was uncertain and tricky; by no means is it a "stunt" design. You have only to handle its controls to prove that.

### The Dual Valve.

The obvious position for the dual valve, is, of course, the S.G. stage, which we proceed to work overtime as an L.F. amplifier, in addition to its normal duties of H.F. amplification. To do this we feed back the

(Continued on next page.)

### THE CIRCUIT THAT SAVES A VALVE

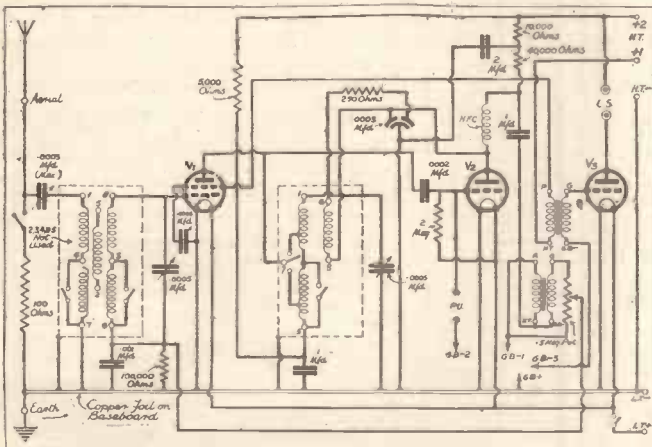

By using the S.G. valve for L.F. amplification as well as for H.F., two low-frequency stages are obtained. The L.F. output from the S.G. valve is via its screening grid, which is joined to the primary of an L.F. transformer.

valve results from three valves. This may sound remarkably like "something for nothing," with the suspicion that there is a snag somewhere. But there is not, and the receiver, in spite of its novelty, is a thoroughly practical proposition.

### Improved Results.

Now, although the average well-designed S.G.-Det.-L.F. receiver is a most efficient three-valver, we can, if we feel like it, pick plenty of holes in its performance. For instance, selectivity is often not all that it might be, except where an expensive band-pass tuner is used; while a little more sensitivity would be well worth having,

superhet, the diode detector, Q.P.P. and "Class B." amplifiers, for example, are all revivals of old ideas. And in the case of the reflex circuit, we need no excuse at all because the modern version is so much an improvement on the original.

It was only after the Technical Editor had suggested to me the possibilities of the

### COMPONENTS COMPACTLY ARRANGED

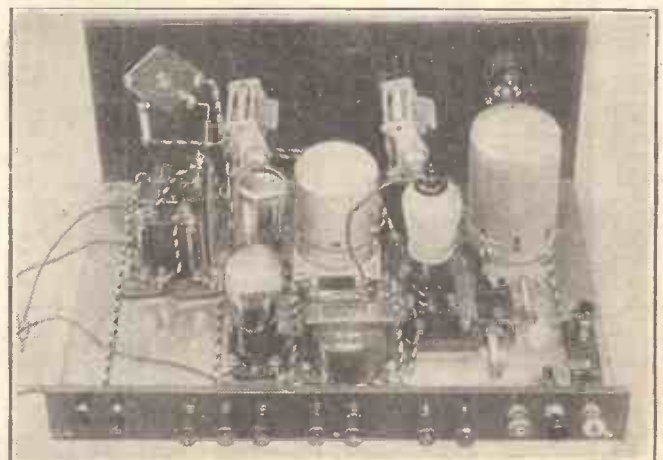

A marked feature of the layout is the disposition of the parts, which enables all leads to be kept reasonably short and direct.



# THE P.W. "REFLEX"

(Continued from previous page.)

L.F. output from the detector into the grid circuit of the S.G., where the L.F. signal is further amplified before passing to the output valve.

The simplified diagram on the preceding page illustrates the amplification of the signal from aerial terminal to loudspeaker, the net result being that we get the benefit of another L.F. stage without having to use an extra valve. The full advantage of the scheme is, of course, only realised when receiving distant stations; for local reception the receiver's sensitivity is far higher than we need, hence the incorporation of two separate volume controls.

### Difficulties Overcome.

The skeleton circuit diagram possibly makes the receiver seem simple enough. So it is, in theory, but its practical application is not so easy as it looks. You can well imagine that coupling the detector anode circuit back into the grid circuit of the S.G. is asking for trouble, as the possibilities of H.F. interaction and L.F. instability are by no means small, to say the least of it.

In addition, the S.G. is not the best type of valve from which to get easily an undis-

torted L.F. output. However, modern technique provides ways and means of getting over such difficulties. After considerable experiment to eliminate all unnecessary complications, the completely stable and workable circuit described in this article was evolved.

There are several points of particular

requirements for selectivity and absence of background noise.

The second tuning circuit, embodying the Ferrocart coil, is arranged as an auto-transformer coupling between S.G. and detector, the load of both valves being tapped across part of the grid coil on both wave-ranges. This scheme of connections,

added to the unique characteristics of the Ferrocart inductance, is mainly responsible for the high degree of selectivity and the efficient H.F. amplification of the receiver.

Reaction is applied to this second H.F. circuit by means of the usual differential condenser, the series resistor of 250 ohms serving to stabilise control on the long wave-range, where parasitic oscillation would otherwise occur and nullify the effect of reaction.

The next valve stage is a normal grid detector, the L.F. output coupling being a parallel-fed auto-transformer, with the volume control potentiometer connected across the effective secondary terminals A and G. The lead from the moving contact of this potentiometer is connected to the bottom end of the aerial coil, the .001-mfd. condenser being essential here to complete the H.F. circuit to L.T. negative.

## PERFECTLY STRAIGHTFORWARD OPERATION

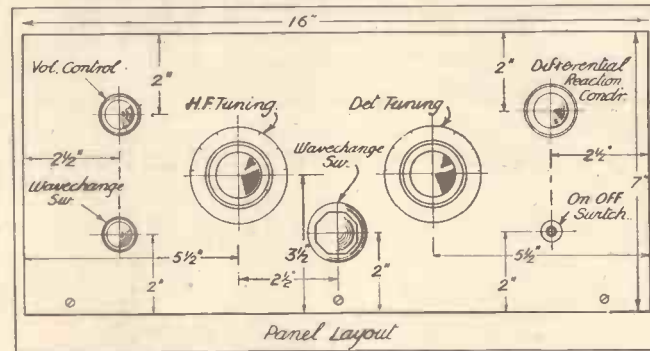

Although the circuit used is of a special nature, there is nothing unusual about the set's operation, which is precisely the same as for a "straight" receiver.

interest in this. The aerial tuning, although otherwise quite normal, has the reflexed L.F. input connected in circuit with it at the "earth" end. The type of coil windings used here were chosen as best fulfilling the

### Preventing Instability.

The resistance in parallel with this condenser serves to prevent the pick-up of external interference and any tendency to

## FOIL ON BASEBOARD SIMPLIFIES THE WIRING

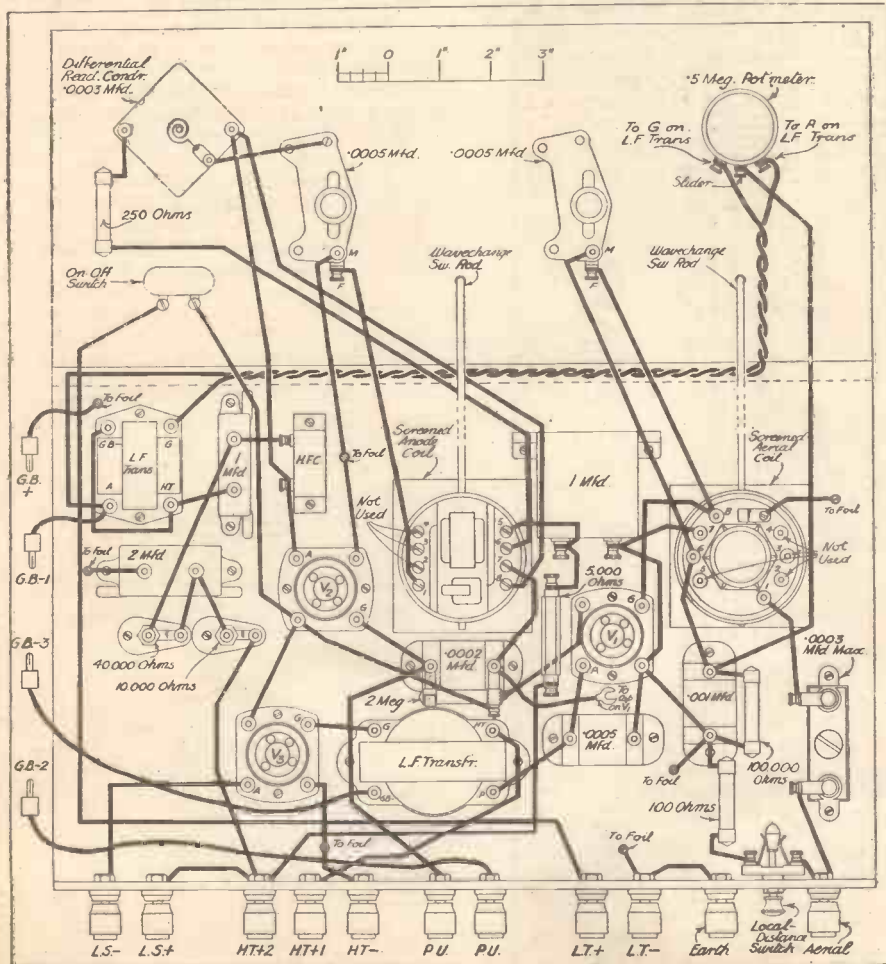

In a number of cases, earthed points are taken direct to the copper foil which covers the baseboard, thus considerably shortening the connecting wires. Note the twisted leads going to the potentiometer controlling the L.F. feed to the S.G. valve.

## ACCESSORIES TO EMPLOY

- LOUDSPEAKER.**—Rola, Amplion, Celestion, Marconiphone, Ferranti, H.M.V., Blue Spot, Atlas, Ormond, Epoch, G.E.C.
- BATTERIES.**—H.T., 120 volts: Siemens, Lissen, Ediswan, Ever Ready, Pertrix, Drydex.
- G.B.,** to suit valves: Drydex, Ediswan, Siemens, Lissen, G.E.C., Marconiphone, Ever Ready, Pertrix.
- L.T.,** 2 volts: Lissen, Exide, Ediswan, Pertrix, Block.
- MAINS UNITS.**—Requires two H.T. taps to deliver current to suit valves; 120 to 150 volts max.: Ferranti, Ekco, R.I., Heayberd, Regentone, Atlas.
- AERIAL AND EARTH EQUIPMENT.**—Goltone "Akrite," Electron "Superial," Radiophone "Receptru" down lead, Graham Farish "Filt" earthing device.

L.F. instability, both of which may occur if this resistor is omitted.

Instead of attempting to take out the amplified L.F. signal from the anode circuit of the S.G., leading to complications of both H.F. and L.F. circuits, we use the screen itself as the L.F. "anode."

### Simplified Design.

This is an obvious improvement on the original dual valve circuit, where no such separation of the H.F. and L.F. outputs was possible.

The design of the receiver has been reduced to the simplest terms consistent with efficient operation, and you can rest assured

(Continued on next page.)



# THE P.W. "REFLEX"

(Continued from previous page.)

that the choice of components, their number and layout, was only made after experiment had eliminated all but essentials.

The panel controls may seem to you to be rather overdone, but they are not all tuning controls. Separate wavechange switches are necessary owing to the disposition of the two coil units which permits a simpler layout and easier wiring than if they had been ganged to one knob.

Apart from the copper foil on the baseboard, which incidentally makes wiring up easier, no screening is necessary as both coils are "canned"; the taller one on the right, as seen from the back of the set, is the aerial coil, and the other, the Ferrocart inter-valve coil.

### Layout Details.

In front of the second tuning condenser is the detector valve, which feeds into the first L.F. transformer just beneath the reaction condenser. In front of the Ferrocart coil is the second transformer, feeding the output valve. You will notice that sufficient baseboard space has been reserved here for a choke output filter, or an output transformer, because the inclusion or omission of either is so much a matter of individual requirements according to the type of speaker used. The additional wiring is, of course, quite simple.

The H.F. volume control for local-station reception takes the form of a 100-ohm resistor, which, when the switch between Aerial and Earth terminals is closed, partially short-circuits the

input to the aerial coil. This prevents H.F. overloading of S.G. and detector valves.

At the same time, L.F. overloading of the S.G. is prevented by the potentiometer control on the panel, which need not be turned to maximum except for distant stations. This control of the L.F. input to the S.G. is of some importance, because the result of such overloading is not only audible distortion, but L.F. insta-

bility as well. The receiver is quite well behaved, however, provided the potentiometer volume control is not forgotten when tuning in a strong transmission.

## PICK YOUR VALVES FROM THIS LIST

Make.	S.G.	Det.	Output.
Mullard	P.M.12	P.M.1H.L.	P.M.202 or P.M.2a
Cossor	220S.G.	210H.F.	220P.A.
Mazda	S.G.215	H.L.2	P.220a or P.220
Marconi	S.22	H.L.2	L.P.2 or P.2
Osram	S.22	H.L.2	L.P.2 or P.2
Eta	B.Y.6	B.Y.1815	B.W.604
Hivac	S.210	H.210	P.220

## FERROCART COIL FOR SELECTIVITY

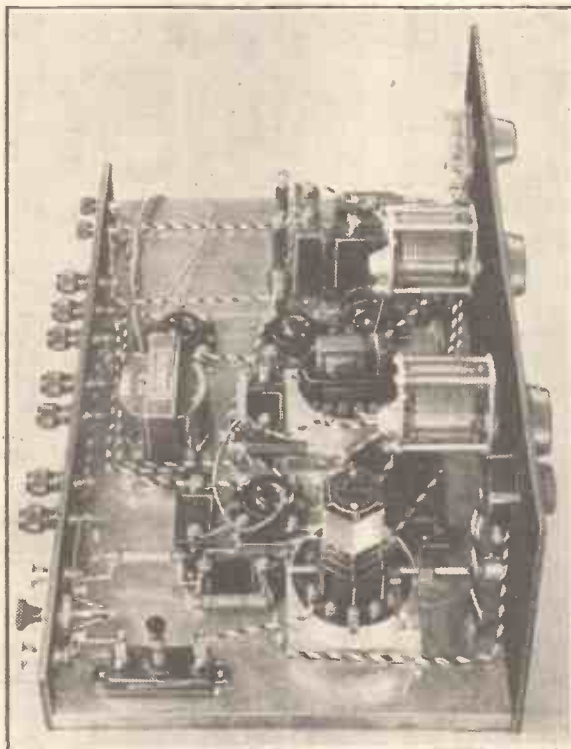

A Ferrocart coil is employed between the screened-grid valve and the detector, the object being to give the set greater selectivity than that usually obtained with an ordinary three-valver.

The construction of the receiver is not any more difficult than that of a straight three-valver. Assemble first your components, test them if possible, and proceed in accordance with the accompanying wiring diagram.

The points requiring special mention are few. I find that a neat finish to the baseboard is obtained if the copper foil is stretched along the board and folded under at each end, the overlap of 1/2 inch being secured underneath with drawing pins or small screws. If the foil reaches you in a rather tarnished state, polish it up with metal polish so that all wires earthed to it will make good contact.

### Raising the Aerial Coil.

In the photographs you will see that the Telsen coil is raised above the baseboard by a small wooden block (3/4 inch thick). The sole purpose of this is to achieve a symmetrical panel layout by bringing the wave-change knob into line with that of the other coil, and although not essential, is so easily done as to be worth while.

Before screwing down each baseboard component, especially if alternatives are used, make certain that all metal parts not to be earthed will not make contact with the foil. If in doubt, slip a piece of paper underneath before screwing down.

Some of the wiring will be more accessible if carried out in two stages, components such as the transformers being screwed down after the preliminary wiring has been completed.

(Continued on page 464.)

## YOU SHOULD USE THESE COMPONENTS WHEN BUILDING THIS "REFLEX"

Component.	Make used by Designer.	Alternative makes of suitable specification recommended by Designer.	Component.	Make used by Designer.	Alternative makes of suitable specification recommended by Designer.
1 Panel, 16 in. x 7 in.	Peto-Scott	Goltone	1 250-ohms resistance with wire ends or terminals	Dubilier 1 watt	Graham Farish "Ohmite"
1 Baseboard, 16 in. x 10 in.	Peto-Scott	—	1 2-meg. grid leak	Graham Farish	Dubilier, Lissen, Igranic, Ferranti
1 Cabinet to suit above	Camco	Peto-Scott, Direct Radio, Osborne	1 Screened coil	Telsen No. 216	—
2 .0005-mfd. condensers (var.)	Polar (slow-motion)	Ormond, J.B.	1 Screened Ferrocart coil	Golvern F.3	—
1 .0003-mfd. diff. reaction	Graham Farish	Telsen, Polar, Ormond, J.B.	1 H.F. choke	Lissen	Lewcos, M.C., Telsen
2 1-mid. fixed condensers	T.C.C. type 50	Dubilier, Telsen, Ferranti	2 On-off switches	Igranic and Ready Radio	Telsen, Lissen, Wearite
1 2-mfd. fixed condenser	—	—	3 valve holders (four pin)	Benjamin	W.B., Telsen, Lissen
1 .001-mid. condenser	Dubilier 610	T.C.C., Telsen, Ferranti, Lissen	1 L.F. transformer	R.I. Hypermite	Igranic "Midget," Varley "Nictet," Bulgin "Senator"
1 .0005-mid. condenser	Goltone	Telsen	1 L.F. transformer	Igranic "Acme" 3:1	R.I., Telsen, Ferranti
1 .0002-mid. condenser	Lissen	R.I., Igranic, Varley	1 terminal strip, 16 in. x 2 in.	Peto-Scott	Goltone
1 .0003 max. compression condenser	Graham Farish "Ohmite"	—	11 Indicating terminals	Belling-Lee	Eelex, Clix, Igranic
1 5-meg. potentiometer	Graham Farish "Ohmite"	—	7 Wander plugs	Delex	Goltone, Clix, Igranic, Belling-Lee
1 40,000-ohms resistance with vertical holder	Graham Farish "Ohmite"	—	2 Accumulator spades	Clix	Bulgin
1 10,000-ohms resistance with vertical holder	Dubilier 1 watt	Graham Farish "Ohmite"	4 yds. insulating sleeving	Lewcos	Goltone
1 100,000-ohms resistance with wire ends or terminals	Dubilier 1 watt	Graham Farish "Ohmite"	6 yds. 18-gauge tinned copper wire	Lewcos	Goltone
1 5,000-ohms resistance with wire ends or terminals	Graham Farish "Ohmite"	Dubilier 1 watt	Piece copper foil .004-gauge 18 in. x 10 in.	Peto-Scott	—
1 100-ohms resistance with wire ends or terminals	Dubilier 1 watt	Graham Farish "Ohmite"	Flex, screws, etc.	—	—



TWO features of Christopher-Stone's "Edwardian Melodies" that pleased me were the several records (in some cases only fragments) of contemporary and past great singers, and the orchestral rendering (by the B.B.C. Theatre orchestra) of familiar tunes, which we generally hear sung by mediocre singers. As there was no attempt to force the latter seemed more tuneful than ever.

Christopher Stone must be a little weary of receiving compliments, but the way in which he supplied the necessary information without the slightest suggestion of butting in, or interfering with the progress of the concert was really marvellous.

His reminiscences on Lily Elsie singing "I Love You So," filled one with regrets that she is now only a name to many of us.

The "Slavery" talks have all had their good points so far, but I think Mr. James on West Indian Slavery will take some beating. His own family story, of course, which he wove into the talk, added to the general interest, while his reference to the West Indian cricketers now touring in England was equally valuable to him and interesting to us.

## THE LISTENER'S NOTEBOOK

Topical jottings on radio programmes and personalities.

It always seems to me that when a man looks into the past for parallels to present-day conditions, and finds them, he is suggesting that wireless talkers, say 1,000 years hence, will be able to do the same thing, and as successfully, when reviewing world affairs in 2030. The inference is obvious.

Mr. R. Ellis Roberts did this rather emphatically when he brought to listeners' notice four new books, "Japan, in the 10th Century," "Richard Cœur de Lion," Dante's "Inferno," and "Peter Abelard," although he declared that to reveal the past is to aid our understanding of the present.

Mr. Roberts has rather a tragic way of reading

verse, that seems gradually to infect his own more natural style of talking as his talk progresses. This characteristic is inclined to put one off, when, actually, the listener ought to bring out his library list and add to it forthwith.

So it is definitely decided to finish with the Evening French talks next winter. I am sure this is a mistake. M. Stéphan and Mlle. Camille Vierre will be sadly missed.

Extraordinary as this decision is, I think the decision not to discontinue the Spanish and German talks as well more extraordinary still. French is the most universally studied of the three languages. This is obviously true when one recalls that in the schools French is a compulsory subject, German and Spanish usually optional or alternative to Greek or Latin.

I know, of course, that every licence-holder doesn't listen-in to these conversations, but I feel certain that there must be hundreds who regard them as an excellent continuation to the French they did at school. As a refresher course too, they are invaluable.

(Continued on page 461.)

# LAST WEEK of "RADIO-PICS"—POST NOW

ALL-CASH FIRST PRIZE!

# £25 AND 50

WIRELESS "EXTRAS" For Runners-Up.

The Consolation Prizes will all be very useful to set builders as they include: Loudspeakers—Ganged Condensers—Coil Units—"Class B" Transformers, etc.

THIS is the Sixth and Final Week of our free "Radio-Pics" Competition; so you must now complete your entries and send them without delay—if you wish to be in the running for the grand prizes offered. £25 awaits the winner, while there are 50 valuable "wireless extras" for runners-up.

Solve this last set of puzzles—No. 6—remembering that each little picture represents the name of a wireless station at home or abroad. The puzzles are perfectly straightforward, but as a further guide all this week's answers can be found in the usual short list below. Each other set in the contest has its own "key" list, too.

### HOW TO SEND IN!

As you find the answers, write them IN INK (in block letters) in the spaces underneath the puzzles; then this week, sign your name and address, also in the five previous sets, see that all the solutions are filled in, and pin all six sets together in order, to form one complete entry. Place the attempt thus completed in a properly stamped envelope, and post to:





POPULAR WIRELESS "Radio-Pics,"

5, Carmelite Street, London, E.C.4 (Comp.), so as to reach there not later than Friday, June 23rd, 1933, the closing date. Any entries arriving later will be disqualified.

## FINAL SET of "RADIO-PICS" No. 6.

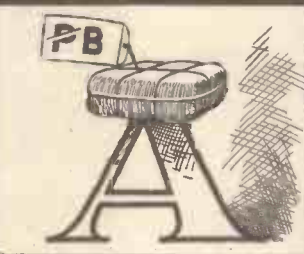
As for the purpose of the competition, wireless stations all over the world are being used, the following short guide list of names is given for reference with this week's pictures.

- ROYAL OAK
- STOCKHOLM
- BUENOS AIRES
- COLONIAL
- LANGENBERG
- SYDNEY
- NORMANDIE
- CHELMSFORD
- VIENNA
- RIGA
- FLAGSTAFF
- GENEVA
- BOMBAY
- KING
- BARCELONA
- ST. JOHNS

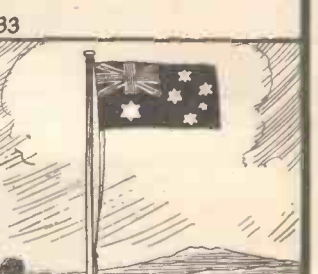
<p>CH</p> 	<p>PB</p> 	
<p>31</p> 	<p>32</p> 	<p>33</p> 
<p>34</p>	<p>35</p>	<p>36</p>

In entering POPULAR WIRELESS "Radio-Pics" contest, I agree to accept the Editor's decision as final and legally binding.

SIGNED.....

ADDRESS.....

The FIRST PRIZE of £25 will be awarded to the competitor whose solution of the complete series of puzzles is correct, or most nearly correct—and the other prizes in order of merit. No competitor may receive more than one prize, or share of a prize, and in case of ties the Editor reserves the absolute right to divide the prizes, or their value, as he thinks fit. All solutions must be written IN INK on the "Radio-Pics" puzzle-sets. Any number of different attempts may be made, but each attempt must consist of a full series of the six sets,

which must be quite separate and distinct from any other attempts. Entries including sets mutilated, or bearing alterations or more than one solution in each space, will be disqualified. No responsibility can be taken for delay or loss in the post or otherwise, nor will proof of posting be accepted as proof of delivery. No correspondence will be allowed. The decision of the Editor will be final and legally binding, and entries will only be accepted on this understanding. Employees of the proprietors of POPULAR WIRELESS must not compete.

PRIZES MUST BE WON—NOTHING TO PAY—QUICK RESULT!



# THE DEATH RAY — WHAT MARCONI SAYS

Statements in the Daily Press recently have referred to Marconi's death ray and other sensations. In this interview with Our Special Correspondent, the Marchese explains what his views are on the uses of wireless in war-time with particular reference to his latest wonder—the micro-wave.

THE League of Nations and delegates at the Disarmament Conference must have read with horror and consternation a few weeks ago of the Marchese Marconi's predictions regarding death rays, wireless-controlled aeroplanes and other devilish instruments of war. Who will care for the prohibition of big guns, poison gas and so on if the great scientist can achieve all the things of which he talks?

Fortunately, the Marchese Marconi, when I interviewed him on this question of wireless in the next war assured me that he was speculating rather than predicting.

### The Floating Laboratory.

"I am not emphatic about anything in the science of wireless," he declared with a laugh. "We know that anything is possible and I should be the last to declare that even the death ray was impossible. So when I talk of death rays and radio bombs I am merely mentioning them as possibilities. Indeed, I don't think we are anywhere near the death ray yet."

Here I questioned The Master Mind of Radio regarding the experiments he has been carrying out during the winter months in his floating laboratory—the famous yacht "Elettra." All the world knows by now that he is deep in investigations of the properties of wavelengths below one metre—"micro-waves" he calls them.

"Isn't it a fact," I asked, "that you experience a heating effect near your micro-wave transmitters?"

"Oh, yes," he replied. "That's true, but only for a yard or so in front of the aerial. I suppose we might say that this is on the track of the death ray, but the power is very small—a mere thirty watts or so. I think that sort of death ray is impracticable for a long while yet. We can't get the power, you see."

### Secret Talks at Sea.

"Why can't you get the power?" I asked.

"The valves won't stand it," was the answer. "I want two or three kilowatts in the micro-wave aeriels, but the valves melt. We'll get the valves eventually, and I predict big things for micro-waves then. Already I have spoken one hundred and sixty-eight miles with wavelengths of about fifty centimetres, and I can see that micro-wave apparatus is going to be extremely useful for all sorts of things. Thus ships at sea, in a fleet, for instance, can talk to one another quite secretly because the micro-waves don't get out of hand like fifteen-metre transmissions do."

"Why, the fifteen-metre transmissions astonished us by turning up in Australia when we only intended them to be heard a

few miles! The micro-waves pass right through the Heavyside layers, so there is no risk of them being reflected back to the ears of the enemy. For trench warfare micro-wave sets are ideal. One-man micro-wave wireless sets are quite feasible, because the aeriels are so small—just an inch or two long."

### Packets of Explosives.

Then I broached the subject of the "Radio Bomb," which was suggested by Mr. H. G. Wells in a recent broadcast when he spoke of packets of explosives being directed and landed so as to cause destruction in any desired part of the world.

"That is a question of wireless control," said Marconi, "and I have already told you that aeroplanes and so on could be directed by wireless if necessary," he continued. "Mr. Wells is not far wrong in his prediction you see, because I imagine we could easily send a flying radio bomb and control it by wireless, landing it just where we wanted it. But if we tried to send it too far the enemy could get on to the same wavelength, turn the bomb back and use it to their own advantage. An amusing possibility, but one which would have to be prepared for," he added with a smile.

thunder caused me much more trouble than the electrical disturbance."

He spoke of the possibilities of micro-waves for broadcasting. "The steel frames of London's buildings might have an undesirable effect," he said. The same difficulty, it seems, might apply to police wireless. "But there are a lot of things I want to try out," concluded the great scientist, "and I shall be very busy in my laboratories for months to come before I can answer all your questions. I return to Italy at the end of June, and intend to start straight away again on my micro-wave researches. Perhaps next time I come to London I shall have something really interesting to tell you." And by the manner in which he passed this last remark I gathered that he had something up his sleeve, if the truth be told.

## STATION NEWS

Some interesting facts concerning Foreign Broadcasting Stations.

Hamburg gives one stroke on his gong for a one-minute interval, two strokes for two minutes, etc. The wavelength, 372 metres, is next below the Scottish Regional.

The Norwegian, Swedish and Finnish stations all close-down with the words "God Natt."

To minimise fading effects many of the German stations are broadcasting on special aeriels.

Kalundborg's new transmitter is to have a power of 50 kilowatts, as compared with the 7½ kilowatts now employed.

Three groups of directional aeriels are erected at the Prangins (League of Nations) station in Switzerland, for transmission to various parts of the world.

When Eiffel Tower decides to repaint its "mast"—the Tower itself—no less than 45 tons of paint are required for the job!

The 15-kw. ultra short-wave station working from the Funkturm, Berlin, is the highest-powered station in Europe on a wavelength of only about 7 metres.

Preparations are being made in Czechoslovakia for a national short-wave broadcasting station.

### IN THE PATH OF A BEAM

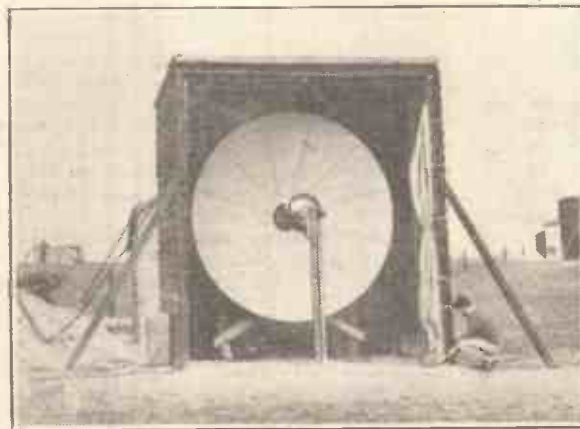

Marconi pointed out that although it was true that a heating effect was experienced near micro-wave transmitters, this only held good for a yard or so in front of the aerial. The aerial in this picture is the 18 cm. apparatus used for cross-channel working.

Marconi told me a lot about his micro-waves. How he found them free of all interference, for instance, and what a treat it was to be away from all atmospherics. "Even during a thunderstorm," he said. "I was able to listen with the headphones on, and when vivid flashes of lightning occurred I only heard a little click. The



# THE LATEST VALVES

During the last few months many important valve developments have taken place and the most recent of these are described below.

By DUDLEY KEITH.

**D**URING the past few weeks numbers of new valves of all sorts have made their appearance on the market. Valves for "Class B" amplification, for automatic volume control in A.C. sets, H.F. pentodes, and so on.

Many of these new valves we have shown in practical application in our set designs, but readers may like to know a little more about them than appears in such constructional descriptions.

We will, therefore, take some of the more outstanding types and discuss them a little more fully. First let us consider the last two Mazda valves to appear, the "Class

## 2½ WATTS OUTPUT

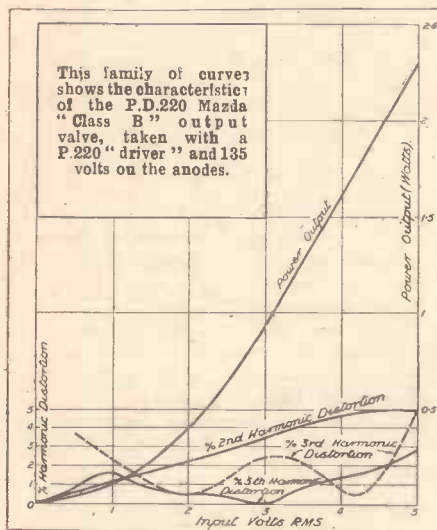

B" type and the special portable output valve of the straight variety.

The "Class B" valve, whose curve you see here, is known as the P.D.220, and is rated at 2 volts 0.2 amp. With a maximum H.T. voltage of 150 and a suitable "driver" valve, say the P.220, it will give a maximum undistorted output wattage of 2,500 milliwatts.

### A Small Bias Advisable.

It is so arranged that at all anode voltages the valve can be used with zero grid bias, though it is a good plan to use a -9-volt bias cell as a means of reducing the quiescent anode current, especially when a high anode voltage is applied. If this is done a resistance must be placed across the bias battery so that it runs down at approximately the same rate as the H.T. battery.

The P.D.220 is a high efficiency valve, for with a "driver" valve output of only 65 milliwatts we get a full 2,500 milliwatts output from the "Class B" stage.

At 120-volts H.T., the most usual voltage for "Class B" operation, the quiescent anode current of the P.D.220 should be 2 milliamps, and with a P.220 "driver" valve and transformer ratio of 1.5 to 1 we get a power output of 1,500 milliwatts over all.

With a smaller "driver," such as the L.2 and a transformer ratio of 2 to 1 the power output is 1,000 milliwatts.

The Ferranti "Class B" valve, too, is worth careful consideration, for the makers claim the enormous maximum wattage of 3,000 milliwatts from the valve. This is obtained with an anode voltage of 150, with a Cossor 215P. as "driver." With 120-volts H.T. the maximum wattage is 2,000 milliwatts, while the average anode current consumption is round about 10 milliamps. The valve is known as the H.P.2, and is now available.

The new portable set output valve is the Mazda P.215, which is a small power valve fitted with a high-efficiency low consumption filament. It takes only .15 amp., and with a mutual conductance of 1.7 and impedance of round about 4,500 it provides an output of from 60 to 180 milliwatts with H.T. voltages of from 100 to 150. The grid swing changes at those voltages from 9.0 to 13.5. The anode consumption is 3.0 to 5.8 milliamps, so that the valve is truly ideal for small consumption battery portables. The optimum load is 15,000 ohms at 100-volts H.T. and 11,000 ohms at 150.

The Mullard new high-frequency pentodes are worth careful consideration by set builders. As will be remembered they were used, three of them, in our recently described "Four-Pen-Four," and the multi-mu H.F. pentode is a valve of the highest efficiency.

### High Amplification.

The valve has the normal type of 4-volt 1-amp. heater, and is rated for a maximum H.T. voltage of 200, with a maximum auxiliary grid voltage of 100. The amplification factor is as high as 5,000 and at the minimum grid bias setting of 1.5 volts, the mutual conductance of the valve is 2.5.

By increasing the grid bias to -22 volts, the mutual conductance of the V.P.4, as the valve is termed, can be reduced to 1 per cent of its maximum value, so the valve is a most efficient multi-mu amplifier of great magnifying powers.

It is more effective than the average S.G. valve, and as an automatically controlled amplifier it is ideal. In addition, there is the non multi-mu pentode, the S.P.4, which is an H.F. valve of not quite so high an amplification factor, and intended primarily as mixer valve in superhet circuits. It is, however, as was seen in the "Four-Pen-Four," an excellent anode-bend detector in ordinary receivers, and can be confidently recommended in such a capacity.

### Dual-Purpose Valves.

In addition to what may be called the straight valves, we have had several examples of dual-purpose "tubes," such as the double-diode triodes and pentodes. These are primarily to provide straight-line rectification of H.F., and then to undertake L.F. amplification so that the diode rectification shall not need any extra valve in the set owing to its non-amplifying properties.

The ordinary leaky-grid detector also amplifies at L.F., and most small sets using it need only one following L.F. valve to provide loudspeaker strength output. In the case of the diode rectifier a further stage of L.F. is required because the diode does not amplify at all.

It was with the idea of overcoming that difficulty, as well as providing other advantages that the double-diode-triode was designed. This valve, of which Ferranti, Marconi and Osram have at the moment examples on the market, with Mullard following very shortly, provides pure rectification and L.F. amplification in the one "tube," but it also allows a variety of circuits to be used in which either half or full-wave rectification can be carried out, and automatic volume control of different kinds can be included.

A practical application of this was shown in our "Double D.T." receiver published some weeks ago. Full details of one of the valves was also given last week.

These double-diode triodes are known under varying nomenclature according to the make. For instance, the Ferranti valve is called the H.4D., the Marconi and Osram valves are listed as M.H.D.4, while the Mullard will be known as the T.D.D.4. Why this variation is necessary I cannot say, it seems a pity, but there it is.

### The D.D. Pen.

A more complicated arrangement of the double-diode principle has been put on the market by Cossor, in the D.D. Pen, which was used by us in the design of the "Double-D. Pen" receiver recently described.

This valve not only incorporates the advantages of the double-diode system, but it includes in the bulb instead of the triode amplifier a multi-mu pentode. This enables automatic volume control, or gain control, as it should really be called, to be carried out on the H.F. side of the receiver as usual, and also on the L.F. side, for the multi-mu pentode is subjected to the A.V.C. potentials from the diode in the same way as the H.F. stages of the receiver.

## FOR PORTABLE SETS

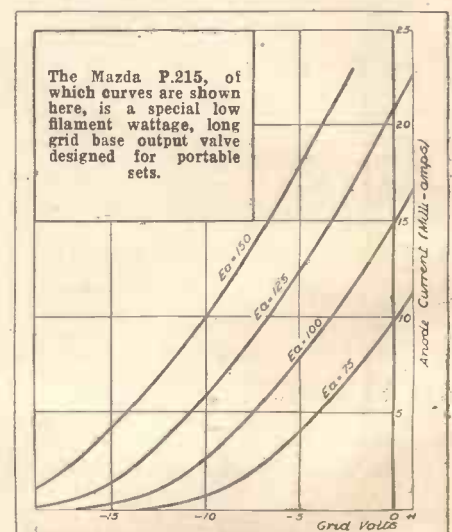

This is particularly important in that it allows most accurate control of volume to be obtained.



# ECKERSLEY EXPLAINS-



In giving some "inside facts" about aerials, our Radio Consultant-in-Chief, P. P. Eckersley, explains, among other interesting things, that "the higher the better" does not apply, irrespective of all other considerations.

**S**OME people imagine that the higher an aerial, whatever else happens, the better the reception. But this is not true.

If you wanted to receive seven-metre transmissions and shoved up a 700-metre length of wire you would be disappointed. Actually, if an aerial is longer than half a wavelength, the top half starts acting against the bottom half—that is, cancelling it.

In short-wave work, though, aerials are apparently much longer than the wavelength. But the cancelling effect is overcome in a clever way. Without worrying about why—believe it or not—the radiation from an aerial (or its power to receive) might be expressed as in Fig. A.

Here it will be seen that each successive half of the long wire cancels the effect of the other half. The aerial as shown would get (and radiate) nothing.

**Part is Non-Radiating.**

But if the cancelling halves could be included as lengths of wire, but be prevented from radiating, then the halves left could do some work and all work together and help one another, too.

So in short-wave work, very often, an aerial is used much longer than the natural wavelength, but it is made effective by including in the aerial wire a piece of "wrapped up" (and therefore non-radiating) aerial.

The next time you see a beam station you will see that it is made in this way: first, you will notice the cross arms on top of the mast. These support triatics from which are suspended, on one side, the

reflecting screen, on the other side the aerials.

But the aerials are much longer than the wavelength used, and so you will see (a third, a fourth, a fifth of the way down them) the wrapped-up pieces of aerial which distribute the currents in the aerial just as in Fig. B, but prevent one set of half-wave aerials from radiating.

The more aerials you can put on top of

**LONG AERIALS FOR S.W.'s.**

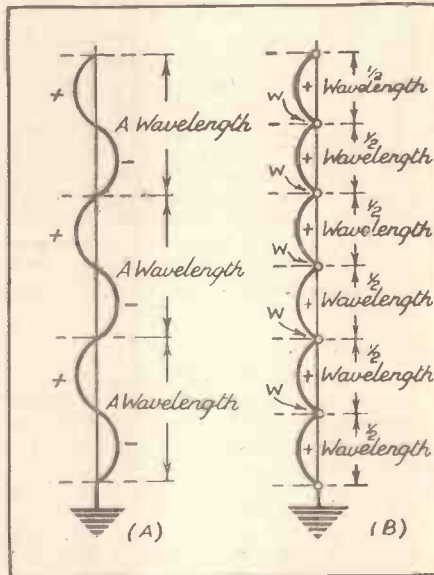

If an aerial is several times the wavelength, the radiation is cancelled out as at A. But by "wrapping up" the negative sections, as at B, this cancellation effect is avoided.

one another like this the stronger the radiation in a horizontal direction. And radiation in a horizontal direction is wanted, so that the short waves go skimming off the earth tangentially, and hit the underside of the Heaviside layer obliquely—not normally.

These things having been said, let me disillusion those who think to apply all this to broadcasting reception.

A half wavelength of a typical medium-wave station is—what? Well, say 600 feet. To get even two aerials you would want masts 1,200 feet high!

So, in broadcasting, the higher you can get the aerial, on the whole, the better.

Again, remember the horizontal piece only increases the effective height of the vertical part. If you had the

masts and masts were not expensive, you should always go up vertically for greater efficiency. But masts are expensive, and the horizontal top of the aerial is, as I said before, a way to increase the efficiency of the vertical part without making it longer.

Lastly, do not think that, for broadcasting, the multi-wire aerial is better, by any real margin, than the single wire.

"Wireless" is not "induction," and because, when in a dynamo you spin three wires in series through a given magnetic field and get three times the voltage than if only one was spun, you do not therefore get three times the loudness of reception when you have a three-wire aerial than when it has only one wire.

With an ordinary set the aerial is important to a certain degree. 30 feet high as against 5 feet high would make a substantial difference—but it is not important enough to warrant raising a 30-ft. aerial by 5 feet, say, or putting in another wire—and so on.

**The Ingenious Schoolboy.**

I remember so well a story of an ingenious schoolboy who wanted 200 volts to polarise an electrometer. The laboratory in which he worked had several plugs which gave power from the D.C. mains. The D.C. mains gave 110 volts.

The boy went to one plug and measured (by a voltmeter) 110 volts almost exactly. He marked one hole of the plug (+) and the other (-) because his voltmeter told him which was which.

Then he went to the other plug. Again he measured 110 volts. He marked one hole of this plug (+) and the other (-).

"Now," said he, "here is one plug giving 110 volts and here is another plug giving 110 volts; if I connect them in series to my electrometer I shall get 220 volts, and that will be all right."

As a result of this experiment the boy in the lab. learnt two things—the necessity to draw diagrams of connections before starting an experiment, and the wrongness of the theory that only the branch circuit fuses "blow" when you clean short-circuit the mains with a fat piece of wire.

Obviously you cannot connect the mains in series with itself, just as you cannot connect a battery in series with itself; but you can connect a battery in series with the D.C. mains.

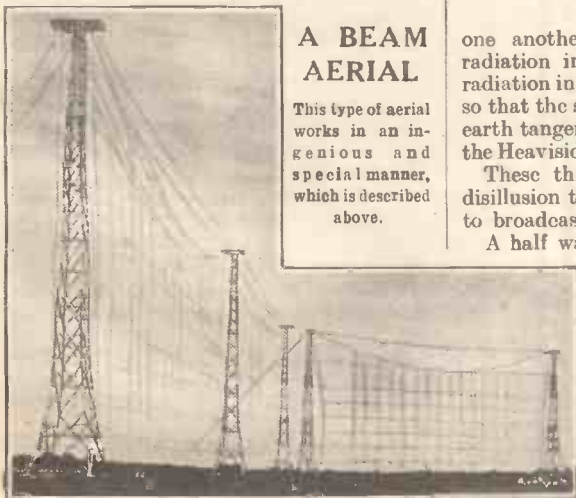

**A BEAM AERIAL**

This type of aerial works in an ingenious and special manner, which is described above.



THE MIRROR OF THE B.B.C.

By O.H.M.

# THE B.B.C. AND MILITARISM

Some Outstanding O.B.s—The Northern Command Tattoo—From the Isle of Man, etc.

**A**CCUSATIONS of militarism are being hurled at the B.B.C. from all sides, and it certainly *does* look as though there is some justification for the fears of the various pacifist organisations. Within a very short space of time the B.B.C. are broadcasting two or three tattoos, the R.A.F. Display and the Greenwich Naval Pageant—they would have to work hard to provide a more warlike series of broadcasts than that!

Sir John Reith, however, does not take these accusations seriously. He regards the attacks on his organisation as opportunism and nothing more. He knows, as well as most people do, that the B.B.C. is essentially pacifist, and at times even out-pacifists the pacifists by its refusal to fight them.

Nevertheless it is unfortunate that the B.B.C. should provide grounds for such accusations of militarism, and I have no doubt that Sir John will be asked to receive a good many deputations before the summer is out.

The strength of the B.B.C.'s defence lies in the answer that all these apparently warlike relays are designed to aid charity.

## Opera from Dresden.

In co-operation with the Central German Broadcasting Company and the Reichs-Rundfunk-Gesellschaft, the B.B.C. will carry out an interesting relay on Saturday, July 1st, when London Regional listeners are to hear Act 1 of "Arabella," the latest opera of Richard Strauss, as it is given at its first performance in the State Opera House at Dresden.

The opera will be conducted by Clemens Krauss, with Ena Plaszke van der Osten as music producer. Opera lovers should find this an hour's real treat.

**I** AM always glad to be able to pass on news of price reductions, especially when, as in the present case, the alterations affect receivers and components of outstanding merit.

As and from the first of this month, the price of the Columbia "Radiograph Four" is 23 guineas, which represents a reduction of 9 guineas. This price will be effective for both A.C. and D.C. models, and when I tell you that I always regarded it as excellent value for money at the old price of 32 guineas, you should not require any further persuasion to buy now while the going is good! To my way of thinking, it's a remarkable proposition.

Incidentally, important reductions are also announced in the prices of two other well-known Columbia instruments. The Model 355, which is an all-electric four, is now to be retailed at 12 guineas instead of 16 guineas, and the old price of 17 guineas for the famous Columbia portable superhet has been reduced to 13 guineas.

## Accommodation at Headquarters.

Some of the staff at Broadcasting House, who work in the basement in rooms without windows, have had reason to congratulate themselves on their good fortune during the hot days.

As a rule one hears nothing but grumbles from them, for usually they work under ungenial conditions, to say the least of it. The Governors of the B.B.C. are well aware of the plight of the basement staff,

## A GOOD CROP OF MICROPHONES



It is quite usual for a dozen or so microphones to be employed in America for important speeches. Duplication, apart from the number of separate concerns interested, is largely responsible for this, several microphones being coupled to ensure satisfactory reproduction.

but until Broadcasting House is extended they can do nothing about it.

This reminds me that the B.B.C. have now acquired all the adjoining property to Broadcasting House, and are ready to extend the building as soon as the economy cuts permit.

## Some Outstanding O.B.s.

A busy day for the Outside Broadcast

Department is due on Saturday, June 24th, when three outstanding events have to be relayed during the same afternoon.

The first is the R.A.F. Display from Hendon; secondly the First Test Match (against the West Indies, at Lord's), and thirdly, the Amateur Golf Final at Hoylake.

The most interesting will undoubtedly be the R.A.F. Display, for listeners will be able to hear the world's fastest aircraft whizzing through the air, dropping bombs, taking part in aerial combats, and so on, whereas in the other two O.B.s they will hear only the commentator and perhaps nothing more exciting than an occasional "How's that?" from Lord's, and the "whack" of the ball from Hoylake.

Squadron-Leader Helmore is again making the commentary on the Display, while Bernard Darwin is due to comment on the golf.

## The Northern Command Tattoo.

Another tattoo broadcast, that of the Northern Command which is held at Knaresmire, Yorks, is in the programme for Saturday, July 8th. Listeners will have the advantage of the services of a commentator in assisting them to follow the course of events as presented by the men of several famous Northern regiments.

The scene will depict the Tower of London, and on the White Tower in the centre will be posted twelve trumpeters to sound the opening fanfare.

Tattoo will be beaten first by drums and fifes in the style of William of Orange, and then as it is done at present by the drums and bugles of the Durham Light Infantry.

## Freedom of the Seas.

The Greenwich Night Pageant will be relayed from the Royal Naval College, Greenwich, on Saturday, June 17th.

The broadcast is called "The Freedom of the Seas," and opens with a scene in which English seamen are heard singing shanties. This will be followed by Holst's Marching Song, typifying the coming of war, and the playing of Nancy Lee, signalling the mobilisation of the Naval Reservists on August 2nd, 1914.

(Continued on page 450.)

## Good News from H.M.V.

Anything by way of a price reduction in the range of instruments produced by H.M.V. is news that can be hailed with a particularly lusty cheer!

It is common knowledge that H.M.V. instruments generally set a standard that is equalled by few and excelled by none, hence the importance of the reductions that have just been made in the prices of the "Superhet Portable Six" and the "De Luxe Radio Four."

Their respective prices are now 13 guineas and 12 guineas, and at the new low price levels one cannot but regard them as being among the industry's best value of the day.

It is only because of the tremendous popularity of the instrument in question that the reductions have been made possible.

Next week I hope to be able to give you news of important price reductions in one or two other famous ranges.



Weekly jottings of interest to buyers.

## Ferrocarts Down in Price.

From Colvern comes the news of an important reduction in the price of Ferrocart coils. Henceforth types F1, F2 and F3 will retail at 37s. 6d. for the set, which represents a saving of 12s. 6d. It's hot work playing about with a soldering iron this weather, I know, but what a temptation!



# THE NEW MULLARD *Screened* PENTODE



**'BUT MY CIRCUIT WAS DESIGNED FOR A SCREENED-GRID VALVE'**

## V.P.4

## S.P.4

That's what he said when we told him of the new Screened Pentode. "But even then," we said, "the new Screened Pentode will plug into it, because Mullard designed this new H.F. valve to plug into any H.F. holder in any and every A.C. circuit."

He was surprised. He was gratified. He was the ordinary, everyday listener who had dabbled in radio for the sheer pleasure of it, and knew quite a bit about it. And he admitted admiration for the new Mullard invention. "Pentode Power for the H.F. stage," he said. "That's what we've wanted — but I didn't think that would ever be possible." Mullards, the originators of the output Pentode, have now perfected this valve improvement for you. It is the greatest valve development for years. It affects *you!* Ask your dealer for details. He will be enthusiastic himself about the new Screened Pentodes — **WHICH SPEAKS VOLUMES.**

**TYPE V.P.4 for H.F. STAGES**

**TYPE S.P.4 for the DETECTOR STAGE**

ASK T.S.D.—Whenever you want advice about your set or about your valves — ask T.S.D.—Mullard Technical Service Department—always at your service. You're under no obligation whatsoever. We help ourselves by helping you. When writing, whether your problem is big or small, give every detail. and address your envelope to T.S.D., Ref. C.S.L.



# Mullard

**THE · MASTER · VALVE**

The Mullard Wireless Service Co., Ltd., Mullard House, Charing Cross Road, London, W.C. 2



## FROM THE TECHNICAL EDITOR'S NOTE BOOK



## A VERY USEFUL DEVICE

THERE are several ways by which selectivity and volume can be controlled, some moderately simple, and others fairly complicated.

A great deal can be said for the idea of inserting a "semi-variable" in series with the aerial circuit, but this has a snag. The capacity range chosen as suitable for selectivity adjustments on the medium waves is often unsuitable for the long waves.

On this band the selectivity problem is less acute in any case, and so it is nearly always advantageous to short circuit such a series condenser when you are switched over to it.

An extremely attractive alternative from the above is provided by the Pressland "Cop," an ingenious device which actually costs less than the average "compression" condenser.

It has the further advantage that it can be added very easily to an existing set whatever its circuit.

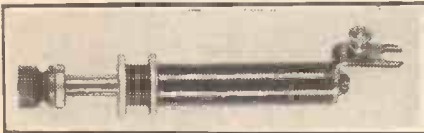

The new Terminal Cop.

The new Terminal model (price 2/-) can replace the aerial terminal on the receiver—an easy fitment—and at once a perfect control is made available.

The Terminal Cop is a perfectly straightforward piece of apparatus of ingeniously simple design.

In effect it is a well-made and smooth-working tubular condenser. The capacity range is 00001 mfd. to 00015 mfd. and this is covered by the movement of a plunger.

And at the maximum end it automatically shorts out when the plunger is pushed right in. Therefore, it can be switched out of action in an instant if and when desired.

As a "front door" volume control it operates very well indeed, and as such is also technically sound. And, needless to say, its selectivity controlling powers are equally good.

It is definitely a device to be recommended either to those who wish to add a valuable refinement to an old set at moderate cost, or to those building new receivers of conventional design.

## WAVELENGTH CALIBRATION

Many of you will no doubt remember my remarks concerning the Telsen gang condenser with wavelength calibration. And no doubt a large number

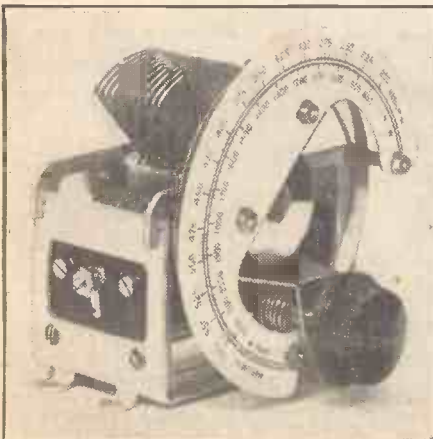

This Telsen variable condenser has its dial calibrated in wavelengths.

of those who did sigh for a similar construction in the single type.

Well, Telsen have "come up to scratch" as usual, and there is now a Telsen variable with all the appropriate features and advantages of that excellent gang.

But don't imagine for a moment it bears the appearance of a two-gang cut in half. It doesn't; it is a finished individual unit, sleek and self-contained.

The frame is a marvel of robust ingenuity, and I don't think I have seen anything better in radio engineering.

It has a rock-like stability of construction plus a smooth, clear-cut modelling.

The same thing applies to the excellent slow-motion movement which combines a velvety action with an impressive structural solidity.

It is inconceivable that slip and backlash could develop in it, however vigorously it might be handled.

The dial is translucent, and the scale light is very nicely placed. But you don't have to use that if you don't want to, as the engraving is sharp and clear.

We have used this Telsen condenser in conjunction with a Telsen coil and find the calibration to be remarkably good.

It is certainly an extremely attractive component from every point of view.

## THE LISSEN "CLASS B" TRANSFORMER

I expect that in these enlightened days most people are conversant with such tricks of advertising as the presentation of a huge building as the offices of the "X.Y.Z. Corporation," whereas, in fact, the "X.Y.Z. Corporation" occupies only one floor.

But it is a trick that is still played to some extent. Recently, however, I saw something in the nature of an antithesis of it. It was an aerial photo purporting to show the Lissen factory. And even so, the photo indicated a pretty extensive factory.

Having recently examined the Lissen factory at close quarters though, I was able to appreciate the fact that Lissen could give only a most modest representation of their truly enormous premises, even with the aid of a number of "bird's-eye" views.

Not that that would worry Lissen who are, of course, big enough not to have to bother about such trifles.

All this came into my mind as I examined the Lissen "Class B" "Hypernik" L.F. transformer, the product of acres of plant. In itself a small, neat component, but the number of men, directly and indirectly, contributing to its construction would form an excellent theme for a guessing competition.

Its technical specification is as follows. Primary inductance, 25-15 henries at 0.5 milliamperes (an excellently informative description, that); primary resistance, 500 ohms approx.; secondary resistance, 400 ohms approx.; overall ratio 1-1.

Thus it will be seen that it conforms with the requirements for efficient "Class B" working, and these are, of course, rigidly essential.

And the fact that it has been included in several of our important "Class B" sets, will provide concrete evidence of the fact that we consider it in every way entirely satisfactory.



Lissen's "Class B" Hypernik transformer.

## THE GARRARD PICK-UP

At one time, and not so long ago at that, it was generally considered that every pick-up should, as a matter of course, have a rising characteristic at the

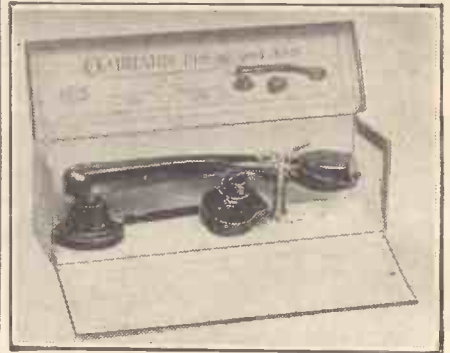

A high-class instrument.

bass end in order to compensate for the inherent bass deficiencies of records.

But now that it is becoming fashionable to include tone control in sets, exaggerated correction in the pick-up itself is not necessary, and at times even inadvisable.

I like the response of the Garrard Pick-up, for there is a modest bass lift and otherwise a substantially straight line.

It is a good pick-up, and is sufficiently sensitive for normal detector cutting-in, and is free from marked resonances.

It is fitted with a first-class arm that is easy to fit to any normal motor board for good tracking.

It can be purchased with or without a volume control, but as this suits the pick-up particularly well, I would advise constructors to take it in.

## ELIMINATORS AND SHORT WAVES

## A Reader's Experiences.

The Editor, POPULAR WIRELESS.

Sir,—I suppose there must be many of your readers who attempt, with varying degrees of success, to use short-wave adaptors in conjunction with battery-driven sets, but who fail hopelessly when the inevitable eliminator is installed.

In the majority of cases there will be a pronounced hum, and total inability to bring the set to its most sensitive condition by means of reaction.

To ensure any degree of success, it is necessary to use a mains unit similar to the "Heayberd" H.T.S. Major. (This particular unit's smoothing condensers total no less than 23 mfd., and a double choke is used also.)

From the information in that useful publication, "The All-Metal Way," the reader should encounter no difficulty.

The "no-load" voltage of the H.T.S. is about 500 v. Even at 17 m.a. it has only fallen to about 450 volts. This appears to be the minimum voltage to apply to the R.C. coupled detector with normal anode and decoupling resistances. Many people seem to overlook this point.

Having taken the trouble to ensure the valves are working under correct conditions, and that all mains and L.F. component casings are earthed, there may still be considerable hum present.

The steps taken to remove this are as follows:

(1) Completely enclose the eliminator in an earthed copper box.

(2) Use screened cable for connecting the mains to the eliminator, and earth the metallic covering.

(3) If earthed lead-covered cable is not used for the house wiring, replace the wiring to the mains socket, not forgetting to earth the lead covering.

In spite of all these precautions, I encountered a very bad hum and low-frequency oscillation between 17 and 20 metres which almost defied all attempts to eradicate.

Eventually two 01-mfd. condensers were connected in series across the mains, and the centre point earthed to the lead covering of the mains. There was no improvement. Connecting to the earth terminal proved no better, but connecting to the metal panel of the S.W. adaptor completely cured the trouble. I won't attempt to explain why! (The panel was already earthed through L.T.—)

When the broadcast set is in use these two condensers, with the junction connected to the aerial instead of to earth, provide an efficient "mains aerial."

Yours faithfully,  
Sheffield, GEO. E. COCKER.



# RECOMMENDED WRINKLES

## A SIMPLE RHEOSTAT.

TAKE a fibre strip (No. 62) or select a piece of  $\frac{1}{8}$  in. wood about half an inch wide and three inches long. Wind on this some 28-gauge Eureka wire (bare), leaving about  $\frac{1}{2}$  of an inch between each turn. The wire must be wound tightly, so that it cannot slip. Secure the two ends by winding them round eyelets at each end of the mount. Next obtain a small spring clip such as is used for fastening papers together and clamp this on to

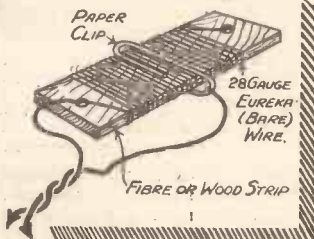

A fibre strip, a paper clip, and Eureka wire make this efficient, home-constructed resistance.

the edge of the resistance. A wire fixed to this forms one terminal, whilst either end of the Eureka wire can be used as the other.

## VARIABLE DRILL.

A HOME-MADE variable drill made of spring steel or an old hacksaw blade  $\frac{1}{4}$  or  $\frac{3}{8}$  in. thick is a handy way of drilling holes in ebonite from  $\frac{1}{16}$  in. to  $\frac{1}{2}$  in. in  $\frac{1}{16}$ ths. It will drill  $\frac{1}{16}$  in. hole in no time and it does away with all the drills necessary for wireless and saves a lot of time.

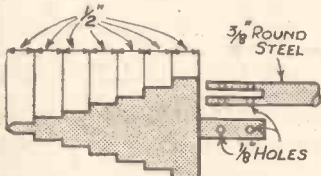

This one drill takes the place of the many which are usually needed for wireless work.

The slot in the round piece of steel to be riveted on drill for the purpose of using same in a brace can be cut with a hacksaw.

## BINDING FLEX ENDS.

THE fluffy ends of cloth-covered flex look very untidy. Here is a good way to make a neat and lasting job without a single knot.

Get a 2d. haul of fishing line because this is greased, strong, and thin. Lay



Greased fishing line, finished with shellac, forms the basis for this neat finish to untidy flex leads.

## ONE GUINEA FOR THE BEST WRINKLE!

Readers are invited to send a short description, with sketch, of any original and practical radio idea. Each week £1 ls. will be paid for the best Wrinkle from a reader, and others will be paid for at our usual rates.

Each hint must be on a separate sheet of paper, written on one side of the page only. Address your hints to the Technical Editor, "Popular Wireless," Tallis House, Tallis Street, E.C.4, marking the envelope "Recommended Wrinkles."

Will readers please note that the Editor cannot, in any circumstances, guarantee to return rejected Wrinkles, and that payment for published hints is not made until ten days after they appear.

The best Wrinkle last week was sent by J. M. Petrie, 18, Marsden Road, Southport, Lancs, to whom a guinea is being awarded.

a loop lengthways on the flex, letting the top of the loop hang over the end of the flex, and start winding about an inch down, keeping your thumb on C. Keep on winding until you cover the fluffy end, and pass the end of the cord B through the loop. Now take hold of A and pull, not letting the top windings relax in the process. Pull until you have the end B tucked well down inside the windings, and then cut at C. This is a good way of clamping connecting leads together before entering the set.

A coat of shellac or copal varnish gives it a very neat finish.

## DOPING THE CONE.

FOR those who have a home-made brown paper cone speaker, this wrinkle is well worth trying. All that is needed is a stiff mixture of shellac, a brush and a fire. First turn the outer edge of the cone over an eighth or a quarter of an inch all round. This can be glued or stitched. Then give the cone a liberal coating of shellac on either side. When dry insert a piece of wire through centre hole of cone, and hold in front of fire till shellac melts. (This causes it to soak through the paper.) It should then be left about ten minutes to set, after which it can be reassembled, and will give a clearness equal to many of the best commercial speakers. The idea of turning the edge over is to act as a stiffener. I have also had much better results by mounting the unit in front

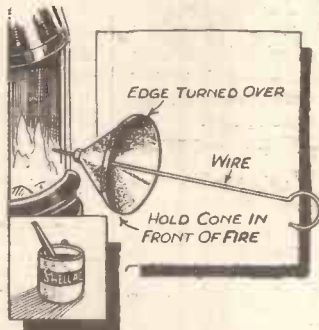

Shellac is used again here for improving a brown paper speaker cone.

of the cone instead of the rear. Possibly because the unit emits a certain amount of sound itself.

## MAGNETISING YOUR SCREWDRIVER.

ONE of the handiest tools is a magnetised screwdriver. It is very useful for getting into those annoying places where you cannot get your hands to place screws into their holes. With a little care anyone can magnetise an ordinary screwdriver. Stroke the blade of the screwdriver in one direction, as in Fig. 1, with a magnet. Falling

this, wind a coil of insulated wire round the blade (Fig. 2) and run a current of electricity from an old H.T. battery.

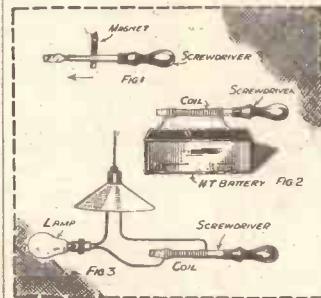

A magnetised screwdriver looks after screws in awkward places.

If you have D.C. mains, wind a well-insulated coil of wire round the blade of the screwdriver, remove the lamp from its holder, and put a plug in with two pieces of flex running from the terminals, join one side of the mains on to the lamp, the other side on to one end of the coil on the screwdriver, and the other end of coil to the lamp. (Fig. 3). Switch the light on for a few seconds and the job is done. This is not possible with A.C. mains.

## PROTECTION FOR COILS.

SOME time ago I was wiring up a set, when tightening the terminals with pliers which slipped now and again, the result was frayed windings on one side of the coil.

I then thought of the following scheme before starting on the other side. I got a half-pound cocoa tin, placed it over the coil, and proceeded with the job. This dodge is also applicable when a screwdriver is being used, as depicted in the sketch.

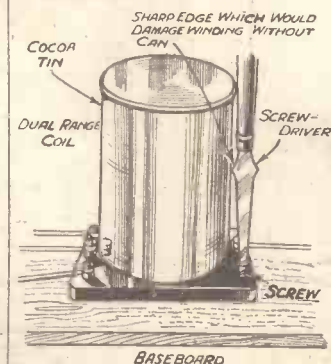

The delicate windings of unshielded coils can be protected by slipping an old cocoa tin over them.

## A HINGE HINT.

DID you know that when you are constructing cabinets which have hinged doors, tops, etc., that the easiest method of hanging these is to let the hinges in only one of the pieces which call for the hinge sides?

In the door, for preference, or in the case of a top, in the back of receiving rail. Taking a top, for example, if you let in the hinge to its full closed thickness and screw its rightful side in position, then set in the other half's screws, or, if they are long, some dab points to stick up to the extent of one-eighth of an inch, by simply pressing down the top on to these after it has been positioned, you will see exactly where the proper screws are needed.

In the case of a door, after the hinge has been screwed up door side, it is only necessary to set the door in position, mark where the hinges are to rest on the frame style, transfer these marks to the edge, then, whilst the opened door is being held in position with one hand, press back and screw the second half of the hinge in place.

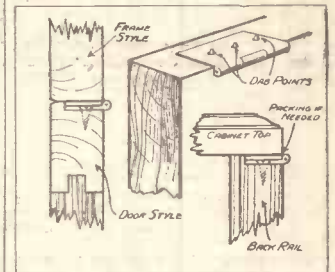

Try fixing your hinges this way when building a cabinet with lid or doors.

If there is not enough clearance between the joining woods, pack out behind the hinge with thin cardboard.

## SUBSTITUTE FOR A DIAPHRAGM.

PHONES are still being used, either for station searching or as an occasional crystal set, and it sometimes happens that the diaphragm gets rusty or damaged. A useful temporary diaphragm can be found in the thin triple covering used so universally for sealing coffee or tobacco tins. The latter should present no difficulty to pipe smokers, as the sealing disc on a 2-oz. tin will provide quite a passable diaphragm. The disc should preferably be cut with a sharp penknife, taking care to bend it as little as possible. After removing

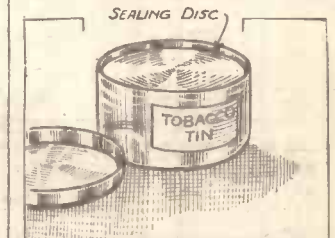

The metal sealing disc from a tin of tobacco makes an excellent improvised diaphragm.

and trimming to correct size with scissors, the rough edge should be smoothed with a fine file or emery cloth. The disc must now be pressed as flat as possible with a heavy domestic iron or other suitable means, after which it is ready for use.



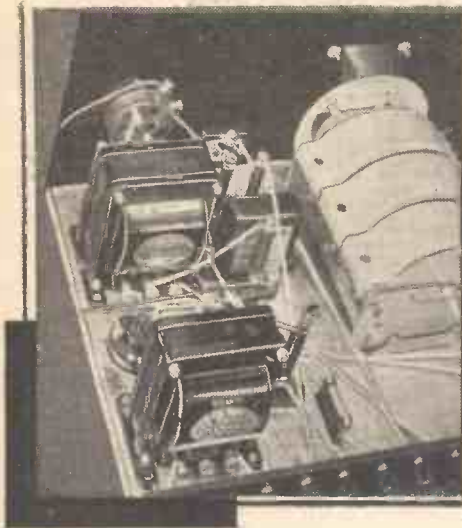

# "CLASS B" AND "DRIVER"

by J. C. JEVONS

The conventional method of "Class B" amplification calls for the use of a special "driver" stage to make good any losses due to grid current. In this article our contributor describes how it may be possible to produce similar results on entirely different lines.

**T**HE distinctive feature of the "Class B" amplifier, as compared with ordinary push-pull or Q.P.P., is that each valve is driven, in turn, beyond the point where grid current commences to flow.

In the ordinary way, of course, this would at once introduce distortion. In ordinary practice L.F. valves are always operated with a negative grid bias sufficient to ensure that the working point is always well below that at which grid current sets in.

### Generous Power Output.

But in applying a strongly negative bias to the grid one naturally increases the internal resistance of the valve, so that it requires a higher plate voltage to produce a given output.

However, this is exactly what we want to avoid, because the particular merit of "Class B" amplification is that it produces a very generous power output—as much as 2 watts, if necessary—without requiring a higher plate voltage or taking any more plate current than can be supplied by a dry-cell battery.

In other words, it puts the owner of a battery-driven set on practically the same footing, so far as plenty of undistorted volume is concerned, with the listener who has the advantage of being able to run his set from the electric mains.

The objection to grid current in an amplifier may not be very obvious at first sight, but it amounts to this. As soon as the grid becomes positive relatively to the filament, a current commences to flow from the filament on to the grid, and then through the input-transformer windings, back to the filament again.

### Voltage Drop.

Now a current cannot flow in any circuit without producing a voltage drop across it, and in this particular case the drop is in opposition to the applied signal voltage. That is to say, the grid does not "hold" the full signal voltage, but drops a certain fraction—depending in amount upon the impedance of the input circuit—directly grid current sets in.

The result is that the signal voltage is "flattened out" to a certain extent during each positive half-cycle. During the negative half-cycle nothing of the sort happens, because grid current is not passing. But if two successive half-cycles are treated

differently by the valve—one being "flattened" and the other not—the resulting reproduction must obviously be unbalanced and distorted.

In "Class B" amplification one gets over this difficulty by using a special "driver" unit consisting of a valve designed to deliver considerable power into a step-down coupling transformer with a low-impedance secondary.

The "driver" stage supplies sufficient power to the amplifier to make good any losses due to grid current. That, and the special low-impedance input, keeps the signal voltage in proper shape and prevents any flattening effect.

### A COMPENSATOR VALVE

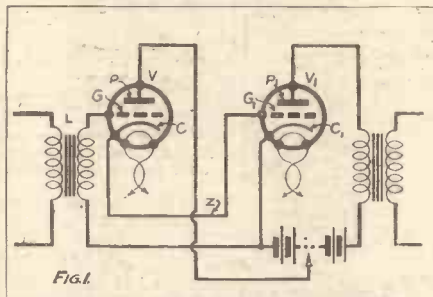

The valve V<sub>1</sub> is the main amplifier, the valve V acting as a grid current "compensator" thus preventing distortion on the positive grid swings.

To get the best results it is necessary to use the special "driver" stage referred to. One might, of course, drive a "Class B" amplifier direct from a high-impedance detector valve and input, but the power output would fall off, which means that the real advantage of the system is lost.

### A Future Possibility.

It is perhaps on the cards that some time in the future we may discover a way of simplifying "Class B" amplification and getting the same results without the additional equipment at present required. But, on the other hand, one seldom gets anything really worth while without having to pay for it, and certainly the extra cost of the "driver" stage is not excessive.

Attempts have, in fact, already been made, particularly in America, to produce similar results to "Class B" on different lines. One such arrangement is illustrated in Fig. 1.

The underlying idea is that, as previously explained, grid current distorts one half-cycle of the applied signal, but not the other. If, however, a certain amount of grid current is allowed to pass during each half of the applied signal, i.e. during the negative as well as the positive half-cycle, then one effect could be balanced against

the other—leaving the output free from distortion.

Granting this to be the case, a much larger output could be obtained. For instance, instead of biasing the grid to the point A, in Fig. 2, and limiting the input voltage to a swing between the points B and C—so as to prevent the grid from going "positive"—one could choose the point A<sub>1</sub> as the initial bias and swing the grid from the point B<sub>1</sub> negative to the point C<sub>1</sub> positive. Under these circumstances the normal output from a single L.F. amplifier would be more than doubled.

In the circuit shown in Fig. 1 the valve V<sub>1</sub> is the main amplifier, whilst the valve V acts as a "compensator" for grid current.

It will be noticed that the grid G<sub>1</sub> of the main amplifier is connected directly to the cathode C of the compensating valve, whilst the grid G of the latter is joined to the cathode C<sub>1</sub> of the former. Actually the space between the grid and cathode of the valve V forms part of the input circuit of the valve V<sub>1</sub>.

### Ensuring Good Reproduction.

When the grid G<sub>1</sub> of the amplifier V<sub>1</sub> is positive, a small current flows from that grid through the connecting lead Z to the cathode C of the compensating valve. Here it joins the main stream through that valve and returns to the cathode C<sub>1</sub> through the H.T. battery.

On the other hand, when the grid G<sub>1</sub> is negative, the cathode C to which it is joined is also negative. That is to say, the grid G is positive relative to its own cathode C. But with a positive grid the valve V naturally passes an extra current, which "balances" that taken during the preceding half-cycle. In this way the normal cause of distortion is removed, and the amplifier V<sub>1</sub> gives true reproduction over a positive grid swing as well as a negative.

### GETTING MORE VOLUME

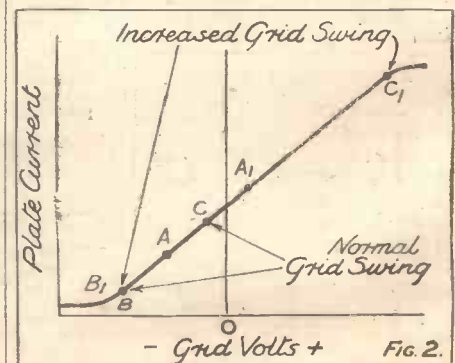

If the valve could be positively biased so as to increase the available grid swing a considerably greater L.F. output would be obtained.





# ASSEMBLING THE C.R.T. VIEWER

**A** NOTABLE advance has been made in television, thanks to the efforts of a young Londoner. It brings nearer the day when vision, synchronised with sound, will be a home entertainment within the reach of everyone.

"Reception of television without mechanical aid is now an accomplished fact. Instead of the 'scanning mirror' method, which is now in use, the cathode-ray system is used.

"I saw scenes, enacted in Broadcasting House, received and reproduced in a room in Charing Cross Road without wires or motor. They were seen in the wide end of a glass tube, shaped like a megaphone.

"The results are a sharper picture with far less flicker and far more perspective than I have yet seen. All the gear necessary, in addition to the cathode-ray tube, is a battery, resistance and valves. These, with the tube, cost about £12, which for the first time brings practical television reception within reach of every amateur experimenter in the country. It is to the amateur experimenter that the country should look for the ultimate triumph of television, as it was the amateur experimenters who were responsible for modern practical radio.

### The Secret Discovered.

"The secret of good reception of television has now been discovered, but television has yet several years to go before it will have reached the same stage of perfection as radio."

So says Garry Allighan, the well-known radio journalist, in a recent issue of "The Evening Standard," after he had witnessed a public demonstration of the "P.W." television viewer, given by Messrs. Ediswan in Charing Cross Road, London. And he is right. The secret of good television reception undoubtedly lies in the cathode-ray method despite criticism which is levelled at it from a certain untechnical quarter.

This criticism is particularly ridiculous in that it is levelled at the cathode tube not as

We have now reached a most interesting stage in the construction of the "Popular Wireless" Cathode-Ray Television Viewer—that of assembling the various sections forming the complete outfit. The connections for testing out the viewer prior to fitting it into its cabinet are fully described by

**K. D. ROGERS**, Chief of the "P.W." Research Department.

a receiver of television but as a producer of X-rays or some similar harmful emanation.

### IN THE LABORATORY



Checking over the apparatus ready for the reception of one of the B.B.C. television transmissions.

"We know little of the cathode tube," our critic is reported to have said—(we agree, he apparently does not know much

about it)—"and it is probable that the tube gives rise to rays that are definitely harmful. The cathode-ray system of television is a risky process," etc., etc.

I am not going to go deeply into the technical answer here. Dr. Roberts, who has done a great deal of cathode and X-ray work, is fully discussing the question in a later issue of POPULAR WIRELESS, but I should like to assure readers that there is absolutely no cause for alarm at such ill-founded criticism.

### There is Nothing Harmful.

The cathode-ray tube is a "soft" tube, and what X-rays it might manage to emit with high-voltage operation are so soft as to fail to pierce even a few inches of air, let alone have the slightest effect on the human system or eyes. Probably the average luminous watch is far more risky a companion, and no one questions the wisdom or otherwise of wearing that popular adornment.

Probably one of the factors that has had most to do with the birth of this silly rumour is the fact that the light emitted from the cathode tube is not only *apparently* highly actinic and ultra violet in character, but that it spreads over such a wide surface, and therefore must, so it seems, cause powerful radiations.

That it is *not* highly actinic or ultra violet in character is proved by the fact that to photograph the cathode ray fluorescence we need ultra rapid panchromatic plates, and even then exposures of half a second or more are necessary for anything like a "result." Ordinary plates are unaffected by this "ultra violet" light with any exposure under a matter of many minutes.

### Persistence.

As regards the luminosity. This is a feature of persistence of vision, for the cause of the apparently continuous brightly illuminated area is a small spot having a diameter of slightly more than a pin's head (not a hatpin, Mr. Critic—an ordinary pin), a fraction of the size of a

(Continued on next page.)

### HOW THE DEFLECTORS ARE CONNECTED

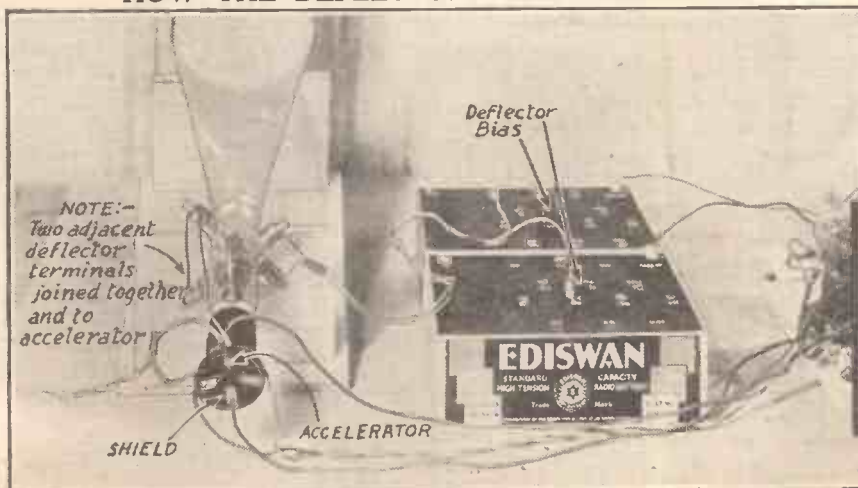

Two of the adjacent deflector terminals are joined together and connected to the accelerator, while the remaining two deflectors are taken direct to two separate bias batteries as shown in this photograph.



# ASSEMBLING THE "C.R.T." VIEWER

(Continued from previous page.)

luminous watch's second hand), but this rushes about so rapidly that it gives the

appearance of a bright patch some inches in length and about 1½ inches in width. This you will be able to see for yourselves when you have completed the assembly of the television viewing apparatus—quite a simple matter, though it looks complicated. I must make it clear at this point that, though I am about to describe the assembly

of the cathode ray apparatus in what might be termed "bench" form, it is not intended that the apparatus be permanently left in that manner. After the first tests have been completed, the operating details being given next week, we shall describe the construction of an easily-made, but handsome cabinet, (Continued on page 454.)

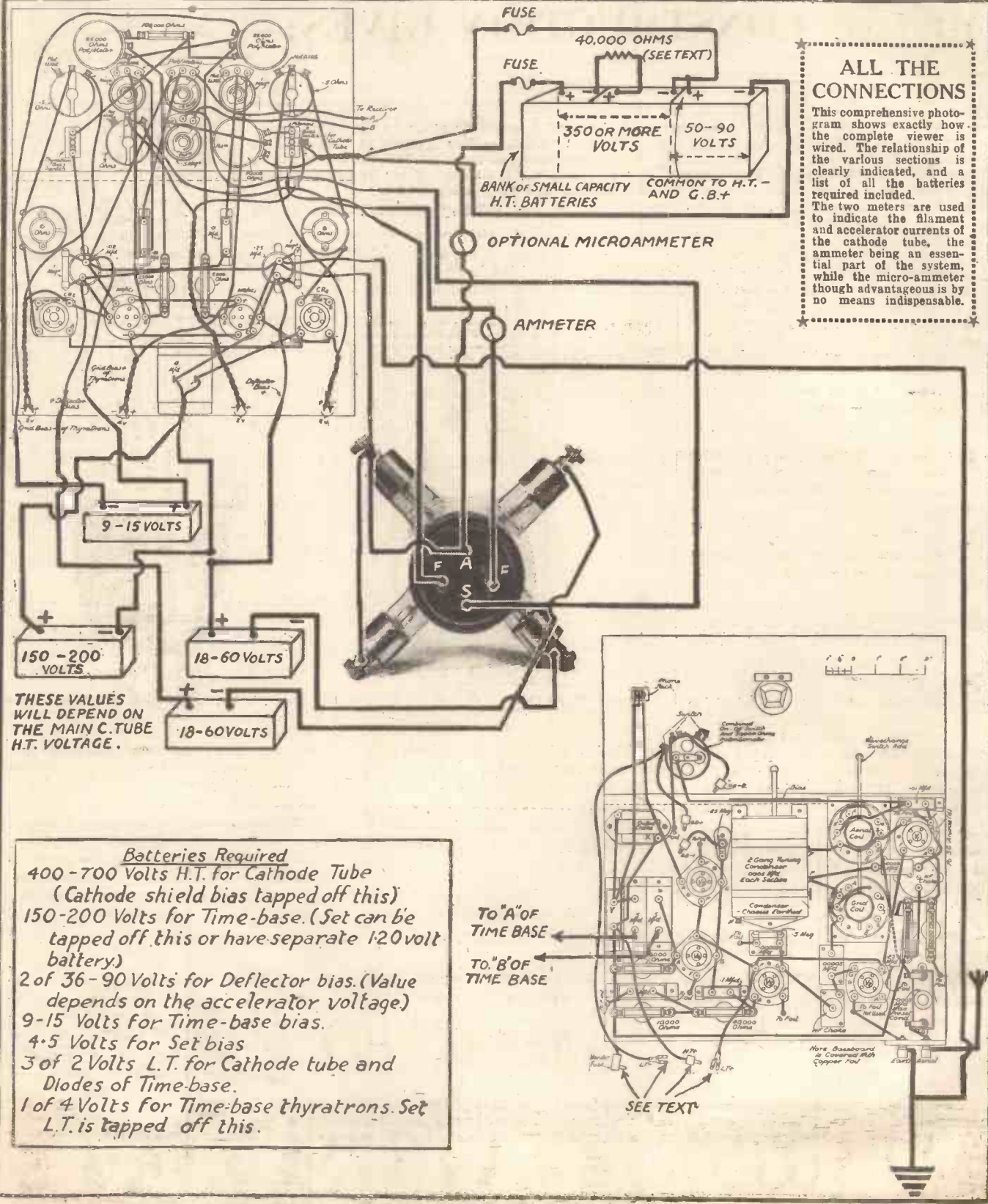

## ALL THE CONNECTIONS

This comprehensive photograph shows exactly how the complete viewer is wired. The relationship of the various sections is clearly indicated, and a list of all the batteries required included. The two meters are used to indicate the filament and accelerator currents of the cathode tube, the ammeter being an essential part of the system, while the micro-ammeter though advantageous is by no means indispensable.

THESE VALUES WILL DEPEND ON THE MAIN C.TUBE H.T. VOLTAGE.

- Batteries Required**
- 400 - 700 Volts H.T. for Cathode Tube (Cathode shield bias tapped off this)
  - 150-200 Volts for Time-base. (Set can be tapped off this or have separate 120 volt battery)
  - 2 of 36- 90 Volts for Deflector bias. (Value depends on the accelerator voltage)
  - 9-15 Volts for Time-base bias.
  - 4.5 Volts for Set bias
  - 3 of 2 Volts L.T. for Cathode tube and Diodes of Time-base.
  - 1 of 4 Volts for Time-base thyratrons. Set L.T. is tapped off this.

TO "A" OF TIME BASE  
TO "B" OF TIME BASE

SEE TEXT

Note: Baseboard is covered with Copper Foil



# R I G I D

## METAL CONSTRUCTION GIVES:—

- 1** GREAT MECHANICAL STRENGTH due to cylindrical anode and interlocked electrodes. The Marconi Catkin Valve can be knocked or dropped in a manner which would be disastrous to a glass valve.
- 2** GREATER UNIFORMITY due to elimination of inaccurate glass pinch and bent supporting wires, and to the extreme accuracy of the electrode alignment.
- 3** ABSOLUTELY CONSISTENT PERFORMANCE, as the anode in direct contact with air promotes cooler running, hence reducing chances of gases and water vapour being set free during life.
- 4** SMALLER SIZE and improved appearance. Valves can be sent by post in the ordinary carton without extra packing.
- 5** RUBBER MOUNTING and rigid interlocked electrodes, which eliminate microphonic effects and reduce hum.
- 6** A SOLID METAL SHIELD—better screening than metallising on a glass bulb.
- 7** A BASE which cannot work loose or come off.

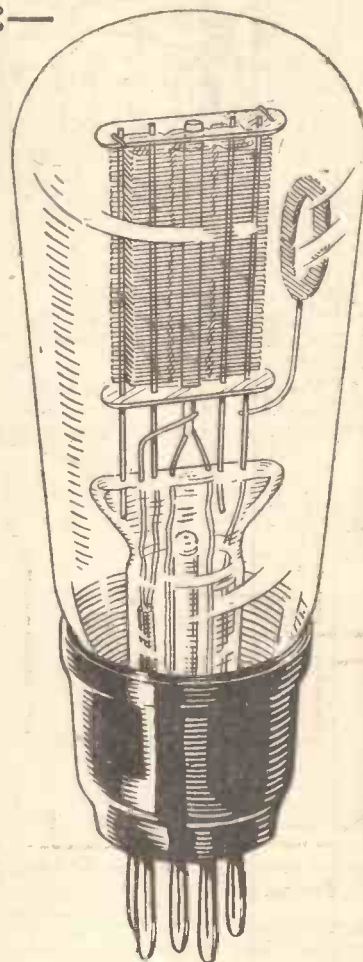
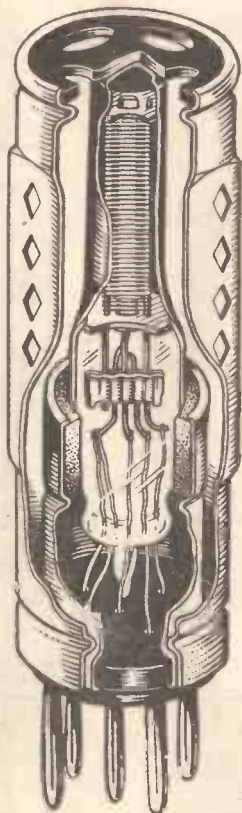

Hitherto the valve has changed little since Professor Fleming first invented it in 1904. Throughout all these years it has remained a delicate assembly of bent wires and welded joints in a fragile glass bulb. In the CATKIN VALVE, Marconi have overcome at one stroke all the weaknesses inherent in such construction. In characteristics, the A.C. CATKIN VALVES now introduced are similar to the existing glass types and can therefore be substituted for them in most modern A.C. Mains receivers.

The types at present available are : \*vms4. A.C. Variable-Mu. S.G., price 19/- . . . \*MS4B. A.C. Screen Grid, price 19/- . . . \*MH4. A.C. General Purpose Triode, price 13/6 . . . MPT4. A.C. Power Pentode, price 20/-.

\* With or without screening cover.

Write to the Marconiphone Company Ltd., 210 Tottenham Court Road, London, W.1, for a folder describing these remarkable new valves.

We show here a cut-away drawing of the screened Marconi triode Catkin Valve MH4 in comparison with an equivalent glass valve drawn to the same scale. Note how the grid and heater of the former are rigidly locked at both ends inside the metal anode, which, in its turn, is rubber mounted and metal-armoured, and compare this with the glass valve, with its fragile pinch, many bent wires and delicate joints.

ASK FOR THE UNBREAKABLE



# MARCONI CATKIN VALVE



## ASSEMBLING THE "C.R.T." VIEWER

(Continued from page 452.)

in which the whole of the gear can be housed, making the cathode ray television viewer a complete, household instrument.

The construction of the double time-base and the vision radio receiver has been described, and all we now require in addition are the cathode tube itself (Ediswan type T), a wooden carrier, which can be knocked up in no time, an ammeter reading to 2 or 3 amps. (A Sifam model is O.K., and this will do for the final cabinet to be described later) and, if possible, though it is not essential, a micro-ammeter reading to 100 or 250 micro-amps.

As regards H.T., I should start off with about 400-450 volts for the cathode tube, increasing it to 700 or so when you have got it working. The higher voltage is a great advantage in the increase of picture modulation and brilliancy it gives, but until you are used to working the outfit you may feel happier with less.

### Small Capacity H.T. Cells.

The H.T. and the various bias batteries can be made up of the smallest capacity H.T. batteries available—there is no need to use super- or double-capacity cells. The only place where a good battery is required is that used for the vision receiver, and for the operation of the time-base. This battery can be common if desired, though for experimental purposes you may prefer to use separate batteries.

This assembly being in the nature of a try-out assembly, no provision is made for battery switching other than that already incorporated on the receiver and time-base for disconnecting the bias-potentiometer connections and switching off the cathode tube filament. In the final cabinet model proper switches will be employed to take care of this necessary operation.

### A Battery Box.

For experimental purposes it is a good plan to rig up a box for the main H.T. supply (to the cathode tube) so that it can be switched off readily and will be out of the way of stray pieces of wire or unauthorised and inquisitive hands. Such a box, with a suitable lid, and carrying on it the control switch and a small fuse (60 milliamp or less) will be a decidedly useful aid to the tests you will have to carry out prior to finally housing the receiver in its special cabinet.

It cannot be too strongly stressed that

the testing of a piece of scientific apparatus, such as this viewer, cannot be undertaken in a hurry, or a slap-dash manner. It must be carried out properly, and with due regard to careful arrangement of the inter-connecting leads, all of which should be made of good rubber-covered flex.

### Connections Made With Flex.

Apart from short-circuits anywhere, the slightest leakage between certain parts or connections may result in failure to get the viewer working properly, while a disconnection may result in a blow-out of the cathode tube.

## USES AN ORDINARY VALVE HOLDER

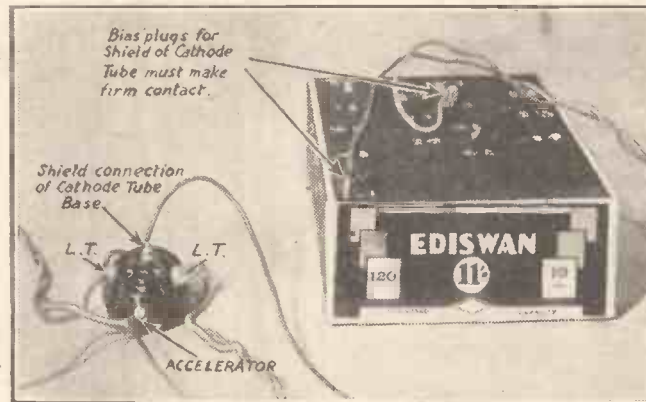

The cathode ray tube fits into an ordinary four-pin valve holder, the connections to which are indicated above. As in other parts of the circuit, it is of the utmost importance that these connections should be securely made.

So use good flex, free from whiskers, and go slowly over each connection, checking it with our diagram and with your set and time-base wiring, and making every connection rock firm.

## DISPOSITION OF THE ELECTRODES

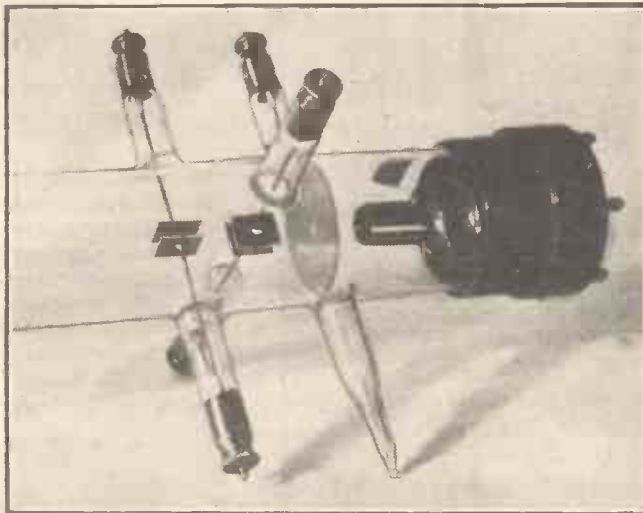

An illustration of an experimental cathode ray television tube which gives a very clear idea of the relative positions of the cathode shield, the accelerator (note the hole through which the electron stream passes), and the two pairs of deflector plates. The connection to the accelerator in this case is made on the side of the tube instead of to an anode pin as in the Ediswan T tube used by "P.W."

This latter feature is most important, for we do not want any of the leads to come off, or to make uncertain contact. As a matter of fact, failure to make contact in the bias supply leads to the cathode tube shield may result in serious damage to the filament of the tube.

Note that two adjacent deflector terminals on the tube (going to different sets of plates) are joined together and taken also to the anode pin of the tube (the accelerator terminal). It does not matter at first which pair of deflector terminals is chosen as long as they are adjacent. We shall find by experiment if the ones chosen are the most suitable.

The bias for the shield of the cathode ray tube—a matter of between 50 and 75 volts (for voltage of 350-700 H.T.) is tapped in at the end of the H.T. supply. In other words you can supply, say, 400 volts H.T. for the tube's accelerator by means of four 120-volt batteries in series, the last battery being used for H.T. and bias, the negative H.T. plug being the bias plus.

### The Tube Works

#### Like A Valve.

This scheme is optional to the separate bias battery method. It does not matter how the bias is obtained provided it is reliably applied—there must be no loose or risky plug contact anywhere.

As regards its operation the cathode ray tube can be regarded in the light of an

ordinary three-electrode valve—i.e. the variations of voltage on its grid (shield) modulate the electron stream. *But it is not so robust to minor hardships as the thermionic valve, and so must be treated more circumspectly.*

The normal valve does not suffer serious damage if the bias is momentarily removed, though that is a practice that cannot too strongly be condemned. The cathode tube is in great danger if such a circumstance occurs, for on removing the bias (H.T. and L.T. being on), all focusing of the electron stream is stopped and the electron current rises tremendously.

### Resistance To Protect Filament.

The result is a very great strain on the cathode, which is really a sort of hot point at the tip of the filament rather than the whole filament, and such an electron surge causes lumps of the emissive material to be torn off, the mechanical tearing being strong enough in some cases to fracture the filament. So take care you never remove the bias while the tube is "on."

There is a way of minimising the risk by placing a resistance in the H.T. feed (a convenient place is in the coupling between two of the centre blocks of 120 volts), so that the rise of accelerator current is kept somewhat in check. A resistance of 40,000 ohms is a useful value, and this, while not affecting the operation of the tube, will to some extent safeguard the tube against sudden surges.

The radio viewer can take its H.T. from one of the two cells used for the time-base 4-volt supply, the negative L.T. of the set being common with the negative L.T. on the 4-volt battery. It must be remembered in this television viewer that the accelerator and two deflectors of the tube

(Continued on page 459.)



# B.I.

## ENAMELLED WIRES

### 8 SPECIAL FEATURES

1. High dielectric strength and free from pinholes.
2. It is tough and will withstand severe handling.
3. Enamel is highly elastic and will not readily fracture.
4. Will resist temperatures which would char any fibrous insulation other than asbestos.
5. Under ordinary conditions, retains all its qualities year after year.
6. The enamel is non-hygroscopic, thus avoiding short circuits where damp occurs.
7. The gauge of the wire, both under and over the enamel, is accurately constant, making it ideal for coil winding.
8. Entirely British made.



The B.I. have been manufacturing enamelled wire since it first came into use, and long experience, constant research and the use of the finest machinery available have led to the production of B.I. Enamelled Wires of a consistently high standard of quality. For all fine windings where economy of space is essential, there is nothing to compare with the perfect insulation of B.I. Enamelled Wires, which are made in all usual sizes down to 0.002-in. diameter. Write for full particulars.

**BRITISH INSULATED CABLES LTD.**

CABLEMAKERS AND ELECTRICAL ENGINEERS

**PRESCOT—LANCS.**

Telephone No. : Prescott 6571.

London Office : **Surrey House, Embankment, W.C.2**

Telephone Nos. : Temple Bar 4793, 4, 5 & 6.

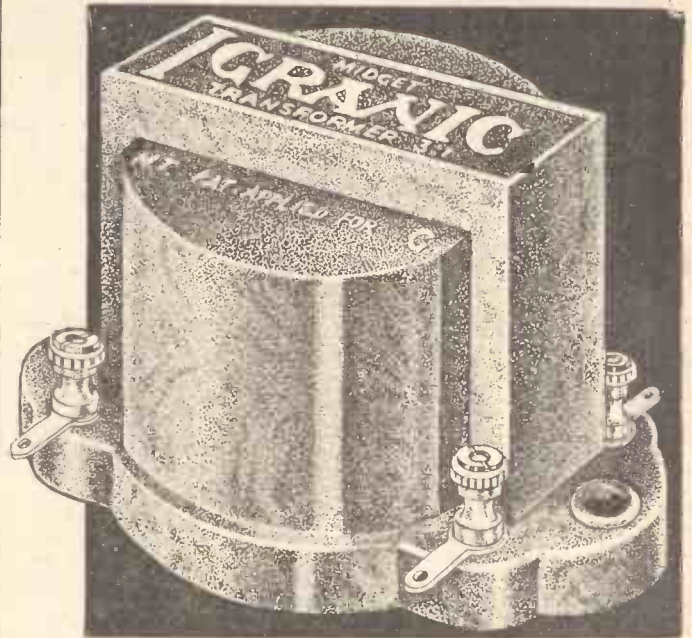

*A Transformer I purchased in February 1925 is still in constant use and as good as ever . . . My slogan after all these years is "Once a user of Igranic, always a user of Igranic."*

*"Igranic Enthusiast," Leyland, Lancs.*

### IGRANIC MIDGET TRANSFORMER

Igranic have specialised in Transformer manufacture since the inception of Broadcasting, and many years of experience and costly research has led to the production of the "Midget" Transformer—unsurpassed for quality and performance. This wonderful Transformer renders the highest standard of tonal purity without a trace of "drumming." Its production reaches a standard never previously attained by a Transformer of such reasonable price. Supplied in ratios 3-1 and 5-1. Price **10/6**

*The Igranic Acme L.F. Transformer, the Transformer "par excellence," is specified for "The 'P.W.' REFLEX."*

*Supplied in ratios 3-1 and 6-1. Price 17/6.*

*Write for fully illustrated Catalogue No. R.203 of Igranic Quality Components.*

Igranic Electric Co. Ltd., 149 Queen Victoria St., E.C.4.

**IGRANIC COMPONENTS WILL BE THE MAKING OF YOUR SET**



# THE SUPER-HET. SIMPLY EXPLAINED

By **BERNARD BARNARD**

AS most readers are aware, the superheterodyne principle of reception is not new. It has had a long and varied career, during which it has touched the crest of popularity and, at times, fallen into the troughs of disuse.

At the present moment it is again coming to the fore. As is generally known, an extraordinarily high order of selectivity is obtainable with this type of receiver; present-day broadcasting conditions demand sets which will receive programmes clear-cut from stations separated by not more than 9 kilocycles. The superhet fulfils this demand.

Another problem, however, is introduced once this selectivity has been obtained, and this is the difficulty of maintaining a sufficiently high standard of tonal quality. As will be shown later, it is not possible to cut off carrier-wave frequencies of 9,000 cycles without also removing

The selectivity demands of present-day broadcasting conditions and the advent of tone-compensating devices has renewed the popularity of the superhet. Readers will therefore be specially interested in this simple and practical explanation of how such receivers work.

however, control our amplifier to pick and choose programmes, for it will only work on the one wavelength to which it is tuned.

If it were possible to select the station we wish to hear and then alter its wavelength to that at which our amplifier is set, then quite obviously we have a receiver which is both selective and stable. Altering the wave-

length of a broadcasting station at the receiving end sounds a very tall order; but actually it can be done.

In order to understand how this wavelength is changed, it will be necessary to consider for a few moments a simple acoustic experiment.

### Combining Sound Waves.

If we strike two similar notes on a piano at the same time, we shall hear quite clearly a distinct beat in the sound produced; the sound appears to rise and fall alternately, and the rapidity, or frequency, of this rising and falling is the difference in frequency between the two notes which were struck. You can prove this by first sounding two notes which are very close together and then two notes which are farther apart on the keyboard; in the first case the beat will be very slow, but in the second case you will notice that it is very much faster. This rising and falling of sound is known as the "beat" and the speed at which it takes place is called the "beat frequency."

Actually, this phenomenon occurs whenever two similar wave motions are superimposed one upon another, and if two oscillating currents at radio-frequency are mixed together, then a beat frequency equal to the difference in frequency between these two oscillations is produced.

It is by making use of this that we are able to change the frequency and therefore the wavelength, of any transmitting station to any desired figure.

Suppose we have tuned our amplifier to a frequency of 100 kcs.; if we wish to

(Continued on page 458.)

### A PRACTICAL DEMONSTRATION

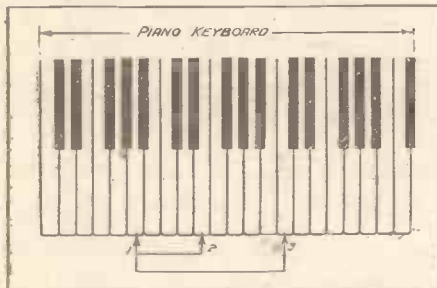

If two different notes on the piano are struck at the same time a distinct "beat" will occur. The frequency of the "beat" will depend upon the difference in frequency between the two piano notes.

audible sounds of this frequency from the reproduction.

This difficulty of combining quality and selectivity has been the chief cause of the superhet's chequered career, and only recently has the advent of tone-compensating devices and pentode valves, which favour high-note reproduction, enabled us to tackle the problem with some hope of success.

### In New Guise.

The superhet of a few years ago was undoubtedly an awesome spectacle. Apart from its size, which was always excessive, it was undoubtedly a cumbersome set to operate, and the quality of reproduction obtained was extremely poor. The present-day superhet, however, is usually no larger than a normal straight receiver, and is capable of giving good reproduction.

A receiver such as this, whilst being desirable to-day, will undoubtedly be a necessity to-morrow, and it is therefore

thought that a brief and simple explanation of how this most interesting receiver works will be of benefit to all those readers of POPULAR WIRELESS who wish to be in the van of radio progress.

Let us first discover the essential features of a super-selective receiver. Broadly speaking, selectivity is proportional to the number of tuned circuits employed, and theoretically we could obtain knife-edged tuning simply by employing multiple tuned H.F. stages. In practice, of course, definite limits are imposed since beyond a certain point it is almost impossible to keep the receiver stable owing to interaction between the various tuning circuits which cannot be suppressed if any useful stage gain is to be obtained. Another obvious limitation is the number of tuning controls.

Supposing we construct an H.F. amplifier which, instead of having variable tuning condensers, has pre-set condensers across each of the tuning controls. By careful adjustment of these condensers we can

### THE FREQUENCY DIFFERENCE

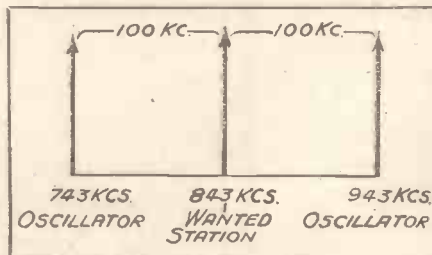

The intermediate or beat frequency is equal to the difference between the oscillator and tuning circuit frequencies. In the above example the beat frequency is 100 k.c.

tune this amplifier to function at one particular wavelength (or frequency) only.

Now, this amplifier, which may consist of as many as four or five stages, will have, in effect, plenty of tuned circuits; but there will be no variable controls, no long leads, and the coils with their pre-set condensers, can be adequately screened from each other. We shall, therefore, have obtained the desired factor for producing selectivity whilst avoiding the circumstances which produce instability. We cannot,

### OBTAINING THE "BEAT"

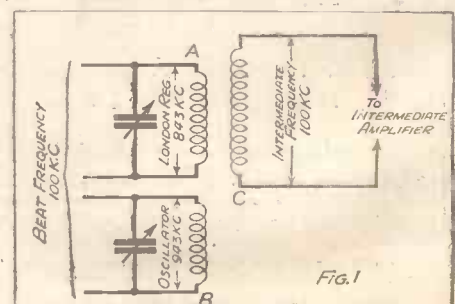

The tuning circuit of the set is closely coupled to a second circuit, which embodies a local oscillator valve.



# R & A Reproducers

are continually specified by Set Designers because of their uniform high standard of excellence

—specified because they are the product of British Capital, Materials and Labour, and because they give a performance not equalled by any other similarly priced instruments. Let the repeated recommendations of the experts be your guide—choose R & A for complete and lasting satisfaction.

#### POPULAR WIRELESS—

"1933 Four," "Sky Hawk," "Uni-dial Two," "Apex," "Fireside Console," "A.C. Three," "P.W. All-In Three," "A.C. Airsprite," "Ferro Q," "Airsprite Two," "Westector Super," "The Q.P.-B," "Class B Four," "Ferro B Portable," "Double D.T.," "Regulite Two," "H.A.C. Short-Waver," "L.B. Four," "Catkin Three," "D.C. Airsprite," "4 Pen 4."

#### AMATEUR WIRELESS—

"New Century Super," "Clarion Voice Two," "Melody Ranger," "B.B.C. National Two," "James Push-Pull Three for Q.P.P.," "Everybody's Home Radiogram," "Up-to-the-Minute Three," "Melody Ranger 2-valver."

#### PRACTICAL WIRELESS—

"Ferrocart Q.P.P. Hi-Mag. Three," "Q.P.P. Three Four," "Double Diode Three."

#### MODERN WIRELESS—

"Diodion," "Programme Prince," "Mu-Tone," "Two-valve Amplifier," "Metric Three," "Vari-Four," "Diodion Super Seven," "A 6-watt A.C. Amplifier."

#### WIRELESS CONSTRUCTOR—

"S.T.400," "Q.P.P. Amplifier," "Straight Tune Three," "Bestector Super."

#### WIRELESS MAGAZINE—

"New Style Battery Radiogram," "Narrow Pass Three," "Frame Aerial Version of the Easy Tune 60," "Simple Tune Three."



*Let the opinion  
of the experts  
Guide You!*

REPRODUCERS &  
AMPLIFIERS LTD.,  
WOLVERHAMPTON.



*They recover  
power while you sleep*

The recuperative powers of Pertrix Batteries are amazing—steadily and constantly through the hours when they are inactive they build up their power for the next day's radio. Thus, week after week, month upon month, Pertrix H.T. Batteries continue to give that generous output of steady current so vital to the true rendering of speech and music. IT'S THE PATENT PERTRIX PROCESS THAT MAKES THIS POSSIBLE—NON-SALAMONIC CONSTRUCTION MEANS INFINITELY LONGER USEFUL LIFE.

Fit

# PERTRIX

Non Sal-ammoniac  
H.T. BATTERIES

Complete your equipment with a Pertrix Accumulator.  
Your Radio Dealer can supply you.

BRITANNIA BATTERIES LTD.  
233, SHAFTESBURY AVENUE, LONDON, W.C.2.  
Works: Redditch (Worcs.)



# THE SUPERHET SIMPLY EXPLAINED

(Continued from page 456.)

receive London Regional (843 kcs.) we shall have to change its frequency to this figure, or produce a frequency of 100 kcs. which has the same modulations as the London station's transmission.

## IN SIMPLIFIED FORM

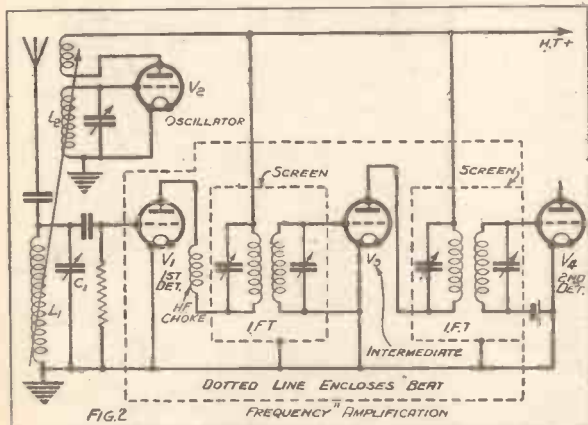

FIG. 2  
In this simplified superhet circuit,  $L_2$  is the oscillator tuning coil, and  $L_1$ ,  $C_1$  the tuning coil and condenser, which are adjusted to the wavelength of the wanted station.  $V_2$  is the intermediate amplifying valve.

If we mix with the London transmission a locally generated frequency of 943 kcs., then, by the process explained above, a beat frequency of 100 kcs. will be produced.

This we can feed straight into our amplifier.

Reference to the Fig. 1 will make this quite clear; coil A, which is tuned to London's wavelength, is closely-coupled to coil B, which is carrying oscillations generated by a local oscillating valve, the frequency of which is controlled by the condenser across it. Coil C is tuned to 100 kcs., and is coupled to both of the others and therefore picks up the 100-kc. beat frequency only. It will be quite clear that the speech modulation of the London frequency will be present in the beat frequency, for any change in the oscillations in coils A or B will produce similar changes in the current generated in coil C.

### What the "Mixer" Does.

A complete but simplified circuit is shown in Fig. 2 and this is actually a superheterodyne set "undressed."

The first coil and variable condenser ( $L_1$  and  $C_1$ ) select the station to which we wish to listen; the valve ( $V_1$ ) is known as the "first detector" or "mixer" and it is here that the oscillations generated by  $V_2$  (the "oscillator") are introduced into the circuit.  $L_2$  carries the local oscillation, and the beat frequency is set up in  $L_1$  as a result of the coupling between  $L_1$  and  $L_2$ . This frequency is amplified by our specially designed amplifier which is separated from the rest of the circuit by the dotted line.

In practice the amplifier is known as the "intermediate," and the beat frequency as the "intermediate frequency."

The last valve,  $V_4$ , is an ordinary rectifier, often of the anode-bend variety, and functions in a normal manner.

Having thus generally explained how the

superhet works, it will be as well to "tidy up" the rather ragged-looking circuit in Fig. 2, and present it in a more practical form.

### An Enormous Difference.

Fig. 3 shows a typical superhet receiver, and you will notice at once that it closely resembles the old-fashioned multi-H.F. set, inasmuch as, if we ignore the unfamiliar oscillator valve, and substitute variable condensers for the trimmers across each of the I.F. coils, the circuit immediately becomes that of an H.F. transformer-coupled receiver.

A little thought will show the enormous difference as regards simplicity that exists between the I.F. amplifier and its H.F. counterpart; the coils forming the I.F. transformers are quite small, usually being layer-wound and, as these have carefully matched inductance, the pre-set condensers need only have a small maximum capacity. In fact, the coils and condensers may be housed in metal cans of very small dimensions with consequent economy of base-board and panel space.

It will be noticed that the first valve in the re-

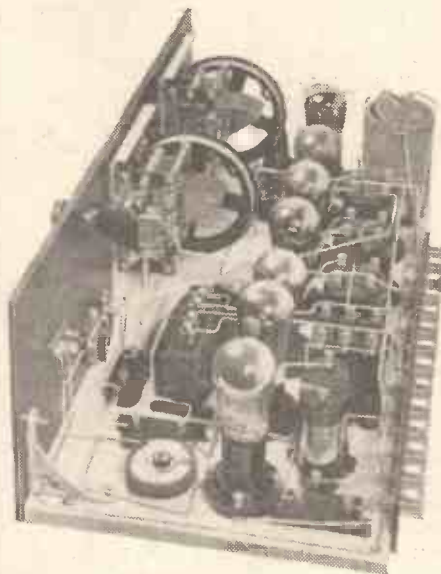

arranged diagram is a normal screened-grid H.F. amplifier; this valve is often helpful in ensuring that the impulses from the transmitting station shall be sufficiently strong to "mix" properly with the locally generated oscillations; it also acts as an efficient stopper of re-radiation from the "mixer" circuit which would otherwise cause anguish

and heart-burnings among listeners for some miles around.

We may now summarise the functions of a superhet as follows: the desired station is first selected by means of an ordinary tuned circuit and then amplified by an S.G. valve; the strengthened signal is then fed across a coil tuned to its wavelength; to this coil is coupled another coil which carries a separate oscillation of slightly different wavelength to the received signal, and the result is the production of a "beat frequency," whose wavelength is that to which the intermediate frequency amplifier is tuned.

### Dealing With Difficulties.

In practice there are several "snags"; this is to be expected in a rather complicated multi-valve set, so we will leave the cause and prevention of these difficulties and deal with them in a further article.

# ENTHUSIASTIC OVER "P.W." SET

Another Reader's "Cosmic" Reception.

The Editor, POPULAR WIRELESS.

Dear Sir,—Some months ago I built the "Cosmic III. Star" from a copy of your paper, but instead of buying new valves I tried the valves from my previous set, and obtained very good results on long and medium waves, but short waves were hopeless. Recently, however, I purchased three new valves as specified, and the results were amazing. I am so pleased with the set that I feel I must send you a list of stations received, together with a short-wave log compiled this week-end. I spent just over four hours in all listening to short-wave stations, and these excellent results were obtained on a 7-months' super-capacity (120-volt) battery. Goodness only knows what will happen when I get a new one.

I should very much like to make the "Cosmic IV." for if these results are obtained from a three-valve set, the four-valve one should be a real super set. Unfortunately funds will not run to this set at the moment.

### An American "Radio Times"?

Can you let me know if the National Broadcasting Company of America issue any journal giving their programmes, a paper similar to our "Radio Times," and if so where I can obtain a specimen copy. I want only one copy just to get an idea of the type of programme America transmits, and from one-week a copy I could see when the various "hours" are broadcast, since they are "on the air" at the same time each week.

Wishing you all success with your excellent paper.  
Yours faithfully,  
H. H. SELF

Beccles.

ED. NOTE.—Our correspondent's list is far too big to publish, there being nearly 70 ordinary as well as a large number of short-wave stations!

In the U.S.A. there is no equivalent of the B.B.C.'s official organ, but their daily and Sunday papers make a big feature of the radio programmes.

## INCORPORATING A PRELIMINARY S.G. STAGE

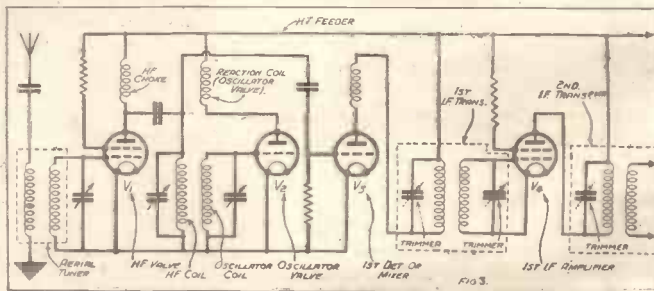

The early superheterodynes were not only cumbersome, but the reproduction was usually distinctly poor. The photograph shows a superhet which was designed some years ago, prior to the S.G. valve and tone-compensating devices. Above is a circuit in which the first detector is preceded by an H.F. amplifying stage.



## MIRROR OF THE B.B.C.

(Continued from page 446.)

The next phase is "Admirals All." with the ghosts of Drake and Nelson appearing in the hour of England's need. This will be introduced by Drake's Drum and "Twas in Trafalgar Bay." Finally, there will be a march past of all the performers in the pageant and a Pageant of the Grand Fleet, to the accompaniment of a fantasy of British sea songs.

### From the Isle of Man.

Northern listeners have come to regard the Tynwald week broadcasts from the Isle of Man as an annual feature of the wireless programmes, so that they will welcome their appearance this year during the first week of July.

The relays start on Sunday, July 2nd, with a service from St. Mary's Church, the oldest in Douglas, which stands on the quayside. The service will open with the singing of the Man fishermen's evening hymn, called "The Harvest of the Sea," and is to include an address by the Lord Bishop of Sodor and Man.

On the following day the Tynwald ceremony will be described to listeners in the form of a running commentary. The ceremony is the promulgation of the laws in the Tynwald Court, which is the joint meeting of a nominated council with the House of Keys, one of the oldest legislative assemblies in the world.

## ASSEMBLING THE "C.R.T." VIEWER

(Continued from page 454.)

are at earth potential, by virtue of the connections via the time-base and the set. They are also 400 or so volts above the shield, and at H.T. voltage to the filament and filament battery of the cathode tube and two of the deflectors.

This is important, for it is so usual to have every H.T. point in a radio set above earth potential, that the use of points at earth potential and yet above other points may at first be difficult to realise. The result is, of course, that the filament, two deflectors and shield of the cathode tube are at H.T. below earth. This should strongly be borne in mind.

The connections to the filament, accelerator and shield of the cathode tube are carried out by an ordinary four-pin valve holder, as shown in one of the photographs. In the wiring diagram, however, we show the connections going straight to the tube base pins. As in the ordinary valve, the filament and anode pins are used for filament and anode (or accelerator), and the grid pin is for the modulation controlling electrode, the shield (corresponding in effect to the grid of a valve).

### Connections to Deflectors.

The last cathode tube we used in our experiments, and illustrated here, has the connections to the deflectors coming out through glass horns some way down the tube from the bakelite base. The final Ediswan type T. tube, however, has, I believe, the deflector leads taken along inside the glass, to the base, which is a

The ceremony takes place on the famous mound near Douglas, constructed of turves brought from every parish, and symbolical of the island's institutions. The week will also include a variety entertainment on Monday, July 3rd, relayed from the Coliseum at Douglas.

### The Royal National Eisteddfod.

Two talks about the Royal National Eisteddfod of Wales will be included in West Regional programmes of the near future. The first, to be given by Mr. J. Walter Jones in the series "Looking at Things," on Tuesday, June 25th, will deal with the Proclamation Ceremony.

Thousands of people attend this time-honoured ceremony, and many feel that it could very well be made more attractive than it is. This year it is to take place at Neath on Thursday, July 6th, and Mr. J. Walter Jones, who is chairman of the Neath Library Committee, will discuss ways in which more pageantry and colour could be introduced.

The other Eisteddfod talk will be given during the Welsh interlude for Daventry National listeners on Saturday, July 1st, by the Mayor of Wrexham, where this year's "National" is to take place.

### "Regional Revellers."

Mason and Armes, the well-known Birmingham artistes, are to be responsible for putting on this concert party entertainment in the Birmingham studio for Midland Regional listeners on Monday, June 26th.

little wider. Here they are brought out to four large terminals.

Their relative positions correspond exactly with those on our tube, and the connections to adjacent terminals and to the accelerator, as shown in the link-up diagram, are exactly the same. It is only the appearance of the tube that has been altered somewhat.

When connecting up the two 2-volt L.T. batteries for the diodes on the time-base, make sure that the batteries do not touch each other. This seems ridiculous, I know, but we have found that in many instances there can be sufficient leakage between these two cells, via the surfaces of the containers, to upset completely the operation of the time-base.

After all, the cells are connected via the diode filaments to the anodes of the thyratrons and to the .25 and .02-mfd. condensers respectively, so that leakage between the two circuits would naturally upset the control of the H.T. supply to the condensers.

### Carefully Check the Wiring.

Such an effect is obvious when you have it pointed out to you, but in practice it is easy to let the glass containers of the two L.T. cells touch without realisation of the fact that it is just that touching that is throwing out the timing of the thyatron flashes.

With the whole apparatus connected up in accordance with the diagram, and with voltages available as suggested in the article and the diagram, I am going to ask you to wait till next week before you switch on and commence your television reception. In the meantime, check over every connection again and again, making sure that everything is not only correctly connected, but is connected *firmly* with no possibility of coming undone.

# PILOT AUTHOR KITS

Exact to Specification

## P.W. REFLEX

Described this week.

KIT "A" Delivered Carriage Paid on First Payment of

10/6

Authors' Kit of First Specified Parts, including ready-drilled panel, but less valves and cabinet. CASH or C.O.D., carriage paid, £5/13/6. Balance in 11 monthly payments of 10/6.

KIT "B." As Kit "A." but with valves only. Delivered, carriage paid, on first payment of 13/8. Balance in 11 monthly payments of 13/8. Cash or C.O.D., carriage paid, £7/9/0.

KIT "C." As Kit "A." but with valves and cabinet. Delivered, carriage paid, on first payment of 16/-. Balance in 11 monthly payments of 16/-. Cash or C.O.D., carriage paid, £8/14/0.

## DOUBLE "D" PEN

Described last week.

KIT "A" Delivered Carriage Paid on First Payment of

16/-

Authors' Kit of First Specified Parts, including ready-drilled panel, but less valves and cabinet. CASH or C.O.D., carriage paid, £8/14/0. Balance in 11 monthly payments of 16/-.

4 Valves £3 : 18 : 0 1 Peto-Scott Cabinet 15/-

## PETO-SCOTT — FIRST WITH TELEVISION KITS 1927. FOREMOST TO-DAY

### CATHODE RAY TELEVISION RECEIVER

Delivered Carriage Paid on First Payment

KIT "A" of 10/4

Authors' Kit of First Specified Parts, including ready-drilled panel, but less valves and cabinet. CASH or C.O.D., carriage paid, £5/13/0. Balance in 11 monthly payments of 10/4.

KIT "B." As Kit "A." but with valves only. Delivered, carriage paid, on first payment of 16/4. Cash or C.O.D., carriage paid, £8/18/6.

KIT "C." As Kit "A." but with valves and cabinet. Delivered, carriage paid, on first payment of 17/9. Balance in 11 monthly payments of 17/9. Cash or C.O.D., carriage paid, £9/13/6.

### CATHODE RAY TELEVISION VIEWER

Delivered Carriage Paid on First Payment

KIT "A" of 7/9

Authors' Kit of First Specified Parts, including ready-drilled panel, but less valves and cabinet. CASH or C.O.D., carriage paid, £4/5/0. Balance in 11 monthly payments of 7/9.

KIT "B." As Kit "A." but with valves only. Delivered, carriage paid, on first payment of 17/-. Cash or C.O.D., carriage paid, £8/5/0.

KIT "C." As Kit "A." but with valves and cabinet. Delivered, carriage paid, on first payment of 18/6. Balance in 11 monthly payments of 18/6. Cash or C.O.D., carriage paid, £10/0/0.

### CONQUEST

KIT "A." Authors' Kit of First Specified Parts with ready-drilled chassis, but excluding valves and cabinet. Cash or C.O.D., carriage paid, £2/2/6. SEND ONLY 15/-. Balance in 11 monthly payments of 15/-. Set of specified valves, £2/4/6. Oak cabinet as specified, £1/15/0.

### PILOT "CLASS B" CONVERTER KIT

Converts your present battery set to "Class B." Complete, including "Class B" valve, wire and screws, etc. Full-size Blue Print, and assembly instructions. Cash or C.O.D., 37/6, car. pd. or 5/- down and 7 monthly payments of 5/6.

PETO-SCOTT CO. LTD. 77, CITY ROAD, LONDON, E.C.1. Telephone: Clerkenwell 9406/7.

West End Showrooms: 62, High Holborn, London, W.C.2. Telephone: Holborn 3248.



# Short-Wave Notes *By* W.L.S.



A weekly chat by our popular expert, dealing with many interesting aspects of current short-wave practice.

I SUPPOSE it is somewhat natural that the excitement of the Crystal Palace 5-metre tests should have been responsible for a wave of 5-metre enthusiasm. Personally, I have not been able to tear myself away from 5-metre work ever since, and I have other evidence of activity in this direction.

Reports are still arriving at the time I write these notes. Certainly the little transmitter "up aloft" succeeded in shaking them up a bit on that memorable 21st of May!

Apart from 5 metres, the 20-metre amateur band seems to have come in for the greater part of the listening nowadays. T. C. (Wakefield) logged 16 American and Canadian amateurs, all on 'phone, in 21 minutes on that band. He also reports hearing V L K (Australia) on 'phone, regularly, on a one-valver with no aerial or earth!

## Increase in Enthusiasm.

Certainly the American amateurs appear to be "twelve a penny" on 'phone lately. One simply can't avoid them. I think the main reason is a tremendous increase in enthusiasm over telephony, as distinct from C.W. work.

This is all to the good, but it is going to lead to plenty of interference and a rather troublesome transition period. We shall all eventually have to equip ourselves with far better amateur-band receivers than we use at present.

I have no use for the man who decries the use of telephony by amateurs, providing that they know their job properly. The painful attempts at it that we sometimes hear from Continental amateurs are better forgotten than remembered, but we can't avoid the plain truth that the future of radio lies in telephonic communication. Morse Code will be remembered only as a temporary makeshift when the year 1980 comes along.

## Short-Wave Clubs.

J. R. (Dorking, Surrey) asks me for the addresses of any popular short-wave clubs. As I haven't kept trace of the various local short-wave organisations that have made themselves known to me, I should be glad if the leading light of any club in J. R.'s neighbourhood would write to the said J. R., c/o myself.

W. H. G. brings up the question of valve-base coils once more. A "valve-base" coil, for the benefit of those who haven't met

the beast, is a coil wound either on the base of a defunct valve, or on a section of small-diameter tubing in which are mounted four valve legs. The whole thing plugs into a valve holder, and was once thought a lot of.

Right at the beginning of the craze I tried several forms of these coils, and never got on at all well with them. To start with, I don't like the idea of such a small diameter for short-wave coils; I don't like the idea of a solid former; and I certainly don't like the idea of plugging them into a fairly high-capacity valve holder.

However, in spite of all this, W. H. G. apologetically tells me that he likes them and has always had good results with them. So be it, W. H. G. None of us knows anything about radio; and no man can explain the differences between theory and practice except by pulling a John Henry face and saying "It's all wrong."

That the future of amateur radio lies in telephonic communication as opposed to the Morse Code is the considered opinion of our Short-Wave expert, who also deals this month with Russian Stations, the Importance of Patience and Short-Wave Horrors! And did you remember the Whitsun listening competition?

## HELPFUL WORK BY AMATEUR



Mr. E. N. Hitchcock, who runs the amateur station G 5 H C, in Gloucestershire. He recently communicated with the Michigan University Expedition in polar regions, and relayed a message for them to America. Mr. Hitchcock is seen operating his transmitter.

Incidentally, I like W. H. G.'s description of the three short-wave horrors: T.H., H.C., and P.R. (threshold howl, hand capacity, and ploppy reaction).

Readers are still writing to inform me

that the Russian stations have dropped their "EU" prefix and are now using "U" only, but I think their commercials still commence with "R."

None of us mind what call signs they use, so long as they keep their commercial stations out of amateur bands.

## The Listening Competition.

I am afraid that, in the excitement of the 5-metre tests, I forgot to remind you all, in the last set of Notes, about the listening competition during Whitsun week-end. However, I have no doubt that the enthusiastic ones remembered the original announcement of the dates, and I hope to have a crop of logs in by the time these notes appear.

V. I. E. (Liverpool) has sent me in a beautiful log of amateur stations covering two or three days, during which time he seems to have heard mostly South Americans and Russians. He asks me to note the way in which he can "shift bands" in a split second.

It is certainly very useful to be able to do that, especially if one is out for real DX and doesn't want to miss a single station.

I wonder how many times I have announced that I regard Patience (with a capital P, please!) as the most essential quality for a short-wave listener who hopes to be successful? I have just noticed an Editorial in an American paper on this very theme.

## Often the Case.

The writer says "If your temperament is impatient, then the short waves are not for you." One paragraph I should like to quote in full: "Frequently the owner of an expensive set is dismayed because some young boy with a simple one- or two-valve set 'pulls in' almost everything in creation, whereas he himself cannot do so with his expensive outfit. On the other

hand, if the youngster is given a chance to play with the 'big set' he will not only duplicate his own former success, but will pull in many additional foreign stations besides."

## Be Patient.

I think it is an undoubted fact that half the complaints that reach me about receivers could be better explained by the temperament of the operators than by any references to the sets themselves. I have seen people cover a band of about 5,000 kc. in one huge swoop and say, "No, nothing on but a lot of Morse." Why, they haven't even started listening!

I often amuse myself by listening to what is apparently nothing at all for fifteen or twenty minutes on end. By that time it has usually developed into an identifiable distant station. Patience is not only a virtue; it is an absolute necessity for the short-wave man.



# RADIOTORIAL

The Editor will be pleased to consider articles and photographs dealing with all radio subjects, but cannot accept responsibility for manuscripts or photos.



Every care will be taken to return MSS. not accepted for publication. A stamped and addressed envelope must be sent with every article.

All Editorial communications should be addressed to the Editor, POPULAR WIRELESS, Tallis House, Tallis Street, London, E.C.4.

All inquiries concerning advertising rates, etc., to be addressed to the Sole Agents, Messrs. John H. Lile, Ltd., 4, Ludgate Circus, London, E.C.4. The constructional articles which appear from time to time in this journal are the outcome of research and experimental work carried out with a view to improving the technique of wireless reception. As much of the information given in the columns of this paper concerns the most recent developments in the radio world, some of the arrangements and specialities described may be the subjects of Letters Patent, and the amateur and the trader would be well advised to obtain permission of the patentees to use the patents before doing so.

## QUESTIONS AND ANSWERS

### THE "AIRSPRITE" TWO.

L. Y. (Bournemouth).—"Finally I have decided on your "Airsprite" Two, as other readers seem specially pleased with it. So can you tell me when the description of how to make it was given in 'P.W.', and also where to write, and how much?"

The constructional details of the "Airsprite" Two were given in "P.W.," No. 500, dated February 25th, 1933.

This number and other back numbers of "P.W." which are still in print can be obtained from the

### HOW IS YOUR SET GOING NOW?

Perhaps your switching doesn't work properly? Or some mysterious noise has appeared and is spoiling your radio reception? Or one of the batteries seems to run down much faster than formerly?

Whatever your radio problem may be, remember that the Technical Queries Department is thoroughly equipped to assist our readers, and offers its unrivalled service.

Full details, including scales of charges, can be obtained direct from the Technical Queries Dept., POPULAR WIRELESS, The Fleetway House, Farringdon Street, London, E.C.4.

A postcard will do. On receipt of this an Application Form will be sent to you post free immediately. This application will place you under no obligation whatever, but, having the form, you will know exactly what information we require to have before us in order to solve your problems.

**LONDON READERS, PLEASE NOTE:** Inquiries should NOT be made by phone or in person at Fleetway House or Tallis House.

set (S.G., Det. and Pentode, with ganged condenser) to the London Regional, and settled down for an evening programme, which was received perfectly at first.

"But after half an hour or more it got a bit weak, then weaker, and weaker still, very gradually, till it could hardly be heard at all.

"I didn't investigate at the set immediately, because it is upstairs, and I was half-dozing downstairs in front of the loudspeaker. But my wife noticed it got slowly weaker and weaker, and eventually I bestirred myself, and went upstairs to see what was wrong.

"When I first turned the tuning dial the set seemed very dead, and none of the usual lively foreigners were heard. I was just wondering where to begin looking for the trouble when I found that it had gone again! There was no sudden click, nor anything to account for it, and all I had touched was the tuning knob. but for some reason or other the set had returned to full strength, and we went on with the programme again, everything working perfectly.

### Trouble Spotted by Chance.

"For a week after that I used the set frequently on home and foreign programmes, and it was perfect.

"Then to-night it went off again, gradually, just as before!

"It might have taken hours to find it only I happened to spot that one section of the ganged condenser was out of line with its neighbour. And on gently pressing it I found it was loose on the common spindle.

"I moved it back with my finger, and got London Regional coming through strong again. But as I watched it the loose section started to slip out of line again very slowly and, of course, the programme got lower and lower in strength, until I could hardly hear it.

"The fixing to the spindle was by a screw  
(Continued on next page.)

publishers. The address is The Amalgamated Press, Ltd., Back Number Dept., Bear Alley, Farringdon Street, London, E.C.4. The price is 4d. per copy, post free.

### A PECULIAR DETUNING FAULT.

A. S. (Maidstone).—"It must be four or five years ago since I wrote to you about a peculiar fault which had given me a great deal of trouble on my first set. And you suggested that the queer alterations in tuning which I was then getting were due to a bad earth connection.

"That proved to be quite true, and as soon as I put in a good earth the tuning shifts disappeared, and I never had the same trouble on any other set.

"But I have had a far more puzzling one this past ten days or so, and now I have discovered the cause I would like you to tell other 'P.W.' readers, in case they get the same and waste time looking in the wrong place for the fault.

"What happened was this. I tuned in the

We invite readers to support our Advertisers—care being taken to accept only announcements of reputable firms!



The Camco "Tablegram"



"We're Fluxite and solder—the reliable pair; Famous for Soldering—known everywhere!"

We're HERE to remind you—whatever your set; If something goes wrong you'll be glad we met!"

See that Fluxite and Solder are always by you—in the house—garage—workshop—anywhere where simple, speedy soldering is needed.

## ALL MECHANICS WILL HAVE FLUXITE IT SIMPLIFIES ALL SOLDERING

All Ironmongers sell Fluxite in tins; 4d., 8d., 1s. 4d. and 2s. 8d. Ask to see the FLUXITE POCKET SOLDERING SET—complete with full instructions—7s. 6d. Ask also for our leaflet on HARDENING STEEL with Fluxite.

FLUXITE LTD., (Dept. 324), Rotherhithe, S.E.18

### FOR ALL REPAIRS!



LOUDSPEAKERS REPAIRED 3/-. L.F. Transformers 3/-. Phones 3/-. Any type. Year's guarantee. 48 hours' service. Mains transformers, eliminators, and moving coils quoted for. Keen terms. Satisfaction guaranteed. Mains equipment converted for different voltage mains. HATTON & BREEZE, All Radio Repairs, 30, Mount Street, BATTLE, SUSSEX.

### THE IMPROVED "TONIC"

self-generating trickle-charger kit keeps 2-volt accumulators fully charged. Electric mains and charging stations unnecessary. Ideal for remote places. 7/- each, postage 9d. Particulars, testimonials, with pleasure. WILLIAMS, Netherend, Cradley, Birmingham.

### ADVERTISERS PLEASE NOTE!

The Rate for a one-inch single Column Advertisement is 30/-

Minimum Space Accepted: Half-an-inch .. 15/-

Send Remittance with instructions to

JOHN H. LILE, LTD., 4, LUDGATE CIRCUS, LONDON, E.C.4.

Telephone - City 7261.

### A COMPACT RADIO-GRAM CABINET

This cabinet is specially suitable for converting your set into a modern radiogram—takes up very little room. Ample space for batteries, speaker, set, motor, pick-up, etc. Price 55/-, finished shaded walnut. See it at our showrooms, and send coupon for FREE Camco Cabinet Catalogue.

Carrington Manufacturing Co. Ltd., Showrooms: 24, Hatton Garden, London, Holborn 8202. Works: S. Croydon.



Post in 1/2 envelope.

NAME.....

ADDRESS.....

24 P.W. ....



# ENGLAND LED!

## AMERICA FOLLOWED

S. G. Brown's Battery Superseder was years in advance. For Car, Wireless and all Battery Receivers.



No H.T. Batteries needed with a **SUPERSEDER**

H.T. D.C. from your Filament battery indefinitely.

A boon and blessing to all H.T. battery users. Reduced from £3 15s. to

1,000 other  
bargains in our  
SALE LIST P.

**37'6**  
from us only.

**ELECTRADIX RADIOS,  
218, UPPER THAMES ST., E.C.4.**

**AMBITIOUS ENGINEERS WANTED**  
to apply for our free 250-page Hand-book. Gives details of A.M.I.Mech.E., I.E.E., A.M.I.A.E., G.P.O., etc., Exams., outlines latest Courses in Mech., Elec., Motor, Radio and Aero. Engineering, and shows clearly where first-class vacancies occur each year. Send P.C. for FREE Hand-book immediately to **BRITISH INSTITUTE OF ENGINEERING TECHNOLOGY, 401, Shakespeare House, 29, Oxford Street, W.1.**



### BIG OFFER OF SHORT WAVE PLUG-IN COILS

Nos. 2-9 turns. AIR DIELECTRIC STAND. ARD SIZE. 4 for 2/4, 8 for 4/6, all post paid. The set of eight covers whole S.W. range. Base-board Coil Holders, 6d.

**8d.**  
each  
usual  
price  
1/5d.

**SCIENTIFIC SUPPLY STORES (Wireless) LTD., Dept. P.W., 126, Newington Causeway, Elephant & Castle, London, S.E.1. Phone: Hop 4177.**

**IF YOUR RECEPTION  
IS GOOD**

**SUPERIAL**  
THE AERIAL WHICH MADE BROADCASTING POPULAR  
ELECTRON'S SUPER-AERIAL

**WILL MAKE IT PERFECT**



The most selective and powerful aerial ever devised. Extra heavy rubber insulation abolishes masts, poles, insulators and separate leads-in. The first and only efficient indoor or invisible aerial. Don't be misled into buying inferior imitations. Superial is strong, cheap, efficient and lightning proof.

£100 Free Lightning Insurance—send in your Form to-day. From all Dealers.

100ft 3'6: 75ft 2'6: 50ft 1'9: 25ft 1'  
THE NEW LONDON ELECTRON WORKS LTD EAST HAM LONDON E.6

## RADIOTORIAL QUESTIONS AND ANSWERS

(Continued from previous page.)

and 'hairy' washer, and when I tightened up this little screw the plates held fast again, and, of course, the set now tunes again perfectly. Have you ever known a case like that before?"

Yes; but we are glad to be able to reproduce your letter containing a full description of the trouble because mechanical faults of this kind are rare, and can be extremely puzzling. Especially if, as in your first experience, the readjustment of the set corrects the trouble—apparently on that first occasion you turned the control "full in" or "full out" and this lined up the two sets of plates for a time. Later they worked loose again, and, of course, that detuned the set and caused the programme to weaken.

### LOUDSPEAKER WORKING IN A CAFÉ.

"LOUDSPEAKER".—"In addition to the patronage of motor-drivers, etc., I have worked up a nice little café trade, most of the takings being late at night. And standing near one of the tables I have the 'Airsprite,' so customers can always have music if they want it.

"But my friend who arranged the building of the set asked me if I knew that you had published a warning about using any sort of wireless set for this. He was not sure how long ago it was, so could you give me the date of the article, as I do not want any trouble just when things are beginning to look up?"

It is true that a recent legal decision concerns the right of the proprietor (or lessee) of any café, restaurant, public house, dance hall, hotel, etc., to which the public is admitted, to reproduce the broadcast programmes for the benefit of the customers of his establishment. You will find the details referred to on page 256 of "P.W." number 569, dated April 29th, 1933.

### TERMS USED IN CATHODE RAY TELEVISION.

To help those readers who have not seen all the articles on our television viewer, we are listing a short glossary of terms used (The glossary is not, perhaps, strictly accurate from a pure definition point of view, but will serve our purpose).

**ACCELERATOR:** The anode of the cathode tube through which the free electrons pass.

**SHIELD:** The focusing cylinder round the filament or cathode of the tube. By means of the shield we modulate the electron stream and obtain our picture light and shade.

**TIME-BASE, OR DOUBLE TIME-BASE:** The four-valve device (already described) used to control the scanning of the cathode beam to form the "frame" of light in which the pictures are formed.

**DIODE:** As applied to the television viewer this is a valve used as a current feed control and stabiliser for H.T. on the time-base.

**THYRATRON:** A special mercury vapour-filled valve which, together with the diode, controls the scanning speed of the cathode ray, and also carries out the necessary synchronising control. The two thyratrons used are of the indirectly-heated cathode type.

Those few explanatory words should help the reader in following the practical application of cathode-ray television, for in our next article these names will crop up frequently.

### THE TONIC CHARGER.

In the review of this Charger Kit on page 407 of "P.W." dated June 3rd, the address of the maker should have appeared as Mr. T. R. P. Williams, Netherend, Cradley, Birmingham.

## TECHNICAL NOTES

Some diverse and informative jottings about interesting aspects of radio.

By Dr. J. H. T. ROBERTS, F.Inst.P.

### Pentode Distortion.

THERE always seems to be a difference of opinion as to whether a pentode valve can really be relied upon to give distortionless reproduction. The main advantage of the pentode is that it will deliver a larger signal output for a given input than an ordinary valve of similar anode current consumption.

As regards the quality of the reproduction from a pentode, this depends very largely upon the use of a suitable balanced speaker and upon various other conditions, which I have mentioned before. If these conditions are not properly fulfilled you may get a very unfavourable impression of the pentode valve and this no doubt accounts for a certain amount of prejudice against this valve, or rather against the quality of the reproduction from it, amongst many listeners.

### A Hard Tone.

Notwithstanding this, there are some people who still think that, even when the pentode valve is given every possible chance, with a proper balanced speaker and regulated input and correct anode voltage, it still gives a "hard" tone with over-emphasis of the upper register. Such a disadvantage, however, can be very largely overcome by using a suitable tone-corrector and also, of course, proper input transformer for the loudspeaker.

In these circumstances, I think you will need to have a very critical ear before you will perceive anything wrong with the reproduction. Personally, I am a great believer in the pentode output stage, because I think that its advantages, especially for small receivers limited to the minimum number of valves, completely outweigh any alleged or even any real drawback in the matter of quality of reproduction.

### Varying Amplification.

By the way, the amount of amplification which is obtained from a single low-frequency stage following the detector can be varied quite a good deal according to the type of valve used for the detector and the coupling with the power valve. The detector, for instance, may be one with a steep slope and medium impedance. But if the output of this stage is passed on to a small pentode valve, there is considerable danger of overloading the valve.

For some reason, which I have never quite been able to make out, it seems to be the fate of the pentode valve to be overloaded. I suppose the idea got about, in the early stages, that the pentode was the business for giving enormous amplification and volume at a simple jump, and therefore the poor thing was consistently overloaded.

The fact is, as I have mentioned more than once before, that the pentode gives a big "stage gain," but the advantage of this

(Continued on next page.)



## TECHNICAL NOTES

(Continued from previous page.)

is rather in the smallness of the input for producing what we may vaguely call a "normal" output than in the largeness of the output for what we may call a normal input.

### Unstable Circuits.

It is, in fact, often better not to push matters too far in connection with the detector, but to be content with less stage gain and better quality. There is always a tendency to try and get the maximum amplification from a given number of valves, but if you can restrain this desire, and go in for quality rather than quantity, you will get much more satisfactory results.

You can take it as a fairly general rule that when any circuit is pushed to the limit, or even near the limit, you will get instability and bad quality.

### Three-Valve Efficiency.

Talking about getting the most from a valve, there are many people who consider that the only kind of three-valve set which gives you the real benefit of modern valve improvements and stands up to present-day requirements is the conventional screened-grid H.F., detector and pentode output. Certainly this combination has made an enormous difference to the efficiency and popularity of portable sets.

Speculation turns a good deal on what developments will be in the variable-mu

It is obvious that if the grid bias can be automatically regulated in accordance with the strength of the incoming signal and to the required amount, the volume of the reproduction will remain sensibly uniform, and the only point is how to arrange matters so that this adjustment of the grid bias on the variable-mu valve takes place automatically. This is done in various ways, one of the simplest of which is by applying the voltage developed across the ends of a resistance to the grid of the variable-mu.

### Variable-Mu.

The voltage across the ends of the resistance will vary in accordance with the strength of the signals, and so forms a very convenient automatic means of regulating the variable-mu grid voltage. There are, of course, one or two disadvantages in practice at present in the use of this automatic arrangement, because if you are searching about the dial for different stations you get the same amplification of background and other noises.

There are, however, methods, which I have not the space to go into at the moment, by which even this can be obviated, the sensitivity of the receiver remaining very low until a station is tuned in, when the sensitivity automatically rises.

### Mains Aerials.

With many types of mains set you use an ordinary earth and aerial, but with some types of set you can use an aerial which in effect consists of the mains lead. This is often done by means of a connection—through the condenser, of course—between the aerial coil and some part of the mains lead, such as a point on the primary of the power transformer.

This condenser, by the way, should be well able to stand up to a fairly high voltage, and it is usual to employ a condenser which has been tested to a D.C. voltage several times the r.m.s. value of the mains; in fact, it is not too much to use a condenser tested up to 1,000 volts D.C., bearing in mind the possibility of this being subjected to momentary peak voltages very much greater than the normal voltage of the mains.

### Curious Effects.

A curious thing about a mains aerial is that results often vary in a surprising way. You will sometimes find, for instance, that even on A.C. mains you will get a much better result when connecting to one terminal of the power supply than the other. Again, you will sometimes find that you get different results from different plug points, and the only thing to do is to fiddle around until you get the best.

If you don't want to make a direct connection to the power supply you can try an insulated wire run for a length of a few feet along with the power leads, one end of this wire being taped and left free, and the other end being connected to the aerial coil.

## BUILDING A CATHODE RAY TELEVISION VIEWER.

Several readers have pointed out that a decimal point appears to have been dropped before the figure 5 in the thirteenth item in the list of components on page 382 of "P.W." dated 3/6/33.

This is true, and the item should read "2.5-ohm Variable Resistances," which agrees with the wiring diagram on that page.

# COLVERN FERROCART COILS

INCREASED sales . . . increased production facilities . . . mean reduced costs.

Prices of Ferrocart coils reduced from 1st June, 1933.

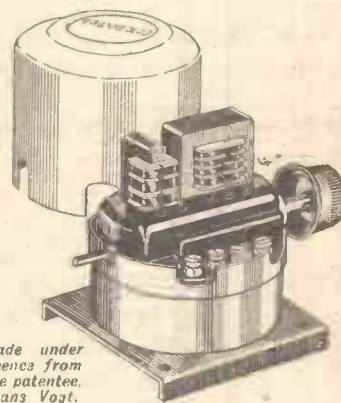

Made under licence from the patentee, Hans Vogt.

**Type F1, F2.** Input Band-pass filter. Constant selectivity, ganging unaffected by variation in aerial reactance, symmetrical resonance curve.

**Type F3.** Auto transformer intervalve coupling with reaction, ganging perfectly maintained on both wave ranges by transfer of tapping point in correct turns ratio, practically constant reaction.

NOW 37/6 per set.

Required for the P.W. "Reflex"

1-Type F.3.—12/6

# COLVERN

MAWNEYS ROAD, ROMFORD, ESSEX.

London Wholesale Depot, 150, King's Cross Rd., W.C.1

## NEXT WEEK!

all about

This Year's

## ECONOMY THREE

Out on Wednesday, 3d.

Order "P.W." Now!

valve, which is now increasing so much in popularity.

This valve is really, as most of you know, a modification or development of the screened-grid H.F. valve, and its characteristic property is that its sensitiveness is regulated by the grid bias which is applied to it. If the grid bias is increased the amplification is decreased, and *vice versa*, a decrease in the amplification in this way being accompanied by the capacity of the valve to handle stronger signals without distortion.

You can see at once how valuable this is in a receiver when you want to pick up feeble long-distance signals at one time, and at another time to be able to handle the powerful signals from near-by stations.

### Automatic Control.

A further development of the same principle is the use of automatic control, in which the grid bias on the variable-mu valve is automatically adjusted, being *decreased*—to increase amplification—when the incoming signal is feeble and being *increased*—to decrease amplification—when the incoming signal becomes stronger.





**AGAIN!  
EXCLUSIVELY SPECIFIED  
for the "Double-D Pen"**

A Super Mains Unit was required for the "Double-D Pen" . . . so the designer naturally specified Heayberd. Build this set to-day—and make it all-electric with the Heayberd M.W.1 Mains Unit. This unit has an alternative output switch offering a choice of two outputs: 30 ma. at 150v. or 50 ma. at 200v. There are three H.T. tappings, 40/120v. Var., 175v. and 200v. (Max.). In addition a raw A.C. supply of 4v. 5 amps. is provided. Supplied complete in neat metal case—ready to switch on. Incorporating Westinghouse Rectifier and Heayberd components. Guaranteed Three Years. **127/6**



**Post Coupon**

for Heayberd handbook on Mains Working

Enclose 3d stamps for New Handbook of Mains Equipment. Packed with Technical Tips, Service Hints and diagrams

Mr. \_\_\_\_\_  
Address \_\_\_\_\_

**F.C. HEYBERD & Co.,**  
10 FINSBURY STREET, LONDON, E.C.2  
One minute from Moorgate Stn

**LOUD SPEAKERS REPAIRED, 4/-**  
(Blue Spot a Speciality, 5/-)  
Transformers and Headphones, 4/-. Eliminators, Mains Transformers and Moving Coils quoted for. 24-Hour Service. Trade Discount. Clerkenwell 9069.  
E. MASON, 44, EAST ROAD (nr. Old Street Tube Station), LONDON, N.1.

**RADIO SUPPLIES**  
Send your list of Radio needs for our quotation. Kits, Parts, Sets, etc. Everything in Radio stocked, prompt delivery. 7 days' approval. Catalogue free. Taylex & Standard Wet H.T. replacements stocked.  
P. TAYLOR, 57, Studley Rd., Stockwell, London

**The Paper  
for the Boy  
of To-day!  
MODERN  
BOY**

Every Saturday - 2d.

**THE P.W. "REFLEX"**

(Continued from page 441.)

The connections between the first L.F. transformer and the potentiometer are made with a length of twin flex run along the baseboard just behind the panel. All wires making an earth return to the copper foil are most easily secured by screwing them down under small 3/8-in. brass roundhead wood screws.

Having checked over your wiring and arrived at that most interesting stage when all is ready for the first test of the new receiver, resist the temptation to rush through the job of connecting up leads and batteries. A little extra time spent here may save much more in tracing mistakes later on.

Nothing special is required in the way of valves. For the output stage the largest power valve you can afford to run, and for the detector the usual H.L. type. For the dual stage you will require a low-impedance S.G. such as the Cossor 220 S.G., which I use with the original receiver. A multi-mu valve is definitely unsuited for this stage.

**H.T. and G.B. Values.**

The terminal H.T. +2 takes the full H.T. voltage available (up to 150 max.), and H.T. +1 between 80 and 90 volts. Any other voltage here may cause L.F. howling, and certainly loss of sensitivity.

The grid-bias voltages are normal, with the exception of G.B.—1, which should generally have 3-volts negative. For slightly more sensitivity for very weak stations this may be reduced to 1 1/2 volts, but not less than 3 volts is advisable for local-station reception if distortion is to be avoided.

Before switching on see that both coils are switched to the same wave-range, that the aerial series condenser is screwed well down, that the "local-distance" switch is open, and that the volume control is at maximum.

With the receiver so adjusted for normal sensitivity, without reaction, the local station, if within a reasonable distance, will be received so strongly as to seriously overload all three valves. In the final tests on this receiver, using an indoor aerial some 15 miles from the London twin transmitters, it was necessary not only to close the "local-distance" switch, but also to turn the volume control more than half-way down before overloading was eliminated. Full volume was then obtained with more than ample selectivity for the complete separation of both stations.

**Searching for Foreigners.**

Reverting to the conditions for normal sensitivity, you can proceed to run over the dials after foreigners, increasing sensitivity to maximum with the aid of the reaction control. When you hit a strong station you may get an increased howl if excessive reaction is being used. The remedy is obvious.

Tuning on the second condenser dial is noticeably sharp, and both dials need to be accurately tuned for maximum results. But tuning is not difficult, as you soon find that they keep well in step over both wave-ranges, the left-hand dial running about five degrees behind the other.

When the receiver was on test, volume controlling was necessary on quite a number of stations. The high sensitivity gave the

"feel" of a four-valver, while selectivity was above the average for a receiver with only two tuned circuits.

When you have become familiar with the receiver, which in operation is rather more interesting than the normal three-valver, you will, I expect, try the effect of altering the aerial series condenser for the degree of selectivity you require, and of slight adjustments of screen and grid-bias voltages for maximum sensitivity.

Once you are satisfied about these preliminary adjustments, there is nothing further to bother about, your only controls being the tuning and reaction condensers, with an occasional touch on the volume control.

**THE LISTENER'S NOTEBOOK**

(Continued from page 442.)

And what about those listeners who have religiously followed M. Stéphan in the past, and who are now beginning to follow him with ease? What a waste of time it will have been, for French has to be "kept up." If it isn't, it goes!

Even if the "stoppage" is only to be for a season, what a lot of good work will be undone! It is such a pity that this decision should be reached just when listeners are beginning to find the talks really useful.

Will anything else be found for M. Stéphan to do? If anybody is a microphone personality, then I'm sure M. Stéphan is! We mustn't let him go! Well, that's what I feel about it.

I hear there may be improvements in the arrangement of the B.B.C.'s official programmes. These improvements aren't, in my opinion, as vital as, say, alterations in the times allotted to the various items.

For instance, I always think it extraordinary that the B.B.C. should send Mr. Vernon Bartlett all over Europe for news (a costly business this!), and then give him a paltry quarter of an hour to broadcast what he has discovered.

The White Coons are at present a significant factor in B.B.C. humour. I just roared with laughter over that school-room episode. That's the sort of stuff we want.

And, as I've said before, Stanley Holloway completely eclipses a number of the B.B.C.'s alleged humorists.

Another name to add to our list of new broadcasters is that of Mr. Tom Walls. It was appropriate that he, as winner of last year's Derby, should be asked to give a talk on the history of that classic race. And what a happy choice it was!

Being a surprise item, the talk was all the more acceptable. Tom Walls proved himself a first-rate broadcaster, perhaps because he just chatted away.

May we hear him again, on any topic. It matters little what. He would always be worth listening to.

Mabel Constanduros came up to scratch wonderfully again in "Grandma Spots the Winner." These Buggins sketches never seem to lose any of their freshness, despite the frequency with which they occur. This can't be said of the work of all artists who have been on the air as long as Miss Constanduros has.

**ALL ABOUT PHOTO-ELECTRIC CELLS**

A NEW BOOK.

Sir Isaac Pitman and Sons, Ltd., have just published a book entitled "Photo-electric Cell Applications" (8s. 6d.), which should command a wide sale.

It was written by R. C. Walker, B.Sc. (Lond.), and T. M. C. Lance, Associate I.R.E., and deals with the subject in a very practical and interesting manner.

The use of photo-electric cells in television, talkies, gramophone recording, electric alarms and advertising is dealt with, and much of the ground covered is of an entirely original character.

We have not seen any other book encompassing so comprehensively the practical aspects of photo-electric cells.





**THE FIRST AND FOREMOST RADIO WEEKLY.**  
 Scientific Adviser: **SIR OLIVER LODGE, F.R.S.** Chief Radio Consultant: **P. P. ECKERSLEY, M.I.E.E.**  
 Editor: **N. F. EDWARDS.**  
 Technical Editor: **G. V. DOWDING, Associate I.E.E.**  
 Assistant Editors: **P. R. BIRD and A. JOHNSON-RANDALL.**  
 Chief of Research Department: **K. D. ROGERS.**

*The Paper that Made Wireless Popular*

**A TRIBUTE  
 NEW STATIONS  
 OUTPUT CONTROLLER  
 REPORTS REQUIRED**

# RADIO NOTES & NEWS

**NEWS VALUES  
 THOSE CATKINS  
 RADIO REMEDIES  
 MILKY WAY WIRELESS**

**A Birthday Tribute.**

ON June 12th that Grand Old Man of Science, Sir Oliver Lodge, celebrated his eighty-second birthday. A great age, as men reckon; but "it is the spirit that quickeneth," and Sir Oliver will never be really old. We dedicate these three paragraphs to him in respectful and grateful tribute, with congratulations.

**What He Was and What He Did.**

BORN in 1851, at Penkhill, near Stoke-on-Trent. First Professor of Physics, Liverpool University, in 1881. Went to Birmingham University as its first Principal, in 1900. Knighted in 1902.

He patented, with Dr. Muirhead, a system of wireless telegraphy and, of supreme importance, invented the "tuned" radio circuit. He has prosecuted classic researches in his attempts to wrest from the ether some of the secrets of its nature, and is also famous for his championship of what is generally known as Spiritualism.

**Sir Oliver To-day.**

THE calibre of the man may be gauged when you consider that, officially, he "retired" in 1919. During the fourteen years which have since elapsed, he has written books and numerous articles, proved himself to be the ideal broadcaster, carried out his work as our Scientific Adviser and continued his research into the spheres of ether and spirit.

But I think that his noble inspiration of his fellows is his chief title to the place he holds among those others who have made their lives sublime.

**Two New Stations.**

IF all goes well Cape Town and Western Province will be served by the most up-to-date station in the Union by the end of the year, made and erected by Marconi's, on behalf of the African Broadcasting Corporation, at Milnerton. The studio will be situated in a new building at the corner of Darling and Plein Streets.

The station's masts will be the 600 feet towers which were constructed for the South African Marconi Co. before the advent of the "Beam" system.

**The Next 5 X X.**

THE new B.B.C. station at Droitwich, which is to replace the existing National long-waver, Daventry 5 X X, is expected to be in operation about the

end of next year. Its power will be 100 kilowatts.

Several points of interest may be noted about this station. It is being built over a layer of salt. It will employ the largest glass and copper valves in the world. Each of its six monster valves will be provided with a separate generator.

Altogether, this station will be in line with the very latest technique and should be heard easily all over the country.

## ACHIEVEMENT!

How many radio journals can claim to have initiated an entirely new design of such merit that it has been duplicated all over the world?

¶ That is just one of "P.W.'s" claims to have set a world-fashion! For our short-wave adaptor was duplicated in millions, and has sold widely in every country of the world.

¶ "P.W." is always first with the really important new ideas. In connection with the recent valve developments alone, this journal gave

**THE FIRST DETAILS FOR CONSTRUCTORS**

of sets embodying the Multi-Mu Pentode, "Class E.s," the Double-Diode Triode, the Westector, All-Metal Valves, the Low-Bias Multi-Mu, and the Double-Diode Pentode.

¶ This is not self-aggrandisement. It is fact.

To set a world-fashion, and to be always first with news of really important developments is this journal's idea of

## SERVICE

**New B.B.C. Appointment.**

IN order to relieve Sir John Reith of much detailed work, Colonel A. G. C. Dawnay has been appointed "Controller, Output Division" of the B.B.C. Colonel Dawnay will be the chief of the

various directors of programmes and it is to him, therefore, that we must look in future for the provision of broadcast material. His position is a vital one. We wish him luck and we hope that precedent and expediency will not too greatly affect his decisions or sway his judgment.

**Pity the Poor Broadcaster.**

BROADCASTING, like writing notes for "P.W.," must be honeycombed with pitfalls, so that the wretched performer does not know from one moment to another whether his next step will land him into trouble.

I will admit, however, that the fellows who lie in wait for "Ariel" are extremely friendly. But when a man at Inverurie—Scotland!—writes to the papers to say that he is disgusted because Gillie Potter says, "Good-evening, England," and because an announcer called Mollison an Englishman, it is time, I suggest, that the B.B.C. made it known that it has a job in hand of such a size and importance that no account can be taken of the scruples of minds so narrow that Euclid's definition of a "line" fits them perfectly.

**An Old Society.**

FOUNDED in the same year as was the B.B. Company and "P.W.," the Hackney Radio and Physical Society is now in its twelfth year. Its meetings are held at 8 p.m. every Monday at the Hackney Electricity Halls, Lower Clapton Road, E.5. "P.W." readers who wish to join the Society or attend one of its meetings should apply to the Hon. Sec., Mr. A. F. Rogerson, 19, Sewdley Street, Clapton, E.5.

**Reports Welcomed.**

OUR old friend, C. S. P. (Shortlands), who draws my attention to the "fan" whose "input" was so great that he was "choked," tells me that he now operates a fully-licensed transmitter and would welcome reports on his signals, which are now in Morse on about 42 metres, but will be augmented later by telephony on 170 metres. Call-sign, G 2 G B.

All reports will be acknowledged. C. S. P. has worked fifty-four stations in thirteen countries since March. We are proud of him, and we like him because he recognises that "P.W." leads in radio.

*(Continued on next page.)*



# ARIEL CONTINUES HIS RUNNING COMMENTARY ON RADIO

## What Says the P.R. Society?

**I**n a reputable technical electrical weekly I read that in the Irish Free State the radio licence fee is £1 per annum for schools and institutions, £5 for hotels and restaurants, and £1 per week for cinemas and halls to which the public is admitted.



Our own Postal Administration, a wise and very far-seeing establishment, limited its fee to ten shillings, and dodged the responsibility of licensing anybody to do anything involving the infringement of copyright.

## The International S. W. Club.

**M**R. A. E. BEAR, the European representative of the I.S.W.C., tells me that the response to my note of May 6th was "really wonderful." Happy to oblige! The London Chapter of this club enjoyed a demonstration of the "Catkin" valve on June 9th. "P.W." readers were invited, but the notice reached me a week too late for publication in time. All those who from time to time send me notices of meetings would do well to observe that on the date when Mr. Bear's letter reached me (May 30th) I was preparing my Notes for June 17th.

## The B.B.C. and News Values.

**I** DO not know who compiles the B.B.C.'s News Bulletins, but I think that he or they ought to take lessons in "news values" from a newspaper man. Considering that the ether-space allotted to news is so small, the inclusion of an item about Gandhi breaking his fast with orange-juice was ill-advised. Luckily nothing was said about the nanny-goat! Surely the B.B.C. ought to know that this country is not specially interested in played-out demagogues and their desperate attempts to keep in the limelight.

## SHORT WAVES

A wireless announcer tells us that, when he is broadcasting, something strange and fluid seems to flow from his listeners to him. In some cases, but for the walls and distance in between, something strange and solid would reach the announcers.—"Punch."

We read in a contemporary that 1,436,800 odd factory-made receivers of all classes were sold during last year.

Ours must be one of these—it's certainly rather odd.

In Athens there is a monument to Adam. In all places where there is a loudspeaker, there should be a monument to Eve.

If all the wireless sets now in use were piled one on top of the other in Trafalgar Square they would probably fall down.

"The Loudspeaker is replacing the Scarecrow" we read in the "Children's Newspaper."

The only drawback is that it's nothing like so silent.

In order to encourage the "Come to Britain" movement, a loudspeaker van is to tour in the Netherlands.

That ought to drive them over here in shoals.—"Punch."

## Replies to Correspondents.

**G. W. F. (Upper Clapton).—**Thanks for your letter. Contents noted. Glad "P.W." has helped you so much.

**J. F. S. W. (Bishopsgate, E.C.).—**Fifty-four stations on the "P.W." Ferro-B. Portable is a magnificent testimonial to our circuit and your constructive and operational skill. We appreciate your appreciation highly.

**F. N. T. (Buxton).—**No! Our sets are the result of organised team work. We have no pet geniuses (or genii) in Tallis House.

**L. R. (Looe).—**Kind of you, friend! But before these lines are printed I shall be away on my great expedition to plant a copy of "P.W." where it never before trod, so to speak. Nevertheless, I love your country and your hospitable offer. Consider your hand shaken.

## This "Catkin" Business.

**S**EVERAL ideas occur to me in connection with this "Be Brutal to the Catkin" wave which is sweeping the country.



Firstly, as it does not have appeared to many people that the real function of a "Catkin" is radio reception, I offer the suggestion that it should be used to break the hearts of rebellious and destructive servant maids. Secondly, railway porters could be trained with it. Thirdly, instead of kicking the furniture the much-ried paterfamilias could be given his "Catkin," and a coke-hammer, and the free use of the back-yard.

Finally, perhaps H. M. Bateman would delight us with a cartoon entitled "The man who Cracked a 'Catkin'!"

## Goat-Gland Brinkley.

**J**UST by way of a concession to the holiday spirit let us consider the case of J. R. Brinkley, the Kansas goat-gland broadcaster. Dr. B. began to broadcast the virtues of his goat-gland treatment from his own station, KFKB, in 1930. His licence to practise was revoked and the Federal Radio Commission would not renew his licence to broadcast.

Then he nipped across the border to Mexico and struck up with station XER, of 100 kw., a change from his old 5 kw.! Listen for him on 408 metres, for he has recently increased his power to 500 kilowatts!

## Remedies by Radio.

**I**N passing I may mention that Dr. Brinkley began commercial life as a telegraphist. With his first station, at Milford, Kansas, 14 miles from the centre of the U.S.A., he won the *Radio Digest* popularity contest. Small wonder, for he made Milford prosperous.

The goat business boomed, and an Arkansas man, described as "goat and bee man, postmaster, and preacher on the side,"

used to send him on the average 40 goats weekly. Whilst it is not true that he offered G. B. Shaw a free treatment, it is history that he sent a whole goat to a newspaper editor who had attacked him.

Milford loves him so much that it tried to re-name itself Brinkley, but was restrained. Meanwhile, if you feel queer, try for XER, and go all goatwise!

## The Unromantic Dealer.

**A**N Essex police court case has revealed an instance in which all the lure of femininity combined with gipsy lore failed to part a radio dealer from his treasury notes.

Enter the sirens, clad exotically, to one Mr. W. J. Marshall, of Witham. He entered into converse with 'em, about the repair of a radio set. They sought in vain to bemuse his sense of business with talk of fortunes, luck, and the rest, all the while edging towards the till.

Taking some One Pounders from the till, one Delilah began demonstrations of "good luck," etc. Her omission to replace those innocent bits of paper aroused Mr. Marshall's passion for the rules, and so it all ended in restoration and fines and all sorts of unromantic things.



## Radio Rockefeller Grabs Extra Mile.

**T**HAT'S a good American caption! It leads up to the news that the scientists have calculated that John D. Rockefeller, in his office 850 feet high in that much advertised "Radio City," seventy stories high, will travel more than a mile farther each day than the folk on the ground floor. And much good may it do him!

Another frightful fact is that by the time a plummet has fallen down the lift shaft the earth's rotation has carried it about five and one-third inches out of the vertical. Such, my friends, are the horrible things which happen to honest plummets in Ameriky!

## Messages from Milky Way.

**A**S a result of long research in the world-famous laboratories of the Bell Telephone Co., Mr. K. G. Jansky has been able to announce the discovery

of radio waves 14.6 metres long, which he calculates originated in the Milky Way.

I am glad to observe that Mr. Jansky, being a scientist, does not go off into baseless speculations about

"Messages from the Galactates"; rather does he take the view that there is no indication whatever that these waves result from any intelligent striving for communication with us. And so he has spoilt in advance a lot of fine, colourful journalism.





# This Year's "ECONOMY" THREE

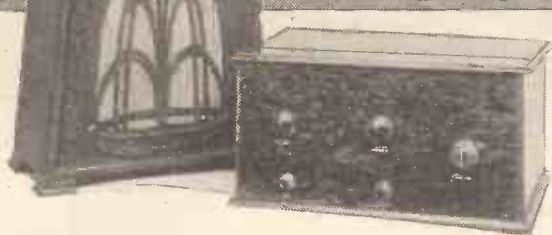

WHEN the original "Economy" Three was described in "P.W." (May 10th, 1930), it was stated that a simple and straightforward circuit, using relatively low-cost components, was capable of providing the set-builder with first-class results from a large number of British and foreign stations.

Was this claim too modest? It would seem so, for right from the date of first publication until the present time we have received a steady stream of appreciative letters about the "Economy" Three.

### When Simplicity Scores.

Our regular readers will have noted that in the letters published most of the writers express surprise at their own successes with the set, apparently under the belief that economy and simplicity are almost incompatible with plenty of programmes, at good strength and quality.



But that is not so. As a matter of fact, in certain circumstances, many of the more complicated sets can compare almost unfavourably with a simple set, just because it is simple.

Having no frills or furbelows about it, there are no tricky adjustments to make. No tinkering is required, no finicky trimming. The set just makes the most of all that the aerial feeds into it, to the great enrichment of the loudspeaker.

### Impressive Performance.

This Year's "Economy" Three is not intended to be a mere modernisation of that original circuit, but is an up-to-date application of the same principles which were so successfully employed before. Ease of construction; standard components; few controls; simple screening—these are virtues which have a homely ring when enumerated, but which nevertheless can result in a far-reaching and impressive performance.

The photographs and wiring diagram show the utter simplicity which characterises the design in practical form. Nearly all the components are arranged on the flat baseboard, where there is ample room allowed for even the most butterfingered novice to carry out the wiring without difficulty, or danger of instability arising from bad spacing.

On the panel we have the reaction and two tuning condensers, the former being used only for the weaker and more distant stations, if required.

At the back of the set we have a pair of terminals at each end, for loudspeaker and aerial and earth connections respectively. Between them is mounted the on-off switch (on a bracket, which can be home-made from a piece of brass strip if desired).

For wave-changing there are two switches, which operate on the aerial and H.F. coil units, these being placed on the panel immediately below the respective tuning condensers. (They are pulled out for medium waves, and pushed in when tuning for the long-wavers such as Radio Paris, Huizen, Kalundborg and the new Luxembourg station; which latter, incidentally, was brought in at enormous strength on the tests of the original model.)

Owing to the high

amplification produced by modern valves the input to the S.G. valve (that section generally called the "aerial end" of the set) must be shielded from unwanted interaction with the subsequent stages of amplification; and this is achieved quite effectively by the upright metal screen, which subdivides the set.

It is easily fixed by a couple of screws and only three wires pass through it, so the screening really is simple, as stated above.

About actual construction very little need be said, as it is merely a matter of choosing the components from the accompanying list of suitable makes, and assembling and wiring them as indicated in the illustrations. The mounting of the condensers, etc. is better done before the panel is fixed to the baseboard,

this latter being accomplished by three equidistant screws driven into the baseboard from the front. (Panel supports are unnecessary, as the screen does all that may be required in this line.)

Note that as a preliminary the baseboard itself is covered with foil, and that the direct connection to this of many of the "earthed" wires simplifies the constructional work. These connections are clearly indicated on the wiring diagram.

### Eliminating Terminals.

The valves required are detailed separately, and it will be seen that they are of the ordinary screened-grid, detector and power types. The battery leads which feed them go direct to the appropriate points in the set instead of to separate terminals, and at the point where the twisted cord emerges from the set it should be firmly fixed to the baseboard by a binding, and fixing screw, or other hold-fast. Apart

(Continued on next page.)

Every "P.W." reader will remember the original "Economy" Three which achieved such great popularity when it was first published. Here is a worthy successor to its famous namesake—**REMARKABLE POWER—EASY TO BUILD—INEXPENSIVE IN COST.**

Designed and described by the "P.W." RESEARCH DEPARTMENT.

★ ★ ★

## WELL-TRIED & THOROUGHLY RELIABLE

The circuit of this year's "Economy" Three is of a perfectly straightforward nature. The shunt-feed method is used for coupling the S.G. valve to the detector circuit, and the L.F. stage is transformer coupled. It is a thoroughly well-tried circuit which can be relied upon to give excellent results.

★ ★ ★

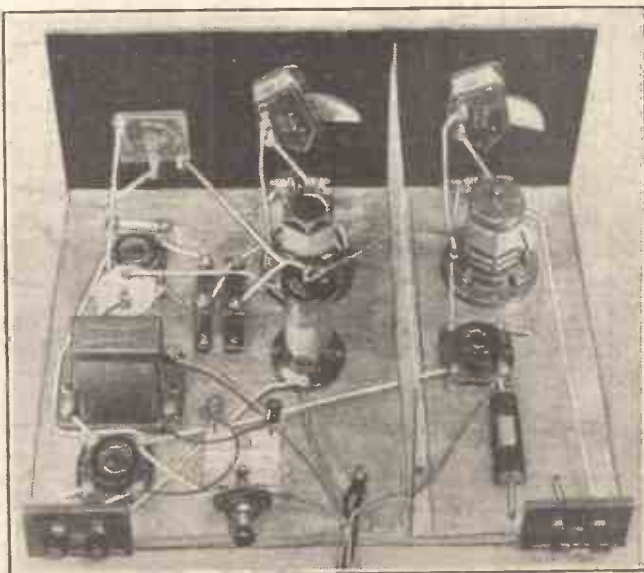



# "THIS YEAR'S ECONOMY THREE"

(Continued from previous page.)

from the obvious need for preventing unwanted "shorts" there are no points where even the novice is likely to err. And the risk of a short to the foil is completely removed by slipping cardboard discs under valveholders, etc., before fixing them, so that should a tag bend over and touch the "floor" it contacts with the insulating card instead of the conductive foil. Properly insulated wires and a little care in use will prevent the screen from cutting any of the wires passing through it.

### Straightforward Operation.

Information about the best high-tension and bias voltages to use will be supplied with the valves themselves, the H.T.+1 lead being that for the screen of the H.F. (S.G.) valve, and H.T.+2 for the detector (V2). The power valve (V3), and the anode

of the S.G. valve are both supplied from H.T.+3.

No knowledge of the circuit employed is required in the operation of the receiver, but for those who do not read circuit diagrams with certainty it may be as well to mention the set's chief features. Aerial selectivity is controlled by the variable condenser contained in the first coil unit, an adjusting knob on the top of this being provided for obtaining the requisite sharpness of tuning. For maximum sharpness, screw knob down.

The S.G. anode is shunt-fed through the H.F. choke, and differential reaction is applied from the detector to the second coil unit. To couple the power valve to the detector ("leaky-grid" type) an L.F. transformer is employed. No output filter was incorporated in the last stage

## USE THESE VALVES FOR BEST RESULTS

Make	S.G.	Detector	Output	Output for mains unit
Mullard	P.M.12	P.M.1H.L.	P.M.2A.	P.M.2P2
Cossor	220S.G.	210H.L.	220P.A.	230X.P.
Marconi	S.22	H.L.2	L.P.2	P.2
Osram	S.22	H.L.2	L.P.2	P.2
Mazda	S.G.215	H.L.2	P.220	P.220A.
Eta	B.Y.6	B.Y.1815	B.W.604	B.W.604
Hivac	S.G.210	H.210	P.220	P.220
"362"	S.G.	Detector	Power	Power

## SIMPLICITY AND ECONOMY

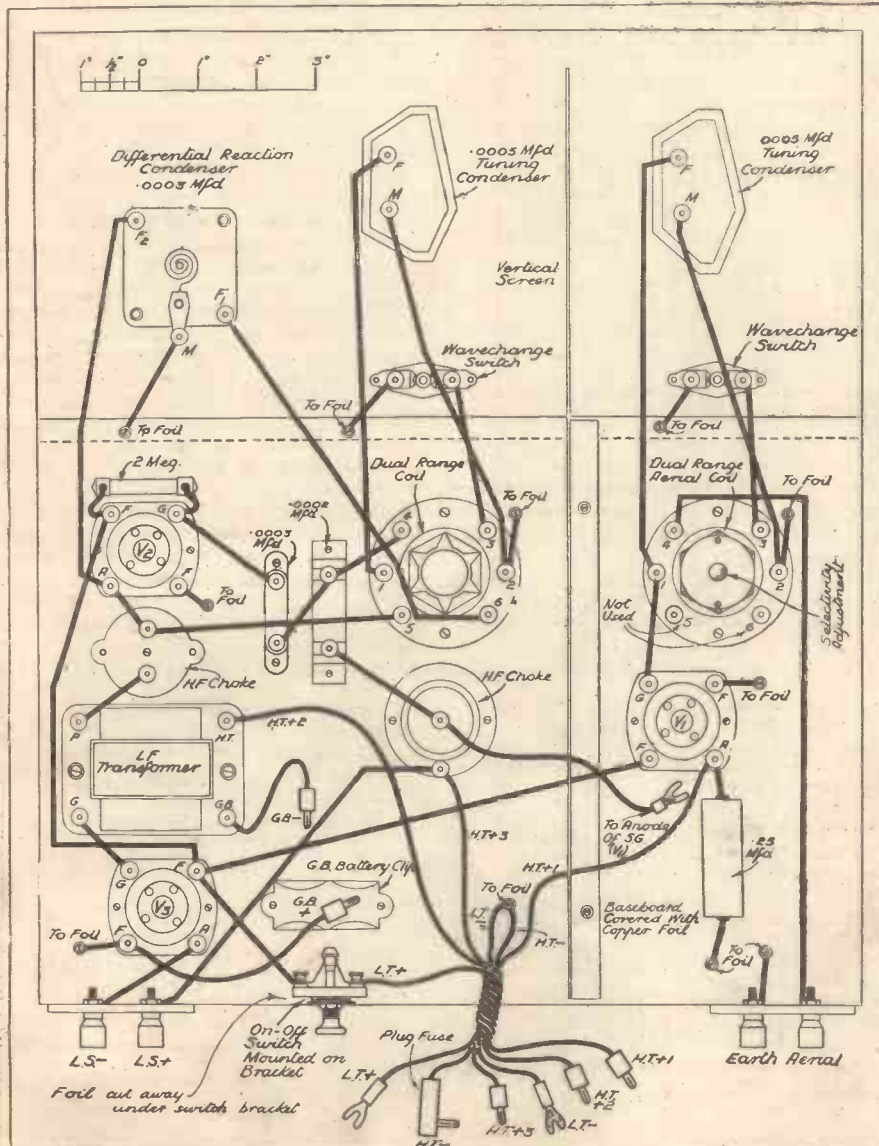

because this is already provided in so many modern loudspeakers.

The operation of such a straightforward arrangement as this resolves itself into first setting the selectivity adjuster on the coil unit to the required degree, and then tuning simultaneously on the two main controls, keeping the two circuits "in step" all the while. The "in step" position is easily recognised by the extra "liveliness" displayed, and it will be noted that the dial readings are then approximately the same.

### Handling Reaction.

For the benefit of those users who are accustomed to using detector-L.F. circuit arrangements with only one tuning control, it may be advisable to remark, in passing, that all such receivers are different in one important respect from the type of set we are now dealing with.

The difference lies in the relative importance of the reaction control when the set is being operated for long-distance reception.

With any set not employing an H.F. amplifying valve it is a matter of great importance to get the tuning closely supported by reaction, so that weak stations

### ACCESSORIES WE RECOMMEND.

**LOUDSPEAKER.**—B.T.H. Blue Spot, Rola, Amplion, R & A, Marconiphone, H.M.V., Celestion, Ormond, G.E.C., Epoch, Atlas, Ferranti.

**BATTERIES.**—120-volt H.T. Drydex, Siemens, Pertrix, Lissen, Ever Ready, Ediswan, Magnet, Silver Knight.

G.B. to suit output valve: Ever Ready, Siemens, Ediswan, Magnet, Lissen, Pertrix, Drydex, Silver Knight.  
2-volt. L.T.: Exide, Ever Ready, Lissen, Pertrix, Block, Oldham.

**MAINS UNIT.**—120 volts, 30 milliamps (or to suit output valve): Ekco, Ferranti, R.I., Regentone, Heayber, Atlas.

**AERIAL AND EARTH EQUIPMENT.**—Electron "Superial," Goltone "Akrite," Graham Farish "Filt" earthing device.

are not overlooked when the tuning dial is being rotated.

Moreover, the comparative non-selectivity of such sets, in which the first valve is the detector, renders the application of quite an appreciable degree of reaction advisable, on the grounds of improved selectivity.

### Two Tuned Stages.

But with a set like "This Year's Economy Three" we find that the interpolation of the screened grid amplifying stage between

(Continued on next page.)

Here are all the details you will need for wiring-up. The baseboard is covered with copper foil, which, with the aid of the vertical screen, provides perfect stability on both wavebands.



# "THIS YEAR'S ECONOMY THREE"

(Continued from previous page.)

the aerial and the detector results in a great improvement in these respects. Even the distant stations will "come in with a roar," and the two tuned stages make for better separation, so that on neither ground is reaction so necessary as before.

In fact, instead of having to "nurse" the set to keep it near the oscillation point, the operator merely has to tune it. So normally the reaction control is set at minimum, and left there.

Then, in searching for distant programmes, one hand is placed on each tuning dial, and whilst one condenser reading is slowly increased by a progressive rotation, the other is turned backwards and forwards a little at successive dial positions, thus keeping the second circuit roughly in tune with its fellow.

### Daylight Tests.

When an unfamiliar station is heard one dial is rapidly adjusted to the position at which the programme is best received, and then this dial remains stationary whilst the other is "brought into step," where a marked increase in volume is immediately discernible.

Should they be necessary, the benefits of reaction may then be applied. But in the majority of cases the tuning dials alone are all that have to be attended to.

Incidentally, this knack of keeping two tuning dials in step is very easily acquired from a little practice during daylight hours, when few stations are on the air. At such times the effects of correct tuning, as compared with tuning which is out of step, are very clearly recognisable by the extra liveliness of the former condition; the faint hiss of the loudspeaker being much more easily recognised when there are only a few programmes to blanket it.

We have mentioned this question of correct tuning procedure at some length, because it is one that often slightly puzzles

the constructor who changes over from a one-tuning-dial to a two-tuning-dial set. The rare need for reaction is naturally puzzling to him, after a long experience of its benefits with the other type of set.

### Easy to Handle.

But we must emphasise that the two-tuning-dial types of receiver (including "This Year's Economy Three") are not a whit more difficult to operate—in fact such sets are much easier to handle than the detector with reaction type of receiver once it is realised that the reaction dial need be used but rarely.

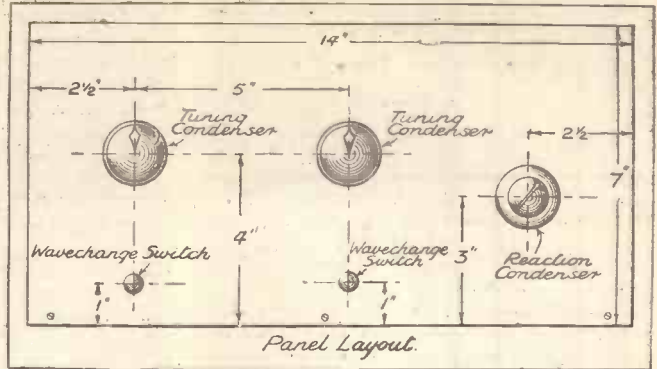

The two panel switches enable the coils to be changed over from medium to long waves, and vice versa. The L.T. "on-off" switch is located on the back of the baseboard immediately behind the G.B. battery.

## ADJUSTABLE SELECTIVITY

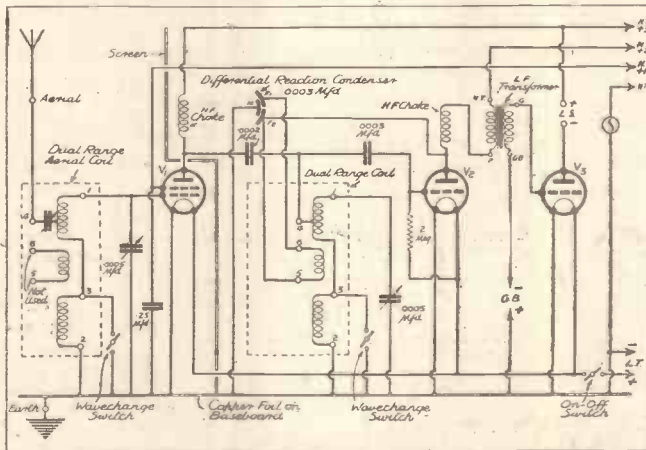

Although the circuit arrangement is such a simple one, the set is capable of bringing in a large number of programmes at good loudspeaker volume. The selectivity can be varied by adjusting the small knob on the top of the aerial coil.

When it is used the very considerable sensitivity of the set is greatly enhanced, and the receiving range will be extended accordingly.

Furthermore, reaction is able to increase the selectivity when skilfully applied. And this is a most useful feature. Although it

possesses certain advantages of its own, a simple circuit of this kind cannot hope to compare with elaborate band-pass schemes when it is a question of shutting out powerful but unwanted stations. And the best way to enhance selectivity is to reduce the input to the set by lightly coupling the aerial, and then to compensate with the reaction control as much as may be necessary.

But in normal situations well away from the local station it will not be necessary to sharpen selectivity with reaction, the selectivity adjustment on the first coil unit being sufficient for the purpose.

### Absence of Complications.

In conclusion it will be noted that there has been no attempt to adopt a stunt circuit to achieve phenomenally low-cost results. Yet this is a true economy receiver because it is perfectly straightforward, without extras and complications. The H.T. battery consumption is low, or if a mains unit is employed the cost of running is almost negligible.

Even on short and indoor aerials—for which, incidentally, the circuit is particularly suitable—there will seldom be need to do any coaxing with reaction, but if wanted, a very virile and effective control is there, with which the weakest and most distant stations can be strengthened.

## THE PARTS REQUIRED TO BUILD "THIS YEAR'S ECONOMY THREE"

Component.	Make used by Designer.	Alternative makes of suitable specification recommended by Designer.	Component.	Make used by Designer.	Alternative makes of suitable specification recommended by Designer.
1 Panel, 14 in. x 7 in.	Goltone	Peto Scott, Becol, Lissen	1 Screened H.F. choke	Bulgin H.F.9	Goltone, Wearite, Graham Farish
1 Baseboard and copper foil, 14 in. x 10 in.			1 0005-mfd. fixed condenser	T.C.C.34	Dubilier, Telsen, Ferranti, Lissen
1 Cabinet to fit above	Peto Scott	Camco, Pickett, Direct Radio	1 0003-mfd. ditto	Dubilier 610	T.C.C., Lissen, Telsen, Ferranti
2 0005-mfd. solid dielectric variable condensers	Telsen	Graham Farish	1 L.F. transformer	Ferranti A.F.10	Telsen, R.L., Lewcos, Igranice, Varley
1 0003-mfd. differential reaction condenser	Graham Farish	Telsen, Lissen, Ready Radio, Igranice, J.E.	1 Standard screen, 10 in. x 6 1/2 in.	Magnum	
1 Dual range coil	Lissen L.N.5189		1 brass bracket for on-off switch		
1 Dual range coil	Lissen L.N.5314		2 Terminal blocks	Sovereign	Belling Lee, Bulgin, Igranice, Clix, Ealex
1 H.F. choke	Slektua	R.L., Lissen, Telsen, Varley, Bulgin, Igranice, Graham Farish	4 Indicating terminals	Belling Lee "R"	Bulgin, Goltone, Igranice, Clix, Ealex
3 Two-point push-pull switches	W.B.	Telsen, Lissen, Wearite, Goltone	3 Yards insulating sleeving	Goltone	Wearite
3 Four-pin valve holders	Benjamin	W.B., Telsen, Lissen, Clix	4 yds. 18-gauge copper wire	Goltone	Wearite
1 2-meg. resistance with wire ends or terminals	Dubilier, 1-watt	Graham Farish "Ohmite," Ferranti, Goltone, Igranice	5 Wander plugs		Clix, Goltone, Bulgin, Igranice
1 .25-mfd. fixed condenser	T.C.C., 250	Dubilier, Telsen	1 Wandertape	Belling Lee	Belling Lee, Ealex
			2 Accumulator spades	Clix	Belling Lee, Ealex
			1 Bias battery clip	Bulgin No. 2	
			1 Anode Connector	Clix	Belling Lee



# SHORT-WAVE NOTES

BY [illegible]

All the interesting news and views of current short-wave practice.

**C**ORRESPONDENCE is accumulating once more, so that this week's notes must take the form of replies to the queries that are of general interest. First of all, I must mention that there appears to have been some "dirty work" abroad on May 21st. for we have been receiving reports of G G Q B's "Crystal Palace" transmission which mention gramophone records.

G G Q B and his fellow-operators did not take a gramophone up the tower, and they transmitted no music of any kind whatever. All transmission was on speech and interrupted C.W. Two or three of these reports even mention the titles of the records.

Fortunately, only about three of the reports are concerned; all the rest have been double-checked beyond the slightest doubt. (Those that mention the gramophone come from the Leicester Chapter of the I.S.W.C., and from London.)

### Untuned S.G. Stage.

A. B. T. (Fort Portal, Uganda) calls me to task for belittling the importance of the untuned S.G. stage in front of a detector. I mentioned that I had never had a great deal of success with it; he considers it "the very thing." He says that it results in "no dead spots, beautiful reaction, and treble the mag."

A. B. T. also recommends the pentode as a detector. Personally, I have always kept off it, as the charm of a single-valver, to me, is the quietness of the background.

A pentode single-valver sounds to me more or less like an ordinary two-valver. Anyone interested can easily try it out without any modifications except the connection of the extra terminal to H.T. positive.

G. T. (Nottingham) writes to tell me that

### SIMPLIFYING S.G. RECEIVERS.

**W**ITH many receivers employing an S.G. valve and mains unit a separate H.T. tapping is provided for supplying the screen of the valve. But where this is not done the scheme shown below can be used instead.

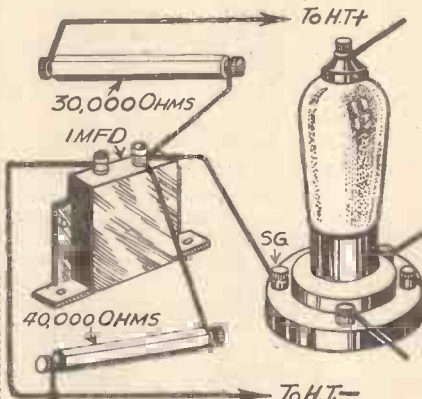

By using two resistances as indicated here, a separate screening-grid tap is rendered unnecessary.

With this arrangement the screen voltage is regulated automatically, the ratio of the two resistances deciding the exact value of the applied voltage. The resistance values shown are those that are most suitable for present-day S.G. valves.

he finds the best time for the 49-metre "Yanks" is between 5 and 6 a.m. This is quite in keeping with the usual summer conditions, although I am rather surprised to hear that they are better than they were at midnight or 2 a.m. Early birds please note! A worm worth getting.

### The 29.7-Metre Mystery.

Since several correspondents have been asking me for the addresses of the R.S.G.B. and the A.R.R.L., I am taking the opportunity of publishing them both herewith. R.S.G.B., 53, Victoria Street, London, S.W.1; A.R.R.L., 38, La Salle Road, West Hartford, Conn., U.S.A.

The unidentifiable station on 29.7 metres that several readers mentioned a little while back has turned out to be a new station at Madrid. This is not a broadcasting station, but merely works traffic with South America.

If anyone hears the call-sign W9 USA during the next few months, they may be interested to know that it is being operated in the big Exposition at Chicago. It is what we might call a "quasi-amateur" station, in that it will operate in the amateur bands and generally do the work of an amateur station, although from the equipment point of view it is probably better off than a good many high-power commercial stations!

### Short-Wave Crowding.

W9 USA will be working in the 80-metre band, both on telephony and code.

From rumours floating "across the pond" I gather that we may expect quite a crop of new American broadcasting stations on the air by the winter. We are soon going to come up against a brick wall, in the shape of the "full-up" notices on the short-wave broadcast bands. Interference is becoming a bit of a problem already—O X Y (Denmark) moved recently to avoid the two Empire stations G S B and G S C, in the 31-metre band.

**T**HE recent hot spell robbed listening-in of a good deal of its appeal. Thus, I couldn't notice without a sigh (I confess this with shame) that Messrs. King Hall and Hall were still arguing the toss over matters economical, that "Design in Modern Life" had reached instalment No. 8, unable to forge ahead of "Industrial Relations," which had also reached its 8th discussion, that Mr. J. D. M. Burke continued to make progress with the story of his musical Experiences, that A Doctor had still lots more to say to A Mother. And so on. And I say, I sighed!

It was probably due to the heat, but I felt I couldn't raise much enthusiasm for these questions. Yet I persevered, because I realised my obligations.

By way of experiment, I listened, one evening, to the nightly reading of verse. I was hoping to discover whether it could have that effect on me that many claim it to have on them. Well, frankly, it didn't.

Actually, I listened to William Watson's "Ode in May," read by Robert Harris. I didn't hear it all, but this wasn't my fault, for it began a little before 10.35. However, I missed very little.

But, had I heard it all, I would still have the same criticism to make. It is so ridiculously short that it loses its significance altogether. Sandwiched between items of more ponderous dimensions, this reading is like a pebble on the beach, which, if removed, would never be missed.

Surprise has been expressed that the reading of verse, which is ideal for the microphone, has been so long in establishing itself as a regular broadcast

## THE LISTENER'S NOTEBOOK

Some points from the programmes, and comments on interesting items recently served up by the B.B.C.

item. Satisfaction is now felt that in these nightly five-minute affairs recognition is being made of the poets and lovers of poetry.

All I can say is that these people are easily satisfied. What is one short poem, taking less than five minutes to read, in a whole day's broadcasting? Why not emulate the Continental stations and go the whole hog by giving us at least twenty minutes? Nothing less than this is worth while.

John Watt is to be congratulated on completing another successful series of Songs from the Shows. His success is due, in no small measure, to the selection he makes.

He always seems to provide exactly what listeners want. He may begin another series as soon as he likes—and the sooner the better.

I thought the Tattoo broadcast was a memorable one. Incidentally—the weather behaved appropriately—it was cooler, and one didn't mind staying indoors.

While the spectacular side of this unique performance is not caught by the microphone, to anyone who has seen the Tattoo in previous years, this is easily recalled. However, the wonderful efficiency of the army is recognisable, especially as the outside broadcast de-

partment is now so expert in carrying out this sort of broadcast.

The Massed Bands illustrate the point in a marked way. Although the prolonged applause made it clear that evolutions of some kind were going on, one could tell also from the alternating crescendos and diminuendos that such was the case. One's imagination was thus aided in visualising the scene.

Personally, I liked the Massed Bands best of all. The Adagio from Beethoven's Sonata Pathétique is so familiar that the authorities might have been afraid of introducing it into this programme.

Results, however, more than justified the inclusion. Its appeal was greater than ever. It proved to be the *pièce de résistance* of the music played by the bands.

I liked the recital of marching songs from the Studio as well. I liked the vigour of the Wireless Male Voice Choir. Stuart Robertson needs no introduction, of course.

It is very apparent that Mr. Cyril Dalmaine is doing magnificent work at the B.B.C. What a colossal amount of time he must devote to rehearsals! Such perfection as he attains can only be attained by assiduous rehearsing.

And this reminds me of two other groups of singers—the Wireless and the English Singers. I would like to hear more of both of them.

I like the ease with which they sing. Never is there the smallest suggestion, even in the longest phrase of the longest drawn-out note, that they will peter out. They seem to be able to go on for ever without taking a breath.

This is, I think, one of their most distinctive characteristics.

But to return to the Tattoo. The Omdurman episode made poor stuff for a broadcast, so the B.B.C. wisely read an authentic eye-witness account of the campaign with suitable background noises coming from Aldershot. Altogether, not a very distinguished item, but we'll let that pass.

It gave me a bit of a shock to see announced that in the middle of the Tattoo broadcast there was to be fifteen minutes of Ambrose and his Orchestra from the May Fair Hotel. It is incredible to me that such an interpolation could even be contemplated, let alone decided on.

The B.B.C. thought better of it, however, when the time came, and made a last minute alteration. Even so, it took them some minutes to decide, but after a silence lasting minutes, the Massed Bands came back again.

Ambrose is excellent in his proper place, but that place isn't a military tattoo.

I am pleased to hear that an unusually good selection of outside broadcasts is being provided in the near future. There is no doubt about the popularity of "O.B.s," for the B.B.C. now has an excellent team of commentators.



# ECKERSLEY EXPLAINS-



There are two ways of dealing with a question, giving a bare answer or incorporating an explanation of the whole matter, when this is possible. Our Radio Consultant-in-Chief adopts the former procedure first and then goes on to expand his replies in his own inimitable fashion.

(1) Question: "I hear of two types of condensers, one called inductive and the other non-inductive. Surely the inductance in a condenser must be negligible at almost any frequency compared with the capacity."

Answer: No! The (relative) inductance is extremely big.

(2) Question: "Is there not a defect in resistance-capacity magnification that a correctly designed amplifier introduces a time constant between the resistances and capacities which spoils the performance?"

Answer: No!

(3) Question: "Is there any reliable method by which one can measure the response of a loudspeaker or a microphone, and what methods are generally used?"

Answer: Many are used but no two give the same results.

### Tuned Circuit Impedance.

(4) Question: "What are the formulae for giving the impedances of a tuned circuit, and how can I use them?"

Answer: Series circuit.

$$Z_s = \sqrt{R^2 + \left(\omega L - \frac{1}{\omega C}\right)^2}$$

Parallel circuit.

$$Z_p = \frac{\omega L}{\sqrt{R^2 + \left(\omega^2 L^2 \left(\omega C - \frac{1}{\omega L}\right)\right)^2}}$$

(very nearly).

When R is resistance of coil, L is inductance, C is capacity in series with coil ( $Z_s$ ) or across coil ( $Z_p$ ), and  $\omega = 2\pi f$ , where f is frequency.

Now let us see how such answers could be expanded, amplified, illuminated, and you can tell me which way you like best.

### Two Different Types.

Take No. 1, above, first. Well, condensers can be made either by using flat plates, separated by flat pieces of insulation (and squashing the result as flat as it will go), or by taking two strips of insulation to stop the plates from making contact.

In the former case one set of plates are connected together by many short strips all bunched on one terminal, while the other set of plates are similarly at the opposite ends of the pancake connected to

the other terminal. But in a rolled-up affair one piece of strip is attached to one terminal and the other strip to the other terminal.

Very high-frequency currents change their direction quite often—so muddled do they get, sometimes, they don't know whether they are going there or coming back. When they are told to go right into that rolled-up condenser at one end of a strip and round and round and round till they get to the middle and then round and round and round out again, they just say "sorry, we haven't got time."

### Relatively High Inductance.

But when they see a lot of parallel strips showing that it's only a step into the condenser and back, they're all for it. So for high-frequency currents we find the rolled-up condenser has got a lot of inductance impedance relative to its capacity, and so we ought to use the non-inductive type.

(2) I must say I find it difficult to expand my first answer, because we all know that resistance coupling works well and in many cases works better than anything else, and so a correctly designed amplifier cannot

(b) To design the amplifier to have such a factor of safety that it will never run into grid current, because it's only when grid current flows that the time constant has a deleterious effect upon performance. In fact, the answer is "No!"

(3) It is frightfully difficult to measure quantities implicit in loudspeaker output, and relate them to a criterion involving ear senses. In acoustics even three wrongs can make a right; a "bad" loudspeaker in a "bad" room might satisfy a "bad" ear, for example!

The difficulty is to get a microphone, say, which does in fact give equal electrical response for equal change of pressure. It is difficult to find a starting point, because at first blush it looks as if you must make a perfect loudspeaker to test an imperfect microphone.

Then, again, the only way to avoid absolutely all the effects of walls, floors and ceilings is to have none, and that implies hanging yourself in air.

### Standing Waves.

Moreover, the finite size of either microphone or loudspeaker causes standing waves between them, and you have to be ingenious to avoid these—some swing the microphone and take an average reading.

The best apparatus I ever saw for measuring these quantities was due to Stuart Ballantyne in America. He could plot you the output of a loudspeaker on a log scale in a few seconds, and

I think the result of the plot told you as much as it was good for you to know.

(4) You can only expand a formula when the formula will develop into a series. And if I suggested to the Editor expanding any formulae into a "series," he would, I think, destroy me. So, series or parallel, I leave this expansion to you, if you can manage it!

## EXPERIMENTING WITH RADIO ECHOES



Two famous scientists, Professor Appleton (standing) and Lord Rutherford, examining the apparatus used in experiments on radio echoes at the new King's College Laboratories. Note the cathode-ray tube that is similar in appearance to the one used in F.W.'s Cathode-Ray Television scheme.

obviously have the defect of a wrong time constant between its resistance and its capacity.

There are two ways to avoid a wrong time constant:

(a) To design the amplifier with a very slightly falling "bass" characteristic undetectable by ear.



## STATIONS WORTH HEARING

A review of recent conditions on the "broadcast" bands, including details of stations that are coming in well, and other information that will enable you to get the best results when searching for foreigners.

By R. W. HALLOWS, M.A.

READERS may remember that at the very beginning of the year I predicted that we were in for an excellent summer for long-distance reception. My reasons for doing so were partly because so many powerful stations would be at work on both wavebands, and partly because the approach of a sunspot minimum made it likely that we should have reasonable freedom from atmospheric interference.

The prediction has been amply borne out. One can safely say that never in the history of wireless has there been a summer when anything like the present results could be obtained.

With the exception of two or three stations at the very top of the medium waveband and one or two near the bottom of the long waves, the great majority of the winter stations are still with us, and so good is their field strength that loudspeaker reception from a score or more is obtainable on most nights of the week.

### Effects of Lucerne.

Even the phenomenally hot spell in June made little or no difference to results. The receiving set in fact now possesses at the height of summer the liveliness which it used to have but a year or two ago only in the depth of winter.

It is rather interesting to notice that the worst received broadcasting stations at the time of writing are those above 510 metres on the medium waveband and below 1,300 metres on the long waves. It appears that the whole belt between about 510 and 1,200 metres is the worst affected by summer conditions.

Rather luckily for us long-distance listeners only a small part of this is at present devoted to broadcasting and the stations that it contains are mostly of no great importance. Next year, when the Lucerne Plan comes into force (at least six months must elapse between its official adoption and the time when the wavelength changes are actually made) much more use will be made by broadcasting stations of this intermediate band and more sets than now will be made to cover it.

### On Long Waves.

The Lucerne Plan will have some very interesting consequences. If whole-hearted co-operation can be obtained from all the countries concerned and strict measures taken to repress wavelength wandering, it should be a very great success, making for greatly improved reception. But there are very few stations whose wavelengths will not suffer at any rate slight changes.

Oslo and Kalundborg are the only two of the long-wave stations that are not now so good as they were. Kalundborg is usually weak, and on several recent occasions a heterodyne has been noticeable. Oslo is quite feeble. This falling away is not likely to occur in future years since new high-

power transmitters are under construction at both stations. Huizen, Radio-Paris and Zeesen are consistently good, and the Eiffel Tower is usually well heard, though it has odd days when the volume is below normal.

Both Warsaw and Motala are quite reliable, and Luxembourg is an enormous transmission. Under the Lucerne Plan, by the way, Luxembourg is assigned a wavelength low down in the medium waveband. It is to be hoped that means will be found of compelling the station to adopt this, though there is some doubt on the point

## TWO TIPS THAT CONSTRUCTORS SHOULD TRY

### A READY-MADE AERIAL.

THOSE listeners—and they are many—who live in third, fourth, or fifth floor flats, often find it impossible to erect an outdoor aerial and impracticable to arrange for an indoor one.

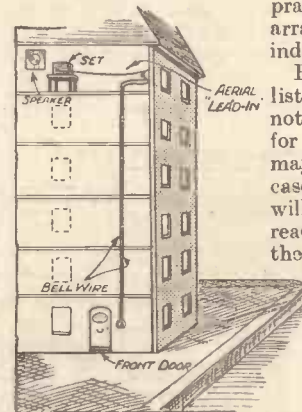

door on the ground level makes a long, vertical aerial, connection to it being easily made via a fixed condenser.

But such listeners need not despair, for in the majority of cases an aerial will be found ready made in the electric bell system.

Bell wiring running from a top-floor flat to the

since it will mean almost entirely reconstructing the transmitter, which was specially designed for a wavelength in the neighbourhood of 1,200 metres.

The station authorities, however, have themselves entirely to blame, for they went on with the construction though a long wavelength was refused, and for some little time now they have obtained a hearing by grabbing a wavelength and shouting down opposition by the use of gigantic power.

### Budapest and Munich.

Of Budapest we shall probably not hear much until the new big transmitter comes into operation, as it should before the end of the summer. Munich, despite its 60 kilowatts, is now not reliable, though good reception occurs on certain evenings.

Vienna's new Bisamberg transmitter is

in regular operation, but it appears that full power is not being used on every night. Every available kilowatt seems to be pressed into service on Saturday nights, and those who have not previously logged the station should look for it then.

Brussels No. 1, Florence and Prague are always good, except that I have noticed an occasional heterodyne on Prague. Langenberg is reliable, and Lyons Doua is apparently using at least ten times the power officially assigned to it in the list of stations, for reception at full loudspeaker volume is always obtainable.

### All the Year Round.

Beromunster is greatly improved and no longer suffers from heterodyne troubles. Rome and Stockholm have proved themselves to be all-the-year-round stations.

Belgrade can be received on most nights, though the volume is generally small. There will be a different tale to tell about this station and about Madrid when the new transmitters are at work.

Katowice continues to show a fine record,

### JOINING FLEX.

A JOIN in flex which will look neat and which is less likely to suffer from faulty insulation than other methods is made as shown in the sketch.

### MAKES A NEAT JOB

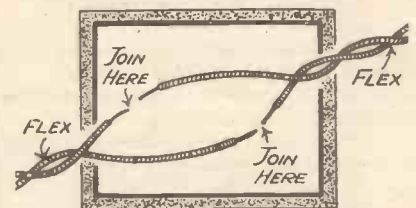

By staggering the joints the bulge produced by the insulating tape is kept reasonably small.

Instead of having the ends of the flex level, make one end in each case longer than the other.

Then join long to short and bind with tape in the ordinary way, which will result in a neat finish.

and Sottens is much better heard than it was. The Italian station Bari, though sharing a wavelength, occasionally comes through strong enough to drown interference. Leipzig is well received. Both Hamburg and Strasbourg have been consistently good for some little time.

### Distance in Summer Time.

Hilversum, Heilsberg and Turin are first-rate. Bratislava seems to have got rid of heterodyne troubles and is now coming in splendidly. Frankfurt shows fine volume, and Trieste has been phenomenally strong of late. Both Nürnberg and Fécamp have furnished excellent reception.

Long-distance listening used to be regarded as mainly a winter pastime. This year's experiences show that the D.X. (long distance) season may be said to extend from January 1st to December 31st.



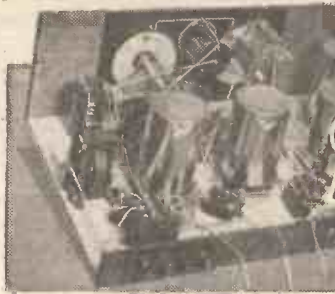

# THE SUPER-HET SIMPLY EXPLAINED

By **BERNARD BARNARD**

**L**AST WEEK we discussed the method of producing a beat frequency by means of mixing two different radio frequencies, and how this is applied in a superheterodyne receiver.

In passing, it may be of interest to mention the word "heterodyne" is simply a more "high falutin'" name for "beat," which accounts for the label attached to this particular type of receiver.

Those amateurs who have handled a superhet of three or four years ago will probably remember that there were always two definite settings of the tuning condenser controlling the oscillator valve for every station, and that this considerably added to the difficulty of operating the set.

### Cause of Two Tuning Positions.

With a modern set the difficulty is not generally apparent, since the oscillator condenser is usually ganged with the other condensers and cannot therefore be moved independently; but the phenomenon is still present and can give rise to more obscure "snags" if precautions are not taken.

But, before dealing with the effects, let us discover the cause of there being two such positions of "tune" for each station.

We found, you will remember, that a station frequency of 843 kilocycles, when "mixed" with an oscillator frequency of 943 kcs. produced the desired "intermediate" frequency of 100 kilocycles.

In other words, the intermediate frequency is numerically equal to the difference between the station frequency and the oscillator frequency.

### "Second Channel" Interference.

But the oscillator frequency is variable and can be set at any frequency within fairly wide limits, so that it is quite obvious that a setting of the condenser which gives a frequency of 743 kcs. will also give the desired beat of 100 kcs.

In practice, the "upper" position, i.e. that giving the 943 kcs., is chosen and the condensers so ganged that the oscillator circuit is always 100 kcs. (or whatever the intermediate frequency may happen to be) off tune with the circuit carrying the signal from the transmitting station.

Now the existence of the second tuning position or "second channel," as it is called, gives rise to a curious form of interference from unwanted stations which has for a long time been one of the biggest bugbears of the superhet.

The elimination of this trouble has called for a type of aerial tuning which is unusually sharp and, in a modern superhet, a band-pass aerial tuner is normally em-

In this, the second and final article on the working of the superheterodyne, our contributor deals with the practical difficulties which face designers and describes how these are successfully overcome in the latest receivers.

ployed. When it is remembered that the unwanted station may very well be a nearby powerful transmitter, the difficulty will be readily appreciated.

The next "snag" in order of importance is probably the difficulty of maintaining good tonal quality.

As is well known, the transmission of sound on a carrier-wave causes the production of waves of different frequencies, according to the pitch or frequency of the sounds; if a very high note is sent out the carrier-wave frequency will increase or decrease by a considerable amount.

It is beyond the scope of this article to

a superhet is the problem of attaining complete stability whilst, at the same time, securing the greatest possible amplification per stage; the question of interaction between components is not likely to prove serious for, as previously pointed out, the intermediate transformers are extremely compact and can be completely screened with ease. The wiring, too, is very simple and straightforward and all leads can be kept short.

### Careful Decoupling Needed.

The chief cause of instability is the leaking of high-frequency currents into the L.F. stages, and to prevent this, it is necessary to decouple all H.T. feeders with the greatest care and make sure that all H.F. chokes and other H.F. stoppers are thoroughly efficient.

General inefficiency will be brought about if the intermediate stages are not accurately matched; cheap I.F. transformers are very bad in this respect and it is poor economy to invest in them.

## ADJUSTING THE INTERMEDIATES

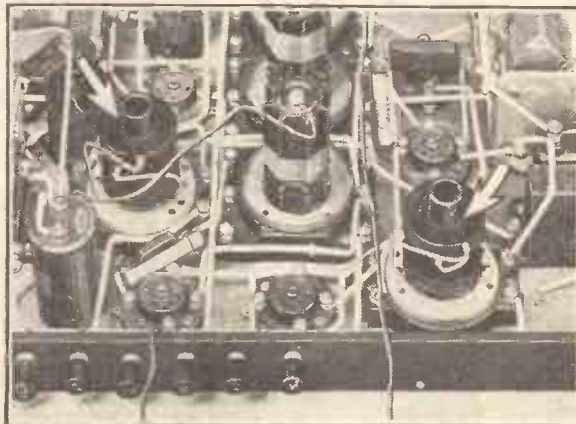

The two intermediate transformers which are indicated by the arrows in this section of a modern superheterodyne receiver have adjustable primaries—a refinement which enables accurate matching to be achieved.

You will find that I.F. transformers are sold in sets that have been carefully matched before packing; this means that the inductance of the coil contained in them is, as near as possible, exactly the same for each transformer, and that the natural frequency of them is the intermediate frequency for which they were designed. However, the added capacity of the wiring and valves when they are in circuit will be sufficient to alter this natural frequency considerably and careful adjustment of the trimming condensers across each coil will be essential before good amplification can be obtained.

### Matching and Ganging.

The question of matching and ganging is also very important in the case of the coils and condensers comprising the variable tuning circuits.

Since it is desirable to gang all controls, very small discrepancies

in the inductances of the tuning coils can be tolerated, so that here again it will pay the amateur constructor to buy from trustworthy firms and to eschew the "cheap and nasty." If you are contemplating building a superhet you cannot do better than to purchase coils, condensers and I.F. transformers from firms advertising in this journal; you will thereby rule out the possibility of "buying a pup."

Finally, unless you have had previous experience with superhets, do not be too ambitious and try to design one for yourself from the hints given in this article; this is not intended to be a constructional article!

deal with the theory of modulation and side-band production but, from the foregoing, it is obvious that to ensure correct reproduction, a complete band of frequencies must be allowed to pass freely through the receiver in order to include all the frequencies transmitted, above and below the station's carrier frequency.

Thus, to give good quality on London Regional, all frequencies between about 838 and 848 kcs. must be allowed access to the detector valve or attenuation of high notes will result, unless steps are taken to give the L.F. amplifier a peak at the top of its response curve.

The next difficulty met with in designing



THE MIRROR OF THE B.B.C.

By O. H. M.

## THE COMING "PROMS."

The Hallé Orchestra—Those Free Advertisements—"The Roads of England"—Speedway Thrills—Test Match and Southport Golf, Etc.

NEWS which everyone expects and welcomes is contained in the announcement that the Promenade Concerts at Queen's Hall are to begin towards the end of the summer. The opening date is Saturday, August 12th, and the series will go on for eight weeks until Saturday, October 7th.

This will be the thirty-ninth Summer Season under the conductorship of Sir Henry Wood and the seventh under the auspices of the B.B.C.

### B.B.C. and Hallé Orchestra.

Meanwhile, after negotiations lasting for several months, arrangements have been made by the B.B.C. with the Hallé Society which should be of benefit to the orchestral amenities of Manchester and the North generally. These include the broadcasting of ten of the Hallé Society's concerts during the next season and the release of such members of the B.B.C. Northern Studio Orchestra as the Society may require for their full season of Thursday concerts in the Free Trade Hall, with special facilities for the further release of these members on certain occasions.

At one time many of the orchestral players in the present Northern Studio Orchestra were leading players in the Hallé Society's orchestra. The arrangements also include the augmentation of the Northern Studio Orchestra on thirty occasions during the period October to April, the players being taken from the Hallé Orchestra.

### Those Free Advertisements.

How many thousands of pounds' worth of free advertisements are broadcast annually by the B.B.C.?

If the figure were revealed I think there would be a good deal of astonishment and something of an outcry from various interested concerns, for, despite most careful efforts on the part of the B.B.C., it is a fact, as every listener knows, that proprietary names and articles are frequently mentioned on the wireless. Everything possible is done by the B.B.C. to "warn off" artistes, lecturers, and others who indulge in this illicit form of advertising.

Sir John Reith has recently taken the matter up in person and has now ordered a full inquiry to be made into the extent of the broadcast advertising practices of certain persons. His attention was drawn to the matter during the Derby broadcast, when the commentator—quite unintentionally, as it afterwards appeared—referred more than once to a well-known brand of spirit.

Sir John estimated that the advertisement broadcast throughout the country and from

the Empire Station and all over North America was worth well over £20,000.

### Cinema Organ for Broadcasting House?

Now that the Concert Hall organ is complete and working satisfactorily the Governors are being pressed to agree to the building of a full cinema organ, complete with all the most modern "effects" and noises.

It is argued that the musical high-brows have been given a magnificent instrument, which, however, is not suitable for jazz or the more popular light music, as a "Wurlitzer" would be. The modern element are all for it, but unfortunately those whose opinion carries most weight on music matters at Broadcasting House are dead against it.

Even so I believe that the strongest objections are being made on the grounds of lack of accommodation, and if this be so it is possible that the cinema organ will only be installed in a few years time when Broadcasting House is extended along Portland Place.

### "The Roads of England."

The first Children's Hour play to be included in the Empire programmes will be

## HOME CONSTRUCTION!



A model electrically driven boat of all-metal construction, built by P.W.'s Technical Editor for his small son. Note the wireless aerial!

I AM rather surprised that no one has yet tackled commercially the problem of spark suppression in motor-car and motor-yacht radio installations—at least, not to my knowledge.

It's not a very difficult matter, and some heavy duty resistances of from 30,000 to 50,000 ohms in series with each of the sparking plugs would, no doubt, be sufficient completely to overcome the difficulty.

If my own experiences recently on the Norfolk Broads are any indication, I am confident that big business awaits the firm which first produces a resistance specially for the job. I went over rather more than a dozen motor-cruisers, and not in one single case could the radio be used while the boat was under way!

This is a serious suggestion, for once to the manufacturer and not to the buyer. I am hopeful that one of our enterprising friends in the trade will act upon it, for I shall then be able adequately to answer several outstanding letters.

transmitted to listeners in the Indian zone on Thursday, July 20th. It is called "The Roads of England," by L. du Garde Peach.

It will be interesting to see if the Children's Hour broadcasts are as much appreciated in distant parts of the Empire as they are in England.

### Coming Commentaries.

Here are some details, brief but quite sufficient, for listeners who revel in running commentaries and broadcast descriptions of sporting events:

Colonel Brand and Captain Wakelam will be on duty at Wimbledon every day during the Tennis Championships meeting to describe the play as and when it may be desirable to do so. This will be their seventh year on the job, which they can be relied upon to do efficiently.

### Speedway Thrills.

Running commentaries on some of the heats in the speedway Test matches will be broadcast from Wembley on Thursday, June 29th. These Test matches began in 1930, when England won three out of four matches. We won the rubber again in 1931, but last year Australia won by three matches to two.

Although we lead by ten matches to five, Australia is only twenty points behind the Mother Country—675 to 695. The commentaries are certain to provide some thrills.

### Test Match and the Ryder Cup.

The Test match between England and the West Indies will be described by Mr. Howard Marshall on the last day, Tuesday, June 27th. Mr. Bernard Darwin will also tell listeners about the play in the Ryder Cup, Anglo-American golf contest at Southport on the same day.

### "Round the Stations."

"Round the Stations" programmes, which were really "dips" into the  
(Continued on page 485.)



Weekly Jottings of interest to buyers.

### "Cabinet" Switches.

"P.W." recently called attention to the need for long bush toggle switches for cases where it is more convenient to fit the on-off control to the side of the cabinet.

In the light of these remarks I am interested to learn that Messrs. Bulgin have found a satisfactory solution, not by

lengthening the bush, but by producing a neat escutcheon plate by means of which any one of their standard switches can be fitted to cabinets up to 1½ in. thick.

The Bulgin type E.2 toggle switch escutcheon is recessed in such a way that the actual switch control knob is below the surface of the cabinet—definitely an advantage from the point of appearance, and one which minimises the possibility of the switch being moved accidentally by the domestic's duster!

### Mullards' Latest.

Well to the fore, as usual, Messrs. Mullards earn for themselves a pat on the  
(Continued on page 486.)





# HERE IT IS! CLASS "B" AMPLIFICATION AT ITS BEST

As Battery Set owners you have always been up against the problem of how to obtain a really good power output without H.T. Battery costs becoming ruinous.

Class "B" amplification is not quite so simple as you might be led to think, and we recommend you to discuss the problem carefully with your radio dealer or write to our Technical Service Dept. (The Mullard T.S.D.).

We have designed the P.M.2B to fit in with your needs, to give you, from a battery set, an output comparable with that of a well-designed all mains receiver, but with no more drain on your H.T. Battery than a small power valve.

#### POINTERS TO THE P.M.2B.

A very low mean anode current (i.e., the average anode current over, say, an evening's broadcast).

Takes no more filament current than the ordinary power valve.

ASK T.S.D.—Whenever you want advice about your set or about your valves—ask T.S.D.—Mullard Technical Service Department—always at your service. You're under no obligation whatsoever. We help ourselves by helping you. When writing, whether your problem is big or small, give every detail, and address your envelope to T.S.D., Ref. C.Y.L.

# Mullard

## THE · MASTER · VALVE

The Mullard Wireless Service Co., Ltd., Mullard House, Charing Cross Road, London, W.C. 2

Arks





# LEAGUE OF NATIONS CALLING

The village of Prangins is near Nyon, which many British holiday makers have probably visited if they have been to the Lake of Geneva. Colorex is near Bellevue, also in the Lake of Geneva district.

As one approaches the station, eight huge lattice masts come into view. The building looks like a typical Swiss power station. Some of the aerial masts, too, look like the pillars which carry the high-voltage cables over the country.

### A Curious Mixture.

Broadcasting and communication with other countries for League messages are carried out mostly on the short waves, and although I have done no listening during my stay here, I understand that the short-wave Radio Nations is now a useful addition to listeners' short-wave logs.

The impression one gets on entering the transmitter hall is curious, especially to a traveller who has seen big broadcasters in every country, such as Daventry 5 X X, Radio Paris and Mühlacker.

There is such a curious mixture of gear of all types. The only thing which strikes a homely note is the Marconi short-wave broadcaster, which is continually working on various wavelengths between 14 and 40 metres.

**B**EING neither a confirmed militarist or pacifist, I went by invitation to the League station with an open mind.

It certainly is an amazing place.

The broadcaster, popularly known as Radio Nations, is at Prangins, just outside Geneva. Prangins is not much more than a village and the transmitter, which covers most of the surrounding fields, has completely transformed the district.

Prangins now looks very much like the Königs Wusterhausen group of transmitters in Germany. I expect this similarity is heightened by the fact that German engineers have built the big aerial masts.

Only the broadcaster is at Prangins, the receiver is some distance away at Colorex, so that there is no interference from Radio Nations.

### Like No Other!

There is no other station like Radio Nations in all the world, for its parts have been selected from wireless manufacturers in countries which are members of the League.

I was told that Britain's contribution is a short-wave transmitter by the Marconi engineers, who have also built a group of short-wave aerials. The Standard Telephones and Cables, who are building our new Empire short-wave broadcasters, have supplied a large amount of telephone gear.

### Used By Delegates.

French engineers (the Societé Française Radio-Electrique) have also installed a short-wave transmitter, and the German Telefunken engineers have put up transmitting and receiving aerials. Holland has provided valves, and most of the electrical power machinery is built by Swiss engineers.

I learned from my guide that although certain sections of Radio Nations will be used for ordinary broadcasting (League of Nations propaganda and international talks) the short-wave transmitters will be useful for delegates to Geneva who wish to send urgent instructions on matters that arise during their stay.

### Speeding Up Communications.

Without having to wait for cabled replies, they will be able to consult officials of the Government in their own country by the short-wave transmissions from Radio Nations, and so time will be saved.

The Colorex receiver is to become a listening centre so that delegates may go there to hear broadcasts from other countries during keen discussions of League work.

Besides broadcasting regularly, the League of Nations station at Prangins just outside Geneva, is available for communication purposes by delegates to the various conferences. The station and the gear, which comes from a variety of countries, is described below

By OUR EUROPEAN CORRESPONDENT.

### SEEN FROM THE AIR



There are a number of different masts and aerials at Prangins, and this view of the two biggest masts was taken from an aeroplane flying on the regular Stuttgart-Geneva route.

★ ★ ★

### FOUR DIFFERENT WAVES

Below you see the Marconi short-wave transmitter which is permanently tuned to four different wavelengths, any one being instantly selected by switch gear.

### An Impressive Sight.

The corner of the transmitter hall in which this is installed faces out towards a field in which there are the peculiar short-wave aerials, and the tall, narrow windows behind the short-wave panels make an impressive sight.

This broadcaster is much bigger than I expected. There are large water-cooled valves in the final stage, for instance, which is usually a sign that a broadcaster is handling high power!

A control engineer stands at two slightly sloping panels in front of the short-wave broadcaster. The four panels of this section of the transmitter are on a platform above the floor.

I have inquired how it is that although the wavelength can be rapidly changed to any wavelength, there is no variation. I am told that it is because crystal control is not used here (so many banks of crystals would be needed for each wavelength), but Marconi-Franklin master-oscillators are

(Continued on page 486.)

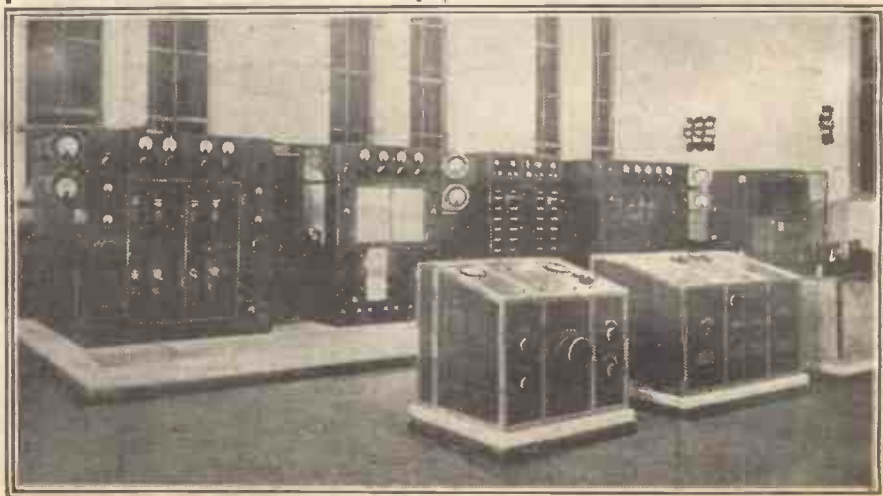





# OPERATING CATHODE RAY TELEVISION

**I**n its complete form the television viewer that we have been describing will fit into a neat cabinet that will enable it to take its place in the house as a piece of furniture, just as does the radiogramophone. But before it is packed away in the special cabinet we shall describe next week, it should be thoroughly tested and made to work properly, for nothing is more annoying than to have to dismantle an outfit of this nature after it has been carefully packed away in a cabinet.

### Flexibility of Voltage.

Last week we gave the full connections and the voltages required for normal working. We, in our tests, used voltages from 350 to 800 on the cathode tube accelerator, and it must rest with the individual constructor how much potential he applies.

It is useful to remember, however, that one can look upon the cathode ray tube in much the same way as an output valve—that is, the more H.T. it has on it the more brilliant will be the picture and the more shield modulation you can apply without distortion of the image.

The cathode tube will distort the picture in the same way as the output of a valve will be distorted if too much grid input is applied to the valve, and in the same way as with the ordinary valve, increase of anode voltage means more grid bias, so with the cathode tube increase of accelerator potential requires a necessary increase in shield bias, and of deflector bias.

All are variable, however, by either wander plugs or potentiometer control, and in the case of the shield 60 volts maximum should be available for 350 volts on the accelerator, and 90 volts maximum bias if 700 to 800 volts are used.

### Protecting the Tube.

For the deflectors up to 60 volts will be required; this being variable by means of wander plugs, the bias on the shield being varied by the potentiometer control marked 1. Note that in the time-base all the potentiometers controlling bias are so wired that the bias is increased as the knobs are rotated clockwise.

The first thing to do when carrying out the preliminary operation test is to check up all the connections, seeing that not only is everything correctly connected but that all connections are really tight. Have everything connected except cathode H.T. plus, and the L.T. to the diodes and thyratrons.

Several batteries in series will have to be used for the H.T. supply to the cathode tube, and the bias connection is tapped off so that bias positive is common with H.T.

negative. This reduces the risk of the bias connections coming out while H.T. is applied.

Another safeguard against any damage being done to the tube should such an event occur is a 40,000-ohms resistance connected in series between two of the battery units forming the accelerator H.T. supply. We suggest that this be inserted somewhere about the middle of the whole bank of batteries.

Small 60-milliamp or even smaller fuses are inserted in the H.T. positive and the H.T. negative leads to the accelerator of

time-base if these two batteries are allowed to come together.

The connections to the cathode tube were shown last week, but the following hint may save much time in adjustment later on. The four deflector terminals on the tube are connected as follow. Place the tube with the anode (accelerator) pin at twelve o'clock, when the four deflector terminals, looking from the base of the tube, will take up positions corresponding to 10, 8, 4, and 2 o'clock.

"Nos." 10 and 8 are adjacent, and belong one each to two pairs of deflectors inside the tube, they should be connected together and to the anode pin of the tube. "No." 4 should be connected to a deflector bias minus plug, and this should be inserted in that deflector bias battery that is connected at the positive end to the .25-mfd. condenser on the time-base.

### Direction of Scanning.

The remaining deflector terminal "No." 2 should be connected to the second deflector bias battery, whose positive goes to the .02-mfd. condenser on the time-base. This arrangement of connections is essential in order that the scanning shall be in the right direction, namely from bottom to top and right to left on the screen.

Now let us start to get things in operation. The set is connected up to aerial and earth and after it has been tuned-in, by means of the headphones, to the London National (this can be done before television commences) it can be switched off and left till the rest is going.

On the cathode tube itself will be maker's directions as to the exact maximum filament current and this should never be

(Continued on next page.)

\*.....\*

**This is the first full description ever published of how to operate a home - constructed Cathode - Ray Television Viewer. It gives minute directions of the whole procedure necessary to "tune-in" a broadcast television transmission—not a complicated process, when using "P.W.'s" specially developed simplified apparatus.**

**By K. D. ROGERS, Chief of the "P.W." Research Department.**

\*.....\*

the tube, and a microammeter is used (if you have one handy) in series with the positive side.

The ammeter is in series with the L.T. supply, as already shown last week. A word about the L.T. supply. That for the thyratrons (4 volts) can be tapped off at 2 volts for the radio set, the negatives being common. But care must be taken that the two L.T. batteries feeding the diodes do not touch one another. The reason for this is that there is sufficient leakage in the battery casing to upset the action of the

## THE ALL-IMPORTANT DEFLECTOR CONNECTIONS

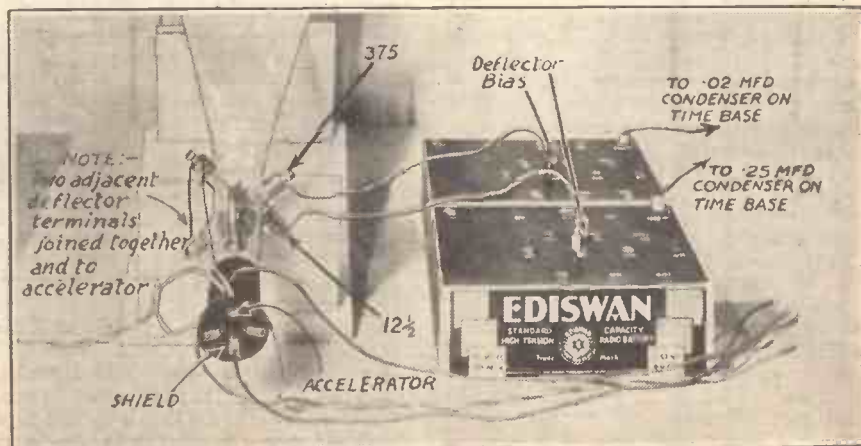

The connections to the two biased deflector plates should be particularly noted, as these are of the greatest importance if the picture is to be scanned in the right direction (i.e. from right to left).



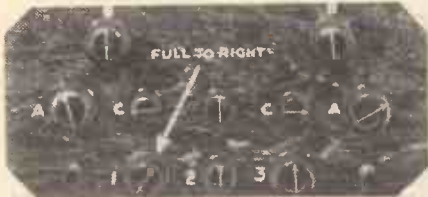

The first knob to set is Number 1.

work more in the dark, but varying the deflector bias will soon result in the light appearing on the screen. Having obtained the light spot, turn knob No. 1 to the right until the spot nearly disappears, then turn slightly to the left, and it will be found that the spot will focus to a small round circle of greenish-blue light.

**STEP BY STEP—**

exceeded, as a matter of fact, the current can be kept about "half a point" lower for most purposes. The correct current will be about .9 to 1.25 amp. in all probability, but individual tubes will differ slightly. Hence the need for the meter.

Now, with all connected up, but with cathode tube H.T. positive switched off, and the switches on the time-base off, we can commence to set the gear in operation. First turn knob 1 hard over to the right, that gives the tube full bias as a safeguard. Then turn knob 3 hard to the left, this gives the least cathode tube filament current. Also turn knobs A and A full to the left. Set the thyatron bias at about 12 volts, the deflector bias at about 48, and the time-base H.T. at 200.

**Setting Filament Current.**

Next, pull out the switches on the time-base, leaving the H.T. to the cathode tube still off. The ammeter will begin to read, probably going to about .5 amp. Increase this by turning knob 3 slowly to the right until the reading is about one point below the maker's figures. As the filament warms up this reading may increase slightly.

Having checked this, reduce to about .5 amp and switch on the anode potential to the cathode tube. Then increase the filament again to its right value. Nothing will be seen in the tube until the shield bias is reduced. This is done by turning knob 1 very slowly to the left, watching the tube for signs of a ray on the screen all the time. Do not turn the bias control knob to more than half-way round towards the left.

If nothing is seen at half-way round, leave the bias adjustment there and remove one of the deflector bias negative plugs; you should then see the ray flash over to one side of the screen. If not, reduce the deflector bias on both deflectors to about 9 or 12 volts.

**Finding the Spot.**

If you are using a microammeter in the H.T. lead to the cathode tube it will be of great assistance, for on switching on with knob 1 to the right you will get no reading, but on decreasing the bias (turning knob to left) the reading will gradually go up. Stop the bias decrease when the microammeter reads about 30 microamps. At this point you have got the ray operating, but the deflector bias is such that it is not falling on the screen.

Without the microammeter one has to



Follow by adjustment of Number 3, and the two knobs marked A.

Knob 1 can now be left, and we can turn our attention to the setting of the time-base. Alter the bias on the deflectors until the spot is about one inch in from the right of the screen and one inch up from the foot. If it is found that the alterations of deflector bias do not move the spot either horizontally or

**—ADJUSTMENTS OF THE—**



Next pull out the two switches and turn Number 3 to the right.

vertically, but obliquely, the tube should be rotated on its axis until this effect is obtained.

This is to counteract the influence of the earth's magnetic field, which sometimes has a marked effect on the cathode ray. Having obtained the spot of light in the right position the thyratrons and diodes can be switched on. Being in an experimental form this can be done merely by connecting up the L.T. circuits, the H.T. being already on, there is no need for a filament switch, until the outfit is housed in its cabinet.

Being of the indirectly-heated variety the thyratrons will take half a minute or so to heat up, and while this is taking place the two filament rheostats on the baseboard can be adjusted.

That on the right, looking from the panel

end should be turned full on (to the left) while that on the right should be about two-thirds to three-quarters on. Final adjustments can be made later.

The diodes will now be alight, and on the thyratrons being hot they will commence to flash when knobs A are turned, that on the right flashing very rapidly, and the one on the left quite slowly. The speed of the flashing can be adjusted by knobs A and A.

**Extent of Scanning.**

Turn the left-hand knob A hard to the left when it will be found, probably, that the left-hand thyatron will cease flashing. If it does not, turn the left-hand baseboard rheostat to the right until it does cease.

Then, if you look at the tube screen you will see that the spot of light is no longer a spot, but a line running vertically up the screen. Its length can be controlled by adjusting knob B on the right-hand group on the panel, and the length of the line should be arranged to be four inches long.

With this adjusted, turn knob A of the left-hand group, when it will be seen that the line now moves across the screen from right to left. The speed of this traverse can be adjusted by knob A, while the extent of the traverse is controlled by B of the left-hand group. Adjust this until the length of traverse is about 1 1/2 inches.

**The Number of Lines.**

Now comes the final part of the setting. We have so to arrange things that we get a framework on the screen consisting of thirty of the vertical lines travelling across the screen at the rate of 12 1/2 complete traverses per second.

The best thing to do is to "play about for a bit" with controls A and B in each section of the time-base, watching the effects you produce.

**—"P.W." CATHODE RAY—**

By this means you will learn quite a lot about the action of the various controls which will be a great help later on.

You will notice that as the right-hand A knob is turned to the right the number of lines increases, while turning the left-hand knob A to the right, the rapidity with which the lines travel to the left is increased.

It may be found that the lines are a  
(Continued on next page.)

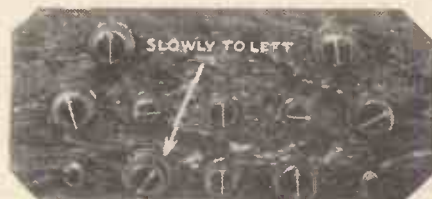

Set Number 3 for correct filament current, and adjust Number 1.

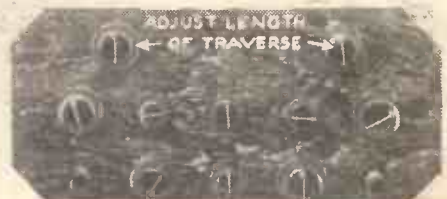

We can now turn our attention to the setting of the two time-base circuits.

**—TELEVISION VIEWER**



## OPERATING CATHODE-RAY TELEVISION

(Continued from previous page.)

bit fizzy, if so, adjust knob 1 very carefully until they are sharp, commencing the adjustment by turning fully to the right, when the lines will vanish, and then slowly to the left until sharpness is reached. You will notice, if you use a microammeter that as the knob 1 is rotated to the left the reading on the meter gradually increases. It must never be allowed to exceed 40 to 50 microamps.

Now adjust knob A of the right-hand group until you can count thirty lines. Keep the length of the lines 4 in. all the time. The next task is to check up the speed of the right to left movement, so that it is exactly 12½ times per second. This is not so easy unless you have handy either A.C. or a constant frequency record of 50 cycles.

### A Test Frequency.

If you have either of these you can apply 50-cycle modulation to the time base through a pick-up adaptor inserted in V.3 of the radio set. Only a weak modulation need be used, and the A.C. from the mains can be applied via a 4-volt L.T. transformer of the usual mains type through a couple of condensers.

In the event of this test being available you will see that the luminous portion of the cathode-ray screen will be broken up into black bands running vertically. The knob A on the left should then be adjusted until the bands number four, and remain fairly steady in position. Note, all the time you must readjust the right-hand knob A to retain thirty lines on the screen.

If this test is not available we must

realised, however, that adjustment of the 12½ side will throw out the number of lines a little.

For television the radio set is used, connected as shown in last week's diagram. The station should be tuned fairly fully in, and then the strength of the output applied to the time base is separately controlled by knobs C and C, and by the central control. The strength of the impulses given to the cathode tube is controlled by knob 2.

### Lines Broken Up.

With television on you will notice that the lines on the cathode-ray tube are broken up by splashes of black. These can gradually be resolved into black horizontal bands by the adjustment of the knobs marked A, especially the right-hand one. Do not worry about what happens to the length and breadth of the picture at first, but slowly adjust these knobs until you get the black bands, fairly thick ones, running horizontally.

Then by further adjustment of knob A on the right, you should be able to get rough images on the screen. You will notice, however, that sometimes these images will suddenly start to run up or down off the screen. This means the viewer is out of synchronism. Adjustment of knobs C should help to stop that, with final control being exercised by the centre knob on the time-base panel.

You must not expect to get things going exactly right first time, the handling of the television viewer will come after practice, and you will then be able to switch on just before a broadcast and get everything with ease.

We shall be glad to answer any question concerning the viewer, for it is a quite new technique in radio reception, and there is quite a lot to get used to. Messrs. Ediswan, too, will be glad to lend any assistance in their power on the subject.

## LOOKING-IN TO LONDON



Tuning the "vision" receiver in the complete Cathode-Ray Television outfit. The special cabinet shown will be described next week.

proceed without it to try the set on actual television. Make sure of the thirty lines, however, for it will not be difficult to get the right scanning speed of 12½ per second if these lines are correct. It must be

### Final Control.

When the television viewer is operating properly, it will be found that the synchronising of the pictures can be adjusted by a slight turn of the centre knob, with perhaps a little adjustment of the two C knobs, which control the strength of the synchronising impulses.

The modulation of the cathode-ray tube is controlled by the knob marked 2, and this should be turned to the right as far as it will go without the picture becoming "frayed" at the ends or wrinkled, denoting that the tube is being overmodulated.

The last step of all is to re-focus the picture by means of the knob 1. This re-focusing will need only slight adjustment, and for best results the picture should not be so sharply focused as to be broken up

into its component vertical lines

Once set all these adjustments can be left, and the viewer is ready for use at any time a transmission is in progress, slight control of the synchronism being necessary.

# PILOT AUTHOR KITS

Exact to Specification

CASH—C.O.D.—H.P.

THIS YEAR'S ECONOMY THREE

Described this week.

**KIT "A"** Delivered Carriage Paid on First Payment of **5/3**

Author's Kit of First Specified Parts, including ready-grilled panel, but less Valves and Cabinet. CASH or C.O.D. Carriage Paid, £2/17/9.

**KIT "B."** As Kit "A," but with Valves only. Delivered Carriage Paid on first payment of **8/3**. Balance in 11 monthly payments of 8/3. Cash or C.O.D. Carriage Paid, £4/10/0. Specified Valves, £1/12/3.

Balance in 11 monthly payments of 5/3

**KIT "C."** As Kit "A," but with Valves and Cabinet. Delivered Carriage Paid on first payment of **9/8**. Balance in 11 monthly payments of 9/8. Cash or C.O.D. Carriage Paid, £5/5/0. Peto-Scott Cabinet, 15/0.

## PILOT "CLASS B" CONVERSION KIT

Converts your present Battery Set to "Class B" Amplification. Complete with all necessary components, including Peto-Scott Driver Transformer, Peto-Scott "Class B" Output Choke, W.B. 7-Pin Valveholder, "Class B" Valve, wire and screws, etc. Full-size Blue Print, Assembly Instructions and Diagrams. Cash or C.O.D., 3/6. **5/-** only

Balance in 7 monthly payments of 5/6

All "Class B" Components and other parts unobtainable from your local dealer SEND C.O.D. We have largest Radio Stocks in the Country. Orders over 10/- sent post paid.

## WORDER BARGAIN Q.P.P. KIT formerly 79/6 NOW 59/6

4-valve S.G. Q.P.P. Kit "A," less Valves and Cabinet. Complete with all components. Send 3d. in stamps for Full-size Constructional Chart. Or 12 monthly payments of 5/6. Q.P.P. Conversion Kit. Converts your present Battery Set to Q.P.P. Cash or C.O.D., £1/12/6. Formerly 42/6. Or 7 monthly payments of 5/-.

**LISSEN ALL-ELECTRIC SKYSCRAPER** 3. Complete with 4 Valves and Constructional Chart in sealed Lissen carton. Cash or C.O.D. Carriage Paid, £7/19/6. **14/8** only

Balance in 11 monthly payments of 14/8

**SET OF 3 OGRAM GATKIN VALVES.** S.G., Detector and Pentode. Cash or C.O.D. Carriage Paid, £2/12/6. **7/3** only

Balance in 7 monthly payments of 7/3

**BOLA PERMANENT-MAGNET MOVING-COIL SPEAKER P.6.** With Universal tapped input transformer. Cash Price, £2/9/6. Carriage Paid. **4/6** only

Balance in 11 monthly payments of 4/6.

## PETO-SCOTT "CLASS B" MOVING-COIL SPEAKER

SEND **2/6** ONLY Just pay a further 2/6 on delivery. Balance in 5 monthly payments of 5/6. A permanent-magnet moving-coil unit designed specially for "Class B" and Q.P.P. output. Equally efficient with ordinary Power or Pentode outputs. Extremely sensitive. Perfect quality. (Cash or C.O.D., Carriage Paid 25/-.) State whether for "Class B," Q.P.P., Power or Pentode. **5/2** only

**NEW BOLA F.5 (P.M.14) "CLASS B" MOVING-COIL SPEAKER.** With "Class B" input transformer. £1/12/6. Carriage Paid. Balance in 6 monthly payments of 5/2. **5/2** only

**ATLAS ELIMINATOR.** Type A.C.244. Send Three Tappings. S.G. Detector and Power Output 120 volts at 20 mA. Cash or C.O.D., £2/19/6. Carriage Paid. **5/6** only

Balance in 11 monthly payments of 5/6.

**IMPORTANT** Parts, Kits, Miscellaneous Components, Finished Receivers or Accessories for Cash, C.O.D. or H.P. on our own system of Easy Payments. Send us a list of your wants. We will quote you by return. C.O.D. orders value over 10/- sent carriage and post charges paid.

**PETO-SCOTT CO. LTD.** (Est. 1819) 77, CITY ROAD, LONDON, E.C.1 Telephone: Clerkenwell 94067. West End Showrooms: 62, High Holborn, London, W.C.2. Telephone: Holborn 3248.



THIS IS  
**Opportunity**  
INDEED

**DONT FAIL TO GRASP IT NOW**

Money-Saving **ECONOMY**  
FOR THIS YEAR'S  
**"ECONOMY 3"**

**THE SPECIFIED  
SLEKTUN  
H.F. CHOKE**  
an Essential for the Set  
**AT CLEARANCE PRICE**

Used and specified by the designer of the "Economy 3," this choke is a very superior job. Exceptionally high inductance is combined with low self-capacity. D.C. Resistance extremely low. List price is 4/-. Offered to readers of "Popular Wireless" at only 2/6.



**4/6**  
**2/6**  
Post Free

**SAVE MONEY**

The famous high-grade Slektun Components—brand new and bench-tested—are being sacrificed to clear our enormous stocks.



**SLEKTUN "SUPER" TRANSFORMERS**

The finest L.F. Transformer ever made. Specified in most leading sets. Patented process prevents short-circuited turns. Windings hermetically sealed and all paper interleaved.  
Ratios—2:1, 3:1, 4:1, 5:1.  
List price, 8/6. Offered at

**8/6**  
**5/6**



**SLEKTUN  
DUAL-RANGE  
SCREENED COILS**

These coils have a particularly low-loss construction and exceedingly wide range—185 to 2,300 metres with a .0005 mfd. variable condenser.

**6/6**  
**4/6**

Aerial coil or H.F. with reaction. Both listed at 6/6 each.

A wonderful offer at only 4/6 each.



**OTHER SLEKTUN COMPONENTS**

at Clearance Prices!  
Slektun Short-Wave Chokes. Were 2/9 now 2/6.  
Super-Het. Chokes. Were 5/- now 3/6.  
General Purpose L.F. Chokes. Were 7/6 now 4/6.  
"Colt" L.F. Transformers, 2:1, 3:1, 4:1, 5:1. Were 4/9 now 2/6.  
Slektun Balanced Armature Loud-speaker Units. Were 8/6, now 5/6.

Obtainable at these prices and post free only from  
**THE CABARET ELECTRIC CO. LTD.**

182, VAUXHALL BRIDGE RD., WESTMINSTER, S.W.1.  
Telephone: Victoria 5022.



THE JULY NUMBER OF  
THE  
**WIRELESS  
CONSTRUCTOR**  
CONTAINS  
FULL DETAILS OF  
THE  
**DOUBLE-PENTODE  
THREE**

The First Tablegram to use  
an H.F. Pentode  
and

Details for making a unit that will give  
you the whole world on an ordinary  
broadcasting set—

**A SHORT-WAVE  
SUPERHET  
CONVERTER**

SPECIAL ARTICLES AND FEATURES ARE  
ALSO CONTRIBUTED BY

**JOHN  
SCOTT-TAGGART,**  
A.M.I.E.E., F.Inst.P.,

and include

What is Electricity?  
Questions I am Asked.  
From My Armchair.

IN THE JULY

**WIRELESS CONSTRUCTOR**

ON SALE EVERYWHERE

PRICE 6d.



# RECOMMENDED WRINKLES



## SPEAKERS IN SERIES.

MANY listeners nowadays use two loudspeakers, one in each room, wired in series, either speaker being switched on or off at will by connecting an ordinary switch across each instrument to short-circuit the windings. It is, however, possible when using this arrangement to short-circuit both speakers at the same time, thus taking the load from the anode circuit of the output valve.

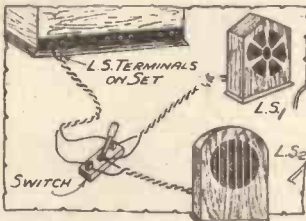

By using a single-pole change-over switch either or both speakers can be joined in circuit.

The valve manufacturers' instructions issued with pentode valves indicate that this must not occur, and it may be rendered impossible for it to do so by switching the speakers with a single-pole, double-throw switch. The switch may be mounted on the panel or on either loudspeaker, and it is wired as shown in the diagram. Either speaker is available by placing the switch-lever in the appropriate position, while with it in the middle position ("off") both speakers are in use.

## SAFETY-PIN SWITCH.

A HANDY and useful switch can be made from two safety-pins. Cut the head off one pin and the pin off the other. Now arrange them, and secure to a board with small staples,

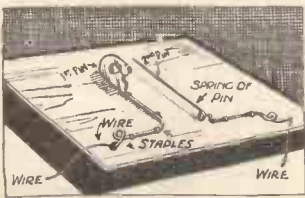

The cheapest switch possible.

as shown in sketch, and then solder wire on to them for connecting up. All that is necessary to make the circuit is to press the point of the safety-pin under the head of the other.

## ADJUSTABLE COUPLING.

TO users of sets employing the "Moderator," the following may prove very handy in finding the best coupling for the coil, and enables changes to be easily made.

The adjusting piece from an old pair of ear-phones is brought into use and bent with pliers, as shown in sketch. If a short bolt is slipped through the

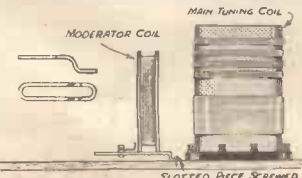

A simple method of finding the best coupling position.

slot of the metal and then through the foot provided on the "Moderator" coil and held by the top of a terminal, the coil can readily be moved along the slot to the best position for any reception conditions.

## POLARITY INDICATOR.

TAKE a glass tube, about 1/2 in. in diameter and about 2 1/2 in. long. It is filled with a mixture of salt and water and stopped at both ends by corks, preferably of rubber.

Through the centres of both corks are passed two pieces of 16 or 18 gauge wire, the ends being taken to two terminals on a small baseboard.

When a D.C. potential is applied to the indicator, the negative pole will be indicated by bubbling.

## A "WET" RECTIFIER.

PERHAPS it is not generally known that an efficient and cheap rectifier is within the means of even the most financially depressed. If a strip of aluminium and lead are put into a strong solution of bicarbonate of soda, and an A.C. current is passed through the cell, then a rectified current will result, with the aluminium as the +. Two or three such cells connected in series, produce an even more rectified current. This fact may be utilised for

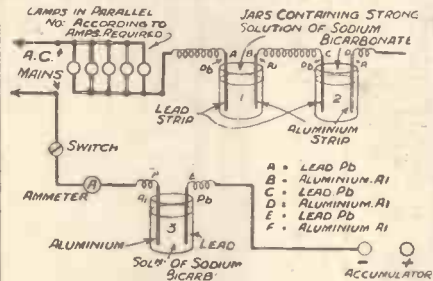

A cheap rectifier that is very satisfactory for accumulator charging.

the charging of small accumulators, as my sketch shows.

In calculating the amperage (required for your accumulator) divide the total wattage of the lamps in parallel by the voltage of your A.C. mains. This figure is the number of amperes passing through the circuit. This is, of course, checked by the ammeter.

After considerable use of the rectifier renew the solution. If a heavy current is passed through the rectifier, the temperature of the solution may reach boiling point, so that a cooling device (such as an outer jar containing cold water) is advisable.

## AN ANTI-RUST TIP.

EVEN if they are placed in a tin box, steel tools have a way of going rusty, unless they are kept thoroughly greased.

The problem of furnishing a dry container for your tools can be solved in the following way:

Cut out a sheet of perforated zinc that will just fit inside a fifty-size cigarette tin. Screw this down by means of small screws to two 1/2-in. battens whose length is equal to the inside width of the tin. This zinc grid fits into the bottom of the tin and underneath it is placed a small quantity of common tea leaves, previously

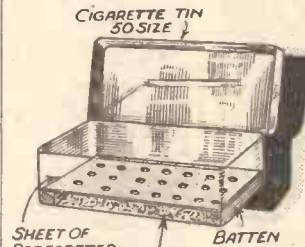

A simple dodge to prevent your small tools rusting.

thoroughly dried by baking in the oven. Tea, being a very hygroscopic substance, absorbs all the moisture from the air in the tin, thus preventing tools, placed above the zinc grid, from rusting. If the workshop is very damp the tin should be placed periodically in the oven (with the tools removed) to dry out the tea.

## EMERGENCY CONTROL KNOB.

IT sometimes happens that a control breaks at a time when no spare is available. A useful expedient is an ordinary cotton reel; this, of course, is usually available. The thread should first be removed when a suitable size has been found. The reels are made of hardwood and the

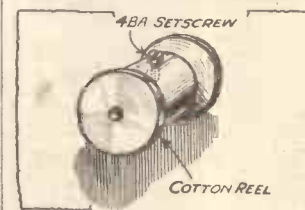

Using a cotton reel as a control knob.

centre hole is not far off the standard 1/4 in., but if too large it is an easy matter to adjust to size by inserting metal or card packing.

To secure knob, a hole should be

drilled in the appropriate position, making it a little smaller than a 4 B.A. screw. This is inserted in the hole and will soon cut a thread in the hardwood, thus acting as a set screw.

A knob of this simple type works very well for reaction; it would also operate a variable condenser in case the slow-motion dial gets damaged or ceases to function.

## FLASHLAMP FUSE.

AT some time or other many wireless enthusiasts will burn out valves which may be saved by fitting a fuse in the H.T. negative lead; special fuse lamps are somewhat expensive, while fitting an ordinary flashlamp bulb is not safe, but by a simple process a reliable fuse may be made which will burn out at about 50 milliamperes. Take a 2.5 flashlamp bulb and puncture it by inserting a white-hot darning needle, either hold the needle in a pair of pliers or fit it into a handle and hold the point over a gas jet or stove, and the bulb in the other hand, and when the needle reaches white heat prod into lamp and withdraw it while still hot.

## BASEBOARD SCREENING.

MOST receivers to-day require screening, but it is often difficult to know what part to screen, and copper or aluminium foil is expensive to cut up for experimental work. An



easy way to avoid this is to use the foil from an old fixed condenser of about 1 mfd. This can be laid on in strips on the baseboard or on the panel, or it can be pasted on cardboard and it is quite effective in practice.

## REMOVING INSULATION.

A SIMPLE gadget for removing the insulation from almost any size of wire in a few seconds can be made from a piece of steel 4 in. long, 2 in. wide, and about 1/2 in. thick. At one end drill a few holes to take the fixing

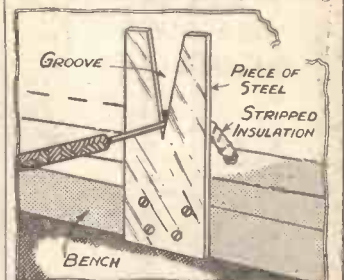

The gadget is screwed to the bench. screws, then cut a V-shaped groove with a hacksaw at the other end. The inside edges of the V groove must now be filed sharp to provide the cutting edges of the tool. This done, the wire to be stripped is simply inserted in the V as shown and given a sharp pull.

## ONE GUINEA FOR THE BEST WRINKLE!

Readers are invited to send a short description, with sketch, of any original and practical radio idea. Each week £1 ls. will be paid for the best Wrinkle from a reader, and others will be paid for at our usual rates.

Each hint must be on a separate sheet of paper, written on one side of the page only. Address your hints to the Technical Editor, "Popular Wireless," Tallis House, Tallis Street, E.C.4, marking the envelope "Recommended Wrinkles."

Will readers please note that the Editor cannot, in any circumstances, guarantee to return rejected Wrinkles, and that payment for published hints is not made until ten days after they appear.

The best Wrinkle last week was sent by T. M. Eaton, 10, Eecmead Avenue, Keaton, Harrow, to whom a guinea is being awarded.



FROM THE TECHNICAL EDITOR'S NOTE BOOK

# TESTED AND FOUND?

## TONE CONTROL

IN the average radio receiving outfit there are so many untamed and even uncontrolled factors, that the reproduction is a rather uncertain quantity. I am not going to enlarge on that statement; it is a definite and incontrovertible fact.



This is the Bulgín "Controlatone."

And in view of that, one cannot but admit that tone control is of great value. Quite apart from its practical application, there is no doubt that its presence pleases many listeners; they can adjust the quality to what they think it should be, and it is then so obviously right that they have achieved perfection!

In any case, it frequently happens that a large degree of tone control is definitely essential, such as when a high-pitched pick-up and a pentode coincide. (What a combination!)

And that is where a Bulgín "Controlatone" would be extremely useful. The "Controlatone" is a straightforward condenser-variable-resistance type of control very neatly compacted into the one easy-to-mount unit.

It is available in two types, "A" for use with triodes and "B" for pentodes (the retail price for either is 5/-).

Apart from pentode and speaker peak correction, the "Controlatone" is able to eliminate heterodyne whistles and record scratch.

## SLOW-MOTION TUNING

It is a common misconception that a good slow-motion dial will add to the selectivity of a set. Actually, it plays no part in the functional or, shall I say, circuit processes of the receiver.

On the other hand, it can certainly indirectly affect the performance. If it is an efficient dial it will enable even the inexpert listener to tune so closely that the practical expert would find it extremely difficult, if not impossible, to duplicate the results with a plain dial.

But a faulty slow-motion dial can be most annoying and play havoc with one's station-finding activities. I can write feelingly because one of the dials on my own household set has developed bad slip. The scale moves in "fits and starts."

Fortunately, the makers have produced improved models and, when I get the time, I shall replace the faulty specimen for one of these.

Slip is not the only fault encountered in slow-motion dials. There is also backlash, which is a looseness in the coupling between the main spindle and the control knob.

However, neither of the above blemishes figures in the Magnum slow-motion dial, the movement of which is particularly sound and gives a smooth and non-slipping drive.

It is also a very easy device to install, and it can be mounted on the panel or screwed to the baseboard, or secured to the frame of a ganged condenser.

The frame is of steel, and the whole assembly is rigid. The stout bush on which the scale is mounted accommodates condenser spindles of 1/4-inch diameter.

A pilot light is conveniently mounted above the handsome brass (oxidised copper finish) escutcheon. The dial can be supplied with a 0-100 scale, and with a scale marked in wavelengths to suit Magnum canned coils.

I have only one criticism to make, and that is that the indicators are rather too far from the scale.

There is a space of nearly a quarter of an inch. A variation in the reading of about six degrees occurs as the dial is inspected at different angles.

Apart from that, the Magnum slow-motion dial is a fine component, and good value for money at its retail price of 3s.

## INSULATED WIRING

The growing popularity of chassis types of sets and the use of screening (the *lavish* use of screening, I might almost say, in view of the infiltration of the canning industry into the radio component-making trade!) in modern sets, makes it necessary for the constructor to pay greater attention to wiring.

One of the days when the same 22 or 24-gauge cotton-covered wire which was employed for home-made coils could be used for wiring up the set.

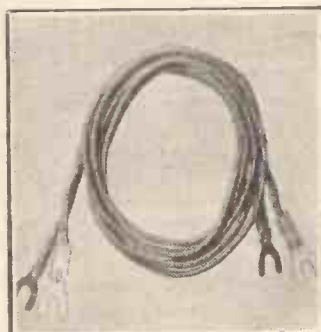

These are the handy length leads supplied with the "Dix-Mipanta."

Either a very well-insulated wire or bare wire plus "spag-hetti" is almost invariably essential.

To meet this demand, Brasse, Ltd., are making "Securite" connecting wire and "Secura" varnished insulating sleeving.

The former is a tinned copper conductor, first cotton-covered and then sheathed with a glazed and coloured covering of a tough nature having good insulating qualities. It is pliable, too, and when, on sharp bends, cracks appear these are due to a movement of the material, which is laid on spirally.

Incidentally, "Securite" strips easily, a feature all constructors will appreciate.

Usually, it is only the single-cotton-covered conductors which are easy to handle, and one is rather apt to regard it as inevitable that difficult stripping should accompany efficient insulation.

The "Secura" sleeving is equally well made, and is a closely-woven fabric tubing carrying a resilient varnishing in various colours. We can recommend this material to our constructors.

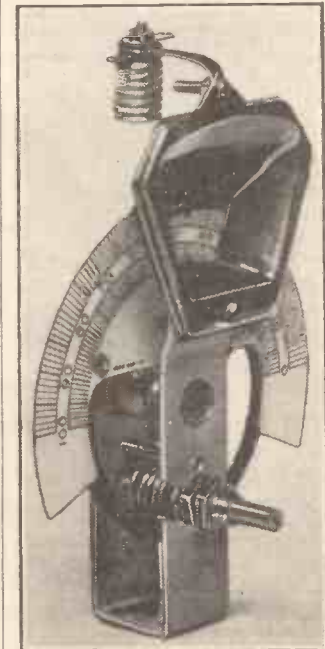

The Magnum slow-motion dial.

## AN EXCELLENT TESTER

The "Dix-Mipanta" (Electradix Radios) really is a vest-pocket meter. It measures only 2 1/4 x 2 1/4 x 1 1/2 in., and there are no projecting knobs or terminals.

But despite its compactness, it has a wide, open scale allowing adequately close readings to be obtained.

This instrument has been designed for service men and others desiring to check both A.C. and D.C. voltages.

It has the following ranges 0 to 7.5 volts (this range corresponds with a low resistance coil, 100 ohms, and enables milliamperes to be read direct on the lower scale), 0 to 150 volts and 300 volts. The current taken on these higher ranges is approximately 12 milliamperes at full scale.

The "Dix-Mipanta" is, of course, a moving-iron instrument, and is one of the most attractive devices of its kind I have ever had come my way.

Although it costs only 19s. 6d., complete with a pair of test leads and plugs, it fulfills its purposes every bit as well as a whole team of separate and more expensive meters.

It should prove a most popular instrument.



The "Dix-Mipanta" Universal vest-pocket tester.

## CONNECTING A LIGHTNING SWITCH

Details of the correct wiring for a single-pole change-over switch.

EVERY outdoor aerial should be equipped with an efficient earthing switch, or some form of lightning protector.

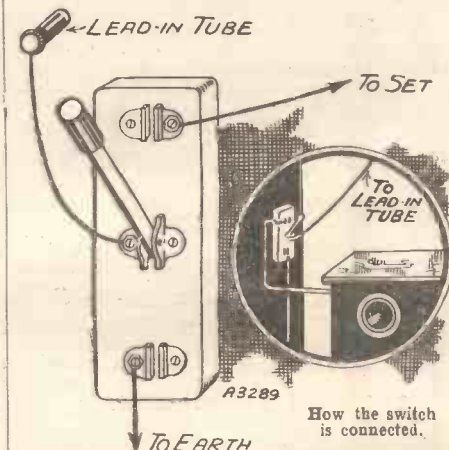

This remark applies particularly in the summer months, when atmospheric disturbances are at their worst.

A switch of this type is not so much necessary for protection against direct strikes, which luckily are almost unknown, but more as a safeguard against static charges accumulating on the aerial and small surges induced by a nearby storm.

The control should be connected in a similar manner to that shown in the drawing, close to the lead-in and well away from curtains, etc. If possible it is better to mount it outside the window, although this precaution is not really essential.



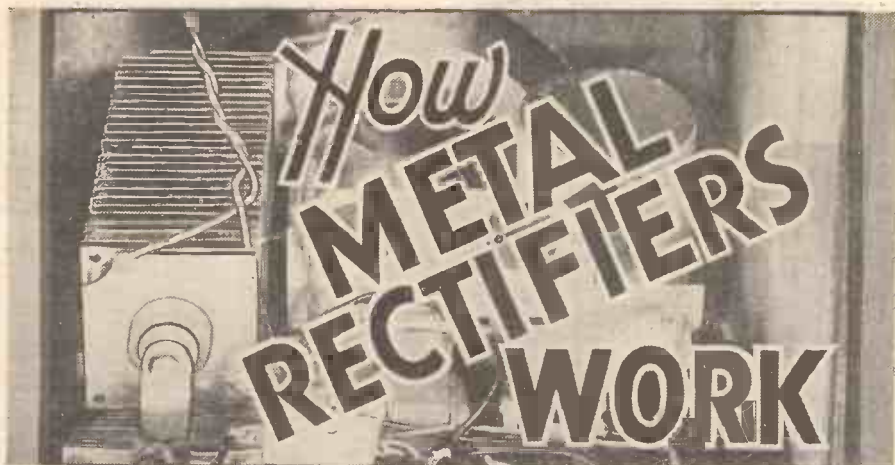

**R**ECTIFICATION is the technical term given to the process of connecting alternating current electricity so that it can be used on apparatus requiring direct current electricity. Alternating current is not continuous in one direction, but alternates, the voltage of one terminal continually changing from positive, through zero to negative, back to zero, and then positive again.

**Converting to D.C.**

On 50-cycle supply mains this would take place 50 times per second. This kind of electricity, continually changing its polarity, by being first negative and then positive is of no use to the plate of our valve, or for battery charging. Fig. 1A shows a typical curve of an alternating current.

Rectifiers are employed to make this alternating current flow in the same direction all the time—in other words, to make it direct current—the kind required for H.T. supply for our radio set.

**METHOD OF CONSTRUCTION**

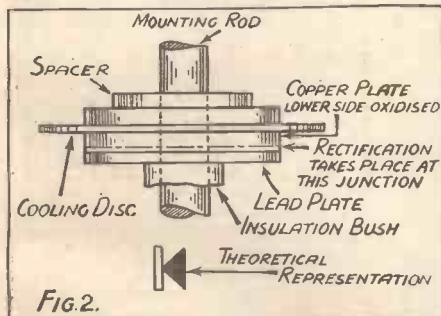

Fig. 2. The assembly of a "single" metal rectifier. Usually a number of plates are connected in series.

Fig. 1D shows a typical "curve" of a direct current.

Apart from the metal rectifier, other types used are the thermionic valve rectifier, the electrolytic rectifier and the gas discharge rectifier. The metal rectifier is very much suited for radio work and has the following good points to recommend it.

There are no valves to break or burn out, no electrolytes, no moving parts and it requires no maintenance. It is compact,

Metal rectification is a simple and convenient method of converting A.C. to D.C. for radio sets. The principles upon which these rectifiers work are ably and interestingly dealt with by our contributor, L. A. HODGES, Graduate I.E.E.

has only a small temperature rise and internal connections are brought out to external terminals so that it can be readily connected in a circuit. It has a long life, is highly efficient and economical to run.

The metal rectifier is a copper-oxide rectifier, the latter term suggests chemical action, but actually no chemical action takes place in metal rectification—the action is electronic at a permanent junction between the copper and copper oxide.

Research has shown that the oxide layer consists of cuprous oxide near the copper and cupric oxide near the surface. Cuprous oxide falls in the class of semi-insulator and cupric oxide in the class of semi-conductor, so that if we have a plate of (say) lead pressed into contact with the oxide, we have the equivalent of a leaky condenser with a "graded" dielectric, whose plates are the lead plate and the copper base.

**Basic Principles.**

The rectifying action results from the distribution of dielectric forces being sufficient to attract electrons across one of the oxide boundaries when the lead is positive with respect to the copper, but not when the potential difference is reversed. The plate of copper with oxidised

**A HALF-WAVE CIRCUIT**

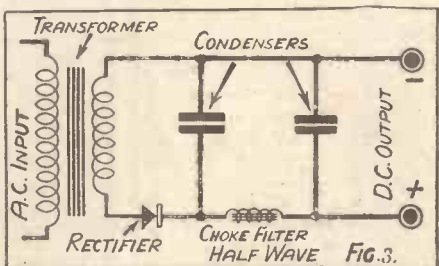

Fig. 3. Simplicity of connections is a feature of the metal rectifier, especially in a half-wave circuit.

surface in contact with the lead has a much lower resistance when the current is passed from the lead to the copper than when the current flows in the opposite direction. This ratio of resistances is the basis of the metal rectifier.

A single unit is shown in Fig. 2, along

with the theoretical representation. The practical rectifier consists of a number of units assembled under pressure in series or parallel, in such a way as to meet the various voltage and current capacities required.

For radio application either half-wave or full-wave rectification can be employed. Half-wave rectification allows the current to flow in one direction only, and prevents its flow when it attempts to flow in the opposite direction.

**Typical Arrangements.**

Full-wave rectification (the better to use) makes use of both directions of flow, converting both alternations into a flow in one direction only.

Comparisons for the rectification that takes place for 2 cycles are shown in Fig. 1 B. and C. The half-wave rectifier has the advantage of simplicity and cheapness,

**BEFORE AND AFTER**

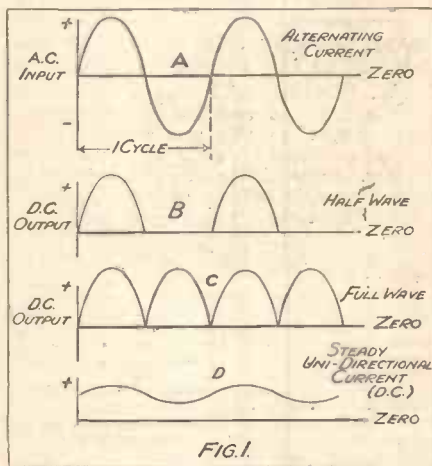

Fig. 1. This diagram shows A.C. wave-form before rectification (A), after half-wave and full-wave rectification (B and C), and after smoothing (D).

and is used in small H.T. metal rectifiers and grid-bias rectifiers.

Fig. 3 shows a typical half-wave circuit and Fig. 4 a full-wave circuit, "bridge connected." Other full-wave rectifier methods are "the voltage doubler" circuit and "the centre tap" circuit, all of which have advantages over the half-wave rectifier.

In conclusion the reader will observe how well the metal rectifier can be applied for radio, this application of the metal rectifier being only one of numerous uses it can be put to when an alternating current has to be converted to a direct current.

**AN ALTERNATIVE SCHEME**

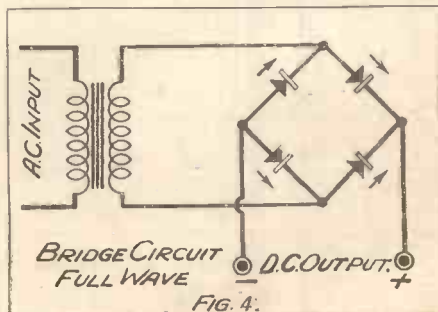

Fig. 4. Full-wave rectification is obtainable in this way without a centre-tap on the transformer. The four rectifiers are built as one component.



# RADIOTORIAL

The Editor will be pleased to consider articles and photographs dealing with all radio subjects, but cannot accept responsibility for manuscripts or photos.



Every care will be taken to return MSS. not accepted for publication. A stamped and addressed envelope must be sent with every article.

All Editorial communications should be addressed to the Editor, POPULAR WIRELESS, Tallis House, Tallis Street, London, E.C.4.

All inquiries concerning advertising rates, etc., to be addressed to the Sole Agents, Messrs. John H. Lile, Ltd., 4, Ludgate Circus, London, E.C.4.  
The constructional articles which appear from time to time in this journal are the outcome of research and experimental work carried out with a view to improving the technique of wireless reception. As much of the information given in the columns of this paper concerns the most recent developments in the radio world, some of the arrangements and specialties described may be the subjects of Letters Patent, and the amateur and the trader would be well advised to obtain permission of the patentees to use the patents before doing so.

## QUESTIONS AND ANSWERS

### DISAPPOINTING INCREASE IN AMPLIFICATION WITH PARALLEL-FEED.

R. W. (Newport).—"I was very pleased with the results of parallel-feed for my L.F. transformer, when this was arranged with entirely separated primary and secondary windings. But with the idea of getting some increase in amplification I converted to auto-feed, by joining both secondary and primary to the coupling condenser.

"But now amplification seems definitely less than before, instead of greater. Why is this?"

Probably you have connected the primary and secondary windings in opposition, instead of to aid one another.

Try reversing the secondary connections, leaving everything else as it stands, and you will probably get the desired increase.

### ADDING A STAGE OF "CLASS B" AMPLIFICATION.

S. L. H. (Retford).—"Can I use a Ferranti OPM 12c Q.P.P. output transformer in conjunction with my loudspeaker when the output valve is a 'Class B'?"

"(The loudspeaker has no filter choke, but is direct in the power valve's plate circuit.)

"If so, please give connections to add this transformer to a 'Class B' valve holder (7-pin type), and the wiring for 'Class B' transformer, so that I can work this latter straight off my S.G., Detector, L.F. set, using the small power valve (at present acting as the output valve) as the driver for the last stage."

The Q.P.P. output transformer is quite suitable, and all you will need in addition is the "Class B" valve and special valve holder, the "Class B" transformer, some wire and a small baseboard on which to mount these components.

Place the valve holder centrally between the transformers, and arrange these latter with the H.T.+ and P. terminals outwards in the one case, and the variable ratio terminals outwards in the other.

Then wire as follows: P. on the "Class B" transformer to the set's -L.S. terminal, (the one that goes to the power valve's anode). H.T.+ terminal on the "Class B" transformer to the L.S.+ terminal on set and also to the H.T.+ terminal on the Q.P.P. transformer.

E. terminal on the "Class B" transformer to No. 4 terminal on the valve holder, and to the L.T.- terminal on set by means of a flex lead. Another flex lead goes from the L.T.+ terminal on set to the No. 5 terminal on the valve holder.

One of the G terminals on the "Class B" transformer to the No. 1 terminal on the valve holder. Its No. 2 terminal to the other G terminal on the "Class B" transformer.

The No. 3 terminal on the valve holder goes to one "plate" terminal on the Q.P.P. transformer. Its other "plate" terminal goes to the No. 7 terminal on the valve holder.

Leave the No. 6 terminal on the valve holder without any wiring.

All that remains to do then is to connect the loudspeaker to the output terminals of the Q.P.P. transformer instead of to the set itself, as before. It should be joined to the two terminals which are marked 1:7:1.

We assume by the way, that your set is using 120 volts H.T., since that is a good figure at which to work the "Class B" valve. If so its bias will need no readjustment when the output valve is made to work as the "driver" by means of the above-described wiring.

### THE "AIRSPRITE" TWO AND AN A.T.B. ADAPTATION.

W. R. C. (Throwley, Faversham, Kent).—"I had to write you re the 'Airsprite' Two. I have been a regular constructor and reader of 'P.W.' for a number of years, but, honestly, for a cheap, efficient two, you cannot beat the above.

"Practically all of the components I used in building came from 'junk box,' and the

## HOW IS YOUR SET GOING NOW?

Perhaps your switching doesn't work properly? Or some mysterious noise has appeared and is spoiling your radio reception? Or one of the batteries seems to run down much faster than formerly?

Whatever your radio problem may be, remember that the Technical Queries Department is thoroughly equipped to assist our readers, and offers its unrivalled service. Full details, including scales of charges, can be obtained direct from the Technical Queries Dept., POPULAR WIRELESS, The Fleetway House, Farringdon Street, London, E.C.4.

A postcard will do. On receipt of this an Application Form will be sent to you post free immediately. This application will place you under no obligation whatever, but, having the form, you will know exactly what information we require to have before us in order to solve your problems.

**LONDON READERS, PLEASE NOTE:** Inquiries should NOT be made by phone or in person at Fleetway House or Tallis House.

results obtained are amazing, very selective, good quality and volume, and above all, I have not found very much overlap, that alone is a very big item, considering the selectivity of the set.

"I adhered to the special transformer quoted for this set, and altered a reaction condenser for 'A.T.B.' I must admit A.T.B. has opened my eyes, it's a simple and most efficient invention.

"Now a few words of praise for an old-timer (I haven't heard or seen many reports), viz., the 'Eckersley' Three.

## "P.W." PANELS. No. 126. LANGENBERG, GERMANY.

Using a power of 60 kilowatts, on a wavelength of 473 metres, Langenberg is one of the best-received German regional stations.

Its programmes are those of Cologne, and the station is operated by "Westdeutscher Rundfunk." It works at intervals all day, from (about) 7 a.m.

The distance from London is about 311 miles.

"I built this set when first described in 'P.W.' At first I encountered slight trouble with 'spaghettis,' but after changing over to 'Ohmite' resistances my troubles ended, and this set still puts a good many straight threes in the shade, but as I said previously, A.T.B. has opened my eyes, and should very much like to fit A.T.B. to this old pal.

"Can this be done with improved results? My transformer is a 'R.I. Dux,' and the reaction condenser Lissen air dielectric, which is easily adapted."

There is no reason why you should not get some, if not all the benefits of A.T.B., by comparatively slight alterations to the old set. Try the following scheme, in which we give the new arrangement of detector's plate circuit, etc., as far as necessary.

You will, of course, need one of the special self-shortening differential reaction condensers; and the terminal on the set of fixed vanes that will not be affected by the shorting strip is the one for the lead from the coil's reaction winding.

The other "fixed plates" terminal on the reaction condenser—that is to say, the side which the shorting strip does come into play when the moving vanes are "all in"—will be joined to earth, L.T., etc. And this arrangement gives the necessary flexibility of reaction control for automatic tone balance.

For it will be evident that when the moving vanes are turned so that they come opposite to the non-shortening fixed vanes of the differential, full reaction effects will be obtainable.

If the moving vanes are then turned halfway round the reaction effect will be correspondingly reduced, and half the possible feed-back will be side-tracked across the earthed fixed vanes route. Whilst if the moving vanes are brought still further round in the same direction there will be no capacity route via the reaction winding because the moving plates will have completely disengaged from that set of fixed plates and will be facing the earthed fixed plates, instead.

Finally, at the very limit of the moving vanes travel (in the same direction) they will contact with the shorting strip, and thus short the differential condenser out of action altogether. This corresponds to the method in which the reaction balance was obtained in the "Airsprite" designs.

The moving vanes of the differential reaction condenser must be connected to one side of a .01-mfd. fixed condenser. The other side of this fixed condenser goes to the plate of the detector and to one side of the H.F. choke to which that point is already connected. The other side of this H.F. choke (and the resistance) go to one side of the coupling condenser, the other side of which goes to the 5 meg. volume control resistance.

In the plate circuit of this valve is joined the primary winding of the compensating L.F. transformer (usual connections), and this completes the arrangements for Automatic Tone Balance with this particular type of set.

### EFFECT OF ALTERING THE VALUE OF THE DECOUPLING RESISTANCE.

J. F. (Chester).—"I seem to have struck a bit of a bad patch, first with a nasty crackle, which for a long time spoilt reception, and which did not disappear until I put in a new decoupling resistance. This stopped the crackle, certainly, but I now get reaction only at the 'full-out' end of the dial, and results seem weaker all round.

"Might this be wrong value of decoupling resistance, as I do not know what number of ohms it is?"

Yes. It is almost certain that you have too high a resistance in use. We expect that the provision of a new resistance of the correct value, as before, will completely cure the trouble.

### "POLSKIE RADIO."

C. L. (Belfast).—"I wired up for parallel-feed as you suggested, and the improvement in quality is amazing, so there is no doubt the distortion was due to saturation of the transformer, as you suspected.

"I now get the foreign stations very clearly, and there is one I should like you to identify

(Continued on next page.)



## RADIOTORIAL QUESTIONS AND ANSWERS

(Continued from previous page.)

if you can. I get it when set for Athlone, or just a fraction below his wavelength.

"The announcement, so far as I can catch it sounds like 'Bolshie Rah-deo,' and although I suppose it cannot be that, the language is like I should expect Russian to be. It fades a good deal, and is often not there at all. But after Athlone is quiet it sometimes comes through at very nearly the same strength.

"There are both man and woman announcers. Can you tell me who it is likely to be that I hear on this wavelength adjustment?"

We have no doubt that what you took to be "Bolshie Rah-deo" was really the words "Polskie Radio," a term used by all the Polish stations to denote the country of origin.

The Polish station on the wavelength just below that of Athlone is Katowice—the actual wavelength being 408 metres, as compared with the 413 metres of Athlone.

The announcer—or, rather, the senior announcer—at this station runs a feature called "The Letter Box," in which he replies to listeners abroad who write to him, reading out their names and addresses which are often English.

He uses the French language for this purpose, and is easily recognisable by his deep voice and pleasant chuckles, for he apparently greatly enjoys his mail! He is generally in great form on Friday nights, from eleven p.m. onwards.

### X-RAYED

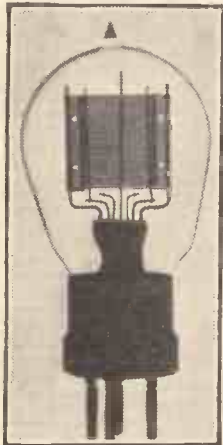

An interesting and unusual photograph of an early valve as seen by X-ray apparatus.

The actual name Katowice is pronounced in Polish as "Kattoveccha." Other Polish station-names can often be heard, as the station does a fair amount of relaying. It generally gives the "Good-night" in French ("Bon soir") as well as in Polish ("Dobrei Nocy.")

### "CENTRE TAPPING" BY A RESISTANCE.

C. R. N. (Bournemouth).—"I have a fancy to try 'Class B' and Q.P.P. amplification with ordinary valves, on the lines of the 'Q.P.B.' set you described last April (22nd). But I also want to use ordinary transformers instead of the special types, if possible, even if results are not quite so good on that account.

"What I thought was to try the stunt which I got from 'P.W.' last winter, obtaining a centre tap on the transformer by connecting a resistance across its winding and taking a centre tap on this instead of on the winding itself.

"If you think it would work, what values do I need for the transformer and for the choke in the output?"

It certainly would not work with "Class B." You must have the correct apparatus for Q.P.P. and "Class B," and there is no chance of getting anything worth listening to by the method you suggest.

### PREVENTING HAND CAPACITY ON THE SHORT WAVES.

F. T. (Salisbury, Wilts.).—"I have been tempted by the short waves before, but all my attempts have been foiled by the same cause—hand capacity. One of my pals wants me to help him in building (and buying!) a really good two-valver, and his idea about curing hand capacity troubles is to use a choke output filter, as for a loudspeaker circuit, although the set will generally be worked on 'phones. Does this sound a hopeful way to you?"

"I am asking not merely to save-myself trouble and disappointment, but also because I feel that if I try again on the short waves, and get fed up once more on account of hand capacity, bang goes the making of a short-wave fan! I don't think I could go to all the lengths of excitement and hope only to end in the same old blind alley once more.

"His other ideas sound pretty good to me (such as lining under the baseboard and behind the panel with copper foil, earthed, and also a really good earth connection direct by a short lead), so I confess I am itching to try if there is a good chance of success. Please say if you think this choke circuit is a good idea."

We have no hesitation in saying it is an excellent method of preventing hand capacity, and in conjunction with the earthing arrangements should result in a set that is completely free from the very annoying effect which has hitherto spoil your short-wave enjoyment.

In the majority of instances a good choke filter arrangement is in itself quite sufficient to ensure success, but should the old complaint crop up again, you can always get advice upon how to deal with any such unusual case by detailing the symptoms to the Technical Query Department.

There are numbers of possible "shots in the locker" (chokes in the 'phone leads, for instance, or extra by-pass condensers), but which particular one of these should be tried can be decided only by consideration of the details of the set in question, after it has been decided what is likely to be the cause of the failure of the usual cures and preventatives.

### INCREASED H.T. IMPROVES THE QUALITY.

G. L. (Birkenhead).—"I always thought that higher high tension would be likely to cause bad quality to get worse. But to my surprise I find that an objectionable 'jar' on my set on certain notes has quite disappeared with extra H.T. voltage. Is that very unusual?"

Apparently your bad quality was due to an incorrect H.T. voltage, which has now been remedied, and there is certainly nothing unusual in correct H.T. improving the quality. In fact, it is axiomatic that you cannot possibly get satisfactory quality with insufficient H.T., which is apparently what you had been trying to do.

### MIRROR OF THE B.B.C.

(Continued from page 474.)

transmissions of several stations, were a popular feature of the wireless fare in the days of crystal sets and when comparatively few receivers were capable of reaching out as the most modest valve set can do at the present time.

This being so, one would have thought that "Round the Stations" was a thing of the past. But not so Mr. T. P. Maley, whose production is to be given in the Glasgow studio on Saturday, July 15th.

The programme is really a series of humorous sketches, each of which takes place in some kind of a station—an Aberdeen filling station, a Clapham tube station, a Belfast fire-station, and a Pollokshields police-station, among others.

### Petersen v. Cook.

Thousands of people will be sitting up late on Monday, June 26th, to hear the eyewitness account by Mr. Emlyn Michael of the fight between Jack Petersen and George Cook, which takes place that night at Cardiff. The result is expected at about 11 p.m., and, according to the prophets, it should be a good contest.

Petersen is, of course, the heavyweight champion of Great Britain; while Cook was heavyweight champion of Australia, although he has not defended his title, since most of his recent bouts have taken place in England.

GRAHAM FARISH LTD., MASONS HILL, BROMLEY, KENT.

## Easy Terms

### AMAZING BARGAIN

#### Q.P.P. KIT formerly 79/6

4-Valve S.G. Q.P.P. Kit "A" less Valves and Cabinet. Complete with all components. Send 3d. in stamps for Full-size Constructional Chart.

**NOW 59/6**  
Or 12 monthly payments of 5/6

#### CLASS "B" CONVERSION KIT

Converts your present Battery Set to "Class B" With Amplification. Complete with all necessary components, including "Class B" Valve, wire and screws, etc. Full-size Blue Print. Assembly Instructions and Diagrams. Cash or C.O.D. 37/6. Balance in 7 monthly payments of 5/6.

REGENTONE W.I.F. H.T. ELIMINATOR. Cash or C.O.D. £2/7/6.	Send 4/4
Balance in 11 monthly payments of 4/4.	Only
BLUE SPOT UNIT AND CHASSIS. Type 99P.M. Including matched transformer. Cash Price, £2/19/6. Carriage Paid.	With 5/6
Balance in 11 monthly payments of 5/6.	order
BLUE SPOT PERMANENT MAGNET MOVING COIL SPEAKER. 29P.M. With input transformer. Cash or C.O.D. £1/12/6. Carriage Paid.	With 5/2
Balance in 6 monthly payments of 5/2.	order
NEW ROLA FS. (P.M.14) "CLASS B" MOVING COIL SPEAKER. With "Class B" input transformer. £1/12/6. Carriage Paid.	With 5/2
Balance in 6 monthly payments of 5/2.	order
ATLAS ELIMINATOR. Type A.O.244. Three tappings. S.G., Detector and Power Output: 120 volts at 20 m/A. Cash or C.O.D. £2/19/6. Carriage Paid.	With 5/6
Balance in 11 monthly payments of 5/6.	order

Send detailed list of your requirements for our lowest quotations by return.

Any Components including "CLASS B" Parts for all "P.W." Kits Cash, C.O.D. or H.P. Orders over 10/- sent post paid.

**To NEW TIMES SALES CO. 56 Ludgate Hill, London, E.C.4.**

Please send me .....  
for which I enclose £  s.  d. Cash/Deposit  
Name.....  
Address.....  
P.W. 24/6/33



## LEAGUE OF NATIONS CALLING

(Continued from page 476.)

used. There are four separate M.F. wavelength controllers, operating on a comparatively long wavelength, and harmonics are selected by a bank of valves.

There are switches which pick out any wavelength from 14 metres upwards, so that by simply setting the keys the station operator can broadcast on practically any short wavelength he wants.

The water-cooled valves are in a big box like a picture frame, around which all the meters are mounted.

The next panel on the right has some large glass valves. I could not say that the heat is terrific, but it is certainly noticeable. It is surprising that the glass does not melt, but I was told that it is a special kind of silica glass.

At many other broadcasting stations where there is crystal control, they take extraordinary care to keep the crystal always at a constant heat, so that the wavelength does not wobble. I asked how this trouble is prevented at Radio Nations

### Automatic Temperature Compensation.

They told me that the Marconi-Franklin master oscillators are automatically compensated for temperature changes which, in that part of the world, is important, as often the nights are cold after a very hot day and the transmitter would need constant readjustment to keep the wavelength right.

In another part of the hall is the short-

wave transmitter built by the French S.F.R. engineers, and as I had been told that either broadcaster could be used on the same aerial, I was curious to know how this was done.

All the short-wave aeriels are brought by two feeder lines to a commutator box where are ordinary change-over switches. In spite of the huge power of the British plant (it broadcasts on 20 kw. during the day), the aeriels can be changed over from one broadcaster to another as easily as you move your lightning safety switch!

### Many Large Generators.

Many short-wavers which are world-famous are really very small when you come to visit the station, but Radio Nations is an exception. There are big generators specially for the short-wave broadcasters.

H.T. comes from huge rotary generators which handle the 10,000-volt supply. There are little railings round each, for a meddlesome visitor would otherwise be electrocuted. In the same room there are direct-current machines driven by A.C. motors, giving the 30-volt supply for the large valves.

There are separate little machines on concrete slabs for nearly every valve panel, and my guide told me that the wiring took weeks of hard work.

Back in the offices of the League Secretariat, in Geneva, I was shown a map illustrating the countries which are in regular touch with Geneva through the Radio Nations broadcasts. Geneva recently sent a programme to America, and this was relayed over one of the huge station chains in the States.

## THE LINK BETWEEN

(Continued from page 474.)

back this week with the introduction of a new and remarkably efficient screened high-frequency pentode valve.

The advent of this new valve definitely puts paid to multi-H.F. stage sets, for with two of these valves in cascade it is possible to get a total amplification of 100,000 or more. Even allowing for loss of signal strength due to the use of highly selective circuit arrangements, the overall amplification is terrific, and I can well imagine that a pre-H.F. volume control will probably be necessary even on what are normally the weakest of stations.

To obtain the full benefits of this new valve it is naturally desirable to use it in circuits specially designed for the purpose. It is, however, possible to use it in any existing mains set in which ordinary screened-grid valves are used, and substitution can be effected without making any alteration to the circuit.

Mullard screened H.F. pentodes are the same price as ordinary screened-grid valves.

### Marconiphone "Magic" I

I make no secret of the fact that in my mental file of the worth-while things in radio the Marconiphone model "253" has always held a prominent position.

In any case, there is no need to make a secret of it now, for apparently my views are shared by thousands of others. The popularity of the set has been so great that increased production facilities have enabled the Marconiphone Company to reduce the price by five guineas.

At the new price of 11 guineas (A.C. or D.C.) it is a proposition which no one can afford to overlook. Personally, I think that this latest demonstration of Marconiphone "Magic" is even better than the show so named which was put on at Olympia last year.

### For the Constructor.

I have just seen at close quarters one of the natty little soldering outfits that are produced by Fluxite. The outfit consists of a special "small-space" soldering iron with non-heating metal handle, an efficient pocket blow-lamp, Fluxite, solder, etc. The price of 7s. 6d., which includes full instructions, is, I think, very moderate.

While it is true that for ordinary purposes soldered connections are not absolutely necessary these days, there are in the construction of a set a hundred and one ways in which a "spot" of solder can be helpful, and the difficulties of making an effective soldered joint are easily overcome with this outfit.

# THE PERFECT PAIR!

Make your set look like a professional job by fitting a Utility Straight Line Dial, the modern and commonsense tuning system. Fitted with a Utility '0005 Condenser, the

Straight Line Dial costs

9/6

Sold separately if desired. Write to us if your dealer cannot supply.

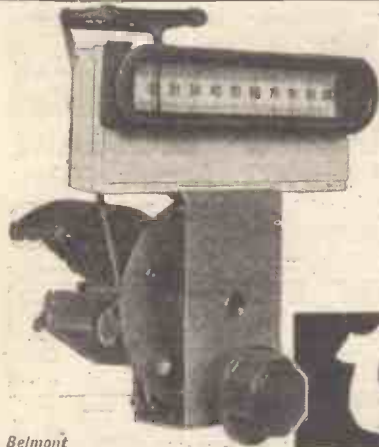

**WILKINS & WRIGHT**  
LIMITED,  
Utility Works, Holyhead Road,  
Birmingham.

London Agent: E. R. MORTON Ltd., 22 Bartlett's Buildings, Holborn Circus, E.C.4.

## NEW RADIO FOR OLD

Hundreds of new and second-hand Receivers of every description for immediate exchange. Scores of Genuine Bargains. We **BUY, SELL** and **EXCHANGE** any make of Radio. State your requirements, and post this Coupon for further information.

**LONDON PIANO & RADIO LTD., (Exchange Dept.),**  
3, Argyll Street, Oxford Circus, W.1.

My present set is a .....

and I require.....  
Please send me further particulars without obligation.

Name.....

Address.....

You'll recommend it to your friends

## OSBORN RADIO-GRAM CABINET FOR 70/-



**MODEL No. 234.** Beautiful Queen Anne style Radiogram cabinet, 3' 3" high x 2' 6" wide x 1' 6" deep. Takes panel 19" x 12", or smaller. Ample room for any type of gramophone motor, including Garrard Automatic Record Changer and largest H.T. and L.T. batteries made. Accommodation for 35 records each side of set, by omitting records storage cabinet, takes panel 27" long. Height between baseboard and motor-board, 12". **PRICES:** Machined Ready to Assemble, Kit of Parts: Oak, £3.10.0; Mahogany, £3.15.0; Walnut, £4.10.0; Assembled Ready to Polish: Oak, £4.10.0; Mahogany, £4.15.0; Walnut, £5.10.0. Assembled and Polished: Oak, £5.10.0; Mahogany, £6.5.0; Walnut, £7.5.0.

**OSBORN-SUPER ACOUSTIC BAFFLE-BOARD.**

Prevents 90% speaker worry. Any size hole cut.  
**FREE, 18" x 18" 3/-; 24" x 24" 5/-; 30" x 30" 8/-; 36" x 36" 11/3.** Carriage Paid U.K.

Send for Free Sample

**ALL MODELS CARRIAGE PAID**

**WRITE FOR FREE CATALOGUE.**

**CHAS. A. OSBORN (Dept. P.W.),** Regent Works, Arlington St., New North Rd., London, N.1. Tel.: Clerkenwell 5095. Showrooms: 21, Essex Rd., Islington, N.1. Tel.: Clerkenwell 5634.



# TECHNICAL NOTES

Some diverse and informative jottings about interesting aspects of radio technique.

By Dr. J. H. T. ROBERTS, F.Inst.P.

## Resistance Variations.

IN most types of resistance, whether rheostat or potentiometer, the resistance varies more or less uniformly over the resistance element. This, however, means that the current in the circuit in which the resistance is included will *not* vary uniformly, because it is obvious that the smaller the resistance, the greater the relative effect of the same amount of variation.

For instance, if you have a circuit the natural resistance of which is, say, 10 ohms, and you include 90 ohms resistance in series with it, then if you reduce the 90 ohms to 80 ohms, the total resistance of the circuit is reduced from 100 to 90; that is, by one-tenth.

If, however, you bring the resistance right down to 10 ohms, the total resistance of the circuit is 20; and if you now make a reduction of 10 ohms in the variable resistance, you will reduce the total resistance of the circuit from 20 to 10; that is, by 50 per cent. So you see that a change of 10 ohms at one end of the scale has a very different effect from an equal change at the other end of the scale.

## Logarithmic Grading.

There are some kinds of resistances and potentiometers, however, in which the resistance element is "graded," so that a given movement of the slider introduces different amounts of resistance-change at different parts, the net result being that—assuming it is a potentiometer used as a volume control—there is a reasonably uniform variation in the sound output from the set.

Some resistances in potentiometer controls are arranged with logarithmic windings, in order to get uniform variation. In the ordinary way, a "straight" resistance or potentiometer can be connected either way round, but it goes without saying that if the resistance element is "graded," it must be connected into the circuit the right way round, otherwise the effect will actually be worse than with a "straight" resistance.

## Electrolytes.

My remarks two or three weeks back about a special battery electrolyte which I came across in Paris have brought me a number of letters, and amongst them is one from Mr. T. Taylor, of 45, Fratton Road, Portsmouth, who says that he has had on the market for some time past an electrolyte which he calls "Radiumite," which has all the advantages I mentioned. In particular, he claims that sulphating troubles are minimised, and the efficiency and life of the cell are greatly increased.

## Radio Standards.

The Department of Scientific and Industrial Research tells me that the Wireless Division of the National Physical Laboratory and the Radio Research Station at Slough are to be combined into a new

Radio Department of the National Physical Laboratory, the superintendent being Mr. R. A. Watson Watt, who is well known for his researches in connection with the electrical conducting layers in the upper atmosphere.

The Wireless Division at the N.P.L. has, since it was formed in 1920, done a good deal of work on the development of radio-frequency standards, selectivity problems, aerial arrangements and the generation of very short waves, as well as methods for the measurement of fundamental quantities necessary in accurate circuit design. In future the National Physical Laboratory will assume direct responsibility for the maintenance of radio standards in exactly the same way as it is at present responsible for many other national standards.

The work of the Radio Research Station in the study of the passage of wireless waves over the ground, and of the effects

## COMING SHORTLY!

Full details of

# AN AMAZING RADIO DEVELOPMENT

WATCH "POPULAR WIRELESS"

Every Wednesday : : Threepence

of fading, has materially helped the B.B.C. in estimating the coverage of broadcasting stations, and in planning the present Regional Scheme.

## Sidebands.

Those of my readers who are interested in the theory of sidebands should look up an important paper read before the Institution of Electrical Engineers in April by Mr. A. H. Reeves, and entitled "The Single Sideband System Applied to Short-Wave Telephone Links." This paper contains a mass of information on this important subject, and relates particularly to the value of the single sideband method in reducing the operating costs of radio telephone links which are not working to full-load capacity. For instance, it is found that on an existing typical link, either with light or heavy traffic, the single sideband "suppressed carrier" system should save 87 per cent of valve replacement costs and 90 per cent of the cost of power.

An interesting subject dealt with in the paper is a somewhat new form of filter on the "balanced reaction" principle.

## Multi-Mu's.

It used to be a very simple matter to control volume when sets were not limited as to the number of individual controls, (Continued on next page.)

EVERY DESIGNER  
of  
EVERY CIRCUIT  
published by

EVERY PAPER  
exclusively recommends

# FILT

THE EVER-DAMP  
EARTHING DEVICE

EVERY EXPERT  
*can't be wrong!*

Sold by all  
Dealers or  
post free  
from Sole  
Makers.



2/6  
COMPLETE

Graham Farish Ltd., Masons Hill, Bromley, Kent.

## THE IMPROVED "TONIC"

self-generating trickle-charger kit keeps 2-volt accumulators fully charged. Electric mains and charging stations unnecessary. Ideal for remote places. 7/- each, postage 9d. Particulars, testimonials, with pleasure, WILLIAMS, Netherend, Cradley, Birmingham.

## LOUD SPEAKERS REPAIRED, 4/-

(Blue Spot a Speciality, 5/-.)  
Transformers and Headphones, 4/-. Eliminators, Mains Transformers and Moving Coils quoted for. 24-Hour Service. Trade Discount. Clerkenwell 9069.  
E. MASON, 44, EAST ROAD (nr. Old Street Tube Station), LONDON, N.1.

## AMBITIOUS ENGINEERS WANTED

to apply for our free 250-page Hand-book. Gives details of A.M.I.Mech.E., I.E.E., A.M.I.A.E., G.P.O., etc., Exams., outlines latest Courses in Mech., Elec., Motor, Radio and Aero. Engineering, and shows clearly where first-class vacancies occur each year. Send P.C. for FREE Hand-book immediately to  
BRITISH INSTITUTE OF ENGINEERING TECHNOLOGY,  
401, Shakespeare House, 29, Oxford Street, W.1.

# EASY TERMS

Everything wireless supplied on lowest terms. Prompt delivery guaranteed. Price list free on request.

★ ★ ★ With Order

NEW BLUE SPOT 99 PERMANENT-MAGNET MOVING-COIL UNIT.

Cash Price £2/19/6

And 11 monthly payments of 5/6.

→ 5/-

"CLASS B" KIT, consisting of Multitone driver trans. and output matching choke, Cosmor 240 B valve and special valve holder. Free instruction book with every order. Cash Price £1/15/3 or 6/- with order and 6 monthly payments of 5/6.

12 EXIDE W.H. HIGH-TENSION ACCUMULATORS (120 volts, 5,000 M/A.).

The cheapest and best High Tension Supply where Mains are not available.

Cash Price £3/15/-

And 11 monthly payments of 7/-

ATLAS ELIMINATOR A.C.244. Three H.T. tappings. 20 M/A output. Cash Price £2/19/6

And 11 monthly payments of 5/6.

ALL CARRIAGE PAID. QUOTATIONS BY RETURN.

To avoid delay will customers kindly send first payment with order.

→ 5/-

THE LONDON RADIO SUPPLY CO., Ltd.,

Dept. P.

11, Oat Lane, Noble Street, London, E.C.2.

'Phone: National 1977.



**ELECTRADIX BARGAINS****The  
DIX-MIPANTA**

A wonderfully versatile Moving-Iron, Multi-range portable or panel meter for

**A.C. or D.C.**

**THREE RANGES OF VOLTS:**

0-7.5 v. 0-150 v.

0-300 v. (3 Scales).

Used for Milliamps reads:

0-12½ m/a. and  
0-75 m/a.

A 2-Guinea Tester for

**19/6**

Complete with Test Heads.

**AUTO-KINECAM** nearly new 16 m/n. 3-speed Cine Camera F2.6 Cinar lens. In leather case with stand. £9 10 0.

**KODASCOPE**, Model C, 16 m/n. Projector with electric motor and resistance for D.C. Power Transformer for A.C. £6 10 0.

**PATHE** 9 m/n. Baby Cine Projector with electric motor. £4 4 0.

**MICROPHONES FOR HOME TALKIES** and Movies. Maximum efficiency and minimum price.

Buttons, 1/-; Volume Controls, 6d.; No. 1 Speech Pendant Mike, 6/6; Marconi W/T Trans. Hand Mike, 15/-; No. 12 Ring Pedestal, 18/6; Lecture Desk Mike, 65/-; Pub. Address Amplifier, £5; Browns £20 model, £12; West. Electric, £14.

Write for Bargain List P/24.

**ELECTRADIX RADIOS,**  
218, UPPER THAMES STREET, E.C.4.

Famous Maker's Offer! **£5 Radio-Gram CABINET for 65/-**  
**SEVEN DAYS' FREE TRIAL**  
(OR 10/- MONTHLY)  
Polished Oak 1 and Piano built! The acoustic tone brings a fine thrill. Makers to Radio-Press, B.B.C., 3,000 clientele.  
MODELS FROM 35/- to £15.  
Photographs and List FREE.  
**PICKETTS** Piano-Tone Cabinets,  
P.W., Albion Road, Bexleyheath  
£6-15-0

**RADIO SUPPLIES**  
Send your list of Radio needs for our quotation; Kits, Parts, Sets, etc. Everything in Radio stocked, prompt delivery 7 days' approval. Catalogue free. Taylex & Standard Wet H.T. replacements stocked.  
**P. TAYLOR, 57, Studley Rd., Stockwell, London**

The Famous  
**"SILVERTONE" 2-VALVE BATTERY MODEL**  
This highly selective long-range 2-valve Wireless Set has 2-volt super-sensitive detector valve transformer coupled to 2-volt power valve. Two aerial tapplings—one for selectivity, one for volume. Tuning dial and reaction dial, waveband switching. Con type loud speaker. In handsome Oak cabinet. Guaranteed with a clearly written instruction leaflet, so that anyone can secure perfect results immediately. Mullard valves included, nothing extra to pay. Price 32/6, or sent C.O.D. 1/- extra.  
Trade inquiries invited. **C. REDVERS (Regd.), 20, Colchester Street, London, S.W.1.**

**EASY PAYMENTS**  
"There's no place like HOLMES."  
The first firm to supply Wireless parts on easy payments. Eight years' advertiser in "Popular Wireless." Thousands of satisfied customers.

**EPOCH "CLASS B" P.M. M.C. SPEAKER 32/6**  
4/6 Deposit and 7 payments of 4/5.  
Any Epoch Speaker Supplied.

	De-posit	Monthly Payments
LISSEN SKYSCRAPER Kit	89/6	8/3
TELSEN 325 Star Kit	39/6	5/5
EXIDE H.T. Accum. 120v.	83	6/7
EKCO Eliminator 2 G. 18	67/6	7/5
CELESTION M.C. P.M. 35/-	4/10	7 of 4/10
B.T.H. Pick-up	25/-	4/8

Parts for any Kit Set. Any make of Speaker.  
New Goods Obtained for Every Order.  
Send us a list of the parts you require and the payments that will suit your convenience, and we will send you a definite quotation. Anything Wireless.  
**H. W. HOLMES, 29, FOLEY STREET, Great Portland Street, London, W.1.**  
"Phone: Museum 1414.

**TECHNICAL NOTES**

(Continued from previous page.)

but now that we specialise in single-knob tuning and ganged condensers, and so on, volume control becomes a different proposition, since it is so important not to interfere with the tuning of high-frequency circuits. We have to remember that the use of some forms of volume control when connected in the H.F. portion is liable to upset the matching of the ganged circuits, which is bad for the one-knob tuning principle.

The multi-mu valve, however, which I mentioned in these Notes just recently, gets over these disadvantages, since it can be used for automatic control or for control by hand operation, and it does not—or I should say, need not, if properly worked—upset the ganged circuits.

**"Mutual Conductance."**

I am often asked the meaning of different radio terms, and one which crops up more than most is the term "mutual conductance." This term seems to puzzle quite a lot of newcomers to radio, though, of course, the old hands are quite familiar with what it means.

First of all, the word "conductance" is, in a general way, the inverse or opposite of "resistance." It is obvious, on the face of it, that the greater the conducting power of anything the lower its resistance, and vice versa, so that, broadly, conductance obviously has something to do with the conducting property.

In actual fact the term "mutual conductance" as applied to a radio valve has

to do with the way in which the anode current increases as the grid voltage is decreased.

**"Slope."**

You know that if you increase the grid bias you will decrease the anode current, and vice versa. Now the relationship between a change in the one and the corresponding change in the other determines what is sometimes known as the "slope" of the curve of the valve or, more briefly, the "slope."

For instance, suppose the anode current is 12 milliamps with 3 volts grid bias, and that when the grid bias is increased to 4 volts the anode current drops to 10 milliamps, then the change in the grid bias is 1 volt and the corresponding change (which is thereby brought about) in the anode current is 2 milliamps. The "slope" is the change in the anode current divided by the change in the grid bias which, in this case, is 2 divided by 1, that is 2.

**Figure of Merit.**

This factor of change in anode current divided by change of the grid bias (that is the change in the grid bias which causes the change in the anode current) is the factor which is sometimes referred to as "mutual conductance."

Some people prefer to think of the mutual conductance as a sort of general "factor of merit," of the valve because, other things being equal, the better the slope the better the performance of the valve. Note that I say particularly "other things being equal," because you cannot simply take the valve with the steepest slope without having regard first of all to its other characteristics.

**ROUND  
THE RECORDS**

Some hints on choosing the new numbers.

I REALLY must take my hat off to the Gramophone Company for their ingenuity in the production of novelty records. Some little time ago the "revived" Caruso records were announced, and remarkably clever has been the way in which the super-imposing of the old voice on new accompaniments has been done. The latest release of this series is "Celeste Aida" and "Je crois entendre encore." (H.M.V.)

Now a newcomer to recording has been treated in a somewhat similar manner—Danny Malone, the young tenor everyone has been making such a fuss about.

In this case he has been recorded on H.M.V. singing the "Londonderry Air," a song that suits him perfectly, by the way, and then re-recorded singing it again in harmony with his first record. The result is Danny Malone singing a "duet" with himself! You should hear it, for it is worth getting.

Another novelty is the Neo Bechstein piano recording. The Neo Bechstein is a new type of piano in which strings vibrate close to microphones, the resultant L.F. being amplified and reproduced by a loud-speaker.

Whilst it resembles in external appearance and size the ordinary baby grand, the

construction of the piano is vastly different internally. No sounding board is employed, but above each group of five strings is a microphone, eighteen of these delicate electrical instruments being used to cover the whole range of notes.

A varied assortment of effects can be obtained from the instrument, from a harpsichord to an organ. It needs a new technique in manipulation, and the two records just issued by H.M.V. are particularly interesting as they mark the commencement of something quite new in the musical world, and a fresh harnessing of electrical science to music.

It is quite possible you will not like the records. I do not care for the first one—it seems somewhat too sugary and insipid, but the second record gives one a better idea of what the Neo Bechstein is capable. The discs are "Clair de Luxe" with Chopin's "Prelude in C Minor" on the other side, and "Young and Healthy" with "Look What You've Done" on the second. Both are H.M.V., and the numbers are C2567 and B4432 respectively.

"Imperial" records are doing very well lately. I especially like some of their latest, including Val Rosing singing "That's my Home," Jack Payne's selection from "The Kid from Spain."

On "Broadcast" Sandy Powell is still going strong, his latest effort being entitled "Sandy's Happy Home," and it will delight his many followers.

Finally, lovers of dance music should listen to Billy Cotton and his band on Regal-Zonophone playing "Underneath the Harlem Moon" and "Hustlin' and Bustlin' for Baby," two discs of distinction.

-K. D. R.