

# MY RADIO CINEMA—By G. V. Dowding

# Popular Wireless

Every Thursday  
PRICE  
3d.

No. 346. Vol. XIV.

INCORPORATING "WIRELESS"

January 19th, 1929.

*In this issue*

**"AN  
ALL-  
WAVE"  
H.F. UNIT**



*Special Features in This Issue*

**THE 1929 "TRINADYNE"  
Accumulator Economies. B.B.C. and Publishing  
WHITE PRINT No. 7**

# WHY WORRY WITH BATTERIES?



Model "B"  
L.T., H.T. & G.B.  
Eliminator.

By substituting Met-Vick all-electric Valves for your existing valves the new Met-Vick Model 'B' Eliminator enables you to dispense with batteries altogether, and operate straight off your Electric Supply.

Connected to a wall plug or lamp socket, the model "B" will provide you with heater current for your valve filaments, 5 tapings for the high tension supply to your valves, and automatically regulated grid bias taps for your last stage.

Model "B" Eliminators can also be obtained for supplying H.T. and G.B. only.

<p>L.T., H.T. &amp; G.B. <b>£8 0 0</b></p> <p>A special model for 25 periods is supplied at £10 0 0</p> <p>List M.S. 4745</p>	<p>Prices of 'Met-Vick' Model 'B' Eliminators for providing 180 Volts on the last valve. Complete with S.P. 41/U rectifying valves. 100-110 volts or 200-250 volts, 40-100 periods.</p> <hr/> <p>Ask for leaflets shown.</p>	<p>H.T. &amp; G.B. <b>£7 7 0</b></p> <p>A special model for 25 periods is supplied at £9 5 0</p> <p>List M.S. 4746.</p>
---	--	---

*These eliminators are eminently suitable for the operation of the Met-Vick A.N.P. receivers' described in leaflets S.P. 7117/2 and S.P. 7117/4 and for 3 and 4 valve receivers listed in leaflet M.S. 4742.*

# MET-VICK ELIMINATORS

*Other types of Met-Vick Eliminators for A.C. and D.C. circuits are briefly referred to below and the corresponding leaflet numbers given.*

*Ask your own dealer for copies or write direct to*

**Metro-Vick Supplies Ltd., 155, Charing Cross Rd., London, W.C.2.**

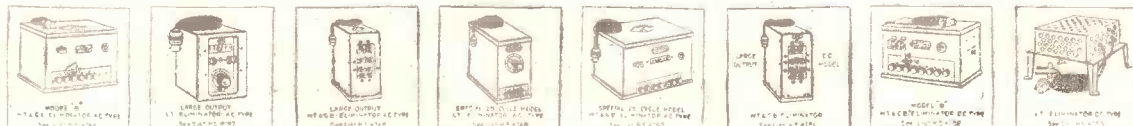

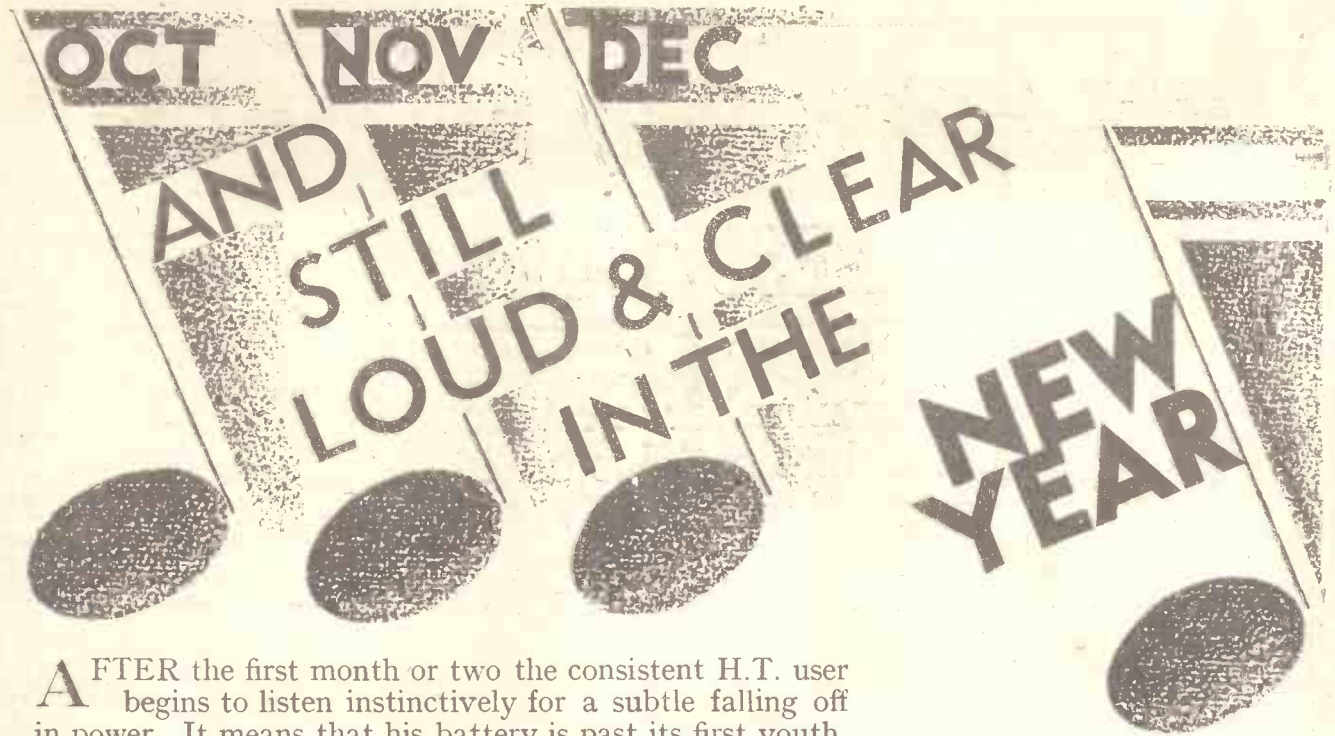

**A**FTER the first month or two the consistent H.T. user begins to listen instinctively for a subtle falling off in power. It means that his battery is past its first youth.

If a Marconiphone "long life" battery was installed, he will discover something. The demands of the last quarter will appear to have taken little from its effectiveness. As a matter of fact, they *haven't*.

That jubilant self renewal—the feature of the Marconiphone long life battery—goes right on into the new year still giving crisp and colourful interpretation to hundreds of programmes.

What an investment. If you've not started the year with a Marconiphone battery, resolve to make this good beginning with your next renewal. Stocked by all Wireless Dealers.

**Marconiphone "Popular" Batteries.**

66-volt	-	-	-	-	9 6
108-volt	-	-	-	-	15 6

**Marconiphone High Tension Batteries.**

66-volt	"New Standard"	12 6
108-volt	"New Standard"	21 -

**Large Capacity Batteries.**

60-volt	-	-	-	-	20 -
---------	---	---	---	---	------

**Marconiphone Grid Batteries.**

9-volt	-	-	-	-	1 9
16-volt	-	-	-	-	3 6



THE  
**MARCONIPHONE**  
 CO., LTD.,  
 210-212,  
 Tottenham Court Road,  
 London, W.1.

# MARCONIPHONE HIGH TENSION BATTERIES

# Make sure this month of your copy of The WIRELESS CONSTRUCTOR

The February number is a "star" issue containing up-to-date articles on every phase of radio construction.

The Special Contributions include:—

## The Pentwin

A wonderful 2-valve set.

## A Variable H.T. Unit

## The D.C. Four

and

## Adding Punch to Your Short-Waver

A specially efficient and simple amplifier.

## Long Waves on the New Business Man's Four

## What the Pentode Really Does

## Chats at the Work-Table

## Experimenting with the 31 New Circuits

etc., etc., etc.

***BUY YOUR COPY NOW!***

ON  
SALE  
EVERY-  
WHERE

**The Wireless  
Constructor**

PRICE  
6d.

**Pep up your  
Radio  
for  
the  
winter  
months**

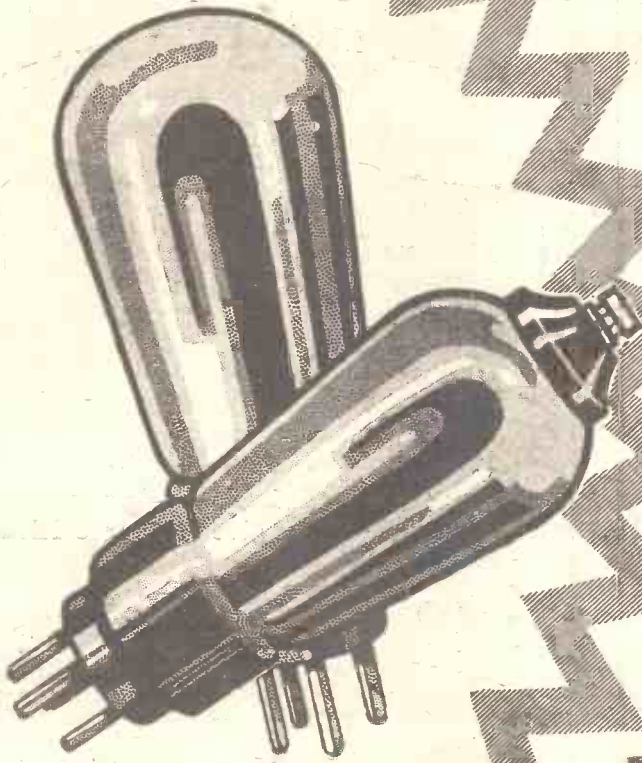

**EDISWAN**  
NEW HIGH EFFICIENCY  
**VALVES**

*Write to-day for catalogue of complete range of Edison Valves to The Edison Swan Electric Co., Ltd. (Publicity Dept.), 123/125, Queen Victoria Street, London, E.C.4.*

v.7.

**EDISWAN — the 100% BRITISH VALVE**

# 1000 MILES WITHOUT AN AERIAL



The Ducon was successfully used by Mr. F. Dearlove for communication between Labrador and Pittsburg.



"... Once I actually communicated with a Station in Pittsburg, using no aerial or counterpoise, but simply plugged by means of a "Ducon" adaptor to the lighting circuit! ..."

Extract from article in "Modern Wireless" of December, 1928 — "Further Adventures in Labrador," by Mr. F. Dearlove, Chief Wireless Operator appointed by Sir William Grenfell to link up the Labrador outposts by means of Short-wave Wireless.



No Aerial troubles are ever encountered when using a Ducon. Simply plugged into an electric lampholder and connected to a set, the Ducon replaces an aerial. It consumes no current and is perfectly safe.

Price - 5/-

"TOREADOR SCREEN-GRID FOUR"

This set incorporates the latest developments in Receiver design — full constructional details free on request.



Advt. of Dubilier Condenser Co. (1925) Ltd., Ducon Works, Victoria Road, North Acton, London, W.3.

Q215

## USE THESE LEWCO LITZ WOUND COILS IN THE "COSSOR MELODY MAKER"

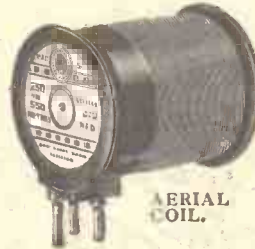

AERIAL COIL.

Ref. MAC 5, 250-550m. ... 7/6  
Ref. MAC 20, 1000-2000m. ... 8/6



ANODE COIL.

Ref. MAR 5, 250-550m. ... 7/6  
Ref. MAR 20, 1000-2000m. ... 8/6

From tests made we find that medium wave Litz wound coils 250-550m. give greater efficiency.

## AND THIS IN THE "MULLARD MASTER THREE"



Ref. QAS.

Have you tried the LEWCOS QAS Coil? Dual coil range: 250-550m. and 1000-2000m. Fits exactly into receiver according to blue print.

Price 15/- each.

# LEWCOS COILS (REGD.)

"Give greater efficiency to any receiver."



LEWCOS RADIO PRODUCTS FOR BETTER RECEPTION

The London Electric Wire Company and Smiths Limited  
Church Road, Leyton, London, E.10.

Telephone: Walthamstow 2531. Telegrams: 'Lewcos, Phone, London.'

Trade Counter and Cable Sales:

7, Playhouse Yard, Golden Lane, London, E.C.1.

# PHILIPS LOUD SPEAKERS



**H**ERE are the finest Loud Speakers yet produced—without one you have never heard, radio as it really is. Hear one of these Speakers to-day; it will be a revelation. There is nothing as good as Philips Loud Speakers, which have a world-wide reputation behind them.

Type 2007, supplied in three different colours:  
 Orange, black and gold }  
 Violet, black and gold } . . . . . £5 - 5 - 0  
 Brown, black and gold }  
 Type 2016, Mottled red . . . . . -50-  
 Type 2026, Grey . . . . . -50-

# PHILIPS

*for Radio*

S.I.

# Make the Melody LOUDER and CLEARER



You get surprising volume with  
Cossor Valves . . . the Valves  
which made possible the won-  
derful Cossor Melody Maker.  
The melody they give is crystal clear  
and loud enough to fill the house.  
Whatever type of Set you own, Cossor  
Valves will improve reception.  
They improve any Receiver.

with  
**COSSOR**  
VALVES





# Popular Wireless



Scientific Adviser:  
 Sir OLIVER LODGE, F.R.S.  
 Editor:  
 NORMAN EDWARDS.  
 Technical Editor: G. V. DOWDING, Grad.I.E.E.  
 Assistant Technical Editors: K. D. ROGERS, P. R. BIRD,  
 G. P. KENDALL, B.Sc., A. JOHNSON RANDALL.



## RADIO NOTES AND NEWS.

Canadian Broadcasting—Beware of Cables—Bathing and Washing—Those Everlasting Foundations—“Ariel” as Young Moore—Bratislava Begins—Round the World for 15s.

### Canadian Broadcasting.

I SEE it stated in one of the Canadian papers that an effort is to be made to secure the repatriation of Major Gladstone Murray in connection with a new broadcasting organisation to be formed in Canada. Major Murray, of course, is a member of the B.B.C. Control Board, and has had a good deal to say in the evolution of British broadcasting policy during the last five years.

And when one comes to consider the fact that his origin is Canadian, and that, as a former Rhodes Scholar, he was presumed to be an able and representative Canadian, it looks as though the powers-that-be in Canada regard him as a strong and favourable candidate for the position of Executive Head of a Canadian B.C. if one were approved and set up.

### Beware of Cables.

I HOPE that all inexperienced aerial-erectors will learn a lesson from the fatalities which have recently occurred as a result of aerial wires in course of erection coming into contact with cables carrying power. The way to avoid trouble is a simple one, viz., if there is any sort of wire passing across the sphere of your operations, give the job up. If the wires are for telegraph or telephone use get expert help, but if they carry power—get off and stay off. Better an indoor aerial than an untimely grave.

### Bathing and Washing.

HERE is something livelier. “Reynolds’ News,” giving its readers advice about preparing the set for action, says, “A poor crystal may be restored by judicious chipping and a bath of strong whisky or brandy if alcohol cannot be got.” This temperance whisky and brandy is just the stuff for America. Also, “The H.T. will often gain renewed strength for a while if stood in water for five minutes and afterwards put before a fire for fifteen.” This process would wash the outside of my H.T. container or dilute the acid inside—or do both. Shan’t try it.

### B.B.C. Sensation.

THE news that the B.B.C. is to set up a department to provide it with ideas for improving the programmes is almost stunning to a highly strung person like me. It comes like an unexpected clap

of thunder. I had cherished the belief that the people who have been preparing the programmes up till now were paid to deliver “ideas.” Evidently the Board of Governors feel that, after all, someone with ideas is really needed in the B.B.C. on the entertainment side. Mr. R. E. Jeffrey is to take charge of the new department, and we wish him the best of luck.

### Those Everlasting Foundations.

WIRELESSLY speaking, I live only for the weekday when the 2 L O programme will not include “The Foundations of Music,” a feature which has been regularly presented for longer than I care to recollect. Can we not get a bit higher, if only into the basement? Speaking at Bradford in December, Mr. J. H. A. Whitehouse is reported as saying, “You couldn’t run a broadcasting service if you put ‘Annie Laurie’ across all the time.” Mr. Whitehouse is a B.B.C. man, and I hope he will tell his Corporation a similar thing in regard to the subject of this paragraph.

### Radio Pictures in U.S.A.

THE broadcasting of pictures is beginning to boom in America. The “Electrical Review” says that according to “Science” twenty-one stations will soon be “on the air” with picture services, of which nine are now in operation. A ten-million dollar company has been formed to make and sell picture-receiving sets. The General Electric Company at Schenectady is broadcasting regularly on three different frequencies, including 790 kilocycles (W.G.Y.).

### A Loss to Radio.

OUR readers, and especially those abroad who do not regularly see home newspapers, will regret the death of Mr. Willie Rouse, known as “Wireless Willie,” which occurred in a nursing home on December 22nd. This gentleman was a favourite microphone artiste, a sterling, refined humorist, and his death leaves a

(Continued on next page).

## DUBLIN'S DOINGS.



Checking the broadcast transmission from the control room at Dublin, 2 R N.

## NOTES AND NEWS.

(Continued from previous page.)

sad gap in the sparse ranks of first-class wireless entertainers. "P.W." proffers its sympathy to his friends and relatives.

## Schoolboy Humour.

JANUARY generally sees school reports and the never-failing crop of schoolboy "howlers." Here are a few with an electrical or radio flavour: "Talligraphy is Morse but radio is listening-in to music and other sounds." "An accumulator is a heavy sheet of lead soaked in acid and they charge 1 and 6 to charge it." "A dry cell is in a flashlamp with two brass strips and several volts." "Telephony is two sorts, wireless and ordinary. Ordinary costs two-pence but wireless many £'s and then perhaps you hear nil." "Hertz invented sparks but Marconi went to New South Wales and flew a balloon, thus bridging the Atlantic with a faint S.O.S."

## "Ariel" as Young Moore.

ON New Year's Eve, at a party, they made my usual glass of water strong by adding a lump of sugar to it—and I prophesied and said that 1929 would be about as long as 1793, but that more farmers would be ruined; that a great increase in long-distance radio-telephony would be observed; that "P.W." would lead the way with the most ingenious and efficient sets; that Oxford would win provided only that Cambridge lost; that the reception of 3 LO on a "P.W." two-valver would be a commonplace; that picture-reception would be three jumps ahead of television; and that the B.B.C. would continue to be the best of all broadcasting enterprises, bad and good as it is.

## A Prince of Talkers.

THE American Academy of Arts and Letters is to award a gold medal for good diction by a radio announcer. This is, I presume, intended as an encouragement of "talkies." In this connection I should like to draw to the notice of the Academy the claims of the Prince of Wales, who, by speaking to the microphone for a few minutes, succeeded in collaring £55,000 for the miners within a few hours. If it is true that "money talks," then our Prince has the diction which should please an American academy.

## French Radio Taxes.

MORE talk again of levying taxes on receivers in France; crystal sets 10 francs, and valve sets up to 80 francs, according to the number of valves. The estimated gross revenue from all this is about £360,000 per annum, but it is doubtful whether the French will pay up without some assurance that a large part of the proceeds will be spent on radio interests. As a matter of fact, they don't even pay the existing nominal tax of 1 franc.

## Poet v. Jazz.

IT'S amusing to note that someone wrote to a Yorkshire newspaper complaining that the B.B.C. allowed Mr. J. Drinkwater to intone "nonsensical children's verse" for twenty-five minutes over scheduled time, thus robbing his guests of Jack Payne's Dance Band!

## A New Year's Treat.

OUR big brother, "Modern Wireless," celebrates the New Year with an absolute buster of a January number. Constructional articles about no less than five different receivers are given, including a particularly topical one entitled "The Any-Mains Four." A special article, "Marconi—the Man and His Work," by the Editor, gives new facts and pictures relating to the great inventor. One of the best resolutions you could make is that you will be a 1929 "M.W."-ite.

## Uncle Arthur's Union.

IT was jolly to meet "Uncle" Arthur Burrows again a few weeks ago, as cheery as ever. He is the Secretary-General of the Unione Internationale de Radiophonie and was in London with a commission ap-

## SHORT WAVES.

"Ether for a Husband," says a headline. There are probably moments when some of them would welcome it as a substitute for the more usual form of gas.—"Passing Show."

## HOW TIMES HAVE CHANGED.

In 1924: "Gee, that's a fine radio you've got; sounds like a phonograph."  
In 1929: "Say, that phonograph's all right; sounds just like the radio."—"Radio News."

She was only a wireless fan's daughter, but she knew how to "loud-speak."

The Height of Snobbishness.—The radio announcer who would not announce for a station unless they had an exclusive wave.

## WHERE NIGHTS ARE SIX MONTHS LONG.

Explorer: "I knew a fellow who listened to fifteen hundred bedtime stories in one night."  
Listener: "He must have been a lunatic."  
Explorer: "No, he was an Eskimo."  
"Radio News."

"Buy Aerial Self-raising Flour. Easiest and Best."—(Advt.)

Presumably, this should be sprinkled on the mast, or perhaps on the wires?

All the joy in the world,  
Is now freely unfurled,  
By artists of talent and fame;  
And life's worth the living—  
One endless thanksgiving—  
Since we got in the radio game!

pointed to study programmes and administration. Needless to say, the B.B.C. soon had them in the hands of the radio education cranks, and they had to go and see the kids wasting priceless time on radio lessons at a Council school.

## New Central European Station.

A NEW station is to be erected shortly at Bratislava, Czecho-Slovakia. Its power (antenna) will be 12 kw. It will be the largest of a chain of five stations which are contemplated, and will perform a service similar to that of the new B.B.C. high-power regional stations.

## Armistice Night in Australia.

I AM very glad to hear from H. W. B. (W. Australia) that the 5 SW broadcast of the Albert Hall Armistice Night proceedings were successfully received at the Antipodes. H. W. B., an old R.F.A. man, lost a lot of sleep over it, but I am sure he does not regret a single wink. It must have been a wonderful experience. He says that PCJJ and 5 SW are about equal there—but he says nothing about the cricket Test teams. (!Nuff said!)

## The Big Bang.

MULLARD'S tell me that they had to evacuate Mullard House, by police order, during the bust-up which tore so much of gold-paved London up a few weeks ago. I understand that during the course of the explosions and fire an optimistic employé wanted to put a Mullard valve down the worst manhole in order to demonstrate its (the valve's) invulnerability, but that he was not allowed to waste the firm's time on so easy a test!

## The "Hams" Are Alert.

WHENEVER my Barts. and other keen ether-dredgers seem fast asleep I have but to describe what I imagine to be a new DX feat for them to spring to attention and show me how wrong I am. Thus cunningly do I obtain a lot of interesting reports.

For instance, I mentioned the reception of 6 AG (W. Australia) and, as you know, we found that 6 AG was a regular job with a number of readers. Now I can't stop the flood I have let loose. I don't want to; but if I hear much more about 6 AG I shall try a crystal on him.

## What is One to Do?

MOST of my correspondents on this subject regard 6 AG as fairly easy meat, though, as a matter of fact, it is good work to get him. But one of them, R. G. B. (Peterculter) has the impression that my original note savoured of scepticism, and he therefore assures me that he himself got 6 AG the same evening as did T. W. M. M. Almost like a Scotch conspiracy, isn't it? "Shikari" (Malpas) gets 6 AG and Nairobi, on 0-v-2, besides Melbourne and the Yanks. He asks why W. L. S. does not have more space for S.W. Notes. Dunno! But think of the quality!

## Round the World for 15s.

THE Boy's Brigade continues to shoot at me. A young struggler on the leash, J. A. O. (Burry Port), aged "not yet fifteen," says that when he was twelve he was such a keen radio fan that his father couldn't keep his pipe-spills alight. He says, also, that if he could afford a transmitting licence, he would build a station at a cost of 15s., and would "guarantee reception around the world."

I think that it would pay any amateur transmitter to get the lad his licence so that we could find out about this wonder circuit. J. A. O. has a three-valver which has bagged more than 120 stations, and he is making the "Antipodes Adaptor."

## The First Broadcaster.

PLEASE see page 772 of "P.W." for December 15th. I have been lucky enough to discover a man who actually heard what was, perhaps, the first radio broadcast. It was done by Dr. De Forest in 1909, ably assisted by Caruso.

S. C. C., of Plymouth, tells me that as wireless operator on the "Celtic"—now of blessed memory—he received the transmission while in New York Harbour. The receiver was the old "magnetic detector," and the signals were clear though weak. Evidently we must "hand it to" De Forest. Much obliged, S. C. C. How goes it?

ARIEL.

# The 1929 "TRINADYNE"



Another of "P.W.'s" most popular and most effective circuits revised and brought right up to date. Using only one valve, this novel set has a wonderful punch. It has all the merits of a dual amplifier without the usual "snags."

Designed and described by The "P.W." RESEARCH DEPARTMENT.

THE fascination of this sort of set is not very far to seek. It is the same attraction which once made the reflex circuit so popular, namely, the fact that you can get loud-speaker results of quite pleasant volume on one valve if your aerial is even a fair one.

People sometimes object that to build such a set costs just as much in components as to make an ordinary two-valver, but even so, there is the price of the extra valve itself to consider, likewise the question of running costs.

### The Real Attraction

Anyway, such objectors miss the real point, which is that even if special circuits like this actually cost more to build and run (which they don't), their fascination is still great enough to cause the keen constructor to make them up.

If you are human at all you must find a certain satisfaction in asking people to listen to your set, and then, when they ask how many valves, in replying very casually, "Oh, only one!" The surprise which usually follows is very soothing and enhances your reputation as a wireless wizard wonderfully. Did someone mutter "How

childish!"? Well, why not? What's the good of having a hobby, if you've got to be thoroughly grown-up and dignified-over it?

Anyway, we got lots of fun out of this little set, and the experiments which led up to it, in the "P.W." Research Dept., and we think any reader who builds it will be pretty sure to do likewise. It was quite a surprise to us, even though we knew that much can be done with a circuit of this general type, and it is likely to be something

of a revelation to anyone who has only handled one-valvers of the ordinary kind.

The earlier forms of the Trinadyne circuit were remarkable little receivers, as many of the older readers will remember, and there was no real reason why they should go out of fashion as they appear to have done. It is probably just a natural result of the succession of new sets and circuits always appearing that they have been in danger of being forgotten.

We felt so strongly that it was to be regretted that such very useful little circuits should be neglected that we undertook a special series of experiments on their later forms. It was hoped to develop from them something at least as good which should be specially suited to modern requirements and capable of assembly with modern components throughout.

### Greater Stability

The task was a rather difficult one, but the final result is a  
(Continued on next page).

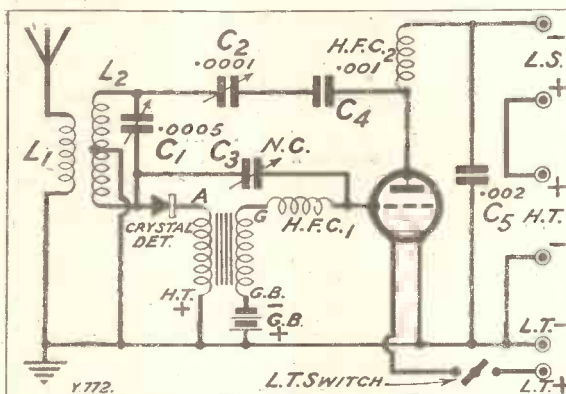

## COMPONENTS AND MATERIALS REQUIRED.

- 1 Panel, 12 in. x 7 in. x 1/2 in. or 1 in. (Radion, Beool, "Kay Ray," Ripault, Trolite, Red Seal, Trolleborg, Ebonart, etc.).
- 1 Cabinet to fit, with baseboard 7 in. deep (Camco, Bond, Raymond, Lock, Peto-Scott, Gilbert, Pickett, Arcraft, Caxton, etc.).
- 1 .0005-mfd. tuning condenser (Formo, Lotus, Cyldon, Lissen, Utility, J.B., Igranic, Ormond, Dubilier, Ripault, G.E.C., Pye, Raymond, Burton, Colvern, Bowyer-Lowe, etc.).
- 1 On-off switch (Benjamin, Lotus, Lissen, Burne-Jones, Igranic, Peto-Scott, etc.).

- 1 .0001 or .00015-mfd. reaction condenser (Peto-Scott, J.B., Lotus, Dubilier, Ormond, Bowyer-Lowe, Igranic, Burndept, Burton, etc.).
- 1 Panel-mounting crystal detector (either cat's-whisker type, such as the G.E.C., or semi-permanent, such as the Brownie or R.I.-Varley).
- 1 Sprung valve holder (W.B., Igranic, Lotus, Burndept, Ashley, Pye, Marconiophone, B.T.H., Bowyer-Lowe, Wearite, Burton, Burne-Jones, etc.).
- 2 H.F. chokes, preferably of different makes (Lissen, Igranic, Burne-Jones, Leweos, Climax, Colvern, Cosmos, Bowyer-Lowe, R.I.-Varley, Peto-Scott, Wearite, etc.).

- 1 Baseboard-mounting neutralising condenser (Gambrell, J.B., Burne-Jones, Peto-Scott, Bowyer-Lowe, etc.).
- 1 L.F. transformer, low ratio (R.I.-Varley, Ferranti, Lissen, Igranic, Marconiophone, Brown, Philips, Mullard, etc.).
- 2 Single-coil sockets (Lotus, Peto-Scott, etc.).
- 1 .002-mfd. fixed condenser and 1 of .001 mfd. (T.C.C., Lissen, Mullard, Dubilier, Igranic, Clarke, Goltone, Magnum, etc.).
- 1 Terminal strip 10 in. x 2 in. x 1/4 in., and 8 terminals (Belling & Lee, Igranic, Eelex, etc.).
- Wire, flex, screws, G.B. plugs, etc.

THE 1929 "TRINADYNE."

(Continued from previous page.)

circuit which we think will get full marks. It possesses all the original circuit's remarkable power and sensitivity; it is more selective; it can be assembled with standard modern components throughout, and it is decidedly "safer," i.e. any good make can be used for any of the parts, and there is nothing unduly critical about it anywhere.

Now let us take a look at the final circuit chosen for the 1929 version, after many comparative tests with alternative forms. First, you will notice that it has an aerial circuit of the modern "semi-aperiodic" type, ensuring a good degree of selectivity.

This circuit consists of the plug-in coil  $L_1$ , and by varying the size of this inductance you can get different degrees of selectivity to suit your own requirements, suit the circuit to your aerial, and so on.

The Secret of the Circuit.

The aperiodic aerial circuit is tightly coupled to a tuned secondary consisting of the centre-tapped plug-in coil  $L_2$  and the variable condenser  $C_1$ , and here we begin to find the special features which distinguish the 1929 circuit. By certain special arrangements we have been able to arrange the

whole circuit with entirely standard components, the key to the whole scheme being the use of a centre-tapped coil for the secondary circuit.

With the aid of this unit we have been able to put the crystal detector across only half the tuned circuit, and so get improved selectivity. The other half of the tuned circuit is thus left free, and we have used this to form a reaction circuit of the Hartley type.

Improved Reaction.

The reaction arrangements are the special feature of the 1929 circuit and are the real reason for its improved performance. You will see that a neutralising type condenser is fitted, and this is for the purpose of feeding a little H.F. energy on to the grid of the valve, which would otherwise act purely as an L.F. amplifier.

It is thus made to carry a little H.F.

current as well, and is so made capable of producing the reaction effects which give the circuit its sensitivity.

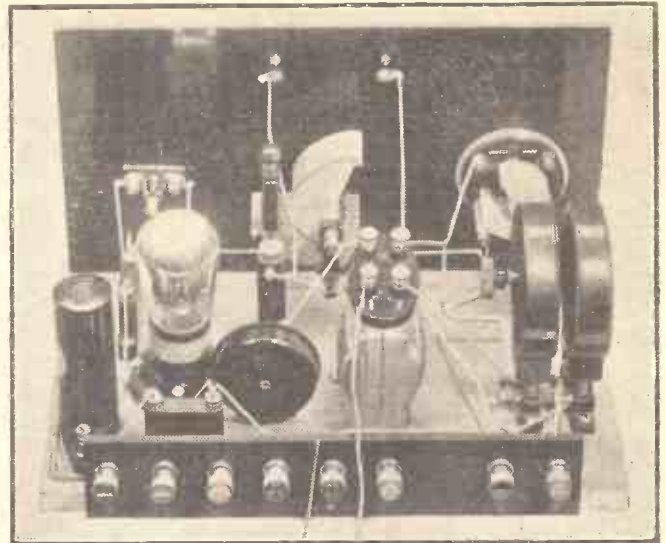

Here is the completed set with valves and coils in position: a neat and efficient assembly.

By the way, it may perhaps be as well to explain for the benefit of readers who are not familiar with the circuit that it is not really a reflex at all. The valve acts as an L.F. amplifier, and its only "dual" function is that it is also used to produce reaction. No attempt is made to make it function as an H.F. amplifier.

Actually, better results are obtained in this way, with far greater freedom from "snags." The fact is that the amount of H.F. amplification obtained with the older reflexes was practically nil, and their sensitivity (when they had any!) was almost entirely due to inherent (and often badly controlled) reaction effects.

A Hint for the Constructor.

So much for general points about the new circuit. Now let us get down to practical matters. So far as the constructional work is concerned there is little to be said, for it is a very simple job of assembling and wiring up.

Just one point should perhaps be mentioned, and that is a warning as to alterations to the layout. The set is not really critical, but if you do make any alterations be careful what you do with the two H.F. chokes, and do not put them any closer to each other or to the tuning coils than they were in the original set.

The secret of success with any of these special circuits is largely a matter of correct adjustments, so first of all you must be prepared to spend a little time finding the right setting for the crystal and getting the hang of the circuit generally. Let us start with the question of selectivity.

How to Adjust Selectivity.

This depends upon the size of the aerial coil  $L_1$ , and for an average sized aerial you will want a No. 35 for medium selectivity, and a No. 25 for sharper tuning, but slightly less volume. On a small aerial a No. 40 or even 50 will be the medium selectivity sizes, and No. 35 for high selectivity.

For the secondary coil  $L_2$  you require a  
(Continued on next page).

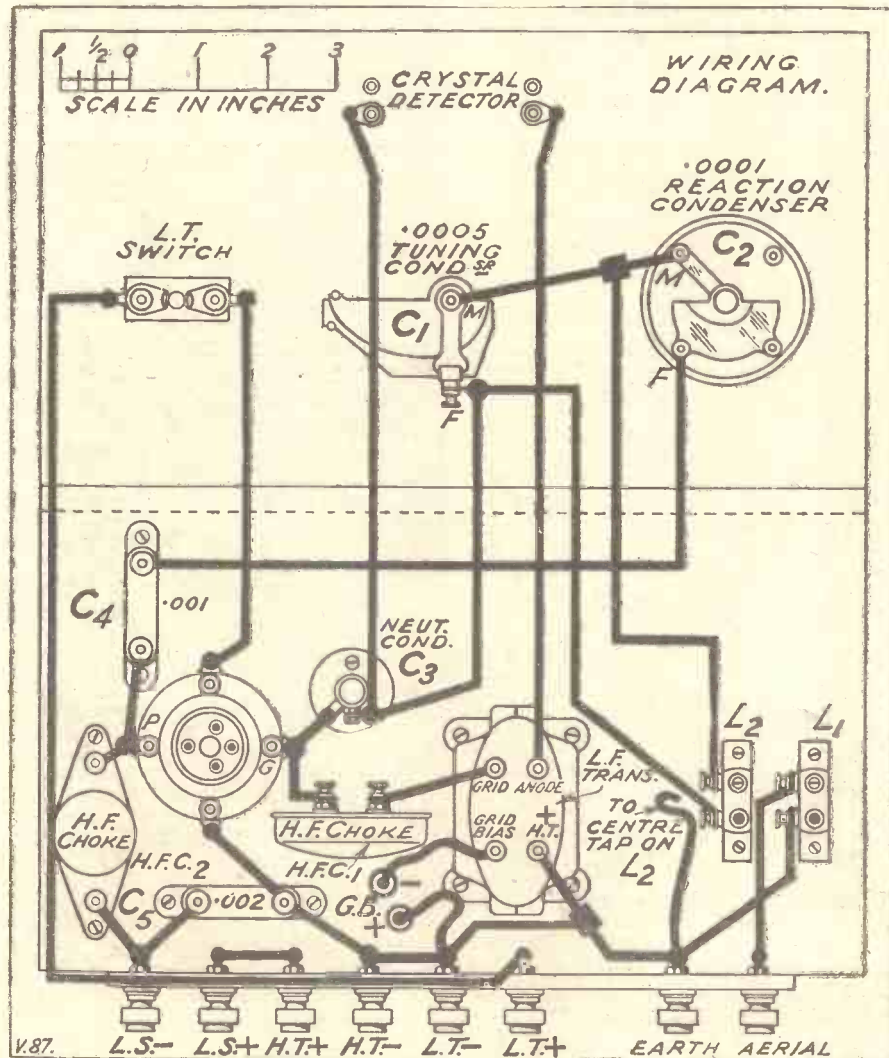

**THE 1929 "TRINADYNE."**  
(Continued from previous page.)

No. 60 centre-tapped type for the ordinary broadcast waves. For the long waves the size here is No. 250, with a No. 75 or 100 in the aerial circuit ( $L_1$ ) according to the degree of selectivity you want.

Correct reaction control is a very important point with this set, and it is well worth while to spend a little time on it. Circuits of this general type cannot, as a rule, be expected to give such smooth and gradual control as the simple Reinartz one-valver, but with care something not far short can be obtained.

**An Important Adjustment.**

The first point to note in this connection is that the setting of the neutrodyne type condenser has a considerable effect on the reaction control, and enables you to suit the requirements of any given valve. Start operations with this condenser set about half-way between minimum and maximum, and see what sort of reaction control you get.

If the receiver oscillates very easily, and rather fiercely, with only a small setting of the reaction condenser, reduce the setting of the neutrodyne condenser. If, on the contrary, it is difficult to get reaction, increase the setting of the neutrodyne. Once the correct adjustment is found for a particular valve it can be left permanently, and all actual reaction control done on the reaction condenser proper.

The choice of a valve is a question

demanding a little consideration. If you want the best possible quality of reproduction on the local station, a small power-valve should be used (2-volters work well in this set). This will enable you to work a loud speaker on the local at quite pleasant volume and very good quality indeed.

For the greatest volume and sensitivity, on the other hand, particularly on distant stations (when headphones will be used), a valve of rather higher amplification factor and higher impedance is best, in other words, one of the L.F. type, with an

for circuits of this type is always the same: give the valve as high a voltage as you can afford up to the limit of safety fixed by the makers (usually 120 volts).

Until you get at least 100 volts at work you do not really get the full benefit of the circuit, and, moreover, lower voltages may cause the valve to start rectifying instead of amplifying properly.

**Grid Bias and Reaction.**

Grid bias should be adjusted exactly as usual in accordance with the valve maker's instructions. Then test the reaction control, and try a trifle more bias, noting whether it results in a smoother control. It does with some valves, so it is just worth trying.

You should note, by the way, that if you go too far with this over-biasing you will upset the working of the valve and cause it to rectify, just as though the H.T. voltage was not high enough. You can tell whether this is happening by lifting the cat-whisker of the

crystal, and noting whether you can still hear strong signals.

When the circuit is working properly you should only have quite faint signals with the crystal out of action. If they are loud you may be sure that all is not well with the valve, and you should take the necessary steps to make it amplify properly.

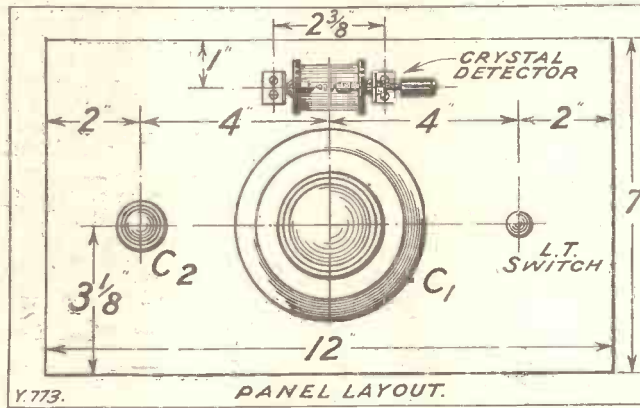

impedance of perhaps 7,500 to 15,000 ohms, or a little higher.

The choice will evidently depend largely on how near you are to your local station: If you are within, say, eight miles, a power type is advised, while for greater distances the higher magnification L.F. type will be best.

As regards H.T. voltage, the golden rule

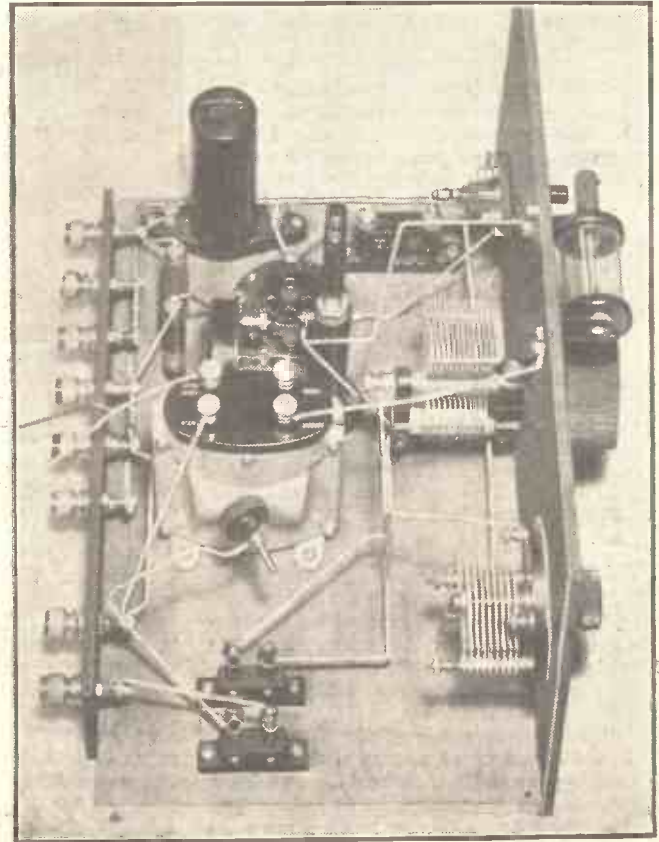
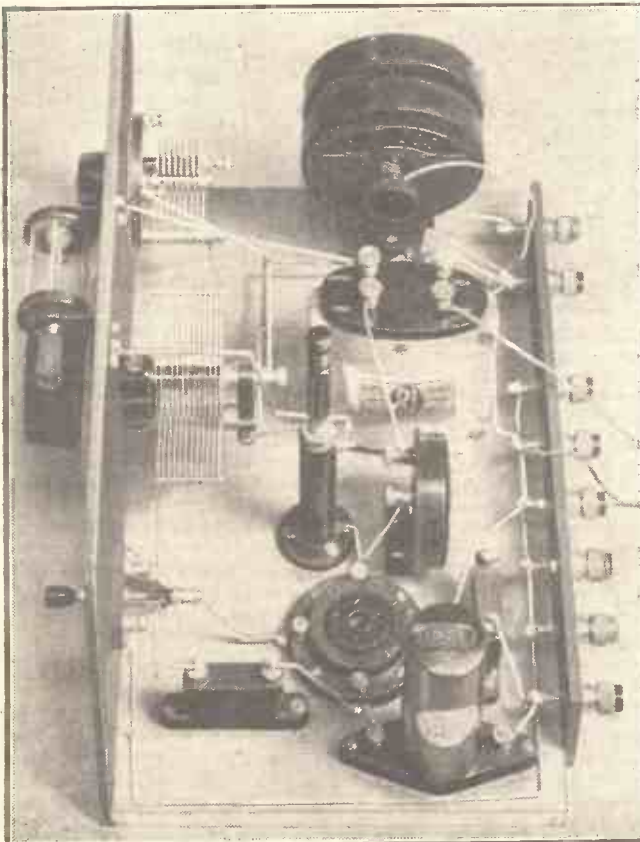

Two views of the 1929 Trinadyne, which show both the layout and wiring of the set very clearly. Note the two different makes (and shapes) of H.F. choke used and the plug which is taken to a centre-tap on one of the coils.

# THE B.B.C. AND PUBLISHING.

The Public and Parliamentary interest in the important question of the B.B.C.'s recent publishing activities is briefly outlined below.

By THE EDITOR.

OUR readers have probably seen in the newspapers that the publication of the B.B.C.'s new journal, "The Listener," has aroused a considerable controversy. It is maintained by newspaper-interests that the B.B.C.'s plan to publish the new weekly journal is unfair, and, furthermore, that the Postmaster-General's action in refusing to receive a deputation of bodies representing the newspaper and printing industries of the country is very much to be deplored.

The Secretary of the Newspaper Proprietors Association wrote to the Postmaster-General on December 15th, stating that it was considered that unfair advantage was being taken of the terms of the B.B.C.'s charter in publishing the new paper, and asking him to receive a deputation. On the 19th a reply was received, stating that the publication of the journal was within the discretion of the Corporation, and that no useful purpose would be served by receiving a deputation.

## Permissible Under Charter.

On a further occasion, the Postmaster-General refused to receive a deputation, again reiterating his view that the publication proposed by the B.B.C., i.e. "The Listener," was permissible within the power granted to the B.B.C. by its charter.

On receiving this refusal, the following letter was sent to Mr. Baldwin, the Prime Minister:

"The Association representing the London and Provincial Press, the periodical and weekly newspapers and the Master Printers are much perturbed at the action of the B.B.C. in entering the publishing business, in which they are concerned in a large way. These Associations are satisfied that it was never intended that the Corporation should undertake such operations. They have requested the Postmaster-General to receive a deputation, which he has declined to do. They therefore have no alternative but to appeal to the Prime Minister.

"I will not now develop the reasons which led them to make this request, except to say that the B.B.C.'s activities in this respect are entirely contrary to the industrial and trade policy which you and your colleagues have laid down from time to time.

## Unfair Competition.

"The B.B.C. are paying no income tax, and yet they are competing with firms who do, and are diverting trade from legitimate trade channels. They are not only publishing newspapers, but operas, handbooks, and books for use in schools.

"If it is the policy of the Government that these extensive powers, with their far-reaching possibilities, should be run by a Government department, it is just as well that the fact should be made known, as what applies to newspapers and periodicals applies also to other trades.

"I may say that the associations concerned represent, at a low computation, some £200,000,000 to £300,000,000 of capital, and employ vast numbers of men and women.

"On behalf of the Newspaper Proprietors Association (representing the London morning, evening, and Sunday newspapers), the Newspaper Society (representing the provincial newspapers), the Periodical, Trade Press, and Weekly Newspaper Proprietors Association, and the Federation of Master Printers and Allied Trades of Great Britain and Ireland."

## B.B.C.'s Reply.

This letter was signed by Mr. T. W. McAra, the Secretary of the Newspaper Proprietors Association.

The B.B.C., in defending their action in producing the new paper, "The Listener,"

## THEIR RIGHTFUL ROLE.



It is in bringing famous people to the microphone, and in introducing public personalities into private homes that the benefit of broadcasting is felt. This picture shows Earl Jellicoe in the London Studio.

stated that the new journal is designed to replace a substantial proportion of the educational pamphlets and booklets which have appeared regularly during the last few years. There are no proposals to establish any new series of publications.

POPULAR WIRELESS understands, on excellent authority, that this widespread condemnation of the B.B.C.'s action in bringing out another journal in competition with vested interests has caused quite a stir at Savoy Hill, and that, in consequence, the policy of "The Listener" will be considerably modified. It is quite clear that the storm of protest which has been aroused by this new publication may lead to litigation with a view to altering the terms of the B.B.C.'s charter and in curtailing further publishing activities.

There is no doubt that, from a legal point

of view, the production of this paper, "The Listener," is at the moment justified, but on moral grounds it is to be deplored that the B.B.C. should continue its ill-advised policy of enlarging its publishing activities, thus competing on an unfair basis from the financial point of view with commercial interests.

## Not Their Business.

After all, we have to bear in mind that the B.B.C. is a Government Department and, on political grounds, it is unwise that any of the B.B.C. publications should come under the term of subsidised journals by a Government Department. Another point is, of course, that the listener's money is being used to float this publication, and although there is no suggestion that any profits accruing from the paper would be spent on increasing and improving broadcasting in this country, it is felt (and justifiably so) that the income derived by the B.B.C. from licence fees should be sufficient to carry on broadcasting without recourse to securing further income by the publication of journals which compete on an unfair basis with existing ones, and with the existing rights of newspapers and periodicals generally.

We hope that the B.B.C. will take a tip from the storm they have aroused by the publication of this new journal, and that in future they will refrain from producing new publications, and turning themselves into a publishing business, when it is morally understood that their business in life is to give broadcasting entertainment.

## New Talks.

In the syllabus of talks and lectures issued by the British Broadcasting Corporation, and covering the period up to next April, several new features will attract the special interest of listeners.

On Monday evenings there will be a special set of talks on "Crime and the Criminal," in which

Mr. Laurence Housman, Dr. Cyril Burt, Lord Feversham, Colonel Turner (of Wakefield Prison), and Lord Lytton will take part. On Tuesday evenings Sir Walford Davies will continue his talks on "Music and the Ordinary Listener."

On Wednesdays, in place of last session's symposium on "My Aims in the Theatre," there will be a series on "The Future of the Cinema."

## Another Serial.

Mr. Vernon Bartlett will continue his talks on "The Way of the World" on Thursdays; on Fridays there will be a topical or general talk, and on Saturdays there will be another experiment in broadcast fiction, a serial story in six episodes by Mr. Holt Marvell, called "Six Strange Saturdays."

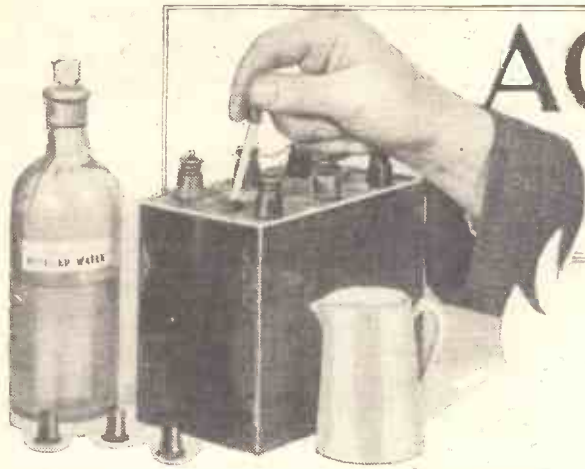

# ACCUMULATOR ECONOMIES

Helpful Hints on the Choice of an Accumulator for Long Life and Efficiency.

By J. F. CORRIGAN, M.Sc., A.I.C.

**P**ERHAPS, in common with nearly every radio amateur and experimenter, you have, at one time or another, echoed the query, "What is the best accumulator?"

Truth to tell, however, there is no "best" accumulator in the strictest sense of the word; for all the secondary batteries of this type which are manufactured by reputable concerns may be depended upon to function efficiently, provided they are given reasonable treatment.

### Two Important Factors.

But in purchasing a new accumulator, the amateur has such an overwhelming series of models to choose from, that he is apt to become rather dismayed at the task, particularly so, of course, if he has not completely left the novice stage of the radio art.

To put matters briefly, however, the effective choice of an accumulator depends mainly upon two factors, viz., the type of service for which it is required, and the amount one is willing to pay for the instrument. Cheap foreign-made accumulators are generally a snare and a delusion, and there is no gainsaying the fact that if you want a reliable article of this nature, you have to be prepared to pay a reasonable price for it.

For the man whose purse is limited, the

best value in the accumulator line consists of the glass-box type of accumulator, containing one pair of plates only. These cells are very sturdily built, and they will stand a lot of knocking about without injury. Their disadvantages are that they must be charged very slowly, and that a relatively low charging current must be used. Furthermore, owing to the comparatively wide separation of the plates, the internal resistance of accumulators of this type is rather high, which fact somewhat reduces their working efficiency for power use.

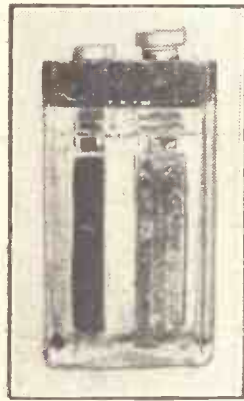

Glass-box single-cell type of accumulator.

Still, however, accumulators of this type are about the cheapest and the most trouble-free of any, and, for such reasons, they make their special appeal to the beginner with the valve set.

At the same time, however, accumulators of the multi-cell type, enclosed in celluloid cases, are perhaps the more popular articles on account of the fact that they can be put to a more varied number of uses. They are generally easier to charge, and a little variation in their standard rates of charging does not exert so great an influence upon the discharge rates of the cells as it does in the case of the heavy-plate glass-box type of accumulators.

Besides which, of course, accumulators of the celluloid case type are ever so much the more portable articles, especially when a number of accumulator cells are being dealt with.

Such, in general, are the pros and cons of the two types of accumulators. But, of course, there are details which ought to be considered before the purchase of a new accumulator is embarked upon.

### Details to be Considered.

Take, for instance, the reasonable life of the accumulator. Even with relatively heavy working, this ought to comprise a good three years. If, however, attention is regularly paid to the careful charging of the accumulator, you may easily rely

upon its lasting a good deal longer than the stipulated three years.

In order to obtain the maximum length of life from an accumulator, its rate of discharge should not appreciably exceed 1-12th of its ampere-hour rating. Which means to say that, in selecting your accumulator, you should multiply the total current you are likely to require by 12, and then choose an accumulator of that rating. Some authorities, of course, stipulate that an accumulator should not be discharged at a greater rate than 1-20th of its capacity, but, for most usages, a discharge rate of 1-12th of an accumulator's capacity will do no harm.

### Construction of the Plates.

When purchasing a new accumulator, there are several minor details which should be given due attention. Look at the construction of the plates, for instance. Are their internal connections well and sturdily made, or are they merely fastened together anyhow? If a cell is badly made in this respect, corrosion troubles are easily liable to occur at these areas of internal connection within the cell.

Then, again, do the plates reach nearly to the bottom of the cell? If so, it is a bad point, for a well-made accumulator will have its plates cut short at a distance of at least three-quarters of an inch from the bottom of the cell, this construction

(Continued on next page.)

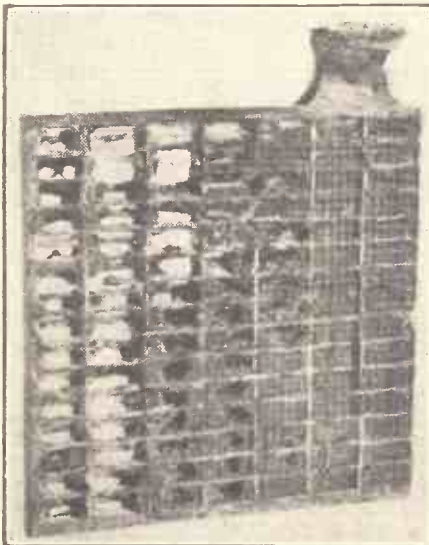

The positive plate of an accumulator with a portion of the active material removed, to show the construction of the plate.

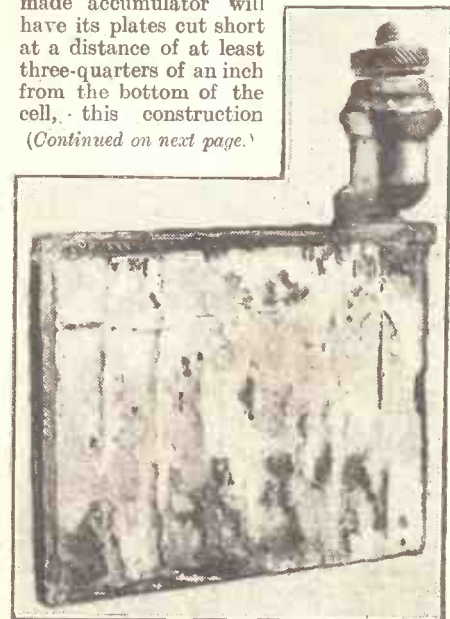

The sulphated plate of an accumulator, this being caused by faulty charging and discharging.

## "AND THAT'S THAT!"

By H. J. B. C.

AMONGST my correspondence recently was a letter from a friend in which the following paragraph appeared:

"I am sorry to say that my set has failed to function. Apparently the valves are burnt out, for it was going well and then there was a sudden cessation. I can only suppose that the loose lead from the Pentode valve wobbled a bit, and that's that!"

I knew that he had installed, quite recently, a three-valve set, using a screened-grid valve, a detector, and a pentode valve, so I paid him a visit to see exactly what had happened. Readers are, of course, aware that with a pentode valve there is a terminal on the cap which has to be connected to positive high tension, the exact voltage varying between 80 and 120, the connections being made clear from Fig. 1.

### The Pentode's "Flex."

A flexible lead is joined usually between the cap terminal and a convenient point which connects to H.T. +. In some cases this is a separate terminal provided on the terminal strip, while in other cases it is joined to a component terminal passing to H.T. +, for example, the primary H.T. + terminal of an L.F. transformer.

In the set I examined I found that the pentode valve had been removed from its holder and a power valve substituted in its place in order to make comparisons for volume and purity of reproduction. The

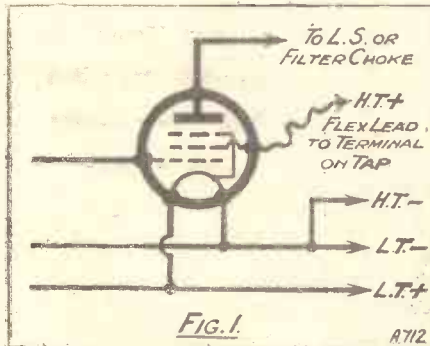

flex lead was connected to the L.F. transformer terminal, and had been left inside the set, the disconnection having been effected *only* at the Pentode cap terminal. It is easy to picture what had happened.

### Three Valves Destroyed.

An untoward vibration had been imparted in some manner, with the result that this flexible link which was "alive" to the extent of 80 volts had touched an L.T. + connection, bringing about the demise of three good valves and a financial loss to the tune of between two and three pounds.

If, by chance, this wandering lead had attached itself to an L.T. - connection somewhere in the set, then the H.T. battery would have been shorted out. It is all right to be wise after the event, but the exercise of a little caution would have prevented any damage.

When using pentode valves (or screened-grid valves for that matter, as similar arguments apply to both), be sure and switch off the set before making any adjustments either internally or to the G.B. and H.T. wander plugs. Furthermore, since the connection to the terminal on the cap of the pentode valve, or the terminal on the top of the glass bulb of the screened grid valve, is made usually through the medium of a short length of flex wire, take precautions to ensure that no damage will occur.

### Guarding Against Burn-Outs.

One of the safest plans is to provide a spare terminal mounted on ebonite and screwed to the baseboard, and bring the appropriate H.T. connection to this terminal, and then join the flex lead from the valve to it. Another very efficient method is to arrange a socket on the baseboard, suitably insulated from the wood, of course, and let the flex link terminate in a spring which can be conveniently inserted into, or withdrawn from, the socket, as occasion demands.

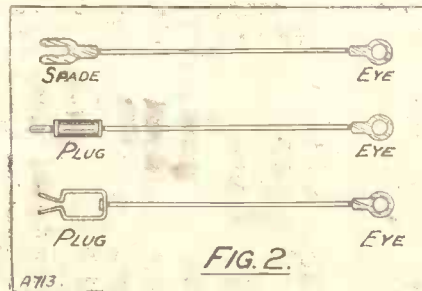

In addition, see that the connection is made to the valve first before inserting it in the valve holder, and then when ready connect the lead to the point provided. Conversely, if removing a screened-grid or pentode valve, first disconnect the end of the lead remote from the valve and the wire is then rendered "dead."

To jog one's memory that this is the safest course, I find it best to terminate one end of the lead in an eye tag and the other in a spade tag or plug, according to circumstances (see the sketch of Fig. 2). By attaching the eye under the valve terminal, it will not slip off if the terminal head is loosened and this should serve to remind you that the end to disconnect is that attached to the spade tag or plug.

In itself, this may appear a small item, but it should be the means of preventing you from writing a letter couched in terms similar to those of the opening paragraph.

## PATENT PROTECTION.

If an inventor or would-be inventor draws up his own provisional specification for a patent, the cost of protecting his idea provisionally is only £1 for the stamp fee.

The filing of a provisional patent specification does not give the inventor the status of a patentee, but it secures his right for a period of nine months, during which he can complete the necessary patent.

## ACCUMULATOR ECONOMIES.

(Continued from previous page).

being necessary in order to allow an adequate space for falling sediment, which would otherwise form an accumulation and make contacts between the lower edges of two or more of the plates, thus causing internal short-circuits within the cell.

The terminals of an accumulator, although they may appear to be mere details, exercise a great influence upon the life and usefulness of the cell. Any good make of accumulator will be fitted with terminals which are at once massive and convenient to handle. The best types of accumulators are fitted with non-corrosive terminals—a great saving of time in maintaining them in an electrically clean condition thus being effected. And, of course, when purchasing an accumulator, you will take care to see that the under-connections to the terminals are well made. Otherwise, your instrument may suffer the fate of many others, and have to be scrapped after a year or two's use, owing to the terminals dropping off in virtue of the corrosion of their under connections.

### Very Important "Cases."

And finally, if your choice of an accumulator lies in the direction of a celluloid case type of cell, see that the case itself is efficiently made, and that it is likely to hold together throughout the life of the cell. The case should be fairly transparent in order to enable the owner to observe periodically the condition of the plates and to check any tendency to sulphating which perhaps might crop up upon occasion. Flimsy cases are worse than useless. They are always giving trouble, and it is doubtful if they can ever be repaired really satisfactorily.

Accumulators—"de-luxe" of the celluloid variety contain separate celluloid cases for each pair of plates, the whole series then being bound up together in a sort of celluloid crate. This is the type of battery which the amateur should aim at obtaining if funds permit.



The negative plate of an accumulator.



# FREE!—WITH NEXT WEEK'S 'P.W.'

A Thirty-Two-page Book no reader can do without.

The "P.W." Constructor's Guide supplies a long-felt want. It is just the thing the amateur has been waiting for. With every issue of next week's "P.W." a copy will be given away—Free. Don't miss it.

Order  
Next Week's  
"P.W." Now,  
and get your  
copy of this  
Invaluable  
Book  
**FREE!**

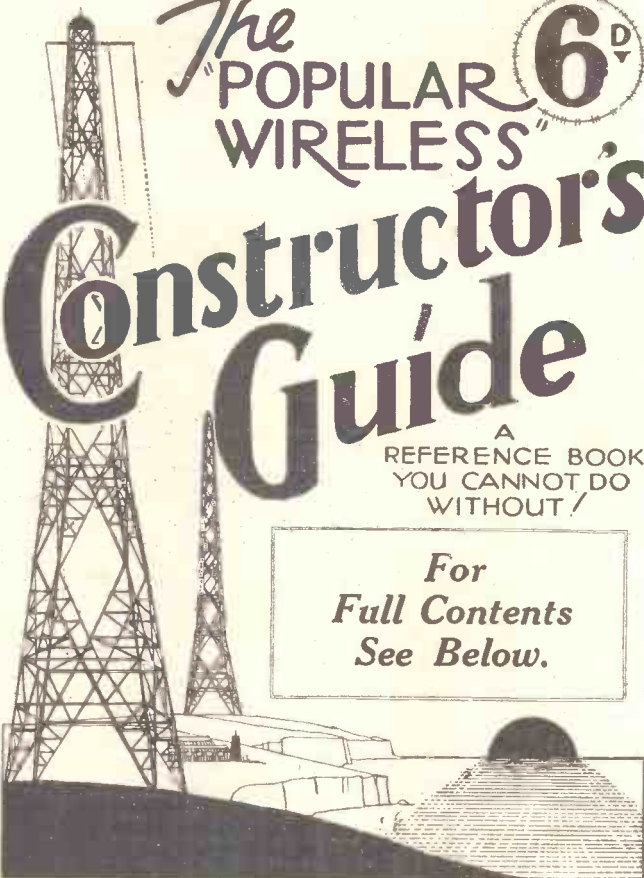

*The* "POPULAR WIRELESS" **6<sup>p</sup>**  
**Constructor's Guide**  
A REFERENCE BOOK YOU CANNOT DO WITHOUT!  
*For Full Contents See Below.*

This great  
"P.W." Gift Book  
is unique, and  
supplies concise  
information in a way  
you have  
always wanted  
but have never  
had before.

## CONTENTS:

A Simple Method of Neutralising.  
Interaction Between Aerials.  
B.A. Screw Sizes and Drills.  
Aperiodic Aerial Coupling.  
The "P.W." Radio Dictionary.  
The "P.W." Standard Wave-Trap.  
A Simple Testing Scheme.  
Outside Interference.  
Specific Inductive Capacities.

Loud-Speaker Extension Leads.  
Fitting a Potentiometer.  
Comparative Resistances.  
Aerial Length and Height.  
Radio Sensitive Crystals.  
The "P.W." Standard Loading Coil.  
British Standard Plug-in Coils.  
"P.W." Selected Circuits.  
Hints on Tuning.

All About Wire.  
Mains Units and Chargers.  
Set-Building Tools.  
How Many Valves?  
Standard Panel Sizes.  
Unofficial Abbreviations.  
Telegraphic Codes:  
1. Morse Code. 2. "Q" Code.  
Accumulator Notes.

High Resistance Voltmeters.  
Testing an L.F. Transformer.  
What is a Baffle?  
Valves You Should Use.  
Make Your Own Fixed Condenser.  
The World's Broadcasters.  
Leading Short Wavers.  
Choosing a Loud Speaker.  
Radio Diagram Symbols.  
S.G. Valves and Pentodes.

## LATEST BROADCASTING NEWS.

BURNS NIGHT  
ARRANGEMENTS

A GOLF BALL ARGUMENT—  
ROMAN CATHOLICS AND  
BROADCASTING—NEW  
BRIDGE BROADCASTS—  
“BALANCED RATIONS” BY  
RADIO—WALES v. SCOT-  
LAND RUGGER COM-  
MENTARY.

## Burns Night Arrangements.

FRIDAY, January 25th, Burns' Night, will receive extra special attention from the B.B.C. this year. The programme will be relayed from Poosie Nancy's Inn, the home of "Tam O'Shanter." Dr. Joseph Hunter, President of the Dumfries Burns Club, will give the "Immortal Memory" toast.

On the same evening, Welsh listeners will hear speeches relayed from the Cardiff Caledonian Society's Dinner, and dance music from the ball which will follow on. Newcastle will take a similar flood of oratory from a local Caledonian function. Aberdeen is going one better. There a party of "aborigines" from the far north-east are giving a local Burns programme on Wednesday, January 23rd.

## A Golf Ball Argument.

At 9.20 p.m. on Friday, January 25th, Mr. Bernard Darwin and Captain Harry Graham will discuss the size of golf balls at 2 L O.

## Roman Catholics and Broadcasting.

Since the appointment of the Rev. C. C. Martindale, S.J., to represent the Roman Catholics on the B.B.C. headquarters' Religious Advisory Committee, there has been a marked revival of interest in radio possibilities among Catholics. Father Martindale is taking the London studio service to-morrow evening, Sunday, January 20th. Notable Catholics in the B.B.C. include Mr. Cecil Graves, Lord Grey's nephew.

## New Bridge Broadcasts.

The B.B.C. is arranging a series of Bridge broadcasts, the first of which will take place at 11 p.m. on Monday next, January 21st. Specially selected hands will be published beforehand, and listeners will be invited to play them according to their own ideas afterwards listening to the way in which they are played by experts.

Each hand will contain some point of general interest either in the bid or in the play of the cards, and perhaps in both. Then at the end of the game the experts, whose names, Mrs. Stafford Northcote, Major Browning, Mr. Manning Foster, and Mr. Jack Dalton, are familiar to all who follow the game seriously, will each explain why the bids were made and the cards played in a particular manner. Altogether there will be six broadcasts in the series, and they will be given fortnightly from 2 L O and most other stations.

## “Balanced Rations” by Radio.

Some months ago Professor V. H. Mottram gave a series of talks on Food Values, in the course of which he mentioned a bewildering number of things we should consume in order to supply our bodily carburetters and gear-boxes with the requisite quantities of vitamins and other essential, though mysteriously worded, products of calorific worth.

The only question left for listeners to decide was whether to eat cabbages for breakfast or porridge for supper and generally to determine for themselves the best method of preparing meals containing the right proportion of everything required to

## DUBLIN CALLING.



Mr. Hughes, the announcer at the Dublin station. No doubt a great proportion of our readers will have heard announcements from Dublin, which is now working on a wave-length of 319 metres and a power of 1 kilowatt.

produce the correct results. The outcome was that Professor Mottram and the B.B.C. had a pretty hefty postbag asking for recipes incorporating the various food-stuffs, so that while the talks were extremely valuable in educating people on what to eat and what to avoid, they left listeners somewhat in the air as to how to do so.

Professor Mottram is not going to be caught like that again in his next series of talks, which are to be given on Wednesday evenings, and he has accordingly arranged a number of what he describes as “balanced ration” recipes, and these are to be broadcast on Friday mornings from 5 X X.

The recipes will be framed on the lines of the previous Wednesday evenings' talks, and should do much to assist the ever-growing number of people who are adopting the sensible view that unless we employ science in food preparation we can easily lose much of what it can give us in other ways. The first batch of “Balanced Ration” recipes will be broadcast on Friday morning, January 25th.

## Wales v. Scotland Rugger Commentary.

Mr. L. J. Corbett, captain of the England Rugby XV in 1927-28, is giving a running commentary on the Wales v. Scotland “Rugger” International match which is to be played on Saturday, February 2nd, on St. Helen's Ground, Swansea.

This is the ground where, owing to its being used for cricket during the summer, the spectators are kept some distance from the touchline in order that the turf shall not be damaged.

Visiting players are sometimes adversely affected by these strange conditions during the first part of the game, and once, some years ago—also in a Wales v. Scotland fixture—the crowd broke down the fence. The broadcast description of the game will be heard from London and Daventry as well as from the Welsh stations.

## TECHNICAL NOTES.

By Dr. J. H. T. ROBERTS, F.Inst.P.

## VARIABLE CONDENSER DESIGN

NOISELESS CONTACT—CONTROLLING REGENERATION, ETC., ETC.

## Variable Condenser Design.

WITH all the improvements which have taken place during the past two or three years in variable condensers, you might think there was little left to improve. But I have before me particulars of some of the new variable condensers appearing on the American market in which several important changes in design and construction have been made.

The needs of the U.S. amateur in the New Year, what with changed frequency bands and more limited territory, call for a higher standard of performance, and in consequence a great deal of new apparatus is coming forward, designed to fulfil the more stringent requirements.

The condenser in question is issued by the Radio Engineering Laboratories.

## Noiseless Contact.

It departs from the normal practice in that it is fitted with a rugged die-cast “Y”-shaped end-plate in which is mounted the double conical bearing. An unusual feature

of this bearing is that the shaft runs in a tiny pool of mercury and so is free from the electrically noisy contact which is so often a bugbear in tuning elements.

Several types of condenser are provided, each with this end-plate assembled as standard. In one of these, which is fitted with a single stator and a single rotor plate, the capacity range is made adjustable by provision for the longitudinal movement of the stator plate. In a second type the capacity range can be varied by the adjustment of a lumped adjustable capacity built into the condenser. In all the models the plates are of heavy brass.

## Controlling Regeneration.

In most regenerative receivers there is a tendency to produce excessive regeneration on the lower wave-lengths, that is, on the high-frequency range of the condenser. As many of such receivers incorporate a fixed condenser across the primary of the first L.F. transformer, the removal of this

(Continued on page 1032.)

# A single note from over eighty strings



## SILENCE BEFORE and SILENCE AFTER

A single note is struck upon the keyboard—a single string vibrates—notice how sharply defined the note is against the background of the succeeding silence.

It is just like that when a note impinges upon the background of silence in which a Lissen Transformer amplifies. Each note is given its full value, each instrument its characteristic tone; high notes suffer no distortion, low notes come through in all their sonorous beauty.

*Whatever set you have or whatever circuit you are building, this is the kind of amplification you want, and a Lissen Transformer will give it to you.*

### The LISSEN SUPER TRANSFORMER

This Super LISSEN Transformer is made in two ratios,  $3\frac{1}{2}$  to 1 and also  $2\frac{1}{2}$  to 1. The  $3\frac{1}{2}$  to 1 is suitable for use in either the first or the second stage of an L.F. amplifier, or can be used in cascade for both stages, and with practically any valve. The  $2\frac{1}{2}$  to 1 transformer is suitable for use after a high impedance rectifier valve without fear of distortion or loss of high notes and overtones. The price is the same for both ratios.

19/-

### The famous 8/6 LISSEN Transformer

Has won for itself the reputation of "The Transformer that will never break down." Suitable for all ordinary purposes. Turns ratio 3 to 1. Resistance ratio 4 to 1

8/6

# LISSEN

## TRANSFORMER

LISSEN LIMITED,

8-16, Friars Lane, Richmond, Surrey

(Managing Director: Thos. N. Cole.)

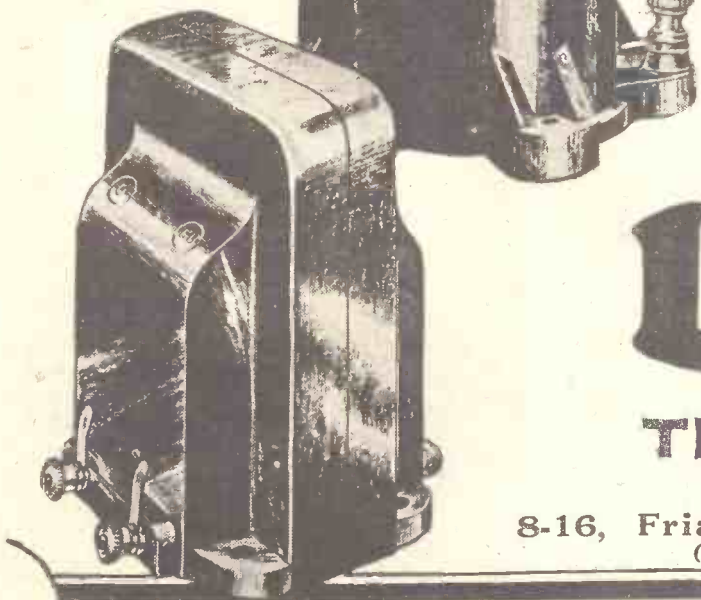



T.C.C. Electrolytic Condenser. Capacity 2,000 mfd. In a case 5 inches high. Price 15/-.



T.C.C. Flat Type Mica Condenser. Capacities from .001 mfd., 1/10 to .01 mfd., 3/6.

# MR. WEDGWOOD DID NOT MAKE KNIVES & FORKS!



**J**OSIAH WEDGWOOD was a specialist. He devoted his whole life to one thing—the making of pottery. Again and again he failed, but, undaunted, he persevered until ultimately his pottery became the fashion of the period and is still to-day in great demand.

Like the Burslem potter, we are specialists. For nearly a quarter of a century we have made nothing but condensers. And because we have never deviated from our task.—never expended our energy in the making of other components—the name T.C.C. on a condenser is accepted throughout the world as the undisputed hall-mark of accuracy and dependability. For this reason the Admiralty, the G.P.O., and the Cable Companies of the World consistently use T.C.C. Condensers. For this same reason, too, it will pay you to use T.C.C. Condensers in your next Set.

## FOR OVER 22 YEARS WE HAVE MADE NOTHING BUT

# T.C.C. CONDENSERS

THIS COUPON  
BRINGS FREE

BOOK

I enclose 1d. stamp. Please send me book which tells me how I can build an L.T. or H.T. Eliminator.

P.W., 19/1/29.



**Positive and Negative**

**M**ANY amateurs experience a difficulty in remembering which is the positive electrode of an ordinary flashlamp battery, and which is the negative one.

The matter is not a difficult one to remember, however, if due attention is paid to the construction of the battery. Flashlamp batteries, in common with all forms of dry cells, are, in reality, modifications of the wet Leclanché type of cell. Now, in this cell the carbon rod forms the positive element, and the zinc rod the negative one.

Consider now an ordinary flashlamp battery. Here, also, the inner carbon rod of each component cell is the positive electrode of that cell, whilst the outer zinc covers of the cells are the negative electrodes.

In flashlamp batteries, however, the various positive and negative electrodes are all joined up in series, and the result is that the positive electrode of the battery comprises the shorter strip of brass on its outer surface, whilst the negative electrode is the longer



A typical flashlamp battery.

brass strip which is connected underneath to the zinc casing.

Perhaps this may be somewhat tedious to remember as it stands. But if you bear in mind the fact that the longer brass strip of the battery always originates right at the edge of the battery, and that it is thus obviously directly connected to the zinc casing under the cardboard cover, you will not have much trouble in retaining the polarity of a flashlamp battery in your mind.

In a word, therefore:

Longer Strip of Battery .. **NEGATIVE**  
Shorter Strip .. **POSITIVE**

**Threshold Howl.**

One of the best ways of getting smooth reaction effects on short waves is to fit a potentiometer across the low-tension leads and connect the slider of this to the filament end of the grid leak.

Amongst the alterations which may be tried to cure a threshold howl in a short-wave set are, alteration of the grid leak, of L.F. transformers, the insertion of by-pass condensers into the circuit, and alterations in the spacing.

A selection of short articles covering many subjects of especial interest to the home-constructor of radio receivers, contributed by various of "P.W.'s" well-known technicians.

Very often a low-frequency filter output of the type used for loud speakers will prove equally advantageous for the 'phones in a short-wave set in preventing threshold howl.

**Insulating the Screwdriver.**

Ofttimes enough there exists a certain amount of danger in attempting to tighten up some refractory screw amid the "innards" of a receiver which is already connected up and is, in fact, in working order. The danger, of course, lying in the fact that a long screwdriver might very easily slip off the screw—particularly if the latter occupies an inconvenient position—and might, therefore, short across the H.T. and L.T. circuits of one or more valves, thus causing the filaments to burn out in an instant.

Complete protection from this possible danger, however, can be obtained by insulating the screwdriver in the manner shown in the illustration. All you require for the purpose is about an 18-in. length of oiled silk, or, better still, rubber tape. Secure one end of the tape to the end of the screwdriver blade by means of a dab of some firm adhesive, such as Chatterton's compound. Then neatly wrap the tape around the blade until it covers all but half an inch or so of the metal at the end. This done, another dab of Chatterton's compound will fasten down the remaining end of the insulating tape with adequate security.

It is, in fact, always useful to have one or two screwdrivers prepared in this fashion, for they allow greater freedom of movement when working among H.T. circuits, and for dealing with electrical mains they serve a very excellent purpose, shortly lessening, as they do, the danger of short circuits being made across two or more of the mains leads or cables.



A screwdriver with its blade covered with insulating tape.

**A Useful Wire Measurer.**

The little readily-made gadget illustrated herewith will serve a most useful purpose, in the hands of any busy constructor, saving, as it is capable of doing, much time which would otherwise be taken up in the measuring off of approximate lengths of wire.

As will be seen by a glance at the picture, all this handy wire measurer consists of is a piece of stout cardboard, which is rigid enough to be handled rather roughly without bending or cracking.

Having procured a piece of such material about 7 in. or 8 in. in length, and about 6 in. broad, cut out on its upper and lower edge

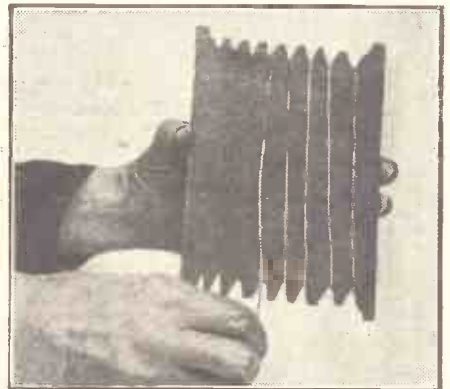

Measuring wire with the very simple device described.

a series of V slots, the distance from the bottom of the one row of slots to the bottom of the opposite row being exactly 6 in. Cut, also, in the piece of cardboard two projecting pieces on each side of the row of slots in order to prevent the wire from slipping off. The wire measurer will now be ready for use, and if it is given a coating of varnish of one variety or another, it will become moisture proof, and will remain in good condition indefinitely.

A length of wire wound once round this gadget will measure just 1 ft. Thus, supposing you have to measure off quickly 4 ft. of wire or flex, all you have to do is to run the wire round the measurer four times, and your length of wire will be more or less accurately measured out.

**A Precaution.**

Be careful not to leave your set connected to aerial and earth when it is not in use for receiving at any time of year. Thunderstorms are apt to come not only in summer and when they are about the aerial may become charged to a very high potential. Though there is little real risk of fire, the set may be seriously damaged if these large voltages are applied to it.

(Continued on next page.)

## FOR THE SET BUILDER.

(Continued from page 1007.)

An earthing switch, provided that it is large and well-insulated, is quite a good protection; but the best method of all is to disconnect down-lead and earth wire from the outside terminals of their respective leading-in tubes, and to devise some means of hooking them together. They then swing clear away from the house, and a good path to earth is provided for anything that may come along.

### Keeping the Soldering Iron Warm.

How the outer container of an old and broken thermos flask can serve a really tremendously useful purpose will be seen in the illustration below. Every radio amateur is more or less only too familiar with the difficulty which is always experienced in keeping even a heavy soldering iron sufficiently hot enough when it is used for outdoor work. Such a task is bad enough during the warm days of the summer, but in the winter it becomes almost impossible of attainment.

However, the use of the device described here will be found to make matters very considerably easier in this particular respect.

Obtain the container of an old thermos flask, and, after cleaning it out, cut a piece



The Thermos Soldering Iron Container.

of wool or flannel to line the interior sides. Glue the fabric to the sides, and then set the container apart for a few hours in order to enable the glue to dry. In drying, the glue will contract the fabric, so that careful working in this respect will result in a nice flat surface being given to the wool lining of the container.

Next, obtain a small quantity of sheet asbestos. This can generally be procured at any ironmonger's emporium. Cut the asbestos to a suitable size, and then glue it

to the wool lining of the thermos flask container. In this instance, however, allow for an overlap of the asbestos at the neck of the container, as shown in the photograph. This latter will go a long way towards preventing the cold air from entering the container.

### Holds Heat Well.

The device will now be ready for use. After heating the iron to a slightly higher temperature than that required for the actual soldering operation, place the iron in the heat-insulated container, and carry it out to the area of operations. You will find that by these simple means, the iron will keep sufficiently hot for a surprisingly long time.

The device is, of course, equally useful when employed for ordinary soldering work at the bench, the double layer of heat-insulating materials within the thermos container retaining the iron's heat very efficiently.

## PRACTICAL PARS.

**I**n modern sets, especially of the multi-valve type, the H.T. positive plug should never be altered while the set is working, but the L.T. switch should always be in the off position when this is done.

Where power or super-power valves are employed it is not advisable to alter the grid-bias plugs while the set is working owing to the very great effect upon the resistance of the valve and consequently upon the filament plate current of the valve.

The reproduction from a loud speaker depends not only upon the instrument itself, but also in a degree upon its position in regard to neighbouring walls.

If you have a cone cabinet with a hole at the back by means of which the reed unit may be adjusted, you will possibly find it is not advisable to stand this close up against the wall.

### SAFETY FIRST.

Owing to the way in which electric light, etc., switching is installed it is not generally safe to rely upon the switch which cuts out the input to a mains unit, etc. (It is safer to pull the plug right away from the house wiring socket, than merely to switch off.)

If you use a mains unit do not forget that fog and mist across the switch terminals of an external aerial-earth switch may form a conductive path capable of carrying quite a considerable current.

Where high tension is taken from direct-current mains it is advisable to have a fixed condenser in the earth lead and another in the aerial lead, so that leakage cannot take place from either of these points.

Never make any adjustments inside a set which is deriving H.T. from the mains unless both the filament and the high-tension current are switched off.

Remember, that if you are deriving current from the D.C. mains, your aerial may be at high potential and capable of giving a shock to anyone standing on the ground and touching the wire, especially if the ground is moist.

### Reading and Plotting Valve Curves.

I am sure that there are quite a number of readers who are not familiar with the art of reading valve curves, and a very simple explanation of how to do this may be helpful.

First have at hand a valve curve such as is usually supplied in printed form with most of the valves which are supplied by our manufacturers. Along the bottom horizontal scale you will read grid volts negative from a zero point on the right hand. From this point is a vertical scale which reads anode current in milliamps.

### Simple Procedure.

Having grasped this the rest is simple. On the chart you will find plotted a number of curves which are representative of different H.T. voltages applied to the plate of the valve or valves.

Supposing you apply 80 volts H.T. and decide to use, say, a negative grid bias of 4 volts. To find the consumption factor you simply draw a line straight up from the 4-volt negative point on the bottom scale until it meets the 80-volt H.T. curve, and then travel straight across horizontally to the vertical scale, which will indicate how many milliamps are consumed by the particular valve in use under these conditions.

If, however, the filament of the valve is being under run, or over run, this reading will not be correct, as the filament heating

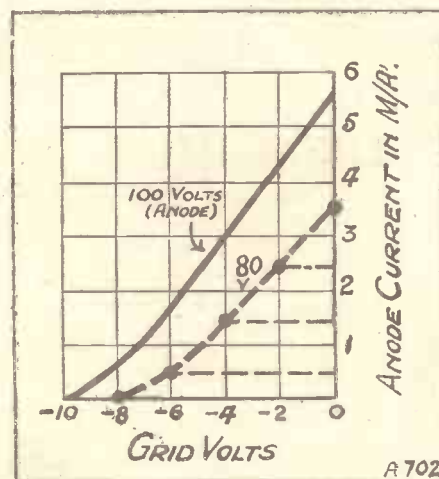

as specified for the valve also has a direct bearing upon the anode current consumption factor, although this is not commonly realised.

The best thing to do in this respect is to see that the correct filament voltage is applied.

### Checking Emission.

Now, supposing we wish to provide a curve for a valve for which we have no curve as a reference. For this a milliammeter should be placed in series with the H.T. lead and a reading taken with a minimum negative grid voltage applied; or we may start at zero grid volts.

By reading the milliammeter a point may be marked on a chart. This process is repeated at various stages of applied negative grid voltages, and the points marked each time, then the various points are joined up to form a curve. The whole process is quite simple and is a useful check on the emission of the valve under test.



Whatever circuit you are building, use Lissen Fixed Condensers throughout; because then you get precise values, you get condensers which never leak and never vary, you get condensers which always deliver all their stored-up energy—all the time. And they are accurate to within 5 per cent of stated capacity. On these qualities in your fixed condensers may well depend the selectivity of your set, the volume and purity of reproduction—therefore use Lissen Condensers always and you will have condensers which will remain constant throughout the life of the receiver.

### LISSEN FIXED CONDENSERS

Can be used in every published circuit.

.001 to .001 mfd. each	.. .. .	1/-
.002 to .006 mfd. each	.. .. .	1/6

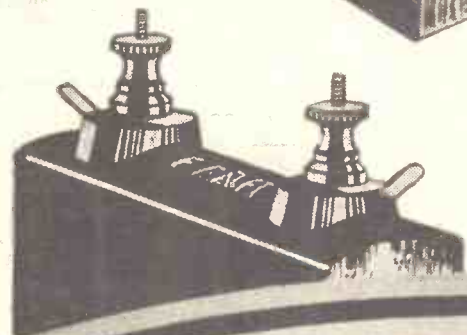

### LISSEN MANSBRIDGE TYPE CONDENSERS

Hermetically sealed in a non-conducting case, cannot be short-circuited on the case. Deliver all their stored-up energy and have the biggest margin of safety of any condenser made. Self sealing.

.01 to .05	.. 1/9	5 ..	2/3
.1	.. 1/9	1 ..	2/6
.25	.. 2/-	2 ..	3/6

LISSEN LIMITED, 8-16, Friars Lane, Richmond, Surrey

(Managing Director: Thos. N. Cole.)

# The Easy Way TO PERFECT RADIO

### MOVING COIL LOUD SPEAKERS.

All leading makes supplied.

Magnavox. **Send only 14/8**  
Balance in 11 monthly instalments of 14/8.

Marconiphone. **Send only 11/7**  
Balance in 11 monthly instalments of 11/7.

Rice Kellogg. **Send only 15/2**  
Balance in 11 monthly instalments of 15/2.

**EKCO H.T. ELIMINATOR.**  
A famous product by a famous firm. Variable tapping 0 to 120 and 1 fixed 120. Maximum output 16 m/a. Model r.VA.20. For A.C. Mains rectification by valve. **10/-** and 11 monthly payments of 10/- DOWN.

**THE MULLARD MASTER THREE STAR.**  
Complete Sets of components for all the latest Mullard Star sets are available. For example, the Mullard Master Three Star. **Send only 10/-**  
Balance in 11 monthly payments of 15/3.

**CONSOLE LOUD SPEAKER CABINET.**  
Handsome polished Console Cabinet in mahogany, dark oak or golden oak, including baffle board. **Send only 8/3**  
Balance by 11 monthly payments of 8/3.

**ULTRA DOUBLE ACTION AIR COLUMN LOUD SPEAKER.**  
This loud speaker automatically segregates high notes from low notes. Two distinct units in the one loud speaker. Perfect reproduction over the whole range. Full details of various models in our big list. Standard model. **Send only 8/3**  
Balance by 11 monthly payments of 8/3.

## ALL YOUR RADIO NEEDS ON EASY TERMS

Send a list of your requirements for a quotation by return. Expert technical service and advice free of charge.

### FERRANTI SIMPLE 3 VALVE SET

This unique receiver, described in the constructional chart distributed with "P.W." January 5th issue, has already gained extensive popularity. For the complete kit of components and polished oak cabinet, excluding valves, batteries and speaker, using A.F.3 transformers. **10/-**  
Send only  
Balance in 11 monthly instalments of 13/4.

Write, call or phone for everything radio:

## PETO-SCOTT CO., LTD.,

77, CITY ROAD, LONDON, E.C.1.  
Telephone: Clerkenwell 9406.  
62, HIGH HOLBORN, LONDON, W.C.1.  
Telephone: Chancery 8268.  
4, MANCHESTER STREET, LIVERPOOL.  
Telephone: Liverpool Central 2134.  
New Manchester Branch:  
33, WHITELOW ROAD, CHORLTON-CUM-HARDY.

### CELESTION C12 LOUD SPEAKER.

An instrument combining handsome appearance with all-round efficiency. **Send only 10/-** and 11 monthly instalments of 13/9.

### COSSOR MELODY MAKER.

Complete kit, including valves in sealed carton. This wonderful Set can be built in 90 minutes. **Send only 10/-**  
Balance in 11 monthly instalments of 14/7.

### REGENTONE MAINS UNITS.

Comprehensive range of dependable Units for A.C. and D.C. Mains. As an example: Model W.1a for A.C. Mains. 1 variable tapping 0 to 100 volts, 1 fixed 90 volts and 1 power. Maximum current 30 m/a at 180 volts. **Send only 13/1**  
Balance in 11 monthly instalments of 13/1.

### OLDHAM D.C. CHARGER

and 120 volt H.T. Accumulator. The charger incorporates Westinghouse Metal Rectifier under licence. Safety fuse prevents overload. The Accumulator is one of the finest made. **Send only 10/10** and 11 monthly instalments of 10/10.

### POST THIS COUPON for OUR BIG LIST

Full details of everything Radio on Easy Terms, please.

NAME.....  
STREET.....  
TOWN.....  
P.W.19/1.

# TELSEN TRANSFORMERS



The TELSEN "RADIOGRAND" Transformer at 12/6, and the "ACE" (a compact, light and efficient instrument specially designed for Portables) at 8/6, are two models which have achieved overwhelming popularity with Radio enthusiasts. Install a TELSEN and note the extraordinary amplification and purity. Entirely British, guaranteed 12 months, and obtainable everywhere. Ratios 5-1 and 3-1, shrouded and with detachable feet.

Illustration shows the "RADIOGRAND."

TELSEN ELECTRIC Co., Ltd.,  
207, Aston Road, Birmingham.

# CLARKE'S "ATLAS" PIRTOID TUBING

By reason of its wonderful insulating properties Pirtoid Tubing is the ideal former. It is especially suitable for the making of High Frequency Transformers, Aerial Coils, or any of the specified solenoid coils for special receivers.

Pirtoid Tubing can be had in any Diameter, Wall or Length; it is easy to drill, unbreakable, and is highly insulative.

There is no substitute for genuine Pirtoid Tubing—nothing else that will give as good results.

Write for details and prices to  
H. CLARKE & CO. (Manchester)  
LTD.,

"ATLAS" WORKS,  
OLD TRAFFORD,  
MANCHESTER.

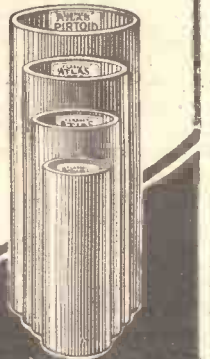



**"EVERYBODY'S" THREE.**

The Editor, POPULAR WIRELESS.

Dear Sir,—I have looked through your columns during the last week or two for a constructor's report on the "Everybody's" Three, but have failed to see one, and the thought that nobody, perhaps has written prompts me to pen this.

There are so many good points about it, that it is really difficult to choose which to give prominence to, but the main one is, it certainly does all you claim for it.

The tuning range with one suitable set of coils is: 1,000 to 2,000 (approximately) and 250 to 550 metres (A1, 40 coil; A2, 60; and reaction 30); and these two wave-bands have brought me over forty stations during the past week, all on the loud speaker, but I have no means of identifying at least half of these.

It was as you stated in the latter part of the text, the volume given by this set was so great that it would overload an ordinary power valve. I tried firstly two in parallel with marked improvement, but have had to substitute these with one of the super-power class to get the present A1 results.

I have departed from your instructions in two cases, namely, a 32-henry choke instead of the 20, and a 100,000-ohm resistance in place of the 50,000, as I had both these components on hand, but with these departures the results are exceptionally good.

The reproduction I am getting at present with this set coupled to a large cone speaker of the floating edge-baffle type, is far and away better than I have ever experienced before.

The only fault I can see is, that reaction is very sharp, but I am hoping you will suggest a remedy for this, as it makes tuning at present rather a ticklish job.

Hoping other readers of your paper have had the same measure of success, I remain, sir,  
Yours truly,  
Lancashire. R. H. WHALLEY.

**TESTING POLARITY.**

The Editor, POPULAR WIRELESS.

Dear Sir,—For testing polarity, I generally use a piece of "blue-print" paper (the genuine ferro-prussiate kind, not the ink-printed variety so largely used for circuit diagrams, etc.).

To use, moisten the paper (just lick it!) and apply to leads; a white mark will appear at the place touched by negative lead.

This is much more convenient than the glass of water method, which requires wires, as a piece of paper can be applied in any position, for instance, to the pins of an ordinary lampholder.

Yours truly,  
S. PIERRE SMITH  
(Reader of "P.W." from No. 1)  
Brighton.

**REGARDING LOUD SPEAKERS.**

The Editor, POPULAR WIRELESS.

Dear Sir,—I have never seen in any of the wireless journals an explanation of why a loud speaker reproduces the volume and quality of sound that it does. I have in mind the average cone speaker, a piece of paper not under any great tension such as the string of an instrument, reproducing in quality and volume the notes of all instruments including the drum, which is a well stretched skin fixed on its carrier.

**H**AVING now embarked upon 1929 (although 1929 conditions, as far as Washington is concerned, have been with us for some time), we may settle down to make a review of the position as a whole. My own feelings in the matter are that the short-wave listener is better off altogether than he was in 1928, while the amateur short-wave transmitter is in a distinctly worse plight than was ever the case before.

**Amateur Band Invaders.**

While the commercial short-wave stations have now moved well away from the majority of the short-wave broadcasters, the amateur bands are by no means free of invaders. The amateurs were told, in a semi-apologetic way, that although the bands allotted to them would be narrow, the lower ones at least would be exclusive. At present, at any rate, this is very far from being the case. A G J, Nauen, U O K, Vienna, and all our own Air Ministry stations are settled comfortably right in the 40-metre amateur wave-band. The latter particularly are turning out signals that would be sufficient evidence for the cancellation of the licence of any amateur transmitter. Their notes are practically "raw A.C." which is now forbidden.

**CORRESPONDENCE.**

**"EVERYBODY'S" THREE.**

**TESTING POLARITY—REGARDING LOUD SPEAKERS—THE "OLYMPIA" FOUR—PCJ'S TRANSMISSIONS.**

Letters from readers discussing interesting and topical wireless events, or recording unusual experiences are always welcomed; but it must be clearly understood that the publication of such does in no way indicate that we associate ourselves with the views expressed by our correspondents, and we cannot accept any responsibility for information given.—EDITOR.

The surface idea of the strings and drums and the resonance of their carriers, and the volume of air displaced by the wind instruments, is very different from that of the paper of the cone.

This might interest some of your readers.  
Yours faithfully,  
Bexhill-on-Sea. P. W. L. ANDREW.

**THE "OLYMPIA" FOUR.**

The Editor, POPULAR WIRELESS.

Dear Sir,—I have just completed the construction of the "Olympia" Four, published in your issue of September 22nd, and feel I must write and congratulate the "P.W." Research and Constructional Dept. on a really first-class set.

Although I have been for a matter of two years a keen reader and constructor of "P.W." sets I have always been something of a "sceptic"—never quite getting what I expected, always dissatisfied until now. From crystal set I worked up through the "Chitos" One and Two, "Handyman" Two, several 3's including the "Sceptic's" Three, and always grumbling. Finally I built the "Everybody's" Three, and found that I still wanted more. I wanted pure reproduction with a good choice of programmes, and was willing to keep on until I got it. Well, to cut a long story short the "Olympia" Four has given me all I ask, at last, and I am fully satisfied and deeply grateful. As for quality—I listened all this evening to music from Langenberg and every instrument was clear and faithfully reproduced. What has surprised me most is the deep, rich tone, and remarkable selectivity, with a wave trap. I have used a Lissen L.F. choke and wound my own coils, as given with the "Derby" Three. Thanking you again.

Gratefully yours,  
Manchester. H. W. MILLS.

**PCJ'S TRANSMISSIONS.**

The Editor, POPULAR WIRELESS.

Dear Sir,—Being a short-wave enthusiast I am interested each week by the usual short-wave article in POPULAR WIRELESS. I turn automatically to this particular page every week as soon as POPULAR

WIRELESS arrives, to devour its contents. You will remember, probably, that in the early summer I wrote you stating that I was receiving PCJJ on the "General Purpose" Three (using two valves), at loud-speaker strength, and I hold confirmation of programme from this station. You will now see why I am interested in the short-wave articles, as for the last two months this station, which was my pride and joy, has completely disappeared, and cannot even be heard in 'phones. Your correspondent, Mr. Brownsword, of Carmarthen, is not alone in not hearing the Dutch short-waver at present. The remarkable part is that 2 X A F 2 X A D, and 3 L O come in as usual. There must be hundreds of enthusiasts who would like to know the reason of this phenomenon, and I for one would be grateful to POPULAR WIRELESS if you could supply the reason or likely reason.

Regarding the "General Purpose" Three, this is a wonderful set. What about a long-wave-no-coil-change version of it?

Wishing yourself and POPULAR WIRELESS a continued prosperous New Year.  
Yours faithfully,  
Plymouth. P. LOCKYER.

The Editor, POPULAR WIRELESS.

Dear Sir,—In answer to Mr. H. W. Brownsword's question in "P.W." of December 29th, I can give him some information. PCJJ has been very erratic this last month here, sometimes I have had him at full loud-speaker strength and sometimes I could get his carrier-wave only, on headphones. Last night (January 3rd) I could only just get him on 'phones at 6.30, to-night I am getting him at full speaker strength at 6.30 to 7.30, with little fading. I do not agree with W. L. S. rebuilding another set if one can't get PCJJ. Lately I could not get PCJJ, but Melbourne (3 L O) was plain on the loud speaker, which proves that my set is not at fault. I am using a Mullard Master Three, which has answered very well for all wave-lengths.

Could the correspondents when speaking of finding stations state if they receive them on 'phones or speaker?

Yours truly,  
J. STEAD-LEAKE.  
Guernsey, Channel Islands.

The Editor, POPULAR WIRELESS.

Dear Sir,—Referring to Mr. Brownsword's letter in a recent issue of "P.W." I have not been able to receive PCJJ for some five weeks past, and reception previous to that fell off very badly. It is certainly not a fault of receivers which I anticipated in my case, nor is it a "dead spot," as Morse stations either side of Eindhoven's dial setting have a tremendous amount of "punch." Condenser readings have not altered and 2 X A D and 2 X A F come over very well indeed. The unit used is the premier model of the "Antipodes Adaptor" on which I have done some very good work. 3 L O, 2 F C, 2 X A D, 2 X A F, 2 X G, 5 S W, A F K, 7 M K, being among the stations received. I have, however, not yet picked up the Dutch station your correspondent mentions. Wishing "P.W." every success during the coming year.

Yours faithfully,  
Bristol. R. W. FELLENDER.  
(Note: PCJJ is now called PCJI—Ed.)

**SHORT-WAVE NOTES.**

By W. L. S.

The question is, are the commercial stations knowingly straying outside the bands allotted for their use, or is it that their frequency-measuring apparatus is not so accurate as that which is held to be necessary for amateur use by our G.P.O.?

I have recently been using a very interesting and promising scheme for short-wave C.W. reception, although it is of no interest whatever to those who only wish to listen to broadcast. It consists of the use of a tuned 1,000-cycle amplifier in place of a note-magnifier, utilising a screened-grid valve for the purpose.

The whole thing is arranged in quite a "straight" circuit, the 1,000-cycle tuned circuit (in series with the anode of the screened-grid valve) consisting of the secondary winding of a Ford coil (with core removed) shunted by a .02 fixed condenser. This gives tuning sufficiently

sharp for the purpose and has the effect of "peaking" all C.W. signals more or less strongly at 1,000 cycles or so.

Naturally, with a very efficient amplifier producing a very sharply defined peak, it would be difficult to read any C.W. stations except those that are rock-steady, like the crystal-controlled ones. With the Ford coil, however, the peak is not too sharp, and the effect is simply one of increasing the selectivity of the receiver by a great amount.

**Separating C.W. Signals.**

Two C.W. signals that would normally be interfering with each other quite seriously can be completely separated, simply by the expedient of tuning one of them till a beat-note of roughly 1,000 cycles (quite a comfortable note to read) is produced, and thus making full use of the amplifier.

Speaking roughly, I should say that a given signal is 200 per cent stronger when tuned to produce a 1,000-cycle beat-note than when a beat-note of 400 or 500 cycles is given. The effect of tuning in musical broadcast on this amplifier is absolutely indescribable! It reminds one forcibly of the very early days of broadcasting and carbon microphones at their worst.

## MY RADIO-CINEMA.

"Fireside Talkies," cheap picture receivers and other fascinating things are made possible by the Technical Editor's latest invention. In this article he describes his scheme and gives a few details regarding the proposed B.B.C. test.

By G. V. DOWDING, Grad.I.E.E.

A WEEK or two ago there were brief Press references to one of my latest inventions, and no doubt those "P.W." readers who noticed them wondered why it was that nothing had appeared about it in our own journals. Let me assure them right away that neither myself nor any of my present activities are disassociated from "P.W." The Press merely recorded the fact that the B.B.C. are going to test the invention and the description of the scheme was sketchy because I had supplied but meagre details.

So far you could count the number of people who are acquainted with the full technical details on the fingers of one hand—and, at that, on the one hand of a man minus a few digits! Readers may certainly rest assured that the first intimate description of the invention will appear in these pages.

### Concerning Demonstrations.

There are several reasons why I am withholding the telling of the full story until the B.B.C. test is concluded and one is connected with the securing of foreign patents, while another is quite a personal reason. I may be quite wrong in thinking so, but my experience has tended to make me believe that there are a lot of people who will leap forward with criticisms (generally quite futile) about an invention before closely studying the matter, and without any other evidence before them than that of second-hand, word-of-mouth information.

Therefore, I am going to make criticism impossible until the whole business is demonstrated. The B.B.C. test is to be carried out very shortly, and immediately following this, demonstrations will willingly be given to any committee, scientist, etc., who cares to ask for one, and who can offer a satisfactory reason for so doing—obviously we cannot give a series of free entertainments to mere sensation-mongers!

Also, let me add, there will be no commercialisation of the scheme until it is generally admitted to be completely satisfactory in every way. Already I have been approached by numerous financiers and some well-known business men, but to every one of these I have returned the same answer—"Nothing doing until the idea is tried out under stringent conditions," or words to that effect. To those who have asked me what I am going to do with the patents providing everything proves O.K., I have said that in this country at least the B.B.C. should have some say.

### No Landlines Needed.

Regarding the B.B.C. test—the first official one—I should like to make it clear that the demonstration will be carried out under conditions as closely approaching normality as possible. Thus, the transmitting and receiving ends will be connected by ether throughout the investigation. There will be no landline link or even a multi-wave radio channel.

It matters not to me whether the transmitter is in America and the receiver in London, or the two points are in the same street. Place the transmitter at Aberdeen, if you like, and wherever normal broadcasting can be picked up on a normal valve set, I can dump down my receiving end just as happily without upsetting the normal transmission effects of the "emitter."

### Simple Synchronising.

But perhaps some of you did not read the Press announcements, and do not yet know what my scheme is, so I will give you a very brief summary of its main features. The invention definitely is NOT the combination of radio and the home cinema projector. That, in my opinion at least, does not constitute an original idea. No doubt many hundreds have mentally connected together these two forms of entertainment, and probably there have been attempts to do it.

No; my patents relate primarily to an extremely simple method of synchronising which I hope to be able to prove makes the

which synchronism is needed other than automatic telegraphs?

Thus Baudet synchronism, the correcting cam of the Hughes' gear, vibrators and phonic wheels, shift-the-hands correction, the modified Western Union, Western Electric, Murray, and the Sims-Reeves arrangements and I are moderately well acquainted. And if you fire a hundred questions at me regarding synchronising by magnetic pendulums, synchronous motors, isochronous trip-relays, and etc., I will guarantee to answer a good many of them.

And when it first occurred to me some time ago that broadcasting was waiting for a simple synchroniser in order to simplify radio-cinemas, picture receivers and other such things, I carefully reviewed all the above systems—without hitting one useful idea! It is not practical to ask a listener to lumber himself up with fifty or a hundred pounds worth of complicated instruments. A telegraph office can stand for a five-hundred-pound box of tricks, but most broadcasters would surely shudder at the idea of spending as many shillings on an accessory. I would for one! You can do all sorts of wonderful things with complicated mechanism, but simplicity as well as reliability must be the keynotes of public service.

### Robust Mechanism Wanted.

The listener would quite rightly decide to wait until something of a simple, unforbidding character was invented—apparatus which could be switched on and left to its own devices and would not be staggered by a static or need gentle nursing. He doesn't even want one delicate relay; he wants robust mechanism that the younger son can jab pencils into without serious ill-effects—to the mechanism, anyway!

Is there such apparatus which will synchronise a Berlin broadcaster with a Littlehampton listener if needs be? Apparatus which will work a home talkie (if you want and can afford a home projector costing £8 upwards), work in addition a four or five-pound picture receiver, a broadcasting race game costing still less, other eminently practical and

fascinating things, and yet itself come within the region of the pockets of most listeners? I trust shortly to be able to prove that there is.

Does it make television possible? It might some day, but there are other problems to be solved before television can arrive. In the meantime, I hope to be able to give you something that ostensibly will have the appearance of true television. A brilliantly lighted screen drama in the drawing-room every bit as technically perfect as one projected in a West End cinema with voices and noises as good as the B.B.C. can send them out, and as good as you can get them on your set. Should be better than the best ordinary "talkie," shouldn't it?



Mr. Dowding (right) discussing with Mr. Kendall the design of the simple three-valve set which will probably be used in connection with the Radio Cinema and Picture test.

"home-talkie" a really practical proposition. It also can be applied to other things. The same apparatus can be used, for instance, for the reception of the still pictures now being transmitted from 5 X X, Vienna, etc. Given simple synchronising apparatus, many things become practical which were before of merely academic interest.

The science of synchronisation is by no means new to me. In fact, in all humility, I think I can say that I know a fair amount about it. For quite a number of years it was my lot to tinker about with telegraph apparatus at the Central Telegraph Office. And synchronisation cannot be met with anywhere else in such bulk as in telegraphic gear. Can you think of anything else for

# AN "ALL-WAVE" H.F. UNIT



To get real H.F. amplification on waves below 50 metres has long been the cherished dream of the short-wave enthusiast, and a dream it has remained until comparatively recently. The arrival of the screened-grid valve, however, has put a very different complexion on the business, and the dream is beginning at last to come true in sober fact.

The possibilities of the valve for short-wave work were recognised some considerable time ago in the "P.W." Research Dept., and we have carried out experiments with a great many different kinds of circuits. We have got results of some sort with practically every circuit tried, better in some cases than others, of course, but with most they were quite encouraging.

#### Producing a Universal Design.

So many of the different schemes tested gave good results that it could only be concluded that the difficulty of getting a screened-grid H.F. valve to work on short waves was much less than could have been expected. Accordingly, we were encouraged to proceed and try to work out a more or less universal type of design for a unit which could safely be put in the hands of our readers with the assurance that it could be depended upon to work with practically any set.

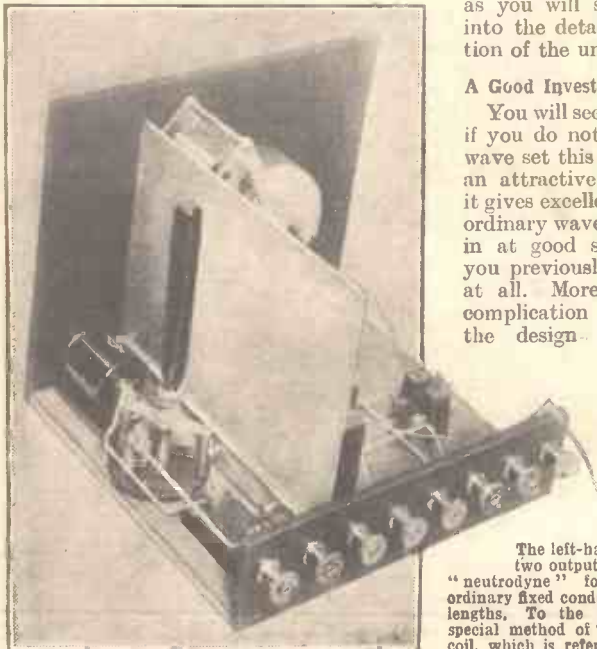

\* \* \* \* \*

**H.F. Units of the past have been unsuitable for short-wave amplification, but this novel "P.W." Unit strengthens up American and other stations in a wonderful way. It is easy to build, too, and inexpensive!**

**Designed and described by  
The "P.W." RESEARCH DEPT.**

\* \* \* \* \*

In this we have succeeded to a greater degree than we had dared to hope, after a series of experiments, and have also gone further and produced a unit which can be used on any wave-length from about 17 metres upwards. The change from one wave-band to another is perfectly simple, and merely means changing a single-coil and moving a couple of tapping clips.

The results which the unit will give on the ordinary broadcast band and on the long waves used by 5XX and similar stations are well up to standard, for nothing has been sacrificed here to make it suitable for the shorter waves. The only changes necessary on going down to short waves, apart from changing the single coil, are a matter of moving the tapping clips, as you will see when we go into the details of the operation of the unit.

#### A Good Investment.

You will see, then, that even if you do not possess a short-wave set this H.F. unit is still an attractive proposition, for it gives excellent results on the ordinary waves, and will bring in at good strength stations you previously could not find at all. Moreover, the extra complication introduced into the design by the special features which fit it for short-wave work are very slight indeed. By



The left-hand picture shows the two output coupling condensers, "neutrodyne" for short waves, and ordinary fixed condenser for other wave-lengths. To the right is shown the special method of "clipping" the grid coil, which is referred to in the article.

building such a unit you will provide, remember, for the day when you *do* decide to go in for short waves.

Just what the unit will do is a point of interest to possible constructors, and we will endeavour to give you an idea of its capabilities under average conditions. On the broadcast waves this is what you may expect if your set is of the detector and L.F. type (the one for which the unit is intended): all those stations which you previously got on the loud speaker will come in at increased volume and improved quality, since you will no longer need to use so much reaction.

#### What It Will Do.

Those stations which previously were weak, even with the full permissible amount of reaction, should come up to good speaker strength, while a whole string which previously you could not hear at all, should be heard at quite fair strength with just a little delicate tuning, and a moderate amount of reaction.

On the short waves the amplification is not so great (this seems inevitable), but it

*(Continued on next page.)*

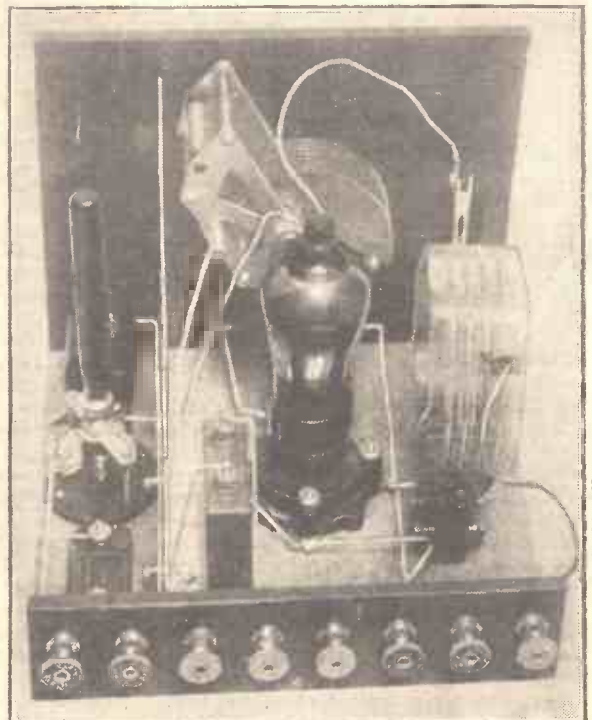

## AN ALL-WAVE H.F. UNIT.

(Continued from previous page.)

is still sufficient to make a simply amazing difference to the performance of any short-wave set which does not already incorporate a stage of H.F.

Those elusive American stations which previously you could only hear in a distorted uncertain fashion because you had to work on the very edge of oscillation (except on very good nights), can now be heard almost any night at greater strength and with far better quality. This, of course, is simply because you do not need to use so much reaction to get the necessary volume, and so tuning is less critical, quality much better, and also fading is not nearly so bad.

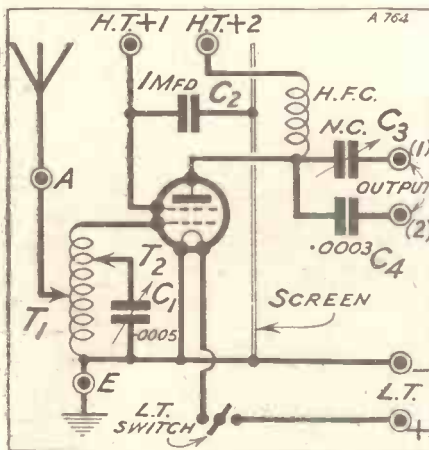

Actually, on good nights they often come in almost as well as a strong station on the broadcast band, and can be put on the loud speaker far more often than you would believe until you try a stage of H.F. A unit like this quite changes one's ideas of the possibilities of short-wave work.

Just one word of warning: Don't expect an H.F. unit to make the local station appreciably louder, for in most cases it won't. It may even make it a trifle weaker if you live very close to the local, because it will feed such a strong amplified carrier-wave into your set as partly to choke your detector valve. (If this happens, of course, the cure is simple: just de-tune the H.F. unit a little.)

### The Secret of Success

Now for the details of the circuit. The whole secret of the universal usefulness of this unit depends on the fact that we have found it possible to use one of the perfectly standard H.F. amplifying circuits, with only very slight modifications, as you will see as we go through it in detail.

The H.F. valve has the usual tuned grid circuit, made up of the variable condenser on the panel and the plug-in coil on the baseboard. To this the aerial is auto-coupled in a very simple manner. On the ordinary waves an "X" coil is used, and the aerial tapping clip is then attached to one or other of the special terminals on the coil.

For short waves one of the special bare wire coils such as the Atlas or Igranic is

used, and the aerial clip is then attached to a turn near the middle of the coil. Its exact position for the best results, of course, can be determined by trial when a station has been tuned in, but it is not critical, and a point near the middle usually serves quite well.

The tuning of this circuit calls for a word of explanation. On the ordinary waves it is done in just the usual way, with the condenser across the whole coil. To do this, the tapping clip on the end of the flex lead from the fixed vanes of the variable condenser is put on the grid terminal of the valve socket.

### Special Tuning Circuit.

For short-wave work a better effect is obtained by tuning only about half the coil, and this is easy to arrange. Just transfer the tapping clip mentioned above to one of the turns of the bare wire coil somewhere near the middle. Tuning is then much less critical and the unit becomes easier to handle in consequence (it is actually quite easy, for reasons which we shall see later).

All this part of the unit constitutes the "input" side of the circuit, and is on one side of the screen. On the other is the "output" circuit, and this is very simple, since the scheme is the one known as "parallel feed."

In the anode circuit of the valve is an H.F. choke, and from the anode end of this two leads are taken off, one to a small variable condenser of the neutrodyne type and the other to a fixed condenser of .0003 mfd. These are the two alternative output leads, and it is arranged that you can take the output of the unit across to your set through either the neutrodyne type condenser or the larger capacity fixed one. (Note the two alternative output terminals.) These two terminals are intended to meet different conditions, as we shall see later.

Constructional work need not detain us long, for the unit is simplicity itself to make. Just one point: You will notice a screen across the baseboard at one point, and this is one of our standard type with a row of perforations across the lower edge, so you need have no fear of any difficulty here. There is no drilling whatever to be done, but just remember to use covered wire for, at any rate, all the wires which pass through holes in the screen.

Success on the short-waves is always to some extent a matter of making just the right adjustments, and this unit is no exception. However, it is much less critical than the average "det. and L.F." short waver, and it is just a matter of carrying out a few adjustments in a systematic way before you settle down to use the unit.

First of all comes the question of the

H.F. valve and its working conditions. The unit is designed for the upright type of S.G. valve, the 2-volt type having been used for all our tests.

This type has been found to work best in this unit with a voltage of 100-110 on the anode and 70-75 on the screening electrode (terminals H.T. +<sub>2</sub> and H.T. +<sub>1</sub> respectively). These voltages are not a bit critical, and a few minutes spent adjusting them after you have picked up a station will settle the matter once and for all.

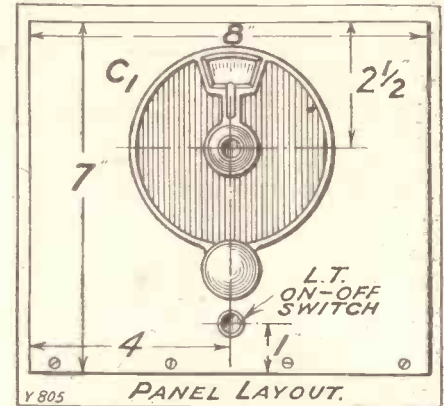

Now, about coil sizes: For the 5 X X range you want a No. 250, and a No 60 for the ordinary broadcast waves, both these to be "X" coils. For the interesting band of short waves between 20 and 35 metres a 4-turn coil is correct. For the next range above, which takes in certain amateur waves (45 metres, chiefly) a 6-turn coil is wanted.

For the lower half of each of these short-wave tuning ranges you should place the tapping lead from the variable condenser on a point near the middle of the coil, but for stations near the upper end of each range it is as well to put the clip on the grid terminal of the valve. Otherwise you

(Continued on page 1017).

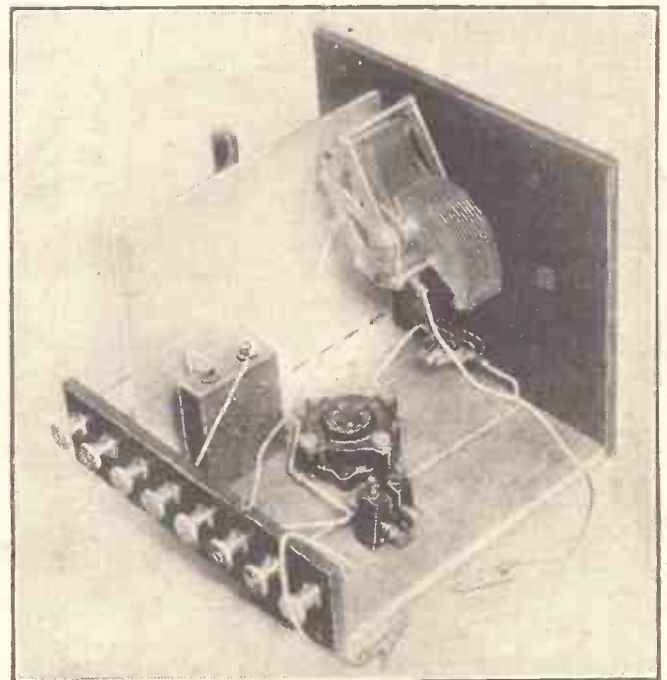

Here you see all the components which make up the input circuit, the output components being on the other side of the screen.

# A WORD ABOUT BACKGROUND and its importance in true reception

Listen to the orchestral rendering of a selection that is broadcast from a studio.

Let the same orchestra broadcast the same selection from, say, the Queen's Hall, and how different the reception will be!

This difference is largely due to the echo, the drapings, the "atmosphere"—the background. And the difference is essential to faithful reproduction. In the case of the Queen's Hall broadcast, it is the presence of the background in its true proportion that makes for the *true* rendering.

The "dead silent background" fetish is misleading, because it suggests that a Transformer *could, of itself,* generate parasitic noises, which in a good Transformer is impossible.

The Transformer designer's aim is to capture every note, each minute signal variation, the true "atmosphere," and to amplify it faithfully—whether it be at a frequency of fifty cycles per second or eight thousand. Before investing in a Transformer send for a copy of the Ferranti book—"True Radio Reproduction," and learn the reasons why the Ferranti curves are the envy and admiration of the whole wireless world.



# FERRANTI

FERRANTI LTD.

HOLLINWOOD

LANCASHIRE

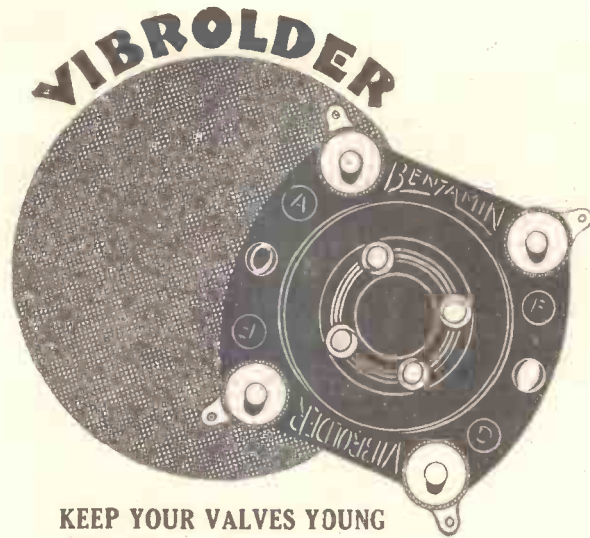

**KEEP YOUR VALVES YOUNG**

The valve's life depends on the valveholder—use Vibroliders and keep your valves young. Vibroliders give perfect contact, are absolutely shock-proof and follow air spaced low-loss design. They are the valveholders with a name and efficiency entirely their own. Price **1/6**

**BENJAMIN**

Benjamin Electric Limited, Brantwood Works, Tottenham, London, N.17

*Fit a*

**BRITISH GENERAL**



**AERIAL TUNING UNIT and be sure of every wave-length**

Alterations do not affect the set which has a British General Tuning Unit, which covers ALL Wave-lengths between 250-2,000 metres. Plug-in coils are designed for a very small range and with the new B.B.C. and Foreign wave-lengths you may find reception difficult. Fit a British General Tuning Unit and make certain. Easy fixing. Price **18/6** simple tuning.

From all good dealers, or direct from

**BRITISH GENERAL**

**MANUFACTURING CO., LTD., BROCKLEY, LONDON, S.E.4.**

**TO HOME CONSTRUCTORS!**  
*Build the Peerless "Resonic 2"*

Anyone can build this set in 60 minutes. No drilling. No soldering. All Wires cut and bent. JUST ASSEMBLE and then immediately enjoy the radio entertainment which is of splendid tone and comes in at good loudspeaker volume. Circuit allows use of standard valves (1 H.F. & 1 Power). Blue Print and easily followed Diagram of Connections included with every set. Cabinet and full Kit supplied in Carton.



Regd. No. 456002

**£3.15.0**

Obtainable from all dealers or  
**THE BEDFORD ELECTRICAL & RADIO CO., LTD., 22, Campbell Rd., BEDFORD.**



(Registered Trade Mark.)

**THE LATEST!**

**PINLESS FORMER**  
which is **FOOLPROOF.**

The ORIGINAL Becol Low Loss Former made in sizes 1 in. up to 4 in. outside diameters. LOOK FOR TRADE MARK.

Write for Becol Handbook on Wireless Circuits, giving data and illustrations. Price 4d. Post Free.

Ebonite Sheets, Panels ground to size, Rods, Tubes, Mouldings.

**THE BRITISH EBONITE CO., LTD., HANWELL, LONDON, W.7.**



**THE 100% Broadcast Receiver**  
**BUILD and OPERATE in ONE EVENING**

**FORMO**  
**"Screened 3 Grid"**

Obtain a Broadsheet from your dealer and read why you should—**Completely Screen the Grid**

**EXTRACT FROM LETTER RECEIVED.**

"We have now had an opportunity of having this set made up and tried out, and find it is all you claim for it. It is, in our opinion, the finest three-valve set we ever saw."

The above is one of many **UNSOLICITED TESTIMONIALS**

Send post card for **FREE FULL-SIZE LAYOUT PLAN** and wiring instructions.

**THE FORMO CO.,**  
Crown Works, CRICKLEWOOD LANE, N.W.2

# AN ALL-WAVE H.F. UNIT.

(Continued from page 1014.)

may find difficulty in reaching up to a station near the top of the ranges specified.

Now about those alternative output terminals. Well, No. 2 is the one to use whenever you can, both for short and ordinary wave work, since this usually gives the strongest signals. However, on

short waves it generally pays to use No. 1 when atmospheric are very bad, for although signals are slightly weakened thereby, the atmospheric are weakened still more, and so you get a better ratio of signals to noise.

To connect up the unit to your set, proceed as follows: Disconnect aerial and earth from your set, and connect them to the approximate terminals on the unit instead. Wire up to the batteries (the same L.T. must be used for both set and unit, otherwise you must remember to run a wire from E on the unit to E on your set), and then join one of the output

terminals on the unit to a suitable point on the set.

This last is a vital point. For a short-wave set which has a separate aerial coil it will be OK in most cases to connect the output terminal to the aerial terminal on the set and use in the old aerial coil socket a coil of the same size as the one in the secondary socket, coupling the coils as tightly as possible (assuming that one of them is movable). For a set such as the "Sydney" Two in which the aerial lead was tapped on to the tuned grid coil, connect up as before and set the tapping about two-thirds of the way up the coil towards the grid end.

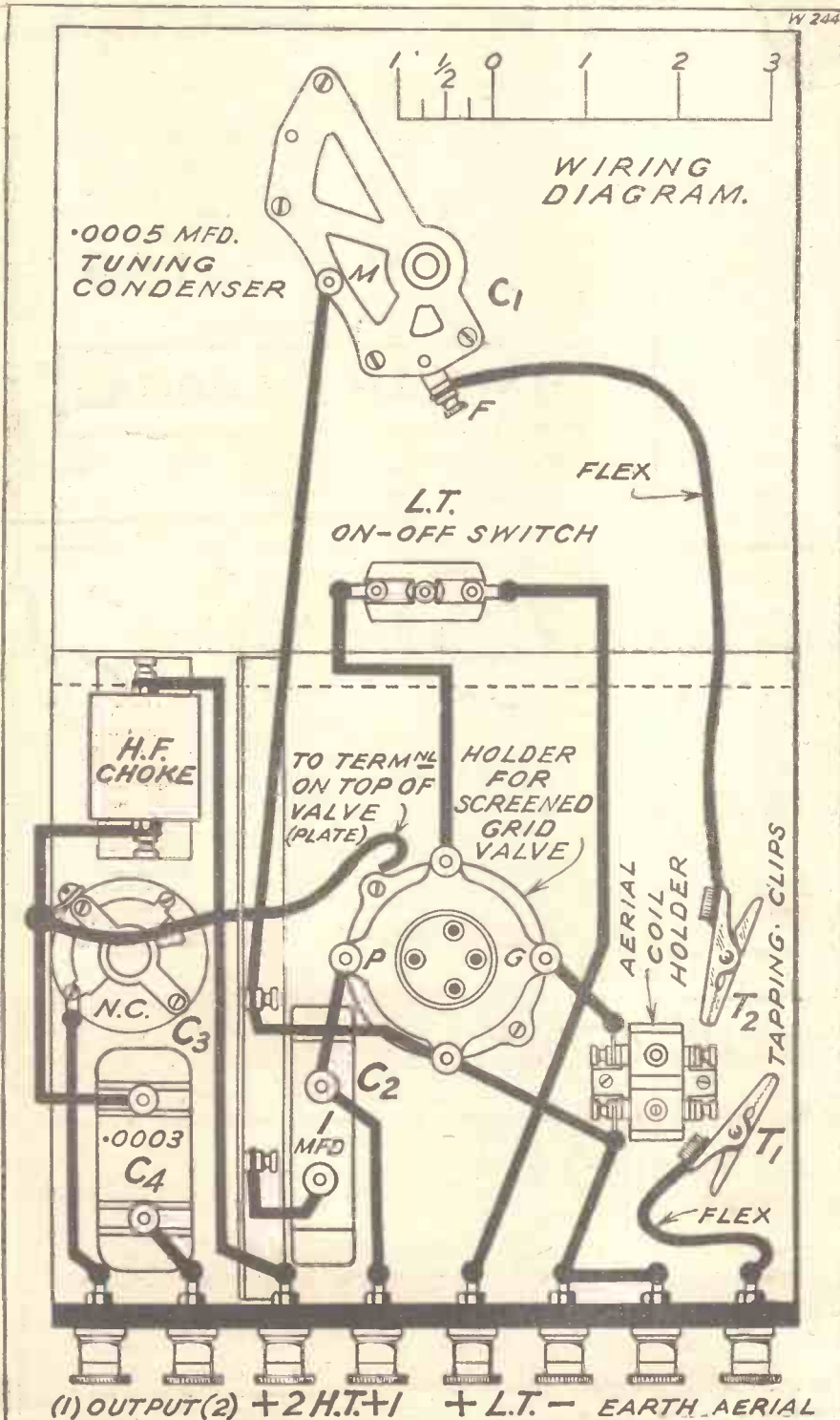

### COMPONENTS REQUIRED.

- 1 Panel, 7 in. x 8 in. x  $\frac{1}{8}$  in. or  $\frac{1}{4}$  in. (Beclon, Resisten, "Kay Ray," Tro-lite, Trelleborg, Ebonart, etc.).
- 1 Cabinet to fit, with baseboard 7 in. deep (Raymond, Pickett, Cameco, Lock, Artercraft, Gilbert, Caxton, Bond, Peto-Scott, etc.).
- 1 .0005-mfd. variable condenser, slow-motion, or with vernier dial (Lotus, Igranic, Cyldon, Utility, J.B., Lissen, G.E.C., Colvern, Marconiphone, Pye, Burton, Ormond, Bowyer-Lowe, Ripault, etc.).
- 1 L.T. switch (Lissen, Benjamin, Lotus, Burne-Jones, Burton, etc.).
- 1 Sprung valve holder (W.B., Benjamin, Lotus, Igranic, Wearite, Burton, Formo, Pye, Ashley, Burndept, B.T.H., Marconiphone, Burne-Jones, Bowyer-Lowe, etc.).
- 1 Single coil holder (Burne-Jones, Igranic, Lotus, etc.).
- 1 Fixed condenser of .0003 mfd. (Mullard, Dubilier, T.C.C., Lissen, Igranic, Goltone, etc.).
- 1 Mansbridge type condenser of 1 mfd. (Any size between .2 and 1 mfd. will serve). (Lissen, Ferranti, Dubilier, T.C.C., Mullard, Hydra, etc.)
- 1 Standard "P.W." screen, 6 in. x 7 in. (Ready Radio, Paroussi, Burne-Jones, etc.).
- 1 Neutrodyne type condenser.
- 1 H.F. choke capable of working well on both long and short waves (A few examples are the Bowyer-Lowe "Long Range," Wearite All-Wave model, Lewcos, etc.).
- 1 Terminal strip, 8 in. x 2 in. x  $\frac{1}{4}$  in., and 8 terminals (Eelex, Igranic, Burton, Belling & Lee, etc.).
- 2 Tapping clips, wire, flex, screws, etc.

For the broadcast waves the input lead should be connected straight to the grid side of the tuning condenser in the set (usually the fixed vanes). To enable you to do this easily it is suggested that a special lead should be brought out of the set, either to a new terminal, or through a flex lead.

This may seem a bit of a nuisance, but it is inevitable with any screened grid H.F. unit.

You will not find that tuning in stations with the H.F. unit in place is at all difficult on the short waves, contrary to one's natural expectations. Curiously enough, the tuning of the unit is comparatively flat. Consequently, it makes the operation of a short-wave set really easier since signals are stronger and easier to find. However, this really calls for a short separate article, which will appear next week.

FROM THE TECHNICAL EDITORS NOTE BOOK



PHILIPS LAMPS LTD.

THERE are quite a lot of novel points about the Philips Gramophone Pick-up type 4005. To begin with it is rather small and is unusually light in weight, while its rectangular shape is uncommon. It resembles no other pick-up in appearance. Externally, another unusual feature is that it has not got the set screw type of needle holder, but has instead a chuck arrangement which grips or releases the needle in an instant. Internally it has a filter arrangement for eliminating needle scratch.

It did not take us long to discover that the Philips pick-up provides a very excellent performance. Indeed, we are inclined to think that it is the best that has yet come to our notice. It is remarkably sensitive, and both the high and the low register are clean and bright. Also it appears to be extremely light on the records with regard to wear.

With the Philips pick-up we also re-

ceived a Philips gramophone amplifier, type 2781. In its way this instrument is just as unique. It incorporates a Philips transformer and makes use of a pentode valve. Thus, with only the two stages, considerable amplification is obtained. The amplifier is contained in a metal case, and is most compact.

It is fitted with a multi-flex cable having substantial terminals on it for battery

Traders and manufacturers are invited to submit radio sets, components and accessories to the "P.W." Technical Department for tests. All tests are carried out with strict impartiality, under the personal supervision of the Technical Editor, and readers are asked to note that this weekly feature is intended as a reliable and unbiased guide as to what to buy and what to avoid.

connection purposes. At the one end are the input sockets, on-and-off switch and volume control, and at the other end the output sockets. The Philips pick-up and amplifier operate remarkably well together, as is only to be expected.



This is the Philips Gramophone Amplifier.

AN EARTHING TUBE.

Most listeners find that a water-pipe makes an excellent earth connection, but in many instances a "direct" earth to the ground will provide much better results as well as being almost essential for complete protection against lightning. One way of arranging the second kind of earth is to bury a metal pail, bath or other such object and connect a lead to it. A somewhat easier scheme is to use an earthing tube.

One such device was recently sent us for testing purposes by Quint Tube, Ltd., of Cannon Street, London. This tube, the full description of which is the Quint

(Continued on page 1020)

Try this Approval The "RADIOLA"

Wireless Bureau will be sent you on 7 days free trial and if not entirely satisfied we will refund money in full instantly. The RADIOLA is what you have always wanted—a high-class Wireless Bureau at makers' prices—the only cabinet of its type and price on the market to-day. In many beautiful models—oak or mahogany.

Used by Radio Press for "2.D.A." "Big Ben," by Percy Harris; "Binowave Four" by W. James, etc. See Jan. "Wireless Magazine" page 528. Phone: Bexleyheath

from 75/-

Over 3,000 delighted users have bought RADIOLAS through the Post. Why not you? Write for Illustrated Lists to-day, to the makers

PICKETT'S Wireless Cabinets

P.W. WORKS BEXLEY HEATH N. LONDON

More Sound Waves From Day's

PORTABLE SETS THAT YOU CAN RELY ON

SELECTOR 3 Comprising 1 S.G. Valve, Det., and Pentode Valve (Oak). 20 Gns.

SELECTOR 5 In Blue leather carrying case, 12 stations charted. 30 Gns.

M.H. 5 In Brown leather carrying case. A really handsome unit. £27 10 0

SPECIALLY DESIGNED FOR USE on A.C. with Cossor, Igranikit, G.E.C. or Mullard Master 3, THE REGENTONE W.I.B. Unit, delivery 120 v., 18 M.A. £4 19 6

ALL EKCO A.C. and D.C. Units in stock from 29/6 each.

ALL AMPLION, B.T.H., MULLARD, PHILLIPS, CELESTION AND MAGNAVOX SPEAKERS IN STOCK.

SPECIAL LINES

SOLDOMETA Pocket Soldering outfit for 2/6

Mogen H.T. Generator, 400 v. 200 m.a. output From £22.

PORTABLE GRAMOPHONES All the best makes in stock. Prices from £2 15 to £10.

SMALL TABLE GRANDS All the leading makes always available for immediate delivery. Prices from £6 10 to £8 10, and other larger models.

RECORDS

H.M.V.	3/- to 10/-
Columbia	3/- to 12/6.
Zonophone	2/- to 4/-
Brunswick	3/- to 8/-
Parlophone	2/6 to 4/6.
Radio	1/3.
Duophone	1/6.

Don't fail to visit our Gramophone Saloon when you next call. Radio or Gramophone Booklets free on request.

For the Best in Radio

WILL-DAY LTD.

(THE BEST IN THE WEST)

19 LISLE STREET, LEICESTER SQUARE, LONDON, W.C.2. Telephone: (2lines) Regent 0921 and 0922 Telegrams: Dittos, Westlund, London



# Now!

## A wonderful New Transformer

..... with a  
marvellous  
performance  
on the lower  
tones.....

With the new Cossor L.F. Transformer you'll hear the roll of the drums — the double bass — the piping of the piccolos — the violins — you'll hear every instrument faithfully reproduced. Fit this wonderful new Cossor Transformer to your set and get a new standard of realism. The superb reproduction of the famous Cossor Melody Maker is largely due to its Cossor Transformer. A Cossor Transformer will give your set a better tone than it has ever had before. See one at your Dealer's.

Price **21/-**

Made and guaranteed by  
the makers of the famous  
**COSSOR VALVES**

# The COSSOR L.F. Transformer

Adv. A. C. Cossor Ltd., Highbury Grove, London, N.5.

**TESTED AND FOUND.**

*Continued from page 1018.)*

Biflex Earth Tube, is made of pure copper, but its construction is reinforced by the provision of longitudinal flutes or corrugations so that it is as capable of resisting driving shocks as a steel tube. It does not tend to buckle when driven into the ground. The price of this earth tube is 2s. 6d.

**ELODEN LOUD SPEAKER.**

Messrs. Eloden Muller & Co., of Berlin, are the manufacturers of the Eloden Loud Speaker and the sole agent for the United Kingdom is F. L. Lesingham of Victoria Street, London, S.W.1. The price of the speaker is £3 15s. 0d., and there is a more powerful type for use in large halls for dancing, etc., at £6 5s. 0d. Mr. Lesingham



The Philips Amplifier with its metal cover removed.

recently brought one of these Elodens along to our laboratory.

The speaker is of somewhat unusual appearance, being rectangular in shape, and having dull coloured gauze over practically the whole of its surface. Apart from the speaker appearing to have a slightly predominant peak at a point not indicated in its laboratory response curve, the results are of a high order of merit. In fact, they are very close to good moving-coil standard of perfection. It is stated that the Eloden speakers are completely covered by licence from the Standard Telephones & Cables Co., Ltd., and that the trade in this respect are fully protected.

**LEWCOS LOADING COIL.**

After designing the "P.W." Standard Loading Coil, we drew up a full specification, copies of which were circulated to the trade. This specification asked for a coil having a certain inductance and with certain definite tappings. The majority of the standard loading coils produced by the trade very closely followed the actual dimensions of our original design, but the Lewcos version has broken completely away from this. That, of course, does not matter so long as the coil conforms electrically with the specification. And this it does!

The Lewcos coil has the appearance of a plug-in type fitted, instead of with the usual socket and pin, with a small base, enabling it to be directly mounted on the baseboard of a set. The coil is of the completely enclosed type somewhat like an ordinary Lewcos tapped coil.

Thus the 216-turn end of the coil has its terminal brought out at the centre, while

the 25, 60, and 80-turn tapping terminals are distributed around the periphery of the device. The 0 terminal is at the base. Altogether the design is a complete departure from the usual make-up of the "P.W." Standard Loading Coil. Nevertheless, we have found it fulfils its requirements every bit as well as our own shape of coil.

In some layouts this different make-up may easily be an advantage, while many constructors may perhaps prefer its appearance. The price is 7s. 6d. In the sample coil we have before us as we write, we notice that two of the terminals are very loose in their settings, but presume that this fault does not occur in the production specimens.



The Lewcos Loading Coil.

**BATTERY BOOKLETS.**

The Standard Wet Battery Co., recently sent us copies of two new booklets they have produced. One deals with the maintenance and use of wet batteries and the other describes the products of the firm. The booklets are available free to all interested "P.W." readers who care to write for them.

YOURS FOR 20/- WITH ORDER



GENUINE COSSOR PARTS ONLY SUPPLIED

**The New Cossor "MELODY MAKER"**

Scrap the dud, obsolete Set and send at once for this Wonderful Set. REMEMBER, NO FUSS OR FORMALITIES AND NO WAITING. DELIVERY FROM STOCK.

SET A.—The New Cossor Melody Maker Kit in Sealed Carton, complete with every component, including valves for making the above three-valve screened-grid set (for further description send for Maker's pamphlet). CASH £7:15:0  
TERMS—20/- with order and 9 monthly payments of 16/6

SET B.—The New Cossor Melody Maker Kit complete as above, and with M.P.A. Cone Loud Speaker, EXIDE 2-Volt L.T. Accumulator and 2 60-Volt British "long life" H.T. Batteries. CASH £10:10:0  
TERMS—20/- with order and 12 monthly payments of 17/3

SEND FOR PAMPHLET W.3 PHONE: NORTH 4430.

**FOSTERS (HIGHBURY) LTD.,**  
74, Highbury Park, Highbury Barn, London, N.5

**WEARITE COMPONENTS**

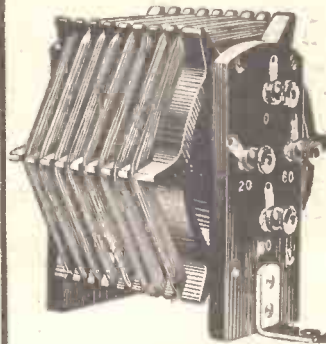

STANDARD LOADING COIL

AS SPECIFIED IN "POPULAR WIRELESS" AND "MODERN WIRELESS" CIRCUITS.

Price 7/6 each.

FORMER UNWOUND 5/-.

**H.F. CHOKE (Standard) 6/6**  
do. (Short Wave) 4/6  
do. (Combined) 9/6

**Push-Pull Switch . . . . 1/-**  
(With Terminals)

**WRIGHT & WEAIRE, LTD.,**  
740, High Road, Tottenham, N.17  
Telephone: Tottenham 3847-3848.

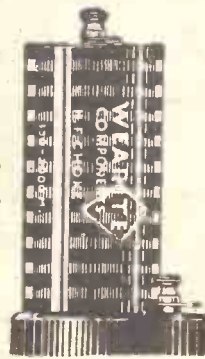

# BUILD EVERY SET WITH

# LOTUS

# COMPONENTS



Lotus Verner Dial, 4/9.

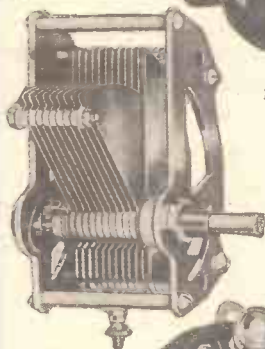

Lotus Variable Condensers. from 5/-.

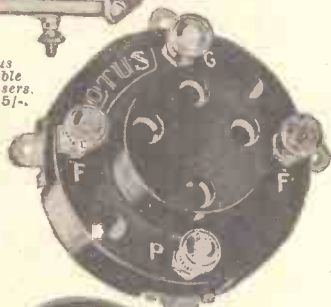

Lotus Buoyancy Valve Holders. Miniature and Standard Types, 1/3 to 1/9.



Lotus Dual Wave Coil, now made with lid, 15/-, 16/6, 21/-.

Made by Garnett, Whiteley & Co., Ltd., Lotus Works, Broadgreen Road, Liverpool

Lauson

## A Happy, No-Drudgery, Spare-Time Business for YOU



Here is your chance to become a Master Man in a Spare-Time Business which is expanding enormously; one which is competing successfully against large combines.

Just sit down and think over this carefully. Our enormously successful Patents are in great demand everywhere. They have become tremendously popular, and as the Wireless and Electrical Business extends, which it will do and is doing to an unthinkable degree, this demand will increase proportionately. We will license you to manufacture our articles under our own Patent Rights, so that you can participate in the Big Profits.

**Profits Guaranteed!**

### No 'Plant' Needed.

No special knowledge or skill is needed and you will find no difficulty about the manufacture. With our new and improved process no expensive "plant" or machinery of any kind is required, and, even though you have not the slightest knowledge of Electricity or Wireless, you can commence to turn your spare hours into GOLDEN Hours! There is no drudgery. Indeed the work is so simple and easy that you require no special accommodation—the kitchen or any spare room can be your workroom—and the whole of the family, including the children, can help you. The work is of fascinating interest and your profit is only limited by the amount of time you have to spare.

We positively Guarantee your profits. Only a limited number of persons are allowed to manufacture. There is not the slightest chance of your market being overcrowded. If necessary we will purchase all your stocks—a fact which assures that you make PROFIT whatever may be the peculiarities of your own case!

### Earn up to £300 a Year!

£300 a year EXTRA can easily be yours. New vistas will open out to you. It will smooth the way to success and enable you to be independent of employers and industrial upheavals. All those luxuries and necessities you have long desired will be yours! Let us hear from you NOW! You are not asked to attempt to revive a "dud" industry but are offered a Novel and Live Business—a growing business! Somebody is going to make a BIG PROFIT in your district and that somebody can be YOU! Send the coupon AT ONCE and full free particulars will be forwarded. Any questions you ask will be answered fully. We have nothing to hide—no expensive "plant" to sell you. This is a Plain, STRAIGHTFORWARD, MONEY-MAKING Proposition, one that has been established a decade! As man to man, can you afford to let it pass by?

### Send this Coupon NOW!

To Mr. V. ENGLAND-RICHARDS,  
The England-Richards Co., Ltd.,  
1112, King's Lynn, Norfolk.

Sir—Please send me at once, and FREE, full details as to how I can Make Money at Home in my spare time. I enclose 2d. stamp for postage.

Print your name and address boldly in capital letters on a plain sheet of paper and pin this Coupon to it.

"Popular Wireless," Jan. 19th, 1929.

All Manufacturers' WIRELESS GOODS advertised in "POPULAR WIRELESS" can be obtained BY POST from YOUNG'S C.O.D. Send us a note of your requirements and goods will be dispatched per return of post.—You pay the postman.—No Extra Charge.



1929 COSSOR MELODY MAKER Complete Kit with 3 Cossor Valves in Sealed Cartons **£7.15.0** Any part sold separately.

### PARTS for the NEW COSSOR MELODY MAKER CIRCUIT

1 Push-Pull Switch 1/-, 2 Var. Condensers 7/-, 2 Slow Motion Dials 7/-, 1 '0001 Reaction Condenser 5/6, 1 6-ohm Rheostat 2/-, 1 H.F. Choke 5/-, 5 Valveholders 4/-, 3 T.C.C. Condensers 8/-, 1 Grid Leak 3 Meg. 1/-, 1 Igranic Transformer 14/-, Wire, Terminals, etc., 3/-.

Young's Special Price, **£2-17-6**

### EXTRAS REQUIRED

1 S.G. Valve £1.2.6, 1 R.C. Valve 10/6, 1 Power Valve 12/6, 1 Accumulator 13/6, 1 108-volt Sure-a-Lite H.T. Battery 14/3, 1 9-volt Grid Battery 1/6.

Special offer of coils for the 1929 Cossor. B.B.C. 6/- pair. 5 X X 7/6 pair.



### MULLARD MASTER 3 STAR

Components as specified by Mullard:—3 Lotus Valveholders 3/9, Colvern Combined Wave Coil 17/6, Permascrope Transformer 25/-, Climax L.F.A. Transformer 25/-, Climax H.F. Choke 7/6, Benja. in Battery Switch 1/3, '0005 Ormond Log Condenser 6/-, '00035 5/9, 2 Slow Motion Dials 10/-, Mullard '0003 and 2 Meg. 5/-, Panel Bracket, 6d., Mullard '0001 Fixed 2/6.

Young's Special Price, **£5-9-9**

Q Coils: Finston 17/6, Lewcos 21/-, Colvern all-wave 17/6.

### CABINETS FREE with above KITS

200 Page Catalogue Free.

### BLUE SPOT UNITS

SPECIAL .. 21/- .. 66k .. 17/6  
66a .. 21/- .. 66k .. 25/-

66-VOLT H.T. BATTERIES, 3/11  
Postage 1/- extra

# YOUNG'S

Note Our Only Addresses:

40 & 41 STOCKWELL ST.  
GLASGOW

Telephone, Bell 2149  
Telegrams, "AERIAL." GLASGOW



# RADIOTORIAL

All Editorial Communications to be addressed to the Editor, POPULAR WIRELESS, Tallis House, Tallis Street, London, E.C.4.

The Editor will be pleased to consider articles and photographs dealing with all subjects appertaining to wireless work. The Editor cannot accept responsibility for manuscripts and photos. Every care will be taken to return MSS. not accepted for publication. A stamped and addressed envelope must be sent with every article. All inquiries concerning advertising rates, etc., to be addressed to the Sale Agents, Messrs. John H. Lile, Ltd., 4, Ludgate Circus, London, E.C.4. The constructional articles which appear from time to time in this journal are the outcome of research and experimental work carried out with a view to improving the technique of wireless receivers. As much of the information given in the columns of this paper concerns the most recent developments in the radio world, some of the arrangements and specialities described may be the subject of Letters Patent, and the amateur and the trader would be well advised to obtain permission of the patentees to use the patents before doing so.

## QUESTIONS AND ANSWERS.

### A SHORT-WAVE PROBLEM.

SHORT-WAVE CONVERT (Warwickshire).—"I am strictly limited as to expenditure, and with the amount I am prepared to spend I am unable to buy both a good H.F. choke and a variable condenser. Left over from a previous set I have a good '0003 mfd. variable condenser with vernier, which I thought would do for the reaction, but either I shall need to make my own H.F. choke or else I shall have to get a very cheap variable condenser for the aerial circuit.

"Which is my best plan—to buy a really good variable condenser and to make my own H.F. choke, or should I be wise in putting up with a less expensive condenser and purchasing a really first-class H.F. choke with the money so saved?"

For short-wave work it is absolutely essential to use a first-class variable condenser for tuning the grid circuit. Furthermore, it is necessary to use a choke of low self-capacity, but as this latter need have only a comparatively small inductance it is quite possible to make a good H.F. choke for a few shillings. You can wind a suitable choke with wire of fine gauge, say 32 or 34 D.S.O.

About an ounce of the wire will be required, and a former for it can be an ordinary glass test tube (obtainable at any chemist for a few pence). About one hundred turns of the wire should be wound on the tube, and in order that each turn shall be separated from the next, a thread of about the same thickness as the wire should be wound on at the same time.

Each turn of wire will thus be separated from the next by the thickness of a thread, and when the coil is finished the thread can be removed, leaving a spaced winding. The test tube can easily be mounted by means of a cork which is screwed down on to the baseboard.

### THE SPARKING ACCUMULATOR.

B. J. (London, E.11).—"When I collected the accumulator they told me that the connecting strips had not been brought with it, so I took it home and started to connect it up there. It happened that I was using 2-volt valves, so I started to connect the different cells up in parallel, but when I connected the positive of one cell to the positive of the next a spark occurred, so I took the connecting bar off again!

"A moment's thought convinced me that no spark should have occurred when two terminals of the same polarity were connected together, so I thought I must have been mistaken and tried to connect the negative of the first cell to the negative of the next. This time there was no doubt whatever—a large spark took place directly the two negatives were connected together. The spark is so big that I am certain it is quite unwise to connect the two together, and I am wondering whatever

can be the cause of it and what I can do to overcome the difficulty?"

From your description we are afraid that the cell has been charged backwards. That is to say, that its polarity has been reversed by careless charging.

Probably what happened was that when on charge the central cell was turned round so that its negative was placed where its positive should have been. Consequently, when the heavy charge passed through the cells, the centre one, connected wrongly, was rapidly discharged, and then charged in the opposite direction by the current flowing through it.

In consequence the pole of it which should be positive and is marked positive, is probably much more negative than the other terminal. We should

## "P.W." TECHNICAL QUERY DEPARTMENT

### Is Your Set "Going Good"?

Perhaps some mysterious noise had appeared, and is spoiling your radio reception?—Or one of the batteries seems to run down much faster than formerly?—Or you want a Blue Print?

Whatever your radio problem may be, remember that the Technical Query Department is thoroughly equipped to assist our readers, and offers an unrivalled service.

Full details, including scale of charges, can be obtained direct from the Technical Query Dept., POPULAR WIRELESS, The Fleetway House, Farringdon Street, London, E.C.4.

A postcard will do: On receipt of this an Application Form will be sent to you free and post free immediately. This application will place you under no obligation whatever, but having the form you will know exactly what information we require to have before us in order to solve your problems.

take it back to the charging station and demonstrate what happens when the two cells are connected in parallel.

### REDUCING SELF CAPACITY.

E. G. T. (Bournemouth, Hants).—"To construct the H.F. choke I want about 1,500 turns of the fine wire, wound upon a solenoid tube. I have no means of winding except by hand, but I should like to keep the self-capacity as low as possible. Which is the best way of winding by hand—to put the turns on side by side as far as possible, in several layers if necessary, or wound on 'anyhow'?"

The best method of keeping the self-capacity low in ordinary methods of winding is to make the coil in spaced sections. First of all mark off the former across the space the wire will take into fifteen equal sections.

(Continued on page 1024.)

# PERFECT PRECISION COMPONENTS

**ENSURE ULTIMATE SUCCESS!**

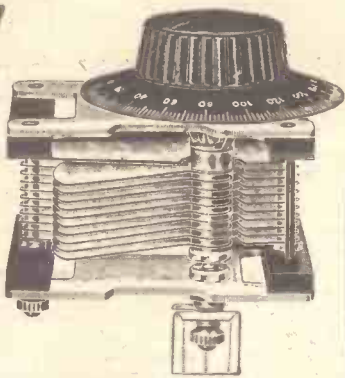

**ORMOND LOW-LOSS CONDENSER.** Capacities .00025, .0003, .0005, .001, with or without friction control. Prices from 6/6.



The **ORMOND LOUD-SPEAKER** for quality and power. Supplied in Oak or Mahogany. Price £4-4-0.

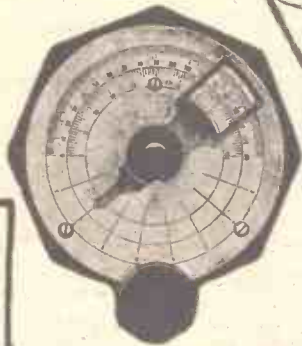

The Popular Ormond **SLOW MOTION DUAL INDICATOR DIAL** (Ratio 16-1) as illustrated, or in black. Price 5/-.



Fit the Ormond **BALL-BEARING TURN-TABLE** to your portable or frame Aerial Receiver, 6/-.

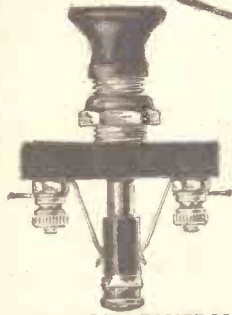

**PUSH-PULL SWITCH.** Two-point type, price 1/3; Three-point type, price 1/6 (one-hole fixing).



**FRICION CONTROL DIAL:** 4-in. Dial with direct drive and slow motion (Ra. 55-1), 7/6.



You will agree that makeshift methods never pay—carelessness in the construction of any set is the precedent of troubles galore. But has it occurred to you that the same truth is equally applicable to every component you use?

Why ask for trouble? Insist upon Ormond—the finest components made—and enjoy that security and satisfaction which none but the best can afford.

*All Good Dealers Stock them!*

Leaflets and Booklets on request also details of our complete Receiving Sets



**THE ORMOND ENGINEERING CO., LTD.,**  
 199-205, PENTONVILLE RD., KING'S CROSS, LONDON, N.1  
 Phone: Clerkenwell 9344-6. Grams: "Ormondengi, Kincross."  
 Factories: Whiskin Street and Hardwick Street, Clerkenwell, E.C.1.  
 Continental Agents: Pettigrew & Merryman, Ltd., "Phonos House,"  
 2 and 4, Bucknall Street, New Oxford Street, London, W.C.1.

## £10,000 SALE GOVERNMENT SURPLUS RADIO AND ELECTRICAL BARGAINS

The new List just issued offers a wonderful opportunity of purchasing at extraordinarily low prices which can never be repeated.

**AERIAL EQUIPMENT, ACCUMULATORS, CONDENSERS, DYNAMOS AND MOTORS, ENGINES, INSTRUMENTS AND LABORATORY EQUIPMENT, LAMPS, PHONES AND SPEAKERS, MICROPHONES, RELAYS, RESISTANCES, SWITCHES, RECORDERS, TRANSMITTERS, VALVES, ETC.**

Send a stamped addressed envelope for a free copy. It will save you Pounds.

Goods mailed to any part of the world.

**HAVE YOU ORDERED YOUR  
DIX-ONEMETER YET?**

**ELECTRADIX RADIOS,**

218, UPPER THAMES ST., E.C.4.

St. Paul's and Blackfriars Stns. Phone: City 0191.

## RADIOTORIAL QUESTIONS AND ANSWERS

(Continued from page 1022.)

Then wind the first 100 turns in a pile in the first section, the second 100 in the second section, and so on until all the turns are on and the former is filled.

### "EKCO" D.C. MAINS UNITS.

We have been requested by Messrs. E. K. Cole, Ltd., manufacturers of Mains Power Radio, to rectify an erroneous description of their D.C. Model 1F.10 which appeared in their advertisement in the January 12th issue of "Popular Wireless." The description given was that of the "Ekco" Isolating Transformer, but should have read as follows: "Ekco" D.C. Model 1F.10.10. milliamperes. Voltage tappings at 60, 90 or 120. D.C. Mains only. Price 17s. 6d.

### CONNECTIONS FOR A TWO-VALVE AMPLIFIER.

I. M. (Birmingham).—"Can you give the connections in words for a good two-valve amplifier employing the following parts: L.F. transformer, one wire-wound resistance, 250,000 ohms, one grid leak, 1.5 megohms, one mica condenser, .01 mfd., two valve holders, terminals, etc.?"

In addition to two input terminals and the two output terminals you will need an L.T. negative and an L.T. positive terminal, a grid-bias positive and a grid-bias negative 1 and 2, and also an H.T. positive terminal.

The wiring should be carried out as follows: The positive input terminal to one side of the wire-wound resistance. The negative input terminal to the remaining side of this resistance and to the .01 mica condenser.

The grid of the first amplifying valve is connected to the other side of this condenser and to one side of the grid leak. The remaining side of the grid leak goes to grid-bias negative 1 terminal.

L.T. positive terminal is joined to both of the valve holders, the remaining side of each filament terminal of the valve holders going direct to L.T. negative,

which is also joined to grid-bias positive. The plate terminal of the first valve holder is joined to one side of the primary of the L.F. transformer, the other side of which is joined to positive output terminal and to H.T. positive.

One secondary terminal of this L.F. transformer goes to the grid of  $V_2$ , and the other secondary terminal to grid-bias negative 2. The final connection is the plate of the second valve holder to the negative output terminal.

### LOOKING AFTER THE L.T. BATTERY.

M. T. W. (Henley-on-Thames).—"I certainly have got no kick against Father Christmas this year, for the family have clubbed together and presented me with a fine one-valve set, through which I have been introduced to uncles and aunts I never heard of, church services that I would not have missed on any account, and some extremely interesting foreign people occasionally (with whom I should feel a great deal more at home if I could only understand a word they said).

"Being rather a long way from the town, I am anxious that the accumulator should last as long as possible in good condition, and as I have never looked after anything of the kind before I should be glad if you would give me some hints on the proper way to treat the accumulator."

One of the most important things to remember is that charging and discharging the battery should be done only within the limits laid down by the maker. No accumulator should stand for long periods when discharged or partly discharged or sulphation is sure to commence.

A watch should be kept to see that a sediment does not form at the bottom of the cell, as if it is allowed there is a possibility of serious damage. A cheap voltmeter should enable you to watch the voltage pretty accurately, and this should be checked while the accumulator is supplying current to the set. When newly charged the voltmeter should show 2.1, and as it runs down this voltage slowly drops until it reaches the lowest safety limit of 1.18 volts. On no account allow the voltage to drop below this.

In addition to a voltage test the specific gravity or "strength" of the acid should be tested frequently with a hydrometer, which can be obtained for a few

(Continued on page 1026.)

# 25' MASSIVE SUPER H.T. BATTERY FOR 13'9

Carriage Paid

## TO ALL PURCHASERS OF P.R. VALVES

As an advertisement we will send one of these 25/- SUPER H.T. Batteries and a P.R. Valve for one inclusive sum of 16/3. In other words, the Battery costs 13/9 and the valve the usual 3/6. These Batteries are better than anything else ever offered, and must not be compared with the ordinary H.T. Dry Batteries, which are only about a quarter the size. "P.R." Batteries are SOMETHING NEW. They absolutely cannot "bulge" or "blow" because they are built not to. There can be no weeping because there is no sal-ammoniac. The internal parts are separated by a non-porous, non-conducting thoroughly insulating material which no other Battery possesses, consequently "P.R." Batteries have long life, great recuperative power, and give a steady current all the time. "P.R." H.T. IS THE CHEAPEST FORM OF H.T. YOU CAN FORGET IT FOR A YEAR.

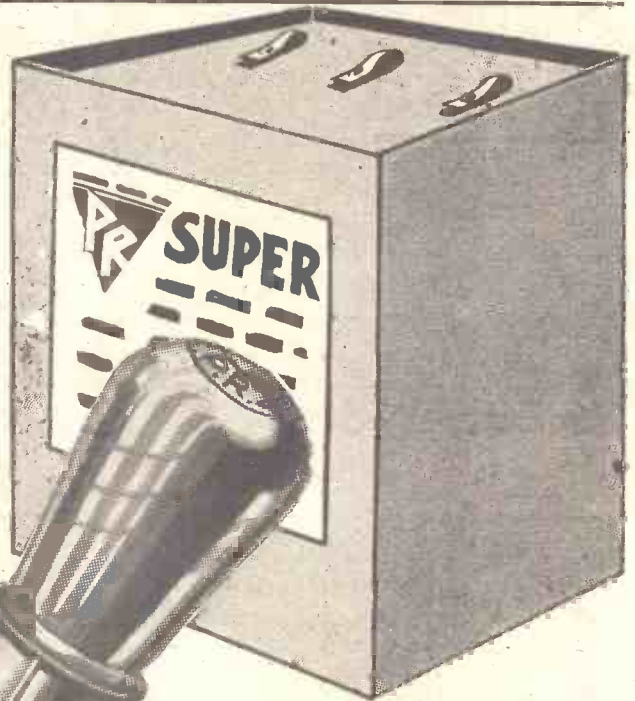

LIST OF DULL EMITTERS						
	Type	Fil. Volts	Amp.	Imp. Ohms	Amp. Fac.	
<b>3/6</b> Post 4d.	PR 2	2	.095	28,000	13	H.F. Det.
	PR 3	2	.095	15,000	8	L.F. R.C.
	PR 4	2	.095	120,000	32	H.F. Det.
2 valves, 6d.	PR 9	3.5-4	.063	18,000	14	H.F. Det.
	PR10	3.5-4	.063	10,000	8.7	L.F. R.C.
3 " 6d.	PR11	3.5-4	.063	88,000	40	H.F. Det.
4 " 9d.	PR17	5-6	.1	18,000	17	H.F. Det.
	PR18	5-6	.1	9,500	9	L.F. R.C.
	PR19	5-6	.1	80,000	40	H.F. Det.
<b>POWER 7/6</b> Post 4d.	PR20	2	.15	7,000	6	Power
<b>SUPER-POWER 12/6</b> Post 4d.	PR40	4	.15	7,000	6	"
	PR60	6	.1	5,000	6	"
	PR120	2	.3	2,750	4	S.P.
	PR140	4	.2	2,500	4	S.P.

45-volt Super. Effective voltage after 6 months' use, 39 volts. Heavy, discharge type for multi-valve sets, effective life 1 year. Weight, 12 lb. Carriage paid.

# 13/9

Three of these Batteries are ample for the biggest multiple valve set with super-power valves. Their amperage is enormous.

L.F., H.F., R.C., AND DETECTOR IN 2, 4 and 6 VOLTS. P.R. DULL EMITTER (British made) VALVES challenge comparison with ANY OTHER VALVE ON THE MARKET. It was only by new methods of manufacture that the P.R. Valve at 3/6 became an established fact.

### OUR GUARANTEE.

All valves despatched by return of post under guarantee of Money Back in Full if not satisfied. All valves are carefully packed and breakages replaced. Callers invited.

Call, Write or Phone. Telephone: City 3788. (Opposite Post Office Tube.)

**P.R. VALVES, 17-44, PATERNOSTER SQUARE, NEWGATE ST., LONDON, E.C.4.**

**BEST WAY TO ALL STATIONS**

DARIO

VALVES

**—AND THE CHEAPEST WAY, TOO,**

guaranteeing utmost satisfaction. Just look at the prices below—made possible by reason of the biggest valve output in the world. Radio without Dario can never be radio at its best. SUPERLATIVE FINISH - LOWEST CONSUMPTION

TWO VOLTS.		FOUR VOLTS.	
General Purpose, '05 amp.	5/6	General Purpose, '05 amp.	5/6
R.C.C., '06 amp.	5/6	R.C.C., '07 amp.	5/6
Super-Power, '18 amp.	7/6	Super-Power, '1 amp.	7/6
Super H.F. & R.C.C., '18 amp.	7/6	Super H.F. & R.C.C., '1 amp.	7/6
Pentodion, '15 amp.	21/-	Pentodion, '15 amp.	21/-

*From your dealer or direct:*

**IMPEX ELECTRICAL, LTD.**

(Dept. B)

5/6

538,  
High Road,  
Leytonstone,  
E.11.

7/6

## MAKE YOUR OWN CONE SPEAKER

The New Wonder "Nightingale"

### CONE UNIT

Exactly as fitted to our Cabinet Cone Speaker. Guaranteed to give results equal to the most expensive Loud-Speakers yet made.

*Full constructional details with each Unit.*

### GRAMOPHONE ATTACHMENT

Reduced from 32/6 to 15/- solely as an advertisement for the famous Bullphone Nightingale Loud-Speakers. Cobalt Magnet guaranteed for all time.

*With 4-inch Diaphragm.*

Instantly converts your own Gramophone into a full power Loud-speaker, giving a wealth of pure, undistorted volume which must be heard to be believed.

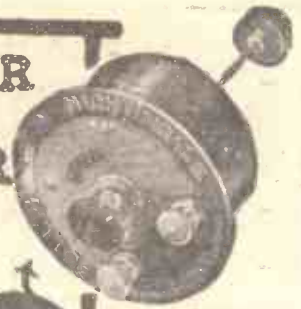

15/-

SATISFACTION GUARANTEED or money refunded!



AS FITTED TO OUR £6 POST HORN

BUY ON EASY TERMS

5/-

Secures this Speaker

Mahogany finish with plated arm and stand.



The Nightingale "DE LUXE"

50/-

CASH

or 5/- deposit and 11 monthly payments of 5/-

21 in. high with 14 in. Bell, Mahogany finished with plated arm and stand.

Send Deposit NOW!

*Obtainable from your Local Dealer or direct from:—*

BULLPHONE LIMITED

38, HOLYWELL LANE, LONDON E.C.2.

NIGHTINGALE SPEAKERS

# A Superlatively good valve-holder for



# 1/3

A widely used and recommended product has come down in price. The W.B. Antiphonic Valve-holder now costs 1/3—an unusually reasonable price for a first-class Valve-holder.

Manufacturers of the famous Whiteley Boneham Loud-speakers. Prices from 4/6.

## WHITELEY BONEHAM

WHITELEY BONEHAM & CO., LTD.,  
Nottingham Road, Mansfield, Notts.

## RADIOTORIAL QUESTIONS AND ANSWERS

(Continued from page 1024.)

shillings from any electrical shop. The plates of the accumulator should always be covered by the acid, and any losses by evaporation should be made good by distilled water.

Finally, remember that the exterior of the battery should be kept in good condition, the terminals being kept clean by being thinly coated with petroleum jelly to prevent them being attacked by the acid.

### SOME GRID-BIAS HINTS.

R. S. T. (Coventry).—“Is it possible to do without grid bias? The battery always seems in the way, and I wonder if it is really necessary or whether the set would be just as good without it?”

Correct grid bias effects a very great saving of high-tension battery current, and in addition it exercises a marked improvement on the quality of reproduction and safeguards the set against noises which otherwise might mar reception.

If the following hints are observed your grid-bias troubles will automatically disappear. Make sure that the plugs fit tightly into the sockets and that they are reasonably clean. Cut away the frayed edges of the flexible wire, for these “whiskers” may give rise to short-circuiting troubles. Long flexible leads, which are apt to shake and to move the plug about, can easily be held securely if an ordinary elastic band is fitted over the battery, and the plugs are drawn under this before being placed in position.

In many batteries the positive plug is placed so close to the 13-volt negative socket that if the grid-bias positive plug is carelessly adjusted it will bridge the gap between the two and short the 13-volt cell. This of course should be guarded against, as a faulty cell here may affect reception in the whole set.

Grid-bias batteries when stood upon the baseboard should not be allowed to slide about when the set is moved, nor should they be hung in place only by their connections. It is very easy to mount a grid-bias battery securely and may save expensive accidents. Most grid-bias batteries have a cardboard lid to protect them from metallic contact whilst in the dealer's hands. The purchaser very often throws such lids away, but if screwed direct to a baseboard they make convenient stands in which this battery may be held in position on the baseboard.

### A WAVE CHANGE ADAPTATION.

CRYSTAL SET (Watford).—“At present my crystal set will not tune to the long waves but it uses two coils, one of which has one end connected only to the aerial, the other end being connected to the other (tuning) coil, to earth, to the condenser and the telephones. I think it is called loose coupling, and I should like to know if it is possible to put in a loading coil for 5 X X, and also a switch to bring the set down to the short waves at a moment's notice.

“If this is possible, what will the connections be?”

The alterations can very easily be carried out—as follows:

At the point where the two coils are joined together disconnect them from the earth, condenser and telephones, and join them instead to a coil holder for the loading coil, the other side of which goes to earth, etc. Across this extra loading coil holder connect an on-off switch, so that when the switch is on it shorts right across the coil holder.

The final connections will then be as follows: Aerial to one side of the aerial coil, the other side of this to one side of the small tuning coil, to one side of the switch and to the loading coil. Remaining side of the loading coil and remaining side of the switch are joined to earth, to tuning condenser and the telephones. The other telephone terminal goes to one side of the crystal, the other side of this goes to the remaining side of the variable tuning condenser and to the free side of the small tuning coil.

### NOT NEUTRALISED PROPERLY.

T. F. A. (Pembroke).—“The set is evidently a long-distance getter, but the trouble is I cannot get it neutralised properly, because I am not sure of the way to do this. I have seen a method in ‘P.W.’ but, unfortunately, cannot find that back number and should be glad if you would tell me how I am to make sure that the H.F. valve really is neutralised properly.”

The following method of neutralising is recommended for use in sets employing one stage of H.F. and provided with a reaction control.

(Continued on page 1028.)

All the best radio reading of the month will be found in the January issue of

# MODERN WIRELESS

Profusely illustrated, the contents include

- Editorial.
- On the Short Waves.
- Put Radio Into Cold Storage.
- The “New-Year” Three.
- The Quest for Quality
- The Trend of Development.
- The Cooley Picture-Transmitter.
- Switch Off!
- Questions Answered.
- The “World-Wide” Five.
- Marconi—the Man and His Work.
- Cross-Road Components.
- The “Selective” One.
- Be Kind to Your Valves!
- Five Million Volts.
- The Search for Selectivity.
- The Concerts of Europe.

- Have You Heard WHO?
- A Talk on Tellurium.
- In Passing.
- The “Any-Mains” Four.
- A Magnifying Dial Indicator.
- Testing Tetrodes.
- What Readers Think.
- The “Six-Sixty” Receiver.
- My Broadcasting Diary.
- In Our Test Room.
- Radio Abroad.
- Operating the “Invincible” Five.
- Television Notes of the Month.
- Radio Notes and News.
- Making a Wireless Work-Bench.

And a special supplement for the Music-lover,  
“RADIO AND THE GRAMOPHONE.”

JANUARY ISSUE. ON SALE EVERYWHERE. PRICE 1/-

# BLUE-SPOT USERS!!

Get the Floating Cone that makes a perfect Loud Speaker in 5 minutes—TO-DAY!

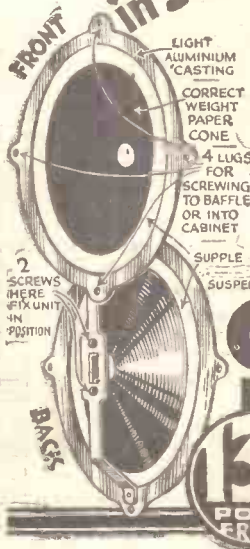

THIS IS NOT A KIT OF PARTS, BUT AN EFFICIENT, COMPLETELY ASSEMBLED FLOATING CONE.

Simply two screws and the unit is in place—and the whole ready to screw on to a baffle board or into a cabinet, making a first-class loud speaker that will reproduce with fascinating realism at infinitesimal cost! A sound job, too—perfectly assembled—light aluminium casting, correct weight pure rubber suspension, post paid and ready for fixing at once.

## GILMAN'S FLOATING CONE

Send P.O. for 13/- to-day to Manfrs., J. S. Gilman, Portland House, 73, Basinghall Street, E.C.2. Orders in strict rotation. “Blue-Spot” Unit (adjustable type, 66K), supplied at 25/- extra if desired. Phone: London Wall 9892.



OR FROM YOUR DEALER



# Making a New Cabinet ?

If so, stain it with Johnson's Wood Dye and be assured of 100% perfect results. JOHNSON'S WOOD DYE is the standard for all woodwork, furniture and floors where a permanent, penetrating stain is required. It is easy to use, does not show laps or streaks, and penetrates so deeply that scratches cannot reveal the natural colour of the wood. Johnson's Wood Dye dries in four hours and brings out the beauty of the grain without raising it. Makes inexpensive soft woods look as artistic as hard woods.



## JOHNSON'S WOOD DYE

For sale by Woodworker Supply Stores and all Ironmongers from 9d. up. Is made in 18 beautiful shades.

Write for FREE descriptive price list and particulars of JOHNSON'S WOOD DYE and JOHNSON'S WAX POLISH.

**BUY A 9d. TRIAL SIZE**  
You will be pleased with results.

**S. C. JOHNSON AND SON LTD.,**  
(Dept. P.W.), WEST DRAYTON, MIDDLESEX.  
MAKERS OF JOHNSON'S WAX POLISH.

Experts select the "GOLSTONE" POWER TRANSFORMER!

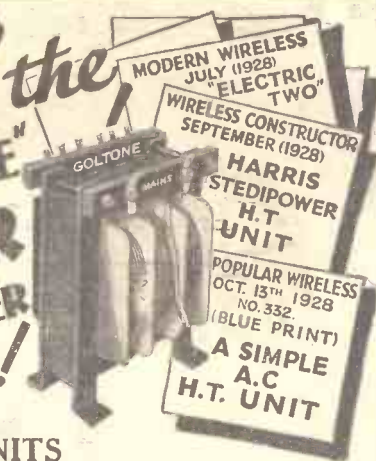

FOR H.T. BATTERY UNITS

Working from A.C. Mains. Made in Two Types.

**TYPE D.W.,** For Full Wave Rectification. Maximum Current Output 80-100 milliamperes. No. R14a/10, Price £1 : 12 : 6.

**TYPE S.W.,** For Half Wave Rectification. Maximum Current Output 30 milliamperes. No. R14a/5, Price 18/6.

From all first-class Radio Stores—Refuse Substitutes. If any difficulty write direct.

Radio Catalogue R119A (P.W.), sent FREE on request.



London Depot: 5 & 6, Eden St., Hampstead Rd., N.W.1. Phone: Museum 4032/3.

# PAREX

SCREENS

COILS

### AN H.F. ALL-WAVE UNIT

(Described in this issue)

**STANDARD COPPER SCREEN** (as specified) 3/6

### WHITE PRINT No. 5

**STANDARD COPPER SCREEN** 9" x 6" .. 4/-  
**H.F. CHOKES**, each .. 3/6

### WHITE PRINT No. 7

**UNTARNISHABLE COPPER SCREEN**, with terminal, 12" x 6" 4/6  
**STANDARD LOADING COILS**, each .. 7/6  
**AERIAL and INTER-VALVE S.W. COILS** ea. 8/6  
**H.F. CHOKES** (as specified), each .. 3/6

From your Dealer or direct from

**E. PAROUSSI,** 10, FEATHERSTONE BUILDINGS, HIGH HOLBORN, W.C.1.  
Phone: Chancery 7010.

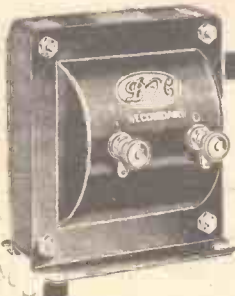

## D.X.

HERE is the famous D.X. Transformer which is setting a standard in value for money and is already known wherever radio is heard of. A really first-class piece of workmanship, conscientiously made in accordance with modern scientific principles at a price that places it within the reach of all.

Write to us for leaflets and particulars of this Transformer and give one a trial. You cannot fail to be delighted. Send for particulars of our new circuit, the D.X.3

**8/- Retail**  
Ratio 3 to 1.

**D.X. COILS LTD., 542, Kingsland Rd., E.8**

# NEVER SAY DIE!

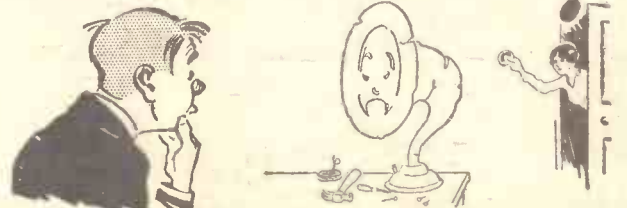

# UP MAN AND TRY



# FLUXITE

IT SIMPLIFIES ALL SOLDERING

FLUXITE is sold in tins, price 8d., 1/4 and 2/8.

Another use for Fluxite: Hardening Tools and Case Hardening. Ask for leaflet on improved methods. **FLUXITE LTD.** (Dept. 324), Rotherhithe, S.E.16.

**SOLDERING SET COMPLETE**

7/6

or LAMP only, 2/8

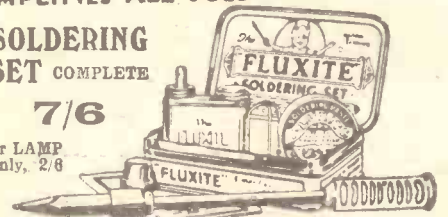

## RADIOTORIAL QUESTIONS AND ANSWERS

(Continued from page 1026.)

The unquestioned merit of Celestion lies not only in the refined beauty of its appearance but more



Model G12

Model from 15/100 Made under License

in its almost unbelievable realism

# CELESTION

The Very Soul of Music

British throughout  
Insist on your Dealer demonstrating, or call at our

SHOWROOMS:  
106 VICTORIA ST SW1  
(One Minute from Victoria Station)

FIRST ON MERIT  
ON DEMONSTRATION.

First, set the reaction control at minimum and likewise the neutralising condenser. Now, on setting the tuning condensers so that the two tuned circuits are in step with each other, it will probably be found that the set is oscillating.

To test for oscillation touch one or other of the sets of plates of the tuning condensers (this may be either the fixed or moving, according to the particular set).

You will probably find that the set will only oscillate under the above conditions when the two circuits are in tune with each other, and this can be used as an indication. It is convenient to perform the operation at some point near the middle of the tuning range.

Now, increase the capacity of the neutralising condenser. (In the case of such condensers as the Gambrell "Neutrovernia" this means screwing downwards.) Test at intervals for oscillation as this is done, and you will presently find that the set has ceased to oscillate and will not recommence even when the tuning dials are slightly readjusted.

Now increase the reaction a little, until the set once more oscillates, and again increase the neutralising condenser setting until oscillation ceases. Slightly readjust the tuning condensers again, to make sure that the set is completely stable once more. Proceed in this way until it is found that the correct adjustment of the neutrodyne condenser has been "overshot."

Once this point has been passed it will be observed that further increases of the neutrodyne condenser setting no longer stop oscillation but cause it to become stronger.

The object is to find such an adjustment of the neutralising condenser as will permit the greatest setting of the reaction condenser to be used without producing oscillation. It will then be observed that when the two tuned circuits are in step and the set is

## The "TITAN" THREE!

brought to the verge of oscillation a slight movement in either direction of the neutrodyne condenser will cause the receiver to break into oscillation.

It is to be understood that in the preceding notes, where a reaction condenser is spoken of, any form of reaction control may be understood.

### "NEWCOMER TO RADIO."

H. J. R. (Peckham).—"In reference to the articles written by Mr. G. V. Dowding entitled 'The Newcomer to Radio,' commencing September 1st in POPULAR WIRELESS, I am a bit puzzled as to the correct wiring of the set.

"I have completed the one-valve stage and cannot get a sound. My reaction condenser has three terminals like the one in the actual set, but two are connected to the fixed vanes, and the other to the movable. I should like to know which of the two fixed terminals should be connected to high tension or earth.

"Concerning the H.F. choke, I have a Lissen. Does it matter which way round the choke is connected? If you could give me some idea on the above questions I shall be extremely obliged."

Regarding the reaction condenser terminals, it does not matter much which way the condenser is connected, provided you use one wire to the moving plates and the other to the fixed plates. As there are two fixed plate terminals it does not matter which one of these you use and regard as the "fixed," but make sure that your other reaction condenser connection comes from the moving and not from the other fixed vane connection.

The choke that you have is quite suitable and it does not matter in the least which way round it is connected. The reason that you have so far been unable to get any signals would appear to be either a faulty connection or a dud component.

This does not necessarily mean bad workmanship on your part, but it sometimes happens that even when for instance, a valve, is plugged into the valve holder, one of its legs does not make contact with the corresponding socket of the holder, and consequently the valve is either getting no current, or no input or no output.

Similarly, it sometimes happens that a coil does not make contact in its coil holder, so that apart from

(Continued on next page.)



## EVERY VALVE SET USER NEEDS A WATES "three in one" VOLT-AMP RADIO TEST METER

YOU may have a baseboard full of components— BUT you cannot hope to obtain really perfect QUALITY in reception unless you have that perfect set control ensured by accurate Volt and Amp readings! All you want is a Wates Meter. With its three readings on one dial feature it has an immensely wider range of usefulness—yet it costs no more than single-purpose instruments. Obtain one now and let it reveal what a world of difference lies in the expert handling of your set. Obtainable from your dealer or direct, complete with explanatory leaflet.

Stocked by Halford's Stores, Curry's Stores, and all Radio Dealers.

### READINGS:

- 0—150 VOLTS.
  - 0—6 VOLTS.
  - 0—30 MILLIAMPS.
- Res. 5,000 ohms.

### PRICE

# 8/6

Crystallised black finish. Fully guaranteed.

THE STANDARD WET BATTERY Co. (Dept. P.W.), 184-188, Shaftesbury Ave., LONDON, W.G.2.

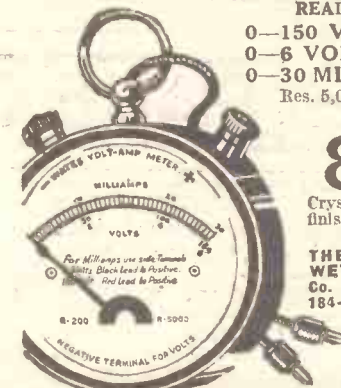

Three in One

M.B.

**HEADPHONES REPAIRED 4/-**  
Transformers 5/-, Loudspeakers 4/-, All repairs remagnetised free. Tested, guaranteed and ready for delivery in 24 hours.  
Discount for Trade. Clerkenwell 9069.  
B. MASON, 44, East Rd., City Rd., N.1.

**REPAIRS**  
Any make of L.F. Transformer, Loudspeaker or Headphones repaired and despatched within 48 HOURS—TWELVE MONTHS' GUARANTEE with each repair. 4/- Post Free.  
Terms to Trade.  
**TRANSFORMER REPAIR CO.**  
"Repairs" Dept.,  
214, High Street, Colliers Wood, London, S.W.19.

**DARIO Super H.F.**  
means Super Radio  
See page 1025.

## RADIO ODDS AND ENDS.

**W**HAT a wonderful hobby wireless is! It doesn't matter in what aspect of wireless your chief interest lies, you will always find ample to interest you, new developments to follow and fresh ideas to investigate.

Are you mechanically inclined? Then you will find in wireless all the opportunities for constructional work you could possibly desire. There is little in a wireless set that the enthusiast with the little necessary skill, few tools and some patience cannot make. Brass parts to be worked, turned, filed and polished. Some of them intricate, some simple. Copper switch blades, spring clips and contacts to be made. Ebonite coil formers, bushes, framework for valve holders. Aluminium brackets, screens, or even condenser parts. Fixed condensers to be made, coils to be wound, chokes to be constructed.

### Theoretical Possibilities.

The above are but a few of the pleasant tasks that surround the experimenter with the constructional bent.

Perhaps your particular strength lies more along theoretical lines. Then here is a wide field indeed for your analysis. The simpler problems deal with questions of receiver design, the winding of efficient inductances, the construction of L.F. transformers, the combination of apparatus of different characteristics to produce certain desired results, the examination of circuits which have inherent drawbacks either in construction or operation, and the solution of the problems that thereby arise. More complex problems are those involving the use of advanced mathematics and they deal with anything under the sun relating to wireless, from the Heaviside layer to electron emission.

On the other hand you may be keen on actual practical experimental work, comparing different H.F. amplifying circuits as regards their efficiency, stability and selectivity, or L.F. circuits as to their behaviour when dealing with different frequencies, and other work of this description. Here again there is sufficient to keep you occupied for years, and faster than you settle one set of problems new discoveries and fresh developments give rise to new.

### Collecting Meters.

Work of this description often results in new inventions, for difficulties may be encountered during such experiments that eventually lead to a means of overcoming them, and a new contribution has been made to the wireless science.

For myself, I study and practice every possible aspect of wireless—but I have one weakness that presents a fascinating side to wireless research, and is, in fact, a hobby within a hobby.

I collect meters!

Notwithstanding the fact that I have a Universal meter that gives me everything from microamps to 150 amperes, I also possess three—no, four—milliammeters giving ranges of 0-3, 0-10, 0-25, and 0-50 milliamps, to say nothing of a meter which

gives me 0-150 milliamps, 0-5 amps, 0-50 amps and 0-500 amps.

The Universal also gives me milli-volts to 600 volts. Yet I have managed to acquire four other voltmeters, one of which only supplies a range not covered by the other. This, again, is an instrument which gives me up to 1,000 volts.

Then I must not forget the micro-ammeter which gives readings of 25 micro-amps per division. This is an extremely valuable instrument for making really fine measurements. It can be used for measuring weak crystal currents, or for showing small changes in current. In this case it must of course be carefully backed off, and the greatest care has to be taken in handling it. It is also necessary when using a slide-back voltmeter since it enables very accurate results to be obtained.

Besides these I have three thermo-electric meters; two hot wire, with different ranges, and one thermo-couple.

### Bargain Hunting.

It might be thought that all these meters represent a considerable outlay, but this is where the particular pleasure of this kind of collecting comes in. They have almost all been acquired at figures representing only a tithe of their actual value. Some I have bought down the Farringdon Road, some in the Caledonian Market, others at all kinds of odd junk shops all over town.

Other apparatus that I have also acquired in this manner are such instruments as a megger, a Wheatstone bridge, a Seibt condenser, a calibrated resistance box, a Weston relay, an old P.O. relay and a multi-circuit P.O. key; also microphone transformers, transmitters, and all kinds of other useful apparatus which can be picked up for nominal prices.

## NEXT WEEK

Be sure not to miss your copy of "Popular Wireless," containing our Great FREE GIFT to readers.

In Farringdon Road, for instance, I bought for 6d. a set of brass "bits" which were all that remained of an old P.O. key. I polished and lacquered them, made a new return spring adjuster and fitted a new spring, mounted it on a thick piece of ebonite with three terminals which I bought for another 6d.—and there I had a good, solid, smooth-working key that is the envy of many.

The only real outlay that was required was for the contacts, and these need not cost much if the key is only going to be used for low-power work.

The chief thing to remember when buying this kind of apparatus is that you must examine it very carefully before buying, and even then you must be prepared to take the risk of being "had." Weigh up the price they are asking against the price it would cost new, and this will give you an indication as to what condition it may be in.

### Beware of "Dud" Stuff.

Never pay what they ask for it if you buy it in a street or open market. You can always get it about a third cheaper.

If you buy in an auction take more care than ever if you cannot test the component or get a guarantee that it is in working order. I once wasted a hard-earned pound by buying an ex-Marconi hot-wire ammeter which was burnt out!

C. P. A.

## RADIOTORIAL QUESTIONS AND ANSWERS

(Continued from previous page.)

the actual wiring of the set it will be necessary for you to look over it very carefully and try to check the connections through, if necessary by means of the 'phones or dry-cell method. Another point which it is worth the newcomer's while to notice is that the fault may not lie inside the set itself but in one of the batteries or one of the leads to these.

If your valve is one of the kind that lights up when it is switched on you can easily observe whether it is getting current from the accumulator, but some dull-emitter valves do not give any glow to indicate whether they are alight, and in such cases it sometimes happens that a bad contact at the L.T. battery may go undetected and so starve the valve of its necessary filament current.

If the accumulator terminals appear to be dirty, wipe them over with a cloth which has been dipped in a strong solution of soda, or gently remove any impurities from the terminals with a file or emery paper. Make sure also that none of the wire is frayed or broken and that the aerial comes straight down to the set, without touching any metal gutter or anything of that kind which would short away all the signals to earth.

If you watch all these points you will doubtless discover that somewhere there is a complete break or short in the circuit which has been preventing you hearing the programmes, and when this is put right you will find the set O.K.

Do not forget that if the wiring and components are all in order it is absolutely impossible for the set to fail to give you the results you desire, and although a difficulty in getting these at first is very discouraging then it is all the more pleasure when the set does work to think that you were able to find the trouble and put it right.

### THE B.B.C. AND TELEVISION.

The following statement, issued on October 17th, 1928, by the B.B.C., has been sent to the Press, with a request for publication.—The Editor.

"In agreement with the Post Office, the B.B.C. required a studio demonstration of the Baird television apparatus before considering whether there should be public experiments in which a B.B.C. station would participate. A demonstration took place at the offices of the Baird Television Development Company, Ltd., on October 9th, and was attended by administrative and technical officials of the Corporation.

"The opinion of the B.B.C. representatives was that, while the demonstration was interesting as an experiment, it failed to fulfill the conditions which would justify trial through a B.B.C. station.

"The Board of the Corporation has decided that an experimental transmission through a B.B.C. station shall not be undertaken at present. The Corporation would be ready to review this decision if and when development justified it."

The Baird Television Company has not yet intimated to the B.B.C. any claim of improvement. Any such claim would be examined by the B.B.C. with a view to determining whether the above decision should be modified.

### A WAVE-TRAP COIL.

M. E. P. (near Twycross).—"How many turns of wire were there on the actual coil of the 'P.W.' wave-trap, and where should the tappings be?"

The coil itself consisted of .04 turns in a single layer of No. 28 D.C.C. wire. As the coil is wound on the 2-in. diameter former, tappings are made at the sixteenth and twenty-fourth turns, these being the alternative positions for the aerial tap.

The ends of the coil winding are secured by the simple process of passing them through two small holes drilled in the tube at the correct points, whilst the two tappings may be made in a variety of ways. If desired, for example, the whole coil can be wound without making any tappings whatever, and the sixteenth and twenty-fourth turns can be prised up slightly with the blade of a pocket-knife, two short pieces of matchstick, about half an inch long, being driven underneath them.

# K. RAYMOND

27 & 28a, LISLE ST., LONDON, W.C.2

Come to LEICESTER SQUARE TUBE  
This address is at the back of Daly's Theatre. Phones: Gerrard 4637 and 2821

## WE ARE OPEN

ALL DAY EVERY DAY Hours 9 a.m to 8 p.m.  
ALL DAY SATURDAY Sat 9 a.m to 9 p.m.  
ALL DAY THURSDAY Sunday morning 11-1

140 p. CATALOGUE  
ILLUSTRATED  
ALL LATEST  
COMPONENTS 3

**GYLSON CONDENSERS**  
Triple Gang and Shields, £4/17/6; Dual for "Furze-mill," 25/6; Synchrators for "Inceptor," 47/6. LISTS FREE.

**DARIO RADIO MICRO VALVES**  
2v. G.P.R.C.C. 5/6 ea.  
4v. SUPER POWER 7/6 ea.  
Post Extra.

**P.R. VALVES STOCKED**

**C.O.D. SEND ORDER. PAY POSTMAN. (U.K. Only). Must be over 5/- value.**

**ORMOND**  
S.M. Drum Dial, 5/-; Rheostats, 6, 15, 30 ohm, 2/-; Midget .0001 max., 4/-; Log. .0005 and 4" Dial, 8/-; Log. .0003 and 4" Dial, 5/6; S.L.F. No. 3 same price. We always stock all ORMOND PARTS.

Copper and Aluminium Screens (all sizes) or made to order.  
P.W. Screening Boxes 12/6  
P.W. Loading Coils... 7/6  
Harlie Wave Selector 12/6  
Tunewell Dual 3 Star 7/9  
Combined Wave Q 3 Star... 15/-  
Scott's All-Wave Tuner 13/6  
DX Set 4 Short Wave 7/6  
DK L.F. Standard Ratio... 8/-  
Wello L.F. Power... 11/6  
Wello Standard... 8/6

**LEWCO'S O.A.C.5. 10/6; O.A.C.20. 12/6; O.S.P.5. 10/6; O.S.P.20. 12/6; P4 to 14. 3/- each; P16 to 22. 4/- each. Touchstone Coils, 30/- pair. C.T. Coils, 3/6, 5/3. Q Coils: Q.A., 15/-; Q.S.P., 21/-.**  
ALL LEWCO'S PRODUCTS.

PLEASE MAKE OUT LIST FOR SPECIAL QUOTATION IF OVER 25/- IN VALUE.

**MULLARD 3 STAR**  
CIRCUIT AND QUOTATION  
Sent Free of Charge.

## "EMPIRE" TWO KIT OF COMPONENTS

"P.W.," 8/12/28.  
4 B.B. Coil Sockets, 4/-; Neut. Condenser, 4/6; .0005 Variable, 6/-; S.M. Dial, 3/6; .0003 Fixed, 1/-; .001 do., 1/-; .0001 Reaction, 4/-; H.F. Choke, 5/6; Formo. Lissen, or DX L.F., at 8/6; W. Change Switch, 1/6; 2 Sprung W. Holders, 2/6; Terminal Strip and 10 Terminals, 4/-; Wire, Screws Flex, 2/-; Ebonite Panel, 3/6.

The above lot, post free, 42/6  
COILS, CABINET, and VALVES EXTRA.

**SIFAM H.R. VOLTMETER 7/6**

**WATES' 3-in-One TEST METER 8/6**

READINGS  
0-150 volts  
0-30 milliamps  
0-6 volts  
Res. 5,000 ohms

Ebonite cut while you wait at 4d. square inch, also 4 in. at 3d. Only the best supplied. Drilled Panels for all Circuits

**KITS of parts for all Circuits. Make out LIST for keen quotation. DON'T worry, if it's Wireless WE HAVE IT.**

**"Q" COILS**  
Lewco's and Finston always in stock. Made under Mr. Reynier's license. 250 to 2,000 metres on one coil. QA, 15/-; QSP, 21/-; QAB, 21/-; QAM, 21/-; Master 3 Star, 17/6. (Leaflets Free.)

**BLUE SPOT 66K (101) BALANCED ARMATURE 25/-**

Squire Cradle Frame, 12/6 for (Blue Spot). Cone Kit, 2/6. Free plywood damping washer with 15/- kit.

**COUPON No. 48.**  
ONLY ONE COUPON ON ANYONE ORDER  
If you spend 25/- or more you can buy for 3d. extra any one (only) of the following:  
S.M. Dial, 100 ft. 7/22 Copper Aerial, 12 yds. Lead-in Fuse and Holder, 12 Nickel Terminals, 60K Coil, H.F. Choke, Permanent Detector, Battery Switch, .0003 and 2-meg. Leak, 9-volt Grid Bias, Panel Brackets, 6-pin Coil Base, 100 ft. Insulated Aerial, Loud Speaker Silk Cord, 30 ft. Covered Connecting Wire, Ebonite Panel, 9 x 6, 12 yds. Twin Flex, 100 ft. Indoor Aerial.

## OPERATING THE 1929 FILADYNE

Further notes on the novel and effective two-valve set described in last week's issue of "P.W."  
By J. ENGLISH.

WHEN making the battery connections the third H.T. + terminal is used for the connection to the inner grid terminal of the tetrode via a flexible lead terminating in a spade terminal. Where the tetrode is not used this flexible lead is omitted and the terminal used for the H.T. negative connection, joining it to the adjacent L.T. negative terminal. Otherwise the H.T. negative lead must be taken to L.T. negative of the accumulator.

We will now presume that all constructional work has been completed, and that the receiver is set up on the bench for testing. First of all you require the necessary valves, which for the second stage are the tetrodes A.P.412 L.F., for average volume, and the A.P.412 Power for larger inputs, or a three-electrode power valve of the type S.P.18/R, Dario Super-Power, etc. In some cases a larger power valve may be advisable where the volume from the local station is considerable, to avoid overloading

## The "TITAN" THREE!

and consequent "blasting," but the valves already mentioned will handle quite an appreciable input without distortion.

### Modern Valves.

For the detector stage we have the usual Filadyne valves, such as the D.E.R., D.E.3, D.E.2 L.F., etc. These valves, although obsolete types, are very efficient Filadyne detectors, so that if you have one of these old valves amongst your stock it can now be put to good use.

Of the modern valves, a particularly good specimen is the Dario Super H.F., which I can thoroughly recommend for this set. This valve has an unusual double-electrode assembly (two anodes, two grids and two filaments in parallel) which appears to be particularly suitable for Filadyne conditions.

### Economical to Run.

This type of valve certainly gives very good results on low anode voltages, and I have obtained a good loud-speaker output from the two valves with only 6 volts H.T. on the detector! Moreover, under Filadyne conditions it requires barely half its normal filament current so that it is anything but wasteful of battery power.

You can also try a P.M.2 D.X., if you have one handy, using a low anode voltage up to 25 volts, with a maximum filament voltage of 1 volt.

Several other modern valves refused to work at all in the detector stage, but the valves which I have found to be particularly

(Continued on next page)

# EELEX TREBLE-DUTY TERMINALS

Eelex Treble Duty Terminals are different and better. 40 indicating tops to the Terminal can be obtained, all different wording, and six coloured tops for any special uses. By using coloured flex in conjunction with Eelex Treble Duty Terminals, the possibility of a wrong or accidental connection is minimised and you have the ideal "safety" system of connections.

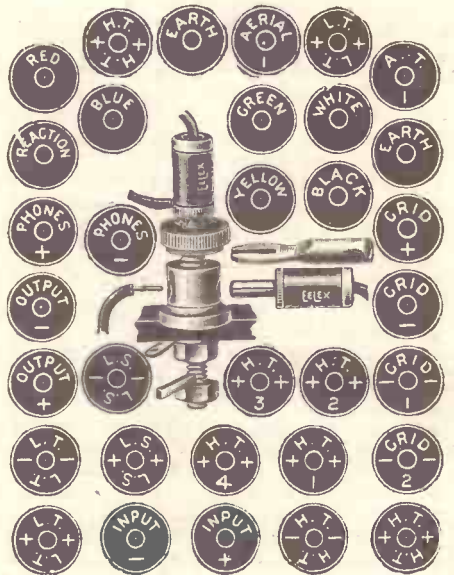

Eelex Treble-Duty Terminals are nickel-plated and hold securely spade, plug, pin eye or just plain wires. (T2LC) 4½d. each. With plain top only (T2LN) 3d. each.

## EELEX MOISTURE-RETAINING EARTH



Your earth is more important than your Aerial. In addition to carrying the same current it has to provide an adequate path to earth should lightning strike your aerial.

The Eelex Earth Bowl collects and holds all available moisture, improves with age, and being entirely buried is not subject to atmospheric conditions. Supplied with 9 ft. of heavy rubber-covered wire and connector, 5/6 each. Postage 9d.

Write for the new EELEX gnomes Booklet T.72 Free on application.



Eelex House, 118, Bunhill Row, Chiswell Street, London, E.C.1.

'Phone: Clerkenwell 9282-3-4.

## OPERATING THE 1929 FILADYNE.

(Continued from previous page.)

suitable are not the only ones, as it has not been possible to try every one of the multitude of modern valves. You can easily try out your stock of valves, and I shall be very interested to hear of any additions to my list.

In the table were given the correct filament voltages for the Filadyne valves, with suitable anode voltages. The filament voltage can be adjusted with a voltmeter temporarily connected across the detector valve-holder filament terminals, but if you do not possess such a thing you will find in the table another column giving the approximate rheostat settings, the figures being the fraction of the resistance element in circuit.

The right way to get the set working, having given the valves the proper filament and anode voltages, is to push the reaction coil almost inside the 4-in. former, put the aerial clip on the lowest tapping and rotate the potentiometer knob until the familiar rushing sound of oscillation is heard. Then it should be easy to pick up the strong carrier of the local station, reducing reaction by moving the potentiometer towards the negative side. Always work as near to the negative end as possible.

### Coming Shortly.

## THE "TITAN" THREE

**DON'T MISS IT!**

If reaction is too fierce pull out the reaction coil slightly; too much filament current produces the same result. Louder signals are obtained when the aerial clip is moved on to the fourth tapping near the middle of the coil, with some loss of selectivity, of course. If you want the local station only this does not matter, and you can even connect the aerial clip to the top of the filament coil, if the aerial is small, for maximum volume. When searching for weak signals you will find tuning easier if you decrease the reaction coupling, although the closer the coupling the louder will be your signals up to the point where "backlash" occurs.

### The Set in Action.

I have intentionally tested this receiver under very unfavourable conditions, using a small indoor aerial and a long earth lead with a poor earth connection. This aerial system, situated about 12 miles from 2 L O was not one that any self-respecting amateur would use, but in spite of that, ample volume was obtained on 2 L O, and comfortable volume from 5 G B. A considerable number of stations was received on the 'phones, several being quite audible on the loud speaker.

Obviously, given a good aerial and earth system, these results can be surpassed, so that the set should give you satisfactory volume on the local station, the choice of a few alternative stations, and plenty of "pull" for 'phone reception of the more distant ones.

# YOU NEED HELP

It is very difficult to prosper in life without a little help.



## LET ME BE YOUR FATHER

I have acted as father and adviser to thousands of others. I give advice free and when I do so I feel the responsibility of a father, either in advising a career or in guiding our students to success. Having been the self-constituted father and adviser to thousands of others, it is possible I may be able to help you and guide your footsteps so that you may make a success of your life.

**THE MOST SUCCESSFUL AND MOST PROGRESSIVE  
CORRESPONDENCE COLLEGE IN THE WORLD.**

**IT IS  
QUITE TRUE**

and I state most emphatically that there are thousands of men earning less than half of what they could earn simply because they do not know where the demand exceeds the supply. Thousands of people think they are in a rut simply because they cannot see the way to progress. This applies particularly to Clerks, Book-keepers, Engineers, Electricians, Builders, Joiners, etc. They do not realise that in these particular departments the demand for the well trained exceeds the supply. In Technical trades and in the professions employers are frequently asking us if we can put them in touch with well-trained men. Of course, we never act as an employment agency, but it shows us where the shortage is. In nearly every trade or profession there is some qualifying examination, some hall-mark of efficiency. If you have any desire to make progress, to make a success of your career, my advice is free; simply tell me your age, your employment and what you are interested in, and I will advise you free of charge. If you do not wish to take that advice, you are under no obligation whatever. We teach all the professions and trades by post in all parts of the World, and specialise in preparation for the examinations. Our fees are payable monthly. Write to me privately at this address, The Bennett College, Dept. 106, Sheffield.

### COMMERCIAL

Accountancy  
Advert. Writing  
Salesmanship  
Army Certific. Courses  
Auctioneering and Estate Agency  
Auditing  
Banking  
Book-keeping  
Civil Service  
College of Preceptors  
Commercial Arithmetic  
Commercial Law  
Company Law  
Costing  
Economics  
English and French  
Executorship Law  
Foreign Exchange  
General Education  
Modern Business Methods  
Police Entrance and Promotion Courses

### COMMERCIAL—Con.

Secretaryship  
Workshop Organisation

### INSURANCE

Exams. for Agents and Officials, F.C.I.I.  
Motor, Fire, Life, Marine  
Employers' Liability  
Auctioneers, F.A.L.P.A.

### TECHNICAL

Teacher of Handicrafts  
Applied Mechanics  
Architectural Drawing  
Building Construction  
Clerk of Works' Duties  
Boiler Engineering  
Boiler Making  
Chemistry  
Civil Engineering  
Concrete and Steel  
Draughtsmanship

### TECHNICAL—Con.

Electrical Engineering  
Practical Mechanical Engineering  
Engineering Costing, Quantities and Specifications  
Foundry Work  
Heat Engines  
Heating, Ventilating and Lighting  
Internal Combustion Engines  
Marine Eng., B.O.T.  
Mathematics  
Matriculation  
Metallurgy  
Motor Engineering  
Naval Architecture  
Pattern Making  
Post Office Examinations  
Road Making and Maintenance  
Sanitation

### TECHNICAL—Con.

Builders' Quantities.  
Costing and Estimating  
Shipbuilding  
Structural Engineering  
Surveying and Levelling  
Surveyors of Works, R.E.  
Telegraphy and Telephony  
Town Planning  
Transport, A.M.Inst.T.  
Wireless Telegraphy  
Works Managers' Course

### MINING

Fireman's Exam.  
2nd Class Mine Manager  
1st Class Mine Manager  
H.M. Inspector  
Mining Elect. Engineer  
A.M.E.E.  
Mining Mech. Engineer  
Mine Surveyor

Note Address:

**THE BENNETT COLLEGE,  
Dept. 106, SHEFFIELD.**



**A BOOK YOU MUST NOT MISS!**  
"ENGINEERING OPPORTUNITIES" is the most complete hand-book on Engineering Exams, and Courses ever produced. It describes over 60 Exam. and home study courses in all branches of Mechanical, Electrical, Motor and Civil Engineering, including WIRELESS. We **ALONE Guarantee—"NO PASS—NO FEE"** This book should be in your hands—it is a mine of valuable information and advice. We offer it FREE, which is of interest.  
Write for your copy now stating branch or Exam.  
**BRITISH INSTITUTE OF ENGINEERING TECHNOLOGY,  
101. Shakespeare House, Leicester Sq., London, W.C.2.**



Protect Your Set  
with the

## AERMONIC Safety Earthing Switch

Scientifically designed to adequately protect your set in all conditions. Has a fuse between the aerial and the set, thus giving security from lightning even if the set is left connected. Soudly made with Bakelite cover to keep it waterproof. Price 4/6.

If dealers can't supply we send Aermoric Post Free, post free on money-back guarantee.  
**JAMES CHRISTIE & SONS Ltd., 236, West St., SHEFFIELD,  
or London Agents: A. F. Bulgin & Co., 10, Cursitor St., E.C.4.**

**ALL APPLICATIONS FOR ADVERTISING SPACE IN "POPULAR WIRELESS" MUST BE MADE TO THE SOLE ADVERTISING AGENTS, JOHN H. LILE, LTD., 4, LUDGATE CIRCUS, LONDON, E.C.4.**

Finished in black or beautifully grained mahogany.



36

neat-accurate and inexpensive

Watch for Brownie's latest triumph in artistic moulded Bakelite—"The Dominion Vernier Dial." Special non back lash slow motion drive gives very accurate tuning, while the action will fit any condenser and the new design of the dial will enhance the appearance of every set. See this latest Brownie production at your nearest radio dealer.

**BROWNIE** WIRELESS

"DOMINION" VERNIER DIAL  
The BROWNIE WIRELESS COMPANY (G.B.) Ltd.  
MORNINGTON CRESCENT LONDON, N.W.1

TRADE MARK "RED DIAMOND" REGR

THE RECOGNISED DETECTOR FOR ALL CIRCUITS USING CRYSTAL RECTIFICATION. By Insured Post, 2/3, or 2/9 with shield. Can be mounted on brackets or through panel.

Once set always ready. Not affected by vibration. Each one is tested on broadcast before despatch and is perfect.

Of all high-class Radio Dealers or Sole Makers:

**JEWEL PEN CO. LTD.**  
(Radio Dept 48)  
21/2, Gt. Sutton St., London E.C.1

**RD 40**  
**2/-**

**EASY PAYMENTS**

The first firm to supply Wireless parts on easy payments. Five years advertiser in "Popular Wireless." Thousands of satisfied customers. Send us a list of the parts you require, and the payments that will suit your convenience, and we will send you a definite quotation. Anything wireless.

**H. W. HOLMES, 29, FOLEY STREET,**  
Phone: Museum 1414. Gt. Portland St., W.1.

The Picture Paper with the MOST News

**SUNDAY GRAPHIC**

PLEASE MENTION "POPULAR WIRELESS" WHEN REPLYING TO ADVERTISEMENTS

**TECHNICAL NOTES.**

(Continued from page 1004.)

condenser will help considerably in keeping down oscillation on the shorter waves.

A correspondent sends me a hint which is useful in this connection. It has for its object to retain the fixed condenser in circuit at longer wave-lengths and to cut it out as the wave-length increases.

**Automatic Connection.**

The fixed condenser is assembled in position on the baseboard, close to the variable tuning condenser and a short piece of springy brass strip or steel strip (such as watch-spring) is attached to the shaft of the tuning condenser. A similar piece of spring strip is attached to one of the terminals of the fixed condenser and these springs are so bent and arranged (I am sorry I have no diagrams with these notes) that the two spring strips make contact, whilst the variable condenser is in the longer wave-length range and cease contact when the variable condenser moves into the shorter wave-length range. You

**The "TITAN" THREE!**

will have no difficulty in figuring out how to arrange these spring contacts to meet the case.

**Shielding.**

Shielding is one of the most important considerations in the design of a receiver using screened grid valves in the H.F. circuit. When properly employed these valves are capable of providing several times as much amplification as the usual type but, of course, if the circuits have not been designed with corresponding care, the anticipated results will not be obtained.

Plate shielding is essential in the circuits using these valves if high efficiency is to be obtained. Not only is it necessary to place all components of the circuit within shielded compartments, but the valve itself and the control grid lead must also be shielded.

**Control-Grid Lead.**

It is a comparatively straightforward matter to make the shielded compartments, but the shielding of the grid lead sometimes presents a problem. This useful object can, however, be quite easily achieved by using fairly heavily insulated wire for the control-grid lead and then winding strips of tinfoil (or "silver paper") in spiral fashion over the insulation.

When the control-grid lead has been "bandaged" in this way, contact with the

(Continued on next page).

**"DON'T COVET"**

Your Neighbour's Wireless Set

**BUILD YOUR OWN RECEIVER— BUT BE SURE to Buy on the Best Terms from THE P.D.P. CO., LTD.**

**EVERYTHING WIRELESS ON EASY TERMS**

New Cossor Melody Maker, Master Three Star, etc.

**BEST MONTHLY TERMS** quoted by return for all Receivers and Components.

**CASH ORDERS promptly executed**

**COILS** for all "P.W." Circuits supplied. Goods sent C.O.D. by return.

Call at showrooms or post your list of requirements.

**The P.D.P. Co., Ltd.**  
(Dept. P), 121, CHEAPSIDE, London, E.C.2.  
Phone: City 9846

**MONOTUNE ENVELOPE FREE.** Send 1/2 for comp. Construct. Envelope of this 40-station single tuning Set by Allinson. 1/- allowed off first 10/- order for any radio goods. Circular and List parts free.

**INCREASE YOUR RANGE.** Particulars of my new SCREENED GRID UNIT which gives great selectivity and almost unlimited range to Monotune, Melody Master-3 or any similar Set. Immediate despatch of Polar, Colvern, Mullard Telsen, Lotus, McMichael, Du-bilier Radlax or other standard goods, cash on delivery or Easy Payments for lists of parts.

**ORDER YOUR PARTS C.O.D.**

A. E. OAKLEY, 43, CARLETON RD., LONDON, N.7.

**ALL THE REFINEMENTS OF THE 12/6 MOVING COIL**

**SUPERIOR IN TONE VOLUME**

The "P.R." Loudspeaker Unit is driven by a fully balanced electro-magnetic armature under the influence of powerful permanent magnets, hermetically sealed and absolutely foolproof. It swings to the weakest impulse, bringing out the treble notes and the rich double bass of the organ. Fitted with a simple tonal adjustment that "stays put." Most powerful Unit giving full strength from a 2-valve set! No extra H.T.

Ask your dealer for one or send your remittance direct  
**P.R. PRODUCTS, 17D, Paternoster Sq., London, E.C.4**

**Write for the New DARIO Folder**

See page 1025

**Advertisements**

As far as possible all advertisements appearing in "Popular Wireless" are subject to careful scrutiny before publication, but should any reader experience delay or difficulty in getting orders fulfilled, or should the goods supplied not be as advertised, information should be sent to the Advertisement Manager, "Popular Wireless," 4, Ludgate Circus, London, E.C.4.

**daimon**

**STANDARD HIGH TENSION BATTERIES with GRID BIAS**

No. 16217 "Daimon" Battery 60 volt with Grid Bias 7/3 each  
No. 16219 "Daimon" Battery 100 volt with Grid Bias 12/3 each

From all good dealers.



**TECHNICAL NOTES.**

(Continued from previous page.)

silver paper or tinfoil may be obtained by winding the bared end of another piece of wire several times around it, and making a secure mechanical joint. Care should be taken that where one strip of silver paper ends and another commences there is good contact between them, and it may even be desirable to wind two or three turns of fairly fine wire around the control-grid lead at each junction of the shielding strips, so as to make doubly sure.

**Soldering to Iron.**

Experimenters occasionally find it necessary to make a soldered joint to iron or steel. Using the ordinary practice you will generally find that it is not nearly so easy to get the solder to "wet" the iron in the way which it does with brass or copper. The following is a way in which the process is much simplified and a neat and permanent soldered connection may be made.

**Copper Plating.**

The part of the iron or steel which is to be soldered is first cleaned thoroughly with a file or sandpaper. It is then dipped in a strong solution of copper sulphate, made by dissolving about one teaspoonful of copper sulphate crystals in an ounce of water. Copper sulphate is obtained in the form of deep-blue crystals and can be bought very cheaply from any chemist. Remember, however, that it is rather poisonous and, therefore, should not be left lying about. The solution should be stirred with a small wooden stick or with a piece of copper strip.

You will find that when the iron or steel is dipped into the copper sulphate solution it will soon acquire a copper deposit, and this forms an excellent basis for the solder which will then be found to "run" much more easily and uniformly.

**A New Battery.**

A new type of H.T. dry battery is being turned out by the Burgess Battery Company in a form which occupies very little "floor space," but which is very tall. It has been aptly described as being of the "skyscraper" design.

A significant note in the production of these batteries may be found in the fact that they are specified for use with the photo-electric cell and the Neon tube. Also, they are found to be a space-and-weight saving factor in radio-equipped aeroplanes, for which they were originally designed. They are marketed in two types; one is a battery having a voltage of 108, which measures 15 in. x 3 3/4 in. x 2 3/4 in., and weighs 6 1/2 lb. It is equipped with four terminals and provides the following values: 36, 72 and 108 volts.

**The Skyscraper.**

The other is similar in design but has a maximum of 144 volts with a 54-volt tap. It measures 13 3/4 in. x 3 in. x 3 in. and weighs 5 1/2 lb. A novel method of construction is used in these batteries which consists of combining the cylindrical cells in stick form, not unlike a roman candle. Seventy-two cells, 3/4 in. x 2 1/4 in., are used in the 108-volt battery. The 144-volt battery consists of 96 cells, 3/4 in. x 1 1/4 in., corresponding in size to those used in the most compact H.T. batteries.

(Continued on next page.)

**THIS AMAZING BATTERY SUPPLIES AMPLE CURRENT FOR "MOVING COIL" & "PENTODE" WORK**

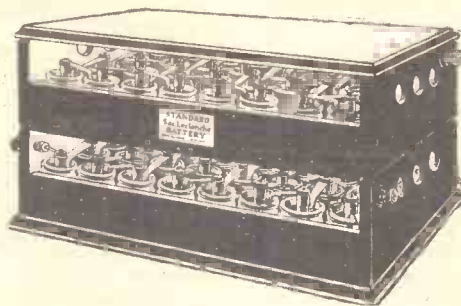

**96 VOLT "UNIBLOC" UNIT**

(No. 2 Cells.)

Assembled complete ready for use. Delivered on first payment of 7s. 6d. and five monthly instalments.

Cash Price **£2/3/11**

For Moving Coil and Pentode Work No. 3 or 4 Cells are recommended.

**NON-VARYING H.T. SUPPLY**

It delivers a smooth, non-varying H.T. supply, free from the ripple and voltage drop associated with ordinary H.T. work.

The current is smooth and powerful, and puts a real punch into your reception.

It contains no acid—every cell and every part is instantly interchangeable—and it re-charges itself over night.

**LONG LIFE**

It will outlive any H.T. Battery made, and deliver its full current to the last moment, after which it is easily and cheaply replenished at a fraction of the cost of replacing a dry H.T. Battery.

Hardly known two years ago, these batteries are now giving constant service to thousands of delighted owners, all over Great Britain.

**CASH OR DEFERRED TERMS**

Halford's Cycle Stores, Curry's Stores, and good class Wireless Dealers can supply same on cash or deferred terms.

Any voltage supplied. If any difficulty, write to us.

**FREE BOOK**

Send for our interesting Free Book, full of data on H.T. Supply, details of Spare Parts, and simple maintenance, etc.

**STANDARD**

SAC RECLANCHE

(The Wet H.T. Battery Co.)

Head Offices, Showrooms and Warehouse (Dept. P.W.), 184-188, Shaftesbury Avenue (Near New Oxford Street end), London, W.C.2.

**DARIO**  
This week's best bargain  
See page 1025.

Make **The DAILY SKETCH**  
YOUR Picture Paper

PLEASE be sure to mention "POPULAR WIRELESS" when communicating with Advertisers. THANKS!

**Literature Art and Music**

**T.P.'s Weekly**

Every Saturday 2d.

T.P.'s WEEKLY is the paper for thinking people—it will keep you up to date with everything in the worlds of art, music, and literature. It is an intellectual entertainment—a kindly guide to richer and fuller knowledge.

## NEW COSSOR MELODY MAKER

PROMPT DELIVERY.

We are in a position to give immediate delivery of the New Cossor Melody Maker Kit.

CASH PRICE **£7-15-0** Carriage Free

or 10/- with order and 11 monthly payments of 14/6.

We also supply all other Wireless Apparatus that is on the market, under our easy payment scheme.

Send list of requirements to:—

**LONDON RADIO SUPPLY COMPANY.**  
11, Oat Lane, London, E.C.2.  
Telephone: CITY 1977.



### WET H.T. BATTERIES

Solve all H.T. Troubles.

SELF-CHARGING, SILENT, ECONOMICAL.

JARS (waxed) 2 1/2" x 1 1/2" sq. 1/3 doz.

ZINGS, new type 11d. doz. SACS 1/2 doz.

Sample doz. (18 volts), complete with

bands and electrolyte, 4/3, post 9d.

Sample unit, 6d. illus. booklet free.

Bargain list free.

AMPLIFIERS 30/-, 2-VALVE SET 24/-

P. TAYLOR, 57, Studley Road, STOCKWELL, LONDON

### EBONITE BUSHES



FOR MOUNTING ON METAL OR WOOD

PERFECT INSULATION

Two required for each hole.

Orders under 1/- send 1d. postage.

NUMBER 1 2 3 4 5 6 14

Hole in Bush: 4BA, 2BA, 3/8", 5/16", 3/8", 7/16", 1/2"

Price each: 1d. 1d. 1d. 2d. 2d. 2d. 2d.

(Complete List of sizes free on application.)

DAREX RADIO CO., Waldram Rd., Forest Hill, London, S.E.23. TRADE SUPPLIED.



### CLAROSTAT

VARIABLE RESISTANCES FOR VOLUME, TONE, DISTANT CONTROL, ELIMINATORS ETC.,

As frequently specified by The Experts:

• HIGH QUALITY • LOW PRICE •

New 20 Page Brochure free on request.

Many unique circuits.

**CLAUDE LYONS LTD.**  
76, OLDHALL ST., LIVERPOOL.

PLEASE MENTION "POPULAR WIRELESS" WHEN REPLYING TO ADVERTISEMENTS

## TECHNICAL NOTES.

(Continued from previous page).

### Indicators.

The usual polarity indicator consists of a solution of phenol thalein in a small glass tube with a stopper at each end and suitable electrodes pushed through the stoppers.

A somewhat simpler polarity indicator consists of a glass tube, say, 2 in. long and 1/2 in. diameter, with a stopper at each end, and electrodes as before, but the electrolyte consisting of a solution of ammonium chloride. When the indicator is used, bubbles will appear at the negative pole.

### Speaker Improvements.

Notwithstanding the great popularity of moving-coil-type loud speakers, progress in loud-speaker design still continues, and I listened recently to a new type of loud speaker which is certainly in advance of anything which I have previously heard.

### Heavy Field Drain.

Talking about moving-coil loud speakers, many experimenters hesitate to employ a speaker of this type owing to the fact that—if he is to rely upon low-tension current from his L.T. battery for energising the field—he is afraid that the current consumption will be altogether too heavy for his battery.

I have seen speakers in which the field-windings require a current up to 5 amperes which, of course, is a very heavy drain on any ordinary L.T. battery such as is used for radio purposes. Where this condition exists, it is due either to bad design of the speaker or—what perhaps should be included in the same heading—to the magnetic material being unsuitable.

Cast steel should be used for the pot and, in fact, steel may be used for one part of the magnetic circuit and soft iron for another. But the point to bear in mind is that, unless the magnetic circuit is designed for efficiency, there will be a great wastage of energising current.

There are many moving-coil loudspeakers working from 6-volt supply which consume no more than about 1/2 ampere of field current and which give excellent results and compare quite favourably for sensitivity with the best of cone-type speakers.

## THE NEW CROXSONIA RADIO PANEL SENSATION

ASTOUNDINGLY LOW PRICES

POSTAGE FREE

ANY SIZE CUT

WRITE FOR NEW FOLDER "P"

Mahogany Finish - 1d. square inch or part inch  
 Black Gloss Finish - 1d. " " " " "  
 Black Matt Finish - 1d. " " " " "  
 "Wireless World" writes:—  
 "Good insulation, infinite resistance. Free from leakage. Exceedingly strong. Not liable to warp. Recommended."  
 Recommended for all specified sets, including Cossor Melody Maker and Mullard Master Sets, as being efficient and satisfactory in every respect.  
 Agents' Addresses:  
 John Henry Smith, 139, Anlaby Road, Hull.  
 L. H. Helyar, 82, Chamberlin Road, Norwich.  
 A. Stredwick & Co., 27, The Mkt., Chatham.  
 Boynton & Co., Ltd., 34, Bradford St., B'ham.  
 Samples and Prices to Trade.  
 Telephone: Clerkenwell 7853.

## CROXSONIA

10 SOUTH STREET MOORGATE E.C.2

## 11th YEAR—12,000 SUCCESSES ENGINEERS!

The way to rapid advancement to a well-paid, executive post in any branch of engineering is through the wonderful home-study courses of The T.I.G.B.



Write TO-NIGHT to find out how The T.I.G.B. can help YOU; state your age and experience and mark your letter "Confidential Advice."  
 (Moderate Fees—Easy Installments)

### FREE BOOK

"Everything about Engineering: how to become A.M.I.Mech.E., A.M.I.E.E., etc."—the greatest book ever published on Opportunities for the Engineer.

The Technological Institute of Great Britain, 209, Temple Bar House, London, E.C.4.

## Keep on Saying DARIO for Radio

See page 1025.

PLEASE MENTION "POPULAR WIRELESS" WHEN REPLYING TO ADVERTISEMENTS

# Insist on "Utility" Condensers

You can obtain "Utility" Condensers in Square Law, S.L.F., or Logarithmic pattern illustrated. The unique mechanical features of these instruments are emphasised in the illustration; you can mount them for Thumb-control or Baseboard operation. If Vernier adjustment is required we fit the "Utility" 4-in. slow-motion Dial for the purpose. Ask to see "Utility" Guaranteed Components at your dealers.

Write for "Utility" Catalogue.

**WILKINS & WRIGHT, Ltd.**  
"Utility Works," Holyhead Road, Birmingham

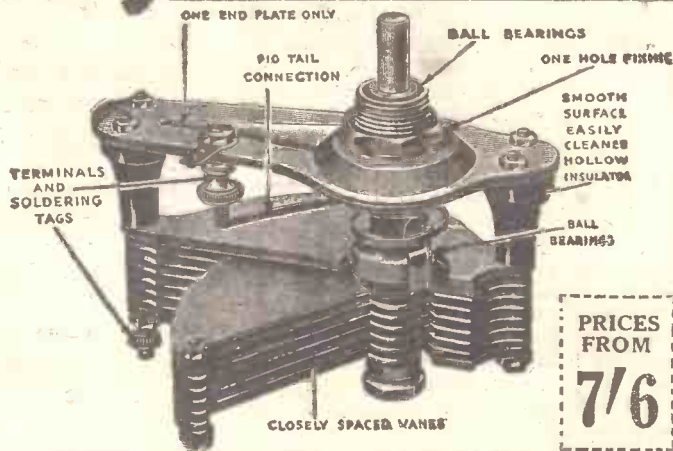

PRICES FROM

## 7/6



THIS design is one which will be found specially attractive to the more advanced constructor, giving a high degree of selectivity on both wave-bands with exceptionally good amplification. Correspondingly, it requires a little more skill to operate it to the best advantage than the simpler type.

It incorporates one high-frequency valve, detector with reaction, and two L.F. stages (one resistance and one transformer coupled). It tunes over both the 250-550 metres and 1,000 to 2,000 metres wave-band without changing of coils, two simple push-pull switches on the panel accomplishing the change-over whenever desired.

The H.F. stage employs a circuit arrangement which has been found extremely efficient, with special features which enable the best results to be obtained on both wave-bands. On the lower waves the simple form of the parallel feed circuit is used, with a variable feed tapping on the coil  $L_4$  which enables you to suit different types of valves and also control the degree of selectivity.

**Special Long-Wave Circuit.**

On switching over to the long waves the circuit is altered somewhat. Stability is no longer obtained by adjusting the feed tap on the detector grid coil (the adjustment found best for the low waves is left permanently set), but by means of the neutrodyne condenser, N.C. This condenser, by the way, only functions on the long waves, and is put out of action by the switching arrangement on going over to the lower wave-band.

The coils for the lower wave-band ( $L_1$  and  $L_2$ ,  $L_3$  and  $L_4$ ) are specially wound ones to suit the circuit, while the additional long-wave coils ( $L_5$  and  $L_6$ ) are "P.W." standard loading coils. The low-

# THE "P.W." "WHITE PRINTS."

## A NEW SERVICE FOR OUR READERS.

**White Print No. 7. :: :: A Wave-Change Four-Valver.**

This week we publish the seventh of our White Prints. This page may be easily and safely torn out—along the dotted line overleaf—and the White Print filed. In due course you will thus have available an encyclopaedic collection of the best circuits used in modern radio practice. A "White Print" will be published on the last page every week in "P.W." until further notice—THE EDITOR.

wave coils are of the type originally used in a set called the "Quick Change" Four, and can be bought ready made if desired.

**COMPONENTS.**

- 1 Panel, 21 in. x 7 in. x 1/4 in.
- 1 Cabine (with baseboard, 12 in. deep, and panel brackets).
- 2 .0005 mfd. variable condensers.
- 1 .0001 or .00015 mfd. reaction condenser.
- 2 Push-pull on-off switches of usual wave-change type.
- 1 L.T. on-off switch.
- 4 Sprung valve holders.
- 1 Copper or aluminium screen, 12 in. x 6 in.
- 1 Neutralising condenser.
- 2 H.F. chokes.
- 2 Standard loading coils.
- 1 Pair "Quick Change" Four coils.
- 1 R.C.C. unit (see diagram for values).
- 1 L.F. transformer, low ratio.
- 1 Output filter choke, about 20 H.
- 1 Fixed condenser, .0003 mfd.
- 2 Fixed condensers, .001 mfd.
- 2 Mansbridge type condensers, 2 mfd.
- 1 Grid leak, 1/2 meg. and holder.
- 1 Grid leak, 2 meg., and holder.
- 1 Terminal strip, 19 in. x 2 in. x 1/4 in., and 10 terminals.
- Wire, screws, flex, G.B. plugs, etc.
- Materials for coils, if desired.

For the benefit of those who may desire to wind their own, a very brief specification

follows. Both units are wound on tubes 3 in. diameter and 3 1/2 in. long.  $L_2$  is of 60 turns of No. 24 D.C.C., and  $L_1$  has 25 turns of the same wire with tapings at 10, 15, 20 turns.  $L_4$  is the same as  $L_2$ , except that it has tapings at 10, 15, 20, 25, 30 turns.

The reaction winding  $L_5$  has 30 turns of any fine gauge of wire, such as No. 32 D.S.C., and is in the same direction as  $L_4$ . General details of mechanical make-up you will be able to gather from the drawing.

**Valves and Voltages.**

The L.F. side is of quite a standard type, while the constructional work is quite straightforward and calls for no special explanations, so we can go on next to operating matters. Suitable types of valves are these: for  $V_1$  and  $V_2$ , H.F. type, impedance about 20,000 ohms. For  $V_3$  (first L.F.) one of the L.F. or G.P. type, impedance about 7,500 to 15,000 ohms. For the last stage a power or preferably even a super-power is advised.

Battery voltages should be just the normal ones, i.e. H.T. + 1 (H.F.) 80-100 volts, H.T. + 2 (det.) 60-80 volts, H.T. + 3 (L.F.) 100-120 volts. The only point really here is to adjust the H.T. on the detector with a little care to get the smoothest reaction control.

**The Output Circuit.**

You will notice that the last valve is provided with an output filter circuit for feeding the loud-speaker, and this is a very desirable feature whenever the last valve is a fairly large one. Not merely does it protect the speaker from the possibly harmful effects of the large anode current, but it also enables a higher effective H.T. voltage to reach the power valve. The reason, of course, is to be found in the low D.C. resistance of the output choke.

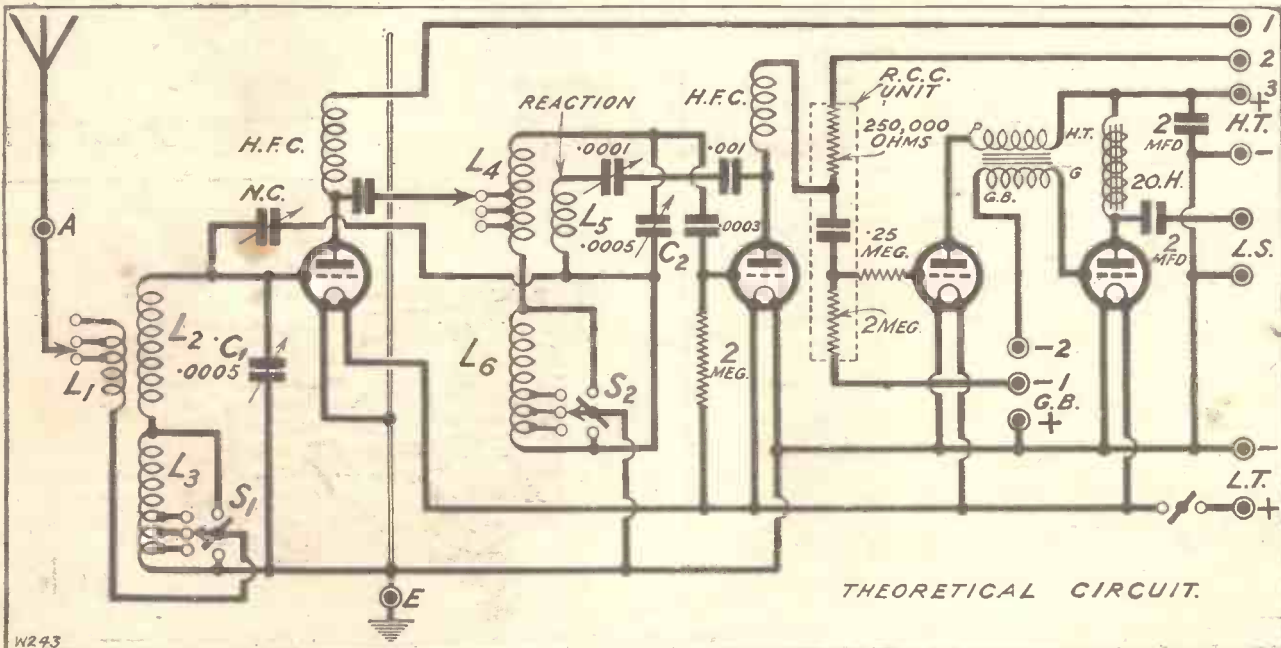

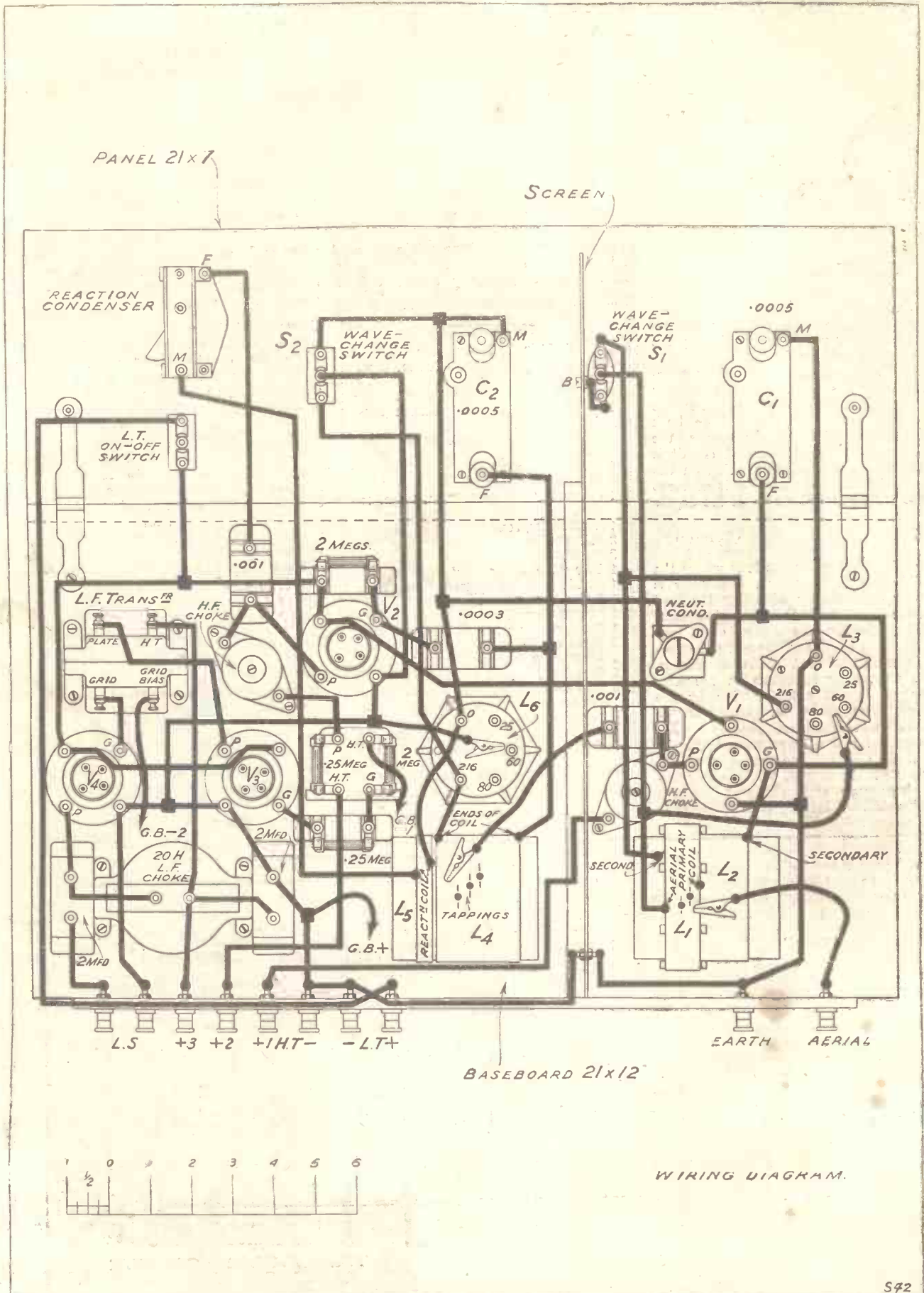

ENDURANCE



*In a recent Cape to Cairo and London car endurance test Mullard Valves were unhesitatingly chosen for the radio installation in the car.*

A seven months' journey—over mountains, through rivers, across some of the roughest country in the world—and not a single valve breakage or replacement during the whole journey.

Mullard Valves were chosen because experience had proved their reliability; this severe test again confirmed their supremacy. Under the most adverse conditions the travellers were able to maintain communication and to enjoy the B.B.C. programmes in their lonely camps.

*Use Mullard Valves in your receiver. Use them for reliability, for strength, for tone, volume and distance.*

**Mullard**  
**THE MASTER VALVE**

**Carries 15 Milliamps  
without Saturation**



*The*  
**BI-DUPLEX L.F. TRANSFORMER**

This workmanlike piece of engineering represents a new and improved Transformer design. Bi-duplex is a name to conjure with all over the world and it is the employment of this exclusive system of winding that has caused its success.

It can be used after a power or super-power Valve, and will carry anode currents up to 15 m.a. without becoming saturated.

When experimenters are striving to obtain the utmost purity of reproduction, they take care to avoid overloading the last valve, but often lose sight of the fact that one of the earlier valves may be overloaded. By employing a power valve in this stage one can ensure that the input to the last valve is undistorted, and thus obtain full benefit from the super-power Valve in the last stage.

The use of two transformer-coupled stages is becoming increasingly popular. In this case we recommend using our Straight Line Transformer in the first stage and the Bi-duplex in the second, especially when the last stages push-pull.



**Varley**  
LTD

PRICE  
**27/6**

**THE MARK OF BETTER RADIO**

Kingsway House, 103, Kingsway, W.C.2. Telephone: Holborn 5303.

**The only L.F. choke  
of its kind**



The R.I. & Varley L.F. Choke is the only one of its kind. With numerous applications it possesses the same degree of real efficiency in

each case. Firstly, it is a really good choke for eliminator smoothing circuits, both H.T. and L.T. On a load of 100 milliamps it is still a long way from saturation point—it is the only choke, at a popular price, which can be used for L.T. smoothing where series connected filaments are used.

As an Output Filter Choke it can be used equally well after a single power valve or 3 super-power valves in parallel. One has indeed only to refer to the pages of any of the wireless journals of to-day to realise the extent to which the R.I. & Varley L.F. Choke is being used by the Technical Experts in this country.

28/14 Henries, 0.103 m/a  
260 ohms D.C. Resistance,  
**£1 : 1 : 0**

14/7 Henries, 0.100 m/a,  
120 ohms D.C. Resistance,  
**£1 : 1 : 0**

*These Chokes have a huge iron circuit, adequate inductance and Low Resistance.*

