

FOUR MORE 6d. BLUE PRINTS FREE.

# Popular Wireless

Every Thursday  
PRICE  
3d.

No. 194. Vol. VIII.

and Wireless Review

February 13th, 1926.

Scientific Adviser: SIR OLIVER LODGE, F.R.S., D.Sc.



### Contents.

How to Make  
A One-Valve Unidyne,  
An "H.F., Det., L.F." Receiver,  
A Two-Valve Amplifier, and  
A Two-Valve and Crystal  
Reflex Receiver.

More Practical Ideas.  
Hard Circuits Made Easy.  
"A Talk on Clerk Maxwell,"  
by Sir Oliver Lodge, F.R.S.

Our cover photograph this week shows some American naval cadets listening to a broadcast programme on the bowsprit of their ship, which they find is the best spot aboard for reception.

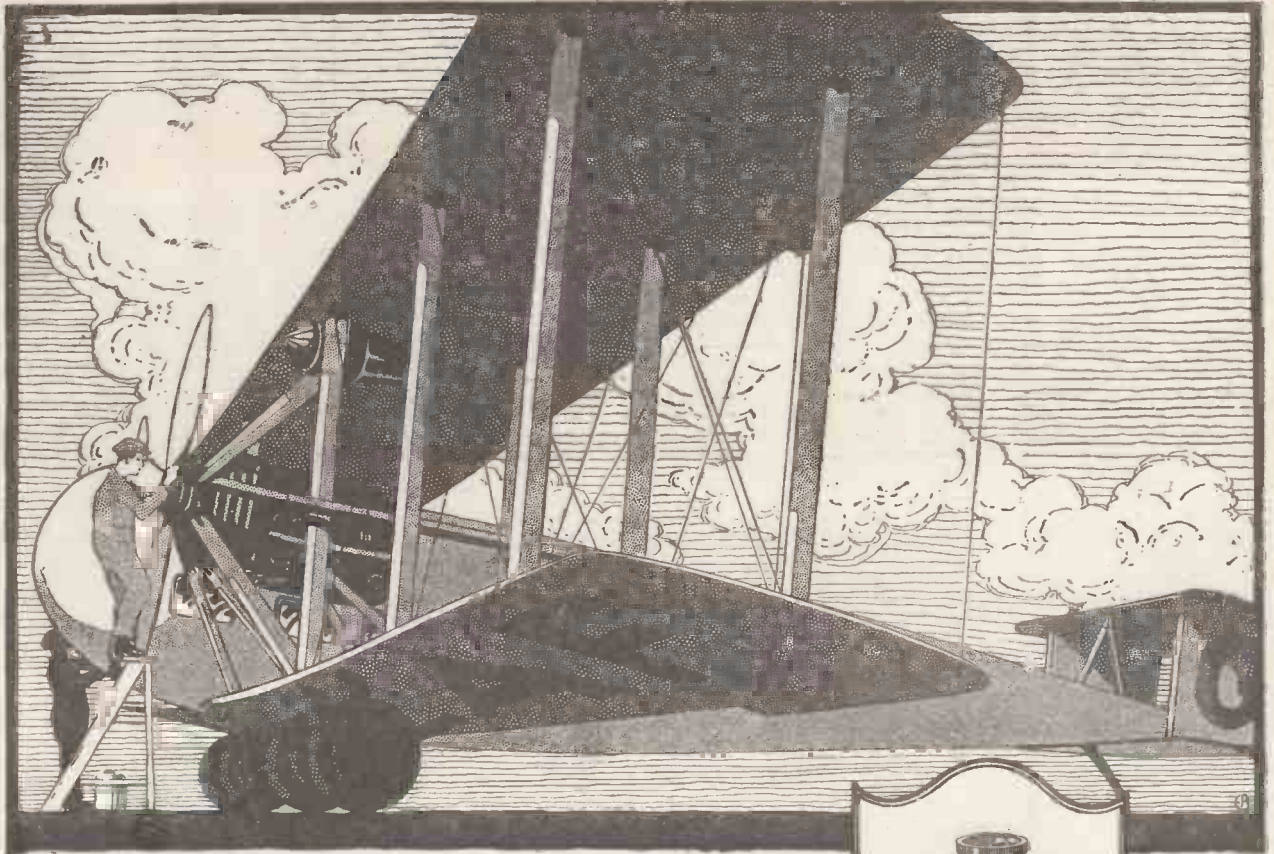

# Dubilier everywhere

—with the Services

Dubilier Condensers are used wherever the exacting requirements of Service conditions make accuracy and constancy essential. British Government Services use large quantities of our products annually, and we supply practically every government in the world.

The Dubilier Condenser Co. (1925) Ltd. manufacture Fixed Mica Condensers, Variable Air Condensers, Anode Resistances, Grid Leaks, the Minicap Switch, the Ducon Aerial Adaptor, the Mansbridge Variometer, and the Dubrescon Valve Protector. The Company are also sole concessionaires for the products of the Mansbridge Condenser Co., Ltd.

*Specify Dubilier*

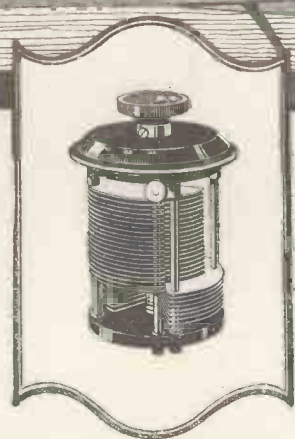

*The Duwaton Variable Condenser for Series. Parallel working. Gives a complete tuning range over the whole wave-length band.*

0-0007 mfd. ... 30/-





Type  
HQ

**Loud  
Speakers**

- Type H 1**  
21 ins. high.  
120 ohms £5 5 0  
2000 ohms £5 8 0  
4000 ohms £5 10 0
- Type H 2**  
12 ins. high.  
120 ohms £2 5 0  
2000 ohms £2 8 0  
4000 ohms £2 10 0
- Type H 3**  
15 ins. high.  
2000 ohms £3 0 0
- Type H 4**  
10 ins. high.  
2000 ohms £1 10 0

Such a reputation for fine workmanship has been woven around the name Brown that prospective purchasers know in advance that each of the new models will fulfil every requirement for volume, tonal purity and beauty of outline.

S. G. Brown, Ltd., N. Acton, London, W.3

*Retail Showrooms* : 19 Mortimer Street, W.1.  
15 Moorfields, Liverpool. 67 High Street, Southampton.  
*Depots (Wholesale only)* : 13 Bushy Park, Bristol.  
Cross House, Westgate Road, Newcastle.

**Loud  
Speakers**

- Type HQ**  
20 ins. high. 120  
ohms, 2000 ohms and  
4000 ohms £6 0 0

**Cabinet Type**  
120 ohms, 2000 ohms  
and 4000 ohms in oak  
or mahogany £6 6 0

**Q Type**

The Loud Speaker de  
luxe. In all resist-  
ances £15 15 0

BRITISH **Brown** THROUGHOUT

# "BEST WAY"

## GUIDES FOR WIRELESS CONSTRUCTORS

*The two latest Numbers Now on Sale Everywhere*

### AMPLIFIERS

Amplifiers to add to any type of receivers either crystal or valve; note magnifiers for increasing signal strength to any required volume are fully described, and an H.F. Amplifier for increasing range of reception are notable features of this book, while the construction of a Reflex amplifier which transforms any crystal set into a dual amplification valve receiver is explained in detail. All articles are fully illustrated with clear photographs and in every case point-to-point wiring check lists are given supplementing the theoretical, wiring and pictorial diagrams.

### LOUD SPEAKER SETS

A range of specially designed loud-speaker receivers to suit all pockets and all purposes. Purity of reproduction has been given foremost consideration throughout from the economical one-valve Reflex to the more ambitious four-valve set capable of receiving a large number of stations. Handsome in appearance these receivers will bear comparison with much more costly sets, but are well within the scope of the non-technical home constructor. The well-known "Best Way" practice of providing theoretical, pictorial and practical wiring diagrams, clear photographs, point-to-point check lists and fully explanatory text is a feature of this book.

**CONSTRUCTORS USING THESE BOOKS CANNOT GO WRONG**



Of all Bookstalls

Price **6<sup>D.</sup>** each

Of all Newsagents

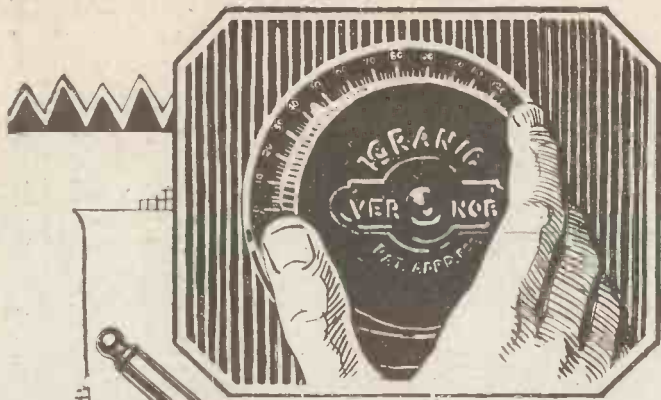

# Little IGRANIC Radio Devices that make a *big* difference



**IGRANIC-PACENT UNIVERSAL PLUG**

(Pat. No. 213220.)  
This is one of the most popular in use to-day. Standard equipment on many well-known makes of loud speakers. To connect—insert cord tips in connector springs and clamp shells together. Polarity stamped on connector springs.

PRICE (black) 1/8

**IGRANIC VERNOB Vernier Control Knob**

Patent No. 223010.

A very attractive instrument for fitting to any rotary tuning device to obtain fine vernier adjustment. Designed to fit 1/4 in. spindles, but with a liner will fit 3/8 in. spindles. Price complete with liner and 180° scale, 6s.

In Radio as in any other pursuit it is often "the little things that count" and upon the efficiency of the minor components and accessories may depend success or failure. Therefore it behoves every Radio constructor who aims at obtaining a high standard of performance from his radio receiver, to exercise the utmost care in choosing these small components.

There is the IGRANIC "VERNOB" VERNIER CONTROL KNOB, for instance, which enables a fine vernier movement to be imparted to any rotatable component which is not provided with means for vernier control.

Pressing the knob slightly forward gives a direct positive drive on the spindle for rapid adjustment, while rotation of the knob in the normal position gives an exceptionally fine movement which makes a wonderful difference when tuning-in "that elusive station."

So it is with all other IGRANIC RADIO DEVICES—they enable the best possible results to be obtained even under adverse conditions.



**IGRANIC TELEPHONE CONNECTOR**

Patent No. 223469.

A handsome and useful addition to any set. Provides connections for addition of four pairs of telephones; automatic in action. Price 8/6



**IGRANIC-PACENT DOUBLE CIRCUIT JACK**

Generally used between stages to permit of 'phones or loud speaker being plugged-in according to amplification required. PRICE 2/6



**IGRANIC RADIOLOC**

With this component built into your circuit you not only have a master filament control, but also a positive guard against damage to your valves and batteries. When the key is out your set is "locked" and "off"; safe from meddling fingers. The Radioloc provides perfect electrical conductivity, yet occupies a very small space, and little of it is seen on the panel. Price with two keys, 3/-

Ask your dealer about them

Write for **COMPANY** List Z. 980.



Exclusive Manufacturing Licensees of Patent Radio Essentials.

149, Queen Victoria Street, London.

Works: BEDFORD.

BRANCHES: BIRMINGHAM, BRISTOL, CARDIFF, GLASGOW, LEEDS, MANCHESTER, NEWCASTLE.

The IGRANIC Instructional Carton for constructing a six-valve Supersonic Heterodyne Receiver according to the Igranic design. Contains a comprehensive, fully illustrated descriptive handbook, full-size general arrangement drawings, wiring diagrams and drilling template. Obtain a copy from your dealer. PRICE 2/6



# DULL EMITTERS

—now is the time to face the facts

**C**LEVER advertising can sell anything once—but if the commodity does not live up to its advertised reputation then the manufacturer gets no repeat orders. His business is built upon shifting sands, the product declines in popularity and eventually disappears. On the other hand, if the article is a good one users are only too glad, not merely to keep on buying but also to testify to its merits and further its sales.

When the Cossor Valve was first introduced its novel constructional features created great interest. The sceptically-minded bought Cossor Valves deliberately to prove to their own satisfaction the fact that an arched filament almost totally surrounded by a hood-shaped Grid and Anode could make no material improvement in sensitiveness or volume.

But those who came to scoff remained to praise. Throughout the length and breadth of the land you'll find Cossor users enthusiastically acclaiming the superiority of their valves. Not merely because actual experience proves them to possess a longer life—not merely because comparative tests show them to be more sensitive to weak signals—not merely because they are entirely free from annoying microphonic noises—not merely because they yield a much purer tone. Their popularity cannot be ascribed to any one of these features but to the rare combination of them all.

And now comes the Wuncell—the first really *long life* Dull Emitter. Dull Emitters are no new discovery. They have been in existence for several years—but there is a vast difference between the laboratory specimen and the valve produced under modern manufacturing conditions in mass production. Two bugbears have always been present in the evolution of the perfect dull emitter. One the difficulty of obtaining absolute uniformity of performance, and the other, of producing a robust valve.

Not until these difficulties were definitely overcome was the Wuncell placed upon the market. The wonderful reputation enjoyed by the Cossor Bright Emitter valve could not be prejudiced by the hasty manufacture of a dull emitter merely to meet a clamorous demand.

Uniformity of performance and exceptional sturdiness are the two outstanding features of the new Wuncell. These are no idle platitudes as many thousands of Wuncell users can already testify. They are due solely to its unique filament.

Instead of whittling down the filament to secure low current consumption at the risk of fragility, that used in the Wuncell, by reason of a most elaborate process is *built up layer upon layer*. The result is a filament quite as stout as that used in any bright emitter valve. Its electron emission, however, is so vastly increased that only very little electrical energy is required to operate it. In daylight, for example, its glow is practically invisible, while at night it can only be compared to the luminous figures on a watch.

With such a filament mounted in arch formation and further secured at its centre by a third support, it is small wonder that the Wuncell was described by *Amateur Wireless* as being "almost everlasting." Valve users would do well to note that this type of filament is not obtainable in any other make of valve.

Uniformity of construction is safeguarded in the big Cossor factory through the provision of the most accurate machinery that human ingenuity can devise. Gauges accurate to one ten-thousandth part of an inch—workers long skilled in the most delicate operations—systematic tests taken during every process—the courage to discard every valve which does not reach the pre-determined standard of excellence—these are some of the reasons why the Wuncell is rapidly supplanting all bright emitter valves.

A. C. COSSOR LTD.—Highbury Grove, London, N. 5  
MANUFACTURERS OF COSSOR AND WUNCCELL VALVES

# Popular Wireless

Scientific Adviser:  
Sir OLIVER LODGE,  
F.R.S.

Consultants:  
Dr. J. H. T. ROBERTS,  
F.Inst.P.  
J. F. CORRIGAN, M.Sc.,  
A.I.C.  
C. E. FIELD, B.Sc.



Editor: NORMAN EDWARDS, M.Inst.R.E., F.R.S.A., F.R.Q.S.

Technical Editor:  
G. V. DOWDING,  
Grad.I.E.E.

Assistant Technical  
Editors:  
K. D. ROGERS,  
P. R. BIRD.

## RADIO NOTES AND NEWS.

Low - Power Feat — New 5 X X Feature — Hilversum's Harmonics — Railway Radio —  
"P.W." in Siberia — Dame Nellie Melba.

### New Loud Speaker.

A NEW type of loud speaker has just been invented by Dr. N. W. McLachlan. Claimed to be a most important advance towards the perfect reproduction of broadcasting, it has been demonstrated by the inventor to the R.S.G.B. The whole arrangement is designed to prevent any possibility of distortion, but unfortunately it is not yet on the market.

### One-Valve Results.

HOW many broadcasting stations should a good one-valve set be able to scoop in? It's a fascinating question, the answer depending upon all sorts of things such as locality, skill in handling, etc.; and some favoured mortals can collect about a dozen stations any evening, whilst others can't get away from the local. A Tunbridge Wells reader informs me that he has secured over forty stations upon a straight single-valve set, including the following:

### Periodical Tours Abroad.

DUBLIN and thirteen B.B.C. stations, five French, two Dutch, nine German, six Spanish, three American, and Radio-Bern, Prague, Oslo, and Rome.

He says: "This lot I receive periodically, but not every time I try for them." I know a lot of people with super-hets. who spend their time wishing they could say as much as that.

### Fight by Radio.

SOME time ago it was announced that an imitation prize-fight would be broadcast from 2 L O. Now I hear that, instead of realistic imitations, the

actual contest for the Lonsdale Belt, at the National Sporting Club, on Feb. 22nd, will probably be broadcast. Twenty-five

**ANOTHER 2/- GIFT  
NEXT WEEK!**

**Four More 6d. Blue Prints.**

**Order Your Copy Now!**

completed, but most listeners are hoping that the B.B.C. will give every encouragement to the development of this form of broadcast. It certainly seems to get more good fun over the ether in a given time than almost any other kind of entertainment.

### The Wide, Wide World.

BRITAIN'S giant radio station at Rugby, the range of which is world-wide, is now undertaking a radio-telegraph service to liners at sea in any part of the globe. This applies to vessels fitted with C.W. receivers, and the rate is to be 1s. 6d. per word. Full particulars of the service can be obtained at any Postal Telegraph Office, where a list of the vessels which can be reached under the new arrangement is available.

### Low-Power Feat to India.

AN excellent low-power feat has been accomplished by Mr. L. Bland Fagg, A.M.I.R.E. (2 G O). He has been working with a station in India, nearly 6,000 miles away, with an input of only 12 watts. This must be something like a record for low-power transmission, so far as Great Britain-India is concerned.



Birmingham's popular Station Director, Mr. Percy Edgar, at work at 5 I T.

minutes are allowed for, so there will be time for a short talk by Lord Lonsdale, or another well-known sportsman, as well as for the noises of the actual fight in progress.

### Listening Time.

THE new broadcast revue, which is to take the place of "Radio Radiance," will be called "Listening Time." At the time of writing the arrangements for the "opening night" have not been

### New 5 X X Feature.

THE Daventry station, with a "parish" that measures hundreds of miles across, has always been a bit of a problem as regards its "local news." Other stations could prattle of municipal measures and give residents little tit-bits about the neighbourhood; but 5 X X has too powerful a voice for local gossip, and consequently it was always at a loose end

(Continued on next page.)

## NOTES AND NEWS.

(Continued from previous page.)

whilst the other stations gave out their local items. Now the B.B.C. has decided to include a shipping forecast in the 5 X X programme at 10.25 on week-days, and 9.10 p.m. on Sundays. And in future, while other stations are engaged upon local news, 5 X X will tell the trawlers and inshore shipping all about the tides and channels, and the way the wind blows.

## Hilversum's Harmonics.

I HAVE just heard from "P.W.'s" correspondent in Holland, Mr. W. Peeters, that there is no truth in the rumour that Hilversum has been intentionally transmitting upon short waves. It will be remembered that a Southend reader picked up signals from the Dutch station upon a low wave-length, but Mr. Peeters assures me that this must have been a harmonic. Certainly Hilversum is still up on 1,050 metres, and means to stay there.

## Railway Radio.

THE G.W.R. (Bristol) Radio Society carried out a very interesting experiment recently, when an attempt was made to pick up broadcasting in a train passing through the Severn Tunnel. A Burndept 7-valve super-het. was employed, and though signals faded away in the tunnel, the carrier-wave of the Cardiff station could be heard faintly. Half a mile from the Welsh end, when the train had travelled clear of the waters of the Bristol Channel, music was picked up at good strength.

## Tuning-in Through the Tunnel.

PLENTY of stations were picked up and reproduced upon twenty loud-speakers whilst the train was travelling at full speed in open country. San Sebastian was the star turn, but Brussels was a good second of the distant stations, that included Dortmund, Berne, Hamburg, and Radio Catalana (Barcelona).

There is little wonder that the tunnel damped results, for it has a maximum depth of 50 ft. below the surface, and is covered by about 80 ft. of water. The thickness of the tunnel casing itself is fifty bricks!

## The "P.W." Two-Valver.

A WEST Croydon reader—Mr. V. C. Moggs, 12, Pawsons Road—tells me that he heard Prague Radio Journal (Czecho-Slovakia) on 368 metres one Sunday evening between 11 and 12. The announcer was thanking British readers for the reports of reception sent in, which shows how well signals have been received here from this new station. Mr. Moggs was able to hear musical items 8 ft. away from his 'phones, using "The 'P.W.' Two-valver."

## —And Thirty-nine Others.

AFTER Prague had closed down at 11.50 a turn of the condenser brought in what appeared to be Seville, and this station provided entertainment until 1 a.m., closing down with chimes in the studio.

At the end of his report this reader says: "I have made up about forty 1 and 2 valvers from 'P.W.', and not one was a disappointment."

## "P.W." in Siberia.

DO you know where Tomsk is? Not Tom, but Tomsk.

Well, it's a little old home town right away in Siberia, and apparently "P.W." has found its way there, for this week I've had a letter from a comrade in Tomsk. His address is A. Kalachnikoff, Tomsk, Siberia, Russia (Krasnoarmeiskaja St. 66). And this is what he says:

## "Non Money."

I BEG your pardon if I take away your time, but I understand it will be a great kindness from your part, if you'll accomplish my begging because I've

## FROM DAME NELLIE MELBA

1st February, 1926.

The Editor, "Popular Wireless."

Dear Sir,—Amid the sadness of bidding goodbye to so many good friends of mine up and down the country it has been a pleasure to note almost everywhere a quickening in musical appreciation. To-day there are gratifying signs that the British audience begins to hear as well as listen; and if the result is to be a musical revival the credit for it will be due in no small degree to men like Hallé, Henry Wood, Eugene Goossens, Landon Ronald, Albert Coates, Hamilton Harty, and a number of other pioneers in London and certain provincial centres.

Yet mainly, so it seems to me, the secret of this new interest is to be found in the astonishing enlargement of the audience for music accomplished by the gramophone and broadcasting. Although I believe I was the first prima donna to make a gramophone record and the first to broadcast, I have not, whilst recognising the possibilities of these devices, ever accepted either of them uncritically, and I am well aware of the flaws in wireless as that science is practised to-day. But, just as I have followed the gradual perfecting of the gramophone, so I think one may look forward to like improvements in wireless. Broadcasting and the gramophone are certainly the two most eloquent missionaries to the musical heathen in our midst.

Yours truly,  
NELLIE MELBA.5, Chesham Place,  
London, S.W.1.

non money to pay you. I understand it is a great insolence from my part such a asking, but if you'll stand in my situation you'll understand me, and send me your remarkable journal. I beg you give a place in your excellent journal to following lines:

## A Friendly Correspondence.

ENGLISH Amateurs, An Russian Amateur will put in touch with you, and have a friendly correspondence and close acquaintance. Also I am interested very in receiving radio books and different radio parts, variable condensers, dials, potentiometers, rheostats, knobs, ebonite panels, and so on, and so on.

"From my part I am able to give only following things: Russian post stamps, and paper money emitted during a revolution, Russian postcards with views. To enable me answer and help me pay a postage, please send each time some international reply coupons on amount about one shilling. I wait your letters with impatience!"

## The Personal Touch.

A POSTSCRIPT says, "Please send magazines only register. If to you will be of interest my stamps, paper-money, and postcards, I with great pleasure will send them to you. I regret very that I unable to send you money, but if ever I'll have them, it will be my first duty to send them to you. It will be very pleasant to me if you will have a personal correspondence with me, and send me your photo. Write what interested you in our life and radiolife—I'll try to satisfy you by writing you a particular letter, about this. Hoping that from this on we will be friends."

So if you feel that a friend in Tomsk would be a friend indeed, you should drop a line, but don't forget about the "P.W.'s," components, registration, and bobsworth of reply coupons!

## A Disappointment.

DID you ever know the ether more scgygy and turbid than it was during International Radio Week? One night I stuck it till 4 a.m. and tried every set I own, finally going to bed in high dudgeon, without logging anything worth losing beauty sleep for. It's comforting to know it was the same all over the world as in Britain, and we must just hope for better luck next time.

## The Dublin Station.

THE Editor of "The Irish Radio Review" asks me to make public the following notice: "With reference to the transmissions of 2 R N, the Dublin broadcasting station, we beg to advise you that your readers' reports of the reception will be welcomed. Reports should be addressed to the Editor, "The Irish Radio Review," 179, Great Brunswick Street, Dublin, Ireland.

## Flying Wireless.

ACCORDING to the "Morning Post," passengers travelling in one of the French London-Paris aeroplanes are now able to listen in to broadcast programmes. A twin-engined Farman Gobiath, belonging to the Air Union, has been fitted with a 7-valve set, placed in the front part of the cabin. The mechanic attends to it, and tunes in London, or Paris, and the 12 passengers are able to listen in on 'phones.

It is stated that in spite of the roar of the mighty engines, reception is good. That's nothing; I used to own a 7-valve set that roared so loud that you'd never get a chance to notice the buzzing of any mere aeroplane engine!

## "Happies."

TEIGNMOUTH Radio Society is being inaugurated to-night (Thursday), and I should like to take the opportunity to wish them "Happies" on their birthday. "Look in the ether, Teignmouth, and you will find some beautiful concerts, jazz, and jam-(ming). And whatever you do, don't forget to put your 'P.W.' in the wireless cupboard, every week, Teignmouth; Uncle Ariel's got something good for you every Thursday, you know.

"Happies" to all you other children, too. I must go now, 'cos Eddie Tor wants me. Good-bye, children, Good-bye—"

ARIEL.



# A Talk on Clerk Maxwell

by Sir Oliver Lodge  
F.R.S.



James Clerk-Maxwell.

THE work and influence of a great man cannot be measured by his length of years. It is sometimes said that the best and most original work, even of a man of science, is done during the years between twenty and forty, or even, some say, between twenty and thirty, before he gets too much absorbed in the work of the world, and before the freshness of his genius has crystallised into habit.

Certainly some of the greatest men have died young, sometimes amazingly young, considering what they accomplished and the influence they have exerted on posterity. The world was redeemed by a Life lasting only thirty-three years.

Apart from statesmanship and politics, which seem to require a measure of seniority, the chief advantage of long life is that great men become better known to their contemporaries, and receive more appreciation from the generation immediately following. They become, in fact, better known to the public.

## Unrecognised Genius.

But, in so far as actual achievement is concerned, their best work is usually done while they are still young, before the enthusiasm of youth has evaporated, and before their vitality is impaired, or their time consumed by the cares of this world and the demands of social and family life.

Men who die young, before they have reached the public ear, cannot become well or generally known; their subsequent reputation must depend on the piety of their co-workers, who appreciate them and are able to understand and expound their work. Posterity has a much better and truer comprehension of them than their immediate followers have.

So it has been in science with Hertz, and Carnot, and Fresnel, and Moseley, and FitzGerald, and Thomas Young; and in another branch of activity so it has been with Keats and Shelley. So also it is with Clerk-Maxwell.

Everyone is familiar with the name of Lord Kelvin, who acquired years and honours, but comparatively few know much about the work of James Clerk-Maxwell; yet he was a man of equal magnitude, some think even greater. But it is not for us to make comparisons. Some think that in his influence on the progress of science and in his innate powers of perception and mathematical ability he was comparable to Isaac Newton! However that may be, there is no doubt that his life work was far greater than is generally known.

Some men are fortunate in their biographers, others are not. Clerk-Maxwell was one of the unfortunate ones. And, indeed, his own modesty and simplicity may have tended to lead his contemporaries to take him more nearly at his own valuation than was reasonable or right.

## "Kinetic Theory of Gases."

The outward circumstances of his life were merely these. He was born in 1831, and died forty-eight years later. He was Professor of Physics first at Aberdeen; then at King's College, London; then at Cambridge, where he built the Cavendish Laboratory with funds provided by the then Duke of Devonshire, a member of the famous house of Cavendish. His scientific writings began at a very early age, for he might almost have been called an infant prodigy; and they have been collected into two large rather unwieldy volumes. Like Newton, he did some fine work on the Theory of Colour and of Colour Vision, devising a geometrical scheme of representation which has been used by all explorers in this field since.

But a great deal of his work was connected with the behaviour of atoms and what is called the "Kinetic Theory of Gases." A gas is a structure in which the atoms or molecules are independent of each other, and fly about in all directions at random, colliding with each other and rebounding, filling every vessel in

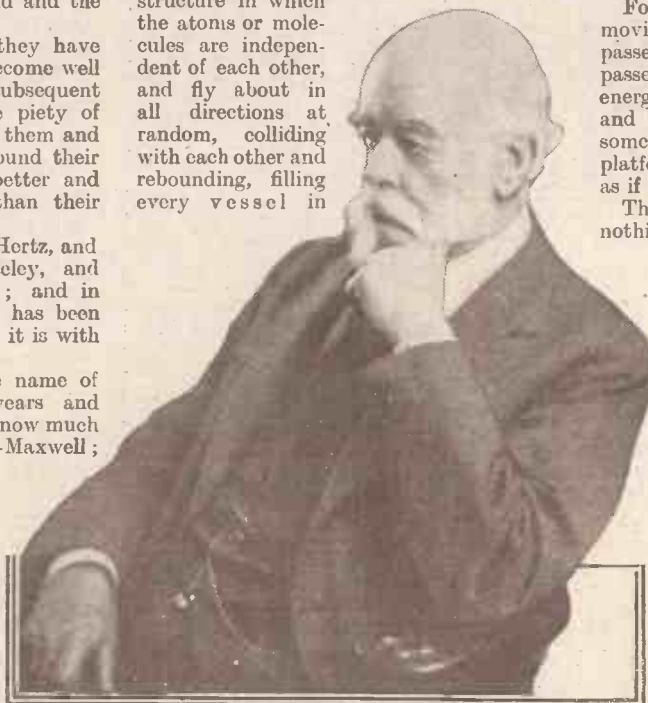

A recent photograph of our scientific adviser, Sir Oliver Lodge, F.R.S.

which they are put, and exerting pressure on its walls by the bombardment, but not cohering together in the least. If they cohere, the gas liquefies.

The gaseous laws of pressure, temperature, and volume can be elaborated by the behaviour of random flying perfectly elastic particles, independent of each other; and that is what a gas is.

But a gas has a certain amount of viscosity, a property possessed in an exaggerated manner by treacle. If air in a vessel is stirred, it soon comes to rest, sooner than if it were water; the motion is wiped out by friction. But it must be a peculiar kind of friction in a gas; for if the molecules are independent of each other, how can they rub and cling together? As a matter of fact, they do not; and Maxwell gave the theory of gaseous viscosity as due to diffusion—the diffusion of particles among each other.

## Interesting Damping Effect.

For instance, a perfectly frictionless moving train might be brought to rest by passengers getting in and out of it; every passenger getting in consumes some of the energy of the train in getting propelled, and every passenger getting out wastes some of the energy of the train on the platform. So the train would be stopped as if by friction when there was no friction.

Thus, by the diffusion of particles and nothing else, viscosity between layers of moving gas can be simulated. By considering the problem in detail he made the unexpected prediction that the viscosity of a gas within certain limits would be independent of the pressure—that is, independent of the amount of gas in the vessel. For in a rarefied gas the greater mobility would make up for deficiency in number; and this prediction he subsequently verified by careful experiment. He also showed that the energy of all gaseous particles, whatever their nature, and whether light or heavy, would be on the average the same—a law which, as the "law of equi-partition of energy," has had a great effect on science

(Continued on next page.)

## A TALK ON CLERK-MAXWELL.

(Continued from previous page.)

and has led to brilliant discoveries of exceptions. Hence the Quantum.

But, after all, the greatest work of Maxwell's life was the assimilation of Faraday's experimental researches in electricity and magnetism, and with great ingenuity throwing them into a mathematical form, the advantage of which is that thenceforth their consequences can be deduced in a semi-mechanical or algebraic manner by people not possessing the intuitive genius of Faraday himself; and, moreover, refined calculation enables results to be obtained



One of the new 10 kw. water-cooled valves in use at the Rugby Station compared with the average valve used for reception.

far beyond the possible range even of a Faraday.

It was thus, that in 1865 Maxwell discovered the true nature of light, which, though used by humanity from time immemorial, had never been understood. Numberless attempts had been made to work out a theory of the ether which should explain light on mechanical principles, the principles of ordinary vibration of a medium.

These had carried people a certain distance, but sooner or later they all failed. Maxwell showed that light was not a mechanical vibration at all, but a purely electrical or electro-magnetic phenomenon.

### Electrical Character of Light.

Just as Benjamin Franklin had identified lightning with electricity—which was comparatively a simple though rather sensational thing to do—Maxwell identified light with electricity and magnetism: an iden-

tification which was by no means simple, and not at all sensational in the popular sense. He did this first in 1865, and in 1873 published his great and standard two-volume treatise on "Electricity and Magnetism," in which "Light," so to speak, became one of the Chapters, being incorporated with Electricity as a Province or self-governing State in an Imperial constitution.

### Commencement of Wireless.

The discovery was received, as usual, with conservative hesitation by the senior Authorities of the period, and was not fully accepted till long after. It was hardly known on the Continent, and was looked at askance by some in this country. But among some of the younger men, beginning their scientific career, it aroused great enthusiasm and led them to wish to find a means for making light or radiation by purely electro-magnetic methods.

This was reserved for Hertz, who, in '87 and '88, a quarter of a century after the discovery, brilliantly verified it, and began the actual production of those waves which make broadcasting possible to-day.

Hertz developed their theory on Maxwell's lines, and showed how every detail could be explained on Maxwell's theory when more fully developed and worked out. Indeed, until the discontinuity of electricity was discovered, and the electron and the quantum made their appearance, everything in electrical science and engineering could be explained by Maxwell's theory.

But it was a continuous theory of the Ether; it did not allow for discontinuities, or rather it only suspected

them in an initial manner, and made no provision for them in the equations. All that represents work which has been done since. Maxwell's discontinuous work in the kinetic theory of gases is now pressed into the service of electricity, and by the two together he still dominates the field. Gas theory is now applied to electrons, and even to radiation. Astonishing!

### Foundation Stone of Modern Science.

James Clerk-Maxwell has been the inspiration of most of the brilliant young mathematicians and experimenters who disport themselves with such admirable results in this twentieth century. Maxwell might have been alive to this day; he would have been only ninety-four.

But for all practical purposes his influence is as live as ever. He has written his name large on the history of science; and posterity will rejoice, not only at the wonderful discoveries that are being made now,

but at the astonishing genius which laid their foundations and made the super-structure possible.

## A SIMPLE SAFETY DEVICE.

By a Correspondent.

THE earthing of the aerial during severe local thunderstorms is purely a matter akin to insurance. If you do not do it you may have reason to be sorry. The simple device about to be described enables the aerial to be earthed *outside* the house by an operation performed *inside* the house. The operation consists only of pulling out a pin, and the apparatus can be made from oddments. (See Figure below.) Through the ebonite wall-tube passes a brass rod having a sliding fit. On the outdoors end of the rod is placed a bit of spiral spring, then a nut, a washer and a wing-nut. A piece of brass

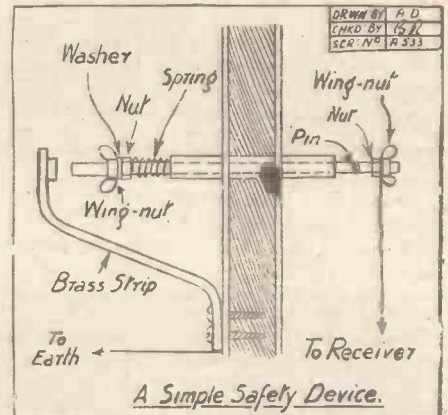

strip is bent, as shown, and fastened to the wall. A contact piece soldered to the strip is a refinement well worth while. From the strip a lead is taken to earth.

### Simple Action.

In the indoors end of the brass rod a hole is bored to receive a pin, which can be made of metal rod or stout wire, with an easy fit. A nut and wing-nut also are fitted, as shown in the diagram. This nut and the outside brass contact must be adjusted so that when the brass rod is pulled inwards far enough to bring the pin hole clear of the ebonite tube the other end of the rod breaks contact with the brass strap.

This action puts a tension on the spring. When it is desired to earth the aerial the pin is removed, the spring relaxes and carries the rod outwards to make contact with the strap, thus securing connection to earth. To unearth the aerial all one has to do is to pull back the rod slightly and reinsert the pin.

## NEXT WEEK.

FOUR 6d. BLUE PRINTS FREE!

ORDER YOUR COPY NOW  
AND DON'T MISS THIS MAGNIFICENT GIFT.



# A UNIDYNE DETECTOR WITH REACTION

The Set designed, described and constructed by the "P.W." Technical Staff. The diagrams for this set are on the Blue Print given away with this issue.

**M**OST of our readers will be familiar with the principle of the Unidyne receiver, which was introduced to the public in the pages of this journal in 1924. For the benefit of new readers, its characteristic feature can be expressed in a few words—it requires no H.T. battery.

### No H.T. Battery Needed.

The trouble and difficulty attached to the maintenance of an efficient high-tension supply led to an investigation as to the possibilities of reducing this to a minimum, or abolishing it altogether. The Unidyne circuit, as shown in the blue print, gives the receiver which was evolved as the result of many experiments, and, although there is no H.T. battery whatever in the circuit,

of an unusual type, which is known as a "four-electrode valve." Nearly all the other valves used for wireless reception have three electrodes, namely, the filament, grid, and plate (or "anode"). These are extended through the base of the valve in the form of four legs, two for the filament, one for the grid, and one for the anode.

In the four-electrode valve (that is necessary for the operation of the Unidyne circuit) there is one filament, one anode, and two grids. The filament has the usual two legs, and the other electrodes one leg each, so that the complete valve has five legs, and is inserted into a five-leg socket, which is shown near the aerial terminal on the blue print.

### What the Set Will Do.

Before considering the actual connections to the valve, it may be as well to supplement the statement regarding results obtainable with the Unidyne one-valve receiver. It has been found to work with great efficiency under all sorts of conditions, and has attained tremendous popularity as a long-distance receiver. In innumerable cases readers of POPULAR WIRELESS have succeeded in picking up broadcasting direct from America upon the receiver shown, but this, of course, is only possible when conditions are good and when skill in handling the receiver has been attained.

Like all ordinary one-valve sets, the Unidyne is quite unsuitable for loud-speaker work, but it excels in 'phone-signals, and it has one noteworthy peculiarity. This is its "crystal clearness" in reproduction, which is so marked in comparison with reception using an H.T. battery that it has been testified to and remarked upon in innumerable cases. Probably this crystal clearness has something to do with the excellent long-distance reception which has been achieved, for when the noisy background due to the use of an H.T. battery is removed, very weak signals become extraordinarily clear, thus making a vital difference to the clear reception of announcements from stations across the Atlantic, or at other great distances.

Another advantage of the Unidyne receiver is the fact that it is distinctly more selective than the ordinary one-valve

set, and this, again, partially accounts for its great success as a long-distance receiver. It will be found to be unusually responsive to its controls, but nevertheless the set is in no way difficult to handle.

The photograph of the complete receiver shows that it is a neat and compact little instrument. The tuning is carried out by means of coils in the usual two-coil holder, in conjunction with a variable condenser. On the left of the receiver are the two aerial and the earth terminals. The provision of two aerial terminals allows the tuning to be placed either "in series" or "in parallel," thus rendering the set suitable for the reception of either long-wave or short-wave broadcasting.

### The Coils and Valve.

By comparing the photograph closely with the blue print, it will be seen that the lay-out of the latter need not be strictly adhered to, so long as the circuit connections are unaltered. For instance, instead of the "precision" rheostat (which is of the wire-wound type), a carbon compression filament resistance could be used. Similarly, a different variable condenser could be

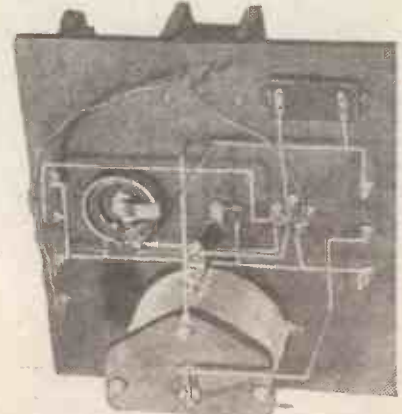

The wiring at the back of the panel. This view should be compared with the blue print.



Note.—The coils shown in this photograph are the ready-made type ("Lissenagon").

This photograph shows the complete Unidyne set ready for connecting up.

the volume obtainable is at least as good as the ordinary one-valve set, which requires a potential of from 30 to 80 volts from such a battery.

In order to accomplish this result, standard components are used throughout, with one exception, viz., the valve. The Unidyne receiver requires a special valve

employed (provided that its maximum capacity is .0005 mfd.).

One of the details upon which a great deal of the success of the set will depend is the type of tuning coil employed. Probably the best coils to use are the home-made spider-web or basket type, but if a ready-made coil is preferred, the "Lissenagon" is recommended.

For ordinary B.B.C. stations the best size of coil to use is a 75-turn ("Lissenagon," basket, or spider-web), with the aerial condenser in series. It is essential that a good variable-grid leak which is capable of adjustment over a wide range of resistances should be employed. The grid leak shown in the photograph is a "Bretwood," which, on test, gave extremely good results. The actual two-way coil holder used in this instance was one of the Polar cam-vernier type, which is capable of both fine and coarse adjustment, and is, therefore, a great asset when tuning in to long-distance stations.

The valve itself, which, it has already been stated, must be of a special type, is called the "U.C.5 valve," but there is an earlier valve equally suitable for this circuit called the "Thorpe K.4." Either one or

(Continued on next page.)

# THE P. W. BLUE PRINT CIRCUIT No. 2

## UNIDYNE DETECTOR VALVE WITH REACTION

6d.

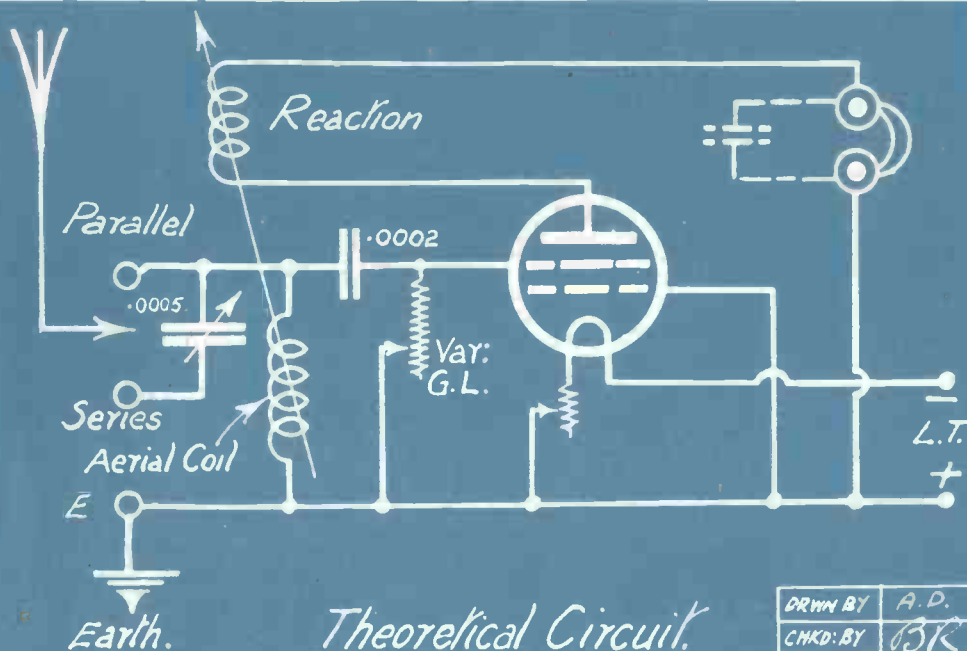
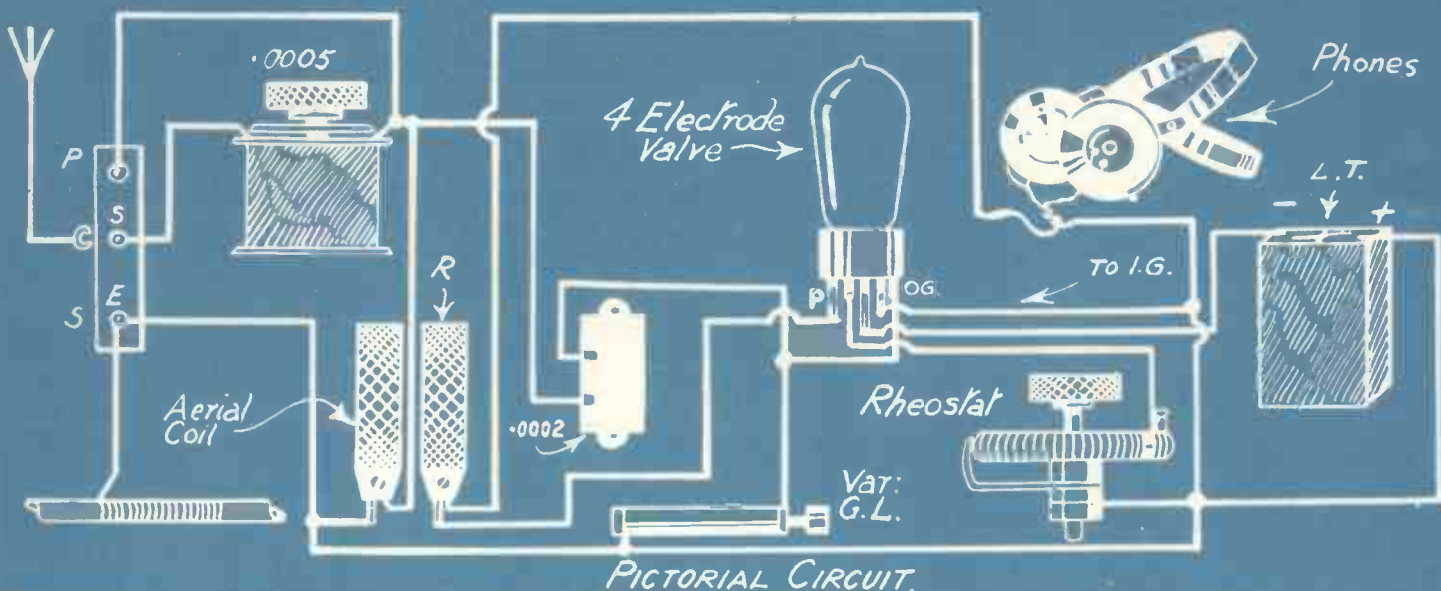

### LIST OF COMPONENTS.

- 1 panel 8 x 7 x  $\frac{3}{16}$  ins.
- 1 cabinet to fit panel, 4 $\frac{1}{2}$  ins. deep.
- 1 variable condenser, .0005 mfd.
- 1 variable grid leak, .5 to 5 megohm.
- 1 rheostat of good quality.
- 1 two-way coil holder.
- 1 fixed condenser .0002 mfd.
- 5 valve sockets.
- 7 terminals.
- Wire, screws, transfers, etc.

### ACCESSORIES.

- 1 pair high resistance phones.
  - 1 phone condenser .002 (optional).
  - 1 accumulator (4 or 6 volt).
  - 1 U.C. 5. or Thorpe K. 4 valve.
  - 2 Lissenagon coils (75 and 100 turns).
- (For 5XX 150 and 200).

DRWN BY	A.P.
CHKD. BY	BR
SER. NO	BP 3

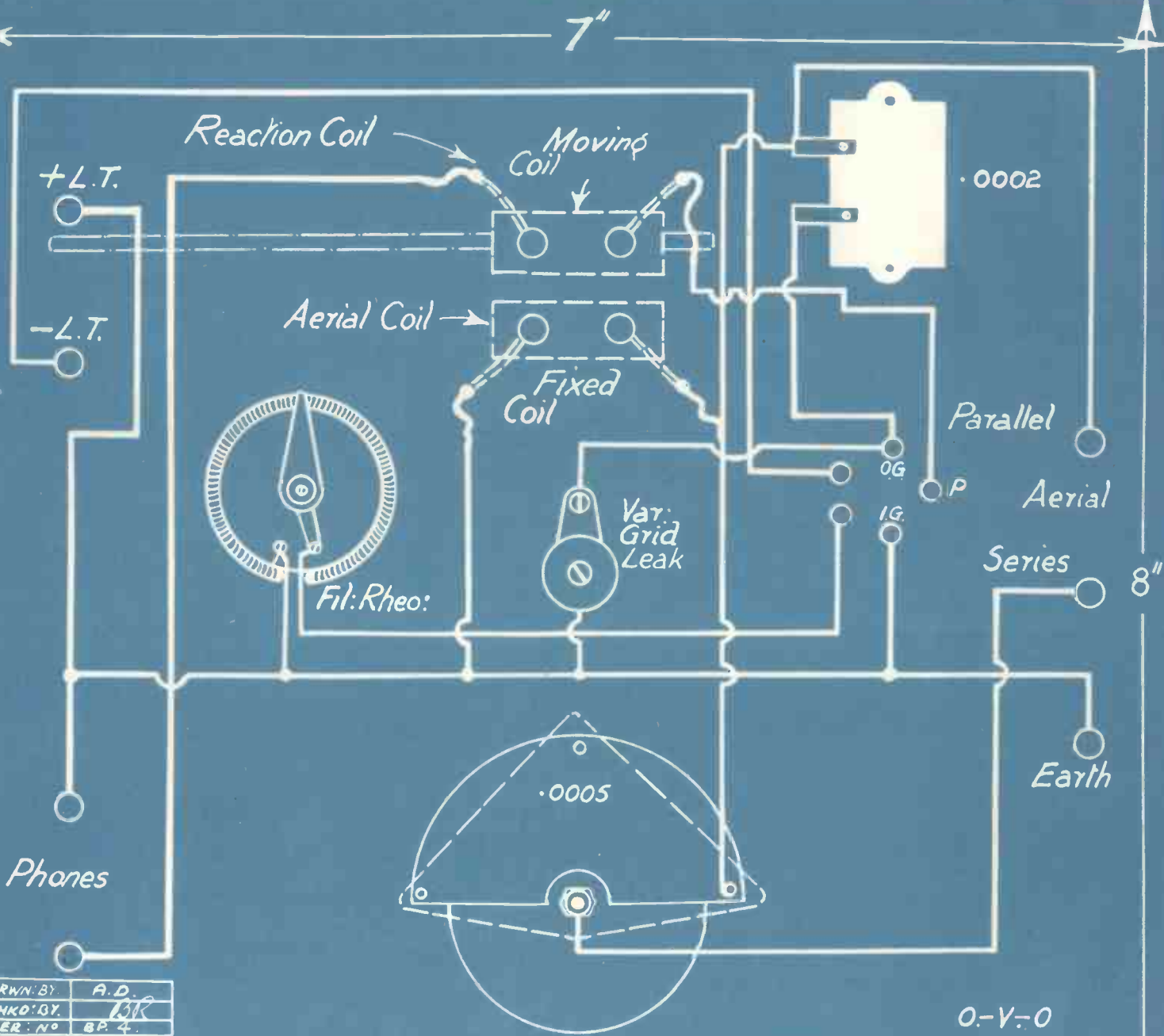

DRAWN BY: A.D.  
 CHECKED BY: B.R.  
 SER. NO: 8P.4.

0-V-0

**THE P.W. BLUE PRINT CIRCUIT No. 2.—UNIDYNE DETECTOR VALVE WITH REACTION**

This is a simplified H.T.-less circuit for one valve. It is unsuitable for loud-speaker work, but phone reception over very long distances is possible under good conditions. NOTE.—If the set does not oscillate try the effect of reversing the leads to the reaction coil. For "Series" tuning connect aerial lead to "Series" terminal, leaving "Parallel" terminal without external connection. For "Parallel" tuning connect aerial lead to "Parallel" terminal, and join "Series" terminal to the earth terminal externally.





The Set designed, described and constructed by the "P.W." Technical Staff. The diagrams for this set are on a Blue Print given away with this issue.

IN last week's issue of "P.W." it was stated, with reference to the H.F. and Det. receiver described, that an L.F. amplifier could be added if desired. For the benefit of those who desire this extra amplification, a 3-valve set, similar to that described last week, but with a stage of L.F., has been designed and will be described hereunder.

when trying to pick up stations whose wave-lengths are within, say, 30 metres of that of the local.

Local reception on the three valves should be loud enough to operate a loud speaker within a distance of 15 miles or so from a relay station, 40 to 50 from a main station, and about 150 or so from 5 X X. These ranges are only approximate, and in many cases will be exceeded if local conditions are good. The wave-length range of the set is, of course, universal, as plug-in coils are utilised, and these can be changed at will.

There is nothing difficult about the construction or operation of the set, if the constructor carefully follows the enclosed blue print of the circuit and checks his wiring from the photographs and point-to-point list of connections.

The main components used in the set photographed were as follows: Wates K type variable condensers, Yesly two-coil holder, Dubilier leak and condenser, "Goltone" L.F. transformer, Lissenstat Minor rheostats. These can be

substituted by wire-wound resistances if desired, while any of the above components can be replaced by other makes, provided reliable apparatus is employed.

The wiring was carried out with Glazite wire, this forming a very neat and efficient means of connecting up the components, while the insulation provided ensures freedom from accidents due to two or more wires inadvertently touching. It is not necessary to solder all the connections though by so doing more permanent and efficient joints are made.

The panel-drilling diagram provided with this description is correct for the components mentioned above, and will not necessarily hold good if different types and makes of components are employed. The blue-print wiring diagram has been made as simple as possible, so that whatever makes of components are used there will be no difficulty in following the various connections.

#### Easy to Build.

The receiver is an easy one to build and to operate, so that the constructor can expect success with it, even if it is his first attempt at a valve receiver, provided that he takes care over the connecting up, and handles the set carefully when he has built it.

Special care must be taken that the coil holder connections are good. A great many failures can be traced to the use of faulty coil holders, for many of the cheap variety do not make efficient contact between the screws on the holders and the brass sockets and plugs. It is advisable, therefore, to pay a few shillings more and make certain that the holder is efficient. Economy on such items very rarely pays, and may be the cause of endless trouble and dissatisfaction.

The L.F. transformer should be one suitable for "first stage" amplification, and it is essential that this be of good design and reliable manufacture if satisfactory loud-speaker results are to be obtained.

#### Suitable Valves.

After wiring up, the set should be thoroughly cleaned and all traces of flux should be removed from the connections. Stray beads of solder should also be unearthed from their hiding places between variable condenser vanes, etc., and removed. Small traces of solder in between the vanes of a condenser can give rise to the most baffling troubles and may defy detection for a considerable time. It is best, therefore, to suspect their presence at the outset and search amongst all moving parts before connecting up the receiver for test.

As regards valves, general purpose types of either dull or "bright" emitter class may be used, but it is best to utilise valves specially designed for the task they have

(Continued on next page.)



A photograph of the complete set showing the lay-out of the main components.

This receiver has a switch incorporated in it, so that the L.F. valve can be cut out if desired, and reception upon two valves can be carried out.

#### Results Obtainable.

Thus the DX properties of the H.F. and Det. 2-valve set are available with an optional stage of L.F., which can be switched in at will when louder signals are desired, or to operate a loud speaker. No additional controls—save that of a filament rheostat and a switch—are necessary for the third valve, so that the set is as easy to handle as the 2-valve set described last week.

For the benefit of those who did not see the article mentioned, it will be as well to run over the various qualities of the receiver, giving a rough idea of what may or may not be expected from it.

As regards selectivity, the set is quite up to the average, and will enable the listener to cut out his local station, if he is not very close, and receive a large number of other B.B.C. and Continental stations. It is usually better to switch off the last valve

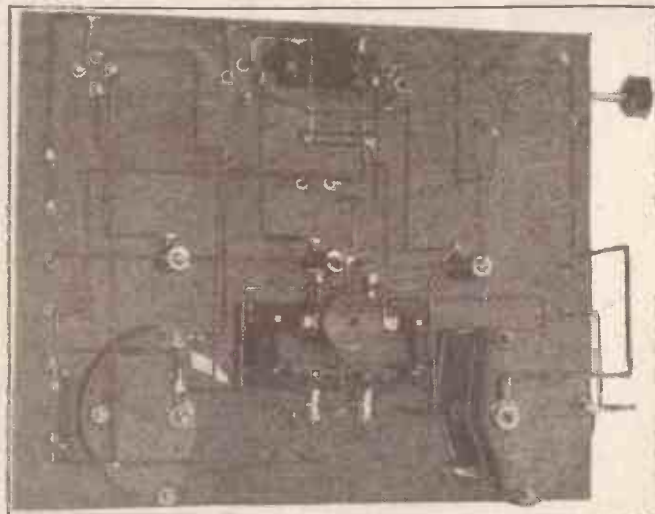

This view of the wiring should be studied in conjunction with the point-to-point directions when the connections between the components are made.

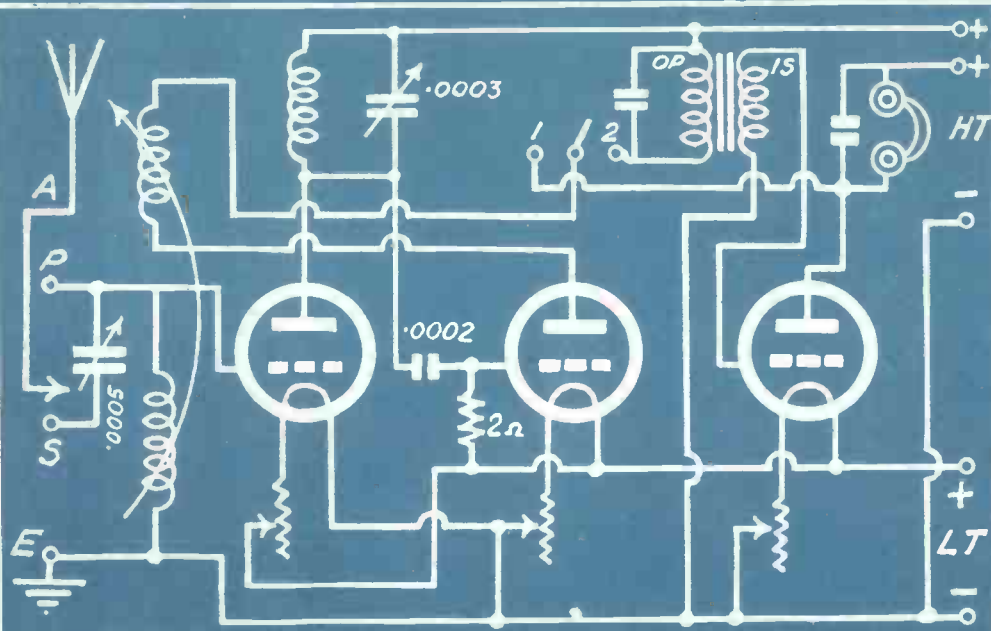
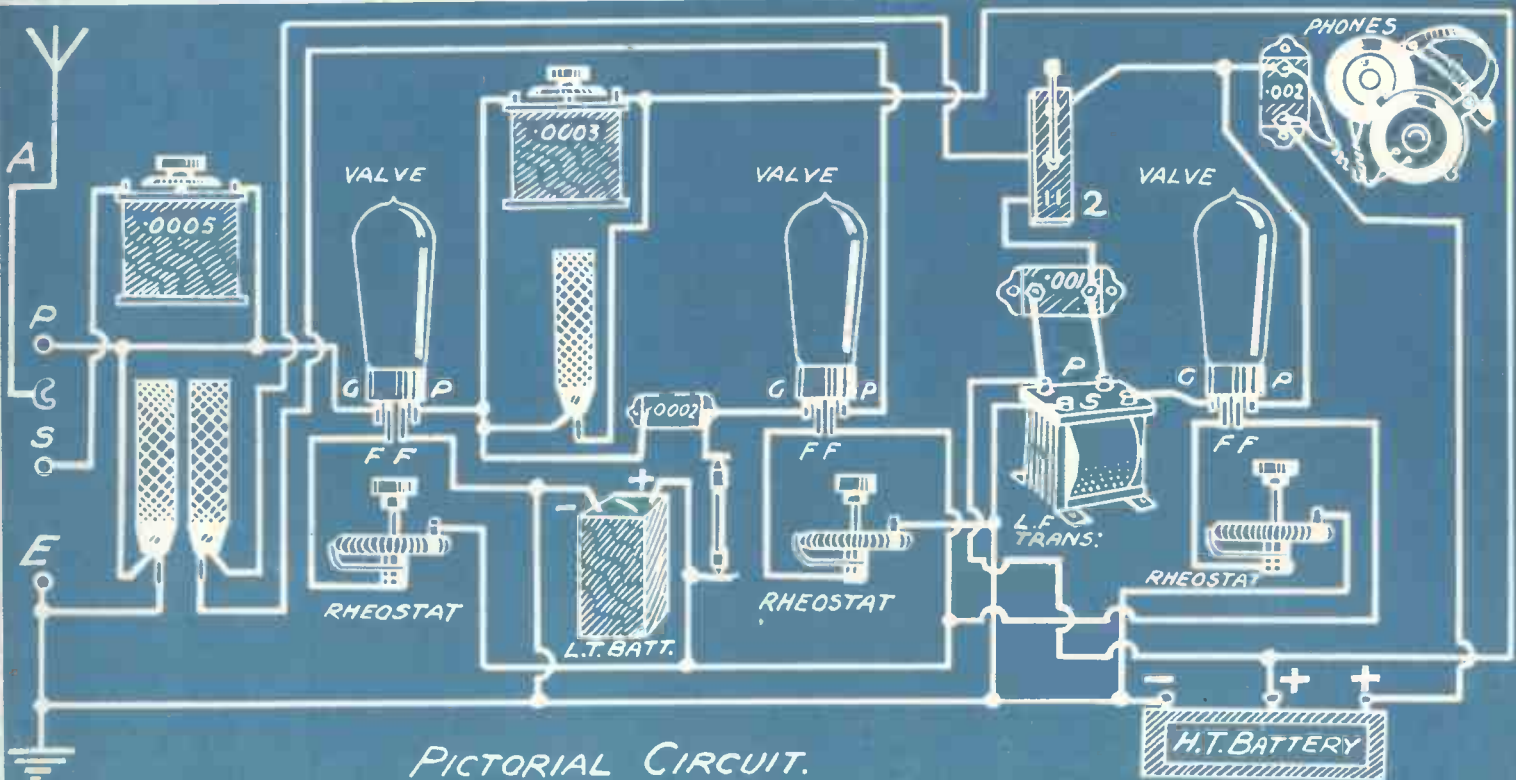

THE P. W. BLUE PRINT CIRCUIT No. 19  
H.F. DETECTOR AND L.F. (WITH  
SWITCH TO CUT OUT L.F.).

LIST OF COMPONENTS. 6d.

- 1 panel 12 x 10 x 1/4 ins.
- 1 box to fit, 4 1/2 ins. deep.
- 3 valve holders.
- 3 filament resistances.
- 10 terminals.
- 1 L.F. transformer, 1st stage.
- 1 S.P.D.T. switch.
- 1 two-way coil holder.
- 1 single coil holder (for panel mounting).
- 1 2-megohm grid leak.
- 1 .0005 variable condenser.
- 1 .0003 variable condenser.
- 1 .0002 fixed condenser.
- 1 .001 fixed condenser.
- 1 .002 fixed condenser.
- Wire, screws, transfers, etc.

ACCESSORIES.

- 1 H.F. valve.
- 1 detector valve.
- 1 L.F. valve.
- H.T. and L.T. batteries, according to valve makers' specifications.
- 3 coils, two 50's, one 75. For 5XX, A 150, reaction 100/150, and 250 anode.
- 1 pair phones and or loudspeaker.

DRAWN W.D.  
CHKD BY R.L.  
SER NO. BP37



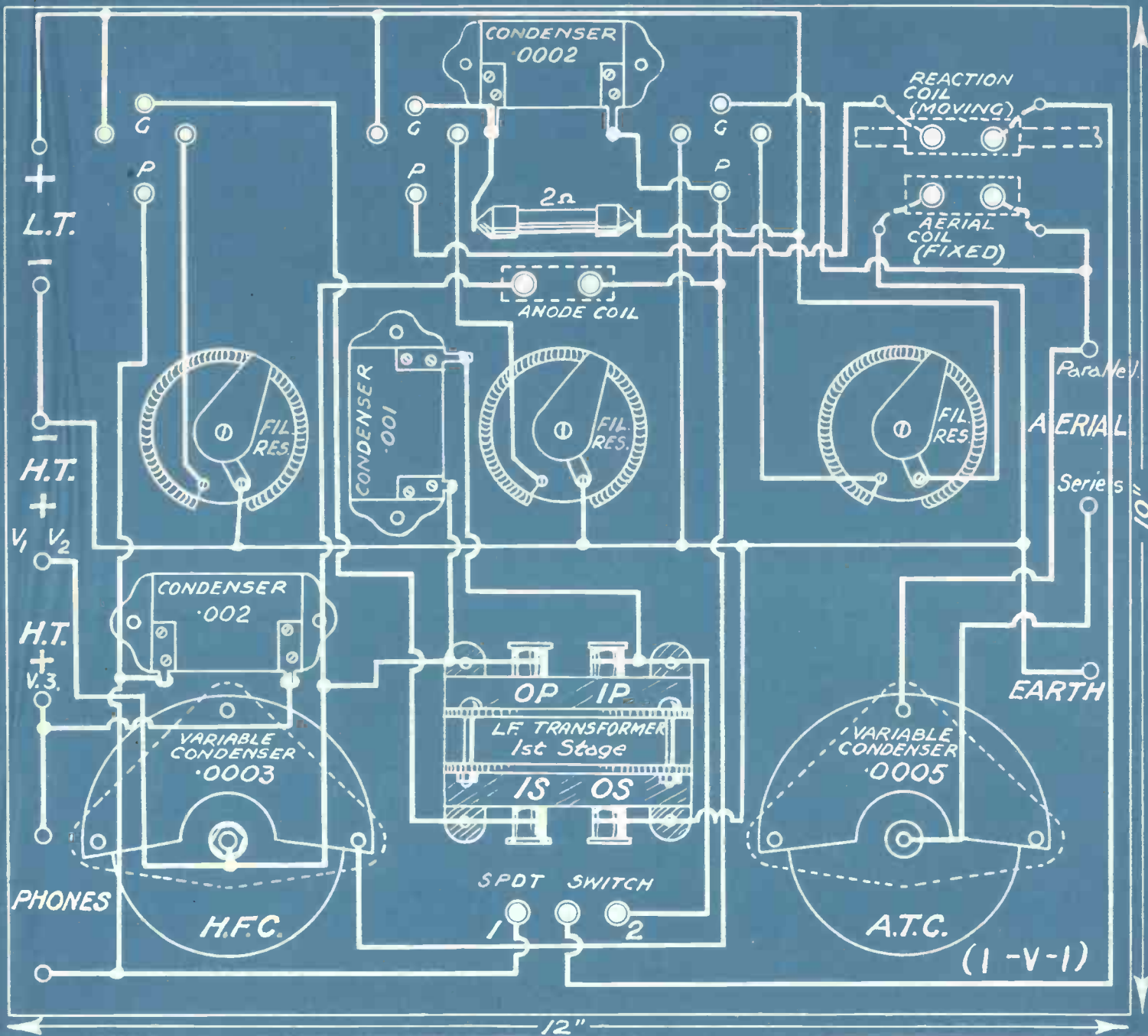

DRWN BY **W.D.**  
 CKD BY *MA*  
 SER. NO. **BP38**

**THE P. W. BLUE PRINT CIRCUIT No. 19—H.F. DETECTOR AND L.F. (WITH SWITCH TO CUT OUT L.F.).** Good all-round circuit for long-distance reception, or for short-range loud-speaker work.  
**NOTE.** For "Series" tuning connect aerial lead to "Series" terminal leaving "Parallel" terminal without external connection. For "Parallel" tuning connect aerial lead to "Parallel" terminal and join "Series" terminal to the "Earth" terminal externally. As L.F. transformer design is not standard it may be necessary to reverse the leads to O.P. and I.P., or to O.S. and I.S. In some cases it is an advantage to reverse the leads to the L.T. battery.

# H.F., DET. AND L.F. RECEIVER.

(Continued from previous page.)

to perform. For instance, the first valve should be one recommended for H.F. amplification, and having a fairly high impedance. The second valve can be either a general purpose valve or one of the special detectors now on the market and made by the Mullard Radio Valve Co.

In the last stage a specially designed L.F. valve should be employed, or a "power" valve can be used, there being a large number of the latter designed to suit all convenient voltages.

### Handling the Set.

The tuning of the set is not a difficult matter, both condenser dials being rotated at the same time, while reaction is used as a means of bringing up signal strength when required. It will probably be found that the tuning on the aerial condenser is sharper than that on the anode owing to the fact that the reaction is obtained by coupling the reaction coil to the aerial coil, and reaction always increases the selectivity of the circuit to which it is applied.

Constructors are advised to practise tuning on the nearer stations before expecting results from more distant transmissions, as in all receivers it is necessary to tune with care and to be familiar with the set before the best can be expected.

The L.F. stage can be used for increasing weak signals, but it must be remembered that the sudden switching in of the L.F. stage may throw the reaction control slightly out of adjustment. The filament rheostat of the L.F. valve must be turned on or off, according to whether the valve is required or not, as well as the S.P.D.T. switch provided for cutting in or

out the plate circuit, and bringing the 'phones or loud speaker into the plate circuit of either the third or second valve.

Further L.F. amplification of either transformer, choke or resistance-capacity type, can be added without difficulty if desired, while a second stage of H.F. could be used, a separate unit being added to the set without necessitating many alterations in the latter.

A good outdoor aerial is best with this set, though fair results can be obtained using an indoor aerial. A "frame" is not advised, as this decreases the range by at least 80 per cent.

Separate H.T. control is provided on the set for the last valve, and this should be varied according to the valve used. A rough idea may be obtained by the information that under test the valves used were of the '06 general purpose type (D.E. 3 valves being employed) and the H.T. used was 48 volts for the first two valves and 75 volts for the last valve. A power valve in the last stage would take more H.T. and would give louder results, but would cost a little more to provide and would need a larger H.T. battery.

### Details of Coils and Valves.

Atlas plug-in coils are shown in the photographs, but any well-designed coil can be used or home-made spider-web coils may be inserted if desired. The sizes of coils used will depend upon the wave-lengths required, but those suitable for B.B.C. wave-lengths are given in the blue print. Series tuning (explained on the blue print) should be used for stations whose wave-lengths are below about 400 metres, as louder results are then obtained, though a larger coil will be necessary. A rough rule is that with series tuning the aerial coil should be of the same number of turns as the anode coil, and for parallel tuning one or two sizes smaller. Thus for 2 L O 75 aerial (series) and 75 anode should be O.K., while

for parallel a 50 or 35 aerial and 75 anode will be required. Reaction of 50-75 turns should be sufficient.

### POINT-TO-POINT CONNECTIONS.

Aerial parallel terminal to fixed plates of .0005 variable condenser, socket of fixed coil holder, and grid socket of first valve holder.

Aerial series terminal to moving plates of .0005 variable condenser, earth terminal to plug of fixed coil holder and to L.T. negative.

L.T. negative is also connected to H.T. negative, to one side of the second and third rheostats, and direct to one filament socket of the first valve holder. L.T. positive is connected direct to one filament socket of the second and third valve holders and to one side of the first rheostat.

The remaining filament socket of each valve holder should be connected to the remaining tag of the corresponding rheostat.

Plate socket of first valve holder to plug of anode coil holder, fixed plates of .0003 variable condenser, and one side of grid condenser. Other side of grid condenser to one side of grid leak and grid socket of second valve holder. Other side of grid leak to L.T. positive.

Socket of anode coil holder and moving plates of .0003 variable condenser to the first (top) H.T. positive terminal.

Plate socket of second valve holder to plug of moving coil holder, socket of which goes to the centre contact of the S.P.D.T. switch. Right-hand contact of switch to I.P. of L.F. transformer, O.P. to top H.T. positive terminal, I.S. to grid socket of third valve holder, O.S. to L.T. negative.

Plate socket of third valve holder to bottom 'phone terminal, left-hand contact of switch, and one side of .002 fixed condenser. Other side of .002 fixed condenser and top 'phone terminal to bottom H.T. positive terminal.

A fixed condenser is connected across the primary (O.P. and I.P.) terminals of the L.F. transformer.

Total cost of receiver about £4 18s. 6d.

### SUITABLE VALVE COMBINATIONS.

L.T. Volts (Accumulator)	H.F.	Det.	L.F.
2 volts	A.R.D.E. (Red) W.2	A.R.D.E. (Red) W.1	P.V.6 D.E. W.1, W.3
	D.3 (H.F.) D.E.2 H.F. B.3	D.3 (Det.) D.E.2 L.F. B.3	D.3 (L.F.) D.E.2 L.F. B.3
	D.06 (H.F.) P.2 ORA Red Ring (Mullard), etc.	D.06 (Det.) P.1 ORA Red Ring, etc.	D.06 (L.F.) P.1 Green Ring (Mullard), etc. P.V. 3 L.S. 3
4 volts	G.P. Bright Emitters following Power Valves: B.4	B.4	B.4
	D.F.A.4 D.E.5 B., etc.	P.V.5 D.E. D.E.5, etc.	(B.4) P.V.5 D.E. (D.E.5) D.E.5 A, etc.

In the case of the use of bright emitters for the H.F. and Det. stages, we advise D.E. power valves for the L.F. position, any of the valves mentioned in the L.F. column at 6 volts being suitable.

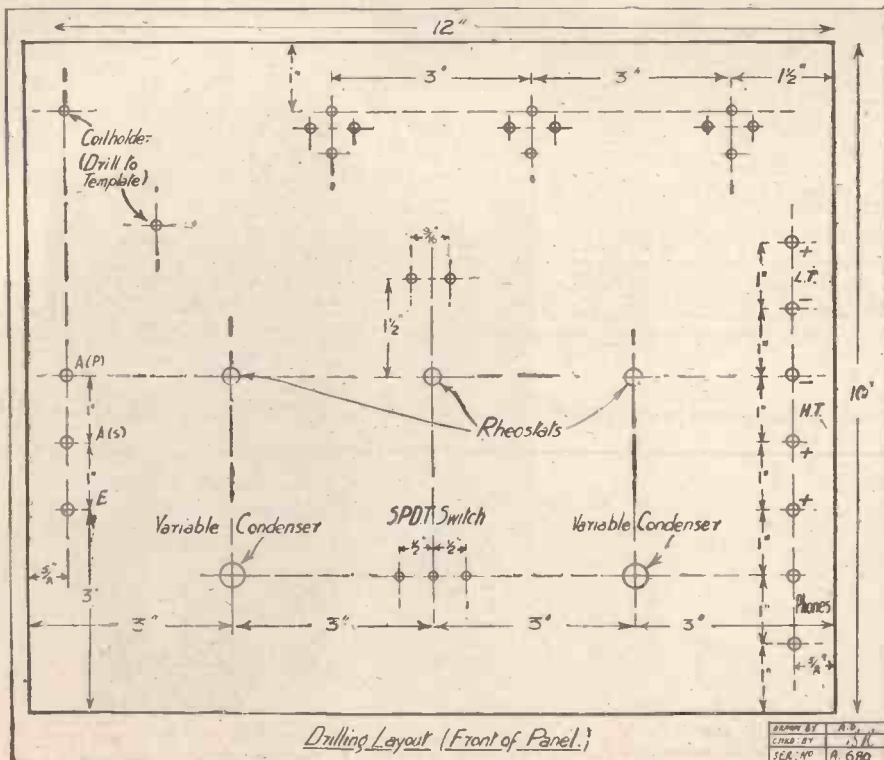

DESIGNED BY A.S.  
 DRAWN BY J.S.H.  
 SER. NO. A. 680



# Headphones

It is only with the aid of a good pair of headphones, such as those by A.J.S., that you can do real justice to your receiver. It is surprising what people miss, who try to search for stations with a loud speaker. Undoubtedly the best procedure is to tune in with headphones till the best results are obtainable, then switch over.

A.J.S. Headphones are unique in many respects. First of all they are ultra-sensitive, they are comfortable to wear by ladies or gentlemen. There is nothing grotesque in their appearance, as their lines follow the contour of the head. There are no adjustment screws to get lost or damaged, yet they are easily adjusted. When once the correct setting has been found, they "stay put" until such time as a fresh adjustment is required, and they do not flop about when removed from the head.

PRICE per pair 20/-

A.J.S. Loud Speakers should be used when it is desired to obtain the very best acoustical results from your receiver. On demonstration you will find them difficult to beat, either for purity or by overloading.

Prices from 35/- Fully described in Publication No. 118.

# A.J.S.

**A. J. STEVENS & CO. (1914), LTD.,  
RADIO BRANCH, WOLVERHAMPTON.**

Telephone : 1748 (7 lines).      Telegrams : "Reception, Wolverhampton."

**London Showrooms : 122/124, Charing Cross Rd., W.C.2**

Telephone : Regent 7161-2.      Telegrams : "Ajayessco, Westcent, London."

**Glasgow Showrooms : 223, St. George's Road, Glasgow.**

Telephone : Douglas 3449.      Telegrams : "Reception, Glasgow."

**A. J. STEVENS & CO. (1914) LTD.,  
Radio Branch, WOLVERHAMPTON.**

Please send Publication No. 118 describing Loud Speakers and Headphones.

NAME .....

ADDRESS .....

P.W. 13/2/26 .....



Models with wood  
flares in Mahogany  
or Oak. Beautiful  
Reproducers.

**£4-15-0**

# A. MUNDAY, LTD.

Electrical and Wireless Engineers,

59, WATLING STREET, E.C.4

(One door from Queen Victoria Street and Queen Street.

Tele. : CITY 2972.

AND AT 45, EASTCHEAP, E.C.3

Tele. : ROYAL 4632.

All makes in stock of  
Neutrodyne and Heterodyne  
Components and Parts,  
English and American.  
Igranic Super-Het Kits and  
new Components in stock.

- - Tuning Dials - -



## Keep your Accumulator fully charged for $\frac{1}{2}$ per day

THE old idea was to wait for the accumulator to be completely run down and then to put it on charge. This was expensive and inconvenient. The Rectalloy Charger, on the other hand, gives a daily trickle charge. It is permanently plugged into the electric light socket and connected to the accumulator. By switching over from Set to Charger your accumulator

receives a gentle trickle charge from the mains to bring it up to concert pitch until the following evening. In this way your accumulator is always kept fully charged.

In two voltages 100/120 volts and 200/250 volts alternating current. Complete ready for use, nothing more to buy.

**65/-**

If you would like to build this Rectifier yourself, write for Illustrated Folder giving particulars and prices of parts—FREE.

**RECTALLOY, LTD.**

The Sole Makers of  
The Rectalloy Charger.

VULCAN HOUSE, 56, LUDGATE HILL, E.C.4.

P.S. 4609.

## 700 SUPERB COLOURED PLATES

# A Wonder Book for CHILDREN

The complete work will contain nearly **3,000 ILLUSTRATIONS** including upwards of **700 FULL PAGE COLOUR PLATES** reproduced from actual photographs skilfully and accurately coloured in the glowing hues of Nature

### SUPERB FOLDING ART PLATE FREE!

A Superb Folding Art Plate of "The Human Family" showing all the Races of Mankind in their native dress and including no fewer than 296 complete figures, will be presented to purchasers of LANDS & PEOPLES. The complete plate measures 17½ inches by 18½ inches, is printed in full colours, and will be given in two sections, the first section with Part 1 and the second with Part 2.

### A COLOUR PAGEANT of the Lands and Races of the World.

THE CHILDREN'S COLOUR BOOK OF LANDS & PEOPLES is the most vivid, instructive and fascinating book ever published. Never before has any book been produced which unlocks, and flings so wide, the doors of the world. Never before has any book attempted to show so vividly the wonder and interest of life as it is to-day in every corner of the globe. LANDS & PEOPLES is first and foremost a book of pictures—the 16 full-page COLOUR plates which each part will contain constitute an epoch in the history of publishing. Every one of these plates is a photograph which has been skilfully coloured by an expert artist in the exact colours of Nature. The letterpress will serve as a commentary on this marvellous collection of photographic illustrations, and although the articles have been written expressly for young people, it will be found that their interest for parents and teachers has not been diminished. No set geographical order will be followed. It has been aimed to make the turning of its pages as nearly as possible equivalent to a kind of zig-zag tour round the world. Mr. Arthur Mee—the Editor of the famous CHILDREN'S ENCYCLOPEDIA—has written a fascinating introduction which appears in Part 1.

A Work of absolutely Unrivalled Educational Value.

Fortnightly Parts  
**1s./3d. per Part.**

# Children's Colour Book of LANDS & PEOPLES

PART 1 Now on Sale. 1s./3d. Buy a Copy TO-DAY!





*"Charging bills - 2<sup>d</sup> a week"*

*What is your weekly accumulator bill?*

# Louden VALVES

**BRIGHT EMITTERS      DULL EMITTERS**

**4/6**

Filament Volts .. . 4.5 to 5.  
 Filament Amps .. . 0.4  
 Anode Volts .. . 40 to 80.

Made in two types.  
 F1 (Plain Louden) for Detection and L.F. Amplification.  
 F2 (Blue Louden) for H.F. Amplification.

**8/- and 9/-**

(4-VOLT.)      (6-VOLT.)  
 Filament Amps .. . 0.1.  
 Anode Volts .. . 40 to 80.

Each made in two types.  
 FER 1 for Detection and L.F. Amplification.  
 FER 2 for H.F. Amplification.  
 N.B.—These valves consume only one-seventh of the current taken by ordinary bright emitters. They will work straight off a 4-v. or 6-v. accumulator without alterations to filament resistances or set. **When ordering please state clearly the type and voltage required.**

All Fellows apparatus can be inspected and purchased at 20, Store St., Tottenham Court Rd., W.C. (Phone, Museum 9200); 34, Bridle-Smith Gate, Nottingham, and Dominions House, Queen St., Cardiff.

**HOW'S THIS?**

Messrs. Fellows Magneto Co., Ltd.  
 Dear Sirs,

Some time ago, availing myself of your offer in the Wireless Papers, I purchased two Dull Emitters, and have since rejoiced, as my charging bills are cut down to about 2d. a week and my set has much clearer reception than hitherto—in fact, I am very proud of my Louden D.E.'s.

Yours faithfully,  
 N. R. (Redhill)

What is your weekly accumulator bill? Why make frequent journeys to the charging station and pay heavy charging bills? Louden Dull Emitters reduce these charges and these journeys to ONE-SEVENTH over ordinary bright emitters. There is no finer dull emitter on the market and THEY ONLY COST EIGHT OR NINE SHILLINGS. Fill in this coupon now!

WRITE FOR 40 pp. ILLUSTRATED CATALOGUE, FREE.

To THE FELLOWS MAGNETO CO., LTD.  
 CUMBERLAND AVENUE, PARK ROYAL, WILLESDEN, N.W.10

Name.....  
 Address .....

Herewith Remittance Value.....

Please forward me.....Louden Valve(s) Type.....  
 on conditions as per your advertisement.

Please write clearly in Block Letters, enclose postage (4d. for each valve), and register Cash or Treasury Notes.

P.W. 13/2/26.

E.P.S.76.



THE GLORY CORNER



This is the Glory Corner at the Bennett College. We give it that name because it contains in bundles about One Hundredweight of letters which we have received from Grateful and Successful Students. We keep all these thousands of unsolicited testimonials as a fountain of inspiration and because we are really proud of them. Having helped thousands of others to achieve success and advancement, it may be possible that we can help YOU.

I am assisted by a large and expert staff and the advice we give is sound: If we cannot help you we will say so; if we can we will tell you how.

We have FREE booklets setting out the possibilities in connection with each of the subjects shown in the lists; send for the one in which you are interested, or ask for MY PRIVATE ADVICE, which also is free. You incur no obligation.

**Have You ANY Ambition?**

We guarantee tuition until successful. Most moderate charges, payable monthly. All text books free. No extra fees.

**EXPERT TUTORS FOR EVERY DEPARTMENT**

**COMMERCIAL**

- Accountancy
- Advert. Writing
- Salesmanship
- Army Certif. Courses
- Auctioneering and Estate Agency
- Auditing
- Banking
- Book-keeping
- Commercial Arithmetic
- Commercial Law
- Company Law
- Costing
- Economics
- English and French
- Executorship Law
- Foreign Exchange
- Modern Business Methods
- Secretaryship
- Workshop Organisation

**TECHNICAL**

- Applied Mechanics
- Architectural Drawing
- Building Construction
- Clerk of Works' Duties
- Boiler Engineering
- Boiler Making
- Chemistry



Yours sincerely,

*J. Bennett*

**TECHNICAL (contd.)**

- Civil Engineering
- Concrete and Steel
- Draughtsmanship
- Electricity
- Engineering
- Foundry Work
- Internal Combustion Engines
- Marine Engineering
- Mathematics
- Matriculation
- Metallurgy
- Mining
- Mine Surveying
- Motor Engineering
- Naval Architecture
- Pattern Making
- Quantity Surveying
- Sanitation
- Shipbuilding
- Structural Engineering
- Surveying and Levelling
- Telegraphy and Telephony
- Town Planning
- Wireless Telegraphy
- Works Managers' Course

**WE SPECIALISE IN PREPARATION FOR ALL EXAMINATIONS IN CONNECTION WITH THE ABOVE SUBJECTS.**

Note Address: The Bennett College, Dept. 106, Sheffield

WE TEACH BY POST.



**"POPULAR WIRELESS" Advertisement Rates**

WHOLE PAGE £40      QUARTER PAGE £10  
 HALF PAGE .. £20      EIGHTH PAGE £5

Narrow Column Advts. (3 cols. to page) per inch 30/-  
 Minimum Space accepted - - - - half inch 15/-

NO SERIES DISCOUNTS. ALL ADVERTISEMENT COPY SUBJECT TO EDITORIAL APPROVAL      COPY AND BLOCKS MUST BE IN HAND 11 DAYS BEFORE DATE OF ISSUE TO ENSURE PROOFS.

ALL Communications respecting advertising must be made to

JOHN H. LILE LTD., 4, Ludgate Circus, London, E.C.4

'Phone: City 7281

KEEP YOUR WIRELESS  
SET IN "TUNE"

# Osram Valves

for Broadcasting

*The G.E.C. - your guarantee*

OSWALD J. RANKIN  
OFFERS

MORE PRACTICAL IDEAS

READERS who are interested in the spade method of tuning crystal receivers should experiment with various different metals, and finally adopt the one considered most suitable. The most convenient way to do this is to use the spades in conjunction with a standard plug-in coil which is mounted in the fixed

coil plug is required for any number of different spades; with the former arrangement each spade is fitted with a plug.

Most experimenters are well acquainted with the circuit arrangement of the so-called fool-proof crystal set which is designed to receive the usual local station and also the high-power station, 5 X X. (See upper diagram in Fig. 2.) A simple D.P.D.T. knife-switch, S, is wired up as shown to effect the change over from the "local" coil, C1, to the loading-coil, C2, so that the two coils, being then in series, may be tuned to the higher wave-length of the high-power station.

Automatic Tuning.

A most convenient arrangement, especially when the receiver is fitted with a reliable fixed detector; but old or obstinate people will not tolerate those condenser adjustments every time the change is effected. It follows, therefore, that the fool-proof crystal set would become a more attractive proposition if the switch and condenser could be set simultaneously. Here surely is a chance for the serious experimenter;—only one remaining fly to extract from the ointment—eliminate the condenser adjustments.

Think of the wasted movement of those switch arms, and consider the possibility of switching the coils and setting the condenser by moving only one control—the switch. No easy problem, yet it is a possibility. The lower diagram (Fig. 2) indicates

a fairly good starting-point. A fibre pinion might be fitted to the hinged end of one of the switch arms and made to engage a fibre gear attached to the condenser spindle. (For obvious reasons metal gears could not be used.) The complete throw of the switch arms sets the condenser accurately with C1, or with C1-C2, providing

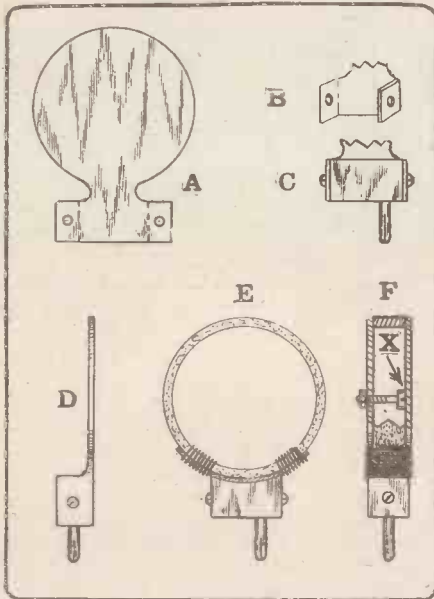

Fig. 1. Fitting "spades" to ordinary coil plugs.

socket of a two-coil holder, and arrange each spade on the plug-in system by employing either of the simple methods outlined in Fig. 1.

Diagrams A to D show how the spades may be fitted to standard coil plugs. Cut out each spade as shown at A, and bend to right angles at the dotted lines so as to form a simple clip, as at B, which is then clamped firmly to the ends of the coil plug, as shown at C and D. Alternatively the spades may be arranged as shown at E and F where a cardboard ring, cut from a 3-in. diameter cylindrical coil former, is mounted in any convenient manner to a standard coil-mounting plug, and permanently closed on one side with a disc of thin sheet ebonite which is drilled through the centre.

Interchangeable Spades.

A small bolt is soldered at X to the exact centre of each circular spade. Thus any spade may be quickly fitted over the open side of the mounted ring and clamped to the ebonite disc by means of a small nut or fly-nut. With this arrangement only one

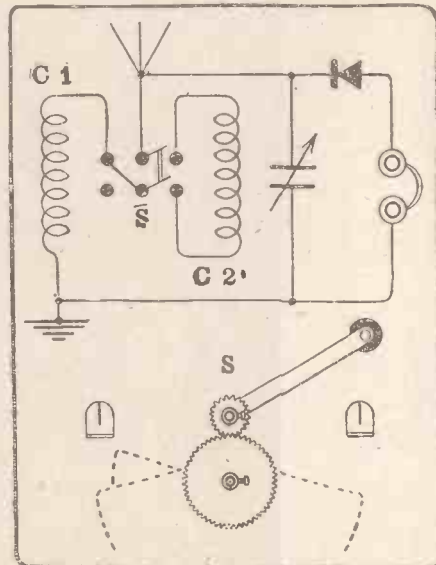

Fig. 2. An idea for a "fool-proof" set.

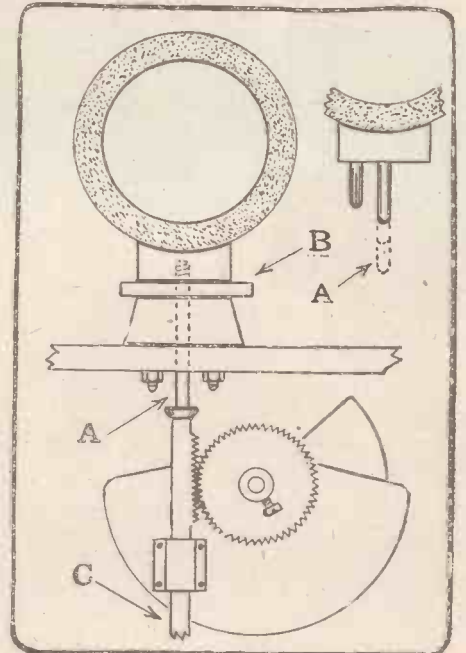

Fig. 3. A method of automatically setting the condenser.

the two adjustments are previously ascertained, that the ratio of the gears is correct, and that they are set so that the condenser plates are in the correct position when the switch blades are pressed hard down into the clips.

The Condenser Mechanism.

Such an arrangement would be of little commercial value, for when once adjusted to any particular aerial and earth system, it is extremely unlikely that it would function on another, since there are no two aerial systems alike. It is, therefore, only suitable where it is possible to experiment with the gear settings on the actual aerial to be used in conjunction with the set.

The same remarks apply to the arrangement shown in Fig. 3, where a similar device is adapted to standard plug-in coils. Here a small ebonite rod, A, is screwed into the lower portion of the coil plug,

(Continued on next page.)

## MORE PRACTICAL IDEAS.

(Continued from previous page.)

between the metal plug and socket, this being made to depress and actuate a brass rack which engages a fibre pinion fitted to the condenser spindle. A suitable compression spring should be fitted to the lower end of the rack at C, so that the condenser plates and rack are returned to a normal setting every time a coil is withdrawn from

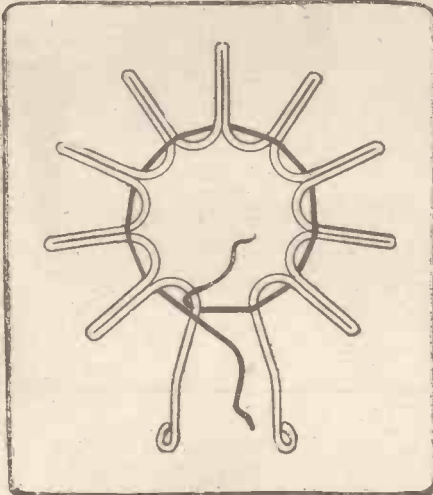

Fig. 4. A method of winding aperiodic coils.

the socket. The travel of the rack, will, of course, depend upon the length of the ebonite plungers fitted to the coil plugs, and the diameter of the pinion.

### Aperiodic Coils.

A positive stop, B, consisting of a small piece of sheet ebonite, should be fitted to the coil-socket as shown, and the condenser should be set accurately with the coil when the latter is pushed hard down on the stop. The method of mounting the condenser, and the arrangement of the rack and pinion is, of course, purely a matter of "tinkering." When experimenting with gadgets of this description one's aim should be simplicity. Unnecessary complications can only result in failure.

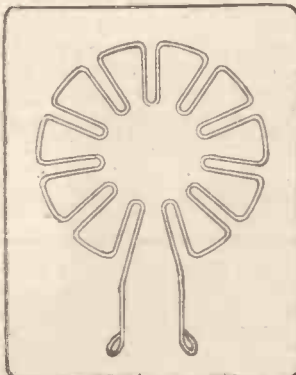

Fig. 5. Another aperiodic winding.

The aperiodic aerial coil is very popular amongst DX experimenters. This usually consists of one, two, or three turns of thick wire wound over the tuned coil and connected direct to aerial and earth. With the arrangements suggested in Figs. 4 and 5, the tuned coil is wound over the

aperiodic coil, the latter consisting of a thick wire structure which forms a simple spider former (Fig. 5). The coil and the "former-coil" may be mounted on an ordinary coil plug which is provided with two extra contacts, or two plugs may be bolted together and used in conjunction with specially arranged sockets.

A simple jig will be required for the arrangement shown in Fig. 5. This may consist of a piece of thick board and a few nails, which are driven in at the points where the bends are made. A glance at the sketch will suggest the design and general arrangement of the jig; two circles are marked off on the board, eleven nails being driven in round the inner circle, and twenty nails round the outer circle. An ordinary card inductance former may be used as a template for marking off the board.

### Novel Variometer Mounting.

Fig. 6 suggests what is considered to be an improved method of mounting small card variometers. It will be seen that the inner coil is fixed and the outer coil movable, this somewhat drastic plunge from the orthodox arrangement permitting much finer adjustments, especially when an extension handle is fitted to the right-hand side of the outer coil. A stout brass bracket, A, a similar bracket made from spring brass, B, and a sheet ebonite bracket, C, form the main supports, the inner coil being clamped to the end of the ebonite bracket by means of a small terminal to which is joined one end of the winding.

The other end of this winding is joined to the terminal at the opposite end of the bracket, the ends of the outer coil winding being soldered to the two spindles, which are kept in good contact with the brass brackets and their clamping terminals by means of the spring bracket at the lower end, and a spring washer with lock-nuts at the top end. Thus dangling flexible leads are avoided, and the instrument may be used either as a vario-coupler or as a variometer, the latter effect being obtained by simply joining the central left-hand terminal (beginning of inner coil winding) to the lower left-hand terminal.

The problem of fitting the metal spindles to the movable coil often presents a difficulty, and it may be well to consider a few possible methods which, although far from being perfect, will be found more or less satisfactory in the hands of the careful operator. It is high time that experimenters directed their efforts to this distressing state of affairs; the simple card variometer is most efficient electrically, but (vulgarily) a "wash out" mechanically, and simply because nobody has bothered about improving the spindles and mountings.

The inventor's dream of a manufacturer swooping down upon him and swallowing him up before seeing his invention might

almost be realised if some experimenter could produce a simple, cheap and efficient pair of detachable spindles and sockets for variometers. Possibly the ideas outlined in Fig. 7 may provide a little food for thought.

The most usual "home-made" arrangement is shown at A, where a small metal plate is soldered into a recess filed on one end of the spindle and attached to the edge of the card by means of small bolts or rivets. Diagram B shows how an improvement is made by providing a simple clip, so that both sides of the card are supported

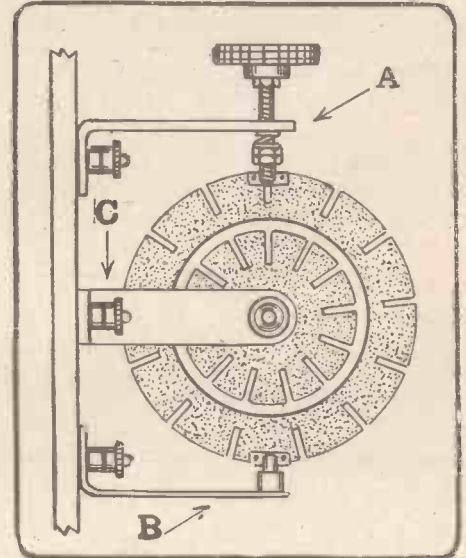

Fig. 6. Using the outside variometer winding as the rotor, and the inner as the stator.

at the joint, and Diagram C shows a little idea which is well worth pursuing. Here the clip is arranged as shown, so that the two points may be pushed through the card and fastened down in the same manner as an ordinary paper clip (See E). The clip might consist of a simple stamping as shown at D, but the difficulty to be overcome here is the attachment of the round spindle to the curved portion of the clip. Other designs are shown in Figs. F, G, H and I.

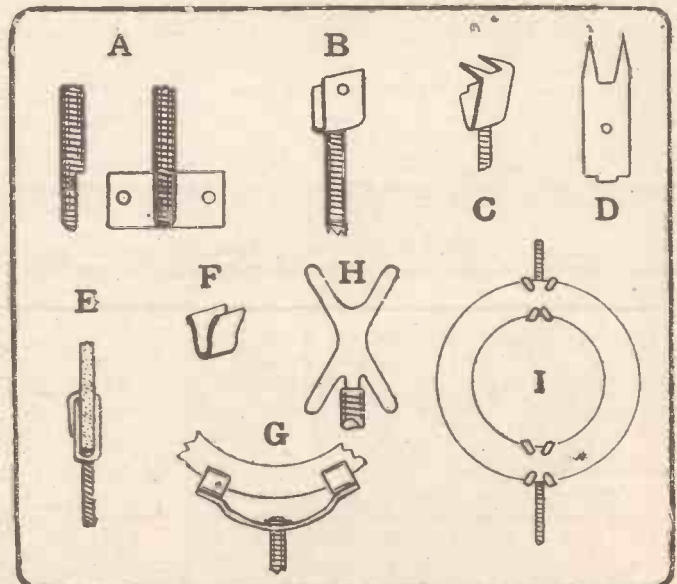

Fig. 7. Some useful ideas for the mounting of variometers so that detachable spindles are available.



**REFLEX** circuits have proved themselves to be not merely of experimental interest, but of real value to those who require maximum amplification with the least possible number of valves. It is often a somewhat difficult matter to sort out a theoretical circuit diagram of a multi-valve reflex set, so we will consider how to build up a few circuits employing dual amplification, from a knowledge of first principles.

In Fig. 1 is shown a popular circuit for the reception of broadcasting, which comprises an H.F. amplifier, a valve detector, and a note magnifier. The action of this circuit is as follows:

Signals received by the aerial produce currents in the aerial coil, and these impart impulses to the grid of the first valve. By the action of the valve, magnified variations of current flow in the plate circuit, through the primary winding of the H.F. transformer,  $T_1$ . Similar currents are

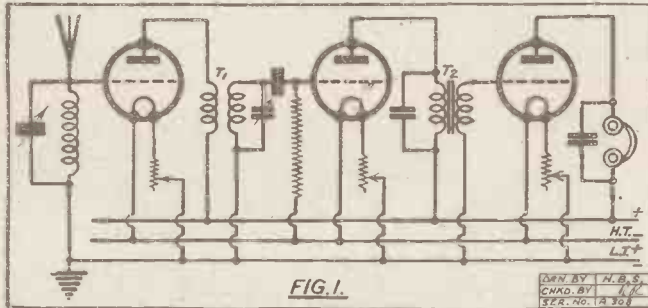

produced in the secondary winding, and impulses are applied to the grid of the detecting valve.

On account of the rectifying action of the grid leak and condenser, L.F. variations are sent out from this valve, through the primary winding of the iron core transformer,  $T_2$ . Similar currents in the secondary winding apply impulses to the grid of the last valve, which sends magnified speech or music currents through the telephones. So much for an ordinary three-valve circuit, which is probably quite familiar to all readers.

**Reflexing the First Valve.**

Now, since each valve in the circuit magnifies signals, it is evident that the first valve has not nearly so much energy to deal with as either of the other two. In other words, the first valve is having an easy time of it. It would, therefore, be a great economy if we could give this valve the additional duty of magnifying the output from the detector, and so dispense with the third valve altogether.

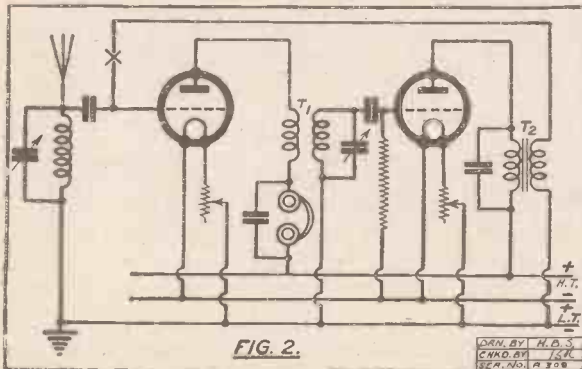

## HARD CIRCUITS MADE EASY.

By **C. E. FIELD, B.Sc.**  
(Staff Consultant.)

### III.—Multi-Valve Reflex Circuits.

This is the third of Mr. Field's popular series of "easy explanations" of various complicated circuits used in reception.

The most obvious way of carrying this out is by simply joining the secondary winding of the L.F. transformer to the grid and filament of the first valve instead of to a third valve, as in Fig. 1. Here a difficulty is encountered, for the transformer winding would be connected directly to the ends of the aerial coil, which would short-circuit it.

This trouble is easily overcome by connecting between the grid and the aerial coil a small fixed condenser, which will effectually prevent L.F. im-

in any case, as a precautionary measure) a 400-turn duolateral coil should be inserted at the point X to serve as a radio-frequency choke.

The telephones must, of course, be connected in the plate circuit of the last note magnifier, which in this case is the first valve, so that they are joined, as shown, in series with the primary winding of the H.F. transformer, and shunted by a condenser which by-passes H.F. currents. If the self-capacity of the telephone windings is relied upon for the conveyance of H.F. currents, signals may be choked, and capacity effects may be noticeable when handling the telephone leads.

**A Powerful Circuit.**

An alternative method of feeding back the L.F. impulses to the dual valve is to take the upper connection from the L.F. transformer secondary to the bottom end of the aerial coil, instead of directly to the grid. In this case, a condenser must be connected across the ends of the transformer winding, to allow the passage of H.F. currents, and at the same time to force L.F. impulses through the coil on to the grid.

This circuit, with the addition of a note magnifier, is shown in Fig. 3. As in any other circuit the addition of a stage of note magnification is effected by replacing the headphones by the primary winding of an L.F. transformer. Hence, in the arrangement given in Fig. 3, the plate circuit of the first valve contains the primary windings of an H.F. and an L.F. transformer in series.

A very powerful dual amplification circuit is obtained if two dual valves and a

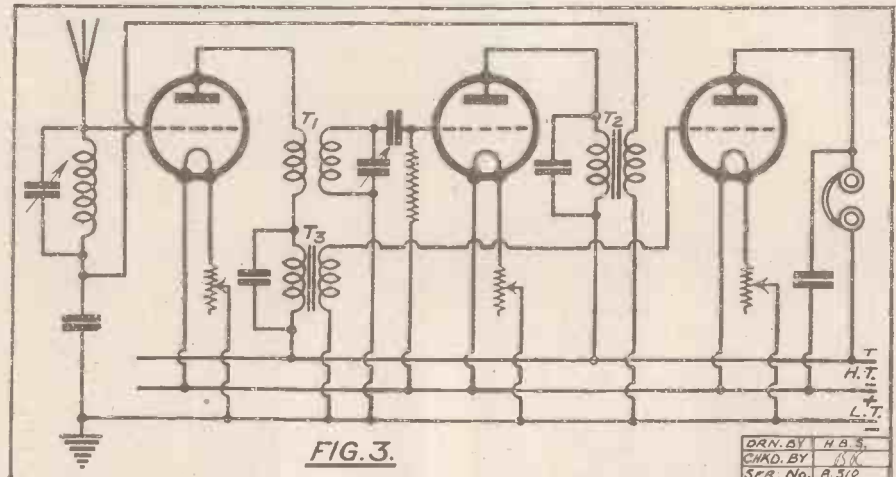

pulses from leaking down the aerial coil, and at the same time will allow H.F. signals to be applied to the grid, the circuit being then as shown in Fig. 2. By simply changing two connections and inserting a fixed condenser, therefore, we have dispensed with one valve, and obtained a thoroughly reliable circuit.

If the L.F. transformer is of a good design, no serious leakage of H.F. currents from the aerial should take place through the secondary winding, but it may happen that the self-capacity of the latter is sufficiently great to rob the grid of a portion of the H.F. impulses. In this case (or

detector are employed, the results being nearly equal to those from a corresponding five-valve straight circuit, although the H.F. side of the circuit suffers, because, in order to avoid distortion due to over-running of the valves, the dual valves must be of a type suitable for L.F. rather than for H.F. amplification.

In a circuit of this type, the question arises as to which valve shall first receive the L.F. currents fed back from the detector. The best arrangement is to feed back from the detector to the last H.F. valve, so that the valve which is handling the strongest radio-frequency signals deals with a smaller amount of L.F. energy than does the valve which deals only with the weak initial impulses from the aerial.

(Continued on next page.)

## HARD CIRCUITS MADE EASY.

(Continued from previous page.)

This is carried out in the circuit shown in Fig. 4, the action of which is as follows: Signals from the aerial are amplified in the ordinary way by the first valve, the output from which, passing through the transformer,  $T_1$ , causes impulses to be applied to the grid of the second valve. These are again amplified, and, by means of the transformer  $T_2$ , passed into the detector. The rectified current from this valve is then made to affect the grid of the second valve by means of the L.F. transformer  $T_3$ . This valve now amplifies the signals at L.F., and passes them on to the first valve by means of  $T_4$ .

### A Long-Range Receiver.

The condensers  $C_1$  and  $C_2$  provide paths for H.F. currents in the plate circuits of the first two valves, and  $C_3$  and  $C_4$  cause the outputs of the L.F. transformers to be applied between the valve and filaments.

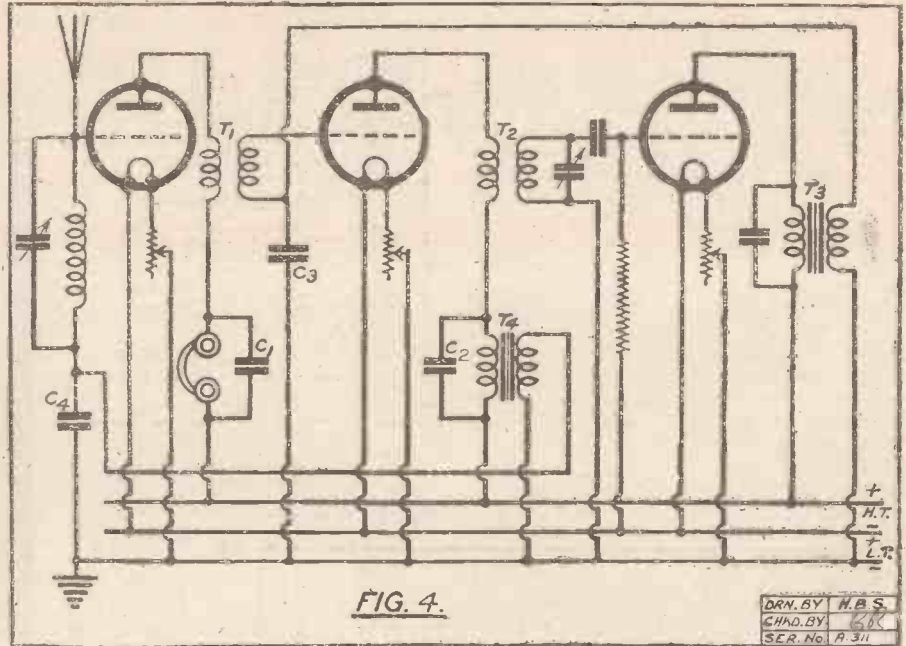

FIG. 4.

DRN. BY H.B.S.  
CHD. BY G.K.  
SER. No. 19.311

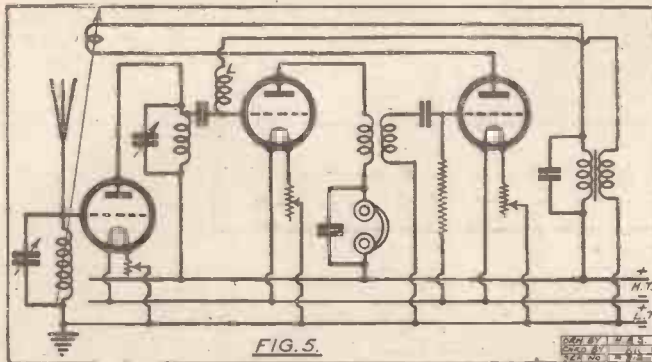

FIG. 5.

On account of the loss of efficiency for H.F. amplification which almost inevitably occurs in a dual valve, it is in many cases advisable to keep one valve solely for H.F. use. Thus a set may consist of one H.F. valve, one dual valve, and a detector. In this case, especially when reaction is introduced, the first valve should be the H.F. amplifier, L.F. currents being fed back into

## NEXT WEEK'S GIFT

FOUR MORE 6d.  
BLUE PRINTS  
FREE TO EVERY  
READER.

Order Your Copy NOW!

the grid circuit of the second. This arrangement, a diagram of which is shown in Fig. 5, is more stable and sensitive than one in which the first valve is dual.

In the circuit shown, it will be seen that L.F. currents are fed back by the method first discussed in this article, through the choke coil L. Tuned-anode coupling is employed between the H.F. and dual valves, and a reaction coil in the detector plate circuit is coupled to the aerial. This is an excellent circuit for both long-range and loud-speaker work.

## CORRESPONDENCE.

Letters from readers discussing interesting and topical wireless events or recording unusual experiences are always welcomed, but it must be clearly understood that the publication of such does in no way indicate that we associate ourselves with the views expressed by our correspondents, and we cannot accept any responsibility for information given.—Editor.

### THE B.B.C. PROGRAMMES.

The Editor, POPULAR WIRELESS.

Dear Sir,—I should like to make a few remarks on what I think of R. S. Rudland's criticism of the B.B.C.'s programmes. Firstly, as to the Spluttered Talks, I should like to hear our dear friend R.S. make a few remarks before a microphone. For myself, I do not think I should like the job, and I admire the speaker's pluck, as I should imagine it needs some nerve. Besides that, some of the talks are highly educative, and are not twaddle. I take it that the B.B.C. are out to satisfy everyone, and their attempts so far, in my opinion, have been very successful. If you do not like a certain item, do not listen to it—there are others that do. Now, if we had more dance music, would not that get a trifle monotonous? Lastly, the programme that is sent out to us at the cost of less than a penny per day is remarkably good.

Trusting you will see some of my logic.

Yours faithfully,

S. F. BULL.

8a, Henderson Road, West Croydon.

### UNIDYNE SUCCESS.

The Editor, POPULAR WIRELESS.

Dear Sir,—Just a line re the Unidyne. I feel sure it is worth pushing and is second to nothing for the first two valves of any set. I have messed about with the Reflex two-valve for a fortnight and given it up as not to be compared with the straight O.V.I. I have added a second stage of Unidyne L.F. and am delighted with its performance on loud speaker. I have a four-valve H.T. set on the top front of cabinet, using the A.C. current for L.T. and an 80-volt H.T. accumulator. Below this I have four variable condensers mounted in dustproof compartments, then below this I have the O.V.I. Unidyne loose tuning condenser with vernier on left, and a Hare & Parham three-coil stand in front of set so that I can use this outfit for any set I feel inclined to use.

I now couple the output of Unidyne to centre of D.P.C.O. switch, the 'phones to one end and the other to the primary of first L.F. transformer in four-valve set above; by turning over switch from 'phones 2 L.F. stages are added, and these are permanently coupled to loud speaker and one switch to cut out one stage of L.F.

This makes the best four-valve set I have ever heard, and can be regulated by Unidyne detector rheostat in a wonderful manner. With one L.F. stage added with H.T. it is better than the majority of four-valve sets and with two it is most powerful.

Again thanking Messrs. Dowding and Rogers, and wishing the best of luck to POPULAR WIRELESS, an easy first in wireless journalism,

Yours faithfully,

ALFRED FRANCE,

33, Church Street, Rotherham.

### A SURPRISING COINCIDENCE.

The Editor, POPULAR WIRELESS.

Dear Sir,—The following incident may be of interest to you. At 11 p.m. on a recent Friday I put on my 'phones to listen for anything that may have been on when the first signal which I heard (a weak D.C. note) was calling "Studley thanks for Q.S.L." and it was an Argentine amateur!

The remarkable part is I had only heard this amateur once before when I sent him the report he was thanking me for, and the chance that I should put on the 'phones when he was calling me was one in a hundred.

I think when one hears one's name called in Morse 8,000 miles away unexpectedly, it makes wireless a thrilling pastime.

Yours sincerely,

T. A. STUDLEY.

6, Rutland Road, Harrow, Middlesex.

(Continued on page 1376.)

The Editor, POPULAR WIRELESS.

Dear Sir,—I have been reading the very straightforward letter of Mr. R. S. Rudland's, criticising the B.B.C. I disagree with him. Like all great concerns the B.B.C. is subject to much abuse, chiefly because it is a success, but our friend is very unfair. To the majority of listeners the talks and lectures given by the B.B.C. are very interesting, because they are educative and instructive and, needless to say, are essential features to the success of wireless broadcasting. In his letter Mr. Rudland compares the Sunday programmes given on the Continent with our own. Does he expect jazz or tango to be broadcast on Sunday? I have listened to both stations on Sundays, but for real music give me the B.B.C.'s. Where can he listen to better programmes than our own? Such as symphony concerts, operas, and various other musical programmes. On one point in his letter I agree with him, that is with reference to the late hour dance music is broadcast, the reason being, I suppose, the better programmes come first.

I would finally like to add my congratulations to the thousands of others in praise of the B.B.C.

Yours faithfully,

FRANK MORGAN.

28, Temple Street, Newport, Mon.

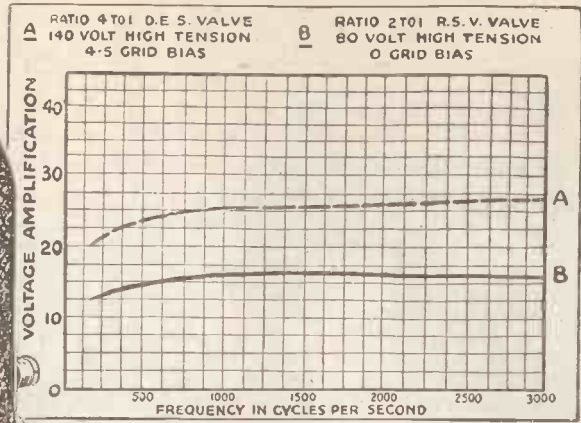
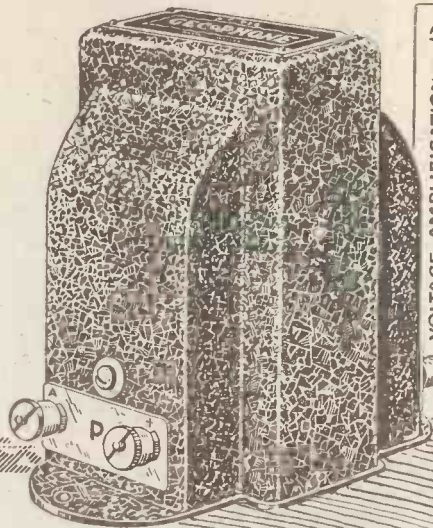

**Points of Superiority!**

High insulation between primary and secondary prevents leakage and ensures maximum amplification.

Primary of high inductance provides even amplification over the main range of audio-frequencies.

The whole is contained in a drawn metal case, providing adequate shielding.

Connections conveniently made to slotted terminals.

# Distortionless!

A new GECOPHONE Transformer of outstanding merits and efficiency

Years of working experience in the manufacture of telephone transformers by The General Electric Co. Ltd., lie behind the new GECOPHONE Low Frequency Transformer—a unique guarantee of perfect design. Already it is acknowledged the supreme radio transformer—trustworthy, super-efficient and absolutely distortionless!

Ratio 2 to 1. Cat. No. B.C. 720. Recommended for use with general purpose valves, such as OSRAM types R, D.E.R., D.E. 3., etc. PRICE **22/6**

Ratio 4 to 1. Cat. No. B.C. 725. Recommended for use with low impedance valves, such as OSRAM types D.E. 4, D.E. 5., or D.E. 6. PRICE **25/-**

## GECOPHONE

(Registered Trade Mark)

# Low Frequency TRANSFORMER

*Your wireless dealer sells it!*

# BROADCAST NOTES.

By O. H. M.

Another Mystery Play—"Listening Time"—Weather Forecasting—  
Caruso Records—B.B.C. and Unified Control—Broadcasting a Diver.

THE new mystery serial, successor to the "Mayfair Mystery," has been arranged for March 1st, 3rd, and 6th. The mystery of the death of Robertson attracted widespread interest just before Christmas, but I gather that the new mystery will be even more popular. A friend of mine in the east told me the other day that he regards the new broadcast serial as the best thing that has been done in Radio drama so far, either here or in America.

The plot is intriguing. Three men and one woman are cast on a desert island from a derelict ship. Each man represents a distinctive type in society. All four are destined to spend the rest of their lives on the island. The problem is—Which, if any, of the three will the woman marry? Substantial prizes are to be given for the correct solution and the most concise explanation of the solution.

The speech of his Royal Highness the Prince of Wales, which is to be relayed from a public dinner on the 15th, promises to be of a particularly stirring character from the point of view of the broader Empire vision.

"Listening Time" is the name of the new B.B.C. revue, the first edition of which will be given on February 13th. It is a sign of how advanced is the dramatic organisation of the B.B.C. that already the second and third editions are being rehearsed.

## The B.B.C. Dance Band.

It is good news that the suggestion that I made on this page some time ago about the B.B.C. Dance Band is being acted upon. I hear that George Grossmith is hot on the job, and that the London Radio Band will soon make its bow. In addition to its studio work, the London Radio Band will be available for restaurants and outside dances. This is all to the good.

A friend of Lord Dunboyne, the expert on long-range weather forecasting, tells me that Lord Dunboyne has proposed to the B.B.C. that he should be given a chance to try out some of his methods through the microphone.

There appears to be evidence that although the B.B.C. is favourably disposed to the idea, there are deep-rooted objections on the part of the orthodox weather experts of the Air Ministry, who are responsible for providing the day-to-day weather broadcasts. I know something of the remarkable results attained by Lord Dunboyne, and I sincerely trust that he will be given a run for his money.

On purely entertainment grounds, it would be of wide interest to listeners to be told what the weather is to be like during the summer and autumn.

But, apart from this, there is really a scientific aspect to the whole thing, although one which naturally would not appeal to the official mind at "Bolo House." Another issue is involved, and that is the tendency of the B.B.C. to allow certain Government

Departments to exercise undisputed sway over their respective programme features.

In this connection I am not quite happy about the relations between the B.B.C. and the Ministry of Health and the General Medical Council. It seems to me that the G.M.C. has a very strong influence over our broadcasters through the Ministry of Health.

## Future Musical Items.

On the anniversary of Caruso, February 22nd, it is proposed to broadcast from London the best gramophone record of the great singer at the height of his career.

This reminds me that we have not yet had the promised voices of the distinguished dead which we were told some months ago were being dug up in the British Museum. I am sure many listeners would like to hear the voices of Gladstone, Tennyson, Queen



A photograph of the recently opened studio at the Birmingham Broadcasting Station.

Victoria, and others, broadcast of course, in appropriate settings.

Sir Edward Elgar's masterpiece "The Apostles," performed by the Hallé Orchestra at Manchester, will be broadcast simultaneously from all stations on March 11th.

This should be a red-letter day for music-loving listeners.

## The Broadcasting Committee.

The Broadcasting Committee completed its hearing of evidence on Thursday, February 4th. Two dozen witnesses have been given hearings, and more than a hundred other varying expressions of opinion have been received. One point emerges with absolute certainty. That is that British broadcasting is to continue under a system of unified control.

On other points it is gratifying to know that the tendency of the Committee is increasingly in the direction which I forecast on this page six months ago. The probable outcome of the enquiry will be that the Committee will recommend the Postmaster General to introduce legislation to constitute a permanent regime of broadcasting. The present Board will be recast. The members of the B.B.C. will be paid off at par, and the Company liquidated.

Lord Gainford will preside as Chief Commissioner over the new broadcasting authority. Mr. Reith will be the chief executive Commissioner, and Sir William Bull the Parliamentary Commissioner.

The new Board will consist of about seven other members in addition to the three I mention. Not more than two of these will represent the wireless trade. The five remaining members will be nominated by the Government, and I should not be surprised to see all of them drawn from the Broadcasting Committee itself. One woman is bound to be included, and I would back the chances of Dame Meriel Talbot. For the remaining vacancies there will be some competition, and I am not ready as yet to hazard a guess.

I hear that on March 8th there will be a special broadcast from a diver submerged in a good many fathoms of water. Listeners will hear straight from the diver what he is doing and how he feels at the bottom of the sea. I confess that stunts of this description interest me enormously, and I was alarmed the other day to hear from a prominent programme official of the B.B.C. that in his opinion the era of stunts in broadcasting had finished. If there were to be no more stunts, then broadcasting would decline. Even the highbrows must recognise the fact that we live in an age of stunts.

Journalism, business, politics, and even religion, are kept alive through periodical stunts, which excite the public imagination. If broadcasting is to be vital it must go on stunting more and more.

# FERRANTI INTERVALVE TRANSFORMERS

TYPE A.F.4. →

17/6

THE BEST AT THE PRICE



← TYPE A.F.3.

25/-

THE BEST AT ANY PRICE

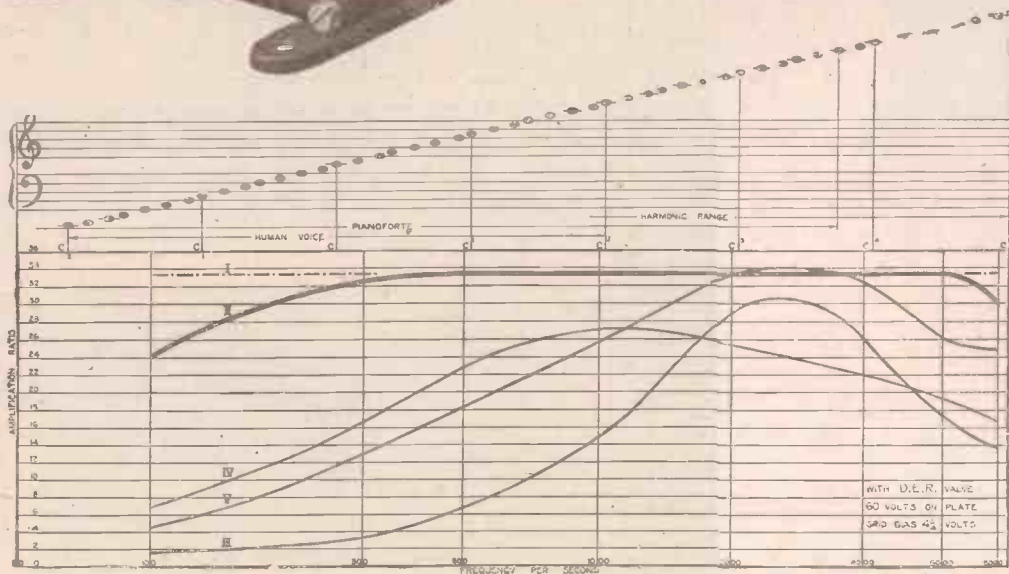

Curve I. Perfection.  
 Curve II. FERRANTI A.F.3.  
 Curves III, IV & V. other transformers.

ASK YOUR  
 DEALER FOR  
 LEAFLETS  
 Wa 401 and  
 Wa 402.

# Probe the Ether!



Get new and far distant stations with the perfection and freedom from distortion of the high-power telescope!

A postcard to us will bring you a descriptive matter and technical data of utmost importance. You cannot afford to miss this.

## POWER EQUIPMENT COMPANY LIMITED

KINGSBURY WORKS, THE HYDE, HENDON, N.W.9.

Telephone: Colindale 6196-7.

Telegrams: "POWQUIP, Hyd., London."

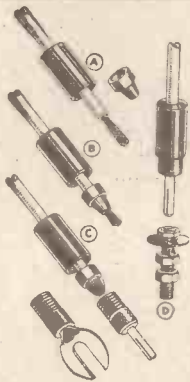

## LISENIN

POSITIVE GRIP PLUGS & SOCKETS  
Pat. No. 245586.

THERE can be few amateurs who have not been troubled with broken leads, or said hard things about faulty connections. Of the whole set there is probably no part which is so often abused as the connections. "Lisenin" Positive Grip Plugs alleviate this evil. They are designed to take the smallest flex up to 5 m/m cable. Sleeves and indication discs red and black. N. Plated. PRICE 6d. Plug and socket complete, or Spade End Terminal. Obtainable of all dealers. Liberal Trade Discount.

Sole Manufacturers and Patentees:—  
THE LISENIN WIRELESS CO.,  
1a, Edgware Road, London, W.2  
Telephone: Paddington 2734. Tel. Address: "Posgrip, Padd., London."

Plug and Socket or Spade End, 6d. each.

Price 3/9

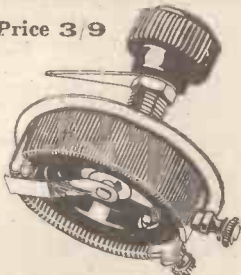

## THE NEW DUAL RHEOSTAT

The great popularity of Dull Emitter valves has given rise to an increasing demand for Dual Rheostats, and by employing them it is possible to use bright or dull emitter valves at will. The introduction of the C.E. PRECISION RHEOSTAT met with the approval of the wireless public, as was evidenced by their large sales, and we feel confident that C.E. PRECISION DUAL RHEOSTATS will enjoy an equal measure of popularity. These Dual Rheostats have two distinct windings, one high and the other low resistance. A definite stop is fitted between them, thus eliminating the possibility of the arm travelling too far and causing a burn-out. One-hole fixing is provided for, and the silvered dial is calibrated for both dull and bright emitters. Like all C.E. PRECISION Components, these Rheostats are GUARANTEED and thoroughly TESTED before dispatch. They are obtainable through all reliable dealers.

C. EDE & CO.,  
High Road, Byfleet, Surrey.

ALL Enquiries to London Electric Stores, Ltd.,  
9, St. Martin's St., Leicester Sq., W.C.2.

C.E. PRECISION RHEOSTATS, 7 and 15 ohms, 2/9, 30 ohms, 3/-  
C.E. PRECISION POTENTIOMETERS, essential for efficient H.F. control, 3/9.

Used in such Famous Circuits as: The 1926 Unidyne 2-Valver; The Marcuse Short Wave Receiver; The Household 3-Valver; The Trinaryne 1-Valver, &c.



allo allo!  
Ici les émissions de la Compagnie Française de Radiophonie...  
Poste de Clichy...

A touch on the vernier and there's the voice quite clear... What is it? Sounds like French... But what are they saying? You simply don't know.

## Here is the way to master French in a few months

By the Linguaphone method you learn French (or any other language you wish to acquire) just as you first learned English—by hearing it spoken.

You simply slip a Linguaphone record on your gramophone whenever you have a moment to spare and listen while a native teacher talks to you—talks with the perfect Parisian accent, while you follow, in the special pictorial text-book, not only the written text but also the composite pictures which include every object named by the record and illustrate all the actions described.

The Linguaphone repeats the lessons as often as you wish, when you wish, at the speed you wish.

And in a few months you will be able to listen enjoyably to any French station you tune in, understanding everything that's said—announcements, lectures, words of songs, and so on.

English, Spanish, German, Italian, Afrikaans, and even Esperanto can be learned by Linguaphone. Radio enthusiasts will remember that Esperanto has been adopted as the official language of the International Radio Association.

### You can test the Linguaphone Free

The conversations on the fifteen double-sided records which make up the Linguaphone course cover most common objects and situations. There are no "grammar book" sentences. You learn how to say and understand the ordinary things of every day.

We will send you the Linguaphone outfit to try for seven days absolutely free. If you don't find it all we claim, just send it back. There's no obligation on your part at all.

# LINGUAPHONE LANGUAGE RECORDS

FRENCH · SPANISH · ITALIAN · AFRIKAANS  
GERMAN · ENGLISH

### Post this Coupon for full details

To the Linguaphone Institute, 100, Napier House,  
24-27, High Holborn, London, W.C.1.

Please send me your 24-page illustrated book telling all about the Linguaphone Language Records, the free trial offer, prices, the convenient terms of deferred payment, and the Linguaphone method of learning.

FRENCH  SPANISH  ITALIAN  GERMAN  
 AFRIKAANS  ENGLISH  ESPERANTO

Put a cross by the language you wish to learn. It is understood that this request involves me in no obligation whatever.

NAME .....

ADDRESS .....

AUSTRALIA—Box 2838 G.P.O., Sydney. FRANCE—1, Rue Lanterne, Lyons. SOUTH AFRICA—95, Hospital Road, Durban. HOLLAND—Zwart Janstraat 138, Rotterdam.

**T**HE Government Broadcasting Committee of Inquiry, having heard evidence given by at least two dozen people, has now commenced the interesting task of sifting the wheat from the chaff and is preparing its official report.

A good deal of time has inevitably been wasted by the hearing of evidence offered by people who find the limelight of a public inquiry rather dazzling; but, on the whole, the Committee has shown a praiseworthy patience and a real desire to learn what all critical schools of broadcasting have to say.

One of the last sittings of the committee was arranged in order that Mr. J. D. Chisholm, of Secret Wireless Ltd., might offer evidence. He said his company had perfected a system of secret wireless which enabled signals to be received only by those for whom they were intended.

It was possible by the company's method for individuals to communicate privately with each other by wireless. A head office of a newspaper might communicate with its branch offices, or vice versa, whilst at the same time a competitive journal might be doing likewise, neither knowing what the other was doing. By the Secret Wireless system a great range of programmes operated by different broadcasting companies from different stations could be made available.

**How Many Pirates?**

Mr. Chisholm stated that it was understood that there were 1,700,000 receiving licences in force, and that there were probably no fewer than 5,000,000 "pirates" who evaded payment. This company's system, he believed, would eliminate the "pirates," and the increased demand for the new type of instrument would reduce the price of valve sets. By selling 6,000,000 copies of their weekly programmes at a penny each the broadcasting companies would secure a sufficient revenue. The State might charge 1s. a year for a licence for a receiving set.

Mr. Chisholm said the system involved the using of three wave-lengths, but there was only one wave-length in use at a time. The official programmes of the companies would tell the listener in the combinations to be worked on his receiver.

Mr. Chisholm, it will be seen, estimates that there are 5,000,000 "pirates" in this country—a figure which, we venture to say, errs on the side of generosity. We should estimate the "pirates" at half a million; but then we are, perhaps, less generous than Mr. Chisholm. When asked how he arrived at the conclusion that there were 5,000,000 "pirates," his answer was to the effect that the B.B.C. had stated there were 10,000,000!

We have no recollection of the B.B.C. making this statement; and, according to the Chairman of the Committee, 10,000,000 "pirates" would mean that there are more "pirates" than there are houses in the country!

**Highbrows and Lowbrows.**

Sir Hugh Allen, in giving evidence before the Committee, dealt with a subject which should prove of great interest to those gentlemen who, for want of a better word, are known as "lowbrows."

Sir Hugh referred to the evidence given by Sir Walford Davies, who, he said, had stated that the mass of the people was starved

**CURRENT TOPICS.**

By THE EDITOR.

Evidence and the Broadcasting Committee—The Future of Broadcasting.

as regards good music, and that they were getting a surfeit of the bad. Sir Hugh imagined that no one was obliged to listen, and therefore it seemed to him that it would be hardly right to say that listeners were "starved" to-day. If one could hear one good thing a day every day of the year, one could hardly be starved in that direction. The whole nation had been enfranchised as regards music and they found it rather difficult to make proper use of it. Sir Hugh maintained that no bad music should be broadcast, and on this point he was tackled by Captain Ian Fraser, M.P., who asked him to define "bad music."

\* \* \*

We were present at this sitting of the Committee, and there was no doubt that Captain Ian Fraser's question made Sir Hugh put on this thinking-cap. Said

**A THIRD 2/- GIFT**

Still another selection of four 6d. Blue Prints will be given away with every copy of "P.W." next week.

**ORDER YOUR COPY NOW!**

Captain Fraser: "Is a tune bad which is only worth remembering for a short time?" and Sir Hugh replied: "Probably, because all good tunes are permanently wearable. Good music is like good material; you can wear it for many years."

"If a tune is bad," asked Captain Fraser, "because it only wears a short time, you would not have it broadcast?"

"I would rather have a selection made of such tunes," replied Sir Hugh, "as, in the opinion of those who really know, will stand the test. There are some experts who will say which music will wear and which will not."

"Is there any merit in a tune which gives people pleasure, even for a short time?" was Captain Fraser's next question. "I think some people get pleasure out of things which are obviously bad for them," was Sir Hugh's rather trite reply. He went on to explain that children eat a large amount of sweets which are not good for them, and drew the rather far-fetched analogy that, although there is a lot of pleasure in eating, it may be harmful; and just as there is a lot of pleasure in listening to bad music (in the case of the lowbrows), there is also a lot of harm. But Captain Fraser would have none of this.

"I hear a new tune," he said, "and I get violently sick of it, but for the time I get intense pleasure. Should I resent and resist this because it is bad music?"

Sir Hugh said some of the tunes might be good ones, and he added that there is good jazz and bad jazz, good dance music and bad dance music, good classical music and bad classical music.

At this point the chairman interposed, and said:

"But we do not hear bad classical music?" And in shocked surprise Sir Hugh replied, "Oh, sir!"

No doubt many of our readers who take a wicked pleasure in listening to the "Rachmaninoff Prelude," "In a Monastery Garden," "Poet and Peasant," and other delectable melodies, will side with Captain Ian Fraser, and no doubt an equally large number will agree with the somewhat austere views of Sir Hugh Allen.

**Pleasing Listeners.**

But whatever arguments the highbrows may advance, and whatever argument the lowbrows may advance, the fact remains that so long as the B.B.C. pleases, or attempts to please, an audience which, at a conservative estimate, amounts to 10,000,000 people, there will be an internal warfare between these two musical camps.

We maintain that it is no business of the B.B.C. to decide a musical standard of test for its auditors. Its primary business is to give the public what it wants, and the best way out of the difficulty is to make a 50-50 proposition of it. If some listeners are frankly pleased at what Sir Hugh describes as "bad music," let them have it. You can take a horse to the water, but you cannot make it drink; and you can bring a listener to the telephone or loud speaker, but you cannot prevent him not listening if he does not want to listen to the musical programmes sent out by the B.B.C. based on intellectual standards, or unintellectual standards, as argued by Sir Hugh Allen and Captain Ian Fraser.

\* \* \*

We have already suggested that the future of broadcasting lies in the direction of fewer and more powerful stations. As our readers know, this policy is favourably regarded by the B.B.C., but it appears that this policy has created some qualms among listeners, especially among those who have sets capable only of receiving programmes broadcast by the relay stations.

We should like to make it clear that if the new scheme of substituting high-power stations for the present low-power stations is put into practice, listeners will not be deprived of any of the essential facilities which they now enjoy.

As has been pointed out in the daily Press, the very essence of the new scheme is to provide still greater facilities for those now within the range of relay and main power stations. The new scheme would also provide easier reception for listeners who, at the present time, are somewhat outside the official area of the B.B.C. stations. And the B.B.C. have definitely stated that no station, however small the number of listeners served by it, will be closed unless its functions can be better undertaken by another.

The advantages of the new policy are obvious. For one thing, the limitation of B.B.C. stations in this country would go a long way towards removing the bugbear of interference.

It has been estimated that on the present wave-band allotted to the B.B.C. there are at least one-third too many stations in this country.



# Technical Notes

Conducted by our Staff Consultant, J. H. T. ROBERTS, D.Sc., F.Inst.P.

## A New Super-Het. Development.

SOME interesting results are reported in a recent issue of the "Radio World" (New York) as a result of tests on the new "antenna coupler" developed by the Superadio Company. The purpose of this coupler is to form an effective link between the super-heterodyne set and the outside aerial. It has long been one of the aims of the super-heterodyne enthusiast to find some means of availing himself of the extra distance-reception qualities of the extended or outdoor aerial. For example, to be equal in pick-up sensitivity to, say, a 70-foot aerial, it is estimated that a specially wound loop of at least 30 feet square would be necessary. Thus any efficient means of coupling the super-heterodyne receiver to an outdoor aerial, or indeed to a good indoor aerial, should afford many advantages.

The outside aerial is not, of course, connected directly to the frame-aerial terminals of the super-het. for, if this were done, the ordinary coupling coil would act as a miniature loop and the selectivity would be much impaired.

The new coupler has a special three-circuit coil, which, with the tuned circuit, maintains the selectivity, and is, in fact, claimed to improve it. Each instrument is tested separately before being despatched, and is accompanied by an individual calibration chart and blue print.

In tests on this device, which were made by the "Radio World," using an outdoor aerial, it was found that a 20 per cent. increase in distance-reception was obtained, 40 per cent. increase in volume, and 50 per cent. increase in selectivity. Many distant stations were obtained which could not previously be brought in with the loop aerial, and the great increase in signal strength permitted economy in current consumption. This coupler is marketed by the Superadio Company, 136, Liberty Street, New York City.

## An American Innovation.

An innovation in connection with receiving sets is the introduction of what is described as a Wheatstone bridge. This has been introduced by Mr. Powell Crosley, jun., the very well-known American radio manufacturer, who states that he has incorporated for the first time in a receiving set a Wheatstone bridge, a laboratory measuring instrument for balancing in each H.F. stage. It is claimed that this feature makes it possible to obtain great cascade amplification at long wave-lengths and at the same time to secure perfect balancing at all wave-lengths.

## Dealing With Interference.

Complaints are frequently received from listeners that they suffer interference from local causes, such as electrical machinery, high-frequency medical apparatus, and so on. One of the principal offenders in this

respect is the battery charger of the vibrating reed type, and this trouble has become so acute in certain parts of the world, notably in the United States, that special local bye-laws have been enacted, making it an offence to operate a battery-charger of

H.F. resistance and inductance. A published paper containing the data will soon be available.

The coils which were used were of different shapes and were wound with different kinds of wire. Of the coils, the loose basket weave coil and the single layer coil appeared to have the lowest H.F. resistance; 24 gauge D.C.C. wire is a suitable size of conductor, although 32 to 38 Litz wire appeared to have somewhat less resistance. This apparently holds good for the entire broadcast range and for all the shapes of coil which were investigated.

Collodion was found to be a suitable binder for supporting the turns of coils of certain shape. There was a noticeable reduction of resistance obtained by suitably spacing the turns of an ordinary single layer coil.

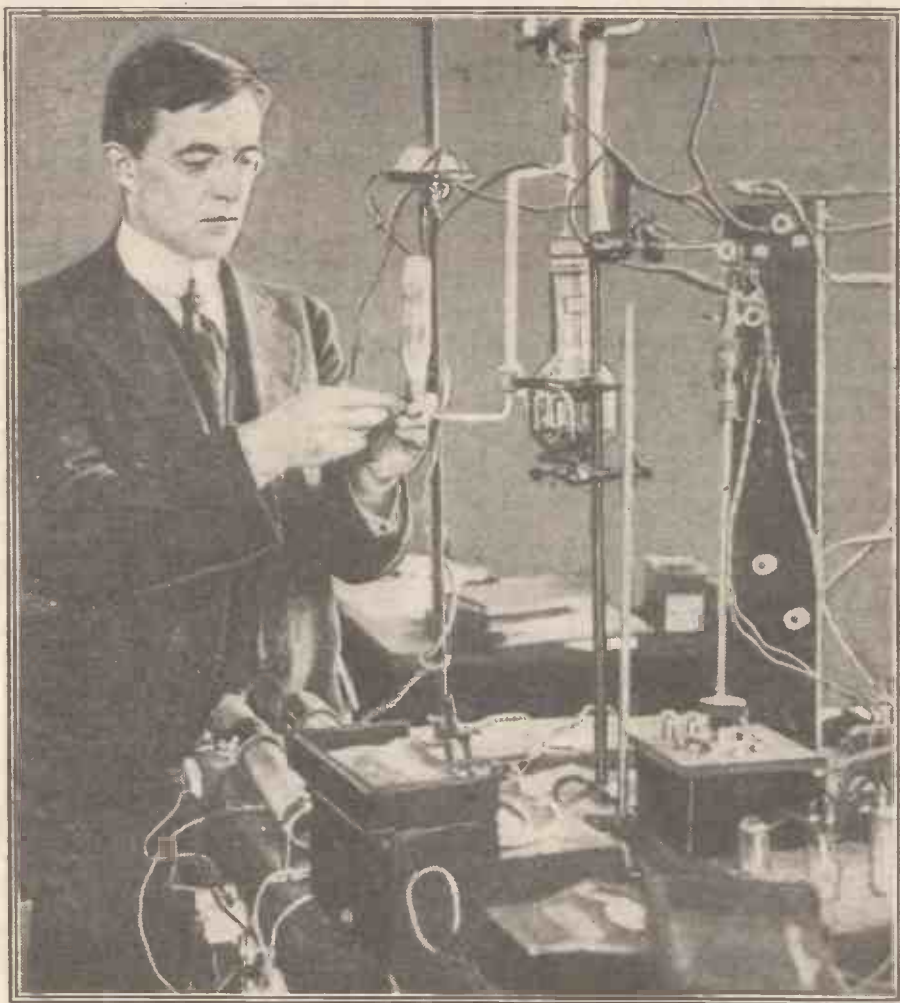

Dr. Irving Langmuir, who has succeeded in establishing his right to important valve patents after a twelve years' legal struggle in America, at work in his laboratory.

the vibrating type between certain hours, such as between 6 o'clock in the evening and 5 o'clock in the morning.

## Important Coil Investigations.

Referring to the remarks which I made recently in these Notes on the subject of varnishes or binders for high-frequency coils, some very important and interesting tests have recently been made by the Bureau of Standards, Washington. The investigation embraced many types of so-called "low-loss" coils designed for broadcast frequencies, and had particular reference to

This investigation is probably the most complete and most important which has yet been carried out on the subject of the H.F. resistance, the inductance and the various other properties of receiving coils, and a full account of the results obtained will be given in these columns, as mentioned above, as soon as they are available.

## Television a Close Possibility.

Monsieur Belin, the famous French scientist who is so closely identified with researches on television, has recently made

(Continued on page 1378.)



THE handsome and spacious ballroom of the Savoy Hotel is only half lit. A subdued pink lighting reveals an empty floor and unoccupied chairs and tables, but at one end of the ballroom there is great activity.

The Savoy Orpheans, prior to starting their evening performance, are rehearsing a new number. The conductor, Mr. Debroy Somers, (he has not had time to change his brown suit), is a contrast to the austere black and white of his band. Mr. Somers is just as pleasant and satisfying to watch as his band is to listen to. He is a young Irishman of thirty-four, but looks considerable younger.

**Wireless Enthusiast.**

"I am a great enthusiast of wireless," he told me during an interval of the rehearsal, "and whenever I have a spare moment, and alas! it is so seldom, I listen-in to America. We have a splendid set here at the Savoy, and the reception is really remarkably perfect. I think wireless is the greatest invention in existence, and when one views its possibilities, one cannot but realise how powerful an asset it is.

"While I have the greatest admiration for the entertainment side of wireless," he told me, "I must say that I think the broadcasting of so much syncopated music is overdone. Too much of any kind of entertainment belittles its popularity, and just now there is so much of what is known as 'jazz' music that it is apt to become monotonous."

**Classical Music Preferred.**

In Mr. Somers' opinion the listeners who use the broadcasting of syncopated music for dancing purposes are in the minority. Wireless serves a bigger and better purpose than the gramophone by the fact that it is a first-hand entertainment.

He would not be surprised to learn, he added, that only about ten per cent of the listeners danced to broadcast music.

"I would suggest that the kind of music they like is the kind we include in our special performances, such as we gave in London at the Queen's Hall. We included such items as Gershwin's 'Rhapsody in Blue,' which is regarded as the classic in 'symphonised-syncopation,' as I would prefer to name this music. I was never in favour of the word 'jazz,' and how out of place it is can be imagined when we play Wagner, or the Slavonic dances. I am sure listeners-in would welcome more classic music on the wireless, and that is the music I prefer to broadcast.

"New numbers are so few and far between that we shall have to revert to the classics. Symphonised syncopation has lost its novelty and its 'newness,' so if it does not remain of first-class entertainment value it will diminish in popularity."

**Fifty New Tunes per Week.**

Broadcasting has given the Savoy Orpheans the largest audience of any band—an audience of millions. The story of how this band started is too well-known to repeat it here, except perhaps to mention that Mr. Somers collected the men from all over the world. They are all "stars," and journeys totalling 110,000 miles were made to bring them together. The result has been a perfect band.

Almost 8,000 different tunes were tested to obtain the band's original repertoire of

**THE ORPHEANS.**  
Mr. Debroy Somers'  
Views on Broadcasting.  
By "ARIEL."

200 tunes. Fifty different tunes are tested each week to bring the repertoire up-to-date.

"On the nights we broadcast I do my best to make my programmes just as suitable to listeners as to the Savoy clientèle. I suppose I am something of a highbrow, for if I had my own way I would play nearly all classical music and special exhibition numbers," said Mr. Somers.



A recent photograph of Mr. Debroy Somers.

As an example of the tremendous popularity of the Savoy Band he receives a huge correspondence from wireless "fans." The mail from Berlin and Vienna is particularly heavy, and only the other day a letter from Germany asked that they should make gramophone records of Franz Lehar's latest operetta, "Paganini." This was a happy coincidence, for the Orpheans have made these records.

**World-Wide Requests.**

"We have been heard in all kinds of places," continued Mr. Somers. "I was told recently by Senatore Marconi that we have been heard in China. We have also been one of the chief amusements behind the Riff lines during the Moroccan war.

"We receive many curious requests for special numbers. Quite often I get requests from liners leaving the South African coast for dance numbers to be played two days later for their ship dance. As far as possible I accede to these requests. Many liners at sea wireless their requests."

An amusing incident occurred at the hotel the other evening. A Scotsman, who had listened-in at Glasgow to the band for the last year came to hear them play. Great was his astonishment when he saw they were

white men. He had always thought they were negroes, and he went away slightly disappointed!

**Broadcasting from the Air.**

"For the first time recently we broadcast from an airplane," continued Mr. Debroy Somers, "and they tell me it was very successful. So great was the noise inside the machine, and there was so little room to move about, that I had to shout in the ear of each of my men what I wanted done. I would not like to conduct always in this way!"

I asked Mr. Debroy Somers whether he was in favour of broadcasting being run by a government department when the B.B.C. licence expires in 1926.

"Certainly not," was his emphatic rejoinder. "I don't like a government department running anything. There would be too much red tape about it. I hope to see the B.B.C. licence renewed. Considering the enormous difficulties they have had to cope with they have done very well.

"But I will say that, much as I like and admire broadcasting, I feel that an orchestra loses a lot on the wireless. A great many of the finer points of the band are lost. I have often listened-in to my own band playing, and I must say that I have been disappointed. The result is not the same.

**The Last Broadcast.**

"But the B.B.C. is rendering a great service to the world. I often receive letters from invalids and bed-ridden listeners-in who greatly appreciate the musical programmes. This is where broadcasting is so valuable, and in making those who suffer happy is a task to which we are all eager to contribute.

"In 1926," concluded Mr. Debroy Somers, "I, for one, feel convinced that broadcasting will come into its own as a perfect and enjoyable entertainment.

"According to present arrangements, the Savoy-Orpheans and the Savoy-Havana Bands and, of course, the Savoy-Tango Bands, will be heard by listeners in Great Britain and Europe—and, I expect, American fans will be listening for us also—for the last time on the evening of February 27th.

It is a strange thought, and although we have now been broadcasting for so long, we are apt to forget that as we play in the Savoy ballroom, people are listening to us thousands of miles away. At the same time, I shall be very sorry to lose my radio audience from a sentimental point of view.

"Apart from everything else, a radio audience is to my mind a most useful, helpful, and informative one. Their letters help and stimulate one to an extent that can only be given by the most rapturous concert audiences, like those, if I may modestly claim, which came to the concerts at the Queen's Hall, and on our Provincial tour.

The radio critic, I have found, if he has any criticism to offer, generally makes it in a constructive form.

"To my mind, broadcasting owes a great part of its success to the criticisms which are being continually offered by listeners.

"I take this opportunity of sending, through POPULAR WIRELESS, my greetings and farewell for myself and my band to our millions of friends of the air."

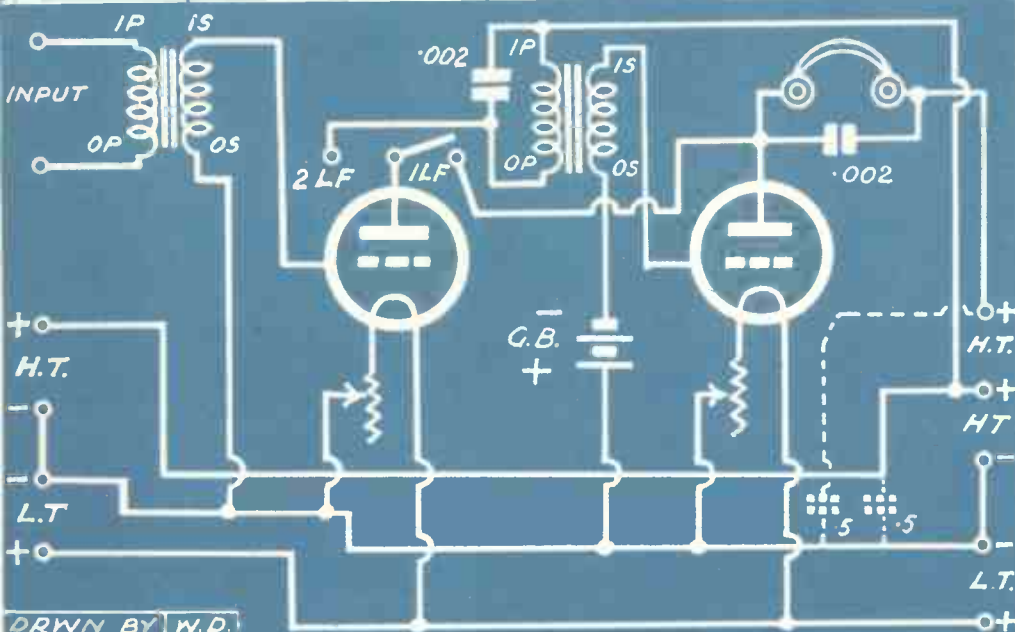
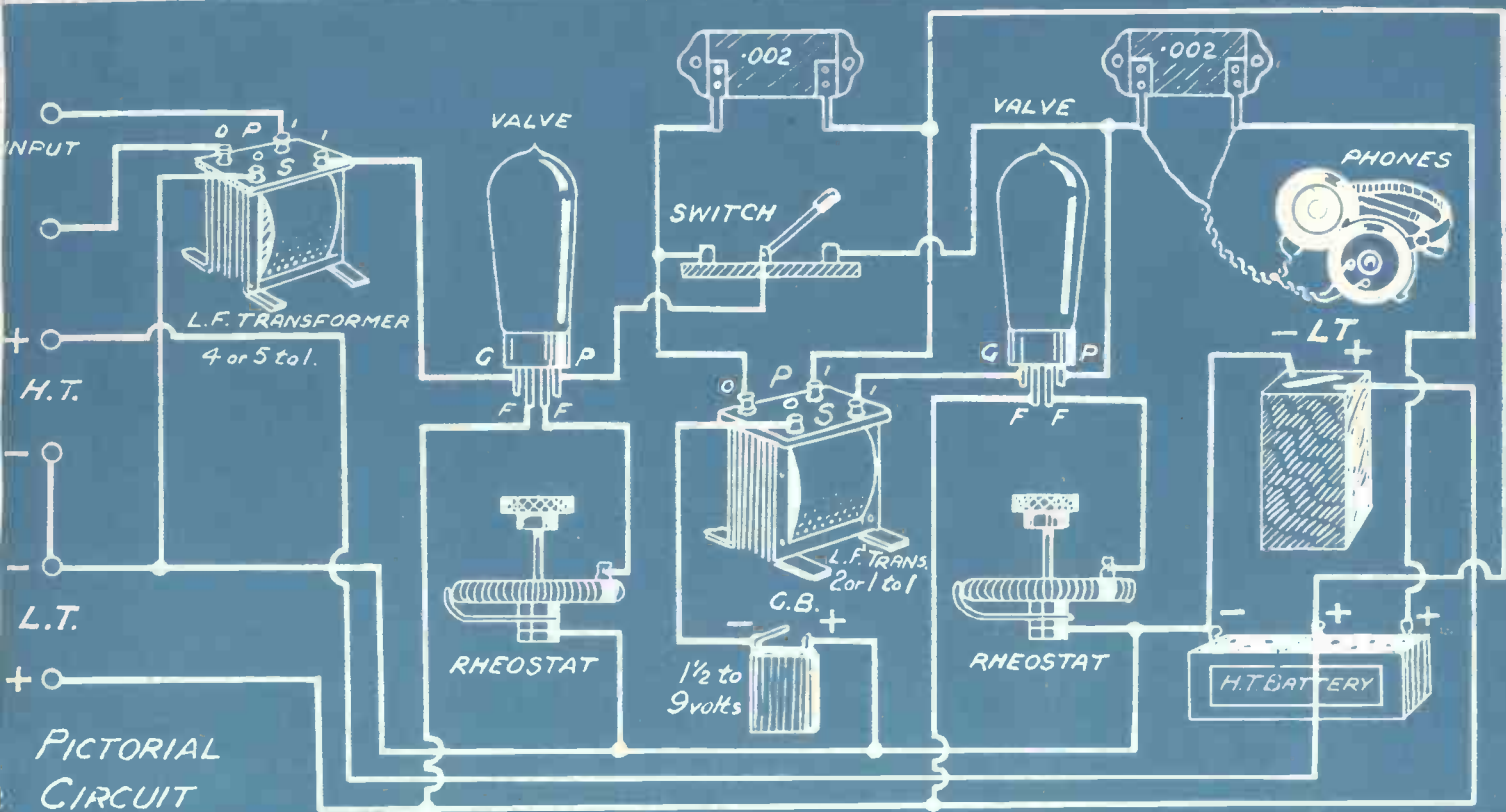

THE P. W. BLUE PRINT CIRCUIT No. 14  
TWO-VALVE L.F. AMPLIFIER  
WITH SWITCH TO CUT OUT  
LAST VALVE 6d.

LIST OF COMPONENTS.

- 1 L.F. transformer (first stage).
- 1 L.F. transformer (second stage).
- 2 filament resistances.
- 2 valve holders.
- 15 terminals.
- 1 panel 8 x 8 x 1/4 ins.
- 1 box to fit 4 1/2 ins. deep
- 1 S.P.D.T. switch.
- 2 .002 fixed condensers.
- Wire, screws, transfers, etc.

ACCESSORIES.

- 1 valve (for first stage L.F.).
- 1 "Second stage" or "Power" valve.
- H.T., L.T. and grid-bias batteries, to valve makers' specification.
- 2 .5 fixed condensers for placing across H.T. terminals (optional).
- Phones and/or loudspeaker.

DRWN BY W.D.  
CHKD BY 151  
SER NO. BP23

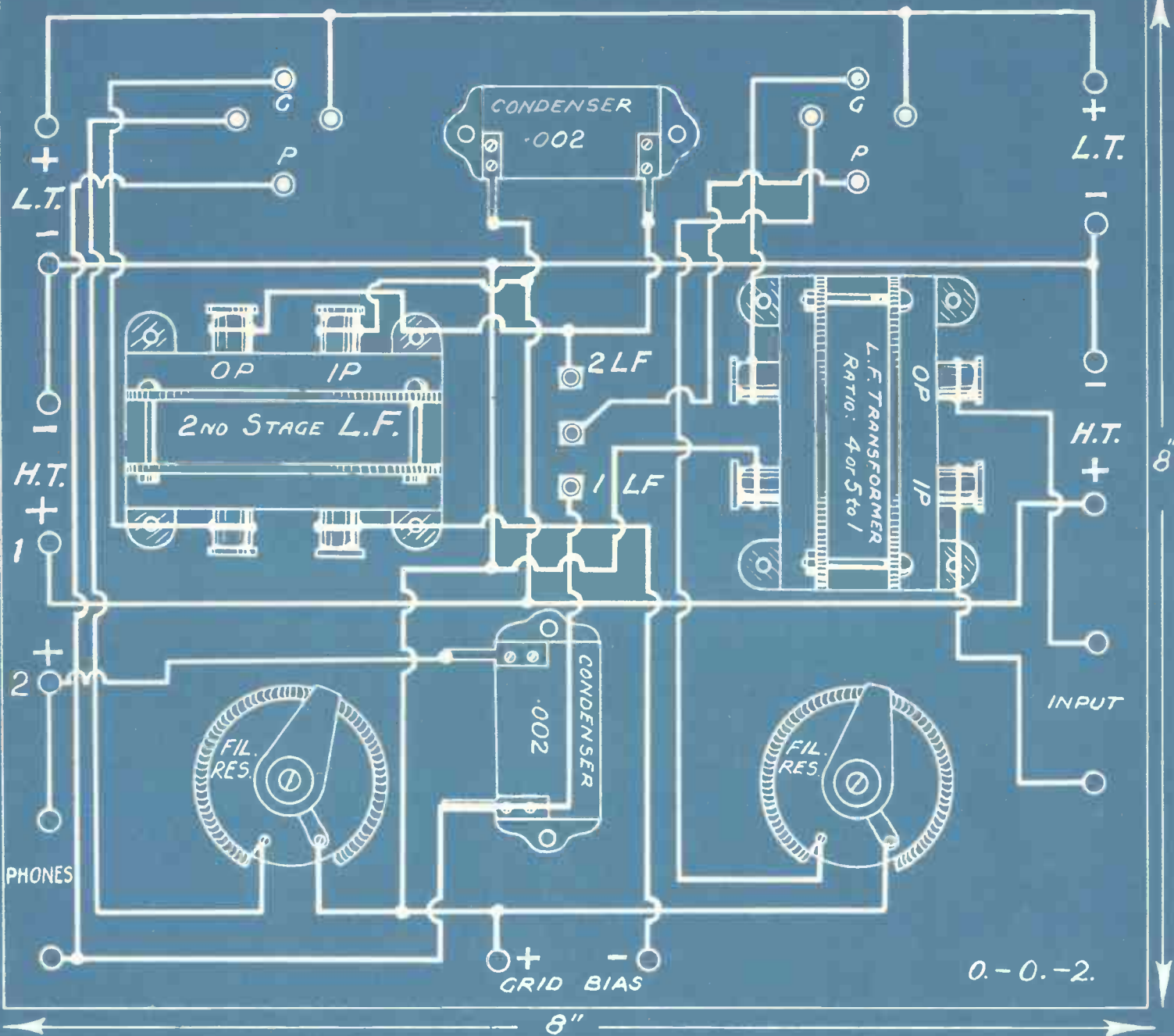

DRAWN BY	W.D.
CH'KO BY	<i>W.D.</i>
SER: N°	B.P.28.

THE P. W. BLUE PRINT CIRCUIT No. 14—TWO-VALVE L.F. AMPLIFIER, WITH SWITCH TO CUT OUT LAST VALVE. This circuit is suitable for adding to valve or crystal set for loudspeaker work.

NOTE.—When added to a valve set, the wires in the amplifier which connect L.T. negative to H.T. negative are unnecessary and these terminals should *not* be joined, or the H.T. negative terminal should be left without any external connection. As L.F. transformer design is not standard it may be necessary to reverse the leads to O.P. and I.P., or to O.S. and I.S.

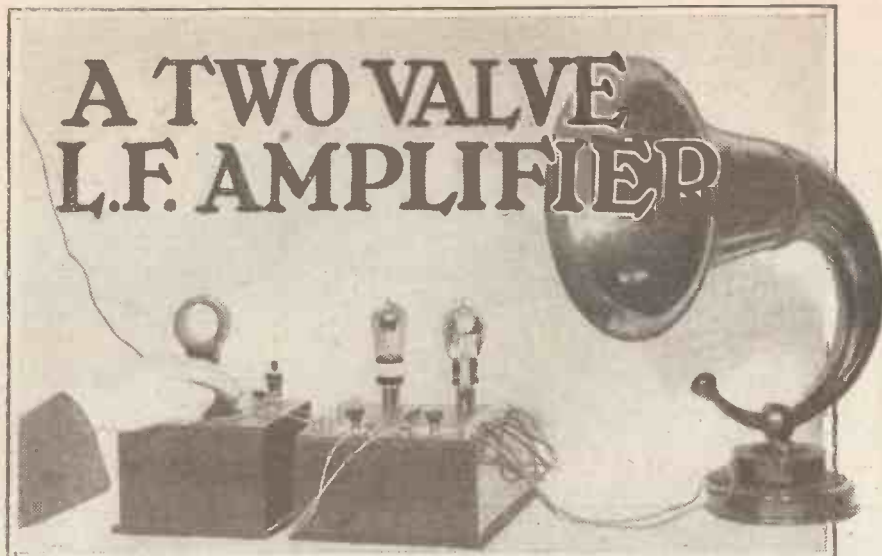

The Set designed, described and constructed by the "P.W." Technical Staff. The diagrams for this set are on the Blue Print given away with this issue.

THE purpose of an amplifier is, as its name suggests, to amplify, although in the case of an L.F. amplifier it would, perhaps, be more correct to say magnify. An L.F. amplifier does not increase range of reception to any considerable extent, or at least, if any such increase eventuates it must be regarded as incidental and therefore as a gain. Its purpose is to take received signals from a set and magnify them—make them louder so that either clearer telephone reproduction is obtained or a loud speaker operated.



The neatness and symmetry of the amplifier will appeal to constructors.

In the case of a crystal set it is generally necessary to employ two valves to obtain the volume required for a loud speaker, for such an instrument in itself is not the efficient magnifier of sound as it is apparently thought to be by many people. A valve set, on the other hand, is capable of delivering much louder signals than a crystal set, so in certain cases one extra valve employed as an L.F. amplifier will be all that is needed.

Therefore, the two-valve amplifier described in this article is provided with a switch so that either one or two valves

can be used. It forms an instrument that will prove useful to both listeners and amateurs.

#### Suitable L.F. Transformers.

L.F. amplifiers are very easy to build and very easy to handle, for they embody none of the tuning controls or critical apparatus of H.F. amplifiers. Constructors must not tackle the job too lightly as, nevertheless, L.F. amplifiers demand a certain amount of care in assembly and operation if optimum efficiency is to be obtained.

Distortion can very easily occur if unsuitable transformers or valves are used. The first consideration is the transformers. These must be chosen carefully for the work they will have to do. One will occupy what is known as the first stage and the other the second. The Lissen T1 and the Energo used in the original set operate very well together. Other makes can, of course, be used if desired. The first stage transformer should have a 4 or 5 to 1 ratio, and the second 2, 3, or 4 to 1. It is very advisable to use high-class transformers of reputable make, for they are the "life centres" of an instrument of this nature.

The filament rheostats should have ample resistance, the 30 ohm Precisions are to be strongly recommended. The only other components required are fixed condensers and any good make such as Lissen, Dubilier, etc., can be used, a single pole double-throw switch and the various valve-sockets, terminals, etc.

#### Commencing the Wiring.

The panel drilling is quite straightforward, as will be seen by the accompanying diagram. Templates for the valve sockets and other panel drilling information has, of course, appeared in our new Radiatorial series "For the Constructor."

The transformers are mounted on the back of the panel by means of countersinking screws and nuts. After the various terminals, etc., have been mounted, the wiring can be proceeded with. The blueprint shows this, while a separate check is provided in the point-to-point guide accompanying this article.

It will be noticed that, both in this guide and the theoretical circuit, specific transformer connections are given, while in the wiring diagram the secondaries are not marked, the reason for this is given in the note at the foot of the blue print. Reference is also made to a point concerning H.T. and L.T. minus connections.

#### Optical H.T. Condensers.

Glazite was used for wiring the original amplifier and can be thoroughly recommended to constructors. There are rather a large number of connections and, in the panel space available, the use of bare wire would be difficult and, indeed, rather dangerous. Glazite has a very attractive appearance, however, and can be soldered as readily as the "bare tinned."

Soldering is, of course, advisable whenever possible, although such must be carried out carefully and a good non-acid flux, such as Fluxite, used.

The wiring completed, transfers can be fixed on the panel and a case or cabinet prepared. This should be 4 in. deep and can be 8 x 8 in. internally or externally. In the latter case, the panel is merely dropped over it and screwed down by means of countersinking screws: in

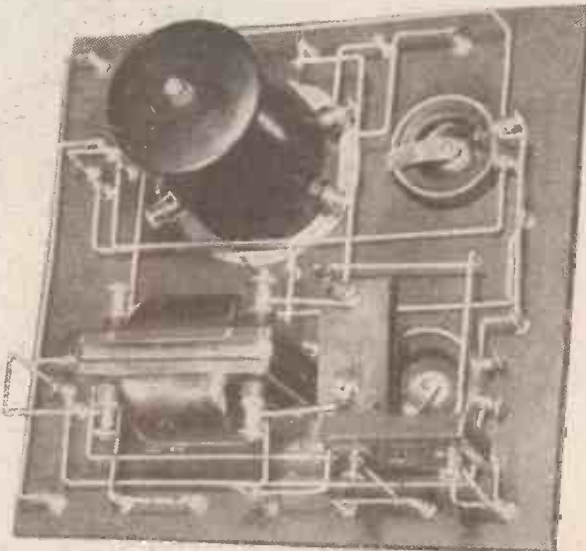

The wiring is carried out with Glazite, which gives the upper panel lay-out a neat appearance.

the former, fillets must be provided as the panel will drop into the case, its surface being either level with the top edge or slightly above, according to taste.

Two large fixed condensers of about .5 mfd. capacity can be connected, one across H.T. minus and one H.T. plus, and the other across H.T. minus and the other H.T. plus if desired. This is purely a refinement, but one that can be included in the amplifier if desired. Probably no difference at all in reproduction will be noticed subsequent to the addition,

(Continued on page 1359.)

# ORMOND(E) still leading — as in 1886

MANY people will recall the victories of "ORMONDE," who in 1886 carried off the Triple Crown—winning the Two Thousand Guineas, the Derby, and the St. Leger. In the whole of his career *he was never beaten*, and is generally regarded as *the best horse of all times*.

Since then the name "ORMOND" has repeatedly been associated with success. To-day, in the World's Long Distance Race, the "ORMOND" Condenser Mount easily comes in first, leaving behind it a field of stragglers.

For a magnificent finish, back "ORMOND"

## SELECTIONS FOR TO-DAY:—

### BALL-BEARING FRICTION CONTROL CONDENSER

- 0005 ... .. 15/-
- 0003 ... .. 14/6
- 00025 ... .. 13/6

IDEAL RATIO: 55-1

Brass End plates, highly nickelled finish.



Regd. Trade Mark

199-205 PENTONVILLE ROAD  
Phone. Clerkenwell 9344-586

KINGS CROSS, LONDON, N.I.  
Grams Ormondengi-Kincross.

Factory. WHISKIN ST CLERKENWELL . E. C. I.

**EASILY FIRST IN EVERY FIELD**

# Another "Lotus" Triumph!

THE delicacy of your Valve filaments are subject to microphonic elements from numerous sources. The LOTUS Buoyancy Valve Holder has been specially designed and constructed to counteract and dissipate these disturbances, and will, by its original and unique spring construction, absorb any shock, protect your valves and eliminate all microphonic noises.

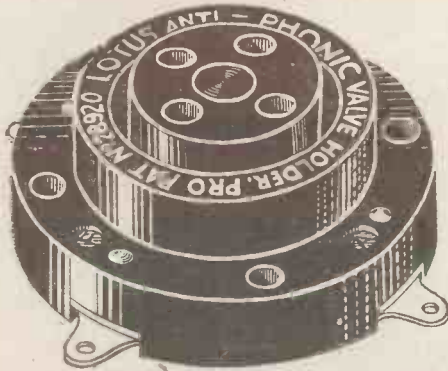

TOP VIEW.

Valve sockets and springs are locked together by a mechanical process, making a definite and permanent connection. Bakelite mouldings, nickel silver springs and phosphor bronze valve sockets. Nickel plated.

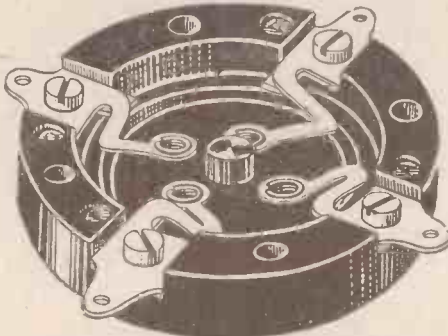

UNDERSIDE SHOWING SPRINGS.

## The LOTUS Buoyancy VALVE HOLDER Anti-Microphonic

*Designed and made by the manufacturers of the LOTUS VERNIER COIL HOLDER, and obtainable from all reliable Radio Dealers.*

Garnett, Whiteley & Co., Ltd.,  
"LOTUS" Works, Broadgreen Rd., LIVERPOOL

2/3



Patent applied for

## The New Duplex Terminal

WHILE it has not been found possible to improve the design of the T.C.C. Mansbridge Condenser, important alterations have been effected in the actual metal case. The new T.C.C. Mansbridge is fitted with Duplex terminals. A quick connection can now be made by means of the milled head. Soldering can still be carried out—a lug being fitted as shown.

One further improvement to be found in the use of a metal top instead of a pitch sealing compound. Thus the danger of heat affecting the Condenser during soldering is now completely abolished.

Once more T.C.C. demonstrates its ability to lead the way in condenser design—its 20 years' experience places it in a unique position for building genuine Mansbridge Condensers accurately and economically.

T.C.C. Mansbridge Condensers are now supplied in green metal cases in all values from .005 mfd. to 4 mfd. Your Dealer stocks them

Get the new T.C.C. Mansbridge



## T.C.C. Mansbridge Condenser.

Telegraph Condenser Co., Ltd., Kew, Surrey.

Gilbert Ad. 4554.



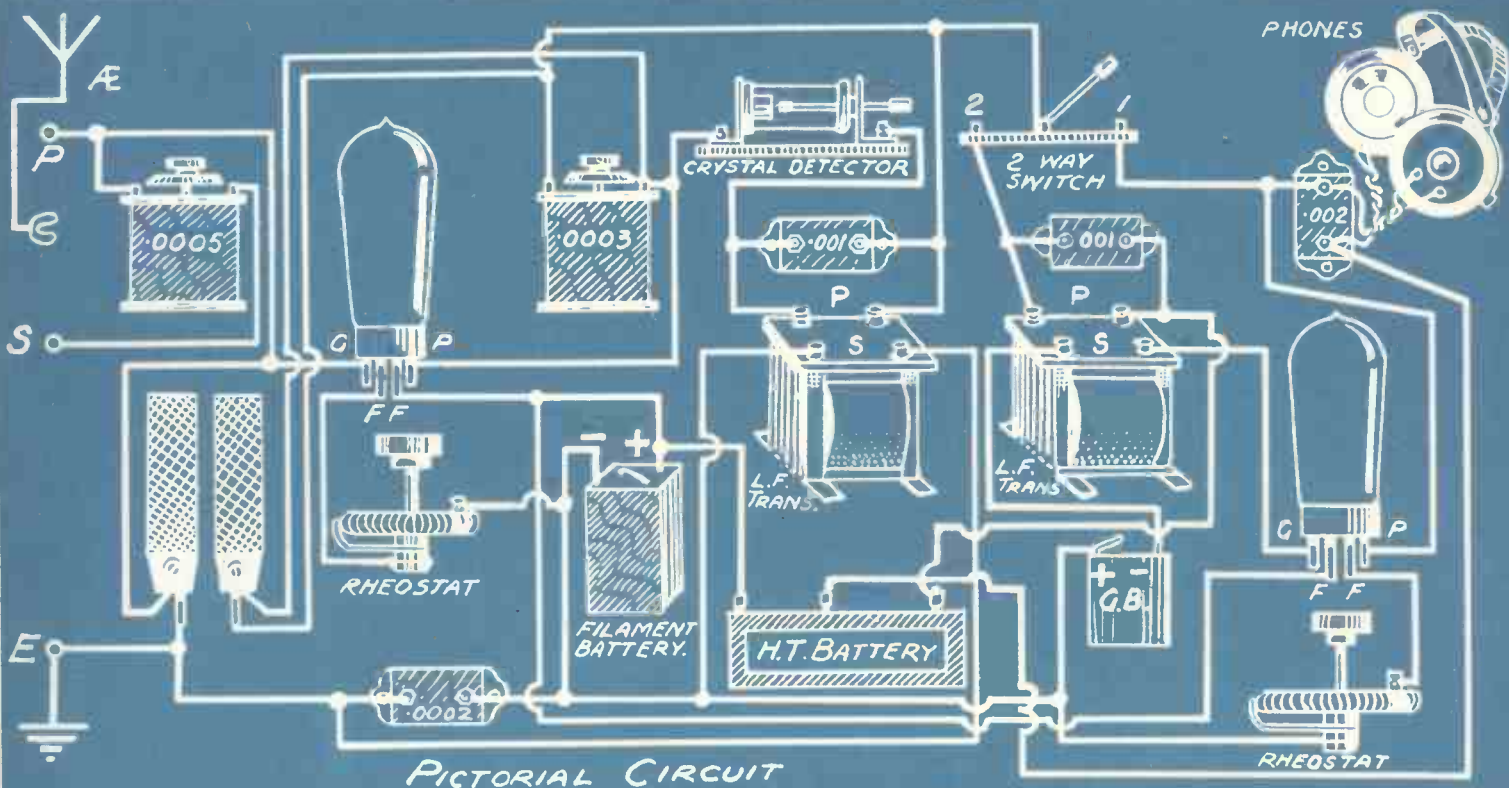

PICTORIAL CIRCUIT

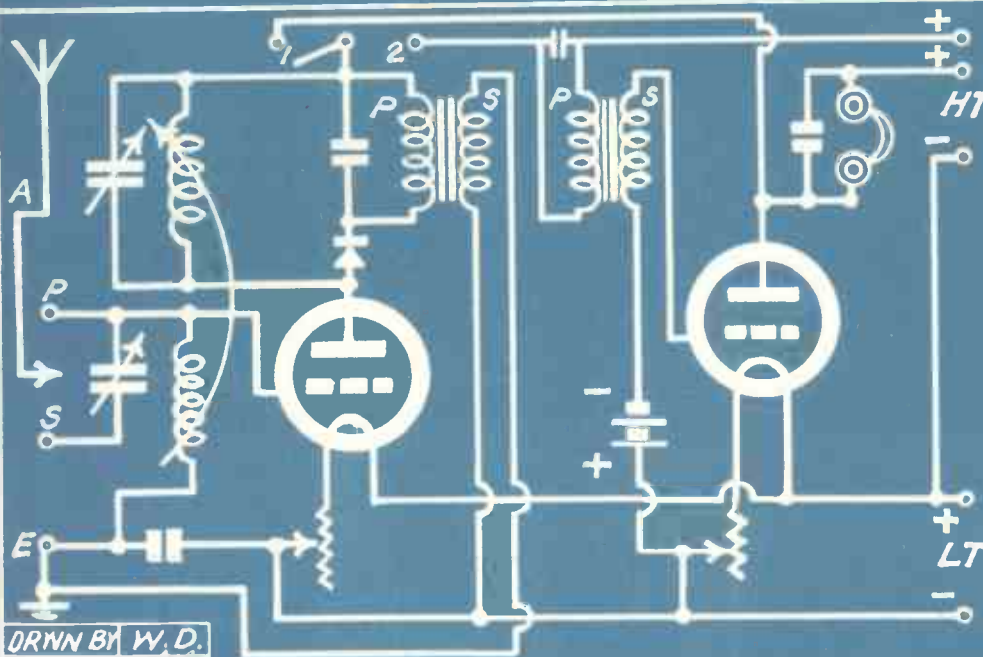

THEORETICAL CIRCUIT.

THE P. W. BLUE PRINT CIRCUIT No. 18  
VALVE-CRYSTAL REFLEX AND L.F.  
AMPLIFIER (WITH SWITCH TO CUT  
OUT L.F.).

LIST OF COMPONENTS.

6d

- 1 panel 12 x 10 x 1/4 ins.
- 1 box to fit, 4 1/2 ins. deep.
- 2 filament resistances.
- 2 valve holders.
- 1 two-way coil holder.
- 1 crystal detector.
- 1 L.F. transformer, 1st stage.
- 1 L.F. transformer, 2nd stage.
- 1 S.P.D.T. switch.
- 12 terminals.
- 1 .0005 variable condenser.
- 1 .0003 variable condenser.
- 1 .002 fixed condenser.
- 1 .0002 fixed condenser.
- 2 .001 fixed condensers.
- Wire, screws, transfers, etc.

ACCESSORIES.

- 1 "General purpose" valve.
- H.T. and L.F. batteries, according to valve makers' specification.
- 1 pair of phones.
- 1 L.F. or power valve.
- 2 coils, 75 and 50 (200 and 250 for 5XX).
- 1 grid bias battery.
- Wire, screws, transfers, etc.

DRWN BY W. D.  
CHKD BY BIL  
SER. NO. B.P. 35.







The Set designed and described by the "P.W." Technical Staff. The diagrams for this Set are on the Blue Print given away with this issue.

**A**LTHOUGH the enormous popularity attained by reflex sets has tended to wane slightly of late, this type of circuit remains one of the most popular and economical it is possible to use for loud-speaker results.

As is now generally known, the first valve of such a receiver is a dual amplifier, handling both H.F. and L.F. currents simultaneously. The first valve amplifies at H.F., passes on the amplified currents to a crystal for rectification, and then amplifies

merely for switching in or out of circuit the second valve, which acts as the second L.F. amplifier.

Even when only one valve is employed this circuit is sometimes capable of extremely long distance telephone reception, but it does not excel in this, as it does in clarity of reproduction, on account of the fact that a reflex receiver is invariably less selective than one employing a straight circuit.

When situated close to a broadcasting station it is quite possible, in some cases, to work a small loud speaker from the one valve alone; but, generally speaking, it will be found that the fact that a further stage of amplification is available renders the receiver an extremely good all-round set, suitable with one valve for 'phones or local loud-speaker work, and with two valves for still greater volume when required.

#### All Wave-lengths Covered.

It will be seen from the blue print that either series or parallel tuning can be employed, the change over being readily made by means of the two aerial-terminal system, which is explained at length on the next page. This modification means that the receiver can be employed with equal facility either upon long waves (5 X X), or upon the shorter waves used by the various main and relay B.B.C. stations.

Results with this receiver will, of course, partially depend upon the aerial employed, and there is no doubt that a good outdoor aerial is by far the most satisfactory one to use. Where this is impossible an indoor aerial (similar in shape, etc., to the outdoor type, but under the

rafters or strung beneath the ceiling) can be utilised.

Very near to the broadcasting station it is possible to use a frame aerial with this set. But this is only a last resort, as an indoor aerial is greatly to be preferred to this, and, of course, an outdoor aerial is still more efficient.

This set is not at all difficult to build; but, nevertheless, the blue print should be carefully studied, and where possible adhered to, as regards spacing, etc.

#### Constructional Details.

Construction is commenced by drilling the panel, the dimensions for this being given in the drilling lay-out on the next page. It will be noticed in the photograph that both of the L.F. transformers employed are of compact size. If larger transformers are used, the spacing may have to be modified slightly, and it is advisable to keep the two as far apart as possible, unless, of course, they are shrouded, in which case this precaution is unnecessary.

Little need be said about the wiring, as the blue print is self-explanatory; but care should be taken in the choice of the components. Either the wire-wound or the carbon-compression type of rheostat may be employed, the former being extremely robust, and the latter having the advantage of requiring little panel space. The total resistance of the filament resistances will, of course, depend upon the requirements of the valves employed, and details of these are invariably given by the manufacturers of the valves.

#### Suggested Components.

In this receiver the filament rheostats used were "Lissen majors," and two small fixed condensers were also of Lissen make. The .002 fixed condenser which is fixed across the output terminals is a Cosmos Permacon. The variable condensers used can, if desired, be fitted with a vernier adjustment, although those used in the original model shown in the photographs did not embody this refinement. The .0005 aerial condenser shown is a Lamplugh, whilst the .0003, which tunes the anode circuit, was supplied by Messrs. Peto-Scott. This firm also provided the coil holder, which is of the usual two-coil type, giving very satisfactory adjustment; and also the

(Continued on page 1363.)



The appearance of the complete receiver is clearly shown by this photograph.

them again at L.F. A further stage of straightforward L.F. amplification is provided by the second valve.

Since the introduction of the "P.W." Combination Set," receivers of this kind have been in use under all sorts of conditions and in all parts of the country, and there is no doubt that it is one of the best two-valve hook-ups it is possible to obtain for clear reproduction. This is partially due to the fact that the detector employed is a crystal, which, it is well known, is capable of giving clearer results than the average valve detector.

#### One or Two Valves Available.

The circuit now to be described, although on the lines of the "P.W." Combination Set," is much simpler, and the switching has been reduced to a minimum. The S.P.D.T. shown in the photographs is employed

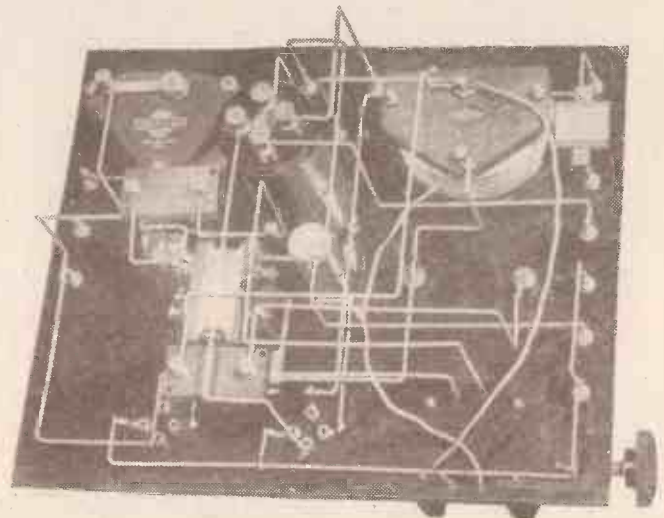

This photograph should prove of assistance to constructors when the wiring of the set is being undertaken.

# Silvertown

## WIRELESS ACCESSORIES

Quality guaranteed by over 50 years electrical manufacturing experience.



**B.570. 10-WAY INDUCTANCE OR CAPACITY SWITCH (Patent 226245.)**

This is a simply and compactly constructed component, suitable for numerous and varied circumstances where it is desired to vary the impedance of a circuit, or for opening and closing a plurality of circuits by the manipulation of a single member. It enables the experimenter to build up large capacities, and is an invaluable addition to any set. Price 5/6 each.



**VARIABLE CONDENSERS (For panel mounting).**

Strongly constructed. Moving vanes are shaped to give low minimum capacity. Fitted with a stop to allow of a movement of 180 degs. only. From 5/6 each.

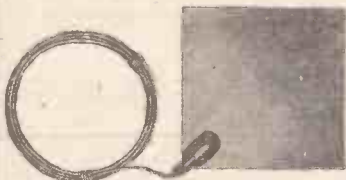

**1752. EARTH PLATES.**

Size, one foot square, complete with 10 ft. of insulated lead-in wire well soldered on. Price 4.- each.

**B.565. DOUBLE COIL HOLDERS.**

Comprising one fixed and one moving coil holder, mounted on ebonite panel  $3\frac{3}{4}$  in.  $\times$   $2\frac{1}{8}$  in.  $\times$   $\frac{3}{8}$  in. thick, together with four finished and lacquered double terminals. Weight  $8\frac{1}{2}$  oz. Price 6/6 each.

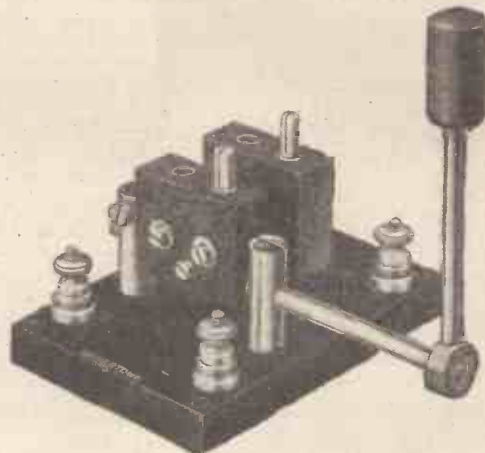

**B.601. SILVERTOWN VERNIOMETER. (Patent Applied for).**

The Silvertown Verniometer is a most ingenious device for applying slow motion to variable condensers, coil holders, variometers, etc., consisting of an ebonite dial and knob (0-180 degs.), fitted with wormwheel bracket and wormspindle, micrometer barrel and pointer, complete with fixing screws. Gear ratio 240-1. Fitted with instantaneous release. Backlash entirely eliminated. Hand capacity reduced to a minimum. Suitable for the following makes of condensers: Silvertown, Buradept, Igraic, Polar, Sterling, Ormond, Jackson, Devicon, Utility, Ashdown, Lamplugh, Ediswan, Edison-Bell, Bowyer-Lowe, Atlas, W. & M., A.J.S., etc., etc. Price 6/- each.



**AN AID TO ENTHUSIASTS.**

We have prepared a logging chart for recording wavelengths, condenser settings, etc., of those stations which require careful calibration to tune in. A copy of this chart, printed on stiff card, with hanger, can be obtained free of charge at any of our Branches or from any high-class dealer.

Makers:

**THE SILVERTOWN COMPANY,**

106, Cannon Street, London, E.C.4.

Works: Silvertown, E.16.

BELFAST: 75, Ann Street.  
 BIRMINGHAM: 15, Martineau Street.  
 BRISTOL: 4, Victoria Street.  
 CARDIFF: Pier Head Chambers, Buft Docks.  
 DUBLIN: 70, Middle Abbey Street.  
 GLASGOW: 15, Royal Exchange Square.  
 LEEDS: 1, New York Road.

LIVERPOOL: 54, Castle Street.  
 LONDON: 100 and 102, Cannon Street.  
 MANCHESTER: 16, John Dalton Street.  
 NEWCASTLE-ON-TYNE: 59, Westgate Road.  
 PORTSMOUTH: 49, High Street.  
 SHEFFIELD: 88-90, Queen Street.





**FOR FINE TUNING.**

**CLIMAX FOLDING FRAME AERIAL.**

Where fine tuning is required, use the Climax Folding Frame Aerial, by far the best and most efficient aerial obtainable.

Combines the advantages of both the pancake and solenoid types of windings and has a centre tapping for use with special circuits. Made to open or fold in a few seconds.

**THE CLIMAX FOLDING FRAME AERIAL 30/-**

(Prov. Pat. No. 26,818/25.)

Special Model with additional series-parallel switching for long-wave stations ... 35/-

Showrooms: 557, HIGH HOLBORN, W.C.1. Telephone - - Holborn 2538.

Get the genuine CLIMAX. If you have any difficulty send your order direct to us.



**RIGHT FOR MAXIMUM SIGNAL STRENGTH.**

**CLIMAX POPULAR PLUG-IN DETECTOR.**

This unique design, based on the stylographic principle, automatically applies that difficult and delicate micrometer pressure necessary for maximum signals, and maintains the delicate adjustment, despite jolts, by a separate hold-on catwhisker container. Gives the loudest possible crystal reception with the simplest possible adjustment.

**CLIMAX POPULAR PLUG-IN DETECTOR** fitted with Climax Auto-micrometer Catwhisker and Climax Superb Crystal. Price **3/6**

**CLIMAX AUTO-MICROMETER CATWHISKER** (Prov. Pat. 21,001/25) With Climax Superb Crystal. Price **2/-**

**CLIMAX RADIO ELECTRIC, Ltd.,** Quill Works, Putney, London, S.W.15 Telephone: Putney 2599. All Communications to above address



**An evening with a Remarkable New Circuit**

Although hundreds of wireless enthusiasts have responded to our advertisement which offered for sale the Ormsby Long Range Selective Circuit, there are undoubtedly many who are perhaps a little sceptical. To dispel all doubts concerning the extraordinary performance of this circuit, we give in illustrated form the results of an evening's actual test on 4 valves, under normal conditions with a 75 feet aerial 25 feet high, eight miles from London.

This circuit is extremely selective without loss of volume and for purity of tone it is irreproachable. **500 MILES ON LOUD SPEAKER.**

This circuit will give loud speaker results 500 miles away and will **CUT OUT THE LOCAL STATION.** The Circuit Envelope contains 2 simple wiring charts, layout and template for baseboard and valves, and full instructions for building. Send Postal Order for 2/6.

**8/6** CUT OUT LONDON.

**9/20** BOMB speaker results

**8/20** PRAGUE on speaker

**10/5** CARDIFF speaker results

**9/5** PARIS speaker results

**11/00** MADRID speaker results

Please state if for 3 or 4 valves, and write name and address clearly.



**2/6**

**M. ORMSBY & CO.**  
28, PAGE ST., WESTMINSTER.  
LONDON. Phone: Victoria 1987.

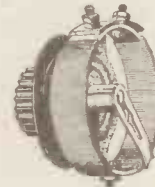

**Two in One!**

The new Dual Rheostat = a "Peerless" product in every way. Specially designed to meet the demand for a resistance equally applicable to bright or dull emitters. It has two windings—one offering a resistance of 6

ohms, whilst a continuation of this is of 30 ohms resistance. The resistance element is wound on a hard fibre strip under great tension. One hole fixing is provided and the terminals are placed in convenient positions. The contact arm has a smooth silky action, and all metal parts are nickel-plated.

**3/9 PEERLESS 3/9 DUAL RHEOSTAT**

Ask your Dealer or send direct.

**THE BEDFORD ELECTRICAL & RADIO CO., LTD.**  
22, Campbell Road, Bedford.

**STOP!**

The Hall Mark of "Quality" Ebonite

is

Guaranteed Free from Surface Leakage.



It is Ebonite not a substitute.

Registered Trade Mark.

Do not be put off with imitations—look for the Brand.

**THE BRITISH EBONITE Co. Ltd., Hanwell, LONDON, W.7.**

*There are many good Coils—*  
But for Complete Efficiency use **SLEKTUN**

INDUCTANCE COILS

The following National Physical Laboratory Figures Constitute a Record:  
COIL OF 200 TURNS INDUCTANCE: SELF-CAPACITY: 1770 MICRO-HENRIES 3 MICRO-MICROFARADS

Send a p.t. for illustrated booklet—  
SLEKTUN, WELLINGTON HOUSE, BUCKINGHAM GATE, S.W.1

**YOURS FOR £1**

The Radiosun, Ethovox, Amplion, Primax, Brown, Amplion Radiolux.

You can select any one of these world's Famous Loud Speakers, and we will deliver it free to your address for ONE POUND. The balance of purchase price we will accept by extended monthly payments.

WRITE TO-DAY.

**HENRI & CO.**  
160, Victoria St., London, S.W.1.

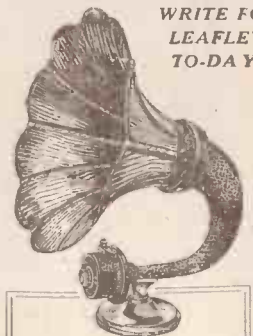

WRITE FOR LEAFLET TO-DAY.

Every one of these highest grade instruments is FULLY GUARANTEED.



# SOME BROADCAST CRITICISMS.

(BY OUR SPECIAL B.B.C. CRITIC.)

IT is generally recognised that broadcasting is in its infancy, but the lustier an infant happens to be the more essential it is that his early years shall be accompanied by just and reasonable correction.

It would obviously be unjust and unreasonable, however, to rebuke a child of three because he has not yet contrived to gain the knowledge and experience of thirty years, but that is the treatment that the majority of wireless critics obstinately mete out to the B.B.C. when they cavil at the composition of its programmes.

Having regard, not only to the diversity of interests for which it has to cater, but also to the appalling magnitude of selecting suitable items for many more than 365 programmes per annum, the B.B.C. is doing wonderful work, and is developing its ability at an incredible speed.

When it is remembered in addition that, prior to three short years ago, there was literally no standard by which to estimate the suitability of items of entertainment for the microphone, it must be obvious that the only just and reasonable course is to encourage the infant to develop, and to restrict criticism to the elimination of palpable faults that have already arisen, in the hope of obtaining the best value from the entertainment that is already at our disposition.

## Over Elaboration.

The best entertainment in the world will inevitably fail to be appreciated if it be marred by faults in presentation. Broadcasting to-day is being criticised captiously by listeners, and by the many who are (not only from motives of unselfishness) opposed to progress.

It is essential, therefore, to eliminate ruthlessly those general faults that tend to irritate the casual listener, before delving into the major issues. If a desultory listener can detect no concrete cause for complaint, the B.B.C.'s real audience must surely derive the acme of satisfaction from what is placed before them, on the score that a dish of food is appreciated primarily for the way in which it is cooked and served rather than its food-value. In the hope of helping, I am going to call attention to some of the easily-to-be-corrected faults I have recently observed.

Over-elaboration of announcements strikes me as being very irritating to a listener. Every item, with the personnel involved, is fully set forth in the "Radio Times," and also in the columns of all the daily papers, but the announcers insistently waste time by going through the entire rigmarole before each item—sometimes more than once.

Incidentally, the announcers are not alone in this. Mr. James Agate, in his Dramatic Talk recently, afforded a concrete example by reading out a list of questions that he proposed to answer, and by announcing again each individual question as he dealt with it. I would mention here that I could hear a band practising, presumably in another studio, throughout his talk!

Another improvement would be achieved if announcers and others who read their items would eschew the use of paper that crackles audibly as each page is turned.

I maintain that, with the exception of news that may have come to light after the publication of the evening papers, the news bulletins are redundant. Mild excerpts from the less hectic news that listeners already know scarcely constitutes either information or entertainment, and the recent innovation of the inclusion of the winner of the 2.30 race in the 10 p.m. bulletin can only be described as feeble to a degree.

## An Outstanding Success.

Programmes should be timed more accurately—or perhaps performers should be compelled to adhere to the time allotted to them. It often happens that an item has to be eliminated in order to regain lost time; if, however, the inclusion of such an item was justified in the first place, it follows that a section of listeners must have been looking forward to it, and must therefore be disappointed by its omission.

The "Pickwick Club" was an excellently-conceived appeal to Dickens lovers, but was marred by the fact that, apart from being too long for its entertainment value, most of the characters lacked personality, and many were not clearly audible. I blamed my "set" for this, until the advent of "Mr. Micawber" lifted the show right up, and the artiste in question scored a personal success. The concerted laughs, too, were woefully ragged and lacking in spontaneousness.

The concluding presentment of "Radio Radiance" marked an outstanding success for Eddie Morris, who, I am glad to know, is being retained by the B.B.C. It is true that some of the material could have been improved, but I am not concerned with that point of view at the moment. In one sketchlet, however, the hoof-noises, introduced to give colour to the idea that the performers were riding in a hansom cab, were rather indicative of a horse that is weary of standing about too long. Also, the laughter and applause in the studio may have been justified by some action or grimace on the part of the artistes, but listeners were often unable to reconcile it with anything that had immediately preceded it.

## "By Request."

Without joining in the discussion as to whether Talks should be curtailed, I urge that lecturers should be instructed to adhere to normal language. For instance, Mr. Filson Young couched his interesting description of the Battle of Jutland in melodramatically adjectival phrases that I am sure he would never have dreamed of utilising in his always enjoyable literary work.

The inclusion of women's voices in the soldiers' choruses in the recent revival of the Military Tattoo was a palpable mistake, and in his talk on "Production for Amateurs" Mr. C. Harold Ridge allowed his voice to drop to inaudibility at the end of his sentences.

A very bad instance of duplication of items was permitted to occur on January 31st, when Joseph Slater played Schubert's "Moment Musical" as a flute-solo during the afternoon and William Murdoch rendered the same morceau on the pianoforte in the evening. Each rendering was duly announced in the published programmes, so that it cannot be urged that the artistes surprised the B.B.C. by unwittingly selecting the same piece.

It is to be hoped that the B.B.C. will not suffer a development of the bad concert-world custom of announcing items as being "By Request." This formula generally cloaks an artiste's belief that the item in question is the cream of his repertoire, and is always unconvincing, especially in the case of a little-known performer.

# FOREIGN RADIO NEWS.

FROM OUR OWN CORRESPONDENTS.

## Talks to Farmers.

SOME time ago the Radio-Toulouse station started broadcasting some "Talks to Farmers," giving technical advice by experts, both experienced practical men and lecturers of agricultural colleges.

This has proved of such benefit to the farming community that the provincial General Council has petitioned the directors of the station to make this a regular feature. In future, there will be a daily "talk to farmers" at 5.45 p.m. (French time), while every Tuesday at 9.15 p.m. there will be a technical lecture on the practical application of chemistry to agriculture.

## Radio a Necessity.

The Federation of French Radio-clubs has issued a manifesto announcing the most strenuous opposition to the principle of state taxation of radio in any shape or form.

"Radio," the document claims, "is a necessity nowadays, not a luxury. It is one of the most democratic of institutions, a powerful help to school instruction and to the diffusion of knowledge on hygiene, morality and social questions."

## Cologne's Radio Show.

Radio has taken its share in the festivities which marked the evacuation of the Cologne zone by the Allied troops, and a radio exhibition was opened there on January 30th, which lasted a week.

Although it is being held in connection with the "liberation" of this part of the Rhineland from Franco-British occupation, the show is not restricted to German firms, but includes a number of interesting exhibits by British and French as well as Swedish firms. As is the case at most radio exhibitions on the Continent, American firms are conspicuous by their absence.

## Radio in Rhineland.

The unexpected difficulties raised by the German authorities in granting radio licences in the Rhineland after the Allied prohibition had been removed have apparently now been solved, and some indications

(Continued on page 1380.)

# THE HAPPY FAMILY

*"Affinities"*

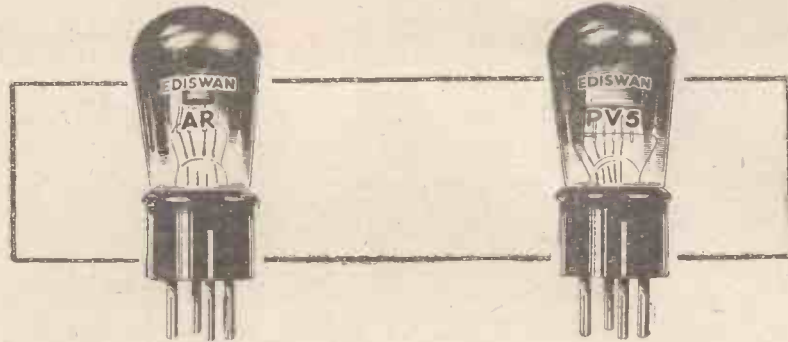

There is a decided affinity, a quite definite link between each Edison Receiving Valve and Edison Power Valve. The Receiving Valves are supplied either H.F. or L.F. and the best Power Valve to use is shown in the table opposite.

They always get on well together. It's like that in every large family. Always two that will work—or play—better with one another than with anybody else. Every Edison valve has its family affinity.

It gives good service in any conditions . . . the best service when it is employed with its "twin."

*The Valves to Use.*

Receiving.	Accumulator or Battery Volts.	Power.
A.R. - -	6	P.V.5
A.R.D.E. - -	2	P.V.6
A.R. '06 - -	3	P.V.8

*With these groups and Edison H.T. and L.T. Accumulators the ideal is attained.*

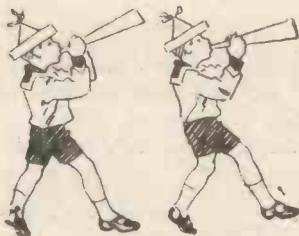

THE EDISON SWAN ELECTRIC CO., LTD.,  
123-5, Queen Victoria Street, London, E.C.4.

## EDISWAN VALVES

Will Improve ANY Set

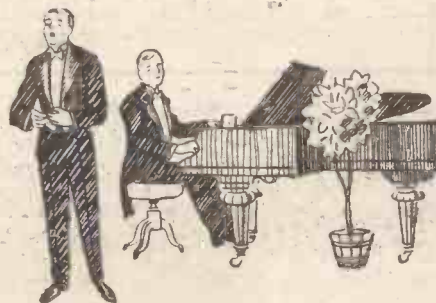
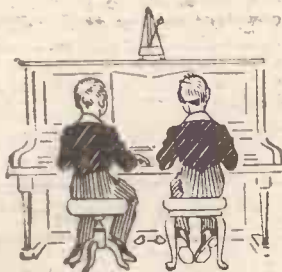

**Ediswan Valves are entirely British Made.**



Traders and manufacturers are invited to submit wireless sets and component parts to the "P.W." Technical Dept. for test. All tests are carried out with strict impartiality in the "P.W." Test Room under the supervision of the Technical Editor, and the general reader is asked to note that this weekly article is also intended to provide a reliable and unbiased guide as to what to buy and what to avoid.—EDITOR.

A VERY attractive tear-off Calendar has been produced by the Mullard people for use in wireless showrooms. It is both artistic and original in design. Radio dealers are advised to get in touch with the Mullard Wireless Service Co., Ltd., before their stock is exhausted.

The days of cat's-whisker "crystal tickling" are numbered, for the automatic type of detector is rapidly becoming exceedingly popular. Quite recently we received a very excellent example of this up-to-date type of instrument for test, known as the Cymosite Auto Detector. It is a very solid little piece of apparatus, and its mechanism is both novel and effective in its simplicity. A small knob, which can be rotated in either direction, is the only adjustment, and this provides both a

continuous series of pressures and a continuous series of surfaces between the two crystals employed. Very sensitive adjustments are possible, although none is by any means critical from a mechanical point of view. On the contrary, excellently stable settings are available throughout the whole range of movements. Results were very good indeed when this Cymosite Auto Detector was used in a straightforward crystal set; while further tests showed it to be eminently suitable for valve-crystal reflex work.

It makes a neat panel fitting, and its connections in a circuit can immediately be reversed merely by turning the whole detector round, as it is supplied with slotted brass "feet" for slipping under two terminals. It retails at 7s. 6d., and should attract considerable attention.

A coil plug of interesting design has been produced by the Reflex Radio Co., Ltd., of 198, Lower Clapton Road, London, E.5. Instead of consisting of one solid block of insulating material with a socket and plug embedded in it, the article is moulded so that two pillars rising from the base are formed. There is, therefore, a reduction of solid insulating material, air being introduced instead. It follows best "low loss" principles, and, as bakelite of good quality is used, is highly efficient in its "overall" insulating qualities, as was proved on a "megger" test.

An L.F. transformer, reasonably priced at 15s. 6d., which deserves to command attention is the Telsen, made by the Telsen Electric Co., 207, Aston Road, Birmingham. It is shrouded and given a black crystalline finish. With its neat, bright terminals generously and symmetrically spaced and its neat indicating plates, it has the attractive appearance of a "Lilliputian" power station transformer.

(Continued on page 1368.)

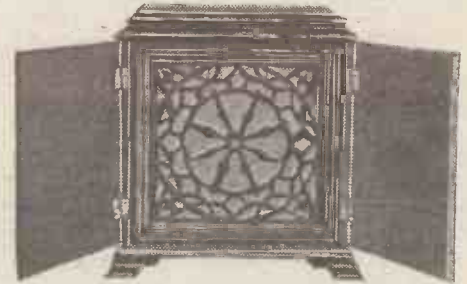

An artistic loud speaker: the "Beco" de Luxe.

# Ripaults

L.F. INTERVALVE TRANSFORMER  
FOR PURE  
REPRODUCTION



SHROUDED  
RATIO 3-1  
13/6

RATIO 5-1  
14/6

Of All Dealers.

RIPAULTS LTD.,  
1, King's Road,  
St. Pancras, N.W.1.

## H.T. FROM THE MAINS

The TUDORADIO MAINS UNIT converts your ordinary lighting current into a perfect H.T. supply. The never-ending expense and trouble of H.T. batteries is eliminated once and for all. Moreover, reception is improved.

The TUDORADIO MAINS UNIT can be fitted to any set to give a constant output at 100-120 volts on A.C. or D.C. supply without any risk of damaging valves or set. Current consumption is negligible and there is no trace of hum or ripple.



PRICES:  
Direct Current Unit, any voltage, £3 : 10 : 0  
Alternating Current, any voltage, £6. (Royalty 12/6 extra.)

## The TUDORADIO MAINS UNIT

FOR ALTERNATING OR DIRECT CURRENT

Write for Brochure giving full particulars to:—

The TUDORADIO Co., Ltd.,  
Tudor Works,  
Park Royal, London, N.W.10

Phone: Wembley 41.

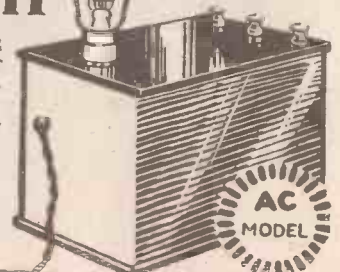



*"Just listen to the difference  
this LEWCOS Coil makes!"*



*In the LEWCOS  
Coil the makers  
of "Glazite" have  
achieved another  
outstanding success.*



**C**LEAR as a bell the typical French orchestra came through as the listener tuned in with his LEWCOS Coil. Coil after coil had been tried and discarded in an endeavour to realise that rare selectivity and fine tuning so essential to complete radio enjoyment.

A LEWCOS Coil makes ALL the difference—try one and judge for yourself. Each LEWCOS Coil is tested in our laboratory. It is then boxed and sealed up, and reaches you in perfect condition. Ask your radio dealer for a demonstration.

*Does your set need a*

# LEWCOS

*Inductance Coil?*

THE LONDON ELECTRIC WIRE CO. & SMITHS, LTD.,  
(Makers of Electric Wire for over 40 years).  
Playhouse Yard, Golden Lane, London, E.C.1

## *Why* **LEWCOS COILS** *give better tuning*

1. The LEWCOS Coil embodies high electrical efficiency with great mechanical strength.
2. The LEWCOS Coil is very selective, resulting in extremely fine tuning.
3. The LEWCOS Coil has an exceptionally low high-frequency resistance with a corresponding increase in signal strength.

**All LEWCOS Coils  
bear this LEW seal**

*This  
Mark*



*Guarantees  
Quality*

**APPARATUS TESTED.**

(Continued from page 1366.)

It is interesting to note that its primary winding consists of 6,100 turns of 42 S.W.G. and its secondary 28,000 turns of 45, giving a ratio of 4.6 to 1. From this it will be judged that the component has ample primary impedance, and does not gain in ratio by losses in that direction. Amateurs may criticise the fineness of the wire and wonder how 42 stands up to "surges"; but, as a matter of fact, 42 is quite a usual gauge to employ in wireless transformers, and purchasers of the Telsen are covered against breakdowns by a guarantee issued by the makers.

On actual test we found the Telsen to be pleasingly efficient. Frequency distortion was inappreciable even at the limits of the middle ranges, while amplification was robust and the tone mellow. Owing to its high primary impedance and moderately high ratio it can be used in both first and second stages with advantage.

Some plug-in coils, especially those that fit rather tightly into their holders, begin to look rather "secondhand" after a few months' service. Constantly pulling them out by giving them a series of combined transverse shakes and vertical tugs loosens their settings and sometimes damages their windings. Messrs. Aston and Manders (1917), Ltd., of Willesden, N.W.10, have produced a coil with a patent handle that cannot succumb under such treatment. It

must be remembered that a good contact is necessary, and some coil holders err on the side of tenacity, so that there is not much else that can be done to solve the problem. However, the "Compton" coil sent us by the above firm, and fitted with their patent handle, gets over the difficulty, for it will stand a pull or push to the extent of a 28-lb. pressure without damage.

Owing to a typographical error which occurred in the announcement of the Radi-Arc Electrical Co., Ltd., the postal district was shown as W.1, whereas the correct address is Bennett Street, Chiswick, W.4, to which all communications should be sent.

The need for geared variable condensers has long been felt in the States, and American practice is gradually influencing the design of British radio components. Straight-line frequency variable condensers are also becoming extremely popular, and we have just tested a model of this description marketed by the Service Radio Co., Ltd., of Stoke Newington.

The condenser has a gearing system of wheels and bevels and gives a steady drive with a "step-down" of 100-1. This enables very accurate tuning to be done, and as this gearing only comes into action if the smaller of two concentric knobs is used, the condenser is one that should appeal to the radio enthusiast. Constructed on the low-loss principle, the condenser is well made of heavy gauge brass and is altogether an efficient job. For short-wave work the condenser should be extremely useful.

Resistance-capacity coupling has for some time been popular in this country for low-frequency amplifiers, and now that there are plenty of valves specially designed for this type of amplifier there is no excuse for listeners to put up with distorted results. Amongst the valves we have recently tested must be mentioned the Mullard D.F.A.4 which is eminently suitable for resistance coupling. With an impedance of 27,000 ohms and filament voltage of 5.5 volts at .2 amp. the valve makes an economical amplifier with a good amplification factor. We have had three of these valves going in a set for some time, and can heartily endorse the makers' claim that they are "master" valves.



Testing the sections of a Marconiphone "Ideal" transformer before assembly.

BLOCK
BLOCK



## A Wonderful Battery

THE Fuller "BLOCK" Batteries are unique. They retain their charge for extraordinarily long periods of intermittent service and are practically proof against mechanical injury. Block Accumulators are ideal for Car lighting, &c., while in Radio Work the High-Tension Block Battery has decided advantages over Dry Cell Batteries.

Note these remarkable points:—

1. Sulphating to any serious extent cannot occur through standing in a discharged state or accidental discharge by short-circuits.
2. Internal short-circuiting is impossible.
3. Actually you can short-circuit externally without damaging the blocks. (Can you name any other accumulator that will stand so severe a test?)

Made and Stocked in a wide range of types and sizes.

Write for List No. 250 D.

FULLER'S UNITED ELECTRIC WORKS, LIMITED  
CHADWELL HEATH, ESSEX.  
Telephone: Ilford 1200,  
Telegrams: "Fuller, Chadwell-Heath."  
London Depot: 176 Tottenham Court Rd., W.1  
Museum 9008





BLOCK

ACCUMULATORS - SOLID - NO PLATES

USE  
FULLER  
Ebonite

174-42



## Loud Speaking Excellence

FOR excellent volume, with exceptional purity of tone and clarity, the "Beco" Hornless Loud Speaker is infinitely superior to previous loud speakers. The "Beco-de-Luxe" (British made) is an artistic piece of furniture for any home, and the volume from it will fill a large hall. Obtainable fitted in either oak or mahogany cabinet. Oak, £5 : 0 : 0. Mahogany, £5 : 5 : 0

# BECO

### HORNLESS LOUD SPEAKER

*Extract from "BROADCASTER": "We can unhesitatingly recommend the new 'Beco-de-Luxe' Loud Speaker, for we are of the opinion that on account of its exceptionally pleasing appearance and splendid qualities as a reproducing instrument it has a great future before it."*

THE small 1926 "Beco"—  
a very efficient and  
attractive model—gives unusual  
volume, with crystal clarity.



Nickel Plated 52/6 Oxydised Silver or Copper 55/- "The 1925-26 BECO."

Dept. P.W., British Electrical Sales Organisation,  
623, Australia House, Strand, W.C.2.

Telegrams : Becospeker, Estrand, London.

Telephone:  
CITY 7665

# Announcing



## the New Range of Six Sixty Valves

THE increasing demand for all types of Receiving Valves has proved to us that, despite the excellent all-round qualities of the original 660 Electron Dull Emitter Valve, the general Radio public require specialised valves for definite circuits.

Our new range, embodying the latest developments of modern scientific research, will prove the continued and greater success of Electron 660 Valves.

And remember, no matter what type you choose, each valve is carefully designed to carry out its particular job, and bears the Six Sixty Mark of PERFECTION OF QUALITY



- S.S.1 (Blue Disc), Bright Emitter General Purpose Valve. Voltage—3.7 volts, consumption .66 amps. . . 8/-
- S.S.2 H.F. (Red Disc). D.E. Suitable as a Detector when followed by Resistance or Choke. Voltage—2 volts, consumption .3 amps. . . 14/-
- S.S.2 L.F. (Green Disc). D.E. Suitable for small and medium-sized Loud Speakers. Voltage—2 volts, consumption .3 amps. . . 14/-
- S.S.3 H.F. (Red Disc). D.E. Suitable as a Detector when followed by Resistance or Choke. Voltage—3 volts, consumption .06 amps. . . 16/6
- S.S.3 L.F. (Green Disc). D.E. Suitable for small and medium-sized Loud Speakers. Voltage—3 volts, consumption .06 amps. . . 16/6
- S.S.4 D.E. L.F. Amplifier and Loud Speaker Valve. Voltage—5 volts, consumption .25 amps. . . 22/6
- S.S.5 D.E. H.F. Amplifier and Detector Valve. Voltage 5.5 to 6 volts, consumption .06 amps. . . 24/6
- S.S.6 D.E. Resistance Capacity Amplifier and Detector Valve. Voltage—5 volts, consumption .25 amps. . . 22/6
- S.S.7 D.E. Power Valve. Voltage—3.7 volts, consumption .1 amp. . . 22/6

Write for leaflet  
S.S.I.7 for full  
particulars.

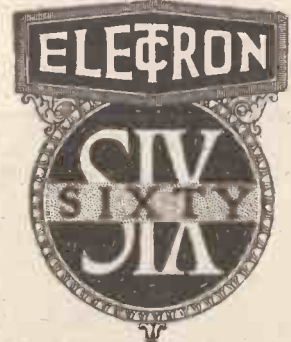

BETTER BY SIX TIMES SIXTY

The Electron Co., Ltd., Triumph House, 189, Regent Street, London, W.1.

# RADIOTORIAL

All Editorial Communications to be addressed to The Editor, POPULAR WIRELESS, The Fleetway House, Farringdon Street, London, E.C.4.

Editor:  
NORMAN EDWARDS, M.Inst.R.E., F.R.S.A.,  
F.R.G.S.

Technical Editor:  
G. V. DOWDING, Grad.I.E.E.

Assistant Technical Editors:  
K. D. ROGERS. P. R. BIRD.

Scientific Adviser:  
Sir OLIVER LODGE, F.R.S.

Staff Consultants:  
Dr. J. H. T. ROBERTS, F.Inst.P.; J. F. CORRIGAN, M.Sc., A.I.C.; C.E. FIELD, B.Sc.

Foreign Correspondents:  
F. M. DELANO, Paris; Dr. ALFRED GRADENWITZ, Berlin; L. W. CORBETT, New York; P. F. MARTIN, Italy; W. PEETERS, Holland.

The Editor will be pleased to consider articles and photographs dealing with all subjects appertaining to wireless work. The Editor cannot accept responsibility for manuscripts and photos. Every care will be taken to return MSS. not accepted for publication. A stamped and addressed envelope must be sent with every article. All contributions to be addressed to The Editor, The Fleetway House, Farringdon Street, London, E.C.4. All inquiries concerning advertising rates, etc., to be addressed to the Sole Agents Messrs. John H. Lile, Ltd., 4, Ludgate Circus, London, E.C.4.

The Editor desires to direct the attention of his readers to the fact that, as much of the information given in the columns of this paper is of a technical nature and concerns the most recent developments in the Radio world, some of the arrangements and specialities described may be the subject of Letters Patent, and the amateur and trader would be well advised to obtain permission of the patentees to use the patents before doing so.

**PATENT ADVICE FOR READERS.**

The Editor will be very pleased to recommend readers of POPULAR WIRELESS who have any wireless inventions to patent, or who desire advice on patent questions, to our patent agent. Letters dealing with patent questions, if sent to the Editor, will be forwarded to our own patent advisers, where every facility and help will be afforded to readers.

**TECHNICAL QUERIES.**

Letters should be addressed to:  
Technical Query Dept.,  
"Popular Wireless,"  
The Fleetway House,  
Farringdon Street,  
London, E.C.4.

They should be written on one side of the paper only, and **MUST** be accompanied by a stamped addressed envelope.

Queries should be asked in the form of the numbered questions: (1), (2), (3), etc., but may be accompanied by a short letter giving any necessary additional particulars as briefly as possible.

For every question asked a fee of 6d. should be enclosed. A copy of the numbered questions should be kept, so that the replies may be given under the numbers. (It is not possible to reproduce the question in the answer.)

**IMPORTANT.**—If a wiring diagram, panel lay-out or list of point-to-point wiring is required, an additional fee of 1/- must be enclosed.

Wiring diagrams of commercial apparatus, such as sets of any particular manufacture, etc., cannot be supplied. (Such particulars can only be obtained from the makers.)

Readers may submit their own diagrams, etc., for correction or for criticism. The fee is 1/- per diagram, and these should be large and as clear as possible.

No questions can be answered by 'phone. Remittances should be in the form of Postal Orders.

## Questions and Answers

**BROKEN CIRCUIT PUZZLE.**

"AMATEUR" (Glasgow).—Why is it one can obtain signals on a one-valve set when the grid circuit between the earthed side of the inductance coil and the filament is broken?

Leakage through the panel or other intervening "insulating" material is the probable reason.

**H.T. FROM MAINS.**

H. G. D. (Fleetwood) and others.—I am desirous of making the chokes shown in the diagram of H.T. from mains, as per "Valve Experimenter's Handbook" (P.W. 176). What are the constructional details?

The chokes are wound on a solid cylindrical former 1 in. x 5 in., consisting of 22-gauge soft iron wire. After arranging this in a neat bundle, the whole should be given a coat of shellac, and over this a layer

(Continued on page 1372.)

## VOLUME AND LONG-DISTANCE RECEPTION

are the CHARACTERISTICS of the

### "GOLTONE" (Regd.) VALVE SETS

EXTREMELY SELECTIVE. (BRITISH MADE) SIMPLICITY IN TUNING.

Polished Oak Cabinet, high-grade finish. Ample space is provided inside the Cabinet for the Batteries, whilst the Loud Speaker can be placed on top. The only Wires on view are those connecting to the Aerial, Earth and Loud Speaker, and the whole presents an extremely neat and tidy appearance.

Complete with ALL Accessories, including "Goltone Junior" Loud Speaker, Sampson Accumulator, Volex Battery, Valves, Aerial Set, Plug-in Coils, Marconi Royalties. No extras required.

**TYPE "B" TWO-VALVE SET**

Gives Loud-Speaker reception within 40 miles of main B.B.C. Stations and 150 miles from Daventry High-Wave Station. Complete with All Accessories as above. Price £12:2:6

**TYPE "B" THREE-VALVE SET**

Gives greater volume over a much wider radius than the Two-Valve Set. Complete with All Accessories as above. Price £15:17:6

**TYPE "B" FOUR-VALVE SET**

Receives the majority of British and Continental Stations with extraordinary volume on Loud Speaker. Complete with All Accessories as above. Price £18:8:0

B.D.P., George Road, Mossil Bay, South Africa, writes: Oct., 1925.

I have a 4-Valve "Goltone" Receiver giving me perfect results.

I can work out Stations on the Loud Speaker any time during the day, our stations being 210, 600 and 700 miles away.

Send for large Illustrated Radio Catalogue No. R/113, post free on request. Dealers should enclose Business Card or Memo. for Trade Terms.



GOLTONE PRODUCTS ARE STOCKED BY THE LEADING RADIO STORES. WRITE DIRECT IF UNOBTAINABLE.





## RADIOTORIAL QUESTIONS AND ANSWERS.

(Continued from page 1370.)

of empire tape is wound. The core should then be roughly divided into five sections (a good plan is to make a number of small discs of cardboard with a hole in the centre so that they fit tightly on the former). The choke should be wound with 2½ lbs. of 28 S.C.C. wire.

As this constitutes approximately 1300 yds. in each of the five slots, 260 yds. of wire should be wound in each. One slot having been wound, the wire is carried on to the next slot until the five slots are wound. The whole can then be covered with empire tape and the choke conveniently mounted on a board, the two ends being brought out to two terminals.

### EXTRA FILAMENT RESISTANCE FOR DULL EMITTER VALVES.

T. B. S. (Croydon).—Can you tell me how to work out what extra resistance is required when using a dull emitter instead of a bright emitter on the same accumulator?

First of all, it is necessary to discover the resistance of the dull emitter valve when it is to be used. If it is one of the types which take .06 amps. at 3 volts, then the resistance of its filament will be  $\frac{3}{.06}$  (in accordance with Ohms law  $R = \frac{V}{C}$ ) that is, 50 ohms.

Now if a 6-volt accumulator is to be used, obviously the total resistance in circuit must be such that when it is divided into 6 it gives .06, and no more. .06 divided into 6 will give this value, which is 100 ohms, and this will be required in the circuit. The filament of the valve will contribute 50 ohms, leaving another 50 to be provided. 10 ohms will be covered by the wiring and the ordinary filament resistance, and thus a fixed resistance of 40 ohms should be employed in the particular example given.

In formula form,

$$R = \frac{V^2}{C} - \frac{V^1}{C}$$

where

R = total additional resistance required, which will include that provided by the filament rheostat in use;

C = normal current consumption of the dull emitter valve which it is desired to use;

V1 = the voltage specified for the dull emitter valves by the makers;

V2 = the voltage of the accumulator or battery in use.

### PERIKON DETECTOR.

J. P. (Manchester).—Will an applied potential through a potentiometer increase signals on a receiver employing a perikon detector, copper pyrites and zincite?

Sometimes this does so, but not in every case. Any way, the applied potential must be very small. A single dry cell would suffice as an experiment.

### LOOSE-COUPLED TUNING.

"MORSE-JAMMED" (Southend-on-Sea).—What is the best form of tuning for a valve circuit, not too difficult to operate, which will overcome the intermittent jamming due to ships?

I wish to use a detector and L.F., but with some form of selective tuning that is adjustable for the various conditions of the jamming, that is sometimes fierce, and at other times comparatively quiet.

The circuit reproduced herewith shows an excellent method of minimising such interference. The tuning arrangement includes an aerial (primary) coil, and a secondary coil, which can be switched in or out of circuit as required by means of a D.P.D.T. switch.

When the switch is thrown to the left the primary acts as a simple aerial coil, and is joined through

the switch contacts to grid and filament in the ordinary way.

Primary and secondary coils are mounted in a two-way coil holder, and if the secondary is moved right away from the primary straightforward searching can be carried out. If jamming from one particular station is troublesome, the secondary coil can be made to act as an inductively-coupled wave-trap.

It will be seen that the secondary coil is connected to a variable tuning condenser, but not to any other part of the set. If, therefore, it is brought near to the primary coil and tuned sharply to the interfering oscillations, it will act as an absorption wave-trap. Much of the interfering energy will be absorbed by this circuit, especially if the degree of coupling is varied carefully until the best possible results are obtained.

Such an arrangement is specially suited to counteract interference from one particular station, because the tuning condenser can be left adjusted (and also the degree of coupling), so that the jamming is at a minimum.

If, however, several ships are working intermittently, it is generally better to use a primary and a secondary tuning circuit. This can be accomplished by throwing the switch over to the right, which disconnects grid and filament from the aerial circuit, and places them instead across the tuned secondary.

The primary (aerial) circuit is now tuned to the desired signal, and although the jamming is present in this circuit, the secondary circuit (which is controlling the detector) is comparatively free, especially if the coupling between primary and secondary coils is loose.

### TUNING-IN DISTANT STATIONS.

"NOVICE" (Bedfordshire).—I have purchased a 2-valve set, which, I am told, consists of an H.F. and a detector valve.

Having no friends interested in wireless in the immediate neighbourhood I cannot obtain any information as regards tuning the set, which appears to be working O.K., but on which I cannot receive distant stations, although I receive whistles (which I take to be their carrier waves).

Can you inform me how I can receive distant stations?

(Continued on page 1374.)

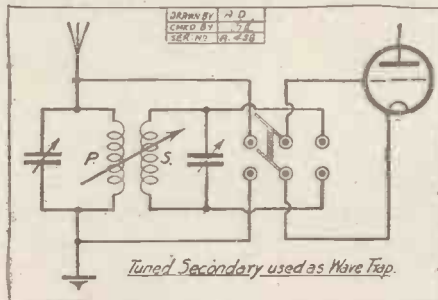

# EDISON BELL RADIO

IMPROVE YOUR RECEPTION BY USING EDISON BELL INDUCTANCE COILS

WRITE FOR CATALOGUES

WRITE FOR CATALOGUES

PRICES

2/6, 3/6, 4/6

THE COIL WITH A

TORTOISESHELL BINDING.

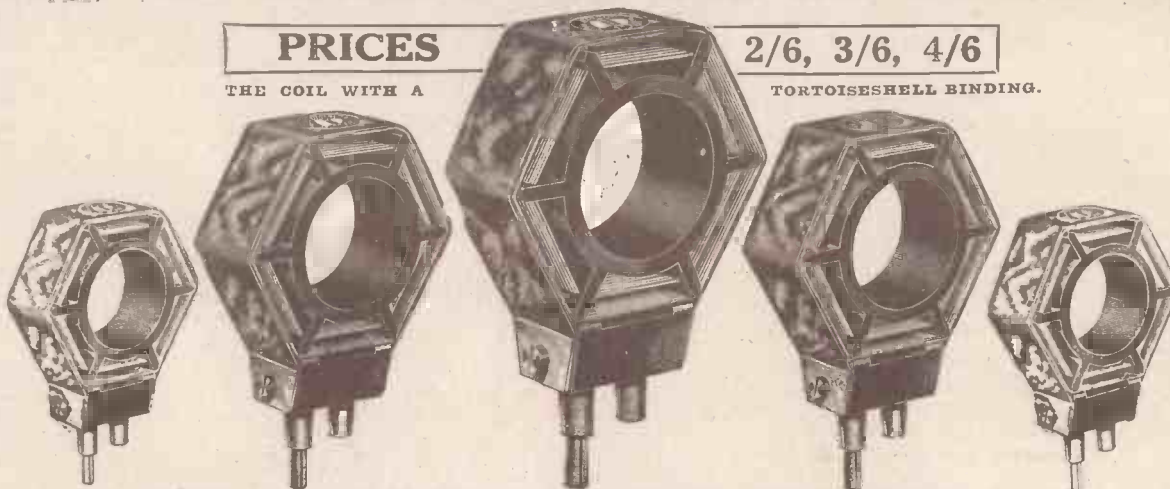

A ROW OF THE WORLD'S FINEST INDUCTANCE COILS  
COIL NUMBERS:—15, 20, 25, 35, 40, 50, 75, 100, 120, 150, 200, 250, 300, 400.

MANUFACTURED by an ALL-BRITISH FIRM with 33 YEARS' REPUTATION for QUALITY.

J. E. HOUGH, LTD., Edison Bell Works, LONDON, S.E.15, and HUNTINGDON.



**Have you read page 1359?**

**I**T'S well worth while studying. For there you will find, not only constructional details of a really first-class receiver, but also the secret of L.F. Amplification. Do as the experts of POPULAR WIRELESS do—fit the Energco "Orphean"—the shrouded, low-frequency transformer that gives distortionless, clear-toned reproduction throughout the complete range of audible frequencies. That it is used by a number of leading receiver manufacturers is additional proof of its superiority.

Combining purity of tone with extreme mechanical strength, the "Orphean" should be in every music lover's and experimenter's receiver. All good Dealers stock it.

**Ratio 1-3, 19/6 Ratio 1-5, 21/-**  
**Other ratios, 21/- Open type, 15/-**

*There are many other "Energco" products—all equally good. Ask your Dealer to show you the famous "Energco" Coils and H.F. Transformers or send direct for illustrated lists.*

**Energco**

**PRODUCTS LIMITED,**  
**1, St. James's Street, E.C.1**  
Telegrams: "Energotrad, Smith, London." Telephone: Clerkenwell 7360.



**20/-  
down**

**—and this superb set is yours**

**YOU** buy your House by deferred payments. You purchase your furniture out of income, and perhaps even your motor-car by the same up-to-date methods. Then why not choose a really good Wireless Set and pay for it as you use it. How much more satisfactory to buy out of income a really worth-while Set capable of

giving the very best possible results, in preference to something considerably cheaper and less satisfactory. Each of the instruments listed here is fully tested and guaranteed, and the prices include tuning coils, Marconi Royalties and handsome polished mahogany cabinet. Now read particulars, and see how easily any one may be yours.

**All Concert de Luxe, Type B.**  
*(as illustrated)*

Finished Instrument complete with 3 B.T.H. B5 Valves, 4 volt 20 act. amp. hour Acc., Sterling Baby Loud Speaker, 99 v. Hellesen H.T. Battery  
20/- down and 13 monthly payments of 30/-

**2-Valve Reflex Receiver.**

Finished Instrument complete with 2 B.T.H. B5 Valves, 4 volt 10 act. amp. hour Acc., 100 volt H.T. Battery, Ultra Loud Speaker.  
20/- down and 10 monthly payments of 20/-

**4-Valve Family Receiver, Type B.**

Finished Instrument complete with 4 B.T.H. B5 Valves, 4 volt 20 act. amp. hour Acc., Sterling Baby Loud Speaker, 99 v. Hellesen H.T. Battery  
20/- down and 15 monthly payments of 30/-

**FREE.** Send us your name and address on a post card and we will send you a copy of our latest 56-page Booklet which describes in detail a large number of well-known Receiving Sets. Not only can you purchase ready-built Sets from us on our generous instalment terms, but we will supply you with the complete kit of parts so that you can construct the Set yourself, and gain experience in so doing.

**NEW TIMES SALES CO.,**  
**Vulcan House, 56, Ludgate Hill, E.C.4**

P.81009.

**CYLDON**

Pronounced **SILDON.**

**THE ARISTOCRAT OF BRITISH CONDENSERS**

A condenser that meets the growing American competition and acknowledged by all who have seen and tested it as the finest instrument made in this country. It is in every way the perfect

**GROUND ROTOR**  
**STRAIGHT LINE WAVE-LENGTH**  
**VARIABLE CONDENSER**

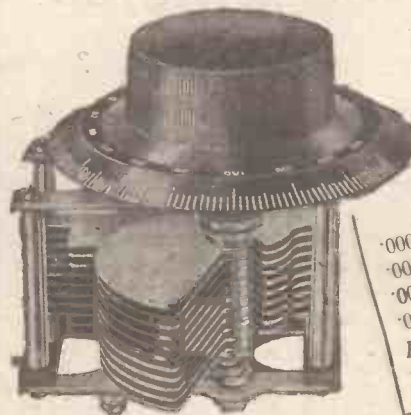

Complete with 4in. knob dial  
 '0005 mfd .. 17/6  
 '0003 mfd .. 16/6  
 '00025 mfd .. 16/-  
 '0002 mfd .. 15/6  
 From all Good Dealers or Supplied Direct—  
**POST FREE.**

**SYDNEY S. BIRD** "Cyldon Works," Sarnesfield Road, ENFIELD TOWN, MIDDLESEX. Telephone: Enfield 672.

## RADIOTORIAL QUESTIONS & ANSWERS.

(Continued from page 1372.)

I know my aerial and earth are all right as I have had a crystal set working from 5 X X on them.

You are evidently receiving the carrier waves but do not know how to resolve them.

On a set of your description there are usually two variable condensers, a 2-way coil holder, an isolated coil holder, and two filament rheostats.

Assuming you know the correct coils to plug-in and that everything is connected up correctly, you proceed as follows: First turn on the filament rheostats. If the valves take 4 volts and a 4-volt accumulator is used they should be turned right on, so that all resistance is out of circuit. Should you, however, be using a 6-volt accumulator, the rheostats must only be turned on about two-thirds of the way round, otherwise the filaments of the valves will be over-run.

Having adjusted the filaments the reaction coil should then be moved towards the coil to which it is coupled.

Usually the reaction coil is coupled to the aerial coil, but on some sets it is coupled to the anode coil.

The important thing to remember, however, is that whatever coils are coupled together, they should never be so close together that the set howls, as this causes interference to nearby sets.

A good method of adjusting the reaction coil is to bring it gradually nearer the anode or aerial coil and while doing so keep on tapping the aerial terminal with a wetted finger.

While a series of clicks will be heard even when the reaction coil is at 90 degrees with the anode or aerial coil, these will be suddenly intensified on bringing the reaction coil closer.

In practice, it will be found satisfactory if the set starts oscillating silently when the reaction coil is brought up to within approximately 45 degrees of the coil it is coupled to, although if it oscillates (heard by the intensified click) when the reaction coil is farther away, a smaller reaction coil should be used, and the same process repeated.

Having got the set almost oscillating, the reaction coil is left in this position. The two variable condenser dials are then rotated *simultaneously*, both starting at about the same number of degrees.

It is always a good plan to start at 90 degrees on each dial, as then you can tune down so many metres, and also (by rotating the condenser toward 180 degrees) tune up an equivalent number.

If the set gets away from the oscillation-point when the condensers are set at 140 degrees or more, then the reaction coil can be brought slightly closer to the other coil.

When the carrier wave of the transmitting station is heard the condensers are rotated until it is at its maximum volume, and the reaction coupling is loosened as far as possible.

Should, however, speech or music be distorted, the reaction should be "loosened" further by moving it away from the other coil. Signal strength will then decrease slightly, but it will be found that the distortion has disappeared.

It is always advisable to incorporate vernier adjustments on the variable condensers, as without their use weak signals are sometimes passed by, while they give a certain amount of selectivity and often rid distant stations of interference.

(NOTE.—This reply has been reprinted at the request of many readers.)

### SIMULTANEOUS BROADCASTING.

A. B. C. (Torquay).—When the B.B.C. stations are simultaneously broadcasting, does one receive the sum of the transmissions, or only the one station, as in a usual separate programme transmission?

Each of the stations, although all are transmitting the same programme, is using its own particular wave-length, as is the case when it is broadcasting its own individual programme, so that one only actually hears the station to which one's receiver is tuned.

### CRYSTAL SET PHENOMENA.

J. T. W. (Essington, near Wolverhampton).

—Can you tell me what caused the following? I am using a crystal set, with a D.P.D.T. switch for switching from 5 X X to 5 I T, and I left the switch open last night while I was talking.

After a while I put the 'phones on, and, forgetting the switch was open, I thought the crystal was "off" so I touched it. As soon as the cat's-whisker touched the crystal there was a very loud crackling noise in the

'phones, and a small blue light was on the crystal where the whisker was in contact with it.

What with the noise in the 'phones and the blue spark on the crystal I dropped the 'phones thinking there was lightning about, but it was a quiet night and was snowing slightly.

I came in and touched the crystal again, with the same result, except that the noise in the 'phones had changed to a loud buzzing, which could be heard ten feet away. I then thought the 'phones were at fault, so I put the switch over for 5 X X, which was as loud reception as ever. What caused this?

By the way, I can "work" a "Tom Tit" speaker from 5 X X, about sixty miles away, and from 5 I T, twelve miles, and can hear Manchester faintly on the speaker.

I can get Stoke-on-Trent and Nottingham on 'phones, and hear words quite plainly without any effort. London and Cardiff are much fainter.

I have got all stations named repeatedly for persons who have come to hear my set, for which I have to thank "P.W."

The cause of the crackling noise and of the blue sparks was an electrical charge upon the aerial. This would appear to have been a fairly powerful static charge, caused by the snow. The flakes of snow had been electrified in the clouds, and each one touching the aerial had imparted a slight charge to it, as it was insulated from earth (by the open switch). It thus became heavily charged, and when earthed through the crystal a fairly large current passed, causing the phenomenon you noticed.

### QUERIES RECEIVED.

G. C. (Wrexham), F. C. (Rathmines, Dublin), T. D. (West Kensington), and numerous others. —Your queries are not of sufficient interest to be answered in the "Radiotorial" columns. If a reply by post is required, the rules of the Query Department (as set out under the heading "Radiotorial") should be carefully observed, and the questions repeated in full.

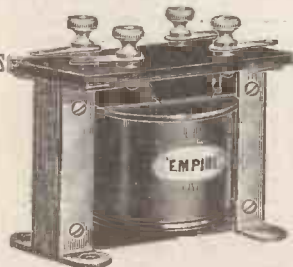

# BUY! BRITISH GOODS

THE H.T.C. "EMPIRE" L.F. TRANSFORMER Price **7/6**

POSTAGE 3d.

12 MONTHS GUARANTEE and money back if dissatisfied. Guaranteed Distortionless Standard Ratios 4-1.

### WHY BUY A FOREIGNER?

If your dealer cannot supply send direct to the manufacturers.

This transformer makes an efficient Choke when P.O. and S.I. are short circuited between the terminals. P.I. and S.O. are then connections of a choke of 2,000 ohms resistance.

THE H.T.C. ELECTRICAL CO., LTD.,  
2, Boundaries Road, BALHAM, S.W.12.

Telephone: BATTERSEA 374.

# and now

## The REFLEX COIL mounted!

A combination of two such outstanding components as the Reflex Coil and the Reflex Coil Plug cannot fail to be appreciated by Wireless Enthusiasts who insist upon getting the utmost out of their sets.

This new addition to the Reflex family more than upholds its hereditary efficiency, and its cost is remarkably low.

No. 25 ... 2/8	No. 200 ... 4/9
.. 30 ... 2/8	.. 250 ... 5/3
.. 35 ... 2/8	.. 300 ... 5/2
.. 40 ... 2/9	.. 400 ... 7/-
.. 50 ... 2/10	.. 500 ... 7/6
.. 60 ... 2/11	.. 600 ... 8/-
.. 75 ... 3/-	.. 750 ... 8/-
.. 100 ... 3/2	.. 1000 ... 10/-
.. 125 ... 3/6	.. 1250 ... 11/-
.. 150 ... 3/8	.. 1500 ... 12/-
.. 175 ... 4/3	

From all good dealers.  
Get one for your set to-day!

**REFLEX means BETTER RECEPTION**

REFLEX RADIO CO., LTD., 198, Lower Clapton Road, London, E.5.

Telephone: CLISSOLD 2538.



# "Ware H.F. Resistance!"

says **CLIXIE**



"CLIXIE"

**Retail Prices:**

- CLIX with Locknut 3d.
- CLIX Adapter with Locknut 2d.
- CLIX Insulators (6 colours) 1d. each.
- CLIX Bushes (6 colours) 1d. each.
- CLIX Twin Plug complete 1/-

"H.F. resistance is distinctly a point to be reckoned with," says CLIXIE. "And here's another to think over while the reckoning's going on. Connections can be responsible for as much as 90% of the H.F. resistance in wiring between components.

"I say can be because commonly they are not. Commonly they're CLIX the plug-socket; and the H.F. resistance of CLIX is practically zero. Here's the reason why—and part of the reason why you should use nothing but CLIX:

"On the hard brass rod from which CLIX is machined-turned, a skin of special nickel-silver alloy is imposed by a bathing process. It is on this skin that the milli-ampere currents function: its high electrical conductivity cuts resistance clean out."

Are you well connected? Try

## CLIX

The Electro Link with 159 Uses

Obtainable from all Wireless Dealers or direct from the Patentees:

AUTOVEYORS LTD., 84 VICTORIA ST., LONDON, S.W.1



# PANELS & CONDENSERS

ARE

## GUARANTEED

Then Why be Content with Inferior Substitutes?

Ask your dealer or write to us direct

PARAGON RUBBER MANUFACTURING CO. LTD. SCULCOATES HULL



# SCRAP YOUR H.T. BATTERY!

If your Electric Supply is by DIRECT CURRENT obtain H.T. Current through the

## 'EKCO' H.T. UNIT (Prov. Pat.)

by just attaching adaptor to lamp-socket, reading lamp or power plugs!

**USERS' OPINIONS.**

"The UNIT works very well, and I am very pleased with it."—H. E. W., FOXEARTH.

"I may add that under test your UNIT was very silent in use—in fact, better than any I have tried so splendidly."—H. H., ACTON.

of these units."—J. H. (Wireless Dealer), CHESTER.

"I am well satisfied with the 'EKCO' UNIT—it works my two-valve set splendidly."—H. H., ACTON.

"I have tested the UNIT very carefully and the results obtained are all that can be desired."—C. F. D., LONDON.

UNITS TO SUIT } from 29/6 PARTICULARS ALL SETS } SENT FREE.

E. K. COLE (Dept. A), 505, London Road, WESTCLIFF-ON-SEA.

# K. RAYMOND

Hours of Business 9 to 8 DAILY  
9 to 9 SATURDAY  
(LISLE STREET) 11 to 1 SUNDAY

TWO SHOPS—so you will ALWAYS find ONE OPEN

27 & 28a LISLE STREET, LEICESTER SQUARE, W.C.2

Phone: Opposite DALY'S GALLERY DOOR (Back of Daly's Theatre) Gerrard 4637 BE SURE IT'S RAYMOND'S

**RECOGNISED WEST END DISTRIBUTOR** of the manufactures of Edison Bell, Jackson's (J.B.) Polar, Ignite, Peck, Burek, Lotus, Magnum, Burndep, Lotus, Dublinter, Marconi, Dorwood, Sterling, Success, P.T.E., McMichael, Lissen, Woodhall, U.L., E.L., Bowyer-Low, Amplior, Forno, Brunet, Ormond, Newey, P & M, and everything that is worth sticking. Every component made to obtain goods, 100%.

**UNSOLICITED TESTIMONIAL.** 332 Cranbrook Rd., Ilford, Essex Messrs. Raymond— I am writing to let you know the wonderful change your new type condenser has made in my one valve Straight set. On Sunday evening (with 210 working) I was successful in receiving Radio Berne, Dublin, Hamburg and Newcastle at excellent phone strength. All these stations had previously passed me by. I can only say that if there is a 100 p.c. condenser you'll get it. Harry R. Fricker.

**KAY-RAY STRAIGHT LINE FREQUENCY VARIABLE CONDENSER THE CONDENSER OF THE FUTURE** Pigtail connection to rotor gives silent working. Special Spring top Bush gives a firm but easy movement. Supreme selectivity. Each station has a clear tuning space.

**LOW LOSS** also with Ebonite ends. PLEASE STATE Distinct and definite Radio LOW LOSS OR reception. **EBONITE ENDS.** Precision workmanship.

Including knob and dial as sketch.	Including knobs and dial as sketch.
•0003 ... 5/11	•0003 ... 7/11
•0005 ... 6/6	•0005 ... 8/6
With geared dial 12-1 ratio 6/- extra.	With vernier Post 6d. per set.

**HEADPHONES.**—Genuine Dr. Nespor adjustable, 12/11. Genuine Telefunken adjustable, 14/11 pr. Genuine N. & K. stamped on case, 12/11. Lightweight, 13/6. Genuine Ericsson (E.V.) Continental, 10/8. Genuine Brunet, 11/9. 13/11. BRITISH Sterling, 22/6. B.T.H., 20/-. Ericsson, 22/6. Brandes Matched, 20/-. Brown's A.2, 30/-. Do. Featherweight, 20/-. All makes stocked. C.A.V. 27/6. Sterling, Dinkle, 30/-. Bags, 50/-. Primax, 27/7/0. Any model obtained immediately. Telefunken model, very fine speaker, 13/11. Nespor model, 13/11. Your old speaker accepted in part exchange or bought outright (always a party of good secondhand ones on sale). Callers only.

**LOUD SPEAKERS.**—Brown's, 30/-. 60/-. 120/-. Amplion, 25/- to 27/7/0. C.A.V. 27/6. Sterling, Dinkle, 30/-. Bags, 50/-. Primax, 27/7/0. Any model obtained immediately. Telefunken model, very fine speaker, 13/11. Nespor model, 13/11. Your old speaker accepted in part exchange or bought outright (always a party of good secondhand ones on sale). Callers only.

**VALVES.**—Cosmos (Met. Vickers), D.E.11, 12/6. S.P.18, Red or Green, 12/6. A.45, 7/6. Neutron .06, H.F. or L.L., 12/6. Cleartron .08, 12/6. C.15, 12/6. Ad. Mullard, Edison, Cosmor, Marconi, Osram Valves, 8/-. 14/-. 16/6. 18/6. 22/6. 24/6. 30/-. (Bright, D.E., and Power stocked.) Your burnt-out valve taken in part exchange for each British valve purchased. Usable valves bought or exchanged.

**PHILLIPS' Valves.** Well known as fine valve, .06, 8/11. Bright R., 5/6. Four Marconi for Undine, with extra connection can be used as ordinary valve.

**L.F. TRANSFORMERS.**—Ferranti A.F.3, 25/-. A.F.4, 17/6. Eureka Converter, 25/-. 2nd Series, 21/-. Baby list of 2nd, 15/-. Reflex, 15/-. Forno shrouded, 10/6. Success (Black), 21/-. Royal, 20/-. Ormond newest model, 15/6. Waters' Supra, 10/6. Croix (newest model), 7/6. Marconi 'Ideal', all stages, 30/-. each. C.A.V., 15/-.  
**EBONITE VARIOMETERS.**—Ball Rotor, 4/6. Standard, 3/11. Duplex for 5XK and B.U.C. 7/6. Papped Variable Coupler, 200/800 metres, fine instrument, 3/11. Marconi series-parallel, 16/-.  
**MOUNTED COILS:** STAR.—25, 1/3; 35, 1/6; 50, 1/9; 75, 2/-; 100, 2/3; 150, 2/6; 175, 2/9; 200, 3/-; 300, 3/3. GRAM (Patent 206233), air-spaced, mounted, 25, 1/6; 35, 1/6; 50, 1/8; 75, 1/11; 100, 2/3; 150, 2/6; 200, 2/11; 250, 3/3; 300, 3/6; 400, 3/9. UGRANIC (Honeycomb)—25, 35, 4/3; 50, 4/6; 75, 4/10; 100, 6/3; 150, 7/-; 200, 8/-; 250, 8/6; 300, 9/-; 400, 10/-; 500, 10/3; 600, 11/-; 750, 12/6; 1,250, 15/6; 1,500, 17/6. LISSEN.—25, 35, 4/10; 50, 5/-; 60, 5/5; 75, 5/4; 100, 6/9; 150, 7/-; 200, 8/5. LISSEN X.—50, 6/-; 60, 6/4; 75, 6/5; 250, 9/9. FINSTON.—35, 1/6; 50, 1/9; 75, 2/-; 100, 2/6; 150, 2/9; 200, 3/6; 250, 3/9; 300, 4/0. OSWELL.—3/-.

**VALVE HOLDERS.**—BENJAMIN 2/9; Lotus, 2/3; Apex, 1/6; Excelsior, 1/3; Sterling Non Pong, 4/3; Burndep, 5/-; Magnum, 5/-, 2/6; Bowyer-Low, 3/-; Alud, 1/3; H.F.C., 1/6; 1/9; Aerometric, 1/3; Bretwood, 1/9.  
**SETS OF PARTS.**—One valve amplifier, 14/11. ST.100, 74/-. Twin-valve, Loud Speaker, 80/-. P.P.V.2, 30/-. One-valve Reflex, 41/-. Efficient valve set, 30/-. All-Concert De Luxe, 118/-. Simplicity 3, 62/-.

**FIXED CONDENSERS.**—Dubliner •0001, 2, 3, 4, 5, each 2/6. •001, 2, 3, 4, 5, each 2/6. Grid Leak 2/6. Edison Bell, •001, 0001, 2, 3, 4, 5, 1/-. •002, 3, 4, 5, 6, 1/6. •0003 and grid leak, 2/-. (Post 2d.) Threlca, 1/6 and 2/- each. Dorwood, 2/6.  
**VARIABLE RHEOSTATS.**—Ormond 6 or 30 ohms, 2/6. Finston, 6 ohms, 2/3; 30 ohms, 2/6. Waters' Microstat, 2/9. Lissen Wire, 7 or 35 ohms, 4/-. Do. Potentiometer, 4/6. Poerless Dual, 3/3. Burndep, 4/6 to 7/6. McMichael, 4/6 to 7/6.

**VARIABLE CONDENSERS.**—Polar Standard, 10/6. Junior, 5/6 each. Bowyer-Low Popular, 10/6. Igranic, 24/-, 21/-, Collinson's Low Loss, 21/-, 20/-. Utility, 5/6, 10/9. Vernier 2/8 extra. Low Loss stocked. Jackson Bros. Standard, 10/1, 9/6; •0005, 1/-; •0003, 7/-; with vernier 4/- each extra. Gearod •0005, 15/-; •0003, 13/-; Low Loss, 10/6, 9/-. Ormond new geared friction drive, •0005, 15/-; •0003, 13/6. With vernier 1/6 each extra. Ebonite ends same price. Newey 4 point, •360 in. geared control, square law, 15/-, 17/6.  
**ARABIC GRID LEAKS.**—Lissen, Watmel, 2/6; Bretwood, 3/-; Lissen Anode, 2/6; Watmel, 3/6; Bretwood, 3/-.  
**COIL STANDS.**—Lotus 2-way, 7/-; 3-way, 10/6 (extension handles extra). Polar 2-way, 6/-; 3-way, 9/6. Sterling Triple, 21/-. Kay Ray geared 2-way, 3/11. Back of panel, with knob and dial, 2/11. Panel 2-way, 2/-. Goswell, 3/- Standard, 2/9. All makes stocked. Ebonite coil plugs, sharp, brass sides, 5 for 3/6. Standard, 3 for 2/-.

**SUNDRIES.**—Mansbridge TCC 2 mfd., 4/8; 1 mfd., 3/10; 25, 3/5; 5, 3/-; •01, 2/-; •02, 2/-. C.F.E. Transformers—McMichael, all valve-lengths, 10/- each. A6, 10/0; A7, 12/6. Stradia 300/600, 1,100/3,000, and Neutrodyne, 5/6 each (made by Stirling's, Ltd.). Magnum, Burne-Jones all 7/- each. Matched, same price. Bowyer-Low's 7/- each. Crystal Detectors.—Enclosed Burndep, 4/-. Mic-Met, 4/6. Micrometer, 2/3. Open Polar, 3/6. Permanent RI 6/-. 7/6. Liberty, 3/6. Kay Ray, 2/6.  
**COILS.**—H.L.—10. Lissen, 10/-, Success 10/6.  
**GEARED DIALS.**—Pelican Universal, 12/-, 6/-, latest model. Combine, 5/6.

Lissen Loud Speaker Unit, 13/6; Reed, 1/-, All Lissen, Marconi-Phone, Sterling, A.J.S., etc., available parts stocked. Customers buying 25 worth goods (non-proprietary) at full prices given a pair of Bruncor or Ericsson Continental 'phones free, or, if spending 30/-. can buy a pair of 'phones value 12/6 (my selection) for 4/- extra. All orders accepted on condition of payment at 27 Lisle Street, London, W.C.2. Cash should be registered. In case of complaint, please always repeat previous correspondence to save delay.

**GALLERS.**—The next items for you only. No post orders. See last week for full list, or, better still, CALL American boxes, with lid and base board, 12 x 8 x 8, 8/-; 16 x 8 x 8, 10/6; 18 x 8 x 8, 11/6. Open boxes 12 x 8, 11/4. Galvanized 3/- upward. Batteries, Adico, 100 volts, 12/6; 60v., 6/11. B.B.C. Large Size, 60v. 8/11; 56v., 5/3. Grid Bias, 9v. tapped 1/1, 1/9 to 2/6. Neutron flash lamps, 6 for 2/6. 64d. each. Siemens Ebonite cut while you wait. Matt. 3/16th at 3d. sq. in.; 1 at 2d. sq. incl. Reduction large sizes. Scrap ebonite on sale. Terminals, Brass, 1d.; Nickel, 1 1/2d. and 2d., nuts, washers. Heaps of small parts on counter for your set. Cheap valves from 2/9. DOC wire, 16 to 28 svgs. Accumulators, 2v., 40, 7/11; 4v., 40, 13/11; 4v., 60, 17/11. All sizes. Lead-in Tubes from 6d. Earth Tubes, 2/3 up. Climax, 5/-. Insulators, aerial wire, Electron, Red and Black Flex, 12 yds. 1/6. Rubber lead-in, 10 yds. 1/-, Enclosed detector, 9d., 1/3, 1/6, 1/9. Bus bar, Bleevinc, Cold connecting wire, Glazite, etc., etc. Usable valves bought. Secondhand goods purchased or exchanged subject to approval. No secondhand goods to be sent by post nor are any given by post. Special inclusive prices noted for orders over 22/-.

**TO WIRELESS GOODS MANUFACTURERS AND MERCHANTS, EXPERIMENTERS, Etc.**

By Order of the Liquidator. Without Reserve.  
**13, HIGH HOLBORN, W.C.1**

HENRY J. SHAW is instructed to sell BY AUCTION WITHOUT RESERVE, ON THURSDAY, FEBRUARY 18th, at 11-30 prompt, the Complete Stock of a Wireless Goods Factor, including 200 POLAR RADIOPHONE 7, 3 & 2-Valve Sets in Chippendale, Jacobean, and Globe Wernicke Cabinets, Polar L.F. & H.F. Amplifiers, 120 POLAR BLOK Crystal Sets, Combined Crystal and Valve Sets, and 1, 2, 3, 4, 5-Valve Sets, 40 ELWELL Portable Sets, ELWELL ARISTOPHONE 1, 2, & 4-Valve Sets, ELWELL Loud Speakers, 500 POLAR CAM VERNIER Coil Holders (3 and 2-way), 3,000 POLAR UNIVERSAL 2-way Coil Holders, 500 DUBILIER Fixed Condensers, 500 prs. POLAR Headphones, 80 prs. Gambreco Headphones, B.T.H. Headphones, 100 IGRANIC TRANSFORMERS, 300 Holderstats, 150 Lissenstats, 400 POLAR Variable Condensers, 50 ELWELL VARIOMETERS, ELWELL Rectifying Units, ELWELL H.F. Transformers, ELWELL H.F. & L.F. Tuning Units, 22 MAGNAVOX Loud Speakers, WESTERN Electric Loud Speakers, POLAR BLOK Cabinets, fittings and parts, POLAR BLOK large assortment of small accessories, 4,000 Coils of Aerial, 200 Coils of Flexible, Large Quantities of Lead-in and Connecting Flex and Insulated Wire, 300, New 2, 4 & 0 Volt Accumulators. On view day previous and morning of sale. Catalogues from the Auctioneer: 85, Newington Causeway, S.E. 1. Phone: Hop 3862.

**PATENTS, TRADE MARKS,**  
Inventions Advice Handbook & Consultations FREE.—B. T. KING, C.I.M.E. Regd. Patent Agent (G.B., U.S. & Canada), 146A, Queen Victoria Street, London, E.C. 4. 40 years' references. Phone: Cent. 682.

**RADIO REGISTERED PANELS**



7" x 5", 1/-	8" x 5", 1/2
7" x 6", 1/3	9" x 6", 1/7
10" x 8", 2/1	11" x 8", 2/3
10" x 9", 2/4	12" x 8", 2/6
11" x 9", 2/7	12" x 9", 2/10
12" x 10", 3/-	14" x 10", 3/5
14" x 12", 4/-	3" thick
	Post Free

Money back guarantee that each and all Panels are free from surface leakage, Megger test Infinity. Callers, cut any size, & quote by Post, or Phone Clerk-enwell 7853. Sample & prices, post free to the Trade.  
**CROXSONIA CO., 10, South St., MOORGATE, E.C.**

**THE 'PHONE REPAIR SERVICE**  
'Phones Rewound and Remagnetized... 4/6  
'Phones Remagnetized and Readjusted... 2/1  
Loud Speakers and Transformers Rewound...  
Earcaps, Leads, Diaphragms. Postage extra.  
The H.R.P. Co., 46, St. Mary's Road, Leyton, E.10

**EBONITE BUSHES**



FOR MOUNTING ON WOOD. PERFECT INSULATION.  
Orders under 1/- send 11d. NUMBER 1 2 3 4 5  
postage. Size of hole 4RA, 2BA, 1/4", 5/16", 3/8"  
Price each: 1d. 1d. 1d. 2d. 2d.  
**DAREX RADIO CO., Standard Works, Forest Hill, S.E. 13.**

The BROWN A at 22/6 or A2 at 15/- are the best for use with the P.W. Paper Diaphragm, Loudspeaker, Frames, &c. Stamp for List.  
**GOODMANS, 68, Farringdon Street, E.C. 4.**

**WHEN replying to advertisements please mention "Popular Wireless and Wireless Review" to ensure prompt attention. THANKS!**

**NEAR L.F. TRANSFORMERS**  
ALL RATIOS  
Maurice Bobin,  
21 Warwick Lane, London, E.C. 4  
Phone: Cen. 4872

**CORRESPONDENCE.**

(Continued from page 1348.)

**JAZZ AND THE CRITIC.**

The following is a copy of a letter we have received from Mr. Jack Hylton:

The Editor, POPULAR WIRELESS.  
Dear Sir,—I should be most glad if you can find it convenient to be present at a rendering of "The Selfish Giant," a symphonic phantasy by Mr. Eric Coates, which my band is to broadcast on Thursday evening.

I gather from an address given by you at Hull, in which you refer to jazz as  
"vulgar,"  
"blatant,"  
"grotesque,"  
"boisterous,"  
"degrading,"

and "a lapse from the normal," that your acquaintance with this form of musical expression is less exact than your mastery of oratorio. In all fairness, then, it seems to me that you owe it, if not to yourself and your considerable public, at least to us who express ourselves in jazz, to hear this phantasy by Mr. Coates, which is to be played by a purely jazz band for the great public of listeners-in prior to being recorded in a more permanent form.

I cannot think that either the work itself or your rendering of it will impress you as in any sense "degrading."

Believe me,  
Yours faithfully,  
(Signed) JACK HYLTON.

Dr. Henry Coward, M.A.,  
2, Moorgate Avenue,  
Sheffield.

**LIMITATIONS OF DX RECEPTION.**

The Editor, POPULAR WIRELESS.  
Dear Sir,—In the issue of "P.W." No. 192, you ask readers to let you know about DX reception. It would be of extraordinary interest if it is such nonsense will accept your invitation. It is such nonsense the way some people write, and the way advertisements are worded so often, both give much heart-burning. I refer to 30 programmes in an evening; or any of 40 stations at will, etc., etc.

Now, as regards this part of the world, with a fairly powerful 5-valve neodyne receiver the following is a fairly representative statement. In two hours after dinner I can pick up some 30 different stations, all on the loud speaker, and a great many at fair volume. But to say one can listen to 30 different programmes, with pleasure, is absurd!

Five or 6 is the utmost one can expect: 5 X X, 2 L O, 6 B M, of course, can always be counted on, loud, only using 4 valves. Then Radiola and Berlin (K W) will come in, also one or other of the following: Berne, San Sebastian, one of the Madrides, Toulouse, Hamburg (slightly heterodyned by Bournemouth), and one or two other German stations; also Birmingham.

But it is very seldom that one can listen to a programme from any of these (lower wave) for more than ten minutes at a time, then the eternal Morse starts, and if it is a foreign station it fades right out. Occasionally I've got Berne or Brussels so loud that I've switched off one valve. On 'phones one sometimes can listen better, on four valves, but bad Morse on 'phones is a terrible infliction.

This brings me to another point, of consolation to those who don't own powerful sets. It is quite possible for a two-valver, using 'phones, to listen to several distant stations far more pleasantly than can the five-valver. There is no doubt that one or two stages of H.F. do bring in a lot of unwanted noise. I only hope more readers will write to you, and that you will then be good enough to give us a digest of their various experiences.

Yours truly,  
C. LANG (Lt.-Col.).  
Whytegates,  
Church Crookham,  
Hants.

**POLARITY TESTS.**

The Editor, POPULAR WIRELESS.  
Dear Sir,—In a recent number in a reply to "P.M.", who asks for details of a cheap polarity indicator, you recommend a mixture of sodium sulphate and phenolphthalein.

This is certainly cheap, but I should like to recommend to "P.M." and to your readers generally, a method which is just as efficient, far cheaper, and far more convenient—because the materials are already in every home—than the one suggested by you.

If "P.M." will cut an ordinary potato into two, and if he will fix two wires from the mains into this, he will find that the potato will first bubble at one lead, and that then it will turn green by the other lead. The lead turning the potato green is the positive. The wires should be placed about two inches apart in the potato on the house mains, and closer together for lower voltages.

Yours truly,  
D. S. SAKLATVALA.  
2, St. Albans Villas,  
Highgate Road,  
London, N.W. 5.

**MORSE CODE LESSONS.**

The Editor, POPULAR WIRELESS.

Dear Sir,—On looking through some foreign radio papers, I notice that several Continental broadcasting stations have taken up the practice of giving lessons in the Morse code.

This seems to me to be a very good idea, and I have little doubt that it would prove popular in this country.

I have already written to the B.B.C. concerning this, and am awaiting a reply.

You will no doubt admit that the percentage of listeners in the British Isles who are able to read Morse is deplorably small, and yet there must be many thousands who would be delighted with the idea of picking up a message in code and being able to understand what it was all about.

If put to the vote, I am almost certain that an overwhelming majority in favour of the adoption of this idea would result.

Yours faithfully,  
M. WILLIAMS,  
39, Tottenham Court Road,  
London, W.1.

**RE SUNDAY PROGRAMMES.**

The Editor, POPULAR WIRELESS.

Dear Sir,—I have read J. H. Horsley's letter re above in a recent issue of POPULAR WIRELESS, and admit the two paragraphs are a little misleading, but I had in mind the fact that De Groot only figures on the Sunday programmes at irregular and well-spaced intervals.

Being cognisant of the fact that criticism does its value unless a suggestion or constructional policy accompanies it, I suggest the only solution to the difficulty is that the B.B.C. wash out all their stations (except 5 X X), and erect three, or perhaps four, high power stations, situated so that they will cover the whole of England, Scotland, and Wales. The wave-lengths to be arranged so as to give fair margin for tuning, and each station to have an entirely different programme. This would, I believe, give everyone the choice of at least two programmes. Technical difficulties may arise, but no doubt these could be overcome, and I certainly think the proposition would be more economical, both from a maintenance and a programme point of view.

It would certainly clear the ether of at least fifteen or sixteen stations that are struggling for a hearing.

After all said and done the majority of listeners settle down to one programme for the evening, and it is only due to the fact that they have no alternative programme, which gives rise to so much searching and the oscillating nuisance.

I always experience more interference from oscillators on Sunday evenings than at any other time during the week.

Yours faithfully,  
R. S. RUDLAND,  
39, Gipsy Road,  
Welling, Kent.

**A STRAIGHT THREE-VALVER.**

The Editor, POPULAR WIRELESS.

Dear Sir,—With reference to my recent letter giving results obtained from my straight 3-valver, I have been inundated with requests from readers asking for particulars, and I find it impossible to reply in detail to all of them individually.

I should be grateful, therefore, if you could find space to publish the enclosed "back-of-panel" wiring diagram, which I think is self-explanatory. I constructed the set from various diagrams, etc., I saw from time to time in your columns, and the set gives excellent selectivity and is very easy of control, although tuning is very sharp.

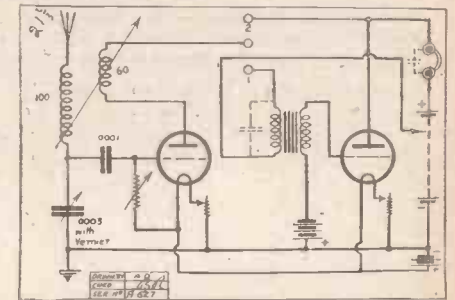

The Improved Chitos referred to on page 1377.

Using 2-volt D.E. valves, which I find the most reliable type, although any type almost will do. Best results are obtained from the three H.T. + leads as follows: H.T.+1, 15 volts; H.T.+2, about 36; H.T.+3, about 45, but best values of H.T. are, of course, only found by experiment, and these have a large bearing on results.

(Continued on next page.)

**CORRESPONDENCE.**

(Continued from previous page.)

If the H.T.+1 wander-plug is taken from H.T. battery, and plugged into grid socket of H.F. valve, we get a rather interesting circuit—I can work my L.S. from 2 L O or Bournemouth with it, quite easily. (Of course, the valve has to be taken off!) Since I last wrote I have logged, in addition, R, Barcelona (325 m.), Voxhaus, Hanover, the two new Cadiz stations, Bilbao, Zurich, Geneva, and I think Moscow.

Hoping this will not take up too much of your valuable space, and wishing all my correspondents the best of luck with this circuit.

Yours faithfully,  
B. M. FARRAR.

41, York Road.  
Hove, Sussex.

**IMPROVED CHITOS RECEIVER.**

The Editor, POPULAR WIRELESS.  
Dear Sir,—I enclose an improvement I have worked out on our old friend Mr. Childs' Chitos (see

*For the Constructor*

No. 5.—Cutting Out an H.F. Valve.

How to insert a single-pole double-throw switch for cutting out an H.F. valve (tuned anode) is shown above.

The existing lead from plate to grid condenser is broken, and the grid end is joined to the centre of the switch. Two new leads are then necessary, as shown by the heavy black lines.

One connects the lower switch contact to the grid of the preceding valve, and the other joins the top contact to the plate of that valve.

page 1376). I have tried this, and have given it to several friends, who have also tried it out, while one has told me he has just won third prize with it at an exhibition in Manchester.

I find it slightly more selective than Mr. Childs' original. L.F. can be added without separate H.T. batteries. Trusting this will be of interest to "P.W." and readers.

Yours faithfully,  
J. T. MULLIN.

5, Cowley Road, Waton,  
Liverpool.

**A WONDER BOOK FOR CHILDREN.  
700 COLOUR PLATES.**

**T**HE CHILDREN'S COLOUR BOOK OF LANDS & PEOPLES is the most vivid, instructive and fascinating book for children ever published. It is being issued in fortnightly parts, and will be far and away the most sumptuous pictorial work on record—an intensely interesting pageant of the existing races of mankind, and the places in which they live. When complete it will contain nearly 3,000 illustrations, including upwards of 700 full-page plates reproduced from actual photographs skilfully and accurately coloured in the glowing hues of nature. The work is printed on costly art paper, and the price is 1s. 3d. per part only—value that is little short of extraordinary. Part I is on sale everywhere to-day.

**CLEARTRON CHARACTERISTICS**

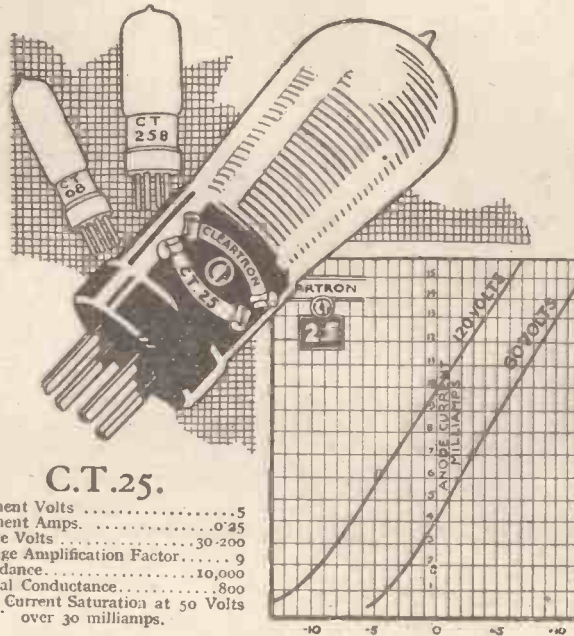

**H**ERE we show you the electrical characteristics of the CLEARTRON Dull Emitter C.T.25; we could talk to you for hours about its general excellence. But charts and talk cannot convince like an actual trial. Give it a "try out" and prove by your experience that CLEARTRON valves in your set mean vastly increased volume and greater distance; operatic purity, keener selectivity and longer life. And unless the C.T.25 produces all these claims and all these advantages it will be replaced without cost or question—our IRONCLAD GUARANTEE sees to this.

Type	Accumulator or Battery volts	Fil.volts.	Fil. amp.	Purpose	Price
C.T.08.	Dry cells	3	0.08	H.F., L.F. Detector	12/6
C.T.15.	2 volt Accumulator	1.8	0.15	H.F., L.F. Detector	12/6
C.T.25.	6 volt Accumulator	5	0.25	H.F., L.F. Detector	15/-
C.T.25.B.	6 volt Accumulator	5	0.25	General purpose resistance coupled amplification	15/-

**CLEARTRON RADIO LIMITED**

1 CHARING CROSS, LONDON AND BIRMINGHAM.

Telephone: Regent 2231/24

Grams: Cleartron, Strand, London.

British



Made

**TECHNICAL NOTES.**

(Continued from page 1354.)

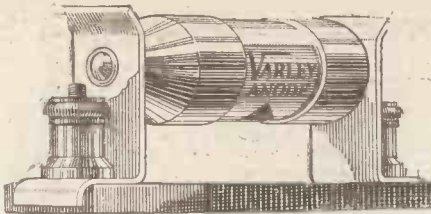

**The Varley Constant Wire-Wound Anode Resistance.**

A RESISTANCE wound on the famous Varley Bi-Duplex system, eliminating all inductance between turns.

It is absolutely immune from the effects of heat, damp or any atmospheric change, and therefore perfectly constant in action. The maximum current-carrying capacity is from twelve to fifteen milliamps.

For intervals coupling where freedom from distortion is the first consideration, use the Varley, Wire Wound and Weatherproof.

**SEE THAT YOU HAVE A VARLEY for Silence, Perfect Tone & Efficiency.**

Complete with **7/6** Clips and Base

Without Clips and Base 6/-  
60,000 ohms, 80,000 ohms, 100,000 ohms.

Write for Leaflet.



**Constant always**

**THE VARLEY MAGNET Co., WOOLWICH**

(Proprietors: Oliver Pell Control, Ltd.), S.E.18.

Telephones: Woolwich 888, 889.

**THE "GEM" SPARE COIL RACK.**

A High-Class Moulded Rack to hold 8 spare coils. Each position plainly marked. Complete with fixing screw. **2/9** Post Free From **W. H. WHITE,** 5, Saxon St., Leicester.

**The FAMOUS GENERAL RADIOPHONES.**

**YOURS for 6<sup>d</sup> DEPOSIT**

Latest Standard Model General Radiophones (made by the well-known General Radio Co., Ltd.), Super Sensitive and Highly Efficient. Receivers matched in tone. Magnets of highly expensive Cobalt steel. Diaphragm triple tested. Beautifully comfortable. Highly finished, weight 7 ozs. Fully guaranteed. Sent on receipt of 6d. deposit. If satisfied, send 2/6 on receipt and balance by instalment of 3/- monthly until only 21/- is paid. Price full cash with order (or within 7 days of receipt), £1.

**SIMPSON'S (BRIGHTON) LTD.**  
Dept. 1823, 94, Queen's Road, Brighton, Sussex.

**2-VALVE AMPLIFIER, 35/-**  
1-valve Amplifier, 20/-, both perfect as new; Valves, 4/6 each; smart Headphones, 8/6 pair; new 4-Volt Accumulator, celluloid case, 13/-; new 66-Volt H.P. Battery, guaranteed, 7/-; 2-Valve All-Station Set, £4. Approval willingly.  
**P. TAYLOR 57, Studley Road, Stockwell, LONDON.**

**Two Remarkable Coil Plugs**

"The Quick Fix" for Basket Coils, with detachable Pin and Knob, securely mounts all size coils, permits fullest action and quick adjustment. Low-loss reversible Plug and Socket. Solid Ebonite.

1/3. Postage 2d.  
Each **Universal Patent Plug** is a marvel of efficiency and neatness. Expanding Band quickly and firmly mounts any size coil. Perfect Low-loss reversible Plug and Socket. Adds fine finish to all Home-made Coils. Send to-day to **Woodman, Utley & Harris, Broad Street Chambers, Broad Street, Sheffield.** Trade Enquiries Solicited.

an important announcement to the effect that he has succeeded in reducing television to a really practical proposition. At a recent demonstration between Paris and Malmaison (where Monsieur Belin carries out his experiments) the inventor telephoned his assistant, who was in Paris, and as the assistant, Monsieur Lummiere, answered the call, his face was visible on a small screen attached to the telephone instrument at Monsieur Belin's end of the wire.

The principle of the apparatus is the use of a steel disc which revolves at a very high speed, and which has a large number of silvered facets mounted upon it, the purpose of these facets being to reflect, with very high frequency, beams of light which fall upon them. By these means a picture is "decomposed" point by point, and after transmission is effected by wireless methods, the picture is then reconstructed, somewhat after the manner of a half-tone, the dots, however, following one another with such extreme rapidity that the phenomenon known as the "persistence of vision" plays a part similar to that which it plays in the reproduction of cinema pictures.

Monsieur Belin states that before the end of the present year he hopes to perfect the invention, so that there shall be no difficulty in people not only speaking to one another by long distance telephone, but actually seeing one another at the same time by means of wireless.

**Amplification Factors.**

Readers frequently ask questions concerning the determination of the amplification factor of a valve. The method is briefly as follows: The filament should be raised to its normal temperature, and the normal H.T. should be applied to the plate. A variable grid bias should be applied, and this should be adjusted, readings being taken until the grid bias necessary to bring the valve near to the centre of the straight part of its characteristic curve has been found.

The anode current should be observed by means of the milliammeter. The grid bias should then be varied by some small amount—say 1½ volts. This will bring a change in the plate current, but the plate current may, however, be brought back to its original value by a corresponding alteration or adjustment of the H.T. voltage. When this has been done, we have an approximate figure for the amplification factor, which is the alteration of the H.T. voltage necessary to restore the anode current to the original value, divided by the alteration in the grid voltage which disturbed the anode current.

For example, supposing a change of 1½ volts in the grid bias required a corresponding change of 12 volts in the H.T. in order to compensate for it and keep the anode current constant, the amplification factor would be 12 divided by 1½, that is 8.

**Battery Connections.**

Questions are often asked also as to the relative advantages of connecting the positive and the negative terminal of the low tension battery to the negative terminal of the high-tension battery. It is common to connect the negative terminals of the

(Continued on next page.)

**Britain's Best in Radio!**

**THE LAMPLUGH FILAMENT RHEOSTAT**



6 ohms.. 3/-  
15 " .. 3/3  
30 " .. 3/6

Mechanically and electrically sound, one-hole fixing and unbreakable. Designed to give perfect control of filament emission. Fit them to your new set and secure efficiency.

If your dealer cannot supply—we can! Send for list,



This Mark is our Guarantee.

**S. A. LAMPLUGH LD.**  
KING'S RD., TYSELEY,  
BIRMINGHAM.

Sole Distributors for London and Southern Counties.  
**The Empire Electric Co., 303, Euston Rd., London, N.W.**

**THE MIRACLE 2-VALVE RECEIVING SET**  
Is the world's greatest Wireless Bargain. Stations over 400 miles distant clearly heard on the Loud Speaker. Easy Payments. List free.—**WORLD'S WIRELESS STORES, WALLINGTON.**

**GLASS TUBES FOR WETH.T. BATTERIES**

Best English Make at Lowest Prices

**I. ISAACS & CO.,**  
North London Glass Bottle Works,  
106, Midland Road, N.W.1

Phone: Museum. Telegrams: Isaglasbot, Kincross, London. Established 100 years.

**REPAIRS SETS PHONES TRANSFORMERS**

Officially Approved by Radio Association.  
ALLWORK GUARANTEED—LOWEST RATES—24 HOURS SERVICE  
**JOHN W. MILLER, 68, Farringdon St., E.C.4.**  
Phone: Central 1950.

**4-ELECTRODE VALVES.**

Genuine Philips 4-volt, 9/-; Thorpe, 10/6.  
**3 DAYS APPROVAL, POST FREE AT OUR RISK.**  
Aneloy Products, 36, Camomile Street, London, E.C.3.

**SPECIAL NOTE**

All communications concerning advertising in "Popular Wireless" must be sent to

**JOHN H. LILE Ltd.,**

**4, Ludgate Circus, London, E.C. 4.**

(Phone: CITY 7261)

and NOT to the Editorial or Publishing Offices.

## TECHNICAL NOTES.

(Continued from previous page.)

batteries together, although some experimenters believe that in certain cases an advantage is obtained by connecting the negative H.T. to the positive L.T.

When the H.T. negative is connected to the L.T. positive, it is evident that the voltage of the low-tension battery is added to that of the high-tension battery, and although this amount—perhaps three to six volts—may seem small, it may sometimes make a considerable difference to the performance of the set, particularly where a comparatively low value of the high tension is being used.

By this method, however, most of the anode current is made to pass through the low-tension battery, and it will usually be found, especially for short-wave work, that it is better to have the anode current return directly to the negative lead. It is for this reason that it is usual to connect together the negative terminals of the two batteries, leaving the positive voltages on opposite sides of the common negative.

The advantage gained by the addition of the low-tension voltage to the high-tension voltage is, of course, rendered more insignificant if the low-tension battery is of the 2-volt accumulator or 1½-volt dry cell type, such as are now so largely used in connection with dull-emitter valves.

At the same time, it is always worth while trying the reversal of the connections of the low-tension battery. The question of the grid bias is, of course, another and much more important point that may arise in this connection, and should not be lost sight of.

### A Photo-Electric "Organ."

An interesting experiment was carried out recently at Schenectady by Dr. Peter Wold, Professor of Physics at Union College, when he introduced via Station W G Y the "Song of the Electron."

A photo-electric cell was connected to the broadcast transmitting circuit, and a disc with rows of perforations was placed between the cell and a source of light. A battery, 135 volts, was connected between the potassium coating and the plate of the photo-electric cell. When the perforated disc was rotated slowly, so that an intermittent beam of light of L.F. interruption fell upon the photo-electric cell, a correspondingly low-pitch sound was produced, this sound rising in pitch as the speed of revolution of the perforated disc was increased.

In the demonstration referred to the disc carried four rows of holes, the outer row containing 48, the next row 36, the next 30, and the innermost row 24. By passing the beam of light through different rows the lecturer could obtain different sounds, and by passing through two or more rows simultaneously he could produce a musical chord. It has been said that in this way a photo-electric "organ" could be produced.

The experiment is really a modernised version of an ancient experiment in physics, but the introduction of the photo-electric cell was a convenient and interesting method of adapting it to broadcast transmission.

**IF there is anything in these pages that you do not like, please let us know what it is when writing to us.**



## The Spirit of Adventure

THOSE courageous mariners of old were not content to take life as they found it. For them the humdrum spelt inaction. So leaving the sheltered comfort of their homes they set out to brave the dangers of the unknown—to return, maybe, with rich prizes.

It was this same restless spirit which prompted the designers of the Eureka to forsake the old and seek new ideas in transformer construction. The extent of their success can be gauged by the fact that the Eureka is now the largest selling quality transformer on the market. Obviously such a rapid recognition of merit is proof of the many exclusive features possessed by the Eureka. The non-laminated core—the 2½ miles of wire—the hermetically sealed contents—the coppered steel case. These are the features which have built up a nation-wide reputation for Eureka.

Eureka Concert Grand . . . 25/-      No. 2 . . . 21/-  
Baby Grand, Nos. 1 and 2 . . . 15/-      Reflex . . . 15/-

# EUREKA

# Take the Strain!

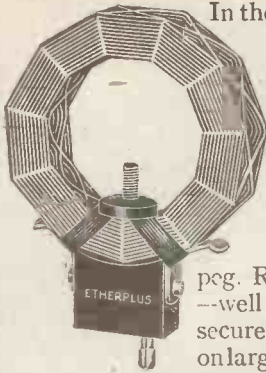

In the Etherplus + H.E. Coil the whole strain of fixing and removal is taken by an ebonite mounting-pog. Rigid winding—well air-spaced—securely supported on large side plates.

**RETAIL PRICES:**

W/1/25 ..	1/8 each	W/6/150 ..	3/- each
W/2/35 ..	1/9 "	W/7/200 ..	3/9 "
W/3/50 ..	2/- "	W/8/250 ..	4/6 "
W/4/75 ..	2/3 "	W/9/300 ..	5/- "
W/5/100 ..	2/9 "		



## MANDAW

9/15, Whitecross St., London, E.C.1

**HEADPHONES REPAIRED**

Re-wound & re-magnetised 5/- per pair, Loud Speakers repaired 5/-. Transformers re-wound 5/- each. All work guaranteed and tested before delivery. Write for Trade Prices. Phone: Clerk. 1795. MASON & CO., 44, East Road, City Road, N.1.

## EASY PAYMENTS.

**LOUD SPEAKERS.** Any make. Your selection. Ampion, Brown, Sparta, Sterling, etc. Quarter deposit. Balance six monthly payments. Accumulators, Headphones and parts, similar terms. Send a list of the parts you are requiring and we will forward you a quotation on the hire purchase system. H. W. HOLMES, 29, Foley Street, Great Portland Street, W.1. Phone: Museum 1414

## GET TO KNOW Pickett Brothers for Radio CABINETS



Being actual manufacturers of Wireless Cabinets we can offer an unrivalled selection of De Luxe and Parlour Models which should be of considerable interest to you. Prices ranging from 1/6 to £5 0 0 from stock or made to order in 7 days, and expertly constructed to your own specification. Write for Illustrated List. Estimates sent post free. Panels for any cabinet and complete accessories can be supplied. 160-page Accessory Catalogue, post free, 3d. Get your Cabinet built by PICKETT BROS. (Members B.B.C.), P.W. Cabinet Works, Bexley Heath (nr. London). *It will repay*

**WHEN** replying to advertisements please mention "Popular Wireless and Wireless Review" to ensure prompt attention. THANKS!

## 25/- buys the famous Dunham 2-VALVE LOUD SPEAKER RECEIVER COMPLETE

with all necessary Valves, Batteries, Telephones for long-distance stations and Brown Loud Speaker, balance payable £1 per month for 11 months. Send two penny stamps for catalogue of 14 different sets we make, or your deposit to-day for quick delivery. C. S. DUNHAM, Radio Eng. (Lanc. of Marconi Sc. Inst. Co.), P.W. Catalogue Department, 234-B, Brixton Hill, London, S.W.2. Established over four years ago. Members of the B.B.C. since its inauguration.

## FOREIGN RADIO NEWS:

(Continued from page 1364.)

of the rapid growth which radio may be expected to have in this virgin soil is shown by the fact that in Coblenz alone close on 2,500 applications have already been filed for a receiving set permit.

### Real Radio Canaries.

A novelty was staged last week by the Austrian station in Graz, where a show of canaries was being held.

Microphones were installed near the cages of the prize-winning birds, whose songs were thus broadcast for the edification of listeners.

### Two New Austrian Stations.

The opening of the new Vienna station "Gross-Radio-Wien," on January 30th, marks the opening of a new era in the development of Austrian radio. Simultaneously comes news from Russia of the inauguration of a new broadcasting station at Tuapse, about 75 miles S.E. of Novorossik, on the Black Sea. This station has started broadcasting daily between 3 and 4 p.m., with alternative wave-lengths of 1,200 and 1,800 metres. The Tuapse station uses 4 kilowatts and its call sign is XXXXRAN.

### Too Much Radio!

Complaints are being made, apparently not without some reason, that Madrid is over-blessed with radio.

This is due to a queer kind of motor vehicle which perambulates the streets of the capital all day, fitted with a receiving set and four loud speakers, and broadcasting all on its own over the whole city the programmes and messages not only of Spanish, but also of foreign stations.

While radio is an admirable thing at home, many people in Madrid incline to think that they would like sometimes to be able to take a stroll through the streets without being pursued by the strains of jazz bands or the shrill notes of a prima donna.

### Can One Steal a Wave-length.

Considerable attention is being paid in radio circles here to the reports from America that proceedings are being instituted in Chicago against the Zenith Radio Corporation for alleged piracy in appropriating a certain wave-length which is said to belong to some other broadcasting concern.

Whether, so far as continental European countries are concerned, anyone can "steal" a wave-length; whether, in short, there is a property right in a wave-length, seems exceedingly doubtful. Jurists will follow very attentively the legal arguments brought up on both sides during the hearing of this Chicago case, with a view to formulating changes in the law to meet similar cases.

### Radio Poetry.

The competition for the best piece of original verse written specially for broadcasting, which, at the first time of asking, proved barren of suitable works, has, on being repeated, resulted in a "Morning Symphony," by Mlle. Yves Calsennes, being awarded the prize.

The poem, which is quite short, is notable for the qualities that make for good effects in broadcasting. The authoress, on being asked what were the points she bore in mind in this connection, replied:

"I think the words must be chosen, other things being equal, for their sonority. Anæmic words, of which there are many in every language, are utterly unsuited to broadcasting.

"I believe, too, that it is a great advantage to use more than one voice. Simultaneous use of a deep and of a clear high voice, result in a kind of vocal stereoscopic effect. Their separate use is also an advantage, as it varies things for the listener."

In accordance with this view, one male and two female voices are used in the prize-winning poem. The remarkable thing about the work apart from its new form, suggested by the necessities of broadcasting, is that it is purely descriptive. There is no action in it, nothing beyond mere description to hold the listener's attention, which makes the striking success obtained by the work, on being broadcast, all the more remarkable.

*Liberty*

**PERMANENT DETECTOR**

*The Original One-Hole Fixing Detector*  
**Stops Fiddling with Catswhiskers**

Every "Liberty" tested on actual broadcasting and is fully guaranteed.

Tested and Unanimously recommended by the Wireless Press

from all Dealers or direct

**PRICE 3/6**

50% More Efficiency  
50% Lower Price

**The 100% DETECTOR**

Refuse inferior imitations. Insist on seeing name "LIBERTY" Fixing in panel (1-hole fixing) brackets or to existing detector terminals by 2 pieces copper wire.

**THE "Liberty" Detector gives more sensitive reception. Permanently than a catswhisker gives. Temporarily. No hunting for that special spot lost by the slightest vibration. The "Liberty" is entirely unaffected by vibration, sensitive all over, and that loud spot cannot be lost. EADI-ARC Electrical Co., Ltd., Bennett Street, London, W.4.**

## ADVERTISEMENTS

FOR THESE COLUMNS ARE ACCEPTED UP TILL 5 P.M. ON WEDNESDAYS FOR THE FOLLOWING WEEK'S ISSUE, RATE 30/- PER INCH; MINIMUM SPACE ACCEPTED, HALF-INCH AT 15/- CASH MUST ACCOMPANY INSTRUCTIONS AND BE SENT TO THE SOLE ADVERTISING AGENTS,

JOHN H. LILE, LTD.,  
4, LUDGATE CIRCUS,  
LONDON, E.C.4.

PHONE CITY 7261.

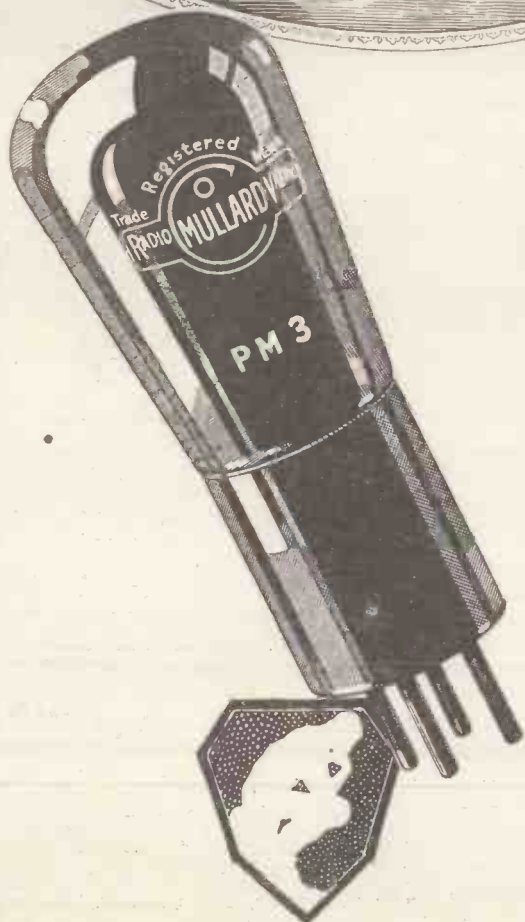
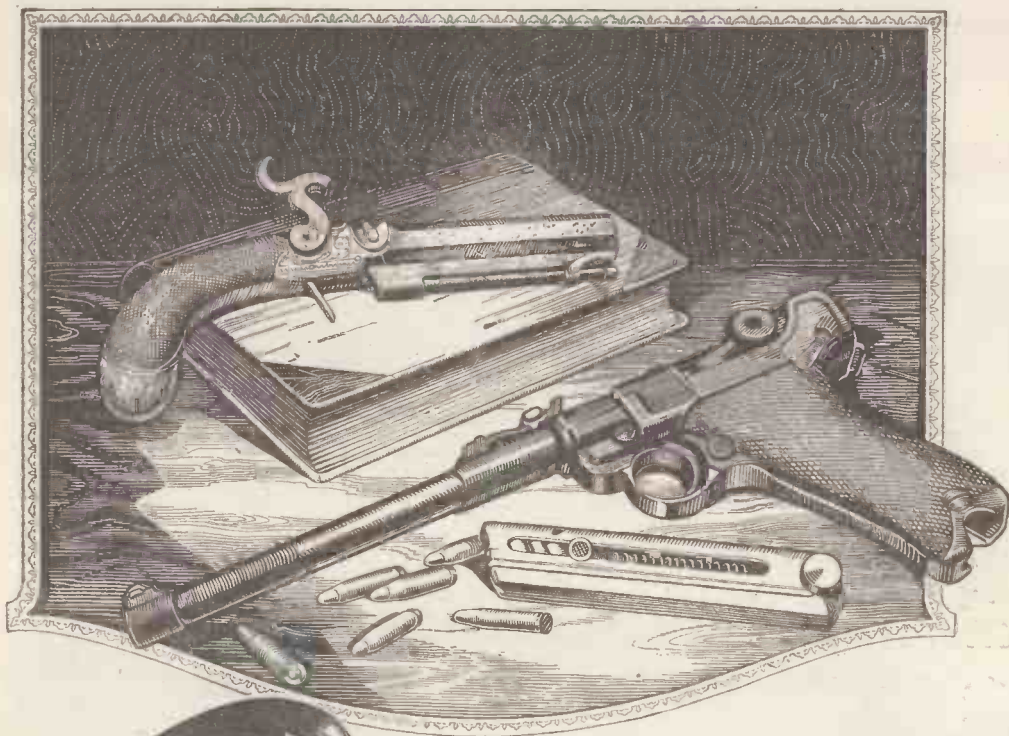

# Less Recharging

**T**HE boon of less recharging—a happy gift of modern science. Not a single valve in your receiver need consume more than *one-tenth ampere* if you take advantage of the wonderful "N" Filament. This filament is so economical of heating power that no sign of glow can be discerned and its low current consumption makes each accumulator charge last seven times as long.

You can now have the P.M.3, a general purpose valve with the wonderful "N" filament that reduces the total consumption of your set to **ONE-SEVENTH** and gives pure and powerful reception free from microphonic disturbances.

The ideal combination—P.M.3 Valves followed by a P.M.4 in the last stage—the finest loud speaker valve ever produced.

Ask for the P.M.3 . . . . . 16/6  
and the P.M.4 . . . . . 22/6

THE WONDERFUL "N" FILAMENT VALVES

# Mullard

**THE MASTER VALVE**

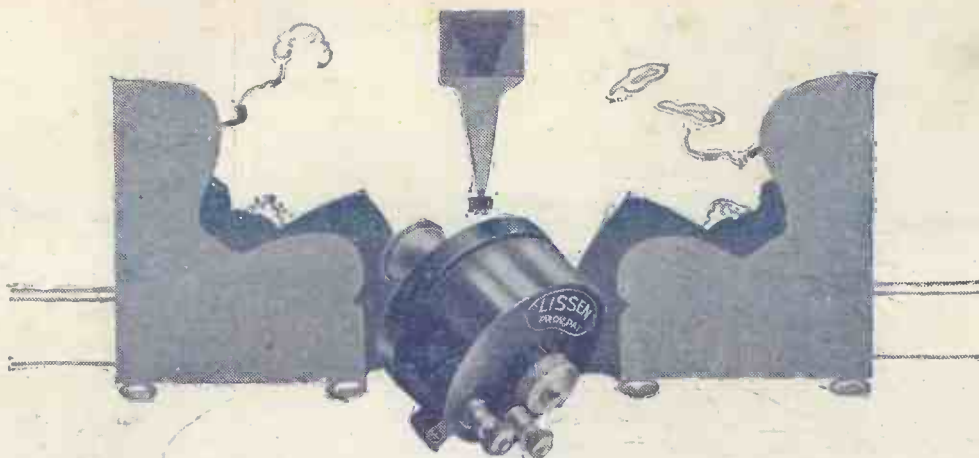

## Build your own Loud Speaker and discard your headphones

Gone are the days of troublesome 'phones. The Lissenola brings loud speaker convenience to every home at a record in low price. For 13s. 6d.—less than the cost of headphones—you can buy the Lissenola, which only needs the addition of a horn to make it a powerful, full-sized instrument yielding results equal to an expensive loud speaker.\*

Compare the price last. Make this test before buying: Go to your dealer—ask him to put on the best loud speaker he has in stock—then use the same horn on the Lissenola, and see if you can notice any difference.

You can build a horn yourself—with each Lissenola we give you full-size exact patterns and clear instructions how for a few pence you can build a big horn of proved efficiency. The illustration above shows the effective horn you will build. It can be covered with fancy paper or painted so as to resemble a factory-made article.



In addition, the Lissenola will fit the

tone-arm of any gramophone, instantly converting it into a radio loud speaker.

By using the Lissen Reed (sold separately for 1s.) the Lissenola will carry a cone or any other diaphragm working on the reed principle. You can quickly make a paper diaphragm yourself.



\*The secret of the Lissenola's remarkable efficiency rests in the effective manner in which the electro-magnetic sound-reproducing system is concentrated.

Your dealer will gladly demonstrate and supply—or post free by return from the makers—price 13/6, or with Lissen Reed 14/6.

## BUY THE LISSENOLA and build your own Loud Speaker

Lissen Limited, 8-16, Friars Lane, Richmond, Surrey

\*Phone: Richmond 2285 (4 lines).

\*Grams: "Lissenium, 'Phone, London."

L.11