

The Post Office Electrical Engineers' Journal

R. ROE
PEZ. 1

VOL 73 PART 1 APRIL 1980



THE POST OFFICE ELECTRICAL ENGINEERS' JOURNAL

VOL 73 PART 1 APRIL 1980

Contents

Editorial	1
Thick-Film Technology : An Introduction A. G. Saunders	2
The MOST Director Part 2—Store Loading, Maintenance and Traffic Metering K. H. Grunwell and D. Walton	8
Monarch 120—A New Digital PABX A. R. Potter	14
System X : Subsystems Part 1—The Digital Switching Subsystem J. N. A. Risbridger	19
Architecture of System X Part 3—Local Exchanges G. P. Oliver	27
An Experimental Solar-Collection System for Domestic Hot Water—R. W. August	35
Architecture of System X Part 4—The Local Administration Centre A. A. Waliji	36
The Second International Telecommunications Energy Conference—D. A. Spurgin	42
Measurement and Analysis Centres : Operational Activities and Achievements B. G. Sapsford	43
System X : Design and Support Part 3—Software Development Facilities S. R. Loomie	47
Teleprinter No. 23 : A New Teleprinter for the Telex Service W. F. Garrett	54
The Post Office Telecommunications Museum, Taunton : Britain's Oldest Telecommunications Museum—P. J. Povey	62
Reorganization of Telecommunications Headquarters	63
Profiles of Senior Staff	64
Institution of Post Office Electrical Engineers	68
Notes and Comments	69
The Associate Section National Committee Report	70
Associate Section Notes	70
Forthcoming Conferences	71
Post Office Press Notice	71
Book Reviews	26, 53

Published in April, July, October and January by *The Post Office Electrical Engineers' Journal*,
2-12 Gresham Street, London EC2V 7AG.

Price: 70p (£1.05p including postage and packaging). Orders by post only.

Annual subscription (including postage and packaging): home and overseas £4.20.
(Canada and the USA \$10.00.)

Price to British Post Office staff: 48p.

© 1980: The Institution of Post Office Electrical Engineers.

Let Herman Smith supply your Equipment Practice requirements

The British Post Office, in conjunction with the telecommunication equipment manufacturers, have developed a new racking system for transmission and other equipment applications.

This is to replace existing 62 Type practice, which Herman Smith have manufactured for many years. It will house equipment in very sophisticated miniaturised forms and will offer a far greater packing density.

Herman Smith on their part will manufacture the metalwork for this new type of racking and supply any company or public body.

The company has full and adequate facilities to make and inspect this equipment—both the rack and the incorporated shelves—to the exacting requirements.

At present, the company is supplying 62 Type wired assemblies and racks to the Post Office and is fully approved for Post Office manufacture and also to 05/24 M.O.D. standards.

Cabinets and sheetmetal fabrications can be made to customers' special requirements.

Enquiries to Peter Bowen,

HERMAN SMITH LIMITED
Cinder Bank Works
Netherton, Dudley
West Midlands DY2 9AH
Telephone: Dudley 52791

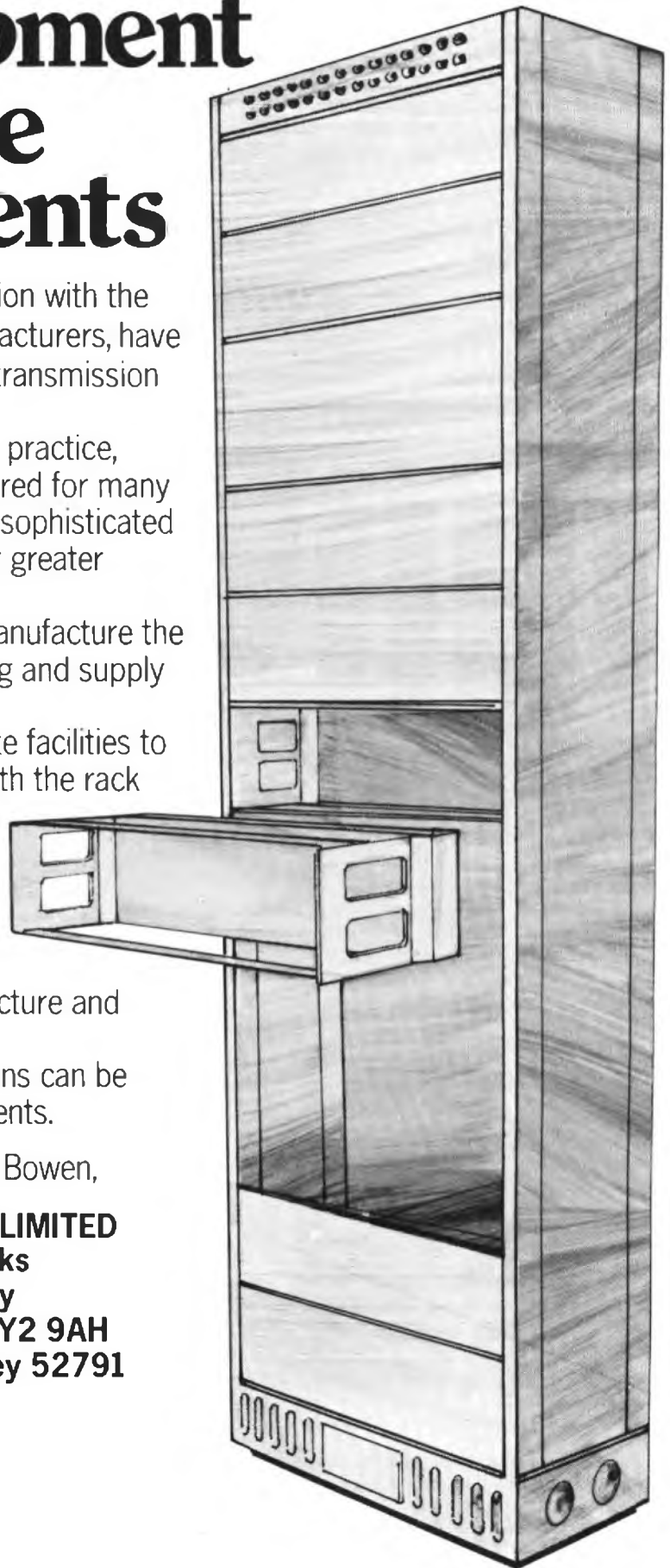

THE MICROWAVE RADIO FOR EVERY USE

*Selected by the Post Office. Again!

Frequency Agility

The TCM-6 is tunable across each band from 1.7 to 15.35 GHz. Change bands by plug-in RF module replacement.

Full Performance

Color video with FM or digital subcarrier channels, 1800 FDM voice channels, 34 Mb/s digital data or wideband radar video.

Fixed Link or Portable

Simplex, duplex and diversity operation in tripod, tower or rack mount configuration.

Proven Operation

Used worldwide from arctic to desert environments by major television and telecommunications administrations.

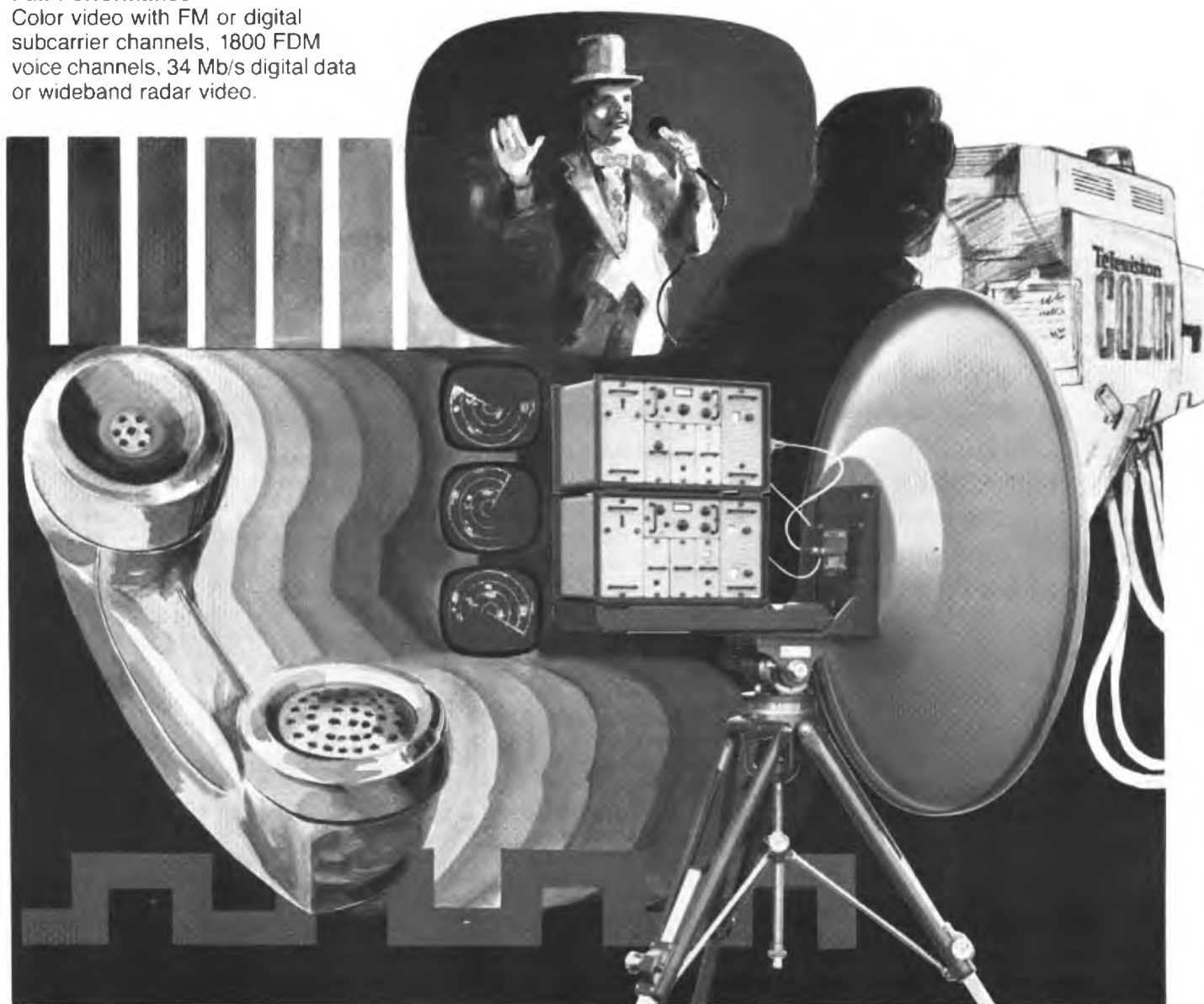

* TerraCom has been awarded Post Office contract 580678DD for the supply of 50 TCM-6 portable, tunable microwave links. The equipment will be used for telephony and television transmissions in the 2 GHz, 2.5 GHz, upper 6 GHz and 12 GHz bands. This award follows a previous Post Office contract awarded in 1979 for 22 TCM-6 links.



Loral Corporation

9020 Balboa Avenue San Diego, CA 92123 U.S.A
Phone: (714) 278-4100 TWX: TERRACOM SDG 910-335-1202

COAXIAL RELAYS

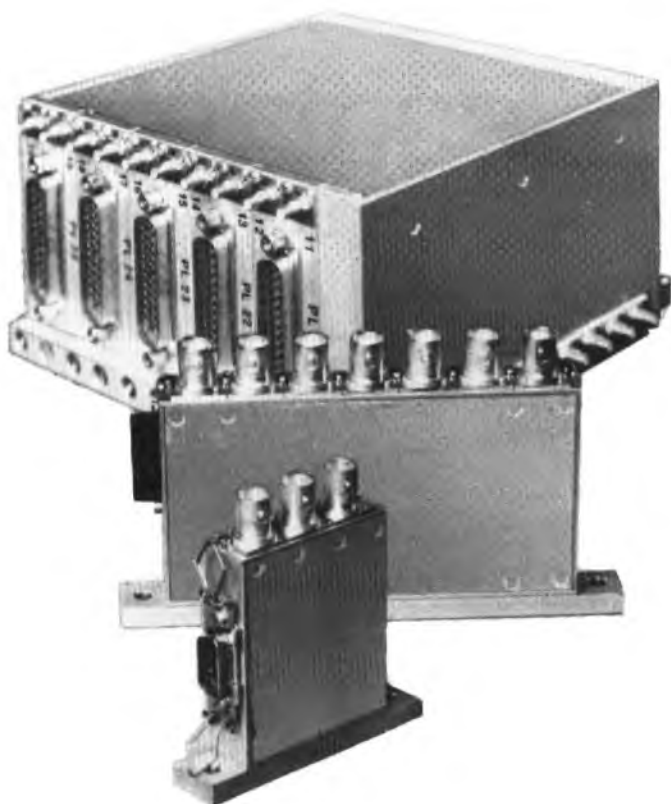

ALL UNITS CAN BE SUPPLIED WITH OR WITHOUT CONTROL UNITS FOR REMOTE APPLICATION.

APPLICATION

- CLOSED CIRCUIT TELEVISION.
- ANTENNA/AERIAL SELECTION.
- TELEVISION SWITCHING.
- TRANSDUCER/SENSOR MONITORING.
- LOW NOISE SIGNAL SWITCHING.
- VIDEO SWITCHING.
- EQUIPMENT TEST POINT MONITORING.
- LOW POWER TRANSMITTER SWITCHING.
- SECURITY CAMERA SCANNING.
- TRANSMISSION LINE TESTING.

CIRCUIT APPLICATIONS

THESE RELAYS ARE USED EXTENSIVELY IN SINGLE UNIT APPLICATIONS, BUT DUE TO THEIR STYLE AND CONSTRUCTION THEY ARE FREQUENTLY USED IN HIGHLY COMPLEX SWITCHING NETWORKS.

WILL BE SHOWN AT EUROCOM 80, COPENHAGEN.

RF COMPONENTS

PLUMPTON HOUSE, PLUMPTON ROAD
RYE PARK, HODDESDON, HERTFORDSHIRE
ENGLAND EN11 0EB

Telephone: Hoddesdon 63603 (STD Code 09924)
Telex: 265849

THESE LINEAR COAXIAL RELAYS ARE MULTI-WAY UNITS DESIGNED TO OPERATE THROUGHOUT THE D.C. TO U.H.F. SPECTRUM. HIGH QUALITY REED SWITCHES ARE USED IN CUSTOMER SELECTABLE CONFIGURATION ACHIEVING EXCELLENT INSERTION LOSS AND ISOLATION TOGETHER WITH ACCURATE RESISTANCE LOADING OF THE UNSELECTED CHANNELS.

THE STANDARD RANGE OF UP TO 26 INPUTS USING B.N.C. CONNECTORS AND UP TO 32 INPUTS USING S.M. CONNECTORS CATER FOR BOTH THE 50Ω AND 75Ω MARKETS, OFFERING A SELECTION OF CONTROL VOLTAGES AND CONTROL CONNECTORS.

THE MATRIX COAXIAL RELAYS ARE MULTI-WAY WITH SEVERAL R.F. INPUTS AND SEVERAL R.F. OUTPUTS ARRANGED IN A MATRIX CONFIGURATION GIVING FROM 20 TO 640 CROSSPOINTS AS STANDARD BY CUSTOMER SELECTION. ANY NUMBER OF CROSSPOINTS CAN BE SELECTED AT ONE TIME. THESE RELAYS OPERATE THROUGHOUT THE D.C. TO U.H.F. SPECTRUM.

CONSTRUCTION

EACH RELAY INCORPORATES FIELD REPLACEABLE REED ASSEMBLIES AND COILS MOUNTED IN A ROBUST ANODISED ALUMINIUM BODY. THIS FORMAT GIVES HIGH PHYSICAL AND ENVIRONMENTAL DURABILITY WITH GOOD ACCESS FOR SERVICING.

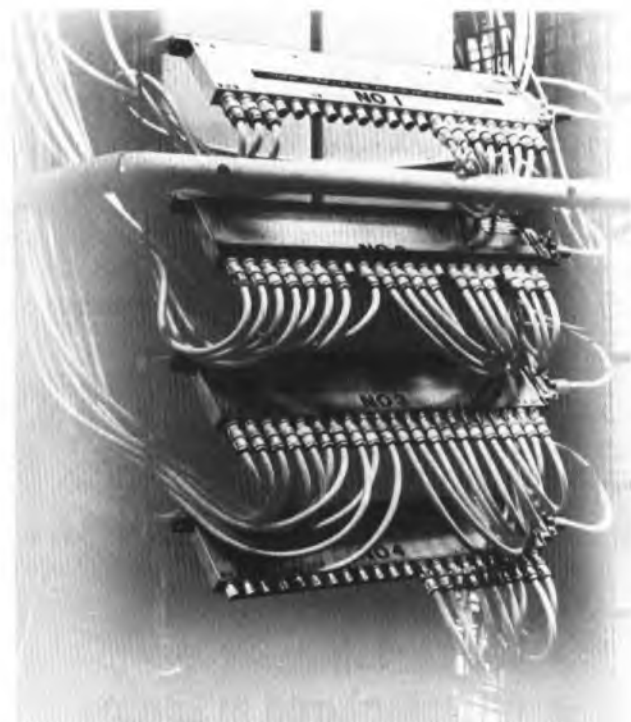

STANDARD R.F. COMPONENTS COAXIAL RELAYS AS SUPPLIED TO THE BRITISH POST OFFICE.

THE RELAYS (BPO CODE 1003A) SHOWN ARE USED AS PART OF A NEW MAINTENANCE AID IN REPEATER STATIONS FOR THE TAKING OF MEASUREMENTS ON FREQUENCY-DIVISION-MULTIPLEX TRANSMISSION EQUIPMENT, AND WERE REFERRED TO IN AN ARTICLE IN THE POST OFFICE ELECTRICAL ENGINEERS' JOURNAL (Vol. 71, p. 50, April 1978).

The Telecommunications Optocoupler

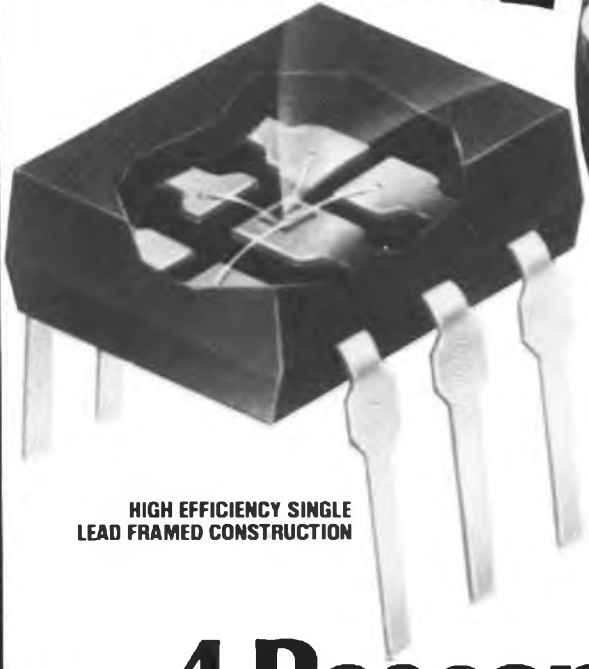

HIGH EFFICIENCY SINGLE LEAD FRAMED CONSTRUCTION

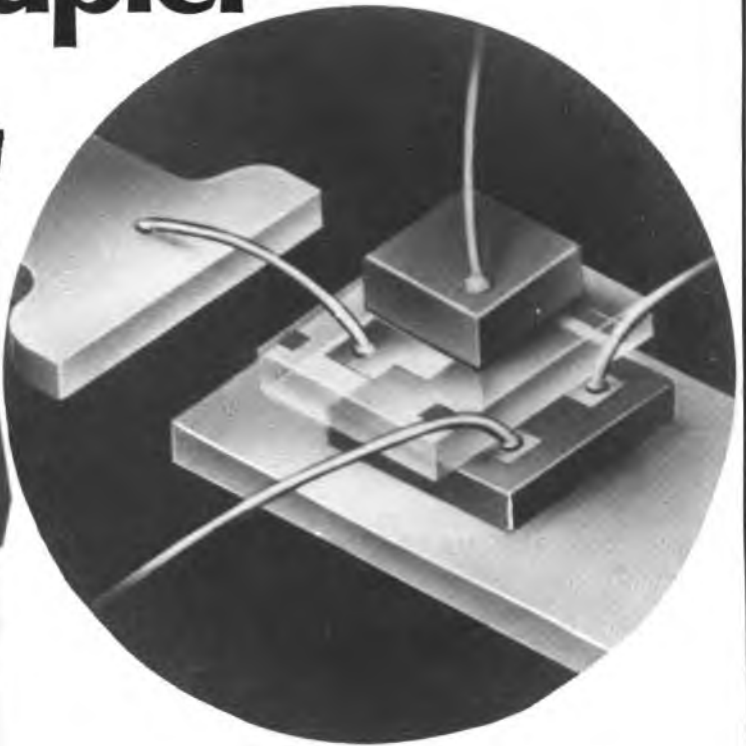

GENERAL ELECTRIC'S PATENTED ION-FREE GLASS CONSTRUCTION

4 Reasons to specify General Electric*

- ★ Higher Performance
- ★ Longer Life
- ★ Manufactured in Europe
- ★ Broad range of components

you need at competitive prices...5000 volt isolation couplers...a wide range of **PROELECTRON** and **JEDEC** registered couplers...high output **PROELECTRON** and **JEDEC** registered IRED'S... the highest sensitivity SCR couplers available ...specify G.E.

No matter what you need...
 ...G.E.'s broad line includes everything to optimise your design. Most important, you'll find everything

International General Electric of New York Ltd.,
 Park Lorne, 111 Park Road, London NW8 7JL, Tel: 01-402-4100



*Trademark of General Electric Company, U.S.A. which has no connection with an English firm of a similar name.

The Post Office Electrical Engineers' Journal

EDITORIAL

BOARD OF EDITORS

J. F. P. Thomas, B.SC., C.ENG., M.I.E.E., Chairman

A. J. Barnard, C.ENG., M.I.E.E.

K. Chinner

E. Davis, C.ENG., M.I.E.E.

L. W. F. Vranich

A. W. Welsh, C.ENG., M.I.E.E.

G. White, B.SC., PH.D., SEN.MEM.I.E.E.E.

Managing Editor

D. J. Holmes

Assistant Editor

A. R. Lawrence, C.ENG., M.I.E.E.E.

Secretary-Treasurer

B. Farr

Advertisement Manager

N. G. Crump

A series of pen pictures of senior staff in the Telecommunications Business of the British Post Office (BPO) commences on page 64 of this issue of the *Journal*. Notwithstanding that the practice of publicising senior staff appointments was discontinued by this *Journal* in 1972, the Board of Editors now believe that, as a consequence of the recent reorganization of Telecommunication Headquarters (THQ) (see page 63 of this issue), it would be of interest to BPO readers to see biographical details of senior staff and to know the designation of the posts they now hold. The series will be confined to appointments at Director level and above and commences in this and the next issue with present incumbents; future changes and new appointments at this level will be reported as they arise.

The first measurement and analysis centres (MACs), which provide the facility to measure automatically the quality of service provided by the BPO telephone network, came into operational service during 1979. Because each Telephone Area in the BPO telephone network is to be provided with a MAC, the interest in this project throughout the BPO is considerable. Therefore, included in this issue (page 43) is an article which discusses the control and use of the information available from a MAC; the results and experience gained from the initial MAC installations are also discussed.

The editors would be pleased to receive articles for publication from authors in Areas and Regions. Similar appeals for articles have been made in the past, but the response has not always been encouraging. If an author would first like to discuss the content of a proposed article with the editors, perhaps with a view to seeking advice from a specialist THQ duty, or to establish the suitability of a proposed topic, then the editors will be very pleased to help.

Thick-Film Technology: an Introduction

A. G. SAUNDERS, B.Sc., M.Sc.†

UDC 539.23; 621.38.049.77

The use of thick-film circuits within the British Post Office has increased rapidly over the last two or three years. New equipments now being developed for optical-fibre, digital-switching and transmission systems all make use of thick-film circuits. This article explains how thick-film circuits are made and guides a would-be user through the many different techniques involved in choosing the correct approach for his application.

INTRODUCTION

The thick-film process is a method of applying conductive, resistive and insulating layers to a ceramic base, termed a *substrate*, to form the basis for a part of or a complete electronic circuit. The basic techniques used, ceramic glazes and screen printing, have been known for hundreds of years, but they were not applied to precision electronic circuitry until the 1960s. Thick-film is so called because the layers produced are 10–30 μm thick, compared with thin-film circuits, produced by evaporation and sputtering, which are a few tenths of a micrometre thick. Thick-film circuits can range in complexity from simple resistor arrays to complex hybrid circuits containing several attached integrated circuits. The term *hybrid* refers to the mixing of more than one technology; for example, thick-film-plus-thin-film or thick-film-plus-silicon devices.

Thick-film circuits are generally used where integration of a circuit is required, to eliminate discrete components, but for some reason a monolithic silicon integrated circuit is not feasible or cannot be justified. These reasons might include high power dissipation, high voltage, a requirement for high precision resistors or the low quantity required. The cost of designing a custom-designed silicon integrated circuit is high, and the lead time to produce the first samples is of the order of months. The high design costs, plus the high production costs, mean that silicon integrated circuits are cost effective in long production runs only. Design of a thick-film circuit is much easier and production costs are lower, and therefore the break-even point comes at much lower quantities. Thick-film circuits are thus used for specialized functions where the production quantities required are not high enough to justify the cost of a custom-designed silicon integrated circuit, or where one or more of their technical advantages carries weight.

SCREEN PRINTING

The technique used for laying-down the conducting, resistive and insulating patterns of the circuit is screen printing. This is a process whereby ink is forced through a mesh by a squeegee, and is used in many other areas apart from thick-film technology. In its most basic form, the equipment needed is a mesh screen, a squeegee and something on which to print; but, for thick-film circuits, more sophisticated screen printing machines are used to give better control and reproducibility. The screen consists of a mesh stretched tightly over, and fixed to, a metal frame. The mesh material used for the production of thick-film circuits is generally stainless steel or polyester, and mesh counts are commonly 790 or 1280 /mm (200 or 325 per inch). In order to produce the required pattern, areas of the screen through which ink is not required to pass

are blocked off by a stencil. This stencil is produced by coating the mesh with a photosensitive emulsion which is then exposed to ultra-violet light through a mask bearing an actual-size image of the circuit pattern. The opaque areas of the mask correspond to areas where it is desired to deposit ink on the substrate. During exposure, the ultra-violet light causes cross-linking of the polymers in the emulsion, which makes it insoluble in water. The unexposed areas can then be washed away, leaving the exposed areas to form the stencil on the mesh.

During printing, the screen is held above, but out of contact with, the substrate on which the ink is to be deposited. The gap between the underside of the screen and the top face of the substrate is about 1 mm. The squeegee is drawn across the screen, carrying the ink in front of it (see Fig. 1(a)). The downward pressure of the squeegee deflects the screen so that it makes contact with the substrate in a line. When the squeegee passes over the open areas of the stencil, the ink is forced through the mesh on to the substrate (see Fig. 1(b)). As the squeegee progresses, the screen area it has passed returns to its undeflected position, but surface tension causes the ink that has been held in the screen to remain on the substrate (see Fig. 1(c)). At this stage the ink surface is textured by the mesh pattern of the screen, but the viscosity characteristic of the ink is such that the shearing of the ink by the squeegee reduces its viscosity (pseudo-plastic behaviour). Therefore, the ink is able to settle in the first few seconds and the mesh pattern is smoothed out. The viscosity then starts to increase again to its original value which prevents the ink from spreading too much. After completion of a print stroke, the squeegee is raised and returned to its starting position. The ink is redistributed over the screen either by a separate spreader or by the squeegee itself. The process being carried out is shown in Fig. 2.

The amount of ink deposited on the substrate during the print stroke depends on several factors controlled by the screen. These are

- (a) the area of the stencil aperture,
- (b) the thickness of the mesh,
- (c) the mesh size (that is the proportion of the aperture that is filled by threads of the mesh), and
- (d) the thickness of the emulsion below the mesh.

By appropriate choice of the values of all these factors, the amount of ink deposited is controlled, and hence the screen is used as a metering device.

SUBSTRATE

The base material on which a thick-film circuit is made is the substrate. This is generally square or rectangular, either 0.635 mm or 1.0 mm thick. Typical sizes for thick-film circuits are 12.5 mm \times 12.5 mm up to 50 mm \times 25 mm. The substrate material consists of 96% aluminium oxide (alumina) bound together with a glassy flux consisting of

† Research Department, Telecommunications Headquarters

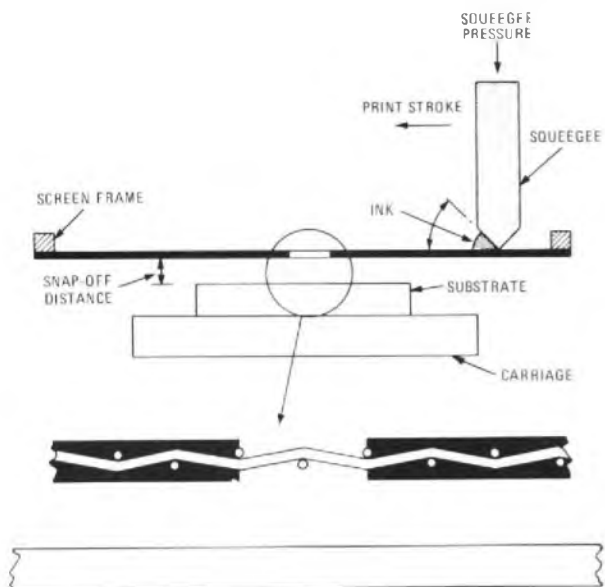

(a) Start of squeegee stroke

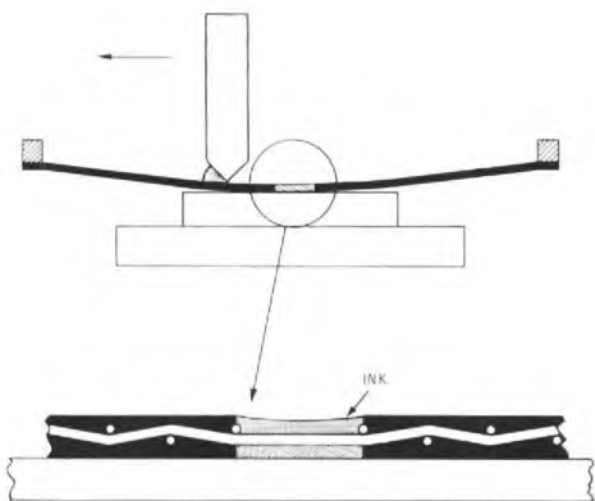

(b) Squeegee passing aperture in mesh

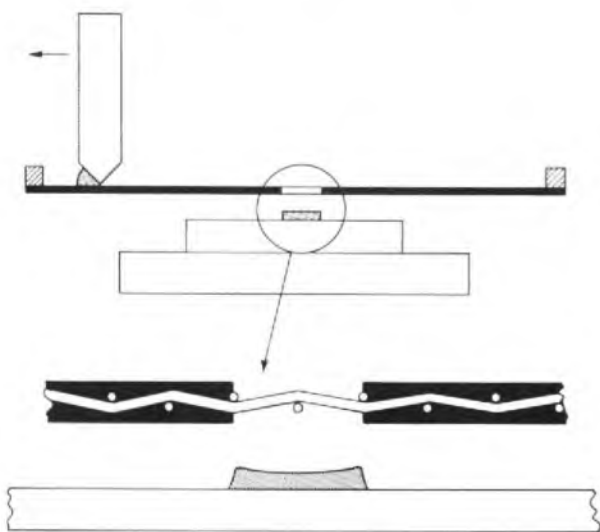

(c) End of squeegee stroke

FIG. 1—Principles of screen printing



FIG. 2—Screen printing

calcium, magnesia and silica. Substrates with higher proportions of alumina (for example, 99.5% alumina) are available, but the adhesion of fired inks to this material is inferior. It does, however, have better thermal conductivity. For very-high-power applications, beryllia substrates can be used, exploiting the higher thermal conductivity of this material, but these are generally avoided because of the health hazards associated with working with beryllia. A new type of substrate has recently been introduced, aimed mainly at the domestic-appliance market. This is the porcelain-coated steel substrate, which generally works out cheaper than alumina for substrate sizes greater than 75 mm × 75 mm. Special inks have been developed for lower-temperature firing because the porcelain cannot withstand such high temperatures as alumina. The temperature coefficient of resistance of resistors produced on these substrates is inferior to that of resistors on alumina and hence they are not really suitable for close-tolerance applications.

INKS

Inks used in thick-film printing fall into 3 categories: conducting, resistive and insulating. Most inks consist of a finely divided metal or metal oxide (for conductors and resistors respectively), plus a glass frit. These components are mixed with resins such as ethyl cellulose, solvents such as terpineol or butyl carbitol, and small amounts of wetting agents. The resins and solvents are present to make the powders into a paste suitable for screen printing. The solvents are driven off during the drying of the inks after printing, and the resin binder is burned off during the early stages of firing. Hence, the fired film consists of a mixture of metal or metal oxide plus glass frit.

Conductor materials generally contain one or more precious metals, sometimes with trace-element additions to modify their properties. Gold conductors have high conductivity, can be printed in fine lines (down to about 0.125 mm), are suitable for eutectic bonding of silicon chips and can have wires attached to them by thermo-compression bonding. However, gold is the most expensive conductor material and it is unsuitable for soldering with tin-lead solders, since these dissolve gold. A solderable alternative to gold is platinum-gold, but this has higher resistivity. For circuits where components are to be attached by soldering, the normal choice of conductor is palladium-silver. This is solderable with tin-lead-silver solder and tinning with solder also reduces its otherwise relatively-high resistivity. Where it is desired to have gold for die and/or wire bonding, but leads also have to be attached by soldering, it is possible to print gold and palladium-silver in the appropriate places on the substrate and to put a solder-dam or glaze to prevent the solder reaching the gold. The properties of some thick-film conductors are summarized in Table 1, and fuller details can be found in reference 1.

TABLE 1
Properties of some Thick-Film conductors

Material	Typical resistivity	Line definition	Suitable for eutectic attachment of silicon chips	Suitable for thermo-compression wire bonding	Suitable for aluminium ultrasonic wire bonding	Solderable with tin-lead-silver	Approximate relative cost (palladium-silver = 1)
Gold	3 mΩ/□	125 μm	Yes	Yes	*	No	3-7
Alloyed gold	5 mΩ/□	125 μm	Yes	Yes	Yes	No	3-7
Platinum-gold	80 mΩ/□	125-200 μm	Yes	Yes	Yes	No	4-7
Palladium-gold	†10-100 mΩ/□	175-250 μm	Yes	Yes	Yes	Yes	4-5
Palladium-silver	25 mΩ/□	150-200 μm	No	No	Yes	Yes	1

† Resistivity depends on palladium-to-gold ratio

* Bonds degrade at high temperatures

As already mentioned, conventionally fired conductors consist of metal particles bound together and to the substrate by glass frit. During firing, the frit melts and sinks through the conductor to the interface with the substrate, where it mechanically binds the substrate and metal particles. The presence of glass in the bulk conductor reduces its conductivity and may reduce the adhesion of wires bonded to the conductor. To overcome these difficulties, glass-free gold conductors, called *reactively-bonded* conductors, have been developed. These contain copper oxide particles as the bonding agent, instead of glass frit. During firing, the copper oxide reacts with the alumina of the substrate to form copper-aluminium oxide compounds, which bond the gold to the substrate. Reactively-bonded gold requires higher firing temperatures than fritted conductors and their properties are usually only fully required for microwave applications. Many modern gold conductors are of mixed bonded type that use both the frit and the reactive-bonding mechanisms.

Base-metal conductors such as copper and nickel, have been developed in an attempt to reduce the cost of conductors, but these have not found general acceptance because they require pure nitrogen atmospheres for firing. Also, a complete range of nitrogen-firing resistors and dielectrics is required.

The composition of resistor inks is similar to that of conductors, except that the metal is replaced by a metal oxide. Early resistor materials used palladium-silver or palladium oxide, and the properties of the resistor were developed by oxidizing the palladium during firing. This needed very close control of firing conditions to produce the required results. Hence, fully-reacted systems were developed where the formation of the oxide had already occurred before firing. Most of these systems are based on ruthenium dioxide, although one major ink manufacturer has ranges based on bismuth ruthenate. Conduction in the fired resistor is basically by point-to-point contact of the resistive particles which are bound together by the glass frit. The proportion of frit to resistive component in the ink determines the resistivity; with a high glass content, there will be fewer point contacts to carry the current and hence the resistivity will be high. Other elements are added to the resistor materials to modify their properties, notably to control their temperature coefficient of resistance. Temperature coefficients of resistance of thick-film resistors are generally negative below room temperature and positive above room temperature; the best materials have coefficients of ± 50 parts per million. Inks are produced with different resistivities and most manufacturers have different families suited to different applications; for example, low temperature coefficient of resistance on gold-containing conductors, low temperature coefficient of resistance on silver-

containing conductors, inks for high-voltage applications and lower tolerance inks for consumer-type circuits.

Dielectric inks are used for insulation where it is desired to form cross-overs and multilayer circuits, and also for thick-film capacitors. The inks consist of a dielectric or ferroelectric oxide powder plus a glass frit, or a recrystallizable glass frit, suspended in an organic binder. During firing, the dielectric is bonded to the substrate by the glass or, in the case of the recrystallizable frit, the dielectric crystallizes and precipitates from the glass. Dielectrics are available with a wide range of relative permittivities from low ($\epsilon_r \approx 10$), for crossovers and multilayers, to high ($\epsilon_r \approx 1750$), for printing capacitor dielectrics. Thick-film capacitors are formed by printing a layer of conductor, covering this with a layer of dielectric, then printing a second layer of conductor, as shown in Fig. 3.

The materials having high relative permittivities tend to have high dissipation factors, low-voltage strengths and are sensitive to temperature and moisture. Hence, for applications where stable capacitance is important, discrete chip capacitors are used, rather than printed capacitors. When printing crossovers, dielectrics for multilayer circuits or capacitors, it is usual to print 2 separate layers on top of each other to prevent pinholes causing short circuits. Dielectric materials are also used as solder-dams to prevent solder encroaching on to gold conductors, and glazes are used for covering resistors to improve their stability. These resistor glazes are formulated to fire at temperatures about 250-300°C below the resistor firing temperatures, so that the resistors do not drift in value when the glaze is fired.

FIRING

All the inks used for thick-film applications described in the previous section require firing to produce their final properties, and this is usually carried out in a belt furnace. After printing, the substrates are baked at approximately 120°C for 10 min to dry off the solvents in the ink. They are then passed through a belt furnace having a temperature profile similar to that shown in Fig. 4.

During the rising portion of the profile, the binders are burned off. An adequate flow of air must be provided to oxidize the hydrocarbons and to remove the combustion products (water vapour, carbon monoxide and carbon dioxide) from the furnace. The temperature rise must be at a controlled rate so that bubbling does not occur, and so that the



FIG. 3—Section through a thick-film capacitor

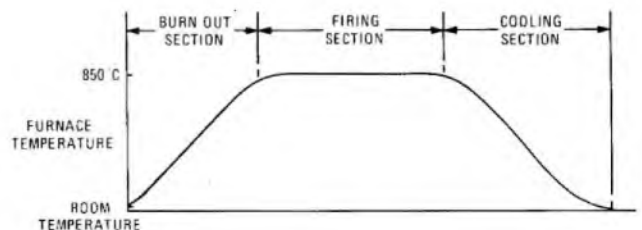

FIG. 4—Furnace temperature profile

burn out of the binder is complete before the glass frit starts to flow. Many materials are specified to be fired at 850°C, which has the advantage of one common furnace profile for all processes. The profile has a flat portion at this peak temperature, so that the substrates spend approximately 10 min at peak temperature. The time spent at peak temperature is critical for resistors; over-firing generally causes lowering of the resistance, and under-firing has the opposite effect. The substrates then pass in to the cooling region where they cool at a controlled rate to anneal out stresses that have been set up.

Firing is generally carried out after each printing process, but on circuits where more than one resistor ink is used, it is common to print each ink and dry it, until all resistors have been printed, then to fire all the resistors together. This avoids some resistors receiving multiple firing, which could alter their value. For the same reason, resistor firing is the last 850°C process carried out on the substrate, and further processes, such as overglazing, are carried out at lower temperatures.

RESISTOR DESIGN

The resistance of a thick-film resistor, like any other block of material, is given by the formula

$$R = \frac{\rho L}{Wt}$$

where R is the resistance,

ρ is the bulk fired resistivity of the material,

L is the length of the resistor between terminations,

W is the width of the resistor, and

t is the thickness of the resistor.

This expression is valid if the effect of the terminations is negligible; this is the case if $L \geq 1$ mm and if the ratio L/W lies between about 0.3 and 4.

For a given screen and printing conditions, the thickness



FIG. 5—Adjusting resistors by air-abrasive trimming

of the resistor can be made constant. Hence, the formula reduces to

$$R = \rho_s \left(\frac{L}{W} \right)$$

where $\rho_s = \frac{\rho}{t}$ and is called the *sheet resistivity*.

Sheet resistivity is expressed in units of ohms per square (Ω/\square); that is, the resistance of a square resistor ($L = W$) of the specified thickness. Inks are available with sheet resistivities from $1 \Omega/\square$ to $10 \text{ M}\Omega/\square$. The ratio L/W is termed the *aspect ratio*. Using the above formula, it is possible to begin to calculate the sizes of thick-film resistors. There are however certain limitations. Aspect ratios are usually limited to the range $0.33 \leq L/W \leq 5$. Hence, it is necessary to use different inks with different values of ρ_s for resistors more than a decade apart. There is a minimum length and width for resistors, usually 1 mm. Also, power handling capability must be taken into account; the maximum dissipation is usually 160 mW/mm^2 .

Thick-film resistors generally have a spread of about $\pm 20\%$ about their mean fired value. This tolerance can be improved by trimming the fired resistor, a process which involves removing some of the resistor material, thereby increasing the value of the resistance. Two methods are commonly used. Air-abrasive trimming involves abrading the resistor with a jet of alumina powder (see Fig. 5). A single wide cut removes resistor material along one edge of the resistor, thereby reducing its width and hence increasing its value (see Fig. 6).

The alternative method is laser trimming, in which a laser beam is used to make a cut in the resistor by vaporizing the resistor material. The cut can be a single plunge cut (Fig. 7(a)), but since laser trimming is very fast, it is common to use other cut configurations, so that the final stage of the trim occurs more slowly. This can be achieved by making several plunge cuts from opposite sides of the resistor (Fig. 7(b)), or by making the final part of the cut run parallel to the current path through the resistor (called an *L-cut*) (Fig. 7(c)). In both methods of trimming, the resistor value is continuously measured during adjustment and the trimming ceases when the desired value has been reached.

Laser trimming is a much faster operation than air-abrasive trimming, both as regards actual cutting time and setting-up time. The small size of the laser beam enables multiple probes to be used to probe all resistors simultaneously, whereas in air-abrasive trimming only the resistor being trimmed is probed, to allow room for the trimming nozzle to move. The control of the laser positioning and the resistance measurement is done under computer control. Laser trimming produces stress in the resistors, since localized melting of the resistor occurs. This stress is relieved by cracking of the resistor glaze at the end of the laser cut, which causes parameter drift

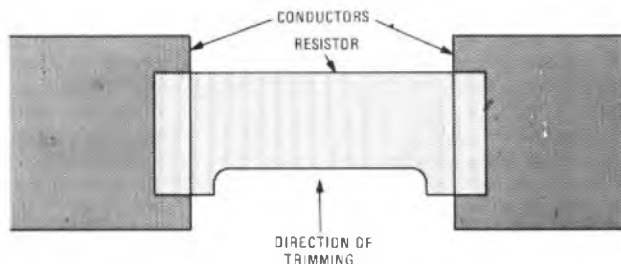

FIG. 6—Air-abrasive trimming configuration

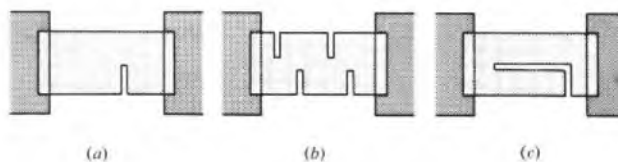

FIG. 7—Laser trimming configurations

during ageing. The drift can be minimized by appropriate choice of material and careful control of laser settings. Laser trimming is a cleaner operation than air-abrasive trimming however, and it is possible to adjust circuits after active components have been added, to adjust the function of a complete circuit rather than adjusting individual resistors. For small-scale production, air-abrasive trimming can give resistors trimmed to $\pm 0.5\%$, and these are free from the stresses and possible microcracking introduced by laser trimming.

Since trimming can only remove resistor material, resistor values can only be adjusted upwards. Because of the $\pm 20\%$ tolerance on fired value, it is usual to design resistors so that the mean of the distribution of values is at 75% of the final value. This means that resistors at the high end are still able to be adjusted up to their final value, and resistors at the low end can be trimmed without reducing their width by more than 50%. It is necessary to restrict the amount of trimming to avoid hot spots. Air-abrasive trimming is better in this respect because the resistor is narrowed more uniformly than in a single laser cut.

COMPONENT ATTACHMENT

The thick-film portion of a hybrid circuit usually consists of resistors, perhaps printed capacitors, plus interconnecting conductors. Other components are then added as miniature discrete components or as bare semiconductor dice.

Dealing firstly with passive components, multilayer ceramic chip capacitors are commonly used, in sizes from 1.27 mm \times 1.02 mm \times 1.02 mm up to 5.59 mm \times 6.10 mm \times 1.78 mm. Capacitance values are available from 1 pF - 1 μ F, the high-value capacitors having the largest physical size. For high-value capacitors, chip tantalum capacitors may be used. Where inductors are required, it is possible to print spirals of conductors, but these are inefficient in terms of inductance per unit area. Miniature chip inductors are a better solution; these are available with inductance values from 0.01-10 000 μ H, both fixed and adjustable, and physical sizes are similar to those of chip capacitors. Both chip capacitors and chip inductors are in the form of rectangular cubes with metallized end terminations.

These chips can be attached to circuits either by soldering or by the use of a conductive epoxy resin. For soldering, the conductor must be of a solderable type (that is, not gold) and the usual technique is to apply a solder paste to the areas where components are to be attached, to place the components in position, and then to heat the whole circuit until the solder paste flows. Conductive epoxy resins contain silver or gold filler to make them conduct and can be used on all types of conductor. The epoxy resin is applied to the substrate, the components are placed in position, and the resin cured by heating to a temperature of typically 150 C for 30 min. Disadvantages of solder attachment are that it is difficult to remove all flux residues completely and solders are less flexible than epoxy resins; hence, they are less well able to absorb the stress caused by thermal mismatch between component and substrate.

Resistors are also available in chip form. These are used where one resistor of a value very different from all the others on the circuit is required, making it uneconomic to print. They are also used for high-tolerance resistors, since they come ready-trimmed. Both thick and thin-film chip resistors are available, and they can be attached either face down by soldering or with conductive epoxy resin, or face up, with the terminations made by wire bonding (see Fig. 8).

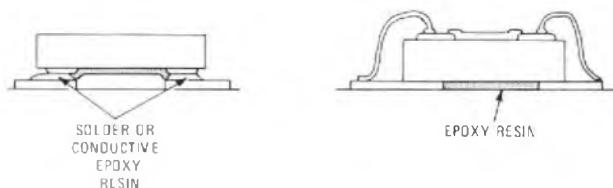

Fig. 8—Chip resistor attachment

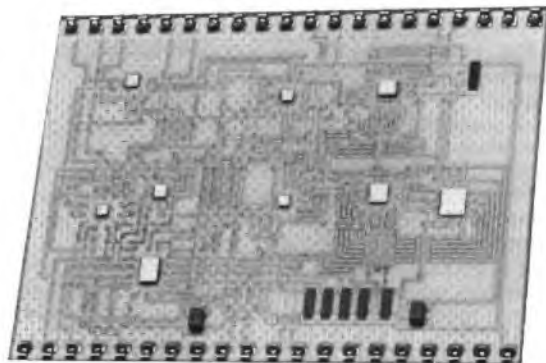

Fig. 9—Thick-film substrate with bare semiconductor dice

Active components for hybrid circuits can be either bare dice (see Fig. 9) or ready-encapsulated. Bare dice are smaller in size, but have the disadvantage that they cannot be burned in or fully electrically tested before being used in the hybrid circuit. Thus, it may be necessary to rework a circuit after initial testing to remove faulty dice and replace them. For high reliability, bare dice need to be encapsulated in a clean hermetic environment; hence, if bare dice are used on a hybrid circuit, the entire circuit must be in an hermetic package. This ensures that the chips are protected from water vapour and other contaminants. The attachment of semiconductor dice to the substrate can either be by using conductive epoxy resin or, if the die is silicon and the area to which it is to be attached is gold, by eutectic bonding. Eutectic bonding requires a higher temperature (370°C) than epoxy-resin bonding and care has to be taken that this high temperature does not damage devices already on the substrate while the bonding takes place. To achieve this, various forms of localized heating are used to heat only the area where the die is being attached. A further disadvantage of eutectic bonding is that a faulty die can be removed only by remelting the eutectic, at a temperature in excess of 370°C, which could lead to damage to other good dice. Epoxy-resin-attached devices can be removed by heating them to only about 300°C. For these reasons, epoxy-resin die attachment is generally preferred, but may result in long-term reliability problems.

Connexions from the bonding pads of the chip to the conductors on the substrate, and from the conductors to the package leads, are made by wire bonding. The two basic techniques are ultrasonic wedge bonding, using aluminium wire, and thermocompression ball bonding, using gold wire. Variations on the latter technique include thermosonic (that is, heat plus ultrasonic vibration) ball bonding of both gold and aluminium wires, and pulsed-heat ball bonding. Both these techniques are ideally suited for hybrid circuit bonding, because the addition of energy through the bonding tool, either as ultrasonic vibration or heat pulses, means that the substrate can be kept at a low temperature. This avoids softening of epoxy resins and damage to active devices, which could occur if they were kept at a high temperature while a large number of bonds was made.

Whichever bonding technique is used, it is almost inevitable that somewhere there will be an interface between gold and aluminium, since chip metallization is generally aluminium and conductor tracks and package leads are usually gold. Gold and aluminium in contact at high temperatures, particularly in the presence of silicon, form intermetallics. The intermetallic region develops voids, which increase bond resistance and eventually cause the bond to break².

The ball-bonding techniques which keep the temperature low help in this respect, since there is less likelihood of intermetallic formation at low temperatures, but there still seems cause for doubt about the reliability of the bond. Where aluminium wires are used, the interface occurs on the substrate rather than on the chip, and alloyed gold conductors have been developed to give improved bond-strength ageing characteristics³. These conductors contain an added element

which slows the formation of gold-aluminium intermetallics.

A recently developed technique for attaching chips to thick-film substrates is tape automated bonding⁴. A plastic tape similar to 16 mm or 35 mm film is plated with a pattern of copper and gold conductors which overhang a hole in the middle of the film. These overhanging leads are attached to the chip by solder/eutectic bonding or by thermo-compression bonding. For solder/eutectic bonding, the metallization on the tape is tin-plated copper. Before the chips can be bonded to the tape, bumps of gold are plated on to the bonding pads of the chip, or at the ends of the leads, and these bumps form the connexion between the chip and the tape. Once bonded to the tape, the chips can be tested and burned-in, since contact can be made to the conductors on the tape. To attach the chips to the substrate, the chip plus leads is cut out of the tape and then usually the chip is bonded to the substrate with epoxy resin. The leads are thermo-compression bonded to the substrate conductors in a gang-bonding operation, where a heated tool compresses all the leads simultaneously. This eliminates the need for individual wire bonds.

As previously mentioned, bare-chip hybrid circuits need to be packaged hermetically. Hermetic packages for large substrates are expensive, and so it is sometimes preferred to use hermetically-sealed active devices and a low-cost secondary package. Packaged active devices take up more space than bare chips, but an added advantage is that the devices can be tested before attachment to the hybrid circuit. Examples of such hermetic packages are ceramic dual-in-line packages, flat packs, metal-glass packages (for example, TO 18), and chip carriers. The latter are similar to flat packs but without leads. Connexion is made through the ceramic wall of the package by metal tracks buried in the ceramic, which terminate in gold-plated contacts on the base. For applications when reliability requirements are not so stringent, plastic-encapsulated active devices may be acceptable, and transistors and diodes are available in SOT 23 and Micro-E configurations. All these encapsulated devices are usually attached by reflow soldering. It is not usual to mix bare chips and encapsulated devices on the same circuit since any flux from soldering can contaminate the bare chips.

PACKAGING

The final packaging method for a thick-film circuit usually depends on what the circuit contains and what reliability is required. For a passive resistor network, a soldered-on lead frame followed by a conformal coating of plastic is usually adequate. Such coatings are usually in the form of powders which are applied by dipping the pre-heated substrate into a fluidized bed, then curing. They are called conformal because they follow the contours of whatever is under them, as opposed to being moulded. Soldered-on lead frames plus conformal coating can also be used on hybrid circuits containing active devices provided that, if a reliable product is required, the active devices are themselves hermetically packaged. Conformal coatings applied directly to bare chips are not reliable for the same reasons that plastic-encapsulated integrated circuits are not yet reliable enough for some applications. The lead frames can be clipped on to one or both edges of the substrate to produce single-in-line or dual-in-line configurations. After removing the tie bar, there are pins on a 2.54 mm pitch.

The next stage in sophistication is to attach lead frames and then stick a ceramic cover over the circuit using epoxy resin. This type of packaging can be used on bare-die hybrid circuits, since the epoxy resin is not directly in contact with

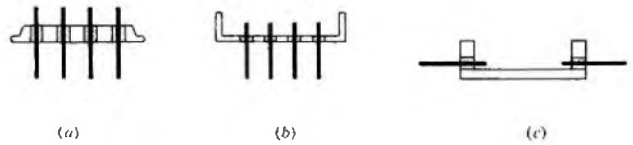

FIG. 10—Sections through hermetic packages

the surface of the dice, but there are doubts about the technique, since most epoxy resins are permeable to moisture; hence, the enclosed volume will not stay dry for very long, and gases liberated from the epoxy resin may themselves be detrimental to bare chips.

For high reliability, hermetic packages are used. These are generally expensive because they are often gold plated, and there is a wide range of styles and sizes available. This latter characteristic may at first seem an advantage, but it means that the economies of mass production of packages are never achieved. Common styles of package are the platform header (Fig. 10(a)), solid side wall (Fig. 10(b)) and flat pack (Fig. 10(c)).

These packages are either of metal construction with leads passing through matched glass-to-metal seals, or of ceramic. The metal packages can be sealed by welding on a lid, and all of the packages can be sealed by soldering lids using a gold/tin preform, or soft solder and a soldering iron. The latter technique is not recommended because it is likely that flux residues will be sealed inside the package, which will later contaminate and affect the reliability of the circuit. The welding techniques are generally brazing, forming an alloy between nickel on one component and gold on the other. Single-shot projection welding can be used for packages up to about 100 mm perimeter. For large packages, seam welding (a series of overlapping spot welds) is used. Other welding techniques include laser and electron-beam welding. All techniques have the aim of sealing the lid to the header by localized heating, without allowing the contents of the package to get too hot.

CONCLUSION

An introductory review of the processes involved in thick-film technology has been presented to enable the user to make an informed choice of technology for his application. More details of the processes and materials can be found in books on the subject, such as those listed in the bibliography.

References

- 1 Thick-Film Conductor Survey. Electrical Research Association Report No. 75-43. (Electrical Research Association, Leatherhead, 1975.)
- 2 PHILOFSKY, E. Intermetallic Formation in Gold-Aluminium Systems. *Solid State Electronics*, Vol. 13, p. 1391, 1970.
- 3 HOROWITZ, S. J. *et al.* Connecting to Gold Thick-Film Conductors: Performance and Failure Mechanisms. Proceedings of the International Conference on Thin and Thick-Film Technology, Augsburg, Sept. 1977.
- 4 OSWALD, R. G. *et al.* Automated Tape Carrier Bonding for Hybrids. *Solid State Technology*, Vol. 21, p. 39, Mar. 1978.

Bibliography

- HARPER, C. A. (Ed.) *Handbook of Thick-Film Hybrid Microelectronics*. McGraw Hill, 1974.
- HOLMES, P. J., and LOASBY, R. G. *Handbook of Thick-Film Technology*. Electro-Chemical Publications, 1976.

The MOST Director

Part 2—Store Loading, Maintenance and Traffic Metering

K. H. GRUNWELL and D. WALTON†

UDC 621.395.341 : 621.382.3

Part 1 of this article described the design principles and call-routing facilities provided by the MOST director. Part 2 describes the methods of loading store information, the built-in fault reporting and maintenance facilities and the traffic-metering system.*

OUTLINE OF COMMON-CONTROL FACILITIES

Fig. 2 of Part 1 of this article showed the control and routiner portion of the MOST director system accommodated on the 3 central shelves of the MOST director rack. The facilities provided by the common control can be divided into 4 sub-systems as follows:

- (a) the triplicated translation-store and its associated power supplies (described in Part 1),
- (b) the translator-control subsystem, which provides the facilities for loading, monitoring and changing the information stored in the translators and metering stores; the subsystem also provides buffer storage, visual-display and print-out facilities for fault and routine information from the system monitor,
- (c) the system-monitor subsystem, which deals with faults in co-operation with the translator-control subsystem, carries out routine tests of registers and collects some of the traffic-metering information for the traffic-metering system, and
- (d) the traffic-metering subsystem.

TRANSLATOR-CONTROL SUBSYSTEM

The translator-control subsystem comprises the translator control unit, visual-display control unit, visual-display unit, teleprinter interface unit and the tape-recorder unit; a block diagram of the translator-control subsystem is shown in Fig. 13. In addition to loading, monitoring and changing the stored information in the translators and meter stores, this subsystem provides storage for fault and routine information from the system monitor for display and/or printing.

† Network Executive, Exchange Systems Department, Telecommunications Headquarters

* GRUNWELL, K. H., and WALTON, D. The MOST Director, Part 1, System Outline, Technology and Call-Routing. *POEEJ*, Vol. 72, p. 266, Jan. 1980.

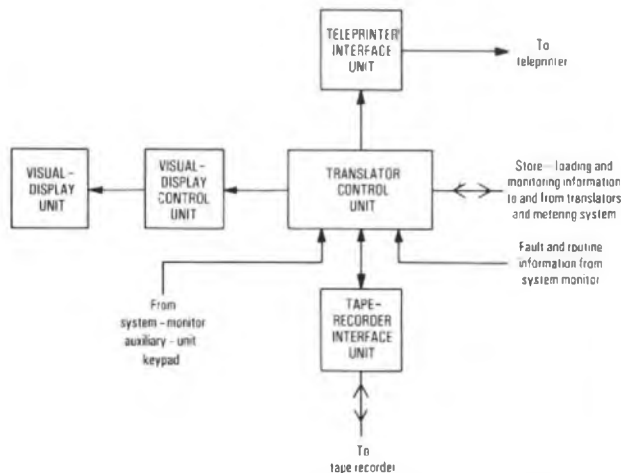

FIG. 13—Block diagram of translator-control subsystem

Translator Store Control

Loading, monitoring and changing of store information is effected by using the store-access switches, the keypad mounted on the translator control unit, the keypad mounted on the system-monitor auxiliary unit, and the display provided by the visual-display unit.

Monitoring and Checking

The translator to be monitored is selected using the appropriate keys and switches on the translator-control and system-monitor auxiliary units. The instruction buttons ADDRESS, STEP, etc. are mounted on the translator control unit and the digit buttons, —, 1 to 0, T, U, V, W, and X are mounted on the system-monitor auxiliary unit, (see Fig. 2 of Part 1). The contents of a particular store are displayed on the top two lines of the visual-display unit when the ADDRESS button is operated followed by 4 digit-buttons corresponding to the required store address. Once the content of a store is displayed, operation of the STEP button causes the contents of the subsequent stores in the numerical sequence to be displayed on lines 3 and 4 of the visual-display unit. Repeated operation of the STEP button causes the content of subsequent stores to be displayed. When the screen is full, operation of the ADDRESS button causes the screen to be blanked. Subsequent operations of the STEP button cause the next 7 store-contents to be displayed. Fig. 14 shows the visual-display screen with a typical display of store information.

Loading

The store to be loaded or changed is accessed as previously described under monitoring. Following display of the existing store content, operation of the DATA button causes two 'dashes' to be displayed in the first two character positions on the centre line of the visual-display unit. The two dashes are displayed automatically when the DATA button is operated, indicating that no automatic alternative-route number is required. If a primary automatic alternative route (AAR) is to be loaded, the AAR button is operated before the DATA



FIG. 14—Display of typical store information

button; the dashes are not written automatically. The first two digits keyed are the automatic alternative-routing number. The translation to be entered is keyed using the digit buttons on the system-monitor auxiliary unit, each digit is displayed when it is keyed following the dashes on the centre line of the visual-display unit. The translation-word format is shown in Table 2 of Part 1. As the translation is being keyed in, a *sum check* signal is generated by the translator-control-unit circuitry, using the first 17 digits of the translation including the automatic alternative-routing digits. The *sum-check* signal is compared with the last 3 digits keyed and, if comparison is achieved, a SUM-CHECK CORRECT lamp is lit on the translator control unit. Illumination of this lamp indicates that the translation is valid and may be entered into the selected store by operation of the ENTER button. The sum-check facility has two functions in the system):

(a) a check can be made of each store for corrupted data, and

(b) unauthorized changing of store information is prevented because the correct sum-check digits must be known for a translation before the system will accept the information for entry into the store.

The initial loading of a store at a new installation will be carried out using the procedure previously described but, once a translator is loaded, its content can be transferred to the other two stores by manipulating the store-selection switches and by operating the TRANSLATOR-TO-TRANSLATOR (TTT) button. The transfer of the content of one store to another is completed in approximately 400 ms.

Loading a Store from Magnetic Tape

The tape recorder is connected to the tape-recorder interface unit as described above, and the translator to be loaded is selected using the store-access switches. With the tape recorder switched to REPLAY, operation of the LOAD-FROM-TAPE (LFT) button when the *lead-in* tone is heard causes loading to commence. During the loading sequence, the content of alternate stores is displayed on the visual-display unit.

Destination-Call-Count Meters Store-Loading

The destination-call-count meter (DCCM) store to be loaded is selected by using the meter X, meter Y and store-access switches. The content of the store selected will be displayed on the visual-display unit following operation of the DCCM, ADD buttons and any 4 digit-buttons. A new code, consisting of the AAR digits and 6 address-digits, can be keyed following operation of the DATA button, and the code is entered into the store on operation of the ENTER button. No sum check is carried out during this operation.

Recording of Store Content on Magnetic Tape

The security of the store system is further enhanced by the

ability to transfer the store content, suitably coded, to magnetic tape. This facility allows a store to be reloaded in approximately 13 min in the very unlikely event of the content of all 3 translators losing the contents of their stores. The recorder used is a standard cassette tape recorder, connected to the system by a flexible cord plugged into the tape recorder interface unit. The store providing the information to be recorded is selected and connected to the tape-recorder by using the data-store selection switches. The store address from which recording is to commence is keyed as previously described, the tape recorder is switched to RECORD and the recording starts when the LOAD-TO-TAPE (LTT) button is operated. If the whole store-content is to be recorded, *store-address No. 1* instruction is keyed as the *start* address and recording stops automatically when the last store content has been recorded.

Storage and Display of Routine and Fault Information

Routine and fault information is received from the system monitor for display on the visual-display unit and the teleprinter. Routine information is displayed only on the visual-display unit, whereas fault information is displayed and printed out. Storage for up to 5 messages awaiting print-out is provided in the translator control unit and, when the storage capacity is full, a signal is sent to the system monitor to prevent collection of further information until a store space becomes free.

Tape-Recorder Interface Unit

The tape-recorder interface unit provides an electrical interface between the translator control unit and a magnetic (cassette) tape recorder. Information in the form of 80 bit translations and 16 bit addresses can be encoded by the modem into frequency-shift-keying (FSK) signals and transferred, in this form, to the magnetic tape. Similarly, on replay, the FSK signals can be decoded back into compatible binary signalling of 80 bit and 16 bit words and transmitted in this form to the translator control unit.

For encoding purposes, the unit converts a negative logic *zero* signal to a frequency of 3456 Hz and a negative logic *one* signal to a frequency of 2160 Hz. The modulation process is controlled by a counter, which divides the ϕ_1 clock by 100 or 160, depending on the binary input state (see Fig. 15). For a logic *zero* input, the 345 kHz clock is divided by 100, and for a logic *one* input the clock is divided by 160.

The demodulation process is controlled by a phase-locked loop integrated circuit. This contains a voltage-controlled oscillator (VCO), which is set to a free-run frequency of 2808 Hz (midway between the incoming FSK frequencies).

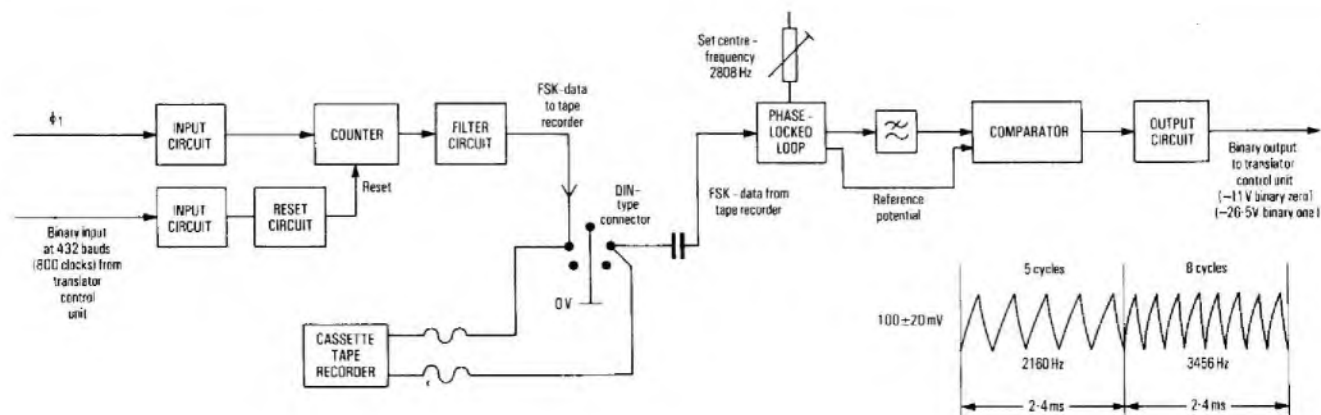

FIG. 15—Tape-recorder interface unit

When a frequency change is detected, the VCO frequency, which is compared with the incoming frequency, changes, and the error voltage produced is filtered and used to reconstitute the binary waveform.

Visual-Display Control Unit

The visual-display control unit (VDCU) controls the display of alpha-numeric characters on a television receiver. Information is presented to the television receiver from other units to enable fault data, register input and output information when progressing a call, translator-store information, and keyed information from the data keypad to be displayed.

Each character is made up of seven 5 bit rows (see Fig. 16) but, to provide an acceptable aspect ratio of 5:14, each row of the character is displayed twice, thus giving a character depth of 14 lines on the screen. A further 4 blank lines are allocated for line spacing and one horizontal position is left spare to allow a space between each character; thus, each character is formed in a 6×18 matrix.

The basic structure thus provides for 17 lines of 30 characters, but this is reduced to 15 lines of 20 characters because of the need for margins and line and frame fly-back. A block diagram of the VDCU is shown in Fig. 17.

The basic clock-frequency is derived from a 2.7 MHz crystal oscillator which is fed into a divide-by-12 counter. Outputs are taken from counts 2, 4 and 6 to derive the 4-phase clock required to drive the MOS integrated circuits.

Data is presented to the input in serial form at a system clock speed of 345 kHz and is fed via a parallel-to-serial converter and a serial-to-parallel converter to change the input operating speed to that of the visual-display unit (that

is, 500 kHz). This data is fed into integrated circuit (IC) D4015 in ASCII code and stored on a 9 bit shift register. The control information is acted on within the IC and the character information is placed into a buffer store. IC D4015 also derives the signals for frame fly-back, line fly-back, addressing of the read-only memory (ROM), store transfer data and reset synchronization. Also included is a 510 bit shift register which circulates a single logic one to indicate the position of the next character that is to be written on the screen.

The information in the 9 bit shift register in IC D4015 is transferred to 6 store ICs (IC D4016), each of which consists of a 510 bit shift register with a write input and the facility to transfer 30 bit at a time into a 30 bit register having a read output. Thus, the 510 bit registers hold information in ASCII code to display 17 lines of 30 characters, and the 30 bit registers each hold 1 bit of the ASCII code apertaining to the 30 characters of the line being written.

The outputs of the 6 store ICs are in parallel, and their data is presented in serial form to two ROMs, which therefore receive sequentially complete ASCII codes for the characters to be displayed. The ROM then translates the ASCII code into a character code apertaining to the line-scan number (see Fig. 16). Thus, the ROM output for scans one and two is 00100, and for scan three the output is 01010. The line-scan numbers applied to the 2 ROMs from IC D4015 are different; this factor enables character rounding to be achieved, as explained below.

Because each character requires 18 line scans, the data in the 30 bit register must be presented to the ROM 18 times. During the time taken to achieve this, the 510 bit store will have cycled through 540 bit (that is, one complete cycle plus 30 bit). The conditions are thus satisfied for the transfer of the next line of information to the 30 bit stores.

Character Rounding

Character rounding compares 2 bit of a given line data with 2 bit of the previous line data and 2 bit of the next line data. The bits compared are those which would appear in the same time-slot of the horizontal line-scans immediately above or below the 2 bit of the line being written. Comparisons are made for every bit of the line being written and decision is made as to whether character rounding is required. (Logic one in the character code modulates the cathode-ray-tube screen display during the normal clock pulse and produces a bar 0.5 bit long on the screen. If character rounding is required, the screen display will also be modulated during the inverted clock-pulse: this action elongates the bar by 0.5 bit.)

The ROMs are therefore addressed differently and their outputs are taken via 5 bit shift registers which serialize the output data: this is fed via a comparator network before transmission to the visual-display unit. The outputs from the 5 bit shift registers include a sixth bit (a logic zero) to provide the 1 bit horizontal space between characters.

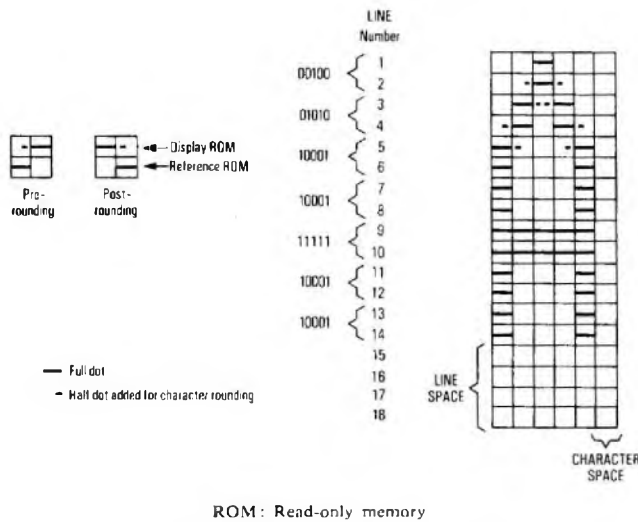

ROM: Read-only memory
FIG. 16—Construction of display character

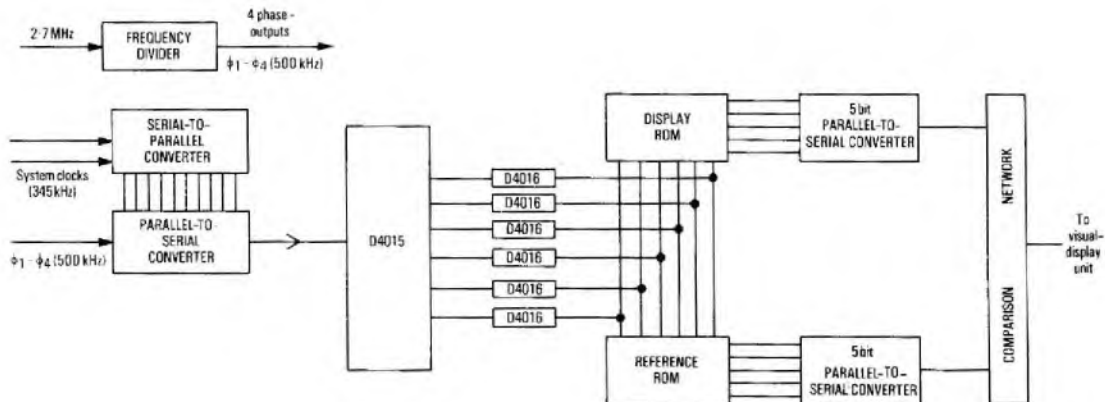

FIG. 17—Block diagram of visual-display control unit

Visual-Display Unit

The visual-display accepts a composite video signal from the visual-display control unit at a nominal 625-line standard. The video signal is amplified and used to drive the cathode of the cathode-ray tube. The synchronization pulses are separated from the video signal by the line and field processor to produce line and field waveforms, which are amplified and fed to the scan coils. The line output transformers also generate all the HT voltages and the EHT voltage to the tube.

The low-voltage supply to the video circuits is derived from the -50 V supply by a fly-back switching converter, which feeds a linear regulator to produce the required voltage.

SYSTEM-MONITORING SUBSYSTEM

The system-monitor subsystem comprises the system-monitor control unit, system-monitor auxiliary unit, routiner comparator unit and the comparison register, as shown in Fig. 18.

The registers and translators are scanned sequentially by the system monitor to collect fault data and, at the same time, either to apply live traffic comparison, or to generate routine test calls, to the registers. It takes approximately 500 ms to complete a full interrogation of a register-translator system.

The sequential scanning is controlled by the system-monitor control unit, which sends, in turn, *XY* address of each register and translator as serial data to the system-monitor auxiliary unit, where the data is converted into discrete signals and connected to the appropriate X and Y highways. The receipt of both *X* and *Y* select signals cause the register or translator to return a signal on the tester highway to the system-monitor control unit, to indicate that the position addressed is equipped. In response to the equipped indication a *status demand* signal is transmitted to the accessed unit via the

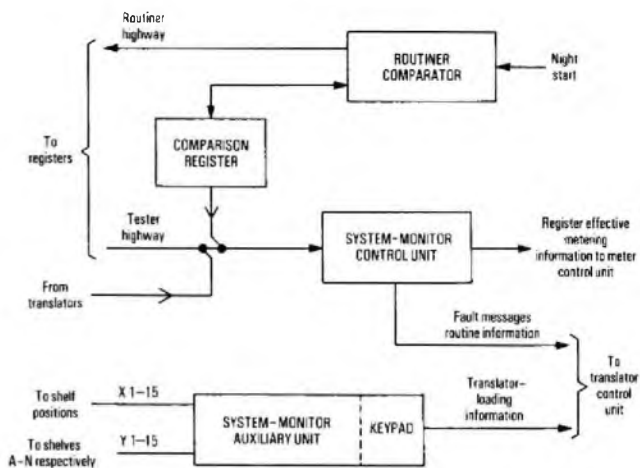

FIG. 18—Block diagram of the system-monitor subsystem

Y highway, which replies on the tester highway with a *status reply* signal. The *status reply* signal is decoded by the system-monitor control unit, and the response to the accessed unit is dependent upon the result of the decoding; for example, a *proceed-to-send* signal causes the accessed unit to send the requested information on the tester highway. The complete range of *status demands*, *status replies* and information transfers is shown in Table 5. The information received by the system-monitor control unit is decoded and distributed as follows:

(a) Fault information is sent to the translator control unit, including the address of the accessed unit, for display on the visual-display unit and for printing out.

TABLE 5
Fault-Data Collection

Status Demand from System Monitor (Y Highway)	Status Reply from Register or Translator (Tester Highway)	System Monitor Action	Unit Interrogated Response	System Monitor Action
What is your status?	Free (register)	Interrogate next unit	—	—
	Ready-to-send call accounting data (register)	Proceed-to-send (data)	Sends 160 bit of data	Reset error-message store in unit interrogated (Note 1)
	Ready-to-send fault data (register)	Proceed-to-send (data)	Sends 160 bit of data	Reset or lockout (Note 2)
or	Ready-to-send fault data (translator)	Proceed-to-send (data)	Sends 160 bit of data	Reset
	Lockup (to first code Selector) (Note 3)	Busy (register)	Interrogate next unit	—
Locked out (register)		Interrogate next unit	—	—
Locked up (register)		Interrogate next unit	—	—
Just been seized		Operate test-relay (Note 4)	—	—
or	On test (register)	Either proceed-to-send (data) or release test-relay	Sends 160 bit of data	Reset (at end of call)
	I am comparison register	Proceed-to-send (data)	Sends 160 bit of data	Reset (at end of call)
	No data (translator)	Interrogate next unit	—	—

Notes: 1. Error message store is reset on receipt of *lockout*, or *release test-relay*.

2. *Lockout* sent if 10 incorrect successive seizures received.

3. *Lockup* sent to enable register to lock-up to first-code selector under certain fault conditions.

4. Interrogate next unit if another register is already on test.

(b) Call-accounting data is sent to the call-accounting equipment.

(c) Register effective metering information is obtained by examination of the call-accounting data and is forwarded to the traffic-metering system.

The information received is also used in conjunction with the routiner comparator unit and the comparison register to apply tests to the registers in two modes, known as *day-time mode* and *routiner mode*.

Day-Time Mode

The status reply *I have just been seized* indicates that the accessed register is seized but not yet returning dial tone. Provided that no other register is on test at the time, receipt of this status reply by the system-monitor control causes the comparison register to be connected in parallel with the accessed register using the routiner highway. Both registers receive the incoming digits. The resulting outgoing digits and release sequences of each register are compared by the routiner comparator. If the output of both registers agree, the register on test is taken off test on the next access scan. If a disparity is detected between the outputs of the two registers, a print-out is initiated, via the translator control unit, giving all the relevant data from each register.

Routiner Mode

The routiner mode of testing can be initiated manually at any time, or automatically by a clock pulse from an external source and, provided that a live call comparison is not in progress, the system-monitor switches to routiner mode. In this mode, an additional scan is started to control the sequential testing of the registers and, if the routine was started automatically, to stop the sequence when all registers have been tested. The additional signalling sequence performed by the system monitor when in routiner mode is shown in Table 6. Under automatic start conditions, each free register is connected in parallel with the comparison register and both are tested with 10 pre-selected test calls, which are pulsed out from a repertory dialler in the routiner comparator over the routiner highway. The output pulses and release sequences of both registers are compared by the routiner comparator and, if a disparity is detected, the data stored in each register is

printed out along with the registers' identity. A manual start can also initiate the test of each free register as above but, under manual control, the test sequence can be modified as follows:

(a) each free register can be tested with just one selected test call from the 10 stored,

(b) one register can be tested continuously,

(c) any register can be selected manually for test by setting up its identifying code on switches on the system-monitor control unit, and

(d) if a particular fault is being investigated, any number can be entered manually into a register on test from the keypad on the system-monitor auxiliary unit.

Each week, on receipt of a pulse from an external source, a demand is initiated by the system monitor to check and reset a bistable in the registers which is set by a live call on the registers. This action proves that each register has processed at least one live call during the previous week; any registers not having processed a call are identified and their identity is printed out.

TRAFFIC-METERING SUBSYSTEM

The traffic metering subsystem enables traffic studies to be carried out in considerable depth. The subsystem is capable of driving up to 80 meters. There are 40 destination-call-count meters (DCCMs) each of which can be assigned to a particular address code. The 38 register-effective meters monitor various levels of effective calls and can distinguish between 3 different tariff periods and two register classes-of-service. The remaining two meters are used to count register seizures and ineffective calls. A block diagram of the traffic-metering subsystem is given in Fig. 19.

Destination-Call-Count Metering

Each DCCM meter has a store associated with it which can be programmed with a code corresponding to an address code from one of the translators. Every register is connected to a shelf metering highway. When a register has been seized and it has achieved a complete comparison (that is, has selected a translation for use on that particular call), it sends a pulse down the metering highway. The metering subsystem is

TABLE 6
Test Data Collection

Status Demand from System Monitor	Status Reply from Register	System Monitor Action	Unit Interrogated Response	System Monitor Action
<i>What is your status</i>	<i>Free</i>	Operate test-relay	—	—
	<i>Ready-to-send call-accounting data</i>	Print <i>busy</i> Step to next unit	—	—
	<i>Ready to send fault data</i>	Print <i>busy</i> Step to next unit	—	—
or	<i>Busy</i>	Print <i>busy</i> Step to next unit	—	—
	<i>Locked out</i>	Print <i>locked out</i> Step to next unit	—	—
<i>Lockup</i>	<i>Locked up</i>	Print <i>locked up</i> Step to next unit	—	—
or	<i>Just been seized</i>	Print <i>busy</i> Step to next unit	—	—
<i>Read seizure toggles</i>	<i>On test</i>	Proceed-to-send (data)	Sends 160 bit of data	Reset (at end of call)
	<i>I am comparison register</i>	Proceed-to-send (data)	Sends 160 bit of data	Reset (at end of call)

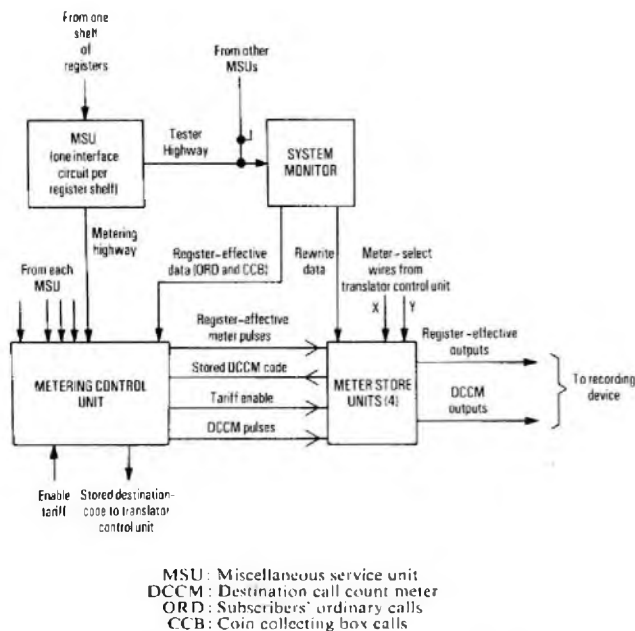

FIG. 19—Block diagram of traffic metering subsystem

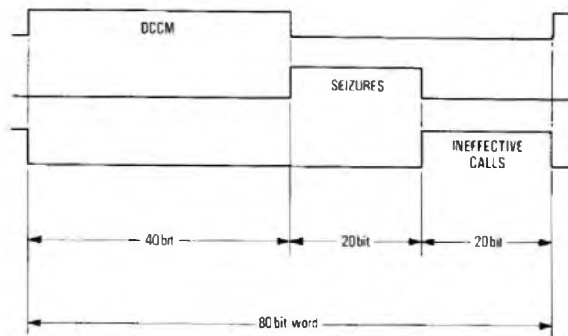

FIG. 20—Register-metering time-slot allocation

way, but in a different time-slot from the DCCM pulse. The relationship between the DCCM, seizure and ineffective time-slots is shown in Fig. 20. The seizure meter is incremented for every one of these seizure pulses received.

If a call does not proceed to a normal-release condition, but culminates in a forced release or in an abandoned-call release, it is known as an *ineffective call*. In this case, the register places another pulse on the metering highway in a different time-slot. A meter is provided to count ineffective calls.

Divide-By Options and Meter Rates

Each meter output can be individually strapped to either $\div 1$, $\div 10$, $\div 100$ or $\div 1000$. In addition, all the meter outputs can be strapped to give either 10 pulses/s, 20 pulses/s, 40 pulses/s or high speed (approximately 16 kHz).

POWER SUPPLIES

Before being connected to any equipment units, each of the -50 V power supply inputs is routed via input filters, which reduce ripple voltages and eliminate spurious voltage-transients. The filtered output is taken via fuses to the slide-in units as necessary and also to -50 V to -26.5 V power-supply units, which are used to drive most of the system.

The power-supply units are provided

- (a) one per shelf of registers,
- (b) one for each translator,
- (c) one for the system-monitor equipment, and
- (d) one for the translator-control equipment.

The -26.5 V output is produced by switching the -50 V input for approximately half of the time at 40 kHz, and by smoothing the output with a filter. The output voltage is monitored and used to modulate the pulse width to achieve voltage control. Back-up over-voltage protection is provided by a *crowbar*-type thyristor circuit.

To power the transistor-transistor logic (TTL) integrated circuits in the control area, two 5 V power system switching regulators are used. The units generate a voltage of $+7.5$ V with respect to the -26.5 V supply line (that is, -19 V). This voltage of -19 V is applied on a per card basis to an IC voltage regulator to produce a power supply rail of -21.5 V. The $+5$ V required by the TTL ICs is thus available between -21.5 V and -26.5 V.

ACKNOWLEDGEMENT

This article has described the broad principles of a unique system developed jointly by Pye TMC Ltd. and the Telecommunications Development Department of the BPO. The project has been a model example of co-operation between the BPO and Industry, and the authors wish to thank all those who have been involved for their endeavours to bring this project to its successful conclusion.

continually receiving data from a translator in the same way as the register. If a pulse is received on the metering highway at the same time as the stored code agrees with the address code on the rewrite-data input being received from the translator, the meter associated with that store is incremented.

The contents of any DCCM store can be displayed on the visual-display unit and changed, if desired, via the translator control unit.

Register-Effective Metering

At the completion of a successful call (that is, one that culminates in a normal release), data is retrieved from the register by the system monitor via the tester highway, which includes details of the number dialled by the subscriber and the class-of-service strapped to that particular register. From this information, the system monitor determines

- (a) whether the register class-of-service was ordinary or coin-collecting box,
- (b) the initial digit dialled into the register, and
- (c) in the case of an level-0 call, whether the call was an international subscriber dialled (ISD) call, or a specially-selected national number dialled (NND) call, or neither of these.

This selected information is transmitted to the metering subsystem where, for each class-of-service, it is re-assembled in the following 6 groups:

- (a) level 1,
- (b) levels 2-9,
- (c) level 0,
- (d) levels 11-16,
- (e) ISD, or
- (f) NND call (specially selected).

(Note: Groups (c), (e) and (f) are not mutually exclusive).

Each of the groups ((a)-(f)) is capable of driving 3 meters, one for each tariff period, but only one will normally be enabled at any particular time. In addition, two spare meters are available which can be strapped to record any individual initial digit within the range of group (b) and group (d), or any combination of these.

Register Seizures and Ineffective Calls

When a register is seized it puts a pulse on the metering high-

Monarch 120—A New Digital PABX

A. R. POTTER, B.SC., C.ENG., M.I.E.E.†

UDC 621.395. 2: 621.374

Monarch 120 is a digital-switching telephone-exchange system for use at customers' premises. The system, which uses stored-program control techniques, provides a greater range of customer facilities than that provided by existing PABXs. Also, the system is designed to provide data-transmission facilities to meet the present-day and future needs of customers who require a modern business communications centre.

INTRODUCTION

A new private automatic branch exchange (PABX) has been developed by a joint British Post Office (BPO) and industry team¹. The system, designed for the telephone-equipment rental market, has a capacity of 24–120 telephone extensions. Although its name during the development phase of the project was Customer Digital Switching System No. 1 (CDSS1), the system will be marketed under the title of *Monarch 120*.

The Monarch 120 system exploits the techniques of stored-program control (SPC) and digital switching by using A-law pulse-code modulation (PCM), to provide a product that has the following major features:

- (a) it has an advanced range of customer facilities;
- (b) the equipment is compatible with modern office accommodation, because it is small in size and operates from the public mains-supply;
- (c) simple plug-and-socket connexions are used to permit easy installation and maintenance;
- (d) in addition to the standard telephony services, the system has the ability to handle the future demands of modern businesses for a range of data facilities; and
- (e) the central processor aids in the diagnosis of faulty units.

In many ways, the design of the Monarch 120 system is broadly compatible with the design of the System X family of public exchanges and has taken account of the future evolution of BPO telephone network. In particular, the integration of digital transmission and switching functions has been a major factor in controlling costs and has enabled an advanced services capability to be provided.

OVERALL SYSTEM ORGANIZATION

The Monarch 120 system consists of a central equipment unit, which is a single free-standing cabinet approximately 1.7 m high and 0.6 m² in cross-section, and an operator console, which can be positioned up to 300 m from the central equipment unit. The operator console will be the subject of a later article in this *Journal* and is therefore mentioned in this article only where it is relevant to the description of the system. The equipment cabinet is fitted with 2 shelves of common equipment: the control and switch hardware is mounted at the top of the cabinet and the power supply unit is mounted at the bottom. The intervening 5 shelves house the analogue-digital line interfacing circuits; the number of shelves provided is dependent on the number of extensions provided at a particular installation. In addition, space exists above the control shelf for electro-mechanical meters for recording calls made, or other miscellaneous equipment. The equipment cabinet (with front cover removed) is shown in Fig. 1(a).

Occupying 4 printed-wiring boards (PWBs) on the control

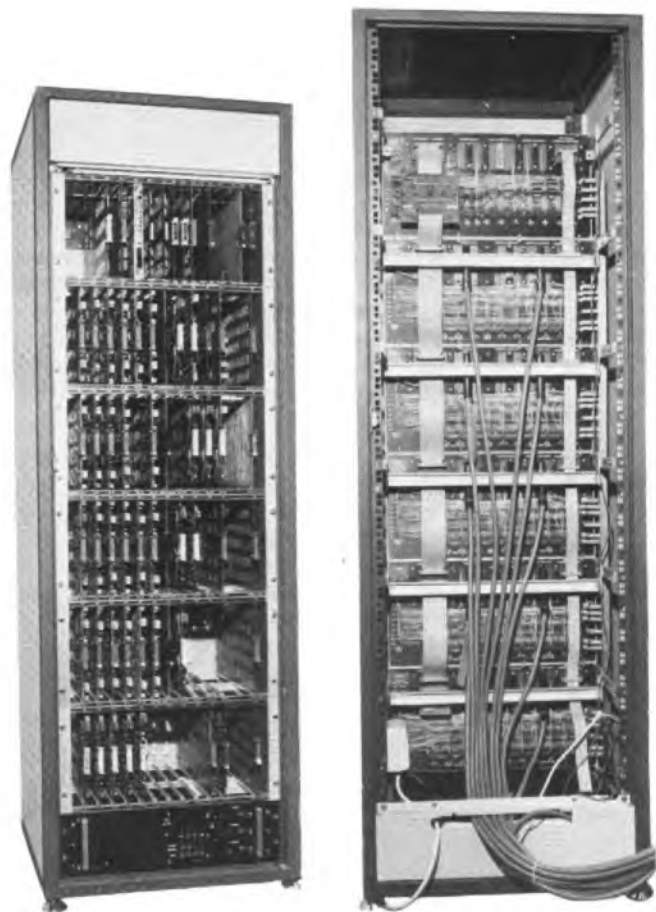

(a) Front view

(b) Rear view

FIG. 1—The Monarch 120 system equipment rack

shelf, a microprocessor and various memory circuits provide the central control function for the system. Two other PWBs provide buffer storage for interfacing signalling between the control and the peripheral line-interface circuits. On the other PWBs within the control shelf are provided the central digital switch, conferencing circuits, tone generation, and oscillator and waveform generation for the system. No replication of equipment on the control shelf is provided, because the inherent high reliability of the digital integrated circuits provides an acceptable failure rate for this small size of PABX.

† Research Department, Telecommunications Headquarters

Because the Monarch 120 system is a digital switching system, each analogue line terminating on the exchange has to have an analogue-digital interface. A variety of line units are used to cater for the different types of circuits terminating on an exchange; however, in each case, a standard interface is used between the line unit and the remainder of the exchange. Up to 32 individual line units can be accommodated on each line shelf, these being provided by either 2 or 4 units to a PWB. The first 6 positions on the line shelf accommodate the 4-port PWBs—these are generally extension-line interfaces; the 4 remaining positions are available for 2-port PWBs. At one end of the line shelf is a multiplexing card, which interfaces digital speech and signalling highways between the line units and the control-shelf equipment. A further degree of provisioning flexibility is provided, since 2-port and 4-port PWBs are electrically compatible. Finally, a central position in the line shelf can accommodate a PWB of fallback relays, which, under conditions of system failure, connect exchange lines through to a number of designated extensions; if this facility is not required, a simple by-pass PWB is provided instead.

The power supply unit provides conversion between the public AC mains supply and the 4 DC voltages used by the system. An installation comprising a fully-equipped cabinet and 2 operator consoles, and operating at the design traffic maximum of 32 simultaneous calls, requires approximately 600 W of mains input power. Power is distributed to the control and line shelves via a busbar, and the built-in over-voltage and over-current protection circuitry obviates the need for output fusing of the supply. An electronic ringer circuit, housed in the power shelf assembly, provides the standard 75 V RMS 25 Hz ringing signal. If required, on-site replacement of the power supply unit can be speedily effected, since the unit can be slid out from the front of the cabinet.

A view of the rear of the equipment cabinet, displayed in Fig. 1(b), shows how the interconnexion of the various assemblies of the Monarch 120 PABX is achieved. External lines from the distribution frame terminate on plug-ended cables on the line shelves. Between the control shelf and the line shelves, a ribbon cable, consisting of standard lengths between each shelf, carries the multiplexed digital speech and signalling highways and timing waveforms used by the system. In addition to this main cable, a small ribbon carries the ringing signal and a small number of common services signals from the power supply. A number of connectors are provided on the control shelf to give access between an external data link and the central control, to enable interconnexion between the digital switches and controls of two Monarch 120 cabinets and for the termination of a 2.048 Mbit/s PCM line system in a future development.

DIGITAL SWITCH AND SIGNALLING FUNCTIONS

A block diagram of the architecture of the switch and signal-handling circuits is shown in Fig. 2. All line units in the exchange operate synchronously and produce 8 bit PCM samples every 125 μ s. During this time interval, each line unit sends to its shelf multiplex 9 bits, comprising the 8 PCM bits and 1 bit of signalling information. Thus, the data rate between a line unit and the shelf multiplex is 72 kbit/s and an 8 bit signalling word is used with a repetition period of 1 ms, as illustrated in Fig. 3.

The shelf multiplex assembles 32 of these 72 kbit/s streams in a fixed order and in a bit-interleaved fashion onto an internal highway running at 2.304 Mbit/s. The shelf multiplex then separates the speech and signalling data for onward transmission to the input time-switch and signalling-input cards at 2.048 Mbit/s and 256 kbit/s respectively, reformatting the speech and signalling into 32 individual slots of 8 bits with the appropriate repetition

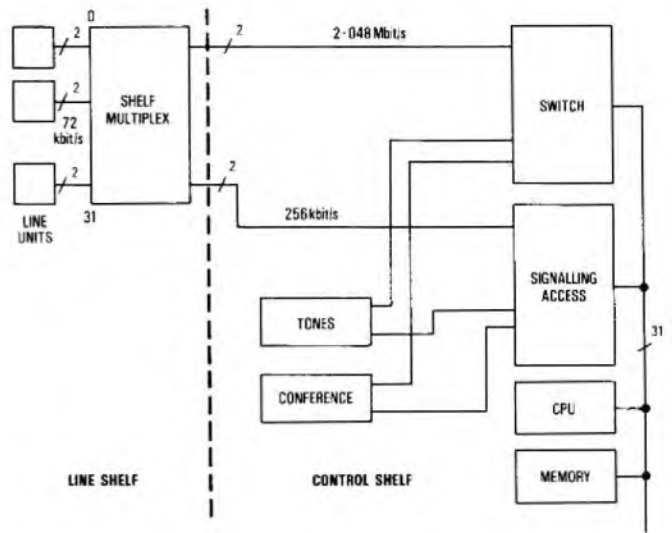

Fig. 2—Block diagram of the Monarch 120 system

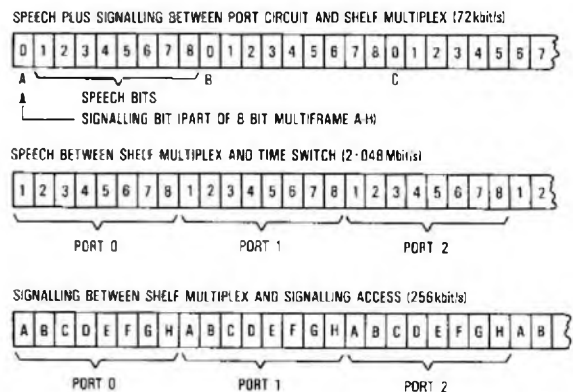

Fig. 3—Basic data formats associated with shelf multiplex

rate. The reverse direction of transmission is handled in an opposite fashion and can be considered as completely separate from the transmit direction of transmission; however, within the shelf multiplex, some common hardware is used for the storing and reformatting of the information. The digital switch for the Monarch 120 system is a single-stage time-switch which is fabricated on 3 PWBs: the input time-switch, the cabinet interface and the output time-switch. The digital switch has been structured in this manner to permit future flexibility, in that the system hardware may be readily adapted to enable 2 cabinets to operate alongside each other as a single exchange unit. This option has not been exercised in the initial development and, at present, the cabinet interface board is a passive link between input and output time-switch PWBs, and the output time-switch performs only demultiplexing of the PCM streams. In addition to the individual line units on the exchange, the digital switch provides access to the tone generator and conference units provided on the control shelf. A further PWB position is also left for future enhancement of the system (for example a digital 2.048 Mbit/s line system interface) and, to this end, the unit has external access via a socket on the control shelf back-plate.

A total of eight 2.048 Mbit/s highways access the input time-switch, 5 from the individual shelf multiplexes and 3 from the miscellaneous PWB positions on the control shelf. Each highway is first converted from serial to an 8 bit wide parallel format and then all highways are multiplexed to-

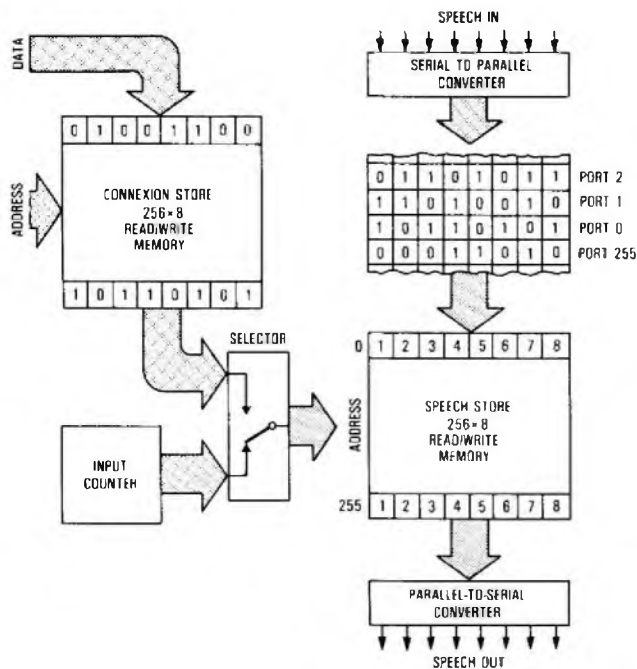

Fig. 4—Block diagram of the Monarch 120 system time-switch

gether and written sequentially into the time-switch speech store (a 256×8 bit read/write memory). A block diagram of the digital switch is shown in Fig. 4. The cyclic writing of information into the speech store is controlled by an input counter. To connect one port on the exchange to another (a port can be an individual customer, a tone source, a multi-frequency (MF) signalling receiver, etc.), it is necessary to read out the relevant contents of the speech store at a time corresponding to the output port connexion identity. Because the content of the speech store varies from call to call and during the different phases of a call, a connexion store (also a 256×8 bit read/write memory) is used to control this acyclic reading of information from the speech store onto an 8 bit parallel highway to the cabinet interface and onward to the output time-switch PWB. At this PWB, the speech channels are demultiplexed back onto the 8 highways and are converted to serial transmission for onward transmission to the shelf multiplexes etc. The connexion store contents are output cyclically every $125 \mu\text{s}$ to control the reading of data, and the connexion-store contents are updated from the central processor every time a switch path is set up or cleared. Because every port has a time-slot on the highways within the exchange and within the speech and connexion stores, the switch is completely non-blocking. This factor simplifies the overall control and dimensioning of the exchange.

Signalling input and output PWBs provide a buffering and access capability between the shelf multiplexes and the central processor unit (CPU). A 256 kbit/s highway carrying 32 signalling channels (8 bit/channel, repetition rate 1 kHz) is converted from serial to parallel transmission, multiplexed with the other highways and written cyclically into a 256×8 bit read/write memory. This information is updated at the 1 ms repetition rate of the signalling and, in this way, the up-to-date signalling status of each port is made available to the CPU at anytime. In the reverse direction, the CPU causes an 8 bit data word to be placed into a location within the 256×8 bit read/write memory in the signalling output PWB. This data word is then repeated to an individual port every 1 ms until it is updated.

CONTROL

The central control for the Monarch 120 System is provided by a single microprocessor (8085 type) and the memory circuits for holding program and working data information. The organization of the CPU and the means of access to the signalling and time switching PWBs is shown in Fig. 2. Linking between all the units is provided by a parallel bus system consisting of 8 data and 20 address lines. The microprocessor supervises the item of hardware which may access the bus, and a further 3 lines are provided to control the reading and writing of data between the microprocessor and the other PWBs. To read or write data to the signalling and time-switching memories does not require the full 20 bit of addressing capability that the bus provides. Partial decoding of the address bus is therefore provided on the signalling input PWB and only 8 bits of the address bus are extended beyond this point.

Three types of memory are provided. Programmable-read-only memory (PROM) is used for storing the basic control program for the exchange. Two PWBs are used, each with a capacity of 48 Kwords, each of 8 bits. Read/write memory or random-access memory (RAM) is used for storing working data such as information concerning calls in progress. In this case, a single PWB with 16 Kwords each of 8 bits is provided. Finally, a non-volatile memory board is used to store data which needs to be changed during the life of the exchange, but this information must be protected against power supply interruptions. To this end, a form of low-power RAM is used, together with an on-board battery to ensure that information is retained for a protracted period if power is removed from the board. A total of 8 Kwords are provided, of which 4 Kwords are used for fault information, facility usage and individual extension metering records. The remaining 4 Kwords store the database, which is the information describing the basic configuration of the exchange (equipment/directory number translations, location of particular line unit types and facilities available to particular extensions, etc.). In order that this database may be transported to site, 4 Kwords of PROM is also provided on this non-volatile memory PWB to provide an initial database. This is copied into the RAM where, subsequently, it can be updated to meet the ongoing operational needs of the customer.

The heart of the control is the CPU. Apart from the basic microprocessor, a number of other important hardware items are located on the CPU PWB. Three serial data input/output channels are provided for communication with external hardware. One of these channels is available at the front of the CPU PWB, and facilities exist to enable a portable teletype or similar machine to be plugged-in and used to interrogate the exchange. The other two channels are available from the back of the cabinet via sockets on the control shelf assembly, and these are used for data-logging equipment and inter-cabinet communication.

A special logic circuit has been developed to monitor the correct operation of the microprocessor. This circuit, known as the *watchdog*, expects to receive a signal from the microprocessor every 100 ms. If the watchdog does not receive the appropriate signal when expected, the watchdog forces a *warm-start* interrupt to be applied to the microprocessor. This warm-start interrupt causes the suspension of the software process running at that instant and returns control to the operating system software, which activates the scheduling of the next process waiting to be run. The occurrence of a warm start is logged and, in some circumstances, can cause loss of a call. If 13 signals from the microprocessor are missed by the watchdog (each being followed by a warm start) without a 25 s timeout expiring, then a *cold-start* interrupt is applied. This forces a complete restart of the program which, in turn, clears all calls and working data storage in the exchange before attempting further processing. If a further 3 signals to the watchdog are missed, again without the timeout expiring,

then 2 further cold starts are followed by the watchdog halting the processor and forcing the exchange to go into the fallback state. In this latter state, an urgent alarm is produced and a number of designated extensions are connected directly to exchange lines to provide a contingency service.

In addition to the main memory, the CPU is provided with a small memory to enable a wide repertoire of testing of the whole exchange to be carried out with the system off-line (that is, the system is not switching telephone calls). This maintenance and diagnostic program has been provided in addition to program in the main memory that runs maintenance and diagnostic tests on-line (that is, while the system is running in its normal operational mode) and permits fault diagnosis to be carried out even if the main system programs are prevented from running.

Finally, the CPU board is provided with a number of switches and a 2-digit hexadecimal display at the front of the PWB. The display is used to indicate those tests which are failing and also the current status of the system: for example, whether the system is running normally or in a restart cycle. Use of the switches enable various operational modes to be invoked and the following facilities are available:

- (a) on-line maintenance and diagnostic testing can be inhibited,
- (b) the hexadecimal fault display can be cleared and alarms reset,
- (c) a total system reset can be forced,
- (d) the watchdog cold-start operation may be inhibited, and
- (e) off-line maintenance and diagnostic testing can be invoked either manually with complete testing and display of results, or by wider interactive teletype control to force particular tests.

LINE INTERFACE CIRCUITS

Since the Monarch 120 system uses a digital switch, it is necessary to provide an analogue digital interface for every analogue line terminating on the exchange. In a fully-equipped unit, 70% of the cabinet volume is taken up with these circuits, so it is obvious that their cost is critical to the viability of the exchange. However, because of the very large number of line interface units required, it is possible to apply modern design techniques to their construction, including the use of custom-designed integrated and thick-film circuits. A block diagram of the extension line interface is shown in Fig. 5, from which it can be seen that the circuitry is divided into two areas: that handling the interfacing of line signalling conditions (including the provision of line-current feeding) and that dealing with the 2-wire-to-4-wire conversion and analogue/digital speech signal processing.

Line current feeding is achieved via an electronic quasi-constant-current circuit; the current varies from 31 mA on a short extension line to 26 mA on a limiting (1200 Ω) loop. This technique of current feeding provides for a significant power reduction over the constant-voltage feeds used in conventional transmission bridges. In addition, a much improved balance can be achieved in the 2-wire-to-4-wire converter (because the telephone characteristic of varying its impedance with line current is suppressed) and the reliability of the carbon trans-

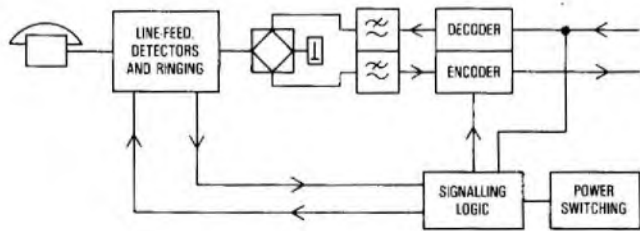

FIG. 5—Block diagram of extension line circuit

mitter is significantly improved. A miniature transformer provides for the conversion of the balanced AC signal on the line to the unbalanced signal for presentation to the electronic 2-wire-to-4-wire converter. A blocking capacitor is used to prevent DC passing through the transformer, and this design enables a very compact realization of the transformer to be achieved. Although it does not deal directly with signalling, one very important function implemented in this area of the circuit board is a power-down circuit. This enables power to the 2-wire-to-4-wire and speech signal processing circuitry to be removed when the line is idle and enables further significant power savings, even on relatively-busy PABX installations.

Thick-film technology has been used to fabricate much of the electronics associated with the line-current feed, loop and called-subscriber-answer detectors and power-down circuitry. Single-in-line packages provide a very-high circuit-packing density on the PWB and the discrete elements are kept to a relatively-small number, thus minimizing assembly, testing and repair costs.

A line unit signalling interface (LUSI) chip provides the necessary logic for formatting the various signalling conditions for forward transmission to the CPU; in the reverse direction, it provides static outputs for driving the various applicators of signalling. The LUSI uses an uncommitted logic array (ULA)², which is provided by a supplier as a custom-designed digital integrated circuit, fabricated from standard gate cells interconnected in accordance to a specification provided by the customer. This procedure enables custom-designed chips to be made for a relatively-low cost and without the delays usually associated with this type of development.

The ULA array used in the Monarch 120 system has 225 cells, of which approximately 180 are used in realizing the LUSI function. Because this chip has to be powered constantly, a low-power circuit with a typical dissipation of 30 mW is used. Two variants of the LUSI chip are used: the extension line interface circuits use a limited range of signalling functions and the chip is contained in a 16-pin dual-in-line package; the exchange line circuits use a 24-pin version with access to all 8 signalling bits for each direction of transmission.

The Monarch 120 system uses the standard A-law PCM format for handling speech signals. At present, it is necessary for the PCM encoder/decoder (codec) to have low-pass filters associated to cut-off frequencies above 3400 Hz. These filters and the associated 2-wire-to-4-wire conversion circuits have been realized using resistor/capacitor networks, which are fabricated as single-in-line thick-film circuits, and operational amplifiers.

A PCM codec circuit which exploits modern techniques of signal processing has been developed. Analogue-to-digital conversion is achieved using a delta-sigma modulator, followed by digital circuitry which converts from the delta-sigma code, at its sample rate of 2.048 MHz, to PCM at the standard 8 kHz sample rate³. A similar process is used in the reverse direction of transmission. The advantage of this technique is that it minimizes the complexity and precision of the analogue circuit at the expense of digital circuitry, this latter being readily realizable using large-scale integration (LSI) technology. The modulator/demodulator element has been realized using a combination of discrete and thick-film techniques and the code-converter function is achieved using a single LSI chip. This LSI chip was originally designed and fabricated at the BPO Research Centre; however, the requirements of the project were such that commercial versions of the chip were required and two semiconductor manufacturers, General Instruments Microelectronics Ltd, and Ferranti Ltd, now supply compatible versions of the device.

Each line interface unit is mounted separately on the PWB (see Fig. 6), although they share common facilities such as power and waveform distribution. The various interfaces provided as 2-port units differ from the extension-line interface mainly in the way that signalling is handled. The ex-

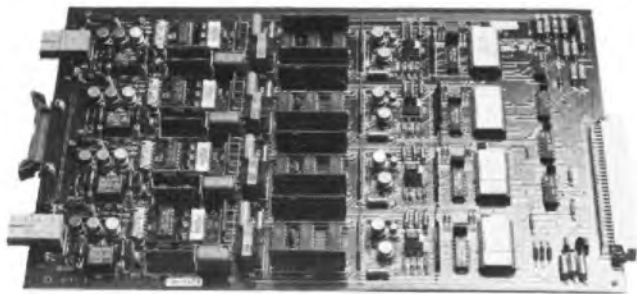

Fig. 6—Extension-line unit interface card

change-line interface uses conventional earth-calling with loop-disconnect impulsing through to the public exchange, although it is expected that MF signalling will be used when this capability becomes available. A variety of inter-PABX signalling interfaces are possible; units capable of handling SSDC5 are now available, and SSDC10, SSAC13 and SSAC15 units are currently under development. A console line interface and MF signalling receivers also plug into 2-port positions.

TRANSMISSION

The Monarch 120 system uses 4-wire transmission within the exchange and, since connexions between extensions and exchange lines must of necessity be of low loss, it has been necessary to pay particular attention to impedance matching at the 2-wire-to-4-wire conversion points to ensure that good stability margins and sidetone performance are achieved. To this end, as has been already outlined, a constant-current line feed is used for the extension telephones to minimize impedance variations with different line lengths. In addition, the input and balance impedances of the 2-wire-to-4-wire conversion circuits have been designed to best match the particular type of terminal to which they are connected; the design of the 2-wire-to-4-wire converter used in the Monarch 120 system permits these input and balance impedances to be varied independently.

In a 4-wire environment, a circuit designer has control over transmit and receive gains. (Where PCM coding is being used, 'gain' is a rather loose term, being the effective translation between analogue level and digital numbers and vice-versa.) This facility enables different losses to be achieved on different types of connexion within the exchange and, although a relatively-low loss is used on extension-to-exchange calls, a higher loss (typically 6-9 dB) is present on extension-to-extension calls. This is an important feature because, traditionally, internal calls on PABXs have been too loud and have poor sidetone performance.

MAINTENANCE AND DIAGNOSTICS

The Monarch 120 system has a sophisticated range of testing and fault reporting facilities. Under normal system operation, testing is being carried out regularly under the control of a background program. The control area is largely self testing in that the background program can cause the memory to be tested, and the watchdog on the CPU ensures that the processor is running in a correct fashion. Testing of the remaining hardware is achieved with the help of a test-line unit, which occupies a 2-port position within the system.

The test-line unit sends an alternating digital check pattern which is routed through the digital switch and back for test purposes. This procedure ensures that the central area of the switch is functioning correctly. A similar test is applied to the signalling-input and signalling-output PWBs, although in this

case the CPU initiates a check pattern which is merely turned around by the test-line unit. The individual line circuits and the associated highways to them are checked by a 400 Hz tone from the tone generator, which is routed to the line unit under test. This tone is reflected around the 2-wire-to-4-wire converter due to the natural unbalance, and it is then routed to the test-line unit for analysis. Only a simple check of the tone can be done in this way since the level reflected is rather variable; however, this test ensures continuity of the serial paths within the system and ensures that the given line circuit is at least operational. Failure of any test causes the test-line unit to output the appropriate message to the CPU.

A signalling test is also carried out for individual extension-line units where one of the 8 signalling bits initiated from the CPU is turned around; thus, by alternating the pattern, a test of signalling path continuity can be carried out.

A proportion of the equipment cannot be tested easily without the addition of further hardware, notably the MF receivers and the exchange-line circuits. In these areas, a fault may degrade service, but will not necessarily result in a complaint from a customer. A statistical check of these circuits is therefore carried out to see whether an individual unit suffers a significantly greater proportion of calls which clear prematurely. At present, this check is only being applied to the MF receivers but will be extended to the exchange-line circuits in a later release of the software.

If a test fails, a fault-analysis program is run in an attempt to identify the faulty area of equipment; for example, a group of line circuits failing on a given shelf can implicate the shelf multiplex. Once this has been done the fault is logged for subsequent interrogation and the appropriate alarm given, both to the operator console and to an alarm unit (which is accessed via the test-line unit). Using the man-machine communication facilities, a technician can then interrogate any faults present on the exchange, either via the operator console or the front of the CPU.

CONCLUSIONS

Development of the Monarch 120 system began 4 years ago and, following extensive trials, the first production units are now going into service with the BPO. The system is manufactured by Plessey and GEC Private Systems Divisions at Nottingham and Coventry respectively.

Development of the system is still not complete however, since the ongoing march of technology will permit major improvements to be achieved in the coming years. In addition, the existence of a digital switching system at the customers' premises which has the same digital coding format as the System X public exchanges will, in the future, enable a sophisticated range of data facilities to be added. Customers with the Monarch 120 system will, in fact, find they have a system capable of providing a true business communications centre for the 1980s.

ACKNOWLEDGEMENTS

Acknowledgement is made to colleagues, in both the BPO and Industry, who have contributed to the success of the Monarch 120 project.

References

- ¹ GRIFFITHS, D. J. Big Advance for Small PABX. *POTJ*, Vol. 30, No. 1, p. 26, Spring 1978.
- ² TONGE, J. D., GAUNT, D. L., and KENDALL, J. P. Programmable Logic and Microprocessors. *POEEJ*, Vol. 70, p. 136, Oct. 1977.
- ³ EVERARD, J. D. A Single Channel PCM Codec. *IEEE Journal of Solid State Circuits*, Vol. SC-14, No. 1, Feb. 1979.

System X: Subsystems

Part 1—The Digital Switching Subsystem

J. N. A. RISBRIDGER, C.ENG., M.I.E.E.†

UDC 621.395.345: 681.32

A multi-part article describing the subsystems used in the System X family of digitally switched exchanges commences here with description of the digital switching subsystem. Other parts of the article will be published in later issues of this Journal and will include descriptions of the processor utility, the network synchronization, common-channel signalling, software, subscriber switching, maintenance control, signalling interworking and analogue line-termination subsystems.

INTRODUCTION

The large range of exchange sizes in the System X family of digitally switched exchanges and their wide range of applications (for example, trunk and local exchanges) led, in the interest of economy, to some differences in the detailed design of the digital switching subsystem (DSS) for the early exchanges. The trunk exchange application is met by the DSS-A, which is controlled by the large processor utility (PU) subsystem; the local exchange application is met by the DSS-B, which is controlled by the small PU subsystem. However, the design has made extensive use of units which are common to both the DSS-A and the DSS-B. The prime difference between the two variants is that DSS-B does not use a full space-switching stage because this is not needed at the lower end of the exchange-size range.

FUNCTIONAL REQUIREMENTS

The main function of a DSS is to switch 64 kbit/s duplex speech paths (that is, 4-wire switching) between any 2 routes connected to the exchange; the speech paths terminate on the DSS as time-slots (TSs) in a standard 2·048 Mbit/s 30-channel pulse-code modulation (pcm) system¹.

The DSS is a full-availability switch in which any channel of any PCM system may be connected to any channel of any other PCM system; an exception is TS0, which is at present reserved for internal use by the DSS.

As well as providing the route switching function for normal speech-path connexions, the DSS also provides paths for multi-slot connexions, semi-permanent paths for private circuits, message transmission subsystem (MTS) signalling channels, TS 16 channel concentration for the signalling interworking subsystem (SIS), access switching for multi-frequency (MF) receivers/senders, tones, multi-party connexions and recorded announcements.

The DSS supplies sufficient information to enable management to assess the traffic performance of the switch. Additionally, under fault conditions, the DSS provides a diagnostic and maintenance capability so that a fault can be identified and repaired, and the switch reconfigured to maintain the required quality of service while the fault condition lasts.

The Standard Network Interface

To enable the DSS to switch digitally-encoded speech directly it must

(a) terminate 2·048 Mbit/s, 32 time-slot, high-density-bipolar (HDB3) encoded digital signals (for example, those originating

from the analogue line termination subsystem (ALTS) and 30-channel PCM multiplex),

(b) derive timing-information from the receive digit stream,

(c) identify TS0 for frame-alignment purposes (thus enabling the switch hardware to operate in time synchronism),

(d) monitor error rates on the receive digit stream, detect line system alarms, take the appropriate local action, and extend alarms to the maintenance control subsystem (MCS).

Basic Switch Operations

The DSS offers a number of basic switching facilities to the user subsystems, mainly to the call processing subsystem (CPS), but also the MTS, the SIS and the MCS. These subsystems communicate with the DSS handler software using the standard interprocess task-passing mechanism (a *task* is a fixed-length message of 8×16 bits) used for intercommunication in the PU subsystem.

A user can initiate a path set-up (*allocate*) or a *clear-down* operation by specifying the 2 DSS termination numbers on the switch block; for example, *allocate AB* signifies *connect terminations A and B together*, where the 2 ends of the path are known as the *A* and *B* terminations. The DSS will always allocate and clear both *A-to-B* and *B-to-A* paths (that is, duplex connexions), but the user can request the DSS to enable the path in one direction only; for example, simplex path *A-to-B*, with path *B-to-A* reserved). This latter facility is used for multiple paths where a particular channel termination is connected to several others (for example, to fan-out from a tone source), and is achieved by the user requesting a number of separate *allocate* commands. If the DSS receives an *allocate AB* request which attempts to form a multiple path by enabling 2 paths onto a single transmit-channel, then this request is rejected because it constitutes a path clash, which is of importance in fault detection.

Path Trace

This facility allows the user to determine the B-end of a connexion by specifying the A-termination. The identity of the B-termination is returned to the user by giving the users equipment termination number, thus requiring the DSS to hold a translation table. The path-trace facility is of particular use under fault-reconfiguration conditions.

Traffic and Performance Measurements

A DSS provides facilities for the management statistics subsystem (MSS) to measure the amount of traffic on each time-switch (a basic building block in the switch), the number of path set-ups during a fixed period, and the number of path set-ups failing due to congestion.

† System X Development Department, Telecommunications Headquarters

FAULT RECOVERY AND DIAGNOSTICS

A DSS performs automatic tests, as necessary, to detect faults. Following detection of a fault, the DSS takes action to locate the fault to a security area and informs the MCS, which will request the DSS to remove the faulty equipment from service.

The DSS also provides diagnostic programs to locate faulty equipment below a security area, and has the capability to alter the sequence of these programs at the request of the MCS. Before bringing a new or repaired item of equipment into service, the DSS can request the MCS to initiate acceptance tests.

RELIABILITY

The basic structure of the DSS is chosen so that the British Post Office (BPO) requirements for switching-equipment total and partial losses are economically achieved. These losses are defined as equipment malfunctions that last for more than 10 min or those losses that require the attention of maintenance staff to restore service. Some typical examples of the effects of these requirements are given below.

(a) A small DSS terminating 32 PCM systems and handling 250 erlangs of traffic should have a mean-time between failures (MTBF) for total loss of 200 years.

(b) A small-to-medium size DSS terminating 128 PCM systems and handling 1000 erlangs of traffic should have a MTBF of 110 years for a partial loss, where a partial loss in this instance constitutes a loss of access to and from 32 PCM systems; for example, on failure of a time switch.

(c) The largest exchange, of up to 20 000 erlangs, should have a MTBF for total loss of 1000 years.

This latter requirement determines the method of securing such centralized functions as the control and waveform generation.

There are also further reliability requirements for short breaks lasting less than 10 min, and allowances for call set-up failures and premature releases. All these factors have been considered, and have resulted in a design of DSS that achieves a satisfactory quality of service.

BASIC STRUCTURE OF THE DSS

In determining the structure of the DSS, many factors were considered. In addition to the need to meet the full range of requirements described earlier, the design of the DSS had to be economic in terms of cost and power throughout a wide range of exchange-size applications.

The structure of the DSS permits growth by the addition of switching modules as the need arises. The use of low-power devices and microprocessors is an essential part of the DSS design, and they contribute to its cost effectiveness.

The block structure of the DSS-A for trunk exchanges is shown in Fig. 1. The DSS-A uses a duplicated switch-matrix to ensure reliability of operation, and triplicated primary-waveform generating equipment to ensure continuity of waveform supplies.

The DSS-B design can be regarded as a sub-set of the DSS-A design, as the full space-switching stage is omitted and replaced by a pattern of links which serve as a distributed space-switch. The alarm monitor unit and the central-control unit are also omitted, as these functions are provided in software, which runs on the small PU.

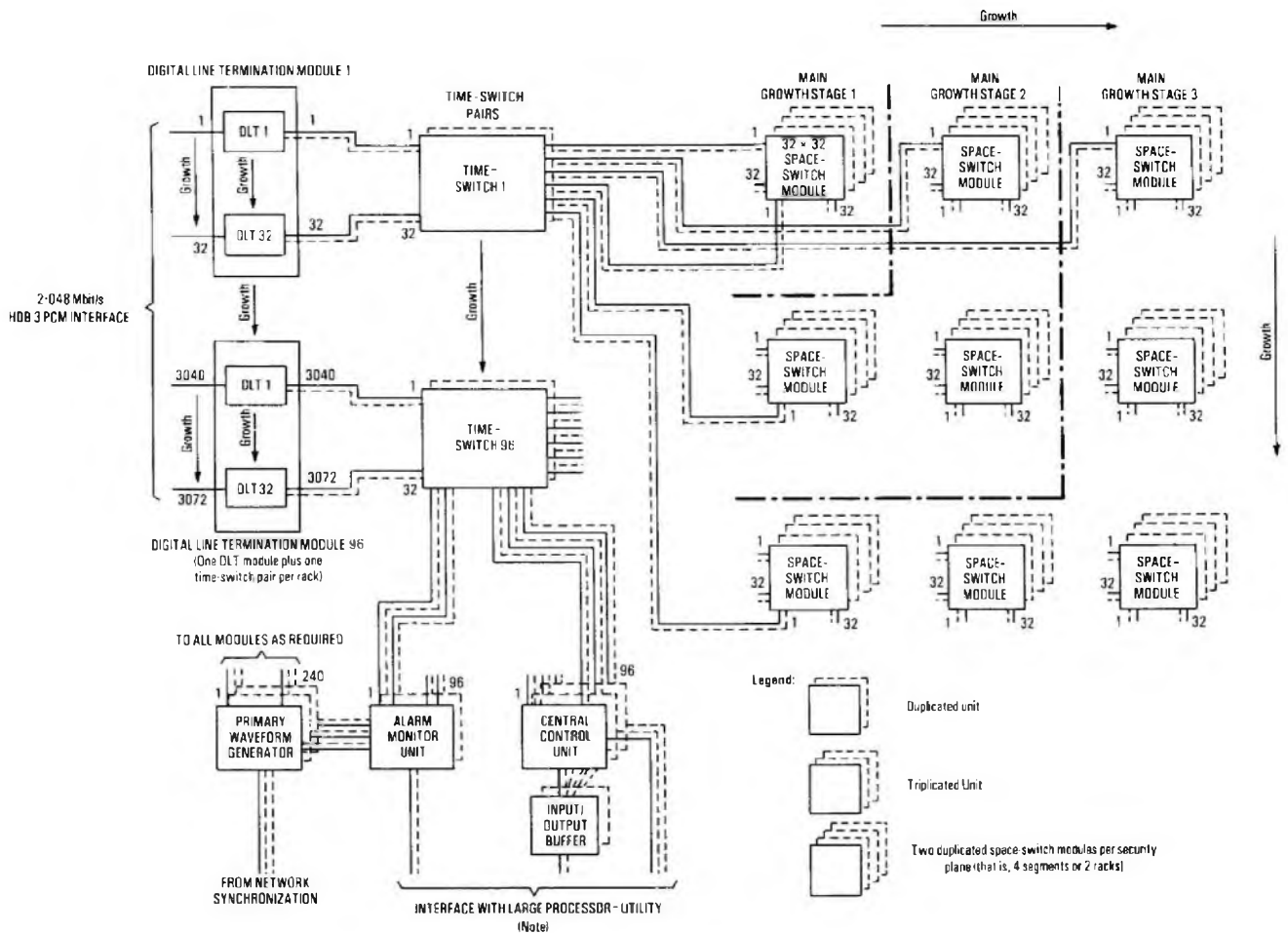

Note: Provides access between the switch handler and maintenance software and the switch hardware

FIG. 1—Block diagram of digital switching subsystem—type A

The Basic Building Units

In System X terminology, the basic building blocks are known as *functional entities*; in theory, these are implementation independent and have enduring interfaces. This structure gives the capability for design updating to incorporate new technology and for the removal of certain blocks where an application may require a different hardware/software balance.

The Digital Line-Termination Unit

The digital line-termination unit (DLT) provides

- (a) the interface to the 2·048 Mbit/s PCM line systems,
- (b) error detection and alarm indications, both internal for the DSS and external for the transmission line systems,
- (c) pattern insertion for path checking, and loop-back facilities to aid fault location and diagnostics, and
- (d) the frame-alignment function.

The aligner provides an elastic buffer store that decouples the time of arrival of the PCM system frame-alignment pattern (frame start time) from that generated locally in the DSS. This function is essential for independent synchronous operation of the DSS hardware. The aligner also has the characteristic of being able to repeat or omit a frame of information under conditions of slip (for example, as a result of asynchronous operation), thus preserving the alignment of time slots at the input to the switch, without loss of frame synchronism.

The Time Switch

The time switch contains two speech stores, each with an associated control store, and additional central-control firmware† and hardware enabling the contents of an input time-slot to be transferred to any outgoing time-slot.

The Space Switch

The space switch allows the spatial connexion of two highways in the trunking.

The Central Control Unit

The central control unit (CCU) uses a combination of hardware and firmware to perform the path-selection function. The CCU also provides a general-purpose facility for accessing the trunking.

The Alarm Monitor Unit

The alarm monitor unit (AMU) is realized in hardware and firmware and deals mainly with alarm preprocessing; for example, monitoring, persisting and filtering functions. The AMU also provides separate access for the DSS maintenance software to permit, for example, the DLT to be instructed to lock to a particular plane.

The Primary Waveform Generator

The primary waveform generator (PWFG) provides the basic 8 kbit/s frame-start reference timing for the DSS hardware, and the basic 2·048 Mbit/s clock waveform, which is derived from the network synchronization subsystem (NSS) timing unit or the local synchronization utility (LSU), depending on the application.

The Input/Output Buffer

The input/output buffer (IOB) provides the interface between the DSS-A control hardware and the large PU, and is mainly concerned with the storing and queuing of messages passing between the handler software and the CCU.

The Input/Output Module

The input/output module (IOM) is a simplified version of the IOB, and passes control and alarm messages between the

DSS-B handler software and the switch-block hardware.

The Switch Handler Software

The switch handler software provides an interface between the DSS and the user subsystems. The functions performed by the switch handler software vary with the application, from rudimentary task-handling functions to path selection.

The Maintenance Software

Maintenance software provides a range of fault location, diagnostic and database updating facilities; this enables the switchblock to meet its quality-of-service requirements and provides the maintenance staff with the information and access required.

THE SWITCH-BLOCK TRUNKING

The trunking of a DSS uses a symmetrical 3-stage switch network realized as a time-space-time structure. This structure was chosen for its good teletraffic properties; in particular, the relative independence of the grade of service on any imbalance of loading on the external routes. At the largest-size DSS, 3072 PCM systems can be terminated. This circuit capacity is realized by using 96 time-switches and a 96×96 space switch. Teletraffic studies indicate that a grade of service of 0·0001 at a channel loading of 0·8 erlangs is achieved if each stage of the trunking is non-blocking.

The trunking also provides a flexible growth structure based on the scale of provisioning of the space switch. In the DSS, three major growth steps (a) 32×32 , (b) 64×64 and (c) 96×96 are provided and, within each major step, minor steps are provided by sub-equipping.

The design of the switching stages represents a compromise of many factors: for example, the number of edge-connector pins per slide-in-unit affects the modularity of the central space-switch, and physical separation of the racks affects timing tolerancing and the speed at which the switch highways operate. The cost effectiveness of the design depends largely on the extensive use of large and medium-scale integrated semiconductor devices in this and other areas of the DSS.

The time-switches each serve a maximum of 32 PCM systems and are split into receive and transmit directions of transmission. For the speech path functions, a receive speech-store terminates the receive time-slots and the transmit speech-store terminates the transmit time-slots. Each speech store is non-blocking (for example, an input time-slot can be connected to any one of the 1024 outgoing time-slots provided it is not in use), and is implemented as two 1024×9 bit store blocks; one is written while the other is read, the read and write operations alternate between the two stores in consecutive frames². This action overcomes any access-timing problems since each store can operate at 4·096 Mbit/s, which is convenient in terms of component availability. The speech stores are controlled by associated receive and transmit control-stores from a microprocessor, which receives its commands from a central control. The overall bit rate of the time switch is 8·192 Mbit/s. Information is transferred between the transmit and receive halves of the time switch and the space switch at the rate of a 9 bit parallel word in each 8·192 Mbit/s digit period.

In practice, because of timing-tolerancing problems on the highway cables and their associated driving/terminating logic, two separate highways are provided between each time switch and the space switch in each direction, which operate at 4·096 Mbit/s with a co-routed timing references at 2·048 Mbit/s. These two highways carry the odd and even time-slots and terminate on a pair of space-switch segments. This structure, when extended to 32 time-switches, provides the row and column interfaces to a pair of basic 32×32 space-switch modules providing one plane for main growth stage 1. Extension to the other growth stages (64×64 and

† Firmware is a program residing in a programmable read-only memory

96 × 96) is made by adding further pairs of interfacing highways to and from the time switches; this is easily achieved without affecting the existing highways. The space-switch crosspoints also operate at a speed of 4.096 Mbit/s. An overall view of DSS trunking is shown in Fig. 2.

Security

Unless adequate security techniques are used, a highly integrated structure for the DSS trunking could produce problems because a single fault can cause a considerable loss of switching capacity and the premature release of calls in progress. For example, the reliability requirements for a time-switch handling traffic from 32 PCM systems must have an MTBF of 200 years.

The security technique used is synchronous duplication, with fault detection, using the insertion of a parity bit (often called the *ninth wire*) across each plane of the switch. Parity is inserted at the receive side of the digital line termination (DLT) (input to the receive time-switch) and is checked at the transmit side of the DLT, where a valid data sample is selected for transmission to line. However, not all faults result in parity errors, and a further comparison of data between planes is performed to detect any other discrepancies. The detection of any parity errors is alarmed to the DSS maintenance software, via the alarm monitor unit (AMU).

Digital Switching Subsystem—Type B (DSS-B)

Because the DSS-B is much smaller than the DSS-A, it is possible to omit the space-switching stage; the time-switches are interconnected by space-switch interface multiplexing and demultiplexing SIUs, which are provided within the time switches. Own-exchange time-switch connexions require the provision of an additional SIU to connect directly the receive and transmit halves of a particular time-switch; this SIU also provides a time-delaying function. This form of trunking configuration gives the improved grade of service required for the small local exchange; for example, ignoring multiple paths for the distribution of tones, an installation comprising a single time-switch will be non-blocking. The switch block receives its control from the handler software in the small PU subsystem, via a secured pair of input/output modules.

The Space Switch

Composition

The space switch consists of retiming buffers and multiplexers; the latter are the crosspoints. The space switch is implemented in such a way that each of 9 wires (8 + 1 parity) forming a 512 time-slot highway pass through a different SIU. (This arrangement is particularly useful for diagnostic purposes.) Each SIU of the space-switch matrix is a 1 bit 32 × 8 switch, which connects 32 inputs to 8 outputs; 9 of these SIUs form a basic space-switch building block which can be sub-equipped to provide an 8 × 8 space switch to interconnect 8 time-switches. Similarly, two and three sets of these building blocks can be used to provide a 16 × 16 and 24 × 24 space-switch segment. Four 32 × 8 building blocks provide the basic 32 × 32 space-switch module (known as the *first main-growth step*) and will occupy 3 TEPI-(H)[†] shelves. Because of their low-power dissipation, two of these modules can be accommodated on one TEPI-(H) equipment rack, and form the two segments of a space switch in one security plane. Four modules on two racks constitute a duplicated 32 × 32 space switch, which can provide the central stage for an exchange of 8000 erlang traffic-capacity.

The main growth steps can be seen in Fig. 1. (A 64 × 64 switch module occupying 8 racks gives a traffic-carrying capacity of 16 000 erlangs, or a 96 × 96 switch module occupying 18 racks provides a traffic capacity of 24 000 erlangs.)

Timing

All crosspoints in the space switch operate synchronously and differences in highway cable lengths between the time and space switches are compensated by selecting a phase of clock from the secondary waveform generator (SWFG) that enables the data to be launched at the appropriate time.

Growth

The highway cables between the time and space switches are arranged in independent groups so that the additional cables required for growth can be added without interruption of service.

The Time Switch

There are 3 phases of timing through the trunking: time of

[†] TEPI-(H) is the designation of the System X equipment practice, which will be described in a later issue of this *Journal*

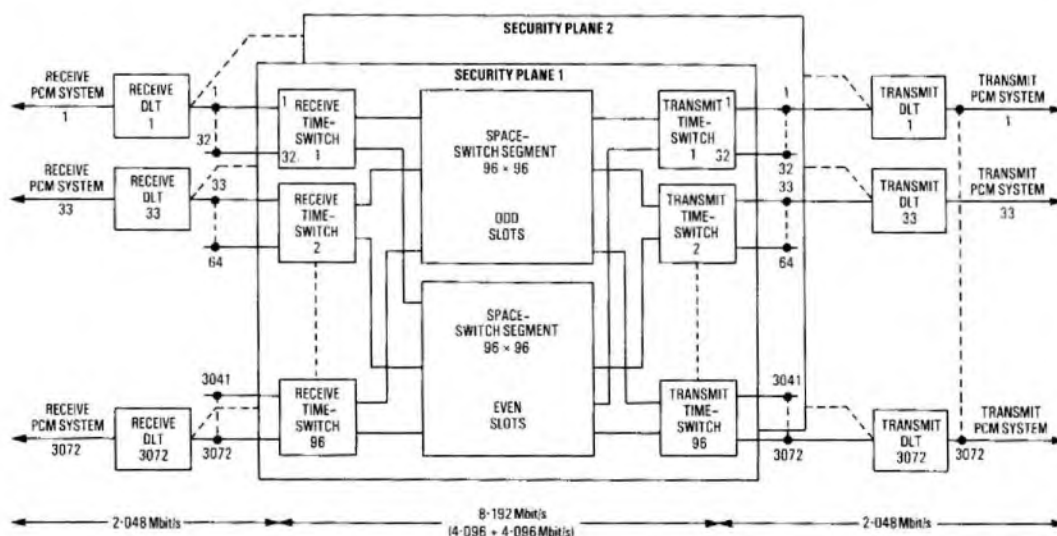

FIG. 2—Trunking arrangements

reception from line, time allocated by the control for a path across the exchange via the space switch, and time of transmission to line. By using the receive and transmit speech-stores, the time switch provides the required buffering between these events.

The Receive Speech-and-Control Stores

The time-switch store organization is shown in Fig. 3. The incoming 8 bit speech samples plus a parity bit are written cyclicly into the receive speech-stores under the control of a cyclic counter; that is, in strict order of arrival time, channel 0, PCM system 0, into speech-store location 0, etc. The reading operation is controlled by the receive control store, which circulates at internal time-slot or cross office slot (XOS) time and contains 1024 store locations, which are numbered sequentially in internal time-slot order 0-1023. The time of reading of the speech store depends on the internal time-slot chosen by the control, which results in the required incoming PCM channel address being loaded into the required internal time-slot store location in the control store. The read operation (known as *acyclic read*) is completed by the address being outputted at the required XOS time, which enables the required speech sample to be read from the speech store location onto the parallel highway into the space switch. The address consists of 12 bits: 5 bit define one out of 32 PCM systems; 5 bit define one out of 32 channels; a *busy* bit, which indicates that the internal time-slot is in use; and a parity bit.

The Transmit Speech-and-Control Stores

The transmit speech-store holds the speech samples from the time of reception from the space-switch highway until the time of transmission onto the required PCM channel/system. Speech samples from the space-switch highway are written cyclicly into the speech store in internal time-slot order 0-1023 (internal time-slot 0 into location 0, etc.). The acyclic read is controlled by the transmit control-store, which circulates at outgoing PCM-channel time. The control store locations are numbered sequentially in order of PCM channel and system, and the time of reading depends on the address of the required internal time-slot being outputted at the required PCM channel and system time. The address consists of 12 bits: 10 bit define one out of 1024 internal time-slots; a *busy* bit, which indicates that an external channel is in use; and a parity bit.

Additional Functions Provided by the Time Switches

The control-store *busy* bits are used by the control when interrogating the trunking for free paths. As well as providing the speech-store addresses, the control stores also control the application of idle codes. These are injected into free time-slots in the speech path and are used for the guidance of plane selection and error-detection logic in the DLT, and also into free outgoing PCM channels for line transmission reasons. The control stores contain parity bits; violation of parity within these stores causes the speech path to be corrupted and, in turn, to violate its parity. This causes the DLT to detect the fault immediately and to trigger the fault-location process, thus enabling the DLT to select speech samples from the good plane until full reconfiguration takes place.

Space-Switch Control

The space switch also requires a control store circulating at the internal time-slot rate. This store contains a 7 bit address and parity bit to enable addressing of up to 96 crosspoints in the column it controls. For simplicity of interfacing to the control, these control stores are provided in the time switches. Control information is passed to the space switch in the form of a column address in parallel with the speech data, between the time switch and the space switch.

Central Control for Time Switch

The time switch receives its control commands in the form of 40 bit messages from the CCU or the IOM. These messages are interpreted by a microprocessor, which controls the reading and writing of addresses into the control stores and checks that the data is correctly written. The microprocessor has the role of collecting alarm information from the DLT and passing it to the maintenance software when the AMU is not provided.

Equipment Rack Requirements

A complete receive and transmit time-switch and its power and waveform supplies can be accommodated on a single TEP1-(H) equipment shelf. Two such time switches, one for each security plane, together with an equipment shelf to accommodate their associated DLTs, are accommodated on one TEP1-(H) equipment rack. A maximum size DSS would therefore contain 96 equipment racks.

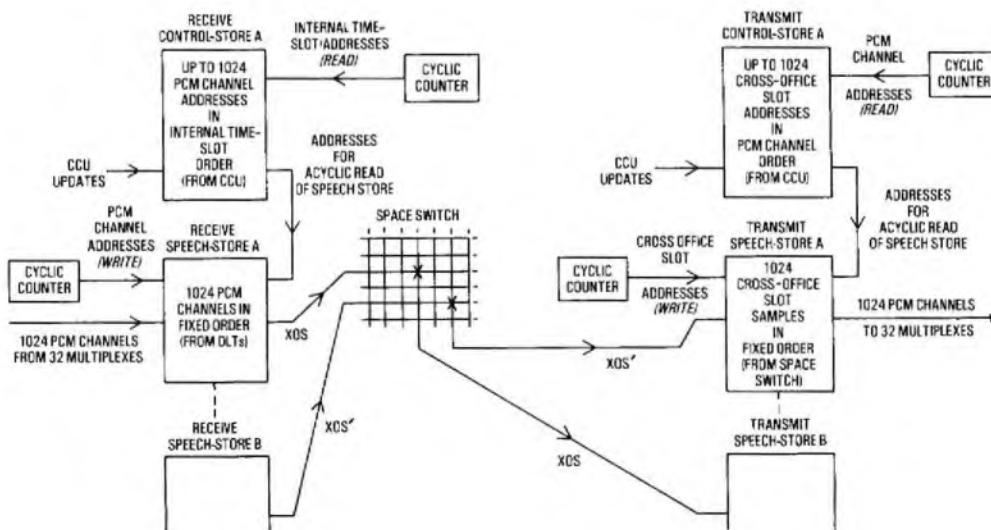

FIG. 3—Time-switch store arrangement

SWITCH-BLOCK CONTROL

The call-handling software provides the simpler and less time-consuming functions of interfacing to the user subsystems, message validation, checking of maintenance states, relaying *allocate* and *clear* commands between the CCU and processor via the IOB, and the checking for correct responses. The main path selection function is implemented in the CCU micro-processor firmware. The main functions of the CCU are path searching followed by the co-ordination of path set-up and clear down, and general manipulation of the time switches, both for normal call-handling and maintenance purposes. Thus, the commands available in the CCU are the obvious ones of set-up and clear down, plus special commands for use in association with fault location and reconfiguration; for example, the copying of information from one time-switch to another, which is a facility used when returning a time switch to service.

Since the CCU handles all traffic commands offered to the switch-block, it must be highly reliable; this need for reliability has resulted in synchronous triplication being used as the security method. This is probably the only method that can meet the requirements for total loss, and has the added advantage, with majority decision, of providing a means for rapid fault-detection and location. This triplicated structure is extended to include the control and status highways between the CCUs and each of the time switches, majority decision being performed at the time switches. The same method is also used between the CCUs and the 2 IOBs. Because of its relatively-small size and its simplicity (compared with the CCU) and to reflect the duplicated input/output structure of the PU, the IOB is duplicated. The 2 IOBs operate in main and standby mode with periodic change-over. The control configuration is shown in Fig. 4.

Path Selection

Path selection is performed by examination of the *busy* bits, which give the status of each of the 1024 internal time-slots on a highway from the receive time switch to the space switch. These *busy* bits are relayed continuously

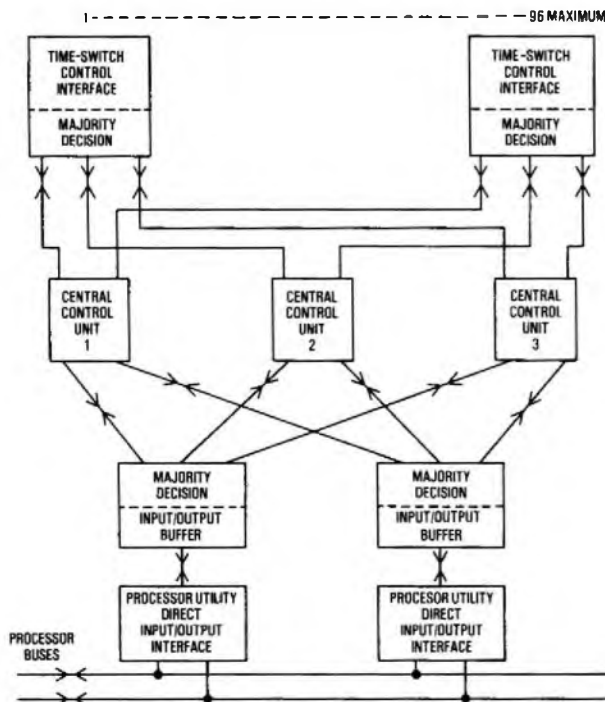

FIG. 4—Arrangement of central control units and input/output buffers

from each of a maximum of 96 time-switches in each plane to the 3 CCUs, via status lines. The *busy* bits from each of the 1024 internal time-slots are repeated every frame (125 μ s). The time switches, status lines, and CCUs all operate in synchronism and are locked to frame start time, thus allowing the CCU to compare the *busy* bits when searching for a new path.

The operation of the CCU and its interaction with the time switches is best understood by considering a *set-up* command, as explained below.

Processing of a Set-Up Command

In a normal call set-up operation the CCU receives the command to connect terminations A and B. Each termination is specified in terms of the addresses of a time switch, PCM system and channel. On reception of a command, the CCU then selects the 2 status lines from time-switches A and B and, by comparing the *busy* bits, performs the path search. This action involves the finding of a free internal time-slot, using a path-search algorithm that ensures efficient packing of the internal time-slots on a highway to provide the required grade of service. Due to the fixed timing relationship between the 2 simplex paths forming a duplex connection, the finding of a free path between receive time-switch A and transmit time-switch B implies a free path between receive time-switch B and transmit time-switch A, see Fig. 5. In practice, the CCU uses the timing relationship between the 2 simplex paths of the internal time-slot to perform the path search, and uses the *busy* bits from the A and B receive control-stores only (for example, the CCU compares internal time-slot A0 with time-slot B512, A1 with B513, etc.) and will never take longer than $1\frac{1}{2}$ frames (1 frame = 125 μ s) to complete a search.

It is not necessary to check whether the space-switch control store is free because only duplex connexions with internal time-slots 512 apart are set up. This ensures that the space-switch control store is always free if the receive control-store 512 time-slots away is free.

Once an internal time-slot has been found, the CCU sends a 40 bit message to the A and B time-switches in each plane, see Fig. 6. The message contains the command, the external-channel number, the *XOS* (cross office slot or internal time-slot) and the space-switch crosspoint to be selected. These

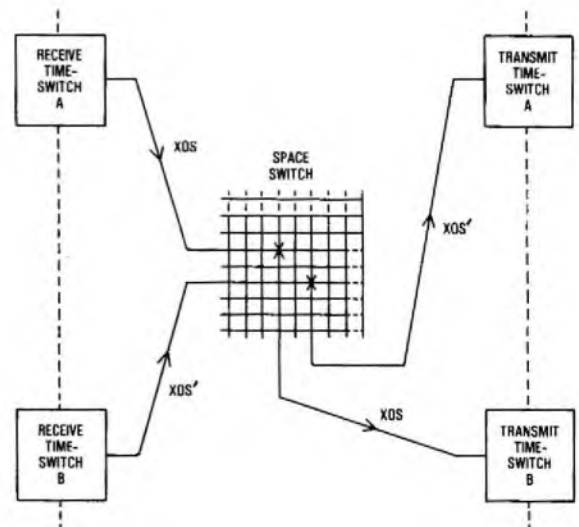

Notes: (1) $XOS = XOS' + 512$.

(2) A free path from receive time-switch A to transmit time-switch B via XOS implies a free path from receive time-switch B to transmit time-switch A, via XOS' .

(3) A free XOS path on receive time-switch A to the space switch and a free XOS' on the path from receive time-switch B to the space switch, indicates a free duplex-path between A and B without reference to the transmit time switches.

FIG. 5—Fixed relationship of the two simplex paths of one duplex connexion

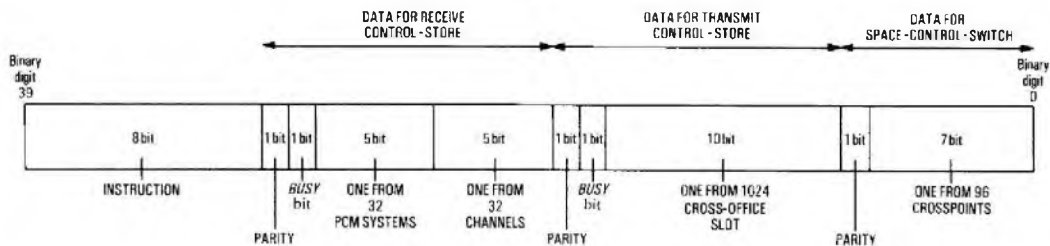

FIG. 6—Format of a CCU to time-switch message

messages are interpreted by the time-switch to write the appropriate data into the transmit, receive and space-switch control stores. The XOS data has to be modified by the time-switch to address the receive control-store.

DSS MAINTENANCE

DSS maintenance, as with all subsystems comprising System X, is co-ordinated by the MCS via standardized interfaces and protocols. The MCS confers with the DSS maintenance software in terms of *resources* (time switch, DLT, PCM system, circuit, translation table, etc.) and *verbs* (insert, remove, out-of-service, etc.), using the standard task-passing interface. Generally, these resources map fairly closely to the physical equipment entities (for example, a time switch), but there are some exceptions. The MCS constrains the DSS to a standardized method of fault reporting, on-line updating, and diagnostic control. These functions are clearly seen in the structure of the DSS software.

Fault Reporting and Location

Following detection of a fault (for example, a speech-path parity fault by the DLT) and subsequent analysis by the DSS fault-location software, the DSS informs the MCS to take a particular resource out-of-service and report the fault to the maintenance staff.

Fault location is concerned with deciding the most appropriate resource to take out of service for the fault conditions that have been detected. This does not mean that the resource reported necessarily identifies a particular item of equipment, but the fault will have been located to, say, a particular security plane and the switch quality of service is not impaired. For example, faults in a space switch are generally reported against the time switch which controls the particular space-switch column in which the faulty crosspoint is found.

Extreme care is taken to distinguish between certain fault conditions (for example, between DLT and time-switch faults) because an error in fault reporting could cause the removal of 32 DLTs, rather than a time switch in one security plane.

Fault reports contain the initial symptoms of the fault, but insufficient information to locate the fault to an individual card or group of cards; this can be done only by running a diagnostic program.

On-Line Update

On-line updates are concerned with recording maintenance states, both the state of equipping of subsystem resources and also the resources that are in or out of service at any one time. There is a standard set of maintenance states and commands (*verbs*) from the MCS to achieve this. The on-line update (OLU) software in the DSS records securely any changes to these states, using the processor utility mechanisms for securing storage, and also initiates any necessary changes to the DSS hardware, such as locking DLTs to a good plane

and masking of alarms which may be required as a consequence of the OLU request from the MCS.

Diagnostics in Relation to Fault Location

Fault location is constrained to take the most likely resource out of service for a particular fault condition and to achieve this rapidly, such that reconfiguration can take place and thus preserve the quality of service. Diagnostics performs a much more detailed analysis of the fault on the out-of-service resource, and will resolve the fault down to a small number of cards.

The DSS diagnostic software is initiated by the MCS and does not have the same tight runtime restraints imposed on it as the fault-location software. The DSS diagnostic software performs a large number of tests to find out

- (a) which bits are affected,
- (b) which groups of time-slots are affected, and
- (c) which DLTs are affected.

From the results of the above tests, the faulty cards can be deduced; for example, a fault which effects speech-path data between 2 time-switches, and only one bit of a word, can be diagnosed to a faulty space-switch matrix card.

The MCS also provides some second line (manual) facilities for altering the running of the DSS diagnostic sequences, and the ability to do a controlled checkout when returning equipment to service.

Fault Detection and Location Techniques

The techniques adopted within the DSS depend on the structure and method chosen for securing the hardware units. In the trunking arrangements, widespread use is made of parity for the detection of faults in the speech path and control stores in the time- and space-switches of each security plane. Additionally, a comparison is made between the planes to produce a discrepancy alarm. This action also avoids the need for an internal time-slot transmission-path check for each call. Faults are detected both as a result of live traffic and periodic routing; the latter also checks the operation of the fault detectors.

Speech path fault-location is triggered by discrepancies or parity faults detected at a DLT. If the fault persists, a path check is performed on the failed connexion, followed by the allocation and path checking of test connexions to TS0 of the same DLT. Depending on which path checks fail, and in which planes they fail, a DLT or the time switch involved in the original connexion is deduced to be faulty.

Time-switch control-store faults are detected either by the CCU detecting invalid data in the control stores, or by detecting discrepancy or parity fault conditions at the DLT, resulting from normal requests to allocate a path. Parity-corrupted messages and illegal input/output protocols are the principal means of fault detection for the I/O buffer (IOB).

In the primary waveform generator (PWFG) and CCU,

where triplication is used to secure these units, fault detection is primarily done by majority decision with error-detection logic. Additional detection for the IOB and the CCU is performed in the call-handling software.

Reconfiguration

The action required to remove from service the various resources of a DSS differs widely between the resources. As an example, the removal from service of a time switch is described below.

All failure modes of the failed time-switch must be considered. This involves instructing all the units around the failed time-switch to ignore the information being sent by that time switch. The action taken is

(a) locking the DLTs connected to the failed time-switch to the good plane,

(b) informing the alarm monitor unit to ignore the alarm information from the failed time switch,

(c) marking the software status maps, such that, on subsequent switch requests, the CCU is told to ignore the faulty time switch, and

(d) tracing existing paths through the failed time-switch, using the good plane and marking the connexion in the time switch at the other end of the failed plane to a *reserved* state.

Action (d) above is required because the failed time-switch may be sending faulty data into the space switch. The faulty information will therefore be received by all transmit time-switches which have paths from the failed time-switch. The data is prevented from being sent to the DLT by marking the transmit control-stores as *reserved*. This results in an idle code pattern with bad parity being sent to the DLT, which causes it to take data from the other switch plane in preference to the bad parity data sample, and thus maintains service.

CONCLUSION

The design of the DSS described in this article will be used in the early orders of System X exchanges to go into public service. As discussed in previous articles on System X^{2,3}, great care has been taken in determining the basic architecture so that the subsystems can evolve and take advantage of developing technology.

Work has already started on an updated revision of the DSS to achieve a considerable size and power reduction. The revised DSS will meet the same functional and reliability requirements, with the same external interfaces to other subsystems and the differences between the present small and large versions of the DSS will be eliminated.

ACKNOWLEDGEMENT

The author wishes to thank his colleagues in the BPO System X Development Department for their assistance in the preparation of this article and to acknowledge the work of the Plessey Development teams in the detailed design of the DSS⁴.

References

- ¹ VOGEL, E. C., and McLINTOCK, R. W. 30-Channel Pulse-Code Modulation System. *POEEJ*, Vol. 71, p. 5, Apr. 1978.
- ² VANNER, N. J. Architecture of System X, Part 2. *POEEJ*, Vol. 72, p. 142, Oct. 1979.
- ³ OLIVER, G. P. Architecture of System X, Part 3—Local Exchange. *POEEJ*, Vol. 73, p. 27, Apr. 1980.
- ⁴ PHILIP, A. S. The System X Digital Switching Subsystem, *Plessey Systems Technology*, p. 5, Sept. 1979.

Book Review

Antennas and Propagation: IEE Conference Publication No. 169. Institution of Electrical Engineers. xxvi + 638 pp. 774 ills. £26.00.

This is a report in two volumes, 450 pages on antennas and 180 pages in the propagation section, giving the full text of papers submitted to the conference, held in November 1978, and reflecting the wide range, depth and international nature of current work in these areas.

Most of the antenna work applies to microwaves, although new developments are reported on high frequencies (HF), very high frequencies (VHF) and ultra high frequencies (UHF). A notable feature of the microwave antenna papers is the number that are directed towards improved performance; in particular, the achievement of lower side lobes is well represented. For example, one theoretical study of the wide-angle pattern of a conventional asymmetric Cassegrain antenna used at earth stations suggests that, by adopting an improved offset-feed design, an envelope factor of $26-33 \log \theta$ might be achieved. This would permit satellite spacings of 1.6^{θ} in orbit. Several papers deal with multiband feeds, and the use of dichroic reflectors in such designs, and there is some interest shown in arrays, especially to achieve particular polar diagrams.

For VHF and super high frequency (SHF) working, the emphasis is on cheap, wideband elements of low wind loading that can be combined into arrays to give the required performance. Some practical work on active adaptive antennas is also reported.

With improved specifications, measurements have become more difficult and time consuming. Computer aided measurement using near-field probing to determine far-field patterns is now well established. A new development reported is measurement at an intermediate distance using existing range facilities combined with modern techniques of synthesis.

The propagation papers are fewer in number, probably reflecting the timing of the conference, but they still represent a wide range of work from very low frequencies to millimetric waves. There are two papers on propagation over water at VHF and SHF, and one valuable paper on HF propagation in urban areas. Some new formulae for the prediction of the performance of HF circuits, aimed at the user rather than the propagation scientist, are also presented.

The papers on terrestrial line-of-sight propagation are mostly concerned with rain effects at higher frequencies, and only one paper reports on multipath events; only one paper deals with cross-polar effects, at 11 GHz and, as it concerns a short hop, the emphasis is again on rain effects.

Papers on slant-path propagation are mostly the final results from the 20 and 30 GHz ATS6 and COMSTAR satellites, although there is a report on a few extreme events on the SIRIO satellite at 11 GHz.

In summary, this is a very useful collection of papers for the specialist, and for users concerned with planning and operation, who wish to keep up-to-date over a broad area.

S. G. YOUNG

POEEJ, Vol. 73, April 1980

Architecture of System X

Part 3—Local Exchanges

G. P. OLIVER, B.ENG., C.ENG., M.I.E.E.†

UDC 621.395.34: 621.315.722

Previous articles in this Journal have described the technical principles of System X^{1,2}, introduced the architecture³ of the System X family of digital exchanges, and described the large trunk-exchange system⁴. This article describes aspects of the System X local exchanges.

INTRODUCTION

It is a fundamental principle of System X that a common range of subsystems is used to make up the individual exchange types. Hence, the local exchange uses the equivalent subsystems to the trunk exchange. However, certain additional subsystems are added for subscriber switching, call accounting and automatic announcements.

Since outline descriptions of most System X subsystems have already been given in previous articles¹⁻³ and detailed descriptions will be given in future articles in this *Journal*, this article presents only a system overview of the design and operation of the local exchange.

SYSTEM REQUIREMENTS

System X was conceived and specified for the British Post Office (BPO), but the design aims to meet the present and future needs of any telecommunications administration wishing to offer the latest services and facilities to its customers in a way that is economic, flexible and enduring. Other administrations around the world have similar needs which could well be met by System X, albeit with minor modifications to cater for local variations. System X is therefore designed for world markets, adopts international standards wherever possible, and provides flexibility to incorporate necessary variants through its modular structure.

System X is a family of digital switching telephone exchange systems, each playing a key role in the overall telecommunications network of the future. The local exchange has an important place in this family because, firstly, it is the most numerous system in the network and, secondly, because it is the prime agent for providing services to customers.

Size-Range of Local Exchanges

The catchment area for a local exchange is conditioned largely by local-line distribution techniques, and may result in a local exchange area containing anything from a few tens of lines to many thousands. The ideal local exchange design would cover this whole size range economically with the same design throughout. However, it is found in practice to be more cost-effective to sub-divide the range and optimize the system design for each sub-range. In the past, this has led to different systems; for example, electronic exchange systems TXE2 and TXE4.

Modern technology permits techniques to be used which achieve cost-effectiveness with very much less divergence between the designs of small and large systems; however, some differences are still necessary in certain areas. System X is a modular system design and, wherever possible, large-size exchanges are achieved by replicating the modules used in the small-size exchanges. However, there are situations in which

it is more cost-effective to develop an alternative module for use in the larger sizes. For this reason, the total range of local-exchange size is divided into the sub-ranges of *small*, *medium* and *large*.

The initial System X local exchange development was for a small-to-medium size local exchange with a traffic limit of 1000 erlangs. The subsystems are now designed to be assembled in arrangements that achieve the capacities shown in Table 1.

TABLE 1
System X Local Exchange Operating Objectives

Unit	Termination Capacity	Switch Capacity (erlangs)	Processing Capacity (busy-hour call attempts)
Multiplexer	24 or 30	4 or 5	
Concentrator	2000	160	8000
Small local-exchange	2000	160	8000
Medium local-exchange	10 000	2000	80 000
Large local-exchange	60 000	10 000	500 000
Combined local and trunk exchange	10 000 subscribers or 5000 trunks in combination	2000	80 000

Concentrators and Multiplexers

In situations where a local exchange area contains less than a few hundred lines, it may not be justified economically to install a full-facility System X local exchange. An alternative way of providing customers in such areas with the full range of services is to connect them to a local exchange in another area. This can be done in two ways: a multiplexer can be used to connect up to 30 customers over a digital transmission system to a distant local exchange, or a concentrator can be used to connect up to 2000 customers to a route of up to eight 30-channel pulse-code modulation (PCM) digital transmission systems.

The System X concentrator is an outstationed subscriber switching sub-system (SSS), containing all the necessary signalling and switching functions to concentrate the customers' traffic onto the common route into the parent local exchange. All control is normally provided by the parent exchange, though there is an optional isolation facility that permits some call handling if the concentrator should be isolated from its parent.

† System X Development Department, Telecommunications Headquarters

Customer Facilities

System X local exchanges will offer a number of supplementary services to customers. The services to be offered will depend on the marketing policy of the administration, but the early exchanges are likely to offer the following facilities.

Abbreviated Dialling

The abbreviated-dialling service enables a customer to allocate a single digit or a two-digit code to a telephone number which is used regularly.

Diversion

The diversion service enables a customer to divert incoming calls to another number.

Three-Party Service

The three-party service allows the calling of a third party during a call, and transfer if desired.

Call-Waiting Service

The call-waiting service provides the facility for a customer to be given an indication during a call that another call is waiting.

Call Barring

Under the control of the customer, the call-barring service enables either incoming or outgoing calls to be barred.

Automatic Alarm-Call

The alarm-call service enables a customer to arrange for the receipt of an alarm call without the involvement of an operator.

Repeat Call

The repeat-call service enables the number dialled by a customer to be stored in the exchange so that the customer can initiate a repeat attempt if necessary.

Advice of Call Duration and Charge

The advice-of-call-duration-and-charge service provides for an announcement to be given automatically at the end of a call of the relevant call-duration and charge information.

Itemized Billing

Itemized billing of call information can be recorded by the exchange.

Most of the above facilities are under the full control of a customer by dialling appropriate service codes from his own telephone. With the help of only a list of service codes and instructions, it is thought that the customer will be prone to making mistakes, and will be deterred from using these facilities. A novel feature of System X is the use of guidance announcements to tell the customer what to do next. These announcements are assembled by the automatic announcement subsystem (AAS) from an in-built library of words and phrases, and are constructed to suit each call. For example, if a customer wishes to arrange for his incoming calls to be transferred to another number, he starts by dialling the service code *21*. He then hears the announcement: "*Basic Diversion Service. Dial the telephone number to which you want your calls diverted followed by square*". The customer then dials the number (for example, 212355 #) and hears the announcement "*All incoming calls will be diverted to telephone number 212355*". In this way, the customer is helped to use the service, and receives confirmation that his instructions have been recorded correctly. Note that customers would generally be offered these facilities in conjunction with a multifrequency signalling (MF4) keyphone, which offers very much faster dialling, and the additional star (*) and square (#) keys.

These supplementary facilities and the use of voice guidance have been achieved by exploiting the power of the processor control and the digital switching of System X. In this way, a better and more helpful service can be provided to customers.

Administrative Facilities

Supplementary customer-facilities are perhaps the external gloss of a modern switching system. Less publicized, but more important, are the improved facilities offered for maintenance and management of the exchange. An administration wants, and System X offers, a highly accurate and flexible system of call accounting, a comprehensive statistics collection arrangement for traffic monitoring, a fast and reliable automatic fault-detection and isolation procedure, and facilities for simple and rapid changing of exchange data such as routings and directory numbers.

These facilities are built into System X as modules of hardware and software, as appropriate. Although each local exchange is fully capable of operating from a local control point only, the normal practice in the UK telephone network will be to work via a local administration centre (LAC). Data will flow between the local exchange and the LAC over message transmission links, enabling data such as bulk charging records to be recorded onto magnetic tape at the LAC, and enabling maintenance staff at the LAC to interrogate or change certain types of exchange data by use of a visual-display terminal. For example, it will be possible for the maintenance engineer to remove a particular piece of equipment from service by keying in the appropriate commands. The command language used for this sort of operation is a special man-machine language which follows the CCITT[†] recommended standards.

Future Services

Once a reasonable penetration of System X exchanges has been achieved in the UK telephone network, the BPO will have an integrated network based on processor control, high-speed data message signalling, and offering 64 kbit/s channels for carrying customers' traffic. Initially, transmission between a local exchange and its customers will be of conventional analogue form, but techniques for extending the 64 kbit/s digital channel to the customers' premises are already well advanced. With these techniques and System X the BPO will be able to offer services that exploit the full data-capacity of the 64 kbit/s transmission path.

Ideas on the future exploitation of such an integrated services digital network are well advanced, although they are not yet at the stage of full implementation. Thus, System X exchanges have been designed with this capability in mind, though further hardware and software modules will need to be provided when the exact form of the services is known.

System Structure

The local exchange system structure (see Fig. 1) is based on two major elements: a digital switch, which interconnects the 64 kbit/s channels of 2.048 Mbit/s digital multiplexes by a combination of time and space switching; and a main processor, which comprises processing hardware and storage, together with a software operating system to provide a secure environment for the exchange control programs.

Subsystems

Around the digital switching subsystem (DSS) and the processor subsystem (PS) are placed:

(a) the message transmission subsystem (MTS), used for communicating with other System X installations by means of

[†] CCITT—International Telegraph and Telephone Consultative Committee

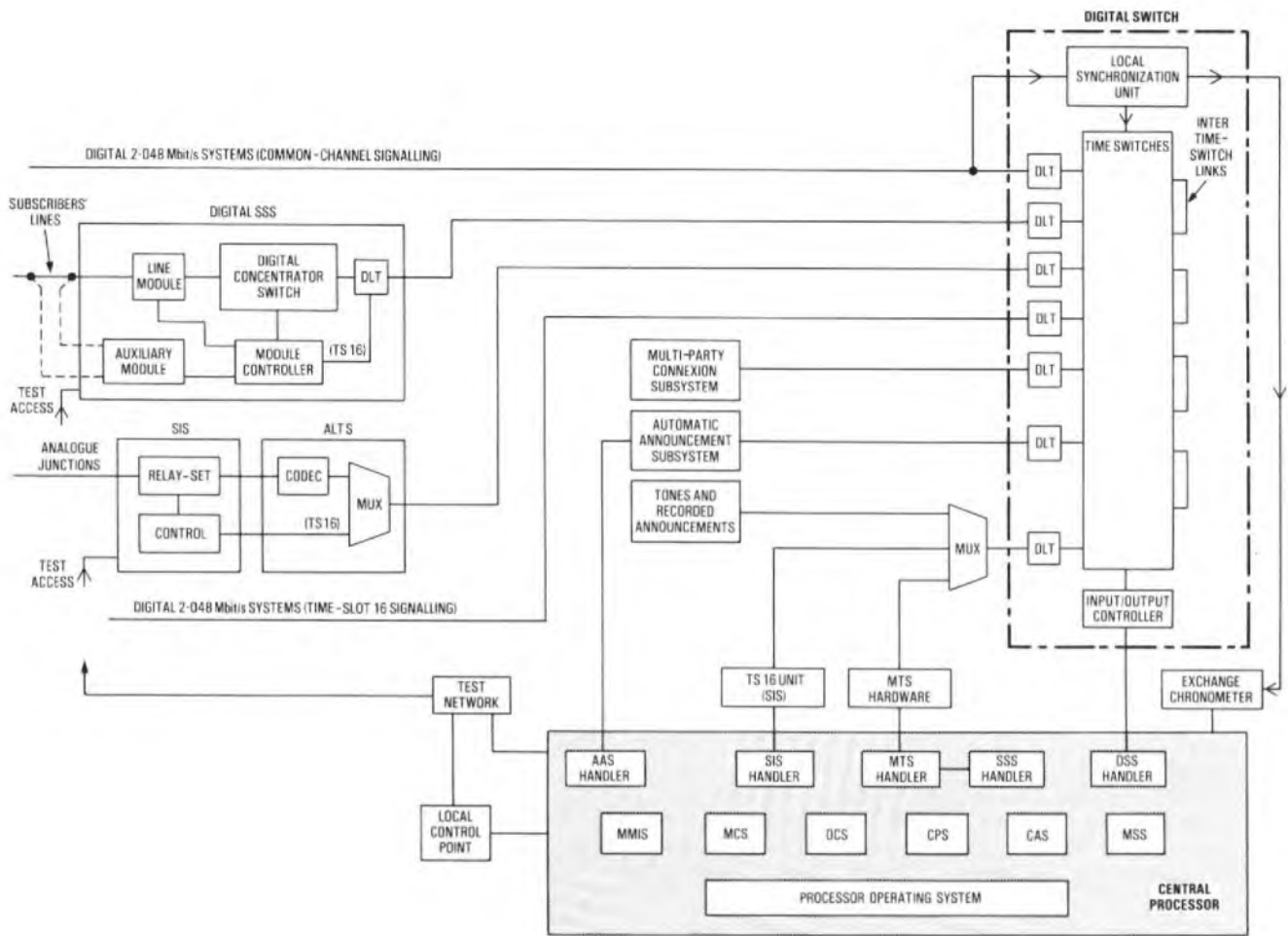

AAS: Automatic announcement subsystem
 CAS: Call accounting subsystem
 CPS: Call processing subsystem
 DLT: Digital line termination
 DSS: Digital switching subsystem
 MCS: Maintenance control subsystem

MMIS: Man-machine interface subsystem
 MSS: Management statistics subsystem
 MTS: Message transmission subsystem
 OCS: Overload control subsystem
 SIS: Signalling interworking subsystem
 SSS: Subscriber switching subsystem

FIG. 1—Block diagram of a System X local exchange

common-channel signalling in a 64 kbit/s channel or a 4.8 kbit/s data path.

(b) the signalling interworking subsystem (SIS), used for converting existing types of junction and trunk signalling into message form for processing by the exchange control programs,

(c) the subscriber switching subsystem (SSS), used for converting subscriber line signalling into message form, and for concentrating traffic from a variable number of lines onto channels in a limited number (2 – 8) of 2.048 Mbit/s digital multiplexes.

(d) the analogue line terminating subsystem (ALTS), used for converting analogue transmission signals (speech and other waveforms) into digital form, and vice versa,

(e) the multi-party connexion subsystem (MPCS), which enables three or more parties to participate in a telephone conversation,

(f) the automatic announcement subsystem (AAS), used for assembly of announcements as required from digitally-recorded segments of speech, and

(g) the network synchronization subsystem (NSS), which provides basic exchange timing signals, in synchronism with the network as a whole, if required.

These subsystems contain some of their own control functions, often using microprocessors, to carry out basic repetitive types of function. Most of these subsystems also have a software part, known as a *handler*, which runs on the main PS.

There are also software-only subsystems which, together with the handlers mentioned above, make up the exchange control software. The subsystems are

(a) the call processing subsystem (CPS), which controls the progress of each call and carries out the register/translation function,

(b) the call accounting subsystem (CAS), which derives and stores the charging information for each call in bulk and itemized form as required,

(c) the maintenance control subsystem (MCS), which co-ordinates the handling of system malfunctions, the operation of test and maintenance procedures, and the modification of exchange data by maintenance staff,

(d) the management statistics subsystem (MSS), which collects traffic data,

(e) the overload control subsystem (OCS), which monitors the processing load, and delays or sheds less-urgent work as necessary, and

(f) the man-machine interface subsystem (MMIS), which provides facilities for communication between the exchange and the maintenance staff.

Trunking

The exchange switching networks are contained within two of the hardware subsystems: the digital switching subsystem (DSS), and the subscriber switching subsystem (SSS). The reason for this separation is that the DSS is a general-purpose

digital switch for switching traffic that is already concentrated, and is the only form of switch required in trunk and tandem exchanges. Local exchanges require concentration stages of switching and, following the modular approach to System X design, this is provided, when required, as an additional modular subsystem to be added to the main digital switch.

The separation of the concentrating switch from the central switch has the added benefit that the concentrating switch is suitable for location at another exchange site as a remote concentrator unit. This is achieved by interposing standard digital transmission systems between the concentrating switch and the central switch. For control purposes, the concentrating switch remains under the control of the exchange software in the normal way, with control message communication via time-slot 16 of the digital transmission systems.

The DSS is described in an article on p. 19 of this issue of the *Journal*. At present, the DSS can be configured in two forms: one for large systems and the other for small-to-medium systems. In both cases, the DSS has the same time-space-time structure although, in the smaller case, only 4 time-switches need to be interconnected for a 1000 erlang exchange (see Fig. 2). This small amount of space switching (4×4) can be provided physically as part of the time switches, and so there is no separate space switch.

Each time-switch serves up to thirty-two 2.048 Mbit/s multiplexes of 32 time-slots. Time-slot 0 is used for external synchronization purposes, but time-slots 1-31 can all be switched through the DSS as 64 kbit/s transparent bi-directional data-channels. Thus, one time-switch carries up to 992 channels, and the smaller version of the DSS with 4 time-switches serves a total of 3968 channels. Any channel can be connected to any other channel, with very low probability of internal blocking. It is possible to overlay connexions; for example, where several channels require simul-

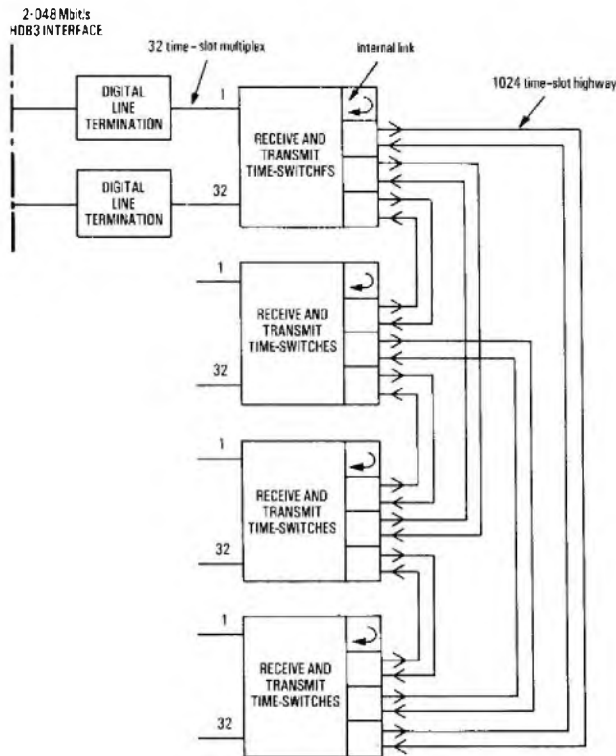

HDB3: HDB_n is one class of highly-redundant ternary codes, known as *high-density bipolar*, of the order n , where n is the maximum number of consecutive zeros in the HDB_n signal. In this case, $n = 3$
 Note: One security plane only is shown

FIG. 2—DSS trunking arrangement for small-to-medium local exchange

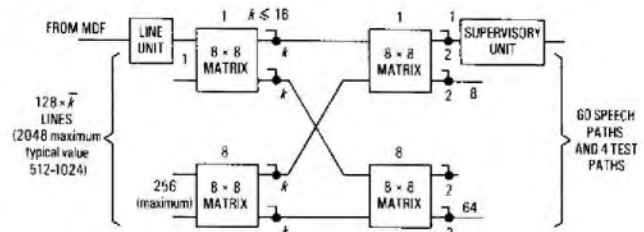

FIG. 3—Analogue SSS trunking

taneous connexion to engaged tone. It is also possible to leave connexions set semi-permanently to provide control signalling paths through the exchange.

The SSS has been developed in both analogue and digital forms. In its analogue form, a 2-stage reed-relay switching network (see Fig. 3) is used to concentrate traffic onto supervisory circuits, which provide line-feed, ringing, and necessary line-signalling functions. From the supervisory circuit, the transmission signals are taken to an ALTS for conversion to PCM digital multiplex form.

The 2-stage network is made up of 8×8 reed-relay matrices, and has the fixed number of 64 inlets on the concentrated side and a variable number of up to 2048 outlets on the subscribers' line side. The links between the A and B switching stages are arranged in a mixing pattern to assist traffic balance, and can be commoned together to achieve a concentration factor (k) of up to 16. This variable concentration enables the same design of network to be used in low and high subscriber-calling-rate situations; the object in all cases is to achieve a traffic loading of about 0.6 at the supervisory circuits connected to the network inlets.

Sixty supervisory circuits are provided for one such concentrating network, this number corresponding with the 60 transmission channels provided by a pair of 2.048 Mbit/s PCM digital systems. Any subscriber's line can be connected to any one of these 60 channels, provided a free path through the network can be found. The supervisory circuits are identical in function, and can be used for originating or terminating calls. The remaining 4 inlets of the network are not required for calls, and are used for test access.

This type of concentration network exhibits internal blocking, and there is a significant probability that a particular free line cannot be connected to a particular free supervisory-circuit because the internal link between the relevant A and B switches is in use on another call. However, the network is used to provide connexions between a particular line and any free supervisory-circuit, both for originating and terminating calls. This method of operation has been called *ends-to-middle* selection, and it exploits the power of the central digital switch, which has extremely low internal blocking and is able to connect any predetermined pair of channels with near certainty of success.

Rapid technological developments have now made it cost-effective to deal with subscriber line signalling and to convert from analogue-to-digital transmission on an individual line basis; a digital SSS has been developed to achieve this. The digital SSS is functionally equivalent to the analogue SSS, being an alternative realization of the same subsystem and exploiting the evolutionary structure of System X. However, there are fundamental differences in the structure of the two versions of the subsystem.

Digital technology enables a large amount of switching to be provided by relatively few components and, because of this, the digital SSS contains a digital switching network which has no internal blocking, and can be extended on its concentrated side (inlets) to connect up to 8 PCM digital multiplexes (240 channels) in addition to growth on its line side (outlets) to serve up to 4096 lines (see Fig. 4).

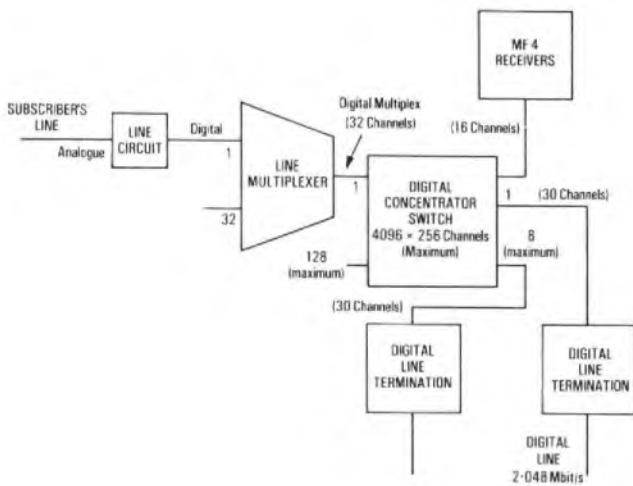

FIG. 4—Digital SSS trunking

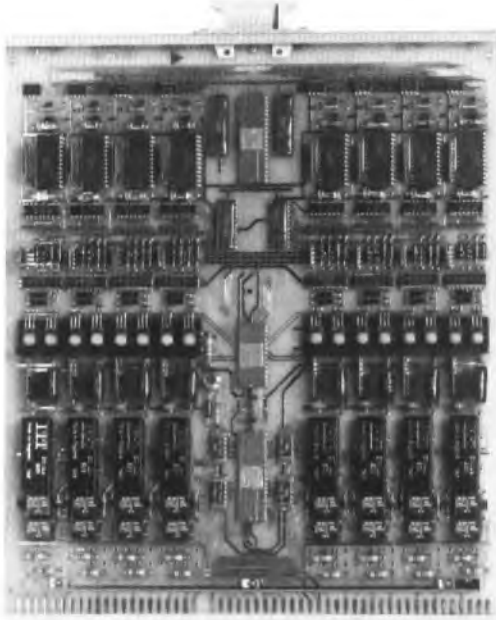

FIG. 5—Prototype line unit (8 subscribers) for the digital SSS

Subscriber lines are connected to individual line units, which provide all the supervisory circuit functions and the analogue-to-digital conversion previously provided by the ALTS. Modern technology, including the use of large-scale integrated coders and filters and thick-film hybrid circuits, enables 8 of the line units to be mounted on one slide-in unit (see Fig. 5). The digital signals from 32 such line units are multiplexed together and connected to a time-switch outlet. The time switch can have up to 128 of these multiplex outlets and therefore switches up to 4096 channels. On its inlet side, the time switch has 256 channels for concentrated traffic; 240 of these are connected to the channels of up to 8 PCM digital multiplex systems, and 16 channels are used for MF4 signalling receivers.

The time switch contains up to 4096 channel stores on its outlet side, each with an 8 bit receive store and an 8 bit transmit store. These stores are loaded and unloaded continuously with PCM samples from and to the line units, via the 32 channel multiplexes. Internally, the time switch operates in a parallel time-switching mode between the channel stores and a pair of parallel highways, one for each direction of transmission (see Fig. 6). These highways are 8 bit wide and operate at 2.048 Mbit/s, providing a multiplex of 256 time-slots for concentrated traffic. Channel stores can be unloaded (received) and loaded (transmitted) to and from any of these 256 time-slots, providing full-availability switch-

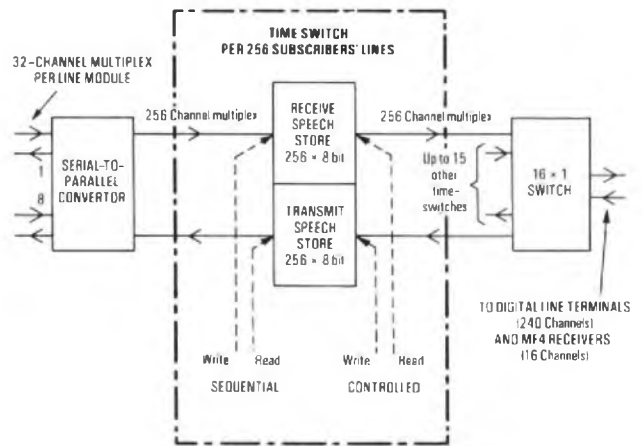

FIG. 6—Block diagram of digital concentration switch

ing between the 4096 channels on the outlet side, and the 256 channels on the inlet side. A digital source of tones is associated with the switch, enabling any one of the tones to be injected into any channel.

The standard supervisory and line circuits of both analogue and digital SSSs are designed to cater for most of the lines. However, certain lines such as subscriber-private-meter lines require special line signals, and these are provided from an auxiliary circuit connected in series with the normal line circuit.

The exchange trunking is also used to carry signalling and control information, although normally such paths are left permanently switched, and are reset for maintenance reasons only. Often, but not always, this information is present in the time-slot 16 of each PCM multiplex system connected to the central DSS. The DSS switches these signalling and control channels via semi-permanent paths to the appropriate control logic units. Such channels include the control paths for SSS and SIS hardware, and the common-channel signalling channels used by the MTS for signalling to other System X installations.

Control Hierarchy

The main PS† is at the core of the exchange control, and offers a highly secure and sophisticated environment for software, including sanity checks, backing-store facilities, and man-machine interaction. The processing power of the PS, although large, is finite, and the system design therefore relieves it of the more time-consuming and repetitive functions that can readily be carried out by microprocessors associated with other exchange hardware. Such functions can include scanning for signals and path selection.

The modular subsystem structure of System X enables each control option to be considered on its merits, and permits evolution to different balances of central and distributed control as technology provides alternative solutions. Two examples in the local exchange architecture are the DSS and the SSS, which illustrate these points.

The large version of the DSS (up to 96 time-switches) has to handle a very large rate of switching requests; this requires that the DSS has its own dedicated control system external to the main processor. For the small-to-medium size local exchange, only 4 time-switches are required, with a correspondingly lower rate of switching requests. At the smaller sizes of exchange, it is vital to reduce the amount of control hardware since this represents a significant proportion of the exchange cost; therefore the control functions of the DSS (in particular, path selection) reside as software on the main processor, and use up to 10% of its power. This means of control avoids the need for a dedicated DSS control unit, although there is still an element of distributed control in the

† To be described in a later issue of this *Journal*

microprocessors in each time switch. Although this version of DSS uses more software control than the larger version, it carries out the same function, and is functionally identical as seen from other subsystems.

The second example, the SSS, illustrates the evolution that has taken place within the same system architecture in moving from the analogue to the digital version of the subsystem. The analogue SSS makes extensive use of microprocessors as hardware microcontrollers. For example, one such microcontroller continuously scans a group of 16 line units for calling conditions. When a signal is detected, the microcontroller generates a control message, which is collected and channelled via a 64 kbit/s control path through one of the time-slot 16 channels serving that module (see Fig. 7).

The message, multiplexed in with other control messages, traverses the DSS and is buffered in input/output control logic at the periphery of the main processor. Software in the main processor receives each such message and passes it to the appropriate part of the program; in this case, the part of the SSS handler software dealing with call origination. Similar microcontrollers exist in other parts of the hardware. For example, a microprocessor controls 4 supervisory circuits, detects loop-disconnect dialling, answer signals, and applies ringing, etc.

The digital version of the SSS has introduced an additional stage of microprocessor control. Microprocessors are used to control groups of 32 lines, detecting and applying signalling conditions as required (see Fig. 8). They are connected via high-speed serial control paths to a microprocessor module

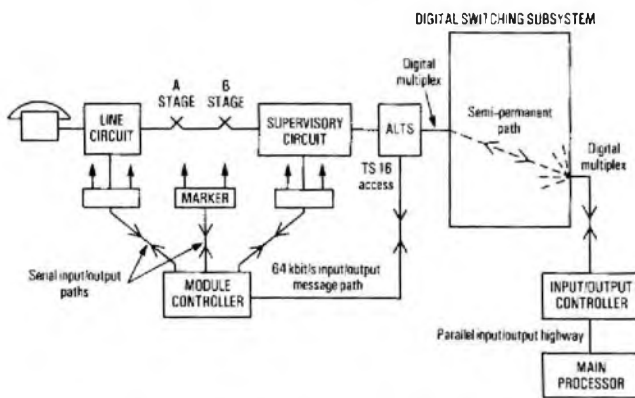

FIG. 7—Block diagram of analogue SSS control message path

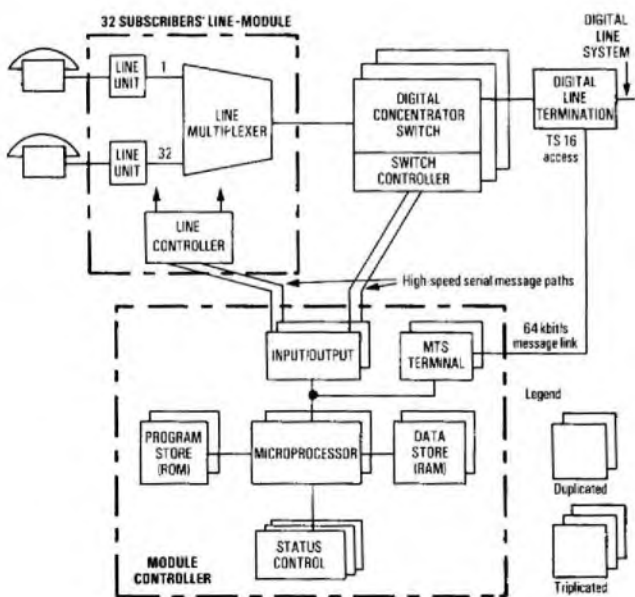

FIG. 8—Structure of digital SSS control hardware

controller, which contains much of the SSS handler software previously located in the main processor. The software in this module controller communicates with software in the main processor (for example, the call processing subsystem (CPS)) via messages transferred on a 64 kbit/s data path provided by a time-slot 16 in one of the digital multiplexes serving that module. A variant of the common-channel signalling MTS is used to convey these messages in a transparent and secure way so that, functionally, the message flow between the SSS and the CPS is the same as if the SSS handler software remained on the main processor.

The main processor used for the small-to-medium size local exchange is duplicated and used in a worker/standby arrangement. For medium-to-large local exchanges, the System X multiprocessor configuration will be used. Some changes to software are required because of the different security configurations of these processors, but these are kept to small well-defined program areas and, in general, the same control programs are used for all local exchanges.

SYSTEM OPERATION

The software that controls the system is constantly ready for operation. Within the software is contained program to deal with every eventuality that may arise, either in call-handling, fault situations or maintenance operations. When no calls exist in the system, parts of the software are continually watching for external stimuli, performing checks, and monitoring the passage of time. Any activity in these areas will lead to the relevant part of software being run to analyse the situation and carry out the appropriate actions. For simplicity in describing the operation of the system, one sequence only is considered. In practice, the processor is sharing its time between many hundreds of simultaneous operations, all at different stages and of different types.

Call Handling

Call handling involves the interplay of several subsystems, each carrying out its own functions and each communicating with the other by messages. These messages are generally between software programs on the main processor and are called *tasks*. To illustrate the way in which calls are handled, consider the setting up of a call between two subscribers; in practice, this involves something of the order of 30 000 program steps to be executed by the main processor, and so it is possible to describe the operation only superficially here.

The *seize* condition from the calling subscriber is detected by the line unit hardware and is reported to SSS software. The SSS software reports the seizure to the CPS and, at the same time, selects and commands the hardware to operate a free path in the concentrator switch.

On receiving the *seize* message, which includes the identity of the calling subscriber, the CPS checks the subscriber's service mark to ensure that it is valid for originating calls, and allocates a data area in the processor for storing call details. The CPS then instructs the SSS to proceed with the reception of digits.

The SSS then arranges for a connexion to an MF4 digit receiver if there is a likelihood of receiving MF digits. The SSS connects dial tone to the speech path by appropriate command to the hardware.

The digit-receiver microprocessor reports each digit to the SSS handler software, which forwards them to the CPS. The CPS stores the digits in the call-record data area and, when sufficient digits have been received, it searches its translation tables. These may give a routing, or indicate that more digits are required. In the case of an own-exchange call, the equipment number of the called subscriber will be given when all digits have been received. Using this equipment number, the CPS then checks the state and the service mark of the called subscriber and, if valid for terminating calls, proceeds with the call. To do this, the CPS instructs the SSS to set a path

through the relevant concentrator network to the called subscriber's line.

The SSS first checks the state of the line; if the line is free, the SSS selects and operates a path in the concentrator switch and replies to the CPS giving the identity of the selected circuit between the SSS and the DSS.

The SSS then arranges for ring tone to be connected to the calling-subscriber's line and for ringing current to be connected to the called-subscriber's line. The SSS supervisory hardware monitors for and detects the *answer* condition, and the controlling microprocessor removes ringing current from the line and sends an *answer* message to the CPS.

The CPS then instructs the DSS to connect the transmission path between the supervisory circuits connected to the calling and called lines, and the call is established. At this point the CPS sends call details to the MSS for traffic-recording purposes and to the CAS for charging purposes.

At all stages during this sequence, the control software has been applying checks and time-outs to guard against errors or loss of information. In addition, a security copy of call information is stored by the standby processor, which can take over call-handling if a fault should develop in the worker processor.

During the stable speech phase, the software on the main processor takes no further action on the call. The supervision of the call is left to the peripheral microprocessors, which continuously monitor for a clearance condition.

The clear-down sequence is dependant on the type of call, and the hardware is not allowed to release calls unless instructed to do so by the CPS. Thus, a clear condition from a calling or a called subscriber is reported by the SSS to the CPS, which then carries out the appropriate checks before organizing the clear-down sequence.

During clear-down, the CPS sends end-of-call details to the MSS for traffic recording, and to the CAS for charging. If necessary, the CPS arranges for a subscriber who has not cleared to be given an announcement that the other party has cleared.

Supplementary Facilities

Supplementary facilities are provided almost entirely by additional programs in the CPS, although other subsystems are involved; for example, the SSS has to deal with extra signals, including the *recall* signal. Supplementary facilities have two distinct aspects: their control, and their use. For control of facilities, a customer starts a call by dialling a service code. The CPS recognizes this code and arranges for a connexion to a free automatic announcement-channel, and for the AAS to generate the appropriate announcement. Immediately after the announcement, the CPS connects dial tone, and awaits further digits. These digits are then interpreted by a program specific to the particular service requested, and may lead to the storing of supplementary information against that customer's identity for use in future call handling. For example, the customer may have dialled a new personal short code for his future use, or he may have dialled a directory number to which he wants his calls transferred.

The use of supplementary facilities is invoked at various stages of a call. For example, the use of the short-code service is recognized immediately from the dialled prefix**; the use of 3-party service commences after a *recall* signal is detected during a call; an automatic alarm-call is initiated within the system.

In all cases, the responsibility for the call lies with the CPS, which must check the validity of the customer's request by examination of his service mark. In some cases (for example, diversion), a supplementary service modifies the treatment of all normal calls, and the CPS detects that such action is required by its checks on service marks during all call processing.

The provision of supplementary services exploits the power

and flexibility of the processor to control such varied operations, and the speed and the flexibility of the digital switch in rapidly making and remaking the necessary alternative connexions required for some services. As System X exchange networks become established, it will be possible for the speed and capacity of common-channel signalling between exchanges to be exploited to enable exchanges to collaborate in supplementary service call-handling across the network.

Call Charging

Call charging is the responsibility of the call accounting subsystem (CAS), which receives call details at the beginning and end of each call and calculates and accumulates the bulk record of charge units for each customer. This is done in an extremely secure manner by using duplicated non-volatile storage.

Calls originating from customers with coin-collecting box or private meters require special treatment, since charging information must be generated continuously during the call. This responsibility is delegated to the SSS, which is given the appropriate charge rate at the start of the call and is required to generate the periodic meter pulses. At the end of such calls, the SSS reports the charge it has accumulated for the call to the CAS for checking and recording.

Itemized accounting is available by setting a customer's service mark. Where this is done, the CAS arranges for the bulk record to be incremented as normal and for the itemized details to be recorded, either locally on magnetic tape or by transfer of the information to the LAC for later processing by the billing system.

Facilities are available for authorized personnel to read the contents of a customer's charge record at any time, and to modify the charge rates stored within the system. The system enables different charge rates to be stored for each half-hour of the day.

Traffic Recording

Statistical information on the number of calls and traffic levels must be collected from a number of places in the system, and sifted to produce traffic records necessary for managing the system. The information resides as data in the software of various subsystems, and it has to be passed as required to the management statistics subsystem, which collates and categorizes the data before it is transferred for off-line processing and analysis.

Most of the information is derived from call details passed from the CPS to the MSS as soon as each call is set-up, and when each call is cleared. Included in these details are the type of call, the identity of the caller, the route or service requested, and details of the state reached by the exchange in dealing with the call; for example, call successful, called-subscriber engaged, etc. The MSS can sort this information to collect statistics on such things as the traffic being generated by each class of subscriber and the traffic being carried by each route.

Additional information on traffic intensities at various points in the system is obtained by periodic scanning and counting by a subsystem. For example, the SSS can be requested by the MSS to measure the traffic on its MF4 digit receivers, which it does by regularly examining its data records and counting the number of receiver channels in use. This particular software procedure is exactly analogous to the methods used for traffic recording in electro-mechanical systems, though the results are held electronically as data records, which can be passed via data link or magnetic tape to a suitable processing centre.

Fault Handling

Fault situations are detected by hardware or software checks, and may arise due to equipment failure, noise-induced errors,

or latent design faults. Extensive system-proving should eliminate the majority of design faults, but the random nature of telephone traffic will almost certainly present some untested combination of conditions to the exchange.

A large proportion of the system software is devoted to fault handling, since faults must be identified, contained and diagnosed for maintenance action. In addition, if a fault is detected during the handling of a call, special program sequences must be invoked to complete the call successfully if possible, or at least to terminate it in a controlled manner.

Each subsystem contains its own fault-handling programs and, as far as is possible, deals with the fault by itself, merely reporting the fault details to the maintenance control subsystem for logging. If the fault reports concerning hardware are definitive, the subsystem is instructed by the MCS to busy the particular item; alternatively, the fault reports may indicate a possible problem that needs confirmation. In the latter case, the subsystem can keep a count of fault reports against items of equipment, and identify those involved in an abnormal proportion of reports. In many instances, it is possible for specific tests to be invoked to check suspect equipment.

Software checks are performed at all stages of processing, and can indicate that invalid data exists, or that an invalid situation has arisen. Again, a count can be kept of these reports and, if they arise too frequently, the suspect part of the program can be refreshed with a new initial copy of data or program.

The maintenance control subsystem keeps a secure record of hardware fault reports, and controls the completion of taking equipment out of service in a secure manner. The fault details are reported to maintenance staff via the man-machine interface subsystem (MMIS) and the MCS associates any subsequent diagnostic or repair actions with the original report. In this way, the MCS keeps track of the state of the system, and can prevent incorrect or inappropriate manual procedures.

Data Changes

Maintenance staff can change data records held within the system by operating a visual-display terminal either at the exchange or at the local administration centre. A defined man-machine language conforming to CCITT recommendations is used for transactions between the man and the system. The transactions are controlled by the MMIS, which provides software for checking and handling all data input and output. The MMIS passes all requests for data changes to the maintenance control subsystem, which analyses their meaning and validity and co-ordinates the functioning of other subsystems, each of which is responsible for updating their own data.

Security of access is carefully controlled by the MMIS checking that a user has entered a valid user code and the appropriate password. This information, together with the identity of the terminal being used, gives the user the right to access certain procedures and certain types of data, referred to as *resources*. Having successfully established access to the system, the user enters a command code specifying the action he requires, and the resource involved. He follows this with any appropriate data for that command.

For example, to change a subscriber's number, the user enters the command *change directory number* followed by the existing number and the new number. This information is passed from the MMIS to the MCS, which initiates the particular update sequence for changing a directory number. Typically, the MCS sends a request to the CPS for the subscriber's equipment number. The MCS then requests the SSS to put the subscriber temporarily out of service so that the change of number can proceed without causing data discrepancy. The MCS then commands both the CPS and the CAS to amend their data tables to the new directory number and, when this is complete, the MCS commands SSS to return the

subscriber to service. Similar procedures are provided for all alterable data in the system, several hundred different types of transaction being possible.

Program Changes

Although the use of stored-program control offers great flexibility, the exchange software is large and complex and it requires thorough proving before it is committed to service. To minimize program changes, variable exchange characteristics are held as data, which can be readily changed. Nevertheless, it is necessary to change the program occasionally, either to correct design problems or to add new features to the exchange.

The program is stored in the processor in a read-write electronic store, and back-up copies are held either on magnetic tape, drum or bubble memory. The processor configuration for the small-to-medium size system is a duplicated processor; one processor carries the exchange load and the other keeps itself updated with call data and acts as a standby. New copies of program are loaded via magnetic tape into a backing store; from the backing store, the programs are loaded into the main store of the standby processor. At a suitable moment, a processor change-over is initiated from the processor with the old program to the processor with the new program. The second processor, now acting as standby, is then loaded with the new program.

If the program changes also involve changes to data structures, then further procedures are carried out to load the processors with new copies of exchange data at the same time as the new program. As far as possible, this operation is carried out without interruption to service though, if data changes are involved, calls being set-up may be rejected. In these cases, the operation would be performed during a period of light traffic.

CONCLUSION

Subsystems have been designed and developed to meet the needs of the full range of System X local exchanges. Where possible, the subsystems are the same as those used for trunk exchanges and, in all cases, they conform with common System X hardware and software design standards. The design is highly modular and makes extensive use of software control to provide a comprehensive and flexible range of facilities for customers and the administration. The first System X local exchanges to be manufactured are in the small-to-medium size range. One such exchange has been installed at the system contractor's premises for system development work; a second has been exhibited in Geneva at the TELECOM 79 Exhibition; further exchanges are now being manufactured for installation in the UK network for public service in 1981. The modular subsystem architecture has enabled the system to be developed to a tight timescale by teams within the BPO and UK Industry, and has provided an enduring framework for further development to take account of advances in technology and to provide new services. ♦

ACKNOWLEDGEMENTS

The author wishes to thank his many colleagues both in the BPO and UK Industry for their contribution to the development described in this paper.

References

- 1 MARTIN, J. System X. *POEEJ*, Vol. 71, p. 221, Jan. 1979.
- 2 JONES, W. G. T., KIRTLAND, J. P., and MOORE, B. W. Principles of System X. *POEEJ*, Vol. 72, p. 75, July 1979.
- 3 TIPPLER, J. Architecture of System X. Part 1—An Introduction to the System X Family. *POEEJ*, Vol. 72, p. 138, Oct. 1979.
- 4 VANNER, N. J. Architecture of System X. Part 2—The Digital Trunk Exchange. *POEEJ*, Vol. 72, p. 142, Oct. 1979.

An Experimental Solar-Collection System for Domestic Hot Water

R. W. AUGUST†

INTRODUCTION

In 1976, the South Eastern Telecommunications Region's newly-formed Fuel-Economy Group started to have serious thoughts about utilizing solar energy in an attempt to reduce consumption of fuel for heating domestic hot water in British Post Office buildings. There were many press articles published at that time, but none of them gave any meaningful data on the practical design or efficiencies of solar-collection systems. Other enquiries failed to provide any further information. In view of this lack of information, it was decided that a trial installation should be provided and its performance monitored.

CHOICE OF SITE

The telephone exchange at Slough was chosen, primarily for the following reasons:

(a) The building has a draw-off rate of domestic hot water in excess of 5450 litres (1200 gallons) per day. During the summer months this water is heated by an ancient oil-fired boiler with an overall efficiency in the order of 25%. From the outset, therefore, any small savings would be worthwhile in the long term.

(b) The building has a reasonable area of flat roof at its south end, adjacent to the cold-water storage tank room, with easy access to the boiler feed pipe, and space was available for a heat-exchanging tank.

(c) There was unlikely to be any problem with obtaining planning permission because the building is adjacent to a large industrial site.

SYSTEM DESIGN

The system was to be a simple one, with the capability of being extended if necessary. With such a high draw-off rate of hot water there was no possibility of heating the water to high temperatures; therefore, the intention was to pre-heat the water by a small amount before feeding it to the boiler. It was hoped that a high efficiency would be obtained by heating a large amount of water through a small temperature rise. Thus, the low temperature in the heat-exchange tank would keep losses through the insulation low, and a high differential between panel output temperature and tank temperature would keep heat-transfer efficiencies high.

The initial installation was designed around 6 collector panels each of 1 m² surface area. The panels were the cheapest available at that time. Each panel consisted of 4 vertical copper pipes 15 mm in diameter spaced on 150 mm centres and connected at the top and bottom by copper manifolds 28 mm in diameter. The front of this grid was covered with a copper sheet 0.25 mm thick, coated with a matt-black absorber and soft-soldered to the vertical pipes throughout their length. The absorber assembly was mounted in a deep aluminium tray with fibre-glass insulation at the back, polyurethane strips around the sides and a glass plate surrounded by a rubber gasket over the front. The panels were mounted on an angle-iron frame inclined at 45° and facing due south.

The panels were connected to a heat-exchange tank situated inside the tank room, with the return fed via a domestic-heating circulating pump and a flow-meter. The sealed

1800-litre tank, complete with a transfer coil, was purpose-made by a local firm. The tank was fitted with a 25 mm thickness of rigid insulation. A cold-water feed was taken from the main storage tank via a flow-meter into the bottom of the transfer tank and the output from the top of the transfer tank fed to the hot-water calorifier.

The pump was controlled by a commercially available controller, consisting of a simple differential amplifier connected to 2 temperature sensors in such a way that if the temperature of the water at the top of the panels was higher than the water in the tank, the pump would run. The actual differential on the system was 4°C, and the flow rate through the panels was kept low at 760 litres/h.

Protection from frost damage was achieved by using a thermostat at the bottom of the panels (assumed to be the coldest point) which caused the pump to run if the temperature dropped below 5°C, thereby preventing freezing. This method was chosen for safety reasons in preference to the use of anti-freeze solutions.

PERFORMANCE

To monitor the performance of the system, a 6 point chart recorder was connected to monitor the temperatures at salient points within the system. It was possible, from these charts, to calculate the amount of heat that was actually collected and transferred to the hot-water system. The system was run for some 18 months, including the severe winter of 1978-79, and recordings showed that there were measurable heat gains even when the air temperature was below zero.

Typical figures obtained during July, August and September 1978 were:

- (a) temperature rise across the transfer tank, 5°C,
- (b) heat output of between 2-3 kW/h, and
- (c) total weekly output of 90-110 kW h/week.

From insolation data (that is, the maximum amount of solar energy available per square metre of collector surface area) for the Slough area, it was calculated that the system was 62% efficient and that some 1400 litres of heating oil would be saved each year at a present-day cost of £154.

DESIGN DEFICIENCIES

The shortcomings of the system were mainly in the design of the heat-exchanger coil and the collecting panels. The results suggested that a coil with a larger surface area would have enabled more heat to be recovered. The panels were found to be lacking in insulation, with heat being lost through the rear of the panels and by contact between the copper sheet and the aluminium casing.

VIABILITY

The system described was not financially viable, the payback period being in the order of 12-15 years. However, this was partially caused by the inflated installation costs due to the monitoring facilities provided. These facilities were essential to the exercise and the data collected has proved invaluable. There are now cheaper, more efficient panels available and, with an improved heat exchanger, a cost-viable system could be installed.

As a result of the experimental system, a new system with a 23 m² collector having a forecast payback period of 5-7 years is being installed.

† South Eastern Telecommunications Region

Architecture of System X

Part 4—The Local Administration Centre

A. A. WALIJI, B.SC. (ENG.), A.C.G.I.†

UDC 621. 395. 34; 621. 395. 743

This article describes the architecture of the local administration centres, which collect data from exchanges under their control and carry out the functions of maintenance, service management, network management and call accounting for those exchanges. The functions and realization of the associated network are also described.

INTRODUCTION

The local administration centre (LAC) is a system which provides a Telecommunications Authority with the means of co-ordinating the network administration activities for an area of a telecommunications network in which System X exchanges predominate. The LAC is at the node of a star-configured ancillary network, used to convey administration data from both System X and non-System X exchanges to a central information-handling capability located at the LAC. Technical realization of the ancillary network is based on hardware and software developed for the System X telecommunications network. This article describes the functions of the ancillary network, its technical realization and, in particular, the architecture of the LAC system.

† System X Development Department, Telecommunications Headquarters

NETWORK ADMINISTRATION

Network administration consists of 4 activities: maintenance, service management, network management and customer billing.

Maintenance

Maintenance of a telecommunications network involves the reception of malfunction reports, the initiation of diagnostics, co-ordination of manpower effort to clear the faults, and the restoration of the equipment to its working state.

Service Management

Service management comprises day-to-day activities concerned with the provision, cessation and alteration of subscriber service and facilities.

Network Management

Network management, in the short term, consists of making the optimum use of the existing network by relieving both route and exchange congestion by appropriate equipment reconfigurations. In the longer term, network management consists of planning and dimensioning the renewal and growth of the telecommunications network.

Customer Billing

Customer billing comprises collection of data for production of bills.

ADMINISTRATION OF A SYSTEM X EXCHANGE

There are several features in the design of a System X exchange which influence the methods employed in its administration. Firstly, the information required for network administration is available within exchange processors and can be outputted either locally in the exchange or, via a data link, at a remote centre. Secondly, the human interface with the network is via a high-level man-machine language (MML), which enables control of the network through keyboard and visual-display terminals (VDTs) which can be located either locally or remote from the exchanges. Thirdly, the reliability of the exchanges is such that only the larger exchanges require the attendance of staff throughout normal working hours.

From the point of view of an exchange and network administrator, the significant parts of a System X exchange can be represented as shown in Fig. 1. There are 3 subsystems which provide the administration data: the call accounting subsystem (CAS); the management statistics subsystem (MSS); and the maintenance control subsystem (MCS). The man-machine interface subsystem (MMIS), in association with the

SUMMARY OF ABBREVIATIONS USED IN THIS ARTICLE

ADCU	Alarm display and control unit
ASU	Alarm supervisory unit
ATS	Alarm termination subsystem
BCTS	Bulk-data transfer subsystem
CARP	Call-accounting reconciliation process
CAS	Call accounting subsystem
CPS	Call processing subsystem
CPU	Central processing unit
CRU	Concentration receiving unit
CSU	Concentration sending unit
DPE	Data Processing Executive
FSP	Fault servicing process
HDLC	High-level digital link control
IPP	Interface package process
LAC	Local administration centre
MCS	Maintenance control subsystem
MMCS	Mass memory control subsystem
MMIS	Man-machine interface subsystem
MML	Man-machine language
MSS	Management statistics subsystem
MTS	Message transmission subsystem
NMSP	Network management and statistics process
PC	Peripheral controller
PS	Processor subsystem
SRU	Signal reception unit
STU	Signal transmission unit
TBU	Terminal buffer units
TIS	Terminal interface subsystem
UPS	User process subsystem
VDT	Visual-display terminals

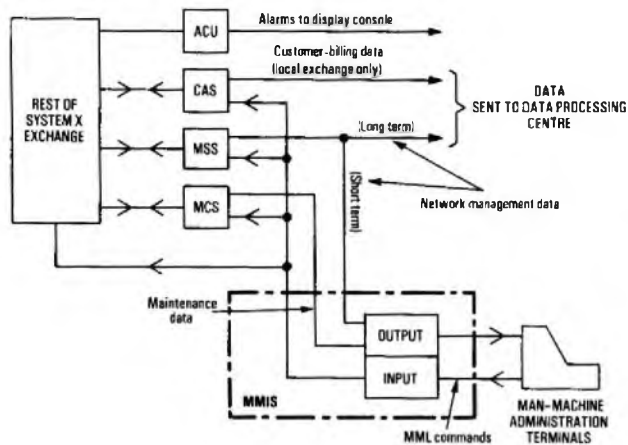

FIG. 1—Administration data flow in System X exchange

terminals, provide the capability through which the exchange can be controlled. The alarm control unit (ACU) concentrates alarms to an appropriate display console.

The data output from the exchange can be categorized broadly into 2 groups. The first group of data consists of long-term network management and customer billing data, which requires further processing at centres operated by the BPO Data Processing Executive (DPE). The second group of data consists of short-term network management and maintenance data which is presented at man-machine display devices so that immediate action can be taken in response.

Most maintenance, service management and short-term network management activities can be carried out through MML, although some activities may require additional manual work to be performed on the exchange equipment.

ADMINISTRATION OF A SYSTEM X NETWORK

The features of System X exchanges outlined in the preceding section confer the following benefits when the administration of a number of exchanges is co-ordinated at an LAC which is located centrally within the catchment area of the exchanges:

(a) Short-term network management can be undertaken with a better knowledge of the network, thus avoiding the problems where, for example, several exchanges independently choose to re-route traffic over a single route outgoing from one exchange.

(b) If the option to locate staff independently of the exchange is taken, it will be possible to co-ordinate the maintenance effort needed for the exchanges because access is available to a central database of information at the LAC.

(c) Administration functions originate at a number of geographically distributed locations; for example, a Telephone Area Sales Office, the General Manager's Office and the maintenance staff base. The LAC can, if desired, provide remote man-machine terminals with access to the exchanges within its catchment area in order to help carry out these functions.

(d) The LAC can be used to store and forward bulk data, such as customer billing and long-term network management information, thereby economizing on lines to the DPE centres.

The topology of the network in the vicinity of an LAC is shown in Fig. 2.

DESIGN ASPECTS

A local administration centre is required to

- (a) handle the ancillary network interface,

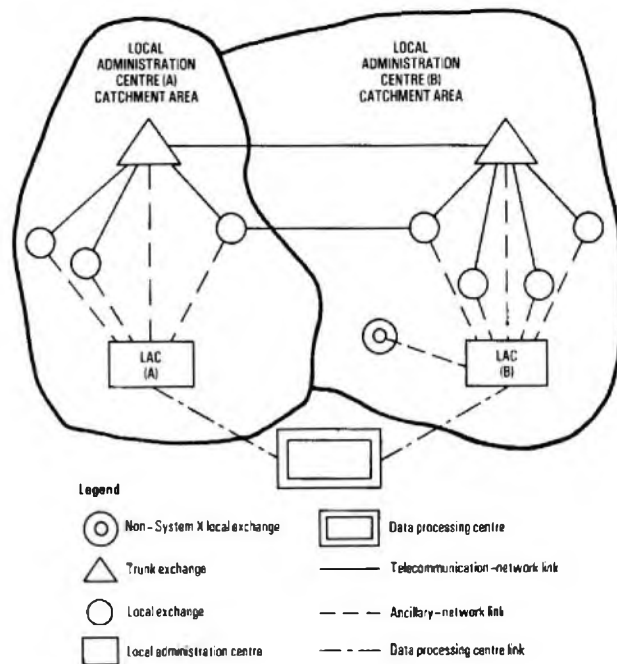

FIG. 2—System X ancillary-network topology

(b) take part in the transfer of administration data from the exchanges,

(c) operate an on-line database of information concerning the performance of exchanges in its catchment area,

(d) handle the man-machine interface and provide real-time access both to the database and to the telecommunications network via the ancillary network,

(e) handle the link to computers operated by the DPE, and

(f) take part in the transfer of data to the DPE computers.

Use of System X Technology

The design of an LAC is based on the use of components and techniques developed for the System X telecommunications network. The processor subsystem (PS) is based on the processor used in medium-sized exchanges¹ and provides the main processing resource, and the ancillary network links to exchanges are based on the message transmission subsystem (MTS)². The techniques for transferring administration data over the ancillary network are similar to those used for the transfer of common-channel signalling messages between System X exchanges. The access to an LAC database and the telecommunications network is through an MMIS, which is identical to that in System X exchanges. This commonality of operation enables the maintenance of an LAC to be carried out along similar lines to those of a System X exchange.

Other Design Considerations

The design of an LAC was influenced by several factors.

Part of the maintenance data refers to alarm events which have to be acknowledged immediately, without the need to engage in man-machine access procedures that require security validation by the LAC processor. Also, it was required that the acknowledgement procedure should be achieved via a simple man-machine interface.

Inevitably, in an LAC catchment area, there will be a number of unattended non-System X network nodes (for example, unattended automatic exchanges (UAXs), electronic exchanges (TXE2s) and transmission repeater stations) whose maintenance could be co-ordinated at the LAC. Alarm handling for these network nodes should be similar to that for System X exchanges.

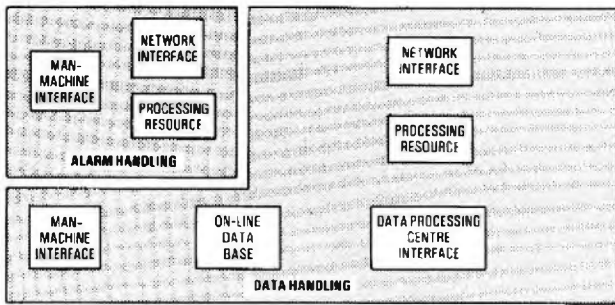

FIG. 3—General structure of an LAC

There may be a residual set of alarm events which cannot easily be conveyed via exchange processors; for example, cable pressurization faults and other environmental alarms.

The above considerations have resulted in the design of the LAC being realized in 2 separate parts, as shown in Fig. 3. The data-handling part is based on a processor and an MTS, as described above. The alarm-handling part is based on the processing resource of a microprocessor and is called an *alarm termination subsystem* (ATS). The ATS also provides an independent ancillary-network interface based on voice-frequency (VF) links, over which the alarm information is received and acknowledged via a simple man-machine interface similar to the VDT and keypad used in the BPO Prestel service.

RELIABILITY CONSIDERATIONS

The reliability of the LAC equipment is expressed conveniently by a mathematical parameter called *availability*; in a simplified manner, this can be expressed as

$$\text{availability (for a specified period)} = \frac{\text{uptime}}{\text{uptime} + \text{downtime}}$$

The exchange processor subsystem is required to provide continuous service (that is, availability = 1) for a period of 30–40 years. Such a stringent requirement necessitates the provision of replicated central processing units (CPUs).

However, the LAC need not be staffed 24 h/d. The design of data transfer protocols between an exchange and an LAC provides for the diversion of data to a back-up tape if the LAC is not available. And, because of the requirement for an independent alarm link, exchange to LAC communication is secured against processor failure. These considerations indicated that a processor subsystem with a single CPU was sufficient for the LAC.

ARCHITECTURE OF THE LAC

A block diagram of the architecture and relevant environment of an LAC is shown in Fig. 4, which indicates the relationship between hardware and software as realized in the implementation of an LAC.

Because the software for each subsystem resides within the processor main memory, the boundaries of all subsystems, except the ATS, overlap that of the processor. The communication between the software and the subsystem hardware, which, in most cases, is microprocessor controlled, takes place via a direct input/output block, which is part of the processor hardware. Additionally, residing within the processor main memory are software subsystems which have no associated hardware. The functional division of an LAC and the relevant subsystem features providing these functions are listed in Table 1.

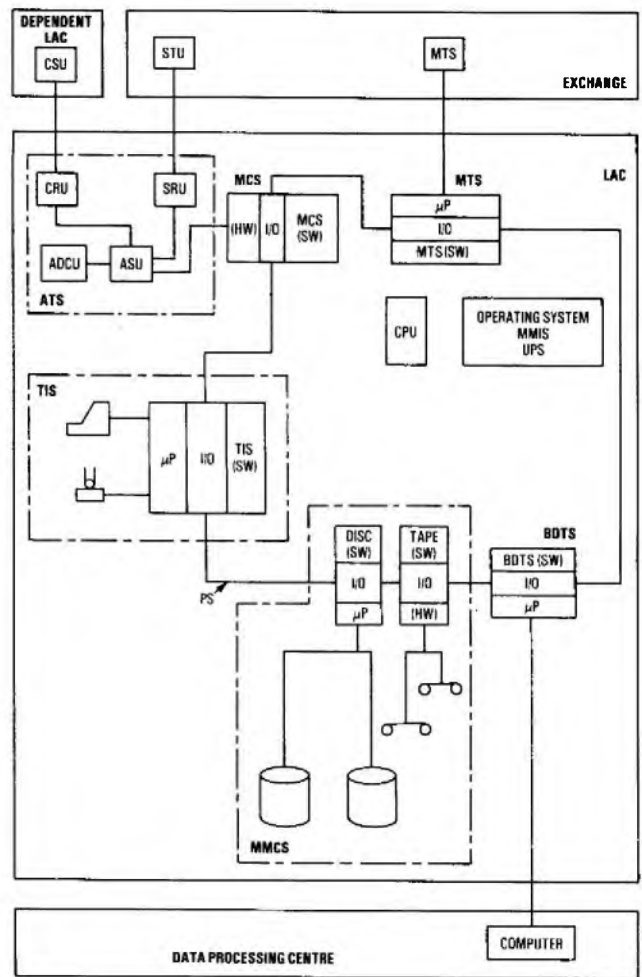

I/O: Input/output SW: Software μP: Microprocessor-controlled hardware

FIG. 4—LAC subsystem structure

SUBSYSTEMS

Processor Subsystem

The processor subsystem (PS) will be described in a later issue of this *Journal*. The PS is a communications processor; its most significant features are high reliability, real-time response and flexibility in meeting a range of throughput capability, both in terms of the size and the variety of data that an LAC is required to handle. The PS consists of a single CPU.

Message Transmission Subsystem

The LAC message transmission subsystem (MTS) is similar to the MTS at a System X local exchange, although the MTS software is designed to handle up to 60 MTS links instead of the 16 links in use at the local exchange. However, the average traffic per link on the ancillary network will be much smaller than that in the telecommunications network. The MTS links are designed to operate at 64 kbit/s using a channel of a 30-channel pulse-code modulation (PCM) system. However, if the digital line plant is not available between the LAC and exchanges, the MTS could be operated in the range 4.8–56 kbit/s by using analogue links incorporating modems.

An exchange can either be connected directly to the LAC via an MTS link, or it can be quasi-associated with the LAC. In the latter case, data is routed via an intermediate node, possibly a trunk exchange which provides signal transfer capability as part of its MTS facilities.

TABLE 1

Functions and Relevant Subsystems of an LAC

Function	Subsystem	Hardware	Software
Processing resource	Processor subsystem	CPU, input/output	Operating system
Network interface	MTS	Terminal logic unit	MTS handler
Man-machine interface	TIS	Terminal buffer VDTs character printers	Terminal handler
DPS interface	BDTS	Link terminating unit	BDTS handler
Data base	MMCS	Disc Cartridge tapes	Disc handler Tape handler
MML syntax analysis and output formatting	MMIS	None	CANAL process TYPER process Interface Package process
Maintenance and overload control	MCS	Alarm interface unit and staticizer	Maintenance control and overload process
Data handling	UPS	None	CALENDAR CARP NMSP FSP
Alarm handling	ATS	Alarm supervisory unit Alarm display and control unit Signal reception unit	Alarm handling software in microprocessor main memory

Terminal Interface Subsystem

In the terminal interface subsystem (TIS), the terminal handler software interworks with the MMIS and man-machine terminals (VDTs and character printers) via up to 3 microprocessor-controlled terminal buffer units (TBUs), each of which can control up to 12 terminals. A TBU controls the queueing of output messages to terminals on a priority basis and multiplexes keyboard input messages into the MMIS.

Bulk Data Transfer Subsystem

The bulk-data transfer subsystem (BDTS) is concerned with transmitting, via data links, bulk data (structured into files by LAC application software and stored on discs) to up to 3 remote DPE centres. The data links will utilize the high-level digital link control (HDLC) protocols for file transfer; the protocols are based on CCITT† Recommendation X25.

Mass Memory Control Subsystem

The mass memory control subsystem (MMCS) provides mass storage for the LAC database, and provides a buffer for bulk data destined for data-processing centres. The subsystem consists of microprocessor-controlled disc and cartridge tape

units, the software handlers and the database management software running on the LAC processor.

Disc units are microprocessor-controlled and are duplicated for security. Each disc has a storage capacity of 80 Mbytes. The number of cartridge-tape units is variable according to local circumstances of a particular installation.

Man-Machine Interface Subsystem

The man-machine interface system (MMIS) is a software only subsystem and is identical to the type used in System X exchanges. The MMIS consists of 3 processes: command analysis (CANAL), output formatter (TYPER) and interface package process (IPP). In a System X exchange, the MMIS communicates with up to 8 man-machine terminals via the peripheral controller (PC). In the LAC, the MMIS communicates with up to 36 terminals via the TIS.

The MML input at a terminal conforms to a syntax which is based on CCITT Recommendations³. The main role of the CANAL process is the analysis and checking of the syntax. The CANAL process is also concerned with validating the user access to the system. The MML output from the system is the responsibility of the TYPER process, which converts binary messages into man-readable characters which conform to the International Standards Organisation specification ISO 7. The TYPER process also formats these characters in accordance with the instructions contained within the binary messages. The functions of IPP are described later in this article.

Maintenance Control Subsystem

The maintenance control subsystem (MCS) is similar to the System X exchange MCS, and reports the LAC faults to the fault servicing process. However, the MCS includes 2 additional features: it incorporates the functions of generating management statistics; and it provides the overload control for the LAC. The MCS hardware consists of a staticizer, through which LAC hardware faults are input into the MCS software to produce a fault report, and an alarm interface unit through which the software outputs alarms to the ATS.

User Processes Subsystem

The user processes subsystem (UPS) is a software only subsystem and comprises a suite of processes that performs the specialized functions of the LAC. There is one process for handling data originating from each of 3 exchange subsystems: CAS, MSS, and MCS. These processes are, respectively, the call-accounting reconciliation process (CARP), the network management and statistics process (NMSP) and the fault servicing process (FSP). A further process, known as *CALENDAR*, holds schedules of data transfers and other activities to be carried out in the network.

The above processes are the main processes within the UPS. Other processes handle input of data from cartridge tapes, which is a useful facility for use when the ancillary network link to an exchange is unavailable for a long period and for file handling (including the creation, deletion and update as well as file access and analysis of data in the database).

Alarm Termination Subsystem

The structure of the alarm termination subsystem (ATS) has many similarities with that of processor-based subsystems. The main processing resource is the microprocessor-based hardware called the *alarm supervisory unit* (ASU). The network interface is via the signal reception unit (SRU), which interworks over a 110 baud VF link with the signal transmission unit (STU) located at the alarm reporting node. Conditional on whether the LAC is the parent or a dependent, the ATS includes either the concentration receiving unit (CRU) or the concentration sending unit (CSU) respectively. The ASU

† CCITT—International Telegraph and Telephone Consultative Committee

controls up to 10 man-machine terminals called *alarm display and control units* (ADCU) and controls the queuing and formatting of alarm messages.

Up to 100 alarm-reporting locations can be connected to an ATS. Thus, in a LAC connected to the maximum of 60 System X exchanges, the ATS could cater for an additional 39 non-System X nodes, the remaining connexion being to the LAC. Furthermore, up to 9 dependent LAC CSUs can concentrate alarms to a parent LAC CRU. Thus, the parent ASU caters for alarm reception from up to 1000 reporting locations.

SOFTWARE

The LAC software within the PS is implemented using the techniques of structured programming. Each function is implemented within self-contained code known as a *process*; the interfaces to other processes are rigorously defined. Structured programming not only allows independent development of processes, it also enables enhancements of facilities by introducing additional processes within the existing software structure.

Inter-process communication within the processor is handled by a mechanism called *task-passing*. A task consists of information which a sending process enters in a set of general-purpose registers within the CPU. A task contains the address of the destination process and the data to be transferred. If one task is not sufficient to pass all the data, the sending process can use a set of buffer registers which are also accessible by the destination process. In this case, the task includes the address of buffer registers. When the task is assembled, the sending process requests an *interrupt* signal and is then suspended. The operating system responds to the *interrupt* signal by starting the relevant destination process.

As shown in Table 1, the LAC software can be divided into 3 parts: the operating system, utility software and user software.

The operating system controls the overall operation of the PS. The operating system can be considered as having access to the CPU, to which it allocates a utility or an application process, depending on their respective priorities.

The utility software comprises all the interface handler programs shown in Table 1 plus the MMIS and the MCS programs. These programs provide general facilities for user-defined application processes on a utility basis.

Both the operating system and the utility software are required whatever the application to which the processor is put, whether in the LAC or in an exchange. The application-dependent set of programs, called the *user software*, performs the specific functions of a particular installation. In the LAC, the user software comprises all the programs in the UPS.

In describing the operation of the LAC system, the terms introduced to name the software are particularly helpful in identifying its use. A simplified view of the LAC system operation is to assume that any activity is initiated by a user in the UPS. For the sake of consistency, a terminal operator can also be considered as a user of the terminal handler process of the TIS and the MMIS when communicating with the LAC system. As many users may be trying to access the utility software simultaneously, some queue discipline must be provided, and this is done by the operating system.

ANCILLARY NETWORK CONTROL HIERARCHY

Inter-exchange signalling in the System X telecommunication network can be considered as subject to a 2-level hierarchy of signalling protocols, as illustrated in Fig 5. At the higher level, call processing subsystems (CPS) communicate control information for routing a call. At the lower level, the MTS conveys this control information to the destination exchanges, without change, except that it adds check and link-control information which is removed by the destination MTS. This

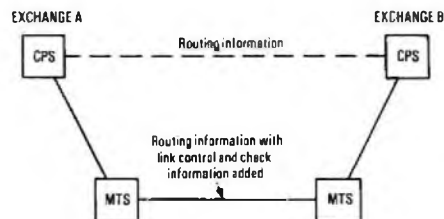

FIG. 5—Hierarchy of common-channel signalling protocols

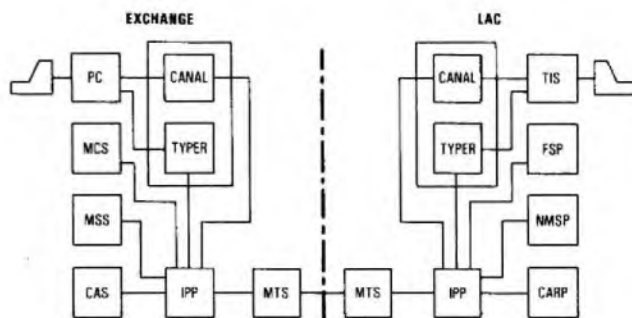

FIG. 6—Hierarchy of ancillary-network data-transfer protocols

TABLE 2

LAC Process for given Exchange Subsystem

Exchange Subsystem	LAC Process
Call accounting subsystem	Call-accounting reconciliation process
Management statistics subsystem	Network management and statistics process
Maintenance control subsystem	Fault servicing process

Note: The reason why one of the entities at the same level of control hierarchy is called a *subsystem* and the other a *process* is historical, and arises from an arbitrary choice of names during the development of the System X project. The difference in name has no significance in practice.

hierarchical network-control, with lower levels being transparent to the higher levels, is an important feature of the System X network. This form of control permits independent development and updating of each level, an increase in the number of levels, and interposition of additional levels between existing levels.

Full advantage is taken of this flexibility in the control structure in the design of the ancillary network. The 3 sources of administration data in the exchanges (that is, CAS, MSS and MCS) produce data with differing processing requirements. For each of these subsystems there is a corresponding process (see Table 2) in the LAC with which each particular subsystem communicates over a single MTS link, in a manner analogous to communication between the 2 exchange call-processing subsystems outlined above.

Unlike the 2-level hierarchy between exchanges, the ancillary network employs a 3-level hierarchy. An intermediate level is created between the subsystem/process and the MTS levels by interposing an interface package process (IPP). The functions of the IPP are

- (a) to route incoming messages to a destination subsystem/process,
- (b) to control the throughput rate for optimum MTS link handling, and

(c) at the exchanges, to control the diversion of data to LAC back-up tapes when the LAC is overloaded or when the LAC is not available during, for example, a data link failure.

The control structure of the ancillary network is illustrated in Fig. 6, which shows the symmetry between the exchange and LAC designs. The symmetry of the control structure and the similar environments for data at exchanges and the LAC enables the inter-process communication mechanism described above to be used for communication between processes located in different processors.

When generating an itemized billing record, the CAS sends a task containing the information to the CARP through intermediate IPPs and MTSS and the CARP sends an acknowledgement task back to the CAS to complete the transfer; thus, 3 processes are required to be run on the exchange and the LAC processors. In operation, each process requires the use of the CPU, which can be allocated only on the basis of priority. In order that the data transfer is achieved smoothly a great deal of attention was paid to the design of these protocols.

The fact that the task-passing mechanism underlies not only the inter-process communication within a single processor but also the inter-processor communication, has an important consequence as far as man-machine interaction is concerned. Following an input from the terminal, CANAL assembles a task for the destination subsystems/process, which can be either in the same processor as the CANAL or in a remote processor. Thus it becomes possible to exercise control of exchanges from the LAC terminals and to access the LAC database from the exchange terminals.

DATA-HANDLING WITHIN AN LAC

Having described the structure of an LAC and the links over which data is transferred between the exchanges and an LAC, mention is now made of what the LAC does with the data it receives. For this purpose, 4 explanatory examples are considered. The first two examples are concerned with the data which is stored at the LAC and then forwarded to a data processing centre. The third and fourth examples are concerned with the handling of a fault report, which gives opportunity to discuss man-machine interaction.

(a) Itemized Billing Record

Itemized call-account records are generated by the local exchange CAS, which sends a request to the LAC CARP for the transfer of information. When ready, the CARP accepts the request and, on receipt of the record, the CARP subjects the record to a rigorous check, and uses the MMCS to store the record securely on a disc file. The CARP then sends an *acknowledgement* signal.

The file of itemized billing records is sent regularly to the data processing centre via the BDTS link. The BDTS link will operate under HDLC protocols with its own hierarchy of control. The concept of user and utility software is still valid in this situation. User software associated with the BDTS will retrieve the file data from the MMCS and transfer it to the DPE computer centre.

(b) Quarterly Bulk Billing Records

A UPS process called *CALENDAR* holds a schedule of transfer of quarterly bulk bills from each exchange in the LAC catchment area. The schedule is created and updated through MML. At the appointed time, the *CALENDAR* process triggers the CARP to request bulk bills from a particular exchange. The CAS holds quarterly bulk billing records for the customers. The CARP sends the request for transfer to the CAS and the situation outlined for the previous example ensues.

(3) Exchange Fault Report

When an exchange-user subsystem detects a malfunction, it sends a report to the MCS, whose function is to locate the fault to a small area of the system. The reporting subsystem may not necessarily be the faulty area. The MCS generates the fault record on the basis of its own initial diagnostics. The TYPER process is used to convert the binary data into man-readable characters in accordance with the ISO 7 specification. When the record has been assembled, it is sent across the MTS link to the LAC FSP.

The FSP creates a data-base file of fault records which provide the basic information to co-ordinate the maintenance activities. The FSP sends all faults in the alarm category to an *alarm log*, which is a hard-copy printer. In addition, the FSP uses the facilities of the TIS to alert the LAC staff by switching a *Message-Waiting Indicator* on a VDT. This indication invites the staff to retrieve the fault record, which is available in the TIS queue.

(4) Exchange Fault Clearance

In addition to being available at the VDT, an alarm report is reported independently over the alarm link and is displayed on the ADCU and acknowledged. In the record that the FSP creates from the fault report, a space is available for staff to enter scheduling detail, stock position and clear information. Once the fault has been scheduled, it becomes accessible to staff from a terminal located at the exchange or at the LAC. Further information about the faults, such as recurrent-fault analysis, can also be made available.

The 4 examples describe how, depending upon the user facilities, the various types of data can be presented, either to the staff or for analysis within the LAC. The latter is done periodically through housekeeping functions of the LAC UPS: for example, the database is periodically scanned to create a fault docket file of cleared fault information. The file is then transferred to the DPE centre for further analysis and is also copied to tape and archived in the LAC for future reference.

The terminals of an LAC are distributed among different functional areas of a Telephone Area administration and it is possible to route various categories of data to specific terminals. Thus, there is a flexibility in the design of an LAC, which can be adapted to suit a wide variety of administration arrangements.

CONCLUSION

The System X network provides opportunities for the co-ordination of network administration based on the LAC. In the design of the LAC, full advantage was taken of the technology developed for the System X telecommunication network. This article has described how the user subsystems of the exchange and the LAC have been developed within an integrated framework of data-transfer protocols and commonality of the processor subsystems.

All exchanges within an LAC catchment area are accessible through terminals of the LAC. When connexion is established to a particular exchange the man-machine transaction takes place as if the terminal is connected directly to the exchange. The LAC therefore provides the means by which the control of a large number of exchanges can be extended to a small number of functionally organized locations.

The buffering of bulk data allows independent development of exchange to LAC and LAC to data processing centre protocols. This factor is important because, although the LAC needs to keep step with the development of the System X network as work practices evolve and are agreed, the interface to the DPE centre must accord with existing billing and processing procedures.

This article has indicated the manner in which an LAC can be used by exchange staff, but discussions are continuing

between the Operational Departments of the BPO and the staff side representatives to determine how best LACs can be used in the BPO telephone network. The LAC design is sufficiently flexible to enable a wide range of staffing arrangements to be envisaged, based on man-machine communication through terminals having access to centrally-held information relating to a number of exchanges.

The flexibility of the design allows different or new administration facilities to be added later as experience of using this new tool grows.

ACKNOWLEDGEMENTS

The author wishes to thank those colleagues in the BPO and

UK Industry on whose work this article is based and those who provided assistance in the preparation of the article.

References

¹ TIPPLER, J. Architecture of System X. Part 1—Introduction to the System X Family. *POEEJ*, Vol. 72, p. 138, Oct. 1979.

² JONES, W. G. T., *et. al.* Principles of System X. *POEEJ*, Vol. 72, p. 78, July 1979.

³ CCITT Recommendations Z 311–Z 359, Vol. IV, Orange Book, Oct. 1976.

The Second International Telecommunications Energy Conference

The second International Telecommunications Energy Conference (INTELEC 1979), held in Washington, D.C., from 26–29 November 1979, was attended by over 450 delegates from all over the world. More than 80 papers were presented on a wide range of power and energy topics.

The British Post Office (BPO) delegation of Mr. D. J. Richman, Head of Energy, Transport and Accommodation, Mr. D. A. Spurgin, Head of Building Services, and Mr. I. G. White, Head of Telecommunications Power Division, presented papers on *The Identification and Correction of High Energy Telecommunications Buildings*, *Low Energy Cooling for Digital Telecommunications Systems*, and *Cardiff Telephone Exchange Total Energy Project*. All of these papers were well received and a useful discussion followed each of them. In addition, 4 British manufacturers (Chloride Technical, Emerson Electric Industrial Controls, R. A. Lister Power Plant and Cayson Engineering) also presented papers, the last jointly with Mr. R. Pine of the BPO.

A technical exhibition was associated with the conference, at which more than 40 companies displayed their products; Telconsult, the BPO's telecommunications consultancy service, and 7 British power plant and battery manufacturers

were represented on the British stand.

The British delegates to the conference also made useful study visits to the Bell Telephone Company Laboratories, the American Telephone and Telegraph Company, two telephone operating companies and two manufacturing firms to examine plant and installations. Views were exchanged on energy management and power practices within the UK and the USA, which should prove of great value to the Business's energy conservation and power-development programmes.

The third INTELEC conference is to be held in London from 19–21 May 1981. This is being organized by the Institution of Electrical Engineers in association with other bodies, including the Institution of Post Office Electrical Engineers. The BPO and British manufacturers are represented on the organizing committee, which is being chaired by Mr. I. G. White. Further information about this conference can be obtained from INTELEC Conference Department, IEE, Savoy Place, London, WC2R 0BL. Those considering offering papers for the conference should note that synopses must be submitted by 30 May 1980.

D. A. SPURGIN

Measurement and Analysis Centres: Operational Activities and Achievements

B. G. SAPSFORD, B.SC., C.ENG., M.I.E.E.†

UDC 621.395.31:621.395.36

Previous articles¹⁻⁴ in this Journal have described the system concept and equipment used at measurement and analysis centres (MACs), which provide the facility to measure automatically the quality-of-service given by the British Post Office (BPO) public switched telephone network. Each Telephone Area in the BPO telephone network is to be provided with a MAC.

This article discusses the control and use of the information that is outputted automatically from a MAC arising from test-call failures. The results and experience gained from the initial MAC installations are also discussed.

INTRODUCTION

A previous article² in this *Journal* described the daily and monthly activities of the processor part of a measurement and analysis centre (MAC). The print-outs associated with those activities were also discussed.

In this article, attention is directed to the control and the use of day-to-day information that is outputted automatically from a MAC arising from test-call failures; the control and use of information obtained on demand is also discussed. Reference is made to other information that can be obtained at a MAC and used to assist the local staff in identifying points of failure in the British Post Office (BPO) telephone network. Comment is included on the experience gained and the results obtained from the first MAC installations, which came into operational use during 1979.

HANDLING OF DAY-TO-DAY OUTPUT

If the output of a MAC processor is not controlled in a logical manner, the output of paper would be excessive and the MAC staff would need to spend an inordinate amount of time attempting to digest the information available to them and, consequently, would not have sufficient time in a working day to pass on the information to the staff at exchanges where improvement to service is required. The generation of paper output can be at a peak when exchange units are first connected to a MAC, or when the MAC is first brought into operation. Clearly, the generation of excessive amounts of paper must be avoided and, to make effective use of the information obtainable from the MAC processor, consideration must be given to the various categories of output and how they should be handled.

A number of different fault reports can occur while the processor is making, or attempting to make, test calls. These reports can be classified into 2 broad categories:

Category 1 Fault reports of category 1 status are those for which prompt action should be initiated.

Category 2 Fault reports of category 2 status are those which need to be collated with other information or failed-call details before action is initiated.

Category 1 fault reports must be dealt with as they arise. They are caused, basically, by either failure of MAC equipment (for example, concentrator or access equipment) or when test calls in *measurement sequences* fail to be established correctly. A category 1 print-out will occur if a control limit has been broken, or when a subsequent test call has failed.

It may not be possible to deal immediately with category 2 failures because a degree of *analysis* may be required to establish a fault pattern from which action can be initiated.

Clearance of failures in category 1 will be the major activity during the initial period after a MAC has been brought into service, especially where units are identified as having a high fault rate. Once the initial faults have been cleared then attention can be given to the *analysis* of failures and to the more obscure faults that, nevertheless, affect service.

PERFORMANCE TARGETS AND CONTROL LIMITS

To achieve clearance of the high number of faults expected to be found initially, it is essential that the flow of information is restricted to ensure that the information output to the staff at the MAC is of manageable proportions. One effective way of reducing the amount of information printed out is to set the control limits to a high value; for example, 20 failures in 500 calls for MS1. It is important to note the difference between the terms *control limits* and *targets*. Performance targets are set by a local Telephone Area organization to achieve a required quality-of-service in terms of plant defects or congestion; for example, a failure rate of 2% due to plant defects. Control limits are a variable parameter input to the MAC data to achieve a controlled indication of a deteriorating quality-of-service. Control limits are provided for certain MSs and call-failure types, as shown in Table 1.

TABLE 1
Provision of Control Limits for given Measurement Sequences

Measurement sequence (MS)	1	2	3	4	5	6	7	8	9
Plant defects (PD)	✓	✓	✓	✓	✓	✓	✓	✓	✓
Plant engaged (PE)				✓	✓				
Wrongly charged (WC)	✓	✓	✓	✓		‡			

✓ Facility provided

‡ Proposed facility

The relationship between performance targets and control limits is given by

$$A = T + 1.645 \sqrt{\left\{ \frac{T(100 - T)}{N} \right\}}, \text{ and}$$

$$X = \frac{AY}{100},$$

† Network Executive, Exchange Systems Department, Telecommunications Headquarters

where T is the target percentage, N is the sequence sample size, X is the number of failed calls, Y is the size of the control sample, and A is the minimum value of the result that indicates that a target has been broken by a statistically significant amount. (An asterisk is printed on the appropriate unit's result-sheet on such an occasion.)

Referring to the example quoted earlier, for an operational target of 2.0%, this gives $A=2.72$ and a control limit of X equal to 5 when Y equals 200. Setting the control limit to 20 failed calls in 500 ensures that a longer period will elapse before attention is drawn to the fact that the service has deteriorated significantly. Clearly, this situation must not be allowed to continue for very long and the control limits must be reset as soon as it is practicable. However, in the initial period following the installation of a MAC and before its results are used for management control purposes, sensible use of the control limits parameters are to be encouraged. Once a control limit is broken, details of all subsequent failed calls are printed out for that unit's measurement sequence until the count is back within the defined parameters.

CALL-FAILURE INFORMATION

The content and procedures for handling the day-to-day call-failure information are now considered.

As explained in an earlier article², when a MS test-call fails, all relevant information is transferred into the analysis sequence 1 (ASI) file. When spare time-slots occur, up to 10 repeat test calls are made in an attempt to locate the failure. Information on call failures is printed-out automatically at a MAC. The information relates to those call failures which have been

- (a) entered into the ASI file,
- (b) held for trace, or
- (c) found clear after 10 attempts.

Details of call failures held for trace should then be passed directly to the exchange concerned. If an alarm unit and printer are provided at the distant exchange, the information can be transmitted automatically from the MAC. Exchange staff at the distant exchange can then carry out the necessary fault location and clearance activities. A sample of the type of print-out that occurs in a MAC is shown in Table 2.

Information of the type shown in Table 2 forms the bulk of the automatic print-outs that occur during the normal daily operations of a MAC. If all the information is to be used, then a degree of correlation, with other relevant information, may be required. Clearly, the ASI CLEAR ON TRY 10 information (with reference to the original ASI entry to give the fault category) should not go unheeded. A reference to the possible use of this information is given later in this article, as is the condition which leads to the statement CONTROL LIMIT BROKEN.

INFORMATION ON DEMAND

To further assist telephone exchange staff in the location of faulty items of equipment, reports on certain activities can be obtained from the processor information files by entering commands on the keyboard printer.

Many such reports are also printed automatically either during or at the end of the month. A description of the reports which occur automatically at the end of the month were given in a previous article² in this *Journal*.

Call-Failure File

The most commonly used print-out is that which relates to information contained in the failure file. Each exchange unit has its own file in which failures, noted during MSs, are stored. Each failure file holds 100 entries and is operated on a rolling basis (that is, when failure 101 enters the file, failure 1 is ejected and failure 2 replaces failure 1, etc.). Consequently, if an exchange unit has a low failure rate, the file can contain failures which occurred over more than one month.

A suitable command causes the processor to print either all or a selected category of failures recorded for a particular MS of a particular exchange unit. If the command ALL is not specified, the details of the type of failure required are entered. The details specify the required answer-condition received and an indication of the routing digits sent before the condition was received, and the type of metering failure. A typical print-out is shown in Table 3.

From the example shown in Table 3, it is evident that metering problems were occurring at tariff change-over periods each day. Engineers at the particular unit can therefore be alerted to look for the problem with much more detailed information to hand. A number of other coincidences also exist in the example and the reader may care to identify these.

Other Information Available on Demand

It is possible to obtain information on demand which can be used to check on the operation of the MAC processor. This is a particularly useful facility, especially at times when the processor or an exchange unit has been out of service due to a fault condition. The relevant information refers to

- (a) the current sequence sample size (for each unit),
- (b) the sequence start point,
- (c) the current block number for a sequence,
- (d) the input data format,
- (e) any inhibited items,
- (f) console commands (a list of last 187 commands), and
- (g) the time and date of the print-out.

Other stored information is also available on demand; the more important items include

TABLE 2
Sample Print-Out of Call Failure

10.10	21.11.79		ASI ENTRY	NU
CLARKTOWN	MS2	1	51 27194	
10.21	21.11.79		ASI HELD ON TRY 2	TNT-NSP
SECTOR	MS1	2	2532	
10.32	21.11.79		ASI CLEAR ON TRY 10	TNT
CLARKTOWN	MS2	14	51 27194	
10.40	21.11.79		PD CONTROL LIMIT BROKEN	NT
MAINFRAME	MS4	8	0089 2078	

NU: Number unobtainable TNT: Test number tone NSP: No subsequent pay tone PD: Plant defect NT: No tone

TABLE 3

Typical Print-Out of Call-Failure Information

>PR, FAIL, MS2, UE1041, ALL							
UNIT NAME CLARKTOWN			UNIT CODE E0141				
Sequence Number	Access Position	Routing Digits	Destination Number	Route Code	Answer Condition Received	Metering Failure	Date and Time
MS2	11	59	1652	0061	RT		03.09.79 11.57
MS2	14	56	2323	0061	NDT/S		03.09.79 12.10
MS2	22	959	305399	0021	TNT	-NSM	03.09.79 12.49
MS2	39	89	0625	0061	BT		03.09.79 14.17
MS2	74	90	59051	0037	NU	-04	03.09.79 17.06
MS2	14	56	3217	0061	NDT/S		04.09.79 13.32
MS2	33	7	95165	0061	TNT	-NSM	05.09.79 12.54
MS2	29	59	3967	0061	TNT	-SOM	07.09.79 08.49
MS2	20	7	54161	0061	NT		07.09.79 16.10
MS2	22	7	56856	0061	NT		07.09.79 16.28
MS2	37	3	90373	0061	TNT	-NSM	07.09.79 17.56
MS2	16	91	736289	0006	UR	-01 -PM	10.09.79 11.18
MS2	18	913	4398	0015	TNT	-NSM	10.09.79 12.50
MS2	14	56	1205	0061	NDT/S		10.09.79 16.56
MS2	44	7	51393	0061	NT		12.09.79 08.06
MS2	78	70	7132	0061	NT	-FM	12.09.79 14.27
MS2	42	51	2854	0061	TNT	-SOM	13.09.79 08.47
MS2	67	7	59913	0061	NT		13.09.79 14.47
MS2	84	56	4179	0061	NT	-FPT	14.09.79 09.23
MS2	53	49	3871	0061	UR	-FM	14.09.79 10.13
MS2	65	913	2737	0015	TNT	-NSM	14.09.79 12.47

RT: Ringing tone
 BT: Busy tone
 UR: Unrecognizable
 FM: False metering

NDT/S: No dial tone or seizure
 NU: Number unobtainable
 NSM: No subsequent metering
 FPT: False pay tone

TNT: Test number tone
 NT: No tone
 SOM: Subsequent over metering

- (a) a summary of the results of the last *N* calls,
- (b) a list of test calls on a sequence, and
- (c) a list of test numbers at a single destination.

INFORMATION FROM OTHER SOURCES

The information output from a MAC is only as good as the quantity and quality of the information input to the system. Therefore, to achieve the best possible results, it is appropriate to input to the organization of a MAC all relevant information from all possible sources. Reference centres have been set up in many Telephone Areas over the years and they have proved a valuable aid to network maintenance. However, reference centres could never achieve all that may have been expected of them because of the restricted sources of information, namely reports of failures from operators, and customer complaints. With the advent of the MAC system it seems right to couple the reference centre activities to those of the MAC. This does not mean that reference centres should be closed and all information transferred to MAC. In many cases this would be impracticable and inadvisable.

Most MACs are to be located in exchange buildings that serve large towns or areas of large cities and, in consequence, it makes sense to bring the reference centre serving the town or city section and its surrounding dependent exchanges into the MAC organization. Other reference centres should be retained and certain information output from the MAC could be inputted to these reference centres to enhance their input information.

Examples of information that may be used by the reference centre/MAC organization are as follows.

ASI CLEAR ON TRY 10

When a MAC processor is searching for a fault that has been detected in one of the MSs, up to 10 test calls are made to try to locate and hold the failure. Should the 10 attempts fail to reproduce the failure, the information to that effect is output on the keyboard printer. Information is therefore available to establish that a fault exists, but information on the location of the failure is not immediately to hand. It would make sense, therefore, to add this knowledge to the other infor-

mation for correlation purposes to further assist engineers in the location of faults.

EVENING FAILURES

During the evening sending session, MSs 1, 2, 3 and 9 are operative on the respective exchanges. No ASI calls are initiated from the failed calls in the evening MSs because very few exchanges are staffed during this time. The details of the last 20 failures encountered during the evening session on each exchange are printed out at the MAC for action by the staff the following morning. Clearly, if use is to be made of this information, a degree of correlation must be carried out with previous failures or other information obtained in a similar time period.

LESSONS FROM THE FIRST MAC INSTALLATIONS

Since the commissioning of the first 10 MACs in the period July 1977 to March 1978, experience has been gained in the organization and effective operation of the MAC system. The remaining MACs are due for delivery in the period January 1980 to October 1981, and the experience gained in the first MACs will provide a good basis from which other Telephone Areas can commence operations.

Experience has shown that it is not sufficient just to install the MAC equipment, switch it on and pass the results to the engineers concerned. The success of a MAC depends upon many factors, the most important of all being the relationship that is established between the MAC staff and the Area exchange maintenance staff concerned. One of the important functions of a MAC is to assist the exchange staff to improve the service offered to customers. To enable this objective to be achieved, the field staff concerned must be informed regarding the MAC's capabilities. It has been found beneficial to bring exchange staff to a MAC when their exchange is first connected to the system and, through the medium of a short training course, apprise them of their MAC's capabilities. It is important that maintenance staff appreciate that the facilities of a MAC are there for everyone to make use of when the need arises. A MAC should never be regarded solely as an Area management tool with which to gather statistics.

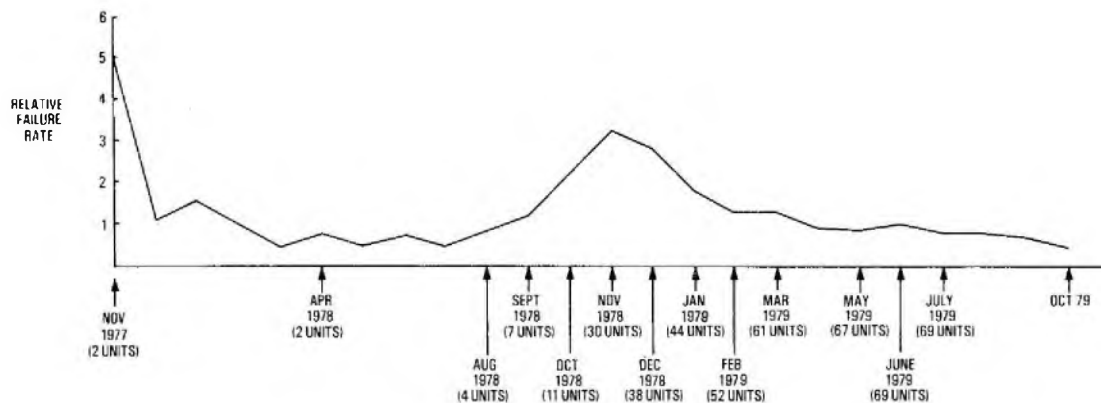

Fig. 1—Relative failure rate of particular MS1 calls

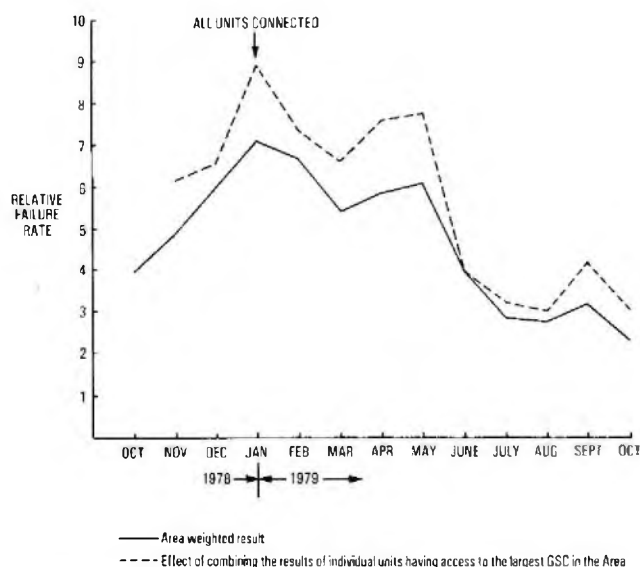

Fig. 2—Relative failure rate caused by plant defects on MS4 calls

It must be stressed that some exchanges, when they are first connected to a MAC, have an indicated performance which the MAC system can greatly assist in improving. This may have been due to a deficiency in the method previously used to measure the performance, or a combination of such a deficiency and ineffective management of the exchange unit's maintenance activities. Whatever the cause, it has been found necessary to provide assistance, in addition to that available from the MAC, to the exchange unit concerned. Such assistance has been given in many of the early MACs by attaching to the MAC, under direction of the MAC supervising officer, a special fault investigation team which is available to assist in the clearing up of problem areas. This approach has proved very effective and, in the early period when the MAC system is being loaded, has contributed greatly to the way in which the Areas performances have improved.

Examples of the improvements so far achieved are shown in Figs. 1 and 2. Fig. 1 shows a failure rate in MS1 over a period of 2 years since the MAC was commissioned. The points to note are

- (a) the early failure-rate reduction due to faults being found in the initial small number of units,
- (b) the continuing improvement,
- (c) the way in which the failure rate, although rising, is contained to a reasonable level when more units are connected, and
- (d) the eventual reduction of failure rate as further experience is gained and effort directed.

Fig. 2 shows the results of MS4 test calls (that is, local exchange to group switching centre (GSC) routing) from another MAC. As with the results shown in Fig. 1, in the early months when the units are being connected, a positive increase in failure rate is noticed. As the faults were cleared, the failure rate declined and, although the level achieved so far is not yet acceptable, continued effort in the Area will no doubt achieve the objective. The dotted line shows the effect which the largest GSC and its dependent exchanges is having on the Area's performance. Once the Area performance is within an acceptable figure then attention must be given to the units with higher-than-average failure rates.

CONCLUSION

The first 10 MAC installations have now been completed. Installation of the remaining 51 MACs is now under way and the MAC project is planned to be completed during 1982.

The basic philosophy behind the MAC scheme has been shown to work. Engineers and managers now have at their disposal a tool which will enable the service offered by the telephone network to be improved. The full potential of the MAC scheme has yet to be realized, but if the enthusiasm generated by the early installations can be continued into the full national programme, the success of the project should be assured.

As with all operational computer-based schemes, changes to software programs are required from time to time. To this end, a support system, to be known as the *Management and Support System (MASS)* will be established at Baynard House in London. This system will provide the mechanism by which clearance of software faults and provision of additional enhancements can be programmed and tested before the software is issued to the MACs. The MASS will also act as a central archive for all programs used at a MAC. Technical support will therefore be available from THQ, but the real success of the project will depend upon the organization established in each Telephone Area and the support given to the scheme by management at all levels.

References

- ¹ SAPS FORD, B. G. Measurement and Analysis Centres, Part 1, System Concept and Equipment Description. *POEEJ*, Vol. 70, p. 243, Jan. 1978.
- ² SAPS FORD, B. G. Measurement and Analysis Centres, Part 2, Processor Programming and Operation. *POEEJ*, Vol. 71, p. 28, Apr. 1978.
- ³ JAMISON, M. L., and HOLLOWAY, S. I. Measurement and Analysis Centres: Measurement Techniques and Hardware Design. *POEEJ*, Vol. 71, p. 148, Oct. 1978.
- ⁴ SPIEGELHALTER, B. R., and BROWN, R. S. Measurement and Analysis Centres: Software Design. *POEEJ*, Vol. 71, p. 233, Jan. 1979.

System X: Design and Support

Part 3—Software Development Facilities

S. R. LOOME, M.Sc.†

UDC 621.395.34: 681.3.06

The development of System X exchanges has necessitated the provision of a comprehensive range of support facilities. This article explains the facilities that have been provided for the software aspects of System X and also provides a glimpse of future developments in this area.

INTRODUCTION

The output from the design stage of an exchange control function in software is a series of documents. At the completion of the design phase, software engineers translate the information contained in the design documents into the series of instructions residing upon, and controlling the operation of, the digital computers which are at the heart of System X exchanges. The series of instructions are written in a telephony-oriented real-time programming language, and the translation of software in this form into that which is loaded onto the target-computer memory requires sophisticated conversion tools. These conversion tools are programs which run on commercially-available mainframe support computers.

It is necessary to test that, when executed, the exchange control software is logically correct. The provision of target-computer simulators and test-message generators (programs which also run on the mainframe support computers) enables preliminary testing of the software. Thus, the totality of software development facilities is contained within two subsystems:

- (a) the mainframe support computer (and associated communications equipment) subsystem, and
- (b) the language-translation and test subsystem.

MAINFRAME SUPPORT COMPUTER SUBSYSTEM

In general, processors designed to control a telephone exchange are not well suited to software development unless considerable quantities of additional software are developed to provide the necessary data handling, storage manipulation, and editing functions.

These features form an integral part of most commercial computers and, to minimize unnecessary development, the British Post Office (BPO) has chosen to use standard commercial computers on which to develop the software which will ultimately run on the exchange-control processors. These computers are termed *software development utilities* (SDUs). This approach has the additional advantages of

- (a) enabling software development to be undertaken in advance of the availability of target processors, and
- (b) reducing the demand for scarce development time on the target processors.

The computing resources were initially provided by the BPO in the form of a computer bureau operated by Baric Computing Services Limited. However, with the provision of appropriate computing facilities, the main software development support has been moved to the BPO Computing Centre at Derby. In addition, the firms participating in the System X project have made their own provision for computing facilities.

Although the software development tools are made available on the various computers, all software produced for System X must eventually be presented for BPO acceptance on the Derby SDU. Facilities have therefore been established to enable the transfer of software between development utilities.

Table 1 lists the support computers currently in use, and a block diagram of a typical computer installation is given in Fig. 1.

System X software is being developed jointly by the participating firms (GEC, STC and Plessey) and the BPO at a number of development sites throughout the UK. A variety of factors prevent the computing facilities from being located at the development sites; in consequence, sites have to be provided with remote access to at least one of the computers

TABLE 1
Computers in Service for Software Development

Identity	Machine		Users
	Type	Location	
D1	ICL 2960 ¹	Derby	All
D2	ICL 2960 ¹	Derby	All
M1	ICL 1904S	Feltham ²	Plessey
M2	ICL 1904S	Feltham ²	GEC, Plessey, BPO
Computel	2xICL 2960 ¹	Bracknell ³	GEC, STC
PCC	1xICL 1906S	Addlestone ⁴	Plessey

Notes: ¹ An ICL 2960 machine emulating an ICL 1900 series machine
² Baric Computing Services Ltd.
³ Computel Ltd.
⁴ Plessey computer centre.

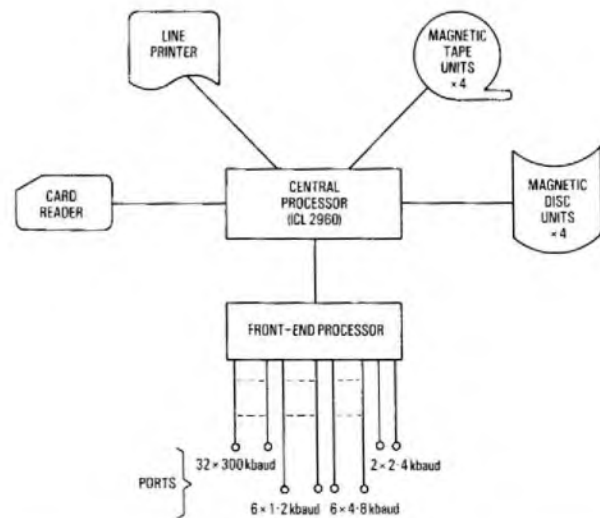

FIG. 1—Block diagram of a typical System X computer installation

† System X Development Department, Telecommunications Headquarters

which carry the development tools. In practice, all development sites have access to the BPO computers at Derby.

Individual software products have to be combined to form integrated units, and the combination of these units eventually forms the full system software. Since the individual products may be created on different support computers, a mechanism is provided, via magnetic tape, to permit the transfer of these products between the computers, thus enabling the integration and testing of the products. The final phase of this activity is the formal acceptance of the software on the Derby SDU.

Once the various software subsystems have been built and tested, those required for a particular exchange installation are assembled together on the Derby computer, and copied to magnetic cartridge for transfer to, and loading onto, the target-exchange processor.

Remote Access to Computers

Users may access the support computers remotely in either of two ways:

- (a) through interactive terminals (for example, teletypes) which give the user a high priority on the computer, or
- (b) by a *remote job entry* facility routed via a remote batch terminal (RBT); this facility offers a lower priority but a wider range of facilities.

Interactive Terminals

Interactive terminals permit the entry, manipulation and output of users' programs but, because of their interactive nature (that is, the continual dependence on an operator), these terminals tend to be slow in operation and, consequently, are only suitable for the handling of relatively-small amounts of data or program. An advantage of interactive terminals is that they allow the user speedy manipulation of his programs; for example, when carrying out editing and testing functions.

Included in this category of terminal are

- (a) teletypes with operating speeds of 10-120 characters/s, and

(b) visual-display units (VDUs) operating at 10-300 characters/s.

The above types of interactive terminal may be supplemented by other low-speed devices such as paper-tape readers and punches (for teletypes) and hard-copy units, which produce paper copies of the contents of a VDU screen.

Remote Batch Terminals

Remote batch terminals (RBTs) provide a wider repertoire of facilities and include a GEC2050 minicomputer to perform the necessary data-handling and formatting functions. The RBT allows the user to submit jobs to an SDU (for example, instructions for the execution of a program) to obtain: listings of a program; outputs from programs; and other outputs, mostly of a diagnostic nature. The RBT will also produce paper-tape or magnetic-cartridge versions of such listings or outputs. Local copying between these devices is also available and allows, for example, the contents of a cartridge to be printed on a line printer.

A 300 lines/min lineprinter is provided at each RBT, together with a 500 characters/s paper-tape reader and a 110 characters/s paper-tape punch. For System X applications, the paper-tape facilities are supplemented by a magnetic-cartridge unit, which enables writing to, and reading from, data cartridges that use 6.35 mm ($\frac{1}{4}$ inch) magnetic tape with a 4-track serial format.

Each cartridge has an ultimate data capacity of 2.880 Mbytes (1 byte = 8 bit), although this is reduced in practice to around 2 Mbytes by the inclusion of labelling, checksums, etc. on the tape. Such cartridge facilities provide the mechanism for transferring software from the support to the target-machine environment. User control of the RBT is exercised through a teletype.

Communications

Communication between the terminals at development sites and the SDUs is provided over dedicated private circuits or via the public switched telephone network (PSTN).

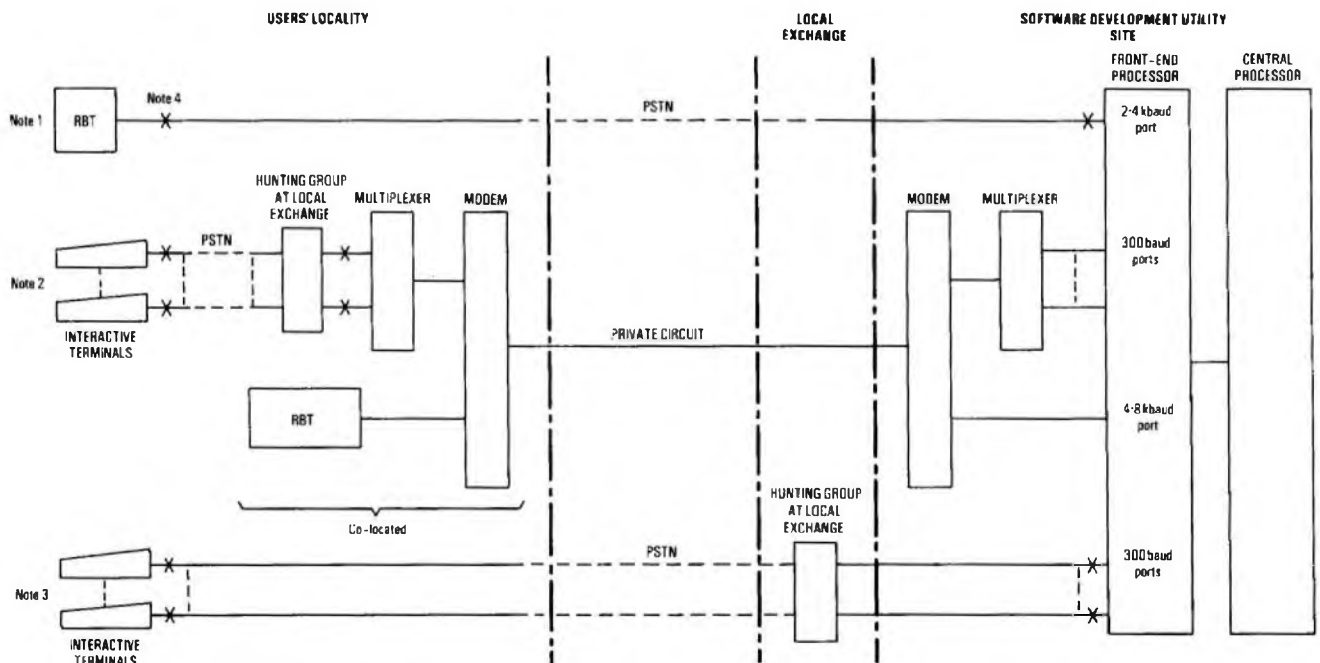

- PSTN: Public switched telephone network
 Notes: 1. Routing of remote batch terminal (RBT) via PSTN
 2. Routing of RBT and interactive terminals (multiplexed) via a private circuit
 3. Routing of interactive terminals via PSTN
 4. A cross indicates the location of modems

Fig. 2—Typical examples of communication paths to the software development utility site

Various communications configurations have been provided, according to the requirement of the users. Thus, a particular RBT may be connected to one private circuit or, by manual switching, to one of several private circuits giving access to a number of SDUs. Alternatively, an RBT may be connected to the PSTN to allow dialled access to any of the SDUs.

The private circuits conform to the BPO tariff-T specification to give a guaranteed performance for data rates up to 2.4 kbaud, although these circuits are usually found to be capable of working at rates of up to 9.6 kbaud. Consequently, it has generally been found possible to multiplex together, on a single circuit, the communication paths of an RBT operating at up to 4.8 kbaud and several low-speed (300 baud) interactive terminals. In such cases, a 4-wire reserve circuit using 2 exchange lines is provided as a standby for the private circuit.

Multiplexing techniques are also used to allow users of interactive terminals to access a distant SDU by dialling a local number. Hunting facilities at the local exchange assign each caller to a port (an input/output connexion) of a multiplexer situated in the exchange. This multiplexer communicates with a similar unit at an SDU site via a private circuit. The unit at the SDU site de-multiplexes the signal into channels, which are connected to individual ports on the SDUs front-end processor (the front-end processor handles all transactions between terminals of all types and the SDU). At present, this arrangement allows users in London to access the Derby computers by dialling London numbers, and East Anglian users can access the Derby computers by dialling an Ipswich number.

Hunting arrangements have also been provided at the exchange local to the SDU so that users can access the SDU from anywhere in the country by using a single exchange-number. Some typical communication configurations are shown in Fig. 2.

Modems and Multiplexers

The 9.6 kbaud data links are served by CASE 440/96 modems. These modems have 2 ports: each port is capable of handling a range of data rates, and the data streams applied to these ports are multiplexed together within the modem. In one arrangement, shown in Fig. 2, the RBT is assigned to one port with a data rate of 4.8 kbaud, and the low-speed terminals are multiplexed together using a CASE 670 multiplexer to form, typically, a 4.8 kbaud data stream, which is applied to the second port of the modem.

Where an RBT is operated on a data link which is limited to 4.8 kbaud, single-port CASE modems type 450/48 are used. RBTs operating on a dialled service are restricted to 2.4 kbaud and, in this case, BPO Modems No. 7C are used.

Terminals operating at a speed of 300 baud and provided on a dialled service use BPO Modems No. 13 at the terminal, and BPO Modems No. 2B at the distant end. A few dialled-service 1200 baud terminals have also been provided and these use BPO Modems No. 20.

LANGUAGE-TRANSLATION AND TEST SUBSYSTEM

The language-translation and test subsystem comprise the set of tools, all of which are realized in software, to enable the development and partial testing of exchange-control software. The two main functions of such tools are that they enable

(a) the translation of the control programs (written in the POCORAL high-level language) into the machine code of

the target machine (processor utility (PU))† or pre-processor utility (PPU)), and

(b) the testing of the control programs on the support computers (off-line) and on the target machines (on-line).

The products which comprise the set of testing and translating tools are the

- (a) compiler,
- (b) linker,
- (c) lister,
- (d) sorter,
- (e) emulator (target-machine simulator),
- (f) dictionary translator,
- (g) cross-referencing program, and
- (h) software-message generators (off-line and on-line).

A set of these tools has been produced for both the PU and the PPU, and each set is known as a *language system*. Because the target machines have been subject to progressive design changes, it has been necessary to provide a number of versions of each of the basic-language systems.

The language systems are specified as single entities with a defined set of quantitative limits, or processing capacity, and an example of some of these limits is given in Table 2. The majority of these limits are dictated by the size of the data areas available to the software development tools, but some limits are necessary because of restrictions imposed by the target machine(s). The structure and use of the language-system products will be described in the sections which follow but, initially, the definition and implementation phases will be briefly described.

The Language-System Development Process

Each language system is defined by the BPO in an outline system description document, which describes the facilities to be included, quantitative limits, etc. The definition document is passed to the implementation teams—the BPO Research Department for the compiler, GEC for the linker, lister, sorter, emulator, dictionary translator and cross-reference program, and Plessey for the software-message generators. Each of these teams then produce detailed system descriptions for each of their products and all interfaces are agreed.

During the implementation stage, the products are produced and tested individually. When sufficient confidence has been gained in each of these products a period of integration begins, under the control of the BPO, to test fully the interworking of the programs. The acceptance-testing phase completes this process prior to submission of all files into the software master library and their release to users.

The Translation Function and Program Listing

The high-level language selected for the System X software is known as POCORAL, which is an adaptation of CORAL 66¹. POCORAL² was defined by the BPO Research Department

TABLE 2
Examples of Quantitative Limits of Language Systems

Component	Maximum Size
External-file size	64 Kword*
Number of segments	128
Number of source lines	32767
Number of program identifiers	1500
Number of POCORAL blocks	255
Number of local variables	256
Array dimension range	16383 (first dimension) 4095 (second dimension)
Number of macro parameters	15
Number of procedure parameters	40
Block nest depth	30

* Example system limit on PU systems

† The System X processor utility will be the subject of a later article in this *Journal*

and includes facilities to enable information transfer between control software processors and to ensure data integrity. The standards defined for software production allow for low-level assembler code (that is, machine code) to be used for time-critical sections of the software, and it is therefore necessary for the translation tools to recognize both high-level and assembler level code. The POCORAL language allows these assembler-code inserts within the language reserved words "CODE BEGIN" and "END".

The translation function is performed by the compiler. It is desirable (for management and design-methodology considerations) to split complete programs into independently designed, written and compiled units called *segments*. Another tool, the *linker*, is required to combine the compiled segments to form a completed program.

In terms of the program structure units mentioned in a previous article², the complete program produced by the linker is a System X process, and segments may be modules or submodules at the designers' choice. A further tool, called the *lister*, is used to produce a listing of the process, together with the machine code which has been generated by the compiler. This is useful for program checking and testing. The functional blocks of the basic translation tools are shown in Fig. 3.

The Compiler

A block diagram of the POCORAL compiler is given in Fig. 4. The macroprocessor, whose function is to expand all the CORAL macroprograms in the source code with POCORAL statements, forms the first pass of the compiler. The output from this pass is a representation of the input code in *token* form, a token being a numeric code for a language symbol such as "BEGIN". The basic path through the compiler is from macroprocessor to syntax analyser, but if formatted input/output statements exist, then the formatted I/O processor is invoked.

The formatted I/O processor recognizes the I/O constructs in the macroprocessor-output token file, and performs syntax analysis on these constructs and generates code in token form to invoke the PU and PPU operating system I/O routines.

The next phase of translation entails the syntax and semantic checking of the token file. The output of the syntax analyser is a reconstitution of the input file into an intermediate language (IML).

Syntax checking is performed at two levels: the syntax at the bottom level is defined in terms of POCORAL basic symbols (for example, +, -, :); the syntax at the top level is defined in terms of discrete subsets of the POCORAL syntax, which are formed by combinations of the basic symbols. It is at the top level that the order of elements is of importance. IML code is produced at each level of syntax checking.

The final pass of the compiler is the code-generation pass. The code generator is the most complex of all the compiler packages. The IML code is used by the code generator to

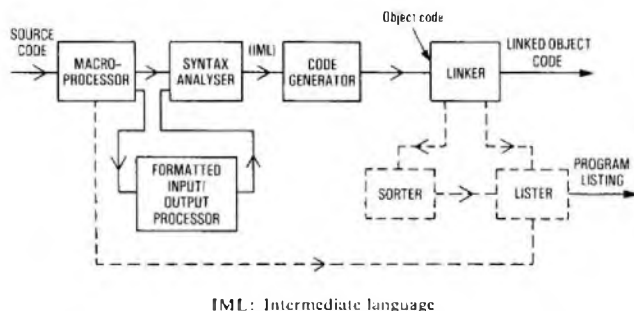

FIG. 3—Basic POCORAL machine-code translation functions

select the required code skeleton (target-machine instruction sequence). Separate procedures within the code generator handle the general register usage and operator expansion, and the procedures include an assembler. The assembler is invoked when the IML code for "CODE BEGIN" is recognized and the assembler code is translated by the assembler. Control of the translation remains with the assembler until the "CODE END" IML code is reached. Control is then returned to the main code-generator sequencer. The IML file is thus translated by progressive running of the code-generator routines.

After successful compilation of a segment of a code, two output files are produced by the compiler: the SJ01 file, which contains the segment header information (for example, type of data, memory space requirements); and the SJ02 file, which holds the program in its compiled form, usually called *object code*.

Compilation error reporting is handled by the error-reporting package. Each pass of the compiler has a defined interface with the error-reporting package (see Fig. 4). These files contain a coded representation of the errors found during the compilation, and consist of an error number and the line number on which the error was detected. The error number is used to identify a message which contains information on

- (a) the severity of the error (for example, compiler failure, user error, object-machine limitation), and
- (b) the phrases to be printed for the user.

The minimum severity to be notified can be selected by the programmer by inputting the required error-severity code.

The Linker, Sorter and Lister

The main functions of the linker are

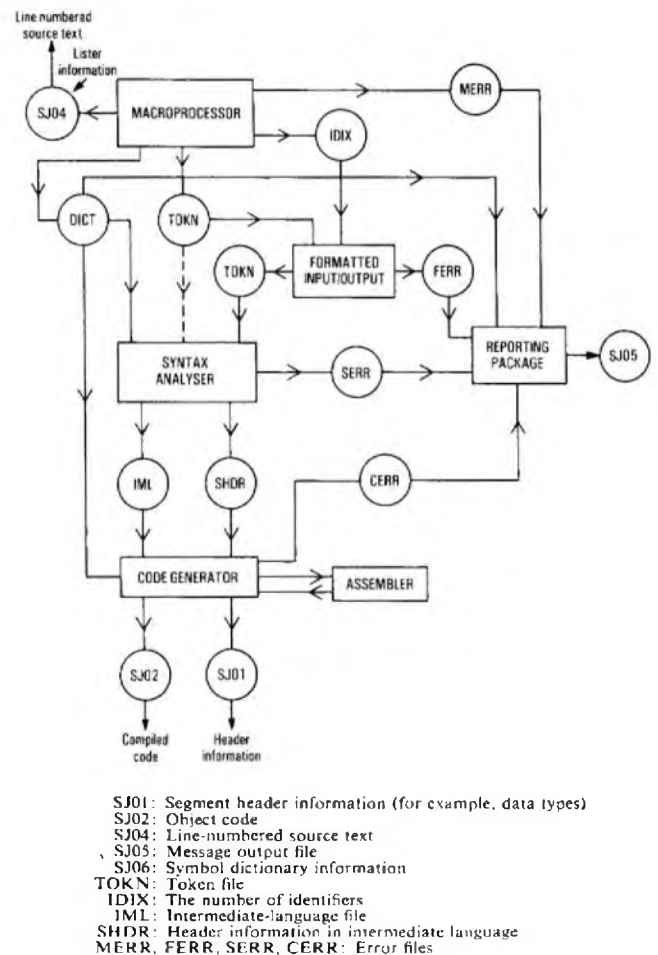

- SJ01: Segment header information (for example, data types)
- SJ02: Object code
- SJ04: Line-numbered source text
- SJ05: Message output file
- SJ06: Symbol dictionary information
- TOKN: Token file
- IDIX: The number of identifiers
- IML: Intermediate-language file
- SHDR: Header information in intermediate language
- MERR, FERR, SERR, CERR: Error files

FIG. 4—Structure of POCORAL compiler

(a) to combine the separate compiler segments into a process (the unit of software which is time-scheduled on the target machine), and

(b) to translate the conceptual addresses allocated by the compiler into virtual addresses.

The interfaces to the linker are shown in Fig. 5. The compiler generates the machine code and data, and allocates space for this in a number of conceptual storage areas for each segment. The conceptual areas are

- (a) executable code,
- (b) common read-only data/read-write data,
- (c) common array read-only data/read-write data,
- (d) local read-only data/read-write data,
- (e) local array read-only data/read-write data, and
- (f) external file.

The linker has the job of locating each conceptual area in an area of real target-machine storage. When this has been done, the object code, which consisted of a string of directions to place values for data and instructions into conceptual areas, will now exist as data and instructions in the correct place in real storage.

Because instructions often contain references to data, the linker also determines the values of those instructions which could not be known until the address allocation had been done. Finally, the linker determines the values of instructions that lie in the program in one segment, but which refer to something in another segment.

The real-storage allocation strategy of the linker ensures that execute-only, read-only and read-write parts of the instructions and data are placed in suitably protected storage in the target machine.

The virtual addresses for processes to be run on the PU can be specified directly by the programmer (by the use of linker directives) or they can be allocated automatically by the linker. Physical addresses can be specified by linker directives for PPU-resident programs. To exploit fully the file structure and virtual-memory facility on the PU, it is possible to specify that two or more external files are to have the same virtual-

start address. Information to input directly the operating-system-table data for a process (for example, number, priorities, timeouts and physical input/output addresses) can also be added in the form of linker directives.

The output from the linker consists of the linked object code, logging (for example, start-address file length, page utilization) and error messages and listing information consisting of register usage, dictionary and scoping data, etc.

The translator products will therefore generate from a source file and the appropriate directives the linked object code, which can be loaded into either the emulator for off-line testing or directly onto the target machine for on-line testing. Program listings are produced by the lister package. An example listing is shown in Fig. 6. It can be seen from Fig. 6 that, together with the line-numbered source code, the following information is available:

- (a) the original line-number when a CORAL macro-program has been expanded,
- (b) the machine-code or data generated for each line,
 - (i) for instructions, the instruction mnemonic and the address occupied,
 - (ii) for data, the address occupied and the contents (in hexadecimal), and
- (c) for each line, an indication of which source variables have been temporarily located in machine registers (with identification of the registers used).

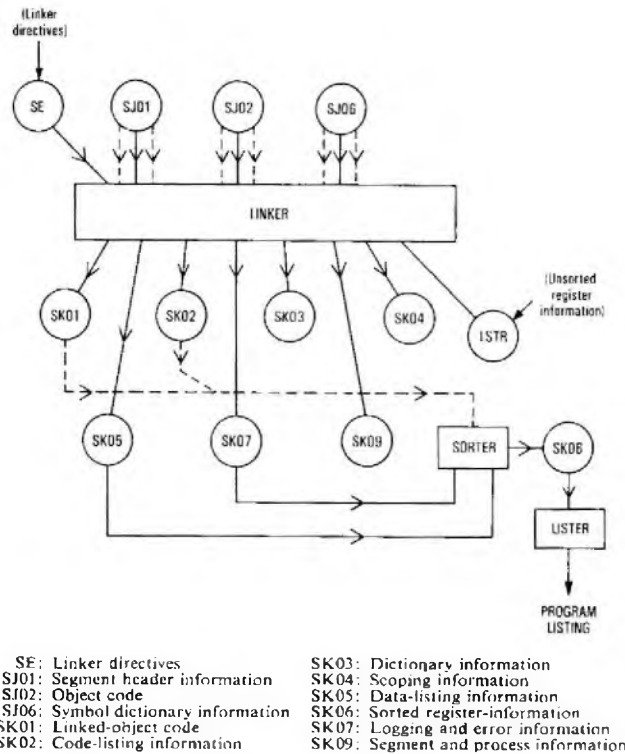

FIG. 5—Linker input/output and lister interfaces

```

0 'OPTION' (413:0,100:1) COMMENT:COMPILER OPTIONS;
1 'MAIN' SEGMENT 'SEGI'
2 'DEFINE' X'4'
3 'BEGIN'
4 'INTEGER' J;
5 'INTEGER' I;
6 'DO' I:=0 'STEP' 1 'UNTIL' 4
7 'DO' J:=1+5;
8 'CTRAP(0); COMMENT:OPERATING SYSTEM
9 'END' MACRO-CALL TO TRAP;
10 'FINISH'
    
```

(a) POCORAL source program

```

0 'OPTION' (413:0,100:1)
1 'MAIN' SEGMENT 'SEGI'
#00 #00000 #9600 LLU(B0, #0000)
#00 #00001 #9600 LLU(B1, #0000)
#00 #00002 #9600 LLU(B2, #0000)
#00 #00003 #96F0 LLU(B3, #0000)
#00 #00004 #B806 JU(#0006)
#00 #00005 #B806 JU(#0006)
2 'DEFINE' X'4'
3 'BEGIN'
4 'INTEGER' J;
#02 #00208 #0000
5 'INTEGER' I;
#02 #00209 #0000
6 'DO' I:=0 'STEP' 1 'UNTIL' 4
7 'DO' J:=1+5;
#00 #00006 #9C02 ILU(B, #0200)
#00 #00007 #F410 LCF(G1, #0000)
#00 #00008 #E80A JU(#000A)
#00 #00009 #ED11 LADD(G1, #0001)
#00 #0000A #F514 LCF(G1, #0004)
#00 #0000B #E811 JF(#0011)
#00 #0000C #B800 JU(#0000)
#00 #0000D #1491 PCPY(AC, G1)
#00 #0000E #ED96 LADD(AC, #0006)
#00 #0000F #C098 STAC(B2, #0008)
#00 #00010 #B809 JU(#0009)
8 'CODE'
9 'BEGIN'
10 'JUMP'
#01 J
#00 #00011 #1481 PCPY(G0, G1)
#00 #00012 #B809 STG(B2, #0009)
11 TRAP(0)
12 J;
#00 #00013 #E930 TRAP(#0000)
13 'END'
14 ;
15 'END'
#00 #00014 #E930 TRAP(#0000)
16 'FINISH'
    
```

(b) Lister output

FIG. 6—Example listing

Program Testing

The output files from the linker include the linked object code and dictionary information for the process. Software tools are provided to enable program (process) testing both on the target machine, and off-line on one of the mainframe computers provided for software production and testing. The linked object code is loaded directly into the emulator or onto the target machine. However, the dictionary information requires translation into the format of a linked object code file. The dictionary translator performs this function.

A general-purpose cross-reference program is included in the language system for use during the program debugging phase. The cross-referencer provides information on a range of debugging points; for example, the source code line-numbers on which a particular identifier occurs and the points within the program at which specific registers are loaded.

To ease the debugging process and to conserve the use of the target machine, a suite of off-line testing programs is provided as part of the language-translation and test subsystem. The tools available are an emulator and a software message generator.

The Emulator

The emulator provides an off-line testing environment for module/process testing. Its function is to realize a virtual machine for testing purposes which is as close as possible to a single central processing unit (CPU) of the target machine. Hence, two basic emulators have been produced—one for PU emulation and one for PPU emulation.

Incorporated into the emulator is a command language which affords control of the loading and running of a process on the virtual machine and gives access to its data areas and machine registers. Within the command language, it is possible to use high-level language references (for example, line numbers, identifiers), which significantly eases the debugging process. The emulator consists of 4 main modules:

- (a) a syntax analyser, used for command language analysis,
- (b) an emulator, used for the emulation of machine instructions, etc.,
- (c) a loader, for the simulation of the loader facilities, and
- (d) a process allocator, for the simulation of the task passing, periodic-interrupts facilities, etc.

The operating-system processes are included in the emulator either by direct emulation or by the provision of the process functions within the emulator. Whether a particular operating-system process is emulated or provided directly depends on the relative efficiencies of each technique for the process in question.

The debug language for use with the emulator allows the following program-control functions:

- (a) execution of one or several machine instructions,
- (b) running to a break-point,
- (c) execution of high-level statements,
- (d) printing-out the contents of specified registers, store locations, etc., and
- (e) setting-up of conditional commands, macros, etc.

The debug language has been designed to be as similar as is possible to the debugging language on the target machine, so that very little difficulty is encountered when on-line testing takes place.

The Software Message Generator

Software message generators (SMGs) have been produced to aid both off-line and on-line testing. The function of an SMG is to extend the testing environment so that the external interfaces of the process under test can be examined. Inter-process communication is via an 8-word communicator called a *task*. The software message generator is initialized so that it will accept tasks from the process under test and provide

the appropriate response tasks. Four basic versions of the SMG have been produced: on-line and off-line versions for both the PU and the PPU. The on-line SMGs work directly with the operating system of the machine, whereas the off-line variants operate with the emulator.

The SMG has two modes of operation, a multi-shot mode for the simulation of events in real time, and a one-shot mode. In one-shot mode, the SMG sends tasks to the process(s) under test in the order in which they are specified in the command data file provided by the engineer. After sending a task, the SMG checks that the correct number of response tasks (as specified in the response data file) are received before sending the next task. In multi-shot mode, the SMG maintains an internal clock and tasks are transmitted with the periodicity specified in the command data file. In this way, it is possible to send several tasks to a set of processes simultaneously (mainly used for on-line testing). A mechanism for specifying task response times is available whereby the SMG responds with an acknowledgement task if the trial process is operating within the specified period.

The 4 basic parts of the SMG test data are:

- (a) a command data file, which specifies the order of the tasks to be sent;
- (b) a task data file, which specifies the format of the tasks;
- (c) a response data file, which specifies the response tasks as received by the SMG and, in multi-shot mode, the time "window" within which they should be received; and
- (d) a suite data file, which specifies the suite of processes to be included in the test.

The test data is prepared on the off-line support computers and facilities are available for converting this into a machine-loadable form for on-line testing, either on paper-tape or on magnetic cartridge.

For on-line testing the test data and test processes are loaded onto the machine and the SMG TEST mode is entered. The test is then controlled from the terminal. Several levels of control are available to the user, ranging from the instigation of the transmission of tasks from the terminal to the completely automatic running of the process. Timing for this mode of testing is derived from the internal CPU clock.

At the completion of an SMG run, a results file which shows the tasks transmitted, responses received, response timings, etc. is available.

NEW DEVELOPMENTS

Work is now beginning on a new set of software development facilities to support a CCITT† standard language for stored-program control systems. The language is called *CHILL* (a contraction of "CCITT High Level Language"). The *CHILL* is a more advanced high-level programming language than *POCORAL* and is therefore better in a number of respects. The main reason for its use in System X is one of international standardization. The production of a fresh set of software development facilities provides the opportunity to incorporate more advanced tools and to put to effect the lessons learnt from the operation of the existing set of support tools for System X.

Five features of the proposed new facilities are now broadly described:

CHIC—A Standard Intermediate Code

Most present-day compilers are split into two parts: a *front-end* or syntax analyser, which converts the program into a string of specifications and operations in order; and a *back-end*, or code generator, which converts the operations into the actual machine codes to do the operations (this feature was illustrated earlier in this article). This modular approach

† CCITT—International Telegraph and Telephone Consultative Committee

reduces the cost of compiler production because new target-machines can be accommodated by the production of a new code-generator only (not a whole compiler), and language extensions can, in some cases, be accommodated by attention to the front-end alone.

The code in which the specifications and operations are transmitted from front-end to back-end is termed *intermediate code*, and a special code, termed *CHIC* (an abbreviation for *CHILL Intermediate Code*), has been designed. Besides containing program operations, the CHIC code contains a great deal of debugging information and, in addition to the code generator, the CHIC code will be used by testing and debugging tools.

Optimization

Related to software, *optimization* refers to the collection of mechanized techniques directed at improving the speed and size of programs generated from high-level language representations. There are two broad classes of optimization techniques. Firstly, *global* optimization refers to the logic of the overall program, and enhances program speed by re-ordering operations or inhibiting unnecessary repetition of operations. The CHILL tools will achieve this class of optimization by processing CHIC code. Secondly, *peephole* optimization refers to exploiting special cases and short cuts in the target machine's instruction set, and these techniques will be applied in code generators.

Interpretation for Testing

Reference has already been made in this article to emulation of the target machine as a vehicle for program testing, and the CHILL facilities will continue to provide for this. However, an alternative approach will be supported; namely, an *interpreter* for the CHIC code. This interpreter will operate on the CHIC code and simulate the effects of its operations. It will, in essence, be an emulator of an imaginary target machine having CHIC as its instruction set. Advantages of the interpreter are that:

(a) it operates on CHIC, which is a target-machine independent code, and hence only one basic design of tester is needed no matter how many target machines there may be,

(b) CHIC is closer in form and concept to CHILL than machine code, so it is easier to provide debugging tools that allow the programmer to refer to the program in high-level (CHILL) terms, and

(c) it is expected to consume less time on the support computers than emulation.

Test Tools

Besides reproducing the basic test facilities of the earlier

systems, the CHILL tools will provide for more advanced testing aids; for example,

(a) identifier concordance and attribute tables (these show where each program identifier is defined and used and what type of object it is),

(b) flow analysis, determining all the paths which need to be exercised to check fully a program, and

(c) dynamic analysis, measuring run-times and finding the program sections, which account for most of the execution time.

Access Mechanism

Present systems for POCORAL have the user accessing different software development tools independently and, in many cases, each has its own philosophy for control commands and error messages. The CHILL set of tools will be accessed via a common access mechanism. Besides reconciling all programs to a common style of operation, the CHILL set will allow the user to specify logical jobs such as *compile*, *link* and *optimize* without the user having to be aware of the various tools which need to be separately invoked to do what is, to him, a single job.

CONCLUSIONS

This article has shown the variety of tools that together constitute the software development facility for System X. A considerable investment in terms of men and materials stands behind the comprehensive range of facilities which have been in use for some time by the System X software development teams. As with most tasks, the quality of the tools play a significant part in the productivity achieved, and software is no exception. In a project of the scale and importance of System X, the aim must always be to pay close attention to the need for good support tools, for the benefits of achieving this aim, particularly in the relatively new area of software engineering, can be enormous.

ACKNOWLEDGEMENTS

The author would like to thank the members of the BPO SDF teams who contributed to this article and whose work, in conjunction with that of the System X SDF teams in industry, has been described.

References

- ¹ Official Definition of CORAL 66 (HMSO 1790) SBN 11 470221 7.
- ² COOPER, T. R., and HELLEUR, R. J. System X Software Engineering. *POEEJ*, Vol. 72, p. 240, Jan. 1980.

Book Review

Electrical Drawing for Technicians 1. F. Linsley. Newnes-Butterworths. x + 83 pp. 135 ills. £3.75.

This textbook is the first of many that will be written to cover the learning objectives of Technician Education Council courses, and its twelve chapters provide useful information for the students of the electrical and electronic drawing courses. Exercises are given at the end of each chapter and model answers are included to enable the student to test his ability.

The author makes full use of the British Standard Institute recommendations, but unfortunately the drawings which illustrate the text do not follow the general principles of BS 308, 1972, *Engineering Drawing Practice*.

It is essential, when students are asked to "copy the outlines that appear in the textbook and to learn the significance of every line", for drawings to be very carefully checked before publication. In this book the example drawings are of a low standard.

F. KING

Teleprinter No. 23: A New Teleprinter for the Telex Service

W. F. GARRETT, B.Sc. (ENG.), C. ENG., M.I.E.R.E., A.M.I.E.E.†

UDC 621.394.625.3: 621.394.34

A high proportion of the annual capital investment in the UK Telex service is devoted to the customers' equipment; the introduction of a new teleprinter is therefore a significant event in the evolution of that service. The Teleprinter No. 23 is only the third teleprinter terminal to be supplied by the British Post Office for Telex and represents a revolutionary technological advance over its predecessors. The article details the main features of this first generation electronic teleprinter.

INTRODUCTION

Telegraphy, the oldest form of long-distance electrical communication, is notable for the evident increase in complexity, with time, of the line terminating apparatus. The achievement of a wide range of facilities through the development of complex mechanisms, and the ability to produce terminals in large quantities at low cost and with high reliability, made possible the introduction of Telex—by far the most successful of the non-speech communication services introduced to date.

Telex is a world-wide service, the basic characteristics being defined by the International Telegraph and Telephone Consultative Committee (CCITT); this service continues to show considerable growth despite the introduction of competing services. Within the UK, there are 79 500 Telex connexions and growth in 1978–79 was 11%; system growth in 1979–80 is expected to be nearly as good.

With home and export markets of such long-standing potential, the introduction of electronic technology, with its capacity for reducing complex mechanisms and control sequences to silent, easily manufactured modules, might have been expected to take place in the early-1960s. However, although developments involving electronic tube and transistor circuitry were undertaken by a number of companies worldwide, very few came on the market. This was because of the highly-developed state of the mechanisms used in the well-established page-printing teleprinter products, and the volume of the electronic circuitry needed to achieve equivalent functions.

Although integrated circuits offered an improvement in the cost-reduction of electronics, it was not until the availability of large-scale integrated (LSI) circuits that electronics could be used in place of complex mechanisms on a cost-effective basis. Thus, teleprinter technology is unusual in that it has changed from the traditional (electro-mechanical) to the modern (LSI electronics) with little evidence of the intermediate stages seen elsewhere.

The extent to which electronics can be substituted for mechanical systems is determined by practical considerations, such as the need to move paper and the necessity for an impact printing method where more than one copy of recorded information is required, as is usually the case. Evolution in the office environment and practice may lead to changes in both these areas, but the first-generation of electronic teleprinters give much the same customer facilities as their predecessors, although with some enhancements.

The British Post Office (BPO) Teleprinter No. 23 is a first-generation electronic teleprinter, which is currently being introduced to UK Telex customers' use after considerable evaluation and field-trial experience. It replaces the Tele-

printer No. 15, which was introduced in 1968 and which is now being phased out of production.

TECHNICAL FEATURES OF TELEPRINTER No. 23

Terminal Configuration and Construction

Where electro-mechanical technology is used, most Telex/telegraph terminals comprise a teleprinter and a separate control unit joined by a signalling and power-supply cord. The teleprinter performs only the very basic functions, while the control unit carries all the operator controls, control circuitry, power supplies and signalling components. Flexibility is achieved by associating a range of control units with a common teleprinter. In the Teleprinter No. 23, the use of electronics has enabled the teleprinter and control unit to be integrated into a single unit of modest size and weight; the line-signalling supply and associated components (that is, barretter and line filter) are, however, mounted in a small external unit. Flexibility is achieved firstly by the presence or absence of diode straps on a printed-wiring board (PWB), and secondly by exchanging the PWB carrying the line interface components for another having a different capability.

The normal arrangement at a customer's premises (Fig. 1) is for the Teleprinter No. 23 to be mounted on a purpose-designed plinth (Plinth, Teleprinter No. 1), which has an internal shelf to accommodate the line signalling unit (Unit, Terminating No. 11). A card callmaker (Auto-dial No. 302)¹ can be attached to the right-hand side of the plinth. If the customer does not wish to use the plinth, the teleprinter can be mounted on a table and the line signalling unit fixed to a wall or to some other suitable surface.

It is currently intended that all Teleprinters No. 23 supplied to the BPO will be to the automatic send-receive (ASR) configuration and will therefore have paper-tape ancillaries as standard.

Construction is modular, and the units are mounted on a rigid cast-aluminium base. Overall protection is effected by a single-piece moulded Noryl thermoplastic cover, having a clear polycarbonate visor designed to minimize sound emission and spurious light reflections.

Operator access is through a lift-up lid, to which a polycarbonate lectern is fitted. The page-printer paper is mounted internally, and the paper tape for the punch is mounted externally. Tape punch cuttings (chads) are collected in an externally mounted see-through plastics box. Light and mid-grey, the BPO house-style colours for telegraph apparatus, are used on the cover and base respectively; the plinth is mid-grey overall.

Printer

The page printer (Fig. 2) is the major mechanical unit of the

† Marketing Executive, Product Development Unit, Telecommunications Headquarters



FIG. 1—Teleprinter No. 23 Telex terminal

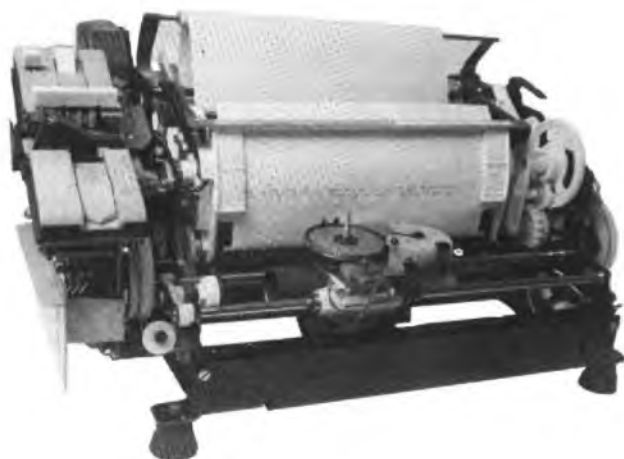

FIG. 2—Page printer unit

teleprinter. It includes the common drive motor, paper-tape punch and the mounting for the internally-stowed paper roll. Removal is effected by withdrawing the cover and power-supply plugs and the connector to the main electronic logic board, whereupon the unit can be lifted upwards away from

the base. The punch unit is mounted on this unit, so as to derive motive power and synchronism from the printer; its presence or absence does not affect printer operation.

The printing method incorporated in the Teleprinter No. 23 is known as *printing-on-the-fly*. A horizontal, continuously-rotating print wheel, with fully-formed symbols facing outwards at the periphery, is positioned in front of the paper. At the time required to print a given character, an electronically-controlled hammer, located behind the paper, impacts on the selected character face through the single or multi-ply paper medium. As the fount is continuously inked, the top (outward-facing sheet) is imprinted with the character; undercopies are produced through the impact on interleaved carbon or pressure-sensitive papers. Because the paper is trapped between the moving type fount and the hammer for only a short time, no paper drag or perceptible smearing of the printing occurs.

The print wheel and hammer assemblies are mounted on carriages on either side of the paper. The carriages are linked through a common towing wire, and move across the paper, one character pitch (2.54 mm) at a time. A feed-and-print action is used, this being completed in one revolution of the print wheel; if printing stops for more than 500 ms, the print wheel drops so that the last character printed is visible.

Because the paper must be fed behind the paper feed-roller and upwards between the print wheel and the hammer, the combined paper-guide/feed assembly and hammer carriage can be unfatched and rotated to simplify loading of paper. This allows the paper leading-edge to be fed into a slot in the paper guide so that when the assembly is restored to its normal working position, and the paper torn off by the saw-tooth knife edge, it is accurately placed ready to feed upwards through a slot in the cover. Continuous rolls of paper of width 210 mm (A4) and 216 mm, from either the internal roll or an external dispenser, can be used without resetting the paper guides.

Inking of the fully-formed type faces is achieved through the use of a porous, ink-impregnated plastics roller, which rests against the print wheel and is enclosed in a simple cassette. Renewal of the cassette is substantially less frequent than that usually associated with ink ribbons and it only requires the operator to clip in a replacement.

Discrimination between the text of incoming and outgoing calls is usually achieved using a 2-colour ink ribbon. As an ink-roller can provide only single-colour printing, an alternative method of marking is required. The method adopted in the Teleprinter No. 23, as a customer option, is to print 4 hyphen-like marks beneath the first 4 character positions of each line where the related printing is the local copy of transmitted information (see Fig. 3). This has the advantage

CHAIRMAN'S STATEMENT (FROM 1978/79 REPORT AND ACCOUNTS)

THE POST OFFICE HAD A DIFFICULT YEAR BUT MADE SOLID PROGRESS IN MANY FIELDS WHILST HAVING TO OVERCOME A NUMBER OF TRANSPORT, WEATHER AND INDUSTRIAL RELATIONS PROBLEMS.

IN THE YEAR ENDING 31 MARCH 1979, WE ACHIEVED A TOTAL PROFIT OF £375.1 MILLION (LAST YEAR £367.7 MILLION). THE THREE BUSINESSES, TELECOMMUNICATIONS, POSTS AND NATIONAL GIROBANK, EACH TRADED PROFITABLY AND MET THE FINANCIAL TARGETS SET BY THE GOVERNMENT.

(a) Transmitted message print-out

CHAIRMAN'S STATEMENT (FROM 1978/79 REPORT AND ACCOUNTS)

THE POST OFFICE HAD A DIFFICULT YEAR BUT MADE SOLID PROGRESS IN MANY FIELDS WHILST HAVING TO OVERCOME A NUMBER OF TRANSPORT, WEATHER AND INDUSTRIAL RELATIONS PROBLEMS.

IN THE YEAR ENDING 31 MARCH 1979, WE ACHIEVED A TOTAL PROFIT OF £375.1 MILLION (LAST YEAR £367.7 MILLION). THE THREE BUSINESSES, TELECOMMUNICATIONS, POSTS AND NATIONAL GIROBANK, EACH TRADED PROFITABLY AND MET THE FINANCIAL TARGETS SET BY THE GOVERNMENT.

(b) Received message print-out

FIG. 3—Illustration of the two types of print-out obtained

that, where multi-ply paper is being used, each copy has the distinguishing marks, unlike the 2-colour ink ribbon system where only the top copy carries this distinction.

Tabulation is assisted by the use of a print-wheel retaining nut having an extension that serves as a pointer. The related scale markings at 2.54 mm intervals are located at the bottom of the visor.

Printer Operation

The motive power for the page printer (and the paper-tape punch) is derived from a single-phase fan-cooled induction-type motor. Unlike most electro-mechanical teleprinters, where the motor speed determines the transmission and signal reception performance, the motor speed does not have to be closely controlled because the timing for sending and receiving line signals is provided by the crystal-controlled electronic logic. The printer motor must rotate the printer mechanism slightly faster than the rate of incoming characters; although this is not critical, it is essential that operation of the hammer is kept in phase with the print wheel. This is achieved by a ferrous toothed wheel, located on the same shaft as the print wheel, which gives timing pulses to the electronic logic via a pick-up coil near its edge. The correct time for firing of the electro-magnet activated hammer is determined by a character-position monitor, which counts the pulses derived from the 67-tooth ferrous wheel. Start and finish of each print-wheel cycle is indicated by the modified pick-up coil waveform arising from a 5-tooth gap.

The alphabetic (upper-case), numeric, punctuation and graphic characters used in the UK national variant of Inter-

national Telegraph Alphabet No. 2 (ITA2)² are cold formed on a steel disc using the *coining* process. They are arranged in the 2 groups assigned to *letter-shift* and *figure-shift*. The hammer is manufactured from hardened steel and the impact surface is squared off and flat.

Paper and print-head movement is achieved through a function unit which is located adjacent to the right-hand side plate (see Fig. 4), and which consists of 3 independently operating mechanisms cycling on a common drive-shaft. As the printing action can take place in either half of a print-wheel revolution, the function mechanisms cycle at twice the print-wheel rate, so that they operate before printing takes place. The function unit, through 3 separate electromagnets, controls

- (a) the feeding of the type-wheel and hammer carriages, one character pitch at a time, and lifting the print wheel to the operating level,
- (b) the tripping of the carriage-return, and
- (c) the feeding of the paper, one line at a time.

In each case, the mechanism cycles freely with its functional output inhibited until the selecting magnet is energized, whereupon the resultant function is completed within one full turn of the function-unit drive shaft. Lowering of the print wheel to give print visibility is under the control of the electronic logic and is effected by a fourth electro-magnet.

The print-wheel and print-hammer carriages are moved along together by separate steel wires, connected to common carriage-feed drums activated by a feed wheel—the wires wind off the left-hand drum on to the right-hand drum during the carriage-feed action. The carriage-return spring, acting

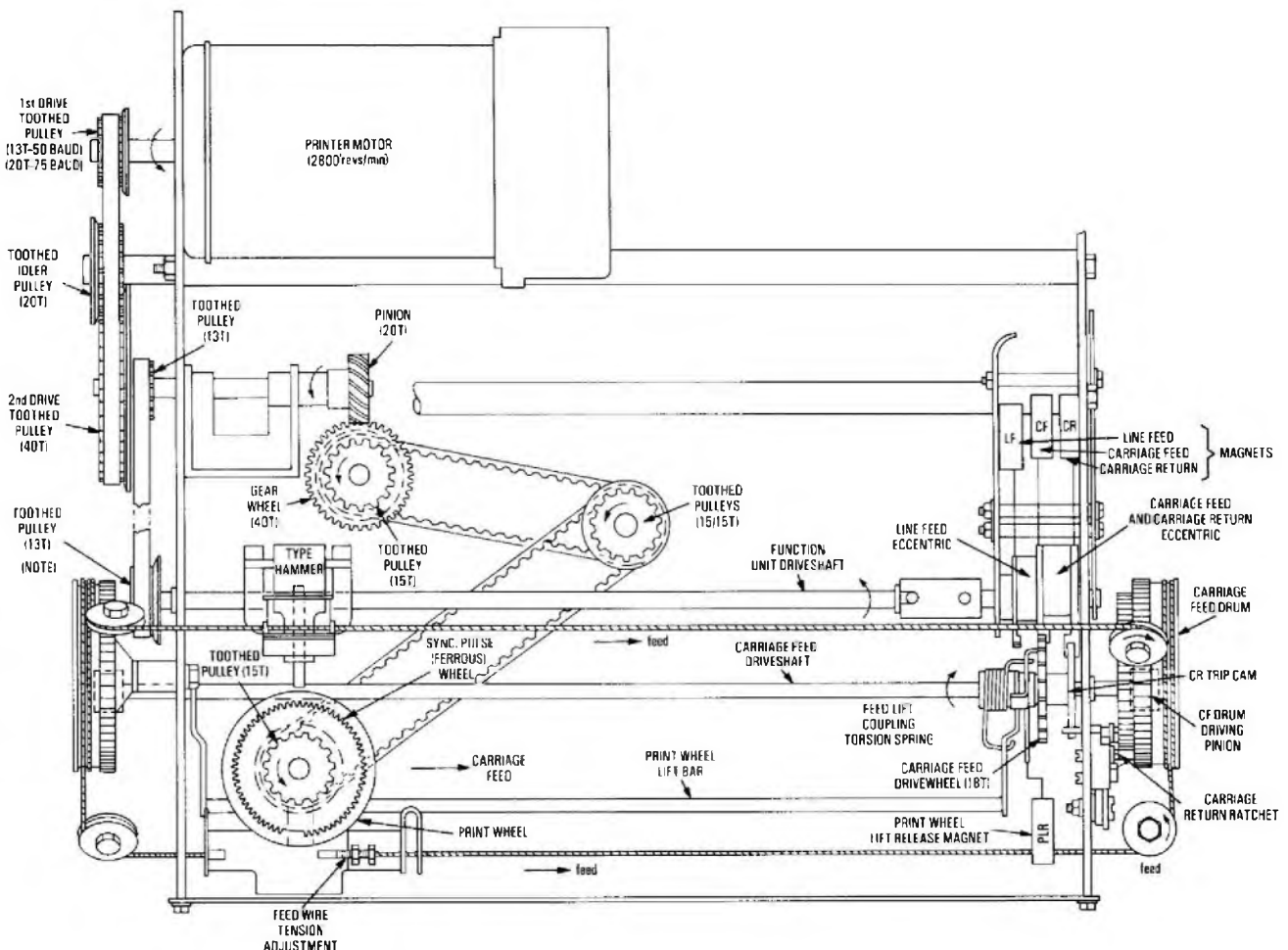

Fig. 4—Outline of printer design

against the feed movement, is coiled inside the left-hand drum, and each feed movement is held by engagement of a retention pawl on the right-hand drum; disengagement of this pawl triggers carriage-return. End-stop retardation of the carriage is effected through a combined friction brake, acting on the inside surface of the left-hand drum, and an air dashpot.

Keyboard

The Teleprinter No. 23 keyboard module is readily removed for maintenance and is basically mechanical in operation; that is, a small number of transducers is shared by mechanical means between all the keys, rather than by each key having an individual transducer, as is usually the case with 'electronic' keyboards. Designs of the shared-transducer type are relatively cheap; they also have the operational virtues that the key forces can be easily changed and the keyboard can be physically locked in those circumstances where it is required to be ineffective.

The principle of operation is that 6 identical, freely-moving, castellated bars are drawn by a single electromagnet towards the left-hand end of the keyboard, against the action of 6 springs. When any one key is depressed, the edge of a metal plate, which forms part of each key, enters the slots in the castellated bars. After a total movement of 4 mm against an average key force of 2 N, a microswitch operates, causing the electromagnet to release and allowing the bars to move in the direction of the spring pull. The bottom edge of each key plate is slotted to represent a particular code combination; consequently, each key when depressed allows some bars to move while impeding others, the combination being unique to each key. Those bars that move strike piezo-electric crystals in a mounting block located at the right-hand end of the keyboard. The resulting simultaneous pulses from the struck crystals, having an amplitude of about 18 V peak, correspond to the code combination for the depressed key, and are fed to a storage stage in the electronic logic.

To generate the required ITA2 code combination, 5 moving bars are required; the sixth is used to indicate whether the transmitted code combination needs to be preceded by *letter-shift* or *figure-shift*. Used in association with a 7-character keyboard store, this permits automatic case insertion, thereby removing the need for the operator to key the shift separately. This same store also permits the new-line facility, and caters for bursts in operator keying speed when the short-term generation of characters exceeds the cadence rate to line; if the store becomes full, the keyboard is locked until the store has emptied. Dual operation of adjacent keys on the same row, a major cause of operator keying error, is mechanically prevented by means of a saw-tooth slider at the front of the keyboard assembly.

Operator Controls

Operator control of a Teleprinter No. 23 terminal is effected primarily through the row of push-button switches (see Fig. 5) mounted on an acoustic baffle immediately behind the keyboard assembly. The switches have (in most cases) integral lamps, which serve to indicate the facilities selected, calling state or alarm condition; the switches are arranged in functional groups to assist operator selection. The functions of the push-buttons and associated lamp indicators are shown in Table 1.

In addition to the main operator controls, there are 3 ancillary controls located under a flap cover at the right-hand end of the keyboard. The switch at the front controls the incoming call alarm, the central one gives single or double line spacing of the printed text, and the switch at the rear can be used to control other optional facilities.

Electronic Logic

The electronic control system (excluding electronics in the

power-supply unit) is mounted on 4 PWBs (Fig. 6), which are identified as follows:

(a) Main Board

This board embodies the terminal control and unit interface logic, the most complex parts of which are realized in high-threshold metal oxide silicon (MOS) custom-designed LSI circuit elements. Five MOS/LSI chips are used, each having separate functions as follows:

- IC No. 1—logic circuitry associated with the paper-tape punch.
- IC No. 2—logic circuitry associated with the transmitter and paper-tape reader,
- IC No. 3—logic circuitry for Telex and machine control,
- IC No. 4—logic circuitry associated with the keyboard unit and answer-back board, and
- IC No. 5—logic circuitry associated with the printer unit.

To link the functions performed by the different chips, a time-division multiplexed data bus system is used. Six bus lines carry data, and a seventh is the flag line, which carries the signal for data transfer. The whole logic operates from signals generated by a crystal-controlled oscillator, except for the printing and associated mechanical functions where control is synchronized by a pulse train derived from print-wheel rotation. The crystal-controlled oscillator has a fundamental frequency of 200 kHz.

Discrete electronic components are used on the main board to provide interface amplifiers (for example, with the keyboard piezo-electric transducers), and drives to the various electromagnets on the printer and paper-tape units. Also included are the edge-connector sockets for the answerback, line isolator and under-line marker boards.

By assembling all the LSI and interface components on a

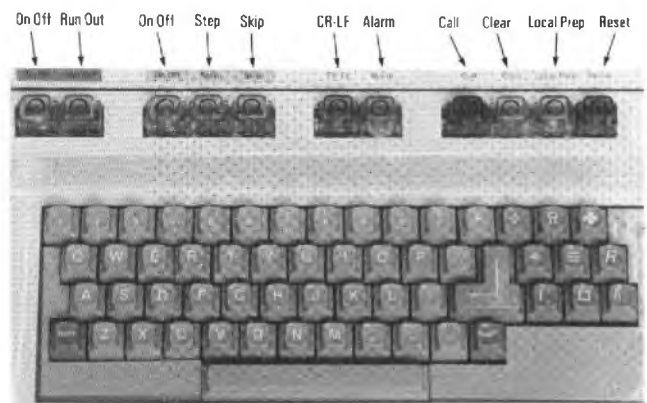

Fig. 5—Primary operator controls and keyboard

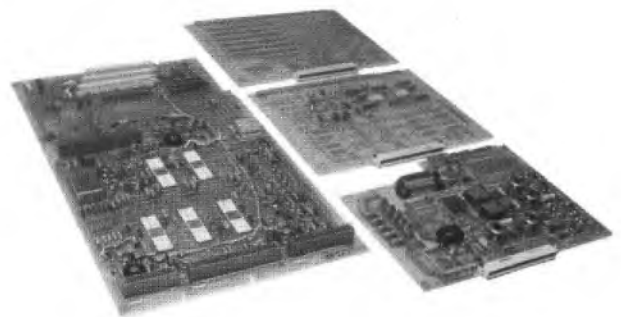

Fig. 6—Printed-wiring boards used in Teleprinter No. 23

TABLE 1
Push-Button Controls and Associated Lamp Indicators

Position Left to Right	Designation	Function of Push-Button control	Colour	Condition for Lamp Operation
1	ON OFF (Note 1)	Control of the paper-tape punch	Clear	Tape punch switched on
2	RUN OUT (Note 1)	When held operated, punches continuous letters (ITA2 Combination No. 29) into tape for start and finish identification	Clear	No lamp fitted
3	ON OFF (Note 2)	Control of the paper-tape reader when terminal is in <i>off-line</i> or <i>on-line</i> modes	Clear	(i) Reader switched on with tape present (ii) Each time STEP control is operated
4	STEP (Note 2)	Steps tape one character through reader each time it is operated	Clear	No lamp fitted
5	SKIP (Note 2)	Steps tape one character through reader, without transmission or printing, each time it is operated	Clear	No lamp fitted
6	CR—LF	Gives one CR—LF action on printer when pressed and released; gives continuous LFs when operated for more than 1 s	Red	Printing positions 55–69 for <i>end-of-line</i> indication
7	ALARM	To draw operator's attention to terminal	Amber	(i) When the paper tape low, tape tight, and tape out sensors are operated (Note 3) (ii) Incoming call while in <i>local prep</i> mode (iii) J/Bell received from line (iv) Incoming call alarm (optional) (Note 4)
8	CALL	Initiates call establishment	Green	(i) <i>Proceed-to-select</i> received from exchange (ii) Incoming call (iii) Call established following interruption of <i>local prep</i> mode
9	CLEAR	Disengages terminal from line	Clear	No lamp fitted
10	LOCAL PREP	Allows off-line use for practice and tape preparation	Clear	In <i>local prep</i> mode
11	RESET	Resets terminal to <i>stand-by</i> from <i>local-prep</i> mode; cancels (optional) incoming call and J/Bell alarms	Blue	Incoming call while in <i>Local Prep</i> mode Incoming signal while in <i>tape prep</i> mode

- Notes: 1. The label has a blue background corresponding with a marker on the paper-tape punch
 2. The label has a yellow background corresponding with a marker on the paper-tape reader
 3. The lamp glows steadily and the terminal emits an audible interrupted tone; these conditions remain until the cause of the alarm condition is removed
 4. The lamp flashes in synchronism with an audible tone alarm

single board, the use of cable forms, with their inherent liability to pick-up unwanted signals, is avoided. Three socket connectors are located at the front of the main board for the ribbon cable plugs associated with the tape punch, tape reader and keyboard units.

(b) Answerback and Option Board

This board carries the 20-character answer-back information and the facility option matrix. Selection is effected by cutting out diodes to give the required answer-back format and terminal configuration.

(c) Line Isolator Board

This carries all the circuits that interface the external transmission and control lines with the terminal's electronic control system. Isolation from high external voltages is provided. The external connexions are through a PWB-mounted D-type connector.

(d) Underline Marker Board

Discrimination between incoming and outgoing text is normally provided. If this facility is not required by the customer, removal of a link inhibits the operation. This board also carries components that electronically minimize the possibility of carriage bounce by delaying the resetting of the carriage feed pawl.

The main board is mounted horizontally beneath the print unit; the other three boards are mounted vertically under a removable cover at the rear of the print unit and cannot be interchanged because of offset connectors.

Distortion and Margin

As both the transmitted and received signals are processed electronically by using a crystal-controlled time-base, transmitter distortion and receiver margin are precisely determined and are not subject to change because of component wear, adjustment or lubrication state. The transmitter distortion is less than 1%, while the receiver margin is in excess of 45%.

Power-Supply Unit

This unit is self contained and totally enclosed, except for the ventilation apertures. Access to the electronics and connexion strips is through removeable covers. The equipment AC mains supply terminates within this unit and is distributed, via external connectors, to the elapsed time-meter (fitted as an aid to maintenance) and the induction motor; the latter is controlled through the internal motor-start relay contacts and the external start and run capacitor box.

A total of 8 stabilized, overload and over-voltage protected DC rail voltages are available from the power unit, though not all are used when the terminal is configured for ± 80 V double-current signalling. The rail voltages and uses are given in Table 2.

The terminal operates on an AC mains supply having a voltage in the range 210-240 V, 50 Hz, and power consumption in the quiescent mode is approximately 30 W. When operating, the power consumption is about 100 W.

TABLE 2
Power-Unit DC Rail Voltages and Use

Voltage	Use
+12 V	Positive rail for logic system, including LSI
-12 V	Negative rail for logic system, including LSI
+5 V	Supply for ICs
+30 V	Supply for keyboard resetting magnet
+32 V	Constant-current supply to charge print-hammer capacitor
+14 V	Supply for energizing function unit, tape punch, and tape-punch and tape-reader magnets
15-0-15 V	Signalling supply for optional low-level output

ANCILLARIES

Tape Reader

The paper-tape reader (see Fig. 7) is a completely self-contained unit, mounted to the left of the keyboard and in line with tape issuing from the punch; it incorporates spring-loaded taut-tape and tape-out sensors, and the character being read can be seen through slots in the tape gate. The tape hole/no-hole character code information is read mechanically through lightly sprung lever sensors, which directly activate single-pole twin contacts; the resulting 5-unit parallel output is fed to the electronic logic.

The mode of operation of the reader is read-before-feed, but the state of the code contacts is not transferred to the electronic logic until the feed electromagnet actually receives an energizing pulse; this allows the contacts maximum time to settle following tape movement. Operation of the electromagnet activates a feed pawl attached to the armature, which engages with a ratchet wheel on the same shaft as the tape feedwheel. Each operation of the armature advances the tape by one hole pitch (2.54 mm).

Paper-Tape Punch

The paper-tape punch unit is a separate entity which is attached to the left-hand side of the page printer (see Fig. 7), and is operated independently of the printer except for using the same motive system and source of control signals. Drive from the printer motor is through toothed belt reduction gear trains, which cycle the punch continuously at the character rate, in synchronism with the print wheel.

Rotary-to-linear motion for punching and stepping the 17.46 mm wide paper tape is obtained from an eccentric on the drive shaft. Punching and stepping occur at different points of the cycle to give a punch-before-feed action sequence, which allows viewing of the last character punched.

Six electromagnets control the punching of the 5 code holes and the smaller feed hole. A cam on the eccentric presents the electromagnet armatures to the pole-faces on each cycle; therefore, only a small holding current is required to maintain

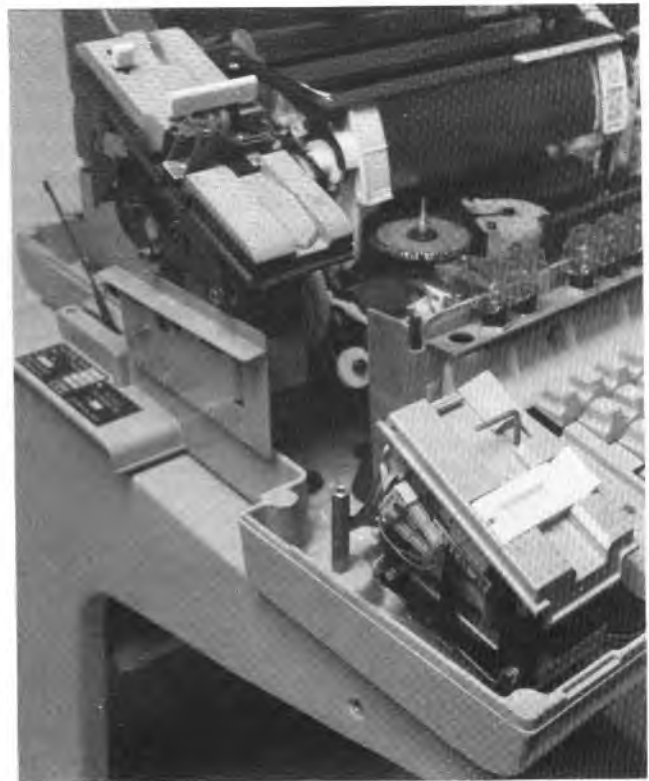

FIG. 7—Paper-tape reader and punch units

the magnet(s) operated and effect punching action. Tape advance is by means of a friction drive, which impels the tape against the punch reference edge, and is linked to the action of the feed hole punch so that no movement occurs without a feed hole.

Forward movement of the central bar lever parts the feed rollers so that a new tape can be passed unimpeded through the punch from the tape reel. Operation of a second lever at the rear moves the tape backwards, one character pitch at a time, to provide for tape correction by overpunching. Paper cuttings from the punch are collected in a see-through plastics box, which can be readily removed for emptying.

LINE TERMINATING UNIT

For double-current signalling to the UK Telex network, an external terminating unit must be associated with the Teleprinter No. 23; the unit is compact and is connected to the teleprinter line isolator PWB by a signal cord. Its 80-0-80 V signalling supply is electronically stabilized and protected against overload by fuses and a resistor bulb (barretter). The transmitted signal passes to the SEND wire through a standard BPO low-pass T filter.

Connexion of the terminal to AC mains power is through the mains lead of the terminating unit, from which the power supply is distributed to the teleprinter and card callmaker (where fitted) by separate cords.

The terminating unit provides a suitable point for terminating the SEND, RECEIVE and SIGNAL EARTH wires of the exchange line, and those wires used for remote control and signalling from the card callmaker. A *test* facility disconnects the terminal from line, at the same time it switches in a local loop test circuit for full service checks.

OPERATIONAL FEATURES OF TERMINAL

Keyboard Layout

There are clear operational advantages to be gained, particularly in terms of operator training and conversion times, from having the keyboards of typewriters and Telex terminals as alike as possible. When the Telex service commenced in the UK, the teleprinter used (Teleprinter No. 7) incorporated a 3-row keyboard, which had only a very basic similarity to the, then, generally accepted typewriter keyboard layout. Its successor (Teleprinter No. 15), introduced in 1968, conformed with the BPO policy of trying to achieve the highest degree of commonality between the keyboards of these 2 classes of office machine; the 4-row keyboard used assigned one character per key and no variations in the original layout have been introduced.

The Teleprinter No. 23 has a refined version of the earlier 4-row keyboard, in which the typewriter practice of assigning 2 characters to some keys is incorporated, the uppermost character being selected by coincident operation with the SHIFT key. The layout (see Fig. 5) corresponds closely with the British Standard³ for typewriter keyboards, a notable exception being the location of the + (plus) key in the numerals row because of its use in Telex as an *end-of-selection* signal.

Keys having a control function that relates directly to the line signal are integrated into the keyboard, but are differentiated by colour. The symbols incorporated are those specified by CCITT² and represent a departure from the previous BPO practice of using abbreviations. Those characters that are inadmissible for international Telex communication—ITA2 Combination Nos. 6, 7 and 8 (corresponding to %, @ and £, respectively in the UK)—have their symbols coloured red. The distinctively-shaped NEW LINE key has the same effect as the corresponding key on an electric typewriter, but the generated character sequence to line is *carriage-return, line-feed, carriage return*.

Facility Options

It is expected that the Teleprinter No. 23 will be primarily used on Telex by the BPO, but that some terminals will be used in-house and on private-circuit telegraphs. A range of options is catered for, so allowing the terminal to be configured to meet many system and customer needs.

Facilities are selected through the presence or absence of specified diodes in the answer-back and option PWB. To save time and the need for soldering operations, the answer-back section of new boards is fully equipped with diodes; it is therefore only necessary to cut out the appropriate ones to give the required answer-back sequence. The diode arrangement in the facility section is wired to suit terminals for UK Telex operation; alternative system requirements are met through appropriate rearrangement of the diode straps.

The transmission rate to and from line may be at 50, 75 or 100 bauds and printer speed can be varied by changing the motor gear. The printer operation in the *local* mode can be at a higher rate than that dictated by the line signal, thus permitting consistently faster operation of the keyboard and punch during message preparation. For example, when sending or receiving a message over a 50 baud circuit, the printer would operate at 6 $\frac{2}{3}$ characters/s; in the *local* and *tape prep* modes, it could be made to operate at 10 characters/s.

Effect of Interrupting Calls

If an incoming call occurs while the terminal is being operated in the *local* mode, the keyboard is immediately locked to prevent any further characters from being keyed. The punch is also switched off (with the last character punched corresponding to the last character printed), and the paper is advanced by 4 lines to separate the existing local record from the record associated with the incoming call. This safeguards the paper tape under preparation against corruption, and enables the terminal to acknowledge the call and to send the *answer-back* signal on receipt of the *who-are-you* signal without delay.

Simultaneous Tape Preparation and Transmission

When a connexion has been established an existing message tape can be transmitted in the normal way by using the paper-tape reader. If the LOCAL PREP button is operated, the keyboard, printer and punch (switched on automatically) can be used to prepare another tape, without any interference with this transmission. This simultaneous operation in *on-line* and *local* modes is known as the *tape prep* mode, and is maintained for as long as the connexion remains established, or until the *local* mode operation is cancelled by operating the RESET button. If an incoming signal is received from line, the blue alarm lamp is switched on, the reader and punch are stopped (without mutilation of characters), the keyboard is locked and the carriage returned, simultaneously with the paper being advanced by 4 lines.

Transferability of Answer-Back and Option PWB

If it becomes necessary to exchange Teleprinters No. 23 for any reason, the answer-back and option PWB can be transferred to the alternative equipment to produce the same answer-back response and terminal configuration.

Safety

It has long been BPO policy to make its teleprinters as safe as is reasonably practicable, so that operators, maintenance staff and the network are not subject to avoidable risks. A heightened awareness of safety needs has been created by new legislation, notably the Health and Safety at Work Act; this, in conjunction with the new technology used in the Teleprinter No. 23, has resulted in the incorporation of safety

features not previously found in similar office equipment.

Although the electro-mechanical content of the terminal has been much reduced, a few hazards remain to catch the unwary; these have been guarded against by operational safeguards and by the careful use of warning labels. If an operator raises the lid without first having disconnected the AC mains as instructed, possibly to replace the paper roll, then the drive to the motor is cut before a finger-sized gap appears. If access is attempted while an established call is in progress, this also has the effect of clearing down the call and extending the *ABS* condition to the exchange, thereby preventing incoming calls. Normal terminal operation, in any mode, is possible only when the lid has been fully lowered.

Hazards to maintenance staff can never be entirely eliminated, but their training makes them aware of the nature and location of the likely danger points. However, to minimize inadvertent contact, internal covers are provided; these must be removed before access to potential hazard areas is possible.

In order that a terminal can be operated fully during a maintenance examination, it is necessary to have an over-ride for the interlock that prevents operator access. A special switch has been provided for this purpose; the switch is inaccessible to an operator and cannot be left operated by maintenance staff when the main equipment cover has been replaced. A guard against possible non-insertion of the cover plug associated with the lid interlock is provided by the switching on of the red lamp associated with the CR-LF control and disconnection of the dial; only when this plug is restored does the terminal present its normal operating state.

Electrical safety is achieved through close attention to inter-unit earth bonding, and careful specification and containment of those items carrying AC mains. Isolation from the lines and control leads is through transformers and optocouplers. Motor damage from over-heating is prevented by means of a thermal cut-out in the stator winding.

TESTER

A special-purpose tester (Fig. 8) is available as an aid to the maintenance of the Teleprinter No. 23. Known as the *Electronic Maintenance Analyser* (EMA), it has the BPO designation Tester No. 266A. The EMA is substituted for the main board in the base of the teleprinter, and allows testing of the mechanical units (printer, punch, keyboard and tape reader), correct functioning being indicated by means of a meter and lamps. It can also be used to test the voltage and ripple levels of the DC supplies from the power unit, but does not permit the testing of the PWBs. Protection is provided against fault conditions or malfunctions, which might otherwise cause damage to a PWB.

The EMA is intended as an aid to servicing and maintenance of the Teleprinter No. 23 under workshop conditions. It assists in determining whether a fault is mechanical or electronic in nature, and can be used to check a unit statically and dynamically for correct functioning following adjustment or replacement. These tests can be made to a more onerous specification than that required for correct operation using the main board.

All the accessories necessary to enable the EMA to be used with the Teleprinter No. 23 are housed within the lid cover, which also carries the operating instructions.

CONCLUSION

A high proportion of the total UK annual capital investment in Telex is allocated to the customer terminal apparatus; the introduction of a new teleprinter is therefore a significant event in the evolution of the national Telex service. A new Telex terminal (Teleprinter No. 15) was last introduced in 1968 and is currently being replaced by the Teleprinter No. 23.

With the introduction of the Teleprinter No. 23, a number



FIG. 8—Electronic Maintenance Analyser (Tester No. 266A)

of benefits are expected to accrue to both the Business and its customers. In particular, the use of modern technology has permitted the cost-effective substitution of electronics for complex mechanisms—except for those basic functions related to printing, paper movement and tape punching/reading. Consequential improvements in reliability and versatility, accompanied by reductions in size, weight, sound emission, routine maintenance and first cost, have followed.

The Teleprinter No. 23 is the first full-capability electronic teleprinter to be provided by the BPO for Telex customers' use. It is a first-generation electronic terminal giving some enhancement in features and facilities over the equipment it supersedes, but, at the same time, retaining the virtues of simplicity of operation and giving good-quality printing.

Because of the pace of technical advances in electronics, and marketing pressures arising from the development of office systems and new services that will compete with Telex, the Teleprinter No. 23 is unlikely to be in production for as long as its predecessors; however, it is expected to give good service for many years, and to be a most useful machine in making the transition from the electro-mechanical teleprinters predominant today to the advanced electronic technologies that will be used in future Telex terminals.

ACKNOWLEDGEMENTS

To meet the particular requirements of the BPO, the Teleprinter No. 23 is a variant of proprietary equipment designed, developed and manufactured by JTT Creed Ltd. to a Company specification. The author wishes to acknowledge the assistance of colleagues and ITT Creed in the preparation of this article.

References

- ¹ SIMMONDS, T. G., and BURTON, P. A. Repertory Diallers. *POEEJ*, Vol. 62, p. 188, Oct. 1969.
- ² CCITT Recommendation F1. International Telegraph Alphabet No. 2. Orange Book, Vol. II, 3.
- ³ British Standard 2481. Typewriters. British Standards Institution, London.

The Post Office Telecommunications Museum, Taunton: Britain's Oldest Telecommunications Museum

P. J. POVEY†

The decade 1945 to 1955 was a period of reconstruction after the ravages of war and of rapid expansion of Britain's telecommunications system. Some of the telecommunications equipment that was being scrapped at this time had been due for replacement at the outbreak of hostilities in 1939, but the war-time shortages of men and materials had made this task impossible. The historical value of this equipment was recognized by the author who felt that certain items should be preserved. As there was no museum in the UK specializing in telecommunications, many of the more interesting artefacts that had been selected were stored in boxes. The acquisition of this equipment led to the idea of setting up a museum; this was realized in the early part of 1957 when a Post Office Telecommunications Museum was opened in Taunton.

The building which houses the Museum is situated next to the Head Post Office in Taunton's main street. It is undoubtedly much older than the oldest exhibit within its walls and probably dates back to the seventeenth century. The building is by no means perfect accommodation for a telecommunications museum, but its many odd corners, and steps at every turn, give it charm and character.

Schools in particular have welcomed the services that the museum offers. As well as conducted tours of the museum with explanations of the exhibits, talks illustrated with slides are given in the nearby lecture theatre of the County Schools' Museum Service. The museum's reputation with schools is in part due to the curator's book, *The Telephone and the Exchange**, which many of the schools use as an introduction to telecommunications. Classes that have used this book in their studies want to see examples of the equipment they have read about. School parties often travel considerable distances to the museum because, apart from the slightly newer museum in Oxford, it is the only one that provides these services.

The principal difference between telecommunications museums and most other types of museum is the very short timescale of telecommunications history. The telecommunications system has evolved, and is continuing to evolve, at an extraordinary rate, and equipment can, in some cases, be conceived, developed, brought into service, superseded, scrapped and totally disappear within a space of ten years. In these circumstances, an important function of a telecommunications museum is to earmark older equipment of potential historical interest for preservation while it is still available. The STD equipment which was in use at the Bristol Central Telephone exchange serves as an example. Bristol was the first telephone area to have STD installed. The system was inaugurated by Her Majesty the Queen, who made the first STD call from Bristol to Edinburgh in 1958. Calls were processed by cold-cathode equipment which was then considered to be very advanced. Important new developments are fully reported in technical publications; in the case of the STD equipment at Bristol, there were extensive reports in the national press. In contrast, when equipment reaches the

end of its working life, it generally disappears without publicity; if equipment is to be saved, a curator must be very well informed about day-to-day technical developments and changes taking place in the world of telecommunications.

When it was decided to scrap the equipment in the Bristol Central Exchange, arrangements were made for a complete photographic record to be taken before recovery work started. Sufficient equipment was selected to enable the museum to construct a working display. But the quantity of available equipment far exceeded the museum's requirements; this made it possible for other museums to be offered similar sets of equipment.

Because there have been so many developments in telecommunications within living memory, a great deal of useful information can be gathered from older members of the staff and from people who have retired from the British Post Office. Information obtained in this way has proved to be very useful. For example, a few years ago the museum acquired a small automatic telephone exchange which had originally been installed in Zelah in Cornwall in 1930 and which had served that community for 37 years. The exchange had been very well maintained, but much of the work had diminished its value as an historical exhibit: for instance, original parts had been systematically changed for more reliable modern ones, and modifications had been made in order to provide additional facilities, such as a 999 service. Fortunately, it was discovered that the engineer who had maintained the Zelah exchange for many years had moved to Taunton, and it was possible to obtain a great deal of useful information from him. It took two years to find the parts needed to restore the equipment to its original state, but it is now possible to dial calls through the exchange from typical telephones of the period.

Although it is always preferable to preserve equipment in working condition, the first priority is to safeguard its authenticity, whenever this is possible. Only components and materials of the period are used: unfortunately, these are often very hard to find. Even the wire used in telephone exchanges has changed considerably over the years, and minor components are often museum pieces in their own right.

As well as a permanent display in Taunton, temporary exhibitions are set up in other places from time to time at the request of an Area or Region. Telephone Centenary Year was particularly busy and, in all, thirteen exhibitions were mounted either by the museum independently, or as part of the Regional public relations effort. Fortunately, the museum has a very large reserve stock which enables exhibitions to be staged elsewhere without depleting the display at Taunton.

A new facet of the museum is the sound archives, which include not only recordings of people recalling events connected with the history of telecommunications, but also of working equipment. For example, there is a recording of the spectacular noise made by a Wheatstone perforator, the forerunner of all punched-tape machines, and the voice of an expert operator describing how he is using it.

The events which led to the establishment of the museum at Taunton were purely fortuitous, but experience has shown that its good road and rail links make it a first class site.

† Curator, BPO Telecommunications Museum, Taunton

* *The Telephone and the Exchange*. P. J. Povey. Pitman Books. 128 pp. illus. £3.60.

THE REORGANIZATION OF TELECOMMUNICATIONS HEADQUARTERS

The old organization of Telecommunications Headquarters (THQ) was set up at the beginning of the last decade on a functional basis, with separate Departments responsible for such functions as development, service, planning, finance, etc. With this form of organization, rarely could any particular task be carried out entirely within one Department and often there was doubt where the responsibility for action lay. In consequence, many issues had to be decided at a higher level than was really necessary. The output, measured in terms of decisions and results, did not match the effort expended.

The new organization (shown in the diagram) has been designed to overcome these shortcomings. It is based on the identification of four main tasks:

- (a) to research into, identify and exploit major new openings in technology,
- (b) to provide a national telecommunications network which is as good as the technology can make it,
- (c) to exploit the potential of all forms of telecommunications for our customers and to ensure that they are aware of what is available, and
- (d) to guide and stimulate the field operations of the Business.

To fulfil these tasks, three new Executives have been created; respectively,

- (a) the Technology Executive,
- (b) the Network Executive, and
- (c) the Marketing Executive.

The fourth task will be undertaken by the Deputy Managing Director concerned with Operations and the new Service and Performance Department.

Within the new Executives, each Director and his Department, and each Division and its head have their own tasks to

do, clearly related to the main task of the Executive. These tasks are formed along natural boundaries of the work, which of course differ between the Executives. The structure of each Executive is designed to allow as many decisions as possible connected with a particular objective to be taken within the Divisions and Departments by people who both understand the specialist issues involved and have the power to take those decisions.

In addition to the three main Executives, other specialist units will support the Managing Director and his two Deputies. The Business Planning and Strategy Department will prepare the Business Plan, which will set out the overall strategy for the Business, thus ensuring that new areas needing attention are recognized in time and tackled by the appropriate Executive. The Overseas Liaison and Consultancy Department, as its name implies, will be responsible for the growing role of the Business in providing, in conjunction with industry, services for overseas customers.

At the same time, the International Executive, the Procurement Executive and the Data Processing Executive have each been structured to make them symmetrical with the new THQ so that they can work effectively with it. Finally, there remain two functional units: Personnel, and Finance and Management Services. Some of their work spans the whole Business and is therefore most effectively handled centrally. However, some finance and personnel expertise is required in each Executive and each will therefore have its own finance and personnel staff.

In this and the next issue, the *Journal* is publishing profiles of the senior staff in THQ and, subsequently, similar profiles of senior staff throughout the Business will be published as appointments are made.

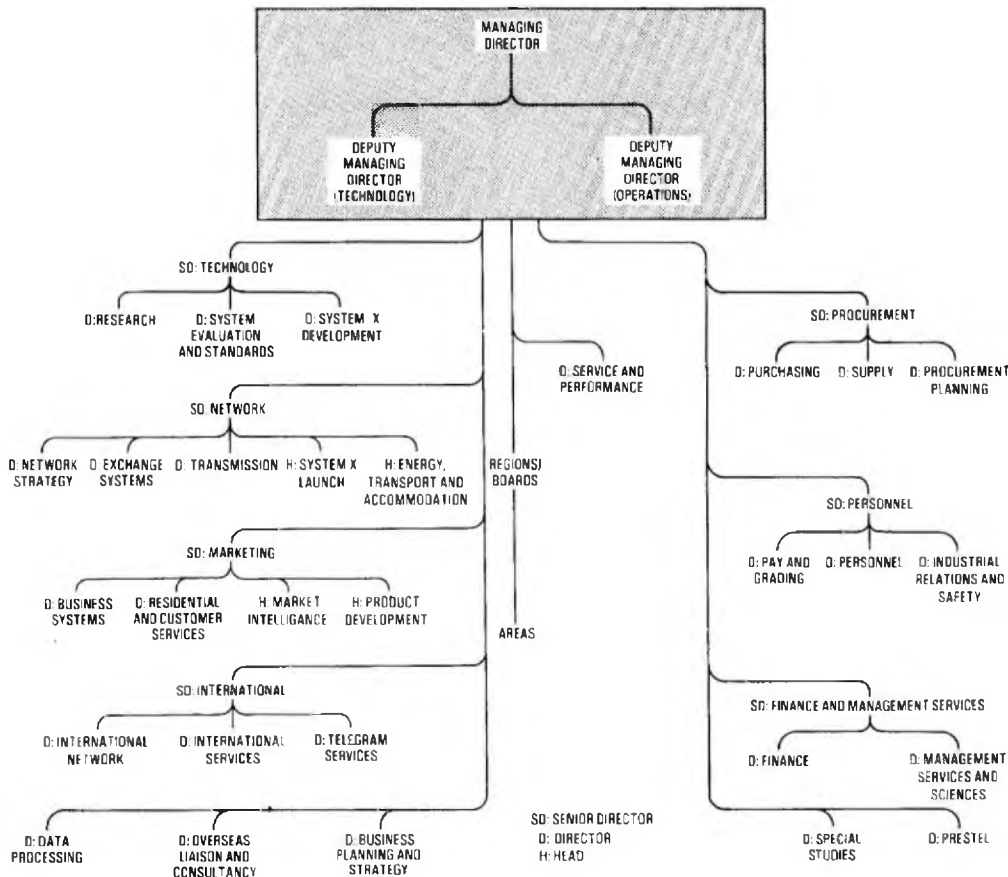

Profiles of Senior Staff

MANAGING DIRECTOR: TELECOMMUNICATIONS

P. F. BENTON, M.A., F.B.I.M.



Peter Benton was educated at Oundle School and Queens' College, Cambridge, where he studied Natural Sciences. From 1953 to 1955 he served in the Royal Engineers in Egypt and Cyprus.

Mr. Benton was, until recently, a Director of Gallaher Limited. He joined the company in 1971 to direct its engineering operations throughout the world. He has been Chairman of two of Gallaher's major subsidiary companies, Mono Pumps and Saunders Valve; during his chairmanship the latter company twice received the Queen's Award for exports.

Before joining Gallaher, Mr. Benton spent seven years with management consultants McKinsey and Company, working in Britain and the United States of America, mainly in the gas and electric-power industries.

While with McKinsey he worked from 1967 to 1971 with the British Gas Council and area boards in developing the industry's structure, strategy and management processes to cope with the change to North Sea gas. Earlier in his career he spent some time with the Unilever and Shell companies, in technical and marketing divisions.

Mr. Benton has been a Vice-President of the British Mechanical Engineering Confederation and was, until 1979, Chairman of the NEDO Sector working party on heating, ventilating, air conditioning and refrigerating equipment. He is a member of the Economic and Financial Policy Committee of the Confederation of British Industry, and a Fellow of the British Institute of Management.

DEPUTY MANAGING DIRECTOR: OPERATIONS

J. M. HARPER



John Harper entered the British Post Office (BPO) as an Assistant Principal. He was Private Secretary to Sir Gordon Radley, then Director General of the BPO, from 1956 to 1958. From 1958 to 1964 he was a Principal in Inland Telecommunications, responsible for policy for exchange systems and STD, including the numbering scheme, and for early work on electronic facilities.

In 1965 he became involved in the early stages of the 1969 reorganization of the BPO. In 1966 he was promoted to Assistant Secretary in the Reorganization Department with responsibility for what is now the PO Act of 1969, notably for recasting the telecommunications monopoly in its present form.

From 1969 to 1971 he was Director: North Eastern Telecommunications Region. He returned to Telecommunications Headquarters in early 1972 as Director of Purchasing and Supply. He played a major part in the commercial arrangements for System X development and led the commercial team. In March 1975 he was appointed Senior Director: Planning and Purchasing, and in January 1978 Assistant Managing Director. During 1978 and 1979 he was responsible for the reorganization of THQ. He has had a special interest in the future of the business in the terminal and service area, now to be carried forward by the Marketing Executive.

As Deputy Managing Director in charge of Operations, he is responsible under the Managing Director, Telecommunications, for the day-to-day operation of the services provided by the Business, and for oversight of Regions.

DEPUTY MANAGING DIRECTOR: TECHNOLOGY

J. S. WHYTE, C.B.E., F.ENG., M.SC.(ENG.),
F.I.E.E.



John Whyte's early career was spent in the former Radio Branch where, amongst other things, he was closely involved with the first application of point-to-point microwave radio systems in the UK. Transferring to Research Branch in 1957, he became involved in the early research on digital systems. From 1965 to 1968 he was seconded to HM Treasury, where he headed the unit responsible for stimulating data-processing applications in all Government departments. On his return to the British Post Office (BPO) as Deputy Director of Engineering, he took charge of Long Range Studies.

As Director of Operational Programming, and later as Director of Purchasing and Supply, he was responsible for the implementation of the switching replacement policies and for the adoption of TXE4 as the main interim local switching system.

When he became Senior Director of Development in 1977, he strongly supported the drive to accelerate the development of System X, expanded BPO research activity in the study of optical-fibre transmission, and stimulated British Industry to initiate production of operational systems. In July 1979 he was appointed to his present post to coincide with the implementation of the first stage of THQ reorganization.

Mr. Whyte is a member of the Council of the Electrical Research Association and of the Executive Committee of the National Electronics Council; he is also President of the Institution of Post Office Electrical Engineers, a Freeman of the City of London and a Liveryman of the Worshipful Company of Scientific Instrument Makers. He was recently appointed to the Science Consultative Group which advises the BBC on science and technology broadcasting. In February 1980 he was elected to the Fellowship of Engineering.

For many years he has been a keen photographer and mountaineer; less energetically, he is a regular opera-goer.

SENIOR DIRECTOR: FINANCE AND MANAGEMENT SERVICES

W. P. KEMBER, F.C.A.



Bill Kember who is a chartered accountant, joined the British Post Office (BPO) in 1972 in Central Headquarters; he moved to his present job the following year.

Before joining BPO he worked for Shell International, British Oxygen and for the management consulting arm of Coopers and Lybrand.

In the Telecommunications Business, Bill Kember has been particularly concerned with improving financial controls to bring them up to the standard required by a very large industrial and service undertaking.

Bill Kember is this year's Chairman of the Visitors' Committee of the Royal Institution.

SENIOR DIRECTOR: INTERNATIONAL

J. HODGSON, M.A.



Jim Hodgson joined the British Post Office (BPO) 30 years ago and his connexion with international services started 8 years later when he was transferred to the External Telecommunications Executive (ETE) to help plan the Commonwealth round-the-world telephone cable system. He then spent two years as Head of the International Telegraphs Division before he was seconded to the Cabinet Office as a member of the economic secretariat.

Returning to the BPO in 1964, he spent 3 years in the former Inland Telecommunications Department. His first job there was to review the legislation governing telecommunications services; afterwards he became the Head of the Inland Telephone Operations Division.

From 1967 he was Vice-Director of the ETE with special responsibility for the international lines network. In this period he represented the UK in INTELSAT, supervised the development of the submarine cable and high-frequency radio networks, started off the team whose work eventually resulted in the current Commonwealth Telecommunications Financial Arrangements, and carried out a major review of ETE's organization.

Jim Hodgson has now been Head of the BPO's international and maritime services for over ten years, initially as Director and latterly as Senior Director. In this period, international traffic has grown sevenfold, and new automatic services have largely replaced the old manual services. Three international gateway centres have been built, Goonhilly earth station expanded and Madley earth station brought into service. Major submarine cable projects such as CANTAT 2, TAT 6 and the 'new generation' cables to the continent have also been added to the network.

As the new International Executive enters the 1980s, Jim Hodgson looks forward to further rapid growth and diversification of the international, maritime and telegram services.

SENIOR DIRECTOR: MARKETING

G. J. POCOCK



Gordon Pocock joined the British Post Office (BPO) as an Assistant Principal in 1954 after he had taken a degree in English at Oxford. After a post in the Inland Telecommunications Department, he worked for a spell as Private Secretary to Sir Gordon Radley, before he moved into Buildings work in the then Administrative Headquarters of the BPO. In 1964 he worked on the financial arrangements for Commonwealth co-operation in telecommunications, the first of his assignments in international services.

When it was decided to change the status of the BPO from a Government Department to that of a Nationalized Industry, he worked on the preparation of the legislation, and its passage through Parliament, of the Post Office Act of 1969. Later, he moved into the Secretary's Office under its first Chairman, Lord Hall.

After a period in charge of graduate recruitment, he returned, in 1973, to the international services as Deputy Director. He moved to Marketing Department early in 1979, where part of his job was to help in the reorganization of the marketing function; the move was the prelude to his appointment as Senior Director.

In the academic world, he is known for his work on French literature, on which he has published two books. He is active in matters of local history, and carries out research on the development of Richmond, Surrey, where he lives.

SENIOR DIRECTOR: NETWORK

R. E. G. BACK, C.ENG., F.I.E.E.



Ronald Back joined the British Post Office in 1942 as a Youth-in-Training at Canterbury. After service in the Royal Signals, he returned to exchange maintenance at Maidstone before moving in 1949 to Headquarters as an Assistant Executive Engineer.

As an Executive Engineer he acted as liaison officer between the then Construction Branch and its consultants and contractors in the construction of deep-level tunnels for cables and equipment. This was followed by a period during which he worked on the design of external plant for radio stations.

On his appointment as a Senior Executive Engineer in 1961, he led a group providing microwave-radio systems; in 1965 he was appointed Assistant Staff Engineer concerned with the provision of satellite earth stations, a task he continued as Head of Division. During this period, the experimental Aerial 1 at Goonhilly was re-equipped for continuous service, Aerial 2 was provided and Aerial 3 construction commenced.

After promotion to Deputy Director in Network Planning Department, Mr. Back was responsible for transmission planning and the Submarine Cable and Marine Divisions. During this period these latter divisions undertook the provision of the CANTAT 2 cable and the acquisition by long-term leasing of the new cables, *C. S. Monarch* and *C. S. Iris*.

His move to Service Department came in 1975, initially as Deputy Director and later as Director, a post he held until taking up his present appointment in July 1979.

SENIOR DIRECTOR: TELECOMMUNICATIONS PERSONNEL

D. P. WRATTEN, B.SC., F.B.I.M.



When Don Wratten joined the public service in 1940 at the age of 15, he was too young to be graded as a clerk, so he started as a Storehand in the Air Ministry. Regrading the next year to what he calls 'the lowest form of clerical life' (a Temporary Clerk, Grade 3) meant less money but possibly more status.

He joined the British Post Office (BPO) in 1950 as an Assistant Principal, after he had served in the Meteorological wing of the Royal Air Force and gained a degree at the London School of Economics. Much of his early career was spent on the commercial side of telecommunications, with spells in the Postmaster General's office where he served as personal assistant to, in all, four ministers. In 1959 he was seconded for a year to Unilever Ltd. to study their management style and to learn all he could about the then mysterious subject of marketing. Later he joined a small team led by the then Mr. William Ryland to study in depth the Bell System of America, in particular the reasons that made it such a successful telecommunications organization.

This experience stood him in good stead when he became a founder member of the newly-created Marketing Division in 1964, and its head in 1966. The following year he was appointed Regional Director of the Eastern Telecommunications Region, from which congenial position he was, in 1969, pulled out abruptly by the Postmaster General, John Stonehouse, to take charge of the newly-launched National Giro service, which was experiencing severe teething troubles. After five years getting Giro firmly established, and a short spell in charge of the Data Processing Service, he found his way back to Telecommunications in 1975 when he took up his present appointment.

SENIOR DIRECTOR: TECHNOLOGY

J. ALVEY, C.B., B.SC.(ENG.), DIP.N.E.C.,
C.ENG., F.I.E.E.



John Alvey was born in New Malden, Surrey, and educated at Reeds School, Watford. After serving in the Royal Navy during the war, he attended the Northampton Engineering College, London and, in 1950, obtained a degree in electronic engineering. On graduation he joined the Admiralty as a Scientific Officer, the start of a distinguished career in the Ministry of Defence (MoD). From 1972 he was with the Procurement Executive of the MoD, most recently as a deputy secretary, where he combined the roles of Chief Scientist, Royal Air Force, and Deputy Controller, Air Side Research and Development. Mr. Alvey became a Fellow of the Institution of Electrical Engineers and a Chartered Engineer in 1976. In the recent New Year honours he was made a Companion of the Bath.

He joined the British Post Office (BPO) at the beginning of 1980 as the Senior Director of Technology in the new Technology Executive, Telecommunications Headquarters, where he is responsible for the £90 M BPO research and development programme, which is aimed at applying the most advanced technology to improve existing services and at providing new services for telecommunications customers.

John Alvey is married, has three sons, and lives in Guildford. His leisure interests include reading, rugby football, small-bore rifle shooting and the theatre.

DIRECTOR: RESIDENTIAL AND CUSTOMER SERVICES

F. LAWSON



Frank Lawson began his career in the former Ministry of Labour after leaving University College, London, and the London School of Economics and Political Science. He joined the British Post Office (BPO) in 1957 and, to begin with, served in both the postal and the telecommunications branches. This was followed by a period as a Private Secretary to the Postmaster General and to the Assistant Postmaster General.

On promotion, he returned to telecommunications to take responsibility for the inland telegram service. He also held posts in personnel and pay and grading before he became Personnel Controller in the North Eastern Telecommunications Region in 1968.

Frank Lawson later returned to Telecommunications Headquarters as Head of Service Policy Division with responsibility for a wide range of issues, including the telecommunications monopoly; for the third time in his career he was concerned with the inland telegram service.

A few years ago Mr. Lawson achieved his ambition of entering the Marketing Department as Head of Sales and Installation. In this post, and as Deputy Director of Marketing, he was concerned with initiating new services, (for example, radiopaging), and for introducing new approaches in marketing techniques, and establishing the product management concept. Next to marketing, his great enthusiasm is in harmonization of services and facilities in the Conference of European Posts and Telecommunications Administrations: he is the Chairman of the working group concerned with these aspects. He also maintains close contact with developments in North America.

DIRECTOR: SYSTEM EVOLUTION AND STANDARDS

L. R. F. HARRIS, M.A., C.ENG., F.I.E.E.



Roy Harris joined the British Post Office (BPO) in 1947, and for more than 30 years has been deeply involved with electronic switching.

Following brief spells in the Long Range Planning Division and as Head of Electronic Switching Research, Mr. Harris became Head of the joint BPO Industry Advisory Group on System Definitions in 1968, and led the studies which not only laid the technical foundation of System X, but which also pointed to the need for a co-ordinated attack on its development by the BPO and Industry. As Director of Telecommunications System Strategy he saw this crucial development through its early definition phases and the establishment of overall strategies for its exploitation.

Mr. Harris has a particular interest in the global harmonization of telecommunications services, and is personally involved in European studies of the Integrated Services Digital Networks of the future.

A strong supporter of Industry's export endeavours, Roy Harris led the preparations for the British Telecommunications stand at TELECOM 79 in Geneva, which so successfully launched System X and many other products and services on world markets. He is on the Board of British Telecommunications Systems Ltd., the new company set up to promote System X overseas.

As the Director of System Evolution and Standards, Mr. Harris has the challenging task of creating the best possible foundation for future systems development, and of ensuring that telecommunications standards across the board are as effective as they can be.

DIRECTOR: SERVICE AND PERFORMANCE

H. TOMLINSON



Harry Tomlinson, a dour northerner, started work in a coal mine, served in the Royal Navy and, in progressing from Youth-in-Training to Director, did most of the engineering jobs that the business can offer at Area and Regional levels. As General Manager, Manchester Central Area, he acquired a keen interest in the work of telephone operating and clerical staff.

A short period as Planning Controller gave Harry the opportunity to influence auto-manual-centre plans and the IDD programme for the North Eastern Telecommunications Region and, as Service Controller in the same Region, to influence marketing strategies and to help operating staff through the redundancy problems of the mid-1970s. At the same time, he served as the Regional representative on the Viewdata Appraisal Group.

Harry was torn from his northern eyrie to join Telecommunications Personnel Department as Head of Training; later he moved on to become Head of Productivity Improvement. Early in 1979 he became the last Director: Telecommunications Management Services. He is now engaged in shaping and building the new Service and Performance Department, the principal job of which he sees as being to improve understanding between the Regions and Telecommunications Headquarters. Harry dissipates his spare time in gardening, tinkering with electronic gadgetry, and lending a hand with Red Cross and disabled welfare.

DIRECTOR: RESEARCH

C. A. MAY, M.A., C.ENG., M.I.E.E.



Charles May joined the British Post Office (BPO) in 1948 as a Probationary Engineer after he had obtained an honours degree in the Mechanical Science Tripos at Christ College, Cambridge, and served in H.M. forces in India. On promotion to Senior Executive Engineer in 1957, he became the BPO's liaison officer for the early electronic exchange equipments, and worked on the development of magnetic drums.

As an Assistant Staff Engineer, Mr. May moved into the computer field, where he played a leading part in the successful installation of many of the BPO's early computers, and provided a consultancy service to other computer users. His interest in computers continued after his promotion to Staff Engineer in 1967; in 1969 he moved to become Head of the Established Telephone Exchange Systems Branch.

In 1970 he was appointed Deputy Director with responsibility for the whole field of telephone exchange system development. This included the final development of TXE4, the initial work on TXE4A, the enhancement and cost-reduction of TXE2, and considerable activity in connexion with the new international switching centres.

Mr. May has occupied his present post since 1975 and, during this period, has seen the completion of the move of Research Department from Dollis Hill to Martlesham.

DIRECTOR: INTERNATIONAL SERVICES

M. MORRIS



Mike Morris joined the British Post Office as an Assistant Principal in 1959, and worked initially in the Inland Telecommunications Department (ITD) and in the Secretariat of the Pilkington Committee set up by the Government to consider the future of broadcasting in the UK. As a Principal from 1964, he worked in ITD Planning Branch on co-ordination of the capital investment programme, and as Secretary of the Standing Telecommunications Advisory Committee (STAC). He was Private Secretary to the last three Postmasters General. Promoted to Assistant Secretary, he set up the first corporate planning unit in the Telecommunications Business, and then worked for a year in the External Telecommunications Executive (ETE), co-ordinating various personnel and industrial relations matters in the field of international telegraphs. He was Deputy Director, Finance and Personnel, in the London Telecommunications Region, and became Director of Telecommunications Management Services in 1976, being very much concerned with manpower planning and similar issues. He became Director of ETE in 1979. On the reorganization of ETE in October 1979 he became Director of International Services, concentrating on service, business strategy and international arrangements, but remaining administrative head of what is now called International Telecommunications.

DIRECTOR: OVERSEAS LIAISON AND CONSULTANCY

J. F. P. THOMAS, B.SC., C.ENG., M.I.E.E.



Frank Thomas joined the British Post Office Research Station at Dollis Hill in 1937. He became a Probationary Inspector in 1942 and a Senior Executive Engineer in 1957.

Much of his early career was spent in the physics laboratory, where he worked on a wide variety of tasks, including investigations into magnetic materials.

In 1948 and throughout the 1950s he worked on the design of repeater components and terminal equipment for submarine systems, including the first Transatlantic Telephone Cable (TAT 1); he also contributed to many other aspects of the project, in particular the laying of the cable across Newfoundland.

In 1963 he was promoted to Assistant Staff Engineer in the old LMP Branch, with responsibilities for planning the inland trunk network; in 1966 he took charge of the Branch as Staff Engineer. His time in LMP Branch coincided with a marked expansion of the inland trunk network which continued unabated through all the changes in the BPO's organization during the birth of Corporation status. These changes brought his Branch into Network Planning Department (NPD) which he left in 1970 when he became Deputy Regional Director of the London Telecommunications Region, first on service and then on planning.

However, he still retained a strong interest in his old department and it was no surprise when he returned to NPD in 1972 as Deputy Director in charge of the Line, Radio, Datal and Submarine Division. Within a few months he was appointed Director: NPD, a post which he retained until the Telecommunications Headquarters re-organization in 1979.

In common with other members of THO he showed increasing concern during the 1960s and 1970s at the decline in British Telecommunications performance overseas, and now heads the Overseas Liaison and Consultancy Department, which is dedicated to reversing this decline.

DIRECTOR: PURCHASING

C. A. P. FOXELL, B.SC.



Clive Foxell joined the GEC Hirst Research Centre in 1946 as a Student Assistant and obtained an honours degree at the University of London by part-time study. After carrying out research on transistors and other semiconductor devices, he was appointed Manager of the GEC research activity in this specialization. With the expansion of their interest in large-scale integration, he was appointed Managing Director of GEC Semiconductors Ltd. in 1970.

In 1975 he joined the British Post Office (BPO) as Deputy Director of Research at Martlesham, with special responsibility for microelectronics, materials and optical-fibre systems. After 3 years, Mr. Foxell joined the Procurement Executive of the BPO as Deputy Director to cover the field of switching, transmission, and research and development products. As Director of Purchasing he is responsible for the bulk of the orders placed by the BPO with industry; currently they amount to about £1000 M a year.

Mr. Foxell is involved in the work of professional institutions and is a Fellow of the Institution of Electrical Engineers (IEE) and of the Institute of Physics. He is a past Council Member of the IEE and is currently involved in their future conference programme.

He has published papers and lectured widely on microelectronics. A member of several Government and university advisory bodies, he is at present Chairman of the Science Research Council Information Engineering Committee.

The Associate Section National Committee Report

NATIONAL TECHNICAL QUIZ

As reported in a previous issue, the 1979-1980 National Technical Quiz Final will take place at the Institution of Electrical Engineers Theatre, Savoy Place, London, on the afternoon of Friday 25 April, 1980. The dinner following the final of the competition will be held this year at the Regent Palace Hotel, Piccadilly Circus, London. Tickets will be available at £5 each from Chris Webb, (0409) 253687 or Mervyn Dibden (0722) 5634.

This year, hotel accommodation can also be booked at conference rate at the same hotel through the above officers, who will give the prices on request.

NATIONAL DIRECTORY AND RULE BOOK

The Secretary has now produced a new national directory and

a complete set of rules; would centre secretaries who have not yet received a copy please contact the Secretary, as he may have had incorrect information. Any up-dating information will be gratefully received.

ANNUAL CONFERENCE 1980

The Annual Conference this year will be held at the Technical Training College, Stone, on Friday 16 and Saturday 17 May. For the first time, the conference will start on a Friday afternoon and will be preceded by a brief National Executive Committee Meeting.

I hope that this year all regions will be represented by at least one delegate to allow all regions full participation in National business.

M. E. DIBDEN
Secretary

Associate Section Notes

ABERDEEN CENTRE

The 1979-1980 session has been quite a busy one for the Centre so far. Two rounds of the National quiz (Regional competition) have taken place. In the first round Aberdeen defeated Motherwell but in the second round lost to Inverness. A friendly contest was also arranged between teams from the Associate section and the senior section; this resulted in a very narrow win for the senior section.

The lecture given at the centre by Mr. D. L. Gaunt of the Research Department on microprocessors produced the largest attendance to date; and those who attended found it very informative. Trips were also arranged for members: an evening visit to the British Airways helicopter base at Aberdeen airport, and a day visit to Hewlett Packard Ltd. in Edinburgh, who manufacture some of the test equipment used by the British Post Office.

J. H. McDONALD

BELFAST CENTRE

The annual general meeting of the Belfast Associate Centre was held on 5 September 1979, when the following officers were elected:

President: Mr. S. P. Covles, C.ENG., M.I.E.E. (General Manager, Belfast Telephone Area).

Chairman: Mr. F. X. Colgan.

Vice Chairman: Mr. S. L. Wilson.

Secretary: Mr. D. McLaughlin.

Treasurer: Mr. C. C. Smith.

Quiz Organizer: Mr. B. G. Thompson.

A visit to Cregagh TXE4 exchange proved so popular that two additional visits were organized to meet the demand.

November saw everyone concentrating on the technical quiz, with 6 teams competing for the Belfast Centre championship; the Malone Exchange retained the trophy. Two Belfast teams also travelled to Downpatrick to compete in a friendly quiz to encourage the launching of a new Centre in that district. However, the month ended on a sad note for us with

the defeat of our champions in the Regional quiz final, which attracted entries from five centres.

The 1980 programme began in January with a lecture and demonstration of Prestel; members are looking forward to a busy calendar of activities during the remainder of the session.

D. McLAUGHLIN

LUTON CENTRE

Writing at the end of 1979, I find myself looking back on another very successful year for the Luton Centre. Our membership is still increasing, although the rate of increase has moderated in recent months.

Activities arranged for our members since the April 1979 annual general meeting have included 2 talks, 2 films shows, and 6 visits.

The first talk in April, about *Prestel*, attracted 40 members. It was given by Jim Stead who left the Bedford area some years ago to join the Marketing Division in THQ. Jim brought along a fully operational Prestel set, and some members were able to gain first-hand experience of the system.

Visits were organized to the Bristol Model Railway exhibition; the British Post Office's (BPO's) Research Centre at Martlesham; Mullard's radio astronomy observatory at Cambridge; a gruelling but enjoyable trip to Desford colliery; and Capital Radio.

In early October, Ken Drew, one of our members, gave a talk entitled *Steam on the Road*. Ken was well qualified to talk on this subject, since the steam road-roller which he owns and regularly exhibits at rallies was restored by Ken himself. After the talk there was a presentation to the ex-chairman of the Centre, Peter Harries, who has now retired from the BPO. Peter was presented with a scroll and an engraved tankard, and made an honorary life member of the Centre.

Outings have been planned for the future. These include a visit to London Transport's underground depot at Acton; Corby steel works; and the United States airforce base at Alconbury.

P. OSBORNE

Forthcoming Conferences

Further details can be obtained from the conference department of the organizing body.

Institution of Electrical Engineers, Savoy Place, London WC2R 0BL.
Telephone: 01-240 1871

Radio Spectrum Conservation Techniques

7-9 July 1980
Institution of Electrical Engineers

Microwave Solid-State Devices and Applications

7-18 July 1980
Vacation school at University of Leeds

Transmission for Telecommunications Purposes

7-12 September 1980
Vacation school at University of Aston

Stored-Program Control of Telephone Switching Systems

7-12 September 1980
Vacation school at University of Essex

Switching and Signalling in Telecommunications Networks

14-19 September 1980
Vacation school at University of Aston

Optical Communication

16-18 September 1980
University of York

The Impact of New LSI Techniques on Communication Systems

1-2 October 1980
Institution of Electrical Engineers

International Telecommunications Energy Conference

19-21 May 1981
Royal Lancaster Hotel, London
Papers: Synopses by 30 May 1980

Institute of Physics, 47 Belgrave Square, London SW1X 8QX.
Telephone: 01-235 6111.

Physics of Dielectric Solids

8-11 September 1980
University of Kent

European Solid-State Device Research Conference

15-19 September 1980
University of York

MEPL Ltd., Temple House, 36 High Street, Sevenoaks, Kent TN13 1JG. Telephone: (0732) 59533

Microwave

8-12 September 1980
Warsaw

Post Office Press Notice

EURONET ENQUIRY SERVICE

A six-language computer directory-enquiry type service, detailing hundreds of sources of information available throughout the European Economic Community (EEC), has been brought successfully into operation by the British Post Office (BPO).

The service is a guide to the wide variety of computer databases accessible through DIANE—the Direct Information Access Network for Europe. DIANE's databases are all available through EURONET—the EEC-wide packet-switched data-transmission network that provides users in the Community's nine member countries with immediate access to the computers on which the databases are stored.

Through EURONET/DIANE, which started working on a provisional basis in November 1979, users will eventually have on tap a wealth of scientific, technical, legal and socio-economic data. Terminals providing access to the data will be installed in customers' own premises; typical users will be national and local government offices, research centres, educational establishments, public corporations and industrial and financial institutions.

The EURONET/DIANE enquiry service now being provided by the BPO gives general information about the system and basic details of the host computers connected to it and the databases offered. Users call up this information on their own EURONET terminals. There is also operational news of the network and details of EURONET's representatives in each of the participating countries.

At present, 8 computers, acting as hosts to 38 databases, are

linked into the network. Eventually, the network will bring about 175 databases on 23 computers.

Customers are linked to the computers through packet-switching exchanges (PSEs) in London, Frankfurt, Paris and Rome, or through remote access centres in Amsterdam, Brussels, Copenhagen, Dublin and Luxembourg. In addition to the enquiry service, London also houses the network management centre.

For the time being, users in the UK access the EURONET PSE in London by private circuit or the public telephone network, using Datel services or comparable data-transmission systems. Later this year, they will instead use Britain's own inland public packet-switched service (PSS), which is due to come into operation in the Spring.

The EEC contract for the enquiry service was awarded to the BPO as a result of the expertise its network-planning engineers have acquired in packet-switching techniques. The service is based on a Perkin Elmer 8/16 minicomputer, with 10 Mbyte of disc store, which the BPO has been using for some years to support a large part of its packet-switching development.

The machine played an important role in developing information retrieval protocols and software for the experimental and international packet-switched services. And it has also been used in further development work that will facilitate PSS implementation this year.

For the enquiry service itself, collating and inputting EURONET/DIANE data on to the enquiry system's disc files is undertaken by a multinational EURONET launch team within the EEC, as part of the job of bringing the network into operation.

INDEX TO ADVERTISERS

Advertisements

Communications, advertisement copy, etc., should be addressed to Mr. N. G. Crump, The Advertisement Manager, POEEJ, Room 506D, 2-12 Gresham Street, London, EC2V 7AG (Tel: 01-357 2089).

No responsibility is accepted by the Journal for any of the private or trade advertisements included in this publication.

Dale Electric	5
Eurep Ltd., Northeast Electronics	7
GEC Telecommunications Ltd.	6
Herman Smith Ltd.	1
International General Electric of New York Ltd. .. .	4
R.F. Components Ltd.	3
Terracom	2

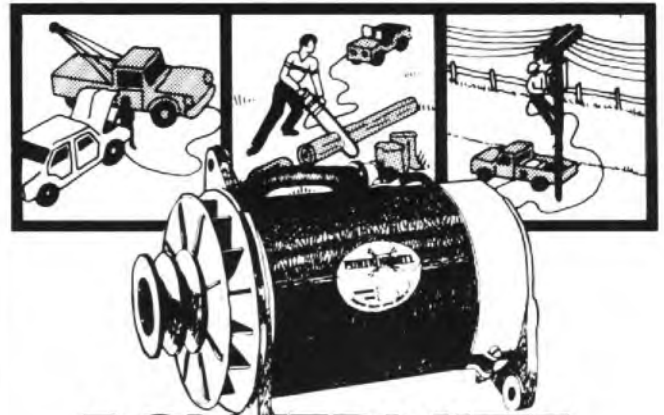

POWERMITE

CONVERTS YOUR VEHICLE ENGINE INTO AN AC GENERATING SYSTEM

Save labour, time and lives when AC electric power is needed on the spot. Power to operate Floodlights—Power Saws—Drills—Cutters—Pumps—Blowers—Compressors—Respirators etc. Especially valuable for rural and isolated areas.

- Mounts easily on any car or truck engine
- Safe to use under all conditions

- Will not affect vehicle electrical system
- Designed and built for long hard service
- Can be re-installed on new vehicles
- Guaranteed for one full year
- Delivers 3,500 Watts

DALE

Emergency Products Division
Dale Electric of Great Britain Ltd,
Queen Margarets Road Industrial
Estate Scarborough,
North Yorkshire YO11 2YH, U.K.
Telephone: 0723 71371 Telex 52163

The Post Office Electrical Engineers' Journal

Copyright

The entire contents of this *Journal* are covered by general copyright, and special permission is necessary for reprinting long extracts, but editors are welcome to use not more than one-third of any article, provided that credit is given at the beginning or end, thus: "From *The Post Office Electrical Engineers' Journal*".

The Board of Editors is not responsible for the statements made nor the opinions expressed in any of the articles or correspondence in this *Journal*, unless any such statement is made specifically by the Board.

Subscriptions and Back Numbers

The *Journal* is published quarterly in April, July, October and January, at 70p per copy (£1.05 per copy including postage and packaging); annual subscription: £4.20; Canada and the USA: \$10.00.

The price to British Post Office staff is 48p per copy.

Back numbers will be supplied if available, price 70p (£1.05 including postage and packaging). At present, copies are available of all issues from April 1974 to date with the exception of the April and October 1975 issues; copies of the July 1970 and April and October 1973 issues are also still available.

Orders, by post only, should be addressed to *The Post Office Electrical Engineers' Journal*, 2-12 Gresham Street, London EC2V 7AG.

Employees of the British Post Office can obtain the *Journal* through local agents.

Binding

Readers can have their copies bound at a cost of £5.25, including return postage, by sending the complete set of parts, with a remittance, to Press Binders Ltd., 4 Iliffe Yard, London SE17 3QA.

Remittances

Remittances for all items (except binding) should be made payable to "The POEE Journal" and should be crossed "& Co."

Advertisements

All enquiries relating to advertisement space reservations, copy, proofs, etc. should be addressed to The Advertisement Manager, *Post Office Electrical Engineers' Journal*, 2-12 Gresham Street, London EC2V 7AG (Telephone: 01-357 2089).

Distribution and Sales

Correspondence relating to the distribution and sale of the *Journal* should be addressed to *The Post Office Electrical Engineers' Journal* (Sales), 2-12 Gresham Street, London EC2V 7AG.

Communications

With the exceptions indicated above, all communications should be addressed to the Managing Editor, *The Post Office Electrical Engineers' Journal*, NE/PI2, Room S 08, River Plate House, Finsbury Circus, London EC2M 7LY (telephone 01-432 4840).

Model-Answer Books

Books of model answers to certain of the City and Guilds of London Institute examinations in telecommunications are published by the Board of Editors. Copies of the syllabi and question papers are not sold by *The Post Office Electrical Engineers' Journal*, but may be purchased from the Department of Technology, City and Guilds of London Institute, 76 Portland Place, London W1N 4AA.

The GEC Keyphone 89 puts Brigine Albrecht in touch with Air France or her Dutch fiancé

Whether the call is to the same building or a different continent, it begins and ends with the familiar telephone.

The GEC Keyphone 89 is an established high-reliability design based on advanced technology and the ergonomic factors required for modern pushbutton signalling. The keys are 'dished' to minimise errors and incorporate a "fall-through" action to ensure positive operation. The design incorporates features which make it suitable for operation in a wide range of climatic and environmental conditions.

The GEC Keyphone 89 is a self-contained pushbutton telephone using the latest Largescale Integrated Circuit techniques. It will replace a rotary dial telephone without any modification to the exchange equipment. The electronic circuits which incorporate a 20-digit store, are powered over the line and no batteries are required in the telephone.

Whether the call is to the same building or a different continent, The GEC Keyphone 89 is an aesthetically pleasing telephone available in a range of seven colours and is equally at home in a domestic or business environment.

GEC

Telecommunications



GEC manufacture telephones for world markets: table and wall-mounting models, pushbutton telephones, switching telephone systems, and subscribers carrier equipment.

CF 10

GEC Telecommunications Limited

Telephone Division, Whinbank Road, Aycliffe, Co. Durham, England. A Management Company of The General Electric Co. Ltd., of England.

International troubleshooter.

You can use Northeast Electronics' modular signaling test display just about anywhere in the world.

Plug-in modularity makes the Model 2760 Signaling Display a most versatile, powerful and easy-to-use test set. Northeast Electronics supplies a wide range of modules for both CCITT and North American signaling and supervision systems. You select the exact modules for your application to build a powerful, custom-designed signaling display and analysis unit that can solve the toughest problems. Choose from among: **CCITT** Dial Pulse, CCITT = 5-Register, CCITT = 5-Line, CCITT = 4, R2/MFC, AC 9/11... and **NORTH AMERICAN** Dial Pulse, MF, SF, DTMF.

The Model 2760 can be operated in three modes: 1) to display dialed numbers, 2) to detect signaling problems, and 3) to measure actual pulsing parameters. Simple push-button programming selects the correct mode for the task and the skill level of the operator.

Model 2760 features a dual, 16-digit display, 240-digit memory and ability to compare incoming calls with one of ten preprogrammed 16-digit numbers. The unit may be bridged

anywhere on 2-, 4- or 6-wire circuits without disturbing normal service.

The proven, universally adaptable 2760 is available now to help improve toll call completion, increase revenue and make maintenance easier and faster. For full details, call or write Northern Telecom, Inc., **Northeast Electronics Division**, Airport Road, Concord, New Hampshire 03301. Telephone (603) 224-6511, Telex: 94-3453, TWX: 710-361-1886.

nt northern telecom

NEW! Call or write for our free International Telecommunications Test Equipment Catalog.

