

SUPPLEMENT

TO THE POST OFFICE ELECTRICAL ENGINEERS' JOURNAL

Vol. 70 Part 2

July 1977

Contents

ISSN 0309-2720

CITY AND GUILDS OF LONDON
INSTITUTE EXAMINATIONS 1976

TELEPHONY B, 1976	33
TELEGRAPHY B, 1976	37
COMPUTERS B, 1976	41
LINE PLANT PRACTICE B, 1976	45

QUESTIONS AND ANSWERS

Answers are occasionally omitted or reference is made to earlier Supplements in which questions of substantially the same form, together with the answers, have been published. Some answers contain more detail than would be expected from candidates under examination conditions. For economic reasons, alternate issues of the Supplement are published in 32-page and 16-page sizes.

TELEPHONY B, 1976

Students were expected to answer any 6 questions

Q 1 (a) Draw a trunking diagram to show the routing of an STD call from a local automatic Strowger exchange as far as the first selector at the trunk exchange.

(b) Describe the principal functions of

- (i) the metering-over-junction relay-set,
- (ii) the register-access relay-set, and
- (iii) the register-translator.

A total of only 7 functions need be described.

A 1 See A6, Telephony B, 1973, Supplement, Vol. 67, p. 45, July 1974, and A2, Telephony B, 1974, Supplement, Vol. 68, p. 37, July 1975.

Q 2 For a Strowger PABX catering for about 40 extensions,

- (a) draw a trunking diagram,
- (b) describe the sequence of operations on a call dialled to the main exchange from an extension, and
- (c) describe the sequence of operations when an extension handset is lifted but dialling does not take place.

A 2 (a) The trunking diagram shows the main features of a PABX catering for up to 49 extensions.

(b) Access to the public exchange may be barred electrically to specified extensions; other extensions can obtain an exchange line by dialling 9. When the handset of an extension is lifted, the contacts of a line relay in the line circuit mark the calling extension on the line-finder banks, and send a signal to activate the common START circuit. The START circuit allocates a free line finder LF to find the calling extension. The extension line is switched through the line finder to the associated connecting circuit, which is a 2-motion selector. The connecting circuit sends back PABX dial tone.

Under the control of the caller's dial, the connecting circuit steps to level 9, where the vertical marking bank is arranged to transmit a signal via the START circuit to a free exchange-line circuit. The connecting circuit also extends a signal, via line finder LF, to mark the calling extension as having demanded an exchange line. Line finder EF, associated with the allocated exchange line, searches for this marking condition, and switches the extension line through to the exchange-line circuit. The connecting circuit is released, and line finder LF becomes available for use by other extensions.

The calling extension receives dial tone from the public exchange, and may proceed to dial into the public network.

(c) A calling extension is connected to a connecting circuit as described in part (b). If the caller then does not dial within a reasonable period of receiving dial tone, the connecting circuit must be forcibly released. Otherwise, the grade of service would deteriorate and congestion may occur.

The common equipment remains activated while a call is being set up, and produces a timing pulse every 30 s. If 2 successive pulses reach the connecting circuit before it is stepped, the second pulse forcibly releases the connecting circuit and its line finder. In the extension circuit, the line relay is forcibly released, but a cut-off relay remains held to the calling loop.

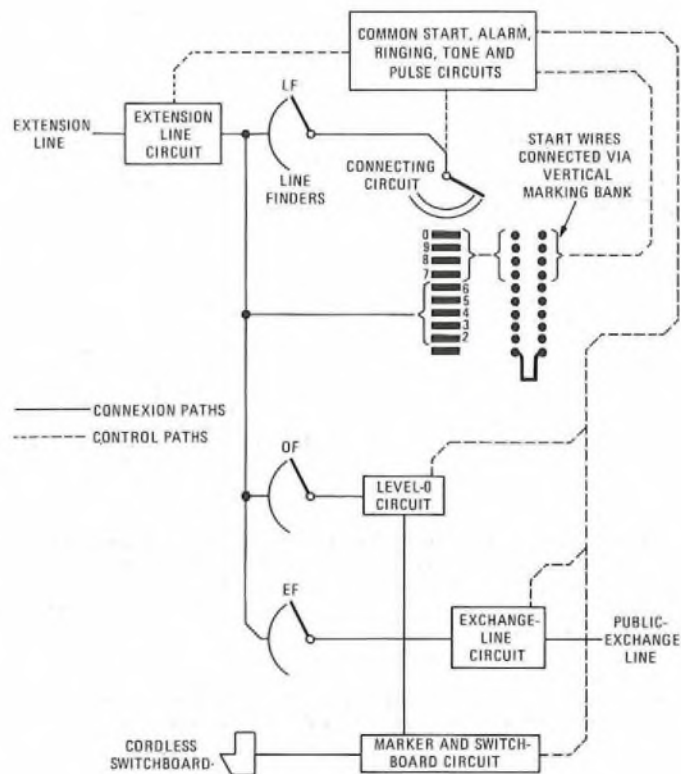

The extension line remains in this "parked" condition until the handset is replaced, and a "permanent-glow" alarm is given at the switchboard.

Q 3 (a) Design the best grading for subscribers' uniselectors having 48 trunks to first selectors. Assume a single home position.

(b) A group of 60 uniselectors originates a total busy-hour traffic of 11.5 erlangs. The system is arranged so that 80 residential lines, each originating 0.05 erlang in the busy hour, are served by 10 of these uniselectors. What is the average busy-hour traffic from each of the remaining uniselectors?

A 3 (a) For single-home-position uniselectors, the availability, A , is 24. The preferred number of grading groups, g , is given by

$$g = \frac{2N}{A}$$

where N is the number of trunks.

$$\therefore g = \frac{2 \times 48}{24} = 4.$$

For 4 grading groups, there are 3 methods of arranging the trunks: individually, in pairs, and as full commons. Let a , b and c respectively be the numbers of individual trunks, pairs and full commons in the availability. Then,

$$4a + 2b + c = 48, \dots (1)$$

$$\text{and } a + b + c = 24. \dots (2)$$

Subtracting equation (2) from equation (1) gives

$$3a + b = 24. \dots (3)$$

Since $b > 0$, the maximum value of a is 7. If $a = 1$, then $b = 24 - (3 \times 1) = 21$, and $c = 24 - (1 + 21) = 2$ (from equations (3) and (2)). The values of b and c for values of a between 2 and 7 can be similarly evaluated, and are given in the table. The sum of the successive differences, S_{SD} , of each arrangement is also given, where

$$S_{SD} = |a-b| + |b-c|.$$

a	1	2	3	4	5	6	7
b	21	18	15	12	9	6	3
c	2	4	6	8	10	12	14
S_{SD}	39	30	21	12	5	6	15

The arrangement that produces the lowest value of S_{SD} offers the smoothest progress from individual trunks to pairs, and from pairs to full commons. Thus, the best grading is 5 individual trunks, 9 pairs and 10 full commons. The grading is illustrated in the sketch.

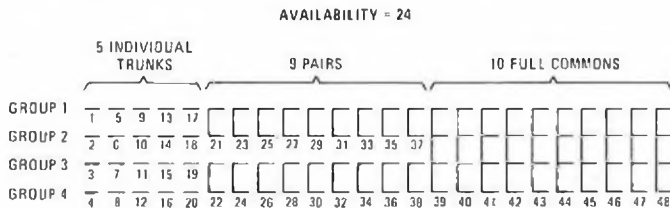

(b) The busy-hour traffic originated by the 80 residential lines is $80 \times 0.05 = 4$ erlangs, and this is carried by 10 uniselectors. The remaining 50 uniselectors therefore originate $11.5 - 4 = 7.5$ erlangs in the busy hour. Hence, the average busy-hour traffic from each of the remaining uniselectors is $7.5/50 = 0.15$ erlang.

Q 4 For a large non-director linked numbering scheme, the number ranges for the main exchange and 2 of its group-selector satellites are:

- main: 20 000-29 999,
- satellite A: 40 000-43 999,
- satellite B: 47 000-48 999.

(a) With the aid of trunking diagrams, describe the routing of

- (i) own-exchange calls within satellite A, and
- (ii) calls from one of the other satellites to satellites A and B, using the main exchange as a tandem switching centre.

(b) Under what circumstances would direct junctions between the various satellites be provided instead of the arrangement described in part (a) (ii)?

A 4 (a) The sketch shows a simplified trunking diagram illustrating the linked numbering scheme.

(i) Own-exchange calls within satellite A are routed via level 4 of first selectors, levels 1, 2, 3 or 0 of second selectors, third selectors and final selectors.

(ii) By including additional level-4 second selectors in the main exchange, other satellites (such as satellite C) can route their level-4

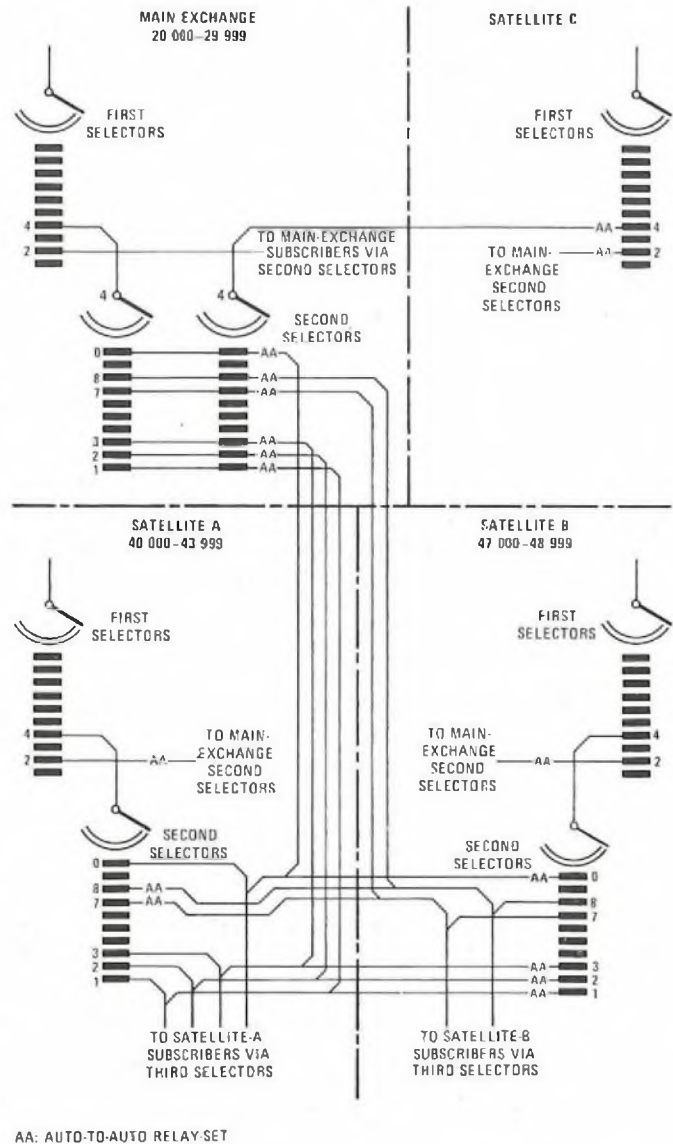

calls via the main exchange, which then acts as a tandem switching centre for calls from satellite C to satellites A and B.

This method could also be used for level-4 calls originated at satellites A and B, but would have the disadvantage that own-exchange calls would involve the use of relatively expensive junctions to and from the main exchange.

(b) In a linked numbering scheme where each exchange has a discrete initial digit, all exchanges can be directly linked by junctions trunked from first-selector levels. The unusual feature of the scheme described in this question is that satellites A and B share the same initial digit. This requires the junctions from satellite A to satellite B to be trunked from level-4 second selectors at satellite A to level-47 and level-48 third selectors at satellite B. Similarly, junctions from satellite B to satellite A are trunked from level-4 second selectors at satellite B to level-40, level-41, level-42 and level-43 third selectors at satellite A.

This offers the possibility of tandem switching at the main exchange for traffic from satellite C, if this exchange originates only a small amount of traffic to satellites A and B. Tandem routing reduces the total number of junction circuits by effectively combining 2 small junction groups into one larger group from satellite C to the main exchange. Similarly, the traffic originated by all the other satellites to satellites A and B is combined into one large group from the main exchange to each of satellites A and B.

However, tandem routing is less advantageous if the other satellites originate substantial volumes of traffic to satellites A and B, and direct routes may be justified. This is because the combination of 2 or more large groups of junctions does not raise the average occupancy of each junction to the same extent as when smaller groups are combined. The overall length of a tandem routing, compared with a direct route, is also an important consideration, favouring direct routes between neighbouring satellites.

Q 5 With the aid of sketches of the circuit elements of a final selector, explain

(a) the circuit operation from when the selector steps to the called line until the caller hears

- (i) ringing tone,
 - (ii) busy tone, and
 - (iii) number-unobtainable tone,
- and

(b) how a positive-battery metering pulse is applied to the P-wire when the called subscriber answers.

Q 6 (a) Draw battery-testing circuit elements for a uniselector-hunter in which the testing relay has

- (i) a single winding of low resistance, and
- (ii) one winding of low resistance and a second of much higher resistance.

(b) For each case, explain the importance of the low-resistance coil.
 (c) For case (a) (ii) above, briefly explain why an improved performance can be obtained by an arrangement that reverses the current in the high-resistance winding.

A 6 (a) (i) Sketch (a) shows a battery-testing circuit element in which the testing relay has a single winding of low resistance. This is known as a *marginal-operate* testing circuit. When 2 such relays in parallel test one P-wire, neither operates.

(ii) Sketch (b) shows a *marginal-hold* testing-circuit element, in which the testing relay has 2 windings: one of high resistance and one of low resistance. Two relays can test and operate in parallel, but neither holds.

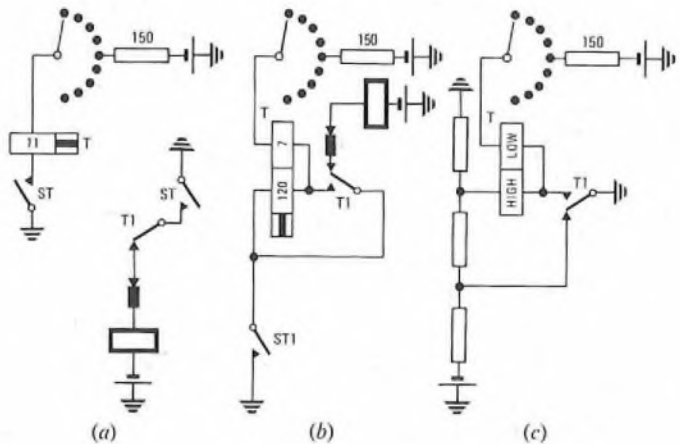

(b) In each of the above cases, a low-resistance winding is used so that an initial guarding condition is applied to the P-wire. The low-resistance guarding earth reduces the P-wire potential to about 6 V, which is insufficient to permit another testing relay to operate on the same outlet.

(c) Sketch (c) shows an improved 2-winding testing arrangement known as a *differential testing circuit*. Operation of the testing relay takes place in a way substantially similar to that in the circuit of sketch (b), as does the application of the initial guarding earth. The benefit of this circuit is derived from a reversal of current that occurs in the high-resistance winding when the relay operates.

In the situation where a single relay tests a P-wire, the reversed current, which opposes the holding current in the low-resistance winding, is insufficient to impair the holding function. However, when 2 relays test and operate in parallel, the currents in their low-resistance windings are approximately half the normal value. This lower value is virtually neutralized by the opposing current in the high-resistance winding. This improves the reliability of the safeguard against double-switching, compared with a circuit in which both relays are required to release.

Q 7 (a) State 6 important facilities provided by an assistance relay-set at a sleeve-control auto-manual switchboard.

(b) Sketch a simplified circuit of the relay-set, and briefly explain how each of the facilities is provided.

A 7 (a) Six basic facilities provided by the assistance relay-set at a sleeve-control auto-manual switchboard are to

- (i) return a holding-and-guarding earth on the P-wire,
- (ii) return ringing tone to the caller,
- (iii) provide a lamp calling-signal on the switchboard,
- (iv) extinguish the calling lamp and disconnect ringing tone when a plug is inserted in the jack,

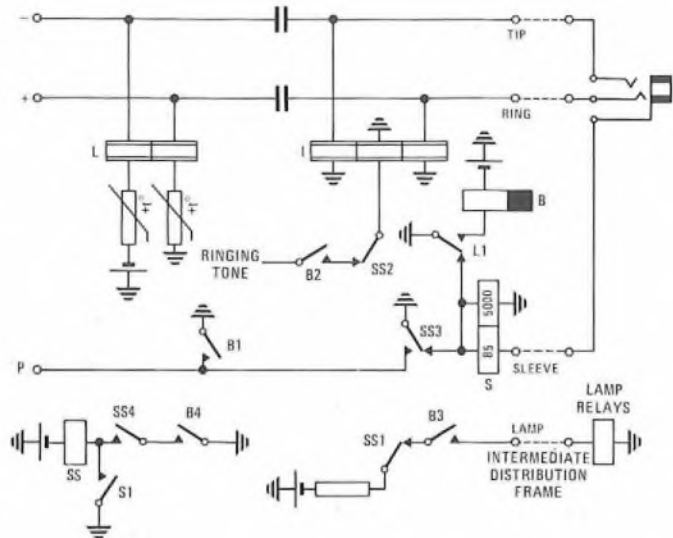

(v) apply supervisory signals to the answering cord circuit under the control of the caller's instrument, and

(vi) provide manual-hold facilities if the caller clears before the plug is removed from the jack.

(b) The sketch shows the simplified circuit of an assistance relay-set providing the above facilities. The circuit operation is described below.

(i) Relay L operates when the subscriber's loop is extended from the preceding group selector. Contact L1 operates relay B, and contact B1 returns the holding-and-guarding earth.

(ii) Contact B2 returns ringing tone to the caller via retarding coil I.

(iii) Contact B3 energizes the associated lamp relays, over the LAMP wire, to light the calling lamps on the switchboard.

(iv) A plug, inserted into the jack, applies battery potential to the SLEEVE wire, operating relay S. Contact S1 operates relay SS. Contact SS1 releases the lamp relays, contact SS2 disconnects ringing tone, and contact SS3 allows relay S to hold over both coils.

(v) The supervisory lamp in the sleeve circuit of the answering plug cannot light while the 2 coils of relay S are connected in series to earth. However, when the caller clears down, relay L releases, and contact L1 short-circuits the high-resistance coil of relay S. The supervisory lamp then glows, relay S remaining held over its 85 Ω coil.

(vi) While the plug remains in the jack, relay S is operated, holding relay SS. Contact SS3 maintains a holding earth on the P-wire, so that, if the caller clears down, the consequent release of relays L and B does not cause the preceding selectors to release. The connexion is held until the operator removes the plug from the jack.

Q 8 (a) Describe the sequence of operations involved in setting-up an own-exchange call at a TXK1 (crossbar) local exchange. Illustrate your answer with a block diagram of the equipment involved.

(b) How would your answer to part (a) be modified in the case of a call incoming from an adjacent Strowger exchange?

A 8 (a) The sketch shows a block diagram of the equipment involved in setting-up an own-exchange call in a TXK1 exchange.

When such a call is originated, a signal is passed from the line circuit to that distributor switch B (DSB) to which the line has direct access. Provided one inlet of that DSB is free, the switch extends the calling signal to the common line marker, where the caller's DSB outlet is identified. (Note that DSB inlets are connected to distributor switch A (DSA) outlets, and DSB outlets are connected to the line circuits.) Only one call at a time (either originating or terminating) can be handled by the line marker.

The line marker instructs the DSB to mark all of its free links to DSAs. Each DSA consequently marked is instructed in turn to mark its free local transmission relay-groups (LTRGs). When a free LTRG has found a free register (via the register allotter), a signal is returned from the relevant DSA to the line marker. The line marker switches the DSB inlet through the DSA to the LTRG, and the speech and control wires are extended to the register. The LTRG returns an earth on the P-wire to operate the DSB bridge magnet, thereby switching the call through the DSB. The P-wire earth also operates relay K (the guarding relay) in the subscriber's line circuit. The register returns dial tone to the caller. The DSB signals to the line marker, which releases the marked DSAs not subsequently used to establish the connexion. The DSA and DSB that were used to establish the connexion are now available for use by other callers.

(b) When the caller clears down, the holding loop is removed from the pulsing relay (relay A) in the final selector. The release of relay A allows relay B (the guarding relay) to release slowly, in turn releasing relay CD. A contact of relay B removes the holding earth from the P-wire, but a contact of relay CD reconnects a release-guarding earth shortly afterwards (a period of about 20–30 ms).

During the short period of disconnection of the earth from the P-wire, relays H in the group selectors, and relay K in the subscriber's unselector, release simultaneously. Contacts of relays H release relays CD in the group selectors. Contacts of relays CD re-apply individual release-guarding earths to the P-wires of each group selector, and energize the rotary-magnet stepping circuits to drive the wiper carriages out of the banks so that the selectors can restore to their normal positions. (In the final selector, energization of the rotary magnet is dependent on the release of relays B, H and E (relay E is the rotary pulse-control relay). In the unselector, the release of relay K causes the unselector to self-drive to its home position.

In the group and final selectors, the release-guarding earths applied by contacts of relay CD are maintained until the wiper carriages have completed their restoration, when off-normal contacts N release and

remove the release-guarding condition. All selectors are then available for further use.

(b) In the British Post Office, it is normal practice at public exchanges to give the caller (who pays for the call) full control over the release of the connexion, in the manner described in part (a). If it is required that a call should be released by either the calling or called telephones, according to which is cleared down first (as is done in some PABXs), then the circuit element shown in sketch (b) would be appropriate in the final selector.

If the caller clears down first, relay A releases, and a contact of relay A short-circuits relay B, which releases slowly (as in the conventional arrangement). If the called subscriber clears down first, the release of relay D (the called-party-answer relay) also applies a short-circuit to relay B, causing it to release slowly. Relay B would not release to a momentary disconnection of the called line caused, for instance, by flashing the receiver rest. A contact of relay F (the ring-trip relay) is included to ensure that any short-circuiting of relay B by contact D cannot be effected until the called subscriber has answered and tripped the ringing current.

TELEGRAPHY B, 1976

Students were expected to answer any 6 questions

Q 1 (a) What characteristics of an underground cable affect a square-wave d.c. telegraph signal? Sketch graphs to show their effect on

- (i) the current at the transmitter, and
- (ii) the voltage at the receiver.

(b) Sketch and describe a circuit arrangement that could be used to improve the response of a teleprinter receive magnet.

A 1 (a) A transmission line has 4 primary characteristics: resistance R ohms, capacitance C farads, inductance and leakage. For a modern cable, the inductance and leakage are small, and a d.c. teleprinter signal is significantly affected only by the resistance and capacitance of the line. These characteristics are normally distributed evenly along the line, and a length of line can thus be represented by the T-network shown in sketch (a), with the capacitance concentrated at the midpoint. When a voltage, V volts, is applied by the transmitter, the capacitor is initially uncharged and acts as a short-circuit; the transmitter current, I_T , has the initial value $V/(R/2)$ amperes. As the capacitor charges, the potential difference across it rises from zero to V volts; when the capacitor is fully charged, no current flows in the capacitor path. If a receiver, which normally has resistance (R_1) and inductance, is connected in the circuit, the current at the transmitter is as shown in sketch (b), with the initial value decreasing until the steady-state value $V/(R + R_1)$ amperes, is reached. The voltage at the receiver, V_R , rises exponentially, as shown in sketch (c).

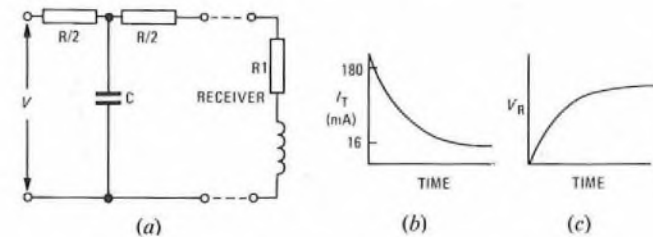

Typical values for a line are $R = 880 \Omega$, $C = 2 \mu F$, $R_1 = 4 \text{ k}\Omega$ and $V = 80 \text{ V}$. Hence, the initial transmitter current is $80/440 = 182 \text{ mA}$, and the steady-state value is $80/4880 \text{ A} = 16 \text{ mA}$.

(b) See A1, Telegraphy B, 1973, Supplement, Vol. 67, p. 47, July 1974.

Q 2 (a) For a teleprinter, draw a timing diagram to show

- (i) the ideal instants of selection for an incoming 50 baud $7\frac{1}{2}$ unit signal, and
- (ii) the effect of the functions of the receive mechanism.

(b) Describe the effect caused by the receiving teleprinter's motor running slightly slower than the transmitting machine's motor.

A 2 (a) (i) Sketch (a) shows the ideal instants of selection, A–E, for an incoming 50 baud $7\frac{1}{2}$ unit signal. The ideal instant of selection has zero duration, and is at the exact centre of each signal element,

giving a theoretical margin of 50%. This ideal can be closely approached by an electronic teleprinter.

(ii) A mechanical teleprinter requires a finite time to read the polarity of each element, and any change in the signal during the selection period is not recognized. The signal polarity must be registered before selection begins. The duration of the period depends on the design of the machine, the manufacturing tolerances and wear. As shown in sketch (b), the period is ideally centred on the theoretical instant, and lasts for 4 ms in a well-adjusted machine, giving a margin of 40%.

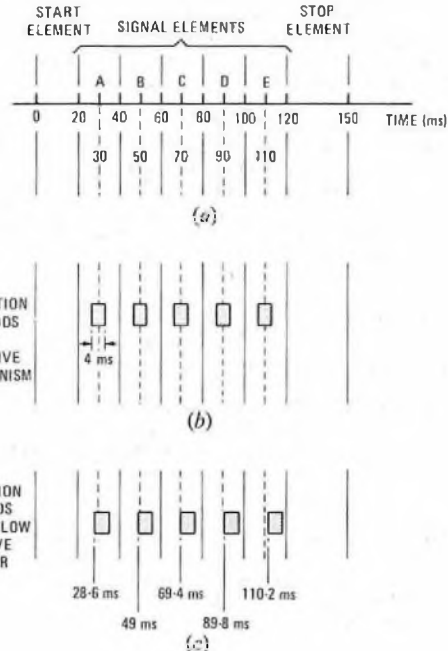

(b) If a receiving teleprinter's motor is running slightly slower (say, by 2%) than the transmitting machine's motor, the selection period for the fifth element suffers the greatest effect. Sketch (c) shows that this selection period, which normally starts at $108 + (108 \times 2/100) = 110.2 \text{ ms}$. This however does not adversely affect the fifth transition, which occurs at 100 ms, as the margin between this transition and the selection period is improved to 10.2 ms, compared with 8 ms for a motor running at the correct speed.

The fourth selection period would start at $88 + (88 \times 2/100) = 89.8 \text{ ms}$, and would continue for 4 ms to end at 93.8 ms. This gives a margin to the fifth transition of $100 - 93.8 = 6.2 \text{ ms}$.

Expressed as a percentage, the margin of the machine is therefore reduced to $(6.2/20) \times 100 = 31\%$. This compares with a margin of 40% for a machine running at the correct speed. A character with more than 31% distortion would probably be mutilated.

Q 3 A fault is reported by a Telex subscriber.

- (a) How should the fault be localized?
- (b) What records of the fault should be kept, and what are the reasons for keeping them?
- (c) If a maintenance officer visits the station and repairs the fault, what further routine tasks and tests should be performed before leaving the station?

A 3 (a) A Telex fault is normally reported by telephone to the local telephone operator or direct to a Telex testing officer. Emergency attention is given outside normal working hours.

The testing officer receiving the report may speak to the subscriber to help assess the likely location of the fault. Certain faults require a field maintenance officer to visit the installation; others may require the circuit to be tested using the engineering control board or a test final-selector.

The circuit may be monitored or intercepted towards the station or the exchange, to localize the fault by establishing whether the correct circuit conditions are present, and by checking the performance of the equipment. Line faults can be further localized by co-operation with testing officers at intermediate points. If the line and exchange equipment is satisfactory, a maintenance officer is sent to the subscriber's premises. (A test final-selector gives access to only the line, not to the exchange equipment.)

(b) For each fault reported, an entry is made in a report register, with a reference number allocated for checking purposes. An entry is also made on the subscriber's fault card to compile a complete fault history for the subscriber. For faults passed to testing officers in distant exchanges, reference numbers are obtained so that checks can be made on faults not cleared or requiring special attention. Similarly, reference numbers are used if a maintenance officer visits an installation.

Entries on a subscriber's fault card are scrutinized each time a report is made, and repetitive or long-duration faults are reported to the supervising engineer, who may decide that a special investigation is needed. The information on the card can also form a basis for judging complaints of poor service.

From the report register, statistics for fault categories, and faults carried over from one day to the next, are prepared. The statistics give management information on the quality of service, and assist in formulating service policies, and in assessing changes of policy.

At most stations, a meter records the number of hours for which the teleprinter has been in use. Reference to the reading, each time a fault is reported, gives a more accurate appreciation of the frequency of machine faults.

(c) Before a maintenance officer leaves a station, an inspection is made of the machine and control units to check the functions of the keys and lamps in originating and clearing a call. The state of lubrication and cleanliness of the machine is also checked. The machine is tested in local operation, and the margin and distortion determined by exchanging test messages with the exchange.

Q 4 For a subscriber's Telex installation,

- (a) draw a diagram to show the circuit locations of fuses,
- (b) explain the purposes of the fuses and state their approximate ratings,
- (c) explain why (i) ballast resistors and (ii) a circuit-breaker are used in place of fuses at certain points in the circuit, and
- (d) draw a sketch to show the construction, and explain the principle of operation, of either a ballast resistor or a circuit-breaker.

Q 5 Outline a suitable method for the transmission of telegraph signals over

- (a) the long-distance telephone network, and
 - (b) the local telephone network.
- Draw diagrams to illustrate each answer.

A 5 (a) See A3, Telegraphy B, 1975, Supplement, Vol. 69, p. 45, July 1976.

(b) The sketch illustrates the double-current earth-return method of transmitting telegraph signals over the local telephone network.

Positive and negative 80 V potentials are applied to the transmitter contacts via ballast resistors. Resistor R1 and capacitor C1 form a spark-quench circuit that prevents the back-e.m.f. from the inductive receive magnet from causing sparking at the transmitter, with the consequent fouling and pitting of the transmitter contacts. Resistor R2 limits oscillating currents in the filter, which can occur with a mismatched line; such currents cause excessive distortion of the signal. The low-pass filter, consisting of inductors L1 and L2 and capacitor C2, has a cut-off value of about 140 Hz, and is provided to attenuate the higher harmonics of the square-wave signal transmitted to line, thus reducing interference in adjacent telephone circuits in the same cable.

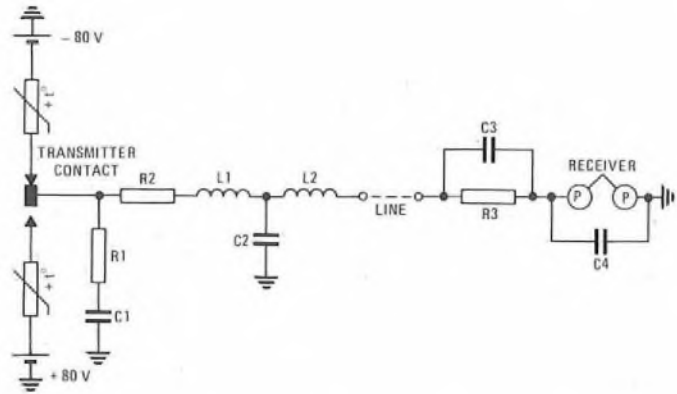

Resistor R3 is a high-value resistor, provided to improve the time constant of the receiver. The time constant is the time for the current in an inductive circuit to rise to about two-thirds of its final value, and is proportional to the inductance divided by the resistance. Thus, if the resistance is increased, the time constant is shorter, and the current in the receiver rises more rapidly. The receive relay therefore responds more quickly and the signalling speed is increased. This effect is enhanced by the use of a parallel capacitor (capacitor C3) which discharges through the receiver on each transition, passing an extra surge of current through the magnets. By suitable choice of resistor R3 (4 kΩ) and capacitor C3 (2 μF), the line signal can be restored virtually to a square wave. Capacitor C4 prevents inductive surges, caused by the movement of the receiver tongue, from being transmitted to line and causing interference.

Q 6 A character has been correctly received by a teleprinter.

- (a) Describe the cycle of operations of the printing mechanism.
- (b) How does the cycle of operations differ when a non-printing character is received?

A 6 The following description applies to the British Post Office Teleprinter No. 15.

The incoming signals are received on an electromagnet, the armature of which moves from side to side in response to the line polarity. The sketch shows the mechanism concerned with selecting and printing a character.

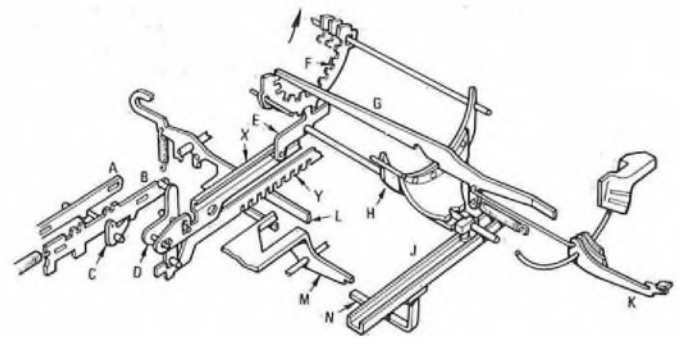

Note: Students would not be expected to include as much detail as is shown in the sketch given here.

The character is identified by 5 pairs of links A and B, the position of each pair depending on the polarity of each of the 5 received character elements. For a -80 V (mark) element, link B is held in the position shown in the sketch; for a +80 V (space) element, link B is released by detent C, which is turned in a clockwise direction by link A, so that link B moves in response to a restoring spring.

Link B operates bell-crank D, which has 2 functions: it moves code-slat X vertically upwards to select the required type, and moves comb-bar Y horizontally to the right to select a non-printing function (if appropriate).

Movement of code-slat X causes selector bell-crank E to move, controlling the counter-clockwise movement of type-basket sector F. Code-seeker bars (G), one for each primary and secondary printing character, are arranged across the sectors, but are held just clear of the sectors by printing-bail H. When all the element combinations have been marked by movement of the sectors, print-bail J moves to carry printing-bail H to the left, allowing the code-seeker bars to fall

on the sectors. Only one code-seeker bar falls into a path across the sector slots and engages with bail H, which continues to move to the left. The selected bar thus moves to the left and swings type-face K upwards to print the character.

The horizontal movement of comb-bars Y positions the slots such that, if a non-printing character is received, a function-control lever (L) moves into a path across the slots. Movement of any of the function-control levers moves the front extension of the print-suppression lever (M) into the path of extension N of print-bail J. This prevents any movement of print-bail J, so preventing the action of the printing mechanism.

- Q 7 (a) Draw a sketch to show the layout of the main items of equipment in an automatic Telex exchange.
 (b) Show on the sketch typical interconnecting cables.
 (c) Explain how the floor loading is determined for one rack of equipment.

A 7 (a) and (b) Sketch (a) shows a typical layout of equipment in an automatic Telex exchange, with interconnecting cables.

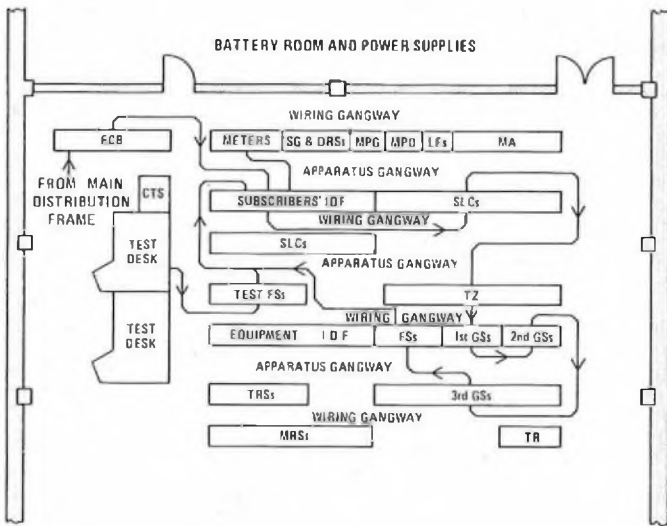

Note: Connexions not shown to equipment IDF between each switching stage, and to miscellaneous/common apparatus and trunk relay-sets

- CTS: Cable-turning section
- DRSS: Distribution relay-sets
- ECB: Engineering control board
- FSS: Final selectors
- GSs: Group selectors
- IDF: Intermediate distribution frame
- LFs: Line filters
- MA: Miscellaneous apparatus
- MPD: Meter-pulse distribution
- MPG: Meter-pulse generator
- MRSs: Miscellaneous relay-sets
- SG: Signal generator
- SLCs: Subscribers' line circuits
- TR: Traffic recorder
- TRSs: Trunk relay-sets
- TZ: Time-zone equipment

(a)

(c) The method of determining floor loading is illustrated in sketch (b), which shows group-selector racks. The floor-loading calculation for one rack takes into account the weight of the rack (which is a downward force of 7.3 kN for a group-selector rack), the floor area occupied by the rack, and half the floor area of the adjacent apparatus and wiring gangways. End gangways are ignored.

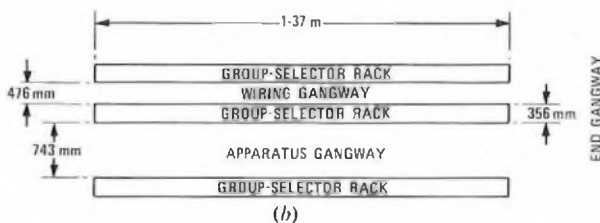

The floor loading (in pascals)

$$= \frac{\text{weight of rack}}{\text{floor area of rack} + (\text{floor area of adjacent gangways})/2}$$

$$= \frac{7.3 \times 10^3}{1.37 \times 356 \times 10^{-3} + \frac{1.37 \times (476 + 743) \times 10^{-3}}{2}} \text{ Pa,}$$

$$= 5.52 \text{ kPa, (which is within the permitted loading of } 8.6 \text{ kPa).}$$

Q 8 (a) Describe and explain the structure of the International Telegraph Alphabet No. 2.

(b) Sketch and describe a short section of perforated paper tape suitable for use with a tape-reader on a Telex circuit.

(c) Describe briefly the action of a machine used by an operator to prepare a perforated tape.

A 8 (a) The International Telegraph Alphabet No. 2 is a teleprinter code in which each character is represented by a combination of 5 sequential signal elements of equal duration. Each of the signal elements takes one of 2 binary states, so that the number of possible combinations is $2^5 = 32$. This is insufficient to accommodate the alphabet, the numerals and the punctuation marks. To overcome this difficulty, each combination is assigned 2 characters, with *letter-shift* and *figure-shift* characters selecting which of the alternatives is to be printed by the teleprinter. Certain functional characters, such as *carriage return*, *line feed*, and *word space* are common to both cases. The *letter-shift* character is arranged to have 5 *mark* (or negative) elements, so that it can be used as an erasing signal when preparing paper tape, since the tape is perforated only for *mark* elements.

A section of the International Alphabet No. 2 is shown below. The conventions used for the binary conditions of each element are:

mark : space,

negative polarity : positive polarity (British Post Office),

stop : start (element polarity),

Z : A

Combination No.	Letters Case	Figures Case	Code Elements				
			1	2	3	4	5
1	A	-	Z	Z	A	A	A
2	B	?	Z	A	A	Z	Z
3	C	:	A	Z	Z	Z	A
4	D	Who are you?	Z	A	A	Z	A
5	E	3	Z	A	A	A	A
24	X	/	Z	A	Z	Z	Z
25	Y	6	Z	A	Z	A	Z
26	Z	+	Z	A	A	A	Z
27	Carriage return		A	A	A	Z	A
28	Line feed		A	Z	A	A	A
29	Letters shift		Z	Z	Z	Z	Z
30	Figures shift		Z	Z	A	Z	Z
31	Space		A	A	Z	A	A
32	Not used		A	A	A	A	A

(b) See A6, Telegraphy B, 1974, Supplement, Vol. 68, p. 35, July 1975.

(c) A machine used for the preparation of punched tape is called a *perforator*, and consists of a mains-operated driving motor, a keyboard assembly, a control unit, a perforator assembly and a tape-roll holder.

Sketch (a) illustrates the arrangements for encoding the required character and starting the perforation process. The depression of one of the keys moves appropriate combination bars for the character required; bars associated with *space* elements move to the left, and those associated with *mark* elements remain stationary. The key also moves the trip bar to the left to set in motion the perforating mechanism. (Sketch (a) shows character R being selected.)

The control-unit release mechanism is operated by trip lever B, so that a clutch engages a continuously revolving driving gear to drive a control cam shaft, which rotates half of a revolution each time a key is depressed. This cam shaft operates the locking frame to lock the combination bars against the premature operation of a second key, and operates a perforating bar. The perforating bar releases a second clutch, and a perforating cam shaft rotates half of a revolution.

Sketch (b) shows the punching mechanism. The combination bars control 5 selector bars (A), each of which is either withdrawn from between the anvil and one of the 5 punches (for a *space* element) or

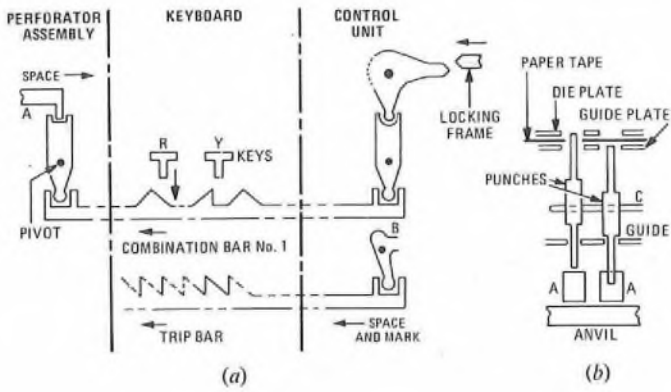

remains stationary (*mark* element). In sketch (b), the left-hand selector bar is shown positioned for a *mark* element, and the right-hand selector bar for a *space* element.

The paper tape is held between the die plate and guide plate of a punch block. During the movement of the perforating cam shaft, the punch block and tape are moved downwards over the punches. The punches set for *space* elements are free to move downwards under the tape. However, the punches set for *mark* elements are prevented from moving by the selector bars, which rest on the anvil, and these punches perforate the tape. After perforating, the punches are all restored to a normal position by the action of a withdrawing bracket (C). The paper tape is supplied with feed holes and, late in the restoring movement of the punch block, a toothed wheel rotates to feed the tape forward by one feed hole, a distance of 2.54 mm. The next character is then punched.

that the mercury wets the faces of the reed by capillary action. The capsule is filled with hydrogen at high pressure, and sealed. An operating coil surrounds the capsule. The complete relay is enclosed in a metal can.

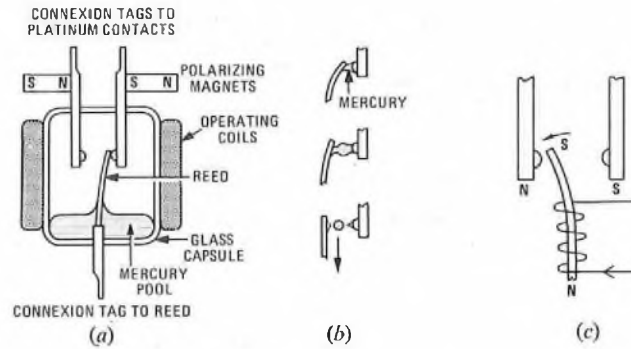

When the reed touches one of the contacts, electrical connexion is established by a bridge of mercury; the liquid is confined to the contact dome because the area of the pole-piece surrounding the contact is oxidized before assembly. When the contact begins to open, the mercury stretches to a thin neck (as shown in sketch (b)), which rapidly breaks as the mercury changes to a spherical shape under surface tension; the sphere finally drops into the pool of mercury. The break action is fast, preventing heavy sparking. Any spark that does occur causes the mercury to vapourize, and the vapour condenses on the sides of the capsule and returns to the mercury pool.

The action of the relay is illustrated in sketch (c). The energization of the operating coil in the direction shown causes the formation of north (N) and south (S) poles in the reed. The free end of the reed moves in the direction shown in accordance with the law that unlike poles attract and like poles repel.

(b) In this type of relay, there is no contact wear and, consequently, the contact faces require no maintenance. The contact area is larger than for dry-contact relays because of the small pool of mercury surrounding the contact. The contacts are very reliable, and the life of the relay is in excess of 10^9 operations. The relay is small and can be mounted directly on a printed-circuit board if desired. Failure of the relay entails complete replacement, which can be done quickly and easily. The relay is light, and can be operated at speeds up to about 300 bauds.

The relay has several disadvantages, the main one being that it must be mounted within 30° of vertical. Any deviation from this causes the mercury to short-circuit the contacts or cease to wet the reed. If the relay is stored for some time, the contacts may become bridged by mercury and, before use, the relay should be vibrated, or operated electrically with no load, to shake the mercury into the pool. If the relay were operated with voltage applied to the contacts and a mercury bridge across them, oxide would form and insulate the contacts. The relay is not as sensitive as a conventional telegraph relay: it requires a larger magnetomotive force.

- Q 9** Draw circuit diagrams to show
- the interconnexion of 2 teleprinters using double-current signals and having local records,
 - the connexion of several teleprinters to form a broadcast network, and
 - the connexion of several teleprinters to form a conference network.

A 9 (a) The sketch shows the interconnexion of 2 teleprinters having local records, using double-current signals.

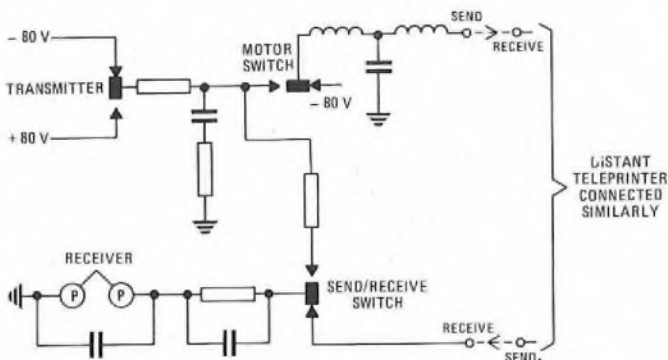

(b) and (c) See A4, Telegraphy B, 1974, Supplement, Vol. 68, p. 34, July 1975.

- Q 10** (a) Draw a sketch, and describe the operation, of a telegraph relay with mercury-wetted contacts.
- What are the advantages and disadvantages of this type of relay, compared with a dry-contact telegraph relay?
 - A telegraph relay in correct adjustment is used to repeat signals at the distant end of a physical circuit. Sketch typical waveforms to show the effect of the relay on the signals.
 - What is the effect on the signals if the relay introduces bias distortion?

A 10 (a) Sketch (a) shows the construction of a mercury-wetted relay. A nickel-iron reed, with one end immersed in a pool of mercury, is encapsulated in glass with 2 polarized platinum contacts. The faces of the reed are granular, grooved and plated with nickel, so

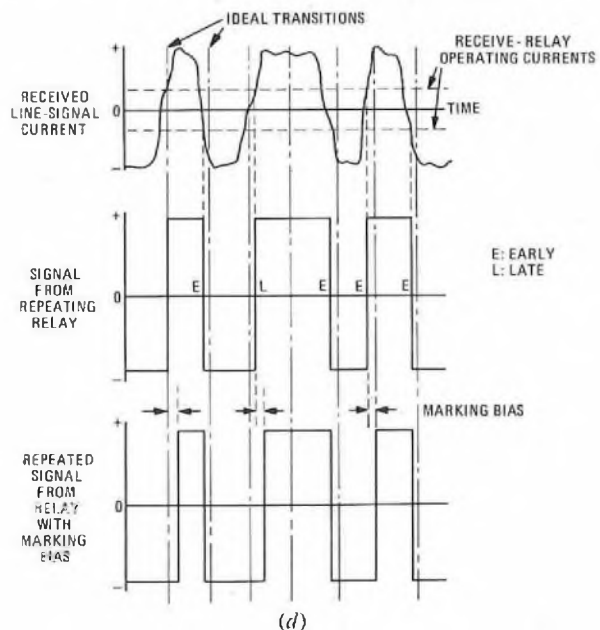

CORRECTION

TELEGRAPHY B, 1975 (Supplement, Vol. 69, July 1976)

A 7 (a) (ii) In the first line of the second paragraph, "transit" should read "intercontinental". In the eighth line, "transit" should read "keyboard".

COMPUTERS B, 1976

Students were expected to answer any 6 questions

Q 1 (a) With the aid of a circuit diagram, explain the operation of a bistable element having a stepping input and direct-setting inputs (a clocked bistable element).

(b) Using the logic symbol for the bistable element drawn for part (a), draw a logic diagram of a binary counter that will count from binary 0 to 9 and restore to 0 again. Use a timing diagram to explain the operation of the counter.

A 1 (a) The logic circuit of a bistable element having a stepping input (labelled CLOCK) and direct-setting inputs (labelled CLEAR and PRESET) is shown in sketch (a). The pulse-forming circuit is a resistive-capacitive network that produces a narrow voltage spike at the leading and trailing edges of the clock pulses. In the following description, it is assumed that the CLEAR and PRESET inputs are at logic 0, output Q is initially at logic 1, and output \bar{Q} is initially at logic 0. Positive logic is assumed, so that a positive-going transition represents a logic 1 pulse.

Initially, gate G1 is enabled by output Q, and gate G3 is inhibited by output \bar{Q} . The next positive-going transition from the CLOCK input is therefore transmitted through gate G1 to the input of gate G2, thus setting output Q to logic 0. The output of gate G3 remains at logic 0. All inputs to gate G4 are thus at logic 0, so that output \bar{Q} is changed to logic 1. The bistable element thus changes state.

When the input pulse ceases, the outputs of gates G1 and G3 are at logic 0, and the element is held in its new state by output Q applied to gate G2. The feedback conditions are such that gate G1 is inhibited and gate G3 is enabled.

The next positive-going transition from the CLOCK input is transmitted through gate G3 to the input of gate G4, thus setting output \bar{Q} to logic 0. All inputs to gate G2 are thus at logic 0, and output Q changes to logic 1. The element thus again changes state.

The element therefore changes state at half the frequency of the clock, and can be used as the basic unit of a binary counter.

If, at a point just after the cessation of an input pulse, the PRESET input is set to logic 0 and the CLEAR input to logic 1, the CLEAR input sets output Q to logic 0. All inputs to gate G4 are at logic 0, and output \bar{Q} is set to logic 1. Similarly, if the PRESET input is set to logic 1 and the CLEAR input to logic 0, output \bar{Q} is set to logic 0 and output Q to logic 1.

(b) The logic diagram of a binary counter that will count from 0 to 9 and restore to 0 again is shown in sketch (b). The counter is constructed from 4 bistable elements of the type described in part (a), although the PRESET inputs are not used. For each stage, output \bar{Q} is used as the stepping input to the subsequent bistable element. A timing chart for the counter is shown in sketch (c).

Before the first positive-going transition from the CLOCK input, all the bistable elements are cleared; that is, all the outputs Q are set to logic 0. When the first positive-going transition occurs, bistable element B1 is set; that is, output Q_0 becomes logic 1. On the second positive-going edge, output Q_0 reverts to logic 0, and output \bar{Q}_0 becomes logic 1. The positive-going edge of \bar{Q}_0 sets output Q_1 to logic 1. The timing chart illustrates how this process carries through the counter. Outputs Q_0, Q_1, Q_2 and Q_3 give a binary count of the number of positive-going clock-pulse transitions received, with output Q_0 being the least significant digit.

On the tenth positive-going clock-pulse transition, the counter sets itself to 1010, but this state is held only momentarily because the

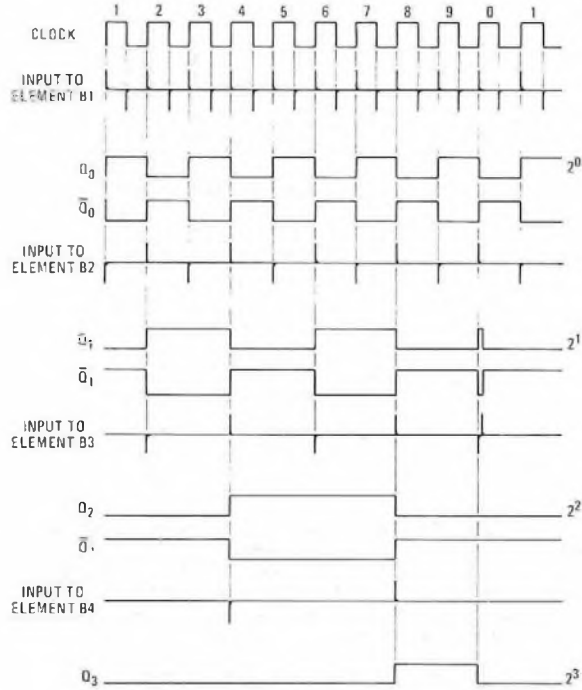
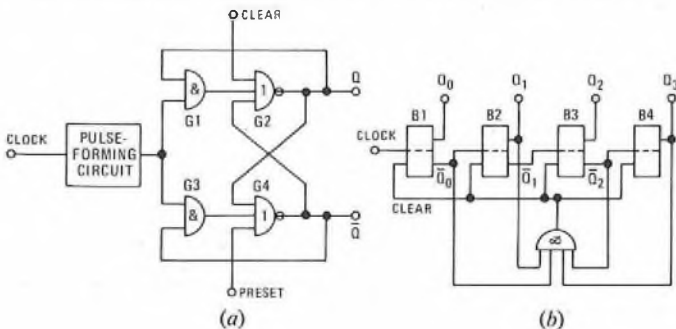

Note: The stepping inputs to each stage are fed via pulse-forming circuits, giving the transitions shown

(c)

AND gate detects the condition and applies a short pulse to the CLEAR inputs. All the outputs Q are thus reset to logic 0.

(In practice, it is necessary to arrange for the AND gate also to trigger a timing circuit that disconnects output \bar{Q}_1 for a brief period. This prevents the positive-going transition, produced as bistable element B2 restores from its momentary operation, from interfering with the reset condition of bistable element B3.)

Q 2 (a) Carry out the following conversions, showing all working:

- (i) denary 237.718 75 to binary and octal notations, and
- (ii) binary 101 110.101 110 1 to denary and octal notations.

(b) Express binary 1 101 100 111 100 111.010 110 10 in hexadecimal form.

A 2 (a) (i) To convert the denary number 237.718 75 to binary form, the integral and fractional parts are considered separately. The integral part is repeatedly divided by 2, the remainders being noted in reverse order, and the fractional part is repeatedly multiplied by 2, the resulting integers being noted in their correct order.

Integral Part		Fractional Part	
Quotient	Remainder	Result	Product
237 ÷ 2			
118	1	1	0.718 75 × 2
59	0	0	0.437 50
29	1	1	0.875 00
14	1	1	0.750 00
7	0	1	0.500 00
3	1	1	0.000 00
1	1		
0	1		

$\therefore 237 \cdot 718 \ 75_{10} = 11 \ 101 \ 101 \cdot 101 \ 11_2$

Since $8 = 2^3$, each 3 bit binary group can be converted to an octal digit by writing its denary value.

$\therefore 011 \ 101 \ 101 \cdot 101 \ 110_2 = 355 \cdot 56_8$

(ii) To convert the binary number $101 \ 110 \cdot 101 \ 110 \ 1$ into denary form, each binary digit is multiplied by its weight, and the results are added together.

Binary Digit	Weight	Result
1	$2^5 = 32$	32
0	$2^4 = 16$	0
1	$2^3 = 8$	8
1	$2^2 = 4$	4
1	$2^1 = 2$	2
0	$2^0 = 1$	0
1	$2^{-1} = 0 \cdot 500 \ 000 \ 0$	0 \cdot 5
0	$2^{-2} = 0 \cdot 250 \ 000 \ 0$	0
1	$2^{-3} = 0 \cdot 125 \ 000 \ 0$	0 \cdot 125
1	$2^{-4} = 0 \cdot 062 \ 500 \ 0$	0 \cdot 062 \ 5
1	$2^{-5} = 0 \cdot 031 \ 250 \ 0$	0 \cdot 031 \ 25
0	$2^{-6} = 0 \cdot 015 \ 625 \ 0$	0
1	$2^{-7} = 0 \cdot 007 \ 812 \ 5$	0 \cdot 007 \ 812 \ 5
Total:		46 \cdot 726 \ 562 \ 5

$\therefore 101 \ 110 \cdot 101 \ 110 \ 1_2 = 46 \cdot 726 \ 562 \ 5_{10}$

Converting each 3 bit binary group into its denary value gives

$101 \ 110 \cdot 101 \ 110 \ 100_2 = 56 \cdot 564_{10}$

(b) A hexadecimal number has a radix of 16. The 10 decimal digits 0-9 are used, together with 6 more digits: usually A, B, C, D, E and F, which represent 10, 11, 12, 13, 14 and 15 respectively as single characters. Since $16 = 2^4$, each 4 bit binary group can be converted to a hexadecimal digit by writing its denary value (or the code letter representing the denary value, if appropriate).

$\therefore 1101 \ 1001 \ 1110 \ 0111 \cdot 0101 \ 1010_2 = D9E7 \cdot 5A_{16}$

Q 3 (a) Draw a block diagram of the logic circuit needed to perform binary division by hardware, and explain its operation.

(b) Verify the diagram by illustrating how the logic performs $110 \ 000 \div 110$.

A 3 (a) The hardware needed to perform binary division, using a parallel-restoring technique, is shown in the sketch. At the start of the process, the divisor is stored in register B and the double-length dividend is stored in the accumulator (most significant bits) and register Q (least significant bits).

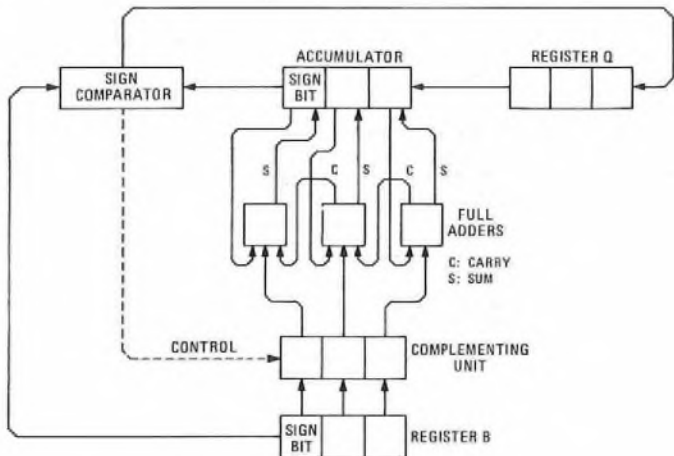

At each stage of the process, the contents of register B are subtracted from the contents of the accumulator, and the result is placed in the accumulator. The complementing unit is used to obtain the

negative value of the contents of register B, and the full adders are used to perform the subtraction by adding the negative values to the contents of the accumulator. If the sign bit in the accumulator is the same as the sign bit in register B, the sign comparator is set to logic 1. If the sign bits are different, the contents of the accumulator are restored by adding the contents of register B (the complementing unit being switched off), and the sign comparator is set to logic 0.

After either of the above operations, the entire contents of the accumulator, register Q and sign comparator are shifted one place to the left. The most significant bit of register Q is transferred to the least-significant-bit position of the accumulator, and the contents of the sign comparator are placed in the least-significant-bit position of register Q. The number of times the operation is performed is one greater than the number of bits in register B.

At the end of the process, the quotient is stored in register Q, and the remainder in the accumulator.

(b) To obtain the result of $110 \ 000_2 \div 110_2$, it is necessary first to add the relevant sign bits, and then hold the resulting numbers in registers of sufficient length to perform the calculation. For this particular calculation, all registers must hold 4 bit, and the calculation becomes $0011 \ 0000_2 \div 0110_2$ (or $48_{10} \div 6_{10} = 8_{10}$).

Using the technique described in part (a), the sequence of operations is as shown in the chart.

Operation	Accumulator	Register Q	Sign Comparator	Register B
First Stage	0011			0110
Subtract (B)	<u>0110</u>			
(Sign bits different)	1101			
Restore (A)	0011		0	
Shift left	0110	0000		
Second Stage				
Subtract (B)	<u>0110</u>			
(Sign bits identical)	0000		1	
Shift left	0000	0001		
Third Stage				
Subtract (B)	<u>0110</u>			
(Sign bits different)	1010			
Restore (A)	0000		0	
Shift left	0000	0010		
Fourth Stage				
Subtract (B)	<u>0110</u>			
(Sign bits different)	1010			
Restore (A)	0000		0	
Shift left	0000	0100		
Fifth Stage				
Subtract (B)	<u>0110</u>			
(Sign bits different)	1010			
Restore (A)	0000		0	
Shift left	0000	1000		

(A): Contents of accumulator
(B): Contents of register B

Hence, the quotient (register Q) is $1000_2 = 8_{10}$, and the remainder (accumulator) is $0000_2 = 0_{10}$.

Q 4 (a) Draw the truth table for a binary full adder.

(b) From the truth table, produce Boolean expressions for the sum and carry, and minimize these expressions.

(c) Draw a logic diagram of a binary full adder, using AND, OR, NOT and EQUIVALENCE logic elements.

A 4 (a) A binary full adder is a device which adds 2 binary numbers, A and B, one digit at a time, together with the carry digit, C, from the previous stage of addition. Its output consists of sum and carry digits. The truth table for a binary full adder is shown in the table.

Inputs			Outputs	
A	B	C	SUM	CARRY
0	0	0	0	0
0	0	1	1	0
0	1	0	1	0
0	1	1	0	1
1	0	0	1	0
1	0	1	0	1
1	1	0	0	1
1	1	1	1	1

(b) From the truth table, a Boolean expression for the sum is

$$\text{SUM} = \bar{A} \cdot \bar{B} \cdot C + \bar{A} \cdot B \cdot \bar{C} + A \cdot \bar{B} \cdot \bar{C} + A \cdot B \cdot C.$$

Minimizing the expression gives

$$\text{SUM} = A \cdot (\bar{B} \cdot \bar{C} + B \cdot C) + \bar{A} \cdot (\bar{B} \cdot C + B \cdot \bar{C}).$$

The element $(\bar{B} \cdot \bar{C} + B \cdot C)$ is called an EQUIVALENCE element; the output is logic 1 only when the inputs are identical. It is given the symbol $(B \equiv C)$. The element $(\bar{B} \cdot C + B \cdot \bar{C})$ is called an EXCLUSIVE OR element; the output is logic 1 when one, and only one, of the inputs is at logic 1. It is the inverse of the EQUIVALENCE function, and is given the symbol $(B \neq C)$.

$$\therefore \text{SUM} = A \cdot (B \equiv C) + \bar{A} \cdot (B \neq C).$$

A Boolean expression for the carry is

$$\text{CARRY} = \bar{A} \cdot B \cdot C + A \cdot \bar{B} \cdot C + A \cdot B \cdot \bar{C} + A \cdot B \cdot C.$$

Minimizing the expression gives

$$\begin{aligned} \text{CARRY} &= B \cdot C(\bar{A} + A) + A \cdot (\bar{B} \cdot C + B \cdot \bar{C}), \\ &= B \cdot C + A \cdot (B \neq C). \end{aligned}$$

(c) A logic diagram of a binary full adder, using AND, OR, NOT and EQUIVALENCE logic elements, is shown in the sketch.

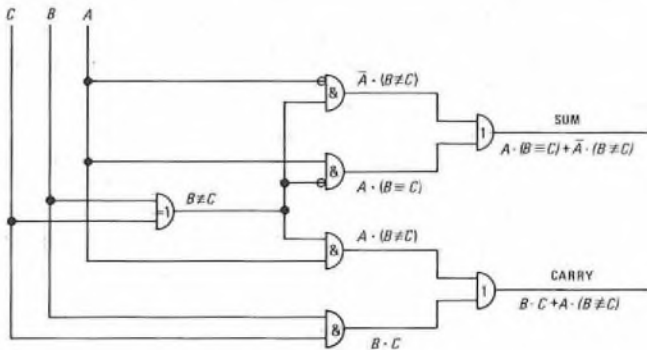

Q 5 (a) Draw the circuit diagram, and explain the operation, of a simple NOT logic element having a speed-up capacitor.

(b) Sketch the graph of the gate in part (a), and use it to explain how the speed-up capacitor improves the switching speed of the gate.

A 5 (a) The circuit diagram of a simple NOT logic element having a speed-up capacitor is shown in sketch (a).

When zero potential (defined as the high level) is applied to the base of the transistor via base resistor R1, the base current is zero and the transistor is in the off state. The collector current consists of only the leakage current, and is therefore small. Thus, the potential difference across collector resistor R2 is also small, and the output potential is almost $-V_{CC}$ volts.

When $-V_{CC}$ volts (defined as low level) is applied to the base of the transistor, the base current is sufficient to switch on the transistor. The potential difference between the collector and emitter is almost zero, and the output potential is virtually zero (that is, the output is high level).

If the low level is defined as logic state 1 and the high level as logic 0 (that is, assuming the negative-logic convention), the operation of the gate is given by the following truth table.

Input	Output
0	1
1	0

The circuit is, therefore, a NOT logic element.

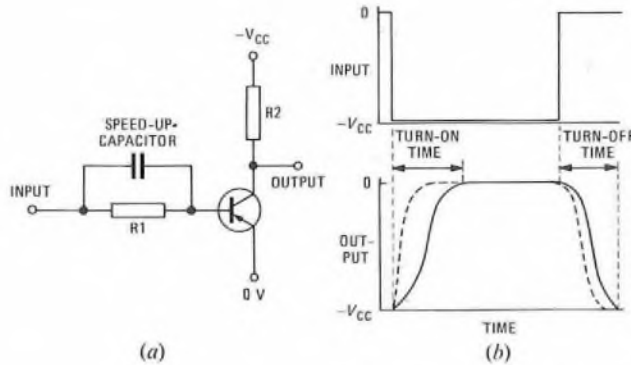

(b) As illustrated in sketch (b), the transistor takes a finite time to switch on when an input potential is applied to the base. This is called the turn-on time, and it can be reduced by overdriving the transistor. Overdriving is achieved by applying a base current in excess of that required to drive the transistor into saturation; the collector current thus aims to reach a higher final value than that required, but in the same turn-on time. When the collector current reaches its saturation value, it ceases to rise. Thus, the turn-on time is reduced.

The overdriving current has the disadvantage that it forms an excess stored charge in the base of the transistor, and this charge has to be removed when the transistor is switched off. This tends to increase the turn-off time.

A speed-up capacitor improves the switching speed of the gate without increasing the turn-off time. When the input potential is applied to turn on the transistor, the capacitor draws a large charging current. This current, added to the current through resistor R1, overdrives the transistor and reduces the turn-on time, as shown by the dashed line in sketch (b). The charging current reduces exponentially as the capacitor charges, and the base current eventually becomes equal to that required to saturate the transistor.

When the transistor is turned off, the speed-up capacitor rapidly discharges, taking its discharge current from the base. This removes the excess stored charge from the base and, thus, the overall turn-off time may be reduced, again as indicated by the dashed line.

Q 6 (a) Explain the function of a sequence-control register.

(b) With the aid of a block diagram of the register structure of a typical digital computer, explain the sequence of operations for the extraction and execution of a relative jump forward.

(c) How does the sequence of a relative-jump instruction vary from that of an indirect-jump instruction?

A 6 See A5, Computers B, 1969, Supplement, Vol. 63, p. 32, July 1970, and A6, Computers B, 1972, Supplement, Vol. 66, p. 65, Oct. 1973.

Q 7 (a) Why are mnemonic codes used for writing assembly-level programs?

(b) Explain some of the typical restrictions imposed on the assignment of mnemonic codes.

(c) Devise a mnemonic code and, with a comprehensive key, explain in detail its functions. Use the code to write a program that uses address modification to input 100 characters from a paper-tape reader and store them in 100 successive store locations in a data area called LIST.

A 7 (a) Mnemonic codes simplify the writing of assembly-level programs by allowing characters to be assigned to machine-code instructions and addresses. Thus, each instruction and address has a recognizable identifier that can be used in programs in place of the binary machine code. The mnemonic code is usually a set of abbreviations, designed to be readily interpreted.

(b) The number of characters in each mnemonic is often restricted, so that the abbreviation is necessarily concise. It is not normally permissible for the first character of a mnemonic to be a numeral.

(c) Table 1 shows a mnemonic code of the type used for a simple computer having one accumulator and the ability to handle only single-address instructions.

Table 1

Mnemonic	Meaning
LOAD A	Load the content of store location A into the accumulator
STOR A	Store the content of the accumulator in store location A
ADD A	Add the content of store location A to that of the accumulator, and store the result in the accumulator
SUB A	Subtract the content of store location A from that of the accumulator, and store the result in the accumulator
JUMP A	Execute next the instruction at address A
JEQ A	Execute next the instruction at address A if the content of the accumulator is zero
READ	Read one character from a paper tape
STOP	End of program

Table 2 gives the required program, using the mnemonic code described above.

Table 2

Address	Instruction	Comments
	-	Store location COUNT is initially set to 100
	-	Store location ONE is initially set to 1
L1	READ	Reads character from paper tape
L2	STOR LIST	Stores character in data area LIST
	LOAD COUNT	Loads counter into accumulator
	SUB ONE	Subtracts 1 from counter
	JEQ L3	If counter is zero, program finishes
	STOR COUNT	Returns counter to store
	LOAD L2	Loads instruction L2 into accumulator
	ADD ONE	Modifies address in instruction
	STOR L2	Returns instruction L2 to store
	JUMP L1	Jumps unconditionally to start
L3	STOP	Program finishes

Q 8 (a) With the aid of a timing diagram, explain how the binary word 010 111 001 is stored in a disc backing store, using the following methods of recording:

- (i) non-return-to-zero, and
- (ii) return-to-zero.

(b) Explain what is meant by the following terms, used in connexion with disc storage:

- (i) sector (block),
- (ii) packing density, and
- (iii) drop-out.

A 8 (a) Sketch (a) is a timing diagram, illustrating how the binary word 010 111 001 is stored on a disc backing store.

(i) In the non-return-to-zero system, the magnetic recording surface is always magnetized in one of 2 directions. The direction of magnetization is changed only when the information is changed from logic state 1 to logic state 0, or vice-versa.

(ii) In the return-to-zero system, each binary digit is represented on the recording surface by one of 2 directions of magnetization, corresponding to logic states 1 and 0. The surface between digits is not magnetized.

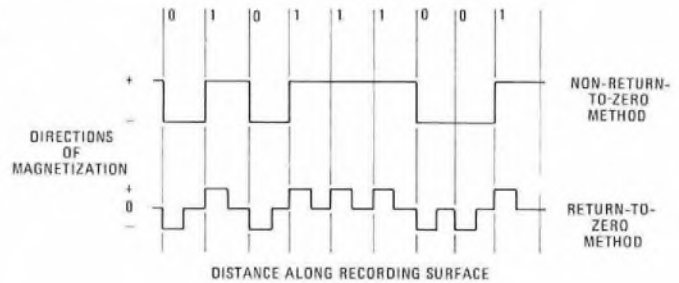

(a)

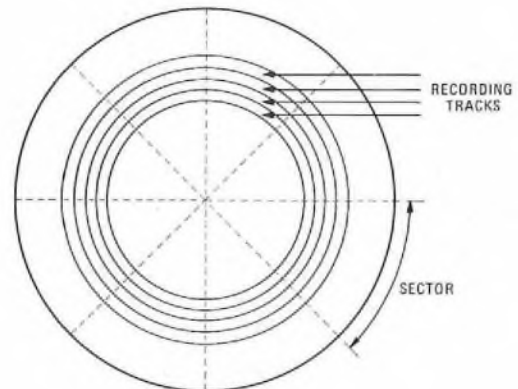

(b)

(b) Sketch (b) is a plan view of a magnetic disc.

(i) Information is stored on a number of concentric tracks, and the disc can be considered to be divided into a number of sectors (or blocks), as shown by the radial dashed lines. Sectors are used in the addressing of areas of the disc for read/write purposes. Information can be identified by track and sector numbers. The same amount of information is held on each track within a sector.

(ii) Packing density (or recording density) relates to the amount of information that can be stored in a given length of track around the disc. It is normally quoted in binary digits/unit length. So that the amount of information on each track within a sector is constant, a higher packing density is necessary on tracks nearer the centre.

(iii) The term drop-out refers to information being lost because of damage to the oxide magnetic surface of the disc. It is impossible to store information in a damaged area.

Q 9 (a) Draw a diagram of a diode function generator that has 6 break points and produces a positive output for either polarity of input.

(b) Explain how the generator is adjusted to represent particular functions.

(c) How can a more accurate approximation be obtained?

A 9 See A8, Computers B, 1973, Supplement, Vol. 67, p. 57, Oct. 1974.

Q 10 (a) Draw a diagram of an operational amplifier that is used to sum 2 analogue values, showing clearly the position of input and feedback components.

(b) What is meant by the virtual-earth concept, as applied to an ideal operational amplifier? Applying this concept to a summing amplifier, derive from basic principles a formula that gives the output voltage in terms of the input voltages and input and feedback resistances.

A 10 See A10, Computers B, 1974, Supplement, Vol. 68, p. 49, Oct. 1975, and A8, Computers B, 1975, Supplement, Vol. 69, p. 55, Oct. 1976.

LINE PLANT PRACTICE B, 1976
Students were expected to answer any 6 questions

Q 1 (a) Why is it necessary to have an overall transmission plan when considering circuit losses?

(b) What is the maximum transmission loss at 1.6 kHz allowed for a local-line circuit?

(c) What is the maximum signalling resistance allowed for a local-line circuit?

(d) Fig. 1 shows a subscriber's line connected to an exchange. From the values given in the table, calculate the maximum length of 0.40 mm diameter conductor that could be used to keep the line within both the transmission and signalling limits.

Conductor Diameter (mm)	DC Loop Resistance (Ω /km)	Planning Attenuation (dB/km)
0.40	275	2.20
0.63	109	1.38
0.90	55	1.04

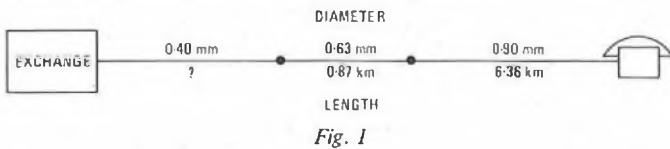

A 1 (a) To ensure that speech is satisfactory between any 2 telephones in the national and international networks, the worst transmission loss permissible is defined. This standard is the overall transmission loss, and it is important to be able to assess the transmission loss contributed by each section of the network.

(b) and (c) In the British Post Office national network, the maximum transmission loss at 1.6 kHz allowed for a local-line circuit is 10 dB. The maximum signalling resistance (loop resistance) is 1 k Ω .

(d) The loop resistance of the 0.63 mm diameter section of line is $109 \times 0.87 = 94.83 \Omega$, and the loop resistance of the 0.90 mm diameter section is $55 \times 6.36 = 349.8 \Omega$.

Thus, the maximum allowable loop resistance of the 0.40 mm diameter section is $1000 - (94.83 + 349.8) = 555.37 \Omega$. Hence, the maximum permissible length of this section to meet the signalling limit is $555.37/275 = 2.02$ km.

The attenuation of the 0.63 mm diameter section of line is $1.38 \times 0.87 = 1.2$ dB, and the attenuation of the 0.90 mm diameter section is $1.04 \times 6.36 = 6.61$ dB.

Thus, the maximum allowable attenuation of the 0.40 mm diameter section is $10 - (1.2 + 6.61) = 2.19$ dB. Hence, the maximum permissible length of this section to meet the transmission limit is $2.19/2.20 \approx 1$ km.

The more stringent limit is due to the attenuation, and the maximum length of the 0.40 mm diameter section of line is 1 km.

Q 2 A copper wire, 2 mm in diameter, is suspended between 2 poles. The breaking stress of the wire is 468 MPa, and the maximum dip allowable is 630 mm. The wire weighs 270 mN/m, and a factor of safety of 4.4 is required. Calculate the maximum span that can be used.

A 2 The tension, T newtons, of a suspended wire is given by

$$T = \frac{WL^2}{8D} \text{ newtons,}$$

where W is the weight per unit length of the wire (newtons/metre), L is the length of the span (metres), and D is the maximum dip (metres).

The maximum tension in the wire is given by

$$T_{\max} = \frac{f_{\max} A}{S} \text{ newtons,}$$

where f_{\max} is the breaking stress of the wire (pascals), A is the cross-sectional area of the wire (metres²), and S is the factor of safety.

Equating T and T_{\max} gives

$$\frac{W(L_{\max})^2}{8D} = \frac{f_{\max} A}{S},$$

where L_{\max} is the maximum possible span length.

$$\therefore L_{\max} = \sqrt{\frac{8D f_{\max} A}{WS}} \text{ metres,}$$

$$= \sqrt{\frac{8 \times 630 \times 10^{-3} \times 468 \times 10^6 \times \pi \times 1 \times 10^{-6}}{270 \times 10^{-3} \times 4.4}} = 79 \text{ m.}$$

Q 3 (a) Describe, with the aid of sketches, 2 types of copper-sulphate half-cell used for potential measurements in electrolytic-corrosion investigations.

(b) State the conditions under which each type of half-cell is used.

A 3 (a) Sketch (a) shows one type of copper-sulphate half-cell. This type consists essentially of a porous pot containing a saturated solution of copper sulphate, in which an electrolytic copper rod is immersed. The pot is sealed with a rubber muff containing a bung that holds the copper rod.

Sketch (b) shows an alternative design of half-cell, consisting of a slim plastic tube having a porous pointed wooden plug at the base. Again, the tube contains a copper-sulphate solution and an electrolytic copper rod. A rubber cap seals the half-cell.

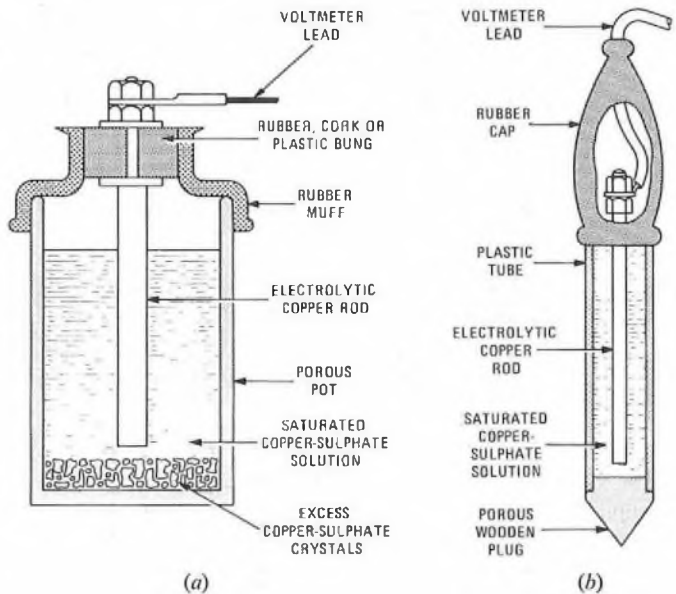

(b) The type of half-cell shown in sketch (a) is used for taking measurements in a cable joint-box by placing the cell in water on the floor of the box, in close proximity to the cable under test.

If tests are to be made on a buried cable, the type of half-cell shown in sketch (b) is used, as it can be inserted in the soil near to the cable.

Q 4 A 50 Hz power line runs close to an overhead telephone line, as shown in Fig. 2, which is drawn to scale. Fig. 3 shows the relationship between mutual inductance and separating distance. To what value must a fault current in the power line be limited for the induced longitudinal voltage in the telephone line not to exceed 430 V?

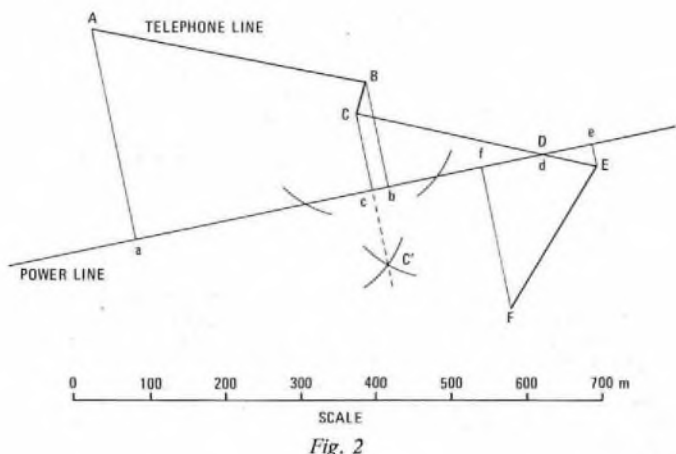

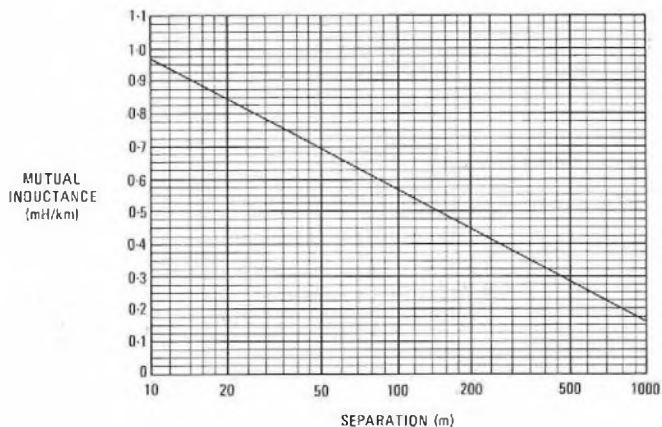

Fig. 3

A 4 The telephone line in Fig. 2 is divided into sections A-B, B-C etc., as shown. Ordinates Aa, Bb etc. are erected normal to the power line at the start and end of each section. The ordinates are drawn using the standard geometrical construction process of striking arcs; to illustrate the process, the construction arcs for ordinate Cc are shown, but those for the other ordinates have been omitted for clarity.

The length of the ordinate at the start of each section, d_1 metres, and that of the ordinate at the end of each section, d_2 metres, are measured, and the mean separation, $(d_1 + d_2)/2$ metres, between each section and the power line is calculated. Hence, the mutual inductance per unit length of each section, M millihenrys/kilometre, is read from the graph in Fig. 3.

The length, l kilometres, of each section when projected onto the power line (ab, bc etc.) is measured, and thus the mutual inductance of each section, Ml millihenrys, and hence the total mutual inductance, is calculated.

The results are shown in the table, taking into account the cancelling effect of sections running from right to left by considering them to contribute negative mutual inductance.

Section	d_1 (m)	d_2 (m)	$(d_1 + d_2)/2$ (m)	M (mH/km)	l (km)	Ml (mH)
A-B	280	140	210	0.43	0.34	+0.15
B-C	140	100	120	0.54	0.02	-0.01
C-D	100	0	50	0.69	0.23	+0.16
D-E	0	30	15	0.90	0.07	+0.06
E-F	30	190	110	0.55	0.15	-0.08

Total mutual inductance: 0.28

The induced longitudinal voltage in the telephone line, E volts, is given by

$$E = 2\pi f M I \text{ volts,}$$

where f is the frequency of the power supply (hertz), I is the fault current (amperes), and Ml is in henrys.

$$\therefore I = \frac{E}{2\pi f Ml} \text{ amperes,}$$

$$= \frac{430}{2\pi \times 50 \times 0.28 \times 10^{-3}} \text{ A} = 4.9 \text{ kA.}$$

Q 5 Describe, with the aid of sketches, the following items of equipment, used for measuring air pressure in cables:

- (a) the tube-type manometer, and
- (b) the aneroid-type manometer.

A 5 (a) A tube-type manometer is basically a mercury barometer with the top of the tube left open to the atmosphere, as shown in sketch (a). This type of manometer is used in the field for measuring air pressures in pressurized cables. The instrument is machined from solid perspex to ensure that it is robust enough for field use. The scale is movable so that, with no air pressure applied, the scale zero can be aligned with the level of mercury to compensate for variations in atmospheric pressure.

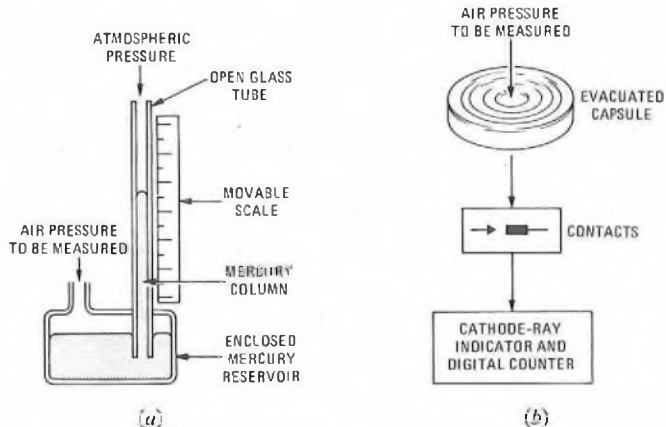

(b) An aneroid-type manometer works on the principle of the aneroid barometer, in which the faces of an evacuated corrugated-steel cylinder move with variations in applied pressure. This movement actuates a gearing mechanism to drive a pointer over a scale. In the manometer shown in sketch (b), the gearing mechanism is replaced by electrical contacts, which move in relation to the pressure on the evacuated capsule.

The contacts form part of a circuit having a cathode-ray indicator. This displays an exclamation-mark pattern and, by turning a knob associated with a digital counter, the dash can be made just to touch the dot. The pressure value is then read from the counter. In effect, the digital counter is a form of micrometer, measuring the amount by which the contacts are displaced by the pressure being recorded. This type of manometer is a high-precision instrument, and can detect very small changes in pressure.

Q 6 It is required to identify a pair of wires in a cable passing through a joint-box that contains several cables. Describe, with the aid of sketches, the method of locating

- (a) the correct cable, and
- (b) the correct pair within that cable.

Include in your answer details of the equipment used.

A 6 (a) To identify one cable among several in a jointing chamber, a low-power oscillator, a search coil known as a *block probe*, an amplifier and headphones are used. The oscillator has an output of 15 mW at 1 kHz, and the tone can be modulated at between 2-20 pulses/s. The block probe is illustrated in sketch (a), and consists of a 10 000-turn inductive coil wound on the centre limb of a cylindrical E-section ferrite core. A capacitor is wired in parallel with the coil to tune it to 1 kHz, and the whole is contained within a 50 mm polyethylene cube. The probe can be fitted with a telescopic handle for ease of operation. A coaxial cord connects the probe to the amplifier.

The cable to be located is first identified at a known point, such as a main distribution frame or cross-connexion point. A spare pair is selected, preferably in an outer layer or unit if the cable is large, and the oscillator is connected across the pair, with its output adjusted to give an interrupted tone. To increase the strength of the signal current, the pair is short-circuited at the end remote from the oscillator, if practicable. The sheath, foil moisture-barrier, conductors surrounding the pair and any armouring wires or tapes do not seriously screen the signal.

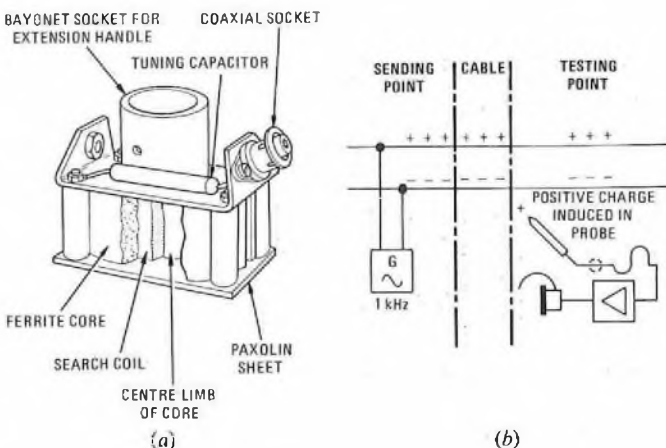

The current flowing in the pair produces a magnetic field. The block probe is passed among the cables until the correct cable is identified.

(b) The identification of a pair in an open cable joint is carried out using the same equipment, except that the block probe is replaced by a pencil probe. The pencil probe is a 130 mm long capacitive probe having a brass-rod electrode extending from the inner conductor of a coaxial cord. The electrode and the screened conductor are sheathed in moulded rubber, although the tip of the electrode is exposed. Detection in this case is easier if the pair connected to the oscillator is open-circuit at the remote end.

The pencil probe is used to locate the position of the wanted pair by bringing the tip near a group of wires; this makes it possible to detect whether the group contains the marked pair. By sub-dividing the joint into smaller groups, the wanted pair is eventually identified. The loudest tone is heard when the tip touches the marked conductors and, to confirm that the correct pair has been selected, the conductors are short-circuited with the metal tip, thus significantly weakening the signal. Sketch (b) illustrates the principle of the method; the instantaneous charge is shown for one point in the signal cycle.

An alternative method of using the probe is to place it inside a shirt pocket, waistband or watch strap. It is then possible to locate the marked pair using the fingers; the level of tone heard is loudest when the wanted pair is held between the finger and thumb. This method relies on the capacitance of the body to complete the probe circuit.

Q 7 Describe, with the aid of sketches, a method of terminating a 2-6/9-5 mm coaxial pair.

A 7 Cables containing 2-6/9-5 mm coaxial pairs are normally manufactured with 2 or 4 pairs, or multiples thereof; an exception is the 18-pair 60 MHz cable. The method of terminating such cables is therefore described here, and illustrated in the sketch. (Termination of a single 2-6/9-5 mm pair is described in A5, Line Plant Practice B, 1971, Supplement, Vol. 65, p. 49, Oct. 1972.)

(a) The polyethylene protection and lead sheathing is removed from the cable. The paper tape is secured with a cotton tie near the sheath, and the paper is removed as far as the tie.

(b) The interstitial pairs are laid back, and the coaxial pairs are cut to the required length.

(c) A cotton tie is placed round the numbered paper tape of each coaxial pair, and the paper removed as far as the tie. The steel tapes of each pair are cut to length and temporarily secured.

(d) The inner and outer conductors of each coaxial pair are cut to length, cleaned and tinned. An outer-conductor ferrule is slid over each outer conductor.

(e) Each inner conductor is soldered to the centre pin of a sealing-end.

(f) Each ferrule is correctly positioned, and soldered to the outer conductor at one end and to the shell of the sealing-end at the other.

(g) The paper and steel tapes of each coaxial pair are secured with a binding of adhesive brown paper tape.

(h) The interstitial pairs are jointed to pairs made up of single PVC-covered wires of 2 colours (red and black), and paper sleeves are placed over the joints.

(i) An earth wire is soldered to the sheath.

(j) The interstitial pairs are separated into groups and placed in PVC tubes. The tubes and the earth wire are placed in a rubber cable sleeve for support and protection. The remote ends of the pairs are terminated on plug-type connectors.

(k) A further 130 mm of polyethylene protection are removed, and 25 mm of the lead sheath adjacent to the protection are treated with plumbers' blacking. The rest of the exposed sheath is tinned.

(l) The gland is fixed in position on the sheath. A 180 mm length of rubber hose is placed over the gland and secured with a hose clip. A second hose clip is placed at the top of the hose to maintain it in a circular form. Cotton wool is placed round the coaxial and interstitial pairs at the cable butt.

(m) Epoxy resin is poured into the hose until it is full. The resulting encapsulation serves as an air block. When the resin is cured, which takes about 24 h, the hose and clips are removed.

(n) A lapping of self-amalgamating tape is placed on the exposed sheath from the gland to the polyethylene protection. A lapping of black plastic adhesive tape is placed over the self-amalgamating tape from the gland to a point 13 mm onto the polyethylene protection. In each case, 50% overlapping is used.

(o) An identification label is placed over the encapsulation.

Q 8 With the aid of sketches, describe a directly-buried type of loading pot suitable for use in conjunction with an armoured cable.

Q 9 (a) Describe in detail, with the aid of sketches, a method of constructing a reinforced-concrete manhole suitable for a 6-way duct route located in a carriageway.

(b) Describe, with the aid of sketches, the iron fittings that would be used.

A 9 See A6, Line Plant Practice B, 1973, Supplement, Vol. 67, p. 52, Oct. 1974, and A4, Line Plant Practice B, 1975, Supplement, Vol. 69, p. 50, Oct. 1976.

Q 10 (a) Give an account of the causes and effects of cable creepage.

(b) Describe, with the aid of sketches, 2 types of anti-creepage device.

A 10 (a) Cable creepage is the movement of cables in their ducts or jointing chambers, and often results in damage to the cables and joints. Although creepage can occur on steep gradients, or where there is subsidence due to mining, it is most often due to disturbances from road traffic. Cables tend to move in the same direction as that of the nearest traffic flow. Creepage is most pronounced

(i) where there is an unstable subsoil, such as clay, shingle or peat, or where the ground has been artificially built up,

(ii) under roads carried on embankments, or having deep ditches on each side,

(iii) where poor road surfaces are laid on firm subsoil, and

(iv) on long straight sections of road.

Creepage is, in general, confined to cables in earthenware self-aligning ducts. Polyethylene cables tend to creep at twice the rate of lead cables.

There are 2 theories explaining cable creepage: one assumes a surf-riding effect, and the other a conveyor-belt effect. These theories are briefly discussed below.

Surf-Riding Effect The wheel of a heavy vehicle, travelling along a macadam road surface above a duct line, causes a travelling depression in the surface. The surf-riding theory assumes that transmitted shock waves give the duct line a travelling depression (of a small amplitude) into which the cable, being flexible, falls. Sketch (a) illustrates the situation; for the purpose of the illustration, the amplitude of the depression is exaggerated. The leading slope of the depression is steep,

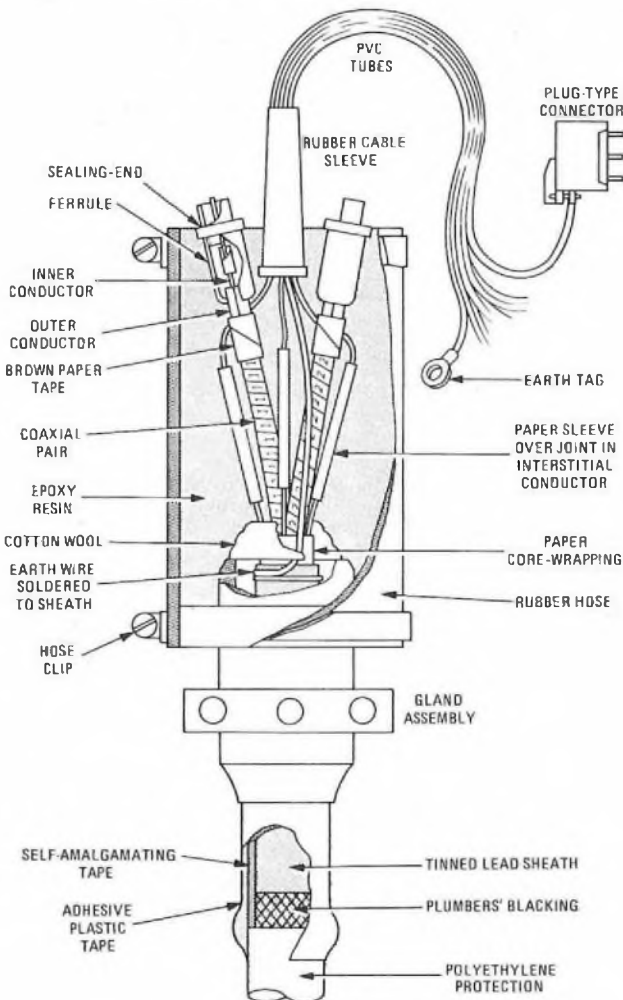

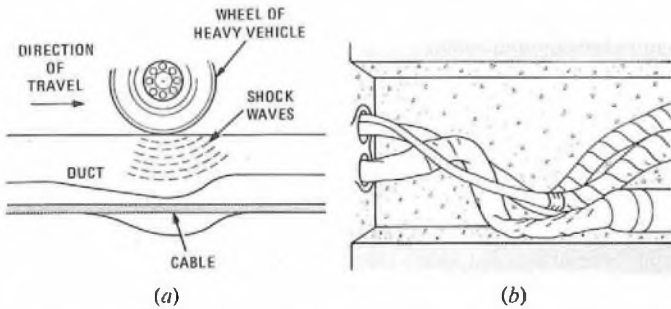

while the trailing slope is shallower. The upward thrust of the duct has a practically zero horizontal component on the leading slope, whereas the cable tends to rest on the trailing slope, so that there is a horizontal component of thrust tending to push the cable forward. (The effect is similar to the manner in which a surf-rider advances by sliding down the face of a wave.) The extent of the movement is very small, being about 0.025 mm, and is within the elastic limit of the cable.

Conveyor-Belt Effect The conveyor-belt theory assumes the duct to be vibrated longitudinally with a saw-tooth action. Since duct joints are not rigid, each duct can execute a small-amplitude forward-and-backward movement, and creepage occurs if the backward movement is rapid and the forward movement slow. (This is the principle of the shaking conveyor belt.) A travelling depression from the passage of a heavy vehicle causes the following series of movements, which result from a force transmitted along a line approximately 45° forward of a perpendicular line originating at the vehicle's axle and passing through the duct line.

- (i) The duct is forced rapidly forward, breaking the static friction between the cable and duct.
- (ii) The duct is forced rapidly backward, past its rest point, again breaking the static friction.
- (iii) The earth mass recovers slowly, and the duct moves forward approximately to its original position, carrying the cable with it; the movement of the duct is too slow to overcome the static friction.

The effect of creepage is illustrated in sketch (b). Cables are creeping in from the left-hand side, and the extent of the distortion of the cables and joints indicates that the rate of creeping in is greater than that of creeping out. If creepage were allowed to continue, the lead sheaths and joints would probably fracture, resulting in cable breakdown.

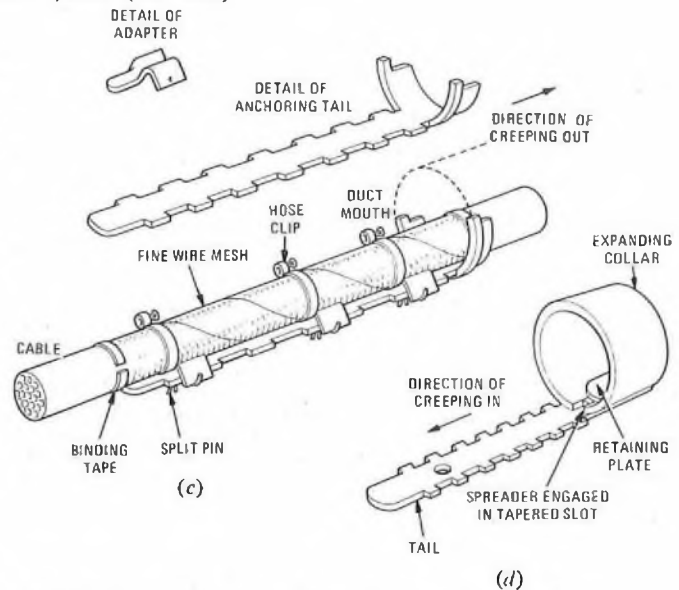

(b) There are 2 basic types of anti-creepage device designed for use in jointing chambers: one to prevent cables from creeping in, and one to prevent them creeping out.

An anti-creep-out device is shown in sketch (c). It is a galvanized-steel anchoring tail having notched edges, welded to a collar that fits in the mouth of a duct. The cable is first wrapped in wire mesh, which is secured with a binding of plastic tape. The anchoring tail is wrapped with a bedding of plastic tape, and 3 adapters are fitted to notches in the tail; each adapter has a tongue that faces against the direction of creepage. A pin-and-buckle type hose clip secures each adapter tongue to the cable, and the adapters are prevented from lifting by split pins. The whole assembly is wrapped in protective tape.

An anti-creep-in device is illustrated in sketch (d). With this device, the action of the cable in creeping in is to drive a spreader that expands a split collar. The collar, in expanding, grips the inside of the duct mouth. The tail is wrapped with a bedding of plastic tape, and the spreader end is placed inside the duct. The split collar is put in the duct mouth, and the tail pulled forward so that the spreader engages a tapered slot in the collar. The collar expands to give initial grip, and the cable is secured to the tail in the same way as for the anti-creep-out device.

MODEL ANSWERS

CITY AND GUILDS OF LONDON INSTITUTE EXAMINATIONS FOR THE TELECOMMUNICATIONS TECHNICIANS' COURSE

Back numbers of the *POEEJ* are available, complete with model-answer Supplements containing model answers to past examinations of the City and Guilds of London Institute Telecommunication Technicians' Course. A list of those available, showing the examinations covered in the respective model-answer Supplements, can be obtained by writing to *The Post Office Electrical Engineers' Journal*, Room S 09, River Plate House, Finsbury Circus, London EC2M 7LY.

MODEL ANSWER BOOKS

A series of 6 model-answer books is also available, in which selected answers from past examinations have been collected together to cover the following subjects.

	Price (post paid)
Elementary Telecommunication Practice	60p
Telecommunication Principles A	60p
Line Plant Practice A	60p
Radio and Line Transmission A	85p
Telephony and Telegraphy A	85p
Telecommunication Principles B	85p

Orders, by post only, should be addressed to *The Post Office Electrical Engineers' Journal* (Sales), 2-12 Gresham Street, London EC2V 7AG. Cheques and postal orders, payable to "The POEE Journal", should be crossed "& Co." and enclosed with the order. Cash should not be sent through the post.