

A UNIQUE RADIO MAP FREE FOR READERS

# MODERN WIRELESS

1/-

Vol: XVI. N° 59

NOVEMBER 1931

THE "MODERN WIRELESS"

A 2/6<sup>d</sup> GIFT FREE

BROADCASTING MAP OF THE WORLD

The **CONTENTS** include  
FULL HOW-TO-MAKE DETAILS OF  
THE "M.W."  
**A.C. "SUPER-QUAD"**  
*For Distance and Quality*

FOR THE LONG-DISTANCE LISTENER  
A Special Supplement—  
**THE WORLD'S PROGRAMMES**  
How, When and Where to Hear Those  
Foreign Stations.

ALSO IN THIS ISSUE:  
THE "UNI-COIL" THREE  
THE "LOCK-TUNE" JUNIOR  
etc., etc., etc.

COVERS EVERY INTERESTING  
ASPECT OF RADIO  
TO-DAY

CHIEF CAPT. P. P. ECKERSLEY M.I.E.E.





CAN BE ACHIEVED  
WITH THE  
**LEWCOS**

Regd.

**SUPER-HET COIL KIT**  
(2 I.F.T.P. Coils & 1 Extenser Oscillator Coil)  
WHICH IS EXCLUSIVELY  
SPECIFIED FOR THE "A.C."  
**"SUPER-QUAD"**  
RECEIVER DESCRIBED IN  
THIS ISSUE.

The extraordinary selectivity of LEWCOS Super-Het Coils was recently demonstrated at Brookmans Park to the Press when the National transmission was cut out in one degree of 180 degree dial and the Regional transmission received clear of any interference.

THE LONDON ELECTRIC WIRE  
COMPANY AND SMITHS LIMITED,  
CHURCH ROAD, LEYTON, LONDON, E.10.

Telephone: Leytonstone 3636 (10 lines).  
Telegrams: "Lewcos, London."

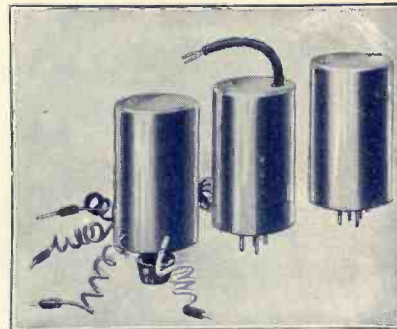

(Protected by provisional Patent Specification)

2 I.F. Coils, Ref. I.F.T.P.  
at 10/6 each

1 Extenser Oscillator Coil, Ref.  
EX/O.F.C.126, at 12/6

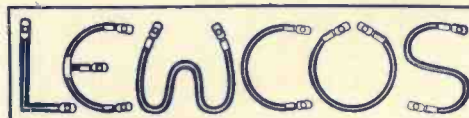

**SPAGHETTI RESISTANCES**

The LEWCOS SPAGHETTI RESISTANCES are obtainable in all standard sizes, ranging in price from 9d. to 1/6



The LEWCOS Super H.F. Choke is recognised as standard by all experts.  
PRICE reduced to ... 6/-

**LEWCOS RADIO PRODUCTS FOR BETTER RECEPTION**



# CONTENTS

Vol. XVI. No. 59. MODERN WIRELESS. NOVEMBER, 1931.

	Page		Page
Editorial	417	Give Your Valves a Chance	474
The "M.W." A.C. "Super-Quad"	418	My Broadcasting Diary	475
Getting Grid Bias	426	A Radio Reckoner	479
The Manchester Exhibition	427	Radiogram Volume Control	484
Trouble Tracking	445	Questions Answered	487
The "M.W." "Uni-Coil" Three	446	On the Short Waves	488
Do We Want Those High Frequencies?	455	In Passing	492
The World's Biggest Valve	457	Recent Record Releases	496
Microphone Music	458	On the Test Bench	498
The "Lock-Tune" Junior	460	A Screened-Grid Fallacy?	500
At Your Service	466	Where Constructors Score	503
The Mysterious Microphone	468	Radio Echoes From Space	508
The New Valves	469	Writing Plays For Radio	512
Operating the "M.W." "Super-Quad"	471	Radio Notes and News	516

SPECIAL SUPPLEMENT, "THE WORLD'S PROGRAMMES," PAGES 429-444  
(See page 429 for contents of this section).

*As some of the arrangements and specialities described in this Journal may be the subject of Letters Patent the amateur and trader would be well advised to obtain permission of the patentee to use the patents before doing so.*

Edited by **NORMAN EDWARDS.**

Technical Editor: **G. V. DOWDING**, Associate I.E.E.

Radio Consultant-in-Chief: **Capt. P. P. ECKERSLEY**, M.I.E.E.

Scientific Adviser: **J. H. T. ROBERTS**, D.Sc., F.Inst.P.

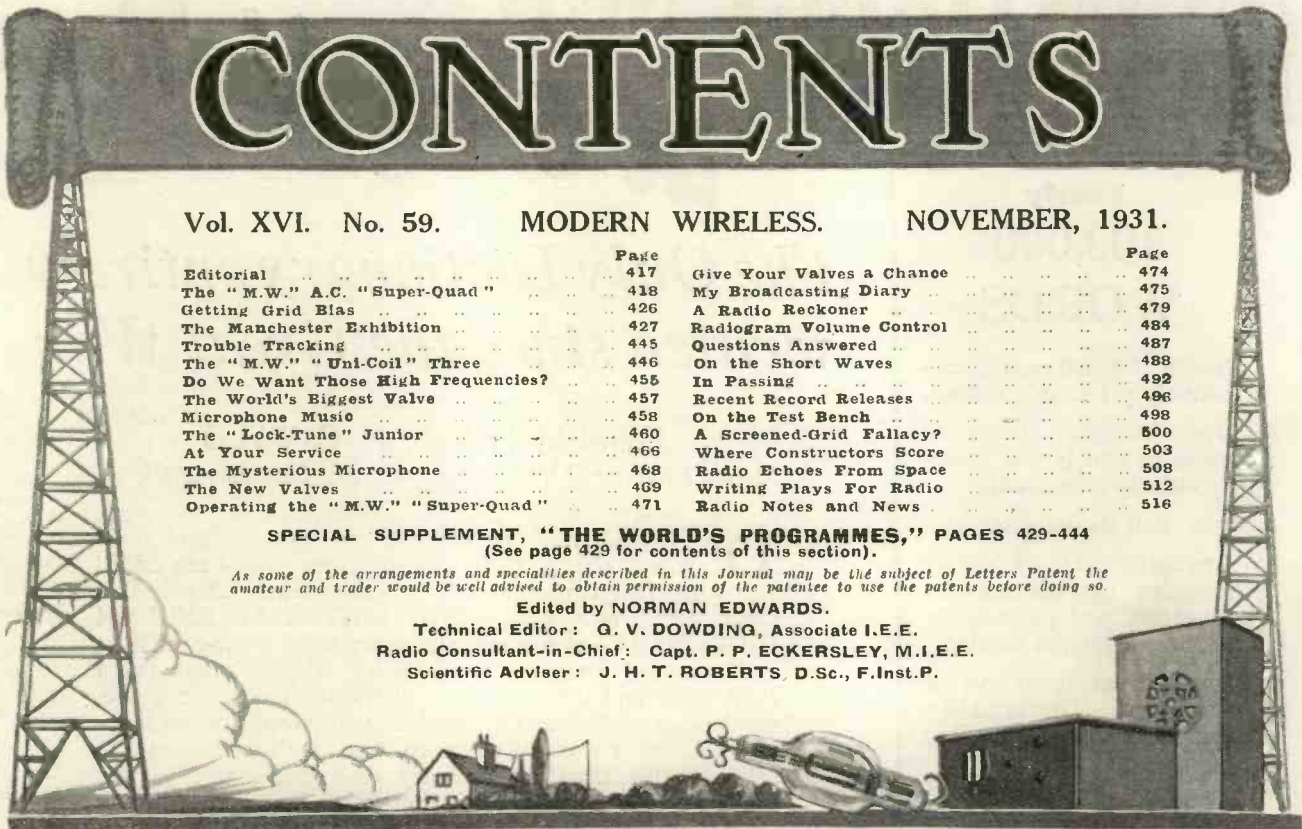

**FREE! STROBOSCOPIC  
GRAMOPHONE SPEED-  
TESTER—78 & 80 R.P.M.**



**FOR ALL INTERESTED IN  
PERFECT  
GRAMOPHONE REPRODUCTION**

Correct, steady Turntable speed—a pick-up that faithfully interprets all the beauty of tone which modern electrical recording has placed upon your record—correct Volume Control; these are the three first steps towards Perfect Reproduction. These conditions can easily be satisfied—

Let your Motor be our famous

**"DIEHL" "ARISTOCRAT" (Induction Type)**

It sells for only 84/-, Complete with Automatic Stop, etc. It is guaranteed for two years and backed by the World-famous Singer Organisation. It is positively "hum-less" and non-interfering. Models available for all Voltages.

Our "AUDAK" "ELECTROCHROMATIC" PICK-UP, Price 84/- complete with specially designed Volume Control and Leads, and designed by Maximilian Weill, the acknowledged foremost authority on reproduction devices, is the best Pick-up made. Why not use it?

*Booklet describing both instruments, free and post free. Request at the same time one of our Stroboscopic Speed-Testers (illustrated), printed on stout white card.*



**CLAUDE LYONS, LTD.**

Head Offices: 76, OLDHALL ST., LIVERPOOL

London: 40, BUCKINGHAM GATE, WESTMINSTER, S.W. 1



# AN ENTIRELY NEW DICTIONARY

*in 6<sup>d</sup> weekly Parts*

Nearly  
**100,000**  
WORDS

Nearly 100,000 words accurately yet simply defined.

Over 300,000 shades of meaning clearly and interestingly differentiated.

Full etymologies.

Pronunciations simply indicated for the man-in-the-street, and phonetically indicated for the scholar.

Hundreds of thousands of quotations illustrating phrases, modern usages and idioms.

A book for every home, every school, every library, and every office.

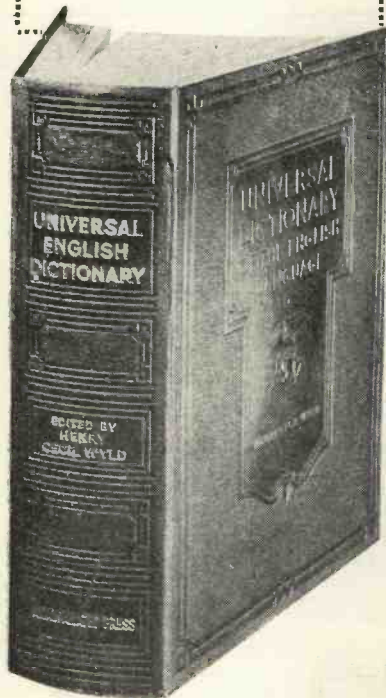

*The Only Dictionary entirely written since the Great War*

Edited by Professor H. C. WYLD

*Merton Professor of English Language and Literature at Oxford.*

**D** ICTIONARIES, like other things, grow out of date. Words change their meanings, new words are added to the language and pronunciations alter. This monumental new work—**THE UNIVERSAL ENGLISH DICTIONARY**—is the only dictionary to be entirely written and compiled since the Great War. The task has taken eight years and the result is a dictionary unique in scope, scholarship and system; completely authoritative and up-to-date. As a work of reference it is much more complete and valuable than the ordinary desk dictionary, yet its form, a single large-page compact volume, is immeasurably more convenient than the larger American compilations which have hitherto been the only alternative to the immense and costly Oxford Dictionary.

The Editor of the **UNIVERSAL DICTIONARY**, Professor H. C. Wyld, Merton Professor of English Language and Literature at Oxford, enjoys an international reputation as a leading authority on our language. He has been assisted in his task by a staff of first-rank experts.

The **UNIVERSAL DICTIONARY** is to be complete in one volume, but to bring it within the reach of all it is being published in convenient weekly parts at the small price of 6d. each. A great advantage of this new work is the fact that the parts can be bound at home in an ingenious self-binder. The volume is built up week by week and the parts are kept in perfect condition and are immediately available in a handy form for reference. When the volume is complete it will be in every way like an ordinary book because it—

## **Binds into ONE Large Page Volume**

The unique and ingenious Self Binding Case shown on the left is available to subscribers to the **UNIVERSAL ENGLISH DICTIONARY** at a **GREATLY REDUCED PRICE**. The complete work can, by this means, be built up week by week, each part being bound in it as it is published. Full particulars of this remarkable offer will be found in the early parts. Of course, for those who prefer it, the **UNIVERSAL DICTIONARY** may be bound in the ordinary way when the weekly parts are all issued.

# THE UNIVERSAL ENGLISH DICTIONARY

*First Three Parts Now on Sale—Buy Them TO-DAY! 6<sup>d</sup>.*

each



**The No Substitute Kit**  
**IMMEDIATE DELIVERY**

**PILOT AUTHOR'S KITS**  
**FOR A.C. "SUPER-QUAD"**  
*This is the Kit the Author Used*  
**PILOT AUTHOR'S KIT**

Any reputable dealer will gladly supply you with a **PILOT AUTHOR'S KIT** for the A.C. "Super-Quad." Don't accept a substitute kit made up of substitutes.

**DOMINATING FEATURES**

Chosen and first specified by the Technical Department of "Modern Wireless" Officially approved, therefore, by an established technical authority you can trust implicitly. Backed by Peto-Scott himself, twelve years' Radio Experience and world-wide reputation. Enables the Author's published Set to be duplicated exactly in every respect.

**DETAILED LIST**

CHECK this list of parts with the Author's specification, photographs and diagrams on pages 418-425 of this issue.

- |   |    |      |
|---|----|------|
| 1 Peto-Scott panel, drilled ready for assembling, 16" x 7" ...                  | 7  | 0    |
| 1 Baseboard   | 1  | 6    |
| 1 Cydon double-gang Extenser, .0005 mfd., with insulated cam and disc drive ... | 1  | 16 0 |
| 1 Cydon Extenser, .0005 mfd., single disc drive, as above                       | 16 | 6    |
| 2 Bulgin Spaghetti resistances, 600 ohm   | 1  | 6    |
| 1 Bulgin Spaghetti resistance, 700 ohm  | 1  | 3    |
| 2 Lewcos Spaghetti resistances, 1,000 ohm                                       | 1  | 6    |
| 1 Varley Spaghetti resistance, 2,000 ohm  | 9  |      |
| 2 Varley 30,000-ohm Spaghetti resistances                                       | 2  | 0    |
| 1 Colvern 50,000-ohm volume control   | 5  | 6    |
| 1 Dubilier 2-mcg. grid leak with holder   | 2  | 9    |
| 1 Ferranti .0003 mfd. grid condenser  | 1  | 6    |
| 2 Telsen fixed condensers, 1-001 and 1-002 mfd.                                 | 1  | 0    |
| 3 Formo 1 mfd. fixed condensers   | 1  | 1 8  |
| 1 T.C.C. 1 mfd. fixed condenser   | 3  | 10   |
| 1 T.C.C. 2 mfd. fixed condenser   |    |      |
| 1 Dubilier non-inductive .04 mfd. fixed condenser                               | 2  | 0    |
| 1 Lewcos H.F. choke   | 13 | 6    |
| 1 Varley H.F. choke   | 15 | 0    |
| 1 R.I. band filter coil   |    |      |
| 1 Wearite type A.C. Extenser oscillator coupler                                 | 1  | 17 6 |
| 2 Wearite bandpass intermediates  | 12 | 6    |
| 1 Telsen L.F. transformer, ratio 1-7  | 1  | 0    |
| 2 Sovereign two-terminal mounting blocks  | 2  | 0    |
| 4 Belling-Lee indicating terminals Metallised flex, screws, etc.                | 3  | 6    |
| 4 Belling-Lee H.T. plugs  | 1  | 0    |
| 1 Sheet of foil copper, 16" x 7" x 12   | 2  | 0    |

Kit "A." Cash or C.O.D. **£9 14 3**

**SPECIAL ITEMS SENT C.O.D.** You pay the postman. We pay all charges.

- |   |    |      |
|---|----|------|
| 1 Cydon double-gang Extenser, .0005 mfd., with insulated cam and disc drive ... | 1  | 16 0 |
| 1 Cydon single disc drive Extenser, .0005 mfd., as above                        | 16 | 6    |
| 1 R.I. band filter coil   | 15 | 0    |
| 1 Dubilier non-inductive .04 condenser  | 2  | 0    |
| 1 Wearite type A.C. Extenser oscillator   | 1  | 17 6 |
| 2 Wearite band-pass intermediates   |    |      |

★ Any parts supplied separately if value over 10/- Sent carriage paid or C.O.D. All post charges paid.

**COMPLETE KIT PRICES**

**KIT "A"** Author's Kit less Valves and Cabinet

CASH or C.O.D. **£9 14 3**

or 17/10 down & 11 monthly payments of 17/10

**KIT "B"** Author's Kit with Valves less Cabinet **£14 6 9**

or 26/3 down and 11 monthly payments of 26/3

**KIT "C"** Author's Kit with Valves and Cabinet **£15 16 9**

or 29/- down and 11 monthly payments of 29/- Heayberd Type "M.W." A.C. Mains Unit as specified, **£6 7 6**

**PRICES TABLE FOR OTHER "M.W." SETS.**

ITEM NO.	SET	KIT "A," less Valves and Cabinet.	KIT "B," with Valves less Cabinet.	Kit "C," complete with Valves and Cabinet.
200	"LOCK-TUNE" JUNIOR (Author's Kit)	CASH or C.O.D. <b>£5 16 11</b> or 10/9 down and 11 monthly payments of 10/9	CASH or C.O.D. <b>£7 15 11</b> or 14/4 down and 11 monthly payments of 14/4	CASH or C.O.D. <b>£8 15 11</b> or 18/2 down and 11 monthly payments of 18/2
201	"M.W." "UNI-COIL" 3 MODEL 'A' (Author's Kit)	CASH or C.O.D. <b>£3 15 2</b> or 6/11 down and 11 monthly payments of 6/11	CASH or C.O.D. <b>£5 2 8</b> or 9/5 down and 11 monthly payments of 9/5	CASH or C.O.D. <b>£6 2 8</b> or 11/3 down and 11 monthly payments of 11/3
202	"M.W." "UNI-COIL" 3 MODEL 'B' (Author's Kit)	CASH or C.O.D. <b>£3 15 0</b> or 6/11 down and 11 monthly payments of 6/11	CASH or C.O.D. <b>£5 2 6</b> or 9/5 down and 11 monthly payments of 9/5	CASH or C.O.D. <b>£6 2 6</b> or 11/3 down and 11 monthly payments of 11/3
203	"SUPER-QUAD" Battery Model (Author's Kit)	CASH or C.O.D. <b>£8 11 0</b> or 15/8 down and 11 monthly payments of 15/8	CASH or C.O.D. <b>£11 13 0</b> or 21/4 down and 11 monthly payments of 21/4	CASH or C.O.D. <b>£12 13 0</b> or 23/2 down and 11 monthly payments of 23/2

**ACCESSORIES**

**COSSOR MELODY MAKER**  
 Type 234. Screened grid detector, and power. Complete with specified valves and cabinet. Cash Price **£8 15 0** Balance 11 monthly payments of 12/6 **10/-** Send Only

**AMPLION MC.6 MOVING-COIL SPEAKER.** Permanent magnet. With output transformer. Complete. Cash Price, **£3 7 6**. Balance in 11 monthly payments of 6/2. **6/2** Send only.

**ROLA PERMANENT MAGNET SPEAKER.** Complete with input transformer. Cash Price, **£2 17 6**. Balance in 8 monthly payments of 7/1. **7/1** Send only.

**V3 KIT RADIO FOR THE MILLION.**  
 Powerful, selective, and ultra modern. Employs screen grid detector, and power valves. With valves, less cabinet. Balance in 11 monthly payments of 10/10. Cash Price **£5 17 6**. **10/-** Send only.

**KELSEY SHORT-WAVE ADAPTOR**

Add more stations to your set. Plug direct into your battery or eliminator operated receiver. Complete with instructions. Sent C.O.D. Postage free. Pay the Postman. Mahogany or Oak Cabinet **7 6**. Nothing more to buy—no valves or any extras. **37/6**

**EXPRESS ORDER FORM**

To PETO-SCOTT CO. LTD. Please send me C.O.D., CASH/H.P.

.....

.....

for which I enclose Cash/H.P. Deposit & s. d.

Name.....

Address.....

.....

M.W.11/31

**C.O.D. CASH H.P. as usual**

**PETO-SCOTT**

PETO-SCOTT CO. LTD. Head Office: 77, CITY ROAD, LONDON, E.C.1. Clerkenwell 9406. 62, HIGH HOLBORN, LONDON, W.C.1. Chancery 8266. MANCHESTER: 33, WHITELOW ROAD, CHORLTON-CUM-HARDY. Phone: Chorlton-Cum-Hardy 2028. NEWCASTLE, STAFFS: 47, ALBANY ROAD.





**COMPLETELY SCREENED COILS**

The coils used in the Cossor Empire Melody Maker are completely screened in metal "pots" entirely eliminating direct pick-up, thus further improving selectivity.



**SERIES AERIAL CONDENSER**

The variable Series Aerial Condenser permits adjustment of selectivity to give the fine tuning necessary to cut out powerful local stations.



**EXTERNAL WAVE-CHANGE SWITCH**

Wave Change Switching is effected by operating the switch at the end of the cabinet—"in" for long—"out" for short.



**COSSOR METALLISED SCREENED GRID VALVE**

Even better performance is ensured by the Cossor Metallised Screened Grid Valve which eliminates stray couplings thus improving selectivity.

# All-British Screened Grid Radio

— a high power, 3-valve "All-Europe" Wireless Set for **£6.15!** at a record low price

**N**O matter how much you pay you cannot buy a more powerful 3-valve Receiver than the Cossor Empire Melody Maker.

This remarkable Set incorporates all the most up-to-date features of design. Due to the efficiency of its Cossor Valves the Cossor Empire Melody Maker has an outstanding performance. Its range is enormous. Its selectivity is remarkable. It will bring in all the main European

programmes even while your local station is working. — Even costly factory-built Receivers cannot give better results.

The Cossor Empire Melody Maker is available in two types—Model 234 for use with batteries and accumulator and Model 235 which works from the electric light mains. Send at once for full particulars of the model that interests you—use the coupon below.

*Supplied as a complete set of parts including valves & cabinet Obtainable from all the best Radio Retailers*

## COSSOR EMPIRE Melody Maker

**MODELS 234 & 235 BRITISH MADE**

### Battery Model 234

Price includes latest types of Cossor Metallised Screened Grid, Cossor Detector and Power Valves, handsome oak cabinet and all parts necessary for home assembly of the complete Receiver as illustrated... **£6.15**

*Hire Purchase terms 15/- deposit and 9 monthly payments of 15/-*

### All-Electric Model 235

Price includes handsome oak cabinet, latest types of Cossor Metallised Mains Screened Grid, Metallised Mains Detector, Mains Power and Rectifier Valves, Cossor Heavy-duty Mains Transformer, all the parts necessary for assembling the complete Receiver and full size Constructional Chart.

**£9.19.6**

*Hire Purchase terms 20/- deposit and 10 monthly payments of 20/-*

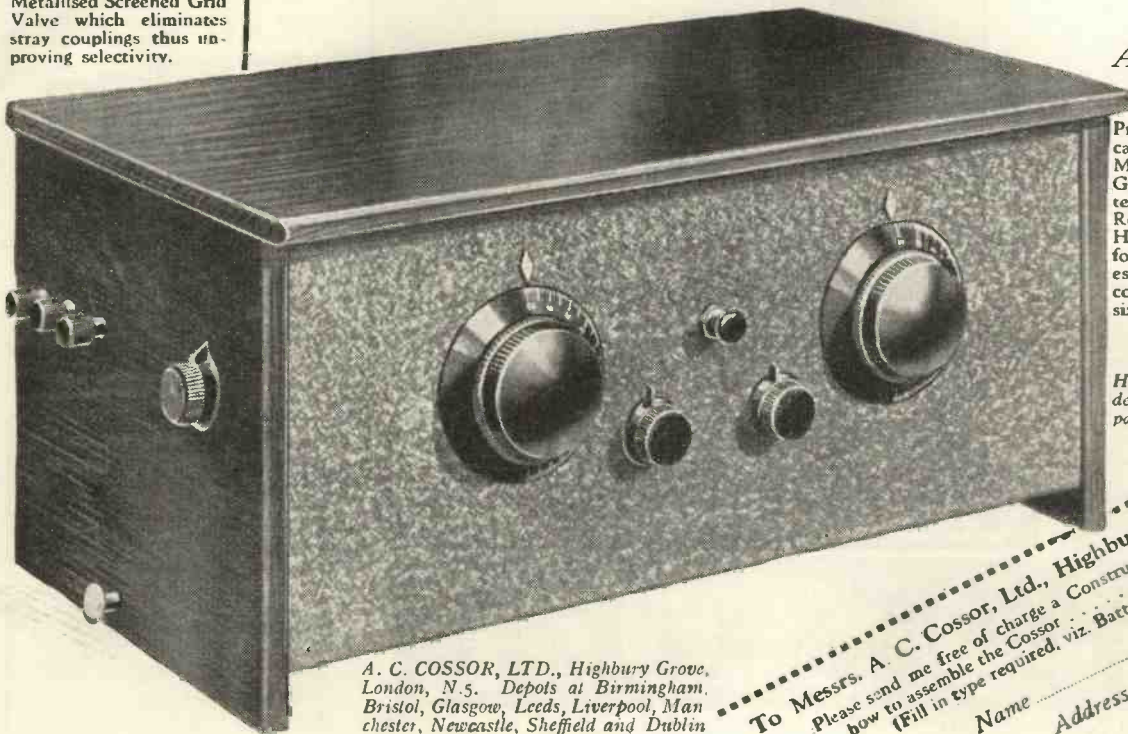

A. C. COSSOR, LTD., Highbury Grove, London, N.5. Depots at Birmingham, Bristol, Glasgow, Leeds, Liverpool, Manchester, Newcastle, Sheffield and Dublin

To Messrs. A. C. COSSOR, LTD., Highbury Grove, London, N.5  
Please send me free of charge a Constructional Chart which tells me how to assemble the Cossor Melody Maker.  
(Fill in type required, viz. Battery operated or All-Electric.)  
Name \_\_\_\_\_ Address \_\_\_\_\_  
"M.W." 11/31  
© 9125



# MODERN WIRELESS



Vol. XVI. No. 59.

BRITAIN'S LEADING RADIO MAGAZINE

NOVEMBER, 1931

## Unique Gift for Our Readers—This Month's "M.W." Sets—The Great Licence "Drive."

THIS month we are presenting to every reader of MODERN WIRELESS the "M.W." Broadcasting Map of the World. This map has taken months to prepare, and if you look into it closely and note the number of stations which our map draughtsman has had to locate and mark on the map you will realise that it was no light task we undertook when we decided to give our readers the most comprehensive broadcasting map of the world ever designed.

The map shows you short-wave stations, television stations, and normal broadcasting stations, and we suggest you have the map pasted against solid cardboard and hung up in your wireless den.

This is the best way to keep the map from tearing or getting crinkled. It would be better still, of course, if you could give it a border of passe-partout.

As a practical means of reference to the location of foreign stations and their wave-lengths it will prove of the utmost value to every owner of a long-distance receiver. And apart from the immediate aid it renders, the map represents the most complete pictorial guide to the world's broadcasting stations that is now obtainable, at any price.

Its index—printed as a part of the map itself—shows you how to locate the stations, and gives the various wave-lengths, the whole forming a complete representation of the world's broadcasting system.

Readers will note that we have marked the map at the extremely low price of 2s. 6d., which will be the cost when this month's issue of "M.W." is sold out. This is likely to happen quickly, so tell your friends to secure their copies while the maps are being given away.

### This Month's "M.W." Sets

THERE are three sets we wish to draw your attention to in this issue:

1. The A.C. "Super-Quad";
2. The "Uni-Coil" Three;
3. The "Lock-Tune" Junior.

The A.C. "Super-Quad" speaks for itself. As our readers will remember, the "Super-Quad" was the first really efficient four-valve super-het to be designed for the home constructor, and already it has achieved wide-spread popularity.

We have received hundreds of letters from readers asking for details of a "Super-Quad" which will operate from the alternating current mains, and the version of the receiver which we publish in this issue will show you exactly how to build this excellent super-het. for operation from the A.C. mains.

The "Uni-Coil" Three is presented in two models. Each model uses a different tuner, so that the constructor is left to choose the one which appeals to him most. In either case you will find this set reasonably inexpensive to build. It is a good, reliable, easily-constructed loud-speaker receiver, which we strongly recommend to your notice.

The "Lock-Tune" Junior is a three-valve version of the well-known "M.W." "Lock-Tune" Four. The "Lock-Tune" Four seemed to attract such attention, and there were so many requests for a three-valve version, that we feel sure the "Lock-Tune" Junior will, as they say, "catch on."

You will note that the design is rather interesting, and has an outstanding feature in the form of a system of centralised and ganged control, so arranged that there is minimum loss in sensitivity. Incidentally, the control is very easy.

You will find this "Lock-Tune" Junior a powerful set, capable of giving excellent loud-speaker results from many distant stations.

### The Great Licence "Drive"

THE licence "drive" by the G.P.O. radio detective vans has had more publicity in the newspapers than is usually given to the divorce of a popular film star.

It is said the "drive" has already proved very successful. Maybe, but it would have proved more successful if the P.O. sleuths had been a little more mysterious about their "mystery" vans.

The average "pirate" probably realises the P.O. mystery vans are not quite so dead certain of locating the pirate set as the P.O. would like the tax-dodgers to believe.

Anyway, about 80,000 pirates are reported to have hauled down their flags in London alone. Net result—something like £40,000 more income from licences. It is estimated by some newspapers that, in all, there are 400,000 pirates in London. If this estimate is correct, what must be the figure for the whole country?





*The Latest Triumph in "Modern Wireless" Technique*

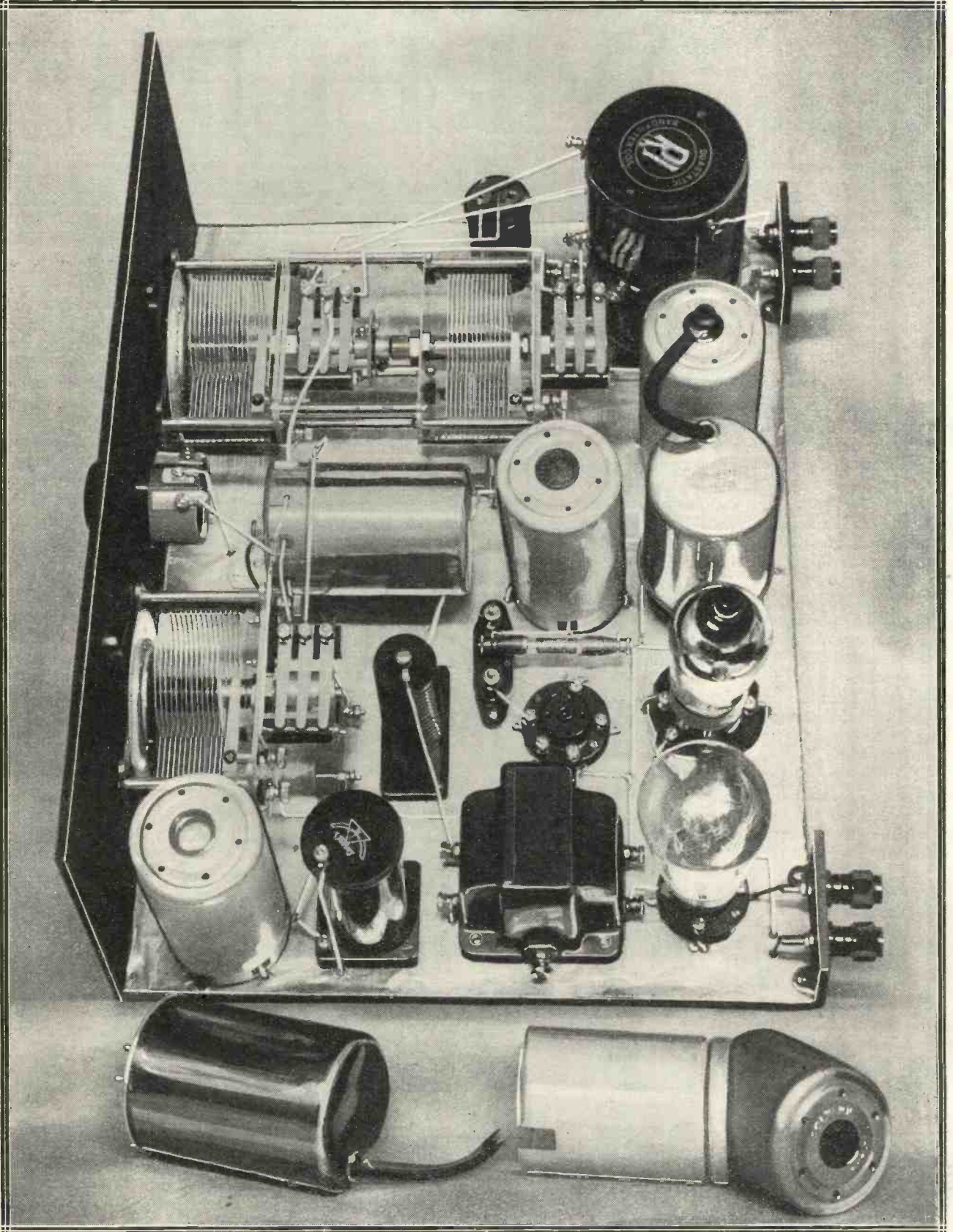



# The "M.W." A.C. "Super-Quad"

Described by  
K. D. ROGERS

A Super-Het. Circuit—Uses Ordinary Aerial—A.C. Valves—Automatic Grid Bias—Self-Screening Components.

"Without Doubt, One of the Finest Sets of Modern Times."

## THE PARTS INCORPORATED IN THIS QUALITY LONG-DISTANCE RECEIVER

### PANEL

16 in. × 7 in. (Perrucol, Peto-Scott, Becol, Wearite, Goltone).

### CABINET

(Ready Radio, or standard type Camco, Peto-Scott, Pickett, Osborn, Gilbert). (Baseboard 12 in. deep).

### EXTENSERS

1 Double-gang .0005-mfd., with cams insulated, and disc drive (Cylidon).  
1 .0005-mfd. single disc drive, with cam not insulated (as above).

### RESISTANCES (see text)

2 600-ohm Spaghetti (Bulgin, Telsen, Varley, Leweos, Graham Farish, Goltone, Lissen, Igranie, Magnum, Ready Radio, Peto-Scott).  
1 700-ohm Spaghetti (Bulgin, etc.).  
2 1,000-ohm Spaghetti (Leweos, etc.).  
1 2,000-ohm Spaghetti (Varley, etc.).  
2 30,000-ohm Spaghetti (Varley, etc.).

1 50,000 volume control (Colvern, Sovereign, Regentone, Varley, Wearite, Igranie).

1 2-meg. grid leak, with terminals, or with holder (Dubilier, Mullard, Igranie, Graham Farish, Telsen, Watmel, Ferranti, Ediswan, Lissen).

### VALVE HOLDERS

4 Large 5-pin (W.B.).  
3 Ordinary 5-pin (W.B., Telsen, Igranie, Lotus, Wearite, Bulgin, Graham Farish, Burton, Lissen, Clix).

### FIXED CONDENSERS

1 .0003-mfd. grid condenser (Ferranti, Mullard, Graham Farish, Telsen, Ediswan, T.C.C., Dubilier, Igranie, Lissen, Goltone).  
1 .002-mfd. (Telsen, etc.).  
1 .0001-mfd. (Telsen, etc.).  
3 1-mfd. (Formo and T.C.C., Dubilier, Telsen, Igranie, Lissen, Helsby, Ferranti).  
1 2-mfd. (T.C.C., etc.).  
1 .04-mfd. (Dubilier non-inductive).

### CHOKES AND COILS

2 H.F. chokes (Leweos, Varley, Ready Radio,

Telsen, Sovereign, Atlas, Lotus, Graham Farish, Parex, Wearite, R.I., Tunewell).

1 Band filter coil (R.I., Leweos, Varley band-pass coil).

1 Oscillator unit (Wearite type A.C. extender, Leweos, Colvern type K.O.M.W.).  
2 Band-pass intermediates (Wearite, Leweos with pigtailed, Colvern).

### TRANSFORMER

1 L.F. (Telsen 1-7, R.I., Ferranti, or medium ratio Igranie, Graham Farish, Varley, Mullard, Lotus, Leweos, Lissen).

### MISCELLANEOUS

4 Screening covers for valves (Colvern, type V.S.).  
2 Two-terminal mounting blocks (Sovereign, Belling & Lee).  
4 Indicating terminals (Belling & Lee, Ealex, Igranie, Clix, Goltone).  
Metallised flex, flex, screws.  
Glazite, Laeline, Jifflinx, Quickwire.  
H.T. plugs, etc. (Belling & Lee, Clix, Igranie, Ealex).

If you were asked which was the most sensitive type of circuit for radio-telephony reception on medium and long waves what would be your answer?

Or let me put it a little differently. Supposing you had the choice of a set containing anything up to five valves and were asked to design a circuit which would make the most of these five valves, what sort of receiver would you choose?

They are difficult questions to answer, there are so many things to be considered: for in our choice of five valves we can have one, two, or even three stages of H.F., or, alternatively, three, two, or one L.F. stage. Sensitivity, which means not only volume on the local station, but what is more important still, the power and ease of operation to get distant ones, is the first consideration, and therefore one H.F. and three L.F. stages is out of the question.

### Simplicity of Tuning

Three H.F. stages are no longer wanted nowadays, so we are left with the two H.F. and two L.F. stages. A good arrangement, you say, but unless it were ganged somewhat difficult to control. And difficulty in control or tuning means in effect loss of sensitivity.

We could band-pass the circuit and gang it, but the difficulty in construction and screening would be immense, and although undoubtedly we should get a very sensitive receiver at the end of it, the difficulty in construction and of adjustment rather precludes this style of circuit from

being the success that the general listener demands, and which we might wish.

On these grounds, therefore, the two H.F. and the two L.F. circuit must be abandoned. What, then, is to be done? A little thought will clearly show that the super-het. type

## BALANCED CONTROL ON BOTH WAVE-BANDS

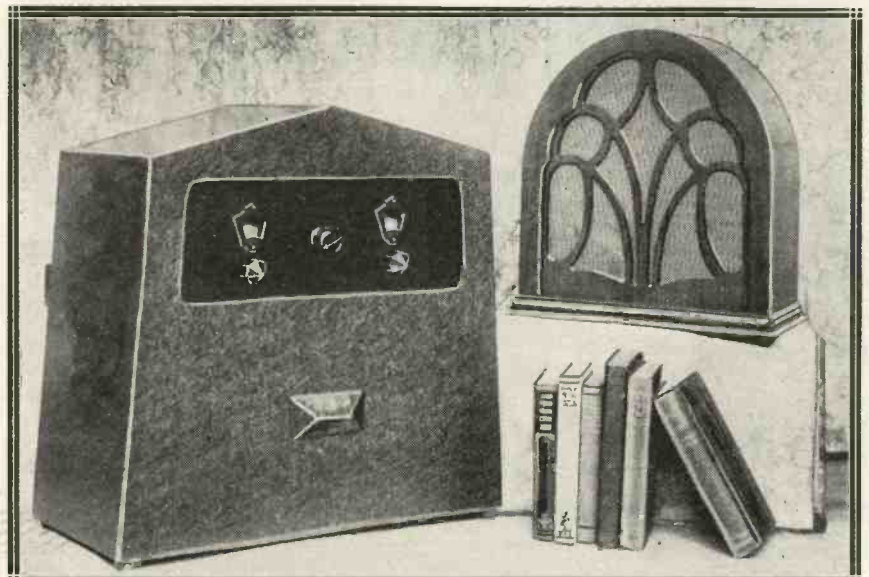

In operation the volume control (centre) is seldom readjusted, but station after station comes in clear-cut and with wonderful volume as the two tuning controls are rotated. Note that there is no need for switching at all, the long and ordinary waves being completely covered by the Extensers.



of receiver is undoubtedly the best combination of five valves if we want to combine sensitivity with ease of adjustment, ease of tuning, and simplicity of construction.

Having decided that the super-het. is undoubtedly the best type of circuit, the thought will probably strike you that if we can make the super-het. of mains valves (either A.C. or D.C.),

using indirectly-heated valves, we shall get the acme of sensitivity with the maximum of controllability.

How shall we best use our valves? This is obviously the next question,

## Coloured Leads Simplify the Oscillator Unit Wiring

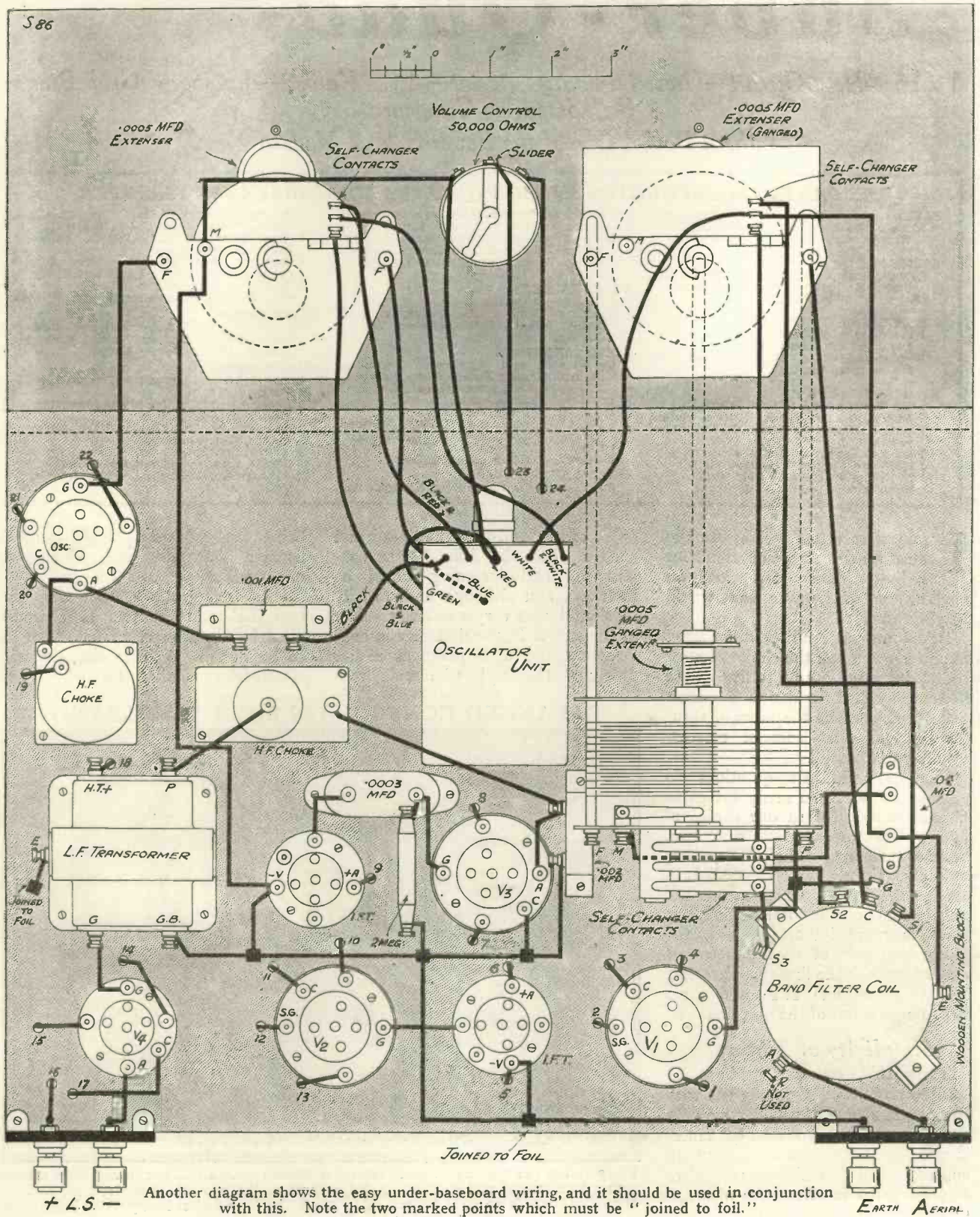

Another diagram shows the easy under-baseboard wiring, and it should be used in conjunction with this. Note the two marked points which must be "joined to foil."

★ L.S. —

EARTH AERIAL



## Two-Band Tuning Without Any Switches

and answers itself by force of circumstance. At the present moment there are no double-grid mains valves available, so that a separate oscillator is a necessity.

The position does not really affect the pulling power of the set, because the separate oscillator is really as good in the way of providing oscillation as the double-grid valve, and it gives us a chance to use a screened-grid valve as the first detector or "mixer" valve—thus producing a very sensitive arrangement for the first two valves.

### Separate Mains Unit

The remaining three valves obviously fall into the categories of intermediate, detector, and note-magnifier. And there we have our set.

The choice between A.C. and D.C. valves was made in favour of A.C. because there is undoubtedly far more demand among home constructors at the moment for A.C. than for D.C. But you will notice on looking through the photographs and the diagrams that though it is an A.C. receiver, the set part itself is kept completely free and separate from what may be called the mains portion.

In fact, it was decided that it would meet home-constructors' requirements far better if this latter were a commercial unit, giving H.T. and L.T., which could be attached to the receiver either externally or placed in the bottom of the cabinet, rather than included in the wiring and layout of the set itself.

A good commercial unit has its advantages over the home-constructed one in that it is usually far more compact, and in the one we have chosen it carries with it a three-years' guarantee against breakdown due to faulty workmanship. Moreover, there is little chance of any danger arising or any trouble occurring due to faulty connections or bad wiring.

### Based on Famous Circuit

The circuit is based upon the famous "M.W." "Super-Quad," described last month, and which created such a sensation at the MODERN WIRELESS stand at Olympia; but for the purpose of the A.C. version of the "Super" we have used a different type of

## Four of the Valves are Separately Shielded

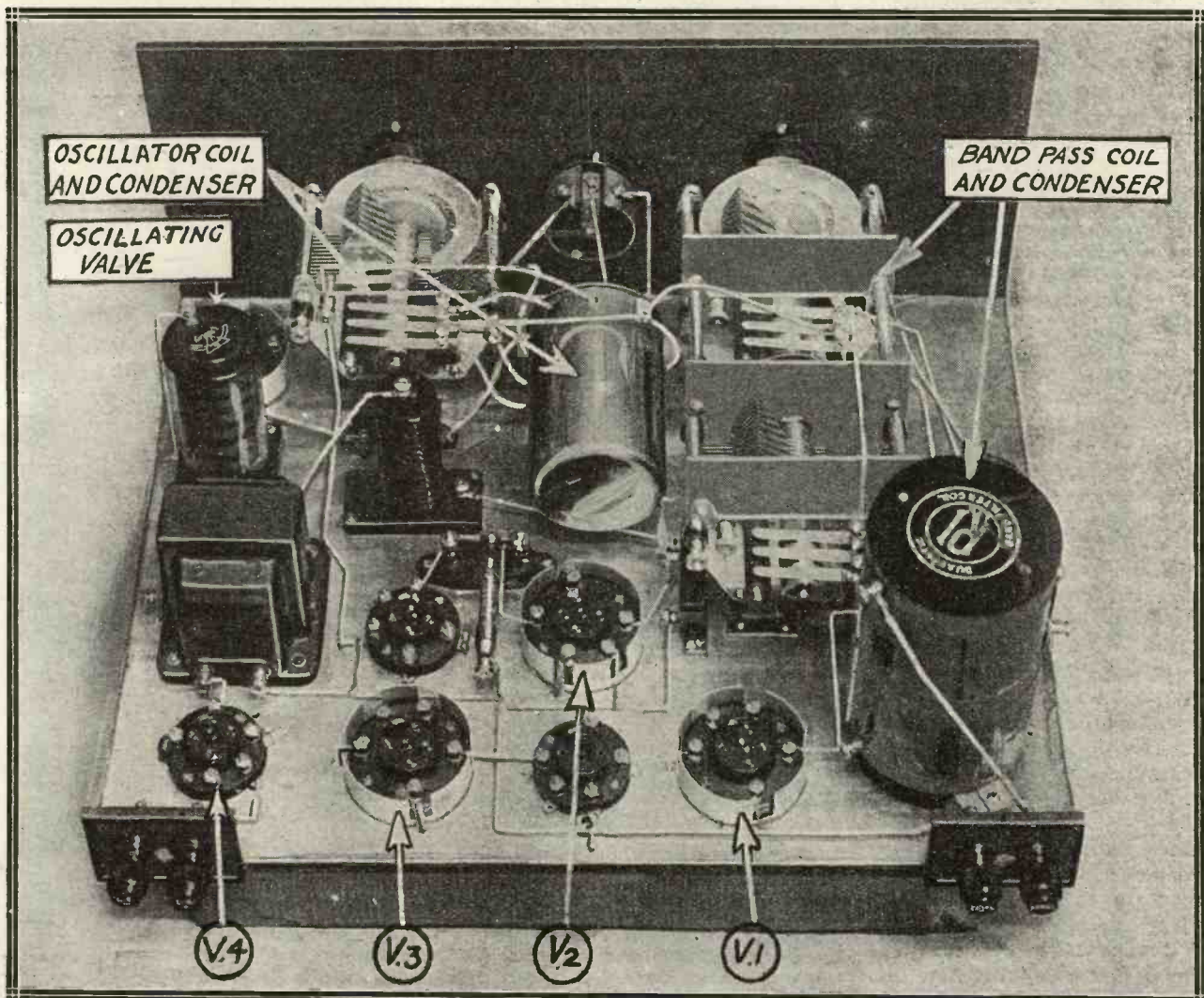

The valves  $V_1$ ,  $V_2$ ,  $V_3$  and the oscillator valve are contained in special shields which fit on to metal bases in which their valve holders are fixed. These bases and other important items are easily spotted in this photograph.



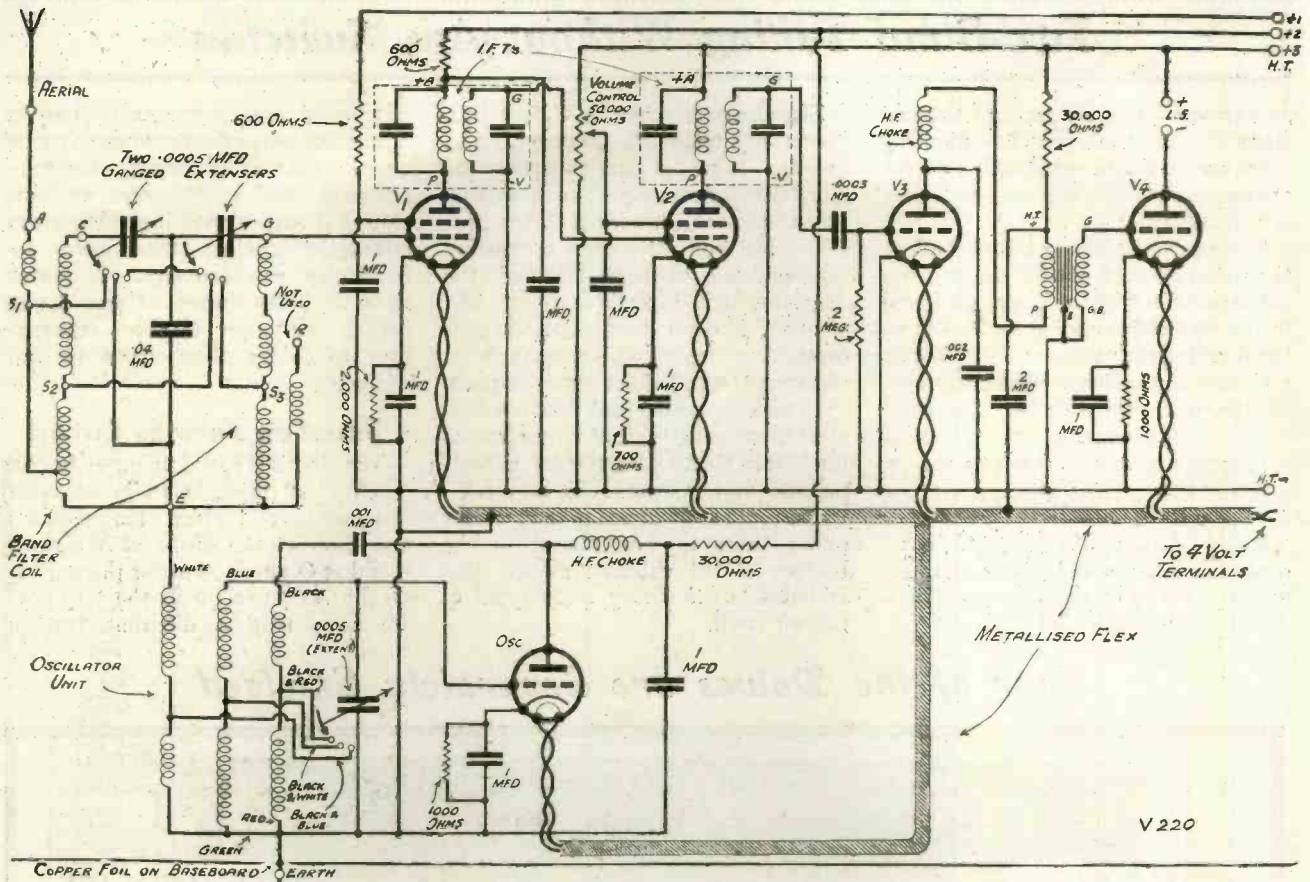

The circuit is discussed in detail in the article, and its main features will be clear from this diagram. The oscillator valve and its associated tuning components are grouped below the remaining part of the circuit.

cabinet, which can be used as an alternative to the ordinary "American" type of cabinet for the housing of the set. In this we can place below the receiver itself the mains unit, thus keeping the whole set perfectly compact and convenient.

**Using Ordinary Cabinet**

For the sake of those who use a standard cabinet, however, the set has been designed on a standard-sized panel and baseboard, and only one very slight alteration in the design has to be made when the American type of cabinet is to be used. This consists of using an 8 in. by 14 in. panel instead of a 7 in. by 14 in., and mounting the baseboard up on the panel, so that a convenient space is left underneath for the de-coupling condensers, which in our model are fixed to the two battens running along the baseboard on the underside.

As in the case of the battery "Super-Quad," the results obtained from this receiver are simply remarkable. The ease of tuning could not possibly be improved upon, and the combination

**HOUSING THE POWER UNIT**

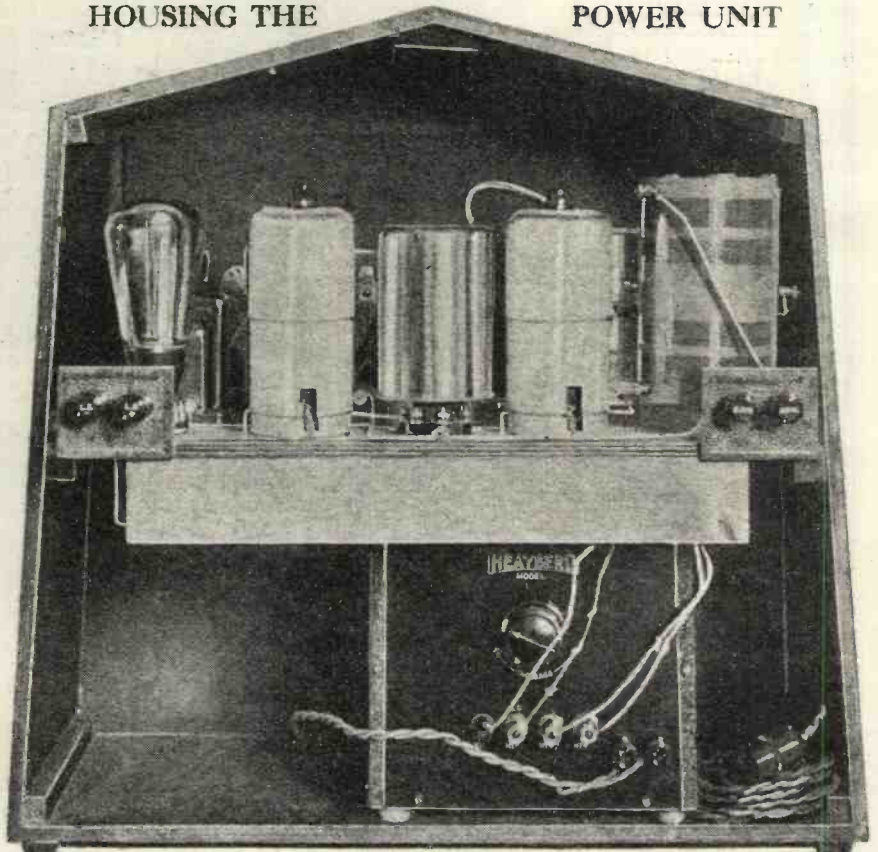

There is plenty of room for a big unit inside the cabinet, as shown. (The two left-hand terminals on this, by the way, are not used, and in the later Healyberd models supplied for this set they are omitted.)



## Power Obtained from a Separate Mains Unit

of Extenser control and band-pass aerial circuit enables the maximum selectivity and ease of handling to be obtained.

It is a set with which you cannot help getting stations. As you slowly turn the oscillator and the tuning condensers, stations come in one after the other with almost monotonous regularity, and, such is the sensitivity of this set, almost monotonous equality of volume.

### No Reaction Necessary

There is never that getting hold of a faint station and struggling to bring it up with the aid of reaction. No reaction whatever, except, of course, the inherent reaction of the oscillator valve, is employed in the set; and do what you will, you cannot make it go into a howl. The volume control is included expressly for the purpose of decreasing volume, and not for bringing in a second oscillation in order to coax in a weak transmission.

It operates in potentiometer fashion on the screening grid of the intermediate H.F. valve, and as these valves vary somewhat plenty of latitude of control is of value. With the knob turned well to the left you get less volume, or with it well to the right you can go right up to the peak point of sensitivity of the H.F. valve, and just a little bit beyond it as you increase the screening-grid voltage to rather more than its most sensitive value.

### Sensitive Detection

With the mains unit recommended for use with this receiver there is a voltage control intended for use in ordinary sets for the screened-grid H.F. amplifier, but we use it to control the voltage on the screening grid of the first detector, or "mixer" valve, and by this means can adjust it to its most sensitive condition, thereby doing away with the need of adjustable grid bias on that valve.

Consequently, the biasing of the whole receiver is perfectly automatic and does not have to be set by the constructor at all. It is done in the usual way by by-pass resistances in series with the cathodes of the valves. These values as given are suitable for most valves, but it is advisable to check up the resistance values with the valve makers, or by the valve curves.

Tuning-in stations with this receiver is perfectly uncanny. You will be turning the knobs with absolutely dead silence in the speaker until suddenly a programme will arrive at practically its full volume. A slight adjustment of band-pass or oscillator tuning control will bring it up to its maximum volume and there you are. When you want to change your station, you simply

controlled by a double-gang Extenser of the Cyldon disc-drive type. This is an important component, because unless it is perfectly constructed the double-gang arrangement of the set will be completely ruined.

The Cyldon Extenser is supplied with an insulated metal cam, which makes contact with the three springs as the extenser rotates into the medium-wave position. This

### HOW IT LOOKS BEHIND THE PANEL

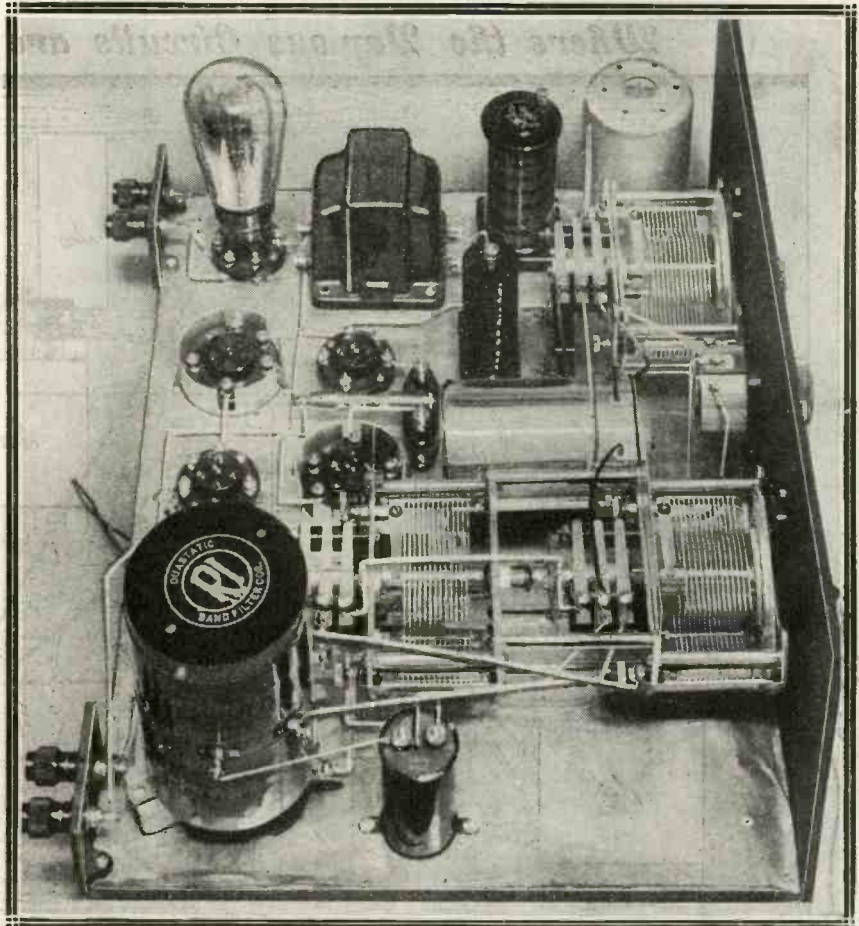

The compact coils make the wiring quite an easy job, as can be seen here. Note how the band-pass coil is raised by a block of wood to keep it well clear of the metal "floor."

turn the dials slowly, the programme immediately disappears and another one takes its place as soon as the wavelength of the receiver is correctly adjusted.

The absence of fiddling and what is usually known as searching is one of the strongest points of this remarkable receiver, which is without doubt one of the finest sets of modern times.

But to get on with the constructional details. As you see, a band-pass aerial coil is fitted, and is

cam is supplied with two fixing screws, small grub screws, which clamp it to the main spindle, and also one central grub screw which, when the extenser is to be used with a band-pass coil, must not be screwed home.

### The Extenser Cam

This is very important, because this cam is a universal one, and can be fitted either insulated from the moving spindle of the extenser, or else in metallic contact with it for use in circuits in which a common



## It Multiplies Your "Alternatives" Amazingly

connection between the spindle and the cam is required.

This central grub screw is for this purpose, and when screwed right home makes contact between the cam and the moving spindle. When it is not screwed home this contact is absent, and the cam is insulated from the rest of the extenser except when it is rotating against the three contact springs.

Provided with the extenser will be a leaflet explaining this point, but we

receiver, but there are one or two points which should be brought forward. The first is our usual point concerning the layout, which is even more important in this set than ever. This must be kept exactly as shown.

### Position of B.P. Coil

It will be noted that the band-pass aerial coil unit is well at the back of the receiver, and that there seems to be a waste of space between the aerial unit and the panel to the left

Another point in particular is this. A special oscillator coupler for this set has been made by the firms mentioned in the list of components, and this special coupler must be used. It has more contacts than usual and has been specially designed for use with an extenser oscillator control and separate oscillator valve. The leads to the oscillator coupler are coloured, and it is absolutely essential that the connections to this oscillator be correctly made, and that no other

## Where the Various Circuits are De-coupled

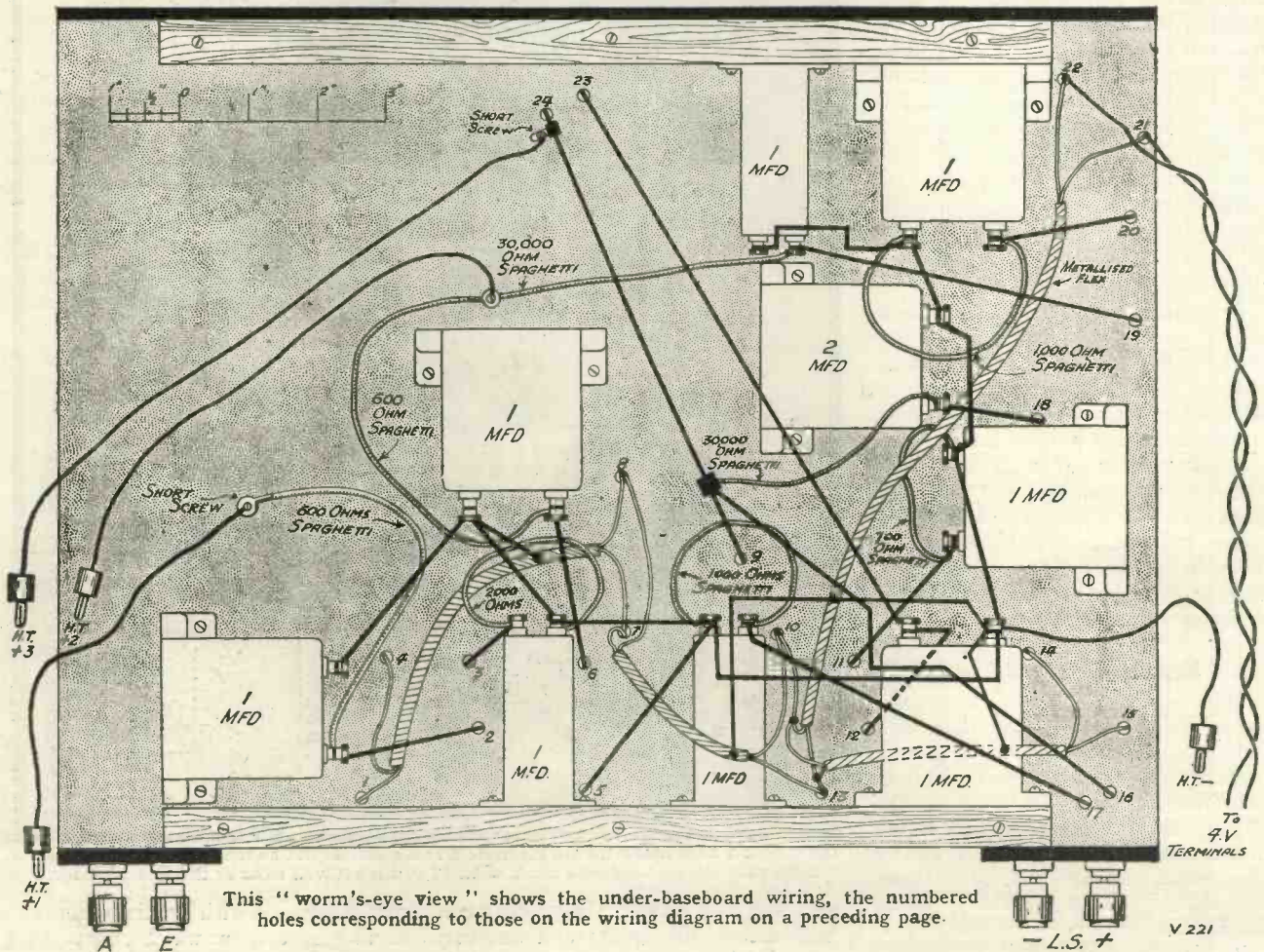

mention it here because it is a very important feature, and unless fully understood can completely ruin the operation of the receiver. When using the Cyldon extenser in this set do not screw home the main central grub screw. The cam must remain insulated from the central spindle of the extenser.

There is not very much to be said about the actual construction of the

of the condenser when looking from the front of the set.

### Short Leads Employed

This space was left for a definite purpose, because it is essential that no long leads be taken between the aerial tuning unit and the "mixer" valve, and you will find that short grid and plate leads are features throughout the set.

type of oscillator be substituted for it.

There are no screens in the receiver in the ordinary way, but a metal-covered baseboard is employed. This assists in shielding the heater wiring from the grid and plate circuits of the set, while Colvern cans are used over the valves. These not only act as useful screens, but greatly add to the appearance of the set, which we think



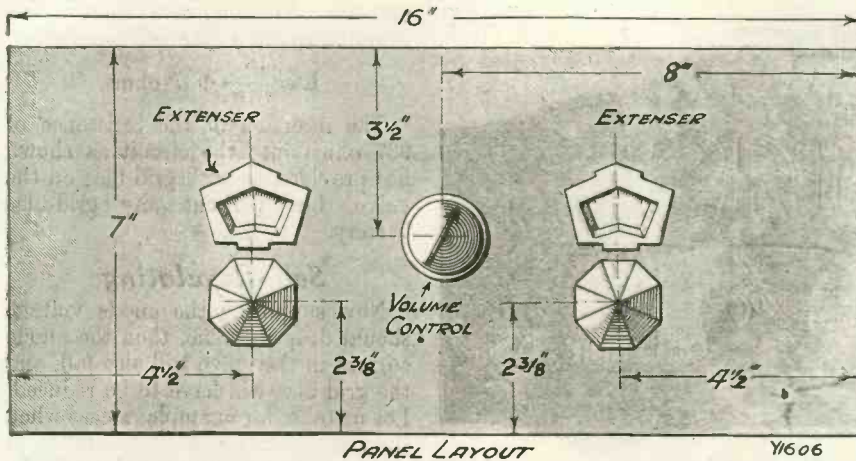

The panel simplification is backed up by an uncanny ease of operation. When on long waves the dial readings are red, and they are black for medium waves, there being no switching to bother about.

you will agree looks a very "professional" job.

A word about the heater wiring. This is carried out with braided flex as supplied by the London Electric Wire Co., Ltd., and the braid, which consists of copper, is earthed throughout the set. As the de-coupling resistances and condensers and the automatic grid-bias components, together with the heater wiring, are placed underneath the baseboard, two wiring diagrams are supplied, and the points where the wires go through the baseboard are numbered.

### The H.F. Chokes

A further important feature about the set construction concerns the H.F. chokes in the detector and oscillator circuits. These chokes must be of good and reliable make. Consequently, it is advisable to keep to the components specified in the list, especially where these chokes are concerned.

Little more need be said about the construction of the receiver except that it should be carried out very carefully, and every connection should be tested to see that it is O.K. before the receiver is put on final test.

### Three H.T. Tappings

There are three H.T. positive tappings and one negative tapping which go to the mains unit. No. 1 goes on to the socket on the mains unit which is marked "S.G."; No. 2 goes next door to it; and No. 3 goes next door to that. The flexible wires taken down from the heater of the oscillator valve are joined to the mains unit L.T. terminals, the aerial and earth and the loud speaker are put on and the set is ready for use.

As regards valves, the makes shown in the list of accessories are perfectly

satisfactory and these should be adhered to if success is to be achieved.

### Valve Screening Cans

There is one other point in the construction which we ought to have mentioned and that concerns the Colvern cans. It will be noted that in the case of four valves the large W.B. valve holders are used, and in the other case a small one. The large ones are employed because they exactly fit the Colvern cans, the bases of which have slots corresponding to the terminals on the valve holders, while the top portions of the cans are telescopic and adjustable to

height. The cans, of course, are earthed by their contact with the metal foil on the baseboard of the set, which it completely covers. By the way, if the Colvern oscillator and intermediates are used you will find there are only six (instead of eight) flexes from the oscillator to join up. These are connected according to colour, as represented in the wiring diagram, and the other connections are not necessary with this particular model.

### ACCESSORIES

Loud Speaker. (Amplion, Undy, H.M.V., Celestion, Blue Spot, B.T.H., Mullard, W.B., Graham Farish.)

Valves. 2 A.C./S.G. valves, 2 A.C./detector valves, 1 A.C./power valve (Mullard, Mazda, Cosmor, Osram, Six-Sixty, Tungram, Eta). (The bias resistances for the S.G. valves vary slightly in value according to the make, and the correct value should be obtained from the makers. Usually 700 ohms is about correct for the amplifier and 2,000 ohms for the S.G. detector.)

Mains Unit. (Heyberd type M.W., Tunewell.)

As regards the operation. Having placed the valves in their positions,  $V_1$  being the "mixer,"  $V_2$  the intermediate H.F. valve,  $V_3$  the detector,  $V_4$  the output valve, and the remaining one the oscillator, the adjustments are made on a fairly weak station.

(Continued on page 522.)

### BELOW-THE-BASEBOARD BY-PASSING

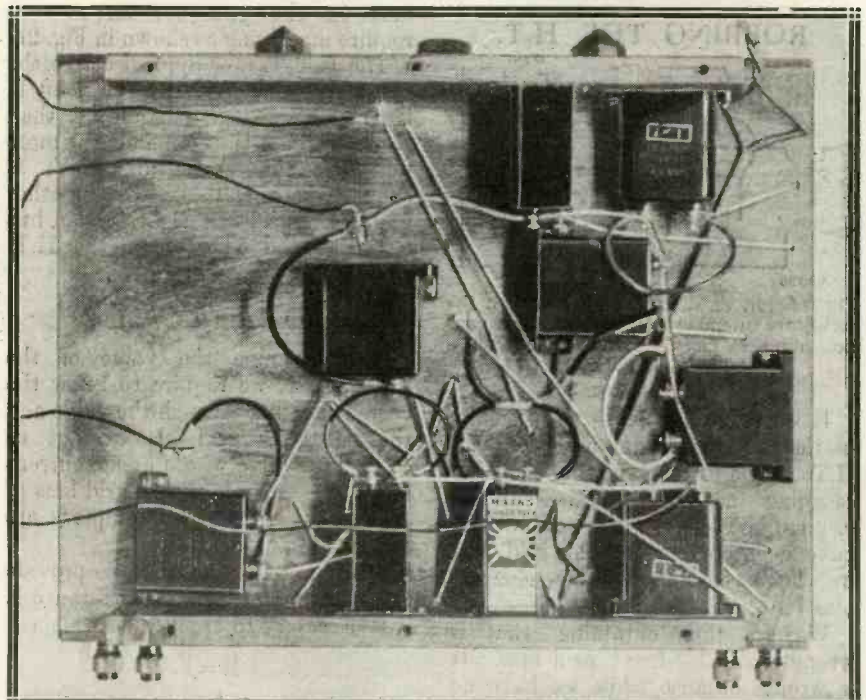

Careful de-coupling is a feature of this receiver, and all the resistances and condensers for this purpose are tucked away out of sight, below the baseboard.



# GETTING GRID BIAS

Is there such a thing as "Free G.B."? And, anyway, how is it obtained? This article interestingly answers those questions.



IN the reports of various sets one reads that automatic grid bias is provided. Sometimes the term "free" grid bias is used. Let us see just what these terms mean.

In a battery set we generally have three batteries—the filament accumulator, the high-tension supply, and the grid-bias battery. These are connected as shown in Fig. 1A, which shows a one-valve amplifier.

## One Big Battery

It will be observed that the grid-bias battery is really a continuation of the high-tension battery. That is, if the H.T. supply is 120 volts and the grid-bias battery 9 volts, from H.T.+ to G.B.— will read 129 volts on a voltmeter. The battery connections only are shown in Fig. 1B.

## ROBBING THE H.T.

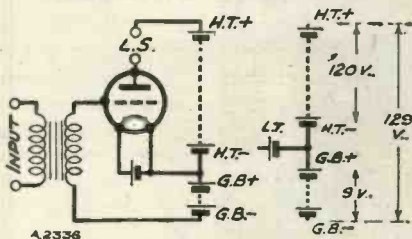

Fig. 1A (on the left) and Fig. 1B (on the right) are intended to show that you cannot take G.B. from the H.T. battery without losing H.T. volts.

If we take our L.T.— to +9 volts on the H.T. battery, giving us only an H.T. value of 111 volts, then by plugging in the grid bias—at the original H.T.— terminal we shall still have negative bias on the grid, but we have eliminated the separate bias battery.

We are thus obtaining what is wrongly called "free" grid bias. It is wrong, because while we have no separate battery for grid bias, we still have bias on the valve, but—and this

is important—it is at the expense of the H.T. potential.

A wireless set is like any other power unit, something cannot be obtained for nothing.

## Certainly Not "Free"

This is the principle of all "free" grid-bias connections, namely, we obtain grid bias at the expense of the high-tension supply. Let us apply this idea to an A.C. set, or a set with an H.T. eliminator, and let our circuit be a one-valve amplifier as shown in Fig. 2A.

The grid is now at a negative potential compared to the filament. This is what we require for grid bias. Supposing we have no suitableappings on the eliminator, but just H.T.+ and H.T.—, then to obtain bias on the grid our circuit will require modifying as shown in Fig. 2B.

The H.T. is now applied across the valve and resistance R. The point K is thus at a higher potential than H.T.—. That is, the filament is more positive than the grid, which is connected to H.T.—. Or, in other words, the grid has negative bias, but again at the expense of the H.T. voltage.

## How Many Ohms?

To determine the value of the resistance R we require to know the current passing through the valve and the necessary grid bias. Let us consider a valve whose anode current is 16 milliamperes with a grid bias of 15 volts. Then 16 milliamperes are also passing through R.

By Ohm's Law, in order to provide a voltage of 15 across the resistance R it is necessary to apply the formula:

$$R = \frac{E}{C}$$

Where E is the required volts across R, and C is the current in

amperes. Applying our values in this formula we have

$$R = \frac{15}{.016} = 937 \text{ ohms.}$$

The insertion of the resistance of 937 ohms into the circuit as shown has provided us with grid bias on the valve, but without any grid-bias battery.

## Self-Regulating

Now supposing the anode voltage should drop in value, then the anode current in the valve will also fall, and the grid bias will have to be reduced. Let us take, for example, a case when the voltage on the anode has fallen so that the current passing through the valve is reduced to 12 milliamperes.

We still have 937 ohms at R, but owing to the reduced current the volts across it are now reduced according to the formula:

$$R \times C = E, \text{ or } 937 \times .012 = 10.5 \text{ volts.}$$

Thus the bias volts have been reduced automatically from 15 to 10.5. This is called "automatic" grid bias.

This principle may be applied to any number of valves, provided we consider the total current passing through R and the various grid-bias voltages.

## "AUTOMATIC" G.B.

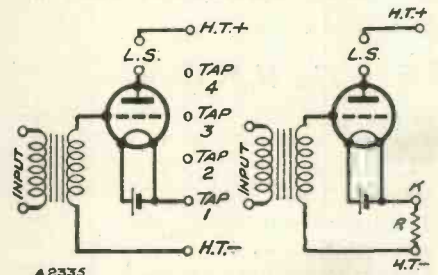

Fig. 2A (left), Fig. 2B (right). Applying mains grid bias to a one-valve amplifier.

## GERMAN JOTTINGS

ON March 31st last there were 3,731,681 radio listeners in Germany. Compared with the figures published on December 31st, these figures show an increase of 6.3 per cent, and compared with the figures for the previous year the increase is 15.2 per cent.

A new high-power station is to be built close to Munich. It will be one of eight at present being built in Germany, of which three are already in operation—Heilsberg, Mühlacker, and the new Königswusterhausen. It will probably be ten miles due east from Munich and will be ready for tests about May, 1932.



# The Manchester Exhibition



An interesting article about the Northern National Radio Exhibition, by a member of the "M.W." technical staff.

**L**ONDON, Manchester, Belfast, Glasgow! The radio trade is being kept busy for some weeks bustling round from exhibition to exhibition as the public demand of "What's the Latest?" is answered all over the country.

British broadcasting has been going on for some eight years now and yet records are still being broken at the chief radio exhibitions, both for the number of firms exhibiting and the number of people who come to examine their goods.

## Continually Expanding

More space was taken at Olympia, London's show centre, this year than ever before, and I hear that the whole of the floor space is to be occupied next time. Doesn't look like a failing industry does it?

And a great echo of Olympia has been ringing round the City Hall, Manchester. The north has always been enthusiastic where radio is concerned, and now that the two twin Northern stations are in full operation the interest in things "ethereal" has increased tenfold.

Witness the show at Manchester—the centre of the Northern radio region and trade axis of the north. Never before has such tremendous energy been put into the presentation of radio developments outside London. The organisers of the Manchester show—the "Manchester Evening Chronicle"—have this year combined with Provincial Exhibitions, Ltd., and the Radio Manufacturers' Association to "show the world" in no uncertain manner.

## A Huge Success

And they have surely succeeded. The Northern National Exhibition has been the biggest success that the north has known. Everybody,

or so it would seem from the crowds thronging the City Hall, has not only been there, but been twice.

## Every Stand Different

The City Hall is not too inviting externally, but—inside! And didn't those radio firms let themselves go in the decorative schemes.

None of that polite blue and gold, everything standardised, appearance that does much to make the London show a formal, official business. No, the Mancunians let themselves go when it came to colour, and splashed it on with a lightheartedness and abandon that was a joy to see.

Not that the effect was inharmonious—not a bit of it. On the contrary, the result was a warmth of tone that spelt welcome in a way even more certain than if it had been emblazoned in flaming letters across the interior of the building.

## A Marked Contrast

The contrast between Manchester and London is marked indeed. You feel in London that the people at the Radio Show are "quite glad to see you" and they have made things perfectly "nice" for you, but up north there's a "that's the stuff to give 'em" spirit that makes you

feel they are welcoming you with open arms, with a "come along in; what do you think of this?" expression. London is grand in its stateliness, but Manchester is glorious in its sheer enthusiasm.

## COVERS ALL WAVE-LENGTHS

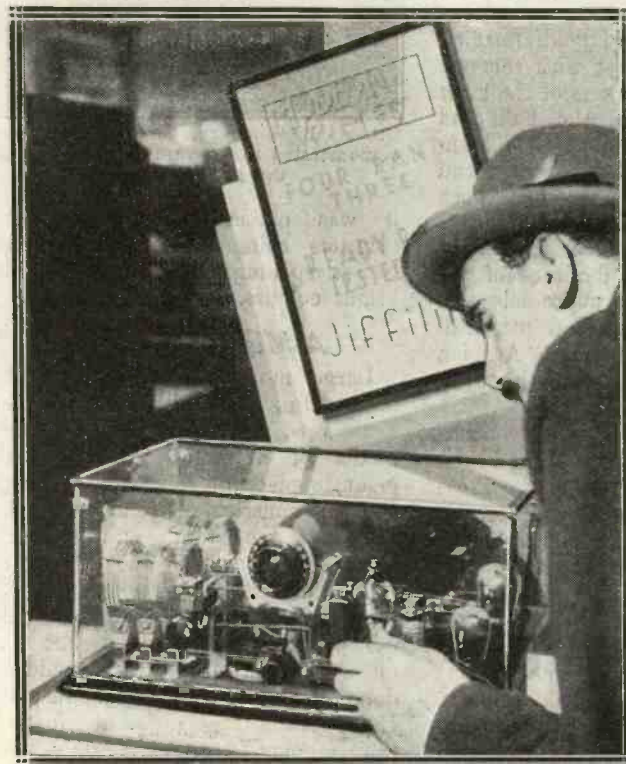

Examining a glass-panelled model of the "M.W." "Four-Band" Three—which was on show at the recent Exhibition.

## Full of Energy

As I said before, the interior of the City Hall during the North National Radio Show was a perfect riot of colour, no two stands were alike and yet the effect was as perfect in harmony as a blazing flower garden in June.

Shorn of restrictions we saw our old Olympia



## The North is to be Congratulated on Her Show

friends vying with one another to attract the attention of the visitor. And they were all there, too: Lotus, Ward and Goldstone, Colvern, G.E.C., Exide—all the old friends.

### The "Polar" Bears

Polar's (Wingrove & Rogers) had a fine pitch near the entrance, whence they announced their presence with two gigantic Polar bears. Farther on we came to the gaily decorated stand of Pertrix, the famous battery people; while Mullard and Ediswan, not far apart, challenged each other in decoration and ingenuity of exhibit.

Huge models of P.M. valves supported the counters of the Mullard stand, while Mazda had repeated their characteristic display and in addition invited the public to come and test their valves.

For this purpose a special collection of meters had been arranged so that by pressing a button the valve inserted in the valve holder had its characteristics taken and read off from the meters. A novel and valuable "stunt," for "seeing is believing."

### An "Eastern" Touch

Passing on, after taking the pulse of the valve, one was struck by a flash of blue, red and gold, forming a very strong contrast with the rest of the show. It was one of the most original dressings in the hall, and gave one the impression that Manchester and its traditional rain had vanished and that we had been transported to the East.

We expected to see the stand inhabited by dusky denizens of the desert instead of the polite salesmen and demonstrators of Ferranti, Ltd. For this corner of the "Arabian Nights" was the temporary home of this famous transformer firm.

Almost next door another concern well known in "L.F." circles had their stand. This was R.I., Ltd., whose chief exhibit was a group of Stenode receivers in the centre of the stand, surrounded by components of all kinds.

### Components Galore

Igranic, nearby, were showing one of their big public address amplifiers, in addition to a full range of components.

Telsen—the well-known component manufacturers—had laid

themselves out to attract the home-constructor. Huge models of their various components, sets from the Telsen blue prints, and all sorts of interesting displays were in evidence on this attractive stand.

Sydney S. Bird was showing the famous Extenser in great prominence, together with a model of the "M.W." "Super-Quad," while Messrs. Formo included a number of Extensers and the "Wireless Constructor" "I.E." receiver among their exhibits.

Cossor's stand was one that caught the eye in no uncertain manner, for

### SOME TURNTABLE!



One of the huge gramophone turntables demonstrated by Garrard, compared with the normal article.

it was particularly original, the counters being supported on great letters spelling the firm's name in bright colours.

### A Mighty Model!

Large models are becoming the usual thing in exhibitions, but the last word was the Westinghouse model of a metal rectifier. This gigantic piece of work was so large that it constituted practically the whole of the stand, and, in fact, the "office" was in the interior of the edifice.

The Manchester Show not only deserved to be a success, but was an eye-opener as to what could be done in the way of radio display. Every stand was different, for all the famous firms not only had their own ideas as to what constituted an attractive decorative

scheme, but many were allowed to express themselves as they liked. The result was stupendous. Manchester certainly can show how to run a radio show.

\*\*\*\*\*  
**THE "SHORT-WAVE" THREE**  
**IN KENYA**  
*An Appreciation from an Overseas Reader.*  
 \*\*\*\*\*

Sir,—I am sure you will be interested to know how the "M.W." "Short-Wave" Three, which appeared in your issue of October, 1930, works, half a mile from the Equator!

I had made several sets in England, but had never even heard a short-waver, or had anything to do with them. I wrote to a friend in England asking him to send me a good circuit out, along with all the necessary components.

While the cabinet was in the making I had the set working on a small table, and really must say that results far exceeded my fondest hopes—having made several adjustments and tried different valves. Without the L.T.—, etc., connected to earth, the set was very unstable, but making this connection soon put matters right, and the only remaining trouble was very bad hand-capacity, this only holding good, however, in the case of about 18 metres to 30 metres.

### No Hand-Capacity

Screening made little difference. But as soon as the cabinet was ready, and the set and batteries installed, volume increased and hand-capacity totally disappeared. The upkeep of batteries is the main trouble out here. For charging my accumulator I use an old car dynamo driven from a grist mill, and this worked very well indeed.

But as regards results. The weather affects reception to a great extent. For instance, when the evening is cloudy, Nairobi—the local station—comes through with very good volume, while Chelmsford is best on a fine, starlight night. Stations received on the loud speaker are:

Nairobi, Chelmsford, Rome, Paris, Moscow, Saigon, Schenectady, Pittsburg, P.C.J., and a German whom I have not placed yet, while I have several amateurs. Thanking you for a jolly good circuit.

W. A. NORTH.

Kenya Colony.



# THE WORLD'S PROGRAMMES HOW, WHEN AND WHERE TO HEAR THOSE FOREIGNERS

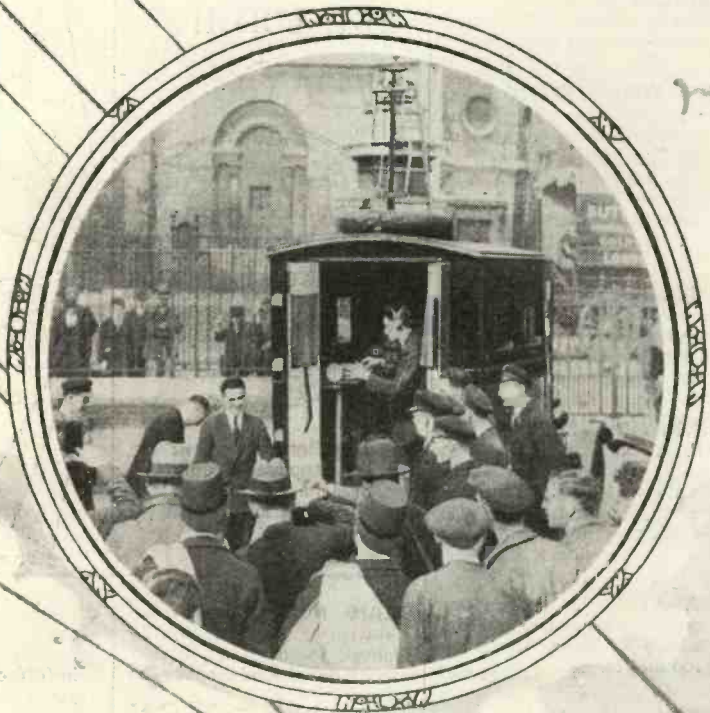

All the excitement in the circle above is due to a "radio detective" van in operation near St. Martin's-le-Grand, London.

## CONTENTS OF THIS SPECIAL SUPPLEMENT

Station Information	What the Distant Stations are Doing
Radio in Berlin	The "M.W." Map
News from Far and Near	When Those Foreign Announcers Speak
How Many Miles?	
Countries to Listen For—Italy	





# STATION INFORMATION

News and Views about Radio Stations, Culled from all Parts of the World.



**KALUNDBORG** has joined the band of European stations to employ lady announcers.

**IRISH FREE STATE'S** new transmitter, to be erected in the Athlone district, is now being manufactured at Chelmsford. It will be much more powerful than any B.B.C. transmitter—probably 120 kw.

**BRESLAU** is expecting its new transmitter to be testing within the next four months.

**NEW YORK'S** television announcer, Miss Towers, has already had a proposal of marriage from an engineer who tuned in W 2 X A B, and was charmed with her voice and features, as heard and seen "over the air."

**SCOTLAND YARD** has recently made several important captures by means of its radio communications to the Flying Squad.

"**STRATHNAVER,**" the new P. & O. liner, carries not only the most up-to-date radio transmitting and receiving apparatus, but also a Marconi depth-finder for taking soundings.

**CUXHAVEN,** the German station that gives free medical advice to ships, works on 160 metres.

**OSLO** has been badly heterodyned of late, apparently by Soviet stations.

**WASHINGTON** is to have a relay station, but the Americans, characteristically (and aptly) enough, are choosing to call it a "booster" instead of a relay station.

"**MOUNT RADIO**" is the somewhat grandiloquent name solemnly bestowed on the hill on which the new Trieste station has been erected. It was baptised with due form and ceremony.

**LEIPZIG'S** new station is to have a power of 150 kw.

Mexican station, working on 450 metres. Programmes will be broadcast in English and Spanish before the end of the year.

**ROME** and the other Italian stations that were reported to be sacking their lady announcers have all reconsidered that decision.

short-wave relay on 42.9 metres.

**VIENNA** is equipping some of the city buses with radio.

**FRANKFURT'S** new station is not expected to be working until February.

**RÉALTOR,** about 13 miles north of Marseilles, is favoured as the site for the new station to serve that area.

**MARSEILLES** is said to be allotting five million francs as the likely cost of its new station to replace the one destroyed by fire in August.

**COPENHAGEN** has recently increased its orchestra from 28 to 58 performers

**RADIO TRIESTE,** the new Italian transmitter on 247.7 metres, pronounces its name like "Tree-ess-tay."

**PRAGUE** is working on its new transmitter at Cesky Brod all day at intervals, commencing about 7 a.m. It can be identified most evenings after dark, immediately above the North Regional transmission. Its name sounds like "Radio Praha."

"**SCHWEIZERISCHER LANDESENDER**" is a call that will puzzle many listeners. It is heard on a wave-length of 459 metres (just below Lyons La Doua), and belongs to Beromunster, the newly-installed Swiss Regional station.

## USING A FRAME AERIAL

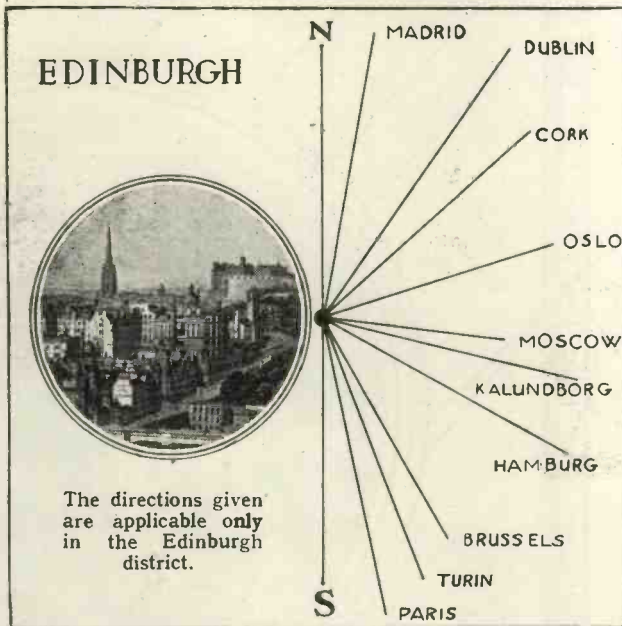

**RADIO NIMES,** the French station which was recently closed for overhaul, is now on the air again on 237.2 metres.

**GENOA,** which was recently closed for a week, is to use considerably higher power in future.

**VILLA ACUNA,** Mexico, is to be the site for a big new

**CT 1 A A,** the new Lisbon station, is privately owned, and has a

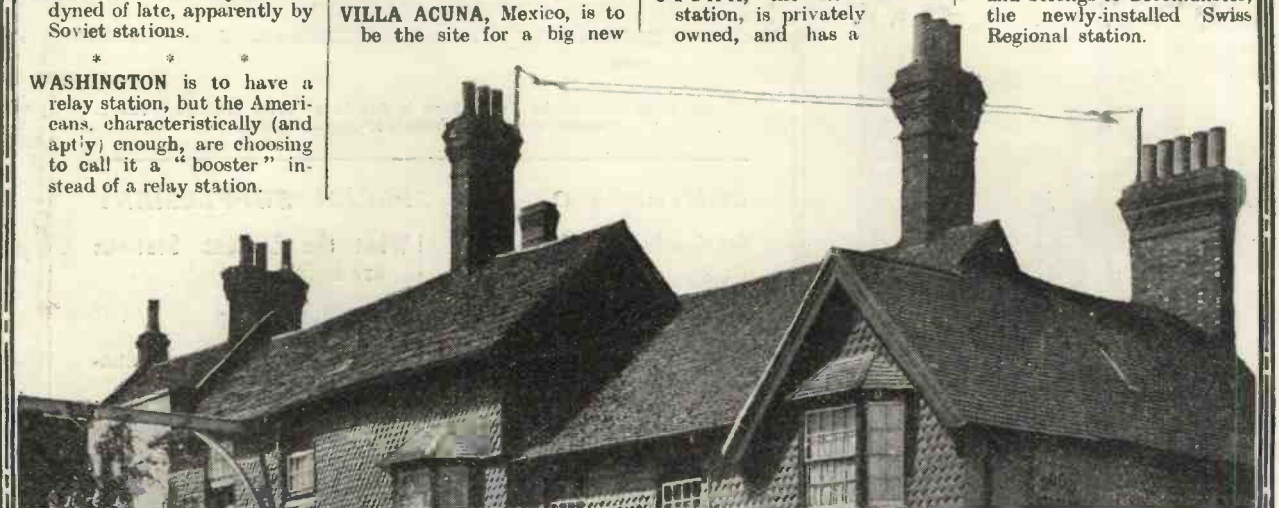



# Radio in Berlin

Germany, like ourselves, has about four million licensed listeners; and also, like ourselves, she has just held a giant Radio Exhibition, where all the latest developments were represented. Here is an informative review of this great Show based on a personal visit.



By OUR SPECIAL CORRESPONDENT

**I**N the words of their own Postmaster-General, the German radio industry has more than maintained its position in the difficult times through which the country is passing. Certainly the English visitor to the Berlin Exhibition would not suspect the shadow of any financial disaster, nor would he notice any falling-off either in production or in the power to purchase radio sets.

## A GOOD MOVE

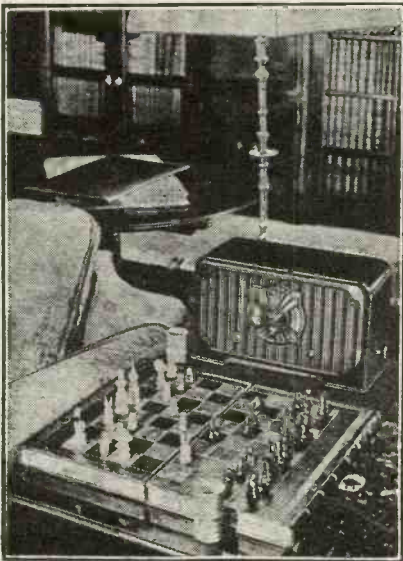

There is a growing tendency to make sets small and compact, and this multi-valver is quite dwarfed by the chess-board.

The Exhibition as a whole is on a much larger scale than anything we have yet succeeded in producing. The main reason is, of course, that the Berlin site is more suitable in every way than Olympia for the purpose in view.

## Plenty of Room

Not only is there ample accommodation for the 325 trade exhibitors, but also for the enormous crowds of visitors which throng the Show each day. The restaurants and cafés, in particular, are admirable examples of

what can be done to cater for the weary sightseer.

The main showrooms are grouped around the aerial tower of the well-known Witzleben station, which forms one of the most distinctive landmarks in the whole of the city. The tower itself is located in the Charlottenburg district, a fashionable residential quarter lying just beyond the famous Tiergarten in the West End of Berlin.

Close by is the enormous new Rundfunk Haus, now the official headquarters of German broadcasting.

## Built for Radio

In fact, the whole quarter seems to be dedicated to broadcasting and radio. It forms a definite centre of wireless interest on a large and distinctive scale.

Germany has a population nearly double that of England, though the official number of broadcast listeners is roughly the same as ours—around the four million mark. There is no doubt, however, that broadcasting has been rapidly growing in popular favour over there—particularly during the last year or two—and if the success of the Berlin Exhibition can be taken as any criterion I should say that before long the number of German listeners will be nearer five million than four.

Taking a world survey, the total number of broadcast listeners is estimated at just over thirty-two millions. Stated in terms of households, this means that only about seven in every hundred are equipped

## DIRECT DIALLING

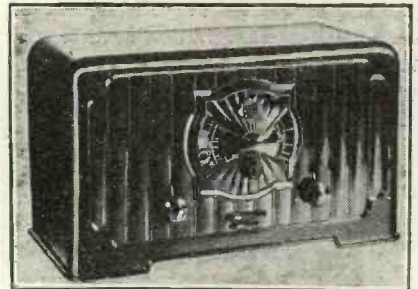

A close-up of the set shown in a preceding column, disclosing the large dial with names of stations fixed to it, to facilitate tuning.

with wireless, so that there is plenty of opportunity for future world-wide development in the industry.

In Europe, Denmark comes first in the proportion of radio-equipped homes to population, Great Britain third, and Germany fifth. At the present time, however, I believe that interest in radio is as vigorous and alive in Germany as in any other part of the world.

The German broadcast system

## MILES OF THEM!

Berlin is much better off for room than the London Exhibition, as the exhibits are shown in the special building designed for radio shows. Here is a typical bay on the opening day.





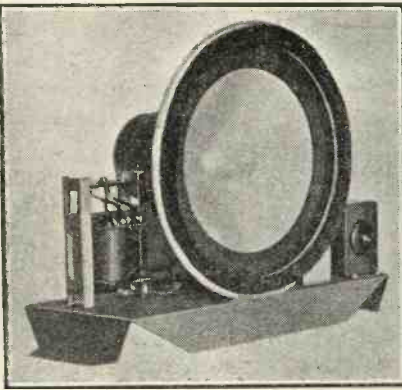

A moving-coil speaker for use with A.C. mains.

differs in certain respects from our own. In this country the P.M.G. is in a sense the sole "owner" of the ether, and he has given an exclusive licence for broadcasting to the B.B.C. In Germany the control of the ether is also in the hands of the Post Office, or the Reichspost, as it is called, but this Department has granted several different companies the right to broadcast.

**Private Enterprise**

One is the Funkstunde, who operate the Witzleben station in Berlin, and another is the Deutsche Welle, who run the educational side of the Koenig-

**AN OUTSIZED VALVE**

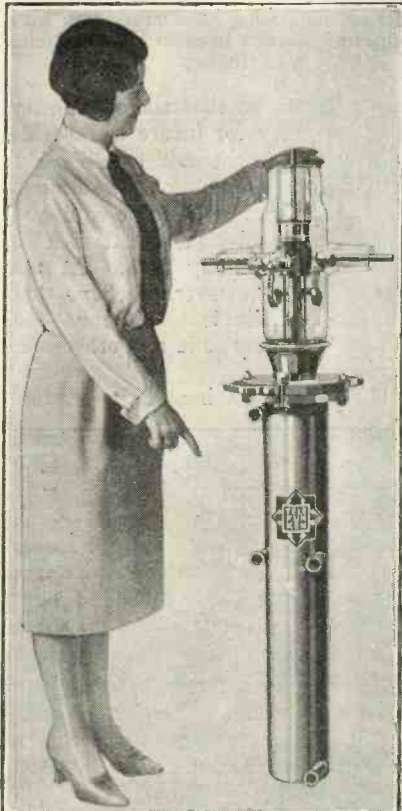

This gives you a clear idea of the size of a 150-kw. transmitting valve.

**Bigger than Britain's**

wusterhausen programmes. There are also various other auxiliary broadcasting companies, but all are now represented by a central company under the control of the Reichs Rundfunk.

The term Rundfunk, it should be explained, simply means broadcasting. Funk is the German word for "spark" and dates back to the early days of the spark transmitter. Most people have heard of the well-known

organisation called the "Deutsch Funkhilfe," which trains selected members of its association to track down "noisy" motors and similar sources of local broadcast interference. Once the source of disturbance is located, the Association proceeds to take prompt steps to have it removed.

They point out, in the first place, the unfairness of interfering with the right of the listener to receive the broadcast programme in peace and

**AN ORCHESTRAL OPENING**

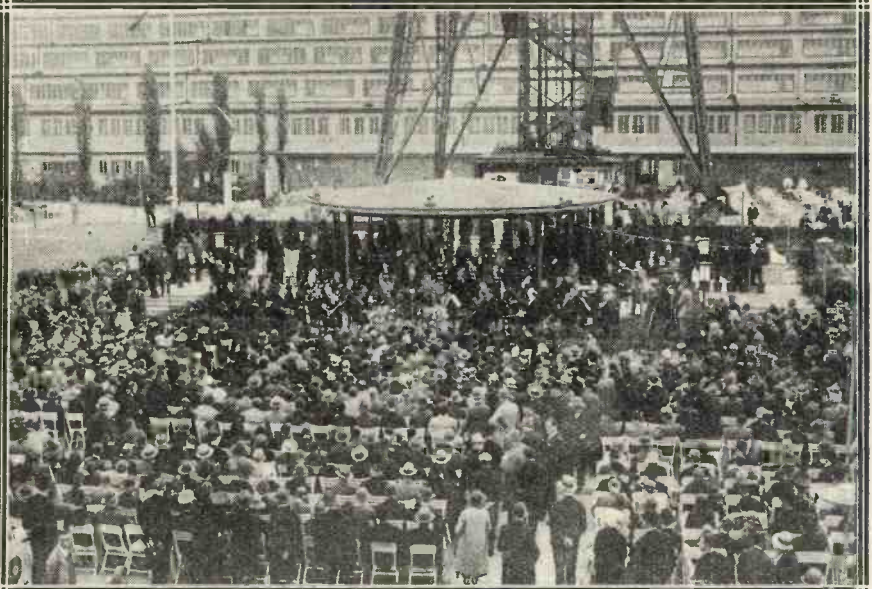

In the gardens at the foot of the great radio tower the Berlin Radio Orchestra assembled to give the show a good musical send-off. The proceedings were broadcast from all German stations.

Telefunken Company, whose name can be translated as "distant spark." In the same way Rundfunk means "round-about" spark, or "broadcast" transmission.

**High Licence Fee**

The German licence fee paid by each listener is two shillings a month, or rather more than double our own rate. It is shared between the broadcasting service and the German state authorities.

One of the most interesting features of the Exhibition is the attention paid to ways and means for preventing local disturbances. This has always been a strong point in Germany, and this year innumerable "gadgets" of all kinds are being sold for rendering electric motors and high-frequency apparatus innocuous to broadcast listeners in the neighbourhood.

In addition there is a strong national

quietness. If this kind of argument proves insufficient, they soon proceed to harsher measures and usually prosecute the owner of the offending plant in the local Courts.

Here they can depend upon the sympathetic help of the broadcasting authorities, and it is satisfactory to note that in nearly eighty per cent of the cases where legal action has been taken an order has been obtained either to have the source of disturbance made harmless, or alternatively to have it put permanently out of action.

**Seven Thousand Strong!**

In the stall of the Deutsch Funkhilfe at the Exhibition it is stated that no less than 7,500 authorised members are now actively engaged in tracking-down and eliminating "man-made" static.

It is significant of the German



## Many All-Electric Sets

attitude towards this kind of nuisance—which, by the way, is rapidly growing in our own country without any apparent means of control—that the official broadcast authorities render every possible assistance in keeping it in check.

Not alone do they encourage the Funkhilfe Organisation, as previously mentioned, but they also carry out an extensive publicity campaign,

and the difficulty of "ganging" for uni-control.

Some excellent models were to be seen of receivers containing two stages of S.G. amplification. Screening and ganging are both up to a high standard, whilst the performance is undoubtedly good.

Among components chief mention should perhaps be given to the wide range of loud speakers shown. The

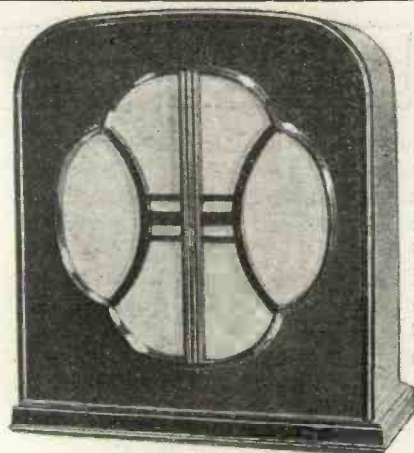

The German loud speakers are very similar in appearance to equivalent British models.

## INSIDE THE MAIN BUILDING

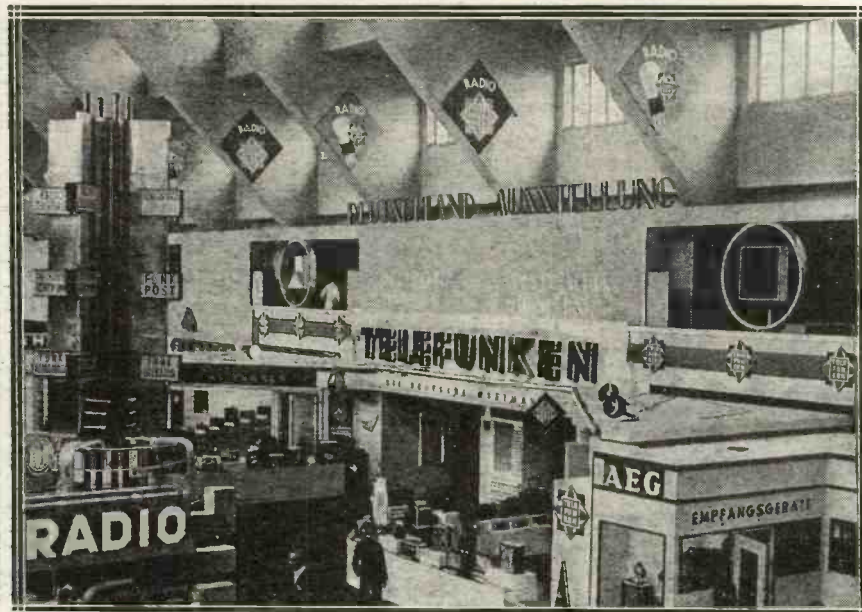

Exhibitors at the Berlin Show were able to vary their displays to a much greater extent than the British firms showing at Olympia. There was much more room for the goods, and for the visitors as well.

on their own initiative, against those who wantonly spoil the ether for broadcast reception.

Most of the receiving sets shown fall into two groups. The first is the cheap two-valve receiver for loud-speaker reception from the local station, but without any claims to selectivity. In nearly every case they are mains-driven. The other is the five- or six-valve receiver for long-distance working. Here, too, the all-mains type is very much in the ascendency.

### Super-Hets Not Popular

Curiously enough, the super-het type of circuit does not seem to be popular. The German designer has evidently not made the same progress in this direction as we have at home. Apparently, he dislikes the added complication of the frequency-changer

moving-coil type, fitted with permanent magnets, were chiefly in evidence at the higher level of prices, whilst the balanced-armature 4-pole instrument came a good second, both in performance and price.

### Handy Testing Sets

It is typical of German thoroughness that "testing outfits" of various kinds were a distinct feature of the Show. Every possible kind of measurement, covering all types of valves, and including A.C. and D.C. tests, could be effected with the aid of a compact outfit costing only £5. A simpler set, suitable for the home constructor, could be had for 30s., whilst a handy universal tester, consisting of a 5-scale combined voltmeter and milliammeter, sold for 12s. 6d.

Among the minor attractions the

"Auto-Skala" of the Telefunken Co. seemed a very popular feature.

Sets of from 20 to 200 flat clips, each marked with the name of a particular broadcast station, are adapted to fit firmly over the edge of an unmarked tuning-scale at the point where the station in question comes in, so that subsequent tuning is simplified. A further advantage lies in the fact that the position of any particular clip can be altered in the event of the official wave-length being changed.

A useful novelty is an electric motor, sold as a separate unit, and

## SHIFTING STATIONS



About 200 station name-plates can be fixed to the dial of this set (which is illustrated also on the first page of this article). They can be detached and refixed in a moment by a spring-clip action.



## Many Amazing Midget Models

adapted to be fitted to any gramophone and to drive it from the mains through belt gearing. A combined table lamp and wireless receiver, the lampshade forming the loud speaker, is another exhibit perhaps worthy of mention, whilst a "slumber pillow," having an earphone buried in the middle with the object of lulling one to sleep to the strains of broadcast music, may at least be ranked as a curiosity.

### Directional Radio

The Heinrich Hertz Institute gave some striking demonstrations of directional transmissions and reception on a 2-metre wave, controlled by a piezo-electric crystal oscillator.

Ultra-short-wave energy of this type promises to play a large part in the future development of broadcasting, more particularly for supplying large towns with local programmes, free from interference, in combination with a simple short-wave adaptor fitted to a standard broadcast set.

The advantage of such a system of radiation lies in the fact that it can be restricted to cover any required area, without causing any disturbance in districts outside that area.

For amateur transmitters the Deutsch Amateur Sendedienst, which is associated with the Amateur Relay League, had an interesting exhibition of short-wave apparatus both for transmission and reception.

### Low-Power Transmitters

A feature of their sets is a simple and effective method of wave-changing from 10 to 200 metres by means of a rotary switch. One of their transmitters, working from Berlin, with a 6-watt input has recently been working with Australia over a range of 12,000 miles.

In the gramophone section a new type of "everlasting" needle was shown, consisting of a wire core embedded in graphite. Most permanent needles are so hard that they tend to damage the record, but in this case the graphite is soft enough to abrade normally, whilst at the same time adequately protecting the working point.

The television side of the Exhibition comprised apparatus marketed by the Fernseh A.G., Baird, Bosch, Loewe, and Zeiss-Ikon firms, showing that interest in this subject is widen-

ing. The Loewe Company are exploiting a particularly interesting cathode-ray system developed by Von Ardenne. Perhaps the most interesting television exhibit was one demonstrating the effect of gradually increasing the number of picture elements per unit area. A series of moving pictures were shown on different panels in which the "grading" varied from 1,200 elements to 30,000, the definition in the latter being exceptionally clear and distinct.

The craze for midget receivers which first started in America is now invading Europe, more particularly Germany, if one is to judge by the models shown at the recent Berlin

back-coupled detector valve, transformer-coupled to a pentode output. This, too, is adapted both for medium and long-wave reception, and is also operated from the mains.

### Remarkably Inexpensive

In both cases the cost is in the neighbourhood of £5. Although reception from the local station is of first-rate quality, long-distance working is naturally somewhat handicapped by the small number of valves in circuit.

*German Valves.* On the whole, the price of valves seems to be rather lower in Germany than here. The battery-driven three-electrode

## FAMOUS FIGURES IN GERMAN RADIO

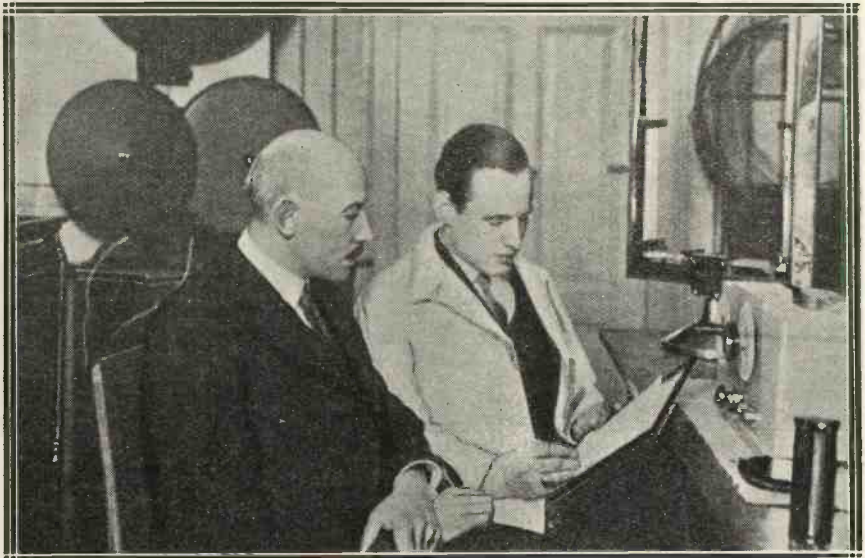

To the left is Dr. Loewe, whose inventions are well known in this country, and with him is Manfred von Ardenne, the prominent research worker in radio and television.

Exhibition. At first sight, these "Tiny Tim" sets certainly make a favourable impression, both as regards performance and price.

### Three Valves in One

One interesting midget set is marketed by the Loewe firm, and is built up around a single multi-electrode valve, containing three separate sets of resistance-coupled stages, all mounted in the same glass bulb. A switch is provided for changing over from the medium- to the long-wave stations, and provision is made for using a gramophone pick-up. The set is driven entirely from the mains.

Another model comprises a single

valve costs from 5s. to 10s.; the similar indirectly-heated type, from 14s. to 16s.; screened-grid amplifiers, from 12s. to 20s., according to type and characteristic; whilst pentodes vary from 19s. to 22s.

The method of rating valves also varies in some respects from that used by us. In addition to the ordinary amplification factor, or "mu," the term "Durchgriffe" is used. This is the reciprocal of "mu" expressed as a percentage.

There is also a factor called the "Gute" (otherwise the "goodness"), which is the product of "mu" and mutual conductance. Mutual conductance, by the way, is called "Steilheit" (or steepness).



**BEROMUNSTER** (450 metres) relays the Berne, Basle or Zurich programme, and uses a clock, striking two notes repeatedly, as an interval signal.

**SKOPLJE**, the new high-power station in Yugo-Slavia, is reported as almost ready for regular transmissions. Tests will be carried out on 2,300 metres, and should be started by the time these words are in print.

"**RADIO SUISSE ROMANDE**" is the name announced by Sottens, the new Swiss Regional station, which is often heard well on 403 metres, immediately above the Midland Regional wave-length.

**DURBAN** has constituted a drive against radio pirates, and a direction-finding equipment has been installed on a motor-bike and sidecar to trace listeners who dodge the 25s. licence.

**GRAHAMSTOWN**, South Africa, is still in hopes of persuading the African Broadcasting Co. to erect a relay station there to serve eastern coastal districts.

**RADIO VALENCIA**, the new-comer on about 271 metres, is said to be the Radio Catalana transmitter, removed to Valencia.

**EIFFEL TOWER** has recently been making high-power morning tests (counting, etc.). Apparently its power

## NEWS FROM FAR AND NEAR



was very greatly increased for this purpose.

**LISBON** is now working on 291 metres, and listeners who have never tuned in to Portugal may be able to hear this station from 9 p.m. onwards, immediately above the British relays.

**VIENNA** caused considerable interest by its long-wave tests on 1,255 metres.

**HAVRE** is now working a free medical service to ships, in conjunction with the stations at Marseilles and Bordeaux. In cases of emergency, doctors at these towns advise captains of ships by radio how to treat illness on board until the ship reaches port.

**TOULOUSE** recently staged an underground broadcast

from the subterranean river at Padirac.

**PARIS** recently had a brief interruption in the Ecole Superieure programme owing to gale damaging the aerial.

**MARSEILLES P.T.T.** station was recently burnt down, and a temporary transmitter has been installed in its place. Wave-length, 315 metres.

**SUNDSVALL**, the Swedish station, on 542 metres, has been coming over exceptionally well recently.

**TRIESTE** has been picked up strongly in all parts of this country. The power is 15 kw.

**RADIO BARCELONA** obtained some fine long-distance results when communicating with the Graf

Zeppelin flying to and from South America.

**LYONS LA DOUA**, which has been picked up recently at great volume in this country, sometimes uses a bell as an interval signal.

**LODZ**, the Polish station on 235 metres, has been trying out its new transmitter with great success.

**SCHLOSS SOLITUDE** is the appropriate name of the German listening post, which carries out duties equivalent to those of the B.B.C.'s reception station at Tatsfield

**TOULOUSE** is being highly spoken of in Germany because of its sporting offer to pick up and relay transmissions from Graf Zeppelin when that airship was out of range of the German stations.

**BUENOS AIRES**, recently arranged a "Mad Hour," consisting of musical and vocal items from the inmates of an asylum. Apart from an unrehearsed difference of opinion in the studio, it went off excellently.

**RENNES, LILLE, BORDEAUX, TOULOUSE, LYONS AND LIMOGES** are the six centres chosen for regional stations in the latest French broadcasting scheme

**BERLIN** has opened a radio library in its new Broadcasting House, and many thousands of books are already available.

# HOW MANY MILES?



SOME DISTANCES	
HAMBURG . . . . .	449
HEILSBERG . . . . .	868
HELSINKI . . . . . (HELSINGFORS)	1131
HILVERSUM . . . . .	232
HORBY . . . . .	635
HUIZEN . . . . .	236
KALUNDBORG . . . . .	542
KATOWICE . . . . .	835
KAUNAS . . . . .	1016

KONIGSWUSTERHAUSEN (ZEESEN)	588	KOSICE . . . . .	962
--------------------------------	-----	------------------	-----

—FROM LONDON	
1180 . . . . .	LAHTI
311 . . . . .	LANGENBERG
537 . . . . .	LEIPZIG
1306 . . . . .	LENINGRAD
760 . . . . .	LJUBLJANA
1047 . . . . .	LWOW
458 . . . . .	LYONS
786 . . . . .	MADRID
598 . . . . .	MILAN



Countries to Listen for:—

# ITALY

Italy has contributed so much to art that we are apt to forget that radio listeners and scientists alike owe a special debt to that country, where Marconi was born.

The Italian broadcasting service is—fittingly enough—an extremely good one, which can be sampled any night in this country by the possessor of a sensitive radio set.

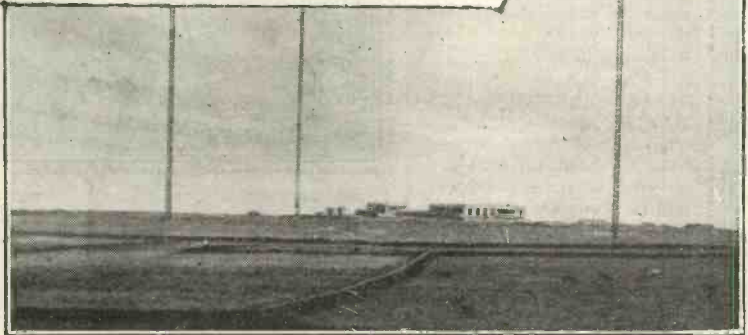

The Italian programmes are singularly well received in this country. Although Rome itself is about one thousand miles from the centre of England, it is a favourite alternative programme for many listeners, on account of its strength and the reliability of reception.

In addition, Turin, Milan and the new stations at Trieste and Palermo are all extremely well picked-up in this country. And whilst Naples and Genoa are not so notably outstanding they are frequently heard when conditions are good with great ease and clarity.

The Italian broadcasting system was reorganised two or three years ago, and since then many important improvements have been effected. The full scheme of reorganisation has not yet been completed, but it is now well advanced and has certainly proved of great benefit to the British long-distance listener.

**Do You Know Her ?**

One of the factors which made for easy identification of Italian programmes was the decision to employ women as announcers. Probably "Miss Radio Roma" is the best-known announcer in Europe; and a great many of her admirers in this country were glad when the recent decision to employ men instead of women was revoked, on account of the storm of protest it raised.

Apart from the official broadcasting stations themselves, another Italian programme of extreme interest originates in the Vatican. This station, which was designed

under the personal supervision of Marconi, fulfils the Pope's ambition to link the catholic world to its centre by short-wave radio.

The city of Rome, Italy's capital and the seat of the Papacy, has a population of well over half a million. It was founded about 750 B.C.

**The Eternal City**

As the centre of the growing Roman Empire it early attained to the eminence of the world's foremost city. From it went forth the legionaries, to conquer.

Britain, with most of the known world, lay for long under the domination of the Caesars. But wild hordes of barbarians from the north challenged the martial

supremacy of the legionaries. Finally, they threatened Rome itself, and the legions were all recalled to repel the invading Goths.

As all the world knows, they failed. Rome fell—and later Italy, dismembered and shattered, became a prey to warring races and to the machinations of intriguing princes.

**Literature and Art**

Strangely enough, her glory lived, and grew. Split into small states, even into isolated cities—like Genoa and Venice—these communities produced world-figures and works of art and literature that are immortal.

Genoa, the birthplace of Christopher Columbus—Florence, the city of Dante, of Michael Angelo

and of Leonardo da Vinci—Milan, Venice, Rome, all are imperishably linked with the story of civilisation.

**Names of the Past**

Among the great names always associated with Italy are Galileo, St. Francis, Garibaldi, Cicero, Raphael, the Caesars, Virgil, St. Paul, and Savonarola.

Curiously enough, it was Napoleon who was partially responsible for restoring Italian unity: for after he was crowned King of Italy, in Milan Cathedral, there was a sensible lowering of interstate borders and a breakdown of city-from-city isolation. This tendency culminated in recent times in a united and prosperous Italy, worthy of her glorious past.

**Volcanic Variety**

Italy has a 2,000-mile coastline, and no part of the actual peninsula is more than about 70 miles from the sea. Alps in the north, active volcanoes in the south, world-famous lakes, fertile plains, beautiful ports like Naples and Venice, busy manufacturing cities and an extraordinary variety of plant life make it an unusually fascinating country to visit.

And now we can "visit" Italy nightly—and sometimes even in daylight—by radio. We can hear the music and the operas, expressing the characteristic Italian love of life and beauty.

A good set will link Britain direct with the cities that were, at one time, linked with us only by Caesar's legions.



**ITALY'S STATIONS**

Name.	Remarks.
Bari	Under construction.
Bolzano	453.2 metres
Firenze	Under construction.
Genoa	312.8 metres
Milan	500.8 "
Naples	331.4 "
Palermo	212.6 "
Rome	441.2 "
Turin	(273.2 " but works on 296.1 metres.)

**HOW TO KNOW THEM**

- Milan.—Is frequently interfered with by ships' jamming, but is linked with Turin and Genoa, the announcement being "Eh-yar Milano, Torino, Genova."
- Naples.—Relays with Rome. Closes down with "Buona Notte a Tutti."
- Rome.—Lady announcer says: "Eh-yar Roma," or "Eh-yar Roma-Napoli."
- Turin.—The famous nightingale call-sign (used also from Milan and Genoa) is frequently used during intervals in the programmes.





Now winter is approaching stations are beginning to come in at much greater strength than they have been for some time. Yes, and so are the heterodyne whistles. Promise of a good DX winter seems fairly certain, and even now American stations are beginning to be heard on the medium waves, though, as yet, their strength is poor and static very troublesome.

If the coming winter approaches the last "season" as regards DX work we are certainly in for a good time. There is no denying that last season was almost perfect and that many persons who had not heard America did so then.

#### South Africa

I have frequently wondered whether South African transmissions have definitely been received in England on medium waves. There is, of course, the unfortunate circumstance that South African and European stations transmit at the same times, and, consequently, the weaker stations are difficult to hear. However, when conditions were favourable last year I attempted to receive South Africa.

By the time I had made the set selective enough volume was cut down rather badly. Even so, I was able to log almost every European between 200 and 500 metres.

After looking up the wavelengths of the African transmissions I turned my attention to receive Z T J (Johannesburg), the most powerful South African transmitter. I did not receive even a carrier. I then turned my attention to Z T D (Durban)—still no luck.

Then I turned to Z T C (Cape Town). Tuning just below Hamburg (for Z T C is just below that station) I picked up a faint carrier. Upon resolving it music was heard. Announcements appeared to be made in English, but of this I could not be certain.

I think that this was the Cape Town transmission, for all the European stations around that wave

## WHAT THE DISTANT STATIONS ARE DOING

Some notes and news from a long-distance listener's log.

were tuned in and the transmission gave every evidence of being a "real DX" one.

Considering the good times experienced last year by European "fans," it is interesting to note that I have only heard of one person in the United States having received Europe then. The fan who claims this reception is located in Chicago, and in characteristic Chiccanco style says that he has "knocked on the spot" London and various stations in Germany and France.

#### A Fine Effort

Even so, this fan was astounded at my having received and verified W G B B, the 100-watt New York station. He informed me that the station is rarely heard in Chicago.

Coming back to "modern times," I must say that my best received European stations at present are Mühlacker, Heilsberg, Frankfurt, Hamburg, Langeberg, Zeesen, Cologne, Milan, Trieste, Rome, Toulouse (Radio), Marseilles (P T T), Vienna, Prague, Moroska-Ostrava, Bratislava, etc.

Genoa has come in on two occasions at moderate strength. Dublin also puts over a good signal at times, and with its sponsored programmes puts over rather better programmes than previous. The Northern National does not come in well here, but the Northern Regional can be considered a "local."

On short waves reception on my

set has often been exceedingly good, but has had lapses from time to time. The Trade Union Moscow station on 50 metres is, at present, the best received transmission, as far as strength goes, but unfortunately the purity of transmissions gives much to be wished for.

The programmes from this station, though at first interesting, become somewhat tiring after a time, and I cannot say I consider Moscow puts out much of an entertaining nature as a rule. I have, however, been highly amused by some of the propaganda talks they put over.

The "big noises" around 30 metres are Zeesen, Lyngby, Rabat, W-2 X A F and W-1 X A Z. On a Sunday evening a variety of programmes can be taken from Rabat, Zeesen and Lyngby, and quite enjoyable times spent with them.

#### Across "The Pond"

2 X A F is still my best received American station, though at times 1 X A Z surpasses him. 2 X A D has not been heard by me much, owing, in large measure, to my not paying as much attention to stations below 20 metres as I might.

Nevertheless, when I have been "down there" I have had very satisfactory reception from the Javan stations, P L B, P M B and P L F, and also from several French Indo-China, Madagascan and U.S. telephone stations. P C K (Kooftwyk), and other Dutch stations, besides L S G (Buenos Aires).

African stations have been prominent by their absence lately. Earlier in the year I received 7 L O (Nairobi) at good strength on various occasions.

I also logged Z T J (Johannesburg) at fair strength soon after it started transmitting. Since that, however, I have heard nothing from Africa, except Rabat, which almost always puts over a strong signal.

There are now quite a number of African transmitters broadcasting on the short waves, and for the benefit of those who are not aware of the fact a few details will be useful. Z T J, the Johannesburg station transmits on both 49'4 and 31'4 metres. Another Johannesburg transmitter, with the call letters Z U 6 X, transmits on 40 metres. Z T D (Durban) has a short-wave relay on 45 metres.

#### Times Not Known

I am, unfortunately, not in possession of the schedule of these transmitters, but the knowledge that they are there is something. As I have said, I have only heard Z T J on 49'4 metres, and none of the others have been heard by me as yet.

One of my latest, and farthest, received stations is Z L W, the Post Office station at Wellington, New Zealand. This transmitter was doing P.O. work and came in at about the same strength as the Sydney beam station. This is the second telephony station I have received from New Zealand, as some time ago I logged a musical programme radiated on about 50 metres from a Christchurch transmitter.

As regards Australia, I have only heard the telephone stations and have been either occupied or forgotten to listen when 2 M E, 3 M E and 3 L O have been broadcasting.

In conclusion, I should say that things point to a good DX winter. L. W. O.

## A Roman Vista—the Church of St. Peter, and the Vatican



The dome of the Church of St. Peter inspired Sir Christopher Wren when he designed St. Paul's Cathedral for London. The rather forbidding building to the right is the Vatican, in the grounds of which the Pope recently had a short-wave station erected. It can be heard all over the world.



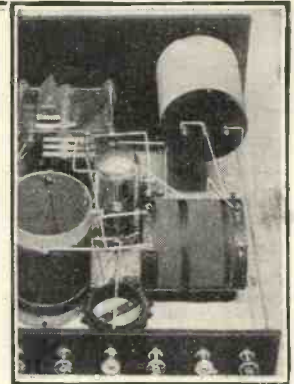
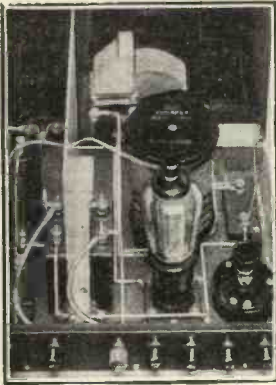

**A UNIQUE GUIDE TO RADIO RECEPTION**  
**THE "M.W." MAP OF THE**  
**WORLD'S BROADCASTING STATIONS**

**A** WORLD-RECORD in monthly radio journalism is established by this number of MODERN WIRELESS. With every copy there is given away a specially compiled and absolutely unique map of the whole world's broadcasting system.

It shows, in one extraordinarily vivid presentation, the universal distribution of radio. It shows about one thousand wireless stations, together with wave-lengths and similar relevant information the like of which has never before been available to the public.

**A Stupendous Task**

It is a wonderful map—as you will appreciate when you have had time to study and to use it. But before we consider its practical side, and its value as an aid to station-identification, we think it will interest our readers to consider how its presentation to them was made possible.

The need for such a map has always been apparent ever since broadcasting got into its stride.

And there must have been many attempts to provide a comprehensive map of the world's broad-

casting stations. But the difficulties always seemed insuperable. Absolutely insuperable.

They were so many, and so serious. For long the making of such a map was considered, re-considered, and then voted impossible; and although to knock "im-" out is one of the "M.W.'s" staff's special delights,

days of radio, when there were just a few dozen stations, maps had been prepared. But then the stations began to multiply, they crowded closer and closer, some took up short

**GREAT GIFT FOR OUR READERS**



On the actual map you will find this space is occupied by a complete index of all stations, which enables each one to be located in a moment.

In the lower corners of the map are provided enlargements of the two areas with the most stations—Europe and the eastern half of U.S.A.—and "closer-ups" are given of congested cities where necessary.

such a stupendous task as a specially-compiled and entirely new world-embracing map really did not seem practicable.

For one thing, there was no precedent. Even a last year's map of the radio of the world would have afforded something to go on—but no such thing existed!

True, right back in the early

waves, others relayed somebody else—and then the professional map-makers had to give it up!

Knowing the German reputation for map-making and tabulation, inquiries were instituted by "M.W." in Berlin; only to find that Teutonic thoroughness had quailed at the thought of an up-to-date radio map of the whole world. Nothing doing in Germany.

**Not Even America**

America, likeliest of all to undertake such a spectacular compilation, was combed with equally dishearten-

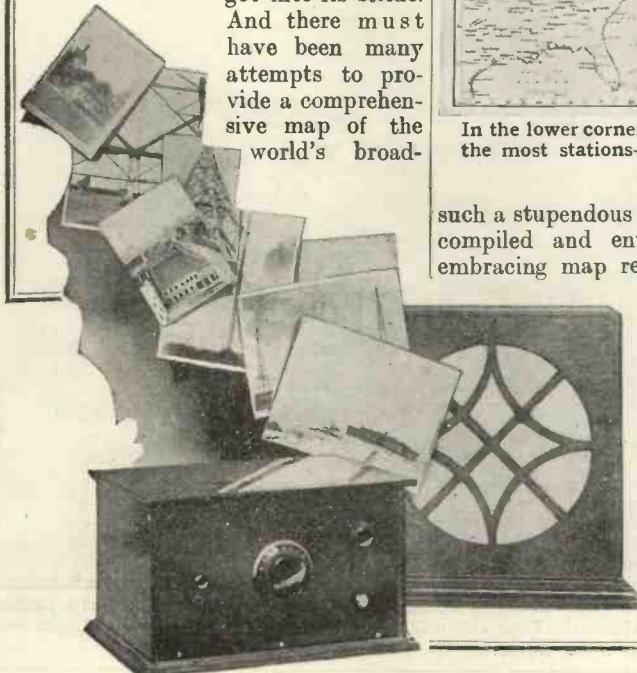



## A Feat Unequalled in Radio Journalism

ing results. Plenty of other maps, but no reasonably recent *radio* map of the whole world. "Fail, Columbia!"

And yet—it was such an attractive idea. The very "impossibility" of the task made it alluring to "M.W." And, moreover, if anybody in the world could do it, surely we were best equipped for the formidable feat.

### Good Printing Needed

The mere size alone would put most would-be competitors out of the field. For to get every officially-listed station on one map demanded

### HAVE YOU HEARD HIM?

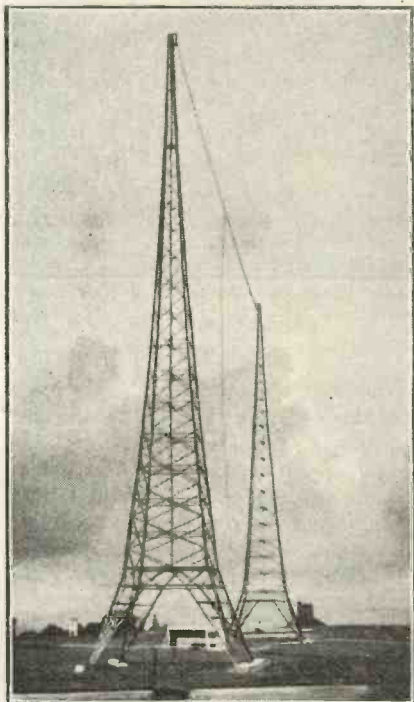

The masts and station buildings at Sottens (Switzerland), officially styled "Radio Suisse Romande," and working on 403 metres.

unusually clear printing; and even then such a very big map would result that most printing works would be unable to cope with it.

### Some of the Difficulties

Tentative suggestions as to size, etc., were made to "M.W.'s" own printing-works—and received joyfully. "Do it? Of course we can do it. Biggest plant in the world. Handle anything," was the encouraging tenor of the reply.

But could such a map be drawn up in time? Could it be indexed and

cross-referenced sufficiently, and yet be easy to use? Could it show the simply enormous concentrations of stations in areas like New York?

These were only some of the questions. Even more serious seemed the difficulties of differentiation—how to distinguish a special television station from an ordinary one, and both from those with short-wave relays? How to indicate time differences and congested areas, without cluttering up the map with wearisome detail?

### "Snags" All Overcome

As each reader can now see for himself, every difficulty was finally surmounted. The work of actual drawing was entrusted to the well-known cartographer, Mr. J. T. Rankin—and, somehow, he finished it in time.

From official information supplied from Switzerland by the International Bureau of the Telegraph Union, the location and designation of all officially recorded broadcasting stations were obtained. Staff-work, more staff-work, and an extremely liberal supply of midnight oil, enabled the hitherto untackled task to be completed.

### Shows World Distribution

Now that the map is placed before every reader it makes clear to all the main facts of radio-distribution on a world basis. It shows that amazing concentrations occur in two widely separated areas—Europe and the United States.

Europe, where the science of wireless communication was born, is actually less thickly dotted with stations than the U.S.A., where actual broadcasting has been so successfully developed. The rest of the world is—comparatively speaking—nowhere!

### "WAY DOWN RIO"



A South American centre of broadcasting progress—the Rio de Janeiro station.

Inset into the main map are smaller ones showing these highly developed districts in full detail. And every station is easily identified by the reference numbers in the index.

### Finding the Stations

Just a word about these cross-references, each consisting of a letter and a number. At the top of the map, near the clocks, are the letters

### NEXT MONTH

The December issue of "M.W." will be the

### Christmas Double Number

Make Sure Price 1s. 6d. Order Now

from A to Y. They appear again along the bottom of the map, each representing a definite division between the meridians of longitude. Thus, for instance, Cape Town comes under O, and Perth (Western Australia) under U.

### Comprehensive Index

Similarly, the sides of the map are numbered from 1 to 12, these numbers being encircled to distinguish them from the parallels of latitude. And thus the numbers and the letters show where every station is to be found on the map.

In the index, for example, Cape Town is given as O9, and Perth



**"HEARD BETWEEN ITEMS"**

Brief notes of particular interest to short-wave listeners, dealing with transmissions below 50 metres.

**D**ID you know that HS1PJ (Bangkok, Siam) has been broadcasting to the King of Siam in the U.S.A. ? The 24.45-metre wave has been used for this purpose, and the transmissions have been relayed by KKZ (Bolinas, California) on 22.17 metres.

Most of the transatlantic telephone services that used to amuse cavesdroppers are now "strictly private." They are all using some frequency-conversion scheme that effectively prevents anyone from understanding more than one word here and there.

Incidentally, it is, of course, a punishable offence to divulge anything heard from any transmitting station other than general broadcast matter.

Every now and then, at about 10 p.m. W2XAD may be heard

giving his forthcoming programme schedule in Morse. This makes excellent practice for those whose Morse wants brushing up, especially as it is sent by hand, and the transmitting operator, being human, makes a slip now and then.

WGY programme, Friday, August 14th, on 19.56 metres. The following times are given in G.M.T.: 20.00. Musical programme, N.Y. 20.15. Roger Sweet, tenor, N.Y. 20.30. Stock reports and prices —" and so on *ad nauseam*.

The above is all repeated on "voice" at the end.

The general form of the bulletin is: "The following are items of the

L. H.

**ARE FOWLS FOND OF RADIO?**

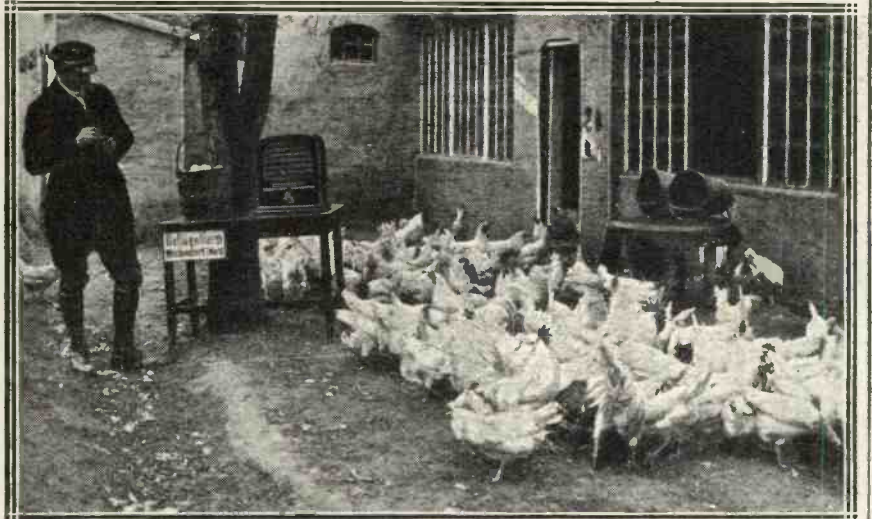

This German farmer believes that his birds are healthier and lay better if they listen frequently to cheery music.

(Western Australia) as U.9, the combination of the letter and the figure giving the necessary locality in which to look.

In addition to these references, the index contains figures against each station, indicating its wave-length (or wave-lengths). Thus an extraordinary condensation of information is made possible on the one single sheet.

To get the full benefit from this great gift readers should note the different classes of dots that denote different classes of stations. (See remarks under title on map.)

**Television Stations**

Of very special interest are the square dots denoting stations devoted to television. There are many of them, mostly in the smaller map in the left-hand bottom corner depicting the eastern half of the U.S.A.

Yet another valuable feature is "Time-at-a-Glance." This is obtained from the clocks, showing the hours at the different meridians; and although local variations make it impracticable to depict all local time exactly, the varying hours on the clock faces show the basis of world time.

**THE "M.W." MAP OF THE WORLD'S BROADCASTING STATIONS**

—continued from previous page

Another significant feature for special mention is the preponderance of short-wave stations in distant lands. From the distribution of these one could almost deduce the scientific fact of the wonderful distance-spanning properties of the short-wave transmitter.

Many other interesting and indeed fascinating aspects of the "M.W." Broadcasting Map might be dealt with, but we have room to say only a few words more. And these we must devote to the question of permanency.

**Official and Up To Date**

In such a constantly-changing and ever-shifting science as radio development there can be no real permanency. New stations are opening all the time, old ones disappearing.

One almost insurmountable obstacle

to the original compilation of the map was this continuous shuffling and re-shuffling of the world's stations and sites; and it was not until we could obtain the complete, authentic and official records, corrected up to date, that we could undertake the task.

That correction goes on continuously as new services are opened and new programmes become available. And even in adjoining pages of "The World's Programmes" news of new stations, not yet officially opened, is given.

**For "M.W." Readers Only**

The great framework of the world's broadcasting, however, remains substantially unaltered. The general disposition of the stations, their classification, their wave-lengths, are now available to "M.W." readers—and to "M.W." readers only—in the compact form of a map which we are proud to present to you.

No other journal in the world has ever made an equivalent gift to its readers. It is a journalistic feat made possible only by the unequalled resources of MODERN WIRELESS—Britain's Leading Radio Magazine.



# HANS IN LONDON

*A very interesting account of our Radio Exhibition, as seen through the eyes of a typical German listener.*

Hans, a very good friend of mine from Germany, decided to come over this year to have a look at the London Radio Exhibition, as he called it. He didn't attach much importance to it.

"All technical progress in radio is made at Berlin, all foreigners come to Berlin to see what the radio world is doing—at least that is what the Press communiqués say—but let's have a look at what you people are doing," said he.

### Top Hat and All!

He came to fetch me on Friday morning, dressed up in morning coat and top-hat. I asked him if he were going to a wedding. He replied that in Berlin he always wore a morning coat for the opening of the exhibition, with a bowler, but English customs demanded a top hat, didn't they?

I gently broke it to him that we didn't have an official opening lasting an hour, beginning with Beethoven's seventh symphony and closing with the annually repeated words: "In spite of the grave economical crisis, our thriving radio industry, etc."

Poor old Hans was feeling quite downhearted by now, but I bucked him with some spirituous liquor and then we set out—without the top hat. At Olympia he had a

look round, wondered why we hadn't green parks round it, and a beautiful garden, but he himself suggested that probably after all land wasn't quite so expensive in Berlin as in London.

### Satisfactory Statistics

attract one ought to be ashamed to stoop to such methods of attracting attention. Luckily he fell over a wire at that moment, or I would have put him on the floor myself. By the time we had argued that Berlin was far too matter of fact, whereas at Olympia one got some amusement thrown in as well, we were in front of the B.B.C. exhibit.

Here he warmed up, smiled and rejoiced. "Just like Berlin," he said, "lovely statistical tables; nothing like them for making everything clear and attracting crowds." He wanted even more of them.

The wireless for the blind stand struck him curiously: "Why does the State not look after them?" I replied that we preferred looking after ourselves and not leaving everything to the State.

### Programmes in Braille

But he did put sixpence into the slot and greatly admired the Braille Radio Times, or was the blonde beauty in charge of the stand responsible for his intent study of it? In spite of what they say, I think the Germans would like to get up their show like ours, only they are afraid of losing their reputation of always being to the point with no frills.

## HOW THEY DO IT OVER THERE

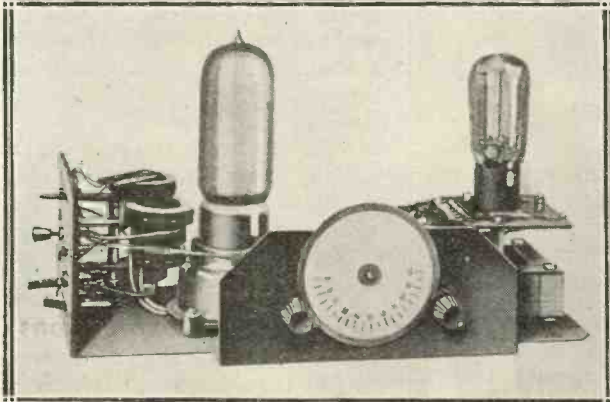

This is a typical German receiver, and is certainly different from those in vogue at our own Radio Show.

Once inside he began to feel himself quite at home. Going round the stands he was delighted to find the innermost parts of nearly every set displayed in front of the public's prying eye. A thing he had missed at Berlin.

### Those Girls!

Of course, he kicked violently at flowers and girls decorating the stands. "They detract one's attention from the seriousness of a purely technical exhibition," said he. I retorted that, quite on the contrary, they attracted the public's attention, whereupon he came along with that age-old argument that if the thing in itself didn't

Hans nosed round everywhere, liking the readiness of those in charge of the stands to tell him all about everything, and admiring the ten-, twenty- and thirty-guinea set and radio-gramophones, but sorely missing the good-looking five- and even three-pound sets he was used to at the Berlin show.

### Should We Dance?

"But what do you export then?" was his next question. I replied that I supposed we exported the expensive models and left the European market for the cheaper, well-made set which sells by the hundred to the Germans.

Speaking of the competition, we touched on French competition: we had both been to the French exhibition held recently. We both smiled, and when I said: "Why, even the French realise that they

are back-numbers in all branches of radio," he just smiled and nodded.

We finished up at the dance floor, where he again began spouting his general ideas about dancing not having anything to do with the "seriousity," as he called it, of a radio show. But he was quiet when I reminded him of the afternoon concerts in the Berlin Exhibitions gardens.

After all, if we have the space and if we like to dance, why not? You can't look at miles of radio sets without feeling you'd like to do something different now, and if

Channel 'planes and the associated land stations, and also the newer "F and L" aeroplane beacon. This transmission takes the form of a number of interlocking "F's" and "L's," which, when the pilot is taking his correct course, merge into one continuous musical note.

### Croydon and Heston

A slight deviation on either side causes either the "F" or the "L" to stand out.

Immediately below this will be found the 'planes themselves. For most parts of this country

## USEFUL FOR BERLIN FLAT-DWELLERS



The German visitor to Olympia was greatly struck by this compact aerial.

you go out there is "No Readmittance."

Hans was pleased to note that British constructors had not been idle during the past year. He had even discovered three or four absolutely new ideas, and was interested in the come-back of the super-het; things which had not impressed him at Berlin.

But I couldn't shake his belief in Berlin being the finest and most go-ahead show. I suppose that is as it should be.

## JUST BELOW 1,000 METRES

*Some notes on an interesting wave-band.*

In the wave-length band between 900 and 1,000 metres, in addition to the radio beacons continuously working, there are all the cross-

Croydon is the strongest station to be heard on this band, although in North London he is fairly weak.

There is also a new station at Heston on about 833 metres.

In South London another good station is Lympe (near Folkstone), who acts largely as a stand-by station for Croydon when the latter cannot receive the 'planes clearly.

### Listening to Lympe

Listen to Croydon on almost any day and you will hear "Hullo, Lympe—can you get the chap, I can't?" Or, less frequently, in the middle of a discourse in French with an Air Union 'plane—"Je ne comprends pas le nom du place que vous avez passé—I say, Lympe, where is the beggar?" or words to that effect. The Croydon operator often waxes humorous.

If you think your receiver is sensitive on the long wave, just see if you can hear Croydon to it, but please, please don't oscillate, particularly if you are on the route or near it.

## HE THOUGHT THEY WERE TOO FRIVOLOUS!



Hans objected to pretty girls at a Radio Show because they took one's mind from technicalities—at least, he said they did!





# WHEN THOSE FOREIGN ANNOUNCERS SPEAK

*The music ceases, and the applause of a far-off audience dies away. Then . . . . ! It is so easy to miss the few quickly spoken words ! There is a moment's silence, and But here is a practical article which will be of immediate assistance to almost every valve-set owner.*

*From a Special Correspondent.*

**H**ow often have you bemoaned the fact that, in spite of your doing very well at French when at school, and acquiring quite a good vocabulary (and even some proficiency in speaking the language), French wireless talks continue to be more or less unintelligible to you ?

### **Train Your Ears**

Perhaps you begin to wonder whether you didn't waste your time trying to learn French, because you fail to follow the French announcers. But don't be downhearted ; it is not your knowledge of French which is wrong, probably it is your ears. I don't mean you should consult an aural specialist ; but your vocabulary may be quite a large one and still you may be unable to understand broadcast French.

You may be able to speak French with a fair amount of ease, but if you refuse to train your ears—and fairly regularly at that—you may listen till the Day of Judgment without properly understanding what French announcers are talking about.

### **A System Necessary**

Like anything else which is worth while, training is necessary, and a system has to be used. And when you use a system you must bear in mind the fact that progress will not be rapid—at least, to begin with. Concentrated effort, and a determination to "stick at it," are absolute essentials.

The Editor has asked me to offer a few hints about a system which I have found really useful in practice.

### **THE VOICE OF GOLD**



Said to have the finest speaking voice in America, Mr. Mac Namee, a New York announcer, commands a salary of £2,000 per month !

Well, let me take one example to begin with. Gramophone recitals are a feature of most of the Continental programmes to-day (especially on Sundays from Radio Paris), and in these recitals there is a constantly recurring announcement made by the announcer. Unlike the amiable Christopher Stone, French announcers cut out all the small talk ; they simply tell you that you are going to hear record No. so-and-so, recorded by such-and-such an orchestra, under the direction of M. so-and-so. You listen to the record, and then the announcer says : " You have just heard record No. so-and-so," etc.

### **Picking Out Expressions**

Now what are the actual words used by the announcer ? If you saw them written down on a piece of paper you would read them probably with the greatest ease ; but the ability to catch the words when broadcast is the very essence of my system.

Everybody gets those familiar opening words " Mesdames et Messieurs " ; but what about : " Vous allez entendre disque numéro mille deux cent soixante-trois enregistrée par . . . Orchestre sous la direction de M. — " ?

Well, if you hear that broadcast in rapid French can you get it ?

After playing the record the announcer repeats the announcement, more or less in the English style, but with the necessary grammatical



## How to Identify Phrases in French

alteration at the beginning: "Vous venez d'entendre" (You have just heard), etc.

Now, the point of my system is this. It is essential that you learn by heart the two expressions "Vous allez entendre" (You are going to hear) and "Vous venez d'entendre" (You have just heard). These two expressions are always used, though as an alternative to the first you may sometimes hear the announcer say: "Veuillez écouter." But if you hear, and recognise, those expressions to-day, for the first time, you will certainly hear them to-morrow without listening for them; and the same applies to other stock phrases and expressions broadcast by French announcers.

### Words Quickly Grasped

At present you may not get the very simple word "disque" (record), or the phrase "Sous la direction de" (Under the direction of), but listen for them to-day and to-morrow and soon they will be a part of your vocabulary, with a meaning which is grasped immediately they are uttered. There will be no pause while you spend a second or two recollecting the meaning of the phrases. And that second or two is usually

### "HIER HILVERSUM"

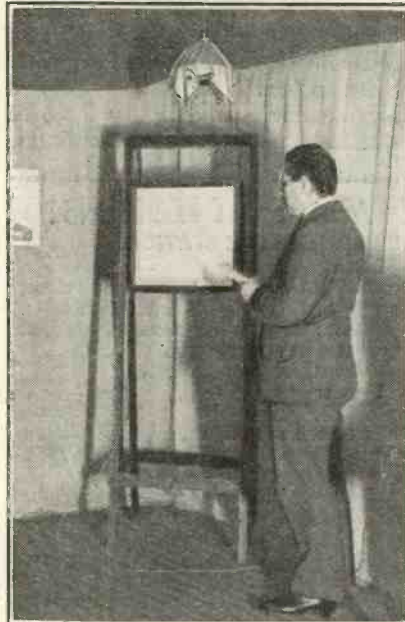

Every three months Hilversum's studio is connected to the Huizen transmitter, and vice versa—a habit that causes much confusion to those not "in the know."

fatal, because you lose the trend of the announcer's remarks and consequently fail to grasp the sentence.

I think you will find the French gramophone recital will have an

added interest if you try my method, because you will more rapidly and more satisfactorily comprehend what the announcer is talking about. Of course, you might say this is slow work. Well, perhaps it is; but it's an old saying that nothing succeeds like success, and the encouragement which understanding the "record patter" of French announcers will give you should spur you on to more concentration and determination to understand the phrases used by announcers in other French broadcasts.

### Listen to Toulouse

I am sure you have often heard a French comedian broadcast, and have wished you could get your ears properly "in tune" with the French accent. And because you can't you have probably said: "Oh, yes, I can read French very well, but I don't speak it!" Which is as good as saying that, despite your satisfactory vocabulary, you consider yourself more

Look for the following article in this series, dealing with the phrases used at the German stations.

## THE BROADCAST CONVICTS OF SOVIET RUSSIA

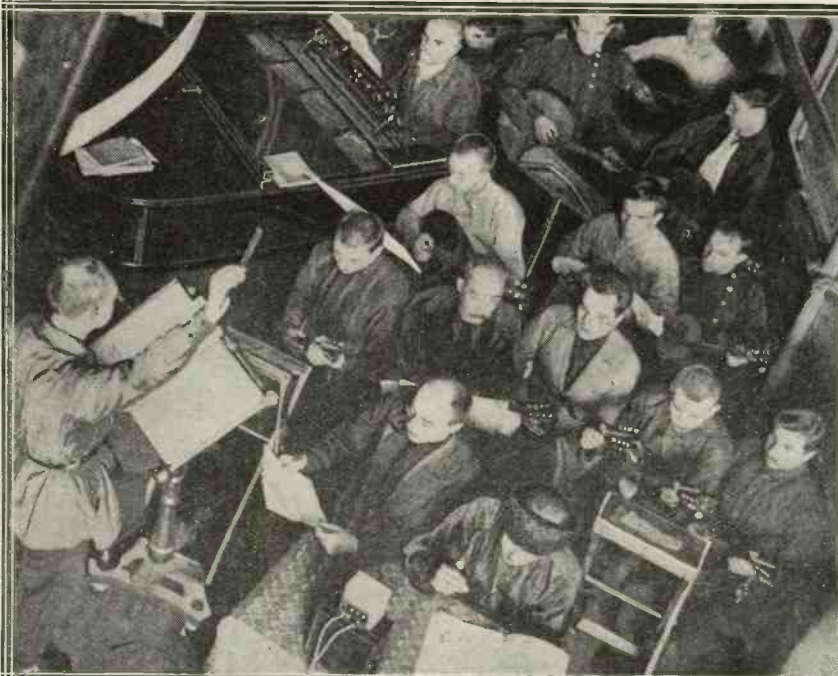

Like the American stations, Moscow occasionally puts on a prison programme, and this view was taken during a broadcast from the Lefortowo Prison, Moscow.

or less incapable of carrying on a conversation in French, or even understanding French words when they are spoken by French people.

I mentioned just now stock phrases. I include call-signs. Listen, for example, to the opening call made by the announcer at the Toulouse station. I suggest that when you listen to it you commit it to memory. You will soon find you recognise it immediately you hear it spoken the next time. (And, incidentally, take my advice and listen in regularly and systematically to the Toulouse station. The announcer has a very pleasing voice, and in addition he talks much slower than the man at Radio-Paris.)

### Adverts. are Helpful

Listen to the advertising announcements which are made each day of the week. You will hear some of these advertisement announcements time after time—for at least a week. Write down on paper as many words as you recognise. You will find that you will not have to listen the second evening for the words you wrote



down the evening before, because they will automatically thrust themselves on you. And on the second evening you will probably add to this list words not already there.

**After a Week**

Do this every evening for a week, and I shall be very surprised if, by the end of the week, you don't find that you clearly understand the

in fact, the real English idea of a French gabble. Even for a good French scholar, method is certainly necessary when listening-in to these French Stock Exchange quotations. You may know all the French numerals, but your ears are not accustomed to the sound of them when spoken. The method I suggest for tackling this difficulty is to be satisfied one evening with picking



A EUROPEAN FAVOURITE.—Marie Luisa Boncompagni, better known to Britain as "Miss Radio Roma."

**EXACTLY WHAT THEY SAY—AND WHAT IT MEANS!**

**STOCK PHRASES YOU CAN HEAR FROM FRENCH STATIONS.**

**Stock Exchange Prices :**

Voici les cours de change (de la Bourse) communiqués par le syndicat . . . . . près de la Bourse (Exchange prices, communicated by the so and so syndicate, near the Stock Exchange).  
Incote (not quoted). Inchangé (no change).

**Before the News Bulletin :**

Voici le premier bulletin d'information (Here is the first News Bulletin).  
Voici le deuxième bulletin d'information (Here is the second News Bulletin).  
Voici le troisième bulletin d'information (Here is the third News Bulletin).  
Or: Voici maintenant quelques informations (News). Then (after advertisement by Announcer): Suite de nos informations (News continued). Or: Voici maintenant la lecture des informations (Literally: Here is now the reading of the news).

**Then, after the News Bulletin :**

La lecture des informations est terminée (News Bulletin is now finished).

**Racing Results :**  
Voici le résultat de la première course, courue . . . aujourd'hui à Vincennes.  
Trans.: Here is the result of the first race, to-day at Vincennes.  
Non courus (Non-starters).  
Tous courus (All ran).

**Programme Announcements :**  
Voici notre programme de ce soir (This is our programme for this evening).  
L'émission que vous venez d'entendre est terminée (The transmission you have just heard is finished).  
L'émission de Radio-Paris, onze rue François premier, est terminée jusqu'à dix-huit heures vingt. (Broadcasting from Radio-Paris, 11 rue François premier, is finished till 6.20 p.m.; or Radio Paris, etc., is closing down till 6.20 p.m.)

**Advertisement Phrases :**  
Renseignez-vous chez votre fournisseur habituel (Enquire at your usual dealers).  
Exigez la dentifrice " — " (Ask for " — " dentifrice).  
Dans un instant, nous allons donner l'heure exacte (In a moment we are going to give the exact time).

meaning of the broadcast advertisement.

Stock Exchange news and prices offer a very good opportunity for repolishing your French numerals. At present you may find them a chaotic medley of figures, often rushed through at a terrific speed;

**THE LADY OF LAUSANNE**



This is charming Angele Golay, who says: "Ici Radio Suisse Romande, studio de Lausanne." (Radiated from Sottens, 403 metres.)

out, say, every "soixante" you hear spoken; or, better still, every number of more than one figure—one of which is "soixante."

**One at a Time**

For example: "Soixante-deux, soixante-huit," etc., but be sure to write them down on paper. Ignore, for the first evening, say, the "quarante," the "quatre-vingts," the "trente," and the "vingt," and concentrate on the sounding of "soixante." Ignore, also, the hundreds—for the time being—and you will find that listening for the "soixante" will unconsciously help you to differentiate it from the other.

**"Acclimatising" the Ear**

On the second evening concentrate on, for example, "trente" something to the exclusion of all other numbers. The ear will soon "acclimatise" itself. And so on, for a week, or even a month, if necessary. Small beginnings are sometimes apt to be boring, but you must be content

with small beginnings; and really it is astonishing how quickly the ears can be trained to catch words instantaneously by this method. Master one numeral per sitting, and you can rely on your ears doing the rest. After all, understanding French numerals, as given in Stock Exchange prices, is no more difficult than reading Morse. And, as many of my readers know, signalmen during the war often mastered the flashlamp and the Morse code buzzer in a month or so.

**How News Will Help**

As a final suggestion, make the most of news of world interest. I remember listening during the recent political crisis to a broadcast item about the latest developments in the situation. I heard this via the National station, and later on in the same evening I heard the news in French from Paris. My point is obvious. You will see immediately how a brief knowledge of the trend of world events will greatly help you in following the news items when broadcast from a French station.

**"RAHDIO VEEN"**

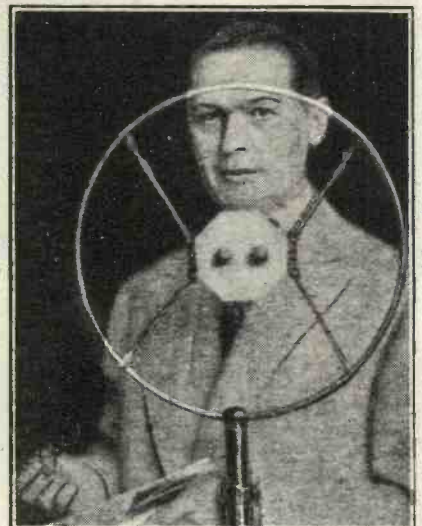

The popular announcer at the Vienna station, which works on 517 metres.



# Trouble Tracking

On this page the Chief of the "M.W." Query Dept. discusses, month by month, some of those common difficulties and troubles which can be so perplexing. This month he deals with distortion and its remedies.



**D**ISTORTION seems to be all too prevalent at the present time, and this month I should like to say something about its causes and to indicate remedies.

Well, the first question you should ask yourself is this: "Is the receiver stable?"

If there is an H.F. stage, does it tend to oscillate when tuned to a station?

This form of instability is particularly unpleasant, and often takes the

form of a high-pitched "hiss" which is in the background all the time. Music may sound "reezy" and harsh.

form of a high-pitched "hiss" which is in the background all the time. Music may sound "reezy" and harsh. The remedy is to rebuild the H.F. side, increasing the screening if necessary, but most certainly separating properly all vital leads and re-arranging the layout. H.F. instability is, in fact, chiefly a matter of design and layout, and is not usually due to any one particular feature.

takes place on the L.F. side. It can occur in a variety of ways. Back-coupling, for instance, is a common cause. How many listeners run their sets from badly overloaded mains units, or use partly run-down batteries? Quite a few, I should say, if one can judge from correspondence. If the set has two L.F. stages, or just one with a pentode output, it is essential to employ a de-coupling device such as a resistance-condenser

to give distortionless amplification, and the valve-makers' instructions on this point must be adhered to.

It is therefore essential to see that the H.T. voltages are high enough, and that the grid-bias battery is capable of doing its work. It is not safe to use a grid-bias battery for a period longer than six to eight months unless means of measuring its voltage are available.

In addition, in spite of the H.T. and G.B. voltages being correct, it is still possible to get very bad distortion by overloading the output valve.

## A Larger Output Valve

There is only one remedy to this, and that is either to cut down the volume or to use a larger output valve.

This means that if the valve is of the small power type it will have to be replaced by one of the super-power class. Such a valve will, of course, require a higher value of grid bias and will take a bigger anode current.

Hence a super-power valve cannot be employed unless the H.T. supply is capable of withstanding the heavier current demand.

It is possible for two transformer-coupled stages to cause a lot of trouble if they won't "pull together." Sometimes an unhappy choice of transformers produce a response curve full of peaks, and no matter how you adjust the H.T. and G.B. voltages the output valve overloads on certain passages.

Moreover, I find that there is a tendency for constructors to choose high-ratio instruments in the hope of getting more "punch."

There is unfortunately a limit to the amplification that can be achieved without distortion and instability, therefore it is advisable to use low-ratio transformers when there are two stages.

## WATCH THESE POINTS

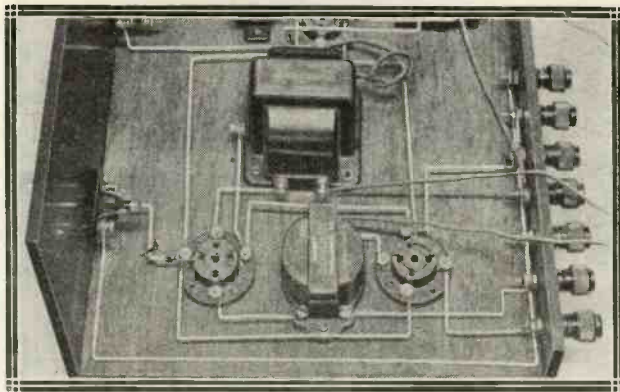

When using two transformer-coupled L.F. stages always take every precaution against instability. Keep the wiring well spaced and as direct as possible, joining the core of one or both components to earth.

unit in the plate circuit of the detector valve.

## De-coupling

With pentode valves the primary grid should be de-coupled, and in some cases it is desirable also to de-couple the intermediate L.F. stage, e.g. when two transformers are employed.

This won't always help you if you happen to be using an overloaded mains unit or a "dud" H.T. battery, because although you may cure L.F. howling and "motor-boating" by de-coupling, you still get distortion owing to the anode voltages being all wrong.

Valves must have their correct plate voltages and grid bias if they are

## L.F. Distortion

It is rare to find a set having screened coils and condensers exhibiting signs that the H.F. stage is not as stable as it might be.

I am afraid, however, that in the majority of cases distortion mainly



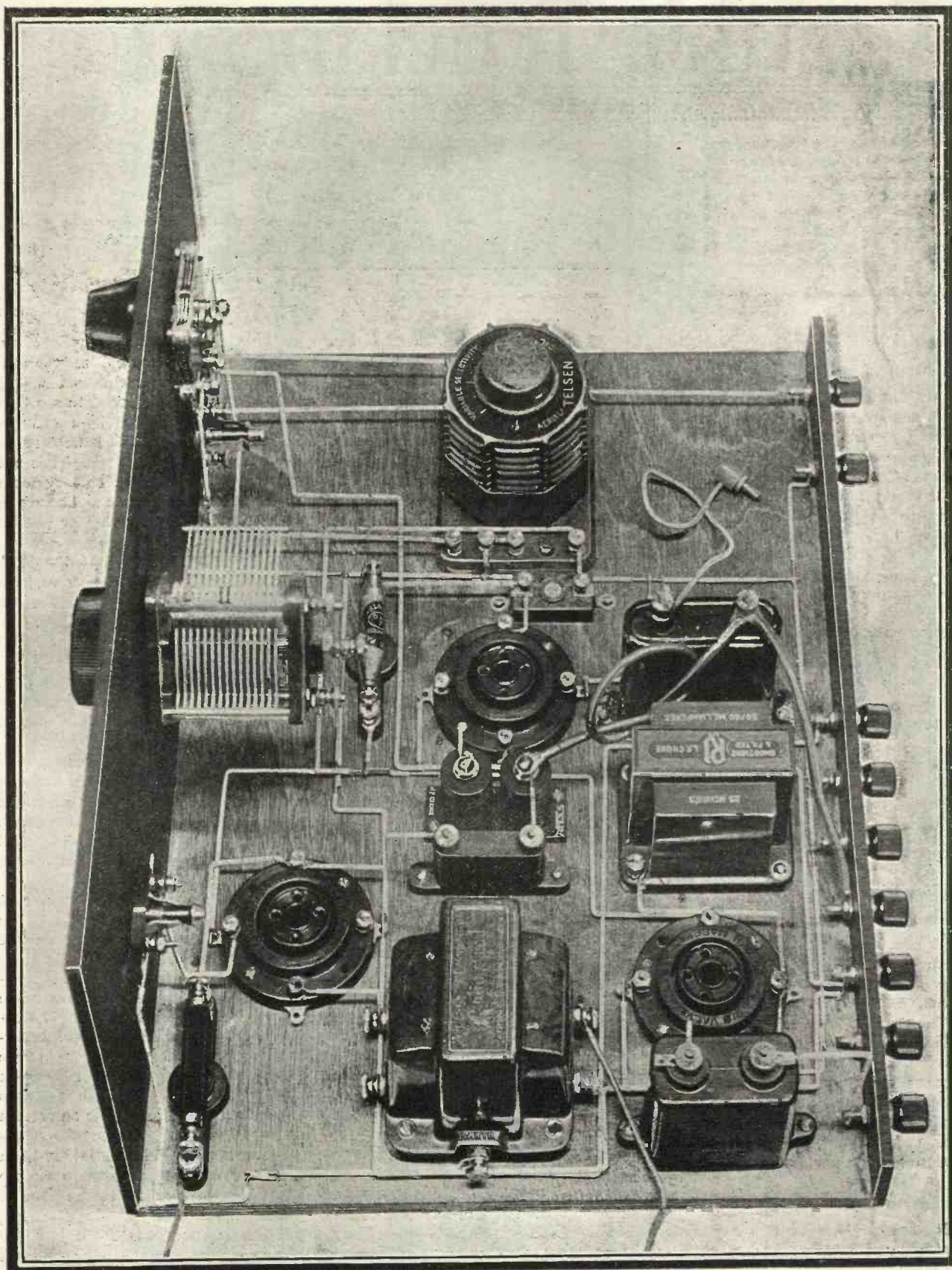

*A Particularly Easy Receiver to Assemble*



# The "M.W." "Uni-Coil" Three

(MODEL "A")

A sound three-valve design which is presented in two models. The only difference between these lies in the tuner unit, and constructors are given the opportunity of choosing that make which appeals to them most. Having read the following article, they will see that there is really no clash of conflicting claims and that each tuner has its own individual advantages and clearly defined attractions.

**T**HE number of home-made three-valve receivers in this country must run into some hundreds of thousands, and it is safe to say that it is still the most popular type of receiver among British listeners.

## Plenty of Punch

The detector and two note-magnifier set has some very definite advantages. It is easy to build, and it gives tremendous power for its size on the local station. It is by no means to be "sneezed at" as a DX receiver and is easy to handle. Moreover, it is inexpensive, and that is a very large and important point in these days of financial crisis.

This month, therefore, we are placing before you a couple of three-valvers of unusual interest; in fact, in one way they are unique in that the two main components are by the same firm.

## Their Own Designs

Not that we have gone along to a commercial firm and said: "Design us a set," but we have taken the tuners and the L.F. transformer in the case of one, and the tuner, L.F. transformer and variable condenser in the case of the other, from the stock of well-known firms, so that the salient features of the set shall consist of commercial components of the same make.

For instance, in the first one to be described, a Telsen aerial coil unit, a Telsen variable condenser and an

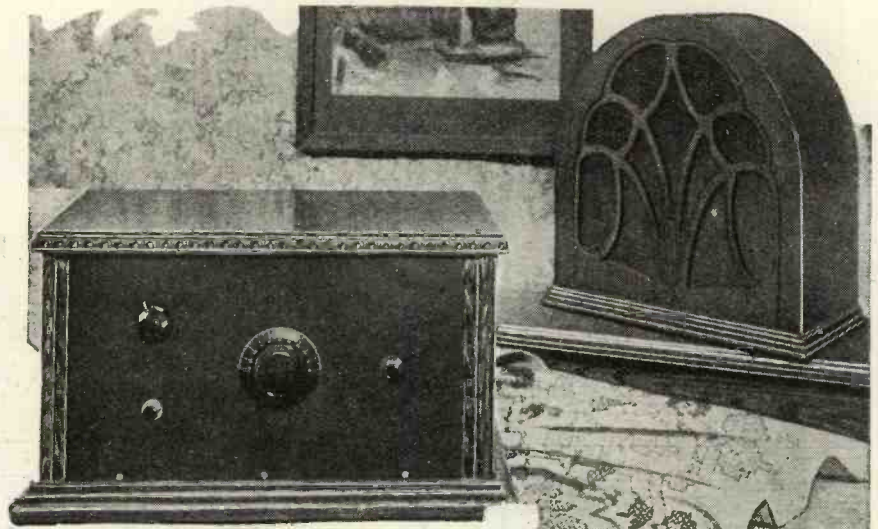

THE CONTROLS ARE REDUCED TO A MINIMUM

L.F. transformer of the same make have been employed, while in the second receiver an aerial tuner and an L.F. transformer of British General make have been used. Thus it will be seen that to all intents and purposes the sets are commercial designs in home-constructed form.

The first set, which includes a Telsen dual-range coil, variable condenser and L.F. transformer, is quite standard in its design, the wave-change being carried out by means of a three-point switch in a manner which is familiar to most of our readers. A feature of the coil, however, is the condenser which is in series with the

aerial, and which is placed in the top of the coil itself. This can be adjusted and left set to suit the particular requirements.

## Very Selective

The selectivity obtainable with this coil is of a high order, and, in fact, greater than in the case of a number of other dual-range coils which we have tested recently. We can unhesitatingly say that it was found extremely efficient; and, moreover, the set makes an extremely cheap three-valver which should give undoubted satisfaction to a large number of home constructors.

## THE COMPONENTS REQUIRED FOR MODEL "A"

### PANEL

14 in. x 8 in. (Permeol, or Wearite, Goltone, Peto-Scott, Becol).

### CABINET

Panel space, 14 in. x 8 in., with baseboard 10 in. deep (Pickett, Ready Radio, Camco, Peto-Scott).

### VARIABLE CONDENSERS

1 0005-mfd. (Telsen, or J.B., Astra, Formo, Ready Radio, Cydon, Graham Farish, Polar, Lotus).  
1 00015-mfd. differential reaction (Ready Radio, or Telsen, J.B., Lotus, Igranic, Polar, Dubilier, Formo, Lissen, Graham Farish).

### SWITCHES

1 "on-off" (W.B., or Ready Radio, Telsen, Bulgin, Igranic, Graham Farish, Peto-Scott).  
1 3-pole (Junit, or W.B., Ready Radio, Telsen, Peto-Scott, Goltone, Wearite, Bulgin).

### RESISTANCES

1 100,000-ohm Spaghetti (Varley, or Igranic, Lewcos, Graham Farish, Sovereign, Peto-Scott, Ready Radio, Telsen, Bulgin, Magnum).  
1 25,000-ohm Spaghetti (Varley, etc.).  
1 2-meg. leak and holder (Graham Farish, or Dubilier, Telsen, Igranic, Ready Radio, Lissen, Ferranti, Ediswan).  
1 1/2-meg. leak and holder (Graham Farish, or Dubilier, Telsen, Igranic, Ready Radio, Lissen, Ferranti, Ediswan).

### VALVE HOLDERS

3 4-pin type (W.B., or Telsen, Clix, Benjamin, Igranic, Wearite, Lotus, Lissen, Bulgin, Burton, Graham Farish).

### FIXED CONDENSERS

1 0003-mfd. (Goltone, or T.C.C., Dubilier, Ediswan, Ferranti, Igranic, Sovereign, Telsen, Graham Farish, Mul'ard).  
1 01-mfd. (T.C.C., etc.).  
2 2-mfd. (Dubilier and Ferranti, or Helsby, T.C.C., Igranic, Telsen, Formo).

### CHOKES

1 H.F. (Atlas, or Varley, Lewcos, Ready Radio, Telsen, R.I., Wearite, Magnum, Graham Farish, Peto-Scott).  
1 output (R.I., or Telsen, Varley, Igranic, Graham Farish, Bulgin, Ferranti, Lotus, Wearite).

### TRANSFORMER

1 L.F. (Telsen, or Ferranti, Lotus, R.I., Igranic, Varley, Lissen, Lewcos, Graham Farish).

### COIL

1 Telsen aerial coil.

### MISCELLANEOUS

9 terminals (Belling & Lee, or Clix, Ealex Igranic).  
1 terminal strip, 14 in. x 2 in.  
Wire (Glazite, or Lacolne, Jiffilux).  
3 wander plugs (Belling & Lee, or Clix, Igranic, Ealex).  
Flex, screws, etc.



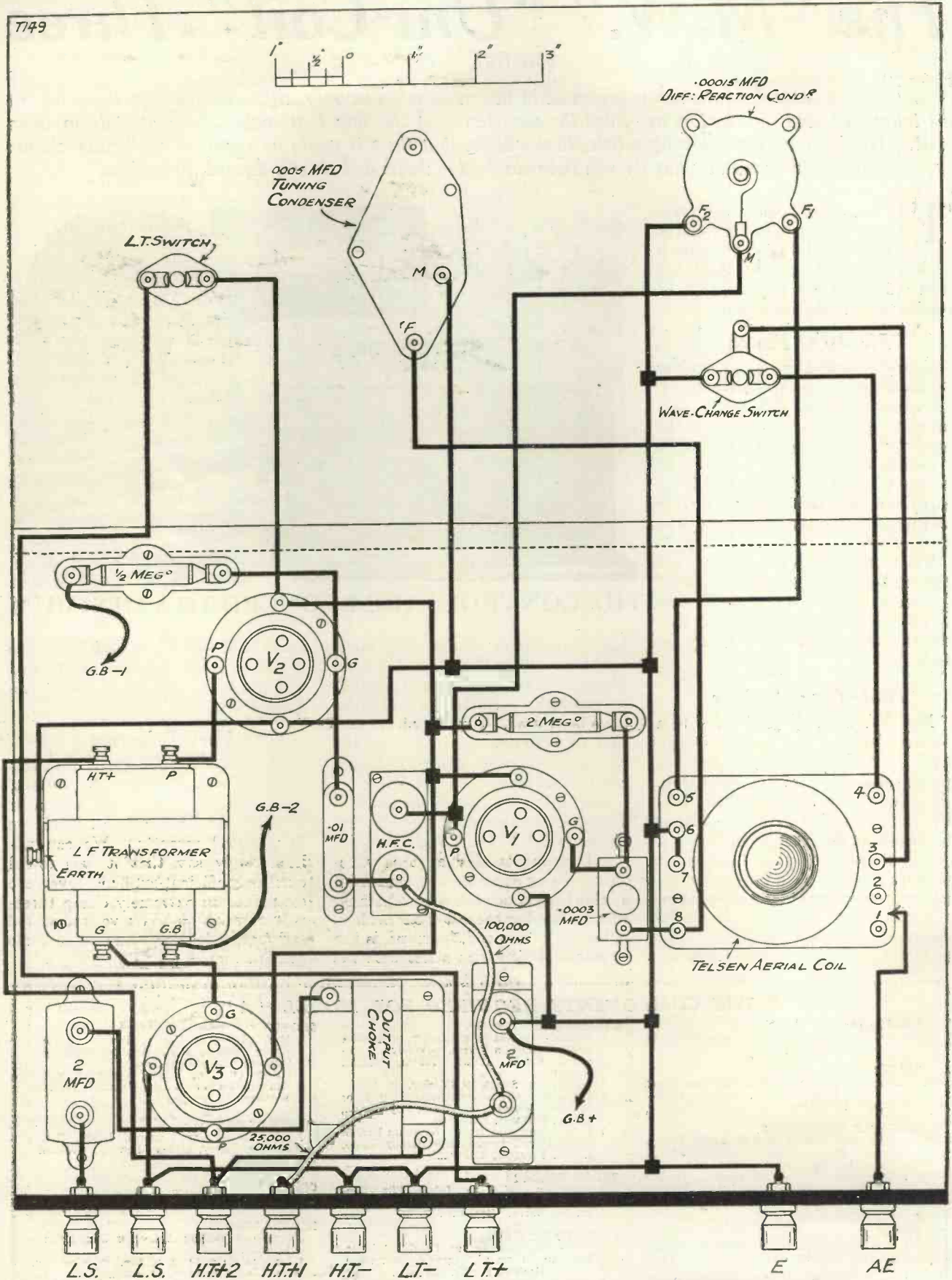

*Note the Simplicity of the Wiring of this Set*



## Sufficient Selectivity for Sharp Station-Separation

### POWERFUL LOUD-SPEAKER PERFORMANCE PROVIDED

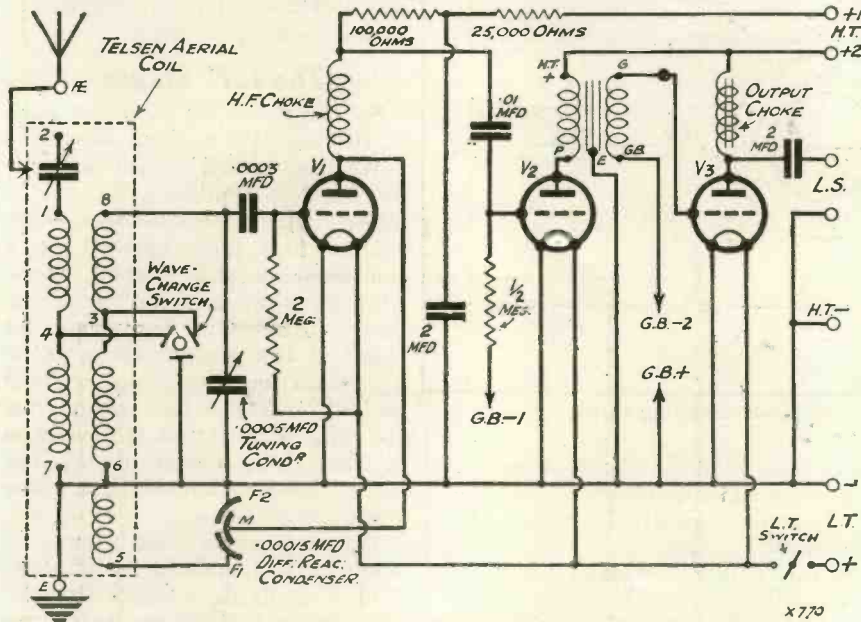

With two good L.F. stages, one resistance-capacity and the other transformer-coupled, adequate power for the operation of a large loud speaker is present.

The connections of the coils are extremely simple. The terminals are numbered, and our diagram shows exactly how these should be connected up. On pulling out the wave-change switch the three contacts are joined together, and one receives the medium waves, while when the switch is pushed in the set automatically tunes on the longer wavebands.

The actual tuning is carried out in the usual manner by the variable condenser, connected as shown, and in fact the receiver is like any other normal wave-changing set, having the advantage over many of them in that it is both selective and highly sensitive.

### Satisfactory Results

At Tallis House, the North Regional station usually needs a certain amount of finding and coaxing on a three-valve set, but on this one the reception was surprising, while the long-wave pick-up of Daventry, Radio Paris and the Eiffel Tower showed that there was nothing more to be desired concerning the sensitivity of the receiver on the long waves.

We have, as far as possible, kept the layout of the two receivers the same, so that it is easy to compare them and see wherein the differences lie, both in construction and in circuit.

Both these sets we feel should be extremely popular, though as regards their tuning arrangements both are entirely different.

### Using Other Tuners

There are, of course, a number of other tuners on the market which will give extremely good results, and

although this month it has only been possible to make up two sets of this description, we feel that it will be of interest to our readers to go further with this matter, and we are contemplating the description of two more home-constructor sets in MODERN WIRELESS in the near future.

### Future Sets

These models, C and D, will also be three-valvers, but it must not be thought that because, as is inevitable, some makes of coils must be omitted from the "uni-coil" series these coils are not efficient or suitable.

It is impossible to have sets for all makes, otherwise MODERN WIRELESS would have no room for other articles and set designs, so it is by force of circumstance that some makes may not be included in our scheme, and not for any other reason, though we shall endeavour to choose those makes that are most popular.

But to get back to model A. The theoretical diagram shows exactly how things are arranged and from it will be seen how the windings of the coils are placed and the connections of the series aerial condenser on the coil unit.

This condenser is extremely valuable on the medium wave-band, as it allows a delightfully easy, but

### A KEY TO THE COMPONENTS USED

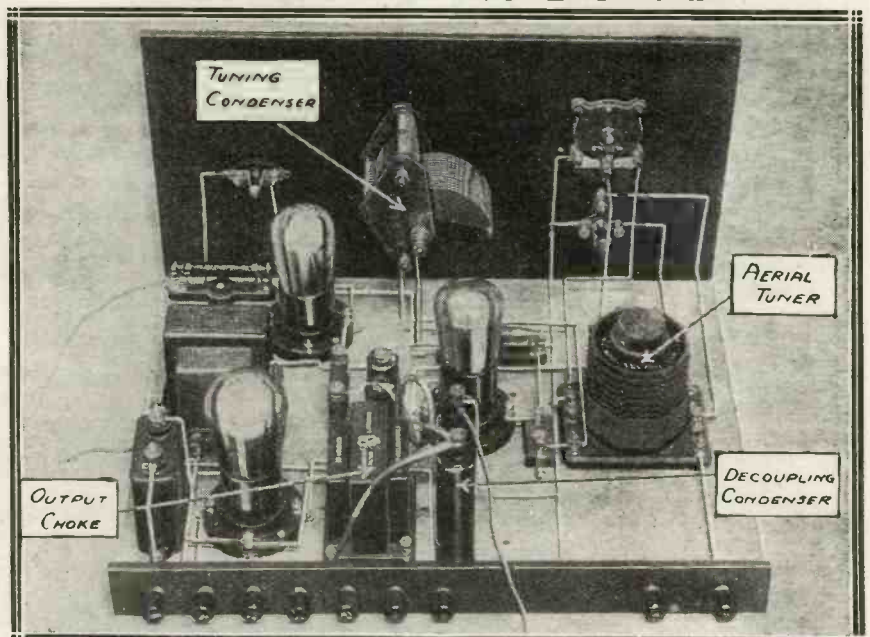

If you compare this photo with the wiring diagram on the opposite page you should meet with no difficulty in identifying all the parts in the set.



ONLY FOUR MAIN PANEL HOLES TO DRILL

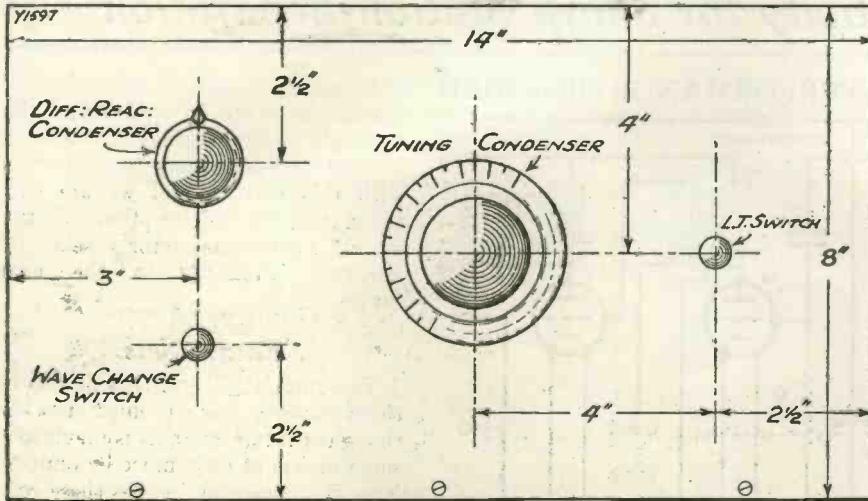

All the panel items are of the single-hole-mounting variety.

effective, variation of selectivity to be obtained.

But it need not be used if not required, for by placing the connection from the aerial terminal on to the terminal of the coil unit nearest the terminal strip (No. 1) the series condenser is automatically out of circuit. As a matter of fact, the wiring diagram shows the lead in question on terminal No. 1.

**Cutting Out the Condenser**

By placing the lead on No. 2 the series condenser is introduced again, and a clockwise rotation of the knob on top of the coil unit brings about the required increase of selectivity.

Naturally, in a simple scheme of this sort some sensitivity must be

purposes, but it is just as easy to arrange Extenser changing, and this, of course, greatly enhances the receiver.

This is how it is done. With the wave-change switch removed one would be left with three wires that must "go" somewhere. One of them is really common with the filament-

earth lead, and this would be taken to the earth circuit, i.e. to moving vanes of the Extenser.

The other two leads go one each to a contact spring on the Extenser. And "that is all there is to it," as they say. Simple, isn't it?

**The L.F. Stages**

So much for the tuning portion of the set. What about the rest?

We have picked an old favourite for the low-frequency side of the set—a plain resistance-capacity-coupled first L.F., followed by a transformer-coupled second stage. An output filter circuit is added, partly to assist in de-coupling, for many of our readers will want to use mains units with the set, and partly to isolate the loud speaker from the direct current and H.T. voltages in the anode circuit of the last valve. Nothing unusual, but a sure getter!

For the valves we rather favour some selection of the order of H.L.2, S.S.-210 L.F., or Mazda or Cossor 210 L.F., and then a P.M.252 or similar type for the output if you are within fifty miles of your local station.

A "VARIABLE SELECTIVITY" ADJUSTMENT

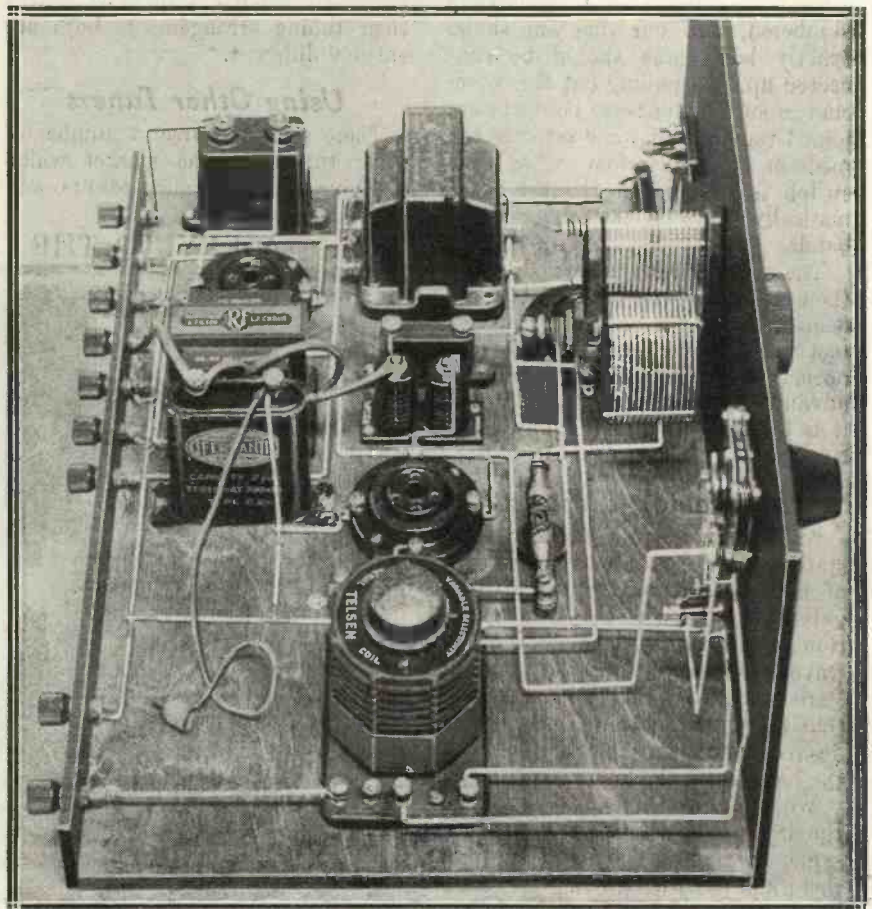

You can set the control on the top of the tuner to give you just that degree of selectivity needed to suit your own aerial and local conditions.

**RECOMMENDED ACCESSORIES**

(FOR EITHER SET)

**Loud Speakers.**—Amplion, Celestion, W.B., Blue Spot, Graham Farish, B.T.-H., Undy.

**Valves.**—1 det., 1 L.F., 1 power or super-power (Osram, Mullard, Mazda, Cossor, Six-Sixty, Lissen, Fotos, Tungsram, Eta, Davio). Milliamp consumption 18 to 20 m.a.

**Batteries.**—H.T., 100-120-volt super-capacity type (Drydex, Pertrix, Ediswan, Magnet, Lissen, Ever-Ready, Columbia)

**Accumulators.**—Voltage to suit valves. (Exide, Ediswan, Pertrix, G.E.C., Lissen.)

**Mains Units.**—Regentone, Tannoy, Heayberd, Ekco, Atlas, R.I., Lotus. (State details of set and type and voltage of mains when ordering.)

lost as selectivity is increased, but this can easily be made up by reaction, the control of which is particularly smooth.

We have used an ordinary three-point switch for wave-change



# The "M.W." "Uni-Coil" Three

(MODEL "B")

In this version a wide wave-range tuner unit embodying a reaction control and panel selectivity adjustment is used. In all other respects this attractive loud-speaker receiver is similar to model "A."

AND now for the second of this interesting series. A glance at the theoretical diagram will show that here a very unique form of tuner is employed, this being the well-known and extremely popular British General tuning unit, which fits on to the panel in the way shown in the photographs and wiring diagram.

## A "Straight" Set

The circuit again is a plain detector-resistance coupled to an L.F. valve and then transformer-coupled to the output valve, with an output choke and de-coupling device in the detector lead. But in the case of the British General tuner which we are now considering, selectivity adjustments and wave-changing are incorporated in the tuner itself, without any requirement of a separate switch.

This includes a device which is a selector switch situated between the two knobs, and enables selectivity to be easily varied. There are five positions marked on the escutcheon: In No. 1 the condenser is placed in the aerial circuit; No. 2 cuts it out; No. 3 gives it a large aerial coupling on medium waves; No. 4 is really for long-wave work, and G means that the aerial is placed direct on to the grid end of the tuner.

The wave-range may also be shifted to cover anything from about 200 metres up to 2,000. This makes it a very useful coil, because one can get the stations on the above bands without leaving any gap not covered by the tuning control, going up in steps and so covering every wave-

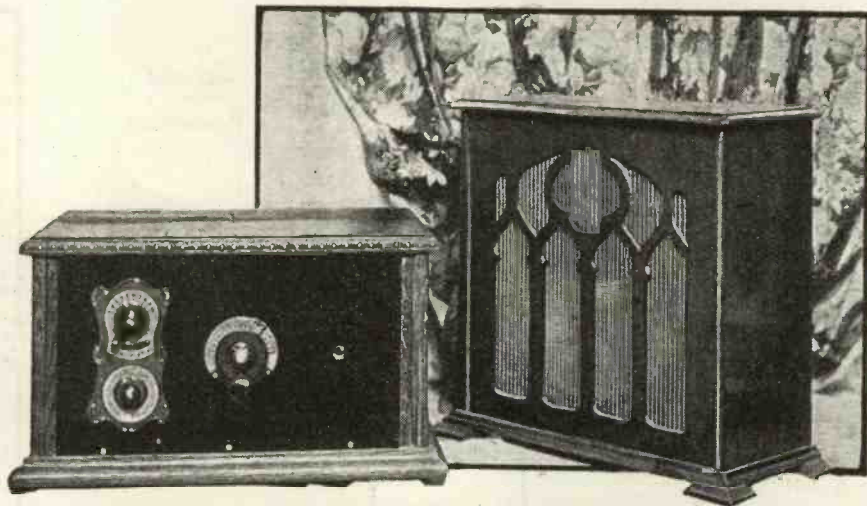

NOTE THE ATTRACTIVE TUNER ESCUTCHEON

length between the two figures mentioned.

The reaction is of the rotor type, and is controlled by the lower knob on the tuner.

You will be able to see from the circuit diagram how the various features of the British General tuner take effect. The wave-length selector knob, which is the top one, actuates a switch which is indicated in the circuit by the arrow attached to the earth terminal.

## Flexible Tuner

It does, in fact, vary the amount of inductance of the coil in operation by short-circuiting sections in the way depicted.

When hard over to the left the lowest wave-lengths are reached, and

gradually bringing the knob round to the right increases the inductance and allows the set to be tuned to higher wave-lengths.

## Step by Step

It is carried out by gradual steps, and it is possible by using adjacent settings to shift, say, the London Regional to two or three different places on the tuning dial by means of this wave-length selector switch. This shows how gradual is the step-up in wave-length for each stud.

When the long waves are required—above 1,000 metres—the selector is turned hard over to the right and the position of the selectivity adjuster is set at CT.

This brings in a series aerial resistance and centre-taps the aerial feed

## AND HERE IS THE LIST OF PARTS FOR MODEL "B"

### PANEL

14 in. x 8 in. (Permol, or Goltone, Peto-Scott, Wearite).

### CABINET

Panel space, 14 in. x 8 in.; baseboard, 10 in. deep (Pickett, or Camco).

### VARIABLE CONDENSER

1 0005-mfd. (Lotus, or Ready Radio, Telsen, Cydon, Igranic, Polar, J.B., Dubilier, Lissen, Formo, Graham Farish).

### COIL

1 British General tuner.

### SWITCHES

1 "on-off" (Ready Radio, or Telsen, Lotus, W.B., Goltone, Igranic, Peto-Scott, Bulgin, Magnum, Graham Farish, Wearite).

### RESISTANCES

1 100,000-ohm Spaghetti (Lewcos, or Telsen, Ready Radio, Bulgin, Sovereign, Magnum, Igranic, Peto-Scott, Graham Farish, Varley).

1 25,000-ohm Spaghetti (Bulgin, or Ready Radio, Telsen, Igranic, Bulgin, Magnum, Sovereign, Varley, Peto-Scott, Graham Farish).

1 2-meg. grid leak (Telsen, or Dubilier, Ready Radio, Graham Farish, Ferranti, Lissen, Ediswan, Igranic).

1 4-meg. grid cak (Telsen, or Igranic, Ready Radio, Dubilier, Ferranti, Lissen, Graham Farish, Ediswan).

2 grid-leak holders (Wearite, or Telsen, Ready Radio, Ediswan, Dubilier, Graham Farish, etc.).

### VALVE HOLDERS

3 ordinary 4-pin type (Graham Farish, Clix, Telsen, Wearite, Lotus, Lissen, W.B., Bulgin, Igranic, Magnum).

### FIXED CONDENSERS

1 0003-mfd. (Dubilier or Ready Radio, T.C.C., Telsen, Ferranti, Sovereign, Igranic, Graham Farish).

1 0002-mfd. (T.C.C. or Telsen, Ready Radio, Dubilier, Igranic, Graham Farish, Ferranti, Sovereign).

1 01-mfd. (Dubilier, etc.).

2 2-mfd. (Helsby and Formo, or Dubilier, Telsen, Igranic, Ferranti, T.C.C., Lissen).

### CHOKES

1 H.F. (Sovereign, or Telsen, Lewcos, Ready Radio, Peto-Scott, R.I., Wearite, Varley, Magnum, Graham Farish).

1 output (Varley, or Igranic, R.I., Telsen, Ferranti, Wearite, Lotus, Magnum, Graham Farish).

### TRANSFORMER

1 L.F. (British General, or Lotus, R.I., Telsen, Igranic, Varley, Ferranti, Lewcos, Lissen, Graham Farish).

### MISCELLANEOUS

1 terminal strip, 14 in. x 2 in.

6 terminals (Belling & Lee, or Elex, Igranic, Goltone, Clix).

3 wander plugs (Belling & Lee, or Clix, Igranic).

Wire (Glazite, or Lacoline, Quickwire, Jiffilux), Flex, screws, etc.



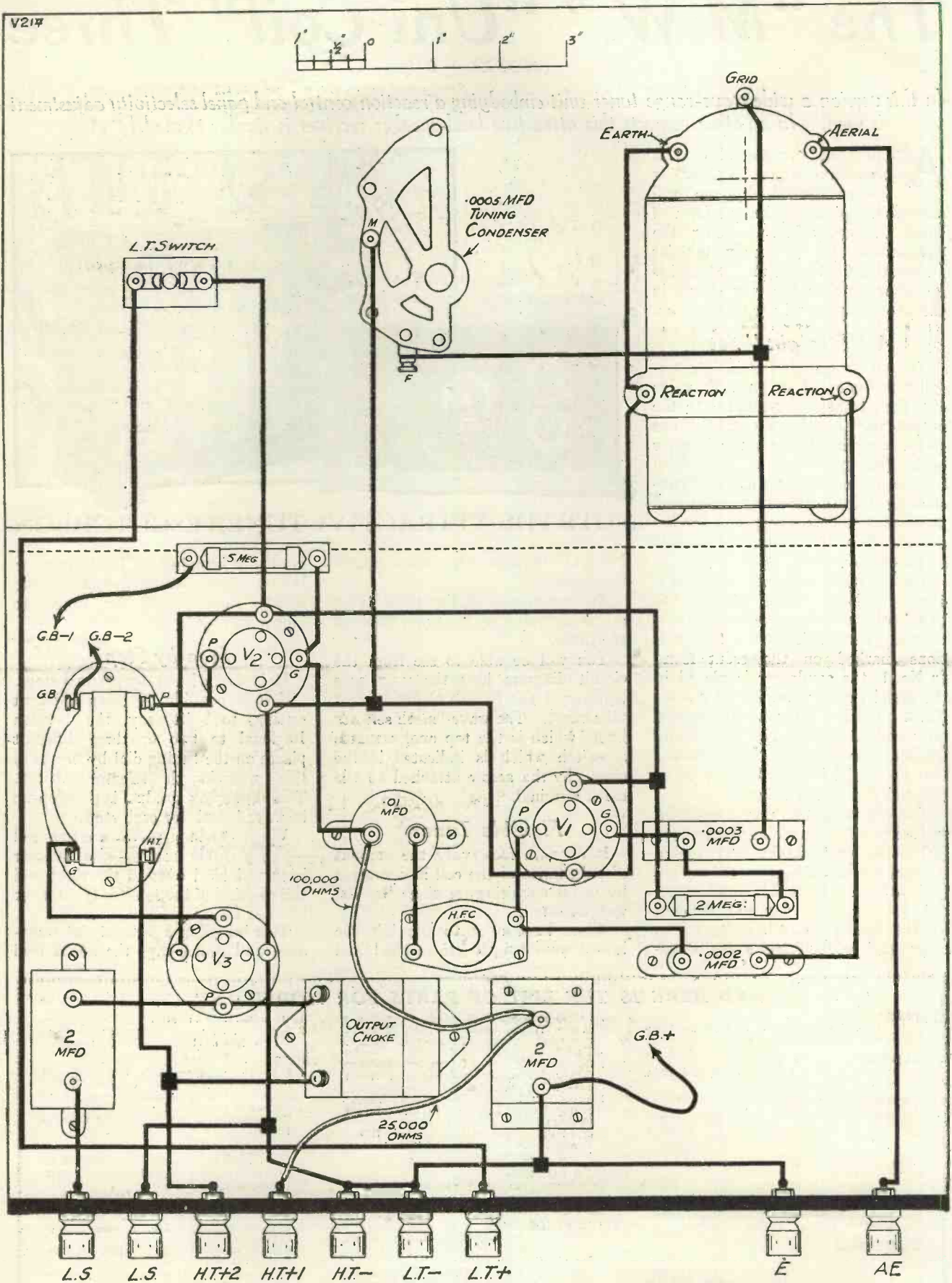

*There are Only About Thirty Leads to Connect Up*



## All Adjustments are Made by Front Panel Controls

### HERE IS THE CIRCUIT DIAGRAM

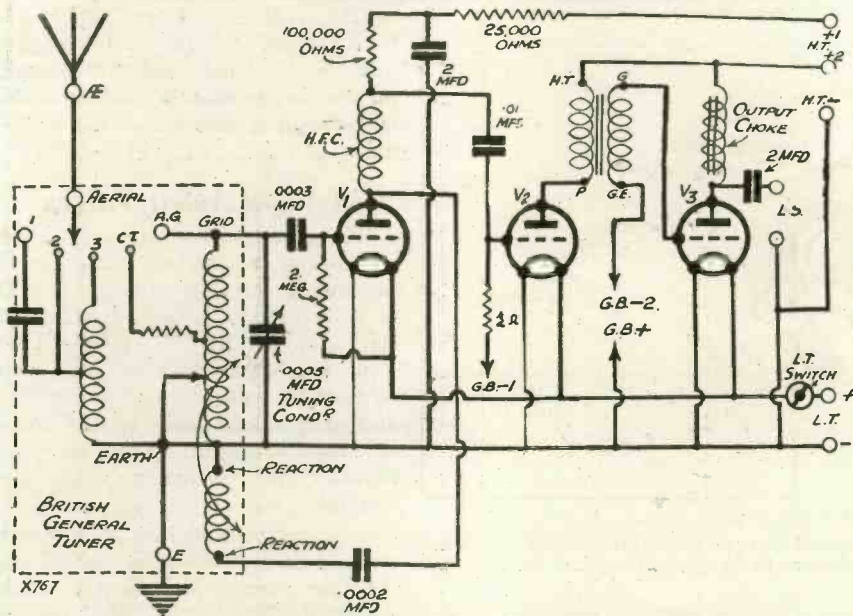

All that part of the diagram which is enclosed within dotted lines is concerned with the tuner unit.

into the grid coil. It is possible, if desired, to take the aerial direct to the grid, but this means a large loss of selectivity without any particularly valuable increase in sensitivity. Except in exceptional cases, this is never used.

The most useful position of the selectivity control is No. 2, where the aerial coupling coil is used, though in cases where local interference is very strong No. 1 would be valuable, bringing in the series condenser as well as the aerial coupling coil.

### Reasonably Selective

The tuner caters for every ordinary circumstance, but being a "plain" tuner you must not expect it, with a simple set of the kind described here, to enable you to tune out your local five miles away and get plenty of foreigners.

Increasing selectivity in a one-stage receiver where only one tuned circuit is employed must of necessity decrease the "pulling" power of the set, and so limit the number of distant programmes it is possible to receive.

The tuner we have used for this model B is a fascinating component to operate, and it is possible to use such a combination of settings that it is inevitably some time before one is sufficiently used to handling it to be sure that the best is being obtained from it.

Not that it is tricky to use; on the contrary, it is extremely simple, but one has to go about the job system-

atically if one is to be sure that justice to the ingenuity of the designer is to be done.

There is no doubt about the "punch" that can be obtained from the British General tuner, and a strength of reception that is surprising can be reached by careful manipulation of the various controls.

### A Useful Template

The mounting of the tuner is not a particularly difficult piece of work provided care is taken, the escutcheon acting as a template. The slot to take the selectivity control arm, of course, is the most awkward job, but this can be done quite well by means of a fretsaw.

This method is better than the more clumsy one of drilling a series of holes round the outline of the piece to be removed and then "smashing" the piece of ebonite out and finishing off by filing.

Such a way of cutting a panel is not only rather clumsy, but is also liable to be inaccurate, and it is very easy to get the slot too large. Not that that would matter in the case

### COMPLETE STABILITY—PERFECT QUALITY

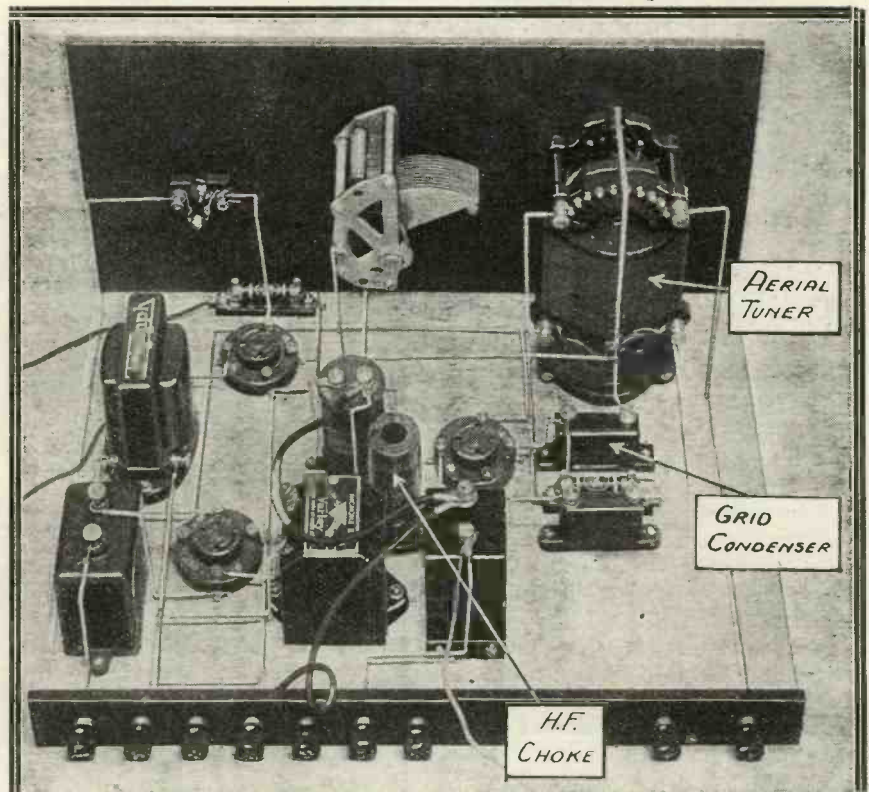

The output circuit arrangement, augmenting the properly de-coupled R.C.C. L.F. stage, provides against "motor-boating" and L.F. howling troubles, and contributes to a real quality performance.



## A "No-Trouble" Set to Make and Use

THERE ARE NO PANEL COMPLICATIONS

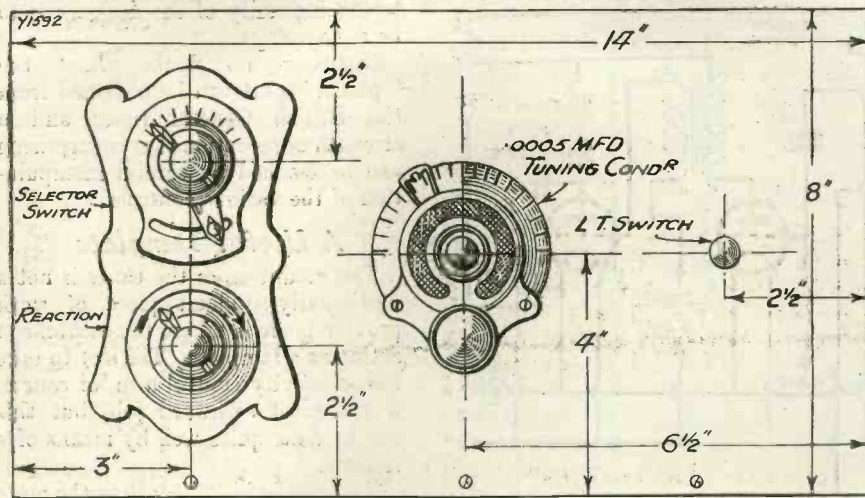

PANEL LAYOUT

Although the "tuner" has a very handsome panel plate it is extremely simple to mount and only two ordinary holes and a slot have to be cut in the panel for it.

under consideration, but the home-constructor should learn to use a fretsaw in such cases. He will be far more satisfied with his work, and he will be able to make it very much neater. Incidentally, the fretsaw method is much quicker besides being surer, so that it has everything in its favour.

By the way, while on the subject of the construction of sets, though it does not apply to the "Uni-Coil" Three any more than to any other home-constructed sets, do you countersink your panel-mounting screws?

### Countersink the Screws

It makes all the difference to the appearance of the set, and a small countersinking bit is a most valuable addition to the box of drills.

Quite a few people use the round-headed brass screws for fixing the panel to the baseboard. These are, however, not nearly so neat as the countersinking flat screwheads, properly sunk in the panel.

You cannot properly countersink the round-headed screws, with the result that they always project from the panel and completely ruin its appearance.

But to return to the model B receiver. We said before that the L.F. side was perfectly normal, and, indeed, except that different components are used, including a B.G. L.F. transformer, it is exactly the same as that of model A.

The reaction is of the magnetic as opposed to capacity-controlled

type, but in this particular circuit an H.F. choke is necessary, and this component is shown in the diagram.

It is amazing the "kick" that can be got out of a "three" of the kind described here when proper valves and H.T. values are used.

So, while remembering that this set is "an ordinary three" and therefore perfectly simple and straightforward to build and to operate, do not forget that if you want the best out of it you should use up-to-date valves.

### A Word About Valves

Plenty of really hot-stuff valves have been placed on the market during the last few months, as will be seen from the article elsewhere in this issue, entitled "Hotting Up Your Set," and it is to your own advantage, apart from giving set designs a fair chance, to use some of these modern miracles, for miracles of efficiency they undoubtedly are.

So many constructors are content to build an up-to-date set, using "all the best parts" and then to crab the result by the use of "yesterday's" valves.

The motor engineer would not dream of designing, or buying, a car with a really "hot" engine and then running it on paraffin. Yet that is what so many constructors do.

### INEXPENSIVE IN BUILDING AND MAINTENANCE

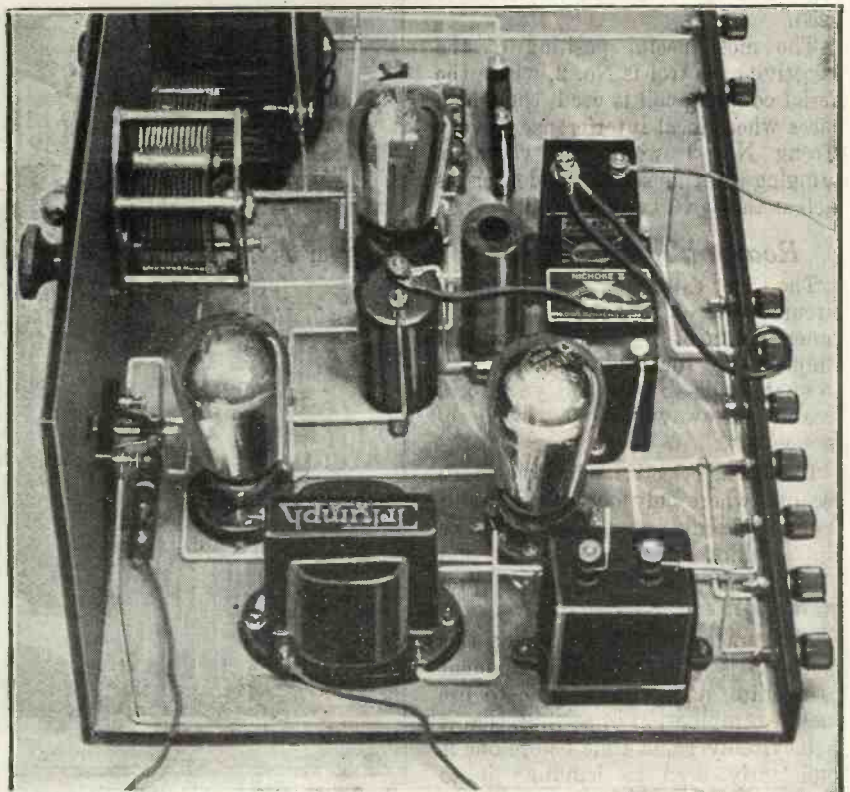

Valve for valve, you will find the "Uni-Coil" Three can hold its own against any equivalent outfit both in initial and running costs.





**W**HAT is this "top" cut-off which is so frequently, albeit so vaguely, referred to? This is the sort of thing one often hears or reads: "Um! That loud speaker is all right, but it has no top," or "There is a definite cut-off in the top register."

On the other hand, it is constantly said that a transformer or, for that matter, a loud speaker which has a peak at three or four thousand cycles is to be commended, because that is the sort of frequency at which so many outfits tend to fail.

### Those Peaks

I will deal with this point first. The average peak usually exhibited is such that no aural difference could possibly result. The human ear is three or four times less sensitive to amplitude changes at the high frequencies than it is to those occurring in the "middle register."

### HARDLY HEARD

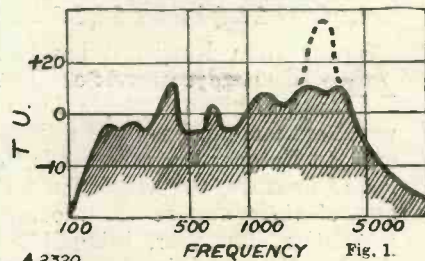

A.2320 Fig. 1. The curve of a good cone loud speaker. A peak such as that one shown dotted would not give much trouble.

And most of those peaks would amount to nothing even were they placed there. Look at Fig. 1. The dotted peak would just manage to "get over," and that curve is drawn on a basis of decibels (transmission

*An attempt to obtain a proper perspective of that "high register," and to adjudge its true value in relation to tone structure.*

units) and not voltage amplification, as are most of our curves!

But don't imagine that you would hear that "peak" as a raucous over-amplification of certain high notes, for it would be nothing of the kind. There would be extremely few notes having such a high frequency emanating even from a big symphony orchestra.

### Notes and Harmonics

There certainly are a number of instruments which can scale up to 3,000 cycles, but they do not often do so. A note having a frequency of 2,000 cycles is quite a high note and one that is very seldom heard in the usual way. Does that surprise you?

However, frequencies above 2,000 cycles have their value, although it is easy to over-rate them.

Personally, I do not think we would lose much if every set had a complete cut-off at 4,500 cycles!

There are no musical notes above about 4,000 cycles, but there are some harmonics. "Ah, harmonics!" I can hear some of you saying, "We must have those or the notes will lose all the individuality imparted to them by the instruments that produced them."

I am as keenly appreciative of the importance of harmonics as anybody. I have written quite a bit about them, but they are tending to develop into a

fetish mainly because they are not fully understood.

Now a harmonic is a secondary tone. When you strike the "middle C" note on the piano you do not hear only the fundamental frequency, 256 cycles, but a family of other frequencies set up by halves, thirds, quarters, fifths, etc., of the string vibrating sectionally, as it were.

### A Piano Test

From this you can see that in terms of frequency a fundamental will always divide exactly into its harmonics. The harmonics of that middle C (256 cycles) are 512, 768, 1,024, 1,280, etc.\*

Obviously, those harmonics which are so high in frequency that they could not if strong enough be heard as distinctive sounds are of no interest to us whatever, so all har-

### "MUSICAL" HARMONICS

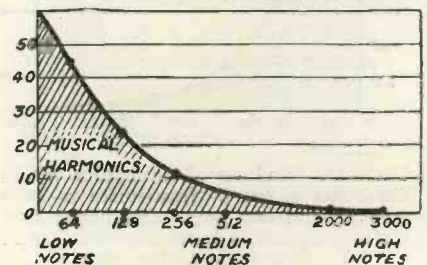

A.2321 The lower notes have many harmonics of frequencies corresponding with those of ordinarily played musical notes.

monics above about eight and ten thousand can be ruled right out.

From 4,500 cycles to 8,000 cycles is less than one octave, although

\*In English "Concert Pitch" middle-C is actually about 264 cycles, but 256 is retained as a "philosophical" standard.—G.V.D.



## The Higher You Go the "Thinner" the Note!

There are over seven octaves below 4,500 cycles! So you see, the higher the frequency band the smaller its "pitch span." But that is no argument against the higher frequencies as such, for it must not be forgotten that although 4,500-8,000 does not comprise a complete octave it does contain 3,500 frequencies, all of which can function as harmonics.

My point is that it embodies but a meagre supply of harmonics which are of vitally useful character. I'll illustrate my point with a homely example. If you have a piano, go to it and strike, first, middle C and then the one immediately below it. Note the difference between the two sounds. And now strike the second and third C's above middle C. I think you will agree that there is less apparent difference between these. And yet there were only 128 cycles difference in frequency between the first pair of notes as against the 1,000 or so between the second pair!

### Another Good Test

A change of four or five cycles is noticeable in a low note, but a variation of hundreds of cycles will pass quite unnoticed by the most critical ear in a very high note. From this it will be gathered that the high frequencies are far less energetic in their contribution to tone values than are the lower ones.

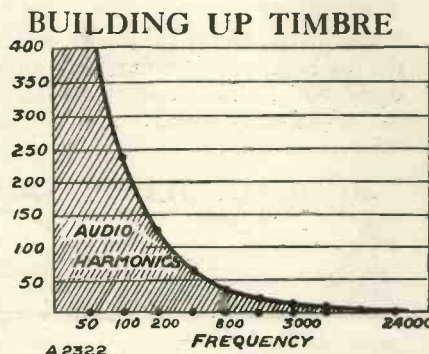

There are hundreds of harmonics within the audio range of frequencies to each medium and low note. But notice how the useful possible harmonics thin off in the case of the higher notes!

Try another experiment with the piano. Run slowly the whole way up the keyboard and notice how the notes lose their richness and become "thinner" as you ascend. That is because each note has far fewer harmonics in the "audio" range than those below it.

(Bottom C has approximately four

hundred and top C only a mere four or five!)

But the top notes of the piano are seldom if ever used and then only for "embellishment" purposes.

### A Question of Power

There are those who might think that although an ordinary note (by which I mean one such as is commonly used in the framing of a melody; in other words, "a middle speech frequency") may have two or three dozen harmonics coming well within the piano scale, the very high ones, too, have their importance in building up "tone."

In practice this is not the case, for the simple reason that the note would have to be struck with a steam hammer for its very high harmonics to develop any worth-while power. This fact again works against the higher notes, as you can easily see.

It must not be thought that I am advocating the complete abandonment of interest in all those frequencies above, say, four or five thousand cycles; indeed, I hope I have clearly proved that they do contribute something to the general result. My purpose in writing this article has been to attempt to define exactly what those "high notes" are.

Strictly speaking, the high notes range up 3,500 cycles or so, after which there are only harmonics. And there won't be many "supporting" harmonics of the majority of the notes played by an orchestra. Several of the leading American manufacturers of radio sets are advertising that their receivers "cut off sharply" at 5,000 cycles, and claim that this is a virtue as it enables them to tune very sharply.

### Perfection and Practice

Well, I have tried cutting off sharply at 4,500 cycles and cannot trace any appreciable loss in quality in doing so. Naturally, I did this at the audio end of the experimental apparatus; I mention that to short-circuit anyone pointing out that there is always a certain amount of amplitude modulation that can quite conceivably carry the highest harmonics.

If perfection is desired we must aim at the reproduction of frequencies up to at least 10,000 cycles. But if it is possible so closely to approach perfection that the ear cannot distinguish the difference by halving that fre-

quency requirement it becomes very much easier and there is no practical loss.

I fancy there is vastly more to be gained in concentrating on the improvement of the 100-2,500 cycles section of the outputs of our sets than by worrying about "top." Get that

### UP THE SCALE

HIGHEST USUALLY PLAYED NOTES

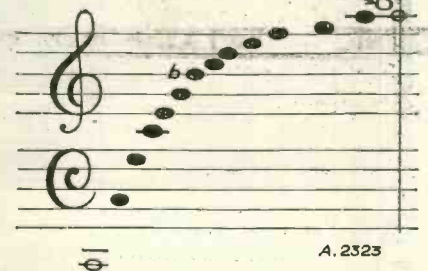

A. 2323

The bottom note is the fundamental, and all the others shown in black are the first dozen of its harmonics.

part straight (and it is nearly possible with even the average outfit) and there will be enough of the high frequencies for at least the time being.

It is in that 100-2,500 field that occurs most of the distressing distortion that you hear on distressed loud speakers. That is where the strident harshnesses, edgy peaks and woofiness are centred. Clear these up and you are a long way towards meeting any criticism. It isn't a peak at 5,000 we want so much as a big lift at 2,000 in most cases, plus a general levelling up below.

## THE WORLD'S LISTENERS

Some surprising figures.

A PART from Russia, it has been calculated that over one hundred million people in the world are more or less regular listeners. In Europe, Denmark heads the list of listeners, the proportion with sets of their own to the thousand population, last year, being 119.5. Sweden is second in Europe with 78.99, and Great Britain third with 77.5 per thousand set-owners. The great increase during the last two years of communal listening and the use of wireless exchanges give radio an important political significance as a means of disseminating propaganda.

J. B.



# The WORLD'S BIGGEST VALVE



By A. S. CLARK.

Great Britain holds all the super-records that really count—the land speed record, air speed record, etc., etc. Now we can include another fine record, that of the largest valve.

A VALVE that makes its own vacuum, that can be taken to pieces with a spanner, that has no glass in its make-up—such is the remarkable new 500-kw. valve made by Metropolitan-Vickers, Ltd. Just think what that 500 kw. means; here is a single valve that will handle more power than the total used by half a dozen of the most powerful European broadcasting stations.

## Ten Feet High!

Its physical dimensions are just as wonderful as its electrical power. For instance, it weighs no less than 1 ton; its anode alone being 3 cwt. in weight. It is 10 ft. high, and "drinks" water for cooling purposes at the rate of 40 gallons a minute!

The valve has been constructed for use at the G.P.O.'s Rugby station, where a 25-kw. valve working on a similar principle has now been successfully used for some time. In effect, with suitable renewals the valve will last for ever—in fact, it should definitely improve with age; just the opposite to the average valve, which gradually deteriorates due to a softening of the vacuum by gases exuded from the electrodes.

## Special Vacuum Pump

Any such gases in the case of this super valve are removed due to the continual evacuating that goes on. The vacuum is thus kept absolutely up to scratch the whole time.

This continual pumping has been made possible by the discovery of a new kind of oil, which boils at quite a low temperature and yet evaporates at ordinary temperatures so slowly that when placed inside a radio valve it does not impair the vacuum. This oil is used in a special pump that has no moving parts and keeps the valve pumped "dry."

The valve is made entirely of metal and porcelain, and resembles some engine rather than other species of its own family. As a matter of fact, it is quite a precision engineering job, some of the parts requiring to be made with accuracy to the one-hundred-thousandth part of an inch.

## ALMOST UNBELIEVABLE

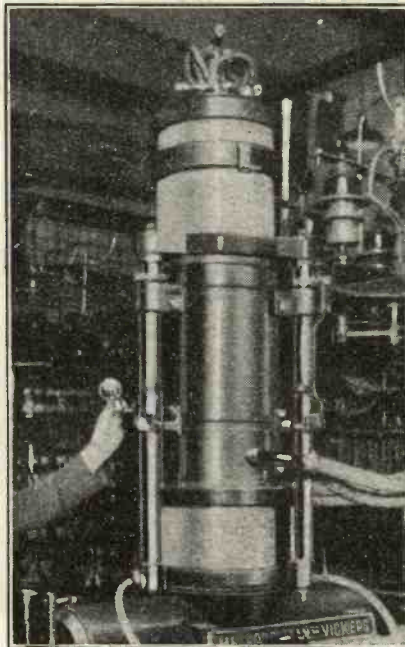

In this picture an ordinary receiving valve is being held alongside the huge 500-kw. valve.

The valve is the practical realisation of an ideal in valve design, for it can be taken to pieces, repaired and re-assembled with ordinary engineering tools in the space of a few hours. Although only 14 in. in diameter it is capable of working the main transmitter at Rugby, thus taking on the work of a whole bank of 50 high-power valves.

In spite of its marvellous performance, the valve has to line up alongside our humble receiving valves when it comes to the principles on which it works. It has a filament, grid and plate in just the same way as any other triode, but there the similarity ceases, at least so far as size and shape are concerned.

## Five Hundred Amperes!

Take, for instance, the filament. This devours 500 amperes, just 5,000 times that of the average receiving valve, and it is made up in nine replaceable sections, the leads to it being water-cooled.

The saturation anode current is in the neighbourhood of 160 amperes. (Someone has kindly worked out that this represents a flow of three hundred thousand billion electrons a second!)

The grid assembly, like the filament, is arranged in nine sections. Each section of the grid controls the emission from one filament section.

We are all used to transmitting valves that have water-cooled anodes, but this one has a water-cooled grid as well. A fact which helps us to grasp a little the enormous power which is handled.

## The Huge Anode

That brings us to the plate, which is, perhaps, the most interesting part of the monster. We have already mentioned that it weighs 3 cwt. by itself, and now it must be mentioned that, in order to facilitate its removal when the valve is dismantled, special hydraulic jacks are incorporated as part of the valve.

The anode is 26 in. long, and instead of the cooling water flowing merely around it, it flows through it by means of a number of holes actually made in the anode itself.



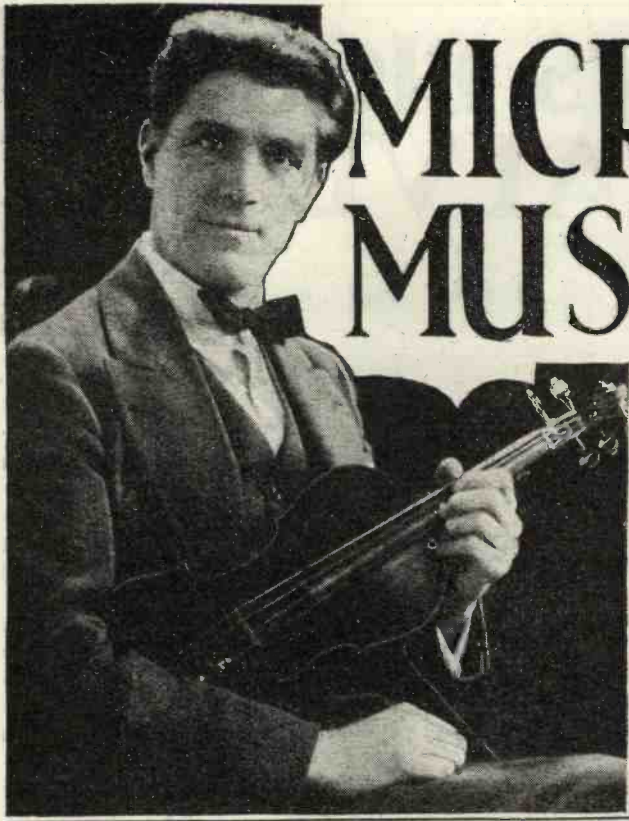

# MICROPHONE MUSIC *by* ALBERT SAMMONS

A photographic study of the author.

It is only since the Great War that a large part of classical music has become at all what one might call universally popular. Before that it was too often condemned by people who had probably seldom had the opportunity even of hearing it.

### *Masters of Melody*

Music composed by Bach, Beethoven and Brahms, the acknowledged masters of melody, was often foolishly stigmatised as "heavy," and mention of these names on a concert programme was formerly sufficient to frighten hundreds of people away.

Before this time, popular opinion, unguided by musical knowledge, ruled our concert programmes strictly. Then came "jazz," born of the agonised desire in war years for immediate expression of jarring emotions.

Now that, too, is rapidly dying, and the classical music which has withstood the test of time is beginning to take an extraordinary hold on the public mind. And undoubtedly one of the greatest influences which has helped this change of opinion is that of broadcasting.

### *Organ and Violin Best*

People who, before "listening-in" became universal used to condemn good music unheard, now take a keen delight in listening in their own homes to sonatas, fugues, nocturnes, symphonies, and overtures, translated by the best living musicians.

By degrees the world is learning that such music is neither tedious nor heavy, but balanced and enchanting, and consists of the most beautiful melodies that the world's musical masters could produce after years of study and improvement.

Radio has given people an opportunity to listen to works which they would not have heard elsewhere, and

fixed in their minds the value of true music.

One big factor which I believe helped to make such music play its rightful part in broadcast programmes is that the organ, and especially the violin, are perhaps the best of all instruments for radio production.

### *Musical Wealth for Ten Shillings*

It is indeed a triumphant step in the march of progress that people of to-day sit in the comfort of their homes listening to the swaying happiness of Boccerini, or to the dreams that weave like fairy gossamer through Chopin's nocturnes, and hear almost as perfectly as if they were at a concert hall.

### "POPULAR CLASSIC" PERFORMERS



The Victor Olof Sextet, which has done a great deal on the microphone to popularise classical music.

Again, there is another factor by which this strange invention of mankind helps music. It has put such music, as was formerly played where only those with money could afford to go, within the reach of every man and woman.

One moderately-priced concert ticket in the old days cost as much as a wireless receiving licence for a whole year, and in a year what a wealth of music—still only one side of radio—can be received!

### *A World Awakening*

I do not think there is any doubt that the music of the great masters is coming at last into its own. Go anywhere you will, to cinemas, theatres, hotels or cafés, and you will hear better music being played, and, what is more, being greeted with ever-increasing enthusiasm by those who hear.

During the last month, for instance, I have heard



# BRITAIN'S GREATEST VIOLINIST DECLARES IT IS A TRIUMPHANT STEP IN THE MARCH OF PROGRESS

extracts from many of the greatest operas—"Faust," "Lohengrin," "Pagliacci," "Il Trovatore," "Madame Butterfly"—and selections of the great works of Chopin, Liszt, Brahms, Martini and Schubert, played in places where, not so long ago, only blatant "jazz" would have been heard.

A world that has just awakened to find that it is good, is beginning to distinguish between music and the cheap imitations, and demands the real and beautiful in place of the grotesque and absurd.

## *Re-birth of English Music*

And it is largely to broadcasting that we owe the change. A hungry world has for a long time been searching for something it could not find, could not even define. A beauty that it desired was missing, and much of the so-called music, like sea-water to one who thirsts, did no more than inflame the desire.

For England in particular, radio has been an inestimable boon. Formerly there was no general recognition of our own music, and it was considered by the world that we had less music of which we could boast than had most of our Continental neighbours.

## *How Radio Has Helped*

Now that impression is changing. Everywhere it is being proved that both English classical music and English musicians can hold their own with those of any other country anywhere, at least so far as contemporary rivals are concerned, and English and foreign audiences alike are reflecting that conviction in their radio demands.

For real music is too great to be merely exclusively

national. Harmony, real beauty of sound, balanced cadences of melody—the whole world has always longed for them. And now world-wide radio has not only brought these things, but given us the opportunity universally to appreciate their greatness and their charm.

No link but radio can bind the musician to an audience of millions, in town and country, city and hamlet. By no means other than broadcasting could the infinitely varied world of musical achievement be reproduced and radiated to all.

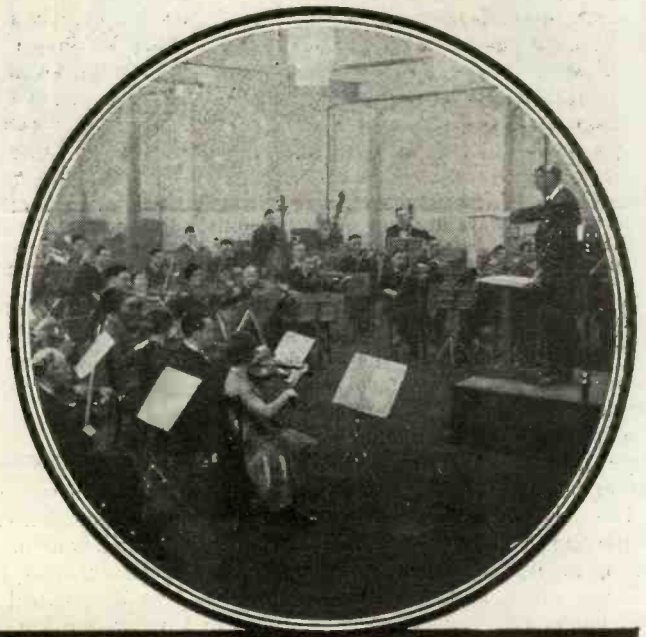

## KNOWN TO EVERY LISTENER



This photograph shows B. Walton O'Donnell and his B.B.C. Military Band, which is not only extremely popular in this country, but has achieved a world-wide reputation by its brilliant execution. In the circle above can be seen the Pall Mall Players.



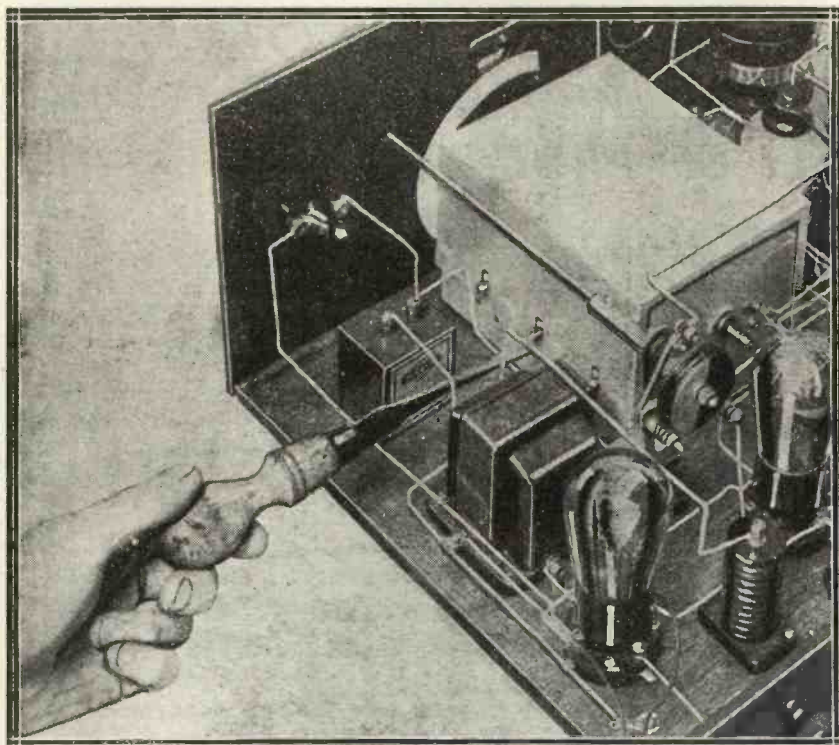

Once in step, always in step! After the initial adjustment of the three sections of the condenser, tuning becomes a matter of turning just one knob. As you see here, this preliminary setting is quite simply carried out, use being made of an ordinary screwdriver.

A FEW months ago we published a four-valve band-pass receiver, entitled the "Lock-Tune" Four, which met with a considerable amount of interest. As a matter of fact, it probably created more interest than any other four-valver published during recent times.

The "Lock-Tune" Four was a set employing a band-pass aerial H.F. arrangement with a tuned-grid ganged detector stage, and using a screen-grid valve, followed by the detector and two note-magnifiers, one resistance- and one transformer-coupled. It was thus an extremely sensitive arrangement, and its sensitivity,

coupled with the amazing selectivity obtained with the band-pass coil, enabled a surprising number of stations to be tuned-in with one-dial control only.

### A Successful Set

No reaction was employed and the triple-gang condenser meant that only one tuning control had to be used. So successful was this arrangement that we determined to follow it with a smaller edition which we have named the "Lock-Tune" Junior.

With the exception of one or two respects the circuit employed here is exactly the same as that for the

# The "Lock-Tune"

Band-pass selectivity, screened-grid sensitivity and "one-knob" simplicity all combine to make this a most magnificent three-valver, which will give long-distance loud-speaker reproduction of the finest quality.

"Lock-Tune" Four, with one of the L.F. stages omitted. The layout has been made particularly compact, and reaction is employed in the detector-grid circuit so that the last ounce of amplification can be obtained.

### Circuit Details

For the sake of readers who are not conversant with the details of the "Lock-Tune" Four, however, we will run over briefly the circuit points of the "Lock-Tune" Junior before we continue with the actual construction of the receiver.

In the first place, in using a band-pass set it is essential for ease of operation that a single-dial tuning control is employed. There are three tuned circuits in a set of this description. The two sections of the band-pass circuit require two variable condensers of .0005-mfd. capacity, while the tuned-grid circuit of the detector needs another .0005-mfd. variable condenser.

Unless ganging were employed we should have three variable condensers:

## HERE IS YOUR GUIDE TO THE COMPONENTS TO BUY

### PANEL

14 x 7 in. (Permol, Wearite, Goltone, Becol, Peto-Scott).

### CABINET

Panel space 14 x 7 in., baseboard 12 in. deep (Peto-Scott, Cameo, Pickett, Osborn, Ready Radio, Gilbert).

### CONDENSERS

1 Triple-gang and disc-drive .0005-mfd. (Utility, Polar, J. B., Cydon, Lotus).  
1 .0003-mfd. reaction (Lotus, J. B., Telsen, Ready Radio, Dubilier, Astra, Polar, Lissen, Parex, Wave-master, Cydon, Graham Farish).

### SWITCH

1 L.T. switch (Ready Radio, Telsen, Colvern, Wearite, Goltone, Lissen, Igranic, Bulgin, Graham Farish, Peto-Scott, Magnum).

### RESISTANCES

2 600-ohm Spaghetti (Bulgin, Sovereign, Graham Farish, Magnum, Telsen,

Peto-Scott, Ready Radio, Igranic, Varley, Lissen, Lewcos).

- 1 25,000-ohm Spaghetti (as above).
- 1 2-meg. grid leak and holder (Lissen, Graham Farish, Ferranti, Telsen, Igranic, Mullard, Dubilier, Varley, Ediswan, Loewe).
- 1 .25-meg. grid leak and holder (as above).
- 1 30-ohm rheostat (Wearite, Colvern, Ready Radio, Igranic, Colvern, Graham Farish).

### VALVE HOLDERS

3 4-pin holders (Lotus, Graham Farish, Wearite, Telsen, Bulgin, Igranic, W. B., Clix, Lissen, Magnum, Formo).

### FIXED CONDENSERS

- 2 .0003-mfd. (Ready Radio, Telsen, Mullard, Igranic, Ediswan, Formo, Lissen, Dubilier, T.C.C., Graham Farish, Goltone).
- 2 .04-mfd. (Dubilier non-inductive).
- 1 2-mfd. (Igranic, Telsen, Mullard, Dubilier, Helsby, Hydra, Ferranti, T.C.C. Formo).
- 2 1-mfd. (T.C.C., etc).

### CHOKES AND COILS

- 2 H.F. chokes (Lewcos, Ready Radio, Telsen, Varley, Graham Farish, Peto-Scott, R.I., Wearite, Magnum, Atlas, Sovereign, Lissen, Parex, Watmel, Tunewell).
- 1 Band-pass coil (Varley, Lewcos).
- 1 H.F. intervalve coil (Varley, Lewcos).

### TRANSFORMER

- 1 L.F. medium ratio (Telsen, R.I., Varley, Mullard, Ferranti, Graham Farish, Lotus, Lewcos, Lissen, Igranic, Goltone).

### MISCELLANEOUS

- 1 Switch mounting bracket, and extension rod 3/4 in. long, for reaction condenser (Wearite).
- 1 Terminal strip, 14 x 2 in.
- 10 Indicating terminals (Belling & Lee, Igranic, Eelex, Goltone, Clix).
- G.B., H.T. and L.T. plugs, etc. (Eelex, Igranic, Belling & Lee, Clix).
- Flox, screws.
- Glazite, Lacoline, Quickwire, Jiffilinx.



# Tune" Junior

Designed and Described  
by the  
"M.W." Research Dept.

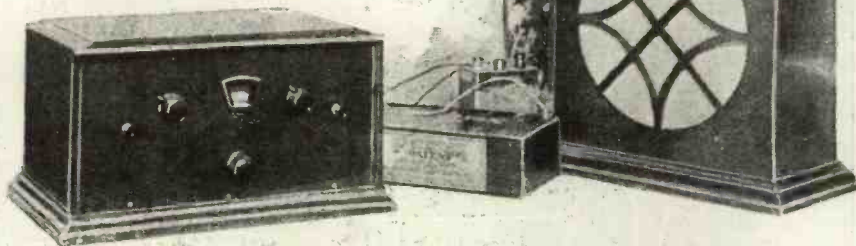

to handle, which would upset the handling of the set enormously.

We could gang the first two, leaving the tuned-grid circuit and the detector separately controlled, resulting perhaps in very slight increase in the amplification, due to the fact that completely accurate tuning of the

loss of strength, but in actual practice this loss is completely negligible, and is, in fact, quite undetectable on the loud speaker.

### Ganging Not Critical

The reason, of course, is that the tuned-grid circuit of the detector is fairly "flat," and therefore very accurate adjustment between this

tained from the screen-grid valve, and one relies completely on the selectivity afforded the set by the band-pass arrangement, and goes "all out" for magnification in the next stage without having to consider the need for selectivity in this circuit at all.

Consequently we have a single tuning control which is extremely easily ganged up, and which will remain suitably ganged for both wave-lengths, for the band-pass coil and the tuned-grid coil are double-wave coils actuated by a switch controlled by a single knob. The coil chosen in this receiver was a Varley Square Peak coil, and its associated H.F. intervalve coil, which latter is completely enclosed in a metal can.

### NOT A SINGLE SCREEN IS NEEDED

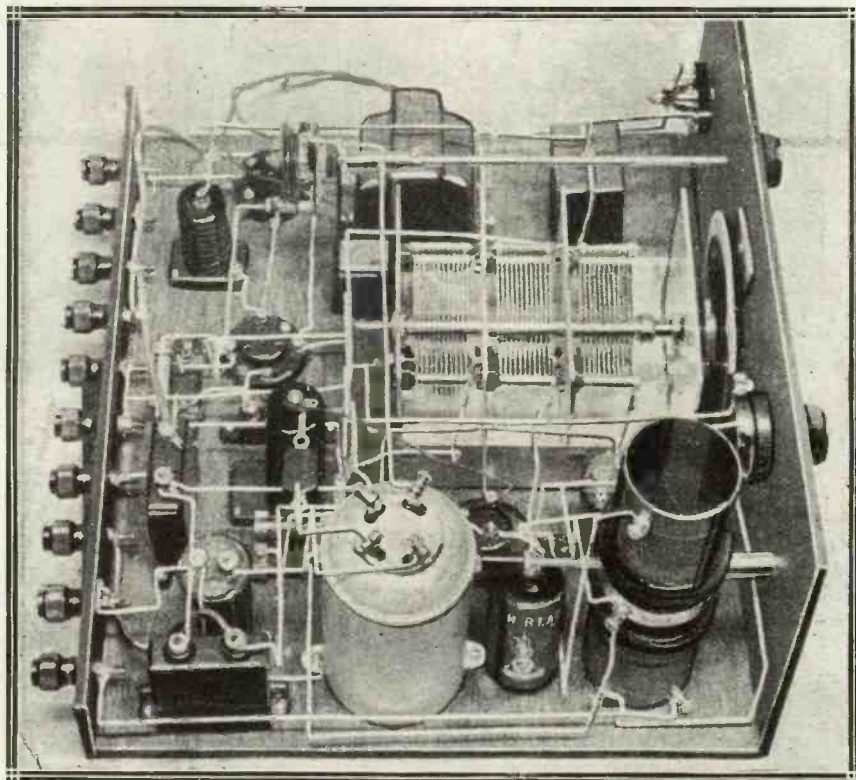

Special attention has been paid to keeping construction simple and within the capabilities of anyone. For instance, no metal foil or other screening is necessary, and yet a more stable receiver could not be built.

band-pass arrangement and the tuned grid would be possible, but in practice this arrangement is hardly worth while.

From the theoretical point of view the ganged tuning gives a slight

circuit and the band-pass coil arrangement is not necessary in order to get the desired amplification.

On the other hand, its very "flatness" and the size of the coil enables tremendous amplification to be ob-

### Reaction Included

The layout is quite simple, as will be seen from the photographs and the wiring diagram, and it will be noticed that reaction is employed. This is carried out between the anode and the detector and its grid circuit by means of a .0003-mfd. plain solid-dielectric type of reaction condenser.

A differential reaction condenser can be used if desired, but there is no particular advantage in this type in this particular set.\* You will, however, by looking through the theoretical diagram, notice a .001-mfd. condenser connected by a dotted line between the transformer side of the H.F. choke in the detector anode circuit and L.T.—

This is an additional condenser which some constructors will like to place in their sets as a form of tone control, and also to assist in by-passing any H.F. which may get past the choke in the detector anode circuit.

Similarly, though we did not find it necessary in designing the original model, a .0001-mfd. condenser may



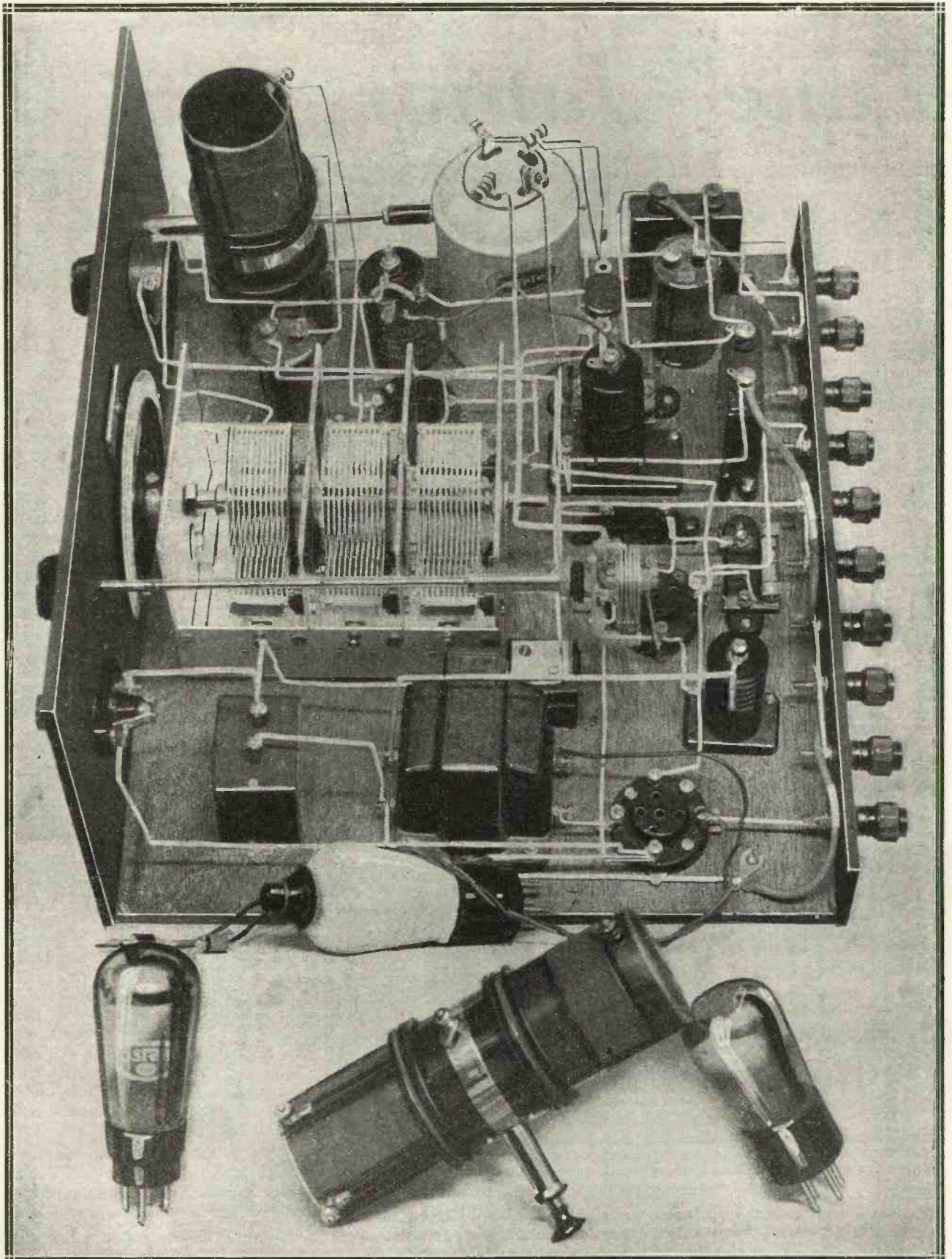

*It Brings in Just What You Want and Keeps the Rest Out!*



## Very Simple to Build—Even Simpler to Operate

be placed between the anode of the detector valve and L.T.— This, however, will depend upon individual circumstances and can easily be tried. It is conceivable that in many cases it will make absolutely no difference to the operation of the set, nor confer any aural advantage on the reproduction.

### High-Note Response

It must be remembered that in using band-pass circuits one is enabled to get a very much greater high-note response than is the case with the average tuned circuit, and consequently a number of people who are not used to band-pass arrangements may consider the reproduction somewhat high-pitched.

It is for this reason that the .001-mfd. condenser is shown in the theoretical circuit, and if you find your reproduction particularly high-

### ACCESSORIES

- Loud Speaker.** (Undy, B.T.-H., Celestion, Mullard, Graham Farish, Blue Spot, Amplion, W.B., H.M.V.)
- Valves.** 1 metallised S.G., 1 detector, 1 small-power type (Cosmor, Osram, Mullard, Mazda, Eta, Six-Sixty, Tungsram, Dario, Fotos, Lissen). (H.T. consumption about 16 milliamps.)
- Batteries.** H.T., 120-150 volts (super-capacity type) (Pertrix, Ever Ready, Lissen, Drydex, Magnet, Ediswan, Columbia). G.B., 1.5- or 9-volt for S.G. valve (as above). 9-15 volts to suit output valve (as above).
- Accumulators.** 2, 4, or 6-volt, to suit valves (Exide, Ediswan, Pertrix, G.E.C., Lissen).
- Mains Units.** To give 20 milliamps. minimum at 120 volts (Regentone, Heayberd, Tannoy, Ekco, Atlas, R.I., Lotus, Tunewell). (State voltage and type of mains and give details of set when ordering.)

the set, this should be carried out as closely as possible in accordance with that shown in the wiring diagram, otherwise you may find difficulty in getting all the components on the baseboard.

### Fixing the Condenser

The triple-gang condenser made by Wilkins and Wright is fastened on the baseboard by means of a couple of screws which pass through holes in the bottom of the condenser chassis, and the reaction condenser is mounted on a bracket to one side and slightly to the rear of the tuning condenser, a long extension rod being used between the reaction condenser and the knob on the front of the panel.

This long extension rod arrangement of the reaction control is a necessity which arises owing to the importance of keeping H.F. leads short,

## No Passengers—Every Component Does Its Duty

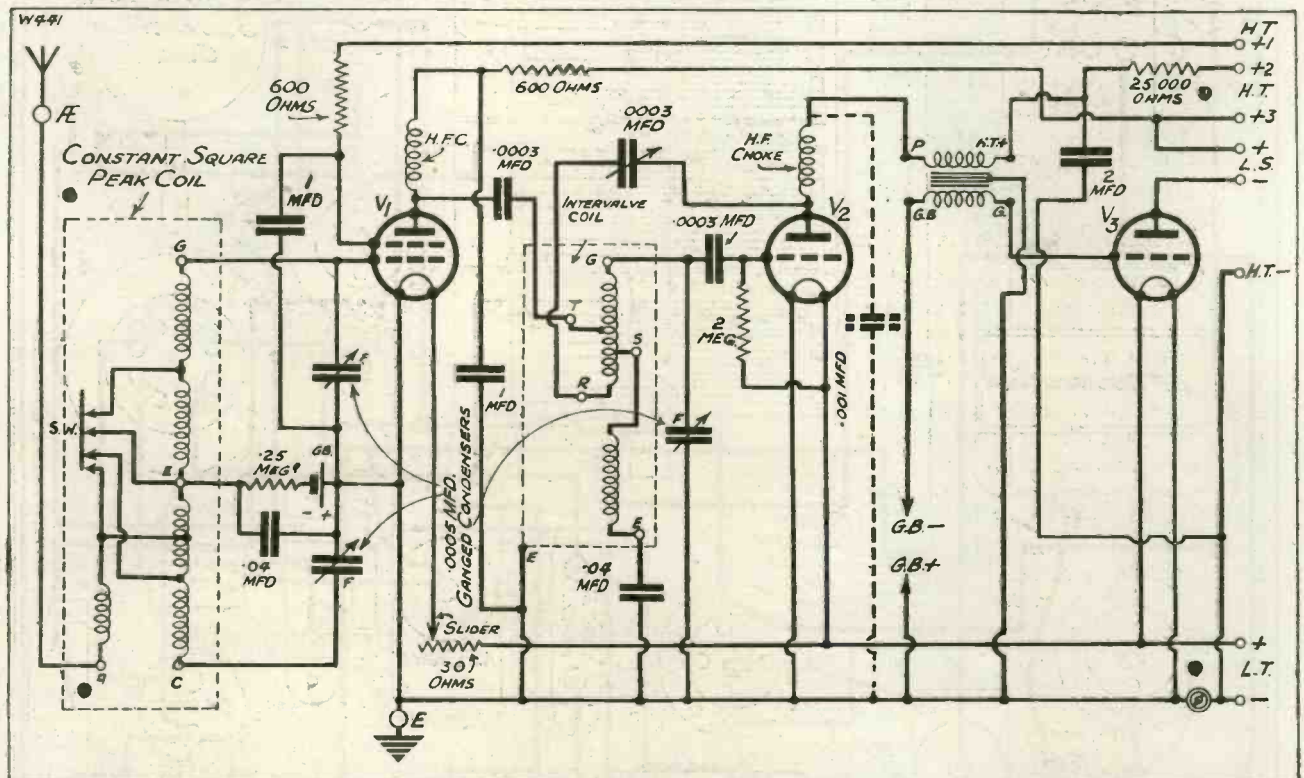

The screened-grid stage picks out the station you want, amplifies it, and passes "good fat" H.F. impulses on to the detector which turns them into first-rate quality L.F. currents. The output stage takes these and deals them out as powerful programmes. Every component works in perfect harmony with the rest.

pitched we would very strongly advise the use of this condenser.

The H.F. circuit has been kept very closely to that advised by the manufacturers of the band-pass coil, and readers should note the .04-mfd.

condenser which is placed in the H.F. intervalve coil circuit so that this coil may be accurately matched up with the band-pass arrangement in the first stage.

As regards the actual layout of

as very strong H.F. impulses are generated in this receiver. Consequently we have mounted the reaction condenser close to the anode of the detector valve, and in order to do that one of the standard brackets







## Three Tuned Circuits Handled as Easily as One

supplied by Messrs. Wright & Weaire for this purpose was used.

It is mounted on a packing consisting of a piece of wood about  $1\frac{1}{2}$  in. to  $1\frac{3}{4}$  in. high, to raise the

The method of ganging the two coils is very simple. They are supplied by the manufacturers with switch and everything complete, and in the case of the intervalve coil

extension rods and an ebonite joint.

What one does is to remove the knob off the coil switch gear and take one of the extension rods, which will be found to fit perfectly on to the back portion of the switch plunger in the Square Peak coil, the plunger of which is threaded, while the ebonite junction piece will join the switch mechanism of the intervalve coil to the free end of this piece of rod.

### REALLY HANDSOME AND SYMMETRICAL

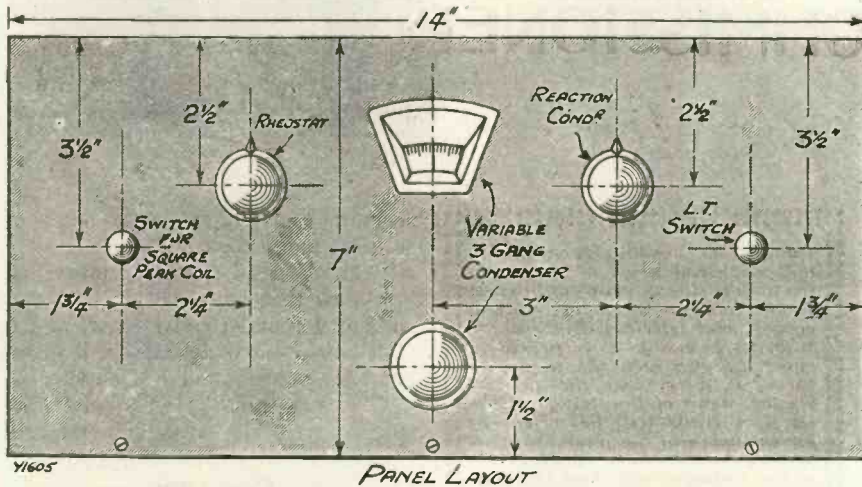

Without in any way affecting the efficiency, a remarkably pleasing panel scheme has been obtained, the upper five items lining up as though on a segment of a circle.

bracket above the baseboard, so that the knob controlling the reaction condenser could conform in position to the general outline of the layout on the panel face.

While discussing the mounting of the reaction condenser, it is perhaps advisable to say that the hole in the panel should be carefully made so that the rod is a fairly tight fit in order that no sloppiness shall exist where the rod passes through the panel.

### The "Band-Pass" Coil

An alternative to this, of course, is to drill a bigger hole and use an ebonite or metal bush for the rod to pass through, but this is a needless complication to the construction.

Care should be taken when mounting the Varley Square Peak coil, because this is placed in a vertical position—and it is not desirable nor possible with the coils ganged to have the bottom of the coil actually resting on the baseboard. It will be spaced above it a matter of  $\frac{1}{2}$  in. or  $\frac{3}{4}$  in., and care must be taken that the hole for the switch control is not drilled too high in the panel, otherwise the top end of the Varley coil will project above the top of the panel and, of course, will foul the cabinet when the set is placed in position, and when the coils are ganged the switch connecting rod will be bent.

with the switch mechanism in the coil itself protruding on either side. Also in the box are a couple of

### A Rigid Assembly

Then when the Square Peak coil mounting is fixed to the panel—for the mounting in this case is of the single-hole variety—and the intervalve coil is screwed to the baseboard by means of the two feet fitted to its case, the whole affair will be perfectly rigid, and one will find that on pulling the switch out both the coils will switch over on the medium wave-band, and pushing the switch in automatically changes both for reception on the longer waves.

The actual wiring up of a receiver of this description is not particularly easy, though, on the other hand,

(Continued on page 523.)

### A GUIDE TO THE MAIN COMPONENTS

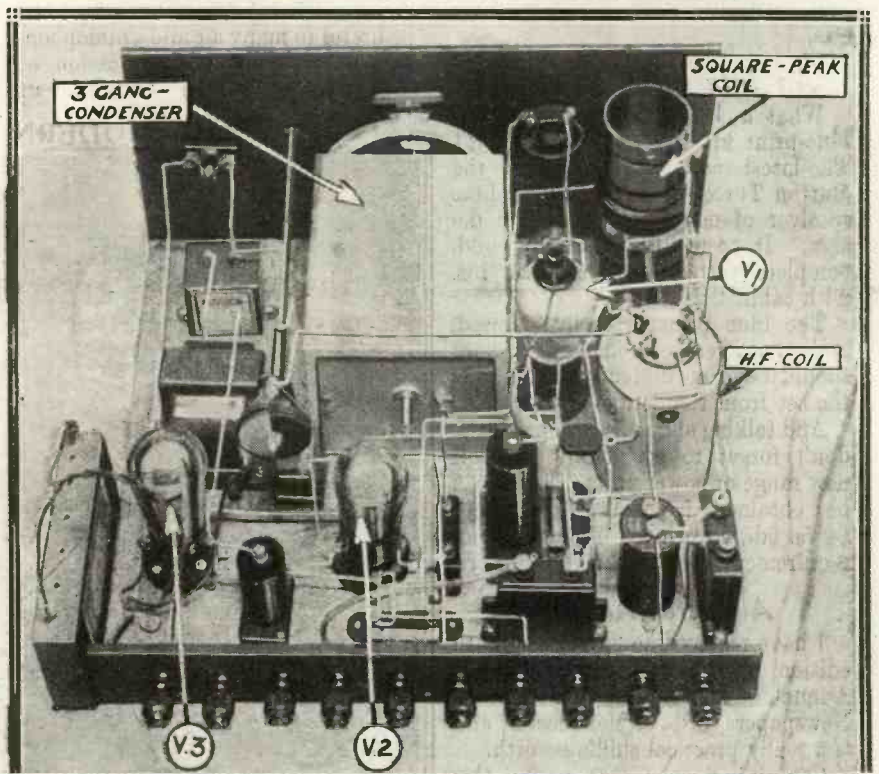

The six items which carry most weight are here specially pointed out. There is  $V_1$ , the S.G. valve;  $V_2$ , the detector;  $V_3$ , the output valve. The 3-gang condenser tunes the Square Peak aerial coil and the H.F. coil which comes between the S.G. and detector valves.



# AT YOUR SERVICE



by  
**OUR TRADE  
COMMISSIONER**



### Telling the Tale

**W**E have received from the National Accumulator Co. a fully-illustrated catalogue of their famous Dagenite batteries. These, as readers will remember, are fitted with the tell-tale float device, so that one can tell at a glance how far a cell is discharged.

Each float (there are three) operates in a separate channel so that there is no fear of their becoming confused or interfering with each other, and the condition shown by the position of each float is quite clear.

The catalogue covers both L.T. and H.T. accumulators, and special jelly electrolyte batteries for portable sets.

### An Interesting Kit Set

What a lot of home-constructor blue-print kit sets there are about! The latest recruit to the ranks is the Burton Three—a screen-grid de luxe receiver of novel and attractive design. It costs but £6 5s. to build, complete with valves, and £7 15s. with cabinet as well.

The blue print is easily followed, and the average home constructor should have no difficulty in building the set from the details given.

And talking about Burton products, don't forget to get details of their new range of power units. These can be obtained from £1 8s. 6d. to £4 7s. 6d., covering a useful range of requirements of D.C. and A.C. users.

### A Useful Annual

I have received a copy of the ninth edition of the "Chronicle Wireless Annual." This is published by Allied Newspapers, Ltd., of Manchester, and is a really practical shillingsworth.

Containing over 200 pages, this remarkable book describes fully the construction of a dozen or so sets and speakers, besides including many

Under this heading each month will be given news of the radio trade that should prove of interest to the home constructor, general reader, and wireless dealer alike. In order to enable us to provide a close link between the manufacturer, retailer, and the general reader, news of the doings of the wireless trade will be welcomed for inclusion in these pages, for it is only by the close co-operation of the manufacturer and the consumer that both sides can be sure that they are getting the best that radio can offer.

articles by various radio authorities. There is a particularly interesting article on home-recording, which will be useful to many a radio-gramophone enthusiast, while the discussion on "Pentode or Triode?" will clear up

some points of doubt in the minds of a great many readers.

"M.W." readers will be interested to know that a special set has been designed round the Extenser, and a full how-to-build description is given in the Annual under the title of "The P.S. Four." A large blue print covers the wiring diagram requirements of all the sets.

### For 1932

Benjamin Electric, Ltd., have a large range of "smalls" for the 1931-32 "season," described in an illustrated catalogue I have just received. A specially interesting feature about the book is the inclusion of three Benjamin circuits which are depicted in photo-pictorial style, and, of course, use Benjamin components as far as possible.

### IN THE MODERN HALL OF MUSIC



Examining one of the many interesting exhibits in a special demonstration hall fitted up by H.M.V. for the convenience of their customers.



## What the Radio Trade is Doing

The circuits are of a "Local-Station Two," "All-Mains Three," and a "Super Four."

But to get back to the component side of the catalogue; naturally valve holders of various types take up a prominent part, as do the various and ingenious types of switches, of which the new double-pole rotary type is especially interesting.

### Radio and Gramophone

The prospective purchaser of a radio-gram will be interested in the illustrated folder issued by Mains Radio Gramophones, Ltd., of Bradford. Numerous types of radio-grams are illustrated, and loud speakers and table model receivers are also included.

Particularly interesting is the M.R.G. Grandmother Clock, an imposing and artistic piece of furniture embodying a four-valve band-pass set and moving-coil loud speaker, the whole forming a pedestal clock of modern design.

The unique control panel of most of the sets is worthy of note. On turning the knob a thin slit of light moves along indicating the wavelengths to which the set is being tuned, so that no mistake about the reading can be made, while at the

Lock's cabinets was wrongly described in the caption of a photograph as of Camco design. Readers should note, therefore, that the particularly handsome cabinet illustrated in column four on the second page of our Stand-

being marketed, the receivers being fitted with loud speaker as an integral part.

But the famous Blue Spot loud-speaker units have not been neglected, and the latest literature on the subject

### SPEEDING UP SALES

Mr. W. B. Lawrence, General Sales Manager of the Pala Battery Co., at Essen during his recent business trip on the Continent.



to-Stand Review in the special supplement last month should have been placed to the credit of Messrs. W. & T. Lock, Ltd.

### Banish the Blues with Blue Spot

A bewildering array of chassis and complete speakers and sets is

shows that there is still plenty of choice in this field of the firm's activities.

### Loudest-Shout Competition

The Gramophone Company, Ltd., announce that the winners of the "His Master's Voice" Loudest-Shout Competition, held at the Modern Hall of Music during the National Radio Exhibition, are:

Ladies' Section: Miss E. K. Strudwick, 74, Cambridge Road, Seven Kings, Essex.

Gentlemen's Section: R. Watkins Pitchford, Esq., 8, Belmont Avenue, New Malden, Surrey.

Miss Strudwick registered 21.5 decibels on the T.U. meter designed in the "His Master's Voice" laboratories.

Mr. Watkins Pitchford was one of a number of competitors who made the needle of the T.U. meter register 22 decibels.

Many thousands of competitors availed themselves of the opportunity of having their voices measured for the first time, under this ingenious scheme evolved by H.M.V.

### "Inexpensive Radio"

That is the motto of Messrs. Hustler, Simpson & Webb, the producers of the famous "Double Two" that created such tremendous interest last season. For 1931-32 they have concentrated on a two-valve all-in-receiver costing only £4 4s., and an inexpensive radio-gramophone for battery operation, priced at £16 16s. complete with valves and batteries.

### MAKING YOUR OWN GRAMOPHONE RECORDS



A recently-introduced method of home-recording that was shown at the Berlin Exhibition employs a sapphire cutter and special record-hardening process.

same time the name of the station is given.

### W. & T. Lock

I must draw readers' attention to the fact that in our last number of MODERN WIRELESS one of W. & T.

being marketed by The British Blue Spot Co., Ltd. The "Goliath" permanent-magnet cabinet speaker is a particularly fine instrument at 110s., while in chassis form it can be obtained for 75s.

Console and table model sets are



# THE MYSTERIOUS MICROPHONE

*There are many uses to which the versatile microphone can be adapted, and in this narrative that fact assumes a vital importance.*

HOWEVER scientifically modern methods of mass production are applied, it is impossible to produce articles at costs below certain very definite limits. This is particularly the case with radio receivers, as there are many processes involved in their construction which as yet cannot be entirely reduced to mechanical bases.

In view of these indisputable facts, the Klecto Radio campaign gave John Dare, the eminent radio consulting engineer, considerable food for thought. One morning, Blazer found him poring over one of the large advertisements as though it were a difficult cross-word puzzle.

## All for Fifteen Guineas!

"You look worried, laddie," observed the ex-inspector of police as he closed the door and skated his felt hat on to one of the desks.

"Hallo, Blazer!" returned Dare, looking up from the newspaper. "I'm not exactly worried, but I confess I'm mighty puzzled."

"How come?" Blazer helped himself to a cigar from an invitingly open box.

"I'm wondering how these people can possibly work at a profit. Look!" The young engineer jabbed his finger on the corner of the full-page announcement.

"Hum! Fifteen guineas! Seems enough to pay for a wireless set these days, doesn't it?" suggested the old detective.

"But what a set! All-electric radio-gramophone with an electric motor, automatic record changer, moving-coil loud speaker, nine-valve super-het, every conceivable modern refinement, and built into what appears to be a most luxurious walnut console!"

## Where Was the Profit?

Blazer yawned politely.

"And note this," went on Dare, his voice rising a trifle. "Free maintenance for two years! Skilled mechanic pays a weekly visit; and this service even includes polishing the cabinet!"

"American?" queried Blazer uninterestedly.

"All British!" amended Dare.

"They ought to do a good trade. And now, laddie, what about that estimate?"

"Sneadle's got the job in hand; it'll be through shortly. But I say, Blazer, I meant to ask you before, what interest has your private inquiry bureau in the building of radio factories—or is it just curiosity on your part that makes you second my professional services?"

"Curiosity? Heck! See me paying good spondulicks to you for that, laddie! No, it's in the way of an inquiry from a bloke who's asked us to put the works on the financial standing of one of his business pals."

"I don't get you."

"I suppose you mean, laddie, why didn't he come to you direct? Well, secrecy is our motto, so we'll change the subject! Fine day, isn't it,

## CAMOUFLAGED RADIO



Territorials receiving instruction in the art of camouflaging a portable wireless station.

John?" Blazer hitched his thumbs into the armholes of his waistcoat, grinned expansively, and leant back with crossed legs into the chair he had taken.

"One of these guys happen to have the name of Herbert King?" pursued the radio expert quickly.

"You said it. How did you guess?"

"Thought there was something fishy about it," mused Dare half to himself.

"About what?"

"Why, this advert, of course! Herbert King is the managing director of Klecto Radio! Full pages in all the daily papers! He must be spending a small fortune. And, I ask you, where's the profit? Where's the catch?"

Blazer ran his fingers through his bristly, greying hair and chewed energetically at his unlighted cigar, but did not answer.

"This other bloke, the one who is after finding out what this King is spending—is he in the radio trade?" queried Dare.

"Did I say who was which? But we'll pass that. Yes, they're both in the same line of business, laddie."

## "It Makes You Think"

"Then either King is out to smash this other bloke by preposterous underselling, or he is just batty—that's all there is to it!"

"It makes you think, laddie—it makes you think!" But I'll be getting along. Perhaps you'll phone those figures through for me?"

For some time after the old detective had gone, Dare sat in his office turning the matter over in his mind. And it was not merely idle speculation. He is the consultant and adviser to many of the leading radio concerns and it is, therefore, his duty to keep as thoroughly conversant as he can with all the intrigues and financial ramifications of the industry. Some of his clients would be very badly hit by this Klecto proposition, and he anticipated many demands on his services in endeavours to combat it. "They can do it, and are doing it; why can't we?" was the kind of despairing question he expected to have thrown at him. And it was no use falling back on the old formula, "They'll soon be in Carey Street," for the simple reason that Klecto Radio might "get away with it," just as Ford and Morris did in the motor world. "But," mused Dare to himself, "the greater the production the more the mechanics they will need for that fantastic service scheme of theirs."

## Dare's Decision

He toyed awhile with the idea that Klecto had purchased a huge bankrupt stock which they had reconditioned, but finally decided, subsequent to a further study of the published specification of the receiver, that this could not be the case.

"Well, there is only one thing for it," he muttered aloud. "I'll have to snoop around and look into it."

(Continued on page 524.)





## THE NEW VALVES

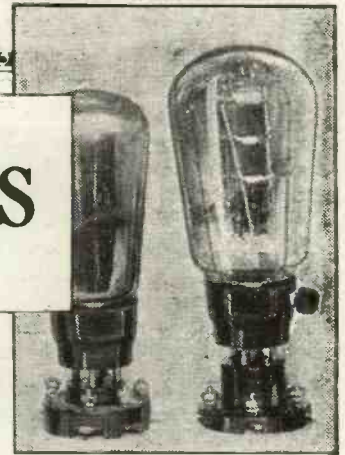

*Many particularly interesting new valves have been brought out during the last few weeks.*

*They are here described*

*By K. D. ROGERS.*

No matter what his set be, the home-constructor, and the listener for that matter, has now an unprecedented number of valves from which to choose.

During the last few months, culminating with the Radio Exhibition, the various valve concerns in this country have been hard at work designing and producing new valves. And wonderful valves they are, too.

### **Wonderful Two-Volters**

Both battery and mains valve users have been well catered for, and some really surprising developments have been made.

Two of the most important battery valves that have been released during the last few weeks are the Mazda 220 and 220A. pentodes. These are wonderful little fellows, the former being specially designed for use in portable receivers.

It has an economical appetite, too. For with an applied H.T. voltage of 120 volts the anode current consumption is only 3 milliamps, while with 150 volts it takes but 5 for its anode circuit.

The output is 370 milliwatts of undistorted power.

The "big brother," the Pen. 220A, is more suitable for average two- and three-valvers, and is excellent in sets of the H.F., Det., and L.F. variety, such as the "Lock-Tune" Junior, described elsewhere in this issue.

### **Improved S.G.'s**

It takes a somewhat larger anode consumption—18 milliamps at 150 volts—while at 120 volts the H.T. current consumption of a set like the one mentioned would be about 20 m.a. But it is worth the extra, because the output power of the Pen. 220A. is remarkable—900 milliwatts at maximum H.T. and

600 milliwatts at 120 volts, at which figure the anode consumption drops to 12 milliamps.

Going to the other end of the set we find that several new S.G. ideas have been introduced during the last few months. The best known are the Cossor metallised types and the Marconi and Osram S.21 and S.22.

The latter valve is a special "hot-stuff" amplifier having a high mutual conductance, while the S.21 was designed to have a long grid swing and less steep slope in an endeavour to minimise "cross modulation," a frequent fault in S.G. amplifiers.

### **Special Detectors**

Newer S.G.'s are the Mazda S.215A. and S.215B., which are worthy team mates of the famous S.215.

Detectors have come in for some "hotting up," and the H.2 and H.L.2 Marconi and Osram (the H.L.2 can be obtained metallised, by the way) are both excellent valves. They are both non-microphonic to an amazing degree, and can be confidently recommended as good, sensitive rectifiers for any type of two-volt set.

### **A Fine Pentode**

The L.P.2 and the P.2 are becoming old favourites, but these have been joined by a pentode which is worthy of note—the P.T.2.

Three new two-volters have been added to the Eta list; one is an H.F.-Det. valve, another a Det.-L.F. type, and the third an output valve of moderate calibre.

Carrying out their usual plan of

## INTRODUCING THEM TO THE PUBLIC



The impressive and artistic display of Mazda valves at the recent National Radio Exhibition where many of the new types of valves were seen for the first time.



## Surprisingly High Mutual Conductance Has Been Reached

see-at-a-glance classification, these Eta valves are called the B.Y.2020, B.Y.1210, and the B.X.604. These figures give us at once the main characteristics of the valves, namely, amplification factors of 20, 12 and 6, with impedances of 20,000, 10,000 and 4,000 ohms respectively.

A special two-volt detector valve has been placed on the market by Tungfram, and is worth consideration. It is known as the P.D.220.

The two-volt double-grid valve, which is now made by most of the leading valve concerns, has achieved instant popularity as a super-het. "mixer" valve. It is, I hear, to be followed by at least one make of A.C. double grid; but as details of this new type are not yet available I cannot divulge its characteristics.

### New Mains Types

And now we are on the subject of A.C. valves let us have a brief look at some of the latest types, for some surprising advances have been made in this branch of valve design.

One of the most famous A.C. S.G. valves has been the Mazda A.C./S.G. This has now got a "big brother" in the shape of the A.C./S.2, a particularly fine amplifier, having an impedance of 600,000 ohms and an amplification factor of 3,000. Obviously it is a valve that wants to be used with care, the screening and coils of the set being designed specially, but under proper working conditions a comparatively large percentage of the amplification factor can be obtained as "stage gain."

The variable-mu valves brought out by Mullard, Marconi and Osram will also create considerable interest

during the next few months. They are indirectly-heated A.C. valves and open up some very useful possibilities.

Cossor mains valves have surprised everybody, for the top score in mutual conductance has been reached by their two output valves, the 41M.P. and 41M.X.P., with the figure of 7.5.

of testing the full range of Six-Sixty A.C. valves, and though it is impossible to go into details in the short space at my disposal, I must register my commendation of this firm's products.

The valves are certainly very good, and it is especially valuable to have in addition to the three different S.G. valves, the two detectors, denoted by the letters G.P. and D. respectively. The latter also makes an excellent first L.F. stage amplifier.

### Those D.C. Valves

So far we have said nothing about the new D.C. valves, concerning which there has been a great deal of speculation and anticipation. Let me say at the outset that, although only three firms have yet placed these new indirectly-heated D.C. valves on the market, three different heater current consumptions have been specified.

This heater current determines the power used from the mains—i.e. the cost of running—and also the type and size of resistance used for series control of the current. In other words, these valves are not interchangeable type for type, and when constructing a set one has to decide once and for all which make of valves one will use, and buy one's mains resistance accordingly.

The state of the parties at the time of writing is this. Mazda (first out): a .5-amp. full range, and a .1-amp. range-less S.G. type (which follows shortly). Marconi and Osram: full ranges of .25-amp. valves. The .5 amp. valves will gradually be withdrawn as the .1-amp. valves are taken up by the public. All these valves are good.

### Standardisation Wanted

But what a parlous state of affairs! It may be that there is hectic competition among the valve concerns, and, naturally, assuming equal efficiency, the .1-amp. valve would win; but such decided competition is unusual in the British valve industry, and, unlike the A.C. valves, one cannot easily compare makes and types, and pick out the best for any particular receiver. It is to be hoped that standardisation will be reached in the D.C. series, as in the A.C.

The ranges consist of S.G. Det. (H. or H.L.), L.F. (H.L. or L.), power, and pentode, and I can say without hesitation that the D.C. valves are every bit as efficient as the A.C. of corresponding types.

### VARIABLE MU

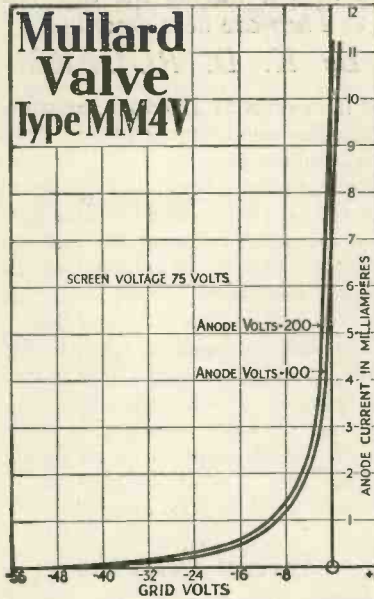

The curve of the Mullard variable-mu S.G. valve.

A mains H.F. pentode valve has also been introduced by this firm—M.S./Pen.A.—and it is said to be capable of great things. Two ordinary S.G.'s accompany it in the catalogue. These are the M.S.G./H.A. and M.S.G./L.A., for high and low amplification respectively.

I have recently had an opportunity

### SOME TYPICAL BATTERY VALVES

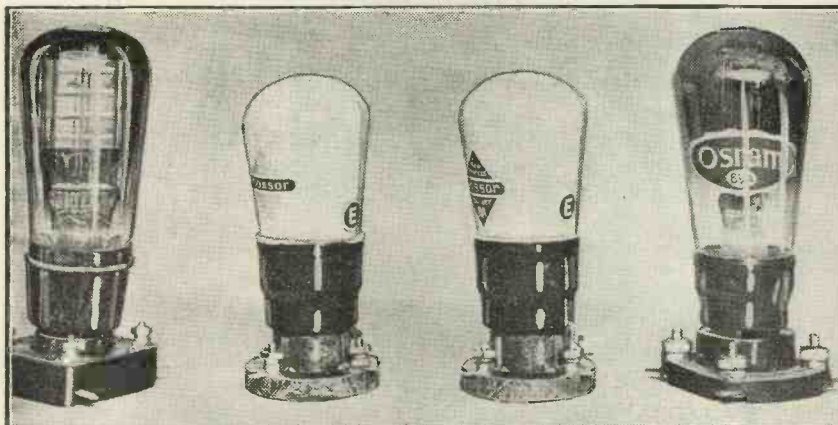

Here we see a Lissen detector, two metallised Cossor detectors, and an Osram H.L.2—all 2-volt battery valves.



# OPERATING THE "M.W." SUPER-QUAD

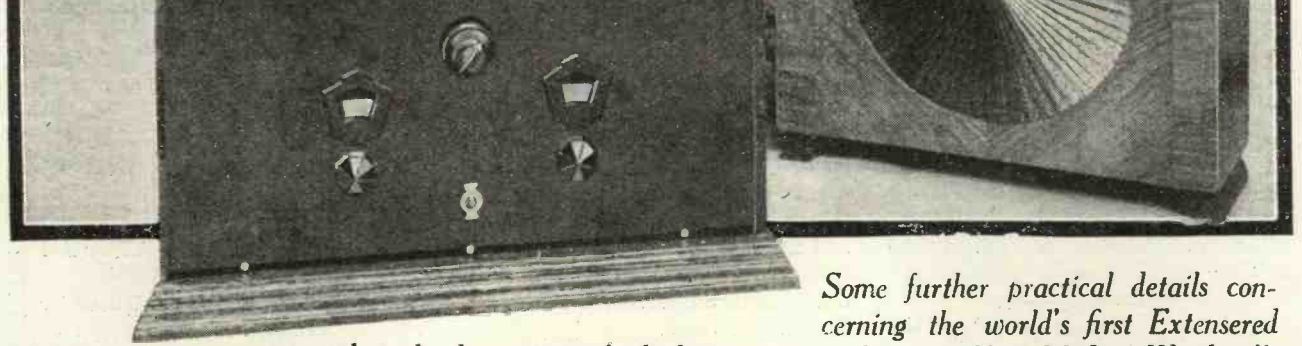

Some further practical details concerning the world's first Extended super-het, the description of which was given in last month's "Modern Wireless."

"Do you know, I get Mühler free from the London Regional at my place at Barnet!" The speaker was a well-known figure in the radio trade and he was referring to the "M.W." "Super-Quad," the description of which was published in last month's "M.W."

## A Well-Earned Tribute

That is a tribute indeed for a four-valve set, and yet it didn't really surprise us. Brookman's Park is but a very short distance from Barnet, and yet such is the knife-edge selectivity of the "Super-Quad" there might have been twenty-five instead of five miles between the station and the listener's aerial for all the effect it had upon the set's powers to get Continentals.

The local station has an allotted dial reading on the "Super-Quad" and from that reading it must not stray. There is none of that annoying "spread" that is so common in the

majority of simple-to-build receivers. No need to "sharpen up" the tuning by enlisting the aid of the reaction condenser every time you want a foreigner that is near in wave-length to the local.

The stations are "anchored" to the dials, as it were, and you can tune in from one to another just as easily as you can select your programme from your list of transmissions.

And no particular skill in handling the set is necessary—that's the beauty of it. A little practice in the art of keeping dials in step and of "rocking," that is all that is necessary to ensure a really big bag of stations.

## How to Tune

Keeping dials in step is particularly easy when you have such smooth and sure control as you get with the Cyldon disc drive, while the red and black disc divisions show you at a glance whether you are on long or medium wave-lengths.

The "rocking" merely consists, in the case of the "Super-Quad," in moving the right-hand control slowly above and below the "in-step" reading so that any slight "out-of-step-ness" shall be traced and allowed for as the wave-band is explored.

## "Rocking" the Oscillator

You see, even if you start with the two dials reading the same when the set is properly tuned in, say, to the London National, it does not follow that they will still have similar readings when in tune at the Northern Regional.

As a matter of fact, in a super-het, as there are two oscillator readings for most stations, it will be extremely unlikely at any point in the tuning graph the two dials will read the same.

What you do, therefore, is to tune in the local, and then, noting the different readings, keep the dials at about the same *difference* all the way over the band, "rocking" a bit to make sure you do not go far out.

## THIS LIST GIVES ALL THE PARTS REQUIRED

### PANEL

16 × 8 in. (Permeal, or Wearite, Goltone, Peto-Scott).

### CABINET

Panel space 18 × 8 in., baseboard 12 in. deep (Pickett, or Camco, Osborn, Peto-Scott, Ready Radio).

### EXTENSERS

1 Double-gang .0005-mfd. Extenser with cam insulated and disc drive (Cyldon).  
1 Single-disc-drive Extenser with cam not insulated (Cyldon).

### SWITCH

1 Double-pole toggle switch (Bulgin).

### RESISTANCES

1 25,000-ohm Spaghetti (Ready Radio, or Magnum, Telsen, Keystone, Bulgin, Varley, Graham Farish, Lewcos).

1 2-meg. grid leak with wire connector, or terminals (Igranic, or Graham Farish). (Other makes with holder can be used, such as Telsen, Ediswan, Dubilier, Ferranti, Mullard, Ready Radio, Watmel.)

1 50,000-ohm potentiometer (Sovereign, or Regentone, Varley, Magnum).

### VALVE HOLDERS

5 4-pin holders (Lotus for valves, and Bulgin for intermediate coils, or Telsen, Clix, Formo, Igranic, Wearite).  
1 5-pin holder (Lotus, etc.).

### FIXED CONDENSERS

1 .0002-mfd. (T.C.C. or Telsen, Ready Radio, Goltone, Ferranti, Igranic, Lissen, Ediswan, Mullard, Dubilier).  
3 .001-mfd. (T.C.C. and Formo, etc.).  
1 2-mfd. (Ferranti, or Telsen, Peto-Scott, Mullard, T.C.C., Dubilier, Helsby).  
1 1-mfd. (Dubilier, etc.).  
1 .04-mfd. special non-inductive (Dubilier).

### CHOKES AND COILS

2 H.F. (Ready Radio and Lewcos, or Telsen, Varley, R.L., Wearite, Peto-Scott, Magnum, Dubilier, Lotus).  
1 Square Peak Extenser coil (Varley).  
1 Oscillator coupler (Ex. Osc. 126) (Lewcos or Wearite), with baseboard-mounting bracket.  
2 Band-pass intermediate (1 I.F.T.126, and 1 I.F.T.126, Lewcos).

### TRANSFORMER

1 L.F. (Telsen, or Ferranti, Igranic, R.L., Varley, Lewcos, Lotus, Goltone, Formo, Atlas)

### MISCELLANEOUS

1 Terminal strip, 16 × 1½ or 2 in.  
10 Indicating terminals (Belling & Lee, or Igranic, Clix, Eelex, Goltone).  
G.B., H.T. and L.T. plugs, etc. (Eelex, Belling & Lee, Clix, Igranic).  
Flex, Glazite or Lacoline, screws, etc.







# Here is the Ready Radio Kit for the "M.W." A.C. "Super-Quad"

**SUPER-HET!**

**"EXTENSER" TUNING!!**

When you buy Ready Radio Kit Components you are definitely assured that they are the finest possible for their particular job. Mr. Kendall\* is your surety. Every Ready Radio Kit Component is chosen by him only after submission to stringent laboratory and broadcast tests. And again, before despatch, they are tested and passed under his personal direction.

\*Mr. G. P. KENDALL, B.Sc., for many years Assistant Technical Editor of "Popular Wireless" and "Modern Wireless," is Chief Engineer of Ready Radio.

## THE "M.W." A.C. "SUPER-QUAD"

	£	s	d.
1 Ebonite panel, 16" x 7", drilled to specification	5	6	
1 Sheet copper foil, 16" x 12"	3	0	
1 "Waldor" cabinet, as specified	1	10	0
1 Gridon .0005-mfd. double-gang Extenser (Type EX.G.2.V) (with insulated cam)	1	16	0
1 Gridon .0005-mfd. Extenser (Type EX.5.V)	1	16	6
2 600-ohm Spaghetti resistances	1	6	
1 750-ohm Spaghetti resistance	9		
2 1,000-ohm Spaghetti resistances	3	0	
1 2,000-ohm Spaghetti resistance	1	6	
2 50,000-ohm Spaghetti resistances	3	0	
1 Sovereign 50,000-ohm volume control	4	6	
1 ReadRad 2-meg. grid leak and holder	1	4	
4 W.B. 5-pin valve holders, large type, 2" diam.	3	4	
3 Junit 5-pin valve holders	2	0	
1 T.O.C. .0003-mfd. grid condenser, type 34	1	6	
2 T.O.C. .002-mfd. fixed condensers, type 34	1	10	
8 T.O.C. 1-mfd. fixed condensers, type 50	1	2	8
1 T.O.C. 2-mfd. fixed condenser, type 50	3	10	
1 T.O.C. .04-mfd. fixed condenser, type 40	1	9	
1 ReadRad super-het choke	5	6	
1 Lewcos H.F. choke	6	0	
1 R.I. band-filter coil	15	0	
1 Lewcos oscillator coupler	12	6	
2 Lewcos band-pass intermediates, with pigtails	1	1	0
1 R.I. L.F. transformer, ratio 7 to 1, type G.F.	10	6	
2 Sovereign two-terminal mounting blocks	1	0	
4 Belling-Leo terminals, type "B"	1	0	
1 Packet of Jimlinx for wiring	2	6	
5 Mazda valves, as specified: 2/AOSG, 2/ACHL, 1/AGP	4	12	6
4 Govern valve screens	11	0	
3 ft. metallised twin flex, flex screws, etc.	2	0	
1 Heayberd unit, model M.W.	6	7	6
			<b>£22 11 6</b>

### Kit A

(Less valves and cabinet) **£16. 9. 0**  
or 12 monthly payments of **£1. 10. 3**

### Kit B

(With valves less cabinet) **£21. 1. 6**  
or 12 monthly payments of **£1. 18. 9**

### Kit C

(With valves and cabinet) **£22. 11. 6**  
or 12 monthly payments of **£2. 1. 6**

If you are building the "Uni-Coil" Three or the "Lock-Tune Junior" write for details and prices.

**ALL-ELECTRIC!!!**

ANY COMPONENT CAN BE OBTAINED SEPARATELY

What more could you want?

TO INLAND CUSTOMERS.  
—Your goods are despatched Post Free or Carriage Paid.



Head Office and Works: Eastnor House, Blackheath, S.E.3.  
Phone: Lee Green 5678. Grams: "Readirad, Blackvil."  
Showrooms: 159, Borough High Street, London Bridge, S.E.1.  
Phone: Hop 3000.

TO OVERSEAS CUSTOMERS—  
Everything Radio can be supplied against cash. In case of doubt regarding the value of your order, a deposit of one-third of the approximate value will be accepted, and the balance collected by our Agent upon the delivery of the goods. All goods are very carefully packed for export and insured. All charges forward.

#### CASH or C.O.D. ORDER FORM

TO READY RADIO LTD., Eastnor House, Blackheath, S.E.3.

TO READY RADIO LTD., Eastnor House, Blackheath, S.E.3.

#### EASY PAYMENT ORDER FORM

Please dispatch to me at once the following goods.....

Please dispatch to me the following goods .....

for which (a) I enclose (b) I will pay on delivery (Cross out line not applicable) £.....

for which I enclose first deposit of £.....

Name .....  
Address .....

Name .....  
Address .....

MW/11/31

MW/11/31





# GIVE YOUR VALVES A CHANCE

*Valves are very willing servants if they are used under "comfortable" conditions, but you must not expect them to give of their best when misused. Read this description of the main points to remember.*

By **W. R. FLOWER.**

**T**HERE can be no doubt that the thermionic valve deserves to rank as one of the wonders of the world. Sealed within its thin glass envelope are the tiny electrodes with which the modern radio wizard performs his marvels of reception and transmission.

A few years ago valves were very expensive things, and they were treated with the deference with which most expensive things are treated. Indeed, if results were to be expected at all the greatest care had to be taken to ensure that the valves received proper treatment, and first-class apparatus, as good as could be obtained, had to be used in conjunction with them.

### *Differing Characteristics*

Valves, in those days, were very tricky things to handle; half a dozen valves would possess as many different characteristics; and anode resistances, condensers and transformers had to be carefully chosen and matched up with the valves with which they were to be used or the latter would often refuse to function at all.

No one attempted to take liberties with them and they were treated in a manner which, after all, is only their due. But so strange is human nature, that no sooner did improved methods of manufacture and the ability to produce valves on the system of mass production cheapen their price, than users began to treat the most important component in their radio sets in a very unfair manner.

### *The Efficiency Increased*

For although the price of valves decreased, their efficiency increased, and the public found that they would give results (of a sort) with apparatus that previously would have spelt

failure. That section of the Press that is devoted to the interests of radio began a campaign to point out to these abusers of the valve their mistakes, a campaign which they have kept up all the time.

### *Expecting the Impossible*

But in spite of this there are still owners of radio apparatus who do not give their valves a chance to show what they are capable of doing when they are treated in a proper manner. One would not expect a workman who was overworked or half starved,

ances and condensers, the actual values of which differed enormously from those at which they were rated, and yet expected to give first-class results. Or cheap no-name transformers have been used as coupling devices, or inefficient and poorly made tuning arrangements have been incorporated in the receiver, and when results have not been up to standard the valves have got the blame.

### *The One Mistake*

Most of this class of people misuse a valve, and do not realise that they are doing so. Let me quote an instance. I was in a shop making a few purchases one day whilst another customer was being served with what was obviously a kit of parts for making up a complete outfit. Good-class components were ordered by this customer, a first-class make of loudspeaker, two good accumulators were added to the order, and the shopkeeper arranged with the customer to erect an aerial for him.

Then came the final order—a 60-volt H.T. battery; and yet it was obvious from the parts ordered that at least one stage of the amplifier portion was to be resistance-capacity coupled. Pity the poor valve that was going to be asked to work under

## AN OUTSIZE IN RECEIVING AERIALS

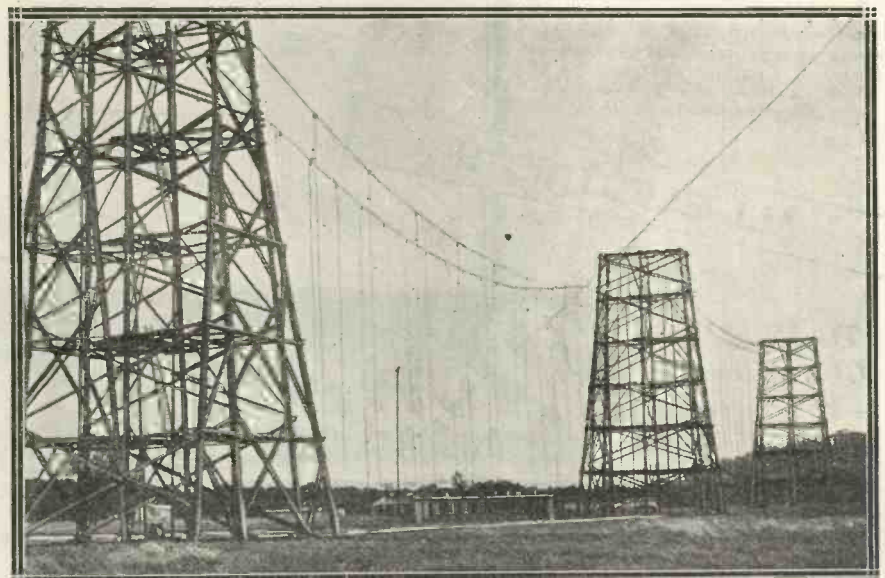

Strange as it may seem, these elaborate masts are not for transmission purposes, being employed at the German station at Geltow for reception from South America.

or who was provided with tools that were shoddy, to give of his best. And why anyone should expect a valve to give of its best when treated in a similar manner is beyond me.

I have seen valves used in conjunction with cheap anode resist-

such circumstances, it would be absolutely starved of one of its most vital necessities, H.T.

And may I mention here that "adequate" does not mean EXCESSIVE. True, one does not often come across anyone that errs on the side

*(Continued on page 528.)*



# MY BROADCASTING DIARY

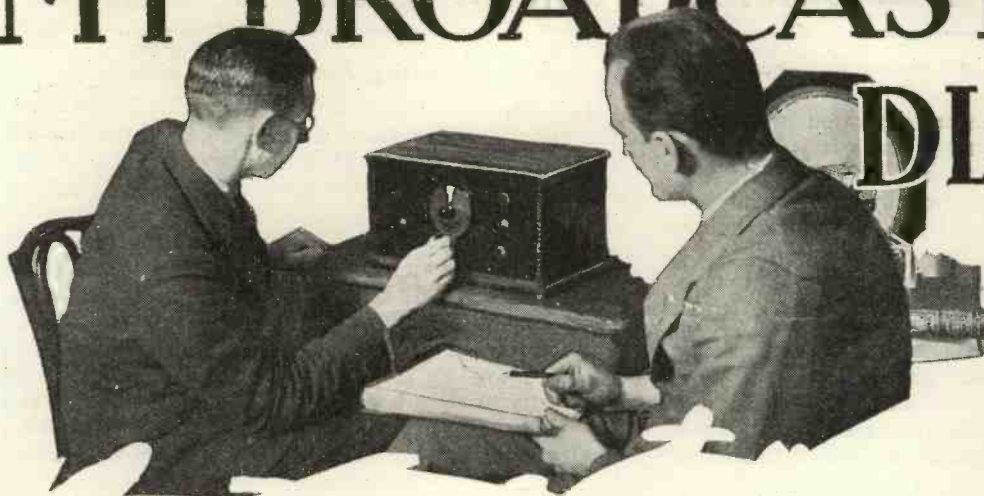

*Our own Broadcasting Correspondent records the progress of the British Broadcasting Corporation, and frankly comments on the policies in force at B.B.C. headquarters.*

## Rome—and After

MY readers will not have entertained high hopes of any results from the Rome Conference. Any real hope of the alleviation of British wireless troubles on the present scale vanished with the refusal of the wireless "administrations" to assemble at Lugano in October to reach an interim plan modifying the Prague Plan, but not prejudicing the deliberations at Madrid in 1932.

The full inside story of how the B.B.C. was foiled in its endeavour to reach a temporary compromise will be told some day. Meanwhile, the significant fact of the situation is that Great Britain, in broadcasting, as well as in finance, has become much more national and much less susceptible to internationalism.

What gave the *coup de grâce* to the Continental co-operation with B.B.C. policy was the sudden desertion of Germany. With Germany and France in alliance the B.B.C. is obviously doing right to protect itself by whatever means it has at its disposal, whatever the consequences to listeners on the other side of the Channel.

I confidently prophesy the early dissolution of the Broadcasting Union. With equal confidence do I look forward to the result of the scramble in the air that will follow. We have the money, we have the power, we have the will to win. Afterwards the whole of Europe will ask for terms, and will take what is left over.

## Lord Gainford at Manchester

Nothing in the past six years has impressed me so much as Lord Gainford's address in opening the Manchester Exhibition on October 7th. There was something of the old inspiration of pioneering broadcasting in Lord Gainford's eloquent survey.

He is, of course, a characteristic north-countryman, although perhaps a little farther north than is comprised within the generous borders of the North Regional service area.

It was in 1925, at the Second Annual Meeting of the old British Broadcasting Company, that Lord Gainford, in language of lasting eloquence, testified his faith in the future of broadcasting, not only as an unexcelled means of distributing culture and entertainment nationally, but also as probably the decisive factor in making possible the ultimate community of mankind.

And now, years later, but still with the same

inspiration, Lord Gainford again looks ahead to still greater triumphs, and is able to comfort us with the substantial hope that radio wisely directed will be the decisive factor in leading mankind out of the morass of economic difficulties which were wholly unexpected in 1927. Here is hoping that Lord Gainford will again inspire us in 1938.

## Regional Dangers

Those who have studied broadcasting from the beginning and who are able to assess and define its present tendencies are not happy about the sudden recrudescence of centralising, based upon excuses of economy.

I hear from Manchester that a good deal of what the North Regional Press recently acclaimed as indicating a progressive devolution has now been so curtailed as to be rendered valueless.

If this is so, it is a great pity. British broadcasting can only survive as a public service utility as long as it

## ELECTRICAL RECORDING



Electrical recording is almost universal nowadays owing to the greater convenience and better quality obtained. Here you see Miss Jeanette MacDonald, the famous star of "The Love Parade," singing before the recording microphone at the Kingsway Hall, London.



## Items of Interest from all Quarters

is aware of and allows for the legitimate claims of every considerable minority.

There is, of course, the severe limitation of available ether channels, but within these limits it is suicidal to concentrate in London more than is absolutely necessary. A stop should be put to the continually erosive tendencies operating against the gallant B.B.C. staff who happen to live outside London.

### Television Prospects

At Marconi House the other day I saw an interesting outline of a new series of experiments with super-short waves for conveying television signals.

Apparently the Marconi Co., and in particular the Senatore himself, are much more interested in television than they have given the public any reason to believe.

### "KEEPING ABREAST OF THE TIMES"



The Radio Show at Olympia this year attracted quite a lot of well-known people. Neither Norman Darewski nor Leonard Henry, the broadcast comedian, could resist it. They are seen listening to a combined clock and radio receiver, which attracted considerable attention.

Of course, I have not seen their practical results, but I am bound to say that their theoretical diagrams were convincing.

Meanwhile, however, Mr. Ashbridge, the Chief Engineer of the B.B.C., has paid a special visit to Long Acre to look over the latest work of the Baird Laboratory. Mr. Ashbridge is constitutionally cautious, but I gather that he was impressed by what he saw and he is determined to take television more seriously than he has done.

Thus it looks as if there might be a neck-and-neck race between Marconi Television and Baird Television. Question: Will the B.B.C. provide transmitting facilities for both?

### Banning Foreign Artistes

It is satisfactory that the B.B.C. is taking a very strong line about foreign artistes and instrumentalists. Already their preference for British artistes was a policy matter, and I understand that not quite 25 per cent of artistes from abroad ever got to the microphone.

But there is now to be a general casting out of the non-British residuum. This action is a good lead to the country, and already orchestras and musical organisations generally are following suit.

Hundreds of foreign musicians will receive their "notices" before the end of the year. The result will be greatly to the advantage of the home product, and I hear that the Incorporated Society of British Musicians is justifiably jubilant at the ultimate triumph of its patriotic campaign.

I notice that in some places it is suggested that the foreigner is being kicked out only temporarily; this I do not believe. I think he will not get back.

### Sir Henry Wood's Future

The thirty-seventh season of Promenade Concerts under Sir Henry Wood has come and gone in an unprecedented wave of enthusiasm. I gather the B.B.C. did much better financially than ever before and that both ends did meet for a change.

There is the usual talk of Sir Henry Wood's future in the general post-mortem. There are those who would replace him next year even if he cares to go on for another season. This, I am sure, would be a great mistake.

The right attitude of the B.B.C. is to encourage Sir Henry to go on with the Proms just as long as he can and cares to. Sir Henry is a unique public figure; his message is of national importance. His health is much better than it was, and there is every prospect of his being able to take next season at all events.

### B.B.C. and Physical Jerks

For more than eight years the B.B.C. has violently resisted suggestions for the broadcasting of physical exercises early in the mornings, as is almost the universal practice in other countries.

Once again the growing forces of the "jerkists" have rallied to the attack, only to be told that economy is now in the way. I used to agree with the B.B.C. about this; but recent listening to Continental health broadcasts and conversations with competent medical people have made me change my mind.

I counsel Savoy Hill to give fresh thought to the subject of the "daily dozen" by wireless.

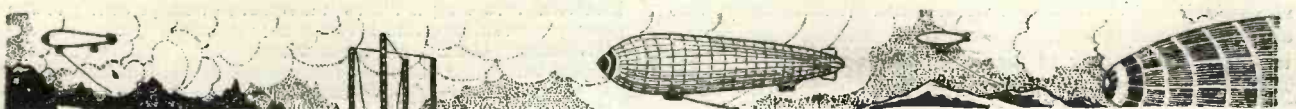



# TELSEN TRANSFORMERS & CHOKES

## TELSEN L.F. & OUTPUT TRANSFORMERS

Telsen transformers have achieved fame in the radio world on account of the high standard of their quality and performance. Designed and built on the soundest engineering principles, these robust, full-size transformers will give not only efficient but enduring service.

## TELSEN L.F. TRANSFORMERS

- Telsen "Ace" Transformer, Ratios 3-1, 5-1 . . . . . Price 5/6
- Telsen "Radiogrand" Transformer, Ratios 3-1, 5-1 . . . . . Price 8/6
- Telsen "Radiogrand" 7-1 Super Ratio Transformer . . . . . Price 12/6
- Telsen Intervalve Transformer, Ratio 1.75-1 . . . . . Price 12/6

## TELSEN OUTPUT TRANSFORMERS

Telsen Multi-Ratio Output Transformer, giving three Ratios of 9-1, 15-1, 22.5-1 . . . Price 12/6

Telsen Output Transformer, Ratio 1-1 . . . . . Price 12/6

Telsen Pentode Output Transformer . . . . . Price 12/6

## TELSEN L.F. CHOKES

- Telsen L.F. Intervalve Coupling Choke, 40 and 100 henrys . . . . . Price 5/-
- Telsen Heavy Duty Power Grid L.F. Choke, 40 henrys . . . . . Price 8/-

## TELSEN OUTPUT CHOKES

- Telsen Output Choke (Plain), 20 henrys . . . . . Price 8/-
- Telsen Output Choke (Tapped), 20 henrys . . . . . Price 8/6

# TELSEN

ALL-BRITISH  
RADIO COMPONENTS

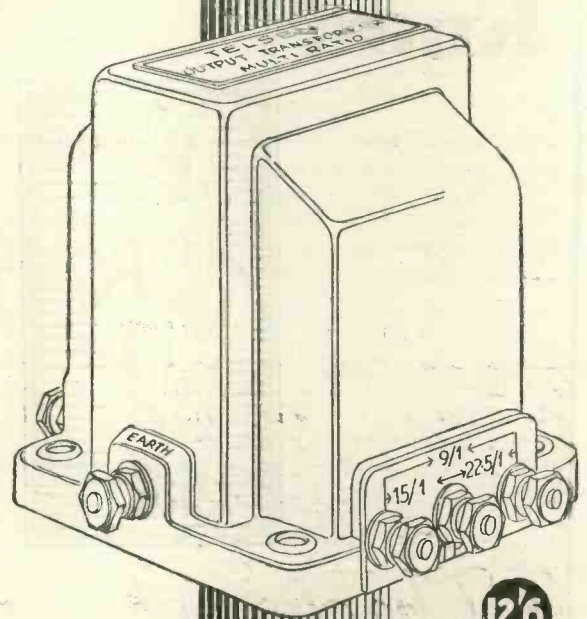

12/6

ACE  
5/6  
RADIOGRAND  
8/6

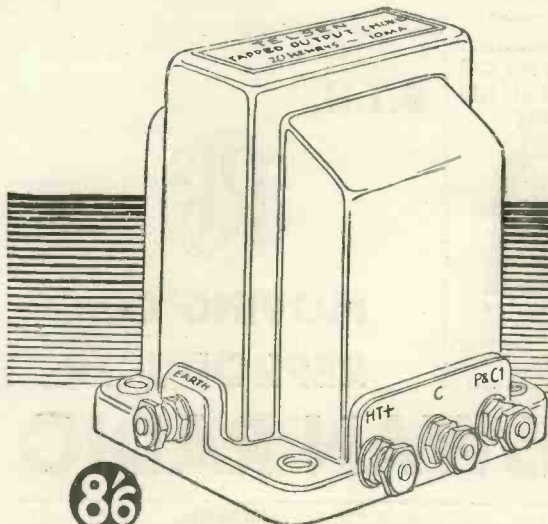

8/6

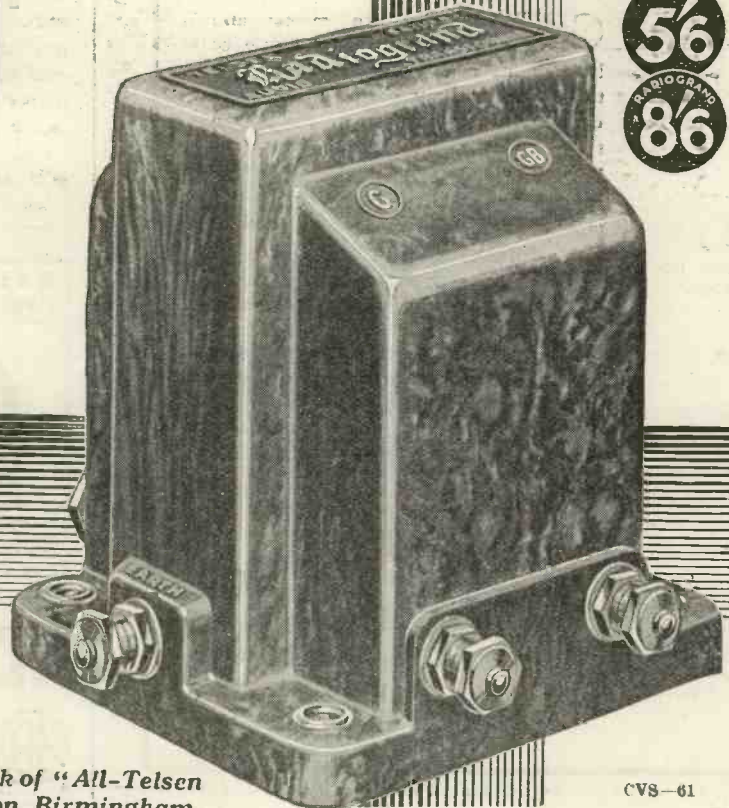

Send for the "Telsen Radio Catalogue" and book of "All-Telsen Circuits" to—The Telsen Electric Co., Ltd., Aston, Birmingham.

CVS-61



# Do You Know?

Historical Signs—No. 1



## The Sign of St. Crispin

CRISPIN, a Christian martyr and shoemaker of Soissons, because of his goodness to the poor in making their shoes without payment, was, after his martyrdom in 286 made the patron saint of the shoemakers. In the middle-ages and onwards the sign of St. Crispin was used by all true craftsmen among leatherworkers.

To-day, in the same way, "the green case" is a recognised sign of condenser efficiency—indicating as it does the product of experience and skill. For every T.C.C. Condenser is the result of a quarter of a century's specialised experience—that of designing and making condensers—and condensers alone. Be sure your next condenser has this backing—be sure its T.C.C.

Look for the initials T.C.C. on the condenser in the green case

# T.C.C.

CONDENSERS

The Telegraph Condenser Co. Ltd. Wales Farm Road N. Acton, W3. ♡ 9141

# 100% BRITISH MADE



1931/2 Models.  
Senior A.C. Model New Reduced Price £7.15.0.  
Senior D.C. Model New Reduced Price £5.5.0

Minor Permanent Magnet Model Price £2.10.0.

Minor D.C. Model Price £1.11.6.

## —and it costs less

If you must have the best possible reproduction it means a B.T.H. R.K. There are many new models available now. In the R.K. range, from the "Minors" at 31/6 (field excited model) and 50/- (permanent magnet) to the Senior A.C. R.K. at £7:15:0, there is a model specially suited to your requirements.

Ask your dealer for a demonstration and full particulars.

GREENWICH TIME FROM THE MAINS



Have you seen the Ediswan A.C. Mains Electric Clock? Ask your radio dealer. Prices from 45/-

B.T.H.



MOVING COIL REPRODUCER

# EDISWAN RADIO



THE EDISON SWAN ELECTRIC CO. LTD.  
Radio Division: 155 Charing Cross Road, London, W.C.2

W.177



# A RADIO RECKONER

By  
**W. A. BARCLAY**  
M.A.

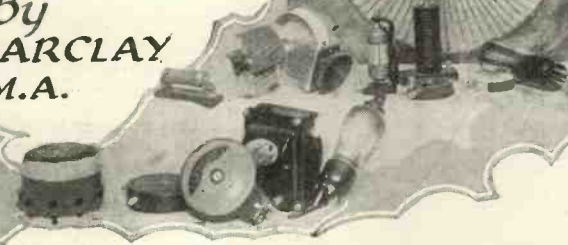

This month we present a series of N-Diagrams which enable you to calculate the reactances of coils and condensers.

**B**EFORE discussing the principles of tuning in radio circuits, it will be well to complete our treatment of the subject of reactance by giving two further N-Diagrams from which reactance values may be obtained by inspection.

These charts are in all respects similar to those that appeared last month, but deal also with the longer wave-lengths employed in broadcasting.

### On Long Waves

The first chart, Fig. 1, shows the relation between the reactance of a coil and the two factors on which it depends, viz., its inductance and the wave-length which is being dealt with. It will be seen that the wave-length scale extends up to 2,000 metres, while inductance values are given up to 1,000 microhenries.

As an example, let us take a long-wave coil whose inductance is 600  $\mu$ H., and find its reactance at a wave-length of 1,800 metres. In this case a line taken through 1,800 metres and 600  $\mu$ H. will meet the diagonal scale in a point between 600 and 650 apparent ohms; hence we may say that the coil reactance is roughly 625 apparent ohms.

### Some Practical Results

At the lower wave-length of 1,130 metres the reactance of the same coil is similarly found to be 1,000 ohms. (Since each small division on the left-hand scale here represents 20 metres, our reading line must pass through a point half-way between 1,120 and 1,140 metres.)

### AN EASY ONE TO USE

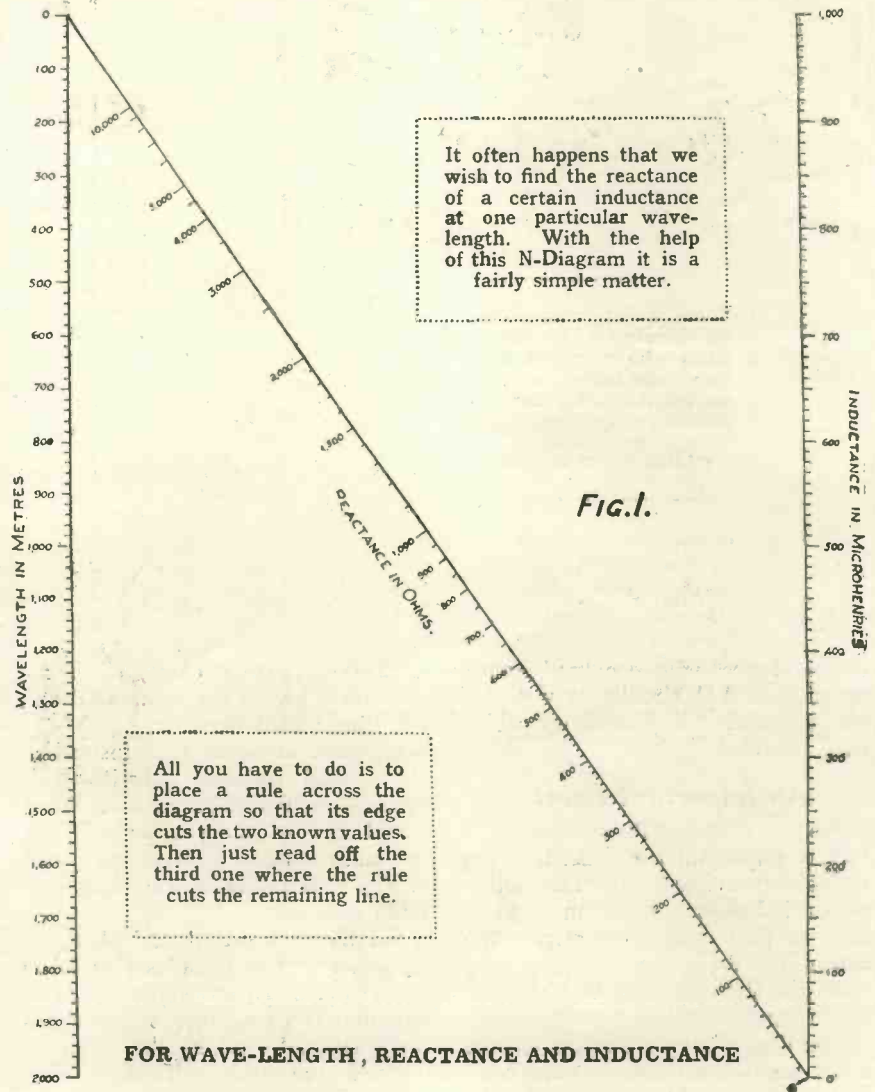



The second diagram, Fig. 2, performs the same office in the case of a condenser. For instance, at a wave-length of 1,800 metres a condenser of capacity 0.0008 microfarad will have a reactance of 1,200 ohms, while at 1,130 metres its reactance will be only 750 ohms.

So far, we have looked upon reactance as a rather peculiar kind

of reactances of each tend to cancel out.

It was seen above that at 1,130 metres an inductance of 600  $\mu$ H. has a reactance of 1,000 apparent ohms. If we place in circuit an additional inductance of similar amount, as in Fig. 3, the total reactance of the circuit at the same wave-length will be 1,000 plus 1,000,

In studying this subject we must remember all the time the peculiar *intangibility* of the concepts we are examining. No one knows precisely what an ohm of reactance is; it is really only a kind of label which we attach to this wonderful effect which occurs in A.C. circuits, in order that we may study their action more efficiently.

Radio workers find it convenient to develop this "labelling" a little further; we thus call the reactance which is due to inductance "positive," and that due to capacity "negative."

### CONDENSERS THIS TIME

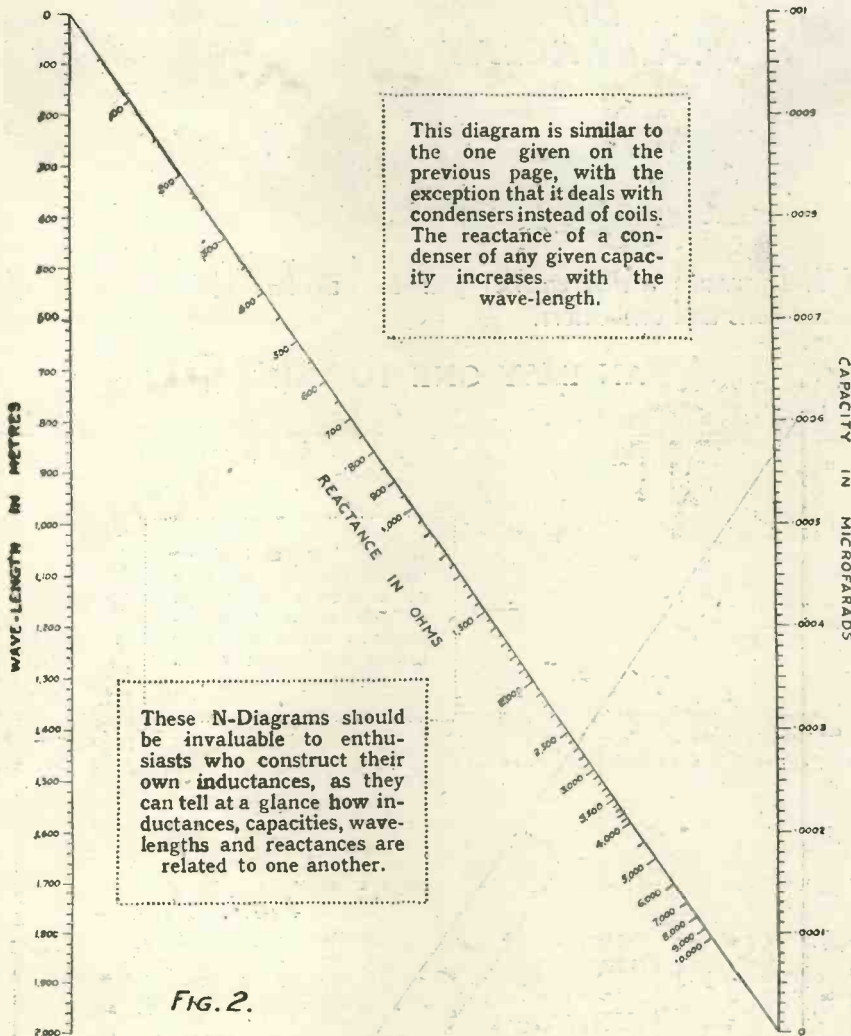

FIG. 2.

of resistance which only becomes manifest in A.C. circuits by virtue of the inductance and capacity which they contain.

#### An Important Point

We are now to take account of a further important fact, viz., that the reactance which arises from the action of an inductance is of an *opposite* kind to that which arises from the action of a capacity.

At first sight this may be somewhat hard to understand, but it will become clearer if we study the effect of placing a coil and a condenser in series with each other and noting how the

or 2,000 apparent ohms, since the reactances are of the same kind and are thus added together.

Suppose, however, that instead of the second coil we substituted a condenser of 0.0008 microfarad. What would now be the reactance of the coil and condenser in series, as shown in Fig. 4, at the same wave-length of 1,130 metres?

We have already found that the reactance of this condenser at 1,130 metres is 750 apparent ohms; we can now find the reactance of the series combination by taking the *difference* between the two reactances, thus 1,000 - 750, i.e. 250 apparent ohms.

#### What Kind of Reactance?

The mathematical signs for plus and minus come in handy in this connection, and before quoting the particular value of a reactance in figures, the appropriate + or - sign is always prefixed in order to show what kind of reactance it is.

Thus the reactance of the coil mentioned above is properly given as + 1,000 apparent ohms, while the capacity reactance is - 750 apparent ohms. The use of these labels or "signs" is helpful in showing why the difference of the reactances must be taken in the circuit of Fig. 4.

In this case, of course, the combined reactances are + 1,000 - 750, which is, naturally, equal to + 250 ohms.

In a circuit such as that of Fig. 4 it will, of course, sometimes happen that the negative or capacity reactance will be equal in numerical amount to the positive or inductive reactance.

The two will then cancel each other out, and the net reactance of the circuit will be exactly zero.

#### Effect When "In Tune"

When this occurs the circuit is said to be "tuned" to the given wave-length. This is a very important condition, and we shall have more to say of it hereafter.

Meanwhile, we may use the N-Diagrams which have been already given in order to find numerical values for a typical case. Usually this would mean a fair amount of multiplication and division, but by using these charts all figuring is avoided, and the whole process is astonishingly easy.

Let us return again to our coil of 600  $\mu$ H., which we found to have a reactance of + 1,000 ohms at 1,130 metres. Now, if we can find a condenser whose reactance at the same wave-length is - 1,000 ohms, the reactance of the two in series at this



**CHALLENGING**  
**INTERESTING**  
**HELPFUL**  
**CRITICAL**  
**SCATHING**  
**TRENCHANT**  
**CONSTRUCTIVE**  
**ENTERTAINING**  
**FORCEFUL**  
**EXPERT**  
**UNIQUE**  
**VIGOROUS**  
**BLUNT**  
**VIRILE**  
**LIVE**  
**OUTSPOKEN**  
**PROVOCATIVE**  
**INFORMATIVE**  
**FRANK**  
**BRIGHT**  
**USEFUL**  
**TOPICAL**  
**INTRIGUING**  
**INSTRUCTIVE**

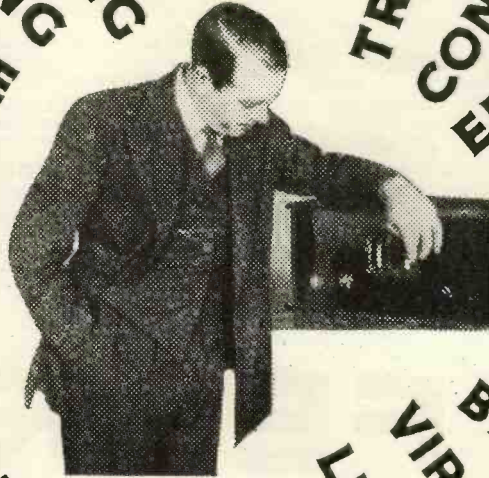

Read **Capt. P.P.**  
**Eckersley's**  

---

**Radio Feature**  

---

every Wednesday in The

**DAILY MAIL**



# FERRANTI CONDENSERS AND RESISTANCES

## FOR POWER SUPPLY UNITS

Most constructors will agree that to provide a Receiver with H.T. power from a dry battery or accumulator, if A.C. Mains are available, is like lighting the house with candles. It's out of date.

If your Set depends on batteries for its power—power that should be ample, constant and silent—and from batteries it seldom is—you will derive lasting satisfaction from a High Tension Power Supply Unit.

In the construction of such a Unit it is of great importance to use components that can be depended upon to stand up to the severe conditions imposed.

As is to be expected, inferior components give inferior service, and are liable to break down under the electrical stresses set up, with possibly serious results to the Receiver and the components of which it is constructed.

Therefore, do not take unnecessary risks. Employ components designed with knowledge of the conditions they have to deal with, and built by Engineers with nearly 50 years' electrical experience behind them.

**FIXED CONDENSERS** for smoothing.  
**RESISTANCES** for voltage dropping.  
**CHOKES** and **MAINS TRANSFORMERS**.

FERRANTI issue free **CHARTS** for the construction of H.T. Power Supply Units to meet all conditions. A copy will be forwarded on request accompanied by 1½d. stamp.

**WHATEVER YOU DO**, put in reliable components. It pays, on the Mains.

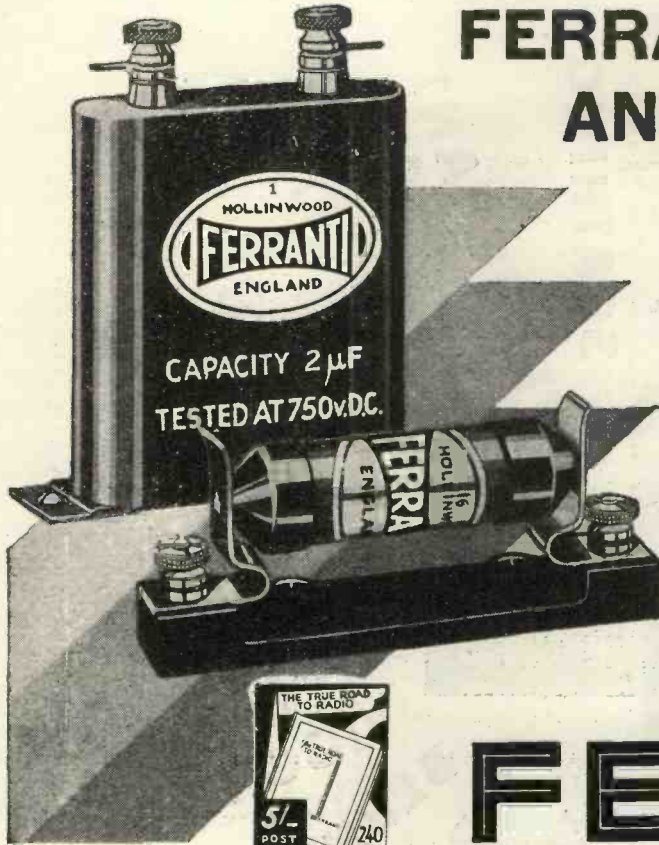

# FERRANTI

FERRANTI LTD. Head Office & Works: Hollinwood, Lancs. London: Bush House, Aldwych, W.C.2



(INDOOR) (LOW-LOSS)

## 7 in 1 AERIAL

has eliminated unsightly, inefficient and costly outdoor aerials.

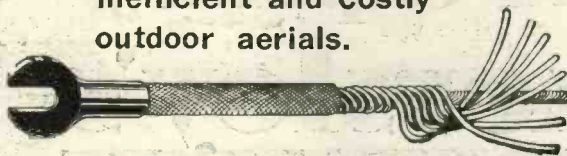

Price: 15ft. 3/9 20ft. 4/6 **LABORATORY TESTS PROVE 25% INCREASE IN SIGNAL STRENGTH**

See also page 522. Have you ever considered the fact that aerials are the only remaining parts of modern wireless reception that have lagged behind in the swift development of wireless?

Do not waste any more money on repairing your outdoor aerial. Simply place the FORMO Low-Loss Aerial around the picture-rail or other convenient place, and enjoy improved and trouble-free reception of stations you may never have heard before.

Packed in Strong Carton ready for use. Obtainable from all Radio Dealers. Catalogue from:

**ARTHUR PREEN & CO., LTD.**, Golden Square, Piccadilly Circus, London, W.1. Crown Works, Southampton.



## SUPER COMPONENTS for "M.W." A.C. "SUPER-QUAD"

For a set which demands the very best—use Wearite—the Components specified.

### PAXOLIN PANEL

Paxolin panel, size 16 in. x 7 in., drilled to specification for the "M.W." "Super-Quad."

Price 7/-

### WEARITE SUPER-HET COILS

Consisting of 1 special Oscillation Unit and 2 Band Filter Coils (as specified by "M.W.").

Price per set of three 37/6

WRITE FOR FREE ILLUSTRATED LIST.

### WEARITE POTENTIOMETER

Wearite Potentiometer, wire-wound, 50,000 ohms.

Price 4/-

### WEARITE H.F. CHOKE

A very fine instrument with a range from 10-2,000 metres.

Specified for A.C. "Super-Quad." Price 6/6

### WEARITE VALVE HOLDER

5-pin valve holder for the A.C. "Super-Quad." Sprung Sockets. Price 1/3

# WEARITE COMPONENTS



## Finding the Reactance on the Long Waves

wave-length will be zero, that is, the circuit will be in tune. From the second N-Diagram given this month we see, by joining 1,130 metres to 1,000 ohms, that the necessary capacity value is 0.0006 mfd.

### The Resonant Condition

It is very important to notice that the capacity of 0.0006  $\mu$ F. thus found is only "in tune" with the given inductance of 600  $\mu$ H. at the special wave-length of 1,130 metres. At any other wave-length this tuned or, as it is sometimes called, "resonant" condition will not exist.

By means of the N-Diagrams given we can easily show that this must be so. Let us take, for instance, any other wave-length, say, 1,300 metres. Then the reactance of 600  $\mu$ H. at this wave-length is found from Fig. 1 to be +870 ohms, while the reactance of 0.0006  $\mu$ F. at the same wave-length is found from Fig. 2 to be -1,150 ohms.

Thus the two reactances do not cancel out, and at 1,300 metres, consequently, the combination of 600  $\mu$ H. and 0.0006  $\mu$ F. in series is not in tune. It will be found, indeed, that 1,130 metres is the only wave-length at which this particular coil and condenser have zero reactance when

placed in series with each other, and it thus appears that the "tuned" or "resonant" condition is always associated with a particular wave-length (or, what comes to the same thing, with a particular frequency).

It is a commonplace of radio to speak of "tuning-in" to a desired

value, while the condenser is constructed so that its capacity may be varied at will. For this reason we speak of the "tuning" condenser, although the coil is, as we have seen, of equal importance in the tuning process.

### Balanced Out

For every wave-length, of course, the fixed coil will assume a different value of reactance. By turning the dial of the variable condenser its reactance to the wave-length of any desired station may be made to vary until it becomes numerically equal to that possessed by the coil for the same station. At this point the reactances balance out, and the circuit is tuned.

The above numerical example of a tuned circuit showed the use of the two N-Diagrams for the longer wave-lengths which appear in this issue. For the medium wave-lengths, of course, the N-Diagrams given last month can be used.

Since the reactances in a tuned circuit cancel out, there is no need to ascertain the reactance of each component separately in order to find the "resonant" wave-length, as there is a much shorter way of doing this by means of suitable N-Diagrams.

### ADDING AND SUBTRACTING REACTANCES

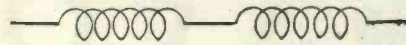

FIG. 3.

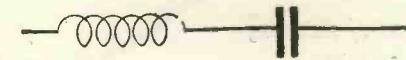

FIG. 4.

A. 2339

If two inductances are placed in series their reactances are added. But if a coil and condenser are connected as in Fig. 4 their reactances are subtracted.

wave-length; if the circuit to be tuned consists of a coil and condenser in series, this simply amounts to adjusting the values of these until the positive and negative reactances "balance out," as it were, at the required wave-length.

In most receivers it is customary to employ coils of fixed inductance

## One of Britain's Best-Known Bands



Nearly everyone has heard Callender's Band broadcast at some time or another. That they put over some good turns goes without saying, and they are here shown entertaining listeners from one of the London studios.





A practical article describing a novel method of switching and volume controlling in radio-gram receivers.  
By C. P. ALLINSON.

**T**HERE is a very strong and rapidly growing tendency among constructors of large receivers of the radio-gram type to simplify the control of these sets as far as possible. For one thing, the ganging of a number of tuned circuits is becoming rapidly more popular, and a large number of designs are now appearing showing circuits especially worked out for gang control.

On my own receiver, for instance, there are only four controls, a number which could be reduced even further with the aid of an extenser.

First there is the tuning control, which consists of four condensers ganged on one spindle and operated on one dial only. Next we have the radio-gram switch, which also switches the set on and off, then there is the wave-band switch, and lastly we have the volume control.

the radio-gram on-off switch. This is shown in detail in the circuit.

It will be seen that this switch carries five sets of contacts, and it will be interesting to enumerate its functions before we go into the actual details of the circuit.

**NEAT AND TIDY**

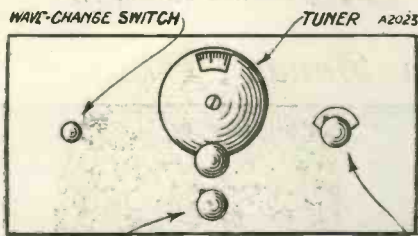

This is the panel layout of the writer's set. Note the small number of controls.

By this means the number of tuning controls to be operated in a receiver can be reduced from two or three to one only, and this is of the greatest possible value when the receiver has to be operated by unskilled hands.

**Too Many Controls**

In many cases a receiver is built by an enthusiastic experimenter who is in business during the day, and the family wish to use the set during his absence, for their own amusement. Where such a set has two or three tuning controls, two volume controls, a reaction control, and possibly one or two other odd switches, the uninitiated are naturally nervous to touch the instrument.

**One Volume Control**

It has been desirable hitherto to fit two volume controls, one for the H.F. side of the receiver, and one for the radio-gram, but by the method of switching which I have worked out I have cut out, not only the component, but also the fitting of the extra control on the panel, and the volume control is now automatically switched over from radio to gramophone when the switch is operated.

The layout on the panel is shown in a sketch on this page, in and it will be seen that this arrangement lends itself to a perfectly symmetrical layout.

In the centre we have the condenser dial, which is of the slow-motion type, the scale appearing through a window in the dial. Immediately below this is the knob which drives the condenser. Below this again we have the volume control, while on either side are the two switches which give the wave-band change (on the left), and the radio-gram on-off switch (on the right).

The chief point of interest in this lies in the switching which is used for

**FIVE-POINT SWITCHING**

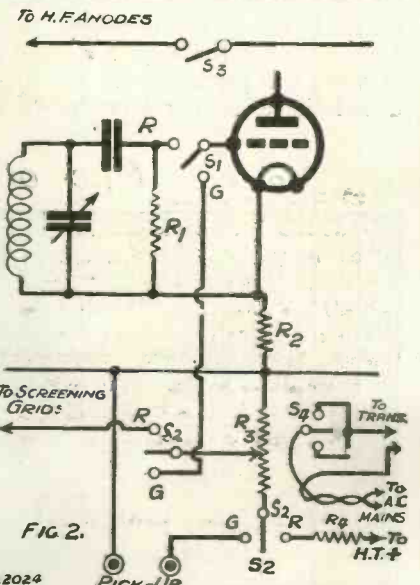

The switching arrangement shown above enables the same volume control to be used for radio and gramophone. It necessitates the use of a five-pole double-throw switch.

Firstly, it is important when you are working on the gramophone amplifier there should be no sign of radio signals filtering through. Since the set in question employs indirectly-heated cathode valves, it is out of the question to break the filament circuits of these valves.



# Convert your radio receiver to an AUTOMATIC RECORD- CHANGING RADIO-GRAMOPHONE or an armchair-controlled radio-gramophone



In a handsome walnut cabinet of compact design is fitted the new "His Master's Voice" automatic record changing mechanism, pick-up and volume control. By connecting it to your radio receiver eight, 10 or 12 inch records (unmixed) may be played at one loading or a single record repeated up to eight times. A unit you have been waiting years for. A.C. or D.C. Model 117.

Price 18 guineas

The new "His Master's Voice" pick-up, volume control, electric turntable motor and automatic start and stop, housed in an oak cabinet of pleasing design. By connecting it to a loudspeaker radio-receiver records may be played from one's armchair. Interchangeable resistances may be clipped in to the volume control to match the pick-up to any radio receiver. A.C. or D.C. Model 116.

Price 10 guineas



## NEW "HIS MASTER'S VOICE"

### RADIO ACCESSORIES FOR THE RADIO EXPERIMENTER

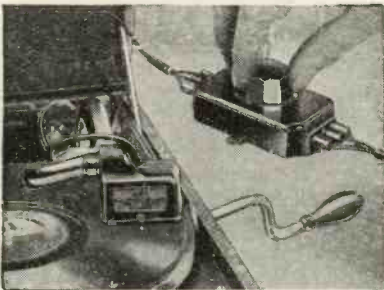

This pick up is similar to the one fitted to all our new instruments. It can be attached easily to any type of tone-arm and is supplied complete with a logarithmic volume control and connecting leads. The weight of the pick-up is 3 1/2 ozs.; it has an input of over 1 volt R.M.S., and a D.C. Resistance of 6,000 ohms.

Model 11

Price Complete 2 gns.

A permanent magnet moving-coil loudspeaker in an arched walnut cabinet of attractive design. It is extremely sensitive and will handle up to 3 watts without difficulty. A universal input transformer incorporated in the instrument enables it to be matched to receivers with triode, pentode or rush pull output.

Model L S.7

Price 5 guineas



These are just four of the thirteen wonderful new "His Master's Voice" instruments which range from an inexpensive portable gramophone costing £3. 5., to a 70 guinea, 9-valve automatic record-changing super-heterodyne radio-gramophone. Amongst this range there is a model to suit you and your friends requirements. Obtain full particulars from your local "His Master's Voice" dealer.

# "His Master's Voice"

The Gramophone Co. Ltd., London, W.1.





## Simplify Your Set with this Systematic Switching

Firstly, because it means that the switch contact would have to be heavy enough to carry a fairly heavy current, and, secondly, because when switching back to radio from gramophone there would be an appreciable interval while one had to wait for the H.F. filaments to heat up again.

### Cutting Out the H.F.

I therefore decided that the best thing to do was to break the high-tension circuit for the H.F. valves and thus eliminate any possibility of radio signals filtering through when working on the gramophone.

circuits are switched should be carefully considered, so as to reduce the possibility of interaction to an absolute minimum.

Since the switch is used for on-off purposes, the set being operated from A.C. mains, it is important, of course, that the contacts carrying the A.C. leads should be at the other end of the switch from those carrying grid leads.

At the same time the contacts which break the H.T. circuit, being to all intents and purposes at earth potential as regards H.F. currents, will give a certain amount of screening effect between contacts either side of them.

is impressed on the grid through the pick-up circuit, and the valve then acts as an amplifier. The value of this resistance will, of course, depend upon the valves you are using, and the current passing in the anode circuit.

### The Potentiometer

The second part of the switch marked  $S_2$  is that which serves to switch over the volume control from radio to gramophone. When connected on the radio side the potentiometer is connected across H.T. positive in series with the resistance, which ensures that when the full potential is applied, i.e. the slider is at the top end of the resistance, the correct value of voltage should be applied to the screening grids.

The slider, of course, goes to these screening grids, all of which are shunted by the usual fixed condensers. The other end of the resistance is connected to earth.

When the resistance is used for pick-up work, one end of the potentiometer is connected to earth as before, to which one side of the pick-up is connected. The other side of the pick-up is connected to the other end of the resistance, while the grid of the detector, which is now an amplifier valve, is connected to the slider on the potentiometer.

### Two Sets of Contacts

The switching is carried out as shown in the figure, two sets of contacts being required to do this. The one set switches over the end of the resistance  $R_3$ , and the other set switches over the slider.

The next set of contacts marked  $S_3$  breaks the high-tension circuit feeding the anodes of the H.F. side of the receiver. And the next set of contacts marked  $S_4$  is the on-off switch.

With the switch in the centre position no A.C. is fed to the input of the mains unit, but with the switch either in radio or gramophone position the contacts of the circuit are closed and the set operated. We thus have five sets of contacts in all on this switch.

Care should be taken when making connections to the switch to see that all soldered leads are thoroughly soldered and that the solder has run properly. A bad joint on the switch will give rise to the most annoying and puzzling symptoms.

### BEHIND THE SCENES AT BELLMORE



Operators in the main transmitting hall at the Bellmore broadcasting station. It is situated near New York, and is better known by its call-sign, W E A F.

Next the switch has to insert the pick-up in the grid lead of its appropriate valve. In the case of my own set I switched the pick-up on to the grid of the detector valve, so that I have a total of three L.F. stages available. For those who do not require so much volume, the pick-up may, of course, be switched into the grid lead of the first L.F. valve instead.

Next the switch has to change over the volume control from radio to low frequency, and, lastly, contacts have to be provided so that the centre position of the switch is off.

It is desirable that the switch used should be of the anti-capacity type, and the order in which the various

It will be seen that the first portion of the switch marked  $S_1$  switches the grid of the detector valve from its tuned circuit on to the pick-up. In order that the valve shall act as an amplifier it is desirable, of course, that a small amount of negative bias be employed.

### Grid-Bias Resistance

In order to obtain this, therefore, a resistance is connected in the cathode lead at  $R_2$ . The grid leak  $R_1$  is connected directly to the cathode, so that when operating as detector the usual leaky-grid condenser rectification is obtained.

When switched over to pick-up, however, a small negative potential



# QUESTIONS ANSWERED

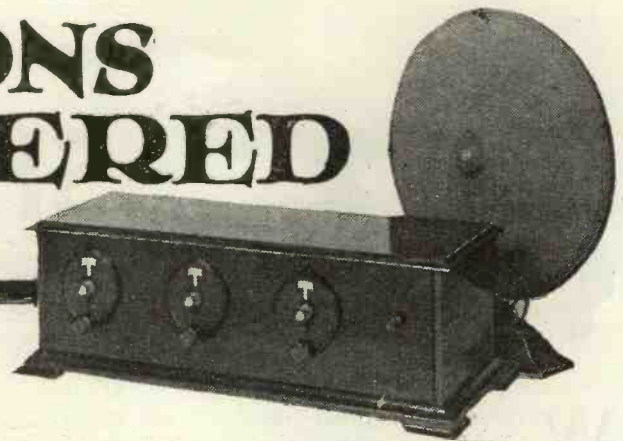

## The "M.W." "Super-Quad"

C. M. (E. Dulwich).—"I have made up the 'M.W.' 'Super-Quad,' which was described in the October issue of MODERN WIRELESS, and I should now like to add a switch and terminals so that I can use a pick-up. Will you please tell me how the alterations may be carried out?"

The modifications to the wiring are as follow: First remove the lead which goes from one side of the .0002 grid condenser to G on the valve holder  $V_3$ . Remove, also, the lead that goes to G on  $V_3$  from one side of the 2-megohm grid leak; this leaves the G terminal free.

Now arrange for a piece of ebonite above the terminals on the back of the set to take the switch and two terminals for the pick-up leads.

The switch used should be a single-pole change-over, either of the push-pull type or one of the special patterns designed for radio-gram switching.

Join the common spindle or the arm of the switch to the grid terminal on the valve holder  $V_3$ . Join one of the other terminals of the switch to the terminal on the grid condenser and the side of the grid leak which you have just disconnected.

Join the remaining terminal on the switch to one of the new terminals on the strip. Connect the remaining pick-up terminal on the strip to G.B.— $1\frac{1}{2}$  volts.

## Adjusting the Volume

If you wish to adjust the volume, then your best plan is to connect a potentiometer volume control across the pick-up itself.

The value of this volume control will depend upon the type of pick-up, and it is usual for the makers to specify suitable resistance values in their literature. The connections for the volume control are as follow.

The moving arm or slider on the volume-control potentiometer is joined

to the new terminal on the terminal strip which goes to one side of the radio-gram switch.

One of the other terminals on the volume control is connected to the remaining terminal on the strip. In addition, the two terminals on the pick-up itself are connected one to each of the terminals on the volume control, which go to the resistance element, that is to say, not to the slider.

## Inter-Wave Coupling

R. C. (Petts Wood).—"For some months I have been using the 'Dual-

The fault may be due to the inter-wave coupling resistance. We have had cases before in which a squeal has developed when the resistance shunted across the coupling condenser (.002 max.) has broken down or if its value has been too high.

## Connecting Fuses

A. L. (Battersea).—"I recently built a four-valve (H.F., det., and 2 L.F.) receiver which worked exceedingly well. Last week I decided to insert a fuse bulb, and since then the set has refused to function, a curious feature being that the fuse bulb lights up when I switch on."

You have probably made a mistake which is a very common one. In sets where H.T.— and L.T.— are joined together the connection is often made on the terminal strip of the set, the L.T.— lead to the valve holders being taken from the H.T.—, and not the L.T.—, terminal shank.

This is quite O.K. until the short wire between the H.T.— and L.T.— terminals on the strip is cut to permit the insertion of a fuse. When the fuse is joined at this point, the current from the L.T. supply, via the L.T.— terminal, has to flow through the fuse bulb before it can reach the lead to the valve filaments. Thus the bulb will light, but the resistance of the fuse will cut down the voltage across the valve filaments, and the set will fail to function properly. The remedy is to transfer the negative filament lead from the H.T.— to the L.T.— terminal.

## Back Numbers

M. C., and others.—Back numbers of MODERN WIRELESS are obtainable from The Amalgamated Press, Ltd., Back Number Dept., Bear Alley, Farringdon Street, London, E.C.4.

The price of an ordinary issue is 1s. 3d., post free, and for a double number, 1s. 9d., post free.

## TECHNICAL QUERIES DEPARTMENT

Are you in trouble with your set?

The MODERN WIRELESS Technical Queries Department is in a position to give an unrivalled service. The aim of the department is to furnish really helpful advice in connection with any radio problem, theoretical or practical.

Full details, including the revised scale of charges, can be obtained direct from the Technical Queries Department, MODERN WIRELESS, Fleetway House, Farringdon Street, London, E.C.4.

A postcard will do. On receipt of this all the necessary literature will be sent to you, free and post free, immediately. This application will place you under no obligation whatever. Every reader of MODERN WIRELESS should have these details by him. An application form is included which will enable you to ask your questions so that we can deal with them expeditiously and with the minimum of delay. Having this form you will know exactly what information we require to have before us in order to solve your problem.

London readers, please note: Inquiries should not be made in person at Fleetway House or Tallis House.

Range' one-valver, which was described in the April issue of MODERN WIRELESS. The set has worked excellently until a few days ago, when it commenced to give a high-pitched squeal which I have been unable to remedy. I find that the trouble is more pronounced on the long waves. I have tried another grid leak without result."





By W. L. S.

*Some notes on past, present and future reception, and on the peculiarities of the 7-metre wave-band.*

WITH the exception of the Exhibition, nothing of startling interest to us has occurred since I last sat down to write these monthly notes. I mention the Exhibition because it is naturally of great interest to all who make radio their hobby. For the short-wave man, unfortunately, it appeared to house very little.

That, however, is the inevitable penalty of being a minority, as we certainly are. Probably the proportion of the stands showing short-wave gear gives some idea of the proportion of listeners who use it! When one has mentioned short-wave condensers, coils, and adaptors, the list is complete.

Readers often write to me and expect me to answer that perfectly impossible question: "Which is best, an adaptor or a complete receiver?" There is simply no answer to this; everything depends upon the individual circumstances.

### Using Two Receivers

Personally, I do sufficient broadcast listening to be able to say that a "Short-Wave-Only" receiver would be of no use to me, had I not a separate affair for broadcast. But not everyone can do this, and for those who cannot an adaptor is useful, always assuming that they want broadcast programmes on the medium band.

The most optimistic of short-wave listeners cannot say that the "programme value" of the short-wave stations is sufficient to enable them to rely solely on their one receiver for 100 metres downwards.

Speaking very, very generally, I should be inclined to say that for the real "dyed-in-the-wool" short-wave man two receivers are preferable, while for the less keen listener an adaptor would fill the bill.

Do not think I am belittling the many excellent adaptors that may be bought or built. The point is that the

real fanatic wants a receiver that he can really experiment with, without the painful necessity of disturbing the family's broadcast receiver!

During the month I have had the interesting experience of hearing myself over half the surface of the globe. To explain this impossibility I may say that I built an exact replica of my own transmitter for a friend who was home on leave from the Malay States, and have since been able to congratulate him on the excellent signals he has been supplying to the input of my L.F. amplifier!

members—nearly all short-wave transmitting men—in practically every part of the Empire in which a man can live, and a chain of efficient short-wave stations is being slowly but surely established all over the world. Even the commercials cannot claim to have linked up the Empire in such a complete and complicated manner.

### The Monthly Reports

Each section now sends its monthly notes to headquarters at London, by radio in most cases, and naturally this has resulted in a speeding up of

## A TRANSATLANTIC SHORT-WAVE TEST

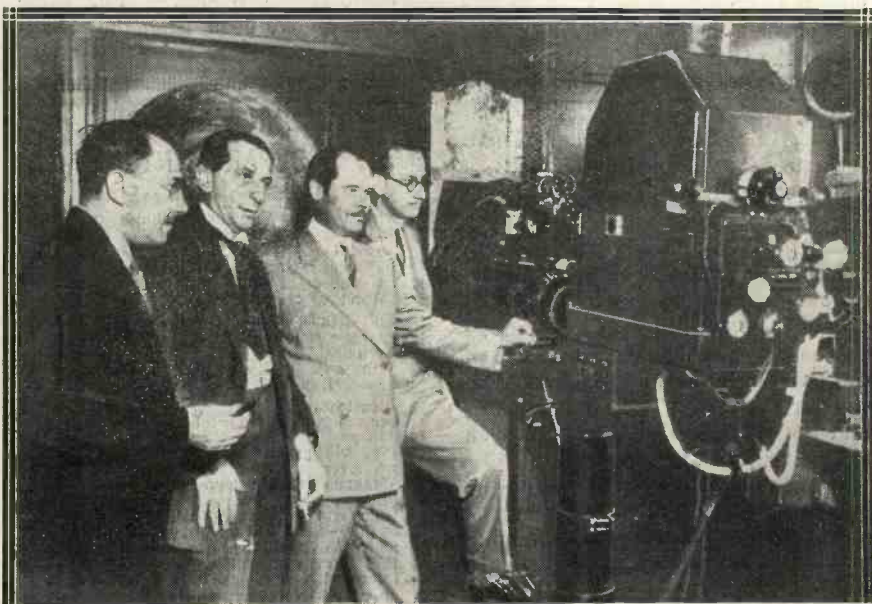

Engineers standing before a short-wave television transmitter during the recent tests between Schenectady, U.S.A., and Berlin. Third from the left is Dr. Alexanderson, of the G.E.C. Research Laboratories.

It is rather an uncanny experience to have an "echo," so to speak, of one's own signals, especially when it comes from such a distance as this.

### A Real Empire Link

Incidentally, the British Empire Radio Union, which was quite a small infant a year ago, is quite at the walking stage now. It boasts active

the news from our overseas friends. This all comes well within the terms of the transmitting licence, since such notes and news naturally refer to the experiments in hand and the work done during the month.

Who would have been bold enough to visualise such a state of affairs in the days when short-wave possibilities were first realised? I don't think



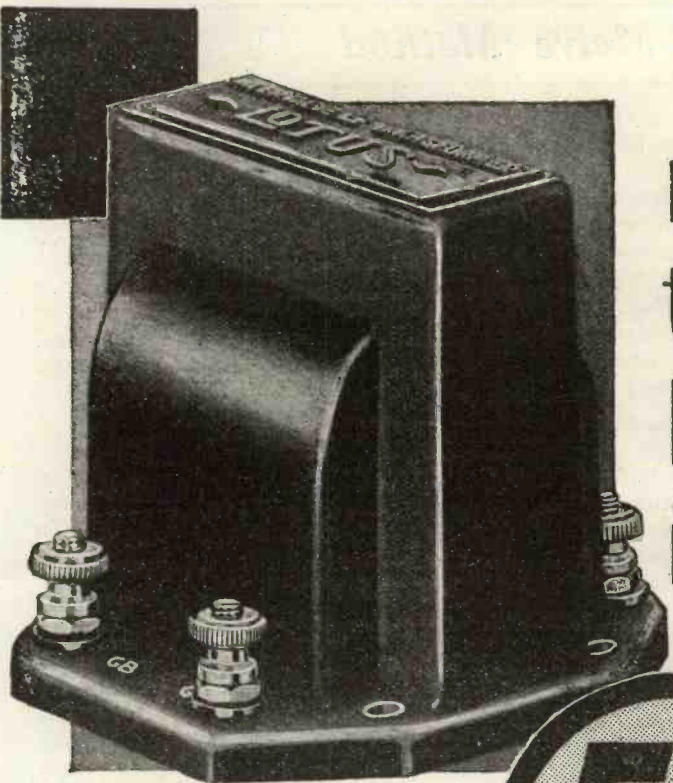

**not a cheap  
transformer  
but a sound  
instrument**

at a very **5/6** low price

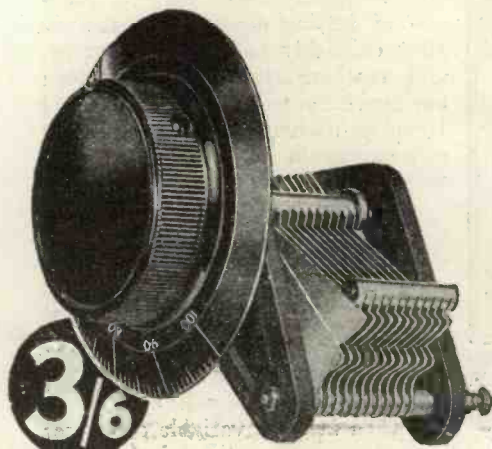

**THE LOTUS RIGID DRIVE LOG  
CONDENSER.**

An inexpensive, small, but highly efficient condenser with heavy gauge aluminium vanes. The endplates are high-grade bakelite mouldings, and the special method of assembly ensures accurate spacing. One-hole fixing is employed and the highly finished Knob Dial, engraved 0/100, is supplied in either Black or Mottled Brown finish.

Capacities .0003, Type KC/3     **3/6** EACH  
and .0005, Type KC/5

**LOTUS RADIO, LTD.,  
MILL LANE, LIVERPOOL.**

All the leading set designers specify LOTUS. They know that for reliability and efficiency they are absolutely dependable.

Follow the experts' lead; insist on LOTUS Components.

This new LOTUS Audio Transformer No 1 is a particular triumph of value, and its performance is equal to many at twice the price. It is designed specially for the use of the home constructor. While small in size, specially designed windings and core give high efficiency, good reproduction and an exceptional straight-line amplification curve.

It is enclosed in a neat brown bakelite moulding, and the core is earthed through one of the fixing eyelets. Ratios 3-1 and 5-1. Type AT/1, Price 5/6.

Every home-constructor should have the new LOTUS Component Catalogue. Ask your dealer or write for your copy to-day.

**LOTUS**  
**RADIO COMPONENTS**



## Snags of the 7-Metre Method

even my own optimism would have led me to such flights of imagination.

### Changing Conditions on the Short Waves

If conditions take their usual turn for this period of the year, I prophesy that the stations below 30 metres will begin to be erratic by the time you read these notes. Generally, in November and December, 20 metres and below becomes a complete wash-out, while the 25-metre group is rather unreliable. Every misfortune has its compensations, and in this particular case we ought to find the 31-32-metre stations bucking up considerably.

What of the 7-metre business? Everyone seems to be asking this natural question nowadays. Candidly, I can only emulate a certain politician who once said "Wait and See." We cannot tell what turn events may take in the next few months, but the success of the German and Dutch experiments might lead one to suppose that our own authorities will not lose sight of the possibilities.

I can take "seven" in my stride quite easily with my own special receiver, which goes down to 5 metres without any alterations. Though I listen there eagerly whenever the mood takes me, my sole reward is the delightfully silent background (un-

fraction of the power that is necessary at present.

The chief snags that I see are these. First, it would need a huge number of stations to cover the country, although for the big towns it would be extremely useful. Second, there is the large bugbear of ignition interference, and other "man-made static," which can, in certain circumstances, play havoc with 7 metres.

### "Optical" Waves

Talking of these very short wavelengths, I wonder how many of my readers know that, below a certain limit, the transmissions possess what are loosely termed "optical" properties? This means that if you can't see the transmitter you can't hear him!

Such obstacles as a small hill or a building will completely divert the radiated waves, so that to possess any range at all the transmitter must be on high ground, or at the top of a mast, or up in a balloon. The vision of innumerable transmitters suspended in balloons often comes to me and causes such unseemly mirth as to cause my associates to regard me with suspicion.

It does not seem long ago that we were struggling wildly with the problem of getting down to 40 metres. How childishly easy it seems now, and yet where is the difference between our modern receivers and the others? I confess absolutely that my present set, except in appearance, is very very similar to the one I used in 1924.

### Nothing Really New

The circuit is the same. Call it Schnell, Hartley, Reinartz, or what you will, the principles are identical, and the layout is almost unalterable. The recipe is: "Take a grid coil, tune it, add a reaction coil and don't, and then insert a variable condenser in such a manner that the reaction can be controlled without having to move the coils about."

And there you have it. Surely it is a little strange that there are not more really fundamental differences between Ancient and Modern.

Radio is, certainly, in a very changing state at the present time, but do we ever meet with any really startling transformations? Even the broadcast listener would not disgrace himself with a six-year-old set, except on the score of quality.

### TRACKING DOWN THE KNOCKS AND NOISES



Berlin has called in radio apparatus to aid in the prevention of unnecessary noise. One of the professors is here shown testing acoustic disturbances with a powerful L.F. amplifier.

The fourth group—those between 47 and 50 metres—cannot be dealt with with any degree of certainty, since conditions on that band appear to be almost independent of whatever may happen elsewhere.

### What the Log Shows

My own personal prophecy regarding the "Yanks" is that W 2 X A F will be the star station for a while. If I am wrong, I shall at least have learnt not to count too much upon my previous years' logs.

naturally so!) and the absence of atmospherics.

Perhaps one day I shall hear a carrier-wave down there. One might even hope for a modulated carrier-wave. And then the short-wave merchants would begin to sit up and take notice.

Of course, it is well known that the range of 7-metre transmissions is very limited. For short-distance broadcasting, however, it should be ideal, particularly as the transmitting stations would be able to use a mere



# TELSEN RADIO COMPONENTS



6d

**TELSEN VALVE HOLDERS.**  
(Prov. Pat. No. 20286/30).

The Telsen four and five-pin valve holders embody patent metal spring contacts, which are designed to provide the most efficient contact with split and non-split valve legs, and are extended in one piece to form soldering tags. Low capacity and self-localing.

- Telsen 4-pin Valve Holder .. Price 6d.
- Telsen 5-pin Valve Holder .. Price 8d.



From 1/6

**TELSEN MANSBRIDGE TYPE CONDENSERS.**

Telsen have installed the most advanced plant in the world for the manufacture of Mansbridge Type Condensers. Only genuine Mansbridge foil paper and the finest linen tissue are employed. Post Office standards of insulation are adopted throughout. The following values are guaranteed within 5 per cent:—

Cap. mfd.	500 Volt Test.	1,000 Volt Test.
-01	1/6	2/6
-04	1/9	2/9
-1	2/-	3/-
-25	2/3	3/3
-5	2/3	3/6
1-0	3/-	5/-
2-0		

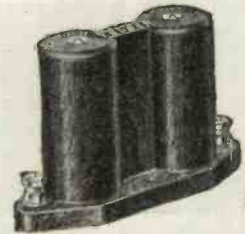

5/-

**TELSEN BINOCULAR H.F. CHOKE.**

Hailed unanimously by the leading experts as the perfect H.F. Choke. The Telsen Binocular Choke is called for wherever highest efficiency is desired. Especially in H.F. amplification is the performance of the Choke of supreme importance.

Its highest inductance (180,000 micro-henrys) and exceptionally low self capacity (0.00002 microfarad) ensure a very high impedance at all wavelengths, and its excellent efficiency curve is free from parasitic resonances. These qualities, together with the restricted field due to the binocular formation, make it the ideal Choke for a high-class circuit ... Price 5/-



5/6

**TELSEN LOUD-SPEAKER UNIT.**

The Telsen Loud-Speaker Unit is pleasing to the most sensitive ear. The deep notes of the bass, the brilliance of the soprano, and the crispness of diction are clearly reproduced without any distortion.

It employs cobalt steel magnets, and the detachable rod which carries the cone is fitted with cone washers and clutch. The entire unit is enclosed in a beautifully moulded bakelite dust cover. Price 5/6

## TELSEN ALL-BRITISH RADIO COMPONENTS

Also include:—

H.F. Chokes	from 2/-
Transformers	5/6
Output Chokes	8/-
Power Grid Chokes	3/-
L.F. Coupling Chokes	5/-
Slow Motion Dial	2/6
Mica Condenser	8d.
Pre-set Condenser	1/6
Variable Condenser	4/6
Spaghetti Resistances	from 6d.
Loud-Speaker Chassis	5/6
Fuse Holder	6d.
Grid-Leak Holder	6d.

Send for the "Telsen Radio Catalogue" and book of "All-Telsen Circuits" to: The Telsen Electric Co., Ltd., Aston, Birmingham.

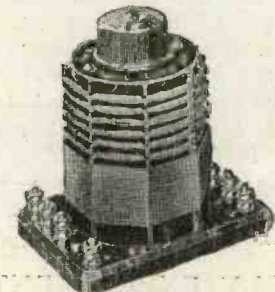

7/6

**THE TELSEN AERIAL COIL**

is the latest development in Dual Range Aerial Coil Design. It incorporates a variable series condenser which can be set to give any desired degree of selectivity, making the coil suitable for ALL districts. This adjustment also acts as an excellent volume control. The wave-band change is effected by means of a three-point switch. A reaction winding is included ... Price 7/6 each.

**TELSEN DUAL-RANGE H.F. COIL AND TRANSFORMER.**

This coil is designed for H.F. amplification in conjunction with screened-grid valves. It can be connected as a Tuned Grid or Tuned Anode Coil, or alternatively as an H.F. Transformer. This Coil also makes a highly efficient aerial coil where the adjustable selectivity feature is not required. Reaction winding is incorporated. When used as an H.F. Transformer the wave change is effected by means of a 2-pole switch. ... Price 5/6 each.



9d

**TELSEN GRID LEAKS.**

Telsen Grid Leaks are absolutely silent and non-microphonic, and practically unbreakable. They cannot be burnt out and are unaffected by atmospheric changes. Telsen Grid Leaks are not wire wound and therefore there are no capacity effects. Their value is not affected by variation in the applied voltage.

Made in capacities ranging from 1.5 megohms. Price 9d.

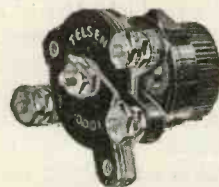

2/-

**TELSEN BAKELITE DIELECTRIC CONDENSERS.**

These Condensers are of a new type and of exceptionally compact dimensions. The moving vanes, which are interleaved with finest quality bakelite, are keyed on to the spindle so that they cannot be pushed out of line and there is a definite stop at each end of the travel. The connection to rotor is made by means of a phosphor-bronze pigtail so that there is no cracking due to rubbing contacts. The connection to the stator vanes is absolutely positive—a very important point.

All Telsen Bakelite Condensers are supplied complete with knob.

Differential Condenser, capacities .0003, .00015, .0001	Price 2/-
Reaction Condenser, capacities .0003, .00015, .0001	Price 2/-
Capacities .00075, .0005	Price 2/6
Tuning Condenser, capacities .0005, .0003	Price 2/-



From 1/-

**TELSEN PUSH-PULL SWITCHES.**  
(Prov. Pat. No. 14125/31.)

The Telsen Push-Pull Switches employ a proper electrical knife switch contact and are soundly constructed on engineering principles. The centre plunger is wedge-shaped, so that as it is pulled out it forces the inner fixed contacts outwards, tightly gripping the moving contacts. There is no fear of cracking with Telsen Push-Pull Switches. Their low self-capacity makes them suitable for use in H.F. circuits.

Telsen Push-Pull Switches—

Two-point	Price 1/-
Three-point	Price 1/3
Four-point (2 pole)	Price 1/6





## The End of the Thunk and Jones Alliance

COMRADES, I bring to this month's dissertation a bruised spirit and a heart that "knocks" and "pinks" like a car two short removed from the scrap-heap. Nay, 'tis not a love affair, nor has my daughter run away with the butcher's boy. *I have broken with my old friend Professor Thunk!* Strictly speaking, he broke with me—but a break's a break, as they say in billiards.

### EARLY EXPERIMENTS!



"... a green chemical when heated emitted a purply-blue stink"

When I was studying chemistry in the days of my milky youth, the teacher used to make me rule my page into three vertical columns which were headed "Experiment," "Observation," "Inference." In the first column I had to describe what I did, in the second what I saw or smelt, and in the third what I thought about it all. The third column was a brute, because how could I infer anything from, say, the fact that a green chemical when heated emitted a purply-blue stink?

Later I learned that even if one is able to draw an inference from an

observed and checked fact the inference is, just as likely as not, a bloomer. There are such a frightful quantity of possible reasons for a fact, especially facts concerning human beings.

Even if you find Egbert on a chair in the larder, his hands and visage smeared with jam, you have to stop before you admonish him, and consider whether it is not possible that the Crown Prince of Abyssinia has paid varlets thus to smear your son out of a spirit of revenge for the battle of Magdala.

As for attempting to do a bit of inference from the acts of one's wife—oh, boy! Leave it well alone and have a smoke.

### An S.O.S.

Old Thunk, the discoverer and sole proprietor of the invisible star, *Alpha Thunkii*, was so used to putting unlicensed interpretations upon every mortal thing which Alphonse did that he clean forgot the dictum of Professor Cyrus Q. Zillerbaumschnitzer, of Otis Yewniversity, Wis., namely, "I rachon thing's ain't nuthin' like what I rackon, neither." Sir Francis Bacon couldn't have put the matter down in a snappier way.

The affair which culminated in the tragic severance of the Thunk-Jones alliance began with a note from Thunk to Jones (that's me) reading: "Dear Mr. Jones, I believe that you are connected in some sense with the Marconi ray system. On the assumption that my data are correct, I should desire you to attend here to-morrow evening at seven, for a consultation. Yours, etc."

Stiffish—but pure Thunk. His epistolary style was half University professor and half mid-Victorian insolence. He had not clearly realised the existence of anything or anyone since he struck the unfortunate *Alpha Thunkii* in 1887.

### Answering the Call

However, to be called into consultation by an astronomer of Thunkian magnitude was an honour not lightly to be ignored, and so I rang the bell at Mortimer's Chambers, Hope Gardens, Putney, in a state of inflated egoism. *The blighter was out.*

Well aware that Thunk was liable to be summoned to keep an appointment with *Alpha Thunkii* at any hour of the day, I decided to enter his flat and await his return. Mrs. Brabs, the relic of Brabs, the Policeman-Astronomer, who had an inkling

### "JAMMING" AGAIN!



Even if you find Egbert on a chair in the larder

about *Alpha Thunkii* in 1886 and gave Thunk the clue, let me in and parked me in the very den of Thunkism,



# THE LOCK-TUNE JUNIOR



**30/-**

W. 306/3.

**Complete with dial**

**Utility**  
**TUNED**

Again "Modern Wireless" designers have specified 'Utility' Condensers, this time for the "Lock-Tune" Three. For this fine 3-valve set the choice is Utility W. 306/3, our very latest fully screened condenser complete with trimmers.

This new condenser is so accurately made and adjusted that it is balanced within one half of one per cent. Never before has a British-made condenser with such a high efficiency ratio been available to the amateur, and he is now assured of the accurate hair-splitting tuning which is imperative if he wants to get the utmost from this circuit.

Remember then to insist on the new Utility complete with Disc Dial, the dial specially made for it.

The following represents the complete range of these wonderful condensers.

Semi-Screened		Totally Screened	
W. 305/2 2 gang	17/6	W. 306/2 2 gang	22/6
W. 305/3 3 gang	22/6	W. 306/3 as illus.	27/6
W. 305/4 4 gang	40/-	W. 306/4 4 gang	42/6
Disc Dial 2/6 extra,			

*Always insist on Utility Condensers, Dials and Switches, the finest in the World. Write for the new Catalogue showing the complete range.*

**WILKINS & WRIGHT Ltd. "UTILITY" WORKS, HOLYHEAD ROAD, BIRMINGHAM**

AGENTS.—London: E. R. Morton, Ltd., 22, Bartlett's Buildings, Holborn Circus, E.C.1. Scottish: E. B. Hammond, 113, Vincent Street, Glasgow. Lancashire and Cheshire: J. R. Lister, 93, Old Road, Blackley, Manchester. Westmorland, Cumberland, Durham, Northumberland, Yorkshire and Derbyshire: H. C. Rawson, Ltd., 100, London Road, Sheffield. Lawrence Fraser, Chelsea House, Lansdowne Road, Bath.



## "At 7.45 it Came In, Covered with a Top Hat"

the gloomiest and dustiest hole I have ever entered, barring my dug-out in Mesopot. in 1917.

If I were to describe the bloke's room you would rise up as one man and run me out of the club, calling loudly for Sanitas and large quantities of fresh air. I will therefore say only that it looked and smelt like a tomb of something buried in 1800 A.D.

### A SUITABLE STATION



He lugged forward an atlas and directed my attention to a pencilled point . . .

Every time I exhaled, nineteen ounces of dust were projected into the air. Every time I inhaled I drew in enough solid matter to ballast the Mauretania—pretty nigh—as Zillerbaumschnitzer would say. So I opened the window—I know that it had not suffered such an indignity since Prof. Huxley died—and fell to a perusal of the current number of "Punch."

### "It" Arrives

At seven-forty-five it came in, covered with a top hat, which it wore on the back of its head, and garnished with a frock coat which might have been the *dernier cri* in 1887. It had in its paws a fragment of glass; so far as I could make out it was the bottom end of a ginger-beer bottle.

"Ah, so there you are, my young friend. I have discovered that observation of *Alpha Thunkii* through this fragment of glass—observation, that is, of its *locale*—indicates that the star is really tripartite. I must work that out. I am disturbed—I am—but what have you been doing here?"

"Oh, amusing myself with 'Punch.'"

"Not—not drink?"

"Naturally not. I see none!"

"Er—you mean—er—Judy?"

"No—a humorous paper called 'Punch.'"

"Dear me, dear me! So there really *are* such things! Wonderful; wonderful! Now, what I wanted to see you about is this."

He drew up a chair and sat down facing me, his hands on his bony knees, which almost touched mine."

"From a few trifling calculations, made by me, on the nature of the rays emitted by *Alpha T.*, I have deduced that the aforesaid rays are—well, shall I say *corkscrew*, in their path; they double back on themselves at regular intervals of time-space. In order to test this I cast about for a practical means. That's where you come in."

### Arranging a Test

"Corkscrews? Well, I—"

"One moment! It is obvious that if a series of waves of the Hertzian type have superposed upon them my corkscrew Alphan rays, they will suffer intermittent weakening, or, in the extreme case, annihilation, whenever the Alphan rays reverse and oppose the field of the Hertzian waves. Is that clear?"

"But—"

"Very good! Now if you can fix up a transmission between two points which I shall indicate, one being in London, we can put this theory to the test at once."

"What is the other point?"

He lugged forward an atlas and directed my attention to a pencilled point bang in the middle of the Gobi Desert.

"That's absolutely out of the question," I said. "There's no station there."

"Tut! Most inconvenient and annoying. I have, however, a second position which would be suitable."

### The Selected Spot

He pointed to a spot in Germany where, as luck ordained, I had a regular correspondent in the form of an amateur named Hopper.

"I might manage that," I said.

"Good! Do so! Next Tuesday, at 9.31 p.m. Greenwich Mean Time."

"What wave-length do you require?"

"Metres, 0'0000013."

"Professor Thunk," I replied, "radio has not yet learned to deal with wave-lengths quite so short."

"Well, well—thereabout, thereabout!"

So I decided to teach him a lesson. We agreed that at 9.31 p.m. Hopper

was to emit C.W. signals in the form of a string of Morse "dots," and that reception should take place in Thunk's room, on apparatus installed by me. With the object of pleasing Thunk, I arranged with Hopper that the string of dots should be cut off for a second or two every few seconds. All well and good!

### "Zero" Hour

On the night agreed, I taxied the receiver round to Thunk's place and hooked it up. Old Thunk seemed pensive and preoccupied; hence his failure to offer me a spot of fluid nourishment. Preliminary signals from old Hop came over beautifully. At 9.31 p.m. G.M.T. the string of dots began. Ponk. Began again. Ponk. And so on. And so forth—as arranged.

"By gum!" I said. "It looks as if Alpha What-dye-call-it is doing the corkscrew biz all right."

Old Thunk listened in. Then he trotted to and fro several times, hands behind, just like Felix the Cat. Then he darted to his desk and began to do lots of algebra, tut-tutting at frequent intervals.

While I was listening-in, admiring the way in which Hopper was doing the job, old Thunk advanced towards me almost menacingly.

"Liar!" he screeched.

### THE FINAL "BUST-UP"!



... trotted to and fro several times—like Felix the Cat.

"I beg your pardon!" I returned. "I mean that I have just reminded myself that Tuesday is Alpha's day off. On that day he skedaddles into remote space and doesn't radiate a two-penny d—n. So it is evident that deception is at work."

"But—"

"Enough!"

"But—"

"Hence!"

So I henced. Cuss all astronomers!



EVERYTHING *The* **S.E.C.** ELECTRICAL  
*your guarantee*

# GECOPHONE

**THE LATEST FEATURES OF ALL-ELECTRIC RADIO ARE PERFECTED IN THESE TWO MODERN RECEIVERS**

**CONSOLE ALL-ELECTRIC RECEIVER  
FOR A.C. MAINS WITH BUILT-IN  
INDUCTOR DYNAMIC LOUDSPEAKER**

PRICE includes OSRAM VALVES and Royalty.

This new development combines, within a beautiful inlaid walnut console cabinet, the latest improved GECOPHONE 4-valve All-Electric Radio Receiver and the popular GECOPHONE Inductor Dynamic Loud Speaker — a mammoth achievement for modern radio requirements. The circuit and controls are similar to those of the "Table Four" (see below)

**HIRE PURCHASE.** Deposit £3.10.0 and 12 monthly payments of £2.8.6. Your dealer will give you full particulars.

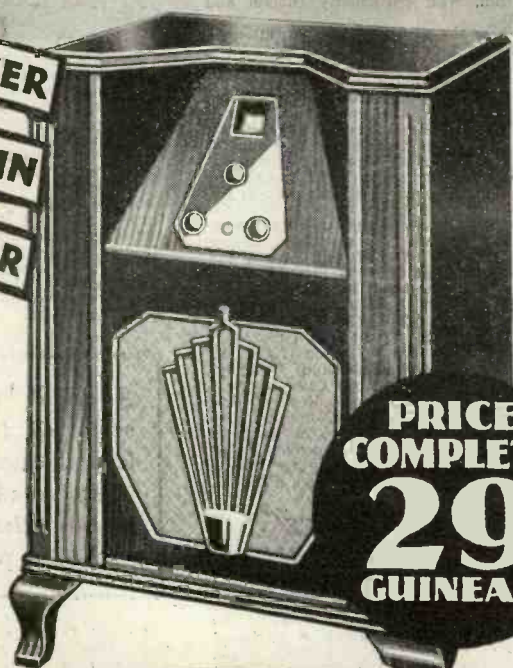

**PRICE COMPLETE**  
**29**  
**GUINEAS**

**TABLE FOUR ALL-ELECTRIC  
RECEIVER FOR A.C. MAINS**

PRICE includes OSRAM VALVES and Royalty.



**PRICE COMPLETE**  
**20**  
**GUINEAS**

**BRITISH PRODUCTS**  
*designed for*  
**BRITISH RADIO CONDITIONS.**

**WRITE** for folder BC5958, which fully describes and illustrates in colours the complete range of GECOPHONE Radio Receivers and Loud Speakers **SENT POST FREE.**

A magnificent new model in which two stages of High Frequency amplification give perfect selectivity. Special features include one knob tuning, local-distant switch, mains aerial device, 5-position switch controls waveband and radio-to-gramophone pick-up changes and mains switching. Walnut cabinet.

**HIRE PURCHASE.** Deposit £2.10.0 and 12 monthly payments of 33/-. Your dealer will give you full particulars.

**SUPREMACY IN RADIO — S.E.C. Radio**

*Advt. of The General Electric Co. Ltd., Head Office and Public Showrooms: Magnet House, Kingsway, London, W.C.2.*





There is rather a big pile of record releases this month, some being left over from last month, when you will remember that several makes had to be omitted from this page.

**BROADCAST RECORDS**

Among the smaller Broadcasts we picked out the following records for pick-up users: Just Two Hearts, a waltz refrain, and You Are My Heart's Delight, from the "Land of Smiles," sung by Sydney Hamilton (736). Selections from On With the Show (on 728), which is in dance rhythm, with particularly tuneful and snappy vim.

Sandy taking the part of the doctor, in Sandy the Doctor, gives Sandy Powell still further scope for his talent (728), while When I Met Sally at the Seaside, by Bobby Comber, repeats one of the most successful seaside hits of the summer season. The Riverside Dance Band play the Lights of Paris, and If You Are Really, Truly in Love, on 733.

The Gershom Parkington Quintet is as good as ever in old favourites on 5245, the Broadcast Twelve type of record; while the Viennese Light Orchestra plays Brahms' Hungarian Dances No. 5 and 8, on 5246 particularly well.

Later releases that we should mention among the smaller Broadcast records are these: Mellow and Bleh, on 763, in To You It's Only Ireland, and My Heart is Where the Mohawk Flows To-night (two sentimental duets), and the following dance numbers—For You and Roll On, Mississippi, Roll On, by Bidgood's Good Boys (757); Heartaches and One Little Raindrop (760), with Time Alone Will Tell and Maybe It's the Moon (759). All four being by Lew Sylva and his Band. Finally, A Perfect Day and Indian Love Call provide a couple of "sugary" organ solos by Reginald New on the Beaufort Cinema Organ (758); and two novelty items are to be found on 755 in Peter Dixon and Dick Anderson's solos on a steel guitar and handsaw respectively. The items chosen are: Dear Old Pal of Mine and Un Pen d'Amour.

**SUPER TWELVES**

Coming to the Super Twelves we find Roll On Mississippi, Roll On and Lazy Day, on 3072; Pardon Me, Pretty Baby, Tie a Little String Around Your Finger, by Jack Harris and his Grosvenor House Band, on 3078; while the Band of His Majesty's Welsh Guards, playing A Highland Sing-Song, with male chorus, is a lively record (No. 3071). With Madame Tussaud's Cinema Organ, the Manhattan Melody Makers play For You and I Found You, a waltz and a slow fox-trot, on 3079; while last, but not least, is the Harvest Festival Service actually recorded in the church of St. Mary-le-Bow, Cheapside, on 3076, which was released during the month of September, though perforce we have had to review it somewhat late.

And here are some of the latest Super Twelve releases. Bob and Alf Pearson—those popular duettists—provide us with two more of their inimitable recordings: I Wanna Sing About You and Whistling in the Dark (3098), the latter being a particularly attractive number.

Those who recollect the earlier musical shows will revel in the San Toy selection, on 3095, in which the Band of H.M. Life Guards revive some of the famous and tuneful airs with which that famous show was full.

Plenty of attractive dance numbers are on the latest "Super" list. Here is a selection. Honey-moon Lane and This is the Day of Days (3103), The Manhattan Melodymakers; while the same combination have recorded I'm an Unemployed Sweetheart and There's Something in Your Eyes, on 3102.

Two discs by Jack Harris and his Grosvenor House Band are worth mentioning. These are 3100 and 3101, and contain these numbers: I'm Sitting at a Table Laid For Two, Just One More Chance. You're My Heart's Delight and You Can't Stop Me from Lovin' You.

**COLUMBIA**

One of the best of Jack Payne's variety novelties has been recently released by Columbia, this

being entitled My Brother Makes the Noises for the Talkies, and is coupled with Skinamalink, the Sergeant, another variety number which is well known to listeners.

Other dance numbers of note are: Tell Me, Darling, and Cupid's Army, by the Berliner Dance Orchestra, on CB325; and I'd Rather Be a Beggar With You, and I'm a Hundred Per Cent in Love With You, by Jack Payne and his B.B.C. Dance Orchestra, with vocal chorus by Jack Payne, on CB310.

Then we have Mr. Flotsam and Mr. Jetsam in Sing a Song of England, on CB559. A very fine record.

**H.M.V.**

A particularly interesting record by Marek Weber and his Orchestra has been made of a collection of famous melodies, and is an excellent recording. Gracie Fields sings a couple of songs from "Sally in our Alley," entitled Fall in and Follow the Band, and the theme song, Sally. Be sure to hear this record. Gracie also has done another record called Only a Dancing Sweetheart.

Another even more famous songster is Maurice Chevalier, who has again been recording, and this time he has done Bon Soir—Good-night, Cherie, and Mama Inez, on B.3923. We do not care for Maurice Chevalier's recordings particularly, as they seem but a shadow of himself as he appears on the screen, and somehow or other he doesn't seem to get over on this record. The recording is as good as usual, however.

A brief selection from some of the records released during the month. They have been chosen because of their special value to the pick-up user.

An old favourite amongst dance friends is Gene Austin, and gives us I'm Through With Love and Without That Girl, on B.3922—an excellent record.

And now for the dance records. First of all we have a record by that famous dance band, probably the most noted in the world and certainly on this Continent, Jack Hylton's. He has chosen a tango, O Cara Mia, and a fox-trot, O Glory, both with vocal refrain, and these are recorded on B.6045.

The High Hatters are an extremely interesting combination, and play Just a Blue-eyed Blonde, and on the other side of this record Rudy Vallee and his Connecticut Yankees play Two Little Blue Little Eyes. The same combination play Just Your Lover, and My Cigarette Lady; while the bolero, Speak Easy, is played by Wayne King and his Orchestra, coupled with a Rumba fox-trot, Sidonie, by Alfredo Grigo and his Sidonie Orchestra. These are both weird tunes with a peculiar rhythm of the modern dance.

The New Mayfair Dance Orchestra plays Only a Dancing Sweetheart and There is Something in Your Eyes, tango fox-trot, on B.6056. This latter band is H.M.V.'s own special combination and is particularly well balanced, which is perhaps only to be expected for recording purposes.

An ever-changeable programme, with something for all tastes to enliven the long dark evenings, is provided by the October output of "His Master's Voice" records.

To begin with there is Dvorak's popular Symphony No. 5 in E Minor, rendered by that superb assembly of artists, the Philadelphia Orchestra, conducted by Stokowski. While Dvorak, the genius son of a Czech innkeeper, was director of the New York Conservatory of Music nearly forty years ago, he wove into his themes the spirit of airs which breathe of the vastness of

the new world, the nobility of nature untouched by the cities of commerce.

Another gem is provided by the Vienna Philharmonic Orchestra in Pique Dame, sparkling with the gaiety of Suppé, a disc to be treasured for frequent use; in fact, one cannot open the evening's concert with more captivating effect.

There is no combination more suited to give us the waltzes of the Strauss's than Marek Weber and his Orchestra, and real soothers after the day's toil are found on C.2198, a Fantasia on Melodies of Johann Strauss, and DB.1543, Fragments from "Der Rosenkavalier."

From "Viktoria and Her Hussar," the musical play which has taken Europe by storm, several tit-bits have been chosen. Marek Weber's band makes us joyful with their glowing reading of the selection. Jack Hylton culls waltzes and fox-trots and Raie da Costa reveals what the piano can do with Following the Drum.

Of the vocal items one must not miss Bockelmann's magnificent singing of the Cobbling Song from the second act of the world's greatest musical comedy, "The Mastersingers." Pertle will be popular with Naples, Your Song is Everywhere, from the film "City of Song," which remains a huge success. He also gives A Dream of Capri, while Derek Oldham adds two more Italian numbers, For Ever and For Ever (Tosti) and 'Tis the Day, by Leoncavallo.

Peter Dawson, still far away in person, is yet with us in voice. In Song of the Tinker he is the cheery citizen of the open road, and with Gypsy John he exactly suggests the rough-and-ready hospitality of the caravan.

To end on a comic note we have those good companions, Alexander and Mose, who air their quaint conception of things in the duologues, Fish Sauce and Auto-Suggestion.

**ZONOPHONE**

We hear from the Zonophone Company that their sales for September were 200 per cent above the sales for September, 1930, due to the recent price reduction. Everyone is taking a keen interest in records at the moment, and the Zonophone list for October will make them even more interested.

The first record, No. 5941, is a selection by the London Orchestra from the famous White Horse Inn, which has been playing in London for many months and is said to be London's most successful musical show. This selection has been carefully chosen and the playing is brilliant.

Next we have two well-known B.B.C. "stars"—Megan Thomas and Herbert Thorpe—singing two popular songs of the moment, which are quite away from their usual serious style, and they make a very good record, too: Hawaiian Stars are Gleaming and I'll Keep You in My Heart Always (5943).

The Salon's version of the "hit" You are My Heart's Delight, should not be missed; and coupled with the waltz from Bitter Sweet it can be thoroughly recommended to all those who are fond of light music charmingly played (5946).

The new Zonophone "stars"—Jack and Jill—have recorded another record of two very popular songs. Their first record—No. 5932—was a great success, and if you have not yet heard it you should get your dealer to play them both over to you. The new one is 5948, Faithfully Yours and I Love You More and More.

Another record which ought to sell well is a real "sentiment" number with a "hot" accompaniment in real "Western" style: My Heart is Where the Mohawk Flows To-night and Rocky Mountain Lullaby, by Bud and Joe Billings (5951).

Four dance records were issued, numbers and titles as under: Blaze Away and Twilight Waltz, Orpheus Dance Band (5952). When the Moon Comes Over the Mountain and By the River Sainte Marie, Arcadians Dance Orchestra (5953). Pardon Me, Pretty Baby and Two Heads in the Moonlight (5954). I'm a Hundred Per Cent in Love and If You're Really and Truly in Love, by the Rhythmic Eight (5955).

All are excellently played, but the two which we think contain the most attraction are Nos. 5952 and 5954. These are played with good effects and fine tempo, and the orchestration is noticeably well done. All these records are excellent value for 1s. 6d. each, and are thoroughly recommended to everyone—there being records in this list to suit all tastes.

**NEXT MONTH**

**SPECIAL XMAS NUMBER**

On Sale December 1st.



# THE NEW TUNGSRAM POWER DETECTORS PD220

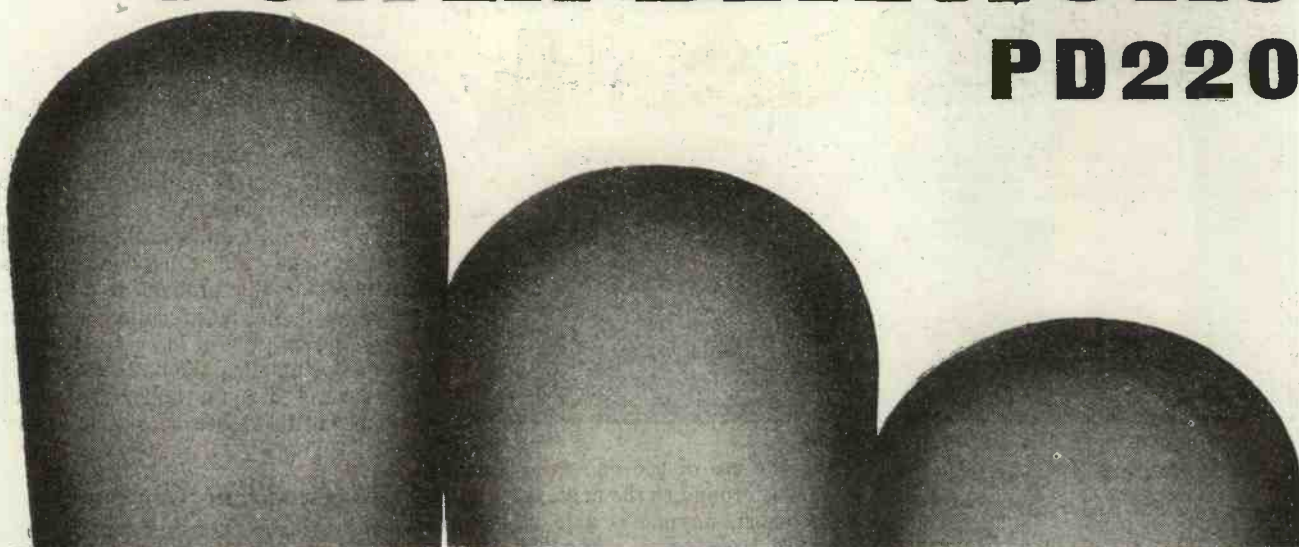

# TUNGSRAM BARIUM VALVES

T.3123

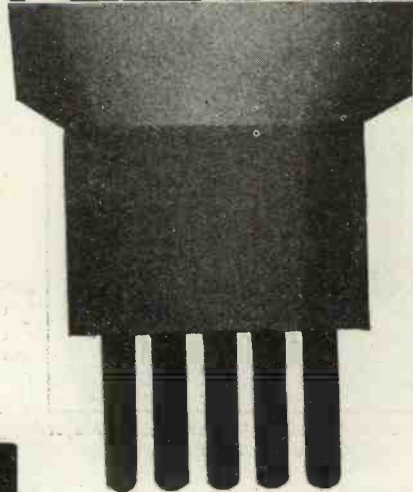
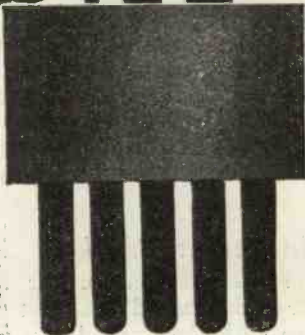
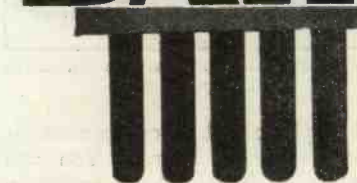

Here are three types from the complete new Tungsr-  
ram range, particularly suitable for portable receivers:  
PD220, a new and specially designed anti-micro-  
phonic detector valve; P220, a new and extremely  
efficient low current consumption power valve;  
L210, an entirely new valve which is mainly  
suitable as detector or first low-frequency amplifier.  
Characteristics are given below.

Type	Fil. Volts.	Fil. Amps.	Max. H.T. Volts.	Amp Factor.	Anode Resistance (Ohms).	Mutual Cond. m/a V.	Price
L210	200	.1	200	16	16,000	1.0	5/6
PD220	200	.2	150	17	10,000	1.7	8/3
P220	200	.2	150	9.5	3,200	3.0	7/9

Write to Dept. S.T.2 for full particulars of the complete new range. Prices from 5/6 to 19/-.  
Tungsr-ram Barium Valves are manufactured under one or more of the following Patent  
Nos.: 289,762, 289,763, 311,705, and 313,154.

**TUNGSRAM ELECTRIC LAMP WORKS (GT. BRITAIN), LTD.**  
Radio Department, Commerce House, 72, Oxford Street, London, W.1

Makers of the famous Tungsr-ram Electric Lamps.

Branches in Birmingham, Bristol, Cardiff, Glasgow, Leeds, Manchester, Newcastle,  
Nottingham, Southampton.

Lamp, Valve and Glass Factories: Austria, Czecho-Slovakia, Hungary, Italy and Poland.  
I.F.S. Organisation, Tungsr-ram Lamps & Radio, Ltd., 11, Burgh Quay, Dublin.  
Tungsr-ram photo-electric cells: Nava "E" (for scientific measurement), £2 17s. 6d.;  
Nava "R" Red sensitive cell (for colour matching devices), £3 3s.; Nava "EH" (for  
talkie work), £3 13s. 6d.



## THE NEW 2 VOLT SUPER DETECTOR AND POWER VALVES



By the  
*Technical*  
*Editor*

# On the



## "Instamat" Output Transformer

THE name "Instamat" is derived from "instant matching of valve and speaker." "Instamat Major" is intended for use with moving-coil loud speakers and its primary will carry up to 150 milliamperes of D.C. without appreciable loss through saturation. It has a pri-

### FOR MOVING COILS

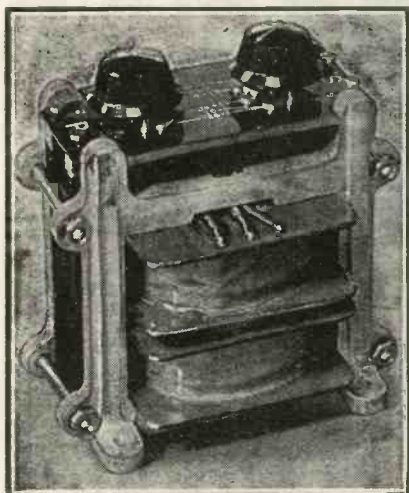

The Ready Radio "Instamat" Major Output Transformer.

mary resistance of only 40 ohms, while that of the secondary is a mere 2 ohms.

The weight of the component is four pounds, and the price 37s. 6d.

The special feature is that by means of two switches a choice of ratios is made immediately available without the necessity of removing a single wire. This renders it possible to carry out the adjustments so that the ear does not forget the sounds resulting

from the use of the one ratio before you swish round to the next.

In short, anyone is able with the greatest ease "instantly to match" any set output to any set.

The "Instamat" undoubtedly does fill a vacant niche, and many amateurs will no doubt welcome it with open arms. Judged as an output transformer alone, it is nothing less than an achievement, as the above characteristics reveal, while the addition of ratio switches gives it great practical value.

It is well made, and the results it gives literally speak for themselves. It is only when you are able to change ratios quickly in such a manner that you realise how important it is to match valves and loud speakers, and how essential for good results is a device of the nature of the Ready Radio "Instamat" Major.

### Ingenious Brackets

The Formo versions of our P.J. coils are constructed in exact accordance with the original specification, and are particularly well made.

Constructors will find the neat little brackets which are supplied render it a simple matter to mount the coils either vertically or horizontally on a baseboard.

These brackets are fashioned from wood, and are so shaped that they can be fitted either inside or outside the coil former, as shown in the accompanying photograph.

### New Ferranti Choke

The Ferranti B.8 choke is designed for general-purpose use, and can be employed for smoothing in a

mains unit or as an output choke in a set.

It has an inductance of approximately 17 henries, and can handle up to 45 milliamperes.

In view of its indisputable technical merits, and the reputation of its makers for the production of high-class, reliable radio components, it is, at the list price of 7s., very excellent value for money. We have used B.8's in several designs, and have found them entirely satisfactory in every way.

### An Excellent Component

We recently received one of the Utility Two-Gang condensers, and a

### P.J.'s BY FORMO



Formo's version of our new medium-wave coil units.

photograph of this component is included in these pages. You will see that it is of the completely screened variety.

Trimmers are provided for each

### AN ALL-PURPOSE CHOKE



The Ferranti B.8 L.F. smoothing and output choke.



# Test Bench

*Our impartial reviews this month mainly concern certain Ready Radio, Formo, Ferranti, Utility, R.I., and Atlas components and accessories.*

section, and these are simple to adjust and can quickly be locked rigidly at the desired settings.

The design of the "Utility" Two-Gang is on scientifically compact lines, and we find the matching of the sections to be precise. It is a cleanly-constructed component and, both electrically and mechanically, is right up to the usual high standard maintained by Messrs. Wilkins and Wright.

## THE "UTILITY" GANG

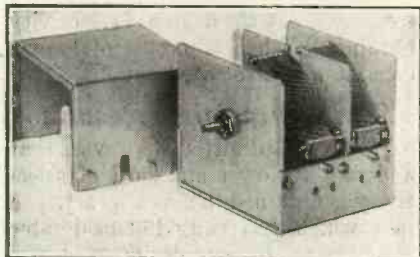

It is completely screened and is particularly useful for band-pass sets.

## Four Atlas Mains Units

We have received and thoroughly tested four new "Atlas" mains units. These are: Model A.2, an H.T. unit (for the smaller and medium types of sets up to three valves or so). It has three tapings, giving 60/80, 90/100 and 120/150 volts.

Model A.K.22 is similar, but incorporates in addition an L.T. trickle-

charger for charging 2-volt accumulators at 3 amperes.

Model A.C.244 is for larger sets, and has a total current output of 20 m.a. at 120 volts. There are three tapings, one of which gives up to 150 volts. Another of these tapings is usefully variable between 50 and 90 volts.

Model A.K.260. This has the same H.T. arrangements as A.C.244, but includes a trickle-charger for 2-, 4- or 6-volt L.T. accumulators.

The prices of these new "Atlas" units are remarkably reasonable, and all are available on the hire-purchase system.

Their designs are perfectly sound, and they are as neat and compact in appearance as any units we have seen.

On test we found their outputs to be right up to specification, and the smoothing decidedly good.

They are obviously constructed in strict accordance with the I.E.E. recommendations, and are built into stout but attractive and well-ventilated metal cases. We can certainly recommend their use with "M.W." sets.

## The R.I. "Dux"

One of the most important innovations of the season is the inexpensive "DUX" L.F. transformer which, while

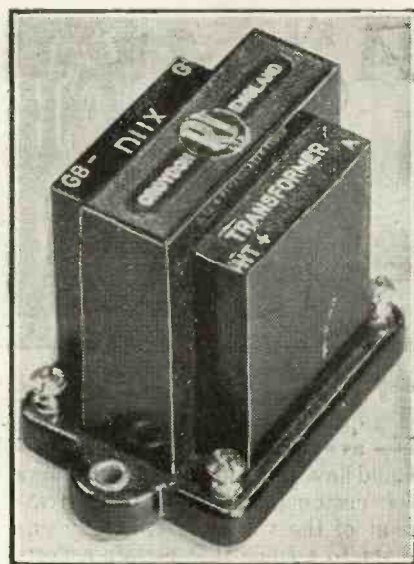

"DUX"—R.I.'s new L.F. Transformer.

retaining the full R.I. standard of design and construction, retails at the remarkably low price of 6s. 9d.

Despite its extremely attractive price, it is given a first-class finish, and is built into a high-grade bakelite casing.

It has a good primary inductance and a low self-capacity, and the results it gives are equal, if not superior, to many L.F. transformers selling at a higher price.

There is no room for doubt at all but that the R.I. "Dux" is a perfectly sound proposition, for laboratory tests are amply confirmed in practice.

We have used the "Dux" in several set designs, and have found it a completely satisfactory component.

It is a general-purpose transformer, and can be used directly in anode circuits, as it can handle up to 5 milliamperes D.C. without saturation troubles.

## Here is the Range of New "Atlas" H.T. Mains Units

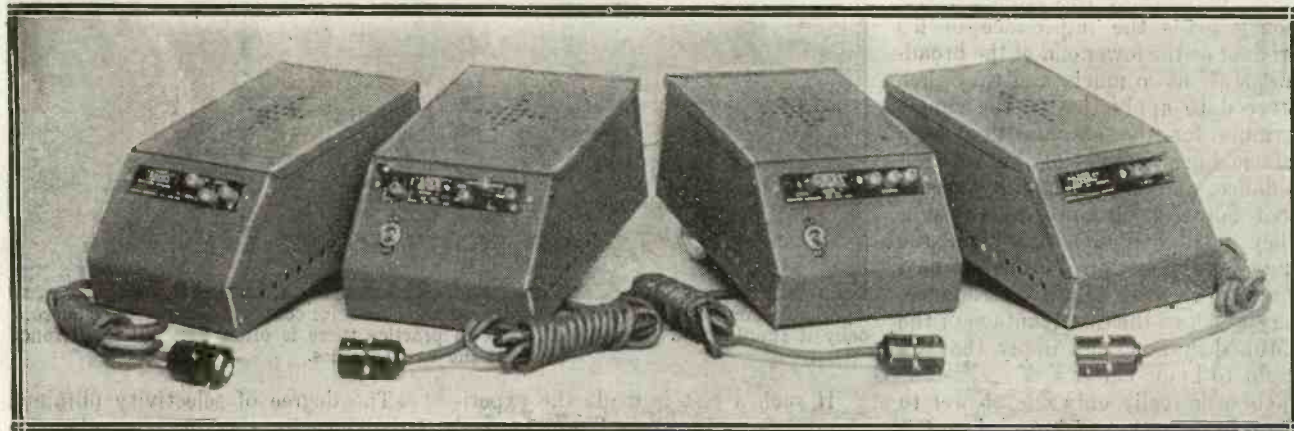

The four new Clarke's "Atlas" mains units to which reference is made on this page. From left to right they are the A.C.244, A.K.260, A.K.22, and A.2.



# A "SCREENED-GRID" FALLACY?

Is the screened-grid valve, after all, quite such a simple proposition as the "theory merchants" would have us believe? If one follows the customary mathematical treatment of the valve too trustfully one is apt to assume that certain aspects of its use are absolutely cut and dried, yet experimental work conducted along certain lines with an open mind is bound to bring phenomena to light which arouse grave misgivings.

### What Readers Say

For example, there is the question of the use of an untuned intervalve coupling. In this method, an H.F. choke forms the coupling device between the screened-grid valve and the succeeding stage, and the scheme has certain advantages which render it very suitable for some specialised types of receivers.

Whenever we use this method in a MODERN WIRELESS set design we know perfectly well in advance what is going to happen. There will almost certainly arrive a number of letters from readers who have been delving into the simpler mathematical theory of the valve, wanting to know why on earth we do it!

### A Gentle Hint

They usually point out that the maker of some particular H.F. choke of more or less standard efficiency gives the impedance of his product at the lower end of the broadcast scale as so much, and they then proceed to apply this to the simple formula for the amplification of a screened-grid valve of known impedance, and show that only a very poor figure is obtained as a result. They next compare this with the amplification obtained from a tuned coupling of good dynamic resistance, very much to the disadvantage of the untuned system, and imply that we ought to know better.

There is really only one answer to make to enquiries of this kind, in the form of a gentle hint that perhaps, after all the theory of the valve is

*Theory and practice do not always go hand in hand, a fact which is strongly emphasised by certain aspects of the working of S.G. valves in regard to magnification and selectivity. Some particularly interesting possibilities are suggested in this article.*

not quite complete, and, therefore, perhaps it would be a good idea to try out the two systems side by side and make an experimental test on their relative merits.

This is not a very easy experiment to carry out quantitatively, because there are so many factors of a variable nature (the effect of feed-back, for example), but even a rough aural test on a weak distant transmission is apt to be very illuminating.

methods is considerably less than he has been led to believe. It is so much less, in fact, that the open-minded experimenter cannot fail to be left with considerable doubts as to whether the mathematical treatment of the problem is, after all, a safe guide.

Then, again, there is the question of selectivity. From the published characteristics of a screened-grid valve it should be possible to predict with some accuracy the degree of selectivity obtainable when a circuit of known constants is associated with it.

### Some Surprising Results

It is now admitted, however, that a definitely lower standard of selectivity is obtained in actual practice, a fact which has caused considerable puzzlement to set designers for a long time past.

### THE QUESTION—TO TUNE OR NOT TO TUNE?

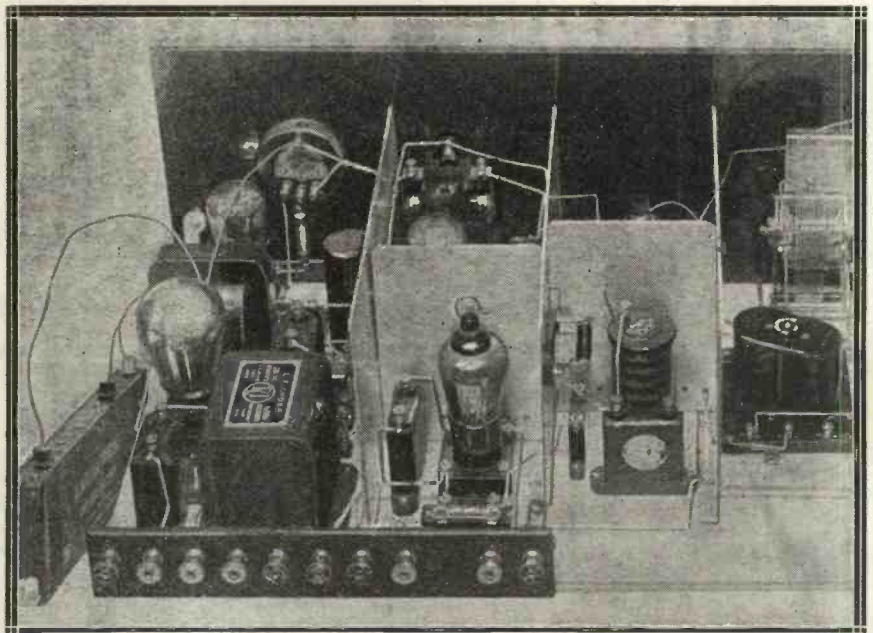

Aperiodic coupling is often used instead of a tuned circuit for coupling S.G. valves. Theoretically it should be a "wash-out," but in practice there is often very little difference between the two schemes.

If such a test is made the experimenter is more than likely to find that the discrepancy in actual magnification which he gets by the two

The degree of selectivity obtained with circuits theoretically adequate has been found to be well below the standard desired, and various



# "WE CONGRATULATE Varley ON THEIR NOTABLE DEVELOPMENTS"

"We congratulate Varley on their notable developments," says a leading Radio Weekly, in reviewing the new Varley Components illustrated on this page.

They are technically suitable products. To meet present-day requirements . . . and present-day pockets.

Build Varley quality into your set.



### NICHOKS II.

The latest addition to the range of VARLEY L.F. CHOKES. Compact, highly efficient and suitable for all ordinary purposes — as Smoothing Choke, Output Filter Choke, etc. Inductance, no D.C., 20 Henries. With 50 m/A D.C., 14 Henries. D.C. Resistance, 450 ohms.

List No. DP 23.

Price **10/6**

## WORTHY COMPANIONS OF THE "SQUARE PEAK" (REGD. TRADE MARK) COIL

### JUNIOR MULTI-CELLULAR H.F. CHOKE

Chokes efficiently on both wave bands, either in Detector or H.F. Stages. Inductance 120,000 microhenries. D.C. Resistance, 350 ohms.

List No. BP 2.

Price **3/6**

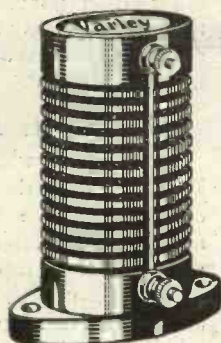

### "TAG RESISTANCE"

Spiral wire-wound. Compact. Can be soldered direct to receiver wiring. 22 different values from 100 to 100,000 ohms.

Prices **1/- to 2/-**

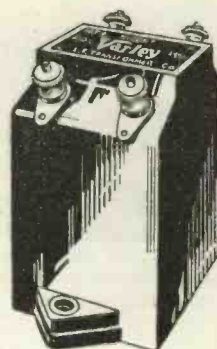

### NICLET L.F. TRANSFORMER

Primary inductance 45 henries with no D.C. Ratio  $3\frac{1}{2}$  to 1. Primary will carry D.C. current up to 5 m/a. When resistance fed ratios of 2.5, 3.5 and 4.5 to 1 are obtainable.

List No. DP 21.

Price **7/6**

# Varley



## Are Those Impedance Figures Misleading?

expedients have been adopted in order to overcome the difficulty. These expedients have mostly been thought undesirable from the point of view of maximum amplification, and they have consequently been used rather shamefacedly as a sort of necessary evil.

For example, where H.F. transformers have been used for intervalve coupling the primary size has been cut down below the theoretical optimum from the magnification point of view; where tuned anodes were employed the screened-grid valve has been tapped across only part of the circuit, and so on.

### A Distinct Discrepancy

Returning to the question of amplification once more, a distinct discrepancy is often noted when intervalve coupling circuits of varying dynamic resistances are tried. It is one thing to prove mathematically

change of the dynamic resistance of the circuit as a whole, but these explanations have not been very convincing.

Such phenomena as the improvement in the resonance curve of a circuit, and so on, can be made to give a very fair idea of the change in its dynamic resistance, yet the change in the amplification obtainable with a given screened-grid valve does not seem to keep pace with the requirements of theory

### The Unknown Factor

Here again one is left with an uneasy feeling that surely there must be some unsuspected factor at work in the screened-grid valve which invalidates, at least to some extent, the usual simple calculations for the amplification of a stage. What that factor may be we are now beginning to suspect, but it is proving an extraordinarily difficult matter to

tuned-anode coupling with a screened-grid valve, and find that our selectivity is below expectations.

An easy way out is to tap the screened-grid valve across only a portion of the tuned-anode circuit. For example, we might include only one half of the coil in the screened-grid valve feed circuit. This is easily done with a centre-tapped coil, and what we notice then is usually that there is a perceptible improvement in selectivity, while the amplification obtained from the stage is not cut down in the way which we should have expected!

### Exceeding Expectations

Assuming that we can predict fairly accurately the dynamic resistance of our coupling circuit, we think we know the impedance of our screened-grid valve, and we can estimate therefrom the effect of the tap on the circuit. Suppose that we note now the results we are obtaining and then try a smaller tap on the coupling circuit, say a one-third position.

We can now predict again the results we should obtain, but if we try to confirm our expectations in practice we are very unlikely to be able to do so. In practice we are pretty sure to find that we are getting distinctly better amplification from our stage than we had hoped for.

From our knowledge of the characteristics of the typical screened-grid valve these results are distinctly unexpected, and in conjunction with the other discrepancies we have noted they go a long way towards confirming our suspicions that some disturbing factor is present.

### What Is Its Impedance?

To sum up, what we find is this. When we cut down the intervalve coupling with a tuned system the amplification obtained per stage does not fall off so rapidly as we should expect. Now, this is what might happen if the impedance of our valve is not so high as we should imagine, and here we begin to see a possible explanation.

The valve really behaves as though its impedance under working conditions was very considerably lower than the sort of figure we have commonly used for our calculations. It is definitely being suspected by many authorities nowadays that as soon as

(Continued on page 522.)

THE DET. PEN. SET'S OUTPUT

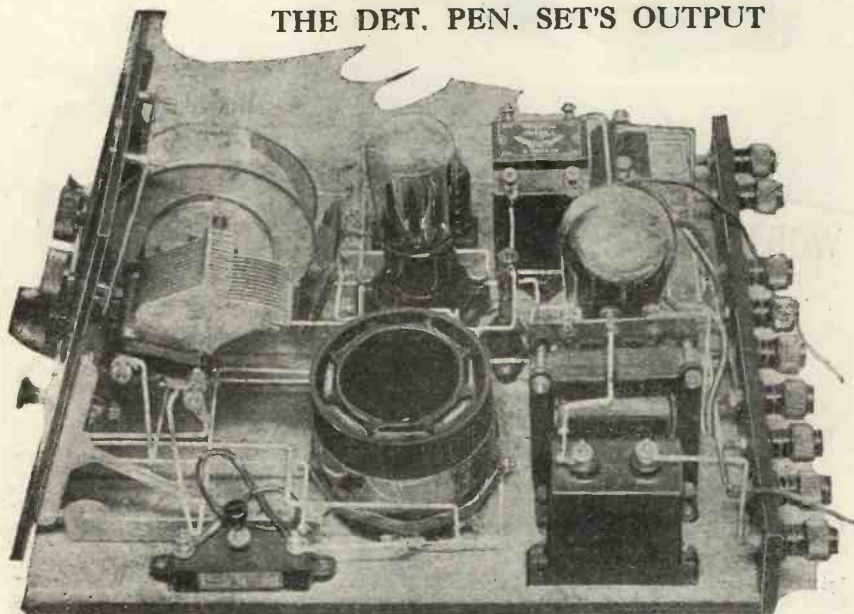

Theoretically the pentode should have a very high impedance output circuit. But in practice it is found that the impedance drops quite considerably when under load, and good results are thus obtainable with only moderate impedance output arrangements.

that a certain improvement in amplification should be obtained with circuits of low H.F. resistance, which means high dynamic resistance, and quite another to demonstrate that improvement in actual practice.

Attempts have been made to explain this phenomenon by pointing out that a lowering of the H.F. resistance of the coil concerned cannot be taken as a safe guide to the

investigate, either practically or mathematically, and so far no really authoritative treatment is available.

### Taps and Selectivity

Before we consider what this mysterious factor may be, let us consider another experimental observation and see that it does not lead us round to the probable cause of our difficulties. Suppose that we are employing a



# WHERE CONSTRUCTORS — SCORE —

By  
the Chief Engineer  
of a Leading Radio  
Firm

*Invidious comparisons are often drawn between home-constructed and commercially-made receivers. But such comparisons do not take into account the enviable position of the amateur when it comes to making up a set to suit certain conditions and requirements so that maximum efficiency shall be obtained. Read in this article how the unfortunate manufacturer strives to make his sets appeal to all customers.*



**H**AVE you ever considered what an enormous advantage you, as a home-constructor, have over the commercial radio manufacturer? (If you are not a home-constructor you are supposed not to be reading this.)

## Better Results

Having just finished your latest "M.W." receiver, and found to your triumph that you are getting better results than old — next-door, who paid twice as much for his set at a shop, you are inclined to put down the mediocre performance of the factory-built set to mere incompetence on the part of the manufacturer. That is not necessarily the case, for there are other reasons, so spare a few moments to pity the poor professional and then congratulate yourself on your good luck. The radio manufacturer not only has to cope with differences of taste and financial resources, but also with widely differing local conditions which are not understood by the non-technical buyer, who suspiciously regards them as the invention of the salesman, devised to cover up the deficiencies of the set he is offering.

## A Difficult Problem

A resident in the immediate neighbourhood of Brookmans Park, for instance, may be roused to fierce anger when he has put down his first instalment on a set selected on the strength of a glowing testimonial from a customer in Norfolk ("original to be seen at our office") if he finds that Jack Payne is invariably accompanied by a cathedral organ, while he cannot hear Graz at all. If the radio manufacturer satisfies his requirements by making the set super-

selective, a customer in Inverness complains that he has banged a whole lot of saxpences and the machine is so sharp it does not give him anything.

If the set is a long-range one it costs far too much, for "Angus Macpherson has a rare wee machine with the aerial connected straight to the grid of the detector that gets him everywhere, and it is cheap, mind ye." So the manufacturer designs a receiver with switches and knobs all over it so that wherever the customer lives he can make it suit his own requirements.

turer to the point of suicide, or to unlawful language, according to his temperament, it is special or "different" orders.

## Very Expensive

It is difficult for those who have not seen the organisation necessary to turn out sets in a manner satisfactory to Mr. Philip Snowden to realise how profits vanish—or, more likely, become a negative quantity—the moment the standard specification is departed from in the most trifling degree.

## SPENDING MONEY TO SAVE MONEY

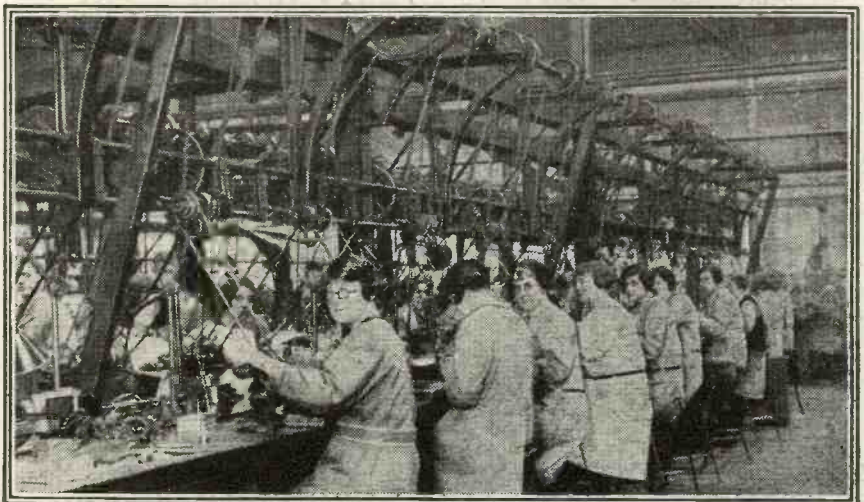

The essence of mass-production is to spare no expense to save money. That may sound a bit "Irish," but, as the author explains, the more times a given thing has to be done the more one can afford for machinery which will save time over the operation.

He then gets letters worded in strong language pointing out that there are too many controls, and it should be made simpler and cheaper and easier to understand. And if there is one thing more than another which drives a harassed manufac-

That is one fundamental law of manufacturing, and another is that to produce at the lowest price the factory must work at the same rate all the year round. Now, in this country there are several times as many sets bought in the winter as



in the summer; consequently a factory which is big enough to cope with the winter demand is more than half idle in the summer.

A business costs nearly as much to run when it is slack as when it is busy, and as the expenses have to be distributed over a smaller number of articles, the cost per article goes up. But, fortunately, there are other countries which can take the sets manufactured in the summer, so one way of keeping the works busy is to export.

**Building for Export**

The radio manufacturer who tries to do his bit to keep the country's export trade going finds that the local station in Patagonia is about 1,000 miles away. And it works on a different wave-length from anything known in Europe.

The same applies to Central Africa, with the addition that any aerial more than a few inches long gets struck by lightning, there are no electric mains or charging stations, batteries have a life of about a week owing to the moisture and heat, and special precautions have to be adopted to render the apparatus unsuitable for ants to nest in. These technical obstacles having manfully been overcome, the result is an appliance totally useless for, say, Paris or for Madrid.



**EVERYTHING  
MUST  
BE TESTED**

Probably the only way in which the manufacturer scores over the home constructor is in that he can afford expensive testing apparatus so that no faulty components need find their way into completed receivers. Here we see coils being tested in the R.I. factory.

Contrast your own position. You have hundreds of constructional articles to choose from, covering almost every conceivable variety. But, even

so, you need not stick rigidly to the specification.

**Everybody Does It!**

Of course, all the best people do, and to depart from the instructions is very wrong, really. All the same, if you do have a special fad you have more chance of making a success of

fied if necessary to suit their conditions. But that method is disappearing.

For one thing, it is natural to grudge the money spent in buying components and providing profits for the manufacturers of them. Then one is at the mercy of those manufacturers, for if any one of them fails

**HOW OVERHEAD CHARGES MOUNT UP**

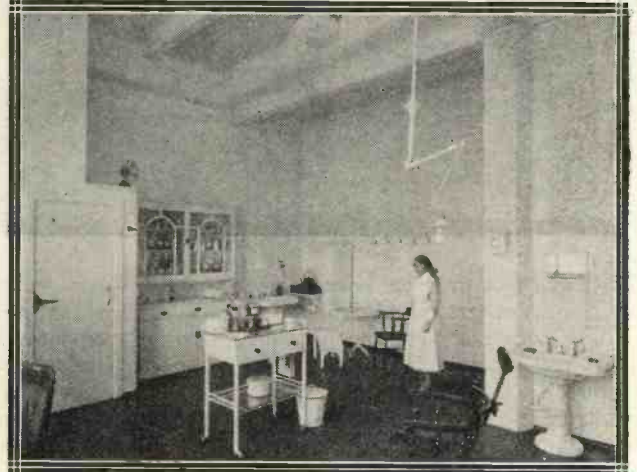

The greater the mass-production the lower the cost of production, but at the same time the "outside" expenses go up, for more must be spent for the benefit of employees on such items as this "Ambulance" Room at the Ferranti Works, which is also a completely equipped dental clinic.

it by carrying it out yourself on the constructional design that comes nearest to it than in trying to persuade a manufacturer to alter his goods to suit you.

to deliver the proper quantity it stops the whole production.

**An Unknown Quantity**

If business is better than was anticipated it is very difficult to persuade all those suppliers to increase their deliveries just at the time they are at their busiest, and if business is bad there is a surplus stock to pay for. Moreover, the manufacturer of one of those components may suddenly take it into his head to improve it, but it may not improve the set in which it is incorporated; it may render it unsaleable.

The most important objection to this method is that those who depart from it, and design their sets as a whole and produce them as a whole, are able to cut out a lot of the most expensive work and produce much more cheaply. True, mass production of radio has hardly commenced in this country.

**Mass Production**

They have had it for several years in America, where it is common for one factory to turn out several thousand sets a day—seven or more valve sets with moving-coil loud speakers, not "threes" or portables—but conditions have not encouraged that sort of thing here. Still, it is moving that way, and a number of firms are nearly there.

There are some radio manufacturers who are home-constructors on a large scale. That is to say, they buy standard components and assemble them according to a design they have obtained from somewhere else, modi-



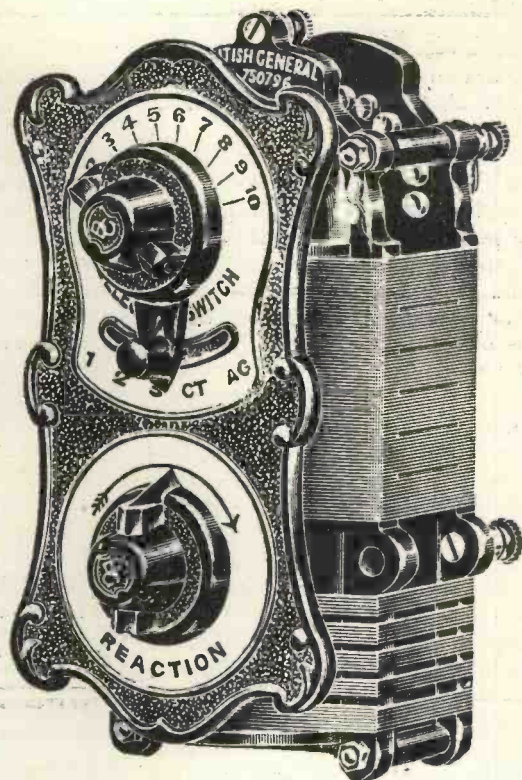

# BRITISH GENERAL

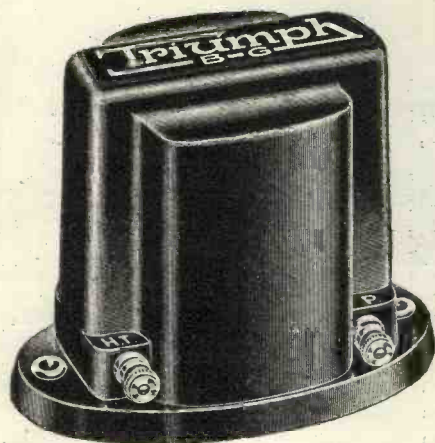

The designer of this remarkable circuit in choosing his components has taken *two* of the famous BRITISH GENERAL range—a tribute to the high opinion in which the products of this firm are held by experts and public alike.

**AERIAL TUNING UNIT.** (As illustrated above.)

Which is a revelation in Tuning-Unit efficiency and design, entirely replacing the old-fashioned coils, and gives "knife-edged" selectivity and covers the entire wave-band from 200 to 2,000 metres on one dial.

Price **14/6**

**TRIUMPH TRANSFORMER.** (As illustrated here.)

A triumph of design, engineering and performance, produced at a remarkably low cost, which has been made possible only by utilising the very latest methods and materials.

Ratio  $3\frac{1}{2}$  to 1 Price **5/-**

**BAND-PASS 10-kc. TUNING UNIT.**

A new achievement in Band-Pass Filters of which we are proud. Interference is entirely eliminated and selectivity (however difficult local conditions may be) is guaranteed. Descriptive literature on application.

Price, including non-inductive coupling condenser, **14/6**

From all Dealers of repute, or direct from the Manufacturers:

**BRITISH GENERAL MANUFACTURING CO., LTD., Brockley Works, London, S.E.4**



## The Wires Cut and Bent to Shape by "Jigs"

The essence of mass-production is to spare no expense in saving money. In case that sounds a little "Irish," let me explain.

If you are going to lick one stamp to stick on a letter, you would need no appliances or machinery other than that provided by Nature. If you have a hundred letters to stamp, you would think it worth the trouble of getting a saucerful of water and a piece of rag.

### An Analogy

It would not be worth it for one stamp, but if there are a hundred stamps only a one-hundredth part of that trouble is expended on each stamp. If you have a thousand letters a day to stamp you would go farther and make use of a piece of machinery which costs more than very many stamps; but as it is capable of franking millions of letters, the cost allocated to each one is negligible in comparison with the amount of time saved.

In the same way, if you are making a single receiver at home, a screw-driver or two is as much as it is economical to provide for the purpose. The small manufacturer finds it worth while to buy a few machine tools—coil-winding machines and other labour-saving devices—while the true mass-productionist spends a vast sum on a new model before he has manufactured a single set.

However, if somebody invents a new valve with twelve electrodes, called a duodecode, which makes his design obsolete before many have been sold, he is, in vulgar parlance, in the soup!

### Big Initial Outlay

But what sort of preparations are necessary to cost so much? Well, obviously a large factory is required for a large output; but we are assuming it is a new model which is being put in hand, not a new business, so a factory will already be in existence. Also, it will have been necessary at one time to spend quite a lot on research laboratories and equipment in order to arrive at a design which is *not* likely to become obsolete too soon.

One of the most troublesome parts of a modern receiver for an amateur to make would be the metal framework or chassis. As a matter of fact, the hand-made samples which a

manufacturer produces beforehand in order to see whether he and others like the look of them cost him a lot of expense and trouble.

But when he gets going he can turn out dozens of chassis a minute for a few pence each. First, draughtsmen have drawn out the chassis in all its details and checked it very carefully; then skilled toolmakers have taken two great blocks of special steel and carved them out laboriously into shapes corresponding to the inside and outside, or top and bottom, of the chassis.

These are then hardened carefully and mounted on a great press which may be capable of exerting a pressure of 100 tons or more. The press is then ready to start work, and the material in the form of sheet steel is fed forward until it engages with a

each time; and, in any case, there are scores of more or less elaborate tools required in a complete receiver for switch parts, condenser vanes, terminal strips, screens, and many other items.

### Wiring Up

The wiring is very carefully studied, as even an inch or two of superfluous wire or an unnecessary joint mounts up in cost if the quantities are very large.

In wiring up a complete circuit it is arranged that each worker connects only a few wires and then passes the set on to another to join up the next few, and so on. The wires have all been bent to shape and cut to length in "jigs" beforehand.

In testing complete receivers the old method of tuning-in to broadcasting has been replaced by tiny

## MAKING MOULDINGS BY THE HUNDRED

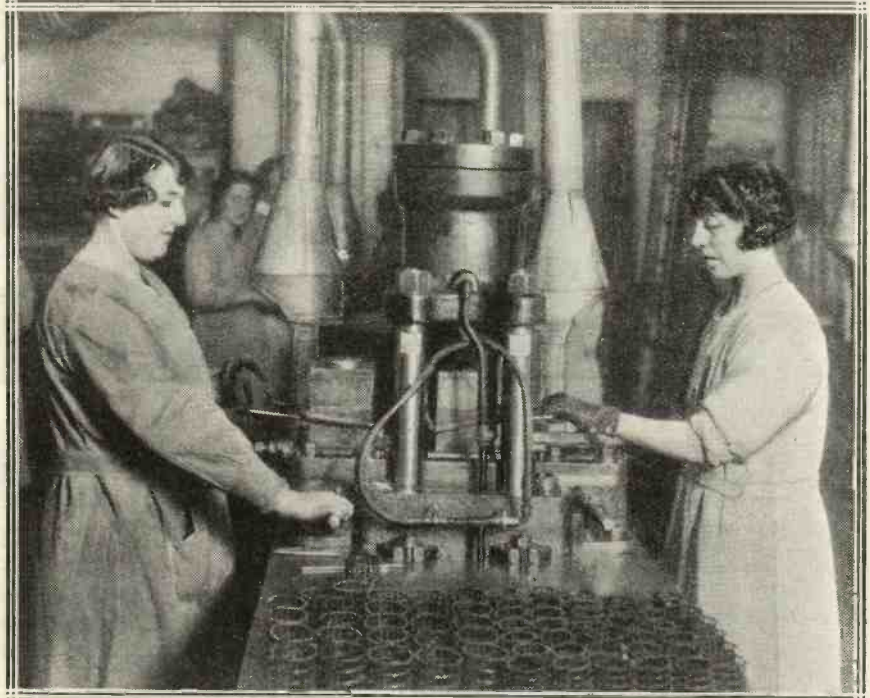

Special tools for making stampings and mouldings are very expensive items, and consequently, although they lessen production costs, it is impossible or make any deviation from the original, unless more special tools are fashioned.

locating device; the operator touches a pedal and one of the blocks is pressed down on the other with the material in between, forcing it into the shape of a chassis.

### Special Tools

It may be necessary or more convenient to produce it in several stages, using different blocks or tools

artificial broadcast stations in screened boxes.

This is the one respect in which the home-constructor may perhaps have some ground for envying the manufacturer, for how much exasperation has been caused by faulty components? And yet to some it would be very tame if everything worked the first time!



MAKE SURE YOU GET CORRECT MATCHING  
AND BEST OSCILLATOR CONDITIONS IN THE  
"M.W." A.C. "SUPER-QUAD"

BY USING **COLVERN** COILS

COLVERN COMPONENTS ARE SPECIFIED  
BY THE LEADING SET DESIGNERS

**COLVERN BAND-PASS INTERMEDIATES**

ACCURATELY MATCHED

When ordering your components for the A.C. "Super-Quad," specify: 1 Colvern Oscillator Coil, complete with screen, Type KOMW, Price 9/6; 2 Colverdynes Band-Pass Intermediates, Type 110, Price 12/6 each; 2 Four-pin Base Adaptors, Price 1/9 each; 1 Variable Colverstat, 50,000 ohms, Price 5/6

For details of the full range of Colvern Components, send for a copy of the Colvern Booklet No. 6.

**COLVERN LTD., MAWNEY'S ROAD, ROMFORD, ESSEX**



# RADIO ECHOES FROM SPACE

Some time ago it was noticed that several seconds after a radio signal had been heard it was received again—as if there were an “echo” coming back from outer space. Here is an interesting review of recent German investigations into this phenomenon.

By Dr. F. NOACK.

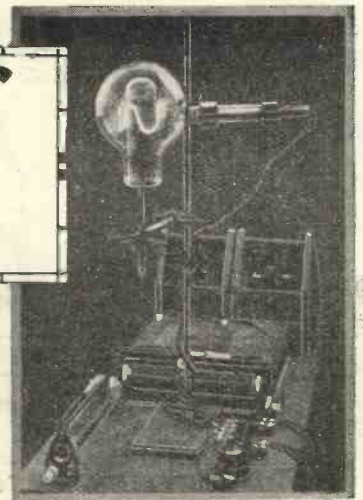

IT was not very long ago that Prof. Stoermer, of Stockholm, succeeded in identifying a terrestrial space echo. To do this one of the Dutch Philips' transmitters was received in Norway, and Stoermer, some seven seconds after the reception of the direct signals, could hear them once more.

## THE MAGNETIC PULL

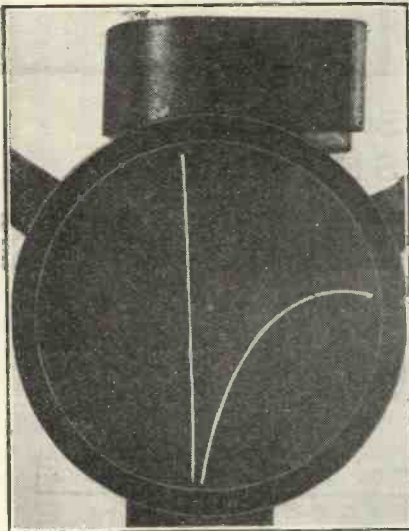

An electron ray is deflected by an ordinary horseshoe magnet. On the left is the path of an undeflected ray.

The conclusion was reached that the waves of the Dutch transmitter had penetrated the atmosphere and were reflected back from the moon to the earth. I considered the moon echo theory as improbable, for the simple reason that a reflection therefrom back to the earth could only take place with the moon in some particular position.

## Due to the Aurora

The theory has now been advanced that the echo was due to the Aurora Borealis, and laboratory experiments

help to bear this out. Prof. Stoermer had studied for over twenty years the problem of the Aurora Borealis and had succeeded in elucidating the appearance they present by mathematical calculations. This brought him to a theory of Goldstein going back to the year 1881, who in a prophetic statement held that the Aurora in all probability could be attributed in some way to cathode rays.

## Cathode Rays

Birkeland, in the year 1896, clearly enunciated that the Aurora could be explained by the supposition that the cathode rays penetrated the atmosphere, decomposed the atoms of the air, and in that way caused the lights. They are deflected in peculiar directions by the magnetic field of the earth and give the Northern Lights the characteristic form and extension. Birkeland showed by an experiment that the Aurora must start at the magnetic poles of the earth.

This experiment is upheld by frequent observations of the Aurora itself from all accessible regions of the Arctic area. The Northern Lights appear almost always in the form of so-called draperies—that is to say, of large curtains of light on the heavens, with their end directed towards the north magnetic pole.

## Solution of the Problem

Moreover, these curtains always take a definite direction with reference to the heavens. These facts pointed out to Stoermer the direction of the Northern Lights, and so he considered them as cathode rays.

The solution of the problem is extremely laborious, but Stoermer was able to determine the action on the cathode rays of the earth's magnetic field, and succeeded in building a model thereof. But Stoermer did not

succeed in confirming his mathematical conclusions by a physical experiment.

Dr. Brueche, of the General Electric Experimental Laboratory, has succeeded in producing an artificial “Aurora Borealis,” which seems to prove the conclusions of Prof. Stoermer.

In order to produce an aurora experimentally, it is first of all necessary to generate cathode rays whose electrons move so slowly that a deflection by the magnetic field of the earth which is very weak shall be possible.

## Magnetically Bent

It is already known that the cathode rays can be effected magnetically more easily the slower they move, but it is not easy to produce cathode rays of this character.

## EARTH ATTRACTION



When this cathode ray tube swings to and fro the light-spot at the free end of the tube moves under the influence of the earth's magnetism.



# Instantly popular— THE NEW H.T.8

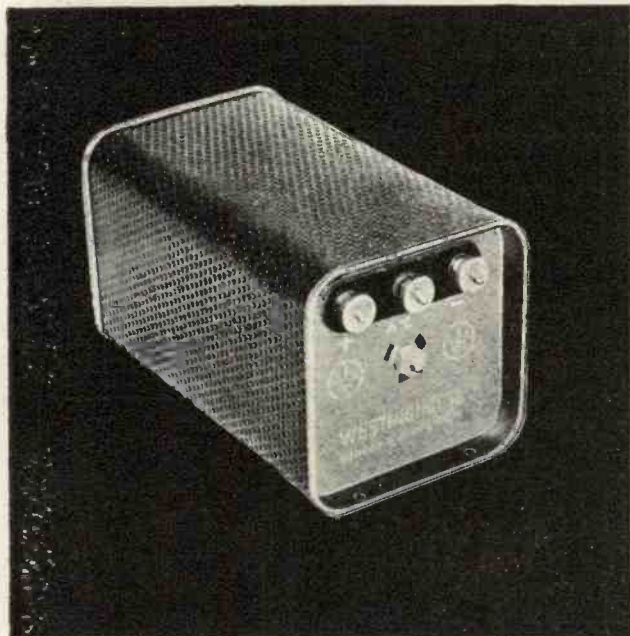

THE H.T.8 Metal Rectifier has become instantly popular for the conversion of three- and four-valve battery-run sets into mains sets; and for incorporating in amateur-built sets of similar design. It has an output of 250 volts, 60 milliamps (after smoothing), with an input of 200-210 volts A.C., using the voltage doubler circuit (\*described in "The All-Metal Way"). The price of the H.T.8 is 21/-.

Other metal rectifiers for amateurs' use are the H.T.5—D.C. output 120 v., 20 m.a.—price 12/6; H.T.6—D.C. output 175 v., 25 m.a.—price 15/-; and H.T.7—D.C. output 200 v., 28 m.a.—price 17/6; and various low-tension types.

*\*The 1932 edition of "The All-Metal Way," which will be sent on receipt of the coupon below with 3d. in stamps, gives all the information required to build an H.T. eliminator or trickle charger, and also full details of running moving coil loud speakers from the A.C. mains. This well-known book has been completely revised, and many questions which were not fully dealt with in our 1931 issue are now discussed in detail.*

## WESTINGHOUSE Metal Rectifiers

The Westinghouse Brake and Saxby Signal Co. Ltd.,  
York Rd., King's Cross, London, N.1. 'Phone: North 2415.

### COUPON

PUBLICITY MANAGER, W.B. & S.S. Co., 82, York Rd., King's Cross, London, N.1.  
I enclose 3d. in stamps, for which please send me a copy of "The All-Metal Way, 1932."

NAME .....

ADDRESS .....

M.W. 11 31



## "A Curtain of Light in the Heavens"

The solution of the problem has been reached by the use of a glowing cathode of very small area and of a peculiar shape of anode. The anode is a tin cone with it send cut off, or truncated, a sort of former. The

### A MINIATURE WORLD

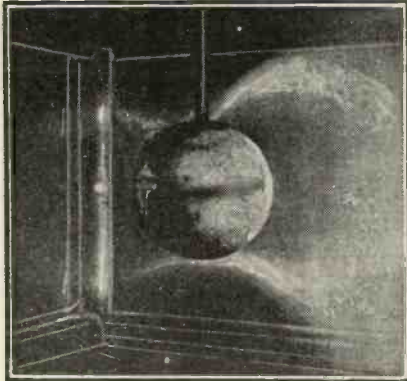

An artificial magnetised "World" with remarkable electron-clouds. Note how these only touch the globe at its poles.

large opening of this anode is brought very close to the heated cathode, and between the two an anode potential of at least 200 volts is maintained.

### Realistic "Lights"

If this system were put together in a glass globe, which was highly exhausted, at the small end of the cone thin threadlike cathode rays would appear which could obtain a length of over 1 metre (naturally, of course, within the tube). These free cathode rays decompose in their path the

atoms of gases which are still present in the tube, so that the path of the cathode rays can be followed by their light just as in a Geissler tube.

These cathode rays can be deflected by a magnet. In some experiments Brueche used a common horse-shoe magnet, but in the experiments which were to bring out the realistic northern light he used a small electro-magnet in the form of a bar about seven centimetres (2 $\frac{3}{4}$  in.) long, which he had mounted in a small hollow globe so as to represent the earth.

### Cause of the Echo

Now if Brueche brought this earth magnet, as we may call it, whose magnetisation was about 20 gaussses, which is 20 times as great as the earth magnetism, into the vicinity of the cathode ray, the cathode ray would be deflected. He could introduce the little cone also into the globe.

The result was that the cathode rays always touched the little terrestrial globe only at the magnetic poles, and not on any other part of its surface. Then there was a separation of the cathode rays from each other, giving a circular section, so that on the surface of the miniature earth similar light beams were produced as are formed in the normal aurora.

The calculations of Stoermer and the experiments of Dr. Brueche have now shown that the cathode rays only touch the surface of the earth at the magnetic poles, but elsewhere maintain a certain distance from the

surface of the earth, so that a definitely sharply limited layer of electrons around the earth results.

The greatest distance from the surface of the earth from the electron layer is in the vicinity of the magnetic equator, the distance of the electron surface from the surface of the earth being greater than the distance of the earth from the moon, a distance which corresponds to the observations of Von Stoermer on the cosmic echo.

The solitary cathode ray is of use, it may be remarked, for the production of aeroplane compasses. If one moves the tube with the cathode ray backward and forward

### THE NORTHERN LIGHTS



The peculiar shape of the aurora borealis gives the effect of hanging draperies.

out of the perpendicular position, the cathode ray under the influence of the magnetic field of the earth will be deflected from its normal path.

The measurement of the deflection is a measurement for the direction of the tube. If the tube is now connected in an aeroplane, the direction of the aeroplane can be accurately determined. The new instrument has the advantage of showing at once its indication without any mathematical corrections, which naturally is exceedingly desirable in aeroplanes.

### Instantly Spotted

If we bring a fluorescent screen to the side of the tube opposite to the hot cathode and anode, the ray produces on this a spot of light, and this seems to oscillate pendulum fashion back and forward if we swing the tube. By means of this spot of light one can determine a departure from the north and south direction, and thus use the instrument as a compass.

### AN AID TO AVIATION

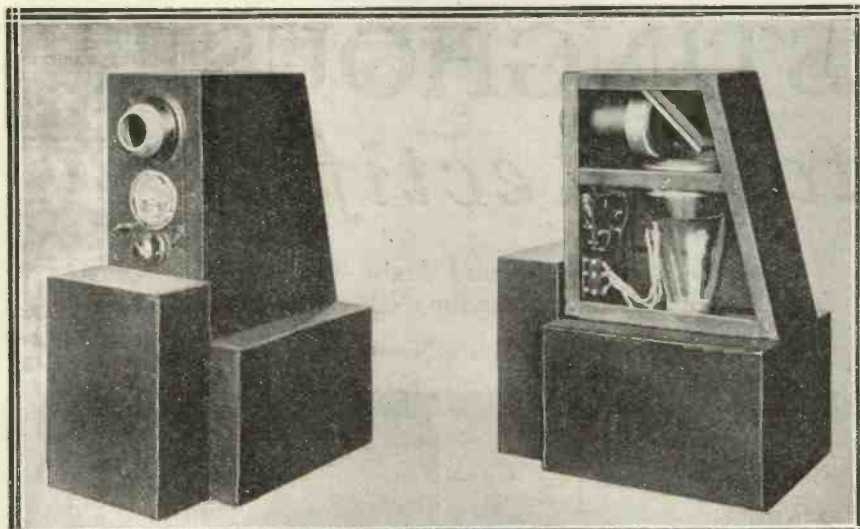

This is an aeroplane compass that operates on the principle of cathode rays deflected by the earth's magnetism.



# B.I. ENAMEL COVERED WIRES

B.I. Enamelled wires are unequalled for the field windings of small motors, measuring instruments, radio transformers, and other pieces of electrical apparatus where space is all-important. They are produced throughout in our own works, from the raw material to the finished wire, and every phase of manufacture is under the strictest control as regards quality of material and accuracy of gauge. B.I. Enamelled Wire is unexcelled for its high insulation, dielectric strength, flexibility of enamel, and general dependability. We regularly manufacture Enamelled wire as fine as ".002" dia.



## BRITISH INSULATED CABLES

LIMITED  
PRESCOT-LANCS

Makers of B.I. Cables

Telephone No.: PRESCOT 171.

London Office: Surrey House, Embankment, W.C.2

Telephone No.: Temple Bar 4793, 4, 5 & 6.

# AMPLION MOVING COILS for Home Constructors

**N**OW no home constructors need be without the very finest reproductive equipment, with AMPLION Moving Coil units at such modest figures. These super-sensitive units will make a world of difference to your results on any circuit; there are many handsome cabinet models, or you can easily fit one to your existing cabinet.

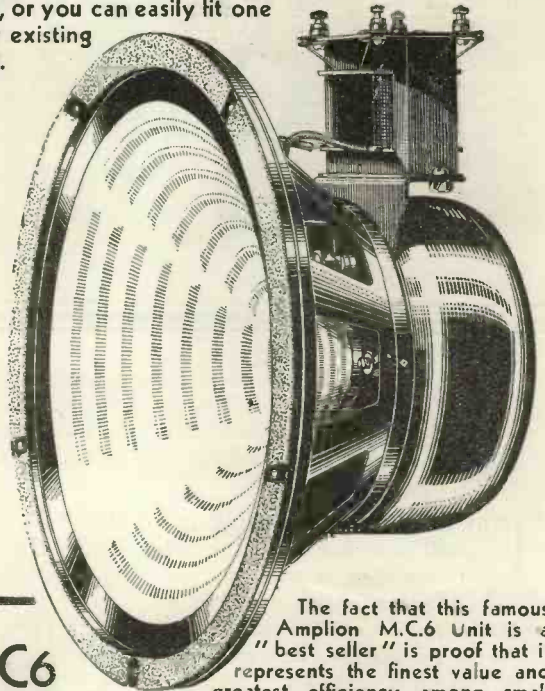

### MC6

UNIT, complete  
with Transformer,

## 67/6

The fact that this famous Amplion M.C.6 Unit is a "best seller" is proof that it represents the finest value and greatest efficiency among small permanent-magnet moving coilspeakers. Its reproduction and sensitivity are really remarkable, and it will handle, without distortion adequate volume for all normal requirements. The universal transformer which is fitted enables the speaker to be correctly matched to either Power, Super Power or Pentode output from Standard British 2, 3 or 4 valve receivers, and provision is made for push-pull.

## CABINET MODELS

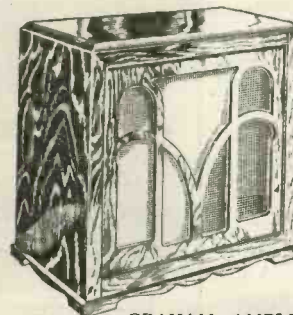

For those requiring a complete cabinet model, the M.C.6 is available in most attractive cabinets of striking design.

M.C.6 Oak - - £5-10-0

M.C.6 Walnut - £5-19-6

or on deferred terms.

**M.C.9 UNIT**, a larger and more powerful unit than the M.C.6. Unit only, £6 (Matching transformer 15/- extra.) M.C.9 in Oak Cabinet, £9-9-0; in Walnut, £10-10-0. All Cabinet models are fitted with transformer. All M.C.9 models on deferred terms.

GRAHAM AMPLION LTD., 26, SAVILE ROW, W.1

royds





# WRITING PLAYS FOR RADIO

*Every wireless listener is a potential radio dramatist, but the many thousands who have tried their hand at play writing for the wireless have failed mainly through lack of knowledge. Given a good story and the observation of a fairly simple technique, it is no very difficult matter to write a play suitable for radio production, and in this article Mr. Val Gielgud tells you how to set about it.*

**T**HE Productions Department of the B.B.C. might well be called The Savoy Hill Sifting House. It receives, on an average, some fifty plays a week—plays on every conceivable subject and in every conceivable style.

All the manuscripts are sifted with care and discrimination through a dramatic sieve, and each has an equal chance of production. But only one or two in every hundred survive the process. The others fall through the meshes, and in the course of time are returned to their disappointed authors.

### Quite Easy

That, to me, is an astounding thing, especially when one considers how wide indeed is the scope of radio drama. I have always held that a person of average writing ability can write a successful broadcasting play, providing he observes a few fairly simple conditions of technique. And yet at least ninety-eight in every hundred would-be playwrights are foredoomed failures from the moment they put pens to paper!

I determined to ask Mr. Val Gielgud, the B.B.C. Productions Director, something of the requirements of radio drama. Nobody

regrets more than himself the large percentage of plays which he has to refuse, and he assured me that lack of knowledge was the chief stumbling block of radio dramatists.

### SCHOOLBOY'S SUCCESS



Mr. Edward Hope-Jones, an Eton boy, whose radio play, "The Smugglers," was recently broadcast.

"Some people are apt to think that what is not good enough for the stage is good enough for the wireless," he said. "We are inundated with plays which, while observing all the niceties of stage technique, have yet failed to achieve stage production. These writers see us either as a last hope or a practising ground.

"My advice is—forget stage technique. Applied to radio drama it is useless. Think only in terms of the microphone, the switchboard, and the studio, and you will at least be working in the right direction."

### Points to Remember

"What about plots?" I asked. "Remember above everything that your subject has to appeal to a cosmopolitan audience.

"There are two subjects, at least, which have the right appeal for a successful play. The first, which would doubtless be more easily written by an inexperienced writer, is—a good story. Any gripping yarn—the sort of story which you cannot put



An "M.W." Representative has a Chat with the B.B.C. Productions Director on this Interesting Subject.



down until you have read its last word is a potential radio plot.

"I do not necessarily mean an adventure story, a mystery story, or a story with an unexpected ending. Write an interesting story. That is half the battle."

"And what is the alternative?"

"A play which expounds ideas—in which the story is secondary to the opinions expressed by the characters. This, you will realise, is a more difficult matter. It is easy to make your characters into puppets, delivering long and rambling speeches.

"That, of course, is useless. The characters in any

ONE OF THE EARLIER ATTEMPTS

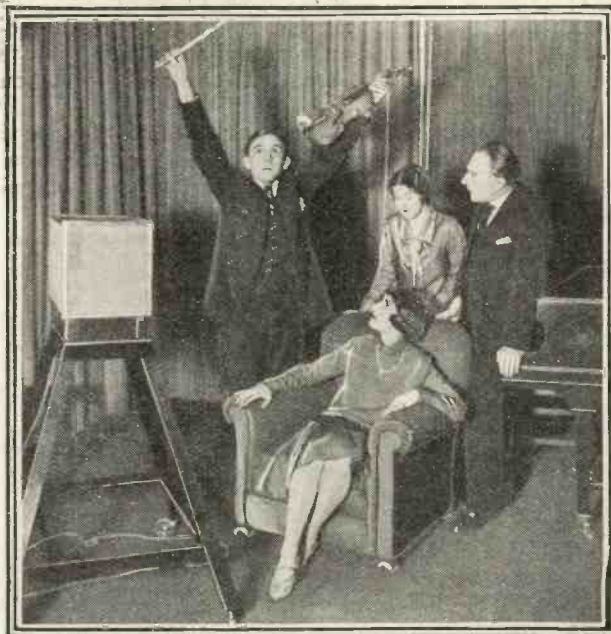

Above is a scene from "Grey Ash," which was produced at Savoy Hill about five years ago. Mr. Val Gielgud himself is seen to the top right. In the circle you see "Independent Means" in progress. This successful radio venture occurred in 1927.

radio play must *live*. They must be characters which listeners will recognise as human beings with thoughts and personalities of their own."

From our discussion on the subject of radio plays, one very definite and very helpful fact emerged. Mr. Gielgud admitted that the field of light comedy is sadly neglected by radio dramatists. Here, obviously, is a great opportunity for people with a sense of humour.

The writing of comedy is a fairly simple business—once a good humorous situation has been obtained. Nearly every comedy is inspired by a *situation*—in how many different ways has the old device of mistaken identity been used?—and the story is built round it.

Some comical episode from one's own life may provide the nucleus of a first-class radio comedy. Think about it!

But to return to my talk with Mr. Gielgud. He told me that it was impossible to over-estimate the importance of music in a good radio play. Dialogue, however well written, is apt to prove tiring to listeners.

A relief can be provided by the discreet use of suitable music as a background to voices, or as a connecting link between the various scenes of the play. The play which provides for the interpolation of music—think hard of your



## Six Studios Can Be Used Simultaneously

light comedy!—is bound to have a wider appeal than that which is confined to conversation.

The radio dramatist must remember, too, the obvious advantages which he has over the stage dramatist, and should not be slow to take advantage of them. Very few people realise, for instance, that the control panel enables six studios to be used simultaneously for one play.

This fact makes for a much wider field of action, to say nothing of the various off-stage effects which can be "put over" as background. You must bear in mind, however, that you are not *obliged* to use six studios; they are there for your convenience should you require them. Generally speaking, a simple plot is more likely to succeed than a complicated one.

### When Music is Invaluable

The use of explanatory narrative in radio drama is all important. "The writer should make up his mind beforehand whether he proposes to introduce spoken explanation into his play or not," said Mr. Gielgud. "There are some plays which are so constructed that they carry themselves, and unfold their stories without any outside assistance whatsoever.

"This method is excellent so long as the development of the plot is not obscured. If narrative is used—and quite often it is essential—the writer should balance it by continually changing the background of his scenes, and it is in this connection that music is invaluable."

For the benefit of inexperienced writers I must add a word or two about characterisation. You must not lose sight of the fact that listeners identify the different

characters only by their voices; and the personalities of the characters must be conveyed through voices. It would be absurd, for instance, to imagine a man of determination possessing a thin voice or a stutter.

A pretty heroine will not speak in a cracked, croaky voice. These, of course, are exaggerated cases, but they serve to illustrate the point. Like the novelist, the radio dramatist must fix the personalities of each of his characters, and make the voice and actions of each commensurate with the personality.

### Think Only of Success

This may seem a formidable proposition to a new writer. And so it is. But he should draw hope from the fact that even such successful radio plays as "Kaleidoscope the First," "Kaleidoscope the Second" and "Squirrel's Cage" lacked much in the fixing of characterisation.

There are a few further essentials to remember. The length of a radio play can be anything between three-quarters of an hour and an hour and a quarter. Prepare your manuscript neatly, typing it (or have it typed) on quarto paper.

Stage directions should be inserted, but they need be nothing beyond an indication of outside sound effects. The producer will co-operate with the "effects" official to elaborate them if necessary.

It is a sound rule to allow a minute and a half for each sheet of your manuscript. Thus a play to last an hour will have a manuscript of forty sheets. Send your play to the Play Library, British Broadcasting Corporation, Savoy Hill, and enclose a stamped envelope.

## COSTUMES MAKE THE CAST FEEL "AT HOME"

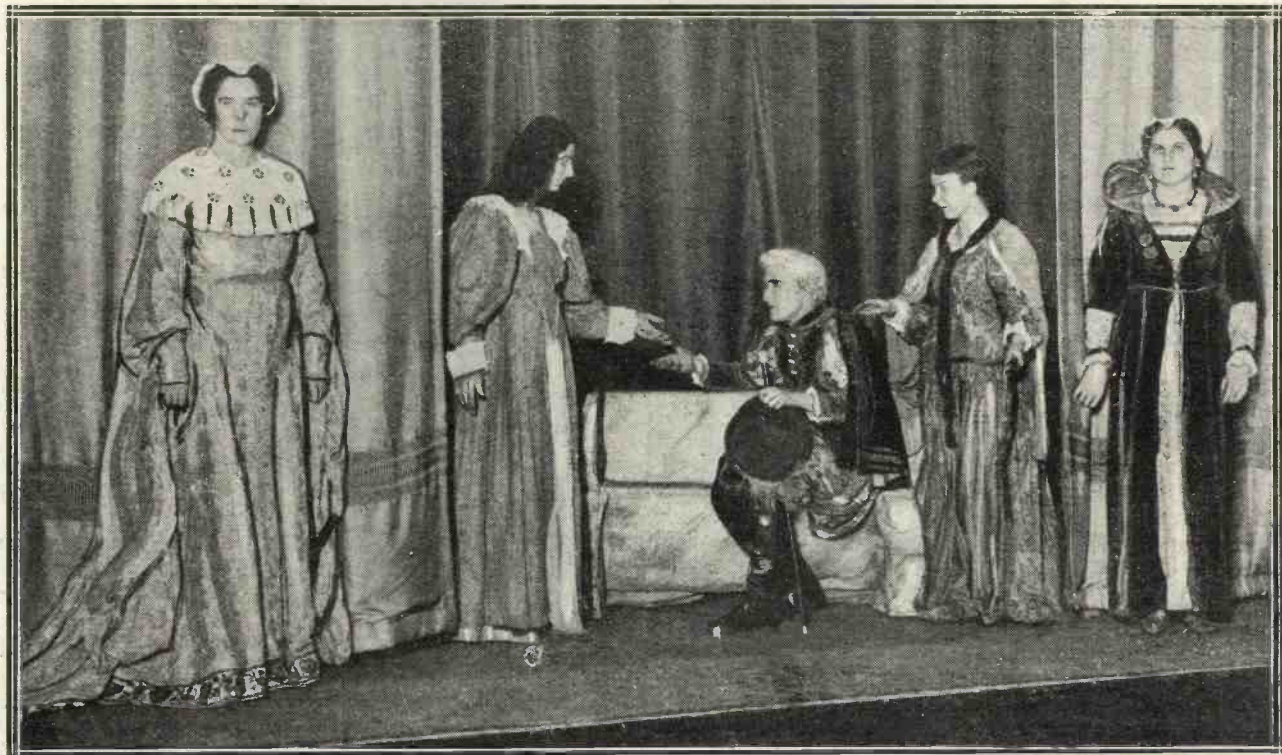

Some radio productions are produced with the cast in costume in order to create "atmosphere," but more usually the artistes appear in their ordinary clothes.



# Specified for the 'M.W.' 'SUPER-QUAD'

**R.I.** components are acknowledged as scientifically and constructionally **BEST**. Their inclusion in all modern circuits is a definite safeguard of time and expenditure.



## **R.I.** DUASTATIC BAND FILTER COIL

gives the correct degree of negative mutual inductance, providing a constant peak separation of 9 kilocycles ensuring absolute selectivity and perfect reception unimpaired by the loss of side-band frequencies. The "DUA-STATIC" Coil is definitely the most improved device available for band-pass tuning

**15/-**

## **7-1** L.F. TRANSFORMER

The lowest priced component consistent with really efficient performance. For all modern high-ratio amplification circuits. Ensures powerful, uniform response, and elimination of unwanted interference frequencies.

**10/6**

Ask your dealer or us for technically descriptive leaflets containing diagrams and full descriptive matter. Get also the new R.I. Catalogue

T.A

L70

The Advertisement of Radio Instruments Ltd., Croydon, England. 'Phone: Thornton Heath, 3211

# 'CLIX'

**CONSTRUCTOR'S KIT**  
Saves you Time and Money.

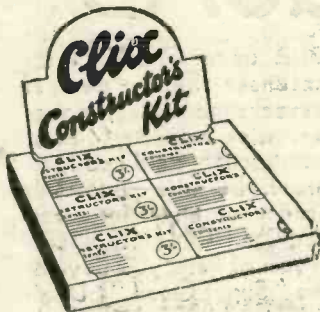

Contains an assortment of nineteen Clix fittings specially selected for the set builder.

Contents:—2 Spade Terminals engraved L.T.; 2 Plugs and Sockets (A and B); 7 Terminals, H.T., L.T., L.S.; 6 Wander Plugs, H.T. and G.B.  
Value 3/5

**3/-**

Buy a Clix Kit for your next set and save fivepence.

Obtainable from most dealers or direct.  
Fully Illustrated Folder "M" Free.

LECTRO LINX LTD.  
254, Vauxhall Bridge Road, S.W.1.

**Cheapest PERFECT Contact**

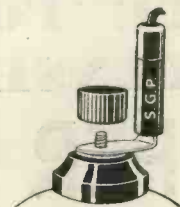

ANODE CONNECTOR 3d  
Horizontal or Vertical.

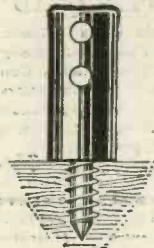

INDOOR AERIAL  
INSULATOR 2d.



"VICEGRIP"  
WANDER PLUG 1 1/2d.

## The "UNI-KNOB"

A Two-Gang Condenser built in a rigid die-cast frame which ensures accurate matching being maintained under all conditions of use.

Air di-electric trimmer is fitted and controlled from the front by a knob concentric with main control. Slow-motion drive. Attractive moulded escutcheon with pilot lamp holder.

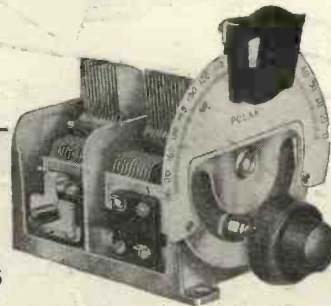

Capacities:  
·0005 x ·0005

**21/-**

Obtainable from all dealers.

# POLAR CONDENSERS

24-page  
catalogue  
on request.

WINGROVE & ROGERS, LTD., 188-9, Strand, W.C.2,  
Old Swan, Liverpool



# RADIO NOTES and NEWS of the MONTH

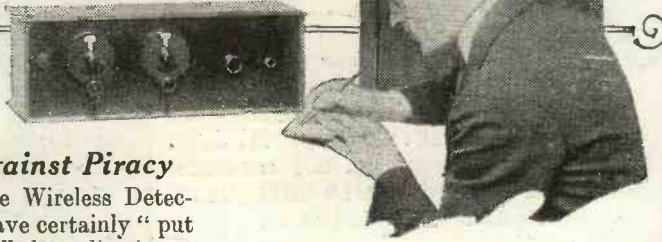

Batteries also sold better this year. Orders were taken for 10,000,000, representing a value of about £4,000,000.

### The B.B.C. Accent

Mr. Baldwin had a few words to say about the B.B.C. accent the other day. In his speech he pointed out that we have lived now to a day when most of us try and talk like the B.B.C., and, in the sacred name of progress, our language is being gradually formed on the model of the captions of the Hollywood films.

### All the Same

"The time was in the House of Commons when you could tell a Member from Worcestershire from a Member from Yorkshire by his talk. We cannot do it now, and I think more's the pity. We are progressing, and in the course of progress the people will be brought to a point where they all get their clothes from the same slop shop, where they all talk the same B.B.C., where they all have the same ideas, where there is uniformity."

### Licence Figures

At the end of 1930 there were 3,391,042 wireless licences in force.  
(Continued on page 518.)

### The Drive Against Piracy

THE Post Office Wireless Detective Vans have certainly "put the wind up" the radio pirates in London. As these words are written, I understand that over 70,000 extra wireless licences have been taken out by people in London alone who would otherwise have continued to use sets unlicensed.

### Good for Chancellor

It appears lots of people are dashing into Post Offices when the wireless van is reported in the neighbourhood and are demanding wireless licences quick.

Certainly the Post Office has had some excellent publicity over this wireless van business, and consequently the Exchequer, the B.B.C. and everybody is going to benefit financially; although I daresay that quite a number of nervous cases will

be handled by doctors who will find new patients in the persons of almost-caught pirates.

### Trade at the Show

Figures are now available in connection with the Radio Exhibition at Olympia, and show that the number of wireless sets ordered is approximately 1,000,000, the value being roughly £10,000,000. Compared with last year the figures are illuminating.

Last year there were 650,000 sets sold, at a value of £7,000,000. Apart from sets, orders for 8,000,000 valves were placed at the Exhibition, representing a value of £3,500,000, as compared with 5,300,000 last year and £2,600,000.

## ACCEPT NO SUBSTITUTE FOR CYLDON EXTENSER IN THE "SUPER QUAD"

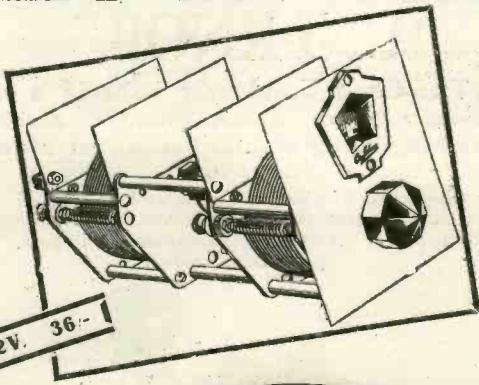

### SPECIFIED FOR THE "SUPER QUAD"

CYLDON Double Gang Extenser. Type ExG2V. Fitted with wedge drive disc type Slow Motion Control. Insulated Commutators Hair-line sight. 5 to 1 reduction. Fitted straight-through spindle and high interstage screening. Price complete 36/-

CYLDON Slow-motion Extenser Type Ex5V, with wedge drive disc type, Slow-motion Control. Hair-line sight. 5 to 1 reduction. Perfectly timed Extenser wavechange switch. Price 16/6

Insist upon CYLDON for Extenser Sets — perfect wavechange switch, noiseless wipe contacts, 4-pillar construction, rigid and fool-proof. Be wise—refuse to accept substitutes for specified CYLDON EXTENSERS in Kits of Parts you buy for the "Super Quad." Don't risk trouble — those who know Extensers build with CYLDON.

S. S. BIRD & SONS LTD. CYLDON WORKS, SARNESFIELD ROAD, ENFIELD

Enfield 2071-2 Grams: Capacity, Enfield



SEND FOR NEW CATALOGUE

# cyldon

FIVE YEARS GUARANTEE





*The* **Lanchester**

**PERMANENT MAGNET MOVING-COIL SPEAKERS**

You cannot afford to be without our new 1932 CATALOGUE, beautifully illustrated and containing full particulars and prices of our Season's products now available.

It contains in addition a mine of useful information, and is

**FREE and POST FREE**

Lanchester Speakers are sold direct to public only on 14 DAYS' FREE TRIAL against cash with order or C.O.D. Their compact dimensions readily permit their incorporation in Portable receivers, and the fascia board simplifies attachment.

**PRICES :**

CHASSIS from £1-10-0 to £3-3-0. Complete in Cabinet from £2-10-0 to £4-15-0. Output Transformer required : extra. See Catalogue.

**NEW 1932 MODELS  
HIGHER SENSITIVITY  
SPEECH PERFECT  
FULL MUSICAL REPRODUCTION**

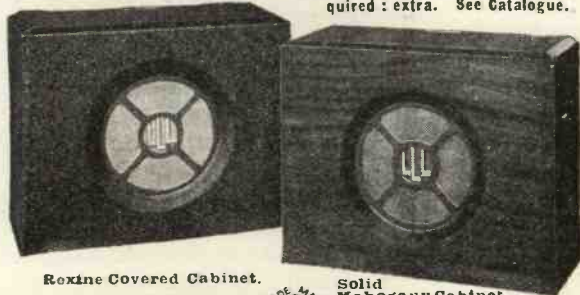

Roxine Covered Cabinet.

Solid Mahogany Cabinet

**LANCHESTER'S LABORATORIES**  
TYSELEY ... LIMITED BIRMINGHAM

**YOU CAN'T GO WRONG!**

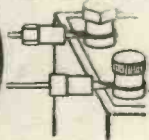
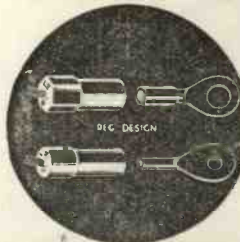

**Belling-Lee Accumulator Connectors.** The most efficient and safest device for connecting accumulator and radio set.

The lead-plated eye-sockets are permanently fastened to the accumulator terminals, and having different sized holes, it is impossible to attach them wrongly to accumulators with non-interchangeable stems. The insulated connectors (lettered L.T.+ and L.T.-) attached permanently to the wires from the set, have different sized sockets and cannot be plugged on the wrong eye. Further, the positive is red and hexagonal, to conform in shape with the positive terminals in certain accumulators, while the negative is blue and round. Thus under no circumstances, deliberately or accidentally, can a wrong connection be made. Being completely insulated even when disconnected, the Connectors cannot blow your valves.

Price 9d. per pair.

Extra pairs of lead-plated eyes for spare accumulators, 3d. per pair.

**BELLING-LEE**  
FOR EVERY RADIO CONNECTION

Agents: Belling & Lee, Ltd., Queensway, Ponders End, Midd.



Engraved wander plug 2d. Battery cords with engraved Wander Plugs and spring grip Spade Terminals. 5, 6, 7, 8, 9, & 10-way. 54in. cords 4 to 6.6. 30 in. cords 2/6 to 5.-. With fuse, 1/- extra. Wander Fuse with 60 m/a fuse, 1/6.

*Tests Everything!*  
**VALVES  
FILAMENT  
ANODE & GRID  
COMPONENTS  
AND CIRCUITS  
H.T. AND L.T.  
MILLIAMPS**

**AS  
INDISPENSABLE  
AS A CLOCK**



Standard Model, for Battery Receivers. Handsomely finished in octagonal Bakelite case, complete with leads.

**12/6**  
Price

*De Luxe Model, 125,000 ohms Resistance, for Electric Receivers, Mains Units, and Battery-operated Sets. In maroon Bakelite case, complete with cables.*

Price

**£2:2:0**

The innermost problems of your radio can be easily diagnosed with an "All-in-One" Radiometer. This wonderful little instrument enables you to keep a constant check on the conditions of every part of the set.

Electric Current, Valves, Batteries, Circuits, Components—everything can be kept under perfect supervision, and the slightest variation in performance instantly traced to its source.

The "All-in-One" Radiometer will save its first cost over and over again by safeguarding your set and making you independent of expensive expert assistance.



The SHERLOCK HOLMES of Radio

**PIFCO**  
**ALL IN ONE**  
**RADIOMETER**

Obtainable at all Stores and good-class Radio dealers. Booklet free from Patentees: PIFCO LTD., HIGH STREET, MANCHESTER.

Ⓟ P2A



**RADIO NOTES AND NEWS OF THE MONTH**  
 —continued from page 516

and this number has since been increased to 3,785,176. "World Radio" recently gave these figures and also an analysis and a map showing how the licences up to December 31st, 1930, were distributed in Great Britain and Ireland.

**How They are Placed**

In England and Wales there were 2,440,480, the London area leading with 595,507; while next in order came Lancashire, 357,314; Yorkshire, 295,549; Warwickshire, 145,323; Surrey, 121,114; Kent, 117,846; and Essex, 102,591. All the other counties were below the 100,000 mark, including Staffordshire, 76,662; Gloucestershire, 70,889; Leicestershire, 49,444; Worcestershire, 35,271; Shropshire, 19,938; and Herefordshire, 8,809. In Scotland there were 210,369 licences, in Wales 113,941, and Northern Ireland 30,745.

**North Regional Facts**

In point of density of licences the North Regional station has the

greatest field to cover, for in Lancashire and Yorkshire alone there were 652,863 licence holders up to the end of last year. This is not surprising considering the density of population, but it shows—as, indeed, the whole of the statistics show—that even in bad times the people of all classes cling to their wireless. And the further fact that already this year nearly 400,000 new licences have been added is a clear demonstration of radio's growing popularity.

**Radio for Flying Scot**

The Flying Scotsman and ten other London and North Eastern expresses will shortly be fitted with wireless receiving sets. This means that the first-class passengers will be able to hire a pair of telephones for, say, one shilling, and listen to broadcast programmes during the journey.

**Broadcasting House**

I wonder what Broadcasting House would be like if it had been really built according to the economic virus which we are all injecting in ourselves these days. It struck me that Broadcasting House is really one of the most luxurious buildings of its kind in London.

I am thinking of the Conference

Room. The walls of this room are clothed in Tasmanian oak. All around are wooden bowls containing apparatus for concealed illumination.

The room is in the shape of a half circle, and is quite fitting for a Prime Minister's study, or else for the den of a millionaire in a Hollywood film.

**Talkie Television**

The newspapers are full of rumours that negotiations are proceeding in London for the introduction of television into British cinema houses.

According to the "Sunday Chronicle," Mr. S. L. Moseley, of the Baird Company, states: "I can't tell you the name of the Company, for I have been placed under a pledge of secrecy, but I feel quite confident that there will be big developments following our negotiations."

**In America, Too!**

It appears that promises have been made that television programmes will be introduced in one of the large cinema circuits in America inside a few weeks. To begin with the shows will last for half an hour, but it is reported that television scenes will be shown on a 10-ft. square

(Continued on page 520.)

**Building a Radiogram!**

**— select your Pick-up from this Range**

If you want brilliant reproduction—sparkling treble, ample bass, crystal clear middle register—you must have a B.T.H. Pick-up. Whichever model you select—the "Minor" at 27/6 or the "Senior" at 45/-—you are getting a product of the engineering skill which has made the B.T.H. Pick-up the recognised choice of radiogram experts. Ask to hear one at your dealer's.



Minor Pick up



Senior Pick-up

"Minor" B.T.H. Pick-up and Tone Arm. Price complete **27/6**

"Senior" B.T.H. Pick-up and Tone Arm. Price **45/-**

"Senior" B.T.H. Pick-up only with adaptors. Price **27/6**



**EDISWAN RADIO**



**PICK-UP and TONE ARM**



THE EDISON SWAN ELECTRIC CO. LTD.  
 Radio Division:  
 155 Charing Cross Road, London, W.C.2  
 Showrooms in all the Principal Towns

W.167



# A TRIUMPH OF MODERN RADIO PRACTICE

J.B. "R" type Gang Condensers, specified in so many leading circuits, are the very latest in tuning devices. Thoroughly shielded and enclosed, with neat clip-on screens to every stage. Very easily fitted, because only round holes need be cut in panel. Capacity, '0005.

There are Trimmers (for adjustment once only) in each stage. A Vernier Disc Drive, scaled from 0 to 180, with a neat bakelite panel plate, is supplied as standard.

Type "R" 1 . . . 12/6    Type "R" 3 (3 gang) 29/6  
Type "R" 2 (2 gang) 21/-    Type "R" 4 (4 gang) 37/-

## "R" TYPE GANG CONDENSERS

Advertisement of Jackson Bros., 72, St. Thomas' Street, London, S.E.1



Telephone: Hop 1837

### A Grand New Gift Book for Boys!



## The Romance of the Skies!

The MODERN BOY'S BOOK OF AIRCRAFT is a magnificent new volume which tells the romance of Man's mastery of the Air in picture and story. It gives the story of Aviation from the earliest days, and contains four full-page Colour Plates, fifteen full-page pictures, and hundreds of photographs and drawings. There are articles dealing with "Aviation as a Career," "The World's Newest Aeroplanes," "The Schneider Trophy Race," and everything else the "air-minded" boy wants to know about.

## THE MODERN BOY'S BOOK OF AIRCRAFT

At all Newsagents and Booksellers 7/6 net.

## BUILD A "MODERN WIRELESS" SET



### SOVEREIGN H.F. CHOKE

Sovereign Components are to-day considered by experts and public as standard in performance and quality. They are reliable, moderate in price and frequently specified in this journal. If it is difficult to obtain these NOW, we will willingly send you the name of your nearest Sovereign dealer. Send also for the Sovereign 1932 Catalogue. "Components for Radio."

## IN THIS MONTH'S SETS

### A.C. "SUPER-QUAD"

SPECIFIED.—A Sovereign Junior H.F. Choke—a thoroughly reliable and well-made component. Despite the small space it occupies, it is well up to Sovereign standards in performance and quality, and contributes largely in making 2/- this set a success. Each

RECOMMENDED.—50,000-ohm Sovereign Potentiometer, for A.C. "Super-Quad." 4/6

### "M.W." "UNI-COIL 3"

SPECIFIED.—Two Sovereign Terminal Blocks. Comparatively unimportant, it is absolutely essential that these be sound and reliable in every way so as not to impair performance. You can rely on Sovereign. Sovereign Terminal Blocks, each 6d.

SOVEREIGN PRODUCTS, LIMITED,  
52/54, ROSEBERY AVENUE,  
LONDON, E.C.1.

## USE SOVEREIGN WHEREVER YOU CAN



**RADIO NOTES AND NEWS OF THE MONTH**  
*—continued from page 518*

screen. Later on it is anticipated that full-length plays will be given.

**Mr. Walton's "Scophony"**

I hear great things are expected of the English scientist, Mr. G. W. Walton, who has been at work on the television problem for some years, and has at last perfected a system which he calls "Scophony."

This system requires one channel only for the transmission of vision, sound and synchronising signals. The channel is reported to be a narrow one, about one-fiftieth of that necessary for normal broadcasting transmission.

**Sound and Sight**

In certain quarters this new development in television is regarded as almost revolutionary in attempting sound transmission as well as television transmission in one channel.

**The Old Lag**

Mr. Walton has left mechanical scanning alone and has relied on a special system for breaking up the

picture. Mr. Walton was not at all satisfied during his experiments with photo-electric cells, and so he set to work to invent one that would work according to his own ideas. I understand that his new cell gives a very large current and does not require enormous amplification by valves as in other cases.

It is also rapid in response, eliminating the old time-lag trouble. I hope that shortly further details of Mr. Walton's ingenious system will be available, and directly they are released for publication you may be sure details will appear in MODERN WIRELESS.

**Rome to Rio**

A lot of the newspapers reported the other day that the Marchese Marconi in Rome had pressed a button which resulted eventually in flood-lighting the statue of Christ on Corcovado Mountain in Rio de Janeiro. Of course, the idea was that the signal from Rome was transmitted by land-line to the wireless station at Coltano, near Leghorn, where it was sent out simultaneously on two wave-lengths, picked up by beam receiver at the Brazilian Wireless Telegraph Company's station near Rio, and then relayed by land-line to lighting apparatus at the base of the mountain.

**Press Accuracy**

The "News Chronicle" was one of the few papers to point out that the energy in a wireless signal reached Rio from Rome, and then operated a delicate relay, which switched on the local electric current, thus providing the illumination for the statue.

**Omitting to Mention Relays**

It is pleasant to find these days that the newspapers are taking more care in reporting such interesting stunts. I remember not so long ago quite a number of newspapers gave the impression on such an occasion as this that the actual current transmitted from a broadcasting station was itself capable of the lighting of lamps at a distance of some thousands of miles away.

**England v. Scotland**

Listeners will be interested to know that the Council of the Football Association recently agreed to the B.B.C. broadcasting one match—that between England and Scotland at Wembley on April 9th.

This is the only variation the Football Association are prepared to make in their opposition to the broadcasting of matches.

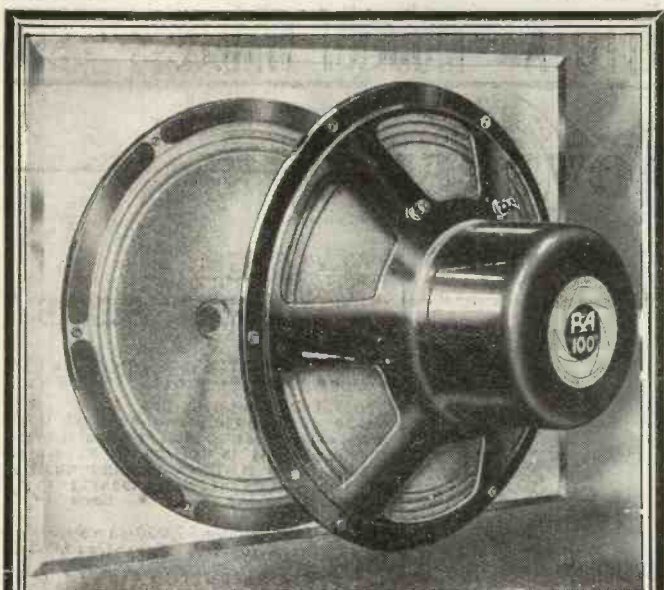

For sheer quality of reproduction the R. & A. "100" stands supreme. Its sensitivity is such that it gives perfect results from small receivers, yet is capable of handling large inputs without distress. Ask your dealer to give a demonstration; compare it with any other speaker at any price, and you will realise there is none to equal it.

The R. & A. "100" Multi-ratio Output Transformer, to suit all power valves, is recommended for use with this Reproducer. Price 12/6

Descriptive Illustrated Leaflet sent free on request.

**REPRODUCERS & AMPLIFIERS, LTD.,**  
 Frederick St., Wolverhampton.

**45/-**

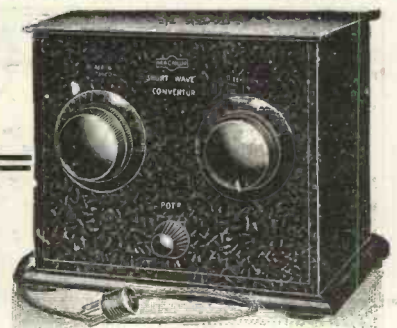

**ENJOY**

the Short-Wave Stations on your present set by means of a **Magnum Converter.**

Connected in a few seconds—No extras required.

**PRICE £3:15:0**

Including two coils 20-40 metres, and 40-80 metres, Plug and Adaptor. Sent on 10 days' free trial against cash.

**WE SPECIALISE**

in the "Lock-Tune" Junior, "M.W." A.C. "Super-Quad" and "M.W." Uni-Coil Three. Supplied as constructional kits, ready wired and tested, or parts separately.

A comprehensive range of lists including a list of short-wave stations and a descriptive booklet on the "Stenode."

Free on request.

**BURNE-JONES & CO. LTD.**

"MAGNUM HOUSE" 296, BOROUGH HIGH STREET, LONDON, S.E.1.  
 Telephone: Hop 6257 and 6258.

Scottish Agent: Mr. Ross Wallace, 54, Gordon Street, Glasgow, C.1.



# Gifts That Always Please



*Take this List when you go shopping!*

### British Gift Books for Boys and Girls of All Ages

THAT ever-perplexing question, "what to give," is easily solved if you give books this year; they are the best gifts and never fail to please. Here are the very best books for boys and girls of all ages—the pick of the Children's Annuals, packed with lively fun in picture and story. They are strongly bound in brightly coloured covers, and most of them contain beautiful coloured plates and many pages printed in colours. If you want a present that will thrill any boy or girl, and one that will keep them happy during the long winter days ahead, you cannot do better than to choose one or more of these famous All-British Annuals—on Sale at all Newsagents and Booksellers.

### For Boys and Girls at School

CHUMS Annual .. .. .	12/6
The MODERN BOY'S BOOK of AIRCRAFT .. .. .	7/6
BOY'S CINEMA Annual .. .. .	6/-
MODERN BOY'S Annual .. .. .	6/-
CHAMPION Annual .. .. .	6/-
HOBBY Annual .. .. .	6/-
HOLIDAY Annual .. .. .	6/-
The NEW ZOO Annual .. .. .	6/-
SCHOOL FRIEND Annual .. .. .	6/-
SCHOOLGIRL'S OWN Annual .. .. .	6/-
BRITISH BOY'S Annual .. .. .	5/-
BRITISH GIRL'S Annual .. .. .	5/-
LITTLE FOLKS' Annual .. .. .	5/-
GOLDEN Annual for Girls .. .. .	4/6
POPULAR BOOK of GIRLS' STORIES .. .. .	2/6
POPULAR BOOK of BOYS' STORIES .. .. .	2/6

### For Boys and Girls from 6-12 Years

PLAYBOX Annual .. .. .	6/-
TIGER TIM'S Annual .. .. .	6/-
PLAYTIME Annual .. .. .	6/-
PUCK Annual .. .. .	6/-
CASSELL'S CHILDREN'S Annual .. .. .	5/-
BRUIN BOYS' Annual .. .. .	3/6
Mrs. HIPPO'S Annual .. .. .	3/6
RAINBOW Annual .. .. .	3/6
BUBBLES Annual .. .. .	3/6

### For Very Little Children

CHICKS' OWN Annual .. .. .	3/6
BO-PEEP'S BUMPER BOOK .. .. .	3/6
TINY TOTS Annual .. .. .	2/6

### For Older People

PICTURE SHOW Annual .. .. .	6/-
"BEST WAY" COOKERY Gift Book .. .. .	4/6

*Easy to Pack—Cheap to Post—Certain to Please.*





**ALL-MAINS RADIO FOR BATTERY SETS AT ONLY 1<sup>2</sup> A WEEK**

For year in and year out, the mere touch of the electric light or power switch provides continuous and smooth H.T. and L.T. power supply, giving clear reception without trace of hum or crackling, at a constant high capacity voltage which greatly increases range and volume. Running costs are fractional: worries of run-down batteries are gone and the expense of constantly renewing dry batteries is eliminated. Incorporating Westinghouse Metal Rectifiers under Licence and, therefore, no renewals or replacements to cause worry or expense are possible.



**BATTERY ELIMINATORS DELIVERED TO YOU FOR ONLY 10/6 DOWN**

And Balance in Easy Monthly Instalments

**"MULTIVO"**

H.T. OUTPUT: 25 m/a.

- 1 variable tapping .. .. . 0/100 volts
- 1 tapping .. .. . 50/90 "
- 1 tapping .. .. . 150 "

Trickle charger for 2-, 4- and 6-volts accumulator at 5 amps.

CASH PRICE: £5 5 0

**"MINIVO"**

H.T. only.

OUTPUT: 120 volts at 20 m/a.

- 1 tapping .. .. . 50/90 volts
- 1 tapping .. .. . 90/100 "
- 1 tapping .. .. . 120/150 "

CASH PRICE: £3 3 0

**"VOLTEX"**

For indirectly-heated valves

H.T. OUTPUT 25 m/a.

- 1 variable tapping .. .. . 0/100 volts
- 1 tapping .. .. . 50/90 "
- 1 tapping .. .. . 150 "

L.T. OUTPUT 4 volts, 4 amps

(Raw A.C.)  
CASH PRICE: £5 5 0

Write for fully illustrated Catalogue "D."  
**ARTHUR PREEN & CO., Ltd.**

Golden Square, Piccadilly Circus, London, W.1. Crown Works, Southampton.

See also page 482.

**A SCREENED-GRID FALLACY?**  
—continued from page 502

a "load" is placed in the anode circuit of a screened-grid valve its working impedance falls quite considerably.

If this be so, we should have an explanation of quite a simple kind for the curious phenomena we have so constantly observed, both from the point of view of selectivity and the amplification yielded by a stage of known constants. In particular, we should have a quite natural and obvious explanation of the behaviour of the valve when the intervalve coupling is weakened by the use of a tapped tuned-anode or other device.

**A Pentode Parallel**

So far, remember, we are dealing only with suspicion. It may prove to be unfounded, and the real explanation discovered elsewhere, but at the moment it seems highly probable that this suspicion will be confirmed eventually.

After all, there is an encouraging analogy to be found in the behaviour of another type of multi-electrode valve, namely, the pentode, which has also been causing considerable difficulty in its practical application. When the pentode first appeared its very high nominal impedance was taken as a basis for the calculation of suitable output circuits, and some very puzzling results used to be obtained.

It was taken for granted that extremely high impedance output loads must be provided, and output transformers were accordingly designed to obtain the necessary conditions. Unfortunately, it was found that fully satisfactory results were not forthcoming with them, and it has been shown only comparatively recently that this valve has indeed a working impedance very much below its nominal rating.

**Ratio Reductions**

Output circuits calculated on this modified assumption have been found to function far more successfully. Output transformation ratios of only some 2 or 3 to 1 are now commonly employed, and with them it is found that far more effective "matching" can be got.

An experience of this type with one form of multi-electrode valve must inevitably lead us to wonder whether something similar may not be occur-

ring with the screened grid, which has, in fact, certain points of resemblance to the pentode.

We have here certainly a problem calling for much future investigation, both in the realms of practical experiment and more complete mathematical treatment. It may perhaps be permissible to point out in conclusion that this article is therefore to be taken rather as a tentative suggestion and an incitement to further investigation rather than a definite pronouncement.

**THE "M.W." A.C. "SUPER-QUAD"**  
—continued from page 425

The aerial tuning will not be found difficult, and when you have found your local station and noted the oscillator readings (and it is just as well to keep a log of the oscillator readings so that you can find stations again rapidly), you should go on and find something like the North Regional, if you happen to be in the London district, or some equally distant transmission, before the setting of the gang extenser is checked, and before the detector valve screening-grid voltage is adjusted.

**Setting the Ganging**

In the original receiver the North Regional came in at 94 on the oscillator dial, but this may vary slightly with individual receivers. Having found the North Regional, tune it fully in and decrease the volume by means of the potentiometer control on the panel, turning it to the left until a moderate volume is heard on the loud speaker. Then either the special trimmers—which can be obtained from Sydney Bird and Sons, the makers of the Cyldon Extenser—can be adjusted, or a slackening of the screw in the flexible joint connecting the two extenders together will allow one section to be moved irrespective of the other. A slight adjustment of the rotors will soon bring the Northern Regional up to its maximum strength.

You will generally find that only a fractional adjustment is required, and although this will throw the automatic switching of the extenser out very slightly, it will not be sufficient to cause any loss of stations, because there is ample scope on the band-pass section of this set for any such adjustment, and no stations at the ends of the ranges will be lost.



**THE GROWING VOCABULARY OF SCIENCE**  
*A work which overtakes arrears.*

**T**HE vocabulary of science multiplies so rapidly in these days that even an expert finds it difficult to keep abreast in knowledge with the many words that are constantly being added to the dictionary. New inventions and discoveries necessitate new words, and these are devised week by week to keep pace with the new ideas.

At no period has the language grown at such a rapid rate as during the past few years, and one result is that dictionaries issued three or four years ago or more are no longer up to date. There are large arrears in their vocabularies to be made up. What can we do then, as intelligent persons, we want to know the meaning of any new term we come across in the course of our reading?

Well, our need has been met in a very adequate way, and no longer must we be content with the old and out-of-date dictionaries which often fail us. A remarkable new work has just been compiled which brings the English language right up to date. It is called The Universal English Dictionary, and is edited by Mr. Henry Cecil Wyld, B.Litt., M.A., the Merton Professor of English Language and Literature in the University of Oxford; with Mr. J. A. Hammerton, Editor of the Universal Encyclopedia, as Managing Editor responsible for the production of the work.

The Universal English Dictionary is a very remarkable book, and it is being issued in a very remarkable way. It is quite a scholar's work and will take its place with the great Oxford Dictionary among the famous and authoritative dictionaries of the English language. But it is also a popular work, suitable for the ordinary person and the ordinary home.

**Wireless Words Included**

Great standard works of this kind are usually issued at a price that is prohibitive for all but the well-to-do. But that is not the case with The Universal English Dictionary: it is being issued in sixpenny weekly parts and will be completed in a year. The first part was published on October 15th, so that three parts are now obtainable from any newsagent's or bookstall.

The book really needs to be seen to be appreciated, and that is why you should go at once and place an order with your newsagent. When complete the dictionary will contain the meanings, pronunciations, and derivations of nearly 100,000 words, and it will include all the latest words that have come into the language as a result of recent discoveries, including those connected with wireless. And what a vocabulary wireless alone has given to us, without mentioning other branches of pure and applied science.

It is something to learn the meaning of a word we have not before come across. It is useful to know its correct pronunciation. But still more interesting is it to know the word's life history, to understand how it came into our language. Sometimes it has been invented quickly to meet an urgent need, and sometimes it has come down to us from far distant ages through a perfect labyrinth of channels. But no matter which of these descriptions be true of any particular word, we shall find its history set forth clearly and succinctly in this great new dictionary—the very latest standard dictionary of English to be compiled.

It is a book that no intelligent and thoughtful person can do without. Certainly readers of MODERN WIRELESS will find it extraordinarily useful. When they see the early parts they will agree.

**THE "LOCK-TUNE" JUNIOR**  
*—continued from page 465*

it is not so difficult that the average home-constructor need be afraid of it. Care must be taken to keep leads to grids and anodes of the various valves well apart, and wiring should be carried out as directly as possible.

(Continued on page 524.)

# BEWARE THE POWER THIEF!

—Is electrical leakage robbing you of money—and the Power your set needs?

**E**LECTRICAL cell to cell leakage has been definitely eliminated. The smooth top H.T. Accumulator with its 10-volt single glass cell provides direct electrical connection between terminals. Thus power leaks away, causing serious waste.

In the Lively 'O' H.T. Accumulator this cannot happen. Each 2-volt cell is separated from its neighbour by an air gap. All the power you have paid for is stored up, being released *only* when

working your Set—there can be no "falling off" in voltage—your set gets *all* the power it needs. Write for free booklet—it tells you all about it.



**LIVELY 'O' H.T. ACCUMULATORS**

**Two Types**

Standard 10 volt unit  
(2,750 Milliamps)

**5/6**

Extra large capacity  
(5,500 Milliamps) per  
10 volt unit

**6/9**

**Send at once—**



To Oldham & Son, Ltd., Denton, Manchester.

Please send me, free of charge, a copy of your book, "More Life for your Wireless."

Name .....

Address .....

M.W. 11/31. ....





**Expressly Designed  
and  
Solely Selected  
by  
'MODERN WIRELESS'  
for the  
"A.C. Super-Quad"**



A remarkable tribute was paid to the sterling quality, efficient and silent operation of the famous Heyberd Mains Units when "Modern Wireless" expressly selected a special "M.W." Unit for their star set—the "Super-Quad." Study the specification and then you will understand why it was chosen.

**HEYBERD "M.W." UNIT**

Output 200-volts at 40-50 ma. Three H.T. tappings : 60-80 volts variable S.G., 180 volts fixed, 200 volts fixed. L.T. 4 volts 5 amps. for A.C. valves. Westinghouse rectification. Solid steel case. Polished bakelite panel. Complete and ready to plug-in. **£6.7.6**

Furthermore, the "M.W." Unit is covered by the Radio World's most amazing warrant—the Heyberd

**3 YEARS' GUARANTEE**

—POST THIS TO-DAY—

I enclose 3d. stamps for special List on the Heyberd "M.W." Unit, also full details of Heyberd All-Electric Units, Kits of Parts, Transformers, together with circuit diagrams.

M.....

Address .....



10, Finsbury Street, London, E.C.2

**THE "LOCK-TUNE" JUNIOR**

—continued from page 523

It is best in this case, as with the majority of receivers, to carry out the filament wiring first, and then tackle the grid and anode leads stage by stage, beginning at the aerial end.

The casing of the intervalve coil should be earthed, while the earthing of the gang condenser, which is carried out by means of a soldering tag on the back of the condenser unit, is also a connection for the moving vanes of the condenser. The vanes of all three sections of the condenser are joined to earth thereby.

Apart from these points, and the fact that the reaction condenser should be mounted as shown and on no account on the panel, owing to the fact that this would necessitate very long leads, there is nothing more to be said about the actual construction of the set or the wiring.

**Long-Range Reception**

The operation needs a little explanation perhaps, especially as it is important that the variable condenser section should be fairly well matched up if successful long-range reception is to be obtained. Without any matching whatever it will be easy enough to tune in the local station, and rough matching can be done on this station as a preliminary adjustment.

Tune in the local station, therefore, and with a small screwdriver adjust the two screws on the right-hand side of the condenser unit (looking at it from the front of the panel), and nearer the panel.

These should be slowly varied till maximum signal strength and sharpness of tuning are obtained; then tune in a station farther away and repeat the process. You will not find it difficult, provided you do it slowly and systematically. It is best, perhaps, to do a third test, using a very distant station, so that the reception is comparatively weak.

**Final Adjustments**

On this last station the ganging up of the third section of the condenser may be carried out, when the hand-pass sections have already been done to your satisfaction. This latter portion, however, will be found extremely simple, and it is the work of a moment or two to complete the ganging.

When this has been done, all that remains in the way of operation is the turning of the condenser knob for tuning purposes, and the manipulation of reaction for bringing in distant stations at full volume, while on the left-hand side of the tuning dial is a small knob controlling the S.G. filament rheostat which enables pre-detector volume control to be carried out when listening to the local and more powerful stations.

As regards the valves in this receiver, it is advisable to use a metallised screened-grid valve, such as the Cossor 215 or 220 S.G., though a non-metallised valve can be used if the constructor particularly wants to use valves he already has.

**Some Suitable Valves**

The detector should be of the H.I.2 variety, a valve having an impedance of something from 15,000 to 30,000 ohms, while the output valve should be of the high-magnification steep-slope variety—that is, P.2., P.M.2A., P.220, etc. These valves do not need a great amount of grid bias, about 9 volts being ample if 120 volts H.T. is used, but they provide a remarkable output wattage for a small input voltage.

Six-volt valves of similar characteristics to those mentioned can be employed, or alternatively the constructor can use 4-volt valves.

The "Lock-Tune" Junior is, of course, designed for use on an ordinary aerial-earth system. It is inexpensive to build, easy to operate, and it is capable of giving remarkable results if handled properly. We feel sure that all our readers will find it a meritorious "small brother" to the "Lock-Tune" Four, the popularity of which is rapidly growing throughout the country from day to day.

**THE MYSTERIOUS MICROPHONE**

—continued from page 468

And this he at once proceeded to do. Initially he presented himself at the big, glaringly new Klecto factory at Hammersmith. The factory manager received him quite pleasantly and even offered his own services as guide.

"I thought we'd soon have you over to see what we are up to, Mr. Dare," he chuckled, as he led the way through one of the huge workshops.

(Continued on page 525.)



**THE MYSTERIOUS MICROPHONE**

—continued from page 524

“Why should you think that?” smiled the radio expert.

“You’re retained by So-and-so’s, aren’t you?” returned the other, mentioning the name of a firm of world-wide renown.

“I see, you think I’ve come to spy out all your trade secrets!” laughed Dare. “No, it’s purely a matter of personal interest.”

“We’ve no secrets, anyway, and I’m glad to show anyone round when time permits,” observed the works manager proudly, as he waved his hand in the direction of a bank of up-to-date moulding machines.

**Askew Appears**

As they were passing through the large and well-lighted drawing office a man in shirt-sleeves hurried by them. His hair was tousled and his large, horn-rimmed spectacles were awry. He held a sheaf of papers in one hand and a pencil in the other.

“Askew?” queried Dare surprisedly, and the other nodded.

“Yes, he is our chief engineer,” he explained.

That information amazed the radio expert, for he knew Askew as a brilliant but quite impractical inventor. Many times in the past the man had visited his office to lay the plans of inventions before him. But, as far as he could remember, every idea had just managed to lack the vital something that so frequently lies between a magnificent brain-wave and a successful commercial invention. It was Askew who had anticipated the screened-grid valve with a method of electrode-capacity isolation which just failed to give in practice the results that seemed feasible according to his, Askew’s, theory. And it was Askew—but the fellow seemed doomed to occupy a permanent place on the doorstep of inventive fame. But now, however, he had evidently suddenly turned into a practical engineer. That indeed was a metamorphosis!

**The Curious Panel**

The tour ended, appropriately enough, in one of the showrooms adjoining the factory, and Dare took this opportunity of closely examining a ready-to-sell instrument. He had already seen enough to assure him that the receiver was a first-class piece

(Continued on page 526.)

**Two Simple Connections**

**complete the job**

Just one hole to drill in the panel—a lead to each filament wire, and the Bulgin Signal Lamp is ready to give its warning light.

The Bulgin Signal Lamp will save you accidentally running down your accumulator and over-running valves by leaving the set switched on.

The current consumption of the special bulb is insignificant, and bulbs cost only 6d. each. Note the unique spring bulb-holder, facilitating the changing of bulbs.

Send 2d. postage for the new 75-pp. Illustrated Catalogue and Manual, giving details of the Bulgin Technical Service.

**BULGIN**  
The Choice of Critics

**A. F. BULGIN & CO., LTD.,** Abbey Road, Barking, Essex.  
Telephones: GRANGEWOOD 3266 & 3267.  
London Showrooms: 9, 10, 11, Cursitor Street, Chancery Lane, E.C.4.  
Telephone: HOLBORN 2072.

**2/6**

**YOUR Radio-Gram “De-Luxe” CABINET**  
made by **PICKETTS**  
Will delight you!

Individually made (no mass-produced), choice woods, exquisitely hand-polished—the sort people desire to possess and keep. (Used by B.B.C.—chosen by experts for over one thousand best sets.) Good acoustics—and **PIANO-TONE** (baffle yields full volume without distortion, the rich cabinet tone that you desire. Only 63/- up to £15 (at makers’ prices). Cash or deferred.

**FREE TRIAL. RETURN at OUR expense if you wish to part with it. (Over 3,000 delighted users.)** PHOTOGRAPHS and List free—from sole makers:—**PICKETTS, Piano-Tone Cabinets (M.W.)** Works, Ablon Road, Bexleyheath.

**—SOLVE ALL H.T. TROUBLES—**

**WET BATTERIES**

**TAYLEX**

**—SELF GENERATING—**

Per doz.	No. 1	No. 2
	s.d.	s.d.
Jars (waxed) -	13	16
Sacs - - - -	12	19
Zincs - - - -	10	11
Rubber Bands(24)	4	4
Terminals - -	8	10

Trade Supplied.

**LONG LIFE : SILENT : ECONOMICAL**  
Sample doz. (18 volts), complete with bands and electrolyte. No. 1, 4/1 No. 2, 5/-; post 9d.; terminals extra. No. 3, with terminals, 7/6 (10.00 milli-amps), sample unit 6d. Orders 10/- carr. paid. New illustrated catalogue post free.

**FREE** Bargain List of Receivers, Amplifiers and Components

**M. TAYLOR, 57, Studley Road, Stockwell, London.**

**PAREX**

**Products PAR-EXcellence**  
are used and recommended for the

**“M.W.” A.C. “SUPER-QUAD”**  
**“LOCK-TUNE” JUNIOR**  
**“M.W.” “UNI-COIL” THREE**

**POLISHED EBONITE PANELS SUPPLIED**  
Cut and drilled to specification

REACTION CONDENSER - - - - 4/-  
DIFF. REACTION CONDENSER - - - - 4/6  
H.F. CHOKE - - - - - 3/6

SPAGHETTI RESISTANCES, ALL SIZES.  
SCREENS AND COILS OUR SPECIALITY.

**E. PAROUSSI** 10, Featherstone Buildings, High Holborn, London, W.C.1  
Phone: Chancery 7010

The Picture Paper with the **MOST News**  
**SUNDAY GRAPHIC**  
and SUNDAY NEWS.

*Here’s a Paper He’ll read right through!*

Read it from cover to cover and enjoy every word—a clean, healthy paper that is packed with fascinating facts about the things which interest a boy most. Such is **MODERN BOY**. Every issue is brimful of thrilling stories and articles on the very latest Invention, Adventure, Hobbies, etc., as well as the best fiction. It is the paper for the youth of to-day.

**Modern Boy**  
Every Monday 2d.





A NEW STYLE OF RADIO-GRAM CABINET!



CARRINGTON MFG. CO., LTD.  
SHOWROOMS:  
24, Hatton Gdn.,  
London, E.C.1.  
Phone: HOL. 8202.  
Works: S. Croydon.

The "Westminster" Radio-Gram Cabinet is one of Camco's new models. Its graceful design and fine walnut finish give it a dignity hitherto unknown in the Radio World. It is built to eliminate all resonance. In Walnut only, £8.10s. Write now for FREE copy of the 1932 24-page catalogue, giving full specification.

Name.....  
Address.....  
M. W. 7

**NEW H.F. CHOKE**  
ADVANTAGEOUS IN ALL  
"STRAIGHT" AND "SUPER" CIRCUITS.



**The "KINVA" SCREENED H.F. CHOKE**

THE LATEST ADDITION TO MODERN SCREENING PRACTICE.

ASSISTS STABILITY, CHOKES EFFICIENTLY, HELPS COMPACT "LAY-OUT."

INCORPORATES MULTI-SLOT LOW CAPACITY COIL OF HIGH INDUCTANCE, UNIFORMLY EFFECTIVE UP TO 3,000 METRES.

ABSOLUTELY FIELDLESS. NO OTHER CHOKE

Regd. Design 766,670  
Reduced View Standard Type.

PRICE, **2/9**

Write for List describing Type "M" with Electrodes for Sub-baseboard Wiring.

offers you all these points, and it's a high-class job at a low price.

In stock at most Dealers. If any difficulty in obtaining, please substitute, and write direct to:

SOLE MANUFACTURERS:-

**POSTLETHWAITE BROS., KINVER, Nr. STOURBRIDGE.**

**YOU CAN USE YOUR SPARE TIME TO START A MAIL ORDER BUSINESS**

that quickly brings you a full-time income. Few pounds capital only needed; no samples or outfits to buy. No rent, rates or canvassing. New method makes success certain.

Send to-day for Booklet.

**BUSINESS SERVICE INSTITUTE**  
(Dept. 319), 6, Carmelite Street, E.C.4.

Make

**The DAILY SKETCH**

YOUR Picture Paper.

**THE MYSTERIOUS MICROPHONE**

—continued from page 525

of work from start to finish, and he had mentally calculated an approximate "cost of production" that left no room at all for profits, and that without taking into account such items as trade discounts and servicing.

As he was bending over inspecting the "works" of the display model a curious thing came to his notice. On the artistically decorated front panel of the set there was an apparently unnecessarily expensive piece of moulding. He now saw that this cunningly concealed a microphone of the miniature "button" type. But this microphone was not connected in circuit. Casually he walked round and glanced at the interior and exterior fittings of the other twelve or so models. They were all equipped with concealed but disconnected microphones!

*Dare's Discovery*

This was an interesting discovery, for there was nothing in the advertised description of the Klecto radio set about a microphone. Returning to his office, Dare spent an hour of his very valuable time considering the matter from every conceivable angle. He had almost come to the conclusion that he was vainly trying to make a mountainous mystery out of a mole-hill of mishandled radio finance, when he suddenly remembered one of the wildest of all Askew's wild ideas, and immediately the various facts and all his suspicions seemed to fit together like a patterned mosaic. He was just rounding off the corners, as it were, when Blazer chose to pay a second visit.

*A Question of Motive*

"Well, my jolly old policeman," greeted the radio expert, "I think I've got that Klecto stunt ironed out."  
"You do, eh, laddie? That's fine. I'd just dropped in to tell you all about it myself," retorted the other calmly.  
"That's smart, Blazer. How did you get on to it?"  
"Easy. Old man King's started to 'jump' all my clients' agents. It's as plain as a pikestaff; he's out to bust him, and I don't know why."

Dare shook his head reprovingly.  
"You must have a motive, you know, my Blazer. You always said that the motive's the king-pin of all successful round-ups, didn't you?"

Tell me, do you happen to know if brother King has got a radio outfit built into any of his private motor-cars?"

The old detective scratched his head.

*The Radio Rolls-Royce*

"How the heck should I know that? Besides, what's it got to do with undercutting prices?" he grunted. "Just a tic, though," he continued. "His 'Rolls' has a radio set stuck in the dashboard—remember reading about it in one of the papers. Yank idea, ain't it? Wonder you hadn't heard about it yourself, laddie. But—"

"Just confirmation," cut in Dare. "I'll put you wise to what I think really is going on. Take a pew, snatch a cigar and make yourself comfy, my peeler. And save up your laughs until I've finished. I'll make it as snappy as I can."

"Now, Klecto Radio have an inventor bird name of Askew as their chief engineer, and I happen to know

NEXT MONTH'S

**"Modern Wireless"**

will be a

**SPECIAL CHRISTMAS DOUBLE NUMBER**

absolutely packed with  
**GOOD RADIO READING**

Make sure you don't miss it.

**Out Dec. 1st. Price 1/6**

that one of the ideas this bloke has thought out is a scheme for 'speaking back' through radio receivers. He reckons—or, at least, once did reckon—that you could so arrange a microphone in a radio set that the set would broadcast back into the ether over a short distance any sounds made near the set itself. This 'talking back,' according to his scheme, is arranged on a wave-length just a tiny bit different from the wave-length to which the set is tuned to pick up the broadcast concert. And by using an extremely selective receiver with a patent filter he proposed to listen to the very faint 'talking back' and so hear at some fairly near-at-hand point everything said in the room in which the wireless receiver fitted with his scheme was installed. No one else would be able to hear it through the powerful broadcasting.

(Continued on page 527.)



## THE MYSTERIOUS MICROPHONE

—continued from page 523

"Don't interrupt, Blazer. Now, every Klecto set is fitted with a microphone, I have found that out. Supposing these service mechanics which regularly visit the houses where there are Klecto sets secretly stick in the rest of Askew's 'talking back' gear in selected receivers, and remove same when they want to at some future date? The Klecto boss is a big financial man, he has heaps of other interests, and he has a car fitted with a radio receiver—perhaps built according to Askew's special filter scheme. He can have a 'back talker' planted in any business rival's Klecto set and run fairly close to his house in the car, and listen to all that is said by this other fellow and his pals! That, my peeler, is why Klecto radio sets are being sold so cheaply! They are high-grade sets at absurdly low prices, and our Mr. King hopes all the big men in the City of London will know a bargain when they see it advertised! If I ever doubted the feasibility of Askew's idea before—or its practicability or application—well, I don't now. Now guffaw, my Blazer."

### Chance for a Chuckle

Blazer obligingly guffawed!

"Laddie, you're the one with ideas! Why bring in this Askew?" he grinned.

"That sneer will keep a bit," said the nettled Dare. "Have the goodness, my graceless peeler, to give me an answer to this. Is eavesdropping, of the type I've suggested, illegal?"

Blazer wiped his eyes and gulped.

"I don't remember it in the official book of words, laddie!"

"Well, I'm going round to see brother King," continued Dare purposefully. "Coming round? He's only in Oxford Street. I'm giving you a chance for another chuckle, you disbelieving old policeman."

Blazer waved a hand helplessly, but picked up his hat and followed his young friend out of the office.

They located Mr. Herbert King in a luxurious suite of offices on the first floor of one of the most prominent buildings in Oxford Street, and had no difficulty in obtaining audience with the magnate.

Evidently he had lunched to his entire satisfaction; for he was in a friendly, expansive mood.

"The Mr. Dare, of course? Yes, of course. Delighted to see you. And Inspector Blazer? Ah, yes, to be sure. Delighted to see you. Beautiful day, don't you think? You, er, wish to see me? How absurd! Of course you do, or you wouldn't be here—"

"You will probably be aware, Mr. King," broke in Dare, cutting him short, "that I represent, indirectly as it were, the interests of many of the leading radio manufacturers, and you will, I trust, forgive me if I venture to draw your attention to the gravity of an irregularity that I believe your concern, Klecto Radio, is guilty of. Not an illegal irregularity, but one which may militate against the general interests of the industry. But, inasmuch as irregular procedure depends for its success upon secrecy, and as I am in the position to—"

### Tackling Mr. King

The radio expert paused significantly and glanced from the financier, who was listening with raised eyebrows and a faint smile, to Blazer, who winked solemnly and gazed up at the ceiling.

"An extraordinary accusation, Mr. Dare, extraordinary," commented King at length. "And what exactly is this irregularity to which you refer, may I ask?"

Dare leant forward and with carefully chosen words, slowly and impressively delivered, outlined the theory he had evolved, although he presented it as though it were a definite statement of fact. Mr. Herbert King listened attentively, and at the conclusion of the recital he reflectively tapped his blotter with a pencil for a few seconds before turning to Blazer.

"Do I understand from your presence here, inspector, that you believe this, er, narrative?" he asked politely, with the smile still flickering over his features. Blazer laughed and grimaced apologetically at his young friend.

### Blazer Backs Out

"I am afraid not, sir," he confessed. "To tell you the truth, I've pretty good evidence to bear out the idea you're just trying to smash a business rival by undercutting on the line of goods he happens to be handling. Don't think there's any harm in telling you that."

"I thank you, inspector." Again Mr. King tapped his blotting-pad ruminatively. Then he dropped his pencil, sat up straightly and placed his elbows squarely on the arms of

(Continued on page 528.)

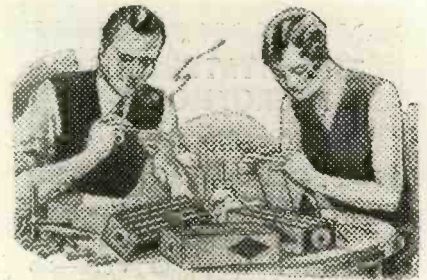

## Any Intelligent Man or Woman CAN Make These and Make Money!

Let us introduce you to Genuine, Honest, Spare-time work at which men and women to-day are making Handsome Profits regularly.

YOU also can commence on your Kitchen Table, in a spare room, or out-house. The work is clean, safe, pleasant, and quite simple. It is the making of our Patented Wireless Batteries. The demand for Wireless Batteries is so enormous that it runs into MILLIONS.

Help us to supply this demand and help yourself to the Profits.

### Many People LIKE YOU Have Doubled Their Incomes!

You can make anything up to £300 a year this self-same way! Think what you could do with all these extra £'s! Why, it means the enjoyment of many luxuries which you have hitherto been unable to afford!

You need not have the slightest previous experience or technical knowledge. There is no expensive "plant" to buy. Only a few small hand tools and presses, most of which you can make yourself at trifling cost. Your profits are only limited by the amount of time you choose to devote to the work. We GUARANTEE you profit, and, if necessary, we will take sufficient of your output off your hands to ensure it, provided only that your work comes up to the easily-attained standard of efficiency—we undertake to continue your training FREE as long as required.

The Market is unlimited and cannot possibly become overcrowded. It is a GOOD, CLEAN, HONEST, STRAIGHTFORWARD BUSINESS which will help you to become your own "Master."

SEND THIS FORM FOR FREE INSTRUCTIONS HOW TO START

### COUPON

To Mr. V. ENGLAND-RICHARDS,  
THE ENGLAND-RICHARDS  
CO., LTD.,

4020, King's Lynn, Norfolk.

Sir.—Please send me at once, and FREE, full details as to how I can make Wireless Batteries and Make Money at Home in my spare time. I enclose 2d. stamp for postage.

Print your name and address boldly in capital letters on a plain sheet of paper and pin this coupon to it.

"Modern Wireless," Nov., 1931.

### Advertisements

As far as possible all advertisements appearing in "Modern Wireless" are subject to careful scrutiny before publication, but should any reader experience delay or difficulty in getting orders fulfilled, or should the goods supplied not be as advertised, information should be sent to the Advertisement Manager, "Modern Wireless," 4, Ludgate Circus, London, E.C.4.



**THE MYSTERIOUS MICROPHONE**

—continued from page 527

his chair. "A great idea! Fascinating!" he exclaimed, half to himself. "But even if it would work—no practical value! Could sit around for hours without hearing anything worth while! People speak such a lot, and say such a little that's worth over-hearing—especially in their own homes. But I certainly was intrigued by the novelty of it—I must say that."

"Was!" interjected the radio consultant, triumphantly, as he met Blazer's astonished and admiring glance.

**The Home Recorder**

"Oh, yes, you were quite right up to a point, Dare. Remarkably clever the way you've got it all mapped out. But it wouldn't work, that was the trouble!" The financier sighed gently and his eyes twinkled. "Ingenious fellow Askew, and we're working another of his ideas on quite above-board lines. No, I'm not even under-selling to smash other people. I'm working Klecto Radio on sound business lines. Every time one of my mechanics visits an owner of a Klecto Radio set he tries to get him to buy one of our Klecto home recorders for making your own gramophone records.

**Those Extras!**

We sell it as a neat little unit—the microphone is already in the receiver, as Dare has spotted, so it can be fitted in a twinkling. The unit costs us about fifteen shillings to make, and we get eight guineas for it. And you'd be surprised at the number of people my men badger into buying one!

"Even so, I don't see how you make

a profit on the whole transaction. I reckoned you were down at least eight pounds on each set," commented Dare puzzledly.

**The Real Secret**

"Ah! Now I'll let you into the real secret," chuckled Mr. King. "Each of my sets needs ten expensive valves, and my designer has arranged that these valves shall get about fifty per cent more current from the electric mains than is good for 'em! He's had over-size power transformers stuck in these darned Klecto sets. Ten valves, see? Ten valves to wear out quickly, and ten valves for my mechanics to replace at retail prices! Got the idea, Mr. Dare? Smart, don't you think?"

"Smart? Heck, it's a (so-and-so) swindle!" grunted Blazer indignantly.

"But Dare laughed.

"Mr. King," he grinned, "allow me to offer you my congratulations." Blazer goggled and would have said something, but the radio expert waved him into silence.

**A Knock-Out for King!**

"You are a philanthropist, Mr. King," Dare continued. "None of those thousands of valves planted in those thousands of so-very-fine-value-for-money Klecto sets which you've probably sold already are going to let their owners down. They'll easily stand fifty per cent 'over-running.' You see, I know them, saw stacks of 'em in boxes at your factory and, what's more to the point, I myself designed them for Very Valves, Ltd., with a specific 60 per cent safety margin! So, Mr. King, as I've already said, you're a philanthropist!"

"Oh, yeah?" whispered the financier faintly as he gazed blankly at a sheaf of advertisement proofs that lay before him.

**GIVE YOUR VALVES A CHANCE**

—continued from page 474

of generosity where H.T. is concerned, but voltages in excess of that stated by the makers to be permissible are sometimes used. And the results of this form of valve misuse are soon going to become apparent inasmuch as the valve will have its useful life considerably shortened.

But too small an amount of H.T. will result in poor results, mostly accompanied by bad distortion; and although no actual harm is done to a valve that is being worked under these conditions, still that valve is not being given a chance.

**Correct H.T. and G.B.**

Then take the grid bias; in spite of all that has been written on this most important matter there are still a large number of listeners who do not understand what correct grid bias means.

I know quite a number of people who, when the H.T. battery is fresh, use about 9 volts on the power valve and leave it at that. Gradually the H.T. battery drops in voltage until its working output is somewhere about 80 volts, instead of, say, 108; and naturally a woolliness creeps into the reproduction.

To sum up this article, read the heading once again and "give your valves a chance." Do not expect them to work well in conjunction with cheap or shoddy components, give them an adequate amount of high tension, adjust the grid bias correctly and in accordance with the anode voltage actually reaching the valve, and, if you must use reaction, use as little as possible.

**INDEX TO ADVERTISERS**

	PAGE
Amalgamated Press Annuals	521
Belling & Lee, Ltd.	517
Bird, Sydney S., & Sons, Ltd.	516
British Blue Spot Co., Ltd.	Cover iii
British General Mfg. Co., Ltd.	505
British Insulated Cables, Ltd.	511
Bulgin, A. F., & Co., Ltd.	525
Burne-Jones & Co., Ltd. (Magnum)	520
Business Service Institute	526
Carrington Mfg. Co., Ltd.	526
Colvern, Ltd.	507
Cossor, A. C., Ltd.	416
"Daily Mail"	481
Edison Swan Electric Co., Ltd.	Cover iv, 417, 518
England-Richards Co., Ltd.	527

	PAGE
Ferranti, Ltd.	482
Forno Co.	482, 522
General Electric Co., Ltd.	495
Graham Amplion, Ltd.	511
Gramophone Co., Ltd.	485
Heayberd, F. C., & Co.	524
Jackson Bros.	519
Lanchester Laboratories, Ltd.	517
Lectro Linx, Ltd.	515
London Elec. Wire Co. & Smiths, Ltd.	Cover ii
Lotus Radio, Ltd.	489
Lyons, Claude, Ltd.	413
"Modern Boy"	525
"Modern Boy's Book of Aircraft"	519
Oldham & Son, Ltd.	523
Postlethwaite Bros.	526
Peto-Scott Co., Ltd.	415
Pickett's Cabinet Works	525
Pifco, Ltd.	517
Paroussi, E.	525
Radio Instruments, Ltd.	515

	PAGE
Ready Radio, Ltd.	473
Reproducers & Amplifiers, Ltd.	520
Sovereign Products, Ltd.	519
Taylor, M.	525
Telegraph Condenser Co., Ltd.	478
Telsen Electric Co., Ltd.	477, 491
Tungsram Elec. Lamp Works (Gt. Britain), Ltd.	497
Universal English Dictionary	414
Varley Products	501
Westinghouse Brake & Saxby Signal Co., Ltd.	509
Wilkins & Wright, Ltd. ("Utility")	493
Wingrove & Rogers, Ltd.	515
Wright & Weaire, Ltd.	482

All communications concerning advertising in "Modern Wireless" must be made to John H. Lile, Ltd., 4, Ludgate Circus, London, E.C.4. Telephone: City 7261



# BEAUTY...

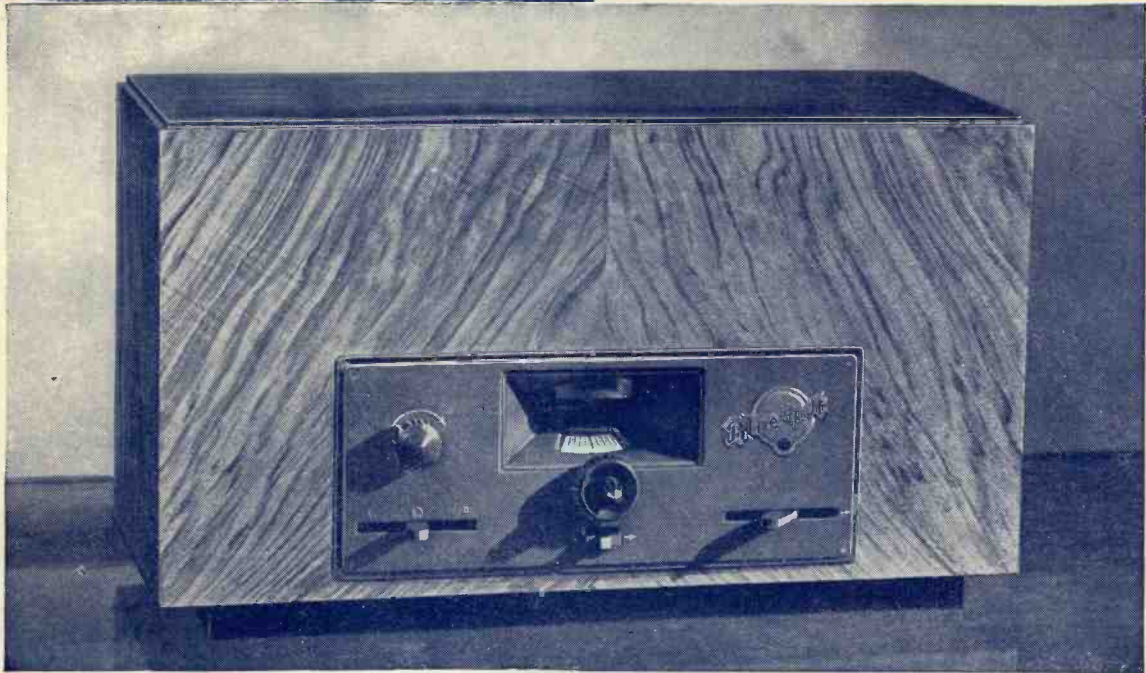

Illustration shows BLUE SPOT Receiver W400 complete with B.R.V.M.A. Valves and Royalties paid, in Walnut Cabinet (but without loud speaker) A.C. - - - £18

This receiver is also available in an Oak Cabinet of similar design to Blue Spot Speaker 100D at the same price £18

#### OTHER MODELS (A.C.).

Upright Grand	"	"	"	27 gns.
Table Grand	"	"	"	25 gns.
WS400	"	"	"	20 gns.

Complete with B.R.V.M.A. Valves, Royalties paid and Blue Spot Speaker embodied in the Cabinet. All models are suitable for 100-240V A.C.



## SUPER RECEIVERS

## in line and tone

BLUE SPOT All Mains Receivers are as good as they look. A wealth of experience, research and experiment is embodied in their circuits.

BLUE SPOT Receivers employ five valves, two screened grid, detector, power output and rectifier. They give you the widest possible choice of broadcast fare. Their range is all Europe. At a turn of the tuning dial you glide miraculously from Oslo to Madrid, from London to far-off Budapest.

Operating BLUE SPOT Receivers is just as simple as that. You plug in and tune in—no batteries, no accumulators to run down. The mains can be used as an aerial, although provision is made for an outside aerial if preferred. The sets can be moved from room to room as desired. They cost no more to run than your dining room light.

BLUE SPOT Receivers do more than bring in a host of stations. Thanks to the wonderful BLUE SPOT Speakers, reproduction is so perfect that you can hear and enjoy all the programmes you tune in. Every sound is as clear and distinct as voices by your own fireside.

Ask your dealer to demonstrate a BLUE SPOT Receiver or send for illustrated catalogue M.W.10 giving full particulars.

**THE BRITISH BLUE SPOT COMPANY LTD.**

BLUE SPOT HOUSE, 94/96 ROSOMAN ST. ROSEBERY AV. LONDON, E.C.1



# 2 VOLT MAZDA MASTERPIECES

TYPE	PRICE
H.210 - - -	8/6
HL.210 - - -	8/6
★ HL.2 - - -	8/6
L.210 - - -	8/6
★ L.2 - - -	8/6
P.220 - - -	10/6
P.220A - - -	13/6
P.240 - - -	13/6
PEN.230 - - -	20/0
PEN.220 - - -	20/0
PEN.220A - - -	20/0
S.G.215 - - -	20/0
★ S.G.215A - - -	20/0
★ S.G.215B - - -	20/0

★ METALLISED

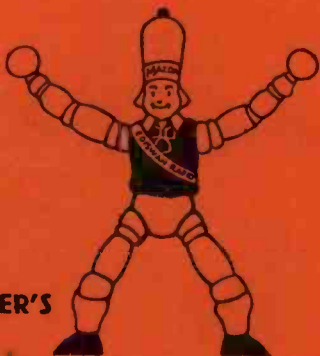

LOOK FOR  
"EDDY" IN  
YOUR DEALER'S  
WINDOW

THE AMAZING

## MAZDA PEN. 220

### Characteristics:

Filament Voltage - - 2.0 volts Anode Current (Max) - 12 mA  
 Filament Current - - 0.2 amps. Screen Voltage (Max) - 150 volts  
 Anode Voltage (Max) - 150 volts Mutual Conductance - 2.5 mA/V  
 At  $E_s = 100$ ;  $E_s = 100$ ;  $E_g = 0$ .

PRICE 20/=

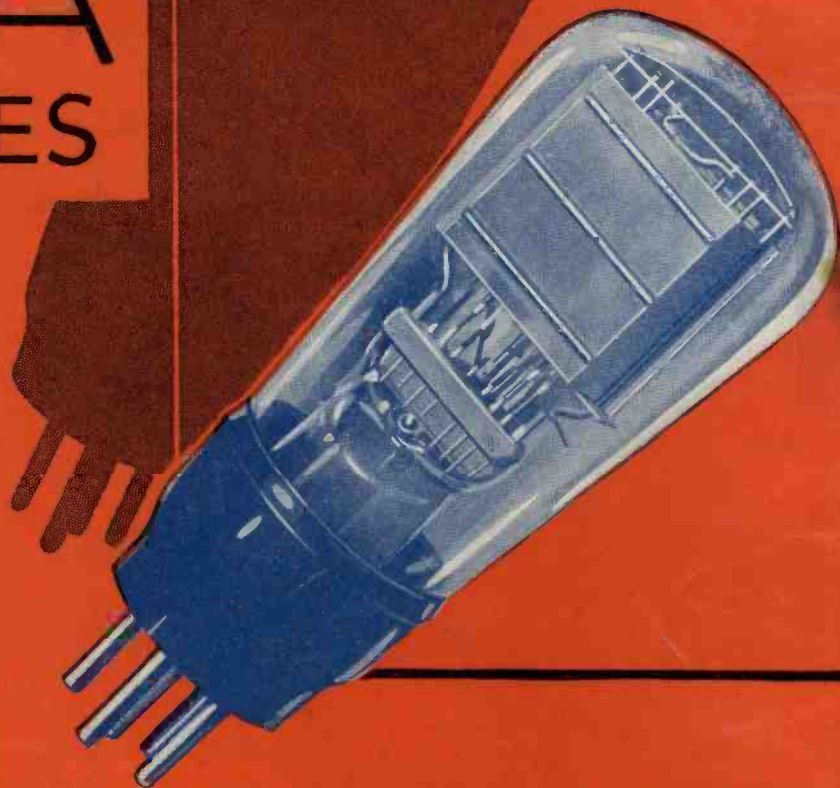

Since 2-volt valves were made, never has there been so amazing a range as this — so much evidence of brilliant engineering — so many valves with outstanding characteristics. Instance the Pen. 220; or pentode, which at once presents the solution to the output stage problem in portable sets, for it gives an astonishingly large output for a combined screen and anode current of under 5 mA. It is a valve H.T. dry battery users have longed for. It is typical of all Mazda 2-volt valves. Mazda 2-volt valves, both metallised and clear bulb types, are sold by all good radio dealers.

# MAZDA

THE  
BRITISH  
VALVES

The Edison Swan Electric Co. Ltd.



155 Charing Cross Road, London, W.C.2