

BUILD THE "HI-LO" REJECTOR

MODERN 1/- WIRELESS

Vol. XV. No. 52

APRIL 1931

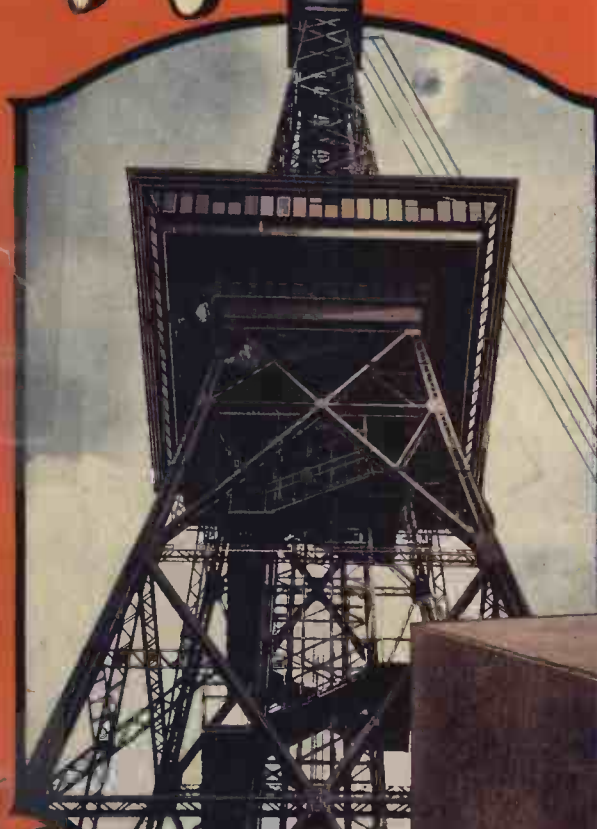

INVALUABLE TO THE
DISTANT LISTENER—
THE WORLD'S
PROGRAMMES
SPECIALLY ENLARGED
SUPPLEMENT INSIDE

In this Issue
THE
PENTODION



ALSO THIS MONTH
COUPLING IN THE SCREENS
FREE THE B.B.C.
By Lt.-Commander the Hon.
J. M. KENWORTHY, R.N., M.P.
THE "SUPERVOX"
A magnificent long-distance loud-
speaker set.
A DUAL-RANGE ONE-VALVER
SEVERAL PRACTICAL AND INTER-
ESTING RADIO-GRAM ARTICLES
ANOTHER "DARE" EPISODE

RADIO CONSULTANT-IN-CHIEF CAPT P. PECKERSLEY M.I.E.E.

for BETTER radio reception

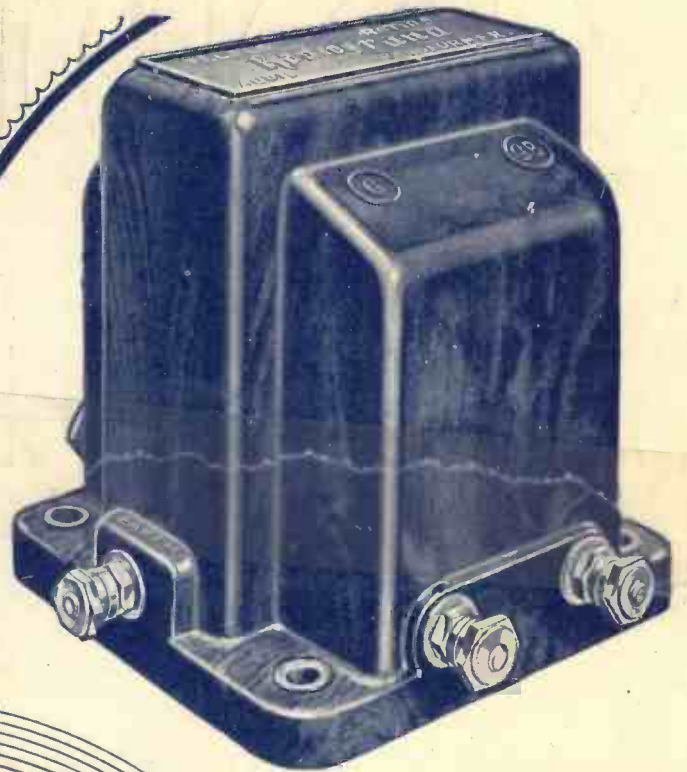

TELSEN L.F. TRANSFORMERS.
 "ACE" - - - Ratios 3-1 & 5-1 8/6
 "RADIOGRAND" .. 3-1 & 5-1 12/6
 "RADIOGRAND" Super Ratio 7-1 17/6



TELSEN H.F. CHOKES.
 Designed to cover the whole wave-band range from 18 to 4,000 metres, extremely low self-capacity, shrouded in genuine Bakelite. Inductance 150,000 microhenries. Resistance 400 ohms. Price 2/6 each.

The confidence shown by experienced designers in choosing **TELSEN Components** for all their important new circuits is reflected in the popularity of these wonderful components among amateur enthusiasts.

For maximum power combined with superb quality of tone, **TELSEN Components**, patented in many features, are unrivalled.

Get the utmost results from your next set by fitting



TELSEN GRID LEAKS.
 Absolutely silent and non-microphonic, practically unbreakable, cannot be burnt out, and are unaffected by atmospheric changes. Not being wire-wound there are no capacity effects. Made in capacities 1, 2, 3, 4 and 5 megohms. Price 1/- each.

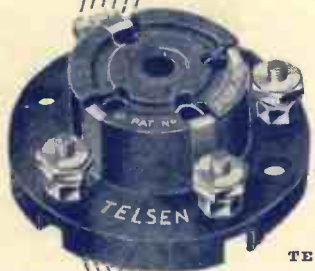

TELSEN FOUR-PIN VALVE HOLDERS.
 Price 1/- each.

TELSEN VALVE HOLDERS.
 Pro. Pat. No. 20286/30. An entirely new design in Valve Holders, embodying patent metal spring contacts, which are designed to provide the most efficient contact with the valve legs, whether split or non-split. Low-capacity, self-locating, supplied with patent soldering tags and hexagon terminal nuts.

TELSEN FIVE-PIN VALVE HOLDERS.
 Price 1/3 each.

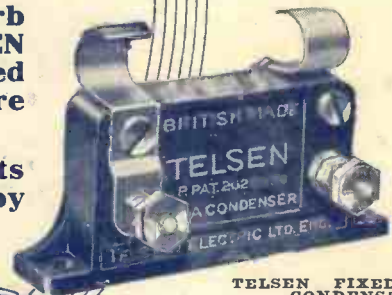

TELSEN FIXED (MICA) CONDENSERS.
 Shrouded in genuine Bakelite, made in capacities up to .002 mfd. Pro. Pat. No. 20287/30 .0003 supplied complete with patent Grid Leak Clips to facilitate series or parallel connection. Can be mounted upright or flat. Tested on 500 volts. Price 1/- each.

TELSEN

COMPONENTS

Advt. of Telsen Electric Co., Ltd., Birmingham

CONTENTS

VOL. XV. No. 52.

MODERN WIRELESS

APRIL, 1931.

	Page		Page
Editorial	359	Recent Record Releases	404
Free the B.E.C.	360	Coupling in the Screens	405
Down in the Control Room	363	The "Supervox"	408
Trouble Tracking	365	Questions Answered	416
The "Pentodion"	366	Loud Speakers in Series	417
Your Aerial and Earth	372	On the Short Waves	419
Valves I Have Tested	385	Reducing Heterodyning	421
Off the Beaten Track	387	For Those D.C. Mains	422
A Dual-Range One-Valver	389	Some Needle Notes	428
At Your Service	393	On the Test Bench	430
The "Hi-Lo" Reflector	395	Round the Turntable	432
Some Readers' Reports	398	In Passing	434
Reliable Joints	398	Mains Motors	436
My Broadcasting Diary	399	A Short-Wave Experiment	440
Re-Distributing "DX"	401	Radio Notes and News	442

SPECIAL SECTION, "THE WORLD'S PROGRAMMES" PAGES 373-384.

As some of the arrangements and specialities described in this Journal may be the subject of Letters Patent the amateur and trader would be well advised to obtain permission of the patentees to use the patents before joining in

Edited by NORMAN EDWARDS.

Technical Editor: G. V. DOWDING, Associate I.E.E.

Radio Consultant-in-Chief: Capt. P. P. ECKERSLEY, M.I.E.E

Scientific Adviser: J. H. T. ROBERTS, D.Sc., F.Inst.P.

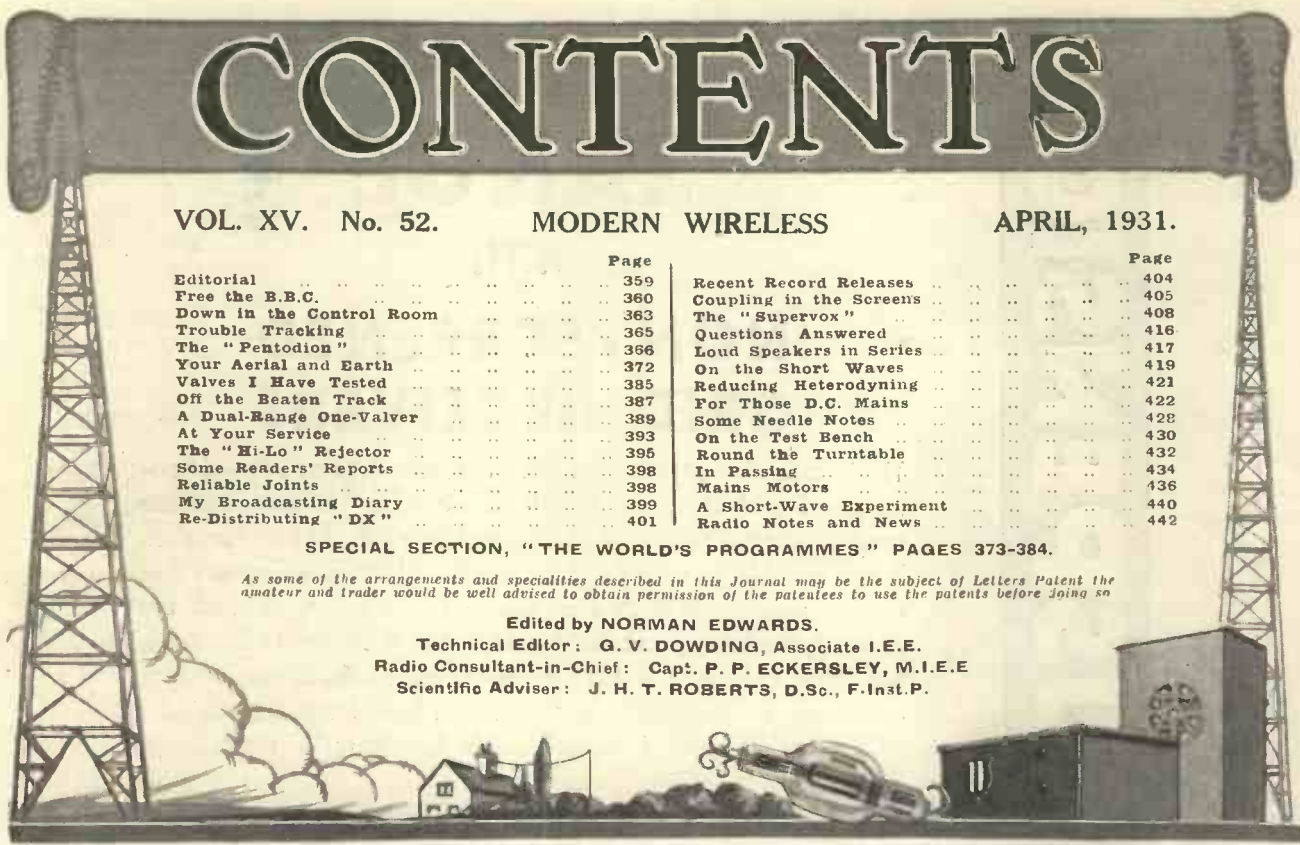

"DEFINITELY IN THE HIGHEST CLASS"

says "The Wireless World."



Brit. Pat. 334,885



PICK-UP and TONE-ARM

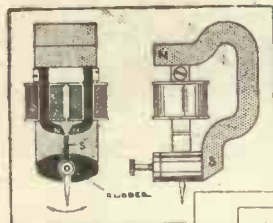

Above. Sectional view of magnet system. Note that the tip of the armature moves across the pole faces and not between them.

Below. Frequency characteristic, showing excellent response at all frequencies.

(Illustrations by courtesy of "The Wireless World")

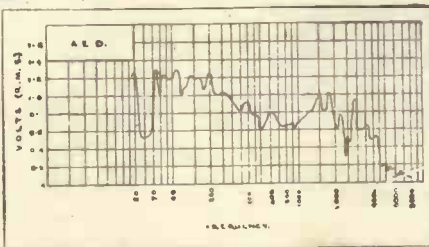

"The damping of the armature is exceptionally light, and from the point of view of freedom from record wear the A.E.D. pick-up is definitely in the highest class. The frequency response curve is of good general form," states the test report published in the March 4th issue of "The Wireless World." Such praise from so high a technical authority *must* guide you in your selection.

The A.E.D. Pick-up gives you more and better volume with less amplification and saves your records. It is your *only* choice.

PRICE **42/-** Complete

AUTO ELECTRIC DEVICES, LTD.,
DIAMOND WORKS, BRIGHTON, SUSSEX.

Telephone: Brighton 2404. Telegrams: "Selfwind, Brighton."

7 POINT SUSPENSION

FOR LONGER RANGE

RANGE

WITH

NON-SCREENED GRID RECEIVERS

The introduction of the Cossor 210 H.L. affords to all users of non-screened grid Receivers a method whereby they may increase considerably the range and efficiency of their Sets at a minimum cost. The favourable grid current characteristics of this new Cossor Valve ensure maximum High Frequency amplification without the necessity for using grid bias. In addition to this special advantage, the new Cossor 210 H.L. incorporates all those well-known advanced constructional features which have long characterised all Cossor Valves. It is obtainable from any Wireless Shop.

For H. F. Amplification

The new Cossor 210 H.L. 2 volts, 1 amp. Impedance 22,000. Amplification Factor 24, Mutual Conductance, 1.1 m.a./v. Anode voltage 75-150. Price **8/6**

A. C. Cossor Ltd., Highbury Grove, London, N.5



MODERN WIRELESS

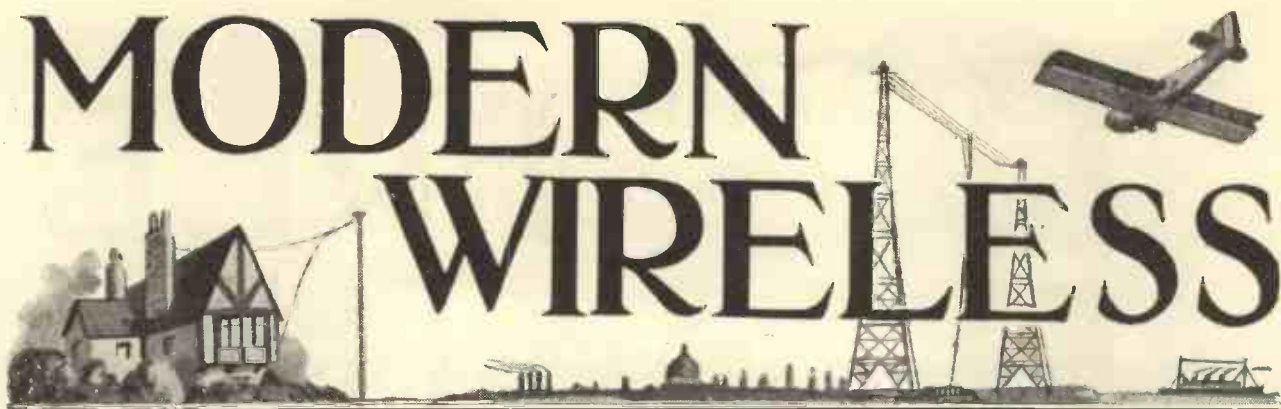

Vol. XV. No. 52

BRITAIN'S LEADING RADIO MAGAZINE

APRIL, 1931

The Need For Selectivity—Striking Set Design—Listen To Those Lions

The Need for Selectivity

JUDGING from the large amount of correspondence we receive from our readers, a good many of them are finding modern broadcasting conditions more and more trying; and in view of the fact that the Powers-That-Be do not seem inclined to tackle the problem of the congested ether before the Madrid Conference in 1932, we are paying considerable attention to the question of Simple Selectivity.

Consequently, this issue of MODERN WIRELESS is something in the nature of a Selectivity Number. More and more stations are being built, and the wave-length problem is becoming more and more serious, and therefore the question of simple selectivity looms larger upon the horizon, not only of the ordinary listener, but of amateurs and experimenters.

You will find that the sets in this issue of MODERN WIRELESS concentrate upon the problem of selectivity. They are, primarily, easy to build and inexpensive; but these two factors do not mean that the receivers suffer in other qualities, such as power, tone, etc.

Striking Set Design

THE most important set is the "Pentodion." This is a particularly novel design. Its appearance is undoubtedly striking, and the set itself is capable of extremely powerful reproduction of both local and long-distance stations. When this set was designed and constructed in the laboratory great care was taken to see that the reproduction should be pure, and the novel type of variable condenser employed was found greatly to facilitate the handling of the set.

Even if you do not build this particular receiver, read about it and study the layout. We are sure you will find it out-of-the-ordinary and interesting.

The "Supervox" is a radio-gram receiver that is ideal for modern conditions of reception. When bearing in mind these conditions we had also in mind the reception not only of local stations on the loud speaker, but of real long-distance stations.

This set uses two S.G. stages, but the controls are kept few in number by the use of a very efficient aperiodic stage. The result is a highly selective receiver.

The "Dual-Ranger" is a neat, straightforward, single-valve receiver which is extremely easily operated. It is, in fact, a very simple station-change domestic receiver, suitable for searching around and bringing in many distant broadcasters.

The "Hi-Lo" Rejector is another practical aid which we offer towards the solution of the problem of Simple Selectivity. This unit can be added to any set, and will wipe out either a high or low wave-length station at the touch of a switch. It is, we venture to say, simplicity itself.

Listen to Those Lions

YOU have probably read in the newspapers about the interesting tests which our contemporary, the "Wireless Constructor," has arranged for April 20th. Perhaps you did not know when you saw this news that the "Wireless Constructor" had arranged the test with Nairobi, the short-wave broadcasting station in Kenya Colony, because—for some peculiar reason—newspapers to-day do not seem to fancy giving credit to any of their contemporaries who arrange interesting and novel broadcast experiments.

However, the fact is that, thanks to the courtesy of the Director of the Nairobi station, our contemporary has arranged to broadcast on April 20th a special programme for British listeners. This programme will include an attempt to relay the roar of lions. In a letter to the Editor, the director of the station states that he is arranging to have microphones taken to a certain spot in the jungle where it is known that lions frequently resort for an evening drink.

Also, people living in Kenya Colony will be invited to come to the microphone for a few seconds in order to broadcast direct greetings to their friends and folks in this country. So if you have a pal or a relation in Kenya it is quite likely you will hear him send his greetings to you on April 20th.

Arrangements are under way at the moment of writing for the B.B.C. to relay this particular broadcast, but, of course, it all depends on how Nairobi comes over on the evening of April 20th. The broadcast will probably start at 8 p.m. G.M.T. and will last about an hour, but for full details we must refer you to our contemporary, the "Wireless Constructor."

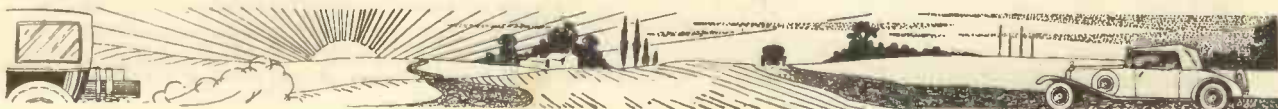



FREE THE B.B.C.

Above is a photograph of the author of this article, and on the right is seen Mr. J. Ramsay MacDonald at the microphone preparing to broadcast a political talk.



THE B.B.C. is a peculiar institution. It is a public Corporation, its directors were nominated by the Government of the day, and it is supposed to have a semi-independent existence and, above all, to be free of political control. The Postmaster-General has some nominal say in the management.

If the Post Office Estimates are discussed in Parliament, which is not always the case, for only a small number of the Government Departments come under the Parliamentary harrow each session, B.B.C. organisation and conduct can be praised or criticised.

No Direct Control in Parliament

Apart from this occasion, however, the make-up of its programmes, for example, or the quality of the entertainment provided for the public cannot be questioned in the House of Commons.

I, as the representative of a constituency, can voice the grievance of the electors who sent me to Parliament if the land telephone wires break down or are not renewed quickly enough, or if the wireless telephone service is bad between Hull and the Continent.

But if these same electors are dissatisfied with the programmes of the B.B.C., and for which they pay just as telephone subscribers pay for the telephone service, Mr. Speaker would call me to order at once if I mentioned the matter on the floor of the House of Commons.

Yet there is an indirect control where politics are concerned; and it has been nothing short of farcical from the start. That the successive Postmaster-Generals of the day have a hand in the matter is obvious to everyone.

The first rule was that nothing controversial should go out over the ether. Now the most interesting subjects in life are the most controversial. There are thousands of subscribers who are only interested in vaudeville, or in educational talks, or in the reading of plays, or in chamber music. But there are thousands more who like to hear on the wireless views on such highly explosive subjects as religion or politics. But the rule was silence where anything argumentative was concerned.

For long a strenuous fight was put up against any use of the wireless at elections. Then this ban was broken in the General Election of 1924. The recognised leaders of the three political parties—Liberal, Labour, and Conservative—were each allowed to broadcast one address.

An Attempt to Lift the Ban

No one else was allowed to address the electorate through the "mike." No one seemed any the worse. The thousands of voters who were unable to get to political meetings were enabled to hear the three elder statesmen, the late Mr. Asquith, Mr. Baldwin, and Mr. MacDonald, at their own firesides.

by
 Lt. Commander
 the Hon J.M.
KENWORTHY
 R.N.M.P.



Discussions on controversial subjects are of great interest to listeners, and above are seen the two participants in such a broadcast with the "chairman" seated between them. On the left is an American broadcaster. It is interesting to note that "freedom of broadcasting" is much greater in the United States.



But though the ban was partly broken at that General Election, it was kept on for by-elections; and is still in operation. In 1926 I fought a by-election myself. The use of wireless would have helped my two opponents far more than myself, for they were unknown men, and I had represented my constituency for seven years and was known to everyone.

Yet for the sake of the infirm and the elderly I made the attempt to have the ban lifted. And in those days we had our own regional station in Hull. But no; this meant entering the realm of political controversy, and the attempt failed.

The Postmaster was adamant, though I happen to know that the B.B.C. officials would have liked the experiment made. Indeed, all through this period of inhibition on "controversy" the B.B.C. staff were fighting for liberty. In the last Parliament, which ended with the General Election of May, 1929, it was decided that a series of talks should take place on political subjects, each of the three organised parties taking it in turns to monopolise the ether for twenty minutes once a week and expand their programmes.

Complete Deadlock for Months

But when it came to an allocation of time there was trouble. The Conservative Party machine insisted on two broadcasts for their spokesmen for every Liberal speaker and every Labour speaker.

The controllers of the other two Party caucuses objected and wanted to have a turn each, the Conservatives only

to have one in three. There was complete deadlock, which lasted for months; and the listeners, knowing in their bones that the Party leaders would put their dullest speakers on the wireless as a matter of course, didn't grieve overmuch. Then came the General Election of 1929, a new Parliament and a new Government was installed at Westminster, and after more haggling, negotiating, arguing and quarrelling it was finally decided that talks should take place on Unemployment, each Party having a turn and nominating their particular spokesmen.

The Mosley-Percy Debate

No subject is more controversial or soaked in politics than Unemployment, its causes and cure; and I suppose there is no topic of greater direct interest to a greater number of people.

The wheel has therefore turned full circle, and the B.B.C., which used to be enjoined on threat of all kinds of pains and penalties to avoid anything controversial, has now been allowed to broadcast talks on the most controversial subject possible.

But although the three Party caucuses are in agreement at last as to the allocation of time, they are firmly determined that no one outside the ranks of strict officialdom shall be allowed to address the listeners. Broadcast politics are under a censorship as severe as anything in Russia.

Debates on abstract subjects or art and letters have, however, been taking place for many months. And amongst these was a debate arranged to take place between Lord Eustace Percy, a Member of Parliament who was Minister of Education in the last two Conservative Governments, and Sir Oswald Mosley, another ex-Minister, on "Tradition."

I don't know what the official view of the Board of the B.B.C. is about tradition; but broadcasting is not old enough to have a tradition of its own, unless it is to follow the example of the American college authorities who put up a notice to say that from the thirtieth of March it should be a tradition of the college that no one was to cross the grass in the quadrangle!

"The suppression of this particular talk was a scandal; and to pretend now that the B.B.C. is independent of political influence after this episode is arrant humbug." So writes the well-informed author of this article, which deals with the vital matter of controversial subjects and politics in relation to British broadcasting.

We Have a Right to Hear Those Who Interest Us

However, all went well until it became known that the subject to be discussed was the tradition of the House of Commons. Now, this is a matter of great controversy and interest at the present time. Recent by-elections, with a tremendous falling off in the number of people who troubled to vote at all, and the general tenure of conversations to be heard everywhere, are very clear indications that an increasing number of people are losing patience with Parliament altogether, and doubting whether it can deliver the goods.

The Cart-load of Bricks!

Nearly all the younger school of active politicians, and one or two of the older ones like Mr. Lloyd George, believe that there is too much tradition in Parliament, that the whole procedure wants rationalising, and that it is incapable of doing its work in the twentieth century with the forms and customs of the eighteenth century.

So strong, indeed, has been the pressure that a special Select Committee of Members of Parliament has been set up by the Government to inquire into the procedure of the House and to make recommendations for its alteration.

The three political caucuses are, of course, opposed to any change in Parliamentary tradition, always have been, and always will be. And down they came like a cart-load of bricks on the poor B.B.C., and stopped what should have been a very interesting debate only six hours before it was billed to take place.

To Stop that "Dangerous Thinking"

He is "news" for the journalists, and his recent political doings have received much notice in the popular Press. I have no doubt that a very large number of subscribers to the B.B.C. would have liked to have heard this debate. But the caucus apparently thought the debate would lead to what the Japanese call "dangerous thinking."

The suppression of this particular talk was a scandal; and to pretend now that the B.B.C. is independent of political influence after this episode is arrant humbug.

The Official Stranglehold

The B.B.C. is the property of the nation, and the people as a whole have a right to hear anyone over the wireless who interests them, on any subject of importance that they want to hear about.

It is not an annexe of the offices of the three recognised Party headquarters, and it is not a means of fortifying the prestige of the Party bosses in this country. It would be just as sensible to say that the religious talks on Sunday should only be given by ministers of the Established Church, nominated by the Archbishop, or that the only music broadcast in the future was to be that of the now officially recognised and subsidised Covent Garden Opera House, and passed by Mr. Snowden. Party politics are in a state of flux in this country. Anyone really interested in their developments has a right to hear unorthodox views as well as the strictly official.

When the Charter of the B.B.C. was granted, the public were insistent that it should be freed as far as possible from bureaucratic influence; Whitehall officialdom was not to strangle this wonderful means of education and entertainment.

But if on some of the most vital subjects of the day the dead hand of official bureaucracy is to control the ether, there is a direct negation of liberty. We might just as well go back to the obsolete Press laws, when no newspaper dared criticise the Government of the day for fear of having its licence taken away.

Right of the Public

There are rebel movements in all three of the old political parties. Rebellions are only justified when they succeed, and it is early yet to say how far these movements will go. But the public of this country have every right to know what is going on, and if they prefer to hear what matters over the wireless they should demand it.

The sooner the B.B.C. is freed altogether from political control and allowed to engage the services of the speakers whom the public wishes to hear, and not only those nominated by the Party caucuses, the better.

MR. BERNARD SHAW AND RADIO DEBATE



In the front of this photograph and to the left of Mr. Shaw is Mr. G. K. Chesterton with Lady Rhondda, who took part in an interesting debate at the Kingsway Hall. Seldom are such debates of a political nature or on matters of very great interest.

Lord Eustace Percy is a scion of a ducal house, with staunch Conservative traditions, and could be trusted to make a brilliant case for altering nothing and leaving everything as it is. Sir Oswald Mosley, on the other hand, whatever else may be said about him, is a rebel.





DOWN IN THE CONTROL ROOM

Every programme that the B.B.C. sends out is controlled—the weak voices are strengthened, the too-loud instruments reduced to a reasonable level, and the change-overs faded out and faded in so that no sudden switch-clicks shall irritate the listening public. This is a particularly interesting account of a personal visit to the Savoy Hill Control Room.

By a Special Correspondent.

THERE is a discussion going on at present about the B.B.C. control room. People who like to “slate” the B.B.C. whenever they can say that the control rooms at Savoy Hill and Manchester are out of date, and that that is why we get so much interference, poor regulation of volume, crackling and annoying clicks due to changes over from one studio or line to another.

To settle this pretty problem I went up to Savoy Hill recently and craved audience with one of the control-room engineers. He was most apologetic in his attitude.

Seven Studios at Once

“My dear fellow,” he said, “you have no idea what a problem we have here at Savoy Hill. Let me take you round and show you things.”

He glanced at the clock.

“The control room will be free now, I expect. We can go down and see the workings thereof.”

We went.

“Here at Savoy Hill” he said, “we have nine studios. I dare say you know that. Six of these have silence cabinets outside.

“You know what I mean—those ante-rooms in which the announcer can shut himself up and listen to the transmissions in the main studio, and in which there is also a microphone so that he can make his announcements without upsetting artistes in the studio itself.”

“We also have one studio for the effects, and down in the basement there are two ‘echo’ rooms. Quite often

during the busy parts of the evening six or seven of these nine rooms are in action at once, and woe betide the control-room engineer who muddles the switches or lets the ‘run’ on one line get on to another, so that Sir Walford Davies is speaking with a background of Jack Payne!

“Also (I don’t know whether you ought to publish this), most of the apparatus in the control room here is five years old, and although Manchester has the very latest studio equipment we shall have something even better in Broadcasting House.

“But for the time being that is hush-hush. Let me show you how these things work. That big box on the wall there, having two rows of numbers on it, is not the servants’ bell indicator. It shows which studios are in use.

“As you can see, at present the only rooms in use are No. 6, where the gramophone broadcast business is done, and No. 3.”

Manchester More Modern

“It looks rather Post Office-ish,” I ventured to remark. “Those ‘phone type plugs and jacks, I mean.”

“That is so,” he said, “but the Manchester control room, although quite the latest thing at present, is even more Post Office-ish in appearance. There the actual control boards occupy two sides of the room, and against these the operators sit as in a telephone exchange.

“A trouble that we have here is that the amplifiers and control circuits are close up to the controls, and it is not easy to prevent interference from one line to another.

Elaborate System of Cue Signals

At Manchester the switching control and test desks are all in different parts, as they should be, and the amplifiers are shielded in big metal boxes."

"Now," I said, "what about the control of volume? Many readers seem to think that the musician technicians you have in this department do not know their job."

"It is very difficult here," he explained. "We have these two meters on this desk, one of which is a volume indicator, and the other a distortion indicator. The men in control listen to the transmission by means of 'phones, or through that loud speaker in the corner of the room, and by means of fader potentiometers he regulates the strength of the transmission.

Making and Breaking Circuits

"Now at Manchester the control man can work either at one of the control desks in the room (which he has to do if he has also to control some simultaneous-broadcast line switching) or, if he has a special musical transmission (the B.B.C. symphony concerts, for instance), he can go into a special cubicle and there work on the volume-control knobs.

"Another thing is that here at Savoy Hill the actual circuits are made and broken by means of the plugs and jacks, but this is not the best way of doing it. A better way is to have an automatic switching control with relays so that the plugs and jacks do not break circuits, but control relays at a distance (perhaps even in another room), and these work pre-selectors in just the same way as railway signals work.

"These interlock, so that, for instance, two studios cannot be put by mistake on the same line. Manchester already has this automatic control.

The Dramatic Control Room

"The much-discussed dramatic control room is really only a string of ten fader potentiometers by means of which any one studio can be brought into action, and no

necessarily at full strength. But, of course, it is not quite so simple as all that, and this part of the Savoy Hill building is virtually a maze of wires.

"That is Wireless"

"By the way, when the dramatic control board is in use our difficulties are increased by the necessity for cue lights. These are indicating lights slung in the main studio and switched on from the dramatic control panel. The man at the panel can thus tell the artistes in each studio when to get ready to say their parts.

"Anyway, I wish that all readers who grumble at present-day control-room work could come and see for themselves the difficulties with which we have to contend. Look at the back of this board, for instance."

He lifted up the flap on one of the control desks and showed me the maze of multi-coloured wires at the back, each plaited into groups of a dozen or so.

"That," he said sarcastically, "is wireless."

AT THE MANCHESTER STATION



LONDON ON THE LEASH



*

To the left is an illustration of the London control room. Under the clock will be seen the indicator showing which studio is in use, etc., and from this photograph a good idea can be obtained of the complexity of the control-room apparatus.

The scene above depicts the apparatus room at the Manchester station.

*

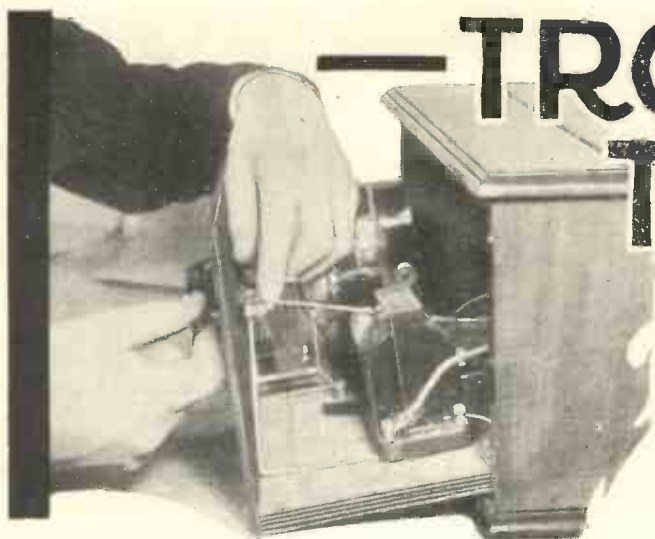

TROUBLE TRACKING

On this page the Chief of the "M.W." Query Dept. discusses, month by month, some of those common difficulties and troubles which can be so perplexing. This month he deals with the effect of alterations to the design of an all-mains receiver, and with the question of faulty components whose values are not up to that specified upon them.

I AM sorry to have to bring this point up again, but I can assure you that it is necessary that I should do so. We are publishing sets in "M.W." designed for A.C. and D.C. mains use. Every one of these designs is most carefully planned.

Some people seem to take a fiendish delight in twisting the layout round and in altering components. Why they should I really do not know.

Circuit Condemned

The remarkable thing is that they then expect first-time results, and if they fail to achieve their object they immediately write the Query Department a letter condemning the design or suggesting that the circuit is at fault.

The "M.W." Research Department is careful to choose transformers, chokes, and other parts, which will permit the required voltages and anode currents to be obtained with ease.

Not as Specified

In spite of this we have readers who simply will insist upon using unsuitable mains units, high-ratio transformers, wrong value condensers, and so forth. Of course, the results are unsatisfactory. I suppose it is the contrariness of human nature, but it makes life hard for the Query Department. There is only one way to get maximum results from an "all-mains" set, and that is to follow the published specification in every particular. This incidentally also applies to battery-operated designs, but an "all-mains" set is far more critical in this respect. I am stressing this point in order to save constructors from disappointment. Besides, the question of cost

must be considered. It is not economical to have to put aside a number of unsuitable parts and to then buy those specified in order to obtain decent results.

No Reaction

This reminds me of another trouble we have been having recently. The "M.W." dual-range coil, if used with a .0001- or .00015-mfd. differential reaction condenser, will oscillate freely on both wave-bands (assuming, of course, correct H.T. values, etc.).

In a large number of cases it has been found that sets employing this coil will not oscillate on the upper portion of the medium broadcast wave-band and on the long waves.

the reaction condensers were well made, the only fault being the maximum capacity, which was definitely below .0001 mfd.

In each case the use of the make of reaction condenser specified definitely remedied the trouble.

If any readers are having trouble with reaction on the long waves, I suggest that they first of all see that their particular reaction condensers are of a make recommended for use in the set.

Check up Voltage

If so, they should then check up the detector H.T. voltage, increasing it if necessary. The valve should be of a freely oscillating type,

DON'T DEVIATE FROM THE DESIGN

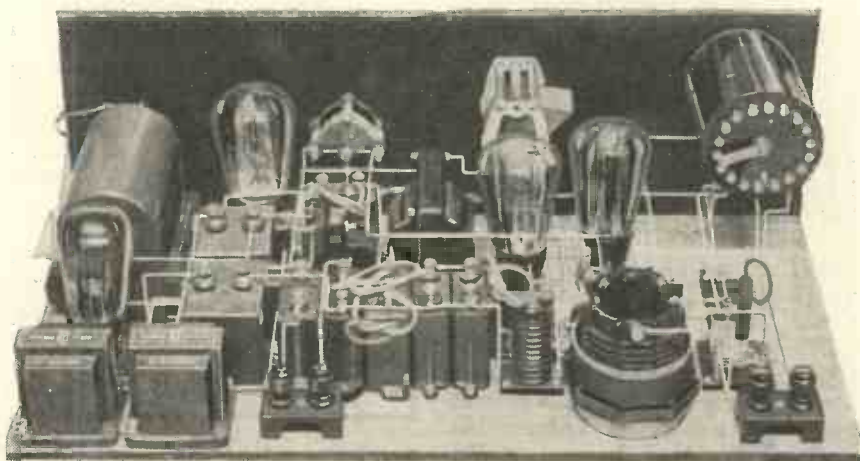

It is not advisable to alter even a small detail in the design of a set, particularly of an all-mains receiver such as the "Star-Power" A.C. set shown in this photograph. Every little point is carefully worked out and tested by the designer.

Owing to the fact that these readers informed us that the reaction condenser was *as specified*, we were at first extremely puzzled and at a loss to suggest a remedy. Upon further investigation we found that

e.g. "H.F." or special detector.

If an H.F. choke is used in the detector anode circuit it must be of good make and, incidentally, the anode resistance should not have a value higher than that specified.

The



The lower knob smoothly controls volume and selectivity.

A detector-pentode receiver of striking design and with an unusually fine performance.

in the way of artistic design and an upright panel, so the idea of using a vertical panel in the finished set was discarded. Instead it was decided that a sloping panel, with only a certain part of it appearing through a vignette, should be used. The result is the unusual but extremely attractive receiver shown in the photographs accompanying this article. The panel is of the ordinary type, perhaps a trifle smaller than usual, but is placed behind a sloping cabinet front of wood, in which an artistic vignette has been cut.

LET'S have something quite different," said the Chief of the Research Department, when he was asked to design a small but powerful household two-valver for this number of MODERN WIRELESS.

Something Different

But there is not very much you can do different in the design of a two-valver unless something freakish is to be admitted into the circuit, and we are very strong against freak sets, because they so often include unnecessary stunts and snags. Occasionally one comes across a freak circuit which will give remarkable results (results which are due to the freak part of the set), and in such a case there is definite value in the circuit.

But "M.W." has no use for a set which has unnecessary complications, introduced simply to make a circuit "different." So, having decided that on no account was "M.W.'s" "anti-freak" motto to be disregarded, it was decided that a good two-valve circuit, having plenty of power, and fully equal to the task of providing good reproduction under the stringent modern conditions set by the present system of high-power broadcasting stations, should be designed, and a conference held between the technical and art departments of MODERN WIRELESS with a view to the design of a really artistic and novel cabinet.

Power from Two Valves

Obviously, in order to get power from two valves, it was necessary that a pentode power output valve should

be employed. This, together with a transformer-coupled detector and the "M.W." dual-range coil, proved to be a very wise choice, and on test the receiver has given really remarkable results.

The first thing, of course, before any discussion as to cabinet was gone into (and although from the theoretical design we knew the circuit would

Unconventional Cabinet

By the use of a rather attractive type of drum-control condenser, which also has a reaction control incorporated in it, and by the careful disposition of the other panel components—namely, the L.T. switch, series

WHAT YOU NEED TO BUILD IT

- | | |
|--|--|
| 1 Panel, 8 in. x 8 in. (Peto-Scott, or Goltone, Parex, Lissen, etc.). | 1 L.F. transformer (Varley Ni-core II, or other compact type). |
| 1 Cabinet (special design), with base-board 12 in. deep (Peto-Scott). | 1 Centre-tapped pentode output choke (R.I. Pentomite, or similar type). |
| 1 .0005-mfd. variable condenser, with reaction condenser incorporated in one assembly (Formo). | 1 .002-mfd. compression condenser (Formo, etc.). |
| 1 .0005 solid-dielectric variable (Ready Radio, or Burton, etc.). | 1 H.F. choke (Watmel, or Lewcos, Ready Radio, R.I., Lotus, Lissen, Varley, Dubilier, Keystone, Magnum, Parex, Wearite, Igranic, etc.). |
| 1 Three-point wave-change switch (W.B., or Bulgin, Ready Radio, Wearite, Keystone, Ormond, Magnum, etc.). | 1 .0003-mfd. fixed condenser (T.C.C., etc.). |
| 1 L.T. switch (W.B., etc.). | 1 2-meg. grid leak and vertical holder (Dubilier, etc.). |
| 1 Pair adjustable panel brackets (Collett). | 2 2-mfd. condensers (T.C.C. and Lissen, etc.). |
| 2 Valve holders (Igranic, or Lotus, Benjamin, W.B., Bulgin, Formo, Clix, etc.). | 2 25,000-ohm Spaghetti resistances (Ready Radio and Magnum, or other good makes). |
| 1 "M.W." dual-range coil (Wearite, or Ready Radio, R.I., Formo, Magnum, Keystone, Goltone, Parex, Tunewell, etc.). | 1 Terminal strip, 10 in. by 2 in., and 9 terminals (Belling and Lee, etc.). |

work) was a thorough test of the circuit in practical form, and a rough layout was hooked-up as compactly as possible, and a comprehensive try-out was inaugurated. Having passed this with flying colours, the Art Department was called in to have a look at the layout and to decide what sort of cabinet it should be given.

There is not a great deal you can do

aerial condenser, and the wave-change switch—a very attractive and artistic design was achieved.

That having been decided upon, the question of cabinet construction was discussed, and it was decided to put it to one of the well-known cabinet makers, and ask him whether he would be prepared to place a cabinet suitable for this set on the market. He

"Pentodion"

Designed and Described by the "M.W."
Research and Construction Department.

immediately decided to do so, and the work in constructing the final set was entered upon pending the arrival of the cabinet.

Intervalve Coupling

Now let us give some details of the set itself. You will see from the theoretical diagram that there is nothing at all stultish about the circuit. There is the ordinary 0005-mfd. series aerial condenser (which has an ingeniously placed shorting strip on it, and which we will discuss later) in series with the aerial lead to the wave-change coil. This wave-change coil is connected in quite the standard way, using "Interwave" coupling for the long waves and, of course, differential reaction is employed between the detector and the reaction winding of the coil.

An ordinary L.F. transformer couples the detector to the pentode. The detector stage is de-coupled by means of a 25,000-ohm resistance and

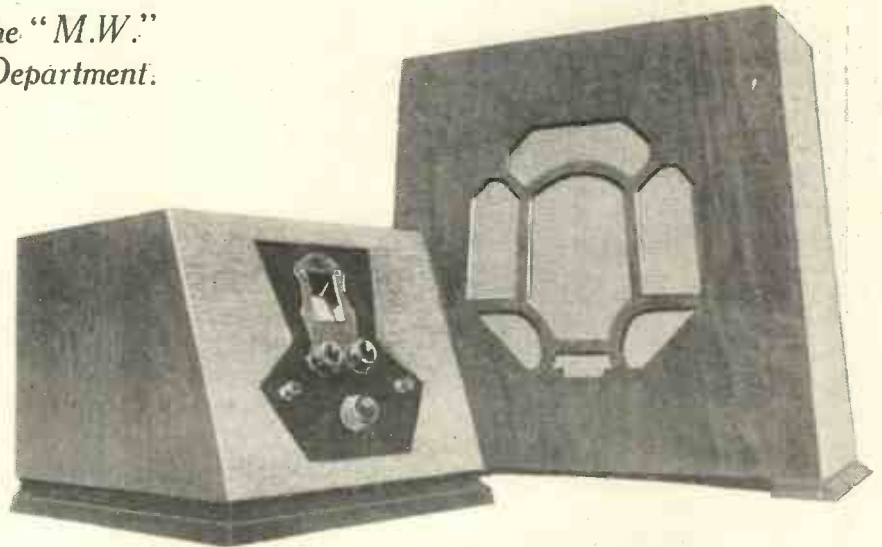

The receiver is uniquely artistic in its appearance.

a 2-mfd. condenser, and the pentode output is carried out through a centre-tapped pentode output choke. This output choke is an extremely important feature, as it enables the correct ratio of impedance between the speaker and the pentode valve to be obtained.

Some little time ago, when the

pentode first came out, it was generally believed that the operating impedance of the valve was very high indeed, and so people went in for high-impedance output circuits. As a matter of fact, the actual working impedance of the pentode is much lower than was thought, and a much more moderate ratio is generally required.

In most cases a ratio of something like two or three to one is generally used, excellent results being given with the ordinary type of loud speaker. This point was mentioned in last month's MODERN WIRELESS, but we are reiterating it here because we feel that there is far too much misunderstanding about the pentode valve, and the sooner that this idea of enormous impedance is corrected the better.

The Output Circuit

There are many loud speakers on the market which have special pentode windings. These, of course, if properly designed, will go direct in the anode circuit of the pentode valve or through a 1 to 1 ratio output, such as the ordinary filter choke, and the centre-tapped choke used in this set is then not required. But with the average loud speaker the pentode output choke as used in this receiver is just about right, thus giving excellent quality,

In certain instances, however, there may be a tendency to a certain amount of "hardness" to exist and

FIVE FIRST-CLASS FEATURES

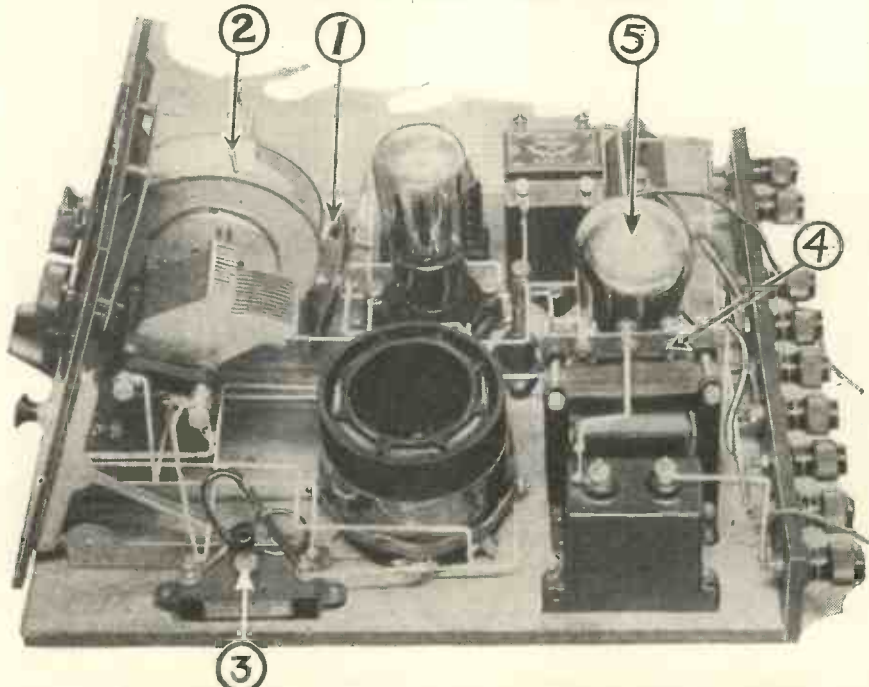

In addition to the "M.W." dual-range coil, the "Pentodion" contains five further fine features, enumerated above. (1) is the differential reaction condenser integral with the novel type of tuning condenser (2); (3) is the "Interwave" coupling device, and (4) the special output choke for the pentode valve (5).

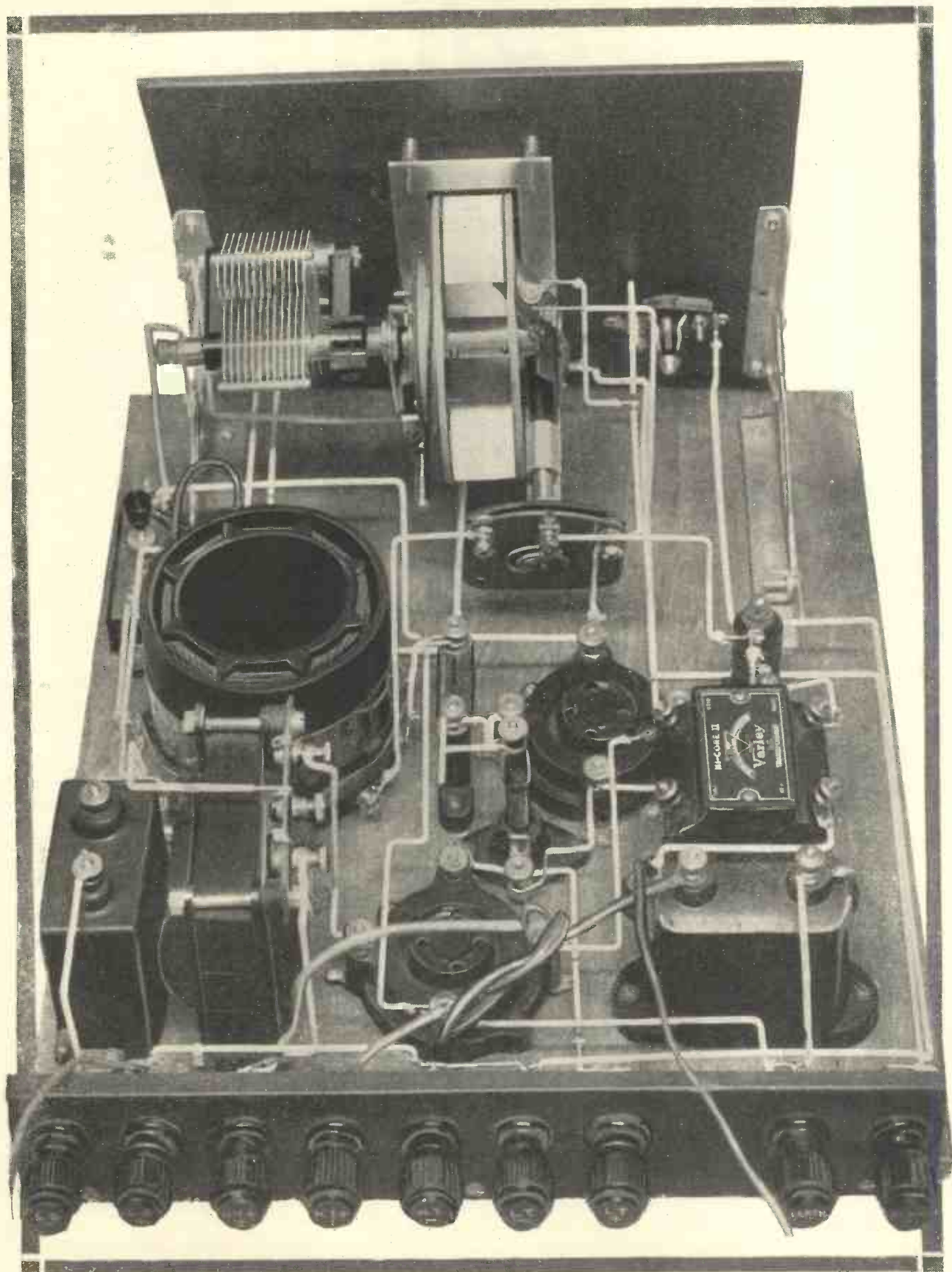

A FINE SET—WHICHEVER WAY YOU MAY LOOK AT IT!

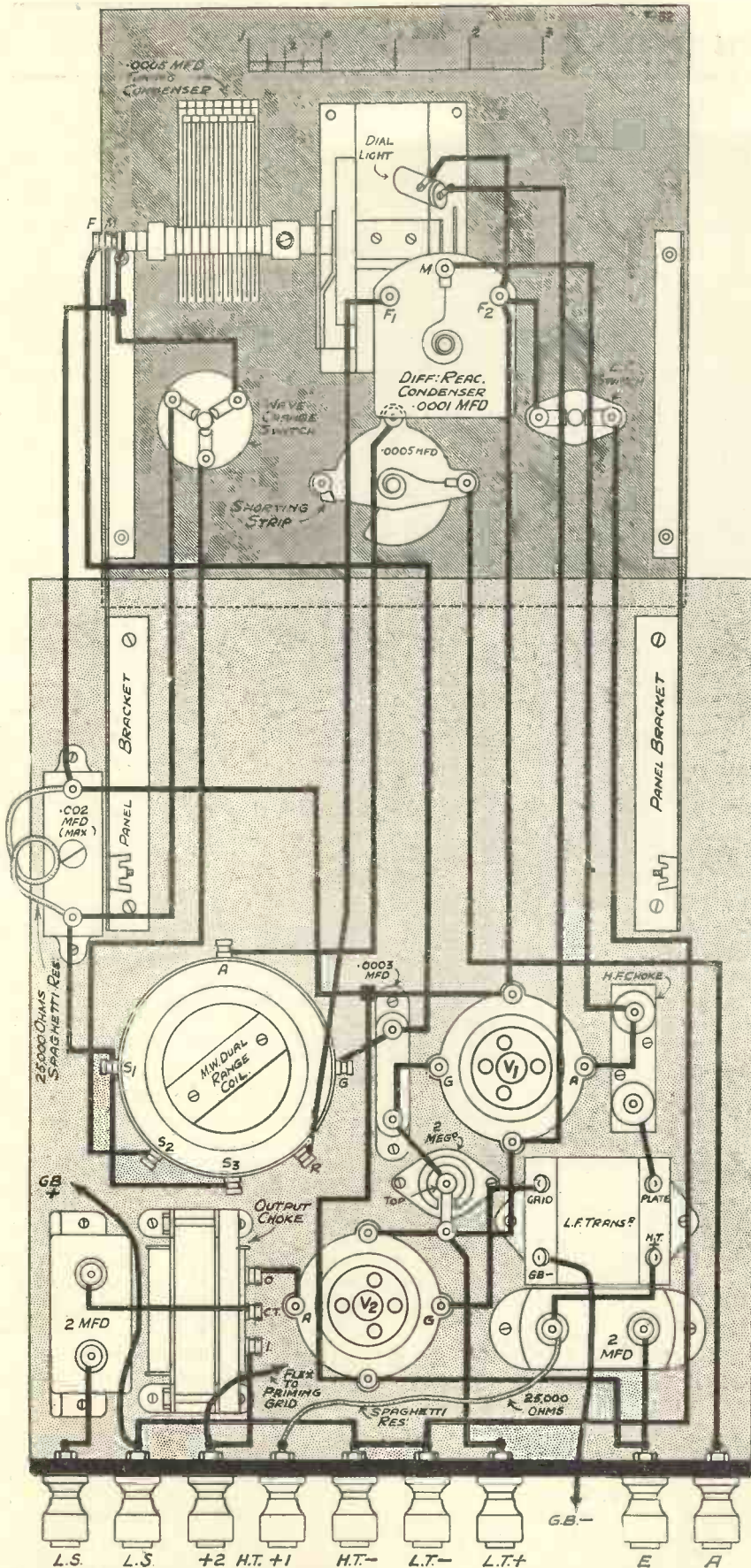

baseboard, and it is easy to screw a couple of grid-bias clips on this back (which is completely detachable for such treatment), and then, after fitting, the back can be placed *in situ* with the flex leads from G.B. —, etc., put in their proper sockets in the battery.

There is another point about the fixing of the set in the cabinet which we will deal with later, but as the grid-bias battery is conspicuous by its absence in the wiring diagram, and there seems to be no place for it, we thought we would clear up that matter first.

Shorting the Condenser

We made mention a little while ago about the series aerial condenser shorting strip. This is not exactly a strip, but a piece of copper foil which must be placed on one of the terminals of the fixed vanes and bent over at the edge across its vanes so that when the moving vanes are turned right over to minimum they make contact with this shorting strip.

So that all you have to do to short this condenser out for long-wave working (for it is usually better out of circuit on the long waves) is to turn the condenser hard over to minimum, when the fixed and moving vanes are automatically shorted and the condenser is thus out of circuit.

The valve holder for the pentode valve used in the set is of the ordinary four-pin variety, and if you have any doubt whether to get a four- or five-pin pentode do not forget to use the right sort of valve holder with the valve you employ.

Most pentodes, however, are of the four-pin variety, with a terminal on the side for the priming grid, but some manufacturers have five-pin pentodes as well. There will be no difference in the operation of the set with a five-pin valve, it is merely a matter of convenience whether you use a four- or five-pin holder.

The Pentode Valve Holder

In the case of the five-pin valve being employed, the priming grid is taken to the centre socket and the terminal on the valve holder belonging to this socket will probably be marked "C" (the same terminal that is used for the cathode of indirectly-heated valves of the five-pin variety).

In wiring-up the five-pin holder (instead of the four-pin, as shown), you would dispense with the flex marked priming grid on the wiring diagram, and take the lead of stiff wire from H.T. +2 to the extra terminal on the valve holder.

High-Class Appearance—High-Class Performance

A POWERFUL AND SELECTIVE CIRCUIT

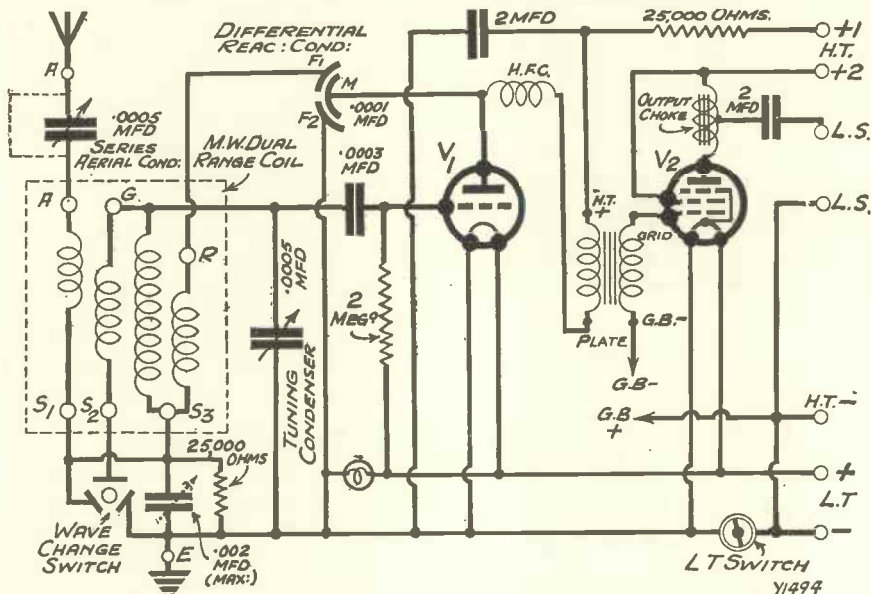

The circuit is conventional and efficient, a dual-range coil and "Interwave" coupling being two strong features. Note the dial light situated in this circuit between the bottom of the leak and the connection to the F_2 vanes of the reaction condenser.

The operation of the receiver is quite ordinary. Tuning is done by the right-hand knob of the variable condenser assembly, and reaction is carried out in the usual way by the left-hand knob. The selectivity control underneath should be set at about maximum and only reduced if you want to increase the selectivity of the set or, when tuned in to the local station, if you want to decrease the volume. On long waves it should be placed right over to minimum, in which position, as we remarked before, the shorting device comes into operation and the condenser is automatically cut out.

Choosing the Valves

When getting the condenser make sure that the little dial light inside which illuminates the condenser scale is of the correct voltage for your accumulator. For instance, if you are using a 6-volt accumulator you do not want a 2-volt light for your condenser. It would not last very long!

The valves, of course, are extremely simple to choose; simply consisting of the detector (an H.F. valve or special detector type), while the pentode should be one of the ordinary pentode types, and not one of the power class like the P.M.24A.

The H.T. voltage required will be anything up to 150 volts, and can be

obtained either from batteries or from a mains unit if this is of really good design.

There is one point we must mention about the biasing of the pentode valve. On no account should a pentode bias plug be removed while the set is in operation; that is, with the filament switched on.

Finally, while discussing the pentode valve we should like to point

out that such a valve should *not* be used with an ordinary small dry H.T. battery. You want one of the super class, because you require anything upwards from 8 or 9 milliamps, according to the valve you choose. Do not forget, however, that when choosing the pentode valve the anode current is not the total current taken from the H.T. battery. There is also that for the priming grid, and in the case of some 6-volt pentodes this may be up to as much as 7 milliamps., with an anode current three times as much where the valve is a large one.

Wave-Change Switching

The wave-change switching is carried out in the usual way. You push the plunger of the switch in for long waves and pull it out for short waves, but as the switch has to make very good contact it is sometimes a little bit stiff in operation and requires quite a forceful push.

That is all right in the average set, but in this receiver the panel and baseboard fit in from the back towards the panel, so that when you are pushing the switch there is no support behind the panel to prevent the set from sliding backwards.

So when you finally fix the receiver in the cabinet, place screws behind the baseboard in the cabinet base so that the set will not slide back.

AN UNUSUAL ANGLE

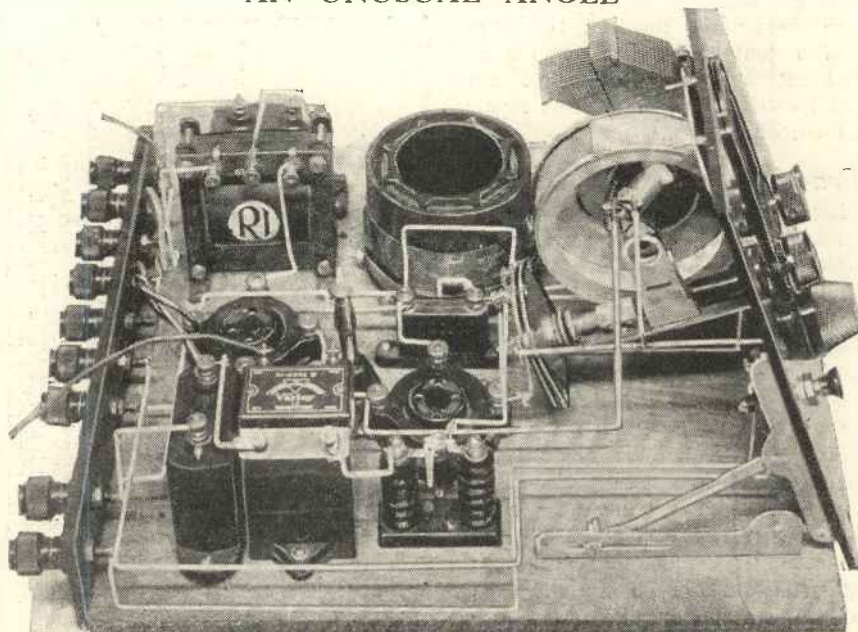

The angle at which the panel is set can be judged from this photograph. About 70 degrees is correct.

YOUR AERIAL AND EARTH

Some practical hints and tips conveyed by humorous inferences. An article that both amuses and instructs in a way which constitutes a distinct breakaway from the conventional.

PLEASE take particular note of the title of this article. It is *your* aerial and earth that I am going to write about. Not, mark you, the wretched affair installed by the man next door. I wouldn't care to write about that, and, I must mention in passing, I wouldn't dare to write about my own lest Jack Payne should make a song about it.

Stout, Strong Wire

No, I am going to tell the whole world about *your* magnificent aerial and earth, and if, perchance, I slip up here and there in my description, I know you will hasten to put things right. Supposing, for example, I happened to mention that you used aerial wire of first-class quality (seven twisted strands of 22-gauge bronze, or suchlike), when, in fact, through some oversight, it so happened you were accidentally insulting the ether with a tentacle of miserably emaciated cotton-covered copper, I am sure I could rely upon you to repair the sad little lapse.

Practicably Perfect Aerial

Remember, it is vital that you should do so, for otherwise you would be letting me down with a colossal bang. You see people will be streaming in from all over the country to examine this wonderful aerial system of yours just as soon as they hear about it. And if Sir John Reith, peeping over your garden fence from behind the shoulders of Tommy Handley and Mrs. Philip Snowden, were to see just one tiny flaw in an otherwise nearly perfect aerial construction, it might make him so annoyed that he'd go straight back to Savoy Hill and broadcast one hundred continuous hours of Scherzi in E Minor.

If I make a few trifling mistakes regarding the *form* your antenna assumes, that won't matter a scrap. As Shakespeare so aptly put it, "Oh, Onion, what of thy shape if thou art strong?"

Now this wondrous aerial of yours flings high into the sky. You have remembered that height is the most

vital factor, and that every inch counts—as the doctor said when he jabbed a hypodermic syringe into his patient's arm.

I need hardly say that you have not made the mistake of thinking a wire laid on a 30 ft. roof is 30 ft. high. You know well enough that that is, from a radio point of view, no height at all.

Your aerial is yards away from roofing, walls, trees, piles of worn-out razor blades and other masses of metal. At one end of your magnificent garden there is a fine mast some 40 ft. high. And this mast doesn't bend in the middle as though it had a tummy-ache, for it is supported by tough, weather-proof ropes anchored to long pegs driven deeply into the ground.

Those Insulators!

And didn't you give the one end of the mast heaps of coats of tar or paint to protect it from the dampness of the soil, and put a little wooden hat on the top to stop the rain getting into the open grain of the wood? Of course you did. Isn't it

a fact that every Sunday morning (when it is fine) you walk up and down loudly singing for the benefit of your neighbours: "Daisies are white, violets are blue, my mast's all right, what about you?"

So far, so very excellent. But what about those insulators?

I know you use proper insulators at each end, but do you find your radio programmes so magnetically attractive that you can't find the time to let down the aerial and clean the insulators every now and then?

NOT A LISTENER'S AERIAL!

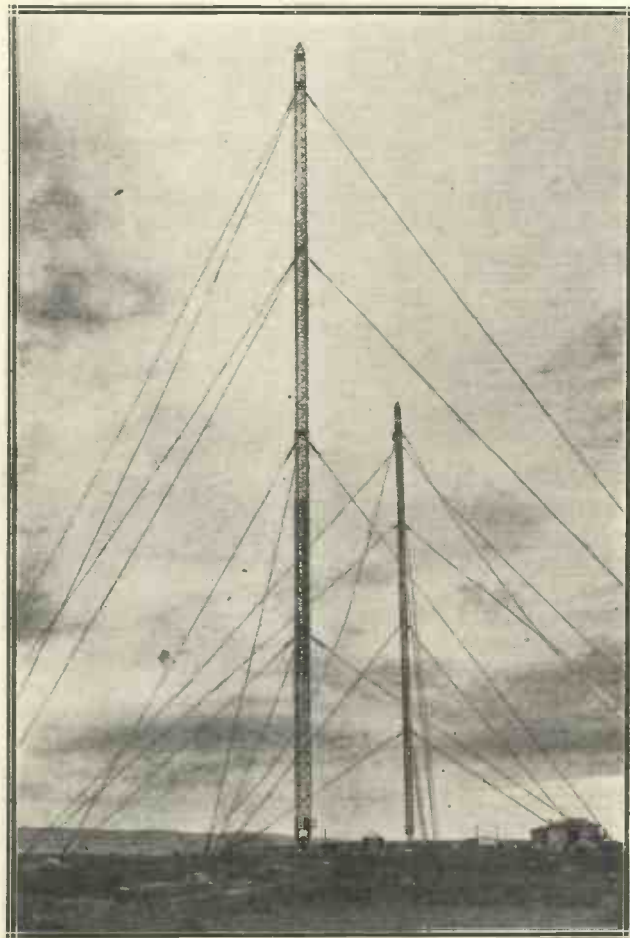

As a matter of fact, this is the aerial equipment of Reykjavik, Iceland's new high-power broadcasting station.

Soot and Dust

I know it's a matter of minor importance, as Adrian Boulton said to the announcer when it was

(Continued on page 453.)

THE WORLD'S PROGRAMMES

WHEN WHERE AND HOW TO HEAR THOSE FOREIGNERS

CONDUCTED BY "D.X."

EXTENDING YOUR TUNING RANGE

Most of us have felt, at some time or other, the desire to tinker with our tuning range. If Vienna (517 metres) is the very top station we can tune in, we long for Budapest (550 metres).

Or if Belfast (242 metres) is our lowest programme, we wish we could tune down to Cork (224 metres).

The trouble is that with the ordinary .0005 tuning condenser we cannot reach all the good programmes at one go, so to speak. If we can tune right down as low as Leeds on 200 metres when the condenser is "all-out," we cannot possibly cover all the interesting stations at the top of the tuning range when it is "all-in."

"Lifting"

It is quite easy for the experimenter to tinker with the tuning range, but it is certainly not a task for the novice. All that is required in the way of material is a couple of crocodile clips, some flex, and a small condenser (preferably variable).

To "lift" the tuning range, as an experiment join a clip to each side of the new condenser (about .0001 mfd. will do) by means of a flex lead, and clip the arrangement across the tuning condenser terminals. Then tune in as usual.

The dial readings of known stations will be lowered, and towards the top of the scale there is space for new stations to come in. But at the bottom of the tuning dial it becomes impossible to go down as low as formerly while the clips are in action.

Difficult To Reduce

If two tuned circuits are used in the set it is necessary to load both with similar condensers, as described. Semi-variable condensers allow this matching to be done quite satisfactorily.

To reduce a tuning range when the coil value is fixed is much more difficult.

In fact, it is so much more trouble in altered wiring, etc., that generally it is not worth while attempting. Especially as the very low programmes are liable to fade badly.

SWITZERLAND'S NEW STATIONS

The powerful "mystery" station whose tests caused considerable newspaper comment some weeks ago, and proved to be Radio-Sottens, is not the only new Swiss station.

The tests referred to above were in English, and could be heard at great strength on 403 metres. They were but one symptom of the Swiss Broadcasting Corporation's new scheme.

In the past few months a new low-power station at Basle has been put into commission (319 metres), and Berne has a new transmitter.

MEN OF MUNSTER MAKING MUSIC



A scene in the main studio of the Munster station, which works (with Aachen and Cologne) on a wave-length of 227 metres.

"Beromunster"

The original scheme envisaged a new German-speaking Swiss high-power station, to be named "Beromunster," the nearest town being Munster. It is 22 miles from Zurich and about 40 from Berne.

(This Munster has nothing to do with the Munster heard on 227 metres, which is situated in Germany. Munster is a common name on the Continent, and is allied to our own "minster.")

At the moment, however, chief interest is centred in the tests of Radio-Sottens, which serves the Lausanne area.

RADIO IN OTHER LANDS

*Happy Snaps of Denmark—
Germany—United States—
India—Turkey.*



The picture above comes from Denmark. It does not represent an early-morning scene, but nevertheless it is a cock-crow broadcast, and a somewhat unwilling bird is shown making acquaintance with the hanging microphone.

He was champion prize-winner at a poultry show, but when in front of the mike he decided that that was nothing to crow about!

In the circle (to the right) is Sir Malcolm Campbell. He is shown at Daytona Beach telling the world of his wonderful speed record.

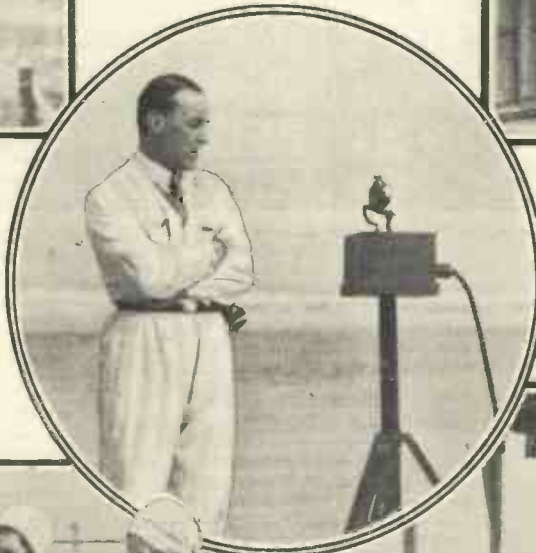

German peasants are shown in the picture above, fitting their cottage for radio reception. Nominally, the idea is to receive market reports/forecasts, etc., for business reasons, but judging by the lady's anticipatory smile she intends to get some fun out of it as well.



Radio in the U.S.A. is not all hard work and worry, judging by this happy snap of WQAM's announcer. He is telling the world about the charms of Miami Beach, Florida, and, to give him his due, he certainly appears to be an excellent judge, with the knack of looking on the bright side of his work.



Here are two pictures showing how radio technique is changing the "Unchangeable East." Above, Mahatma Gandhi is shown addressing thousands of his followers by means of a microphone. To the left is the famous mosque of St. Sophia, in Constantinople. It is reported that the minarets—hitherto sacred to the Muezzin—are now to be used to support broadcasting aeriels.



Every month sees new stations or higher power or some equally interesting development in Europe, and last month was no exception. But can you guess what was the event of the ether during March?

Europe certainly sat up and took notice of the new Warsaw station. Its unequalled power, its unique masts and its situation up on 1,411 metres were all in its favour. But Warsaw does not appear to have created the greatest stir of all last month on the Continent.

It might have been thought that the new Swiss station, testing on 403 metres, and very well situated, both geographically and from a dial-position point of view, would have been the "star turn." But no—there was a greater draw than that. Can you guess it?

The Northern Region

So far as can be judged from reliable and representative reports, the most-looked-for station of all was Moorside Edge, Britain's new North Regional! And for some reason or other the Continent is expecting great things of it.

Probably this interest has been created by the Brookmans Park results, which are so good in many parts of Europe that it has become a firm favourite. But whatever the cause, the fact remains that its sister station, the new North Regional, is at the moment the most hunted-for programme on the European broadcast wave-bands.

It seems rather a pity that so many of the good foreign stations will gabble their call-signs, or leave them out altogether. Especially when others, such as Rome, for instance, are so nice about clear announcements. There is no mistaking Radio Roma, is there?

Bordeaux Lafayette is one of these announcement gabblers, and scores and scores of listeners must have heard his concerts on 304 metres without knowing to whom they were listening. Even if you know what is coming, "Bordolafayet" is a mouthful that is easily missed!

Those Long Silences!

But excellent as the strength of programme from this station has been of late, its identity is often missed for another reason. And that is those prolonged pauses. After an item has finished you wait, and wait, and wait!

Probably there is a good reason sometimes—switching to a new studio, or something. But a station that lets you hang on and hang on to its empty carrier-wave is simply asking for unpopularity with distant listeners.

Bordeaux is by no means the worst offender—I have known Nurnberg, who lives just below Belfast, on 239 metres, leave the microphone breathing sweet nothing

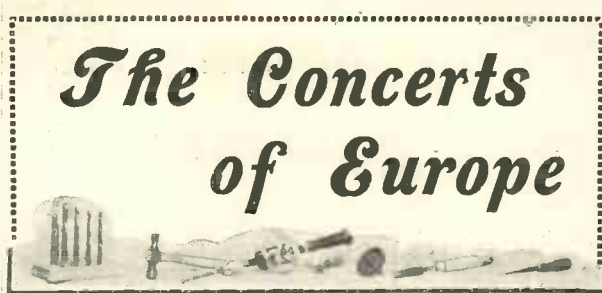

The Concerts of Europe

ings for six minutes, and then come on quite unrepentant and proceed with his programme as though a vacant six minutes was nothing.

Incidentally, it is not always the foreigner who is to blame for this sort of thing. The B.B.C. now has far longer microphone pauses than we used to have. Why!

Switzerland seems to be making a firm bid for notice nowadays. Besides the new Radio-Sottens already referred to, I have had really good reception (on a three-valver) of Sunday concerts from Zurich. If you haven't bagged this station yet, watch for him, about two degrees below Lyons la Doua—that is to say, about half-

way between the Midland Regional and Rome.

The fact that reception conditions are really and truly better now than we were having a few months back seems to be vouched for by many enthusiasts. And that reminds me of a very good comparison test which seems to be coming into favour. Here is the idea:

Instead of trying to "reach out" for all the distant stations you can bag, and judging reception by that, try for the British stations. It makes an excellent test of whether a set is hot-stuff, or merely warm!

My own "three" seemed in such good fettle the other night that I accepted a challenge and went right round the dial looking for "home" stations. 5 G B and Dublin, at the upper end, were easy, but Glasgow, about three degrees below Dublin, was distinctly coy.

Below the Regiona

Manchester, on 376, was none too good either, but clear enough to identify plainly; and slipping below the Regional there was Cardiff going fine on 309.9 metres and Aberdeen, on 301, was almost as loud. So confidently diving through the chorus of the relays, and the London National, we came upon Belfast.

Belfast is only three metres removed from Nurnberg, and this latter, or some other energetic German, was blaring away so vigorously that the separation was not too easy; the set being a trifle flat on this end of its scale. However, Belfast kindly announced himself unmistakably.

Still farther down was Cork, on 224 metres; but this was getting down towards 0 on the dial, and Leeds working on 200 was below the zero mark. However, that bag of British programmes had accounted for all the possibles, and it certainly was a more convincing test of the conditions prevailing than the same number of foreign stations chosen haphazard would have been. So, to paraphrase the Empire Marketing Board, "Try British," if you want to see what a set will do.

Ragged Relays

Have you ever noticed the curious fact that although there are three German stations working together on 227 metres (Aachen, Cologne and Munster), this programme comes over at excellent quality? The three seem to combine into one really good transmission.

Britain, of course, has no less than eleven relays all on one wave (288.5 metres)—but picking these up at long distances in Britain results in a wobbly whistling that lets you know there is something very unusual going on upon this wave-length. Perhaps they sound all right on the Continent if the aerial is far enough away from Great Britain. P. B.

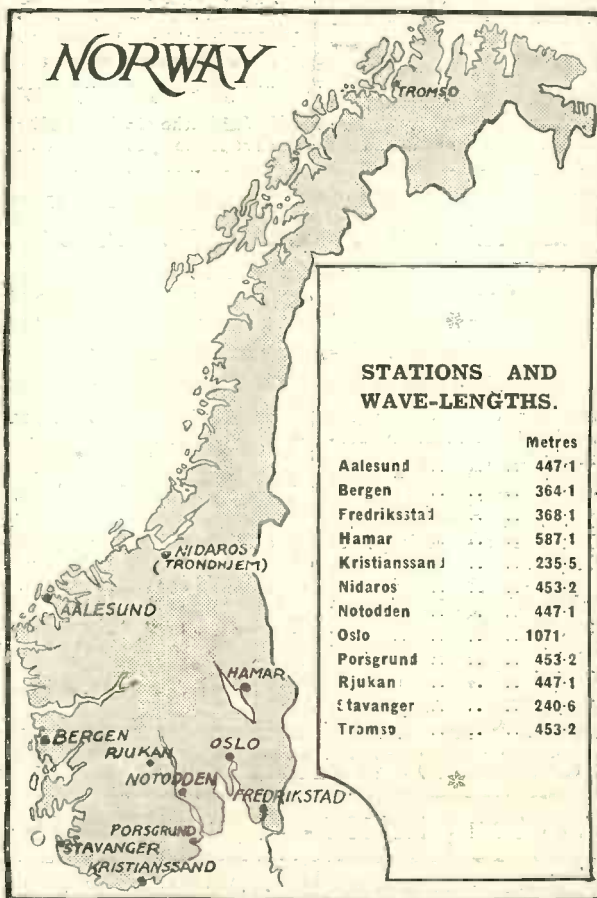

Metres	Station
1875	Huizen (Holland)
1725	Radio Paris (C F R)
1635	Königswusterhausen (Zee-sen) (Germany)
1481	Moscow (Old Komintern)
1445.7	Eiffel Tower (F L E)
1411	Warsaw (Poland)
1348	Motala (Sweden)
1304	Moscow (Trades Unions)
1200	Istanbul (Turkey)
1153	Kalundborg (Denmark)
1071	Oslo (Norway)
574.7	Ljubljana (Yugoslavia)
566	Hanover (Germany)
550	Budapest (Hungary)
533	Munich (Germany)
517	Vienna (Rosenhügel) (Austria)
509	Brussels No. 1 (Belgium)
501	Milan (Italy)
487	Prague (Czechoslovakia)

FIFTY FAVOURITE FOREIGNERS

A selection of well received stations on wave-lengths above 300 metres.

Metres	Station
473	Langenberg (Germany)
466	Lyons (La Doua) (France)
459	Zürich (Switzerland)
447.1	Paris (P T T) (Ecole Supérieure) (France)
441	Rome (R R O) (Italy)
436	Stockholm (Sweden)
424	Madrid (Union Radio)
418	Berlin (Witzleben)
408	Katowice (Poland)
403	Berne (Switzerland)
384	Bucharest (Rumania)
380	Frankfurt (Germany)
385	Toulouse (Radio) (France)
372	Hamburg (Germany)
370.4	Radio LL (France)
368.1	Seville (Union Radio) (E A J I) (Spain)

Metres	Station
363.4	Algiers (N. Africa)
360	Mühlacker (Germany)
349	Barcelona (Radio Barcelona) (E A J I) (Spain)
345	Strasbourg-Brumath (France)
338.2	Brussels No. 2 (Belgium)
335	Cadiz (Spain)
332	Naples (I N A) (Italy)
328.2	Paris—Poste Parisien (France)
325	Breslau (Germany)
322	Göteborg (Sweden)
319	Sofia Rodno-Radio (Bulgaria)
316	Marseilles (P T T) (France)
313.2	Genoa (I G E) (Italy)
312.8	Radio-Vitus (France)
304	Bordeaux-Lafayette (P T T) (France)

News from the Stations



MADAGASCAR is to have a short-wave broadcasting station, convertible to telegraphic transmissions when needed for working to ships, etc.

BUCHAREST is operating a short-waver on Sunday evenings on 50 and 21 metres. Power, 300 watts.

LOS ANGELES and **CHICAGO** are to be the trans-ocean terminal stations of a short-wave network of Press news stations, stretching right across the U.S.A.

FECAMP, which transmits the "Radio Normandie" programmes on 222.9 m., has studios at Havre and Rouen.

ALGIERS (363 metres) usually announces in French, but occasionally uses English, German, Arabic, or Esperanto.

CADIZ (335 metres) is the most southerly station on the Continent of Europe.

POSTE PARISIEN always announces in English as well as in French when closing down (328 metres).

ROME'S cheerful interval signal, which is often heard on 441 metres, is "played" by oscillating valves.

LUXEMBOURG is rumoured to be the proposed site of a super-power station (100 kw.), which is to broadcast in all the languages of Europe.

NEBRASKA'S super receiving station, designed to police the U.S. ether and stop wave-length wobbling, is held up pending a Govern-

ment grant of funds for operating it.

MADRID is the city chosen for next year's World Wireless Conference.

MOSCOW, on 1,304 metres, has been getting over very well lately, and announcements in English at 9.30 p.m. on

site of a powerful station to serve Italian-speaking Switzerland.

TURIN is still working on 296 metres instead of its allotted wave-length of 273.2 metres.

ANKARA, the station holding Europe's longest wave-length (1,961 metres), has been

NEXT MONTH'S "M.W."

The May "M.W." will be a

SPECIAL PORTABLE SET NUMBER

On sale May 1st. 1/-. Order your copy now.

Sundays often enable the station to be identified definitely then.

CONSTANTINE, ALGERIA, has been transmitting on Mondays and Fridays at 10 p.m. on 45 metres.

MONTREAL (C F C F) has arranged to relay the N.B.C. of America programmes in future.

MONTE CENERE is to be the

working just below 5 X X, on 1,538 metres.

RADIO VITUS, PARIS, has been coming in about two degrees higher on the dial, owing to its wave-length having "wobbled" from 312.8 to about 315 metres.

NAPLES is spelt "Napoli" in Italian, so the announcements sound like "Radio Napoleon," but omitting the final an.

RADIO GRENOBLE, FRANCE (328.2 metres), often abbreviates its full announcement (Allo! Ici le poste de radio-diffusion de la region des Alpes à Grenoble) to "Ici Grenoble, P.T.T."

FORT WORTH, TEXAS, has been getting over clearly to this country, though it has only one-fifth of the power of W E A F, W G Y and W J Z, other well-received American stations.

BRUSSELS, SCHAEERBEEK, has been operating a little below his proper wave-length, the new position being about 245 metres—much closer to Belfast than usual.

LAHTI and **KAUNAS**, two of the stations right at the top of the long waves (1,796 and 1,935 metres respectively), both use gongs as interval signals. Between them is **HUIZEN** (1,875 metres), using Westminster chimes.

LVOV (Poland) has one of the hardest names in Europe to recognise. It sounds like "Lah-woof," and the words "Polski Rahdeed," which are frequently used, help one to recognise it as a Polish station.

TEGUCIGULPA, HONDURAS, has been getting over at enormous volume (although its power is only 2 kw.) on 48.62 metres. Announcements are usually in Spanish, but sometimes a mechanised contrivance calls "Cuckoo" three times, and then an American announcer comes on with details of the programme.

HOW THE WORLD'S STATIONS PASS THE TIME

BERLIN - - 1 p.m.	MONTREAL - - 7 a.m.	MOSCOW - - 2 p.m.	NEW YORK - - 7 a.m.	OSLO - - - 1 p.m.
BRUSSELS Noon				PARIS - - - Noon
BUDAPEST 1 p.m.				ROME - - - 1 p.m.
COPENHAGEN - 1 p.m.				SAN FRANCISCO 4 a.m.
Hilversum 12.20 p.m.				STOCKHOLM - 1 p.m.
ISTANBUL - 2 p.m.				VANCOUVER - 4 a.m.
KATOWICE 1 p.m.				VIENNA - - 1 p.m.
MADRID - - Noon				ZURICH - - 1 p.m.



A new wireless station on its way across a North African desert by primitive means of transport.

Below 300 Metres

Some up-to-the-minute information about the finding of programmes at the bottom of the dial.



Great interest attaches to the arrival of the lake steamer with a complete broadcasting station packed away in its hold.

For some months past stations on the lower part of the ordinary broadcast wave-band have been particularly interesting. And if you are one of those who incline to neglect the bottom of the dial you will find upon investigation that you have been missing some good stuff.

Below the 300-metre mark there are no less than 14 B.B.C. stations, but eleven of these are relays, and use the same wave-length (288.5 metres). Giving good service in their own areas, nevertheless these relays are heard in the rest of the country as a distorted caricature of the National programme!

London area, though its power is only 1.2 kw.

Cork is another English-speaking station that has been coming through well in the South of England. It takes the Dublin programme, and when this is jammed or unsatisfactory on 413 metres it can generally be picked up clearly from Cork on 224 metres.

Unfortunately, the Cork programmes often contain blatant advertisements, so that the entertainment value is lowered. But there is a certain charm about the intonation of the lady announcer that generally repays one for an occasional call on Cork.

relaying the Königsberg programmes. Not understanding a word of German, I nevertheless find this a programme of real interest. Quality is good, and the type of music often distinctly delightful.

Although Heilsberg is using 75 kw. in the aerial, he is run quite close in my affections by other German transmissions, using much lower power. These are the Cologne relays and Nurnberg.

Both come over with great reliability and vigour. Cologne shares his wave-length, 227 metres, with Aachen and Munster (the combined relay being associated with the

syren is another sign that you are listening to Nurnberg.

Many other stations working below 300 metres call for special mention, and if asked to select three more I should name Hilversum, Gleiwitz, and Turin. Hilversum (298.8 metres) is so good that many East Coast listeners prefer this programme to any other as an alternative to the London National.

Gleiwitz—who works with the Breslau studio—would be a more striking station if Germany were not already so well represented on neighbouring wave-lengths.

AT THE BOTTOM OF THE DIAL

(The principal European stations working on wave-lengths between 300 and 150 metres.)

- 298.8 { Falun (Sweden)
- Hilversum (Holland)
- 293 { Kosice (Czechoslovakia)
- Limoges (PTT) (France)
- 291 Viipuri (Viborg) (Finland)
- British Relay Stations
- Bournemouth
- Bradford
- Dundee
- Edinburgh
- Hull
- 288.5 { Liverpool
- Newcastle
- Plymouth
- Sheffield
- Stoke-on-Trent
- Swansea
- 287.2 Lyons (Radio) (France)
- 286 Montpellier (France)
- Berlin Relay (Germany)
- Magdeburg (Germany)
- 283 { Stettin (Germany)
- Innsbruck (Austria) (relays Vienna)

- metres
- 283 { Uddevala (Sweden) (relays Göteborg)
- Varberg (Sweden)
- 281 Copenhagen (Denmark)
- 280 Radio Liège (Belgium)
- 279 Bratislava (Czechoslovakia)
- 276.5 Heilsberg (Germany) (relays Königsberg)
- 273.2 Turin (Italy) (See text)
- 272 Rennes (France)
- Trollhätten
- Hudiksvall
- 270 { Norrköping (Sweden)
- Bremen (Germany) (relays Hamburg)
- 268 { Barcelona (E A J 13), Radio Catalana (Spain)
- Oviedo (Spain)
- 265.4 Lille (P T T) (France)
- 263 Moravská-Ostrava (Czechoslovakia)
- 261.3 London National Stn.
- 259 Leipzig (Germany)
- 257 Hörby (Sweden) (relays Stockholm)
- 255 Toulouse (P T T) (France)

- metres
- 253 Gleiwitz (Germany) (relays Breslau)
- 252 Almeria (Spain) (E A 18)
- 249 Juan-les-Pins (Nice) (France)
- 247.7 Kalmar (relays Stockholm)
- 246.2 Schaarbeek (Brussels) (Belgium)
- Turku (Åbo) (Finland)
- Säffle (Sweden)
- Eskilstuna (Sweden)
- Pietersaari (Jacobstad) (Finland)
- 246 { Linz (Austria)
- Cassell (Germany) (relays Frankfurt)
- Kiruna (Sweden)
- Cartagena (Spain)
- 242 Belfast (2 B E) (Ireland)
- 240.6 Stavanger (Norway)
- 240 Radio-Beziere (France)
- 239 { Nimes (France)
- Nürnberg (Germany) (relays Munich)
- 238 Bordeaux Sud-Ouest (France)
- 237 Örebro (Sweden)
- 235.5 Kristiansand (Norway)
- 234 Lodz (Poland)

- metres
- 232.2 Kiel (Germany) (relays Hamburg)
- 231 { Borås (Sweden)
- Umeå (Sweden)
- Malmö (Sweden)
- Hälsingborg (Sweden)
- Cologne (Germany)
- Aachen (Germany)
- Münster (Germany)
- 227 { Cork (6 C K) (Ireland)
- 222.9 Fecamp (France)
- 222.1 Helsinki (Finland)
- 222.4 { Karlstadt (Sweden)
- Flensburg (Germany)
- 218 { Ornskoldsvik
- Björneborg (Finland)
- Salzburg (relays Vienna)
- 216.3 Königsberg (Germany)
- 216 { Malmstad (Sweden)
- Radio Chatelineau (Belgium)
- 214.2 Warsaw, No. 2 (Poland)
- 204 Gävle (Sweden)
- 203 Kristinehamn (Sweden)
- 202 Jönköping (Sweden)
- 200 Leeds (2 L S) (Gt. Britain)
- 196 Karlskrona (Sweden)
- 175 St. Quentin (France)

The distortion is due to the fact that the distant listener hears all the relays coming through together, from their various distances. In any one service area, say, Bournemouth, the local station wipes out all the others and this distortion effect does not exist. But outside the areas of these eleven stations their combined programme makes the well-known "relay-roar," as listeners call it.

The star British station below 300 metres is London National, using a power of 68 kw. But Belfast, on 242 metres, is by no means a weakling, even in the

Lower still is Leeds, right down on 200 metres. This station has never been partial to my aerial, and when Leeds is served by the new North Regional I shall not mourn the 200-metre transmission.

Below Leeds there are only two other European transmissions (excluding the really short waves, of course), but there are plenty of good foreigners interspersed among the English-speaking stations named above.

The best of all, at the time of writing, is Heilsberg (276.5 metres),

Langenberg programme), and often the strength on 227 metres is remarkably good. These three relay stations are crystal-controlled.

Almost equally strong is Nurnberg, who relays Munich on 239 metres. Nurnberg has an annoying habit of long waits with an open microphone, but nevertheless it is an interesting station to "keep an eye on."

Sometimes during the long intervals it plays an air on a musical box—five ascending notes. And a blast on a musical-sounding

And Turin, on 296 metres, is certainly an outstanding programme on many nights.

The famous nightingale call makes Turin an easy station to recognise, and the lady announcer does her part with equal success. Even in an unfamiliar language her clear "Ee-ah Milano-Torino—Genova" is recognisable as Italian for "Here Milan, Turin, Genoa."

An interesting point about Turin is that its wave-length should be 273 metres, but it has borrowed 296, and apparently means to stay there! "D.X."



HAS YOUR FRIEND GONE ABROAD?

Why not send him "Modern Wireless" every month? Make the mail-day a Red-Letter day for him, by keeping him in touch with home.

Send his name and address with 17s. to the Subscription Dept., Fleetway House, Farringdon St., E.C.4, and "M.W." will be sent every month for a year.

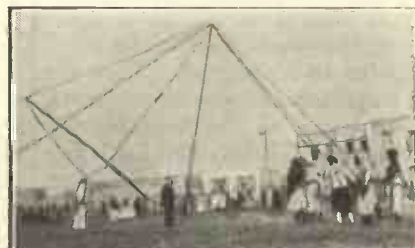

Quite the most interesting feature on the wave-lengths between 1,000 and 2,000 metres is the new Polish station at Raisin, near Warsaw. As a matter of fact, it is the most powerful broadcasting station in Europe, if not, indeed, in the whole world.

* * *
The word "Raisin" is not, apparently, going to be used much. Most of the announcements don't mention this, the actual site of the station, but refer to "Warsaw," where the studio is situated. They don't, however, call it "War-saw."

Notes on Long Waves

Some helpful hints about reception above the 1,000-metre mark.

It seems curious that there should be this falling-off just in this part of the wave-band, because Kalundborg, on 1,153

metres, is exceptionally well-spoken of all over the country. Although my aerial is south of London, I find Kalundborg gets over better than Eiffel Tower.

"To-day" is "To-morrow"

* * *
By the way, don't sit up late trying for Warsaw, as he generally "picks up" at 10 p.m. This is not because he actually goes early to bed, but because his time is two hours ahead of Greenwich, so anything after

metres, is exceptionally well-spoken of all over the country. Although my aerial is south of London, I find Kalundborg gets over better than Eiffel Tower.

* * *
As long-wave tuning is always apt to be flat, here is a good tip for getting accurate dial readings. Keep listening after the station you are in doubt of has closed down, and you may find, after a few minutes' wait, that you

KEEPING A CHECK ON THE WAVE-LENGTHS OF EUROPE



On the left of this photograph you can see the Brussels wavemeter, which is used to check-up the wave-lengths of the transmitting stations. This meter is, in turn, checked up by tuning-fork multi-vibrators.

As pronounced in Polish it sounds more like "Var-show-va." But the English engineers who erected the station have done a lot of announcing in English late at night, and no doubt this helped many a British listener to log the station quite definitely.

Just Above Motala

Apart from the actual name of the station, the words "Polski Radio" will serve to identify it. They are very frequently in the announcements, and as none of the neighbouring stations says "Polski Radio," you can be sure that Warsaw is speaking.

* * *
The wave-length of Warsaw is 1,411 metres, and the dial-setting

10 p.m. is "to-morrow" in Poland! The three long wave stations who share one wave-length (1,200 metres) still seem to be very unhappy about it. The programmes in question are: Istanbul (or Stamboul), Boden, and Reykjavik, and one can never be sure of which is which.

* * *
Istanbul, usually announcing in French, was coming over well a couple of months or so ago; but lately weak carrier waves from him and his fellow "twelve-hundreds" have been the order of the day. Moreover, those carriers "wobbled" quite a long wave from 1,200 metres, and 1,250 would have been nearer the mark sometimes.

are rewarded with a long, piercing tuning note!

* * *
This usually lasts about five solid minutes, so there is plenty of time to get absolutely exact readings. And even after that has ceased you may pick up all sorts of queer dots and ticks that will help in calibration.

"After-hours" Stunts

These "after-hours" stunts appear to be one result of the recent broadcasting conference at Semmering. It was then decided that certain stations should send out test signals; and such a test transmission is worth hours of ordinary speech or music, so far as getting exact dial readings go.



"THE ROSE OF NAPLES."
That is what they call Signorina Rosa, who says the necessary good-nights for Naples on 332 metres. "Buono notte a tutti" is the way she puts it.

Do you ever listen to Europe saying "Good-night" to itself? A good radio set will send you to bed with courteous greetings in a dozen languages, and will let you hear the nocturnal chiming of clocks from the Baltic to the Bosphorus.

Some of these good-nights are well worth hearing. And one soon acquires a friendly interest in the far-off announcer, whether he wishes you "God-nat," "Bon soir," or "Gute-nacht."

In English

Warsaw has been a good station to listen for lately, because its new transmitter (on 1,411 metres) has often announced in English. As Poland's time is two hours ahead of Greenwich, their 1 a.m. is our 11 p.m., and this is a good hour to catch announcers "signing off" for the night.

Incidentally, the Polish stations—Cracow, Katowice, etc.—use the most interesting "good-night" signal in the world. It is the relay of a bugle-call, and can often be heard from these stations at 11 p.m. This call is sounded

"Good-Night, Everybody—Good-Night"

Some interesting items about the way in which the various stations close down their programmes.

nightly at St. Mary's Church, Cracow.

It commemorates a sentry who died at his post, and it appears to end suddenly, as though the glorious tragedy were enacted nightly. A thrilling and impressive good-night.

The melodies with which the various programmes close will in themselves often provide plenty of interest. For sheer distinction a French station closing with "La Marseillaise" is hard to beat.

When the Rome-Naples programme closes, the Royal Italian March, followed by the Fascist Hymn, can be heard. (The announcer's "Buono notte a tutti" means "Good-night, everybody.")

Often, but not always, the German stations play "Deutschland Uber Alles" when closing for the night. This is more familiar to English listeners as a hymn-tune, being known as Haydn's "Austria."



"FATHER OF RADIO."

The Americans give the above term to Mr. H. P. Davis, Vice-President of the Westinghouse Electric and Mfg. Co., because that company founded America's oldest station, KDKA, East Pittsburg. It has now broadcast regularly for more than ten years.

The German announcers often use a closing phrase in which the word "antenna" can be heard. This is a warning: "Please do not forget to earth your aerial." ("Bitte, vergessen Sie nicht die antenne zu erden.")

Turkish Delight

If you can get Istanbul on 1,200 metres (or thereabouts) you will hear the Turkish national anthem when this station closes. The announcements are in French as well as in the Turkish language.

Kalundborg (1,153 metres) has a habit of striking three times on a gong as a closing signal, and the short melody played as a finale is the Danish air, "There is a Beautiful Country." It is certainly a beautiful good-night tune.

The Spanish stations keep very late hours, but their closing words are usually: "Buenas noches, Señores: hasta mañana."

SHANGHAI CALLING!



On the left is Dr. Wen Gu-Ching, Director of the Chinese Radio Administration, with the Minister of Communications. This photograph was taken on the occasion of the opening of the Shanghai station.

Three hundred thousand. That's a good round number, isn't it? And it's the very number to get you round—get you round that difficulty of wave-length and frequency.

Wave-lengths & Frequencies

How They Are Related.

For if you divide any station's wave-length into 300,000 the answer is that station's frequency (in kilocycles). And, similarly, if you know the frequency, dividing it into 300,000 will give you the wave-length. 'S fact.

Look at Leeds, for instance. Works on 200 metres exactly. What's his frequency?

Well, 200 into 300,000 goes 1,500 times. So the frequency of Leeds is 1,500 kilocycles. Easy, isn't it?

Even on the short waves the answers come out right. Take a chap like Barcelona, working on 50 metres. If you want to know his frequency divide 50 into 300,000, and you find that 60,000 kc. is the frequency of Barcelona.

(But don't forget that only Saturday night is Barcelona night. It's really a short-wave club station, with one programme a week—8 to 9 p.m. on Saturdays. So, for all its high frequency, it's an infrequent programme that is provided.)

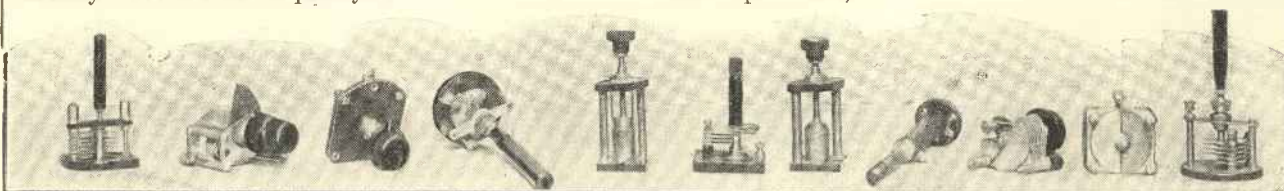

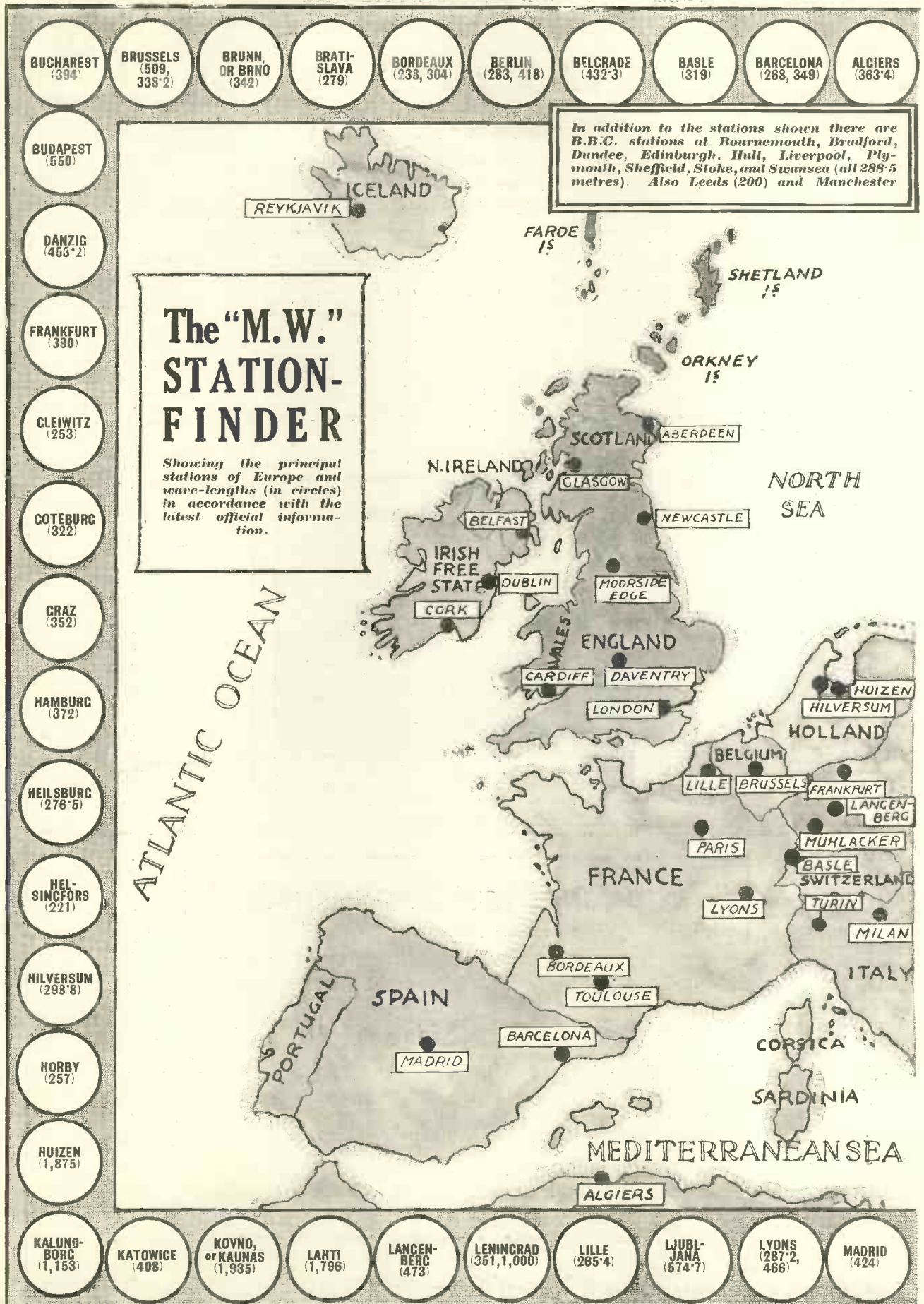



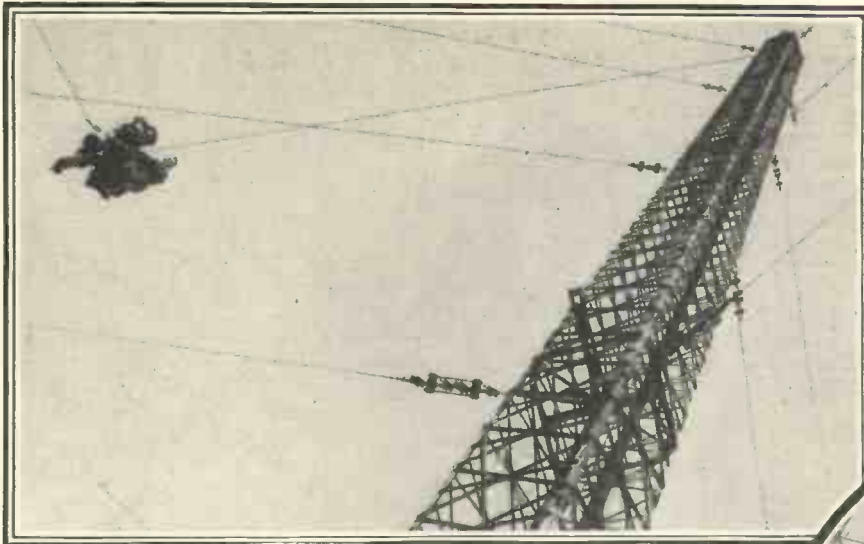

KEEPING THEIR ENDS UP!

Some unusual views of the giant masts used to support famous aerials of Europe.

The picture above was taken at Zeesen, Germany, and shows workmen being hauled up to the top of one of the masts from which the 1,835-metre programme is sent out. This station took over the work of Königswusterhausen in relaying the Berlin programmes.

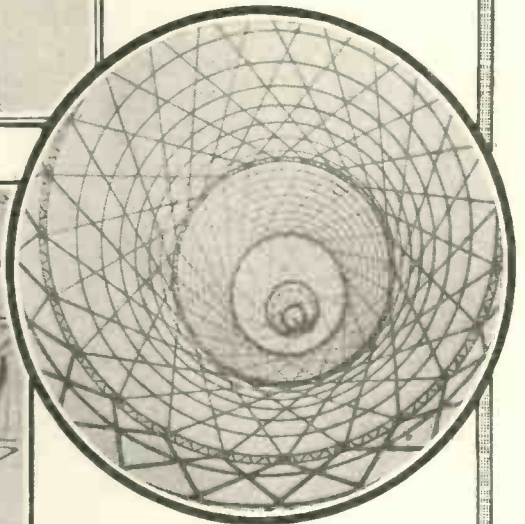

To take this queer lattice-work view the photographer stood under the centre of the mast at Moscow.

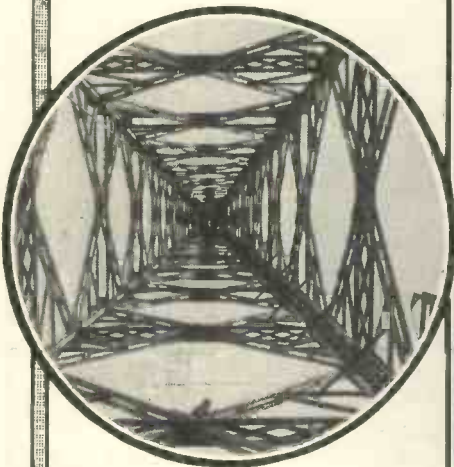

Munich's masts are made of wood, and in the circle one of them is shown from underneath. (Right) One of Königswusterhausen's giants, poised on a huge insulator.

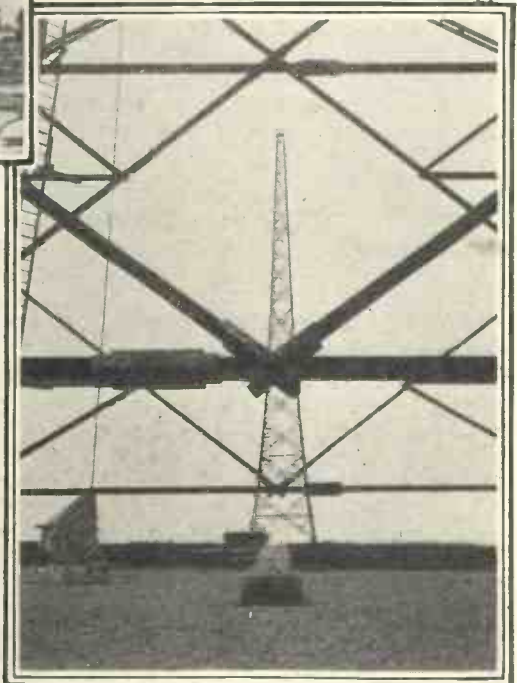
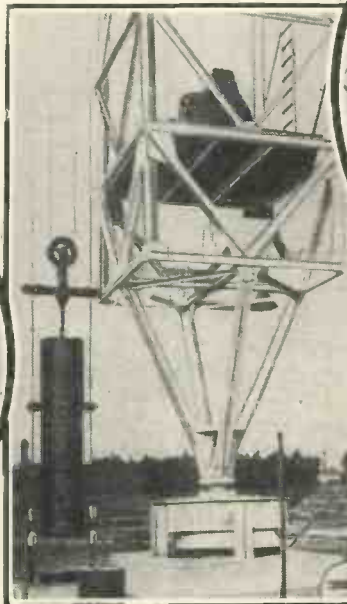

Müblacker, the inseparable chum of the London Regional, is shown above, and to the left is a view of Kootwijk, the famous Dutch short-waver.

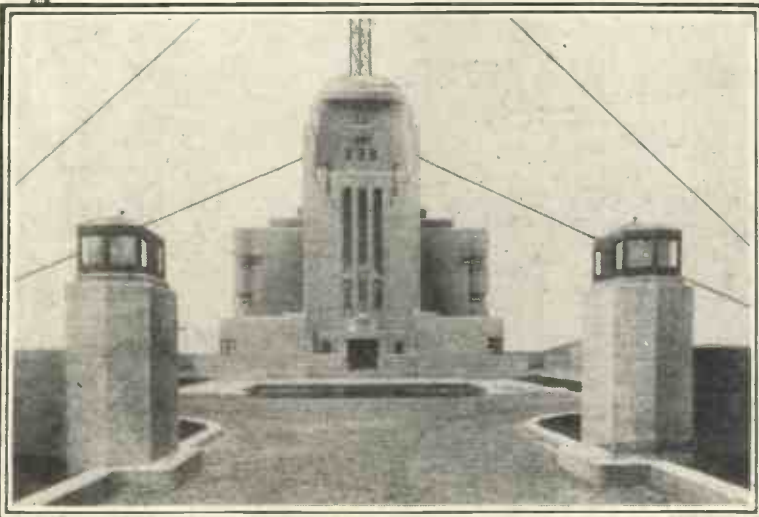

SHORT-WAVE SHORTS

Latest news from the more interesting stations.

Oakland, California. The famous short-wave relay of KGO is again on the air from W6XN.

S. S. "Bremen." This transatlantic record-breaker has been well received here and in America on telephony. Various wave-lengths between 16 and 40 metres.

Sourabaya, Java. Programmes go out on 49.7 metres, usually from 11.40 to 14.40 G.M.T. The call is PK3AN, and Sourabaya opens with the Dutch National Anthem. (Reports gratefully received by Mr. H. Budding, Balistraat 20, Sourabaya, Java.)

Buenos Aires. A service of radio-telephony is to be established between Buenos Aires and Kootwijk, Holland.

Tokio. Recent mystery programmes received on 25 metres in this country are now said to have been from Tokio. (Japan has not long been interested in short-wave transmission.)

2BLX. Reports on signal strength, weather conditions, etc., are invited from any experimenter who hears, on 20 or 42 metres, Mr. J. W. J. Tyrell (2BLX), now with L Coy., Royal Corps of Signals, Jubbul-pore, India.

Eindhoven. Test transmissions with different aeriels are being carried out by PCJ, the Eindhoven short-wave transmitter.

Calcutta. The hours of service at Calcutta are 02.45-03.45 and 13.00-14.00, wave-length 25.27 metres. The call-sign is VUC, and power .5 kw.

Radio Saigon. The programmes of this famous Far-East station goes out with a power of 12 kw. Wave-length 49 metres, call-sign F3-ICD.

Copenhagen. The Danish programme from Copenhagen goes out on short waves as well as from Kalundborg on 1,153 metres. The short-wave relay is from Lyngby, OXY, working on 35.51 metres, from 7 p.m.

Vatican City. The Pope's station at the Vatican is being picked up at great strength in America. Wave-lengths, 19.84 and 50.24 metres.

The Pope's Station. The times of future transmissions have been given as 14.30-15.00 G.M.T. (19.84 metres) and 15.30-16.00 on 50.26 metres. These times are arranged provisionally, and alterations may be made in the near future.

Rabat, Morocco. The relays of the Rabat programme, which go out on 23.36 and 32.26 metres, have been picked up nearly all over the world.

SIXTEEN STAR STATIONS

A selection from the cream of the world's short-wave programmes.

Wave-length in metres	Name of Station	Remarks
19-36	Schenectady, N.Y. (W2XAD)	Relays WGY. Daily (ex. Sats.), 1800-2000; Sundays, 1800-2100.
25-25	Pittsburg East (W8XK)	Relays KDKA, 1700-0300.
25-1	Rome (3RO)	Power of 9 kw.
25-53	Chelmsford (G5SW)	Power of 10 kw. Relays 5XX. Mon. to Fri., 1230-1330 and 1900-2400.
31-28	Eindhoven, Holland (PCJ)	Wed., 1800-2000; Thurs., 1800-2000, and 2300-0300 (Fri.); Fri., 1800-2000, and 0000-0600 (Sat.).
31-38	Zeesen, Germany	Relays various German programmes, generally 1300-0030.
31-48	Schenectady, N.Y. (W2XAF)	Relays WGY. Weekdays, 2230-0400; Sundays, from 2100.
48-86	East Pittsburg (W8XK)	Relays KDKA. Wed. and Sat., 2200-0500.
49-02	Richmond Hill, N.Y. (W2XE)	Relays WABC, 1300-0500.
49-18	Bound Brook, N.J. (W3XAL)	Mon., 2230-2345; Tues., 2200-2300; Wed., Thur. & Fri., 2230-2300; Sat., 2200-2225. Daily (ex. Monday), 0400-0600.
49-34	Chicago, Ill. (W9XA A)	Relays WCFM. Daily, 0200-0500.
49-5	Winnipeg, Man. (VE9CL)	Weekdays, 2330-0130.
49-5	Philadelphia, Pa. (W3XAU)	Relays WCAU. Daily, 1400-2100; Thur. and Fri., 1400-0600.
49-5	Cincinnati (W8XAL)	Relays WLW.
49-83	Chicago, Ill. (W9XF)	Relays WENR. Sun., 0500-0700, 1300-1730, 2030-2300; Weekdays, 0315-0445, and 2030-2400.
50	Nairobi, Kenya Colony (7LO)	Special broadcast on April 20th for British listeners. See "Wireless Constructor," May issue, "Popular Wireless," and daily papers for details.

NOTE.—Short-wave times are usually given in four-letter groups, the first two letters being the hour, and the last two the minutes. (Examples, 10.15 a.m. = 1015; Noon = 1200; 1 p.m. = 1300; 6.20 p.m. = 1820, etc.)

BELOW 100 METRES

A few words for the novice about a fascinating branch of radio.

Nearly all the world's short-wave broadcasting is now done on wave-lengths between 70 and 15 metres. It needs special coils, consisting of only half a dozen or so turns of wire, to reach down to these wave-lengths.

And when you can tune down with these you find a surprising state of affairs there. The short waves are very, very different indeed from the medium and long waves.

For one thing, tuning is incredibly sharp, so you must have a slow-motion dial. The merest touch of the tuning condenser sends you right "through" a programme, too quickly to hear even a chirp!

For another thing, the distances covered are astounding. America comes in sometimes like a local station, and it is not very unusual for a good two-valve set to get Australia or New Zealand.

Yet another curious thing is that the stations that are comparatively near—like Chelmsford, for instance—are not so strong as the far-off stations! And another peculiarity is that during daylight long-distance work is often as good as, or better than, at night. Very peculiar!

Anyone who can handle a reaction properly, and who gets foreign stations easily on an ordinary set, will find short-wave work interesting and easy. But it is not a proposition for the real novice, because of the very sharp tuning. A certain amount of skill is required.

Once you build a short-wave set (or fit your present set with the necessary coils or adaptor) and experiment on these short waves you will find it hard to leave them alone. There is a great and special fascination about working on the wave-lengths below 100 metres.

A Transmission for Constructors

Very special interest attaches to the unique broadcast on April 20th from Nairobi. (See the reference on this page.)

It is hoped that, if conditions permit, this transmission—the first of its kind from Kenya Colony—will be relayed by the B.C.C. to British listeners. The roaring of lions from the equatorial jungle, as well as messages from the Kenya colonists to friends in this country, will probably be included.

Altogether this will be a broadcast of historic interest which every short-wave enthusiast should try to pick up direct from Nairobi.

A SHORT-WAVE LIFE-SAVER



This petrol-driven short-waver is small enough to go into a ship's life-boat. It does 4½ hours per gallon.

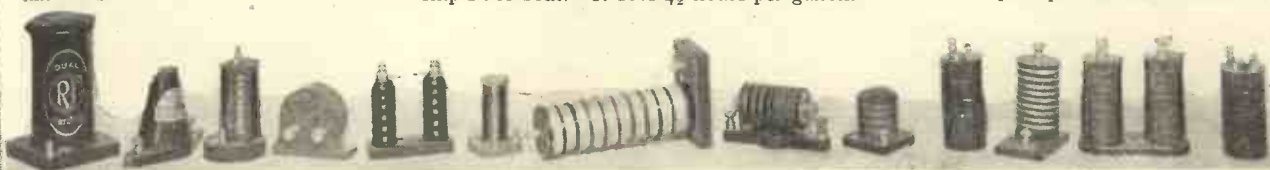

HEARING THE U.S.A.

*Some Hints on
Tuning for American
Broadcasting.*

More and more people with ordinary sets have found that they can pick up America without changing to short waves—in fact, it is possible night after night, at the time of writing. What is the best way to get such super-distance results?

First of all, about the kind of set. Any good long-distance will do, and the coils, etc., are not changed, but everything is left just as for usual reception.

Even a well-handled one-valver that picks up foreign stations may succeed in capturing the U.S.A., but a two-valver has a better chance, while a good three-valver, or a four, will often reap a harvest of several transatlantic programmes at one sitting.

The Wee Sma' Hours

Whatever kind of set is used it needs to be in tip-top sensitive condition. And it is no good looking for American programmes till midnight, when most of the Europeans go to bed.

From about midnight till just after dawn the Americans now come over on the wave-band between 200 and 500 metres; loud on some nights, weak on others, and sometimes unrecognisable. So a certain amount of luck in choosing a good night is needed.

The best way to tackle the tuning is not only to search slowly over your tuning range, investigating every likely carrier-wave, but to vary this with restricted searches for certain pre-determined stations. You can tell exactly

where the famous Americans should come in by comparison with well-received European stations.

In the list on this page are half a dozen American stations, every one of which has recently been heard in this country on ordinary sets. And each U.S. station is "bracketed" between two European stations.

If you know the dial readings of

these two European stations, you know that between them lies the American programme. So you need only search over this restricted area on the dial for the U.S. station in question.

For instance, on my own set London National comes in at 24 deg. and Heilsberg at 29 deg. on the dial. Searching between these two readings at 1 a.m. I recently came across W P G (Atlantic City) at

28 deg. Direct reception over the Atlantic!

One advantage of listening to an American station is that at least every 15 minutes it announces its call-sign clearly. In this case a play was faded out for a moment, and the announcer gave out "W P G (Atlantic City)," with details of the broadcast, etc., with great distinctness.

If your own set happens to be good on long-distance the probability is that you can pick up one or more pairs of the European stations shown in the accompanying list. You may for instance, know just where the Aberdeen and the Bordeaux Lafayette programmes come in on the dials.

And if you know that you know exactly where to look for W B Z, for he is sandwiched between them, as shown.

Another Good Yank

Similarly, to find W G Y (Schenectady, N.Y.) the search would be restricted to the area on your tuning dial between the settings of Manchester and Radio Toulouse—a question of only 3 or 4 degrees on most sets. So that if W G Y is coming over you should certainly "place" him without difficulty.

The U.S. stations in the list are favourites, but others, including a number of quite low-powered transmitters have been "getting over" quite strongly. Don't forget that at these great distances stations fade considerably, and sometimes, if the dials are left alone a weak station may "fade in" stronger and stronger, until from being too faint to hear it gives quite good loud-speaker strength.

F. F.

WHERE THEY LIE

Metres.		
261		London National.
272	W P G	Atlantic City, N.Y.
276		Heilsberg.
301		Aberdeen
303	W B Z	Springfield, Mass.
304		Bordeaux Lafayette.
304		Bordeaux Lafayette.
306	K D K A	East Pittsburg.
309.9		Cardiff.
376.4		Manchester.
380	W G Y	Schenectady, N.Y.
385		Radio Toulouse.
390		Frankfurt.
395	W J Z	Bound Brook, New Jersey.
398.9		Glasgow.
441		Rome.
454	W E A F	New York.
466		Lyons, La Dona.



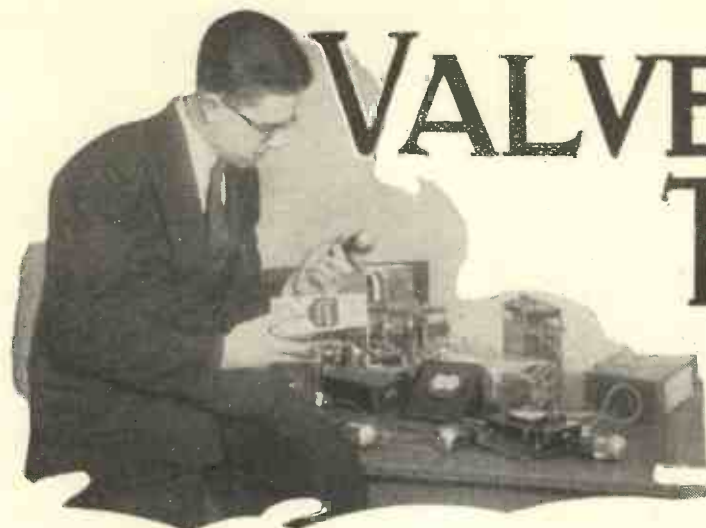

VALVES I HAVE TESTED

A glimpse into the valve section of the "M.W." Research Dept., and some interesting personal experiences.

By K. D. ROGERS.

THE carrying out of all sorts of tests on valves is part of my work in connection with MODERN WIRELESS, and it may interest some of you to have a slight glimpse into the inside workings of the test department which deals, among other things, with new valves and, occasionally, our own old faulty ones.

Valves sent in from manufacturers are not merely shoved into sets, the results noted, and then taken out again. That sort of test is all right from a rough-and-ready point of view; they are all given a very stringent characteristic test, and, in many cases, life tests.

Living Too Long!

Of course, it is impossible in MODERN WIRELESS to report upon the life test of any new valve almost immediately it comes out, and so you very rarely hear anything about the length of life of a valve when reading through our pages.

That is not because they fail in their life tests, but simply because by the time the valve of good manufacture has worn itself out it is almost obsolete at the rate of progress of the present day.

For instance, take the D.E.L.610 and the P.M.4. A specimen of the D.E.L.610 which we had in for test when they first came out is still working well. Its life is not yet over. But you will not find the D.E.L.610 in the maker's catalogue now. Its name has been changed, and if you want a valve with something of the same characteristics you must look it up under the L.610.

The P.M.4 of 1925 and 1926 outlived its existence, if I may put it that way; for the P.M.4 a few years later had quite different characteristics, and the present-day model

bears hardly any resemblance to the 1925 model.

Checking Characteristics

So, honestly, we cannot say we have had such-and-such a valve in for test and it has lasted so many hours. What we do is to give certain valves really stringent tests under working conditions, more as a side line for our own information than for direct publication, while other tests are carried out with an idea of letting the public know how a certain valve behaves.

Present-day valves, with the exception perhaps of the indirectly-heated type, are so standardised and so perfectly manufactured, deviating so little from the published characteristics, that there is very little of unusual interest to be said in our valve reports.

We may get such a valve as the new P.M.1H.L., which has been recently placed on the market. It has an impedance of 18,500 ohms with a magnification of 28. The maximum H.T. voltage recommended is 150. We place that valve on the test bench and we plot its characteristics in the usual way, noting the change in anode current for changes in grid volts, the change in anode current for the change in anode volts, with the grid volts remaining constant, etc., taking its A.C. resistance, its amplification factor and its slope.

The Makers' Figures

We find the slope is good. We find the impedance is suitable for its use as a detector valve or a first-stage L.F., the emission is good, and a good reaction effect in a detector stage can be expected, and high magnification with sensitivity. Finally checking over we find that the characteristics we

WHAT ARE THE CHARACTERISTICS LIKE?



A member of the Research Department testing a new valve. Careful measurements are taken before the valve is tried out in a set, under practical conditions.

The Power Valve That Blew Up!

have arrived at are almost identical with the published curve of the makers. This is as it should be.

The published curve of the manufacturer is roughly the average or standard which they want their valve to have. We sometimes find that a certain characteristic is better, sometimes not quite so good, but it is only a matter of perhaps a few ohms in impedance and a small decimal fraction of the magnification factor; nothing that would matter in actual working.

In Days of Yore

Years ago valve testing was full of surprises. I remember checking one of the old-timers (I won't mention the makers' name as this was not an ordinary valve but an early model), and I had the most exciting time with the milliammeter. With 100 volts on the anode things were pretty much as the makers said. At 120 on the anode the emission went up far more than I expected it to, and with the maximum anode voltage, which I believe was 150 on that particular valve, all sorts of funny things happened. Something like 50 milliamps. were drawn at the "correct bias," accompanied by a beautiful blue glow. H.T. was

bumps, I should like to remind all my readers who may be tempted to plot the curves of their own valves, they will never in all probability get a perfect curve. There are always a lot of little kinks on the characteristic curve. You will not get anything like the smoothness denoted by the maker's curve.

An Exciting Test

That is because the maker's curve is an average. Those little humps and bumps may affect the working very, very slightly, but their effect is negligible and we need not worry about them. So if you check your own valves, perhaps those you thought were really good ones, and find tiny bumps in the curves when you take them very carefully, do not worry. If there are no very nasty bumps it is really the good valve that you thought it was.

WHY WON'T IT WORK?



Examining the connections of an S.G. valve in one of the latest "M.W." receivers. It was found that a leaky valve holder was causing trouble.

hurriedly switched off. Increasing the bias reduced the anode current to something like 35 or 30, and a further increase gave very little further decrease. Still increasing bias produced a sudden drop in anode current; then another flattening out. As a matter of fact, the characteristic curve was full of humps and bumps. The valve was soft, and that specimen was really not suitable for use at all.

And, talking about humps and

Three years ago I had another peculiar experience, this time in an actual test in a set. I was testing an output valve of which I had an early edition, just before it went on the market. The total anode current it consumed was about 35 milliamps. and it was rated at 200 volts H.T.

In tests of this kind I always apply at least 25 per cent extra H.T. above the maker's rating, to test the safety factor of the valve. This time I had

about 250 volts on the plate, and it had been going some hours in a large set under actual working conditions. The results were good, and I was bending over it, having a close look at it because I had noticed that the milliammeter was giving signs of wanting to go up a bit, blue glow was rapidly spreading inside the bulb, and the valve was getting a bit too hot—when, suddenly, with a loud report, the valve burst in my face! I have never found out why, but presume the hot electrodes gave way and touched the glass, and it is the only time that I have ever had anything like that occur.

About Over-Running

I was over-running the valve, I know, but a good valve will stand over-running about 25 per cent in H.T. voltage provided the milliamperage is kept down carefully to something like its maximum current dissipation.

In over-running a valve in this way, however, you must not let the milliamperage go soaring up regardless of the maker's instructions. The power dissipation must not be exceeded if you want the valve to have a fair test, and in general use if you want the valve to have its full life, of course, it is not fair to run it at all at voltages above the maker's recommendations.

In test work one can get a very good idea of the quality and hardness of the valve by such over-running.

The life may be slightly shortened, but the valve, if it is a good one, and is not over-rated by the manufacturers in the first instance, should stand a 25 per cent overload in voltage without any serious effect.

The Safety Factor

It may seem at first sight that it is a silly sort of test to subject the valve to, but it is only by such tests that one can gauge the "safety factor," as it were, of any particular valve, especially a power valve; and, personally, I always give a valve a very strict safety test on the over-running lines.

A good power valve, especially, will stand up to it remarkably well. I know of many cases of L.S.6A.'s running at 550 volts, though they are rated at 400; careful bias, of course, being applied to see that the valves do not seriously over-run from a wattage point of view. But I do not advise readers to try these tricks if they want to get maximum length of valve life.



OFF *the* BEATEN- TRACK

A few words about radio set design and construction in general, and portable and transportable sets in particular.

THERE are those who must have change and variety at all costs. They fly from one thing to another, dreading to linger at any single point (even though they feel a tremendous urge to do so) for fear that they will be called "cabbages."

Of course, change is necessary, it is a part of the machinery of progress. But that kind of change is inevitable, and is always with us, however individuals may strive to resist it.

Nevertheless, that does not prove that variety for variety's sake alone is good. Struggling to be different, and to act differently, can be just as much expressions of a superiority complex as the indications of restless genius.

Only Commonsense

If a certain system has more good points than it has bad ones, then it is only commonsense to stick to it until another one having an even greater bias towards the good can be devised. Otherwise you introduce retrogression, not progress.

Radio can provide many excellent examples. Take, for instance, the vertical panel and horizontal baseboard method of constructing a wireless receiver. This scheme is not a perfect one by any means. Its present standardisation tends to cause set designs to be stereotyped in appearance.

But it has so many advantages that it would be foolish to banish it into obsolescence on that ground alone. It makes for simplicity in set assembly and for accessibility—two qualities of sterling worth where the home-constructor is concerned.

And it is possible to apply the

system in such ways that those who must have variety can be moderately satisfied. We said above that the vertical panel scheme *tends* to cause a sameness in receiver appearance. But it wouldn't do even that if constructors themselves would be a little bit more individual.

BUILDING A PORTABLE ?

If you are interested in portable receivers make sure of your copy of next month's "M.W."—it will contain special articles on the subject.

On Sale May 1st. Price 1/-

A panel-baseboard set should be regarded as a chassis ; there is plenty of scope for variety in cabinet design. A simple "American" type cabinet is never essential, although, of course, it is inexpensive. However, a glance at the catalogue of any big cabinet supplier will show you that there are other kinds of designs at quite reasonable prices more in keeping with drawing-room furniture.

If you want a real breakaway from the conventional, we would advise you to turn your thoughts in the direction of portable and transportable receivers. These need not be as elaborate in construction or as costly to build and operate as many would seem to think.

Much Improved

At one time it was necessary to use at least five valves to get anything really satisfactory in the way of reception with a portable, but modern components and modern valves are so efficient that the same results can be achieved with much more modest

apparatus than a complicated five-valver.

Complete proof of that is to be found in the ever-growing popularity of the portable and the transportable. These instruments are not being used in the open, but are being employed as household outfits because they are compact, easy to keep dusted, and can be moved freely from one room to another.

Is there any difference between a portable and a transportable ? They are often confused, so much so that the terms are becoming as completely synonymous in practice as they are philologically. Correctly, a portable is an entirely self-contained instrument that can be carried by hand fairly easily, while a transportable is a set capable of being moved from point to point, but not necessarily quite self-contained.

Not Difficult

But whatever category they fall into, "pack-up" sets are fascinatingly useful things, especially in the summer. And, as we have already said, they need not necessarily be difficult or expensive to build. But they can be snares and delusions if they don't start right by being designed scientifically.

It is no good taking a standard circuit and compacting its practical expression into the smallest possible space. You head for trouble if you do that.

But if you have any real interest in the matter make sure you get a copy of the next issue of "M.W." In that we will be going very fully into the subject of "carry-around" radio.



A Dual- One-

A highly efficient set that brings in many distant stations, but is nevertheless one of the most simply controlled "home" receivers ever designed.

THE number of pairs of tele-
phones in use at the present
time, were it known, would
probably be rather a surprise to
confirmed loud-speaker fans. At
one time every radio enthusiast
possessed telephones, even if he had
a loud speaker, but many listeners
to-day have never listened-in with
a head-set.

These listeners may be surprised
to learn that quite a number of
people prefer telephones to loud
speakers. Even experts sometimes
avow that they like to listen on tele-
phones for a change, because of the
complete isolation from everything
but the broadcast which results.

Ideally Economical

Many deaf people are able to hear
quite well with telephones, and, of
course, a very large number use head-
phone receivers for reasons of economy.
Naturally, crystal receivers figure
very largely among headphone sets,
but there is a marked tendency for
these to be replaced by single-valvers
now that radio is so much cheaper
than it was a year or two ago.

The single-valver is ideal for tele-
phone use. Its range and volume are
far superior to the crystal receiver,

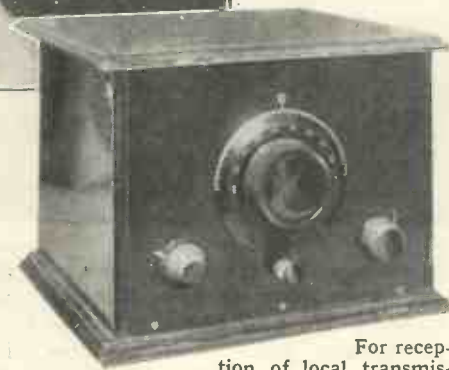

For recep-
tion of local transmis-
sions only one knob, the bottom right-hand
one, has to be touched.

and it is much easier to separate
efficiently the two transmissions of a
regional station with a valve detector
than with a crystal.

A single-valve set nearly always
has to be very much a dual-purpose
receiver. It must be capable of
searching round the ether and bring-
ing in a number of distant stations,
and also of serving as a family re-
ceiver for local listening.

In the latter capacity it is very
desirable that operation shall be as
simple as possible. The simpler the
better.

Station-Change Switch

So we have designed a receiver of
this dual-purpose type in which the
operation for local reception is re-
duced to the absolute minimum.

The receiver can be set for the
reception of one or the other of two
programmes from a regional station,
or for one programme on the medium
waves and one on the long waves.

Only one switch has to be operated
to turn on the set and to choose one
of the two programmes (if they are
both on the medium waves) for
which the receiver is set. With the
switch in the central position the set
is off; pushed over to the right
automatically switches it on and
brings in one programme, whilst when
it is pushed over to the left the other
programme comes in. Just centralis-
ing the switch turns the set off.

Adjustable Selectivity

For searching around, the switch
is just turned to the right, and tuning
carried out in the usual way with the
variable condenser and reaction con-
trol. Selectivity is adjustable within
certain limits by means of the .001-
mfd. maximum compression-type vari-
able condenser in series in the aerial
lead.

Selectivity is of quite a high order,
since one of the efficient "M.W."
dual-range coils is used, but as there

TABULATED DETAILS OF THE COMPONENTS YOU WILL NEED

PANEL
9 x 7 in. (Lissen, or Parex, Goltone, Peto-
Scott, Permcoll, etc.).

CABINET
Panel space as above, baseboard 9 in. deep
(Keystone, or Camco, Pickett, Kay,
Osborn, Lock, Gilbert, etc.).

VARIABLE CONDENSER
1 .0005-mfd. (J.B., or Lissen, Dubilier,
Lotus, Igranic, Ready Radio, Polar,
Cylton, Ormond, etc.).
1 .0001-mfd. or larger, up to .0002-mfd.,
differential reaction (Ready Radio, or
Polar, Lissen, Lotus, J.B., Igranic, Dubilier,
Wearite, Parex, Magnum, Ormond, etc.).

ADJUSTABLE CONDENSERS
1 .001-mfd. max. (R.I., or Formo, Lewcos,
Lissen, Polar, etc.).

1 .002-mfd. max. (Formo, etc.).
1 .0003-mfd. max. (Formo, etc.).

SWITCHES
1 double-pole change-over (Wearite).
1 3-point wave-change (Ready Radio, or
W.B., Wearite, Bulgin, Ormond, Key-
stone, Red Diamond, Magnum, etc.).

COIL
1 "M.W." dual-range (Ready Radio, or
R.I., Wearite, Goltone, Parex, Formo,
Keystone, Magnum, Tunewell, etc.).

VALVE HOLDER
1 sprung 4-pin (Benjamin, or Igranic, Clix,
Lotus, Telsen, Lissen, W.B., Bulgin,
Formo, etc.).

FIXED CONDENSER
1 .0003-mfd. (Dubilier, or Telsen, Lissen,

T.C.C., Igranic, Formo, Sovereign,
Mullard, Ready Radio, Ormond, etc.).

RESISTANCES
1 2-meg. grid leak, with holder (Lissen, or
Ferranti, Ediswan, Telsen, Graham-Farish,
Dubilier, Igranic, Mullard, etc.).
1 25,000-ohm Spaghetti type (Magnum, or
Bulgin, Keystone, Ready Radio, Lewcos,
Sovereign, Parex, etc.).

CHOKE
1 H.F. (Magnum, or Lewcos, Varley, Lissen,
Lotus, Dubilier, Ready Radio, R.I.,
Wearite, Parex, Keystone, Watmel, etc.).

MISCELLANEOUS
1 terminal strip, 9 x 2 in.
8 terminals (Elex, or Igranic, Belling & Lee,
Clix, etc.).
Wire, flex, screws, etc.

Range Valver

Designed and Described
by the
"M.W." Research Dept.

is only one tuned circuit it is not high enough for use in the swamp area of a regional station. When the receiver is desired for use in such areas a change-over type of rejector should be employed with it, when it will be found to become quite selective enough.

"Interwave" Coupling

A suitable rejector for this purpose will be found fully described on other pages of this issue of MODERN WIRELESS.

A glance at the theoretical circuit diagram of this one-valver will show you that the well-known "Interwave" system of coupling is used on long



For telephone reception it would be difficult to imagine a more convenient set, both as regards simplicity of operation and sensitivity.

ment for coupling when working on long waves. It should be tried at different values to ascertain which gives the best results both in regard to volume and selectivity.

You should start with it at mini-

may find that for maximum results from distant stations it is desirable to adjust it slightly when changing from one wave-band to the other. The third compression-type condenser is for setting the station-change part of the receiver.

You will see that with the double-pole change-over switch in one position this condenser is connected in parallel with the normal tuning condenser. With the switch in the other position the condenser is put out of circuit.

MUCH ACHIEVED IN A SIMPLE MANNER

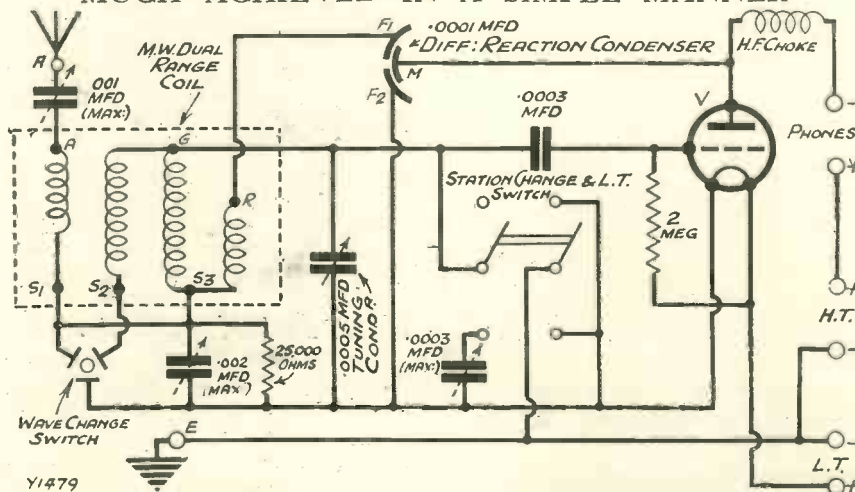

The use of an "M.W." dual-range coil is largely responsible for the efficiency of this one-valver, while the double-pole change-over switch makes the choice of local transmissions an easy matter. Note that this switch turns on the filament when it is put over to either side, the set being off when this switch is in the mid-way position.

waves. This scheme, of course, gives immunity from medium-wave interference when working on the long waves.

The .002-mfd. maximum compression condenser, across which the 25,000-ohm Spaghetti resistance is connected, provides a special adjust-

ment for coupling when working on long waves. It should be tried at different values to ascertain which gives the best results both in regard to volume and selectivity.

The series aerial condenser controls selectivity on both bands, and you

An Important Point

No matter which way over you have the switch, the L.T. is switched on. For this reason it is very desirable to use a D.P.D.T. switch that has a definite middle, or "off," position, otherwise there is a slight risk of the set being left turned on when it is intended to have been switched off.

The adjustment of the station-change arrangements are as follows: First of all we must assume that by experimentation you have found the best setting for the series aerial condenser and the "Interwave" condenser.

We will first take the case of the two programmes sent out on medium waves by a regional station. Pull out the wave-change switch, set reaction at zero, and put the station-change switch over to the right so that the .0003-mfd. compression condenser is out of circuit.

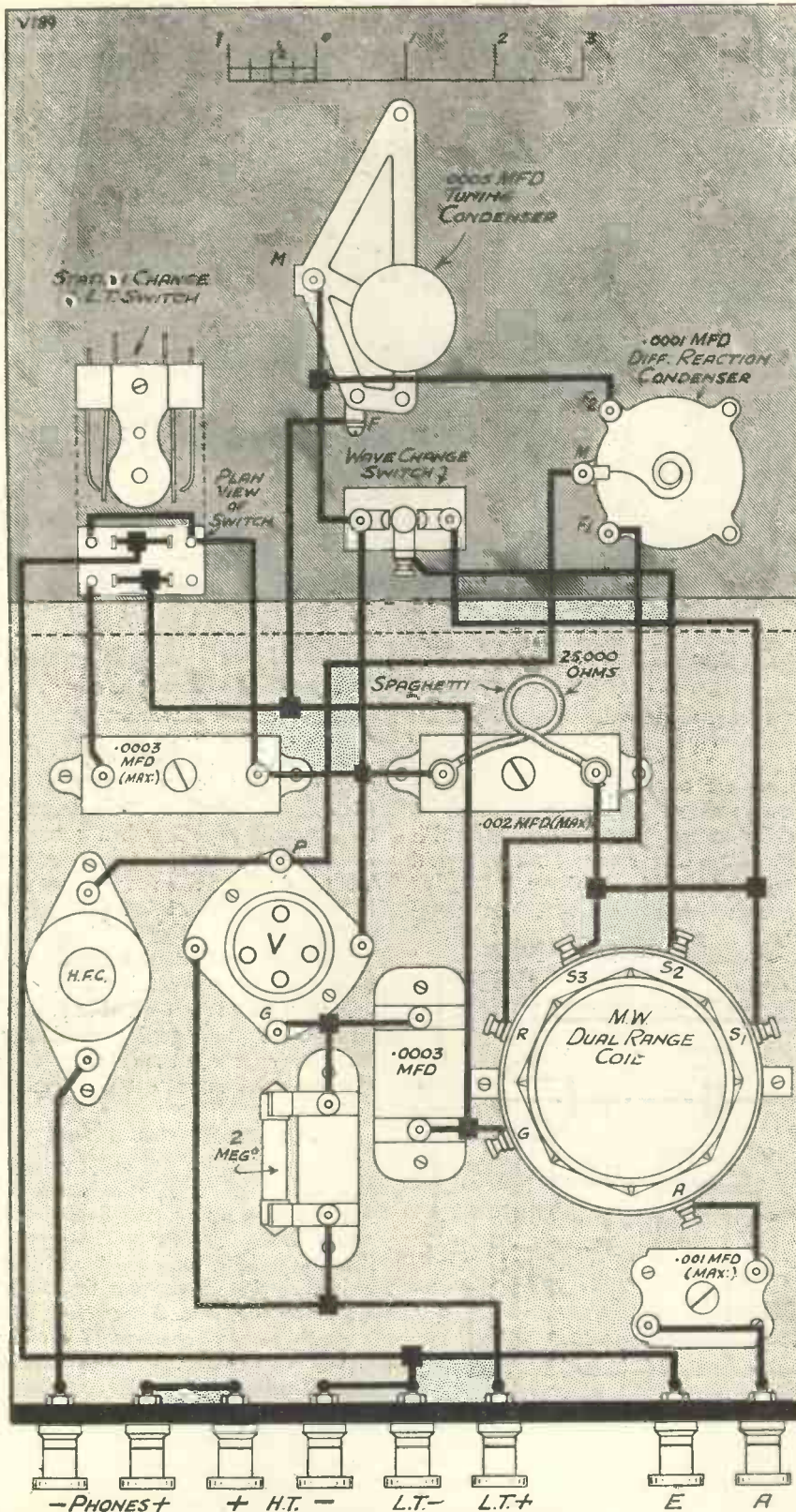

Here is the diagram from which the set has to be wired. You will note that there are three compression-type variable condensers. Normally, once these have been adjusted to suitable values they do have to be touched in connection with tuning.

Now tune in the programme with the lower wave-length, and note the dial reading so that you can set the receiver at a future time, no matter whether the station is broadcasting or not. Then move the station-change

switch over the other way and, with the variable condenser still set at the value just ascertained, tune in the longer-wave station by adjusting the .0003 compression condenser.

The receiver is now set, and a

movement of the switch one way or the other will bring in one or other of the programmes. With reference to the reaction condenser which we told you to set at zero, you can use a little reaction if necessary to bring up the strength of the transmissions, but it must not be so much that it has to be altered when going from one programme to the other.

Long and Medium Waves

Now suppose you wish to set the receiver to tune in the long-wave National transmission, and one station on the medium waves. Put the station-change switch so that the .0003 condenser is out of circuit and tune in the medium-wave station.

Note its dial reading and then push in the wave-change switch. Tune in the long-wave station and note that dial reading, too.

Keeping the station-change switch in the same position, tune in the station with the lower dial reading (of course, with the wave-change switch in the right position according to which wave-band the lower-reading station is on).

“ . . . we have designed a receiver of dual-purpose type in which the operation for local reception is reduced to the absolute minimum.”

When you have done this, leave the tuning dial at this reading, put both switches to their opposite positions and tune in the other transmission by means of the .0003 compression condenser. With one medium-wave and one long-wave station thus tuned it is necessary to change over the wave-change switch as well as the station-change switch when going from one to the other.

A Flexible Receiver

Just make a note of the relative positions of the wave-change and station-change switches. The note about reaction applies in just the same way when the set is adjusted for one medium- and one long-wave station as when two medium-wave stations are concerned.

We have dealt at rather great length with the station-change business, because it is one of the features of the receiver. We also wished to emphasise clearly that it is not necessary with this set to live within range of a Regional station if the choice of two programmes by means of switching is to be available. All that is necessary is to be within

A Dual-Wave Set With a Dual Purpose

'phone reception distance of two stations without the use of reaction.

And now one or two lines about the construction. This is particularly simple, and there are no "snags" or specially critical points about which we have to warn you.

Simple Construction

It is merely a matter of following the two diagrams for layout and wiring. In the wiring diagram you will note that a plan view of the contacts of the station-change switch is given, as well as the elevation.

This is to simplify the showing of the connections, and, of course, the switch is mounted to the panel as shown in the drawing immediately above this plan view. The two pairs of centre contacts are joined together with a short piece of wire and treated as one contact.

The usual three-contact type of wave-change switch is employed, but the make employed in the original set and as seen in the photographs has only two springs instead of the more usual three. The switch works in just the same way as a three-spring, for the third spring is replaced by a connection to the spindle of the switch.

Plenty of Stations

The spindle makes contact with the metal plunger which shorts together the two springs, so that the three points are all joined together. The terminal on the side of the switch provides the connection to the plunger via the metal sleeve in which the plunger moves backwards and forwards.

The valve for this set may be rated at two, four or six volts, and can be of almost any general-purpose type. If you are buying one specially, get an H.F. or special detector type.

One ordinary capacity 60-volt H.T. battery will be quite sufficient. Actually, when searching for distant stations (and, incidentally, you will get a pleasant surprise at their number and clarity if you have not recently used a good single-valver on telephones), it may be desirable to tap in a lower voltage than 60 so as to obtain the best reaction control.

Smooth Control

You want a smooth control, and sometimes a voltage even as low as 30 will prove ample. Of course, when listening to stations which require

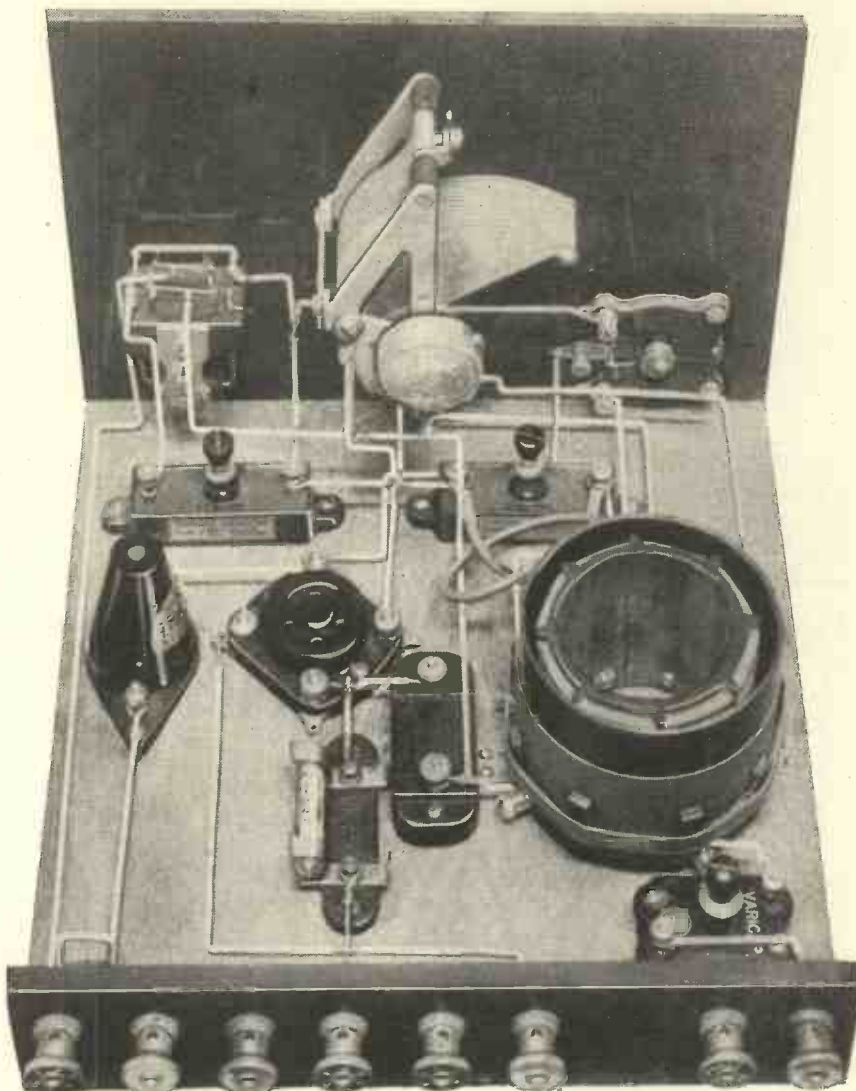

No, there is nothing complicated about this dual-range one-valver, neither with regard to construction nor operation. It is perfectly straightforward, and, incidentally, is just the set for anyone who is going over to a valve set for the first time.

little or no reaction, 60 volts will generally be found to give the loudest reception.

While on the question of loud reception it would be as well to mention that the receiver is capable of working two or three pairs of telephones quite easily. When using more than one pair of telephones it will usually be found better to connect them in series. Sometimes, however, better results will be obtained with them in parallel, particularly if they are all of the same make and type. Anyway, it is a simple matter to try both ways and so find out for yourself which is the better.

Don't reduce the capacity of the series aerial condenser farther than is necessary to give just the right degree of selectivity or the most

satisfactory results. Otherwise you may weaken reception, especially on the long-wave band.

Finding Foreigners

Although we have dealt very fully with the domestic adjustment of the set, namely, the station-change arrangements, we have not gone very fully into the matter of distant reception. Since it is quite likely that models of this receiver will be the first valve sets that many constructors have handled, a few hints on adjustments for receiving weak stations will not come amiss.

We have already indicated that a smooth control of reaction is vitally necessary, and you should set out to obtain this before searching around the ether. First of all, put the wave-

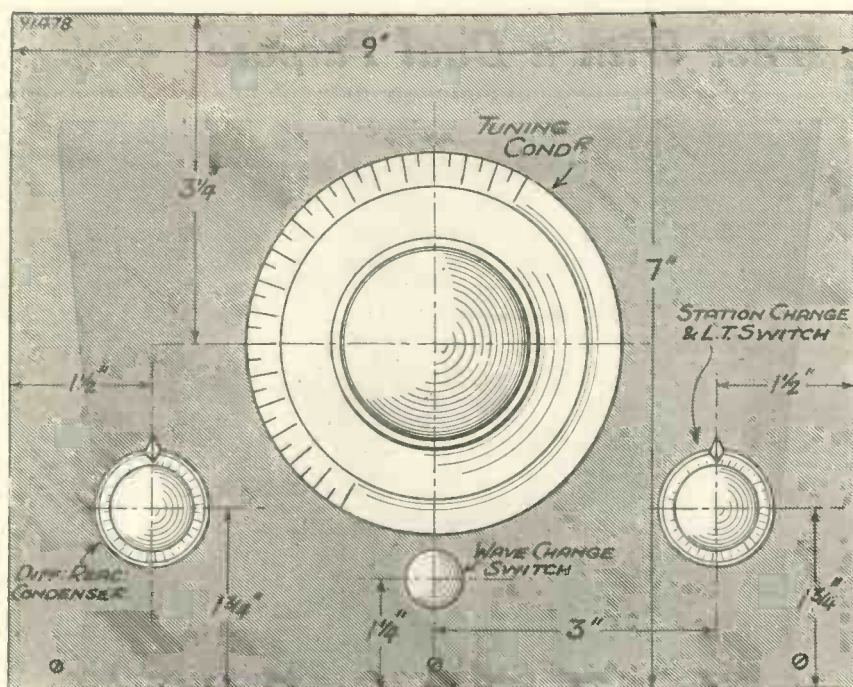

PANEL LAYOUT

The receiver is not confined to use on one band only. The switch seen below the tuning condenser on this drilling diagram enables an instantaneous change from medium to long waves.

change switch to medium waves, and turn the station-change switch so that the extra .0003 compression type condenser is out of circuit.

Now increase the capacity of the reaction condenser until the set goes into oscillation, noting whether it does this with a sudden pop or whether there is a smooth build-up, a rushing noise appearing just before oscillation takes place. If the latter is the case, all is well, but should there be a pop, you must try reducing the value of the H.T.

Searching the Ether

Do this a few volts at a time, trying out the reaction control at each adjustment. If you find that even when the voltage has been reduced as low as 20 the pop is still present, it is not much good trying to remove it by adjusting the H.T. voltage.

In such cases the trouble is usually due to an unsuitable valve. Sometimes the same valve can be employed if a higher value of grid leak is used, say a 3- or 4-megohm one.

If the higher value grid leak does not help matters, it can generally be reckoned that a different valve is desirable. Once you have obtained smooth control on the medium waves it will usually be found that it is satisfactory on the long waves as well, but sometimes a slight further variation of H.T. will be useful.

Having obtained a nice control of

reaction, you can proceed to search for distant stations. To do this it will not be necessary to make the set oscillate. The reaction condenser should be turned so that the set is at its most sensitive position, just before oscillation.

THE MAIN CONTROL



The change-over switch seen in this photograph at the corner of the panel not only controls the L.T., but also changes the tuning from one programme to another.

If it is necessary to have the set oscillating before a certain station can be located, it may safely be assumed that this station will be

Quickly-Changed Programmes

too weak when it is resolved to be worth listening to. You will find plenty of stations if you keep the set just off oscillation the whole time.

To do this necessitates adjusting the reaction condenser as the tuning condenser is altered. A little practice will soon enable you to adjust the reaction the right amount for a certain movement of the tuning condenser.

Using Extension Leads

You will find it a help if you remember that the greater the capacity of the tuning condenser the more the reaction required, and vice versa. Turn the controls slowly and listen carefully, and you will soon be an expert at tuning.

Another thing about which a few extra remarks will be useful is the question of extension leads. Do not be tempted to run these without fitting an output filter.

Actually, of course, the set would work without a filter, but you would run the risk of the H.T. being prematurely run down because of leaks from the extension lead which is attached to H.T. positive and earth. Apart from this, it is just possible that the resistance of extra long extension leads would be enough to weaken results a little, due to their causing a slight voltage drop.

The Output Filter

The connections for an output filter would be as follow: Join the negative 'phone terminal to one side of the L.F. choke, and also to one terminal of a 2-mfd. fixed condenser.

The other side of the choke should be joined to the 'phone positive terminal. The remaining condenser terminal is joined to one of the extension leads, the other one being taken to L.T. negative.

One final point. If you are using the set with a D.C. mains unit to supply the H.T. current, another 2-mfd. fixed condenser will be required for the filter arrangement.

This condenser is connected in the wire which joins the telephones to their L.T. negative extension wire, or to their special earth connection.

Incidentally, with a D.C. H.T. mains unit an output filter is desirable whether extension wires are used or not, otherwise a shock might be received from the telephones.

AT YOUR SERVICE



by
OUR TRADE COMMISSIONER



A New Pick-up

A NEW model of the Marconiphone pick-up—known as the No. 10—is now being supplied in place of the original model.

Fundamentally the instrument is unchanged, and the new model has exactly the same electrical characteristics and performance which has gained for the Marconiphone pick-up its reputation as one of the best on the market.

The price—three guineas—is unaltered. This new model “10” has, however, a greatly improved moulded base, which is larger and more robust than its predecessor. In place of the ordinary screw terminals, the new instrument is fitted with quick-grip spring terminals, which are at once neater in appearance and much more convenient in use.

The familiar polished black of the original Marconiphone pick-up has given place in this latest model to a very pleasing highly-polished brown finish.

Some Fresh Valves

An interesting new series of valves has been placed on the British market this month. I refer to the “Eta” valves, sold by the Electrical Trading Association, Ltd.

Two full series are available (from 7s. per valve upwards), embracing two-volters and directly- and indirectly-heated A.C. mains types.

Finding Out

The German broadcasting authorities are conducting a postal census of listeners to ascertain what types of receivers are in most popular use, in order that the information can be used as a basis for determining the power of the various broadcasting stations.

Here is some varied news of the trade that should interest all readers, whether or not they are connected with the radio industry. Manufacturers, dealers, home constructors and general readers are invited to send items of interest to be included under this heading.

A Radio Doctor

The transmissions from Radio Algiers, especially those programmes intended for the Arabs, are to be interrupted frequently in future so that medical bulletins can be transmitted giving instructions for the combating of malaria.

Plenty of Trade

There are 13,478,000 listeners in the United States, according to the latest return issued by the United States Board of Trade. A notable feature of the return is that the

number of radio-sets is proportional to the number of motor-cars. The states of New York, California, and Illinois show the largest number of receivers, while Nevada comes last with the smallest number.

For Talkie Work

Philips will shortly be releasing a new all-electric amplifier. Rated at 25 watts, the amplifier will be suitable for use in small talkie installations, and for the amplification of music and speech in medium-sized halls.

H.T. Batteries

Long life is claimed for many makes of H.T. battery, but unfortunately not all claims are upheld in practice. Corrosion of the zinc element is a common cause of trouble, and the Grosvenor Battery Co. has tackled the matter with commendable energy and success. In the case of

“TWO BIRDS WITH ONE STONE”



Jack Hylton (third from left) and some of his boys singing a number into the mikes during a recent recording for both talkie and H.M.V. Though he has made a lot of records, this was Jack Hylton's first “appearance” in talkie circles.

Getting Ready for the "Portable Season"

this make of battery the manufacturers claim that the zinc cells are protected by mercury against premature break-up, thus ensuring trouble-free performance and longer life. These Grosvenor batteries are fitted as standard by many of the leading receiver manufacturers, and enjoy an undoubted reputation among those who know.

NEXT MONTH
Special "Portable" Number
On Sale May 1st. 1/-

They are made in a number of various sizes. There is a battery for every make of receiver obtainable. A 60-volt battery costs 7s. 6d., whilst for one of 99 volts the cost is 11s. 6d. These are the red-line series. Two other types are available, the blue and brown line. These are of higher capacities and naturally the prices differ accordingly.

Playing in the Proscenium

It is interesting to note that Mullard's have again come to the fore in the theatrical world. Last time it

was "Little Tommy Tucker," and now we find them providing the interval music during the long interlude from 8 p.m. to 9 p.m. in "Strange Interlude," at the Lyric.

The artistic display of goods is one of the essentials to successful business, as also is a really adequately sized demonstration room. Here we see the new demonstration and showroom belonging to Radio Instruments, Ltd., at their works near Croydon.

Cheaper Spaghetti!

The struggle among the Spaghetti resistance manufacturers is an interesting one. Though only a side-

LISTEN IN COMFORT



The Mullard public address system is employed; two batteries, each of nine speakers, being arranged in the auditorium, with further "H" type speakers in the refreshment bars. Thus those patrons who do not wish to leave the theatre for dinner are entertained during the wait.

Incidentally, the Mullard public address van is touring Scotland, attending sports meetings, etc.

line in most cases, there is nevertheless a miniature battle going on in price lowering. The latest score is 9d., I believe, but possibly someone will come down a penny or two below that. But whether they do or not, the Spaghetti resistance has come to stay; not only is it a most convenient little "component," but it is perfectly reliable, and will carry quite a lot of current. For 9d. you can have up to 750 ohms, capable of carrying 50 milliamps., or 1,000 ohms, which laugh at 30 milliamps. (I am quoting the figures given by Lewcos.) Even the 100,000-ohm "Spag." is capable of dealing successfully with 5 milliamps.

KEEPING AN "EYE" ON THE TALKS



The control-room of the long wave transatlantic telephony section of the Rugby station. All telephonic communication between this country and the U.S. goes through this gigantic radio nerve-centre.

The Portable "Season"

With the "portable season"—why that name is given to the summer months I do not know—coming on, more and more new portables seem to be appearing on the market. But I doubt if the summer is much more a "portable" season than the winter, for surely the self-contained, easily-movable receiver is popular all the year round.

However, season or no season, it is welcome news that the famous Gecophone four-valve 20-guinea portable has been reduced in price to 15 guineas. The set is unaltered, and can be obtained either in a waterproof leather finish, or else as a table model in mahogany. It is claimed that the total anode current does not exceed 11 milliamps.—a surprisingly low figure for a set of this description.



By the "M.W." Research Department.

ONCE upon a time (as the story-books used to say) the more stations that we could hear upon our wireless sets the better we liked them. But nowadays, when Europe hears over two hundred programmes nightly, including many of high power, the cry is often not for more stations but for more selectivity

Stop that Spreading

The really selective modern receiver will pick up station after station, each at its proper adjustment on the tuning dial; whereas on the older non-selective sets a strong local programme spreads over quite a wide tuning adjustment and blots out the other stations which should be heard there.

Although in sets of quite recent design this trouble of flat-tuning has been overcome, there are many older sets still in use which are too good to be scrapped simply because of their tendency to non-selectivity. Fortunately, it is usually possible to add to these some form of wave-trap, or

This article describes an easily-made and very easily-operated device for adding to any ordinary set. It improves your selectivity enormously, by taking out the strong interfering programme, on either long or ordinary wave-lengths, at the touch of a switch.

rejector, or similar device which improves the selectivity without the need for altering the set itself in any way.

At first, when the trouble presented itself, wave-traps were "all the go."

EASY TO ADJUST

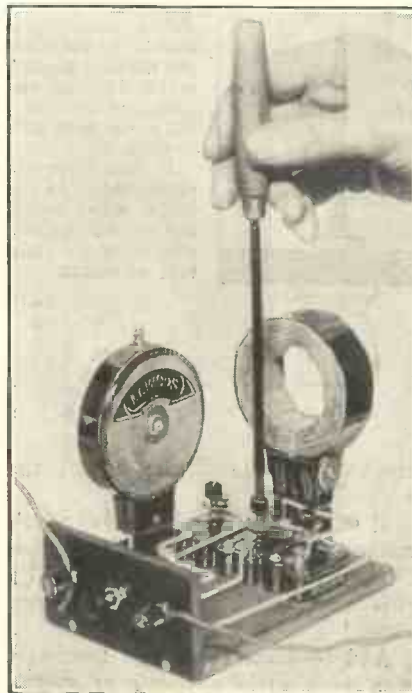

To a certain extent they were successful, but as conditions got more and more stringent the ordinary wave-trap fell more and more into dis-favour.

It often refused to trap properly, and the powerful unwanted station simply ignored it.

Phenomenal Success

So when the B.B.C. introduced the Regional Scheme, entailing two powerful programmes from one station, the ordinary wave-trap simply could not cope. But "M.W." readers found the problem was solved for them by the use of the "Kendall" Rejector.

Using a novel form of condenser-coupling (or Brookmans-coupling, as it is often called), this device attained phenomenal success. And the "Hi-Lo" Rejector, which we present this month, is a form of "Kendall" Rejector.

THE PARTS YOU NEED

INSIDE THE UNIT

- 3 Compression-type condensers, .001 max. (R.I. "Varicap," or Lewcos, Formo, Lissen, Polar, etc.).
- 2 Coil holders (Lotus, or Lissen, Keystone, etc.).
- 1 Push-pull single-pole change-over switch ("Wearite," or Lissen, Bulgin, etc.).
- 2 Terminals, (Belling and Lee, or Eelex, Igranic, Clix, etc.).
- 1 Terminal strip, 4 in. x 2 in.
- 1 Baseboard, 4 in. x 6 in.
- Wire, screws, etc.

CONDENSER COUPLING

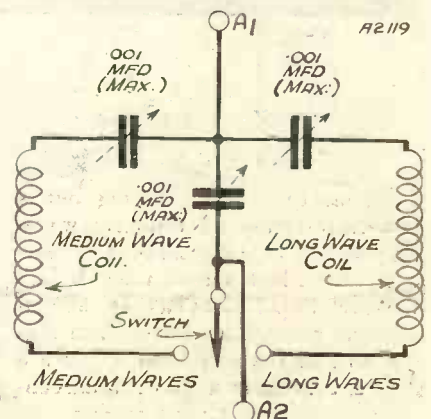

On the left is the list of parts you need, and on the right is a circuit diagram showing the scheme of connections. The method of "setting" the condensers when installing the "Hi-Lo" is shown by the photograph. It is better to employ a long-handled screwdriver than to place the hands very close to the wiring.

As its name implies, it functions on either the high waves or the low. For one of the inherent merits of this particular form of rejector is that it proves just as efficient in separating, say, Radio Paris and Daventry 5 X X, as it does in cutting out, say, the London Regional when we want to hear an adjacent programme.

Two-Fold Rejector

As a great many readers expressed the desire for a two-fold "Kendall"

purchased parts was another desideratum; moreover, the unit must be easy to make, easy to connect to an existing receiver, and easy to put into service on either long or ordinary waves.

Now look at the photographs of the "Hi-Lo" Rejector and notice how perfectly every requirement has been met.

It is small, being built on a little baseboard, with a diminutive panel in front. And all the parts employed in it are standard, of the kinds

Considering that the "Hi-Lo" gives high efficiency at low cost, we think we can fairly claim to have solved the problem which was set to us. It works on any kind of set used with an ordinary (not frame) aerial, except the very, very old-fashioned sets, of course!

Very Few Parts

Now for some details of a constructional nature. First of all we invite your attention to the list of parts required, which is given separately.

You will see that these do not amount to much, for those little semi-variable condensers seem to have simplified and cheapened all auxiliary tuning devices of this type. Besides the parts named, you will need a couple of plug-in coils.

Most of us have stowed away somewhere a selection of "plug-ins," and as the "Hi-Lo" calls for only standard parts it is probable that new coils need not be bought. If, however, you intend to buy the coils as well, get one No. 50 and one No. 250 for ordinary and long waves respectively.

Ordinary "Plug-Ins"

Ordinary coils of the untapped variety are suitable, but if you have "X" coils or centre-tapped coils of the above given sizes they will do equally well.

It is so simple to make that we hardly like to describe in detail the construction of the "Hi-Lo" Rejector for fear of hurting the feelings of the experienced constructor. One look at the photographs will tell him all he needs!

Yet perhaps we ought to say that, simple as it looks, it is easy to impair its efficiency by departures from our layout. High-frequency circuits of this type have wayward habits, and unexpected tendencies to stray may be experienced if, for instance, you alter the positions of the coil holders.

Stick to our dimensions and spacing and you will be safe. The wiring diagram shows the whole thing to scale, so even a beginner can make an exact replica of our original layout.

Easily Set

You will notice that screw-down connections are used, not soldering. Make them really tight and they will be perfectly satisfactory in service.

When you have completed the construction it will take you only a few minutes to set the rejector to cut out either of the two stations that have been bothering you,

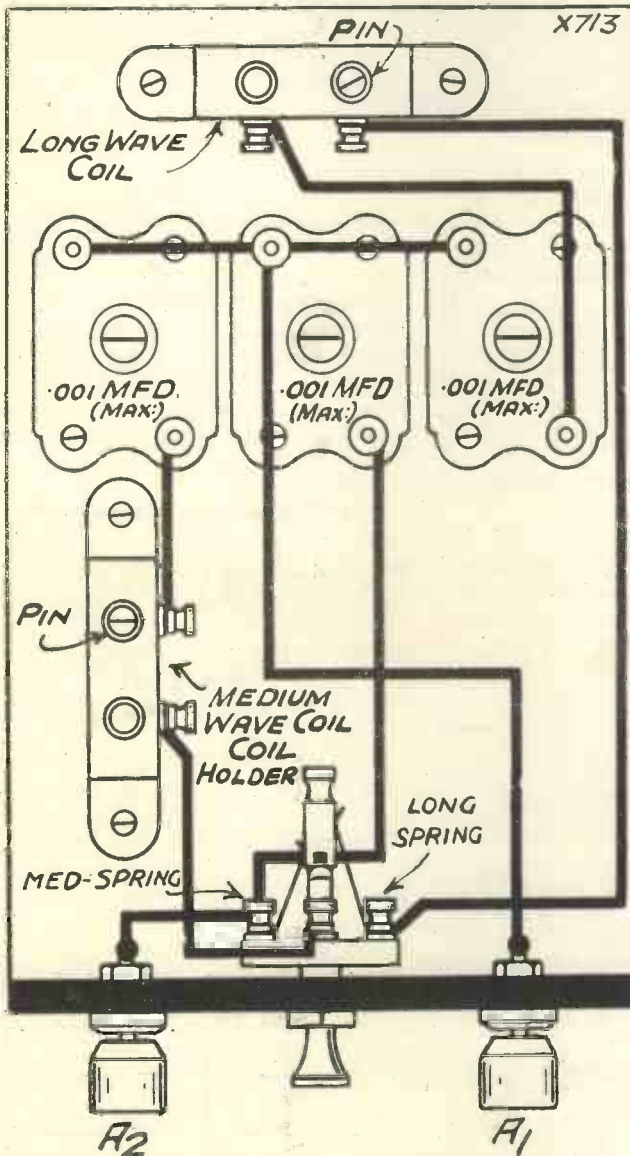

IT IS VERY EASY TO WIRE

There is no need to solder, so the actual connections can be made in a perfectly satisfactory manner by even the most inexperienced listener. This diagram shows, by the thick black lines, how the various points are joined together, and the two photographs on the next page also depict the completed wiring.

Notice that the switch used is of a type with one long and one short spring, the central contact on the plunger making contact with either one spring or the other, but never with both at once.

If you show the photographs to the dealer when ordering you will be sure of getting the right type of switch.

Rejector, capable of cutting out a powerful station on ordinary wave-lengths and of instantaneous change-over to the high waves, the "M.W." Research Department has been experimenting along these lines. The idea was to find the best form for such a device, bearing in mind the usual conditions in which it must work.

Compactness was considered essential, and the use of standard easily-

stocked by the dealer round the corner.

It has two terminals, one of which connects to the aerial and the other to the aerial terminal on your set. So it is easy enough to add to your own outfit!

And between these two terminals is a neat little change-over switch which you push in for long waves and pull out for ordinary wave-lengths.

"Hi-Lo" = High Efficiency and Low Cost

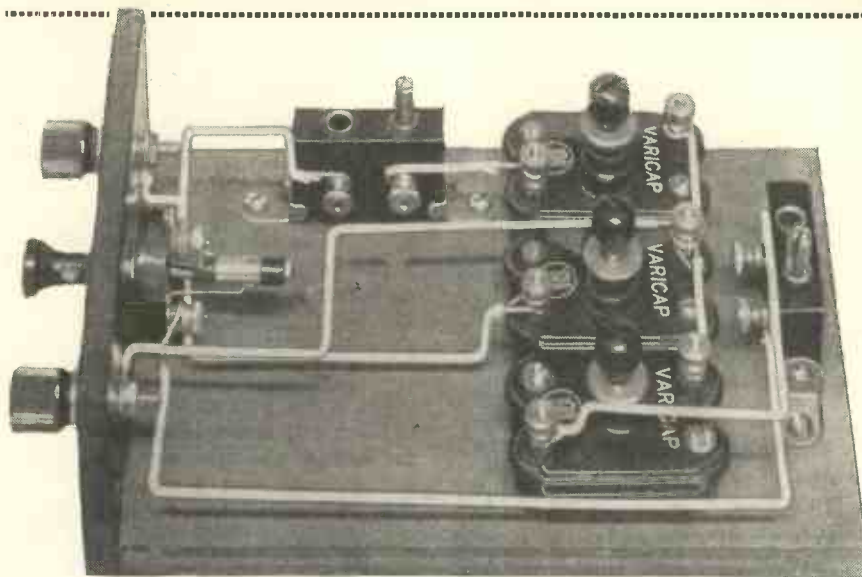

A sideways view which shows that the wiring is the acme of simplicity.

whisper. Leave the unit alone then, and turn to your set.

Now you will find that instead of your local station spreading far and wide, the tuning is as sharp as a needle, and it may even be quite hard to find the programme at first! Moreover, the foreign stations, instead of being weakened as by most selectivity devices, seem actually stronger.

"Knock Him Off"

Encouraged by this first success let us turn to the long waves, the necessary change-over on the unit being made merely by pushing in the switch. Now tune in 5 X X at full strength on the set, and prepare to "knock him off" also!

All you have to do when he is coming in at maximum volume is to leave the set alone; and leave the two condensers which you have already adjusted in the "Hi-Lo" alone. (Once adjusted, as already described,

(Continued on page 398)

but this business of "setting" the instrument needs doing properly.

Once done it is finished with, and you cut out one station or the other by means of the switch. All the more reason, then, why the setting should be done correctly in the first instance.

It is very easy, and yet it is very easy to go wrong. So read the following carefully.

The instrument is connected in series with your aerial, one terminal going to the aerial lead and its other terminal to the aerial terminal on your set. (It does not matter in the slightest whether A₁ or A₂ goes to the aerial, so you can join it up which way suits you better.)

Not Too Close

It should stand near the set, for all such aerial-circuit wiring must be kept as short as possible. But don't place its coils *too* close to any coils on the set.

Because, if one of the coils on the "Hi-Lo" Rejector is placed within two or three inches of coils on the set they will start feed-back tricks which will spoil your selectivity. So watch this point when placing the instrument in position.

Now let us suppose you have been having difficulties in getting Radio Paris clear of 5 X X on the long waves, as well as a troublesome spreading of the local station on ordinary wave-lengths, and let us see how the "Hi-Lo" puts matters right.

For the long waves you need a 250 coil, plugged into the coil holder at the back of the unit. (But if you have a 200 on hand, try that, as most

coils of this smaller size will tune up as far as is necessary.)

For ordinary wave-lengths you need a 50-turn (or thereabouts) coil plugged into the side coil holder.

Let us deal with the selectivity on ordinary wave-lengths first.

With the switch on the unit pulled out, you can tune in the local station on your set as usual. Do that, and then set the left-hand semi-variable condenser (the one near the 50 coil) to maximum. That is to say, screw this condenser down, clockwise, to its "all-in" position.

So far the local station's programme has been going on merrily, but now you *slowly* turn the middle semi-variable condenser. Adjust it gently, listening carefully to the local, until "out goes she," as the youngsters say!

At just one setting of the middle condenser signals go right out, or else down to a soft

THE SWITCH CONNECTIONS

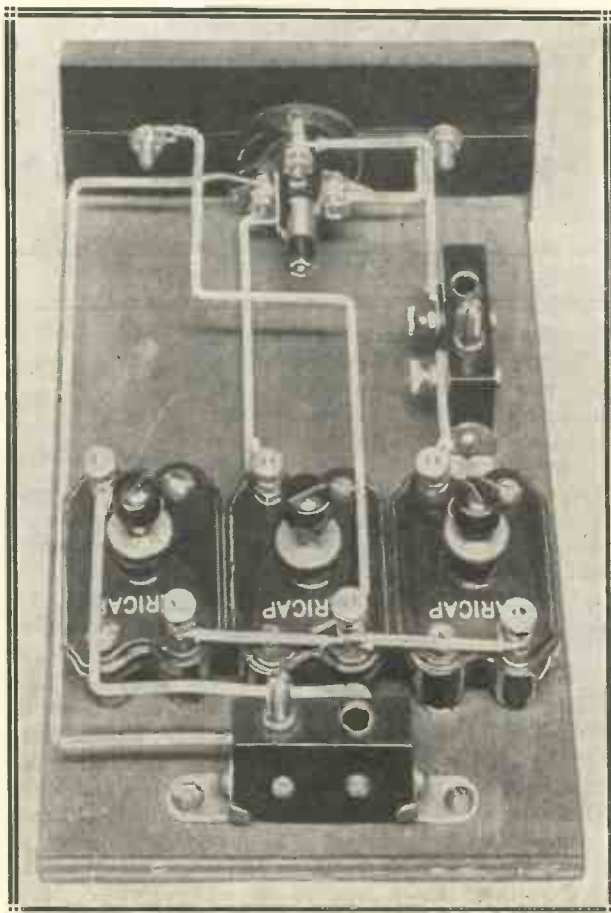

All the connections to the switch are clearly shown in this illustration.

SOME READERS' REPORTS

M.W. "Inter-Axial" Cone—The "Plus-X" Four

Sir,—I am writing to tell you how very pleased I am with the "Inter-Axial" Cone Senior Model. I use a Blue Spot 66R unit, and mounted it on a baffle board nearly one inch thick, 26 in. by 32 in.; behind the board I hinged some legs so that I can stand it up like an easel. The cone and edge came out so beautifully true that I only left a space of half an inch between the baffle board and chassis, instead of three-quarters of an inch as suggested by you.

I use the speaker with a Philips three-valve all-mains set, and the volume, bass, and range are remarkable. Speech, especially from the announcer, is apt to be rather deep in tone unless the power is cut down.

For appearance sake I am thinking of mounting the set in a cabinet, inside measurements 24 in. by 24 in.

Yours faithfully,

GUY H. HOWARD TRIPP.

Chichester.

The "Plus-X" Four

Sir,—I have been very critical of your "Plus-X" Four, a blueprint of which was given away in the December issue.

Now, it is only fair that I hand you a bouquet when you deserve it, and I would like you to know, and any others who are building this set . . . it is great stuff!

After a little initial trouble, a dud condenser (well-known make), the set began to talk . . . but no reaction . . . then, after spacing out these reaction wires as suggested in your description of it . . . along came the foreigners.

Exceeded Expectations

Gee! It has really exceeded my expectations, because my local station is only a mile away and comes in with some gusto, yet I can tune him out by means of the "neut." condenser on the baseboard, and enjoy Mühlacker, Toulouse, Radio-Paris, and other stations I have not been able to decipher owing to the language difficulty.

It is the goods . . . thanks again.

Yours, with very best wishes,

J. CHAMBERS.

Glasgow.

RELIABLE JOINTS

A Very Useful Hint.

THERE are many different methods of making joints in wires. Some of them are efficient; but others, for radio purposes, often fall short of that desirable attribute.

For joining up stout wires there is no better method of connection than the one illustrated in the "close-up" photograph shown here.

From an examination of the photograph it will be seen that the method of joining up is simple enough. Bring the ends of the wires together, allowing at each end several inches of "spare" wire. Twist the wires together two or three times, and then tightly coil the spare end of each wire around the opposite wire. A good pair of pliers will, of course, be brought into operation for this purpose in order to effect a thorough tightness of the wire coils.

Self-Tightening

The joint so made will be found to be a perfectly tight one. Indeed, the more strain it is subjected to the tighter it will become.

If the joint is required to be electrically efficient, merely solder up the central portion of the joint between the opposite coils of wire, having previously, of course, pulled the opposite ends of the jointed wire as much as possible in order to tighten up the connection.

MAKING A GOOD JOB OF IT



This is the tight-grip joint referred to on this page.

they don't need to be touched again.)

To reject 5 X X you slowly adjust the right-hand semi-variable condenser on the unit. Do it quite slowly, as before, and listen to the effect on the programme.

It, too, will suddenly get weaker and weaker, with a very sharp minimum position. Find that setting exactly, lock the condenser if it has the necessary lock-nut, and then leave the unit alone.

Could Not Be Simpler

Now when you try for Radio Paris you will find him quite clear of 5 X X, and, as on the low waves, strength seems actually greater than it did without the unit in action.

Once these preliminary adjustments have been made there is no need to touch the unit again except to work the switch as required. Pull it out to knock out 5 X X, and push

THE "HI-LO" REJECTOR

—continued from previous page

it in when you want to reject the low-wave local. Very simple.

Now a few final observations and we have finished. First of all, there is no need to stick to the stations we have named as examples.

Any two interfering stations can be rejected; and they need not necessarily be on different wave-bands.

If you placed two 50 coils in the unit you could reject, say, one station on about 250 metres and another on about 475 metres; the switch cutting out one or the other according to whether you wanted to tune low down on the dial or at the top of the tuning scale.

But as most people will choose to

cold-shoulder one long and one ordinary wave-length station, we chose to name 5 X X and "the local" for our examples.

Three-Contact Switch

One other point needs stressing. The type of switch to buy.

The kind required is similar in action to the old-fashioned single-pole double-throw switch. In fact, an S.P.D.T. switch can be used.

The theoretical diagram shows you how it works. There are three contacts on it, and always when in use one of them is "off," and the remaining two are active.

An ordinary on-off switch cannot, of course, be used, nor the ordinary wave-change switch. It must be a change-over switch with a central contact that transfers the connections to either one or to the other terminal, but not to both at once.

MY BROADCASTING DIARY



Our own Broadcasting Correspondent records the progress of the British Broadcasting Corporation, and frankly comments on the policies in force at B.B.C. headquarters.

Revival of "Kitesh"

MANY listeners will remember the great stir caused by the broadcast of Rimsky-Korsakov's opera, "Kitesh," when it was relayed from Covent Garden Opera House nearly five years ago.

It is a great work, and listeners will look forward to its repetition in the No. 10 Studio at Big Tree Wharf, on the south side of the River Thames, on Thursday, April 9th, for London Regional listeners, and on the following night for National listeners. The performances will be under the direction of Mr. Albert Coates, who conducted it in 1926.

Adult Education Problems

After protracted negotiation, the "Central Elephant," otherwise the Central Council for Broadcast Adult Education, has agreed to a reduction of the programme time over which it exercises primary control

The reduction is from 300 minutes a week to 240 minutes, it being understood that the "Central Elephant" will have its fair chance to bring forward suggestions for programme items to be included in the general programmes by virtue of their entertainment value.

This reform is of much greater significance because of the addendum than because of the actual agreed reduction. It is believed to be the object of Savoy Hill to apply an ultimate standard of entertainment value, not only to the general talks, but also to the Adult Education Courses.

Therefore, the next logical step will be to put the 240 minutes a week into as much competition with other programme constituents as is being applied to the additional matter.

Licence Revenue Progress

The net increase of 109,000 in the number of broadcast receiving licences during the month of January was greater than for any previous month for more than five years.

It outdistanced the increase for December (85,000), which in itself had been a "record." That there should be such a sudden acceleration was not really expected by the B.B.C., which took the view that the next big speed-up in licences would follow the opening of the new North Regional twin services in April or May.

In the industrial areas of Yorkshire and Lancashire which will be served by the new high-power transmitters at Slaithwaite there is undoubtedly a big field for useful licence development.

One expert, though unofficial, estimate is that 12 months of Slaithwaite will add half a million licences, bringing the total to four million or more.

Sir Harry Brittain and the B.B.C.

It is all too rare that public men of experience and vision take the trouble to make a careful study of

"MIKE" IN THE VATICAN



The Pope addresses the world by radio. Marchese Marconi, who can be seen standing behind the Pope, personally superintended the installation of the Vatican station.

Latest News Items for the Listener

broadcasting in order to form an independent opinion of the merits and demerits of the British system.

Sir Harry Brittain, whose work for the Empire Press Union has done so much to foster intercourse between the newspapers of the Empire, has just completed a careful study of the B.B.C. and of the other chief broadcasting systems of the world.

His conclusion is that the British system is immensely superior to any other, that it is a national asset of which the Mother Country may well be proud. Sir Harry has expressed this view in glowing terms in a special message to the Canadian Press, where violent and unfounded attacks on the B.B.C. have been obtaining some currency.

If there are to be changes on the B.B.C. Board, or additions, Sir Harry Brittain would be a strong candidate and a very popular choice.

The Hon. Harold Nicholson

The Hon. Harold Nicholson, who succeeded Mr. Gerald Barry in the weekly talk on London and its doings, is about to withdraw both from the microphone and from the Press. Mr. Nicholson's chief ambition is understood to be political, and it is said he finds much in common with his friend, Sir Oswald Mosley.

DID YOU HEAR THEM ?



Did you hear Radio Paris broadcasting Jack Hylton and his band from the Opera House, Paris, a few weeks ago? He came over very well, and evidently received a wonderful ovation. Above you see him playing for the talkies.

It has not yet been announced who will succeed Mr. Nicholson at the microphone, but I gather that it is the intention to vary the speaker with greater frequency than hitherto. Mr. Nicholson's decision to withdraw is unlikely to affect the broadcasting of his wife, Miss Vera Sackville West.

Controversial Broadcasting

Ever since the relaxing of the official limitations on

broadcasting controversy, the talks department at Savoy Hill has been naturally straining at the leash to deal with subjects of acute current interest.

More than a year ago there were proposals for informative series of talks and discussions on India and Russia;

BANDS OF GOOD PLAYERS!



Jack Payne and some of his boys who played a football team composed of members of Jack Hylton's band.

both were hung up, that on India being replaced by the two expository talks given by Sir John Simon on his Report.

I understand, however, that the idea of the two controversial series was kept alive. The B.B.C., with justifiable prudence, would not proceed without the agreement of the chief political parties, and without it being recognised that the national interest would not be endangered.

At long last it is understood that the series on Russia will be accepted. The other series is to be postponed. The series on Russia will aim at giving purely objective and informative accounts of what is happening in that vast country.

The North Regional and Sheffield

The B.B.C. has assured Sheffield listeners that the transmitting station in Corporation Street will not be closed down and dismantled until the B.B.C. has definitely proved that the new North Regional station at Moorside Edge gives satisfactory reception for those who do not possess high-powered sets.

Moorside Edge, which is now testing, will serve the whole of the North of England. As usual in the Regional stations, it will have two wave-lengths and will broadcast two programmes simultaneously. It will broadcast the National programme on a wave-length of 301 metres and the Northern Regional on 479 metres.

* * *

A deputation has already met Sir John Reith about the Sheffield station, and it was from him they received the above assurance. Sir John fully agreed that it was no good scrapping the Sheffield station until it was proved that Moorside Edge was thoroughly efficient.





THE recent joint meeting of the Heinrich Hertz Radio Society and the German Electrical Society was expected to provide a sensation in the form of Manfred von Ardenne's address on a new scheme of improving the conditions of wireless reception in city areas. Some preliminary reports in the daily Press having given rise to great interest, the young physicist's first statement of his case, as well as the debate following the lecture, were looked forward to with unusual interest.

Nor did the course taken by that eventful meeting fall short of expectations. Von Ardenne's address proved to be a most valuable contribution to the development of radio engineering.

To Be Tried?

During the debate there was a certain amount of adverse criticism, but the majority of those present were inclined to think that the scheme placed before them was one that, at all events, ought to be given the benefit of a trial. And while by no means all of them were fully convinced of the feasibility of the plan, they, with but few exceptions, realised that Von Ardenne, after all, had been experimenting most thoroughly on the lines suggested by himself, whereas the argument brought forth by his critics rested on mere speculation.

This, for instance, was the attitude taken by Dr. Bredow, Secretary of State for Radio Broadcasting, who heartily thanked the lecturer and promised his support, which, of course, clearly showed that Von Ardenne had won the day.

A detailed account of the new Von Ardenne system which makes it possible to provide several DX programmes for "local" listeners at very little cost. The scheme is being thoroughly tested in Germany and there is a possibility that it may be put into practice.

By Our European Correspondent.

Von Ardenne commenced his address by referring to the unavoidable interference impairing DX reception; and which unfortunately is most

MIXED CURRENTS

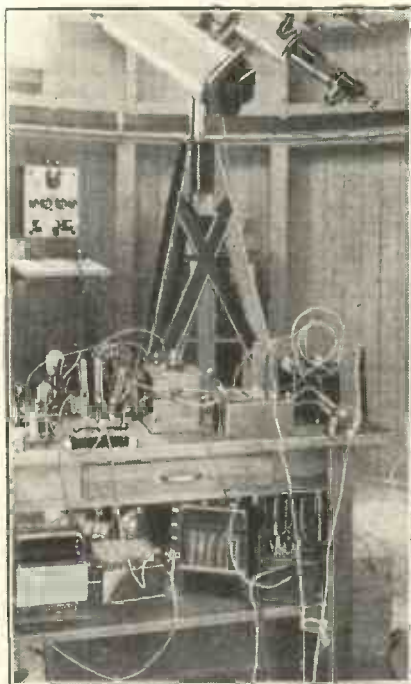

An experimental installation built to show the possibility of simultaneously modulating one ultra-short wave by reverse high-frequencies.

troublesome at those places where the bulk of listeners is concentrated, viz., in large cities. Attempts made to fight interference, in spite of an occasional success, have so far led to no decisive results. In fact, practically all inhabitants of large cities can listen with actual enjoyment only to their own local transmitter.

Local Interference

However, there was a very efficient means of securing unimpeachable reception of distant stations, viz., raising the field intensity of remote transmitters to a point where all interference would be drowned.

The possibility of field intensification is due to the fact that receiving conditions are altogether different in the open country. A comprehensive series of tests made with a transportable outfit enabled the ratio, "signal intensity to interference intensity," in the surroundings of Berlin, to be investigated most thoroughly.

It was thus shown that the field intensity of distant transmitters will; inside the city area, often drop to 10 per cent of the figure recorded in the open country, because of absorption by buildings and conductors. Interference, on the other hand, is in cities fifty to a hundred times as strong as in the country.

Some Average Figures

Remote reception in the open country is, as a rule, of such clearness and strength as to be readily confused with "local" reception. The following comparison should be helpful.

The troublesome scratch of a standard gramophone record is to

the maximum amplitude of the same record approximately as 1 is to 100. The average surging of atmospherics, on the other hand, is to the mean receiving intensity in the country only about as 1 is to 300, i.e. only about one-third of the interference impairing a good gramophone record.

These figures, of course, are averages of readings taken in summer and winter and before and after sunset respectively. Different figures are, of course, recorded in a thunderstorm.

Question of Field Strength

The problem of field amplification, on the strength of these tests, can be stated as follows:

The high-frequency field of radio transmission with its satisfactory interference ratio should be transferred from the open country to the centre of large cities. If in the city there could be operated a relay transmitter radiating the open-country field on exactly the same wave as the remote station, the latter could be listened to ten times as easily, provided the intensity of the secondary field be the same as that of the open-country field.

If the relay transmitter be made somewhat stronger, receiving conditions could be improved, say, a hundredfold, the amplified interference being negligible as compared with the interference affecting radio reception in the city. In fact, this relay transmitter should preferably

RADIATION FROM A LOCAL STATION

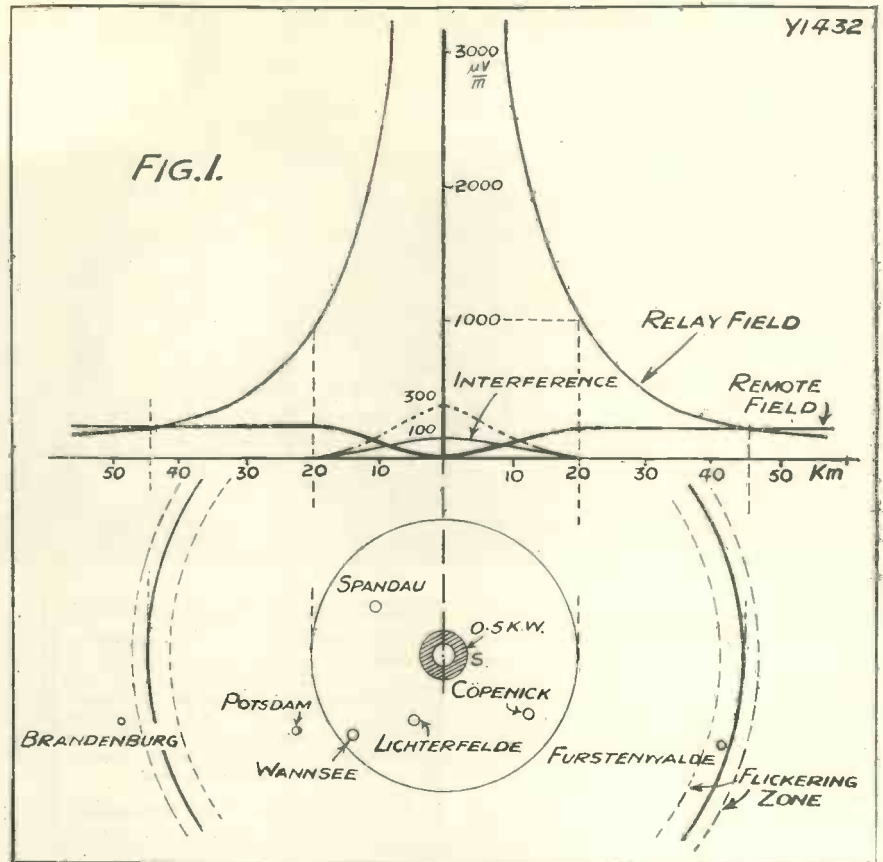

Here you have in diagrammatic form the radiation that could be expected from a small local relay station handing over to the inhabitants the re-broadcasts of distant programmes:

be located just within the city districts subject to the strongest interference, i.e. within the central sections.

Fig. 1 illustrates the magnitude of the field intensity in the neighbourhood of the local city transmitter for the interference field, the remote field and the (eventual) relay field respectively. The relay transmitter being supposed to have a power of 0.5 kw., it will within a circumference of 40 kilometres set up a field of intensity of the same order of magnitude as the normal field of remote stations, for which in the diagram of Fig. 1 a normal average of night reception—viz., 300 microvolts per metre—has been adopted.

FOUR MORE PROGRAMMES FOR BERLIN?

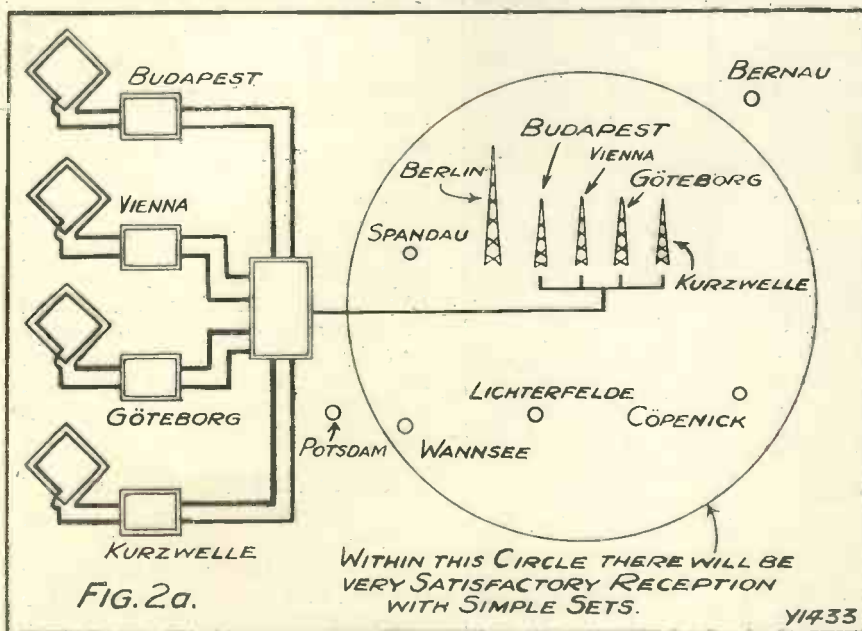

This picture shows how four "re-broadcasts" could be arranged for Berlin. The four receivers (left) pick up the stations named and re-radiate them through special low-power transmitting systems.

Varying Intensity

In the precincts of the city, within a circumference of 20 kilometres around the transmitter, the field of the relay transmitter is already five times as strong as the normal remote field, corresponding to a receiving energy about 25 times as strong. In the interior of the city this ratio will grow to 100 or even 1,000 times, the remote field being absorbed, while the transmitter field increases rapidly.

The third curve in Fig. 1 shows the interference intensity—viz., the average recorded during trips with the

All the Programmes Carried on One Cable

transportable measuring outfit. Interference in the centre has grown to 100, at worst even to 200-300 micro-volts per metre; however, the transmitter field in these sections already is more than 10 milli-volts

and some tens of television transmitters!

The counterpart of the multiple modulation problem is the problem of *gradual de-modulation* of a multiple modulated carrier-wave. In the field amplifier plant the ultra-

anode circuit of the rectifier plant as a filter chain short-circuiting the ultra-frequency.

Preliminary tests made with ultra-short waves as carriers of radio frequencies jointly with the *Radio A.G. Loewe* have given very satisfactory results. A 4-metre wave was used as carrier, modulated with the two first-order carrier-waves 350 metres and 400 metres, which in turn were modulated with speech or music.

ONE COMPLETE VON ARDENNE SYSTEM

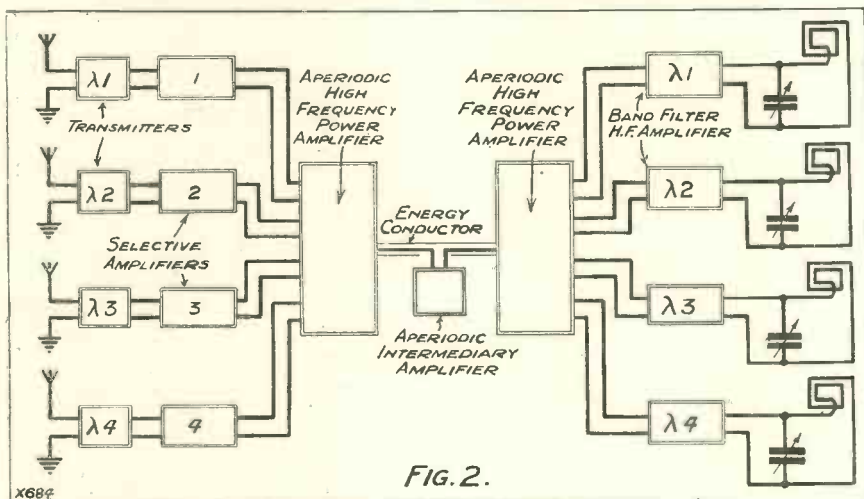

FIG. 2.

The receivers are on the right and the associated relays are on the left.

per metre, thus drowning any interference.

What happens in the annular zone of equal field intensity and at greater distance beyond the 50-k.m. limit is equally interesting.

Referring to Fig. 2—which, in more popular form, is duplicated in Fig. 2a—a multiple reception plant for about 5-6 preferred remote stations is supposed to be at about 30-50 kilometres from the centre. This is equipped with highly selective, valuable receiving sets, the aerials of which are directional.

Compound Relaying

These receivers each receive a station in the most up-to-date technical method, and having automatic fading compensation, so as to keep the output effect constant within wide limits, even in the case of a strongly fluctuating remote field.

The frequency mixture is either transmitted through a cable or by means of an *ultra-short, common carrier-wave*; special tests have shown the remarkable suitability of such waves for the use in question.

On principle it will be seen that a wave of the order of 1 metre can be modulated with a frequency band made up of the frequencies of a few thousand telegraph transmitters, some hundreds of telephone transmitters,

frequency is applied to a first rectifier behind which all the various high-frequency components are allowed to occur as far as possible unweakened.

This is obtained by designing the

Completely Clear

Grid modulation was used in connection with the ultra-short transmitter. The receiver comprised a rectifier stage with a minimum of capacity (multiple valves), loaded with an anode resistance of 30,000 ohms.

Both modulating waves could in the anode circuit of the second stage (acting as amplifier) be tuned selectively and further de-modulated. Two remote transmitters were eventually substituted for the two control transmitters, and when using an 8-metre wave for transmission and a common input amplifier in front of the short-wave transmitter reception in a factory about two kilometres distant could be made as free from any interference as near the transmitters.

PART OF THE TEST APPARATUS



A short-wave receiver used in some open-country receiving tests on which Von Ardenne's scheme was based.



BROADCAST RECORDS

A SURPRISING, but very welcome, cut in prices has been carried out by the Vocalion Company on their famous Broadcast records. The original Broadcast 10-in. has been reduced from 1s. 3d. to 1s., while the exceedingly popular Super Twelve record is now 1s. 6d. instead of 2s. Undoubtedly some of the very finest values in gramophone records have ever seen.

To back up this reduction in price an exceedingly varied programme of records has been released during the last month, while Miss Sophie Tucker has definitely joined the ranks of Vocalion stars. This month she has made one 10-in. and one of the Super Twelves. The former is Make Yourself at Home and It's a Pleasure, on 674, two typical Sophie numbers; while the 12-in. record consists of What Good am I Without You and Makin' Wicky Wacky Down in Waikiki, on 3001. Though we may not always agree that the items are well chosen, there is no denying that Sophie Tucker is a great artiste.

A popular recording on the 10-in. record will be that of the full choir of St. Mary-le-Bow, giving Eternal Father Strong to Save and Fierce Raged the Tempest, on 681, adding still further to the many fine religious records the Vocalion Company have made. The majority of the "tens" this month, however, contain light stuff by various dance bands and entertainers. For instance, we have Bobby Comber singing We All Go Oo Ha Ha Together and Barracky Bert the Soldier, on 676; and Bright and Bruce, on 678, giving us Okay Baby and The Girl Friend of a Boy Friend of Mine.

Outstanding dance numbers are Sweet Jenny Lee and I'll be Blue Just Thinking of You, by Hal Swain and his Band, on 670; and Moonlight on the Colorado and In the Valley of Dreams, by Nat Lewis and his Dance Band, on 672.

In addition to the Sophie Tucker record on the Super Twelves, there is a selection of dance numbers which we should like to bring before your notice. Make Yourself a Happiness Pie and Seven Veils form a couple of attractive numbers by Bob and Alf Pearson, on 3002.

Marius B. Winter and his Dance Band provide us with several numbers, including Okay Baby and A Little Love Song, on 3004; Oh, Donna Clara, on 3017, the reverse side of which holds The Kiss Waltz, by the Manhattan Melody Makers. Somewhere in Old Wyoming and My Bluebird was Caught in the Rain will appeal to a number of people. It is by the Ferracchini's Hawaiian Band, on 3008. Another attractive disc is Popular Melodies, on the Wurlitzer organ at Madame Tassaud's Cinema, by Edward O. Henry, including "Okay Baby" and "A Little Love Song," "What Good am I Without You," "Sunny Days," "Without a Song," and "There's a Good Time Coming." This is 3016.

And now before we leave the "twelves" we must mention two more comedy numbers: Wedding Bells are Ringing for Sally and Roamin' Thro' the Roses, by Billy Marlow, on 3015; and Sitting on a Five-Barred Gate and We All Go Oo Ha Ha Together, by Leslie Sarony, on 3013. There are so many good numbers it is impossible to pick out one above the other for special mention. On the technical side, too, the recording seems to be improving every month.

Of the Broadcast Twelve records (which still remain at 2s.) we are not so enthusiastic. There is the Prelude in C sharp minor, that famous melody by Rachmaninoff, and The Volga Boat Song, on 5217, played by the String Orchestra and the Organ at Madame Tassaud's Cinema; and My Little Irish Cottage, coupled with The Waters of Minnetonka, a couple of vocal items sung by Betsy de la Court, on 5219. These two reproduce very well on the electric gramophone, but they are not exactly outstanding records in the same way as the Broadcast Super Twelve.

COLUMBIA

A very interesting collection is offered by the Columbia people, but we have not received any of the double-track records for test which we mentioned briefly last month, so we cannot report on these yet. One of the most outstanding records, from the point of view of radio set owners, is undoubtedly the B.B.C. Male Chorus record of

Poor Ned and Other Limericks and Bonny Wee Thing. This is a perfect recording and is a most interesting record. It makes a fine companion to "The Blue Danube" choral record of the B.B.C. released some months ago. It is on DB399.

Two excellent tests for pick-up work are the organ solos, one on a cinema organ and the other on the organ of the Central Hall, Westminster. The former is by Reginald Foort, playing Wedding Bells are Ringing for Sally and What Good am I Without You, on the organ of the Regal Cinema, London. This is on DB407 and is an excellent test. The other record is At the Temple Gates (parts 1 and 2), played by Gatty Sellars, with Celeste and Bells and vocal quartette and recorded in the Central Hall, Westminster (DB392). Both are excellent recordings, and apart from their musical value, as we said before, they are excellent tests for gramophone reproduction by pick-up. So also is Billy Mayerl in his pianoforte solo of selections from Little Tommy Tucker and Ever-Green, on DB380.

It is not often that one gets a viola solo, but a couple of numbers by Lionel Tertis, on DB396, namely, Lament and Londonderry Air, a couple of fine old traditional Irish tunes, are well worth hearing. For definition and high-note reproduction the string quartette recording of Allegro Con Brio, by Boccherini, and Siciliana, by the same composer,

A brief selection from some of the records released during the month. They have been chosen because of their special value to the pick-up user.

on DB397, is a very valuable record. So also is that of J. H. Squire's Celeste Octet, playing a Venetian Barcarolle, in two parts, on DX211, a 12-in. record of unusual merit for the pick-up user.

And now we come to two lively dance records, having very different styles in their execution. The first is by Paul Whiteman and his Orchestra, considered by many to be the finest dance orchestra in the world, though we rather doubt whether this title is really deserved, playing In My Heart With You and A Big Bouquet For You, on CB210. The second record is more straight orchestration, being Debroy Somers' Band playing I Bring a Love Song and You Will Remember Vienna, on CB200.

DECCA

The Decca people are still holding their interesting hour's broadcast at 2 p.m. from Radio Paris on Sundays. There seems to be more surface noise with the Decca record than there really need be, and there is sometimes a peculiar hardness in the high register.

This month we have several really interesting items. One of these is a religious recording of Holy, Holy, Holy, with choir and string orchestra conducted by Arnold Goldsbrough, with a reading by the Rev. Pat McCormack, recorded in the crypt of St. Martin's-in-the-Field, London. On the reverse side is Jesus Christ is Risen To-day, by the same choir and string orchestra. This is on K565.

The next on the list (K566) is Vocal Gems from The New Moon, by Olive Groves and Victor Conway. This is a place where a little bit of the hardness could be reduced with great advantage. The dance numbers we have picked out are The Way I Feel To-day, by Spike Hughes and his Orchestra, and Without a Song by the same band, on F2193; Memories of You and You're Lucky to Me, by Roy Fox, the whistling cornetist, and his Band, on F2194. You are sure to hear these numbers and many others if you listen to the concerts from Radio Paris regularly, and, as a matter of fact, this broadcast selection of records provides a very

easy and valuable way of picking out the numbers one would like to get.

H.M.V.

To our mind one of the finest records turned out by H.M.V. this month is yet another one of the Philadelphia Symphony Orchestra, a combination of instruments which is probably unrivalled throughout the world for excellence of technique and performance. Running them very close, of course, is the Berlin State Orchestra, which also record for H.M.V. The Philadelphia Orchestra this month have taken "Carmen" as their subject, and give the Gipsy Dance and Intermezzo and Les Dragons D'Alcala. This is recorded on D1816, and should be obtained by all pick-up users. It is an excellent test record and its musical value, of course, is very high indeed.

Running it close from the point of view of pick-up test work are the Royal Opera Orchestra records of La Maschere (Overture), by Mascagni, on C2018, and the same orchestra playing The Bronze Horse Overture, by Auher, on C1997. These are both records which we feel sure you will like to add to your library.

Acknowledged as one of the finest sacred songs is Carey's Nearer My God to Thee. This is sung on H.M.V. record No. C2150, by Ettie Ackland, with organ accompaniment by Herbert Dawson; while on the reverse side there is Gounod's There is a Green Hill, another exceedingly fine piece of music. The New Mayfair Orchestra selection of Stand Up and Sing, on C2119, is well worth hearing; as is De Groot's rendering of Sous Les Toits de Paris (Under the Roofs of Paris), the famous theme song from the talkie film, and In the Night, on C3745. We do not think this is De Groot at his best, but nevertheless it makes very pleasant listening. Bert Lown and his Hotel Biltmore Orchestra playing You're the One I Care For and Overnight, a couple of foxtrots, on B5968, form two dance numbers with exceedingly interesting orchestration; but Jack Hylton and his Orchestra do not seem to be quite up to usual form in My Ideal and It's a Great Life, on B5933.

Perhaps we have come to expect rather too much of Jack Hylton, and, after all, it is extremely difficult to get novel orchestrations of every dance number. Jack and his Band are getting rather symphonic, if we may use the term, and no doubt this tendency may be excellent from a stage point of view, but it is really somewhat lost in recording. Perhaps it is that the numbers chosen, though tuneful, are not particularly outstanding ones, but the usually vivacious rendering by Jack's boys is rather lacking.

ZONOPHONE

Out of the twenty-nine records issued this month by the Zonophone Company we have received a selection of eight of the best.

The first number contains selections from two exceedingly popular talkies—Whoopie and Love in the Rough (No. 5706)—played with plenty of volume and rhythm by the London Orchestra. Only the most important songs are included in these selections.

Then we have Maurice Elwin, the Zonophone Crooning Troubadour, whose expressive voice is admired by many, singing two of the newest "hits" on No. 5800—The Kiss Waltz, from the film "Dancing Sweeties," and Underneath the Lovers' Moon.

The well-known Wireless favourites, Miss Megan Thomas and Mr. Herbert Thorpe, combine to provide I Love the Moon and The Little Irish Girl, on No. 5802. This record is highly recommended to all who favour these ballad songs.

A record by Bud Billings and Carson Robison is welcome. There is something so very different about the songs they sing and the way they sing them in that fascinating drawl of theirs. The titles this month are Somewhere in Old Wyoming and Drifting and Dreaming, on No. 5809.

On Zonophone No. 5810 will be heard two violin solos played by Norbert Wettnar, who was once Leader in the Queen of the Belgians' Symphony Orchestra—Caprice Viennois, by Kreisler, and Meditation ("Thais"). Technique and tone are extremely good, especially in the Kreisler composition. Really good value for half a crown, and a useful pick-up test.

Of the five dance records issued this month we have selected the two undermentioned as having the snappiest titles. Make Yourself a Happiness Pie, fox-trot with vocal trio, and Tap Your Feet, fox-trot with vocal trio (No. 5813). I Bring a Love Song, fox-trot with vocal refrain, and You Will Remember Vienna, waltz with vocal refrain (No. 5815). No. 5815 contains two "hits" from the stupendous colour film Viennese Nights, which will soon be generally released. Both these records can be whole-heartedly recommended, for they are just as good to listen to as they are to dance to. They are good entertainment.

Lastly, on No. 5817, we have electrical recordings of two grand old marches by the Black Diamonds Band—Washington Grays and Wellington March. This band has been recording for the Zonophone Company for a great number of years and is a thoroughly fine combination.

COUPLING IN THE SCREENS



This article is the result of much experimental investigation and brings forward some points in set construction that are vital to all set builders.

By G. P. KENDALL, B.Sc.

WHEN a receiver design includes a good deal of metal screening it is always tempting to complete a number of the circuits by "earthing" them to the nearest convenient points, and so save quite a lot of wiring.

"Flooring" the Wiring

For example, suppose the set is one of the more ambitious types in which there are vertical partition screens between the stages and a sheet of copper foil covering the surface of the baseboard. With so much metal surface available a very great reduction in wiring can be achieved if it is thought advisable.

Something like half the filament circuit wiring disappears, for instance, if this expedient is adopted. Connect the L.T. negative terminal straight to the copper "floor," and wire one filament terminal of each valve holder to one of the screws securing the holder taking care to see that each screw is making good contact with the metal foil.

You have then only to wire the L.T. positive terminal to the on-off switch and run wiring from the latter to the remaining filament terminals of the valve holders. On the positive side of the filament circuit the current will then flow through the usual wire paths, while on the negative side the circuit is completed through the metal floor.

Some Obvious Attractions

The scheme has obvious attractions, for not merely does it render the wiring easier and quicker to carry out, but the resulting reduction in connections cleans up the interior appearance of the receiver quite noticeably.

Again, if you want to earth the filament circuit, as one generally does, there is no need to run a wire from the nearest point on the L.T. negative wiring to the earth terminal. Instead,

you just drop a lead from the latter terminal straight down to the copper foil on the baseboard.

Here, again, you eliminate a lead which is often of some length, and gain something in speed of wiring and appearance. At the same time, you make certain that you have earthed the metal-work properly, a point which is easily overlooked otherwise.

The leads to the filament circuit from the by-pass condensers in the various de-coupling circuits can be treated in the same way. Instead of running a wire from the appropriate terminal on each condenser to the nearest point on the earth or filament negative circuit, you can drop a wire

straight down to the copper floor, e.g. to one of the fixing screws of the condenser itself.

At the Aerial End

It might seem that this would be a desirable method, for it looks as though it offers an excellent way of getting your shunted currents down to the earth circuit by the quickest possible route. Unfortunately, the matter is not quite so simple as it seems, as I hope to be able to show you presently.

Then, again, a number of opportunities usually present themselves in the tuning circuits for similar exploitation of earthed returns via the metal.

QUITE A SIMPLE CASE

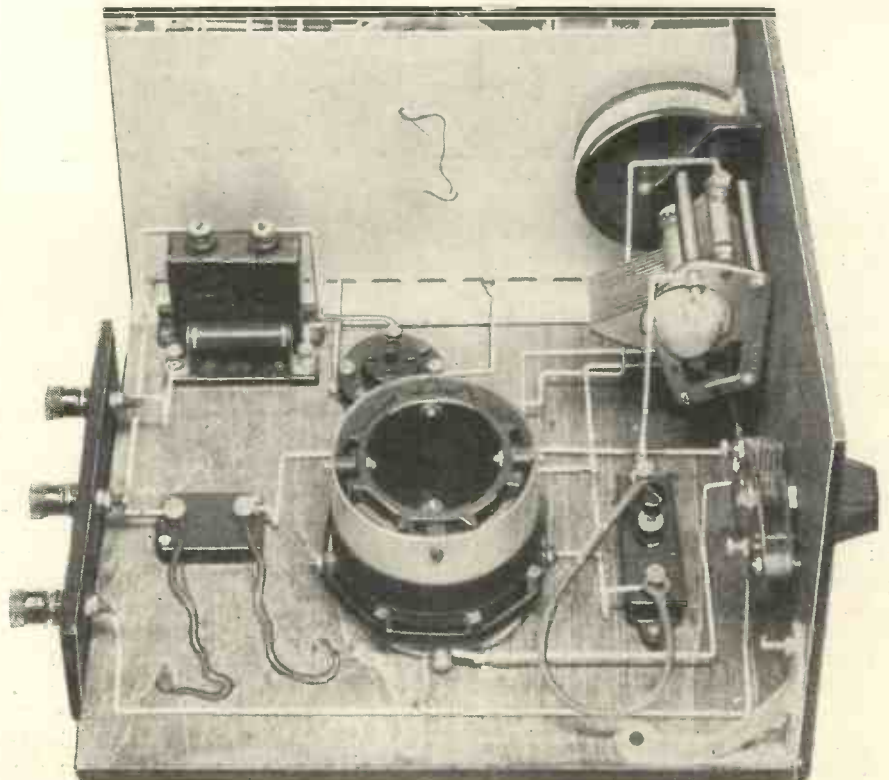

A simple type of screening which can usually be made use of for earthing without much trouble. The temptation to earth, via the screen, everything requiring an earth connection is not so great in this case as in that of a more lavishly screened receiver.

Your aerial lead, for example, will usually run to a coil unit of some kind, and then from there the circuit must be completed back to the earth terminal.

Obviously, if your set has a copper floor you could dispense with an actual connecting lead and just wire a suitable point on the coil unit or the aerial coupling circuit associated therewith to the foil. The aerial circuit currents would then make their way to their exit from the set at the earth terminal via the foil floor.

Condenser Connections

In each tuned circuit a similar expedient could be adopted, modified to fit the particular needs of the case. The moving vanes of each condenser, for example, could in some instances be wired to the nearest convenient point on the screening system; likewise the low-potential end of each tuning coil winding, either direct or through any grid-bias battery which may be required.

The completion of each tuned circuit would thus be provided automatically through the metal, and also the earthing of each to the filament circuit. Once again the result is a notable simplification of the wiring process, and a corresponding improvement in the look of the finished job.

Effect on Wiring

In the reaction circuit, too, some slight reduction in wiring can be obtained by the full use of "returns" through the metal-work. In the usual type of "differential" circuit, for example, it would be done something like this: The lower end of the reaction winding would be wired to the metal floor at the nearest point and also one set of fixed plates on the reaction condenser.

No very great reduction in wiring is thereby achieved, of course, but it generally makes quite a difference to what is otherwise apt to be a rather congested part of the receiver.

So much, then, for the main advantages of the use of the metal-work for the completion of the earthed circuits. They are sufficiently obvious to form a severe temptation when one is wiring up a big receiver, and, indeed, the method is very commonly employed to a greater or less extent in such sets.

I have shown you one side of the

question, and now for the less rosy one. Theory, backed by actual experimental proof, shows that there is a definite element of risk in the indiscriminate use of metal-work in completing certain of the earth circuits, and in this fact is to be found the probable explanation of some of the puzzling early difficulties in obtaining complete stability with large screened-grid receivers.

Another View

In theory, it would seem that the strictly correct procedure is to make no such use of the screening system at all, but merely to earth it at just one point. That, in the experience

GO CAREFULLY!

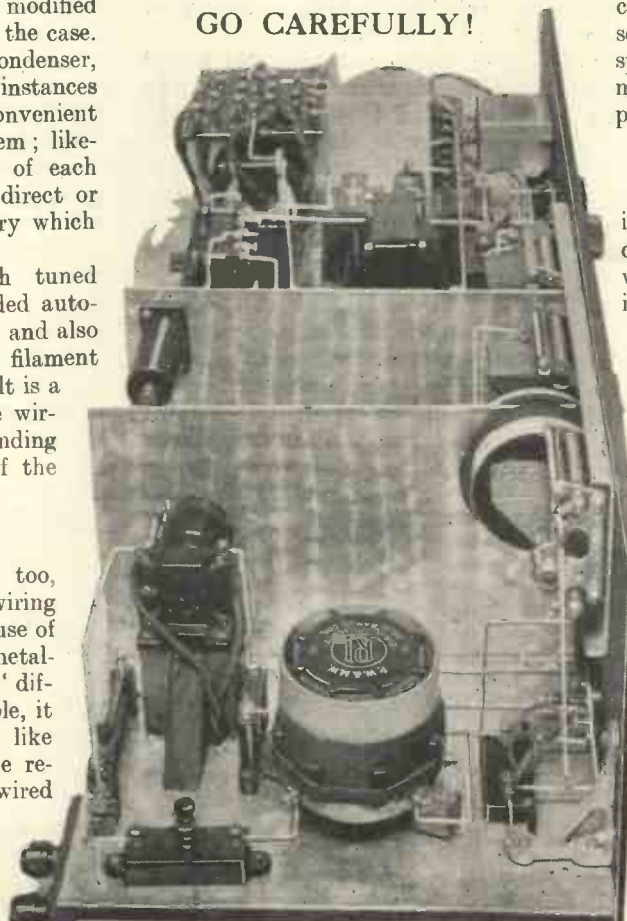

An elaborate set which has a copper baseboard screen as well as the vertical stage divisions. In such a case there is every temptation to use the screen and base as earthing points, but in up-to-date modern designs such a procedure is inadmissible and would lead to no end of instability. Great care and circumspection has to be used before any tuned circuits are screen-earthed.

of the "M.W." Research Department, is to go unnecessarily far, but we have ample evidence that the too trustful use of the screening system for "returns" is quite definitely perilous. Just why that should be is a difficult thing to explain in simple fashion, and indeed it is a matter upon which authorities differ to some extent.

The effect is obvious enough all

the same, whatever the exact cause, for it becomes apparent in the form of instability on the H.F. side of a receiver which looks on the face of it as though it had been designed with an ample margin of safety. You may find, for example, that a set will oscillate uncontrollably, despite the most elaborate use of screening, de-coupling filters in the H.T. feeds, and so on, and will become stable when some of the returns through the screening are replaced with direct connections.

The two main causes of the feedback effects which must be present would seem to be these: In the first place, where adjacent circuits are completed through the metal screening the "return" currents spread out to some extent, and may actually follow the same path in places.

Back-Coupling

Where they thus mingle there is an obvious possibility of "back-coupling," for the medium in which they are flowing is not of infinitely low resistance. Differences of potential must exist in it, therefore, and here we find the voltages which may be handed from one circuit to another and so set up reaction effects.

Secondly, since we have produced differences of potential between different parts of our screening system there is the possibility of back-coupling occurring through the capacities between some of these "live" parts of the screening and the various components mounted near to them.

For Two H.F.'s

These are certainly not the only possible dangers, but they are the ones which seem in practice to be the most notable. Our experience appears to indicate that if they are given due attention in the design of the wiring system any others can be neglected as being sufficiently slight as to be taken care of by the margin of safety present in any properly laid out receiver.

Now, all this is obviously of very great importance in the design of all receivers in which a high level of H.F. magnification is obtained. In general, it is probable that there is no serious chance of trouble from these

Take Care of Those Tuned Circuits

causes in a set incorporating only a single H.F. stage of normal type, but where there are two stages they must be given careful attention.

So far as the home constructor is concerned it just means that when

desirable in order to obtain the degree of stability at which we aim in all our designs.

As a matter of fact, a good deal of our recent work has been done on this actual receiver. We proved in the

our work has led us to believe will be found of general application.

First of all, as might be expected, we have been unable to find any harmful effects in the use of the screening system for the completion of the negative side of the filament circuits. Just a little thought must be given to this point in some cases, however, in connection with the earthing of the tuned grid circuits associated with any valves treated in this way.

FULL OF SCREENING SNAGS

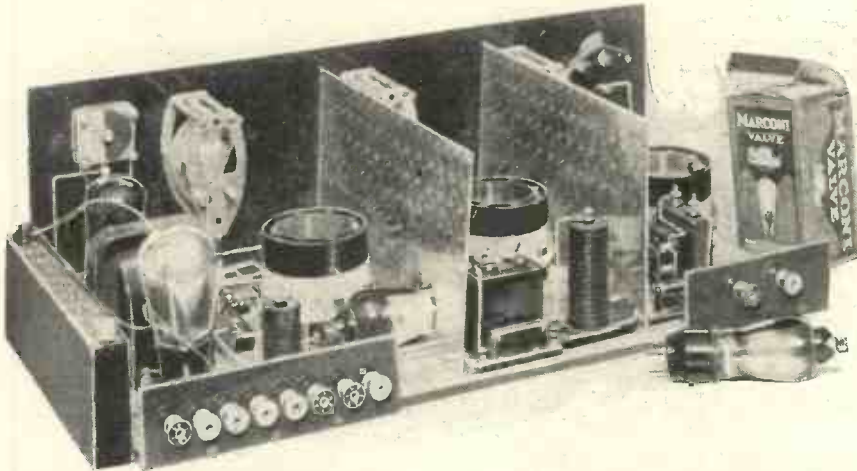

Another example of a much-screened set. It is quite safe to take filament and de-coupling points to the screening, but circuits having H.F. should be carefully considered before they are earthed in that way.

he is following some particular design he should quite slavishly copy the wiring diagram in the matter of earthing to the screens. The original receiver, he must assume, was stable by virtue of the elimination of these troublesome screen feed-back effects, and if he departs from the designer's method of wiring he may experience difficulties with his finished product.

Some "Supervox" Tests

The "M.W." Research Department has done, and is continuing to do, a considerable amount of work on these matters, and the results are being embodied in our current designs for sets of the larger type. This, you will find, is the explanation of some peculiar-looking wiring schemes you will see in certain receivers of this kind which we have published of late.

In the "Supervox" Four, described in our current issue, for example, you will find that certain of the important circuits are completed by means of wire returns where the screening might have been used for the purpose. This was done only after actual tests had proved it to be

course of it that it was possible by an unwise use of screen returns to make this normally well-behaved set

A Safe Rule

The question of the earthing of one side of the condensers used for decoupling appears to be a question rather difficult to decide. In some cases it has been found quite safe to run leads to the nearest point on the screening system, while in others it was advantageous to take the connection straight to the negative filament terminal of the valve concerned. A safe rule would certainly be to adopt the latter method in any case of doubt.

It is undoubtedly in the tuned circuits that it is most important to use discretion in employing screen

THE POPE'S POWER STATION



Very carefully-thought-out screening has to be employed in big transmitting stations. Here we see the interior of the power-house at the Vatican.

become hopelessly unstable! Surely a striking proof of the real importance of the problem.

In conclusion, it may perhaps be of interest to lay down some rules which

returns. In general, it is a wise rule *not* to use such returns at all, but it is commonly possible to use them to some limited extent without harm resulting.



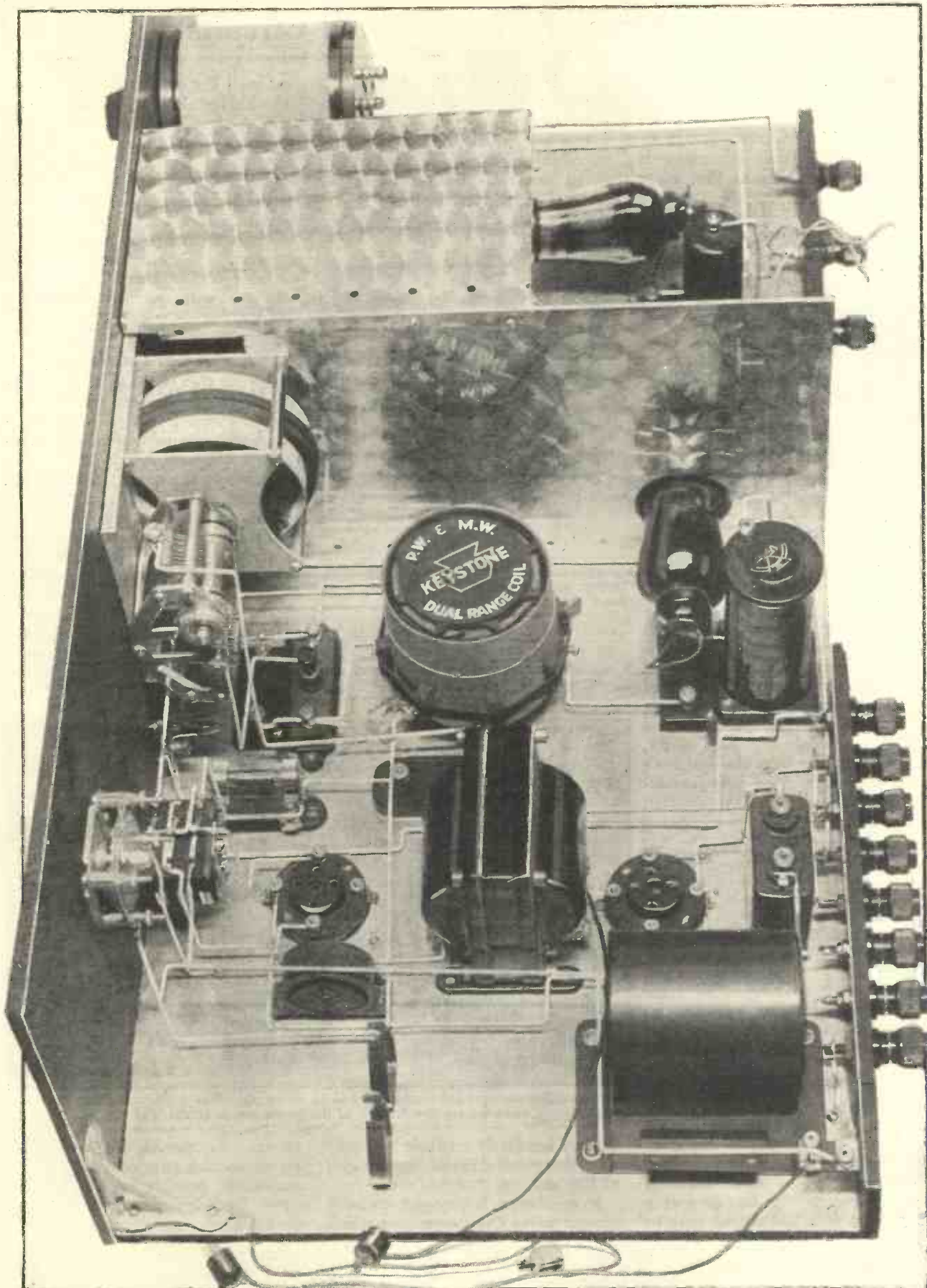

A set to make your heart leap with pride and one which you will find is even better than it looks.

The "Supervox"

Modern conditions are very exacting; but not too much so for this remarkable four-valve receiver, which is backed by the wonderful resources of the "M.W." laboratories. Read below about this specially designed set that gives the finest possible all-round performance.

THE varying methods which are employed to obtain selectivity in receiving sets could quite well be described as "Selectivity Fashions." They come along at periods as radio science advances and conditions require more selectivity.

For a time a new idea is all the rage, and is often to be found in practically all set designs varying from crystal sets to multi-valvers. Some of them are short-lived, some last for a long time in modified forms, and run parallel with new schemes.

Again, they resemble fashions in that some people and set designers stick to an old idea when progress is far ahead of them. A good example of this old-fashionedness is to be found in the use of plain band-pass circuits in straightforward receivers.

Crowded Condition

It is very interesting to note that conditions on the broadcast bands are largely responsible for our selectivity fashions. The number and power of the broadcasters control the degree and type of selectivity required.

There are undoubtedly types of selectivity, although more than one type may sometimes be achieved by

Designed by the "M.W." Research Dept.

the same means. The type of selectivity which will separate a very powerful and very near local station from one or two foreigners may be decidedly different from that required to separate two equally strong stations a fair distance away, but very close together so far as wavelength is concerned.

A SET WITH:—

- Two highly efficient S.G. stages.
- Really simple tuning controls.
- Magnificent volume, range and quality.
- A fine gramophone pick-up system.
- Everything desirable!

When broadcasting first started, most sets used directly-coupled parallel or series tuned circuits. Compared with modern ideas of selectivity, such arrangements were completely devoid of that property.

Nevertheless, they gave us a standard of selectivity at which to start.

No sooner were there a few stations transmitting somewhat irregular programmes than the "loose-coupled" fashion came along and we juggled with two fairly critical tuned circuits.

A simpler scheme soon arrived in the so-called aperiodic aerial circuit and series fixed aerial condensers. These were in vogue for quite a long time and provided all the selectivity necessary. Until the first really powerful locals came along!

Increased Selectivity

Sets were still quite selective enough except for that local, so a type of selectivity that would remove one station and leave everything else as before was devised. It took the form of varying types of wave-traps.

For a period from this time nothing very startling occurred. As more and more stations started up so sets gradually became more and more selective.

All sorts of weird and wonderful schemes came along, but they all seemed to follow the same general course: the fashion for multi-tuned circuits. Things steadily went forward for a time and then conditions began to change very rapidly and large and frequent increases in selectivity became necessary.

FOR THE "SUPERVOX" YOU WILL REQUIRE THE FOLLOWING COMPONENTS

PANEL

24 in. × 8 in. (Peto-Scott, or Goltone, Lissen, Parex, etc.).

CABINET

Panel space 24 in. × 8 in., baseboard 12 in. deep (Cameco, or Keystone, Pickett, Osborn, Kay, Lock, Gilbert, etc.).

VARIABLE CONDENSERS

- 2 .0005-mfd., with drum control (J.B., or Cyldon, Polar, etc.).
- 1 .0001-mfd. or over (up to .0002-mfd.) differential reaction (Lotus, or Ready Radio, Dubilier, Igranic, J.B., Lissen, Ormond, etc.).
- 1 neut. type, about .00005 mfd. (Bulgin, or Keystone, etc.).

ADJUSTABLE CONDENSERS

- 2 .002-mfd. max. (Formo, etc.).

SWITCHES

- 2 3-point push-pull wave-change (Wearite, or Bulgin, Ready Radio, W.B., Keystone, Magnum, Red Diamond, Ormond, etc.).
- 1 3-pole double-throw (Wearite).

RESISTANCES

- 1 25,000-ohm "Spaghetti" type (Magnum, or

Lewcos, Ready Radio, Bulgin, Sovereign, Keystone, Graham-Farish, etc.).

- 2 600- or 500-ohm, and holders (Ready Radio, or Parex, Wearite, Magnum, Keystone, etc.).

- 1 2-meg. grid leak and holder (Lissen, or Graham-Farish, Telsen, Dubilier, Ediswan, Igranic, Ferranti, Mullard, etc.).
- 1 1-meg. grid leak and holder (Lissen, etc.).
- 1 filament rheostat (see text) (Wearite, or Igranic, Lissen, etc.).

VALVE HOLDERS

- 2 horizontal-mounting 4-pin type (Parex, or W.B., Telsen, Lotus, Bulgin, etc.).
- 2 ordinary 4-pin (Lotus, or Telsen, Clix, Igranic, etc.).

FIXED CONDENSERS

- 1 .0003-mfd. (Dubilier, or Telsen, Ready Radio, Ferranti, Mullard, Ediswan, Igranic, Sovereign, Graham-Farish, Formo, etc.).
- 1 .01-mfd. (T.C.C., etc.).
- 2 1-mfd. (F.C.C., etc.).
- 2 .001-mfd. (Lissen, etc.).
- 1 .002-mfd. (Lissen, etc.).
- 1 2-mfd. (Dubilier, etc.).

CHOKES

- 3 H.F. (Varley, Lewcos and Telsen in set. Any good makes).
- 1 output choke (Atlas, or R.I., Igranic, Varley, Bulgin, Ferranti, Wearite, Lissen, Magnum, etc.).

TRANSFORMERS

- 1 L.F. (Ferranti, or Telsen, Igranic, Varley, Mullard, R.I., Lissen, Lewcos, Lotus, etc.).

COILS

- 1 "Star Turn" selector coil (Ready Radio, or R.I., Wearite, Keystone, Magnum, Goltone, Parex, etc.).
- 2 "M.W." dual-range coils (Keystone, or Goltone, R.I., Ready Radio, Formo, Wearite, Magnum, Tunewell, Parex, etc.).

MISCELLANEOUS

- 1 pick-up jack, "single circuit open" type (Bulgin, or Igranic, Lotus, Ormond, etc.).
- 11 terminals (Belling and Lee, or Igranic, Belex, Clix, etc.).
- 2 terminal strips, 10 in. × 2 in. and 6 in. × 2 in.
- 2 panel brackets.
- 2 standard screens (6 in. × 10 in.), copper foil.
- G.B. plugs, flex, Glazite, G.B. batteries, clips.

Band-pass circuits were introduced. Local powerful transmitters became more powerful, and alternative programmes were the order of the day. A type of selectivity that would remove two powerful nearby programmes and leave things otherwise as before was urgently required.

The Best Rejector

Here history more or less repeated itself. Everyone talked of wave-traps again, but double ones this time. The "Kendall" Rejector, introduced by MODERN WIRELESS, set the fashion, and has remained supreme in its own line ever since.

But more and more powerful stations went up abroad, and soon we had to have even greater selectivity. Sets became more selective, but more difficult to handle, until MODERN WIRELESS again stepped into the breach and simplified selectivity with the "Star-Turn" system.

Always

Up to Date

All this is not meant to be a chronological survey of the progress of selectivity, but is intended to show how selectivity has to keep pace with conditions. To show how that the necessary selectivity always arrives. And to emphasise how MODERN WIRELESS readers are always able to be right up to date.

They are shown in set designs how

EVERY DETAIL CAREFULLY PLANNED—

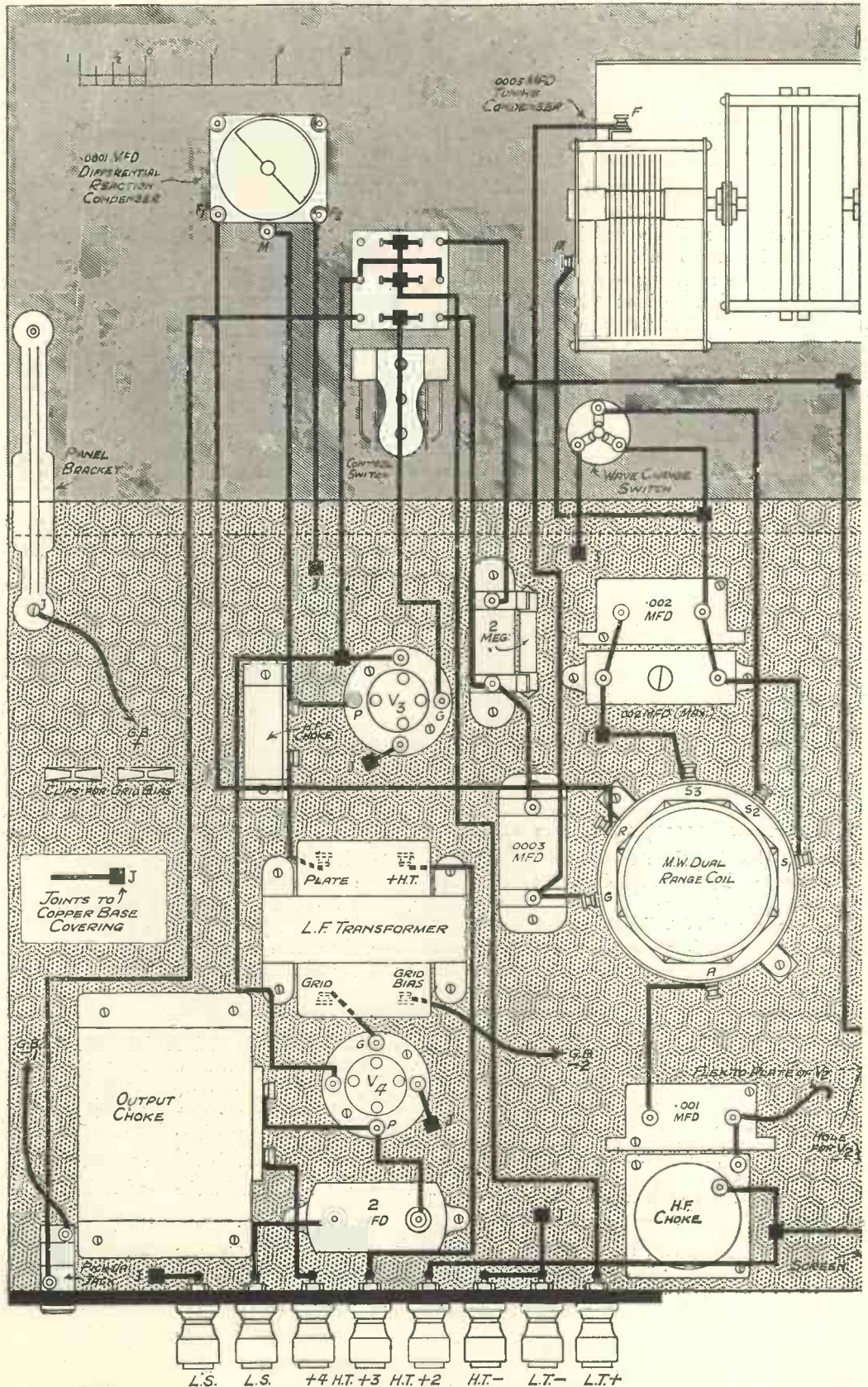

Very special attention has been given to the layout in order that the wiring may be kept short, where this is necessary, and proper separation of leads may result. In view of this, all you need do to be sure of excellent reception is to follow the wiring and layout as shown in this diagram. Note the various points where "earth" connections are made to the copper foil on the baseboard.

—RESULTS ARE A REVELATION

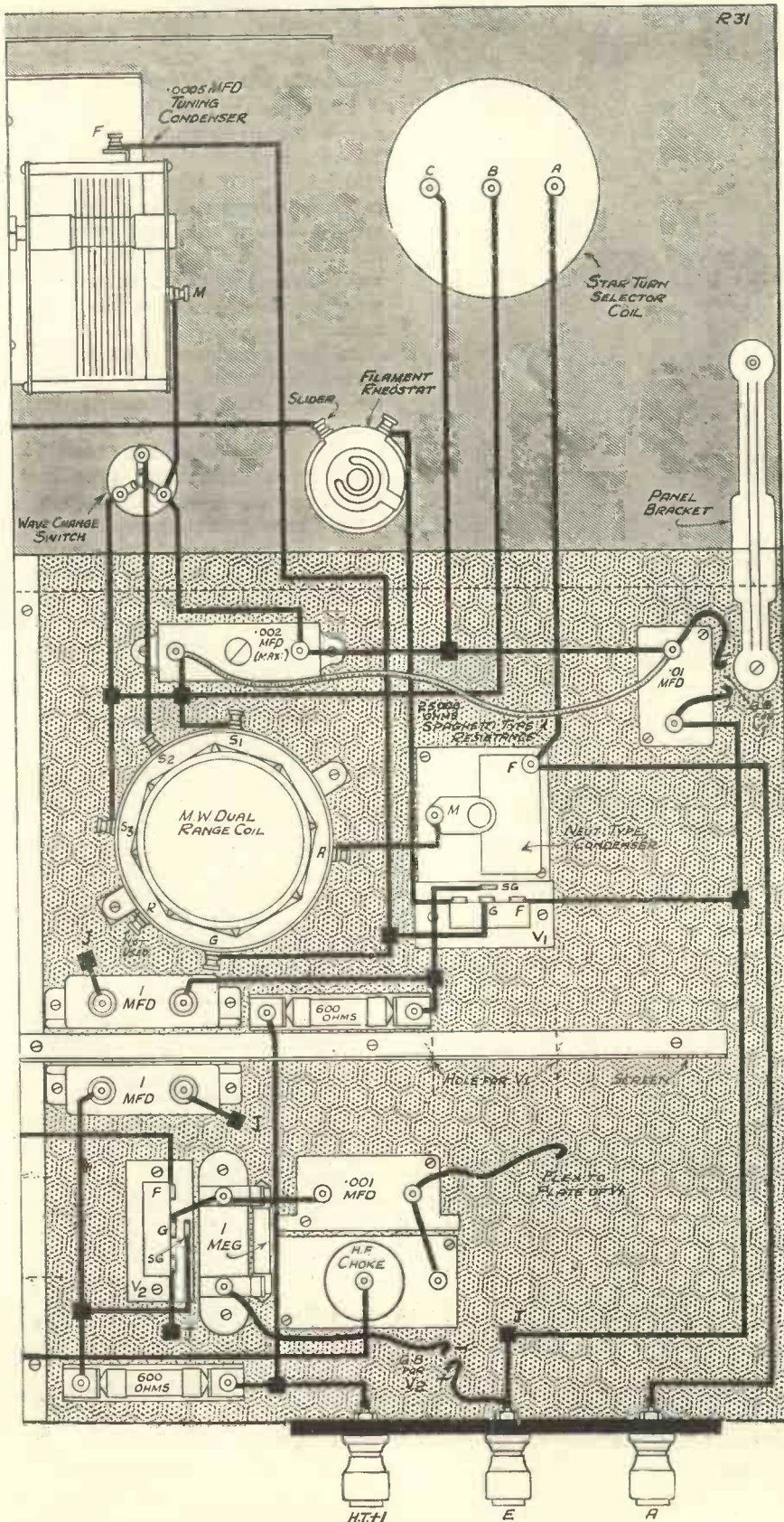

The second S.G. stage, the aperiodic one, is arranged in a separate compartment at the back of the baseboard and directly behind the first S.G. stage. The two tuned circuits are thus brought next to one another, which permits a double-drum condenser to be efficiently employed, thus greatly simplifying the handling of the receiver.

to get just the amount and type of selectivity needed, in the simplest possible manner, and in the most efficient way.

If it is possible to have efficient, selective wave-changing, MODERN WIRELESS readers are shown the best way. Witness the "M.W." dual-range coil.

If it is possible to have one tuning condenser less in a 2 S.G. set, and yet retain ample selectivity and maximum volume and range, MODERN WIRELESS does it. In this case the "Suprovox" four-valver stands as witness.

The Main Features

But that is only one of the brilliant features of this new four. Just look at the theoretical circuit diagram while we run over the main features and points of its arrangement.

The two screened-grid valves are followed by a detector and one L.F. stage. With two really efficient H.F. stages, one L.F. valve is ample for modern broadcast conditions.

A POINT TO NOTE.

"Unlike most schemes for obtaining a high degree of selectivity, it does not weaken the strength of distant stations. On the contrary, it actually increases their strength."—See text.

There is also the great advantage that a silent background is obtained. It often happens, but the reason is not at all obvious, that two L.F. stages with two screened-grid valves bring up the background altogether out of proportion to the strength of the programmes.

The first S.G. valve is aperiodically coupled to the second one. That is to say, the anode circuit of the first S.G., instead of being tuned or coupled to a tuned circuit via a primary winding, consists of an H.F. choke.

Excellent Amplification

This choke has a natural wavelength well above the longest waves included in the long-wave broadcast band. The result is that it offers a high impedance to any broadcast wave, either medium or long.

The reason why this scheme should give such excellent amplification has puzzled many experts. The matter is, therefore, of great interest, and a possible explanation is to be dealt with in a special article.

The plate of the first valve is coupled to the grid of the second via a fixed

H.F. AMPLIFICATION WITHOUT TUNING

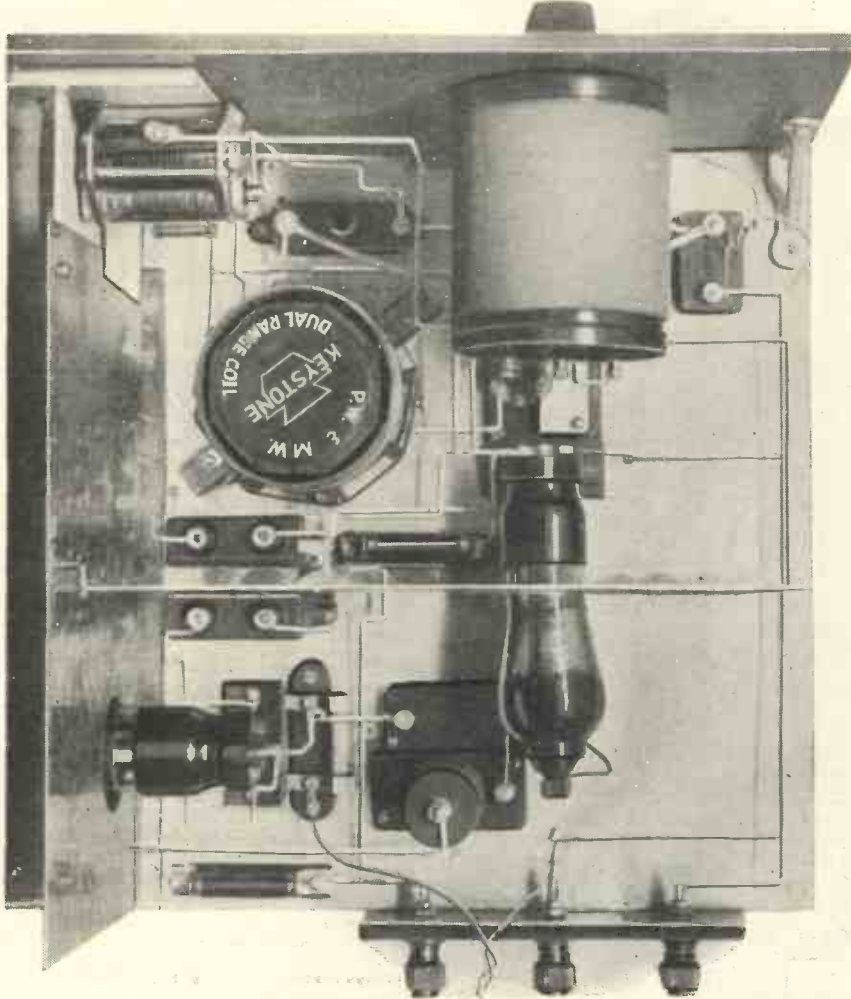

The H.F. choke which is employed to connect the first S.G. valve to the second is clearly visible in this photograph, between the anode terminal of the first valve and the holder of the second.

condenser. The 1-megohm grid leak is necessary so that a suitable value of grid bias may be applied to this second valve.

Cuts Out Interference

Two dual-range coils are employed, one in the grid circuit of the initial S.G. valve and one in the detector's grid circuit. On long waves special capacity coupling is employed, the arrangement in regard to the first coil forming the well-known "Inter-wave" system which cuts out medium-wave interference on the long wave-band.

So far as medium waves are concerned, the aerial circuit comprises the "Star-Turn" selector system. This selector coil is coupled very weakly to the dual-range coil by means of a neutralising type condenser.

This arrangement provides great selectivity with ease of control. Unlike most schemes for obtaining a high degree of selectivity, it does not weaken the strength of distant stations. On the contrary, it actually increases their strength.

Fully Tuned Aerial

The reason is that we have a fully-tuned aerial circuit. But don't imagine that it is just as sharp in tuning as one of the condenser-tuned circuits.

So long as it is approximately adjusted, searching can be carried out entirely with the two .0005 variable condensers. When a desired station

NOTHING BUT THE BEST SCHEMES MAKE UP THIS CIRCUIT

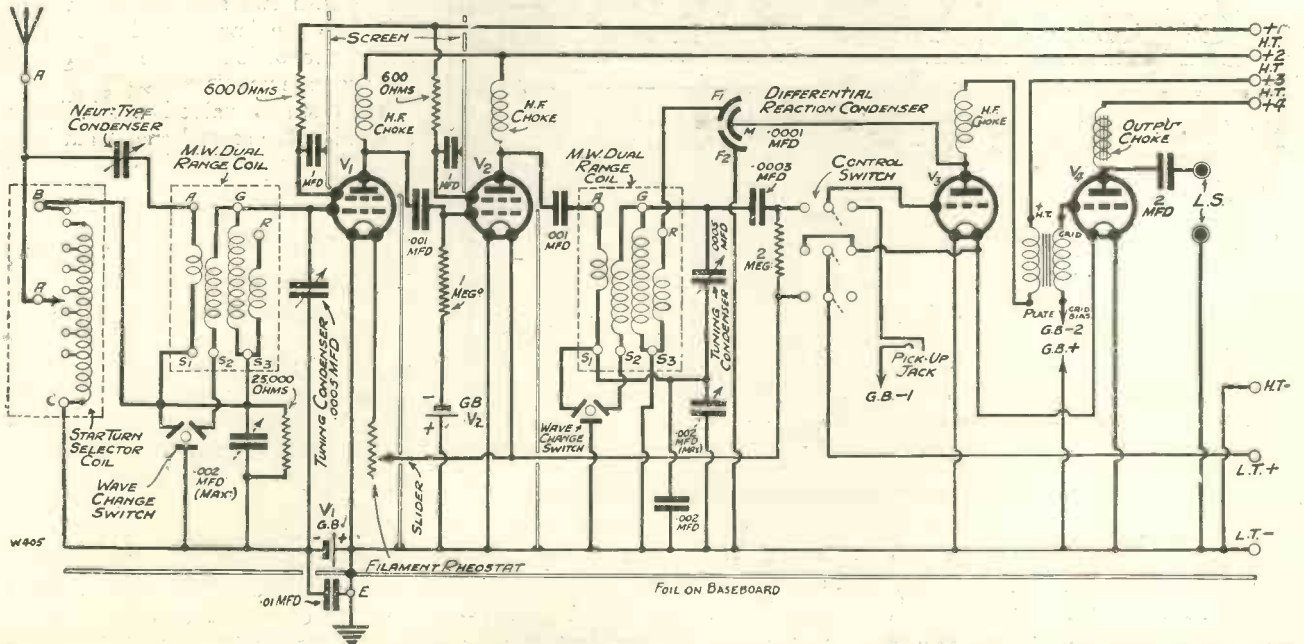

One glance at the circuit diagram is sufficient to enable one to begin picking out the fine features. "Star-Turn" selectivity, dual-range coils, two S.G. valves, special radio-gram on-off switching; these are but a few of the efficient schemes incorporated in the set, and which all help in the production of one of the finest receivers ever published.

A Silent Background is Obtained

is located it can then be brought up to full strength by a slight adjustment of the selector coil.

The neutralising condenser, the "Interwave" compression-type condenser, and the compression condenser in the second tuned circuit, do not require touching once they have been set to their best values for your conditions.

On long waves the "Star-Turn" coil is not in use. It is cut out by turning the arm of the selector switch right round to the right.

This connects the selector arm to the end stud which is represented by B. The aerial is then joined direct to the first dual-range coil.

This is done by two sections of a three-pole change-over switch. The remaining section is used in the normal way for changing over from radio to gramophone.

The reason why two sections of the switch are required for L.T. switching is because when using the pick-up the filaments of the H.F. valves are arranged to be turned out. This economises in both L.T. and H.T. current.

"On-Off" as Well

There is another advantage. Occasionally with radio-gram switching in the detector's grid circuit there is a slight tendency for radio to break

the pick-up itself are made via a pick-up jack.

When the set is not in use for record reproduction it may not be desirable to have a lead trailing from the gramophone to the set. The plug and jack method of connection is then much more convenient than terminals for rapid making and breaking of the pick-up connections.

An output filter is incorporated, as befits an efficient four-valve set. There is one fixed condenser incorporated, but if a D.C. mains unit is employed it is desirable to connect another 2-mfd. fixed condenser in circuit.

To do this you simply break the wire running from one loud-speaker

A FEW OF THE IMPORTANT POINTS IN THE DESIGN

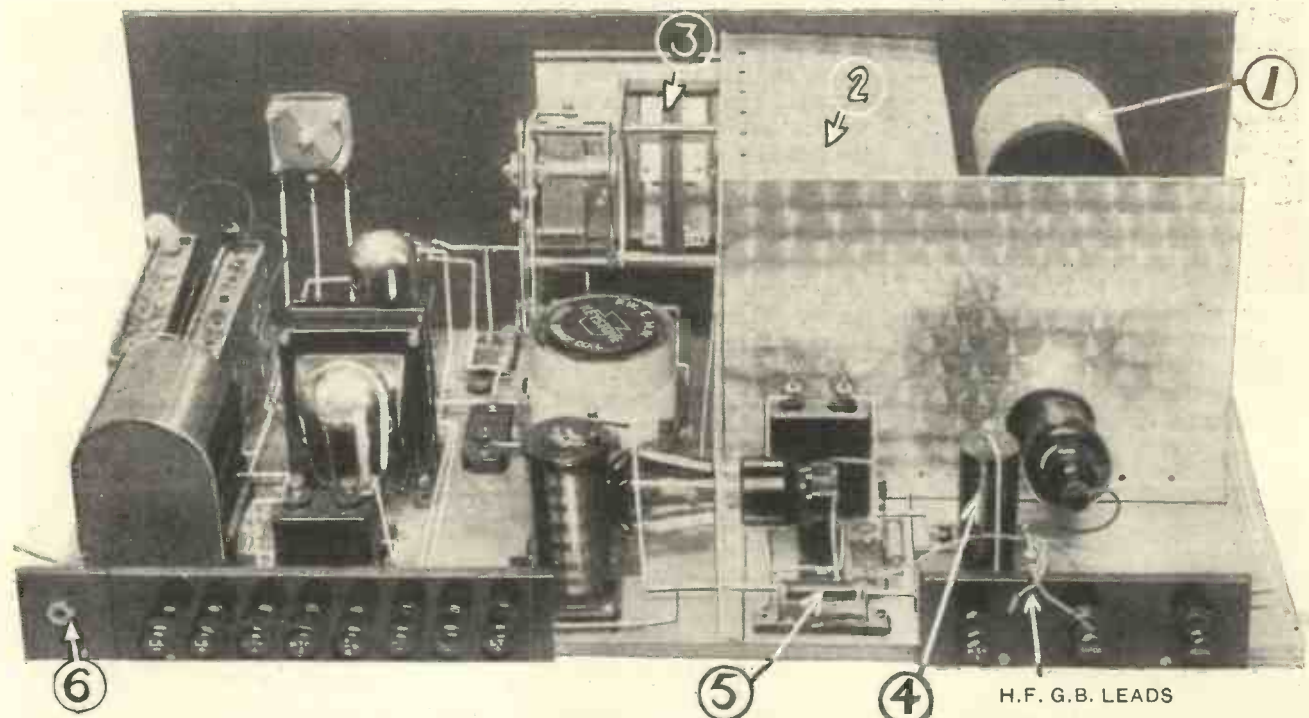

The "Star-Turn" Selector coil, which provides great selectivity, is indicated by (1). (2) is a screening lid to the first H.F. compartment, and is over the top of the first section of the double-drum condenser (3). (4) is the choke in the second H.F. stage; (5) the de-coupling resistance in the screening-grid lead of the aperiodic H.F. valve; and (6) the pick-up jack.

As there is only one L.F. stage it is not necessary to have a volume control on this side of the receiver. It is vitally necessary to be able to adjust volume before the detector valve, however, since with two S.G. valves it could easily be overloaded on a powerful local transmission.

Pre-Detector Control

The volume control takes the form of a filament rheostat for the first H.F. valve, and while on the subject of filaments we may as well consider the L.T. switching.

through on top of the record reproduction. This is quite impossible if the H.F. valves are out of action.

The radio-gram switch acts as the on-off switch for the set. The receiver is "off" with this switch in the midway position, and when it is turned in one direction the detector valve is connected up for radio and the H.F. valves are turned on.

When it is over to the opposite side the pick-up is connected into the grid circuit of the detector valve and the H.F. valves are out. Connections to

terminal to the screen, and join the two resulting ends to the two terminals of the fixed condenser. This extra condenser will prevent any possibility of trouble from shocks or shorts, due to one side of the loud speaker and one loud-speaker lead being "live" so far as the mains are concerned.

H.F. Grid Bias

A point which may have struck you is that one of the G.B. batteries for H.F. bias is shunted by a fixed condenser, whereas the other is not.

The reason for this is simply explained.

The first G.B. cell is actually in an oscillatory circuit, whereas the other one does not have to pass H.F. Also, in any case, since the second one is in series with a 1-megohm grid leak, whose H.F. resistance is many, many times greater than that of the battery, it would not make much difference if this cell were shunted. The first battery is in series with the aerial-to-earth circuit, where every bit of resistance has to be avoided if possible.

Pick-Up Volume

Just one other point requires mentioning, namely, volume control for pick-up work. The radio volume control is of no use for this, since it works on the H.F. side of the set.

An ordinary three-terminal type of volume control, with a value of 1/2 or 1 megohm, should be connected directly across the pick-up. The pick-up plug goes to the slider of this, and to one of its outside terminals.

After all, the turntable end of the pick-up leads is the logical place for this pick-up volume control. Here it is conveniently placed for adjusting the volume to a suitable level for the particular record to be played.

That completes the explanation of the theoretical circuit, and we are sure you will agree that it represents a fine collection of features and good points. There are many things

nature. A sheet of copper foil is arranged over the whole of the baseboard, and special vertical screens separate the H.F. stages and the detector.

FOR FINE SPEAKER RESULTS



EXCELLENT VOLUME AND SUPERB QUALITY

No matter whether the station being received is near or far, the set will give a rendering on the loud speaker such as will surpass your expectations.

There is no tuning for the second stage, and for this reason it can be arranged away from the panel. You will see that it has been placed behind the first H.F. stage, at the back of the baseboard. Consequently, the main vertical screen which runs from the front to the back of the baseboard is separating variable condensers and coils which are not in consecutive stages. There is the aperiodic stage between them.

For this reason any slight field linkage that might arise would assume much more importance than is usually

And now for a point which may prove somewhat of a surprise to you. Usually, when a receiver has a fair amount of screening which is connected to earth, advantage is taken of the fact by connecting every point that has to be earthed to the most convenient and nearest point on the screening.

A Practical Point

Logically, this seems a most sensible thing to do, but, curiously enough, practical experiences indicate that it is sometimes decidedly

MANY STATIONS NEED NOT MEAN MANY CONTROLS

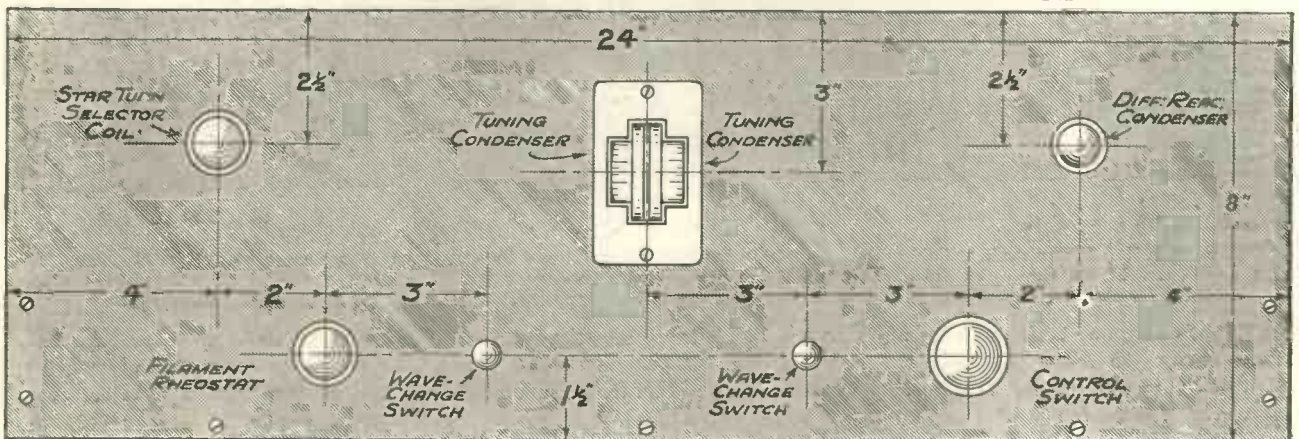

PANEL LAYOUT

The tuning of the receiver for both near-by and distant stations is remarkably simple, particularly is this evident when it is remembered that two highly efficient S.G. H.F. stages are employed, and that a high degree of selectivity is attained.

worthy of special mention so far as the constructional design is concerned, and so a brief review of these will be of interest before we come to the more usual constructional work.

First of all the screening. This is naturally of a rather comprehensive

the case, because the feed-back would be across two stages instead of one. Slightly more screening than is normally employed thus becomes necessary.

It takes the form of a partial lid to the compartment in which the

undesirable. Like the question of aperiodic H.F. stages, the theory is somewhat behind practice, but you will find an interesting article on the subject elsewhere in this issue.

For the reason just outlined, certain points in the receiver are

An Ideal Combination of Efficiency and Simplicity

connected up by ordinary wiring connections instead of being taken direct to the metal-work. So when you come to wire up, follow the wiring diagram very conscientiously and only make direct connection to the screens where they are shown in the diagram.

Condenser Insulation

A point of considerable importance is the insulation of both sets of moving vanes on the double-drum condenser from the framework. Insulating bushes are supplied for this purpose, and you must see that they are fitted in place.

The construction of the receiver is made quite straightforward by the diagrams and photographs. Do not deviate from the design or you may experience trouble.

Follow the layout given for the components and keep the arrangement of your wires as near to that in the original as possible. The panel drilling is perfectly simple and only one point requires reference.

The drum condenser assembly requires a fairly large hole for the drum drives to project through. The best way to cut this hole is to use a fret-saw, which, no doubt, most of you possess.

With regard to the mounting of the components, it should be observed that the coils are raised a little way above the copper foil covering the baseboard by mounting them on small strips of wood.

With components such as the ordinary valve holders where the heads of bolts, to which wires are connected, are visible from beneath the component, and therefore come near the baseboard screen when screwed into place, precautions to prevent their shorting to the baseboard screen should be taken. The best and simplest idea is to arrange a piece of thin cardboard between the component and the baseboard.

Screen Connections

Instead of using two separate terminal strips, one long one may be employed running along the whole length of the back of the baseboard. All wires which are joined direct by soldering or by screws to the screening terminate in the wiring diagram in little black squares labelled with a "J."

The flex lead for the grid-bias positive plug is attached to the screw

which holds one of the panel brackets to the baseboard. Ample room is allowed on the baseboard for the grid-bias batteries, and you will see that clips for two 9-volt units are shown.

Separate grid-bias batteries should be employed for each H.F. valve. Usually 1½-volt cells will prove just right, although with 2-volt valves a slight improvement may be noticed by using instead special cells of the 9-volt variety.

Also, occasionally, with 4- and 6-volt valves the use of 3 volts instead of 1½ sometimes makes a slight improvement. Even if 3 volts does not make any audible improvement, so long as it does not decrease strength it is worth while, because it helps to keep down the anode current consumption of the H.F. valves.

all powerful stations, so that the power valve is not overloaded.

H.T. Voltages

The H.T. voltages in use will depend upon the particular valves used, as also will the grid bias for the power valve. H.T.+1 supplies the screening grids of the S.G. valves, and H.T.+2 their anodes. The detector receives its H.T. via H.T.+3, and the last valve via H.T.+4.

For medium waves the two wave-change switches are pulled out, and the selector coil requires adjusting, as explained at the beginning of this article, in conjunction with the variable condensers. The latter will keep more or less in step on both wave-bands, so that the two drum drives can be moved together with

WHERE THE H.F. IS HANDLED

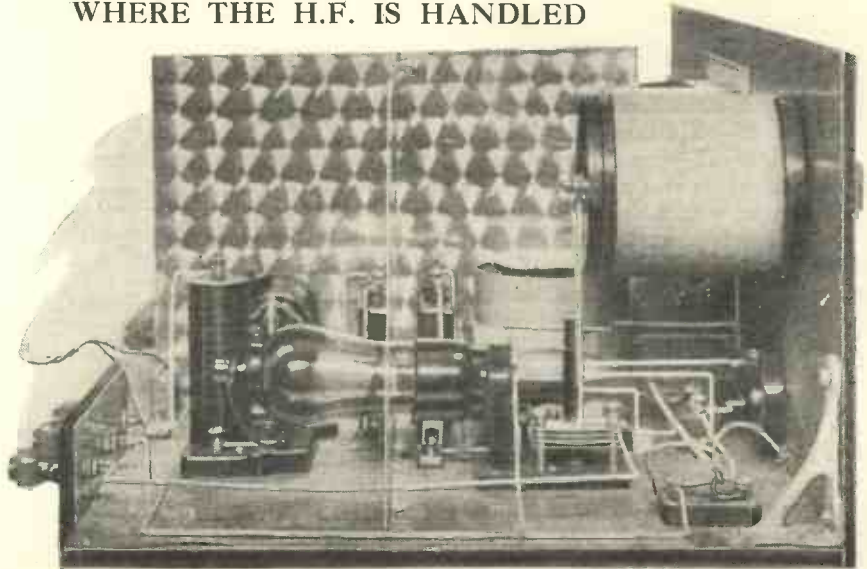

Here you see the H.F. end. The right-hand compartment contains the aerial circuit and the tuned H.F. section, while the smaller compartment is the aperiodic screened-grid portion. Behind the screen seen at the back of the photograph are the det. and L.F. circuits

By the way, note that in series with the second .002 compression type coupling condenser there is another .002 fixed condenser. This is because it was found that the best results were obtained with a coupling value somewhere between .002 and .004 for this position.

The valves to use are as follow: Two S.G. type for V₁ and V₂, a special detector or H.F. type for V₃, and a power or super-power for V₄.

It is desirable to use a super-power valve in the V₄ position in all cases except where dry battery H.T. is employed. In the latter case use a small power valve, but see that the volume control is turned down on

one thumb while searching, thus giving much the same effect as ganged tuning. Once a station has been found a slight separate adjustment of the drums can be made.

Left "Set"

Start off with the two compression-type condensers on the baseboard at minimum and the neutralising type condenser at maximum. These can then be adjusted one at a time to their best settings after a fairly weak distant station has been tuned in.

They should be left at the settings which produce the best volume consistent with the desired degree of overall selectivity.

QUESTIONS ANSWERED

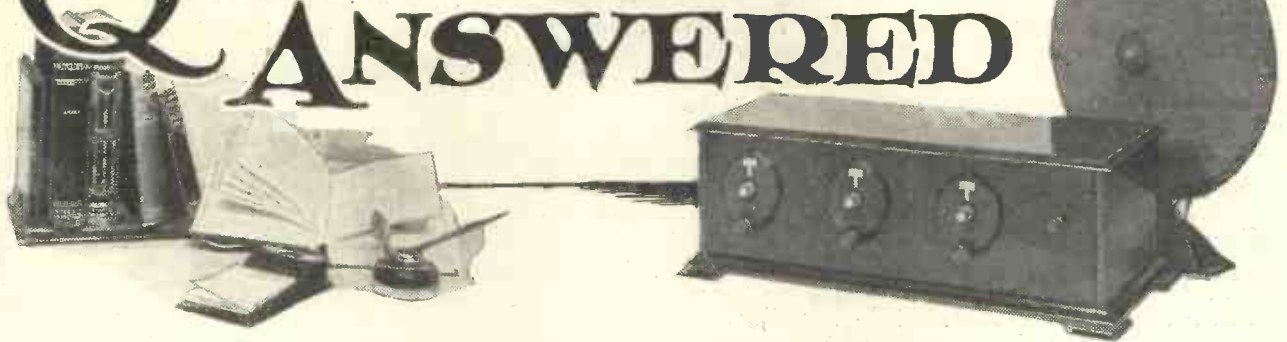

Measuring Resistances

M. G. (Bedford) asks us how to measure anode and similar resistances with the aid of a milliammeter. His meter has a 0-15 milliampere scale, and he wishes to have some idea of the range of values he can measure.

Ohm's law states that the resistance in ohms (R) = the voltage (E) divided by the current in amperes (I), or $I \div 1,000$ milliamps.

The minimum reliable voltage value is 2—viz., that of a single accumulator cell—and the lowest scale deflection which you are likely to be able to read without error is 1 milliamp. Therefore, at 2 volts you can measure a resistance of 2,000 ohms (1 milliamp. deflection) and, at the same voltage, resistances as low as approximately 135 ohms (15 milliamps. deflection). At these low values the resistance of the milliammeter, if it is known, must be subtracted from the final value. The internal resistance of the accumulator can be ignored. Suppose you have an anode resistance of something like 100,000 ohms. Then you will need a higher voltage in order to get a reading on the milliammeter. For example, 100 volts will produce a deflection of 1 milliamp. with a resistance of this value.

It is easy to apply any given voltage if a voltmeter is available, because the H.T. battery can be employed; but this means that you will have to invest in a high-resistance voltmeter, because it is absolutely essential that you should know the applied voltage as well as the current.

Aerials

C. R. (Maidenhead).—"Will a detector and 2 L.F. set work well in conjunction with a small indoor aerial, such as a wire round the picture railing in the drawing-room? I should like to bring in a number of Continen-

tal stations, in addition to the two Brookmans Park transmissions."

In your case, C. R., we suggest a set incorporating an H.F. valve, owing to the fact that an indoor aerial of this type has a very small "pick up." That is to say, the currents available to operate the receiver are extremely minute, and in consequence they need amplifying before detection if good results on distant stations are to be obtained.

An indoor aerial cannot be compared with a good outdoor one, and

TECHNICAL QUERIES DEPARTMENT

Are you in trouble with your set?

The MODERN WIRELESS Technical Queries Department is now in a position to give an unrivalled service. The aim of the department is to furnish really helpful advice in connection with any radio problem, theoretical or practical. Full details can be obtained direct from the MODERN WIRELESS Technical Queries Department, Fleetway House, Farringdon Street, London, E.C.4.

A postcard will do. On receipt of this all the necessary literature will be sent to you, free and post free, immediately. This application will place you under no obligation whatever. Every reader of MODERN WIRELESS should have these details by him. An application form is included which will enable you to ask your questions so that we can deal with them expeditiously and with the minimum of delay. Having this form you will know exactly what information we require to have before us in order to solve your problems. London readers, please note: Inquiries should not be made in person at Fleetway House or Tallis House.

whenever possible an outdoor aerial should be erected unless the set is particularly sensitive. It is unfair to a simple det. and L.F. receiver to expect it to give satisfactory long-range reception with a poor aerial system.

Earthing Switches

A. L. (Chiswick).—"I want to fix up an earthing switch so that I can earth my aerial in the event of a thunderstorm. Can you tell me what type of switch to get?"

Yes, obtain a single-pole change-over switch of substantial construction. Mount it on the window-sill or wall outside the house. Arrange for it some sort of protection from the weather, so as to reduce the possibility of leakages. Join the aerial lead down to the arm of the switch, and connect the lead-in and the earth lead to the two sides of the switch respectively.

Thus with the switch-arm in one position the aerial is joined to the aerial terminal of the set, and with the arm in the other position the aerial is joined to earth.

You can, if you wish, use an earth arrester gap in conjunction with the switch.

Volume Controls

T. C. C. (Wolverhampton).—"I recently tried to fit a volume control to my set. I had a 400-ohm potentiometer on hand, and placed this across the secondary of the L.F. transformer, using the method I have seen described in MODERN WIRELESS. To my surprise I found that I could only receive very weak signals, but when I removed the potentiometer altogether the set worked in a normal manner. Why should this happen?"

The reason your results were unsatisfactory was simply due to the fact that your potentiometer had too low a resistance, and was entirely unsuitable for this type of work. You should obtain a proper volume-control potentiometer having a value of not less than 500,000 ohms. Connect this as before, and we feel sure that you will find the results satisfactory.

You will realise that by connecting a value such as 400 ohms across the secondary you are virtually short-circuiting it. In other words, you might just as well join a piece of wire between the two terminals. It is surprising that you received anything.



How the arrangement of your loud speakers affects the output from your set, and the reasons why the one method of connecting them is generally better than the other.

THERE must be a vast number of listeners who use two or more loud speakers at once. In almost every other house where there is radio you find loud speakers in different rooms connected to the one set and operating together.

Sometimes, it must be admitted, there are two or three loud speakers connected up, but only the one is used at any one time. In such a case the wiring is of little importance providing it is sound; the practical effect is that a single instrument is joined to the receiver.

But when you come to the use of two or more simultaneously, either in order to achieve a distribution of volume or to supply several rooms with speech and music, it is immediately evident that there are two ways in which the connections can be made.

Series or Parallel?

The loud speakers can be joined either in series or in parallel. In the first instance, the energy passes through each in succession, while in the second case it is made to split up and traverse several paths.

These two schemes are illustrated respectively in Fig. 1 and Fig. 2. Obviously, they cannot give identically the same results, and no doubt

SIMPLER WIRING

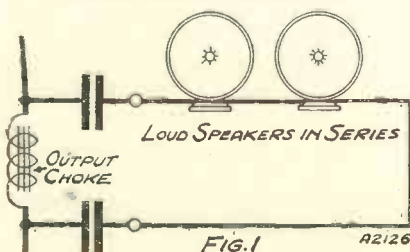

With this method only the one wire is necessary.

many readers have often wondered which is the better.

That is a very difficult question to answer, because so much depends upon individual circumstances. But I must say right away that generally the series scheme is likely to give superior results, and it certainly makes for easier wiring.

PARALLEL PATHS

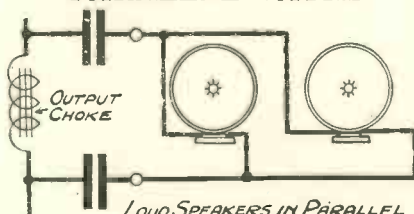

In this case two separate leads are needed for each speaker.

I would like to be able to go into this interesting subject in detail, for the more you study it the more fascinatingly complicated it seems to become. It is very far from being amenable to a simple explanation. However, I'll attempt to sketch the broad principles underlying this seemingly elementary matter. You will find that they comprise ample food for thought!

I will deal with the use of just two loud speakers, and we will imagine that it is desired to operate one in the same room as the set and the other in some other room.

The Output Circuit

The necessity of long leads to serve the distant instrument renders it essential that some sort of properly arranged output circuit should be in the receiver. Quite apart from anything else, you don't want the H.T. walking around the house!

The most popular form of output circuit is the choke-condenser arrangement. An L.F. choke replaces the loud speaker in the anode circuit of the last valve in the set, and the loud speakers are fed through one or more fixed condensers. These offer an easy path to the current fluctuations representing the speech or music, but bar the passage of steady direct current.

The impedance—or, more correctly, the "minus reactance"—located in such shunting condensers will be comparatively small at ordinary speech frequencies, although with the usual capacity values you find in ordinary sets it is rather more than it might be.

Valuable Simplification

It seems to me that something like 10 mfd. would be better than the 2 mfd. ordinarily figuring in such arrangements. However, the reactance will not be much except on the very low frequencies. That means to say that we can, quite legitimately, rule out the shunting condenser or condensers in any general examination of the effects of paralleled or series loud speakers connected across an output choke.

EXIT CONDENSERS

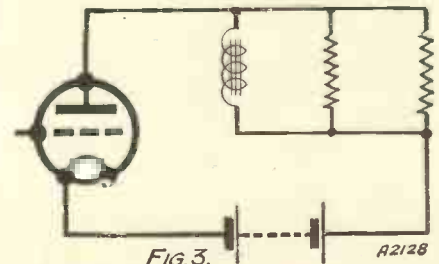

From the point of view of the circuit's A.C. characteristics it is legitimate to regard the effect of the shunting condenser or condensers as negligible.

You are Much Safer with Loud Speakers in Series

That is excellent simplification, as you will agree when you examine Figs. 3 and 4. Now, what are we out to discover? Obviously, the amount of energy each loud speaker manages to get, first, when the two loud speakers are connected in parallel and, secondly, when they are in series. And the scheme that results in each loud speaker getting the most energy, without upsetting the receiver, will naturally be the better.

Impedance Important

The factor that is going to matter more than any other is impedance. Fortunately, we are able to rule out yet another item on this account. And that is the H.T. supply. The effective impedance of either an H.T. battery or mains unit should be so low as not to contribute much one way or the other to the A.C. characteristics of the circuits.

So we can simplify still further and bring in the valve without our diagram

BALANCE AND CONTROL



Mr. H. Haley Simpson at work with his music in front of him, and an engineer entering up the station log, in the Balance and Control Department of the B.B.C., where the volume of broadcasts is delicately adjusted in accordance with the material.

being anything but extremely simple (Fig. 5). This diagram shows three resistances connected to a source of energy. Two of the resistances are in parallel with each other, and these represent C, the impedance of the output choke, and L, the impedance of the loud speakers which are connected across it. And in series you have the third impedance V, and this is the impedance of the valve.

The voltage developed across C, the choke, will depend upon the impedance across its terminals in relation to the impedance of the valve and, of course, the current flowing in the circuit.

If you reduce the impedance of C without altering that of V, the valve, the voltage across C is going to drop. And you will see right away that when loud speakers are joined across the choke the impedance is dropped, because the effect of paralleling impedance is to produce a resultant impedance smaller than either individual impedance.

SYMBOLIC SPEAKERS

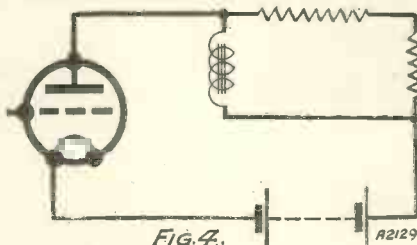

The loud speakers, which are joined in series, are shown as resistances.

No doubt you will immediately note the significance of this. It means that two loud speakers connected in parallel will constitute a much smaller impedance than two loud speakers of similar individual impedance joined in series.

I will give you something of an example. Supposing you had two exactly similar loud speakers each having an impedance at a middle C kind of frequency of 10,000 ohms. In series their impedances

would add up to about 17,000 ohms. (It is not straightforward addition, as with ordinary resistances in series—you take the vector and not the algebraic sum.)

Upsetting the Output

When in parallel those two loud speakers would have an effective impedance of about 7,000 ohms.

Therefore, you will drop the impedance of the output choke very much more by placing paralleled loud speakers across it. And you don't want to upset the characteristics of the anode circuit of the output valve any more than you can possibly help.

Now let us see how much energy each loud speaker will tend to get. When in series the current has to pass through each successively. A certain voltage is developed across the output choke, and the current flow will depend upon the impedance in the loud-speaker circuit. We will take this as the above-mentioned 17,000 ohms plus the (in vectoral addition) impedance of the output choke.

Obviously, the current will be much smaller, providing the voltage remains the same, than if you have the loud speakers in parallel, for the very simple reason that in the latter case the effective impedance will be considerably smaller.

Where the Snag Lies

But the snag is that the voltage does not remain the same—it is quite unable to do so.

With proper design it is possible to arrange that the loud speakers combine with the output choke to constitute an impedance that properly matches that of the valve. A more practical method is a transformer instead of a choke-condenser output.

But in the ordinary amateur outfit using an output choke it is usual to regard the loud speaker as a "dropping impedance" of little real moment.

THE "BARE BONES"

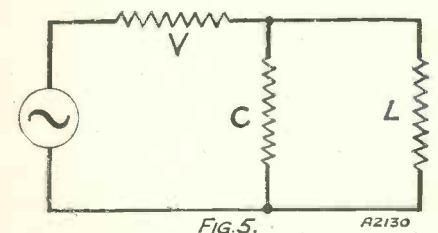

The valve, too, is now illustrated by a resistance symbol.

I hope I have shown it is wrong to do so, especially when several loud speakers are paralleled.

You are much safer with loud speakers in series. You might not get as much power delivered to each speaker as in some parallel cases, but you stand less chance of upsetting the output capabilities of the set, and of placing yourself in the hands of that capricious factor—frequency. For don't forget that, in all probability, the decreasing of the effective impedance of the output choke will mean an increasing susceptibility to frequency change—an unequal treatment of the different frequencies resulting.

... ON THE ... SHORT WAVES

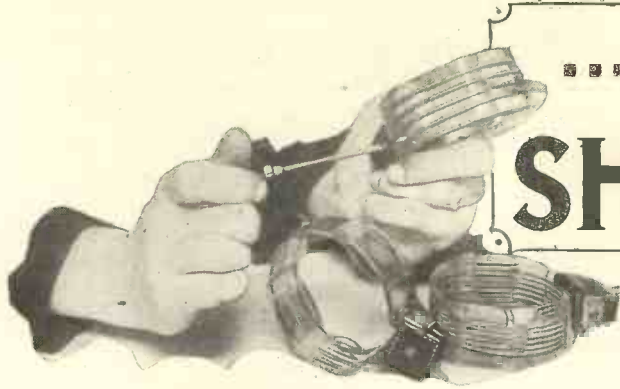

By W. L. S.

Our popular contributor discusses the problems encountered in running short-wave sets on the mains, and gives exclusive information regarding some new stations to listen to.

I HAVE been repeatedly asked why it is that the short-wave receiver changes so little from year to year. "Look," says the enthusiast, "at the very latest broadcast receiver. A metal chassis with a screened-ganged condenser; cans over the S.G. valves; all wiring out of sight; drum control and an illuminated dial; as well as filters and what-nots. And then look at the pukka broadcast receiver of three years ago. Why, it's like comparing a 1914 Ford with the 1931 model!"

To a certain extent I agree. But I must say that I think the changes in appearance have run on ahead of the technical alterations. Candidly, I think that the broadcast receiver I was using three years ago (if it were still in one piece, which it isn't) would put up quite a good show still, even with all these bogeys in the shape of Mühlacker, Heilsberg, the Regional Scheme and the proposed Soviet barrage of kilowatts!

Old and New

On the other hand, my short-wave receiver of three years ago would not, I imagine, afford me much pleasure now, although in looks it does not differ very much from the present outfit.

In my own humble opinion the facts are that broadcast receivers have changed greatly in appearance and in design of individual components and very little in technical perfection. Short-wave sets, on the other hand, look just as old-fashioned as ever, and work much better.

In confirmation of the first remark, examine the piece of apparatus known as the "hand-pass filter" and see whether it is not quite a near relation of the apparatus we were using in 1914.

This criticism of short-wave receivers "stung me into action," as the novelists say, and I am going ahead to produce one that looks really modernistic. If I succeed in doing this and, at the same time, making

the thing work, I shall be highly pleased.

Seriously, however, we short-wave fans have, I think, been rather backward in the way of improving and modernising. It was a tremendous time before an "all-A.C." short-wave receiver was accepted as a commonplace. Even now there are very, very few with single-dial control. And as for short-wave loud-speaker sets (capable of real reproduction, I mean), they are conspicuous by their absence.

The S.G. Detector

Here and now I make a suggestion for an "ideal" modern short-wave receiver capable of giving a reasonable performance. It should consist of a screened-grid H.F. stage, a screened-grid detector, one R.C. L.F. stage, and a push-pull output stage.

The reason for using a screened-grid detector is this. I have recently converted my old set to this system, and I find that quite the most perfect reaction control I have ever met is possible, simply by potentiometer control of the screen voltage. This removes the necessity for one variable condenser at once; the two tuning condensers may quite easily be ganged.

Easy Change-Over

To go over on my existing set to a screened-grid detector, no changes were necessary except the shifting of the lead from the reaction coil away from the plate terminal on the valve holder, up to a flex lead to the cap of the valve.

Right up against the plate terminal (now the screen) I placed a 1- or 2-mfd. by-pass condenser down to earth, and the potentiometer slider

HAVE YOU HEARD HVJ?



These people listened to the Pope via a loud speaker in Westminster Cathedral. The Pope's station, HVJ, works on short waves, and is getting over extremely well.

Of course, A.C. valves should be used all through, and the "power-pack" should be incorporated. Thus the set would have one dial on the panel, a combined main switch and volume control, a mains plug and a terminal for a small aerial.

was, of course, taken to the same point; one end going to earth and the other, through a fixed resistance, to H.T. positive.

After considerable experimenting with this set I find that I get the best results from a screened-grid.

Some New Stations for You to Pick Up

detector with the following constants: Valve, standard 6-volt S.G.; grid condenser, .0002; grid leak, 5 megohms; anode volts, 85-90; screen volts, about 25, but variable up to 45.

Thus if we use a 100,000-ohm potentiometer for controlling the screen volts and wish to make use of the whole travel of the slider, we should connect another 100,000-ohm resistance between the top end and H.T. positive, taking the bottom end direct to earth. With 90 volts on the plate this will obviously give us a variation from 0-45 volts.

I have no reason to believe that the constants would alter seriously for an A.C. screened-grid valve.

New Stations on the Air

The following stations are comparative newcomers and should be looked for if you wish to add to your "bag."

Vatican City, H V J, on 19.84 and 50.26 metres.

"Radio-Saigon," Indo-China, on 29 and 49 metres; transmits on Monday, Wednesday and Friday from 11.30 a.m. till midnight, and on other days for a shorter period, generally in the afternoon.

from his 32-metre wave, and he is now much more consistent and generally stronger than before.

Radio Rabat, on 23.36 and 32.26 metres; transmits from noon to 3 p.m. and from 7.30 to 10 p.m. respectively on the two waves.

Conditions are usually the topic of conversation among short-wave enthusiasts; probably because they are as variable as the weather that forms the staple food for talk amongst Britishers generally. This past month they have been oscillating so wildly from good to bad that it is almost impossible for me to say anything about them.

As a general rule, however, they seem to be quite good and consistent above 40 metres, while they are either very good or very bad below that. No one can tell from one day to the next what they are going to be like.

Hundreds of Them!

One recent week-end, when they suddenly improved and I was logging U.S.A. amateurs literally in hundreds, proved to coincide with the arrival of eighteen sun-spots, as observed at Mount Wilson.

SHORT WAVES ON THE DO.X

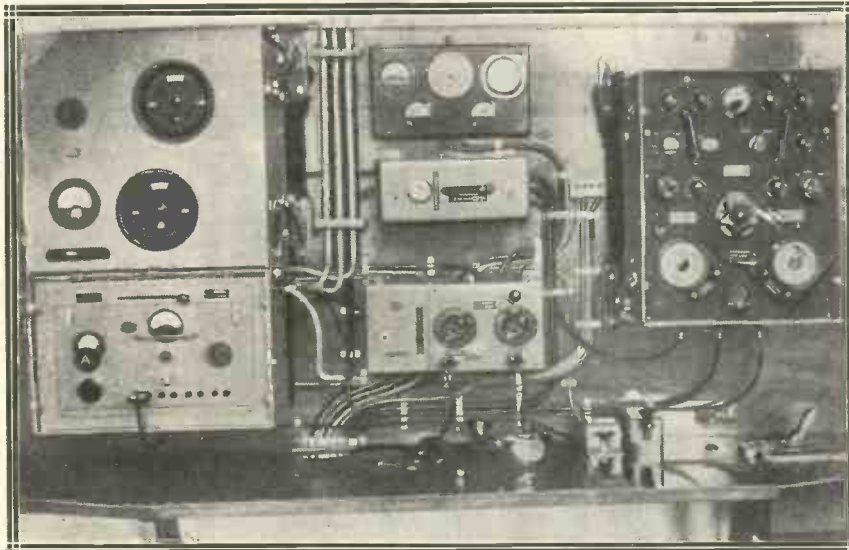

A view of the wide-range (25-3,000 metres) receiver on that giant flying-boat, the Do.X. This installation was fully described in an exclusive article published last month in "M.W."

T I-4 N R H (ex N R H), Heredia, Costa Rica; no definite information about wave-length, but has been heard on about 37 metres. This is a "semi-amateur" station using low power, and very difficult to receive in this country.

Nairobi, Kenya, V Q 7 L O, on 49.5 metres; this is a recent shift

Incidentally, any readers interested in hearing U.S.A. amateur stations on telephony should listen on the 80-metre wave-band in the early mornings. There is no need to start until 7 a.m., but from then till 8 a.m., unless it is an abnormally bad morning, they come over extremely well and in large numbers.

They will all be found between about 82 and 85 metres, since the 'phone amateurs are restricted to a comparatively narrow slice of the band allotted for amateur traffic in general.

They certainly do know how to modulate their high-power transmitters in the States. Comparison between almost any of these stations and our own average 160-metre amateur transmission makes one realise that we do not know everything over here.

On the High-Lows

While on the subject I might refer to the 160-metre wave-length. How many so-called "short-wavers" will tune up as high? I admit that I had some trouble myself in covering the band with the small tuning condenser that I always use. When, however, I eventually succeeded, I found results far better than one could obtain from a broadcast receiver "cut down."

SHORTS FOR CONSTRUCTORS

A Good Fit—H.F. Choke, etc.

An old bradawl trimmed with a file makes an excellent small "screw-driver" for grub screws, etc.

Before starting to drill a panel, centre-punch the positions of the holes to prevent the drill "wandering" from its starting-point. An ordinary nail makes a quite satisfactory "centre-punch."

When screwing an upright panel to a baseboard, insert them both into the cabinet before drilling through the panel into the baseboard, if you want to ensure a good fit.

A home-made H.F. choke coil inserted in each of the 'phone leads is one good method of stopping threshold howl on short waves.

Seventy-five turns of fine wire such as 32 D.S.C. on a 1½-in. former will make a good H.F. short-wave choke.

If your H.T. accumulator appears to leak even when not in use, remember that four or five switches arranged at regular intervals will greatly reduce such a tendency.

REDUCING HETERODYNING

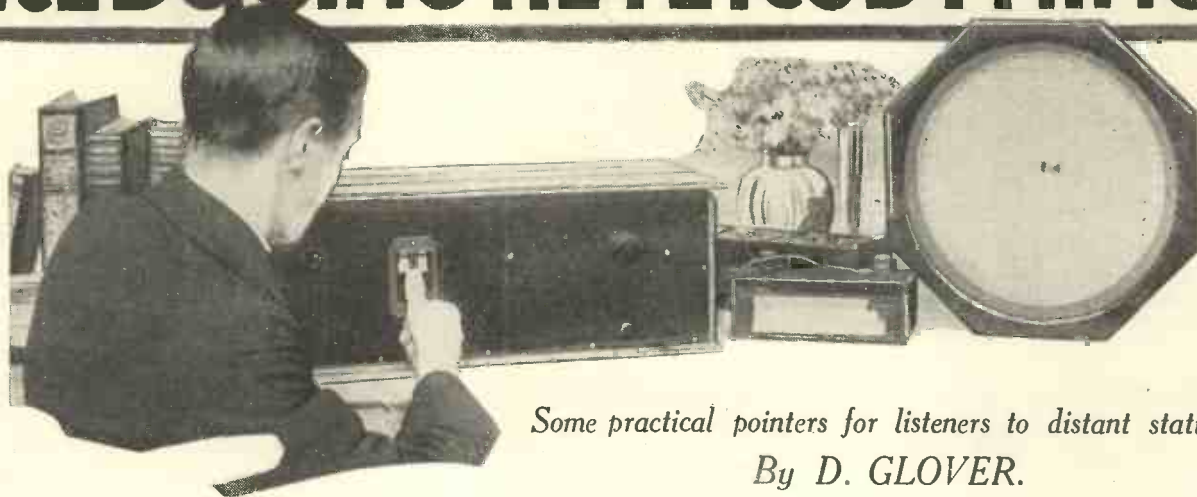

Some practical pointers for listeners to distant stations.

By D. GLOVER.

IT seems to be fairly commonly thought that heterodyning occurs in the ether. That is not strictly true. The actual heterodyning takes place in your receiving aerial.

Heterodyning is the production of a "beat frequency" by two separate currents mingling in one circuit.

The frequency of the beat will be the difference between them. Supposing your aerial had currents of 1,010,000 and 1,000,000 cycles induced in it by two broadcasting stations. A beat frequency of 1,010,000—1,000,000, i.e. 10,000 cycles, would result.

But you have to be able to pick up both stations before the heterodyning can occur.

That is why it is sometimes possible to receive stations clear of heterodyning on a portable where it is quite impossible to do so with an ordinary set. It is done by taking advantage of the directional qualities of the portable's frame aerial. Of course, it happens in cases that the two mutually interfering broadcasters lie in the same direction. When that is so, "wangling" the position of the portable won't help you.

Steering Clear

If, however, the two transmissions are coming in from different quarters, the set can be turned so that it stands badly for the reception of the one station but very well for the other. You may then find that the heterodyning disappears, thus proving that it is not carried on the back of the transmission, as it were, but in reality is generated in your aerial by the mixing up of the two currents, which may be widely different in strength but very close in frequency.

A very weak transmission will often

produce a quite loud heterodyne on a powerful transmission. The reason for this is to be found in the disproportionate powers of high and low notes.

A note of four or five thousand cycles frequency strikes the ear as something approaching a squeak—even those high-pitched clarinets can't get up there.

On the Doorstep!

But it is a common kind of frequency for a heterodyne. And the ear is vastly more sensitive to high notes of such calibre. For equivalent audibility a low note of the order of seventy or eighty cycles has to have thousands of times the power.

So you see, a comparatively weak current is all that is necessary to produce a heterodyne of irritating "loudness."

NEPTUNE CALLING!



A scene on the submarine from which an under-water broadcast was relayed for the benefit of American listeners.

You can frequently lose a heterodyne by skilfully juggling with volume and tuning controls, and it is easier to achieve success if you have both an L.F. and a pre-detector volume control. Most valves tend to have what is known as a "threshold." And I am not referring to that ubiquitous "threshold howl," but to a kind of electrical doorstep.

That is to say, they do not function until something above a certain minimum amount of energy is given to them. A tiny quantity is unable to—"mount the doorstep."

It is more marked in the detector than in the other valves, though I warn you the threshold effect in some valves is so small as to be absolutely negligible from a practical point of view.

However, it sometimes happens that you can reduce the volume of both the stations—the one you want to listen to and the weaker one that is heterodyning it—by operating the pre-detector volume control until a point is reached where the weaker station cannot get through while the other one does.

Side-band Snipping

Another tip worth bearing in mind is that a careful application of reaction can sometimes send up the selectivity of the set to such an extent that side-band snipping takes place—the heterodyning going out with some of the legitimate frequencies!

One of these days we shall no doubt have a simple frequency doubler for receivers that will once and for all put an end to heterodyning. It seems simple in theory, but everybody knows what a world of difference there can be between a theory and a fact!

For

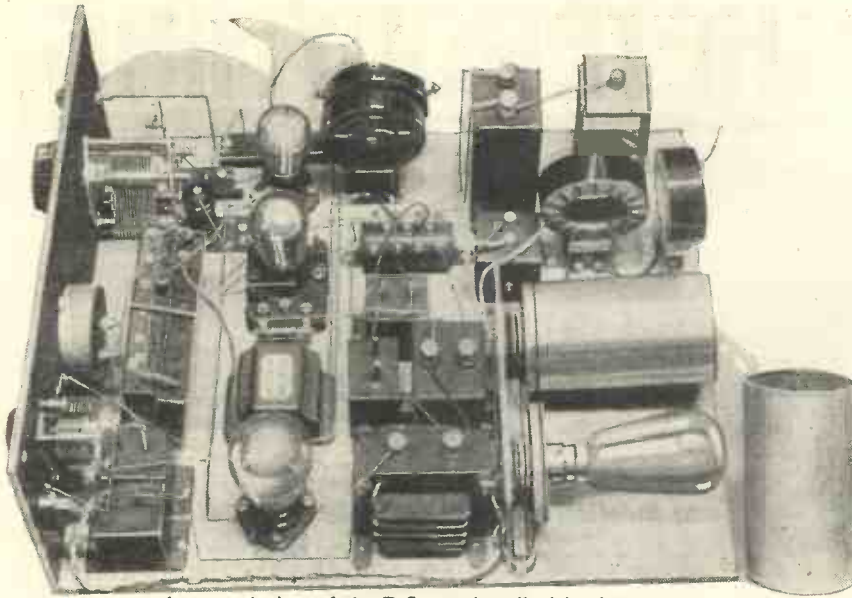

A general view of the D.C. set described in these pages.

MOST D.C. mains receivers have, in the past, been limited to circuits in which it has been necessary to employ either special mains valves, or battery valves taking a similar current throughout the receiver. But in this set a special paralleled-filament system is employed.

No Earth Needed

The circuit developed, after numerous experiments had been carried out, is a particularly interesting one and is well worth your close examination even if you are not wanting to build a set of this kind.

Although it was not deemed necessary to construct this receiver at a minimum figure, it was found that

several of the components could be constructed at home with the simplest of tools.

The first thing which will attract your attention about the circuit is the absence of an earth, which was found to be entirely unnecessary.

The circuit as a whole is perfectly "straight," consisting of a detector with two stages of L.F., the first stage of amplification being resistance-coupled, whilst the second employs transformer coupling. A filter output circuit to obviate the danger of the loud-speaker leads being at approximately mains potential is included in the output stage, and the filter choke and the smoothing choke may be constructed at home if desired. Details for the home con-

struction of the chokes are given below. See also the photograph in one of our end pages.

The former for the windings is the first part to be constructed, and the dimensions for this are given in a diagram. The end cheeks and centre tube can be made from thin cardboard, ebonite, or fibre; cardboard proved quite efficient.

To prevent the cheeks of the former from being forced out when winding, slips of paper are taken through the bobbin and stuck over the face of the two end cheeks.

Choke Construction

It was found that it was advisable to round the corners of the cardboard discs forming the bobbin so as to prevent the wire catching on same during the winding operation, and after the former has been assembled the whole should be dipped into thin glue to ensure that the bobbin is quite rigid.

Now comes the only point at which a certain amount of ingenuity is called for—the winding of the choke. It is surprising how easily this is accomplished if a block of wood is obtained which just slides inside the former.

A fairly large screw is fixed into one end of the wooden former to act as a spindle. The head of this screw is then cut off with a hacksaw so that

SIMPLICITY IS THE KEYNOTE OF THE CIRCUIT

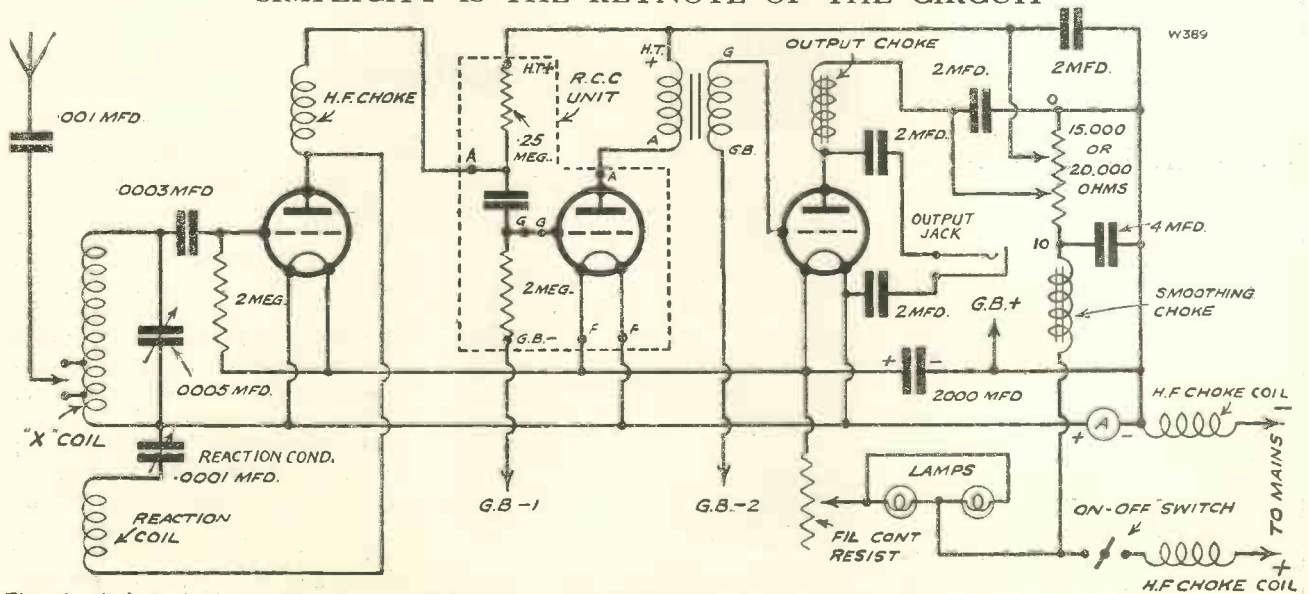

The circuit is perfectly straightforward and conventional. The selectivity is of quite a fair order, though the set was not intended for use without a rejector in the swamp area of a powerful station.

Those D.C. Mains

A SIMPLE ELECTRIC RECEIVER.

Here is described an easy to-build three-valver for the man with D.C. electric supply. It is a powerful little receiver, specially suitable for use outside the "swamp" area of the local high-power station.

Designed and Described by J. R. WHEATLEY.

the screw can be held in the chuck of a small hand brace. The brace is then clamped to the edge of the table, and the result is a very efficient little winding machine.

You will require 1 lb. of 32 gauge enamelled wire for each choke, and each slot should be filled in turn. The ends of the windings may conveniently be held in place by means of a little Chatterton's compound or sealing-wax until each section of the bobbin is full.

Stalloy Stampings

When you have completed the winding, the sections have to be joined in series—i.e. the end of one section to the beginning of the next, and so on. It is best to solder these joints. The actual start of the first section should be soldered to a small length of flex, and to prevent a strain on the wire at the point of connection stick the flex to the bobbin with some Chatterton's compound or sealing-wax.

Each section should be covered with a layer of insulating tape so as to prevent possible damage to the windings.

The core itself consists of approximately one half-gross pairs of No. 4 Sankey stalloy stampings. It will be seen from the photograph that there are two different stampings, one "T" shaped, and the other "U" shaped. Assuming that the "T" piece is on the left for the first layer, at the next layer the "T" piece is placed at the right-hand side and the "U" piece at the left. The core is therefore built up so that the "T" piece is alternately left and then right.

The Aerial Condenser

Pack the centre of the former to its maximum extent, for if the laminations are left loose they will tend to vibrate. Four suitable angle-pieces must now be constructed. You will probably find that small

angle-brackets of approximately the correct size can be obtained from a local ironmonger.

Before clamping the core laminations together by means of these angle-brackets and four bolts, a piece of ebonite should be cut, so that when the choke is finished this strip of ebonite is held in place by the clamping piece.

The two terminals on this ebonite strip must, of course, be arranged so

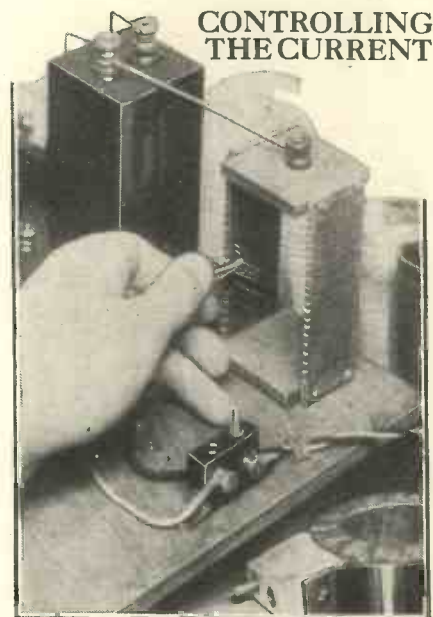

CONTROLLING THE CURRENT

The final control of the filament current is made by means of the resistance shown in this photograph.

that the nuts holding them do not come into contact with the core. The screwing up of the four bolts holding the core together completes the choke.

In series with the mains leads, plug-in coils each of 150 turns are joined. These coils act as chokes, preventing H.F. picked up by the mains from getting through to the set and causing trouble. A series aerial condenser also removes the possibility of a short taking place should the mains have the positive earthed and the aerial come into contact with an earthed object. The usual output terminals have been dispensed with in favour of a jack and plug.

L.T. from D.C.

The L.T. circuit calls for special detailed information, since this incorporates an electrolytic condenser. This component, although of quite small dimensions, has a capacity of 2,000 mfd., and its use is to smooth out irregularities in the L.T. supply.

The mains voltage is reduced to a suitable figure for any voltage of valves by the use of series resistance lamps mounted on the right of the baseboard, whilst a closer control of the voltage is obtained by the use of a special home-made 36-ohm rheostat.

THE PARTS IT CONTAINS

CONDENSERS

- 1 .0005 variable (Lissen, or Lotus, J.B. Ready Radio, Igranic, Ormond, Dubilier, Formo, etc.).
- 1 .0001 variable (Lissen, or Keystone, Lotus Ready Radio, Ormond, J.B., etc.).
- 1 4-mfd. (Dubilier, or T.C.C., Lissen, Igranic, Mullard, Hydra, Filta, etc.).
- 4 2-mfd. (Dubilier, or Igranic, etc.).
- 1 2,000-mfd. electrolytic (T.C.C.).
- 1 .001 fixed (T.C.C., or Telsen, Dubilier Lissen, Igranic, Ediswan, Ferranti, Ready Radio, Mullard, etc.).
- 1 .0003 fixed (Lissen, etc.).

VALVE HOLDERS

- 2 sprung type.

COIL SOCKETS

- 4 baseboard-mounting (Lotus, or Igranic, Keystone, Magnum, Bulgin, Wearite, etc.).

IR D LEAK AND HOLDER

- 1 2-meg. (Dubilier, or Igranic, Ferranti, Ediswan, Lissen, Mullard, etc.).

POWER SWITCH

- 1 on-off (Bulgin, or Igranic).

AMMETER

- 1 reading 0—1 amp. (Sifam, or Bulgin, Ferranti, Weston, etc.).

JACK

- 1 single-circuit (Lotus, or Igranic, etc.).

LOW-FREQUENCY TRANSFORMER

- 1 low ratio (Cossor, or Telsen, R.I., Ferranti, Igranic, Varley, Lotus, Lissen, Lewcos, Mullard, etc.).

R.C.C. UNIT

- 1 with valve holder (Dubilier).

H.F. CHOKE

- 1 (Ready Radio, or Lewcos, Lissen, Varley, Dubilier, R.I., Igranic, Lotus, Magnum, Watmel, Wearite, Keystone, Parex, etc.).

POTENTIAL DIVIDER

- 1 20,000-ohm (Bulgin, or Climax, Wearite, etc.).

MISCELLANEOUS

- 2 batten lamp holders.
- 1 terminal (Belling Lee, or Clix, Eelex, Igranic, etc.).
- 1 panel 14 x 7 in.
- 1 cabinet, and baseboard about 16 in. deep.
- Material for chokes and resistance, lamps, etc.

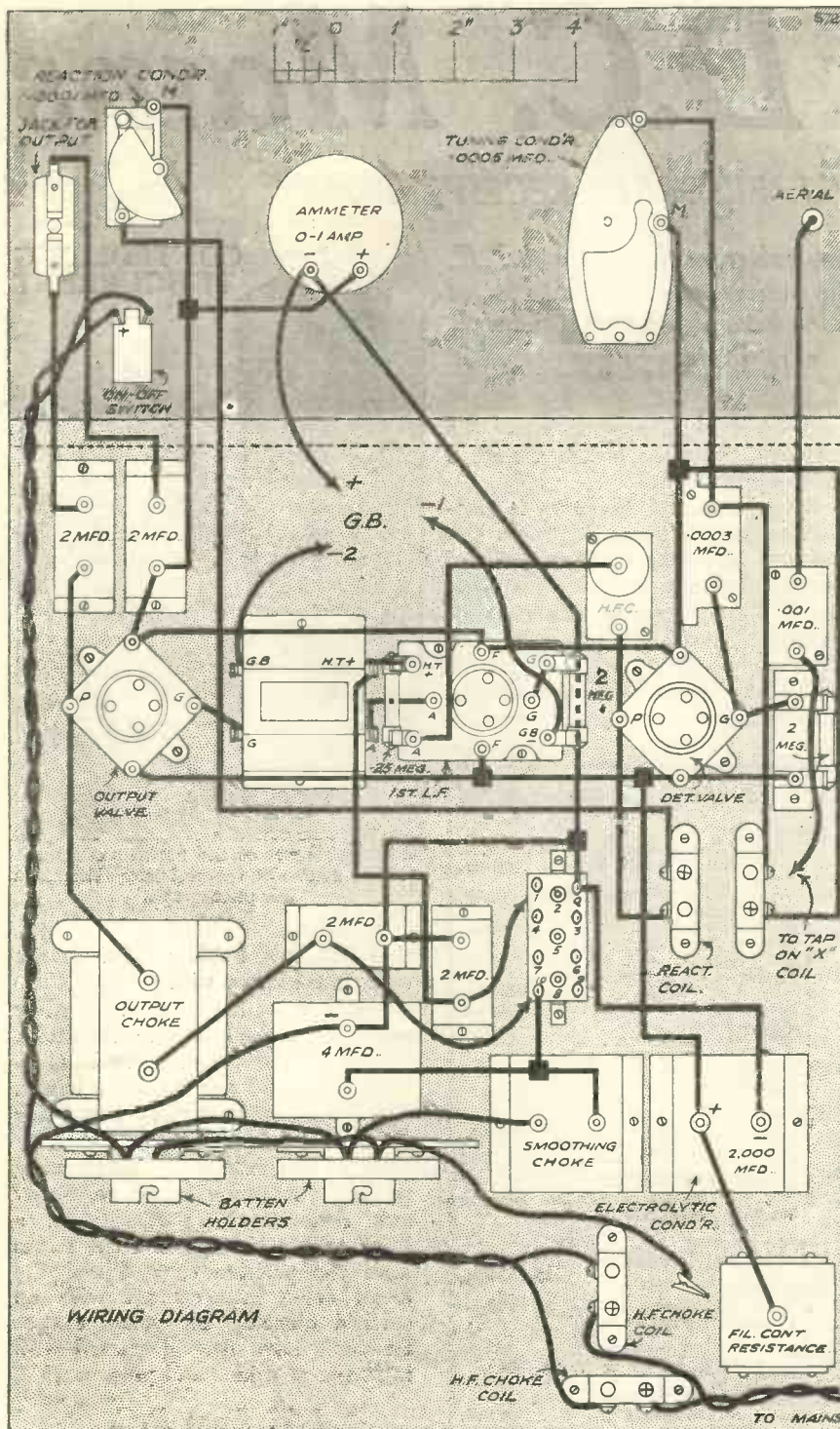

Though compactly arranged, the various components are not unduly crowded. The output choke (left) was home-made, and the smoothing choke can be, if desired.

The method of calculating what lamps are required is quite simple.

The total filament current of the valves is ascertained and a lamp (or lamps) used which passes a current equal to it or slightly more.

Assuming that two valves taking .1 amp. are employed in the first two stages and a .25-amp. valve in the output stage, the total current taken by the set will equal .45 amps. If, therefore, our mains are 200 volts,

one 100-watt bulb can be inserted (the current passed by this lamp being .5 amp.), and further control may be carried out by means of the series resistance, until the meter reads .45 amp.

The method of calculating the wattage of the series lamps (or lamp) is quite simple, and is arrived at in the following manner:

$C \times V = \text{Watts}$, where C = the current it is required to pass in amps. and V = the voltage of the mains.

In certain cases it may be convenient to employ two lamps to arrive at the necessary wattage.

The rheostat employed as a final adjustment has a resistance of approximately 36 ohms and is conveniently variable by means of a clip.

Making the Rheostat

Two pieces of hard wood, 2 in. by 2 in. by $\frac{1}{4}$ in., are required for the foundation of the above rheostat. The actual resistance wire is wound on two strips of slate, $4\frac{1}{4}$ in. by $1\frac{1}{4}$ in., attached to the wooden blocks by means of wood screws.

Thin strips of slate are difficult to obtain, and it is suggested, therefore, that these are cut from an ordinary roofing slate. The cutting should be carried out by means of a hacksaw, and the slate should be finished with the aid of a coarse file. On the two edges of each of the slate strips twenty-six notches must be cut, leaving a space at the top and bottom of the strips of approximately $\frac{1}{2}$ in., the notches being cut $\frac{1}{8}$ in. apart.

The Tapping Clip

One ounce of 32-gauge Eureka resistance wire will be more than sufficient for the resistance element. One end of the winding is fastened under a terminal mounted in the centre of the top wooden block, whilst the end of the winding is fastened under one of the wood screws attaching the slate strips to the bottom wooden block, since this end is not actually required for contact purposes.

An ordinary tapping clip is not in its normal state suitable for making contact with such fine wire, and for this reason the serrations on the jaws should be removed with a file.

The heat radiated by the series lamp or lamps, although not excessive, may cause damage, and could under certain circumstances scorch the polish on the inside of the cabinet. For this reason they are inserted in metal boxes.

Simple Screens

To reduce the cost of the receiver, empty $\frac{1}{2}$ -lb. cocoa tins were employed with the bottom of the tins removed. The lids of the above tins are attached under the two shade rings of the holders for the bulbs by cutting holes in the centre of the lids. In this way it is possible to place the bulb in position and then place the cocoa tin over same.

THE SPLIT SECOND THAT ADDS MONTHS TO BATTERY LIFE



"Time Factor" is considered by Lissen of such importance to the Secret Process that every operation is controlled with laboratory precision



ORDINARY mixing of standard battery chemicals will set up a flow of electric current—current good enough, perhaps, to ring a bell or light a bulb. But in radio every flaw is magnified, every fault amplified, the slightest current variation reflected harshly by the delicate receiving valves. That is why the actual factory methods employed in making a battery are so important—that is why such a difference is noticeable immediately a Lissen Battery is introduced into the receiver.

In the Lissen Battery Factory, precise laboratory methods are used. The quantities of the various chemical constituents of the Lissen Secret Formula are controlled with microscopic accuracy. Their purity is ensured by analytical test; their thorough and complete admixture supervised at every stage.

And here enters the time factor. An appreciation of the importance of this time factor makes all the difference between an ordinary battery with an ordinary battery's life, and a Lissen Battery with a Lissen's Battery's life! In some parts of the Lissen Secret Process the time factor is considered by Lissen of such vital importance that the operations are controlled on a rigorous time-schedule.

The effect of the time-controlled process is shown in the fine response of the battery when the cells are called upon for heavy output over long periods. Then you will find the unique Lissen production methods have put a reserve of chemical activity into the Lissen cells which meet any and every demand for high-tension power. The current always flows steadily and at high pressure—the cells RESIST VOLT DROP WITH A STUBBORNNESS UNKNOWN IN ANY OTHER BATTERY. AND THE LISSEN BATTERY GAINS MONTHS OF EXTRA LIFE.



LISSEN BATTERIES ARE WORTH THEIR PRICE!

60 VOLT 7/11
100 VOLT 12/11

LISSEN LIMITED, Worples Road, Isleworth, Middlesex.



A business-like appearance is given to the panel by the ammeter, which tells you when you have your filament current adjusted properly.

The actual mounting for the two batten lamp holders is a piece of wood of suitable dimensions (3½ by 7 in.) attached at right-angles to the baseboard by means of two brackets, or else a strip of wood. The remainder of the constructional side should not be found difficult, since this is quite straightforward.

Now for the operation of the receiver. In the aerial circuit a 60X coil is required for the medium waves, and a 250X for the long waves. The correct size for the reaction coil is best found by experiment.

The correct reading for the ammeter having already been decided, it is only necessary to set the H.T. according to the valves.

The Valves Required

The following types will be required. In the first position an H.F. type with an impedance of approximately 20,000 ohms and an amplification of from 20 to 25. In the centre position use a valve with an impedance of approximately 10,000 ohms and an amplification factor of from 10 to 15. For the output stage obtain a super-power valve. Do not forget that so long as valves with similar filament voltages are provided, the actual filament current of each valve need not necessarily be the same.

The correct H.T. to apply to each valve is best obtained from the manufacturers' figures. As to the correct method of obtaining these voltages, the following scheme is suggested. A high-resistance voltmeter must be obtained, or, of course, if you have one on hand all the better.

Connect one end of the voltmeter to the negative side of the potential divider, and the other end to the

starting at terminal No. 1. (Don't forget to switch off the mains every time before you alter it.) You will find that a point is reached where the voltmeter is reading the maximum voltage recommended for the valve in the output stage.

H.T. Voltages

Having ascertained this point, disconnect the voltmeter and connect the flexible lead which is supplying the output valve to the above terminal. (Before making this test, G.B.—2, the flexible lead connected to the grid-bias terminal of the L.F. transformer, must be joined to the correct voltage specified by the manufacturers for the H.T. about to be supplied to the output valve.)

With the above scheme all element of doubt is removed as to the voltage you are applying to your last valve.

The setting of the second H.T. tapping—in other words, the tapping which supplied the detector and first L.F. stage—will be rather lower. If you have connected the flexible lead supplying your last valve, for example, to terminal 9, then join the second H.T. plus lead to terminal No. 7. In the case of the first H.T. tapping being joined to terminals lower than No. 9, then it is suggested that the second H.T. lead be joined to a terminal one number lower. Grid bias to G.B.—1 will be between 1½ and 3 volts.

Safety First

A final word of warning: Make quite certain as to the voltage of your mains, and, secondly, do not obtain cheap foreign bulbs for the resistance lamps, since the stated wattage is nearly always greater than the real wattage of the lamp. Finally, don't alter anything in the set unless the mains are switched off first.

MAKING THE CHOKE

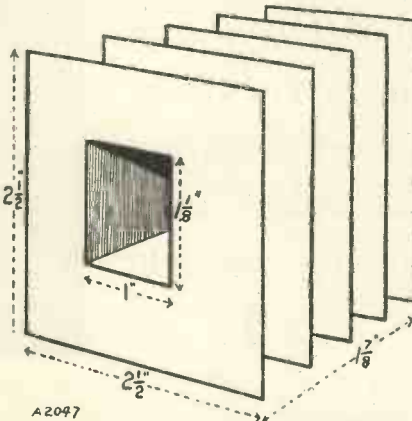

A2097 How the former for the smoothing choke is constructed.

tapping which is joined to the filter output choke. Put the mains switch on and read the voltmeter.

The lead which is joined to the filter output choke can also be tried on the other terminals of the potential divider,

HOW THE PANEL PARTS ARE POSITIONED

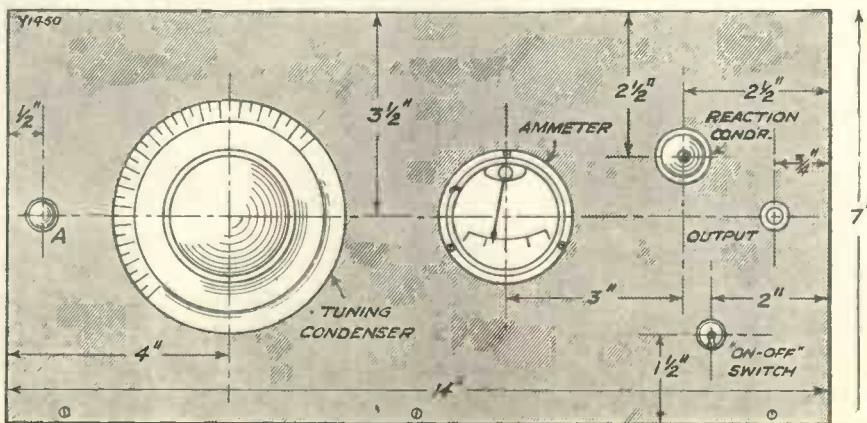

PANEL LAYOUT.

No earth connection is necessary in this set, so only one terminal is mounted on the panel—for the aerial.

FOR 100% EFFICIENCY USE A READY RADIO KIT

THE 'PENTODION'

	£	s.	d.
1 Ebonite panel, 8 in. x 8 in. x 7/8 in., drilled to specification ..	3	6	
1 Cabinet to special design, with 12-in. baseboard ..	19	6	
1 Formo .0005 variable condenser, with reaction condenser incorporated ..	15	0	
1 ReadiRad .0005-mfd. Brookmans condenser ..	3	6	
1 ReadiRad 3-point wave-change switch ..	1	6	
1 ReadiRad on-off switch ..	10		
1 Pair Collett adjustable panel brackets ..	3	0	
2 Telsen valve holders ..	2	0	
1 ReadiRad "M.W." dual-range coil ..	12	6	
1 Varley Nicore II L.F. transformer ..	15	0	
1 R.I. Pentomite output choke ..	1	1	0
1 Formodensers, type H ..	2	3	
1 ReadiRad "Hilo" H.F. choke ..	4	6	
1 ReadiRad .0003 fixed condenser ..	10		
1 Dubilier 2-megohm grid leak ..	1	9	
1 Dubilier vertical grid-leak holder ..	1	0	
2 T.C.C. 2-mfd. fixed condensers ..	7	8	
2 ReadiRad 25,000-ohm link resistances ..	3	0	
1 Ebonite strip, 10 in. x 2 in. x 3/8 in. ..	1	3	
9 Belling Lee "R" terminals ..	2	3	
1 Packet Jifflinx, for wiring ..	2	6	
2 Valves: Detector and Pentode ..	1	11	0
Screws, flex, etc. ..	1	2	
Total (including valves and cabinet)	£7	16	6

KIT "A" (less valves and cabinet) **£5:6:0**
or twelve equal monthly payments of **9/9**

KIT "B" (with valves less cabinet) **£6:17:0**
or twelve equal monthly payments of **12/7**

KIT "C" (with valves and cabinet) **£7:16:6**
or twelve equal monthly payments of **14/4**

THE 'HI-LO' REJECTOR

	s.	d.
3 Formo .001 max. compression type condensers ..	4	6
2 ReadiRad coil holders ..	1	8
1 Bulgin push-pull single-pole change-over switch ..	2	0
2 Belling Lee terminals ..	6	
1 Terminal strip, 4 in. x 2 in. ..	6	
1 Baseboard, 4 in. x 6 in. ..	4	
Wire, screws, etc. ..		
	9	6
2 Coils additional (if required) ..	8	0

TO OVERSEAS CUSTOMERS.
Your Goods are very carefully packed for export and insured, all charges forward.

Ready Radio holds colossal stocks of radio sets, equipment and components. Your order can be supplied from stock. There is no need for you to suffer the inconvenience of delay; you need not accept substitutes—if you send your order to Ready Radio you know that you will get what you order—immediately—and that everything you order will be new and in perfect condition.

'DUAL-RANGE' ONE

	£	s.	d.
1 Polished panel, 9 in. x 7 in. x 3/8 in. ..	3	0	
1 Oak cabinet, with 9-in. baseboard ..	15	0	
1 ReadiRad .0005-mfd. variable condenser ..	4	6	
1 ReadiRad Duograph S/M dial ..	6	6	
1 ReadiRad .00015-mfd. differential reaction condenser ..	5	0	
1 Formo .001-mfd. adjustable condenser ..	1	6	
1 Formo .002-mfd. adjustable condenser ..	2	3	
1 Formo .0003-mfd. max. adjustable condenser ..	1	6	
1 Wearite double-pole change-over switch ..	3	6	
1 ReadiRad 3-point wave-change switch ..	1	6	
1 ReadiRad "M.W." dual-range coil ..	12	6	
1 Telsen sprung 4-pin valve holder ..	1	0	
1 ReadiRad .0003-mfd. fixed condenser ..	10		
1 ReadiRad 2-meg. grid leak, with holder ..	1	4	
1 ReadiRad 25,000-ohm Spaghetti type resistance ..	1	6	
1 ReadiRad H.F. "Hilo" choke ..	4	6	
1 Terminal strip, 9 in. x 2 in. x 3/8 in. ..	10		
8 Belling Lee terminals ..	2	0	
1 Valve to specification: Det. ..	8	6	
1 Packet Jifflinx, for wiring ..	2	6	
Wire, flex, screws, etc. ..	1	3	
Total (including valve and cabinet)	£4	1	0

KIT "A" (less valve and cabinet) **£2:17:6**
or twelve equal monthly payments of **5/3**

KIT "B" (with valve less cabinet) **£3:6:0**
or twelve equal monthly payments of **6/1**

KIT "C" (with valve and cabinet) **£4:1:0**
or twelve equal monthly payments of **7/5**

Send for the Ready Radio Catalogue: A complete encyclopedia of all modern Sets, Speakers, Equipment, Components and Accessories, including everything needed by the set-builder. Price 1/-, post free.

'SUPERVOX' RECEIVER

	£	s.	d.
1 Drilled ebonite panel, 24 in. x 8 in. x 7/8 in. ..	9	0	
1 Oak cabinet, with 12-in. baseboard ..	2	0	0
1 Cyldon Junior Syncratone condenser, .0005 mfd. ..	1	10	0
1 ReadiRad .00015 differential reaction condenser ..	5	0	
1 Bulgin N.7 neutralising condenser ..	4	9	
2 Formodensers, type "H" ..	4	6	
2 ReadiRad 3-pt. wave-change switches ..	3	0	
1 Wearite 3-pole change-over switch ..	4	0	
1 ReadiRad "Link" resistance, 25,000 ohms ..	1	6	
2 ReadiRad 600-ohm resistances and holders ..	5	0	
1 ReadiRad 2-megohm grid leak and holder ..	1	4	
1 ReadiRad 1-megohm grid leak and holder ..	1	4	
1 Wearite rheostat to suit valve used ..	1	6	
2 Junit valve holders ..	3	6	
2 Telsen 4-pin valve holders ..	2	0	
1 ReadiRad .0003-mfd fixed condenser ..	10		
1 T.C.C. .01-mfd. fixed condenser ..	3	0	
2 T.C.C. 1-mfd. fixed condensers ..	5	8	
2 Telsen .001-mfd. fixed condensers ..	2	0	
1 Telsen .002-mfd. fixed condenser ..	1	0	
1 T.C.C. 2-mfd. fixed condenser ..	3	10	
1 Telsen H.F. choke ..	2	6	
1 ReadiRad "Hilo" H.F. choke ..	4	6	
1 Lewcos H.F. choke ..	7	9	
1 Atlas L.F. choke (20 henry) ..	1	1	0
1 ReadiRad "Star-Turn" Selector coil ..	12	6	
1 Telsen "Radiogrand" L.F. transformer, ratio 5-1 ..	12	6	
2 ReadiRad "M.W." dual-range coils ..	1	5	0
1 Bulgin P.15 plug ..	1	6	
1 Bulgin single circuit open jack ..	1	3	
11 Belling Lee terminals, type "R" ..	2	9	
1 Terminal strip, 24 in. x 2 in. x 3/8 in. ..	2	3	
1 Packet "Jifflinx" for wiring ..	2	6	
3 ReadiRad screens to specification ..	6	6	
1 Sheet foil, 24 in x 12 in. ..	3	0	
2 Siemens S.G. cells ..	2	0	
4 Valves to specification: 2 S.G., Detector, and Power ..	2	19	0
Wire, screws, wander plugs, clips, etc. ..	1	9	
Total (including valves and cabinet)	£15	1	0

KIT "A" (less valves and cabinet) **£10:2:0**
or twelve equal monthly payments of **18/6**

KIT "B" (with valves, less cabinet) **£13:1:0**
or twelve equal monthly payments of **23/11**

KIT "C" (with valves and cabinet) **£15:1:0**
or twelve equal monthly payments of **27/7**

TO INLAND CUSTOMERS.
Your Goods are despatched post free or carriage paid.

Cash or Easy Payments

Ready Radio
R.R.LTD.
159, BOROUGH HIGH STREET,
LONDON BRIDGE, S.E.1.
Telephone: Hop 5555 (Private Exchange) Telegrams: READIRAD, SEDIST.

Immediate Dispatch

SOME NEEDLE NOTES



What needles do you use in your radio-gram? Any old thing, or do you choose them carefully? It pays to consider that question closely, as the needle may do much to make or mar your results.

By "SPEARPOINT."

"WHAT'S the point of having all these different needles?" asked a friend, during a chat on radio-grams and gramophones.

The pun was unintentional, I am sure; but after all, when one thinks about it, what is the point of it all?

To the average man with a gramophone who buys a box of 200 needles, it doesn't matter a fig whether he gets "Loud Tone," "Tungstyle," "Spearpoint," "Talkie" or any other kind. That is as far as his technical considerations go.

Choose Them Carefully

All he is concerned with is whether they will give him the result he wants. The "tungstyle" need not be changed after every record, the "talkie" is good, loud needles are bad for some records and soft ones don't seem to bring out the scratch so much, and so on. That seems to be the end of the matter where the average gramophone owner is concerned.

But the man with a radio-gram set, if he is wise, will choose his needles carefully, trying first one and then another variety till he finds the one that suits his particular pick-up.

And really the type of needle employed does make a deal of difference, not only to the loudness of reproduction, but to the quality and even the wear of the record.

Will Not Whip

A pick-up that is rigidly damped is usually fairly sensitive. Very often the rigid damping is used to prevent armature resonance, and consequent over-emphasis of some of the high notes. In this case, a needle of the medium-tone variety, preferably of the "tungstyle" type, may be best.

This is because this needle is not prone to vibration under such circum-

stances, and so will not increase the tendency of the armature to vibrate, and because the compliant section of the needle is all concentrated in a very short tungsten point the needle will not whip.

Effect on Volume

"Tungstyle" needles are very successful with many types of pick-ups, but one well-known needle-armature

A BIT THICK!



Very thick seaweed-lined cellular concrete walls are being used at Broadcasting House to render the studios immune from outside noises. The photo shows workmen placing the seaweed in position.

model I have does not take kindly to them. In this case the armature system is very free, and the needle seems to add just sufficient rigidity to create a tendency to vibrate on certain notes.

In this case the use of the "talkie" and "spearpoint" needle proves best, the former being a long slender needle and the latter one with a flat head and short point. The "spear-

point" is slightly the better, due again no doubt to its rigid stem and short point, but the "talkie" needle is very good. It gives slightly less volume than the other, but the difference is not very marked.

The two needles are very different in character, however. The "talkie" is very hard, and will successfully play both sides of a record (though it is not really advisable to do so if you value the record *very* much), but the "spearpoint" wears pretty quickly, and sometimes I have known one to be useless before the end of one side of a 12-in. disc.

For Bass Notes

Now you will say—one must be bad for the record. Probably the "spearpoint" is the offender in this respect, if either can be said to offend. The wear caused is extremely slight, due to the fact that the needle fits the groove well and does not whip or chatter. True, it wears rapidly—but not rapidly enough to protect the record as in the case of fibre—but if only used for one side the chisel formation that comes to every needle-point is not very serious.

The "talkie" needle, on the other hand, is hard and so can initially be ground to a finer point, and the hardness prevents the chisel-edge appearing perceptibly during one side. The needle is more inclined to whip, however, if a very rigidly damped pick-up is used.

It is a valuable needle to use in a pick-up that has difficulty in following bass notes, due to the slight give in it, though in bad cases of reluctance to follow the sinuations of a deep-note groove the Edison Bell Sympathetic needle is valuable.

This is very thin and almost flexible. It is not advised in most cases where the pick-up can quite well follow the grooves, but on difficult occasions it often helps matters out.

Avoid a "Chatterer"

Many people think a hard needle such as the "tungstyle" is bound to wear the record walls badly. This is not necessarily the case. It beds itself well down to the bottom of the groove, and if the pick-up or sound-box does not chatter when using this needle all is well. It does not go chisel-shaped enough to damage the walls of the grooves to any extent—the needle is too thin—though it must not be turned round between sides of records.

It is the needles that chatter that cause most wear.

FINISH WITH BATTERIES FOR EVER

Big cut in prices
of two most popular
"EKCO" H.T. UNITS

NOW ONLY

~~£2'10'0~~

£1'17'6

D.C. MODEL
I.V. 20

A.C. MODEL
I.V. 20

NOW ONLY

~~£4'12'6~~

£3'19'6

The huge demand for these two models and extended manufacturing facilities have made these big price reductions possible. At £3-19-6 for the A.C. model and £1-17-6 for the D.C. model there is no finer value obtainable.

In three minutes you can put an end to H.T. battery worries for ever and enjoy permanently perfect radio. Just connect the "Ekco" H.T. Unit in place of your H.T. battery, plug the Adaptor on the Unit into the nearest electric-light or power socket, and switch on—that's all. You get ample current and high voltage constantly and permanently at a cost of less than 3/- a year.

"Ekco" H.T. Unit No. rV20 gives a current output of 20 milliamperes. It has three voltage tappings: (1) for grid of S.G. valve; (2) 0-120 variable; (3) 120/150. On the A.C. Model the 120/150 tapping can be reduced to 100 volts in cases where the output valve does not require more. It is suitable for practically all 1- to 5-valve sets at present fed from troublesome and expensive and unreliable H.T. batteries. It fits snugly into all portable sets. It brings an old set up to date, and gives you *permanently* all the improvements in reception and quality of reproduction which you know are obtainable when you have a constant and ample H.T. supply.

See your radio dealer to-day or send coupon now for new "Ekco" Folder.

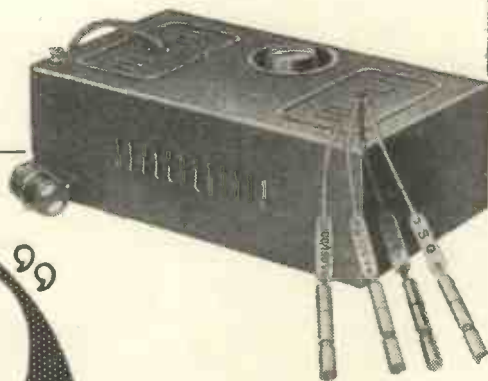

RADIO POWER



SUPPLY UNITS

To E. K. COLE, Ltd.,
Dept. M.W.1,
"Ekco" Works,
SOUTHEND-ON-SEA.

Please send me (a) New Folder describing how I can finish with batteries for ever; (b) full details of the famous "Ekco" All-Electric Sets.

(Cross out item not required.)

NAME.....

ADDRESS.....

By the
Technical
Editor

On the

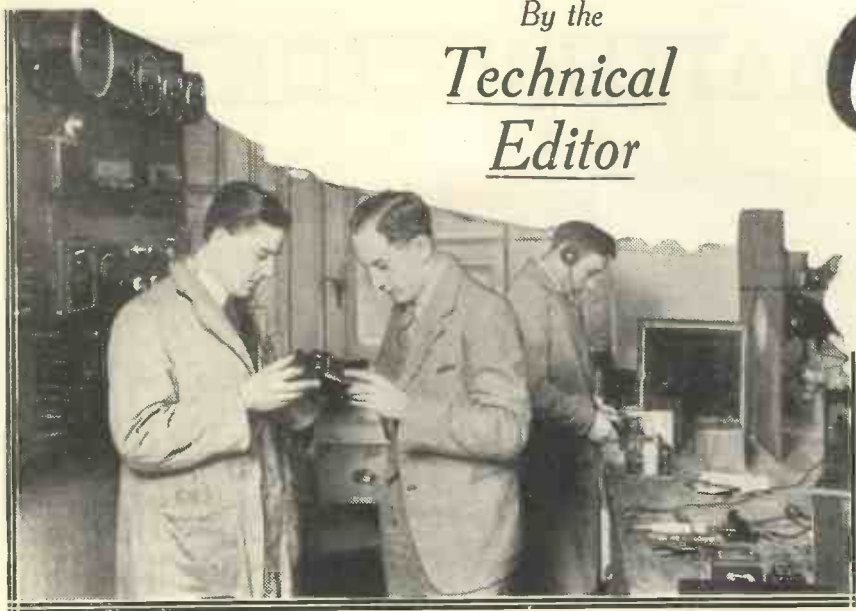

From Formo

YET another leading manufacturer, Formo, has decided to produce the "M.W." Dual-Range Coil. And Formo's are tackling the job with their usual enthusiasm and thoroughness. While adhering strictly to our specification in regard to all the vital winding dimensions, etc., they have introduced a moulding in place of the straightforward tubular former, and this gives the component a greatly enhanced appearance.

A circular base, cunningly designed to cope with any minor variations that might be made in the future, and to provide solid baseboard anchorage, is another feature of this Formo component. We have given a number of samples very careful test and find that they qualify for full approval. Readers can purchase this

particular make of our dual-range coil with every confidence.

Another new Formo line is a fixed condenser primarily designed for mains units and sets. At the time of writing it is available only in 2- and 4-mfd. capacities.

We have no hesitation at all in saying that the Formo mains condenser is the most efficient component of its kind that has so far come our way.

Its insulation resistance is enormously high.

As a practical illustration of this it is worth recording that we charged a 4-mfd. condenser from 200-volt mains and were able to extract quite a respectable spark from it five days later! It is quite probable that the greater proportion of the infinitely small leakage occurred through the "atmosphere."

Loewe Mains Set

We have had the opportunity of testing an all-mains set made by Loewe, Ltd., which employs one of their triple valves. The Loewe valve will no doubt be familiar to most "M.W." readers. It is really a good deal more than a valve, and the triple type not only embodies the elements of three separate valves, but also the main components of a three-valve set.

And it cannot be said that the only advantage is compactness, for Loewe valves are economical in operation and decidedly inexpensive propositions, and that is even including the royalties that have to be paid. Were it not for these . . .!

A Loewe valve for mains operation sounds startling, and anyone could be forgiven for looking hard for snags, but it does not seem to have any. Hum does not come roaring through, and those essential qualities—selectivity and sensitivity—are obtainable in excellent measure.

This Loewe set, the E.B.100, has a built-in loud speaker, and the controls are few and nice to handle.

British General Tuning Unit

What a blessing it would be if only all those "dud" tuning units that figure in an unhappy percentage of

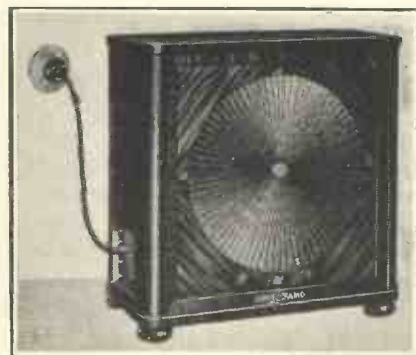

The Loewe E.B.100 A.C. all-mains receiver which uses a triple valve.

commercial sets could be replaced by British General aperiodic aerial-coupled units. We say this feelingly, for we have just been testing, unofficially, a rather widely boosted three-valver.

The two Brookmans transmitters could be heard all over the long-wave band, while even on their own range their mutual jamming was as bad as anything we have ever met!

The British General Aperiodic Coupled Aerial Tuning Unit is a different proposition. It has a selector switch which gives you anything in selectivity from that provided by a direct coupling to what must be the optimum for aperiodic coupling.

A reaction rotor is fitted and the adjustment of this both electrically and mechanically is satisfactorily smooth over the whole wave-band



The Formo version of our dual-range coil is built on an excellent moulding instead of the originally specified simple tubular former.

Test Bench

Formo, Loewe, Ferranti, T. C., and Lectro Linx products are among those reviewed this month.

covered, and this band, of course, embraces both medium and long waves. In construction, too, the unit is a great advance on the majority of units. It is obviously an honest attempt to give the public the best possible at a reasonable price.

New Ferranti Transformer

Home constructors will regard it as good news that there is now available a Ferranti Audio-Frequency Transformer at 11s. 6d. It is the type A.F.8, and though it is small in size and inexpensive in price it is in every way a thoroughbred Ferranti.

With a ratio of 1 to 3.5, it is built into an excellently moulded bakelite case. The D.C. resistance of the primary winding is but 1,000 ohms, and when it is handling the kind of

mechanically strong and entirely impervious to atmospheric conditions.

Their dimensions are in the "postage stamp" category, although they are provided with holes so that they can be screwed to baseboards. Additionally, they can be suspended in the wiring of a set.

After a series of careful tests we have no hesitation at all in endorsing the claims made for these condensers.

Wire-Wound Resistances

Watmel Wireless Co., Ltd., recently sent us a selection of their new Wire-Wound Power Resistances. These are wound non-inductively and are built into very neat bakelite cases. They are, indeed, the neatest little components of their kind that have come our way for some time.

Good terminals are provided, and the values are clearly inset at the top where they can be seen. A very large range of values is available, ranging from 100 ohms (capable of carrying 70 milliamps.), priced at 1s. 6d., up

to 100,000 ohms (which can carry a current of 6 milliamps.), price 7s. 6d.

We carefully measured the resistances of the samples sent us and in every case we found them to be all well within the guaranteed 5 per cent margin.

Clix Anode Connector

Lectro Linx, Ltd., are in production with a vertical type Clix Anode Connector. This is a very handy little device, which solves the problem of safe H.T. connections to S.G. valves. Inasmuch as an insulated socket is provided to terminate the H.T. lead, the danger of short-circuits when removing and replacing an S.G. is reduced to negligible proportions. The price of the vertical Clix Anode Connector is 3d., and we suggest that



Ferranti's new L.F. transformer, the A.F.8 users of S.G.'s will discover that it forms remarkably good value for money.

Cony Terminal Cleaner

The Cony Terminal Cleaner, made by F. Langdon & Co., of 4, Dollis Road, London, N.3, is a gadget which will no doubt find its way into the tool boxes of many home constructors.

It costs only 7½d., but it brings the working surfaces of terminals, however badly corroded, up to the brightness of efficiency in a matter of a few seconds.

Grosvenor Straight-Line Battery

We have just completed our tests on a Grosvenor Straight-Line High-Test H.T. Battery. The sample is one of those 66-volters that sell at 7s. 6d. It is of the standard size, having plainly marked sockets disposed on the top.

It stood up to an intermittent discharge—intermittent inasmuch as we subjected it to periodic loads in order to duplicate ordinary working conditions—and the voltage drop was gradual and surprisingly uniform. The Grosvenor Straight-Line is undoubtedly a good battery.



Formo's have achieved remarkably high insulation resistances in their new mains condensers.

current existing in the average detector's anode circuit the inductance of its primary winding is in the neighbourhood of 35 henries!

There are, of course, several more expensive L.F. transformers having better characteristics, Ferranti's can supply such themselves, but it is dubious whether there are many serious rivals at anything like the same price. The A.F.8 is a fine little transformer, and will deserve the wide popularity it is sure to achieve.

T.C.C. Mica Condensers

The new type M mica condensers, manufactured by the Telegraph Condenser Co., Ltd., are available in fourteen values, from .00005 mfd. to .01 mfd. From .00005 to .0005 mfd. the price is 1s. each. They are particularly small and light in construction, though being completely moulded in with bakelite they are



A group of the T.C.C. moulded bakelite mica fixed condensers.



*A Sensitive Pick-up—Broadcast and Record Reproduction—Which is the Better?
By "TONE ARM."*

I WONDER how many different makes of pick-ups there are on the market. Probably the figure would be a great surprise to us. Anyway, I have just been testing another new one—the A.E.D.

It is built on somewhat different lines from the usual, in that the armature forms the south pole of the magnetic system, vibrating differentially between two north poles. The result is certainly good. It provides a remarkably even response in the middle register and has a very valuable "lift" at the bass end.

The high notes are produced quite strongly enough for all ordinary purposes without any annoying amount of scratch being present.

The A.E.D. pick-up is certainly sensitive, and will quite easily overload the ordinary detector valve if used without a volume control on any but low-modulation records.

Two Stages Sufficient

It is a "two-stage" instrument; three L.F. stages are completely wasted with it. At £2 2s. 0d. it is excellent value, and is made by Auto Electric Devices, Ltd., Brighton. The tone-arm is strongly constructed, and the pick-up head is swivelled so that needle changing is very simple.

* * *

In use the A.E.D. pick-up is rather noisy when used with the "loud" needle for which it was designed. Spearpoints and "tungstyles" also kick up a row in this instrument (I refer to direct noise, of course, not the reproduced sounds), but a "talkie" needle completely cures the trouble.

Naturally, it has an effect upon the response curve, but this is not noticeable aurally—so what does it matter in the average case? I vote for "talkie" needles here, even if they are not the correct ones.

* * *

Radio-gram receivers are exasperating things, aren't they? I have just been having a tremendous

called in a friend who is a musical authority.

He listened first to one and then the other and decided very definitely that, apart from being "more pleasant" to listen to, the radio version was more "correct" than the gramophone.

Quite a Big Job

Accordingly, I am now busily engaged in "cooking" my pick-up so that the "canned" music shall sound like the broadcast version, and it is some job.

* * *

In the first place, the characteristic of a record is not so good as that of the B.B.C.'s broadcasting, so we are up against it at the start. However, as they say, I have "hopes," and then when I have the two almost indistinguishable I suppose I shall come to the conclusion that neither is correct. What a life!

* * *

But, seriously, is it worth it? I really think that we must look at broadcast and gramophone reception as a form of art and not strive for perfect realism. A brass band in one's drawing-room would be rather fierce, wouldn't it? And if here we have to strive after an accurate "miniature," or a pleasant picture

A RECENT ADDITION TO RADIO-GRAMPHONICS

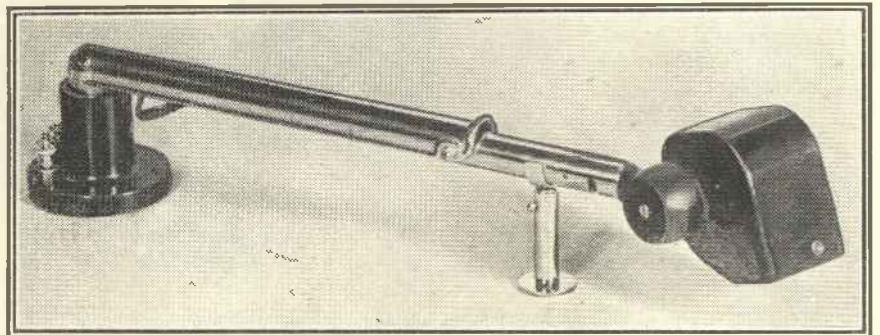

The new A.E.D. pick-up and arm discussed on this page. It has a very good response at all recorded musical frequencies.

struggle with mine. Having satisfied myself that my gramophone side was beautifully realistic in its brilliance, I began to wonder what was the matter with the radio side.

Though brilliant, and apparently well-balanced, the reproduction seemed, I thought, less lifelike than the "harder" gramophone stuff.

Direct Comparison

I went to hear several of the dance bands that the B.B.C. relays, and also got records of them. The result was rather in favour of radio reproduction; apparently I had overdone the high-note business, and so I

of the real thing, why should we not be satisfied with an artistic representation of all forms of broadcasting and gramophone recording?

After all, it is only a matter of balance. If you have more bass than treble in proportion, the reproduction will sound boomy, or dull. Some people call it "very mellow," but your loud speaker can be "mellow" without being hopelessly deep in colouration.

It is really better to lose a little bass (and in the event of too much treble to cut this down a bit) than to have a badly unbalanced state of affairs.

"SOUNDS GOOD
TO ME!"

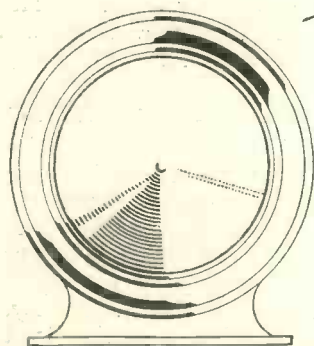

ETA VALVES

BEST BETWEEN AERIAL AND EARTH

With the Eta Valve, purity of tone is only one of many good qualities. Above all, it is dependable. It is a quality valve—but a quality valve at the right price. Meticulous care in manufacture, both in choice of materials, design and workmanship ensures a superlative performance in operation, low current consumption, and long life.

*Ask your radio dealer for particulars of the Eta Valve to suit your set—
there is a wide range for every requirement.*

**THE ELECTRICAL TRADING ASSOCIATION LTD.,
Aldwych House, Aldwych, London, W.C.2**

Telegrams: Eltradax, Estrand, London. Telephone: Holborn, 8139.



Does it Pay to Prophecy?

THE Lady of the House was gazing romantically at a dishful of tarts which she had just withdrawn, red-hot and aromatic, from the oven, when the loud speaker coughed and began: "Here is an S.O.S.—" At this point the Lady slapped the dish down upon the table, and upon my papers, and became attentive. "We must listen to this," she said.

A Social Duty

She always listened to S.O.S.'s, believing it to be a social duty. "You never know," she says, with a solemn look, sending the irreverent members of the family into fits of laughter.

"Here is an S.O.S. Will Mrs. — of 33, The Barnyard, Ippen-under-

HERE IS AN S.O.S.



... looked from one to the other and back again to the loud speaker, pure incredulity shining from her face.

Slooze, take note—that there is too much salt in the pastry."

Amid screams of joy that excellent Lady looked from one to the other and back again to the loud speaker, pure incredulity shining from her face. Then—and, mark you, this is the feminine touch—as quick as

lightning she nipped off a piece of tart and nibbled it, hunting for superfluous salt.

You see? She accepted the apparent miracle of our little joke and turned at once to the mundane question of the salt. That she over-salted her otherwise excellent confections was one of our domestic jokes, and is neither here nor there. We had secretly made a gramophone record of a faked S.O.S., and a "pick-up" did the rest.

"Ah—YOU!" she cried. "I don't believe he said it. It's one of your silly superstitious April the First jokes." Again, observe! Having satisfied herself on the material plane the Woman then turned to enquire into the phenomenon which really mattered.

I thought her scorn about superstition especially fruity, coming from a woman who throws salt over her shoulder, wears rubies because (she says) they are lucky, worries if she sees a black cat on Thursdays and crosses her fingers for a thousand and one reasons. So I rubbed it in gently, and all I got in reply was: "Oh—that's different."

Introducing Bones

Gentlemen, after that, I deem this to be a fitting moment in which to remark that, so far as I can see, love was created in order to prevent men from braining women with a volume of Whatelys' "Logic," bound whole calf, with brass clasps!

Well, chaps, all this reminded me of poor Abijam Bones. Not that "Bige"—as we called him—was worthy to hold a filament, even an

indirectly-heated one, to the Lady of the House. But he was chosen by that inscrutable providence which makes an onion taste like heaven and stink like the dickens to marry into a family which was more superstitious than a tribe of Solomon Islands head-hunters.

The Only Advantage

As a matter of fact, old Bige used to say that he owed the superstition biz only one debt, namely, that his wife's parents had had her well and truly vaccinated on both arms, twice—because she was born under a new moon, on Ash Wednesday, on the left-hand side of the street looking towards the East! This precaution left such a mark (or marks) that Bige never had to buy his missus a real

THAT MEANS GOLD!



"Er—d'you know? You hold your cup in your left hand!"

evening frock or leave his radio set in order to take her out to places where the ladies display the upper arms in public.

Apart from that sweetener, Bige's life under the influence of the black cats and auspicious planets was just one long strangled sob.

"I Was Listening to New Zealand and Heard an Awful Thing . . ."

Personally, I don't mind a bit of magic, such as card-sharpping, or thimble-rigging, or even sixpenny-worth of "tell yer forchune" from a gypsy on Derby Day; but that's all pure and innocent fun. What saddens me is to find a deep-voiced spinster bowing down to a Swastika or flirting with a dream-husband through the medium of a pack of cards.

Or to have my hostess at a balancce-your-cup-and-juggle-with-a-biscuit tea lean forward and say, huskily, "Er—d'you know? You hold your cup in your left hand! That means gold is coming to you. Er—remember *me*, won't you? Tee-hee!" Why—a healthy chicken has more sense! But this isn't Bones.

The Good Advice

Mrs. Bones had graduated in all this nonsensical ju-ju stuff at a type-writing bureau, where, it would appear, all the finest female brains of the suburbs had gathered together. In between typing, these nit-wits used to swop stories of Madame X of Canvey Island, or Isabelita of South-end, the Romany Romancer; they used to read the fates of kings and empires in the tea-leaves, and their own lurid (I don't think) pasts in the lines of their soft hands. And Miss Merkinson, who became Mrs. Bones, was the *crème de la menthe* of 'em all.

ONLY ANGUS McHOOT



. . . a red-haired book-keeper at Bones' office, who had offered to put Bones wise to radio.

One day his friends, observing that Bones looked a trifle distraught with domestic troubles, advised him to take up the construction of radio receivers, especially the "Esoteric" Four.

On the very evening that Bones took home his tools and various "doings," Mrs. Bones had a special vision vouchsafed to her. She had been holding a *séance* during the after-

noon, and Miss Annette, the "Gipsy Queen" of Frognor Pier (June to September), had kindly assisted.

"Ha! What do I see? One very near and dear to you—I see him meet a red man—then all is black—and then he writes in white—and then he leaves you—and—then—he—oh, horrors!—what do I see?—the whole earth heaves—fire—death—"

Beginnings of Trouble

"Take another muffin, dearie, and tell us some more," said Mrs. Bones, thoroughly enjoying herself, though the thought of Bones leaving her made her feel a bit chilly.

The "red man" happened just as Annette had foreseen. He was only Angus McHoot, a red-haired book-keeper at Bones' office, who had offered to put Bones wise to radio. When Mrs. Bones saw Angus she nearly fainted. If the "red man" was true, so also was fire and death and general blazes, as foretold by Annette. Bones blinked at her, as one seeing a pelican at close quarters for the first time; uttered the one word "Smarrer?" and followed Angus into the kitchen.

"Bub—be careful, Abijam," quavered the lady. "Don't go too near to water or hot iron, because I saw a black cat to-day." But Bones was already deep in his first detector circuit.

Half an hour later, Angus, whilst trying to improve the stove, pulled a section of flue-pipe off and—"all was black," just as Annette had prophesied!

At this stage in the evolution of the series of prophecies Mrs. Bones happened to spill the salt and break a glass tumbler—both frightfully fateful things to do! So that when she stepped into the kitchen to dump the pieces of glass and found the two men as black as Ghandi she set up a squawk which awoke all the fowls for a hundred yards along the road in both directions, and many eggs were thereby laid in error.

"Then He Leaves You"

"All was black!" she snivelled. "Then he'll write in white—"

"Ay, marking yon ebonite panel, mistress!" said Angus.

" . . . an' then he'll leave me—Annette said—and then the earth heaves—"

"Come, Louisa!" coaxed Bones, "you are paying too much attention

to these fortune-tellers. It's all rot! Go into the parlour and read all about parliament, there's a dear."

Three hours passed. The set in the kitchen was completed, and as Bones had no aerial the two men sneaked out by the side entrance and made for Angus's house in order to try out the receiver. Mrs. Bones read on, blissfully unaware that Bones had "left her," exactly as Annette had

AT 3.5 A.M.

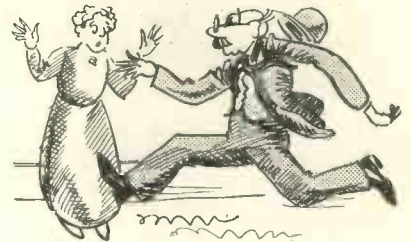

Bones came home—like a tornado.

said! She found it out at 11.30 p.m., and confirmed it at 12.30 a.m. At that time Bones was blissfully ranging the globe from pole to pole.

Meantime, Mrs. Bones, with all the breath at her command, had advised the neighbourhood that she was a derelict wife and mother; that Annette had foretold her desertion—which had been confirmed by the tea-leaves in her cup. Everything was proved up to the hilt. Time—3 a.m.!

The Mundane Things

At 3.5 a.m. Bones came home—not with his boots in his hands, but like unto a tornado.

"Louisa," he shouted, "I've scored a huge success! There never was such luck! I was listening in to New Zealand, and suddenly I heard an awful thing—from some amateur station. There's been an earthquake—fires raging—earth heaving—and this chap rescued his station and installed it in the street amidst the fires and explosions. I could hear them."

Louisa sat up and said weakly:

"Earth heaving? Fires? *Wher* did you say?"

"In New Zealand."

"Oh! *New Zealand!* *Have you locked up and put the cat out?*"

All of which goes to show that (a) you never know; (b) you can't be too careful; and (c) you *must* put the cat out, no matter what happens in New Zealand.

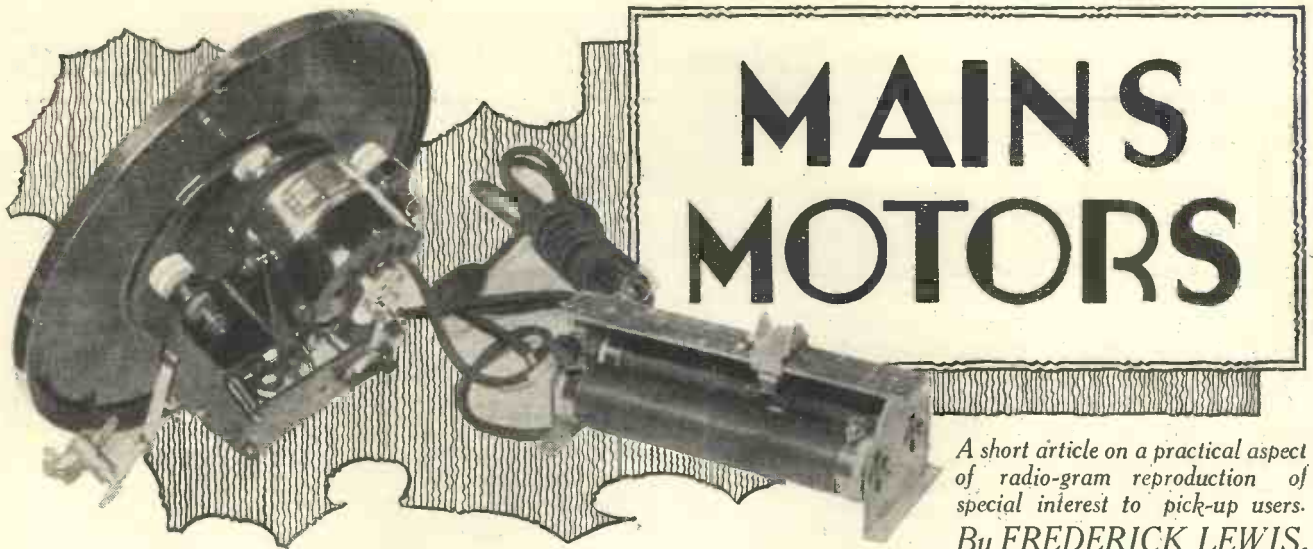

A short article on a practical aspect of radio-gram reproduction of special interest to pick-up users.
By **FREDERICK LEWIS.**

As the gramophone motor is the source of all the energy from which gramophone or radio-gram reproduction is obtained, neglecting in the latter the power which is merely used to amplify that energy transmitted to the pick-up needle by the motor, it is obvious that the motor must be a good one. One that fails to keep regular speed is, of course, quite useless, and so is one that is uneven in running or which transmits vibrations from the motor to the turntable, and hence to the record.

A Vital Necessity

If you look at the question of the gramophone motor carefully, remembering that the transmission of energy is carried out by the rotation of the record and the pressure of the groove walls on to the needle in the pick-up, you will see that the greatest requirement of the motor, apart from vibrationless running, is that it should be able to give up its energy in constantly varying amounts without any reduction or variation of speed.

The governor of a motor will prevent it from running too fast, but it cannot stop it from running too slowly if the power in the motor is insufficient to overcome the friction of the record at certain loud passages, where the amount of energy that has to be transferred to the pick-up is greater than normal.

This is the Snag

Constant speed is absolutely essential, for the speed of the rotation of the turntable must be exactly the same as that at which the original record was recorded, and any variation in speed means a variation in the pitch of the musical reproduction.

In order to get this smooth running, makers of reliable clockwork motors

use very carefully tempered springs, and very large springs, too; but it does not seem quite congruous that the owner of a radio-gram receiver, especially if it be of the electric type driven from the mains, should use a clockwork motor. Obviously, the electric motor is the thing to have if you can possibly use it. And here is where the snag lies.

Is it possible to obtain an electric motor which does not set up some sort of interference with the reproduction? It is possible, but a very careful choice has to be made or else very elaborate screening has to be employed in the mounting of the motor.

All the difficulties in the design of an electric motor centre round the

of the motor as apart from the complications of the gramophone, and constancy in speed in an electric motor depends very largely on its speed, so that when the designers of electric motors began to apply their machines to the coming of the gramophone turntable they were rather up against it. The design of an electric motor that would run slowly and keep perfectly constant speed, and deliver a fair amount of power, is by no means easy.

Ordinary Governor Inadequate

For one thing the ordinary governor as used in the spring motor is, as a rule, quite inadequate when asked to control a slow-running electric motor.

IT WINDS ITSELF UP

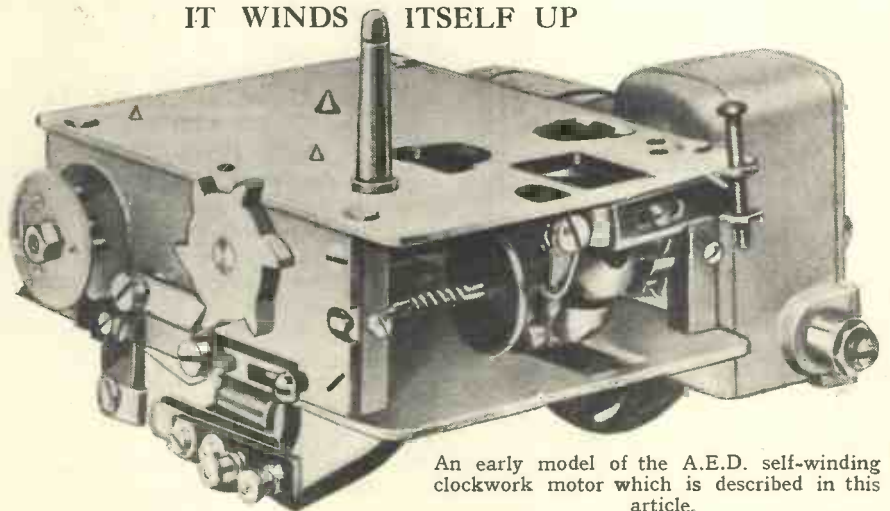

An early model of the A.E.D. self-winding clockwork motor which is described in this article.

fact that although the speed of turntable rotation is small, something like 78 revolutions per minute, that rotation has to be perfectly constant, and it has to give out quite a reasonable amount of power.

Most electric motors are fast-running machines. I am thinking now

Consequently, a very large number of electric gramophone motor designers used fast-running motors and geared them down to the turntable.

Recently I have been carrying out tests with a number of electric motors, both of the universal and A.C. induction type. The results have been

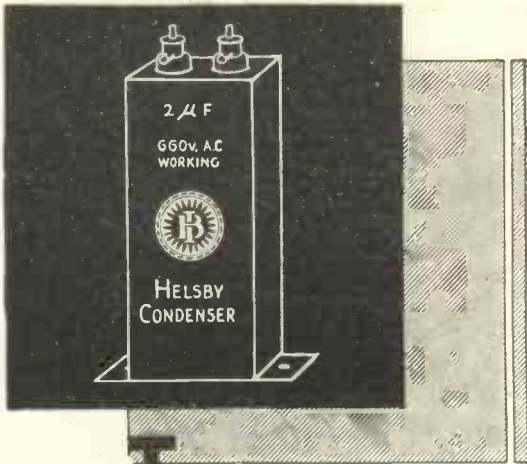

TESTED TO DOUBLE WORKING PRESSURE

Helsby Condensers have been supplied to the G.P.O. and to large manufacturers for thirty years. They are engineer-built, with plates of pure foil, non-hygroscopic, fully tested, and the capacity rating is guaranteed. A boon to the experimenter, for their reliability is unailing.

Ask for Helsby Condensers by name—there is a full range to cover every purpose. Types 212 and 212 T are particularly suitable for eliminator circuits.

HELSEBY CONDENSERS

BEST FOR THE CONSTRUCTOR

If any difficulty in obtaining from your local dealer, please send us his name and address.

BRITISH INSULATED CABLES LTD
PRESCOT... LANCASHIRE
MAKERS OF B.I. CABLES



YOU CAN JUST PLUG IN!

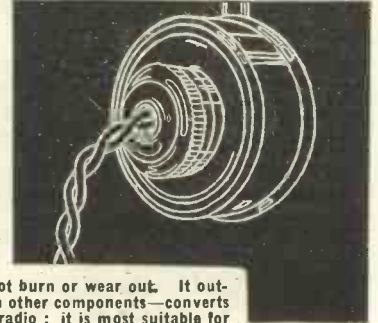

Your mains provide better and more certain reception, with greater economy and considerably less trouble than any battery, however good it may be.

Most mains supply alternating current, which for radio purposes has to be converted to direct current; and for this a rectifier is necessary. Of the various types of rectifiers, the Westinghouse is acknowledged to be the most efficient. Unlike valve or chemical rectifiers, it does not burn or wear out. It outlives your set! Its use—with certain other components—converts "battery-run" into "mains-run" radio; it is most suitable for fitting into amateur-built sets; while anyone who is buying a mains-set will do well to make sure the Westinghouse Rectifier is incorporated—it is found in most good makes. Complete technical details are given in an interesting and lucid manner in our forty-page booklet, "The All-Metal Way, 1931." The coupon will bring you a copy by return of post (please enclose 3d. to cover cost).

WESTINGHOUSE METAL RECTIFIERS

The Westinghouse Brake & Saxby Signal Co., Ltd., 82, York Road, King's Cross, N.I.
 Telephone: North 2415.

COUPON

Please send your forty-page booklet, "The All-Metal Way, 1931." for which I enclose 3d. in stamps.
 Please write in block letters.

NAME.....

ADDRESS.....

M.W. 431.

A Genuine

MAGNAVOX

Moving Coil Speaker

for **57'6**

Birthday of the LITTLE GIANT

Now you can buy a genuine Magnavox moving coil speaker for 57'6. The new Little Giant embodies all the latest developments in moving coil speaker construction and gives the same perfect performance and response which can only be secured with a genuine Magnavox unit. Your dealer will demonstrate this wonderful new model and you will not be satisfied until you have one. Remember that Magnavox originated the moving coil speaker.

MODEL 230.	6-12 volts D.C.	£2 17 6
" 131.	110-130 .. "	£2 17 6
" 131.	180-300 .. "	£2 17 6
" 420.	105-120 .. A.O.	£5 10 0
" 424.	220-240 .. "	£5 10 0

WRITE FOR THE NEW FOLDER—THE MAGNAVOX FAMILY



THE ROTHERMEL CORPORATION LTD.,
 24, Maddox Street, London, W.1.

'Phone: MAYFAIR 0578/9

Continental Sales Office:

27, QUAI DU COMMERCE, BRUSSELS, BELGIUM.

Both Mechanical and Electrical Silence are Essential

very illuminating. Only in two cases did I find that screening was quite unnecessary, and the sparking of the commutators of the universal motors caused very serious interference, which meant that double screening of fairly thick iron was required.

This sparking, with its attendant results, is very difficult to get rid of, and sometimes it is quite impossible to stop the interference without moving the motor some distance from the receiver, screening it well, and also running it from a different power plug or electric light point from that of the set.

Most of the induction motors that I have tested caused an annoying hum which increased and then diminished as the pick-up arm traversed the turntable.

No Luck with Screening

In motors in which this hum has been prominent I have had no luck with screening, however elaborate it was; in fact, nothing reliable in the way of a cure could be found, especially as the trouble seemed to vary according to the make of the pick-up used and, according to the direction in which it traversed the turntable.

In the choice of an electric motor there are far more things to be considered than in the case of a clock-

work variety wound up by electricity. It is made by Auto Electric Devices, Ltd., of Brighton, and is an ingenious device consisting of a powerful clockwork motor with a special relay system attached to a pawl on the turntable gearing, and to a high-speed electric motor which is controlled by the mechanism on the turntable spindle.

Automatically Rewound

With the motor fully wound up, one can start a record, and when about 1½ inches has been played the relay is automatically tripped over ready for the electric motor to be started up when the turntable is stopped.

At the end of the record there is an automatic stop and a hand-control stop, either of which can be used, and as soon as a stop is operated the electric motor is automatically switched on and proceeds to wind up the clockwork motor until it is fully wound, when the relay action comes into play once more and the electric motor is switched off.

This is an ingenious and an exceedingly interesting device, but it has one snag, that is, the mechanical

the electric motor comes into operation.

The loud speaker and the set are switched on again when the motor stops. This prevents any noise due

SILENT RUNNING



One of the latest induction motors to be placed on the British market—the Diehl; a description of it is given in the accompanying article.

It is a very quiet-running machine.

to sparking on the commutator of the motor, which is of the universal type, from being produced in the loud speaker. In some cases it was found unnecessary to use these contacts, because the motor operated quite satisfactorily with the amplifier fully on.

FOR THE MAN WITH A.C. MAINS

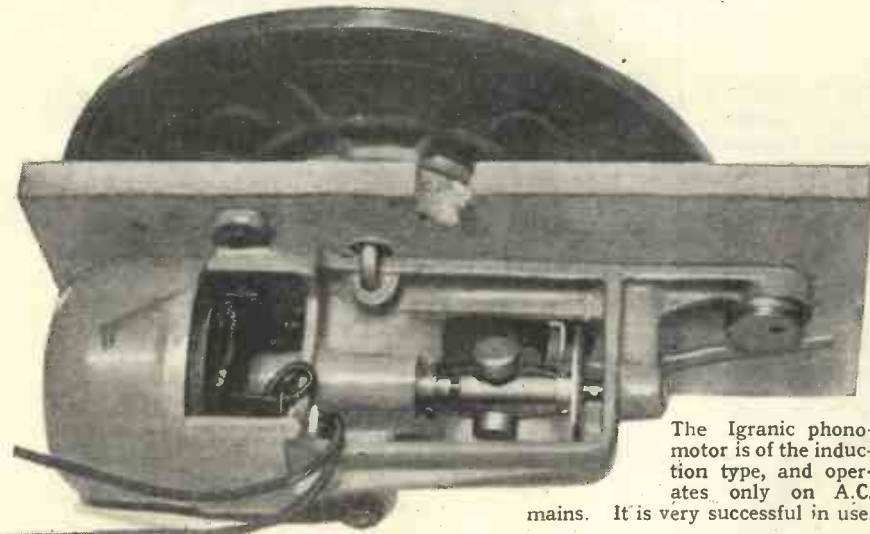

The Igranic phonomotor is of the induction type, and operates only on A.C. mains. It is very successful in use.

work type, mere smoothness of running and mechanical silence do not necessarily mean that the motor is going to be suitable when attached to your radio-gram receiver, especially if the motor is near the amplifier section of the set, but I have found motors which have been completely silent.

noise created by the high-speed electric motor during the winding-up process. The motor is fitted not only with the relay contact operating the electric motor, but also with extra contacts which enable the loud speaker to be cut out of circuit or the amplifier to be switched off as soon as

Dead Silent

For the man with D.C. mains the A.E.D. self-winding motor is certainly a proposition, provided he has a fairly substantial cabinet in which it can be mounted and does not mind a bit of whirring noise while he is changing the record. During the playing of the record, of course, the motor is dead silent, being only of the clockwork variety; but it may be disconcerting to some when changing over a double-sided record, to have this noise interposed between the two sections of the item.

In such a case it is an advantage to fit an ordinary mechanical stop on the turntable so that the electric stop with the switch mechanism need not be used.

The turntable can then be stopped and the record changed over and the second side played before the electric motor is brought into operation. This means, of course, that the electric motor has to wind for a longer period of time than is normally the case; but

(Continued on page 452.)

A SHORT-WAVE EXPERIMENT

A million pounds depending on a radio message—a shady financier who experiments on the short waves—and, of course, Blazer—figure in this latest exploit of John Dare, the wireless consulting engineer.

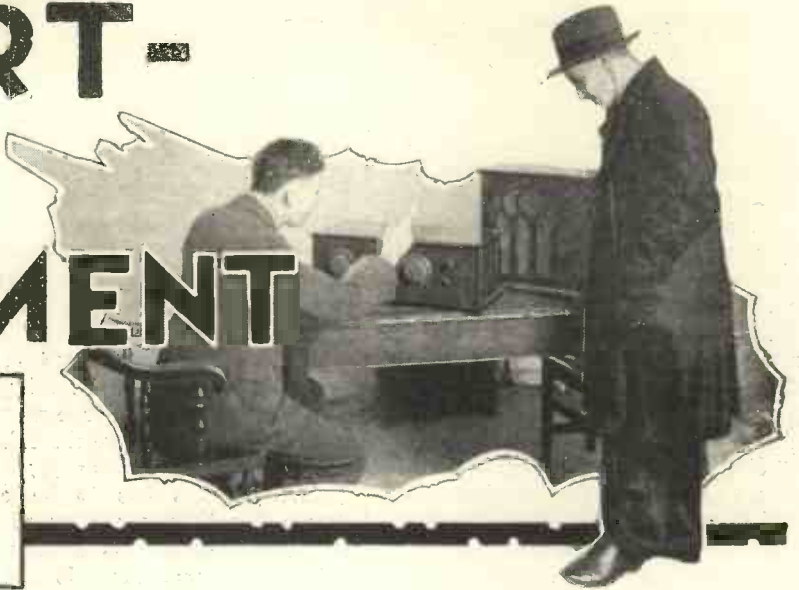

You might picture John Dare's life as being bound up with blueprints abacus and wireless apparatus. And so, to a very great extent, it is. But every now and then he finds himself caught up in a minor whirlpool strangely foreign to the tenets of his accepted profession.

We have followed one or two of his excursions into the realm of "high finance," and it may be mentioned merely in passing that he has had many others. Some of these are not sufficiently out-of-the-ordinary to be worth recording, while others—!

That affair of Sir Pothercary Clarkhop, for instance. That is not his real name—this cannot be given for there are laws relating to "libel."

"Dud" Companies

However, Sir Pothercary Clarkhop, as we will call him, then, is one of those gentlemen who "do" themselves very well by doing others. In short, he is a financier who devotes much of his time to the promotion of "dud" companies. Dare hates him like poison, as the wily money-merchant had once managed to get Dare's name on to the prospectus of a particularly shady proposition. One incidental result is that the radio engineer will now never have anything at all to do with the flotation of companies of any kind.

Clarkhop was also instrumental in shattering one of Dare's fondest illusions—that a man with a hobby

must have *something* good in him. To make matters worse, Clarkhop's hobby was radio!

A.G.T. Again

And when, after the inevitable crash quite recently of Radio Consolidated (which bore Dare's name as Scientific Consultant), Sir Pothercary had the colossal nerve to stop Dare in the

IN THE STRAND



"And when Sir Pothercary had the colossal nerve to stop Dare in the Strand merely to tell him about a special short-wave test he, Sir Pothercary Clarkhop, was shortly going to carry out—"

Strand merely to tell him about a special short-wave test he, Sir Pothercary Clarkhop, was shortly going to carry out, a public brawl very nearly followed!

If you bear all this in mind you will have no difficulty at all in believing that Dare joyfully accepted a certain commission from the Allied Guarantee Trust. Rather than let the job pass to other hands he would have waived his not inconsiderable fee!

Lord Rockmartinset (pronounced Roset), the chairman of the great concern, himself visited the radio engineer's Regent Street office in order to secure Dare's services.

Vast Sums at Stake

"You see," explained the peer, carefully depositing his glistening topper on a convenient desk, "the job may look very simple, but as hundreds of thousands are at stake my board would not be fully satisfied unless we had one of the leading experts to carry it out."

"Thank you, Lord Rockmartinset," Dare said. "Tell me exactly what you want me to do."

"I'll tell you that, and I'll also explain why we want you to do it," returned Lord Rockmartinset graciously. "But I need hardly say that the greatest of secrecy is vital to the success of the whole undertaking. We have received information that the president of the American Unified Trust is to make a public statement in the New York State

"Of Course, it May be a Mere Coincidence!"

Hotel at about 3.20 English time to-morrow afternoon concerning the future policy of his company. Now, as you may or may not know, there has been a considerable mystery attached to the condition of that Trust for some months. Possibly it is sound—even flourishing; maybe it is on its last legs. Nobody on earth knows—except the handful of men who intimately control its destinies.

Enormous Holding

"Our holding in Unified is enormous, and upon the president's words at that meeting to-morrow depends something like a million of our money. If the president has bad news for the world, those Unified shares will tumble to nothing! If his statement is a happy one, the value of our holding

have gone even further, by booking the transatlantic 'phone for the same purpose.

"Obviously, if the shares are going to fall we want to begin dispersing our holding as soon as possible, while if the reverse is to happen we should naturally go into the market as buyers. Through our own immense organisation we shall be able to manipulate things so that the buying or selling is spread over extremely widely, and thus preserve the balance to the last moment.

"And all this has to be done between the time our news arrives and the broadcast of the information by the usual methods. It can be done, Mister Dare, you can take my word for that, although it probably sounds an impossibility. Your help

man of the Allied Guarantee Trust, with an amused smile. "Well, to proceed. In the circumstances we thought it vitally necessary to smarten up our communications and this is how we propose to do it. The speech is being broadcast by the local American radio stations, and we shall have a receiving set right in the middle of all our ticker and telegraph clerks, and they will send either one of two sets of instructions to all our brokers according to the words spoken by the Unified president. Nobody could beat that for speed!" The peer chuckled triumphantly. "And we want you, Mister Dare, to operate the receiving set," he concluded.

Blazer Butts In

Dare shook his head slowly.

"It's a toss-up whether you will get that broadcast over at that time," he argued, "even if I try for that 80-metre station—and that offers the best chances—I cannot possibly guarantee success. I certainly accept the commission, but it must be very clearly understood that it all depends upon atmospheric conditions."

"If you can't do it we shall at least know that no one on earth can," declared his lordship magnificently.

At three o'clock the next day, Dare had all the necessary apparatus installed at the offices of the Allied Guarantee Trust. He was making the final adjustments to the seven-valve super-het when a familiar voice from behind him said:

"Hallo, Dare."

"Blazer!" he ejaculated, twisting round on his swivel chair.

"At your service."

"Knowing how I loathe you, Blazer, I think you might have the decency to keep out of my way," grinned the radio engineer.

It must be explained that Blazer is an ex-inspector of police who is now chief of investigation for the Allied Guarantee Trust. He and Dare might be styled antagonistic friends. Most of the antagonism is on Dare's side, for Blazer is associated with incidents that Dare recalls with no feeling of personal satisfaction.

"Tell me," asked Blazer, pushing his trilby on to the back of his head, and fishing a cigar out of a waistcoat pocket, "why do you twiddle those

(Continued on page 454.)

"HE'D JUST BEEN TRANSMITTING!"



Blazer and a Post Office inspector pay Sir Pothercary a surprise visit, and, in Blazer's words, "Sir Poth blusters like anything and says we are interrupting a short-wave experiment it has taken him weeks to arrange."

will increase tremendously. And why all this secrecy you may well ask? I, and a million others, ask it too.

"But no doubt Unified have their own good reasons for not removing doubts from our minds at an earlier stage. I, personally, cannot understand how the market price of the shares have kept up so well in face of such grave uncertainty. However, you can rest assured that we haven't let the grass grow under our feet. We have made arrangements to have the information cabled over to us at the very earliest opportunity—we

is needed in order that we can cope with a most unfortunate contretemps.

"We learn that a rascal named Clarkhop has tried unsuccessfully to book a transatlantic 'phone call at 'zero' hour to-morrow. That is significant, and it is possible that Clarkhop, who is a financier of bad reputation, is up to some funny tricks on Unified. Of course, it *may* be a mere coincidence. Do you happen to know Clarkhop?"

"I Know Him!"

"Know him!" cried Dare hotly. "I know him, the—I beg your pardon, Lord Rockmartinset, please carry on."

"Apparently he is not exactly a friend of yours," continued the Chair-

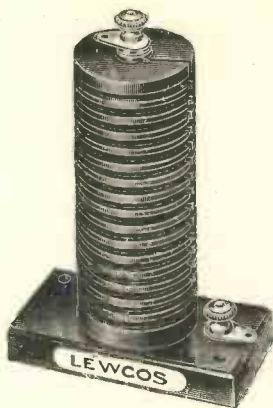
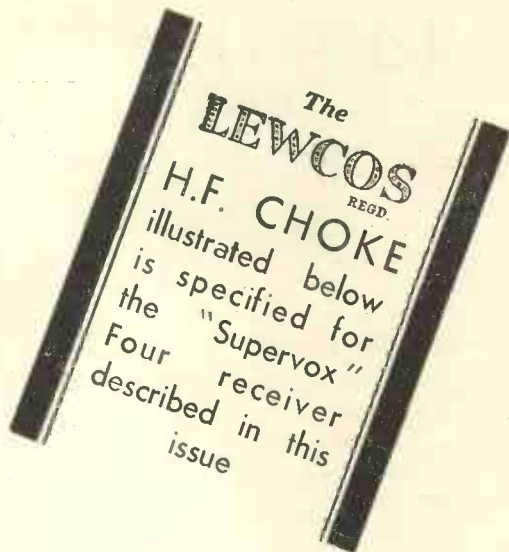

The
LEWCOS
H.F.
CHOKE
Price
7/9



The fine materials and high-class workmanship used in the manufacture of the LEWCOS H.F. CHOKE make it supreme. This component is specially constructed to eliminate self-oscillation. A fully-descriptive leaflet giving tested values will be sent on request. Please quote Ref. No. R.33.

LEWCOS RADIO PRODUCTS FOR BETTER RECEPTION
THE LONDON ELECTRIC WIRE COMPANY AND SMITHS LIMITED, CHURCH ROAD, LEYTON, LONDON, E.10

LOTUS DIFFERENTIAL CONDENSERS

SPECIFIED IN THE "SUPERVOX"
a Lotus Differential Reaction Condenser.
Either '00013 - 5/6 or '0002 - 5/9

In other capacities:—
'00007 - 5/3 '00027 - 5/9
'00034 - 6/-

Also Reaction Condensers from 4/9; Variable Logarithmic Condensers from 5/-, and Drum Dials for Ganged Condensers from 15/3 complete.

Ask for particulars of Lotus Valve Holders
ALSO SPECIFIED IN THIS CIRCUIT.

From every Wireless Dealer.

LOTUS RADIO LTD.,
Lotus Works, Mill Lane, Liverpool.

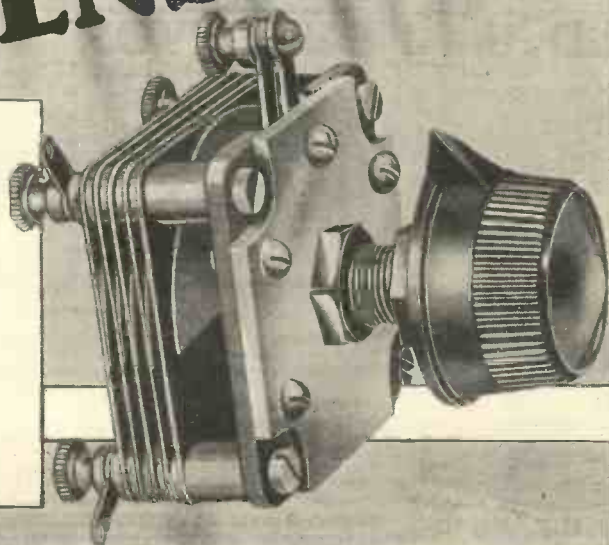

RADIO NOTES and NEWS of the MONTH

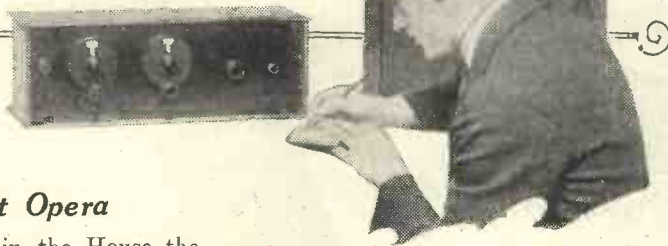

Broadcast Opera

It was revealed in the House the other day, when the Prime Minister was asked whether he proposed to ask the House to consider the grant to Grand Opera, that the Government is not yet in a position to say one way or the other.

Mr. MacDonald pointed out that certain questions are under discussion with the B.B.C., the settlement of which will probably involve a new agreement between the Post Office and the Corporation. It is proposed that this new agreement should include provision in respect of the opera grant, but the agreement will, of course, only provide for the payment of the proposed grant in the event of supply being voted by Parliament for that purpose.

Misleading Licence Figures

The "Daily Telegraph" wireless correspondent pointed out the other day that, although he was surprised that during January the number of licences passed the three and a half million mark (representing an increase in that month alone of 100,000), he was also surprised that this should lead people to express the view that there is little wrong with the programmes.

He then proceeded to give a case as an example. On this particular evening he referred to he found the National programme giving "Foundations of Music" at 6.40, an orchestral concert from 7.45 to 9, at 9.20 Dr. Dyson speaking of the "Progress of

Music," and at 9.40 a chamber concert of music.

Badly-Balanced Broadcasts

He sought contrast, and considered the London Regional programme. Here he found an orchestral concert at 6.40, and another orchestral concert at 8.15; so turning hopefully to the Midland Regional, he found a band concert at 6.40, the same orchestral concert at 8.15, and the Midland studio orchestra at 9.15.

The B.B.C. makes a great to-do about balance from the technical point of view, but it is a pity they don't balance their actual programmes. The official responsible for letting such a dose of music go through from the three stations on one particular evening should have an interview with Mr. Cochran, or some other professional entertainment caterer, and listen to a few useful tips.

Portland Place Peculiarities

One of the special features of the B.B.C.'s new Broadcasting House in Portland Place will be a Tower of Silence. It will run through the centre of the building, and will contain twenty studios.

Each of these studios will be impervious to noise so that rehearsals

(Continued on page 444.)

MAGNUM SHORT-WAVE CONVERTOR

Enables you to enjoy the short-wave stations on your present set, if battery operated, without any alterations or extras. Try it yourself, without obligation or purchase. Including coils. Sent on 10 days' free trial against cash.

10 DAYS' FREE TRIAL
£3.15

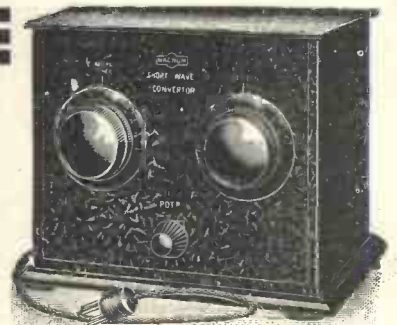

Full particulars with list of leading short-wave stations—Free on request.

BUILD the "SUPERVOX" AS DESCRIBED IN THIS ISSUE FOR £12

£ s. d.	£ s. d.	£ s. d.	£ s. d.
1 Oak Cabinet, 24" x 8", with 12" brassboard	2 0 0	1 Weirite 3-pole D.T. Switch	4 0
1 Ebonite Panel, 24" x 8", ready drilled	12 6	1 Magnum Spaghetti Resistance, 25,000 ohms	1 6
2 J.B. .0005 Var. Condensers with Drum Control	1 9 6	2 Magnum 600-ohm Resistances and Holders	3 0
1 Magnum Differential Condenser .0002	6 0	1 Lissen 2-meg. Leak and Holder	1 6
1 Magnum Neutralising Condensers	5 0	1 Lissen 1-meg. Leak and Holder	1 6
2 Formcondensers .002 max.	4 6	1 Lissen Filament Rheostat	2 6
2 3-point Wave-Change Switches	3 0	2 W.B. Horizontal 4-pin Valve Holders	2 6
		2 Magnum 4-pin Sprung Valve Holders	2 6
		1 Magnum .0005 Fixed Condenser	1 6
		1 Magnum .01 Fixed Condenser	2 6
		2 Magnum .001 Fixed Condensers	3 0
		1 Magnum .002 Fixed Condenser	2 0
		2 Dubilier 1-mfd. Condensers	5 0
		1 Dubilier 2-mfd. Condenser	3 6
		3 Magnum H.F. Chokes	1 2 6
		1 Magnum Output Choke	15 0
		1 Ferranti L.F. Transformer, A.F.8	11 6
		1 Magnum "Star Turn" Selector Coil	12 6
		2 Magnum "M.W." Dual-range Coils	1 5 0
		1 Pick-up Jack	2 6
		11 Belling-Lee Terminals, as specified	5 6
		2 Terminal Strips, 10" x 2" and 6" x 2"	1 9
		1 Magnum Screen Assembly	4 0
		G.B. Plugs, Flex, Clips, etc.	2 9

TOTAL COST - £12:0:0

1 Set of Valves for above (2 S.G., 1 Det., and 1 Power) £2:19:0

Any parts supplied separately as required

"Supervox," ready wired and tested as above, including valves and Royalty, £18.

We specialise also in the "Pentodion," "Dual-Range" One, and all "Modern Wireless" Sets.

BURNE-JONES & CO. LTD.,

"MACNUM" HOUSE, 296, BOROUGH HIGH STREET, LONDON, S.E.1.

Telephone: HOP 6257 & 6258.

Scottish Agent: Mr. ROSS WALLACE, 54, Gordon Street, Glasgow, C.1.



MAGNUM H.F. CHOKE
Specified for the "Dual-Range" One, and hosts of other high-grade sets
Price **7/6**

SPAGHETTI RESISTANCES (WIRE-WOUND)



25,000 ohms, specified for the "Supervox" **1/6**
600 ohms to 50,000 ohms, **1/6**
60,000 ohms to 100,000 ohms, **2/-**
150,000 ohms **2/6**



UNDY MULTIPOLE

Super Dynamic '8'

**FAR IN ADVANCE OF ANYTHING EVER
PREVIOUSLY ATTAINED IN LOUD SPEAKERS**

There is nothing to equal it in the world of radio—an advance in design and capacity which denotes the pinnacle of loud-speaker production. Equally suitable for all from "All Mains" to the smallest "battery" receivers.

Not only is the "Undy" SUPER DYNAMIC fitted with a magnet of unequalled power, but the three tappings on the incorporated auto-transformer enable the perfect adaptation of the A.C. resistance of the speaker to any type of valve, and consequently 100 per cent. result in all cases. This means that whether a low, medium, or high resistance valve is employed in the final stages, the "Undy" Super Dynamic '8' can be adapted to work in complete unison. No other speaker can claim this.

The provision of the volume switch enables the loud speaker to stand a constant anode current of 200 milliamperes and anode voltages of over 500 volts without injury.

On Sale Everywhere

**Greater Volume!
Greater Strength!
Greater Sensitivity!**

British Patent No. 336,930.

PRICE: **70/-** COMPLETE.

"WEARITE" DUAL-RANGE COILS ARE APPROVED BY "M.W."

Use them in the "SUPER-PLUS" FOUR "PENTOGRAM" THREE "RECORD-RADIO" THREE

PRICE **15/-** EACH

Made strictly to specification by "Wearite" to the design of "M.W." and "P.W." experts. Tested and approved by "M.W."—your guarantee of best possible performance. Amazingly selective and sensitive. Specified again and again—abounding proof of their superiority.

Special Illustrated List sent Free on request.

WEARITE COMPONENTS

WRIGHT & WEAIRE LTD.,

740, HIGH ROAD, TOTTENHAM, N.17.



TWO YEARS GUARANTEE

An announcement unique in the Radio world has been issued by the House of Heyberd. With a product only seven months old such phenomenal success has been achieved by huge sales that in future every Model C

HEYBERD MAINS KIT

will be guaranteed against breakdown for a period of two years. Only full confidence in the remarkable quality of Heyberd Components could warrant such a pledge being made.

A.C. KITS from 69/6	D.C. KITS from 52/6
-------------------------------	-------------------------------

Send 3d. stamps for List 947, showing how easy it is to build the Mains Unit best suited to your particular Receiver.

F. C. HEYBERD & CO., 10, Finsbury St., LONDON, E.C.2

MODEL A.C. 150.—
150 volts at 25 ma. Westinghouse Rectification. Assembled in Handsome Metal Case. Requires wiring up only. Screw Terminals. Point to point diagram. Price **76/-**



The NEW Camco WAVERLEY Senior

Radio-Gram Cabinet for Panels 21" x 7"

is one of the many Cabinets described in the

Camco Catalogue

from GARRINGTON MFG. CO., LTD., 24, Hatton Garden, London, E.C.1. (Factory: Croydon.)

FREE

SEND THIS COUPON

Name.....
Address.....

The "Waverley."

M.W.4.

RADIO NOTES AND NEWS OF THE MONTH
—continued from page 442

and various programmes can be carried out without mutual interference.

The Ventilator Problem

How the new studios will be ventilated is an interesting problem which has been successfully solved. Special ducts, almost as large as a tube railway tunnel, have been installed.

Along them will be pumped air from the basement, and a huge suction plant in the roof will draw the foul air out. By means of a refrigerating plant in summer, and warming plant in winter, all the air in the building will be kept at a fixed temperature and will be washed and cleaned before use.

Wait and See

As ever, the Americans are optimistic. Mr. Aylesworth, the President of the National Broadcasting Company, forecasts that there will be Grand Opera by radio television in every American home in three years from now.

Well, as usual, we shall wait and see!

"Charlie" on the Air

Facts are to hand about what Charlie Chaplin was really offered to broadcast in New York. It appears that he refused offers totalling £180,000 for broadcasting advertisements. He was offered £130,000 for twenty-six radio talks of fifteen minutes each. This works out at £333 a minute! He also received an offer for £50,000 from one of the largest public concerns in America.

Many of the papers state that Charlie Chaplin has never broadcast, but, as a matter of fact, he has—once—four years ago.

There were some hopes of his broadcasting in this country—a charity appeal—but nothing came of it.

Training Announcers

There is a movement on foot in America for opening a college for American announcers. It seems that Dr. Bellows, Vice-President of the Columbia Broadcasting, states that British wireless announcing is infinitely superior to American because British announcers are all "Honours Graduates" of Oxford and Cambridge.

Bodo Calling!

Have you heard Bodo? This is a new wireless station broadcasting from inside the Arctic Circle, roughly 1,500 miles from London. It's somewhere around the region of Oslo's wave-length, and was heard for the first time on February 15th. Bodo is the most northerly broadcasting station in the world.

B.B.C. Generosity

In order to give Wales a further opportunity of finding some of the necessary funds for the maintenance of the National Orchestra of Wales, the B.B.C. has offered to maintain the orchestra for another six months. This is decidedly a generous offer, and we are glad to hear that the Cardiff Council has accepted it and will make an early effort to organise a public appeal for further funds.

Rockefeller's Radio

A lot has been written in the papers lately about New York's proposed Radio City. The idea is to house within an area of three city blocks every possible form of entertainment, from Grand Opera to Vaudeville.

This scheme is being sponsored by Mr. John D. Rockefeller, and it
(Continued on page 446.)

THE NEW IDEA

Buy your Radio this 3 Way Plan

C.O.D.

Pay the Postman—we pay all charges.

CASH

With order — carriage paid.

H.P.

Strict Privacy Guaranteed on all Easy Payment Orders.

Peto-Scott, established in 1920, are the founders of the largest Radio-by-Mail system in the country. Any goods to the value of 10/- or more available C.O.D. You pay the postman, we pay all charges. Send for Pilot Chart and Catalogue; over 70 valuable hints and tips.

Let us have full details of your requirements for any "M.W." kits. Quotation by return. **POST US YOUR ORDER FOR GUARANTEED SATISFACTION.**

LATEST "M.W." SETS

COMPLETE KITS EXCLUDING VALVES AND CABINETS

THE SUPERVOX KIT "A" Cash or C.O.D. £8/13/3 or 12 monthly payments of 15/11

The PENTODION KIT "A" Cash or C.O.D. £5/3/4 or 12 monthly payments of 9/6

DUAL RANGE ONE VALVER KIT "A" Cash or C.O.D. £2/11/9 or 12 monthly payments of 4/9

THE HI-LO REJECTOR Kit of Parts Cash or C.O.D. 15/-

"SUPERVOX" PANEL KIT	"SUPERVOX" COIL KIT
Red Triangle Panel (Peto-Scott), 24" x 8" x 1", as used by the author. DRILLED to specification - - - 9/-	2 Keystone "M.W." Dual-Range Coils, as used by the author - - - 25/-
1 5-ply Baseboard, 24" x 12" - - - 1/9	1 Keystone "Star-turn" Selector Coil 10/6
1 pair Die Cast Aluminium Machined Panel Brackets - - - 1/6	Express delivery. Sent per return, C.O.D. Pay the Postman only—we pay all charges
1 Set of Aluminium Screens, ready drilled, as specified, complete with screws - - - 4/6	35/6

FOR THE D.C. THREE
20,000-ohm. Potential Divider (Climax) 9/6
4-mfd. Fixed Condenser (Lissen) 6/-
2-mfd. Fixed Condenser (Lissen) 3/6
2,000-mfd. Electrolytic Condenser (T.C.C.) 15/-

CONVERT YOUR SET INTO A SHORT WAVE RECEIVER
Kelsey Short Wave Adaptor Complete, assembled ready for use **37/6**
and specially packed for immediate delivery. Sent C.O.D., you pay the postman.
Complete Kit of Parts for Home Assembly - - - 31/-

PETO-SCOTT CO. LTD.

77, CITY ROAD, LONDON, E.C.1. Clerkenwell 9405
62, HIGH HOLBORN, LONDON, W.C.1. Chancery 8266

33, WHITELOW ROAD, CHORLTON-CUM-HARDY, MANCHESTER. Chorlton-cum-Hardy 2028
7, ALBANY ROAD, NEWCASTLE, STAFFS. Phone: 67190

Centralab

VOLUME CONTROLS - - -
POWER RHEOSTATS - - -
POTENTIOMETERS

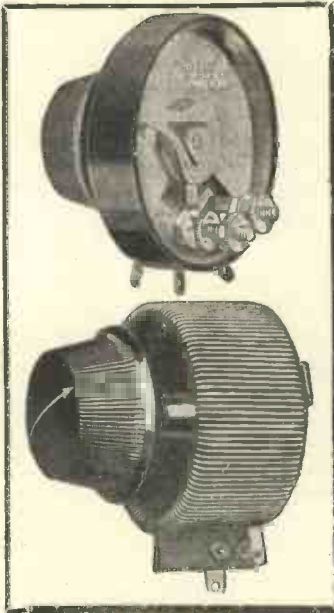

Whether you require a volume control, power rheostat or heavy duty potentiometer, there is a Centralab to take care of your needs.

These famous controls are used as standard equipment by the world's most prominent manufacturers of radio receivers and they are available for you in numerous resistance ranges.

IF YOU HAVE NOT RECEIVED A COPY OF THE CENTRALAB CATALOGUE WRITE FOR ONE TO-DAY. IT'S FREE

TO MANUFACTURERS

Centralab Volume Controls are available in various styles and forms, both single and dual for manufacturing purposes. It will pay you to write for a copy of "Data on Volume Controls."

THE ROTHERMEL CORPORATION Ltd.

24, Maddox Street, London, W.1.

Phone: MAYFAIR 0578/9.

Continental Sales Office: 27, QUAI DU COMMERCE, BRUSSELS, BELGIUM.

LITTLE STORIES OF GREAT MOMENTS



**"Listen—
The machine
is speaking!"**

Hearing the inventor's own voice from the weird machine before him, the startled company little realised they were witnessing a revolution in the pleasures of mankind. They could not see in Edison's phonograph the gramophone or the talking film which have come from it. Yet if its inventor had not dreamed of things greater than selling newspapers and had not devoted his life to doing one thing and doing it well, these things would not have been given to the World.



It is this same spirit of "doing one thing and doing it well" which has, for years, been behind all T.C.C. endeavour. That is why T.C.C. have never made anything but Condensers, and why T.C.C. Condensers are unmatched — for accuracy and dependability.

One of the many types is shown here. It is the T.C.C. 2 mfd. type (for maximum working voltage of 800 D.C. peak value.) Price 10/-.



TELEGRAPH CONDENSER CO., LTD., N. ACTON, W.3.

8044

**An Ideal Gift for
your gardening friends!**



There is no happier gift for gardening friends than a copy of **POPULAR GARDENING ANNUAL**. This very useful book is an illustrated budget of useful advice for amateur gardeners. It contains an immense amount of information, seven coloured plates, and twenty-four art plates from photographs and designs.

**Popular Gardening
Annual** Now on Sale - - **2/6**

RADIO NOTES AND NEWS OF THE MONTH
—continued from page 444

is estimated that it will cost, when put into practice and completed, £50,000,000.

The main building will be let to the National Broadcasting Company, and will be sixty-eight storeys in height.

The Political Broadcasts

The Assistant Postmaster-General, in a printed Parliamentary reply, states that: "I do not consider that it would be in the public interest or in accordance with the wishes of wireless listeners to re-impose the ban on the broadcasting of political and controversial matter, which was renewed in March, 1928."

Then why should the B.B.C. get the wind up and interfere with the Percy-Mosley debate, or why this interference with Mr. Churchill broadcasting on India?

And, again, why let Mr. Dobbs, the well-known publicist, air his views on Russia and the Five-Year Plan? It's all very contradictory.

Soviet Stations

The Soviet Government have definitely approved the construction of six new stations which are to serve the Far East. Some will be completed next year, and it is said they will be strong enough to be heard in India and Africa, and that they will broadcast chiefly programmes in Oriental languages.

On 1,411 Metres

Warsaw's new station is now on the air nightly, but this station doesn't seem to be regularly using its full power yet—or at least up to the time of writing.

It has been said that the power will be 135 kilowatts, and this has been announced in Polish, Czech, English, French, German and Italian, as well as a request for reports from listeners.

Warsaw in Manchester

Reports from Manchester indicate that the Warsaw station is heard at fairly good volume in the evening, but strength during daylight is very poor. Quality appears to be good.

Developments in Hungary

The latest news about a new station comes from Hungary, where it is re-

ported that a station costing £600,000, with a power of 150 kilowatts, is projected.

A new Czecho-Slovakian transmitter at Brno will shortly be on the air, with a power of 35 kilowatts and with a wave-length of 342 metres.

Another new station, Cezka Brod, in Czecho-Slovakia, is expected to begin transmission in about a month's time, with a power of 60 kilowatts, increasing to 120 kilowatts, and a wave-length of 487 metres, i.e. that used at present by Prague.

The delegates to the Madrid Conference are certainly going to have a job of work to do when they meet in 1932!

Television in France

A company has been formed in France with the title of "Television—Baird—Nathan." The objects of the company are to exploit the invention and patents of the Baird Television in France, Belgium, Luxembourg, and in the French and Belgian Colonies.

It is expected that as an outcome of the formation of this company further facilities for television experiments in these countries will shortly be available.

(Continued on page 448.)

**A NEW W.B.
 PERMANENT MAGNET
 MOVING-COIL SPEAKER
 FOR £4.10.0**

So sensitive that any 2- or 3-valve set will drive it—no mains or batteries needed.

Identical with the very successful Model P.M.1, introduced earlier this season—only the Darwin Sheffield-made Cobalt-Steel Magnet is not quite so massive.

Hear this new W.B. Moving-Coil Speaker at your dealer's. Ask him for the free colour folder or write to us direct.

The standard model has a low resistance winding. A multi-ratio step-down transformer must be used between set and speaker, suitable ratios for the average valve set being between 15 and 25/1.

Made by the Makers of the famous W.B. Cone Speakers, Switches and Valveholders.

Whiteley Electrical Radio Co., Ltd., Radio Works, Nottingham Road, Mansfield, Notts

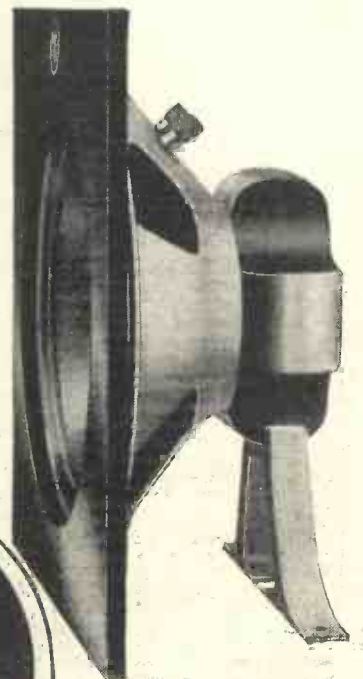

Type P.M.2. Chassis completely assembled with 11½ in. x 11 in. baffle board.

£4 : 10 : 0

A double-ratio step-down transformer can be supplied attached to the Speaker for 15/- extra.

Irish-Free State Distributors: Kellu & Shiel, Ltd., 47, Fleet St., Dublin.

ANNOUNCING THE NEW



'Popular' and 'Modern Wireless' dual range COIL



Scientifically tested and absolutely reliable, it is rapidly becoming the most popular coil for radio constructors. In real bakelite moulding, price **12/6**

Insist on 'Formo' for Efficiency in Radio.

Obtainable from all Radio Dealers. Leaflets from—

Arthur Preen & Co. Ltd.

Golden Square, Piccadilly Circus, London, W.1.

M.B.

The Paper for the Boy of to-day

Every boy likes a clean, healthy paper that tells about all those things which interest him most. MODERN BOY is such a paper. Every week it is packed with the very latest in Invention, Adventure, Fiction, Hobbies, etc. It is just the paper for the boy of to-day and one that his parents will be pleased to see him reading.

MODERN BOY

Now on Sale Buy a Copy TO-DAY 2d.

CHEAPER ELECTRIC RADIO by

REGENTONE

Three new Regentone models at lower prices. A.C. Combined Unit Model W.5.A. (H.T. with L.T. Charger) £4: 15: 0. D.C. Combined Unit Model II (H.T. with L.T. Charger) £2: 12: 6. A.C. Mains Unit (H.T. only—3 fixed tapings) £3: 7: 6. Write for FREE Art Booklet with colour supplement "Cheaper Electric Radio by Regentone"—or get it from your dealer.

Regentone Ltd., Regentone House, 21, Bartlett's Bldgs., Holborn Circus, London. Tel: Central 8795 (5 lines). Irish Free State Distributors: Kelly & Shiel Ltd., 47, Fleet Street, Dublin.



SMOOTH RELIABLE RIPPLE-FREE POWER

EXPERTS the world over know that any battery eliminator or all-electric set is the better for using Dubilier Paper Condensers. There are numerous types to suit every requirement.

A broken-down Condenser may cause damage to valves and other apparatus. Dubilier Condensers will never let you down if you use the correct type—their factor of safety is too great.

Write for our Latest Catalogue.

DUBILIER CONDENSERS

DUBILIER CONDENSER Co. (1925) Ltd., Ducon Works, Victoria Road, N. Acton, London, W.3.

RADIO NOTES AND NEWS OF THE MONTH

—continued from page 446

Low-Power Tests

The British Empire Radio Union had some interesting results early in March. Although using a power no greater than that required for working the smallest domestic electric lamp, it is reported that reliable inter-communication has been effected between New Zealand and Canada, West Indies and Hong Kong, South Africa and Ceylon, with Great Britain as a centre in full communication.

FROM OUR READERS

The "Filter-Tune" Five—The "Inter-Axial."

Sir,—I feel that I must express appreciation of the design for the above set, which is fully up to MODERN WIRELESS standard. The quality of reproduction is excellent.

I was particularly interested in this set, as the circuit, apart from the filter, and one or two small improvements,

is practically that which I discussed with your experts at the Show. It must have been a case of great minds thinking alike.

Even with the three dials in use I do not find tuning at all difficult. The

Regional are separate, though I am not prepared to say what would happen if each were relaying a brass band contest! The same, as regards separation, of course, applies to Rome and Stockholm, while Langenberg is quite clear of the Midland Regional.

Altogether a really remarkable set, not difficult to build and handle, and one which delivers the goods.

Yours truly,

London, S.W.18. BM/BBX7.

The "Inter-Axial" Loud Speaker

Sir,— May I express my appreciation of the loud speaker I have just constructed from details given in your February issue.

I constructed the Junior model for my four-valve portable, and I am extremely satisfied with the results, and if the larger model is better than this then perfection must have indeed been reached.

Previously I used a parchment cone attached to a baffle by a circular piece of canvas material; I used to imagine this was capable of good reproduction. I know now! It certainly was not.

Congratulations and every success.

Yours truly,

Norwich. G. D. SWAIN.

NEXT MONTH

All readers interested in **PORTABLE SETS**

should make a point of ordering the

MAY

"MODERN WIRELESS"

which deals comprehensively with this fascinating branch of radio reception.

Usual Price, 1/- Out May 1st

first trial gave me some fifteen stations on two loud speakers, used in parallel, as well as two or three which were not identified till later, using an indoor aerial and counterpoise, with a .0005-mfd. condenser in each lead, as I use mains H.T. The chief point, however, is that Mühlacker and the London

Differential Condenser
 .00015 cap Compact Integral Pointer.
 Price 3/9 retail.

Formo Condensers
 The Ever-Popular Mid-Log Variable. Small mass of metal, pigtail concealed in shaft, and low loss. Four capacities.
 Price 4/6 retail.

Popular and Modern Dual Range Coil
 The Approved and Recommended Model. Superior finish, moulded. A "preference" line with a big sale. Price 12/6

Formo-Densors. The line with the 1,000's a week sale. Prices 1/6 and 2/3. Full particulars of capacities on request.

FORMO
 ARTHUR PREEN & CO LTD.

MAINS CONDENSER

SET EFFICIENCY CENTRES ROUND FORMO COMPONENTS

THE NEW FORMO MAINS CONDENSERS

Many years of patient research have been rewarded by a discovery which introduces an entirely new standard of electrical efficiency in Mains Condensers. A newly-discovered vacuum process makes leakage infinitesimal, whilst working voltages have been greatly increased—and at no additional cost. Formo Condensers are tested by the sudden application of the test voltage and not, as is usual, through a non-inductive series resistance. The insulation resistance of a condenser is of paramount importance. A condenser having a low insulation value is analogous to a storage tank that leaks!

The new Formo range is obtainable at all Radio Dealers. Fit one and get clearer, better reception.

Cap. Height. Width. Length. Price
 2.0 2½ in. 1½ in. 1½ in. 3/3

Full Range of Capacities.

Full particulars from

ARTHUR PREEN & CO., LTD.
 Dept. M.W., Golden Square,
 Piccadilly Circus, London, W.1.
 Factory - Crown Works, Southampton.

**A
BOOK
OF THE
UNUSUAL**

Fortnightly Parts 1/3 each

MANNERS & CUSTOMS OF MANKIND



MANNERS AND CUSTOMS OF MANKIND is a work of enthralling interest, for it will describe and explain all the strange customs, superstitions and beliefs that survive in every corner of the globe to-day. It will be most generously illustrated with photographs, many thousands of which did not exist a few years ago and have never before appeared in a popular work of this kind. From Ireland to Iceland, from Australia to the Amazon, from the Congo to our own country this amazing work will take us, dealing with such varied subjects as Courtship and Marriage, Magic and Taboo, Religious Rites and Ceremonies, Racial Manners and Etiquette, until we realise that the most fascinating of all studies is that of mankind. Not only does MANNERS AND CUSTOMS OF MANKIND deal with the strange mysteries of uncivilised countries, but tells us, too, of weird customs which still survive in Europe, but are dying out. It is a work that once again proves the old adage that "truth is stranger than fiction." Part 1 contains a beautiful

ART PLATE

entitled "King of the Devils": Monster Siamese effigy; a supplement of **FOUR ART PAGES** in COLOUR, and 90 new photographic illustrations in duotone.

Buy Parts 1 and 2 TO-DAY

Do You Know—

Where Kissing is Immoral and a Punishable Offence?

Why We Touch Wood?

Where in Britain Evil Spirits are Scared with Fires and Shotguns?

Where Trial Marriage is a Regular Routine?

Where the Dead are Buried in Trees?

Where Blood is Shed to Make Rain?

Why a person is "Sent to Coventry"?



1/3
Per Part



SCREENS **COILS, ETC.**

Products PAR-EXcellence
as used and recommended for
THE "SUPERVOX"

"M.W." MATCHED



DUAL COILS
approved 12/6
by "M.W." each
Each coil tested and calibrated on actual broadcasting.
Delivery by return.

The only coil with easily accessible Terminals and Tubular Spacers.

"STAR TURN" Selector COIL 15/-
SET OF 3 SCREENS AS SPECIFIED:
Copper .. 11/6 Aluminium .. 7/6

Copper Foil, 24" x 12" .. 4/-
S.G. Valve Holders .. each 2/-
Differential Condenser, .00015 mfd. .. 4/6
H.F. Chokes .. each 3/6
600-ohm Resistance (with Holder) .. 2/6
Panel, 24" x 8" x 1/2", drilled to specification .. 16/-
Terminal Strips, 10" x 2" and 6" x 2" drilled 2/6

THE "PENTODION"
"M.W." COILS, H.F. CHOKES, as above.
Panel, 8" x 8", drilled to specification .. 5/-
Terminal Strip, 10" x 2", drilled .. 1/9

The **DUAL-RANGE ONE-VALVE**
COILS, CHOKES and DIFF. COND. as above.
Panel, 9" x 7", drilled to specification .. 3/6
Terminal Strip, 9" x 2", drilled .. 1/6

All panels of best polished Ebonite.

SATISFACTION GUARANTEED
E. PAROUSSI 10, Featherstone Buildings,
High Holborn, London, W.C.1
Phone: Chancery 7010

A PUBLIC ELECTRIC SUPPLY AUTHORITY

having recently completed a change-over from D.C. to A.C., has for disposal a quantity of wireless apparatus consisting of:—

220-volt D.C. H.T. battery eliminators, H.T. & L.T. battery eliminators and sundry parts.

This Authority will be pleased to receive tenders for the apparatus. Copies of the schedule may be obtained on applying by letter only to: **Box M.S., JOHN H. LILE, LTD., 4, LUDGATE CIRCUS, LONDON, E.C.4.**



CLAROSTAT

A BRIEF SURVEY
OF THEIR APPLICATIONS
IN THE SCIENCE OF RADIO

(No Charge - Please Refer This)

THE ONLY AUTHORITATIVE AND ENLARGED

FREE!

THIS NEW 48 pp. WONDER BOOK.

Compiled by the staff of Claude Lyons Ltd., and dealing with the many uses of CLAROSTAT PRODUCTS.

Much useful information. *Write Now!*
Not many copies left.

FOR BETTER RADIO RESULTS FIT CLAROSTATS!

REDUCED PRICES.

MIDGET CLAROSTAT .. now 5/-
VOLUME CONTROL .. now 6/6
STANDARD .. now 7/6 & 8/6
POWER TYPES .. now 10/6 & 12/6
CLAROSTAT POTENTIOMETERS 5/- to 8/6

CLAUDE LYONS LTD.
76 Oldhall St., Liverpool.
40 Buckingham Gate, S.W.1

A FINE RECORD

The very interesting experiences of a real DX listener.

To the Editor, MODERN WIRELESS.

Sir,—I've been having a thoroughly exciting time since my last communication to you, and I feel sure your readers will be interested about it. Here it is.

In my last communication I told you how I had logged several American medium-wave stations, and made a gramophone record of one. I fear that since then I have "burned the candle at both ends" rather a lot. However, results have been such that I have not regretted it, and I venture to suggest, neither would you, if you had logged what I have.

You may remember, and you may not, that I left off my last communication with giving details of my reception on November 23rd, 1930. So I will now take up the—eh—"story"!

Only Heard Twice

By the way, before I do so I would like to mention that the station W G B B, Freeport, New York, that I mentioned, was a 100-watt station. What is more, it has only twice been received and verified in Europe—once in Ireland and once by me in Uxbridge. (I got that from W G B B.)

Consequently, I have received W G B B farther east than anyone else in the world. Exciting, isn't it? Funnily enough, I again logged W G B B in 1931. Another 100-watt station I recently logged was W J A C, Johnstown, Pa., which came in quite strongly, though it was frequently "swallowed" by a heterodyne; being on a common wave. Another good catch was W B A A, Lafayette, Indiana; a 500-watt station. (W M C and W B B C, which I mentioned in my last, were both 500-watt stations.)

Two days after my letter to you I logged C M C, Havana, and another Cuban station, and C W O R, Montevideo, and many other North American stations at fair strength.

I was very "bucked" at this catch, and so tried every other night to see what I could get. I left the night between the night I "tried" to have a good night's rest and to recuperate! I wasted much sleep and energy in turning the dials, however, because it was not until the morning of January 5th, 1931, that my "candle burning" was repaid.

Naturally, after all my other bad

nights, I did not expect to get much, only trying to see if by any chance conditions had changed. I switched on and turned the dials. Ah! This sounds better. Conditions had changed. I had struck a "fat" carrier and on resolving it I heard: "I'll never forget the day we met, I'll not do that, I love you yet."

"The Voice of Hollywood"

The words were sung (if that word is correct to express the noise) in a mournful manner, and came from W T I C. I tuned just above W T I C. There was another carrier. It was tuned out—music, announcements. It was K N X ("The Voice of Hollywood"), California. A good catch.

That night I logged W K B W, Buffalo; W J Z, New York; W G Y, Schenectady; W T A M, Cleveland; W T I C, Hartford; W P G, Atlantic City; W E A F, New York; K O A, Denver; W O A I, San Antonio; K N X, Hollywood; W B Z, Springfield; W H A M, Rochester; W R V A, Richmond, and many unidentified. On this occasion I made passable records of W T I C, W P G, K O A, W E A F, W K B W, W T A M, etc.

With these successes I expected something good next day; but no, I could not get America. Nor did I get any American stations at any strength until January 11th, when I logged W P G; W T I C; W J Z; W M A Q, Chicago; W T A M; W G Y; W B B M, Chicago; W E A F, etc. The 14th was another excellent night, and I logged X E D, Reynesa; W K B W; W J Z; W T I C; W P G; W G Y; W O R, New Jersey; W E A F; W L W L, New York; K M O X, St. Louis; W I O D, Miami Beach (Wonderful Isle of Dreams); W J R, Detroit; K Y W, Chicago, etc. On this occasion I made some really good gramophone records of W T I C, W J Z, W O R, W G Y, W K B W, etc., and a snatch of X E D. The last was very indistinct, however.

Proof of Reception

I can, in my imagination, hear some of your readers say: "What! Make good records of America. Why it's hard enough to make bad ones, I should think; take that with a pinch of salt, says I, I don't believe it!" Well, my dear sir, I can vindicate myself from any such disbelievers. My extraordinary claim is easily proved. I am enclosing a gramophone record of re-recordings from some of the original discs I made; the original can be heard on

(Continued on page 451.)

PLEASE be sure to mention "Modern Wireless" when communicating with Advertisers Thanks!

A FINE RECORD

—continued from page 450

application, as ads. would say. You will hear WTIC on one side and WJZ, WOR, WKBW, and WTIC on the other. Now you have heard them, you can guess what a good night that was. Another proof of the clarity and strength of these discs is the fact that four of them are shortly to be broadcast in a special test programme arranged by the Anglo-American Radio Society, of which I am president, and the Travellers Broadcasting Corporation, Incorporated, over WTIC.

Chinese, Too!

January 26th was my record day, and I logged a station giving Eastern music. Announcements were made in Chinese. I easily recognised the lingo, as I have heard it on short waves. The wave-length tallied with CRC, China, and as there are no other eastern stations below 300 metres (except on the high frequencies), and as the wave-length was 235 metres, I feel that I am not far wrong in assuming it was CRC. However, I logged enough programme for verification, which I expect to get in due course. I also logged WJAC (100 watts), WBAA (500 watts), WOAI, WTIC, WEA F, WJZ, WTAM, KMOX, WPG, etc. On the 27th I logged WTIC; WCAU, Philadelphia; WNAC, Boston; WGY; WJZ; WEA F, etc.

I am, at the moment, waiting to try for America, with what results I do not know. It is 1 a.m., and my letter is dated wrongly!

In previous years I have logged KGO, Oakland; WSAI, Cincinnati; WSL, Chicago; WBAL, Baltimore; WOO C, Minneapolis; WSM, Tennessee; WABC, New York; KDKA, Pittsburg; WGN, Chicago; WENR, Chicago; WOC, Davenport; WBAP, Fort Worth, Texas; WHO, Des Moines; KEX,

(Continued on page 452.)

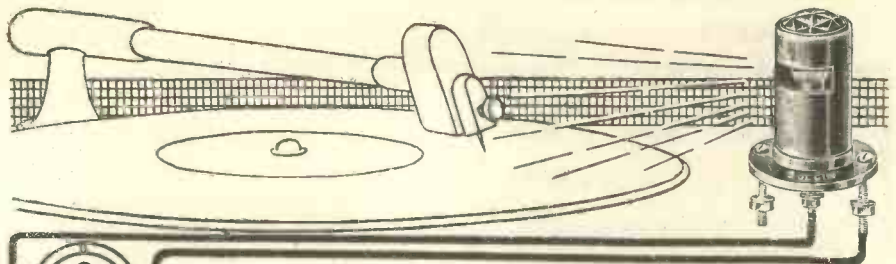

A Light on the Subject!

Don't damage your favourite record. The Bulgin gramophone signal lamp sheds a white light on the turntable, enabling you to place the needle gently in the first groove of the record. It also saves wastage of current by its warning light, indicating that the amplifier is switched on. Look at the easy connections. **2/6** each. Bulbs, 6d. extra. The Bulgin "on and off" Toggle switch is a miniature precision instrument with positive snap action, perfect insulation and high carrying capacity. The perfect contact of this switch ensures its reliable operation up to a limit of 250 volts 3 amp. **1/9** each.

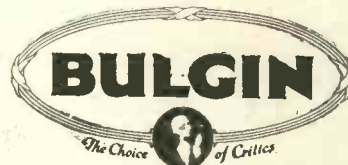
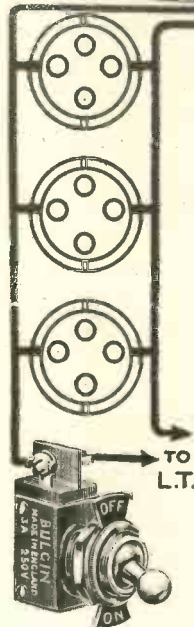

Send for 60-pp. Catalogue. Enclose 2d. postage.
A. F. BULGIN & CO., LTD., 9, 10, 11, Cursitor Street, Chancery Lane, LONDON, E.C.4. 'Phones: Holborn 1072 & 2072.

A Cabinet De-Luxe for YOUR SET
 OR
RADIO-GRAM

"The nicest I have seen," says "Wireless Constructor."

The sort people desire to possess and keep. Tasteful beauty—Piano finish—advantages also of **PIANO-TONE** baffle chamber. The **BETTER REPRODUCTION** that your Set is really capable of gives you a joyous sense of achievement. Sent **ON APPROVAL** direct from the makers. Prices £4 to £15 (Cash or Deferred). You may return at our expense if you wish to part with it. Photographs and List **FREE!**
PICKETS, Radio Furniture (M.W.), Albion Road, Bexleyheath, Kent.

Please be sure to mention "Modern Wireless" when communicating with Advertisers. Thanks!

ELEX

SOMETHING NEW!
TESTING PRODS

Write for List No. S.5.
J. J. EASTICK & SONS, 118, Bunhill Row, London, E.C.1. 'Phone: Metropolitan 0314.

Don't Argue!
Make Sure of Your Facts
by Reading
THIS and THAT
Every Thursday - - - 2d.

CONVERT YOUR BATTERY SET TO A.C. MAINS and get the added efficiency and convenience of Mains-Radio *without altering a single wire*. The Six-Sixty A.C. All-Mains Conversion Equipment includes a set of the wonderful Six-Sixty A.C. Valves to suit your circuit and supplies H.T., L.T. and Grid Bias at a fraction of the cost of batteries—takes no more room.

Price complete from **£8 : 5 : 0**
 Write for **FREE BOOKLET** giving full particulars.



SAY

SIX-SIXTY

FIXED RESISTANCES THAT are FIXED

Totally wire-wound by the famous Varley Bi-duplex method, Varley resistances are guaranteed closely accurate, constant in value, absolutely silent in use and free from breakdown.

Varley



Supplied complete with Universal Holders for vertical or horizontal mounting. The ideal fixed resistances for all radio purposes — your dealer stocks them.

Complete range from 5,000 ohms to 500,000 ohms

Prices: **4/6 to 17/6**

Write for sections B and C of the Varley Catalogue.

Advert. of Oliver Pell Control Ltd., Kingsway House, 103, Kingsway, London, W.C.2. Tel.: Holborn 5303.

A FINE RECORD
—continued from page 451

Portland; KFI, WGY, WTIC, WPG, WLW, WJZ, WBZ, etc., from U.S.A., CFCA and CNRT from Canada. I have also logged 2YR, Rangoon, on one occasion. Many of these stations were received at the beginning of 1928, which was a very good time for reception on medium wave-lengths.

Hoping the above will interest you, also the record.

Yours faithfully,
LESLIE W. ORTON,
President, Anglo-American Radio Society.

Uxbridge.

P.S.—This is a hasty P.S. I am trying for America. Having good luck. Logged WTIC, WJZ, WABC, etc. Had the novel experience of mistaking WTIC for a British station testing. Bournemouth has been testing lately, and I just struck a piano very strong down on the lower half of the dials. It filled the room on the moving coil, and I reduced the volume and used the reaction condenser at minimum position, and turned away. I turned back and heard the call: WTIC, the Travellers, Hartford, Connecticut. Many others coming in very strongly on moving coil.

[The home-made gramophone record was quite good.—Ed.]

MAINS MOTORS
—continued from page 438

this is far better than having a mechanical interlude in the middle of a musical item.

For those radio-gram enthusiasts who have A.C. I would recommend the Diehl induction motor, marketed in this country by Claude Lyons Ltd., of 40, Buckingham Gate, London, S.W.1. The Diehl Mfg. Co., of America, is the electrical division of the Singer Sewing Machine Co., and have for many years been engaged in the production of small electric motors.

Some years ago the company realised that as many houses had radio-gram receivers running as well as sewing machines, the motors of these electric sewing machines must necessarily be of the induction type, and noiseless,

so that no interference is caused either to the owners of the radio-gram set in the same house or nearby neighbours.

Uses Worm Drive

The result is a slight diversion from the firm's usual practice in the production of an induction type motor. This is a particularly interesting piece of mechanism and consists of a carefully balanced spring-suspended induction motor, the shafts of which are driven by a worm wheel and has a clutch mechanism between the turntable and the main drive.

This is in situation because the worm gearing, of course, is irreversible. It also follows that these gears will be strained or even stripped if the motor turntable were stopped by hand without the motor first being stopped.

The Special Clutch

A single-plate cork clutch, which is fitted at the base of this turntable, or on the driving shaft, allows a certain amount of slip to take place in such an event, thereby saving the gearing of the motor. Another interesting feature is a bakelite turntable, which is fitted according to the makers, because its polished, glossy appearance makes it suit any woodwork, and also because the plush lining does not readily strip from the bakelite; and that ruffling-up, which is common with many turntables, does not take place.

Also, metal turntables are somewhat heavy and impose rather a strain upon bearings, which leads sometimes, in the case of poor assemblies, to uneven running, and perhaps noises. Consequently, the flywheel effect of the turntable is negligible, and very great care in the design of the motor has been taken so that the loss of steadiness of speed which the use of a heavy turntable has should not be felt.

Absolutely Silent

The motor is small and extremely easily fitted, and it has the usual type of speed regulator and an automatic snap switch stop which is operated by the pick-up arm as it finishes its course over the record.

But the greatest thing of all about this motor, in my opinion, is that it is almost totally enclosed, and in operation does not cause the slightest amount of hum. Single-hole mounting is employed, one fairly large space having to be cut out of your motor-board when the whole mechanism of the motor can be dropped in.

There are no aggravating little fittings as there are in some cases, and

(Continued on page 453.)

HEINZ!

There are 57 distinct parts in this Double Pole Rotary switch, and each is designed and finished with the engineering precision and thoroughness implied by the name Benjamin. Catalogue No. 1142 describes the switch fully and gives circuits in which it can be used. Have you had your copy?

THE BENJAMIN ELECTRIC Ltd.,
Tariff Rd., Tottenham, N.17.
Tottenham 1509.

3/6

BENJAMIN

Make **The DAILY SKETCH**
YOUR Picture Paper

MAINS MOTORS

—continued from page 452

only this one hole has to be made, when the motor sinks in place with everything on board it and is ready for use. A template is supplied and the motor comes exceedingly well packed.

As regards the use of the motor, I have tried it in many sets, and within six inches of the L.F. portion of an A.C. electrically-operated gramophone, and I failed to get any hum out of it whatsoever. There is a slight mechanical hum if one places the ear close to the turntable, but the motor I used was almost completely vibrationless and dead silent from an electrical point of view.

It has a strong starting point and is powerful enough to run a record with three pick-ups on it—not that you ever want to do this sort of thing—without altering its speed in any way whatsoever. At four guineas it is certainly very remarkable value for money, and I have not yet come across any electrical motor to beat it. Moreover, it is guaranteed against all defects, latent or otherwise, from one year from the date of sale, and it consumes only 18 watts. It needs no screening.

YOUR AERIAL AND EARTH

—continued from page 372

pointed out to him that some of his lads were playing "The Drum Major" instead of a minor fugue. Nevertheless, although a thin layer of dust or soot on an insulator isn't likely to stop that masterful B.B.C. stuff getting through to your set, it must not be forgotten that thin layers become thick layers if they are left too long. And I'm not referring either to hens or horse-racing, but to those films of soil and fog-fruit on your insulators.

However, all this is by the way—quite gratuitous advice for which you may not thank me. Let me continue telling the world about your radio as it is, and not as it might have been. Your one continuous length of aerial wire sweeps majestically down to the lead-in tube and is kept well away from the adjoining brickwork on its journey.

The wire does not creep under the window sash, but efficiently and joyfully parades a one hundred per cent

(Continued on page 454.)

NO SLIP OR BACKLASH

Separate each programme easily with the J.B. Drum Dial. Its smooth and powerful friction drive will move your condenser vanes the merest fraction of an inch without slip or backlash. Its attractive finish will set off any panel. See it at your dealers.

The drum can be earthed to form an anti-capacity shield, since the dial is completely insulated from the condenser. The position of the control knob allows the scale to be brought flush with the panel for easy reading. The ivory scale is reversible to read 0—100 or 100—0.



J.B. DRUM DIAL,
Price 10/6.
Vernier Ratio, 16/1.
Drum Diameter, 4".
Supplied in bronze or oxidised silver finish.

Also
3" diameter drum
(illuminated or plain type), 9/6.



PRECISION INSTRUMENTS

Advertisement of Jackson Bros., 72, St. Thomas' Street, London, S.E.1

Telephone: Hop 1837.

NEXT MONTH

FULL CONSTRUCTIONAL DETAILS OF

THE "M.W." "PORTABLE" FOUR

Just the Set you want for your Summer Outings, and for use in house or garden.

Read all about it in

THE MAY "MODERN WIRELESS"

On Sale May 1st.

Price 1/-

MOUNT YOUR TERMINALS ANYWHERE

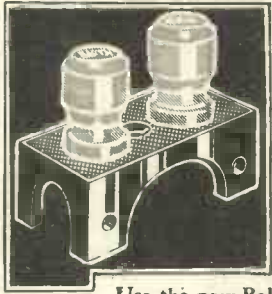

Belling-Lee Terminal Mount

Patent Pending

Use the new Belling-Lee Terminal Mount for your aerial lead-in, for loud-speaker extensions, for battery leads. It takes two terminals of any type and mounts them anywhere, vertically or horizontally—on your base-board, window-ledge, wall, or skirting.

Supplied in separate cartons with Belling-Lee 12 months' guarantee of workmanship and material.

Belling-Lee Terminals
Type "B," 6d. each
Type "M," 4d. each
Type "R," 3d. each

Write for FREE Belling-Lee Handbook, "Radio Connections" (2nd Edition), which illustrates some of its many uses

BELLING-LEE
FOR EVERY RADIO CONNECTION

Advertisement of Belling & Lee, Limited, Queensway Works, Ponders End, Middlesex.

BUILD YOUR OWN RECEIVER!

We now have all parts in stock for the 1931 FERRANTI Screened-Grid Receiver.

EVERYMAN TWO

The set for millions. Completely self-contained. Parts as specified from stock. New Farrand N. & K. Speaker of quality to suit above, £3 10 0.

WILL DAY, LTD., 19, Lisle Street, Leicester Square, W.C.2. Regent 0921-2.

SOLVE ALL H.T. TROUBLES

Per doz.	No. 1.	No. 2.
	s. d.	s. d.
Jars (waxed)	1 3 1 6	
Sacs	1 2 1 9	
Zincs	10 11	
Rubber Bands (24)	4 4	
Terminals	8 10	

Trade Supplied.

WET BATTERIES

TAYLEX

SELF GENERATING

LONG LIFE : SILENT : ECONOMICAL

Sample doz. (18 volts), complete with bands and electrolyte. No. 1, 4/1; No. 2, 5/1; post 9d.; terminals extra. No. 3, with terminals. 7/6 (10,000 milli-amps), sample unit 6d. Orders 10/- carr. paid. New illustrated catalogue post free.

FREE Bargain List of Receivers, Amplifiers and Components.

M. TAYLOR, 57, Studley Road, Stockwell, London.

The Picture Paper with the MOST News—

SUNDAY GRAPHIC

YOUR AERIAL AND EARTH

—continued from page 453

lead-in tube cunningly arranged to prevent rain and draughts getting into the house as well.

Naturally, there is an earthing switch that is brought into action when lightning or Stravinsky is in the air.

In short, you have used that 100 ft. of wire allowed by the P.M.G. to its very best advantage. I would even go so far as to say, and I do so without getting a tape measure on the job, that you have realised that about 80 ft. measured right from your set to the farthest end of the aerial is the ideal length for ordinary reception, and have nipped off 20 ft. and sent it to the Post Office with your compliments and kind regards.

The Man From Tyre

Now, with your permission, we will enter the house. Just as I expected, the set is only a few feet away from the point where the aerial worms its way into the parlour. The lead-in does not have to make a detour round the room in order to complete its travels. You have as much of your aerial wire out-of-doors as is possible; unlike that young man from Tyre, you hate interior lead-ins. But perhaps you haven't heard that limerick—in case you haven't, here it is:

"There was a young man from Tyre,
When buying some lead-in wire,
Who said, You silly goops,
This stuff is all in loops.
Whereas I want the fifty feet straight
and long, like the last line of this
limerick, because it has got to
stretch from the parlour window to
the kitchen fire."

Of course, had yours been an indoor aerial it would have been a different matter altogether. In that case the wire would have to have wandered around the room, perhaps along the picture rail, very carefully skirting that photo of Uncle Jim and making a bold hop over Aunt Eliza's forbidding features.

A "Perfect" Earth

And needless to add, you would have strung the insulated wire as high in the house as was rendered permissible by the architect, keeping it as straight as you could.

As for your earth wire, that's a Scotch biscuit—short and good, isn't it? You have a stout lead soldered to a main water pipe and not merely looped round a gas-pipe or stuck in a flowerpot.

You have realised that the theoretically perfect earth is a stout wire connecting to a network of buried metal plates, but such has proved impossible owing to the presence of a stretch of beautiful concreting just beneath the vital window. However, you are consoled by the practical fact that a good old water-pipe takes some beating, as the plumber said as he happily battered away at the bathroom input.

Remote Possibility

That your internally operated, but externally fitted, lightning switch brings nature's "juice" into the house before it can swoop into the earth doesn't trouble you a scrap. "We might not be as safe as we could be, but at least my aerial and earth leads are widely separated," you murmur deprecatingly.

To which I add, there is as much likelihood of lightning ever striking any one particular aerial, earthed or not, as there is of Adrian Boult playing a solo on a saxophone.

I have said that your aerial system is magnificent—if it were perfect you would deserve to have a front seat in the studio during the broadcasting of every Symphony and Chamber concert for forty years. As it is, you only narrowly escape that dreadful fate!

A SHORT-WAVE EXPERIMENT

—continued from page 440

dials so slowly? Should have thought an expert like you could rake anything you wanted out of the air in a flash."

"You've got to handle a short-wave set much more tenderly than an ordinary outfit," explained Dare patiently, "because the stations are so much more closely packed together on the dials of a short-waver. It is the ham-handed knob-twister such as I imagine you to be, Blazer, that flashes past the station he wants, time and time again, until at last he is prepared to swear that there ain't no such thing. But now, Blazer, I must ask you to move along, please—a

(Continued on page 455.)

A SHORT-WAVE EXPERIMENT

—continued from page 454

phrase with which you are no doubt familiar; the transmission we are after is just coming through, and your board of directors may be here any minute to hear it."

"I'm here to hear it, too, my lad," announced the ex-policeman, with a grin. "My job is to keep an eye on things generally."

"Do You Hear That?"

Dare grimaced, and turned to his set. For a few minutes there was nothing to be heard except a number of odd squeals and groans from the loud speaker and the shuffling of papers from half a dozen clerks sitting before telephones and telegraph machines at the other end of the large, barely furnished office.

Suddenly Dare twisted away from the radio and beckoned Blazer to come nearer to him.

"Blazer," he whispered mysteriously, his face assuming a very grave expression. "Do you hear that station?"

"I can hear a faint rustling like wind blowing through leaves."

"Do you know Sir Pothercary Clarkhop?" continued the radio engineer, with seeming irrelevance.

"Of course. Why?"

Blazer appeared to be puzzled by this turn in the conversation—as well he might. His forehead wrinkled as though he were in doubt as to whether Dare was serious.

"Supposing I tell you," went on Dare slowly, "that there is a doubt in my mind as to whether that station you can hear is really an American station—or even a distant station at all! And supposing I tell you that I know Clarkhop is a keen radio man, and that I know he has tried to book a transatlantic 'phone call to-day! Would all that make you slightly suspicious, knowing what Clarkhop is and how it might pay him to radio a fake message through and make Allied buy or sell those shares according to his own wishes?"

In a Turmoil

"Hades!" cried Blazer. "Where's he hang out?"

"Round the corner, in Lower Duke Street."

"But wait a minute," said Blazer more soberly. "Can't you tell whether or not that radio is as close

as that? Anyway, I can't go rushing round to Sir Pothercary; I'm not a policeman now, and even if I was I don't see that he is breaking the law."

"Remember your duty to your employers," admonished Dare, with a grin that might have meant anything? "Use all the influence you have got at Scotland Yard, the Home Office, and the Ministry of Agriculture and Fisheries to keep him out of the game for an hour or two. But do it quickly, for this stunt will be all over in less than half an hour. Tell you what, get the Post Office to raid him for his transmitting licence. Go with them and see that they hold him in conversation until at least half-past three."

But Blazer, chewing his cigar with great excitement, had already run out of the room!

When, some forty-five minutes later, Blazer returned, it was to find the whole office in a turmoil. Clerks were flying hither and thither with sheaves of papers; managers, and even directors, were flitting through the corridors of the great building as though a day of financial judgment had come.

"It's a Fake!"

The detective hastened his way to the room where he had left Dare and found that radio engineer calmly smoking a cigarette while one of his assistants packed up the wireless gear.

"What's all the excitement?" asked Blazer.

"Seemingly, a simply catastrophic crash in American Unifi.ed," returned Dare. "We got the speech over all right, and what the president said has sent your directors and all their staff moderately crazy. As far as I can gather, their dividends this year will go down at least a farthing per share, in view of what they stand to lose, if they don't shift their Unified holding mighty quick!"

"I must stop that—it's a fake!" shouted Blazer, rushing for the door.

But Dare had sprung up just in time to catch him firmly by the coat-tails.

"Don't be a fool, Blazer!" he cried. "It was a perfectly 'pukka' message."

"Let go, darn you, Dare! I tell you we weren't in time to stop that squirt sending out a fake message—and that's the message you've sent Allied barmy on!"

"Calm yourself, my policeman," admonished the radio engineer, tightening his grip on Blazer's coat.

(Continued on page 456.)



OHMITE

Anode Resistance. All values, 100 ohms to 500,000 ohms.

2/3 each

MEGITE

Grid Leak. All values, 1 megohm to 5 meg-ohms.

2/- each

Ohmite and Megite Resistances are constant in value, of negligible self-capacity and non-inductive. Dead silent and always reliable, they provide the most effective resistance on the market, giving the full range of values required. Supplied with vertical or upright holders of superior brown bakelite construction 6d. extra. *Graham Farish components carry a written guarantee of accuracy.*

Ask your dealer to obtain, or write direct to

GRAHAM FARISH

LIMITED. BROMLEY, KENT

A SHORT-WAVE EXPERIMENT

—continued from page 455

"We've had about a thousand confirmations by cable, by radio, by news agencies, and I don't know by what else."

Blazer relaxed, walked slowly over to a chair, and sank into it. Deliberately removing his hat and placing this carefully on the floor, he spoke slowly but loudly:

NEXT MONTH

A SPECIAL "PORTABLE" NUMBER.

On Sale May 1st. Price 1/-

"I tell you we got to that squirt's office about ten minutes too late. That was the fault of those P.O. people. Ought to have a flying squad, they did! When we got there, me and the P.O. inspector asked for Sir Pothercary, and was shown up to a room where that lad was messing about with the biggest lot of radio I've ever seen in the town of London,

"He'll be Summoned"

"Asked for his licence to transmit and the P.O. bloke showed him his papers. Sir Poth blusters like anything, says we are interrupting a short-wave experiment it has taken him weeks to arrange. Short-wave experiment, my eye! He even had the nerve to show us letters and

cables from America to support his yarn. Good fakes they are, too! And he'd just been transmitting! However, it seems that he hasn't been able to work his fraud after all. Suppose his wave was missing you. Do jump about a bit, those short waves, don't they?"

"They do," agreed Dare, laughing aloud. "And then what happened?"

"Why, nothing, except"—Blazer registered a few signs of triumph—"he hadn't got a transmitting licence, so he'll be summoned for that!"

"So they all lived happily ever after!"

"Wossay?"

"I said, my Blazer, that you are the world's perfect policeman," chuckled Dare happily, and his conscience did not prick him a scrap as he pictured the "innocent" Sir Pothercary Clarkhop being interrupted by invading inspectors right in the middle of his so very carefully planned radio experiment.

THE "M.W." "INTER-AXIAL" A Reader's Success.

Sir,—I have constructed your "Inter-Axial" cone speaker, and I feel I must thank and congratulate the technical staff for a splendid production. The realism in reproduction is really quite uncanny. As I write, there is a man singing, and really seems as if he is in the room. Previously I was using an expensive chassis, costing more than ten shillings, but it won't stand comparison with this one, yet I am using the same unit, so it must be the cone which is making the difference. To those readers who are dubious about the improvement—like I was, I confess—I can only say, try it and see for yourselves.

Yours sincerely,
B. C. KEMP.

N.3.

"FOR THOSE D.C. MAINS"

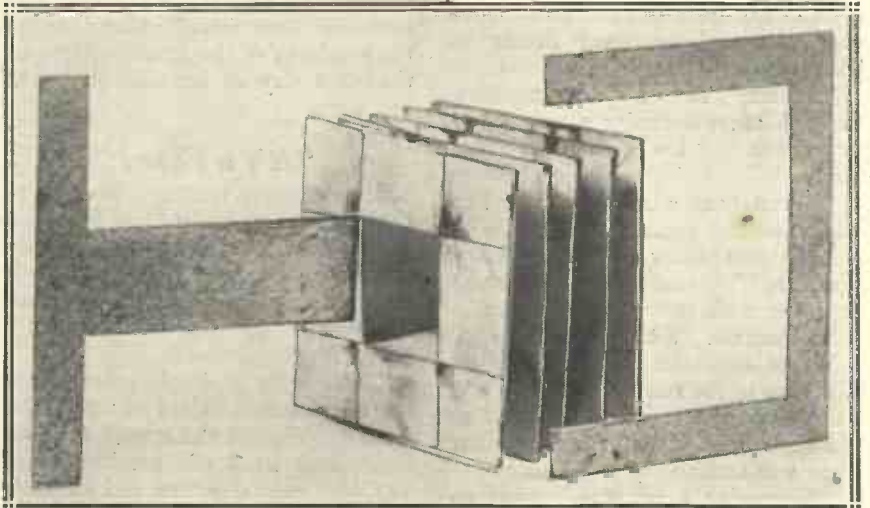

The two parts of the core of the choke are made up—as explained in the article which begins on page 422—from laminations shaped as shown above.

INDEX TO ADVERTISERS

	PAGE		PAGE
Auto-Electric Devices, Ltd.	357	Edison Swan Electric Co., Ltd.	Cover iv
Belling & Lee, Ltd.	454	Electrical Trading Association, Ltd.	433
Benjamin Electric, Ltd.	452	Formo Company	447, 448
British Blue Spot Co., Ltd.	Cover iii	Graham Farish Radio	455
British Insulated Cables, Ltd.	437	Heayberd, F. C., & Co.	443
Bulgin, A. F., & Co., Ltd.	451	Jackson Bros.	453
Burne-Jones & Co., Ltd.	442	London Electric Wire Co. & Smiths, Ltd.	441
Carrington Manfg. Co., Ltd.	443	Lissen, Ltd.	425
Cossor, A. G., Ltd.	358	Lotus Radio, Ltd.	441
Cole, E. K., Ltd.	429	Lyons, Claude, Ltd.	450
Day, Will, Ltd.	454	"Manners and Customs of Mankind"	449
Dubilier Condenser Co. (1925), Ltd.	447	"Modern Boy"	447
Eastick, J. J., & Sons	451	Paroussi, E.	450
		Peto-Scott Co., Ltd.	444
		Pickett's Cabinet Works	451
		"Popular Gardening Annual"	445
		Ready Radio	427
		Regentone, Ltd.	447
		Rothermel Corporation, Ltd.:	
		Magnavox	437
		Centralab	445
		Six-Sixty Radio Co., Ltd.	451
		Taylor, M.	454
		Telegraph Condenser Co., Ltd.	445
		Telsen Electric Co., Ltd.	Cover ii
		"This and That"	451
		"Undy" Loud Speaker	443
		Varley Products	452
		Westinghouse Brake & Saxby Signal Co., Ltd.	437
		Whiteley Electrical Radio Co., Ltd.	446
		Wright & Weaire, Ltd.	443

All communications concerning advertising in "Modern Wireless" must be made to John H. Lile Ltd., 4, Ludgate Circus, London, E.C.4. Telephone: City 7261.

FAIR PLAY for

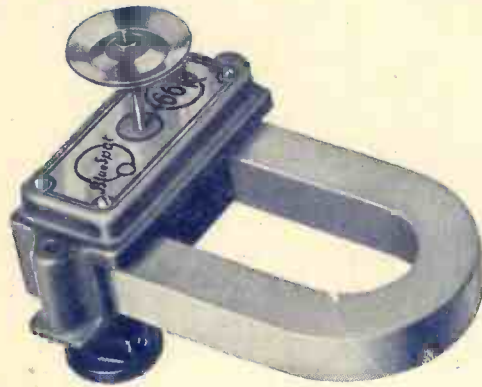

BLUE SPOT UNITS

BLUE SPOT 66K

Type 66K (25 m/a) **25/-**
(as illustrated)

Type 66P (30 m/a) **27/6**

Type 66R (50 m/a) **35/-**

BLUE SPOT CHASSIS

SPECIAL (31 cm.) **10/6**

MAJOR (37 cm.) **15/-**

Suitable for all types of Blue Spot Units.

TO use a Blue Spot Unit with *any* type of chassis is like asking a footballer with size ten feet to play in size eight boots. You *can't* expect the best results.

Millions of Blue Spot Units are at present giving satisfactory service—a fact which proves their merit beyond question. But Blue Spot Units are too good to spoil. That is why you should **INSIST** on having a Blue Spot Chassis and accept no other. A Blue Spot Unit in a Blue Spot Chassis gets as near to perfection as human skill and knowledge can attain.

The 66K Unit is ideal for small and medium powered sets, The 66R is specially suitable for very powerful sets and can handle enormous outputs without distortion or rattle. The Blue Spot Chassis is made with meticulous care and is scientifically accurate in its dimensions from apex to base and in the diameters of both apex and base, thus ensuring at all times a sympathetic response to the vibrations of the stylus of the unit.

It is impossible to be dissatisfied with the performance of Blue Spot Speakers. No higher standard exists to-day.

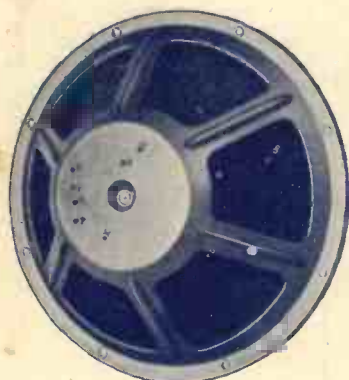

THE BRITISH BLUE SPOT COMPANY LTD

BLUE SPOT HOUSE · 94/96 ROSOMAN STREET · ROSEBERY AVENUE · LONDON · E C 1
'Phone: Clerkenwell 3570. 'Grams: "Bluspot, Isling, London."

Distributors for Northern England, Scotland, and North Wales: H. C. RAWSON (Sheffield and London), LTD., 100, London Road, SHEFFIELD; 22, St. Mary's Parsonage, MANCHESTER; 183, George Street, GLASGOW.



TRADE MARK

For large volume

WITHOUT HUM or DISTORTION

In A.C. mains Sets where the output valve—whether triode or pentode—is directly heated by A.C. mains, hum is difficult to eliminate. A valve using an indirectly heated cathode should therefore be employed.

The Mazda AC/PEN is a high power Pentode capable of an enormous output with only 250 volts H.T. Its characteristics ensure excellent bass response and brilliant high notes and a detector can fully load it without an intermediate stage and complete freedom from hum is assured.



THE
AMAZING

MAZDA RADIO VALVES

CHARACTERISTICS

TYPE	Fil. Volts	Fil. Amps.	Max H.T. Volts	Amp. Factor	Anode Resistance (ohms.)	Mutual cond. mA/V	PRICE
AC/SG	4	1.0 approx.	200	1200	—	—	25/6
AC/HL	4	1.0 "	200	35	11700	3:0	15/6
AC/P	4	1.0 "	200	10	2650	3:7.5	17/6
AC/P 1	4	1.0 "	200	5	2000	2.5	17/6
AC/Pen	4	1.0 "	250	—	—	2.2	27/6



THE EDISON SWAN ELECTRIC CO., LTD.
*Incorporating the Wiring Supplies, Lighting Engineering
and Radio Business of the British Thomson-Houston Co., Ltd.*

Radio Division Showrooms:
155 Charing Cross Road, London, W.C.2
Showrooms in all the Principal Towns.

EDISWAN