

THE MARCONI REVIEW

No. 41.

March-April, 1933.

Editor: H. M. DOWSETT, M.I.E.E., F.Inst.P., M.Inst.R.E.

SERIES MODULATION

With the increasing demand for high quality broadcast transmitters has arisen the question as to the best methods of modulating carrier waves. In the following article a general review of the modulation systems commonly employed is given, and the advantages of "series modulation" over other systems is discussed.

THERE are two widely used methods of modulating the output of a radio-frequency thermionic valve. One of these is performed by variation of the grid voltage, and the other by variation of the anode voltage. In the earliest valve telephone transmitters, the first method was usual, followed later by almost universal adoption of the second. At the present time the latest high power broadcasting transmitters comprise either a combination of two different varieties of grid voltage modulation, or, more commonly, a combination of an anode voltage modulated stage followed by one or more stages of grid voltage modulated amplifiers.

Numerous experiments on various types of valves have proved conclusively that when deep modulation is required, greatly superior linearity of response to the modulating voltages is obtained when these voltages are applied to the anode rather than to the grid of the radio frequency amplifier, and this holds true whether the variation in grid potential is secured by superimposing low frequency voltages on a constant radio frequency input or by a change in amplitude of the radio frequency input itself.

From the point of view of linear response, therefore, it appears definitely desirable to perform the operation of modulation on the anode of the final power stage of the transmitter, or, if this is for any reason undesirable or inconvenient, to limit the number of amplifying stages after modulation to a minimum.

In the field of broadcast transmission, the present requirement of the C.C.I.R., limiting the Distortion Factor to 4 per cent. at the maximum permissible modulation of the set instead of the former 10 per cent. limit, has made the problem of securing substantially linear response at a high percentage of modulation a factor of primary

importance and of some difficulty, it being understood that this harmonic content of 4 per cent. is produced by a very slight departure from a straight line response at any part of the modulation sweep.

The best known method of performing anode voltage modulation is by the "choke-control" or Heising system, which in fact is incorporated in one form or another in the great majority of telephone transmitters now existent.

Provided the power dealt with is low, and that the voltage across the modulator is somewhat high compared to that across the modulated amplifier, excellent results are obtainable by this method, both as regards linearity and frequency response. When, however, it becomes essential to modulate at a fairly high power level, this method introduces considerable difficulties, particularly in the design of the large chokes then required.

These various considerations induced the Marconi Company to investigate the possibilities of the so-called "series modulation" or "constant potential" method, with the specific object of applying it to high powered broadcasting transmitters, the intention being to modulate at such a power level that only one stage of amplification would be necessary after modulation, whatever the final power rating of the transmitter.

The principle underlying series modulation has been recognised as an obvious possibility for years past, but apparently its application has never been regarded seriously until quite recently, at any rate on any considerable scale, probably because the greater convenience of the choke control circuits, with all the cathodes at earth potential, prevented consideration being given to the principal advantage of the alternative method.

The great point in favour of the method is the fact that, as modulation can be performed without the aid of an iron-cored choke or transformer, there is no definite limit to the power that can be dealt with, a satisfactory frequency response being obtainable just as readily at high powers as at low, and it is just this factor that renders the series method so suitable for modern high power transmitters.

It may be as well to state at once that the series method is not capable of dealing with very deep modulation, say 95 per cent. to 100 per cent., with the same freedom from distortion as the choke control method when the latter is arranged to operate with a high ratio of modulator voltage and power to amplifier voltage and power. However, in practice, questions of efficiency and frequency response limit the high quality choke control stage to very low power levels, and the advantages of the obtainable linear amplitude response are lost when the modulated stage has to be followed by several stages of Class B amplification, each one of which adds a definite degree of distortion to a deeply modulated input.

Numbers of broadcasting transmitters have been erected in Europe, in which modulation is performed at a power level of 50 to 100 watts, and two or even three stages of amplification added, and in many of these, considering the carrier efficiency of the amplifying stages, it is very doubtful whether more than about 60 per cent. modulation is possible without exceeding the 4 per cent. distortion limit.

Possibly the highest quality transmitters at present in operation are the 50 kw. sets constructed by the Marconi Company for use in the British Broadcasting Corporation's regional stations, duplicates and modifications of which have been erected in many countries. In these sets there is one stage of amplification between the modulated amplifier and the final power amplifier, this intermediate stage

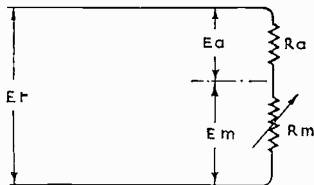

FIG. 1.

operating with low impedance valves so adjusted that the grids are maintained negative throughout the modulation sweep. The distortion introduced by an amplifier of this type is very small, but unfortunately the extremely low conversion efficiency prevents its use for powers above a few kilowatts. This range of transmitters, with carrier powers varying from ten to over one hundred kilowatts, can be modulated more than 80 per cent. with a Distortion Factor of very little above 4 per cent. Even these results, good as they are, scarcely fulfil present requirements, and it is interesting to enquire what improvement is possible by utilising the series modulator, either to control the final stage directly or in combination with one stage of Class B amplification.

Before enumerating results obtained in practice, a brief description of the method and the circuits employed will be given.

The method of varying the anode voltage of a high frequency oscillator or amplifier, by means of a modulating valve connected in series therewith, is obviously extremely simple in principle.

Theoretically, the circuit can be represented, as in Fig. 1, by a source of potential (E_t), across which are connected in series two resistances, one (R_a) fixed in value, corresponding to the modulated amplifier, and the other (R_m) variable in value, corresponding to the modulator.

Assuming these two resistances are initially equal, it is clear that the total supply voltage will be equally divided across them ($E_a = E_m$), and that if the variable resistance (modulator) is varied in value from zero to infinity, the voltage across the fixed resistance (modulated amplifier) will vary from its initial value (carrier setting) to twice that value and to zero, that is to say, the amplifier will be fully modulated.

When these ideal ohmic resistances are replaced by thermionic valves it is not possible to reduce the modulator resistance to zero, or, with a symmetrical grid swing to make its resistance infinite, but by correct choice of the modulator, and by suitable adjustment of the modulator grid bias, such that in the carrier condition the voltage across the modulator is somewhat higher than the amplifier voltage, there is no difficulty in obtaining a peak voltage on the amplifier of twice the carrier value and in reducing this very nearly to zero.

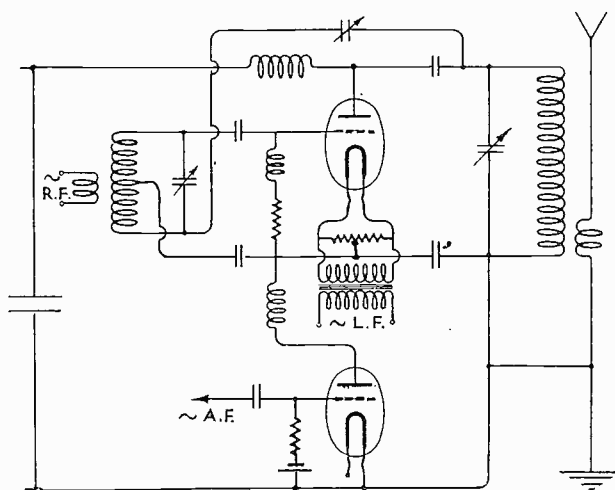

FIG. 2.

A typical circuit for use with this method of modulation is shown diagrammatically in Fig. 2, from which it will be seen that the modulator is connected on the earthed side of the system, while the cathode of the modulated amplifier is at a potential positive to earth. To attempt a reversal of these positions introduces difficulties in applying bias and input volts to the modulator grid, and is hardly practical.

It will also be observed that by interposing suitable blocking condensers between the anode and cathode of the amplifier and its oscillatory circuit, it is feasible to connect the latter to earth in the usual manner. It is important that these blocking condensers should be of a low value in order to avoid bye-passing to earth of the higher modulating frequencies. Similar considerations apply as regards the means for heating the cathode of the amplifier. In Fig. 2 means are indicated for utilising alternating current for this purpose, and care has to be taken in constructing the transformer to have a small capacity between its primary and secondary windings. Tests made when using fifty cycle current for heating have shown that the ripple produced is hardly appreciable, but in certain transmitters arrangements are incorporated for heating by an insulated motor driven D.C. dynamo, and here, again, consideration has to be given to the capacity to ground of the machine and connecting leads.

Fig. 3 shows the anode potential-anode current curves of a typical water-cooled modulating valve of a type suitable for use in a medium power series modulated transmitter. With a curve sheet of this kind at hand it is a fairly simple matter of

trial and error to arrive at the necessary adjustments for a stated power output and permissible degree of modulation.

The total supply voltage requires to be known, and also the safe anode dissipation and anode voltage of the modulator. On a curve sheet as Fig. 3, mark a point C such that the said limits are not exceeded. If E_t is the total voltage, and E_{m1} the voltage across the modulator, then the voltage across the amplifier is obviously $E_t - E_{m1} = E_a$.

The anode current I_a must be equal in both amplifier and modulator in the series circuit, so the resistance of the amplifier system is equal to $\frac{E_a}{I_a}$.

Through the point C draw the load line ABCD such that its slope corresponds to the resistance of the amplifier system, B being a point on the curve $E_g=0$, and D a point on the voltage axis, such that $OB = E_t =$ the total voltage. Making the usual assumption that the sweep of the

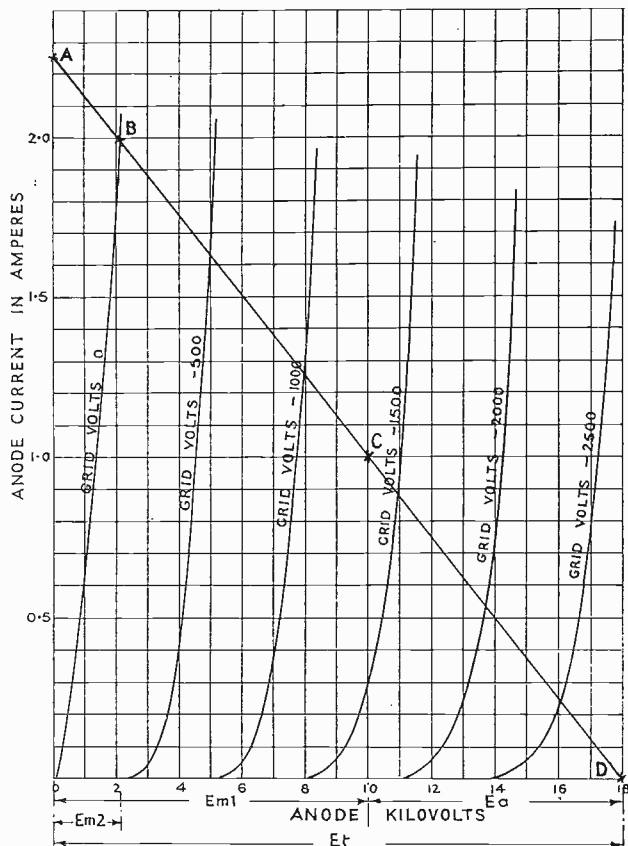

FIG. 3.

state-point must not pass the line $E_g=0$ (point B), the performance of the system can now be computed.

- Let E_t = the total voltage.
- E_a = the voltage across the amplifier.
- E_{m1} = the voltage across the modulator.
- E_{m2} = the voltage across modulator at point B.
- M = coefficient of modulation.

$$\text{then } M = \frac{E_t - E_{m2}}{E_t - E_{m1}} - 1$$

Series Modulation.

The power input to the amplifier is $E_a I_a$, and it is usual to assess about 66 per cent. of this as the radio frequency carrier power.

The overall efficiency of the stage is therefore given by

$$\text{Efficiency} = \frac{66 E_a}{E_t} \text{ per cent.}$$

As the curve sheet Fig. 3 includes actual values, a numerical calculation can be made from the data shown.

The total voltage is given as 18,000 volts, and it is assumed the modulator is capable of dissipating at least ten kilowatts.

The modulator voltage is 10,000, and the anode current, one ampere, requiring a grid bias of about 1,350 volts, so the amplifier voltage is 8,000 with the same anode current, that is, an input of eight kilowatts. At 66 per cent. efficiency this results in a carrier power of 5.3 kilowatts and the overall efficiency amounts to

$$\frac{66 \times 8,000}{18,000} = 29.3 \text{ per cent.}$$

The maximum permissible modulation is

$$\frac{18,000 - 2,200}{18,000 - 10,000} = 1$$

that is, 97.5 per cent.

In most cases it would not be advisable to modulate so deeply as this, owing to the distortion produced by the bending of the characteristics

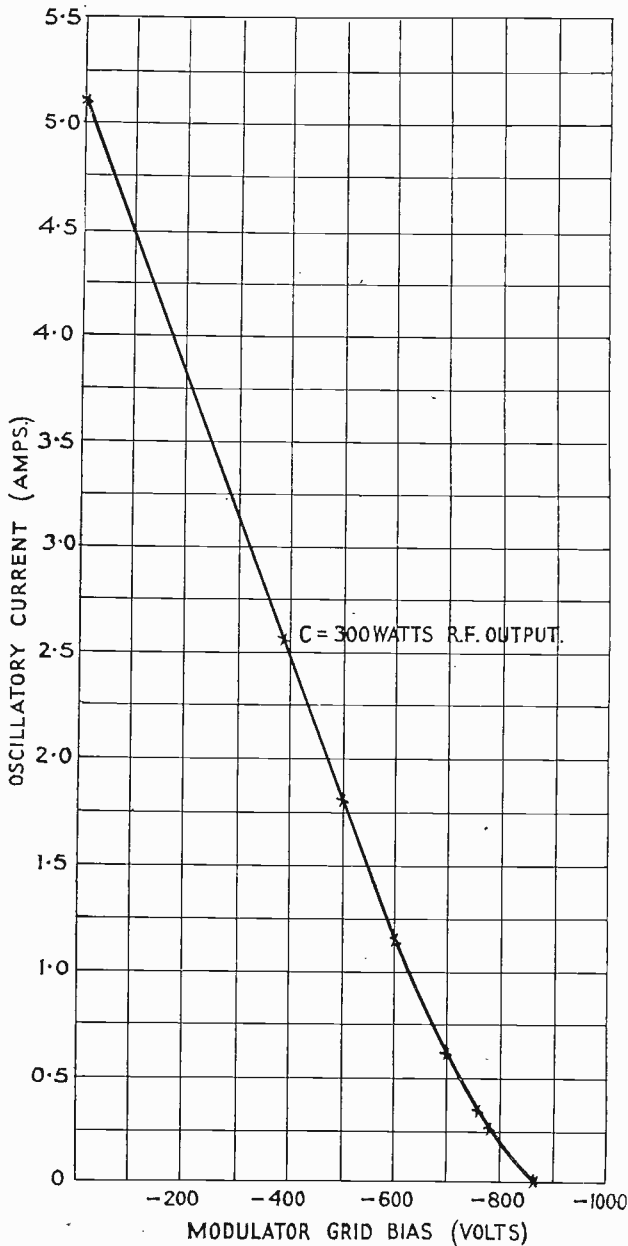

FIG. 4.

Series Modulation.

at the bottom of the curve, but a sweep corresponding to 80 per cent. is possible with negligible distortion.

In Fig. 4 is reproduced a curve in which the oscillatory current in the amplifier circuit is plotted against the grid bias voltage of the modulator, and it will be observed that the output is sensibly linear downwards from the carrier level (marked C) to a point which corresponds to 80 per cent. modulation.

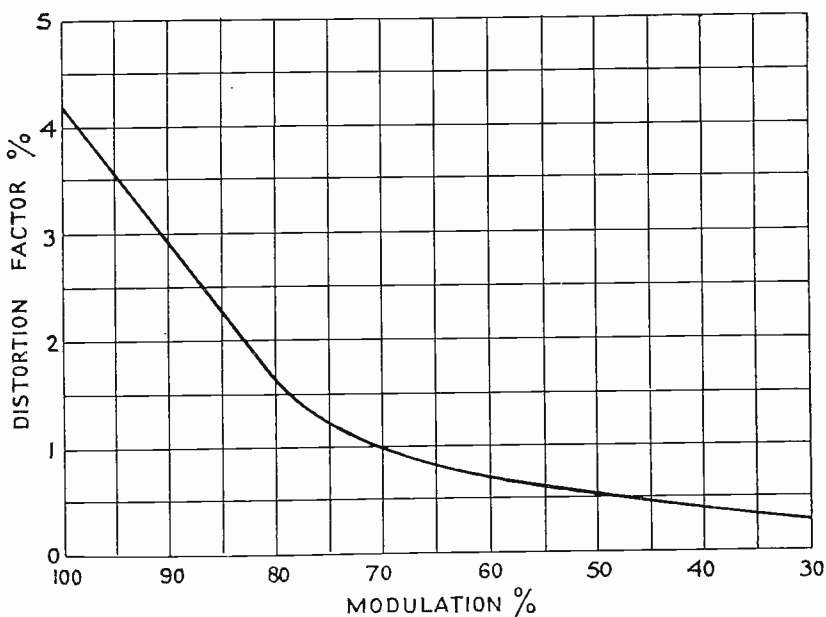

FIG. 5.

In this case the modulated amplifier is a DET3 valve, and the modulator one MT9L valve, the total voltage is 6,000, divided so that 3,600 volts is applied to the modulator and 2,400 volts to the amplifier, and the carrier output is approximately 300 watts.

Fig. 5 shows the Distortion Factor plotted against various percentages of modulation, using a fundamental modulating frequency of 1,000 cycles on a stage consisting of two CAT6 valves modulated by two CAM3 valves at 18,000 volts with a carrier output of about ten kilowatts.

It will be obvious from consideration of the above discussion that the overall efficiency can be increased by adjusting for reduced voltage on the modulator and increased voltage on the amplifier, provided a reduction in the permissible modulation is agreeable, but in practice it will normally be found desirable to so arrange

Series Modulation.

matters that when the modulator grid bias reaches zero the amplifier anode potential reaches just twice its carrier value. Under these conditions it will be found practically impossible to seriously over-modulate the high frequency carrier, and this effect can be definitely prevented by inserting a suitable resistance in series with the modulator grid, under which conditions no increase in positive grid potential will appreciably alter the voltage drop across the modulator from the value reached at $E_g = 0$. It will be clear that in the series modulation method the anode of the amplifier can never become negative with respect to its cathode, as may occur in the "choke control" system. Another point of interest observed in practice is that the connection of the valves in series appears to considerably reduce the tendency to "rocky points," or internal discharges, even although the peak potentials reached during modulation are much higher than those for which the valves are normally rated.

The Marconi Company has so far developed the series method up to an output of some 30 kilowatts, a power sufficient to drive a final amplifier rated at 300 kilowatts carrier energy, which seems sufficient to meet the maximum requirements of broadcasting for some time to come.

The results obtained when the series modulated stage is followed by one Class B amplifier are very satisfactory. With a power ratio between the stages of about ten to one, as indicated above, and with the Class B amplifier operated at about 30 per cent. efficiency it has been found possible to modulate up to 90 per cent., with a Distortion Factor well below the 4 per cent. limit.

As mentioned previously, the series modulation circuit is inherently independent of frequency in its response to modulation over a wide range, and it has not been found difficult to secure a frequency characteristic level within 0.5 dB. from 50 to 10,000 cycles. This feature makes the system particularly applicable to transmitters required to transmit a wide modulation band for television purposes, and its adoption for such uses is a very probable development.

W. T. DITCHAM.

SYNCHRONISATION IN TELEVISION

In the transmission of intelligence by television methods, one of the chief problems is that of maintaining synchronism between transmitter and receiver. In the following article the conditions which have to be met, and the difficulties which have to be overcome, are enumerated and some details are given of systems of synchronisation which have been applied in practice. Only mechanical scanning systems which obtain synchronisation by the use of synchronous motors are considered in detail, and a complete description of the synchronising system used in the Marconi series of Television Transmitters is given.

ALL present television methods can, so far as is known, be divided into two classes,

- (A) those in which mechanical scanning elements are employed,
- (B) those which utilise cathode ray streams as the exploring medium and scan by electrical or magnetic diversion of these rays.

It is not considered necessary here to explain in detail the exact processes by means of which the image of the subject being televised is analysed and converted into a series of electrical impulses, which are transmitted by land line or radio link to a receiver, where the electrical impulses are converted into light variations which build up an image of the subject. Many excellent descriptions of the methods employed both in the case of mechanical and in the case of cathode ray scanning, have been given from time to time. We may refer the reader to a good description of disc scanning methods published in the Bell System Technical Journal for October, 1927, and to articles in "Fernsehen" for April, 1931, No. 2, which deal with cathode ray scanning methods.

From the point of view of synchronisation, all television methods have much in common. The basis of television depends on the operation known as "scanning," by means of which the picture at the transmitting end is analysed into a series of consecutive light impulses or "picture elements," and is synthesised at the receiving end from these elementary impulses to reproduce an image of the original picture.

If we imagine a picture to be broken up into a series of discrete picture elements it is obvious that each picture element will have a definite spatial relationship to the picture. Thus, if the operation of scanning consists of analysing the picture into a series of consecutive picture elements which in turn give rise to a series of consecutive electrical impulses, a set of which impulses corresponding to a complete traversal of the picture being known as a "scan," each electrical impulse has a definite time relationship to the start or finish of a scan.

The distortionless reproduction of the image at the receiving end demands that the time relationship of a particular received picture element to a received scan shall be identical to the corresponding transmitting relationship, in short that the receiver and transmitter shall be in synchronism.

Series Modulation.

matters that when the modulator grid bias reaches zero the amplifier anode potential reaches just twice its carrier value. Under these conditions it will be found practically impossible to seriously over-modulate the high frequency carrier, and this effect can be definitely prevented by inserting a suitable resistance in series with the modulator grid, under which conditions no increase in positive grid potential will appreciably alter the voltage drop across the modulator from the value reached at $E_g = 0$. It will be clear that in the series modulation method the anode of the amplifier can never become negative with respect to its cathode, as may occur in the "choke control" system. Another point of interest observed in practice is that the connection of the valves in series appears to considerably reduce the tendency to "rocky points," or internal discharges, even although the peak potentials reached during modulation are much higher than those for which the valves are normally rated.

The Marconi Company has so far developed the series method up to an output of some 30 kilowatts, a power sufficient to drive a final amplifier rated at 300 kilowatts carrier energy, which seems sufficient to meet the maximum requirements of broadcasting for some time to come.

The results obtained when the series modulated stage is followed by one Class B amplifier are very satisfactory. With a power ratio between the stages of about ten to one, as indicated above, and with the Class B amplifier operated at about 30 per cent. efficiency it has been found possible to modulate up to 90 per cent., with a Distortion Factor well below the 4 per cent. limit.

As mentioned previously, the series modulation circuit is inherently independent of frequency in its response to modulation over a wide range, and it has not been found difficult to secure a frequency characteristic level within 0.5 dB. from 50 to 10,000 cycles. This feature makes the system particularly applicable to transmitters required to transmit a wide modulation band for television purposes, and its adoption for such uses is a very probable development.

W. T. DITCHAM.

SYNCHRONISATION IN TELEVISION

In the transmission of intelligence by television methods, one of the chief problems is that of maintaining synchronism between transmitter and receiver. In the following article the conditions which have to be met, and the difficulties which have to be overcome, are enumerated and some details are given of systems of synchronisation which have been applied in practice. Only mechanical scanning systems which obtain synchronisation by the use of synchronous motors are considered in detail, and a complete description of the synchronising system used in the Marconi series of Television Transmitters is given.

ALL present television methods can, so far as is known, be divided into two classes,

- (A) those in which mechanical scanning elements are employed,
- (B) those which utilise cathode ray streams as the exploring medium and scan by electrical or magnetic diversion of these rays.

It is not considered necessary here to explain in detail the exact processes by means of which the image of the subject being televised is analysed and converted into a series of electrical impulses, which are transmitted by land line or radio link to a receiver, where the electrical impulses are converted into light variations which build up an image of the subject. Many excellent descriptions of the methods employed both in the case of mechanical and in the case of cathode ray scanning, have been given from time to time. We may refer the reader to a good description of disc scanning methods published in the Bell System Technical Journal for October, 1927, and to articles in "Fernsehen" for April, 1931, No. 2, which deal with cathode ray scanning methods.

From the point of view of synchronisation, all television methods have much in common. The basis of television depends on the operation known as "scanning," by means of which the picture at the transmitting end is analysed into a series of consecutive light impulses or "picture elements," and is synthesised at the receiving end from these elementary impulses to reproduce an image of the original picture.

If we imagine a picture to be broken up into a series of discrete picture elements it is obvious that each picture element will have a definite spatial relationship to the picture. Thus, if the operation of scanning consists of analysing the picture into a series of consecutive picture elements which in turn give rise to a series of consecutive electrical impulses, a set of which impulses corresponding to a complete traversal of the picture being known as a "scan," each electrical impulse has a definite time relationship to the start or finish of a scan.

The distortionless reproduction of the image at the receiving end demands that the time relationship of a particular received picture element to a received scan shall be identical to the corresponding transmitting relationship, in short that the receiver and transmitter shall be in synchronism.

This can be seen very simply from consideration of the scanning of a simple figure, say, a black diamond as in Fig. 1. Let us assume that the picture is divided into a series of elementary vertical lines (or scan lines), each line being composed of a number of discrete elements (picture elements). Then assuming the simplest type of transmission possible, the electrical impulses transmitted would be as shown.

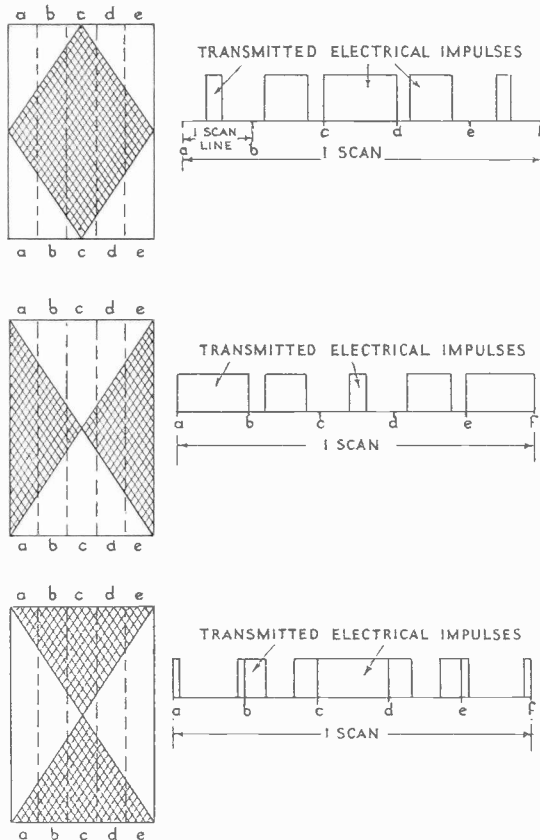

FIG. 1.

The conditions for complete synchronism are twofold.

- (1) Each picture element must take exactly the same time to produce at the receiving end as its generation takes at the transmitting end, i.e., scan line frequency and picture frequency must be identical at receiver and transmitter.
- (2) The time relationship of a received picture element to a received scan must be identical to the time relationship of a transmitted picture element to the transmitted scan.

If condition (1) is not satisfied no intelligible image will be received, for the received picture elements will be in arbitrary positions relative to the received scan.

If condition (1) is satisfied but condition (2) is not satisfied, then the received picture will bear a distinct relationship to the transmitted picture, but will in general be translated in a vertical or horizontal direction or in both directions at once.

Compliance with (1) is known as correct synchronism and with (2) as correct framing or phasing.

Framing or Phasing.

We shall first consider the question of phasing. Incorrect phasing may be of two kinds.

- (1) Vertical translation.
- (2) Horizontal translation.

The first form of incorrect phasing is illustrated in Fig. 1. If we assume vertical scanning, dephasing of the picture in a vertical sense is due to the fact that whereas

both the receiving and the transmitting mechanism are rotating at the same speed, there is a constant lag or lead of the transmitting mechanism, this lag not being an integral number of scan lines. In the figure, if the angle through which the receiver scanning mechanism turns corresponding to the complete length of a scan line is δ° , the dephasing represented corresponds to a lead at the receiver end of ϕ° or to a lag of $\delta^\circ - \phi^\circ$.

The second form of dephasing is also illustrated in Fig. 1. This horizontal dephasing is caused by a lag or lead of the receiving mechanism which is an integral multiple of δ° . In other words, horizontal translation of the picture is caused by the receiving mechanism lagging or leading the transmitting mechanism by an integral number of scan lines.

The two forms of dephasing may, of course, occur simultaneously. We may therefore say that if the dephasing of the receiving mechanism from the transmitting mechanism is zero, there will be perfect synchronism; if it is equal to $m\delta$ where m is any integer, there will be horizontal translation of the picture only; if it is equal to $k\delta$, where k is a fraction there will be vertical translation only; and if it is equal to $m\delta \pm k\delta$ or in general to $q\delta$ where q is any number whatsoever, there will be both types of translation.

Synchronism in the Case of Mechanical Scanning Systems.

The analysis of the picture at the transmitting end is accomplished either by rotating or vibrating mechanism. The simplest method of scanning is by means of a Nipkow Disc, and we shall use this method to illustrate the various problems which arise in synchronisation of television signals.

Synchronisation in the case of a disc transmitter working in conjunction with a disc receiver reduces to the problem of maintaining the two discs at identical speeds and constant and correct phase relationship.

Identity of Speed.

The question as to what is meant by Identity of Speed must next be considered. We shall assume in what follows that the resolution of the picture is required to be identical in both directions. That is to say that in the ordinary systems of scanning, in which the scanning is continuous in one direction and discontinuous in another, that a picture element shall be considered to be an element which is rectangular (and approximately square) and has for its sides the breadth of the scan line.

If we take as a concrete example the case of a disc transmission where 50 scanning lines are employed per picture, and where the scanning is continuous in a horizontal direction and discontinuous in a vertical direction, and where the ratio of the length to the breadth of the transmission frame is 1 : 1, a picture element will be considered to be $1/2,500$ of the total area of the transmission frame.

It has been found by various experimenters that if the transmission and reception speeds differ from one another by no more than an amount which corresponds to half the length or breadth of one picture element, the degree of synchronisation is sufficient for all ordinary purposes. This applies to the case of visual impression only and not to photographic recording.

Synchronisation in Television.

Let us see what the above condition represents in the general case. (Fig. 2).

Let

Number of holes	$= n$
Angular separation of holes	$= \theta^\circ$
Distance of holes from centre	$= r_1, r_2, r_3, \dots, r_n = r$ cms. (mean value).
Separation of holes on disc	$= 2r \tan \theta/2$ cms.
Rate of rotation of disc	$= \phi$ r.p.m.
Picture frequency	$f = \frac{\phi}{60}$ (if one picture per revolution).
Angular velocity of disc	$= \frac{\pi\phi}{30}$ radians per sec. $= 6\phi$ degrees per sec.
Time taken to travel θ degrees	$= \frac{\theta}{6\phi}$ secs.
Let the disc contain square holes of side	$= a$
Let the breadth of the picture	$= b$
Let the length of the picture	$= l$

Then

$$\text{Number of picture elements per scan line} = \frac{2r \tan \theta/2}{a}$$

$$= \frac{l}{b} n$$

Time for one picture element

$$= \frac{\theta a}{12 \phi r \tan \theta/2}$$

$$= \frac{\theta b}{6ln\phi}$$

Thus for synchronism the time lag must not exceed t where

$$t = \frac{\theta b}{12 ln\phi} \text{ secs.}$$

Angular slip must not exceed

$$\psi = 6\phi t \text{ degrees.}$$

Applying this to the above case where $\theta = \frac{360}{50}$, $l = l$, $n = 50$, $\phi = 15$, etc., we have

$$t = .000013 \text{ sec.}$$

$$\psi = .072^\circ.$$

That is to say the phase difference of received and transmitted signals must at no time be greater than .000013 sec., or the discs must be kept in phase to .072°.

The obvious method of maintaining two discs in synchronism is to drive the first disc by a motor which possesses a second winding by means of which alternating impulses are generated whose frequency is a function of the disc speed. At the receiver end the disc is driven by a synchronous motor, so designed that when fed with the synchronising impulses from the transmitting motor, the disc rotates in synchronism with the transmitting disc.

Such an arrangement provides only for maintenance of synchronism, and does not provide for correct phasing. The synchronous motor at the receiving end may, in general, lock into synchronism with the transmitting motor at one of many points, thus providing a stationary picture but one which is not framed correctly.

It is, however, a comparatively simple matter to allow the receiving motor to slip until the correct phasing is obtained and then to allow it to lock into synchronism.

This, or a modification of this, is the method generally adopted for synchronisation of television transmitters and receivers. Various methods of synchronisation differ in the methods adopted for generating, transmitting and utilising the synchronising impulses.

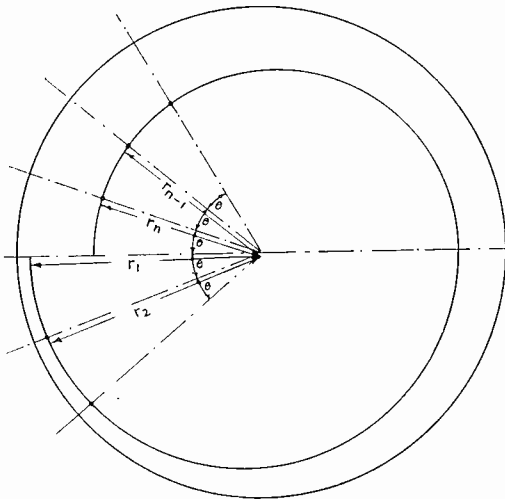

FIG. 2.

where p = picture repetition frequency.
 n = number of picture elements per horizontal scan line.
 m = number of scan lines per picture

f is known as the scan line frequency of the system.

It has further been found that the transmission of television signals does not in general involve the transmission of energy uniformly in the above frequency spectrum. Rather, this energy is concentrated at certain points of the frequency spectrum and these points occur at integral multiples of the scan line frequency of the system.* The scan line frequency as shown above can be defined as the frequency obtained by multiplication of the number of scan lines per picture by the picture frequency. Thus, in the transmission of a picture scanned by a hundred lines fifteen times a second, the scan line frequency would be 1,500 cycles per second, and the transmission of such a signal would necessitate chiefly the transmission of energy concentrated around frequencies of 1,500, 3,000, 4,500, etc., cycles per second.

Frequency Distribution of the Television Signal.

It is well known, of course, that an entirely arbitrary type of signal such as is generated in television transmission, is capable of expansion in terms of a Fourier series, or Fourier integral, and thus may contain all frequencies from zero to infinity. It has been found, however, that the maximum energy of the signal is contained between the frequencies f and f' where

$$f = p.m.$$

$$f' = \frac{p.n.m.}{2}$$

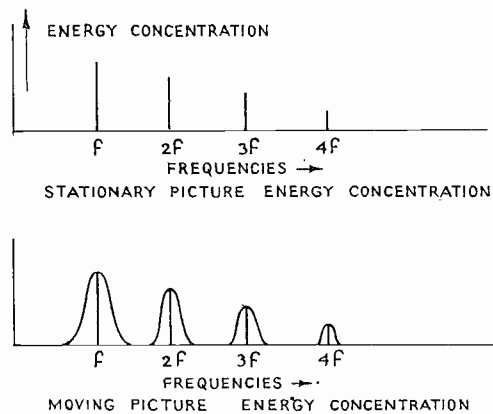

FIG. 3.

* Energy concentrations occur also at frequencies $p, 2p, 3p$, etc., but these are by no means so important as the energy which is concentrated round frequencies $pm, 2pm$, etc.

The actual distribution of energy in the frequency spectrum depends on the type of picture transmitted. In the case of a stationary picture the energy is concentrated sharply at the above-mentioned frequencies. In the case of a moving picture the energy concentration bands become wider as the rate of movement of the picture increases. The mean frequency of the bands, however, still remains at the above-mentioned frequencies. This is represented in Fig. 3, in which frequencies are plotted as abscissæ and the energy concentration as ordinates.

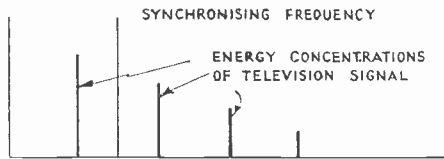

FIG. 4(A).

Synopsis of Synchronisation Problems.

Summarising the above points we see that whatever method of synchronisation

be employed this must provide for,

- (1) accurately keeping the receiving and transmitting motors running at the same speed.
- (2) Framing and phasing the received picture.

Now television pictures are transmitted either over a land line or radio link, and we have briefly investigated the nature of the signal above. It is obvious,

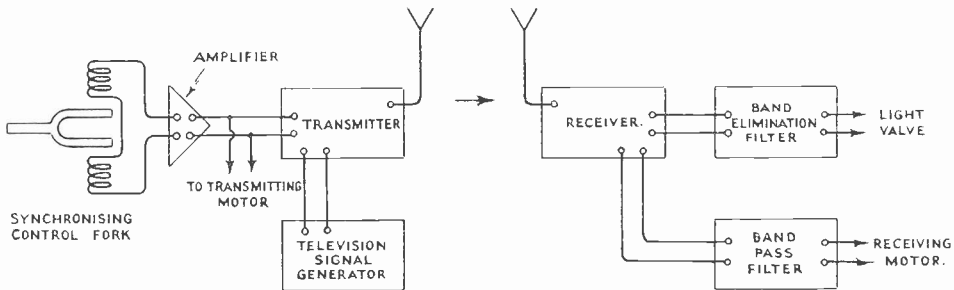

FIG. 4(B).

therefore, that synchronisation impulses must, since they are required to link up transmitter and receiver, be transmitted either (A) along with the television signals, (B) by some entirely separate channel. In case (A) we shall see that the synchronisation signals may actually be part of the television signals or may be inserted into the latter by special means described hereafter.

In case (B) the problem is much simplified. Two methods of attacking it have been employed. In one of these use is made of the network of power lines supplying alternating current to the district in which is situated the transmitter and receiver. This current, which in England possesses, generally, a frequency of 50 cycles per second, can be employed to control the speed of both transmitting and receiving motor, and since everywhere it is of the same frequency and phase (in a controlled "grid" system such as is being rapidly developed in England), the transmitting and receiving motors will be kept in step.

In the second method a frequency is generated at the transmitting station and this frequency is used to control the speed of the transmitting motor. The

frequency is transmitted along a separate land line or radio link to that employed for the television signals, to the receiving station and is there used to keep the receiving motor in step with the transmitting motor.

These systems represent the simplest methods of obtaining synchronism. Both, however, entail additional links between transmitting station, and are, on this account, not always desirable.

If such systems are used, however, synchronisation problems reduce to finding the best type of synchronous motors for the particular system.

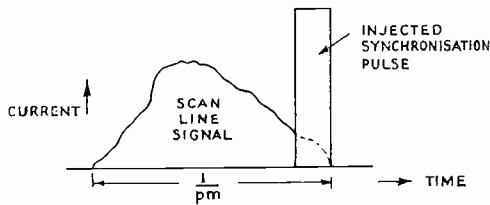

FIG. 5.

We shall not, however, deal further with such methods, but will pass to a consideration of those methods which do not entail a separate link.

We have seen above that the television signal does not cover, in its frequency spectrum, the entire range of frequencies from f to f' , but consists of energy concentrations at f , $2f$, $3f$. It will therefore be quite possible theoretic-

cally to inject a constant amplitude constant frequency impulse in the television signal transmitted from the transmitting station of frequency, say, midway between f and $2f$, to utilise this frequency for controlling the speed of the transmitting motor, and to transmit it along with the television signal to the receiver, where it can be abstracted from the latter by means of filters and employed for keeping the receiving motor rotating at a speed synchronous with that of the transmitting motor. The transmission of such a frequency will in no way interfere with the reception of the television signal.

This scheme is illustrated in Fig. 4.

Fig. 4A shows the position of the synchronising signal in the frequency spectrum of the television signal, and Fig. 4B shows a schematic diagram of the apparatus involved.

This method has not found much favour practically. One of the first methods used for synchronisation was to employ the scan line frequency itself as the synchronising frequency. This frequency is contained, to a greater or less degree, in each picture signal and is due, of course, to the subdivision of the picture into scan lines.

Now if the picture being transmitted is stationary, the picture signals are perfectly periodic, the period being given by $\frac{1}{p}$. Analysis of the signal shows that the predominating frequencies range from pm upwards. If the signal is periodic the amplitude of the component of frequency pm is constant and constant synchronising torque will be exerted on the motor.

In the case of a moving picture, however, frequencies closely adjacent to pm and of varying amplitude, occur (*vide* Fig. 3). These adjacent frequencies give rise to rapidly varying surges which react on the synchronous windings of the motor and cause hunting. This hunting will, of course, become more marked as the speed of motion of the picture increases.

To overcome this difficulty of hunting, a special synchronising impulse is often injected into the signal generated by each scan line, this injection either taking place at the commencement or end of the signal. The injection may be effected in various ways and various methods of treating the injected impulse may be employed. The essential is that the impulses should be of constant amplitude and should contain only the scan line frequency, or higher harmonics of this, but not closely adjacent frequencies. The wave form of a scan line signal with the injected synchronisation signal is shown in Fig. 5.

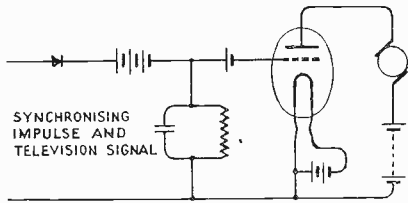

FIG. 6.

Such a synchronising impulse can be generated either by allowing a bright light to fall on the photo cell system at the end of each scan line ("Fernsehen," January, 1931. Die Synchronisierung von Fernsehempfangsapparaten, etc., by Dr. Ing. E. Hudec), by the analogous method of arranging for the scanning spot (in

the case of indirect scanning) to scan a white margin which is always present on the picture to be scanned, or by purely electrical means.

In any case, the power available for synchronisation from such an impulse, is, as shown by Dr. Hudec in the above mentioned article, comparatively small even after amplification. He therefore describes the use of a circuit such as is shown below in Fig. 6, which has the effect of converting the wave form from the square topped impulse shown in Fig. 7(A) to the exponential form shown in Fig. 7(B).

The synchronising signal plus the television signal are applied through a rectifier to a condenser and resistance in parallel, and from there to the grid of a valve, the valve being backed off until only the synchronisation impulse affects its grid potential as shown in Fig. 7(c).

The Marconi Method of Synchronisation.

In any synchronising system, employed for synchronising the speed of rotation of the moving elements at the transmitter and receiver end of a television system, where synchronism is obtained by the use of a synchronous motor at the receiver end and where this motor is kept in synchronism by means of impulses controlled at the transmitter end and transmitted to the receiver end, it is essential,

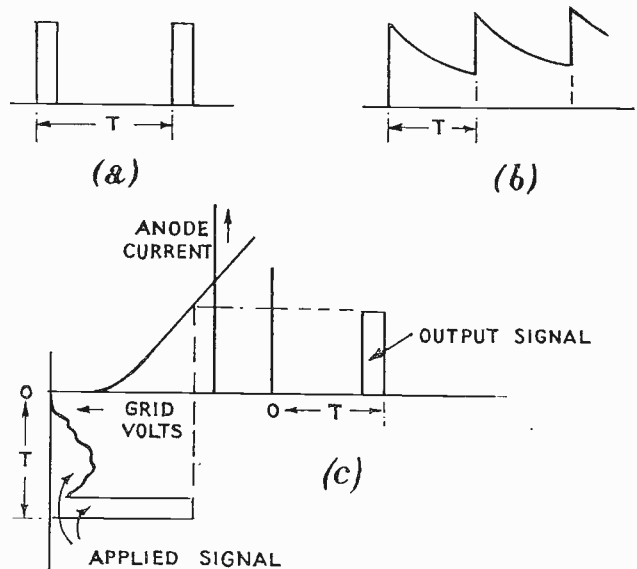

FIG. 7.

Synchronisation in Television.

- (v) that such impulses should not involve an increase in the frequency band necessary for transmission of the television signals;
- (vi) that such impulses should be of a constant character and should not vary with the unavoidable variation of the nature of the television signal.

It is with these points in view that the following system of synchronisation has been designed.

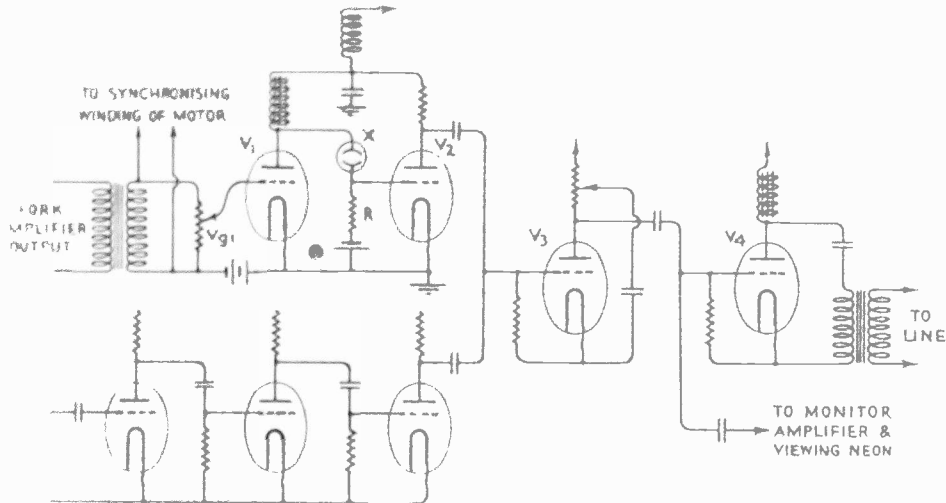

FIG. 8.

The system provides for a synchronising signal of constant amplitude and phase to be transmitted from the transmitter to receiver along with the television signal itself. The system, moreover, does not entail the utilisation of a greater frequency band than is normally employed in the transmission of such television signals.

The motor driving the scanning mechanism at the transmitter end is normally kept running at a constant speed by impulses applied to the synchronising winding of the motor by an electrically maintained fork. This same fork is employed to generate by a suitable electric circuit impulses of a constant character which are transmitted together with the television signal to the receiver end and are there separated by means of a similar electric circuit to that employed at the transmitter end into two constituents one of which, the television signal, is applied to the neon tube or other light source, and the other, the synchronising signal, is applied to the receiver motor.

The action of the system can best be understood by reference to Fig. 8, which represents the arrangement at the transmitter end. The impulses from the fork amplifier are taken to the synchronising winding of the transmitter and also to the grid of an anode bend rectifier V_1 , the signals being applied by means of a potentiometer V_2 . A neon tube X is inserted in the anode of V_1 and couples this anode to the grid of V_2 through a potentiometer R. This tube may be normally biased

so that it is just glowing, but on the point of extinction. When positive half cycles are incident on the grid of V_1 the tube is extinguished, current down R zero and the grid of V_2 becomes less negative. Anode current in V_2 increases, anode volts at V_2 decrease, V_3 grid is actuated and a synchronising signal is sent to line via V_4 . This signal may also be produced in a different manner by causing the tube to light on positive half cycles, in which case the polarity of the system will need to be changed. The television signals are impressed on to the grid of V_3 by means of the normal television amplifier.

By suitably adjusting R the duration of the synchronising pulses can be adjusted as required and if the motor carcase is capable of revolution the scanning line can always be phased so that the synchronising injection takes place at one end of their traverse on the screen. This can be checked by inspection of the monitoring image. When correct phasing has been obtained the complete signal embracing both the synchronising impulse and the television signal can be put to line.

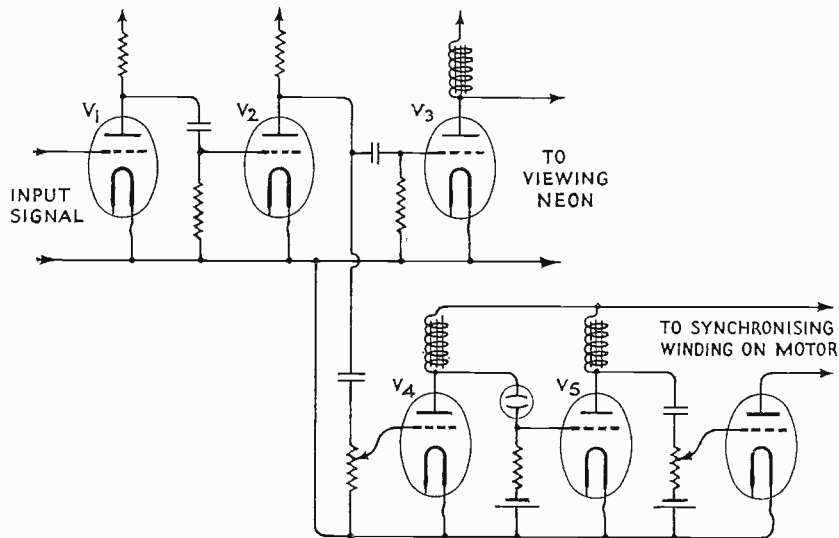

FIG. 9.

The amplitude of the synchronising signals can be adjusted to the desired extent at one of the stages in the amplifier so that it is higher than the picture signal amplitude (Fig. 10). The photo cell and line amplifier may be corrected in such a manner as to attenuate to a desired degree, frequencies below say 400 cycles. By this means unwanted modulation at the same frequency as the injection, i.e., 375 cycles, is reduced to a minimum and high frequencies are amplified as before.

The output stage to the monitor neon may be arranged so that the 375 cycle fundamental picture frequency and the 375 cycle synchronising signal are attenuated to the desired degree. Thus the fundamental frequency of inconstant amplitude will not over-modulate the neon tube causing black patches before a bright picture is obtained.

A capacity C in shunt with the biasing resistance R passes frequencies above 375 cycles practically unattenuated and a strong and detailed picture can be obtained. The narrow black bar which appears due to the synchronising signal does not over

modulate the tube as the voltages at that frequency have been attenuated to the desired degree.

At the receiver end the circuit is shown in Fig. 9. Both picture and synchronising signal are passed to V_1 and after amplification arrive at V_3 and V_4 . The signals from V_3 operate the viewing neon, but signals from V_4 only operate V_5 when the higher amplitude synchronising voltages are applied to V_5 grid. This is accomplished by means of a coupling neon tube biased in a similar manner to that described at the transmitter end. Hence while the complete signal is applied to the neon tube used for viewing the picture, only the synchronising impulses will be passed to the synchronising winding of the motor driving the receiving scanning discs, due to the fact that only the superior amplitude of the synchronising impulses will cause the separating neon tube to glow and to actuate the synchronising amplifier.

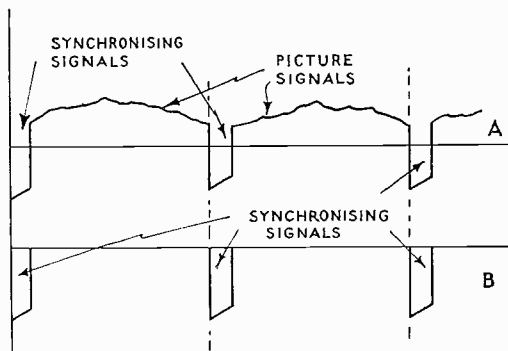

A SIGNAL APPLIED TO VIEWING NEON.
B SIGNAL APPLIED TO MOTOR.

FIG. 10.

This motor can be rotated so that the black bar due to the synchronising signal appears at the top of a picture when the disc will be in synchronism with the transmitting disc.

Synchronous Motor Design.

We have referred above to the synchronous motor, to the alternating current winding of which is applied the synchronising signal. We have also found, on page 12, an expression for the maximum phase displacement which can be tolerated between transmitter and receiver motor.

Now an ordinary synchronous motor has an angular displacement between the impressed and internal back E.M.F., which varies with the load and is about 5 electrical degrees at no-load and about 20 electrical degrees at full-load, and it increases somewhat if the supply volts fall.

Since 360 electrical degrees correspond to 2 pole pitches, 20 electrical degrees mean 10 actual angular degrees in a 4 pole motor, so that even if load variations amounting to only 10 per cent. occurred, the motor armature would fluctuate by approximately 1 degree and this is about 10 times the allowable amount.

The actual synchronous motors used, however, have 100 poles in place of 4, so that the angular displacement for a change of load of 10 per cent. will only amount to $1/25$ th of 1° or $.04^\circ$, and this if used in conjunction with a 50 line scan is well below the maximum amount of displacement which can be tolerated, i.e., $.072^\circ$.

The motor has a D.C. armature wound in the 50 slots formed by the rotor teeth which act as the poles of the 750 cycle alternator. The alternator windings are placed in small slots, with a pitch equal to half that of the rotor slots, cut in the faces of the D.C. poles of the stator.

The magnetic field for both D.C. and A.C. windings is provided by additional exciting coils placed in larger slots in the stator.

The machine is started up in the ordinary way from the D.C. supply and is run up to approximately synchronous speed (900 r.p.m.). The 750 cycle A.C. supply is then connected to the small stator windings and the motor pulls itself into exact synchronous speed.

The power developed continuously at the motor spindle is approximately $1/20$ th B.H.P.

L. E. Q. WALKER.

COMMON WAVELENGTH RELAY BROADCASTING

Owing to the increasing demand among a world-wide public for cheap entertainment from a broadcast source, there has been a tendency towards congestion within the broadcast frequency waveband.

The extent of this congestion can be gauged by the delicate and protracted discussions that recently formed an important item on the Madrid Conference Agenda. One of the chief methods of dealing with this problem among broadcasting authorities, who have to cope with the difficulties and annoyance created by congestion, is to employ the allocated and exceeding precious frequencies at more than one centre; in fact, to multiply the sources of transmission on any one wavelength.

In the following article some indication is given of the nature and possibilities of this form of broadcast transmission.

IN view of the increase in the number of broadcasting stations and the tendency towards more powerful and still more powerful, transmitters the listener-in is at times somewhat painfully aware that no monopoly exists in the ether. But Engineers are continually finding solutions for the apparently insoluble, and no doubt a future decade will see well ordered waves across the ether and greater harmony within the home. Meantime there is a scheme that merits, and has received, considerable attention and this is the simple method of making a single wavelength serve a number of areas by multiplying the sources of transmission; in other words, by erecting common wavelength relay transmitters. Provided certain technical safeguards are adopted this method avoids the unpleasant interference often caused by high power stations, and also it leads to more satisfactory reception over the districts served, for, like light which is usually most effective when distributed, broadcast reception benefits from a distributed emission.

The following notes are in the nature of a brief outline of the factors governing the design of such stations and, as will be apparent, for the sake of clarity they have been written on the basis of the original Relay Scheme exploited in this country.

The B.B.C. scheme covered the following relay stations, all working on a common frequency of 1,040 k.c. (288.5 metres) and spaced apart as indicated in the sketch map on page 23.

Common Wavelength Relay Broadcasting.

Aberdeen	1.0 kw.	Carrier power.
Bournemouth	1.0 kw.	„ „
Bradford	0.13 kw.	„ „
Dundee	0.13 kw.	„ „
Edinburgh	0.35 kw.	„ „
Hull	0.13 kw.	„ „
Liverpool	0.13 kw.	„ „
Newcastle	1.0 kw.	„ „
Plymouth	0.13 kw.	„ „
Sheffield	0.13 kw.	„ „
Stoke-on-Trent	0.13 kw.	„ „
Swansea	0.13 kw.	„ „

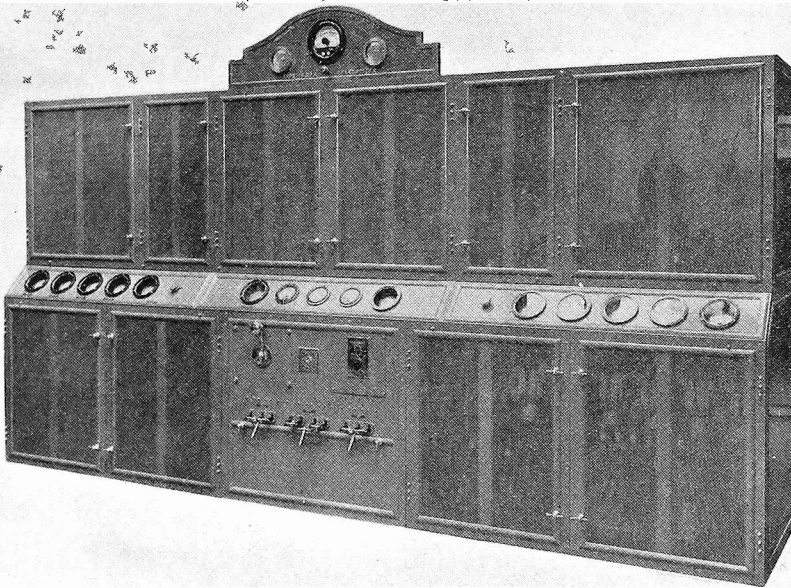

Marconi Type B.R.1 Rebroadcast Transmitter. Carrier Power 250 watts to Aerial.

The original frequency control units employed a fork vibrator, supplied by the Marconi Company. Each unit was mounted on a panel, which also carried the harmonic filter-amplifiers; these selected and amplified harmonics of the fundamental and subsequent frequencies until the final output coincided with the frequency of the transmitter, and was sufficiently powerful to drive the earliest power stage of the latter. Synchronism between the various stations was monitored from one Master Station (Bournemouth) and the method adopted was as follows: Bournemouth transmitted the carrier while the others closed down their transmitters but

working areas that are contiguous or isolated but, in either case, that lie well outside the zone of any high power station transmitting on the same wavelength. Under these conditions experience has shewn a stability per station of 5 : 1,000,000 to be a safe working figure, giving a fair margin of security to listeners-in.

At first sight it might seem as if too fine a distinction were made in discriminating between two degrees of stability, but the cost of apparatus necessary to give a guaranteed control of 1 : 1,000,000 is considerably higher than that for a control of 5 : 1,000,000, hence the issue is a very practical one.

These high limits demand very stable supplies, daily observation of voltages and temperatures and daily checks on performance. Further, however perfect the controlling apparatus may be, it is essential that the various stages of the transmitter itself should be equally carefully designed since there is a risk of frequency scintillation as the result of instability between stages. Thus the behaviour of the control apparatus is wrapped up in the behaviour of the associated transmitting plant.

Crystal or Fork.

At this stage it is well to say that, in the opinion of the Research and Development Departments of the Marconi Company, the greater degree of stability now called for can best be met by crystal control and the Company is at this moment engaged in developing apparatus for which the guaranteed performance is a stability of 1/1,000,000 cycles, over twenty-four hours.

Briefly the scheme followed is the careful manufacture of a very low temperature coefficient crystal, mounted differentially with respect to expansion or contraction. The crystal and carrier are surrounded by double chamber incubation, while such matters as the relative position of the mats and the means of temperature control have received close attention. Finally, the mechanical design of the unit is such that inspection of component parts can be carried out with minimum interference to the re-establishment of working conditions. A certain amount of frequency control is available by means of a variable shunt capacity. The particular oscillator and its associated amplifier stages just described have a final output of five or six watts, but this is entirely dependent on the conditions for which the controlling apparatus is designed, and other types of panels are being built for 50 watts output.

As a matter of interest it should be stated that the Marconi Company are in a position to supply a fork control, but the advice tendered in the foregoing paragraphs is the result of a careful consideration of both the present position and likely future advances.

Before leaving this subject there is another aspect, that of one central control via landlines, but apart from the inherent complication of neutralising phase differences due to length of line circuit, the B.B.C. abandoned this scheme because of the heavy line rental charges incurred.

Power of Relay Transmitters.

The limit of power to which a relay transmitter should be designed is governed by the area to be served, but a limit might be given as 1.0 kw. carrier power. On the other hand, 0.25 kw. is perhaps the most useful rating for general application.

Area Served.

Dealing next with the question of area served, this obviously depends on the ratio of signal strengths at the fringe of the area as between one relay station and another. (In the case of a relay area that is just outside the zone of a powerful regional station, working on a common wavelength, the same principle applies and will be discussed in detail in the next paragraph.) Briefly it may be stated that for similar programmes the strength of the local signals should exceed the strength of the distant station by a minimum of 2.5 to 3 times ; this is the limit for any degree of comfortable local reception and in practice a ratio of 5 is preferable, while some cases may call for a ratio of 10. Taking a field strength of from 3 to 5 millivolts per metre as the required general minimum covering the various types of commercial broadcast receivers, it has been found that the working radius of a relay station varies between 2 miles (3.2 kilometres) to 10 miles (16 kilometres) under the best conditions, i.e., under conditions of minimum interference and maximum transmitter output and stability.

In the case of a powerful regional transmitter it is possible to combine, under favourable circumstances, one or more distant relay stations, but we can now only cite positively the case of the Scottish National Station (50 kw.) and Bournemouth (1.0 kw.): in this particular case the effective range of the Bournemouth Station may be put at 2 miles, since the reflected vertical rays from the Scottish National are fairly strong around Bournemouth and this limits the radius of the Bournemouth service area. Thus, under the conditions cited, where a 50 kw. National Station is relayed on a common frequency by a small distant station, even the maximum relay power of 1.0 kw. carrier is only sufficient for a limited radius. It may be of interest to note that if the reflected rays from Falkirk, the Scottish National Station, create a field of 5 millivolts in the Bournemouth district, some 370 miles away, then the field strength of the local Bournemouth relay station must create a field of at least 25 millivolts, which limits the local radius to 2 miles if on an all-the-year-round basis.

In the case of stations transmitting different programmes on a common wavelength the ratio of local signal to distant signal should be of the order of at least 100, while a figure of 200 has been recommended. We assume that such ratios negative any further consideration of this type of relay.

Common Wavelength Relay Broadcasting.

Finally we arrive at the present stage in the scheme of British Broadcasting. In this country the situation has developed so rapidly since the original relay scheme was inaugurated that the areas then served are now too limited, no longer meeting the demand that is spreading over the comparatively congested intervening country. This has led to the gradual abandonment of the Relay scheme, and among the original stations only Bournemouth will remain on the original frequency of 1,040 k.c., but this same frequency has also been allocated to the Scottish National Station at Falkirk. The country is now served by a chain of National and Regional transmitters on various wavelengths, with one important exception.

This exception is due to entirely local conditions and may not be applicable to any other country. The B.B.C. intend to run two of the National stations, namely, London and Watchet (West National), separated about 140 miles, on a common frequency of 1,147 k.c., and while the common stipulated frequency may be departed from, within limits of a few cycles, it is essential that each station shall not vary more than one part in a million over 24 hours.

It is not anticipated that the direct rays from Watchet will interfere with London listeners because of intervening attenuation, while the reflected rays will be at least five times weaker in the London area than London's direct signals. The object of Watchet is mainly to serve the somewhat congested area of South Wales, and this it can very well do because there will be very little attenuation over the intervening water of the Bristol Channel; on the other hand, the South Wales area is unlikely to be interfered with by London, at any rate not to an appreciable degree. The area some distance to the south-west of Watchet, where attenuation is marked, will be served either by Plymouth or by the new National Station at Droitwich on 1,454 metres (150 kw. Marconi): this latter will also serve an area between Watchet and London.

Conclusion.

To sum up, for countries where the demand is likely to be localised into areas around various centres, in other words where the demand is unlikely to spread to any appreciable extent over the intervening districts, the Relay scheme has been a proved success. It is perhaps correct to state that the B.B.C. still bear in mind a return to some form of small power relay working as a possible future eventuality.

At the risk of repetition it must be emphasised that high class control gear, well designed modern transmitters, and reasonable care in attendance are all essential to the successful working of any scheme of relay broadcasting.

N. WELLS.

Common Wavelength Relay Broadcasting.

APPENDIX I.

The question of synchronous frequency broadcasting was an interesting topic at the recent Brussels Meeting of the U.I.R., and according to the "Journal Télégraphique," the Commission, after examining the experimental results obtained in different countries, has admitted the following figures:—

A. *Synchronised stations transmitting the same programme.*

The admissible value of the ratio of the useful field of the disturbing field is given by the Table hereunder:—

Tolerance of synchronisation admitted.	Less than 1 c/s.	From 1 to 5 c/s.	From 5 to 20 c/s.
Ratio of the Fields	3	5	10

A deviation of 20 cycles per second is the limit of tolerance acceptable.

B. *Synchronised stations transmitting different programmes.*

The admissible value of this ratio is given hereunder:—

Tolerance of synchronisation admitted.	Less than 20 c/s.	From 20 to 100 c/s.
Ratio of the Fields	200 (services of excellent quality, jamming scarcely noticeable).	400 to 600 (service of excellent quality, jamming scarcely noticeable).
	100 (service of acceptable quality, jamming noticeable).	200 to 300 (service of acceptable quality, jamming noticeable).

A deviation of 100 cycles per second is the limit of tolerance acceptable.

APPENDIX II.

The following is a list of papers on the subject of common wavelength broadcasting:—

- P. P. Eckersley and A. B. Howe. "I.E.E. Journal," Vol. 67, No. 390, 1929—The operation of several broadcasting stations on the same wavelength.
- B. Esping. "Technical Bulletin of the Royal Swedish Telegraphs Administration." No. 12, 1929.
- F. Gerth. "I.R.E. Proceedings." March, 1930.
- F. Gerth and Hahnemann. "Electrische Nachrichten-Technik." June, 1930.
- P. P. Eckersley. "I.R.E. Proceedings." August, 1931.
- G. D. Gillett. "I.R.E. Proceedings." August, 1931.

THE OSAKA BROADCAST TRANSMITTER

In the last issue of THE MARCONI REVIEW (Jan.-Feb., 1933, No. 40), there appeared under "News and Notes" a brief reference to the 10 kw. broadcasting transmitter installed at Osaka, Japan.

As this is the first completed example of a new series of transmitters now being constructed by the Marconi Company, some further details may prove of interest.

THE particular feature which differentiates these broadcasting transmitters from those of earlier design is the fact that modulation is performed at such a power level as to require only one stage of amplification (Class B operation) following the modulated stage to produce the desired aerial carrier power.

The object of the new arrangements is to reduce to a minimum the distortion unavoidably produced by Class B amplifiers when deeply modulated, and thereby make it possible to provide an effective degree of modulation without exceeding the Distortion Factor limit of 4 per cent., which has been recommended by the C.C.I.R. as the maximum acceptable.

This feature has been rendered practical in high power work by inclusion of the series, or constant voltage, method of anode voltage modulation, which by dispensing with the necessity of an audio-frequency anode choke or transformer avoids the difficulty of obtaining a level frequency characteristic over a wide band of modulating frequencies, while still retaining the inherent linearity of response of anode voltage modulation. The linearity tests of the Osaka transmitter showed very favourable results, as the Distortion Factor (defined as the root sum square of the second, third, fourth and fifth harmonics of a fundamental modulating tone of 1,000 cycles) at 80 per cent. modulation only just exceeded 3 per cent.

A duplicate transmitter to be erected near Cape Town, produced a measured Distortion Factor only very slightly above the 4 per cent. limit (4.1 per cent. exactly) when modulated 100 per cent.

The same principle (namely, a series modulated stage followed by one stage only of Class B amplification) is being incorporated in several transmitters of much higher power than those referred to above now being constructed or designed by the Marconi Company, including the long wave National transmitter for the British Broadcasting Corporation.

OBITUARY.

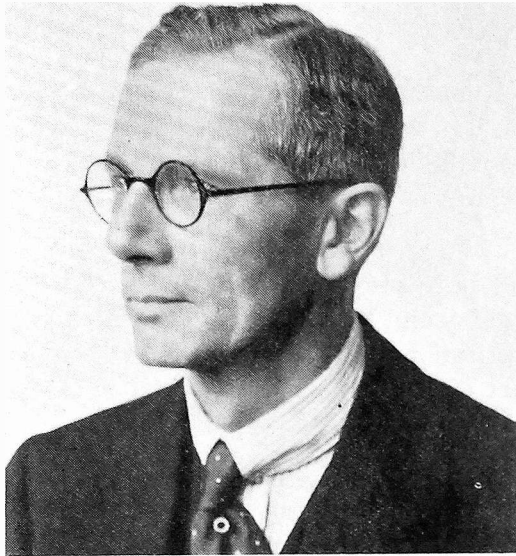

The Rt. Hon. F. G. Kellaway, P.C.

WE have to record with deep regret the death of the Rt. Hon. F. G. Kellaway, P.C., Vice-Chairman and Managing Director of the Marconi Company, which occurred at his home at Westerham, Kent, on April 13th.

Mr. Kellaway was an outstanding figure in the world of communications, and other offices that he held at the time of his death were those of Chairman and Managing Director of the Marconi International Marine Communication Co., Ltd., Deputy Governor and Joint Managing Director of Cables & Wireless, Limited, and Joint Managing Director of Imperial and International Communications, Ltd.

Joining the Board of Directors of the Marconi Company in November, 1922, he was appointed Managing Director two years later, and had played a pre-eminent part in the development of communications during recent years, not only in Great Britain, but practically throughout the world, wherever the widespread interests of the Marconi Company and its associates extend.

Prior to his association with the Marconi organisation, Mr. Kellaway had had a long and distinguished record of public service, having been a Member of Parliament and a Minister of the Crown during the momentous years of 1910 to 1922. He was appointed to the post of Joint Parliamentary Secretary to the Ministry of Munitions in 1916, at the time when plans were made to multiply the output of munitions of war on a vast scale. In 1918 he became Deputy Minister of Munitions.

After the War, Mr. Kellaway was appointed Secretary to the Department of Overseas Trade, and, following the General Election of 1921, Postmaster-General. His period of service as head of the British Post Office was notable for the now historic negotiations between the Post Office and the Marconi Company and other interested parties regarding the organisation of broadcasting in Great Britain, which led to the formation of the British Broadcasting Company—now the British Broadcasting Corporation. In the course of these negotiations, Mr. Kellaway demonstrated that he had the foresight and the practical imagination to visualise the brilliant future that lay before the then infant science and art of broadcasting; it was typical of his rare versatility of mind and attainments that in the same year he displayed very effectively his business capabilities by producing for the first time since the War a surplus of income over working costs in the British Post Office administration.

The funeral took place at Tatsfield, Kent, on April 15th, and a memorial service was held at St. Michael's Church, Cornhill, in the City of London, on April 20th.

THE OSAKA BROADCAST TRANSMITTER

In the last issue of THE MARCONI REVIEW (Jan.-Feb., 1933, No. 40), there appeared under "News and Notes" a brief reference to the 10 kw. broadcasting transmitter installed at Osaka, Japan.

As this is the first completed example of a new series of transmitters now being constructed by the Marconi Company, some further details may prove of interest.

THE particular feature which differentiates these broadcasting transmitters from those of earlier design is the fact that modulation is performed at such a power level as to require only one stage of amplification (Class B operation) following the modulated stage to produce the desired aerial carrier power.

The object of the new arrangements is to reduce to a minimum the distortion unavoidably produced by Class B amplifiers when deeply modulated, and thereby make it possible to provide an effective degree of modulation without exceeding the Distortion Factor limit of 4 per cent., which has been recommended by the C.C.I.R. as the maximum acceptable.

This feature has been rendered practical in high power work by inclusion of the series, or constant voltage, method of anode voltage modulation, which by dispensing with the necessity of an audio-frequency anode choke or transformer avoids the difficulty of obtaining a level frequency characteristic over a wide band of modulating frequencies, while still retaining the inherent linearity of response of anode voltage modulation. The linearity tests of the Osaka transmitter showed very favourable results, as the Distortion Factor (defined as the root sum square of the second, third, fourth and fifth harmonics of a fundamental modulating tone of 1,000 cycles) at 80 per cent. modulation only just exceeded 3 per cent.

A duplicate transmitter to be erected near Cape Town, produced a measured Distortion Factor only very slightly above the 4 per cent. limit (4.1 per cent. exactly) when modulated 100 per cent.

The same principle (namely, a series modulated stage followed by one stage only of Class B amplification) is being incorporated in several transmitters of much higher power than those referred to above now being constructed or designed by the Marconi Company, including the long wave National transmitter for the British Broadcasting Corporation.

OBITUARY.

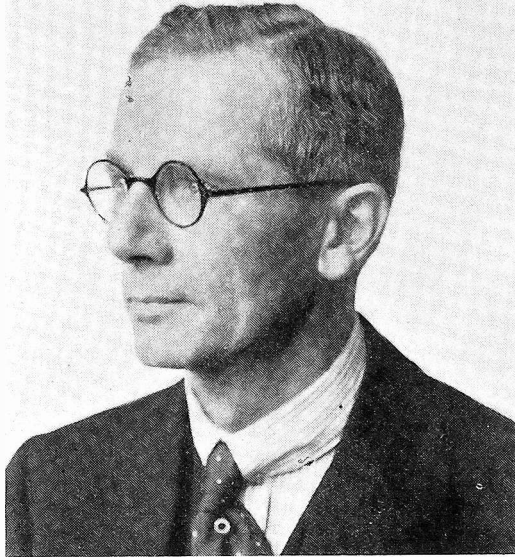

The Rt. Hon. F. G. Kellaway, P.C.

WE have to record with deep regret the death of the Rt. Hon. F. G. Kellaway, P.C., Vice-Chairman and Managing Director of the Marconi Company, which occurred at his home at Westerham, Kent, on April 13th.

Mr. Kellaway was an outstanding figure in the world of communications, and other offices that he held at the time of his death were those of Chairman and Managing Director of the Marconi International Marine Communication Co., Ltd., Deputy Governor and Joint Managing Director of Cables & Wireless, Limited, and Joint Managing Director of Imperial and International Communications, Ltd.

Joining the Board of Directors of the Marconi Company in November, 1922, he was appointed Managing Director two years later, and had played a pre-eminent part in the development of communications during recent years, not only in Great Britain, but practically throughout the world, wherever the widespread interests of the Marconi Company and its associates extend.

Prior to his association with the Marconi organisation, Mr. Kellaway had had a long and distinguished record of public service, having been a Member of Parliament and a Minister of the Crown during the momentous years of 1910 to 1922. He was appointed to the post of Joint Parliamentary Secretary to the Ministry of Munitions in 1916, at the time when plans were made to multiply the output of munitions of war on a vast scale. In 1918 he became Deputy Minister of Munitions.

After the War, Mr. Kellaway was appointed Secretary to the Department of Overseas Trade, and, following the General Election of 1921, Postmaster-General. His period of service as head of the British Post Office was notable for the now historic negotiations between the Post Office and the Marconi Company and other interested parties regarding the organisation of broadcasting in Great Britain, which led to the formation of the British Broadcasting Company—now the British Broadcasting Corporation. In the course of these negotiations, Mr. Kellaway demonstrated that he had the foresight and the practical imagination to visualise the brilliant future that lay before the then infant science and art of broadcasting; it was typical of his rare versatility of mind and attainments that in the same year he displayed very effectively his business capabilities by producing for the first time since the War a surplus of income over working costs in the British Post Office administration.

The funeral took place at Tatsfield, Kent, on April 15th, and a memorial service was held at St. Michael's Church, Cornhill, in the City of London, on April 20th.

MARCONI NEWS AND NOTES

“ROOMS OF THE SCIENTISTS.”

AN interesting and unusual feature of this year's Ideal Home Exhibition at Olympia, London, was a special display entitled “Rooms of the Scientists.” This section of the Exhibition provided a glimpse of the studies and laboratories of some outstanding figures in scientific research and discovery, from Archimedes to Marchese Marconi.

Among such names as Newton, Lister, and Darwin, the progress of electricity was represented by Faraday and Marchese Marconi. A corner of Faraday's laboratory at the Royal Institution had been copied with remarkable fidelity, while the reproduction of part of the wireless room in Marchese Marconi's famous steam yacht “Elettra”—his floating laboratory—portrayed the most modern application of Faraday's basic discoveries.

The “Elettra” cabin was furnished with a Marconi short-wave transmitter, Type S.W.B.4, of the class used by Marchese Marconi for his early experiments in long distance ship-and-shore wireless telephony. An example of the new Marconi micro-wave apparatus was also in the cabin, and other apparatus representing the latest developments in wireless equipment.

Included in a “museum” display next to the Rooms of the Scientists was a selection of early coherers as used by Marchese Marconi in his pioneer experiments in Italy in 1895.

The Marchese and Marchesa Marconi visited the Exhibition on the opening day.

Marconi Television Demonstrations.

DEMONSTRATIONS of television transmission and reception by the Marconi system were a feature of the Exhibition of Television at the Imperial College of Science, South Kensington, London, on April 5th and 6th.

Transmissions of moving figures, both in head and shoulder proportion and full length, and “news” transmissions of letterpress were demonstrated over short land lines.

A 50-line transmitter and receiver were used for the demonstrations of moving images, which were shown on a translucent screen measuring 8 inches by 8 inches, while the “news” transmission and reception reproduced a sequence of letters moving from right to left on a large screen 7 feet long by 1 foot 6 inches deep.

At intervals demonstrations were also given of reception of television transmitted by the British Broadcasting Corporation on 7.75 metres; for the reception of these transmissions a new type of ultra-short-wave receiver incorporating three

high frequency stages fitted with pentodes and a grid current detector was used. In this receiver the image is projected on to a translucent curved paper screen measuring about $3\frac{1}{2}$ inches by $8\frac{1}{2}$ inches.

Wireless for Civil Aviation.

RECENT developments in Great Britain have served to emphasise further that wireless becomes increasingly essential to the progress of civil aviation as it advances beyond the purely "sporting" stage of development and becomes established as a regular public service.



*Marconi aircraft equipment Type A.D.6N
undergoing final tests.*

As new air routes and air services are inaugurated the demand for Marconi equipment increases in proportion, and recent activities in this sphere include the provision of a new Marconi ground station erected for the Air Ministry at the Manchester Air Port, and the installation of an aircraft equipment in an air-taxi operated by Airwork, Ltd., from Manchester, and in six new type air-liners operated by Hill-

man's Airways from their aerodrome at Romford, Essex.

The aircraft equipment fitted in the air-taxi for Manchester and in the new Hillman aircraft is of a type known as the Marconi Type A.D.6N, which has a notably good "power to weight ratio" and is therefore particularly suitable for the smaller classes of aircraft used for commercial operation. The adoption of Marconi equipment by the companies operating these new services is an indication of their recognition that wireless communication is essential to the safe and regular working of modern air services.

A New Beacon for Irish Waters.

ANEW Marconi automatic wireless beacon is to be installed in the Irish lightship "Comet," to the order of the Commissioners of Irish Lights.

The wireless beacon will have an energy of 100 watts in the aerial, and will be operated in conjunction with a submarine sound signalling device, to enable

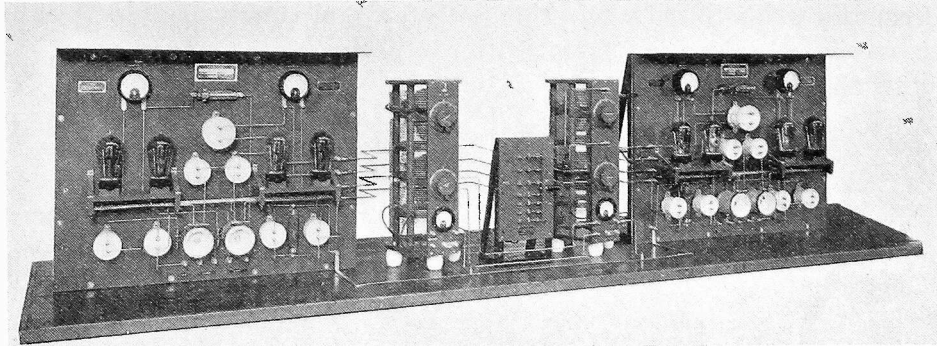

Marconi 100-watt automatic wireless beacon, as installed in the Irish lightship "Comet."

navigators to ascertain not only their position in respect to the lightship but also their distance from it.

During the transmission periods the wireless beacon will transmit a warning dash followed by a series of dots at regular intervals. The submarine sound signalling device will transmit a signal the beginning of which will be synchronised with the end of the five seconds warning dash of the wireless.

Wireless waves travel with the speed of light and are therefore received practically without time lag by any receiving station within the service area of the beacon, while the sound waves emitted by the submarine signalling device travel through water at the rate of 4,800 feet per second. The signals will be arranged so that the number of dots received by wireless before the reception of the submarine signal will be equal to the number of miles the receiving ship is from the beacon. The navigator will thus be enabled to ascertain his distance from the beacon without computation.

The lightship will have a distinctive signal which will be emitted before each transmission.

The provision of lightships with wireless beacons working in conjunction with submarine sounding devices is a development of considerable interest to coastal authorities, and the practice has been widely adopted in many countries. A combined beacon of this type was recently fitted to a light-vessel off the Uruguayan coast, in addition to two wireless beacons in lighthouses.

A chain of 23 wireless beacons is now in operation around the coasts of the British Isles for the safeguarding of shipping. Many installations of this type have also been fitted by the Marconi Company in other countries, and a contract is at present in hand for two new beacons for the Chinese authorities to assist navigation on the important shipping routes to Shanghai and the Yang-tse-Kiang.