

THE MARCONI REVIEW

No. 18.

March, 1930.

Technical Editor: H. M. DOWSETT, M.I.E.E., F.Inst.P., M.Inst.R.E.
General Editor: W. G. RICHARDS.

THE MARCONI RADIO TELEPHONE TERMINAL EQUIPMENT

The following article describes in detail the apparatus required to enable two way communication to be carried on over a combined Radio and Land Line link under commercial conditions.

The necessity for the change from a normal 2-wire to a 4-wire Land Line system is explained, and the use of echo suppressors is discussed. In conclusion, the means provided for checking and controlling the various parts of the apparatus are described.

IT is common knowledge that in the usual local telephone services a subscriber communicates with another by means of a pair of wires used to convey speech in both directions. In this case the communication is said to be on 2 wires.

On radio telephone services, on the contrary, where the radio transmitting station and the radio receiving station are usually situated a few miles apart, it is necessary to make use of a 2-wire line to carry the speech to the radio transmitting station, and of another 2-wire line to carry the receiving current from the radio receiving station to the auditor. In this case the communication is said to be on 4 wires.

To link an ordinary 2-wire subscriber telephone network to a radio channel, or *vice versa*, it is then necessary to provide for a landline device to afford a means of passing from a 2-wire system to a 4-wire system or *vice versa*.

Such an arrangement—called a “hybrid” circuit, Fig. 5 is a kind of electrical bridge in which the four arms are respectively constituted on the one hand by the two pairs of lines of the 4-wire communication, and on the other hand by the two lines of the 2-wire communication system, and an equivalent network balancing as near as possible the characteristics of that line.

With this arrangement, and assuming ideal conditions, no receiving speech current from the 4-wire system can pass into the transmitting line of the 4-wire

system. In practice, however, this state of perfection is never realised, and consequently a certain amount of receiving current always passes into the transmitting line, and reaches the speaker through his own radio receiving station.

As this imperfection of balance exists at both ends, a certain portion of the retransmitted energy is again super-imposed on the speech, thus returning to the subscriber as an echo. This state of affairs is unacceptable in commercial working, because it creates a serious kind of cross-talk which reduces intelligibility, and, in extreme cases, it can set the whole circuit in "singing" condition, and it has therefore been found necessary to introduce special apparatus known as "echo suppressors."

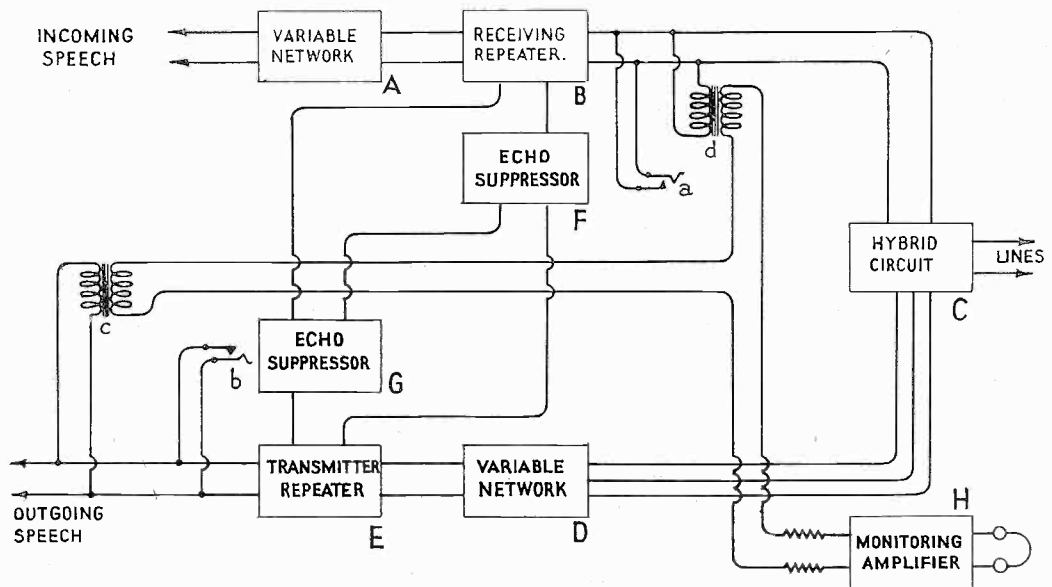

FIG. 1.

The volume of speech reaching the point where the 2-wire system links with the 4-wire radio circuit, in practice arrives with extreme variation of intensity, due to the length of the 2-wire subscriber line, the condition of the microphone, the natural strength of the voice of the speaker, and the way he is talking into or holding the microphone. Consequently, to obtain a normal modulation at the radio transmitter in each case, it is necessary to provide for a monitoring device, which, associated with measuring apparatus, permits the distant control of that modulation.

It is thus found convenient to have some means of calibrating the volume indicator as a function of its corresponding effect on the radio transmitter.

The Marconi Radio Telephone Terminal Equipment.

The whole of the apparatus required efficiently to operate and handle the linking up of a 2-wire to a 4-wire system, involving a radio circuit, is called a telephone radio terminal equipment, and is illustrated, in diagrammatic form in Fig. 1.

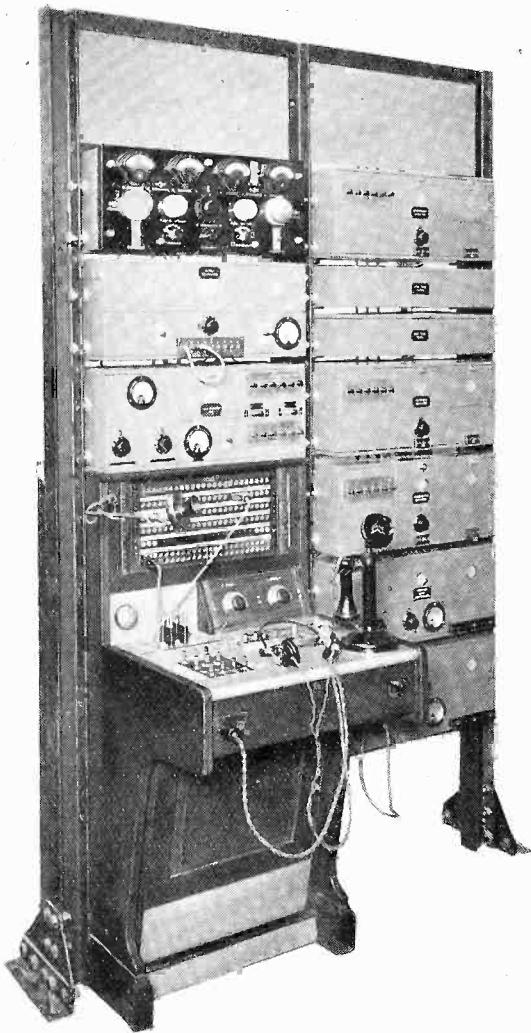

FIG. 2.

As the losses of a unidirectional 2-wire system can always be reduced to a very small degree by means of suitably distributed amplifiers along the line, it is always an advantage to install the equipment as near as possible to the central office of the 2-wire subscriber network into which it has to work normally.

The Marconi radio telephone terminal equipment consists of a number of units supported in an iron frame. Fig. 2. The construction of these units is in every respect similar to that already adopted for the construction of the standard Marconi Beam receiver. This type of construction ensures an excellent electrical screening and an effective protection of all parts against dust, insects and moisture, and consequently will give satisfaction under the most severe climatic conditions.

Mechanical generators used in connection with suitable electrical filters dispense with the need of L.T. and H.T. batteries, but of course, they can be replaced by batteries if so desired. In this case a 120 volt H.T., one 8 volt L.T., and one 24 volt L.T. battery are used.

In the case of the generator battery eliminator equipment, the driven motor can be supplied to suit any mains supply available.

The equipment incorporates the following items :—

Landline Amplifiers.

There are three 2 valve landline amplifiers. The maximum gain of these amplifiers is 40 decibels, and is adjustable by means of a calibrated resistance attenuating network, mounted in the input circuit of the amplifier.

This calibrating network is also used in connection with the valve voltmeter and the 1,000 cycle generator for measurement purposes as hereafter mentioned.

The input transformers are electrostatically screened.

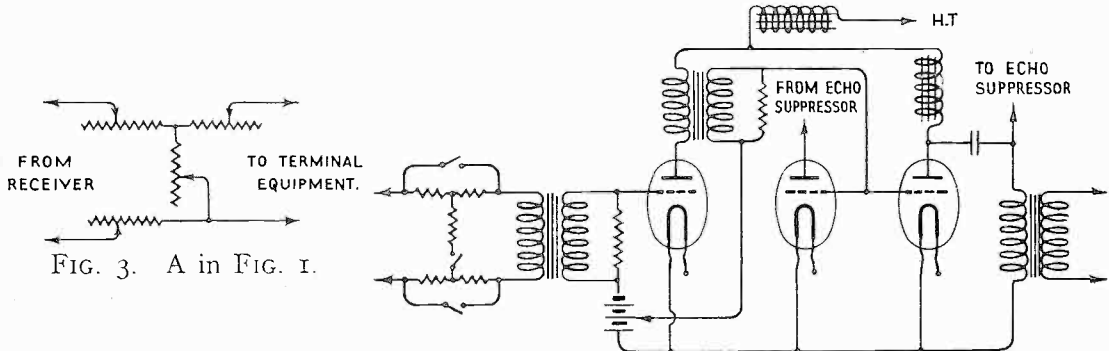

FIG. 3. A in FIG. 1.

FIG. 4. B in FIG. 1.

The input and output impedance of these amplifiers is 600 ohms. The second stage of amplification of these amplifiers is fitted with a coupling valve whose output works into the echo suppressor units, thus preventing any reaction from the echo suppressors into the amplifier itself.

Normally one of these amplifiers is used as a one-way repeater inserted in the line going to the radio transmitter, Fig. 9, and the other in the line coming from the receiving station, Fig. 4.

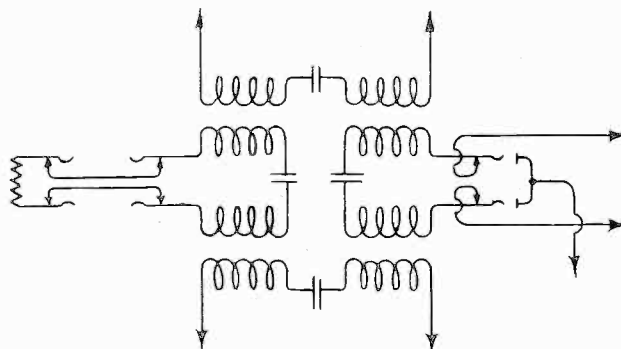

FIG. 5. C in FIG. 1.

The third is used either as a spare or as a monitoring amplifier, Fig. 11, or in conjunction with the valve voltmeter unit for the measurement of noise level.

Chokes and condensers in the L.T. and H.T. supply prevent cross talking.

Jacks permit the measurement of the plate current and the correct adjustment of all the grid bias batteries.

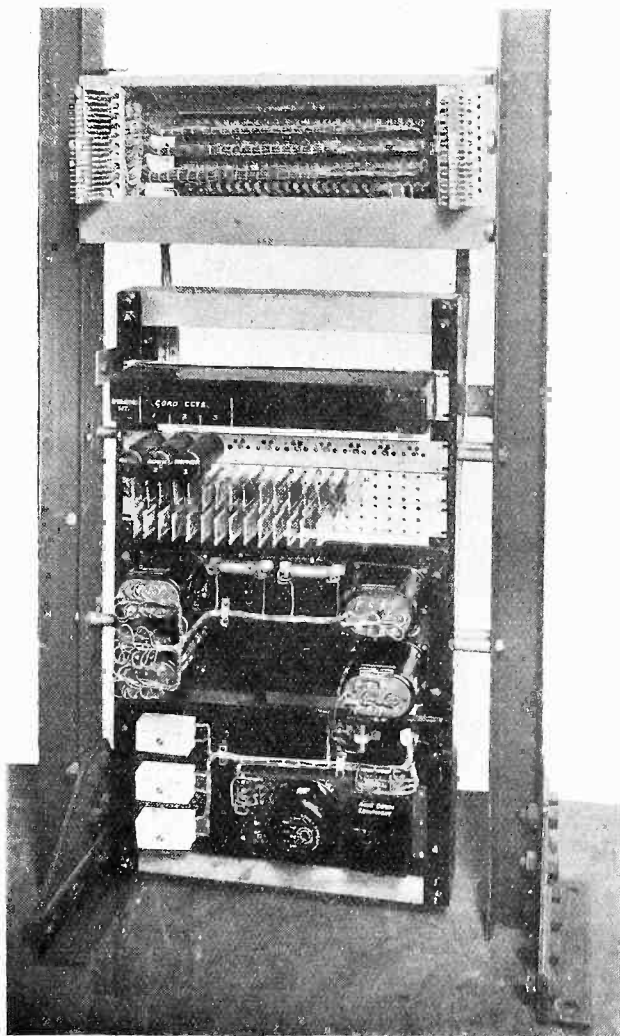

FIG. 6.

amplification in addition to the two-stage landline amplifier already described, and arranged so as to favour all frequencies around 1,000 cycles, thereby minimising inaccurate working due to noise level.

Echo Suppressors.

These are two in number named the receiving and transmitting echo suppressors respectively. With the method adopted by the Marconi Company, the transmitter echo suppressor closes the receiving line of the speaker while transmitting and the receiving echo suppressor of his listener closes the transmitting line of the latter.

As soon as the speaker ceases talking or pauses between words, both lines are automatically freed again.

This arrangement completely prevents any noise coming from the reception end from being superimposed on speech or the cutting of the speech by the echo suppressor, due to accidental coughing or shaking of the microphone by the auditor.

The echo suppressor apparatus, Fig. 10, consists of two stages of L.F. am-

The output of the last stage amplifying valve works into a diode rectifier followed by one stage of D.C. amplification. The output of the latter controls the mechanical relay which paralyses one of the landline amplifiers by short circuiting

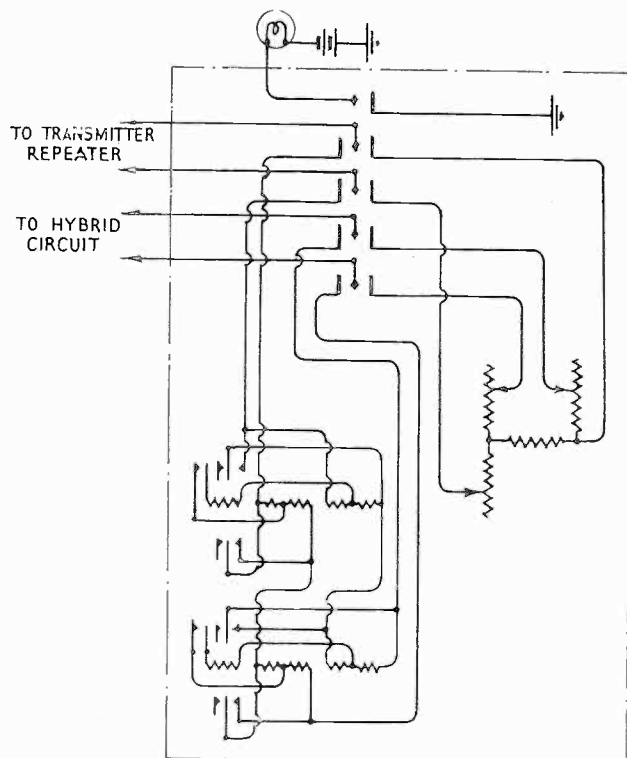

FIG. 7. D in FIG. 1.

the primary of its inter-valve transformer. This operation has been rendered practically noiseless by preventing the D.C. component of the plate current of the first stage valve of the landline amplifier, from passing through that winding.

This arrangement also has the advantage of not altering either the input or the output impedance of the amplifier.

The other contacts of this relay are used to control a lamp indicator showing the normal operation of the system.

The time of closing and the time of opening of that relay under the action of the speech is adjustable as well as the sensitiveness of the device taken as a whole.

The time adjustment of the operation of the device is obtained by:—

- (i) Varying the biasing current flowing in the auxiliary winding of the relay.
- (ii) Varying the time constant of the charge of condensers shunted by resistances which are mounted in the grid of the last amplifying valve.

Jacks and switches permit the checking and adjusting of the plate current of each valve.

The method used for the blocking of the transmitter echo suppressor by the receiving echo suppressor, is very important. This is effected by heavily biasing the grid of the first valve of the transmitting echo suppressor by means of the

rectified current of the diode rectifier of the receiving echo suppressor. This action is instantaneous in comparison with that of the mechanical relay and prevents both

echo suppressors from working simultaneously, which would immediately establish an uncommercial condition.

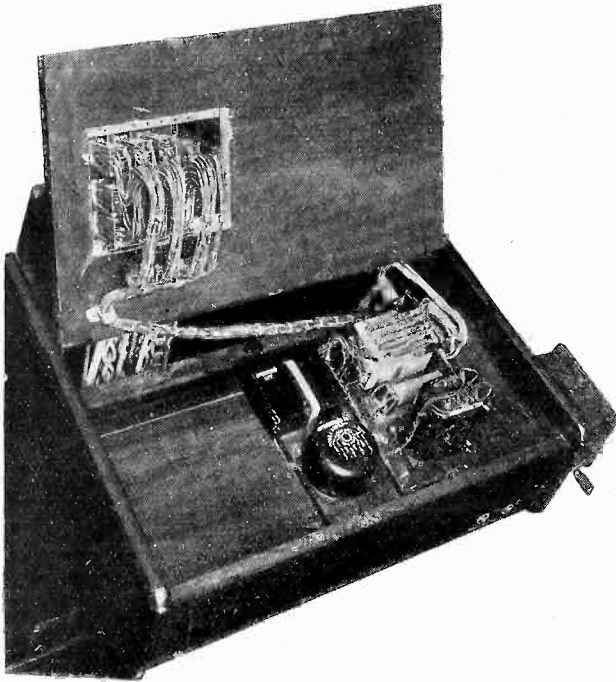

FIG. 8.

Bad balance at the hybrid coils aggravated by the necessity of using a large gain at the receiving landline repeater due to the weakness of incoming speech, might readily bring about this uncommercial condition, if it were not for the action of this special blocking device

The valve voltmeter unit in conjunction with the 1,000 cycles unit, is used to perform a series of measurements which will be indicated later.

The tone generator is designed to permit the calibration of the valve voltmeter, so that a given point of its scale indicates 1 milliwatt in a line of 600 or 900 ohms

which unit is used as zero level in all the measurements.

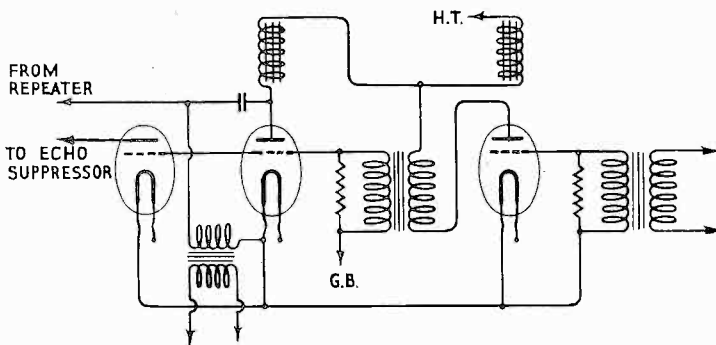

FIG. 9. E in FIG. 1

introduced by its use is below $\frac{1}{4}$ decibel.

To avoid the absorption of energy by the use of the valve voltmeter, its input impedance has been made high in comparison with that of the line. The loss

The tone generator is used for the lining up of the transmitter by adjusting the gain of the amplifier feeding the modulating panel of the transmitter itself, so that a given level output at the terminal equipment can be taken as a basis for its correct modulation.

This generator is also used for morse communication between the stations.

In view of facilitating the adjustment of the balance of the hybrid coil by limiting the range of frequencies in which the balance must be effectuated, low pass filters are used in the circuit leading to the receiving repeater and echo suppressor. Incidentally the time lag which it introduces into the circuit helps the working of the interlocking arrangement between the echo suppressors which we have just described.

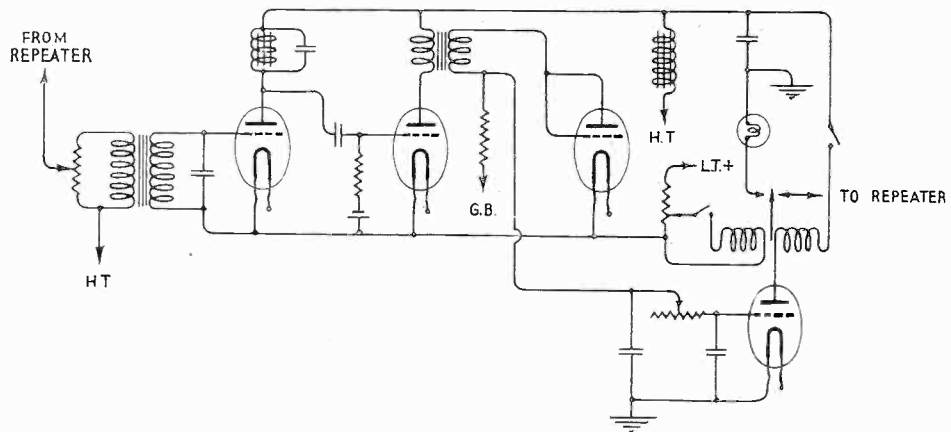

FIG. 10. F & G in FIG. 1.

The control unit consists of a switchboard on which are mounted milliammeters, voltmeters, fuses and switches. It also involves a valve characteristic test circuit and facilities for using the instruments for the adjustment of the grid bias of every valve.

The control table is a compact unit which contains a jackfield and the standard telephone apparatus of this special equipment, and is shown in Figs. 6 and 8. It normally provides for three complete standard trunk cords, each having the three positions of

- (A) Speaking to radio,
- (B) Speaking to landline,
- (C) Speaking to both simultaneously, and

in addition, a monitoring position.

This number of call cords could be increased if desired.

Lamps are used as calling indicators, and a magneto circuit is used for land-line ringing.

The Marconi Radio Telephone Terminal Equipment.

From the diagram it will be noted that all the monitoring coils, hybrid coils, landline amplifiers, echo suppressors, &c., have their inputs and outputs connected to jacks. This permits the testing of each piece of apparatus separately, their replacement by spares or their re-arrangement into any desired combination.

The control table also incorporates two adjustable monitoring attenuating networks, Figs. 3 and 7, introduced in the input circuit of the receiving and transmitting landline amplifiers, which, in conjunction with the valve voltmeter, provides a control of the monitoring circuit.

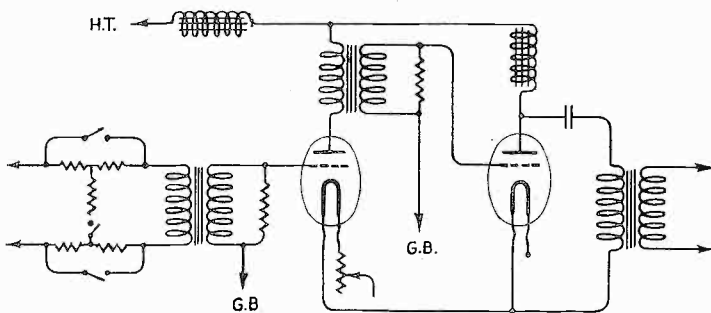

FIG. II. H in FIG. I.

The fact that the adjustment of the modulation for a given speaker will, in nearly every case, differ from the adjustment required for the operator speaking from the terminal equipment, and the necessity of being able to intervene in

the case of misunderstanding or difficulty occurring during a call, complicates the operation, and would normally necessitate re-adjustment of the gain for which, in practice, there is no time. This is completely avoided by the use of an extra relay, which, by moving the splitting key through "monitoring" to "talking," automatically changes the gain of the amplifiers by the introduction of a suitable attenuating network.

Attenuating networks of 4 Db. are introduced in the input and output of the hybrid coils for the purpose of facilitating the balance.

The combination of the valve voltmeter unit, 1,000 cycles generator and the spare amplifier enables the following measurements to be made:—

- (i) To measure the amplification of each amplifier.
- (ii) To adjust the valve voltmeter to read zero level or 1 milliwatt output, or any desired plus or minus value between -50 to $+10$ Db's.
- (iii) The measurement of the balance in Db's.
- (iv) The singing point of the amplifiers for a given balance and adjustment of the gain.
- (v) The testing of the echo suppressors.

- (vi) The measurements of the attenuation of any loop line in Db's.
- (vii) The measurement of the noise level of the line alone, of amplifiers, or of the radio line under commercial working conditions.

The jack and switch facilities permit :—

- (i) The linking up of a subscriber 2-wire circuit with the 4-wire radio circuit.
- (ii) The speaking from the terminal on 4 wires or on 2 wires.
- (iii) The extension from the terminal of the 4-wire system to another 4-wire long distance circuit.

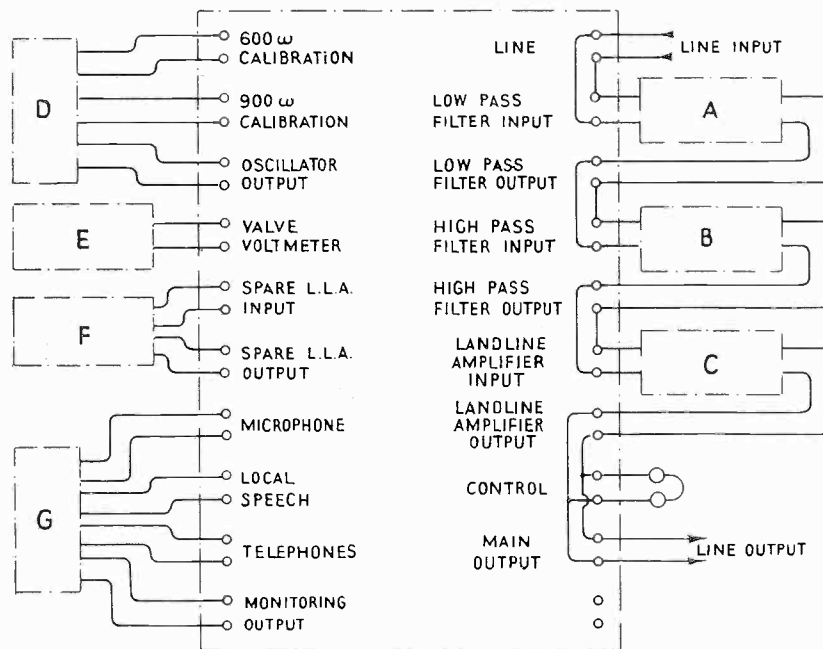

JACK FIELD

- | | |
|------------------------|------------------------------|
| A. Low pass filter. | E. Valve voltmeter. |
| B. High pass filter. | F. Spare landline amplifier. |
| C. Landline amplifier. | G. Landline unit. |
| D. 1,000v oscillator. | |

FIG. 12.

A high impedance monitoring circuit used in connection with the monitoring amplifier, permits the possibility of listening to the conversation independently of the normal monitoring circuit, thus permitting a supervisor or chief of staff to listen from the terminal board or from a distance, for controlling purposes. (C, D & H, Fig. 1.)

Monitoring high impedance input transformers provide a possibility of listening directly and separately to the radio receiving and transmitting lines.

The Marconi Radio Telephone Terminal Equipment.

In the case of very important commercial services, where interruptions of a few minutes cannot be permitted, it is possible to add to the normal equipment an additional lag to the rack, and duplicate the echo suppressors, the landline amplifier, which in case of trouble can be immediately introduced into the circuit in the place of the faulty or doubtful instrument in service. It is also possible to add a standard tone generator giving a constant output of all frequencies of from 10 to 10,000 cycles, for the purpose of equalising lines or measuring lines at any given frequency.

In addition to the radio terminal equipment, it is convenient, if not essential, to have a corresponding terminal equipment at the transmitting station itself.

In the case of a radio telephone service, this equipment can be reduced to one control unit, similar to the one described above ; one valve voltmeter with which the 1,000 cycles calibrating generator can be combined ; one landline amplifier ; a small jackfield unit and a landline box.

This equipment permits the exact lining up of the circuits, and also the checking from the transmitting station and the amount of modulation received from the central office at any time. A spare amplifier in the case of important services is advisable but is not essential.

Fig. 12 gives a schematic diagram of the complete equipment.

G. A. MATHIEU.

A CONSTANT FREQUENCY CONTROL FOR BROADCAST TRANSMITTERS

II.—EXTENSION OF WAVELENGTH

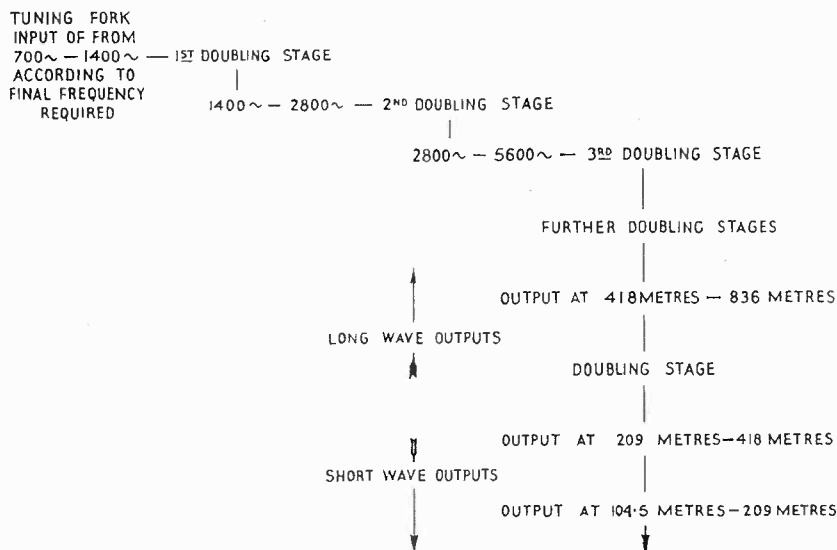

IN THE MARCONI REVIEW for November, 1929, an article describing a constant frequency fork control for broadcast transmitters was given. In this it was pointed out that the particular apparatus described was designed for wavelengths lying between 209 and 418 metres approximately, when using tuning forks whose frequencies lay between 700 and 1,400 cycles.

To avoid any misunderstanding that these wavelengths are the limiting wavelengths at which such apparatus can operate, it may be pointed out here that the final output wavelength of the instrument can be extended both above and below the wavelengths mentioned by the use of suitable tuning forks and doubling circuits.

This point may be more clearly shown if we consider cases where a final wavelength of 150 and 600 metres respectively are required. In the first case a tuning fork would be used, having a frequency of 976.56 cycles, and a further doubling circuit would be added to reduce a wavelength of 300 metres obtainable with the old equipment to the required 150 metres, and in the second case a tuning fork would be used having the same frequency, but a stage of doubling would be omitted from the apparatus, thus giving the required output at 600 metres wavelength.

A TUNING FORK CONTROL FOR SHORT WAVE TRANSMITTERS

The equipment developed for the control of broadcast transmitter frequencies by the tuning fork method has been surveyed in the issue of this journal for November last. The present article describes the extension of the same system to the control of transmitters operating on higher frequencies.

THE frequency separation required between any two neighbouring broadcast stations to avoid interference under present working conditions is of the order of 20 kilocycles, that is, each station is allowed a side-band width of 10 kilocycles. Now, if this side-band width be considered in relation to the transmitter carrier frequency, it will be seen that for a wavelength of 300 metres it is 1 in 100, but, for a wavelength of 25 metres, it is only 1 in 1,200. Each station will eventually wish to use as great a sideband width as possible, the limit being set by interference. If the carrier frequency of a station is liable to vary by 1 in 10,000 at a wavelength of 25 metres, and is yet to occupy only its allotted band-width, the sideband width must be reduced by 1.2 kilocycles. The 1.2 kilocycles so lost may well be sufficient to decide whether a multiplex transmission or a high quality simplex channel is practicable. It is therefore desirable to control the transmitter frequency, provided that the cost of so doing does not exceed the value of the freedom from interference or the additional sideband width so obtained.

The Tuning Fork Control System accordingly finds a field of use for this purpose, and the choice of mild steel for the fork material enables the frequency to be deliberately changed over a small range by change of temperature, without loss of stability.

Tuning Fork and Thermostat.

The type of tuning fork and the construction of thermostat used for controlling the fork temperature have been described already in sufficient detail. It will be remembered that the frequency of the tuning fork depends on the material, the dimensions assigned, and in general on the temperature and the amplitude of the vibrations. The first two factors are chosen in design, the second two are commonly used in the final adjustment of frequency. Forks passing out to customers are therefore provided with a summary of the conditions of calibration, and preferably with the actual drive circuit to be used.

The drive chosen has been described in a previous article, and the only changes made have been the result of operational considerations. In this new design, meters and fine controls are provided for the supply voltages as in the equipment for the longer wavelengths, but the output potentiometer is graduated in steps of 2 decibels,

the total drain on the plate supply being indicated, and arrangements are made so that the operator can listen to the fork without disturbing the circuit.

Multiplier Rack.

The panels used for the broadcast control equipment already described, form the basis from which higher frequencies are obtained. The attainment of these frequencies, however, called for certain modifications in the doubling circuits and transformers.

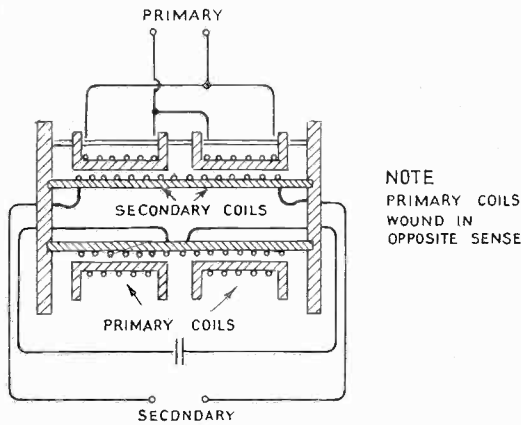

FIG. 1.

The reasons for the changes mentioned were the possibility of resonance at the higher frequencies in the types of transformer previously described, and the danger of oscillation in stages working under the conditions required. The first difficulty could of course be avoided by change of coil design, but there remained the question of keeping a high degree of balance with a different design in the new circuits. The design adopted is illustrated in Fig. 1. The inner coil, split in the centre, forms the secondary. The two outer coils are wound in opposite sense and, connected together in parallel aiding, form the primary. By this means the potential at the extremities is the same, and a symmetrical distribution of capacity currents is obtained. The position of each primary coil can be adjusted over a small range.

The danger of oscillation in high frequency doubler circuits was met by the arrangement shown in Fig. 2. Oscillation frequently occurs owing to weak coupling between the parts of the input transformer secondary allowing the valves to behave as if in parallel. The risk of this trouble is reduced by removing an earth point from the centre of this inductance. In the figure it will be seen that individual grid bias is supplied to each valve, and that the two halves of the winding must therefore be separated by a large condenser. The requisite grid bias is supplied through a resistance of 100,000 ohms to each side. This method has the advantage of causing very slight loss of efficiency, and calls for no fine adjustment.

General Layout.

The photograph of the equipment shows a rack system intended for a station working on about 25 metres. The fork frequency is approximately 1,439 \sim , and thirteen doubling stages are used.

A Tuning Fork Control for Short Wave Transmitters.

The fork is housed in a separate thermostat, an arrangement allowing greater flexibility to meet varying requirements. This thermostat does not appear in the photograph. The control panel for the thermostat is seen as the lowest panel on the right of the racks, and supports the apparatus for an alternating current supply control.

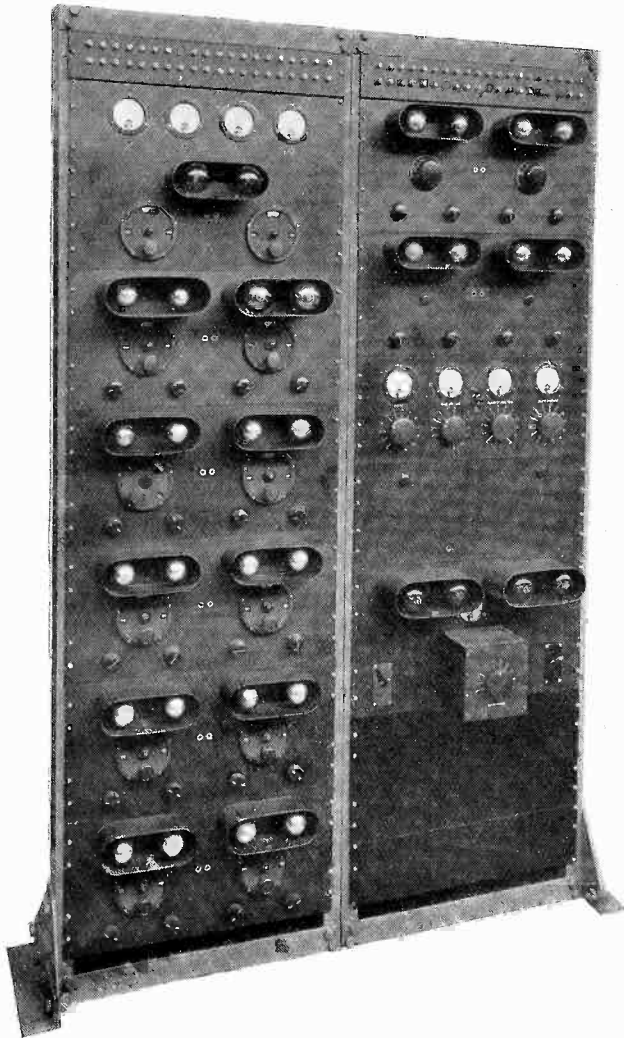

FIG. 2.

As in the broadcast control equipment, individual grid bias for the valves is provided by potentiometers, and the entire structure is at earth potential. The input transformer and secondary tuning condenser of each stage are mounted on two brackets, and a crosspiece. By this means the whole of one tuned circuit may

Above this thermostat control panel, the fork drive panel is placed, and above this again, the control and meter panel for the drive. The next two panels on this rack each contain two doubling stages, as do the four lower panels on the left hand rack. On this latter rack, and above the panels mentioned, there are two panels which contain respectively a doubler stage, together with an amplifier and an optional additional amplifier. It should be noted that the first amplifier stage can be changed to a doubler stage without serious mechanical alteration. Both racks are topped by fuse panels from which various panel supplies are distributed, and to which the main supplies are brought. The left hand rack has in addition a meter panel, so that the supply voltages may be checked and the plate current of any stage observed.

be withdrawn together for examination, while the connecting leads are reduced to the minimum length. In so far as is possible, the components of each panel are interchangeable, and are mounted on the same centres, so that the types of spares carried are reduced to a minimum. Should any trouble arise in the working of the thermostat, it is immediately obvious, since the ungettered valves are mounted

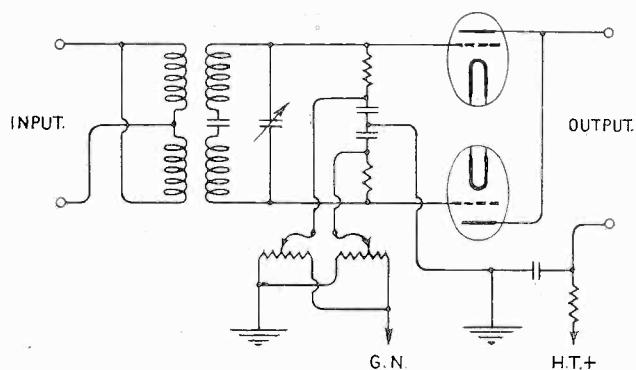

FIG. 3.

on the front of the panel, and a galvanometer shows the working of the relay. The fuses throughout are of the indicating type. Apart from the usual monitoring receiver for the station, the equipment must be available for check when running alone. Accordingly, in addition to the check point in the fork drive circuit already mentioned, a check of the output is provided by arranging the plate current jack of the last doubling stage so that, when a pair of telephones is inserted, any audible frequency modulation is heard as a note. On account of the appreciable high frequency voltage at this stage, very small amounts of modulation are easily detected.

F. M. G. MURPHY.

A PORTABLE CONSTANT OUTPUT TONE GENERATOR AND VALVE VOLTMETER

FREQUENCY RANGE, 20 TO 10,000 CYCLES PER SECOND

The determination of the transmission efficiency of telephone lines circuits and apparatus is of fundamental importance in telephone engineering. Many electrical and acoustic problems are involved in the efficient transmission of speech and these problems become more severe when efficient transmission of music is also required.

In development of wireless telephone apparatus the radio engineer has to deal with problems similar to those encountered in line transmission systems.

The apparatus comprising the system whether it be land-line or wireless, must give perfect reproduction of the original wave form and also give a uniform frequency response over the audible range, i.e., 50-10,000 cycles. On the other hand, it is frequently necessary to have the frequency characteristics of receiving apparatus, amplifiers, repeaters, filters, etc., so shaped as to compensate for distortion which may be unavoidable in lines or transmitting apparatus.

In order to test the frequency characteristics of such apparatus two instruments are required (i) a variable frequency tone generator giving constant power output into a constant impedance throughout the audible range; (ii) a sensitive instrument to indicate the loss or gain of the apparatus under test throughout, this range containing a means of calibration in standard units.

The Tone Generator.

IN any electrical system which is used for the transmission or reception of speech or music, the fidelity of reproduction depends almost entirely on the ability to transmit or receive equally well all frequencies within the audible range. In examining the capabilities of such a system, a tone generator is in general employed to supply a range of pure tones in order that the presence of any distorting influence in the system may be detected. The apparatus must be capable of delivering a pure sine wave of voltage, the frequency of which can be varied continuously over the audible range with the amplitude of the output remaining constant.

It will be realised that such a piece of apparatus has a very wide field of usefulness.

If it is supplied with reliable calibration charts, it can be used as a frequency standard.

It can also be employed in measurements of inductance, capacity and power factor where a source of pure tone frequency is required, and it is necessary to make

measurements at more than one frequency throughout the audible range, and for testing inter-valve low frequency transformers, telephone transformers, acoustical converters, and various types of transformer iron.

In addition to the above, an instrument of this type is essential in testing the modulation constancy of a radio telephone transmitter.

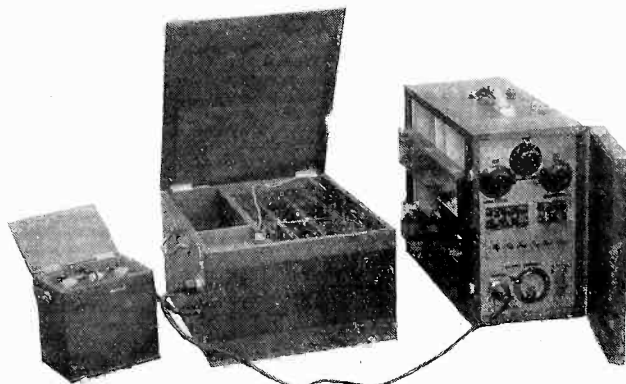

FIG. 1.

When used in conjunction with an audio frequency valve voltmeter the tone generator will be found very valuable for the following purposes.

The measurement of gain in low frequency amplifiers, the loss in low frequency filters, and for taking the characteristic curves and measurement of attenuation for land lines and filters.

Beat frequency oscillators must fulfil several requirements in order to be of the greatest degree of usefulness.

- (A) The output wave shape should be a pure sinusoidal function of time.
- (B) The output voltage on a constant impedance load should not vary over the frequency range.
- (C) There should be a minimum of frequency drift or change in beat frequency of either, or both, of the two oscillators, with changes of temperature, or supply voltages.
- (D) There should be no radio frequency oscillations present in the output circuit.

Technical Description.

The Tone Generator is composed of two separate high frequency oscillators, A and B (Fig. 2). One of these (A) operates at a constant frequency while the frequency of the second (B) can be varied by means of the condensers C and D.

The output of the two oscillators act together into a two-stage Push-Pull amplifier in such a way that the two radio frequencies combine to produce a beat, the frequency of which is equal to the difference between the two.

A Portable Constant Output Tone Generator and Valve Voltmeter.

The relative frequencies of the oscillators A and B are so adjusted that this Beat Frequency can be varied throughout the audible range. The amplifier is capable of giving a power output of 26 milliwatts into a 600 ohms impedance network.

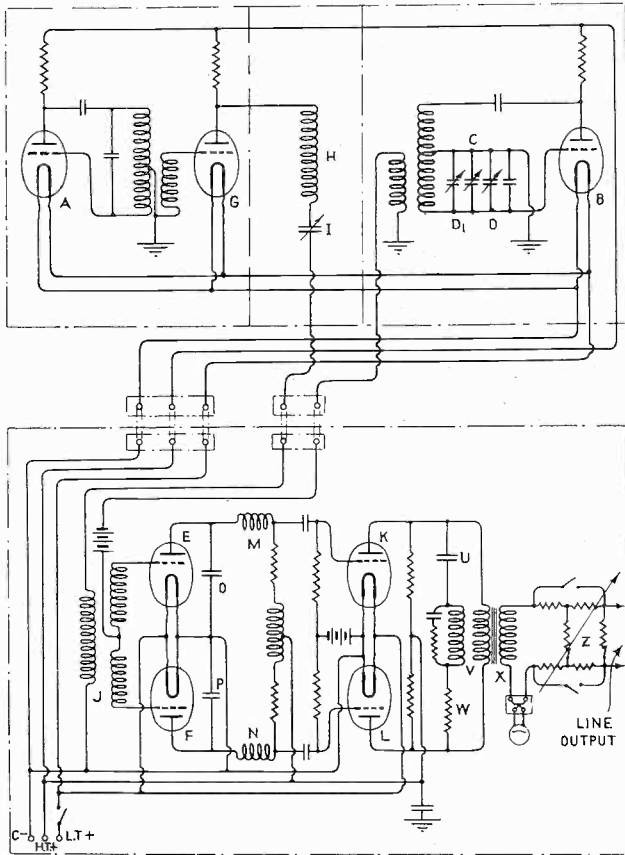

FIG. 2.

The variable oscillator B is coupled directly to the valves E and F which are working in push pull and acting as detectors, the anode bend method of rectification being used.

A coupling valve G is employed to couple the Constant Frequency Oscillator A to the detector circuit, and a special circuit HIJ is interposed in order to suppress harmonics.

The beat frequency from the output of the detector valves EF is then amplified by a single stage resistance coupled push-pull amplifier KL. The two chokes MN and the condensers OP serve effectively to choke back and by-pass respectively the radio frequency components of the two oscillators after rectification.

The output of the amplifier is applied to the 600 ohms impedance network Z by means of a suitable transformer X. The equalising circuit UVW has been introduced to compensate for the non-linear characteristics of this transformer.

A microammeter 0-100 micro-amps. is connected in series with the resistance network Z and the secondary winding of transformer X. This instrument is included to give an indication of the steadiness of the power output over the frequency range and for the zero beat adjustment. The microammeter is operated by a thermo junction.

The maximum power output is of the order of 26 milliwatts and the function of the network Z is to provide a means of controlling this power output. This

network has an attenuation range of 0-40 T.U.'s and can be varied by steps of $\frac{1}{4}$ T.U. It is composed of 8 T.U. pads each of which may be put in or out of circuit by means of a Kellogg switch. The resistances composing each pad are non-inductively wire-wound in slots on an ebonite former which in turn is mounted on the switch itself.

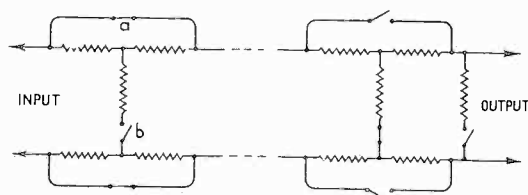

FIG. 3.

Fig. 3 shows the construction of the T.U. pads and method of switching in and out of circuit.

Switches A and B operate together.

The circuit is terminated by a 600 ohms resistance. This resistance is placed in circuit whenever the input circuit to which the generator is connected has an impedance other than 600 ohms.

It will be observed in Fig. 2 that the variable oscillator B has three variable condensers C, D and D' for adjustment. The function of D' is to obtain the zero

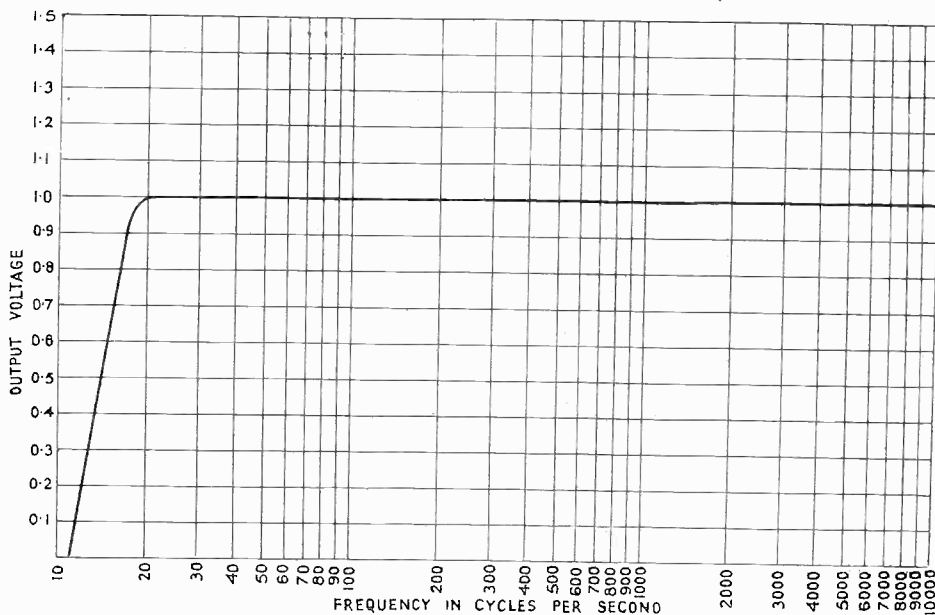

FIG. 4.

beat adjustment prior to setting the generator to work at any desired frequency. The adjustment is very simple and is performed as follows. First condensers C and D are set at zero. The knob of D' is then slowly rotated until the microammeter indicates zero. C and D are then set for the frequency desired by reference to the Calibration Charts supplied.

Construction.

The Tone Generator may be obtained in two forms : (1) The Rack Type ; (2) The Portable Type.

The former is composed of two units, the oscillators being housed in the one, while the amplifier occupies a second. The housing in this case takes the form of wooden cases doubly screened with copper sheet inside and out and intended for mounting in the standard iron frames as used for the Commercial Beam Receiver, etc.

In the Portable Type, shown in the photograph, Fig. 1, the generator is housed in one teak case fitted with handles for carrying. The batteries for filament lighting and anode tension are contained in cases of similar construction.

Alternatively, battery eliminating apparatus for any desired voltage, A.C. or D.C., can be supplied as a portable unit for working from supply mains.

A curve connecting output voltage and frequency for the tone generator is shown in Fig. 4.

The Valve Voltmeter.

This instrument consists essentially of a low frequency amplifier and rectifier B, with a high impedance input giving constant amplification throughout the audible range, an indicating instrument being provided in the plate circuit of the rectifier. Included in the apparatus is a single frequency oscillator A, which is adjustable for power output and which may be used either to calibrate the Valve Voltmeter or as a power generator to impress any given power to line up to 12 T.U. also an attenuating network of 40 T.U. adjustable in steps of $\frac{1}{4}$ T.U., a diagram of connections being given in Fig. 5, and a photograph of the instrument in Fig. 6.

The apparatus was primarily intended for use in conjunction with the Tone Generator described above for taking the characteristics of aerial land lines, and the network impedance has been designed for 600 ohms. The input and output of this artificial line are brought to plug sockets on the front of the instrument.

A terminal resistance of 600 cycles is across the output of the line and may be inserted by means of the switch.

As will be seen from the diagram the Valve Voltmeter has a transformer input, in series with the primary of which are two 3,000 ohms resistances which reduce the input power to a negligible quantity rendering it suitable for use as a Line Monitoring Indicator and for tapping across a pair of landlines, without any risk of taking an appreciable amount of power from the line. The secondary of this transformer has an equalizing circuit across it to ensure the constant ratio of input to indicated output from 40—10,000 cycles.

The power of the 1,000 cycle note oscillator is adjustable by means of the filament resistance. To this oscillator is coupled a resonant circuit comprising an inductance,

A Portable Constant Output Tone Generator and Valve Voltmeter.

capacity, thermo milliammeter and 600 ohms resistance in series. A tap is made on the 600 ohms resistance at 15.5 ohms and a switch is provided to short the larger portion.

The oscillator is capable of impressing via the resonant circuit power up to 12 T.U. on the 600 ohms resistance. The plug socket marked Generator output is connected across this 600 ohms resistance. When switch is at "test," it is across only 15.5 ohms.

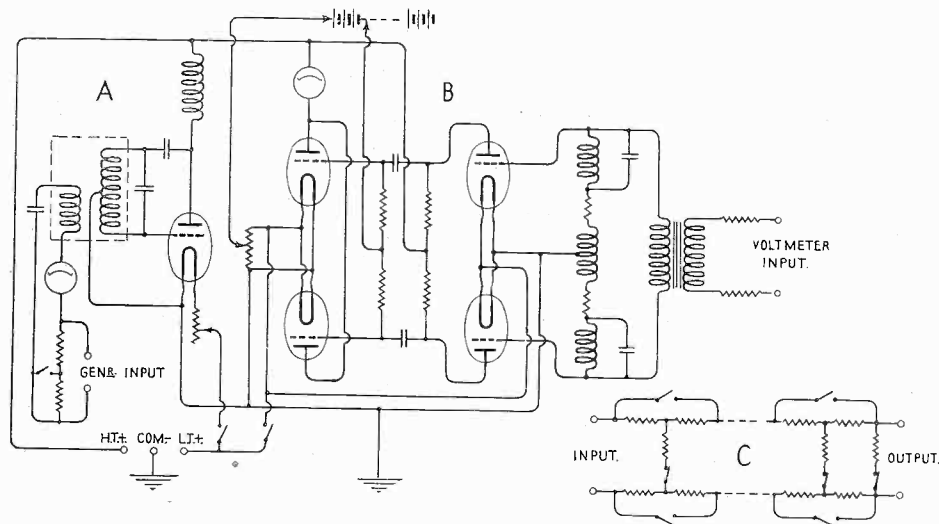

FIG. 5

The Calibration of the Valve Voltmeter.

A standard basis for calibration and measurement has been taken as 1 milliwatt into 600 ohms and is called zero level. This corresponds to a voltage of .775 volts across 600 ohms or to a current flow of 1.29 ma. Such a small current cannot easily be directly measured, and consequently the same potential drop is first produced by a current of 50 m.a. through 15.5 ohms resistance. In order to do this the switch is put to "test" and the oscillator power adjusted to read 50 m.a. The socket marked "Voltmeter input" is connected with that marked "Generator output" and potentiometer adjusted to give any suitable value on the indicating galvo, say 40°.

The valve voltmeter is now calibrated to read zero-level, i.e., 775 of a volt at 40° on the galvanometer.

The Adjustment of the Generator to Give Zero Level into 600 ohms.

The power of the oscillator is first reduced to a minimum and the switch removed from the test position. The oscillator power is then increased again until the Valve

Voltmeter reads 40°. The Oscillator output may now be plugged to line if zero level is to be impressed. If, however, less than zero level, say -5 T.U., which is considered the value for ordinary speech from a carbon microphone, is the required power to be put to line, it is only necessary to insert the attenuating line, Fig. 5, C, between the output of generator and the land line and put in the 5 T.U. switch. In this case the terminating resistance is not switched in.

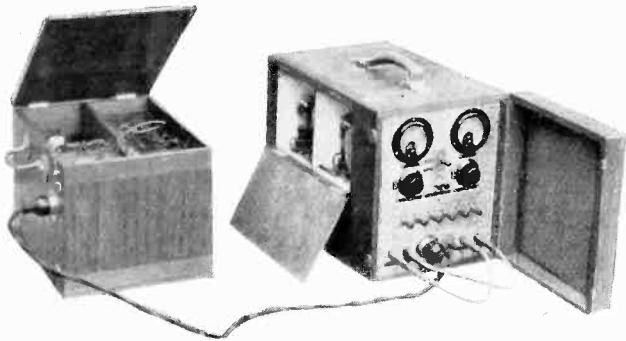

FIG. 6.

The Transmission of a Power to Line Greater than Zero Level.

To do this the Valve Voltmeter is first adjusted to zero level. The generator is then adjusted to give zero level into 600 ohms.

The artificial line is next inserted between the valve voltmeter and the generator (with terminal resistance

switched in); the requisite number of T.U.'s representing the required power above zero level, are switched in and the oscillator power increased until the valve voltmeter reads zero level again. The output of the generator may now be plugged to line.

When the Valve Voltmeter is used in conjunction with the variable Tone Generator, the foregoing applies as far as calibrating the Valve Voltmeter for zero level.

The Adjustment of the Variable Tone Generator to Give Power Values above Zero Level.

The output of the artificial line on the Variable Tone Generator (with terminal resistance not switched in) is connected to the input of the valve voltmeter line (with terminal resistance switched in).

The requisite number of T.U.'s representing the power values required are placed in the valve voltmeter line and the tone generator is adjusted until the valve voltmeter reads zero level. The output of the Variable Tone Generator line can now be plugged to landline.

If power values below zero level are required, the variable Tone Generator is connected with the Valve Voltmeter as before through both lines. All attenuation in the Valve Voltmeter line is now cut out, and the Variable Tone Generator line is adjusted to give zero level; the necessary number of T.U.'s representing the power below zero level required are inserted in the same line. The output of this line may then be plugged to line.

The Measurement of the Incoming Power from a Line.

The Valve Voltmeter is adjusted to read zero level at 40° ; the artificial line (with terminating resistance in circuit) is inserted between Valve Voltmeter and Landline, and the artificial line adjusted so that a reading of 40° is indicated on the galvanometer. The number of T.U.'s left in the line represents the power value above zero level. If the valve voltmeter does not indicate zero level when all T.U.'s are cut out, the incoming power is below 1 milliwatt and the measurement is as follows. A note is made of the reading of received energy, and the local generator adjusted to zero level into 600 ohms; the artificial line is inserted between generator and Valve Voltmeter (with terminal resistance in), and the line is finally adjusted to give reading of received energy. The number of T.U.'s inserted is the power value below zero level of incoming energy.

The Attenuation of a Line at One Frequency.

This may be measured by two valve voltmeters one at each end of the line. The generator of one is used to put a known power to line, and the other to measure the power received. The discrepancy between the two represents the attenuation of the line.

The Characteristic Curve of a Line over the Audible Range of Frequencies.

The Variable Tone Generator is used at the transmitting end, its power to line adjusted by the Valve Voltmeter to a convenient value. The attenuation of the line is measured at various pre-arranged frequencies throughout the range, and a curve plotted from these readings.

The Gain of a Stage of Low Frequency Amplification at One Frequency.

The output of the generator of the valve Voltmeter is adjusted to zero level, this voltage being applied across the grid filament of a valve, the plate circuit of which is connected through the primary of an L.F. transformer to the H.T. supply, and the secondary across the grid filament of a second valve. From the extremities of a 600 ohms resistance placed in series with the anode and H.T. supply of the latter valve, the alternating voltage is passed via two large condensers and the artificial line (with terminal resistance in) to the valve voltmeter. The line is adjusted until the valve voltmeter reads zero level, then the output of the generator is placed across the grid filament of the second valve and T.U.'s cut out of circuit until zero level is again indicated. The difference between the two adjustments of the T.U. pad represents the amplification of the low frequency circuit, i.e., the first valve and transformer.

The Characteristic Curve of a Stage of Low Frequency Amplification.

The Variable Tone Generator is used as a source of energy. The gain in T.U.'s is measured for various frequencies and a curve plotted. Since the output of the tone

generator is constant, only one reading with the generator connected to the second valve is necessary.

The characteristic curve of any intervalve low frequency circuit may be taken by this method.

The Loss in a 600 ohms. Impedance Filter.

This may be measured directly at 1,000 cycles by the method adopted for measuring the attenuation of a line except that only one valve voltmeter circuit is required. The generator included in the unit is used as the source of energy.

The Characteristic Curves of a 600 ohms. Impedance Filter.

These curves may be taken directly by the method used for taking the characteristic curve of a land line. The variable tone Generator is used as the source of energy and the land line is replaced by the filter under test.

In taking curves of filters not of 600 ohms impedance a circuit similar to that adopted for taking the curve of amplifiers may be used. The plate circuit of the first valve must, however, pass through a resistance equivalent to the impedance of the filter to be tested. Across this resistance is connected the input of the filter via two large condensers, the output being terminated by a similar resistance to that included in the foregoing plate circuit. (A valve should be chosen with a high impedance in comparison with this resistance.) The grid filament of the second valve is connected across this terminating resistance. The plate of this valve passes as before, through a 600 ohms resistance to the H.T. supply and is coupled to the valve voltmeter.

The curve may now be taken as previously described except that in order to obtain the value from which the various attenuation values at the various frequencies may be taken, the plate side of the plate resistance of the first valve must be connected through a large condenser to the grid side of the grid resistance. It is only necessary to take this reading at one frequency as the curves of the Variable Tone Generator and Valve Voltmeter are constant throughout the range.

The generator of the Valve Voltmeter or the Variable Tone Generator may be used as a means of impressing a known voltage on the modulating circuit of a Telephone Transmitter for the adjustment of percentage modulation. The latter being particularly useful for taking modulation curves through the range.

Inductance, capacity, and impedance measurements may also be made with these instruments.

The foregoing represents a few of the innumerable measurements possible with this apparatus.

C. G. KEMP.

MARCONI NEWS AND NOTES

SWISS "REGIONAL" BROADCASTING PLAN

MARCONI EQUIPMENT

Switzerland is to have a "regional" broadcasting system, somewhat similar to that which is being instituted by the British Broadcasting Corporation, with three high-power stations—in the German, French and Italian speaking sections of the country respectively—and smaller relay stations where required in the principal towns.

The most powerful of the new stations, a Marconi Type "P.B." 60 kilowatt broadcasting transmitter, has already been ordered from the Marconi Company, and is to be erected at Munster, about twelve miles to the north-west of Lucerne. This station will constitute the main "regional" station for German-speaking Switzerland, which is the largest of the three lingual sections of the country.

While it is similar in design to the transmitters at the London "regional" broadcasting station at Brookman's Park, the Munster station will employ greater power, with 60 kilowatts in the aerial, compared with London's 30/50 kilowatts. It will thus be one of the most powerful stations in Europe, a condition rendered

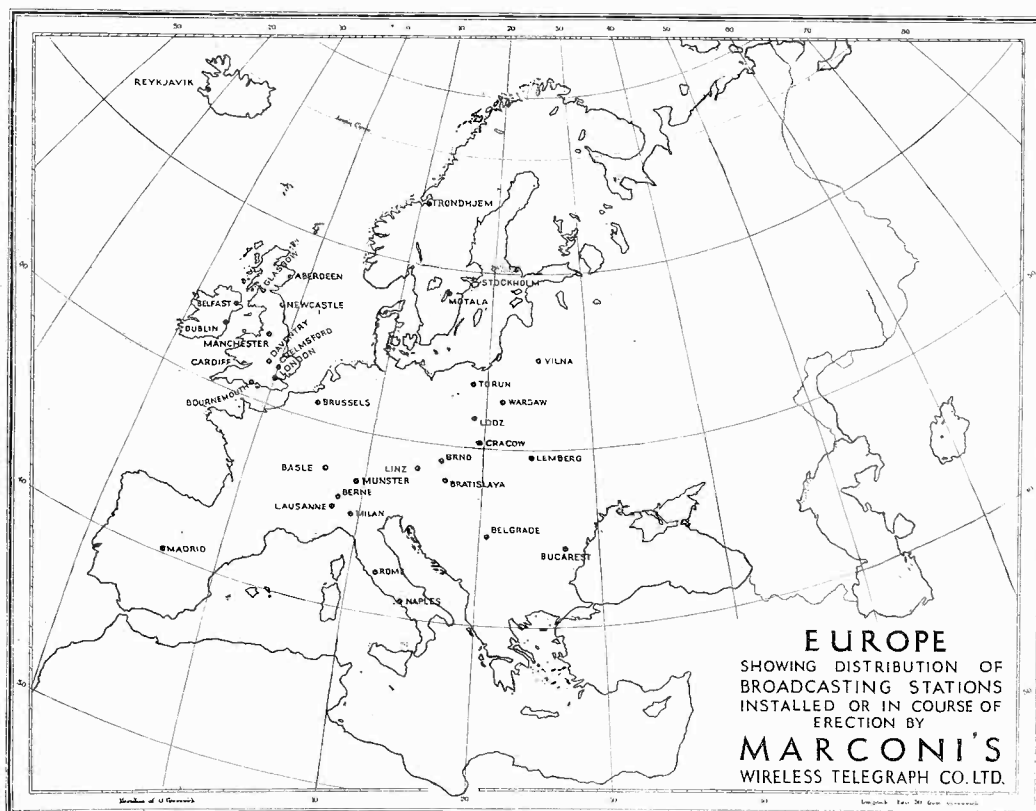

necessary in spite of the comparatively limited area served by the fact that Switzerland, with its valleys, high mountains, and curious screening effects, is one of the most difficult countries in the world for broadcasting.

Studios in Berne, Zurich, and Basle will provide the programmes for the Munster station, which will be allotted the wavelength of 459 metres.

For "Crystal Listeners."

To provide for "crystal listeners" in the towns, Marconi broadcasting stations of $\frac{1}{2}$ kilowatt aerial power are to be erected at Berne and Basle. These stations are of special Marconi design, with crystal-controlled drive to ensure great constancy of frequency.

The new station at Berne will replace the present Marconi 1 kw. "Q" broadcasting station, which was erected in 1925 and which will later be modernised and re-erected elsewhere to play a part in the "regional" plan. At Basle the new station will be the frontier town's first full-time broadcasting station, the broadcasting service having previously been carried out by the Marconi transmitter at the Basle Aerodrome, which is primarily employed for wireless telephony with aircraft.

The reorganisation of the Swiss broadcasting service on the "regional" basis is expected to be completed in 1931, when, in spite of difficult conditions due to the geographical formation of the country, Switzerland will have a broadcasting system as efficient and complete as any in Europe.

This is the second recent Continental broadcasting reorganisation in which assistance has been sought from the experience of the Marconi Company, in September last year the Company having received an order from Poland for high-power and relay stations designed to give crystal reception throughout the industrial and thickly populated districts of that country.

Italy's Short Wave Broadcast Station.

In accordance with the Italian Broadcasting Company's policy of modernising the Italian Broadcasting system a short-wave Broadcasting transmitting station has been erected near Rome to enable the Italian transmissions to be heard in the Italian Colonies and in overseas countries which are outside the range of the Broadcasting stations operating on the normal broadcast wave-bands of 1,340-1,875 and 200-545 metres.

The new station, which in its main features follows the design of the Marconi short-wave Beam transmitter, has been supplied by the Marconi Company and was manufactured at the Marconi Works at Chelmsford.

The station is now completed and tests were started at the beginning of March when transmission trials on 25.4 metres took place. These tests were observed in the Italian Colonies and in a number of overseas countries.

Reports received from India, Australia, and South Africa remark on the stability, the excellent quality, and the great strength of the Italian transmitter. Reports

have also been received from New York and these are equally enthusiastic about the emissions from the new Rome station.

From the tests which have so far taken place on 25.4 metres it is already obvious that Italy is now in possession of a short-wave transmitter which will enable the world at large to listen to the artistic programmes which are a feature of the Italian broadcast system.

Arrangements have also been made to enable the transmitter to operate on a second wavelength of 80 metres which is suitable for reception throughout the whole of Italy and neighbouring countries where the normal broadcast wave-band is indifferently received.



*The Marconi
telephone equipment
installed in the
new Dover lifeboat.*

Wireless for World's Speediest Lifeboat.

The new Dover lifeboat, which with its two 375 h.p. engines is the fastest lifeboat in the world, has been specially equipped for the rescue of aeroplanes which have fallen into the sea. Included in this equipment is a special type of Marconi wireless apparatus which will enable communication to be established with aircraft and other vessels in distress and also with the shore. The wireless installation is known as the Marconi Type X.M.B.I., and is a combined transmitting and receiving set which is totally enclosed, and designed for use under the roughest conditions.

Other boats of the Royal National Lifeboat Institution that have recently been fitted with Marconi apparatus are those stationed at Stornoway and St. Peter Port, Guernsey.

Flying in Fog.

The report of the London *Times* on the trial flight of the British Government Airship R.100 emphasises the importance of wireless in air navigation. The R.100 was in the air for 53 hours, during which she flew more than the distance from London to Egypt, steering in that time an intricate course with perfect certainty through two days of almost complete fog.

The Aeronautical correspondent of "*The Times*" wrote:—

"Major G. H. Scott, who was in supreme command of the flight, said:—

"We have spent two days more or less in cloud. We flew most of the flight using directional wireless to check our course, with occasional glimpses of the ground as a check on our drift. The main lesson of this long flight over a cloud-hidden England is undoubtedly the certainty with which an airship, alone of man's transport vehicles, is superior to the paralysing influence of fog, and all those in the ship were impressed by this fact.'"

The first remark Sir Dennistoun Burney made when he came off the ship was also on the efficiency of the wireless direction finding apparatus.

"On the first night," he said, "we did not see land, after some rocks by the Channel Islands, until we crossed the Essex coast by Felixstowe the next morning, yet we always knew where we were. There was a spell of 15 hours or more blind flying. Then, when we flew over London yesterday about 10 a.m. we picked out the Tower Bridge through the mist, but the next clear view of the earth was when we saw the fishing fleet off Plymouth at 7 o'clock the same evening."

Wireless Navigation for 15 Hours.

The comments of Mr. Neville Norway, now the Chief Engineer of the Airship Guarantee Company, who has been on board on each flight, were even more interesting in their commercial application. He said:—

"This flight has established clearly that airship travel provides the only means of locomotion in which you can go straight ahead in fog at full cruising speed in perfect safety, and with absolute certainty of making your terminal point. We flew by the aid of directional wireless without sight of land for 15 hours in thick fog at any speed we liked to call for; no railway, tram or road vehicle, steamer or aeroplane has that facility. Our course, too, was a changing one. From the Channel Islands we set out for Brighton; having got our bearings from the direction finders at Croydon and Pulham.

"At the appointed time on our dead reckoning, a glow under the clouds indicated the lights of Brighton, and as the course was reset for



Marconi engineers ready for a test flight at Croydon.

each town so the glow of its lights in the clouds at the expected time showed we were keeping an accurate course over an invisible earth."

Weather Reports.

Another valuable test made during this endurance flight was the compilation of weather charts on board by Mr. A. Giblett, the officer specially charged with airship meteorological research. He had the weather information sent to the ship by wireless, and from this prepared the same charts as are normally seen by every newspaper reader each morning. So, in addition to exact knowledge of the ship's position by wireless, the probable changes in the weather were forecast for hours ahead.

"These, on one occasion," Mr. Norway told me," wrote *The Times* correspondent, "showed that the ship was on the wrong side of a storm area, with winds up to 50 miles an hour. There was clear weather indicated on the other side of the storm area, and throughout the first night the ship was driven through the disturbed conditions to find the quieter weather as forecast.

The wireless direction finders at Croydon and Pulham, which provided the airship with its bearings, were supplied to the British Air Ministry by the Marconi Company. They are of the R.g.14 type, specially developed for service in aerodrome ground stations, and during this test flight of the R.100 again justified the implicit confidence which is placed in them by aviators.

Practical Research Work.

The development of wireless for aviation services has been a specialised service of the Marconi Company since it inaugurated the first experiments in ground-to-air wireless communication at the famous Graham-White sheds at Hendon Aerodrome

in 1912. To-day, the Development Section of the Marconi Company's Air Division operates its own aeroplane, and mobile and stationary land stations, at the London Air Port, Croydon.

With these resources the performance of new apparatus is observed in the air, experience having proved that the results obtained in ground operation are no criterion of what may be expected under the more arduous practical conditions of flying service.

The personnel of the Aviation Department of the Marconi Company consists principally of men with practical flying experience in many parts of the world, who are fully conversant with the problems of wireless operation under flying conditions.

The photograph on page 30 shows two engineers of the Development Section of the Marconi Company's Air Division in flying kit, ready to start a short wave wireless test flight in the Company's "Bristol Fighter." Also in the photograph are the two engineers who operate the mobile station in the motor van on the right, which has complete transmitting and receiving equipment for co-operation with the aeroplane. The van is provided with telescopic masts, and actual working conditions between a machine in the air and ground stations can thus be reproduced. The hut in the background is fitted with long and short wave transmitting and receiving apparatus, and acts as a fixed ground station for tests with aeroplanes.

Sudan to U.S.A.

Short-wave wireless messages transmitted by Major C. Court-Treath, the British explorer, from a portable Marconi equipment during his recent expedition in the Sudan were received as far afield as the United States of America.

From camps in the least known parts of the Western Sudan, Major Court-Treath and his party maintained communication with Sudan Government wireless stations



*Major Court-Treath's special short wave Marconi transmitter
in operation in the Sudan.*

throughout his year of travel in the jungle making the British Instructional Film "Stampede." Through the Government stations he was in regular touch with the film company's headquarters in London, while on a number of occasions his transmissions, on a wavelength of approximately 30 metres, were heard at distances of more than 5,000 miles in Detroit, Michigan, and Boston, Massachusetts.

The wireless transmitter used was a specially designed Marconi set of extremely small power and weight, the power being supplied by a portable hand generator.

Wireless to the Rescue.

With gales of almost unprecedented force in many parts of the world, and a disastrous submarine earthquake in the Atlantic, the past winter has been an exceptionally difficult one for long distance wire and cable communications. Under conditions of the greatest stress the value of wireless communication in times of emergency was proved again and again.

When the Atlantic cables were damaged by the submarine upheaval in November and ten out of 21 cables were broken, wireless immediately came to the rescue. Large numbers of telegrams were diverted to the transatlantic wireless circuits, and the enormous capacity of the Marconi short-wave Beam stations was proved by the large amount of extra traffic they were able to handle without undue delay.

When the exceptional gales of December interrupted landlines all over the Continent of Europe the only telegraph communication available for a considerable period between certain countries was by means of the wireless service. In Bulgaria for instance, Sofia was for many days completely isolated from all foreign countries so far as landline telegraph communication was concerned. All exterior telegraph communication was, therefore, conducted by means of the wireless service, emergency wireless services being quickly brought into operation for communication with countries to which wireless circuits were not normally available.