

BRITAIN'S BEST SELLING ELECTRONICS MAGAZINE

No. 48

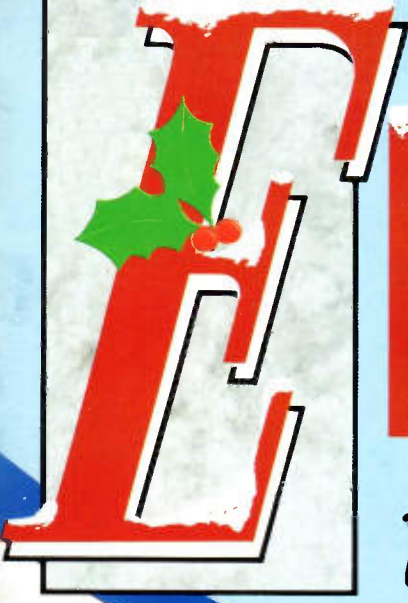

ELECTRONICS

The Maplin Magazine

DECEMBER 1991 • £1.60

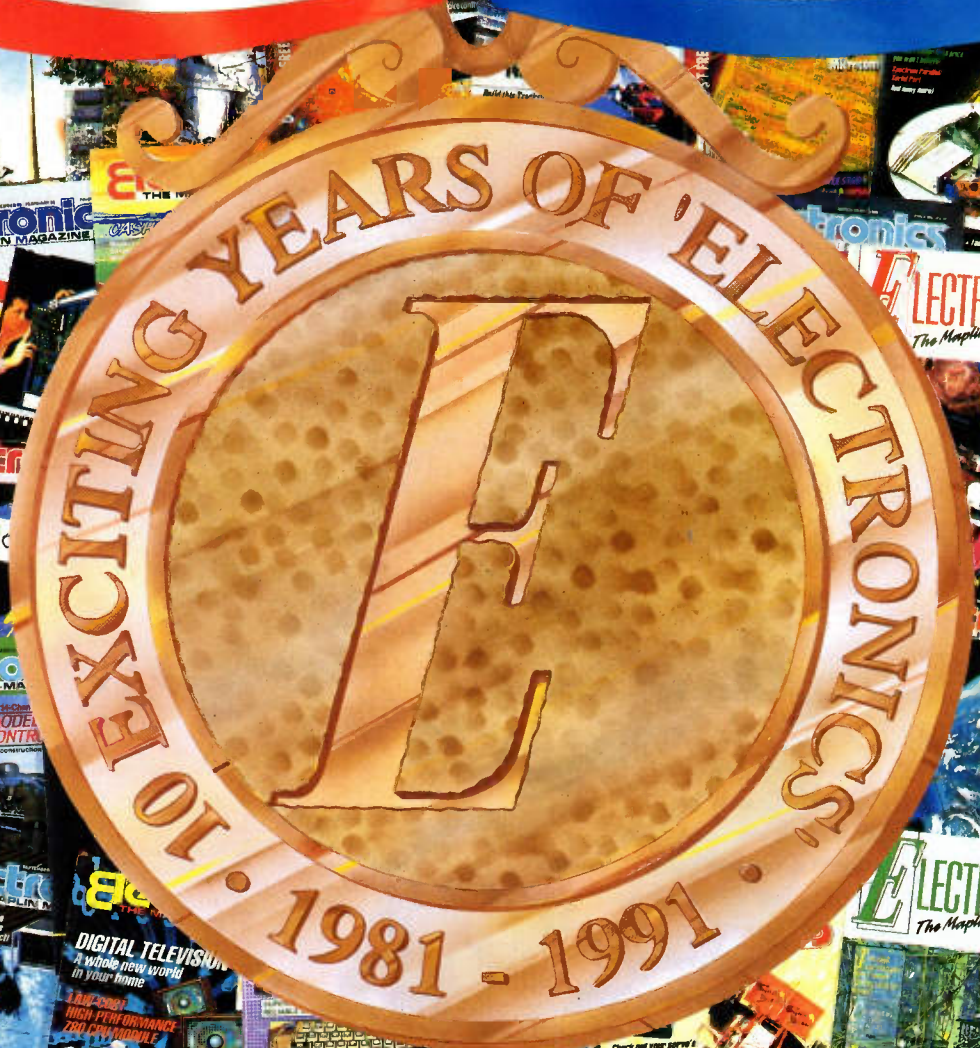

10 PROJECTS FOR YOU TO BUILD!



Twelve great reasons to get Electronics under cover...



Available for the first time! The new Maplin magazine binder that holds twelve issues of Electronics, the Maplin magazine. If you have not got the world of Electronics covered, now's your chance! This great, quality binder comes in hard wearing, laminated art board, that not only looks good on your bookshelf or workshop desk, but is also a great way to build up an Electronics reference library of your own!

Now you can keep all of your copies of Electronics, the Maplin magazine, together and on hand for when you need that extra piece of information. To order your binder simply fill in the order form provided in this issue of Electronics. Only £5.45 (plus £1 handling charge). Order no: XH99H.

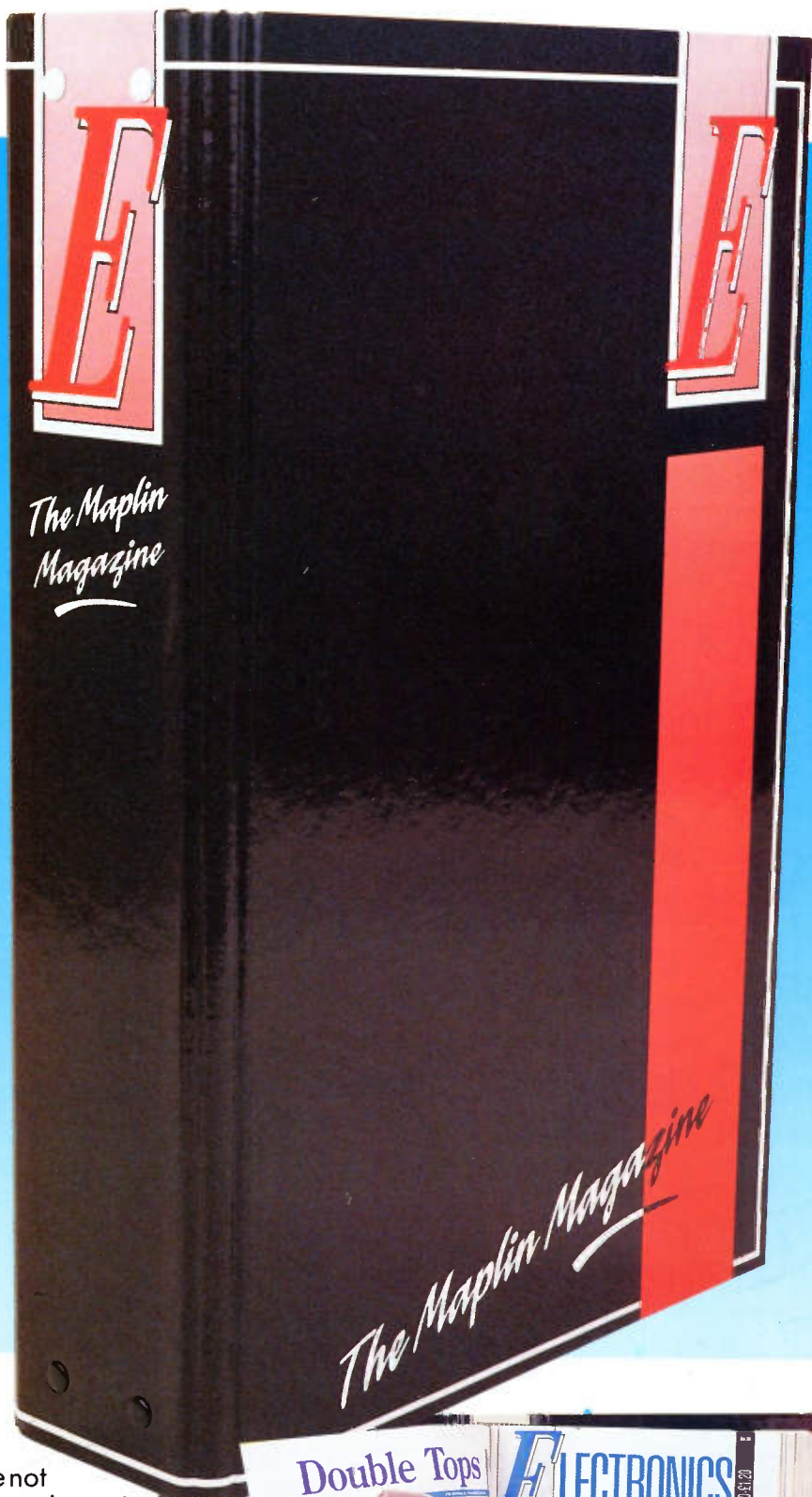

**THE NEW MAPLIN MAGAZINE BINDER...
A GREAT WAY TO GET THE WORLD OF ELECTRONICS COVERED!**

CONTENTS

DECEMBER 1991 VOL.11 No.48

EDITORIAL

■ Hello again, Merry Christmas, and welcome to this extra special issue of 'Electronics'! As you will have seen from the front cover, this month we are celebrating our 10th Anniversary! You too can join in with the celebrations as we've put together a bumper crop of projects for you to build. There's a total of ten projects in all! So even when you're fed up with eating turkey and watching 'The Sound of Music' for the umpteenth year running, you can relax by building some of the super projects, and of course, reading the excellent feature articles. The very first issue of 'Electronics', cover-dated December 1981 to February 1982, also contained ten projects! Since the first editions, which were published quarterly, quite a few changes have taken place. There have been four Editors over the years; Mike Beecher, Doug Simmons, Roy Smith and Myself. Little did I realise, when I picked up the first issue at the Maplin store in Westcliff-on-Sea, that ten years on I would be sitting in the editorial hot-seat! In 1988 the first colour bi-monthly issue rolled off the presses, and just two editions ago the first monthly issue of 'Electronics' was published. Not surprisingly, the editorial and production team has doubled in size since 1981! However, without all of you, our loyal readers, 'Electronics' wouldn't be what it is today - Britain's Best Selling Electronics Magazine - so a very big thank you to you all! And finally, until the New Year's issue (on sale next month!), I hope that you enjoy reading this issue as much as the 'team' and I have enjoyed putting it together for you!

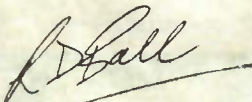

ABC 33,837

- **Editor** Robert Ball
- **Project Development** Chris Barlow, Gavin Cheeseman, Tony Bricknell, Alan Williamson
- **Technical Authors** Mike Holmes, Martin Pipe.
- **Consultant Author** Alan Simpson.
- **Technical Illustrators** Paul Evans, Lesley Foster, Ross Nisbet.
- **Production Co-ordinator** Alan Wraight.
- **Print Co-ordinator** John Craddock
- **Advertising Co-ordinator** Kathy Peters
- **Publications Manager** Roy Smith
- **Development Manager** Dave Goodman
- **Advertising Manager** Vic Sutton.
- **Drawing Office Manager** John Dudley
- **Art Designers** Peter Blackmore, Jim Bowler
- **Published by** Maplin Electronics Plc.
- **Colour Separations** Stirling Graphics Ltd., 16-22 West Street, Southend, Essex SS2 6HJ.
- **Printed by** Severn Valley Press, Caerphilly, Mid Glam. CF8 3SU
- **Distributed by** United Magazine Distribution Ltd., 1-11 Benwell Rd, London N7 7AX
- **Mail Order** P. O. Box 3, Rayleigh, Essex SS6 8LR
- **Retail Sales:** (0702) 554161 **Retail Enquiries:** (0702) 552911. ■ **Trade Sales:** (0702) 554171.
- **Cashtel: (MODEM)** (0702) 552941.
- **General:** (0702) 554155.
- **Fax:** (0702) 553935 ■ **Telex:** 995695

Copyright. All material is subject to world wide copyright protection, and reproduction or imitation in whole or part is expressly forbidden. All reasonable care is taken to ensure accuracy in preparation of the magazine, but Maplin Electronics plc cannot be held legally responsible for its contents. Where errors occur corrections will be published as soon as possible afterwards. Permission to reproduce printed circuit board layouts commercially or marketing of kits must be sought from the publisher.
© Copyright 1991 Maplin Electronics plc.

PROJECTS

4 FESTIVE CHRISTMAS TREE

■ A super seasonal project that complements more traditional decorations.



8 TEMPERATURE MONITOR

■ Guards against excessive temperature, used on its own or with the Amplifier Monitor.

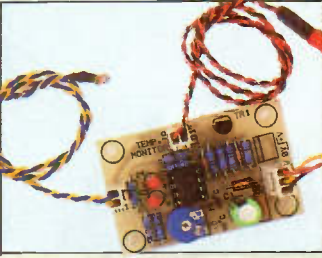

16 FUSE & BULB TESTER

■ The start of a new series of beginners' projects.

24 LOW-COST SIGNAL GENERATOR

■ An affordable multi-function audio signal generator.



32 FESTIVE CHRISTMAS STAR & OPTO SWITCH

■ Two extremely popular projects from Christmas '90.

48 FIBRE-OPTIC MULTIPLEXER

■ Allows 10-channels of information to be transmitted along an optical fibre.

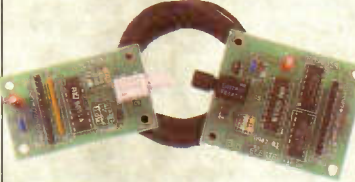

56 DATA FILE: BUCKET BRIGADE DELAY LINE

■ An application circuit for a versatile BBD IC is presented.

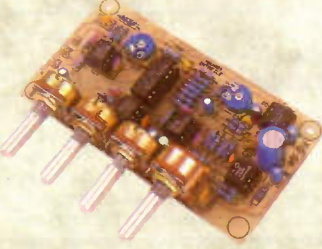

64 LIVE WIRE & MINI METAL DETECTORS

■ Ideal Christmas presents for the handyman.



FEATURES

12 MICROCONTROLLERS IN CARS

■ Deals with applications of microcontrollers in modern cars.

19 SQUARE ONE

■ The final part of this series deals with positive and negative feedback.

40 LONDON TRANSPORT MUSEUM

■ Our roving reporter takes a ride down memory lane.



44 DC POWER SUPPLIES

■ An authoritative new series on designing reliable power supplies.

52 PREDICTING WAVESHAPES

■ Part 4 in this series deals with transformers and mutual inductance.

70 MICROCOMPUTER TESTING

■ Part 1 in a new series about testing and fault-finding on microcomputers.

78 CHRISTMAS EXTRA

■ A humorous look at what 1992 may hold in store.

REGULARS

- | | |
|------------------|-------------------------------------|
| 2 NEWS REPORT | 63 AIR YOUR VIEWS |
| 7 NEWS EXTRA | 72 TOP 20 KITS |
| 39 CIRCUIT MAKER | 76 NEW BOOKS |
| 43 STRAY SIGNALS | 79 COMPETITION WINNERS & NEXT ISSUE |
| 54 CLASSIFIED | 80 TOP 20 BOOKS |
| 62 SUBSCRIPTIONS | |

Prices shown in this issue include VAT at 17.5% (except items marked NV which are rated at 0%) and are valid between 1st November 1991 and 31st December 1991.

NEWS

Report

BT Rings the Changes – Again

Just when we thought we could relax, the government telecomms authority OFTEL have decreed the implementation of a new 10 digit numbering plan for the UK telephone network. From Easter Sunday, April 3, 1994, an extra digit '1' will be added after the '0' at the beginning of area dialling codes throughout the country. Just in case we can't fathom out the changes, OFTEL gives the example of the Bristol code '0272' becoming '01 272'. However, OFTEL will not leave the matter there. Their intention is to allocate the remaining digits '2' to '9' to paging, mobile, free call, premium and PCN services. As a result of the changes, there will be a tenfold increase in the overall capacity of the UK telephone numbering scheme.

At the same time, OFTEL are planning the introduction of '00' as the code for initiating international calls. Meanwhile BT has set up a free helpline for customers requiring information about the code changes. The number to ring is 0800 800 873. Meanwhile, 'Electronics' is investigating the subject of telephone numbering and transferability.

Watch this space for an update in the near future!

Snookered

According to the British Association for the Advancement of Science, a robot has been developed which can perform ear surgery, specifically drilling into the stapes, an inner ear bone that has to be replaced in order to restore hearing in certain cases. When not attending to its medical duties, the robot apparently plays snooker.

Engineering Industry Welcomes Careers Initiative

A nation-wide survey, set-up by the government body 'Institute of Manpower Studies', has been welcomed by EnTRA, the Engineering Training Authority. The survey will investigate the careers information needs of the engineering industry and the attitudes of employers, school teachers, careers officers and young people towards the material and services currently available. The survey is taking place at a time when research shows that the number of young people applying to study engineering has fallen by 14 per cent and that less than half the country's 'A' level students think engineering presents a positive image to young people. Details: EnTRA. (0923) 38441.

Meanwhile, a report published by NEDC entitled 'A Career in Electronics' suggests that, compared to one third of

secondary school boys, nearly three quarters of girls found electronics 'boring'. The reason, says the NEDC, is that there is too much emphasis on the practical engineering side of the subject in schools, and not enough on the diverse uses of electronics in the home and at work. Perhaps a further reason could be that not enough girls read 'Electronics'!

Prize Community

The Commission of the European Communities, Telecomms Division, is organising the European Community Design Prize 1992. The aim is to promote the quality of design within medium-sized industries throughout Europe. Up to five companies from each EC country can compete and an international jury will select the companies which have best illustrated the way design can be used as a management tool. The awards ceremony is to be held in Seville during Expo 1992, and later an exhibition of all the nominations will go on tour to several cities throughout Europe. Details: (010) 32 235 1111.

Watch Out – There could be a Virus about

Come Friday 13th December, editorial advice is to keep your computer firmly in the non-active mode. This date marks 'Danger Day' for computer users – a day on which possible viruses are activated. As The Hoskyns Consultancy point out, there are now more than 300 different types 'now identified and new viruses are being discovered at the rate of one every three days, and there are several which are triggered by a specific date. Hoskyns lists the ten most common as being:

- ★ Friday 13th – the virus destroys the File Allocation Table (FAT) on a hard disk, making access to files impossible.
- ★ Saturday 14th – a variant of Friday 13th, designed to catch those users who advance the data one day to avoid the 13th.
- ★ Canada Day (1st July) – variants delete files, destroy the FAT, or write randomly to a hard disk thereby corrupting files.
- ★ Independence Day (4th July) – effects as for Canada Day virus.
- ★ Columbus Day (10th October) variants of this virus either destroy the FAT or delete files.
- ★ Guy Fawkes Day (5th November) – at least one version displays fireworks on the VDU, others are modified Independence Day viruses.

- ★ St George's Day (23rd April) – believed to be a rewritten version of the original Guy Fawkes Day virus, but with added malevolence. It apparently displays a St George's Cross on the VDU whilst deleting files at random.
- ★ Burns Night (25th January) – a variant of the Guy Fawkes Day virus. This one displays a tartan pattern on the VDU.
- ★ 30th Virus – triggered on the 30th of the four months having 30 days (April, June, September and November). It writes 3330 in hex to the FAT entries, thereby losing track of stored files.
- ★ Birthday Virus – linked to a biorhythm freely distributed in the Netherlands three years ago. This virus destroys randomly on each anniversary of the first date entered as 'birth date' in the biorhythm program.

However, the danger could be even worse than Hoskyns suggest. An eminent German computer virus expert has published a list of known malicious software for MS-DOS systems that includes 979 viruses and 19 'trojans'.

Late Night Pay-TV from the BBC

The middle of next year should see the BBC – that bastion of non-commercial television – launching its own commercial pay-TV service. Those small hours after transmission shuts down, will be filled with commercial-backed or even sponsored programmes. Called 'BBC Select', viewers will have to pay for the privilege of watching the commercials as well as buying a special high-tech decoder. SKY and Channel 3 must be quaking in their well-heeled shoes.

Meanwhile, a note of sporting caution has been struck by the Independent Television Commission, who believe that traditional terrestrial channels will lose out to the free-spending satellite channels. Providing there is enough money in the well, BSkyB will eventually win through. With BBC1, BBC2, ITV, Channel 4, BSkyB, Screensport and Eurosport providing

large doses of sport, the danger would seem to be that of supply rather than demand. In the meantime, for those of us who are perhaps less interested in sport, ITV's Saturday afternoon programming of old films is sport enough.

Smile Please

This year has seen a further record clocked up. No less than 60 million units have been produced by camera manufacturer Canon. This achievement is the result of 54 years of camera production and covers 135 models. The camera story began back in 1933 when a trial production of the first Japanese 35mm focal-plane shutter camera – the 'Kkwanon' took place. The first camera to be sold commercially, and the first commercial camera to be produced in Japan, was the Hansa Canon, a 35mm range finder focal-plane shutter model in 1937. Certainly, Canon haven't stopped smiling since that date.

Puzzled by the terms PMR, CT2, GSM, PCN, DSRR and so on. Well, be baffled no more. Cognito, operators of a public network designed for mobile data and messaging applications in the UK, have produced 'The Cognito Pocket Guide to Mobile Communications'. Copies of the book are available from Elena Tilliatt at Cognito, Newbury on 0635 508200 for just £5.95. For the record: Private Mobile Radio: Cordless telephone (2nd Generation); Groupe Speciale Mobile (the pan-European standard for digital cellular systems; Personal Communications Network and Digital Short Range Radio).

Get Tapping

The Radiocommunications Agency has announced details of the five words per minute novice Morse test. A pass in the test will be required in order to obtain a Class A Novice licence. The test will cover both sending and receiving. Each character will be sent at a speed of 12 wpm, with a longer than normal gap between each character and word to reduce the overall reception speed to five wpm. Details: (071) 215 5000.

Office in a Briefcase goes Travelling



Described as the 'first totally portable office in a briefcase', a system which incorporates software, a Philips PCL200 notebook, a modem and a bubble jet printer (space it seems didn't allow room for a fax or coffee flask),

has been called 'the machine for the times.' At under £4,000 the unit will certainly reduce the costs of setting up an office or help the sales executive keep on the move. Details: (071) 739 4804.



Lightweight Matters

Toshiba has launched an A4-sized, 386SX-based, notebook PC which the company claims to be one of the slimmest, lightest and most rugged portable PCs on the market. The new model weighs in at just 5.5lb and is 41mm thick. Not surprisingly, Toshiba are incorporating some of the smallest components available, including the printed circuit board which can be 'folded' inside the PC, and the world's smallest and lightest floppy disk drive. Whether the specification includes a magnifying glass, is not revealed. Recommended retail price is £3,795. Details: (0932) 841600.

Meanwhile, the International Data Corp is forecasting that the market for notebook computers will escalate some 40% this year. Providing, that is, the parts suppliers can meet the demand from the manufacturers.

Enter the Water-Carrier

Hydro-Electric, one of the newly privatised electricity utilities, is joining the ever increasing number of contenders in the UK telecomms market. The company operations cover about a quarter of the UK total land mass, but a somewhat sparsely populated mass. With canal, cable, rail and electricity authorities joining the UK telecomms supplier club, there will be no shortage of alternatives. Even the France Telecomms Transpac network is contemplating introducing the popular Minitel videotex service into the UK. No doubt telecomms controller OFTEL are already planning to ban the Minitel Chat-Line type services.

BT Performance Guaranteed

BT have reinforced its commitment to customers to provide a 'helpful, polite and world class service'. According to BT chairman, Iain Vallance, BT promises to give customers:

- ★ Value for money
- ★ Excellent performance, backed by guarantee
- ★ Compensation if BT falls short
- ★ An easy way for customers to deal with the company: by phone or face-to-face.
- ★ Attention to customers who have special needs
- ★ A commitment to provide service on demand, within one working day, seven days a week, (but by the end of 1993).

If you have any enquiries over service, ring your friendly BT rep on 150 for residential (151 for the fault reporting service), or 152 and 154 for business users.

A Phone for all Reasons

According to the daily newsletter 'ComputerGram', Motorola are testing a hybrid mobile telephone system where the unit can be used as a cordless phone in the home and a cellular phone in a car.

Communications will also be flying high and wide courtesy of GTE, who have developed an information system which will be available to airline passengers anywhere in the world. The services will include facsimile, financial news, stock market reports, shopping, hotel reservations, sport and weather reports. "We are turning aeroplane seats into personal communications centres for business travellers," says Robert Calafell, GTE Airfone president. The new satellite-based two-way telecommunications system will operate through a network of ground stations which makes possible the voice, data and information services. Details: GTE, (071) 583 1737.

Safe Bet

The Wall Street Journal reports that the thief caught stealing Stalin's telephone from a museum in Georgia said he took it because he thought it would work better than his own.

Lets Twist Again

BT chose the event of the 'infraStructure 91' conference to announce a new international consortium. The 'Unshielded twisted-pair Development Forum', or UDF (I kid you not), has been formed by seven companies to support operation at 100M-bits/sec (100 megabits per second - which, somebody once worked out, is something like transmitting the text for approximately three and a half New Testament bibles, or nearly two million words, in one second) over Fibre Distributed Data Interface (FDDI) local area networks, using unshielded twisted pair cabling. The Club founder members include BT, Apple Computers, AT & T, Hewlett-Packard and Ungermann-Bass.

The UDF subsequently announced that it had completed preliminary testing of a new signalling specification for unshielded twisted-pair wiring, with the ultimate aim of achieving 100M-bits/sec signalling on local area networks. The objective is operation on standard grade UTP over distances from 50 to 100 metres, complying with the European Normalised Standard EN 55022 for electromagnetic compatibility, and its US equivalent, the Federal Communications Commission requirement FCC Class A. Also operation on higher specification 'datagrade' UTP wiring at distances of 100 metres or more, complying with EN 55022 and FCC Class B.

Conference organiser Michael Naughton of international consultancy ANR, commented that by providing product solutions for 100M-bit/sec FDDI on UTP, BT users can take advantage of their existing Ethernet/Token Ring on unshielded cabling and upgrade to FDDI without any change in cabling infrastructure. Details: ANR, (081) 947 2684.

BT Cares Even More

Blind telephone customers nation-wide are now being offered BT bills in Braille for the first time in a joint initiative by BT and the Royal National Institute for the Blind. Partially sighted customers will also benefit as BT is introducing large print bills at the same time. Both services are free of charge. Details: 0800 400454. Whether BT will be providing tranquilisers for customers receiving their quarterly bills is not revealed.

Switch On to PC Radio

Getting into the radio act - there are few UK towns and cities that do not now enjoy the benefits of mass broadcasting channels - IBM has launched the PC Radio. This is a personal computer designed to send data over a cellular telephone or radio network channel irrespective of operating environment. The IBM 9075 PC Radio makes use of the Intel 80186 processor operating at either five or 100MHz, weighs in at six pounds, has an 80-key keyboard, adjustable liquid crystal display plus a thermal printer. The DOS-driven system says the company, will give mobile users the electronic link they need to be efficient and responsive to the needs of their customers. But don't rush for your order-form. The system which to say the least is intriguing the computer world is not expected to emerge in Europe until late 1992.

Meanwhile, miniature 'Dick Tracey' wristwatch-size wireless hand-sets are emerging in the US, reports research group BIS. No doubt, far eastern factories are already busily producing 'genuine fake' models.

A Fishy Tail

Ferranti International is planning to build an artificial 'gill' as part of a UK government study into alternative methods for extracting oxygen from sea water. Continuously charged with its raw material, the device opens up research into systems capable of 'breathing' from sea water. In case you are wondering how it is done, Ferranti

explains that the basic elements of a system using this principle will include the 'loader' or 'gill', a proprietary carrier fluid, an electro-chemical cell and the 'unloader' which separates gaseous oxygen from the carrier. The carrier fluid is the medium which binds, concentrates, and releases oxygen. It is a transition metal compound whose valence state can be reversibly cycled. But whether the Ferranti 'gill' will replace your friendly goldfish remains to be seen.

Software Rules

With some 4 million copies of software programs in some 14 different languages already in the market-place, WordStar International have produced their 'WordStar for Windows' word processing package. Features include page layout, graphics, table generation and advanced connectivity capabilities such as file referencing and LAN support. However, for writers (and the News Editor - Ed.), the package has some exceptional bonus points. 'WordStar for Windows' incorporates the Windows edition of Correct Grammar that is one of the leading syntax and style checkers. In one pass through documents, the program will point out errors in grammar, punctuation, spelling as well as checking the copy for style and readability. Price: £399. Details: (081) 643 8866.

No reference to WordStar, but Computergram reports that a William Zachman of US company Canopus Research is on record as saying "Any bozo can write software, and often they do."

PICTURE CAPTION CHALLENGE



Yes, it is the celebrated weatherman Michael Fish. But just what is he up to?

- ★ Examining a leak in the Met office weather umbrella.
- ★ Camping it up at the girl's brigade annual outing.
- ★ Praying for divine guidance on where to get a replacement battery.
- ★ Doing a song and dance 'Walking in the Rain' audition.

Not quite! Mr Fish is promoting the new Cellnet Mobile Telephone 24-hour, seven days a week weather forecasting service. The Met Office forecasts covers the Greater London area plus 14 regional areas. Each forecast is updated at least three times a day - more in severe weather conditions. If the service is a success, possibly Cellnet Weathercall will be able to splash out on a new broly.

Events Listings

5/8 December. Computer Shopper Show, Wembley, Middx. (081) 868 4466.

Open until 19 January 1992. Michael Faraday 1791 - 1867, National Portrait Gallery, London. (071) 306 0055.

2/5 January 1992. Holiday & Travel Fair, NEC Birmingham.

4/6 February 1992. Portable Computer Communications Show, Wembley, Middx. (071) 383 3323.

Please send details of events for the Diary Listings to The Diary Editor, 'Electronics'.

Ye Merry Festive LED Christmas Tree

by Alan Williamson

This year's festive project is a Christmas tree, decorated with 21 low-current LEDs in three different colours, which light in random patterns.

The circuit can be powered from a battery or a mains adaptor, the supply voltage requirement is nominally +12V dc, although the tree will operate quite happily over the range +9V to +15V. If an unregulated mains adaptor is used e.g. XX09K, it should be set to 7.5V or 9V.

The LEDs can be made to light at different rates/patterns; for this reason three values of R1 have been included in the kit. The lower the value of R1, the faster the rate of change: R1 = 1M slow change; R1 = 330k fast change; R1 = 2k2 twinkle, in a darkened room the LEDs will appear to twinkle like hot cinders in a breeze.

Circuit Description

Referring to Figure 1, IC1 (a to f) is a hex schmitt-trigger inverter, each inverter is configured as a free-running oscillator. Four of the oscillators IC1 (b to e) feed the inputs (2^0 to 2^3) of the LCD 7-segment display driver, whilst IC1a strobos the input of IC2 - latching the random binary number present at that time. The binary number is then decoded and the appropriate LEDs are illuminated. IC1f is used to drive TR1 which in turn switches the supply voltage to the LEDs on and off, thus conserving power and extending battery life.

Construction

A Constructors' Guide is included with the kit, the Guide contains some useful information on component identification and soldering techniques. Begin construction with D1, D2, C7, R7 and R8, followed by the IC sockets, take care with the polarised devices. R1 to R6 and R9 to R15 should be fitted next, then C1 to C6, the rest of the components can then be installed in any order, the PCB pins are fitted from the track side of the PCB.

Prototype Specification

Voltage range:	+9V min.	+12V nom.	+15V max.
Supply current (all LEDs illuminated)			
@ 9V:		12mA nom.	
@ 12V:		25mA nom.	
@ 15V:		36mA nom.	



The complete tree.

The assembled PCB.

ACTUAL
SIZE

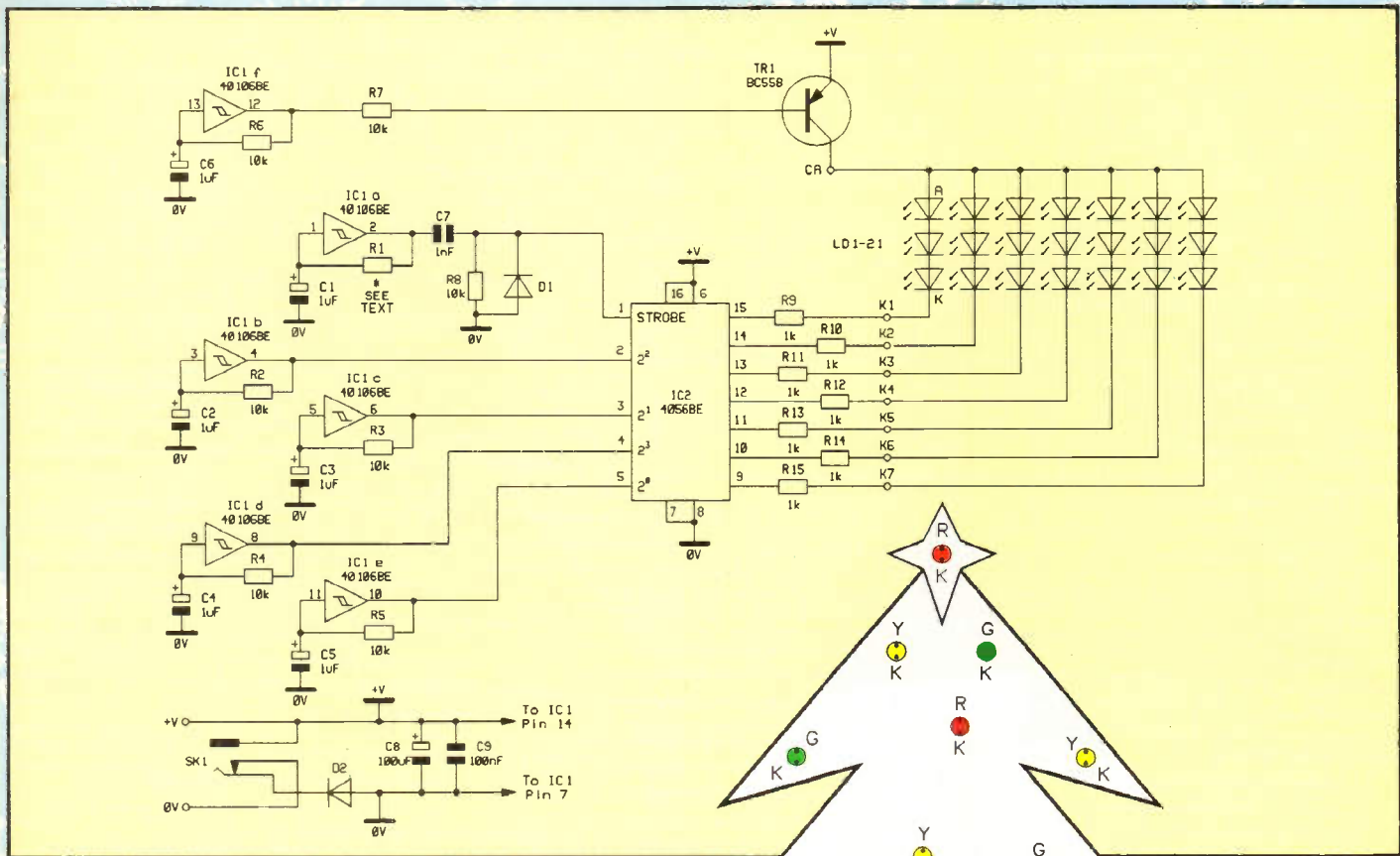

Figure 1. Circuit diagram of the LED Christmas Tree.

Construction of the Tree

Supplied with the kit is a full size template of the tree which can be cut out. Alternatively make a 200% enlargement of Figure 3 (which is printed 1/2 size) on a photo-copier. Your local library or print and copy shop should be able to do this for you for around 10 to 20p.

Stick the template onto a piece of thick card, aluminium laminate, hard-board, plywood or perspex. Do not use metallic materials such as sheet aluminium, etc. as there is the possibility of

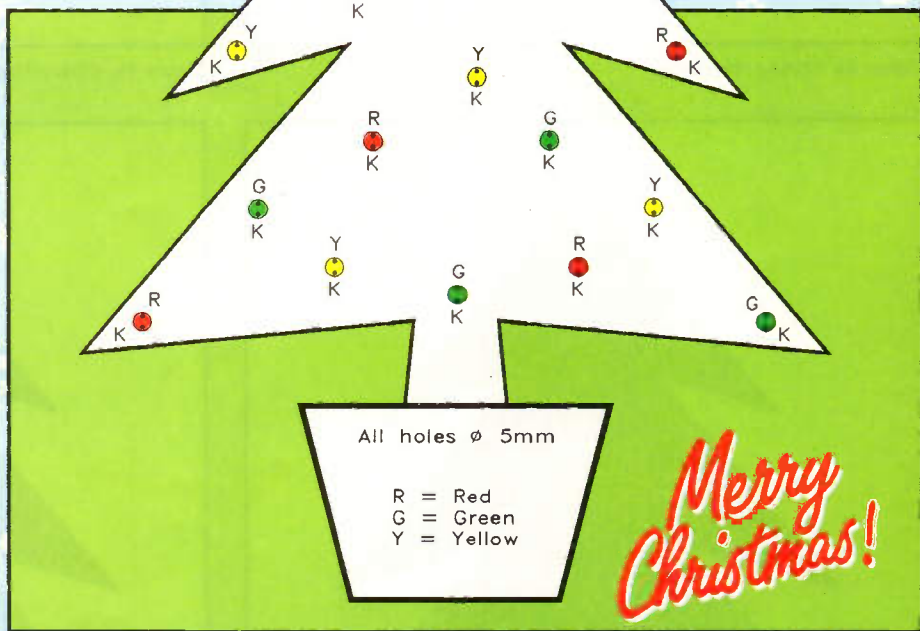

Figure 3. Half-size tree template, LED orientation and colour guide.

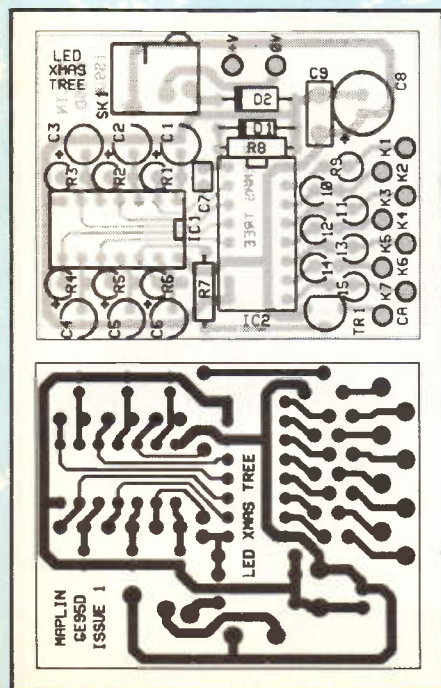

Figure 2. PCB legend and track.

shorting out the LEDs. Drill, cut or punch out the 21 x 5mm diameter holes required, then cut out the tree. Decorate the tree using any materials that take your fancy, alternatively you may be able to purchase a pre-decorated tree which would save you a bit of work.

Referring to Figure 3 as an orientation and colour guide, glue each of the LEDs in place; wait for the glue to dry before wiring up the LEDs. Using the double sided sticky pads (double thickness), stick the PCB onto the back of the 'bucket' part of the tree. Figures 4a to 4d show the wiring for the LEDs. You may wish to choose your own arrangement of LEDs,

Figures 3 to 4d are merely a suggestion; you may wish to do something different, but bear in mind that K2 would be the 'G' segment of a 7-segment display, which is most often on - this is why it is used for the star at the top of the tree.

Testing

To test the tree, connect a battery or mains adaptor to the PCB via the PCB pins marked +V and 0V or the power socket (the tip is +V and the ring is 0V), after a second or so, some (or all) of the LEDs will light, if any group fails to light, check that you have not inadvertently fitted an LED the wrong way round.

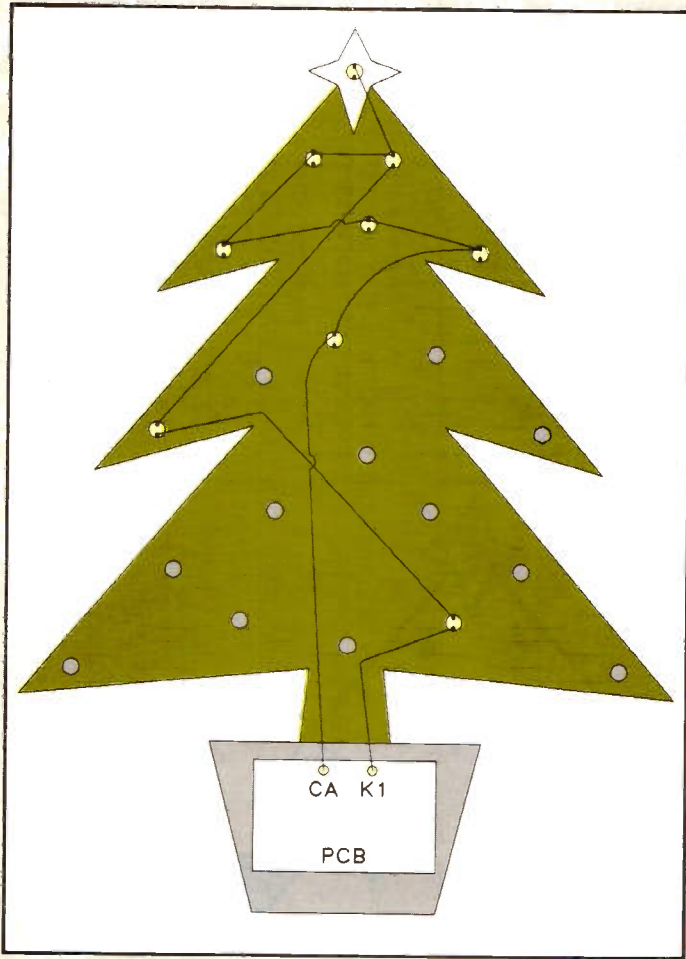

Figure 4a. Wiring stage one.

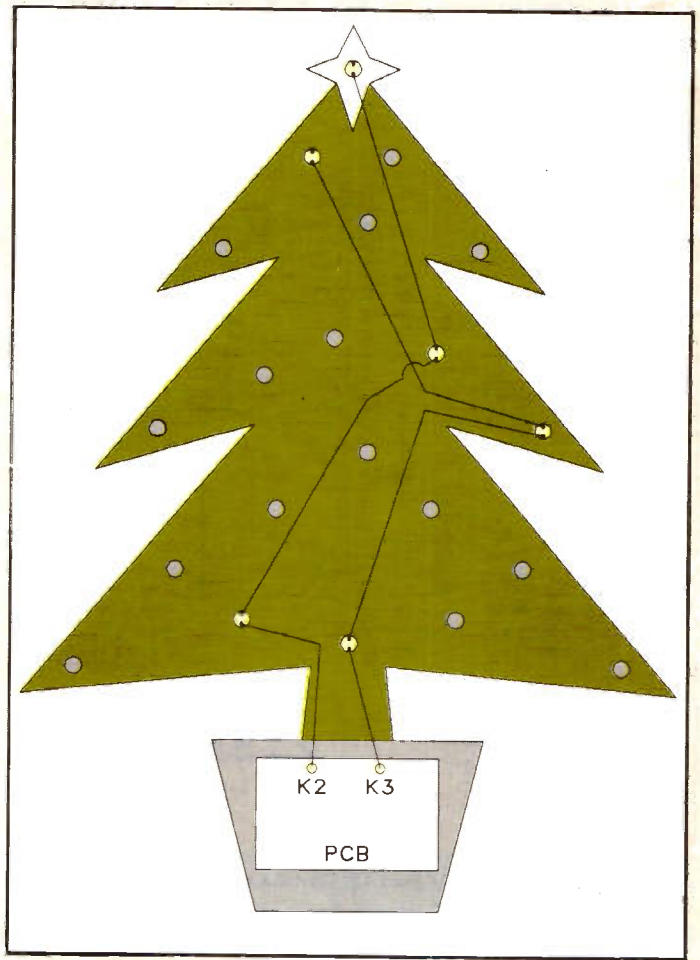

Figure 4b. Wiring stage two.

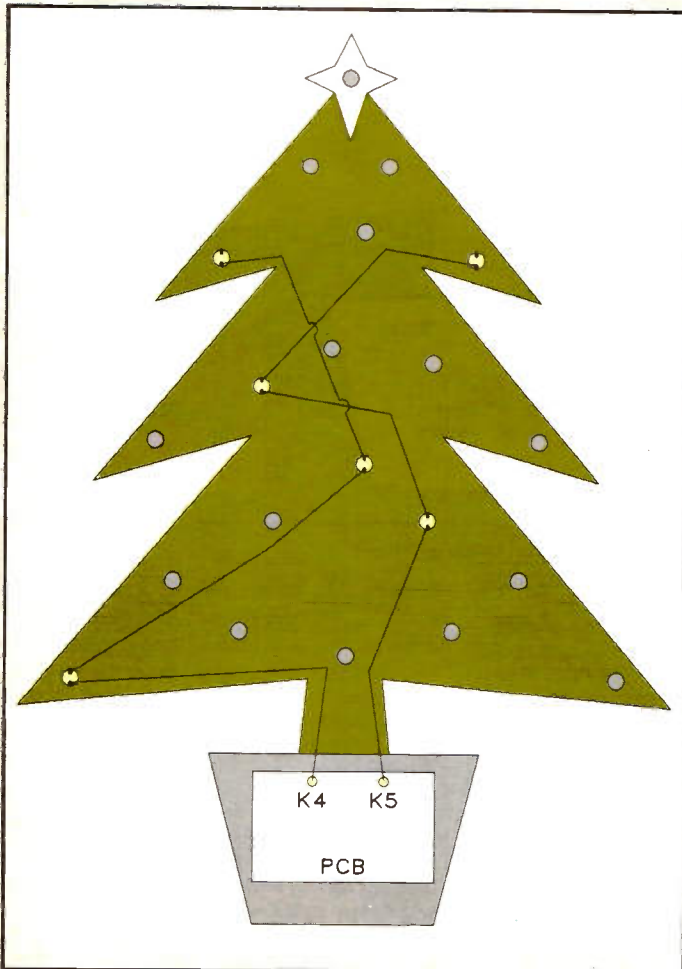

Figure 4c. Wiring stage three.

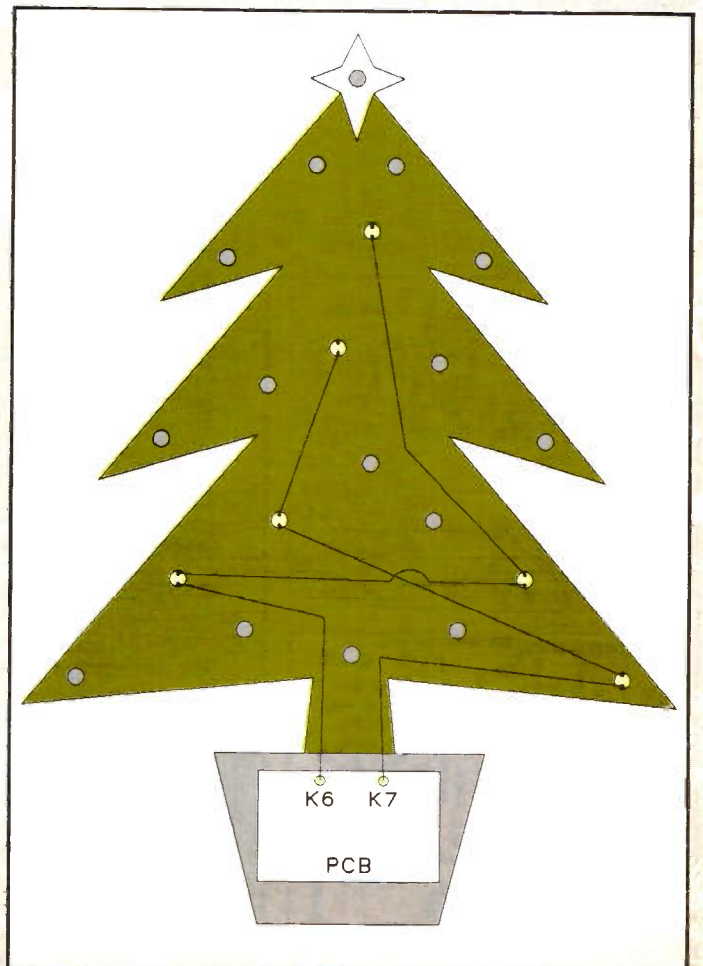

Figure 4d. Wiring stage four.

CHRISTMAS TREE PARTS LIST

RESISTORS: All 0.6W 1% Metal film

R1	2k2 See text	1	(M2K2)
R1	330k See text	1	(M330K)
R1	1M See text	1	(M1M)
R2-8	10k	7	(M10K)
R9-15	1k	7	(M1K)

CAPACITORS

C1-6	PC Elect 1µF 100V	6	(FF01B)
C7	Ceramic 1000pF	1	(WX68Y)
C8	PC Elect 100µF 25V	1	(FF11M)
C9	Minidisc 100nF 16V	1	(YR75S)

SEMICONDUCTORS

IC1	40106BE	1	(QW64U)
IC2	4056BE	1	(QW39N)
TR1	BC558	1	(QQ17T)
D1	1N4148	1	(QL80B)
D2	1N4001	1	(QL73Q)
LD1-21	LED Red 5mm 2mA	7	(UK48C)
	LED Green 5mm 2mA	7	(UK49D)
	LED Yellow 5mm 2mA	7	(UK50E)

MISCELLANEOUS

P1-10	Pins 2145	1 Pkt	(FL24B)
	DIL Socket 14-pin	1	(BL18U)
	DIL Socket 16-pin	1	(BL19V)
SK1	PCB 2.5mm DC Power Socket	1	(FK06G)
	PP3 Clip	1	(HF28F)
	7/0.2 Wire 10m Green	1 Pack	(BL03D)

Double Bubble Sachet	1	(FL45Y)
Quickstick pads	1 Strip	(HB22Y)
PCB	1	(GE95D)
Leaflet	1	(XT25C)
Constructors' Guide	1	(XH79L)

OPTIONAL (Not in kit)

Battery PP3 Alkaline	1	(FK67X)
Power Pack PP6 9V	1	(FM03D)
AC Adapter Unreg. 300mA	1	(XX09K)
Aluminium Laminate Small	1	(XY19V)

The Maplin 'Get-You-Working' Service is available for this project, see Constructors' Guide or current Maplin Catalogue for details.

The above items (excluding Optional) are available as a kit, which offers a saving over buying the parts separately.

Order As LP83E (LED Xmas Tree) Price \$7.95

Please Note: where 'package' quantities are stated in the Parts List (e.g. packet, strip, reel, etc.) the exact quantity required to build the project will be supplied in the kit.

The following new item (which is included in the kit) is also available separately, but is not shown in the 1992 Maplin Catalogue.

LED Xmas Tree PCB Order As GE95D Price £2.45

NEWS EXTRA

Telepoint and PCN Make a Hesitant Start

Some three years and several billion pounds after Lord Young, the then Secretary of State for Trade and Industry (and now head of Cable and Wireless), announced his decision about the operators of Telepoint services using CT2 - second generation Cordless Telephone technology - the industry is in a turmoil. Ferranti Creditphone were first off the telephone mark with over 1000 base stations planned or installed in the London area, within the M25 and other key motorways. It is no secret that Ferranti is keenly seeking a buyer for its 64% stake in the network.

Mercury Callpoint, together with partners Motorola and Shaye, have several hundred sites operational throughout the UK with a set target of 5000 base stations within five years. Now Mercury is backing away fast. The group now sees Personal Communications Networks as the way forward for mobile telephony. "The UK" says Mercury, "has four Telepoint consortia, three PCN consortia and two well-developed analogue cellular operators. This has inevitably squeezed Telepoint into a narrow and more specialist role than was originally envisaged in the UK". And the consortium got precious little sympathy from the telecomms regulator OFTEL. "The demise of Callpoint can be put down to market forces. It is what competition is all about. It is a question of what the market wants", they said.

Meanwhile, the BT-led Phonopoint consortium of STC, France Telecom and Nynex was the first company to launch a Telepoint service in the UK,

and, by definition, the world. The company plans to have 1000 sites within a year, and some 4000 within 4 years. Ultimate targets are some 36,000 sites. The remaining consortium, BYPS - owned by Barclays, Philips and Shell - is also a victim of the changing times what with the Far Eastern company Hutchinson having acquired Philip's and Shell's share of the consortium.

Although no decision had yet been made about technology standards, three operators have been granted licences: Microtel Communications, headed by British Aerospace Systems, and including Millicom UK Ltd. Earlier partners Pacific Telesis UK and Matra Communications have dropped out. Also moving out is Millicom, while Hutchinson has bought a large chunk of the British Aerospace holding.

Mercury PCN consists of Cable and Wireless, Mercury and Telefonica de Espana SA. The consortium expect to commence operations late in 1992. The remaining consortium, The Unitel Group incorporates the interests of STC, Thorn EMI and US West Inc., while member, West Germany's Deutsche Bundespost Telekom is currently considering its PCN strategy.

Hutchison Communications Flexes its Muscles

Move over BT! Make way Mercury! A new telecommunications power is elbowing its way into the UK market - one which is hard to miss. There, behind the bowler's arm at Lords Cricket Ground, is the name

Hutchison. The fact that it is displayed alongside that of Rabbit gives us a clue, Rabbit being the name of the BYPS Telepoint consortium that recently sold out to Hutchison. Earlier this year, Hutchison also acquired the mobile radio-paging business of Millicom Information Services, thereby qualifying as one of seven companies eligible for a national paging licence.

Hutchison bought into the UK cellular radio market by acquiring Quadrant Communications, the Nokia Mobile Phones subscriber base and Millicom's cellular operation. As a result, the

company is now poised to lead the market. On its own merits, the company won a UK government licence - one of only four to be issued - to establish a public mobile data network.

Reverting to the more familiar pattern, Hutchison has now taken over Microtel, a company licensed to supply a Personal Communication Network service, which provides a low-cost alternative to cellular radio. As a result of these takeovers, Hutchison has become a major player in pretty well every area of mobile communications in the UK.



Maplin by Royal Appointment

A garden party was held by HRH The Duke of Edinburgh and HRH Prince Edward, on 10th July this year at Buckingham Palace, in honour of the 35th anniversary of the Duke of Edinburgh Award scheme and the 70th Birthday of His Royal Highness.

Paul Lovejoy, of Maplin's Newcastle

shop, was fortunate to receive an invitation on completion of his Gold Duke of Edinburgh Award - the event was something he will never forget.

The Duke of Edinburgh Award scheme is open to young people between the ages of 14 to 25 - the maximum age for eligible entry is 23. For the Gold level, 5 sections must be completed. Details: (0753) 810753.

TEMPERATURE

FEATURES

- * 39 TO 98°C Temperature Range
- * Active high and active low outputs
- * Trip temperature easily adjustable
- * In-built hysteresis * LED indicator

by Alan Williamson

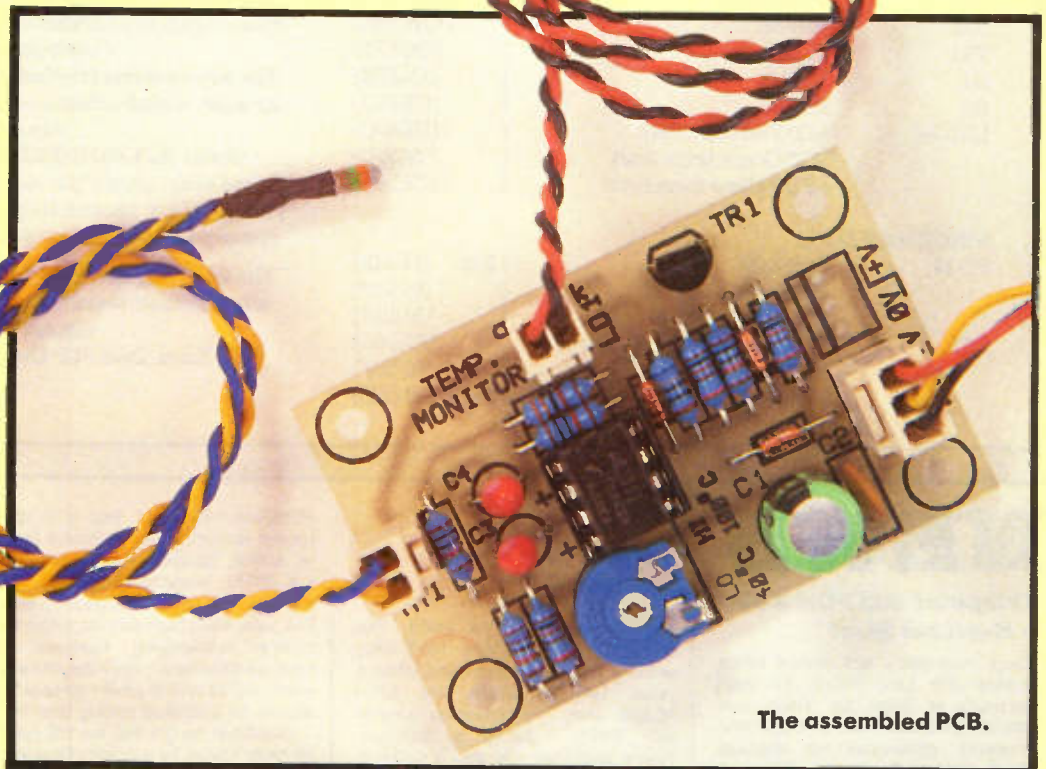

The assembled PCB.

MONITOR

Introduction

The Temperature Monitor described here is an optional 'add on' to the Amplifier Monitor module LP32K (published in 'Electronics' November '91, issue 48), thus providing a complete monitoring system for amplifiers. The Temperature Monitor module can be used with other protection circuits, providing that they have an external trigger input. Alternatively the Temperature Monitor may be used in conjunction with the Zero Crossing Opto-switch LP55K (see page 34 of this issue) to turn a fan on at a preset temperature. The Temperature Monitor circuit is a well-known 'building block' circuit, those of you who are eagle-eyed will remember a very similar circuit as part of the Car Audio Switching Power Supply LP39N (published in 'Electronics' October '91, issue 46).

Prototype Specification.

Supply voltage:	12V nom.	15V max.
Quiescent current		
@ 12V:	3.6mA max.	
@ 15V:	3.9mA max.	
Operating current		
@ 12V:	45.7mA max.	
@ 15V:	56.4mA max.	
Temperature range:	39°C to 98°C	
Low temperature:	trip 39°C	reset 31°C
High temperature:	trip 98°C	reset 86°C

Circuit Description

Referring to Figure 1, the Temperature Monitor is based around a voltage comparator and a thermistor. Below the preset temperature, which is determined by VR1, the voltage at the inverting input

(-) of the comparator is lower than the voltage at non-inverting input (+) which is set by R1 and R2. Whilst this condition persists, the output of the comparator is high. As temperature increases the thermistor's resistance decreases, thus increasing the voltage at the inverting input. When the

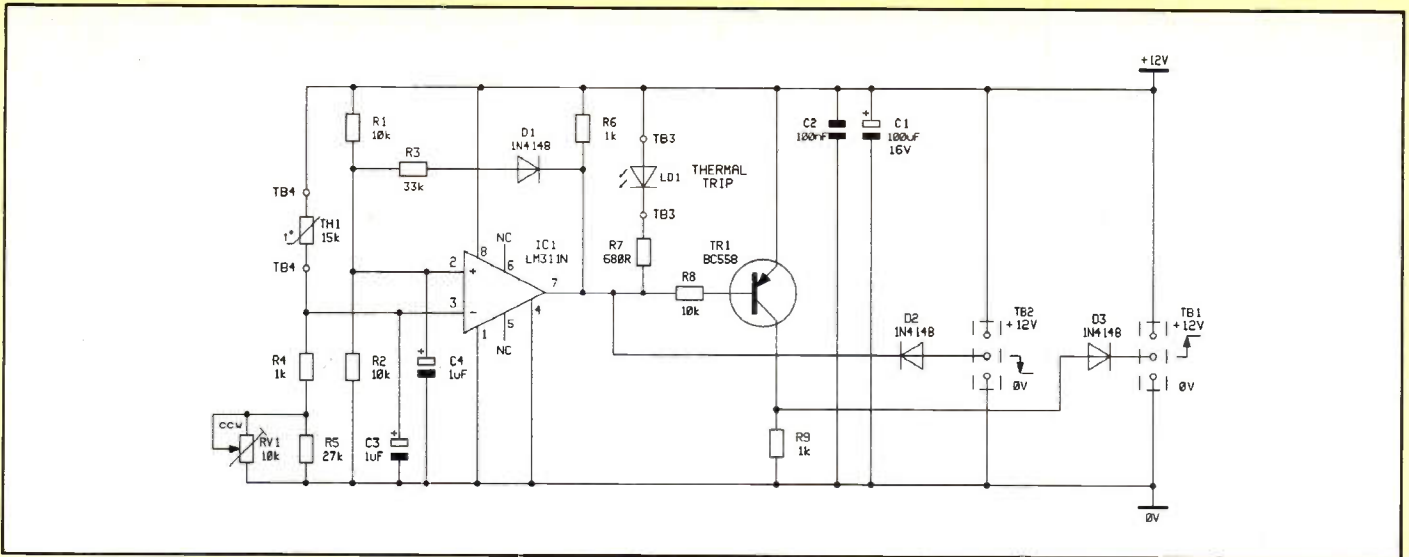

Figure 1. The Temperature Module circuit diagram.

Applications

- * Amplifier protection
- * Power supply protection
- * Automatic fan switching
- * Overtemperature warning

voltage at the inverting input is greater than the voltage at the non-inverting input, the output of the comparator will swing from high to low illuminating LD1. R3 and D1 now come into play, providing around 10°C hysteresis, this is due to R3 and D1 being effectively in parallel with R2; this will prevent the circuit from toggling back-and-forth at the preset temperature. If more (or less) hysteresis is required, the value of R3 can be reduced (or increased) respectively. TR1 is merely an inverter, providing a low to high output, i.e. the opposite of that provided by the output of the comparator.

The temperature range of the module can be altered by changing the values of R4, R5 and VR1, i.e. if VR1 is fully clockwise and the value of R4 is reduced, then the maximum temperature would be over 100°C, but the minimum temperature would also increase; similarly if the value of R4 is increased, the minimum and maximum temperature would be reduced.

Construction

A Constructors' Guide is provided with the kit, the Guide contains some useful information on construction and soldering techniques.

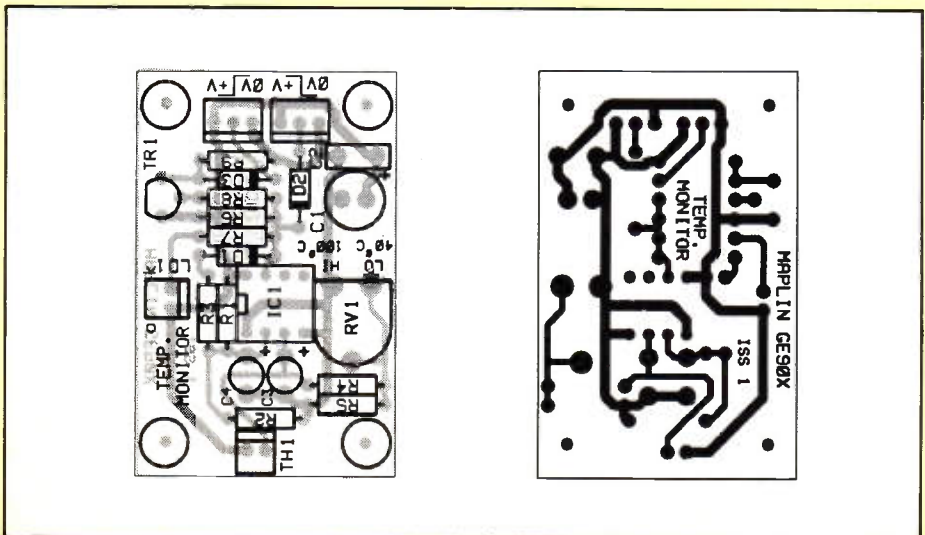

Figure 2. PCB legend and track.

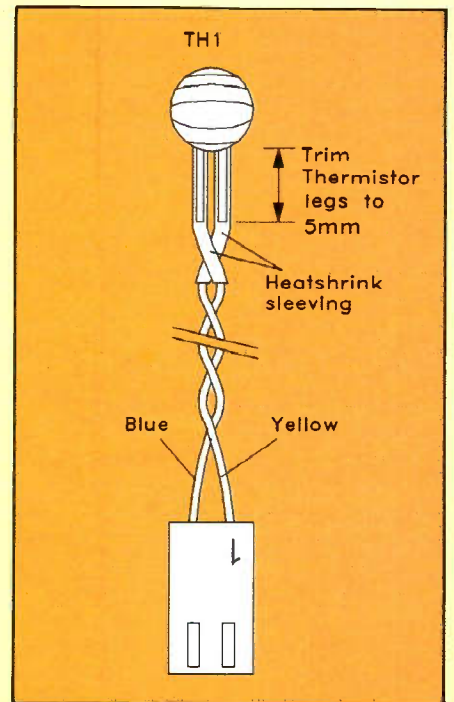

Figure 3. Connecting the thermistor.

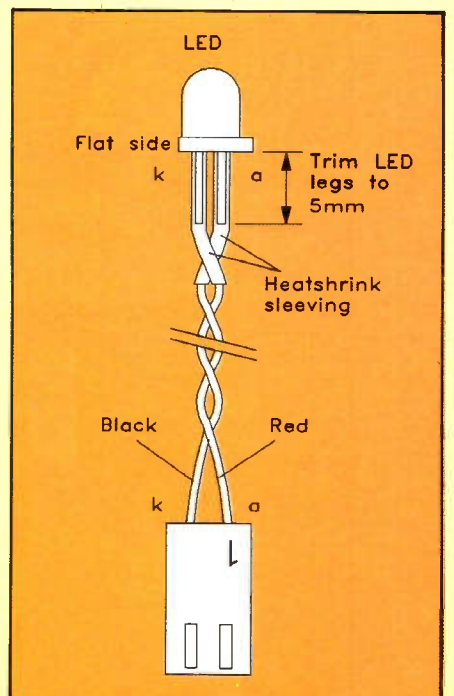

Figure 4. Connecting the LED.

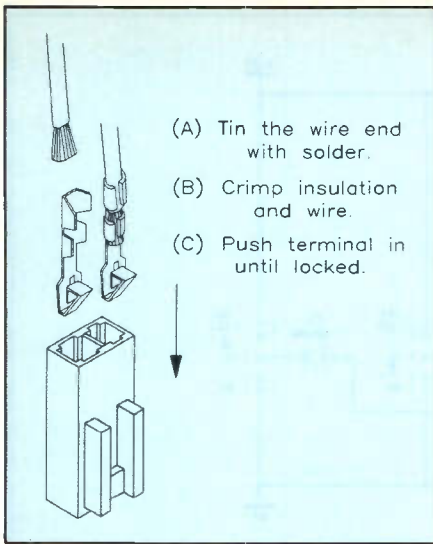

Figure 5. Assembling the minicon connectors.

If you intend to use the Temperature Monitor in conjunction with the Amplifier Monitor LP32K; you will need to use the high to low output, so fit the three-way minicon plug in the position closest to C1 and C2.

If you require the Temperature

monitor to operate the Zero Crossing Optoswitch LP55K, then you will need to use the low to high output, fit the minicon plug in the position closest to TR1.

R7, the LED and associated minicon plug and socket may not be required and can be omitted.

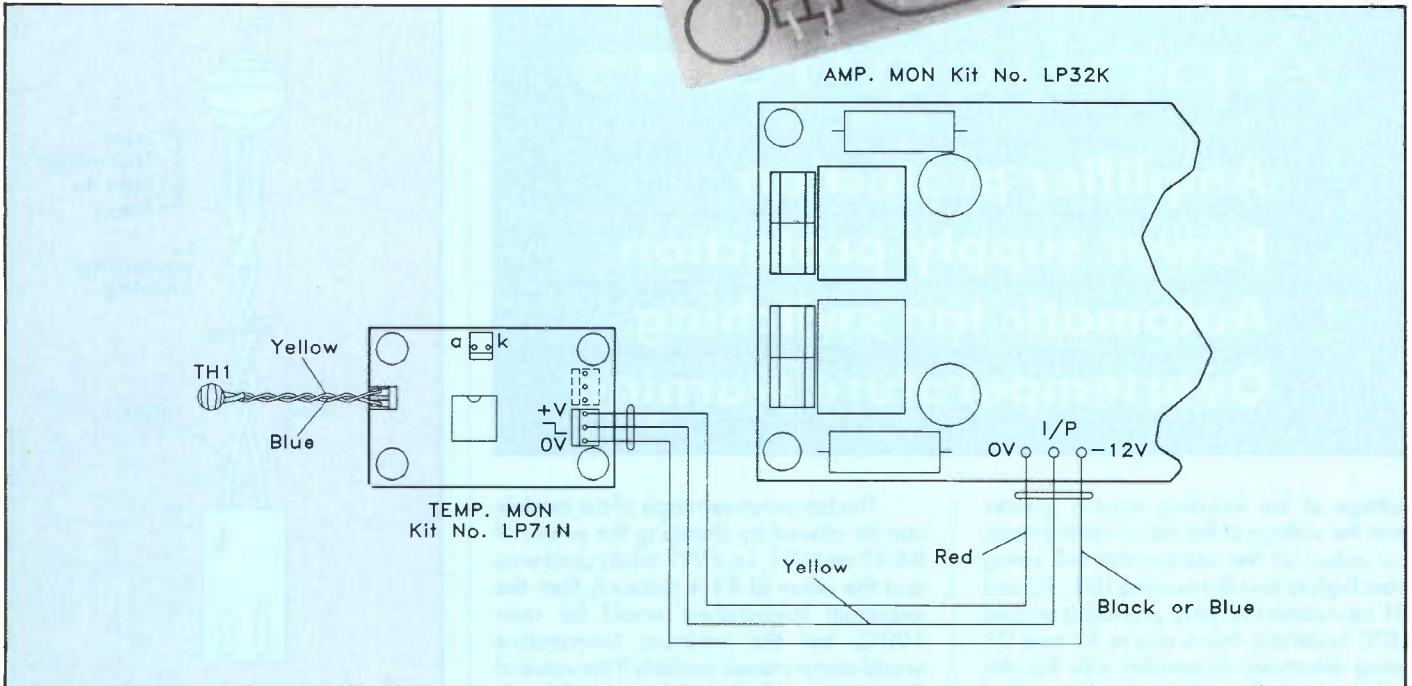
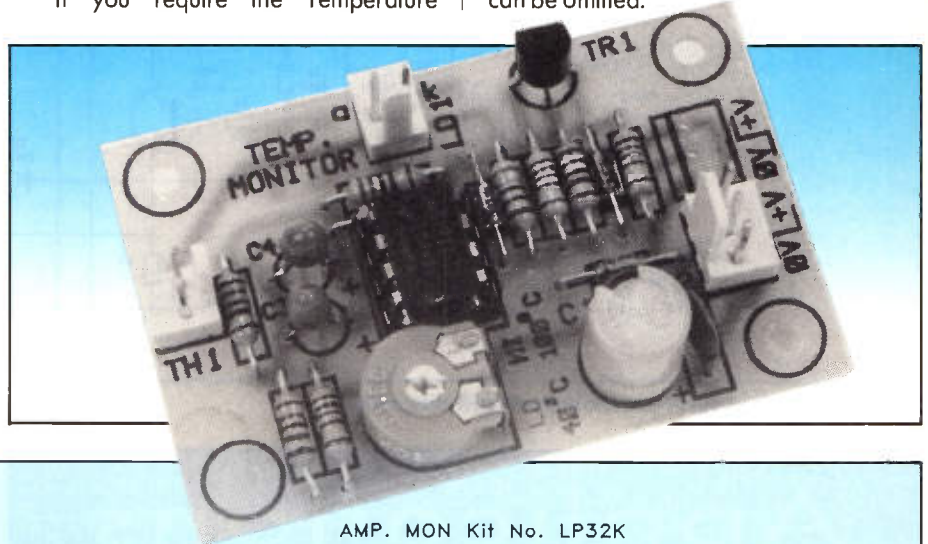

Figure 6. Wiring diagram; shows how to connect the Temperature Monitor to the Zero Crossing Optoswitch.

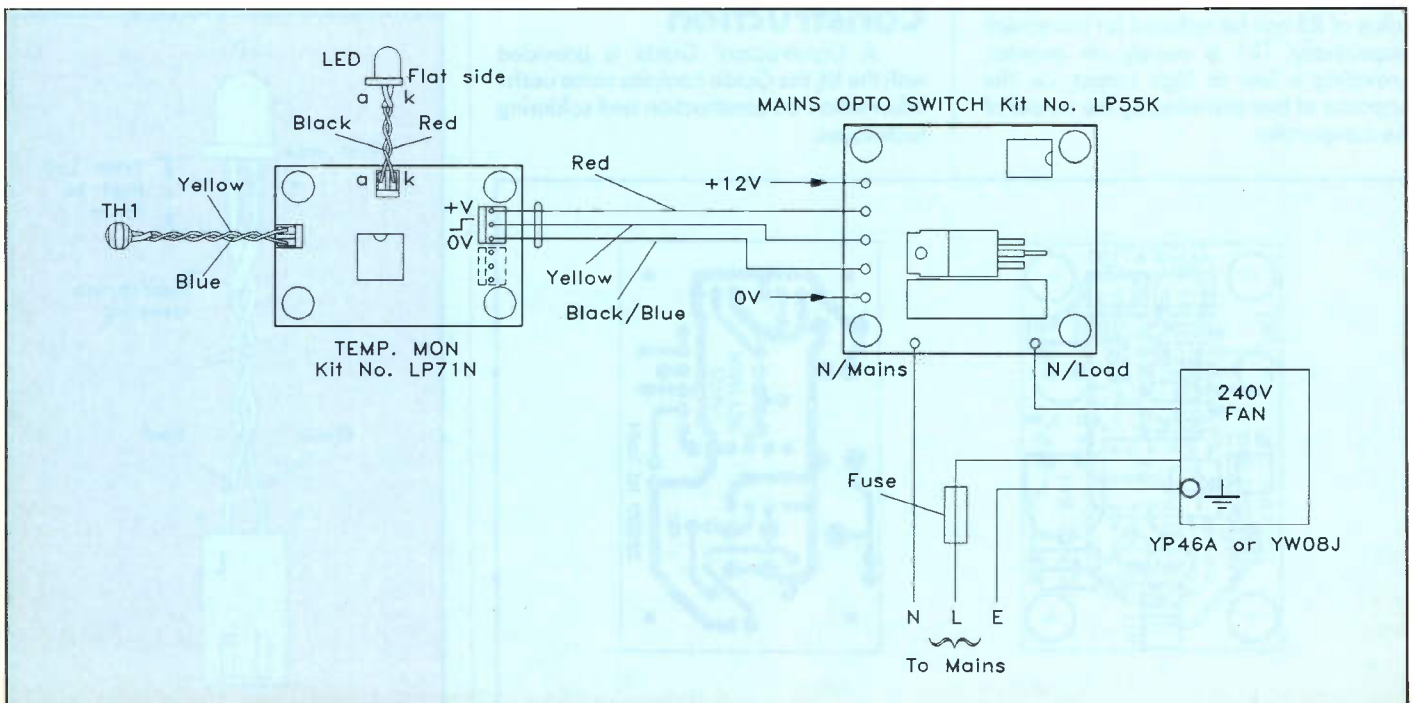

Figure 7. Wiring diagram; shows how to connect the Temperature Monitor to the Amplifier Monitor.

Referring to Figure 2 and the Parts List, begin construction by inserting the resistors, followed by the diodes, and the rest of the components – taking care with the polarised devices. After all the components have been fitted to the PCB, clean off the flux residue with a suitable solvent e.g. PCB cleaner YJ45Y or Ultraclene YT66W. Check the PCB for solder whiskers, bridges and dry joints.

From the cable supplied, cut off the required length for the LED and thermistor and strip off the outer insulation. Crop the leads on the thermistor and LED to 5mm. Strip and tin then solder the appropriate colour cable to the thermistor and LED as shown in Figures 3 and 4. Cut the heatshrink sleeving into four equal lengths, fit the sleeving over the solder joints of the LED and thermistor, *carefully* shrink the sleeving using a heat source i.e. a match, lighter, soldering iron, hot air gun, etc. Twist the two thermistor leads together and do the same for the LED. Fit the minicon terminals to the LED, thermistor as shown in

Figure 5. Last of all, turn the pre-set VR1 fully clockwise.

The Temperature Monitor module is now complete and ready for testing.

Testing

First of all, decide at what temperature you wish the Monitor to trip, the temperature range of the module is between 40°C and 100°C. If you are using the Temperature Monitor in conjunction with the Amplifier Monitor, I would suggest a temperature of 80°C to 85°C would be a good starting point. If you wish to use the Temperature Monitor with the the Zero Crossing Optoswitch to start a fan at a pre-set temperature, then I would suggest a temperature of 50°C to 60°C.

Having now decided at what temperature you wish the Temperature Monitor to trip, you will need some form of thermometer for calibration, this could be a glass type (NOT the medical variety) or some form of digital thermometer, which could be a multimeter with thermocouple,

you will also require a 12V dc supply.

Now is a good time to make a cup of tea because you are going to have to boil the kettle! Pour some hot water into a cup, preferably of the plastic expanded polystyrene type as this will hold the heat, pour the rest of the hot water into a tea pot and add a tea bag. Place the thermometer into the cup and power up the module, wait until the water cools to the required temperature. Whilst waiting for the water in the cup to cool, pour out the tea, add milk and sugar to taste. When the required temperature has been reached, dangle the thermistor in the cup of water and turn the pre-set VR1 anti-clockwise until the LED illuminates. Remove the thermistor from the cup and disconnect the 12V supply.

The Temperature Monitor is now ready for use and can be installed into your amplifier. Figure 6 shows how to connect the Temperature Monitor to the Amplifier Monitor; whilst Figure 7 shows how to connect the Temperature Monitor to the Zero Crossing Optoswitch to operate a fan.

TEMPERATURE MONITOR PARTS LIST

RESISTORS: All 0.6W 1% Metal film (Unless specified)

R1,2,8	10k	3	(M10K)
R3	33k	1	(M33K)
R4,6,9	1k	3	(M1K)
R5	27k	1	(M27K)
R7	680Ω	1	(M680R)
RV1	Hor Encl Preset 10k	1	(UH03D)
TH1	15k Thermistor	1	(FX22Y)

CAPACITORS

C1	Minelect 100μF 16V	1	(RA55K)
C2	Minidisc 100nF 16V	1	(YR75S)
C3,4	Tant 1μF 35V	2	(WW60Q)

SEMICONDUCTORS

IC1	LM311N	1	(QY09K)
D1,2,3	IN4148	3	(QL80B)
LD1	LED Red	1	(WL27E)
TR1	BC558	1	(QQ17T)

MISCELLANEOUS

TB1 or 2	PCB Latch Plug 3-way	1	(BX96E)
TB3,4	PCB Latch Plug 2-way	2	(RK65V)
	DIL Socket 8-pin	1	(BL17T)
	Minicon Ltch Hsng 3-way	1	(BX97F)
	Minicon Ltch Hsng 2-way	2	(HB59P)
	Minicon Terminals	1 Strip	(YW25C)
	4-Wire Burglar Cable	1m	(XR89W)

Heat Shrink CP 16	1m	(BF86T)
PCB	1	(GE90X)
Leaflet	1	(XK99H)
Constructors' Guide	1	(XH79L)

OPTIONAL (Not in kit)

PCB Latch Plug 3-way	1	(BX96E)
M3 Insulated Spacer	1 Pkt	(FS36P)
Double Bubble Sachet	1	(FL45Y)
Minicon Ltch Hsng 3-way	1	(BX97F)

The Maplin 'Get-You-Working' Service is available for this project, see Constructors' Guide or current Maplin Catalogue for details.

The above items (excluding Optional) are available as a kit, which offers a saving over buying the parts separately.

Order As LP71N (Temp Monitor) Price £4.95

Please Note: where 'package' quantities are stated in the Parts List (e.g. packet, strip, reel, etc.) the exact quantity required to build the project will be supplied in the kit.

The following new item (which is included in the kit) is also available separately, but is not shown in the 1992 Maplin Catalogue.

Temp Mon PCB **Order As GE90X Price £1.95**



- ▶ Do you have difficulty in getting hold of your copy of 'Electronics – The Maplin Magazine'?
- ▶ Does your Newsagent always sell out before you can get your copy?
- ▶ Are you fed up with braving the onslaught of wind, rain and keep fit fanatics in your ceaseless quest to find a copy of your favourite electronics magazine?
- ▶ Do you say to your family and friends, "I'm just going outside, I may be gone a little while ..."?
- ▶ Does your dog hide when you return empty handed?
- ▶ Do you resort to reading the Beano, Dandy, Viz or other well known 'comics'?

Then why not ask your friendly local Newsagent to reserve or deliver every issue of 'Electronics – The Maplin Magazine'? Fill out the coupon (below), hand it to your Newsagent and you need never miss an issue of 'Electronics – The Maplin Magazine'.

Dear Newsagent

Please reserve/deliver (delete as applicable) each issue of 'Electronics – The Maplin Magazine' for me.

Name

Address

Signature

'Electronics – The Maplin Magazine' is published monthly and is distributed through your wholesaler by: United Magazine Distribution Ltd. 1 Benwell Road, London N7 7AX. Telephone: 071-700-4600.



MICROCONTROLLERS IN AUTOMOTIVE APPLICATIONS

PART ONE by Jeff Wright BSc (Hons)

Microcontrollers – ‘The work-horse of the modern electronics industry’. That statement may be strong, but it is not an exaggeration, for it is becoming increasingly difficult to purchase any significant piece of electronic hardware that does not contain one or more of these complex ICs. But first, for those who missed the previous introductory article or require a memory jogger, a quick recap on what a microcontroller is. A microcontroller (μC), otherwise known as a single chip microcomputer unit or MCU, is effectively a complete computer control system integrated onto a single chip of silicon. Referring to Figure 1 the main functional blocks of the microcontroller are:

- i) microprocessor core; with optimised instruction set for real time control.
- ii) memory; usually ROM to contain the control program plus RAM to hold variables during program execution.
- iii) I/O and on-chip peripherals; these allow the MCU to communicate with the hardware of the real world application that it is controlling. These peripherals range from simple digital input/output (I/O) ports to complex analogue-to-digital (A-to-D) and digital-to-analogue (D-to-A) converters and timer systems. Table 1 lists some of the ‘peripherals’ that are available on current microcontroller families.

Microcontrollers are available in a range of complexities and power (and therefore price), making them suitable for a very wide range of applications where they can replace standard logic or more complex microprocessor based solutions. The advantages of the MCU over these traditional solutions are, reduced chip count, which brings cost; reliability and size bonuses; and greater flexibility for the

designer – allowing easy modifications to the functionality of the application via the software. These advantages coupled with the devices’ relatively low cost (typically from £0.75 in high volume) have led to microcontrollers being used in a great breadth of applications. With a few exceptions such as industrial control, these MCU applications can be split into two groups; automotive and consumer.

Table 2 gives a non-exhaustive list of microcontroller applications in these two areas. The intention of this short series is to give the reader some more insight into a few of the automotive applications that depend on microcontrollers, and to highlight the properties of particular MCUs that make them suitable for each discussed application.

The automotive industry is widely recognised by semiconductor manufacturers as being the performance driver of the microcontroller market. Originally using microcontrollers with 4 and 8-bit busses, the automotive designer’s quest for more processing power for some applications, such as engine management, has pushed the semiconductor industry into designing first 16-bit and now 32-bit MCUs. Some cars being designed today have more processing power under the bonnet than an average PC!

A well recognised trend in the automotive industry is to introduce new features on up-market cars and then migrate them down onto their mass market vehicles as reliability and user acceptance are proven, and costs come down. This explains why many of the features available on today’s cars (such as electric windows) were yesterday only available on expensive luxury models. However, in many cases these systems are using yesterday’s ‘dumb’ technology and many of the microcontroller applications

MCU Peripheral	Function
Digital I/O port	The basic hardware used by the CPU to access the outside world (read switches, drive LEDs, etc.)
Timer	One of the most common and useful MCU peripherals – allows timing tasks to be accomplished while the CPU does something else.
Serial port	Both synchronous and asynchronous ports are available allowing fast serial communications over short or long distances respectively.
VFD port	Special high voltage output port for driving vacuum fluorescent displays.
LCD port	Special low voltage output port for driving LCD displays. Usually includes multiplexing for large displays.
A-to-D	Analogue-to-digital converter used to read a variety of sensors, etc.
PWM or D-to-A	A pulse width modulated output that can be filtered to produce a programmable analogue voltage, thus acting as a digital-to-analogue converter.
Watchdog Timer	A special type of timer that guards against CPU errors and resulting software runaway.
EEPROM – in addition to ROM	Re-programmable memory that can be used for calibration purposes or for a nonvolatile data store.
PLL	Phase locked loop. Used in tuner applications such as TV and radio.
RTC	Real time clock. Special timer designed to count in real time, i.e. seconds, minutes and hours.
Wake-up port	Modified digital I/O port that can generate CPU interrupts when an input signal changes.
DTMF	Dual-tone multi-frequency generator, used in ‘tone dialling’ telephone applications.
OSD	On screen display. A character generator for showing messages on a TV screen.

Table 1. Commonly available on-chip microcontroller peripherals.

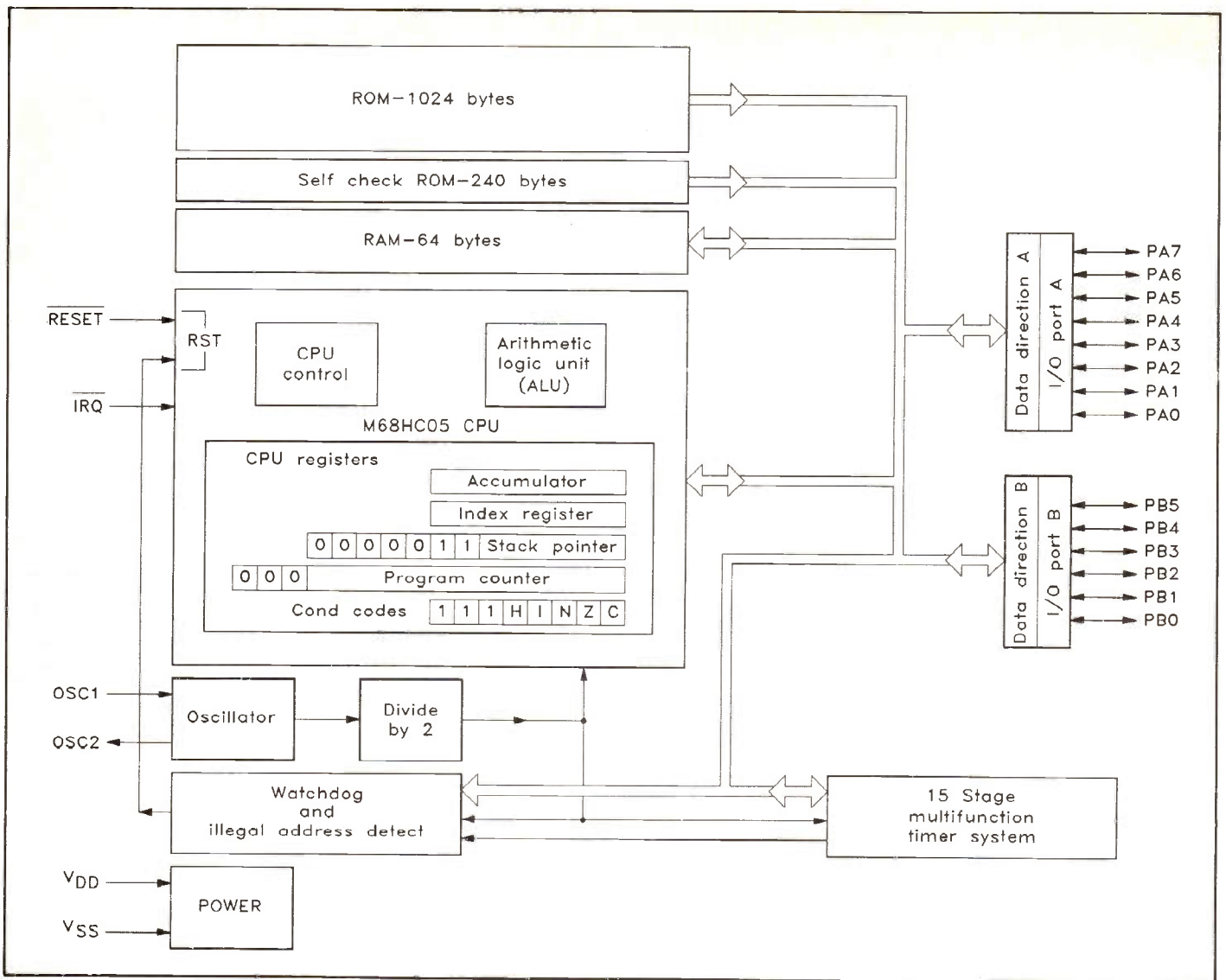

Figure 1. MC68HC05J1 MCU block diagram, showing the basic functional blocks common to all microcontrollers.

of Table 2 are still the domain of up-market vehicles. As the technology migration trend and 'green' legislation continue, this situation will change and within a few years all cars will contain more microcontrollers than wheels! - see Figure 2.

Interfacing MCUs in the Automotive Environment

There is a fundamental problem with using microcontrollers, or digital logic in general, in an automobile; the vehicle electrical system is invariably 12V and logical devices work at around 5V, and would be severely damaged if connected directly to a 12V system. This means that a supply for the MCU must be derived from the 12V supply using a regulator circuit, and that all inputs to the device must be

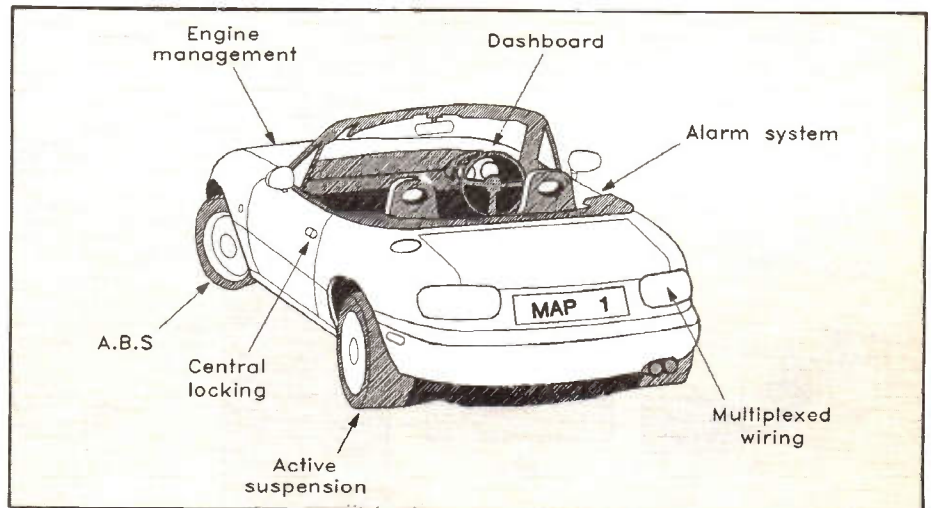

Figure 2. Soon an average car will contain more microcontrollers than wheels!

Automotive	Consumer
Engine management	Television
Alarm system	Microwave oven
Anti lock braking	Telephone
Central locking	Video cassette recorder
Trip computer	Washing machine
Dashboard	Remote control system
Electric windows	Toys
In-car entertainment	Fridges and freezers
Active suspension	Alarm system
Multiplexed wiring	Radio
Seat adjustment	Compact disc player
Electric mirrors	Satellite receiver

Table 2. Typical microcontroller applications.

buffered from the 12V world around it. The MCU is also incapable of directly driving automotive loads, so that external drive circuits must be employed to interface the logic outputs to the 12V loads. The situation is actually even worse than this initial statement implies; the automotive environment is one of the harshest known, with extremes of temperature and the system voltage varying considerably depending on the condition of the battery and whether the vehicle engine is being cranked (when the voltage drops considerably). The biggest

problem however, is the ignition circuit. When the ignition coil switches, large voltage impulses (50 to 100V) can be generated on both rails of the entire electrical system. Although of short duration, these pulses would spell disaster for a logic circuit input. For this reason great care must be taken when designing protection circuits for the electronic hardware in cars. Despite these problems and the associated costs to counter them, the outlay is justified due to the benefits brought by electronics and microcontrollers, in particular to the auto-

or more commonly infra-red (I.R.), to activate the central locking from a wide angle and considerable distance from the vehicle – Figure 5 shows the schematic of such a system. The transmitter uses either a very basic microcontroller or, more commonly, a dedicated logic device such as the MC145026 IC. Instead of using a keypad to determine which code to transmit, the device has its inputs fixed in the factory, into a certain combination of logic levels, so that it will always transmit the same code. The number of inputs allow a large number of different codes to be configured – just like the number of levers in a padlock. Although matched pairs of transmitters/receivers could be employed in this application, the logistics of keeping track of which ‘key’ belongs to which car during production are obviously difficult, never mind how you would handle an owner losing his key and requesting a replacement! For these reasons, intelligence is employed in the receiver to allow it to be customised after production. The microcontroller chosen for the job will include some on board programmable non volatile memory (EPROM or EEPROM) that can be used to store the codes of matching transmitters. This customising of the receiver is often performed by the dealer, just before the new owner gets his car. The memory size of the MCU allows for several key codes, so that multiple keys can be used by different family members. Secure software can be employed to prevent someone from trying to cycle through all the valid codes for the transmitter type until the correct one is found. In its simplest form this could just involve ignoring incoming I.R. codes, for a couple of seconds, after an invalid code has been received – with so many codes to cycle through, this would make the job overly time consuming for the potential intruder. Since the receiver must remain powered up at all times, low power consumption is of vital importance. For this reason the MCU will invariably be a CMOS device, with a special low power SLEEP or STOP mode, where the power consumption will be in the order of micro amps. Any incoming signal will wake the MCU, via the interrupt pin, and it will receive the code and operate the locking mechanism (either solenoid or motor driven), if it matches one of the valid codes stored in its memory. A suitable device for this application would be the MC68HC05P8, which is a close family member to the previously discussed J1 device. Its distinguishing feature for remote central locking is the 32 bytes of onboard EEPROM that can be used to store several transmitter key codes.

To be Continued...

Next month, in the continuing part of this series, engine management systems will be examined.

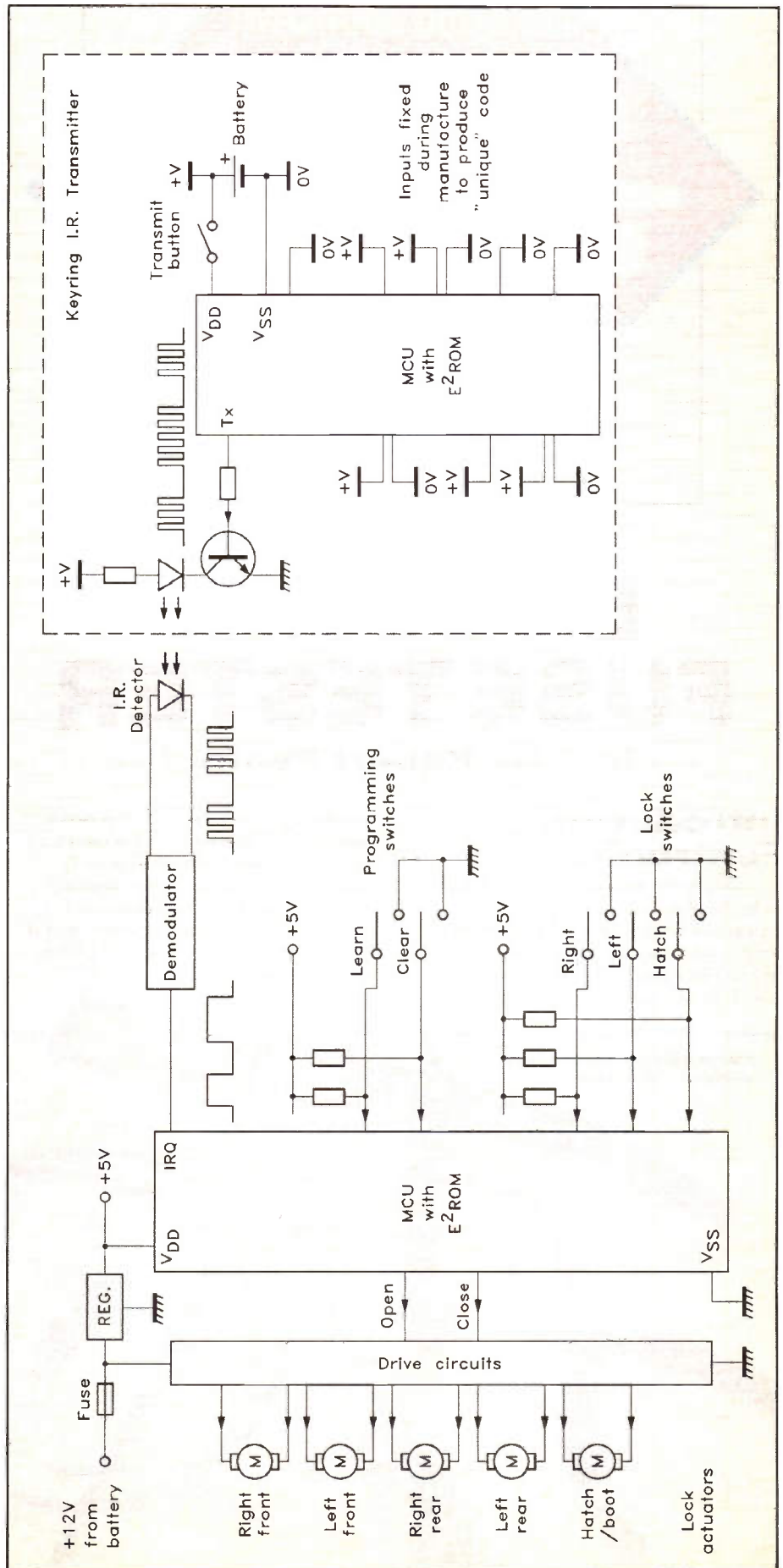

Figure 5. Intelligent remote central locking system.

All
You Need
to Build Your Own

FUN TRONICS

PROJECT
No1

BULB AND FUSE TESTER

Text by Robert Penfold

Introducing Funtronics

This is the first in a series of easy to build electronics projects for complete beginners, who require a simple and fun starter to electronic project building. The projects are ideal for the young person as no

soldering is needed. All the projects are built on the same type and size of plastic 'peg-board'. The only tools needed to build this project, and the others in the series, are a pair of wire cutters/strippers and a small screwdriver; a pair of pliers will also be useful.

This Month's Project

This first Funtronics project is very simple indeed, it is intended to allow testing of bulbs, fuses, switches, etc. The proper name for this project is a 'continuity tester' and is the modern answer to the older 'torch bulb and battery' way of testing circuits. With a bulb-type tester, the battery is connected to the bulb by means of a pair of test probes. If there is an electrical 'path' between the two test probes, the circuit is completed and the torch bulb lights up. A use, which has already been mentioned, is testing fuses; if a good fuse is connected across the probes the bulb will light up – if the fuse is no good the bulb will not light.

Figure 1 is a diagram that shows the parts in the circuit and how they are connected; it is called a circuit diagram. Different symbols are used to show the separate parts and lines show how they are connected together.

In this project, the torch bulb has been replaced with a light emitting diode (LED for short), this is marked D1 on the circuit. The reason for this is that there is a slight problem with the older bulb-type continuity testers, in that the bulb requires quite a high current to flow for it to light up. This means that it is no good for such things as testing for short circuits on circuit boards (as found inside transistorised radios and other pieces of electronic equipment). This is because the high current needed for the bulb could easily damage some of the very sensitive components found in electronic circuits. You would not see the smoke rise, but the components inside would be damaged and no-longer work.

Please note that tools are not included with the kit.



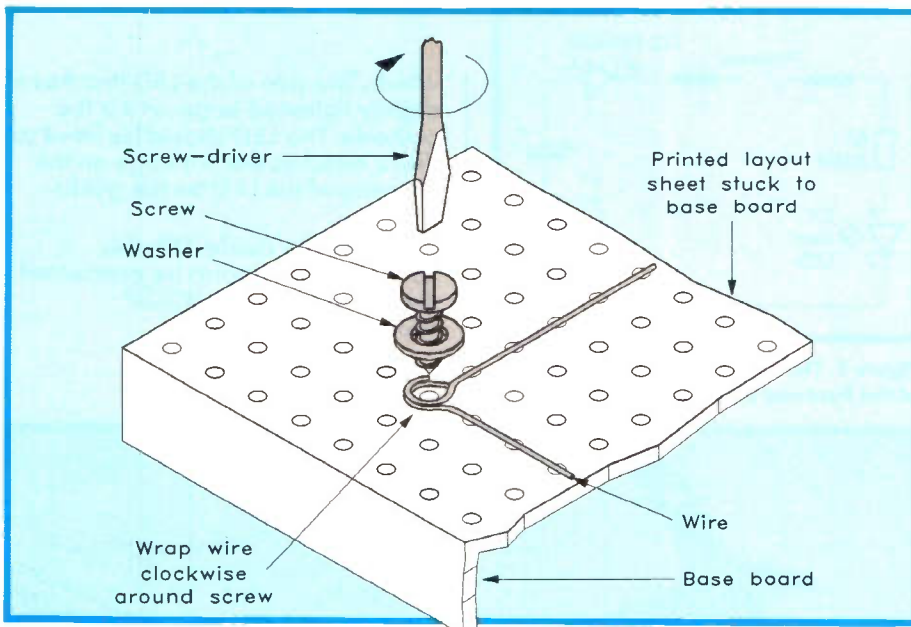
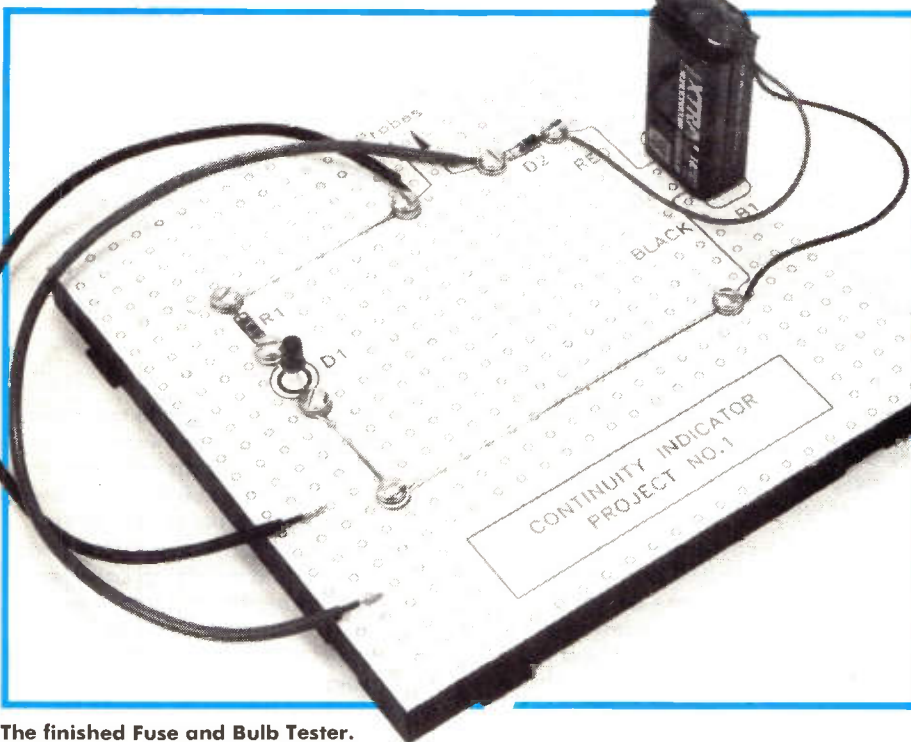

Figure 3. How to fit the wires and components to the board.



The finished Fuse and Bulb Tester.

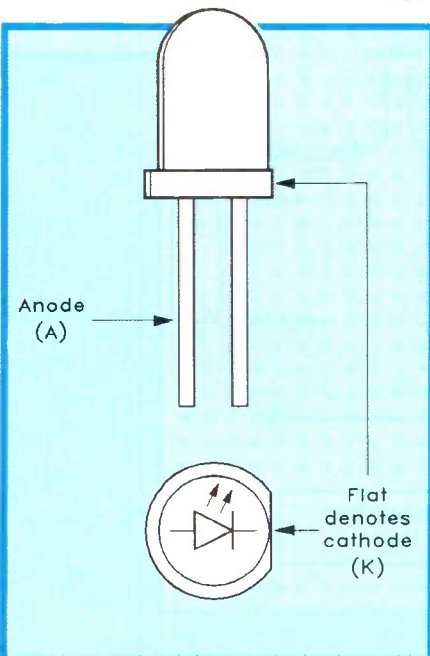

Figure 4. Recognising the LED connections.

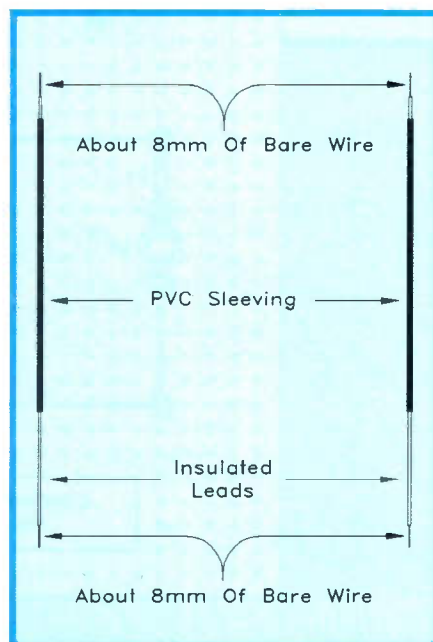

Figure 5. How to make the probes.

twisted together to prevent the wires from spreading out and breaking off. Slide the red sleeving over the red wire and the black sleeve over the black wire. Connect the two wires to the screws on the board marked 'Probes' – the red wire should go to the screw nearest to D2. The free ends of the two wires allow you to make connection with the item to be tested.

e) Lastly fit the battery connector and battery, B1; the connector must be attached to the board with its coloured leads the correct way round.

The battery connector has two press-stud clips on a piece of plastic and two wires coming from it, coloured red and black. The red and black leads should be connected to the board as shown on the layout sheet. The 9V PP3 type battery should be connected to the battery connector, it will only fit properly one way round.

Testing and Use

To test the finished Fuse and Bulb Tester, touch the bare ends of the test probes together (with the battery connected). If the unit is working okay the LED should light up when the probes are connected together. If the LED does not light up, then B1, D1, or D2 may be connected the wrong way round. Check each of these carefully, and also make sure that there are no loose connections.

The Fuse and Bulb Tester may now be used for any continuity tests that you may wish to do. Please remember that the tester must not ever be used on mains wiring or appliances when they are connected to the mains electricity supply in any way. If you are not sure that what you are doing is correct, then the best thing to do is stop and ask someone, who *does* know, what to do.

Another Use

Apart from continuity testing, the unit can also be used as a diode tester. With the diode connected across the test prods one way round the LED should light up, with it connected the other way round the LED should not light; if this happens the diode is working okay. If the LED lights when the diode is connected both ways round, the diode is short circuit and faulty. If the LED does no light when the diode is connected both ways round, the diode is open circuit and faulty.

Availability

The Funtronics Fuse and Bulb Tester is available from Maplin Electronics, through our chain of regional stores, or by mail order, order code LP82D Price £2.95.

Square One

A First Course in the Theory and Practice of Electronics

Part 12 by Graham Dixey C.Eng., M.I.E.E.

Introduction

We have previously seen how feedback from the output of an amplifier to the input can result in oscillations. This may occur deliberately, as in the case of an oscillator, or accidentally, as the result of, perhaps, poor layout. The type of feedback that causes oscillations, or tends to cause them, is known as 'positive feedback'. In this, the final part of this series, we are going to look mostly at the opposite type of feedback, known as 'negative feedback'. As one might expect, negative feedback involves feeding back part of the output so as to oppose the input. The result is that the net input to the amplifier is reduced and the output falls; since the original signal is still the same size, it is as if the gain of the amplifier had been reduced. This effect can be explained by reference to Figure 1.

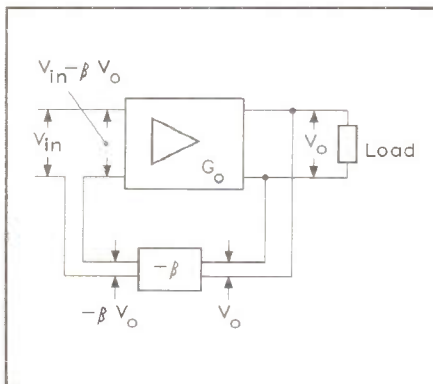

Figure 1. Block diagram for amplifier with series negative feedback.

The input voltage from some signal source is known as V_{in} ; the final output voltage from the amplifier is V_o , which is developed across a load. This output voltage V_o is also applied to a block marked ' $-\beta$ ' (beta); the value of β is equal to unity or less; except in special cases, to be discussed later, β is usually very much less than one. The effect of this 'beta block' is to produce a small voltage equal to ' $-\beta \times V_o$ '. This is the negative feedback voltage. In use it is applied in

series with the input voltage V_{in} ; naturally, this involves breaking one of the input lines in order to insert it. The net voltage between the actual amplifier terminals is now the difference between the original input and this feedback voltage, namely $V_{in} - (\beta \times V_o)$. This is the voltage that drives the amplifier in order to produce the output voltage V_o . Since the amplifier has a gain of G_o times, we can write down the following relationship:

Output = gain \times input

Therefore:

$$\begin{aligned} V_o &= G_o \times (V_{in} - \beta \times V_o) \\ &= G_o \times V_{in} - G_o \times \beta \times V_o, \end{aligned}$$

(multiplying out the brackets)

Therefore:

$$\begin{aligned} V_o + G_o \times \beta \times V_o &= G_o \times V_{in}, \\ \text{(getting the terms in } V_o \text{ together)} \\ V_o \times (1 + G_o \times \beta) &= G_o \times V_{in} \end{aligned}$$

For which:

$$V_o \div V_{in} = G_o \div (1 + G_o \times \beta),$$

(transposing for $V_o \div V_{in}$)

Note that the expression just derived is the gain of the complete amplifier *with feedback* considered from the input V_{in} to the output V_o . This figure is known as the 'closed-loop gain G_c ' and is quite different from the value G_o , which refers to the amplifier alone and is known as the 'open-loop gain'. How different can be seen from the following example:

Example 1. An amplifier with an open-loop gain of 5000 has a fraction of its output, equal to 0.0098, fed back to oppose its input voltage. Calculate the closed-loop gain of the amplifier.

Solution 1. From the question we deduce that $G_o = 5000$ and $\beta = 0.0098$. We simply substitute these two values into the expression for closed-loop gain, namely:

$$\begin{aligned} \text{Closed-loop gain} &= G_o \div (1 + G_o \times \beta) \\ &= 5000 \div (1 + [5000 \times 0.0098]), \\ &= 5000 \div (1 + 49) \\ &= 5000 \div 50 \\ &= 100 \end{aligned}$$

This shows that the application of even a small amount of negative feedback has quite a marked effect on the overall gain of the amplifier. Without feedback the gain is 5000; with feedback it falls 50 times to a figure of only 100.

There is frequently a certain amount of confusion inherent in the idea that there are *two* gain figures. It might seem at first to the beginner as if the original gain value of 5000 has disappeared, to be replaced by the lower one of 100. This isn't strictly true; both figures exist at the same time in the circuit, as a moment's consideration will show.

Without feedback, any input voltage (which we will call V_{in}) would be applied directly to the amplifier terminals; here it would be amplified 5000 times. However, when negative feedback is involved, the same input voltage V_{in} is no longer applied directly to the amplifier terminals because the feedback voltage $\beta \times V_o$ is interposed by breaking the lower input line. What is now applied to the amplifier input terminals is the voltage $V_{in} - \beta \times V_o$. Because this 'difference' voltage is smaller than the original voltage V_{in} , when it is amplified by the amplifier (5000 times), the output voltage V_o is smaller than in the case of no feedback being applied. Some numbers may make this even clearer.

Suppose that the output voltage V_o is 1V; we know from our calculations above that the closed-loop gain is 100 (assuming that $\beta = 0.0098$) which means that V_{in} must be equal to $1 \div 100 = 0.01V$ ($V_o \div G_c$). With the value of β given, the feedback voltage can be determined since it equals $\beta \times V_o$, that is $0.0098 \times 1 = 0.0098V$. We can now determine the net input to the amplifier itself, since we know that this is the difference between the input and feedback voltages.

$$\begin{aligned} \text{Input to amplifier} &= V_{in} - \beta \times V_o \\ &= 0.01 - 0.0098 \\ &= 0.0002V \end{aligned}$$

Now multiply this by the gain G_o of the amplifier and what do you think you will get? The amplifier output is, of

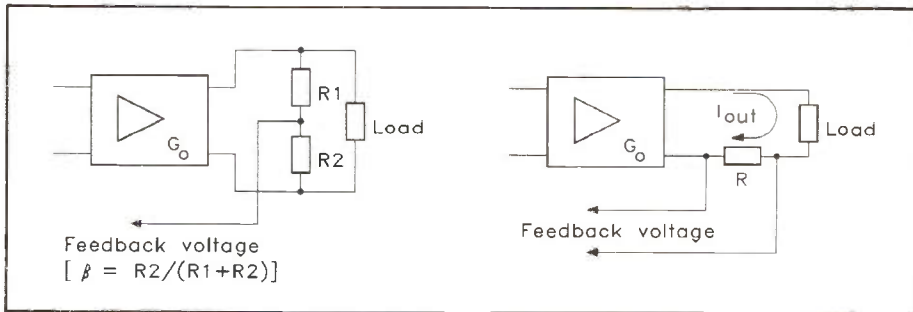

Figure 2. Types of feedback, (a) voltage feedback and (b) current feedback.

course, the answer and its value will be:
 $0.0002 \times 5000 = 1V$

So we have gone full circle and shown that the two gain values do indeed exist at the same time. Any other conclusion would have been nonsense. After all, we haven't done anything to the amplifier so why should its gain be any different from the figure of 5000 that it was originally. All we have done is to move the input terminals of the overall 'amplifying system' further to the left to include the feedback. The input is thus no longer applied to the amplifier terminals directly but to a new pair of terminals from which the overall gain is lower.

The effect as far as the user is concerned is as if the amplifier gain had been reduced. At first sight this might seem something of a disadvantage. Granted, the loss of gain can hardly be put forward as a desirable attribute of this technique, which leaves the possibility that there must be some associated advantages. This is absolutely true as we shall see shortly.

Types of Negative Feedback

The example shown in Figure 1 is termed 'series' feedback, since the feedback voltage is applied in series with the input signal; it is also possible to apply the feedback in parallel, thus giving rise to 'parallel feedback'. Another way of classifying feedback is by the manner in which it is derived. This would mean, in effect, describing the contents of the 'beta block'.

Figure 2 shows two of the possibilities. Diagram (a) is known as 'voltage feedback' because the feedback voltage is 'proportional to the output voltage'. In fact, it is a proportion of it, determined by the ratio of the two resistors R1 and R2. It should be obvious that these two resistors comprise a potential divider, giving a fraction β equal to $R2 \div (R1 + R2)$.

Figure 2b shows a feedback voltage being derived by the flow of output current through a small value resistor in series with the output. Such feedback is then referred to as 'current feedback'. In this case, the value of β is less obvious and is not quoted here.

The fact that feedback can be 'series' or 'parallel'; 'voltage derived' or 'current derived' leads to four possible combinations, each with its own particular characteristics: series voltage

feedback (i); series current feedback (ii); parallel voltage feedback (iii) and, parallel current feedback (iv).

Gain Stability

Stability of gain refers to its ability to remain closely to some predetermined value irrespective of external influences. Such influences include: variations in the supply voltage, variations in ambient temperature, replacement of components (particularly active devices such as transistors and ICs), perhaps as a result of servicing. In certain applications, such as measurement and control, it is important that amplifier gain is maintained very closely (better than 1% for example) to the specified value; at the same time, it is often the case that the gain required need not be particularly high. In such cases it is possible to take an amplifier of very high gain and apply negative feedback to it. The result will be a reduction in gain (to the required value) and the benefit that comes with it is that the new value of gain will be highly stable. This can be shown quite clearly by taking a further example.

Example 2. Suppose in the amplifier of example 1, the open-loop gain of the amplifier falls, for some reason by 50%, by what percentage will the gain with negative feedback (the closed-loop gain) fall?

Solution 2. In this second example we have supposed a very large reduction in gain, from 5000 to 2500 (the stated reduction of 50%). To work out what happens to the closed-loop gain is quite easy. All we have to do is to use the same formula, that we originally used, to calculate that the closed-loop gain was 100. The difference will be that the figure of open-loop gain, that we insert in this

formula must be the reduced value, namely 2500. Thus, we proceed as follows:

$$\begin{aligned} \text{Closed-loop gain} &= G_o \div (1 + G_o \times \beta) \\ &= 2500 \div (1 + [2500 \times 0.0098]) \\ &= 2500 \div (1 + 24.5) \\ &= 2500 \div 25.5 \\ &= 98 \end{aligned}$$

(to two significant figures)

This corresponds to a reduction in closed-loop gain of only 2% (from 100 down to 98). This demonstrates quite graphically how a large reduction in open-loop gain has very little effect upon the gain with feedback (the closed-loop gain). In fact, good as this gain stability is, it is possible to achieve very much better. It is not unusual to take a standard amplifier, with an open-loop gain greater than 100,000 times and apply negative feedback to it in order to reduce its closed-loop gain to only 10 or even less! The stability is then quite phenomenal; the reader might like to consider this as an example to prove the point to himself.

Closed-Loop Gain Depends only on Beta

Well almost, anyway! We can demonstrate this as follows.

Suppose we take another look at the formula for closed-loop gain, namely:

$$\text{Closed-loop gain} = G_o \div (1 + G_o \times \beta)$$

The denominator consists of two terms linked by a plus sign, namely $1 + G_o \times \beta$. If, as is often the case, the term $G_o \times \beta \gg 1$, then we can ignore the 'one' and write the new expression as:

$$\text{Closed-loop gain} = G_o \div G_o \times \beta$$

Which reduces to 'closed-loop gain' = $1 \div \beta$ (since the G_o in the numerator cancels with the G_o in the denominator).

This shows that, provided we stick to the qualifying factor stated above, the closed-loop gain is apparently totally independent of the open-loop gain G_o , and depends solely upon the feedback fraction β . This can't be absolutely true, but how true it actually is can be assessed by referring back to the previous example.

In this case β was 0.0098 and the closed-loop gain was calculated at 100. If we take the approximated expression that closed-loop gain equals the

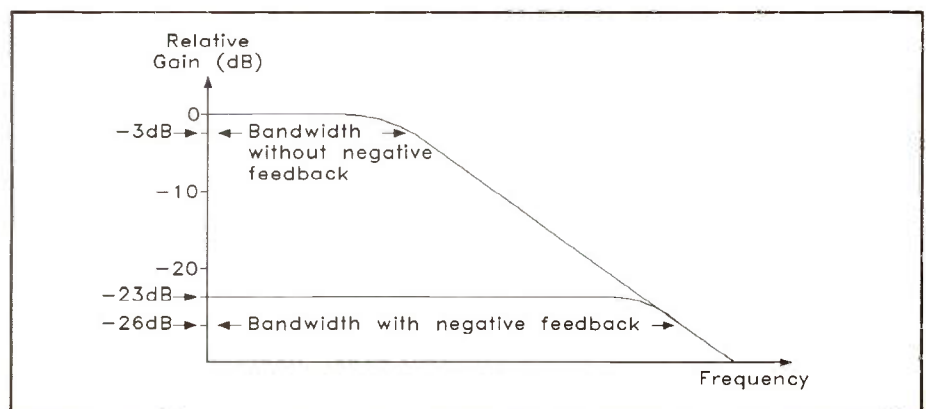

Figure 3. Effect of negative feedback on amplifier bandwidth.

reciprocal of beta, then its value is $1 \div 0.0098$, which works out to be 102, which is very close to the value of 100 calculated, and still quite close to the value of 98 obtained for the case when the open-loop gain had dropped to 2500. Thus, the approximation would seem to be valid under the stated conditions.

Increase in Bandwidth

Another feature of negative feedback in an amplifier is that, as the gain comes down the bandwidth increases. This is illustrated by the graphs of Figure 3. The gain without feedback, that is G_o , is taken as the reference value and labelled 0dB on the vertical axis. Defining bandwidth as the frequency at which the voltage gain has fallen by 3dB from its low frequency value, allows us to mark this as shown. We now assume, quite arbitrarily just to illustrate the principles, that negative feedback has caused a gain reduction of 23dB; this relative value of gain is marked on the vertical axis as -23dB. A further 3dB down on this (to identify the bandwidth with feedback) gives the point -26dB. From this we mark the new bandwidth value. This shows clearly the increase in bandwidth obtained when negative feedback is applied.

Reduction in Distortion and Noise

All amplifiers distort the signal to some extent and also generate noise. The former effect may arise from non-linear characteristics of the amplifying devices; the latter effect is largely due to the random nature of electron movements, but may also include residual mains derived hum from the power supply unit, for example.

In a well designed amplifier these effects may be quite small but there are applications, high-fidelity reproduction for example, where they need to be minimised further. Negative feedback will improve the performance in this respect. In the same way that the use of feedback reduces the gain by a factor $1 \div (1 + G_o \times \beta)$, it reduces distortion and noise by the same factor. Thus, if 'D' is the distortion and noise created within the amplifier without negative feedback, and 'd' is the distortion left after negative feedback has been applied, then:

$$d = D \div (1 + G_o \times \beta)$$

It is usual to express distortion as 'so many percent' THD (Total Harmonic Distortion). The word 'harmonic' arises in this context because distortion always introduces harmonics of the signal frequency. Harmonics are multiples of the original frequency (known as the 'fundamental' frequency) so that, where the fundamental is 100Hz, the harmonics are 200Hz, 300Hz, 400Hz, etc.

Example 3. If an amplifier of open-loop gain 10,000, has a THD figure of 3% without negative feedback, what will be the new figure for THD if a fraction equal to 0.01 of the output is fed back as negative feedback?

TYPE OF FEEDBACK	EFFECT ON	
	INPUT IMPEDANCE	OUTPUT IMPEDANCE
SERIES VOLTAGE	INCREASED	REDUCED
PARALLEL VOLTAGE	REDUCED	REDUCED
SERIES CURRENT	INCREASED	INCREASED
PARALLEL CURRENT	REDUCED	INCREASED

Table 1. Effect of negative feedback on amplifier terminal impedance.

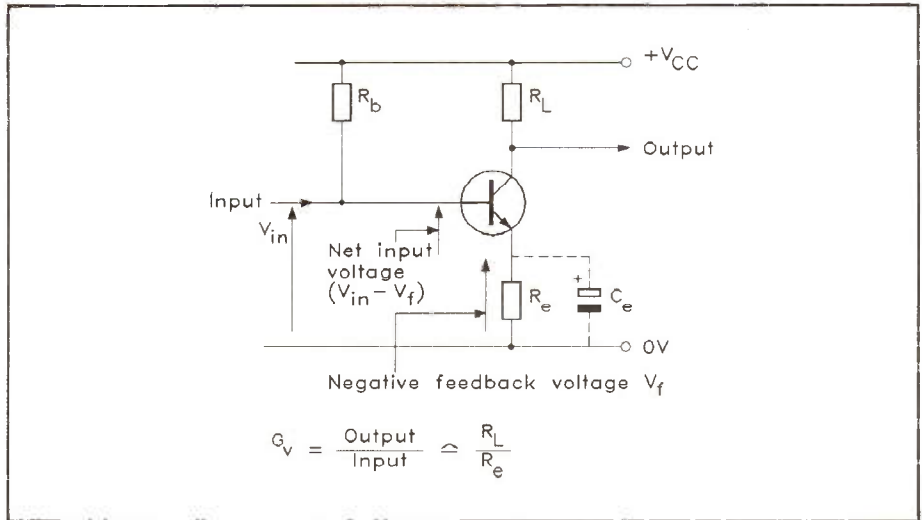

Figure 4. Negative feedback caused by unbypassed emitter resistor.

Solution 3.

$$\begin{aligned} d &= D \div (1 + G_o \times \beta) \\ &= 3 \div (1 + [10000 \times 0.01]) \\ &= 3 \div 101 \\ &= 0.03\% \text{ (approx.)} \end{aligned}$$

Two things one should bear in mind in the matter of using negative feedback to improve amplifier performance:

- (a) Negative feedback cannot make a bad amplifier into a good one, only a good one better!
- (b) Negative feedback cannot reduce distortion and noise in the original signal; it acts only on that generated within the amplifier itself.

Effect of Negative Feedback on Terminal Impedances

By terminal impedances we mean the impedance that appears between the input terminals to the signal (known as the input impedance), and the impedance that appears between the output terminals (known as the output impedance). Proving that anything that happens to these impedances is extremely mathematical and time consuming, so will not be attempted here. However, a summary of these effects for the four types of feedback listed above is given in Table 1.

Negative Feedback Applied in Practice

Figure 4 shows a single-stage transistor amplifier. The bypass capacitor connection across the emitter resistor R_e

is shown in chain line to indicate that it may or may not be in circuit. In practice this may mean that it has deliberately been omitted in order to introduce negative feedback, with its consequent advantages, or it has 'failed open-circuit', causing a loss of amplifier gain – a classical fault.

How does this introduce negative feedback? The signal current flowing in the transistor causes a feedback voltage (V_f) at signal frequency to appear across R_e . When capacitor C_e is in circuit this voltage is virtually zero since the capacitor is chosen so as to present negligible reactance to the signal – this is the bypassing action normally desired. However, when C_e is not in circuit the full signal current flows in R_e producing the signal (feedback) voltage mentioned earlier, by the normal Ohm's law effect. This voltage is in series opposition to the input voltage V_{in} , a fact indicated by the directions of the arrows in Figure 4. This arises because there is zero phase shift between base and emitter. The amplifier is then driven by a net voltage, between its base and emitter, which is equal to the difference between V_{in} and V_f .

A moment's thought shows that this is analogous to the situation represented by the block diagram of Figure 1. What type of feedback is it? Clearly 'series', and since it is produced by the flow of output 'current' in R_e , it is 'series current' feedback.

The circuits of Figure 5 develop this same argument further.

These circuits show that the load has been transferred to the emitter terminal (a) in the case of the BJT and the source terminal (b) in the case of the FET. This

means that the whole of the output voltage is used for negative feedback, being applied exactly as discussed for Figure 4. In other words, $\beta = 1$. Using the assumption that:

$$\text{Closed-loop gain } G_c = 1 \div \beta$$

This gives a value for G_c of unity. This means that the input and output voltages are equal in magnitude and, since the two voltages are of the same phase too, the output apparently 'follows' the input. For this reason, the circuits of Figure 5 are known as an 'emitter follower' and a 'source follower' respectively.

An amplifier that provides an output that is identical to its input may not seem to be very useful as an amplifier. However, there is an aspect to its performance that is of the greatest value; this is the effect that negative feedback has on the terminal impedances. This effect can be judged by reference to Table 1. First we must identify the type of

feedback though.

We may be tempted to say that it must be series current feedback, since the circuits look somewhat like that of Figure 4. However, while it is certainly series feedback, it is 'voltage' type not current. This is because the feedback voltage is proportional to the output voltage. In fact it is equal to the output voltage. Table 1 tells us that the effect of this type of feedback is to 'increase' the input impedance and 'reduce' the output impedance. This makes the circuit useful as what is known as a 'buffer', that is a circuit that can be inserted between a high impedance source and a low impedance load to avoid loading of the former, by the latter.

While the follower circuits of Figure 5 have a theoretical voltage gain of unity, in practice it is often rather less, more likely in the range 0.5 - 0.8. This is due to the fact that the open-loop gain of a single BJT or FET is not likely to be all that high and also due to volt drops in the internal resistance of these devices.

Overall Feedback in an Audio Amplifier

Figure 6 is included as an example of an audio power amplifier in which negative feedback is used to improve performance and define the overall gain. The negative feedback path comprises a pair of parallel components R10 and C4 that couple the amplifier output (junction R10/R11) to the emitter of TR1. The components C3 and R5 are also significant. Capacitor C3 is large enough in value to have little reactance at signal frequencies and acts only as a means of blocking d.c. The d.c. path through TR1 is therefore returned to 0V through the collector-emitter path of TR8. This makes the function of R5 purely an a.c. one. In fact, it forms the lower half of a potential divider, the upper half of which is the R10/C4 combination mentioned previously. The degree of negative feedback is determined as follows.

At low frequencies the reactance of C4 is greater than the resistance of R10 so, with some approximation, $\beta = R5 \div (R10 + R5)$, these two resistors forming a simple resistive potential divider. The feedback voltage is developed across R5.

At middle and high frequencies the reactance of C4 has fallen substantially and this component can no longer be ignored. Since the low reactance of C4 is shunting R10, the combined impedance of the two components is less than the value of R10. Consequently the divider action of the latter components together with R5 favours R5 rather more, resulting in increased negative feedback. Thus as the signal frequency increases so does the amount of negative feedback; the gain falls, on the other hand, so curtailing

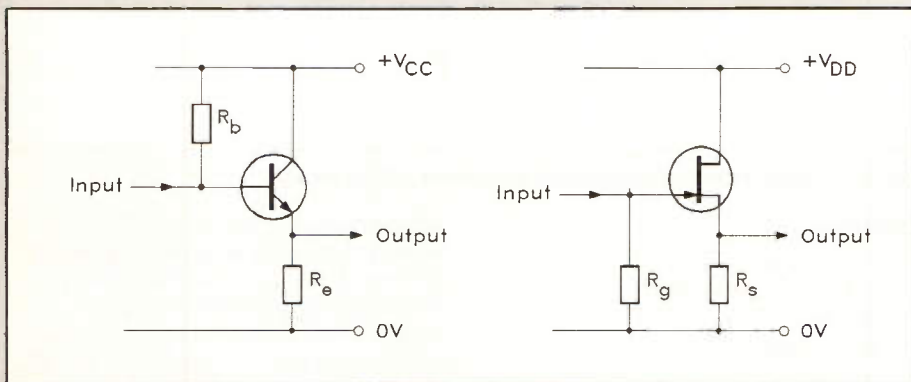

Figure 5. Follower circuits: (a) emitter follower and (b) source follower.

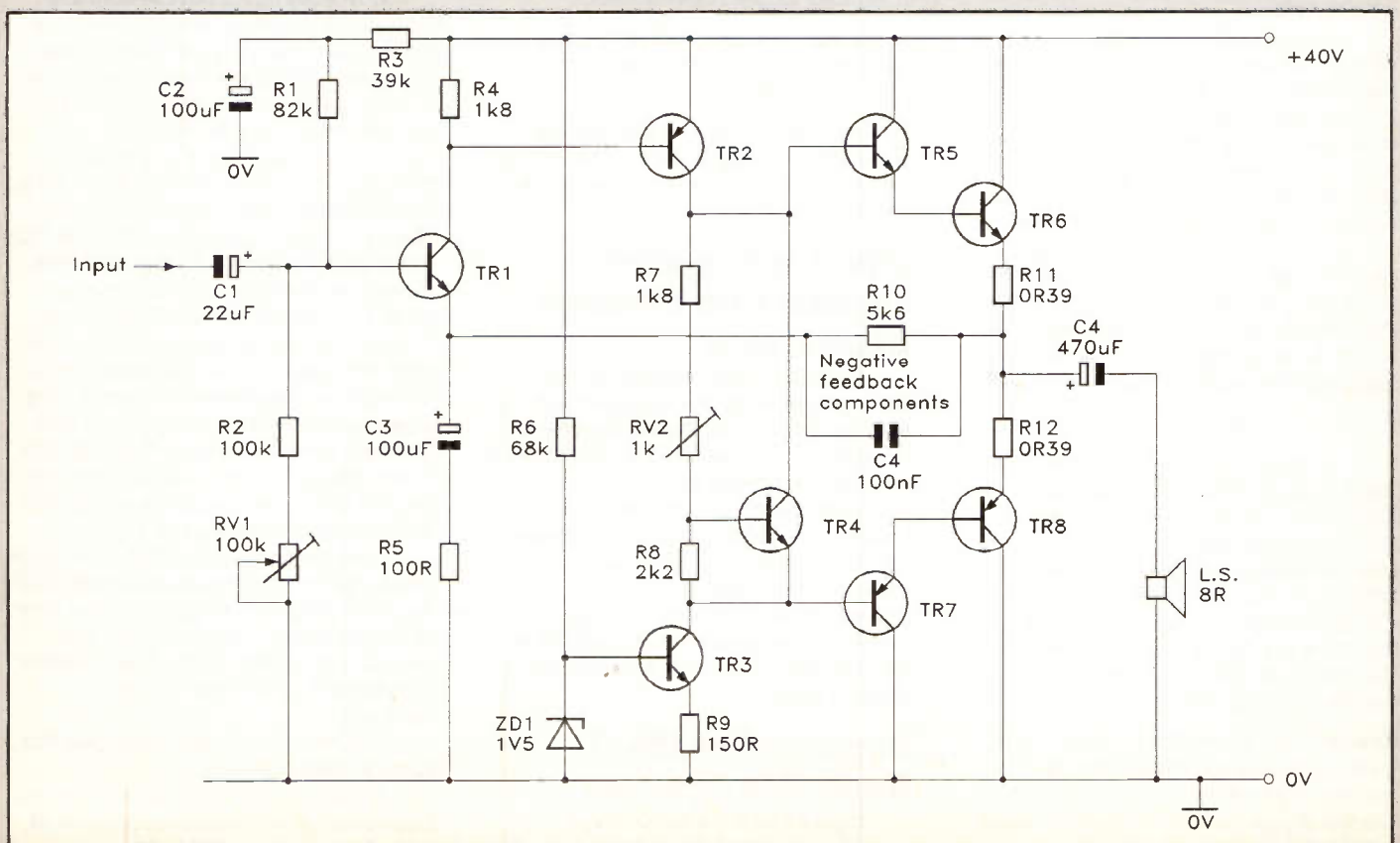

Figure 6. An audio power amplifier with overall negative feedback.

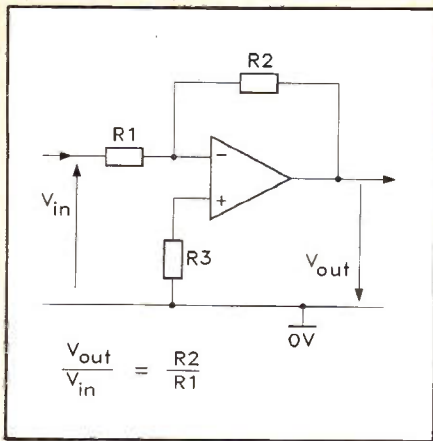

Figure 7. The 'Op-amp' inverting amplifier.

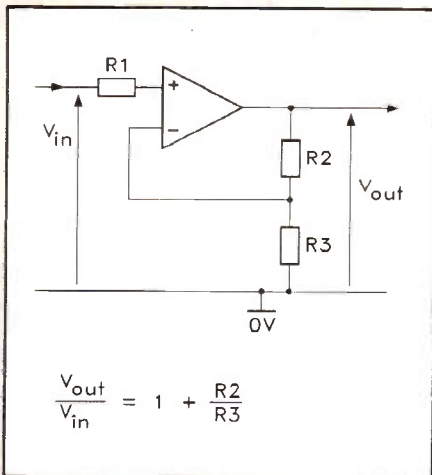

Figure 8. The 'Op-amp' non-inverting amplifier.

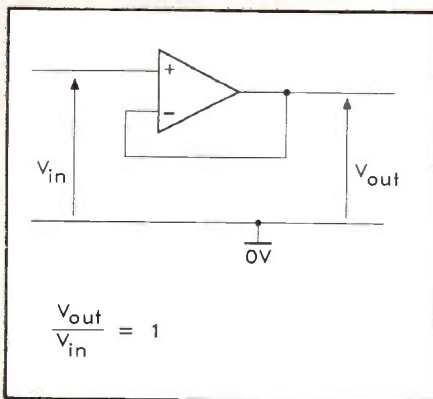

Figure 9. The 'Op-amp' voltage follower.

the amplifier response at higher frequencies.

Therefore, in the circuit of Figure 6, not only does the use of feedback reduce gain and distortion, it also 'tailors' the frequency response at the treble end of the spectrum. Different values of C4 will give different degrees of 'top cut'.

The Operational Amplifier

This is a standard IC amplifier that can be configured for use in a variety of ways. Three possible configurations are shown in Figures 7, 8 and 9, all using negative feedback.

Taking Figure 7 first, this shows what is probably the most common configuration, that of the inverting

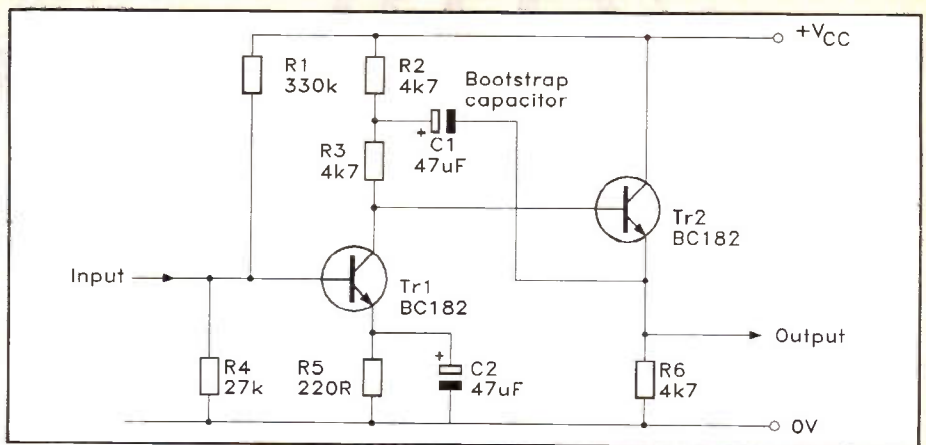

Figure 10. A 'bootstrapped' amplifier using positive feedback.

amplifier. The Op-amp (to use its usual abbreviated title) has two inputs marked + and -, denoting the non-inverting input (zero phase shift from this input to the output) and inverting input (180° phase shift from this input to the output). Feedback occurs from output to inverting input via resistor R2. The gain is defined by the ratio R2:R1. The other, unused, input is strapped to ground through resistor R3. The type of feedback used here is 'parallel voltage', since the feedback is clearly derived from the output voltage and applied in parallel with the input.

Bearing in mind that the open-loop gain of such an Op-amp may well be of the order of 200,000 times, it will be appreciated that, if the gain in closed-loop is defined at some low value e.g. 10, the gain stability will be very good indeed.

The term 'operational amplifier' derives from its original use in analogue computers, where high stability of gain is essential.

It is sometimes necessary to define gain precisely yet maintain the input and output voltages in the same phase. What is needed in such a case is a non-inverting amplifier, such as the one shown in Figure 8. Again the negative feedback is taken from output to inverting input, but the signal is applied to the non-inverting input. Also, the gain is determined once more by only two resistors (R2 and R3), being equal to their ratio 'plus one'.

The circuit of Figure 9 shows the Op-amp equivalent of the emitter and source followers, and is known as the 'voltage follower'. It can be seen that it is merely a special case of the non-inverting amplifier. Consider the formula for the voltage gain of the latter, namely:

$$\text{Gain} = 1 + R2 \div R3$$

What would the gain be if we make R2 equal to zero and R3 equal to infinity? The answer is, of course, 'one'. Now apply this logic to Figure 8. Replace R2 with a short circuit (R2 = zero) and R3 with an open circuit i.e. remove it completely (R3 = infinity) and what is left is the circuit of Figure 9. Well, almost; the analogy is complete if we also delete R1, which we can do since it has no effect on gain.

Positive Feedback in Amplifiers

Finally, it is worth leaving the matter of negative feedback in amplifiers to have a look at a case where positive feedback can be deliberately introduced in order to obtain some specific benefit. It is necessary, of course, to ensure that the amplifier doesn't actually burst into oscillations. Provided that this is ensured, the result can be a dramatic increase in gain. The technique used is called 'bootstrapping'.

The circuit for such an amplifier is given in Figure 10. It consists of two stages, one of which is an emitter follower which, while providing less than unity gain itself is, nevertheless, vital to the operation of the circuit and also provides a useful low impedance output. The base of this stage, TR2, is directly driven from the collector of TR1; the 'bootstrap' connection is completed by capacitively coupling the emitter of TR2 back to the junction of R2 and R3 in TR1's collector circuit. This leads to the following relevant facts.

- (a) The signal potentials at TR1 collector and TR2 base are the same.
- (b) The signal potentials at TR2 emitter and the R2/R3 junction are the same since C1 has negligible reactance.
- (c) The signal potentials at TR2 base and emitter are virtually the same, if the voltage gain of TR2 is assumed to be approximately unity.

What all of the above 'equalities' lead to is the fact that the signal potentials at the ends of R3 are virtually the same. If this is so, then the magnitude of the signal current in R3 must be very small indeed, just as if this resistor had an extremely high value. Since the voltage gain of a common emitter amplifier is directly proportional to the value of the collector load (of which R3 is a part), it follows that the gain of this stage must be very high. In fact, a voltage gain in excess of 2,000 is quite possible.

That concludes this short 'first course' in electronics and it is hoped that readers have found some use in it as a stepping stone to more complex areas of the subject, for which the basic ideas that have been discussed provide the foundation.

LOW COST AUDIO WAVEFORM GENERATOR

by C S Barlow

FEATURES

- ★ Four Frequency Ranges
- ★ Three Output Waveforms
- ★ Push-Button Switching
- ★ High and Low Level Outputs
- ★ Minimal Wiring
- ★ Battery Powered

APPLICATIONS

- ★ Test Tape Production
- ★ Acoustic Engineering
- ★ Testing Projects
- ★ Gain and Phase Measurements
- ★ Setting Filters
- ★ Bandwidth Testing



The assembled unit.
(Box not included in kit).

Specification of prototype

DC power supply input:	$\pm 6V$ to $\pm 9V$
Current at $\pm 9V$:	$\pm 25mA$
Standby current:	$< \pm 1\mu A$
Waveforms:	Sine, Triangle, Square
Frequency ranges	
10 to 100kHz:	9Hz to 105Hz
0.1 to 1kHz:	100Hz to 1.1kHz
1 to 10kHz:	895Hz to 10kHz
10 to 100kHz:	9.2kHz to 106kHz
Output amplitude	
Full:	9V (Pk-to-Pk)
Attenuated:	400mV (Pk-to-Pk)
Output impedance:	600 Ω
Sinewave distortion	
10Hz to 10kHz:	$< 1\%$
10kHz to 100kHz:	$< 4\%$
Triangle linearity	
10Hz to 40kHz:	$< 0.1\%$
40kHz to 100kHz:	$< 1\%$
Square rise/fall time:	$< 2\mu s$

Introduction

To achieve optimum audio performance from home constructed kits, or manufactured equipment, usually requires a degree of testing and alignment. The majority of these tests are of a simple nature which normally require only a small adjustment of a preset component within the circuit. However, commercially available test gear often provide a level of technical sophistication which greatly exceeds that of the unit under test, and this fact is reflected in their high cost. For the hobbyist working on a restricted budget the need for a simple LOW COST audio waveform generator is apparent, and it was for this reason that Maplin have developed this project.

Every attempt has been made in making this kit as straightforward as possible, both in construction and operation. Three of the major stumbling blocks in any project design are as follows:

1. The number of off-board components.

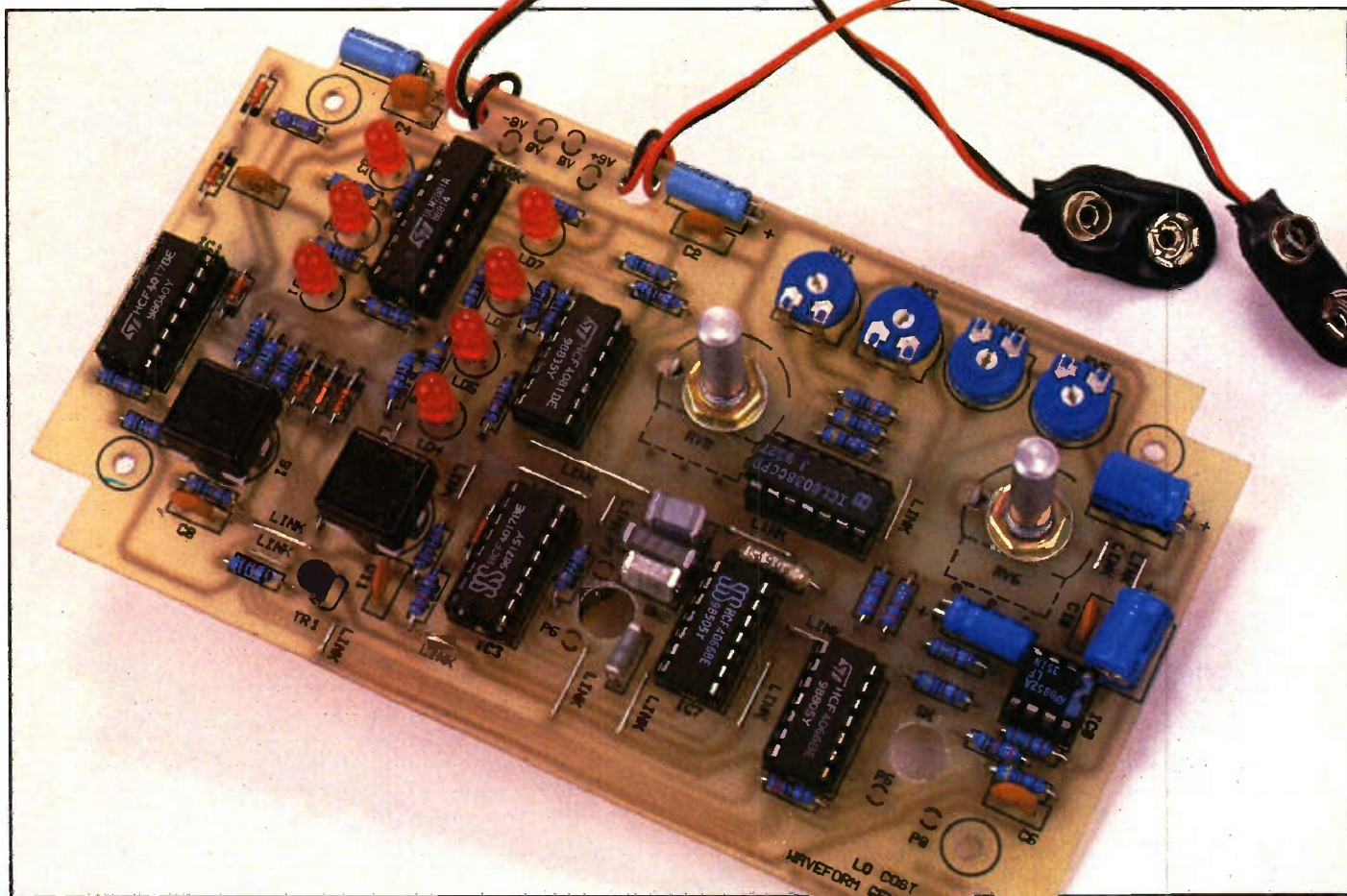

Photo 1. Completed PCB assembly.

2. The amount of wiring to and from the PCB.
3. Long term reliability.

In previous designs using standard rotary and toggle switches large amounts of messy wiring was necessary to hook everything up. Long term reliability was relatively poor owing to the number of moving parts within the switch mechanisms. However, by incorporating electronic switching all three design problems have been reduced to a minimum. This new project uses only two non-locking push-to-make PCB mounted switches to select one of four frequency ranges, one of three waveforms and power on/off.

Circuit Description

The 8038 waveform generator (IC6) is fabricated using advanced monolithic technology and only a few external components are actually required to produce a working system. However, to make it more versatile and controllable does require the following supporting ICs:

Function Control IC1 Power ON/OFF and waveform select.

Function Display IC2 LD1,2,3 Drive and -V power switch.

Function Output IC5 Sine, Triangle and Square output switch.

Range Control IC3 Selects one of four frequency ranges.

Range Display IC4 LD4, 5, 6, 7 Inhibitor.

Range Display IC2 LD4, 5, 6, 7 Drive.

Range Output IC7 Selects timing capacitor value on pin 10.

Output Buffer IC8 Provides a low impedance output.

Taking a closer look at IC6 reveals that the positive power supply is applied to pin 6, with the negative supply connecting to pin 11. The frequency of oscillation is set by two independent factors, the value of the timing capacitor on pin 10 and the sweep voltage applied to pin 7 and 8. Each timing capacitor is selected in turn by the switch action of IC7. For the lowest frequency range the largest value of capacitor is selected, which in this case is the combined values of C13 and C14. The second range switches in C15, next C16 and finally for the top range C17. To set the frequency sweep range a potential divider circuit comprising of RV1, RV2, RV3 and R31 is placed across the supply rails. Between the two preset resistors RV1, RV3 the upper and lower limits are set. Then the wiper of the main frequency control RV2 taps off the final voltage to pins 7 and 8 on IC6.

The symmetry of the three waveforms produced by IC6 is controlled by two fixed and two preset resistors. To achieve a duty cycle of 50%, R32 and R33 on pins 4 and 5 must be of identical value, the two preset

resistors RV4 and RV5 on pins 1 and 12 are used to minimise sine-wave distortion. These corrected waveforms leave the IC on pin 2 sine, 3 triangle and 9 square, the signals then pass through IC5 which is used to select the desired waveform. Setting the amplitude of the waveform is achieved by adjusting RV6, but the impedance at this point is too high for some test applications. To correct this an amplifier, IC8, provides an output that will drive into loads as low as 600Ω. To provide a clean start/stop to the signal when the power is turned on and off the output passes through IC5 before connecting to the output sockets. The maximum output level produced by the generator on SK1 is approximately 9V peak to peak and this can result in overloading the input of some highly sensitive circuits. For this reason a second attenuated output with a maximum level of approximately 400mV peak-to-peak is made available on SK2.

The function and frequency range of the generator is governed by the electronic switching circuits IC1 to 5 and IC7. When the batteries are connected up for the first time, a reset pulse is generated and applied to pin 15 of IC1 and IC3. This ensures that the unit is in its power off mode, and the lowest frequency range is selected. Every time the function push switch S1, or the frequency range switch S2 is pressed a clock signal is generated on

Figure 1. Circuit diagram.

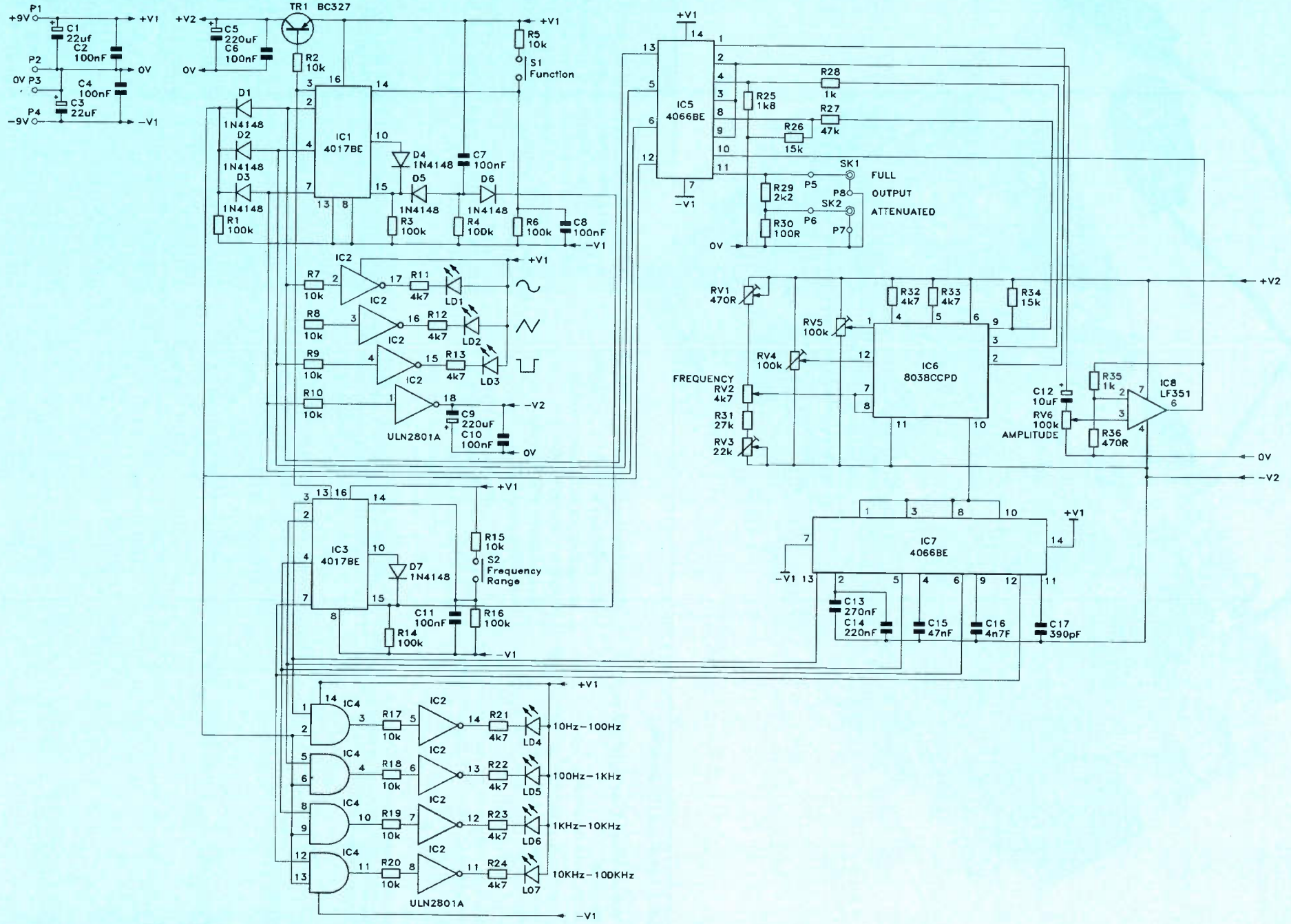

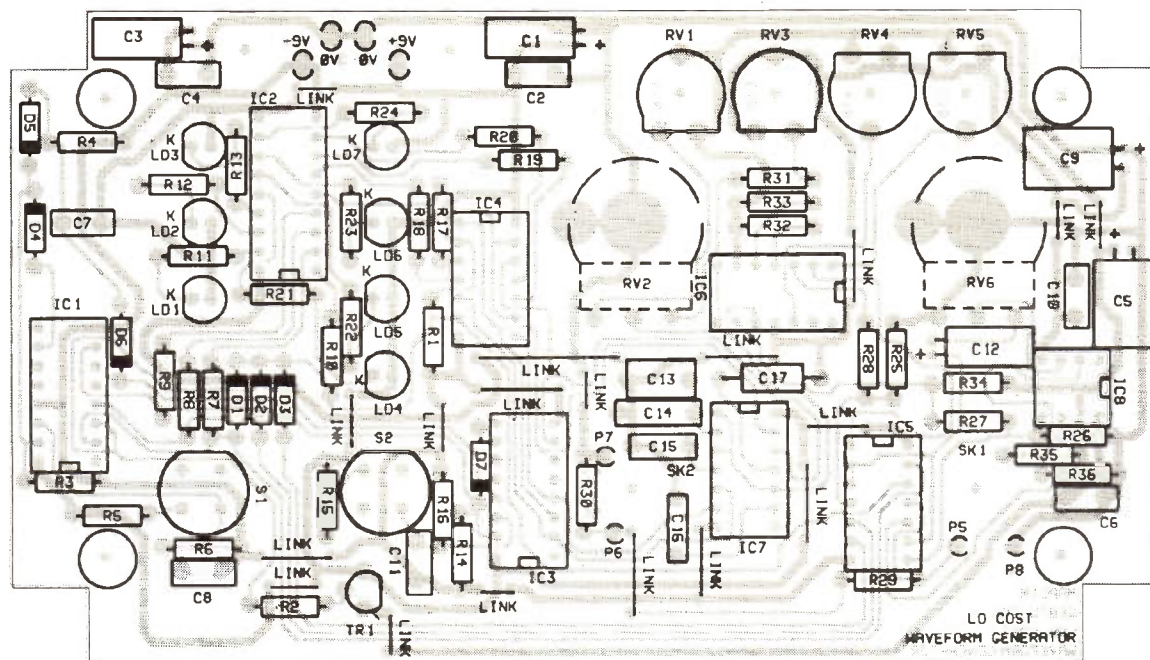

Figure 2. PCB legend and track.

pin 14 of their respective ICs (IC1 and IC3). Each IC has five outputs, the clock signal is used to step through them until the fifth one is reached which sends a reset pulse back to pin 15. The function of each IC pin is as follows:

IC1	Function
Pin 3	Power off
Pin 2	Sine-wave
Pin 4	Triangle-wave
Pin 7	Square-wave
Pin 10	Reset
IC3	Frequency Range
Pin 3	10 to 100Hz
Pin 2	0.1 to 1kHz
Pin 4	1 to 10kHz
Pin 7	10 to 100kHz
Pin 10	Reset

These outputs then control two more circuits which have similar characteristics to each other. To show which mode or frequency range you have selected each contains part of IC2 used to drive the following LEDs:

Function Control IC1	Power ON/OFF and waveform select.
Function	
LD1	Sine-Wave
LD2	Triangle-Wave
LD3	Square-Wave
Frequency Range	
LD4	10 to 100Hz
LD5	0.1 to 1kHz
LD6	1 to 10kHz
LD7	10 to 100kHz

The frequency range display circuit has an additional logic gate, IC4, to blank the display when the unit is in its power off mode, while in the function circuit, TR1 and part of IC2 is used to switch the power rails to IC6 and IC8.

The analogue switches, IC5 waveform and IC7 timing capacitor select, receive the same logic signals as the display circuits. However, this time they are used to activate the desired analogue signal path through the relative section of each IC.

PCB Assembly

The PCB supplied in the kit is a single-sided, fibreglass type, and a copy of its printed legend is shown in Figure 2. This should assist you in correctly positioning each component,

AUDIO WAVEFORM GENERATOR

Maplin

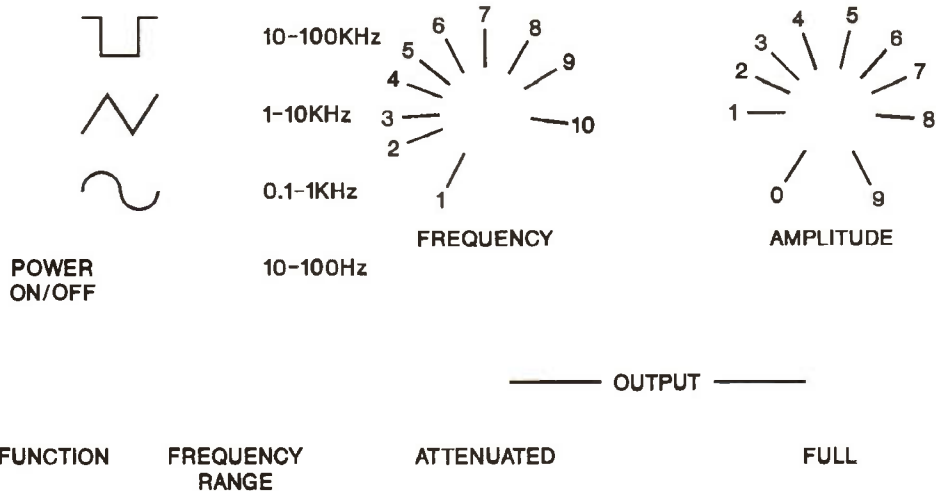

Figure 4. Front panel legend.

as removal of a misplaced item is quite difficult. Please double-check each component type, value and its polarity where appropriate, before soldering!

The sequence in which the components are fitted is not critical. However, the following instructions will be of use in making these tasks as straightforward as possible. For general information on soldering and assembly techniques please refer to the Constructors' Guide included in the Maplin kit. REMEMBER there is only a 10mm gap between the component surface of the PCB and the back of the front panel. Ensure that all the components, excluding the LEDs LD1 to LD7, are as close to the surface of the PCB as possible. Because of this restricted space the taller components must be pushed over so that they lie flat on the surface of the board. The following components have had their outlines printed on the legend to reflect this: C1 and C3, 22µF 25V PC Elect; C5 and C9, 220µF 16V PC Elect; C12, 10µF 50V PC Elect.

It is usually easier to start the assembly with the smaller components. Begin with the resistors R1 to R36 saving the component lead offcuts, using eighteen of these, bend them to fit the link positions on the PCB.

Next install the diodes, D1 to D7, making certain that the band on the component matches the markings on the board. When fitting the transistor TR1 ensure that its case matches the outline on the legend. The majority of the capacitors are installed and soldered in the conventional manner. However, when fitting the polarised electrolytic capacitors – C1, 3, 5, 9 & 12 – the lead nearest the negative symbol (–) on the component goes away from the positive sign on the legend, also remember to mount them as previously described.

When installing the two miniature rotary potentiometers RV2 and RV6 follow the mechanical assembly information provided in Figure 5, ensuring that you fit the correct value pot at each position. When secured, bend down the tags so that they are touching the pads on the track side of the PCB and solder them as shown. The seven LEDs LD1 to LD7 are all mounted 5mm above the surface of the board, see Figure 5. The short lead of each LED is cathode (K); this is also denoted by a flat along one side of the package, which must match up with its outline on the PCB legend.

Next mount the two click-effect push switches S1 and S2 making certain that the body of each switch matches its outline on the PCB. When fitting the IC sockets, make certain that you install the appropriate holder in each position, matching its end notch with the block on the legend.

Finally install the ICs ensuring that all the pins go into their sockets and the pin one marker is at the notched end. This completes the assembly of the PCB and you should now check your work very carefully making sure that all the solder joints are sound. It is also very important that the solder side of the circuit board does not have any trimmed component leads standing proud by more than 1mm, as this may result in a short circuit. The completed prototype PCB assembly is shown in Photo 1.

Final Assembly

The case in which the unit is designed to fit is the 'Metal Panel Box M4005' (WY02C). The main body of the box is moulded in black ABS plastic and does not have to be drilled or cut. In fact, the only preparation is to the aluminium top panel, see Figure 3 front

panel drilling and Figure 4 front panel legend. *Don't panic*, if you do not have the means to produce your own, Maplin have made available a pre-drilled and printed aluminium panel (Order Code KW56L).

After preparing the front panel secure the two Phono sockets SK1 and 2 using the hardware provided, see Figure 5. Solder two short wire links on to each socket and position the solder tags so the wires do not have to cross over when the PCB assembly is attached to the front panel. It is also very important that these tags should not touch any of the components on the board as either could result in a short circuit.

Next mount the PCB assembly on to the front panel, using the four 10mm insulated spacers, and check that all seven LEDs have passed through the panel, see Figure 5. Now connect up SK1 and 2 to the following solder pads: SK1 Centre terminal to P5; SK1 Solder tag to P8; SK2 Centre terminal to P6; SK2 Solder tag to P7.

The only significant amount of off board wiring is to the batteries, see Figure 6. However, this is not a problem since the wires come already prepared with the battery clips. The positive red and negative black wires both loop through a large hole in the PCB, this provides a certain amount of strain relief during the replacement of exhausted batteries.

Finally push on to S1 and 2 the square black click caps and fit the two knobs so that their pointers are at the fully-anticlockwise position. Check that they travel smoothly round to the fully-clockwise position, without scraping on the front panel. This completes the assembly of the unit. Now check your work very carefully, making sure that all the wires and solder joints are sound.

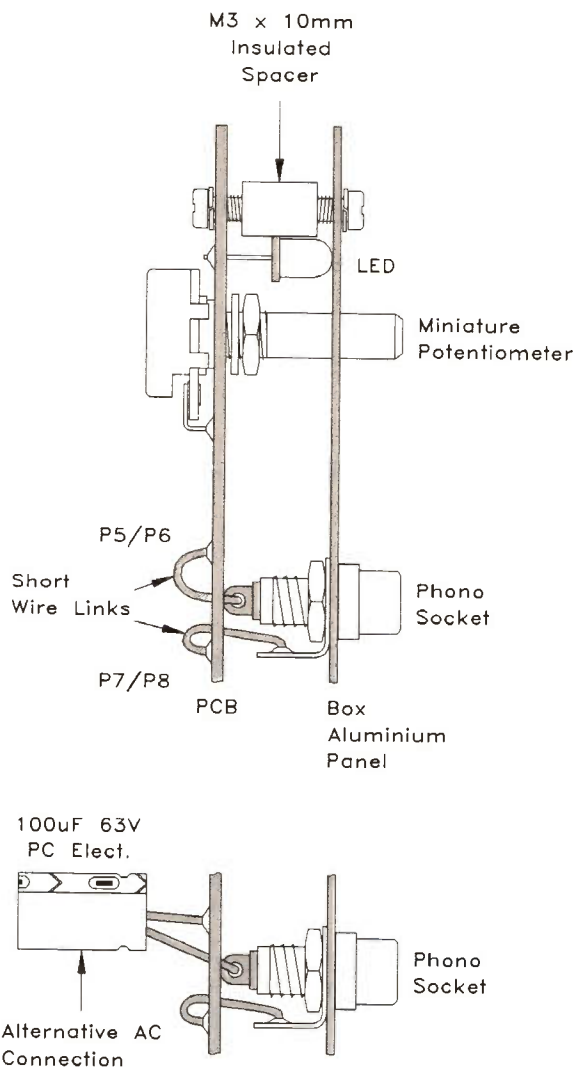

Figure 5. Mechanical assembly.

Testing and Alignment

All the DC tests are to be made using a multimeter and two PP6 nine volt batteries. The readings were taken from the prototype using a digital multimeter, some of the readings you obtain may vary slightly depending upon the type of meter employed. Before you commence testing the unit set the two rotary controls RV2 (frequency) and RV6 (amplitude) to their fully-anticlockwise positions.

The first test is to ensure that there are no short circuits on the power rails before you install the two PP6 batteries. Set your meter to read $k\Omega$ on its $20k\Omega$ resistance range, and connect the test probes to one set of battery terminals. With the probes either way round a reading greater than $4k\Omega$ should be obtained. Repeat this test on the other battery clip which should give a similar reading.

Next connect the two PP6 batteries. Although the power is now connected the generator should be in its power off mode (all LEDs off). To monitor the supply current, set your meter to read DC mA and place it in series with one of the batteries.

Ensuring that none of the LEDs are lit, observe the current reading which should be less than $1\mu A$, some multimeters may not possess sufficient resolution to read this extremely low standby current. Repeat this test on the other battery which should give a similar reading. When the function switch S1 is pressed once the generator should go to its initial power on mode, LD1 and LD4 lit. At the same time the DC current should increase to approximately 25mA in both batteries.

Each time the function button is pressed the waveform indicators LD1 to LD3 should step to the next position, i.e., sine, triangle, square then power off. When the frequency range button is pressed a similar stepping action should be observed on the range indicators LD4 to LD7. When the generator is in its power off mode the selected frequency range is held and can not be advanced until the unit is powered up again. The current drain previously measured should not alter significantly as different waveforms and frequency ranges are selected. This completes the DC testing of the generator, now disconnect the multimeter from the unit.

The DC tests on their own do not prove conclusively that the generator is producing an output, to do this requires some additional test equipment. A simple output test can be performed by using nothing more than a crystal earpiece, or a small audio amplifier system. However, to accurately set up the sine wave purity and frequency limits does require the use of an oscilloscope and frequency counter.

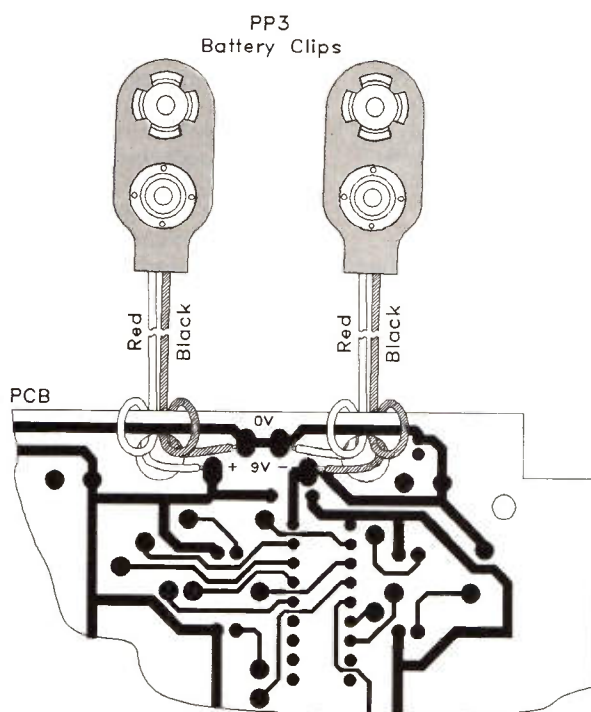

Figure 6. Battery wiring.

Before commencing the alignment set the PCB presets and the front panel controls to the following positions:

1. RV1, 3, 4 and 5 half way round.
2. Frequency control RV2 fully anticlockwise (number 1).
3. Amplitude control RV6 fully clockwise (number 9).
4. Function set to sine wave.
5. Range set to 1 – 10kHz.

Now connect the output of the generator to your oscilloscope's Y input channel. Select a suitable input sensitivity and sweep range, then observe the CRT display. If all is well, a waveform approximately corresponding to the sine wave shown in Photo 2 should appear. However, this is unlikely since the waveform purity presets RV4 and RV5 have to be critically adjusted in order to produce a sine wave with a minimum level of distortion. The effect of incorrectly adjusting these two controls can be seen in Photo 3. When the purity alignment has been successfully completed you should compare the other two waveforms against the triangle and square functions shown in Photo 2.

To set the minimum and maximum frequency control range limits a suitable frequency counter must be connected to the generators output. Some counters can give confusing results if the input signal contains too many harmonic products. For this reason it is advised that the generators sine wave function be used during the following alignment procedure. With its simple analogue dial it is not possible to obtain pinpoint accuracy over all the frequency ranges. In practice a compromise has to be made, and to achieve this the dial must have a certain amount of frequency overlap.

The two presets used to adjust the frequency limits are RV1 for the low end and RV3 for the high end. Altering either of these controls will have an affect on the other, so repeated realignment is necessary to obtain an optimised result. With the frequency control RV2 set to number one (fully anticlockwise) and the lowest range (10 – 100Hz) selected, adjust RV1 for a reading on the counter of 10Hz. Next set the frequency control to number ten and select the highest range (10 – 100kHz), adjust RV3 for a reading of 100kHz. Keep repeating this procedure while checking the other frequency ranges until your generator's calibration closely matches the specification given for the prototype unit shown in this article. Finally, using your oscilloscope check the peak to peak output levels. With the amplitude control set to maximum the full and attenuated outputs should be as follows: Full = 9V Pk-to-Pk; Attenuated = 400mV Pk-to-Pk.

Now carefully position the two PP6 batteries into the left-hand side of the

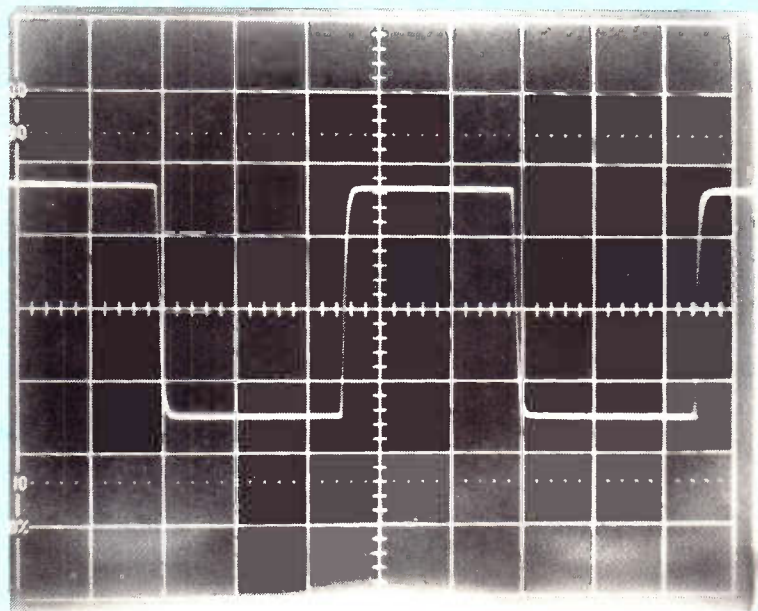
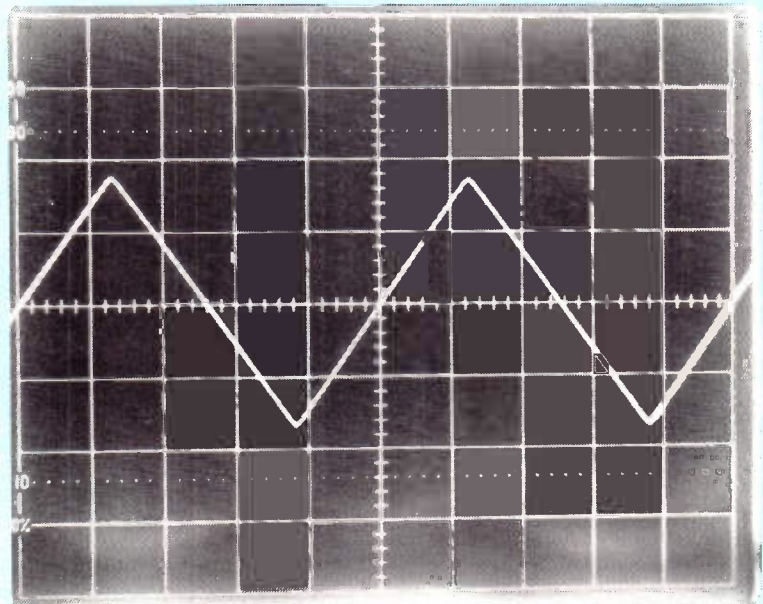
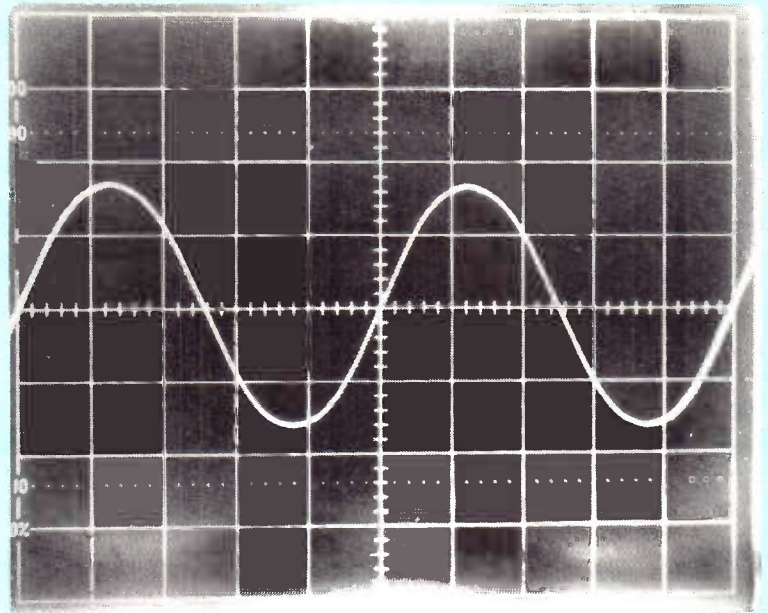
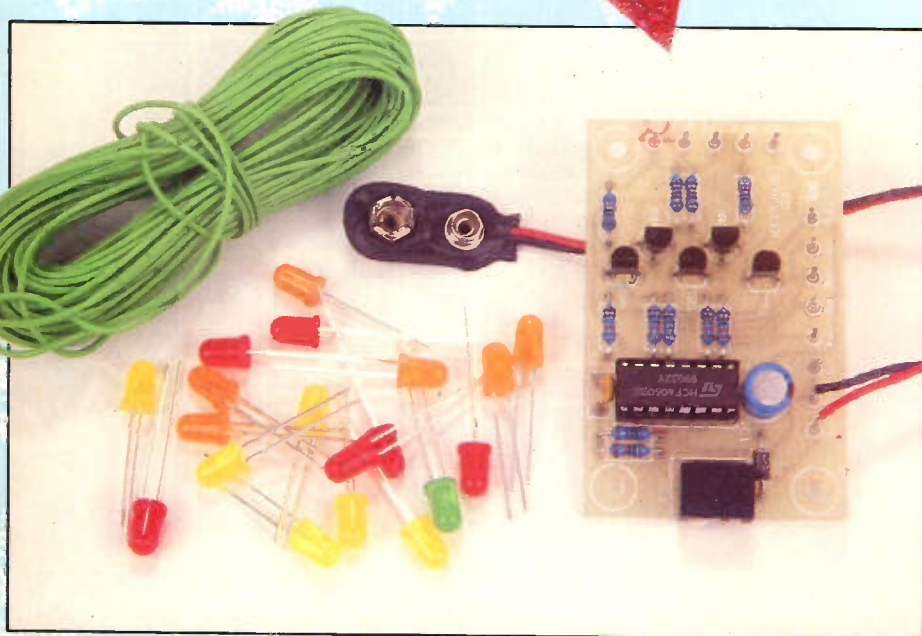
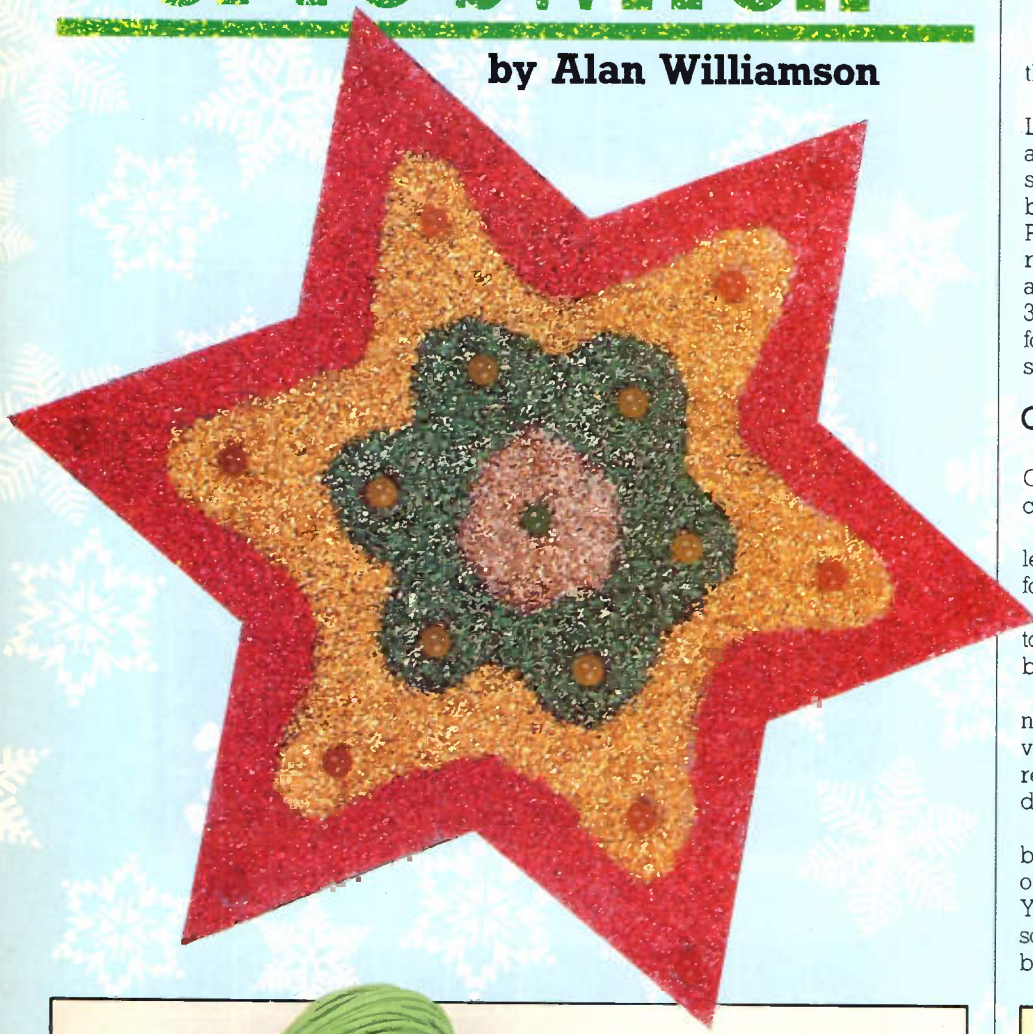

Photo 2. Correct sine, triangle and square waveforms.

Continued on page 38.

CHRISTMAS STAR & ZERO CROSSING OPTO SWITCH

by Alan Williamson



The completed star and LED controller.

These novelty projects are ideal to build for Christmas. The Christmas Star can be built on its own — producing an attractive pattern of flashing LEDs — or used in conjunction with the Opto Switch to make your 'fairy lights' flash as well!

Christmas Star

Figure 1 shows the circuit diagram of the Christmas Star.

The peak current consumption of the LED controller with all the LEDs lit is approximately 70mA, but due to the switching transistor this figure is reduced by half, making the expected life from a PP6 battery around 20 hours. It is therefore recommended that a 6 to 9V DC mains adaptor is used for prolonged use, and a 300mA unregulated supply would be ideal for this application, for example Maplin stock code XX09K.

Construction

Please refer to the Constructors' Guide for hints and tips on soldering and constructional techniques.

Referring to the PCB component legend, Figure 2, assemble the PCB as follows.

Begin by finding the MPSA14 transistor and put it to one side so that it will not be placed into the wrong position.

Insert, solder and crop each component starting with the resistors. The veropins are fitted from the track side, remember that C1 and D1 are polarised devices and must be correctly fitted.

Having completed the PCB it should be now cleaned with alcohol, Ultraclean or PCB cleaner (Maplin stock code YT66W and YJ45Y), then put it to one side so as not to damage it while you are building the festive star.

Pin	Description	
Pin 1.	+V Battery	
Pin 2.	0V Battery	
Pin 3.	0V	
Pin 4.	Direct output	D1 (MSB)
Pin 5.	" "	D2
Pin 6.	" "	D3
Pin 7.	" "	D4 (LSB)
Pin 8.	+V	
Pin 9.	Pulsed supply output	
Pin 10.	Open collector	D1 (MSB)
Pin 11.	" "	D2
Pin 12.	" "	D3
Pin 13.	" "	D4 (LSB)

Table 1. Pin description.

Building the Festive Star

Begin by taking a photostat, or trace around the star printed below and use it as a template, make a star (or any other shape you may fancy) from any material handy e.g. thin plywood, hardboard, perspex or thick card. Metal and other

conductive materials should not be used, otherwise the LEDs could become short circuited. Alternatively a decorative star could be purchased from your local Christmas decoration supplier.

Once the star has been cut out and the 5mm holes drilled for the LEDs, cover the face of the star with baking foil or

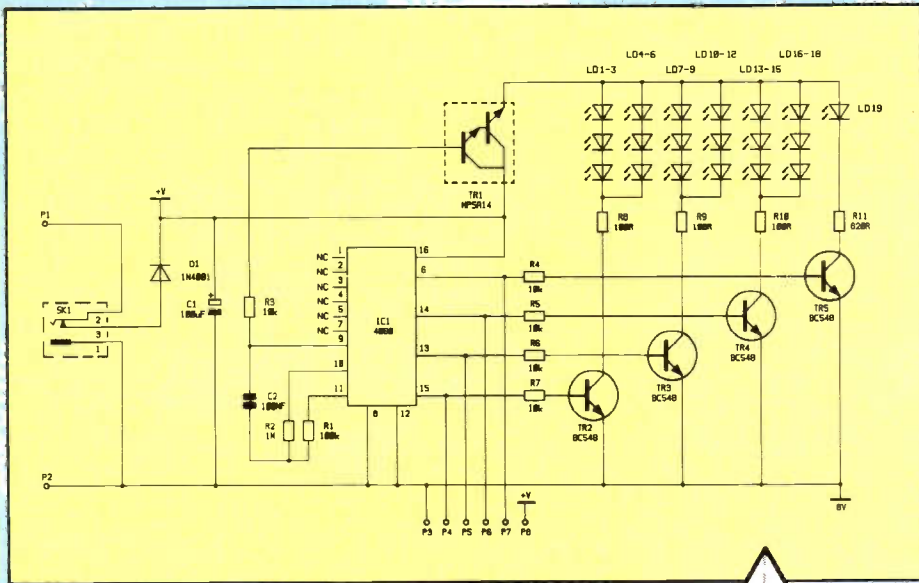

Figure 1. Circuit diagram of the LED Controller.

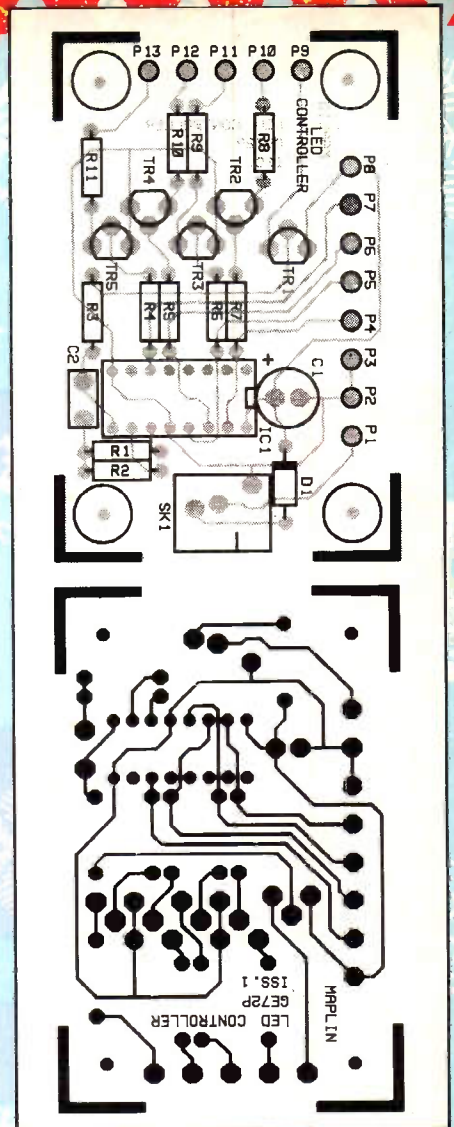

Figure 2. PCB legend and track.

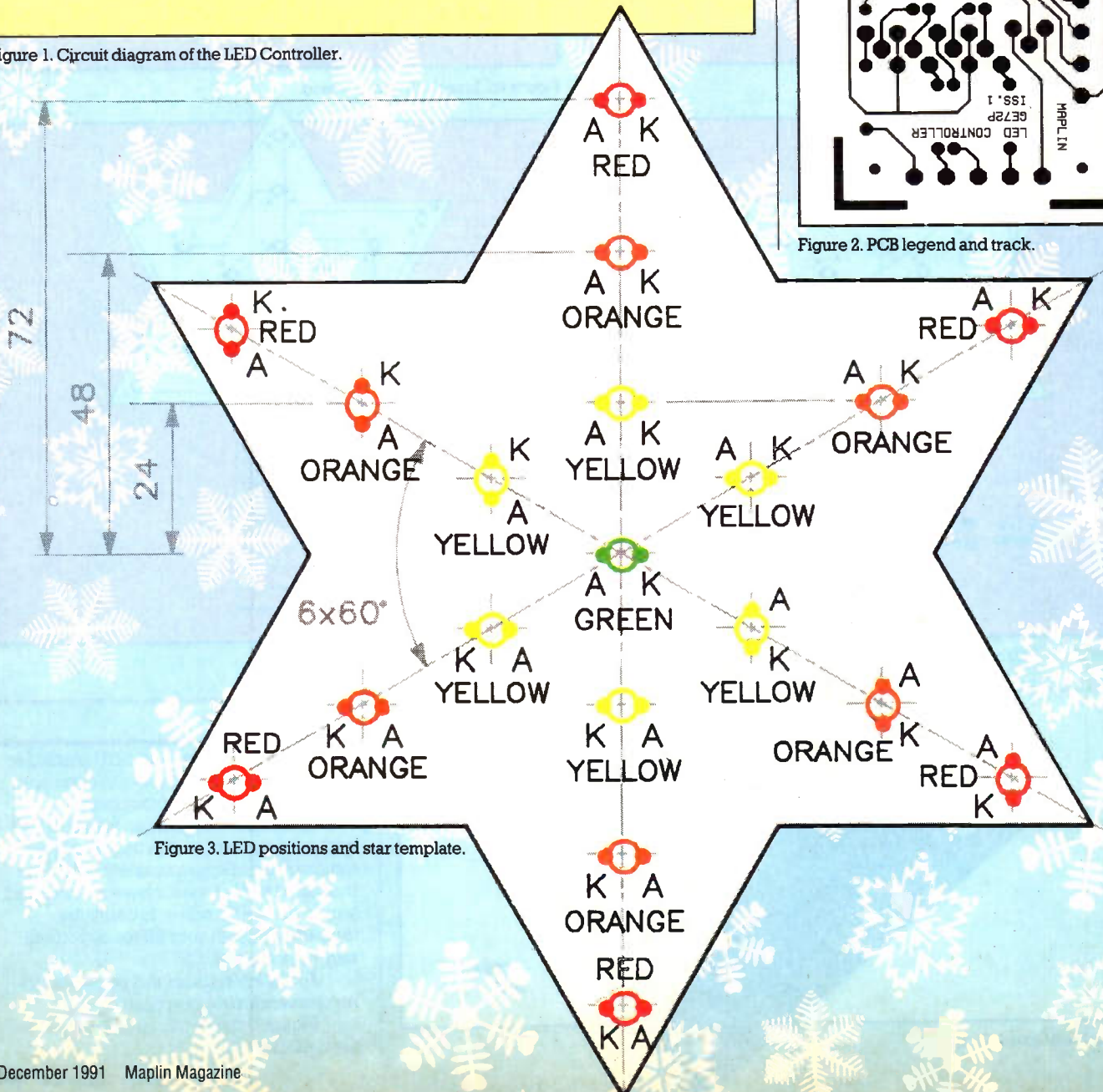

Figure 3. LED positions and star template.



aluminium laminate (Maplin stock code XY19V), or alternatively some silver or coloured glitter to make it look pretty. The next job is to glue the LEDs into the star in the positions shown in Figure 3. Allow the glue to set before attempting to wire up the LEDs.

Connect the LEDs using the cable supplied as shown in Figures 4a to 4d, the cathode being the shorter of the two leads.

Figure 4a shows the common supply to the top anode of each group of LEDs, and the lead to the cathode of the centre LED. Figure 4b shows the first group of LEDs away from the centre, Figure 4c shows the outer group of LEDs which is wired in the same way as the inner group and Figure 4d shows all the LEDs wired up. Having now completed the wiring, the LED legs should be trimmed as short as possible.

Testing

To test the controller, connect the leads from the star as shown in Figures 4a to 4d, and connect a PP6 battery to the battery clip or apply 6 to 9 volts DC to the power socket, the pin of the socket being 0V. The LEDs will start to flash, if any group of LEDs fail to light, check to see if one of the LEDs has been inadvertently fitted the wrong way round.

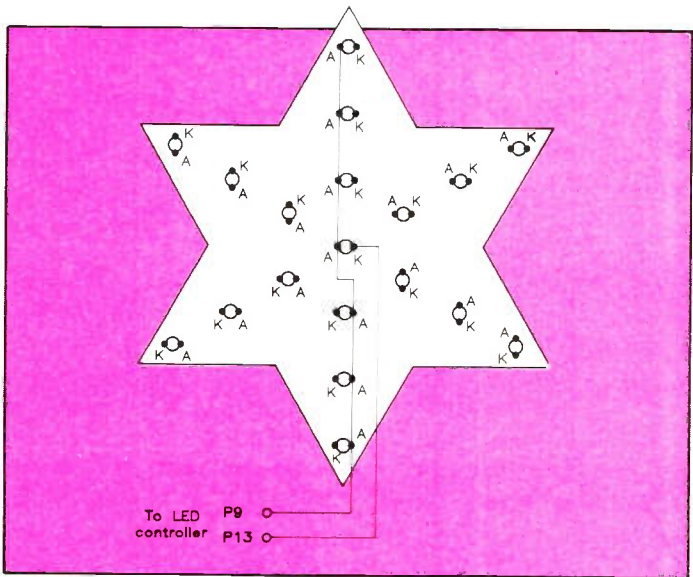

Figure 4a. Common supply and centre LED.

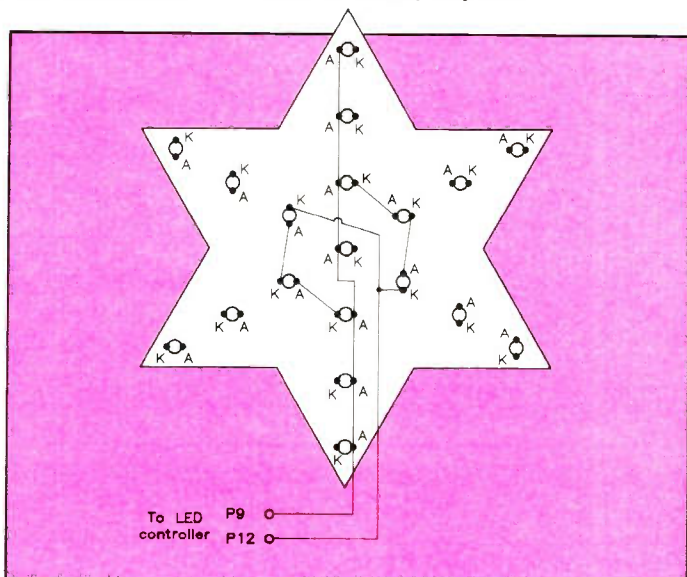

Figure 4b. Inner LED group wiring.

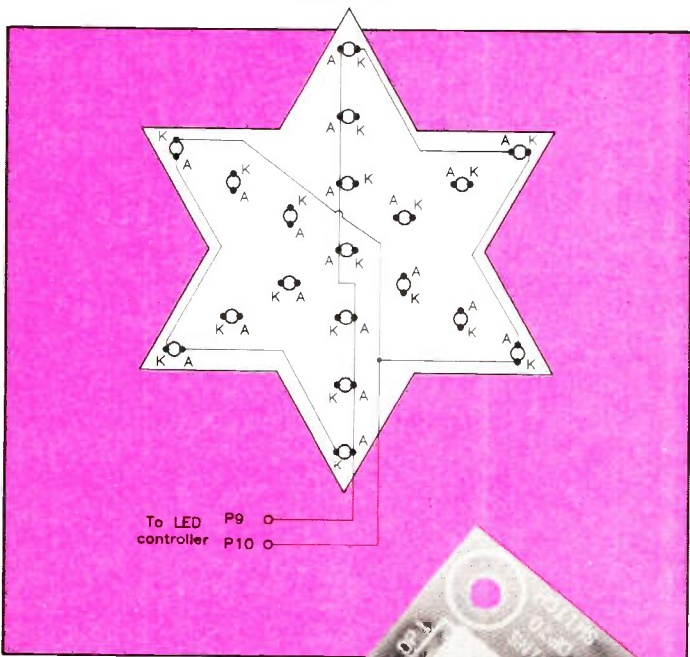

Figure 4c. Outer LED group wiring.

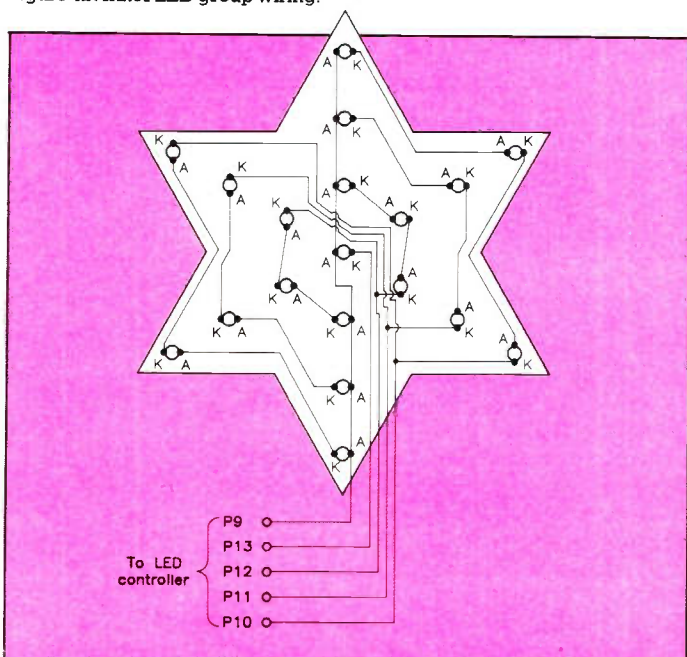
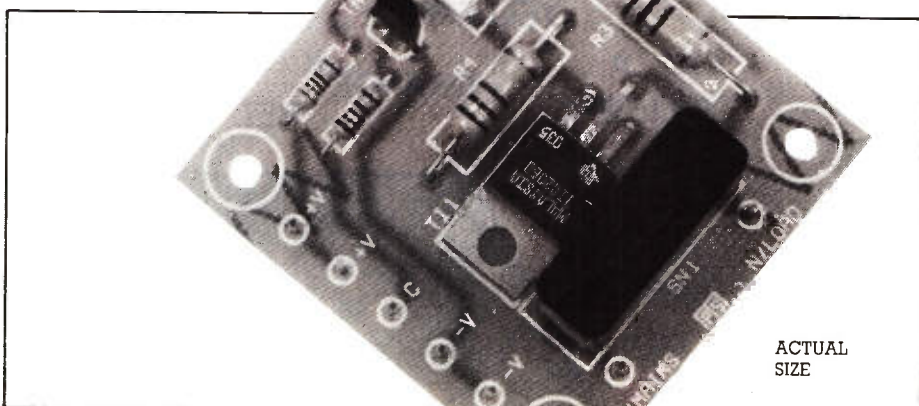

Figure 4d. Completed LED wiring.



The assembled Opto Switch.

Opto Switch

The previously described LED controller for the Christmas star is able to control up to four zero crossing, optoisolator switches, each of which can handle a 250 watt resistive load, with a triac package temperature of approximately 65°C. The triac used here *does not* have an insulated tab, so please *do not* try to verify the temperature with your finger as you will receive a nasty shock!

For safety reasons this project is not recommended for beginners.

Figure 5 shows the circuit diagram of the Opto Switch.

Construction

As mentioned before this is a simple project, but for safety reasons it is *not* recommended for beginners; not only does the mains supply bite – IT CAN KILL! If you have no practical building experience and you would like to build this project, then please study the Constructors' Guide supplied with this kit very carefully.

Referring to Figure 6 and the Parts List, begin construction with the resistors first. The pins are inserted from the track side of the PCB using a hot soldering iron. After the PCB is completed, it should then be cleaned using alcohol, Ultracene or PCB cleaner (Maplin stock codes YT66W and YJ45Y respectively).

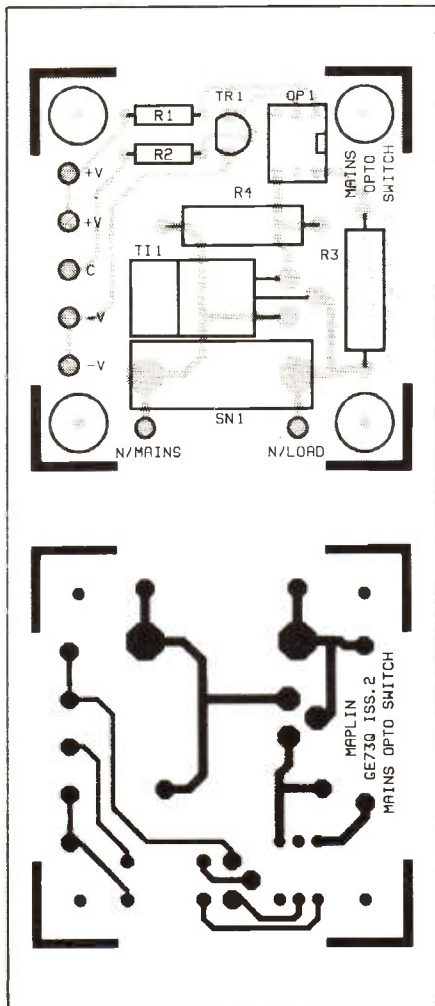

Figure 6. PCB legend and track.

Testing

Before testing can begin, the opto-switch must be safely housed in a non-conductive box; this will prevent possible injury to the user during testing and use. See Figure 7 for drilling details. The wiring of the optoswitch is shown in Figure 8, please follow the instructions carefully.

Having now fitted the project into a suitable box and completed the wiring, testing can now begin. You will need some kind of load, so dig out your fairy lights. Plug the lights into a 13A wall socket to check that they are working properly. Unplug the lights from the wall socket and

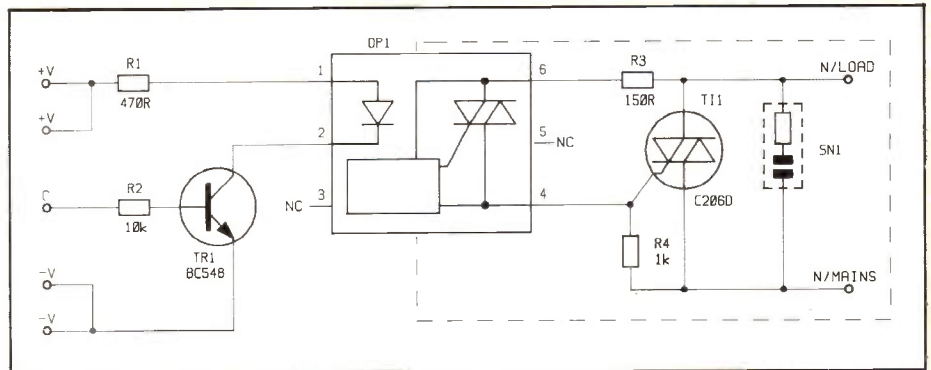

Figure 5. Circuit diagram of the Opto Switch.

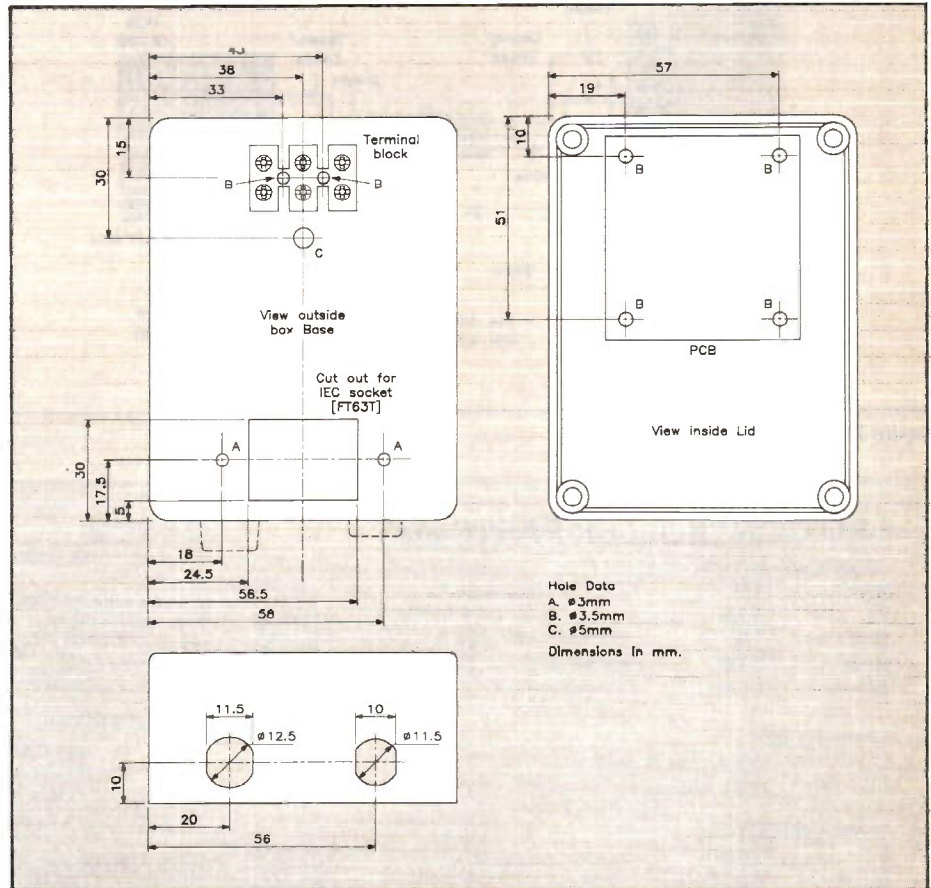

Figure 7. Box drilling details.

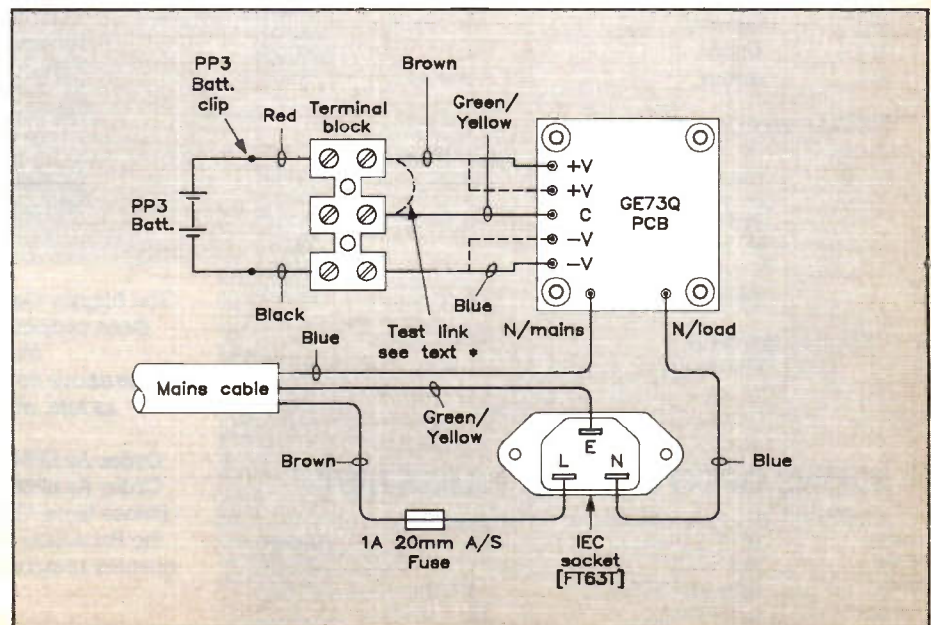

Figure 8. Wiring diagram.

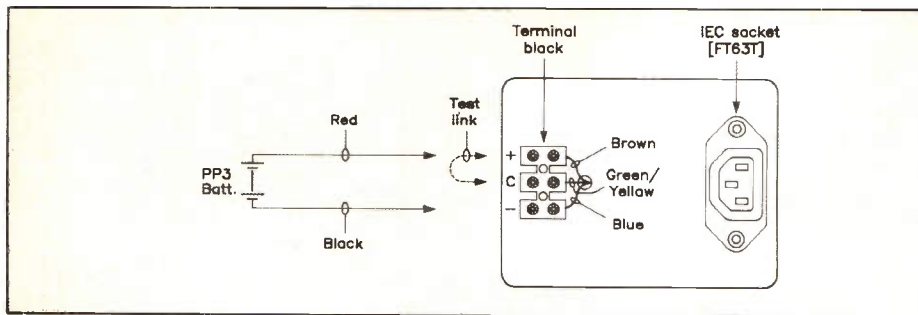

Figure 9. Box assembly.

change the plug if you wish to use the IEC type mains connector, and then plug the lights into the optoswitch's mains socket. Next, connect a 9V DC supply to the terminal block as shown in Figure 9, connect the optoswitch mains lead to a 13A wall socket and switch on. The lights should be off. To turn the lights on, connect a wire link from the battery positive to the control input C. The unit has now been tested and is ready for use. Figure 10 shows the interconnecting wiring between the two modules.

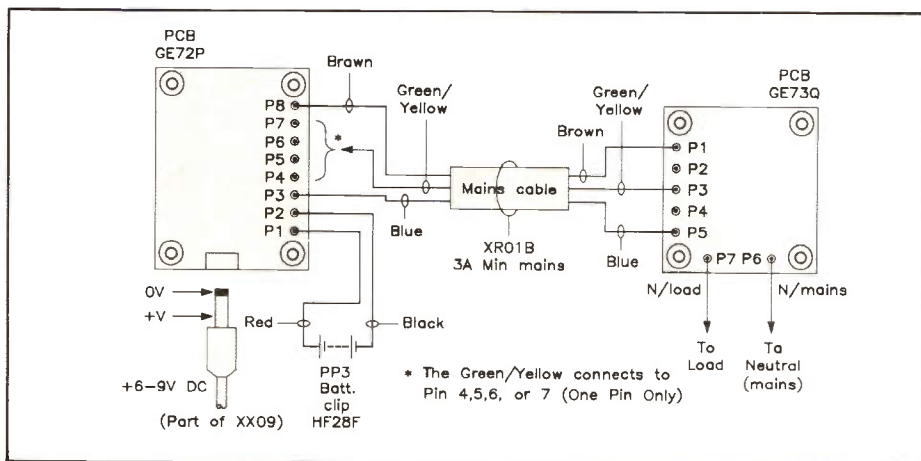

Figure 10. Interconnecting wiring.

Specification

Maximum voltage, control supply: 12V DC
 Maximum voltage, mains supply: 240V AC
 Maximum power rating: 250W Resistive

+V } Positive Supply
 +V }
 C } Control Input
 -V } Negative Supply
 -V }

Note +V and -V pins are duplicated to facilitate other opto switches being connected.

LED CONTROLLER PARTS LIST

RESISTORS: All 0.6W 1% Metal Film

R1	1M	1	(M1M)
R2	100k	1	(M100K)
R3-7	10k	5	(M10K)
R8-10	100Ω	3	(M100R)
R11	620Ω	1	(M620R)

CAPACITORS

C1	100μF 16V Minelect	1	(RA55K)
C2	68nF Monores	1	(RA48C)

SEMICONDUCTORS

D1	1N4001	1	(QL73Q)
LD1-6	LED Red	6	(WL27E)
LD7-12	LED Orange	6	(WL29G)
LD13-18	LED Yellow	6	(WL30H)
LD19	LED Green	1	(WL28F)
TR1	MPSA14	1	(QH60Q)
TR2-5	BC548	4	(QB73Q)
IC1	4060BE	1	(QW40T)

MISCELLANEOUS

P1-13	Pin 2145	1 Pkt	(FL24B)
	DIL Socket 16-Pin	1	(BL19V)
	PC Mtg Power Socket	1	(RK37S)
	PP3 Battery Clip	1	(HF28F)
	PC Board	1	(GE72P)
	Constructors' Guide	1	(XH79L)
	Instruction Leaflet	1	(XK37S)

OPTIONAL (not in kit)

PP6 Battery	1	(FM03D)
-------------	---	---------

CAPACITORS

SN1	R-C Contact Suppressor	1	(YR90X)
-----	------------------------	---	---------

SEMICONDUCTORS

TR1	BC548	1	(QB73Q)
OP1	Zero Crossing Optotriac	1	(RA56L)
TI1	C206D Triac	1	(WQ24B)

MISCELLANEOUS

P1-7	Pin 2145	1 Pkt	(FL24B)
	PC Board	1	(GE73Q)
	Constructors' Guide	1	(XH79L)
	Instruction Leaflet	1	(XK38R)

OPTIONAL (not in kit)

ABS Box MB2	1	(LH21X)
Euro Outlet Skt	1	(FT63T)
Euro Outlet Plug	1	(FT64U)
Terminal Block 2A	1	(FE78K)
Safuseholder 20	1	(RX96E)
Fuse A/S 1A	1	(WR19V)
SR Grommet SR2	1	(LR48C)
Min Mains Black	3 Mtr	(XR01B)
Isobolt M3 20mm	1 Pkt	(JD17T)
Isonut M3	1 Pkt	(BF58N)
Isoshake M3	1 Pkt	(BF44X)
M3 Insulated Spacer 10	1	(FS36P)

The Maplin 'Get-You-Working' Service is available for these projects, see Constructors' Guide or current Maplin Catalogue for details.

The above items (excluding Optional) are available as kits, which offer savings over buying the parts separately.

Order As LP54J (LED Christmas Star Kit) Price £6.25.
 Order As LP55K (Mains Opto Switch Kit) Price £7.95.
 Please Note: Where 'package' quantities are stated in the Parts Lists (e.g. packet, strip, reel, etc.) the exact quantity required to build the projects will be supplied in the kits.

MAINS OPTO SWITCH PARTS LIST

RESISTORS: All 0.6W 1% Metal Film (unless specified)

R1	470Ω	1	(M470R)
R2	10k	1	(M10K)
R3	150Ω 1W Carbon	1	(C150R)
R4	1k 1W Carbon	1	(C1K)

FOR BARGAINS AND MORE, VISIT YOUR LOCAL STORE.

For personal service, visit our shops at:

Birmingham Sutton New Road, Erdington.

Brighton 65 London Road.

Bristol 302 Gloucester Road.

Cardiff 29 City Road.

Glasgow 264-266 Great Western Road.

Leeds Carpet World Building, 3 Regent Street.

London 146-148 Burnt Oak Broadway, Edgware.

120-122 King Street, Hammersmith.

Manchester 8 Oxford Road.

Newcastle-upon-Tyne Unit 4, Allison Court,
The Metro Centre, Gateshead.

Nottingham 86-88 Lower Parliament Street.

Reading 129-131 Oxford Road.

Sheffield 413 Langsett Road, Hillsborough.

Southampton 46-48 Bevois Valley Road.

Southend-on-Sea 282-284 London Road, Westcliff.

Plus NEW stores in CHATHAM, LIVERPOOL and SOUTH LONDON.

Opening soon. Ring 0702 552911 for further details.

MAPLIN STORES NATIONWIDE.

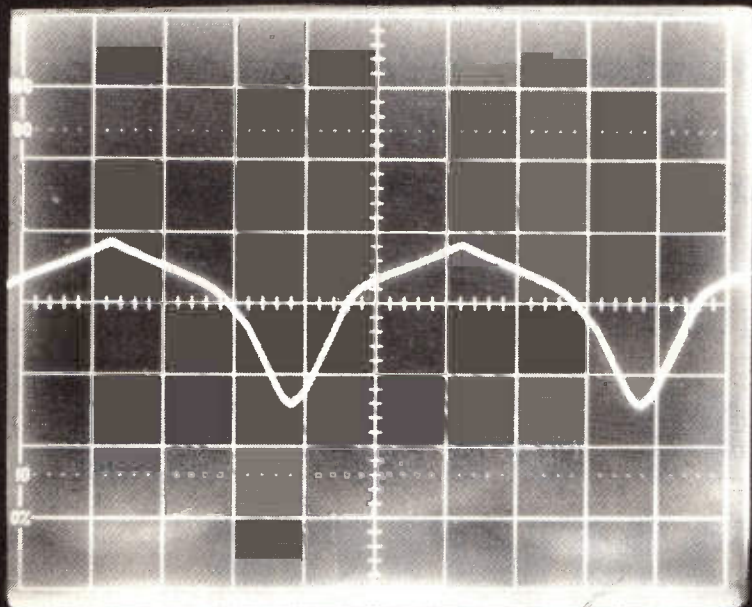
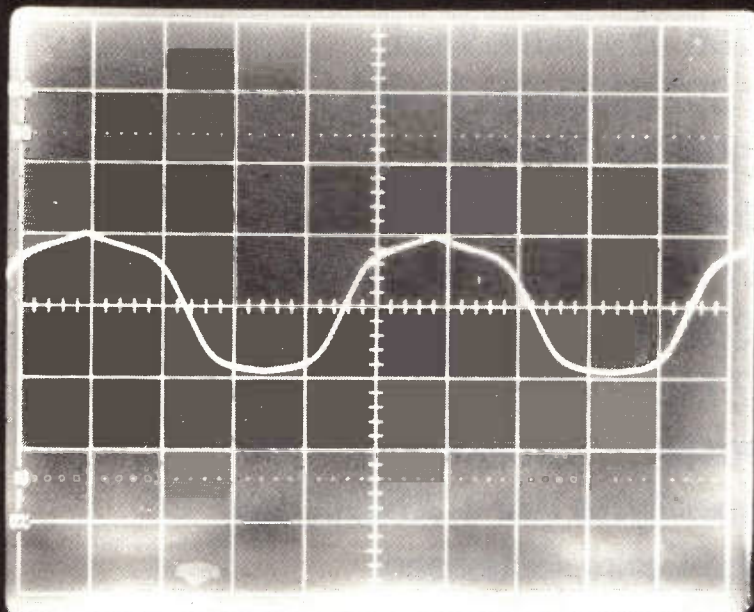
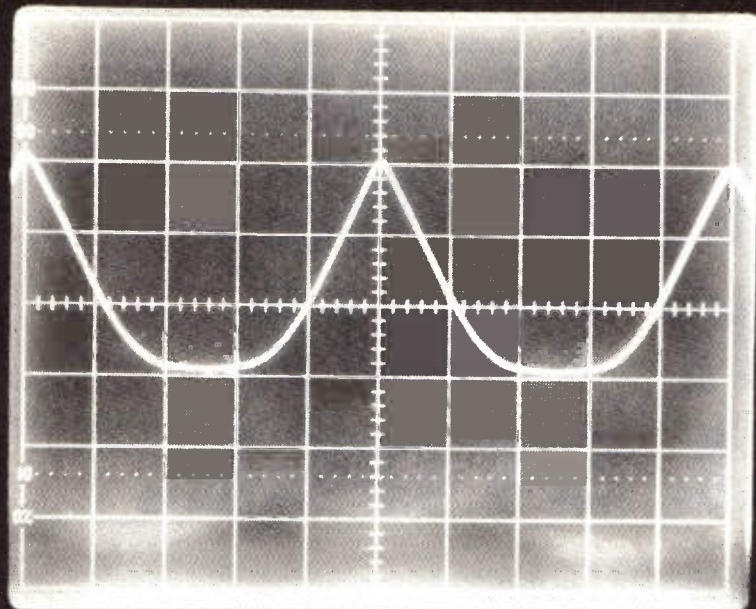

Photo 3. Incorrect sine wave.

Low Cost Waveform Generator
continued from page 31.

box, so that when the front panel is in place they are behind the push buttons and LED indicators. To prevent the batteries from moving around almost any type of non-conductive packing material can be used to restrain them.

Using the Generator

There are many uses to which an audio waveform generator can be applied. In educational establishments they are often used to demonstrate the fundamentals of AC electronic theory. At a more practical level they become vital when applied to testing and fault finding on home constructed projects, or ready built pieces of electronic equipment.

IMPORTANT! THE OUTPUT OF THE GENERATOR IS DC COUPLED. When connected to an established signal input there is unlikely to be any DC voltage present as AC coupling is normally provided within the equipment under test. However, if you intend to probe around inside circuits you *must* use a suitable DC blocking capacitor placed in series with the output of the generator. To ensure good low frequency coupling when injecting the signal in to an unknown, possibly low impedance circuit, it is normal practice to use a high value capacitor, typically 100µF or higher. In order to keep its physical size as small as possible a polarised electrolytic type is often used. To operate correctly you must ensure that it is placed the right way round and its voltage rating is high enough to accommodate the piece of equipment under test. Because the polarity and DC voltage level can change from circuit to circuit this component is normally kept as a temporary feature at the end of the test lead. However, if the type of circuits under test have a known maximum voltage and fixed polarity a suitable capacitor may be placed inside the generator, see Figure 5.

A simple audio output lead can be quickly put together by using a phono plug, a length of screened cable and two insulated crocodile clips. To prevent any loss of signal, or stray electrical noise pick up, this lead should be kept as short as possible, i.e., up to one metre for normal practical use.

The overall performance of the generator is governed by the state of its two PP6 batteries. As these run down the peak output level will drop and the frequency control range will change slightly. Assuming that you start with a good set of full capacity batteries you can expect several hours of continuous use before any appreciable sign of waveform deterioration occurs. When the batteries are exhausted it is strongly recommended that you remove them from the unit as any chemical leakage can result in permanent circuit damage.

AUDIO GENERATOR PARTS LIST

RESISTORS: All 0.6W 1% Metal film (Unless specified)

R1,3,4, 6,14,16	100k	6	(M100K)
R2,5,7,8, 9,10,15, 17,18,19,			
20	10k	11	(M10K)
R11,12,13,	4k7	9	(M4K7)
21,22,23, 24,32,33			
R29	2k2	1	(M2K2)
R25	1k8	1	(M1K8)
R26,34	15k	2	(M15K)
R27	47k	1	(M47K)
R28,35	1k	2	(M1K)
R30	100Ω	1	(M100R)
R31	27k	1	(M27K)
R36	470Ω	1	(M470R)
RV1	470Ω Horizontal Encl Preset	1	(UF99H)
RV2	4k7 Min Pot Lin	1	(JM70M)
RV3	22k Horizontal Encl Preset	1	(UH04E)
RV4,5	100k Horizontal Encl Preset	2	(UH06G)
RV6	100k Min Pot Lin	1	(JM74R)

CAPACITORS

C1,3	22μF 25V PC Elect	2	(FF06G)
C2,4,6,7,			
8,10,11	100nF 16V Minidisc	7	(YR75S)
C5,9	220μF 16V PC Elect	2	(FF13P)
C12	10μF 50V PC Elect	1	(FF04E)
C13	270nF Poly Layer	1	(WW46A)
C14	220nF Poly Layer	1	(WW45Y)
C15	47nF Poly Layer	1	(WW37S)
C16	4n7F Poly Layer	1	(WW26D)
C17	390pF 1% Polystyrene	1	(BX52G)

SEMICONDUCTORS

IC1,3	4017BE	2	(QX09K)
IC2	ULN2801A	1	(QY78K)
IC4	4081BE	1	(QW48C)
IC5,7	4066BE	2	(QX23A)
IC6	ICL8038CCPD	1	(YH38R)
IC8	LF351N	1	(WQ30H)
TR1	BC327	1	(QB66W)
D1,2,3,4, 5,6,7	1N4148	7	(QL80B)
LD1,2,3, 4,5,6,7	Red LED 5mm 2mA	7	(UK48C)

MISCELLANEOUS

S1,2	Click Switch	2	(FF87U)
	Click Cap Black	2	(FF88V)
SK1,2	Chassis Phono Skt	2	(YW06G)
	Knob K14A	2	(FK38R)
	DIL Socket 8-pin	1	(BL17T)
	DIL Socket 14-pin	4	(BL18U)
	DIL Socket 16-pin	2	(BL19V)
	DIL Socket 18-pin	1	(HQ76H)
	PP3 Clip	2	(HF28F)
	M3 Insulated Spacer 10mm	1 Pkt	(FS36P)
	PCB	1	(GE87U)
	Instruction Leaflet	1	(XT16S)
	Constructors' Guide	1	(XH79L)

OPTIONAL (Not in kit)

	Metal Panel Box M4005	1	(WY02C)
	PP6 9V Battery	2	(FM03D)
	Screw-Cap Phono Black	1	(HQ54J)
	Cable Single Black	1m	(XR12N)
	Red Croc Clip	1	(FM37S)
	Black Croc Clip	1	(FK34M)
	100μF 63V PC Elect	2	(FF12N)
	Front Panel	1	(KW56L)

The Maplin 'Get-You-Working' Service is available for this project, see Constructors' Guide or current Maplin Catalogue for details.

The above items (excluding Optional) are available as a kit, which offers a saving over buying the parts separately.

Order As LP01B (Low Cost Sig Gen Kit) Price £17.95

Please Note: where 'package' quantities are stated in the Parts List (e.g. packet, strip, reel, etc.) the exact quantity required to build the project will be supplied in the kit.

The following new item (which is included in the kit) is also available separately, but is not shown in the 1992 Maplin Catalogue.

Low Cost Sig Gen PCB Order As GE87U Price £4.95

The following new item (which is not included in the kit) is also available, but is not shown in the 1992 Maplin Catalogue.

Low Cost Sig Gen Panel Order As KW56L Price £3.95

CIRCUIT MAKER

Circuit Maker is a forum for readers' circuits, ideas and tips. The circuits and information presented here must be considered as a basis for your own experimentation, no warranty is given for suitability in particular applications, reliability or circuit operation. Maplin cannot support, in any way, the data presented here. However, where possible, we will check that information is correct, and that circuits will function as stated.

Ni-Cd Backed-Up Siren for Car Alarms by Andy Truscott

To increase the protection offered by a car alarm it is a good idea to install a battery backed-up siren; suitably placed in an inaccessible location. If a thief manages to locate and disconnect the main alarm control unit, this will be to no avail as the siren will function independently. The chances are that the thief will turn toll and run! To increase protection still

further, install two such sirens in different places.

The circuit has four modes of operation; standby, charging, sounding from external supply and sounding from internal supply. The keyswitch allows the siren to be turned off for installation, etc.

- 1) When the ignition is switched off (assuming Ni-Cd battery pack already charged) and the input is held low (resistance between input and 0V in the range 0Ω to 4k7) and the MPSA14 biased off, the TIP127 is also biased off and the siren is quiet.

- 2) When the ignition is switched on, the constant current circuit formed by the BC212 and associated components charges the Ni-Cd battery pack via the 1N4148 diode.
- 3) When an external supply (+12V) is applied to the input, both the MPSA14 and TIP127 are biased on and the siren is powered by the input voltage.
- 4) If the input lead to the circuit is cut, (resistance between input and 0V > 220kΩ) both the MPSA14 and the TIP127 are biased on and siren is powered by the Ni-Cd pack.

The charging current for the battery pack is set by the 68Ω resistor, this value suited my Ni-Cd battery pack (8.4V Ni-Cd PP3), but this value may need to be altered depending on what charging current is required. This is most easily achieved by inserting an ammeter in series with the Ni-Cd battery pack and selecting a value of resistor that gives the required charging current.

RESISTORS: All 0.6W 1% Metal Film		
68Ω	1	M68R
1k	1	M1K
6k8	1	M6K8
100k	1	M100K
220k	2	M220K

SEMICONDUCTORS

1N4148	3	QL80B
1N5400	2	QL81C
BC212	1	QB60Q
MPSA14	1	QH60Q
TIP127	1	WQ74R

MISCELLANEOUS

Ni-Cd PP3	1	HW31J
PP3 Clip	1	HF28F
Electronic Sounder	1	YZ03D
Min Key Switch	1	FE44X

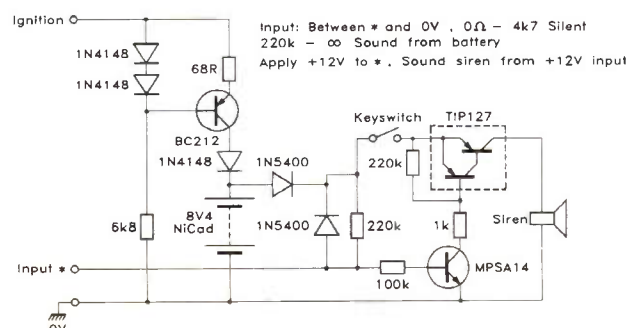

There is one venue in town where nostalgia reigns OK. Where else can you see grown men with tears in their eyes as they lovingly fondle a 1950's trolley bus or gaze rapturously at the sleek lines of a Hansom-cab, last seen plying the streets of London in the last century.

Certainly, the London Transport Museum is all things to all men, and for that matter, women and children too. The museum exists to preserve and display London Transport's historical collections, and to promote interest in the development of London's public transport systems. London has seen many changes in public transport over the years, not all of them, as our nostalgic friends would readily agree, for the better. The horse-drawn Hansom-cab; the tram; the omnibus; the trolley bus; the tube and the Docklands light railway.

London Transport has earned an excellent reputation for its promotion of the arts, and the Museum venture reflects an awareness of the need to preserve the history of transport in London. In fact, a visit to the Museum provides a first class insight into the social and political history and geography of London, coupled with the development and introduction of technology. Such technology made it possible to move people out to the purpose built suburbs such as leafy Golders Green, and beyond. Incredible as it may seem, one hundred years ago, it took longer to get across London than it does now.

As the Museum guide points out, "the foundation of the display is a collection of historic vehicles built up by London Regional Transport and its predecessors since the late 1920s". Although the most eye-catching items in the Museum are the early locomotives and buses, the aim is to demonstrate that there is more to public transport than just the vehicles. It involves large numbers of people, working and planning, to serve the needs of others. It influences, and is influenced by, the economic geography of the city it serves.

Main pic: The London Transport Museum exists to preserve and display London Transport's historical collections and to promote interest in the development of London's public transport systems.

Right: A 12ft. diameter section of 'tube' tunnel demonstrates the Underground's signalling and safety systems.

Below: Digging a tunnel the hard way!

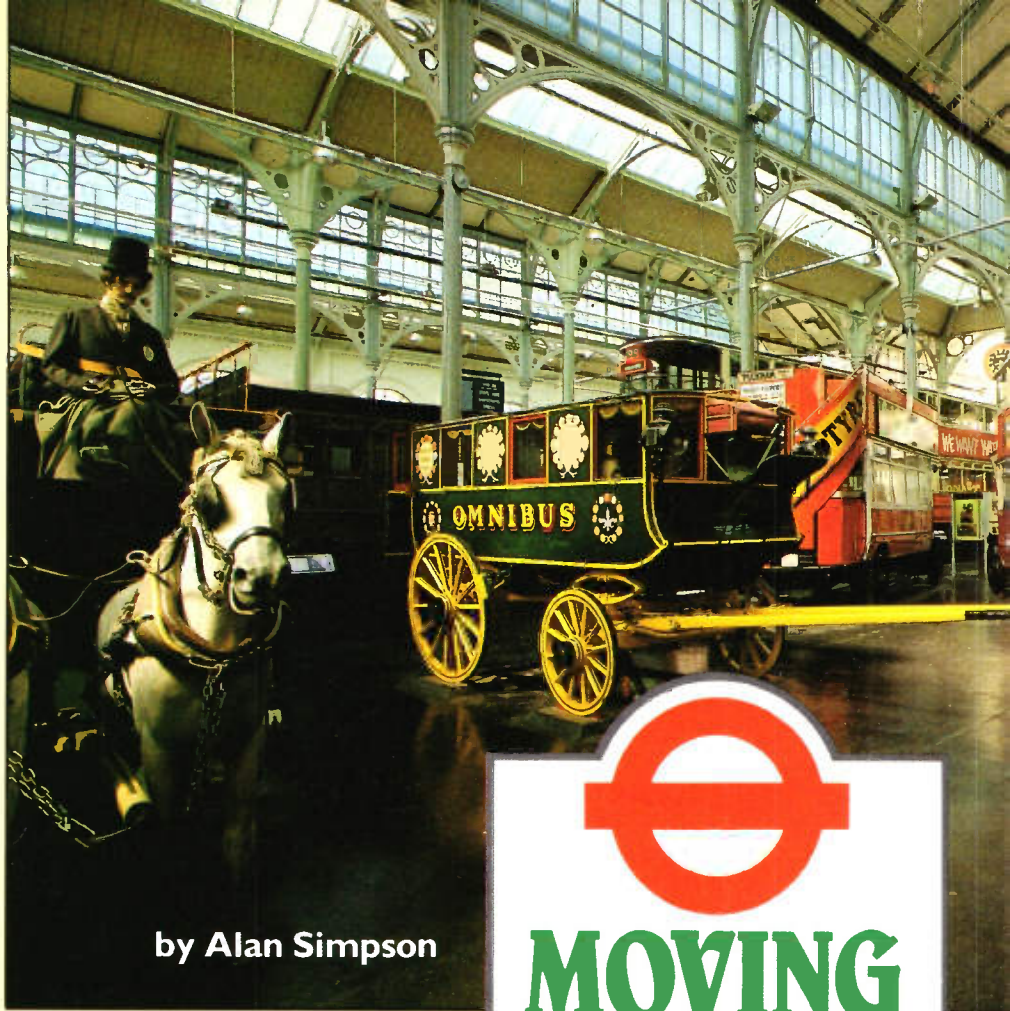

by Alan Simpson

The Museum is housed in the former flower market in the centre of Covent Garden. The beautiful Victorian building, where once London's most famous flower seller, Eliza Doolittle, bought her wares, is now the setting for one of London's more unusual venues. When the building became available some twelve years ago, an enlightened GLC, who did not want to see the area turned into more shops and offices, offered the site to organisations who could best make use of the facilities.

A graphic featuring the London Transport roundel logo (a red circle with a white horizontal bar) at the top. Below it, the words 'MOVING WITH THE TIMES' are written in large, bold, green capital letters. At the bottom of the graphic is a yellow vintage London Transport ticket with various station names and numbers.





OUT AND ABOUT



In fact the building, which is a fine example of Victorian industrial architecture, with cast iron columns and a glazed roof somewhat reminiscent of the great nineteenth century railway stations, made an appropriate setting for a museum of transport. Following two years of conversion and restoration, Princess Anne opened the Museum in March 1980. Last year the Museum attracted some 180,000 paying visitors – 200,000+ if you include children under five and the disabled who are allowed in free.

Interestingly, nearly half of the visitors come from overseas, with only 25% coming from London. Unlike many national museums, visitors tend to come in family-sized groups. Children are particularly well looked after. The Museum has a full-time teacher whose role is to cater for pupils from five to 'A' level.

Getting in Gear

As the official brochure puts it, until the nineteenth century, the River Thames was London's main traffic artery. The first public transport was provided by watermen using small rowing boats. On land it was usually easier to walk than ride in the narrow uneven streets, and the first vehicles for public hire were not introduced until about 1620. By

1805 the number of licensed 'hackneys' in London had risen to over one thousand. For anyone wanting to travel to an outlying village, such as Hammersmith, they would have to take a stage-coach.

1829 saw the first omnibus service in London, running from Paddington to the Bank. 1910, the first reliable, mass-produced motor bus. However, travelling for bus passengers took a considerable turn for the better, when in 1925 the first covered top decks and pneumatic tyres were introduced. The Museum has one original Victorian horse bus on display from the 1870s, as well as an early replica of an 1829 bus made for the 1929 Centenary Exhibition.



Above: A 1938 'tube car', it remained in service on the Northern Line until 1978.

Left: Metropolitan Railway 'A' Class locomotive No. 23, built in 1866 by Beyer, Peacock and Company of Manchester.

Right: One of two Edwardian electric trams exhibited at the museum.

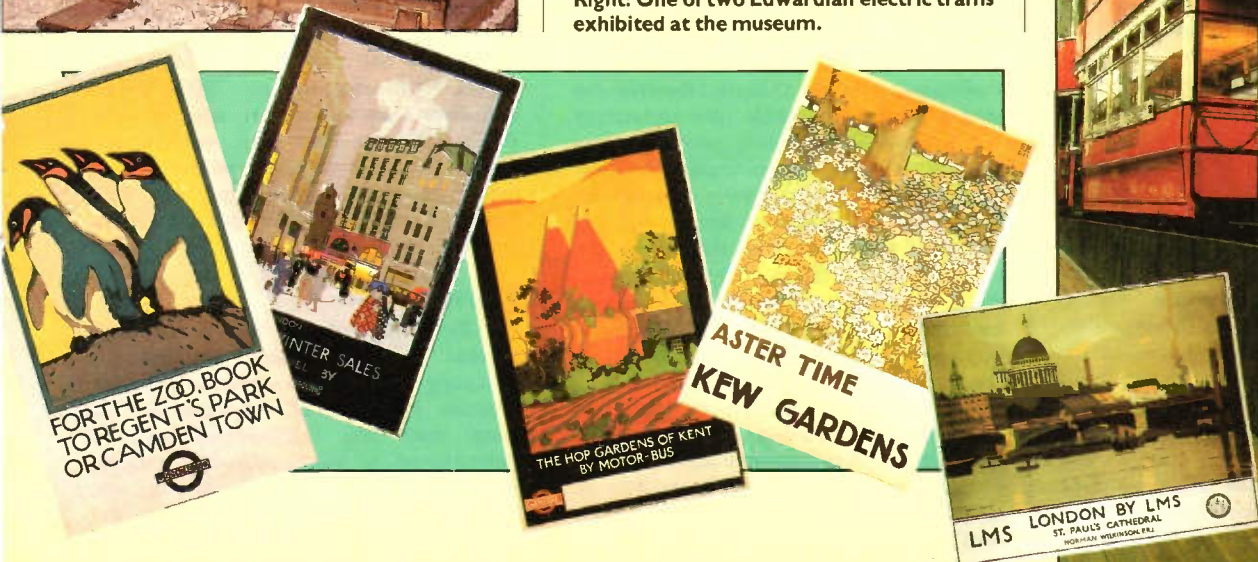



Left: Rapid evolution in the 1920's. 'K' type bus (right), built in 1920, has an open top and cab, and solid tyres. 'NS' type bus (left), built in 1927, has an enclosed top deck and cab, and pneumatic tyres.

Below left: London Transport bus conductor's cap and cash bag with Bell Punch and ticket rack.

Below centre: A computer simulator allows visitors to drive an underground train.

Below: A young visitor at the steering wheel of a 1974 Fleetline bus.



On the Buses

The earliest motor bus on show, which dates from 1910, still resembled a horse drawn vehicle. It wasn't until the 1920s that buses lost their horse-drawn origins. Other models include the much loved Routemaster and RT buses, together with a collection of Green Line vehicles.

1910 is also the date of the Museum's two older trams. The first successful horse tram services opened in 1870, with the first electric tram service coming into operation at the turn of the century. Trams finally gave way to trolley buses in 1952 which in turn were withdrawn in 1962, having been operational since the 1930s. It is here, in particular, that those misty eyed tears can be seen.

Mind the Doors

Without doubt, one of the highlights of the current exhibition is the 'celebration of the centenary of underground electric railways'. Although the first urban underground railway in the world opened for business, between Paddington and Farringdon, in 1863, the world's first deep level electric underground railway opened in the City in 1890.

The centenary, whose sponsors include Otis Elevator, BREL and London Underground Ltd., reveals how the design of

underground railways, (colloquially known by many Londoners as 'The Tube'), have developed over the years. The original steam-train based stock was similar in size and layout to the overground suburban steam trains of the main line railways. However, the tube introduced a totally new technology with purpose-built rolling stock. Among exhibits on show is an example of an early 'padded cell' car which, having no windows, needed a travelling gateman to not only open the metal lattice gates on the end of the platforms, but to call out the station names. Although today's crowded underground carriages have windows, there is little opportunity for passengers to look out of them; or come to that, accommodate a travelling gateman. Visitors to the Tube Centenary enter through a replica of the original entrance to Stockwell station in South East London. Looking to the future, visitors can preview one of the new trains destined for the Central Line.

DIY Exhibition

In no way can the Museum be described as a passive event. Visitors are encouraged to climb into drivers' cabs, ride in lifts (a real lift with noise and movement simulated), drive trains, design tunnelling projects, work signals and conduct basic steam experiments. As the Museum communication manager, Rob Lansdown says, "we have lots of low and high technology on show." At the low technology end is the original Westinghouse braking control and early signalling procedures, including a 'quite remarkable' 4-bit binary train describer storage system, dated circa 1906 which served up to 32 locations.

Stand alone computers drive many exhibits, backed by linear audio tape or continuous loop video tape for sound. Rob is not hung up on any particular brand of computer – cost and flexibility are the key factors. A Commodore Amiga 2000 provides a hands-on train driving experience, while an Apple computer links to a touch screen display. Just about the only problem spot is a model railway. "In the summer, the heat causes the tracks to expand – just like the real thing".

New Look

By the end of next year, a new look London Transport Museum will emerge, enhancing the quality and scope of the present Museum. Much use of interactive displays using laser disk technologies will be incorporated, as will improved educational facilities. Hypertext technologies have not been ruled out. As Rob comments, the principle will be that of following an

environmental thread. The exhibits will stand still – it will be the visitor who will have to work. Also planned is a central computer/communications control room linked, by a cable network, to the rest of the museum's hardware.

The term 'experience' is one much favoured by museum authorities. But in the case of The London Transport event, it is totally justified. If only to see how much bus design standards have declined since the demise of the Routemaster. The Museum also has a veritable Aladdin's Cave shop. Whether it is a copy of a famous London Transport poster, underground map mugs, transport magazines and books, there is something for everybody. Even a Routemaster model bus.

The London Transport Museum, The Piazza, Covent Garden. The nearest underground stations are Covent Garden and Leicester Square. The Museum is open 10 a.m. to 6 p.m., seven days a week.

Admission: Adults £3; Children, OAPs, UB40s, Students £1.50; Under Fives and Disabled FREE.

For further details, Tel: 071-379-6344.



Hold Very Tight! We have no less than six sets of family tickets to give away to the first all correct answers drawn from the famed hat of our editor. Each family ticket admits 2 children and 2 adults – worth £7. The four questions listed are taken from the publication 'London Breaks' – the Official London Transport Guide to enjoying a short stay in London. Please note that multiple entries will be excluded from the draw. Answers on a post card (or a sealed-down envelope) to: The London Transport Museum Competition, 'Electronics – The Maplin Magazine' P.O. Box 3, Rayleigh, Essex, SS6 8LR. Closing date for entries 31st December 1991.

1. Where would you find a befeater?

- a) The Hard Rock Cafe
- b) Smithfield Market
- c) Tower of London

2. What is Rotten Row famous for?

- a) The London Dental Hospital
- b) Horse Riding in Hyde Park
- c) The Serpentine

3. Where did the nightingale sing?

- a) Berkeley Square
- b) London Zoo
- c) Royal Albert Hall

4. The Duke of Wellington belonged to which club?

- a) Royal Automobile Club
- b) The National Film Theatre
- c) The Athenaeum

Stray Signals

by Point Contact

I read the other day that at one American University, the electronics degree course is taught in a Department where there is no laboratory for students to carry out practical experiments. This astounded Point Contact, since there were certainly labs (in those days when he was a freshman) with valve circuits. Though as most of the 'experiments' were set up beforehand by lab stewards, for the benefit of a group of students, they were only 'practical' in a limited sense: one was unlikely to come across the baffling snags that are the common lot of the development engineer in all areas of electronics. In the interests of safety, this was just as well in some cases, for in those far-off days most first-year engineering students followed a common course. So that besides playing about with valve circuits, Point Contact and his peers measured flow of water over a VEE notch weir (d'Arcy's formula, I think), the Euler buckling load of a pin-jointed strut, the efficiency of a compound steam engine etc., etc. (In the mechanical engineering lab, holding down the hit-and-miss governor of the gas engine, so that its RPM built up way beyond rated speed, was sure to bring down the wrath of the chief lab steward, who would explain with gory relish, the possible havoc that could be wreaked by an 8-foot diameter cast iron flywheel disintegrating under excess centrifugal force.)

But to return to the American institution mentioned, the argument runs something like this: why bother to mess about with bits and pieces of hardware that can get lost or broken, or fail to work properly due to some trivial cause totally unrelated to the intended operation of the circuit under investigation (like a dry joint?), when the whole learning experience can be more conveniently and expeditiously carried out using a CAD (computer aided design) circuit simulation package such as SPICE, running on a personal computer? You just input the circuit diagram using the keyboard or mouse, complete with the component values of all the resistors and capacitors, etc. And for transistors, Op-amps and the like, just tell the computer the type number; the simulation program's component library contains the relevant parameters, such as current gain, internal collector/base capacitance and so on, for all the common types. Then you just run the desired analysis

routine, for DC, AC or transient performance, and in the twinkling of an eye there are the results, and Bob's your uncle: now you know just how that circuit will work. Needless to say, this does involve an element of simplification; the circuit that the computer analyses is solely that which you have told it about, with no stray inductance due to wiring, or unintentional stray capacitive coupling due to proximity of components. Of course if you knew what these were likely to be in a real circuit, you could include them in your circuit description, but in practice you don't know, any more than you would in real life. So they are left out of account, and probably the lecturers didn't even mention them anyway. Consequently, new graduates often arrive in industry only to find themselves stumped, when the very first circuit they design doesn't work in practice, even though their CAD package assured them it was fine.

CAD packages are among the most useful and clever programs devised but, like a sharp knife, they need to be handled with care. They will usually give the right answer to the problem as set them, though not always. For their circuit analysis is carried out by numerical methods which converge on the solution by a process of iteration. Sometimes the convergence is slow, taking thousands of iterations to converge, leaving you drumming your nails on the table whilst gazing at a blinking cursor in the meantime. Sometimes, the circuit network is not capable of solution by the methods used by the program, which just fails to converge. The result is that you have no information whatsoever, as to what the simulated circuit would in fact do, if made up for real. But real circuits are not like that, they will always do something, even if it is the last thing in this world that you expected. They will, with luck, just sit there good as gold waiting to amplify any signal you care to apply, or they will oscillate, or squegg, or sulkily and stubbornly sit there bottomed or completely cut-off, but they will never deny you the knowledge of what they intend to do. Contrast this with the educational establishment mentioned earlier, where apparently the Professor actually accepted 'failed to converge' as the right answer to a problem!

Yours sincerely,

Point Contact

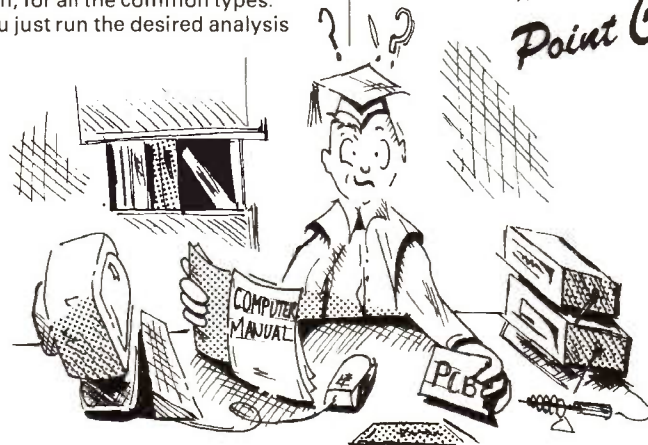

Mains-Operated Linear DC

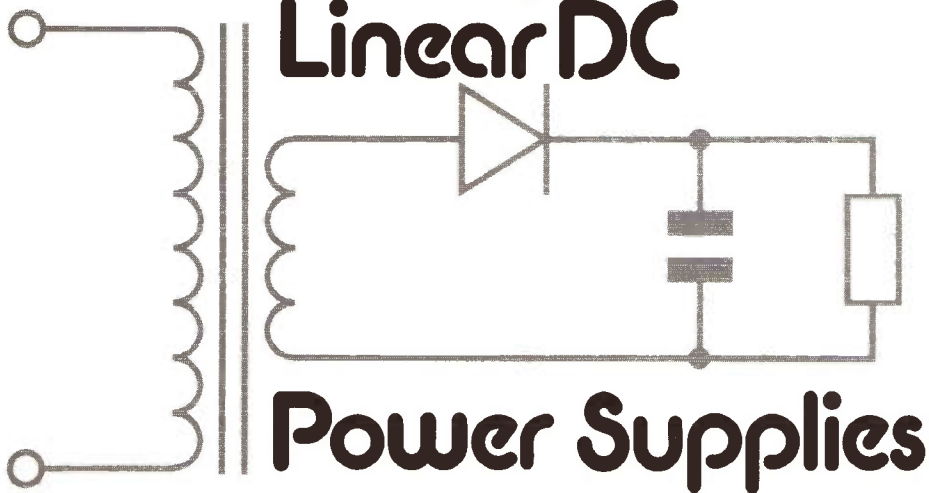

Part One – THE BASICS

by **J.M. Woodgate** B.Sc.(Eng.), C.Eng.,
M.I.E.E., M.A.E.S., F.Inst.S.C.E.

Fairy Tale

Poor Joe Bloggs is in deep trouble. His latest electronic brainchild worked OK on the bench, but it needs three DC power rails, +24V at 1A, -5V at 0.5A and +40V at 100mA. (It's a Tuesday detector for a time-travel machine.) Now he's trying to run it from the mains, using three mains transformers which cost more than he had hoped for, and everything is going wrong:

- the 1A fuse in the 24V supply sometimes blows for no apparent reason.
- the circuit fed from the -5V supply crashes in the evenings but not during the day.
- the +40V supply turned out to produce +50V, so he had to find room for an extra resistor and an electrolytic capacitor to decouple it. Now the transformer is getting too hot.
- Joe is worried that there is no fuse in the mains circuit, but he has no idea what value it should be. He is depending on the 3A fuse in the mains plug, but realises that 3A at 240V means that 720W could be going in, and even more current would be needed to blow the fuse, while the output is only $24 + 2.5 + 4 = 30.5W$. He tried a 150mA fuse ($240 \times 0.15 = 36W$), but that failed immediately, so he is keeping on the right side of the local Fire Brigade. Luckily, the Good Fairy Sunbeam is on hand to explain all the problems, get rid of two of the mains transformers (for full credit - well, this is a fairy tale!) and make everything work properly.

By special arrangement, the GFS has kindly agreed to the publication of these articles. In this one and the next, we look at the basic rectifier circuits, and some of the design methods that have been published previously, while Part 3 will include a quite comprehensive CAD program, written in BASIC and short enough to type in, which has been found to give accurate results in

practice. This program includes the calculation, by iteration, of important values during the switch-on period which would be immensely difficult to derive by other methods.

Rectifier Circuits

We shall mainly be considering rectifiers fed from a double-wound mains isolating transformer, but no doubt some remarks about direct on-line and capacitor-fed rectifiers will appear. BOTH OF THESE LATTER ARRANGEMENTS INVOLVE GREAT RISKS OF SERIOUS ELECTRIC SHOCK HAZARD AND SHOULD ONLY BE USED WITH FULL KNOWLEDGE AND APPLICATION OF THE NECESSARY SAFETY MEASURES!

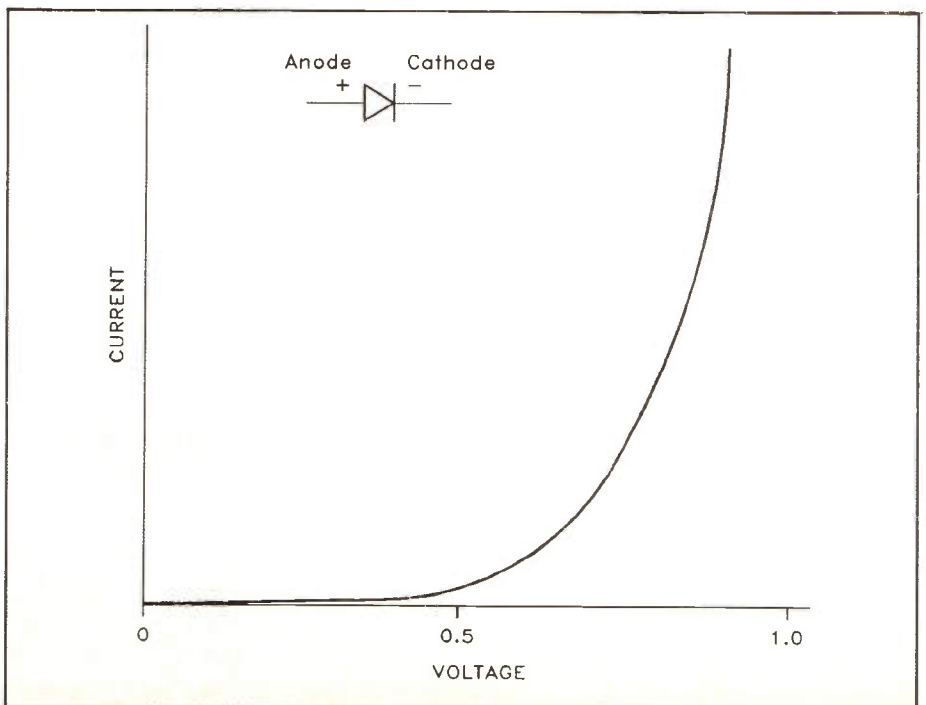

Figure 1. Forward current/forward voltage characteristic of a typical silicon diode.

All our circuits are going to use silicon diode rectifiers, so we should look first at the basic current/voltage characteristic of a typical diode, shown in Figure 1. We can see that the diode conducts freely when the anode is positive with respect to the cathode by more than a small voltage - the 'turn-on' voltage. This voltage is not well-defined; as we consider smaller and smaller currents, the apparent turn-on voltage just continues to fall. We can assume, however, that the turn-on voltage is that voltage which produces one tenth of the maximum current that occurs in the circuit, and for most ordinary diodes this is about 600mV at room temperature, but drops by about 2.5mV for every kelvin ('degree Celsius') that the diode junction temperature is above room temperature. This effect is quite significant; many rectifier diodes are rated at a maximum junction temperature of 175°C, at which the turn-on voltage is only 163mV, and even when operated well within ratings, at a junction temperature of 75°C, the turn-on voltage is only 413mV. Schottky diodes have a lower turn-on voltage of about 400mV at room temperature, and are therefore useful in low-voltage, high-current supplies, but are more expensive. Germanium power diodes are even better, with a turn-on voltage of about 200mV at room temperature and a maximum junction temperature around 90°C, but they are not easily obtainable. Beyond the turn-on voltage, the diode acts approximately as a low-value resistor. In order to minimise heating, rectifier diode resistance is made as low as possible, and is typically less than 0.3Ω.

The Half-Wave Rectifier

Figure 2a is a half-wave rectifier, which is the simplest to describe. The transformer produces an alternating voltage, so that the diode anode is made alternately positive and negative with respect to the cathode. However, current can only flow through the diode when the anode is positive with respect to the cathode, so that the other half-cycle makes

no contribution to the output – hence ‘half-wave’. The circuit shows a capacitor across the load resistor, since this is the usual arrangement. Without it, the waveform of the voltage across the load would look like Figure 2b, half sine wave pulses with gaps. While this waveform has a DC component (it never goes negative), it also has a strong AC component, which can be resolved into components at the mains frequency (50Hz in Europe) and its harmonics (100Hz, 150Hz, etc.). The action of the capacitor is shown in Figure 2c: it smooths out the voltage pulses by supplying current from its stored charge when there is none coming from the diode. While it is discharging, during time t_d , the voltage across it must fall a bit (V_r), and to ensure that it is not too big a bit, the product of the capacitor value and that of the load resistance – the load time constant

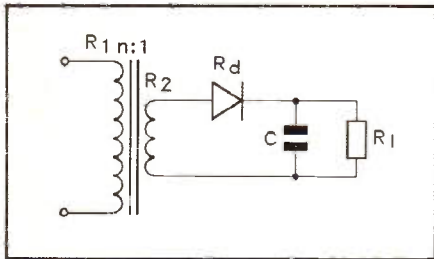

Figure 2a. Half-wave rectifier circuit.

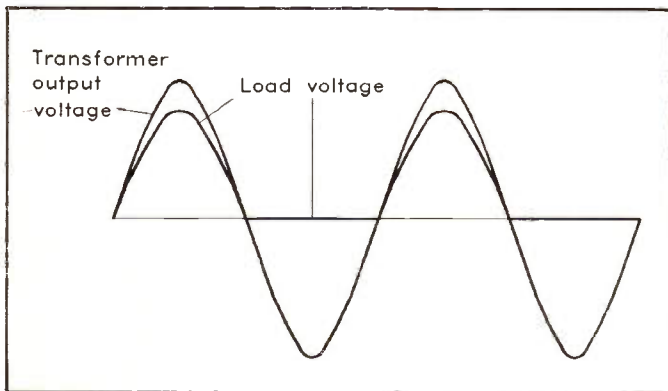

Figure 2b. Half-wave rectifier with no reservoir capacitor: resistive load.

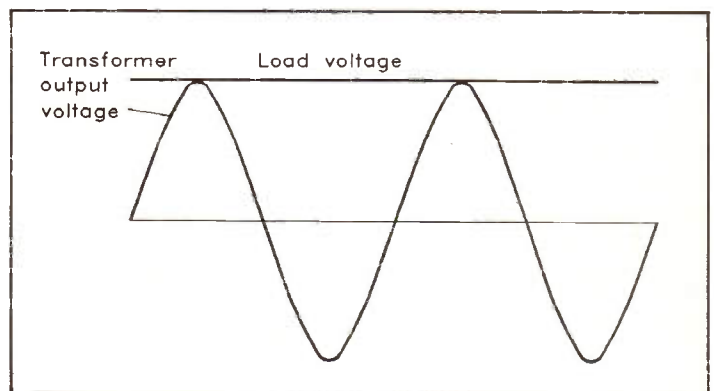

Figure 2c. Half-wave rectifier with reservoir capacitor: no load.

– must be much longer than the time for one cycle of the supply voltage, which is 20ms for 50Hz mains. For example, if the load is 24Ω and the time-constant is to be 100ms, the capacitor value must be $0.1 \div 24 = 0.004167\text{F} \approx 4200\mu\text{F}$, which would be more sensibly written as 4.2mF (millifarad), if people would only stop writing ‘mF’ when they mean ‘μF’. Since the capacitor acts as a ‘reservoir’ of electric charge, and filters out most of the AC component of the load voltage, it is called a ‘reservoir capacitor’ and the circuit a ‘capacitor input filter’. The residual AC component (V_r) of load voltage is called ‘ripple’, and we shall see that the amount of ripple we can accept determines the value of the reservoir capacitor.

Analysis

When we look more deeply into what is happening in this circuit, we find that, if the load resistance is very high, the capacitor charges up, within a few cycles of the input voltage, to the peak voltage of the supply, and the diode current then falls to a very low value, just enough to compensate for any leakage in the capacitor and supply

the very small load current (Figure 2c). If the load resistance is lower, however, the diode current has to recharge the capacitor in the time periods t_c when the diode anode voltage exceeds the capacitor voltage by more than the diode turn-on voltage (Figure 2d). Normally, we want the voltage across the capacitor to vary very little, i.e. the ripple V_r to be small. This means, as we saw above, that the capacitor value has to be large, and this means a large charging current. In fact, the charging current is only limited by R_t , the effective resistance of the secondary winding of the transformer, R_d the resistance of the diode and R_c the effective series resistance of the capacitor.

We can calculate R_t from measurements of the winding resistances R_1 and R_2 (DC measurements are valid), and the transformer turns ratio n , which is equal to the ratio of no-load output and input voltages:

$$R_t = R_2 + n^2 \times R_1$$

R_t is often much larger than R_d and R_c , which can thus be neglected, otherwise we can find values for them in the specifications of the components. Normally, we would like R_s to be very much smaller than R_t , because it represents a loss of efficiency, and if the load current varies (e.g. if the load is an audio final amplifier), R_s causes the

appears it might be. We have a sine wave input voltage to the diode, which has a non-linear current/voltage curve, charging a capacitor through a resistor, which implies an exponential current/time curve, while the capacitor is being discharged by another resistor, giving another exponential curve in the opposite direction. Luckily, provided the capacitor value is large, so that the ripple voltage is small (again), the charging current waveform turns out to be very nearly half a sine wave, of frequency $1 \div (2 \times t_c)$, which is higher than the mains frequency, of course. This is a big piece of luck, because we can fairly easily calculate the average and rms values etc. of half sine waves, if we know only the peak value i_{pk} and the time for the half-cycle, i.e. t_c .

Diode Currents

The calculation of the average and r.m.s. values of the diode current involves integration. For those readers who are perhaps just being introduced to calculus, a practical application will be interesting. Those made nervous by calculus need only take note of the results. The calculations of both the average current and the r.m.s. (root mean square) current involve an averaging operation, and we must be careful about the time interval over which we do the averaging. For the half-wave

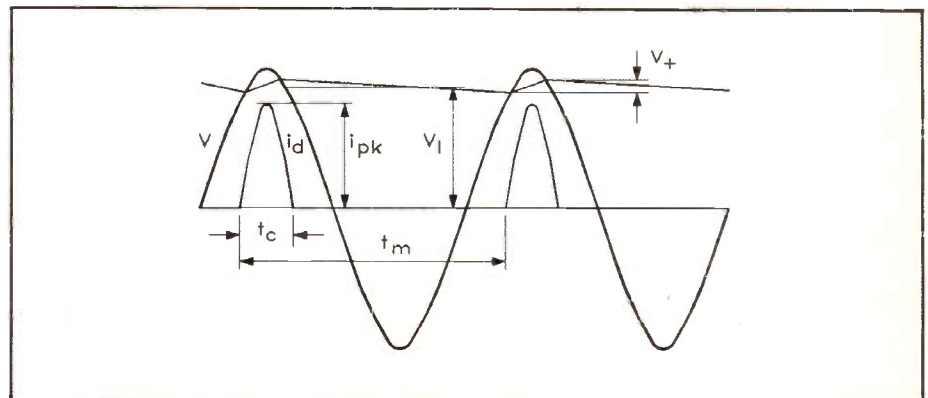

Figure 2d. Half-wave rectifier with reservoir capacitor: resistive load.

supply voltage to vary with the current demand, i.e. the power supply has poor regulation if R_s is not small. Clearly, a very small R_s implies a very large peak diode current i_{pk} and therefore a very short charging time t_c .

Piece of Luck

These calculations wouldn’t be of much use if the waveform of the charging current was as difficult to deal with as it

rectifier, the waveforms repeat after a full cycle of the mains supply, so this is the interval over which we need to find the averages. This analysis follows that of K. L. Smith in Reference 1.

The average current I_{dav} ($= I_1$ if the capacitor leakage current is negligible) is given by the area under the current curve, divided by the ‘length’ t_m of the base. During the time interval t_c , we have a half sine wave, while during the interval t_d we

have no current through the diode. See Formulae 1.

The r.m.s. current I_d is given by the square root of the result of dividing the area under the curve of the current by the 'length' t_m of the base. See Formulae 2.

Since $I_1 (= I_{dav})$ is usually one of the things we know at the beginning of the design process, it is useful to express I_d and i_{pk} in terms of I_1 :

$$i_{pk} = I_1 \times (\pi \times t_m \div (2 \times t_c))$$

$$I_d = I_1 \times (\pi \div 2) \times \sqrt{(t_m \div (2 \times t_c))}$$

Both the peak diode current and the r.m.s. current are much larger than the DC load current. For practical half-wave circuits, t_c is between $t_m \div 8$ and $t_m \div 4$: taking $t_c = t_m \div 6$ gives:

$$i_{pk} = I_1 \times 3 \times \pi = I_1 \times 9.4$$

$$I_d = I_1 \times \sqrt{3} \times \pi \div 2 = I_1 \times 2.72$$

The DC load current flows through the transformer secondary winding, producing DC flux in the core which increases core losses and is likely to cause audible hum from the transformer.

Circuit Voltages

Referring to Figure 2d, the transformer secondary instantaneous source voltage (strictly, the e.m.f.) is:

$$v = V_{pk} \times \cos(2 \times \pi \times t \div t_m)$$

'cos' rather than 'sin' because the zero point of the time axis is at the peak of the

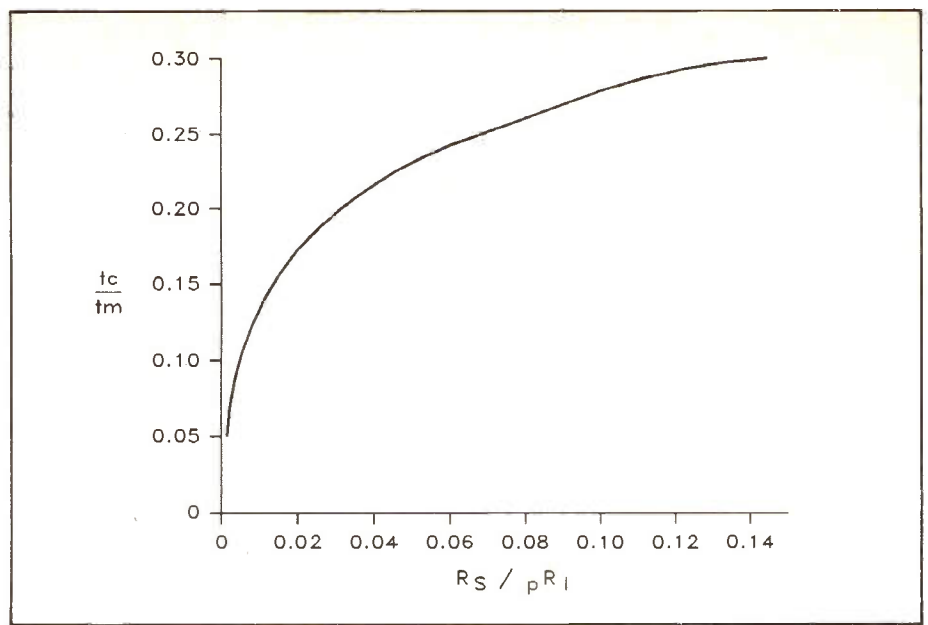

Figure 3. Graph of conduction time/supply period as a function of charging/load resistance.

waveform. The DC output voltage V_1 is the average voltage during the time t_d , which can be seen from the diagram to be:

$$V_1 = V_{pk} \times \cos(\pi \times t_c \div t_m)$$

Note that, for most practical values of $t_c \div t_m$, V_1 is less than the peak voltage V_{pk} , and may even be more than the rms voltage $V_s = V_{pk} \div \sqrt{2}$. If there is no load current, $V_1 = V_{pk}$.

We can express I_{dav} as the average over the time interval t_c of the current driven by

the voltage $(v - V_1)$ through the resistance R . See Formulae 3.

This, although an equation which can only, in general, be solved numerically, enables t_c to be calculated simply from resistance values, and hence the rms diode current I_d and the peak current i_{pk} can be found, for comparison with the diode data sheets. Since it is easy (for the computer) to solve the equation in reverse, Figure 3 shows a graph of $t_c \div t_m$ against $R_s \div (p \times R_1)$. For the present, just ignore the factor p

$$\begin{aligned} I_{dav} &= \frac{i_{pk}}{t_m} \int_0^{t_c} \sin(\pi t \div t_m) dt \\ &= \frac{i_{pk}}{t_m} \times \frac{t_c}{\pi} [-\cos \pi + \cos 0] \\ &= (2i_{pk}t_c) \div (\pi t_m) \end{aligned}$$

Formulae 1.

$$\begin{aligned} I_d &= i_{pk} \times \sqrt{\left[\frac{1}{t_m} \int_0^{t_c} \sin^2(\pi t \div t_m) dt \right]} \\ &= i_{pk} \times \sqrt{\left[\frac{1}{2t_m} \int_0^{t_c} \{1 - \cos 2(\pi t \div t_m)\} dt \right]} \\ &= i_{pk} \sqrt{(t_c \div 2t_m)} \end{aligned}$$

Formulae 2.

$$\begin{aligned} I_{dav} &= \frac{1}{t_m R_1} \int_{-t_c \div 2}^{t_c \div 2} (v - V_1) dt \\ &= \frac{V_{pk}}{t_m R_1} \int_{-t_c \div 2}^{t_c \div 2} \{\cos(2\pi t \div t_m) - \cos(\pi t_c \div t_m)\} dt \end{aligned}$$

which gives:

$$I_{dav} = (V_{pk} \div \pi R_1) \{\sin(\pi t_c \div t_m) - (\pi t_c \div t_m) \cos(\pi t_c \div t_m)\}$$

We can write V_{pk} in terms of V_1 and substitute, giving:

$$I_{dav} = (V_1 \div \pi R_s) \{\tan(\pi t_c \div t_m) - (\pi t_c \div t_m)\}$$

Since $I_{dav} = I_1 = V_1 \div R_1$

$$R_s \div R_1 = (1 \div \pi) \{\tan(\pi t_c \div t_m) - (\pi t_c \div t_m)\}$$

Formulae 3.

(i.e. assume $p = 1$): we shall need this factor later.

It may seem surprising that the value of the capacitor does not appear in the equation for t_c . This is because there is a hidden assumption that V_r is small, or, what is equivalent, that C is large. Under these conditions, t_c is independent of C and V_r is inversely proportional to C . V_r is the peak-to-peak value of the ripple voltage, and this is much more significant in design than the rms value (which is nearly $V_r \div (2 \times \sqrt{3})$).

$$V_r = I_{dav} \times (t_m - t_c) \div C$$

which allows us to calculate the ripple voltage for a given capacitor value, or vice versa. Since t_c is much less than t_m (typically about $0.15t_m$ to $0.25t_m$), and t_m is $1 \div f$, f being the supply frequency, an approximate (pessimistic) value of V_r is:

$$V_r = I_1 \div f \times C$$

since $I_1 = I_{dav}$. This is a particularly useful result: note that V_r is the peak-to-peak ripple voltage.

We need one more equation, which allows us to calculate the transformer

secondary voltage V_s for a given DC output voltage V_1 . We can get this by reversing the second equation in this section, and allowing for the diode turn-on voltage V_d . In a high-voltage power supply, there may be more than one diode, say n diodes, in series. Thus we get:

$$V_s = (V_1 + n \times V_d) \div \{\sqrt{2} \times \cos(\pi \times t_c \div t_m)\}$$

Note that this is the *no-load* secondary voltage, and this brings up an important point regarding transformer specifications. These often quote the *full-load* secondary voltage V_{sfl} and current I_{sfl} , and the percentage regulation r . For proper design, these values are not of direct use unless you happen to want to use the transformer exactly at full load. Otherwise, the no-load voltage and the effective secondary resistance have to be calculated, which is not as accurate as if the manufacturer of the transformer specified them, or V_s and the primary and secondary resistances R_1 and R_2 separately. The equations for the calculations are:

$$V_s = V_{sfl} \times \{100 \div (100 - r)\}$$

$$R_t = (V_{sfl} \div I_{sfl}) \times \{r \div (100 - r)\}$$

Sometimes, even I_{sfl} is not quoted, only a rating in volt-amperes (VA). This figure should be $V_{sfl} \times I_{sfl}$, but the higher figure $V_s \times I_{sfl}$ (or even the still higher figure produced by adding the primary magnetising VA as well) is quoted. Perhaps some transformer manufacturers will read this and improve their specifications (perhaps!).

Another very important point to note is that I_{sfl} must not be less than I_d , the rms diode current, not just I_1 , which is much smaller. Since you cannot calculate I_d until a late stage in the design process, it may be necessary to reconsider the transformer size before the design is complete.

Design steps

The equations above are in the order in which we discovered them, but we need to use them in a different order for designing. We usually start with requirements for the DC load voltage V_1 and current I_1 , and the maximum permissible ripple voltage V_r . We shall see later how to determine what is permissible.

It is not possible to produce an exact design when starting from these values. This is because we need to know t_c to calculate V_s , but t_c depends on R_s , and R_s depends on V_s in a complicated way depending on details of the transformer (such as what wire-gauges are available, if we can have one wound to our specification, or what standard parts are available if we have to buy one ready-made). The design steps are thus as follows:

- Calculate $V_1 \times I_1$, the output power. For a half-wave rectifier, estimate the transformer VA rating as 2.5 times the output power.
- Calculate $R_1 = V_1 \div I_1$ and estimate R_s , either by measuring R_1 for a transformer of the same VA rating as estimated and the same construction, or from manufacturer's data (don't forget R_d and R_c if R_s is less than about 2Ω).
- Estimate $t_c \div t_m$ from $R_s \div R_1$, and hence calculate V_s from V_1 , and I_d from I_1 .

Check with the diode data sheet that this value of I_d is within the rms current rating, AND that the resulting power dissipation is acceptable AT THE AMBIENT TEMPERATURE WITHIN THE POWER SUPPLY, which may be way above the external ambient temperature, depending on how much ventilation can be provided. Also check that i_{pk} is within the corresponding diode rating. If not, i_{pk} can be reduced by increasing R_s .

- Check, for the transformer chosen, that I_d is less than or equal to I_{sfl} , and that R_s is less than or equal to the estimated value. If R_s is less, a small resistor R_x can be added in series with the diode, remembering that it will dissipate $I_d^2 \times R_x$ watts, not $I_1^2 \times R_x$.
- From V_r , I_1 and t_c , calculate the value of the capacitor C .

How Much Ripple?

For many circuits, it is very difficult to calculate the permissible amount of ripple. Op-amps quote enormous figures for 'power supply rejection', but some circuit configurations reduce this considerably. Often, the only way to go is to guess at 5% of the supply voltage and see what happens. However, there is one situation where calculation is not only possible, but often neglected. This is where the power supply feeds a regulator IC, which sometimes tempts people to use a small reservoir capacitor ('well, the chip gives 90dB hum reduction'). To avoid excessive power dissipation in the regulator, the input voltage should not be too much larger than the output voltage. However, the regulator stops working if the voltage difference falls below about 2V (except for low-drop types). So, if we have a 7.5V supply to a 5V regulator, and there is 1V (peak-to-peak) ripple on the 7.5V, the minimum input voltage is 7V, which is only just enough. It would be better to apply the '5% rule', giving $V_r = 0.375V$, and a minimum input voltage of 7.125V, but this is still not sufficient. What if the mains voltage drops by 10%? This could result in a minimum input voltage of 6.375V, at which the regulator would not work at all. We have to settle for, say 7.3V minimum with low mains, giving 8.53V at nominal mains voltage with 5% ripple, and a regulator dissipation of 3.53W per amp of load current. With 1V ripple, we would need 8.7V at nominal mains voltage, and the regulator dissipation would rise to 4.5W per amp at 10% high mains voltage.

Problems Solved (More or Less)!

We can now begin to see the causes of some of Joe's troubles.

- he has chosen his 1A fuse from $I_1 = 1A$, not allowing for the fact that I_d is much larger (about 2.7 times for a half-wave rectifier).
- his 5V regulator is running out of volts when the mains voltage drops, either because he has too low an input voltage or too much ripple, or both.
- he chose the transformer for the 40V supply without realising that at the load

current of 100mA, it would give $V_1 = V_{pk}$.

- he has also forgotten that the transformer has to supply I_d , not I_1 , and that is why it is overheating.

The only remaining problem, the mains fuse rating, will have to wait for Part 3 for a complete solution, but we can already see that the input 'power' (strictly, VA) to a rectifier circuit may be much larger than the DC output power. This represents low efficiency, in the technical sense, and can be much improved over the 40% or so offered by a half-wave rectifier. A car alternator, with 3-phase full-wave rectification, offers over 99% efficiency in converting the AC into DC.

The Full-Wave Rectifier

We can obtain twice the efficiency of the half-wave rectifier by 'filling in' the long capacitor discharge period with another charging pulse. To do this we need another diode and another AC source, whose waveform is inverted with respect to the first. We can obtain this from a third winding on the transformer, connected to the original secondary winding so as to form a continuous winding with a centre tap (Figure 4a).

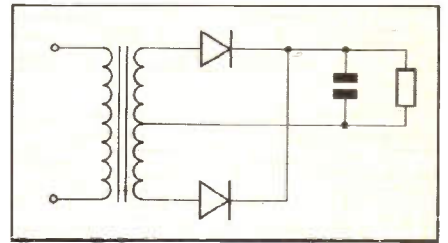

Figure 4a. Full-wave rectifier circuit.

Analysis

Luckily, we do not need to start from scratch with the analysis of this circuit. The waveform diagrams are shown in Figure 4b. Some of the equations stay the same as for the half-wave circuit, while others include a factor of 2 derived from the fact that there are two charging pulses per cycle of the supply voltage. This is the factor p which appears in Figure 3. For a half-wave rectifier, $p = 1$, and $p = 2$ for a full-wave circuit. The equations which change are:

$$R_s \div (p \times R_1) = (1 \div \pi) \times \{\tan(\pi \times t_c \div t_m) - (\pi \times t_c \div t_m)\}$$

hence the inclusion of p in Figure 3,

$$i_{pk} = I_1 \times \pi \div 2 \times t_m \div (p \times t_c)$$

The equation for I_d in terms of i_{pk} does not change, because we now have two diodes, and the equation gives the r.m.s. current for each diode. However:

$$I_d = I_1 \times (\pi \div 2 \times p) \times \sqrt{(t_m \div 2 \times t_c)}$$

Finally, the ripple voltage V_r is obviously reduced, because the capacitor is charged twice as often:

$$V_r = I_1 \times (t_m \div p - t_c) \div C$$

For the full-wave rectifier, $p = 2$, but because t_c is not usually negligible compared with $t_m \div 2$, the approximation:

$$V_r = I_1 \div 2 \times f \times C$$

is very pessimistic. The approximation t_c

Continued on page 51.

10 Channel FIBRE-OPTIC DIGITAL MULTIPLEXER

Wire Limitations

Until recently, electronic designers were restricted in their choice of interconnections between systems. Wire cables have traditionally been the only cost-effective choice until the arrival of inexpensive fibre-optic devices. The designer now has the choice of using conventional wire or advanced fibre-optic communications.

The use of wire cable has several disadvantages, some of which are listed below:

Interconnecting wires act as antennas, funnelling the destructive voltage caused by electrostatic discharge (ESD) to sensitive circuits. Common forms of ESD are: lightning; discharge of a spark by a person,

due to static voltage accumulation; high voltage discharge of a xenon lamp firing; etc.

Radio frequency interference (RFI) from radio, TV stations, computers, etc. can cause errors in data communications. Again, the interconnecting wire acts as an antenna, picking up the RF signals.

Electromagnetic interference (EMI) in wire systems can be caused by inductive pick-up of power line current or interference from industrial machinery. Traditional methods of solving these problems have been to use expensive balanced lines, with differential drivers and receivers, or heavy twisted shielded cables.

Capacitance between wire cables can cause coupling between data lines and, if

FEATURES

- ★ 100% galvanic isolation
- ★ 10 independent digital channels
- ★ Excellent EMI, RFI and crosstalk immunity
- ★ Transmitter compatible with TTL and CMOS logic
- ★ Open collector receiver outputs
- ★ STROBE output for interface with computer systems
- ★ 5V DC power supply required for both transmitter and receiver
- ★ Immune to ambient light
- ★ Extremely high isolation voltage
- ★ Absence of ground loops

Reviewed by Tony Bricknell

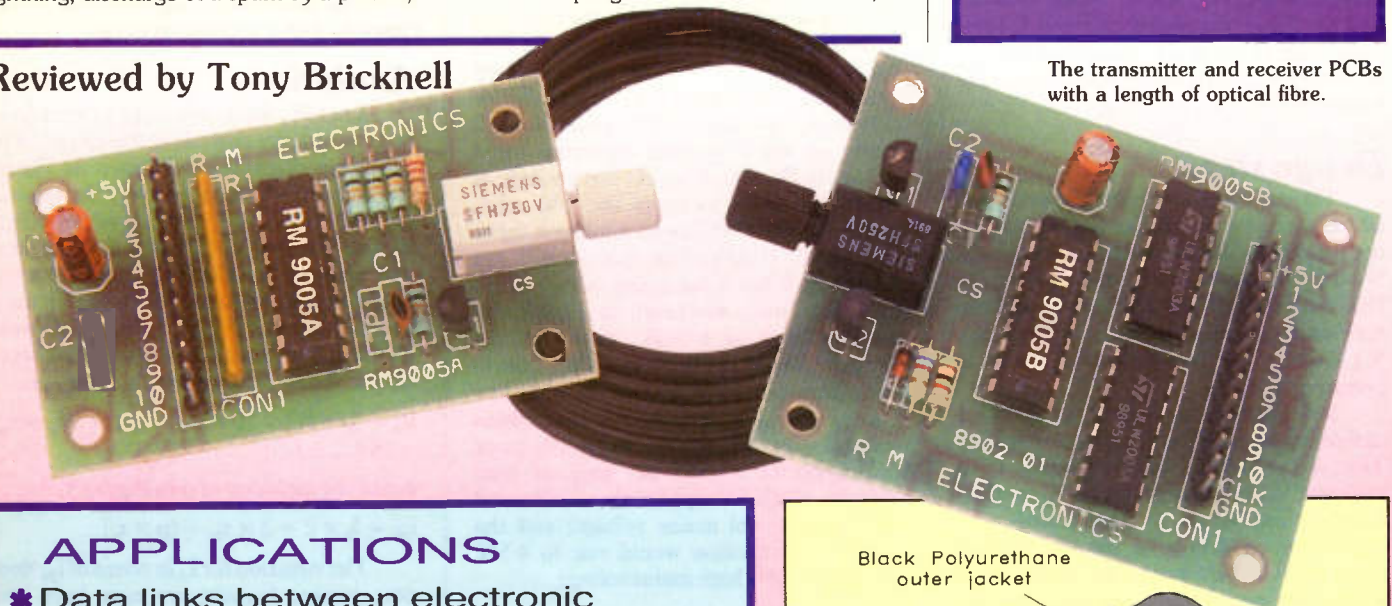

The transmitter and receiver PCBs with a length of optical fibre.

APPLICATIONS

- ★ Data links between electronic equipment requiring galvanic isolation with excellent noise and interference immunity
- ★ Remote connections of switches, tacho's, pulse devices and detectors which demand reliable operation in hostile environmental conditions
- ★ Replacement of shielded cables in digital applications
- ★ Replacement of complex wiring by one single fibre-optic cable

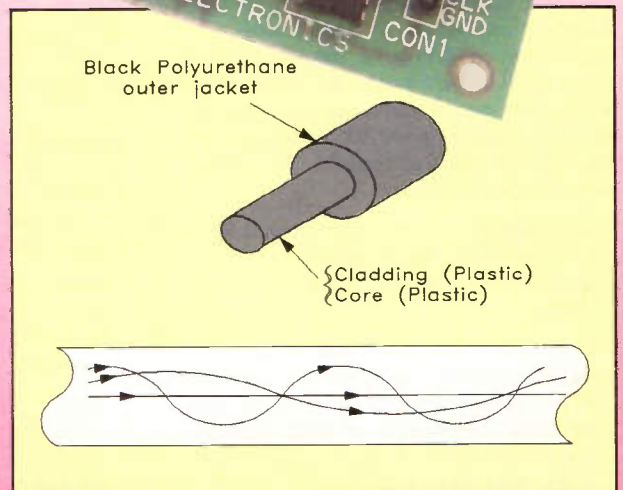

Figure 1. Graded index plastic fibre propagation and cable construction.

the interference is great enough, the data will be corrupted.

Also, the data driving the wire cable can be radiated with the interconnecting wire cable acting as a transmitting antenna, causing interference to neighbouring circuits. Basically, every time a logic level changes in a wire, there is an *overshoot* or *undershoot*, followed by *ringing*. Although the switching frequency may be only a few kilohertz, the ringing frequency depends on the resonance of the wire and may cover a bandwidth of several megahertz.

The Optical Answer

The advantages of using fibre-optics lies in the non-metallic, dielectric nature of fibre-optic cable. Data is conveyed through an optical waveguide by packets of photons, which have no electrical charge and, are therefore, not affected by radio frequencies or other forms of electromagnetic interference.

There are no crosstalk problems as the small leakage of flux, which may occur at the fibre boundary, is retained by the

opaque jacket ensuring that optical signals cannot interfere with each other when fibres are in close proximity. This factor also guarantees security of transmission, for the signal is unable to be externally detected throughout the entire length of the fibre.

In the event of a damaged or broken cable, the escaping flux is harmless in environments where a spark or short circuit from a broken wire could be disastrous. This enables hazardous areas with volatile chemicals to use fibre-optics for control and data gathering.

Plastic fibre is generally of the 'graded index' type, whose refractive index changes gradually from a high refractive index at the centre, to a lower index towards the perimeter. This causes the rays to propagate as shown in Figure 1.

The RM9005 Modules

The 10-channel fibre-optic digital multiplexer is sold as a pair of 'ready-to-use' modules and they are supplied with a

comprehensive instruction leaflet.

The multiplexer consists of two ready built modules (1 × transmitter, 1 × receiver), and a 3 metre length of plastic optical fibre. Figures 2 and 3 show the circuit diagrams of the transmitter and receiver respectively; note that both circuits use an 18-pin mask-programmed microcontroller (IC1, PIC16C54).

Both transmitter and receiver require a regulated DC power supply of 5V. The inputs of the transmitter have 10kΩ pull-up resistors, and are compatible with signals from TTL and CMOS logic or switches, see Figure 4. The receiver's outputs (including STROBE or CLK) are open-collector, which can be connected directly to relays, LEDs etc. For connection to digital logic or microprocessors, external pull-up resistors will have to be employed, see Figure 5.

Connection to the fibre-optic cable is achieved by couplers on the Tx and Rx PCBs. These packages maximise the electro-optical conversion efficiency, by maintaining the axial optical alignment of the emitter and detector with the mating fibre.

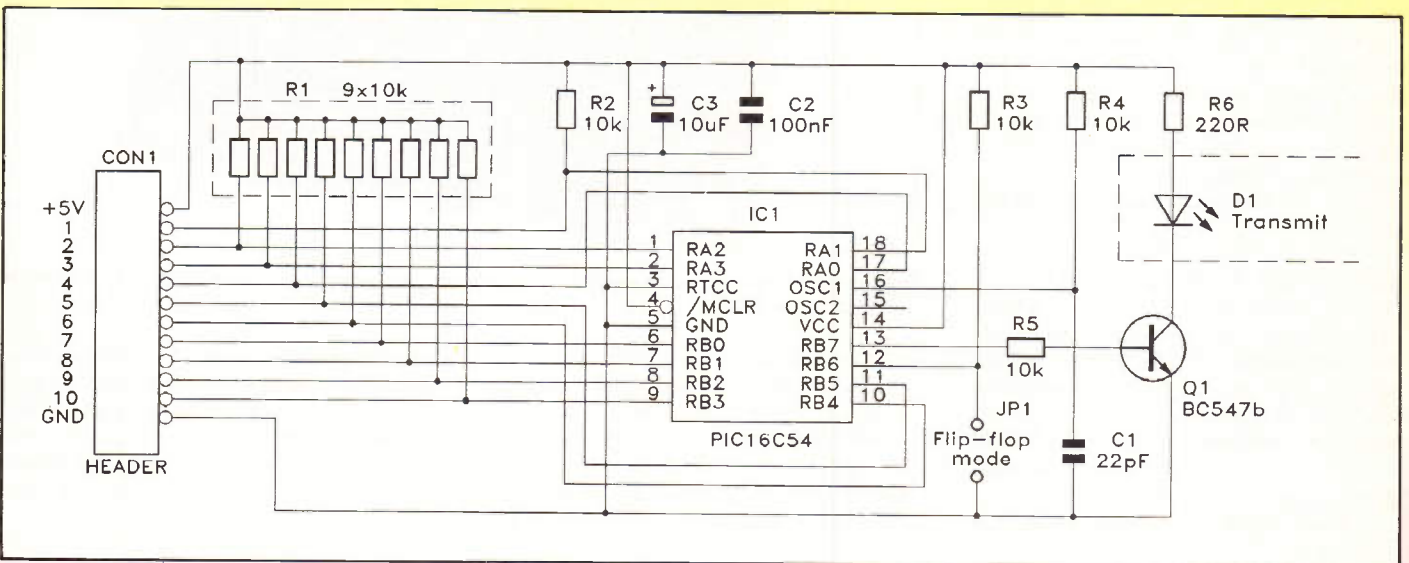

Figure 2. Transmitter circuit diagram.

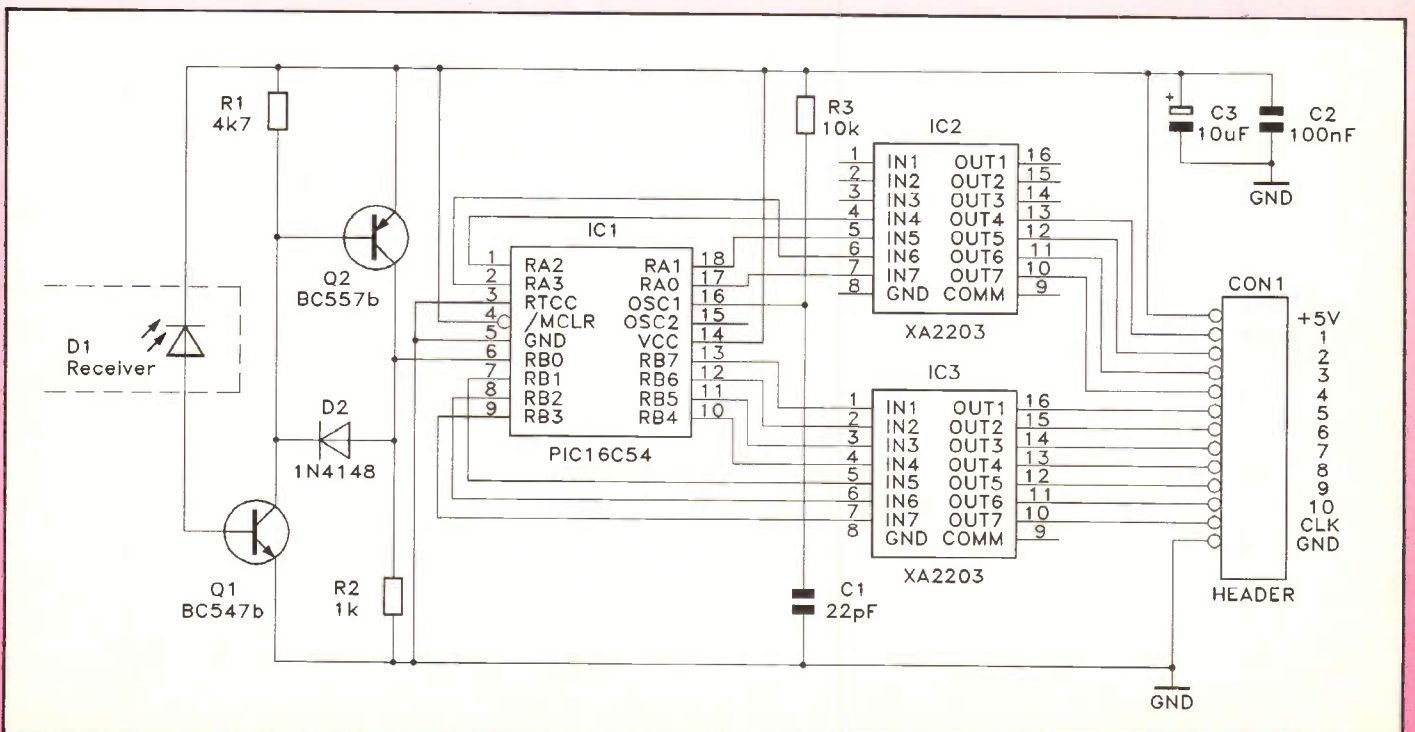

Figure 3. Receiver circuit diagram.

Preparation of the Optical Fibre

Both couplers are designed to be used with 1000 micron (1mm) core plastic fibre, providing an excellent transmission medium for short distance communication. A 3m length is supplied with the RM9005 modules. However, note that the transmitter module can reliably drive up to 20 metres of light guide; additional lengths can be ordered under stock code XR56L.

When cutting the light guide, great care should be taken to avoid scoring the fibre core. Try to make a single, straight cut thus keeping the end as smooth as possible, this being important for maximum light transfer to the couplers. Use a *very* sharp knife for this. Fine emery paper, or the striking edge of a matchbox (but not glasspaper types!) can be gently rubbed squarely across the cut fibre end to polish the surface. Liquid metal polish also helps to develop a smooth finish, and could also be used to finish-off with.

Alternatively, the cut fibre end could be placed close to a naked flame for a few seconds, until the end begins to round off. Excessive heat should be avoided as it will melt the fibre completely. This method has the advantage of producing a near perfect finish and develops a 'lens' in the fibre – ideal for good light transfer. Whichever method is employed, aim for a mirror-like finish on the fibre end if maximum range is required.

Push the prepared end of the light guide, through the fluted cap and into the coupler. Tighten the cap with your fingers only – do not use any tools! Repeat this procedure on the opposite end, so that the light guide is secured to both transmitter and receiver modules. It must be emphasised that careful preparation of the optical fibre ends is of vital importance, if maximum range is to be achieved.

When installing the light guide in a

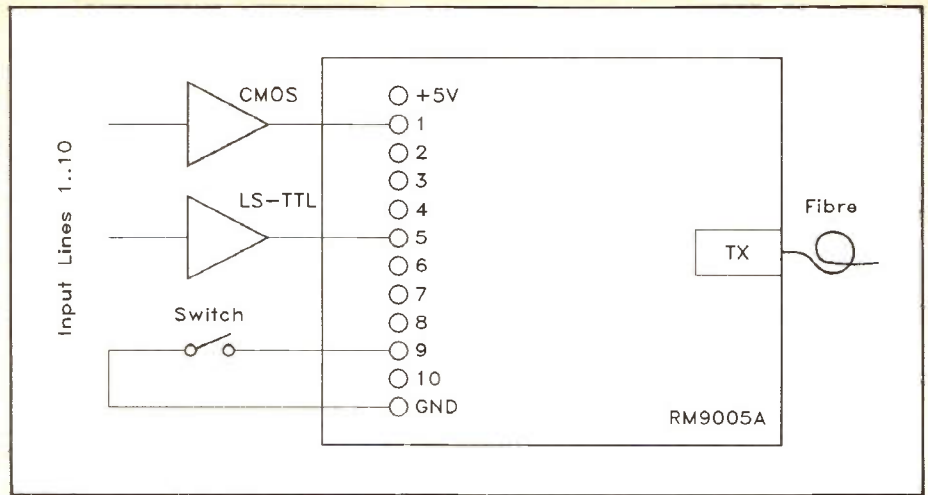
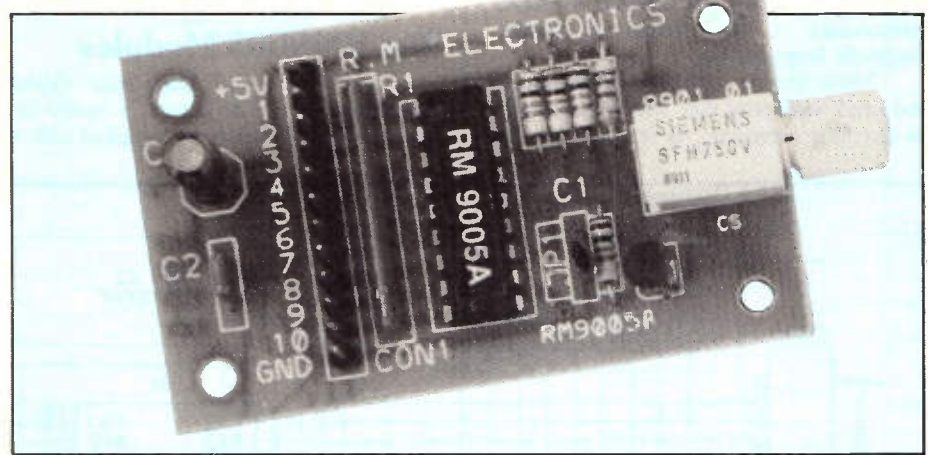

Figure 4. Example connections to the transmitter.



The transmitter PCB.

permanent position, be careful with bends. With reference to Figure 6, the absolute minimum radius of any bend in the fibre should not be less than 20mm. Exceeding the limit could result in cracking of the fibre, which will completely refract light and result in zero throughput. If using clips

to hold the guide in position, be careful not to pinch or damage the outer sheath in any way. Light will escape from and/or enter through pierced sheathing which may give poor results. Excessive heat and some chemical solvents will also damage the guide and should be avoided.

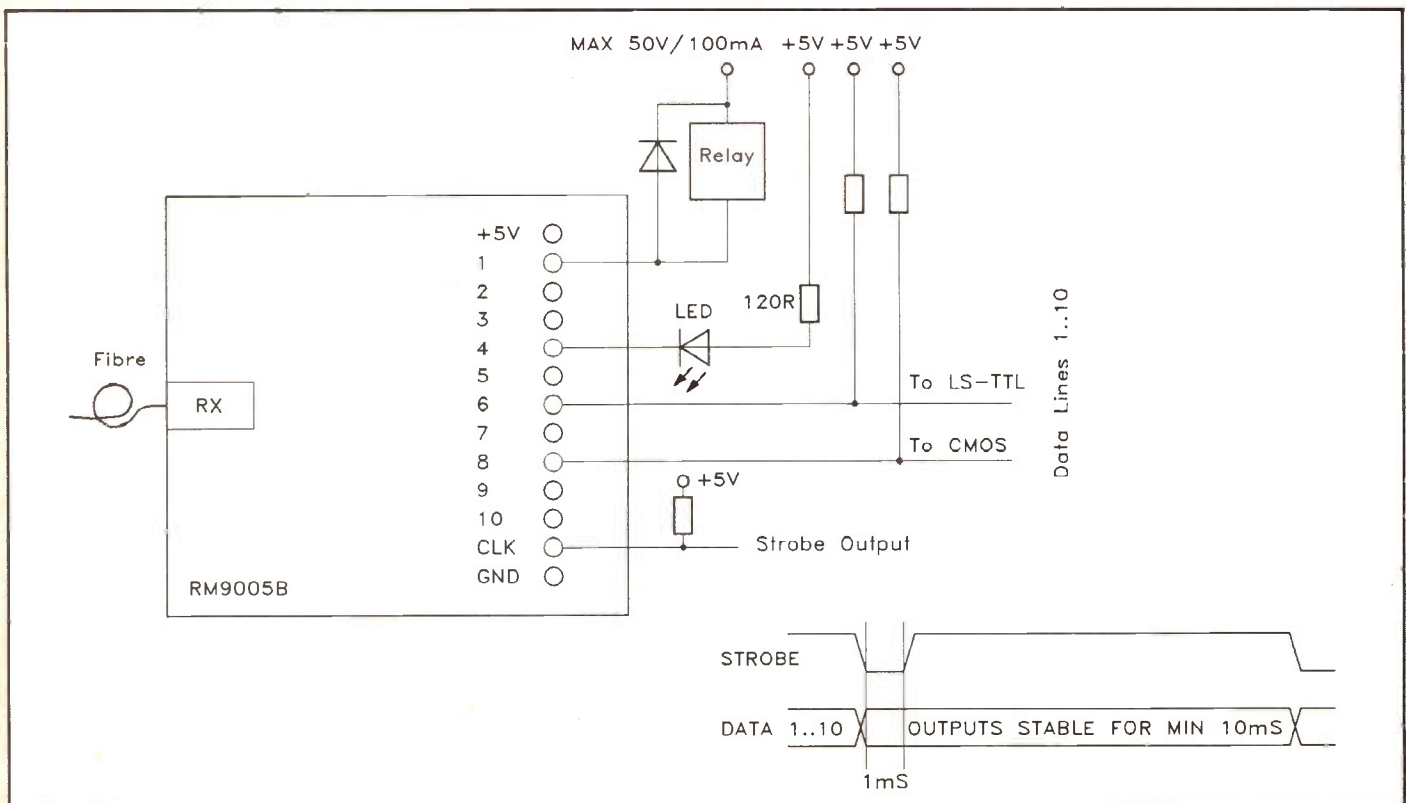

Figure 5. Example connections to the receiver.

In Use

All ten channels are completely independent of each other and are multiplexed on the transmitter. The data is then transmitted in a serial format to the receiver, where it is latched to the outputs after being demultiplexed. The transmission of this information takes 10ms, and new information is only transmitted to the receiver after the status of one or more inputs has changed. The STROBE (CLK)

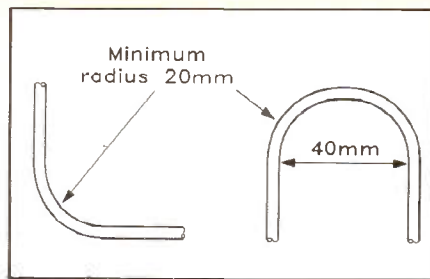
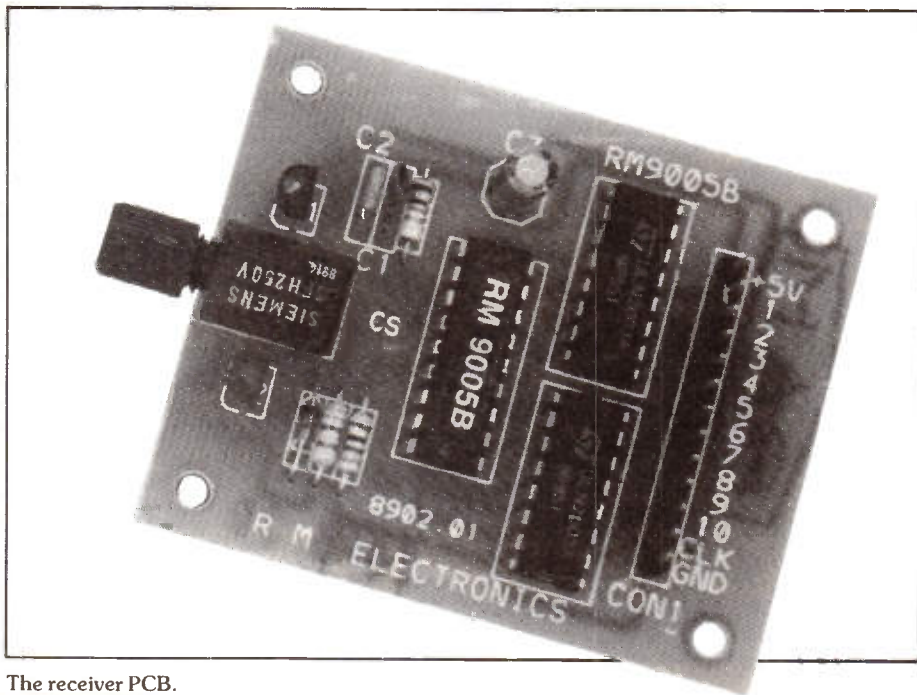

Figure 6. Bending the optical fibre.



The receiver PCB.

output is activated on any new incoming data for 1ms and is active low.

Two modes of operation are available:

With link JP1 *not* installed on the transmitter, the outputs are an exact copy of the inputs. This means that if an input is pulled down for 5 seconds, then the identical output will simultaneously be down for 5 seconds.

With link JP1 installed on the transmitter, the module will enter 'flip-flop' mode. This means that, for instance, when input 4 is activated once, output 4 will switch on and, when input 4 is activated a second time, output 4 will switch off. This makes it very easy to remotely control, say, relays by push-buttons.

Availability

The 10 Channel fibre-optic digital multiplexer is obtainable from Maplin Electronics by mail-order or through their numerous regional stores. The order code is LP84F and the price just £34.95 inclusive of VAT.

Reference

Finally, for additional information on fibre-optic techniques, reference is made to 'Opto-Electronic Line Transmission' by R.L. Tricker (Stock code WS74R).

The next super issue
on sale from
6th December 1991

Mains-Operated Linear DC Power Supplies continued from page 47.

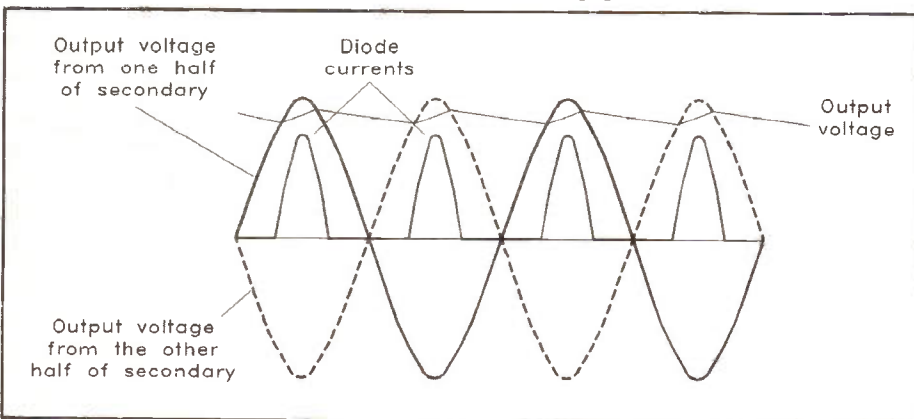

Figure 4b. Full-wave rectifier with reservoir capacitor: resistive load.

$= t_m \div 6$ is practical for full-wave circuits as well as half-wave, and gives:

$$i_{pk} = I_1 \times 4.71$$

$$I_d = I_1 \times 1.36$$

and

$$V_r = I_1 \div 3 \times f \times C$$

In the full-wave circuit, provided R_f is the same for both halves of the winding, there is no net DC flux in the core, so that transformer losses and acoustic noise are less than for the half-wave circuit. Note that R_f is *not* the same for both halves if one half winding is on top of the other. While this does not matter much for a small transformer (say, less than 25VA), larger transformers should preferably have the half-secondary windings arranged side-by-side (or bifilar-wound, if the voltage is not too high for this to be safe).

Measurements on Rectifier Circuits

There are two major snags to be aware of when trying to make measurements on these circuits. The first one is the effect of the impedance of the meter used to measure currents. While this does not normally have much effect on the value of I_1 , if you put the meter directly in series with a diode, the effect on R_s , and thus on i_{pk} , can be up to 10 or more times as great, and far from negligible. The only simple way to make accurate measurements is to include a very low known-value resistor (e.g. 0.1 Ω) in the circuit, and measure the voltage across it, from which the current can be calculated. You then either leave the resistor permanently in place or absorb its value in any other resistor in series with it.

The second snag concerns measure-

ments in circuits where the current has both AC and DC components (such as the diode current). Many digital meters, but not all, claim 'true r.m.s.' measurements, while actually disregarding the DC component when measuring AC, and vice versa. You can check by trying to measure direct current with the meter on an AC range: anything other than an accurate reading indicates a problem, which can be overcome (but only if the meter reads zero or nearly zero on the first test), by measuring the AC and DC components separately and adding 'r.m.s.-wise', i.e.:

$$I = \sqrt{I_{ac}^2 + I_{dc}^2}$$

An 'ordinary' AC current meter, average-responding but calibrated to read r.m.s. values on a sine-wave, cannot be used to measure I_d , because it responds to both components of the current, but to an extent which is difficult to predict, so that the readings will be misleading.

Trailer

Next time, we will look at the bridge rectifier, two sorts of voltage doubler and a 'voltage one-and-a-half', together with methods of getting several supplies from one transformer.

Reference

Reference 1. K. L. Smith, "DC supplies from AC sources - Part 3", *Wireless World*, Vol. 91 No. 1588 (February 1985) (Part of a series of six articles published in September and October 1984, February, May, June and October 1985).

PREDICTING WAVESHAPES USING A COMPUTER

Introduction

In Part 3 we predicted the waveshapes for a Resistor-Inductor circuit. Taking this further, this article is about the primary and secondary currents of a transformer (Reference 1). It contains some theory, the now familiar computer program, and the predicted waveshapes for the two currents (transient followed by the steady state), when the applied emf is a constant. A sinusoidally varying emf is also considered. We conclude with a discussion and suggestions for 'Things to do'.

The function of a transformer is to transfer electrical energy, and does so by transforming the voltage and current to the same or different numeric values (voltage higher and current lower, or vice-versa). This is done to reduce the heating losses in the national grid electrical transmission system, and explains why overhead pylons carry tens of thousands of volts. The voltage is stepped up drastically to keep the current to a minimum, but the power throughput is the same. The heating effect, in joules, is $i^2 \times R t$, where i is the rms value of the current, and t is the elapsed time in seconds.

In addition the transformer is a very effective voltage level changer for deriving the precise voltage or current output required. For instance they are used in battery operated fluorescent light drivers to convert the small, DC battery voltage into an alternating voltage sufficient to operate the fluorescent tube directly. The circuit used is a blocking oscillator, and

the device as a whole is a DC to AC converter. Such transformer based systems are also used to step-up or down AC to AC, DC to DC or AC to DC, and at the same time also provide very necessary electrical isolation. Transformers are essential components in both electrical and electronic engineering.

Although the following theory emphasises the rate of change in current, the fundamental effect is the rate of change in magnetic flux. The current is used because it is related to the magnetic flux via the B-H loop (O-I loop) and it is easier to measure.

Theory

The law for the mutual inductor relates the induced emf (emf) to the product of the mutual inductance (M), and the rate of change with respect to time of the current (si). This law is:

$$\text{emf} = M \times si,$$

(derived from $\text{emf} = N \times d\phi/dt$,
 $M = N \times d\phi/di$).

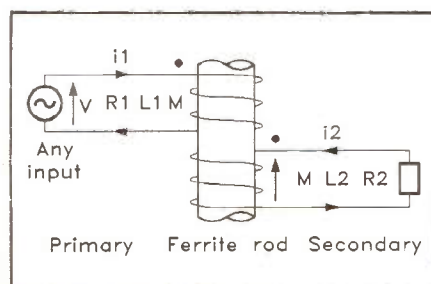

Figure 11. Resistor-inductor/Mutual-Inductor circuit.

Note that the current, which causes the magnetic flux, is in a different conductor than the one associated with the induced emf. Note also that si is written in place of di/dt , as it is easier to write (shorter), especially in the computer program. The symbol s is also used in a useful technique involving Laplace Transforms.

Equations

The equations representing the transformer system shown in Figure 11 are:

$$v = (R1 \times i1) + (L1 \times si1) - (M \times si2)$$

(v is the applied emf);

$$M \times si1 = (R2 \times i2) + (L2 \times si2)$$

$M \times si1$ is the induced emf ($v \times K \times N2/N1$),

where the symbols have their usual meaning (Reference 2), and:

- 1 refers to the primary circuit,
- 2 refers to the secondary circuit,
- M is the value of the mutual inductance between the two coils of wire.

Note that in Figure 11 the 'dot notation' is being used to identify the 'start' of each coil, in relation to the direction of the magnetic field (currents being directed into the dots, with the magnetic fields in the same direction). It is a fact that the induced emf is positive at a 'dot end' when the inducing current (flux) is directed towards a dot and is increasing.

A useful way of rearranging these equations, in order to produce the 'rate' equations, is to consider them as

simultaneous ones in terms of i_1 and i_2 . Hence they can be rearranged to yield:

$$i_1 = \frac{(v/R_1) - i_1 - ((R_2/R_1) \times (M/L_2) \times i_2)}{(L_1/R_1) \times (1 - K^2)}$$

$$i_2 = \frac{((v/R_1) \times (M/L_1)) - ((R_1/R_2) \times (M/L_1) \times i_1) - i_2}{(L_2/R_2) \times (1 - K^2)}$$

(remember that $M = K \times \sqrt{(L_1 \times L_2)}$).

Program

A program to predict the currents for any applied waveform is shown in Listings 7 and 8. As with all the listings in this series, Listing 7 is written in PC GW BASIC, while Listing 8 is in BBC Acorn BASIC (Reference 2).

Some of the interesting statements in both versions of this program include line 160 and line 170, where the rates of change of currents are calculated. The coefficients use the symbols a and b . These symbols are used in systems theory to express a very general set of equations as $y' = Ay + Bu$.

Line 190 predicts the new value of each current using the present value of the rate of change, by LET the new value of the current become the present value plus an increment, where the increment is the product of the present rate of change of current with respect to time and a step in time. The accuracy does depend on the choice of the step in time (h).

Waveshapes

Figure 12 shows the predicted primary current and the predicted secondary current, as well as the constant emf which was suddenly applied at time zero. There are two distinct effects, the first is quicker than the second. Initially the two currents increase, then the secondary current decreases whilst the primary current continues to increase to the steady state value of v/R . There are two time constants, 0.05 and 2 secs., the longer one is approximately $2 \times (L/R)$ ($L_1 = L_2 = 1$, $R_1 = R_2 = 1$, $M = 0.95$).

Figure 13 predicts the effect of suddenly reducing the applied emf to zero. The secondary current quickly changes in magnitude and direction, due to the negative rate of change of the primary current, and hence of the magnetic flux (line 110: 'V = 1 : IF T >= 3.14 THEN V = 0'). Figure 14 predicts the response to an applied emf of $1 \times \sin(1 \times t)$. The steady state currents are 0.64 phase $-20A$ (primary), and 0.43 phase $+25A$ (secondary).

Discussion

Mutual inductance and pulse generators are fascinating topics (Reference 3). The fundamental effect is the magnitude and direction of the rate of change of the magnetic flux associated with the stationary coils of wire. Although $e = N \times (d\phi/dt)$ (Faraday's Law) it is convenient to use $e = M \times (di/dt)$ as the current is easy to measure.

```

10 REM RLM Listing PC version
20 REM Transformer, Mutual Inductance
30 I1=0 : I2=0 : H=.01 : SCREEN 2 : CLS
40 R1=1 : L1=1 : R2=1 : L2=1 : REM R1=0.1
50 K=.95 : M=K*SQR(L1*L2) : D=(1-K*K)
60 D1=(L1/R1)*D : D2=(L2/R2)*D
70 A11=-1/D1 : A12=-((R2/R1)*(M/L2))/D1
80 A21=-((R1/R2)*(M/L1))/D2 : A22=-1/D2
90 B1=(1/R1)/D1 : B2=((1/R2)*(M/L1))/D2
100 FOR T=0 TO 6.28 STEP H : X=T*50
110 V=1 : REM IF T>=3.14 THEN V=0
120 PSET(X,100) : REM zero
130 PSET(X,100-V*50) : REM volts
140 PSET(X,100-I1*50) : REM amps
150 PSET(X,100-I2*50) : REM amps
160 SI1=A11*I1+A12*I2+B1*V : REM rate
170 SI2=A21*I1+A22*I2+B2*V : REM rate
180 REM at time T+H secs : -
190 LET I1=I1+SI1*H : LET I2=I2+SI2*H
200 NEXT T : REM V=1*SIN(1*T) T 12.56

```

Listing 7. PC GW BASIC prediction program.

```

10 REM RLM Listing BBC Acorn version
20 REM Transformer, Mutual Inductance
30 I1=0 : I2=0 : H=.01 : MODE 4 : REM KV law
40 R1=1 : L1=1 : R2=1 : L2=1 : REM R1=.1
50 K=0.95 : M=K*SQR(L1*L2) : D=(1-K*K)
60 D1=(L1/R1)*D : D2=(L2/R2)*D
70 A11=-1/D1 : A12=-((R2/R1)*(M/L2))/D1
80 A21=-((R1/R2)*(M/L1))/D2 : A22=-1/D2
90 B1=(1/R1)/D1 : B2=((1/R2)*(M/L1))/D2
100 FOR T=0 TO 6.28 STEP H : X=T*100
110 V=1 : REM IF T>=3.14 THEN V=0
120 PLOT69,X,200 : REM zero
130 PLOT69,X,V*100+200 : REM volts
140 PLOT69,X,I1*100+200 : REM amps
150 PLOT69,X,I2*100+200 : REM amps
160 SI1=A11*I1+A12*I2+B1*V : REM rate
170 SI2=A21*I1+A22*I2+B2*V : REM rate
180 REM at time T+H secs : -
190 LET I1=I1+SI1*H : LET I2=I2+SI2*H
200 NEXT T : REM V=1*SIN(1*T) T 12.56

```

Listing 8. BBC Acorn BASIC prediction program.

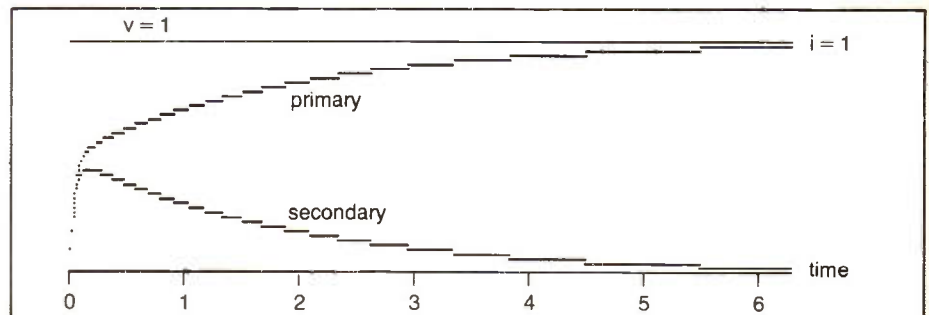

Figure 12. Predicted currents for constant emf.

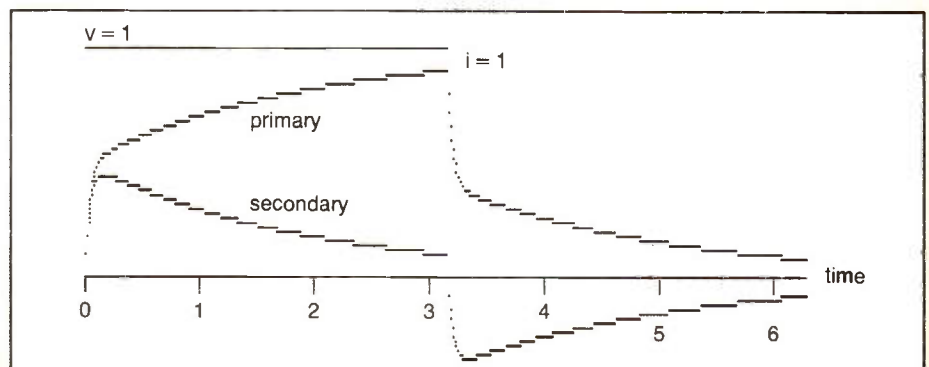

Figure 13. Predicted currents, emf reduced to zero.

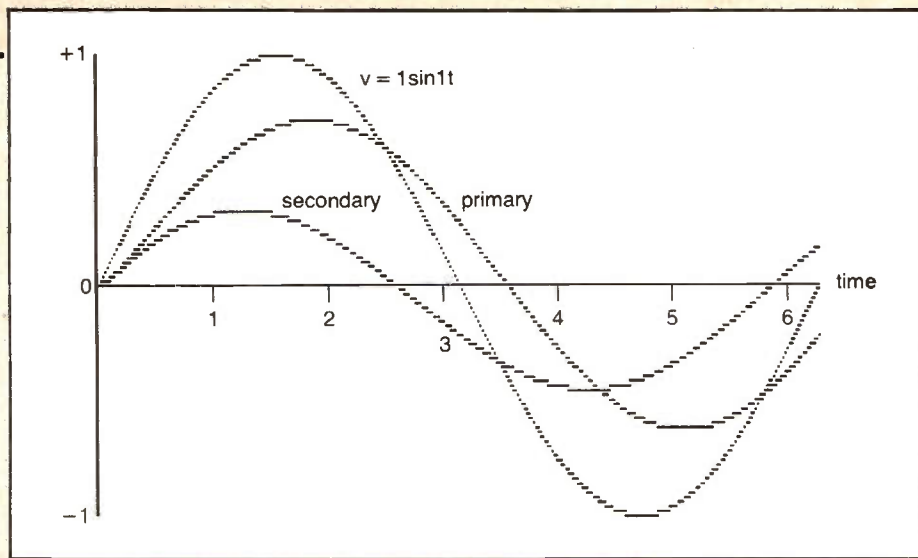

Figure 14. Predicted currents, $v = 1 \times \sin(1 \times t)$. Primary 0.64 phase $-20A$, secondary 0.43 phase $+25A$.

When the emf varies sinusoidally the actual flux in the transformer laminations is low due to the cancellation of the primary and secondary components of the flux. When the applied emf is pulsed, care must be taken not to exceed the maximum flux level of the core, or there will be no induced emfs and hence a high primary current. The flux will vary in accordance with the B-H loop of the magnetic material.

One advantage of using a numeric method is that, at every step of the calculations, the appropriate values of L and M can be deduced from the B-H loop using the instantaneous value of

current. Both the 'rate' equations have a voltage/resistance term; in the secondary equation it is $(v/R_2) \times (M/L_1)$. As L is proportional to N^2 , M/L_1 can be rearranged as $K \times (N_2/N_1)$. Hence the voltage/resistance term can be written as $(v \times K \times (N_2/N_1)) \div R_2$. This indicates that the secondary voltage is linked to the primary voltage by the turns ratio as deduced in the usual transformer theory. Note that the voltage v can be any waveshape, and that in Figures 12 and 13, it is a constant.

The turns ratio in this example is 1:1. The initial values of the currents predicted in Figures 12 and 13 are equal, hence

$i_1 \times N_1 = i_2 \times N_2$ (initially), as deduced in the usual transformer theory. This type of program illustrates the need for much faster computers once the numerical principles have been understood.

Things to Do

An interesting thing to do is to predict the open circuit currents. This can be attempted by using $R_2 = 10$. The primary current is the expected rise from zero to 1A with a time constant of 1 second (L_1/R_1).

Now use $R_1 = 0.1$ ($\tau = 10s$), and note the initial 'linear' rate of change during the first few seconds. This induces a 'constant' secondary voltage ($M \times si1$). In the blocking oscillator circuit mentioned earlier, the transistor is used to reduce the primary current and hence transfer the stored energy to the secondary only. This can be investigated by suddenly changing R_1 from 0.1 to 100 at $t = 3$, say.

Next time in Part 5 the slightly more involved Resistor-Inductor-Capacitor system will be the subject of discussion.

References

1. Higher Electrical Engineering, Shephed, Morton, and Spence, Pitman Press.
2. Predicting waveshapes using a computer, Parts 1, 2 and 3 by Philip Lawton. 'Electronics' Issues 45, 46 and 47.
3. Pulse Generators, edited by G. N. Glasoe and J. V. Lebacqz, Dover Publications inc. 1946.

COMPUTERS

SMARTWARE the best ever integrated package, also Paradox, both original, disk and manuals. £45 each. Mel, 7 Drumcliff Road, Leicester. Tel: (0533) 419742.

PRISM MODEM 2000 £20, Pascal MT+ for PCWs £10, The Desktop Publisher for PCWs, £10. Tel: Wayne (0203) 711170.

POWERTRAN CORTEX, CIRCALEC: commissioned ideal keyboard and steel case, DIY project - £70. Incomplete set 130 ETI magazines 1973 to 1989, £20 o.n.o. (buyer collects). J. Gardner, 79 Sandpit Lane, St Albans. Tel: (0727) 866127.

COMMODORE PET 8096 full size keyboard and tool kit chip. Printer 8023P, twin disk drive 8050, IEEE TO RS232 converter. All with manuals. Also Visicalc Program complete. £100 o.n.o. Tel: (0622) 890957 evenings.

AMSTRAD PC1640 HD20 MD display, 20Mb hard disc, 5 1/4 in floppy drive. Software, manual etc. £325 o.n.o. Intel 8087 - 2.8MHz maths co-processor, £30. Tel: (04027) 20052 evenings (Essex area).

URGENT MUST GO! Amstrad CPC computer paraphernalia, 100s of cassettes, disks, blanks, books, MF2+/Insider. Too much to list here. Buyer collects. Offers around £300 to Shay Madden, 23 Peterborough Way, Craylands, Basildon. Tel: (0288) 726884.

WANTED

SPECTRUM PD/SHAREWARE or details on how I can obtain some. Tel: Alex on (081) 777 6241 evenings/weekends.

ELECTRONIC MAGAZINES or books from 1979 onwards. Tel: (0252) 621505.

INFORMATION and/or books for the Heathkit Mohican Receiver. I will cover costs of copying etc. Tel: (0709) 814010.

SOMEONE TO BUILD a quality 15W stereo power amplifier, complete in case with volume control, to use to drive loudspeakers for a CD player. Will pay for Maplin Kits plus reasonable making-up charge. Write to A. M. Andrews, 56 Tarring High Street, Worthing BN14 7NR.

CLASSIFIED

If you would like to place an advertisement in this section, here's your chance to tell our 33,837 readers what you want to buy or sell, or tell them about your club's activities - absolutely free of charge. We will publish as many advertisements as we have space for. To give a fair share of the limited space, we will print 30 words free of charge. Thereafter the charge is 10p per word. Please note that only private individuals

will be permitted to advertise. Commercial or trade advertising is strictly prohibited.

Please print all advertisements in bold capital letters. Reference Boxes are available at £1.50 each. Please send replies to address below quoting Reference Box Letters. Please send your advertisement with any payment necessary to: Classifieds, Maplin Mag., P.O. Box 3, Rayleigh, Essex SS6 8LR.

A4 PLOTTER must be good but cheap! Intended for PCB CAD, so one colour, one pen would do! Mel Saunders, 7 Drumcliff Road, Leicester LE5 2LH. Tel: (0533) 419742.

TO UPGRADE my XT to an AT, cheap VGA/EGA card, 286 Motherboard, etc. Also drives and controllers, etc. Photo gear to swap/sell. Mel Saunders, 7 Drumcliff Road, Leicester LE5 2LH. Tel: (0533) 419742.

ONCE-BITTEN HIKER seeks circuit for ultrasonic animal deterrent device. Any advice greatly appreciated. Modest payment available. Tel: (0734) 842989 evenings.

ULA 126021M - 101 8409 chip for Acorn Electron. H. Boyd, 2 Chestnut Place, Ellon, Aberdeenshire, AB41 9HF (Scotland).

SERVICE MANUAL/CIRCUIT diagram for Telequipment D52 Scope. Buy or loan. Write to: E. Forshaw, 67 Winifred Street, Ince, Wigan WN3 4SD.

MANUALS FOR HP12S computer. Also compatible disc drive printer and other HP12S equipment. Phone Matt on (0922) 37502 after 5pm.

VARIOUS

UNUSED AUTOMATIC GARAGE DOOR operator. Still boxed. £95. Tel: (0252) 621505.

KEITHLEY 197 intelligent multimeter 5 1/2 digit display, auto, true rms etc. R+S price £600. Mine is £150, no offers, with original manuals. Out of calibration. August 91. Tel: (0685) 811332.

BIG LONG LIST OF BITS memory chips, disk drives, printer mechanisms, LCDs, power supplies, batteries. Send SAE for list to Jim Fricker, 43 Reading Rd, Farnborough, Hants GU14 6UG.

JVC QL ASR transcription turntable, boxed £38. Pioneer SG5 40 Graphic Equaliser, boxed £35. Heathkit AA1214 15 WPC stereo amplifier, handmade, £20. Buyer(s) collect, (0474) 334997.

VHS-HQ PANASONIC NV G45 barcode, 4 heads, 4/8 hour play. Remote control. Edit facilities. Still under guarantee. Superb picture/sound. Unwanted gift. Only £215. Jason (081) 948 1612 (Richmond).

PRIVATELY OWNED 'BLACK PEARL' £50 payout fruit machine. Takes all coins up to £1. Fully working. £100 o.n.o. S Elmer, 19 Brookfield, Bildeston, Ipswich, Suffolk IP7 7EJ. Tel: (0449) 740441.

B & W SECURITY CAMERA plugs directly into video recorder. £50, Infra-Red TX/RX. Beams enclosed; ideal for Alarm/Automation projects - RX/TX pair, £10 each. Tel: (081) 842 1564 evenings.

TWO PHILIPS 1700 series video recorders (heads gone), plus 12 tapes. Any offers considered. Will split. Tel: (0438) 356410 (Stevenage).

GIANT CLEAROUT! Lots of different components including ICs capacitors, resistors, transistors, LEDs, some in large quantities. Send SAE for list to: M.J. Dean, Blenheim, Walton Lane, Bosham, Chichester, West Sussex PO18 8QF.

THURLBY 1905A intelligent digital multimeter (RS 610 - 871) with serial port. £150. Thurlby Quad Mode Dual 30V 1A PSU (RS 610 - 477). £150. Tel: Alan (0795) 476175.

PCB TANKS floor standing, process/wash/etch tanks with temp. control, BARGAIN at £100, cost £350. Also other items, books/hardware/spares/modems/software. Tel: (0638) 663326.

SHOP LED DOT matrix display comes with programming keyboard and instructions. Display size approx. 2.5 feet long, 4 inches high. £200 o.n.o. Tel: Peter (0883) 714070.

MUSICAL

NEW FLIGHT CASE suit full size keyboard PSR47 etc., £30. Keyboard Stand £5. Both Carr. Ex. Seon Smyth 67 East Princes Street, Helensburgh G84 7DG. Tel: (0436) 71181.

YAMAHA DX100 keyboard, 192 preset voices, 24 fully programmable. Fully midi compatible. Four user manuals, mains and midi leads, fabric cover included £120 o.n.o. Tel: (0442) 63334 evenings (Hemel Hempstead).



INTRODUCING OUR

NEW
Cool Cats

'BIG CAT' by Eminence is an exciting new range of awesome high power, super value, top quality loudspeakers. The range is designed exclusively for 'BIG CAT' by Eminence the world's No 1 loudspeaker manufacturer. Find out more about this exclusive new range in the Speakers & Sounders section of the new Maplin catalogue. Available from all branches of **WHSMITH** or Maplin shops nationwide, only £2.75. Also by Mail Order, only £2.95 inc. P&P. Order code CA09K.

DON'T LET THEM ESCAPE!



The 1992 Maplin Catalogue has over 600 product packed pages, including hundreds of new items.

CREDIT CARD HOTLINE



PHONE BEFORE
5pm FOR SAME
DAY DESPATCH

24 HOUR SERVICE · PHONE NOW!

0702 554161

**DATA
FILE**

MN3004 BUCKET BRIGADE DELAY-LINE

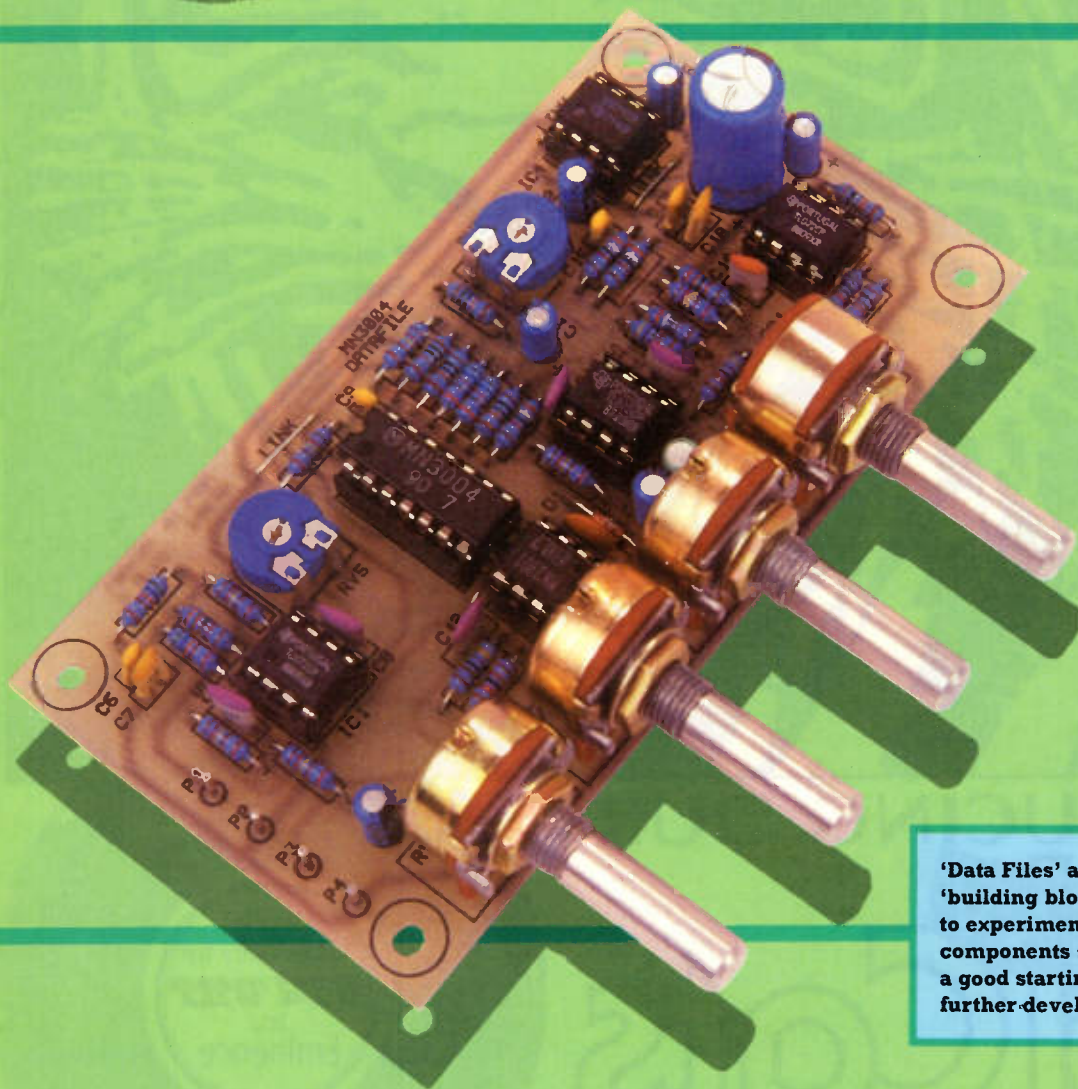

'Data Files' are intended as 'building blocks' for constructors to experiment with and the components supplied provide a good starting point for further development.

FEATURES

- ★ **VARIABLE DELAY OF AUDIO SIGNAL:
2.56ms TO 25.6ms**
- ★ **SINGLE +15V SUPPLY** ★ **KIT AVAILABLE**

APPLICATIONS

- ★ **Tremolo, vibrato and chorus effects** ★ **Variable or fixed delay of analogue signals** ★ **Telephone time compression**
- ★ **Delay line for voice communication systems**

Parameter		Min	Typ	Max	Unit
Drain supply voltage	V_{DD}	-14	-15	-16	V
Gate supply voltage	V_{GG}		$V_{DD}+1$		V
Clock frequency	f_{CP}	10		100	kHz
Signal delay time	t_D	2.56		25.6	ms
Signal frequency response	f_i			$0.3 \times f_{CP}$	kHz
Insertion loss	L_i	-4	1.5		dB
Total harmonic distortion	THD		0.4	2.5	%
Signal to noise ratio	S/N $f_{CP}=100\text{kHz}$ weighted by 'A' curve		85		dB

Table 1. MN3004 Typical electrical characteristics.

Introduction to MN3004

The MN3004 is a 512 stage, low noise, bucket brigade delay line. Figure 1 shows the IC pinout and Table 1 shows some typical electrical characteristics for the IC. The device features low insertion loss, a signal to noise ratio of 85dB, and no gate back-bias is required. Figure 2 shows the MN3004 block diagram, and Figure 3 shows its internal schematic.

Analogue signals, in the audio band, can be delayed by 2.56ms to 25.6ms by adjusting the clock frequency. The device is ideally suited for processing audio signals to produce an artificial delay in public address systems.

Bucket Brigade?

Sampled values of the analogue signal to be delayed are stored in the form of charges on a series of capacitors. Between each capacitor is a switch that transfers the charge from one capacitor to the next, upon command of a clock pulse. Using the old analogy of the 'fire-fighting' method, in which buckets of water were passed along a line, from man to man, a delay line of this sort is known as a bucket-brigade.

Since each capacitor cannot take-up a new charge until it has passed on its previous one, only half the capacitors carry information at

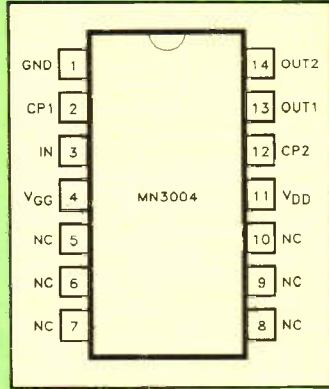

Figure 1. MN3004 pinout.

one to empty the even-numbered buckets, and the other to empty the odd-numbered buckets.

There is, however, a practical drawback to the above method, as the buckets in which the samples are stored must empty *completely* during each transfer. In practice, owing to internal resistance of the capacitors, complete discharge is difficult to ensure. So instead, the system illustrated in Figure 5 is employed.

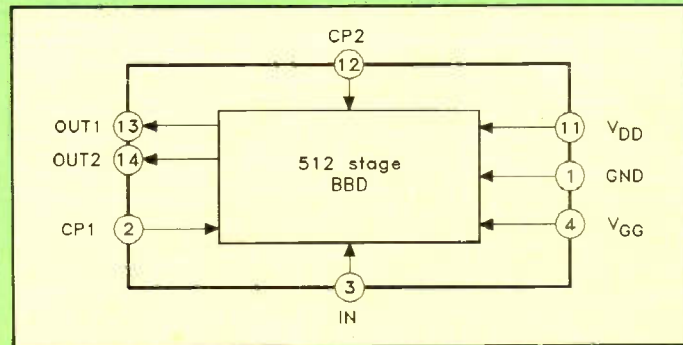

Figure 2. IC Block diagram.

any one-time and the ones in between are empty. Starting from the condition shown in Figure 4a, the transfer proceeds in two stages:

In the first stage, bucket 1 empties into bucket 2, and bucket 3 into bucket 4.

In the second stage, bucket 2 empties into bucket 3, and bucket 4 into bucket 5.

Two antiphase clock signals are therefore required;

Figure 5a indicates the initial condition; buckets 1 & 3 contain samples, and buckets 2 & 4 are full. During the first transfer, bucket 2 fills bucket 1, and bucket 4 fills bucket 3. What remains in bucket 2 is now equal to the original contents of bucket 1, and what remains in bucket 4 is equal to the original contents of bucket 3. During the next transfer, bucket 3 fills bucket 2, and bucket 5 fills bucket 4. So, as

the buckets empty from right to left, the sampled quantities move from left to right.

Kit Available

A kit of parts is available to build a versatile application circuit using the MN3004. The kit includes a high quality fibreglass PCB with screen printed legend to aid construction. Figure 6 shows the circuit diagram and Figure 7 shows the PCB legend and track. A block diagram of the module is shown in Figure 8.

Setting-Up

The module requires a single +15V supply that is capable of delivering at least 40mA. It is important that the power supply is adequately smoothed and regulated to prevent any mains derived noise from entering the system via the supply rails. Power supply connections are made to P1 (+15V) and P2 (0V). Signals to the delay line are applied via P3 (input) and P4 (0V), and signals are output from the module via P5 (output) and P6 (0V). Figure 9 shows the wiring diagram.

Delay Line Biasing

The DC offset at the signal input of the MN3004 must be adjusted for minimum distortion. Starting from a level of half the supply voltage (RV6 set to mid-way), a potential change of up to 2V may be necessary. Connect the module as per Figure 9, set RV5 to its mid-way position, RV3 fully anti-clockwise (no feed-back) and RV4 fully clockwise (pure effect output). Increase the input level by rotating RV1 clockwise, followed by RV5, until the output signal is distorted. Next, adjust RV6 for minimum distortion, and increase the input level for a second adjustment. Optimise the drive margin this way until no further improvement is noted.

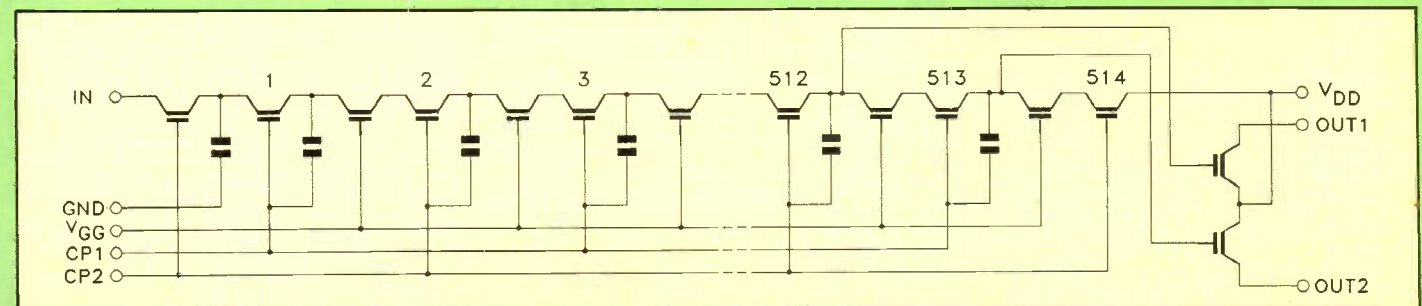

Figure 3. MN3004 internal schematic.

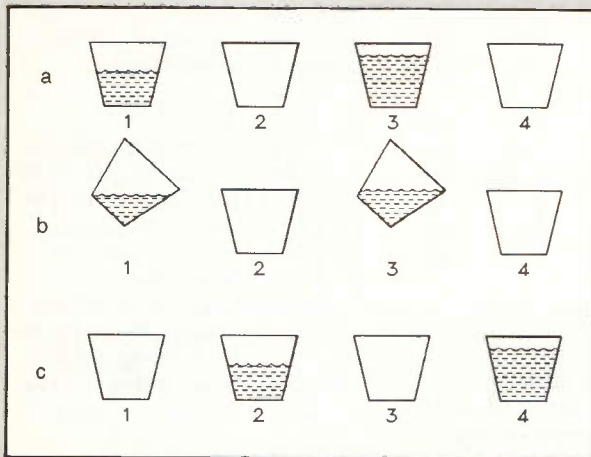

Figure 4. Simplified scheme of sample transfer: Samples in buckets 1 & 3 (a) are poured into empty buckets 2 & 4 (b) causing the samples to move from left to right (c).

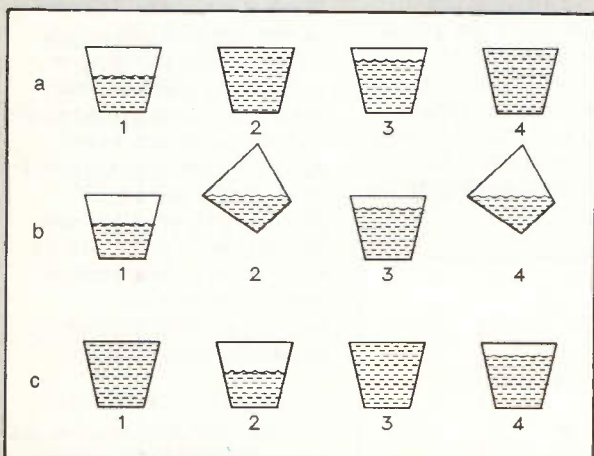
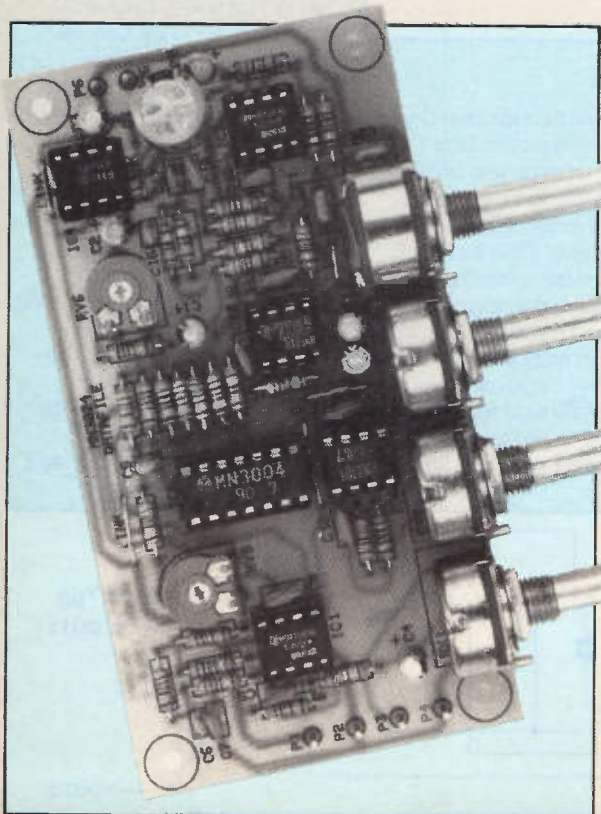

Figure 5. Practical scheme of sample transfer: Buckets 1 & 3 contain samples (a) and, when full buckets 2 & 4 are poured into them (b), the samples move from left to right (c).



The assembled PCB.

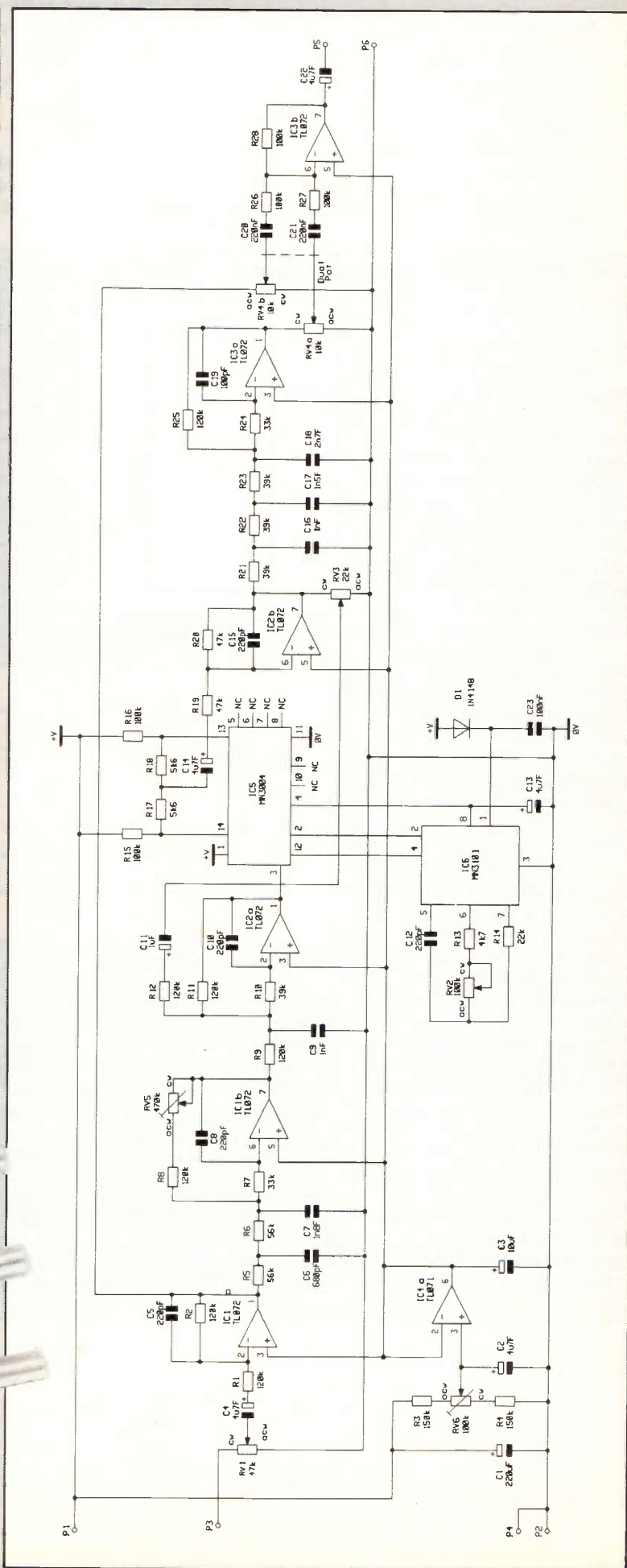

Figure 6. Circuit diagram.

Delay Line Loop Gain

With RV2 (Delay) set to mid-range and RV3 (Feedback) fully anti-clockwise connect an input signal of about 1V peak-to-peak and monitor the output signal. Adjust RV5 so that equal output levels are obtained with RV4 (Mix) fully clockwise and fully anti-clockwise. This can be done with test equipment or simply 'by ear' using a tape or digital signal source.

Applications

The module may be used in many different applications requiring a signal delay time of up to 25.6mS including musical instruments, communications systems and time compression.

As audio signals enter the module they split into two paths, which are re-united again near the output. One of these paths is a direct link from the input of the module to the mixer stage (RV4 & IC3b); the other path is via the MN3004 delay line. Note that, as the MN3004 clock frequency must be at least 3 times the maximum input signal frequency, the delayed signal has a limited bandwidth of 3.1kHz. In practice, this restricted bandwidth is hardly a problem since higher frequencies are also attenuated with natural echoes and reverberation. By varying the signal delay and the

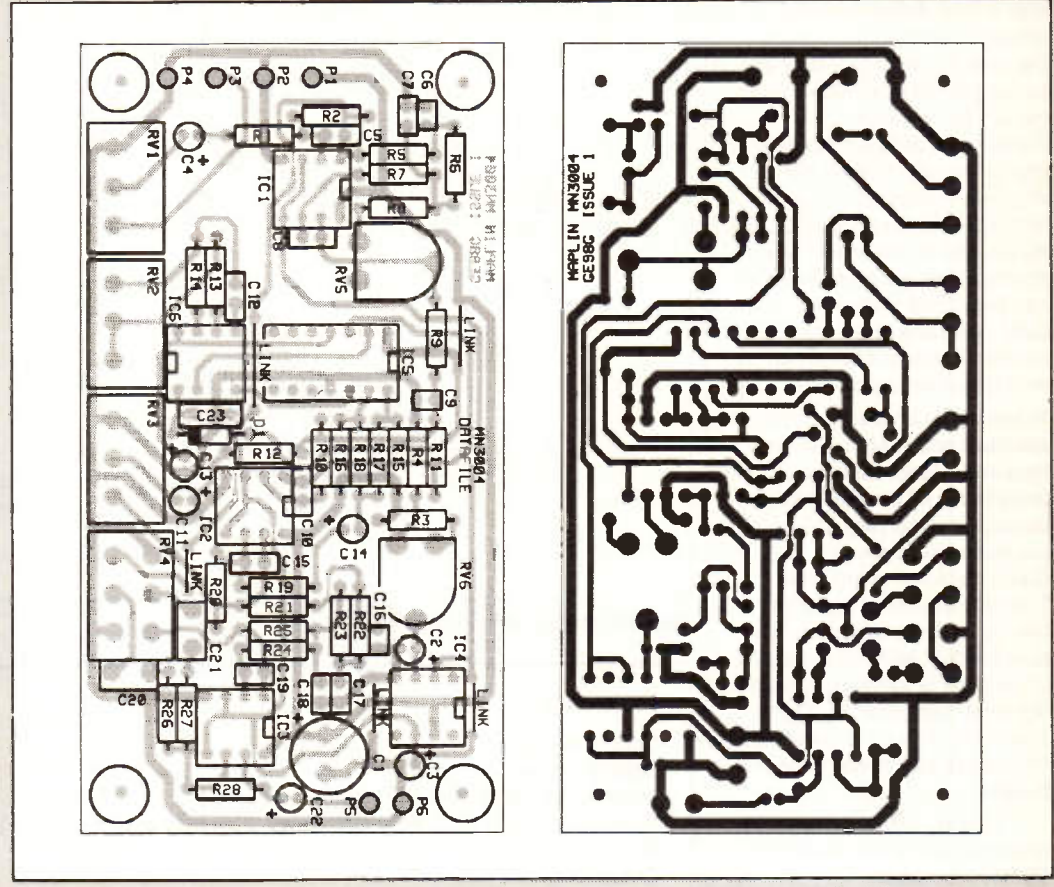

Figure 7. PCB legend and track.

mixture of direct and delayed signals, a variety of interesting effects can be obtained. Here are a few ideas to try:

With equal levels of direct and delayed signals, and a few milliseconds of delay, a 'double-tracking' effect is produced. This makes a single

input sound like a pair of independent, but time-synchronised, outputs. Using this effect a single voice sound can be made to sound like a duet, and a duet made to sound like a quartet.

With a reduced level of delayed signal in the mix, and

a reasonable length delay time, a simple echo effect is obtained. The audio sounds as if it were being played in a softly furnished room with a single hard wall facing the sound source.

When equal levels of direct and delayed signals are used

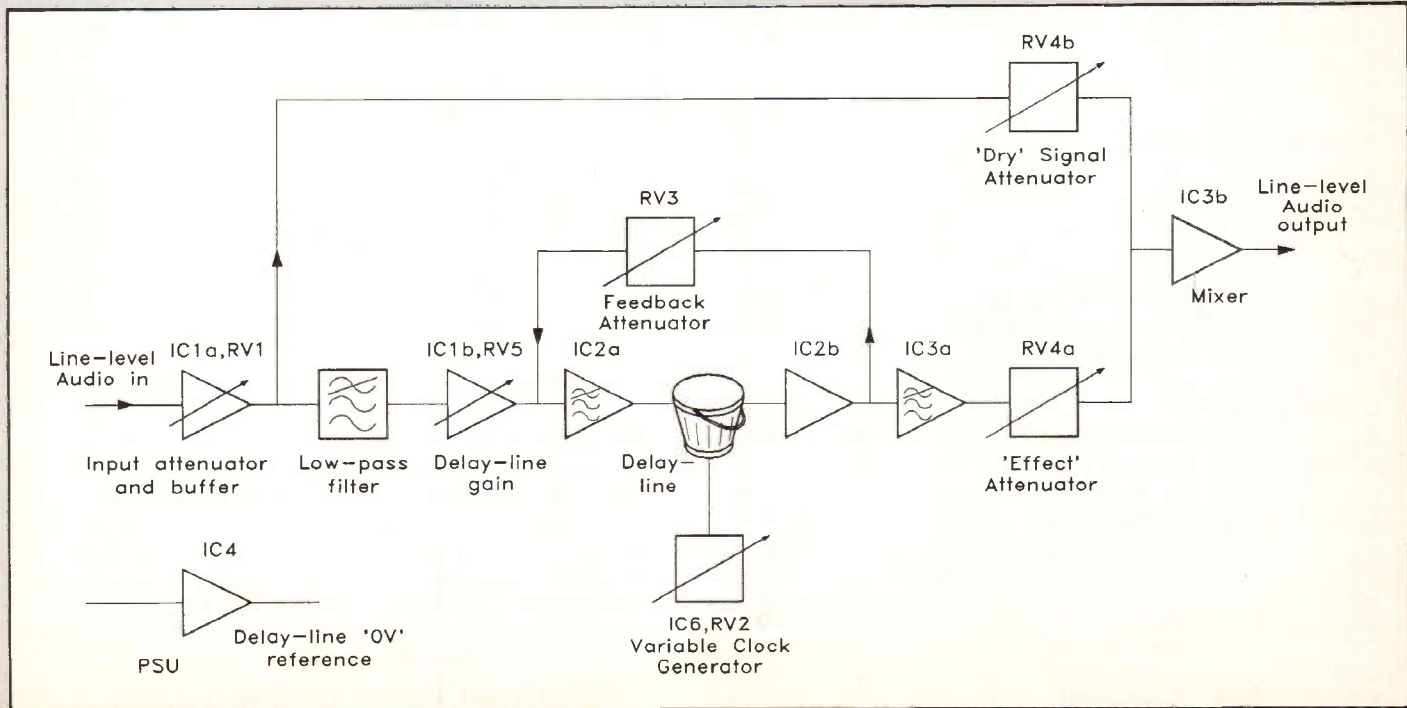

Figure 8. Module block diagram.

with a long delay time and almost maximum feed-back, the sounds seem as if they are being played in a hard-faced cave. The apparent dimensions of this 'chamber' can be varied through the delay-time control, while the 'hardness' of the chamber can be altered by the feed-back control. The apparent sounds can be varied from those of a hard cave, to a small church, or even down to a large but well furnished lounge.

When equal levels of mixing are used with a short delay time and a large amount of feed-back, all sounds give the impression that they are being played inside a small-diameter, hard-faced pipe. The dimensions of the 'pipe' can be varied with the delay-time control, and the hardness of the pipe is variable through the feed-back control. This allows the sounds to be varied from those of a sewer pipe to a bucket.

Finally, Table 2 shows the specification of the prototype MN3004 module.

There's another fascinating DATA FILE next month!

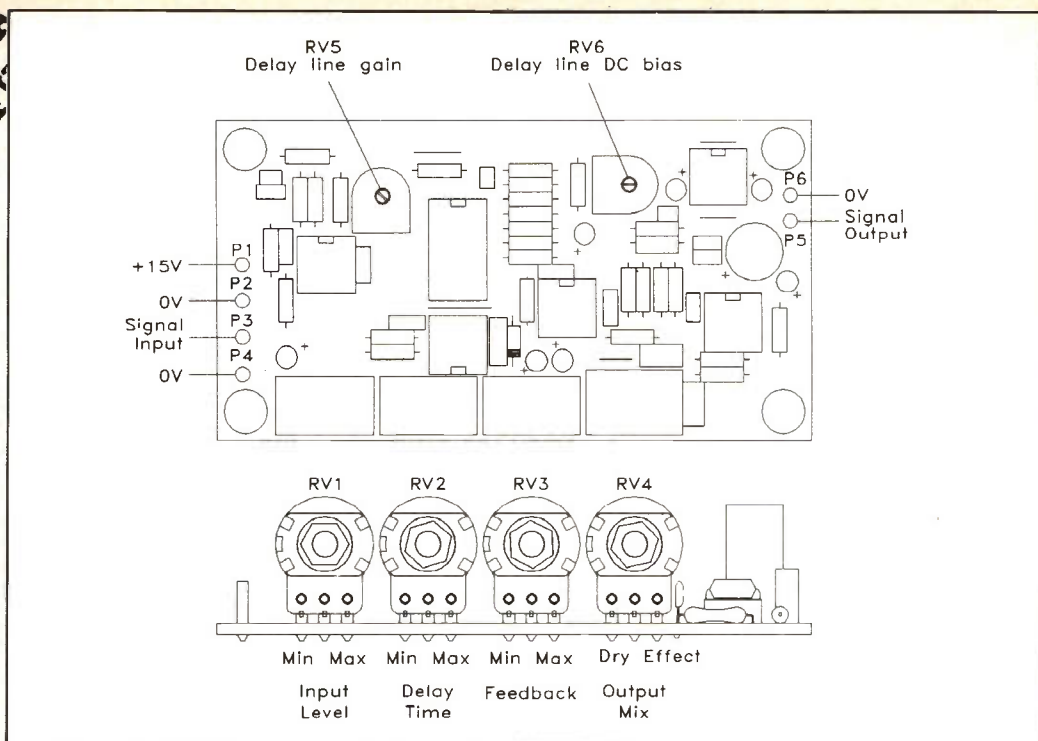

Figure 9. Module wiring diagram.

Parameter	Min	Typ	Max	Unit
Supply voltage	14	15	16	V
Supply current		36		mA
Input signal level (RV1 & RV4 fully clockwise)	1	3		Vrms
Input signal level (RV1 fully clockwise, RV4 fully anti-clockwise)	1	8		Vrms
Input impedance		47		kΩ
Delay time	2		24	ms
Dry signal path frequency response	4		15k	Hz
Delay signal path frequency response	4		3.1k	Hz
Output signal level		1		Vrms
Output impedance		600		Ω

Table 2. Specification of prototype (V_{CC} = 15V).

MN3004 PARTS LIST

RESISTORS: All 0.6W 1% Metal Film (Unless specified)

R1,2,8,9,11,12,25	120k	7	(M120K)
R3,4	150k	2	(M150K)
R5,6	56k	2	(M56K)
R7,24	33k	2	(M33K)
R10,21,22,23	39k	4	(M39K)
R13	4k7	1	(M4K7)
R14	22k	1	(M22K)
R15,16,26,27,28	100k	5	(M100K)
R17,18	5k6	2	(M5K6)
R19,20	47k	2	(M47K)
RV1	Min Pot Log 47k	1	(JM78K)
RV2	Min Pot Lin 100k	1	(JM74R)
RV3	Min Pot Lin 22k	1	(JM72P)
RV4	Min Dual Pot Lin 10k	1	(JM81C)
RV5	Hor Encl Preset 470k	1	(UH08J)
RV6	Hor Encl Preset 100k	1	(UH06G)

CAPACITORS

C1	PC Elect 220µF 35V	1	(JL22Y)
C2,4,13,14,22	Minelect 4µ7F 35V	5	(YY33L)
C3	Minelect 10µF 16V	1	(YY34M)
C5,8,10,12,15	Ceramic 220pF	5	(WX60Q)
C6	Ceramic 680pF	1	(WX66W)
C7	Ceramic 1n8F	1	(WX71N)
C9,16	Ceramic 1nF	2	(WX68Y)
C11	Minelect 1µF 63V	1	(YY31J)
C17	Ceramic 1n5F	1	(WX70M)
C18	Ceramic 2n7F	1	(WX73Q)
C19	Ceramic 100pF	1	(WX56L)

C20,21	Monores Cap 220nF	2	(RA50E)
C23	Minidisc 100nF 16V	1	(YR75S)
SEMICONDUCTORS			
D1	1N4148	1	(QL80B)
IC1,2,3	TL072CP	3	(RA68Y)
IC4	TL071CP	1	(RA67X)
IC5	MN3004	1	(UM64U)
IC6	MN3101	1	(UM66W)
MISCELLANEOUS			
P1-6	Pins 2145	1 Pkt	(FL24B)
	DIL Socket 8-pin	5	(BL17T)
	DIL Socket 14-pin	1	(BL18U)
	PC Board	1	(GE98G)
	Instruction Leaflet	1	(XT24B)
	Constructors' Guide	1	(XH79L)

The Maplin 'Get-You-Working' Service is not available for this project.

The above items are available as a kit, which offers a saving over buying the parts separately.

Order As LP89W (MN3004 Data File) Price £16.95

Please Note: where 'package quantities' are stated in the Parts List (e.g. packet, strip, reel, etc.) the exact quantity required to build the project will be supplied in the kit.

The following new item (which is included in the kit) is also available separately, but is not shown in our 1992 Catalogue.

MN3004 D.File PCB Order As GE98G Price £3.45

**A readers forum for your views and comments.
If you want to contribute, write to:**

**The Editor, 'Electronics – The Maplin Magazine'
P.O. Box 3, Rayleigh, Essex, SS6 8LR.**

Soft Water Generator

Dear Sir,
Two projects would be of interest—
1. An add-on unit to give frequency read-out, the range 10m to 120m A.M. only would do. Many S.W. listeners have good receivers but they lack this facility.
2. Two 'boxes of tricks' have appeared on the market recently, which are supposed to reduce scale in water pipes. They are mains driven and feed coils of wire wrapped round the intake pipe. This appears to exert a magnetic field, or to transmit a frequency of some sort...

**W. H. Rees,
South Godstone, Surrey.**

Thank you for the project suggestion. If anyone is 'in the know' as to how (and if!) these scale reducers work, please drop us a line.

Video Niceties

Dear Sir,
Two points:
1) Projects—although 'budget-priced' audio mixers are available, video mixers are less common. I have yet to see an audio and video mixer at a budget price in the high street shops (or even in your catalogue!!!)
For the many home-video fanatics around these days (myself included), how about combining video and audio (with graphics?) mixing facilities? The video enhancement circuit discussed in your June/July issue could also be included. Some video effects e.g. titles, fades, wipes etc. would also make nice additional features. Combined as one topic, this would make a very useful and interesting project to build, which I'm sure, would have great appeal.

Mr. Maynard's letter—Aug./Sep. issue—what a good suggestion for the future. I think a signal strength meter project for aligning T.V. aerials etc. would make a most welcome addition to one's tool kit.
'Maplin Mag.' Aug./Sep. issue—your low cost home alarm seems a great little project, with good appeal and is very practical. I shall enjoy this one!

2) Monthly magazine—issuing 'The Maplin Magazine' on a monthly basis is a nice idea, particularly as it should mean twice as many projects covered!
Finally a pat on the back for the good and efficient service I have received from you so far in respect of component supply and odd technical queries.

C. Dupont, Poole, Dorset.

Thank you for your suggestions, I'll pass them onto the lab. This is now the third monthly issue of 'Electronics', so I hope that you and the rest of our readers are enjoying the new increased frequency of publication.

December 1991 Maplin Magazine

AIR YOUR VIEWS

Dear Editor



STAR LETTER

This issue, R. Gregory from Gillingham, Kent, receives the Star Letter Award of a £5 Maplin Gift Token for his letter, on adding voltage readings to circuit diagrams.



Dear Editor,
Just received your latest magazine and the articles get better every time. I especially liked the serial about circuit testing, which got me thinking about how to improve the magazine.

I would like to suggest that, when you print circuit diagrams in future, could you also print the voltages at various points so that anyone who has built one of your circuits will find it a lot easier if they have something to compare their readings with. Even the experienced hobbyist would find it

a great help.

As regards previous comments made about using red ink for the prices in the catalogue, speaking for myself I don't mind but would prefer it if it was darker.

Okay, okay, we have got the message! Red ink is out—and that's official—as of the '92 Catalogue. Perhaps people would like to comment on the blue ink? The idea of adding voltages on the circuit diagrams is a good one. I shall have words with the powers that be, watch this space.



Recording Invite

The Federation of British Tape Recordists (affiliated to the International Federation of Soundhunters) holds a British Amateur Tape Recording Contest every year. The contest has various classes (including 'Creative Video') and is supported by the audio industry, but contestants must only be amateurs for whom tape recording does not contribute a significant proportion of their income, and who are normally resident in the UK.

At the present time, this year's entries are still being judged. The contest, founded in 1957, is open to all amateur creative recordists in the UK. Since the early 1980's, the contest has been run by the FBTRC, who took over from the founder of the contest, Douglas Brown who used to contribute a monthly column to 'HiFi News'. Another former supporter and judge was the late Donald Aldous.

The FBTRC is a voluntary organisation of amateur and semi-professional recording enthusiasts. I feel that many of your readers would be interested in entering the contest, the closing date for which is the 30th June each year. Each class has its own trophy, which the winner retains for the year, and from the successful entries the council of the FBTRC select the tapes that go forward to represent Great Britain in the international contest. (This year it is being hosted by Great Britain, courtesy of the BBC, in Manchester.) Details of the contest and the FBTRC can be obtained by contacting me, R. E. Bester, at 193 Ashdown Crescent, Cheshunt, Waltham Cross, Herts EN8 0RL. Please note that enquiries must be accompanied by a stamped addressed envelope, otherwise I will be unable to reply.

**R. E. Bester,
Contest Secretary.**

All Gone Quiet

Dear Sir,
I am writing to ask if your readers could give me some advice about a cordless phone I have.

The phone in question is a British Telecom Freeway, and is about 3 years old. In the last six months or so the phone has started picking up hum from the TV, and the general sound quality of the phone has deteriorated badly (i.e. one of the transceivers may be faulty). The result being that it sounds like you are half way down the street. I would also much appreciate some advice on how to open the casing on the handset, to see if a soldered joint has worked loose).

Could I also take this opportunity to ask your readers, if they could instruct me on how to build a frequency generator to operate in the range of 1MHz right up to 1GHz, for a DIY scanner I wish to build.

**Chris Willoughby,
Woodhouse, Sheffield.**

P.S. I would also like to say that I am one of a possible few who find the red ink order codes easier to use. When copying out long orders, the codes do not sink into the background with the rest of the black and white print. Is all this simply just a matter of colour blindness??!

If there is anyone who can help, please write in and we will pass on your advice.

Satellite is a Non-Starter

Dear Editor,
Reading the review of the 'Satellite Book' (issue 45, page 16) I was astounded by the statement that it is expected that there will be "... satellite TV (with) a 40% penetration..." by 1996.
NO chance! Not with scrambled subscription on an unpredictable number of channels—each priced at the whim of Sky!

Ask any dealer! There's a remarkable resistance to agreeing to Direct Debit commitments! Amusingly, in the States, there is a flourishing trade in 'Decoder Cheats'—they even advertise them ("WHY PAY??")! I suppose it's too much to hope for a Maplin Kit!
Want to bet that Sky will last till 1996? I wouldn't!

**R. G. Young,
Peacehaven, East Sussex.**

P.S. Fancy 'Point Contact' remembering 'Free Grid'! I still recall the cartoons of a serious, bowler-hatted figure...
P.P.S. Whilst none of us admit to knowing how to gimmick decoders, we all know a man who has a friend who does!

Unfortunately we cannot publish a design for a decoder as very quickly we would end up involved in a law-suit. In fact another magazine—not so long ago—was involved in just such a case. As to the longevity of BSkyB, only time will tell!

LIVE WIRE

+ mini-metal DETECTORS

by Dave Goodman

Ideal Christmas gifts for the handy-man
EXCLUSIVE CHRISTMAS SPECIAL OFFER TO 'ELECTRONICS' READERS... YOU CAN BUY BOTH KITS TOGETHER AND SAVE 10%!!!

Introduction

The Live-Wire and Mini-Metal Detectors are two useful and novel tools which complement one another, although each of them can be used independently. They are supplied in kit form and very easy to build. Beginners are referred to the 'Constructors Guide', which is included with each kit.

The Live-Wire Detector will identify the presence of any mains electricity (whether a current is flowing or not) within a distance of 50mm from the detector 'aerial'. Because no contact is required with the conductor, it is safer and far more flexible than a neon screwdriver.

The Live-Wire Detector could be used for

example, to locate any live cables buried in plaster (or indeed any insulating material) prior to drilling holes in a wall.

The Mini-Metal Detector is used for detecting metallic objects which are buried at a depth of up to 25mm. It will sense the presence of both ferrous or non-ferrous metals within the search area, such as iron wall-board nails or brass-headed screws. Potential uses of this handy little device include finding studding within partition-walls and avoiding water and gas pipes when drilling holes.



'SAFETY FIRST' PROJECTS

Live-Wire Detector

- ★ Locates live cables, breaks in mains leads and blown fuses
- ★ No contact with live circuit required!
- ★ Maximum detection range 50mm
- ★ Single 9 volt battery operation

Features

- ★ Simple to build and use
- ★ Robust and compact design
- ★ Time-saving and safe to use

Mini-Metal Detector

- ★ Locates pipes, screws, nails and other metallic objects
- ★ Works with ferrous and non-ferrous metals
- ★ Maximum detection range 25mm
- ★ Single 9 volt battery operation

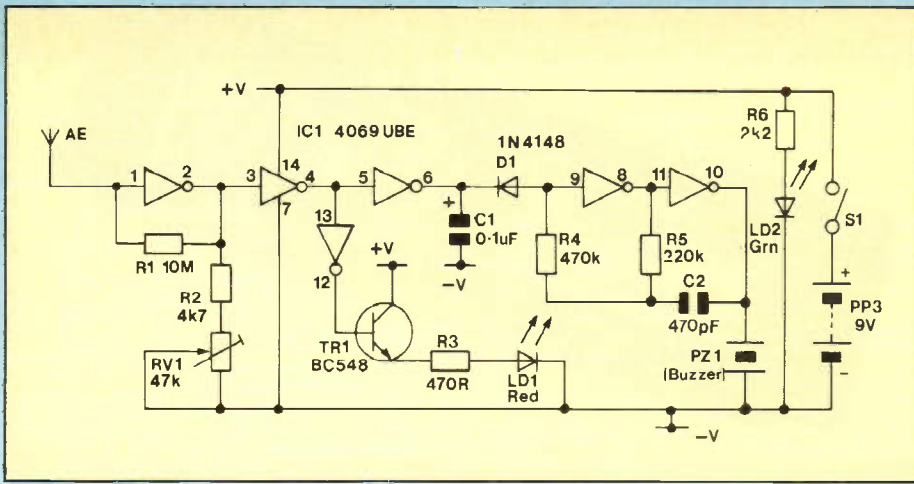

Figure 1. Circuit diagram of the Live-Wire Detector.

Live-Wire Detector

Figure 1 shows the circuit diagram of the Live-Wire Detector.

Construction

With reference to Figure 2 and the Parts List, fit the components, with the exception of the slide switch, as follows: start by fitting each of the resistors into the positions shown. Next, insert the diode in position D1 ensuring that the device is correctly orientated. It is important that each of these components lies flat on the PCB as shown in the photographs.

Fit the two capacitors in their respective positions, noting that C2 is a polarised device which needs to be installed the correct way round. Carefully solder all these components in place and cut off the excess lead-lengths. Now insert IC1 and TR1 (so that their orientation matches up with that shown in the corresponding board legends), and fit preset RV1 in the position indicated. Carefully solder all the leads of these components and cut off the excess leads-lengths.

The red LED (LD1) is inserted into the position marked 'Red' in Figure 2. Likewise, the green LED (LD2) is placed in the 'Grn' position. Correct positioning of these items is also critical, and the cathode (marked 'k' in Figure 2) is the shorter lead of the LED. Adjust the two LEDs until the base of each coloured package is 6mm above the top surface of the board. Holding the LEDs absolutely vertical in that position, solder the four leads and clip off the excess lead-lengths.

Cut the two wires from the battery connector (black = -Ve; red = +Ve), so that they are 50mm (2in.) long, tin them, and referring to Figure 3, insert each in the appropriate hole and solder in place. Cut the wires from the buzzer so that about 25mm (1in.) of each remains, tin them, insert in the two remaining holes on the PCB and solder them in position. Note that buzzer polarity is uncritical. With a small screwdriver or trim tool, adjust RV1 until its wiper points to C1 as shown by the RV1 arrow in Figure 2, and finally check that all components have been inserted and soldered correctly.

Final Assembly and Testing

Referring to Figure 4, place the switch in the box so that its lever protrudes through the rectangular cut-out in the

case. Insert the M2 bolts through the two holes on either side of the switch cut-out, pass them through the mounting holes of the switch and secure the assembly with the M2 nuts. Carefully position the PCB over the exposed switch terminals and locate the LEDs through their respective

holes within the case, now push the PCB onto the switch terminals. It must be checked that the board is mounted flush against the switch prior to soldering, otherwise undue strain could be placed on the PCB tracks - the switch effectively holds the PCB in place. Now solder the switch terminal to the PCB.

Stick the buzzer centrally onto the soldered side of the PCB using a Quickstick adhesive pad, as shown in Figure 5, so that the mounting ears of the buzzer point to the corners of the PCB and the buzzer lead-out wires are nearest the edge of the board. Ensure that the adhesive pad is fixed to the base of the buzzer, and not the top (which has a large central hole on it, from which the sound is emitted). Please note that the diameter of the buzzer may vary slightly. If it is found that it is too large to fit into the box, carefully remove some of the plastic casing of the buzzer with a sharp knife.

Install a new PP3 battery, preferably of the alkaline type, ensuring that it is fitted

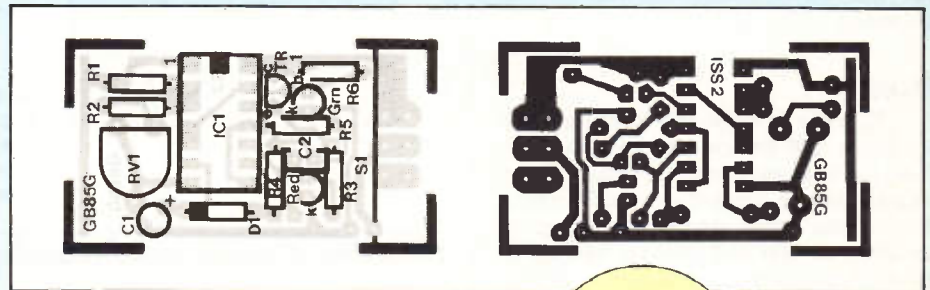

Figure 2. Live-Wire Detector PCB legend and track.

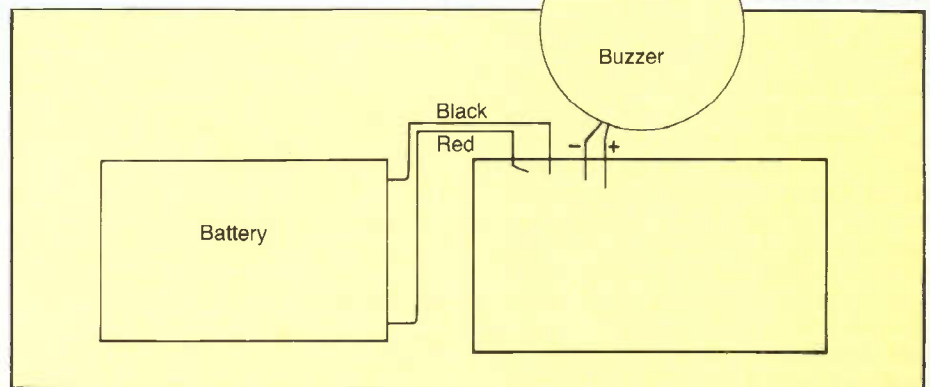
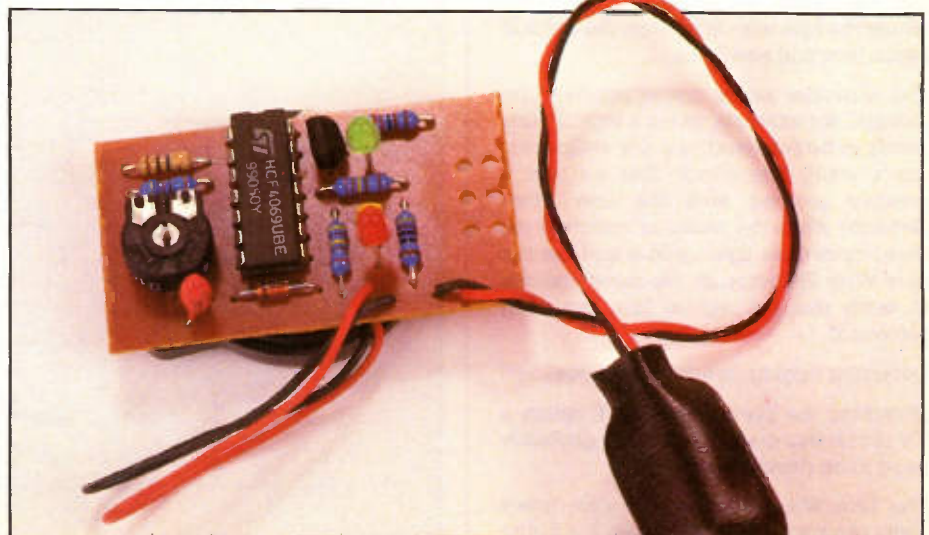

Figure 3. Live-Wire Detector wiring diagram.



The assembled Live-Wire Detector PCB.

to the battery clip the right way round, even a momentary incorrect connection could cause damage. Depending on the position of the on/off switch the Live-Wire Detector may already be switched on, indicated by the green LED glowing, if this is the case, switch the unit off.

Plug an appliance into a mains socket and switch it on. Bring the assembly up to the cable, holding the battery end of the box. Switch the Live-Wire Detector on. The green LED should light and stay on. As you approach the appliance's cable, the red LED should light and the buzzer should sound.

RV1 must now be adjusted so that the unit starts to operate about 2 inches (5cm) from the cable. To increase the sensitivity, turn RV1 clockwise; vice versa to decrease the sensitivity. Do not try to make the unit too sensitive or you will find that it is occasionally triggered by your body, or for no apparent reason.

When RV1 is correctly adjusted, fix the battery into the box using the other sticky-pad, see Figure 4. Finally, secure the box lid on using the four screws provided.

Uses

This unit is extremely useful around the home, and because the user does not have to make actual contact with any part of a live circuit, it is perfectly safe to use. Even if the wires are not connected to anything at one end (i.e. no current is flowing), the unit will reveal if they are live. Some of the many uses that have been identified include the following:

Finding wires concealed by plaster, plastic conduit, floor boards or ceiling panels. However, please bear in mind that the sensitivity of the unit is only about two inches, so do not hammer a four inch nail into a wall where there was a negative reading! However, if you get a positive reading and there is nothing else electrical on that wall, then you can confidently drive home the nail anywhere else. Generally, negative readings should be treated with caution.

The detection of breaks in cables or appliance leads. If a mains lead is suspect, it can be plugged into the mains and the unit run along its length. At the point where the Live wire is broken, the unit will cease to sound and flash.

If a particular mains circuit needs to be isolated, for example, when a switch plate needs to be removed (e.g. for wallpapering a wall), first check that you get a positive reading with the Live Wire Detector when the mains is switched on, then remove the lighting fuse and use the Live-Wire Detector, in the same position to verify that the correct fuse has been removed.

Detecting ringing on telephone lines.

Detecting the presence of EHT within a TV set (in this case, the unit will probably need to be desensitised).

The Live Wire Detector will also detect static electricity, but only when it is being moved into, or through, the static field.



Inside view of the Live-Wire Detector prior to fitting the back panel.

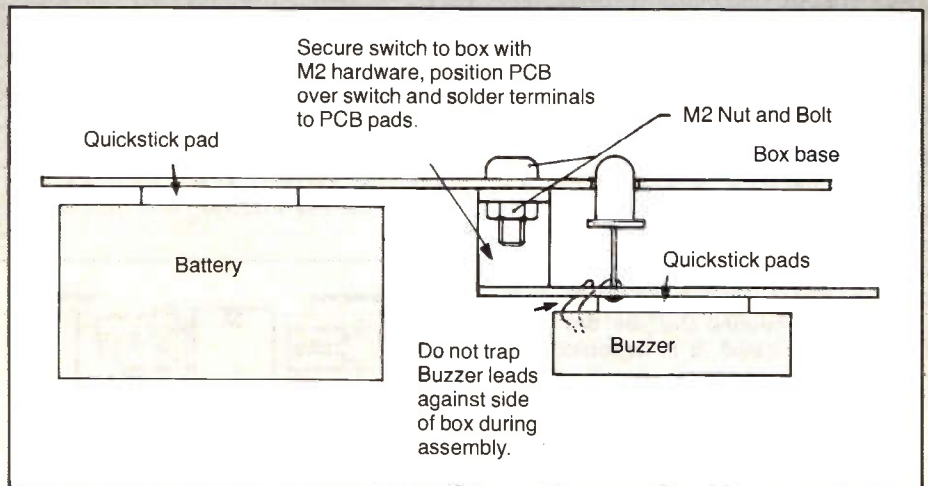

Figure 4. Overall assembly of the Live-Wire Detector

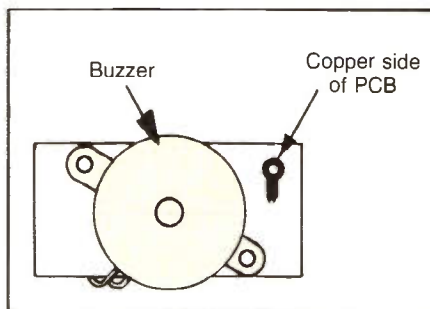

Figure 5. Mounting the Buzzer on the track side of the PCB.

Mini-Metal Detector

Figure 6 shows the circuit diagram of the Mini-Metal Detector.

Construction

With reference to Figure 7 and the Parts List, fit the components, with the exception of the slide switch and the coil, as follows: start by fitting each of the resistors, it is important that each of the resistors lies flat on the PCB, otherwise they will foul the slide switch when the PCB is fitted into the box. Solder the

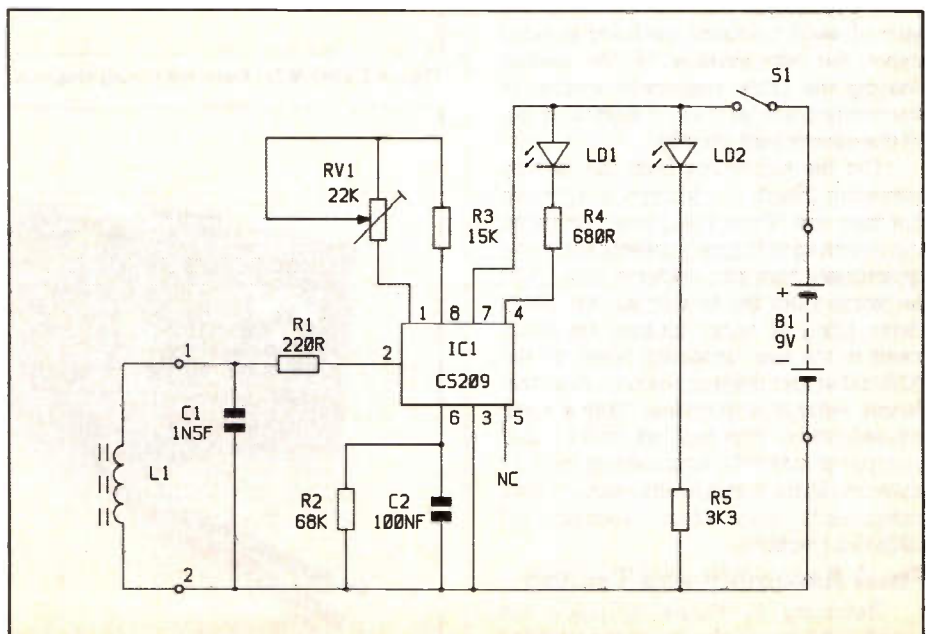
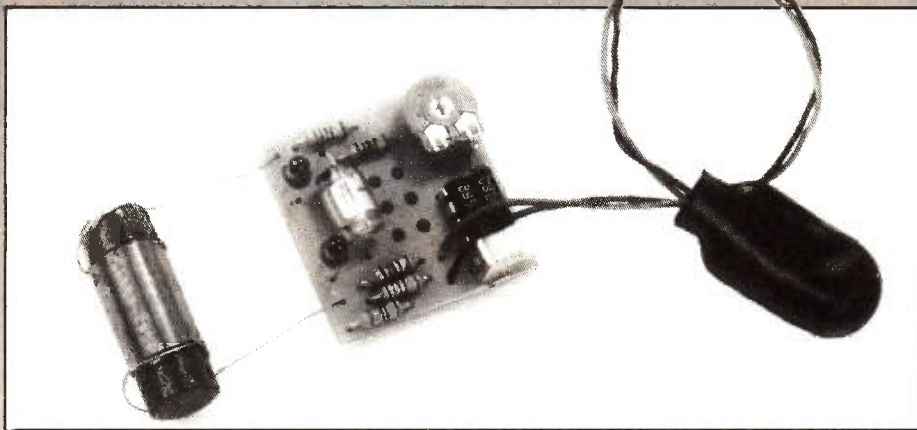

Figure 6. Circuit diagram of the Mini-Metal Detector.



The assembled Mini-Metal Detector PCB.

components in place and cut off the excess lead-lengths.

Insert capacitors C1 and IC1, then C2 and RV1; C2 is easily broken so be extra careful with the legs when fitting. Now solder all components carefully to the PCB and cut off the excess lead-lengths. Cut the battery clip wires to a length of 50mm (2in.), tin them, and solder them to the PCB (black = -Ve; red = +Ve) at the positions marked '-' and '+' in Figure 7. Refer to Figure 8 when mounting the LEDs; both LD1 and LD2 are positioned vertically at 90° from the PCB and at a distance of 6mm from board to LED base. Finally, inspect the completed assembly looking for wrong components and poor soldering. It is worth pointing out that most

project failures can be attributed to poor quality soldering, and therefore thorough checking of your work is recommended.

Final Assembly

Figures 8 and 9 show the final assembly details. Before mounting the PCB and coil in the box, the switch will need to be fitted into position, using the same methods as described in the text for the Live-Wire Detector.

To allow the coil to be fitted, two of the box pillars must be removed, see Figure 9. To secure the search coil, first fit sticky pads onto the inside front and inside top edges of the box. Remove the backing strips and carefully press L1 onto both pads, as shown in Figure 10. Cut the

two connecting wires on L1 to about 50mm (2in.) in length, remove the enamel coating and tin each end. Thread the wires through the holes marked '1' and '2' in Figure 7 and solder into place.

The PCB should then be fitted over the switch terminals exposed within the case, making sure that the two LEDs line up with, and protrude slightly through, their corresponding holes in the case. Solder the assembly in place, once it has been ascertained that the PCB is mounted flush against the switch, otherwise undue strain could be placed on the PCB tracks – bearing in mind that the switch effectively holds the PCB in place.

Testing and Use

Install a new 9V battery, preferably of the alkaline type, ensuring correct polarity, and operate the slide switch so that either LD2, or both LEDs, illuminate. Insert a trimming tool or small screwdriver into the hole above RV1 and turn the wiper fully anti-clockwise. At this stage, only LD2 should be on. Now slowly turn RV1 wiper in a clockwise direction until LD1 just comes on and at this point, back off slightly until LD1 is just turned off. LD2 will illuminate whenever the unit is powered up. Precise setting of RV1 will improve the maximum search range, which can be up to 25mm according to the size of the object being detected.

The third sticky pad may be used for fixing the battery inside the box thus

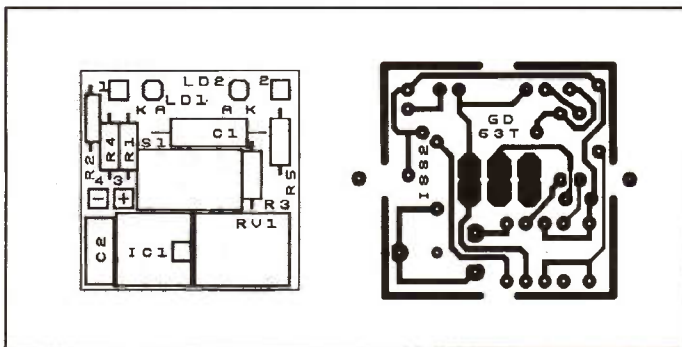

Figure 7. Mini-Metal Detector PCB legend and track.

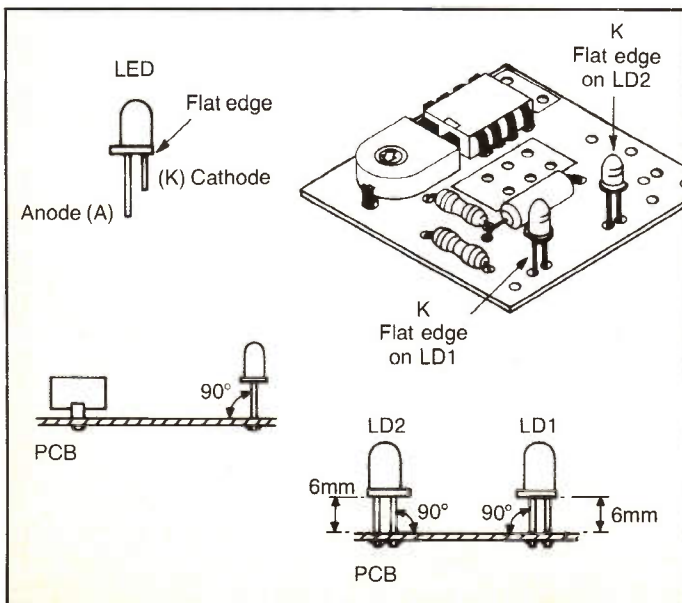

Figure 8. Mounting the LEDs.

**FROM 1/4 PAGE
TO A FULL PAGE.**

**ADVERTISE IN
THE UK'S No.1
ELECTRONICS
MAGAZINE.**

**TEL: (0702) 554155
Ext. 209**

preventing it from bouncing about and causing damage. To complete the project, clip the back panel in place and secure it with the two screws supplied.

To use the Mini-Metal Detector, hold the case with the front edge pointing at the area to be searched. If the presence of very small metallic objects is suspected (these include such items as wire nails and pins in wall-boards), then the case will need to be placed directly onto the wall panel.

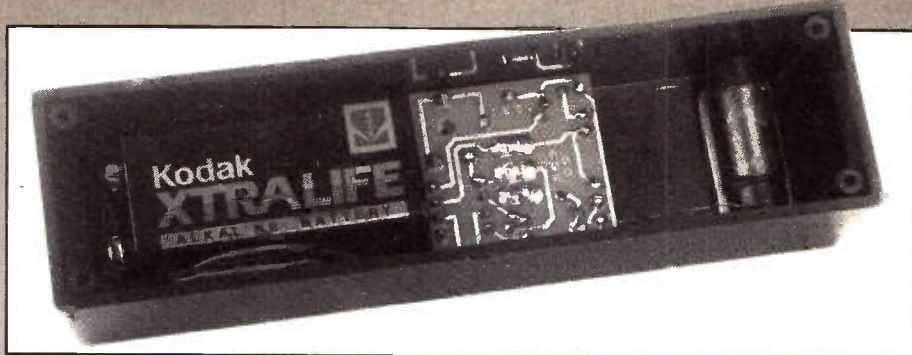

Inside view of the Mini-Metal Detector prior to fitting the back panel.

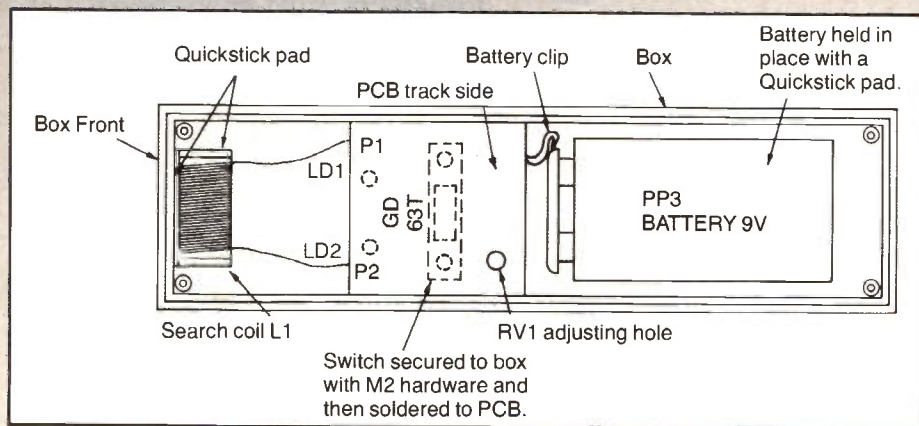

Figure 9. Overall assembly of the Mini-Metal Detector.

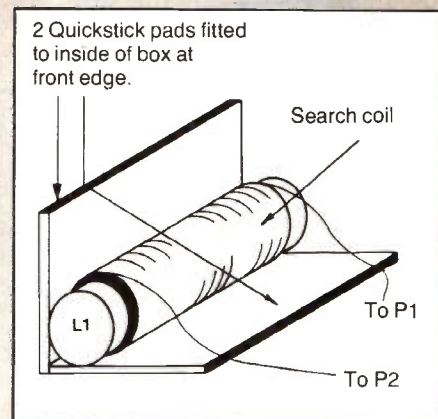

Figure 10. Mounting the search coil.

MINI-METAL DETECTOR PARTS LIST

RESISTORS: All 0.6W 1% Metal Film (unless specified)

R1	220Ω	1	(M220R)
R2	68k	1	(M68K)
R3	15k	1	(M15K)
R4	680Ω	1	(M680R)
R5	3k3	1	(M3K3)
RV1	Horizontal Encl. Preset 22k	1	(UH04E)

CAPACITORS

C1	1% Polystyrene 1500pF	1	(BX58N)
C2	Poly Layer 100nF	1	(WW41U)

SEMICONDUCTORS

IC1	CS209	1	(UH59P)
LD1,2	High Brightness Red LED Min	2	(WL83E)

MISCELLANEOUS

S1	Sub-Min Slide Switch	1	(FH35Q)
L1	100μH Search Coil	1	(JC25C)
	PP3 Clip	1	(HF28F)
	Pozi Screw M2 × 6mm	1 Pkt	(BF41U)
	M2 Steel Nut	1 Pkt	(JD63T)
	Quickstick Pads	1 Strip	(HB22Y)
	PCB	1	(GD63T)
	Mini-Metal Detector Box	1	(JC24B)
	Leaflet	1	
	Constructors' Guide	1	(XH79L)

OPTIONAL (Not in kit)

Alkaline PP3	1	(FK67X)
--------------	---	---------

LIVE-WIRE DETECTOR PARTS LIST

RESISTORS: All 0.6W 1% Metal Film (unless specified)

R1	10M 5% Carbon Film 1/3W	1	(B10M)
R2	4k7	1	(M4K7)
R3	470Ω	1	(M470R)
R4	470k	1	(M470K)
R5	220k	1	(M220K)
R6	2k2	1	(M2K2)
RV1	Horizontal Encl. Preset 47k	1	(UH05F)

CAPACITORS

C1	Tantalum 100nF 35V	1	(WW54J)
C2	Ceramic 470pF	1	(WX64U)

SEMICONDUCTORS

TR1	BC548	1	(QB73Q)
D1	1N4148	1	(QL80B)
IC1	4069UBE	1	(QX25C)
LD1	Mini LED Red	1	(WL32K)
LD2	Mini LED Green	1	(WL33L)

MISCELLANEOUS

S1	Sub-Min Slide Switch	1	(FH35Q)
	PP3 Clip	1	(HF28F)
	Min Piezo Sounder	1	(FM59P)
	Pozi Screw M2 × 6mm	1 Pkt	(BF41U)
	Steel Nut M2	1 Pkt	(JD63T)
	Quickstick Pads	1 Strip	(HB22Y)
	PCB	1	(GB85F)
	Live-Wire Detector Box	1	(FT39N)
	Leaflet	1	(XK07H)
	Constructors' Guide	1	(XH79L)

OPTIONAL (Not in kit)

Alkaline PP3	1	(FK67X)
--------------	---	---------

The Maplin 'Get-You-Working' service is available for these projects, see Constructors' Guide or current Maplin Catalogue for details.

The above items (excluding Optional) are available as kits, which offer savings over buying the parts separately.

Order As LM35Q (Mini-Metal Detector Kit) Price £4.95
Order As LK63T (Live-Wire Detector Kit) Price £4.25

Buy both kits together: Order As MMS00 Price £8.20
 Offer valid till 31st December 1991.

Please note: where 'package' quantities are stated in the Parts Lists (e.g. packet, strip, reel, etc.) the exact quantities required to build the projects will be supplied in the kits.

Watch as you build...

LOUDSPEAKER RADIO RECEIVER



ELECTRONICS

ISSUE 43

Review Extracts:

"The Watch as you build loudspeaker radio kit is fun"...

"The instructions on the tape are clear"...

"A very pleasant and satisfying experience."

Reviewed by David Holroyd

EDUCATIONAL

A COMPLETE EDUCATIONAL 'BUILD-IT-YOURSELF' ELECTRONIC STARTER KIT

WITH FULL STEP BY STEP VIDEO INSTRUCTIONS

Enables the inexperienced to construct a working loudspeaker radio receiver.

Ideal introduction to the mysteries of Electronics.

The NEW video starter kit will help to unravel its unique features and includes:

- ★ Component identification
 - ★ Circuit board construction
 - ★ Soldering
 - ★ Testing and applications
 - ★ Fault finding
- ★ Kit comprises – Instructional Video and all loudspeaker radio receiver parts (PP3 battery not included).

Prices include VAT. All items subject to availability. Please add £1 handling charge.

CREDIT CARD HOTLINE: 0702 554161 or send to Maplin Electronics, P.O. Box 3, Rayleigh, Essex, SS6 8LR.

**NOW
ONLY
£14.95**
SK00A

**PLUS
NOW
AVAILABLE**

**The Maplin
Project Builder
Starter Tool Kit:
Code SK01B
£24.95** A

MICRO-COMPUTER TESTING & FAULT FINDING

by Alan Pickard

Part One - An Introduction to Microcomputer Hardware

Microcomputers and digital systems tend to be fairly reliable in use, and do not require much in the way of routine maintenance. Regular maintenance is usually confined to electromechanical components, such as floppy disk drives and printer mechanisms. The purpose of this series is to describe microcomputer systems, and to look at waveforms and signals from a fault investigation angle.

Much of the content of these articles is based on my activities in teaching this subject practically to students engaged on a BTEC HNC course. By its nature, a magazine article cannot be a substitute for practical experience 'on the bench' and readers will hopefully treat this material as useful background reading rather than a structured set of practical exercises. After following this series, the reader will hopefully have gained some insight into how best to approach investigation or fault-finding on microcomputers, and will observe the precautions and basic rules covered. As with all practical experience in the real world, gaps exist in one's knowledge or experience, and whilst the series cannot cover every practical aspect of a given circuit or system it will enable students, technicians

and hobbyists to learn how to approach a particular problem, whether it is diagnosing a fault or being able to get the necessary information in order to cure it.

Digital systems use digital logic, and a logical or commonsense approach is needed to investigate circuit operation or malfunction. Often people who are more familiar with analogue circuitry, or who have only theoretical knowledge of digital electronics, may be confused or apprehensive when dealing with microcomputer systems. It may be useful to start by defining a microcomputer system as a microprocessor (MPU) with ROM and RAM memory, which has input/output facilities such as a keyboard and monitor display unit. Other 'peripherals' such as a printer (output) and floppy/hard disk (storage) devices are also encountered but are considered to be external to the basic microcomputer or microprocessor-based system. Figure 1 shows the basic system.

This is the simplest representation of a microprocessor-based system, or microcomputer. Its essential components are: the CPU, for example an 8-bit device such as the Zilog Z80 or Rockwell 6502; an input device, which is normally an ASCII keyboard, but could be an output from another circuit or system; the system memory, comprising fixed or nonvolatile memory (ROM) where the operating program(s) reside, and the RAM which is volatile and is used to store user programs.

Series Content

The topics which will be covered are as follows:

- (i) Main PCB, including MPU, memory and support chips.
- (ii) Keyboard, use of ASCII codes.
- (iii) Video monitors and waveform measurements.
- (iv) Floppy disk, including alignment, adjustment.
- (v) I/O circuits and ports, including printer.
- (vi) Using test programs.
- (vii) Component fault examples.
- (viii) A diagnostic/intuitive approach.
- (ix) A fault finding flow chart.
- (x) Range of test equipment to be used.

Assumptions

Some assumptions will be made about the reader's basic knowledge of hardware modules, microprocessor types, operating

systems, high level languages and machine code programming (hexadecimal and decimal, etc.).

Do's and Don'ts

When delving inside a microcomputer there are several basic rules which need to be observed. Firstly, safety. Even though we are dealing typically with voltage levels of +5V and 0V, we still need to bear in mind that mains voltage is present. This is usually contained within the power supply case but it is always possible that there may be a fault inside the case or with the associated mains input lead. Even the mains plug should be considered, unless it is pre-moulded. A previous user may not have connected the plug correctly or safely, or its 'installation' may have been interfered with or abused. Video monitors (black and white), RGB monitors and PC monitors contain much higher voltages than those present on the mains, being in multiples of thousands of volts (8 to 25kV). Great care, therefore, must be taken when working on these units with covers removed. Again, loosely fitted cases (screws missing!), mains plugs and wiring are all sources of hazard to the service technician and of course the user. Safety in connection with the servicing of monitors will be mentioned again when they are covered separately.

The Microcomputer Main Board

This series is based on 8-bit microcomputers, i.e. ones using an 8-bit microprocessor such as the Z80, 6502, etc. The principles discussed will, however, be of practical value for work on PC type machines, although PC maintenance is more modular and leans heavily towards a board replacement 'mentality'.

Assuming that most microcomputers contain a single board (or 'motherboard') we can look at a simple block diagram of its contents. Figures 2 and 3 are examples of actual microcomputer main boards.

It will be noticed that the I/O devices of Figure 1 are not included on the main board. 'Motherboard', incidentally, refers to a circuit board which contains edge connector 'slots', into which one or more 'daughter' boards can be fitted. 8-bit microcomputers such as the Tatung 'Einstein' and the BBC Micro use a main board rather than a motherboard. In the case of the BBC machine, various memory

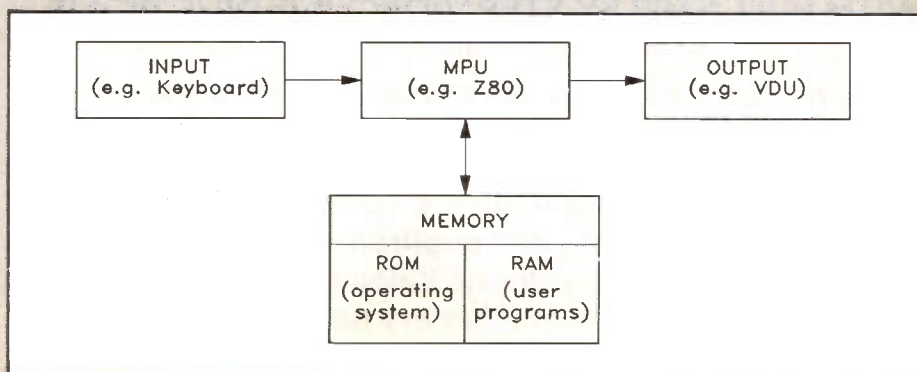

Figure 1. A microprocessor-based system.

add-ons have been devised using mini-PCBs which plug into existing IC sockets rather than circuit board edge connectors. Pictorial detail has been omitted from these two diagrams to aid clarity.

Any time spent on familiarisation with the location of components is time well spent. It is recommended that the experimenter or service technician make themselves familiar with the layout of the main board, and also all the relevant input and output connectors. Service documentation can vary in its usefulness, but often a grid reference layout is available in addition to a list of ICs and their functions. In the case of a board which uses 7400 TTL devices, the appropriate data sheets are essential for checking pin connections, and determining at a glance the content of a particular IC. A microcomputer main board also consists of several VLSI (Very Large Scale Integration) devices, and the individual data sheets (if not provided in the service manual) are invaluable if they can be obtained. The circuit diagram needs to be related to the board layout, and being able to locate the general area of interest quickly is very useful.

Using a Circuit Diagram

Using a circuit diagram should be fairly straightforward, but time can be wasted and confusion caused if an organised approach is not made. A

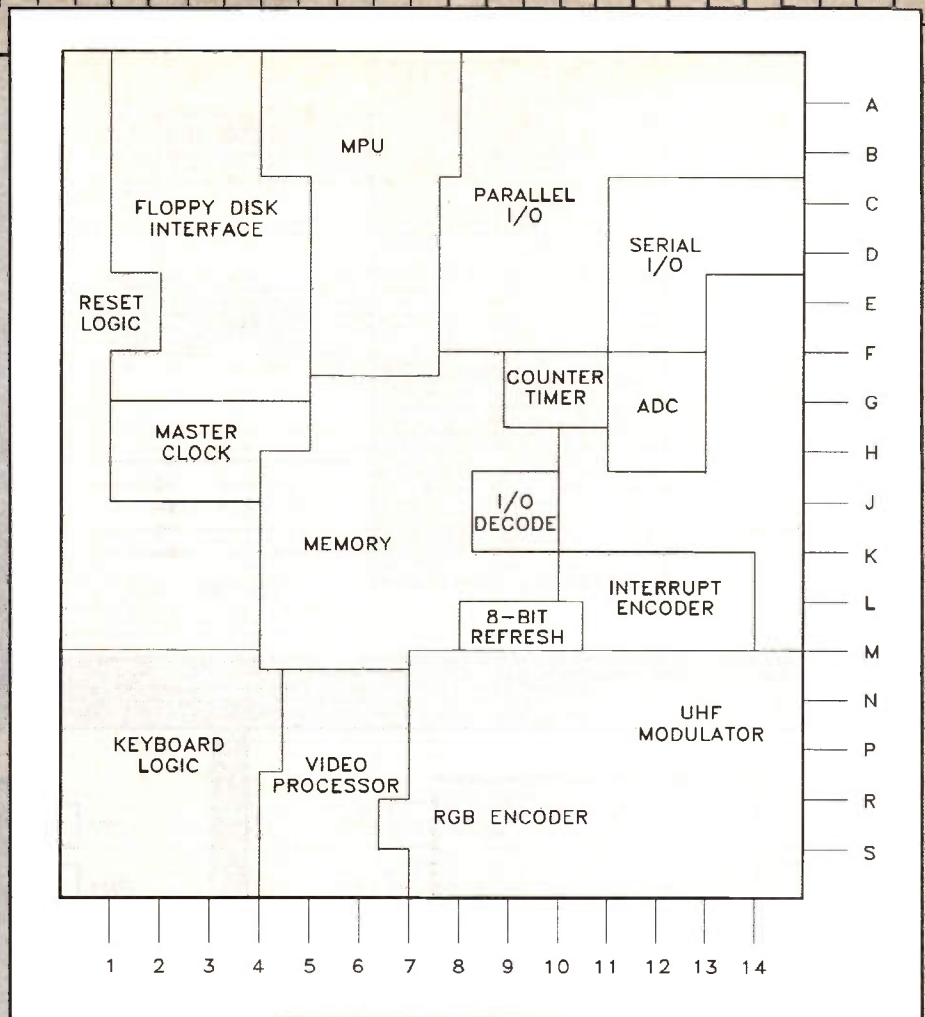

Figure 2. Layout of main PCB Einstein.

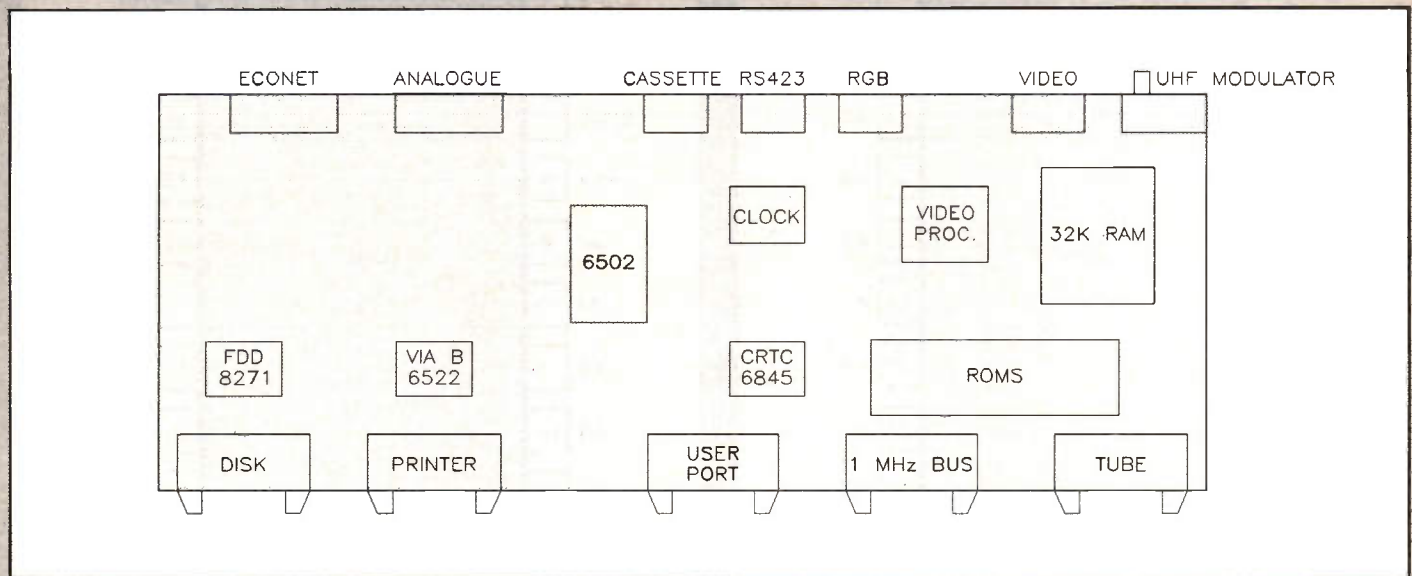

Figure 3. Main board layout and connectors (BBC Micro).

microcomputer main circuit board will contain typically 8 to 10 VLSI devices (40 pin); 20 to 30 14 pin ICs; 10 RAM chips (28 pin) and usually 2 or more ROM chips (also 28 pin). Not only does this represent a very large number of pins, but the standard logic gates with 7400 series packages are not usually placed near each other on the circuit diagram, and can be very difficult to find. For this reason, a PCB layout diagram is extremely useful if available. Annotating a circuit diagram (neatly) is a useful exercise especially if you are new to the circuit. A highlighter pen is ideal for such a task.

The Microprocessor

Assuming that the person delving into the circuit has some basic knowledge of digital circuits, we can now take a look at the main component of the system, namely the microprocessor. An 8-bit microprocessor deals with data in groups of 8 bits (one byte). The 8 bits refers to the size of the microprocessor DATA bus, its main register (the accumulator) and also the other general purpose registers. An 8-bit microprocessor or MPU therefore deals with numbers up to maximum value of 256, derived from $2^8 = 256$. In binary terms this

means a range of values from 0000 0000 to 1111 1111 or 0 to 255 in decimal, where in each case the zero value is included. For completeness, the equivalent hexadecimal range is 00H to FFH. (Numbering systems will be mentioned again later in the series).

8-bit microprocessors, although having an 8-bit data bus, have an address bus which is 16-bits wide. This means that the MPU can address memory locations using a 16-bit binary code providing a range of 0000 0000 0000 0000 to 1111 1111 1111 1111. The corresponding decimal range derived from 2^{16} is 0 to 65535

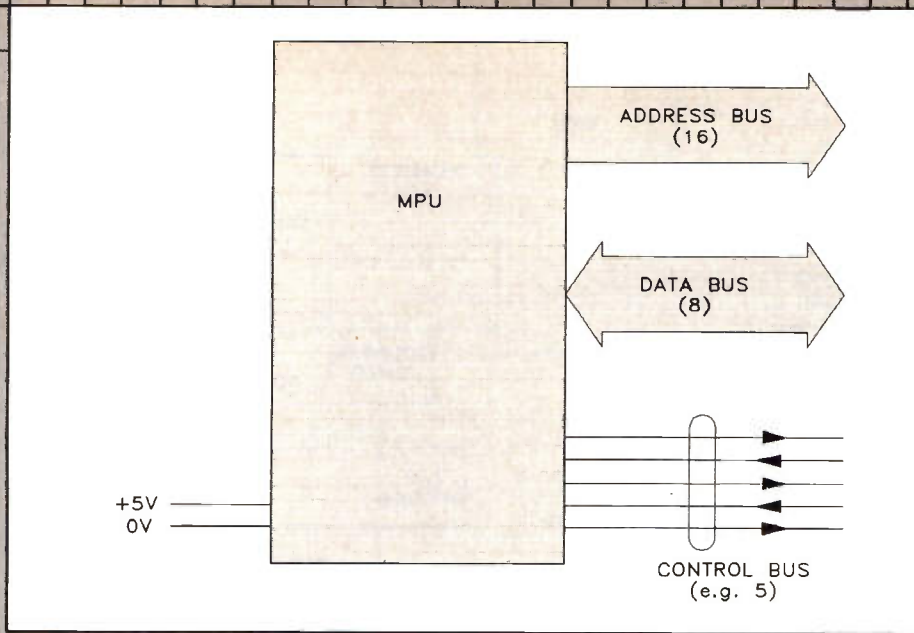

inclusive ($2^{16} = 65536$). 1 Kilobyte is the number of bytes represented by $2^{10} = 1024$. If we divide 65536 by 1024 we get 64, which is where the 64K maximum addressing capability Figure for 8-bit micros comes from.

Figure 4 shows the structure of the MPU system, and Figures 5 and 6 give details of the actual pin connections of the Z80 and 6502. Note that the individual bus lines are not tidily or logically grouped together!

The 8-bit microprocessor device usually has 40 pins, of which 16 are used for the memory address lines and 8 for data lines. The address lines are for accessing any one of 64K memory locations whereas the data lines are used to transfer data to or from a location. In other words, an address is the number of a memory location whereas the data value represents the 'contents' of this location.

Figure 4. Microprocessor system bus.

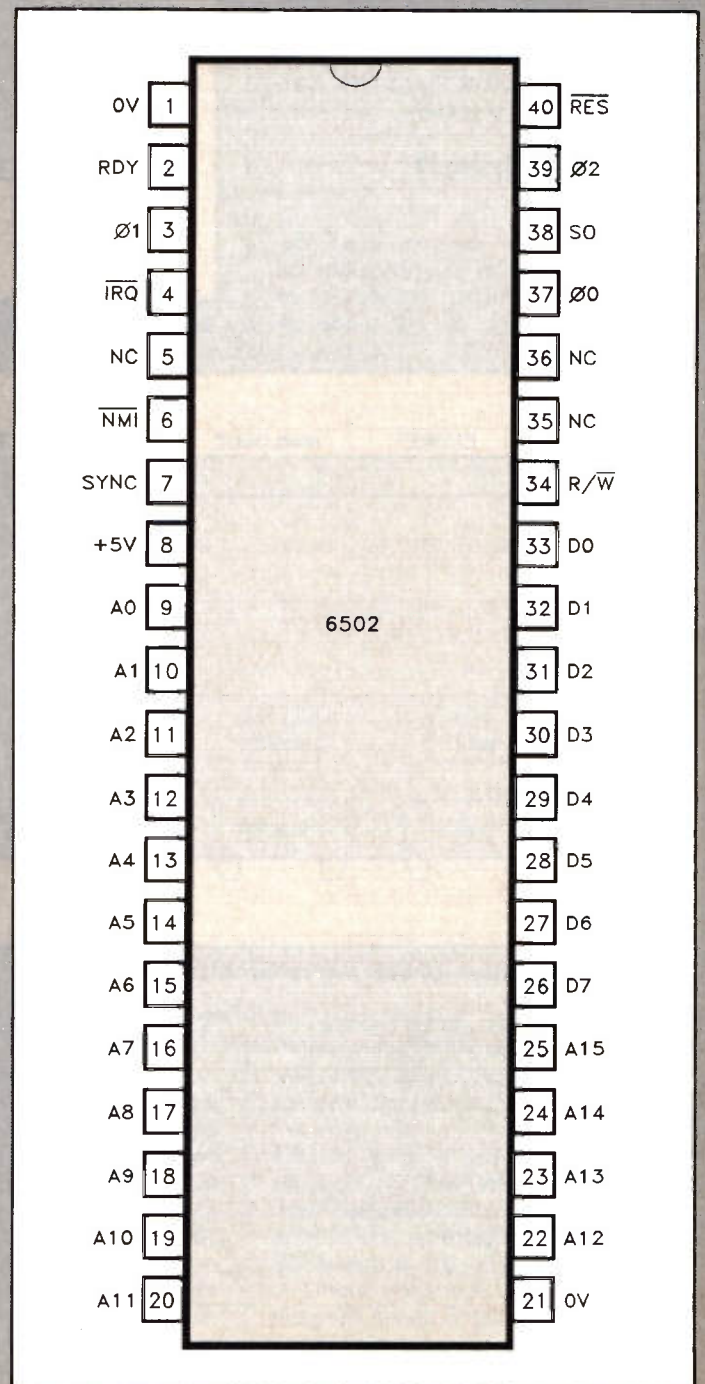
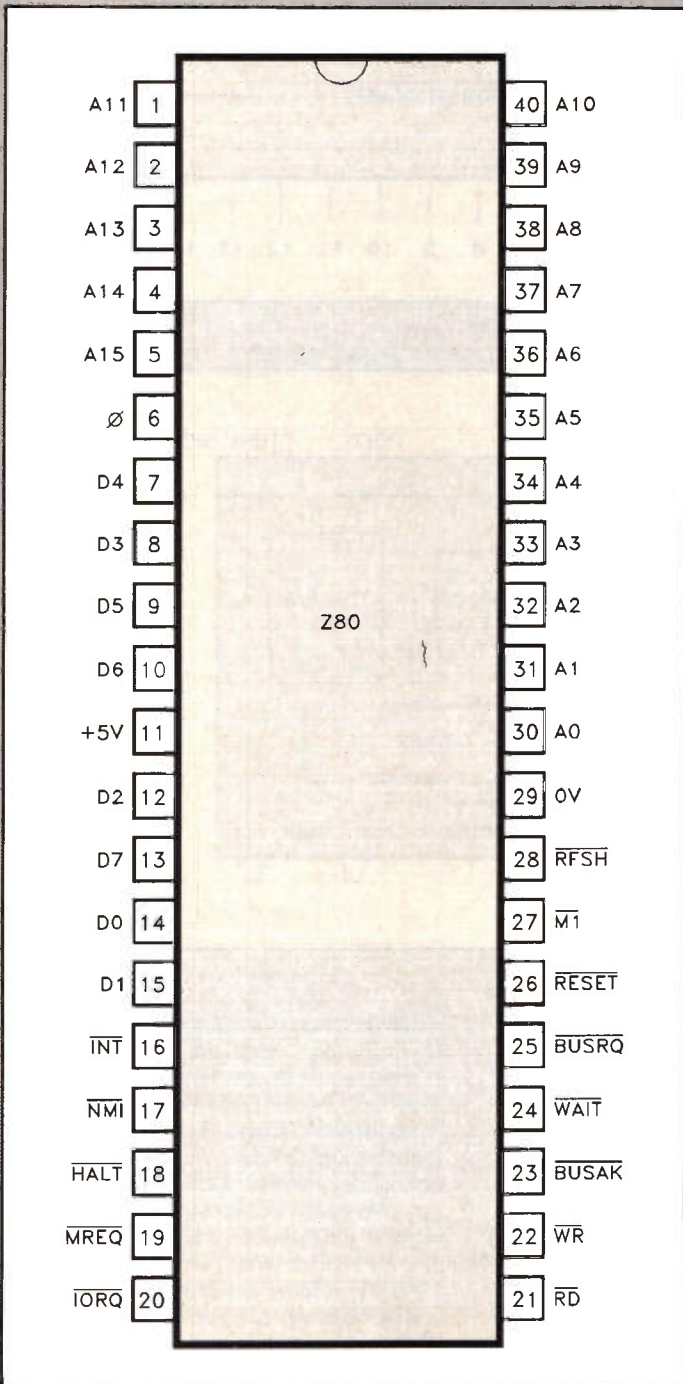

Figure 5. Pin connections of Z80A MPU.

Figure 6. Pin connections of 6502A MPU.

The remaining pins are used for the device power supply (e.g. +5v and ground), the system clock (e.g. two pins) and the remainder for control lines which include, for example, RD (read) and WR (write). The size of the control bus varies from one 8-bit microprocessor to another, but we could expect it to consist of at least five control lines. Although we can talk of a 'control bus' as part of the overall system bus comprising of address bus, control bus and data bus, the control bus actually differs in that it is not standard, and that its individual lines do not all have the same directional operation. The address bus, as can be seen from the diagram, is unidirectional i.e. logic signals travel in one direction only, from the MPU to the appropriate memory device and location. The data bus, however, is described as being bidirectional because memory contents travel from the MPU (a 'write' operation) and to the MPU (a 'read' operation).

Memory Devices

Microcomputer memory devices are basically of two types: ROM and RAM. ROM, which stands for Read Only Memory, is nonvolatile which means that its contents are permanent, cannot be overwritten and remain when power is removed. ROM chips can contain simple 'boot up' programs, monitor programs or even complete operating systems and utilities such as wordprocessor programs. Nowadays, microcomputer systems are disk based rather than ROM based, but ROM chips are still an integral part of the system for 'start up' programs, diagnostic test programs, etc.

RAM devices are volatile memory chips for storing user programs and data. All information in RAM devices is lost when power is removed. RAM stands for Random Access Memory, which is misleading because ROM is also random access memory if 'random access' is taken by definition to mean 'non-serial access'. A perhaps more appropriate description would be RWM - 'read and write memory' - which provides the real distinction between the two types. The maximum memory which an 8-bit microprocessor can address at any one time is 64K. A microcomputer may typically be equipped with, for example, 32K of ROM and 32K of RAM although a particular system does not necessarily need to be fully equipped.

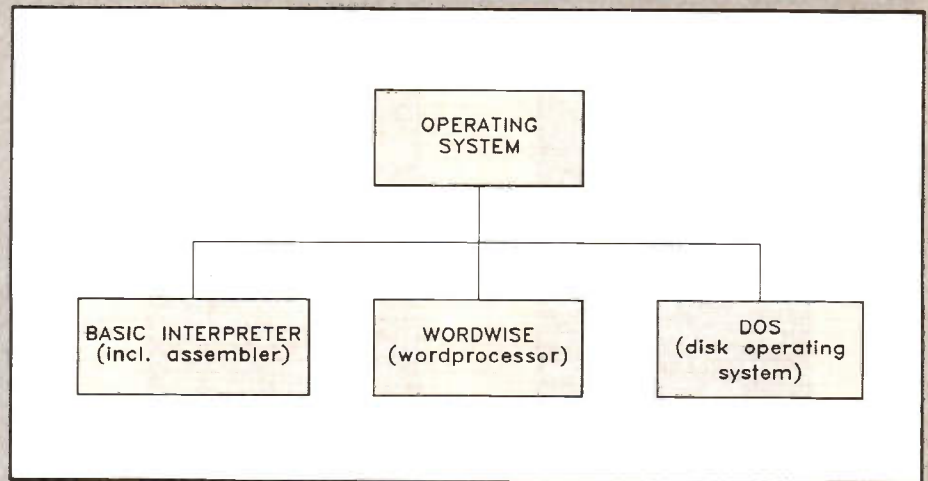

Figure 7. BBC Micro Operating System (ROM based).

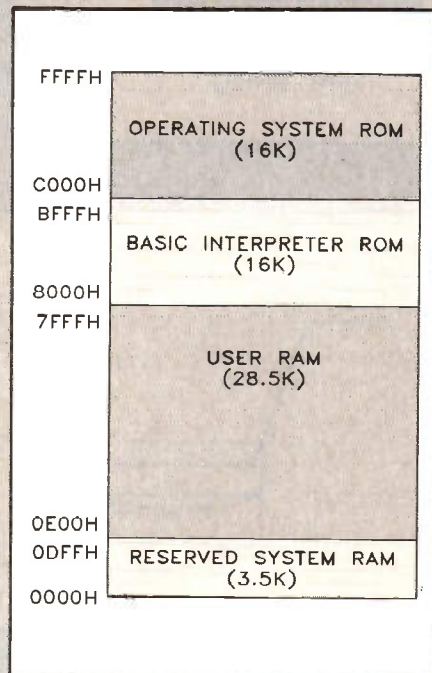

Figure 8. BBC Micro memory map.

Support Chips

A microprocessor is a 40-pin integrated circuit package which uses VLSI (Very Large Scale Integration) technology. There are usually other VLSI devices within a microcomputer system, for example an I/O device such as the Z80A PIO. This device contains complex circuitry, such as two 8-bit ports which will allow the interfacing of 8-bit devices, such as

keyboards and printers, to the system. These devices are usually chosen for their compatibility with the microprocessor device. Fault-finding investigation with these devices requires reference to the appropriate manufacturer's data sheets. Memory devices and support chips will be covered in more detail later in the series.

The Operating System

To carry out any investigation work on a microcomputer requires the user to be either already familiar with the operating system, or able to obtain the required information concerning the use of operating system commands, disc accessing, etc. Two examples of operating systems are as follows:

BBC Micro

The BBC Micro was designed as a ROM-based system with the ability to store programs and files on a cassette filing system. Figure 7 shows the operating system (O.S.) structure. The O.S. is located in a 16K ROM chip and the Basic interpreter (used for running BASIC programs) runs under this O.S.

The operating system and Basic interpreter are located in ROM. Other utilities are also available on ROM as extras, for example wordprocessor programs (such as Wordwise). Most BBC machines still in use have a disk drive facility, and therefore a disc operating system (DOS), but the operating system is still in ROM. Thus the BBC machine is not a true disk-based system. The BBC Micro has 32K ROM and 32K RAM, 16K of the ROM being occupied by the operating system and Basic interpreter. Additional utilities (such as a wordprocessor) stored in 16K ROMs are 'switched in' when required, instead of BASIC. The disk operating system is held in a 4K ROM and uses up RAM space in the memory map. Figure 8 is a simple representation of the whole of the 64K memory map of the BBC Micro.

Unless the position of ROMs in the BBC Micro have been deliberately changed, the machine normally defaults to BASIC after switch on. This being the case, it is easy to load, type in, edit and save BASIC programs.

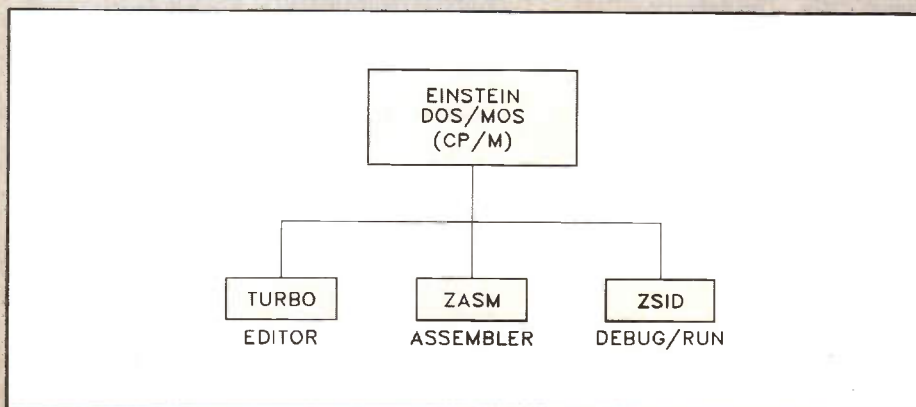

Figure 9 Einstein (CP/M) operating system (disc-based).

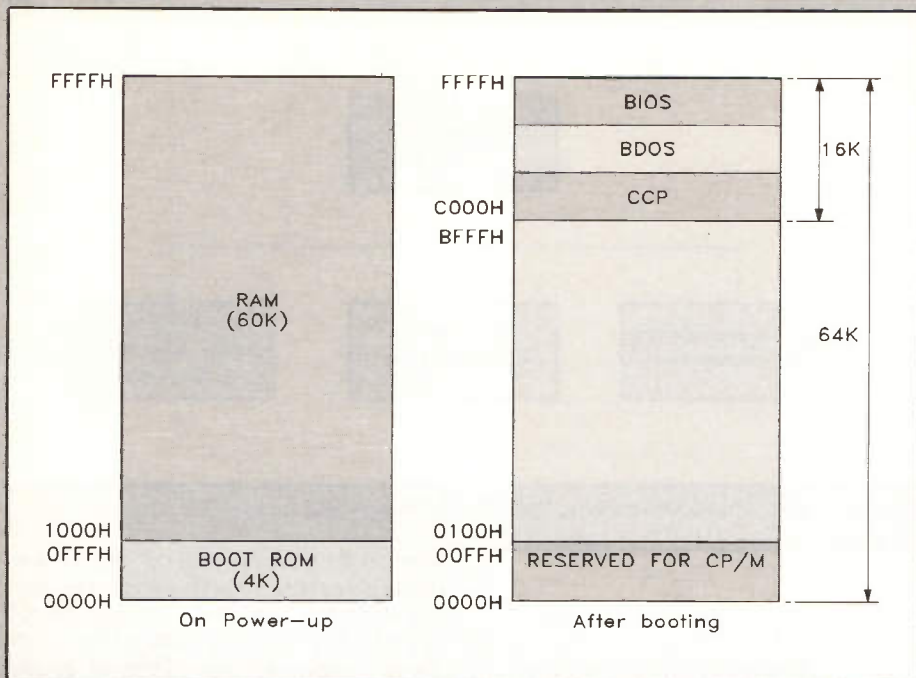

Figure 10. Einstein (CP/M) memory map.

Einstein

This machine is not unlike the BBC Micro in its design, except that it has a (single) disc drive which is integral to its operation. Unlike the BBC machine the Einstein cannot function correctly without such a device because the operating system is stored on disc and must be loaded up each time the machine is powered-up. The operating system structure is shown in Figure 9 where it can be seen that the three different programs (the editor, assembler and debugger) run under CP/M at different times. DOS/MOS (disc operating system/machine operating system) is the name given to the version of CP/M running on the Einstein.

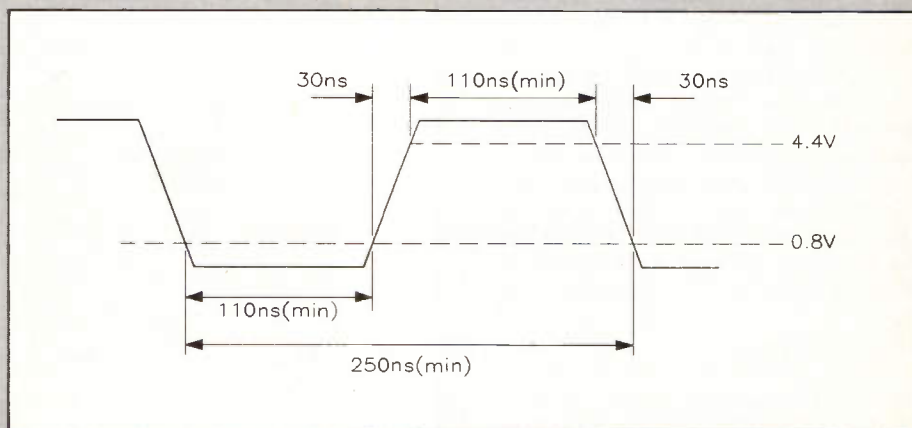

Figure 11. Clock Waveform (Z80 at 4MHz).

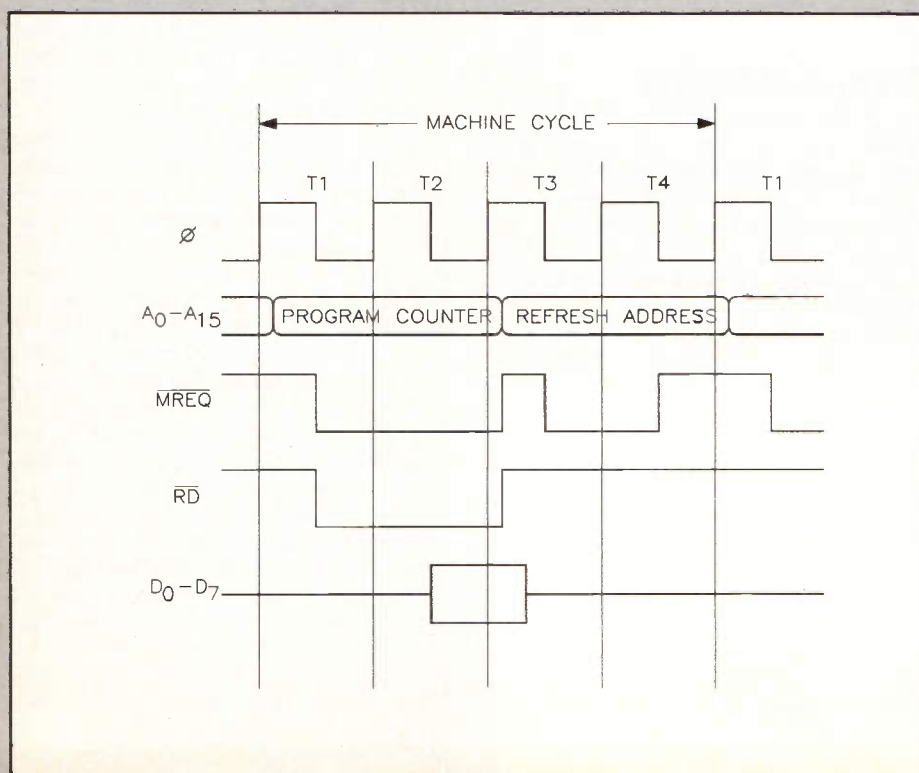

Figure 12. Opcode fetch machine cycle (Z80).

The Einstein is a Z80-based micro-computer, and runs the CP/M operating system. Upon switch-on a message appears naming the computer, and a message inviting the user to press the CTRL and BREAK keys simultaneously is given. If a disc containing the operating system is already present in the drive then this program will be loaded, a prompt appearing on the screen upon completion. Once the CP/M operating system is present in the machine's memory, it will be possible to load (from disc) other programs such as editors, PASCAL compilers, assemblers, etc. It is essential that the user knows how to 'drive' the system under test. For example, the user should be aware of how to load and run appropriate test programs, and must also possess the ability to type in and edit programs where necessary. The Einstein memory map in Figure 10 is a standard CP/M memory map and shows 'before' and 'after' conditions. The boot or 'boot up' ROM merely initiates the microcomputer monitor program and enables the CP/M operating system disc to load the BIOS (Basic I/O

System), BDOS (Basic DOS) and CCP (Console Command Processor) program modules into RAM. After booting up, memory locations from 0000H to 00FFH are unavailable to the user with 0100H being the usual place for user programs to start, i.e. 0100H is the bottom of 'user RAM'.

Figure 11 shows the clock waveform of the Z80 running at 4MHz with details of timing and voltage measurements. This will be referred to again when looking at the use of test equipment.

Timing diagrams related to MPU operation are found on manufacturer's data sheets and in equipment manuals. Figure 12 is a simplified version relating to the 'opcode fetch' process whereby an instruction in a program is 'fetched' from its memory location by the MPU.

A timing diagram shows the relationship between several relevant logic signals which can be observed with an oscilloscope or, more conveniently, a logic analyser. In Figure 12, \emptyset is the clock waveform made of individually labelled clock cycles, or T-states. In this operation a complete machine cycle is made up of four T-states. A0-A15 represent the sixteen address bus signals as an envelope, which

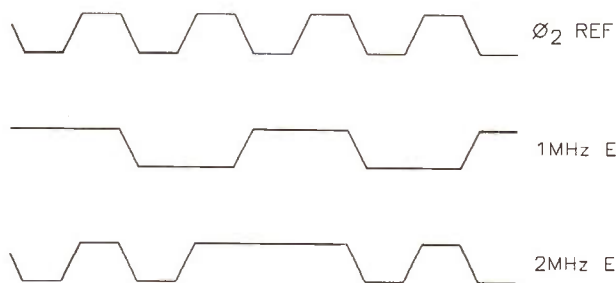

Figure 13. BBC Micro clock waveforms (6502).

is easier to draw than 16 varying bit patterns. MREQ and RD are control bus signals known as 'memory request' and 'read' respectively. D0-D7 represent data bus activity. Again, these will be referred to when looking at test equipment.

Waveforms BBC Micro

The BBC micro is based on a 6502A 8-bit processor which has two clock speeds; 2MHz and 1MHz. The higher speed runs the system whilst the lower speed is used for slower devices such as the ADC (analogue to digital converter) and 6845 CRT controller.

A simple test program can be run to provide useful test waveforms:

```
10 P% = &3000
20 [SEI
30 .START
40 STA &FC00
50 STA &FC00
60 JMP START
70 ]
80 CALL &3000
```

This program consists of a 6502 assembly language program within a BASIC program and will produce the waveforms shown in Figure 13.

The Ø₂ REF waveform can be

observed on pin 39 of the MPU. The 1MHzE and 2MHzE signals are derived from a 16MHz crystal oscillator and other components external to the MPU circuitry.

Einstein

The Einstein microcomputer is Z80-based with a clock speed of 4MHz. The clock signal (Ø) can be observed with an oscilloscope, its probe attached to pin 6 of the Z80. The following simple assembly language program can be used to look at address and data bus activity:

```
ORG 0100H
JP 0100H
```

This is a very simple loop (jumping back on itself) which produces the required bus activity.

Observation of waveforms will be discussed later in the series.

The Next Stage

This first part has looked at micro-computer operation from a general, introductory level. Part 2 will look at keyboard operation, the video monitor and I/O circuits, putting into practice some of the basic guidelines and approaches of this article.

MAPLIN'S TOP TWENTY KITS

POSITION		DESCRIPTION OF KIT	ORDER AS	PRICE	DETAILS IN
1.	(1)	1/300 Timer	LP30H	£ 4.95	Magazine 38 (XA38R)
2.	(2)	Live Wire Detector	LK63T	£ 4.25	Projects 14 (XA14Q)
3.	(3)	MOSFET Amplifier	LW51F	£20.35	Magazine 41 (XA41U)
4.	(4)	TDA7052 Kit	LP16S	£ 4.45	Magazine 37 (XA37S)
5.	(10)	Vehicle Intruder Alarm	LP65V	£ 9.95	Magazine 46 (XA46A)
6.	(9)	Low Cost Alarm	LP72P	£12.95	Magazine 45 (XA45Y)
7.	(7)	Car Battery Monitor	LK42V	£ 7.95	Magazine 37 (XA37S)
8.	(6)	PWM Motor Driver	LK54J	£ 9.95	Best of Book 3 (XC03D)
9.	(5)	Mini Metal Detector	LM35Q	£ 4.95	Magazine 25 (XA25C)
10.	(8)	Digital Watch	FS18U	£ 2.45	Catalogue '92 (CA09K)
11.	(13)	TDA2822 Amplifier	LP03D	£ 6.95	Magazine 34 (XA34M)
12.	(15)	Courtesy Light Extender	LP66W	£ 2.75	Magazine 44 (XA44X)
13.	(-)	NEW ENTRY MSM6322 Data File	LP58N	£11.45	Magazine 44 (XA44X)
14.	(16)	PartyLite	LW93B	£10.25	Catalogue '92 (CA09K)
15.	(11)	Siren Sound Generator	LM42V	£ 4.25	Magazine 26 (XA26D)
16.	(12)	LM386 Amplifier	LM76H	£ 3.75	Magazine 29 (XA29G)
17.	(-)	RE ENTRY LM383 8W Amplifier	LW36P	£7.45	Catalogue '92 (CA09K)
18.	(-)	NEW ENTRY L200 Data File	LP69A	£3.95	Magazine 46 (XA46A)
19.	(-)	RE ENTRY I/R Remote Switch	LM69A	£16.95	Magazine 33 (XA33L)
20.	(19)	U/Sonic Car Alarm	LK75S	£17.95	Projects 15 (XA15R)

Over 150 other kits also available. All kits supplied with instructions.

The descriptions are necessarily short. Please ensure you know exactly what the kit is and what it comprises before ordering, by checking the appropriate project book, magazine or catalogue mentioned in the list above.

Maplin

*Do you Enjoy your work?
Or would you prefer to
Work at what you enjoy?*

If you are an electronics enthusiast and looking for an interesting career with a future, Maplin has the answer.

We currently have vacancies for

TECHNICAL SALES STAFF

FOREST HILL, SOUTH LONDON

These vacancies are being created as a result of the Maplin expansion programme and offer real prospects up to and including Branch Management.

A knowledge of sales, although an asset, is not essential. But, to become part of the team you do need to be self motivated and have a cheerful personality. Applicants should also be smart and have a knowledge of electronic components.

We offer excellent working conditions and job security, plus a good salary with commission and a realistic pension scheme.

Apply in writing enclosing CV to: David Snode, P.O. Box 3, Rayleigh, Essex. Or for further information, ring 0702 554155.

If you are seeking an interesting career in a High Tech environment then contact us

NOW!

NEW BOOKS

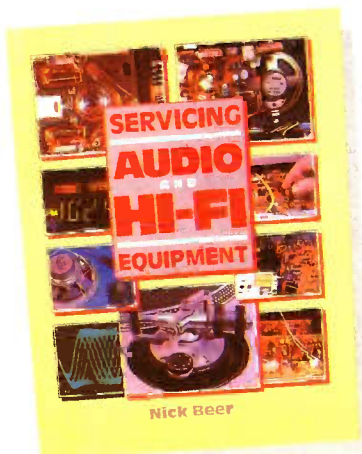

Servicing Audio and Hi-Fi Equipment

by Nick Beer

Written especially for service technicians and engineers, this book is designed as a bench-side companion and guide. Its purpose is to ease and speed up the process of fault-diagnosis, repair and testing of all classes of home audio equipment: receivers, amplifiers, recorders and other playback machines. It is not a textbook, but written in a light style and is equally useful to the hobbyist and domestic hi-fi enthusiast, and anyone who needs help in identifying a problem. It examines both the mechanics and electronics of domestic audio in a down-to-earth and practical way, concentrating on what goes wrong, how to track down problems and how to solve them. The techniques explained are based on hard-won experience on the work bench and in the field, and the book is the next best thing to having a time-served engineer sitting alongside you, advising, guiding, cautioning, and pointing the reader in the right direction.

Sixteen comprehensive chapters range from the simplest AM radio to the intricacies of CD and DAT systems. Along the way, such diverse subjects as servos, speakers, dial cords and 'dirty heads', motors and microprocessors, turntables and transistors are examined, together with the techniques and test equipment needed to sort them out and set them up.

Fully illustrated with photographs, diagrams, fault-finding charts and

circuits, the book also includes a comprehensive guide to manufacturers and suppliers, and a 'symptom index' for quick access to specific advice and suggestions in particular areas. The book is notable especially for offering some advice, as part of the section on repair techniques, about handling SMDs (Surface Mounted Devices), and how to remove and replace these tiny components and what to watch out for. 1991. 252 x 194mm hard cover. 218 pages, illustrated.

Order As WT87U (Service Audio & HiFi) Price £25.00 NV

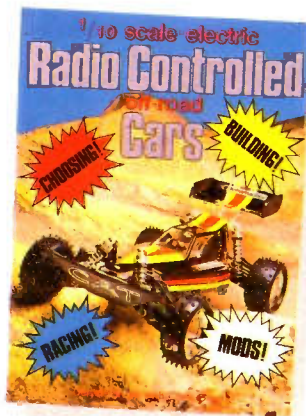

Radio Controlled Off-Road Cars

by Deryck Green and Chris Green

Building and racing radio controlled cars is fun, especially 1/10th scale electric powered 'buggies'. Because of their safety, quietness and versatility they are by far the most popular form of R/C car.

They are, however, quite high tech, considering that quite ordinary 1/10th scale cars are capable of 25mph, which scaled up equals 250mph! Even the bigger and heavier 1/12th scale 'Monster' class electric cars have a scale performance similar to a full sized Ferrari. As with any high tech subject, a certain amount of knowledge is very helpful. In this case, it is even more necessary because different items are made by different manufacturers. In the full sized car world, manufacturers assemble the car, garages maintain the finished product and driving schools teach how

to drive it. With radio controlled cars you are very much on your own, which is where this book will help you.

Although the book is very much aimed at owners of 1/10th scale cars, it should also be of general interest to owners of other types of electric powered R/C cars and models, especially 1/12th 'Monster' class cars. The term 'buggy' has been used throughout this book to describe the vehicle under discussion which is usually any radio controlled car. The term 'car' is not used because it is universally employed to describe a road car, model car, racing car etc. (In conversation however, most owners refer to their 'buggy' as a 'car'.) You will also be given an insight into some other terminology of the sport, and will learn the difference between 'splits' and 'solids', 'reds' and 'yellows', and how to choose, build and modify 'buggy' kits and set up radio equipment. 1990. 231 x 171mm. 112 pages, illustrated.

Order As WT86T (RC Offroad Cars) Price £6.95 NV

Alarms

55 Electronic Projects and Circuits

by Charles D. Rakes

Functioning smoke and fire alarms in the home and workplace save thousands of lives each year. Tripped burglar alarms do scare off would-be intruders. With this book you can secure your home and property without spending a fortune, and no previous experience is necessary.

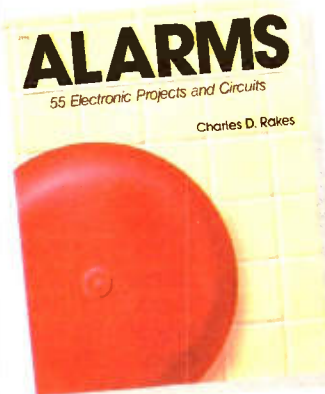

Step-by-step instructions and work-in-progress diagrams are provided, with trouble-shooting advice, for building each project, including installation in your home or car.

The projects include car alarms, with indicators for low/high battery voltage, lighting failure, low brake fluid level,

water overheating, and break-ins; intrusion alarms having sensors for light, proximity, sound, glass breakage, vibration and fence intrusion; burglar alarm control systems with simple or multi input control, and time entry/exit control; alarm indicators and sounders; telephone remote listening and alarm control, from a basic remote unit to adding extra functions; fire and smoke alarms and some miscellaneous alarm circuits moisture and flood alarms, AC motor overload, radiation level, and severe weather warning. You are certain to find something very useful. 1988. 178 pages. 234 x 185mm, illustrated.

Order As WT76H (55 Alarm Projects) Price £12.60 NV

Air Band Radio Handbook

Third Edition

by David J. Smith

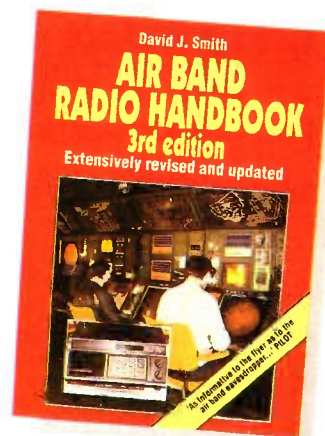

Air band radio listening allows you to eavesdrop on the conversations between aircraft and those on the ground who control them, and is an increasingly popular and fascinating hobby. It not only assists in the recognition of aircraft flying overhead, but also provides an insight into the complex world of air traffic control. The author, who is an air traffic controller by profession, describes the types of air band radio available and how to use them. With the intricacies of air traffic control and its jargon explained, you will be able to translate what you hear into what's actually going on over your head. The book also includes full appendices containing comprehensive, up-to-date lists of VHF, UHF and HF frequencies, call signs etc.

Hailed as the best book on the subject when it first appeared in 1986, this new, extensively revised and updated third edition maintains the book's position as the indispensable guide to the hobby, and the essential companion for every air band radio enthusiast.

1990. 215 x 157mm. 173 pages, illustrated.

Order As WT83E (Air Band Radio Hbook) Price £7.50 NV

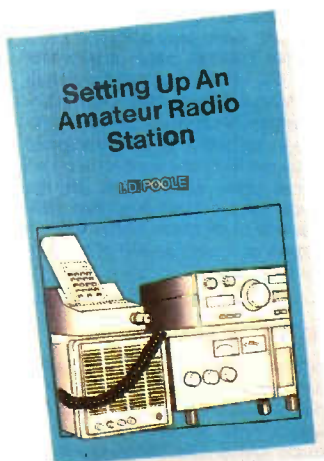

Setting up An Amateur Radio Station

by I.D. Poole

The aim of this book is to give guidance on the decisions which have to be made when setting up any amateur radio or short wave listening station. Often, the experience which is needed is learned by making mistakes, but this can be expensive. To help overcome this, the book gives advice on many aspects of setting up and running an efficient station, and then proceeds to discussing the steps that need to be taken in gaining a full transmitting licence. The topics covered include: the equipment needed; setting up the station; which aerials to use; methods of construction; test equipment; and preparing for the licence. 1991. 94 pages. 178 x 111mm, illustrated.

Order As WT74R (Set Up Radio Station) Price £3.95 NV

Aero Modellers' Handbook

by Les Netherton

Too many people abandon the absorbing hobby of flying model aircraft after their first disastrous



crash-landing. If they had read this book first, things might have been different.

Getting a model aircraft to fly successfully is not difficult, but in addition to possessing the right tools and a certain amount of manual skill, it does require a basic knowledge of what keeps an aeroplane in the air, and how its controls work. These basic principles are the starting point at the beginning of the book. The reader is taken through all the essential principles so that the construction of the first model proceeds on a sound footing. Different methods of assembly are discussed using different materials for fuselages, wings and tailplanes, plus undercarriage construction, making propellers from scratch, and covering and painting the model.

Different types of aircraft are also considered, including gliders, rubber-powered models, diesel, glowplug and electric motors, radio control and control line systems. Finally, having built your chosen model, you are given extensive advice on flying it, correcting the balance, adjusting warps, and dealing with other common problems.

Fully illustrated with drawings, diagrams and photographs, the book is both a first-class primer for the beginner and a sound reference source for the more experienced modeller.

1990. 241 x 163mm hard cover. 218 pages, illustrated.

Order As WT85G (Aero Modellers Book) Price £14.99 NV

Short Wave Radio Listener's Handbook

by Arthur Miller

If you've ever wanted to travel the world without setting a foot out of doors, this is the book for you. In an

easy-to-read non-technical language, this complete guide unravels the mysteries of SWling (Short Wave radio Listening to amateur, broadcast and CB transmissions), and with the help of over thirty illustrations, brings the hobby to life.

Introductory chapters on the equipment needed, the identification of stations heard, and the peculiarities of the various wavebands are followed by instructions on how to verify reception of stations and enter competitions. Detailed appendices give all the information you need to understand what you are hearing, and, if you fancy trying to contact other stations yourself, this invaluable book can help you there, too.

1987. 215 x 158mm. 207 pages, illustrated.

Order As WT84F (SW Radio Listener Bk) Price £7.99 NV

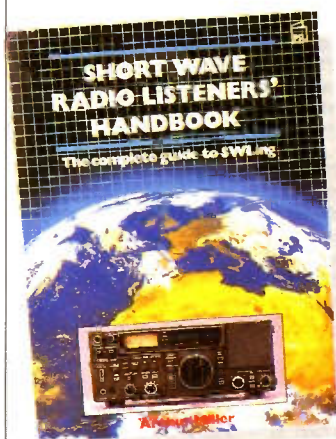

Oscilloscopes

How to Use Them, How They Work

Third Edition

by Ian Hickman

Oscilloscopes are essential tools for checking circuit operation and diagnosing faults. But an enormous range of different models is available, and choosing an instrument suitable for your needs has never been easy, particularly for the hobbyist beginner.



It's true however, that once you've started using a 'scope, you'll wonder how you ever managed before. But what is the right 'scope for a particular application? Which features are essential, and those not so important, for your requirements?

This extensively enlarged edition of this book now includes new material on storage CRTs, DSOs (Digital Storage Oscilloscopes), sampling oscilloscopes, oscillographs, X/Y, X/T and X/Y/T plotters, both stand alone and as existing oscilloscope accessories; UV recorders, laser recorders, and use of dot matrix printers as output devices. In this case PCs are used with 'plug-in' scope and logic analyser cards. There is also additional material on network analysers, intrinsically safe oscilloscopes, display oscilloscopes and fibre-optic TDRs. A new appendix covers the considerations relating to achievable measurement accuracy in various types of oscilloscope – voltage, time, frequency, rise-time etc.; electronic cursors, coupled DVMs etc. This is not intended to be a textbook of any sort, and certainly does not include any constructional details for building your own 'scope, but it is educational for anyone not familiar with the now great variety of these instruments and their capabilities. 1990. 255 pages. 215 x 138mm, illustrated.

Order As WT75S (How Scopes Work) Price £14.95 NV

For a comprehensive range of books and other publications, see the new 1992 Maplin Catalogue.
ON SALE NOW!

Christmas

XTRA

Browsing through the editorial cupboard the other day, in search of a long lost bottle of crusted port, a discarded crystal ball was discovered - filed away under 'future developments'. It was duly sent to our consultant author, Alan Simpson, who duly donned the mantle of 'Old Moore Maplin' to see what 1992 has in store for us all.

JANUARY

Owing to a mix-up by the Maplin research and development team, the lab. photocopier was integrated with the fax machine. As a result, football pool entries, personal income tax returns plus the odd 'Electronics' article ('we never publish 'odd' articles - Ed.') were being shunted around the world at a fast Group 3 rate. Despite a keen demand from Canon to be allowed marketing rights to our MAP-CopyFax system, management decreed a reversion to standard issue fax and copier services.

The DHSS and National Health announce that their comms development programme is now running some four years behind schedule. Andersen Consulting allocates a further 1000 advisors. The new Minister congratulates all concerned and calls for further privatisation.

Maplin announce a New Year shop sale.

FEBRUARY

The 'Electronics' editorial board decides that it would like to see a more international flavour to the regular 'Out and About' features. The roving reporter agrees to buy a bus pass and visit Golders Green. The Purchasing Department at Maplin over-estimates seasonal demand for UM66 Love Me Tender Melody Generator ICs. The research and development team is ordered to design projects using this IC.

Canon UK sends a letter of consolation to the unfortunate operator who during the Christmas office party, fell into the laser printer. Forever etched into her left thigh is the message, Canon does IT better.

Maplin announce a St. Valentine's Day shop sale.

MARCH

Determined to win for the second year running the prize for the best Marketing and PR at the NEPCON Exhibition, Maplin design their stand as an Exocet missile. Although the judges agreed that the theme was innovative, the fact that a mischievous visitor lit the fuse and sent the rocket circling over Birmingham, before heading towards Baghdad, lost several marks.

IT consultants Applied Network Research announce plans to expand their programme of industry surveys. Their first published survey forecasts that

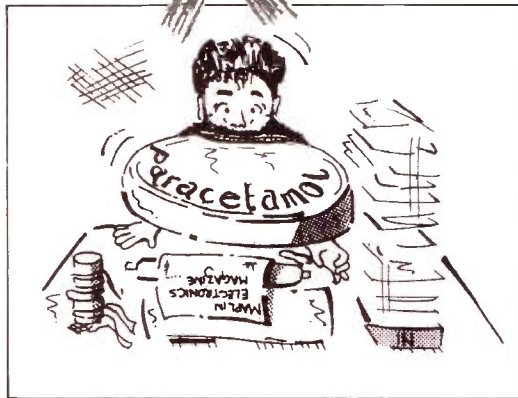

1992 will be a bumper year for industry surveys.

Maplin announce a 'Mad March' shop sale.

APRIL

Maplin directors state that they intend to publish 'Electronics' weekly. The editor immediately indents for a new typewriter ribbon and a repeat prescription of paracetamol. The Board meet urgently and agree to defer the matter. Maplin engineers discover an alternative to ferric chloride etchant after accidentally dropping a circuit board into a freshly-made pot of laboratory tea.

The cross-channel wars hot up. Sealink launch a 'love-boat' service, where passengers will be encouraged not to leave their cars. For those who do, French and English rugby teams will serenade couples and hand out artificial roses while stewards circulate with champagne and oysters. The on-board cinema will only have back-row seats.

Maplin announce an 'umbrella month' shop sale.

MAY

The Maplin research and development team develop a satellite dish LNB small enough to fit onto the head of a pin. However, their seven years work gets damaged when someone uses the pin to clean the departmental ink-jet printer nozzle.

BT announce record profits which equate to £1m every working second of the year. The BT chairman says "... just think how much we could have made had we got rid of all our staff and just used a few robots." Regulatory body OFTEL says that it would be unfair

competition to Mercury who still employ some half a dozen personnel.

Maplin announce a Spring Bank Holiday shop sale.

JUNE

Maplin decide to open a new shop in Milton Keynes. The location is shelved when the property manager reports that he is unable to find the town.

The British Approvals Board for Telecommunications rules that new Porsche-shaped telephones could be attached to the Public Switched Network only if they incorporate lead-free transmission circuits. British Rail's private computer network becomes clogged by a virus. The problem is only discovered when City workers arrive on time for work. A BR employee in East Ham is blamed for the problem; he apparently dialled the central computer's modem and sneezed.

Maplin announce a Wimbledon Fortnight shop sale.

JULY

Maplin announces a new lightweight portable phone, the size of a matchbox. Unfortunately, its transmission range is also in the lightweight category. Just 22 inches in fact. However, Clive Sinclair expresses an interest in the development as a method of networking rival BT and Mercury telephone call-boxes together in London's Tottenham Court Road.

Comms Regulator OFTEL announces that the ringing tone from the new ISDN-2 phone circuits is unacceptable. BT suggests it will release from stock its supply of handle-driven telephone units. OFTEL says this will be unfair to Mercury, Transpac and the manufacturers of Porsche-shaped telephones. Siemens meanwhile ramp up production of handle-driven phones.

Maplin announce a Summer Solstice shop sale.

AUGUST

The National Trust slap a preservation order on that famous bedroom used as a store and selling base by Maplin directors Roger Allen and Doug Simons. The order includes the unsold collection of radio crystal sets and non-metric spanners.

Prime Minister John Major defers the general election by a further year. The thought is that the forthcoming Maplin catalogue will take voters' minds off politics, and that by then a new bed will

have been installed in Guys Hospital. Meanwhile, European Air Traffic Control reveals that it hopes to shortly update its Amstrad 1512 PC to something more able to cope with traffic loads. As a result, airport waits should seldom exceed two days.

Maplin announce an August Bank Holiday shop sale.



SEPTEMBER

The new bumper-sized Maplin Catalogue is issued. WH Smith issue a free trolley with every copy sold.

France Telecom makes a take-over bid for BT, who by now admit that their new trumpet-blowing logo really was a love symbol. Meanwhile, OFTEL promise to investigate the much-discussed French sex-line services over a period of three years. Mercury get into the French act by converting their call-boxes into mock Metro stations.

Maplin announce an end of summer shop sale.

OCTOBER

The Maplin research and development team perfect a floating satellite dish which is suspended by two kites. Because it floats in the air high above viewers heads, local planning will not be involved. However, the Civil Aviation Authority has requested that the kites should not be painted in any vivid colours so as not to frighten pilots.

A government treasury minister is discovered using a cellular phone in a Camden Town bistro to call his girl friend Rebecca. The government falls. Rebecca is appointed interim Minister of Consumer Affairs.

Maplin announce an Autumn shop sale.

NOVEMBER

Maplin are asked to deliver a package to Milton Keynes. To help matters, the motor-cycle courier is provided with a packed breakfast, lunch and dinner.

The government licenses a further 2000 national telephone carriers. An ANR forecast suggests that BT will stop making phones and concentrate on interconnect products.

Maplin announce a Guy Fawkes Day shop sale.

DECEMBER

Maplin is awarded an entry in 'The Guinness Book of Records' for the world's largest catalogue. Norway expands their forest growing plans.

A business executive succeeds in convincing a judge that the reason why his secretary was sitting on his knee was because his lap-top computer had gone on the blink and that the young lady was only acting as a temporary back-up.

Maplin announce a special Christmas Day shop sale.

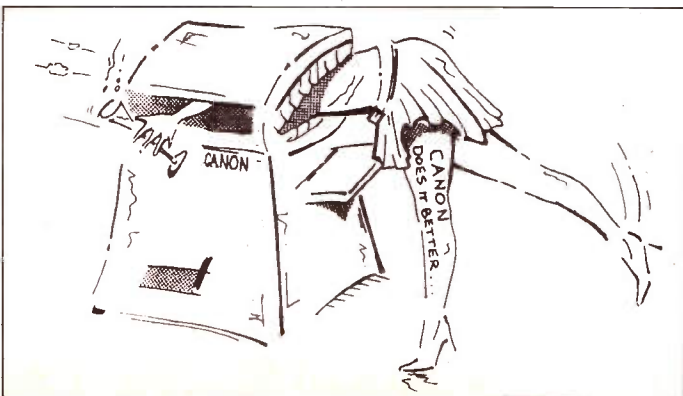

COMPETITION WINNERS

Guess the Personality Competition

The famous personality whose face was hidden in Issue 45 was Robert Penfold! The prize for each of the winners is a copy of 'Getting The Most From Your Multimeter' by Robert Penfold. Ten books were ready and waiting to be won; but only five entrants managed to correctly identify Robert Penfold – all of the other entrants thought it was Nigel Lawson!

Winners of the 'Getting The Most From Your Multimeter' book:

Mr Colin Humphrey, Langdon Hills, Basildon; R. H. Youden, London; Mr Rob Munda, Waterlooville, Hants; Mr Vic Martin, Whitwick, Leicester; Mr Phillip Greenhouse, Kingstanding, Birmingham.

London Dungeon Competition

The questions and correct answers were as follows:

- 1) What caused the Great Plague of London in 1665: **Rats from ships docking in London.**
- 2) Who first proposed the use of a beheading machine during the French Revolution: **Dr Guillotin.**
- 3) Anne Boleyn was the second wife of: **Henry VIII.**
- 4) The 14th October is noted for: **The killing by an arrow of King Harold II.**

The following six lucky(?) people will each receive free tickets to the London Dungeon:

Mr Ian King, Eastleigh, Hampshire; Mr C. J. Smith, Colchester, Essex; Mr G. P. Lee, Margate, Kent; Mr A. Griffiths, Cannock, Staffs.; Ruth Davies, Linton, Cambridge; Mr W. A. Harrison, Reedswood, Walsall.

Spitting Image Rubberworks Competition

The questions and correct answers were as follows:

- 1) Spot the odd one out (Prince Charles, Laurel and Hardy, The Muppets): **The Muppets.**
- 2) Where can you expect to find the Spitting Image programme (BBC1, BBC2, ITV, C4): **ITV.**
- 3) What is the regular TV audience for Spitting Image: **Ten Million.**
- 4) Is the host of the Lickety-Lick game show, Sir Alistair Burnet; a chat show host, a TV news-reader or The Bishop of Salisbury: **A TV news-reader.**

The following six lucky people will each receive free tickets to the Spitting Image Rubberworks:

Mr Neil Walden, Linton Cambridge; Mr R. S. Hines, Fleet, Hants.; Mr A. Holt, Woking, Surrey; Caroline Whitear, Christchurch, Dorset; Mr Luke Orwin, Whitby, N. Yorkshire; Mr G. Wood, Folkestone, Kent.



In next month's super issue of 'Electronics – The Maplin Magazine' there are some really great projects for you to build and features for you to read. The January issue is on sale 6th December 1991, available from Maplin's regional stores and newsagents countrywide, and of course by subscription, see page 62 for details. To whet your appetite, here's just a taster of some of the goodies in the next issue:

SERIAL-TO-PARALLEL CONVERTER

An ingenious module that turns a standard RS232 serial computer port into a versatile 8-bit input/output port. Simple commands are sent to the unit to determine operating modes and read/write data.

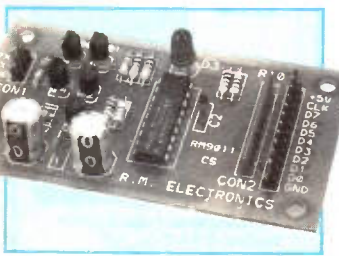

BICYCLE ALARM

A vibration triggered alarm unit with a loud siren; it is easily built and will help prevent bicycle theft. The siren can also be used, independent of alarm operation, as a warning to other road users.

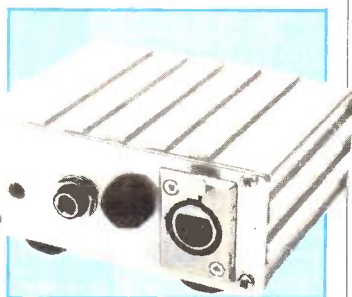

DIRECT INJECT BOX

Overcome problems associated with low level signals and long cable runs by building this high quality unit. To provide immunity from induced hum and noise, the unit allows 'unbalanced' signals to be electronically 'balanced' and provides the necessary buffering to drive long cable runs.

ANALOGUE REVERBERATION

A Data File application circuit for a versatile reverberation IC. Based on the bucket-brigade delay line principle, the unit offers a wide variation of delay and reverberation effects to be produced.

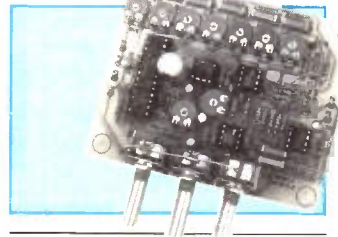

BOOLEAN ALGEBRA

A new series that deals with the mathematics behind digital electronics. Written to complement another new series starting in the January issue – Sequential Logic.

SEQUENTIAL LOGIC

Sequential logic circuits find numerous applications in modern-day electronic equipment. This series deals in depth with the design and application of such logic circuits.

CABLELESS LANS

In certain instances it may be difficult, expensive, or even impossible to interconnect computer equipment by a conventional 'cabled' local area network. This article deals with some of the latest developments in cableless LAN technology.

TRANSISTOR TESTER

The Funtronics series of beginners 'build and learn' projects continues with an easy to build transistor tester.

ELECTRONICS IN AVIATION

A new series that deals with the important role that electronics plays in aviation. The first part takes a look at the historical development of avionic equipment.



COMPETITION

Win a trip to the Capital Radio Studios in London and see first-hand how radio programmes are presented and broadcast!



Plus of course there's all the usual regulars for you to enjoy!
'ELECTRONICS – THE MAPLIN MAGAZINE'
BRITAIN'S BEST SELLING ELECTRONICS MAGAZINE

These are our top twenty best selling books based on mail order and shop sales during September 91. Our own magazines and publications are not included in the 'chart' below.



The Maplin order code of each book is shown together with page numbers for our 1992 catalogue. We stock over 250 different titles, covering a wide range of electronics and computing topics.

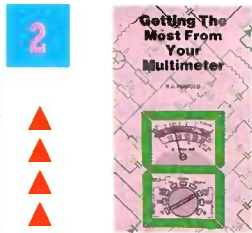

Getting The Most From Your Multimeter, by R.A. Penfold. (WP94C) Cat. P80. Previous Position: 3. Price £2.95.

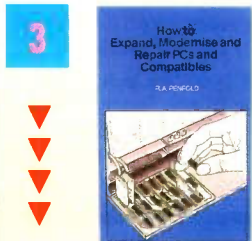

How to Expand, Modify and Repair PC's and Compatibles, by R.A. Penfold. (WS98D) Cat. P104. Previous Position: 2. Price £4.95.

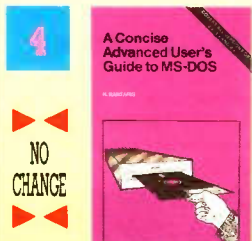

A Concise Advanced User's Guide to MS-DOS, by N. Kantaris. (WS44X) Cat. P102. Previous Position: 4. Price £2.95.



IC555 Projects, by E.A. Parr. (LY04E) Cat. P85. Previous Position: 8. Price £2.95.



How to Use Oscilloscopes and Other Test Equipment, by R.A. Penfold. (WS66V) Cat. P80. Previous Position: 6. Price £3.50.

Number ONE

A Concise Introduction to MS-DOS, by N. Kantaris

This book will help you learn all about MS-DOS on your PC. (WS94C) Cat. P101. Previous Position: 1

Price £2.95



Power Supply Projects, by R.A. Penfold. (XW52G) Cat. P83. Previous Position: 7. Price £2.50.



Scanners, by Peter Rouse. (WP47B) Cat. P93. Previous Position: 14. Price £8.95.



Radio Amateurs Examination Manual, by G.L. Benbow. (WP87U) Cat. P91. Previous Position: 16. Price £6.75.

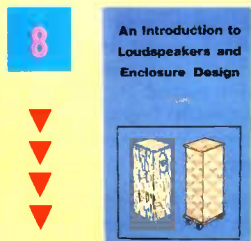

An Introduction to Loudspeakers and Enclosure Design, by V. Capel. (WS31J) Cat. P87. Previous Position: 5. Price £2.95.



Remote Control Handbook, by Owen Bishop. (WS23A) Cat. P83. Previous Position: 9. Price £3.95.



Electronic Security Devices, by R.A. Penfold. (RL43W) Cat. P84. Previous Position: 17. Price £2.50.



International Transistor Equivalents Guide, by Adrian Michaels. (WG30H) Cat. P76. Previous Position: 12. Price £3.95.



Towers' International Transistor Selector, by T.D. Towers. (RR39N) Cat. P76. Previous Position: 11. Price £19.95.



Washing Machine Manual, by Graham Dixon. (WS98C) Cat. P96. Previous Position: 15. Price £11.95.



More Advanced Power Supply Projects, by R.A. Penfold. (WP92A) Cat. P77. Previous Position: 19. Price £2.95.



The Maplin Electronic Circuits Handbook, by Michael Tooley. (WT02C) Cat. P82. Previous Position: 10. Price £10.95.



Audio Amplifier Construction, by R.A. Penfold. (WM31J) Cat. P87. Previous Position: 18. Price £2.95.

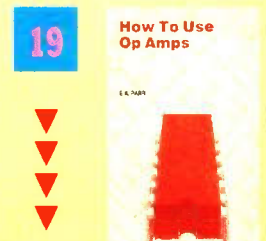

How to Use Op-Amps, by E.A. Parr. (WA29C) Cat. P79. Previous Position: 13. Price £2.95.

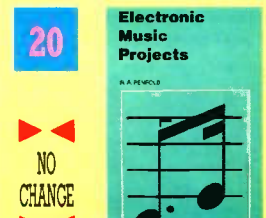

Electronic Music Projects, by R.A. Penfold. (XW40T) Cat. P89. Previous Position: 20. Price £2.50.

BRITAIN'S BEST VALUE FLOODLIGHT WITH PIR SECURITY SYSTEM

GUARANTEED!



UNBEATABLE VALUE!
£29.95
GK05F
 (*500 watt halogen tube - JX53H £3.75 not included in this price)

HELPS YOU PROTECT YOUR HOME AND YOUR FAMILY!



HIGH DEMAND

Because of high demand for our security products and our increased buying power, Maplin Electronics can now offer this exclusive lamp at Britain's lowest price, guaranteed!

GUARANTEE

We guarantee you can't find better value, or the difference refunded. Absolutely no risk to you.

QUALITY CONFIDENCE

Every detector purchased comes with a FULL MONEY-BACK, NO QUIBBLE GUARANTEE.

YOUR TOP TEN FEATURES

- ★ Automatic infra-red sensor, lights up *500 watt tube, when people approach your property
- ★ Adjustable 'on time' ★ Easy installation
- ★ Full 15m detection range
- ★ Ultraviolet/fireproof material
- ★ Water resistant and weatherproof
- ★ Approved to international standards
- ★ Automatic on/off and manual override
- ★ Heavy duty zinc alloy body
- ★ 110 degree detection angle

The FOX Security Floodlight has the latest infra-red technology that detects movement over your chosen area and illuminates it with a 500 Watt Halogen lamp for up to approx 12 minutes which gives you time to park your car, unload the shopping, find your keys, greet your guests or avoid obstructions.

With 500 watts of halogen lighting beaming down on them, any potential burglar becomes clearly visible – so visible it could well be daylight!

Feel safer, more confident with the FOX Security Floodlight. Economical – the system automatically switches off in the daytime to save power.

For your enjoyment the Detector can be permanently switched on, for EVENING BARBECUES etc, by turning the main light switch on, off and on again within 2 seconds. The range of the Detector is such that it is ideal for both residential and commercial use.

Please Note: Offer open to UK residents only (Overseas customers please call 0702 552911).



IT'S YOUR GUARANTEE OF QUALITY

Although this unit may deter intruders, no warranty is given or implied that the unit will provide security or prevent illegal entry.

COMPARISON WITH SIMILAR SECURITY SYSTEMS

SE Essex Branch	Heavy Duty	500 Watt Power	Weather-proof	Automatic Infra-red	Adjustable Timer	Complete with Halogen Tube	Cost of 500W Halogen Tube	Cost of Security System
DO-IT-ALL	●	●	●	●	●	●	£4.24	£71.51
HOMEBASE	●	●	●	●	●	●	£7.75	£49.99
TEXAS	●	●	●	●	●	●	£5.99	£69.99
ARGOS	●	●	●	●	●	●	Not supplied	£47.99
WICKES	●	●	●	●	●	●	£5.49	£49.99
B&Q	●	●	●	●	●	●	£6.59	£86.99
MAPLIN	●	●	●	●	●	●	£3.75	£29.95

(Survey conducted on 6th September 1991)

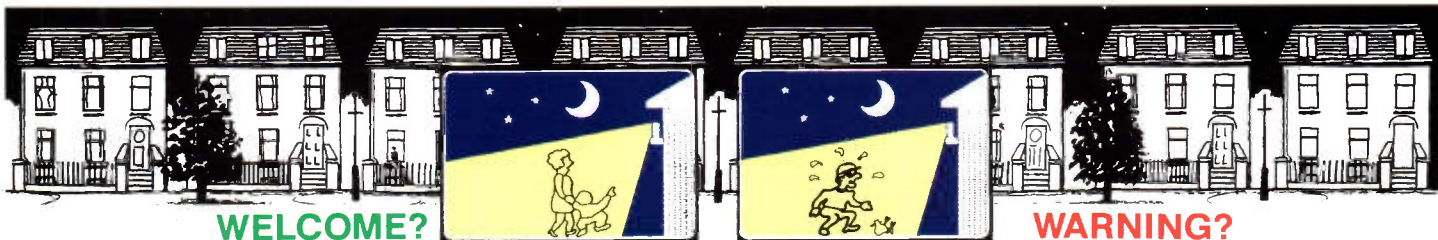

WELCOME?

WARNING?

656 PAGE CATALOGUE



Packed with 1,000's of gifts including Audio/Video, Hi-Fi, In-car Entertainment, Radios, Pocket TV's, Cameras, Tools, Calculators, Musical Accessories, Amplifiers, Microphones, Computer Accessories, PLUS many ELECTRONIC PROJECTS and so much more for you! Catalogue (not lamp) also available at all branches of WHSMITH £2.75 (£2.95 by post).

Maplin ELECTRONICS CREDIT CARD HOTLINE



24 HOUR SERVICE - PHONE NOW! **0702 554161**

All items are subject to availability. all prices include VAT

Access Amex Visa Delete as required

If ordering by Credit Card please sign

Expiry date of Credit Card

Order Coupon Send this coupon to P.O. Box 3, Rayleigh, Essex SS6 8LR

Quantity	Description	Code	Price	Total
	Infra-red detector	GK05F	£29.95	
	500 watt halogen tube	JX53H	£3.75	
			Carriage for 1	£3.95
			Add further	
			£1.35 if more	
			than 1 GK05F	
			Handling	£1.00
			Total	

I authorise you to debit my Credit Card account for the cost of goods despatched.

Credit Card No.

Halogen Lamp and Tube also available at our stores in BIRMINGHAM, BRIGHTON, BRISTOL, CARDIFF, GLASGOW, LONDON (EDGWARE), LEEDS, MANCHESTER, NOTTINGHAM, READING, SHEFFIELD, SOUTHAMPTON, SOUTHEND-ON-SEA and at our 2 latest shops at 120-122 King Street, Hammersmith, LONDON and Unit 4, Allison Court, The Metro Centre, Gateshead, NEWCASTLE. PLUS - New stores opening soon in CHATHAM, LIVERPOOL and SOUTH LONDON. Ring 0702 552911 for further details.

1992 BUYER'S GUIDE TO ELECTRONIC COMPONENTS

Maplin

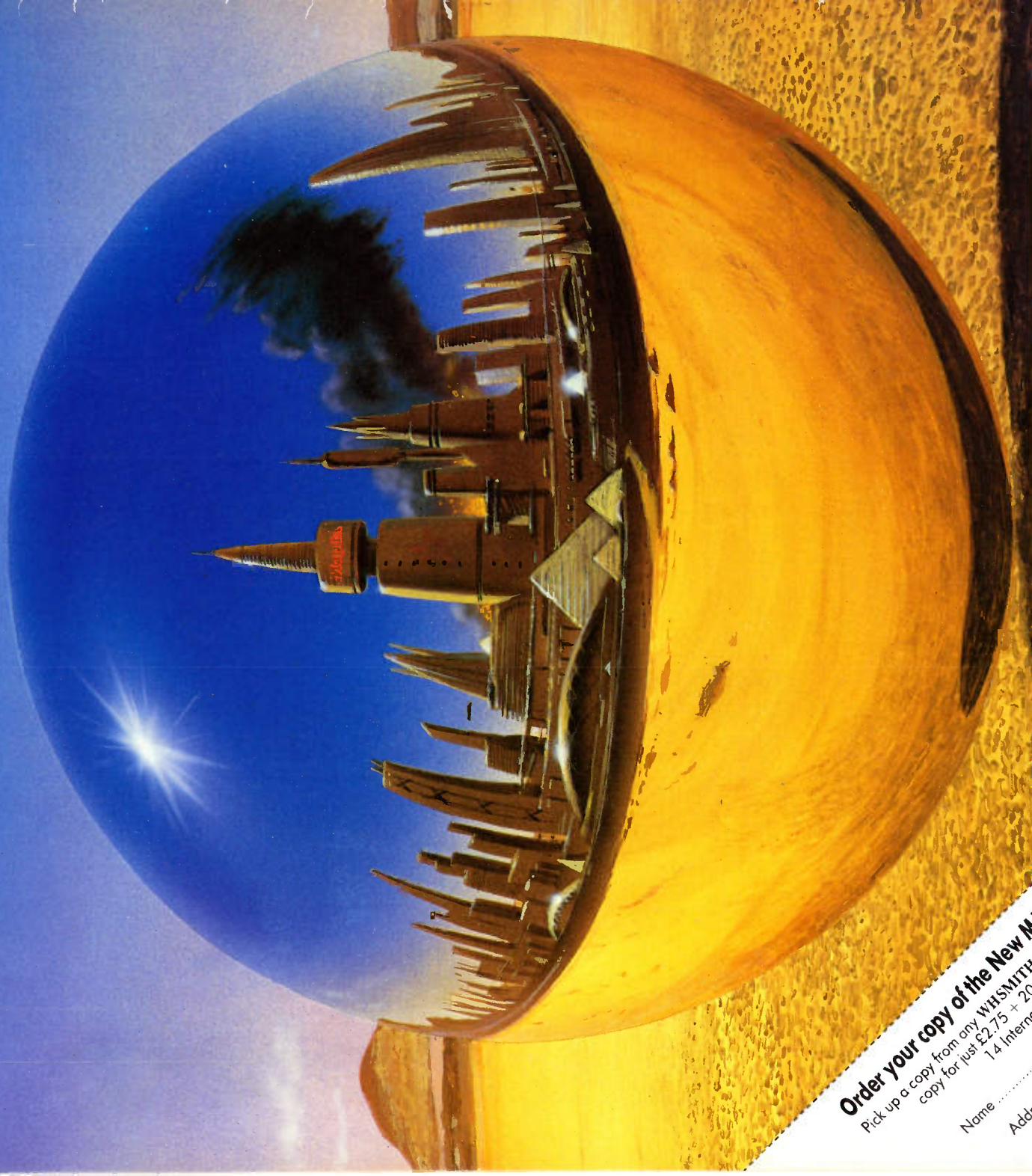

Over 600 product packed pages with
more than 600 brand new products.
On sale now, only £2.75

Available from all branches of WHSMITH and
Maplin shops nationwide. Hundreds of new products
at super low prices!

Order your copy of the New MAPLIN Catalogue on sale NOW!

Pick up a copy from any WHSMITH for just £2.75 or post this coupon now to receive your
copy for just £2.75 + 20p p&g. If you live outside the UK, send £4.85 or
14 International Reply Coupons. I enclose £2.95.

Name

Address

Post Code

Send to Maplin Electronics,
P.O. Box 3, Rayleigh,
Essex SS6 8LR.

MM92