

E

ELECTRONICS

The Maplin Magazine

IR £1.76

No 37

APR-MAY '90 • £1.20

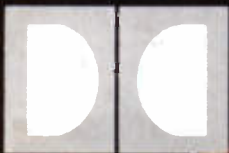

DOLBY STEREO

**What is it?
And how does
it work?**

**FULL FEATURE
ARTICLE INSIDE!**



AUDIO/VIDEO GENERATOR Project • *Beginners Series:* **SQUARE ONE**
WIN TICKETS to the **GRANADA TV STUDIOS** and the **ODEON CINEMA**
Build a **CAR BATTERY MONITOR** and a **CAR TACHOMETER!**

CONTENTS

APRIL TO MAY 1990 VOL. 9 No. 37

EDITORIAL

■ This edition of 'Electronics' is so jam-packed with projects and features there is not enough room for me to tell you about everything that we have crammed in! So here is just a taster of what is in store: there is an Audio/Video Generator project, which is a must for all TV and video enthusiasts. Movie fans will be fascinated by the feature on Dolby Stereo Sound. You may even win tickets to your local Odeon Cinema with our special competition! For the motorist there are two great projects, a superb tachometer and a battery monitor. Starting in this issue is a much requested beginners series – Square One. Also in this issue are details of readers' ideas for updating two of our popular projects and a new series explaining the principles of Switched Mode Power Conversion. There is the chance to tour Granada TV Studios in the Hi-Tech Comes to Coronation Street feature. And of course not forgetting all the usual regulars and features. So what are you waiting for? Read on and enjoy!

R.T. Smith

■ **Editor** Roy Smith ■ **Technical Editors** Dave Goodman, Chris Barlow, Gavin Cheeseman, Tony Bricknell, Allan Williamson
■ **Technical Author** Robert Ball
■ **Consultant Author** Alan Simpson
■ **Technical Artists** John Dudley, Lesley Foster, Paul Evans, Ross Nisbet
■ **Art Directors** Peter Blackmore, Martin King
■ **Art Assistants** Eugene Francis, Phillip Fey, Jim Bowler
■ **Print Co-ordinators** Brian Lauzezzani, Martin Needs, Ken Wakefield
■ **Published by** Maplin Electronics plc
■ **Typesetting by** Inline Design Systems Ltd, 258a London Road, Hadleigh, Benfleet, Essex SS7 2DE
■ **Colour Separations by** Stirling Graphics Ltd, 16-22 West St, Southend, Essex SS2 6HL
■ **Printed by** SVP, Caerphilly, Mid Glam, CF8 3SU
■ **Distributed by** United Magazine Distribution Ltd, 1-11 Benwell Rd, London N7 7AX
■ **Mail Order** P.O. Box 3, Rayleigh, Essex SS6 8LR
■ **Telephone Retail Sales:** (0702) 554161, Retail Enquiries: (0702) 552911, ■ **Trade Sales:** (0702) 554171
■ **CashTel:** (0702) 552941, ■ **General:** (0702) 554155
■ **Shops:** See inside back cover.
■ **Fax:** (0702) 553935 ■ **Telex:** 995695

Copyright. All material is subject to world wide copyright protection, and reproduction or imitation in whole or part is expressly forbidden. All reasonable care is taken to ensure accuracy in preparation of the magazine, but Maplin Electronics plc cannot be held legally responsible for its contents. Where errors occur corrections will be published as soon as possible afterwards. Permission to reproduce printed circuit board layouts commercially or marketing of kits must be sought from the publisher.

© Copyright 1990 Maplin Electronics plc.

Maplin Magazine April 1990

PROJECTS

8 AUDIO/VIDEO GENERATOR

■ A top-flight piece of equipment for anyone involved in TV and video work.

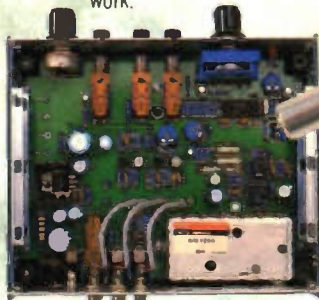

30 ADA ECHO

■ Details of an ingenious idea for updating the ADA Digital Echo.

48 LIGHT LEVEL SWITCH

■ A light sensitive circuit which has dozens of uses.

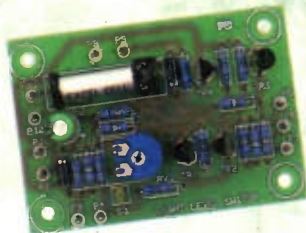

56 CAR BATTERY MONITOR

■ A useful addition to the car dashboard.

62 16 CHANNEL LOGIC TESTER

■ This update describes how it can be connected to a BBC microcomputer.

65 CAR TACHOMETER

■ A stylish and practical design that clearly displays engine speed.

76 DATA FILE: TDA7052

■ A versatile 1W power amplifier ideal for battery powered applications.

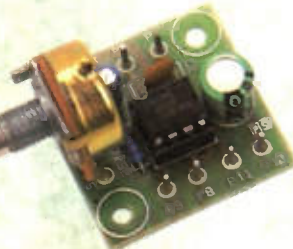

FEATURES

2 HI-TECH CORONATION STREET

■ Take a peek behind the scenes at the Granada TV Studios.

5 MODEL CAR RACING

■ A trip back in time to look at the origins of this popular pastime.

16 SQUARE ONE

■ Back to basics for the start of a new beginners electronics series.

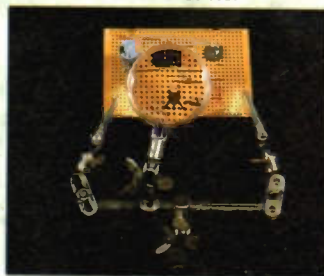

25 MEASURING DISTORTION IN THE HOME WORKSHOP

■ Covers the practical aspects of measuring distortion in audio equipment.

34 COMPUTERS IN THE REAL WORLD

■ Part 5 deals with the subject of serial communication.

40 DOLBY STEREO

■ An in-depth article on the impressive Dolby Stereo sound system that is used in cinemas.



51 BARRED FOR LIFE

■ Lets us in to a few of the secrets of bar codes.

53 SWITCHED MODE POWER CONVERSION

■ All about the black box world of switched mode power conversion.

72 BUILDINGS GET SMART!

■ Some of the pro's and con's of high technology in the office environment.

REGULARS

24 NEWSAGENTS ORDER FORM

31 TOP 20 KITS

32 NEW BOOKS

39 ORDER COUPON

59 NEWS REPORT

63 1990 CATALOGUE AMENDMENTS

71 ODEON CINEMA COMPETITION

75 AIR YOUR VIEWS

78 CLASSIFIED

79 SUBSCRIPTIONS

80 TOP 20 BOOKS



HI-TECH COMES TO CORONATION

by Alan Simpson

Our intrepid consultant author has been 'oop north' to visit the wonders of Granadaland. Amid the high tech wonders, he found himself supping with the stars and admiring Ena Sharples' hairnet.

That's Entertainment

It did not take long to discover that there is a lot more to the Granada Studios Tour than simply paying a 'respectful visit' to Coronation Street. The tour at Granada's Manchester studios takes you behind the television scenes. For well over two hours, you are guided (or conveyed by tram) through highly impressive sets such as that created to resemble 221B Baker Street where Sherlock Holmes' housekeeper Mrs Hudson is on hand to welcome visitors. Similarly, a jovial bobby is on duty in Downing Street and is available to have his picture taken outside Number Ten. Mrs T herself makes a shadowy appearance.

But of particular interest to 'Electronics' readers will be the TV production/control room (you can even sit in the actual director's chair used by

Alfred Hitchcock) and a typical TV studio – mind the booms – and the make-up and wardrobe departments. This is one venue where the special effects do live up to expectations.

You are invited to board a mounted raft which proceeds to plunge perilously through ocean tempests and towering infernos while overhead TV monitors and sound track add to the realism. Only 'Jaws' was missing. Or you can watch yourself disintegrate into a ball of fire, courtesy of opto-mirrors and not a little high-tech.

Sectors are controlled individually by the tour guides assigned to each party. Rather like a stage set; lights, sound and atmosphere can be instantly created and equally instantly switched off.



Outside No.10! Or are they?



Nipping round to the Rovers!

OUT AND ABOUT

Rhubarb, Rhubarb

One of the highlights of the centre must be the realistic reconstruction of the chamber of the House of Commons, built for the 'First Among Equals' TV series. Here you have the chance to occupy the famous front benches and mumble "rhubarb rhubarb", or "hear hear" at appropriate moments of what turned out to be a hilarious debate. And then there is a visit to Main Street, New York, New York; the Berlin Wall (still intact at time of visit) and of course, the famed Coronation Street where you can actually take part in an episode of the long running soap opera.

The Granada Studios Tour which opened in 1988 at a cost of £8.5m, has already attracted over 1m visitors and won several UK tourist awards. One company however who deserve a merit award from Granada is Micronology, the Kingston-upon-Thames systems house. The company is responsible for the design and development of 3 separate computerised systems to manage ticketing, merchandising and bar and restaurant activities.

Each Micronology system operates on its own ICL mini computer, which in turn transmits data to Granada's central accounting system on a network of a further two ICL machines. The ticketing system allows effective management of both pre-booked tours and coach parties, and individual visitors. This allows Granada to control the number of people entering the grounds, and ensures that capacity is not exceeded. This is

STREET



In the control room.



an important factor not just for safety reasons, but for the comfort of the visitors. In the souvenir shops (and yes you can buy a replica Ena Sharples' hairnet), all transactions are captured on EPOS terminals, and input to the merchandising system. In addition, this system has the accounting and stock control facilities normally associated with retailing activity.

Yet more EPOS terminals can be found in the bars and restaurants, for which the company has designed a full point-of-sales system. This system also handles account customers using



Take a tram passed M&S.



Inside 221b Baker Street.

the centre's business conference facilities. So should you be visiting what is billed as Europe's only major TV tour, or having a refresher at the Rovers Return, take a look at one of the 22 EPOS terminals or intelligent tills – and more to follow when the proposed hi-tech theatre is added to the tour.

Alongside the video technology, laser shows and stage effects, including a visit to the stars, the Micronology computers are helping to make it all happen at Granadaland.

Granada Studio Tour Competition

Your chance to win a visit to Granada Studios.

One set of family tickets (four people per set) worth £17.80 will be awarded to the first four correct answers out of the hat.

Send your entry on a post card to:

'Electronics – The Maplin Magazine'
Granada Studios Tour Competition,
P.O. Box 3,
Rayleigh,
Essex, SS6 8LR.

The competition closes 31st July 1990.

★ In 'Coronation Street' the brewery house owning the "Rovers Return" is:

Brown & Porter
Newton & Ridley
Alger & Mile

★ Spot the odd one out:

Ena Sharples
Minnie Caldwell
Mary Scott
Hilda Ogden

★ Who wrote the Granada television drama series "First Among Equals":

Sir Robin Day
Lucille Ball
Jeffrey Archer
Michael Parkinson

★ Which of the following personalities have appeared in "Coronation Street":

Violet Carson
Kim Wilde
Joan Collins
Kylie Minogue

**FOUR FAMILY
TICKETS TO
WIN!**

By Trevor
Tennant

GETTING INTO RADIO CONTROL MODEL CAR

A Brief Historical Background

To find the origins of this increasingly popular racing hobby, we will have to take a step or two back in time to the first half of the century. Early attempts at organised model car racing bore little resemblance to the modern-day contemporary methods. It has to be realized that in the years prior to the First World War, the average person had very little money left, after providing for life's necessities, to 'waste' on hobbies. Unlike today's scene, where all walks of life can be seen at race meetings. In those far off days, racing of any sort was a pursuit of the well-off. Many of the early pioneers were considered to be eccentric by the standards of the day. It was not until the advent of 'Slot Car Racing' (Scalextric etc.) and inexpensive radio control equipment that racing became popular.

Early attempts at racing were in the form of free running cars, powered by rubber motors in the same way that some model aircraft achieve their propulsion. If you think that those cars, when compared to today's equivalent would be quite slow, you would be quite mistaken. Some of the cars packed an astonishing amount of rubber into the chassis and with multi-strand motors and gearboxes, they could return times for straight line sprints that would not be out of place today. As well as rubber motors, a number of people adapted all sorts of clockwork mechanisms to produce some terrifying contraptions. One car I have seen used two very powerful wind-up gramophone motors to achieve four wheel drive. As can be imagined, the cars soon became so fast as to be dangerous. Some form of guidance or steering system became vital for model racing to advance. It is difficult to ascertain where the next development

came from, either the U.S.A. or Great Britain, no-one really knows for sure, but this was the advent of cable car racing (not in the Swiss Alps!). The arrangement consisted of a circular track, laid to a very high standard of flatness. In the centre of the track, a pylon was firmly fixed. The pylon had a rotating arm attached, to which a cable was anchored. The car was fitted with a Panhandle and the free end of the cable anchored to it. At first, the idea was very popular with the people who could afford the engines and the specially engineered parts to build the cars. Initially the speeds achieved were quite modest, mainly because the majority of participants wanted the cars to retain the scale appearance of their full size counterparts. Some of the models were outstanding in scale appearance. The end of the Second World War saw a few American engines like the Dooling 10cc being raced and as soon as the cars were adapted to suit the higher power engines the owners quickly cleaned up the trophies. However, in the early 1960s, the sport faded away. I gather that there are still an odd few continental race-meets, at some of which the speeds break the 300 m.p.h. mark! As with every other sport, once people with money get involved, the whole thing goes into decline.

Around the end of the last war some people felt that something better than watching a car going round in circles was called for. Their solution was 'Rail' racing on purpose made circuits. The first track in the U.K. was the Railromers Club. This track allowed several cars powered by small engines to be raced against one another. The cars were guided by rollers on the underside of the car-body, which straddled guide rails in the track. This system became quite popular. I gather there was a track on the Golden Mile at Blackpool in the early 1960s. Once again this form of racing was quite expensive and once the car was started there was no method of control apart from a fuel cut-out to stop the car. One cannot imagine modern hall owners allowing the smell, smoke and noise of engines that were allowed in those days. The next milestone was a half page article in 'Model Maker'



RRRACINGGGGG

magazine of December 1954. This bombshell, written by T. H. Tebbutt, caused an incredible amount of interest world wide, which later was to give forth to a form of racing where the speed of the car could be controlled. The innocent looking car gave the start to what everyone now knows as slot car racing. Slot car racing in turn became an enormous success, increasing in popularity each year from 1956 onwards. The advent of Scalextric sets furthered the growth of the hobby. At the beginning of the sixties the Americans latched onto the idea in a big way. With the concept of the high street pay tracks, the hobby reached its peak of popularity. The rate of performance increase reached quite absurd proportions, with each manufacturer bringing a faster and more expensive car or motor out each week. It could not go on like this and sure enough the bubble burst in 1969, leaving in particular the Japanese with vast motor resources laying idle.

The level of performance reached by slot cars was very high, but the cars still were not being steered and many people tried all manner of wonderful ideas to make the cars steerable. It may seem so obvious now, but the prospect of radio control seemed almost impossible at the time. The reasons are many, but consider that before the advent of solid state technology and printed circuit boards, the equipment of the period was large, expensive and fragile. The valve equipment used would not stand up to the abuse that car use would inflict. It is amusing twenty plus years on, to see the comments regarding early car radio control systems. One well known boffin of the time declared that, "Radio control of model cars is and will always be impossible!". What he would have made of modern-day cars I do not dare think!

In the early 1970s the first serious radio cars came on the scene. Those cars by today's standards were crude, but valuable experience was gained and the main problem of the very high purchase price of equipment eased. Modern radio equipment in real terms is far better in quality and represents value for money.

Starting Out with Radio Control Cars

Maplin are importing a range of high quality entry level equipment for first timers. Two types of radio package are offered, both very competitively priced. The systems differ mainly in the method of control of the transmitter. The first system uses the traditional twin joy-stick method and costs £39.95 (order code XJ47B). The second system is to my mind the more sensible steering wheel method. This is where the steering wheel movement follows full size practice. The gun type trigger is squeezed to make the car go forward and the trigger is pushed forward to make the car reverse. This Gun-type unit costs £34.95, and the order code is YP62S.

In the car, a radio receiver is fitted which recognises the signals from the two channels of the transmitter and decodes



Young model car test drivers. Ian Niblock, Stuart Tennant and Owen Niblock with Road Winner and Wildcat cars.

them in a manner that actuates the steering servo and variable speed controller servo. The two servo units are of rotary action. The steering servo normally turns the front wheels using a spring loaded bellcrank system. The spring prevents the mechanism of the servo being damaged if the steering is shock-loaded in a shunt. The speed controller can be a simple rotary contact switch with either integral or remote resistors to allow for reduction in the power fed to the electric motor. It is perfectly possible to bypass the servo and change the motor speed electronically. This however, is uncommon on the more basic cars owing to cost considerations.

Both systems (stick and gun controllers) allow the operator to alter the direction in which the servo rotates when the transmitter control is operated. This is an essential feature because it would be difficult to control the car if moving the control to the left caused the car to turn right. Sometimes it is impossible to fit the servo so as to obtain the correct operation of the relevant linkages.

Both receivers feature interchangeable crystals. Up to six different channels can be used with Maplin crystals. It is important that only crystals with matching colours are used for both transmitter and receiver. The transmitter and receiver colours must be the same or the system will not work. Many problems with radio control can be traced to faulty crystals. They are quite delicate and sometimes a bad crash can damage the crystal in the receiver.

The power for the receiver can be supplied from the main motor drive battery in the case of electric cars, by using the BEC (Battery Eliminator Circuit) supplied. For the gun controller set, a BEC set will have to be obtained and fitted. In the case of glow plug engine powered cars, a four cell battery pack should be used. Do not be tempted to cut costs by using dry cells in radio equipment, it will actually work out to be very expensive. Invest in some rechargeable AA pencils and a charger. Both of the transmitters can be charged without removing the cells by using the charging socket fitted. I charge my transmitters using the Maplin AC-DC adaptor, Maplin order code XX09K. With a suitable adaptor, receiver packs can be charged by altering the output voltage switch.

Charging the 7.2 volt battery can be achieved in several different ways. This is a positive minefield of conflicting information. Ask ten experts and you will receive ten different answers! To keep things simple, I suggest you either use the adaptor mentioned with the relevant charge unit and charge the cells for 14 hours. This method is simple but inconvenient unless you have several charged batteries. The better method is to fast charge the battery using the Maplin mains powered charger. The obvious problem is that you will need mains power, which is not normally available away from home or in the middle of a field!

There is a simple kit available to build a 12 volt car battery driven charger, this is also available from Maplin. This features



Gun-type RC system.



BEC RC system.



Hogarth Secondary Modern school, Chiswick, 1949. Pupils with rubber powered cars. Note the variety.

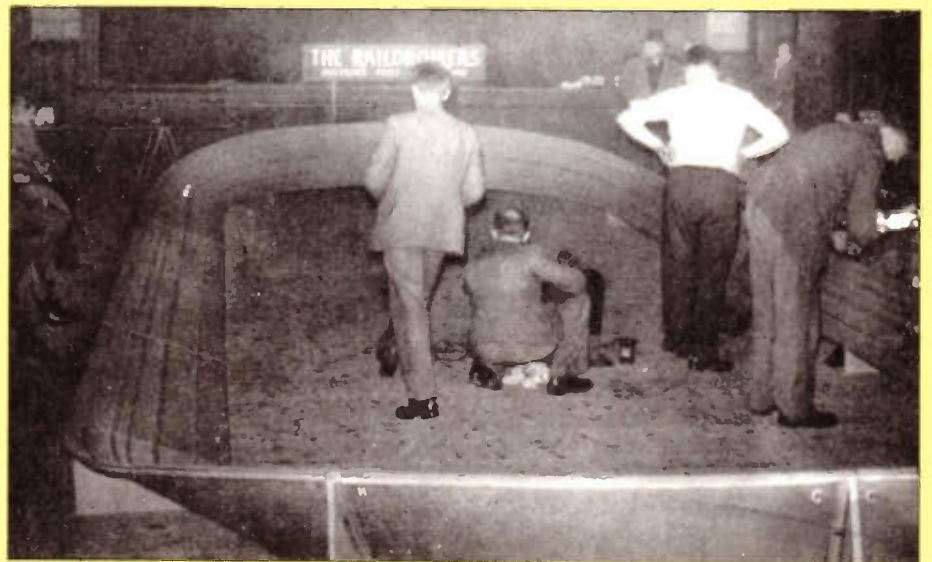

Rail racing, the first of its type in the UK. The track was made from steel sheets and the cars were powered by small diesel engines of maximum size 1.5cc.

an audible 'tick' from an internal transducer and an LED to indicate when the cells are being charged. Under NO circumstances use the so called 'charge cords' to charge cells. I have seen many cells destroyed by them. The problem is that people, being human, make mistakes. It is easy to put the cells on charge and forget about them, only to remember when the cells are overheated and damaged permanently. It is possible to use peak detection and temperature sensitive chargers but I suggest at first that things are kept simple.

A First Car

The Maplin Road Winner car is a ready-to-run, fourwheel drive 1/10th scale off road buggy. It comes complete with a good quality twin joy-stick transmitter. There are trim levers on both sticks to centralise the steering and the speed controller. An LED illuminates when the transmitter is switched on. The crystals can be changed by removing the transmitter back panel. The car's crystal

can be changed by removing the roll cage and body shell to allow the radio equipment compartment lid to be unscrewed. The Road Winner costs £64.95 and the order code is XM04E.

To ready the car for a run, remove the hatch at the bottom of the car. Install 4 AA pencils in the space provided. These power the receiver and servos. The 7.2 volt 1.2 amp/hr drive battery is fitted and connected. Close the hatch checking the polarity. Fit the aerial wire into the plastic tube and push into its socket. Fit the six cells into the transmitter. The car can now be tried out, take it outside with plenty of room so you will not hit anything. Trying to drive it inside a normal size living room is asking for trouble. Table and chair legs are good at breaking model cars.

Firstly, try driving the car slowly in a straight line. If it tends to veer to one side move the steering trim lever in the opposite direction one notch to counter the drift. Check again, it may need several attempts to obtain 'hands off' straight running, which is vital. Set up a simple

rectangular course using some lightweight markers such as empty engine oil containers. With practice you should be able to drive around the markers in either direction just missing each marker. In between each marker the car should be running smoothly and in a direct line. This can be difficult to master and can take a lot of battery charges!

Once you have mastered the marker game take the car to your local club and have a go around the track. Do not be put off if you find things difficult at first. Practice and more practice is the answer. When you can traverse the course without hitting the barriers at each corner then enter a race. If my experience is any guide, it will be a sobering affair. You will find that all of a sudden the track has become clogged with cars which you either hit or they hit you. Persevere and you will improve. Like most things, keep at it and I guarantee that you will grow to enjoy it. I have been racing model cars for nearly 30 years and I still get great pleasure from an enthralling hobby!

AUDIO/VIDEO GENERATOR

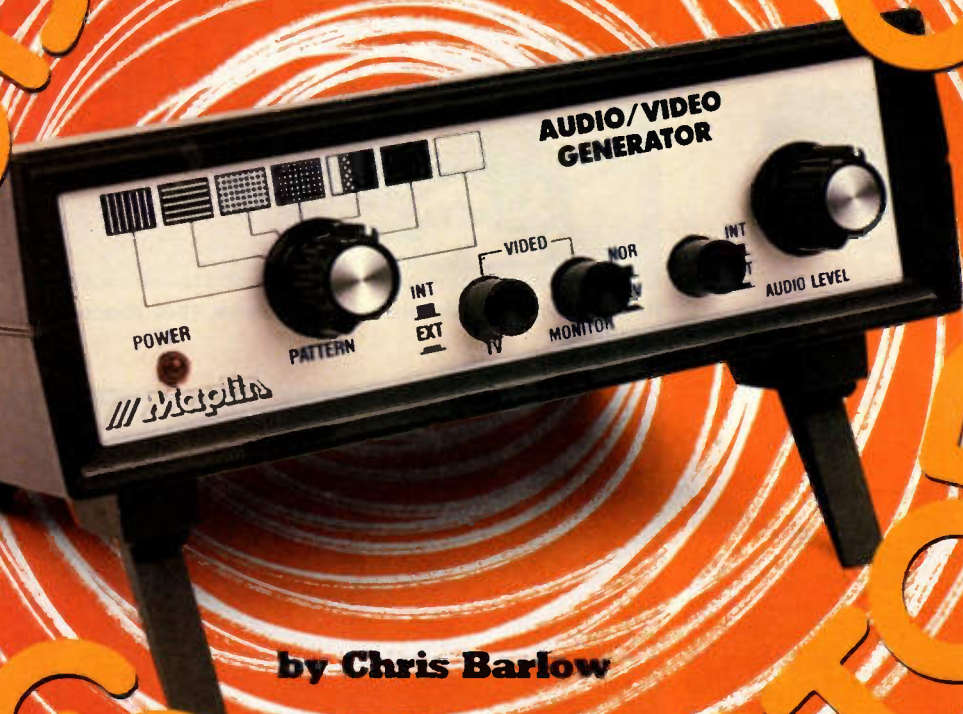

by Chris Barlow

- ★ Internal/External Audio/Video
- ★ Low Distortion Audio Oscillator
- ★ Crystal Controlled Video Timing
- ★ Sync and Blanking to CCIR Standard
- ★ RF and Audio/Video Outputs
- ★ 6MHz Sound Sub-carrier

Specification of Prototype

Power Supply Voltage: 10V to 15V DC
Supply Current at 12V: 195mA

Audio Oscillator –
Waveform: Sine
Frequency: 1kHz $\pm 2\%$
Output Level: 400mV RMS 1k Ω Load
Distortion: 0.015% THD

External Audio –
Input Level: 400mV RMS
Input Impedance: 5k Ω
Bandwidth ± 3 dB: 6Hz to 1.7MHz
Bandwidth ± 6 dB: 4Hz to 2.1MHz
Output Level: 1.7V RMS 600 Ω Load
Distortion: 0.025% THD

Video Generator: Black and white
CCIR Timing: Line frequency 15.625KHz (64 μ s)
Field frequency 50Hz (20ms)

Video Patterns: Vertical lines 16 visible
Horizontal lines 18 visible
Crosshatch 1.4:1 aspect ratio
Dots
Greyscale 8 steps
Blank raster
White raster

External Video: Colour or black and white
Bandwidth: 7MHz
Input Level: 1V peak to peak
Input Impedance: 1M Ω (no termination)
75 Ω (terminated)
Output Level: 1V peak to peak 75 Ω load

RF Output: Channel 36 (591.5MHz)
Sound Sub-carrier: 6MHz
Output Impedance: 75 Ω
Output Socket: Phono

Introduction

When setting up video equipment a stable test pattern is required for evaluating picture contrast, convergence and distortion. In this project, a single integrated circuit is used to generate all the waveforms necessary to produce grey-scale, crosshatch, dot, vertical and horizontal lines. The high accuracy line and field timing is derived from a quartz crystal which provides a very stable frequency reference. The output from the generator is black and white composite video at 1V peak to peak. However, not all TV sets have a direct video input socket, so a UHF modulator has been incorporated to provide an RF output on channel 36. This signal includes a 6MHz sub-carrier for the sound channel which is modulated by a 1kHz tone. The unit can also receive external audio and video signals from a wide range of equipment.

Figure 1. Circuit Diagram.

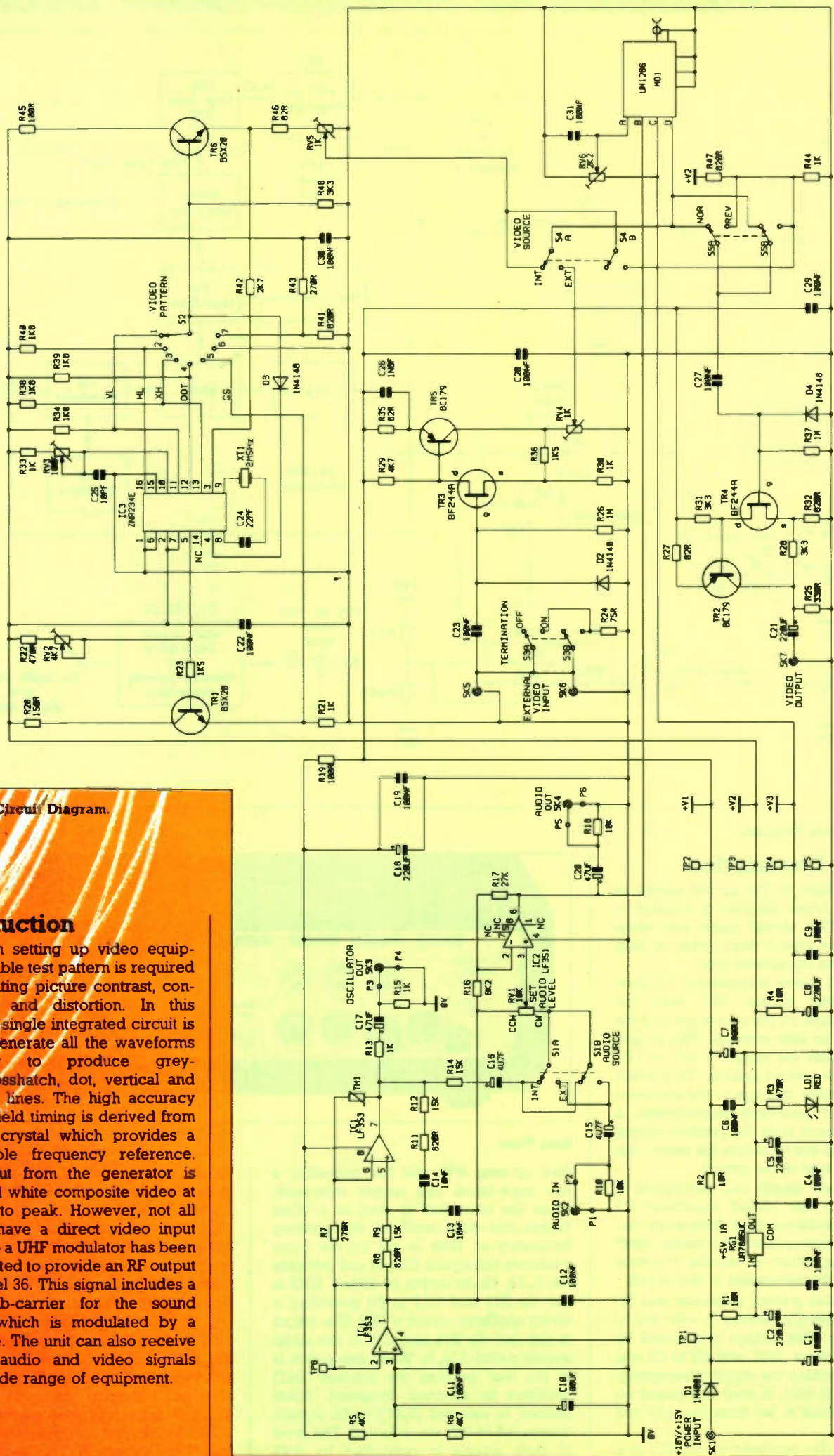

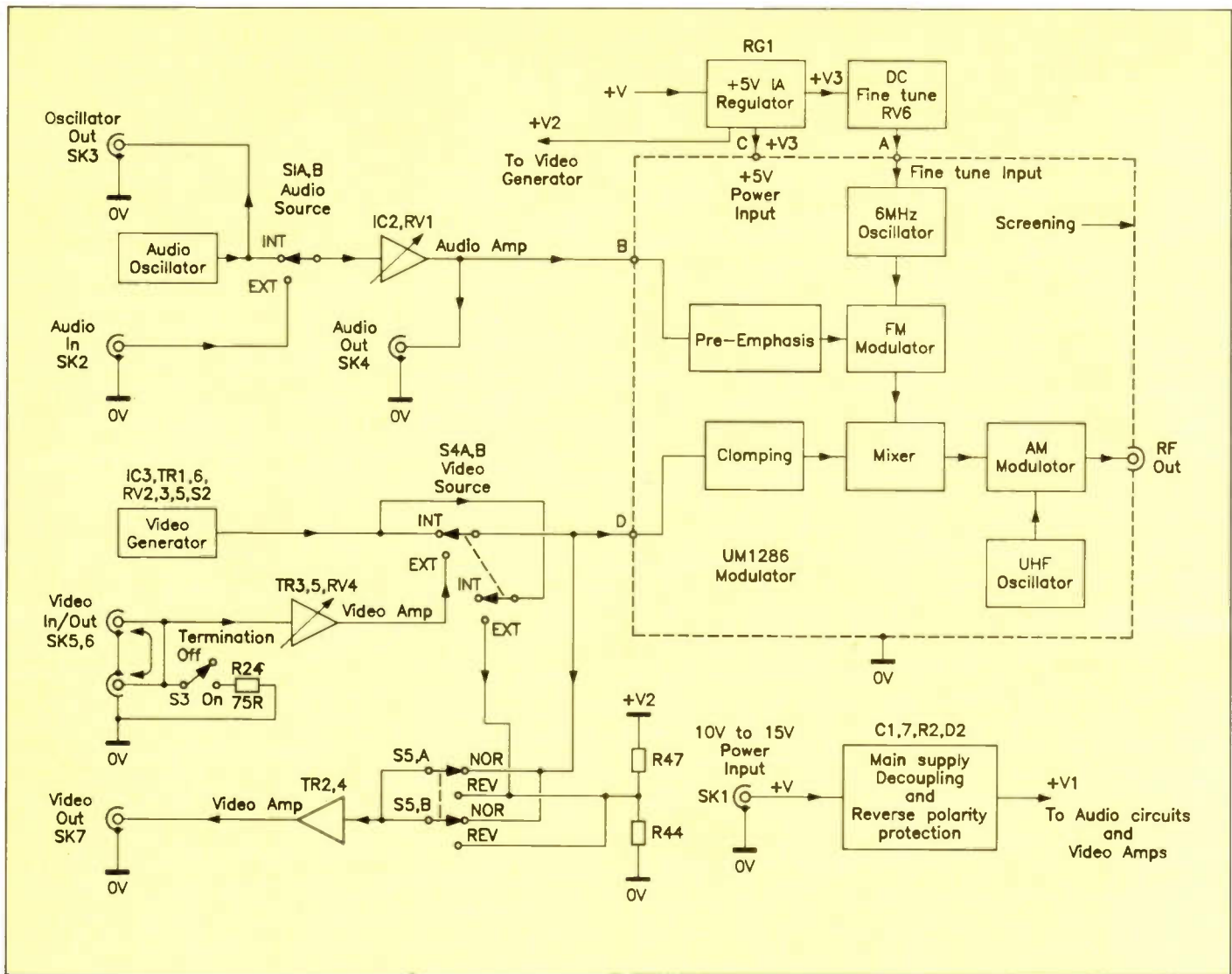

Figure 2. Block Diagram.

Circuit Description

In addition to the circuit shown in Figure 1, a block diagram is detailed in Figure 2. This should assist you when following the circuit description or fault finding in the completed unit.

The DC power is applied to a 2.5mm PCB mounted socket, SK1, with the positive voltage on the centre pin and the negative to its side terminal. This supply must be within the range of 10V to 14V and have the correct polarity. To prevent reverse polarity damage to the semiconductors and polarised components, a diode D2 has to have the positive supply applied to its anode before the power can pass to the rest of the circuit.

The main supply rail decoupling is provided by two 1000µF capacitors C1 and C7. Additional high frequency decoupling is incorporated by using 100nF ceramic capacitors at regular intervals throughout the remainder of the circuit.

The video pattern generator and RF modulator circuits require a +5V stabilised supply. This voltage is obtained by using a regulator, RG1, with C2 to C5 and C8, C9 providing the supply decoupling. The red LED, LD1, is used as a power on indicator which is fed from the +5V rail via R3.

The audio oscillator circuit IC1 is a

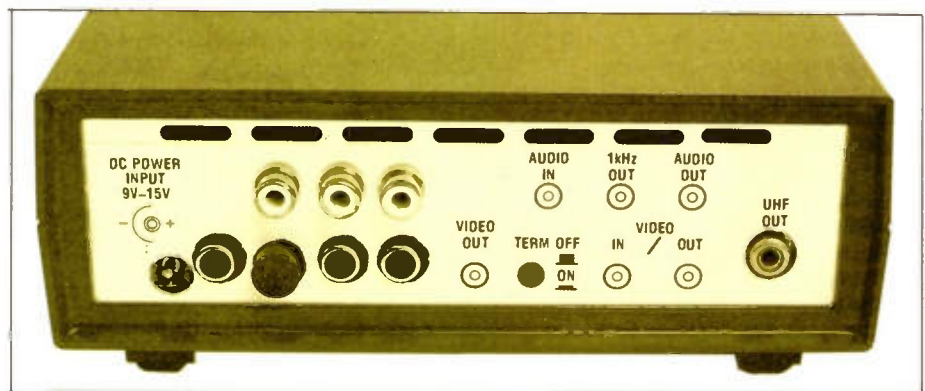

Rear View.

dual op-amp with one half providing a low impedance half supply reference, while the other half is used as a Wien Bridge sine-wave oscillator. Its operating frequency of 1kHz is set by the close tolerance capacitors C13, 14 and resistors R8, 9, 11, 12. Its output of 400mV RMS is fed via R13 and C17 to P3 providing a direct oscillator output at SK3. The output is also fed via R14 and C16 to the audio source switch S1a, b. When this switch is in the 'out' position the internal (INT) oscillator is selected. However, when pushed in external (EXT) audio signals connected to SK2 are selected. The level of both signals is controlled by RV1

feeding the input of IC2. This IC amplifies the audio signals producing an output of up to 1.7V RMS which is fed via C20 to SK4 and to terminal 'B' of the UHF modulator MD1. The +5V power for MD1 is applied to terminal 'C' and a DC bias control, RV6, on terminal 'A' provides fine tuning of the 6MHz sound sub-carrier.

The video patterns are generated by IC3, a ZNA234E. This device makes available all the waveforms necessary to produce greyscale, crosshatch, dot, vertical and horizontal lines, see Figure 3. The high accuracy timing is generated by a 2.5MHz crystal oscillator with XT1 on pins 8 and 9 controlling its frequency. To

set the width of the vertical lines RV3 and C25 are used to control the pulse width timing on pin 10. The greyscale output on pin 5 is produced by a D to A converter from the horizontal counter. This converter is effectively a switched current sink providing 8 equal steps of approximately $60\mu\text{A}/\text{step}$. With the pull up resistors R22 and RV2, 8 voltage steps are produced and adjusting RV2 affects the greyscale spread from black to peak white. This output requires a buffer stage, TR1, before it can be fed to S2. All the other video outputs have a fixed value pull up resistor and go directly to S2 allowing the selection of the pattern fed to TR6. The sync from pin 3 and blanking pulses from pin 4 are mixed to produce a composite video signal at the emitter of TR6. RV5 sets the level of this signal before going to the video source switch S4 and b.

With S4 in its 'out' position the internal (INT) video patterns are selected. However, when pushed in any external (EXT) video signals are routed to terminal D of the RF modulator MD1 and the monitor switch S5. The external video is first processed by an amplifier with an input impedance of approximately one million ohms ($1\text{M}\Omega$), but can be reduced to 75Ω by operating S3. When this switch is closed a 75Ω resistor, R24, is placed across the external video input, this is known as a termination load. The video signals are AC coupled via C23 into the gate of the Field Effect Transistor (FET) TR3, with diode D1 and resistor R2 used to maintain the correct bias level. The

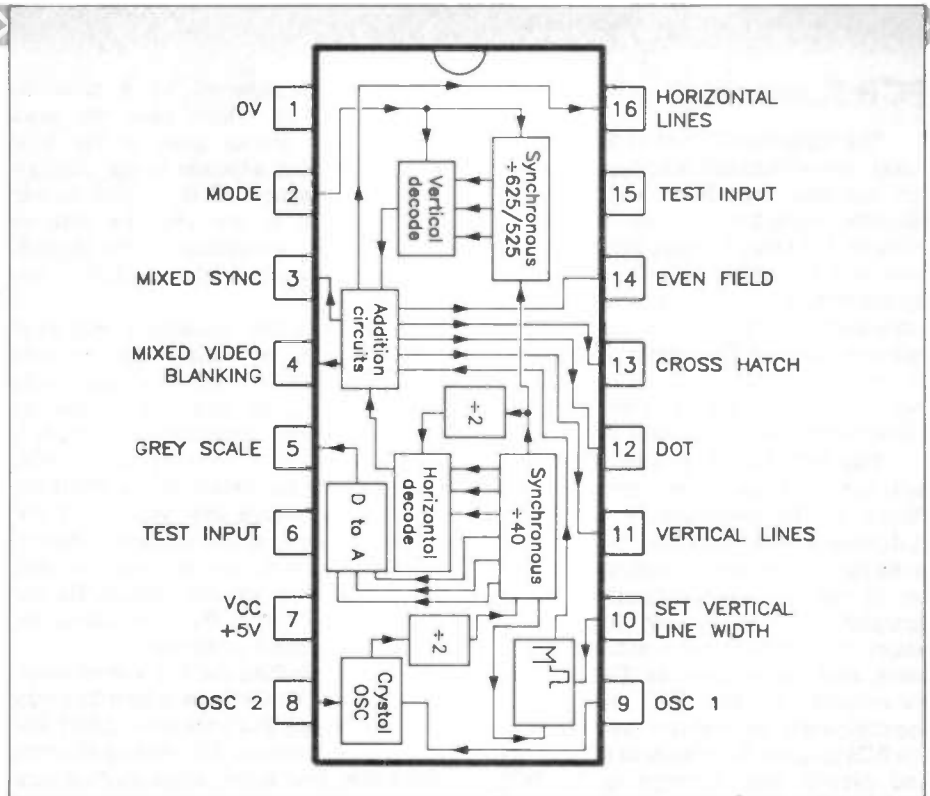
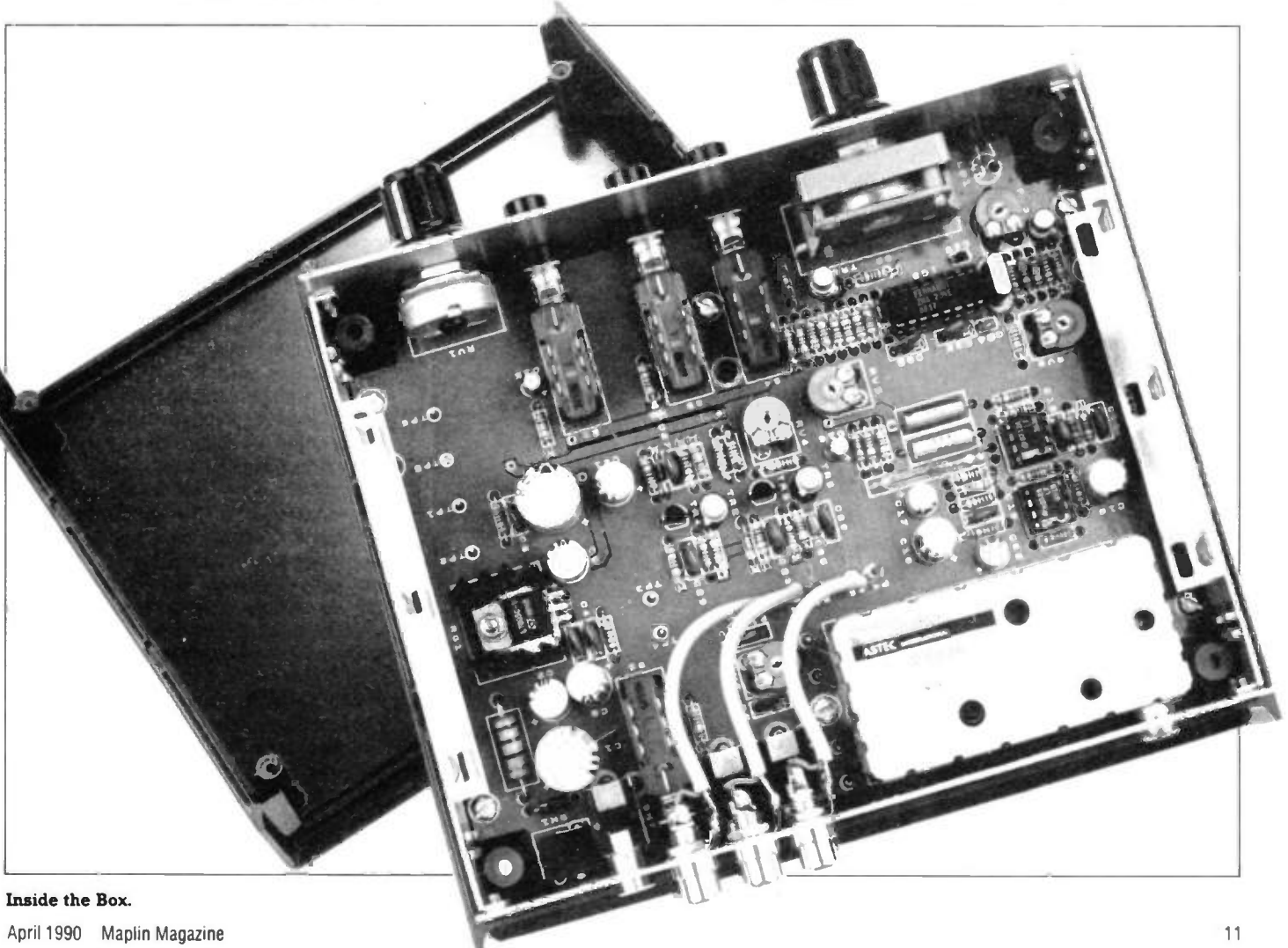

Figure 3. ZNA234E System Diagram.

gain of the amplifier is set by the value of the negative feed-back resistor R36. Resistor R30 is used as the source load for TR3 and the preset RV4 as the collector output load in TR5.

The video output stage TR2 and TR4 function in a similar manner as the external amplifier, but receives its input

from S5. This switch is used to provide the same video information at SK7 as is being modulated by MD1, or when S4 and 5 are both pushed in the external video is modulated and the test patterns reappear at SK7. This has the effect of reversing (REV) the normal (NOR) condition of the video source switching to SK7.



Inside the Box.

PCB Assembly

The glassfibre PCB is of the double-sided, plated-through hole type, chosen for maximum reliability and stability. However, because the holes are plated-through, removal of a misplaced component will be quite difficult, so please double-check each component type, value and its polarity where appropriate, before soldering! For further information on component identification and soldering techniques please refer to the Constructors' Guide included with the kit.

The PCB has a printed legend to help you correctly locate each item, see Figure 4. The sequence in which the components are fitted is not critical, however, the following instructions will be of use in making these tasks as straightforward as possible. It is usually easier to start with the smaller components, such as the resistors. The 10Ω 1W wirewound resistor, R1, is mounted approximately 2mm above the surface of the PCB to allow for even heat dissipation and prevent heat damage to the PCB surface.

Next mount the ceramic, 1% polystyrene and electrolytic capacitors. The polarity for the electrolytic capacitors is shown by a plus sign (+) matching that on the PCB legend. However, on the actual body of most capacitors the

polarity is designated by a negative symbol (-), in which case the lead nearest this symbol goes in the hole *opposite* to that adjacent to the positive sign on the legend. All the silicon diodes have a band at one end. Be sure to position them according to the legend, where the appropriate markings are shown.

Install all the transistors, matching each case to its outline. The voltage regulator, RG1, is mounted directly onto the vaned heatsink and no mica washer or heat transfer compound is required. This assembly is secured to the PCB using the M3 hardware. When fitting the IC sockets ensure that you install the appropriate one at each position, matching the notch in the end of the socket with the white block on the legend. *Do not* install the IC's until they are called for during the testing procedure!

After installing the five preset resistors RV2 to RV6 set them to their half way position. When fitting the crystal XT1 and the bead thermistor TH1 ensure that you don't over heat them, while making sure that they are firmly on the surface of the board. Next install the twelve pins at TP1 to TP6 and P1 to P6 ensuring that you push them fully into the board.

The RF modulator MD1 depends for its electrical screening and mechanical support on four large, flat solder tags,

which insert through the four slots provided in the PCB. To secure the unit onto the PCB simply twist the fixing tags through 90 degrees. When soldering MD1 you must use an iron rated at 25 watts or more to ensure sufficient heating of the tag and solder pad on the PCB. The applied solder should then run freely round the joint until it fills the slot in the board. Make certain that all the wire connections of MD1 are soldered in their correct holes and not touching the metal screening.

Next install the push switches S1, 3, 4 and 5 making certain that they are pushed down firmly on to the surface of the PCB. *Do not* fit the push buttons onto the switches at this stage. Before mounting the rotary switch S2 and the level control RV1 prepare them in the following manner:

1. Cut both shafts to a length of 12mm.
2. Fit a pot nut on to RV1.
3. Remove the nut and shake-proof washer from S2.
4. Position the stop ring for seven ways.
5. Refit the nut on to S2.

Using the two screws and spacers supplied with S2, install the switch making certain that it is fixed firmly onto the PCB. When fitting RV1 ensure that the solder tags go fully into the PCB.

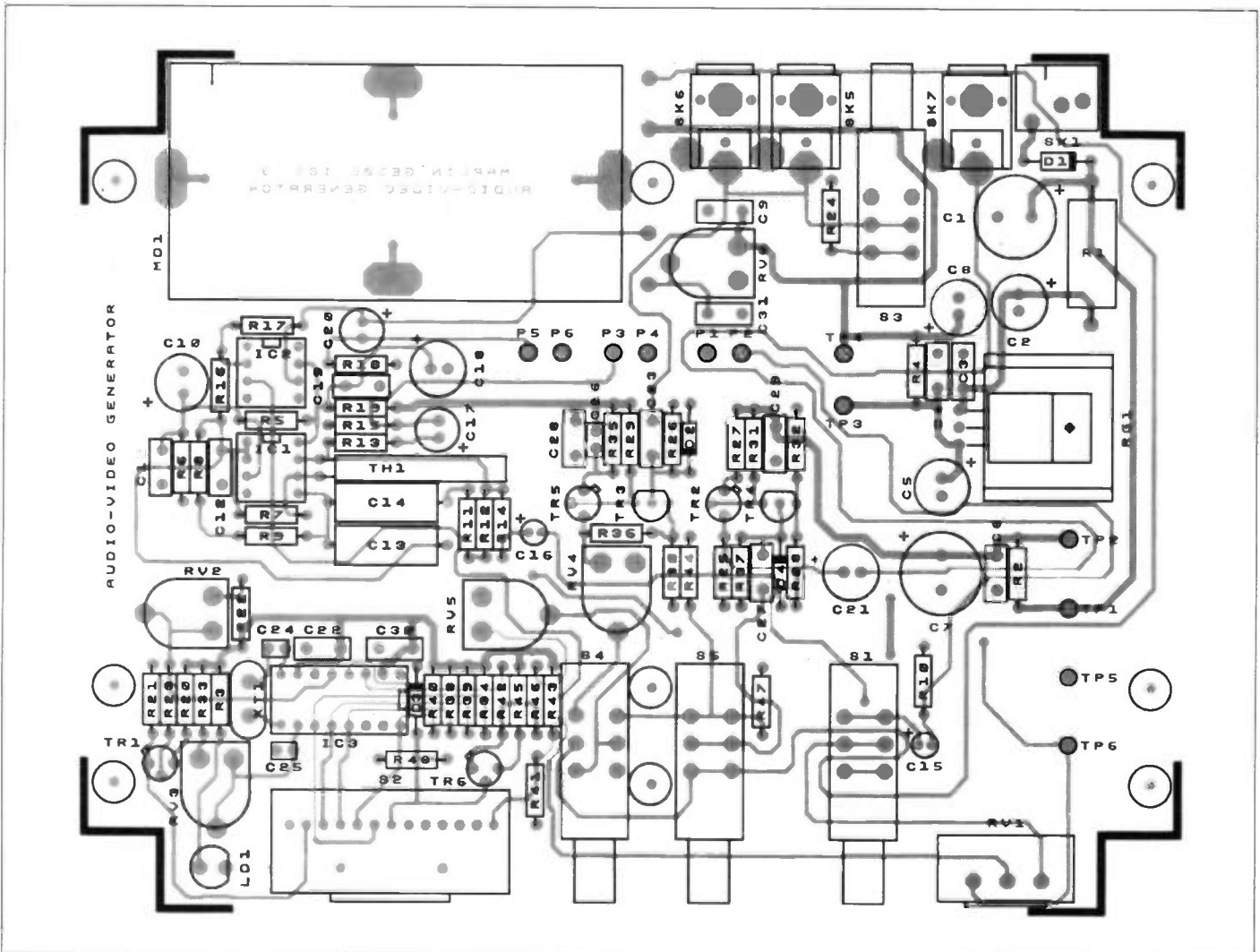

Figure 4. Layout of the PCB.

Next mount the PCB connectors SK1, 5, 6 and 7 ensuring that they are pushed firmly against the board. When mounting the red LED, LD1, it *must* be 7mm above the board and bent over at 90°, see Figure 5. The LED has a short lead and a flat edge on one side of its case to identify the cathode (K) connection.

This completes the assembly of the PCB. The remaining components are connected to the circuit board by cabling at a later stage. You should now check your work very carefully making sure that *all* the solder joints are sound. It is also very important that the solder side of the circuit board does not have any trimmed component leads standing proud by more than 3mm, as this may result in a short circuit.

Final Assembly

The PCB is designed to fit into an instrument case type 3502, with the front and back panels drilled as shown in Figure 6. When preparing the aluminium panels, the optional self-adhesive front and back stick-on panels can be used as

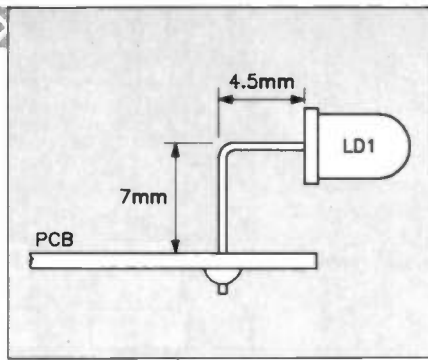

Figure 5. Fitting the LED.

a guide for checking the positioning of the holes. Having completed the drilling, at the same time clearing away any swarf, clean the aluminium panels and apply the trim by removing the protective backing. Carefully position and firmly push them down using a dry, clean cloth until they are securely in place.

Fit the front panel to the video pattern switch S2 and the audio level pot RV1 using the shake-proof washers and nuts provided with the controls. Secure the knobs so that their pointers are at the fully anti-clockwise position. Check that they travel smoothly round to the fully

clockwise position, without scraping on the front panel. Next fit the four round push-buttons onto the plungers of S1, 3, 4 and 5.

Now you can carefully position the red LED through its hole in the front panel, then fit the rear panel using the side-chassis supports and screws supplied with the case. Lower the unit into the bottom half of the case ensuring that the panels slide smoothly into place and all the fixing holes in the PCB line up with the mounting points. Using six No.4 x 1/4in. self-tapping screws secure the PCB to the case. Finally, mount the three phono sockets SK2, 3 and 4 on to the back panel.

Wiring

The total amount of wiring has been kept to a minimum by using PCB mounted switches and connectors leaving only three off-board components. Included in the kit is a half metre length of miniature screened audio cable which should be ample to make up the three links between P1 to P6 and SK2 to SK4, see Figure 7.

DC Testing

The DC tests can be made with a minimum of equipment. You will need a multimeter and a regulated +12V DC power supply capable of providing at least 250mA. The readings were taken from the prototype using a digital multimeter, some of the readings you obtain may vary slightly depending upon the type of meter employed.

Double check that none of the IC's have been fitted into the sockets on the board. The first test is to ensure that there are no short circuits before you connect the power supply. Set your multimeter to read OHMS (Ω) on its resistance range, connect the test probes to TP5 and the anode of D1. With the probes either way round a reading greater than 500 Ω should be obtained.

Next monitor the supply current; set your meter to read DC mA and place it in series with the positive line of the power supply. With the power supply on a

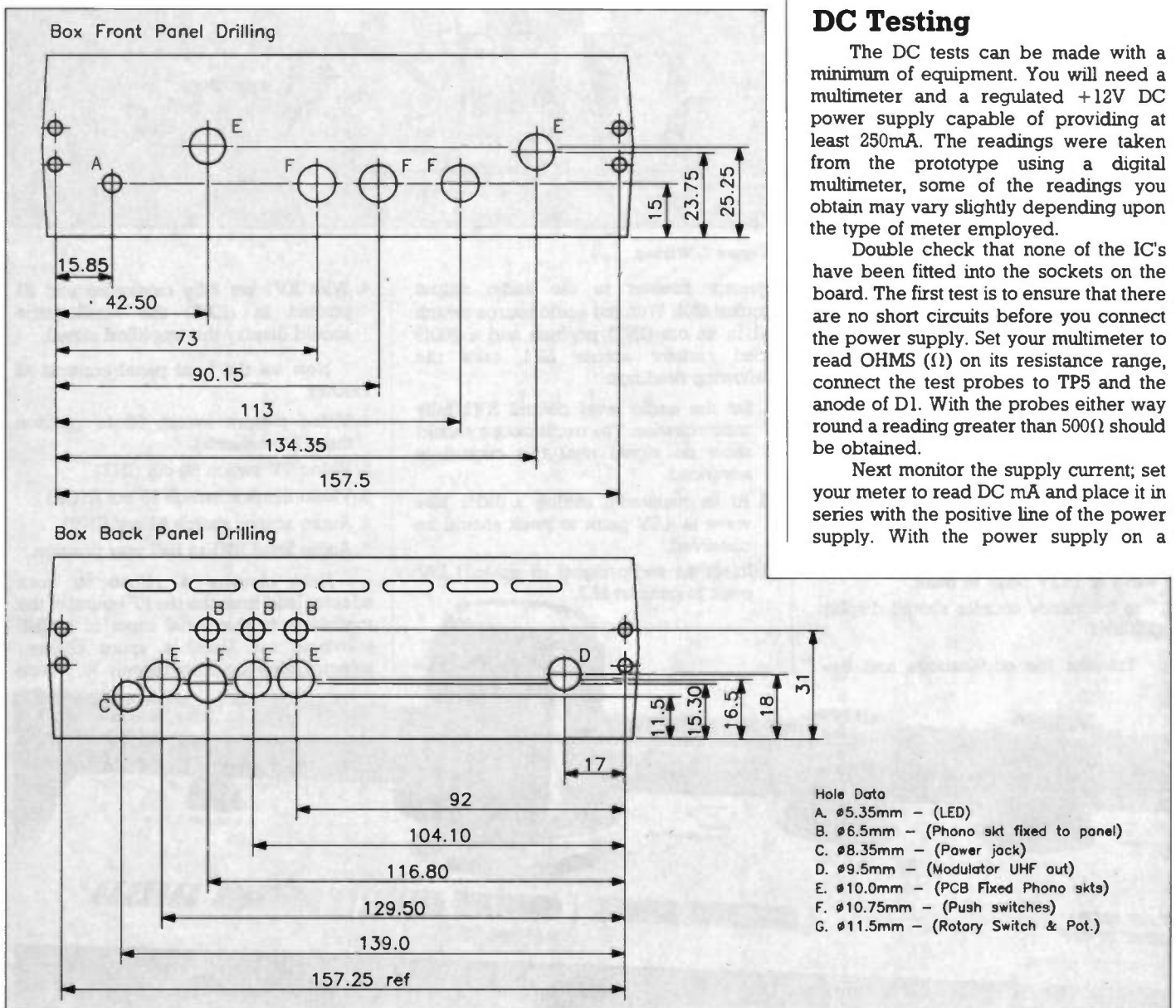

Figure 6. Front and Back Panel Drilling.

current reading of approximately 53mA should be seen and the red LED, LD1, should light up. Turn off the supply and install the IC's making certain that all the pins insert into their sockets properly and the pin 1 marker on the IC package is at the notched end of the socket. Power up the unit and observe the current reading which should now be approximately 200mA.

Remove the test meter from the positive supply and set it to read DC volts. All voltages are positive with respect to ground, so connect your negative test lead to the ground test point TP5. Before taking any readings set the PCB presets and the front panel controls to the following positions:

1. RV1 (audio level) set fully counter clockwise.
2. RV2 to RV6 should be set to their half way position.
3. S1, S3 to S5 buttons out.
4. S2 (video pattern) position one (vertical lines).

When the generator is powered up voltages present on the PCB assembly should approximately match the following readings:

TP1 = +11.0V	TP4 = +4.9V
TP2 = +10.9V	TP6 = +5.1V
TP3 = +5.0V	

This completes the DC testing of the generator, now disconnect the multi-meter from the unit.

Audio and Video Adjustments

To obtain the best results from the generator an oscilloscope and frequency counter should be used. However, good results can be achieved by simply observing the picture on a domestic TV.

The first test is for the audio oscillator and requires no adjustment. Place a 1.5k Ω load resistor across the oscillator output socket SK3 and attach your oscilloscope and frequency counter. The readings should approximately match the following:

1. The oscilloscope should show a sine wave at 1.13V peak to peak.
2. The frequency counter should display 1.00kHz.

Transfer the oscilloscope and fre-

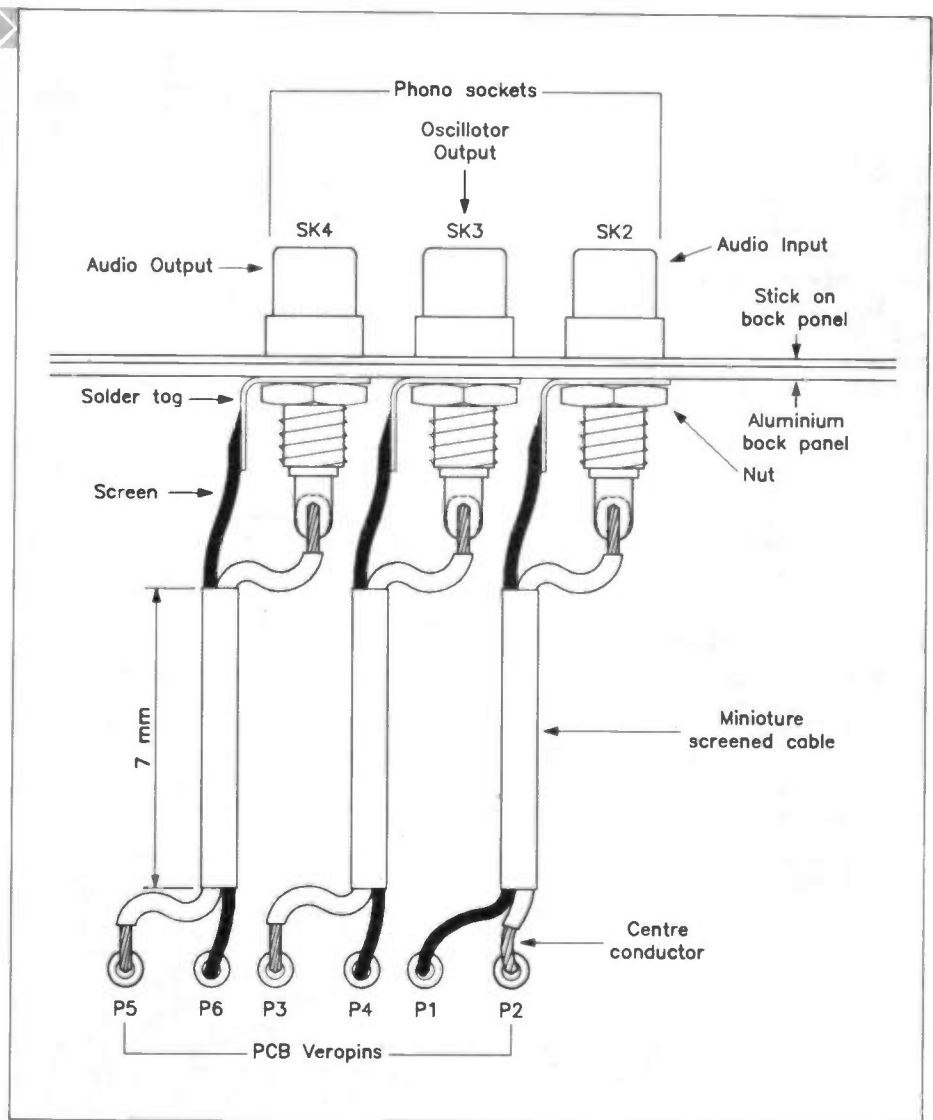

Figure 7. Wiring.

quency counter to the audio output socket SK4. With the audio source switch S1 in its out (INT) position and a 600 Ω load resistor across SK4, take the following readings:

1. Set the audio level control RV1 fully anticlockwise. The oscilloscope should show no signal until this control is advanced.
2. At its maximum setting a 1kHz sine wave at 4.8V peak to peak should be observed.
3. Inject an audio signal of up to 1.13V peak to peak at SK2.

4. With RV1 set fully clockwise and S1 pushed in (EXT) the oscilloscope should display the amplified signal.

Now set the front panel controls as follows:

1. Video pattern switch S2 to position three (crosshatch).
2. Video TV switch S4 out (INT).
3. Video monitor switch S5 out (NOR).
4. Audio source switch S1 out (INT).
5. Audio level RV1 to half way position.

Next connect a phono to coax adaptor lead from the the RF output of the modulator to the aerial input of a UHF television set. Using a spare channel selector, tune to approximately 36, where

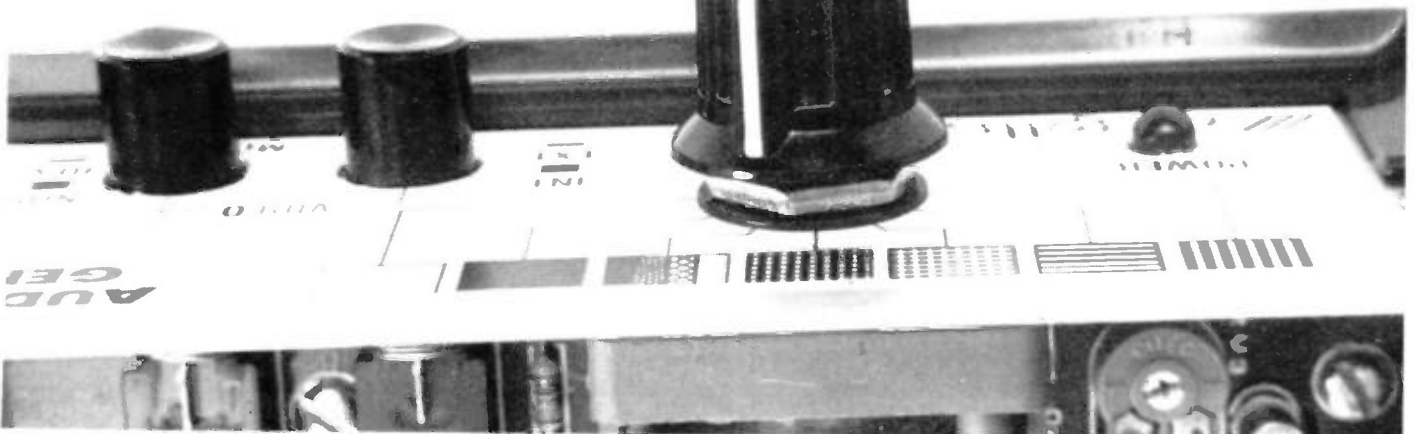

you should find the crosshatch pattern on the screen and a 1kHz tone from the speaker. If there is excessive buzzing on the sound channel adjusting the sub-carrier fine tune, RV6, should minimize this noise.

Connect a 75Ω load resistor or a video monitor to the video output socket SK7. Attach the scope probe to SK7 and make the following adjustments:

1. Make sure that the crosshatch pattern is selected.
2. Ensure that the video switches S4 and S5 are in the out (INT) position.
3. Adjust RV5 to show a 1V peak to peak signal on the oscilloscope.
4. Adjust RV3 so that the vertical lines are the same width as the horizontal lines on the TV or monitor screen.
5. Select the greyscale pattern and adjust RV2 for peak white on the left hand side of the screen, down to black level on the right.
6. With the video input termination switch

S3 pushed in, feed a 1V peak to peak signal to SK5 or 6.

7. Push in the video TV switch S4 (EXT) and adjust RV4 to show a 1V peak to peak signal on the oscilloscope.

This completes the adjustments to the generator, now remove any output load resistors and connecting leads from the unit. Using the screws provided fit the lid of the box and the four rubber feet. The generator is now ready for use.

Using the Generator

To obtain optimum sound and picture quality you must use a regulated 12 volt power supply, capable of providing up to 250mA. A suitable power supply would be mains adaptor YB23A.

The generator has two audio outputs. SK3 provides a low distortion sine wave at a fixed level, while SK4 produces an amplified signal with a variable level controlled by RV1. This output can be switched by S1 to an external audio source applied to SK2.

When the video TV switch S4 is set to internal (INT) the test patterns are selected and appear at the video output socket SK7. However, when this switch is pushed in, signals applied to the video input sockets SK4 and 5 will be selected. If the video monitor switch S5 is then pushed in (REV source) the test patterns will reappear at SK7, but not with the modulated TV output.

If the unit is placed in a video line already terminated by a 75Ω load the termination switch S3 must be in the 'off' position. The 1MΩ impedance present at SK5 and 6 will contribute little to the loading of a 75Ω line, so no attenuation of the signal should be detected.

The unit can be used as an audio/video modulator receiving its signals from a camera, VCR, or almost any composite video source. To achieve this the video TV switch S4 and the audio switch S1 must be pushed in (EXT). The audio level control RV1 should then be set for the correct sound level received by your TV.

AUDIO/VIDEO GENERATOR PARTS LIST

Resistors: All 1% 0.6W Metal Film unless specified

R1	10Ω 1W Wirewound	1	(C10R)
R2,4	10Ω	2	(M10R)
R3,22	470Ω	2	(M470R)
R5,6,29	4k7	3	(M4K7)
R7,43	270Ω	2	(M270R)
R8,11,32,41,47	820Ω	5	(M820R)
R9,12,14	15k	3	(M15K)
R10,18	10k	2	(M10K)
R13,15,21,30,33,44	1k	6	(M1K)
R16	8k2	1	(M8K2)
R17	27k	1	(M27K)
R19,45	100Ω	2	(M100R)
R20	150Ω	1	(M150R)
R23,36	1k5	2	(M1K5)
R24	75Ω	1	(M75R)
R25	330Ω	1	(M330R)
R26,37	1M	2	(M1M)
R27,35,46	82Ω	3	(M82R)
R28,31,48	3k3	3	(M3K3)
R34,38,39,40	1k8	4	(M1K8)
R42	2k7	1	(M2K7)
RV1	10k Pot Lin	1	(FW02C)
RV2	4k7 Hor. Encl. Preset	1	(UH02C)
RV3	100k Hor. Encl. Preset	1	(UH06G)
RV4,5	1k Hor. Encl. Preset	2	(UH00A)
RV6	2k2 Hor. Encl. Preset	1	(UH01B)
TH1	Bead Thermistor R53	1	(FX62S)

Capacitors

C1,7	1000μF 16V PC Electrolytic	2	(FF17T)
C2,5,8,18,21	220μF 16V PC Electrolytic	5	(FF13P)
C3,4,6,9,11,12,19,22,23,27-30,31	100nF Disc	14	(YR75S)
C10	100μF 16V Minelect	1	(RA55K)
C13,14	10nF Polystyrene 1%	2	(BX86T)
C15,16	4μ7F 35V Minelect	2	(YY33L)
C17,20	47μF 16V Minelect	2	(YY37S)
C24	22pF Ceramic	1	(WX48C)
C25	10pF Ceramic	1	(WX44X)
C26	1800pF Ceramic	1	(WX71N)

Semiconductors

D1	1N4001	1	(QL73Q)
D2-4	1N4148	3	(QL80B)
LD1	LED Red	1	(WL27E)
RG1	7805UC	1	(QL31J)

TR1,6	BSX20	2	(QF32K)
TR2,5	BC179	2	(QB54J)
TR3,4	BF244A	2	(QF16S)
IC1	LF353	1	(WQ31J)
IC2	LF351	1	(WQ30H)
IC3	ZNA234E	1	(UK83E)

Miscellaneous

XT1	Constructors Guide	1	(XH79L)
SK1	PC Board	1	(GE10L)
SK2,3,4	2.5MHz Crystal	1	(UK82D)
SK5,6,7	PCB 2.5mm DC Pwr Skt	1	(FK06C)
S1,3,4,5	Chassis Phono Skt	3	(YW06C)
S2	PCB Phono Skt	3	(HF99H)
MD1	Latchswitch 2-Pole	4	(FH67X)
	PCB R/A Rotary 1x12	1	(FT56L)
	UM1286 Modulator	1	(BK66W)
	Pins 2145	1 Pkt	(FL24B)
	Min Screened	1 Mtr	(XR15R)
	Knob KB4	2	(RW87U)
	Knob Sm Latchbutton Black	4	(BW13P)
	DIL Socket 8-pin	2	(BL17T)
	DIL Socket 16-pin	1	(BL19V)
	M10 Pot Nut	1 Pkt	(FP06C)
	Isobolt M3x10mm	1 Pkt	(HY30H)
	Isonut M3	1 Pkt	(BF58N)
	Isoshake M3	1 Pkt	(BF44X)
	Vaned Heatsink Plas Pwr	1	(FL58N)

Optional (not in kit)

Case		1	(YN33L)
AC Adaptor Regulated 300mA		1	(YB23A)
Front Panel Stick on		1	(JP03D)
Back Panel Stick on		1	(JP02C)
Self Tapping Screw No. 4 x 1/4in.		1 Pkt	(FE68Y)
Phono/Coax plug Vid. Lead		1	(FV90X)

The above parts, excluding Optional items, are available as a kit:
Order As LM98G (Aud/Vid Generator Kit) Price £59.95

The following items are also available separately, but are not shown in our 1990 catalogue:

Aud/Vid Generator PCB Order As GE10L Price £12.95
Front Panel Order As JP03D Price £1.98
Back Panel Order As JP02C Price £1.98

Square One

A First Course in the Theory and Practice of Electronics

Part I by Graham Dixey C.Eng., M.I.E.E.

Introduction

The aim of this series is to provide an informal, but certainly not trivial, course of instruction for the newcomer to electronics, or for those who wish to increase their present fund of knowledge. The only assumption made about the reader's present knowledge is that he/she is familiar with some of the rudimentary ideas in basic electrical science, such as may have been gained in CSE studies. Even so, if this knowledge is a bit shaky, it won't matter that much since an occasional 'dig in the ribs' will be given as a form of reminder. Every article will contain a mixture of theory and practice, with at least one project to make, of a simple and inexpensive nature. The entire series will cover both analogue and digital electronics and should be found useful both by the interested non-vocational amateur and to students, whether on GCSE or BTEC courses.

Components – the Building Bricks of Electronics

One has only to scan the pages of an electronic components catalogue, such as the one published by Maplin, to realise what a vast range of components exists. For the newcomer this may well represent utter confusion! Apart from the wide variety of different types of component there is also a wide choice of type within one group. Capacitors are a very good example; they are available in an enormous range of values and in many different forms, with names that mean little to the beginner. Photo 1 shows a small selection of the types of resistor (another common component) and capacitor that one will meet and which it is vital the constructor should be able to identify. Initially, it is wise to follow quite slavishly the types recommended in the parts list for any project undertaken. Later, one may appreciate why a particular type of component was chosen by the designer for a particular application. Photo 2 shows a few examples of what are called 'wound

components', i.e. they are made by winding copper wire onto some sort of former. They may be referred to as 'coils' (generally meaning a single winding) or 'transformers' (where there are two or more windings) but there is a general term – inductor – which can be used instead. And of course there are always the exceptions to confuse us. The ferrite rod aerial shown in this same photograph is obviously also a wound component but nobody would call it either a coil or a transformer; it is simply an aerial!

Passive Components

Resistors, capacitors and inductors are termed 'passive' components. This means that they are incapable of amplifying (increasing) the size of a signal. In fact, they invariably cause the signal to become smaller (attenuated). By comparison, there are components that are termed 'active'; these include transistors of various types and integrated circuits (IC's). The original active components were known as 'valves' (vacuum tubes in the USA); there are still some around but their use is quite specialised nowadays and they are rarely met by amateurs. Oddly they have made something of a comeback in the hi-fi field, where it is claimed they produce a 'nicer' sound.

Circuit Symbols

The *circuit diagram* is a vital means of communicating with others about a specific electronic device or system. However, in order to be able to communicate effectively, it has to have a 'language' which is recognised by all and this language should transcend national boundaries. It achieves this by using symbols that are instantly recognisable by all, whatever their nationality. This scheme more or less works, there being the odd exception, and there being cases of dual standards. Digital logic symbols are a good example. The British Standards Institution have their own B.S. set (which we ought to use) and the Americans have an entirely different set (which we do generally all use). The

safest way is to be familiar with both sets; it's quite easy to pick them up and they will be introduced at the appropriate time. For the moment, Figure 1 shows the circuit symbols for some of the more common components – those that we shall be using in the first few parts of this series.

Codes for Electronic Components

Many small, passive components have their values identified by a simple colour code. This applies to the majority of resistors and to certain types of capacitor. Otherwise, the value is clearly printed on the component (as with aluminium electrolytics) or has a numerical code. Details of both types of code are given in Table 1. The general rule is that the first two colours in the code identify the first two digits of the value, while the third colour (often termed the multiplier) represents the number of zeros that follow.

As an example, a resistor marked with the bands, *red, violet and yellow* has the value of *two* (red), *seven* (violet) followed by four zeros (yellow), which equals $270,000\Omega$ (ohms) or $270k\Omega$ (or just $270k$). Further bands appear on both resistors and capacitors which specify the tolerance, working voltage, temperature coefficient, etc. These needn't concern us too much at the moment.

Integrated Circuits (IC's) and Transistors

The standard practice for identifying the pins on Dual In Line (DIL) IC's is that they are viewed from the top with Pin 1 either immediately beneath a rectangular indentation (when this is viewed at the left hand end of the IC), or adjacent to a small circular mark. The numbering is then anti-clockwise, ending up with the highest number pin immediately opposite Pin 1.

The only safe rule with transistors is to refer to a pin-out diagram for the specified type (unless this is given in the article). The general rule is that the

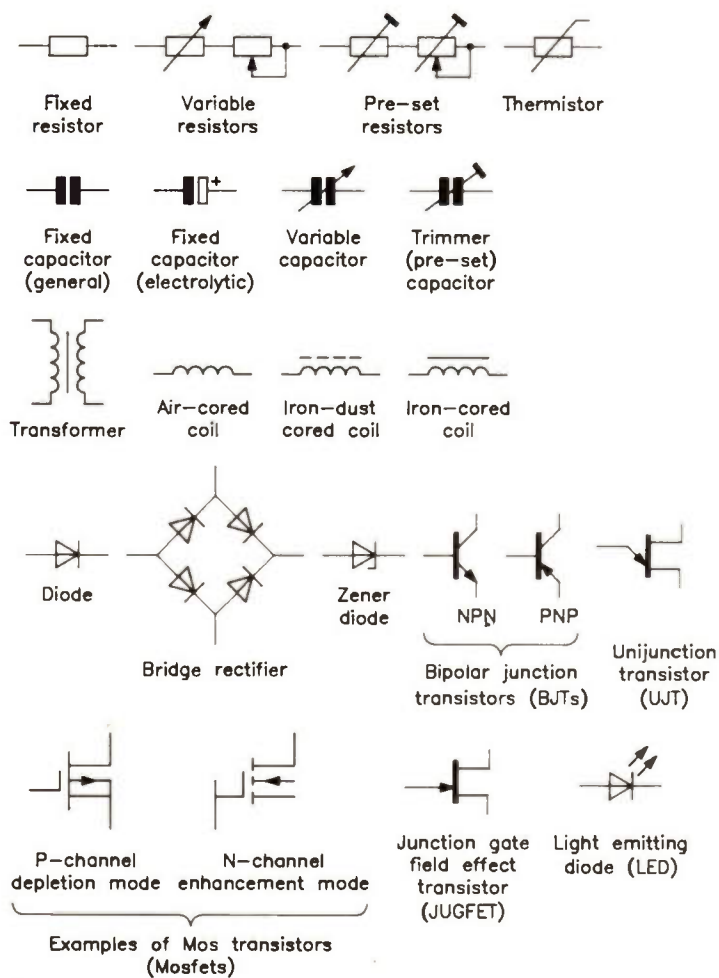

Figure 1. A selection of circuit symbols for passive and active components.

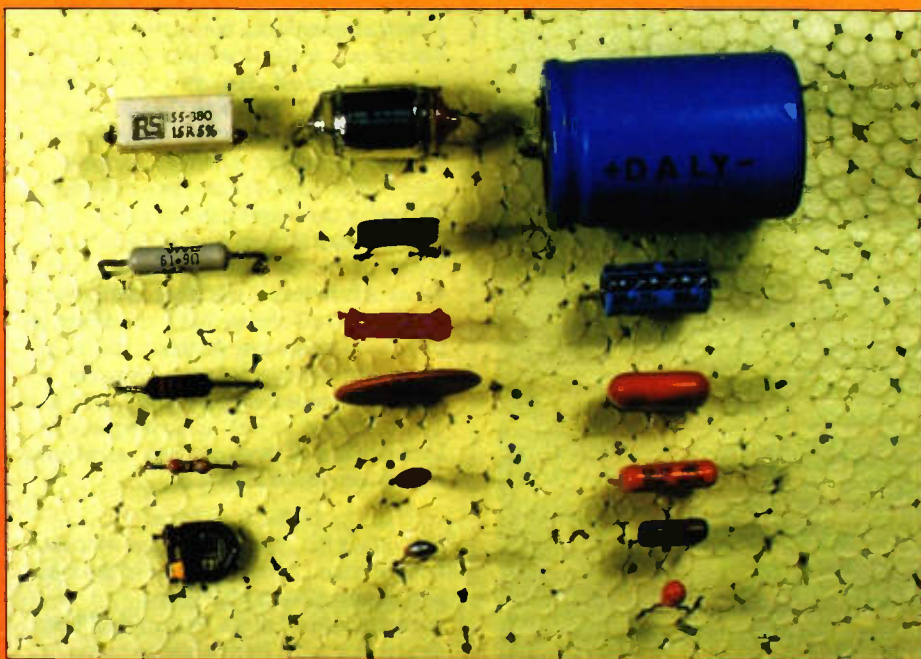

Photo 1. A selection of resistors and capacitors. Reading top to bottom, left to right, the resistors are: wirewound, a precision type, two metal film types and a small carbon pre-set; next, capacitors: polystyrene, silver mica, tubular ceramic, three disc ceramic types; finally, two aluminium electrolytics, three polyester types and a tantalum bead electrolytic.

transistor is viewed from below. Transistors usually have three leads known as Collector, Base and Emitter for Bipolar Junction Transistors (BJT's); or Drain, Gate and Source for Field Effect Transistors (FET's). An introduction to these type of transistor will be given in the next article. For now, they should merely be considered as three-lead amplifying devices.

Units and Magnitudes

Every electrical quantity has a unit in which it is measured. There is a system known as the system of S.I. units (*System Internationale*) which specifies the standard units for the various quantities. However, the standard unit is often, oddly enough, of an impractical size. Table 2 shows a few of the most common units together with their symbols.

Voltage (V or E)	-Volts (V)
Resistance (R)	-Ohms (Ω)
Energy (W)	-Joules (J)
Inductance (L)	-Henries (H)
Time (T or t)	-Seconds (s)
Current (I)	-Amperes (A)
Power (P)	-Watts (W)
Capacitance (C)	-Farads (F)
Frequency (f)	-Hertz (Hz)
Charge (Q)	-Coulombs (C)

Table 2. Common Units.

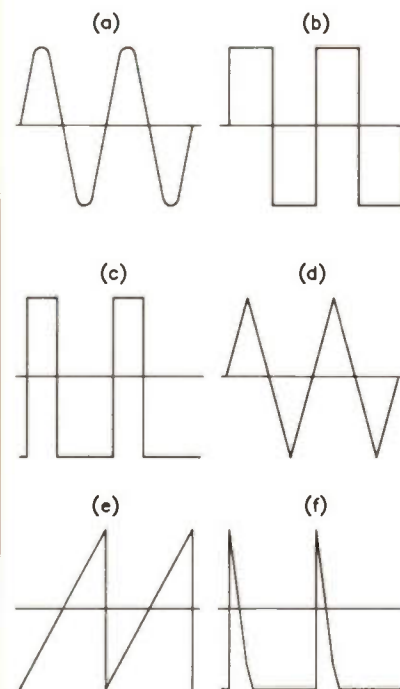

Figure 2. Some of the waveforms met in electronics: (a) sinewave, (b) square-wave, (c) rectangular wave, (d) triangle, (e) sawtooth, (f) pulse.

It should be noticed from this that there is a separate symbol for the quantity itself and for the unit that represents it. This may seem a little confusing at first, but a few examples should make it clear.

'A frequency (f) may have a value of 100(Hz).'

'An inductor (L) may have an inductance value of 15(H).'

'An audio amplifier may have an output power (P) of 30(W).'

In practice, the brackets are usually omitted; here they are used for emphasis.

Returning now to the matter of impractical sizes for units, this problem is overcome by the use of multiples and sub-multiples of the basic unit. These themselves give a good insight into the enormously large or incredibly small size of the quantities that one meets in electronics. Table 3 shows those that are in current use.

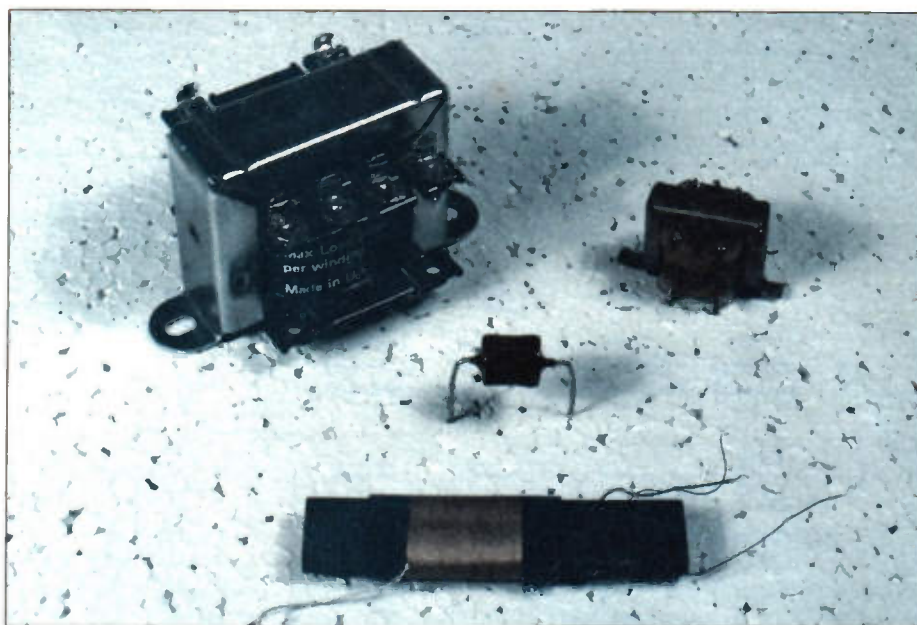

Photo 2. Some inductors: a small mains transformer (left), a miniature audio-frequency transformer (right), a miniature choke (centre) and a ferrite rod aerial.

Sub-multiple	Power of 10	Numerical Value
Pica (p)	10^{-12}	One million-millionth
Nano (n)	10^{-9}	One billionth
Micro (μ)	10^{-6}	One millionth
Milli (m)	10^{-3}	One thousandth
Kilo (k) or (K)	10^3	One thousand times
Mega (M)	10^6	One million times
Giga (G)	10^9	One billion times
Terra (T)	10^{12}	One million-million times

Table 3. Sub-units.

The general rule is that the symbol for the sub-multiple should be a lower case letter and that for the multiple, a capital letter. On this basis, strictly speaking, kilo should be represented by 'K' but common usage has assigned 'k' to it instead. Many examples of this idea will be found just by glancing through the pages of this magazine. Such examples will include, mA (milli-amperes); pF (pico-Farads); MHz (Mega-Hertz), etc.

Signals and Waveforms

The technology of electronics involves the generation and manipulation (or processing) of 'signals', each signal having a shape, known as its 'waveform', which describes it. The latter is actually a plot of voltage (usually, but sometimes current instead) against time. The most common waveform, because it is a natural one, is the sinewave. This is shown in Photo 3 displayed on the screen of a C.R.O. (Cathode Ray Oscilloscope). Figure 2 shows a selection of the most frequently encountered waveforms in electronics. In each case, two complete 'cycles' of the waveform are shown. This should make it clear what is meant by a 'cycle'. It is a complete set of values of the waveform before it starts repeating itself again. Figure 3 shows that a waveform (in this case a sinewave, though it is true for all regularly recurring waveforms) is defined dimensionally by 'amplitude' and 'periodic time' as well as by frequency. Let's explain all three of these terms now, with reference to Figure 3.

The 'periodic time' (or simply 'period') is the time interval that elapses between the commencement of the cycle and its completion (that is, the commencement of the next cycle). This can have a value from a few ns (nano-seconds) at extremely high frequencies to seconds, or even minutes in extreme cases, at very low frequencies. The symbol is T (or 't'). Frequency is the

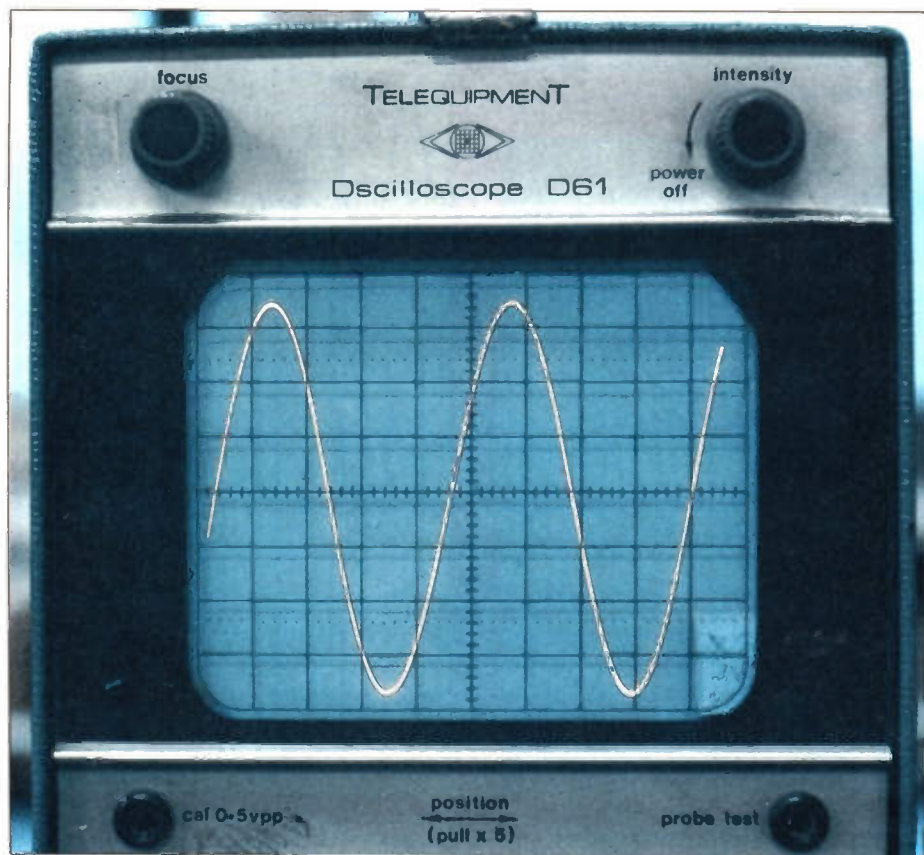
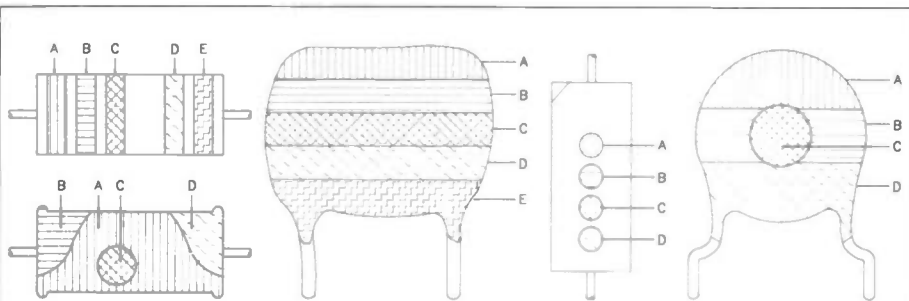

Photo 3. A C.R.O. (Cathode Ray Oscilloscope) displaying two cycles (approx.) of a sinewave.



Colour	Units		Tens		Multiplier		Value tolerance except *			Other	
	Band A	Band B	Band C	Band D	Band E	Band F	Band G	Band H	Band I	Band J	Band K
			resistors	capacitors	resistors	capacitors up to 10pF	capacitors over 10pF	tantalum marking voltage *	resistors	capacitors	
Black	—	0	1	1	—	2pF	± 20%	10V	—	—	
Brown	1	1	10	10	± 1%	0.1pF	± 1%	—	—	—	
Red	2	2	10 ²	10 ²	± 2%	—	± 2%	—	—	250V	
Orange	3	3	10 ³	10 ³	—	—	± 2.5%	—	—	—	
Yellow	4	4	10 ⁴	10 ⁴	—	—	—	6.3V	—	400V	
Green	5	5	10 ⁵	—	—	0.5pF	± 5%	16V	—	—	
Blue	6	6	10 ⁶	—	—	—	—	20V	—	630V	
Violet	7	7	10 ⁷	—	—	—	—	—	—	—	
Grey	8	8	10 ⁸	0.01	—	0.25pF	—	25V	—	—	
White	9	9	10 ⁹	0.1	—	—	—	2V	—	—	
Silver	—	—	0.01	—	± 10%	—	—	—	—	—	
Gold	—	—	0.1	—	± 5%	—	—	—	—	—	
Pink	—	—	—	—	—	—	—	35V	High stability	—	

Polyester capacitor markings (where not colour-coded)
Examples:

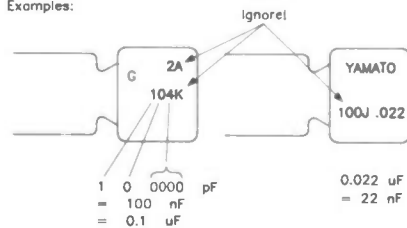

Table 1. Resistor and capacitor coding.

number of cycles per second (unit Hertz you may recall); the old unit was in fact cycles per second (c/s or c.p.s). It should be obvious from this that $f = 1/T$ (and hence $T = 1/f$).

For example:

If $f = 1000\text{Hz}$ (i.e. 1kHz) then $T = 1/1000\text{s} = 1\text{ms}$.

There are, unfortunately, several ways of specifying the amplitude (height) of a waveform. Students on electronics courses are usually eventually convinced after laborious geometric exercises as to the validity of these various ideas. We don't have the luxury of such time so it is going to have to suffice to state what these ways are, without in-depth explanations. The latter can be found in any basic electronic principles textbook if wanted.

Taking the easy ways first, 'peak-to-peak' and 'peak' amplitudes are both shown in Figure 3. The maximum value of a waveform is known as its *peak value*, hence these methods are easy to apply. The 'peak-to-peak' value is exactly twice the 'peak' value. They are easily measured when the waveform is displayed on a CRO, as in the case of Photo 3. The 'average' or 'mean' value of a waveform means just what it says but it may not be clear how it is determined. Taking the case of the sinewave, the

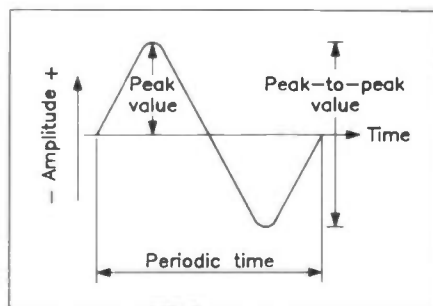

Figure 3. Time and amplitude values for a sinewave.

average over a complete cycle is actually zero – because the positive half-cycle exactly cancels the negative one. This is fairly useless information and to get any value from the idea of average value, it has to be taken over a half-cycle only.

In this case, the average value of a sinewave = 0.636 x peak value.

This is sometimes a useful way of specifying the amplitude of a sinewave but a much more useful method is to use the R.M.S. (Root Mean Square) value. This is the sticky one to explain, because it involves the rather tedious geometric method (or worse!) mentioned earlier. It is the value specified in most cases and its usefulness lies in the fact that it can be used to calculate the 'power' associated with the waveform.

It is determined for a sinewave as follows:

The R.M.S. value of a sinewave = 0.707 x the peak value.

To take an everyday example, the standard British mains supply is said to have a value of 240V. Is this 'peak-to-peak', 'peak', 'average' or 'R.M.S.'? The answer is, as you may know or have guessed, R.M.S. This means that the mains voltage in this country could alternatively be specified as:

Peak value = $240/0.707 = 340\text{V}$; or
peak-to-peak value = $2 \times 340 = 680\text{V}$!

However, there wouldn't be much point in doing so, but it provides a little food for thought, doesn't it?

There are a few cautionary words that ought to be considered at this stage.

- The relationships between peak, average and R.M.S. values quoted above are *only valid for sinewaves*. Square-waves, triangular waves, etc., have quite different relations.
- The majority of a.c. measuring instruments indicate the R.M.S. value of the voltage or current being measured. However, they usually do this by sensing the 'average' value of the waveform and using the relation between average and R.M.S. values for a sinewave in order to calibrate the instrument. This means that, if the waveform being measured is *not* a sinewave, the measurement will be inaccurate.

It was stated earlier that average value = 0.636 x peak value and R.M.S. value = (0.707 x peak value). Therefore, R.M.S./average = (0.707 x peak value / 0.636 x peak value) = 1.11. This value is known as the *form factor* and the value given is, of course, that for a sinewave.

Some Fundamental Laws

In spite of the complexity of much electronic equipment, the simplest laws are the most useful and higher mathematics is rarely of much use to the average technician or engineer, even. A surprising amount of circuit design work can be done using the following simple laws and they are also very useful in estimating the likely working conditions of a circuit so that the effects of component faults can be estimated. Much circuit design does not involve the use of 'magical and complex' formulae, but rather common sense, practical experience and a sound grasp of certain basic principles. The most useful laws are as follows:

- Ohm's Law: this gives the relation between voltage, current and resistance. It can be stated in three possible ways, each of which is nothing more than a transposition of the other two, thus:
 - $V = I \times R$; hence
 - $I = V/R$; hence
 - $R = V/I$.

This law enables us to calculate any one of the quantities V , I or R if the other two are known. There's nothing more to it than that!

There is, however, one restriction; the value of R must not itself depend upon either V or I . In the majority of cases this condition is easily satisfied.

(b) Kirchoff's Laws: There are two of these and they can be explained quite simply with two small diagrams - Figure 4.

(i) The algebraic sum of currents at a junction in a network is zero. This is merely a formal mathematical way of saying that, the sum of the currents flowing *into* a junction equals the sum of those currents flowing *away* from the junction. This is really commonsense, because otherwise one would be faced with the impossible task of explaining where some current had magically appeared from or disappeared to! In Figure 4a the sum of the currents I_1 , I_2 and I_3 equals the sum of I_4 and I_5 . That is, $I_1 + I_2 + I_3 = I_4 + I_5$.

(ii) The algebraic sum of the voltages around a closed loop in a circuit is zero. This is a formal way of saying that the sum of the sources of voltage (e.g. batteries) in a loop equals the sum of the voltages that appear across the various components (e.g. resistors) in the loop. In Figure 4b the 'effective total voltage' acting in the loop shown is $12V - 6V = 6V$, because E_1 and E_2 are trying to send current round the loop in opposite directions, that is they are opposing each other. In the same way that mechanical forces will try to cancel each other out, so will voltage sources try to do so. If they both had the same value, e.g. $12V$, they would have exactly cancelled, leaving no net voltage and no current flow. The actual current flowing in the loop is given by:

$$I = \text{net voltage/total resistance}$$

Therefore, $I = (12 - 6)/(8 + 5 + 11) = 6/24 = 0.25A$

There are three volt drops in the loop, across the resistors R_1 , R_2 and R_3 . These volt drops can be calculated using Ohm's law for each resistor in turn. So that:

$$\text{Volt drop across } R_1 = I \times R_1 = 0.25 \times 8 = 2V$$

$$\text{Volt drop across } R_2 = 0.25 \times 5 = 1.25V$$

$$\text{Volt drop across } R_3 = 0.25 \times 11 = 2.75V$$

$$\text{The total of these volt drops} = 2 + 1.25 + 2.75 = 6V$$

A result that should come as no surprise since it equals the net voltage applied to the loop!

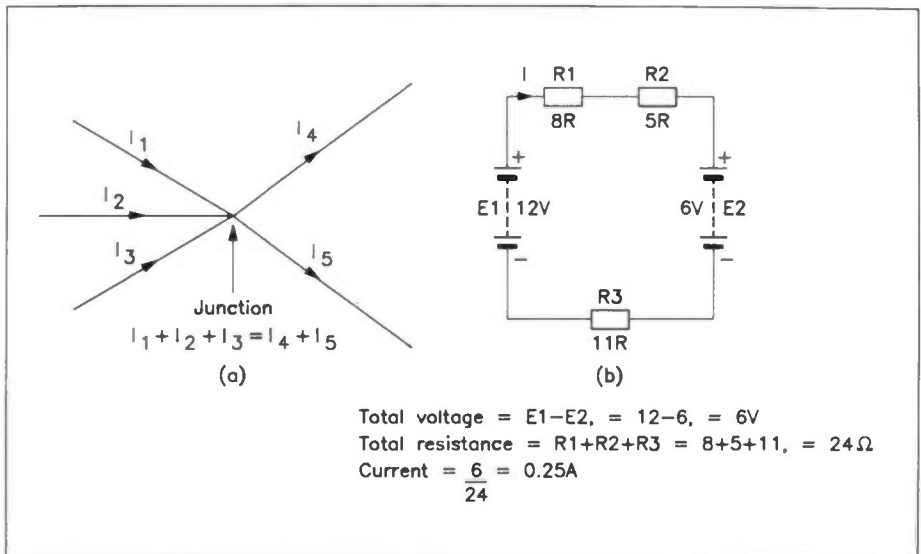

Figure 4. Illustrating Kirchoff's laws: (a) 1st law for currents at a junction; (b) 2nd law for voltages around a loop.

Measuring Voltage, Current and Resistance

A wide range of values of these quantities can be measured using an instrument known as a multimeter. It has limitations as will be discussed eventually, but much useful work can be done with it, and it should certainly be the first instrument to go out and buy. When doing so, one is faced with exactly the same choice as when buying a watch - analogue or digital? The two types are shown in use in Photo 4. It is probably realistic to say that, nowadays, most people would opt for a digital type. There are several advantages.

- (a) They are robust since there is no delicate moving-coil mechanism to become damaged.
- (b) In price pound for pound they offer a higher specification than an analogue type.
- (c) They are unambiguous in their presentation of the displayed value, and generally easier to use.

As a guide to price, a very useful digital multimeter will cost around thirty pounds, and there are even cheaper ones than that, that are capable of doing useful work. Some people, used to analogue meters, still prefer them. It is easier to interpret constantly changing values and to assess average values on an analogue instrument than on a digital meter, where the constantly tumbling digits can sometimes be confusing. There are three 'golden rules' to remember when using a multimeter of either type.

- (i) When measuring a voltage the meter is connected 'in parallel' with the voltage. See Figure 5a.
- (ii) When measuring current the meter is connected 'in series' with the current; this means breaking the circuit in order to insert the meter. See Figure 5b.
- (iii) When measuring resistance do so with the circuit power switched off

and remember that, when measuring across one component 'in situ' in a circuit, there may be other components in parallel that will affect the result of the measurement.

At this stage just note that the term 'in parallel with' means *across* the component, while 'in series' means *in line* with the component. A fuller explanation of series and parallel circuits will appear in the next article. Finally, before connecting the instrument, check that its dials (or push-buttons) are correctly set: AC or DC? V , I or Ω (R)? Correct range selected? Any attempt to measure too high a value on too low a range will result in an error indication on the display in the case of a digital meter. In the case of an analogue meter, the pointer will attempt to wrap itself around the end stop!

Breadboarding a Circuit

This quaint term goes back to the early days of experimenting with wireless (receiver) circuits, when (believe it or not) nails were driven into wooden boards to anchor the wiring and the archaic and massive components had to be securely screwed down. Nowadays, the term merely means any arrangement for making up a circuit, usually for testing or experimenting. There are several alternatives, as follows:

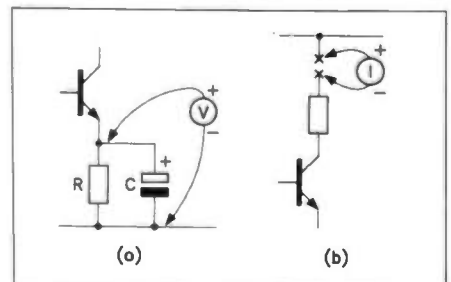

Figure 5. Measuring voltage and current: (a) a voltmeter should be connected IN PARALLEL WITH the voltage to be measured; (b) an ammeter should be connected IN SERIES WITH the current to be measured.

- (a) The use of a 'plugblock' which contains several hundred silver-plated spring contacts. No soldering is required and the life of the board, with care, is more or less indefinite.
- (b) A more permanent alternative is stripboard, which has a matrix of holes through a closely spaced set of copper strips. Components are secured by passing the leads through the holes and soldering them on the copper side. Unwanted connections are removed by cutting out sections of the copper with a special tool. There are two types: 0.1in. and 0.15in. matrix; the former is more useful. Such stripboard can be as good as purpose made etched PCB's, and ideal for 'one-offs' and prototypes.
- (c) Yet another possibility is 'matrix board', which is rather like stripboard but without the copper strip conductors. Special tinned pins are inserted into holes as required, which act to support components and can be linked with copper wire to form the circuit.

These three alternatives are shown in Photo 5.

Soldering

Even if you opt for method (a), the plugblock, sooner or later you will have to master the art of soldering. It isn't difficult. There are certain rules to follow and it takes practice. That's all.

The keyword is 'cleanliness'. That means cleanliness of the work to be soldered and the cleanliness of the iron itself. In general this isn't difficult to achieve. Electronic components are supplied with leads, tags or other connections already tinned (meaning already coated with a lead/tin solder alloy). Only when such components are very old does tarnish on the surface have much effect, and a little extra heat usually works then. Otherwise, if the surface doesn't seem to want to take the solder, it can be cleaned quite effectively using a glass-fibre 'brush'. It should be pointed out that such methods are for 'awkward' situations and are rarely necessary for routine circuit assembly.

In order to make a sound soldered joint, the iron should first be given enough time to warm up to working temperature, usually a few minutes. An iron that is not quite hot enough will *not* make a sound joint! The 'bit' (tip) of the iron should be clean and have a thin tinning of solder. To remove any accumulated deposits from previous soldering (usually black in colour), brush it when hot with a wire brush (a brass wired spark plug brush is an excellent soldering tip cleaner). Then apply the solder to it until it runs smoothly over the working area of the bit. Carefully flick off the surplus solder into a waste bin or wipe on a damp sponge and the iron is ready for use.

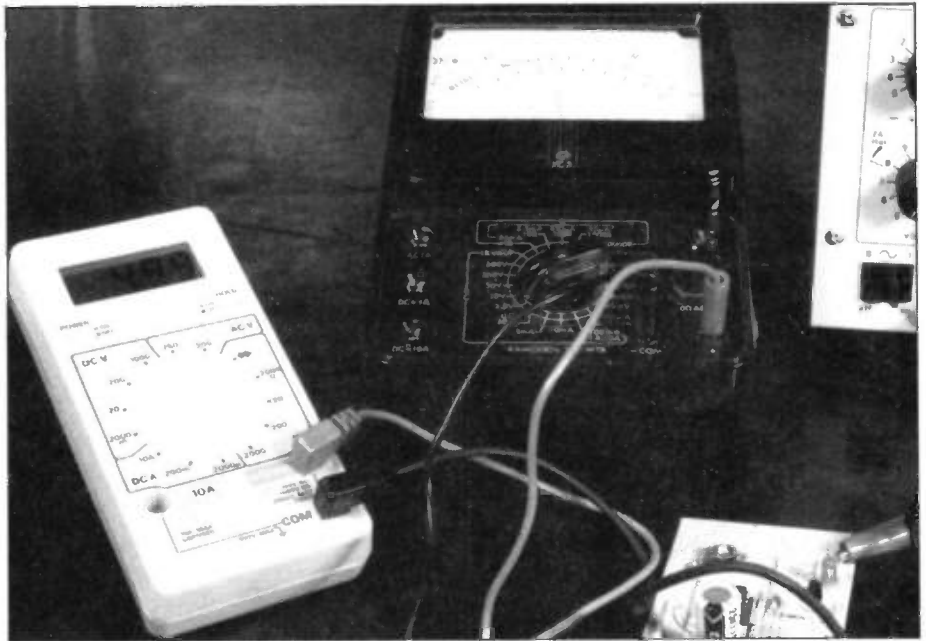

Photo 4. Digital versus analogue meters. Here both are being used to measure a d.c. supply voltage (approx. 5V). Both have sufficient accuracy for this type of measurement, but the digital type is easier to read.

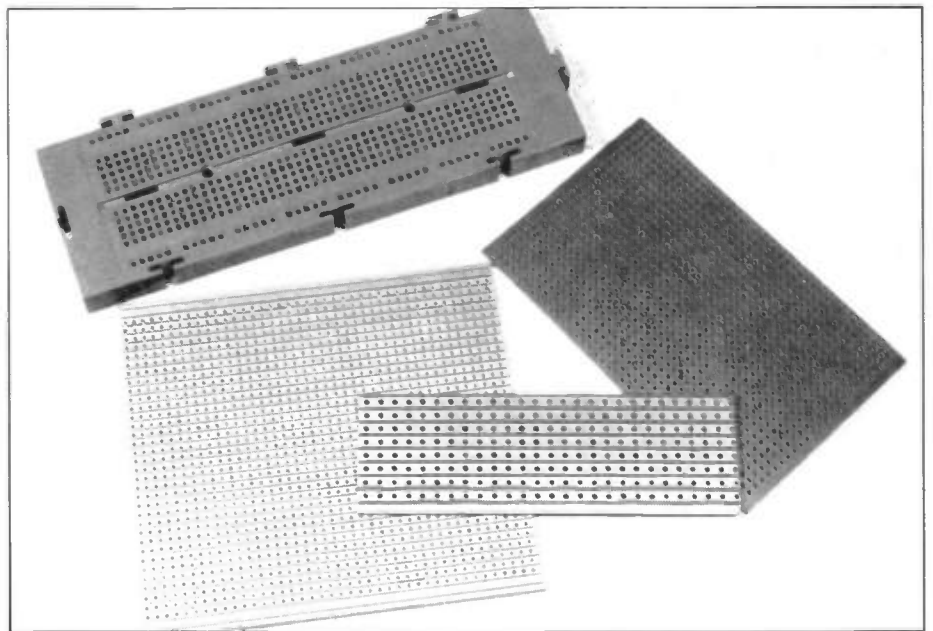

Photo 5. Three types of 'breadboard': plugblock, stripboard (0.1 inch and 0.15 inch pitch) and plain matrix board.

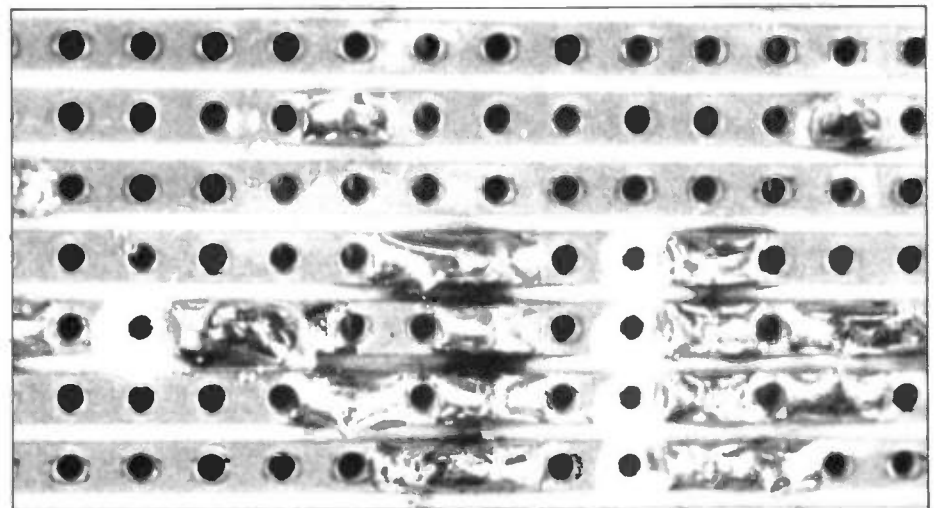

Photo 6. Properly made solder joints. Note the smooth and shiny appearance.

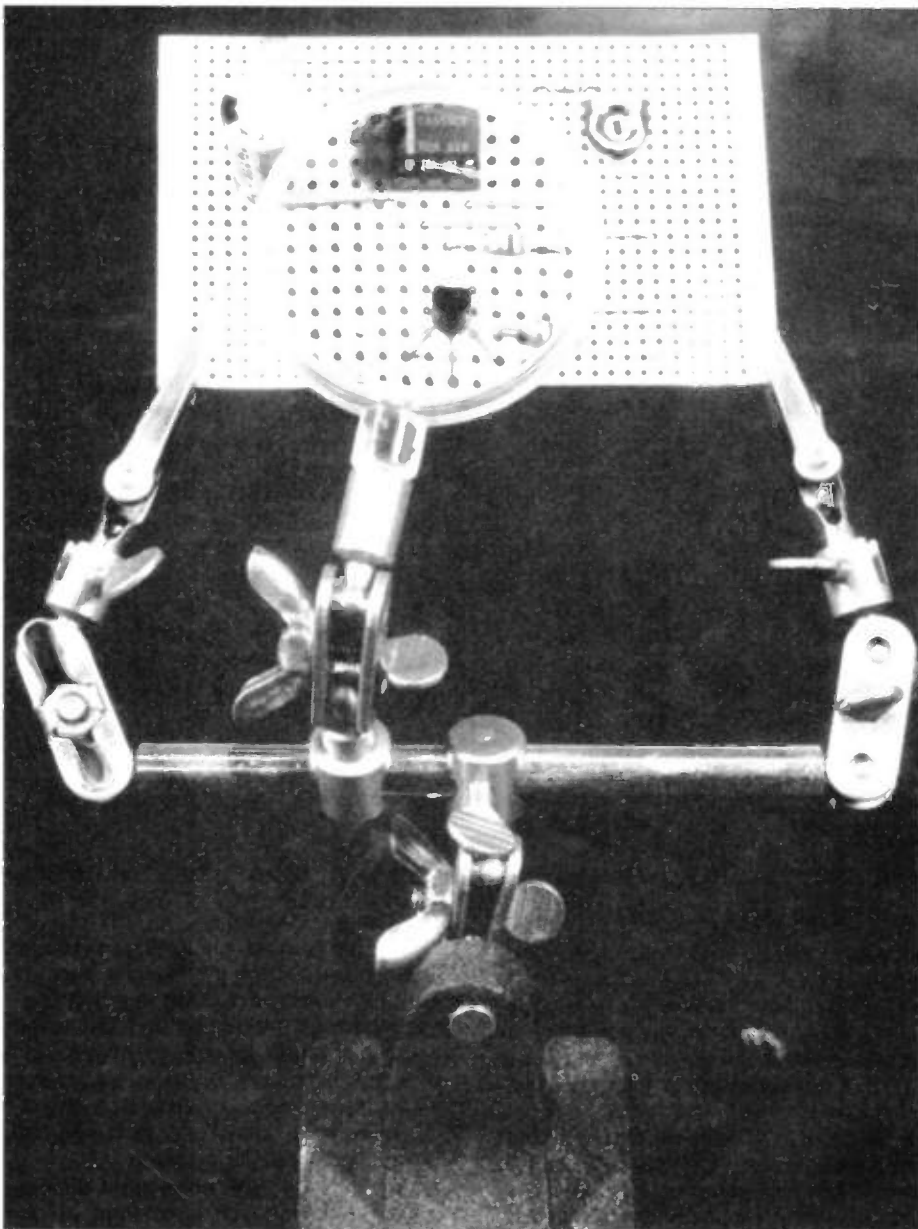

Photo 7. This inexpensive gadget provides a useful 'third hand' for holding the circuit board during assembly. The magnifier can be used to inspect the standard of soldering.

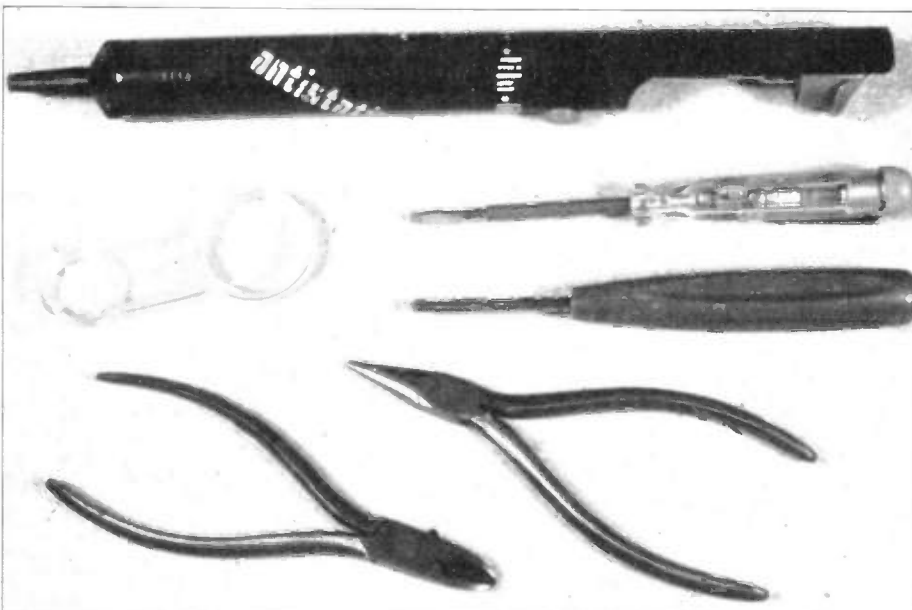

Photo 8. A few of the basic hand tools of electronics, including the 'solder sucker' mentioned in the text. Centre right is a stripboard cutter.

The usual advice given concerning soldering technique is to apply the hot iron tip and the solder to the joint to be made simultaneously. This statement can be modified slightly. The iron should be applied to the joint *first*, followed immediately by the solder, thus allowing the iron to pre-heat the joint area first – the iron should be in contact with *both* surfaces or one of them is likely to remain colder and may not accept the solder properly. When applied the solder should then run smoothly. In practice the molten solder itself will conduct heat to all surfaces requiring it. A good joint is characterised by its shiny appearance and with the smooth and easy way the solder flows into the joint. A 'dry' joint is turgid and often matt in appearance.

Be economical in the use of solder. Use enough for a good joint and no more; large masses of solder don't add extra strength and run the risk of bridging close tracks on PCB's and stripboards. Actually soldering on stripboard is good practice in this respect as the copper strips are quite close. Photo 6 shows how well made joints should look.

If you already know something about soldering you may have noticed that no mention as yet has been made of flux! Quite right too, since it's already contained in the solder, which should be bought especially for electronic circuit assembly and not cadged from the local plumber! This solder is made with hollow channels containing the flux, and consequently may also be known as 'multicore' solder. No extra flux of any other variety is necessary and usually not advised since many of them are corrosive! The exception is 'Fluxite', which is occasionally found useful for soldering certain small assemblies, but its use should be the exception.

Photo 7 shows a very useful device, which effectively provide a 'third hand'. Not only will it hold various sizes of circuit board for easy assembly and soldering, but the built-in magnifier can be used to inspect the work afterwards for possible solder bridges. These handy gadgets cost only a few pounds and are well worth having.

But how do you get rid of solder bridges, or any excess solder due to clumsiness? Really heavy solder deposits can be removed with solder wick, which draws up the molten solder by capillary action when placed on the mass of solder, the latter being heated up with an iron. More subtle than this method is the use of a 'solder sucker', which is primed by pushing down the spring-loaded plunger until it locks. The solder to be removed is then heated with an iron and, when the iron is quickly removed and the tip of the solder sucker put in its place, triggering it will cause the molten solder to be drawn up into the tool's nozzle. That's the theory anyway! It does actually work extremely well but a little practice is required. A testing exercise is to try to remove a DIL IC from an old circuit board by desoldering each pin of the IC in turn!

This useful desoldering aid is shown in Photo 8, together with a small selection of other tools. The solder sucker is one tool that should be in every constructor's tool kit.

Tools for Electronics

Over a period of time a large number of tools, some very useful, some occasionally so, will be acquired. Initial purchases should be bought with quality and not quantity in mind. The very least requirement is for a small pair of side cutters and wiring pliers and a good soldering iron with a fine bit. A wire stripper can be added later if thought necessary, but many people never use one, relying on an acquired skill for stripping the insulation from wire with wire cutters without damaging the wire's conductor. Most people will already have one or two small and medium size screwdrivers; a very useful one to add, if not already owned, is a 'neon' type, which permits the presence of live mains to be detected. Have a look in the tools section of the Maplin mail order catalogue for an idea of the variety of different tools that exist.

This Issue's Project

The first project, the circuit diagram of which is shown in Figure 6, is for a simple but useful circuit, which will generate low frequency pulses. An output stage driving a LED (Light Emitting Diode) gives a visible indication of correct operation of the circuit; it also provides a rough indication of the frequency, which lies in the range 0.1Hz (1 pulse each 10 seconds) to 1Hz (1 pulse per second). The object of the project is manifold. It will provide useful experience in the use of stripboard for small circuit construction, in the handling of small components and will also provide useful practice in soldering. It will show quite clearly whether it is working or not without the need for any test equipment, by the flashing of the LED. When it is built and working it can be put aside for use later, when you will find it invaluable for testing some of the digital circuits that will be met later in the series.

Both sides of the circuit board are shown (Photos 9 and 10); there are very few track breaks required, but those that are needed should be noted carefully. These breaks should ideally be done using the appropriate special track cutting tool, and not a drill bit, knife etc. For this and stripboard generally see page 268 of the 1990 Maplin catalogue. The actual size of stripboard for the project is not critical, but as long as the general layout shown is followed carefully, a slightly larger or smaller piece of board can be used. It is helpful to count the holes between components, for example relative to Pin 1 of the IC, in order to establish correct positions. Wiring pliers should be used to make neat, square bends in leads before

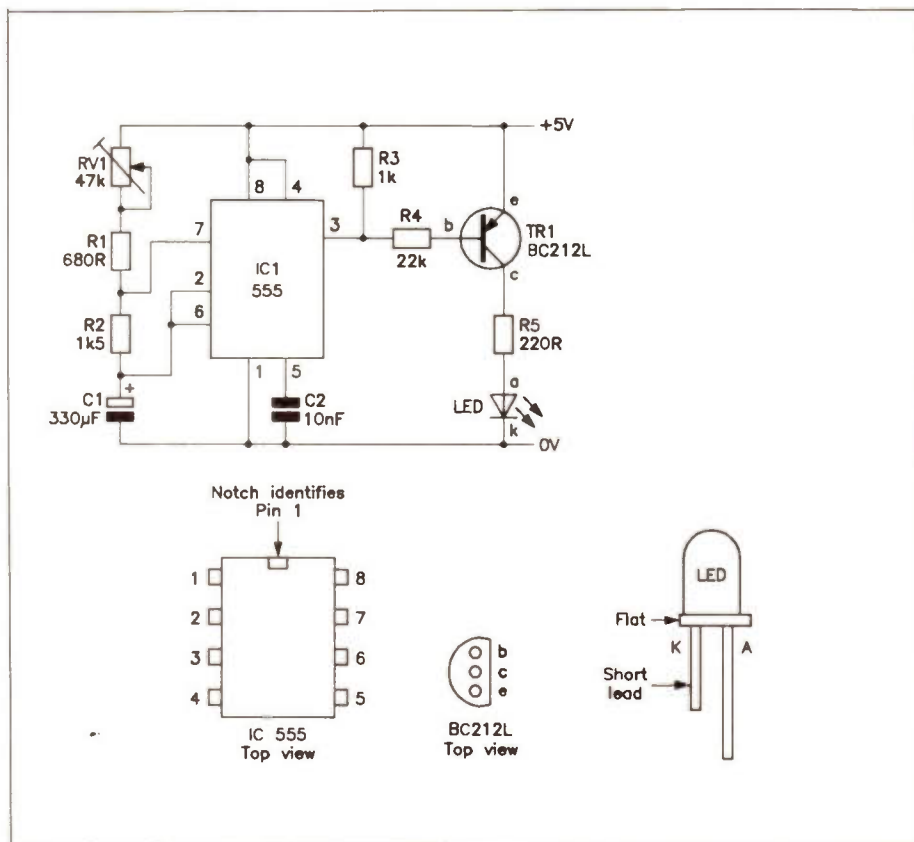

Figure 6. Circuit and component details for the 555 pulse/flasher project.

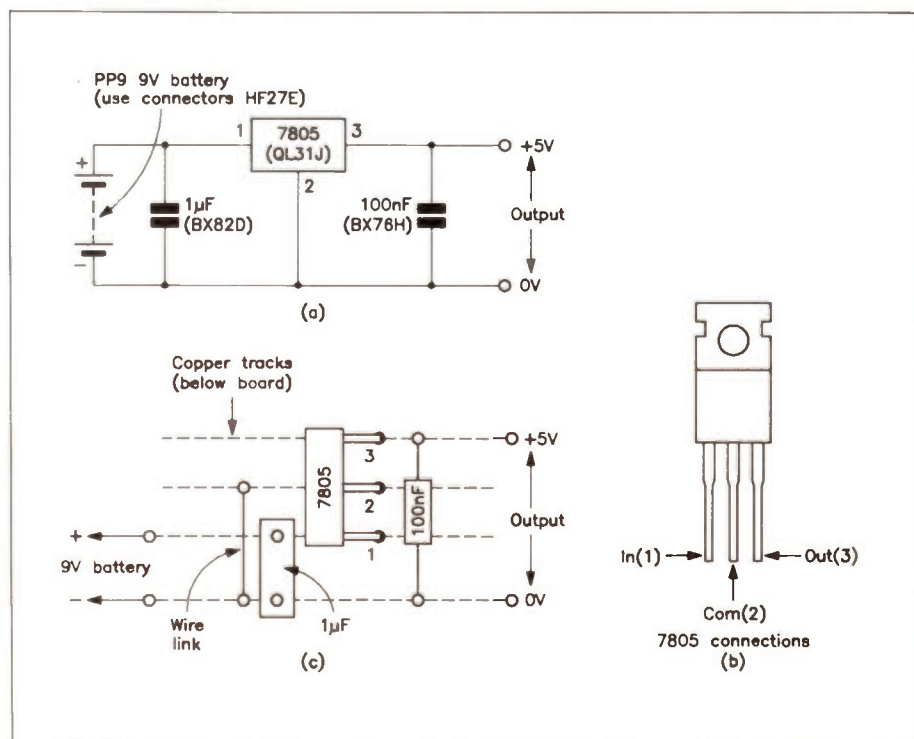

Figure 7. Details of a suitable regulator for the 555 circuit.

dropping them through the board and soldering them; the excess lead on the copper side of the board should then be snipped off close to the soldered joint itself. Handle one component at a time; don't place them all in the board and then try to solder them 'en masse'. Take care not to bridge the copper tracks with too much solder. With stripboard joints, there is often a delay of a few seconds between

the application of iron and solder and the joint actually forming – then it happens quite suddenly. Don't let too much molten solder build up on the bit of the iron during this short time.

Having completed the assembly of the board, it should be inspected to make sure that all components, wire links, etc., are in their proper places, after which power can be applied and, with luck, the

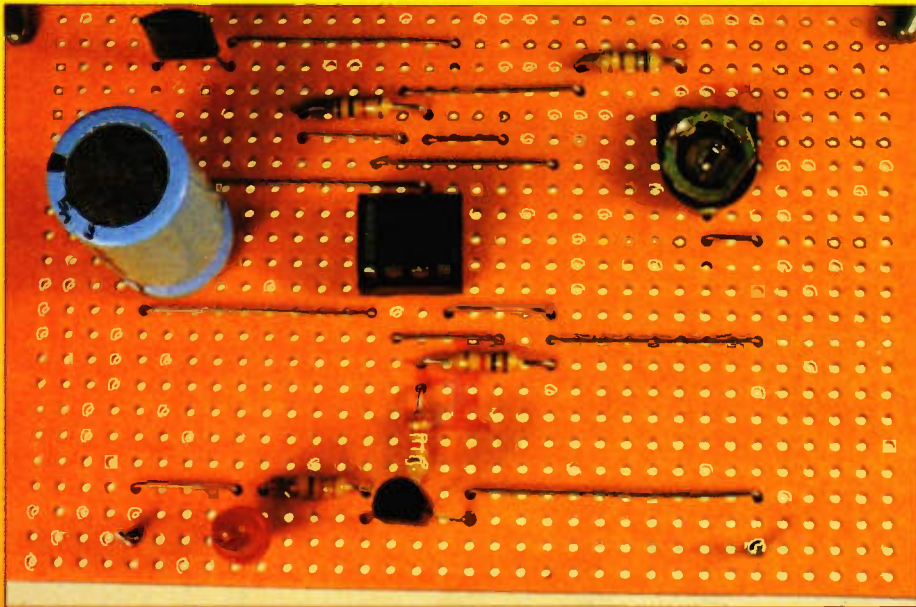

Photo 9. Component side view of the 555 pulser/flasher board. The power connections are made to the pins at the top: +5V left and 0V right.

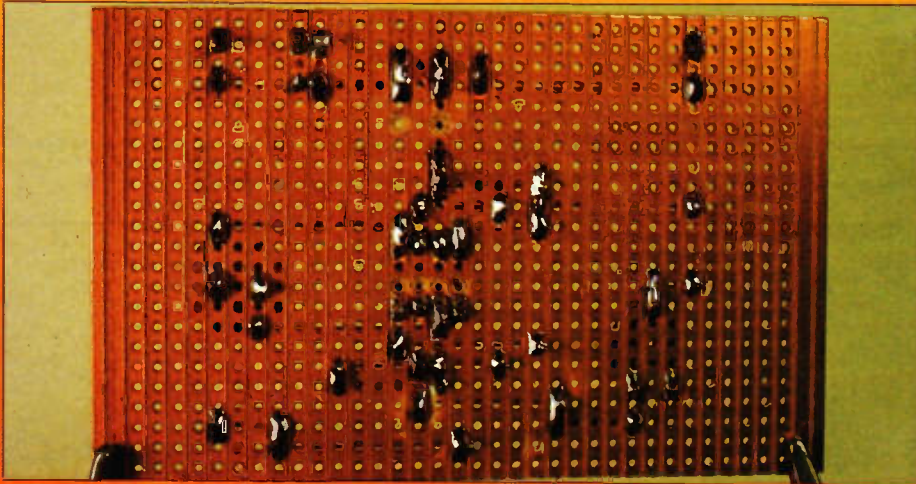

Photo 10. Copper side view of the 555 circuit board. Note how few track breaks there are: a total of six – four between opposing IC pins and two just above the IC on alternate tracks.

LED blinks away to show that all is well. If it doesn't work, then a further visual check ought to reveal that there is a wiring fault after all, or a solder bridge. Rarely will there be found to be a faulty component.

A 5V Power Supply for the Project

This project, in common with TTL logic circuits in general, requires a fairly precise 5V d.c. supply. To keep costs down, as well as to avoid the hazards of building and using mains-operated equipment for people of limited experience, a battery derived supply will be shown instead. It can be built at minimal cost, will give a precise 5V d.c. output and, with the suggested PP9 battery, should have enough life for lots of useful work. The circuit is shown in Figure 7 together with a suggested stripboard layout.

LOW FREQUENCY PULSER PARTS LIST

Ref:	Value	Order Code
R1	680R	(M680R)
R2	1k5	(M1K5)
R3	1k	(M1K)
R4	22k	(M22K)
R5	220R	(M220R)
RV1	47k	(WR86T)
C1	330 μ F	(JL24B)
C2	10nF	(BX70M)
IC1	NE555	(QH66W)
TR1	BC212L	(QB60Q)
LED	Red	(WL27E)
DIL	Socket 8-pin	(BL17T)



- ▶ Do you have difficulty in getting hold of your copy of 'Electronics – The Maplin Magazine'?
- ▶ Does your Newsagent always sell out before you can get your copy?
- ▶ Are you fed up with braving the onslaught of wind, rain and keep fit fanatics in your ceaseless quest to find a copy of your favourite electronics magazine?
- ▶ Do you say to your family and friends, "I'm just going outside, I may be gone a little while . . . "?
- ▶ Does your dog hide when you return empty handed?
- ▶ Do you resort to reading the Beano, Dandy, Viz or other well known 'comics'?

Dear Newsagent

Please reserve/deliver (delete as applicable) each issue of 'Electronics – The Maplin Magazine' for me.

Name

Address

Signature

'Electronics – The Maplin Magazine' is published bi-monthly and is distributed through your wholesaler by: United Magazine Distribution Ltd. 1 Benwell Road, London N7 7AX. Tel: 01-700 4600.



Then why not ask your friendly local newsagent to reserve or deliver every issue of 'Electronics – The Maplin Magazine'?

Here's how:

Fill out the coupon left, hand it to your newsagent and you need never miss an issue of 'Electronics – The Maplin Magazine'

ever again.

MEASURING

Distortion

IN THE HOME WORKSHOP



Ferrograph distortion measurement equipment.

Part 4
Selective Measurements
by John Woodgate B.Sc. (Eng.),
C.Eng., M.I.E.E., M.A.E.S.,
M Inst. S.C.E.

Measuring Distortion Components Individually

We saw in Part 1 that THD measurements are not much help in finding out about the actual distortion-producing mechanisms in a given amplifier. We can't even tell if we have odd-order (symmetrical) or even-order (unsymmetrical) non-linearity, and we can't tell if we have (relatively) tolerable low-order distortion or a parade of high harmonics which will spit and splutter all over the treble end of the spectrum and beyond. In order to find out about these things, and in order to measure intermodulation distortion products, we need a circuit that passes only a narrow band of frequencies, i.e. a band-pass filter. (A circuit which literally passed one frequency only would be singularly useless, because, having zero bandwidth, it would take an infinite time to produce an output signal! This problem of time-delay in narrow-band filters will appear in a practical context later.)

April 1990 Maplin Magazine

Wien Bridge Bandpass Filter

The Wien bridge (Figure 11a) is usually discussed in terms of audio oscillators: it is one convenient way of providing the frequency-determining function. However, the circuit can also perform this function in an active band-pass filter (Figure 11b). The input buffer is required so that the effective value of input series resistor is not affected by the signal source impedance. The circuit can be tuned by making the input and negative feedback resistors variable. The positive feedback controls the Q and therefore the bandwidth: too much will create an oscillator. The gain of this circuit at the centre of the pass-band is $2Q$, so for a centre-frequency of 1kHz and a Q of 100, we get a gain of 200 and a -3dB bandwidth of 10Hz. Anything narrower than this is very difficult to tune. Two of these circuits in tandem are required to give 80dB rejection at twice or half the pass-band centre frequency, so for

tuning four elements have to be ganged together: difficult but by no means impossible. Thus it would be possible to make a tunable wave-analyser using this circuit. A fixed-tuned filter with centre frequency 4kHz and 200Hz bandwidth could be used for TDFD measurements. In all cases, wide-band op-amps should be used to avoid phase-shift errors. Because the filter sections have gain in the pass-band, it would be necessary in a practical circuit to introduce attenuators between the stages, and possibly at the input and output, in order to avoid overload while preserving maximum signal-to-noise ratio. An example of this technique will be discussed in more detail later.

Switched-Capacitor Bandpass Filter

Narrow-band filters are prone to requiring very careful 'tweaking' to obtain optimum performance, and in some cases

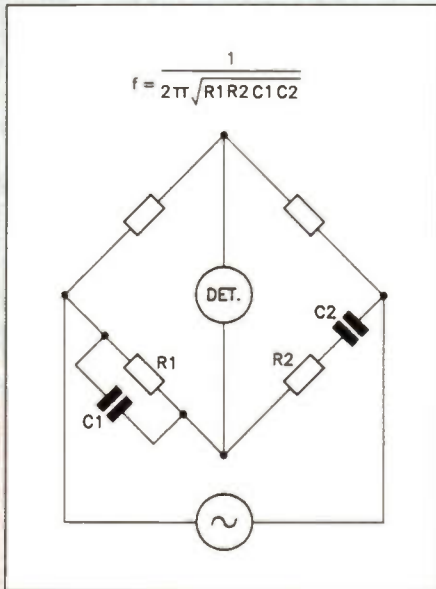

Figure 11a. Wien bridge configuration. It can only balance at one frequency.

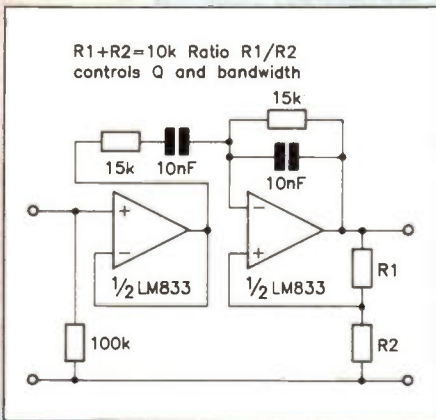

Figure 11b. Wien bridge bandpass filter for 1kHz range.

this tweaking has to be done often, because slight thermal and other drifts affect the performance considerably. This phenomenon is called 'sensitivity', and circuit configurations have been developed which have as little sensitivity as possible, but are inevitably fairly complicated. One of these is the 'state-variable filter', shown in Figure 12, together with the equations for cut-off frequency and Q. You can see that quite a few components affect these characteristics, and they have to be stable and of accurate values.

A clever way round this problem is provided by the fact that on an i.c. chip it is fairly easy to produce pairs of capacitors with an exact ratio of capacitance (such as 10:1). If we connect a pair of these capacitors to an op-amp and a pair of CMOS analogue switches, all on one chip, as shown in Figure 13, we can make a low-pass filter element without external close-tolerance components. What happens is that during the first half-cycle of the clock, C1 charges up, drawing current from the input, and during the second half-cycle, the charge on C1 is dumped into C2. Averaged over several clock cycles, the circuit behaves as if there were an input resistor of value $1/(C1 \cdot f_c)$, where f_c is the clock frequency. The circuit can therefore

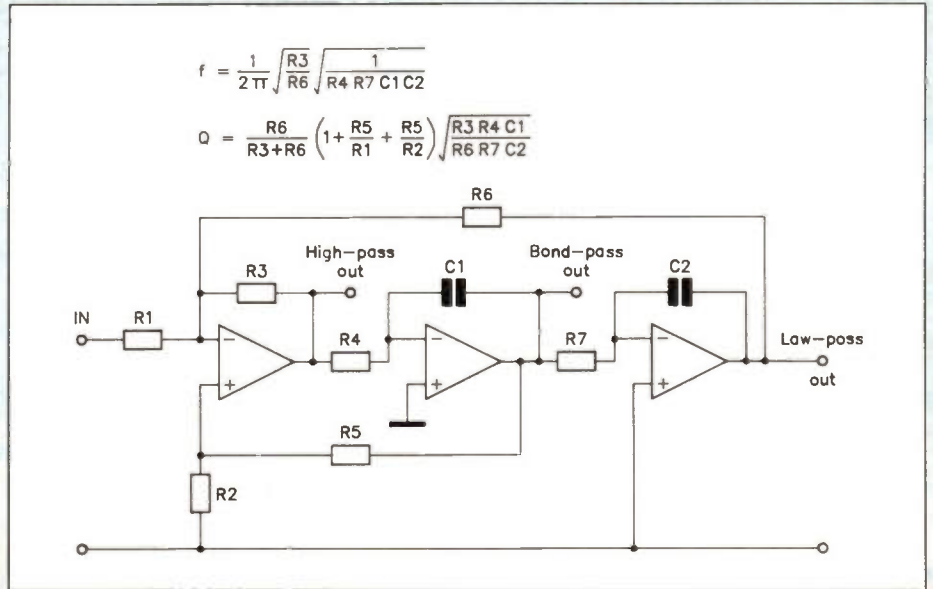

Figure 12. State variable filter (2nd order). Widely used in this form, it requires several precision components.

be substituted for one of the stages of the state-variable filter, and we can make two more on the same chip, so as to produce the equivalent of the complete SV filter. Do it all again, and we (or, rather, National Semiconductor) produce the MF10 dual filter chip (QY35Q), available from your friendly Maplin source.

Figure 14a shows a practical band-pass filter using both halves of the MF10 in tandem. The component and clock frequency values given produce a bandpass filter centred on 4kHz, with a -3dB bandwidth of 200Hz. Each half of the MF10 in this circuit has a gain of 21.5dB (11.8 times), and if we just connected them directly in tandem, not only would the second section overload when the input to the first section was only about 20mV, but the noise output would be over 2mV, so we could not measure any small signals at all! For use with the voltmeter described in Part 3, the filter must handle signals up to 1V at the input, and have an overall gain of 1 as well. In order to achieve this, and at the same time get the best possible signal-to-noise ratio, we have to include attenuation, as shown in Figure 14b. Note that we do not have to allow a large headroom to

accommodate non-sinusoidal waveforms in this case: anything that gets through the narrow bandpass filter will be nearly sinusoidal, so we can work with signals close to the maximum for the MF10. It is worthwhile providing $\pm 6V$ supplies for the MF10 rather than the slightly more convenient $\pm 5V$, because the maximum undistorted output voltage is significantly raised. Note that the MF10 tends to oscillate if asked to drive capacitive loads. The raw output from the filter contains some millivolts of the switching frequency, but this signal is removed by the 20kHz low-pass filter in the voltmeter.

Obviously, this 4kHz filter is intended for TDFD measurements, but the big advantage of the switched-capacitor filter is that it can be tuned simply by changing the clock frequency. Since this is a square-wave signal, all the powerful digital techniques are available for controlling the tuning frequency. For example, it is quite easy to produce a sweep-frequency square wave, covering 1kHz to 1MHz, thereby giving a filter sweep-tuned from 20Hz to 20kHz, which could be the basis of a very simple audio spectrum analyser. This would be much simpler to make than one based on

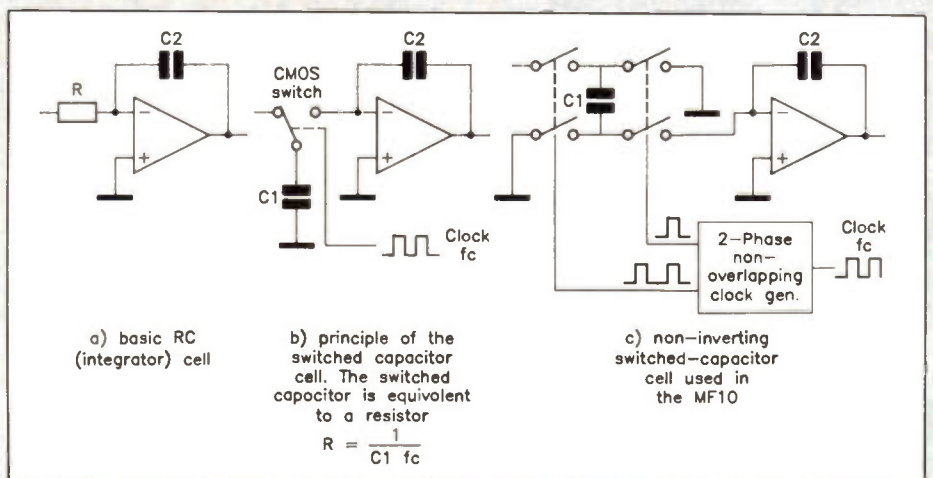

Figure 13. Switched capacitance principle.

the superhet technique mentioned previously, for which some very special components are needed, and are nearly impossible to obtain in small quantities. There is one snag; the bandwidth of the filter is proportional to the centre-frequency, and thus becomes very narrow at low frequencies and rather too wide (for good noise rejection) at high frequencies. The best compromise seems to be 2Hz at 20Hz, leading to 2kHz at 20kHz (the highest recommended Q at 20kHz is 10). This implies a 30dB change in signal-to-noise ratio over the band, exactly the same as for a 1/3-octave filter set. Clearly, it would be useful to be able to vary the bandwidth while the filter is being sweep-tuned. For the MF10, the bandwidth is controlled by resistor ratios, and might be varied by any of the techniques (e.g. FETs or voltage-controlled current sources) used for producing controllable resistance. However, there is another National Semiconductor filter chip (among a range of at least seven), the MF8, which is specifically designed for bandpass filter applications, and has the filter Q, and thus the bandwidth, under digital control, by means of a 5-bit word. The algorithm for changing the Q in 1-bit steps is weird, but can be realised, and it might be acceptable to change it in coarser steps. There is also a new, improved version of the MF10, called LMF100. Perhaps in the next Catalogue . . . ?

The narrow bandwidth of the filter at low frequencies means that the output cannot follow rapid variations in signal amplitude; it is just like a radio receiver with a very narrow i.f. bandwidth, which therefore cannot produce high audio frequencies. So if we are making a spectrum analyser with this type of filter, the sweep rate must be low at low frequencies but can speed up at high frequencies, where the filter bandwidth is wider. The sweep speed can be proportional to the frequency, so that (a little calculus to exercise the grey cells):

$$df/dt = kf,$$

which leads to

$$f = e^{kt} + f_0 \text{ (here } f_0 = 20\text{Hz)}$$

This is exactly what we want to get a display with a logarithmic frequency scale, like a normal frequency response curve, rather than the linear scale that most spectrum and Fourier analysers produce, which squashes the low frequency end of the spectrum into oblivion!

Home-Made Fourier Analyser

No, I am not going to tell you how to do this, because it is mostly a matter of computer software. There is useful information in two articles in 'Electronics and Wireless World' for September and December 1985, by T. Larsen and G. Dyrik, including programs in BBC Basic. Note that most of the problems with memory space mentioned in the articles vanish if you have shadow RAM or any computer with

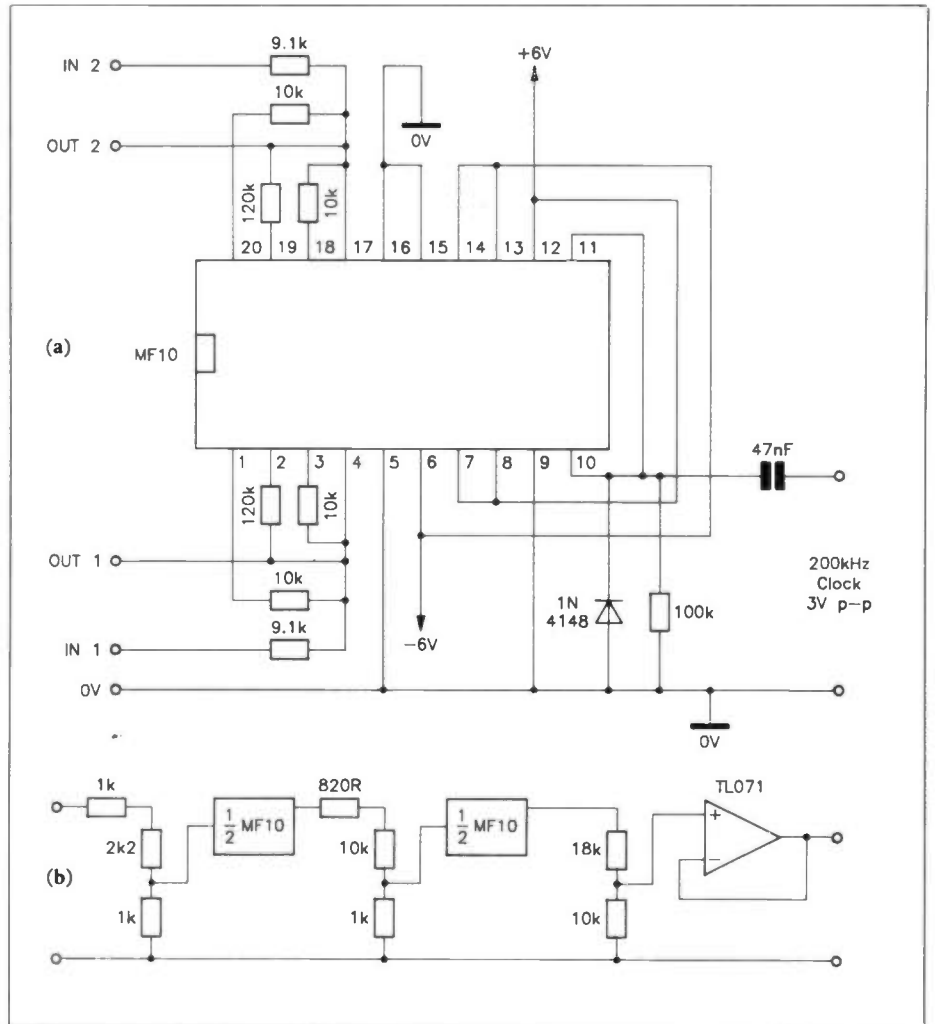

Figure 14. (a) MF10 filter for 4kHz \pm 100Hz. The clock input is arranged for supply from a function generator. TTL and CMOS clocks can also be used (refer to MF10 data sheet). (b) Attenuators for use with the MF10 filter and the basic voltmeter. The requirement for maximum noise is to have 2.8V rms at the output of each filter block when the input and output voltages are each 1V rms.

32K or more of user RAM. However, it requires some very clever techniques to obtain enough dynamic range (say 60dB to 80dB) to measure distortion components with a machine using an 8-bit processor, if the processing time is to remain acceptable. An 8-bit byte can only represent 255 discrete levels, which is no more than 48dB.

Practical Measurements

A series of measurements were made on an LM380 amplifier in the configuration shown in Figure 7a (inverting, low phase-shift). As reported before, the THD on a 1kHz signal, measured at 3.3V output by the balancing technique, was -29dB (3.5%). Using the twin-T notch-filter, the

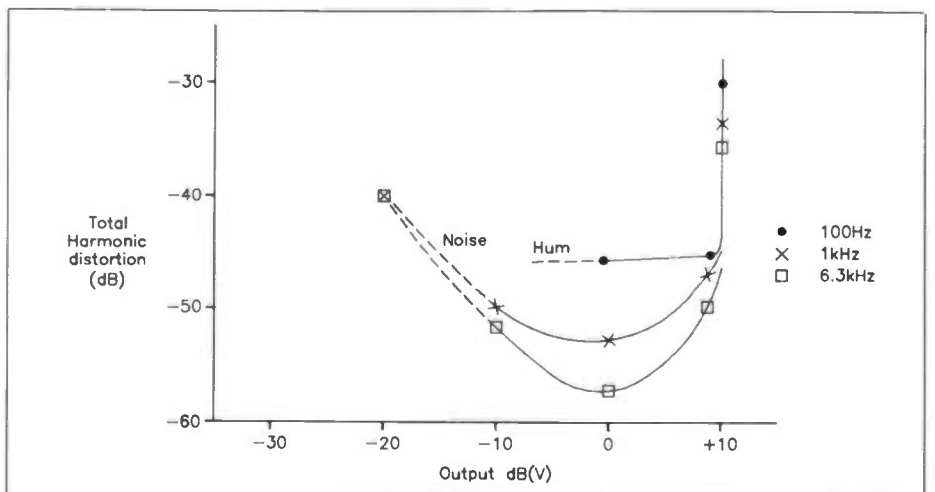

Figure 15. Plot of THD measurements made from an LM380 based amplifier at three frequencies by the notch-filter method.

Output V	Output dB (V)	Distortion (dB)		
		100Hz	1kHz	6.3kHz
3.3	+11	-30	-33	-35
3.2	+10	-45	-47	-50
1.0	0	-46	-54	-58
0.32	-10	*	-50	-52
0.1	-20	*	-40*	-40*

*Mostly mains hum or noise

Table 1. Results of THD measurements from Figure 15.

THD was measured at 100Hz, 1kHz and 6.3kHz, at output voltages of 3.3V, 3.2V, 1V, 320mV and 100mV. All except the first are in the form of 10dB steps. The results are shown in Table 1 and Figure 15.

You may notice that the distortion at 3.3V and 1kHz in this test is lower than the -29dB measured in the balancing test. This is because that test was done with the dodgy power supply which really gave up at 315Hz, while these tests were done with a better power supply. You can also see how rapidly the distortion varies with only 0.1V (3%) change of output voltage near the overload point, and how the hum picked up by the amplifier, and the noise generated in its circuits, obscure the results at low signal levels. 100mV output is only 0.667mW in the 15Ω load, though.

Individual Harmonics

The next test was to look at the individual harmonics produced by a 1kHz signal at various levels. For a totally complete analysis of the distortion performance of the amplifier, this test should be repeated at other signal frequencies. Table 2 and Figure 16 show the results (in decibels), and you can see that hum and noise are not such a problem when selective measurements are done.

We can deduce quite a lot from these figures. For example, we have already seen that the parade of high harmonics is a sign of an amplifier with much negative feedback, which, for the LM380, is built into the chip. In fact, the 53rd harmonic was detectable at 3.3V output, and the 36th at 3.2V, where the output waveform was only just clipped. We can see again the steep rise in harmonic level as the overload point is approached, and just the

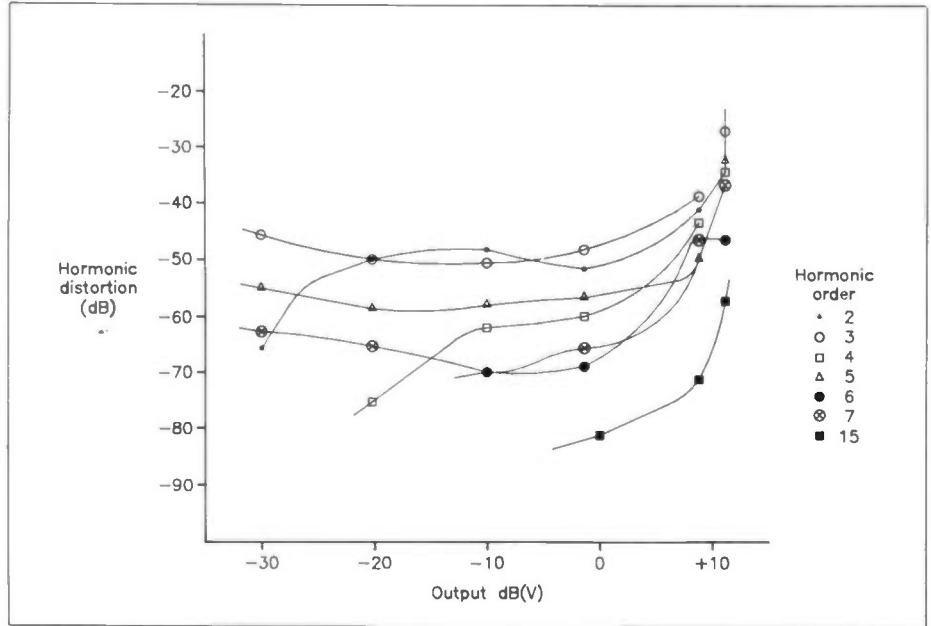

Figure 16. Plot of IHD measurements with LM380 with a 1kHz signal. Measured with a heterodyne wave-analyser.

beginnings of a little crossover distortion at 32mV output, where the odd harmonics are slightly higher than at 100mV.

Modulation Distortion

We now come to the first tests which require two signals, and if we just combine the outputs of two signal generators by connecting them in parallel, each will try to drive current into the output circuits of the other and this usually results in more distortion than we are trying to measure. To avoid this, the two signals must be combined in an attenuating network (there

are other techniques, but this is simple), as shown in Figure 17a. These values are obviously for 600Ω generators, but can be scaled for other impedances.

Measurement results for modulation distortion with input signals of 80Hz and 6.3kHz in 4:1 amplitude ratio are given in Table 3 and Figure 17b. The output voltage is expressed as the r.m.s. value of a sine-wave that has the same peak-to-peak voltage as the two-tone signal, which is 5-4 times the output due to the 80Hz signal alone, or 5 times the output due to the

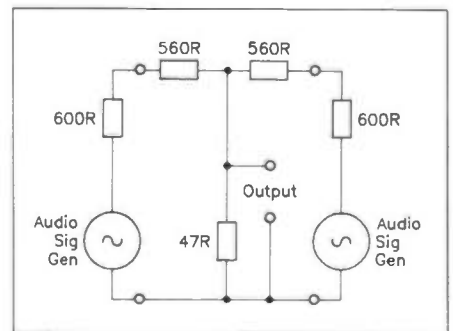

Figure 17(a). Combining two audio generators with minimal distortion.

Output V	dB(V)	Order of harmonic													
		2	3	4	5	6	7	8	9	10	11	12	13	14	15
3.3	+11	-30	-28	-33	-32	-47	-40	-46	-65	-45	-53	-51	-61	-59	-59
3.2	+10	-42	-41	-44	-49	-47	-47	-48	-50	-53	-56	-58	-61	-68	-73
1.0	0	-51	-49	-60	-58	-68	-67	-74	-83	-79	-82	-85	-80	-85	-82
0.32	-10	-49	-50	-62	-59	-70	-70	-80	<-85	<-85	<-85	<-85	<-85	<-85	<-85
0.1	-20	-50	-50	-75	-59	<-85	-65	-80	-73	<-85	<-85	<-85	<-85	<-85	<-85
0.032	-30	-65	-47	<-70	-54	<-70	-63	<-70	<-70	<-70	<-70	<-70	<-70	<-70	<-70

Table 2. Results of IHD measurements from Figure 16.

Output V	dB(V)	Order of MD component													
		8	7	6	5	4	3	2	2	3	4	5	6	7	8
3.3	+11	-60	-44	-45	-38	-38	-35	-34	-34	-35	-37	-39	-45	-44	-60
3.2	+10	-70	-71	-70	-68	-54	-67	-52	-52	-69	-53	-68	-80	-70	-70
1.0	0	<-80	<-80	-70	-72	-58	-66	-50	-50	-66	-58	-72	-70	<-80	<-80
0.32	-10	<-70	<-70	-60	-66	-61	-60	-48	-48	-60	-61	-66	-65	<-70	<-70
0.1	-20	<-60	<-60	<-60	<-60	<-60	<-60	-55	-54	<-60	<-60	<-60	<-60	<-60	<-60

Table 3.

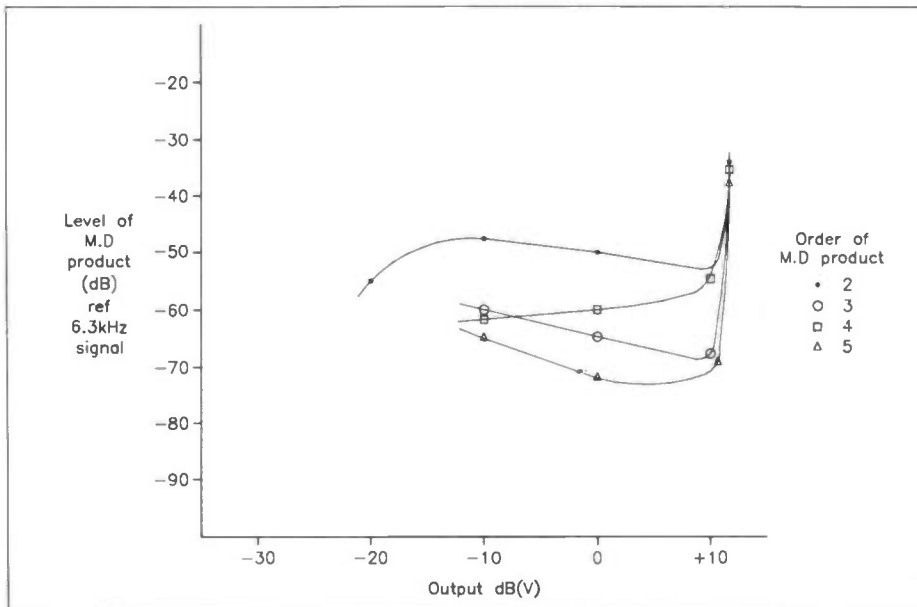

Figure 17(b). Modulation distortion components for the LM380 amplifier 80Hz and 6.3kHz signals 4:1 ratio.

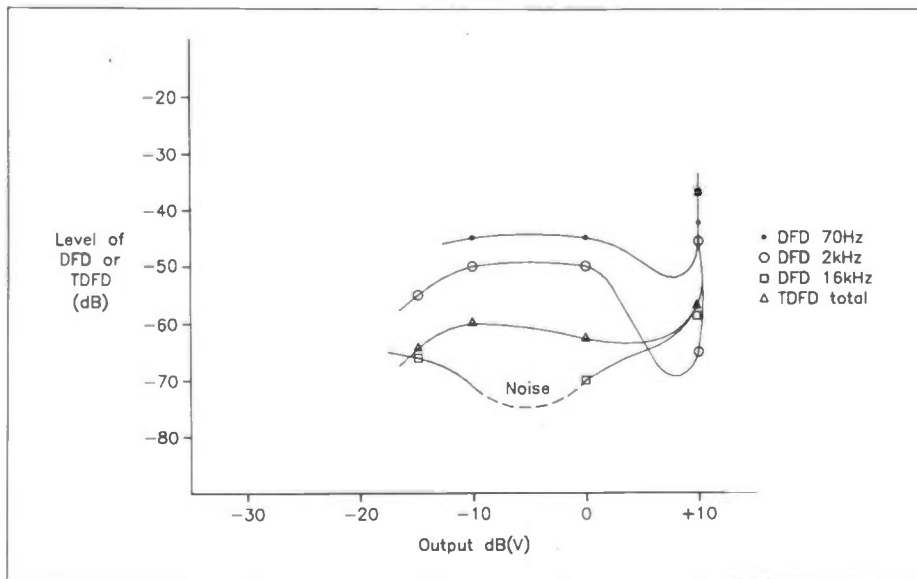

Figure 18. DFD and TDFD for the LM380 amplifier.

Output V	dB(V)	DFD	DFD	DFD	TDFD	TDFD	TDFD
		70Hz	2kHz	16kHz	3950	4050	both
3.3	+11	-43	-46	-38	-51	-45	-44
3.2	+10	-51	-65	-59	-59	-62	-60
1.0	0	-46	-50	-70	-61	-83	-61
0.32	-10	-46	-50	<-70	-59	-74	-59
0.1	-20	<-50	-55	-64	-64	-64	-60

Table 4.

6.3kHz signal alone. As explained before, the distortion components are expressed in decibels referred to the output due to the 6.3kHz signal.

You can see that, in most cases, the two modulation products equally spaced either side of 6.3kHz are of equal level, as the theory predicts (and can explain why some are not equal, with enough persistence). Considering the high-order curvature of the transfer characteristic of this amplifier near overload, shown by the high-order harmonic distortion, it is not surprising that quite high-order modulation products are detectable: in fact the 27th order products were detectable at 3.3V output. This amplifier has quite low modulation distortion at low levels: it might well be a different story if it had a transformer in the signal path!

Difference-Frequency Distortion

Using the combined network of Figure 17a, the difference frequency distortion was measured with equal signals at 1kHz and 1.07kHz (giving a 2nd-order difference-frequency component at 70Hz), and at 18kHz and 20kHz (giving a 2nd-order component at 2kHz and a 3rd order component at 16kHz). The TDFD was also measured, with equal signals at 8kHz and 11.95kHz. The results of these measurements are given in Table 4 and Figure 18.

Once again, we can see the disastrous effects of allowing a high-feedback amplifier to clip, and the rise in high-frequency distortion at low levels, as a small amount of crossover distortion becomes evident.

Curly (or, at Least, Non-Linear) Tailpiece

Those of you who have stayed to the bitter end may well be asking, "What about distortion in the signal sources?" What, indeed. The first job, before measuring an amplifier, is to check that the distortion of the signal generator is adequately low. Since it only has to produce sine-waves, harmonic distortion measurements (preferably of individual harmonics) are sufficient. Measurements should be made at both high and low output levels, to look for effects such as rectification in attenuator switch contacts and mains hum. Perhaps the subject of low-distortion oscillators would make another article . . .

ADA-ECHO



Update

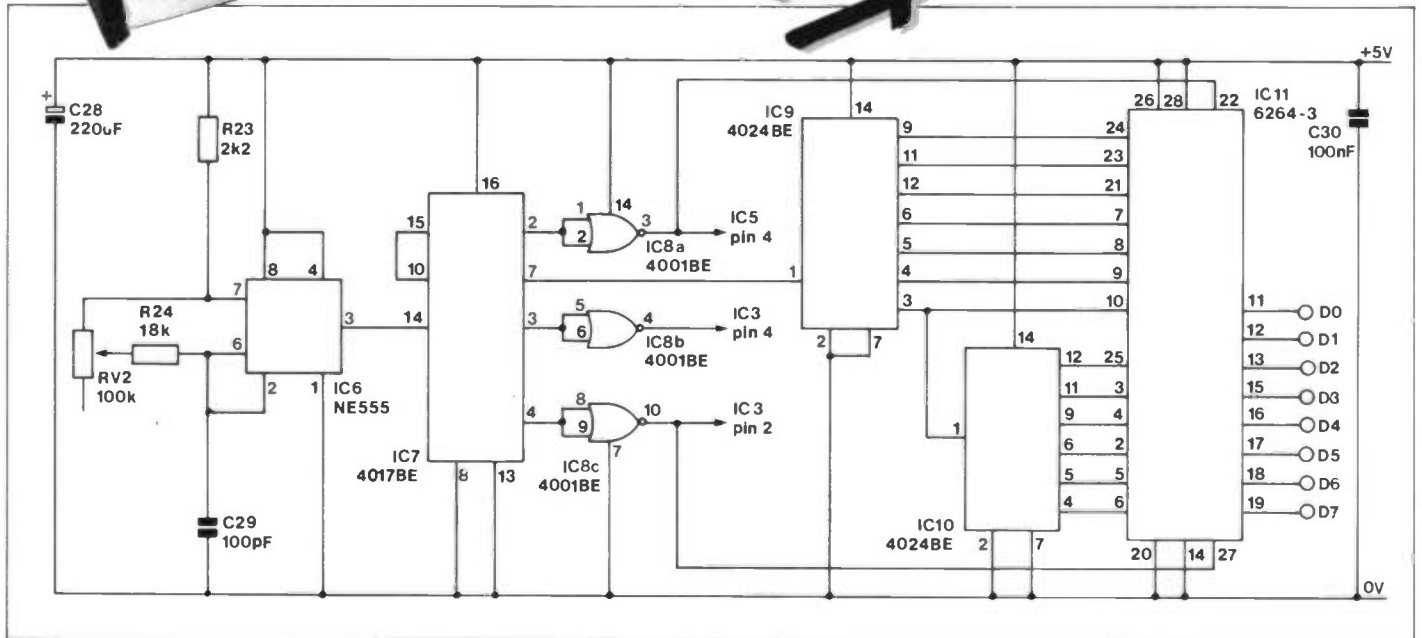

Figure 1. Original Clock, Control and Memory Stage Circuit (Figure 4 of original article in 'Electronics' issue 19).

Introduction

Mr. Graham Moore, one of our readers, has recently completed experiments with the ADA Echo Digital Delay project and he has suggested a couple of simple modifications that he feels considerably enhance the usefulness of the project. The 'ADA Echo' can produce some very good echo effects but in its present form the unit is not capable of other time domain effects such as flanging or chorus. The modifications shown here make some of these effects possible.

Delay Time

The minimum time delay available from the ADA is around 75ms, which is far too long for flanging and chorus effects. Experiments with the delay line clock (IC6) proved fruitless, as in practice it is not possible to significantly increase the

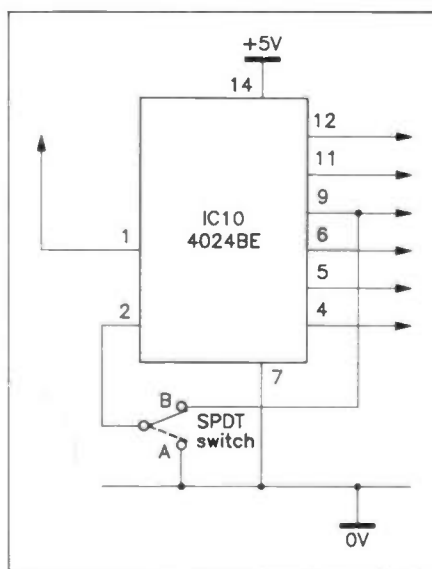

Figure 2. Modification to reduce delay time.

operating frequency while retaining effective operation of the delay. A more effective method was found for reducing the delay time by decreasing the number of counter stages 13 to 9. To effect the modification it is necessary to cut the PCB track between pin 2 of IC10 and 0V and wire in a single pole double throw switch as illustrated in Figure 2. With the switch in position "A" the circuit operates as originally described, but switching to position "B" selects a much shorter delay time than was previously possible.

Modulation Oscillator

Reducing the minimum delay time of the ADA Echo is only half of the answer, as for flanging and chorus effects, the delay time must be constantly changing. Modulation of the delay time can be achieved by applying the output from a low frequency oscillator to pin 5 of IC6

and Figure 3 shows a simple oscillator that is suitable for this purpose. The oscillator produces an approximation of a triangular waveform, the frequency of which may be adjusted using RV1. Modulation depth is determined by the amplitude of the waveform and this is adjusted by RV2. Switch S2 allows the modulation oscillator to be disconnected when required. The oscillator may be constructed on a small piece of stripboard and only need be held in place by the two potentiometers if these are panel mounted.

Suggestions from the Lab

It may be possible to produce different effects by changing the operating frequency of the modulation oscillator; try experimenting with the values of oscillator components, RV1 and C1.

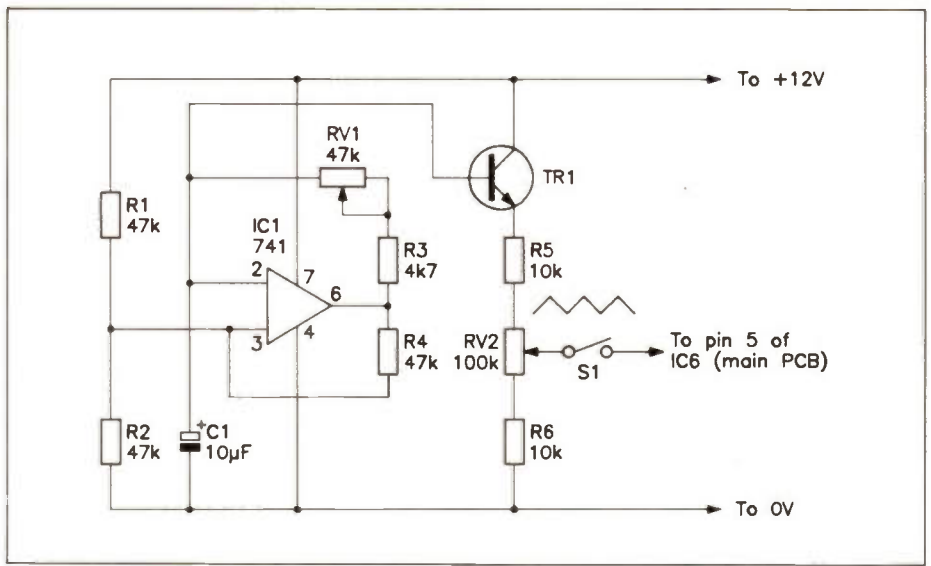

Figure 3. Circuit diagram of the Modulation Oscillator.

ADA Echo Update: Modulation Oscillator Parts List

Resistors: All 0.6W 1% Metal Film

R1, R2, R4	47k	3	(M47K)
R3	4k7	1	(M4K7)
R5, R6	10k	2	(M10K)
RV1	Pot lin 47k	1	(FW04E)
RV2	Pot lin 100k	1	(FW05F)

Capacitors

C1	10µF 50V PC Electrolytic	1	(FF04E)
----	--------------------------	---	---------

Semiconductors

IC1	µA741	1	(QL22Y)
TR1	BC182	1	(QBS5K)

Miscellaneous

S1	Sub Min Toggle A	1	(FH00A)
----	------------------	---	---------

MAPLIN'S TOP TWENTY KITS

THIS LAST MONTH	(1)	DESCRIPTION OF KIT	ORDER CODE	KIT PRICE	DETAILS IN PROJECT BOOK
1.	(1)	◆ Live Wire Detector	LK63T	£3.95	14 (XA14Q)
2.	(3)	◆ Digital Watch	FS18U	£1.98	Catalogue
3.	(2)	◆ 150W Mosfet Amplifier	LW51F	£18.95	Best of E&MM
4.	(5)	◆ Car Battery Monitor	LK42V	£7.95	Best of E&MM
5.	(4)	◆ Partylite	LW93B	£9.95	Best of E&MM
6.	(6)	◆ I/R Prox. Detector	LM13P	£9.95	20 (XA20W)
7.	(9)	◆ Siren Sound Generator	LM42V	£3.95	26 (XA26D)
8.	(13)	◆ Mini Metal Detector	LM35Q	£5.25	25 (XA25C)
9.	(10)	◆ PWM Motor Driver	LK54J	£8.95	12 (XA12N)
10.	(17)	◆ Watt Watcher	LM57M	£3.45	27 (XA27E)
11.	(12)	◆ U/Sonic Car Alarm	LK75S	£17.95	15 (XA15R)
12.	(11)	◆ 8W Amplifier	LW36P	£4.95	Catalogue
13.	(8)	◆ Car Burglar Alarm	LW78K	£7.95	Comp 2 (XC02C)
14.	(-)	◆ LM386 Kit	LM76H	£3.45	29 (XA29G)
15.	(15)	◆ I/R Remote Switch	LM69A	£18.95	33 (XA33L)
16.	(7)	◆ 15W Amplifier	YQ43W	£5.95	Catalogue
17.	(19)	◆ Stereo Pre-amp	LM68Y	£5.25	33 (XA33L)
18.	(14)	◆ TDA2822 Stereo Power Amp	LP03D	£5.95	34 (XA34M)
19.	(20)	◆ Slow Charger	LM39N	£5.95	25 (XA25C)
20.	(-)	◆ 50W Amplifier	LW35Q	£16.95	Catalogue

Over 150 other kits also available. All kits supplied with instructions. The descriptions above are necessarily short. Please ensure you know exactly what the kit is and what it comprises before ordering, by checking the appropriate Project Book mentioned in the list above.

Maplin

Do you Enjoy your work?
Or would you prefer to
Work at what you enjoy?

If you are an electronics enthusiast and looking for an interesting career with a future, Maplin has the answer.

We currently have vacancies for

JUNIOR AND SENIOR TECHNICAL SALES STAFF

At our new store shortly to open in BRIGHTON

These vacancies are being created as a result of the Maplin expansion program and offer real prospects up to and including Branch Management.

A knowledge of sales, although an asset, is not essential. But, to become part of the team you do need to be self motivated and have a cheerful personality. Applicants should also be smart and have a knowledge of electronic components.

We offer excellent working conditions and job security, plus a good salary with commission and a realistic pension scheme.

Apply in writing enclosing CV to: David Snoad, P.O. Box 3, Rayleigh, Essex. Or for further information, ring 0702 554155.

If you are seeking an interesting career in a Hi-Tech environment then contact us

NOW!

NEW BOOKS



A Concise Introduction to WordPerfect

by R.A. Penfold

Wordperfect has now become the most popular word processor for the IBM PC range and the numerous "compatibles" currently in use around the world. The WordPerfect user has a tremendously powerful writing tool at his or her disposal. A word processor of this quality enables you to work quickly but still produce well formatted and accurate documents. Although software of this complexity can be a bit daunting for the beginner, with the aid of this small book you will soon learn to master most aspects of WordPerfect. The book is aimed at beginners to word processing, and assumes a minimal amount of knowledge about computers and running applications programs. Areas covered include how to enter and edit text, and move quickly around large documents. How to perform block operations including move, copy, delete, case change and printing. How to format text ready for printing including the use of advanced features such as newspaper columns and graphics, as well as basic formatting, such as line spacing and setting margins. How to install printers and print out documents using various fonts and printing effects. How to use the mail-merge facilities to customize standard letters. How to exploit useful facilities such as the spelling checker, thesaurus and sort routine. Up to WordPerfect version 5.0 are covered. 1989. 96 pages. 129 x 198mm, illustrated.

Order As WS80B (Cons Int Word Perfect) Price £2.95 NV



The World's Radio Broadcasting Stations and European FM/TV

C. J. Booth

Fun and fascination are yours for the taking – grab your receiver and listen to the world! Discover new cultures and profit from the free flow of information pulsing over the airwaves. Now more than ever before, nations can come closer to knowing and understanding one another, all via the magic of the airwaves. This book will be your up-to-the-minute guide in this wonderland. 1989. 195 pages, 212 x 144mm.

Order As WS71N (Wrlrd Rad & TV Stat) Price £9.95 NV



More Advanced Test Equipment Construction

by R.A. Penfold

Describing some slightly more advanced test equipment projects for readers who have some amount of experience at project building. Full circuit diagrams plus notes on construction are provided. Detailed

notes on any necessary setting up are also provided, together with information on using the projects to best effect. Projects included are: digital voltmeter, digital capacitance meter, digital transistor tester, digital heatsink thermometer, bench power supply, dynamic transistor tester, A.F. digital frequency meter, digital resistance meter, digital current tracer, crystal calibrator and pulse generator. When finished the projects provide a very useful range of test gear for future project development and servicing, and the building of them should prove an interesting and rewarding pastime in its own right. The projects are not strictly suitable for complete beginners, but anyone possessing a modicum of hands-on construction experience should have little difficulty. 1989. 112 pages. 110 x 178mm, illustrated.

Order As WS78K (More Adv Test Equip) Price £3.50 NV

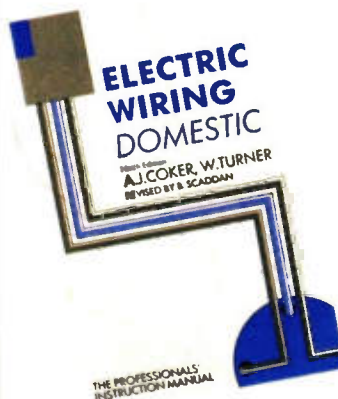

Electric Wiring: Domestic

by A.J. Coker & W. Turner

A clear and reliable guide to the practical aspects of domestic wiring. Provides essential up-to-date information on modern methods and materials in a simple and concise way. This book has been widely used by electrical engineers, contractors and wiremen, who know it as a practical and reliable instruction manual. It also has been found very helpful by many others who are concerned in some way with domestic electrical installations, including heating engineers, architects and maintenance staff. This edition has been revised to take into account the latest amendments to the 15th edition of the IEE regulations and modern techniques, practice and materials. Contents include wiring circuits, ratings, cable sizes and circuit

protection; domestic installation practice, lighting points, socket outlets and portable appliances, fixed appliances, survey of modern wiring systems, installation of conduit systems, using PVC sheathed and MICS cable, prefabricated systems, earthing, inspection and testing. This book replaces *Beginner's Guide to Electric Wiring* on page 84 of the 1990 catalogue which is now out of print. 1989. 198 pages. 155 x 234mm, illustrated.

Order As WS82D (Elec Wiring Domestic) Price £9.95 NV

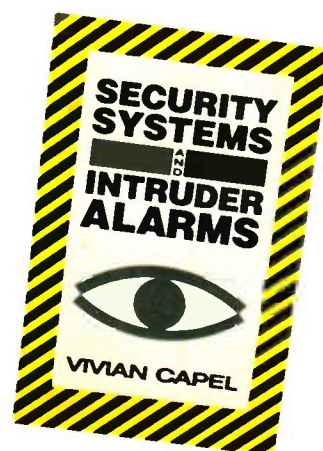

Security Systems and Intruder Alarms

by Vivian Capel

An alarm system and total security coverage is becoming essential in every factory, business and shop. How should you choose, plan and install such a system?

This book is divided into two sections; a general section showing how alarm systems work, what they do, how they can be planned, and how proposed systems can be checked. It also describes countermeasures against other hazards such as shoplifting, employee theft, fire, fraud, liability claims etc., examining control equipment, various types of sensors, going up to closed-circuit TV monitoring and domestic systems. The technical section is more specific dealing with installing and testing intruder and fire alarms, fault-finding and maintenance and the British Standards. Primarily written for managers and business people and installation engineers but will be of interest as a general reference to anyone planning to install a security system. 1989. 280 pages. 190 x 240mm hardcover, illustrated.

Order As WS83E (Security Systems & Alarms) Price £20.00 NV

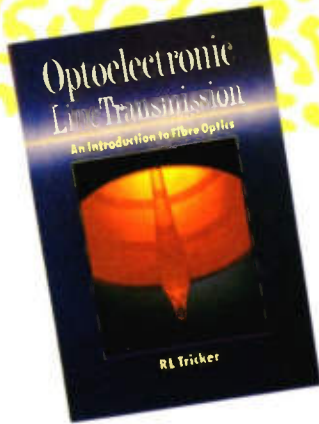

Optoelectronic Line Transmission

R. L. Tricker

The use of fibre optics has become increasingly popular in both commercial and military environments, and although optoelectronics is based upon comparatively simple technology, it is, nevertheless, essential for working engineers and technicians to be aware of the basic fundamentals and capabilities of this modern technique. A chapter on test methods is also included. The book is written in an informative but not mathematical style and is a 'very readable' introduction to fibre optic transmission, appealing to practising electronics and telecommunications engineers, technicians and students. 1989. 161 pages, 234 x 156mm, illustrated.

Order As WS74R (Opto Line Trans)
Price £12.95 NV

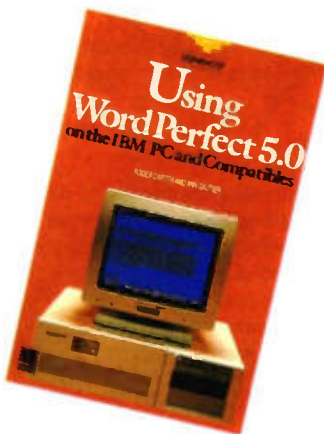

Using Word Perfect 5.0 on the IBM PC and Compatibles

Roger Carter & Ann Gautier

Word Perfect is fast becoming the industry standard word processing package. In the UK it has captured 25% of the market with 2000 copies being sold per month. In the US around 50% of new WP users select WordPerfect. This book is a simple step-by-step guide to both basic and the more advanced features. It is the book for those learning the package from scratch, or if the first four chapters are skipped for those who want to advance further. A short 'activity' is

inserted after each major topic, so the reader can practise what has been taught. At the end of most chapters there is a major exercise which consolidates the main points. The book covers the following areas; starting off, editing, saving and printing, managing documents, advanced word processing, merging and sorting, outlines, indexes and summaries, and finally, graphics. 1989. 351 pages, 215 x 140mm, illustrated.

Order As WS73Q (Using Wordperfect 5)
Price £14.95 NV



Electronic Modules and Systems for Beginners

by Owen Bishop

Forget having to 're-invent the wheel' as it were, and design electronic systems using already established and developed circuit designs. Many oscillators, bistables, monostables and amplifier stages use time honoured techniques that are known to work. This book describes over 60 electronic circuit modules; how they work, how to build them and how to use them. In the process of working with these 'building blocks' you will learn the basic fundamentals of many established designs. Many modern electronics engineers are systems, not circuit, designers. Become such a systems' designer and combine the modules together to make hundreds of different electronic systems, both analogue and digital. To show you how over 25 actual electronic systems are described in detail, covering such diverse applications as timing, home security, measurement, audio, including a simple radio receiver, games and remote control. Although a book aimed at beginners, introducing the principles and practice of electronics, there are plenty of circuit ideas for the more experienced constructor too. 1989. 108 pages. 110 x 178mm, illustrated.

Order As WS79L (Elec Mods & Systems)
Price £3.95 NV

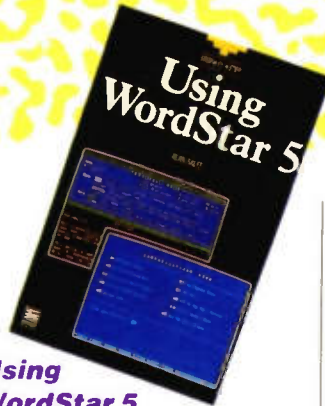

Using WordStar 5

Alan Balfe

WordStar Professional Release 5 is the latest edition in a long line of Industry Standard word processors from MicroPro International - an evolution that began in the founding days of personal computing and will continue into the future. WordStar, in all its variations, is the best selling wordprocessor around the world. Using WordStar 5 is a comprehensive guide to both the basic and advanced features. Intended primarily for those who are new to the program, it covers in depth all aspects from the initial installation through to producing complex documents and formats. In addition it includes separate in-depth chapters about each of the associated programs. The book covers the following areas; getting started, using WSCHANGE, starting the program, editing documents, printing effects, TelMerge, PC-Outline and ProFinder. 1989. 352 pages, 215 x 136mm, illustrated.

Order As WS70M (Using Wordstar 5) Price £14.95 NV

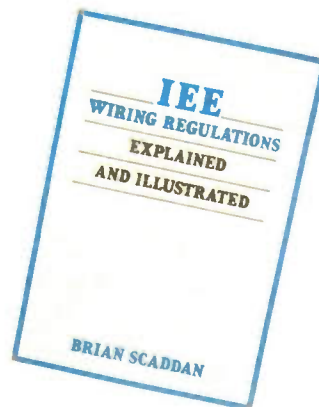

IEE Wiring Regulations Explained and Illustrated

by Brian Scaddan

Written primarily for the student electrical technician or installation contractor who needs to understand the Wiring Regulations and how to apply them, but this knowledge is also essential for anyone contemplating domestic electrical wiring. Full of really useful and practical advice for the electrician, clearly explaining the background to the design principles as

set out in the Regulations and concentrating on the key areas of earthing and bonding, protection and circuit design.

Topics include safety requirements, earthing, protection, control, circuit design and testing procedures. The author is an electrical engineer with many years' experience in the industry and a senior lecturer in electrical and electronic training. Even if you only contemplate tackling the simplest electrical wiring job, you should read this book first. If you are not already familiar with its contents then you will find it a real eye-opener. 1989. 110 pages. 146 x 210mm, illustrated.

Order As WS81C (IEE Wiring Regs)
Price £7.95 NV

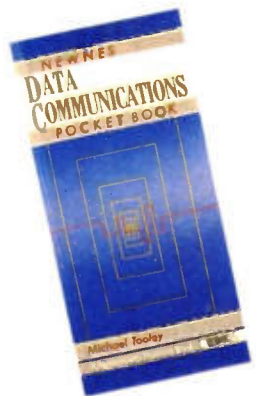

Data Communications Pocket Book

by Michael Tooley

Presenting, in as succinct a manner as possible, information of everyday relevance to the world of data communications. Despite the apparent complexity of the subject, care has been taken to ensure that the book is meaningful to as wide a range of readers as possible. Tabulated reference material has been interspersed with brief explanatory text and relevant diagrams. Invaluable to anyone involved with the interconnection of computer systems: technicians and engineers involved with the installation, commissioning and maintenance of data communications equipment; executives and clerical staff as the 'end users' of data communications related products; and managers involved with the specification and purchasing of such products and systems. Similarly the book should also appeal to the growing number of enthusiasts using data communications for home management and leisure pursuits. 1989. 162 pages. 95 x 195mm hardcover, illustrated.

Order As WS77J (Data Comms Pocket Book)
Price £9.95 NV

COMPUTERS IN THE REAL WORLD

Part 5 By Graham Dixey C.Eng., M.I.E.E.

Serial versus Parallel

When digital data is transmitted from one device to another, there are two ways in which it can be done. The bits may all be sent at once, each bit having its own line, this being known as 'parallel' transmission. Alternatively, the bits may be sent one at a time, that is one after another in what may be called a 'bit stream'. This is known, logically, as serial transmission. Obviously with this latter method only a single line (plus a return) will be needed.

There are two arguments in favour of sending data serially. The most obvious one is that only the two conductors just mentioned, one forward and one return, are required, no matter how many data

bits there are in the words being transmitted. This has an obvious cost advantage in terms of cabling. The second reason for making use of serial transmission is the ready availability of custom interfaces conforming to accepted standards and thus reducing the risks of physical incompatibilities between the computer and peripherals.

Within a computer itself the data is transmitted on a set of parallel conductors, known collectively as the 'data bus'. Because all bits of a data word are sent simultaneously, the speed of transmission is very much higher than that for the serial case. The cost is, of course, the greatly increased complexity of the conductor arrangement or, in the case of parallel data transmission external to the computer, the greater cost of cabling.

The Nature of Serial Data

As already stated, in the case of serial transmission the data bits are sent one at a time, in the form of a 'bit stream' or 'data stream'. Each bit in a data word is allocated its own 'slot in time'. Since the transmission of data in serial form is continuous, but with each data word having a finite length (e.g. eight bits), it is necessary to 'frame' each word with START and STOP bits; this complete set of bits may be referred to as a 'data packet'. Usually a serial line will idle in the logic 1 state until a START bit signals to the receiving equipment that a data packet is imminent. A typical serial data packet is shown in Figure 1. It comprises the START bit (at logic 0), followed by eight data bits, ending with the STOP bit, also a logic 0 level, before returning to the logic 1 idling state. The least significant bit (LSB) is usually sent first. The number of stop bits may variously be 1, 1½ or 2 bits.

Baud Rates

Many serial links are said to be asynchronous, which means that a common clock signal is not sent along with the data. This implies that the frequencies of the data streams must be identical at both the sending and receiving ends. There are a number of standard frequencies which are actually termed 'Baud Rates', these being generally understood to mean the number of bits of data transmitted per second. This is not always strictly true but is close enough for our purposes. The range of Baud rates extends from 50 to 19,200. The lower speeds are for the slow electromechanical devices, such as teletypes (if anyone still uses such archaic devices!), while the highest speeds are for serial communication with a VDU (Visual Display Unit) or with another computer system.

Parity

The continuous transmission of data in the way described above, leads to the ever present possibility of some of the data bits being corrupted, especially if the connecting cables pass through an electrically noisy environment. Such corruption of data would mean the

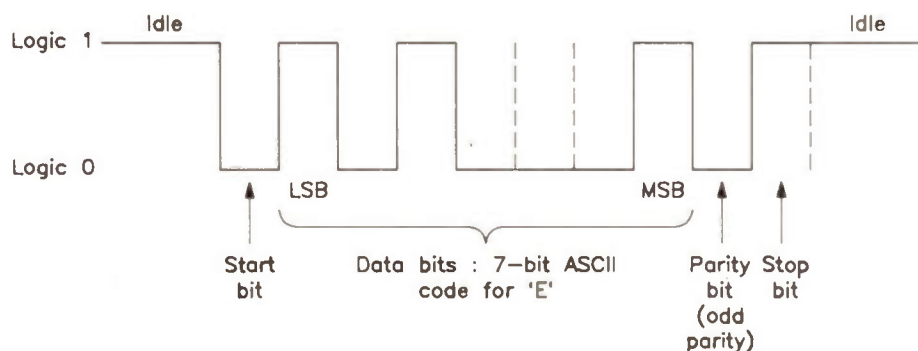

Figure 1. A serial 'data packet' for the character E (ASCII code = 45H). Odd parity is being used.

inversion of one or more bits; that is a logic 0 becomes a logic 1 or vice-versa. Without some means of detecting such errors the transmitted data would be accepted at the receiving end without question. The simplest technique involves sending an extra bit, known as the 'parity bit', with the data word.

There are two strategies that can be followed in determining the value of a parity bit. They are known as 'even parity' and 'odd parity' respectively.

In the case of even parity, the number of '1s' in the word is counted; if this number is even, the parity bit takes the value 0 – so that the total number '1s' in the 'data plus parity bit' is even. If, however, the number of '1s' in the data word is odd, the parity bit takes the value 1 – again ensuring that there are an even number of '1s' in the data packet.

Odd parity follows logically from this, the value of the parity bit being chosen so that there is always an odd number of '1s' in the data packet.

The following examples should make this clear:

DATA	PARITY BIT	
	Even	Odd
01010101	0	1
01101110	1	0
00010011	1	0
11111111	0	1

To conclude the argument, in case there are some lingering doubts, consider the first of the above examples, which is the data word 01010101; this quite clearly contains an even number of '1s', namely four. If this data word is to be sent with even parity then the parity bit must be '0' since the number of '1s' in the word is already even. However, if the data word is to be sent with odd parity, then the parity bit must be a '1' in order that the total number of '1s' transmitted is odd (five).

The natural question that follows from the above is, 'how is the parity bit used to detect an error?'

It must be said at the beginning that this particular method of error checking using a single parity bit is not very sophisticated and will only detect errors where an odd number of bits becomes corrupted. For example, suppose the data word 10011010 is sent as even parity; the parity bit will be '0'. Hence, the data word plus parity bit will look like this.

10011010 (data) + 0 (parity)

This quite clearly contains an even number of '1s' as expected by the receiver and the word will be accepted without question - which is just as well, since it happens to be correct.

Suppose that one bit of the data word becomes corrupted; for example the second bit of the data word changes from 0 to 1. The data word plus parity bit now looks like this.

11011010 (data) + 0 (parity)

If the '1s' are now counted at the receiver, the number will be found to be odd. Since the receiver is expecting an

even number it will 'know' that an error has occurred and will probably ask for that last data word to be re-transmitted. The problem arises, as already mentioned, when an even number of errors occur. For example, if the second and third bits both corrupt to '1s', then the received data will be:

11111010 (data) + 0 (parity)

The data is incorrect but will be accepted since the number of '1s' is even (six), thus conforming to even parity.

Not all serial links employ the parity bit for checking. They either leave it permanently SET (equals 1) or CLEAR (equals 0) or omit it completely.

Data Transfer Modes: Simplex, Full-Duplex and Half-Duplex

A 'simplex' data link allows the transmission of data in one direction only.

In a 'full-duplex' data link, simultaneous transmission of data in both directions is possible.

In a 'half-duplex' data link transmission of data can take place in either direction but only on an alternate basis. That is, while one device is transmitting, the other is listening, or vice-versa.

These modes of operation are illustrated in Figure 2.

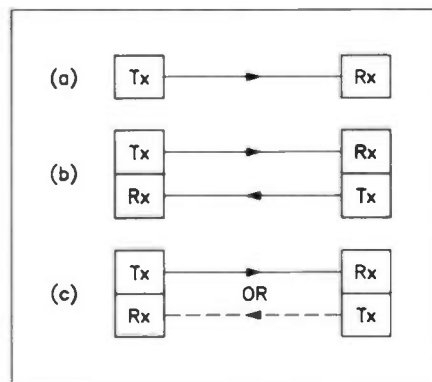

Figure 2. (a) Simplex (b) Duplex and (c) Half-Duplex modes of data transmission.

Parallel-Serial Conversion

When a serial data link is used, for example between two computers, the parallel data format used within each computer has to be converted into a serial format in order to use the single line data path between the devices. There are a number of dedicated LSI chips available for this function. Some of these will now be discussed, in just sufficient detail to give an insight into the features that they incorporate. Some of the mnemonics used may be familiar.

- UART Universal Asynchronous Receiver Transmitter
- ACIA Asynchronous Communications Interface Adaptor
- USART Universal Synchronous/Asynchronous Receiver Transmitter

SIO Serial Input/Output device.

The required functions of the above chips can be summed up as follows, before looking at each chip in more detail.

- (a) Use a shift register to perform the serial/parallel or parallel/serial conversion.
- (b) Select the required Baud rate, number of data bits and stop bits.
- (c) Establish the procedure to be adopted in the event of an error being detected.
- (d) Signal the state of the input or output buffer, that is full or empty.

The 6402 UART

This is an industry standard UART, the block diagram of both the transmit and receive circuitry being shown in Figure 3. To explain in full how the device is used would occupy the space of most of this article, but an attempt to give some idea of its operation will be given here. This device can be used in a wide range of applications including modems, printers, peripherals and remote data acquisition systems. The CMOS/LSI technology used permits clock frequencies up to 4MHz with a power consumption of 10mW or less.

Some aspects of the UART operation are software controlled and some are determined by hardwiring certain of the chip connections. In particular the pins known as CLS2, CLS1, PI, EPE and SBS will be hardwired to a given pattern (from 32 possible patterns) of logic 0s and logic 1s to select the required parameters for number of data bits (5, 6, 7 or 8), parity even, odd or disabled, and the number of stop bits (1, 1½ or 2). These pins are defined as follows.

CLS2 and CLS1 (Character Length Selected) allow four binary combinations, corresponding to the four permitted word lengths of 5, 6, 7 or 8 bits specified above.

PI stands for Parity Inhibited, this condition being obtained when this pin is high (logic 1).

EPE stands for Even Parity Enabled; a high level on this pin produces Even Parity (on transmission) and checks it (on reception).

SBS has two functions when at logic 1, depending upon the selected word length. For a 5-bit word it produces 1½ STOP bits and 2 STOP bits for other word lengths; however, if SBS is at logic 0 it produces 1 STOP bit.

There is a relationship between the clock frequency and the Baud rate. The clock frequency chosen should equal 'sixteen times the required Baud rate'. Thus, for a Baud rate of 1200, the clock frequency should be equal to 1200 x 16 = 19200Hz.

Taking the transmit operation first, the parallel data input is loaded into a buffer when the control line TBRL (Transmitter Buffer Load) is taken low. As this data is loaded into the buffer, the fact that the buffer is now in use is indicated to the transmitting device by the output control line TBRE (Transmitter Buffer Empty) going low. The data in the buffer will then be transferred to the Transmitter Register, the fact of the latter register now

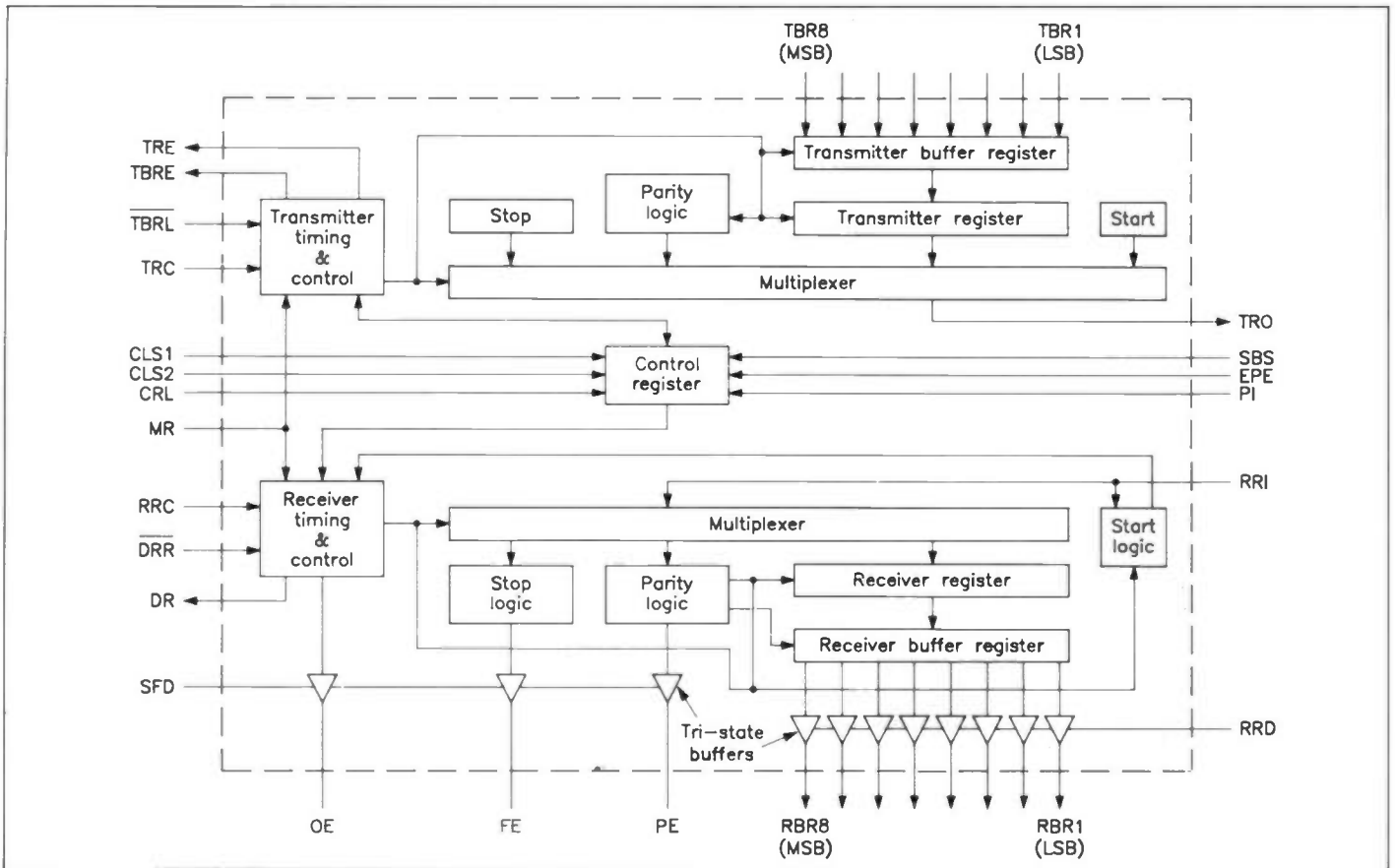

Figure 3. Functional block diagram for 6402 UART.

being in use being signalled by the second output control line TRE (Transmitter Register Empty) going low. Finally the data in the Transmitter Register will be passed to the Multiplexer, to be supplied with the start, stop and parity bits, before the whole 'data packet' is serially shifted out onto the line through the TRO pin. All of this is under the action of a clock that, as stated before, will also set the Baud rate for the transmission.

The receive operation is somewhat more complex. The serial data in arrives on RRI. The Baud rate can be different on receive from transmit. There is, therefore, a separate clock (Receive Clock) and, as before, the clock frequency is 16 times the required Baud rate. The 'data packet' received is loaded into the Receive Register, via the Multiplexer, and when the Data Ready line goes high the parity and format are checked. The data word is then passed to the tristate output via the Receive Buffer, where it can be read by the CPU. Once this has been done, the CPU causes the Data Ready Reset to go low, which clears the Data Ready line. The UART is now able to accept another serial word from the line.

Three types of errors can be detected: Assuming that parity is in use, a parity error will result in the PE (Parity Error) pin going high, this pin staying high until the next valid character is received.

A 'framing error' occurs when the expected STOP bit is not received. The FE (Framing Error) pin will then go high and remain in this state until the next complete character's STOP bit is received.

An 'overrun error' occurs when a character is transferred to the Receiver

Buffer Register before the previous character has been fully read. The corresponding flag for this error is the state of pin OE (Overrun Error) which goes high to signal the error.

The fact that each of the above types of error is 'flagged' at an external pin of the 6402 allows the system designer to initiate an error correction procedure, such as the re-transmission of the character that caused the error.

There are two ways in which a UART can be used, known as the 'unconditional' and 'handshaking' modes. In the case of the former, the idea is that any time a character arrives it gets handled. This is simple but carries the reservation that the rate at which such characters arrive must be limited according to the selected Baud rate. In the 'handshaking' mode the UART decides, by means of control signals, just when it will handle a character. When a UART is used as a serial interface to a VDU/keyboard the unconditional mode is usually the one employed.

The above much abbreviated explanation does, it is hoped, provide rather more than just an indication of how complex the functions of such a chip may be. There is a dual version of the UART known as a DART (Dual Asynchronous Receiver/Transmitter).

The Motorola 6850 ACIA

This device implements the requirements of the standard EIA RS232C serial interface, which is discussed later in this article.

The block diagram appears in Figure 4.

It should be noted that its pins can be defined in 'blocks' with specific functions and relations to the microprocessor buses.

The parallel data connection is made through the eight data pins DO-D7 inclusive. Two address bus lines are used for chip selections, these being identified as CS1 and CS2; thus one of the selected address lines at logic 1 and one at logic 0 will enable the chip. A third address line determines the logic level on the pin RS and, together with the logic level on the R/W line, provides the four binary combinations that control the addressing of the internal registers, known as CONTROL, STATUS, RECEIVE DATA and TRANSMIT DATA, thus defining the mode of operation of the device.

Serial data in and out are via the pins RxD and TxD; these are TTL compatible signals, but they will invariably require external buffering to interface them to the serial devices. The modem-control lines control the interface in an RS232C modem link. There are two clocks, one for receive and one for transmit and, as explained previously, they may be different for the two directions, thus providing different Baud rates.

The 8251 USART

This device, the block diagram for which appears in Figure 5, permits both synchronous and asynchronous serial data transmission. The latter method has been described already and it should be appreciated that the data can be sent at irregular intervals, since the presence of the START bit will always identify the

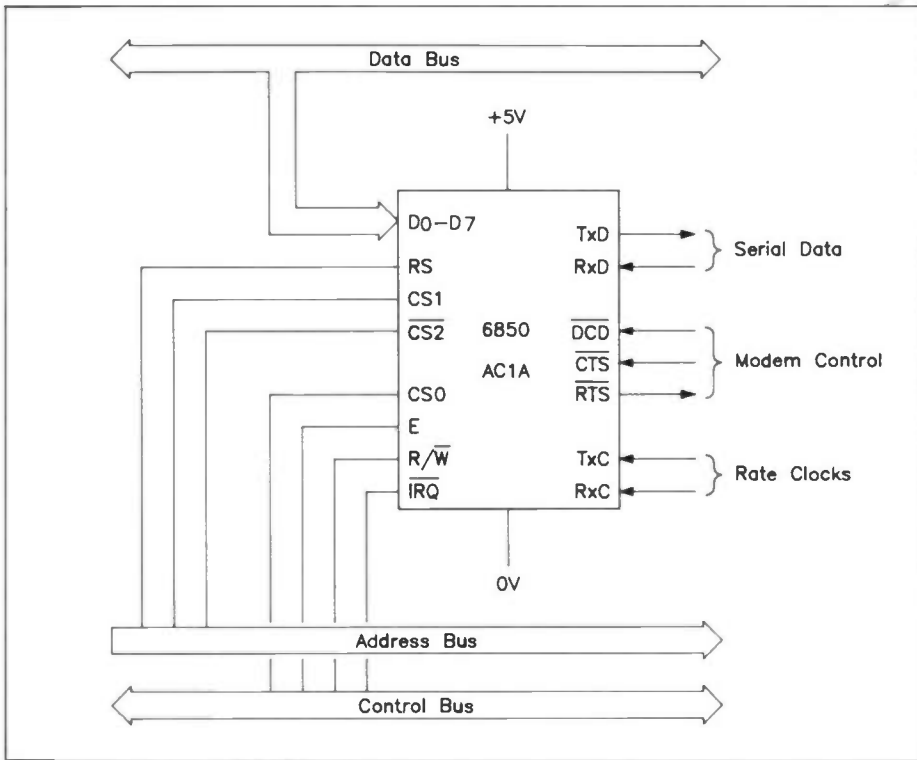

Figure 4. Function diagram for 6850 ACIA.

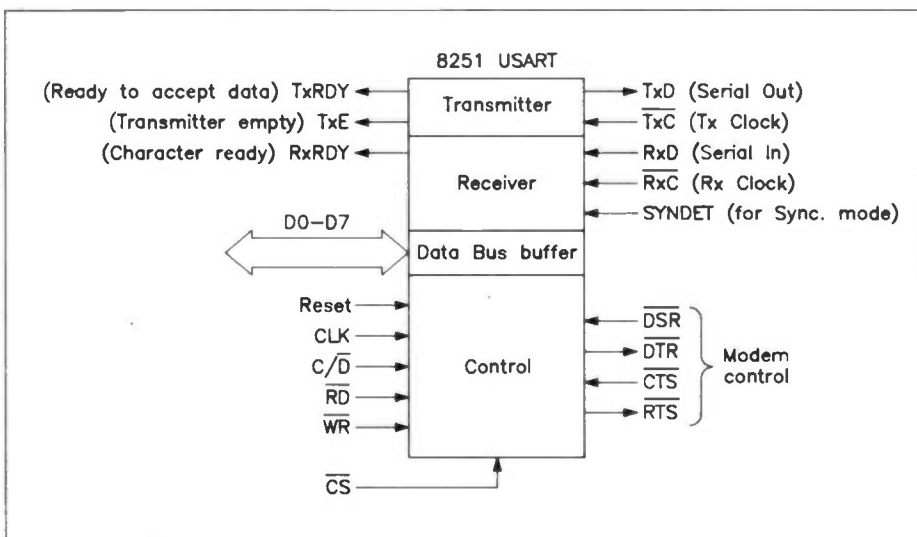

Figure 5. 8251 USART.

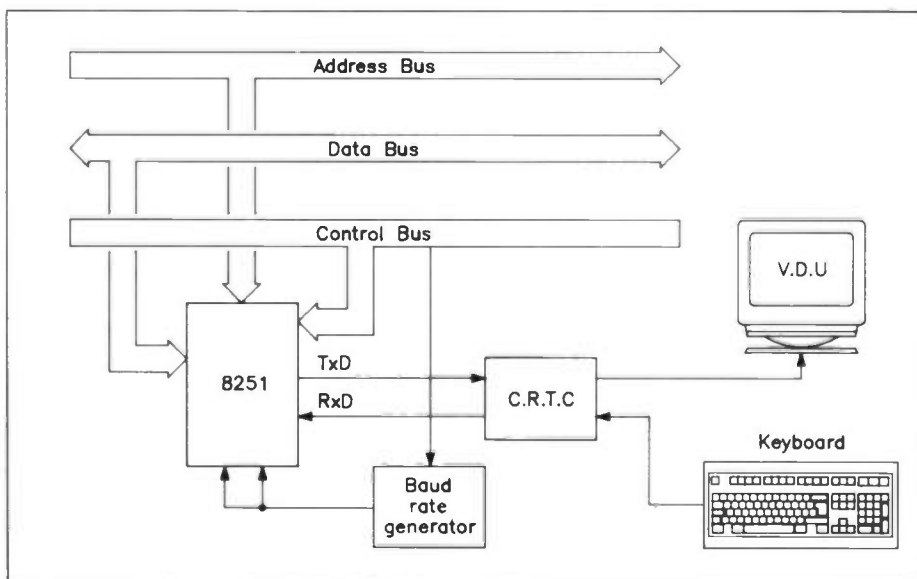

Figure 6. Using the 8251 USART to interface a micro to its keyboard and display.

beginning of new data. In the synchronous method, data is transmitted quite precisely and the precision of the timing means that the START and STOP bits are not required. Instead the same system clock is supplied to both ends of the serial link by means of a separate track. Every data word has its own predetermined 'time slot' into which it fits precisely. Any gaps in the actual transmission are filled by 'null words'. Synchronous systems are very fast but at the cost of greater complexity than asynchronous links.

The 8251 has to have 'set-up' words sent to it after a reset following power-up. This is a common feature of other 'programmable' interfaces and the function of these set-up words is to establish the mode in which the 8251 will operate. Obvious options are: synchronous or asynchronous; read or write; word length and other parameters.

The use of the 8251 as an interface between a CPU and the VDU/keyboard is illustrated in Figure 6. Another important peripheral interfacing device is shown in this case, namely the CRT or Cathode Ray Tube Controller IC.

The SIO (Serial Input/Output Device)

A serial Input/Output controller IC is available for the Z80 CPU but it can, in fact, be used with a variety of other microprocessors.

It provides two independent full-duplex channels with separate control and status lines for modem and other devices. The general facilities are much the same as those already specified for the 6402 in respect of the format of the 'data packet', that is the number of data bits, START and STOP bits, parity, etc. Data rates of up to 800k-bits/s are possible with a 4MHz clock. The usual types of error can be detected and flagged.

The RS232C Standard Serial Interface

This interface standard conforms to a quite old Electrical Industries Association (EIA) standard (a U.S. standard, in fact) and is the one often employed with modems and for large-scale computer serial interfacing. The RS232 signal is bipolar, which simply means that it has two signs, one for logic 0 and another for logic 1. In fact the voltages commonly used are +12V to represent logic 0 and -12V to represent logic 1. See Figure 7. This makes it necessary to perform a conversion between the TTL/RS232C logic levels in both directions of transmission. The interface devices normally used, and shown in use in Figure 8, are the 1488 and 1489 ICs.

This interface may sometimes be referred to under the dual reference RS232C/V.24. The latter is actually a European specification under the auspices of the CCITT and, for practical purposes, may be considered as virtually interchangeable with RS232C.

Data Codes

Probably the best known code is the one referred to as ASCII, which stands for American Standard Code for Information Interchange. Each of the alphanumeric and other symbols on a keyboard have a unique code, which is usually specified in hexadecimal format. In addition to keyboard symbols, various control functions, such as Carriage Return, Line Feed – to quote two obvious ones – are similarly encoded. These hexadecimal values range from 00H to 7FH, those from 00H to 31H being the control values, the remainder being the true keyboard characters. This code is basically a 7-bit code (thus allowing for 128 different characters to be encoded) with the eighth bit being used for parity. It is interesting to note that bits 6 and 7 of the code define the nature of the ASCII character. All those commencing with 00 are 'control' characters; all those commencing with 01 are 'punctuation marks'; all those commencing with 10 are 'capitals', while all those commencing with 11 are 'lower case' letters. In this way the computer is easily able to ascertain whether a character is, for example, for control merely by noting whether the two most significant bits are both 'zeroes'.

An IBM code is the EBCDIC code, which stands for Extended Binary Coded Decimal Interchange Code. This is an 8-bit code used in IBM and other compatible computers. There is more than one version of this code.

Modems

Modem is one of those combination words. The 'MO' part is an abbreviation of MODulator, while the 'DEM' part describes the complementary device, the DEModulator. The purpose of a modem is to allow data to be transmitted over the public telephone network. Since this normally handles speech frequencies in the range 300-3400Hz, the logic levels have to

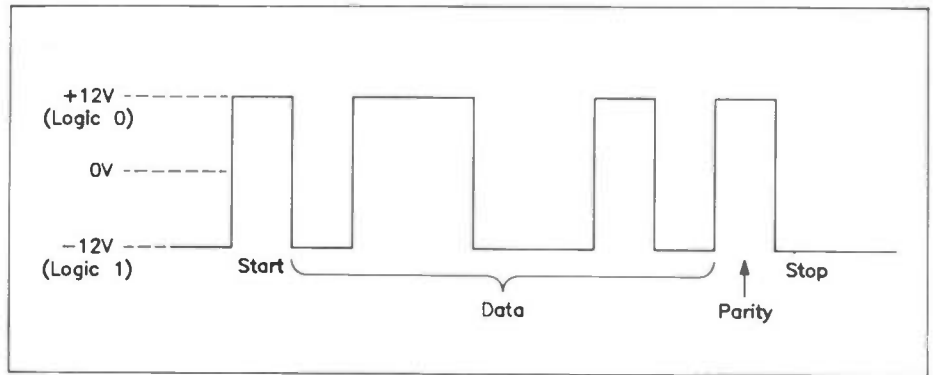

Figure 7. RS232C voltage levels.

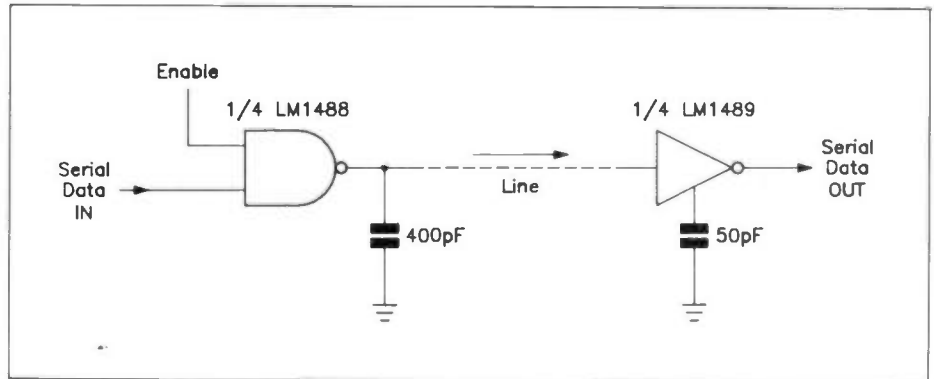

Figure 8. Using LM1488/1489 ICs to implement RS232C levels; capacitors minimise ringing and noise.

be converted into corresponding audio-frequency signals. This can be accomplished by a method known as 'frequency-shift keying' (FSK) in which logic 0 is represented by one tone (e.g. 2100Hz) and logic 1 by another (e.g. 1300Hz). The relationship between a TTL binary signal and its FSK equivalent is shown in Figure 9. The function of each component parts of a modem is now obvious.

The modulator section will have a TTL binary input which it will convert into the corresponding pattern of audio-frequency tones. Its input will be from the

computer and its output will be into the telephone system.

The demodulator will have as its input the audio-frequency FSK signal which it will then convert into the appropriate TTL levels. Its input will be from the telephone line and its output will be into the computer.

Since the signals into and out of the line will be in a serial format, and since the computer(s) will require parallel data, the modem will also include the facilities previously described for serial/parallel and parallel/serial conversion. Modems may use the simplex, full-duplex or half-duplex modes of operation. If the two frequencies mentioned above, namely 1300Hz and 2100Hz are used for the two logic levels, only half-duplex working is possible. For full-duplex operation there must be four frequencies, one pair for the forward direction of transmission and another pair for the reverse direction.

For example:

Channel A might use 1850Hz for logic 0 and 1650Hz for logic 1.

While:

Channel B might use 1180Hz for logic 0 and 980Hz for logic 1

Acoustic coupling of the modem to a telephone handset has been tried in the past as an inexpensive way of connecting the computer into the public telephone network, but it brings its own special crop of problems. It is more usual to make a direct electrical connection instead with suitable isolation arranged to prevent inadvertent connection of mains voltages to the telephone lines, plus various other sophistications. As already mentioned, the usual form of interface employed corresponds to the RS232C/V.24 standards.

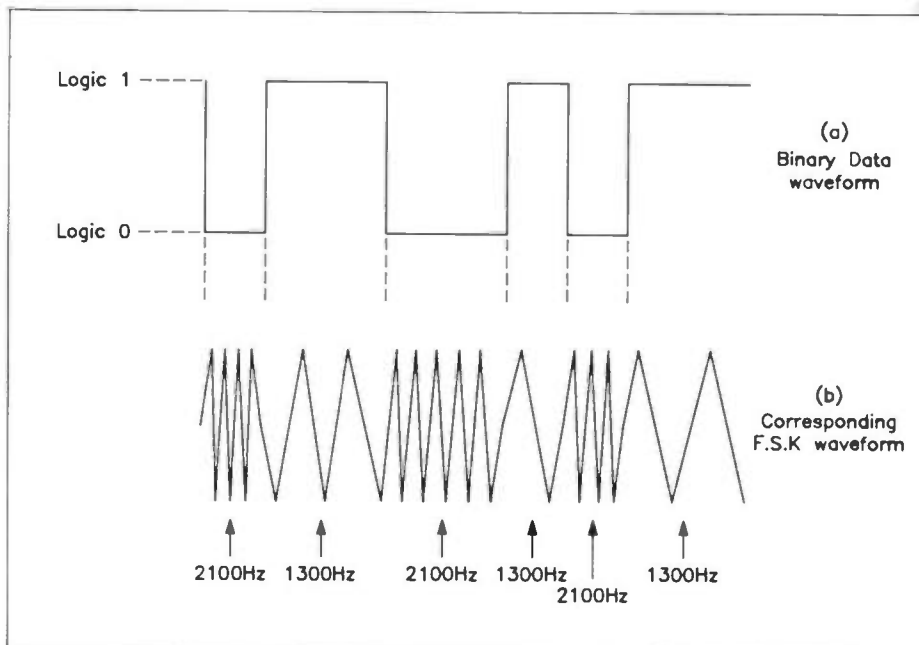

Figure 9. In Frequency Shift Keying (FSK), each bit is encoded as one of two alternative audio frequencies, according to its logic level.



Here NOW in

DOLBY STEREO

Introduction

A mention of the phrase 'The Big Screen', immediately brings to mind the atmosphere of viewing a movie film at the cinema. The experience is seldom recreated in the domestic environment; one of the contributing factors is the lack of 'cinema sound'. Many of the films that are produced for presentation in cinema theatres have specially encoded stereo sound-tracks. This system, developed by Dolby Laboratories Incorporated, uses a special encoding process that allows four channel sound to be recorded onto the two optical sound-tracks used on 35mm movie film. When the film is screened at the cinema, the stereo sound-track is processed (decoded) and the original four channel sound is recovered and reproduced through strategically placed loudspeakers.

This special encode/decode system is called Dolby Stereo. The aim of Dolby Stereo is to enhance the audience's experience by using stereo sound to provide directional information related to the on-screen action. Thus, as a car drives from left to right across the screen, the sound image follows it, so reinforcing

By Robert Ball A.M.I.P.R.E.

realism. A further benefit is the use of a 'surround' channel to reproduce sound effects and ambient sounds throughout the cinema theatre, so projecting the audience into the on-screen action.

Since the introduction of the first Dolby cinema decoder in 1975, over twelve thousand cinemas have been equipped to present films in Dolby Stereo. Over two thousand films have been released in Dolby Stereo, the list includes many popular titles, for example; 'Raiders of the Lost Ark', the 'Star Wars' trilogy and 'Back to the Future'.

Many of the feature films produced in Dolby Stereo have also been released on domestic video cassette and video disc for home viewing. With the advent of satellite television, which has stereo sound capability and terrestrial television broadcasts in NICAM-728 Digital Stereo, there are now a number of different sources of Dolby Stereo encoded movie films. Since these domestic sources automatically have the encoded information present in their stereo sound-tracks, it is possible to retrieve the multi-dimensional sound-track by using the necessary decoding equipment. It is the

intention of this article to explain the way in which Dolby Stereo is encoded and decoded, how Dolby Stereo films are presented in the cinema and how domestic Dolby Surround decoders can be used in the home.

Considering Cinema

We have already established that the aim of Dolby Stereo is to provide stereo sound conveying directional cues, and to reproduce ambience and sound effects. To satisfy this requirement we must consider the layout of a cinema theatre. Generally cinema seating is arranged to allow the largest number of people to see the screen, with rows extending from the far left, through centre, to the far right of the auditorium.

If 'conventional' two loudspeaker (left and right channel) stereo sound were implemented, people seated off centre would lose the proper stereo image and at the left and right extremities, the stereo image would be non-existent; the sound field being predominated by the nearest left or right loudspeaker. To overcome the problem of maintaining the stereo image,

a centre channel loudspeaker is added. By carefully controlling which sounds are reproduced in the left, centre and right loudspeakers, the whole audience will hear sounds emanating from the correct screen location; dialogue becomes firmly anchored to actors faces and vehicle sounds traverse the sound field, following their on-screen sources.

Figure 1 illustrates the layout of a cinema auditorium and loudspeaker placement. Surround channel loudspeakers are located at the sides and rear of the cinema, these loudspeakers 'fill' the auditorium with sound effects; explosions, animal noises, etc, and also add ambient sounds; wind and rain noise, echoes and reverberation. In many cases the movie film's music sound-track is also reproduced, in conjunction with the front channel loudspeakers, through the surround channel loudspeakers. The overall result is much greater depth of sound, which enhances the movie-going experience; transporting the audience into the film, in contrast to just observing what is going on.

To indicate that a movie film presentation is in Dolby Stereo, cinema theatres will advertise on their bill-boards that their auditoria are suitably equipped with the necessary decoding and reproduction equipment. Additionally at the end of a movie film, the credit list will state: Dolby Stereo in selected theatres.

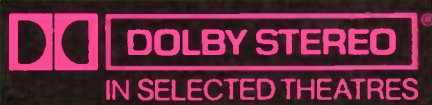

The Dolby Motion Picture Matrix

To achieve the desired effect, we have seen that it is necessary to add two extra sound channels, a centre channel and surround channel, to the existing left and right channels. Dolby Stereo thus requires four channels, and whilst these channels are sometimes recorded on individual magnetic tracks, as with 70mm movie film, the most popular format is 35mm movie film with two optical sound-tracks. Figure 2 shows the two optical sound-tracks on 35mm movie film. Only having two sound-tracks requires the four channels to be somehow combined into two channels. This 'feat of magic' is performed by a Dolby MP (Motion Picture) Matrix encoder.

Figure 3 shows the concept of how the four channels are combined/encoded into two channels. The Dolby MP Matrix encoder has four inputs; left (L), right (R), centre (C) and surround (S), and two outputs; encoded left (Lt) and encoded right (Rt). The left and right input signals pass unprocessed, through the summing amplifiers, to the respective left and right encoded (Lt & Rt) outputs. The centre input signal is attenuated by 3dB (to maintain constant audio power) and is summed equally with the left and right signals. The surround input signal is also attenuated by 3dB, but before summing

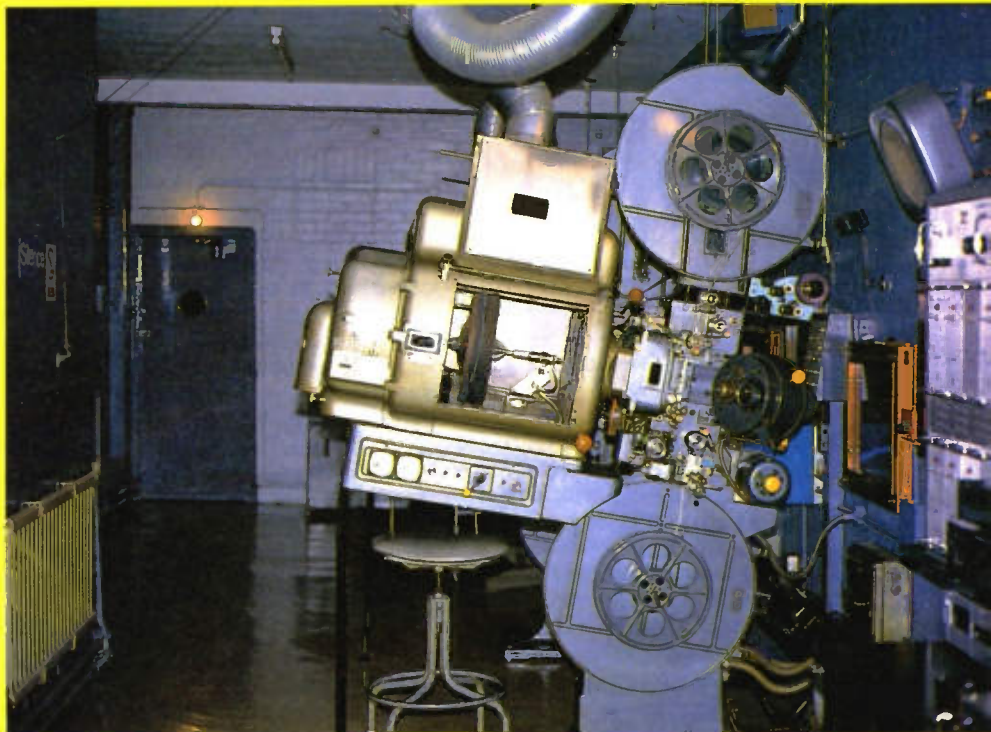

Photo 1. Projection Room, photo shows a Cinemeccannica Victoria 8 Projector (35 & 70mm) equipped with a 3kW Xenon light source. Two different lenses allow for projection in 'normal' 185 wide screen and Panavision/Cinemascope formats.

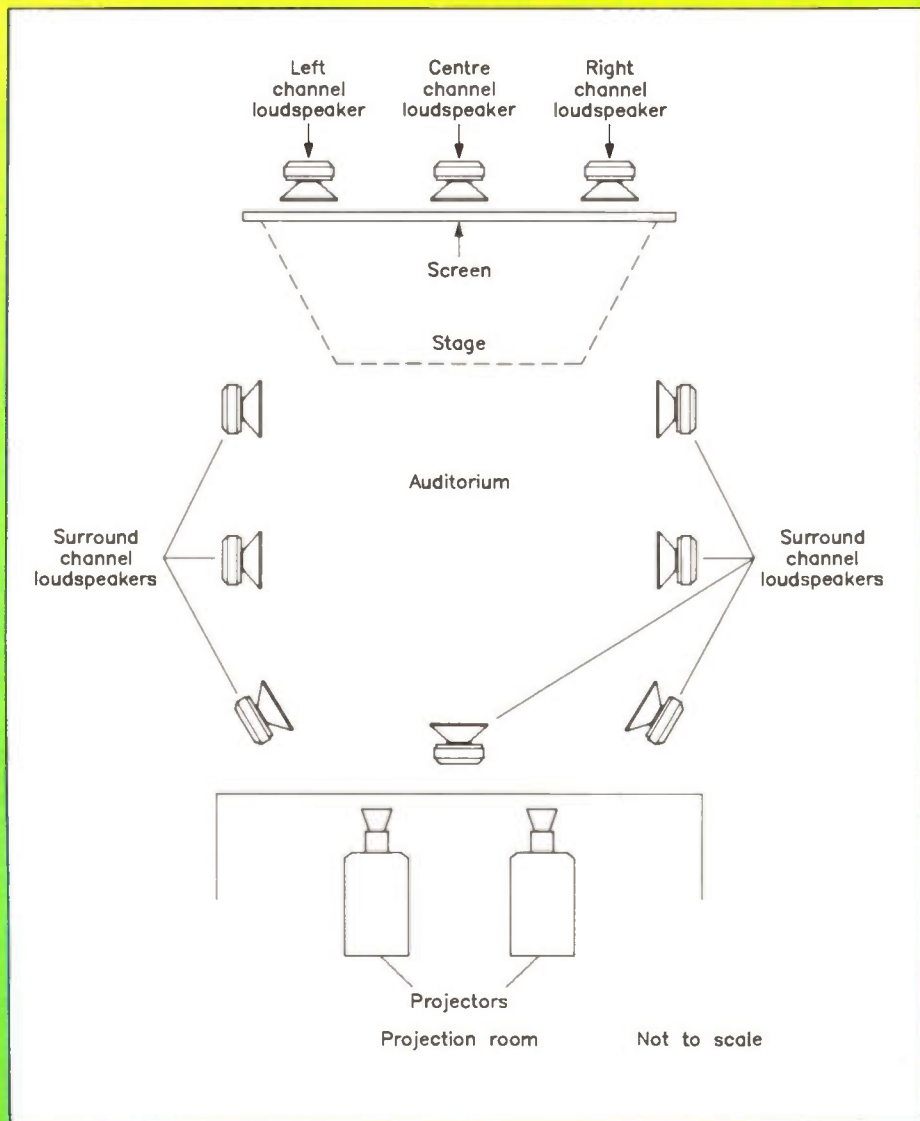

Figure 1. Typical loudspeaker placement in a Cinema.

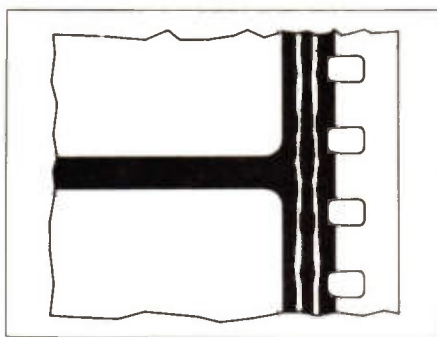

Figure 2. Stereo optical sound-track found on 35mm movie film.

with the left and right signals, the surround signal undergoes further processing: The signal is band-pass filtered, which removes signals below 100Hz and above 7kHz, the signal then passes through a modified Dolby B noise reduction encoder. The matrixing process involves phase shifting the surround signal by $+90^\circ$ and -90° , the phase shifted signals are then summed with the left and right signals. The encoded left and right (Lt & Rt) signals are then recorded onto the movie film's optical sound-track. To ensure high quality reproduction, the matrix encoded film sound-track is encoded using the Dolby A, or more recently Dolby SR, noise reduction system.

The band-pass filtering and Dolby B encoding of the surround signal both play an important role in enhancing the performance of the matrixing process that takes place in the decoder. Imperfections in channel amplitude and phase characteristics would otherwise give rise to noticeable (and very distracting) leakage of signals into the surround channel. For instance dialogue sibilants, if not attenuated, would cause the audience to think that the actors were speaking behind or to the side of them. The additional filtering

and encoding helps to minimise this undesirable effect.

Dolby Stereo – The Tricks of the Trade

With Dolby Stereo, there is no loss of channel separation between the left and right signals, as they remain completely independent. This is also true (but not obviously) of the centre and surround channels. Since the surround channel signal is decoded by taking the difference between the left and right (Lt & Rt) channel signals, the identical centre channel signals in the left and right (Lt & Rt) channel signals will exactly cancel each other out. Similarly, the centre channel is decoded by summing the left and right (Lt & Rt) channel signals, the surround channel signals are 180° ($+90^\circ$ & -90°) out of phase and will also cancel each other out.

The cancellation process, whilst aided by band-pass filtering and Dolby B encoding, relies on the amplitude and phase characteristics of the recording media's two channels being as close as possible. If the centre channel signal in the left (Lt) channel signal is not identical to the centre channel signal in the right (Rt) channel signal, the result would be leakage of the centre channel signal into the surround channel.

The decoder includes additional features to help minimise the effects of signal leakage, these being; active directional enhancement (signal steering) and an audio delay circuit. By delaying the surround channel signal, identical front (left, right and centre) and surround signals, will be heard to emanate from the front loudspeakers before the rear surround loudspeakers. Thus 'fooling' the listener into thinking that the sounds originated from the front loudspeakers.

This very useful 'trick' is known as the 'Haas' or precedence effect, which is only possible because of the way the brain perceives sound. Psychoacoustics (psychology of hearing) is the term applied to such effects, and that would make another article entirely.

Decoding Dolby Stereo in the Cinema

To reproduce the original four channel Dolby Stereo sound-tracks in a cinema theatre, a professional decoder is required, which forms part of a Dolby Stereo Cinema Sound Processor. The decoder recovers the left, centre and right signals for amplification and playback through the three front loudspeakers and also recovers the surround signal which is amplified and distributed to an array of loudspeakers located along the rear and sides of the auditorium.

Figure 4 shows a simplified block diagram representation of a Dolby Stereo Cinema Sound Processor. The optical pre-amplifier provides amplification and equalisation for the two stereo optical inputs (Figure 5 illustrates operation of the optical sound-head found on 35mm projectors). A control input selects which of the two projectors will source the sound-track, the selection is usually performed by a pre-programmed sequence automation unit, which also starts and stops the projectors during reel changes. The Dolby A encoded sound-track is decoded and the left and right (Lt & Rt) channel signals are passed to the Dolby Stereo Decoder, where matrixing and other processing take place to extract the left, right, centre and surround channels. Level meters monitor the signal level prior to decoding by the Dolby Stereo Decoder. The surround channel signal passes directly to the four channel fader, whilst the left, right and centre

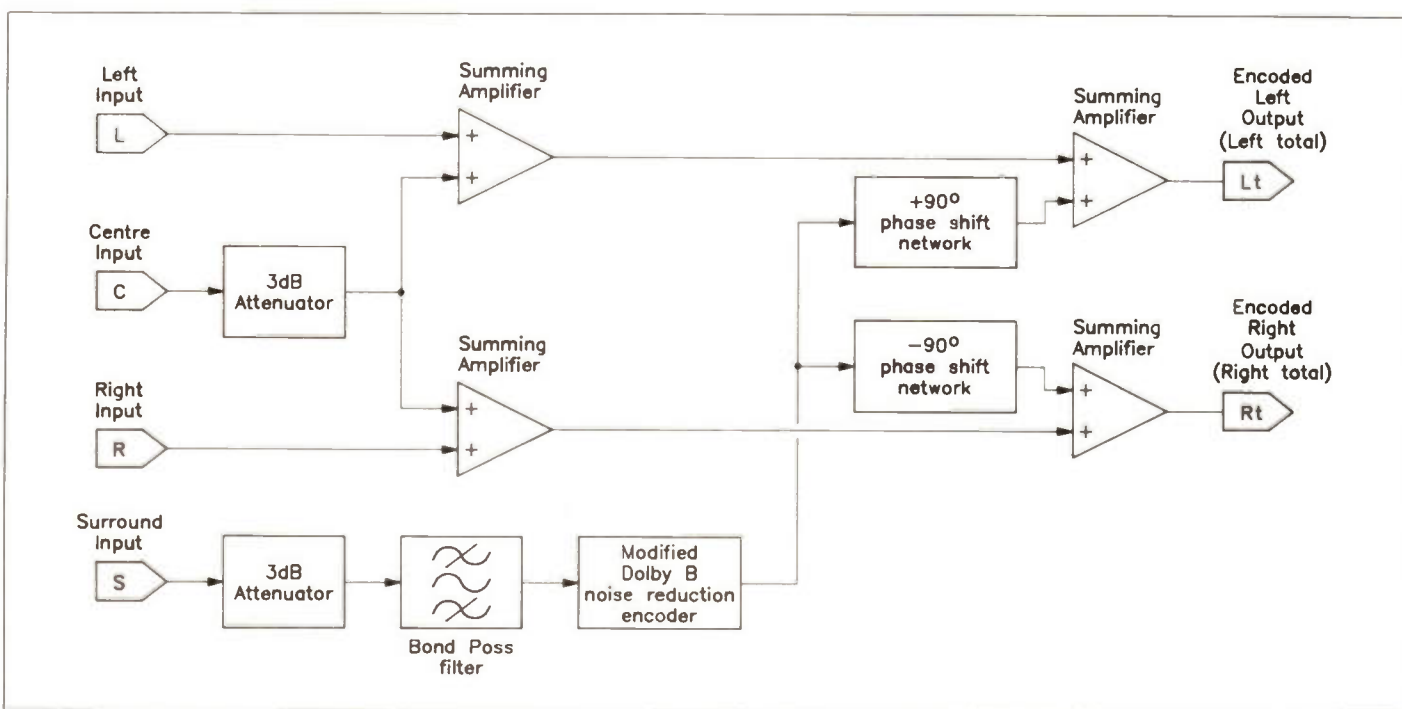

Figure 3. Dolby stereo motion picture matrix.

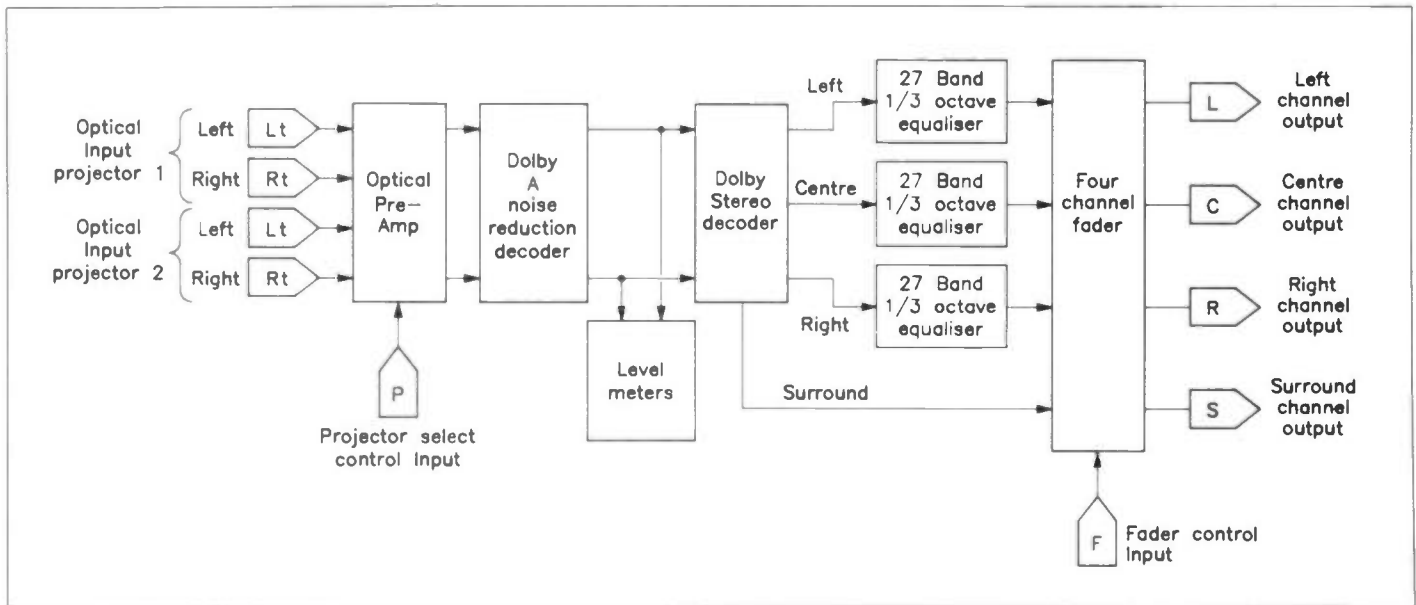

Figure 4. Dolby stereo cinema sound processor.

channel signals are routed via individual 27 band 1/3 octave equalisers and then to the four channel fader. The four outputs are then used to drive separate power amplifiers and loudspeakers.

A typical Dolby Stereo cinema sound reproduction system, using 35mm optical sound-tracks, is shown in Figure 6. Interval music may be played through the sound system, this could be from cassette tape or compact disc and is fed into the Cinema Sound Processor's non-sync input via a separate fader. Incidentally the same amplifiers and loudspeakers may be driven from the four (out of the six) individual Dolby Stereo magnetic tracks on 70mm movie film, in this case the decoder is bypassed.

Domestic Dolby Stereo

Dolby Laboratories soon realised that with availability of Dolby Stereo encoded source material for domestic use, there would be a demand for decoders that could recreate the surround sound effects

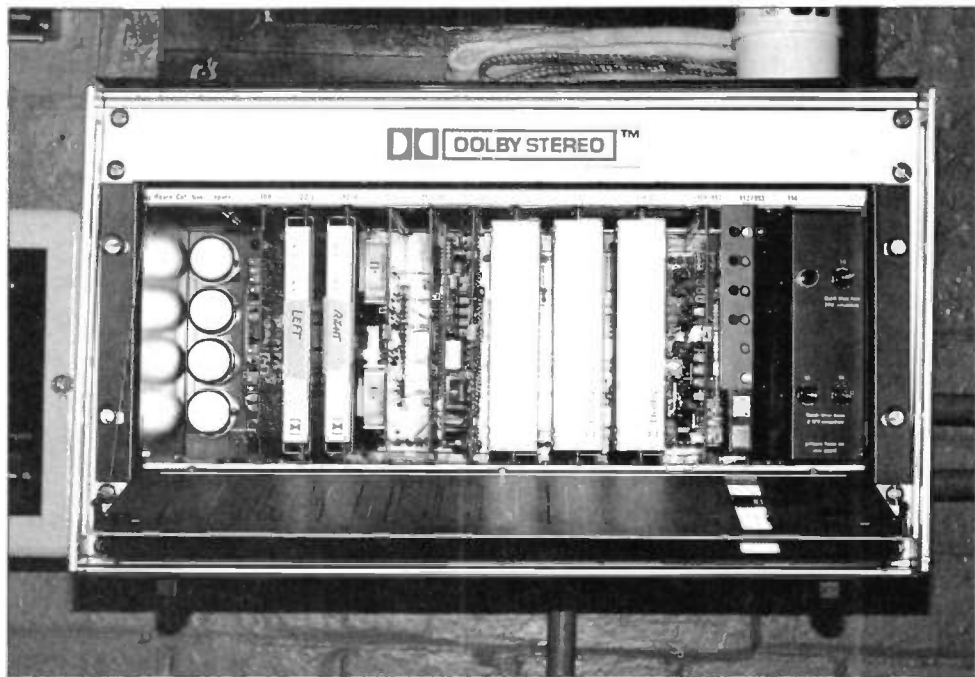

Photo 2. Dolby stereo cinema sound processor, model CP50.

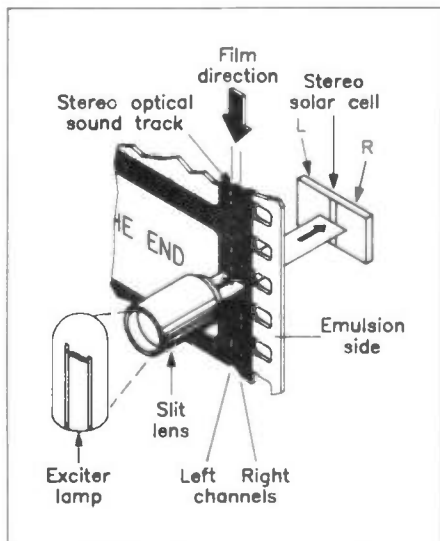

Figure 5. Stereo optical sound-head.

and ambience in 'the front room'. Such a decoder was developed and was introduced in 1982. The domestic version of the Dolby Stereo is called Dolby Surround. The Dolby Surround decoder makes use of a fixed matrix consisting of a simple left (Lt) minus right (Rt) differential amplifier to decode the surround channel signal, this type of decoder is known as a passive decoder. The passive decoder has the advantage of simplicity and reasonable cost. Since the introduction of Dolby Surround, nearly three million decoders have been sold. In 1987 an advanced domestic decoder was introduced, utilizing an adaptive matrix to decode the left, right, centre and surround channels. The adaptive matrix analyses the audio signals and actively steers the various signals, under the control of analogue logic circuits, to the required outputs, thus

increasing separation of the original four channels. This type of active decoder works in a similar way to its professional Dolby Stereo cinema counterpart. The active domestic version of Dolby Stereo is called Dolby Pro Logic. Both Dolby Surround and Dolby Pro Logic decoders will be discussed.

An obvious and very important requirement in domestic systems is that the playback and/or receiving equipment must be capable of providing a high quality stereo signal; i.e. Hi-Fi Stereo video cassette recorder (VCR), stereo video disc player (VDP), stereo satellite receiver or NICAM-728 receiver/decoder. Depending on the make and model of decoder used, additional amplification and loudspeakers will be required (over and above the existing equipment that the user may have).

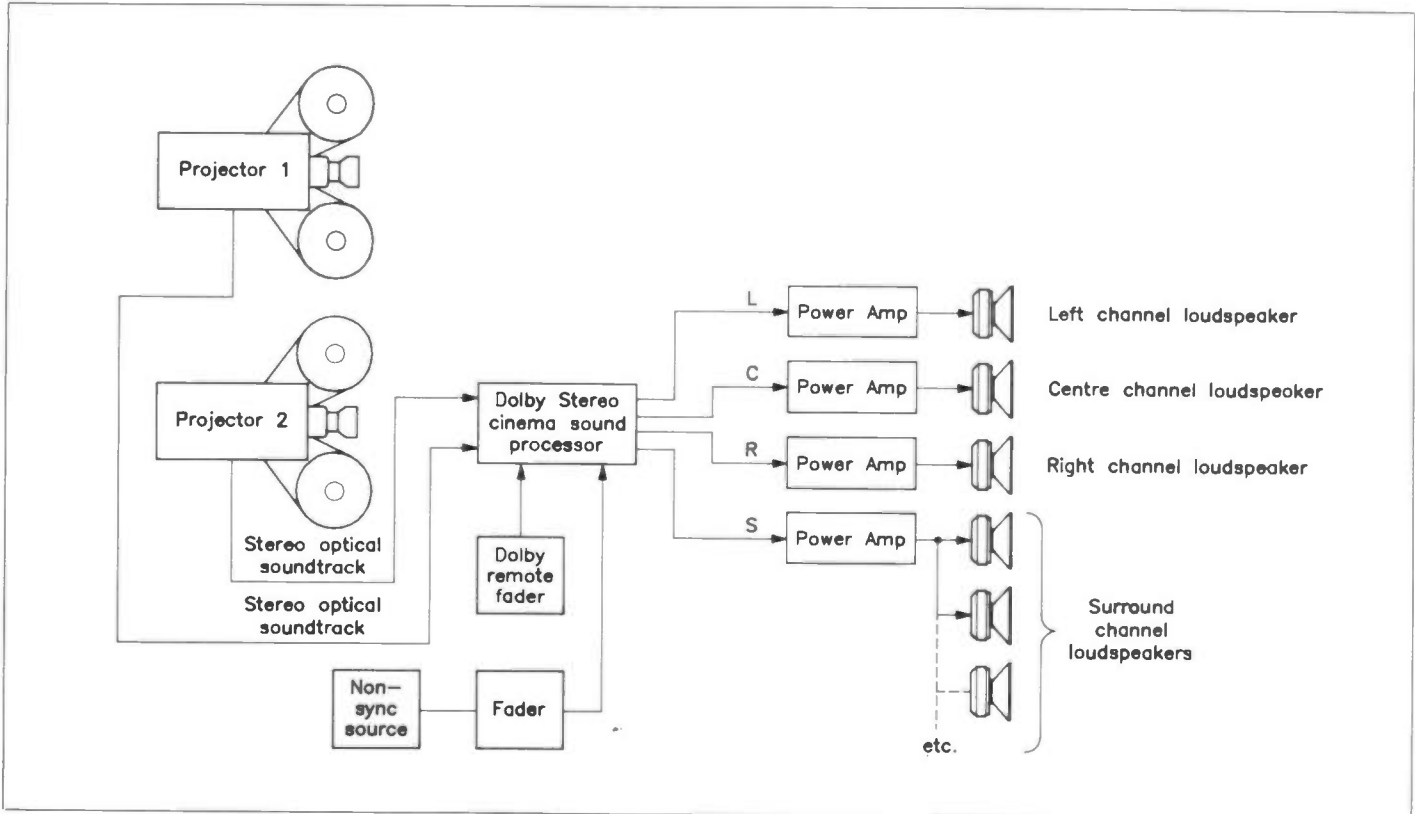

Figure 6. Dolby stereo sound reproduction in a cinema (optical).

Dolby Surround Decoder

The Dolby Surround decoder, as already mentioned, is a simplified version of the professional Dolby Stereo decoder. Figure 7 shows a block diagram of a passive Dolby Surround decoder. The input circuitry buffers the incoming left and right (Lt & Rt) channel signals and provides a means of setting the input signal level and balance. The balance control is used to minimise leakage of front channel signals into the surround channel. Level meters are provided, in either moving coil or LED bargraph form, to indicate the signal levels within the

Photo 3. Sequence Automation Unit, which controls the operation of houselights, curtains, sound and projectors.

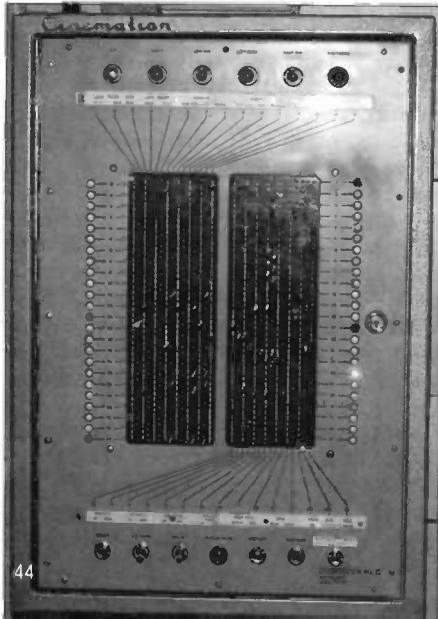

Photo 4. Audio equipment; left of centre, 6 x 200W and 1 x 100W (1.3kW) audio power amplifiers; centre, CD player and cassette recorders; right of centre, open reel tape recorder.

decoder unit. The input level controls are adjusted to give the correct reading on the level meters. The left and right (Lt & Rt) channel signals follow two paths, directly to the left and right output level controls, and to the fixed decoder matrix.

The surround signal is recovered by applying the left and right signals to a differential amplifier ($L_t - R_t$), a requirement of this amplifier is good common-mode performance, as it is responsible for both extraction of the surround signal and elimination of the centre signal from the surround channel. The surround channel signals applied to the differential amplifier are effectively 180° out of phase (+90° & -90°) and are therefore extracted from composite left and right (Lt & Rt) channel

signals. The centre channel signals are in phase and therefore rejected by the differential amplifier. It can be seen that if there is any mismatch in left and right (Lt & Rt) signal levels (or phase), the centre channel information will not fully cancel out and signal leakage into the surround channel will occur.

The decoded surround channel signal is passed through an anti-alias filter (low pass) to prevent spurious audio products being introduced in the audio delay circuitry. The audio delay is used to introduce a 15 to 30ms delay in the surround channel, the delay circuitry, depending on the manufacturer, may be analogue BBD (Bucket Brigade Delay) or digital. As previously explained, the delay

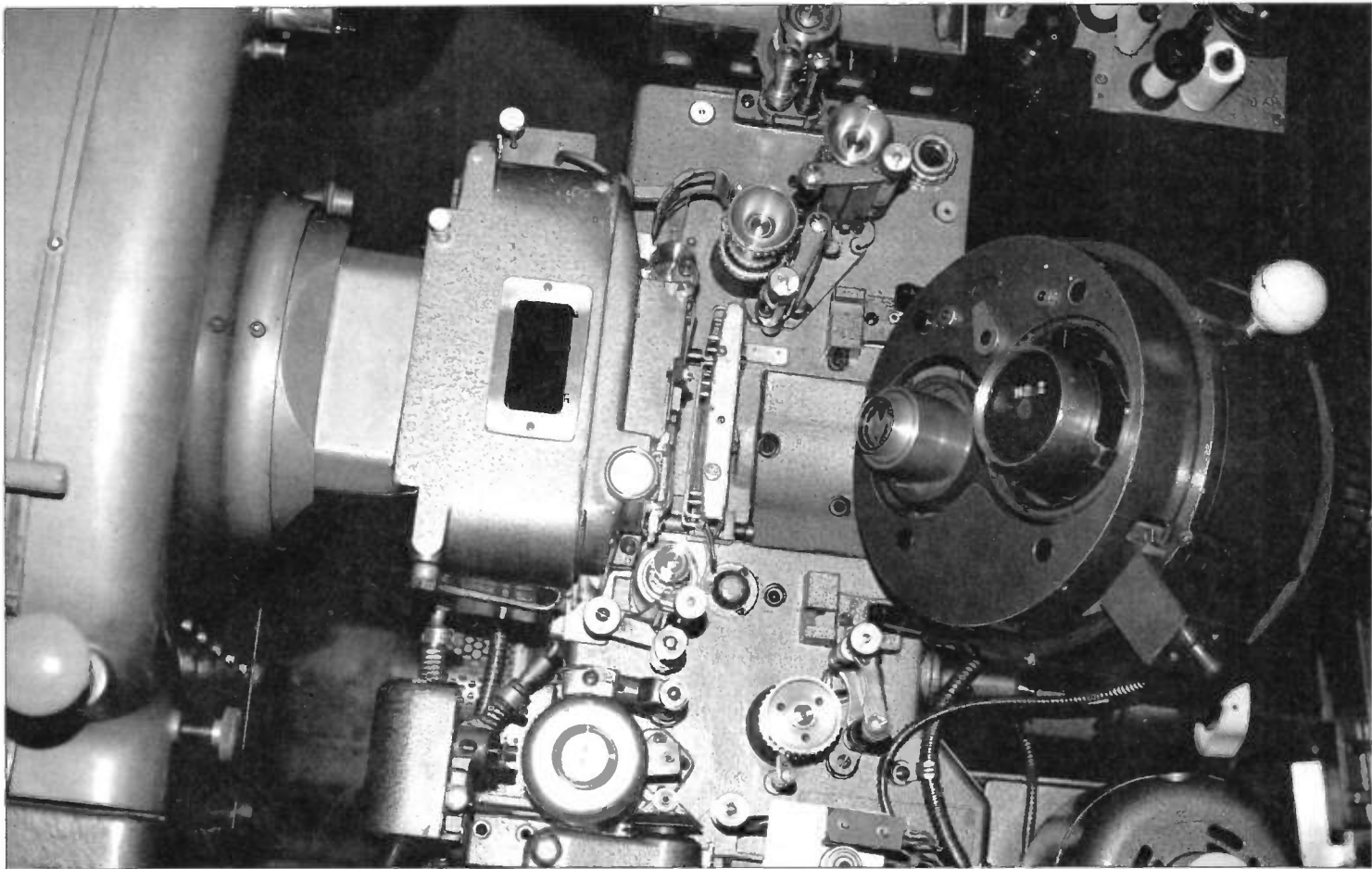

Photo 5. Close-up of projector; film transport, film gate, lenses and optical sound pick-up.

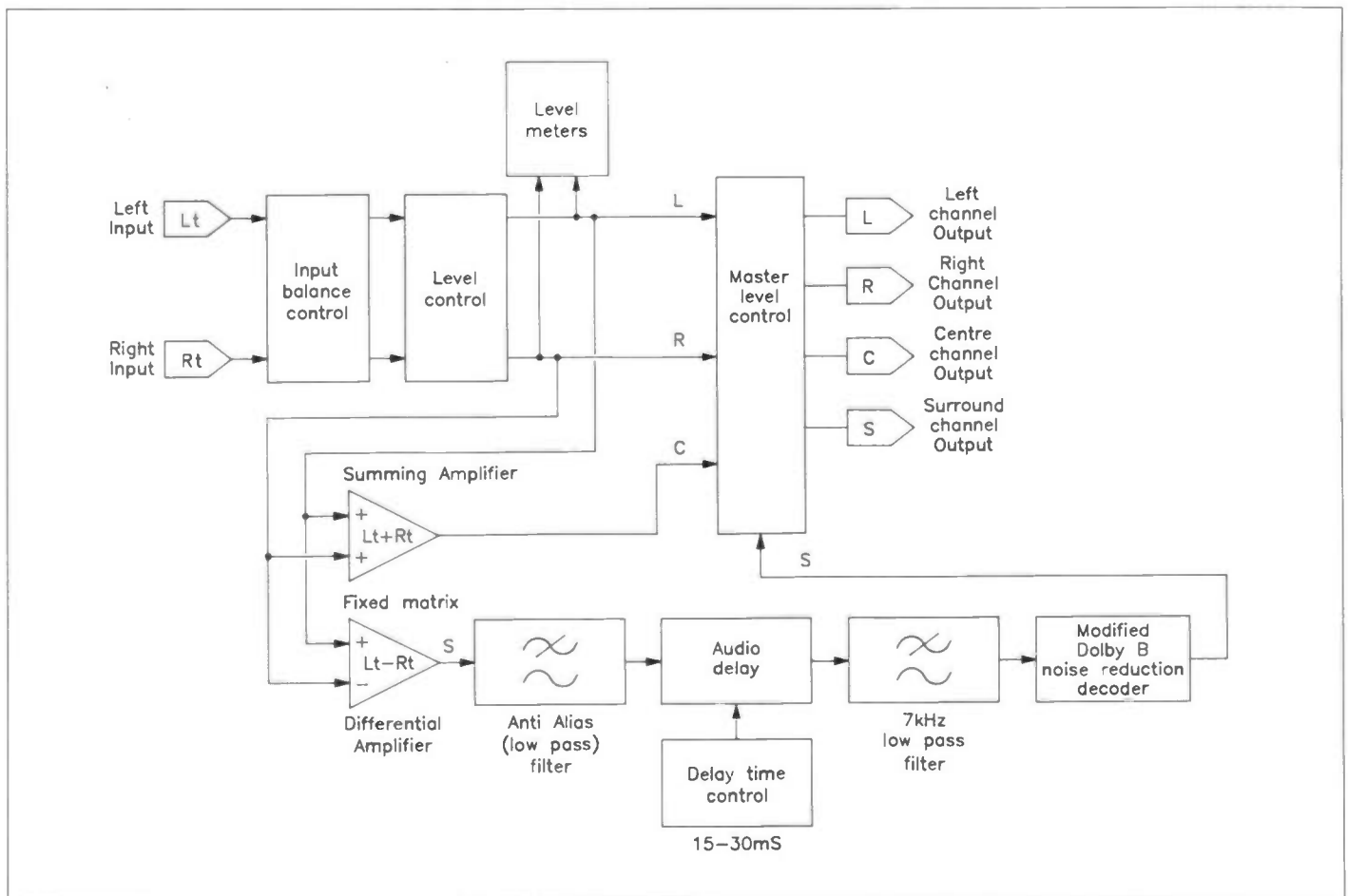

Figure 7. A passive Dolby Surround decoder.

is used to mask signal leakage into the surround channel. A delay time control is provided on some decoders to optimise the Haas effect; compensating for differences in room size and listening position. Following the audio delay is a 7kHz low-pass filter, which serves to remove residual delay clock breakthrough, and since the surround signal was band pass filtered from 100Hz to 7kHz, this filter also removes high frequency front channel leakage signals. A modified Dolby B decoder is used to reduce noise and further helps to reduce front channel leakage. The surround channel signal then passes to the surround output level control.

Although it is usual for only active Dolby Pro Logic decoders to have a centre channel, some Dolby Surround decoders do have a passive centre channel decoding matrix, which, as with the centre channel in cinema theatres, is intended to improve stereo imaging for off centre viewing/listening. This benefit is at the expense of a narrowed stereo image since the passive centre output includes not only the centre channel signal but also the left and right signals as well. Active systems however do not suffer from this limitation, as will be explained later. The passive centre channel matrix is implemented by summing the left and right (Lt & Rt) channel signals, surround channel signals are cancelled out by the summing process, the centre channel signal then passes to the centre output level control.

A standard passive decoder without the centre channel will reproduce left, centre and right signals, without loss of separation. The centre signal appears to come from a 'phantom' centre position, the reason being that two equal level, equal phase, left and right signals will be perceived as a centre signal. However, the viewing/listening position needs to be near optimum for proper imaging.

Note :

(*) Centre channel loudspeaker may sometimes be implemented in Dolby Surround systems, but usually only in Dolby Pro-Logic systems.

(**) Sub-woofer channel loudspeaker is implemented in Dolby Pro-Logic systems only.

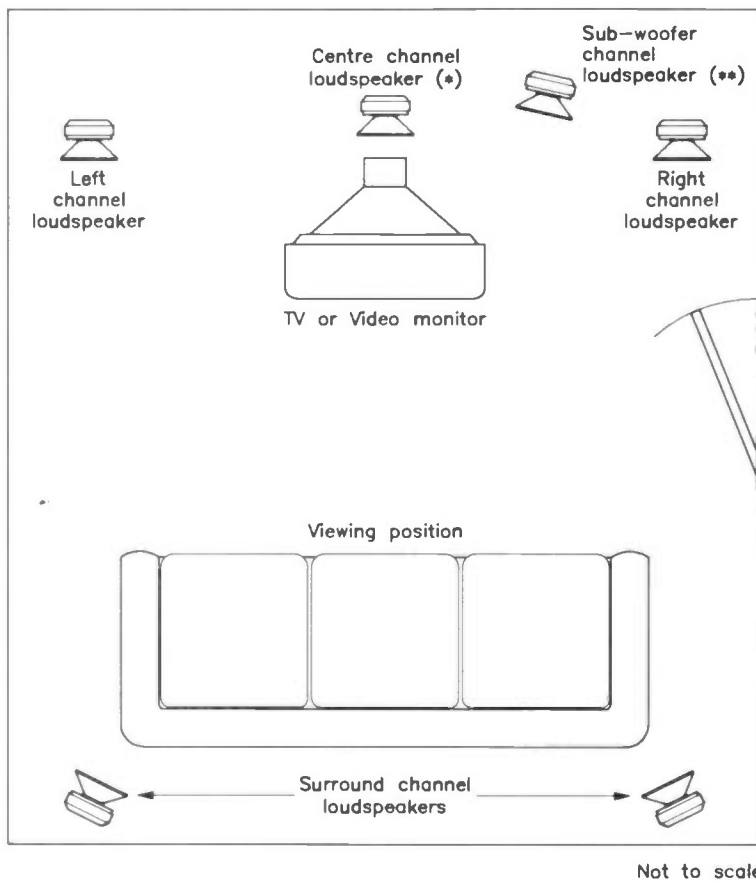

Figure 8. Typical loudspeaker placement in a domestic system.

The outputs from the Dolby Surround decoder are fed to amplifiers; left, centre (if implemented), right and surround, and

to channel loudspeakers positioned around the listening area. A typical room layout, showing loudspeaker positions is shown in Figure 8. Some decoders incorporate amplifiers for directly driving the extra loudspeakers in a Dolby Surround system, the left and right channel signals however, are often reproduced through a separate stereo amplifier and loudspeaker system. Figure 9 illustrates interconnections in a Dolby Surround system.

Dolby Pro Logic Decoder

In today's hi-tech world audio and video systems have taken on literally new dimensions; rear projection video screens are available with picture sizes from 40 to 60 inches and front projection screens with 6 to 12 foot screens. Larger screens are bringing 'The Big Screen' into people's homes, so to match the cinema theatre's professional Dolby Stereo sound system, Dolby Pro Logic was developed. Pro Logic, as previously mentioned, is an active system, the decoder is designed to enhance stereo imagery by using special signal steering techniques.



Photo 6. Long play film multi-platter.

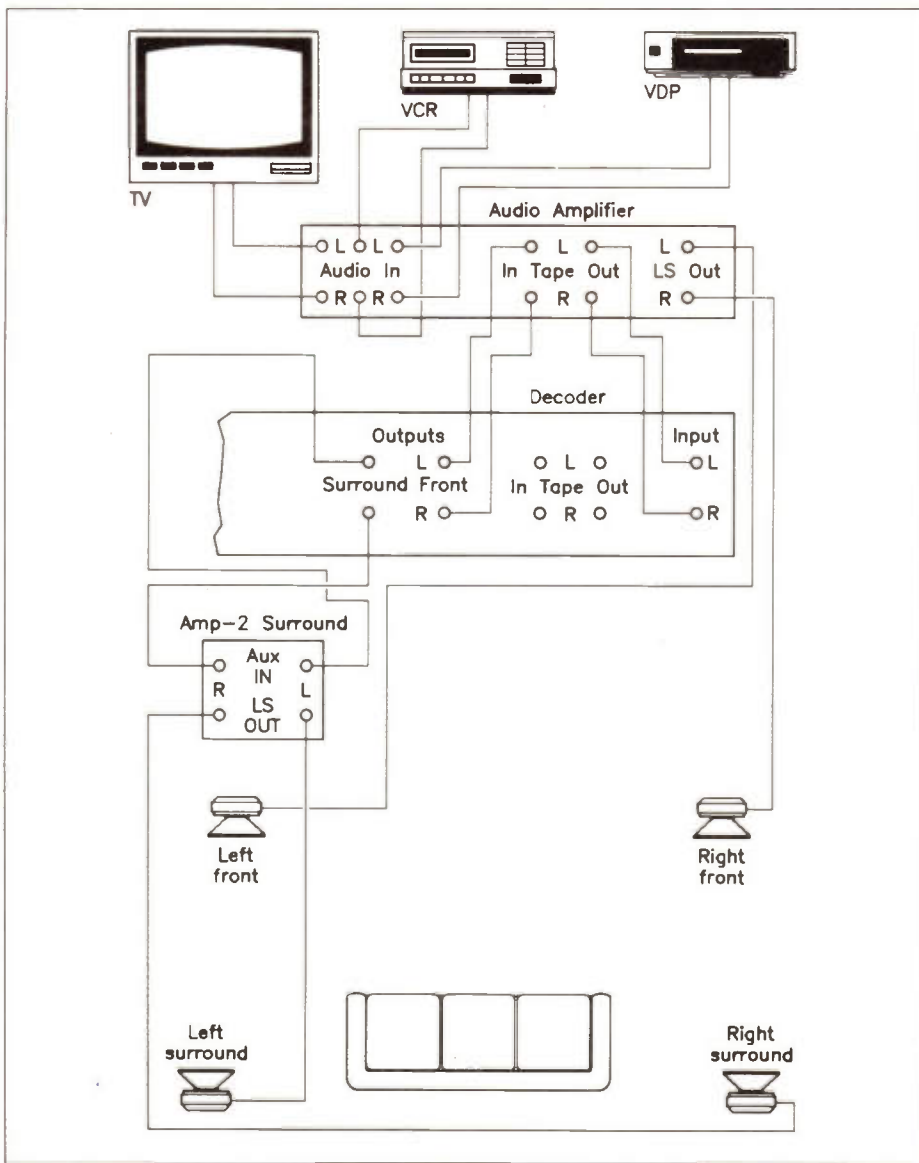

Figure 9. Dolby surround setup.

Passive decoders utilise a simple fixed matrix to extract the surround and, optionally, centre channel signals. The passive decoder maintains good channel separation across the front channels, but it is not possible to obtain the fullest degree of separation from front to surround channels. Active decoders make use of directional enhancement (signal steering) techniques to minimise signal leakage between channels and to increase the listening area. The overall aim is to produce a clearly defined sound field and create directional clues over the whole listening area. Figure 10 shows the overall block diagram of an active Dolby Pro Logic decoder, and it can be seen that there are similarities with the passive Dolby Surround decoder block diagram. As such, with the exception of the adaptive matrix and the noise sequencer, the description for its operation is also similar, and so obviates the need for repetition.

The heart of the Pro Logic decoder is the adaptive matrix, its complexity can be seen from the block diagram in Figure 11. The left and right (Lt & Rt) channel signals fed to the matrix are routed to three areas of circuitry; the analogue control voltage network, the VCA (Voltage Controlled Amplifier) stage and the combining networks. Under unsteered (no directional enhancement) conditions, the outputs from the combining networks are the usual left = Lt, right = Rt, centre = Lt + Rt and surround = Lt - Rt.

The adaptive matrix actively steers signals by adding and subtracting variable amounts of the left and right signal components, so producing the left, right, centre and surround channel outputs, as

Continued on page 69

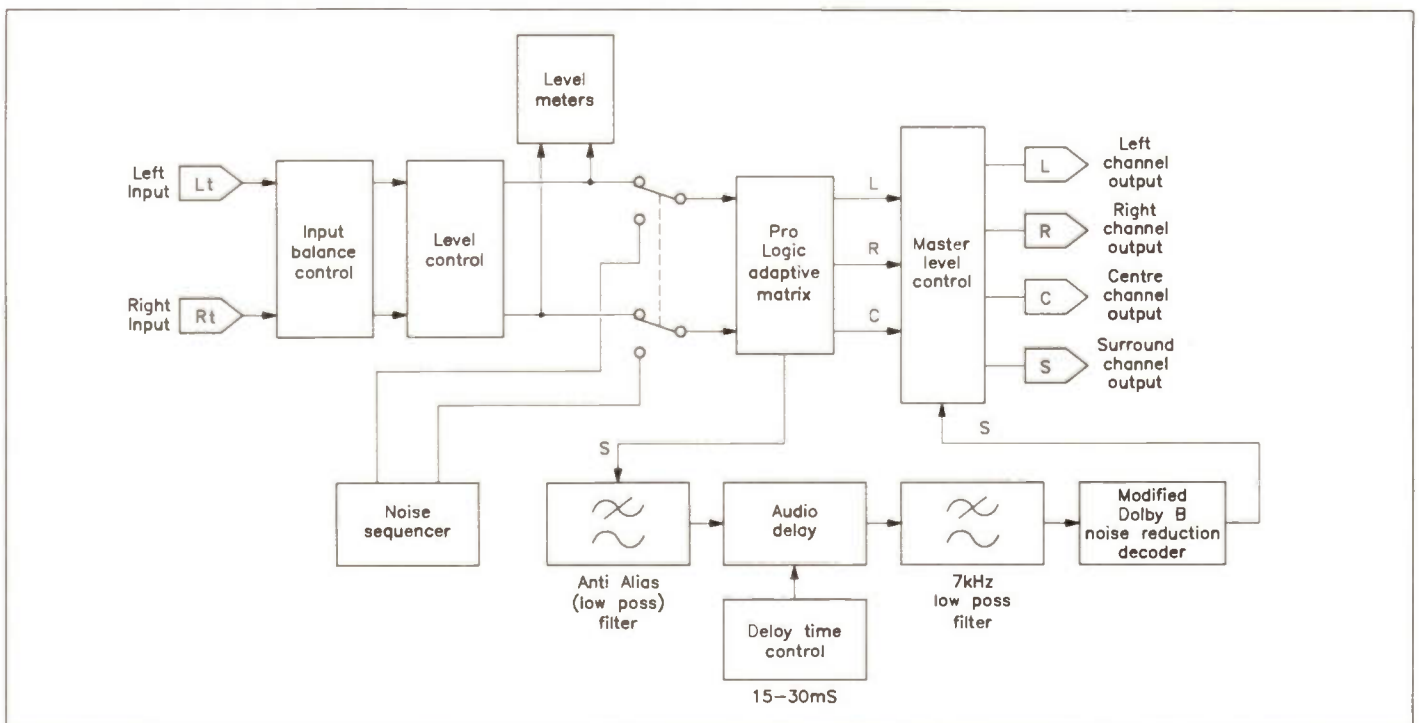

Figure 10. An active Dolby Pro Logic decoder.

LIGHT LEVEL SWITCH

BY GAVIN CHEESEMAN

FEATURES

- ★ Adjustable Trigger Threshold
- ★ Wide Supply Voltage
- ★ Selectable Output State
- ★ Switches Current up to 500mA

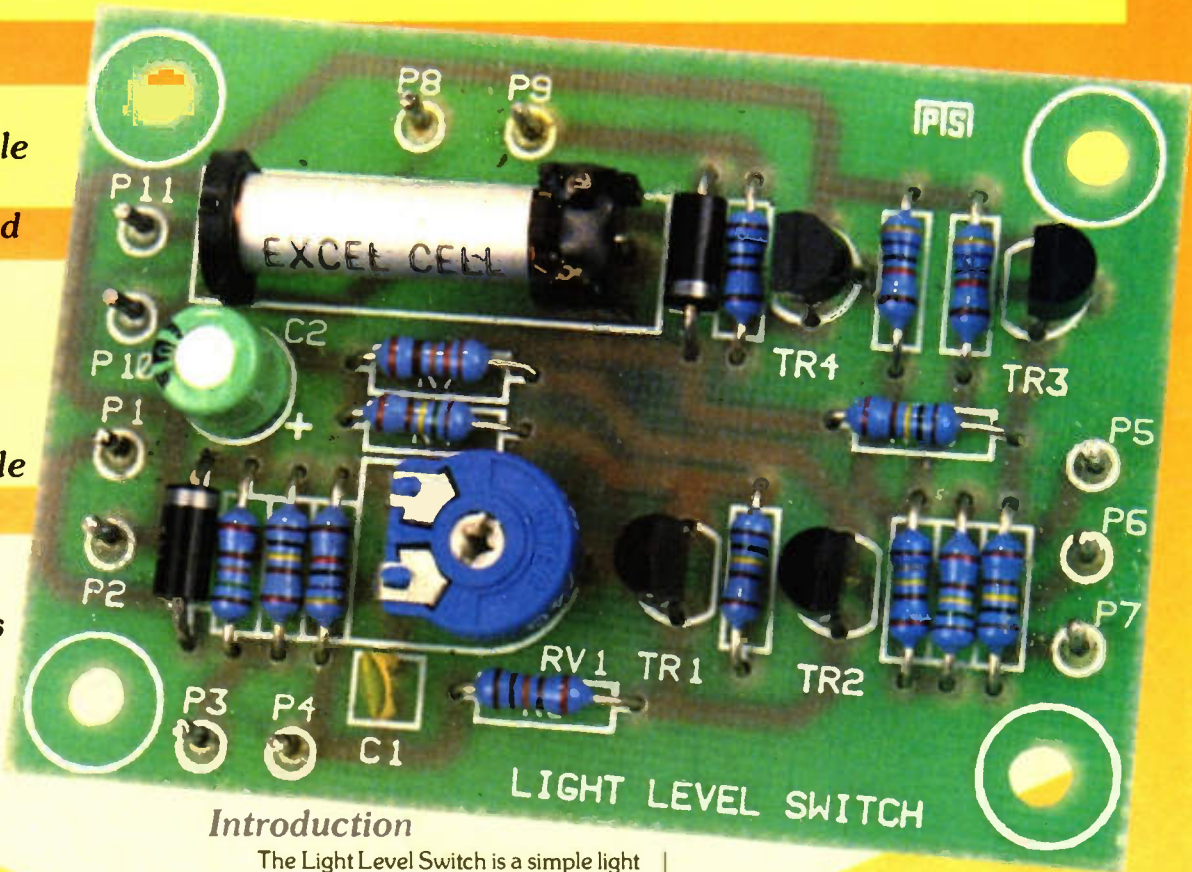

Introduction

The Light Level Switch is a simple light operated switching circuit which operates a relay when the ambient light level rises above or falls below a preset threshold. The module uses an on-board reed relay and is

capable of switching a current up to a maximum of 500mA. A sensitivity control enables different switching thresholds to be set to allow for diverse operating conditions.

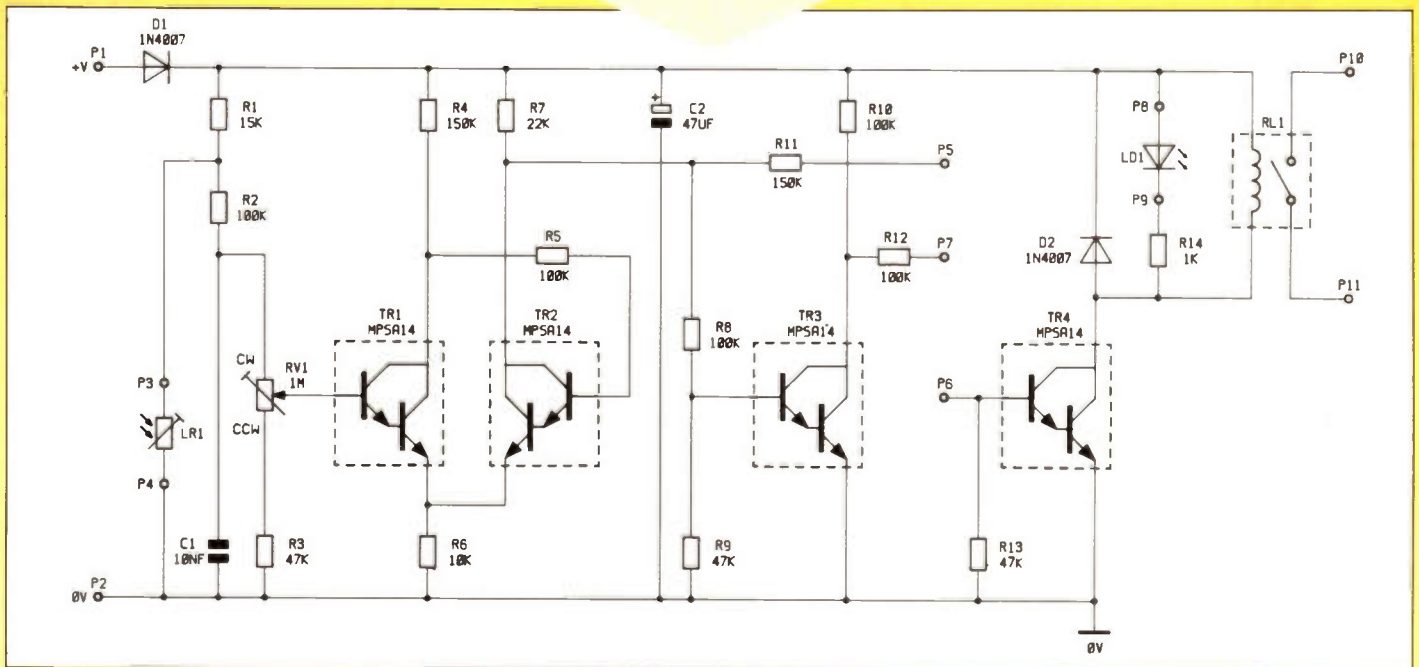

Figure 1. Circuit diagram.

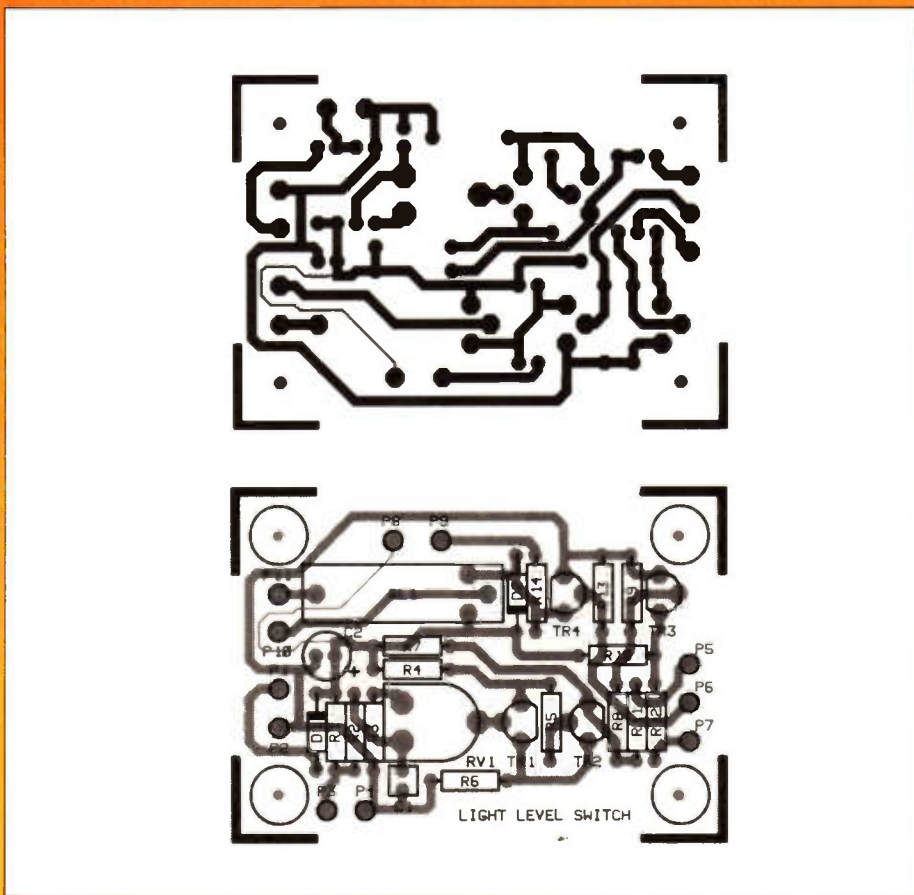

Figure 2. Legend.

Circuit Description

With reference to Figure 1, it can be seen that a light dependent resistor, LR1, forms part of a potential divider network together with resistor R1 and this arrangement provides a voltage which changes with the intensity of light falling on the LDR. The range of voltages produced by the potential divider is determined by the value of R1 and the intensity of light falling on LR1. Capacitor C1 helps to prevent spurious triggering due to high frequency noise. Transistors TR1 and TR2 together with R4 – R7 form a schmitt trigger circuit which provides a pre-determined switching threshold. The circuit must be capable of triggering quickly when the threshold is reached, as changes in ambient light level often take place very slowly and it is not desirable for the circuit to switch on partially during the transition from light to dark or dark to light. A schmitt trigger configuration is an ideal candidate in this case as it possesses a characteristic “snap” switching action. The voltage input level to the schmitt trigger is set by R2, R3 and preset resistor RV1. Darlington transistors are employed in the circuit as they feature a high input impedance and a superior switching characteristic to most single bipolar transistors.

For the circuit to be triggered by either a change from light to dark (normal mode) or from dark to light (inverted mode), it is necessary to include a selectable inverter between the schmitt trigger circuit and output drive transistor TR4. A single pole double throw (SPDT) relay could be used to provide alternative output states but relays typically have a relatively high current consumption which is not desirable in this application. So while transistor TR3 is

used to invert the schmitt trigger output state, a single pole reed relay (RL1) is used as a low current alternative to provide the output switching. Using this method, RL1 is only active when the output is in the 'on' state (P11 switched to P10). Resistors R8 and R9 set the switch-on threshold for TR3, and R10 acts as a load. A 'normal' or 'inverted' output may be selected by connecting either P5 or P7 to P6. Resistors R11 and R12 limit the current to the base of TR4. Diode D2 prevents any high voltage spikes, produced when the relay coil is

de-energised, from damaging TR4. The output state is indicated by light emitting diode LD1 which is illuminated while the relay is active. Resistor R14 limits the current through the LED. Capacitor C2 de-couples the supply rail and diode D1 helps to prevent damage to the circuit if the power supply is accidentally reversed.

Construction

Insert and solder the components onto the printed circuit board referring to the legend (see Figure 2), starting with resistors R1 – R14. Next fit the reed relay RL1; some care is needed when fitting this component as the leads can be easily broken if excessive force is used! Similar precautions should be exercised when fitting preset resistor RV1. When fitting capacitor C2, remember that this is of the electrolytic type and therefore must be inserted with observation for the correct polarity; the negative lead, indicated by a minus (–) sign on the case, should be inserted away from the positive symbol on the PCB legend. Next insert and solder diodes D1 and D2, ensuring that the band at one end of each diode corresponds with that on the legend.

Caution is required with all semiconductors to make sure that they do not become overheated during soldering and that they are fitted observing the correct polarity. Transistors TR1 – TR4 are inserted so that the case corresponds with the outline on the legend. Press the PCB pins into position using a hot soldering iron; it is necessary to heat each pin for a few seconds before insertion to allow it to fit into the hole correctly. When the pin is at the correct temperature, only very light pressure is required to push it into position. Once in place, the pins can then be soldered. Before testing the module, it is a good idea to check your work to make sure that there are no dry joints or solder short circuits! For further information on construction techniques and how to solder, refer to the constructors' guide included in the kit.

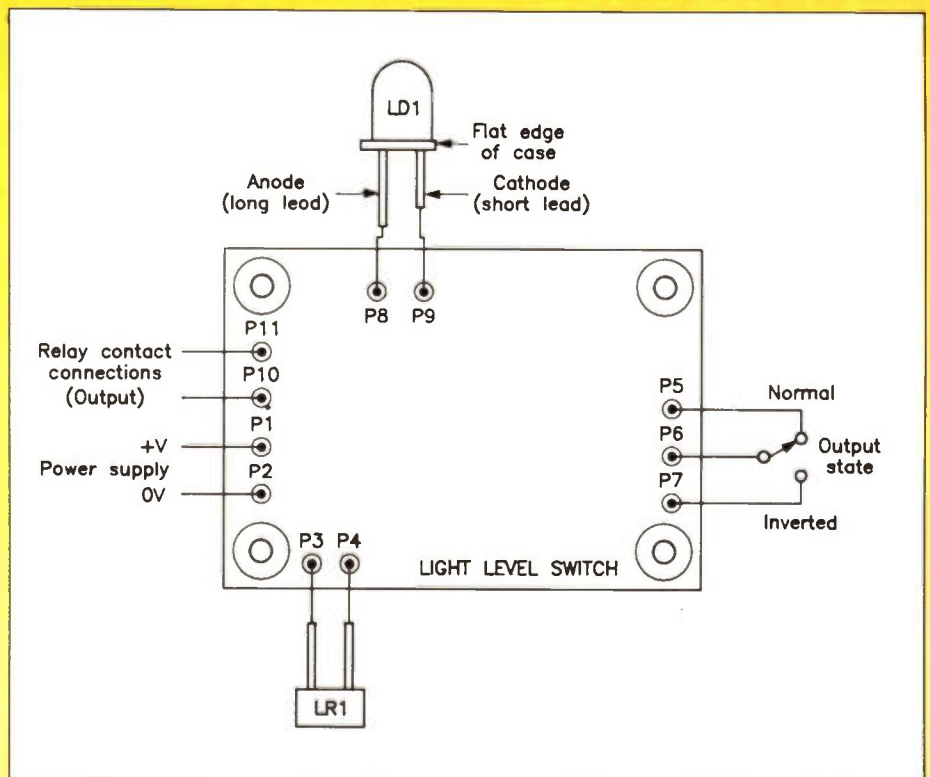

Figure 3. Wiring diagram.

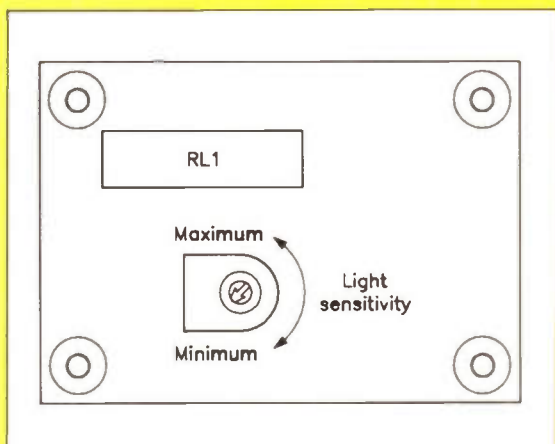

Figure 4. Adjustment of RV1.

Power Supply

The module is designed to operate from a +9V to 14V power supply. It is important that the supply is *stable and adequately smoothed* to prevent any problems with false triggering or unreliable operation. Current consumption depends on the output state and is at a maximum when RL1 is in the 'on' state. The maximum current drain is approximately 19mA (at 12V) with the relay active.

Testing

Figure 3 shows the wiring diagram for the module. LD1 can either be wired directly to the appropriate pins on the PCB or it may be remotely connected via a pair of wires. The anode of the LED is connected to P8 and the cathode (marked by the flat edge of the LED and the short lead) is connected to P9. Light Dependent Resistor LR1 is connected between P3 and P4 and is not a polarised device; once again, this component may be mounted on extended leads but in this case the leads should be kept as short as possible to prevent external noise pick-up. Screened lead (such as XR16S) can be useful for preventing pick-up problems and if this type of cable is used, the inner conductor should be connected to P3 and the screen to P4; however, in most cases the LDR leads can be soldered directly to the PCB pins.

The power supply is connected between P1(+V) and P2(0V). If a multi-meter is available it is a good idea to check

the resistance between the power supply pins to make sure that there are no short circuits; the resistance may start at a relatively low value if C2 is discharged but the value should increase rapidly as the capacitor begins to charge. The resistance between the pins should exceed at least 1000Ω within a few seconds. Because of the directional characteristic of diode D1, the resistance reading obtained will also be dependent on the polarity of the meter probes (which are often not what you might expect!) so if you are not sure, try the test with both polarities.

It is best to test the module in daylight, although bright, white electric lighting can be used. In order to test the unit, P6 is initially linked to P5 and preset resistor RV1 is set to the fully clockwise position. When power is applied to the module and light is allowed to fall on LR1, light emitting diode LD1 should remain extinguished; however, if LR1 is covered such that no light falls on the sensitive surface, LD1 should light and RL1 should activate. Remove the link between P5 and P6 and link P6 to P7. In this configuration LD1 should light and the relay should activate when light is falling on LR1. If LR1 is then covered to prevent light from falling on its sensitive surface, LD1 should extinguish and the relay should switch off. RV1 controls the sensitivity threshold of the module and it will be found that the level of light required to trigger the circuit increases as RV1 is rotated clockwise (see Figure 4).

Power supply voltage	9V – 14V
Power supply current (maximum)	19mA at 12V
Maximum voltage between P10 and P11	50V
Maximum current through contacts (P10 and P11)	500mA
Maximum switching power (P10 and P11)	10VA

Table 1. Specification of Prototype Light Level Switch.

Using the Module

The light level switch is an open ended module which can be used in a wide variety of applications requiring a light activated switch: for example the module may be used to automatically switch on lighting when the daylight falls below a certain level or as part of a system to automatically open and close blinds or curtains.

The unit is capable of switching current up to a maximum of 500mA using the on-board relay: for current levels exceeding this the module could be used to switch an external relay which is suitable for higher power applications. Also the module should not be used to directly switch voltages exceeding 50V or power exceeding 10VA.

It will be necessary to set the sensitivity control for optimum performance in the particular application where the unit is being used and the best setting will be determined by the light level at which the module is required to switch. Because of the hysteresis characteristic of the circuit, the switch-on and switch-off thresholds will be different and this must be taken into consideration when choosing the best setting for RV1.

If required a single pole double throw switch can be connected to the output state select pins (P5, P6 and P7) to enable either the normal or inverted output state to be selected as necessary; a suitable switch for this purpose is Maplin stock code FH00A. Finally, Table 1 shows the specification of the prototype Light Level Switch.

LIGHT LEVEL SWITCH PARTS LIST

RESISTORS: All 1% 0.6W Metal Film

R1	15k	1	(M15K)
R2,5,10,12	100k	4	(M100K)
R3,9,13	47k	3	(M47K)
R4,11	150k	2	(M150K)
R6	10k	1	(M10K)
R7	22k	1	(M22K)
R8	180k	1	(M180K)
R14	1k	1	(M1K)
RV1	1M Hor. Encl. Preset	1	(UH09K)
LR1	ORP12 Light Dependent Resistor	1	(HB10L)

CAPACITORS

C1	10nF Ceramic	1	(WX77J)
C2	47µF 16V Minelect	1	(YY37S)

SEMICONDUCTORS

TR1-4	MPSA14	4	(QH60Q)
D1,2	1N4007	2	(QL79L)
LD1	LED Red	1	(WL27E)

MISCELLANEOUS

RL1	Reed Relay 12V SPST	1	(JH13P)
P1-11	Pins 2145	1 Pkt	(FL24B)
	Constructors Guide	1	(XH79L)
	P.C. Board	1	(GE34M)

A complete kit of parts is available:
Order As LP14Q (Light Level Switch Kit) Price £5.95
 The following item is also available separately, but is not shown in our 1990 catalogue:
Light Level Switch PCB Order As GE34M Price £1.98

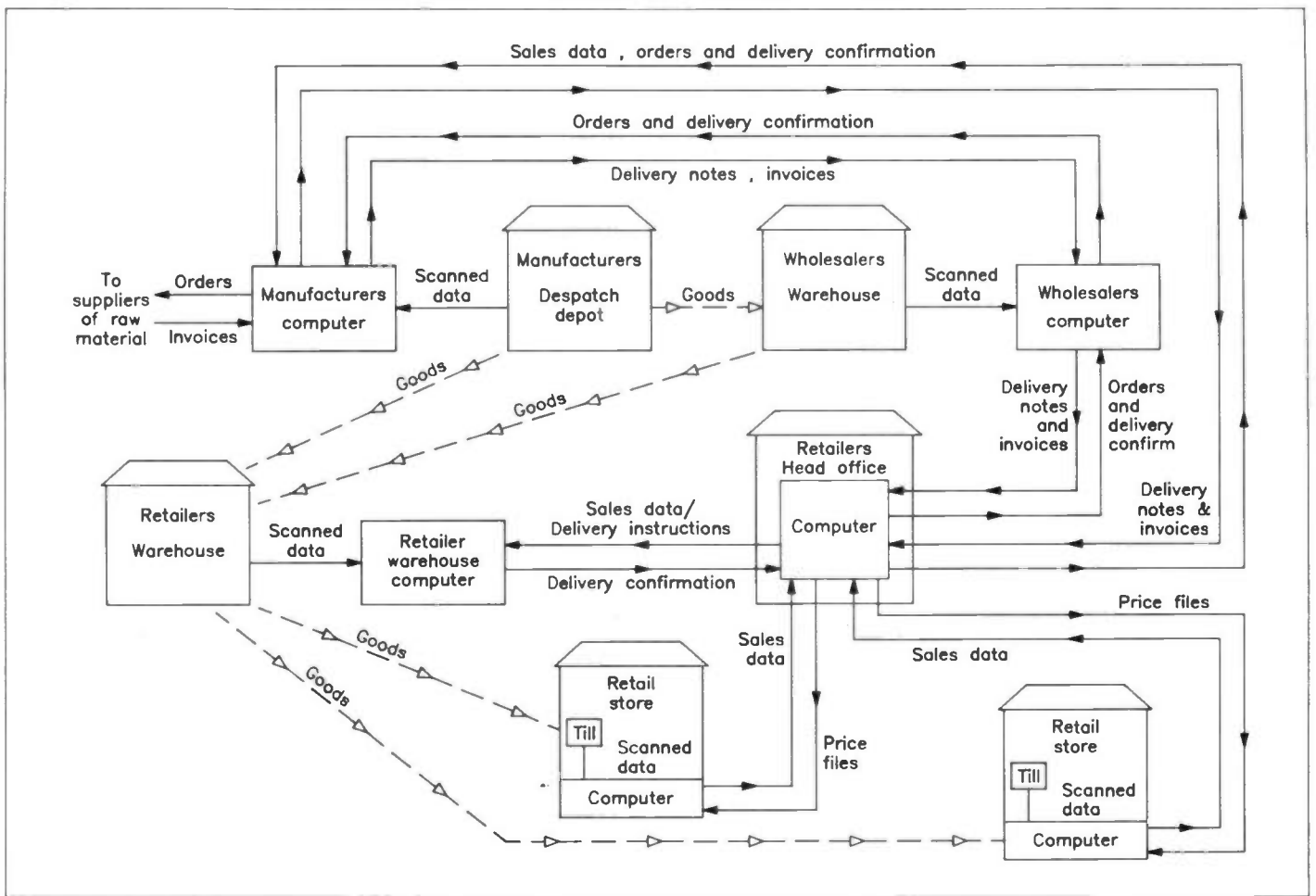

Figure 1. Typical EPOS system.

Introduction

This article takes a look at Barcodes and 'EPOS' (Electronic Point of Sale) and how it is now part of our everyday life.

When supermarkets first appeared in Britain in the 1950s it is unlikely that anyone could foresee the size that these stores would reach. Indeed, the idea of selling hardware as well as foodstuffs on a 'pick and mix' basis would have been thrown out of the window. We now know differently of course. The psychology of serving yourself, coupled with the reduction in manpower (sorry! person power) needed has reorientated the shopping

habits of most of us. The problem now being one of getting our provisions paid for and through the checkout and into our freezers before they have 'gone off' due to the queue. It has been known for people to abandon their selections in the trolley out of sheer frustration. Obviously something had to be done to speed up the flow of goods through the checkout, without sacrificing the accurate totalisation of the bills. The solution for this, as we now know so well, is the barcode!

EPOS

To put the matter into perspective, take a look at Figure 1 which sets the scene on how we get our 'daily bread', and DIY goodies. From this you can see that the customer checkout is very much the tip of

BARRED FOR

by Derek Vaughan (G3RQG)

the iceberg of manufacturing and distribution procedures. As a matter of interest, barcoding is also used in controlling the movement of all the bulk quantities of goods, but in this article we will concern ourselves with the retailing or 'point of sale' versions of the barcode, and hence EPOS.

EPOS being an acronym viz Electronic Point of Sale.

The benefits of using EPOS are manifold, in as much as not only does it keep the checkout queues moving, it also provides a multitude of statistical information regarding which lines are selling best, which are the slow movers, automatic stock replenishment ordering back to central stores, time of day/week when staff can be best utilised, less 'shrinkage' of stock etc. The success of this highly sophisticated system being dependent upon a postage stamp size pattern of lines printed on the product label! Incorporating the symbol at the same time that the label is printed by existing methods incurs no extra costs when many thousands are produced. This is just one of the ways that Barcodes score over alternative systems. Any competent printing house can print a readable code provided that the ground rules are followed. It requires the superimposition of 'dark' bars on a light background in acceptable colour combinations, together with modular structures which will be explained.

So what is so special about the information contained in this printed symbol? Just this. Its structure provides a unique set of details relating to the item enclosed in a particular package, i.e. the country of origin, the supplier's name, the nature of the product, and the price set by the store, e.g. Country of origin: 50 = UK, Company name: 12345 = Sainsco, Product in pack: 57 = beans, Amount contained: 8 = 400gms, Price set: 92 = 42 pence. The 13th digit is a check digit, and it is derived by applying an algorithm to the preceding numbers. This check digit ensures that the code is correctly structured, in much the same way that numbers on credit cards etc. are validated, see Figure 2.

Magic Wand

By scanning a beam of light across the symbol, and detecting the varying amount of reflection and absorption obtained, corresponding electrical signals can then be fed into a suitable processor for digital interrogation, this process being known as reading, scanning, or swiping if it is done with a hand held light-pen (wand).

The actual dimensions of the symbols were agreed internationally, and where possible the symbol is printed at 'nominal size' or 'magnification factor unity'. It is not uncommon of course to see symbols smaller than the nominal size, as some goods are by nature very small, but smaller printing needs closer control of the associated tolerances.

In essence, the EAN code (European Article Number) is represented by a collection of 13 numerals. Each numeral being encoded by 7 modules. Modules can either be dark or light, and their binary equivalents being 1 or 0 respectively. See

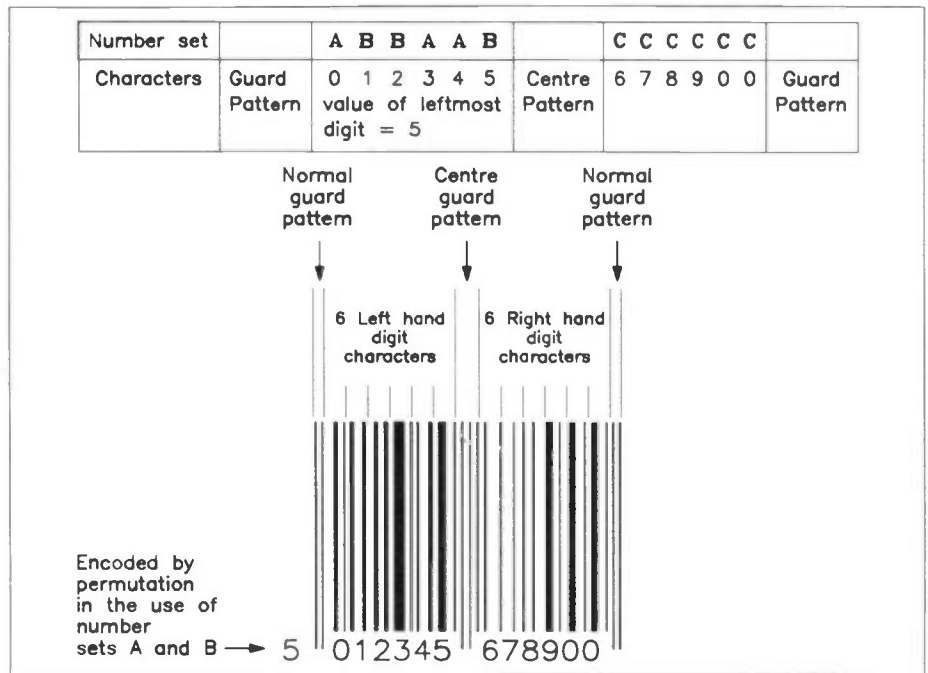

Figure 2. Typical barcode.

Value of Digit	Set A	Set B	Set C
0	LLDDLD	LDLDDD	DDLLDL
1	LLDLDL	LDDLLD	DDLLDD
2	LDLDDL	LLDDLDD	DDLDLL
3	LDDDDL	LDLLLL	DLLLLD
4	LDLDDL	LLDDDL	DLDDLL
5	LDDLLL	LDDLLD	DLDDDL
6	LDDDDD	LLLLLD	DLDDLL
7	LDDDLDD	LLDLDD	DLLDLL
8	LDDLDDD	LLDLDD	DLLDLL
9	LLLDLDD	LLDLDD	DDLDLL

Table 1. Number set discipline.

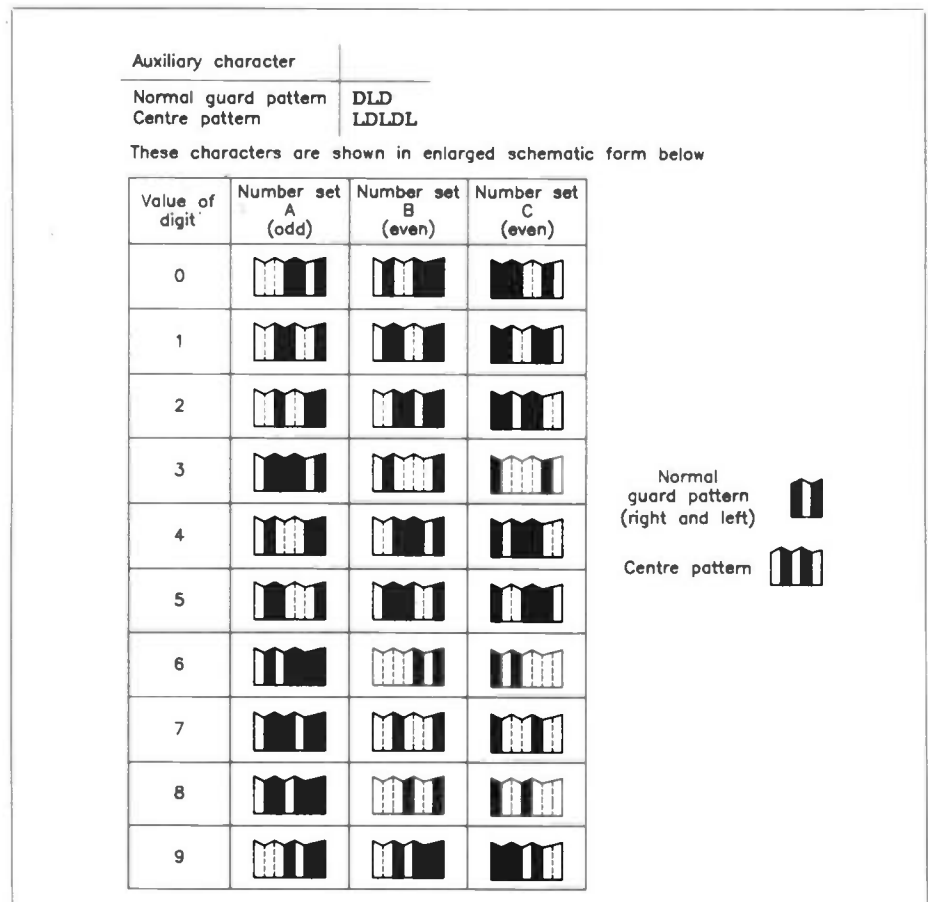

Chart 1. Number set patterns.

SWITCHED MODE POWER CONVERSION

The Secrets Revealed!

Part One by Robert Ball A.M.I.P.R.E.

Introduction

To many people involved in the field of electronics, the Switched Mode Power Supply (SMPS) is a familiar item. This family of power supplies and power conversion units find many uses in domestic, professional and industrial applications. Switched mode power supplies may commonly be found in televisions, video recorders and computers. Even though they are in widespread use, the switched mode power supply is still something of a 'black box' to many engineers. In this series I will describe the operational principles and applications of various common switched mode topologies and hopefully shed some light on this 'electronically taboo' subject.

Linear Versus Switched

It is worthwhile to outline a few fundamentals of power supplies, how linear and switched mode supplies differ and the advantages and disadvantages of both families.

Essentially, a power supply is a device which provides a source of electrical power to operate a piece of electrical or electronic equipment. More specifically, power supplies take the form of a unit (either integral or external to the powered equipment) which converts electric current from one 'form' to another. For example, 240 volts AC mains to 5 volts DC, which might be used to power a digital circuit. The circuitry within the power supply is likely to provide protection and regulation. The protection

circuitry prevents damaging or dangerous conditions occurring if a fault or overload develops. The regulation circuitry ensures that the output of the power supply remains constant under varying input and output conditions. The way in which the control device within the power supply operates can be categorised into two types; linear and switched mode.

Linear Power Supply

Commonly, power supplies are of the step-down type, which as the name implies, accept a high voltage input and provide a low voltage output. Figure 1a shows a circuit diagram of a step down linear power supply. Figure 1b illustrates operation in block diagram form. The input to the power

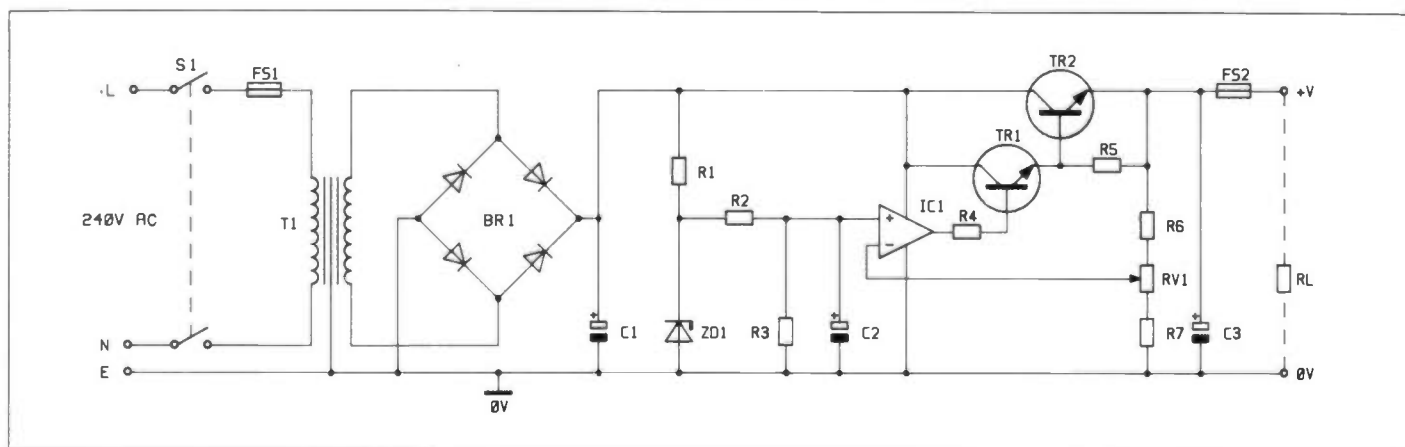

Figure 1a. Circuit Diagram of a Linear Power Supply

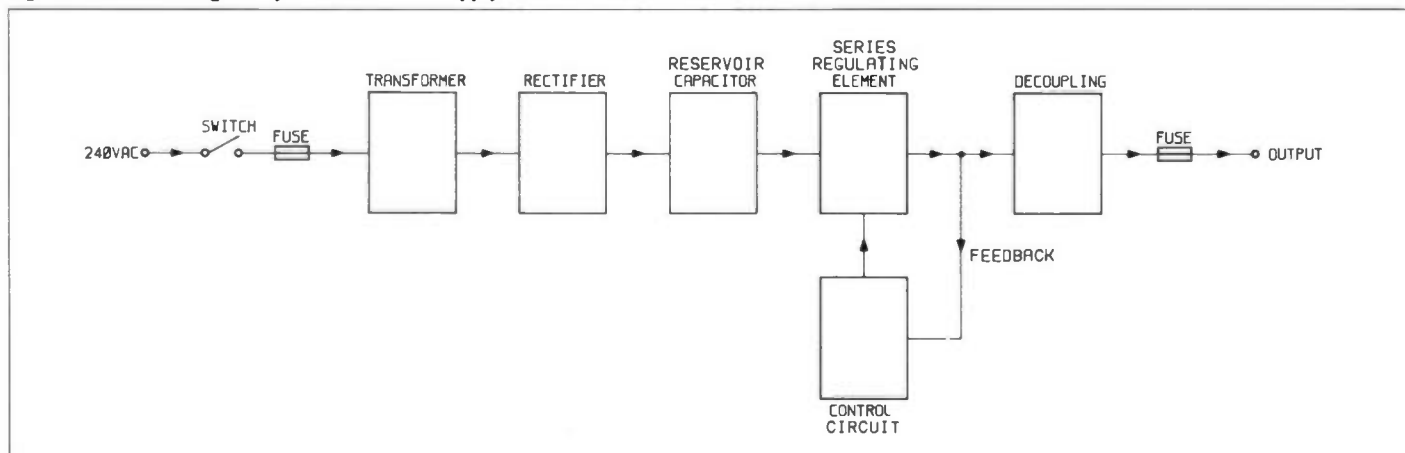

Figure 1b. Block Diagram of a Linear Power Supply.

supply is 240V AC mains, this is fed via the on/off switch S1, through fuse FS1, to the primary of the step-down transformer T1. The AC output from the secondary of T1 is bridge rectified by BR1 and the resulting rectified waveform is fed to the reservoir capacitor C1. TR1 and TR2 are configured as a darlington pair, where TR1 drives the power device TR2. TR1/TR2 act as a series pass element, the degree of conduction is varied by the control circuit. The control circuit, centred around IC1 (an operational amplifier), monitors the output voltage via a potential divider network (R6, RV1 and R7) and compares it with a reference voltage. The reference voltage is provided by R1, ZD1, R2, R3 and is decoupled by C2. If the output voltage tries to rise or fall from its determined level, set by RV1, the control circuit detects the change and varies the conduction of TR1/TR2 to counteract the change. TR1/TR2 operate in the linear mode (i.e. continuous conduction between cut-off and saturation). C3 decouples the output and fuse FS2 protects against overload or short circuit. The regulation circuitry (TR1/TR2 and the control circuit) can be contained in a single device which greatly simplifies circuit design. Devices of this type are the '78XX' (positive supply) and '79XX' (negative supply) series of monolithic regulators. These and other similar regulators may be found, together with application circuits, on pages 451 and 452 of the 1990 Maplin catalogue.

Advantages and Disadvantages of Linear Power Supplies

The advantages of linear regulators are simplicity, good regulation and low output noise. The main short coming of linear regulators is inefficiency, this being due to the power dissipation in the series pass element. A few simple calculations illustrate this. For example: input voltage to TR2 (of Figure 1a), 18V, output voltage 12V, output current 1.5A.

Input power	= $V_{in} \times I_{in}$ = 18×1.5 = 27W ($I_{in} = I_{out}$).
Output power	= $V_{out} \times I_{out}$ = 12×1.5 = 18W.
Power TR2	= $(V_c - V_e) \times I_{out}$ = $(18 - 12) \times 1.5$ = 9W.
Efficiency	= $(P_{out}/P_{in}) \times 100$ = $18/27 \times 100$ = 66%.

It can be seen that 34% of the input power is wasted as heat, this also means that TR2 must be mounted on a suitable heatsink to prevent TR2 from overheating. The problem of power dissipation and efficiency gets worse as input voltages rise. In most cases where output power requirements are small, inefficiency and heat is not a problem. However as output power rises, linear regulators become less and less viable.

It should also be noted that linear regulators can only provide output voltages lower than the input voltage (unless used with a step-up transformer and AC input).

Switched Mode Power Supplies

Certain applications, such as aerospace and avionics equipment, may require a high power, high efficiency and compact power supply and in these applications linear circuits do not satisfy the requirements. In such cases switched mode power supplies are used. As a product of the research and development by manufacturers of switched mode power supplies, the cost consideration has reduced considerably, the result being improved circuit techniques and the availability of components engineered for switched mode use. This type of power supply is now becoming common in less stringent applications.

Basic Principles

The principles which switched mode power supplies use to provide power conversion and regulation are entirely different to linear circuits. Linear circuits work by varying the degree of conduction of a control element whilst switched mode circuits work by varying the duration that an electronic switch is closed. Switched mode power supply circuits work at high frequencies, commonly over the range 25kHz to 250kHz, but operating frequencies up to 1MHz may be encountered. The use of high switching frequency allows the use of (electrically and physically) smaller components. The largest capacitors will

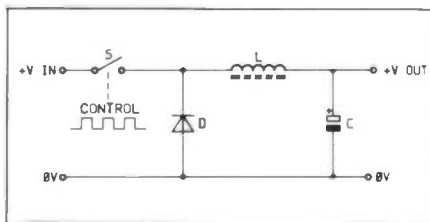

Figure 2a. A Forward Regulator.

normally be the output capacitors, as the ripple frequency is higher in a switched mode supply than for a mains powered linear supply, a smaller value may be used. Similarly, inductors and transformers will be much smaller. This has a three-fold advantage in terms of cost and overall physical size and weight.

There are two main groups of switching circuits:

Switched Mode Regulators

This type of switching circuit provides regulation and conversion of a DC input voltage. The DC output may be of the same or opposite polarity to the input and the output may be lower or higher in voltage than the input. Switched mode regulators employ an inductor and do not provide input to output isolation.

Switched Mode Converters

This type of switching circuit provides

single or multiple DC outputs from a DC input. These outputs may be a combination of output voltages higher and lower than the input and may be of the same and opposite polarity. For example the outputs could be +5V, +12V and -12V. Switched mode converters employ a transformer and often provide input to output isolation.

A power supply using switched mode conversion circuits and/or switched mode regulation circuits is termed a switched mode power supply. Initially we shall deal with the basic switched mode regulator topologies and later on deal with switched mode converters and complete power supplies.

The basic circuit of a switched mode regulator is shown in Figure 2a. It accepts a DC input voltage, V_{in} , and regulates the DC output, V_{out} . The circuit maintains V_{out} under varying V_{in} and load current conditions. The regulation characteristics are more difficult to optimise than for a linear regulator, but its efficiency is higher. Unlike linear regulators, switched mode regulators maintain high efficiency when used with high input voltages. Switched mode regulators of this type are ideally suited to applications which require low voltage, high current outputs from a high input voltage.

The key to the high efficiency is the way in which an electronically controlled 'switch' (power transistor) is operated; it is turned on and off at high speed. Regulation is achieved by varying the duty cycle (mark/space ratio) of the controlling drive signal. Because the 'switch' is either fully on (saturated) or fully off, except for the very brief commutation time, the power dissipation is minimal. This can be shown as follows, with a few theoretical values:

Switch 'ON':

$$\begin{aligned} \text{Voltage across switch} &= 0V \\ \text{Current through switch} &= 1.5A \\ \text{Power dissipated } P &= I \times V \\ &= 1.5 \times 0 \\ &= 0W \end{aligned}$$

Switch 'OFF':

$$\begin{aligned} \text{Voltage across switch} &= 18V \\ \text{Current through switch} &= 0A \\ \text{Power dissipated } P &= I \times V \\ &= 0 \times 18 \\ &= 0W \end{aligned}$$

Obviously this is an over simplification, as in the 'real world' the switching transistor would have a small voltage across it when saturated and allow a small leakage current when switched off and also requires a finite time to commutate. Even so, the example clearly shows why the efficiency is high.

Forward Regulator

The circuit in Figure 2a is that of a forward ('buck') regulator, switch S represents the power transistor and as described, it is switched on and off at high speed. The resulting output from the switch is pulsed DC, which is hardly suitable for powering electronic circuits! For this reason an LC filter circuit is added to integrate the rectangular pulse to a steady DC voltage.

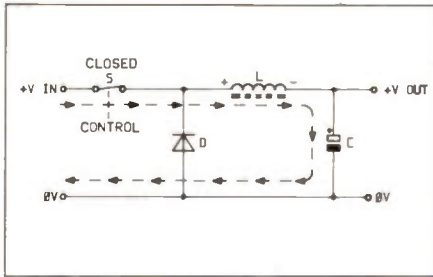

Figure 2b. Current Flow in Forward Regulator – S Closed.

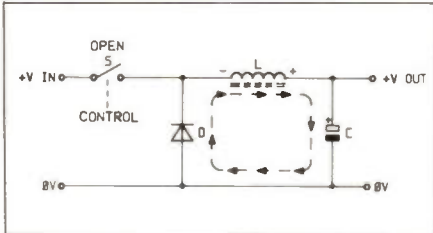

Figure 2c. Current Flow in Forward Regulator – S Open.

Looking at Figure 2b, it can be seen that when S conducts, a current flows through L and charges C. As the current flows the magnetic field in L expands. In Figure 2c, when S commutates, the magnetic field in L collapses, and the polarity of the voltage across L reverses, this forward biases D, causing the current through L to continue in the same direction, releasing the stored energy into C. S conducts again and the cycle repeats. Waveforms associated with

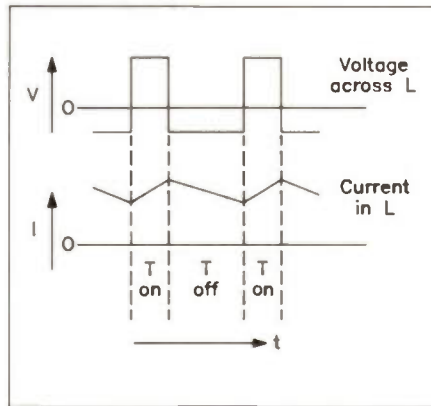

Figure 3. Current Waveforms in Forward Regulator.

the circuit are illustrated in Figure 3.

The output voltage V_{out} equals the average of the waveform applied to the LC filter.

$$V_{out} = V_{in} \times (T_{on}/\tau)$$

where:

T_{on} = conduction time of S

$$\tau = 1/f$$

The control circuit monitors V_{out} and controls the duty cycle of the drive waveform to S.

$$\text{Duty cycle } \alpha = T_{on}/\tau$$

If V_{in} increases, the control circuit will reduce the duty cycle accordingly, so as to

maintain a constant output. Likewise if the load is reduced and V_{out} rises, the control circuit will act in the same way. Conversely, a decrease in V_{in} or increase in load, will cause the duty cycle to be increased.

$$V_{out} = \alpha \times V_{in}$$

Winding It Up

So far we have looked at what power supplies are, and their function. A linear power supply has been examined and we have highlighted its shortcomings. The fundamentals of switched mode power conversion have been explained and we have looked at the forward regulator. In the next part, we will continue by examining the operation of the flyback regulator and the boost regulator, and then take a look at isolated power converters.

References

SGS Power Supply Application Manual. Motorola Power Mosfet Transistor Databook. Unitorde Semiconductor Databook. Unitorde Applications Handbook. Transformer Core Selection for SMPS, Mullard. Soft Ferrites – Properties and Applications, E. C. Snelling. Switchmode – A Designers Guide, Motorola. SMPS – Technology and Components, Siemens. Texas Instruments Linear Circuits Databook. Analogue Electronics Handbook, T. H. Collins.

BARRED FOR LIFE *Continued from page 52.*

Table 1 for the number set discipline, and the accompanying chart with its enlarged views of the respective module grouping.

Note that groups taken from set A always start with a 'light' (0) module, and end with a 'dark' (1) module. Note also that odd parity (i.e. 3 or 5) dark modules are present.

Look now at set B. Note that although the start and finish are light and dark, the number of 1's is either 2 or 4, thus providing even parity.

In set C the groups always start with a dark (1) and finish with a light (0) module, and that even parity (i.e. 2 or 4 1's) is enforced.

This structure ensures the requisite optical separation between any group of numerals, in any combination, and the 'Guard Bars'.

Table 2 shows how the leading digit (5) is encoded by permutation of the number sets in the left half of the symbol.

Note the longer bars positioned at the left and right hand edges of the symbol, and also in the centre. These are known as the 'Guard Bars'. Their purpose is to give signals to the reading device, and the associated software sorting system. The outer guard bars provide 'on' and 'off'

Value of Digit	Number Sets used for coding left half of symbol
0	A A A A A A
1	A A B A B B
2	A A B B A B
3	A A B B B A
4	A B A A B B
5	A B B A A B
6	A B B B A A
7	A B A B A B
8	A B A B B A
9	A B B A B A

Table 2. Coding left half of the symbol.

responses to the light beam, and the code can be read bi-directionally. The centre bars provide a prompt signal, related to the parity change. The areas adjacent to the left and right edges of the symbol are referred to as Light Margins, or Quiet Zones. When a code is read, these margins provide a dwell period where no change in reflection, and hence no change in signal, occur. When the beam strikes the outer guard bar module the resultant signal tells the sorting program to expect the remainder of the

modules to be in pro-rata in widths. This is important, since it is the ratio of the module sizes which is important, and not the absolute dimensions. (The contrast between the dark bars and the background is also important of course to ensure adequate absorption/reflection signal voltages.)

The check digit is calculated by applying a modulo 10 algorithm as follows:-

- (1) Starting with the 12th digit on the right, add all of the alternate digits.
- (2) Multiply the sum obtained in (1) by 3.
- (3) Add all remaining digits.
- (4) Add the result of (2) and (3).
- (5) The check digit is the smallest number to be added to (4) which is divisible evenly by 10.

Example (our tin of beans earlier):

501234557892 C

$$1. 2 + 8 + 5 + 4 + 2 + 0 = 21$$

$$2. 21 \times 3 = 63$$

$$3. 9 + 7 + 5 + 3 + 1 + 5 = 30$$

$$4. 63 + 30 = 93$$

$$5. 100 - 93 = 7 \text{ C} = 7$$

The EAN is therefore 5012345578927.

As a point of interest, you will notice that 'Electronics - The Maplin Magazine' now has a barcode on the front cover!

2ND Time Around

CAR BATTERY MONITOR

NEW

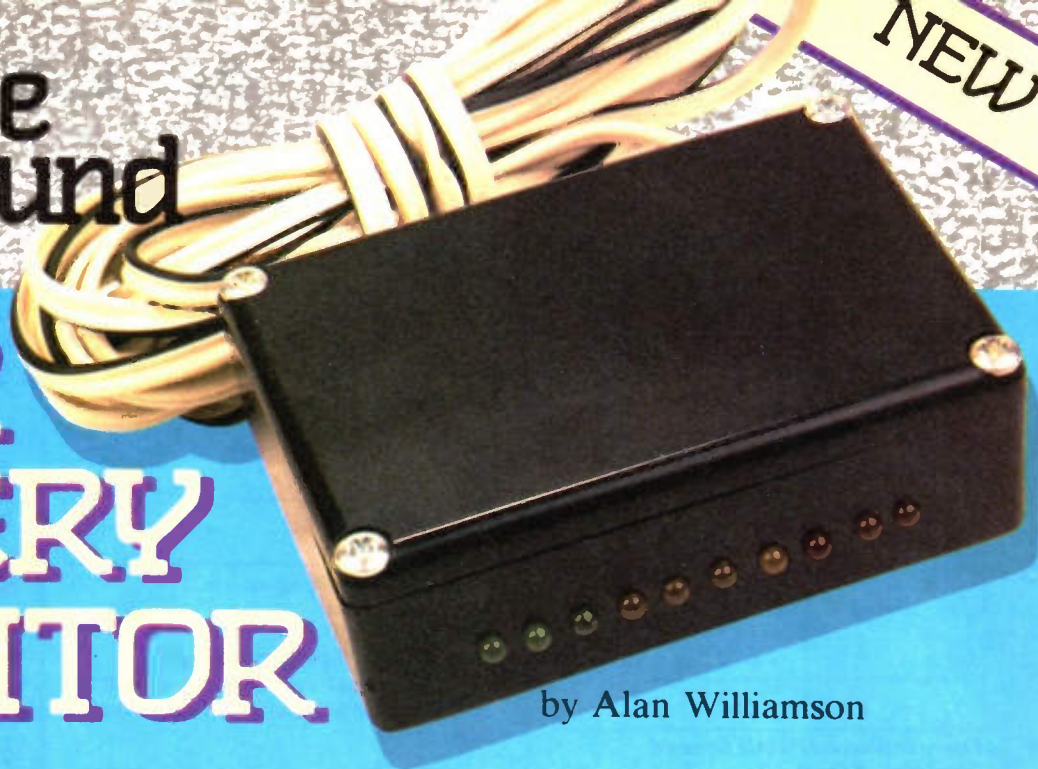

by Alan Williamson

based on a project
by David Hough

Introduction

Many projects from the Maplin range have proved to be very popular over the years. However modern technology and electronic components have a habit of changing, with the result that some of these projects are in danger of becoming obsolete as the originally specified components become unavailable or standards change. In order for some of the more popular projects to remain available, updates and improvements are necessary, and to this end these projects are being reviewed in the series "2nd Time Around". This time it is the turn of the Car Battery Monitor.

Any number of things from a faulty alternator to left-on headlights (or sidelights, even) can result in a flat battery – and the first you are likely to know about it is when you turn the key one morning and the car won't start! The Car Battery Monitor is a useful little unit designed to warn you in advance by displaying the battery's state of charge with a row of ten LED's.

The Monitor consumes a miserly 20mA (it would take 2,000 hours to discharge a 40Ah battery), so it can be left permanently connected to the battery if required. Alternatively it could be connected to the 'ancillaries' side of the ignition switch.

The Car Battery Monitor will even reveal faults like a slipping fan-belt; a problem which prevents the battery from charging properly, but leaves the dashboard battery warning light off. It will even show how the battery is handling the strenuous work of starting the car (did you know it takes some twenty minutes of driving to put back what a five-second start takes out!).

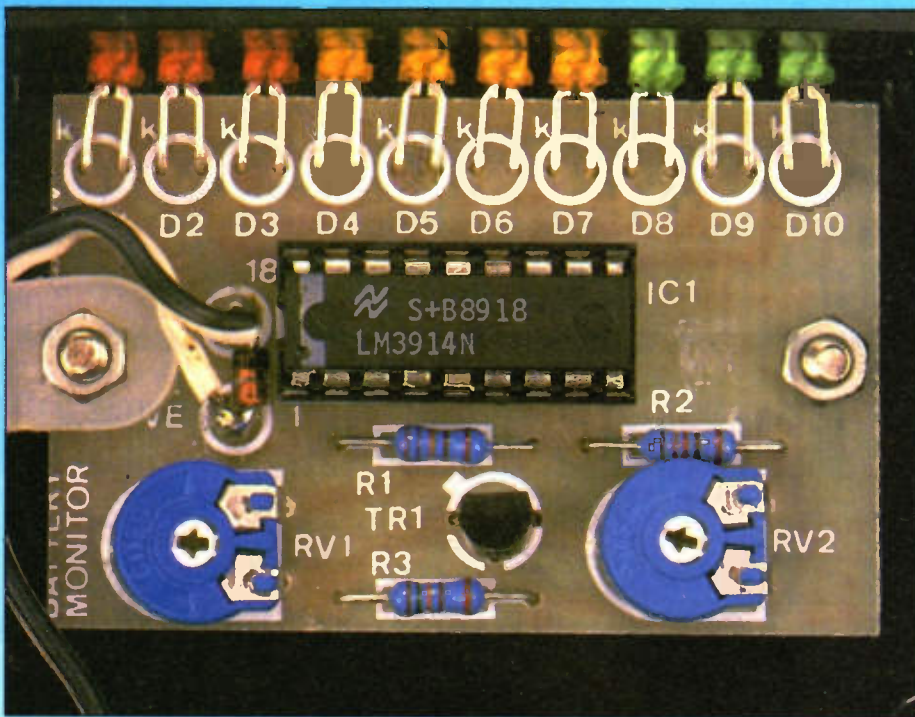

Close-up of the pcb.

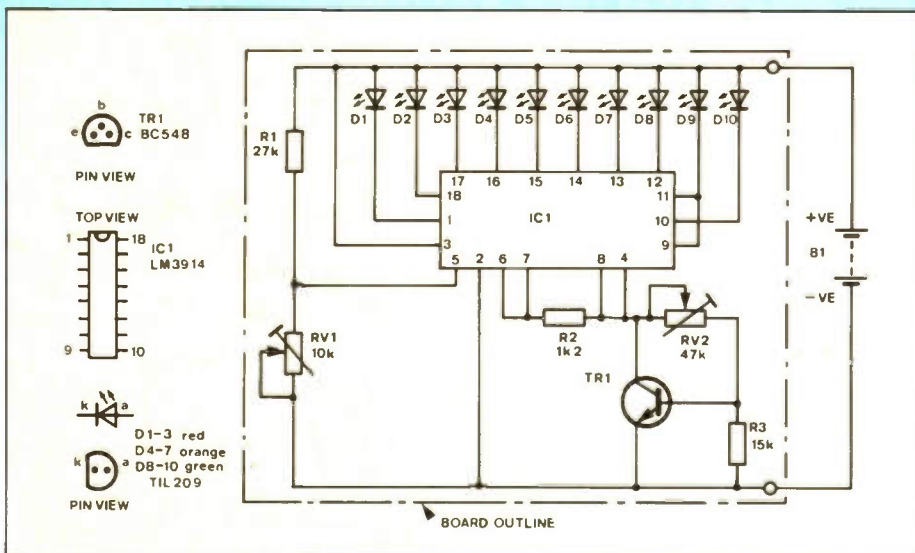

Figure 1. Circuit diagram.

Circuit

The heart of the monitor is the LM3914 bar-graph driver IC, used to drive a row of red, orange and green LED's which together indicate a magnitude of the battery charge voltage in ten steps, approximately $\frac{1}{2}V$ each step from 9V to 14V. The IC contains an input buffer, a potential divider chain, comparators, and an accurate 1.2V reference source. Logic is also included which gives the choice of 'bar' or 'dot-mode' operation – the latter is used in this application. The comparator causes the LED's to light at 0.12V intervals of the input voltage. TR1 acts as an amplified diode, raising the lower end of the divider chain and the negative terminal of the reference source (IC1 pins 4 and 8) to 1.9V. The upper end of the chain at IC1 pin 6 is connected to a reference source output voltage of approximately 3.1V from pin 7. The potential divider formed by R1 and RV1 attenuates the supply voltage and produces the signal input to the comparator, such that a supply range of 9–14V covers the span of the divider chain and is indicated over the whole of the ten segment LED display.

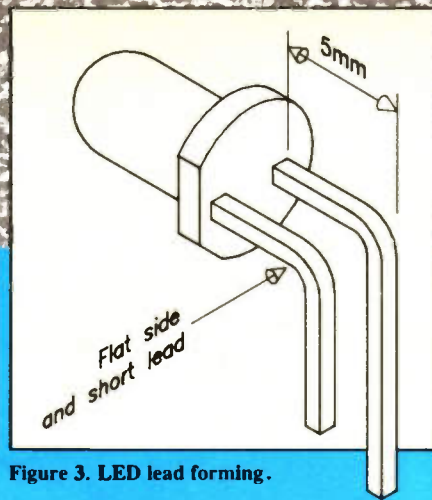

Figure 3. LED lead forming.

The LED brightness is held constant by an internal constant current source.

Construction

If you are a relatively inexperienced project builder then please refer to the constructors' guide supplied with this kit for hints and tips on soldering and constructional techniques.

Construction is straight-forward: first fit the resistors R1 to R3 (solder and crop as you go); next insert the two presets, then fit both veropins from the track side using a hot soldering iron to push them home. Now fit the IC socket and transistor TR1. Please note that the transistor package is *not* the same as the legend on the PCB – see Figure 1 for pin-out details.

Next, identify the polarity of each

LED. Hold the LED with the cathode towards you (the cathode is the shorter lead and adjacent to the flat on the lower side of the package), then with the aid of long-nosed pliers bend the leads downwards through 90 degrees at a point approximately 5mm from the body (see Figure 3). Each LED is inserted from the component side of the PCB and then soldered in position to create a line of LED's at the same distance from the edge of the PCB. Fit in the following order: D1 – D3 red, D4 – D7 orange, D8 – D10 green. Lastly insert IC1 into its socket.

The next job is to drill the holes in the box. Cover the box with masking tape, as this helps with marking out the holes and prevents scratching the box, and it also provides a non slip surface to prevent the drill bit moving. See Figure 4, for hole positions. After having drilled all the holes, the PCB can be fitted into the box using two M3 x 16mm screws, with two M3 x $\frac{1}{4}$ inch spacers under the PCB to position it at the correct height, and the PCB secured with M3 nuts (see Figure 5). The zip wire should now be soldered to the veropins; fit the 'P' clip to the zip wire and

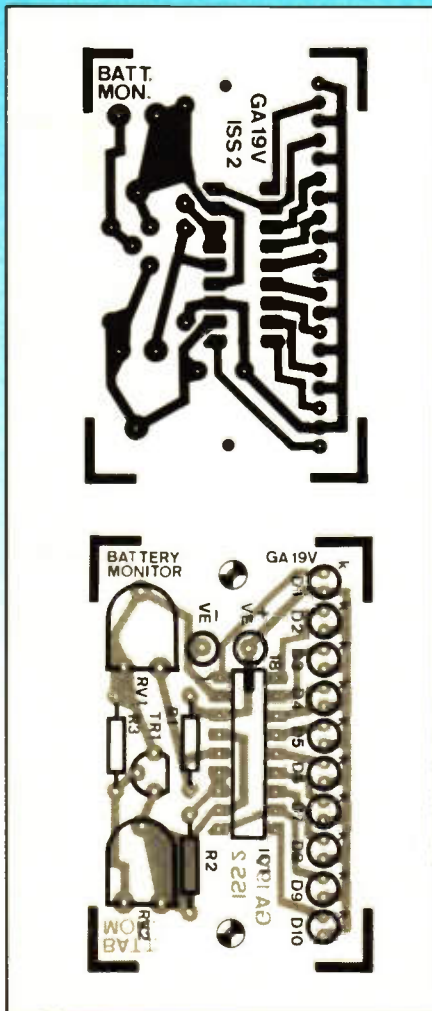

Figure 2. PCB.

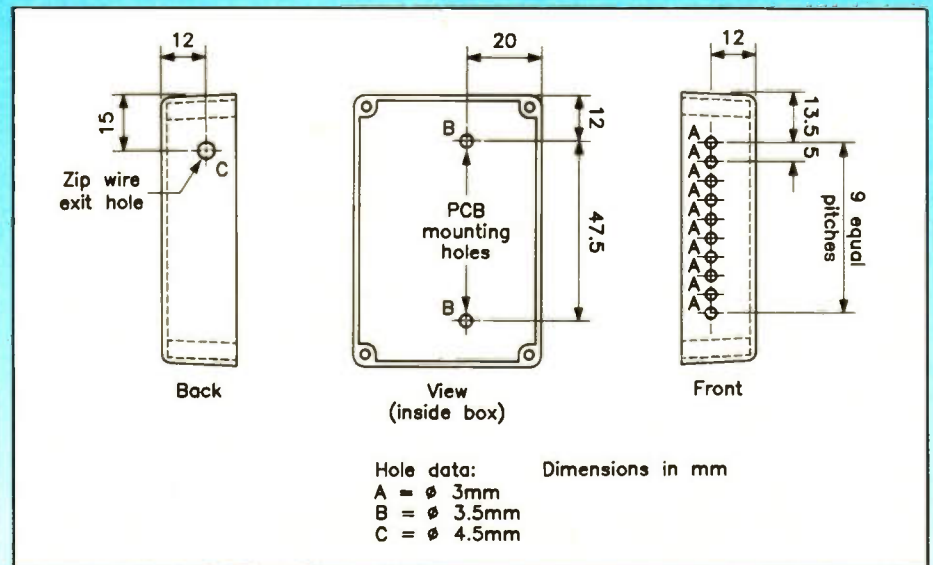

Figure 4. Box drilling details.

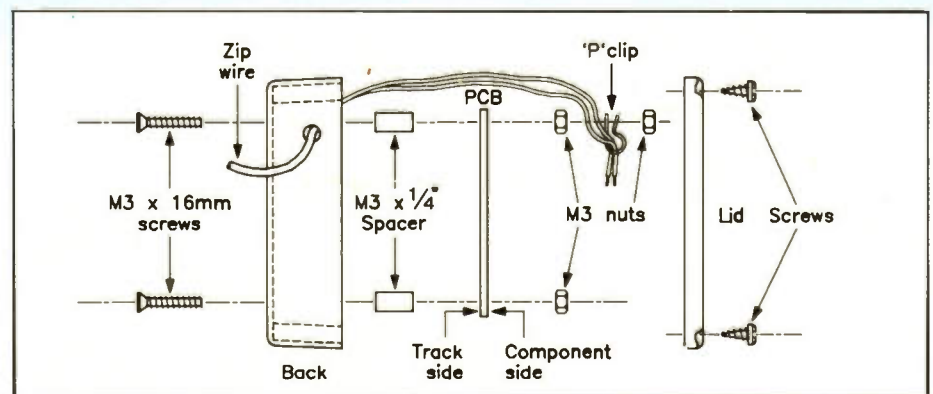
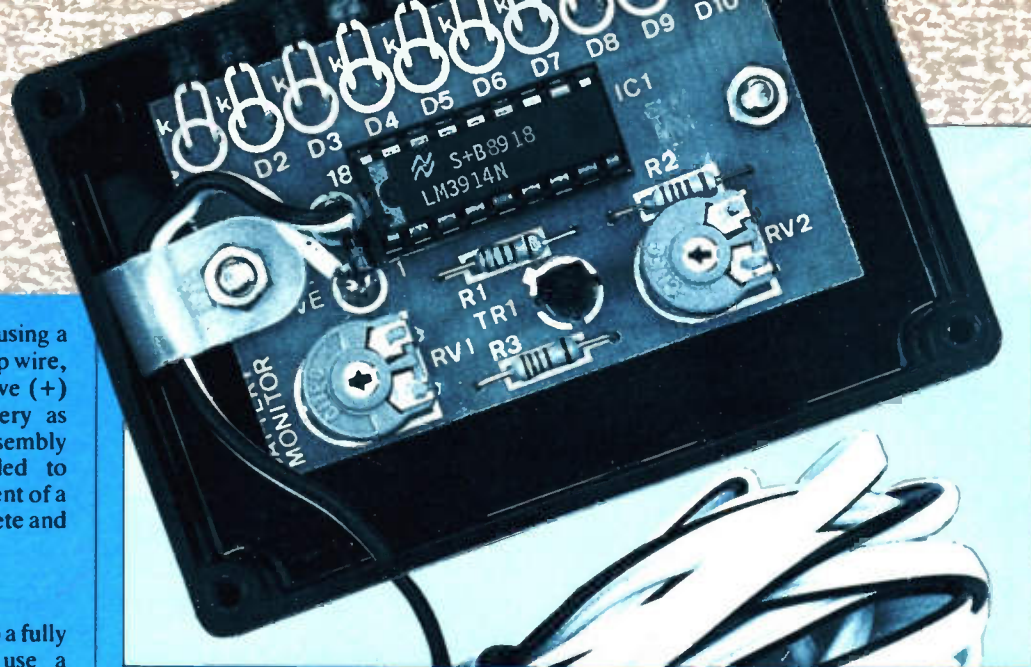

Figure 5. Box & PCB assembly.

secure it to the M3 x 16mm screw using a second M3 nut. Having fitted the zip wire, insert the fuse holder in the positive (+) supply line as close to the battery as possible, see Figure 6 for assembly instructions. The fuse is included to protect the battery wiring in the event of a short circuit. The unit is now complete and ready for calibration.

Calibration

Connect the battery monitor to a fully charged battery, or preferably use a



The finished unit.

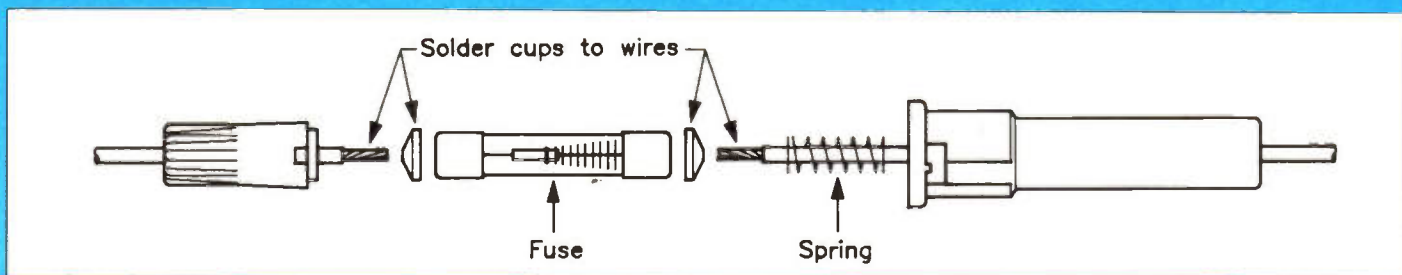

Figure 6. Fuse holder assembly.

variable voltage bench-PSU set to 14V. If this is not possible connect a battery charger to the charged battery and switch it on to ensure that a real 14V level is achieved (max. output from a car's charging/battery system while running is 14V, not 12V). Please note that connecting the battery monitor to the supply the wrong way round will result in permanent damage to IC1!

Set your multimeter to the 2V range, connect the common (black) lead to 0V, and the positive (red) lead to pin 8 of IC1. Using a screwdriver, adjust RV2 until the voltage on the multimeter reads 1.9V. Remove the meter leads, and then adjust RV1 until the top end green LED lights. The battery monitor is now calibrated. All that is left to do now is to screw the back

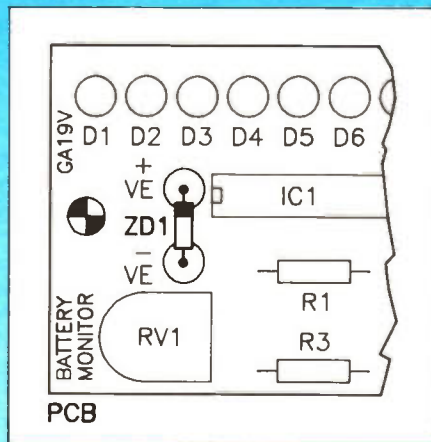

Figure 7. Adding zener diode protection to the module.

cover onto the box, and fit it into your car. Quickstick pads have been supplied to mount the box onto the dashboard if required, and remember to secure the wiring away from hot or moving parts using cable ties (order code BF91Y) as accidents can be expensive if not dangerous. Happy motoring!

Footnote

It has been brought to our attention that there is a possibility of damage to the LM3914 IC in some vehicles due to the possibility of high voltage spikes being present on the supply line. Therefore the optional 15V zener diode should be fitted across the supply veropins as shown in Figure 7.

CAR BATTERY MONITOR PARTS LIST

RESISTORS: 0.6W 1% Metal-Film

R1	27k	1	(M27K)
R2	1k2	1	(M1K2)
R3	15k	1	(M15K)
RV1	10k Hor Encl. Preset	1	(UH03D)
RV2	47k Hor Encl. Preset	1	(UH05F)

SEMICONDUCTORS

D1-3	Mini LED Red	3	(WL32K)
D4-7	Mini LED Orange	4	(WL34M)
D8-10	Mini LED Green	3	(WL33L)
TR1	BC548	1	(QB73Q)
IC1	LM3914	1	(WQ41U)

MISCELLANEOUS

	Batt Mon PCB	1	(GA19V)
	DIL Socket 14 Pin	1	(BL18U)
	Box 301	1	(LL12N)

Zip Wire	3 Mtrs	(XR39N)
P Clip 1/8in.	1	(JH21X)
M3 x 1/4in. Spacer	1 Pkt	(FG33L)
M3 x 16mm Screw	1 Pkt	(JD16S)
M3 Nut	1 Pkt	(BF58N)
Quickstick Pad	1 Strp	(HB22Y)
In-Line Fuse Holder	1	(RX51F)
1/4in. 100mA Fuse	1	(WR08J)
Constructors Guide	1	(XH79L)

OPTIONAL (not in kit)

Zener Diode 15V 1.3W	1	(QF57M)
----------------------	---	---------

The parts listed above, excluding Optional, are available as a kit:
Order As LK42V (Car Batt Monitor Kit) Price £7.95

NEWS REPORT

Bull Makes a Move



First to be featured on the product front this issue is Bull – or Honeywell, as we used to know the company in the UK. The company have launched a new entry PC, the Bull AP-W. Developed in the UK, it can be used as a stand alone PC, or as a workstation on a network. The 20Mb hard disk, monitor, keyboard and DOS costs £1495. But do try an offer.

Bull has also released a new range of printers, both laser and inkjet. Top of the laser range is the VP-100 which provides a rapid ten page-per-minute

capacity with a 300 dots per inch resolution.

Meanwhile, office services company *Strata Business Centres* of London W6 are forecasting that laser prices will continue to tumble this year. That £1000 price barrier will be breached as more and more producers and suppliers get on board that marketing bandwagon. More good news from Strata is that despite the price falls, performances will improve. Details: 01-386-5911.



Fast, Faster . . .

This issue reports on a bumper crop of research projects and developments. Although business may not be in the 'brilliant' class for IBM, their scientists and engineers have been working overtime. As a result, IBM are claiming a world record in magnetic data storage density when they successfully stored a billion bits of information – a 'gigabit' – on a single square inch of disk surface using experimental components.

A billion bits is equivalent to 100,000 double-spaced, typewritten pages; enough paper to make a stack about the height of a three-story building. By achieving this record information storage density in the laboratory, the IBM team says the public can expect significant improvements in the magnetic storage capacity of their computers – from laptops to supercomputers – to continue into the next century.

The experimental dual-element, thin-film recording head unit used in the gigabit demonstration features an inductive write element and a magnetic

resistive (MR) read element. Both elements operate while the head flies over the disk at a height of less than 2 millionths of an inch, a gap so narrow that even visible light can't pass through. Heads in currently available disk drives, IBM points out, fly from 6 to 15 millionths of an inch above the disk surface.

During the gigabit demonstration, information was recorded and read at a data rate of 3.5 million bytes per second. The measured error rates during the gigabit tests were sufficiently low – one per billion, decreasing to one per trillion, if standard error correction techniques are employed – to meet the stringent data integrity requirements of the computer industry. This latter figure is apparently equivalent to transcribing more than 10,000 years of the *Wall Street Journal* before a single mistake is made.

At the same time, IBM researchers have demonstrated for the first time that fast-moving 'ballistic' electrons can be focused and steered as they travel in very low temperatures through gallium arsenide, a semiconductor material with great promise for future

Sound Matters

Minitel, the French videotex terminal, now incorporates a special interface which can act as a domestic high command station. The intelligence factor extends to the remote switching of ovens, central heating, lights and entertainment centres. At least burglars will be given an advance warning that the family are on their way home.

On Guard

Not that BT would deign to cash-in on Minitel developments, but hard on the heels of the new French announcement came news of BT's new closed circuit TV system, Guardstream. This allows 'affordable' live quality surveillance of any number of sites from one central location. Guardstream is an advanced compressed video system which can 'remember' a picture and transmit only those elements which change in it. Furthermore, unlike slow-scan systems, the screen is never wiped so sight of the object of surveillance is never lost even for a fraction of a second. Details: 01-729-6088

Telepoint Battle Stations

Mercury Callpoint is claiming to be the cheapest telepoint personal telephone service so far. By Spring this year, the company aims to have a nation-wide service (in all towns with a population of over 100,000) of some 2000 lines installed. All calls, irrespective of the distance, will be charged at the same rate, that is between 10p and 20p a minute depending on time periods. The handset however will cost you a pricey £200. Plus connection charges of £20 and a monthly service charge of £8. Your News Editor's advice: don't rush; prices and rates must come down.

We now know the three organisations chosen by the DTI to operate the new Personal Communications Networks, described by IT consultants Sterlings as being the poor man's cellular network. As well as Mercury, who were promised a licence, are consortia headed by British Aerospace

(Space Communications) and STC (Unitel).

These licenses will allow the operators to run PCN's in the frequency range 1.7 – 1.9GHz. They are expected to come into service in the early 1990's. The DTI expects them to compete initially with the services offered by the two existing cellular radio operators and even to the fixed telephone network.

Chatlines Curbed

BT, Mercury and OFTEL have all been getting hot under their collars over the issue of chatlines. Mercury says it is selective about the appointment of retail outlets and multi-level marketing schemes, and disassociates itself from chatline calls. OFTEL weighed in with a condition on service providers to make every effort to prevent access by under 18-year olds, and to control the content of the conversations. Just how those conditions are to be achieved is, perhaps wisely, not made clear.

In the meantime, OFTEL might be interested in plans by Mercury to impose a 50p charge on directory enquiry calls – even if the company does claim to answer 90% of all enquires within 15 seconds. Incidentally, that 50p fee will buy you three different searches, so our advice is to save them up. Also the fee is exempt for the disabled and elderly person. Possibly to mitigate the charges, Mercury has promised that all directory enquiry calls will be itemised on their bills.

Order in the House

In an 'unholy' alliance involving the BBC, IBA and Sky TV, a House of Commons satellite service has been introduced. The experimental transmission, which can be interrupted if the satellite channel or transmission link-up is required for commercial purposes, is intended to test the feasibility of creating a new public affairs television channel that would cover the House of Commons, House of Lords and other events of public interest using a dedicated satellite channel.

Battle of the Ratings



It's all systems go at last for Sky's competitor *British Satellite Broadcasting*. This spring sees its launch, and the company is aiming to be in some 3 million UK homes within two years. This is a somewhat higher target base

than that achieved by Sky, who only managed to sign 1.15 million homes by its first anniversary. But this is one battle which it seems Sky can't lose. The company's owner has a 17% stake in BSB!

computers. The discovery raises the interesting idea that 21st century computer architects might be able to use directed beams of electrons in computer chip circuitry, though substantial development hurdles would have to be crossed before the idea could find application.

Under normal conditions, electrons moving through a semiconductor travel only a short distance, called the mean free path, before colliding with atoms, other electrons, or impurities in the semiconductor material, and scattering, in the process losing energy and changing direction. In much the same way, a beacon of light shining into fog quickly collides with water molecules and scatters, losing its focus.

At the same time, IBM are claiming to have fabricated the fastest silicon PNP transistor yet reported, a breakthrough believed to be an important step toward significantly increasing the processing speed of future generations of large mainframes and supercomputers. During operation, the digital circuits built with the PNP transistors switched on and off 25 billion times per second, more than three times as fast as previous generations of PNP circuits.

Fastest . . .

Meanwhile, according to 'Computergram', Fujitsu have been making its own claim to fame with a breakthrough in neuro-computing which links 256 digital signal processors in parallel. This has achieved processing times of 500 million 'blown' synapses a second, "several hundred times faster" than models currently in the market-place, and some 2000 times faster than neural network simulations run on engineering workstations.

Fujitsu is also forecasting a super-computer the size of a laptop computer within the next ten years following the development of a computer chip which runs at speeds up to 1 Terra FLOP (Floating-point Operations); 1 Terra FLOP is equal to 1 million Mega FLOP (10¹² Floating-point Operations every second).

Poster Sized Photo Copies



Canon, seldom absent from 'News Report', have produced a monster 6m x 3m size billboard poster on their B5-A1, the worlds first A1 size colour copier. Now on show in London's Cromwell Road, the poster was reduced from an A1 original. Incorporating the Canon bubblejet ink printing technology, the system produces high

Kick Off for World Cup

In case you hadn't noticed, it's World Cup Football year again, and Sky TV have already scored some impressive goals. Their Eurosport channel which is being sponsored by the likes of Mazda, Toshiba and Sony will provide near continuous coverage.

At the same time, Sky One and Sky News has attracted two premium advertisers - Unilever and Beecham. The deals, worth about £4m each, will give the companies a guaranteed right to programme sponsorship over a two year period.

More revenue news from Sky is the fact that their Movie channel is now being scrambled, with a special decoder box and card being necessary to activate the picture. The card, about the size of a credit card, contains an electronic code which is unique to each subscriber. Sky says that as a full subscription channel it will be able to screen a vast range of top quality films.

All in One

Rank, of Xerox photocopier fame, has managed to combine photocopying, printing, scanning and facsimile technologies that link to a PC. The Faxmaster 21 enables users to scan in paper-based documents for manipulation within PC word processing or desktop publishing files; to print documents, to photocopy documents and to receive and send fax transmissions.

Toshiba Laser Diodes

Toshiba have introduced a range of laser diodes for optical information processing, with applications which include laser printers, optical disc memories, fibre optics and measurement. The laser diodes are fabricated using gallium arsenide technology. Wavelength of light is in the mid-infra red region, with wavelengths from 780 to 830nm. The devices are available with a choice of power outputs in the range 15 to 80mW. The diodes also incorporate a photodiode for closed loop current/light output control.

Move Over Dr Who



Telephone boxes seem to be the UK's biggest growth area. Having reached saturation point in many central city streets, Mercury are now moving indoors. Already found in such exclusive locations as Harrods and 'The Inn on the Park', Mercurycard phones have their installation sights on some 200 Boots stores, 1000 Shell garages and 500 Trust House Forte outlets!

Meanwhile, a joint BT/OFTEL survey has found that 95% of BT boxes were

in working order and that serviceability was being maintained. A point to be noted by card operated-only Mercury call boxes was that in the BT survey, nearly two-thirds of respondents who used public call boxes, said that if more boxes were to be installed, they would prefer them to be cashboxes.

No doubt this response was given before the news got out that BT are abolishing 2p and 5p coins in their call boxes from June this year.

Fast RISCs

A Norwegian company has joined forces with Motorola to develop a RISC (Reduced Instruction Set Computing) processor capable of crunching its way through one billion instructions per second. The device, to be based on ECL (Emitter Coupled Logic) and which will operate at 125MHz, is set to hit the market place by 1992.

EDI Goes Green

EDI has also been occupying the attention of *The Institute for Alternative Futures*. Electronic Data Interchange, they say, will help the universe survive such issues as global warming and overflowing landfills. During the next decade EDI - or whatever it evolves into - will move well beyond its business uses of today to find a comfortable niche in the home as well. The technology will become increasingly important as it becomes a critical component of universal information access.

Getting the Needle

Less chat, more music is promised by the DTI who are planning to lift the restrictions on the amount of needle-time available to broadcasters and cable programme makers. Under UK copyright law, the makers of sound recordings have the right to control the broadcasting, cable distribution and performance in public of their recordings. In the UK, the rights are administered collectively through a centralised licensing body, *Phonographic Performance Ltd*. Less banal chat, says Ray Jones who runs the international Jetprint group based in Worcester, will be a blessing for all.

Meanwhile, a group of French, German and Belgian producers has won backing from the European Commission to develop a pilot network, called the MUSIK project, that will give producers, distributors and the public, access to an electronic classical music catalogue. Automated facilities - in this case electronic data interchange - will

also be tested out with a view to cutting the industry's costs by exchanging orders and invoices over the network.

The European software services group *SD-Scicon* has also been asked to explore the possibility of giving the public access to high-quality recordings via the music catalogue. This would allow customers to listen to part of a recording in which they are interested before they decide to buy.

It's a Dogs Life



A new electronic device now available in the US is the 'Photo-Electronic Talker'. This issues - or rather barks - a command at your pet every time it comes close to that forbidden bed or chair. The cost of keeping your dog at bay is just \$100. Hopefully a remote control unit is available for a relaxation of the rules for humans!

IBA Sees BSB in Action

BSB has demonstrated its transmission and reception system to the IBA. This follows BSB's recent announcement that its access control modules, which facilitate pay-as-you-view and subscription services, have now been delivered.

Getting it in Focus



Camcorders are now better value than ever. The new VL-S8660H from Sharp is very much in the S-VHS-C camcorder league. Features include a built-in digital titling facility; an f1.6 auto focus 12 x power zoom lens, with zoom speed variable from 6 to 25 seconds over the 8 to 96mm focal range.

Weighing in at just 1.5kg (without battery), the unit provides a maximum recording time of 30 minutes with an EC30 videocassette. It can be powered by AC mains, rechargeable nickel cadmium battery or by a 12V DC car battery. Price £1299.99. Details: 01-386-1072.

Fast Breeding Mouse Sales



Logitech is celebrating the doubling of its overall mouse sales from two million by 1988 to four million world-wide in 1989. The company is the biggest mouse manufacturer in the world and has been manufacturing mice since the mid-eighties.

Rupert Armitage, who runs the *Ambit Research Company*, says that the mouse is now the standard part of the graphic-user interface, and is forecasting further dramatic mouse growth in the 1990s.

Networks of the Future

BT has also launched what they call the 'digital communication wire' of the future. The new advanced service to carry voice, data and pictures, is called ISDN 2. This will provide users with two high-speed digital exchange connections on one pair of wires. Benefits claimed include greater flexibility and efficiency, allowing users to use their lines for data or speech at will; better quality telephone services, with faster call set-up; clearer speech and fewer data transmission errors.

Though as comms consultancy ANR comment, "It remains to be seen how successful BT will be with their new service. ISDN 1 did not exactly generate a large number of users." It all depends, says ANR, on the level of tariffs and connection charges pitched by BT.

common with CD. The resolution is 16-bits. The new system utilises a technique called 'depth recording multiplex', which allows the analogue and digital signals to be recorded at different depths in the magnetic tape medium. This means that existing VCRs will not become obsolete, as the new format tapes can still be replayed on older VCRs, albeit without the benefits of digital sound. JVC is hoping that this latest development will firmly establish VHS as a professional, as well as a domestic format.

Warning: Hi-Tech May Seriously Damage Your Health



There is growing uncertainty about the safety of many commonplace electrical and electronic items of equipment. Mobile telephones, personal computers and TVs are coming under close scrutiny; all of these emit non-ionising electromagnetic radiation. Authorities and standards bodies on both sides of the Atlantic are having a major re-think on what is a safe exposure level. It has been suggested that cancer, heart

disease and miscarriages can result from relatively low levels of exposure to non-ionising electromagnetic radiation. Thorough research studies have not taken place and as yet there is no conclusive proof. Britain's standards body, the *National Radiological Protection Board* (NRPB), is due to publish a report in the summer, and in the US the *American National Standards Institute* (ANSI) is set to revise exposure guidelines. High on the investigation list are hand-held transceivers and cellular phones, both of which are held in close proximity to the user's head. An industry expert has said: "Nobody really knows what radio-frequency output does to you."

Avoid Those PAYE Blues

A timely warning has been issued by payroll bureau specialist *Paytrack Centres* that the Inland Revenue intend cracking down on the non, or delayed, payment of PAYE tax due to the authorities. As yet, says Paytrack's Laurence Levan, the new legislation message has not got through to the business manager. The solution, he not surprisingly suggests, is to leave your payroll problems to the experts and get some peace of mind. Details: 01-343-0753.

Picture Caption Challenge

Yet again, British Telecom is issuing a challenge. Is this:-

- ★ The latest thing in coolie hats.
 - ★ A one-man flying saucer.
 - ★ Dennis Thatcher setting out for his local.
 - ★ A new-look lamp standard.
- Give up? Well, it is a BT engineer carrying a dish aerial into position on the roof of a telephone exchange.

Digital Sound for VHS

JVC has developed a digital sound recording system for the VHS video cassette format. S-VHS, launched in 1986, can now offer high quality sound as well as high quality pictures. The sound is digitally recorded and played back at a sample rate of 48kHz - the same as DAT (Digital Audio Tape). In



The logic tester (LK77J) is designed to provide a display on an oscilloscope. This provides a great deal of useful information but it can be difficult to identify which pin corresponds to a particular segment of the display.

Owners of a BBC computer can easily interface the project to the computer's user port. The software is written to run on a standard BBC model B but could be

adapted to other computers. This display provides the image of a 16 pin IC. The pins are coloured red for a '1' and yellow for a '0'. Any pin with a pulsed output will flash.

The hardware modifications are very simple and do not affect the operation of the tester which could be used with the oscilloscope simultaneously. But when it is connected to the user port it is powered by the computer and an external supply

should not be used.

A length of 20 way IDC ribbon cable terminated with a 2 x 10 way IDC socket connects to the computer. Seven connections need to be made to the PCB, the remaining conductors in the cable are left unconnected. A link between pin 13 and pin 11 on IC2 must be soldered on the underside of the PCB.

The cable connections are shown in

Listing 1

10	MODE 1	260	DRAW 500,30	510	LDA &FE60
20	?&FE62=0	270	PROC_ARC	520	CMP #70
30	VDU23,1,0;0;0;0;	280	C=1	530	BNE LOOP
40	PROC_MCODE	290	FOR X=498 TO 854 STEP 356	540	AND #&0F
50	CLS;CLG	300	FOR Y=50 TO 800 STEP 100	550	TAX
60	PROC_OUTLINE	310	PROC_SQUARE (C)	560	LDA &70
70	REPEAT	320	.NEXT Y	570	AND #&10
80	CALL LOOP	330	.NEXT X	580	CMP &73,X
90	PROC_DRAW	340	ENDPROC	590	STA &73,X
100	UNTIL FALSE	350	DEFPROC_SQUARE (C)	600	BNE SKIP
110	DEFPROC_DRAW	360	GCOL 0,C	610	JMP LOOP
120	A%=?&70 AND 16	370	MOVE X-50,Y	620	.SKIP
130	B%=?&70 AND 15	380	DRAW X-50,Y+50	630	RTS
140	B%=B%+1	390	PLOT 85,X,Y+50	640]
150	IF A%=16 THEN C=2 ELSE C=1	400	DRAW X,Y	650	NEXT
160	IF B%>8 THEN X=854 ELSE X=498	410	PLOT 85,X-50,Y	660	ENDPROC
170	IF B%>8 THEN Y=B%*100-850	420	ENDPROC	670	DEFPROC_ARC
180	IF B%<9 THEN Y=850-(B%*100)	430	DEFPROC_MCODE	680	MOVE 650,820
190	PROC_SQUARE(C)	440	DIM X% 500	690	FOR I=25 TO 75 STEP 2
200	ENDPROC	450	FOR PASS%=0 TO 3 STEP 3	700	S=I/100*2*PI
210	DEFPROC_OUTLINE	460	P%=X%	710	X=INT(SIN(S)*50)
220	MOVE 500,30	470	[OPTPASS%	720	Y=INT(COS(S)*50)
230	DRAW 500,820	480	.LOOP	730	DRAW 650 +X,820+Y
240	DRAW 800,820	490	LDA &FE60	740	NEXT I
250	DRAW 800,30	500	STA &70	750	ENDPROC

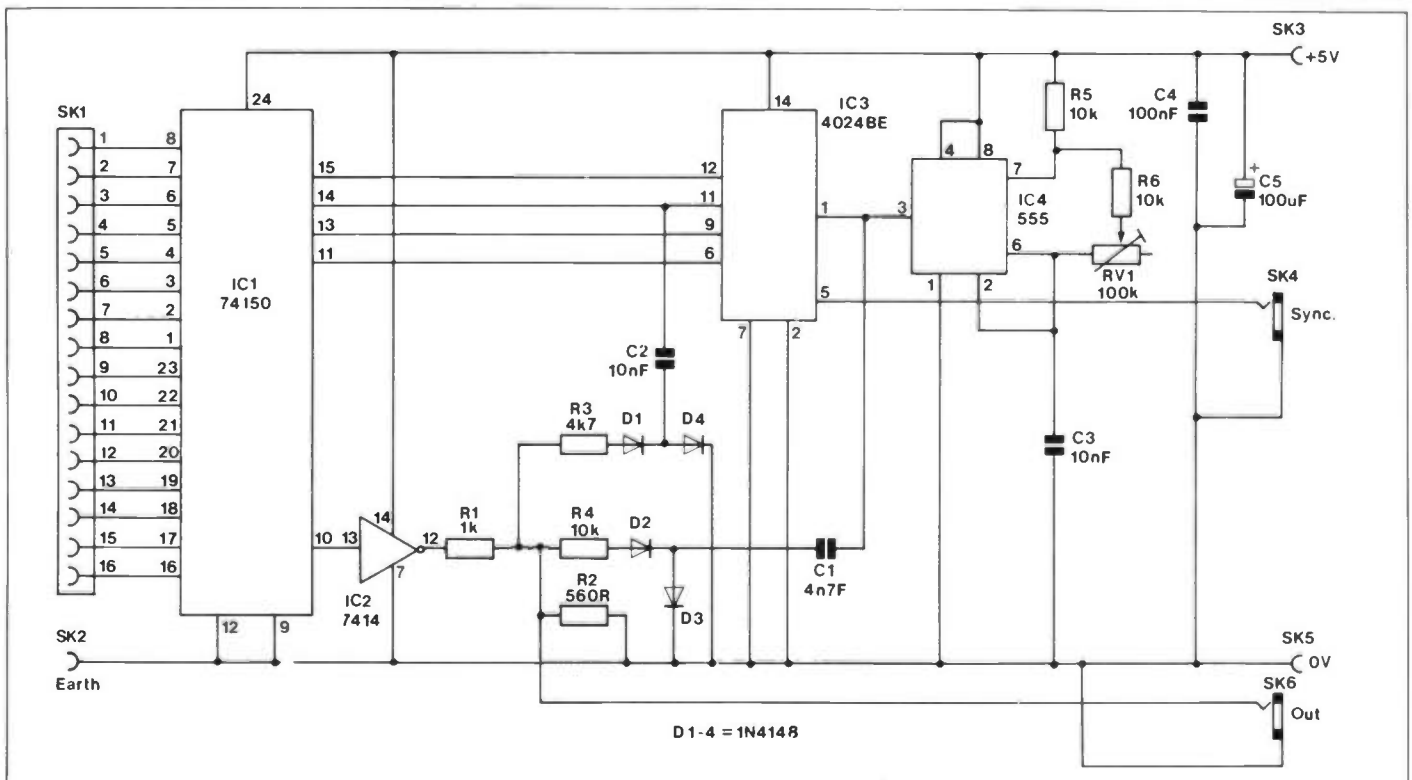

Figure 1. Original circuit diagram (Figure 2 Sept. 1985 Issue).

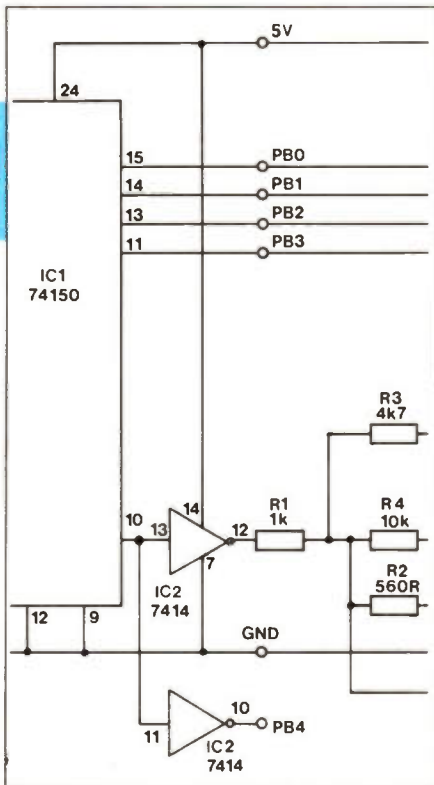

Figure 2. Part of circuit diagram showing modifications.

Table 1 and on the modified circuit diagram.

Hardware enthusiasts might like to experiment with the user port pins PB5 to PB7 to provide logic levels to the IC under



Conductor	Port Connection	PCB Connection
1	+5 Volts	+5 Volts
5	GND	GND
6	PB0	Pin 15 IC1
8	PB1	Pin 14 IC1
10	PB2	Pin 13 IC1
12	PB3	Pin 11 IC1
14	PB4	Pin 10 IC2
		Link pin 11 to pin 13 on IC2

Table 1. Cable connections.

test. Software fanatics might like to modify the display to include the logic symbols for the particular IC. As with the original, the modified tester can only be used with 5 volt logic circuits.

An example program is given in Listing 1. For successful results while running the program, it is recommended that all 16 pins of the IC test clip are momentarily grounded before proceeding with any test.

CATALOGUE AMENDMENTS

Please amend your copy of the 1990 catalogue as follows:

Video enhancers YU13P and YU70M (pages 61 and 62). The rear view pictures of these two items have been transposed, the rear view shown for YU13P should be for YU70M and vice versa.

Casio calculators JK54J (page 69) and JR29G (page 71). Both these calculators now have improved specification at no extra cost. JK54J is now MS80A (was MS-8); JR29G is now FX-4500P (was FX-4200).

'Mastering Electronics' book WM60Q (page 93). The book mentions that PCB's are available from Maplin for building some of the projects described, but this is no longer the case. Stocks have been exhausted for at least two years and will not be replenished. Although reprinted in 1986, the first edition appeared much earlier and boards are now no longer available.

UHF FM 35W Mobile Transceiver XM56L (page 150). The top and inset (front panel) pictures of this item are duplicates of XM55K on previous page. Although very similar, XM56L is model DR-410E, and not another DR-110 like XM55K!

3.5mm Stereo PCB Mounting Jack Sockets JM23A and JM20W (page 174). The electrical and pin-out diagrams for these two are transposed. The drawings shown for JM23A should go with JM20W and those for JM20W should go with JM23A.

Mini-Headphone Splitter RK58N (page 175). The length of this item is 2 metres, not 0.15 metres.

AM/FM Headphone Radio YU22Y (page 200). This item is described as being able to receive FM broadcasts in stereo, which is incorrect, the receiver is mono only for both AM and FM. Description on box makes reference to "AM/FM stereo sound", presumably meaning two ear phones. Red LED is a 'power on' indicator and not a stereo broadcast indicator.

Computer Controlled Graphic Equaliser XM01B (page 206). Last line of last paragraph of description incorrect, vis "the optimum input signal level for lowest noise with lowest distortion is 1V to 3V rms," and should be ignored. In fact input signals which peak above 700mV approx. cause gross distortion from equaliser while any band channels are boosted. Some tape and CD outputs with no output level controls will do this. Consequently all inputs must not exceed 130mV rms if the equaliser is not to be over-loaded.

Surround Sound Processor with Remote Control YU59P (page 207). The first line of the fifth paragraph should read 'With a "hi-fi stereo" video cassette recorder', not 'HQ'. A hi-fi quality recorder is necessary, no other type is good enough. It is correct in saying that tapes must be 'Dolby stereo' types.

SRBP Stripboard JP50E (page 268). This new type 3962 is 160 x 100mm with 39 copper strips, and not 100mm square.

'Miami Storm' Radio Controlled Boat XM37S (page 355). The description omits to mention safeguards that ought to be taken to prevent the ingress of water to sensitive electronic circuitry and mechanical components. We recommend that users seal the top removable hull cover with white PVC sealing tape (e.g. FT24B) all around the edges after installing the battery pack and prior to use on the water, this prevents water getting at the radio receiver. Similarly, greasing all accessible motor gear trains and other mechanical linkages where possible with a suitable grease to prevent corrosion, such as silicone grease (FT24B). We do not recommend however that any attempt be made to completely dismantle the outboard motor assemblies.

70W Horn Tweeter YJ02C (page 480). Physical dimensions shown for this item are incorrect. Overall width and height is 184 x 76mm, depth 160mm, fixing centres 86 x 86 x 64mm (6 holes), Ø5mm; weight 647g.

Modular Switch Plain Bezel FP53H (page 496).

This item is currently supplied in colour blue, not black. Similarly the LED version FP54J may also be supplied in blue. Attempts are being made to see if these can be sourced in black only as originally, until then assume either black or blue will be supplied.

Membrane Switch Keypad BK72P (page 497). Unfortunately the 7-way flat connector mentioned in the description is not fitted to this keypad as indicated. If ordering BK72P then also order EF21X, (£1.36) a flat conductor connector which replaces discontinued BK73Q, and is not shown anywhere in the catalogue.

Adjustable Spanner FY46A (page 537). The maximum jaw opening is 24mm, not 26mm.

Needle File Set 140mm YW63T (page 538). The range of different file shapes as shown in the catalogue is no longer accurate. The number and styles of the files in the set change often and it is now very difficult to describe a complete set in great detail without this information quickly becoming inaccurate. Suffice to say that the set will always comprise a number of needle files offering a broad range of flat, round, half round, square etc. shapes, and which is usually a greater selection than the alternative needle file set JH42V.

High Speed Twist Drill Set FM97F (page 542). No longer containing metric equivalents of imperial sizes, these drills are now labelled and stamped as actual imperial sizes. Range unchanged.

Pocket Min/Max Thermometer YP95D (page 566). The thermometer will only display the stored memories of readings from the selected internal or external sensor. To obtain min/max readings of either, the 'IN/OUT' switch must be selected. The text should read "They can be recalled and displayed at any time by operating the appropriate buttons after selecting 'IN' or 'OUT' on the front of the thermometer."

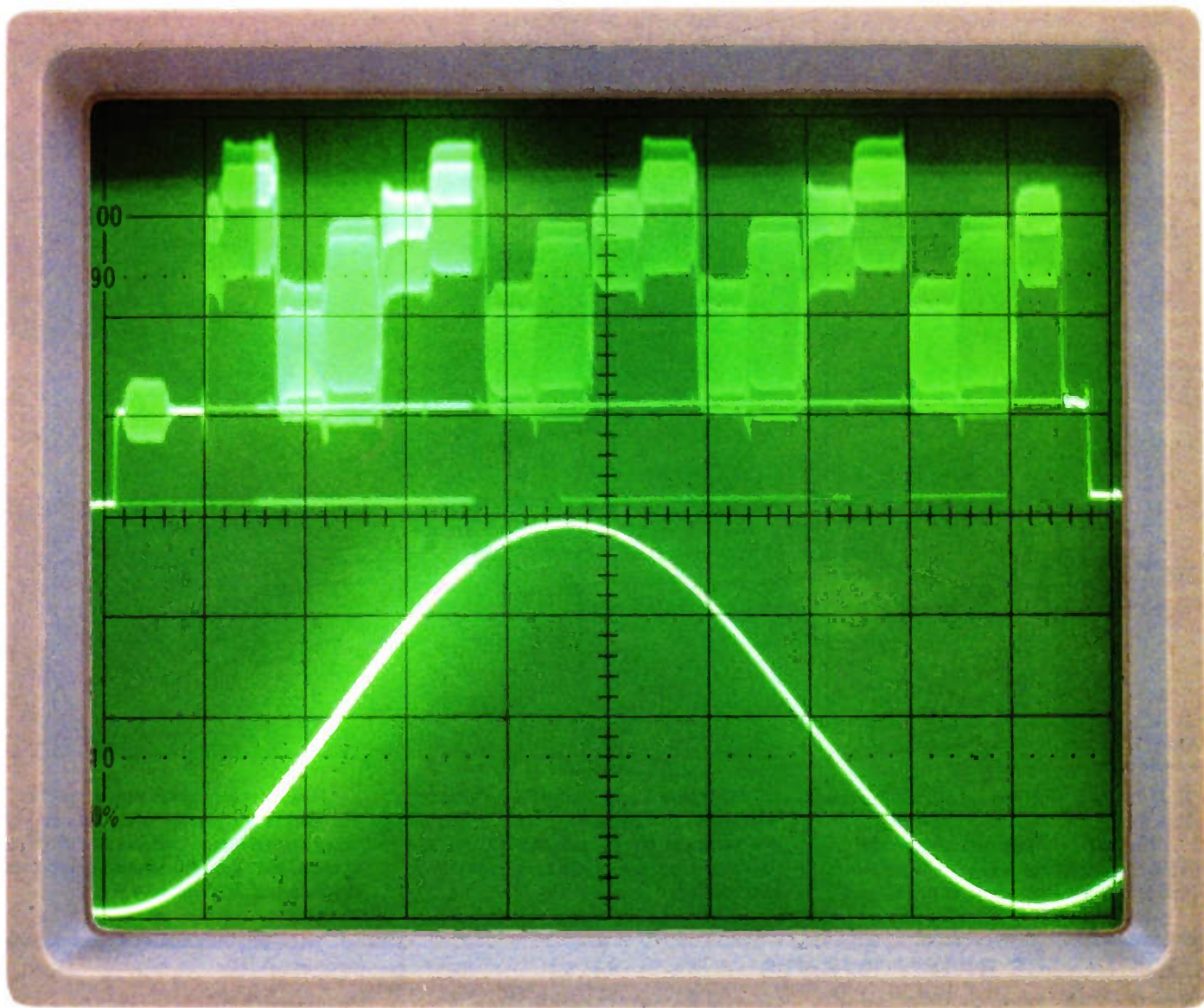

Does yours pass the screen test?

We believe ours do!!!

Precision laboratory oscilloscopes. Triple-trace 20MHz 3 channels-3 trace. XY mode allows Lissajous patterns to be produced and phase shift measured. 150mm rectangular CRT has internal graticule to eliminate parallax error. 20ns/div sweep rate makes fast signals observable. Stable triggering of both channels even with different frequencies is easy to achieve and a TV sync separator allows measurement of video signals. Algebraic operation allows the sum or difference of channel 1 and 2 to be displayed. 50mV/div output from CH 1 available to drive external instrument e.g. frequency counter. Also available, 40MHz triple trace oscilloscope. Similar to the model described above but with 12kV tube that is super bright even at the highest frequencies. This instrument also has a delayed sweep time base to provide magnified waveforms and accurate time interval measurements.

TOA60 (20MHz Triple Scope) £349.95
 TOB60 (40MHz Triple Scope) £549.95

TEST EQUIPMENT – Choose from the extensive range featured in our new 580 page Electronics Catalogue. Available in all our shops or from WHSMITH for £2.25 or £2.75 by mail. No carriage charge if ordering Catalogue only.



20MHz



40MHz

CREDIT CARD HOTLINE

0702 554161

PHONE BEFORE 5PM FOR SAME DAY DESPATCH



Maplin ELECTRONICS

P.O. BOX 3, RAYLEIGH, ESSEX, SS6 8LR.

All items subject to availability, all items will be on sale in our shops in Birmingham, Bristol, Leeds, Hammersmith, Edgware, Manchester, Nottingham, Newcastle-upon-Tyne, Reading, Southampton and Southend-on-Sea.

Add Carriage 75p.

ALL PRICES INCLUDE VAT.

2ND Time Around

CAR DIGITAL TACHOMETER

by Alan Williamson
based on a project by Peter Marriott

Introduction

Particular projects from the Maplin range have proven to be very popular over the years; but unfortunately the technology and the components available have a habit of changing, with the result that these projects are in danger of becoming obsolete. Updates and improvements to some of these projects will be published occasionally under the series title of "2nd Time Around".

Car Digital Tachometer

In these days of ever-higher motoring costs the unit described here will help the driver to change gear at the most advantageous point to save fuel and extend engine life. Anyone using a car to tow a trailer or caravan will also benefit by being able to make the best use of the torque available from the engine.

Conventional tachometers give a display of engine speed on a millimeter, usually with a scale of about 270° arc. Pulses produced by the action of the contact breakers are integrated and fed to the meter to give an analogue display of engine revolutions. The disadvantages are that an average reading is displayed, which can easily lag behind rapid speed changes, and the meters tend to be somewhat fragile. The tachometer described here overcomes both of these disadvantages by counting

pulses and displaying engine revolutions over a very short time, as the digital display is continuously updated. Two digits display the number of revolutions x 100, hence a display of 99 would correspond to 9,900 r.p.m. However, as the unit only has a two digit display, the reading could be in error by as much as 100 r.p.m. compared with true engine speed. The unit is designed for negative earth cars, and if you are not sure of the polarity of your car, a glance at the owners manual or even at the battery connections will tell you.

Circuit

The complete circuit is shown in Figure 1. Pulses produced by the make-and-break action of the engine contact breaker points are fed to IC1a, which is a dual schmitt trigger monostable, via a resistor/capacitor network composed of R1, R2 and C1. This network helps to smooth out any high voltage spikes which may be present on the contact breaker pulses. The zener diode ZD1 limits the input pulse at IC1a to 4.7 volts, to avoid any damage to the device. To prevent any false triggering due to contact point bounce (produced when the points do not open and close cleanly) the monostable period is set to 3 milliseconds by R3 and C2, after which it is ready to be retriggered by the next pulse, and this time period allows for the maximum count for a 4 stroke, 4

cylinder engine of 10,000 r.p.m. – a speed not often attained on normal road cars! The maximum count of 10,000 r.p.m. ($\div 100$ r.p.m.) corresponds to 20,000 pulses/minute and the time for 1 pulse is 60/20,000 seconds or 3ms. A high engine speed would therefore not allow enough time between pulses for triggering the monostable. This design is for 4 cylinder cars *only* and anyone using it on a 6 or 8 cylinder car would have to modify the count period accordingly, or use a compensation factor on the readings – not easy while driving!

The output pulses from IC1a, pin 12, are fed to the count input, pin 11, of IC2. This is a 4 digit counter with both latch and reset. It drives a multiplexed 2 digit display directly, with transistors TR1 and TR2 selecting the digit, and resistors R4 – R10 limiting the segment current. The counter requires latch pulses in order to give sensible readings and these are provided by IC3, TR3 and their associated components. IC3 is the ever useful 555, used as an oscillator whose frequency is controlled by RV1. The oscillator output waveform, arranged such that there is a long high and a short low period, is inverted by TR3 so that a short high period is achieved. This short pulse is used to control the latch of the counter device IC2, so that when this input goes high the information in the counter is transferred to the internal latch and displayed. The

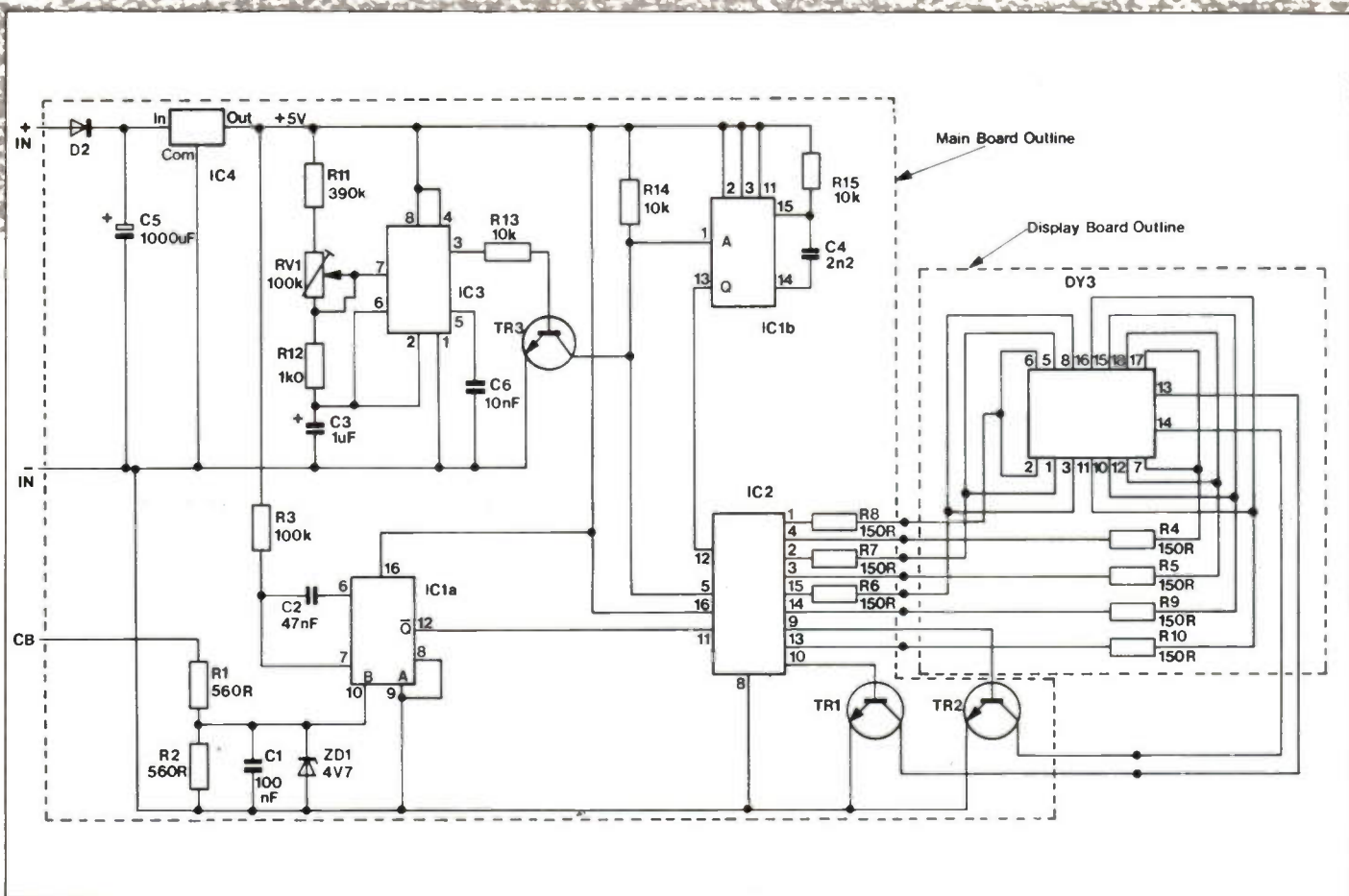

Figure 1. Circuit diagram.

trailing edge of this short pulse is used to trigger the monostable IC1b, whose output pulse is used to reset the counter so that it will start counting from '00' again. The use of a separate monostable to reset the counter ensures that the reset pulse always occurs *after* the latch pulse and a true reading displayed.

Because the supply voltage of a car, nominally 12 - 14V, varies between these limits with engine speed, integrated circuit IC4 is used to derive a regulated 5V supply from this, which is then used to supply IC1, IC2 and IC3 and is important for the stability of the oscillator (IC3). Diode D2 and capacitor C5 remove any noise on the supply.

Construction

Refer to the constructors guide for hints and tips on soldering and constructional techniques if you are an inexperienced constructor. The Digital Tachometer is constructed on two PCB's; the main board and the display board. The display board is mounted at 90° to the main board by being soldered to veropins, and this holds the display so that it can be viewed through the cut-out display 'window' at the end of the case.

Referring to Figure 3, begin by fitting the smallest components first. Check the polarity of C3, C5, and the direction of D1, D2 before fitting, then work your way through the components by size fitting C5, the largest, last. Insert the IC's into the appropriate sockets *only* after all other construction of the tachometer module is

completed, taking the usual precautions with CMOS devices. Note that the negative end of C5 must be close to the pcb or you may find that adjusting RV1 is difficult during calibration!

Display Board

Referring to Figure 4. First mount resistors R4, R5, R9, R10, and the veropins from the *component* side, being careful not to strip the pads off the pcb in the process! A hot soldering iron will help to push the pins home. Don't forget to fit the wire link, this is made from an off-cut from a resistor. Solder and crop the resistors and the wire link. Next fit the display to the pcb; pins 1 to 9 are on the side where the decimal point will be found, and pins 1 and 18 are marked on the pcb. Solder and crop pins 1 to 18. Now measure the required length for the display board pins by offering the display board up to the main pcb, 3-4mm is about right; see Figure 2. If the pins are too short, the connections won't be mechanically strong. After trimming the pins down you can solder the display board to the main pcb. The pins on the display board also require soldering, and if this has already been done, you will find that the two boards will not marry snugly to each other.

Use mains connection wire for power supply and screened wire for the input signal soldered to the three pins. Screened cable is used to stop the emission of R.F. interference, and the outer screening must be connected to earth, preferably at the H.T. coil end. Label the function of each wire at the

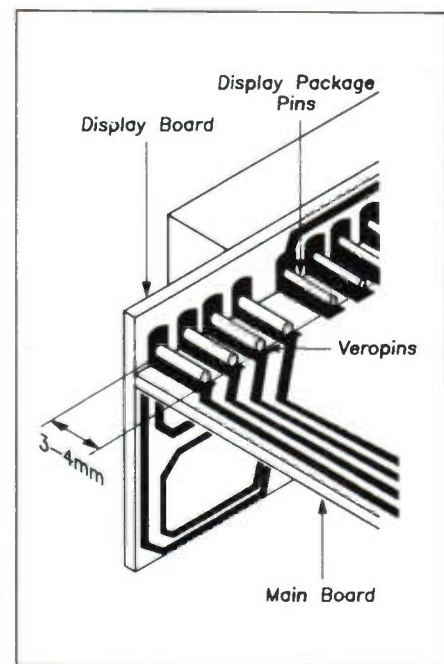

Figure 2. Preparing the veropins for attaching main and display PCBs together.

end that will connect to the car electrics. If you are going to use the optional box, then the front panel of the case is replaced by a piece of red filter cut to size (using the original panel as a template) with a pair of scissors or craft knife. This slots neatly into the case, which is moulded in two sections. As you may have noticed, there is no method of mounting the tachometer into the suggested box, so the alternative is to use quick stick pads. The suggested box also needs to be modified by removing part of the

battery compartment; only the top and front partitions of this need to be removed, the sides will help to keep the pcb central in the box, and the screw holes must remain intact or else the box cannot be fastened together, see Figure 5.

Setting Up

One advantage of a digital tachometer over an analogue type is the ease of setting-up and calibration. Only one adjustment to RV1 needs to be

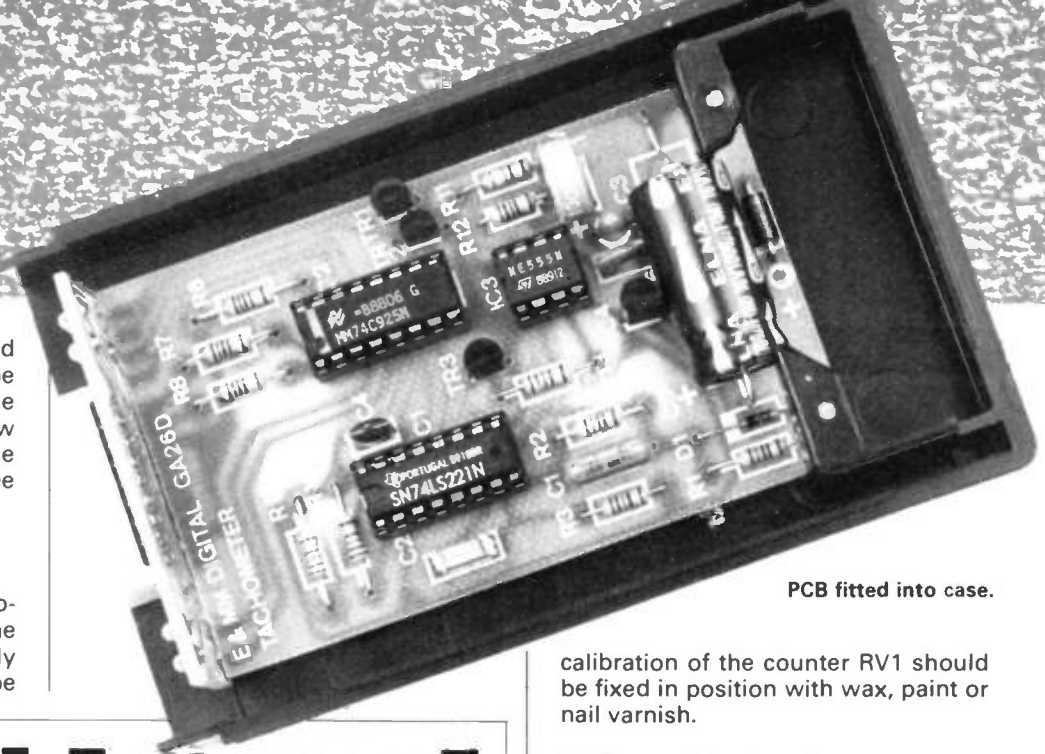

PCB fitted into case.

calibration of the counter RV1 should be fixed in position with wax, paint or nail varnish.

Fitting The Unit Into The Car

After calibration, the unit is ready to be fitted to the car. It is impossible to give detailed instructions for every car but the following notes may be helpful.

- A. It is a good idea to try the unit in various positions for best readability, using adhesive tape, until you are satisfied.
- B. Having decided on the best position use double-sided tape, adhesive pads or two pieces of velcro-tape, one glued to the unit and one glued to the car dashboard. All of these methods, of course, mean that the unit can be removed easily and the dashboard cleaned and left unmarked.
- C. Alternatively, use self-tapping screws through one half of the case into the dashboard. This works well, but unless you can utilise existing screw holes you will be left with holes in the dashboard if you decide to remove the unit.

The three leads must pass into the engine compartment and it is important that they are protected by a rubber or plastic grommet. It may be possible to squeeze them through an existing cable entry or you may have to drill a new hole, but either way make sure they are protected. Connection to the car electrics is fairly straightforward; the tachometer input lead is connected to the CB terminal of the H.T. coil, which can be identified by the lead from the points and distributor to the H.T. coil. 'CB' stands for 'contact breaker', often marked with a '-' minus sign. The supply would best be taken from the ignition switch via a 100mA fuse, so that the unit is switched off when the car is not running. The easiest way of doing this would be to follow the other lead from the H.T. coil (marked with a '+' plus sign) up to the ballast resistor (if fitted), and make the connection to the other side of it, see Figure 7.

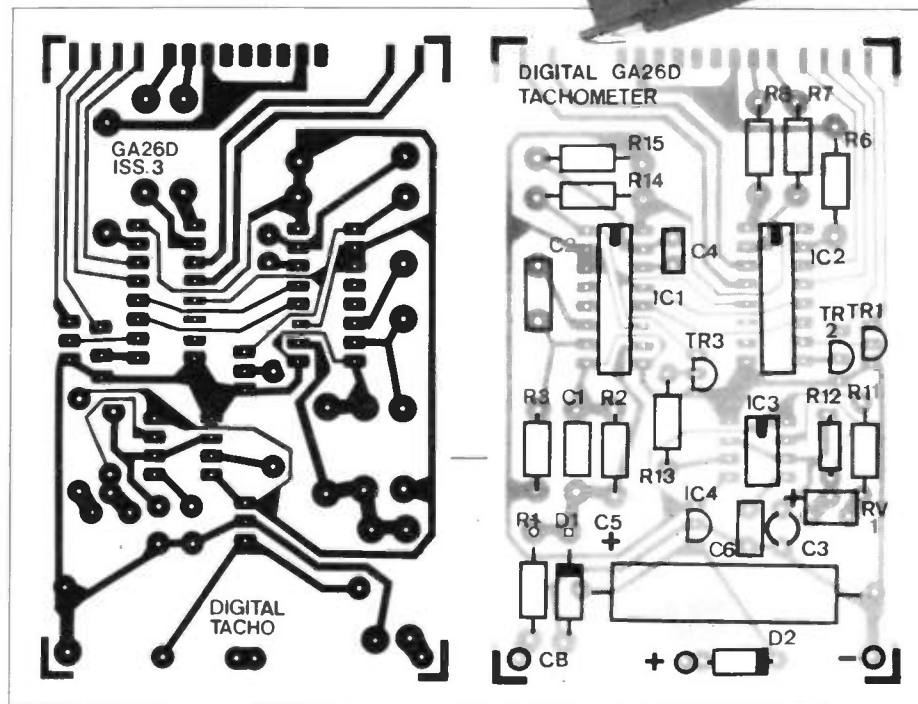

Figure 3. Digital Tachometer main PCB and legend layout.

made and, barring accidents, will prevail for the life of the unit. This setting ensures that the oscillator runs at the correct frequency and the method of calibration depends on the equipment available. Calibration against another tachometer is possible, setting RV1 to give a display of 30 when the standard tachometer reads 3,000 rpm. If you have access to a signal generator, set the frequency to 100Hz (sine or square wave) and the output level to maximum (more than 4.7V). Connect this signal to the I/P pin on the PCB, and again this will simulate

an ignition pulse train input of 3,000 r.p.m.

Alternatively calibration can be carried out against the mains frequency by using a transformer and bridge rectifier to provide a 100Hz signal as shown in Figure 6, and a battery charger is very effective in this role. In either case RV1 is adjusted to give a display reading of 30. Calibration should include a test run for up to half an hour or so for 'warming up' and stabilisation, whereafter it might be noted that RV1 requires further fine tuning. When you are satisfied with the

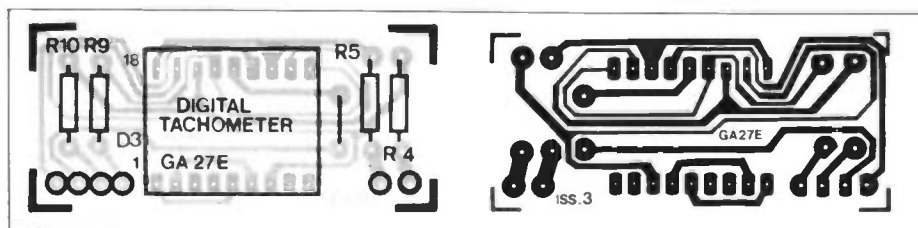

Figure 4. Display board layout and legend.

Not all ignition systems are the same so consult your workshop manual before attempting to fit the tacho. Also please remember that a car engine is a hazardous area – never attempt to fit the tacho, or anything else for that matter, while the engine is running! Also, secure all cables away from hot or moving parts! Anchor them to existing wiring looms using cable ties.

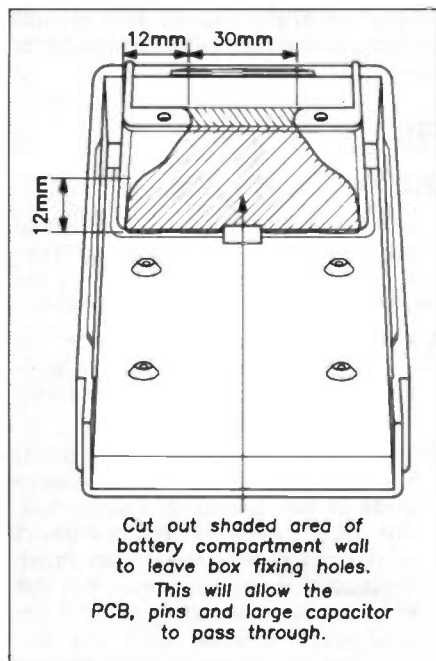

Figure 5. Box modification details.

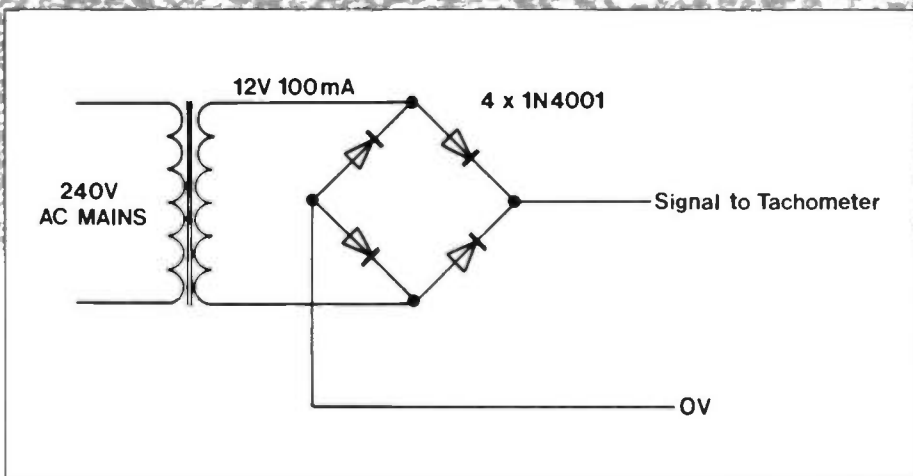

Figure 6. Mains frequency doubler for calibration.

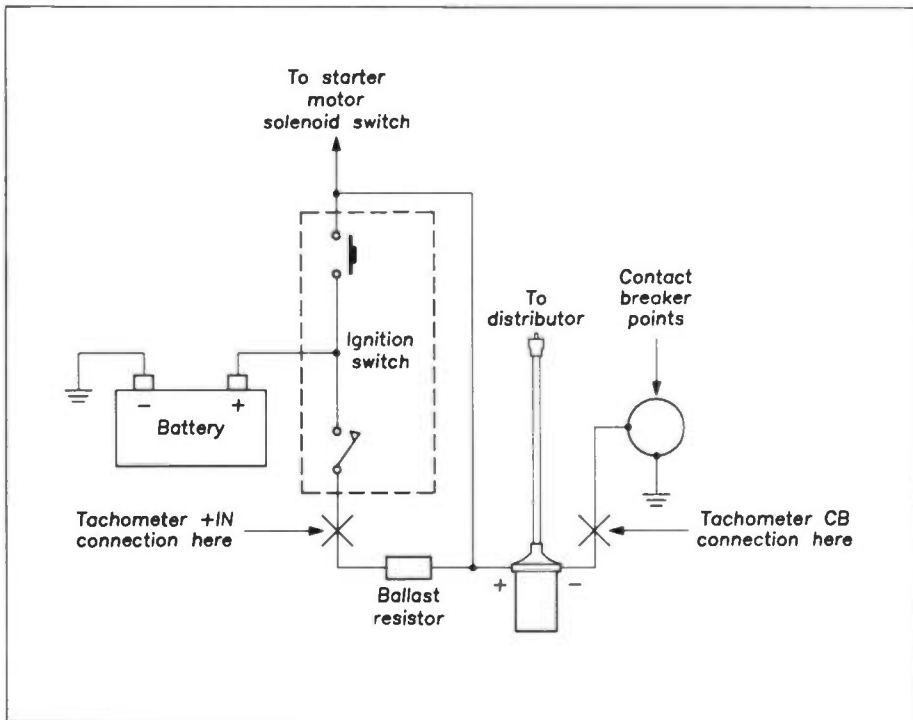

Figure 7. Connecting tachometer to a typical ignition system with contact breaker.

CAR DIGITAL TACHOMETER PARTS LIST

Resistors: All 0.6W 1% Metal Film

R1,2	560Ω	2	(M560R)
R3	100k	1	(M100K)
R4-10	150Ω	7	(M150R)
R11	390k	1	(M390K)
R12	1k	1	(M1K)
R13-15	10k	3	(M10K)
RV1	100k VrtEncl Preset	1	(UH19V)

Capacitors

C1	100nF Polyester	1	(BX76H)
C2	47nF Poly Layer	1	(WW37S)
C3	1μF Tantalum 35V	1	(WW60Q)
C4	2n2F Mylar	1	(WW16S)
C5	1000μF 16V Axial	1	(FB82D)
C6	10nF Disc 50V	1	(BX00A)

Semiconductors

IC1	74LS221	1	(YF86T)
IC2	74C925	1	(QY08J)
IC3	NE555	1	(QH66W)
IC4	μA78L05AWC	1	(QL26D)
TR1-3	BC549	3	(QQ15R)
ZD1	BZY88C4V7	1	(QH06G)

D2	1N4001	1	(QL73Q)
DY3	DD Display Type C	1	(BY68Y)

Miscellaneous

	8-pin DIL Socket	1	(BL17T)
	16-pin DIL Socket	2	(BL19V)
	Dig Tacho Main PCB	1	(GA26D)
	Dig Tacho Display PCB	1	(GA27E)
	Pin 2145	1 Pkt	(FL24B)
	Red Display Filter	1	(FR34M)
	Cable Grommet	1	(LR47B)
	Twin Mains DS Black	3 Mtrs	(XR47B)
	Cable Single Black	3 Mtrs	(XR12N)
	Quickstick Pads	1	(HB22Y)
	Constructors Guide	1	(XH79L)

Optional (not in kit)

	Small Remote Control Box	1	(LH90X)
	In-line Fuse Holder	1	(RX51F)
	1¼" Fuse 100mA	1	(WR08J)
	Velcro Mounts	As Reqd	(FE45Y)
	Cable Tie-Wrap 100	As Reqd	(BF91Y)

The above items, excluding Optional, are available as a kit:
Order As LK79L (Car Tachometer Kit) Price £17.95

DOLBY STEREO Continued from page 47

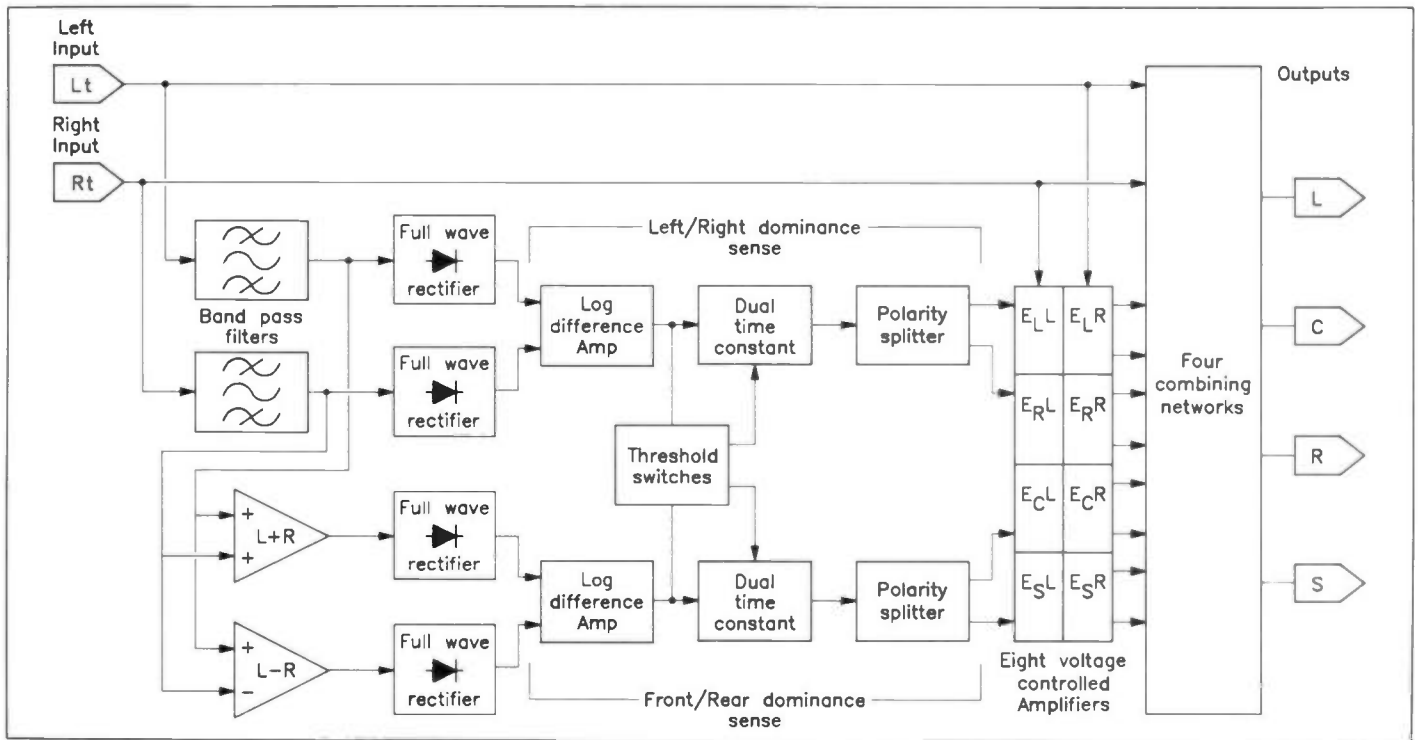

Figure 11. Dolby Pro Logic adaptive matrix.

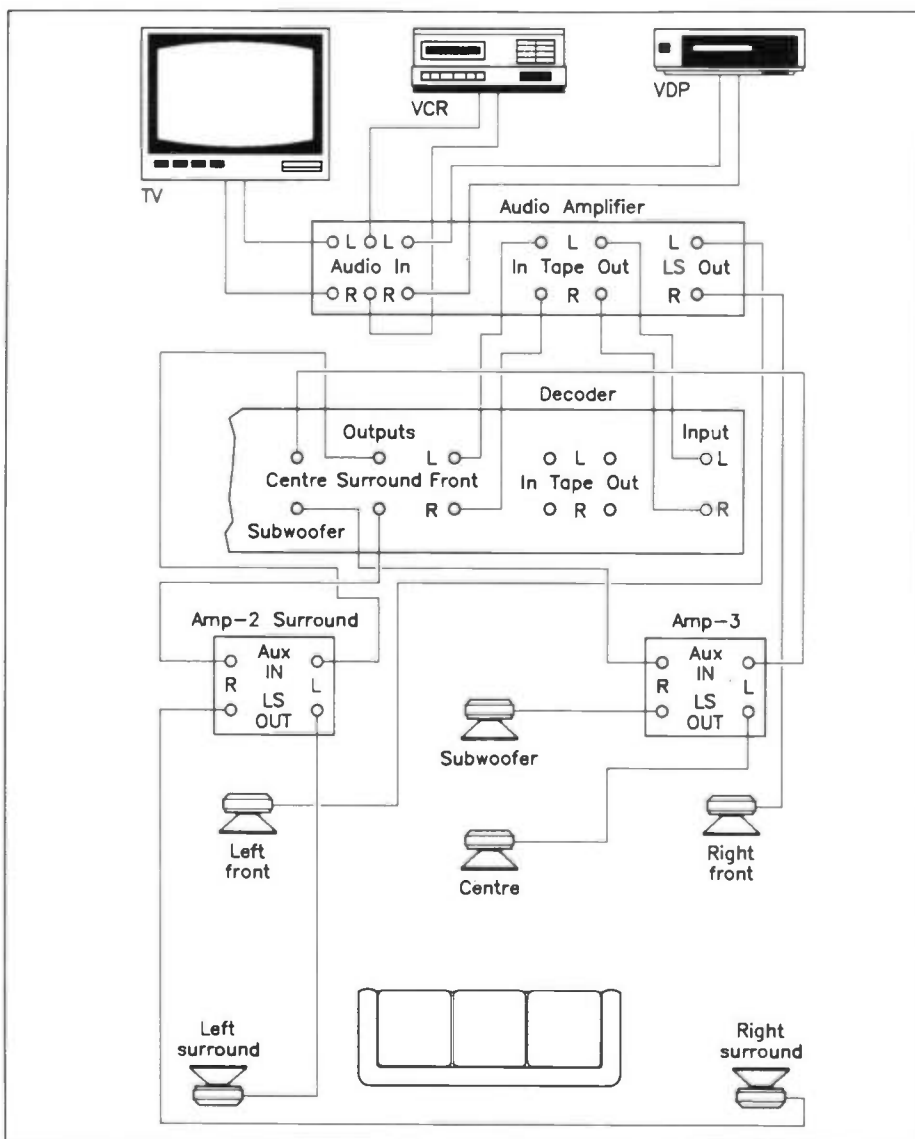

Figure 12. Dolby Pro Logic setup.

shown in Figure 11. To illustrate this; if the input signal has mainly centre channel dialogue, the signal should be predominantly steered to the centre channel output. However, since the centre channel signal is present equally in the left and right channels, the dialogue will also be heard in the left and right channel loudspeakers as well as in the intended centre channel loudspeaker. Signal steering will remove the unwanted centre signal in the left output. This is achieved by subtracting signal components from the left channel, and thus the unwanted signal is cancelled out. Similarly, the unwanted centre signal in the right channel is removed in the same way. Constant sound level is maintained by the redistribution of signals to the various loudspeakers, which is achieved by the signal cancellation techniques described.

Within the sound field of the loudspeakers, it is possible for only one signal to be dominant at any given moment. It is equally possible for there to be no dominant signal. An active decoder monitors and detects the magnitude and direction of the dominant signal and proportionally emphasises it by cancelling unwanted leakage. If, for example, dialogue is present with background music, the dialogue should be heard in the centre and music all around; an explosion to the left of the person speaking should be heard to the left.

Since the circuitry is 'looking' for a signal which has both magnitude and direction, it is best to think of the dominant signal in vector terms. The vector, in an x/y coordinate plane, may be resolved into two components at 90° to each other, and in this case the two are along the left/right axis and the front/rear axis. The circuitry processes each axis separately. In Figure 11, it can be seen how the two

parameters are found; full wave rectification takes place on the reference signals. The differences between left and right, and front and rear are determined. Since loudness is a logarithmic function of sound level, the difference functions are performed by logarithmic difference amplifiers. The outputs from the log difference amplifiers are the vector coordinates and magnitude of the dominant signal.

To make the action of signal steering inaudible, the rate of signal level change is controlled by dual time-constant networks. Threshold comparators sense when the time constants need to be switched from long to short. A polarity splitter separates the resulting control voltage into the two main components of each directional axis. This results in four control voltages, one for each main direction. Obviously it is not necessary to steer in opposite directions along the same axis, so at any given moment, only two of the four control voltages are active. A network of eight VCAs are operated by the control voltages, thus producing eight individual outputs. These signals are added and subtracted to/from the left and right (Lt & Rt) channel signals in the combining networks. Thus finally achieving the steering action required and providing the left, centre, right and surround channel signals at the output of the matrix.

A feature of Dolby Pro Logic decoders is the selection of three different centre modes, these being; ON, OFF and

PHANTOM. The normal setting being 'ON' when a centre loudspeaker is used. The 'PHANTOM' setting attenuates the centre channel signal by 3dB and adds it to the left and right channels, producing a phantom centre image, as with the passive decoder. This allows three-channel operation (left, right and surround) without a centre loudspeaker, but the improved centre localisation is lost. The 'OFF' setting is intended for calibration purposes only. In order to optimise the left/right input balance, the centre signal is shut off and the balance is adjusted until centre dialogue is minimised from the remaining loudspeakers.

A further refinement of Dolby Pro Logic decoders is the addition of a sub-woofer output or bass-splitting function; this enables a smaller centre loudspeaker to be used. This facilitates easier siting of the centre loudspeaker in the vicinity of the TV or video monitor (care should be taken to ensure speaker proximity does not affect picture colour or geometry). The low frequencies from the centre channel are re-directed to a separate sub-woofer channel output for amplification and reproduction through a separate low frequency loudspeaker. The low frequency content of the other channels is also added to improve the overall bass response of the whole system. Alternatively, the low frequencies from the centre channel are re-directed to the left and right channels, where the full range loudspeakers are used.

The adjustment of a surround system

requires care if good results are to be obtained, and to eliminate the guess work, a noise sequencer is provided. The sequencer produces a noise signal that is repeatedly stepped clockwise through the left, centre, right and surround channels, holding for two seconds (nominally) in each location. The user can then compare the levels of all four channels and adjust the volume and balance controls on the amplification equipment to achieve equal sound level in all four channels.

The outputs from the Dolby Pro Logic decoder are fed to amplifiers; left, centre, sub-woofer (if implemented), right and surround, and to channel loudspeakers positioned around the listening area. A typical room layout, showing loudspeaker positions, is shown in Figure 8. Some decoders incorporate amplifiers for directly driving the extra loudspeakers in a Dolby Pro Logic system, the left and right channel signals, however, are often reproduced through a separate stereo amplifier and loudspeaker system. Figure 12 illustrates interconnections in a Dolby Pro Logic system.

Conclusion

I hope that this article has given some insight into the world of Dolby Stereo cinema sound, and the domestic versions of the decoding equipment. Readers may be interested to know that Maplin market a Dolby Surround decoder (YU59P), a review of this unit and how it may be used to provide Dolby Surround at home will be published in the near future.

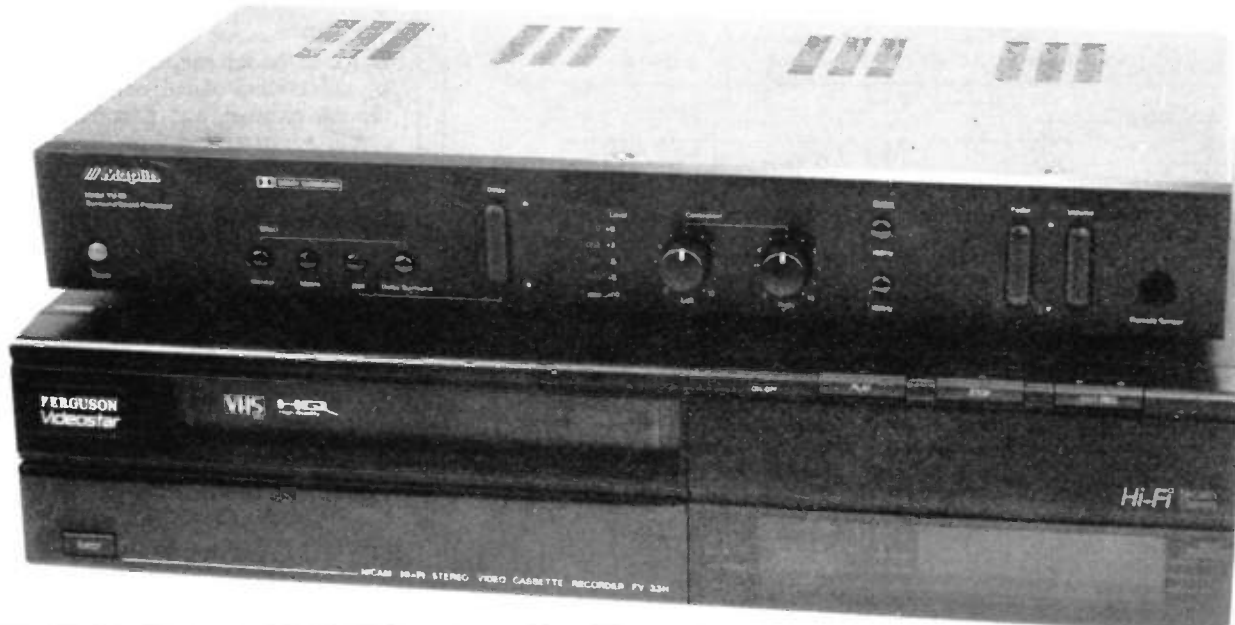

Hi-Fi Video Cassette Recorder and the Maplin Dolby Surround Sound Processor.

<p>Acknowledgements and References</p> <p>Ray Gillon, Film Sound Consultant, Dolby Laboratories Inc. Dale Learie, Licensing Engineer, Dolby Laboratories Inc. Dianne Brissenden, General Manager, Odeon Cinema Southend. Michael Ford, Chief Technician, Odeon Cinema Southend.</p>	<p>Robin Dorking, Senior Technician, Odeon Cinema Southend. Ferguson Video Cassette Recorder supplied by Radio Rentals Ltd, Hockley.</p> <p>Dolby Stereo Cinema Sound Processor Operators Guide, Dolby Laboratories Inc. Dolby Surround Decoder For Consumer Applications, Field Bulletin No. 183, Dolby Laboratories Inc. Dolby Pro Logic Surround Decoder Princi-</p>	<p>ples of Operation, Roger Dressler, Dolby Laboratories Inc. Dolby Surround Sound - Practical Aspects, Graham Carter and John Fisher, Dolby Laboratories Inc.</p> <p>Dolby, Dolby Stereo, and the Double-D Symbols are trademarks of Dolby Laboratories Licensing Corporation. Diagrams reproduced courtesy of Dolby Laboratories Inc.</p>
---	--	---



For a FREE Weekend at Bernies, Jay Seige to The War of the Roses & Pick Steel Magnolias

Courtesy of **ODEON** Cinemas & **Maplin**
ELECTRONICS

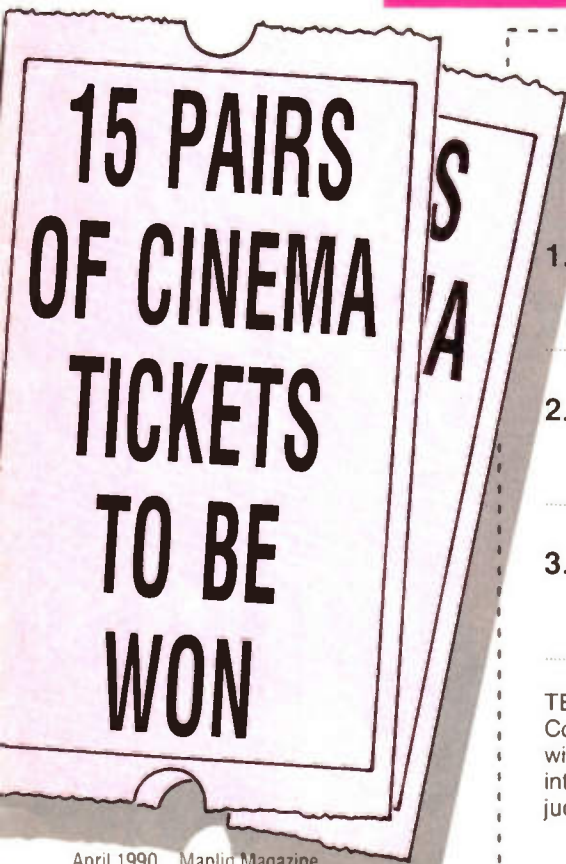

WIN CINEMA TICKETS TO AN **ODEON** CINEMA NEAR YOU!

1. Name the computer in ALIEN?

2. Who 'Came alive' in SHORT CIRCUIT?

3. Who was Luke Skywalker's father?

Just answer the 3 questions opposite about 'characters' from well known films and then please send your entry form to: **THE EDITOR, 'CINEMA TICKETS' COMPETITION, P.O. BOX 3, RAYLEIGH, ESSEX SS6 8LR.**

Name

Address

Post Code

Signature Date

TERMS AND CONDITIONS

Competition closes on 30th April 1990 and is open to UK residents only. No cash alternative will be available. All entry forms showing the correct competition answers will be entered into the DRAW. The first 15 correct entry forms drawn will each win a pair of tickets. The judges decision is final.

*Below: Underwriting room and escalators from Gallery 4.
Main picture: Lloyd's building viewed from the south west.
Inset: The building even has its own 'waiter' outside.*

Today's office buildings, suggests a report from consultants *Butler Cox*, are a mass of trailing cables, tangles of adaptors and plugs and thanks to the inadequate provision of power points, a congestion of wire, inappropriate lighting and poor air ventilation systems. Building designers, engineers, architects and constructors have apparently yet to hear about the IT revolution which has resulted in a tremendous growth in computers and communications within the company.

Adaptor points might well have served yesterday's office where power requirements were probably limited to an electric typewriter, photocopier and coffee machine. Nowadays, an office demands a desktop computer at every workstation, each with shielded power cable points and each interconnected by a wiring network. Those of us who have seen the movies "Wall Street" or "Working Girl" will be left in no doubt about the role that high tech communications plays in business. That role includes much dependence on computer terminals, fax, telex, electronic messaging and of course cellular radio phones. With city traders continuing to deal from the comfort of the *London Groucho* or *Los Locos* clubs, or from their Chelsea-bound Porsche, corporate communications rely on electronic switchboards and relay facilities.

All this electronic activity, then, puts considerable pressure on the office environment if non-information stumbling-blocks are to be avoided. In fact 'stumbling block' would seem to be a most appropriate term, as office staff pick their way cautiously across, round and through assorted cabling runs, the amount of which would seem to be rivalling that of the BT Tower!

Of course the problems are not limited to wiring. The more power used, the more heat generated and with the opening of windows in today's intelligent blocks not exactly encouraged, other ways of dissipating heat must be found. Similarly security and fire precaution networking systems must be provided as well as power back-up facilities.

But what has the intelligent building got to do with 'Electronics' readers? Well, today's building infrastructure, cable development and advances in comms technologies will have a direct bearing on the intelligent home of the future. The need to insert ever more cabling into confined spaces – weight considerations apart – has led to the development of fibre optic cables. As Dr Paul Matthewson of IT cabling specialists *Applied Network Research* points out, a single fibre can replace a nine hundred pair copper cable. When it comes to external networks, while a 78mm strand cable can handle some

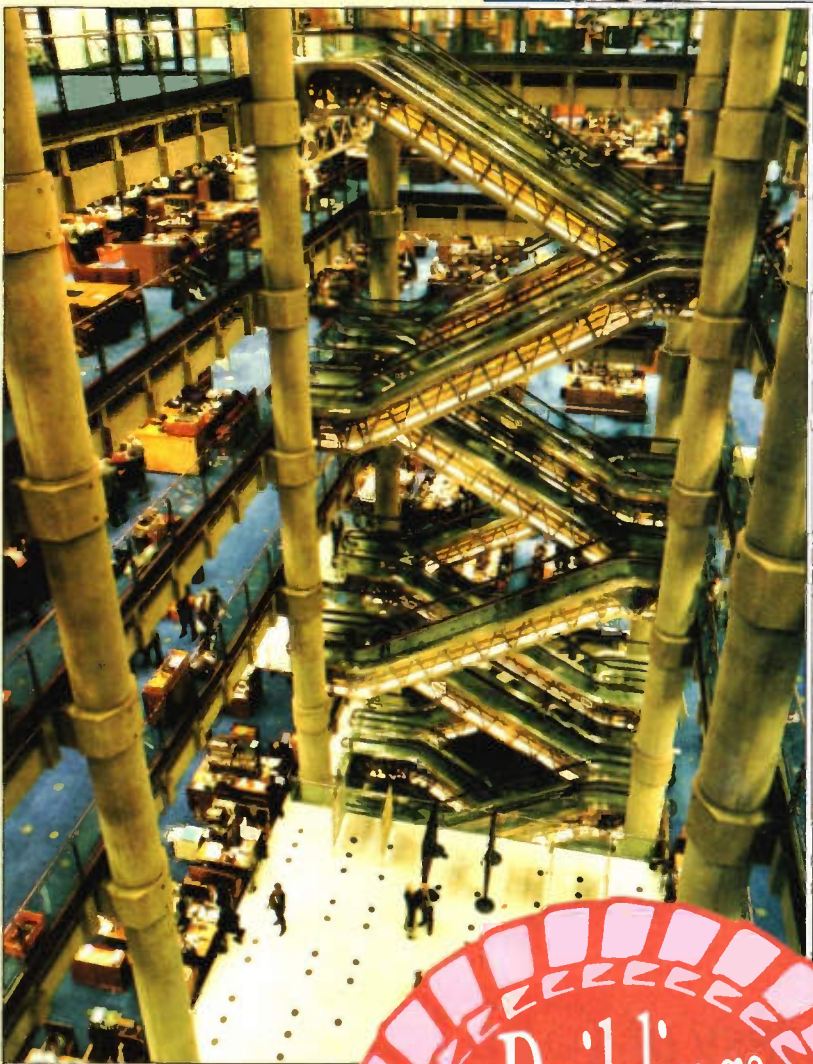

by Alan Simpson

100,000 speech channels given repeaters spaced 1.5km apart, 21 mm optical fibre can handle treble that volume while only requiring repeaters spaced 30km apart.

Candidates for fibre channels include cable TV, entertainment services, data transfer and information channel transmission. Right now there is considerable pressure on the UK DTI to relax the rules in order that BT and Mercury can provide such interactive services as stereo TV, Hi-Fi, radio and telephony. In fact, rules have now been relaxed sufficiently to allow BT to trial a pioneering comms vision for the 21st Century (their words, not those of your reporter).

The 'vision' will use optical fibre pipelines carrying television, high fidelity stereo radio, telephone calls,

Buildings
Get Smart!

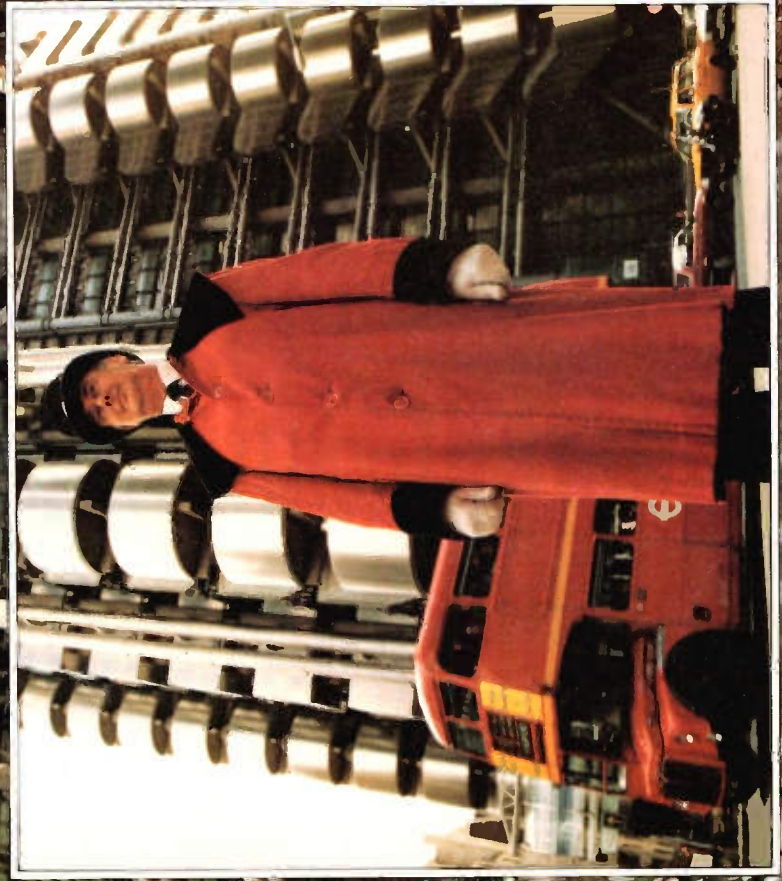
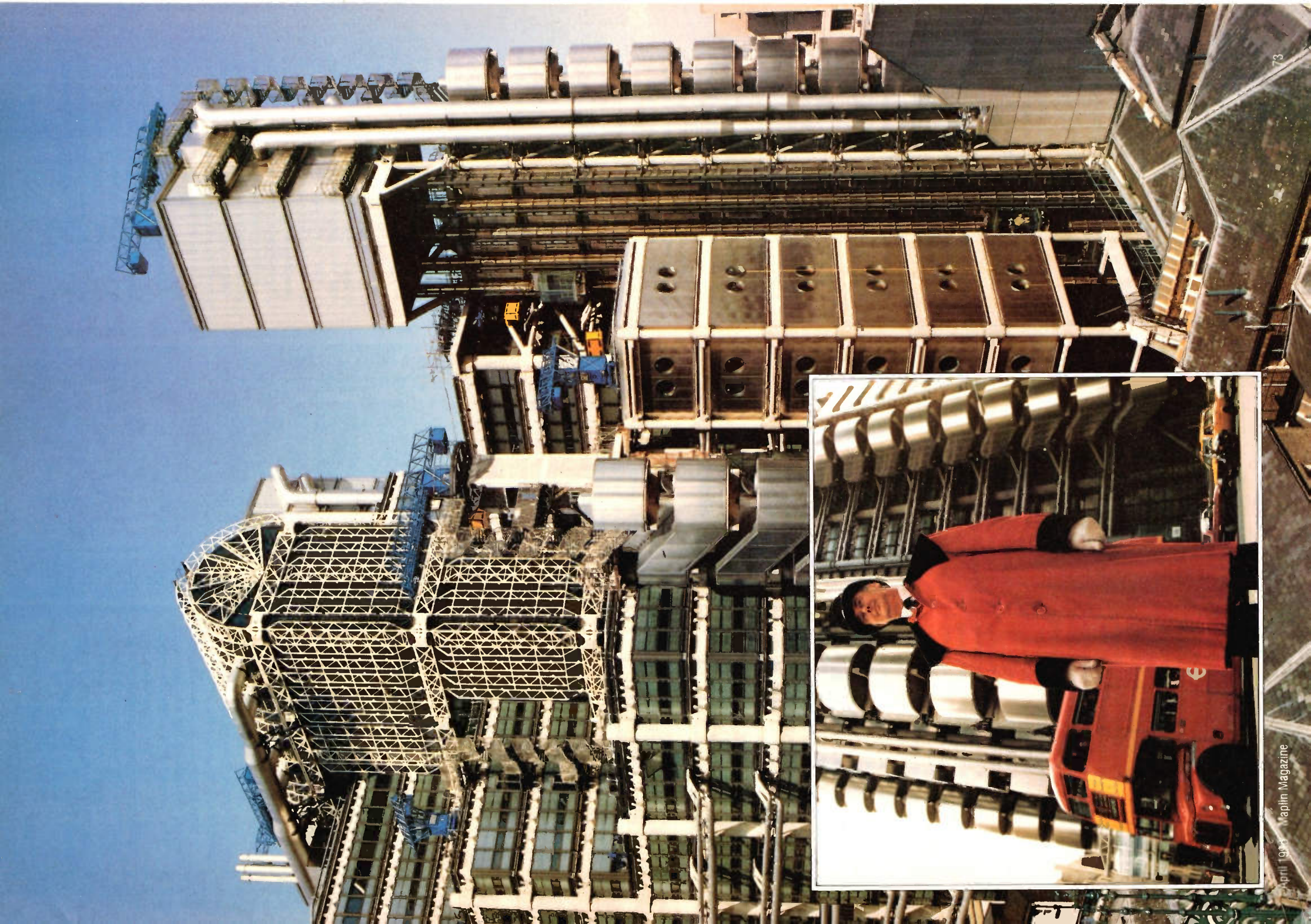

information technology and other interactive services to some 500 houses and businesses in Bishop's Stortford, Hertfordshire. During its two-year run, it will provide industry, as well as BT, with valuable data for planning the advanced commercial communications systems for the next century.

In particular, the trial will enable BT to compare and contrast the operation and cost of two entirely different fibre systems that its research engineers have developed. One is T PON – the Telephony Passive Optical Network, a low cost system using a series of inert fibre splitters, or couplers, to 'siphon-off' services to each customer on the network. Initially these will be just telephone speech and low-speed data, but the system will then be upgraded to B PON (Broadband Passive Optical Network), capable of carrying services such as television, Hi-Fi radio, and a video library.

The other system is Broadband Integrated Distributed Star (BIDS) – an active network using electronic switches to select television, Hi-Fi radio and telephony services. The design incidentally will exploit experience gained in the BT design of a switched star network used by the Westminster Cable TV franchise.

Bending the Rules

At the same time, the UK telecoms industry watch-dog, OFTEL, is under pressure from BT and Mercury, for once acting in agreement, to relax the rules preventing modern wiring schemes for networks being implemented in office buildings. Meanwhile, back in today's intelligent building world, battle lines appear to be forming between the IT designers and building industry contractors and architects. At present neither side appears to understand – let alone acknowledge – the requirements of the other party.

The IT team want more and better trunking and cabling conduits incorporated into the building, together with false floors and suspended ceilings. The building team retort that they have to construct the building at a fixed price which does not allow for such frills and finery. With luck the issue should be resolved in June when the consultancy *Applied Network Research*, in association with building industry authorities, are staging a two-day IT building conference in London. Although whether Prince Charles will be on hand to comment on design formats is not known.

High Tech – Low Points

Most definitely, Prince Charles was not a party to the design planning team responsible for perhaps the most famous 'inside out' building in the UK, the Lloyds Insurance building in the City of London. Despite its claim to be a building of the future, it has turned out to be more a case of 'back to the past' for the occupants! As an intelligent building it scores very few hi-tech points as all involved will readily agree.

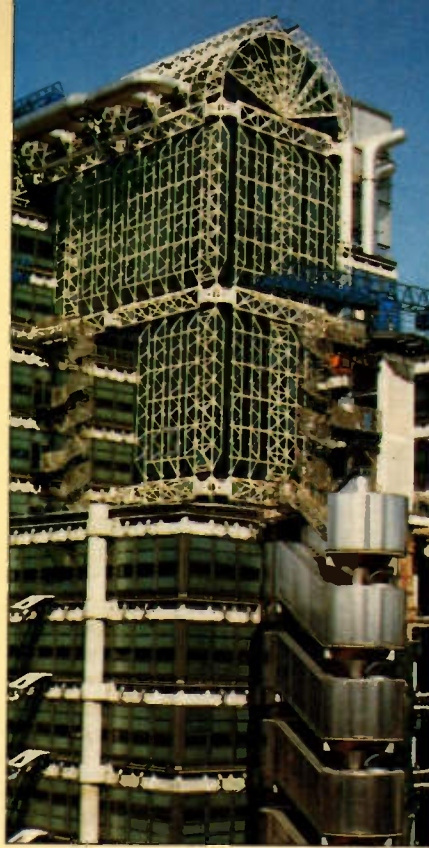

Almost within handshaking distance, one leading financial company has had to rip up its dealing room floor no less than five times in the past six years! Upheaval apart, the cost of such IT diversions are massive. Yet another City dealership had its ceiling cave in under the weight of assorted cabling and trunking. The company concerned obviously had not heard of lightweight fibre optics.

Ceaseless Change

As Rod Homer, who heads the Midland Bank Group Office Network division, comments: "Commercial organisations undergo ceaseless change and the infrastructure must support and enable that. Teams and departments are formed, grow, decline and are disbanded as products, markets and goals change. People move between units taking their specialist skills with them or are retrained in new skills. Buildings must be able to respond to this organisational instability by being; 1, flexible in order to locate departments/functions in any part of the building and for people to move desks or change services without the expense and delay of re-cabling; 2, reactive to demands for changes to business organisation, to changes in methods from paper intensive to screen intensive; 3, cost effective in utilisation of space, in use of specialist skills and in the flow of information.

"All workers in Midland's Head Office buildings will have a desk-top terminal of some sort within the next five years (currently 70% do) and then an increasing proportion will be powerful PC's of 386 or PS/2 architecture. However, given the high volatility of business and the rapid introduction of new technologies, it is neither possible to determine which types of user will be located in any particular building or floor, nor to pre-specify the host and desk-top computing services they will require."

Consultancy *Logica* agrees that many different systems can be involved in a move to a new location – PABX, telex, mainframe, mini and micro-computers, office automation, local area networks, wide area voice and data networks, intercom, paging, dealer boards and command and control systems. Added to that list, says ANR, should be such increasingly important matters as power supply, air conditioning, lighting, security systems and backup.

So what exactly then is an 'Intelligent Building?' According to ANR, it is one which provides the environment which maximises the efficiency of the building and incorporates effective management of resources. Hopefully, it will also be conducive to good working conditions. Meanwhile, *Butler Cox* says that buildings should take into account light reflection from terminal screens, adequate voice and data sockets plus sufficient cooling facilities. Abundant space should be left for power and transmission lines, both within and between floors.

High Tech Snags

Fortunately for the building construction team, hi-tech developments are making life considerably easier. Fibre optic cable is replacing the heavy duty copper cable, saving both space and weight. The snag, and there is always a snag where hi-tech is involved, is not the high cost of fibre optic cable itself but the high cost of terminating or connecting what is normally electronic equipment with a light wave configured cable network.

However, already a compromise solution has been introduced by British Telecom – blown fibre. The techniques of blown fibre is to install empty plastic tubing at strategic points during the building construction stage. These tubes can then be used at a later date to blow fibre optic cable into the required operational environment, without any major disruption. Just about the only hesitation factor is the high licence fee demanded by BT, but no doubt OFTEL are already investigating.

Meanwhile, the move to turn FDDI – the Fibre Distributed Data Interface format – into an international standard has received a major boost from the involvement of digital equipment. The days of coax and twisted pair cabling are now looking increasingly numbered.

Buildings in fact are already becoming smart. Anyone visiting the new Maplin Warehouse at Wombwell will not fail to be impressed by the hi-tech environment. For once it seems that all parties, designers, engineers, technicians and Maplin managers and advisers worked closely together to produce the right goods.

Intelligent buildings could make the difference between winners and losers in today's competitive markets. Because buildings are designed to last for decades rather than years – as is the case with IT developments, the need to plan ahead and build for both today and tomorrow is overwhelming.

Air your views!

A readers forum for your views and comments. If you want to contribute, write to the Editor, 'Electronics – The Maplin Magazine', P.O. Box 3, Rayleigh, Essex, SS6 8LR.

Sounding Off

Dear Sir,
I can't be the only one who isn't in to spare monitors, video and continental TV. My need is just to convert the sound alongside existing TV and run it through the Hi-Fi. Now I don't mind shelling out for the added value in the kit offered, as you have to make a living, but please explain how it can be simplified for my use!

Hugh Haines, Sunderland.

The TV Tuner is designed to provide both demodulated composite video and mono audio (either 5.5MHz or 6MHz FM intercarrier). Additionally an output is provided to feed the 6.552MHz NICAM signal to the NICAM digital stereo TV sound decoder. If you require just 6MHz intercarrier sound, then the NICAM decoder can be omitted and the TV Tuner used on its own. Since the vision demodulator forms part of the AFC and AGC loops, this part of the circuitry, although not required by you, cannot be omitted.

Economy Boards?

Dear Sir,
It is disappointing to see that Maplin have taken the retrograde step of supplying SRBP P.C. board with their kits, instead of the previous high quality fibre glass. SRBP boards suffer from two main defects. Firstly, they are mechanically weak and therefore easily cracked and broken. Secondly, the copper cladding has poor adhesion when heated, with the result that pads tend to 'lift' if a component is desoldered during fault finding or to rectify an error – not unknown during amateur construction. It is agreed that SRBP boards are marginally cheaper than fibre glass, but surely this is of interest only to manufacturers producing large quantities of items. The majority of kit builders usually only construct "one-offs" anyway, so the small increase in the cost of a kit with a fibre glass board will not be a major deterrent. I feel sure that most constructors will not object to paying that little extra for their kits if SRBP is replaced with the far superior fibre glass. I would be interested in your - and other - comments on the above. Finally, when shall we be seeing a Maplin shop in Sheffield, now one of the major cities in England?

R Potter, Chesterfield.

Don't worry we haven't gone back to using SRBP PCB's for our projects! All projects designed after 1984 are supplied with fibre glass PCBs. However projects that were designed before 1984 will have SRBP PCB's supplied, as was specified when the projects were first developed. I can only assume it is one of our older projects that you have built, for which we are still supplying the original SRBP PCB's. For our current projects we favour fibre glass because of the reasons you have mentioned. Panic over? As to your query regarding Sheffield, all we can say is that it's on our list of preferred locations and 'one day' we'll open up there!

Probing Around

Dear Sir,
I am enquiring about a piece of test equipment (used in digital logic fault finding) which I have read about in text books but have not come across in practice. It is a CURRENT PROBE or CURRENT TRACER, the magnetic field detection type (without breaking the circuit). Looking through all the major catalogues, they do not seem to exist. Maplin used to market a current checker (1985) but it is now discontinued. Do you have any information on it and could you by any chance do an article on practical digital fault finding using the above piece of test equipment, it seems a very useful piece of fault finding equipment, if anybody sells them!

D. Lee, Merseyside.
The device you describe is available from Hewlett Packard (HP547A), don't get too excited as it costs around £500! The current checker which we used to sell was a completely different piece of equipment, not intended for digital fault finding, but for measuring current flow in PCB tracks. Some information on digital fault finding using current tracers is in the post to you.

Addressing the Problem

Dear Sir,
With reluctance I am forced to advise you that I wish to cancel 'Electronics' when my present subscription runs out. This is not because of the content of the magazine, which is really excellent, but because of the totally incompetent distribution. Little bits of paper with names on them drafted in a random fashion into plastic bags is no way to distribute a magazine. This month I received 1½ address labels; one my own, the other containing part of an address in Kingsknowe Crescent, Edinburgh. Whoever gets the magazine in Kingsknowe Crescent obviously won't be getting one. Two months ago the package had been opened and resealed by the Post Office to try to find the address and I have also had two magazines in one bag. Quite why you can't get a computer to print the names on standard adhesive labels which can then be automatically stuck on the bags which have been wrapped round the magazine I don't know, but the present system is hopeless. Another problem - why is the magazine not distributed through the magazine trade? Sorry, it is the best electronics magazine going, but this distribution just won't do.

Mr Mitchell, Edinburgh.

Thanks for pointing out the problem to us, until now we thought our address labelling method was a simple and cheap way of doing it. Obviously, it has its problems! Unfortunately we cannot use the sticky label method because of the way in which the magazines are polywrapped, but we are working on an idea of using a 'carrier sheet' which would be dropped inside the wrapper. Obviously we won't be able to improve overnight, but now we are aware of the problem we'll be able to address it!



STAR LETTER

This issue Mr G. Kirby from Dorchester in Dorset receives the Star Letter award of a £5 Maplin Gift Token for his letter on mains electricity safety.



Fuse Holder Confusion

Dear Editor,
After reading the article on construction of the Surround Sound Processor in the February/March issue of electronics, I feel I must write and point out an overlooked error with regards to the fuse wiring. Figure 15, on page 21, shows the live connection being made to the side of the fuse holder, which if probed by an inexperienced finger, would result in a sensation far greater than surround sound will ever be. The live connection should be to the end of the barrel to eliminate the possibility of shocks. Sorry to be 'picky' and keep up the good work.

Safety with the use of 240V AC mains electricity is of prime importance, MAINS ELECTRICITY CAN KILL as can other sources of high voltage; we don't want to loose any of our readers! The fuse holder in the surround sound kit is of the latest 'fully finger-proof' type to BS415, which has a special inner sleeve that prevents contact with live conductors regardless of whether the 'mains in' is connected to the end of the barrel or to the side of the barrel. Top marks for spotting what would have been an error if the old type fuse holder had been used. Perhaps we should have printed details in the article to avoid worry and confusion.



TV Tuner Blues

Dear Sir,
This is a letter of complaint and amazement. Your magazine came through the letterbox of the morning of the 11th January. Good - in it was the eagerly awaited article regarding the TV Tuner module. Ideal, I thought as I had very poor results using an old intercarrier tuner. The vision demodulator is not linear and is producing IP's into the spectrum occupied by the NICAM carrier. So, that very morning I telephone the mail order number on my 'Maplin Club - Priority Service Card' to order a kit:
"Out of Stock"
"Back order?"
"Back order will be fine."
"Delivery date?"
"June."
"Oh, can I order the parts separately?"
"Yes."
"Great - how about a tuner module?"
"Out of stock."
"Oh - how about a PCB?"
"Out of stock."
"Yes, I get the picture, thank you."

I am afraid that is an order you've lost as I will now, as your Editorial puts it, NOT "avoid the possible dangers of fitting my NICAM decoder in my TV set". I am also wondering whether I need the Maplin magazine at all. By the time items are available, I imagine that details will be in the new catalogue anyway. I am sure though that you have more business sense than I do, though the laws of business are obviously beyond me.
Andrew Sinclair, Croydon.

The reason that the TV Tuner kits are not in stock is that some of our suppliers have simply failed to come up with the goods on the promised delivery dates. A case of 'never been in stock' rather than 'out of stock'! We are trying to sort out the problem as quickly as possible. There

are many people waiting for this kit and we really do not like to keep them waiting. When all the parts for a kit are not in stock, the due date on the computer is automatically assigned by default to 6 months ahead, although in practice, a date earlier than this is foreseeable. Please accept our apologies.

Dear Sir,
In reply to Mr R. C. Eade's letter "Telephone Shocker" in magazine No.36 (Feb-Mar '90), and to the Editor, may I point out that with the advent of new digital telephone exchanges now being installed by British Telecom, new Star Services are becoming widely available. One such Star Service is outgoing Call Barring. This service (the use of which requires a telephone capable of tone pulsing), gives five options to bar:
a) bar all calls - except 999 & 151.
b) bar national and international, but not local calls.
c) bar international calls only.
d) bar operator-connected and services - except 999 & 151.
e) bar star-services - except to cancel the call bar using a key code.

Whilst being unable to bar a specific national number group code such as "0898", the service would nevertheless be of great benefit to subscribers in Mr Eade's position.
W Jarratt, Chelmsford, Essex.

Details of BT Star Services are available by dialling your BT Customer Service Office (see telephone directory for local number). Also available from some retailers is a BT Approved device which attaches to a phone socket and at the turn of a key blocks all outgoing calls except 999 calls (incoming calls can still be received).



TDA7052

1 WATT POWER AMPLIFIER

FEATURES

- ★ Low Component Count
- ★ Low Power Consumption
- ★ Short Circuit Protected
- ★ No External Heatsink Needed
- ★ Kit Available

APPLICATIONS

- ★ Radio Receivers
- ★ Cassette Recorders
- ★ Intercoms
- ★ Baby Alarms
- ★ Speech Synthesis Systems

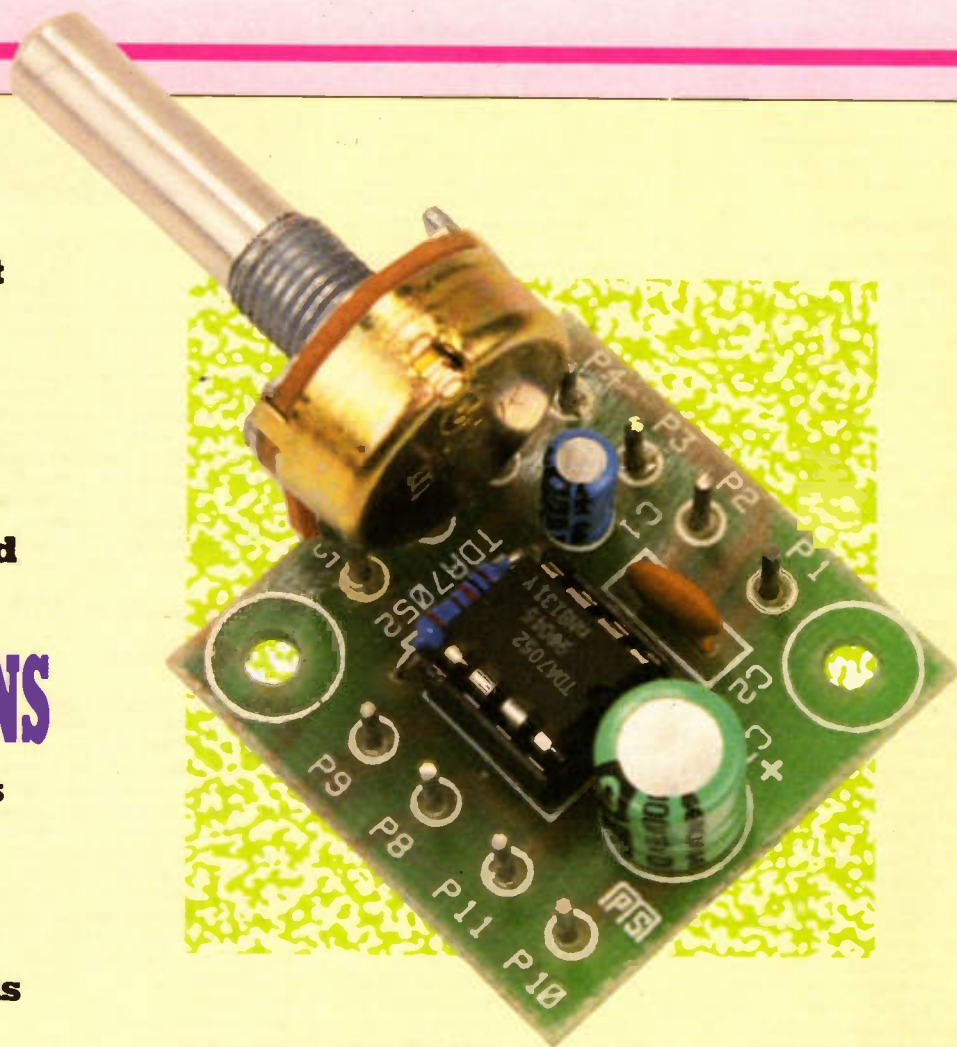

by Gavin Cheeseman

Introduction

The TDA7052 is a 1 watt mono amplifier which is ideal for use in low power battery operated or similar equipment. Because it requires very little in the way of external components to function, the device is ideal for use in portable apparatus. Figure 1 shows the IC pinout and Table 1 lists some typical electrical characteristics for the device. A block diagram of the IC is shown in Figure 2.

IC Description

The device makes use of the 'Bridge Tied Load' principle allowing relatively high power to be developed into an 8Ω load at low voltages. Using this method it is possible to achieve output powers up to 1.2W into 8Ω at 6V with 10% distortion. In addition to power supply voltage, temperature also plays an important part in setting the maximum power limit for the device. The package is capable of dissipating higher power at

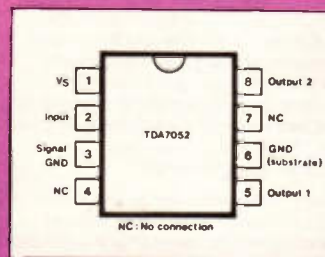

Figure 1. IC Pinout.

lower temperatures and this is illustrated by the power derating curve shown in Figure 3. Amplifier gain is internally set to approximately 40dB making the device suitable for

direct amplification of comparatively small signals to a suitable level to drive a loudspeaker directly. Input impedance is typically around 100kΩ, so input attenuators are fairly easy to implement.

IC Power Supply Requirements

The TDA7052 will operate over a wide range of power supply voltages between 3V and 15V. As with all amplifiers, it is important that the power

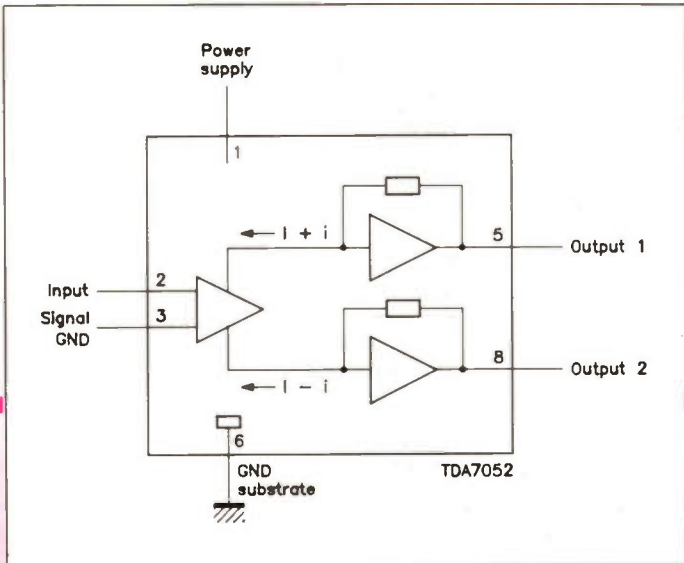

Figure 2. IC Block Diagram.

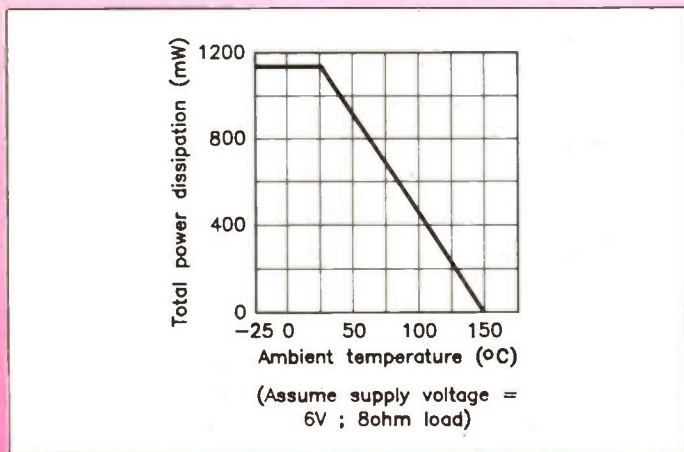

Figure 3. Power Derating Curve.

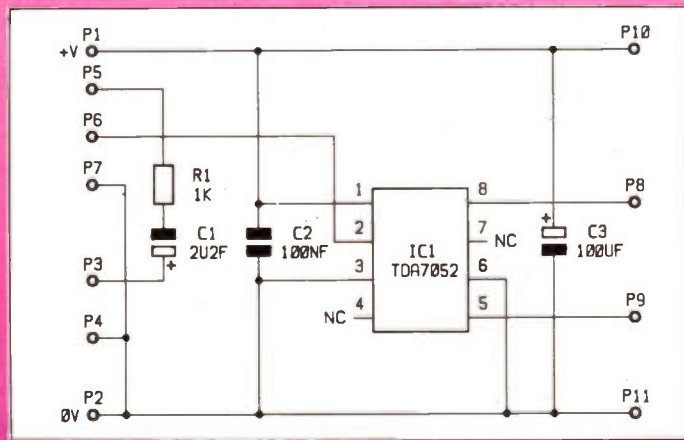

Figure 4. Circuit Diagram.

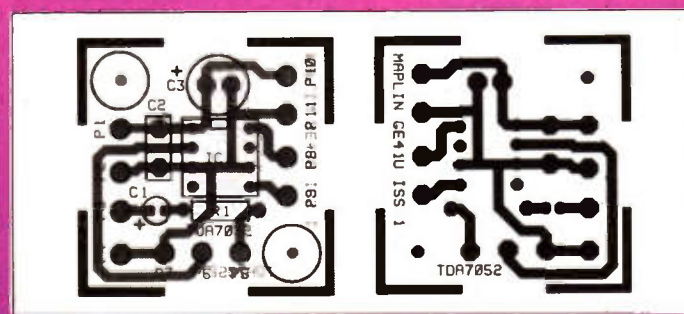

Figure 5. PCB Layout.

supply is properly de-coupled at both high and low frequencies; this prevents any mains derived noise being introduced into the system and also helps to reduce the possibility of instability. IC current consumption is dependent on the load being driven and the amount of power developed. The quiescent current is typically around 4mA. Low voltage operation and the requirement of very few external components makes the TDA7052 ideal for battery operated equipment. The type of battery used will be determined by the maximum current consumption under full load and also of course by the size of the equipment into which the amplifier is to be incorporated.

TDA7052 kit

A kit of parts including a high quality fibreglass PCB is available as an aid to constructors, for a simple application circuit using the TDA7052. Figure 4 shows the circuit diagram of the module and Figure 5 shows the PCB layout. For wiring information refer to Figure 6. PCB pins, P5, P6 and P7 provide for the connection of a rotary potentiometer volume control (RV1) and this component may either be soldered directly to the pins or connected by a short run of cable as appropriate. Long lengths of cable should not be used for this purpose because the amplifier has a high input

impedance and the use of long leads at the input could cause instability problems.

A 3V to 15V power supply that is capable of delivering at least 400mA is required to power the circuit. If a mains derived DC power supply is used it is important that this is adequately de-coupled to prevent the introduction of low frequency noise (mains hum) into the system. Power supply connections are made to P1(+V) and P2(0V).

It is a good idea to use screened lead for input connections to the amplifier module as this helps prevent pickup of external noise and reduces any stray coupling between the input and output; this is particularly important where low level signals are involved. Input signals are applied to P3 (i/p) and P4 (0V) and output (loudspeaker) connections are made to P8 and P9. PCB pins P10 (+V) and P11 (0V) are provided for additional power supply connections to auxiliary

The overall gain of the module is set by the values of R1 and RV1 which act as a potential divider network, attenuating the input signal. With the component values supplied in the kit, the gain of the circuit with RV1 set at maximum is approximately 39dB. Optimum performance and maximum power is achieved when the amplifier is operating into an 8Ω load; however, higher impedance loads may be used with a reduction in output power. A suitable loudspeaker for general purpose use is Maplin stock code YT25C.

Parameter	Conditions	Min	Typ	Max
Supply Voltage		3V	6V	15V
Supply Current	Quiescent, Load Disconnected	4mA		8mA
Output Power	THD=10%, 8Ω Load		1.2W	
Voltage Gain		39dB	40dB	41dB
Total Harmonic Distortion (THD)	Output Power = 0.1W		0.2%	1.0%
Frequency Response		20Hz		20kHz
Output Offset Voltage	Source Impedance (Rs) = 5kΩ		100mV	
Input Impedance			100kΩ	
Input Bias Current			100nA	300nA
Storage Temperature		-65°C		+150°C

Table 1. TDA7052 Typical Electrical Characteristics.

The above specification applies to: power supply = 6V, output load = 8Ω, signal frequency = 1kHz, ambient temperature = 25°C unless otherwise noted.

Applications

Being a general purpose module, the TDA7052 1 Watt Power Amplifier is suitable for use in many different applications where simple but

effective audio power amplification is needed. Typical uses for the module could include low power audio amplification in portable radios, cassette recorders and related devices. Also, the high

gain capability of the circuit makes it ideal for use in intercoms and baby alarms, where the module may be used to amplify signals from a microphone with very little pre-amplification to a suitable

level to drive a loudspeaker directly.

Finally, Table 2 shows the specification of the prototype TDA7052 1 Watt Power Amplifier Module.

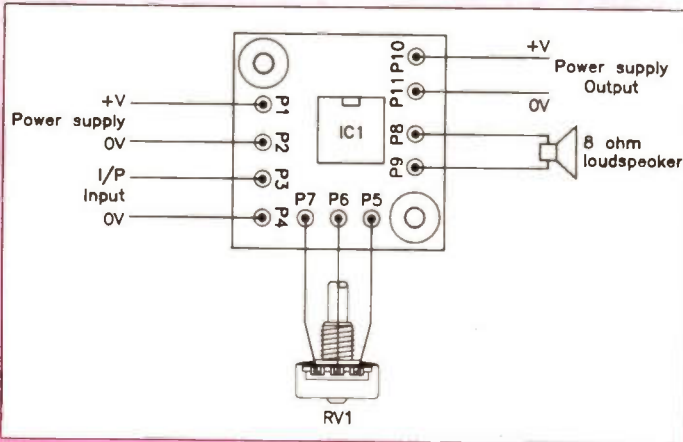

Figure 6. Wiring Diagram.

Power Supply Voltage Range	3V - 15V
Power Supply Current (Quiescent)	4mA at 6V
Power Supply Current (Maximum)	340mA at 6V (For output power = 1W into 8Ω load)
Total Harmonic Distortion (at 1kHz)	0.7% at 0.1W
Output Power (Maximum)	1W RMS at 6V
Voltage Gain (1kHz)	39dB
PCB Size Approximately	32mm x 32mm

TDA7052 1 WATT POWER AMPLIFIER PARTS LIST

Resistors: All 1% 0.6W Metal Film

R1	1k	1	(M1K)
RV1	10k Log. Min. Pot.	1	(JM77J)

Capacitors

C1	2μF 63V Minelect	1	(YY32K)
C2	100nF Ceramic	1	(YR75S)
C3	100μF 16V Minelect	1	(RA55K)

Semiconductors

IC1	TDA7052	1	(UK79L)
-----	---------	---	---------

Miscellaneous

P1-11	Pins 2145	1 Pkt	(FL24B)
	DIL Socket 8-Pin	1	(BL17T)
	PC Board	1	(GE4IU)
	Constructors Guide	1	(XH79L)

A complete kit of parts is available:
Order As LP16S (TDA7052 1W Amp Kit) Price £3.75
 The following item is not shown in our 1990 catalogue:
1W Amp PCB Order As GE4IU Price £1.80

Table 2. Specification of Prototype TDA7052 1W Amplifier.

VARIOUS FOR SALE

SAVBIT solder 24 and 26 s.w.g. £10. Antex iron and bits £2. Ceco 150W TC iron £5. Various terminals most new £5. Two large instrument knobs £1 unused. Tel: (01) 568 6014.

PAIR OF MAPLIN 100W MOSFET AMPS, toroidal transformers, made up in 19" metal case £70. Maplin Sound-To-Light kit £5. Tel: (0539) 722962.

SCOPEX OSCILLOSCOPE SERVICE MANUALS for the following models at £10 each: 4D10A, 4D10, 4D1DB, 456, 14D10, 14D15. S.J. Austin, 8 Greenwood Avenue, Chinnor, Oxfordshire OX9 4HN.

TWO HEAVY DUTY 500 watt fan cooled PSU's. Regulated outputs of 5, 12, 34 volts. £120 each. S.A.E. for spec. C Pointon, 8 Woodland Avenue, Congleton, Cheshire CW12 1LN.

BATTERY CLIPS to suit PP3. 100 clips for £3.50 inc. P+P. Send cheque to C. Bird, 54 Wesley Road, London E10 6JF.

200+ NEW COMPONENTS: transistors, ICs, diodes, resistors, LEDs etc. Minimum value £20. Clearout by hobbyist. £3.00 per bag, five bags £12. Simpson, 42 Wareham Way, Sunnybrow, Crook, Co. Durham DL15 0NG.

DKER'S AUDIO PROCESSOR, as on page 297 Maplin catalogue, LK05F. Kit completely wired and working with Penfold reprint.

Without case or knobs £6. Tel: (0256) 703763.
LASER & CONTROLLER worth £300 can be yours for only £199 o.n.o. Excellent condition. Many uses from school lab to disco special effects. Tel: (0744) 52061.

THANDAR 200MHz LCD Frequency Meter, Thandar 2MHz Function Generator, Fluke 77 autorange multimeter. All excellent condition. £200 or will split. Also ETI modular synthesiser with keyboard - offers. Tel: Paul (0206) 242013.

VARIOUS 110V motors, gear boxes and autotransformers from microfiche machines. 240V timers 0-60s, 0-35s, 0-60min and transformer 100V 6A, 26V 3.2A, 14V 1.6A (220/240 input). Buyer collects. Tel: Burnham (0628) 662643. Any offers?

CELESTION HF 1300 MK2 TWEETERS. 15 ohm, new unused, boxed. £20 pair plus £3 carriage. 4 Cotswold Drive, Garforth, Leeds LS25 2DA. Tel: (0532) 873119.

WATER LEVEL ALARM KIT. Water sounds a loud buzzer, £2.95. 3 hour VHS video cassettes manufactured under licence of JVC,

CLASSIFIED

If you would like to place an advertisement in this section, here's your chance to tell Maplin's 200,000 customers what you want to buy or sell, or tell them about your club's activities - absolutely free of charge. We will publish as many advertisements as we have space for. To give a fair share of the limited space, we will print 30 words free of charge. Thereafter the charge is 10p per word. Please note that only private individuals will be permitted to advertise. Commercial or trade advertising is

strictly prohibited in the Maplin Magazine. Please print all advertisements in bold capital letters. Box numbers are available at £1.50 each. Please send replies to Box Numbers to the address below. Please send your advertisement with any payment necessary to: Classifieds, Maplin Mag., P.O. Box 3, Rayleigh, Essex SS6 8LR. For the next issue your advertisement must be in our hands by 2nd April 1990.

£2.75. Please add 65p p&p. Order now or SAE for list. S. Lord, 6 Stubbing Brink, Hebden Bridge HX7 6LR.

ELECTRONICS TODAY INTERNATIONAL back issues from April 1977 until December 1985. £1.00 each including postage in the UK. Tel: Gerry on (01) 373-6303.

ELECTRONICS, The Maplin Magazine, number 8 to number 29 inclusive. Maplin Project Books five, six and seven. Sinclair Projects December 1982 to September 1984. Offers. Tel: T. Foxcroft on (0452) 612234.

PHILIPS RF GENERATOR PM5321, FM/AM, Int/Ext. modulation, 150kHz to 108MHz, variable output, good condition, valve design. £35. Phone 0543 491867 (Lichfield area).

SALE: Maplin weather satellite receiver fully cased, 137MHz amplifier, Meteosat down converter and pre-amp, channel switching unit, cost over £220. Offers invited. Tel: Thornbury (0454) 417533.

COMPUTERS

New PLA (111) for Commodore 64 computer. £5. Tel: (0394) 271634.

PRINTER SHARER. Automatic printer sharer between 2 PCs, XT's, AT's or compatibles, and one parallel printer. Completely user transparent. No set up required. £39.95. Tel: Leeds (0532) 520573 eves.

ACORN ELECTRON, Cassette recorder, games, magazines, books, joystick interface dustcover leads - £35 ovno. MC 68008L8 - £10. 9" Monitor, spare tube - £20. Tel: Rob after 7pm on 0272 570652.

TWO 8 INCH DISK DRIVES with manuals £35 each. Components, panels £5 a bag. 1m wide case £20. SAE for list. Nick Roberts, 19 Cautley Close, Quantock, Bucks HP22 4BN.

ABSOLUTE ZERO BBS welcomes all new users. We cater for IBM PC, CPM, Amiga. Atari ST. File Xfer & Echomail. Call 01-741-7233 V21-22 BIS. 6pm - 8am weekdays, 24 hours weekends.

EPROM PROGRAMMER attached to much expanded VIC 20. £50 ono. Atari 1020 Printer Plotter, unused. £30. Tel: (0625) 20782.

ORIC ATMOS 4 Colour plotter/printer, data recorder, leads, 2 interface boards and Oric talkback. Also Oric circuit and various books £70. Tel: J.M. Bentley on (0509) 890241.

ATARI 65XE COMPUTER FOR SALE.

Complete with PSU, cassette recorder, video lead and manual. no software. £40. Write to: D. Banham, 3 Elm Road, Wantage, Oxon.

SPECTRUM 128 +2, Interface 1, 2 MICRODRIVES, Microdrive Cartridges.

Connecting Leads, Cheetah 125+ Joystick (including optional Interface). Assorted 48k/128k (tape) software, including Scrabble, Trivial Pursuit, and some Fisher-Price Educational software (suitable ages 5 to 12). Serial Interface & lead for Citizen 120D printer. £200 ono. Tel: T.J. Peel on (0825) 717829.

FOR SALE, 30 boxes of unused 5¼" 96 t.p.i. discs, 10 in a box, with labels etc. Only £6.99 each. Loss of computer forces sale. Please write to: Howel Thomas, 114 Sketty Road, Swansea SA2 0JX.

AMSTRAD CPC-464 with colour monitor; plus over 50 of the best games worth £300, together £200 for quick sale. D. J. Davis, Orington, Kent. 0689 57980.

LINNET V21/23 MODEM in excellent condition C/W Atari ST connecting lead and ST comms. software. £100.00 inc. carr. in UK mainland. Tel: Anthony 0733 311858 after 7pm.

MUSICAL

MAPLIN 'MATINEE' Electronic Organ, professionally built, 2 keyboards, pedals, rhythms, drawbar voicing, rotor sound, etc. Detailed circuit data for easy maintenance. Offers around £200. Woking 733620.

MAPLIN MESS3 ORGAN: 2 keyboards, pedalboard, rhythm unit, drawbars, electronic Leslie stereo (75W + 75W RMS) amplifier. Full working but will break to sections or PCB's. Must Sell. Offers. Tel: Southampton (0703) 695498.

FOR SALE: Organ LC's M108B (2), M147, AY-3-0215 (2), AY-1-0212 (2), M254B, M251B, TDA1022 (2). Offers! Rogers, 39 Goodmayes Close, Bedford MK42 0LX. Tel: (0234) 268433.

WANTED!

WANTED: Oscilloscope dual trace. Tel: 0742 304665 after 6pm. (Sheffield).

WANTED: Circuit info for Hammond J22 Organ (2 manual + pedal). Only existing info: Serial 17668. Date: 6/8/68. Copying, etc negotiable. Richard Lundsell, Ringers, Upper London Road, Braintree, Essex CM7 8QQ.

WANTED: A copy of QIC stream utility software for archive XL 40MB tape stream. Details to: S. Bell, 67 Boyd Street, Newburn, Newcastle on Tyne NE15 8LU.

WANTED: A 4 to 9 inch monitor or TV with video input. Any offers considered. Please write to: C. Beaumont, 207 Neale Avenue, Kettering, Northants. NN16 9HF.

WANTED: Resistor 0-1015 watt adjustable. Unable to purchase. Please contact Liam Kavanagh, 38 Bakewell Road, Burton wood, Warrington, Cheshire WA5 4PA.

WANTED: Instruction manual (or copy) for Hartley oscilloscope type 13A, also service manual (or details) for Spectrum 48K computer, early types. Tel: (07048) 31300.

WANTED: A-Level student would like an old graphics tablet (doesn't have to work) or circuit diagrams. Grateful for anything. Please send to: R. Vernon, 5 Paddocks Green, Mossley, Congleton, Cheshire CW12 3BN.

NOW

6 ISSUES A YEAR!

There are 6 tremendous reasons why you should subscribe to Electronics – The Maplin Magazine

- * Every issue is sent to you as soon as it's published, post free.
- * Packed with interesting and novel projects that you can build with all components easily available.
- * Many features on electronics subjects to keep you up-to-date with latest developments.
- * Minimum advertising space means more pages for you to read.
- * Still far cheaper than the 'Monthlies', most of which are now £1.50 or more per issue.
- * Six times a year means a 50% increase in articles and projects for you to read and build.

To subscribe just send a cheque/postal order for £7.20 made payable to Maplin Electronics, P.O. Box 3, Rayleigh, Essex SS6 8LR. **OR** you can take advantage of our offer of two free issues by completing the coupon below and agreeing to pay by Credit Card or Direct Debit. The two free issues offer only applies if you use one of these two methods of payment. Simply fill in the 'Payment by Credit Card' or 'Payment by Direct Debiting Mandate' and return it to Maplin. Every time, about 1 month before your subscription is due, we will send you a letter giving details of the subscription rate for the next year and telling you the date on which we will charge your Credit Card or debit your bank account. If you do not wish to continue your subscription, you have until that date to let us know, and we will then cancel your authority to bill your Credit Card or cancel your mandate. Otherwise, if you do nothing, your subscription will continue. The authority or mandate you give us does not allow us to charge anything other than the Maplin Magazine subscription. The benefit to you is that you no longer need to remember to re-new your subscription or send off any more cheques or postal orders. Payment is made automatically.



TAKE THE NEXT TWO ISSUES OF THIS MAGAZINE FREE!!

Because we're so certain that once you've seen the Maplin Magazine you'll want to continue to receive it, we're offering to send you the next two issues free of charge with absolutely no obligation to continue. Just fill in the details below and if after receiving two issues you do not wish to continue, just let us know at least one month before the next issue is due and we will cancel your subscription. The two free issues will be yours to keep whatever you decide. If you already have a subscription, fill in the details below and we'll add two issues free of charge to your current subscription. **SEND NO MONEY NOW.** About 2 weeks before the third issue is due, we will charge you £7.20 for the next six issues, unless you have cancelled. This offer is not available to those already paying by Direct Debit or Continuous Credit Card or those who have stopped payment by either method within the last two years. Please start my subscription with issue 38. This offer is open to residents with U.K. addresses only.

EITHER

★ PLEASE ADD YOUR ADDRESS, SEE BOTTOM RIGHT ★

PAYMENT BY CREDIT CARD. Please charge my Credit Card Account

Access Visa American Express Mapcard

I authorise you until further notice in writing to debit my CREDIT CARD account with £7.20 and in future, with any amounts which, after notification, MAPLIN ELECTRONICS PLC. may debit thereto in respect of my subscription to the Maplin Magazine.

Account No.	
Signature	Date

OR

PAYMENT BY DIRECT DEBITING MANDATE in favour of Maplin Electronics plc, P.O. Box 3, Rayleigh, Essex SS6 8LR.

Direct Debit payment option is only open to customers with bank accounts in the UK including Channel Isles, Isle of Man and N. Ireland.

Please note: Instructions cannot be accepted to charge Direct Debits to a Deposit or Savings Account.

Bank Sort Code 	Bank Account Number
--------------------	-------------------------

Name of Account to be debited

The Manager

I authorise you until further notice in writing to charge my account with you any amounts which MAPLIN ELECTRONICS PLC may debit thereto by Direct Debit in respect of my subscription to the Maplin Magazine.

I will inform the bank in writing if I wish to cancel this instruction.

I understand that if any direct debit is paid which breaks the terms of this instruction, the bank will make a refund.

Signature	Date

Enter your address and Maplin customer number, if known.

	Post Code

Maplin's 20 BEST SELLING BOOKS!

These are our top twenty best selling books based on mail order and shop sales during December 1989 and January 1990. Our own magazines and publications are not included. The Maplin order code of each book is shown together with page numbers for our 1990 catalogue. We stock over 250 different titles, covering a wide range of electronics and computing topics.

Number One

Loudspeaker Enclosure Design and Construction by Fane Acoustics

This book contains a broad selection of cabinet designs from small-sized bass reflex cabinets to multi-way power systems. (WM82D) Cat. P99. Previous Position: 1
Price £3.00



2

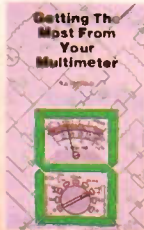

Getting the Most from your Multimeter, by R. A. Penfold. (WP94C) Cat. P93. Previous Position: 2. Price £2.95

3



IC555 Projects, by E.A. Parr (LY04E) Cat. P96. Previous Position: 3. Price £2.95

4



A Concise Advanced User's Guide to MS-DOS, by N. Kantaris. (W544X) Cat. P108. Previous Position: 17. Price £2.95

5



Power Supply Projects, by R. A. Penfold. (XW52G) Cat. P95. Previous Position: 4. Price £2.50

6



Introduction to Electronics, by Pam Beasant. (WPS0E) Cat. P93. Previous Position: 5. Price £3.50

7



Remote Control Handbook, by Owen Bishop. (WS23A) Cat. P95. Previous Position: New Entry. Price £3.95

8



International Transistor Equivalents Guide, by Adrian Michaels. (WG30H) Cat. P89. Previous Position: 8. Price £3.50

9



Radio Amateurs Examination Manual, by G.L. Benbow. (WP87U) Cat. P101. Previous Position: 6. Price £5.00

10



Mastering Electronics, by John Watson. (WM60Q) Cat. P93. Previous Position: 9. Price £4.50

11



More Advanced Power Supply Projects, by R. A. Penfold. (WP92A) Cat. P95. Previous Position: 7. Price £2.95

12



MIDI Projects, by R. A. Penfold. (WP49D) Cat. P100. Previous Position: 18. Price £2.95

13



50 Projects Using Relays, SCR's and Triacs, by F.G. Rayer. (RH30H) Cat. P95. Previous Position: 20. Price £2.95

14



Electronic Security Devices by R. A. Penfold. (RL43W) Cat. P96. Previous Position: 11. Price £2.50

15



Home Electrics, by Geoffrey Burdett. (RO22Y) Cat. P84. Previous Position: 15. Price £4.95

16

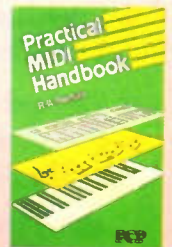

Practical MIDI Handbook, by R. A. Penfold. (WP96E) Cat. P100. Previous Position: New Entry. Price £5.95

17



50 Simple LED Circuits, by R. N. Soar. (RF12N) Cat. P97. Previous Position: New Entry. Price £1.95

18



Towers' International Transistor Selector, by T.D. Towers. (RR39N) Cat. P89. Previous Position: 19. Price £19.95

19



How to Design and make Your Own PCB's by R.A. Penfold. (WK63T) Cat. P92. Previous Position: 16. Price £2.50

20

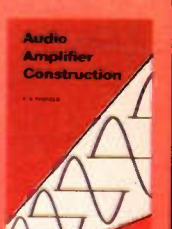

Audio Amplifier Construction, by R. A. Penfold. (WM31J) Cat. P98. Previous Position: 13. Price £2.25

NOW OPEN

WE GUARANTEE A FRIENDLY WELCOME AND THE BEST OF SERVICE AT OUR

NEW SHOP IN READING



Browse leisurely round any of our stores and pick up a bargain **TODAY!**



**NEW STORE IN
NEWCASTLE-UPON-TYNE
NOW OPEN!**

Maplin **HELP SERVE YOU BETTER!**

BIRMINGHAM
Sutton New Road, Erdington.
Tel: 021 384 8411.

BRISTOL
302 Gloucester Road.
Tel: 0272 232014.

LEEDS
Carpet World Building,
3 Regent Street.
Tel: 0532 449200.

LONDON
146-148 Burnt Oak Broadway,
Edgware.
Tel: 01 951 0969.

159-161 King Street, Hammersmith.
Tel: 01 748 0926.

MANCHESTER
8 Oxford Road.
Tel: 061 236 0281.

NEWCASTLE-UPON-TYNE
Bennetts Electrical Superstore,
136-168 Shields Road, Byker.
Tel: 091 224 0990.

NOTTINGHAM
86-88 Lower Parliament Street.
Tel: 0602 410242.

READING
129-131 Oxford Road.
Tel: 0734 566638.

SOUTHAMPTON
46-48 Bevois Valley Road.
Tel: 0703 225831.

SOUTHEND
282-284 London Road,
Westcliff-on-Sea, Essex.
Tel: 0702 554000.

*There's a friendly
welcome in store for you
at any Maplin shop.
Our helpful staff will
often be able to help you
with a technical problem
or a constructional
difficulty.*

For mail order enquiries, please **DO NOT** call our shops as they will be unable to help you.

- ★ Expert Help & Advice
- ★ Credit Facility Available (written details on request)
- ★ Self-Service – browse at leisure
- ★ Open **SIX** days every week
- ★ Shop with confidence with the **Maplin Guarantee**

Before you send your next order to us by post, take a look and see if there's a Maplin shop near you. In our shops you'll find that personal service that even the best mail order operations cannot match. And you can check out the goods **BEFORE** you buy. If you're coming for a particular item, a quick phone call will enable you to be certain the shop has everything you want in stock.

Our shops are pleased to accept Access, Barclaycard, Connect, American Express, Mapcard and cheques up to £50 with a cheque guarantee card. We'll even accept ordinary money as well!

All our shops are close to excellent parking facilities, meters in London and Manchester, and free elsewhere.



BRIGHTON: Opening early 1990
Tel: 0702 552911 for details



**POP IN TO A *Maplin* SHOP TODAY AND DISCOVER
A UNIQUE SHOPPING EXPERIENCE!**

Double Tops

DUAL BAND VHF (45W)/UHF (35W)

FM MOBILE TRANSCEIVER

When only the best is good enough – and

you still want something better . . .

- ★ Cross Band Full Duplex
- ★ 4 Scanning Modes
- ★ 10 Function Memory Channels
- ★ Highly Visible Colour LCD Display
- ★ Illuminated Front Panel Controls
- ★ 5 Channel Spacing Steps
- ★ Built-in Duplexer
- ★ Function Keys have Unique Audible Tone
- ★ Bell Function
- ★ Compact & Lightweight

Accessories Included:

- ★ Hand-held microphone
- ★ Mobile mounting bracket
- ★ Mounting hardware
- ★ Power cable

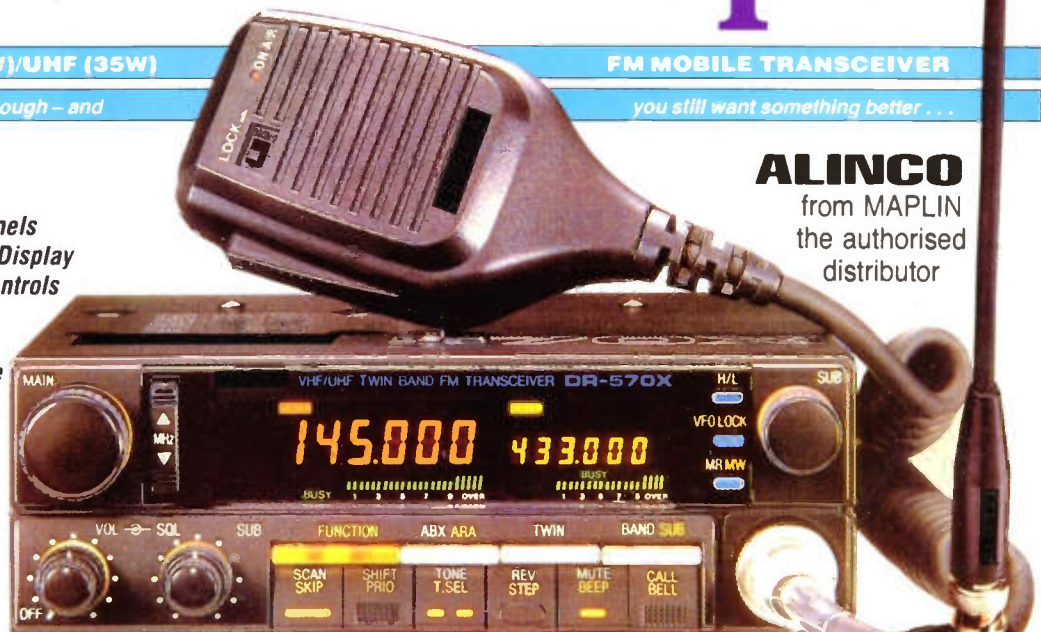

ALINCO
from MAPLIN
the authorised
distributor

This very high quality 2m/70cm FM dual band mobile transceiver has been specially designed to provide maximum performance and operating convenience in an ultra compact package. An impressive array of features gives maximum flexibility in mobile installations. The transceiver has an output power of 45W (VHF) 35W (UHF) and incorporates a high/low power switch. The unit is provided with 10 programmable memories. Channel spacing is in 5, 10, 12.5, 20 and 25kHz steps. There are four scanning modes:

1. VFO scanning of the entire band.
2. Memory scanning of selected memories.
3. Programmed band scanning of a selected segment of the band.
4. Priority scanning allows selection of a frequency, in VFO or memory, to serve as a priority frequency.

A duplexer is built-in so that when an antenna for both bands is in use, only one feeder cable for the transceiver is necessary.

The unit is supplied with a comprehensive instruction manual. It is illegal to transmit with this unit unless you hold a Radio Amateur's Class B (or A) licence.

Quote Reference DBT60 **£499.95**

PLUS TOP VALUE AMATEUR RADIO VHF FM Handheld 2m Transceiver

- ★ Ultra compact, lightweight design
- ★ 6.5W Output Power (with optional 12V battery pack)
- ★ Simple Operation
- ★ Easy to See LCD Display
- ★ 10 Channel Memories
- ★ Battery Save
- ★ Function Lock
- ★ Tone Burst
- ★ Amazing Compact Size Only 3×6×17 cm approx.

A very high quality, lightweight, 2m handheld transceiver, incorporating many useful features. This transceiver is extremely simple to operate, most functions can be performed with one hand!

Quote Reference AHT60 **£219.95**

12V Ni-Cad Battery Pack

For use with either above hand-held transceivers. A 12V 700mAh battery pack with integral DC-DC converter which allows the transceiver to be powered from a car cigarette lighter socket.

A charger is also available for use with this pack. Battery Pack NBP60 **£59.95** Charger NBC60 **£14.95**



VHF/UHF FM Dual Band Handheld Transceiver

- ★ 6W VHF/5W UHF Output Power (with optional 12V battery pack)
- ★ Cross Band Full Duplex Operation
- ★ Frequency selection by Direct Keyboard Entry or Step Up/Step Down
- ★ Automatic Battery Save Function
- ★ 20 Memory Channels
- ★ Built-in DTMF Keypad and Encoder
- ★ Amazing Compact Size Only 3×6×19 cm approx.

This unit is very compact and is one of the smallest dual band transceivers currently available. With the battery pack supplied output power is 2.5W for VHF and 2W for UHF. Frequency selection is either by direct keypad entry of the required frequency or by using step up/step down buttons in increments/decrements of 5kHz, 100kHz and 1MHz. An automatic battery save (ABS) function will extend battery life considerably. There are 20 memories (10 VHF and 10 UHF) for storing operating, offset and tone frequencies. The scanning facility has a priority function which has the ability to scan between chosen VHF and UHF frequencies. A 10dB RF attenuator is switch selectable and can be used in areas of high RF saturation.

Quote Reference DHT60 **£369.95**



Maplin ELECTRONICS

P.O. Box 3, Rayleigh, Essex SS6 8LR.

CREDIT CARD HOTLINE

0702 554161



PHONE BEFORE 5PM FOR SAME DAY DESPATCH

or call in at a Maplin store in Birmingham, Bristol, Leeds, Hammersmith, Edgware, Manchester, Nottingham, Newcastle-upon-Tyne, Reading, Southampton and Southend-on-Sea.

Add 75p for carriage on all mail orders. If only ordering a catalogue, just add 50p carriage. Subject to availability. Prices may change after May 1st 1990.

SEE THE COMPLETE RANGE OF TRANSCEIVERS AND LOTS MORE IN OUR BUMPER 580-PAGE CATALOGUE ON SALE NOW AT ALL BRANCHES OF WHSMITH – PRICE £2.25!