

# INDUSTRIAL ELECTRONICS

OCTOBER 1963 \$4.00

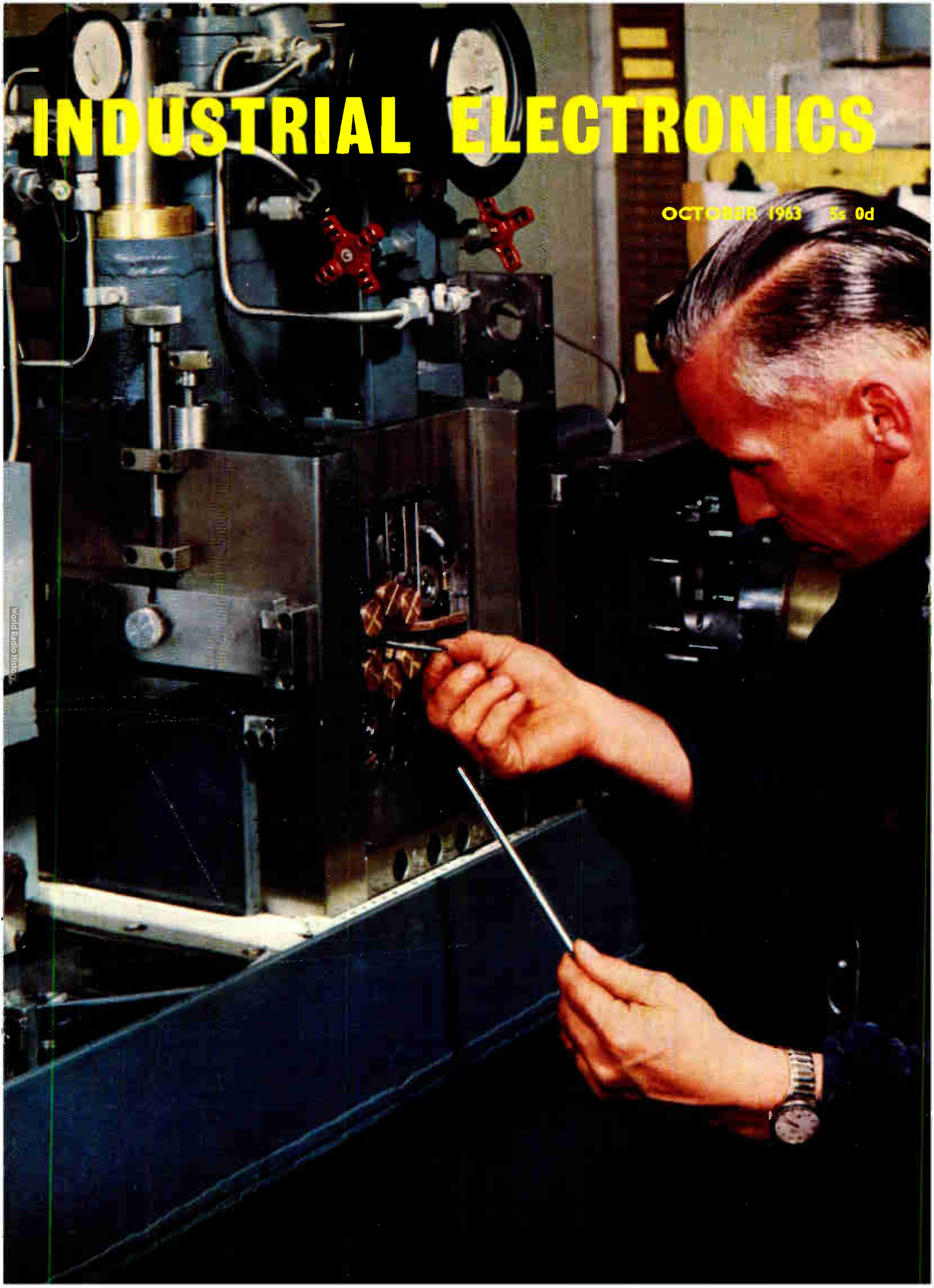

World Radio History

For further information circle 200 on Service Card

# LOOK—NO CONTACTS!

## NORBIT STATIC SWITCHES for automatic control systems NEVER NEED MAINTENANCE

No maintenance, no 'sneak circuits', operation in *any* position, constant speed and a life unaffected by the number of operations.

These are only some of the many reasons why electrical and electro-mechanical engineers, in increasing numbers, are using Norbit static switches instead of relays in a wide variety of automatic control and alarm applications, from lift systems to food processes.

Since they use no moving parts contactless Norbit switches need no adjustments, no cleaning and suffer no mechanical wear or variation in operating speed. 'Time wasting 'cut and try' methods are also eliminated during system design—using Norbits you can plan your complete system on paper and know that what you plan will work in practice.

Furthermore, one basic Norbit gives you any switching function you need. No contacts, no sparking, no heat to dissipate,

unaffected by detrimental atmospheres—dust, abrasive particles, humidity, corrosive fumes, hazardous atmospheres—the reliability of Norbit static switches has been proven in practice and by exhaustive quality testing.

**Here's all you need to know** How does the Norbit switch if it uses no contacts? Just regard the Norbit as a switch which does not open or close, but one which either conducts or does not conduct. Furthermore, there's *no need* for you to know any electronic theory to understand Norbits and apply their many advantages.

**Free to the practical engineer** Write for a free copy of 'Static Switching Simply Explained'. This booklet gives you a completely non-mathematical explanation of Norbit static switches—what they can do and how they can be used. Write today for this practical guide to contactless switching using Norbits.

**MULLARD EQUIPMENT LIMITED**

MANOR ROYAL, CRAWLEY, SUSSEX  
Telephone Crawley 28787



# INDUSTRIAL ELECTRONICS

incorporating *ELECTRONIC TECHNOLOGY*



Volume I Number 13 October 1963

## contents

Editor **W. T. COCKING, M.I.E.E.** 649

Assistant Editor **T. J. BURTON** 651

Advertisement Manager **G. H. GALLOWAY**

### Comment

#### 651 **Ultrasonic Cleaning Systems** *by Alan E. Crawford*

A recent development in ultrasonic cleaning apparatus is the use of barium titanate and lead zirconate titanate elements in the transducers. This has changed the design of the associated equipment and cleaning baths of up to 3,000 gallons capacity are now practicable.

#### 657 **Ultra-Thin Foil Strain Gauges** *by A. L. Window*

Resistance strain gauges have been used for many years. Recent developments have permitted the production of ultra-thin foil and this has enabled the size of strain gauges to be greatly reduced. Standard sizes now range down to only  $\frac{1}{4}$  in. long and still smaller ones can be made.

#### 660 **Automation in the Glasshouse** *by J. A. Irvine, B.Sc.*

The cost of fuel and labour is a major item in the production cost of crops, such as tomatoes, grown in a glasshouse. This article describes automatic controls for regulating temperature, ventilation and humidity.

#### 663 **Automatic Control of a Tailor-Knitting Machine** *by M. Browning*

This article describes the data-handling systems for an automatic knitting machine. The data is stored on tape and controls the knitting of a three-dimensional garment as well as the pattern.

#### 665 **Presentation of Marine Radar** *by J. A. Glasgow*

Radar equipment is described in which a true north-up form of display is obtained but is presented in the form of a ship's-head-up display. Thus the convenience of the latter is secured but at all times true compass bearings can be obtained.

#### 681 **The Broadband Characteristics of Some Basic Transmission Line Elements** *by H. V. Shurmer, M.Sc., Ph.D.*

Design data in the form of universal broadband characteristics are presented for quarter-wave transformers, dielectric-filled sections and for pairs of resistive and reactive obstacles shunted across a transmission line, the latter serving to illustrate the potentialities of semiconductor p-i-n and varactor switching diodes.

*continued overleaf*

Published on the first Thursday after the 5th of each month by  
**ILIFFE ELECTRICAL PUBLICATIONS LTD.**  
Managing Director: W. E. Miller M.A., M.Brit.I.R.E.  
Dorset House, Stamford Street, London, S.E.1.  
Telephone: Waterloo 3333.  
Telegrams: Wirenger, London, Telex.  
Cables: Wirenger, London, S.E.1.

ANNUAL SUBSCRIPTION, HOME £3 0s. 0d.  
OVERSEAS £3 10s. 0d.  
CANADA and U.S.A. \$10.00.



# TWO GUNS

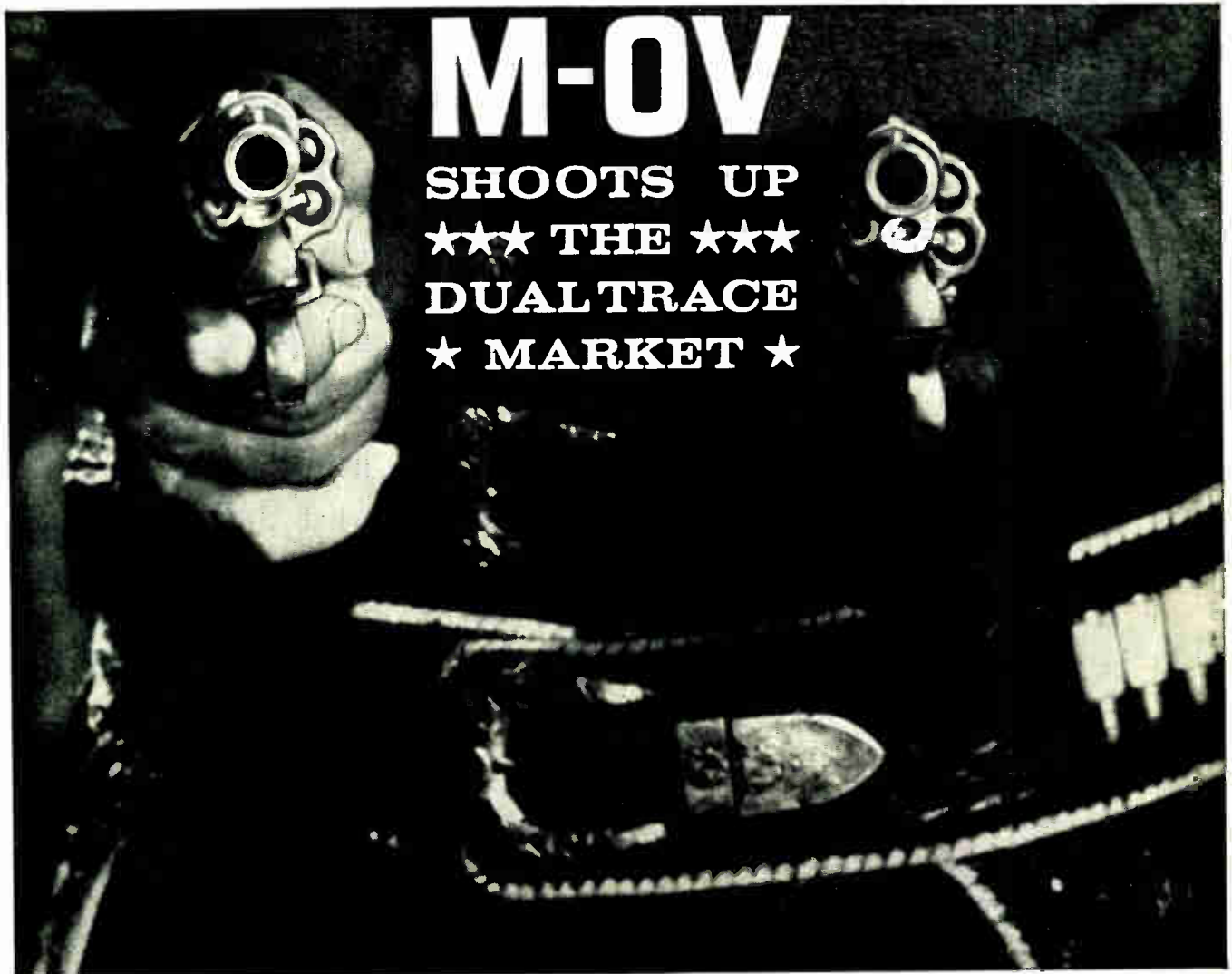

**M-O V**  
**SHOOTS UP**  
**\*\*\* THE \*\*\***  
**DUAL TRACE**  
**\* MARKET \***

Adding to its armoury of cathode ray tubes, M-O V (the quiet-looking hombres from Hammersmith Gulch) announce an entirely new range of double gun tubes that involves a sweeping advance on existing market types.

A new, compact construction method for dual trace tubes ensures closer tolerance on pattern distortion (reduced from 2½% to 1%), and greater sensitivities and scan amplitudes.

Auxiliary electrodes provide for retrace blanking at gun potential, independent astigmatism adjustment and trace superimposition.

Our technical information centre is ready to help with your application problems. Write for full data sheets on these or other M-O V products, or telephone RIVerside 5431. Telex 23435.

Typical operation	1000 H	1000 J	1300 H*	1300 J*
Screen dia	10 cm	10 cm	13 cm	13 cm
Va4	4 kV	4 kV	6 kV	6 kV
Va3	1 kV	1 kV	1 kV	1 kV
Minimum useful scan (each gun)	60 x 80 mm.	40 x 80 mm	60 x 100 mm.	40 x 100 mm.
Area of common scan	40 x 80 mm.	20 x 80 mm.	40 x 100 mm.	20 x 100 mm.
Sx	18 V/cm	18 V/cm	18 V/cm	18 V/cm
Sy	6.5 V/cm	4.5 V/cm	6.5 V/cm	4.5 V/cm

\* Aluminised screen

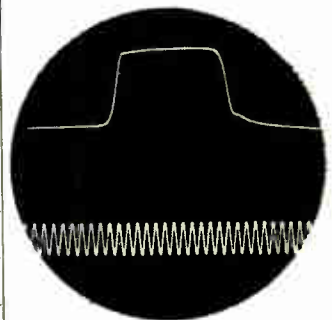

## M-O VALVE CO LTD

BROOK GREEN WORKS · HAMMERSMITH · LONDON W6

# The first major advance in potentiometer design for years ...

After many years of research and development Reliance now announce an entirely new concept in the design of multi-turn wire wound potentiometers. This, combined with new manufacturing techniques provides extremely low inertia, low torque, high law accuracy and multiple tapping facilities for non linear functions. The unit is available in two distinct separate versions:

1. SERIES SYN 11-00 A Synchro Mounting Unit incorporating precious metal winding and precision ball races.
2. SERIES HEL 11-00 A  $\frac{3}{8}$ " diameter Bush Mounting version, plain bearing with standard resistance windings, still retaining high electrical characteristics.

- ★ RESISTANCE RANGE: 20 ohms—150 K ohms.
- ★ LINEARITY:  $\pm 0.1\%$  or  $\pm 0.25\%$  absolute as required.
- ★ TAPPING ACCURACY:  $\pm 0.1\%$ .
- ★ MOMENT OF INERTIA: 0.0004 gm. cm. sec<sup>2</sup>.
- ★ STARTING TORQUE: Synchro Mounting Version 3 gm cm. or better.  
Bush Mounting Version 1 oz.in. nominal.  
or Sealed Version 2 oz.in. nominal.
- ★ ROTATION LIFE: > 1,000,000/360° sweeps.
- ★ NUMBER OF TURNS: Any number up to 10.

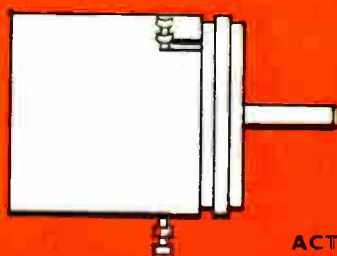
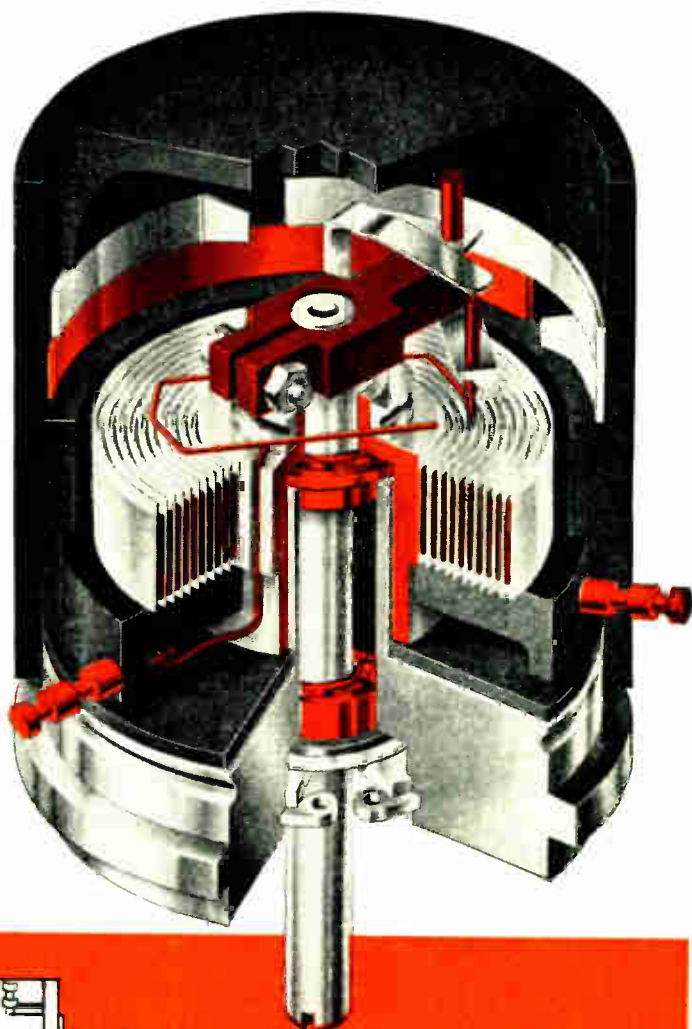

SYN 11-00 SERIES

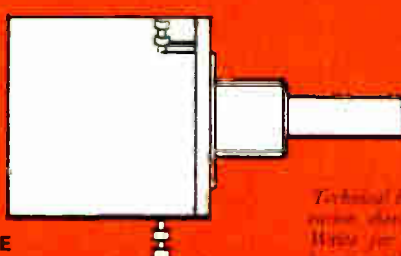

HEL 11-00 SERIES

ACTUAL SIZE

*Technical literature and specifications data are now ready. Write for them to address: LARKSWOOD 8404/7*



**Relcon** TAKES THE LEAD IN POTENTIOMETERS

**RELIANCE CONTROLS LIMITED, RELCON WORKS, SUTHERLAND ROAD, WALTHAMSTOW, E.17**  
Telephone No. LARKSWOOD 8404/7 · Telegrams: Reltrol, London, E.17 A MEMBER OF THE BOOKER GROUP OF COMPANIES

**THE  
SMALLEST  
HIGH  
PRESSURE  
AXIAL  
BLOWER  
IN THE WORLD**

For further information circle 205 on Service Card

The new Thimble blower—believed to be unequalled in performance for a blower of this size—has been specially designed for easy mounting on a densely packed chassis and can direct up to 4.5 cubic feet (127.43 litres) of air per minute on to a selected component. It conforms to all current military specifications.

With an overall length of only 1.6" (40 mm.), a diameter of 1.14" (30 mm.) and weighing 2.5 ounces (77.75 gm.), the Thimble has an output of 2.5 c.f.m. (71.19 litres/min.) at 1.0" (25.4 mm.) s.w.g. or 4.5 c.f.m. (127.43 litres/min.) at .5" (12.7 mm.) s.w.g. on a power input of 10W. It operates on a power supply of 115V or 200V, 3 phase, 400 c/s.

Write or phone for details of the Thimble—the latest addition to the wide range of Plannair miniature blowers: Plannair Limited, Windfield House, Leatherhead, Surrey; Leatherhead 4091.

Plan with  **PLANNAIR**

**Specialists in aero-thermal control**



 PLA90

# Upper frequency limit of Mullard industrial triodes increased

*Efficient Working of Low-loss Plastic Materials Now Possible*

Five established Mullard industrial power triodes with an originally published upper frequency limit of 50Mc/s have now been released for operation at 85Mc/s. This uprating will enable the user of r.f. heating equipment to utilise the higher operating frequencies to achieve efficient working of low-loss plastic materials.

The Mullard range of industrial power triodes was first introduced to meet the requirements of the 27Mc/s industrial, scientific, and medical band but the valves themselves have capabilities well beyond these frequencies. At present, published data quotes the operating characteristics of the valves at frequencies up to 30 and 50Mc/s, but special life tests at higher frequencies have been carried out enabling preliminary figures to be quoted for operation at 85Mc/s and above.

## PLASTIC APPLICATIONS

An important result of this frequency uprating is the easier working of modern plastic materials. Many of the plastic materials manufactured today have low dielectric loss factors. In some cases the loss factor is too low to allow dielectric heating techniques to be used at all and absorption heating by infra-red radiation or other methods has to be employed. The loss in dielectric materials increases with frequency, and by increasing the frequency of operation dielectric heating can be carried out easily and economically.

Other applications where increasing the frequency of operation is advantageous are plastic welding and dielectric preheating. By increasing the frequency of operation in plastic welding, the risk of flash-over with consequent damage to the electrodes is reduced and thinner material can be welded. In the preheating of plastic pellets, the processing times may be effectively reduced by using higher frequencies.

## SPECIAL CIRCUIT TECHNIQUES

To take full advantage of working at these higher frequencies, special circuit techniques must be adopted. Special high-frequency cavity circuits have been developed in the Mullard Applications Research Laboratories. These have greatly improved frequency stability in comparison with previous circuits and have the inherent property of being self-screening, so reducing unwanted radiation from the equipment.

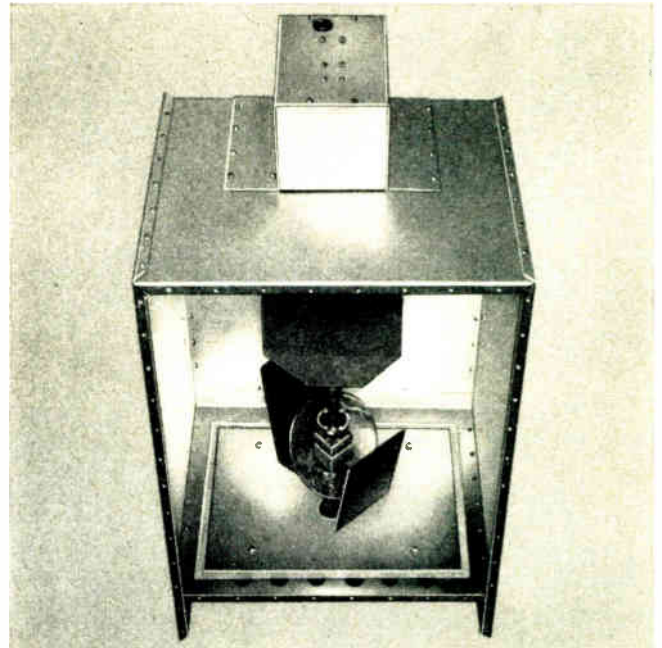

*Mullard industrial power triode TY5-500 undergoing life test at a frequency above 100Mc/s.*

## FURTHER DEVELOPMENTS

Investigations to study the performance of valves and circuits at even higher frequencies are being carried out. These studies are part of a broad programme investigating the problems associated with the generation of power at v.h.f., u.h.f., and microwave frequencies. For information on the higher-frequency operation of Mullard industrial power triodes, please use the reader reply card of this journal (see reference number opposite).

Type No.	$P_{load}$ (kW) at	
	30Mc/s	85Mc/s
TY4-400	0.95	0.90
TY5-500	1.2	1.2
TY6-800	2.1	2.0
TY7-6000	8.5	7.0
TY8-15	14.0	11.8

## What's new from Mullard



## DESIGN AND MANUFACTURING SERVICE FOR SPECIAL-PURPOSE MAGNETS

To meet the demand from industry and research establishments for magnets with higher and more exacting performances, Mullard are offering a complete design and manufacturing service for these specialised assemblies. The service comprises the evaluation of the problem; the design, construction, and installation of the necessary equipment; and the provision of the technical advice and assistance necessary to enable the user to get the best from the equipment. The applications for which Mullard special-purpose magnets have been used include microwave valves and vacuum measurement devices, nuclear magnetic resonance and electron spin resonance equipment, laboratory standards, atomic particle beam deflection, and general research laboratory use.

### FIELD-LOCKING DEVELOPMENT

Electronic field-locking is one of the most recent developments in magnetics and one on which considerable development work has been successfully concluded. One of the aspects of magnet design is the problem of field stability in high-resolution spectroscopy and other applications requiring highly stable magnetic fields. Previously, difficulty has been experienced in holding the required field stability of 1 part in  $10^8$  for the basic magnet for periods longer than about five minutes but this problem has now been overcome by a field-locking device that has been developed.

### STANDARD MAGNETS AVAILABLE

A growing number of standard magnets based on previous successful designs are available and these are particularly useful in the cases where the specification of the required magnet assembly is

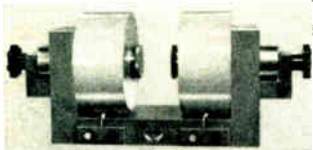

similar to one in the existing range. By accepting an existing type, advantage is taken of the shorter delivery time compared with that of assemblies that have to be individually designed.

A typical example of a standard magnet is the 4in diameter pole electromagnet illustrated, particularly suitable for magnetic susceptibility measurements and allied research applications where a 4in diameter pole and continuously variable gap represent an admirable compromise between size, cost, performance, and accessibility.

## SILICON CONTROLLED RECTIFIER STACKS

A range of heat sinks and stacks for silicon controlled rectifiers is being introduced, similar to the well-known range of heavy-duty power rectifier stacks. With the same built-in safety factors as the power rectifier stacks, the new range enables the full rated current to be drawn from the silicon controlled rectifiers and saves the circuit designer having to design heat sinks and their ancillaries for his equipment.

The first stacks available include an assembly for contactless switching of three-phase supplies, a back-to-back assembly (two diodes and two silicon controlled rectifiers) for the control of a.c. or d.c. power from single-phase supplies, and a diode bridge circuit with a silicon controlled rectifier across the bridge. These stacks incorporate the 16 and 70A silicon controlled rectifiers.

Other assemblies to be introduced later include inverter circuits and chopping circuits for the control of power from d.c. supplies. Stacks for use with 4-7, 10, and 50A silicon controlled rectifiers will also be made available.

## High-Speed Photomultiplier tubes cover infra-red, visible light, and ultraviolet regions

Three high-speed high-gain photomultiplier tubes cover the infra-red, visible light, and ultraviolet regions for such applications as infra-red telecommunications, optics, and scintillation counters for nuclear physics. A new device, the 56CVP, has been recently added to the established types 56AVP and 56UVP.



The 56CVP is a ten-stage device with a semi-transparent caesium-on-oxidised-silver photocathode. The sensitivity of the photocathode is typically  $25\mu\text{A}/\text{lm}$ . The spectral response lies mainly in the red and infra-red regions with the peak response at  $0.8\mu\text{m}$ . Although designed to give a lower gain than the companion tubes in the range (this is because of the much higher dark current of the S1 photocathode), the 56CVP has the same very fast response—a rise time of 2ns—as the 56AVP and 56UVP.

The other two photomultiplier tubes, the 56AVP and 56UVP, are fourteen-stage devices with semi-transparent photocathodes of caesium anti-

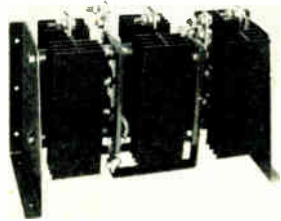

## 50A SILICON CONTROLLED RECTIFIERS

A series of 50A silicon controlled rectifiers is available in the TO-49 encapsulation. These silicon controlled rectifiers are suitable for industrial control applications, and use the same encapsulation as the Mullard 70A silicon controlled rectifier range. The series consists of four devices with peak inverse voltage ratings of 100, 200, 300 and 400V respectively.

The 56AVP has a spectral response mainly in the visible light region while the quartz window of the 56UVP extends the response into the ultraviolet region.

The applications of the 56CVP include infra-red telecommunications and ranging, and optical applications where a very fast response time is required. The 56AVP and 56UVP are intended for nuclear physics applications where a high degree of time definition or high time resolution is required, such as fast coincidence detectors and Cerenkov counters.

### Reader Enquiry Service

Further details of the Mullard products described in this advertisement can be obtained through the Reader Enquiry Service of Industrial Electronics using the appropriate code number shown below.

Higher-frequency operation of industrial triodes .....	206
Special-purpose magnets .....	207
50A silicon controlled rectifiers .....	208
High-speed photomultiplier tubes 56AVP, 56CVP, 56UVP .....	209
Heat sinks for silicon controlled rectifiers .....	210



Mullard Limited, Mullard House, Torrington Place, London, W.C.1. Telephone: LANgham 6633

CAM4

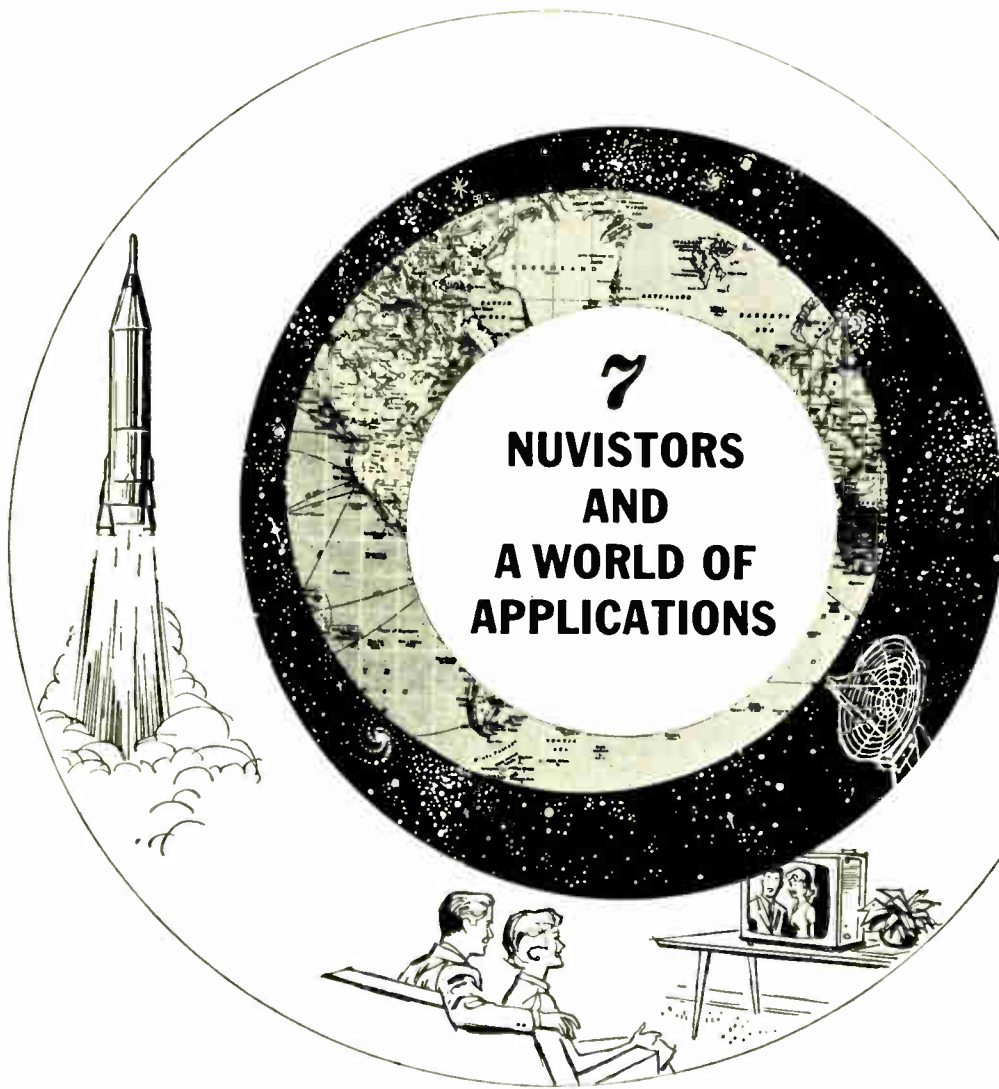

**RCA-7586**  
medium- $\mu$  general-purpose industrial triode



**RCA-7895**  
high- $\mu$  general-purpose industrial triode ( $\mu = 64$ )



**RCA-7587**  
sharp-cutoff general-purpose industrial tetrode



**RCA-6CW4; 2CW4**  
TV and FM tuner triodes



**RCA-6DS4; 2DS4**  
TV and FM tuner triodes with semiretote cutoff characteristic



**RCA-8056**  
medium- $\mu$  triode for low-voltage power supply and small-signal amplifier applications in industrial service at frequencies up to 350 Mc



**RCA-8058**  
double-ended high- $\mu$  triode for cathode-drive amplifier service up to 1200 Mc in a variety of industrial applications

## "Versatile" is the word for the tiny RCA nuvistor!

Nuvistor, with only 7 commercial types, runs the gamut of electronic applications...from satellites to sonobuoys...from electronic test instruments to TV tuners...from guidance and control systems to scientific measuring devices...nearly every major area of electronics.

Why? Because nuvistors provide excellent performance in a small, light package. Consider these important design advantages: Low heater drain • Very high transconductance at low plate current and voltage • Exceptional mechanical ruggedness from their all-ceramic-and-metal

construction • Exceptional uniformity of characteristics from tube to tube • Operation at full ratings at any altitude • Extremely low interelectrode leakage • Low reverse grid current • High stability of characteristics • Low noise.

In addition, nuvistors are in the class of active electronic circuit components least susceptible to damage from nuclear radiation...a vital factor in the design of communications and navigational equipment that must function properly in a nuclear radiation environment.



One more example of the extreme versatility of the nuvistor design principle is this developmental half-size, half-watt rf tuner triode. One of the smallest electron tubes ever produced by RCA, it was developed under research and development contract for the Bureau of Ships, U.S. Navy.

Ask your RCA Representative how nuvistors can benefit your critical circuits. Or, for more information on specific types, write  
**RCA Great Britain Ltd.** Lincoln Way, Windmill Rd., Sunbury-on-Thames, Middx.



**THE MOST TRUSTED NAME IN ELECTRONICS**

**RCA GREAT BRITAIN LIMITED**, Sales Division, Lincoln Way, Windmill Road, Sunbury-on-Thames  
ASSOCIATE COMPANY OF RADIO CORPORATION OF AMERICA. Telephone: Sunbury 5511

## JEDEC SILICON PLANAR TRANSISTORS range further extended

### 2N706

This is a low cost transistor having a minimum value for  $h_{fe}$  of 2.0 at 100 Mc/s. It is suitable for general purpose medium to high speed switching applications and is encapsulated in a TO-18 case.

### 2N706A

This is an improved version of the 2N706 and has a much lower storage time. It is intended for high speed, low power switching and has a TO-18 case.

### 2N708

This is similar to the 2N706 but is somewhat faster, having a minimum value for  $f_T$  of 300 Mc/s. It is intended for use in high speed saturated logic switching applications and is in a TO-18 case.

### 2N743 & 2N744

These are similar to the 2N708 and both have a minimum value for  $f_T$  of 300 Mc/s. But leakage current is much lower for each device and total switching times are less than 40 ns at 10 mA.

### 2N753

This is a higher gain version of the 2N706A which is identical in all other respects. The large signal gain spread of the 2N753 is 40...120.

### 2N1613 & 2N1711

These are high gain, low noise transistors suitable for general purpose amplification and switching applications. They have a collector dissipation of 800 mW, a 60 V collector-base voltage rating and very low leakage currents. Each has a TO-18 case.

### 2N1893

For general purpose industrial applications, e.g. computers and communication equipment having a 60 V supply voltage. Encapsulation in a TO-5 case.

Write, 'phone or Telex for Transistor data sheets to STC Semiconductor Division (Transistors), Footscray, Sidcup, Kent. Telephone FOOTscray 3333. Telex 21836.

## Single and Multi-track RECORDING HEADS

The STC Magnetic Materials Division design and manufacture single and multi-track recording heads for use with nickel and oxide coated magnetic drums. The heads are available as standard types or may be designed

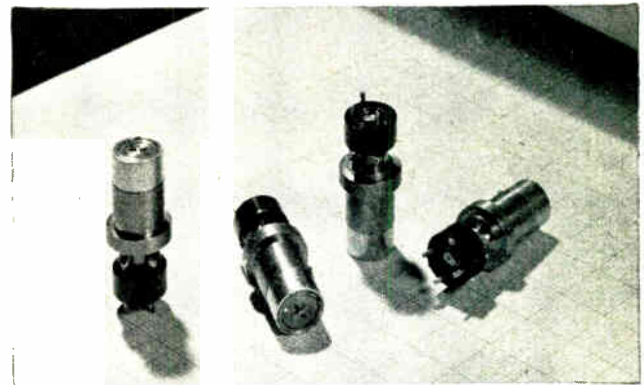

Four types of STC single track recording heads. The clearance adjustment mechanism is built into the heads.

specifically to fit customers' equipment or to meet special application requirements.

STC recording heads are used by the major drum manufacturers for recording and reading in data processing, data transmission and telemetering for civil and military equipments. The heads are precision made, electrically and mechanically, but improved manufacturing techniques have provided economies which offer exceptionally low cost per track. STC recording heads incorporate built-in screening and the clearance adjustment mechanism is also built into the head.

#### CHARACTERISTICS OF TYPICAL RECORDING HEADS TYPES 297-LMA-1A AND 1B

	Type 297-LMA-1A	Type 297-LMA-1B
Number of turns	96 + 96	70 + 70
Inductance measured at 100 kc/s		
(combined winding)	340 $\mu$ H	190 $\mu$ H
Gap width	0.001 in. (0,025 mm)	0.001 in. (0,025 mm)
Track width	0.020 in. (0,051 mm)	0.020 in. (0,051 mm)

#### TYPICAL RESULTS FROM 297-LMA-1A USED WITH A NICKEL-PLATED STANDARD TEST DRUM

Drum diameter	12 in. (30,5 cm)
Drum speed	1500 rev/min
Drum to head clearance	0.001 in.
Pulse repetition frequency	50 kc/s
Write current	54 mA peak to peak
Read out voltage	15 mV peak to peak

Write, 'phone or Telex for data sheets and details of design service to STC Magnetic Materials Division, Edinburgh Way, Harlow, Essex. Telephone Harlow 21421. Telex 81146

## MINIATURE SILVERED MICA CAPACITORS

### MODULAR DESIGN

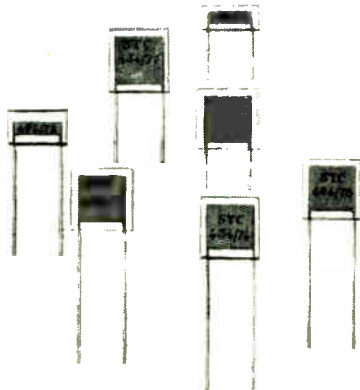

Two new series of STC moulded mica capacitors are now available. Designed for modular circuitry, they have at least one major dimension standard throughout the range.

Range 454-LWA-71 to 77, shown above, covers from 4 pF to 40 000 pF (at 125V d.c.) in seven mould sizes of constant length 0.49 in. (12,5 mm).

In common with the other STC moulded mica series these are high stability capacitors designed to conform to DEF5132. They meet the requirements of humidity classification H6 in the temperature range  $-55^{\circ}\text{C}$  to  $+100^{\circ}\text{C}$  and have a temperature coefficient between  $-20$  to  $+50$  ppm/ $^{\circ}\text{C}$ .

The other modular series—454-LWA-66 to 68—covers from 1 000 pF to 15 000 pF (at 350V d.c.) in three mould sizes which vary in thickness only. They have a standard height of 0.49 in. (12,5 mm) and a constant length of 0.69 in. (17,5 mm).

Other working voltages are available.

### STANDARD DESIGN

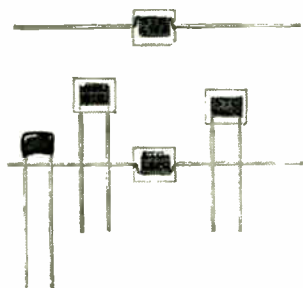

The standard range covers from 4 pF to 100 000 pF at 350V and is produced with both a resin dipped and a resin moulded finish. Also available for 125V and 750V wkg. The range has been extended to include the new subminiature size shown above.

Write, 'phone or Telex for Data Sheets to STC Capacitor Division, Brixham Road, Paignton, Devon, or London Sales Office, Footscray, Kent. Telephone FOOTscray 3333. Telex 21836.

## PULSE MODULATOR VALVES VACUUM TETRODES

The STC range of Vacuum Pulse Amplifier Tetrodes grows steadily as does their reputation for reliable service. The latest valve to be added to the range is type 4B/550E which is a smaller version of the now very popular 4B/603E.

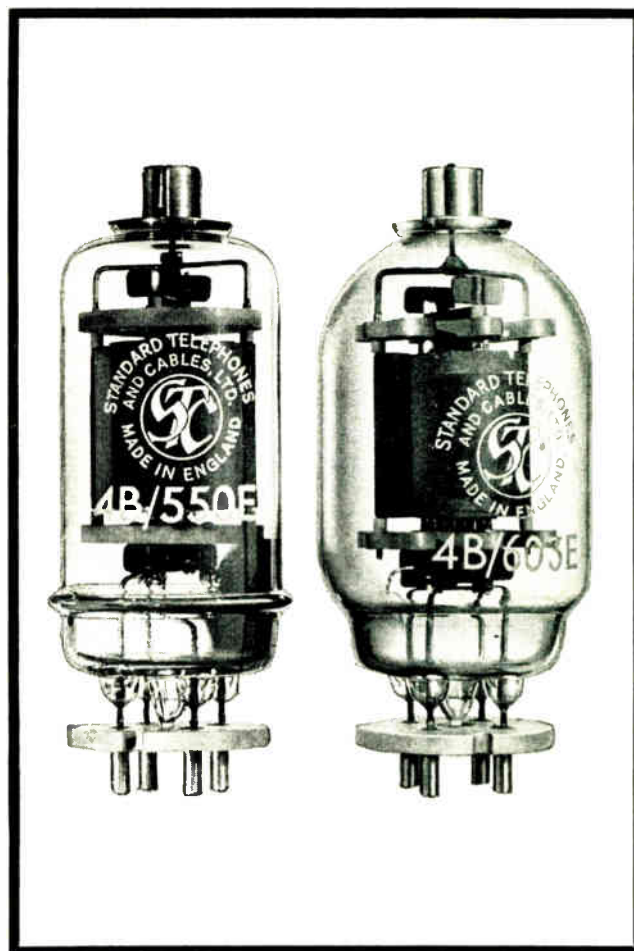

Code	3D21A	4B/550E	4B/603E	4B/602E
V <sub>h</sub> (V)	6.3 or 12.6	26	26	26
I <sub>h</sub> (A)	1.7 or 0.85	1.2	2	2
V <sub>a</sub> (kV)	3.5	12	15	20
I <sub>a peak</sub> (A)	7	10	15	15
V <sub>g2</sub> (xV)	0.8	0.8	1.25	1.25
V <sub>g1 bias</sub> (V) Typical	150	-500	-800	-800
V <sub>g1 pulse</sub> (V) Typical	300	700	1025	1025
Equivalent Codes	CV2659		CV398	CV427

Write, 'phone or Telex for Data Sheets to STC Valve Division, Brixham Road, Paignton, Devon or London Sales Office, Footscray, Kent. Telephone FOOTscray 3333. Telex 21836.

# SILICON CONTROLLED RECTIFIERS for POWER SWITCHING AND CONTROL

These new devices, the most recent addition to the range of Silicon rectifier devices made by STC, are backed by a joint research and development programme undertaken by the Semiconductor Division and Standard Telecommunication Laboratories.

The range, now available from stock, comprises 1, 3, 25 and 70 ampere units with ratings up to 400 volts, all fabricated by a double diffusion process. The device construction is simple but robust, standard packages being used:

Devices actual size

CRS 1 (1 ampere) to VASCA outline SO-3, (JEDEC TO-5)



CRS 3 (3 ampere) to VASCA outline SO-35



CRS 25 (25 ampere) to VASCA outline SO-28



CRS 70 (70 ampere) JEDEC TO-49 (VASCA SO-30A)

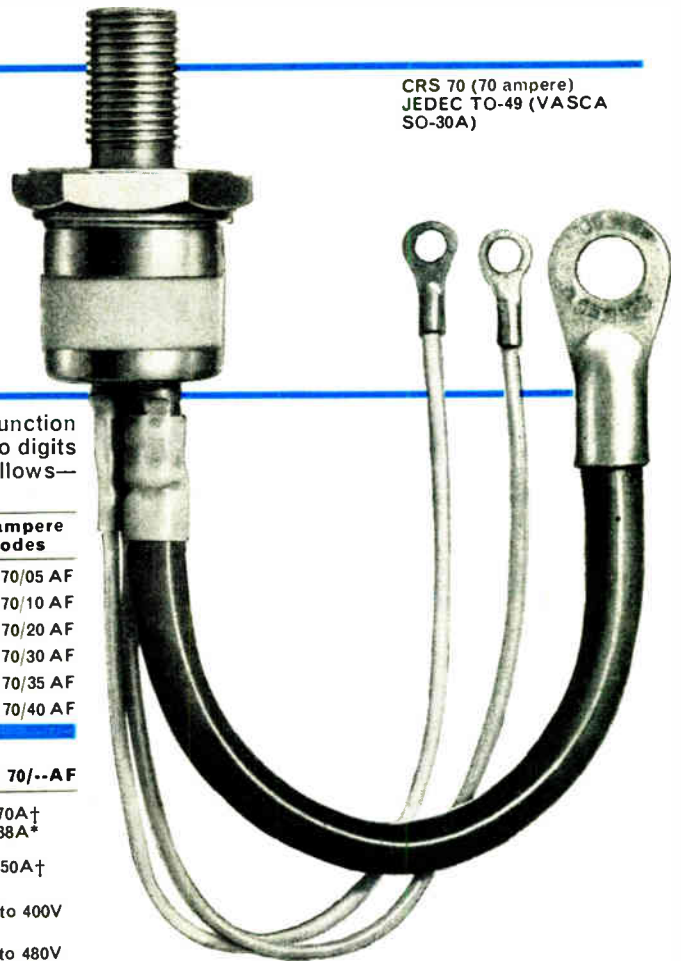

Following the usual STC coding system for all diffused-junction rectifiers, the type numbers are completed by the addition of two digits representing one tenth of the rated crest working voltage as follows—

Rated CWV	1 ampere Codes	3 ampere Codes	25 ampere Codes	70 ampere Codes
50	CRS 1/05AF	CRS 3/05AF	CRS 25/05AF	CRS 70/05 AF
100	CRS 1/10AF	CRS 3/10AF	CRS 25/10AF	CRS 70/10 AF
200	CRS 1/20AF	CRS 3/20AF	CRS 25/20AF	CRS 70/20 AF
300	CRS 1/30AF	CRS 3/30AF	CRS 25/30AF	CRS 70/30 AF
350	CRS 1/35AF	CRS 3/35AF	CRS 25/35AF	CRS 70/35 AF
400	CRS 1/40AF	CRS 3/40AF	CRS 25/40AF	CRS 70/40 AF

RATINGS (Absolute Maximum values)	CRS 1/--AF	CRS 3/--AF	CRS 25/--AF	CRS 70/--AF
Mean Forward Current (Full Conduction Angle)	1.0A† 0.3A*	3A† 0.9A*	25A† 10A*	170A† 38A*
Peak Repetitive Forward Current	5.0A†	15A†	125A†	350A†
Crest Working Reverse Voltage	50 to 400V	50 to 400V	50 to 400V	50 to 400V
Peak Forward Blocking Voltage	60 to 480V	60 to 480V	60 to 480V	60 to 480V
Case/Stud Temperature	125°C	125°C	110°C	125°C
	†at 65°C case *at 110°C case	†at 100°C stud *at 120°C stud	†at 75°C stud *at 95°C stud	†at 90°C stud *at 110°C stud

ELECTRICAL CHARACTERISTICS (at 25°C)	1 ampere	3 ampere	25 ampere	70 ampere
Forward On Voltage . . . . . max.	1.2V	1.3V	1.2V	1.2V
Holding Current (Minimum to hold ON)	20 mA	25 mA	50 mA	60 mA
Forward Blocking Current . . . . . max.	1 mA	1 mA	5 mA	20 mA
Reverse Current at Rated CWV . . . . . max.	1 mA	1 mA	10 mA	20 mA
Gate Trigger Current (Minimum value to trigger all devices)	10 mA	20 mA	50 mA	50 mA

Write, 'phone or Telex for Data Sheets and prices to STC Semiconductor Division (Rectifiers), Edinburgh Way, Harlow, Essex. Telephone Harlow 26811. Telex 81146.



# BRUSH QUARTZ CRYSTAL UNITS

Brush Crystal Company Limited manufacture a wide range of crystal units and are familiar with the problems of frequency selection and control and it is our policy to keep ahead with the crystal units tailored to meet existing and future demands. It is for this reason that we are now able to offer units manufactured to meet the Defence Specification DEF5271A. These possess zero frequency-temperature coefficient AT cut crystal elements which are capable of meeting current requirements for miniaturised communication systems.

Brush replacement Quartz Crystal Units for existing equipment are available to a wide range of specifications. The high stability gold plated units are wire mounted in thermally sealed metal containers. Brush Quartz Crystal units in low loss evacuation glass envelopes are particularly recommended for low ageing rates.

KEEP  
YOUR  
EYE  
ON

## BRUSH



*Brush Crystal Co. Ltd. are playing an expanding role in electrics and electronics. They are alert to the increasing demands of the industry and now add the vast technical resources of the Clevite Corporation of America to their own twenty-five years of experience. This makes it possible to devise, plan and produce the most versatile range of products in Europe—for either tailor-made or mass-produced devices in all divisions. Brush are quickly making a name for themselves as the company you can rely on for advanced know-how, competitive prices and good delivery.*

## BRUSH CRYSTAL

COMPANY LIMITED • HYTHE • SOUTHAMPTON • Telephone Hythe 3031

**“Here’s a really lively character!”**



says Mini Tronic

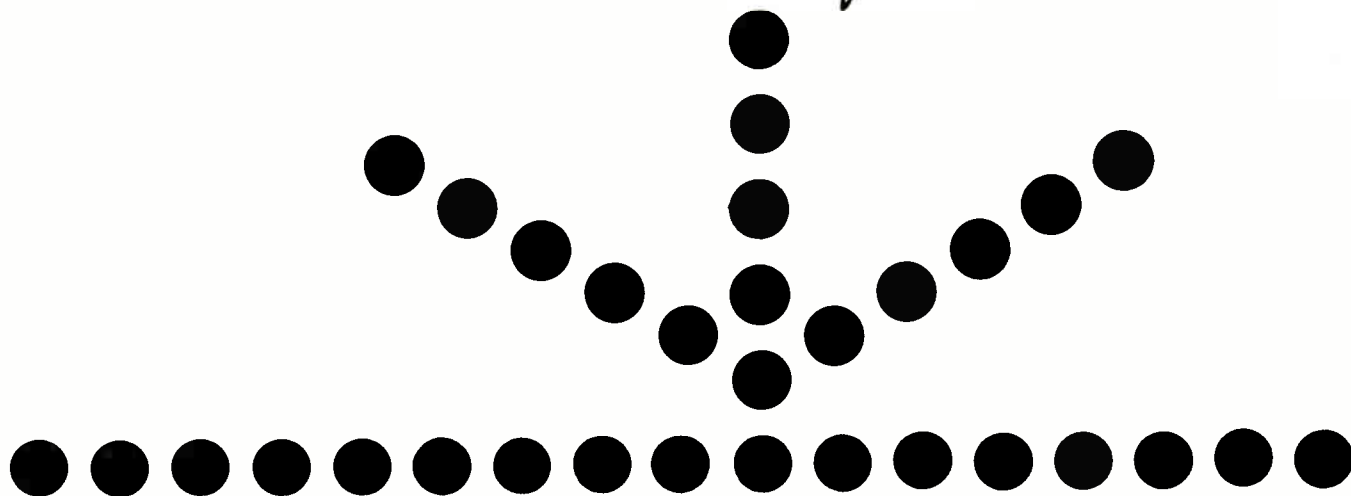

**THE NEW  
HARWIN  
12 Character  
INDICATOR  
UNIT**



The new HARWIN Indicator Unit is a marvel in miniature equipment: Only  $2\frac{1}{2}$ " long  $\times$  1" wide and  $1\frac{3}{4}$ " deep, (excluding plug pins), it is fitted with a plug base and mounting socket for instant interchange without tools, and it uses bulbs of 28, 12 or 6 volts. Although its glass window is only  $1" \times \frac{3}{4}"$ , it gives a brighter display and maximum clarity and visibility. Like all HARWIN miniature electronic components it's a precision made instrument, backed by the HARWIN speed of service. **Send for illustrated leaflet.**

*Smaller... Lighter... Brighter*



**HARWIN**

**Great for miniature electronic components**

**HARWIN ENGINEERS LTD.  
RODNEY ROAD  
PORTSMOUTH, HANTS.  
Tel: Portsmouth 35555 (4 lines)**



# DRIVER AND CONTROLLER UNITS

## FOR SILICON CONTROLLED RECTIFIERS

- \* Transistorised circuitry — entirely static
- \* Available for single- and three-phase circuits
- \* Each driver capable of firing multiples of silicon controlled rectifiers
- \* Encapsulated and shockproof
- \* Low power consumption
- \* Wide input tolerances
- \* Wide range of operating temperature
- \* Automatic control of output

and of course, a full range of  
TRINISTOR silicon controlled  
rectifiers is available from  
Dept. 1E 10/63

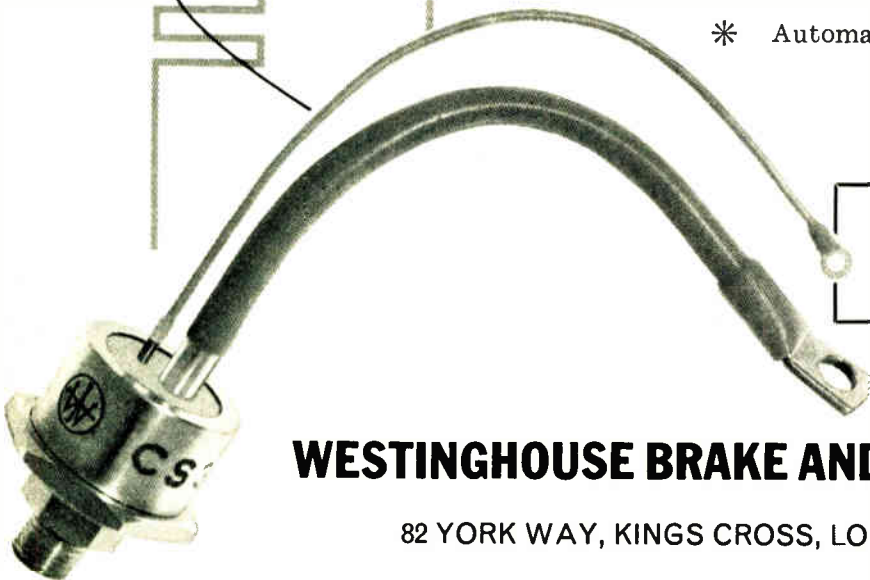

**WESTINGHOUSE BRAKE AND SIGNAL CO., LIMITED**

82 YORK WAY, KINGS CROSS, LONDON, N.1. TERminus 6432



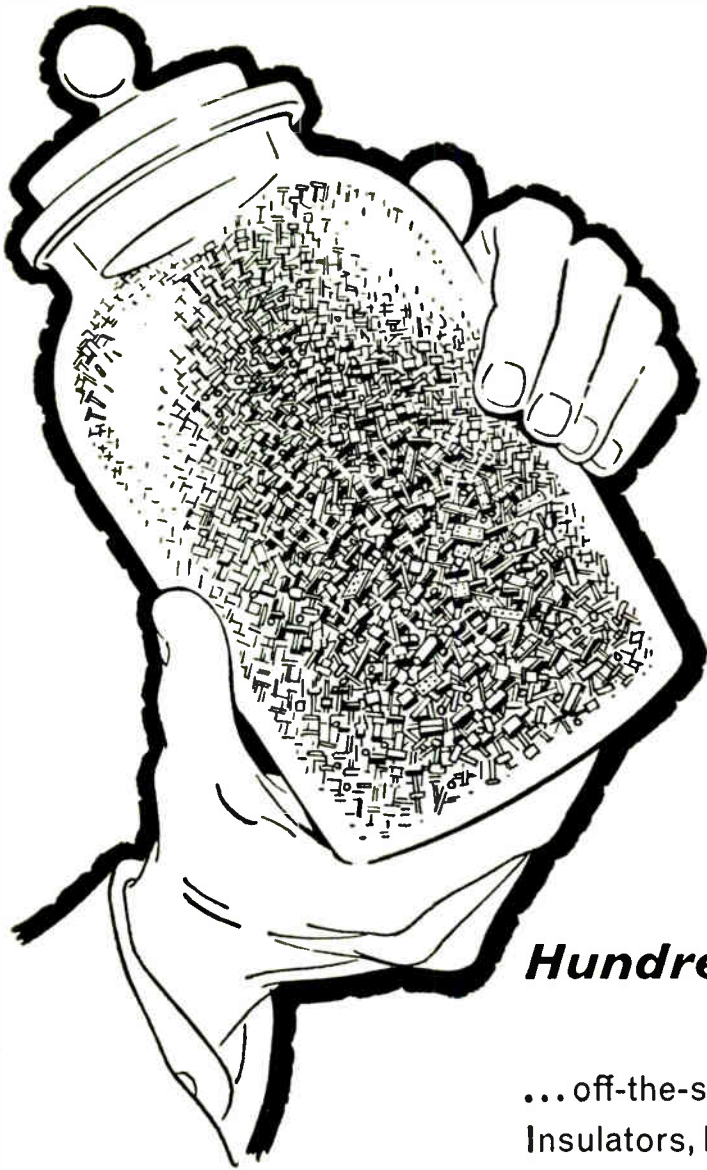

## ***Hundreds and thousands...***

...off-the-shelf — or specially designed for *you*. Insulators, Lugs, Stand-offs, Brackets, Terminal Boards, Chassis Fittings, etc. Watch-maker precision, rigid inspection, post-haste service.



As Mini-Tronic says:  
*'When time and space are light,  
HARWIN see you right'*  
Just telephone or write

HARWIN ENGINEERS LTD • RODNEY RD • PORTSMOUTH  
HAMPSHIRE • TELEPHONE : PORTSMOUTH 35555 (4 lines)

**GREAT FOR MINIATURE ELECTRONIC COMPONENTS**

# HARWIN

# UNCOMMON MARKET...

DELANCO Organisation's Technical Know-How masters the intricate and unusual in component manufacture

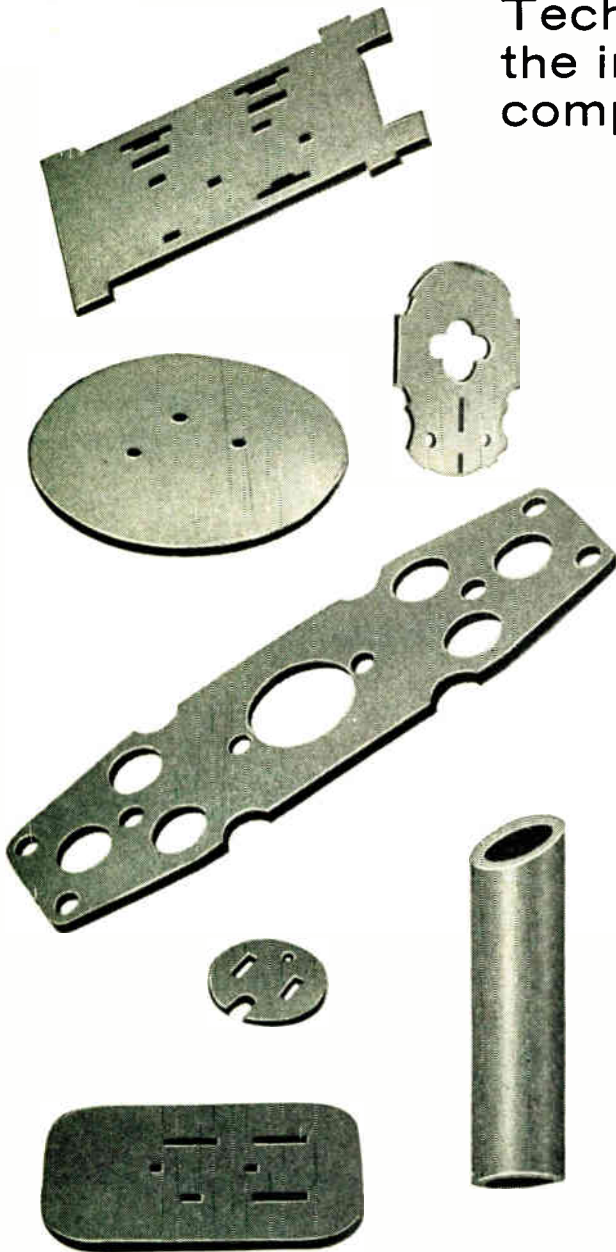

---

Anything uncommon in the way of design calling for the ultimate in tool design skills, is a natural for the Delanco Company. We specialize in the manufacture of components in all types of electrical insulation materials.

Vulcanized Fibre, S.R.B.P. and S.R.B.F. Epoxy glass fibre, Nylon, P.T.F.E., Presspahn, Leatheroid, Varnished cambric and in fact every material used in electrical Insulation. For heat resistance *and* insulation Mica and Micanite. Processes include presswork, forming, routing, moulding, turning, milling and machining.

Our customers include Manufacturers of Domestic and Electrical equipment, Instruments, Motor cars, Aircraft, ships, printing and business machinery, Computers, electric motors dynamos and starters. Copper-clad laminates for printed circuitry are supplied as panels ready for printing.

Technical representatives are based throughout the country, and are available at any time to call and discuss your needs.

Technical catalogues are available and will be sent immediately on request.

---



## **Delanco**

INSULATION MATERIALS AND COMPONENTS

---

ANGLO-AMERICAN VULCANISED FIBRE CO. LTD · Cayton Works · Bath Street · London · E.C.1  
Phone: CLE 8484 · Grams: PROMPSERV, LONDON · Delanco Works · Leonard Street · London · E.C.2

# MULTIPLE MULTIPLE MULTIPLE COAXIAL CONNECTORS WITHOUT SOLDERING by using **A-MP COAXICON**

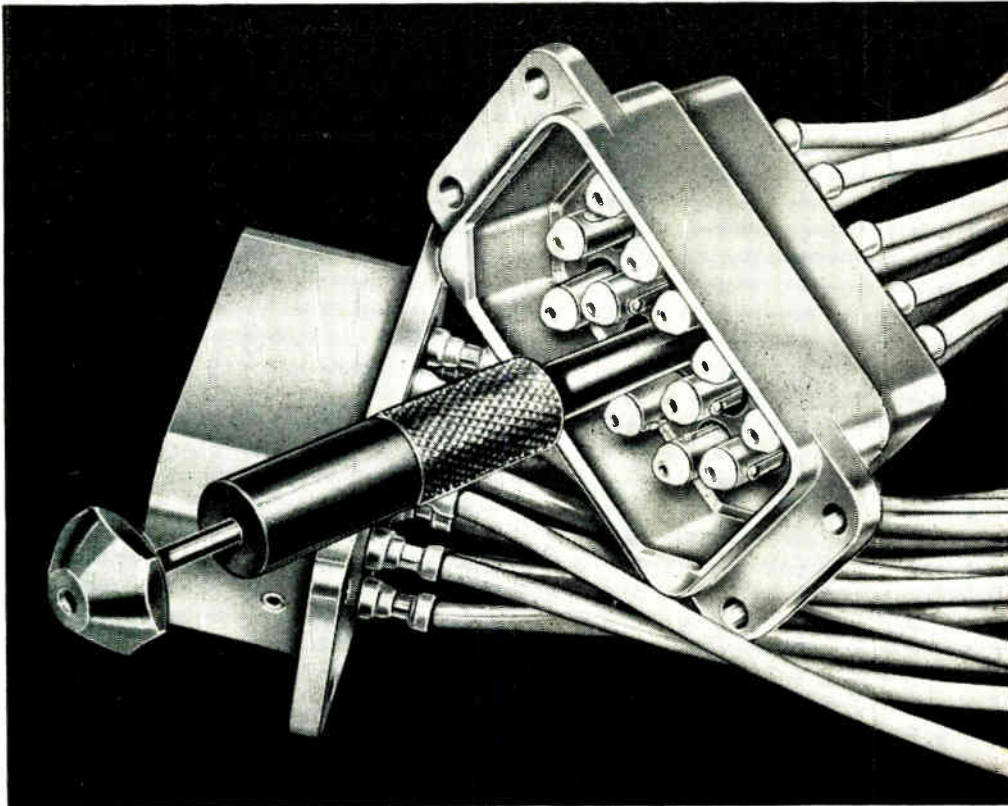

*Extraction for modification is effected instantly by a simple tool.*

This is something unique — AMP crimping technique and precision applied to multiple coaxial connectors.

Individual plugs and sockets are attached to coaxial cable by a single stroke of a hand tool — inner conductor, braid and outer insulation being crimped simultaneously.

Plugs and sockets are then inserted into the corresponding moulding, where they lock by retention springs. Extraction for modification is effected instantly by a simple tool. Maximum efficiency of contact is ensured by the use of gold plated contacts and cantilever beam springs for uniform pressure.

The AMP system gives minimum deformation of the inner conductor, and maintains concentricity of conductor, dielectric and screening braid, resulting in excellent UHF impedance matching.

Plugs and sockets are supplied in optimum sizes for specific cable dimensions. Application time and costs are greatly reduced and consistent results ensured.

Write for full particulars.

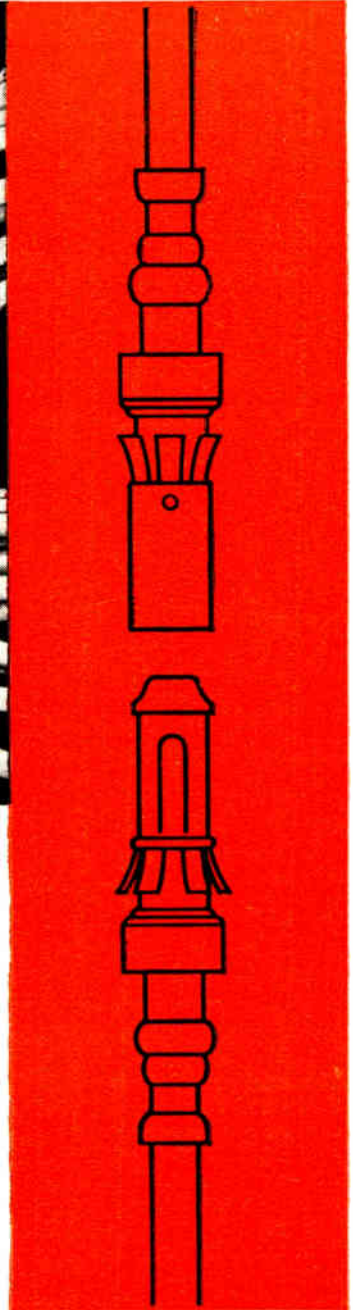

# AMP AMP AMP

## **AIRCRAFT-MARINE PRODUCTS (GT. BRITAIN) LIMITED**

Head Office: AMPLO HOUSE, 87/89 SAFFRON HILL, LONDON, E.C.1.  
Tel: CHAncery 2902 (7 lines) Telex: 23513 Cables: AMPLO LONDON TELEX

SOUTH AFRICA DISTRIBUTOR: S. S. HOWAT & SONS (PTY), LTD., 11-17 WILHELM STREET, P.O. BOX 457 DURBAN, NATAL  
ASSOCIATED COMPANIES IN U.S.A., AUSTRALIA, CANADA, HOLLAND, FRANCE, GERMANY, ITALY, JAPAN AND MEXICO

AP 222



# 'Triple Rating' means 3 sizes of metal oxide film resistors cover most requirements

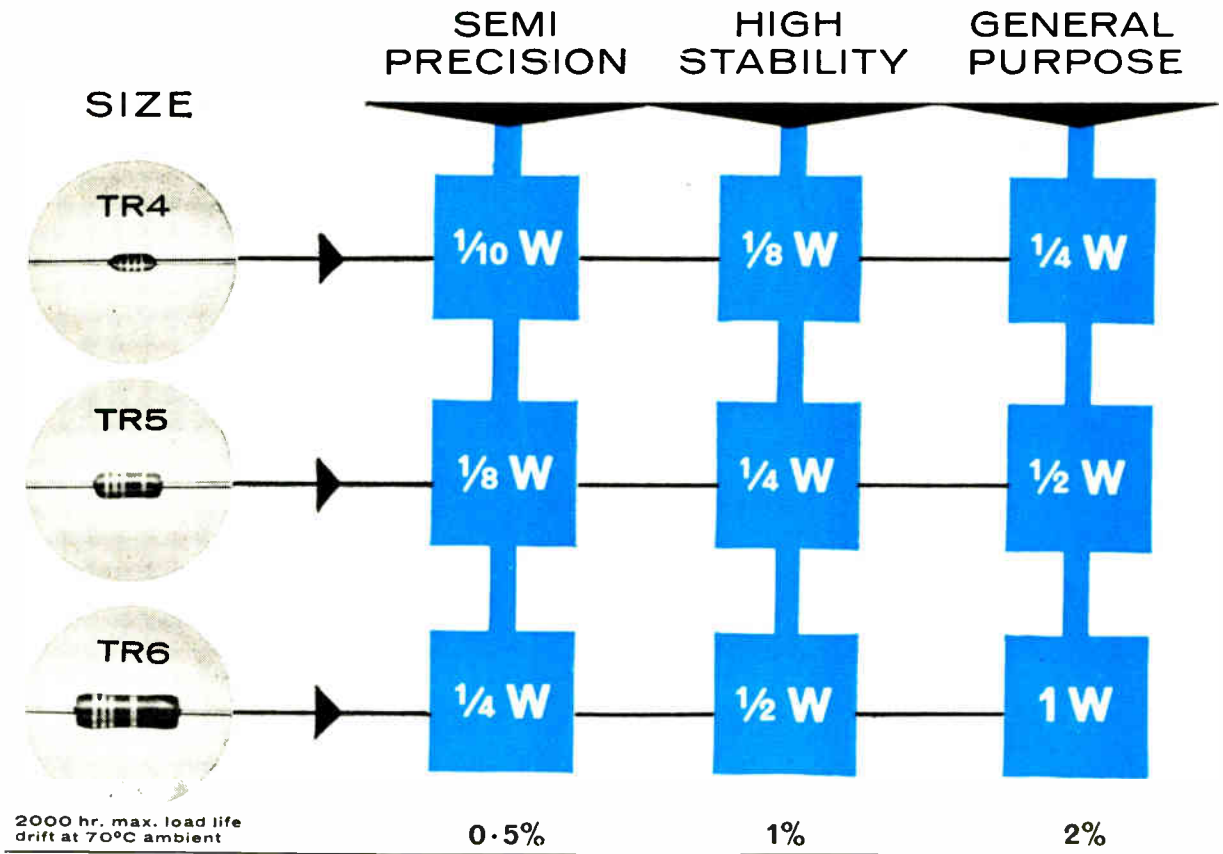

The semi precision resistor NJ60 1/4 Watt and the general purpose CJ20 1/2 Watt are now identical and are supplied colour coded. The same applies to NJ65 1/2 Watt and CJ32 1 Watt resistors. For convenience the various style references are retained; these signify rating and performance. The common link is a basic TR size reference. Thus the same Electrosil resistor can be used at different ratings for semi precision, high stability and general purpose applications. This can result in extensive saving in stock, economy in bulk purchase and standardisation in design. The full test conditions of DEF 5114 which cover the temperature range -55°C to + 125°C can be applied to the triple ratings of each resistor size. The requirements such as maximum change of resistance for 2000 hr load endurance vary according to the rating as indicated. The average change of resistance on load is well within these limits.

## The Electrosil 'Triple-rated' range

	Ohmic Range	Dimensions
TR4	51-150K	0.25" x 0.09"
TR5	10-470K	0.375" x 0.15"
TR6	10-1M	0.593" x 0.19"



Pallion, Sunderland, Co. Durham  
Tel: Sunderland 71557 • Telex: 53273

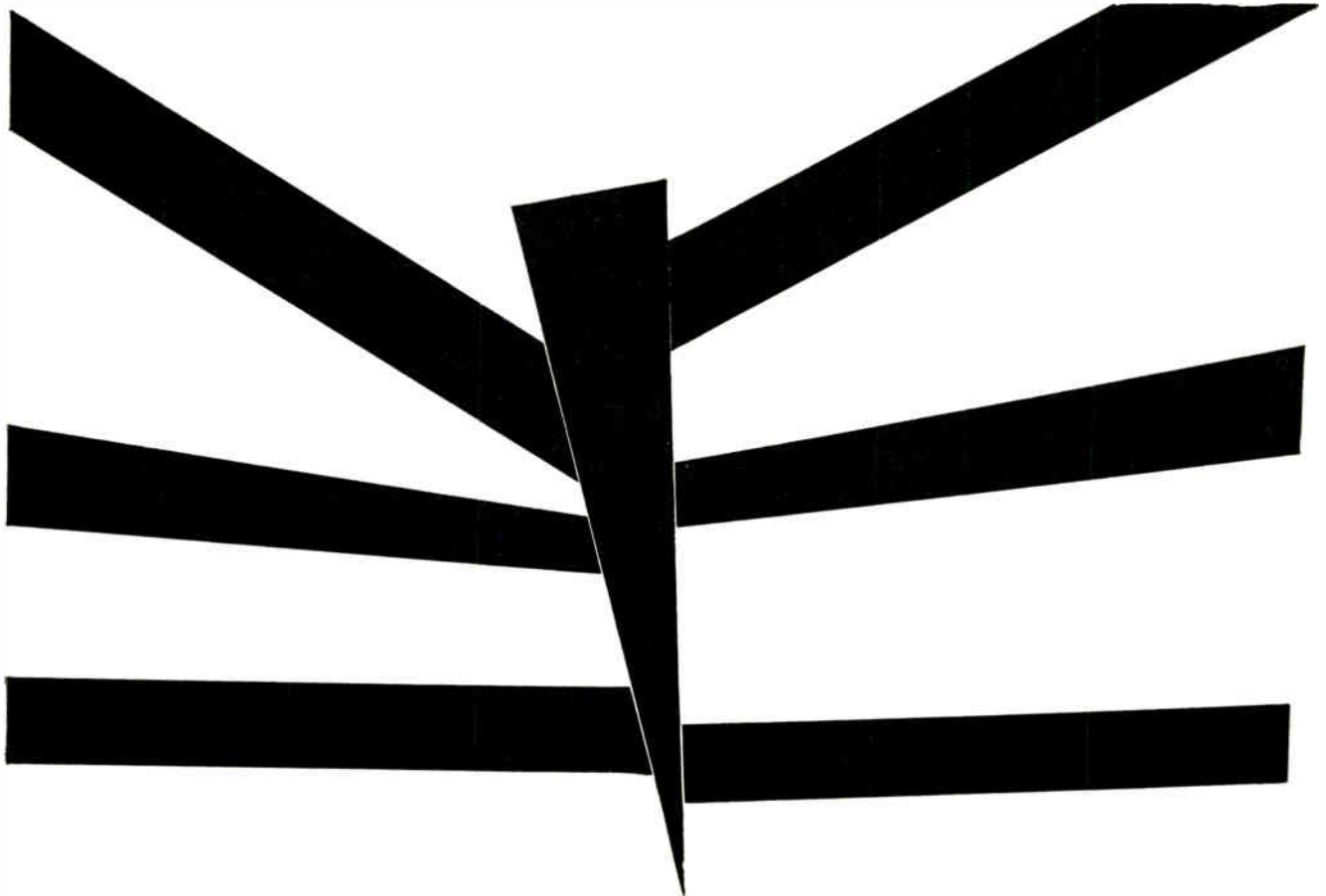

Actual size

## best measure pressure with a CEL transducer

- ★ 0.25% accuracy
- ★ Rationalised output
- ★ Small sample volume
- ★ Compact construction
- ★ Price £36

First of a new series of CEL precision strain gauge transducers, Type XT33 incorporates, as standard, features normally offered as expensive optional extras.

### **Abridged Specification**

Non-linearity & Hysteresis - - -  $\pm 0.25\%$   
Output (rationalised) - - - - 20mV f.s.d.  
Temperature effect - - - - 0.02%/°C

Six ranges from 0-1000 to 0-10000 psi.

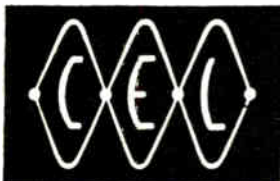

# COUTANT ELECTRONICS LIMITED

TRANSDUCER DIVISION

711 Fulham Road · London · SW6 · Renown 5385

# PLOUGH IN YOUR INVESTMENT



## WITH THE SEVEN STAR FEATURES OF A CORREX PRE AMPLIFIER

- ★ **CHARACTERISTICS.**  
Substantially linear over 90% of characteristic.  
Current gain 500.  
Power gain  $1.25 \times 10^6$ .  
Input  $\pm 10 \mu\text{A}$  into  $170 \Omega$  minimum.  
Output  $\pm 5 \text{mA}$  into  $1500 \Omega$ .
- ★ **STABILITY.** Long term low zero drift less than  $.05 \mu\text{A}$  from  $0^\circ\text{C}$ - $50^\circ\text{C}$  Ambient.  
(Input required to correct change in output).
- ★ **VERSATILITY.** Will operate from most available transducers.
- ★ **RELIABILITY.** No thermionic components or moving parts and therefore requires absolute minimum of servicing.
- ★ **LOW NOISE LEVEL.** Inherent in this form of device due to narrow operational band width.
- ★ **COMPACT.** Flush panel mounting and design for maximum ease of fitting and servicing.
- ★ **ISOLATION OF INPUT.** A number of completely isolated input circuits can be provided, ideal for mixing or D.C. measurement.

# CORREX

For further information write to:—

**PHOENIX TELEPHONES LIMITED**

GROVE PARK • LONDON, N.W.9

Telephone: COLindale 7243.

Telegrams: PHONOFENIX, LONDON, N.W.9

# Let the

## INDUSTRIAL ELECTRONICS

### READER ENQUIRY SERVICE

# help you to obtain more information

Circle the code numbers of the items in which you are interested. Insert your name and address, etc., in block capitals and post the card to us.

We will communicate with the manufacturers concerned and arrange for the information you require to be sent to you without obligation.

*(No postage stamp is required if posted in Great Britain or Northern Ireland)*

### Is this your own copy ?

Each month INDUSTRIAL ELECTRONICS will bring you news of the latest applications, the most recently announced equipment, produced by the rapidly expanding electronics industries of the world.

It is invaluable to all management and production executives, and engineers, in industry generally, who need to be informed of the latest developments in electronic aids to industry.

**MAKE SURE OF YOUR COPIES  
USE THE ORDER CARD NOW**

## INDUSTRIAL ELECTRONICS

## READER ENQUIRY SERVICE

OCTOBER 1963 — For further information circle appropriate number (1F)

Editorial code number—														
1	2	3	4	5	6	7	8	9	10	11	12	13	14	15
16	17	18	19	20	21	22	23	24	25	26	27	28	29	30
31	32	33	34	35	36	37	38	39	40	41	42	43	44	45
46	47	48	49	50	51	52	53	54	55	56	57	58	59	60
61	62	63	64	65	66	67	68	69	70	71	72	73	74	75
76	77	78	79	80	81	82	83	84	85	86	87	88	89	90
91	92	93	94	95	96	97	98	99	100	101	102	103	104	105

Advertisement code number—														
200	201	202	203	204	205	206	207	208	209	210	211	212	213	214
215	216	217	218	219	220	221	222	223	224	225	226	227	228	229
230	231	232	233	234	235	236	237	238	239	240	241	242	243	244
245	246	247	248	249	250	251	252	253	254	255	256	257	258	259
260	261	262	263	264	265	266	267	268	269	270	271	272	273	274
275	276	277	278	279	280	281	282	283	284	285	286	287	288	289

I would also like details of .....

Your Name ..... Position held .....

Name of Firm .....

Address .....

Nature of Business .....

PLEASE USE BLOCK CAPITALS

Postage will be paid by Associated Iliffe Press

No Postage Stamp necessary if posted in Great Britain or Northern Ireland

**BUSINESS REPLY CARD**  
Licence No. SE 591

**"INDUSTRIAL ELECTRONICS",  
DORSET HOUSE,  
STAMFORD STREET,  
LONDON, S.E.1**

OCTOBER 1963

## INDUSTRIAL ELECTRONICS

### SUBSCRIBER'S ORDER FORM

#### Subscription Rates

Home £3 0s. 0d.

Overseas £3. 10s. 0d.

USA and Canada \$10

NAME .....

ADDRESS .....

Please supply

INDUSTRIAL ELECTRONICS monthly for the next 12 months

I will remit on receipt of invoice

Postage will be paid by Associated Iliffe Press

No Postage Stamp necessary if posted in Great Britain or Northern Ireland

**BUSINESS REPLY CARD**

Licence No. SE 591

**"INDUSTRIAL ELECTRONICS",  
DORSET HOUSE,  
STAMFORD STREET,  
LONDON, S.E.1**

# Let the

## INDUSTRIAL ELECTRONICS

### READER ENQUIRY SERVICE

# help you to obtain more information

**INDUSTRIAL ELECTRONICS**

### READER ENQUIRY SERVICE

**OCTOBER 1963 — For further information circle appropriate number** (2F)

Editorial code number—	1	2	3	4	5	6	7	8	9	10	11	12	13	14	15
16	17	18	19	20	21	22	23	24	25	26	27	28	29	30	31
32	33	34	35	36	37	38	39	40	41	42	43	44	45	46	47
48	49	50	51	52	53	54	55	56	57	58	59	60	61	62	63
64	65	66	67	68	69	70	71	72	73	74	75	76	77	78	79
80	81	82	83	84	85	86	87	88	89	90	91	92	93	94	95
96	97	98	99	100	101	102	103	104	105						
Advertisement code number—	200	201	202	203	204	205	206	207	208	209	210	211	212	213	
214	215	216	217	218	219	220	221	222	223	224	225	226	227	228	
229	230	231	232	233	234	235	236	237	238	239	240	241	242	243	
244	245	246	247	248	249	250	251	252	253	254	255	256	257	258	
259	260	261	262	263	264	265	266	267	268	269	270	271	272	273	
274	275	276	277	278	279	280	281	282	283	284	285				

I would also like details of .....

Your Name ..... Position held .....

Name of Firm .....

Address .....

Nature of Business.....

PLEASE USE BLOCK CAPITALS

Circle the code numbers of the items in which you are interested. Insert your name and address, etc., in block capitals and post the card to us.

We will communicate with the manufacturers concerned and arrange for the information you require to be sent to you without obligation.

(No postage stamp is required if posted in Great Britain or Northern Ireland)

Postage will be paid by Associated Iliffe Press

No Postage Stamp necessary if posted in Great Britain or Northern Ireland

**BUSINESS REPLY CARD**

Licence No. SE 591

**"INDUSTRIAL ELECTRONICS",  
DORSET HOUSE,  
STAMFORD STREET,  
LONDON, S.E.1**

### Is this your own copy ?

Each month INDUSTRIAL ELECTRONICS will bring you news of the latest applications, the most recently announced equipment, produced by the rapidly expanding electronics industries of the world.

It is invaluable to all management and production executives, and engineers, in industry generally, who need to be informed of the latest developments in electronic aids to industry.

**MAKE SURE OF YOUR COPIES  
USE THE ORDER CARD NOW**



# HOUSTON SWITCH TO ADVANCE

As from September 1963, a comprehensive range of precision pen recorders previously available only from the Houston Instrument Corporation of the USA, is to be marketed and manufactured in the UK by Advance Components Limited.

Advance will also be responsible for the export marketing of the range and have set up a world-wide distribution network covering all areas except North and South America. These two areas will continue to be serviced by the Houston Instrument Corporation who will also be manufacturing a range of Advance equipments as part of a reciprocal agreement.

For full details on the ADVANCE-HOUSTON range of precision XY & TY recorders, please write to:

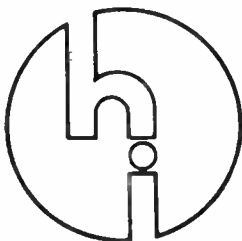

**ADVANCE COMPONENTS LIMITED**

HAINAULT · ILFORD · ESSEX · TELEPHONE: HAINAULT 4444

■ AH/I



# The word gets through



*Portable low cost 'Clearcall' Audio Units like this provide dependable one- or two-way speech links; quickly adapt to changing communication needs in all types of plant.*

# -for better productivity

Modern industry is 'getting the message'. Directives are clearly heard and understood despite noisy surroundings. AEI 'Clearcall' Audio and Carrier Frequency Systems replace crude 'tic-tac' methods of communication, conquer noisy, dusty, fume-laden conditions—in factories, steelworks, power stations, foundries, mines, workshops, railyards. Talk man to man with AEI engineers on your 'communications' problem. Learn how 'Clearcall' apparatus can aid efficiency and productivity for you. Ruggedly-built 'Clearcall' equipments include

handy 'go-anywhere' microphone/loudspeaker units for plant commissioning and maintenance work, crane control and alarm systems, and full-scale works communication networks for keeping 'integrated' production flowing smoothly.

### Is there an 'Electronic Answer' to your problem?

... AEI equipments and AEI experience cover every kind of electronic control application. Get up to date now on latest electronic progress in your special field—by talking to AEI.

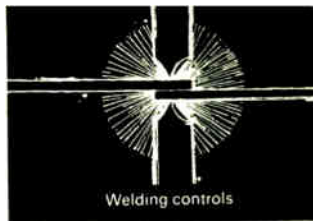

Welding controls

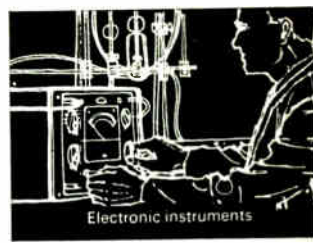

Electronic instruments

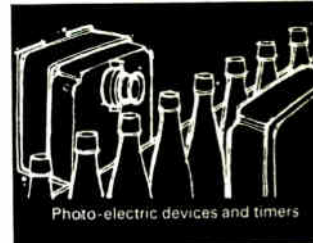
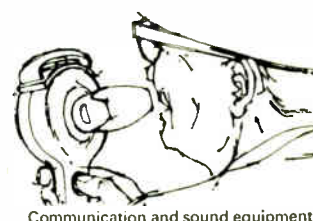
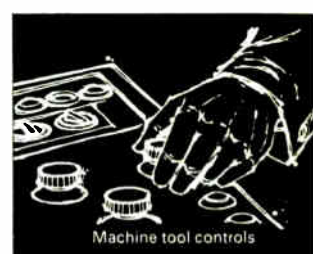

Photo-electric devices and timers



Communication and sound equipment



Machine tool controls

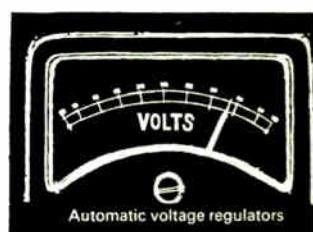

Automatic voltage regulators

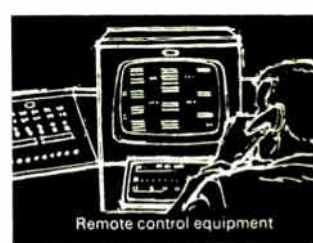

Remote control equipment

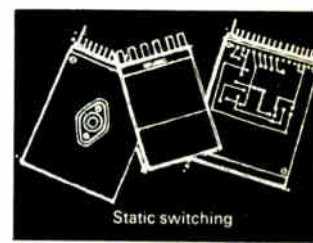

Static switching

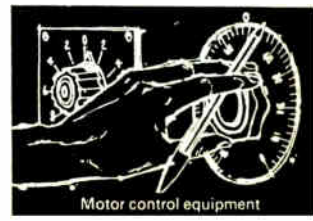

Motor control equipment

**'AEI INDUSTRIAL ELECTRONICS'**  
achieving efficiency *efficiently*



**AEI**

**Electronic Apparatus Division**  
Associated Electrical Industries Limited  
NEW PARKS · LEICESTER

A5803

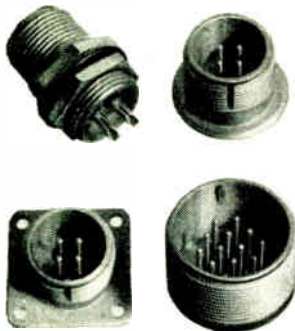

### HERMETICALLY SEALED PLUGS

- Compression glass-to-metal seals.
- Leakage rates of 1, .1, .01 and .001 micron cubic feet per hour at 15 p.s.i.
- Pin contacts and shells are steel.
- Small shell sizes will withstand pressures up to 1,000 p.s.i. and larger sizes up to 500 p.s.i.
- Ranges available include:—  
 GS02 and BFH for MIL C. 5015 series connectors,  
 KPTH for MIL C. 26482 series connectors,  
 MC for MC sub-miniature series connectors.  
 KH for KO miniature connectors.
- Variations in shell style mountings including jam-nut, square and circular flanges, bulkhead fittings, etc.



For further information circle 227 on Service Card

### US ARMY ORDNANCE CONNECTORS

- An extremely rugged weatherproof
- 12 pole connector ideal for prime mover/trailer applications, and arduous field conditions.
- Standardised by NATO.
- F. V. R. D. E., approved. Manufactured in steel hardware throughout.
- Cable connectors shrouded in tough neoprene.
- Positive locking engaging device.
- Cable units provided with self-closing moisture/dust covers.
- Self-closing moisture/dust flaps available for receptacles.
- Other insert arrangements up to 37 poles available.

For further information circle 228 on Service Card



### STANDARD "K" CONNECTORS

- General purpose rugged multi-pole series.
- 8 shell sizes with up to 82 solder type contacts, including coaxial layouts.
- Lightweight aluminium alloy shells.
- Coarse thread quick-disconnect coupling.
- Wide variety of shell styles.
- Positive polarisation.
- Melamine insulators.
- Also available are hermetically sealed and high temperature ranges.

Write for K-7 Catalogue.

For further information circle 229 on Service Card



For further information circle 230 on Service Card

### KO SERIES

- A general purpose lightweight multi-way connector with acme coarse thread coupling.
- Available in three basic shell sizes and four shell styles.
- Insert arrangements of 3, 10, 20, 30, 38 and 50 poles.
- High potential test voltages, from 1,350v. a.c., to 4,050v. a.c.
- Gold plated copper alloy contacts, rated 5 amperes. Solder type.
- Zytel insulation.
- Lightweight aluminium alloy shells.
- Hermetically sealed series with steel shells and contacts also available.
- Positive polarisation.

Write for HMC Catalogue



## TYPICAL EXAMPLES OF

# CANNON CONNECTORS MADE IN GREAT BRITAIN

One tends to associate the symbol CANNON PLUGS with electrical connectors manufactured in the U.S.A., but in actual fact, over 60 per cent of the Cannon connectors sold in Great Britain are manufactured entirely at the Cannon factory in London.

*The facilities of Cannon Electric (Great Britain) Limited, include:*

**connector research, development, design and engineering; a fully equipped test laboratory; machine and model shops; toolroom; injection and compression moulding machines; quality control and inspection, etc.**

All the divisions of the Company are manned by highly competent, qualified personnel with many years background of technological "know-how". The Sales and Engineering Departments provide a Technical Service of the highest calibre and the Company will gladly undertake development contract work.

Cannon Electric (Great Britain) augments and supplements the activities of the parent company factories in the U.S.A., and contributes in no small way in helping to maintain the name CANNON as the world's foremost manufacturer of electrical connectors.

# CANNON PLUGS



**CANNON ELECTRIC (Great Britain) LTD., 168/172 OLD STREET, LONDON, E.C.1. Tel: CLerkenwell 4954**  
 European Enquiries: Cannon Electric International Inc., Bornem, Belgium. Telephone: (03) 77.06.14.

#### Scandinavian Enquiries:

Sweden: Ab Gosta Backstrom, Box 12089 Stockholm 12.  
 Denmark: Tage Schouboe, 7 Skyttegade, Copenhagen.  
 Norway: Morgenstjerne & Co., Wessels Gate 6, Oslo.  
 Finland: OY Chester AB, Uudenmaankatu 23a., Helsinki.



## Comment

Space research is occupying an enormous amount of man-power and its cost is, appropriately enough, astronomical. The communication satellites, which are still in the experimental stage, are offshoots of it. They are, however, in the end expected to be commercial propositions.

The main advantages to electronics of all this work will be improved miniaturization techniques and, above all, better reliability. Indeed, some of these benefits have already accrued.

Working in reverse, electronics has enormously helped the design of satellites and other space craft. In fact, only the computer has made their design possible. All this is well known. What seems at first sight a rather trivial use of the computer has recently been announced by Bell Telephone Laboratories. It is to produce a ciné picture of a model satellite.

The computer calculates the motion of a satellite orbiting a sphere under the influence of gravity and an attitude-control system comprising two single-axis gyros. The motion is not a simple orbital one, for the satellite yaws and turns over.

The results of the calculation appear in the form of the co-ordinates of a perspective drawing of the satellite and are applied to a cathode-ray tube to produce such a drawing on its screen. This is photographed. The calculations need only three to eight minutes of computer time and result in a ciné film of one minute's duration at 16 frames a second.

The object of doing all this is to enable the designer to see for himself what happens. Which goes to show that even highbrow mathematicians cannot always realize the full meaning of their equations and need visual evidence. Since it all leads to better understanding, this usage of the computer is hardly a trivial one after all.

## Seeing in the Dark

During World War II infra-red techniques were used, at least experimentally, in equipment which would literally enable one to see in the dark. Since then great advances have taken place and such equipment is now much more of a practical proposition than it then was.

Basically such systems comprise an infra-red sensitive screen which emits electrons in proportion to the intensity of the radiation falling upon it. It produces an electron picture of the infra-red picture on the screen. This electron picture is focused on to a fluorescent screen which produces a

visible picture, just as in a cathode-ray tube.

One difficulty has always lain in focusing the infra-red picture on the sensitive screen of the converter tube, for optical lenses do not function so well in the infra-red region of the spectrum. Westinghouse Electrical have announced infra-red lenses with relative apertures up to  $f/0.75$ . Designed for the wavelength range 8–12 microns a lens of this kind is constructed as a triplet. The two outside elements are made of germanium, the middle element is made of Irtran-2. This is stated to be a synthetic inorganic material.

It seems a little odd to have a lens

which is not of material transparent to light, but naturally the requirement is for material transparent to the radiation which it must pass. Lens aerials are equally very different from optical lenses.

### **Telstar**

We said last month that Telstar 2 had ceased to operate. Just after we went to press it was announced that it had started to work again! On 12th August it became possible once again to turn on the communications transmitter. At the time of writing we understand that everything is again normal. Just why the equipment should have ceased to function for some two months and then started to work again normally is not known. Apparently it is just one of those things.

### **Proton Radioactivity**

The Nuclear Research Institute at Dubna, near Moscow, claims to have discovered a new kind of radioactive decay, proton radioactivity. Nuclei normally disintegrate by alpha, beta and gamma radiation, by spontaneous fission, or by emitting delayed neutrons. Disintegration by the emission of a proton from a nucleus has been predicted and it is now claimed to have been observed experimentally.

The work has been carried out by Victor Karnaukhov and Gurgun Ter-Akopyan by bombarding a thin nickel target with accelerated nuclei of neon-20. Two isotopes which emit protons in disintegrating were found.

### **Nimrod**

The first operation of a proton synchrotron has been announced by the National Institute for Research in Nuclear Science. An energy of 6.5 GeV with an intensity of  $4 \times 10^9$  protons per pulse was initially achieved, but later 8 GeV was obtained. In further operation  $10^{10}$  protons per pulse at 7 GeV were secured. The design figure is 7 GeV and the object is to obtain  $10^{12}$  protons per pulse.

Nimrod, as it is called, embodies a ring-shaped magnet 155 ft in diameter and weighing 7,000 tons. There is a toroidally-shaped evacuated chamber between the poles of this magnet. Into this is injected a pulse of protons which have been given an initial acceleration of 15 MeV in a linear accelerator. The magnetic field forces them into a circular orbit and they are further accelerated once per revolution by a radio-frequency field. Their final energy is reached after a million revolutions and they are then utilized.

The acceleration period lasts 0.72 second

and during this time the magnetic field and the radio-frequency have both to be increased steadily to maintain the protons in orbit.

### **Thyristors**

This word is being increasingly used for silicon controlled rectifiers. In fact, in the U.S.A. it is well on the way to becoming the accepted term. In this country silicon controlled rectifier, usually abbreviated to s.c.r., is still the most general term.

'Thyristor' is obviously derived by analogy with thyatron and it strikes us as being a good word because most thyristors do, in fact, perform much the same functions as thyatrons. They are virtually solid-state equivalents.

'Silicon controlled rectifier' is a relatively clumsy term and with 's.c.r.' one runs into trouble over the plural, as one always does with abbreviations. We do feel that there is a good case to be made for the general adoption of the word 'thyristor'.

If indeed it is accepted we hope that the changeover period when both terms are in common use will not be too long. It always seems to us bad to have two terms for the same thing. Those who are not fully conversant with the subject are then apt to imagine that the names refer to different things.

### **Closed-Circuit Television**

Next month there is being held at Earls Court an Industrial Photographic & Television Exhibition. The photographic side of it is largely, if not entirely, outside our field. The television part of the exhibition most certainly is not; it is well within it. We understand that closed-circuit television systems will form the main part of the television exhibits, and this is certainly as it should be, for it is the commonest industrial application of television. In our November issue we shall be including several articles dealing with various aspects and applications of closed-circuit television.

Although the photographic exhibits are outside our field, this does not mean that they will not be of interest to our readers. Photo-copying equipment, for instance, is as much used in the electronics industry as in any other. Similarly, in two other exhibitions being held concurrently at Earls Court there are most certainly exhibits of interest to our industry, although there are not many products of it.

These are the Engineering Materials & Design Exhibition and the International Factory Equipment Exhibition. All three exhibitions will be open from 9.30 a.m. to 6 p.m. from 11th to 15th November, and from 9.30 a.m. to 4 p.m. on 16th November.

A recent development in ultrasonic cleaning apparatus is the use of barium titanate and lead zirconate titanate elements in the transducers. This has changed the design of the associated equipment and cleaning baths of up to 3,000 gallons capacity are now practicable.

# ULTRASONIC CLEANING SYSTEMS

By ALAN E. CRAWFORD, M.Brit.I.R.E.\*

THE principle of cleaning by the use of ultrasonic energy in liquids is well known and has found general acceptance in most industries. Many applications of high power ultrasonics for industrial processing have been proposed over the past few years, but apart from a few instances such as drilling and cleaning there has not been the wide exploitation that first seemed possible. The reasons for this are many, but an analysis of progress shows that much of the blame must be attributed to the equipment manufacturers. Laboratory scale experiments have shown the practicality of applications, but the transition from the laboratory to the factory floor is far from easy. While the basic problem of power increase is an obvious one there are many others including reliability of operation, operator training and the economics of capital outlay and running costs.

Ultrasonic cleaning was first described in the late 1930s, but it was not until about 1948 that industry became interested in this new technique. Since this time there has been steady progress in equipment design and the increasing application knowledge has stimulated its use for a wide range of products. Perhaps the major change in equipment has been in the operating frequency. Early ultrasonic cleaners employed frequencies higher than 250 kc/s, while the present trend is to operate at frequencies of less than 30 kc/s. In order to understand the reasons for this frequency shift it is necessary to consider the theory of ultrasonic soil removal.

## Principles of Cleaning

The propagation of a high power ultrasonic wave in a liquid produces a number of different effects. All acoustic waves consist of an alternating pressure front moving at a defined velocity through a medium. The alternate pressure and rarefaction phases produce a phenomenon known as cavitation and this is the major effect used in cleaning. There is a minimum amplitude threshold where this occurs and thus the power level is important. The alternating pressure also produces high acceleration in the liquid and this in turn will accelerate any suspended particles to a high velocity. The direct effect of intense ultrasonic waves on a contaminated surface is to vibrate small particles of the soiling medium by a transfer of momentum from the

moving liquid to the particles. The amount of movement is related to the particle size and the frequency of the acoustic wave, since a wavelength appreciably greater than the largest particle dimension will excite it into oscillation while particles with dimensions approaching the wavelength will move at decreasing amplitudes. Loosely adhering solids are, therefore, broken away from the soiled surfaces and remain in suspension in the liquid if a standing wave is present.

Under normal circumstances cavitation occurs when the peak alternating pressure in the acoustic wave exceeds the external atmospheric pressure. The rapid variation in pressure produces gas or vapour filled voids in the liquid and the eventual collapse of these voids generates intense shock waves. These have pressure amplitudes several orders higher than the initiating pressure and if the implosion occurs adjacent to a soiled surface, particles of adulterant are disrupted and dispersed. Increasing cavitation will eventually reach a point where the surface itself is abraded and it is necessary to impose a time limit or a maximum input energy level if surface destruction is to be avoided.



Multipower transducer  
with 2 in. x 2 in.  
radiating face

\* Sonics Division, Elliott Bros. (London) Ltd.

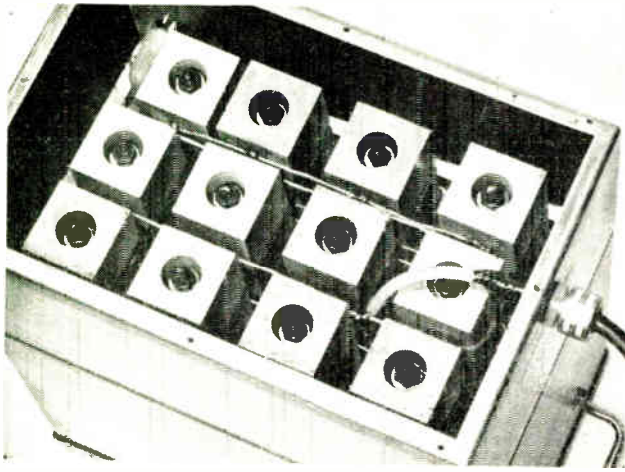

Multipower transducers in position on Elliott-Acoustica 4-gallon cleaning bath

It has been shown that when the frequency is lowered there is an increase in cavitation<sup>1</sup>. Voids in the liquid grow in size due to the rectified diffusion of dissolved gas. As the bubbles increase a point will be reached where they are excited into resonance by the alternating sound field. The oscillations then rapidly increase until the surface structure can no longer support the stimulated stresses and there is a sudden violent collapse. The diameter of the bubble must be smaller than the resonant size and thus at higher frequencies there will be fewer bubbles available for the occurrence of diffusion and the minimum power required to produce cavitation is higher. The ratio of the initial radius to the collapse radius decreases with increasing frequency and the generated shock wave will have a smaller ampli-

Ultrasonic cleaning bath being loaded with work in basket



tude<sup>2</sup>. At a frequency of 10 kc/s the acoustic intensity for cavitation in aerated water at room temperature and normal atmospheric pressure is about 0.3 watt/cm<sup>2</sup>. This increases to 1.0 watt/cm<sup>2</sup> at 100 kc/s and 500 watts/cm<sup>2</sup> at 1 Mc/s. However, the maximum acceleration of particles within the sound field decreases with decreasing frequency and although cavitation is more violent at very low frequencies the lower accelerations prevent rapid removal of loose soil particles from the adulterated surfaces. The nuisance value of the high intensity sound must also be considered in the choice of frequency and this dictates a lower limit of about 20 kc/s. With these factors in mind it is possible to specify the basic requirements of a cleaning system.

1. The frequency should be between 20 and 25 kc/s.
2. The acoustic intensity at any point within the cleaning volume of the bath should be a minimum of 0.3 watt/cm<sup>2</sup>.
3. The solution used in the bath should be chosen after study of the nature of soiling on the contaminated surfaces.

The latter consideration is of great importance and is often neglected with correspondingly bad results. The contaminant can be of many forms and is held to the work surface by a number of forces. In the simple case a clean surface will collect dust due to atmospheric deposition. Electrostatic forces sometimes prevent easy removal, but generally there is no cleaning problem. The most common soiling is found where solid particles are bonded to the surface by an oily film. This film can be either organic or inorganic and if partial carbonization has occurred due to localized heating the removal of the dirt will present greater difficulties. Finally, there is a contamination due to a chemical bond, such as an oxide film. In practice, combinations of all three types are generally experienced.

One of the widely known effects of ultrasonic cavitation is that of emulsification. Oil can be finely dispersed through water to form an emulsion and this process forms the basis for simple ultrasonic cleaning. A soiled oily surface immersed in water and subjected to intense ultrasonic energy will have the soiling removed in distinct phases occurring concurrently. The oil film emulsifies leaving solid particles adhering to the surface and these are dispersed by the transfer of vibratory energy from the oscillating liquid. When oxide film or scale is present, it is generally necessary to soften or reform the surface by chemical means before a cleaning action can take place.

It is obvious that while water can be used, there are distinct advantages in choosing a solution that will dissolve or alter the bonding medium. In the early days of ultrasonic cleaning it was common to employ organic solvents such as trichlorethylene or carbon tetrachloride. While these have advantages in certain cases, modern developments in surface chemistry have now resulted in a range of water soluble detergents that show many advantages over organic solvents<sup>3</sup>. The lower surface tensions allow active cavitation at lower energy levels, and the non-toxic nature of the detergents permits simple open baths to be used. Considerable economies are also shown, often eliminating the necessity of reclaiming solutions after cleaning. The correct choice of a solvent or detergent is thus of the utmost importance and is made after a careful study of the type of soiling present on the contaminated surfaces.

#### Transducers for Ultrasonic Cleaners

An ultrasonic cleaning system has two fundamental components, a bath or tank fitted with ultrasonic transducers and a generator supplying electrical power to the transducers. The transducer is the major part of the system



and two methods of converting electrical energy to high power ultrasonic energy are at present available. Magnetostriction transducers use the change in dimensions produced in certain materials when placed in a magnetic field. Piezoelectric transducers are based on the dimensional change occurring in some crystal structures when an electrostatic field is present. Both systems find uses in ultrasonic cleaners, but magnetostriction transducers are mainly restricted to applications where localized high intensity fields are required<sup>4</sup>.

High power transducers require to be operated at their mechanical resonant frequency for maximum efficiency. This means that the length of the transducer should correspond to half a wavelength of sound in the material at the required frequency. A simple calculation will show that with a polycrystalline ceramic such as barium titanate or lead zirconate/titanate the length for 20 kc/s operation will be between 3 and 4 in. There are many practical difficulties in producing single block ceramic transducers of this thickness and until recently the lowest frequency possible was about 40 kc/s. The introduction of sandwich type transducers has enabled practical low-frequency systems to be produced and the Elliott-Acoustica range of cleaners employs a specialized form of this system known as a Multi-power unit<sup>5</sup>.

### Multipower Transducers

Until recently ultrasonic cleaning tanks operated at frequencies of between 40 kc/s and 80 kc/s. This frequency range did not represent the optimum for efficient cleaning, but was influenced by the availability of suitable transducers. Since all ultrasonic power transducers operate at a fundamental thickness resonance the element progressively increases in thickness as the frequency decreases. It will be realized that thick sections complicate power-supply requirements due to the relatively high energizing voltages

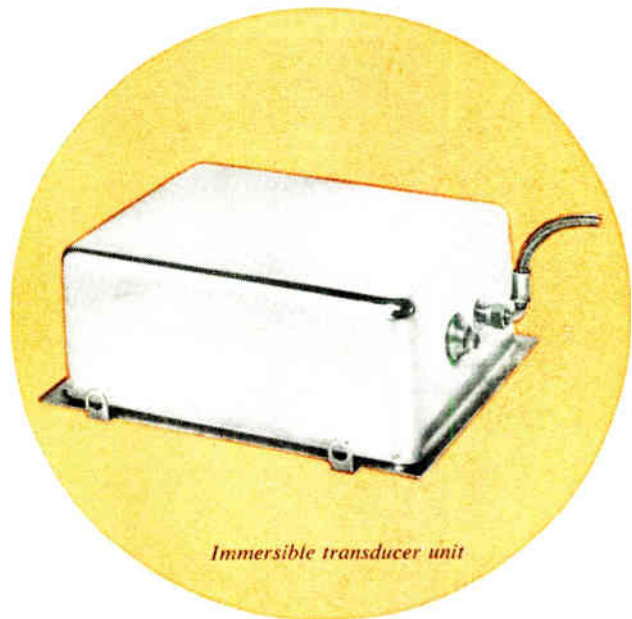

needed to drive the high impedance section. All the known piezoelectric ceramics are poor conductors of heat and the temperature rise in the transducer due to dielectric and mechanical losses can damage the elements.

Initial attempts to overcome these problems and at the same time produce transducers for lower frequency operation were based on the principle of mass loading. In the early days of submarine detection, Langevin showed that a sandwich composed of a thin slice of quartz and two metal masses could be excited into thickness resonance at a frequency governed by the dimensions of the metal blocks<sup>6</sup>.

*3,000 gallon ultrasonic cleaning bath for weapons systems*

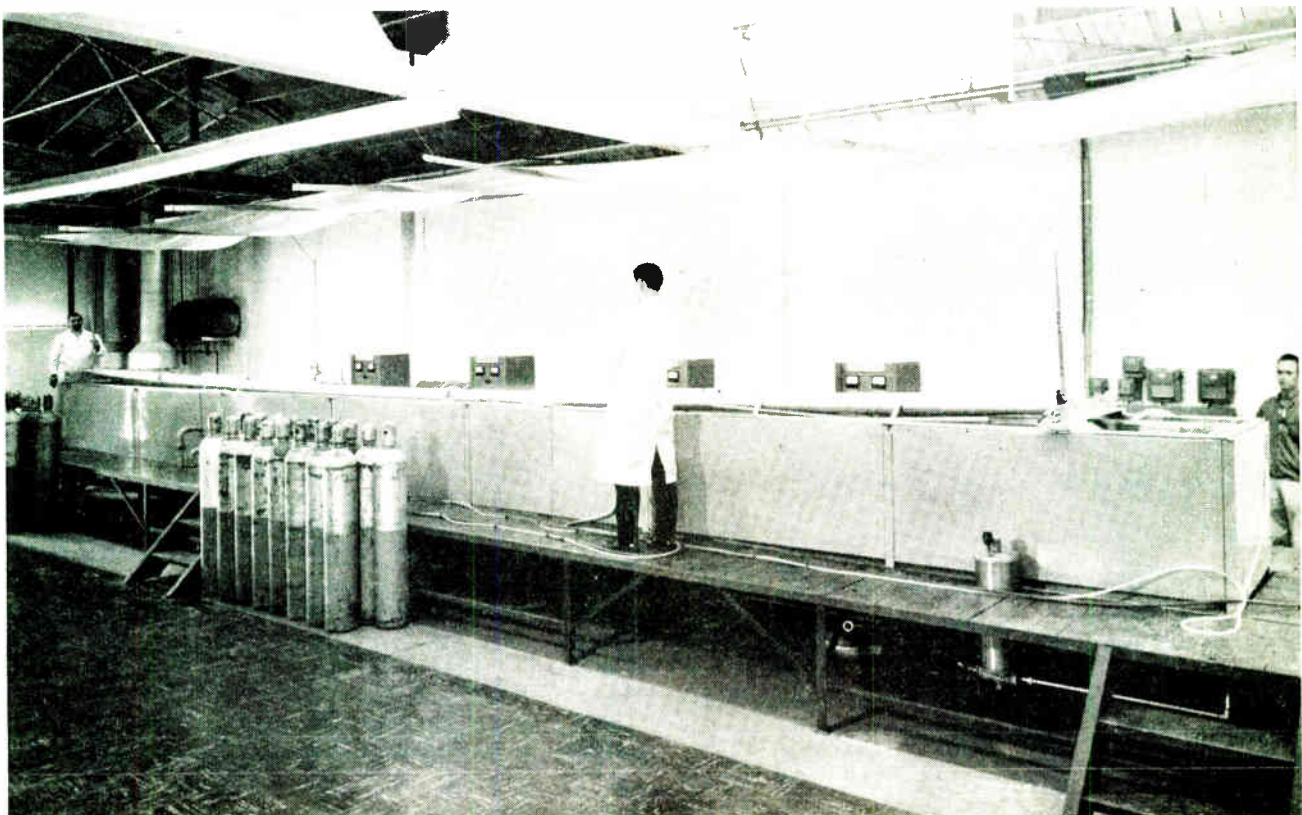

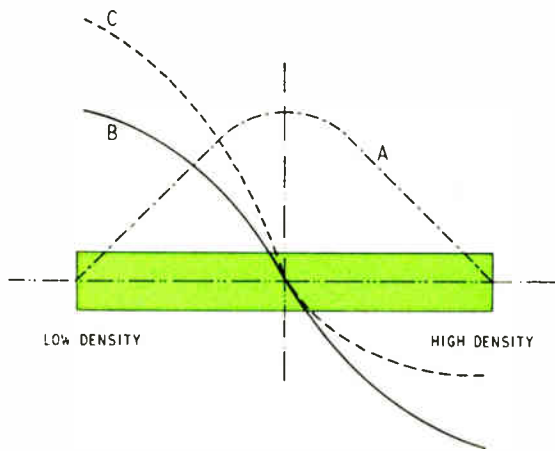

Fig. 1. Stress in a longitudinal vibrator

Subsequent developments in piezoelectric materials enabled the quartz element to be replaced by piezoelectric ceramic and using the Langevin principle it is now possible to design transducers operating at frequencies as low as 10 kc/s.

Sandwich transducers are usually bonded together with epoxy resin as a cement. During the extension phase of the cyclic motion of the transducer considerable stresses are produced across the cement joint and this will limit the maximum amplitude to a value based on the shear strength of the cement. A new form of transducer based on a prestressed structure eliminates this weakness and also incorporates a velocity amplifier. Known as the Multipower transducer it combines a bolted structure with asymmetric operating giving a single face velocity gain<sup>7,8</sup>. Dissimilar metals are used for the two loading blocks, one being of considerably less density than the other. Following the law of conservation of momentum the amplitude at the face of the lighter metal must be higher than that of the heavy metal face. By using the light metal surface as the acoustic radiator there will be an overall power gain at the expense of movement at the face of the heavy loading block. Since ultrasonic power is generally required in one direction only there is little loss in the unused rear loading block. With aluminium and steel as the two materials a gain in front face amplitude of at least 3 to 1 can be produced. Fig. 1 represents the motion of a half-wave longitudinal vibrator. The stress or strain is given by Curve A and reaches a maximum at the nodal points. When the velocity of sound is the same in both sections this point will be at the geometric centre. With loading masses of similar densities the amplitude can be represented by Curve B, while with dissimilar densities the amplitude will follow Curve C. The maximum amplitude in this case occurs at the face of the lower density material and is correspondingly greater with the same energy input.

The sandwich is held together using a spring-loaded centre bolt. The compression is accurately adjusted to provide a suppression of the positive half-wave vibration and thus eliminate the shearing stress across the ceramic-metal interfaces. This type of assembly eliminates the need for cement as a bond although it is still used to assist in the transfer of vibratory energy from the ceramic. A low mechanical  $Q$  is an important feature of the Multipower transducer as this obviates the necessity for precise tuning to resonance and enables full power to be delivered irrespective of the degree of loading on the active face. One of the photographs shows a transducer with this form of construction and is rated at 60 watts with barium titanate elements and 100 watts with lead zirconate-titanate ceramic.

The active face area is 4 sq in. providing adequate power loading for all cleaning purposes.

The choice of the type of piezoelectric ceramic used in transducer construction depends on the required power per unit area and the practical economics of the system. Of the two materials barium titanate shows disadvantages in the efficiency of operation and thus the maximum power dissipation, but this is somewhat offset by the lower price. However, the alternative lead zirconate-titanate possesses a much higher efficiency with the advantage of high temperature operation and Elliott-Acoustica cleaning systems employ this material exclusively. Fig. 2 shows curves relating electromechanical coupling efficiency to temperature for barium titanate. It will be seen that the initial coupling ( $K_p$ ) is higher for lead zirconate-titanate while the Curie point is over 300 °C.

### Cleaning Bath Design

Since no acoustic system can be studied without consideration of the complete structure it is necessary to design cleaning tanks based on correct acoustic principles if maximum cleaning efficiency is to be obtained. The positioning of transducers plays an important part in this study and this in turn is influenced by the proposed application. While individual transducers are capable of producing acoustic energy well above cavitation level there would be little point in mounting a single transducer with 4 sq in. face area on the bottom of a much larger tank. The thin wall of a typical cleaning bath does not act as part of the transducer, but is merely a transmission diaphragm. Secondary vibrations in the tank structure play a minor part in the distribution of cavitation zones and a study of tank parameters has been the subject of a recent paper<sup>9</sup>. Standard Elliott-Acoustica tank assemblies have Multipower transducers mounted on the tank floor with the maximum possible packing density. A photograph shows a typical transducer configuration mounted on a 4-gallon tank and the arrangement of Multipowers ensures the minimum amount of 'dead area' where little cleaning action will occur. Twelve transducers are used in this instance and are energized with an average power input of 500 watts. Each transducer is driven at an intensity of 1.6 acoustic watts/cm<sup>2</sup> of radiating area. Assuming negligible internal losses in the transducers the total output averaged over the tank floor of 813 square centimetres results in an average tank power density of 0.62 watt/cm<sup>2</sup>. In all Multipower cleaning baths there is approximately 125 watts per gallon of liquid at average power, and twice this figure at peak power.

When large tanks in excess of 25 gallons capacity are

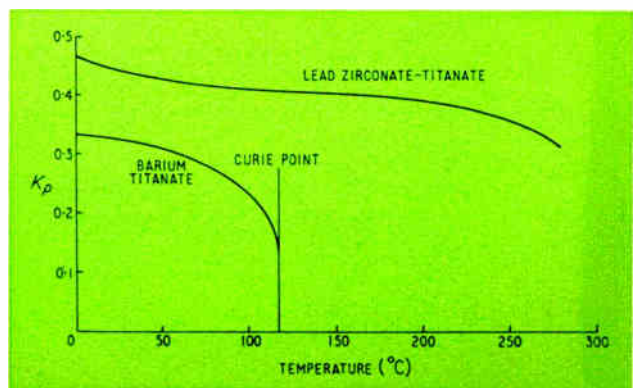

Fig. 2. Influence of temperature on coupling factor for two piezoelectric ceramics

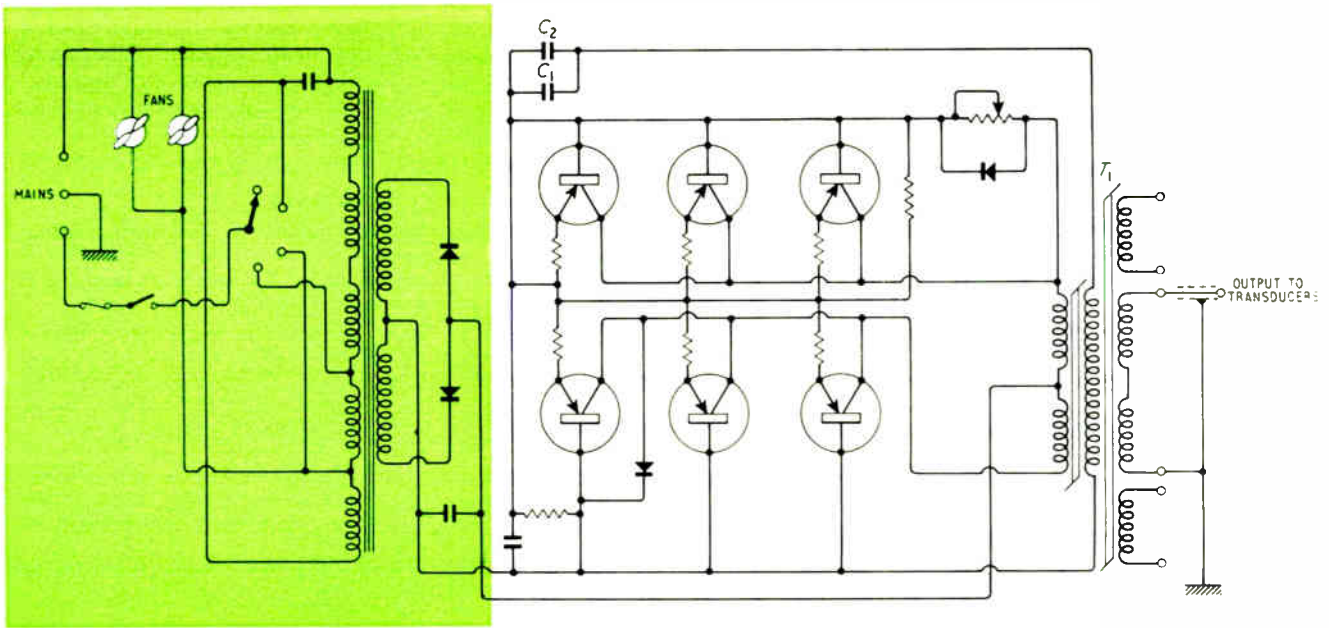

Fig. 3. Schematic circuit of 250 watt Elliott-Acoustica ultrasonic generator

required the permanent mounting of transducers is not always convenient. In many cases the tank dimensions are governed by the maximum size of articles to be cleaned and complete acoustic coverage of the tank floor is unnecessary. Immersible transducers are then used and can be positioned as required. These consist of hermetically-sealed stainless-steel cases containing up to 12 Multipower transducers. The containers are pressurized with dry nitrogen and armoured cables connect them to the power supplies. There is no limit to the size of tank or ultrasonic power using this system of assembly and very large installations can be built. One, which is perhaps the largest to be produced to date, can handle 35 ft long missile parts and holds 3,000 gallons of cleaning fluid. Fifty kilowatts of power feed the multiple immersible transducers, separate outputs being used for individual sections of the tank.

### Power Supplies

Until recently power supplies followed a conventional pattern employing a valve oscillator modulated at twice mains frequency. The frequency was tunable by adjustment of the tank coil inductance and output impedance matching was provided by tapping the tank coil. Since precise matching to the transducer frequency was required the output power was monitored to provide a tuning indication. The reason for a low-frequency modulated output is twofold. Power supplies are simplified with economy of components and the variation of power output to the transducers enables cavitation screens to move out of the acoustic field during the low energy part of the cycle.

The latter is of some importance when high energies are used as large numbers of cavitation bubbles will be trapped in standing-wave formations and will act as acoustic reflectors to the propagated sound wave. This would prevent complete coverage of the bath volume for cleaning action.

The employment of Multipower transducers operating at 20 kc/s and with a low mechanical  $Q$  enables major alterations to be made to generator design. The lower frequency is within the range of easily available power transistors and since sharp tuning is not needed variable frequency control is eliminated. Maximum power can

be delivered irrespective of tank loading and metering is no longer needed. The resulting generator design can be simple and compact, the only control being an On/Off switch.

The Elliott-Acoustica generator also includes a means of frequency modulating the output. While this enables widely mismatched transducers to be used, a major advantage is found in the break up of standing waves with correspondingly better volume transmission of acoustic energy.

The schematic circuit diagram of a 250-watt unit is shown in Fig. 3. This consists of a fully transistorized push-pull self-excited oscillator using six parallel diffused-barrier germanium transistors. The operating frequency

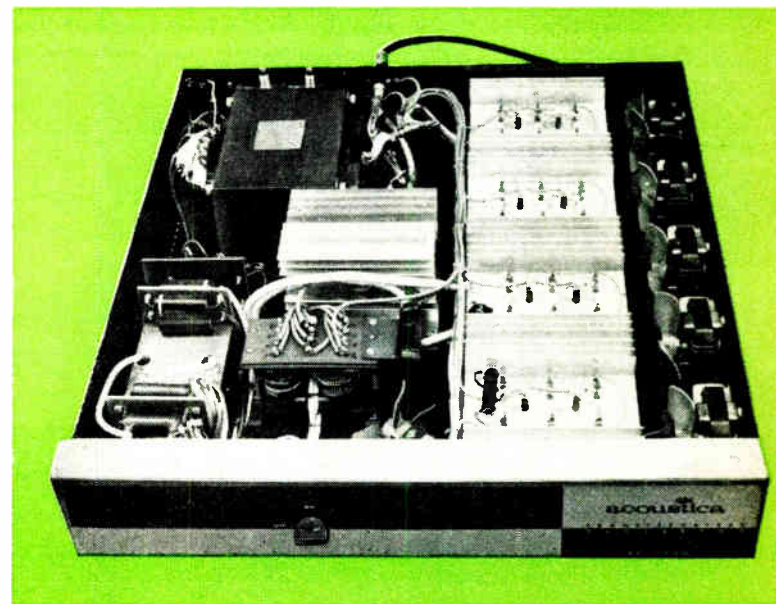

2.5 kW Elliott-Acoustica ultrasonic generator in case 2 ft × 2 ft × 6 in. The standard range of units includes 250 W, 500 W and 1 kW types and larger powers than 2.5 kW are obtained from combinations of units

centres round 20 kc/s and is determined by the inductance of the ferrite-cored output transformer  $T_1$  and the paralleled capacitors  $C_1$  and  $C_2$ . The zener diodes protect the transistors from switching transients. D.c. power for the oscillator is supplied by a full-wave transformer rectifier supply. The small value filter capacitor removes some of the 100-c/s ripple, reducing objectionable tank resonances, but leaves the output heavily modulated at twice mains frequency.

Frequency modulation is developed by periodically saturating the ferrite core transformer. With power supply voltage peaks, the transistor current through the transformer is sufficient to alter its inductance and thus frequency modulate the oscillator over a band of several kilocycles.

### The Future for Ultrasonic Cleaning

Individual industrial applications of ultrasonic cleaning techniques are manifold and can be found in almost every industry. They range from pins to complete missiles, from glass lenses to the recovery of fossils. In the effort to increase productivity their use cuts down man-hours and produces a better product by eliminating the human element.

The wider exploitation of the technique is already forecast by the very large systems now being installed. The rate of expansion rests largely with the willingness of the engineering industry to accept a radically new idea, but the convincing answer lies in practical tests.

### References

- <sup>1</sup> 'Ultrasonic Engineering', by Alan E. Crawford. Butterworths (1955).
- <sup>2</sup> Noltingk, B. E. and Neppiras, E. A., *Proc. Phys. Soc. Lond.*, Vol. B.63 (1950), p. 674; Vol. 64 (1951), p. 1032.
- <sup>3</sup> See for example, Turco Chemical Products Ltd., Tunbridge Wells.
- <sup>4</sup> Myers, J. A. and Goodman, J. E., *Pharm. Journal*, Dec. 1960, p. 585.
- <sup>5</sup> Rich, S., Brit. Pat. No. 868,784 (1957).
- <sup>6</sup> Langevin, P., Brit. Pat. No. 145,691 (1921).
- <sup>7</sup> Crawford, A. E., Paper N.23, 4th I.C.A. Copenhagen, August 1962.
- <sup>8</sup> Crawford, A. E., *Design and Components*, September 1962, p. 8.
- <sup>9</sup> Rod, R. L. Paper presented at Brno, Sept. (1962) (to be published).

## PICKUP CARTRIDGE TESTING MACHINE

Quantity production and 100% testing of components do not often go hand in hand. And with the continuing expansion of the world-wide record-player market, this problem becomes one of increasing importance to manufacturers in this field.

To achieve both these desirable ends, a number of machines have been designed and built by the development laboratory of Garrard Engineering Ltd. They cover many aspects of record-player production but one of particular interest is a machine which simultaneously tests three pick-up cartridges, each for a different performance characteristic.

Despite the complexity of the machine, its operation is simple. It features a turret with four radial arms terminating in holders into which the operator plugs the cartridges, the contacts in these holders connecting with the cartridge tags. Around the body are four stations, on three of which are revolving gramophone turntables; the other is the operating position.

After visual inspection, a cartridge is placed in the holder at the operating position. By means of a foot switch, the turret is rotated 90°, thus moving the cartridge to the first turntable on which is a 33½ r.p.m. frequency test record. The cartridge is automatically lowered on to the record and its voltage output is shown on a meter on the operator's instrument panel.

Following the insertion of a second cartridge at the operating station and its transfer to the 33½ r.p.m. record, the first cartridge is carried to the second turntable. Here it is lowered on to another frequency test record and its output waveform shown on an oscilloscope on the instrument panel. During its travel to the third turntable on which is a 78 r.p.m. test record, the cartridge rotates 180°, thus presenting its 78 r.p.m. stylus to the record. The voltage at this frequency is also shown on the oscilloscope.

A further feature is that each of the turntables is adjustable for position so that each test can be made on an unworn section of the record.



This illustrates the pickup cartridge testing machine

... AIMING AT THE ULTIMATE IN RESISTOR TECHNOLOGY

Great Britain's  
leading resistor manufacturer  
delivers  
**VITREOUS ENAMELLED WIRE WOUND RESISTORS**  
from stock

●  
... a stock backed by 25 years  
product history and screened by  
*Welwyn Quality Control* to ensure  
reliability **AND** performance

●  
... a stock manufactured on a  
planned basis, not accumulated  
from surplus, giving certainty  
of availability of all preferred  
values

●  
... a stock with composite marking  
of Inter-Service Reference Number  
and Welwyn Type Number,  
enabling the system to apply equally  
to commercial or E.I.D. released  
resistors

WRITE NOW FOR FULL DETAILS



**WELWYN ELECTRIC LIMITED**

BEDLINGTON - NORTHUMBERLAND - ENGLAND

Telephone : Bedlington 2181-9 - Telegrams : Resistor' Bedlington.

FACTORIES IN AUSTRALIA AND CANADA

# Potting shed?

Araldite epoxy resins are ideal for potting—but this is not a potting shed. Here Araldite is being used to seal capacitor windings at Telephone Manufacturing Co. Ltd. The Araldite filler cures, with negligible shrinkage, to form a complete seal. It adheres strongly to metal surfaces—provides perfect insulation and resists tracking. It is impervious to moisture. Araldite sealing formulations pour and cure at room temperature. In many cases curing can be speeded up by heating.

May we send you a copy of our publication 'Araldite epoxy resins in the electrical industry'?

**ARALDITE EPOXY RESINS ARE USED:**

- for casting large high-grade electrical insulators and insulation around equipment such as transformers, switchgear components etc.
- for impregnating, potting and sealing electrical windings and components.
- for constructing glasscloth laminates in electrical, nuclear, mechanical and aircraft engineering.
- for bonding metals, ceramics, glass, rubber, plastics, wood etc.
- for constructing tools for forming plastics or sheet-metal, patterns for moulding foundry sand, jigs and fixtures for checking accuracy of assembly etc.
- for chemical resistant-flooring and floor surfacing.
- for anti-corrosion protection of wood, concrete, metals etc.

**Araldite** epoxy resins



CIBA

Araldite is a registered trademark CIBA (A.R.L.) LIMITED DUXFORD CAMBRIDGE TELEPHONE: SAWSTON 2121  
AP787

# ULTRA-THIN FOIL STRAIN GAUGES

By A. L. WINDOW, D.L.C.\*

Resistance strain gauges have been used for many years. Recent developments have permitted the production of ultra-thin foil and this has enabled the size of strain gauges to be greatly reduced. Standard sizes now range down to only  $\frac{1}{16}$  in. long and still smaller ones can be made.

THE electrical resistance strain gauge has become a well-established engineering tool and recent progress in the production of ultra-thin foil materials has given considerable impetus to the development of very small high resistance strain gauges of the etched foil type. The installation of the Sendzimir multi-roll mill at the Crawley works of Telcon Metals Ltd., the magnetic and resistance alloy specialists in the B.I.C.C. group, is shown in the cover picture. It is fitted with Beta-ray thickness measuring equipment. This has enabled electrical resistance alloys to be cold rolled down to thicknesses of 0.0002 in. to very fine limits. Prior to this the thinnest foil which could be rolled accurately was 0.001 in. and although thinner foils had been rolled, the tolerance and quality left something to be desired.

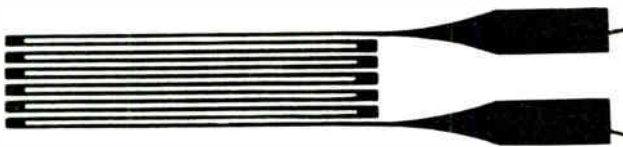

Early foil strain gauge nearly two inches long

The automatic gauge control depends on receiving beta radiation derived from a strontium 90 source. This beam passes through the strip and is backed up by a suitable receiver on the opposite side. The attenuation of the beam is therefore a measure of the strip thickness, and by appropriate application the signal received may be used to register the thickness. The system is, of course, calibrated to the particular material being rolled.

A strain gauge works on the principle, propounded by Lord Kelvin, that the resistance of an electrical conductor changes if the conductor is strained. For most conducting materials the resistance increases with tensile strain and decreases with compressive strain, as a large proportion of the change in resistance is due to the dimensional changes; i.e., change in length and change in cross-sectional area. There is, however, another factor, the change of resistivity of the material with strain, and strain gauge materials are chosen to give a linear relationship between change in resistance and strain with as high a resistance change as possible. The two most widely used materials are a 45-55 nickel copper alloy, and an 80-20 nickel chrome alloy. The nickel copper gives the more linear and repeatable relation-

ship and has a low temperature coefficient of resistance, another desirable property; while the nickel chrome, although it has a higher temperature coefficient, can be used at high temperatures without oxidizing.

The first resistance strain gauges were made by winding a length of fine wire, usually 0.001 in. dia. into a grid in order to achieve a suitable resistance in a short overall length. The grid was cemented on a thin paper backing with a cellulose adhesive, and short heavier gauge lead out wires were welded to the ends of the fine wire element. The whole was then cemented to the surface of the specimen to be tested and the leads to the recording equipment soldered to the heavy gauge lead out wires. Strain gauges are still produced in this way on various backing materials but in 1952 work by the then Saunders-Roe Company (now a division of Westland Aircraft Ltd.) led to the development of the first etched foil type gauge. This type of gauge, which in fact is a small printed circuit, overcame some of the inherent disadvantages of a wire gauge and has proved to have superior characteristics in a number of respects.

Fig. 1 shows a typical outline for a foil type linear gauge and points to note are the gradual change in cross-section from the fine element to the large area soldering tags to avoid the stress concentration at the weld in a wire gauge. The width of the lines of the element, which are usually  $7\frac{1}{2}$  to 10 times the foil thickness and of rectangular section, provides a large area for bonding to the backing of the specimen and excellent heat dissipation enabling much

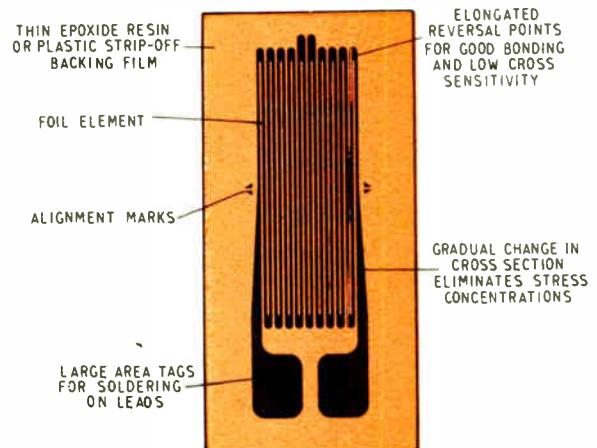

Fig. 1. General form of typical foil resistance strain gauge

\* Westland Aircraft Ltd., Saunders-Roe Division.

larger currents to be used than in a wire gauge. The large bond area and intimate contact allow a large cross-sectional area to be used without increasing the shear stress in the adhesive or backing between the foil element and the specimen. The most important parts of the gauge, when considering shear in the bond are the ends of the grid or reversal points. In the foil gauge these are designed to have a large area by making them long, giving two benefits. It reduces the shear stresses in the bond considerably, thus reducing creep and hysteresis in the gauge, and it reduces the electrical resistance in a transverse direction, making the gauge very insensitive to lateral strains. The backing material is an epoxyethylene film which is dimensionally stable and impervious to water and most solvents.

The first foil gauge was produced from copper nickel foil 0.001 in. thick with an active gauge length of 1 in. and a resistance of 45 ohms. The overall length of the gauge was nearly 2 in. and it is shown in a photograph. While this design showed the advantages of the foil gauge, it was much too big for many purposes and as a gauge measures the average strain along its length it could not be used for measuring the maximum stresses in areas of stress concentrations and gradients. The overall size of the gauge was reduced considerably by redesigning as in Fig. 1 and a gauge with an active length of  $\frac{1}{2}$  in. was also introduced, again on 0.001-in. foil with a resistance of 45 ohms. This smaller gauge proved very popular and the  $\frac{1}{2}$ -in. gauge is still the most widely used size. However, there was an increasing demand for even smaller gauges, and also for high resistances to match available instrumentation. The possible ways of increasing the resistance are:—

1. By increasing the length of the gauge.
2. By introducing more lines thus widening the gauge.
3. By reducing the line width.
4. By reducing the foil thickness.

As smaller gauges were required 1 and 2 were impossible and 3 would be contrary to one of the desirable characteristics of a foil gauge. The only alternative was the most desirable one; the use of thinner foils.

A  $\frac{1}{4}$ -in. gauge was designed to be produced from foil 0.0004 in. thick but as this was not readily available an interim design for 0.0006 in. was introduced. This gauge had to be as wide as it was long to achieve the required resistance. The opportunity was also taken to produce  $\frac{1}{2}$ -in. and 1-in. gauges on 0.0006-in. foils to achieve higher resistances and at the same time very long gauges for use on concrete, torque, diaphragm and rosette gauges were produced from 0.001-in. foil to widen the range available, and high temperature gauges with a strip-off type backing were developed.

With the introduction of the Sendzimir mill at Telcon

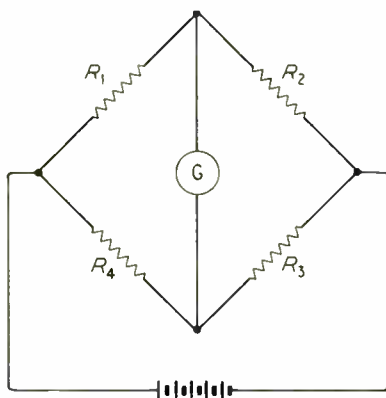

Fig. 2. Basic bridge circuit for a strain gauge. According to circumstances one, two or four of the arms are gauges

Metals Ltd., the 0.0004-in. foil became available and the narrow design of  $\frac{1}{4}$ -in. gauge was produced, becoming the standard design. It was now considered possible to produce foil 0.0002 in. thick and consequently  $\frac{1}{8}$ -in. gauges and  $\frac{1}{4}$ -in. gauges with an overall width of  $\frac{1}{8}$  in. were introduced and these are now in production. Foil thicknesses currently in use are 0.0002, 0.0004, 0.0006, 0.0008 and 0.0010 in. and gauges are made with active lengths from  $\frac{1}{8}$  in. to 4 in. Smaller gauges could be produced down to  $\frac{1}{64}$  in. as they are in America, but as the demand is relatively small production is not commercially worthwhile. The cost of producing very small gauges is high in spite of the fact that less material is required; the lines may be less than 0.002 in. wide, and there are problems of production and inspection.

Strain gauges are normally used in a Wheatstone bridge network in order to measure the small changes in resistance with strain (Fig. 2). The four arms of the bridge may be made up in various ways according to the type of measurement required and the instrumentation used. For the measurements of stress at a point, a single strain gauge cemented to the specimen is used as arm  $R_1$ , and three fixed resistors  $R_2$ ,  $R_3$ ,  $R_4$  complete the bridge.  $R_2$  is usually a strain gauge cemented to a similar piece of material to the specimen but unstrained, in order to provide compensation for temperature and expansion coefficients. Most static strain recorders have fixed resistors  $R_3$  and  $R_4$  built in, but if not, a further two strain gauges can be used cemented to any convenient piece of unstrained material.

For measuring loads or displacements in a calibrated system, the signal can be increased by making more than one arm of the bridge active. For example  $R_3$  can be cemented alongside  $R_1$  thus doubling the signal. If the specimen is strained by bending, then  $R_2$  and  $R_4$  can be cemented on the opposite surface to  $R_1$  and  $R_3$  giving equal and opposite signals and thus giving a total signal of four times that from  $R_1$  alone. In such cases, the signal obtained is often large enough to drive a 0–50  $\mu$ A meter directly without amplification. Alternatively it will certainly drive a galvanometer or galvanometer recorder. Cantilevers based on this principle can be designed to measure loads from a fraction of a gram to hundreds of pounds or deflections from less than a thousandth of an inch to inches or even feet at frequencies from zero to several kc/s.

An alternative to the cantilever is the proving ring which again allows all four arms of the bridge to be active, and which gives a completely linear load-resistance change curve.

Special gauges are produced in the form of a herring bone with the elements at  $45^\circ$  to the axis for measuring shear, or torsion in shafts. These gauges can be connected up to eliminate signals due to bending and end load, and record pure torsion, or to measure the total surface strain due to all these effects.

For measuring fluid pressures, diaphragm gauges are produced for cementing to a diaphragm made up into a pressure cell. Designs are available for pressures from a few inches of water to several thousand p.s.i.

When measuring strains in concrete it is necessary to average over a number of pebbles in the mix to avoid measuring only local effects and it has been found that a gauge length at least four times the aggregate size is required. Gauges of 2 in. and 4 in. lengths are produced to suit model concrete, and normal structural concrete, and 6 in. gauges have been made to suit heavy concrete.

Strain gauges are used in every type of industry for either research, development, production checking or monitoring and it is impossible to single out any particular applications in a short article. However, 'from ladies' shoes to nuclear power stations' gives some idea of the scope of these versatile instruments.



## PHOTOELECTRIC EQUIPMENT IN MULTI-STOREY CAR PARK AT LONDON AIRPORT

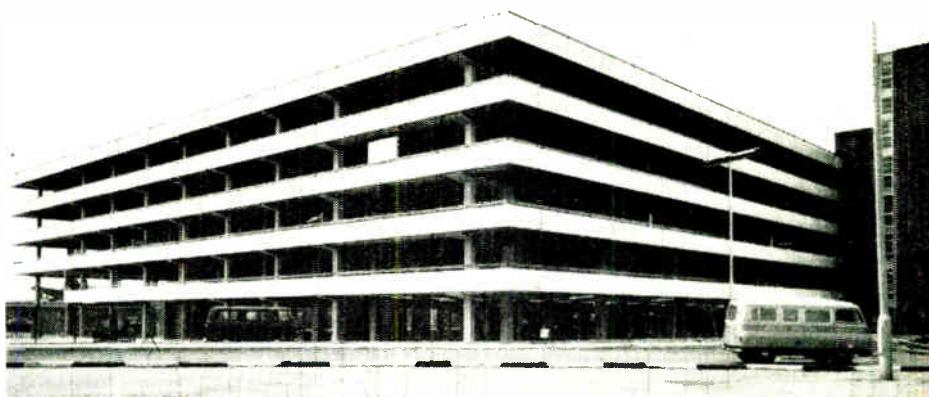

A NEW five-storey car park has recently been opened at London Airport, Heathrow. It has accommodation for 1,150 cars and 20 coaches. The Witton-Kramer Division of G.E.C. (Engineering) Ltd. has supplied, through the K. S. Construction Co. Ltd., all the photoelectric equipment for this car park, where it is used to indicate the number of empty parking spaces on each floor.

The G.E.C. installation consists of 24 sets of transistorized photoelectric equipment, each set comprising a projector, receiver and control unit, together with six special relay control boxes, two counter cabinets and one alarm panel. It is designed for operation from a 12-V d.c. supply so that in the event of power failure, the complete equipment may be switched to battery operation.

One of the counter cabinets is installed in a room adjacent to the car-park entrance and the other counter cabinet, together with the special relay boxes and the alarm panel, are all located in the Superintendent's office situated in front of the building.

### Operation

When a car enters the ground floor, the total number of spaces shown on the ground-floor counter is reduced by one digit. As the car leaves the ground floor and enters the first floor, the ground-floor counter adds one digit at the same time as the first-floor counter subtracts one.

Each floor has an entrance and exit from the floor below and an entrance and exit from the floor above. It is thus necessary for the equipment to be able to count two cars entering or leaving a floor simultaneously. The circuit is so designed with a system of relays, that two cars entering any floor simultaneously at up to 20 mile/hr will both be recorded. No indication is given on the counters if one car enters and another car leaves a floor simultaneously.

Two pushbuttons are provided for each of the six counters on the counter cubicles to notch the counter readings up or down independently to any required figure. When only ten car spaces are left an alarm is given and this takes the form of a klaxon which operates for approximately five seconds. At the same time an indicator lamp board will show which floor is concerned. A reset push-button for the indicator is provided.

Although pedestrians are not permitted to walk up and down the roadways, the possibility of counting individuals is overcome by using double beams spaced approximately 6-ft apart. Both beams must be interrupted at the same time before a count is registered.



*The projectors and receivers installed at the entrance to the building can be clearly seen in this picture*

*This equipment forms part of the installation for indicating the number of cars in the car park*

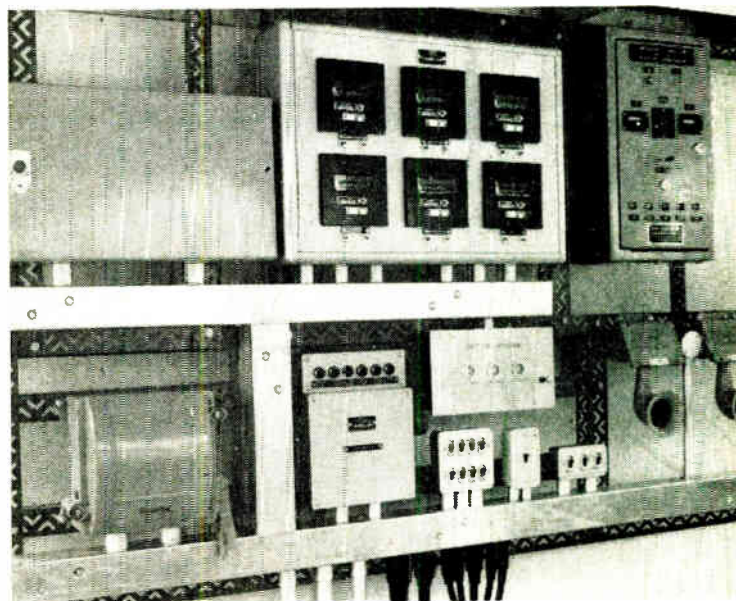



# AUTOMATION IN THE GLASSHOUSE

By J. A. IRVINE, B.Sc., A.M.I.E.E.\*

The cost of fuel and labour is a major item in the production cost of crops, such as tomatoes grown in a glasshouse. This article describes automatic controls for regulating temperature, ventilation and humidity.

Findlay, Irvine Ltd.

**D**URING the recent Common Market discussions it was noticeable that horticulturalists in Great Britain were afraid of the consequences to their industry of joining the Common Market. Their fears were certainly justified, because even now with a tariff on imported glass-house produce, there are many cases of home-grown produce being dearer than its imported counterpart.

If one considers tomatoes, one of the main glasshouse crops, the primary costs of growing are fuel and labour: in Scotland 30% of the wholesale price is taken by fuel and 40% by labour. In the Channel Islands and the Continent the fuel percentage is much lower because of the warmer climate. If British growers are to remain competitive, they must make every effort to reduce labour costs and to use fuel as economically as possible. Automatic control of temperature, ventilation, irrigation and humidity can all be used to reduce costs and improve crop quality. There is great scope for automation in Britain, which, at the present moment, lags behind some other countries, such as Holland.

## Temperature Control

The importance of keeping a glasshouse as *cool* as possible can be understood from the fact that winter and spring heating costs are approximately doubled for every 5 °F increase in inside temperature. Also, some crops may be kept at a night temperature some 20 °F below the optimum day temperature. The ideal glasshouse thermostat should have a differential of less than 1 °F; a fast response to temperature changes, be readily adjustable, accurately calibrated, and have the facility of automatically changing its set point in response to changes in light intensity, when required.

With these requirements in mind, an electronic photo-thermostat was designed, using a transistor as the temperature sensor and a photo-transistor as the light sensor. Transistors are well suited as sensing elements since they have a thermal time constant of about 1 second when the junction is connected to the case, have a sensitivity which is high and linear, and may be situated remote from the main circuit.

Referring to Fig. 1, which shows the  $I_c/V_{be}$  characteristic of a typical transistor, it will be seen that to maintain constant collector current, the base-emitter voltage must be reduced by about 1 mV for every 1 °F rise in temperature.

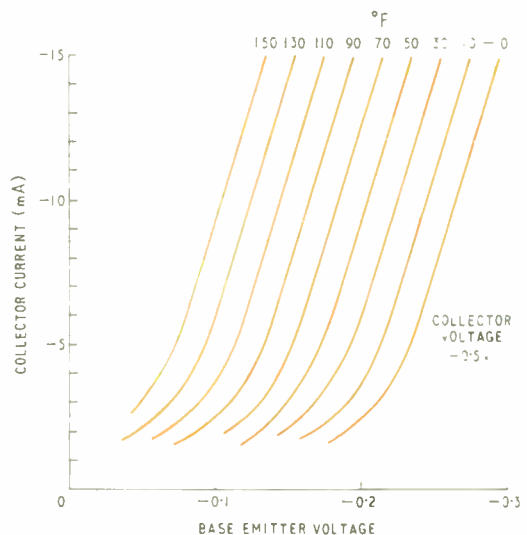

Fig. 1. Transistor characteristics with temperature as a parameter

This figure applies to both silicon and germanium transistors, and is extremely stable. Fig. 2 shows the temperature sensing circuit. The collector current of  $Q_1$  is a function of its junction temperature and base-emitter voltage, which is derived by adding the current flowing in  $VR_2$  and  $VR_3$  in the low value resistor  $R_1$ . For a fixed base-emitter voltage, the collector current  $I_c$  varies only with temperature. Calibration is simple, and is carried out as follows:—

With  $VR_1$  at 'max.' negligible current flows in  $VR_3$ ; the base-emitter voltage is thus controlled by  $VR_2$  so that the desired collector current flows when the transistor is maintained at the maximum temperature to be controlled. The transistor temperature is then reduced to the lowest requirement,  $VR_1$  rotated to 'min.' and  $VR_3$  adjusted to give the same collector current as before. If  $VR_1$  is a linear potentiometer, the temperature setting is linearly related to angular rotation, and only the limits of the temperature scale require calibration, as outlined above. Using standard audio-frequency transistors, the sensitivity is about 4% change in collector current per  $^{\circ}F$  change in temperature.

Fig. 3 shows how the photo-transistor circuit is added. The photo-current flowing in the low value resistor  $R_2$  reduces the base-emitter voltage of  $Q_1$ , reducing  $I_c$  and thereby giving the same effect as a reduction in transistor temperature. The value of photo-current depends on the intensity of illumination of  $Q_2$ , the setting of  $VR_1$  and the value of  $VR_3$ . Calibration consists of fully illuminating  $Q_2$ , setting  $VR_1$  at 'max.' and adjusting  $VR_3$  to give the required change in temperature setting. Fig. 4 shows the complete circuit. The collector current of  $Q_1$  is amplified by an n-p-n transistor  $Q_3$  and a p-n-p transistor  $Q_4$ , which has as its load relay  $R$ . The stabilized d.c. supply for  $Q_1$ ,  $Q_2$  and  $Q_3$  is obtained from a transformer-rectifier-filter system and zener diode  $D$ . With the circuit shown, the range of temperature is 45–95  $^{\circ}F$ , the differential is less than 0.5  $^{\circ}F$ , and the temperature setting can be automatically raised by 18  $^{\circ}F$  when the photo-sensitive circuit is brought into use. Both sensing elements are located in housings which can be placed at the most desirable position in the glasshouse, and connected by ordinary 3-core cable to the main control box which is normally placed beside the heating contactors.

### Ventilation

Most glasshouses are constructed with the ventilators linked together so that all the ventilators on one side may be operated from a single lever or crank. When ventilators are operated by a skilled man, he takes into account greenhouse temperature, wind direction and wind velocity, always endeavouring to ventilate without draughts. Also, to keep the cost of automatic ventilation to a minimum, it is desirable to utilize the existing mechanism as far as possible. With these requirements in mind the Autovent\* system was designed. It is compact, having a variable thermostat, reversible motor, gear box, limit switches and controls in a single housing, leading to simple installation with a minimum of external wiring. A typical installation is shown in one of the photographs. A Terylene cord is connected from the winding drum to the operating lever, passing through a pulley block if a pull in excess of 50 lb is required. The unit is flexible in operation, having an adjustable thermostat, a control for varying the amount by which the ventilators open, and has provision for manual control. In large installations, an Autovent is usually fitted to control each side independently, and, if required, a wind vane can be used to select the ventilators on the leeward side of the house.

\* Registered name.

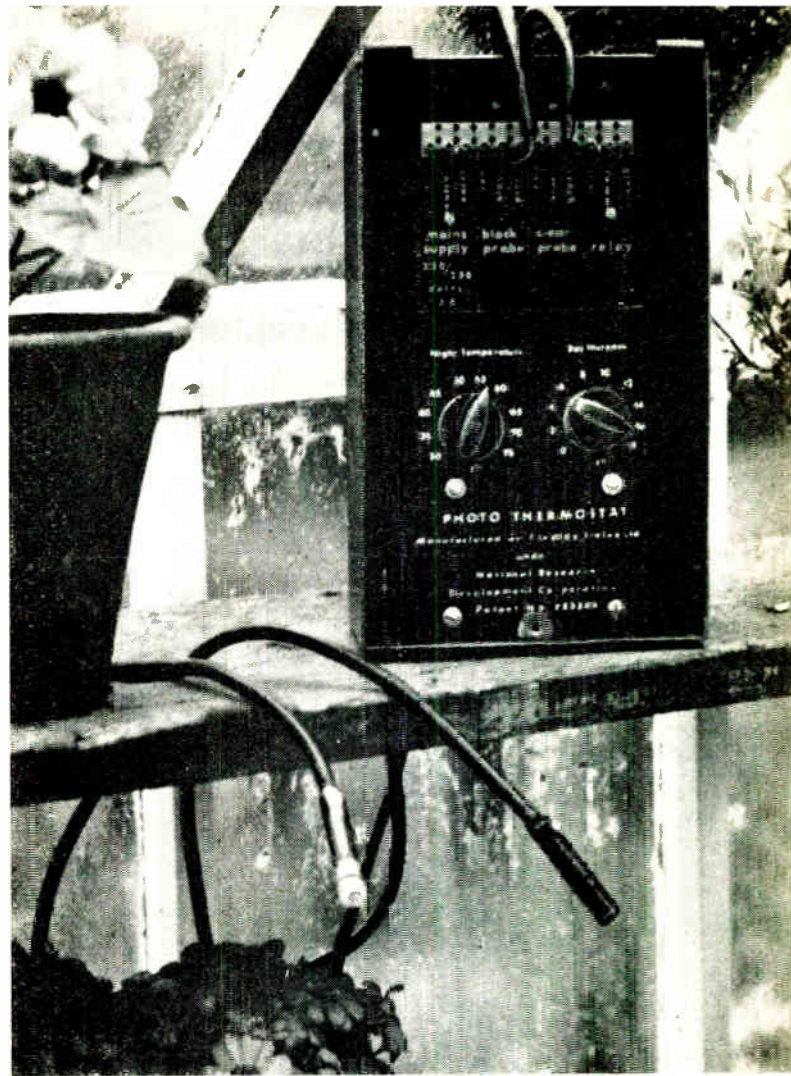

Photo-thermostat control unit

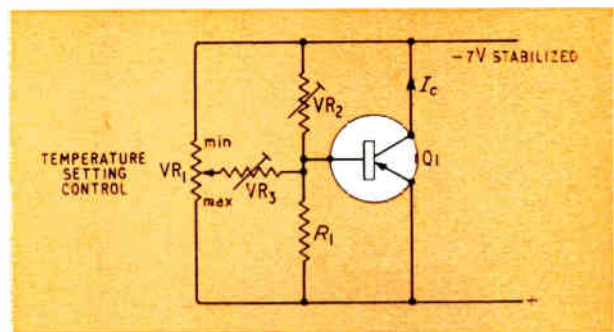

Fig. 2. Basic circuit of a transistor used as a temperature-sensing element

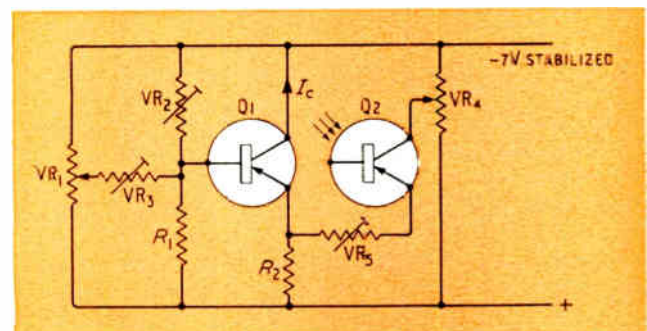

Fig. 3. The circuit of Fig. 1 with a photo-transistor  $Q_2$  added to sense both temperature and light

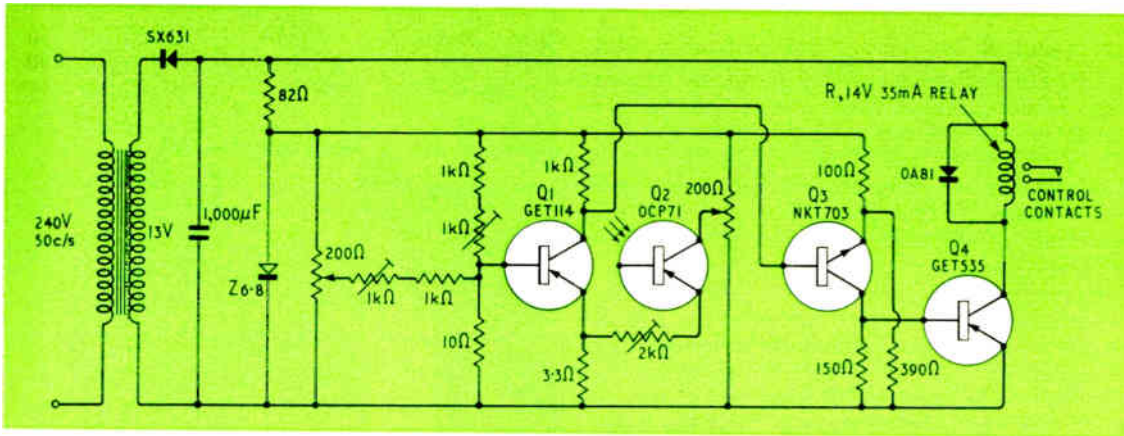

Fig. 4. Complete circuit of the control unit

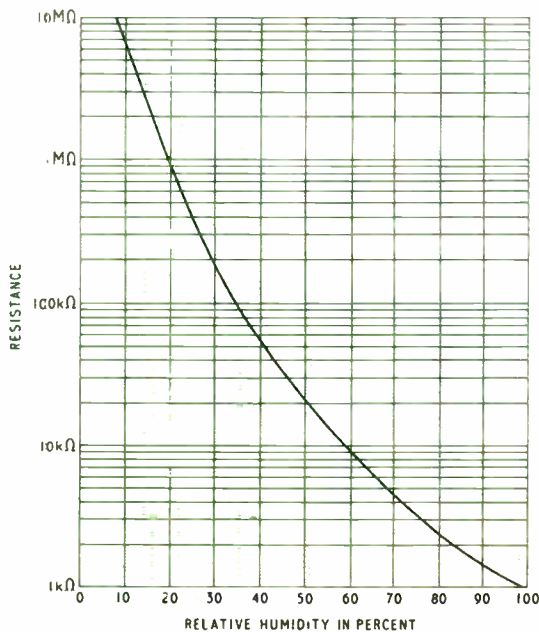

Fig. 5. Characteristic of humidity transducer

*Autovent ventilation control unit*



### Humidity Control

The present method of altering the humidity in glass-houses is to damp down the floor when the atmosphere is too dry, and increase the air temperature when the humidity is too high. Manual control of humidity is crude for a number of reasons. Floors are damped down infrequently and the applied water may evaporate in 30 minutes or still be there next day. It is also difficult to judge the humidity of the atmosphere.

A system of automatic humidity control is at present under development, based on a new type of sensing element whose volume resistivity varies markedly with relative humidity and only slightly with temperature. Fig. 5 gives the resistance-humidity characteristic of a typical element. The drift of this characteristic with time is less than 2%. It can be used as one arm of a Wheatstone bridge, having a phase-sensitive detector indicating whether the actual humidity is above or below the required limits. If below the lower limit, the detector opens a solenoid valve which introduces water to a system of fine sprays directed at the floor. Once open, the valve is controlled by a timer which keeps it open for 1 minute then closes it for a further 30 minutes regardless of humidity. This gives the water time to evaporate and permeate the atmosphere. If, after 30 minutes, the humidity is still too low the sequence of operations is repeated.

If the humidity is above the upper limit, and the glass-house temperature is below a preset figure (normally about 50 °F), the heating system is switched on to prevent mildew and other forms of fungoid growth.

The control systems outlined above are an indication of present day thinking. The future promises to be more exciting still. As the conversion efficiency of electricity to light increases, and the insulation value of building materials goes up, it will be possible to have glassless houses, artificially lit, free from pests and diseases, and with a completely controlled atmosphere, much cheaper to operate than the present glasshouse, and giving predictable results.

### INFORMATION WANTED?

If you require further details of products or processes described or advertised in **INDUSTRIAL ELECTRONICS** you will find it convenient to use the enquiry cards which will be found in the front and back of the journal.

# AUTOMATIC CONTROL OF A TAILOR KNITTING MACHINE



This article describes the data-handling systems for an automatic knitting machine. The data is stored on tape and controls the knitting of a three-dimensional garment as well as the pattern

By M. BROWNING, D.F.H., A.M.I.E.E.\*

**A**n entirely new approach is being made to the design and knitting of tailored or 'three-dimensional' garments. A machine, which is automatically controlled by electronic and servo means, is now under development by Evershed and Vignoles Ltd. for Macqueen Cybernetics Ltd., London.

The knitting machine, embodying many novel features, and the knitting techniques have been widely covered in the textile press. A high degree of flexibility in control and patterning has been brought about by the use of punched plastic tape in the data input systems and it is the purpose of this article to discuss these systems in detail.

The principles of the data input systems depend upon the functions that they control. In order to achieve patterning in a garment needles are either knitted or not knitted as the knitting mechanism, the cambox, passes over them. Therefore the pattern tape, containing data for needle selection, is read in a serial mode in synchronization with the process of knitting.

The other data required is of a line by line nature presenting information for a particular course of knitting, e.g. speed, yarn colour, stitch length and garment width. This implies that the tape be read in a parallel mode. The tape so used is known as the control tape.

## The Basic Tape

An identical black plastic film is employed for both the control and pattern tapes. The tape, which is 5½ in. wide, is driven from standard 35-mm film size sprocket holes, running along one edge of the film. A total of 36 holes can be punched across the width of the tape, the line of the holes being slightly inclined to facilitate serial read-out. By using a black plastic material, the tape is suitable for both optical and electro-mechanical read out systems. Both tapes are used as continuous loops and the plastic material is readily spliced.

## Control Tape Reader

The control tape is read by electro-mechanical means before each traverse of the cambox. Two courses of knitting are produced for each traverse. To obtain sufficient data for the two courses, two rows of holes on the tape are read at the same time.

The actual reading is performed by sensing-brushes bearing on the tape, the presence of a hole allowing the brush to make contact on to individual studs on the platen below. A general view of the reader is given in Fig. 1. The sensing-brushes are mounted on a pivoted arm, shown in the raised position which facilitates the loading of a new tape. The tape, which is in the form of a continuous loop, is carried past the reading position by means of sprocket-

toothed drums. These index the tape on by two rows of holes at a time.

When a tape shift is indicated, the supply to the sensing-brushes is interrupted, prior to their being raised just clear of the tape. The tape is indexed on and the sensing-brushes lowered ready to be energized in the next dwell. This action takes place during the process of knitting, thus reducing the dwell (i.e., 'dead time') period. The action time is approximately 0.5 sec.

At the beginning of the dwell, the supply is restored to the sensing-brushes and read-out occurs, thus setting up the control and decoding relays.

For a typical garment the total number of courses of knitting would be 3,000, which means the tape length is approximately 32 ft. The tape is stored inside the magazine vertically below the reader, in random fashion, and up to 100 ft of tape can be accommodated. It is drawn in and out of this magazine by means of a separate take-up motor driving sprocket-toothed drums. The tape is held against the drums by spring-loaded rubber-faced rollers.

Between the take-up motor and the reader, the tape is formed into a double loop around a pair of floating open-

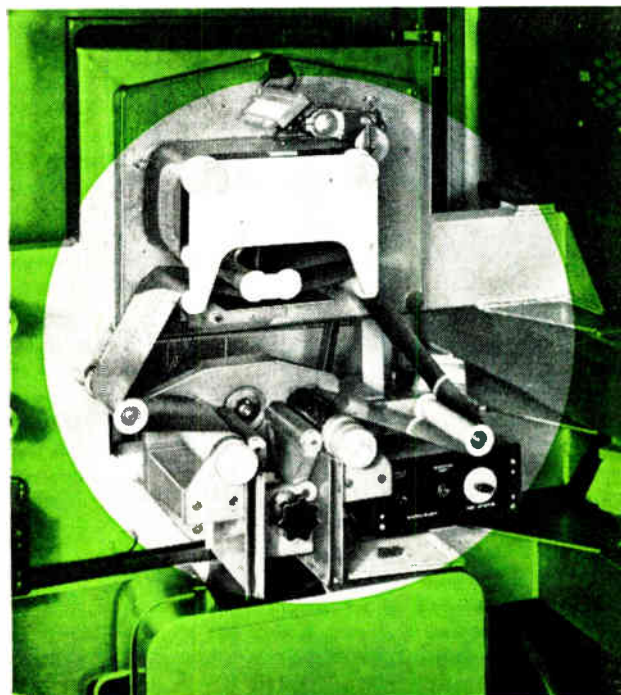

Fig. 1. In this close-up of the control tape reader the punched tape can clearly be seen

\* Evershed & Vignoles Ltd.

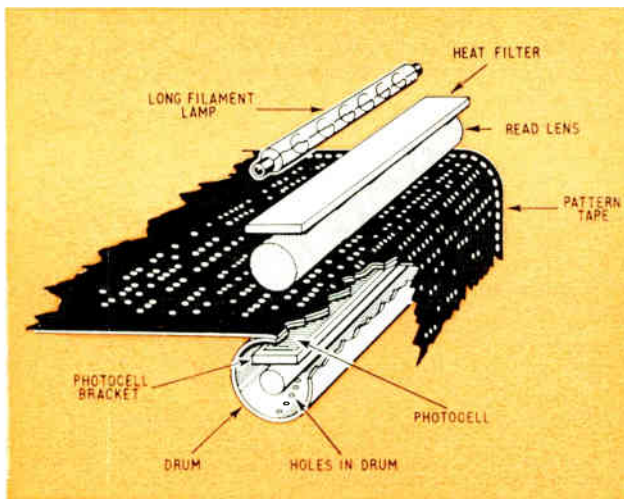

Fig. 2. This diagram shows the general arrangement of the pattern tape reader

ended rollers, thus forming a local tape store. This overcomes the problem of the tape-indexing drive having the additional load of taking the tape out from the magazine. As tape is drawn from the local store, the floating rollers travel across, striking a pivoted arm, thus operating a microswitch which in turn energizes the take-up motor, to restore sufficient tape.

The tape-indexing drive is mounted at the rear of the reader. On initiating the shift cycle a rotary solenoid is energized, raising the latch from a counting mechanism. Simultaneously, an electromagnetic clutch is energized, thus applying power from the driving motor to a gearbox, the output of which drives a camshaft, raising the sensing-brush arm. Also carried on the shaft at the rear of the reader are additional cams to operate the ratchet mechanisms which provide the intermittent movement of the tape, together with cams which operate contacts for external switching functions and for breaking the supply to the rotary solenoid and magnetic clutch after the requisite number of revolutions of the drive motor.

### Pattern Tape Reader

Pattern information is required during the process of knitting, so the tape is read in a serial mode in synchronism with the cambox movement. The method of scanning the tape is shown in Fig. 2. A long-filament light source is mounted above the tape, thus allowing any heat generated to be dispersed vertically. Light passes through a heat-absorbent filter and is focused as a line across the width of the tape. The tape is driven slowly under the band of light. Below the tape is an open-ended rotating drum, around the periphery of which is a helix of 36 holes. Stationary within the drum is a strip of photocells. The gearing between the tape drive and the drum is arranged so that for one rotation of the drum the tape is moved on one row, during which time each hole position in the tape is opposite the photocell, so achieving a continuous read-out.

Signals from the photocells are subsequently amplified and routed to the appropriate magnetic selectors, thus effecting the knitting of the desired needles.

The tape is stored in an identical magazine to that of the control tape and is drawn in and out by a similar drive system. The pattern tape consists of frames  $8\frac{1}{4}$  in. long, the maximum tape length being 100 ft. A double system is employed on the knitting machine, which means that two courses are knitted for each traverse of the cambox ;

thus, there are two reading drums on the pattern reader, one for the leading course and one for the lagging course. As on the control reader, the tape is formed into a local store between the reading drums and the take-up motor drive. In this case, however,  $16\frac{1}{2}$  in. of tape must be held in the local store, this being sufficient for one tape shift. The time for this action is approximately 0.5 sec. Speed of reading is 864 bits per second when using the equipment for knitting in 16 gauge needles.

To extend the patterning facilities in the machine, two pattern readers are employed. The control tape indicates which one is to be used for the next traverse and the tape shift is then initiated prior to the commencement of knitting.

As in the control-tape-indexing drive a rotary solenoid removes the latch from the counting mechanism and by energizing an electro-magnetic clutch, the tape drive is applied, in this case via a differential on to the tape-driving drums. The other side of the differential provides the reading drive input. As before, cam-operated contacts break the supply to the rotary solenoid and magnetic clutch after the requisite number of drive motor rotations.

### Tape Preparation

The punching of both tapes is carried out in the perforator, shown in Fig. 3. The required information, previously prepared and written out on a paper tape, is displayed line by line by means of a back-projection system on to the screen mounted above the keyboard. As the keyboard is set up, a visible display on numerical indicating tubes is used to verify that the information to be punched agrees with that shown by the projector, prior to depressing the punch key. Both the plastic tape and the paper tape then index on ready for the next line to be punched. If the operator observes a mistake, she can press the reject key and reset the keyboard.

The information on the tape is in pure binary form. For the written side of the data-handling an octal code is employed. This accounts for the fact that there are only 12 columns of keys on the perforator, each being numbered from 0 to 7; one column of keys therefore can punch up to three holes.

On removing the tape from the perforator, it is placed in a magazine in readiness for installation in the appropriate reader.

Fig. 3. The tape is perforated by an operator who sets up on a keyboard the numbers appearing projected on a screen from the master chart



# semiconductoritis?



## Reliability + Consistent Quality + Proved Service + Fast Delivery

Semiconductoritis can be cured... prescribe Hughes... service and deliveries will improve immediately and Hughes quality control will ensure no unpleasant side-effects. Hughes prescribe from a comprehensive list of PNP/NPN Silicon planar Transistors, Silicon planar and Germanium computer diodes, Silicon power and Zener diodes and voltage variable capacitors—for immediate and regular application. Be sure, too, that Hughes research is constantly alert for new strains of semiconductoritis\* and will be ready with appropriate remedies.

\*Semiconductoritis: a production frustration caused by the failure or non-availability of solid-state components.

Why not phone or write now for Technical Data or Quotations. Alternatively, our Sales Engineers will be delighted to call and discuss your immediate or future needs.



**HUGHES INTERNATIONAL (U.K.) LTD**

**U.K. SALES: KERSHAW HOUSE, GREAT WEST ROAD, HOUNSLOW, MIDDLESEX. TELEPHONE: HOUNSLOW 5222**  
**OVERSEAS ENQUIRIES: HUSINT S.A., 3 RUE AMI LULLIN, GENEVA**

M & P HM19

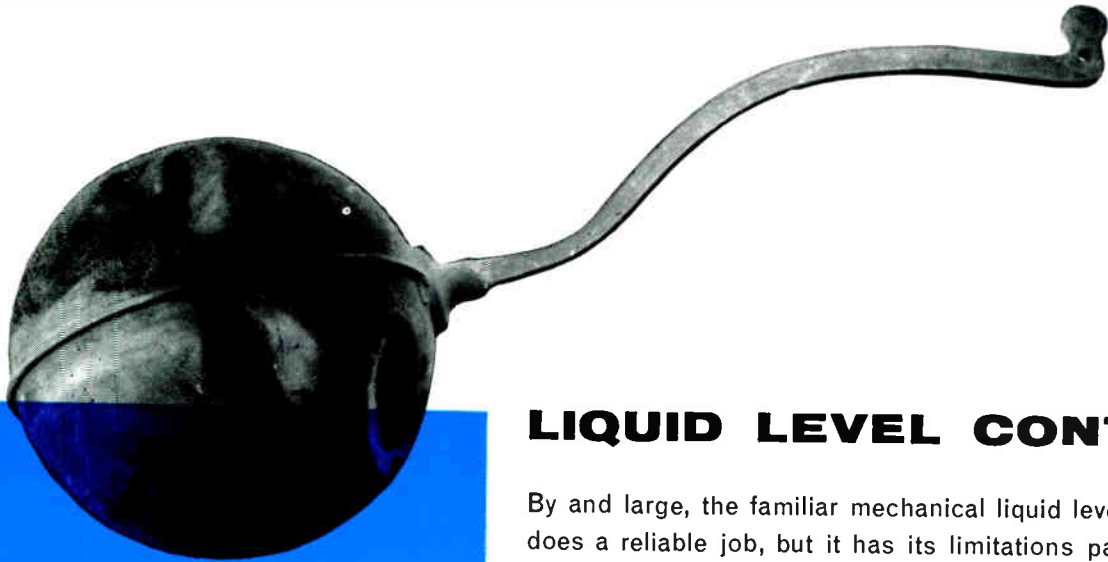

## LIQUID LEVEL CONTROL

By and large, the familiar mechanical liquid level controller does a reliable job, but it has its limitations particularly in precise industrial applications. Here the effective answer is inexpensive cold cathode trigger tubes. Reliable to the point of outlasting the useful life of parent equipments, Ericsson trigger tubes meet the most exacting requirements.

Operating from rectified mains they require no special power supplies, they are not affected by severe transient overloads, they give visual indication of current flow and their characteristics remain unchanged by temperature fluctuations.

With suitable electrodes any substance capable of flow even with only a moderate degree of conductivity can be accurately maintained to predetermined levels or measured and delivered in selected quantities.

The circuit illustrates the simplicity of cold cathode trigger tube liquid level control. For more information and data please write to the address below.

GPE 120T TRIGGER TUBE

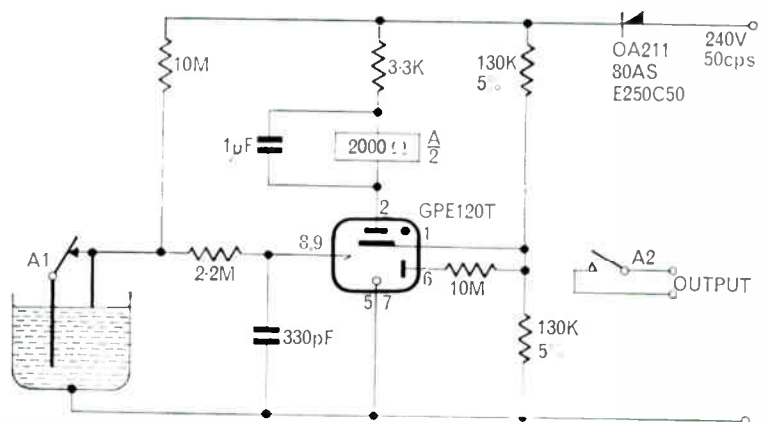

Tube Division  
Technical Services Dept.,  
Beeston, Notts. Tel: 254831.

**ERICSSON TELEPHONES LTD  
ETELCO LTD**



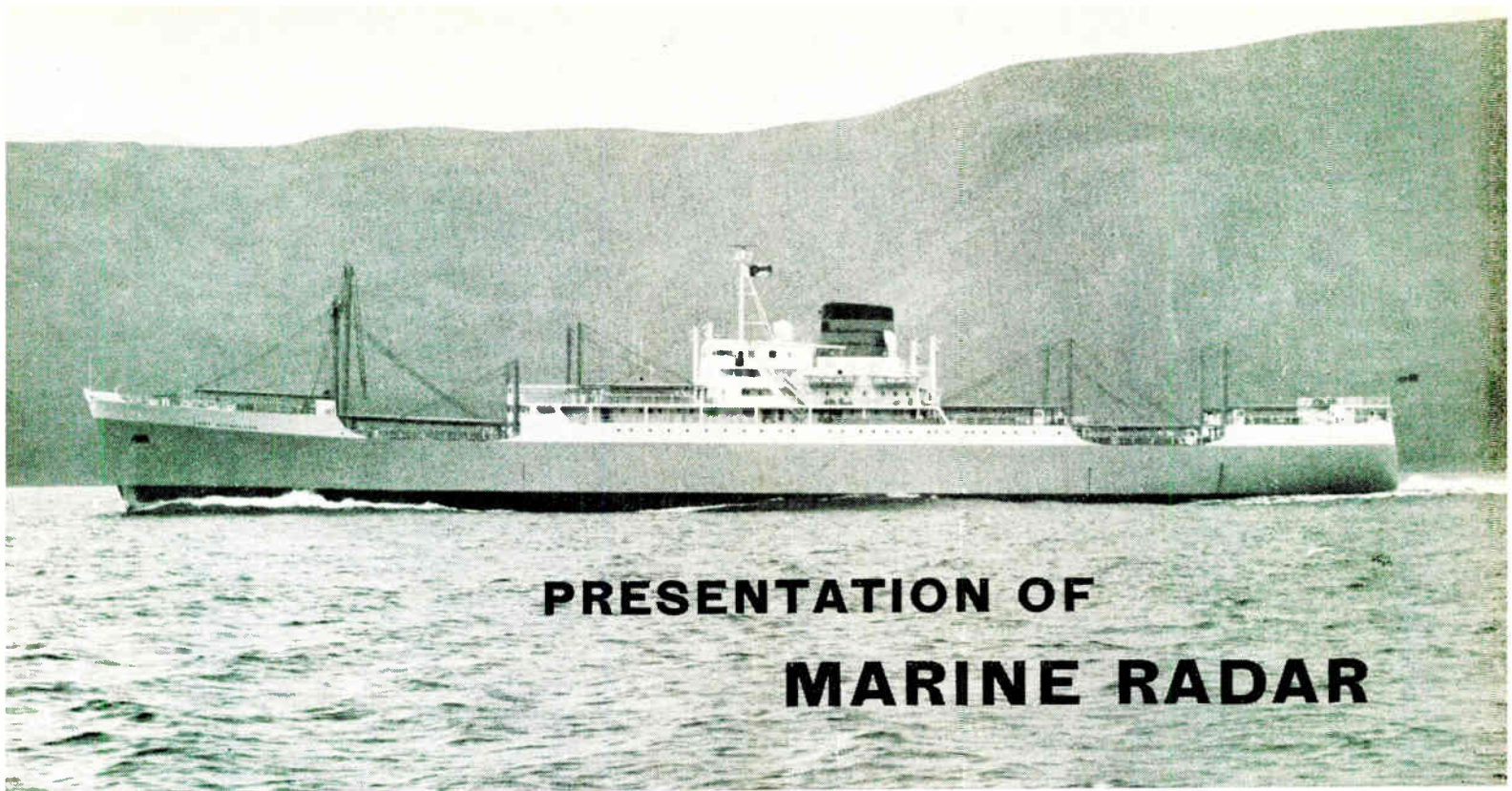

## PRESENTATION OF MARINE RADAR

*Port Nicholson on trials. This ship is fitted with Argus radar (Courtesy Harland & Wolff)*

By J. A. GLASGOW\*

Radar equipment is described in which a true north-up form of display is obtained but is presented in the form of a ship's-head-up display. Thus the convenience of the latter is secured but at all times true compass bearings can be obtained.

WITH conventional marine radars two alternative forms of display have been offered. First, there is the straightforward ship's-head-up presentation and secondly, the stabilized-north-up. This second alternative may possibly have true motion facilities as well if required. Each form of display has its own advantages and disadvantages. It will be shown possible to have the advantages of both, with the disadvantages of neither, combined in one form of display.

With the conventional ship's-head-up display all targets are shown on the radar p.p.i. in their natural position relative to the ship and its direction of travel. For example, targets that are to port of the ship are shown on the port, or left-hand side of the display, targets that are ahead show towards the top of the display—hence the description ship's-head-up.

For the man conning the ship this can be the ideal orientation of the radar picture. If in poor visibility he sees a target on the radar to one side of the screen he knows immediately, more or less intuitively, where he has to look for it outside. As one's own ship is effectively in the centre of the display and other targets shown naturally disposed round it, it is an easy matter to project the target's direction into real space.

As an impending collision is indicated on the display by the approach of a target on a fixed bearing relative to your own ship it is necessary for this condition to be easily detectable. This can be achieved by several methods. One is to make provision for regularly taking bearings mechanically or electronically and another is to utilize a c.r.t. with the longest possible afterglow, making use of the fact that targets leave 'tails'; i.e., a short record of how the present situation has built up. A point may be made here that these 'tails' are not the target ship's wake, but are indications of the target ship's movement relative to your own ship; i.e., not their true courses. The longest available afterglows are not completely sufficient for this and plotters are frequently used. A plotter has a surface for periodically marking the current positions of targets in order to build up a history of the situation, and for more accurate computation of the distance of nearest approach and also assessing degrees of safety.

The effect of yawing and changes in course of your own ship on this necessarily long afterglow is one cause of the failings of the conventional ship's-head-up display for, when your own ship changes course or yaws, targets on the screen smear. If the ship yaws a few degrees a target will show instantaneously on its correct bearing but the afterglow from these previous signals builds up into an arc of the few degrees of yaw and this causes tails from other ships to become broad and distorted. This makes it necessary to wait some time to

\* The Marconi Co. Ltd.

determine the courses of other ships. Also if your own ship has to change course (say  $45^\circ$ ) in taking avoiding action, all targets swing round  $45^\circ$  on the display and the afterglow will have a  $45^\circ$  smear so that time must be lost, waiting for it to clear.

The smearing on the screen and the difficulty in determining the actions of other ships are overcome by the north-up display. With this presentation targets are shown in their positions relative to your own ship indicated geographically as if on a chart; i.e., the most northerly ones at the top, etc. This removes the smearing effect and inaccuracy of bearings because when your own ship alters course targets are not swung round on the screen. A ship in the east is in the east wherever your own is heading. All that rotates on the display is the heading line. (This is a line on the display tube produced electrically, each revolution, when the aerial passes dead ahead.) As targets on this form of display are stabilized it is often called 'Stabilized-North-Up'.

This form of display is recommended by the Radio Advisory Service and Ministry of Transport as bearings may be taken more accurately and these bearings are true compass bearings as opposed to relative bearings. The international steering and sailing rules say 'Risk of collision can . . . be ascertained by carefully watching the compass bearing of an approaching vessel'.

The method of stabilizing the display is by feeding the aerial position information via a differential synchro that is itself driven by the ship's gyro compass to the display unit. As the ship changes course the gyro transmitter drives the differential synchro round and the phasing of the aerial position information is changed to maintain the radar data stabilized to north-up.

There is a further advantage of a stabilized-north-up display in that your own ship's course and speed may be fed into the display as 'offsets' continuously and electronic-

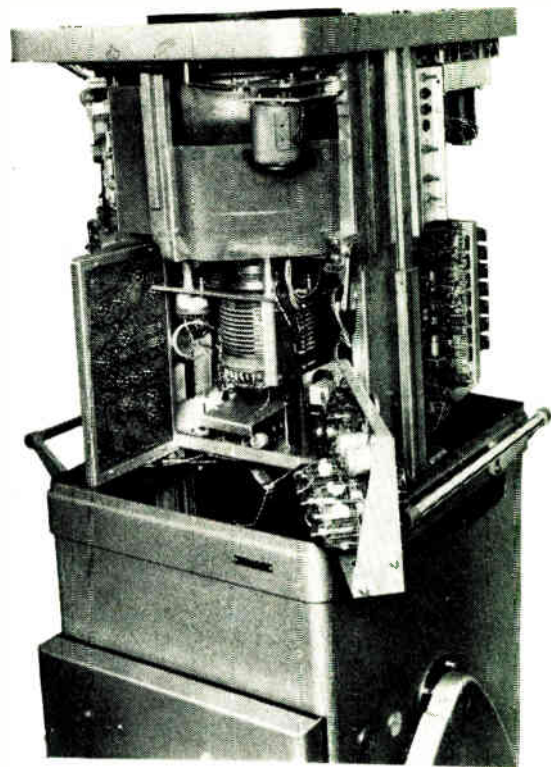

*Here the display unit is shown elevated for servicing. Its weight is taken by constant-force springs*

ally as northings and eastings so that as your ship moves forward so does its position on the c.r.t. This has the effect of making land targets stay still and moving targets move with their true motion. This prevents even the slight smear of fixed targets due to your own ship's motion through the water.

Although this north-up method of display has better characteristics for safety and accuracy it does not appear to be the most commonly used. The reason for this is that it is not so easy to interpret. When the navigator is not only using the radar but is also using his own eyes outside as well as listening for any aural signals, he needs his stimuli in consistent directions. If the vessel were travelling east a target to port would show at the top of the display and a target astern would show on the left; in the worst case, on a southerly course, the display is then reversed; targets to port are shown on the right-hand side. As can be imagined this can cause confusion in times of stress.

It can be seen that neither of these conventional methods of display is ideal for all circumstances. They either smear and are indeterminate or may be presenting the radar data the wrong way round.

#### **True and Natural Presentation of the 'Argus'**

The Marconi 'Argus' display overcomes these apparently incompatible requirements by an effective combination of the two forms of display. First, a stabilized-to-north display is obtained on the c.r.t. to gain its advantages and then the whole c.r.t., with its deflection coils, bearing scale, and plotter, is rotated to give a ship's-head-up presentation so that it may be clearly understood. Provision is made also so that the display may be made to rotate to north-up so that a straightforward comparison with a chart can be made. As this display gives the navigator something extra it has been referred to as a BONUS (Bow Or North-Up

#### *Argus on Elettra III*



Stabilized). The display gives true compass bearings at all times and, as it is north or compass stabilized, it may have 'true motion' added and present the radar picture in the natural way.

### Design Features

In the design great stress has been placed on performance and reliability. The high performance is achieved by the use of a modern high-power low-noise transmitter-receiver system and high definition is obtained by the use of a very short pulse and an ultra-wide video amplifier. The technical details of the radar system are included in Table 1.

Reliability is obtained by using only first quality components and printed boards of the best available materials. The servo system to orient the tube to north-up, and ship's-head-up, is run continuously on switching on to ensure and check satisfactory operation and also that the slip rings that feed the rotating c.r.t. are clean.

The method of achieving a stabilized-to-north display is as previously mentioned. The differential synchro is housed separately from the display in either the true motion unit or in the compass stabilizing unit, whichever is fitted.

Allowance has been made, by use of a plug and socket system, for adding true motion facilities at a later date should they not be fitted with the initial installation. This is considered desirable since true motion has perhaps not been as fully used as it might have been due to its previous restriction to north-up only. Now that the Argus makes it available with a ship's-head-up display it should become more popular and its use increase.

The servo system to maintain the c.r.t. at ship's-head-up or at north-up, at the control of a switch, is a fundamentally simple system utilizing cams, microswitches and relays controlling an orientation motor. This simplicity is possible because a strictly accurate alignment of the ship's-head-up is undesirable. If the orientation servo followed every small movement of the ship's head while the ship was yawing the use of a plotter would prove difficult with the tube and its plotter continuously moving. This is prevented by incorporating a few degrees of lost motion in the system. As the c.r.t. picture is stabilized independently this causes no inaccuracy. This lost motion removes the need for velocity feedback and allows the use of an on/off system. The basic circuit of the orientation servo is shown in Fig. 1.

On switching on the display the relay A being energized causes the orientation motor to run continuously and clean the sliprings. After the thermal element has heated relay A operates and switches the motor to its normal operational

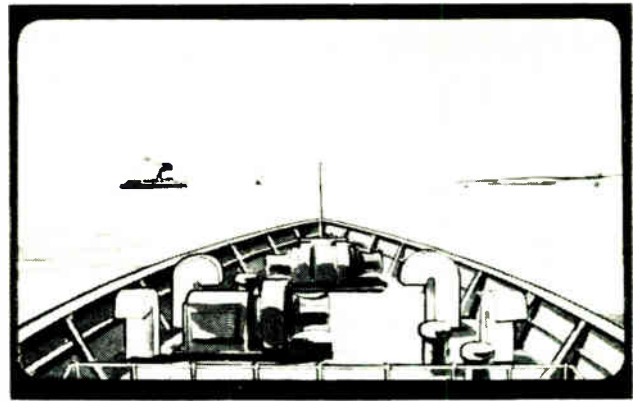

Conventional north-up display (above) and Argus display (below)

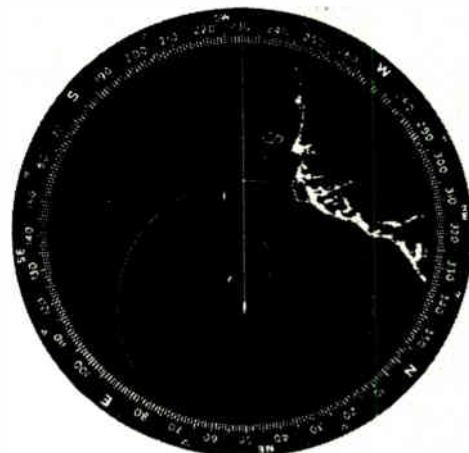
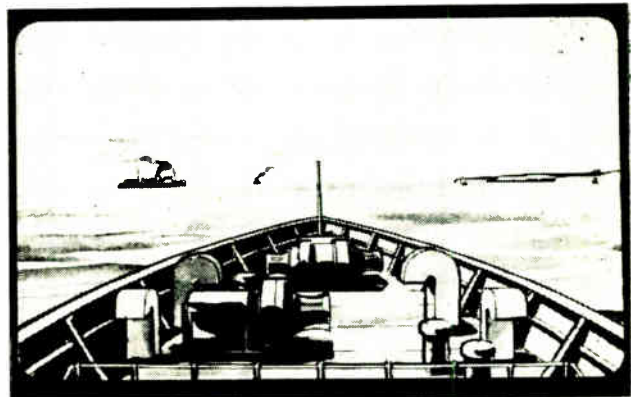

TABLE 1

Diameter of Display Tube	12 in.
Range of Display	$\frac{1}{2}$ , 1 $\frac{1}{2}$ , 3, 6, 12, 18, 24 and 48 n.m.
Minimum Range	30 yards
Range Discrimination	15 yards Short Pulse 100 yards Long Pulse
Range Accuracy	Better than $\frac{1}{2}\%$ of maximum range in use or 30 yards, whichever is the greater
Electronic Bearing Indicator	Digital presentation of true compass bearings
Bearing Accuracy	Better than 1°
Transmitter Pulse Length	0.07 or 0.5 $\mu$ sec dependent on range
Transmitter Power	70 kW peak
Receiver Bandwidth	25 Mc/s when on short pulse 5 Mc/s when on long pulse
Receiver Noise Figure	Better than 11 dB
Aerial Aperture	12 ft
Aerial Beamwidth	$\frac{1}{2}^\circ$ 1 $\frac{1}{2}^\circ$
Aerial Rotation	25 r.p.m.    25 r.p.m.
Total Power Consumption	2 $\frac{1}{2}$ kW from 110 or 220 V d.c. or 50/60 c/s a.c.

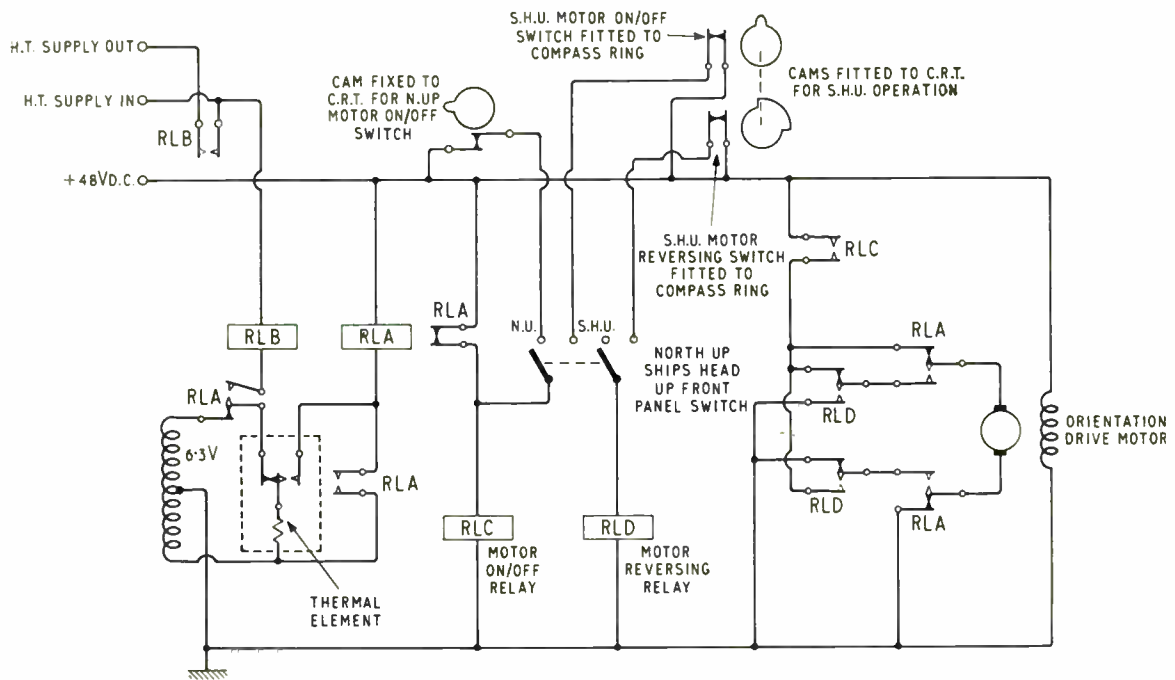

Fig. 1.—General form of the Argus orientation servo system

condition. Relay B applies the h.t. supplies to the electronic parts of the display. Relay C turns the motor on and off. When switched to north-up, assuming that the course is not northerly, the north-up microswitch will be closed and operate relay C causing the motor to run and drive the tube round. When north-up is reached a cam on the c.r.t. mount operates the microswitch which allows the motor to stop.

On switching to ship's-head-up two microswitches are brought into circuit, one to control the motor on/off and the other to control the direction of rotation. These are operated by cams fitted to the c.r.t. mount and the switches are moved round the c.r.t. by a gyro repeater motor. These switches cause the motor to run in the appropriate direction to maintain a ship's-head-up picture. The width of the motor on/off cam incorporates the previously mentioned 'lost motion'.

As the servo is an on/off system the tube rotates, on a

change of course, in a series of small movements sufficiently small and infrequent not to be noticeable.

The mechanical design of the display unit is such that it may be mounted straight on the deck or fitted in trunnions so that an adjustable viewing angle is obtained. Provision is also made for swivel-mounting the display so that it may be viewed from the steering position or elsewhere on the bridge as desired.

#### Acknowledgments

The author wishes to acknowledge the assistance given by the engineers engaged in the development of the display and its associated equipment. Thanks are also due to the Director of Engineering and Research, The Marconi Co. Ltd., and to the Managing Director, Marconi International Marine Co. Ltd., for their kind permission to publish this article.

## MEASURING MOISTURE



The measurement of a wide variety of materials can be made on site with a fully transistorized moisture and density measuring equipment developed by Nuclear Enterprises (G.B.) Ltd. This easily transportable instrument, the NE 8401, can be used by inexperienced operators to give immediate determinations. The depth probes, seen here in use on a building site, can be quickly converted by means of a neutron shield to give surface readings on newly laid concrete roads, soils, concrete beams and rolled surfaces. Installations of a less portable nature are also available to monitor the flow of material along conveyor belts.

For further information circle 42 on Service Card

*The 'switches' are built in circular form, the 625-line sampler being at the top and the 405-line at the bottom. Between them are the low-pass elements which provide storage and interpolation between samples*

# TELEVISION STANDARDS CONVERTER

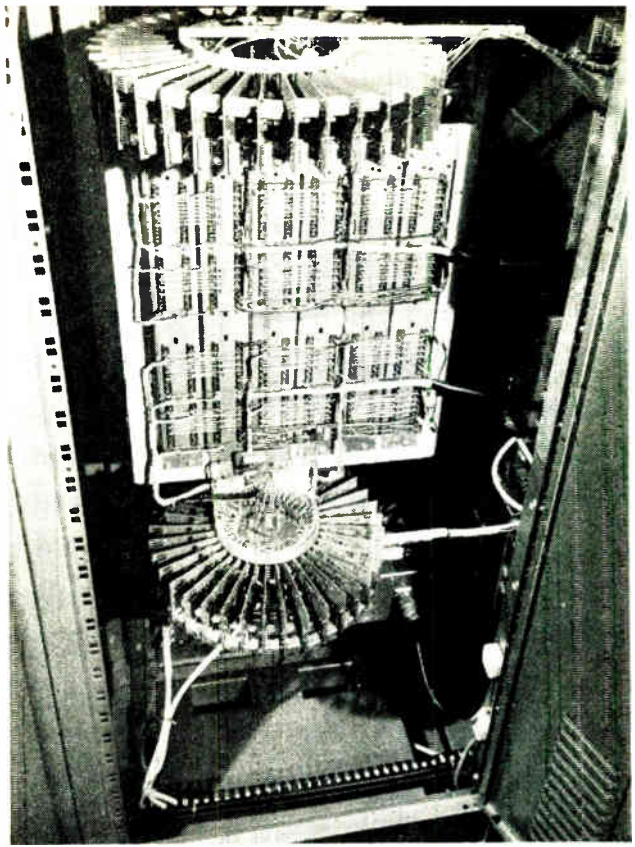

THE B.B.C. recently demonstrated a new electronic standards converter which it has developed. Unlike all previous converters it operates entirely on the video waveform and does not involve any optical methods. In the demonstration a picture produced by a 625-line camera was converted to 405 lines and the two pictures displayed on monitor tubes side by side. Apart from the different line structure there was no visible difference between the two pictures.

Standards conversion in the past has been based upon the idea of using a 405-line camera to view a 625-line picture reproduced on a c.r. tube. The process has involved a considerable degradation of picture quality. Although this may be acceptable for pictures of outstanding interest, many people have felt that it would not be for regular use. Consequently, they have been worried by the prospect of the change of standards which is to take place in the future.

The 405-line transmissions are not to be closed down for 10 years or so and there will be a considerable period when the same programme will have to be transmitted on both 405 lines and 625 lines. It will be desirable to produce the signals in the first instance by a 625-line camera and to develop the 405-line signal from it with the aid of a standards converter. It is thus important that the conversion should be effected without appreciable degradation of picture quality and the new converter enables this to be done.

The 625-line video signal is sampled at about 0.1  $\mu$ sec intervals; that is, 600 times per scanning line. The sampling is done by means of semiconductor switches which provide the equivalent of a 600-contact rotary switch. This switch 'rotates' at the line-scanning frequency, so that the 600 samples per line appear in sequence at the 600 'contacts'. Subsequent 'rotations' of the switch bring further samples from subsequent lines to the 'contacts'. Over a field period, therefore, the samples at any one 'contact' are from a vertical strip across the picture. The 600 'contacts' thus carry the entire picture in a vertically-scanned form.

Each 'contact' is connected through a simple low-pass

filter to a 'contact' of another similar rotary switch. This switch, however, 'rotates' once per line of the 405-line system. The 600 low-pass filters smooth out the samples to provide a continuously-variable waveform corresponding to vertical scanning, and the 405-line switch samples this again to provide the usual 405-line horizontal scanning waveform.

In this way the original samples at about 0.1  $\mu$ sec intervals from the 625-line waveform produce waveforms which can be resampled at about 0.15  $\mu$ sec intervals appropriate to the 405-line waveform.

The method can, of course, be used to convert from 405 lines to 625 lines but it requires the field frequency of the two signals to be the same. It is thus, at present, inapplicable for conversion to or from the 525-line 60-field standard.

## Eliminating Noise in Industry

A new service designed to eliminate noise in industry has been announced by W. A. Hines and Partners, acoustical engineers, of Stanmore, Middlesex.

In factories and offices where excess noise affects efficiency and health, acoustical measurement is made according to British Standard specifications, a full survey is then carried out and a report is prepared detailing the steps which must be taken to eliminate the noise.

When the report is accepted, working drawings and specifications are prepared and, if necessary, applications for planning permission are submitted to local authorities.

Acoustical contractors are then called in to manufacture and install the necessary equipment.

Since the majority of noise problems can be foreseen in advance if acoustic engineers are called in before premises are built or equipped, the firm is also offering a pre-planning consultancy service.

For further information circle 43 on Service Card

# EQUIPMENT

## review

### 1. High Voltage Power Supplies

Brandenburg have added to their range of stabilized d.c. power supplies a new series which provides outputs of up to  $\frac{1}{2}$  A at up to 5 kV. Models with fully variable outputs (the VHC series) and models with fixed outputs (the FHC series) are available.

They provide a highly stable d.c. voltage source with an effective resistance of less than  $5 \Omega$  and a stability of 0.1% for  $\pm 10\%$  input change. Residual output ripple is less than 2 parts in  $10^6$ . Both voltage and current metering are included, as well as overload cut-outs and suitable protection.

The larger supplies are enclosed in ventilated racks mounted on mobile bases while the smaller units are available for rack mounting or in cabinets. The standard input for all models is 200/250 V, 50 c/s, single phase, but alternative inputs are available as required. — *Brandenburg Ltd., 139 Sanderstead Road, South Croydon, Surrey.*

For further information circle 1 on Service Card

### 2. Miniature Variable Transformers

Two further types of miniature variable transformer have been introduced by Philips. They are believed to be the smallest of their kind available commercially, and have a diameter of  $3\frac{1}{4}$  in. and a depth of  $1\frac{1}{2}$  in. Both types may be operated from 50 to 400 c/s inputs.

The first model, type E401ZZ/03, is for use with Continental and American mains. It has an input of 110 V and an output that is continuously variable from 0 to 110 V in one sweep. Maximum output current is 0.5 A.

The second, type E401ZZ/04, is particularly suitable for use with transistorized equipment. Input is 60 V and output is continuously variable from 0 to 60 V in one sweep with a maximum current of 1.2 A.

The transformers are encapsulated in reinforced polyester resin and are

suitable for tropical service. They are designed for panel mounting and when ordered in quantity can be supplied with a spindle of any specified length. Both models are available ex-stock at 58s. 6d.—*Research and Control Instruments Ltd., Instrument House, 207 King's Cross Road, London, W.C.1.*

For further information circle 2 on Service Card

### 3. A.C. Voltage Stabilizer

Claude Lyons announce an addition to their range of a.c. voltage regulating equipment: the type BTR-5 voltage stabilizer with solid-state circuitry.

This instrument employs a standard control system but, due to a new circuit configuration, harmonic distortion is reduced to 6% without the use of a filter. Stabilization is within  $\pm 0.3\%$  of the set output voltage and is unaffected by supply frequency variations between 45 and 65 c/s.

For the most critical applications,

a filter can be provided, either separately or incorporated in the stabilizer (Type BTR-5F), when, at the tuned filter frequency, the distortion is further reduced to below 2% and the stabilization improved to  $\pm 0.2\%$ .

The standard type BTR-5 is priced at £67 10s. and the filtered type BTR-5F at £83 10s., both models being continuously rated at 5 A (1.2 kVA approx.).—*Claude Lyons Ltd., Valley Works, Hoddesdon, Herts.*

For further information circle 3 on Service Card

### 4. Emitter-Follower Unit

250 M $\Omega$  input impedance and unity gain are two of the novel features incorporated in a transistorized emitter-follower unit developed by Wilmot Packaging for use with crystal accelerometers and similar high impedance devices. The quoted input impedance is maintained over a frequency bandwidth of 1.5 c/s to 10 kc/s. Output resistance is 4.7 k $\Omega$ .

The units are cylindrical in shape with a side-mounting bracket. A miniature coaxial socket is situated at one end to receive the high impedance input and a 4-pin socket at the other end accommodates the power and output signal connections. Known as the E.F.6, these units weigh less than 4 oz and can very often be mounted on the job, thus eliminating long coaxial cables.

With this in mind, a second unit, known as the A.E.F.6, has been produced which incorporates an accelerometer as an integral part of the unit, thus completely eliminating coaxial

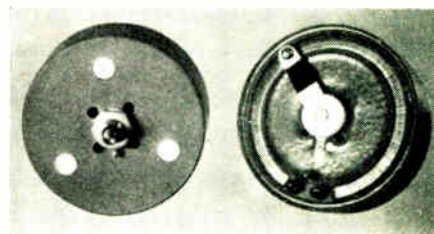
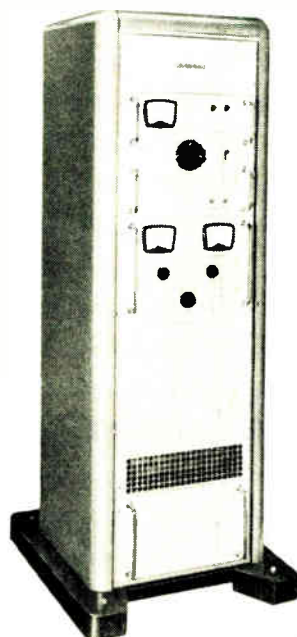

2

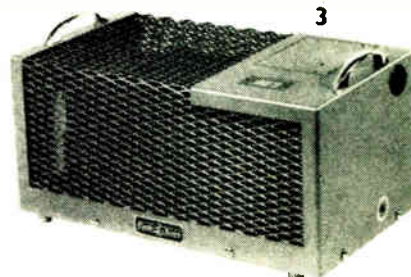

3

leads and connections. The overall specification is similar to that of the E.F.6, with modifications to the case to permit screwed attachment.—*Wilmot Packaging Ltd., Electronics Division, Salisbury Road, Totton, Southampton.*

For further information circle 4 on Service Card

### 5. Photo-Electric Counting System

Photoelectronics (M.O.M.) have announced a high-speed counter with keyswitch-operated electrical reset. This equipment will operate with any of the range of M.O.M. photoelectric projectors and receivers and does not contain any switching relay.

Inside a compact metal cabinet are contained the low-voltage supply transformer for both the transistorized electronic unit and the projector; the electromagnetic counter and the encapsulated solid-state switch unit.

Changes in resistance of the photocell brought about by blocking the light beam cause 24 V d.c. to be applied to the counting unit, the speed of the system being limited only by the maximum speed of the counter itself. The latter will, however, also operate with very slow changes of light.

The electrical reset by a keyswitch ensures that the counter cannot be accidentally reset. The cost of the equipment as a whole will depend on the type of receiver or projector selected, but the price of the unit as illustrated is £24.—*Photoelectronics (M.O.M.) Ltd., Oldfields Trading Estate, Oldfields Road, Sutton, Surrey.*

For further information circle 5 on Service Card

### 6. Inexpensive Tachometer

Now being marketed by C. Denis & Co. for the measurement of rotary and linear speed, the 'Antac' is a fully transistorized solid-state instrument incorporating encapsulated printed-circuitry. It has an accuracy of better than 0.25% (under controlled conditions better than 0.1%) and built-in self-check facilities.

Its input signal is derived from teeth or grooves on the rotating member passing an electromagnetic pick-up (in the case of linear measurement a toothed rack is fitted to the moving member). Alternatively, a photoelectric system can be employed. The 'Antac' receives this signal in the form of pulses, which it converts into a proportional d.c. signal that is used to actuate a pen recorder or milliammeter.

The unit measures  $4\frac{1}{2}$  by  $4\frac{1}{2}$  by 3 in. deep, and weighs 3 lb. It operates from input voltages of 100 to 110/200 to 250 V, 40 to 60 c/s, or 24/28 V d.c., and has an output current of 0 to 1 mA. Price of the standard model is £30 and special models can be supplied for frequency/analogue conversion up to 2 kc/s.—*C. Denis & Co. Ltd., The Forum, High Street, Edgware, Middlesex.*

For further information circle 6 on Service Card

### 7. Plastic Conduit

A plastic conduit which has been successfully used on the Continent for several years is now being marketed in Britain by Critchley Bros. under the trade name 'Betaflex', and will shortly

be manufactured by the same company. It consists of a thin walled tube made from hard p.v.c. into which corrugations are formed as the material is being extruded, giving it considerable strength against crushing, while remaining flexible.

Because of its flexible nature the need for bends or elbows is eliminated and by using either solid brass or moulded p.v.c. adaptors which are offered as accessories, it is readily fitted into standard metal or moulded plastic conduit boxes. Either type provides a watertight joint.

Due to the inherent properties of p.v.c. the conduit is highly resistant to corrosive atmospheres and mineral oils. It can be used with absolute safety inside cubicles containing live terminals at medium voltage.

Betaflex is available in  $\frac{1}{8}$ ,  $\frac{3}{8}$  and 1 in. diameter, and is packed in 50 yd coils. Colour: grey.—*Critchley Bros. Ltd., Brimscombe, Stroud, Glos.*

For further information circle 7 on Service Card

### 8. All-Glass Crystal Units

A range of miniature and sub-miniature, glass-encapsulated quartz crystal units has been announced by Mullard. The new types are identical mechanically but superior electrically to standard metal-encapsulated crystals. Compared with metal types, the all-glass crystals are less liable to aging effects, have a closer initial tolerance and a higher activity. Production crystals in HC-26/U holders can be supplied covering the range 3.5 to 87 Mc/s. Sub-miniature types, using

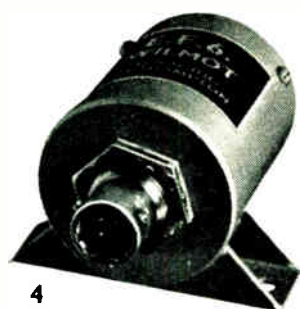

4

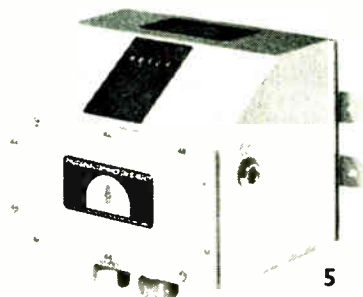

5



6

7

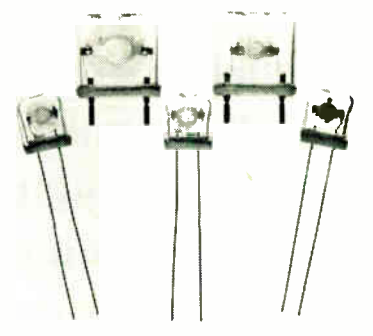

8



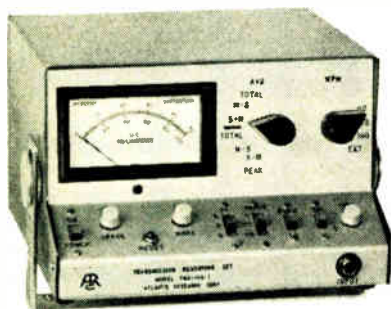

19

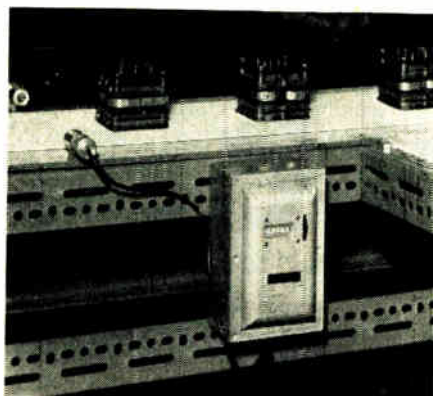

17

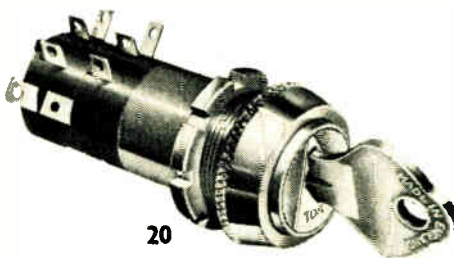

20



18

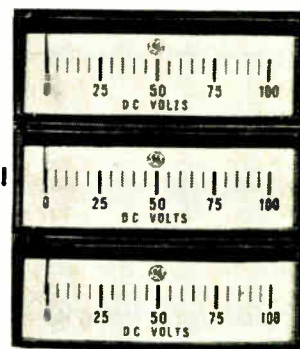

21

The photo-switch consists of an aluminium case 7 by 4½ by 3½ in. containing the electronics together with turned aluminium photo-cell and lamp housings. Long life and reliability is assured by the use of a cadmium sulphide photo-sensitive cell and cold-cathode trigger tube. The lamp is supplied with a low voltage from a transformer which also supplies power for the photo-switch.

Distance of operation can be adjusted to cover the range from ½ to 10 ft by a choice of lamps and photo-cells. Their small physical size (2 in. long × ¾ in. diameter) makes it possible to mount these units in extremely cramped locations. If required the equipment can be supplied with the photo-cell mounted in the side of the case. For mounting purposes a 5-figure resettable counter is fitted in the case containing the switch.

The cell and lamp housings remain operational over the entire range of ambient temperatures normally found in commercial applications, making the units suitable for such diverse situations as frozen food plants, foundries, steel mills, etc. — *Electronics Division, Richard Allan Radio Ltd., Bailey, Yorks.*

For further information circle 17 on Service Card

### 18. 50 Mc/s Divider Plinth

The TSA 850, a 50-Mc/s divider plinth, is the seventh in the range of add-on units manufactured by Venner

to complement and increase the versatility of the two standard frequency counters, the TSA 3334 and the TSA 3336.

The double-width plinth unit enables the counters to measure frequencies of up to 50 Mc/s with a division factor of 10 or 100, as required. Bistable dividers used throughout ensure 5- or 6-digit accuracy of measurement determined solely by the crystal in the counter.

Operating on 200/250 or 100/125 volts, the TSA 850 has a frequency range from 500 kc/s to 50 Mc/s, input sensitivity of 100 mV to 10 V and an input impedance of 2.5 kΩ or 75 Ω shunted by 15 pF. It is light, portable and measures 13½ by 13 by 3 in. — *Venner Electronics Ltd., Kingston By-Pass, New Malden, Surrey.*

For further information circle 18 on Service Card

### 19. Distortion Analyser

Atlantic Research Corporation announces the development of a new low cost telegraph and data signal distortion analyser designated TMS-10A-1. A single easily-read meter may be set to indicate bias, end distortion, or total distortion. Lamps show the sense (marking or spacing) of the distortion.

Modulation rates of up to 600 bauds may be measured using an external oscillator or the standard speeds of 60, 75 and 100 w.p.m. may be internally programmed by means of a front

panel switch. A variation of the TMS-10A-1, the TMS-10A-2 has the additional speed of 135 bauds. Further plans call for inclusion of the 50-baud Telex speed on the front panel control. Other speeds may be added or substituted upon request.

Another front panel control provides the capability of handling 5, 6 or 8 level codes in start/stop signalling. A reversing switch is provided so that signals of either polarity may be accepted. Loop currents may be measured on the meter.

The dual-purpose carrying handle serves as panel protection and may also be used to tilt the case for better visibility and control. With the handle removed, the unit mounts easily in half of a standard 5½ by 19 in. panel for rack mounting. The TMS-10A-1 is less than 10 in. deep and weighs 7 lb. It operates from 115 V ±10%, 50 to 60 c/s. — *Atlantic Research Corporation, Shirley Highway at Edsall Road, Alexandria, Virginia, U.S.A.*

For further information circle 19 on Service Card

### 20. Rotary Switch

The type P2 rotary switch is the latest addition to the Tok range of switches and is intended to provide a means of security and control for a wide range of light duty applications. The nominal rating is 2 A, 250 V. Due to the small dimensions it should prove useful to manufacturers of electronic



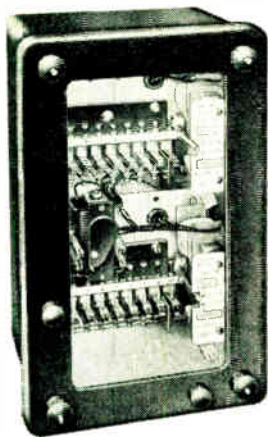

22

equipment in providing an inexpensive means of preventing unauthorized use.

Construction is based on the unit principle whereby moulded units containing two sets of make and break contacts may be added to give multiple switching. Contacts are of fine silver on phosphor-bronze spring leaves, operated by a rotary cam and terminating at solder tags as illustrated.

Two, three or four positions are provided on the standard spring indexing, which is slow break/fast make, and may be operated either by disc tumbler type key or by pointer or dial knob with standard  $\frac{1}{4}$  in. diameter shaft. Mounting in both cases is by one hole fixing  $\frac{3}{8}$  in. diameter for the key switch (type P2/3) and  $\frac{3}{8}$  in. diameter for the knob-operated switch (type P2/1).—*Tok Switches Ltd., 15 Appold Street, London, E.C.2.*

For further information circle 20 on Service Card

### 21. Miniature Edgewise Meters

A range of miniature edgewise panel meters measuring  $2\frac{1}{4}$  by 0.92 in. is now available from the Industrial Electronics Division of International General Electric. Versions are available for either horizontal or vertical mounting; stack-mounting is possible, since all sides of the meter-case are flush.

The meter is 3 in. deep overall, weighs 6 oz and the insulation level is 1,800 V r.m.s. The scale is 1.8 in.

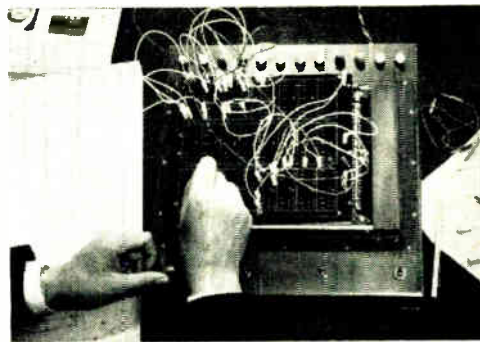

23

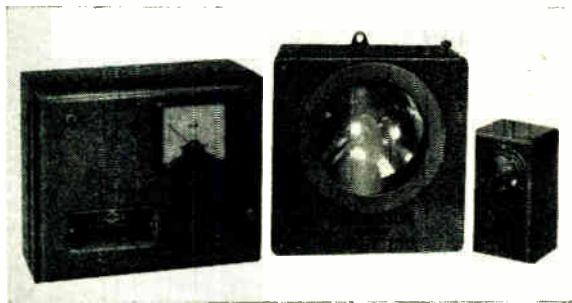

24

long, and accuracy is  $\pm 2\%$  and  $\pm 3\%$  of full scale for d.c. and a.c. respectively.

Standard meters cover the full range from minimum ratings of  $20 \mu\text{A}$  d.c.,  $500 \mu\text{A}$  a.c. and 1 V d.c. or a.c. to maximum ratings of 10 A d.c., 20 mA a.c., 300 V d.c. and 150 V a.c.—*International General Electric Co. of New York Ltd., Industrial Electronics Division, Boulton Road, Reading, Berks.*

For further information circle 21 on Service Card

### 22. Tripping Relays

A range of tripping relays, intended to help simplify circuit design, has been introduced by A.E.I. The series LT relays, while fast in operation, are highly stable to mechanical shock and are protected against spurious operation by transient currents.

Types LTB and LTC employ an auxiliary element to interrupt the coil circuit of the main element, a sufficient delay being incorporated to ensure the correct operation of the series-connected devices. The main elements are provided with magnetic retention in either the operate or reset positions by means of a powerful permanent magnet, no mechanical latch being necessary. The consequent simple mechanical system can operate in less than 10 msec.

The relays are available with either 8 or 16 contacts which can be

normally-open or normally-closed in any desired combination. Type LTB is hand reset, type LTC is both electrically and hand reset. A self-reset relay without an auxiliary element, type LTA, is also available.—*Power Protection and Meter Department, A.E.I. Switchgear Division, Trafford Park, Manchester 17.*

For further information circle 22 on Service Card

### 23. Minipatch

Minipatch, a recent addition to the range of Elliott Minilog accessories, will appeal especially to university and technical college users and to anyone requiring variable logic operation within a Minilog system.

Minipatch is a patch-panel board on which up to twenty-four Minilog elements may be mounted and interconnected by means of normal patch-panel leads. The system is extremely flexible and allows for a great variety of logic operations to be composed with ease from the basic elements.

In its teaching application, the panel can be made to drive a number of different experimental demonstration circuits, e.g., lighting lamps in sequence and driving relays. For industrial applications involving a Minilog system in which details of operation vary from time to time, Minipatch offers a convenient means of varying the logic of the system without the necessity of assembling more than one board.

This board may be mounted horizontally, or plugged into a standard half-board socket.—*Minilog Division, Elliott Brothers (London) Ltd., Elstree Way, Borehamwood, Herts.*

For further information circle 23 on Service Card

### 24. Smoke Detector/Fire Alarm

Radiovisor Parent have added to their range of products a smoke detector fire alarm giving early warning before sufficient heat is generated to start a fire.

The system employs a photo-electric cell receiver illuminated by a beam of light directed over the area to be protected. When smoke enters the light beam the light intensity on the receiver diminishes until the output current of the photocell is too weak to hold the alarm relay in the 'off' position. The alarm circuit closes and remains closed until reset by hand.

Radiovisor claim that warning of fire will usually be given in less than one minute if smoke is generated at ground level and up to approximately 20 ft either side of the line of the light beam.

Three standard models are available

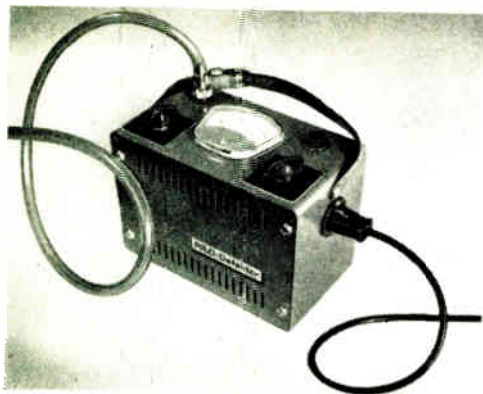

25



26

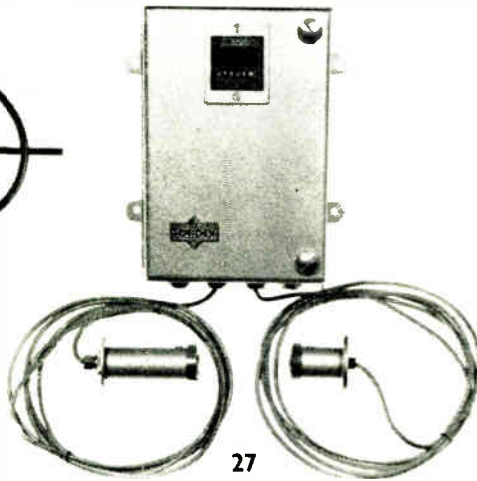

27

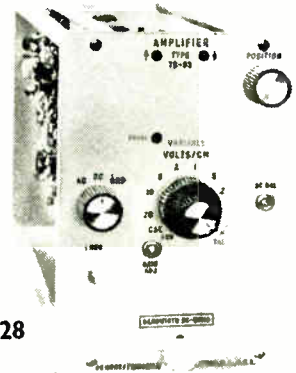

28

EQUIPMENT  
Illustrations by the author  
**review**

operating over light beam lengths of 40, 100 and 150 ft. With the SDF.150 equipment (maximum light beam length 150 ft) warning will be given over an area of 150 by 40 ft=6,000 sq ft. The company will design units to meet specific applications.—*Radio-visor Parent Ltd., Stanhope Works, High Path, London, S.W.19.*

For further information circle 24 on Service Card

**25. Improved Halogen Detector**

The Rilo detector is an instrument for detecting leaks of halogen gases including the refrigerants Freon, Arcton and Frigen. It is made in Switzerland and available from Hird-Brown.

The improved version has a re-styled meter which is illuminated when the unit is switched on. The illumination serves to make reading the meter easy in dark corners as well as giving a clear signal that the unit is on. An audible indication is also fitted as standard. The provision of background level adjustment enables the unit to be used at its highest sensitivity even in a room which is already contaminated.

The Rilo detector has no air intake filter. This improvement ensures that the unit cannot give false readings as a result of filter saturation by gas or dust. This compact and rugged unit, which can be hung from the operator's

neck, requires little or no maintenance. Price: £72 10s.—*Hird-Brown Ltd., Flash Street, Bolton, Lancs.*

For further information circle 25 on Service Card

**26. R.F. Bridge**

Hatfield Instruments have announced an r.f. bridge which has the advantage that measurements can be made with or without direct current or voltage polarization of the object being measured. Furthermore, the source of polarization is not in series with the measuring circuit and thus its impedance is eliminated from the balance equation. This feature has the virtue that the r.f. characteristics of inductors, varactors, diodes, resistors, transformers, etc., can be measured and variations of parameters noted with the application of a wide variation of direct current or voltage. For instance, semiconductor diodes can be measured in the forward direction with current up to 500 mA and in the reverse direction with voltages up to 100 V.

The type LE 300/A1 bridge has the same specification and range of measurements as type LE 300/A. The only external difference is the provision of two additional sockets on the terminal board to which is connected the external polarizing power supply. For most purposes dry batteries, a milliammeter and a suitable rheostat

are all that is required for passing direct current through the object being measured. For voltage polarization, dry batteries can again be used. Where a capacitor or reverse-biased diode is being measured, a voltmeter connected across the battery will indicate the voltage present across the component. Thus, the component is free of any additional connections that could influence the measurement. Existing bridges, type LE 300/A may be modified to include the above feature which does not affect the use of the bridge with the current range of transistor and low-impedance adaptors.—*Hatfield Instruments Ltd., Burrington Way, Plymouth, Devon.*

For further information circle 26 on Service Card

**27. Photo-Electric Batch Counter**

The Londex range of photo-electric control equipment has been extended by the addition of a unit type PE/TR/BC for fast counting and batching.

A six-figure electromechanical counter is fitted to the lid of the control box which has an additional row of digits capable of being set to the batch number required. Counting can be up to five impulses per second and the beam 'make/break' period can be as short as 0.1 sec.

Transistors and photo-diodes are

used with a heavy duty relay to switch the external circuits according to the batching requirements. The contacts on this relay are one 'normally open' and one 'normally closed', each rated at 5 A, 240 V a.c.

This unit is designed for production lines and packaging machines, extension heads with leads being provided.—*Londex Ltd., 207 Anerley Road, London, S.E.20.*

For further information circle 27 on Service Card

## 28. 50 Mc/s Plug-in for Fairchild Oscilloscopes

The band-width and versatility of the Du Mont 765 and 765H series of solid-state, high-frequency oscilloscopes have been increased by the addition of a 50-Mc/s amplifier plug-in unit (type 76-03) introduced by the Du Mont Laboratories Division of Fairchild Camera and Instrument Corporation.

The introduction of another plug-in unit to those already available emphasizes the new concept in oscilloscope design inherent in transistorized instruments: complete flexibility. By utilizing dual plug-in units for all functional circuitry, the same main frame can be purchased as a low-cost, low or medium-high frequency instrument, or a plug-in unit with extended bandwidth capability may be secured for use with the same main frame.

The type 76-03 50 Mc/s unit has a rise-time of  $7\frac{1}{2}$  nsec and a sensitivity of 50 mV/cm to 20 V/cm in nine steps. Simplified, easy-to-operate controls of minimum number are utilized. There is a calibration indicator light and two beam position indicator lights to show direction of off-screen deflection.

Specifications include 200 nsec signal delay, and full 6-cm vertical scan with 3% overshoot and pre-swing.—*Aveley Electric Ltd., South Ockendon, Essex.*

For further information circle 28 on Service Card

## 29. Telegraph Testing Equipment

A. T. & E. has developed at telegraph distortion measuring set (TDMS) transmitter, type 5CBV, designed to work with the latest error-correcting systems now coming into general use. The A. T. & E. set is based on the TDMS 5BV transmitter, and provides normal CCITT test signals at speeds within the recommended transmission rates. These can be offered in the usual manner or as called for by the release pulses generated by the error correcting system.

In operation, these systems call forward the information to be transmitted, which is usually contained on

punched paper tape, by a release pulse derived from the terminal equipment; i.e. the tape message in the auto transmitter associated with the terminal equipment is stepped under the control of the release pulse. If circuit conditions are good the pulses arrive at regular intervals and the tape reader steps continuously.

It is advantageous where testing the terminal equipment to be able to control the associated test gear similarly, and the TDMS 5CBV has been designed to release its test signals in this manner. It allows the selected signals to be released only on the application of the release pulse, and thus the appropriate test message is released into the error correcting terminal in the same way as in the normal operation of the system.—*A. T. & E. (Bridgnorth) Ltd., Bridgnorth, Shropshire.*

For further information circle 29 on Service Card

## 30. Dewpoint Thermometer

Shaw have announced a solid-state dewpoint thermometer giving absolute readings of the dewpoint temperature of air or gases. The self-contained, automatic unit, which employs thermocooled semiconductors, has a wide range of industrial applications.

The light from a lamp, operated from a stabilized voltage supply, is reflected on to a photocell when dew is formed on a mirror surface. The current to the thermomodule used to cool the mirror then ceases, so that the mirror is heated. When the dew evaporates the cooling cycles recommence; thus the mirror surface, of which the temperature is measured continually, cycles between the dew and no-dew conditions.

This prevents drift in any of the circuits due to cooling of the mirror below the dewpoint temperature. An indicator light on the front panel is used to indicate that the dew, no-dew condition is being maintained. This method of operation is claimed to be a significant technical advance over the servo systems which have been used previously in the automatic measurement of dewpoint temperature.—*Shaw Moisture Meters, Rawson Road, Westgate, Bradford, Yorks.*

For further information circle 30 on Service Card

## 31. Trigger Delay Unit

The Philips trigger delay unit, type GM4585, enables the triggering of a time base to be delayed so that the trace begins at any desired point during the period of the signal. Consequently, any particular part of the signal can be made to occupy the

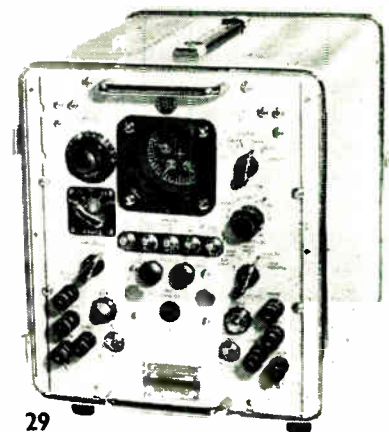

29

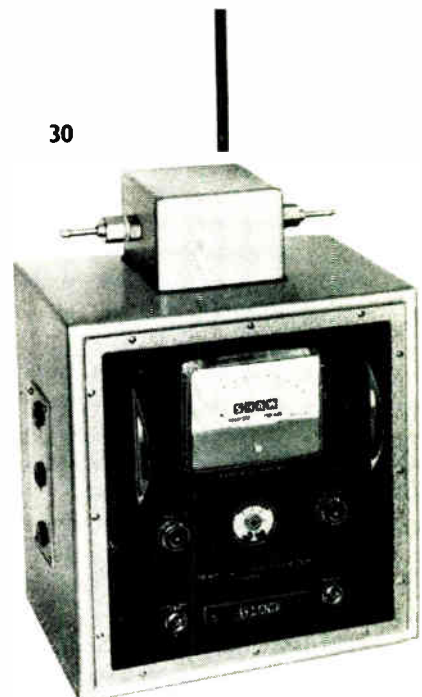

30



31

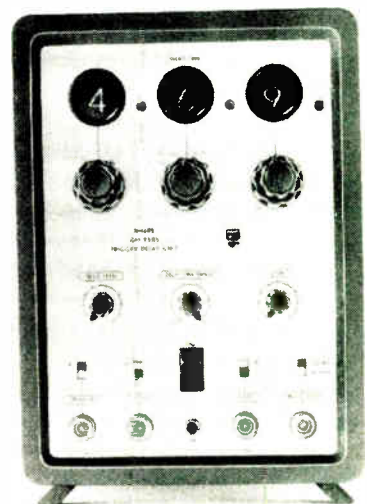

whole width of an oscilloscope display and be examined in detail. For example, a single line of a television video signal can be displayed by feeding the frame pulse to the input of the delay unit and using the delayed output pulse to trigger the oscilloscope.

The delay time is continuously adjustable from 2.5  $\mu$ sec to 100 msec in four ranges, and is indicated by digital read-out tubes. Stability is such that any variations are within 0.01% of the total range value.

In addition to the delayed pulse, the GM4585 provides a sawtooth voltage and a gate pulse which can be used for X-deflection and unblanking of the oscilloscope. The complete signal can thus be displayed and strobed so that the brightness of any particular event is intensified. The intensified part can then, if desired, be made to occupy the whole width of the screen.

A sync separator is also included in the delay unit to aid stable triggering on video frame pulses, and to enable the delayed trigger pulse to be locked to line sync pulses.—*Research & Control Instruments Ltd., Instrument House, 207 King's Cross Road, London, W.C.1.*

For further information circle 31 on Service Card

### 32. Metallized Paper Recording

Recorder Charts have introduced a metallized paper recording process in which a trace is 'burned out' by the application of a small e.m.f. between the metal layer and the stylus. This technique will produce fine traces at high chart and stylus speeds. As the process operates without ink and is easy to maintain, it is particularly suited to portable recording equipment.

Paper tape 40  $\mu$ m thick is given a thin coating of lacquer on one side with a pigment added to heighten the contrast and produce a clearer trace if required. A metal film, e.g., zinc-cadmium, is applied under vacuum to a thickness of 0.1  $\mu$ m, after which the material is usually perforated and printed with the required calibrations on the metallic layer.

In the instrument, the chart passes under an electrode having a large surface area (usually a roller) which is in continuous contact with the metallized surface. A second electrode with a very small contact area and made of high resistance material such as tungsten or platinum-iridium, is employed as the stylus.

The paper can be stored for up to two years in temperate climates without special wrapping; used charts which have to be kept for any length of time may be sprayed with a protective fixative.—*Recorder Charts Ltd., P.O. Box 774, Clyde Vale, London, S.E.23.*

For further information circle 32 on Service Card

### 33. High Pressure Air Purifier

A high pressure air purification plant developed by Hymatic has been designed to handle up to 15 cu ft/min of free air at pressures between 3,000 and 6,000 p.s.i. One of the uses of this equipment is in the production of

small quantities of liquid air for local cooling in electronic equipment such as infra-red detectors, parametric amplifiers and some types of lasers and masers.

As the air liquefiers operate on the Joule-Thompson principle of expansion through a very small orifice, air of an exceptionally high purity is required. The Hymatic plant will purify air at high pressure to a standard better than 3 parts per million of carbon dioxide and one part per million each of water and hydrocarbons. Other operations which may be carried out conveniently with air from this plant include the testing of 'clean' valves, controls and turbo-driven accessories.

The removal of carbon dioxide is achieved with soda-lime, of moisture by activated alumina and of hydrocarbons by activated charcoal; in addition, a small vessel of 'Molecular Sieve' is provided as a final safeguard. Designed to accept air from a normal 6,000 p.s.i. compressor, the system is

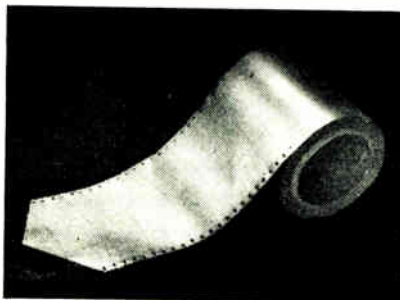

32



34

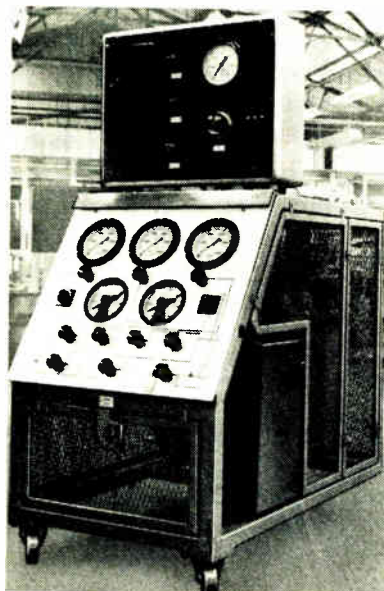

33



35

still appropriate for use with oil-free compressors when it is necessary to remove carbon dioxide, water vapour and stray atmospheric contaminants.

Provision is made for reactivation of the alumina by heat and back-flow purging with air which has been partially cleaned in the first section of the plant. A monitor panel allows a continuous check to be made on air purity.—*The Hymatic Engineering Co. Ltd., Redditch, Worcs.*

For further information circle 33 on Service Card

### 34. Encapsulated Logic Elements

Ferranti have extended their range of elements incorporating germanium transistors and have introduced a further range with silicon semiconductor active elements. The two ranges in production are fully compatible with each other apart from voltage polarity.

The maximum repetition rate under worst conditions is 2 Mc/s for germanium types and over 3 Mc/s for

silicon, while the maximum permissible temperature for the two ranges is 55 °C and 100 °C respectively. The elements are designed to operate on standard supply voltages of 12 V, 6 V and 6 V bias, quite wide tolerances being allowed on these figures.

The form of construction used for these elements allows high-density packaging and wide flexibility of circuit arrangement, while retaining the high reliability factor of individual conventional components. A novel fixing arrangement relieves the connecting wires of all mechanical stress, and facilitates easy replacement of elements from printed circuit boards without causing damage.

Each range, which has been designed to cover the majority of applications in the field of data-processing and control, comprises the following basic types: bistable flip-flop circuit; 5-input AND, NAND, OR and NOR blocks; variable frequency multivibrator; variable period monostable circuit; quadruple emitter-follower unit; dual inverter/amplifier; 5-input diode-coupled NOR block; and trigger/amplifier circuit.—*Ferranti Ltd., Ferry Road, Edinburgh 5.*

For further information circle 34 on Service Card

### 35. 50-Ohm Video Oscillator

Wayne Kerr announce the introduction of a 50- $\Omega$  version of their video oscillator 022D. This model has been developed to meet the needs of post-office and telecommunications engineers, particularly in Continental countries and the U.S.A. where 50-ohm lines are in widespread use.

The unit includes an attenuator providing an output adjustable in 0.5 dB steps from -50 dB to +10 dB on a reference level of 1 mW into 50  $\Omega$ . The frequency coverage of 10 kc/s to 10 Mc/s is achieved with two open frequency scales used in conjunction with a 6-position range switch. Output level is monitored by a meter which indicates at the same time any deviation from 50  $\Omega$  in the load impedance.

The oscillator, which can also provide a square-wave output at 50 or 60 c/s, is suitable for operation from 110 and 200 to 250 V supplies. Available in a portable case, it can also be rack-mounted if required.—*The Wayne Kerr Laboratories Ltd., New Malden, Surrey.*

For further information circle 35 on Service Card

### 36. Miniature Servo Amplifier

An 8½ cu. in. servo amplifier capable of producing 40 W output, has been developed by M. Ten Bosch, Inc.

This transistorized unit meets rigid

environmental requirements and operates within a temperature range of -55 to +125 °C. When operated at 125 °C and 100% duty cycle in free air, it can provide 25 W without an external heat sink. With a heat sink, the full 40-W output is obtainable.

Input impedance is 50 k $\Omega$   $\pm$  5%, and output impedance is less than 25  $\Omega$ . Voltage gain is variable from 1 to 1,000 through an external resistor in series with the input, and gain stability is  $\pm$  ½ dB over the full temperature range. Output voltage is 36 V r.m.s.

The unit is 2 in. in diameter and 2½ in. high. — *M. Ten Bosch, Inc., Pleasantville, N.Y., U.S.A.*

For further information circle 36 on Service Card

### 37. Vibration Threshold Transducer

Inertia Switch have recently announced the type 306 vibration threshold transducer. The unit comprises a normally-closed axial sensitive switch monitored by a remotely-mounted electronic control unit incorporating a latched relay. When excessive vibration (amplitude as low as 0.0005 in.) is detected, the relay is operated and held until manually reset.

This device, which has been developed especially for use on high-speed rotary machines such as turbines, has a frequency response of up to 1.2 kc/s and a nominal sensitivity range from 0.05 to 1.7 g. The control unit operates from a 9 V d.c. supply and the relay contact rating is 5 A, 250 V a.c. or 30 V d.c. (resistive load).

The sensitivity is set by rotating the transducer within its housing; a calibration curve is supplied. The transducer is 3¼ in. square by 1¼ in. deep and the control unit measures 7½ by 5 by ½ in.—*Inertia Switch Ltd., 123 London Road, Camberley, Surrey.*

For further information circle 37 on Service Card

### 38. Automatic Circuit Tester

An automatic circuit tester, introduced recently by Elliott-Automation, enables unskilled operators to test rapidly and accurately the continuity and insulation of complex cable-forms, printed-circuit boards and circuits incorporating relays and similar devices. It can also be used for making resistance measurements.

The tester has a capacity of 100 circuits extendable in multiples of 100 up to a total capacity of 1,000 circuits and can be used for a wide range of different tasks without modification. Checking is carried out at approximately 10 tests per second, varying slightly with the limits of acceptance set for a particular applica-



36



37

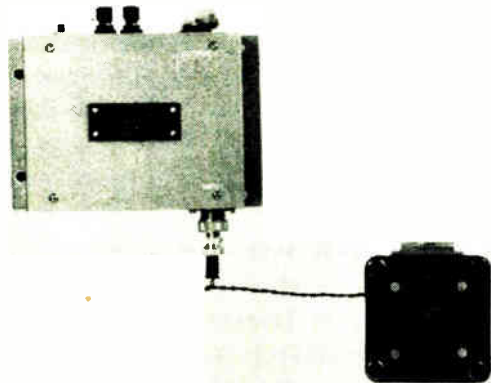

## EQUIPMENT

# review

tion. A continuity test, followed by an insulation test, is applied consecutively to each circuit. A step-on pulse moves the equipment automatically on to the next circuit if the results of the current pair of tests are satisfactory.

The location and type of fault are clearly displayed. Further investigations can be carried out by connecting external test units into the circuit. A special insulation testing facility is provided for circuits where access can be obtained to one end only.—*Elliott-Automation Ltd., Automatic Test Equipment Division, 34 Portland Place, London W.1.*

For further information circle 38 on Service Card

### 39. High Voltage Unit

Carl Zeiss have announced an addition to their range of high voltage units, the HA 60 RE.

Designed on the cascade principle this is a 4-step, selenium rectifier, high frequency unit, stabilized for mains fluctuations and load variations with a continuous voltage setting of 5 to 60 kV with negative polarity.

The unit also includes a filament-heating source, comprising a low-frequency generator with an isolating transformer which can supply 3.5 V at 4.5 A maximum (20 kc/s), and a variable cathode resistor for the generation of bias voltage. Both these are combined with the cascade in an oil vessel.—*Degenhardt & Co. Ltd., Carl Zeiss House, 20-22 Mortimer Street, London, W.1.*

For further information circle 39 on Service Card

### 40. Double-Triode

A double-triode (ECC2000) for television v.h.f. distribution systems and aerial amplifiers has been introduced by Mullard. In addition to being suitable for the single-channel, broadband and distributed amplifiers commonly used in such systems, the valve can also be used in the Y-amplifiers of broadband oscilloscopes.

A neutrode screen in the input section reduces anode-to-grid capacitance (and thus feedback), and enables

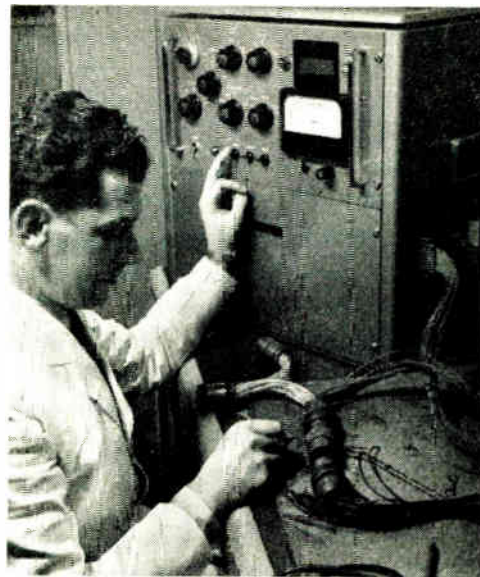

38

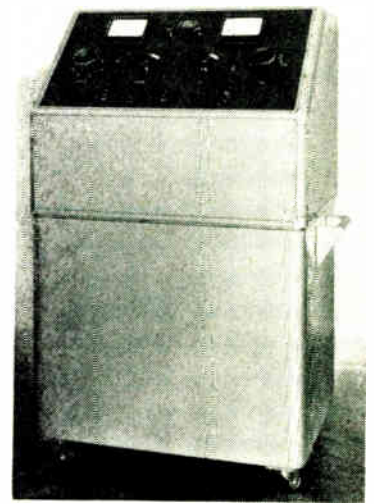

39

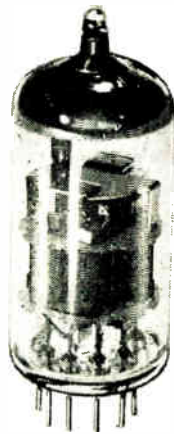

40

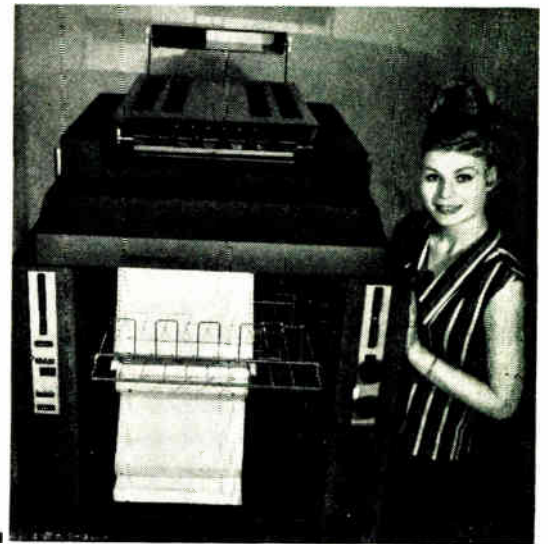

41

the valve to be used in many circuits without neutralization. Mutual conductance of the input section is 13 mA/V at an anode current of 15 mA and 17.5 mA/V at 27 mA. The ECC2000 has a 10-pin base (B10B) which enables the neutrode screen to be earthed separately or used in a neutralizing circuit.

The output section of the valve is intended for grounded-grid operation. It is of conventional form and gives a mutual conductance of 17 mA/V at an anode current of 15 mA and 22 mA/V at 27 mA. The valve can be operated in a low current condition when used as a small-signal amplifier, or in a high current condition when used as a high-gain voltage amplifier or power output stage.—*Mullard Ltd., Mullard House, Torrington Place, London, W.C.1.*

For further information circle 40 on Service Card

### 41. Dyeline Machine

A dyeline printer for use off-line with computer and punched-card output printers is now available in this country from Ilford.

Called the 'Azomatic' it is a high-speed copying machine designed to print from continuous output data at speeds of over 4,000 copies an hour, and in widths of from 4 $\frac{1}{8}$  to 18 $\frac{1}{2}$  in., and lengths of 3 $\frac{1}{4}$  to 20 $\frac{3}{8}$  in. between folds.

As the sheet sequence is automatically maintained, collation is automatic and the machine ensures that, without any post-printing apparatus, a complete set of copies is immediately available for distribution. Furthermore, with the continuous data kept intact, more items are 'on view' at one time, when filed.—*Ilford Ltd., Ilford, Essex.*

For further information circle 41 on Service Card

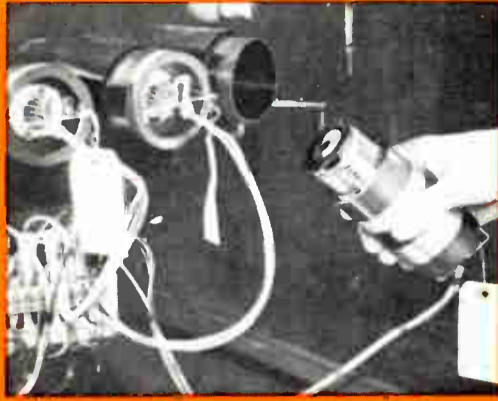

# EMI TOP TUBES

FOR PERFORMANCE & RELIABILITY

No ordinary tubes these! In radar, nucleonics, science, broadcasting and other professional applications, EMI electron tubes have a superb record of performance and reliability. They are precision manufactured to the highest standards of accuracy and EMI's research and development programme covers a wide range of new tubes and techniques. EMI is at the service of design and development engineers in solving application problems.



## Reply card

*Please send me further details of the following*

- Photomultiplier Tubes and Photoconductive Devices
- Microwave Tubes
- Camera Tubes
- Cathode Ray Tubes and Storage Tubes

*Also a copy of the*

- EMI Klystron & Waveguide data selection chart
- Photomultiplier Tube selection chart
- I would like to receive regular information regarding new developments.

NAME AND POSITION

(BLOCK LETTERS PLEASE)

COMPANY'S NAME

ADDRESS

TELEPHONE

EXT No.

These are brief details of some of the EMI special tubes.  
For further information please send the reply-paid card to EMI.

#### PHOTOMULTIPLIER TUBES AND PHOTOCONDUCTIVE DEVICES

EMI is the largest producer of photomultiplier tubes in Europe and these tubes are outstanding for very low values of dark current obtainable, with high gain, photosensitivity and stability of operation. They are supplied with various types of photo cathode for specific applications. 'S' cathode tubes for example are particularly suitable for carbon 14 and tritium counting. Solid state radiation detectors are also available for specialised applications.

#### MICROWAVE TUBES

*EMI Reflex Klystrons* include a wide range of plug-in klystrons and tuneable cavities giving continuous coverage from 3,000 to 12,000 M/cs. ('S' to 'X' band); a new advanced design 'J' band tube is now in the late stages of development. Integral cavity types covering 'K', 'Q' and 'J' band, have improved tuner for good frequency stability and freedom from microphony. A four cavity, water cooled Klystron with a gain of 50 dB and capable of handling peak powers in 'S' band of 100 kW is also available. *Magnetrons*. EMI produces a range of packaged magnetrons for high power pulse operation, designed for use in 'J', 'Q' and 'O' bands.

#### CAMERA TUBES

*EMI Camera Tubes include the following:—*

4½" image orthicons both standard and high sensitivity tubes. C.P.S. orthicon — the ideal tube for systems conversion. A wide range of EMI 1" vidicon tubes including the latest high resolution low heater wattage vidicons (with prefabricated targets). Special vidicons including high sensitivity ultra-violet sensitive tubes for use in UV microscopy, infra-red sensitive tubes and a long lag tube suitable for radar/TV scan conversion or for recording single strobe flash pictures. A recent addition to the range is a tube with a fibre optic face plate.

#### CATHODE RAY TUBES AND STORAGE TUBES

The EMI range of high quality, high precision cathode ray tubes includes all types of radar tubes from 2" airborne radar tubes giving extremely high definition to 21" metal coned tubes.

Oscilloscope tubes include those capable of recording single transients with a rise time of 1 millimicrosecond. Film scanners and TV monitor tubes are also available.

A barrier grid storage tube which is finding wide application in medical electronics and other fields is a new addition to the range.



EMI offers a very wide range of special tubes

Postage  
will be  
paid by  
Licensee

No postage  
stamp necessary  
if posted in  
Great Britain or  
Northern Ireland



EMI ELECTRONICS LTD

VALVE DIVISION · HAYES · MIDDX  
TELEPHONE: HAYES 3888 · EXT 2165

BUSINESS REPLY CARD  
Licence No. SOX 64

EMI ELECTRONICS LTD  
VALVE DIVISION · DEPT. EC5  
HAYES · MIDDLESEX · ENGLAND

EE262 Inc. Electronics Oct



# THE BROADBAND CHARACTERISTICS

# OF SOME BASIC TRANSMISSION LINE ELEMENTS

**M**ICROWAVE engineers nowadays often require to design systems to operate over extremely wide bandwidths of perhaps an octave in frequency, or even more. While, in designing the system, it may be a fairly straightforward matter to compute, for specified circuit parameters, either the power transmission or v.s.w.r., it is helpful at the outset to have a clear conception of the broadband performance of basic elements.

One particular arrangement which figures in numerous components is that of two similar discontinuities or obstacles at a fixed spacing in a transmission line. Our aim is to present simple universal charts for a number of such cases giving the broadband properties when the component is inserted into a line terminated in a matched load.

The fractional power transmitted, insertion loss and input v.s.w.r. are all uniquely defined for lossless systems by the magnitude of the transmission coefficient,  $T$ . Using the 'root power' definition given by Ragan,<sup>1</sup> the following relationships apply, even when the characteristic impedance is different for input and output lines:

$$\text{Fractional Power Transmitted} = |T|^2$$

$$\text{Insertion loss} = 10 \log \frac{1}{|T|^2} \text{ (dB)}$$

$$\text{V.S.W.R.} = \frac{1 - \sqrt{1 - |T|^2}}{1 + \sqrt{1 - |T|^2}}$$

There is an exception to the third relationship with resistive obstacles and special consideration will be given to this case. For all the other arrangements discussed, however, the frequency variation of each of the above three properties, for fixed parameters, may be described by means of a single curve, using a 3-scale ordinate. This has been done for different cases in the various charts, the multiplicity of curves in each covering a range of values for a principal parameter, with frequencies normalized to the value which gives minimum insertion loss. This is determined only by

the spacing of the two obstacles or discontinuities, except with reactive obstacles, when it depends also upon the magnitude of the reactances.

The methods of analysis will not be discussed in detail, as these are well known. Two alternative techniques were used, according to convenience. One of these was concerned with wave matrices, as described by Ragan, and the other involved solving the voltage and current equations for each side of the boundaries associated with the obstacles or discontinuities. Rough checks were made using a Smith Chart.

## Quarter-Wave Transformer

In a quarter-wave transformer, two transmission lines of different characteristic impedances  $Z_{01}$ ,  $Z_{02}$  are joined by means of a quarter-wave section whose characteristic impedance  $Z_{03}$  is given by

$$Z_{03} = \sqrt{Z_{01}Z_{02}} \quad (1)$$

At a frequency such that the section represents an electrical angle  $\theta$ , it may be shown that the magnitude of the transmission coefficient is given by

$$|T|^2 = \frac{(1 - |\Gamma|^2)^2}{1 + 2|\Gamma|^2 \cos 2\theta + |\Gamma|^4} \quad (2)$$

where  $|\Gamma|$  is the modulus of the reflection coefficient at each impedance step, these being equal by virtue of Equ. (1).

At the frequency for which the section is exactly one quarter wavelength (i.e.,  $\theta = \frac{\pi}{2}$ ) the magnitude of the trans-

mission coefficient is unity and there is no net reflected power. If this frequency is denoted by  $f_0$ , the value of  $\theta$  corresponding to any other frequency  $f$  is given by

$$\theta = \frac{f}{f_0} \times \frac{\pi}{2}$$

The broadband characteristics derived from Equ. (2) over

\*Associated Electrical Industries Ltd.

the normalized frequency range 0-2.0 are given in Fig. 1, for fixed values of  $Z_{01}/Z_{02}$ .

It is not until the ratio  $Z_{01}/Z_{02}$  exceeds about 2.0 that the overall reflected power exceeds 10% for any normalized frequency. In order to cover impedance ratios of practical interest, it is therefore most useful in this case to plot the characteristics to a linear scale of v.s.w.r. in the input feeder, rather than  $|T|^2$  and then to add the scales for  $|T|^2$  and insertion loss.

It will be noted from Equ. (2) that the curves will be repeated as  $f/f_0$  is made to exceed 2.0. The reflection coefficient is related to the ratio  $Z_{01}/Z_{02}$  by the expression:

$$\Gamma = \frac{\sqrt{Z_{01}/Z_{02}} - 1}{\sqrt{Z_{01}/Z_{02}} + 1} = \frac{\sqrt{Z_{01}} - \sqrt{Z_{02}}}{\sqrt{Z_{01}} + \sqrt{Z_{02}}} \quad (3)$$

The value of  $|\Gamma|$  is therefore unaltered if  $Z_{01}$  and  $Z_{02}$  are interchanged and so, for a given impedance ratio between input and output lines, the same curves apply to a step-up or step-down transformer. The curves are derived on the assumption that discontinuity capacitances at the transitions may be neglected, and this is usually so. The importance of these will, however, depend on the physical dimensions of the steps and on the absolute value of the frequency scale.

### Dielectric-Filled Section

We now consider the properties of a short section with a lossless dielectric filling introduced into a transmission line. This situation is of common occurrence, for instance when an insulating bead is used to support the inner conductor of a coaxial line. Reflections arise at each interface, owing to the change in characteristic impedance within the dielectric section. The situation is similar to that of the quarter-wave transformer except that, for transmission in either direction, the reflection coefficients at the two interfaces are equal in magnitude but opposite in sign. The overall transmission coefficient is now given by

$$|T|^2 = \frac{(1 - |\Gamma|^2)^2}{1 - 2|\Gamma|^2 \cos 2\theta + |\Gamma|^4} \quad (4)$$

There is no net reflected power when  $\theta = n\pi$  and a length of one half wavelength gives the first maximum in transmission. We note that

$$\theta = \pi f/f_0$$

and, using Equ. (3), obtain the broadband characteristics of Fig. 2, a linear scale for  $|T|^2$  now being chosen. Curves are plotted for a range of values of the permittivity  $\epsilon$ , which is related to the reflection coefficient modulus by the equation

$$|\Gamma| = \frac{\sqrt{\epsilon} - 1}{\sqrt{\epsilon} + 1}$$

Again, the curves repeat for values of  $f/f_0$  exceeding 2.0. Instead of using permittivity as a parameter, the ratio  $Z_{01}/Z_{02}$  could be used, employing Eqs. (3) and (5), and the broadband characteristics would then apply to a section wherein a different characteristic impedance results from a change in dimensions. For such a case, the remarks on discontinuity capacitances made in the previous section would also apply.

### Two Equal Admittances

Two equal admittances spaced along a transmission line give expressions for  $|T|$  of the same form as Eqs. (2) and (4). The situations are somewhat more complicated in that, with reactive admittances,  $\theta$  becomes a function of the angle of reflection coefficient as well as the spacing and, with resistive admittances, the term  $(1 - |\Gamma|^2)$  must be replaced by the transmission coefficient of each obstacle, no longer uniquely defined by the reflection coefficient. A more direct method of obtaining the broadband characteristics in these cases is to consider the overall reflected and transmitted voltage waves,

which may be expressed in terms of the normalized admittance  $A$  and spacing angle  $\theta$  as follows:—

$$\frac{\text{Transmitted Voltage}}{\text{Incident Voltage}} = \frac{e^{-j\theta}}{\left(1 + \frac{A}{2}\right)^2 - \left(\frac{A}{2}\right)^2 e^{-j2\theta}} \quad (6)$$

$$\frac{\text{Reflected Voltage}}{\text{Incident Voltage}} = \frac{-\frac{A}{2}\left(1 + \frac{A}{2}\right) + \left(1 - \frac{A}{2}\right)e^{-j2\theta}}{\left(1 + \frac{A}{2}\right)^2 - \left(\frac{A}{2}\right)^2 e^{-j2\theta}} \quad (7)$$

### Resistive Obstacles

For resistive obstacles, the fractional transmitted power is obtained very readily by substituting the normalized conductance  $g$  into Equ. (6), giving

$$|T|^2 = \frac{1}{\left(1 + \frac{g}{2}\right)^4 + \left(\frac{g}{2}\right)^4 - 2\left(\frac{g}{2}\right)^2\left(1 + \frac{g}{2}\right)^2 \cos 2\theta} \quad (8)$$

The fractional reflected power  $P_R$  is similarly found from Equ. (7):—

$$P_R = \frac{\frac{g^2}{2}\left[\left(1 + \left(\frac{g}{2}\right)^2\right) + \left[1 - \left(\frac{g}{2}\right)^2\right] \cos 2\theta\right]}{\left(1 + \frac{g}{2}\right)^4 + \left(\frac{g}{2}\right)^4 - 2\left(\frac{g}{2}\right)^2\left(1 + \frac{g}{2}\right)^2 \cos 2\theta} \quad (9)$$

The v.s.w.r. is now obtained from  $P_R$  by the relationship

$$\text{V.S.W.R.} = \frac{1 - \sqrt{P_R}}{1 + \sqrt{P_R}} \quad (10)$$

Taking  $f_0$  as the lowest frequency at which transmission of power is a maximum, we have that

$$\theta = \pi f/f_0$$

Fig. 3 shows the fractional transmitted power and insertion loss obtained from Equ. (8) over the usual normalized bandwidth. Fig. 4 shows the corresponding values of v.s.w.r. obtained from Eqs. (9) and (10). It will be noted that the v.s.w.r. for a given fractional transmitted power is always nearer to unity than the corresponding value of the previous diagrams, which related to conditions in which no absorption of power occurred. It is further observed that, for a given discontinuity, the v.s.w.r. is nearest to unity when the power transmission is at a minimum, contrary to the previous cases. The present curves again are repeated for values of  $f/f_0$  exceeding 2.0.

### Reactive Obstacles

With purely reactive obstacles, since there is no absorption of power, the broadband characteristics are uniquely defined by the transmitted power, so we need confine our attention to Equ. (6) only. If, in this equation, the substitution is made

$$A = jb$$

and we then put

$$1 + jb/2 = Y e^{j\psi}$$

it is found that

$$|T|^2 = \frac{1}{Y^4 + \left(\frac{b}{2}\right)^4 + 2Y^2\left(\frac{b}{2}\right)^2 \cos 2(\psi + \theta)} \quad (11)$$

We note that all of the terms in Equ. (11) are frequency dependent, so there is now no normalizing frequency about which to obtain symmetrical broadband characteristics. For a given spacing, with particular values of shunt capacitances or inductances, there will, however, be some frequency for which  $\psi + \theta = \pi/2$ , and this is easily shown to be a condition for no net reflection of power. In the following two sections, we use this as the normalizing frequency  $f_0$  and

Fig. 1. Broadband characteristics for quarter-wave transformer

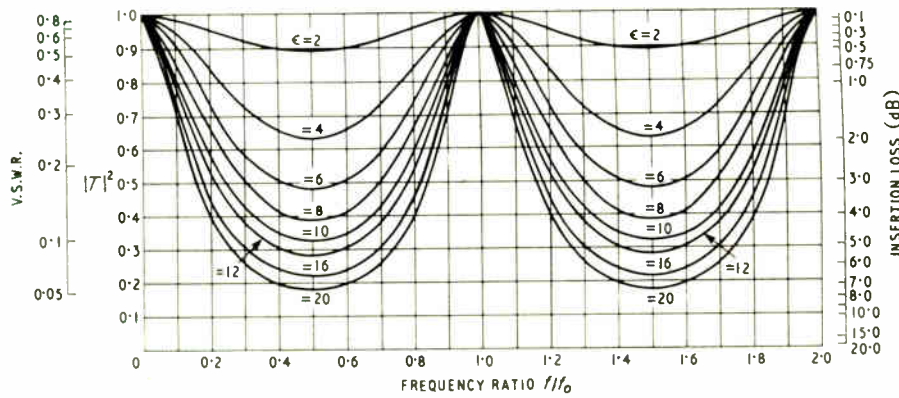
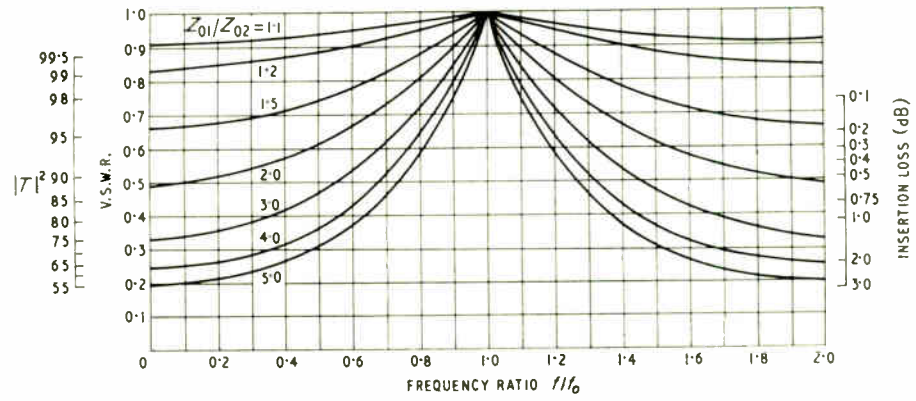

Fig. 2. Broadband characteristics for dielectric-filled section

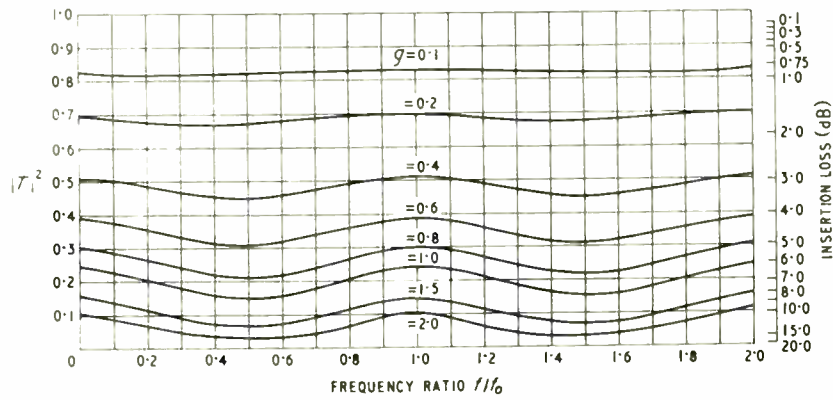
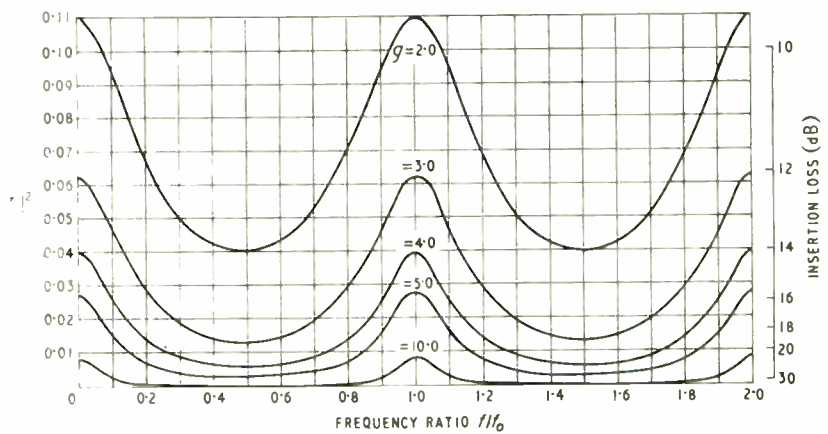

Fig. 3. Broadband characteristics for resistive obstacles



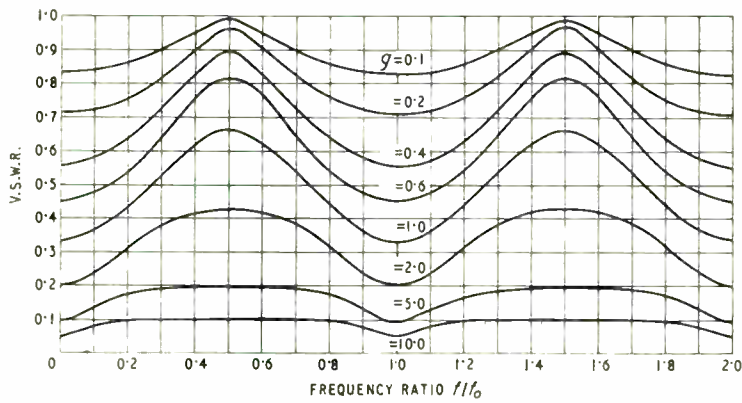

Fig. 4. V.S.W.R. characteristics for resistive obstacles

Fig. 5. Broadband characteristics for capacitive reactances

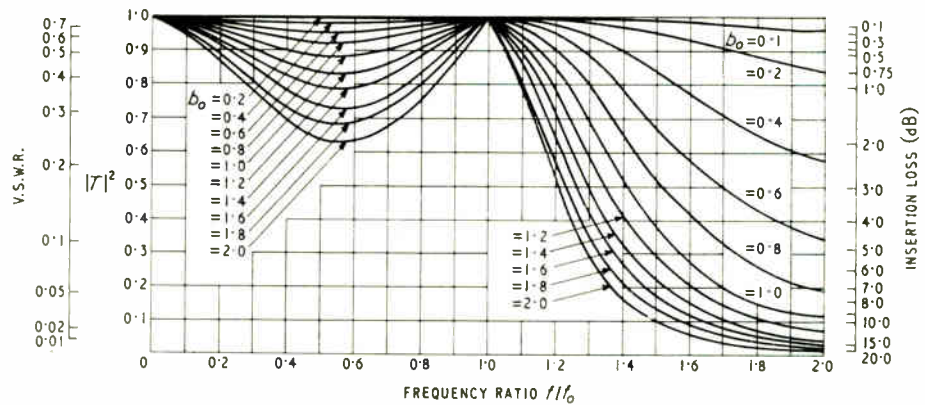
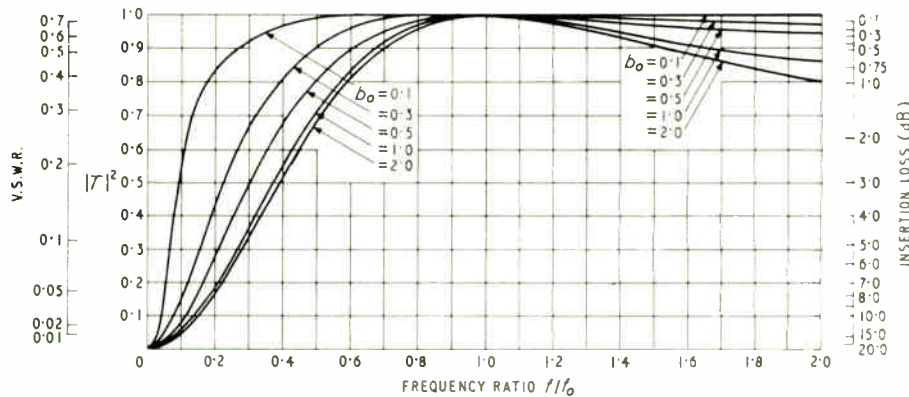

Fig. 6. Broadband characteristics for inductive reactances



present the broadband characteristics in terms of the normalized susceptance  $b_0$  at the frequency  $f_0$ .

### Capacitive Reactances

For two equal capacitances  $C$ , we have

$$b_0 = 2\pi f_0 C$$

with  $\psi_0 = \frac{\pi}{2} - \theta_0 = \tan^{-1}(b_0/2)$

Using the relationships

$$\theta = \theta_0 f/f_0 \text{ and } b = b_0 f/f_0$$

the broadband characteristics may be evaluated from Equ. (11). These are presented in Fig. 5, a 3-scale ordinate being used as in the earlier charts.

### Inductive Reactances

For inductances  $L$ , we have

$$b_0 = \frac{1}{2\pi f_0 L}$$

so that now

$$b = b_0 f_0 / f$$

with the other relationships as before. The resulting broadband characteristics are presented in Fig. 6.

### Use of Charts

The various charts presented enable the broadband characteristics to be obtained readily for quarter-wave transformers, dielectric-filled sections and two spaced obstacles in shunt with a transmission line which are either purely resistive or reactive. For a given spacing between the impedance transitions or obstacles, there is in each case a frequency  $f_0$  at which the overall power transmission is a maximum. This frequency is independent of the magnitude of the discontinuities, except with reactive obstacles. In the other cases it is a straightforward matter to find the spacing corresponding to maximum transmission at some particular frequency or vice versa. Taking this frequency as  $f_0$ , the charts immediately give the broadband characteristics normalized to this.

For reactive obstacles, given the centre frequency  $f_0$ , the corresponding normalized susceptance  $b_0$  must first be obtained. From this, the phase angle  $\psi_0$  and hence the spacing for maximum transmission are found. If, on the other hand, the data are the spacing and a particular operating frequency  $f_1$ , it is necessary first to find  $f_0$ , a graphical solution being the simplest to obtain. For a specified obstacle, this leads to  $b_0$ , which gives the appropriate charted curve, the operating point being obtained by entering this curve at the normalized frequency  $f_1/f_0$ . All other frequencies are then expressed in terms of  $f_0$ .

Extension of the use of these charts to waveguides involves only a modification of the spacing angle  $\theta$ , to take into account the effects of dispersion. Except for reactive obstacles, the charts remain unaltered provided that the base is translated into normalized guide wavelength.

Although practical situations may not in fact often be as simple as those considered, the charts should nevertheless be useful in leading to a rapid approximate appraisal in somewhat more complex cases. The sections on resistive and capacitive obstacles illustrate the considerable broadband potentialities of semiconductor p-i-n<sup>2</sup> and varactor switching diodes,<sup>3</sup> used in pairs.

#### References

- <sup>1</sup> Ragan, G. L., 'Microwave Transmission Circuits', McGraw Hill, 1948.
- <sup>2</sup> Baker, T. H. B., 'Semiconductor Waveguide Switch', *Electronic Technology*, August 1961, p. 300.
- <sup>3</sup> Uhlir, A., 'The Potential of Semiconductor Diodes in High Frequency Communications', *Proc. Inst. Radio Engrs.*, June 1958, p. 1099.

# A Tunable Highly-Selective Distortion Test-Set

By E. R. WIGAN, B.Sc.(Eng.), A.M.I.E.E.

A high  $Q$  circuit, obtained by positive feedback, forms the basis of a simple test-set for measuring the relative amplitudes of harmonics up to the tenth. A feature of the instrument is the rapidity with which measurements can be made.

THE technique was developed to allow rapid and accurate measurement of the first ten terms of the distortion-spectrum (1,2,3, . . . 10 kc/s) generated in a.f. equipment when subjected to a test tone of 1,000 c/s. A conventional wave analyser is not entirely suited to such work, for much time can be wasted in trying to locate and measure those terms which are of very low level—and which may in fact be entirely absent if the equipment tested employs well-balanced push-pull amplification. To avoid this search, the present apparatus has been designed on a comparison, rather than a direct-measurement basis: a local oscillator is provided which can be switched to each of the ten harmonic frequencies, the oscillation being 'locked' to the parent 1,000-c/s test tone. If then the selective amplifier is tuned to the local oscillation it will also be exactly in tune with the corresponding distortion-term, and can safely be brought to its highest possible selectivity *before measurement starts*. By this means it is ensured, even if the distortion term chosen is extremely small, that it will be located and measured within a few seconds; equally the complete absence of a harmonic term can be established with certainty. This is virtually an impossibility with a wave analyser. The analyser has, of course, a much wider frequency range than the test-set which makes measurements only within the 5% range around each of the ten harmonics.

To establish accurately, and in the presence of some degree of circuit noise, the amplitude of each of the ten distortion terms, a selective system is required which shall be capable of  $Q$ -factors between 100 and several 1,000, depending on the harmonic number ( $n$ ) and the noise level, and which shall have a tuning range of 5% (say) to allow for the frequency

drift or inexact tuning of the primary oscillator. To achieve the high  $Q$ -factors needed in the selective amplifier a potentially oscillatory circuit is used with the positive feedback set just short of the oscillation-point.

However, during any tuning operation the degree of feedback must be held constant within very close tolerances indeed or selectivity will be lost; this is because the  $Q$ -factor is proportional to the inverse of the deficiency by which the loop-gain falls short of unity. Tuning is provided by the 'bridged' Wein bridge network shown in Fig. 1; Ref. 1 sets out the theory. The special feature of this network is that, as the tuning resistor is swept over its full range, the voltage-loss through the net remains substantially constant; tuning cannot affect the  $Q$ -factor, therefore. (See Table 1.) The tuning range provided is 5% which is far wider than would be needed, in practice, to locate the crest of a high- $Q$  resonance curve.

The viability of the measurement technique rests almost entirely upon the success achieved in making the  $Q$ -factor independent of the tuning operation, and, as Table 1 shows, the adjustments once made can be expected to remain stable for a year or more; the 'repair' referred to in the Table was the replacement of two capacitors which had drifted and altered the tuning—although not the loop-gain.

#### Arrangement

The block-schematic in Fig. 2 shows that the 'comparator' principle commonly adopted in transmission measuring sets has been employed with some minor variations. The unknown signal, the harmonic term, is compared with a known fraction of a locally-generated signal of the same frequency. In this

TABLE 1

Performance After More Than 12 Months' Use and After Repair of the 5-kc/s Channel

(1) Frequency setting (kc/s)	(2) Tuning Range (kc/s) Min: Max:	(3) Frequency difference (kc/s)	(4) Fine control dial setting for critical reaction (% full scale)	(5) Reaction setting difference at limits of frequency range (% full scale)
10	9.74 10.42	0.68	76	+0.5
9	8.76 9.37	0.61	65	+0.75
8	7.76 8.31	0.55	55	+0.3
7	6.77 7.24	0.47	59	<0.1
6	5.81 6.21	0.41	50	-0.1
5	4.82 5.15	0.33	39	<0.1
4	3.79 4.06	0.265	16	+1.0
3	2.89 3.09	0.2	29	<0.1
2	1.93 2.07	0.14	20	<0.1
1	0.966 1.033	0.077	6	<0.1

An entry '<0.1' in column (6) implies that Q would vary by <50 parts in 10<sup>4</sup> if the tuned frequency were varied by ±5%.

test-set, however, the local oscillator (8) can be given any one of ten frequencies, selected by switch (10), which are 'locked' to the input test-tone (1 kc/s) by a 'spike' generated at (7). The a.g.c.-amplifier (6) makes sure that, if the level at (1) lies between -15 dB and 0 dB, the spike will lock—but not distort—the oscillation. With the comparator-switch (4) to the right the selective amplifier (5) can be tuned precisely to the harmonic to be examined, and when switched to the left the harmonic amplitude (weighted as frequency<sup>2</sup>, by elements (3)) is presented. Voltage-divider (9) is then

adjusted until both positions of (4) yield the same reading on meter (12). Divider (9) is of the 3-decade type described in Ref. 2 and is readable to 1 part in 1,000, interpolations being made, when the signal is small, from the scale of VVM (12) which is arranged to be linear. High-gain amplifier (11) makes it unnecessary for (5) to deliver any but very low level signals to operate meter (12).

The filter-assembly (2a-2b) removes the 1-kc/s component of the distorted input signal and acts as a constant-resistance net of 600 Ω at all frequencies, thus correctly loading the test-object connected at (1). The 6-dB pad (2c), inserted when the 1-kc/s term is measured, copies the impedance and loss introduced by the filter network. RC oscillator (8) is tuned only 'coarsely', by capacitance change, when (10) is operated, any frequency-error being corrected by the 'spike' from (7) pulling the oscillation. The miniature c.r. oscilloscope (13) then shows a sharp sinous line; lack of synchronism makes the picture hazy and can be corrected by trimming the primary 1-kc/s test-oscillator. By counting the number of sinusities on (13) the user can check that the correct harmonic is being observed. Top-to-bottom inversion of the picture indicates an anti-phase term; such information can be most helpful in diagnosing the source of the distortion observed.

To help in setting (5) to maximum sensitivity there is a third position of (4) (not shown) in which the chain (5-11-12) is disconnected and the input loaded by 600 Ω. The reaction is then set so that oscillation is incipient (shown on (13) as a

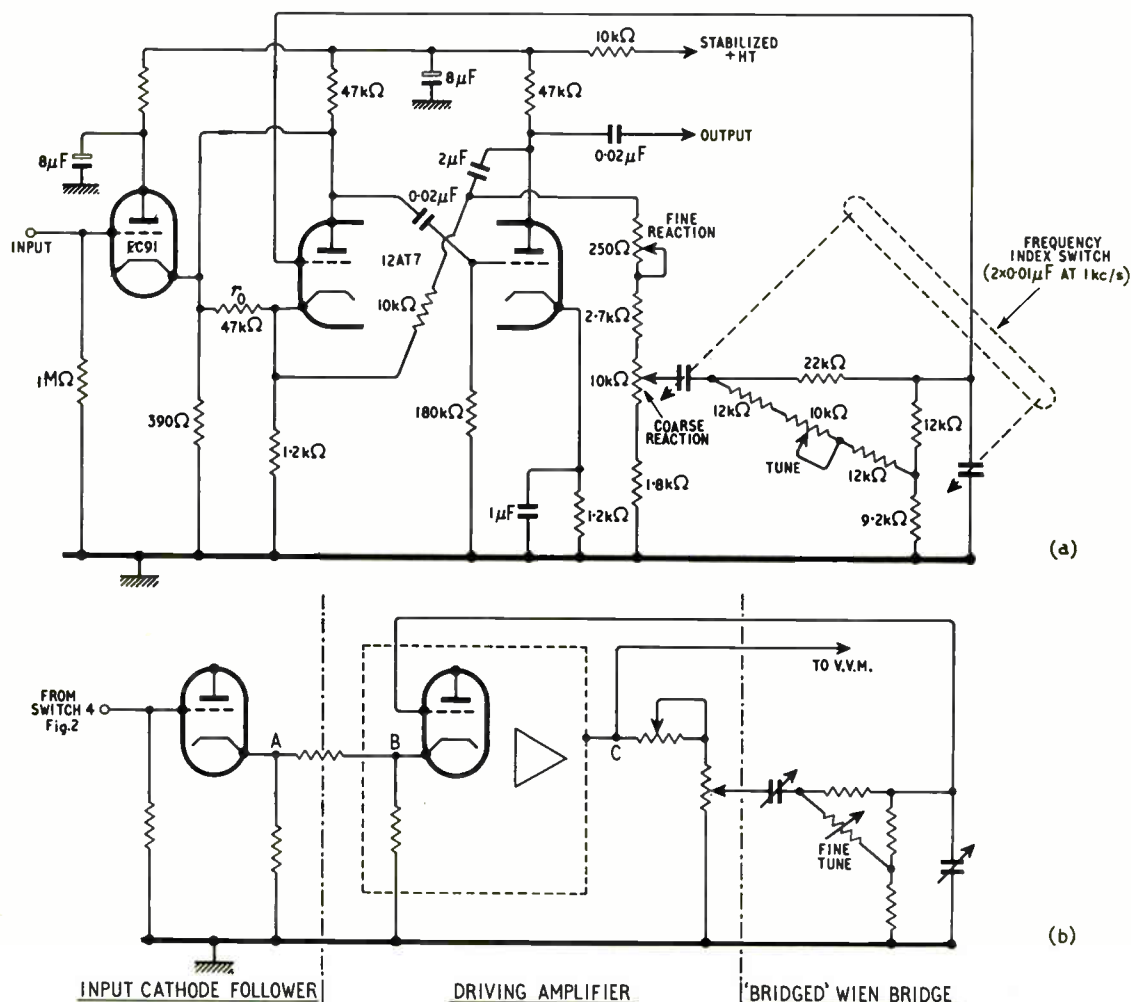

Fig. 1. Selective assembly. Each of the ten harmonics is 'coarsely' tuned by choice of capacitor and then sharply tuned by resistor adjustment in the 'bridged' Wien bridge. A second section of the selector switch, which is not shown, coarsely tunes the local oscillator to the corresponding frequency

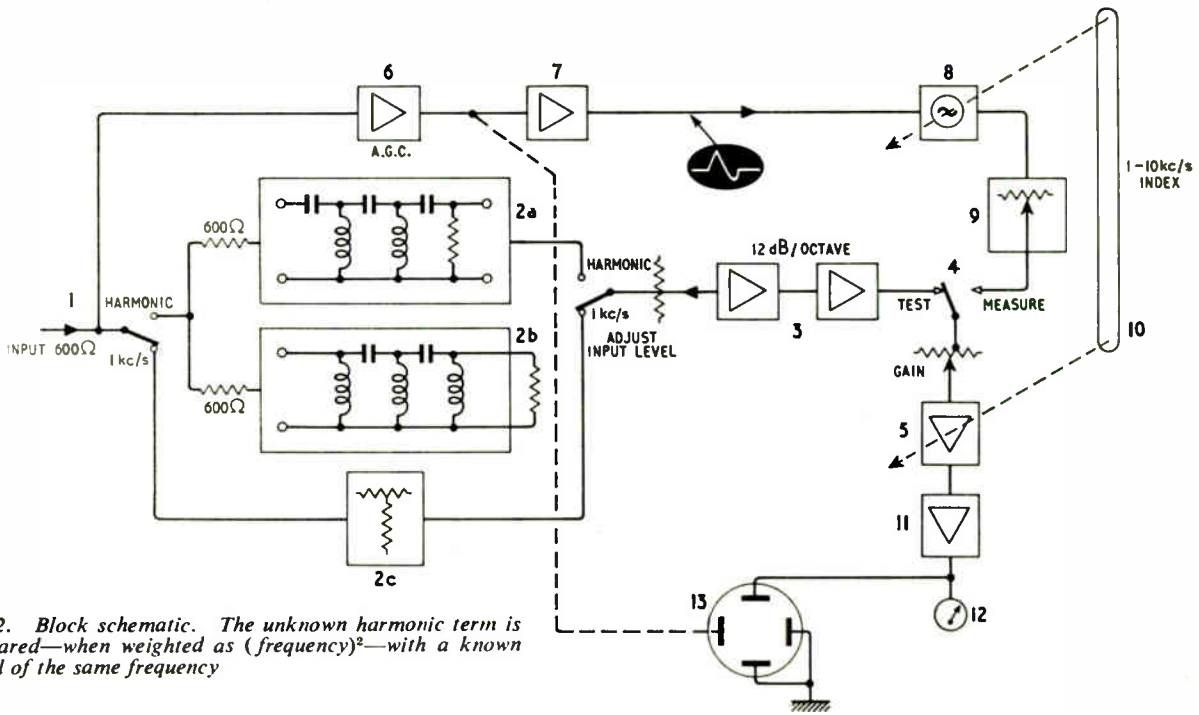

Fig. 2. Block schematic. The unknown harmonic term is compared—when weighted as  $(\text{frequency})^2$ —with a known signal of the same frequency

clean line). At the same time (5), when oscillating, can be roughly tuned by bringing the c.r.o. picture to rest.

By other switches, not shown, the meter (12) can be transferred to monitor the output of (8); another switch-contact, associated with (10), ensures that when the 1-kc/s term is being measured divider (9) is replaced by a fixed pad with the same loss as is introduced by (9) when the dials are set to 100.

With very little experience the measurement of a single distortion term can be completed in 5–10 seconds; thus the complete set of ten can be dealt with in under 2 minutes—a period short enough to justify the assumption that the same working conditions applied to each term of the harmonic series. This is a matter of some importance when tests are being made near the overload-point of the test-object, e.g. a feedback amplifier or the modulation amplifier of a high-power transmitter.

### Limitations and Advantages

Advantages outweigh limitations; very high  $Q$ -factors can be achieved—2,000–3,000 for instance—the system remaining stable over the period of 10 seconds or so needed for a measurement, but a price has to be paid: the selectivity falls if the output voltage  $V_c$  (at point 'C', Fig. 1) from the selective amplifier grows much larger than 50 mV. See Fig. 3.

The effect is due to the extreme sensitivity of the overall gain  $G$  of the selective system to changes in the gain  $G_A$  of the amplifier connected in the positive feedback loop.  $G_A$  falls, although very slightly, as  $V_c$  rises, because of the non-linearity of the valve transfer-characteristics. Fig. 4 shows at (a) the distortion generated in the amplifier when the positive feedback loop is broken, and at (b) the fall in gain ( $\beta$ ) which occurs at the tuned frequency when the loop is closed. These phenomena will be dealt with more fully later, but the shape of the curves in Fig. 3 can be explained in general terms as follows:—

Let us suppose that the gain  $G$  is extremely high because reaction has been set very near the oscillation-point. Then the magnitude of  $G$  is limited only by the non-linearity in the amplifier which appears when a signal is applied. As  $\beta$  in

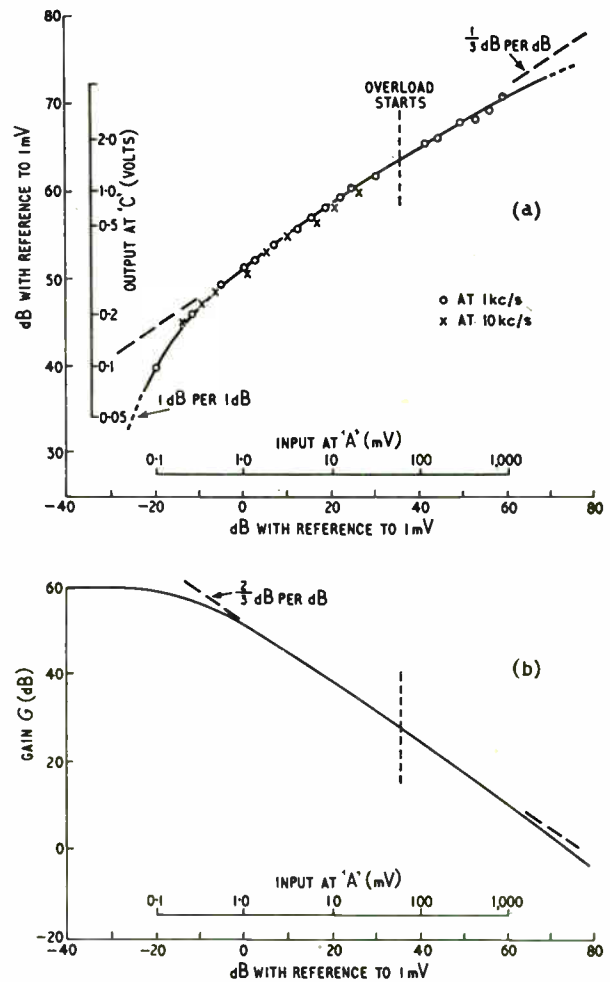
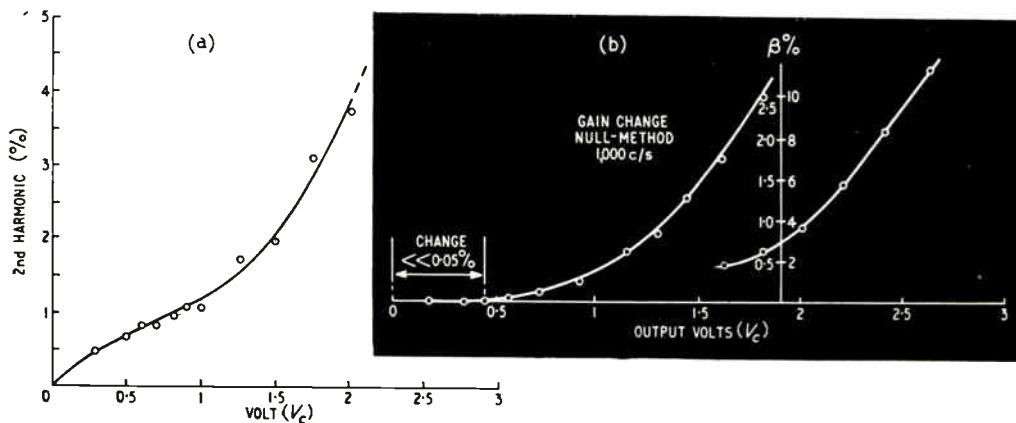

Fig. 3. Influence of distortion in the amplifier. The selective system loses gain when signal level rises



Left: Fig. 4. Amplifier performance: (a) distortion measured as second harmonic; (b) gain changes derived by a bridge method which ignores all harmonics

Below: Fig. 5. Terms used in the general analysis. Definition of primary parameters (a), reference p.d.s and currents (b), parallel injection (c) and series injection (d)

Fig. 4(b) is roughly proportional to  $V_c^2$  it is to be expected that  $G$  will vary inversely as  $V_c^2$ . Because of this effect, when the input voltage ( $V_1$ ) increases, although  $V_c$  rises, the gain  $G$  falls; thus we have approximately:—

$$G = (\text{constant})/V_c^2$$

But  $G = V_c/V_1$

Whence  $V_c^3 = (\text{constant})/V_1$ , which is confirmed by the 1/3 slope of the logarithmic plot of Fig. 3 which takes control once  $V_1$  and  $V_c$  exceed their critical values. On the other hand when  $V_c$  is  $< 50$  mV approx. the selective system behaves very nearly linearly.

Under linear conditions the highest selectivity is possible and Fig. 6 to which such conditions apply, illustrates the outcome when the reaction control is set to three positions. (Relatively low  $Q$ -factors, i.e.  $< 140$ , made it possible to measure accurately both the in-phase and quadrature terms of the voltage vectors. This would not have been possible if  $Q$  was very high.) This diagram is discussed in detail later; here it is sufficient to notice that, at the resonant frequency ( $f_0 = 990$  c/s) Fig. 6(a) demonstrates that the output voltage varies inversely as the degree of positive reaction, while the straight lines and circles of (b) and (c) confirm that the system is behaving in a linear manner. Non-linearity, due to the larger signal voltages, is evident in Fig. 7, both the lines and the circles of Fig. 6 being bent out of shape. The flattening of the circles is responsible for the loss of  $Q$ -factor, which can be seen to be divided by 10 as compared with Fig. 6.

When the test-set is in use the linear performance of Fig. 6 is operative at all times,  $V_c$  being always very small. The adoption of the 'comparator' measurement-technique ensures that  $V_1$  never exceeds the (very small) amplitude of the 'weighted' harmonic under examination, irrespective of the  $Q$ -factor used. The 'weighting' amplifiers (3) in Fig. 2 raise an harmonic percentage  $p_n$  to a level  $n^2 p_n$  and thus prevent  $V_1$  from falling with the order ( $n$ ) of the harmonic term measured; in fact when a high-grade negative feedback amplifier is tested very near to its overload-point the quantity  $n^2 p_n$  tends to remain nearly constant irrespective of  $n$ . (In a well-adjusted push-pull amplifier, however, the even-order terms are depressed or missing.)

Virtually linear performance is essential to high selectivity, but on the other hand the 'compression' phenomenon of Fig. 3 can serve a useful purpose also, by protecting the meter (12) from accidental overload during preliminary adjustments. However, it will be apparent that if the  $Q$ -factor is to be capable of smooth and continuous adjustment up to the highest values, the curve of  $\beta$  (Fig. 4(b)) must have a positive slope; a completely linear amplifier would be unusable. (It should be noted that although the circuit constants of Fig. 1(a) meet the required conditions they were arrived at by trial and error and must not be treated as optimal.)

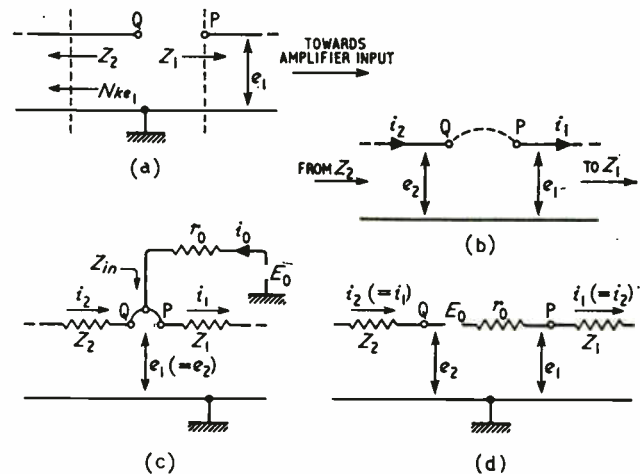

Because this instrument presents all its readings in the form  $n^2 p_n$ , the summation of the nine measurements (at 2,3...10 kc/s) yields the distortion criterion  $C_0$ , dealt with in Ref. 3 which shows that  $C_0$  gives a measure of the audience-reaction to the objective distortion measured.

### Theoretical Considerations

The combination of driving amplifier and frequency-selective network to the right of Fig. 1(b) constitutes a potentially oscillatory system, but when just short of the oscillation-point it acts as a selective amplifier. The cathode-follower to the left serves primarily as a buffer to isolate the selective system from the rest of the measuring equipment; the signal picked up by the selector-switch (4) reappears, slightly reduced, at 'A' and finally at 'B' where it influences the selective circuit. It should be noticed that the resistance coupling 'A' to 'B' is represented by  $r_0$  at 'A' by  $E_0$ , in Fig. 5(c). The injection of external signals into the system by this 'parallel' arrangement is much more practical than the 'series' method of Fig. 5(d) which demands a transformer to isolate  $E_0$  from earth.

We shall now investigate the p.d.s and currents existing in Fig. 5(c), making as few assumptions as possible so that the analysis shall be of general application. The analysis starts from Fig. 5(a) where the positive feedback loop (of unspecified composition) is supposed broken at P, Q; the only assumptions made are that the input terminals of the associated amplifier lie somewhere to the right, and the output terminals somewhere to the left of the figure, a frequency-selective passive network being included in tandem in the loop. In Fig. 5(b) P and Q are shown connected in some unspecified way so that there is a through passage for  $i_1$  and  $i_2$ .



In Fig. 5(a) any p.d. such as  $e_1$  will meet an impedance  $Z_1$ . The amplifier will be excited by some fraction or multiple of  $e_1$  and deliver at Q an open-circuit e.m.f. ( $NKe_1$ ) which will be associated with an output impedance  $Z_2$ .  $N$  may be taken as a real number, independent of frequency and proportional to the open-circuit numerical gain of the amplifier proper, whereas  $K$  represents the loss factor arising from all the passive elements in the loop, including any amplifier gain—or 'reaction'—controls, and the frequency-selective network.  $K$  will, in general, be complex becoming real only at the resonant frequency. In general it is preferable to make  $N \gg 1$  and  $K \ll 1$ .

The following analysis applies to Fig. 5(c) where we have:

$$\begin{aligned} NKe_1 &= i_2 Z_2 + e_2 & (1) \\ e_1 &= i_1 Z_1 & (2) \\ e_2 &= e_1 & (3) \\ i_0 &= i_1 - i_2 & (4) \end{aligned}$$

Eliminating  $e_1$  and  $e_2$  from equations (1), (2) and (3),

$$i_2/i_1 = (NK - 1) Z_1/Z_2 \quad (5)$$

$$\text{and from (4) and (5)} \quad i_0/i_1 = 1 - (NK - 1) Z_1/Z_2 \quad (6)$$

The input impedance at P, Q is defined as:

$$Z_{in} = e_1/i_0 \quad (7)$$

$$\text{Also, from Fig. 5(c)} \quad e_1 = E_0 - i_0 r_0 \quad (8)$$

$$\text{From (7) and (8)} \quad E_0/e_1 = 1 + r_0/Z_{in} \quad (9)$$

Or, defining the gain ratio measured at P, Q as  $G_{PQ}$

$$G_{PQ} = e_1/E_0 = Z_{in}/(r_0 + Z_{in}) \quad (10)$$

which shows that  $G_{PQ}$  will be infinite, and uncontrolled oscillation will start, when

$$Z_{in} = -r_0 \quad (11)$$

The general expression for  $1/Z_{in}$  is obtained from (2) and (6) as

$$1/Z_{in} = 1/Z_1 + 1/Z_2 - NK/Z_2 \quad (12)$$

Thus, from (10) and (12)

$$G_{PQ} = (Z_2/r_0)/(1 + Z_2/Z_1 + Z_2/r_0 - NK) \quad (13)$$

showing that  $G_{PQ} = \infty$  and oscillation will start when

$$NK = NK_{osc} = 1 + Z_2/Z_1 + Z_2/r_0 \quad (14)$$

In practice, when the highest gain and selectivity is required,  $NK$  is set just below this value.

The overall gain available from the complete selective system can be made greater than  $G_{PQ}$ ; for instance,  $e_1$  can be arranged to appear at the input terminals of the main

amplifier, and an amplified voltage obtained from the output terminals.

Consideration of equation (6) shows that  $i_0$  is zero when

$$NK = 1 + Z_2/Z_1 \quad (15)$$

while  $i_1$  and  $i_2$  continue to flow; this suggests an unstable situation, but substitution from (15) into (12) shows that  $Z_{in}$  is then infinite, which from (9) implies that  $e_1$  assumes the value of  $E_0$ . This stabilizes all voltages and currents.

### Calculation of the Selectivity

Initially we shall apply the analysis of the last section to a system such as Fig. 5(c) where the signal is injected externally from the amplifier, but later we shall convert our findings to suit the practical case of Fig. 1 where the injection is made into the negative feedback loop of the amplifier proper.

Selectivity will be derived in terms of the degree of positive feedback and the quantity  $m$  where:

$$f = (1 + m)$$

and  $m$  is the fractional deviation of  $f$  from the resonance frequency  $f_0$ .

We introduce a quantity  $K'$  which is equal to the loss-factor introduced by the 'bridged' Wien bridge of Fig. 1. As is shown in Ref. 2, when equal pairs of resistors and capacitors are used in this bridge, the loss-ratio is:—

$$K' = 1/(3 + j(n - 1/m)) \dots \text{where } n = f/f_0$$

In particular  $K' = K_0 = 1/3 \dots$  if  $n = 1$ ;  $m = 0$ ; i.e., at resonance.

$$\text{Or } K' = K_0/(1 + j2m/3) \dots \text{if } m \ll 1; \text{ i.e., very near resonance} \quad (16)$$

In applying the formulae of the last section  $K'$  alone cannot take the place of  $K$  for we must allow for the effect of the reaction-controls and write:—

$$K = K'S_0(1 - \alpha)$$

where  $S_0$  is the loss due to that reaction-setting which initiates oscillation, and  $\alpha$  is that fractional change in  $S_0$  which is used in practice to obtain selective response. An approximate calculation from the circuit diagram suggests that the full sweep (100 divisions) of the 'FINE' reaction-control will produce a change of 0.05 in the loop gain; thus one division will correspond to  $\alpha = 0.0005$ .

Using Equation 13 we have:—

$$1/G_{PQ} = (1 - r_0/Z_1 + r_0/Z_2) - (r_0/Z_2)NK'S_0 \quad (17)$$

which is conveniently converted to the form  $A - BNK'$  where  $A$  and  $B$  are real constants if—as in Fig. 1— $r_0$ ,  $Z_1$  and

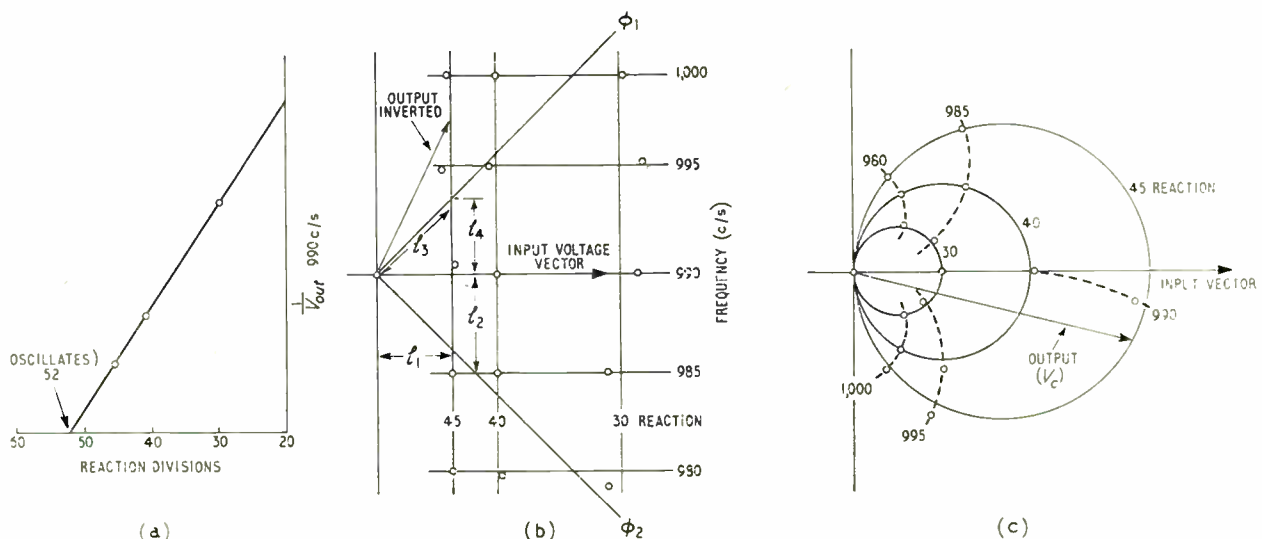

Fig. 6. High-Q resonance. (b) and (c) circles and straight lines would apply to an ideal, linear system. Here with signal level very low ( $V_s \approx 8mV$ ) the selective amplifier system is nearly linear. (a) derivation of the oscillation point

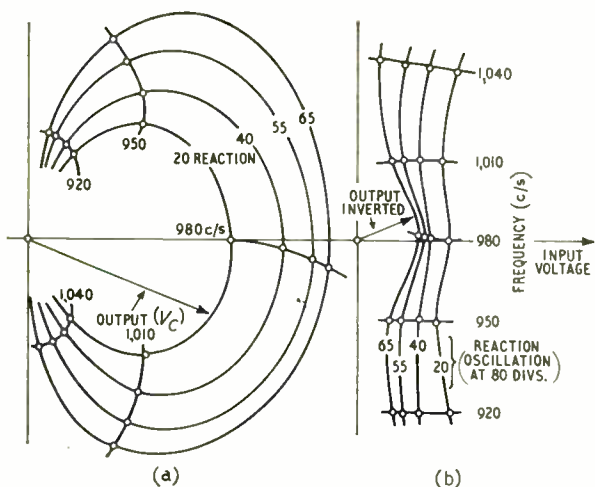

Fig. 7. Resonance under non-linear conditions in the amplifier. The circles and lines of Fig. 6 are distorted; the system loses effective gain as signal level rises

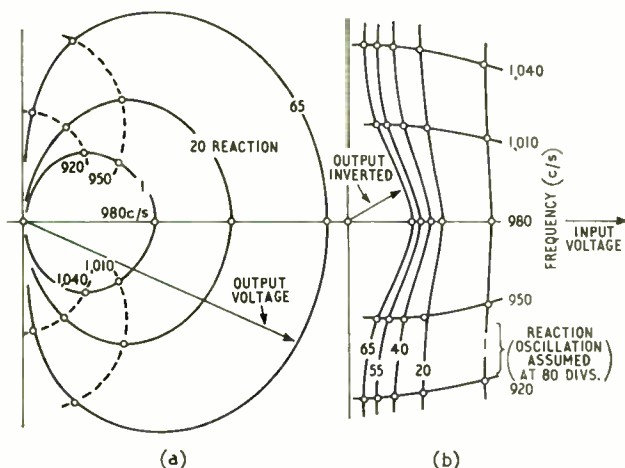

Fig. 8. Computed non-linear performance. Compare Fig. 7: computation is based on the approximation that the curve of Fig. 4(b) is a parabola

$Z_2$  are all resistive. The quantity  $K'$  is under the operator's control, but  $N$  is affected only by the signal amplitude as was shown earlier, and we shall write:—

$$N = N_0(1 - \beta) \dots \beta \text{ increasing as voltage increases.}$$

In total we have:—

$$1/G_{PQ} = A - BN_0(1 - \alpha)(1 - \beta)K' \quad (18)$$

In practice the reaction-setting  $S_0$  is adjusted with no external signal present (so  $\beta = 0$ ), and until oscillation is just incipient (so  $\alpha = 0$ ), and then from equation (19):—

$$1/G_{PQ} = 0 = A - BN_0K'S_0 \quad (19)$$

Reaction is then reduced by some amount  $\alpha$  and the signal applied (which makes  $\beta$  finite) and then from (16), (18) and (19):—

$$1/G_{PQ} = A(\alpha + \beta)/(1 + j2m/3)$$

or, since  $m \ll 1$  in all cases of interest the selectivity is given by:—

$$1/G_{PQ} = A(\alpha + \beta - j2m/3) \quad (20)$$

We are now in a position to test this equation against Fig. 6—discussed in general terms earlier. Here the signals are so small that  $\beta \rightarrow$  zero, and if we make  $m = 0$  the gain will vary as  $(1/\alpha)$  which is confirmed by Fig. 6(a).

Now from the circuit of Fig. 1(b) we have already computed that one division (out of 100) of the FINE control

will change  $\alpha$  by  $5 \times 10^{-4}$  approximately and with this figure we can check equation (20) against Figs. 6(b) and (c).

The horizontal lines are at 5-c/s intervals and as  $f_0 = 990$  c/s they correspond to intervals of  $m = 0.00505$ . The verticals should be in proportion to the reaction-intervals, so by measurement on the figure we can check the ratio  $(2m/3)/\alpha$ ; the diagram gives 0.96 and the just listed yield 1.33—a discrepancy which can be put down to the rough estimate of  $\alpha$  from the circuit constants, for in all other respects the circles and straight lines of the figures conform closely to equation (20).

The  $Q$ -factor for each reaction-setting is found from the two lines  $\phi_1$  and  $\phi_2$  of  $45^\circ$  slope. For instance, with reaction setting 45 divisions  $l_1 = l_3 = l_3/\sqrt{2}$  and by measurement on the diagram  $l_4$  is found to correspond to  $3.6$  c/s  $= (f_0 - f)$ . So  $Q = 137.2$ . Similar checks on the other verticals show that on the average  $Q\alpha = 0.48$ . The selective amplifier is found to be stable when  $\alpha < 0.0005$  so  $Q > 1,000$  is feasible, and in fact, provided there are no surges of mains-voltage,  $Q = 2,000$  or even 3,000 is often achieved for the 10 seconds or so needed for measurement.

When  $V_c \geq 50$  mV Figs. 7 and 8 apply. Fig. 8 has been calculated from equation (20) using values of  $\beta$  slightly different from Fig. 4(b) because a parabolic form of the curve had to be assumed when making the computation. The agreement with Fig. 7, though not exact, serves as a further check on equation (20).

### Signal Injection

It would appear from Fig. 1(b) that  $V_c$  was in antiphase with  $V_A$  and that, since this would alter the sign of  $N$  in the general equations, the behaviour of the network would be modified radically. However, although the analysis is modified somewhat, the outcome is the same. The most noticeable effect of the change is that  $\beta$  has to be written into equations such as (18) *et seq.* as reduced in proportion to the loss of gain due to the negative feedback; also we have to substitute for  $N_0$  the quantity  $q/(qK' - 1)$ , where  $q$  is the 'internal' gain of the amplifier (i.e., between the point C and the input grid, with the negative feedback disconnected) and  $K'$  is, as before, the loss in the RC network and the reaction-controls.

There is no space for detailed proof, but it can be shown that if we substitute  $q/(qK' - 1) = T$  for  $N$  in the general analysis, all the equations (1-15) will apply. (This will be true of any other amplifier in which the feedback path has the same general proportions as in Fig. 1(a), the internal gain being  $\geq 3.0$ .)

Now equations (13) and (14) show that  $G_{PQ} = \infty$  only when  $NK$  has the particular value  $NK_{osc}$ ; the system is stable at both lower and higher values of  $NK$  but when  $K$  is varied  $NK$  cannot pass from the lower to the higher without passing through the oscillation-point and thus the higher values cannot be reached. In the case of  $T$  this situation is reversed: as  $K'$  is increased from zero  $T$ , starting from zero, becomes negative, passes through  $\infty$  when  $K' = 1/q$ , and thereafter becomes and remains positive. The critical value of  $T_{osc}$  is therefore approached from the higher instead of the lower side. All working values of  $G_{PQ}$  are therefore negative, and for selective amplification  $T$  is adjusted—by altering  $K'$ —until  $T$  slightly exceeds the critical value.

### Acknowledgments

Thanks are due to the Director of Engineering of the B.B.C. for permission to publish these notes, and to my colleague, Mr. J. W. Head, for assistance in presenting the mathematical arguments.

### References

- 1 Wigan, E. R., *Electronic Technology*, June 1960, p. 223.
- 2 Wigan, E. R., *Electronic Technology*, September 1960, p. 560.
- 3 Wigan, E. R., *Electronic Technology*, May 1961, p. 163.

# THE NEW ALL-TRANSISTOR MODEL F-80 X-Y RECORDER



Reproducibility	0.1%
Pen Speed	17 inches per second, both axes
D C Voltage Ranges	.5, 1, 2, 5, 10, 20, 50, 100, 200, 500 mv/inch and 1, 10, 20, 50 volts per inch
Input Impedance	10 megohm, 2 megohm
Time Base	7 fixed speeds at 50, 20, 10, 5, 2, 1, 0.5 seconds per inch
Time Base Accuracy	3% all ranges, adjustable to 1% on any range
Dimensions	chart plates 11" x 17 inches
Weight	29 pounds
Power Requirements	115 v 60 cycles 100 watts 220 v 50 cycles

#### Head Office

VARIAN AG  
GUBELSTRASSE 17  
ZUG, SWITZERLAND



**ARCE** thinks small . . .

For further information circle 236 on Service Card

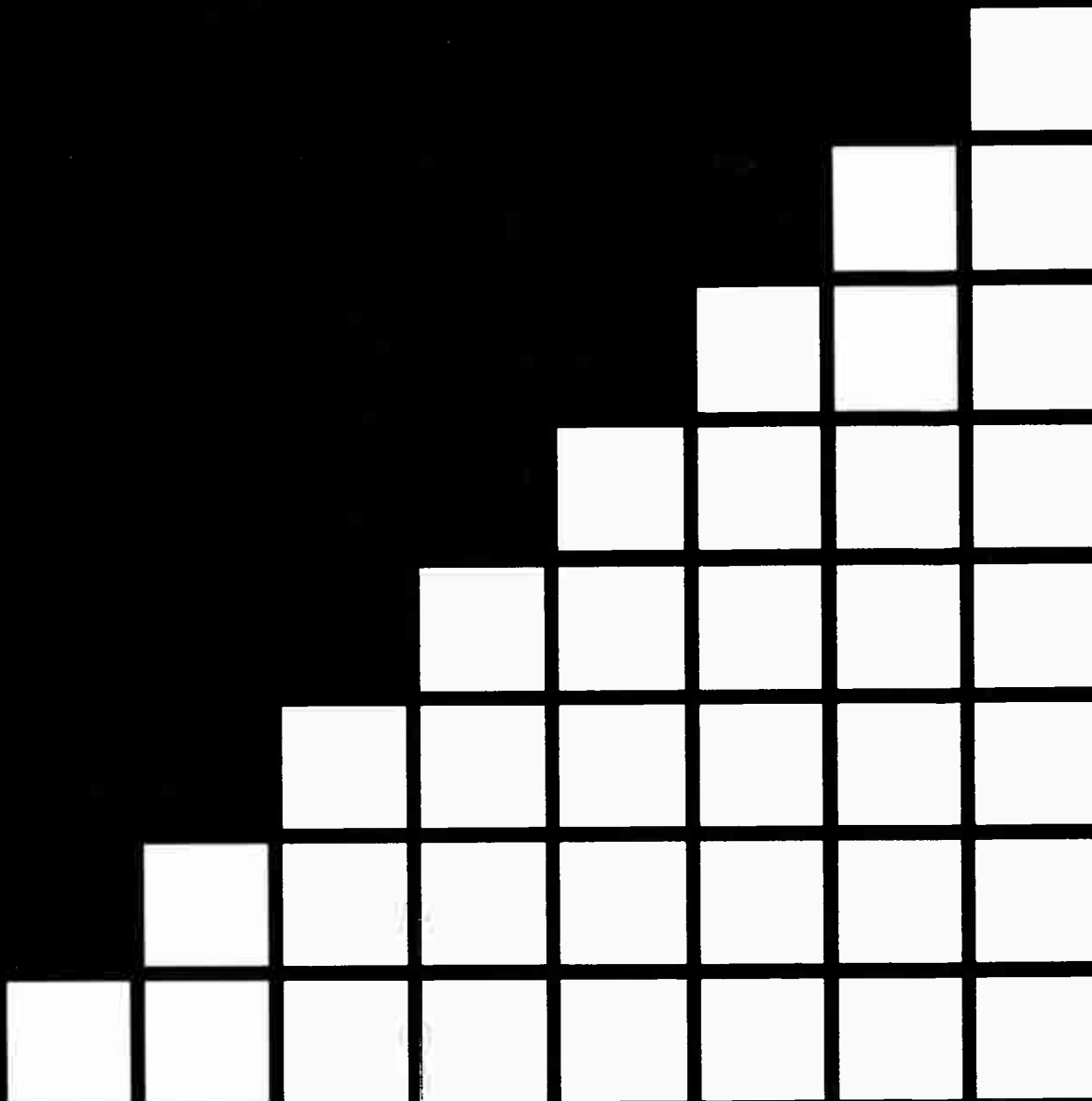

**or big**

---

**AUTOMATION STEP BY STEP BRINGS COMPUTER CONTROL WITHIN YOUR BUDGET**

---

**ARCH.** A vital new concept in process computing which permits step-by-step introduction of computer control in any plant at low cost.  **ARCH.** A range of compatible and proven transistorised analogue and digital modules which work on their own or teamed in a system—ultimately as a network of systems interlinked to give integrated control over interdependent process areas  If there is a way of measuring a process variable then there is a way into **ARCH.** Any kind of input—pneumatic, shaft position, ac or dc, voltage or current—every conceivable form of transducer, every possible type of signal, could be the start of an **ARCH** control network  Make *your* start by finding out more about **ARCH** now.  For details of the modules and applications, for manuals and courses on **ARCH** write:



**process computing division**

A Member of the Elliott-Automation Group. 

ELLIOTT BROTHERS (LONDON) LIMITED / ELSTREE WAY / BOREHAMWOOD / HERTS / ELSTREE 2040



# AMPROBE

INSTRUMENT CORP. LYNBROOK, N.Y.

## DC 50 MILLIVOLT RECORDERS

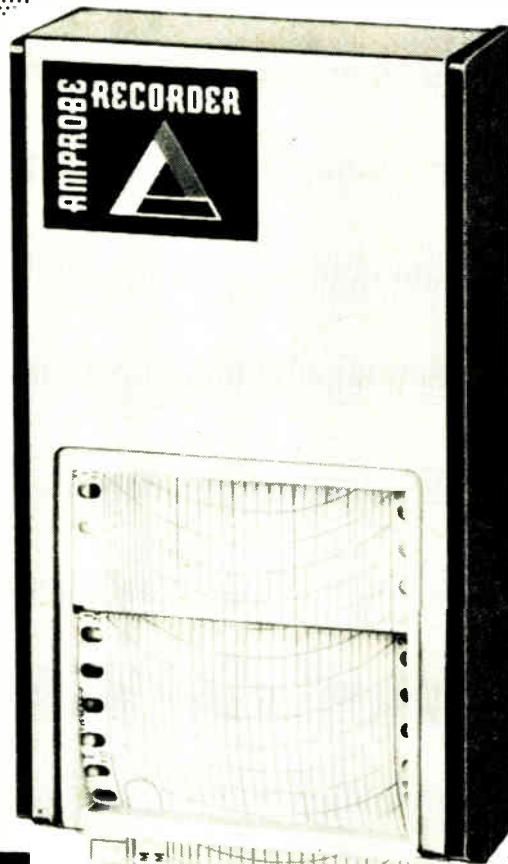

Flush-Mounted

### SPECIFICATIONS

- WEIGHT:** Leather Cased Models: 2lbs., 4oz.
- CHART SIZE:** 2½" wide × 30" long
- CHART SPEEDS:** Standard 1" or 6" or 12" per hour (12" per hour supplied unless otherwise specified).
- POWER REQUIREMENTS:** 230V AC, 50 cycles. Other voltages and frequencies available on request.
- ACCURACY:** ±2% Full Scale Reading.
- METER MOVEMENT:** D'Arsonval, core-magnet.
- IMPRESSION RATE:**
  - One Impression every five secs. at 12" per hr.
  - One Impression every ten seconds at 6" per hr.
  - One Impression every one minute at 1" per hr.

### FEATURES

The Amprobe DC 50 Millivolt Recorders are one of the smallest, lightest and most economical recording instruments available today. Their low input requirements permit their direct use, in almost all cases, without modification of the circuit to be measured. A temperature compensating network permits their use under all temperature conditions . . . from -20°F to +135°F with NO loss of accuracy.

They incorporate such advanced features as:

- **INKLESS OPERATION** and the use of pressure sensitive chart paper that is not affected by heat, cold, moisture or fumes.
- **POSITIVE CHART FEED** for simple, foolproof and non-binding continuous records.
- **DUSTPROOF** through the use of mylar shielding to block out airborne particles.

U.K. MARKETING DIVISION



AMPROBE

ATLAS INSTRUMENTS & ELECTRONICS  
35, Waverley St., NOTTINGHAM



# AUTOMATIC CONTROL OF GRINDER AND PULVERIZER INSTALLATIONS

By D. J. EWINGS\*



*Bagging station of mill producing silica flour from dried sand*

Unusual control problems are set in grinding and pulverizing machinery because of the greatly varying size of the raw material. This article discusses the difficulties and gives details of a successful control system.

**G**RINDING and pulverizing form part of a number of processes such as rock crushing, coal pulverizing and glass polishing. The electronics industry has evolved a range of protective and control devices which enable production efficiency to be improved by allowing plant to operate at maximum power over sustained periods, automatically.

In plant where no automatic control is employed, the grinder or pulverizer load, and hence output, is varied by manually adjusting flaps or gearbox ratios on the feed mechanism. This means that personnel must constantly be watching the grinder or pulverizer motor load current and make the necessary adjustments as conditions vary.

Fig. 1 shows a recorder trace of the grinder motor current of a primary stone crusher working without automatic control. The rapid fluctuations in current are typical of the material being ground; i.e., large stones, producing high current peaks. The method of adjusting grinder current is by adjustment of a variable-speed gearbox fitted to the conveyor motor. The grinder feed conveyor speed is set by the operator at an optimum figure so that adjustments are not normally required. If an excessive amount of material is seen on the conveyor then the operator reduces the speed of the conveyor, so that the crusher is not overloaded. If the amount diminishes, however, he tends not to make any adjustment.

In the particular example, over a typical six-hour shift the average utilization of available plant capacity was 16.7%.

As a first step towards achieving full automatic control, the speed of the feed conveyor can be changed from high to low speed automatically.

\* Lancashire Dynamo Electronic Products Ltd.

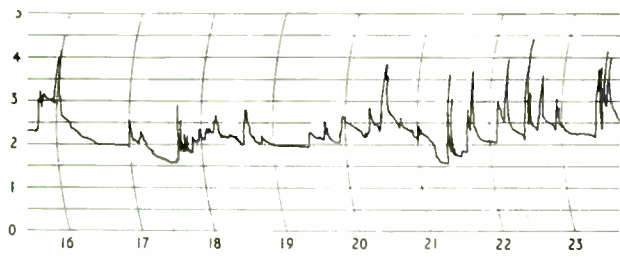

Fig. 1. Record of motor current in a manually-controlled system

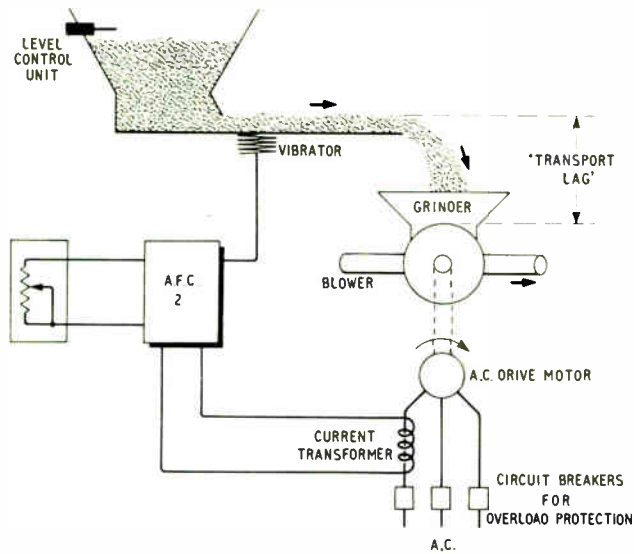
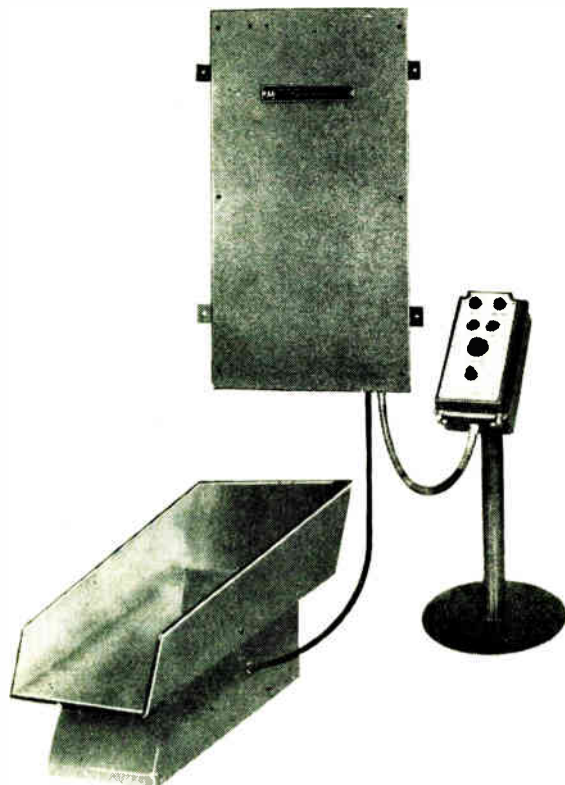

Fig. 2. General form of system using a vibrator conveyor



Vibrodyne AFC.2 equipment gives proportional amplitude control for a vibratory feeder

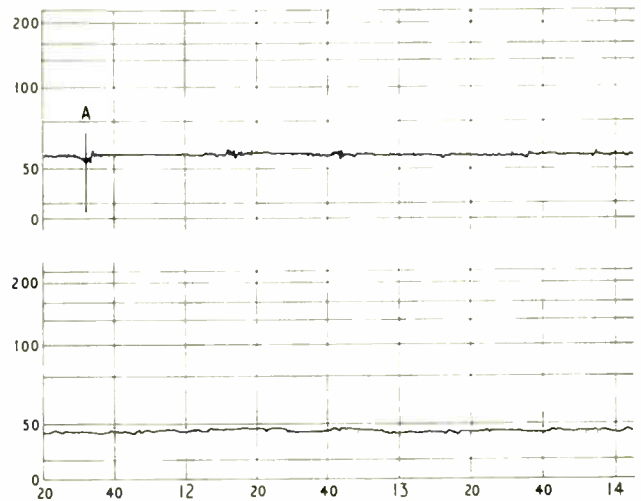

Fig. 3. Motor current in an automatic system

This can be done by employing a two-speed a.c. motor in conjunction with a device that measures the grinder motor load current. When the load current exceeds a fixed upper limit (overload conditions), the conveyor motor is automatically switched to low speed.

This system increases the grinder load to some extent, but it can rarely be set at more than 85% full load. Due to the 'step' nature of the switching control it is also found that the utilization factor will not be more than 60%. Another limitation is that this system can only be used on installations handling one, or very few similar, materials.

A further disadvantage of the simple switch system is that it is quite common to have materials that clog the neck of the hopper (large pieces of stone, etc.), causing an underfeed condition. Under this condition, the feed conveyor will run at its high speed setting, trying to increase the load of the grinder. When the operator sees the reduction in load, he will take steps to free the hopper, which will then overfeed the grinder. Although this condition will be counteracted by the control switching the feed conveyor to its slow speed, there is invariably a lag between the material being fed to the conveyor and its being processed, thus causing a load variation. Material in the so-called 'transport lag' (see Fig. 2) is outside the control of any device, and the conditions described above may cause the grinder motor protection devices to trip out, bringing the whole plant to a standstill.

The only way to stop this happening is to reduce the settings of the feed control device to cater for the 'transport lag', thus resulting in a fall in output and efficiency which is quite serious, and it is often more economic to employ man-power and have no control devices than to reduce the operating level of the grinder so that a semi-automatic system can be used.

One solution is to drive the conveyor with a motor, the speed of which is automatically variable from zero to full speed, and to control this speed in proportion to the grinder or pulverizer motor load. An alternative would be the employment of a vibrating conveyor unit on which the amplitude of vibration is controlled thus varying the speed of material along the conveyor.

The operating characteristics of grinding or pulverizing installations are such that, if they are to operate continuously at high levels with a utilization factor approaching 100%, a fully closed-loop servo system is required. In such a system, the mill or pulverizer motor current is compared



Main control cubicle of grinding mill using Vibrodyne equipment

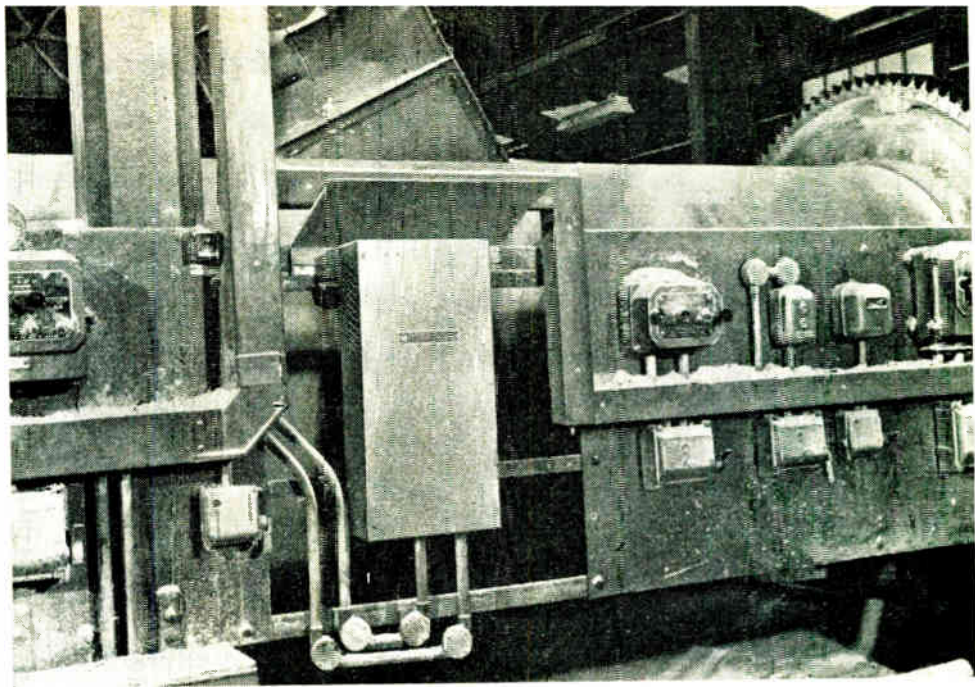

to a highly stable reference source, and any error appearing between the two is used to vary the speed of the conveyor motor (or the amplitude of vibration) over the range zero to maximum. There is, however, the complication of the 'transport lag', the effect of which has already been discussed. Owing to the 'transport lag', to make an immediate correction for a given change in load on the grinder motor would cause the system to become unstable. The error must, therefore, be gradually corrected by the use of an integrating network, thus allowing material in transport to affect the motor current and then correct it.

Such a system caters for contingencies found under normal working conditions. A system must, however, protect the grinder or pulverizer from damage due to accidental overloads. A set of circumstances arise where,

when the feed hoppers run out of material, the grinder or pulverizer motor load will drop and the feed rate gradually increase, trying to deliver more material into the grinder so as to increase its load. The operator then changes over to another feed hopper, which immediately starts to deliver material on to the feed conveyor and into the grinder at a very high rate. This causes the load to increase very rapidly. The transients cannot be anticipated and will, inevitably, be higher than the normal overload settings of the pulverizer motor. The duration of these transients must, therefore, be less than the time delay of the pulverizer motor overloads. To correct this condition within the shortest possible time, a further circuit is required, which will by-pass the integrator circuit and bring the feeder to a standstill, thus preventing any more material, other than that in the 'transport lag' from being delivered. Fig. 3, point 'A', shows a recorder trace of a grinder motor current during the condition described. The system is completely automatic and reverts itself as soon as the current falls to the working level.

Equipments developed by Lancashire Dynamo Electronic Products Limited (M.I. Group), Rugeley, Staffordshire, for this purpose are the Series AFC.2 Vibrodyne, a vibratory plant control equipment, and Series AFC.1 variable speed motor control.

The first unit consists of a half-wave thyatron rectifier feeding pulses at 50 c/s to the vibrator coil. The amplitude is controlled by adjusting the firing part of the thyatron via its grid circuit.

The AFC.1 unit is similar in concept, but to increase the commutator life the motor is fed with a smooth d.c. supply from a full-wave rectifier network. Here the voltage is controlled by the firing part of the thyatrons.

Common to both systems is the control circuit which is a fully close-loop electronic servo shown in Fig. 4.

The required load is set by tapping off a signal from the neon stabilizer. This is compared with the actual load, measured by a current transformer in the motor line. The error between these two separate signals is amplified by the two separate amplifiers and used to vary the output of the thyatron rectifier. This energizes the vibrator and hence feeds the grinder with material affecting the a.c. load and closing the servo loop. If the error exceeds a fixed maximum, the integral (slow) amplifier is by-passed and the thyatron output is instantly cut off. This system is the subject of patent applications.

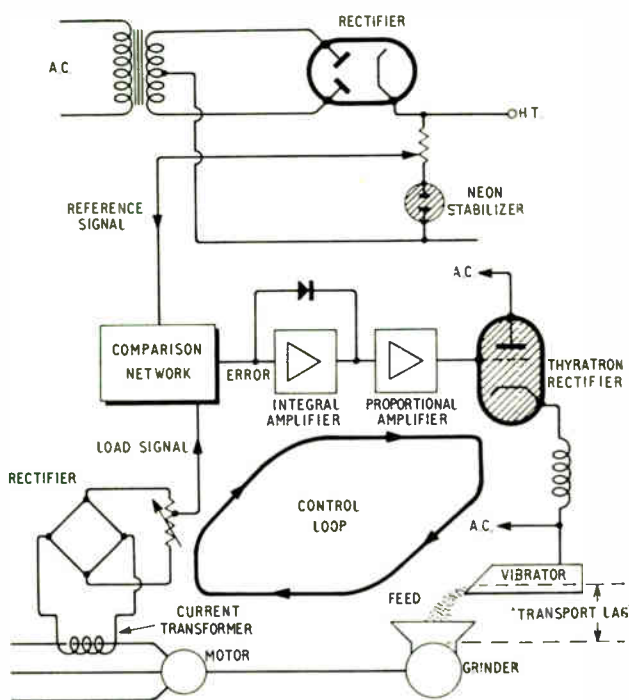
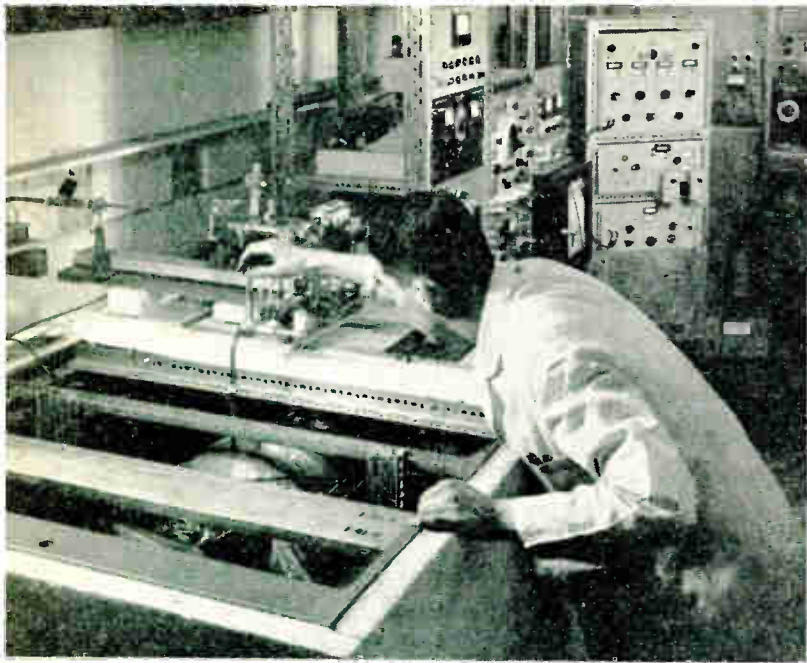

Fig. 4. Closed-loop servo control for a vibrator system



1



2



4

ILLUSTRATED  
NEWS

5

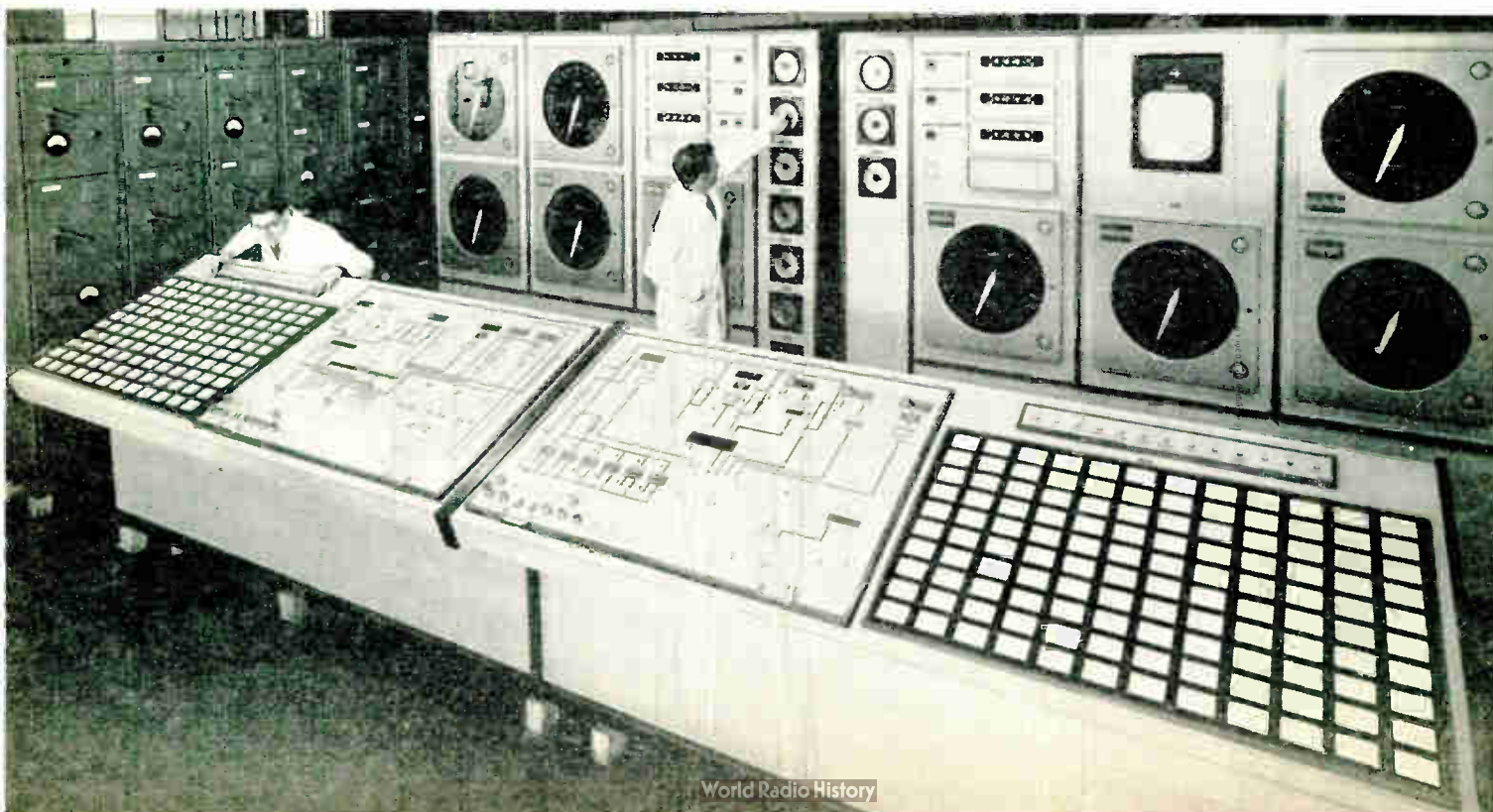

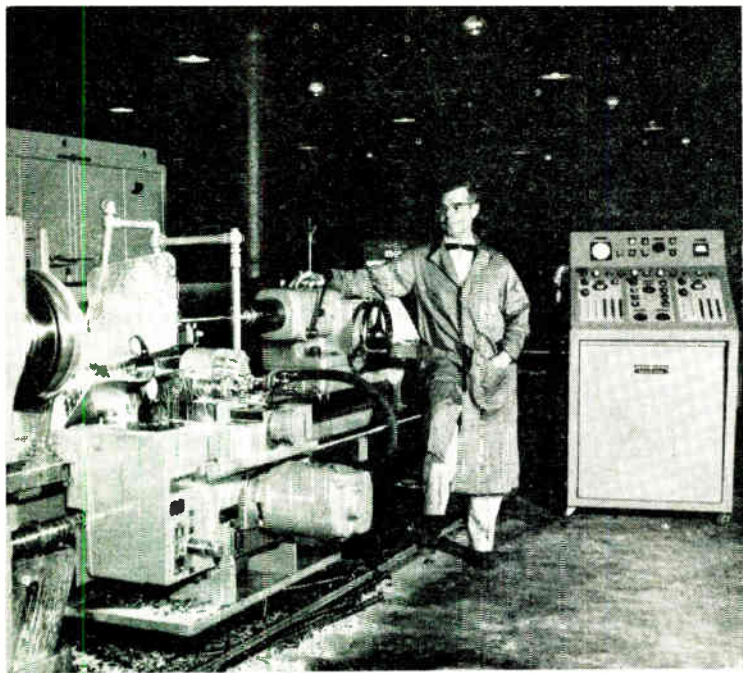

1 At a recent exhibition associated with the 19th International Congress of Pure and Applied Chemistry the Mullard Component Division showed a number of precision electro- and permanent magnets for nuclear resonance, electron spin resonance and other specialist research purposes. This photograph shows the Ticonal permanent magnet designed for the N.M.R. spectrometer at the Physical Chemistry Laboratory of Oxford University. It weighs 3.75 tons and produces a field of approximately 13,000 gauss between pole pieces of 6.5 in. diameter in a gap of 1.38 in. Had the magnet been designed for lifting, it would support about 1,000 tons weight.

2 Discs of silicon, each about three-quarters of an inch in diameter and containing a cluster of a thousand planar transistors, are placed in vacuum deposition machines at the Semiconductor Division of Standard Telephones and Cables Ltd. Aluminium is evaporated on to the discs to facilitate the attachment of the fine gold connecting wires to the transistors. After this evaporation process each disc is sawn up into the individual transistors. The planar technique of manufacture cuts the cost of transistors by processing a thousand at a time, individual handling being required only in the final stages.

3

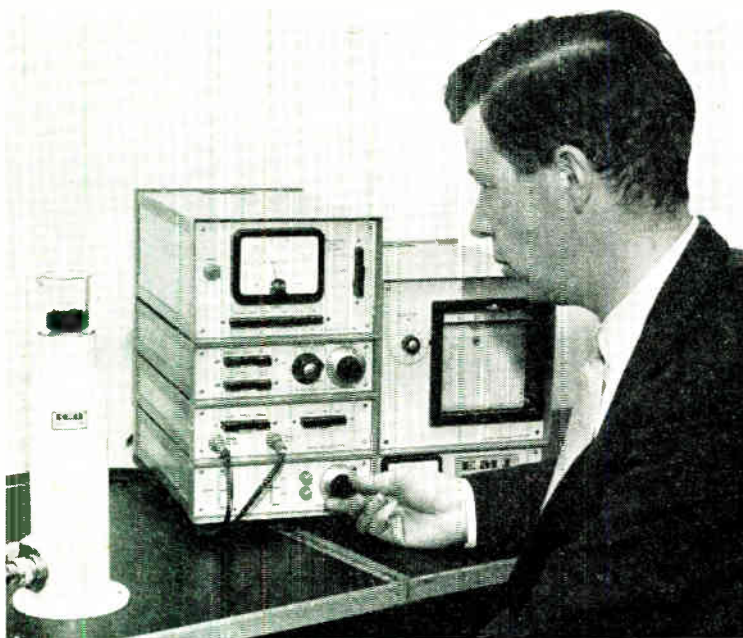

3 Highly flexible numerical control equipment from U.S. General Electric is now available in the U.K. and Europe. Application engineering, sales and service centres have been established in Reading and Frankfurt by the Industrial Electronics Division of International General Electric. G.E. equipment is available for either positioning or contouring control in one to five axes, with any combination of linear or rotary motions. Shown here is a 2509 engine lathe made by The American Tool Works Company, controlled by U.S. General Electric's G.E. Mark II positioning control equipment with two-dimensional tracer.

4 The Vario-Klischograph machine, for electronically engraving four-colour printing blocks, is shown here at W. R. Royle & Son Ltd. It incorporates in the central control panel a Telequipment D33R Oscilloscope. The D33R, when connected to the output signals, allows for close observation of the actual picture signals enabling the operator to check whether original levels are being maintained and to supervise and control the operation of undercolour removal, highlight drop out and limiter. Instruction of new operators is simplified as the effects of the various controls are simultaneously visible on the screen.

**For further information circle 44 on Service Card**

5 The control console and instrument panels for the entirely automatic materials handling and blending system which Elliott-Automation is supplying for the new Wiggins Teape N.C.R. (no carbon required) paper making plant under construction at Neville near Brussels. The system controls the blending of the liquid and solid ingredients in their correct proportions, feeds the blended material to cookers and later distributes it to storage tanks, ready for use in the coating process.

6

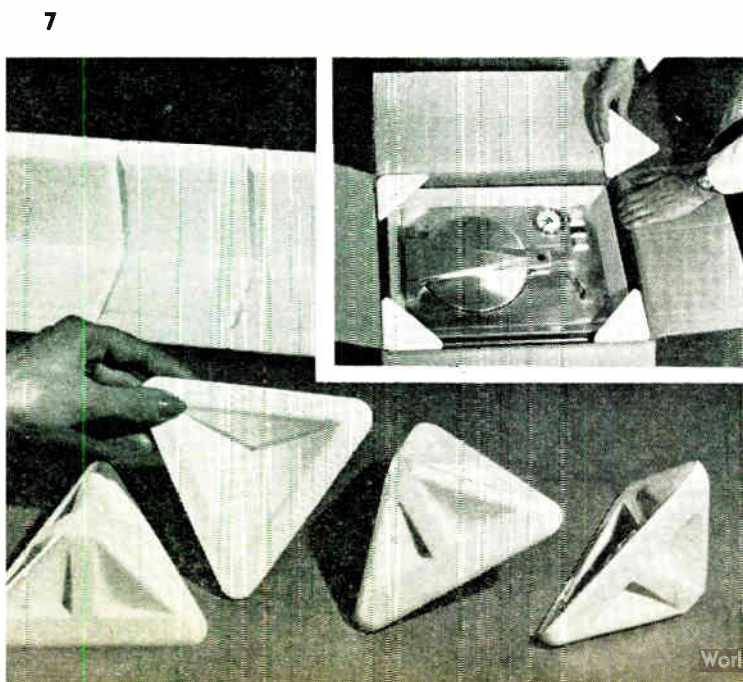

6 A sample of soil from a borehole being checked for natural radioactive thorium and potassium by a probe used in conjunction with a gamma spectrometer. A range of high-resolution scintillation probes is manufactured by E.M.I. Electronics Ltd. for use in gamma spectrometry work. Three probes are available, types GP3, GP4 and GP5 (illustrated), incorporating different sized sodium iodide phosphors. Both crystal and photomultiplier are selected to give a high resolution ( $CO_{60}$ ) of better than 3.5/1. To obtain this high resolution, a separate signal lead is used, and the collector load (100 k $\Omega$ ) and coupling capacitor (50 pF) are integral with the probe. There are, therefore, two connecting leads, one supplying e.h.t. to the photomultiplier tube and the other carrying the signal back to the amplifier.

**For further information circle 45 on Service Card**

7 These packing pieces are made of expanded polystyrene which has good shock absorbing characteristics, is non-abrasive and completely inert chemically. Standard moulded pieces fit over the corners and along the edges of the article, to suspend it so that it does not directly touch any part of the container (inset). This method of suspension packaging, introduced by Venesta Manufacturing Ltd., makes economical use of expanded polystyrene and considerably simplifies the packing process. For export packing, the article can be held in 'double suspension'; i.e., suspended in one container which is itself packed in an outer container in the same manner. When necessary, as in the case of irregular-shaped objects, packing pieces can be moulded to suit any contour.

**For further information circle 46 on Service Card**



### Personal and Company News

The Special Products Division of **Thorn Electronics Ltd.** announce a new high speed delivery service for Tansitor class 'W' and 'S' tantalum capacitors. These items, in quantities up to 25, will be available in seven days from receipt of the order. This is a special service for development engineers and is not intended or available for production quantities.

**Simms Motor Units Ltd.** announce the appointment of Ronald Walter Hillyer, M.I.W.M., M.I.Prod.E., M.Inst.W.S., as deputy chief production engineer. Before joining Simms, Mr. Hillyer was with the Elliott-Automation Group as divisional controller.

Agreements negotiated between **Elliott-Automation** and Consolidated Electrodynamics Corporation of Pasadena, U.S.A., extend Elliott's licence to manufacture and market Consolidated's range of process moisture monitors and process chromatographs to include the principal countries of western Europe.

The appointment has been announced of Peter Elias, A.M.Inst.E., H.N.C., as sales manager of the Industrial Electronics Division of **Burndept Electronics Ltd.**

**Automatic Information & Data Services Ltd.** have announced an expansion of their activities in the field of automation, data processing and telemetry. A statement by the joint managing directors, J. D. Heslop and A. T. Black, C.B.E., also said that A.I.D.S. has sold a 50% shareholding to K.G.M. Electronics Ltd. Mr. Aubrey Baring joins the A.I.D.S. board from K.G.M. as chairman and Mr. Kenneth Shipman as director.

**Telcon-Magnetic Cores Ltd.**, a member of the B.I.C.C. group of companies, announce the opening of a new London branch office and stores at the premises of T.C.C. Ltd., another member of the group. Brian D. Jenkins, B.Sc. (Wales), A.M.I.E.E., has been appointed branch manager. The postal address is: Telcon-Magnetic Cores Ltd., c/o The Telegraph Condenser Co. Ltd., Wales Farm Road, Acton, London, W.3 (Tel. Acorn 0061).

L. John Bayford, A.M.I.E.E., has joined **Texas Instruments** as chief mechanization engineer. He was formerly manager of the Semiconductor Division of the English Electric Valve Company.

The **D.T.V. Group** has taken over the marketing of the complete range of Grundig measuring instruments and test equipment. A permanent display is installed at the group's headquarters, at 126 Hamilton Road, West Norwood, London, S.E.27 (Telephone: Gypsy Hill 6166).

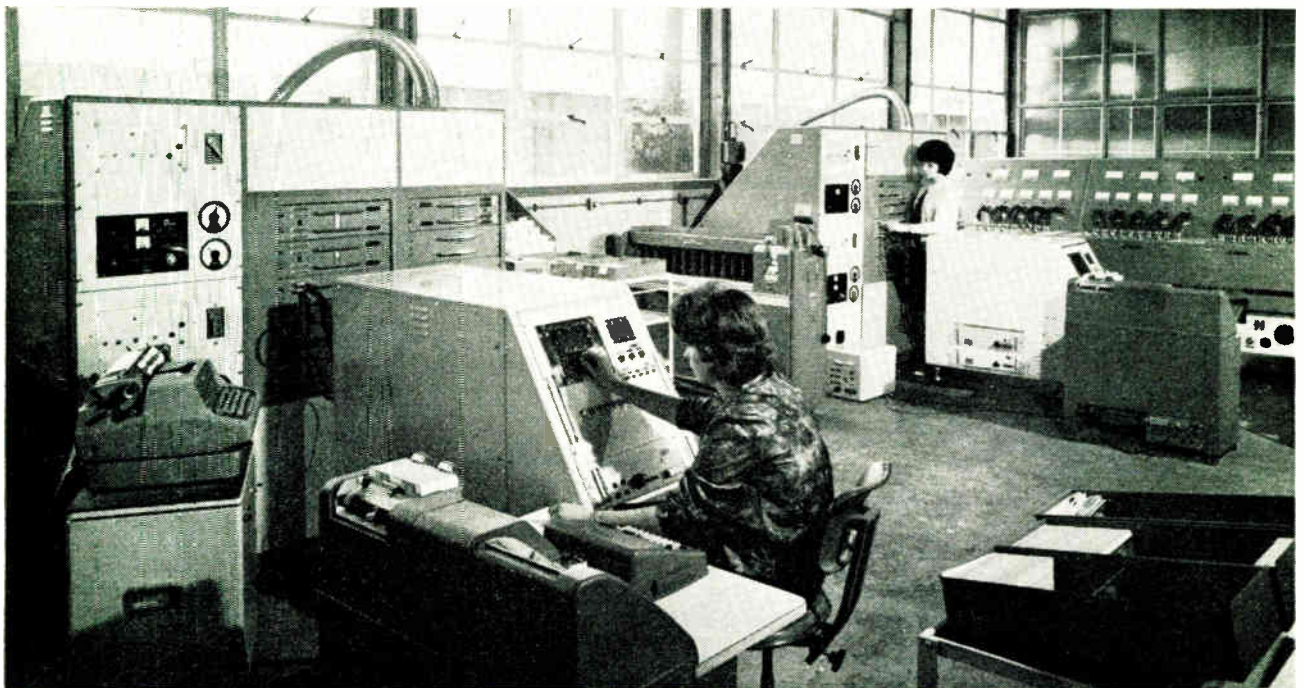

*Part of one of the reliability testing rooms at the Mullard Works. Here transistors are 'soaked' in batches under controlled environmental conditions and then transferred to an automatic tester which measures their parameters and records them on punched paper tape. A computer subsequently analyses the records*

In keeping with their wide range of electronic products, Bryans Aeroequipment Ltd. announce that the company's name has been changed to **Bryans Ltd.** Bryans also announce the opening of their new electronics laboratory, giving a 50% increase in R. & D. capacity. In keeping with these developments, a divisional structure has been introduced: the Electronics Division handling data plotting and digital instruments and the Aviation Division dealing, as in the past, with aeronautical instruments and test equipment.

Senior liaison engineers William Mock and Robert Ferris have joined the newly formed Government and Railways Department of **Osram (G.E.C.) Ltd.** Both have been transferred from G.E.C.'s central G. & R. Department. Mr Mock will be responsible for liaison with British Railways, while Mr. Ferris will be primarily concerned with Government departments.

It is announced that The Garrard Engineering and Manufacturing Co. Ltd. has been renamed **Garrard Engineering Ltd.**

**Marconi Instruments Ltd.** announce the formation of Marconi Messtechnik G.m.b.H. to provide comprehensive sales and service facilities in West Germany for the company's range of electronic measuring instruments. T. Broderick has been appointed manager of the new organization, which will operate from Wolfratshauer Strasse 243, München-Solln.

**British Insulated Callender's Cables Ltd.** announce that F. Waive, J.P., Companion I.E.E., is retiring from the board.

A controlling interest in **Lectroetch (Gt. Britain) Ltd.**, manufacturers of electro-chemical marking equipment, has been acquired by C. Garnett who now becomes managing director. Following the change of control the company has moved to a newly erected factory at Spur Road, North Feltham Trading Estate, Feltham, Middlesex (Telephone: Feltham 4884).

A. B. Tilleray has been appointed sales manager of the Electronics Division of **Research and Control Instruments Ltd.** and R. M. Giles, B.Sc., A.R.C.S., joins the company as systems engineer.

G. B. Townsend, B.Sc., A.K.C., F.Inst.P., M.I.E.E., has joined the Rank Cintel Division of **The Rank Organisation** as technical manager of the Professional Television Department.

**Sealectro Corporation**, of Mamaroneck, U.S.A., announce that G. S. Westbrook has been appointed group general manager responsible for the British branch company at Hershaw and for all continental operations.

**Hellermann Electric** have announced the appointment of two new directors: S. E. Downer and P. Bowthorpe.

The name of the world's first radio company has been changed from Marconi's Wireless Telegraph Company Ltd. to **The Marconi Company Ltd.** This new title has been chosen to avoid the restrictive description of 'wireless telegraphy'. The various company addresses and telephone numbers remain unchanged.

C. R. Webster has joined the Carrion Group of Companies, and is now technical director of **Carrion Television Systems Ltd.**

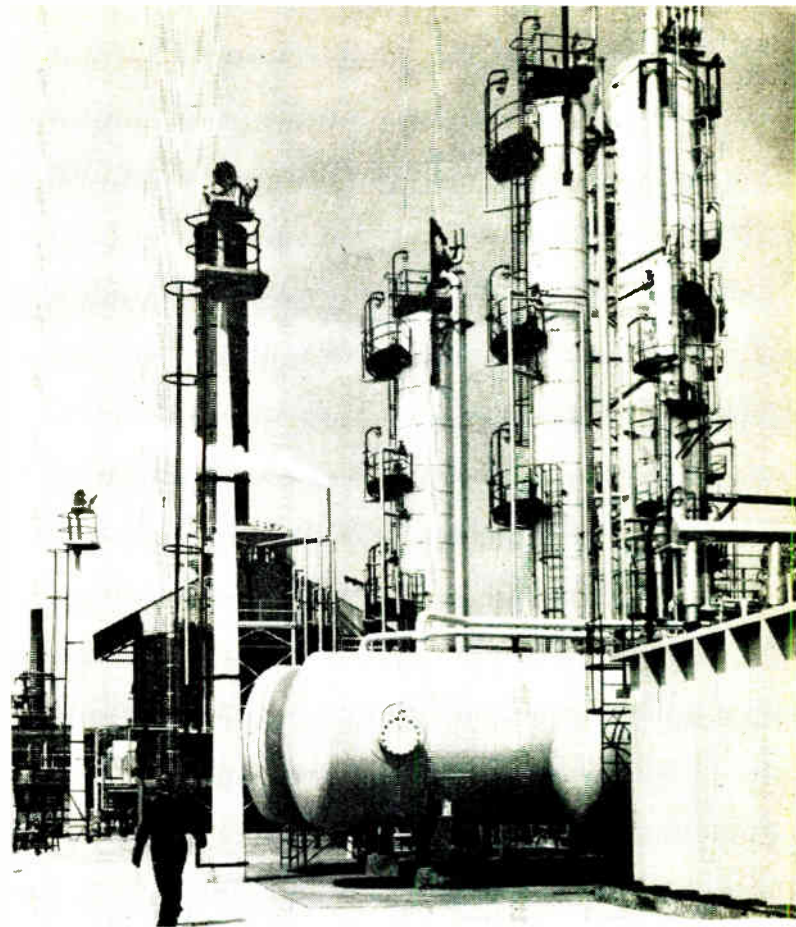

*B.P.'s new crude oil distillation plant at Llandarcy, Wales. This is the first unit of its kind with full electronic control in Britain. Elliott-Automation supplied the complete control system through Kellogg International, who built the plant*

A. E. W. Hibbitt, B.Sc., has become managing director of **Muirhead & Co. Ltd.** J. V. Foll, O.B.E., who has relinquished this position after more than thirty-four years, remains chairman of the board.

**Parmeko Ltd.** have announced the appointment of H. E. Bond as sales liaison engineer for the north of England and Scotland.

**Thorn Electrical Industries Ltd.** are to merge their Special Products Division (incorporating components and connectors) with the subsidiary company, Thorn Electronics Ltd. Alan P. Ross assumes full commercial responsibility for these newly combined activities, as general sales manager of Thorn Electronics Ltd., with sales offices centred at 105 Judd Street, London, W.C.1 (Euston 4433).

**B. & R. Relays Ltd.** have appointed D. S. Knights as area sales manager for southern England.

**Meter-Flow Ltd.** have entered into an agreement with Stuart Meter Corporation of 367 East Alondra Boulevard, Gardena, California, for the sales and distribution of impeller type flowmeters and associated electronics throughout the western hemisphere including South America. Facilities are being installed for calibration and service, and at a later date it is intended to assemble and manufacture in the U.S.A.

The death occurred on August 8th of Leonard A. Morgan, A.F.R.Ae.S., director and general manager, **Smiths Aviation Division.** He is succeeded by A. M. A. Majendie, M.A., F.R.Ae.S., F.I.N., F.R.G.S.

### Weather Radar for Britain's Highest Building

A weather radar aerial is to surmount the 600-ft Post Office radio tower now under construction off Tottenham Court Road, London. The radar, which is being supplied by Decca Radar Ltd., will be remotely controlled from the London Weather Centre in Holborn, where an overall picture of the weather in London and the Home Counties will be displayed, covering an area of approximately 200,000 square miles; a second radar display will be made available in the tower itself in one of the public observation galleries. The equipment ordered, the Decca type 42 A, is a general-purpose weather radar designed particularly for ease of operation and prolonged service with a minimum of maintenance. The transmitter with a peak power of 75 kW feeds a double curvature aerial system for detecting and tracking precipitation to a range of 250 miles. The aerial itself, which rotates at 10 r.p.m., may be tilted from  $-2^{\circ}$  to  $+28^{\circ}$  so that the height to which precipitation extends may be measured. In addition to the radar the tower will carry aerials and equipment for new telephone and television microwave links and will be used for research into the problems of high building and meteorology.

### The 'Computer Workshop'

In January of this year the 'Computer Workshop', whose customers can hire time on an Elliott 803 computer for as little as £4 per hour, was opened by Elliott-Automation Ltd. Although initially there was a rush to use it by other companies and divisions of the Group, outside customers now account for more than two-thirds of the time used. At the present rate of usage, which is still expanding, outside customers alone will more than pay for the first year's operations. Applications have included aircraft design, statistical calculations, structural analysis, calculation of reservoir volumes, the simulation of cargo-port operations, traffic survey analysis, and the design of internal combustion engines.

### Automatic Tank Contents Gauges for Revenue Accounting

The use of Gilbarco-Elliott automatic tank contents gauges, manufactured by Elliott (Treforest) Ltd., has been approved by the Commissioners of Customs and Excise for the purpose of raising revenue accounts in respect of certain oil tanks at Shell's Stanlow Refinery, Cheshire. The installation will be checked periodically to conform with Customs and Excise requirements.

These gauges are used for the automatic measurement of tank contents in refinery installations in many parts of the world. An accuracy of plus or minus 1.5 mm can be achieved, and readings of contents level are displayed at a tankside indicator at ground level, with remote indication of the level together with the average temperature of the tank contents at a central point.

### Temperature and Humidity Control

Productivity can hinge to a great extent on proper conditions of temperature and humidity. In such diverse industries as chemicals, pharmaceuticals, steel-making and packaging, accurate heat control is essential for top-quality processing. And in foundry work, printing and textiles, for example, moisture control is just as vital.

This is the premise of a new 16-page booklet 'Temperature and Humidity' which is published by, and available free from, D.S.I.R. State House, High Holborn, London, W.C.1.

Second in the series 'Automation at Low Cost', it provides an introduction to temperature and humidity control for smaller firms.

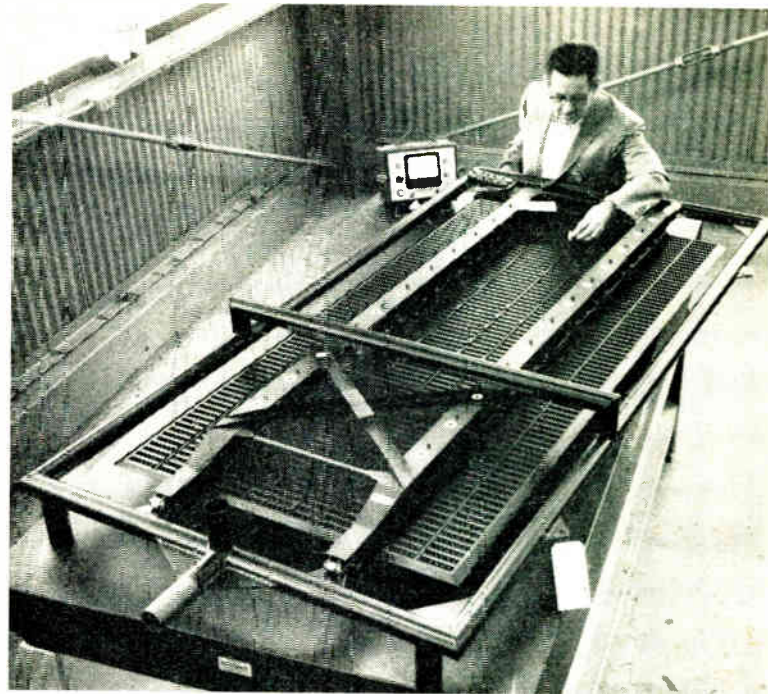

*The Mariner space vehicle scheduled to be launched in 1964 to the vicinity of Mars will derive its power supply from four solar panels, one of which is shown above. These panels, approximately 3 ft wide and 6 ft long, are being made by Ryan Aeronautical Co., who supplied similar structures for the recent successful Mariner II Venus spacecraft*

### International Radio Communications Exhibition

The 1963 R.S.G.B. International Radio Communications Exhibition will be held at Seymour Hall, Seymour Place, Marble Arch, London, from October 30th to November 2nd. This year the B.B.C. will be showing for the first time, together with other government services. Manufacturers' products will include a range of overseas communication receivers new to this country, together with new British types and transceivers for both fixed and mobile working. A wide variety of test equipment, amplifiers, etc. will also be displayed. The show will open daily from 10 a.m. to 9 p.m. Admission 3s.

### Transducer Advisory Service

A variety of new transducer materials in many shapes and sizes is available from an increasing number of manufacturers and considerable appraisal and development work is required before the correct choice can be made for a particular application. To assist designers, Vacuum Reflex have set up a group concerned with this aspect, to advise on, specify and manufacture transducers for all applications. Manufacturing and encapsulation facilities are available for the manufacture of transducers already designed. For further details of these units and advisory service contact Vacuum Reflex Ltd., 6 Soho Street, London, W.1 (Telephone: Regent 5030).

### I.E.E. President and Officers for 1963-64

The president of the Institution of Electrical Engineers for session 1963/64 will be Sir Albert Mumford, K.B.E., engineer-in-chief of the Post Office. New chairmen of the three divisions of the Institution have also been elected as follows: Dr. R. C. G. Williams (Electronics Division), C. D. Wilkinson (Power Division), Dr. J. R. Mortlock (Science and General Division).

# Correspondence

## Stabilized High-Voltage Supplies

Sir,—In *Industrial Electronics* for August 1963, there was a most interesting article entitled 'Stabilized High-Voltage Supplies' by J. P. Holland. Near the end of this article Mr. Holland stated, 'Sometimes a high-voltage high- $\mu$  triode is required for e.h.t. stabilizer operation and no valve specifically made for the purpose proves to be available.'

We wish to bring to your notice that this company has manufactured valves of this nature for some time, and we are enclosing the relevant data sheets for your attention.

As we believe that these valves are alone in this field perhaps it would be of interest to publish this information?

B. HALLIWELL.

Ferranti Ltd.,  
Oldham, Lancs.

Valve Type	HL 10	HL 22	HL 25
Anode kV	20	25	15
Peak anode mA	30	5	5
Mean anode mA	10	0.75	1
Mean anode W	30	4	4
$\mu$	300	900	800

In the table we summarize some of the figures of the data sheets which our correspondent enclosed. The figures are maximum ratings.—Ed.

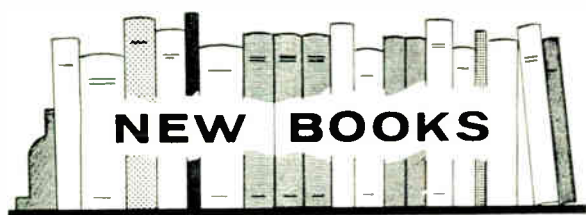

## Electronic Circuit Techniques

Edited by E. E. ZEPLER, Ph.D., M.Brit.I.R.E. and S. W. PUNNETT, B.Sc. Pp. 212. Blackie & Son Ltd., 5 Fitzhardinge Street, Portman Square, London, W.1. Price 35s.

This book has been written by a team of contributors from the department of electronics of the University of Southampton. It is 'primarily intended for those engaged in research or other work who have to use electronic equipment as a tool and so desire some knowledge of its behaviour and functioning'. It is a companion volume to 'Electronic Devices and Networks' and it is assumed that the reader is familiar with this book, or has otherwise acquired the information contained in it.

The arrangement of the material is unusual in that the starting point is a chapter on feedback systems. Chapters on amplifiers and oscillators follow and are divided into audio- and video-frequency, low-frequency and d.c. and radio-frequency. After this come chapters on pulse circuits and waveform generation, modulation and demodulation processes, power supplies, and the capabilities and use of test equipment.

The treatment throughout embodies a considerable

amount of mathematics, although it does not often go beyond the usual complex algebra. It is so frequent that it is necessary to follow it for an understanding of the subject; this is not a book in which one can skip the mathematics in a first reading. A good point is the large number of worked examples.

## Principles of Applied Electronics

By BEN ZEINES. Pp. 425 + xv. John Wiley & Sons Ltd., Glen House, Stag Place, London, S.W.1. Price 53s.

While Chapter 1 is entitled 'Electron Physics', Chapter 2 is 'Introduction', which seems a little odd! The first section of Chapter 1 is headed 'Introduction', while that of Chapter 2 is headed 'Electronics'. In each case this first section is a paragraph which, save for a minor transposition of words, is identical in both!

The first four chapters are largely introductory and cover the general physical principles underlying, and the construction of, thermionic and semiconductor devices. After that are four chapters in which transistor parameters, triodes and multi-grid valves are discussed. Then amplifiers, feedback systems, oscillators, rectifiers, filters and regulators are treated. The last chapter deals with special circuits, such as multivibrators. Detection, modulation and r.f. amplifiers are not covered.

The treatment is in the main of the usual kind, making use of complex algebra, but more use is made of load-line diagrams than is now usual. There are problems after each chapter and, an unusual point in an American book, the answers are given.

## British Semiconductor Survey

By C. M. SINCLAIR. Pp. 124. United Trade Press Ltd. Distributed by Bernards (Publishers) Ltd., The Grampians, Western Gate, London, W.6. Price 15s.

This booklet mainly contains tabulated data on transistors, tunnel diodes, unijunction transistors, p-n-p-n devices, signal and microwave diodes, p-n junction rectifiers, zener diodes and sundry semiconductors.

## Bibliography on Atmospheric Aspects of Radio Astronomy

By WILHELM NUPEN. Pp. 385 + lxii. National Bureau of Standards Technical Note 171. Superintendent of Documents, U.S. Government Printing Office, Washington 25, D.C., U.S.A. Price \$2 (plus 25% postage).

## Problems in Electronics with Solutions. 3rd Edition

By F. A. BENSON, D.Eng., Ph.D., A.M.I.E.E. Pp. 265 + xix. E. & F. Spon Ltd., 22 Henrietta Street, London, W.C.2. Price 42s.

## Basic Mathematics. Vol. 4

By NORMAN H. CROWHURST. Pp. 138 + vi. John F. Rider Publisher Inc., 850 Third Avenue, New York 22, U.S.A. Price \$3.90.

## Introduction to TV Servicing

By H. L. SWALUW and J. VAN DER WOERD. Pp. 272 + xi. (Philips Technical Library) Cleaver-Hume Press Ltd., 10-15 St. Martin's Street, London, W.C.2. Price 45s.

## AM-FM Broadcast Operations

By HAROLD E. ENNES. Pp. 240. Howard W. Sams & Co., Inc., Indianapolis 6, Indiana, U.S.A. Price \$5.95.

Produced in a loose-leaf format with a plastic-ring binder, this book is Vol. 2 of a 'Broadcast Engineering Notebooks' series. Its four sections cover what every operator should know about theory, operations at the

studio, operating outside the studio and operating the transmitter. The technical level is very elementary.

### Electronics Pocket Book

Edited by J. P. HAWKER and J. A. REDDHOUGH. Pp. 288 + vii. George Newnes Ltd., Tower House, Southampton Street, London, W.C.2. Price 21s.

### Solid-Fuel Rocket Propulsion

By J. E. DABOO, B.A., D.C.Ae., A.F.R.Ae.S. Pp. 88. Temple Press Books Ltd., Bowling Green Lane, London, E.C.1. Price 15s.

### Industrial Electronic Circuits Handbook

By EDWARD BUKSTEIN. Pp. 127. Howard W. Sams & Co. Inc., Indianapolis 6, Indiana, U.S.A. Price \$3.95.

The book comprises 53 circuits with a short description of each. It provides a representative collection of data on American electronic industrial apparatus of the simpler kind.

### Understanding Amateur Radio

By GEORGE GRAMMER. Pp. 320. The American Radio Relay League, West Hartford 7, Connecticut, U.S.A. Price \$2.25.

## Manufacturers' Literature

**Encapsulated Rectifier Units.** This 4-page publication is of particular interest to designers and engineers requiring encapsulated rectifier units with current ratings from 1 to 4 A at voltages up to 420 V. These Westinghouse rectifiers can be supplied in bridge, centre-tap or voltage-doubler arrangements. *Westinghouse Brake and Signal Co. Ltd., 82 York Way, King's Cross, London, N.1.*

For further information circle 47 on Service Card

**Westool Solenoids.** In this illustrated 8-page brochure brief details are given of each unit in a wide range of a.c. and d.c. solenoids, including 4 miniature types which have recently been introduced. *Westool Ltd., St. Helen's Auckland, Bishop Auckland, Co. Durham.*

For further information circle 48 on Service Card

**Mullard Special Quality Valves.** This 31-page booklet discusses some aspects of the design and manufacture of Mullard special quality receiving valves, and the methods of control adopted during production. Numerous pictures and diagrams are included.

*Mullard Ltd., Mullard House, Torrington Place, London, W.C.1.*

For further information circle 49 on Service Card

**Sound and Vibration Measuring Equipment.** A 20-page illustrated brochure by General Radio describes its line of sound and vibration measuring instruments and associated apparatus. Among new instruments included are two analysers, a microphone reciprocity calibrator and stroboscopic equipment adaptable to vibration measurement.

*General Radio Company, West Concord, Massachusetts, U.S.A.*

For further information circle 50 on Service Card

**Electrical Insulation Materials.** This comprehensive 24-page publication describes the types of mica supplied by Attwater & Sons, and also illustrates in tabular form types of micanite, phenolic and other synthetic laminates, sleeveings and flexibles. *Attwater & Sons Ltd., Hopwood Street Mills, Preston.*

For further information circle 51 on Service Card

**Properties of the Platinum Metals.** The latest data on the basic properties of platinum, palladium, rhodium, ruthenium, iridium and osmium are set out in this 4-page folder. These metals are used in a wide variety of industries, principally by virtue of their high resistance to corrosion, high melting points and high catalytic activity.

*The International Nickel Co. (Mond) Ltd., Thames House, Millbank, London, S.W.1.*

For further information circle 52 on Service Card

**Brush Recording Systems.** A fully-illustrated, 20-page condensed catalogue containing descriptions and specifications of Brush Instruments' direct writing, light-beam, and direct recording systems; also described in this publication are associated amplifiers, pre-amplifiers, cabinets and enclosures. System flexibility through interchangeable parts is stressed.

*Brush Instruments, Division of Clevite Corporation, 37th and Perkins, Cleveland 14, Ohio, U.S.A.*

For further information circle 53 on Service Card

**Power Supply Rectifiers.** Details of Westinghouse silicon totally enclosed power supply rectifiers are given in this 3-page leaflet. These sets are designed to provide reliable d.c. supplies under extreme conditions of contaminated or dust-laden atmospheres, with the silicon stacks and transformers immersed in oil.

*Westinghouse Brake and Signal Co. Ltd., 82 York Way, King's Cross, London, N.1.*

For further information circle 54 on Service Card

**Electro-Hydraulic Actuator.** This 4-page leaflet describes a high-speed, linear electro-hydraulic actuator originally developed by Servo Consultants for applying a control signal to aircraft structures. It has subsequently found uses in the investigation of vehicle suspension systems and the testing of power controls, its main industrial application being in automatic production machines.

*Servo Consultants Ltd., 162-6 Kensal Road, London, W.10.*

For further information circle 55 on Service Card

**Components for Test Consoles.** Described in this 28-page, 2-colour catalogue are Theta panel-mounted dial assemblies, a.c. voltmeters, phase-sensitive voltmeters and phase shifters. Applications, specifications and full descriptive data are given. *Theta Instrument Corp., Saddle Brook, New Jersey, U.S.A.*

For further information circle 56 on Service Card

**Bakelite Laminated Plastics.** An informative, fully-illustrated, 26-page booklet entitled 'Bakelite Laminated—Properties and Applications' describes in detail the range of laminated plastics produced by Bakelite, and incorporates a fold-out table of the average properties of the principal grades, e.g. electrical insulation, corrosion resistance, weight, strength and machinability. *Bakelite Ltd., 12-18 Grosvenor Gardens, London, S.W.1.*

For further information circle 57 on Service Card

**Cambridge Decade Resistors.** This single-page leaflet describes a range of decade resistors designed for both d.c. and a.c. applications. The accuracy of adjustment for most of them is 0.05%. Boxes with 3, 4 or 5 decades are available as standard, covering ranges from 111.1 to 111,000  $\Omega$ .

*Cambridge Instrument Co. Ltd., 13 Grosvenor Place, London, S.W.1.*

For further information circle 58 on Service Card

## ★ FOR THE BUYER

You must have read about a number of products and processes in this issue of which you would like further details. You can obtain this information very easily by filling in and posting one or more of the enquiry cards to be found inset in the front and back of the journal.



**THERE'S  
A  
RIGHT WAY  
AND  
A  
WRONG WAY  
OF  
DOING  
EVERYTHING**

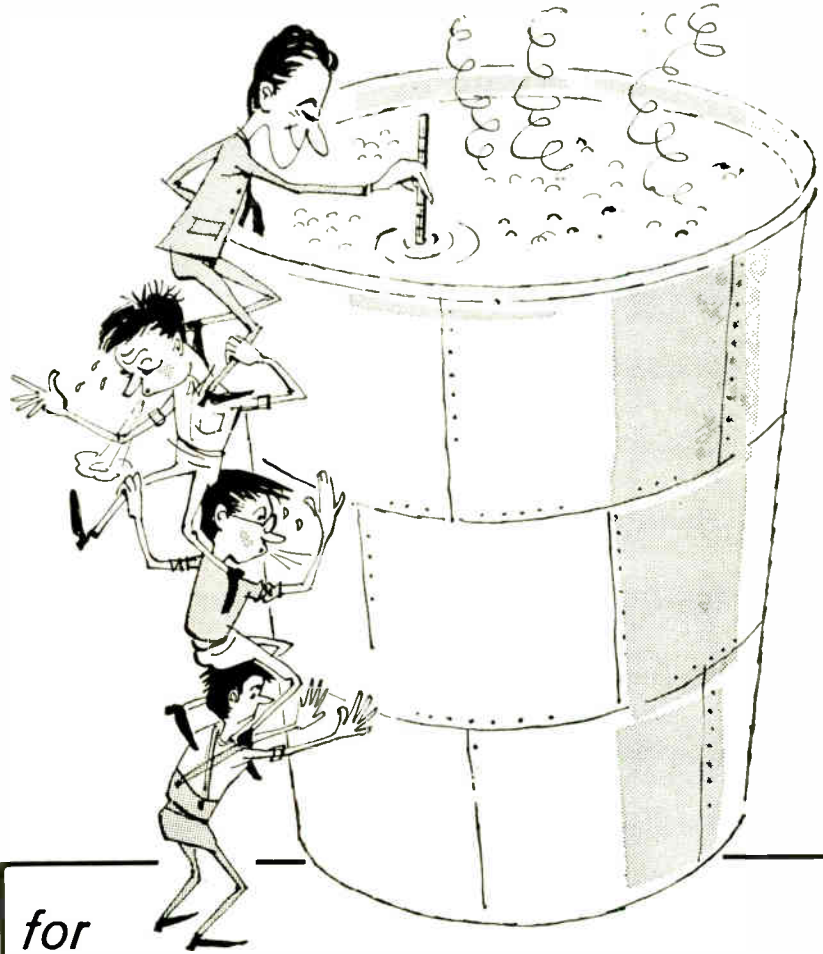

*for*  
**TEMPERATURE RECORDING**  
*you can't go wrong  
with the NSQ*

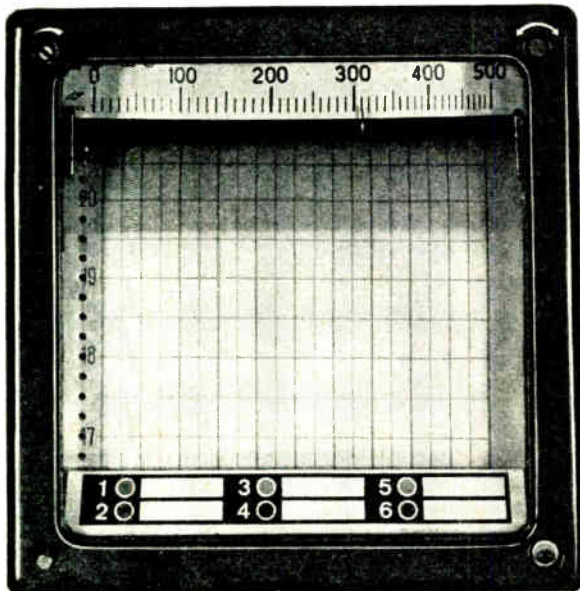

- Up to six points
- Accuracy  $\pm 1.5\%$  at f.s.d.
- Recording width 4"
- Robust and reliable design
- Prices from £108



Further information available on request from:

**R. B. PULLIN & COMPANY LIMITED**

PROCESS CONTROL DIVISION

GREAT WEST ROAD · BRENTFORD · MIDDLESEX · ENGLAND

Telephone: ISLeworth 1212 (9 lines). Grams: Pullinco, Wesphone, London



# AVELEY INSTRUMENTATION

## for Every Electronic Need

\* Fundamental Research.

Virtually all Electronic Measurement and Test Instrumentation for ANY INDUSTRY.

RF/UHF Transmission and Reception.

Electronic and Photographic Recording.

Educational aids.

\* Our application engineers are competent to advise on any electronic measuring problems which you may have, and will suggest the correct instruments for the project in mind.

\* After sales service is ensured by a well-equipped Technical Services Department, repairing and re-conditioning equipment and producing special modifications and accessories as required.

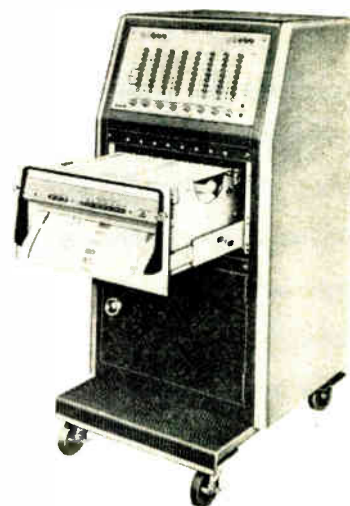
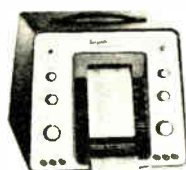

### Direct Writing, Recording Equipment

The Brush range of recording equipment offered by Aveley Electric Limited has been proven to be versatile and thoroughly dependable in industrial and Military applications, the world over.

Amplifiers and transducers are available for complete strain and displacement measuring systems. Industrial equipment includes Surface Analysers.

## Aveley Electric Limited

Distributors in United Kingdom for:

- ROHDE & SCHWARZ
- DUMONT
- NARDA
- BRUSH
- STODDART

For Further Information Write or Phone

SOUTH OCKENDON ESSEX  
 Telephone: SOUTH OCKENDON 3444  
 Telex: 24120 AVEL OCKENDON



# STABILITY

Change in Forward Voltage over life and storage at temperature extremes:

Max ..... 1.0mV  
 Typical Change ..... <0.1mV  
 (at 15 mA Forward Current)

## FERRANTI HIGH QUALITY miniature SILICON JUNCTION DIODES

 **DYNAMIC  
 LIFE  
 TESTING**  
 -48 hours at full rating with  
 EVERY device

- \* MATCHED PAIRS AND QUADS.
- \* VERY STABLE FORWARD CHARACTERISTICS.
- \* MINIATURE SIZE.
- \* GLASS ENCAPSULATION.
- \* MAX. MEAN DISSIPATION 275 MILLIWATTS.

MAXIMUM RATINGS

Type No.	ZS90	ZS91	ZS92	
P.I.V.	50	100	200	Volts
Mean Rectified Current	250	250	250	mA
Max. Reverse Leakage at 25°C	·2	·2	·2	µA
Max. Forward Voltage Drop at 250mA	1.1	1.1	1.1	Volts
Derating over Temperature Range 25°C to 150°C	2	2	2	mA/°C
Ambient Operating and Storage Temperature Range	-55°C to +150°C			

- \* EXTREMELY HIGH RELIABILITY ensured by VERY HIGH STANDARDS OF QUALITY CONTROL DURING MANUFACTURE AND TEST.
- \* STRINGENT TESTING INCLUDING THERMO-CYCLING BETWEEN LIMITS AND FULL LOAD.
- \* P.I.V. RATINGS UP TO 200 VOLTS.

**FERRANTI**  
*First into the Future*

FERRANTI LTD · GEM MILL · CHADDERTON · OLDHAM · LANCS.  
 Telephone: MAIn 6661 London Office Telephone: TEMple Bar 6666



## Soldering Instruments and Equipment

### Illustrated

$\frac{3}{16}$ " BIT INSTRUMENT (List No. L64) IN PROTECTIVE UNIT (List No. 700)

ALL VOLT RANGES  
6/7 to 230/50  
VOLTS

BRITISH & FOREIGN PATS.  
& REG. DESIGNS, ETC.

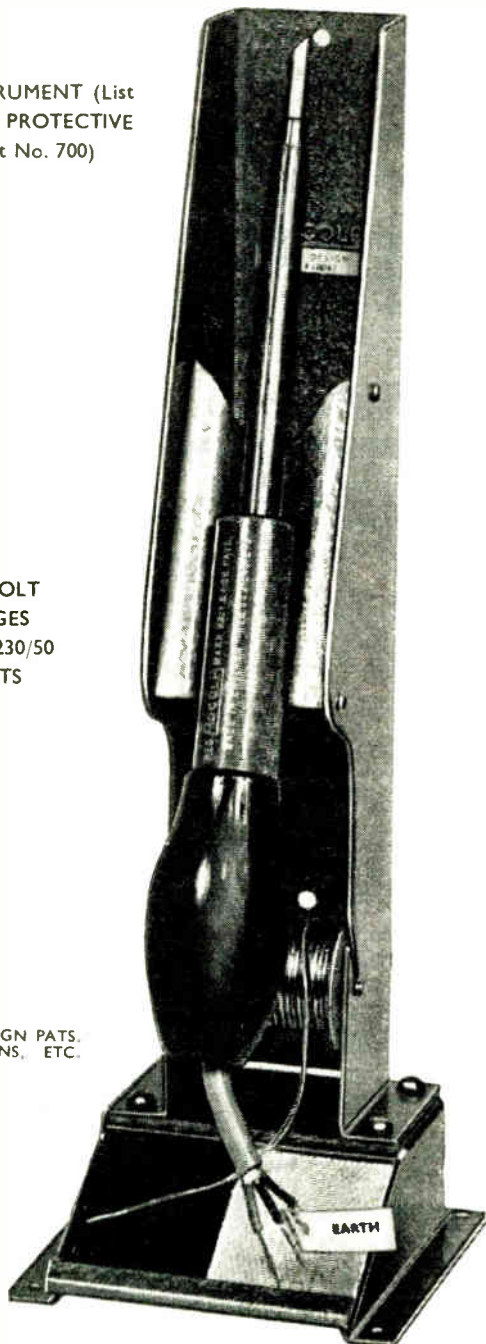

Traditional British Quality and Workmanship  
**ADCOLA PRODUCTS LIMITED**

Head Office, Sales and Service

**ADCOLA HOUSE, GAUDEN ROAD, LONDON, S.W.4**

Telephones MACAULAY 3101 & 4272

Telegrams SOLJOINT LONDON S.W.4

AUSTRALIAN ASSOCIATES: ADCOLA PRODUCTS PTY. LTD.  
673 WHITEHORSE ROAD, MONT ALBERT, MELBOURNE, VICTORIA

SMALL INTRICATE SHAPES  
Consistent Magnetic Properties

**MUREX**

**MAGNETS**

**MUREX LTD**  
(Powder Metallurgy Division)

**RAINHAM · ESSEX · Rainham, Essex 3322**  
Telex 28632 Telegrams: Murex, Rainham-Dagenham Telex.  
London Sales Office: Central House, Upper Woburn Place, W.C.1. Tel. EUSan 8265

WHEN YOU BUY

# TELCON HIGH PERMEABILITY TOROIDAL CORES

YOU BUY

## THE PRODUCT OF FORTY YEARS EXPERIENCE

Telcon Pioneered the Production of Strip Wound Cores which are available in

MUMETAL, SUPERMUMETAL  
RADIOMETAL, SUPER RADIOMETAL  
H.C.R. ALLOY  
PERMENDUR AND SUPERMENDUR

All these alloys are manufactured EXCLUS'VELY by Telcon Metals Limited at Crawley, Sussex, where melting, hot and cold rolling, slitting and core fabrication are carried out under close technical

supervision. Inspection starts with the raw materials, is maintained throughout the production processes and ends with an individual magnetic test on every finished core.

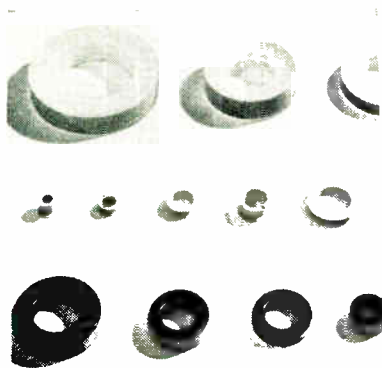

Typical Spiral Cores

WHEN YOU BUY  
TELCON CORES  
YOU BUY  
RELIABILITY

Cores are available in a wide variety of sizes and strip thicknesses down to 0.000125" (3 microns) and full technical information will gladly be sent on request. Core finishes can be made to suit customer requirements which include epoxy resin and other coatings, metal casings and sealed boxes of various plastic combinations.

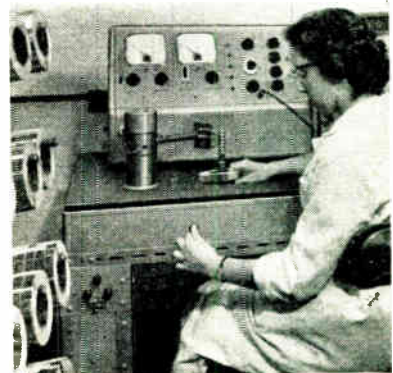

Test Gear for Cores

FOR SPIRAL CORES - WHATEVER THE APPLICATION



# BUY TELCON



Telcon Metals Ltd. P.O. Box No. 12, Manor Royal, Crawley, Sussex. Phone: Crawley 28800. Grams: Telcon Crawley. Telex 87248

Member of the **BICC** Group of Companies



**TRANSFER  
FUNCTION ANALYSER**

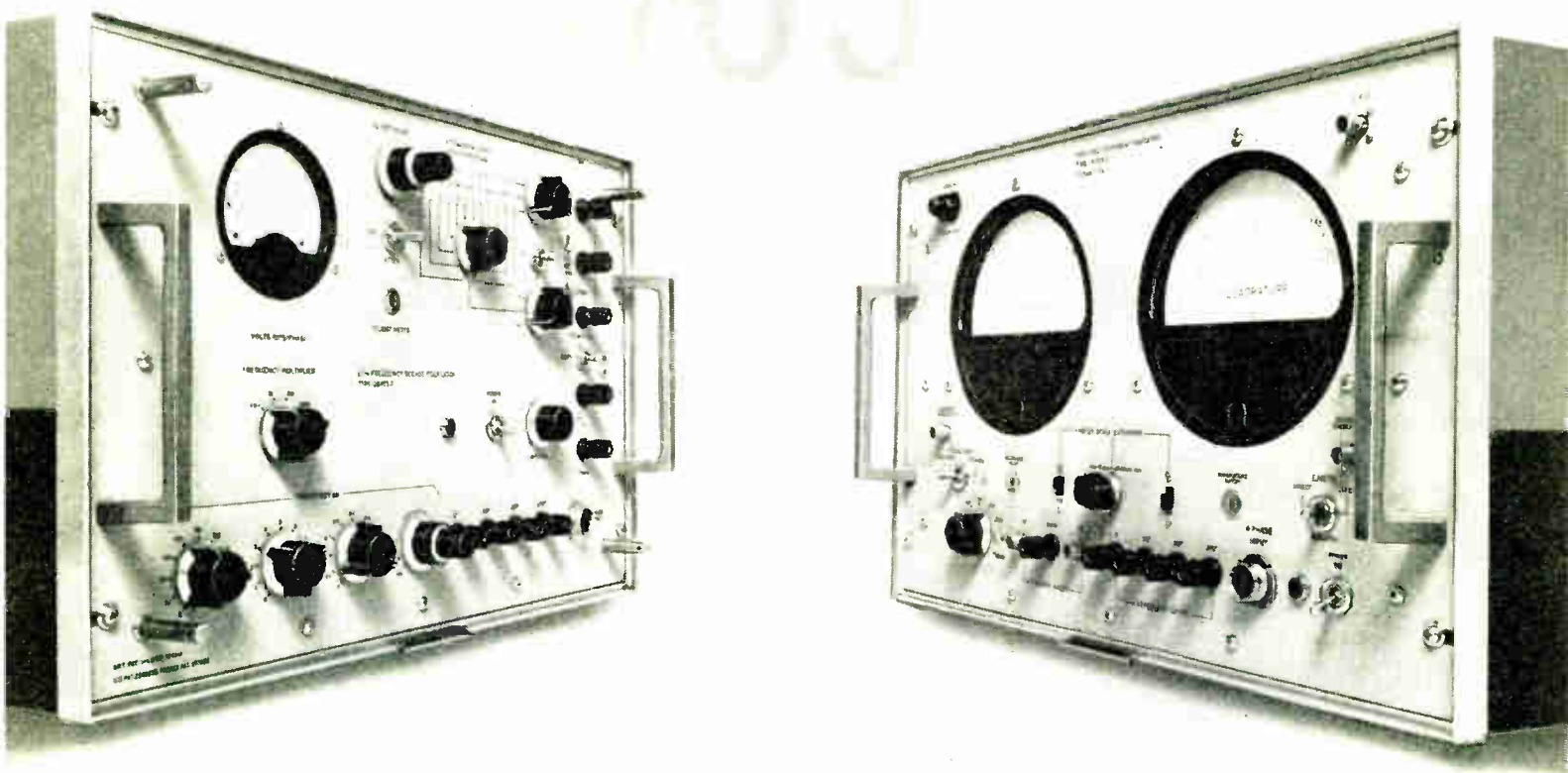

**A tool for progress  
in every industry**

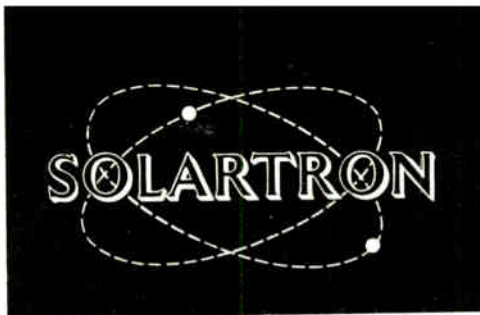

For further information  
circle 244 on Service Card

## TRANSFER FUNCTION ANALYSER

---

# NOW DOWN TO 0.05 c/s

- ★ Extended low frequency coverage down to 0.05 c/s.
- ★ Harmonic and noise rejection improved  
Accurate readings when signal/noise ratio is 1:10
- ★ Meter scale expansion X10 on Reference or Quadrature meters for simplified measurement of small phase angles
- ★ Direct drive facilities for X, Y plotter or Digital voltmeter
- ★ Incremental Phase, and Frequency adjustment for greater accuracy
- ★ New functional presentation

*Detailed information will be gladly sent on request and Solartron engineers are available to discuss applications. Write to:*

---

**THE SOLARTRON ELECTRONIC  
GROUP LTD.** (Instrument Division)  
Victoria Road · Farnborough · Hants.  
Tel: Farnborough (Hants) 3000  
Telex: 8545 Solartron Fnbro  
Cables: Solartron Farnborough

MC & P 5143

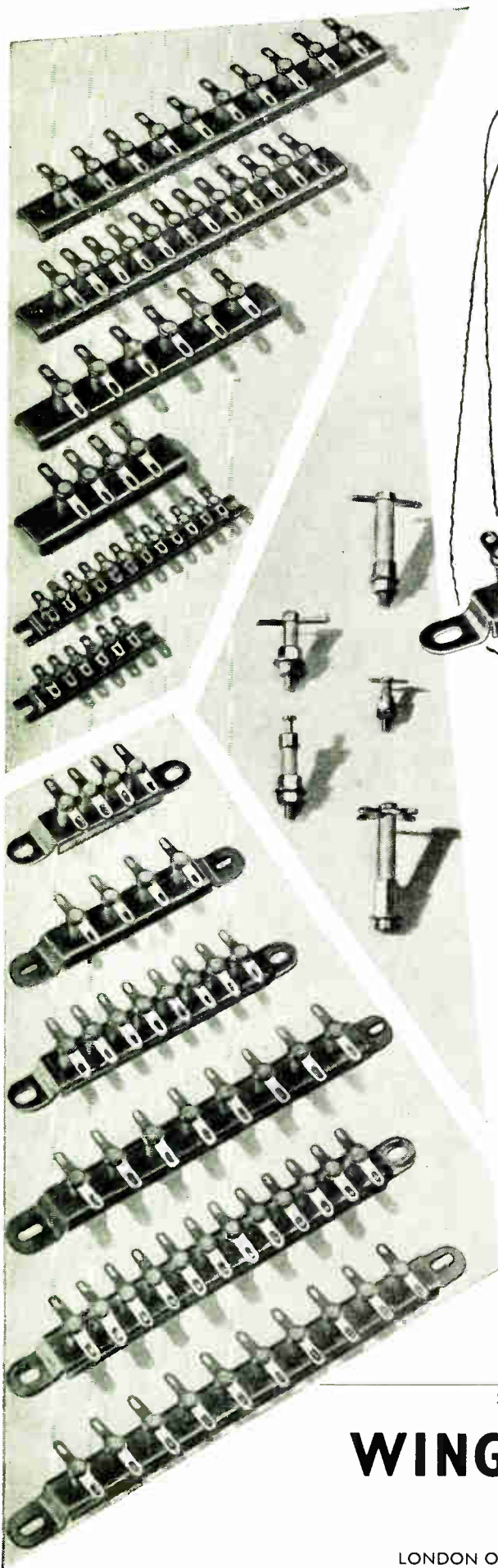

# POLAR

*Terminal Strips and  
Stand-off Insulators*

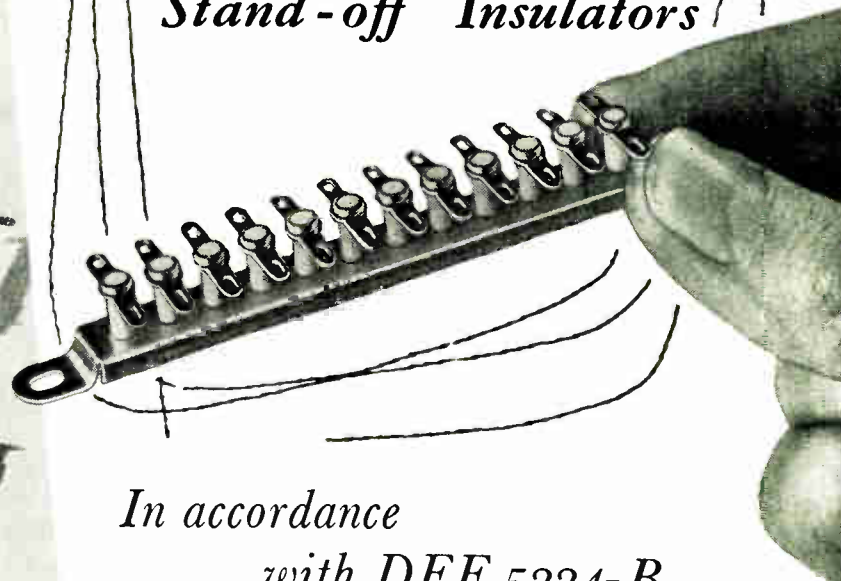

*In accordance  
with DEF 5334-B*

Suitable for all forms of assembly, these high efficiency inexpensive Terminal Strips and Stand-off Insulators are available in a wide range of sizes.

The Stand Off Insulators are mounted by means of Screwed Stems or Tapped holes. Connections may take the form of Tags, Spills or Screwed Stems.

Terminal Strips in Cadmium plated steel with pillars of sintered aluminium oxide, are available in several types with  $\frac{5}{32}$ "  $\frac{1}{4}$ " or  $\frac{3}{8}$ " spacing between terminals. Insulation resistance better than 10,000 megohms.

P.T.F.E. leadthroughs and stand-offs also available. Specialists in high-grade variable capacitors.



*Samples and Prices on application to Department J.E.*

## WINGROVE & ROGERS LTD.

HEAD OFFICE: Domville Road, Old Swan, Liverpool, 13.

Phone: Stoneycroft 2265 Grams & Cables: Components Liverpool

LONDON OFFICE: Paramount House, 75 Uxbridge Road, Ealing, W.5. Tel.: EALing 7046



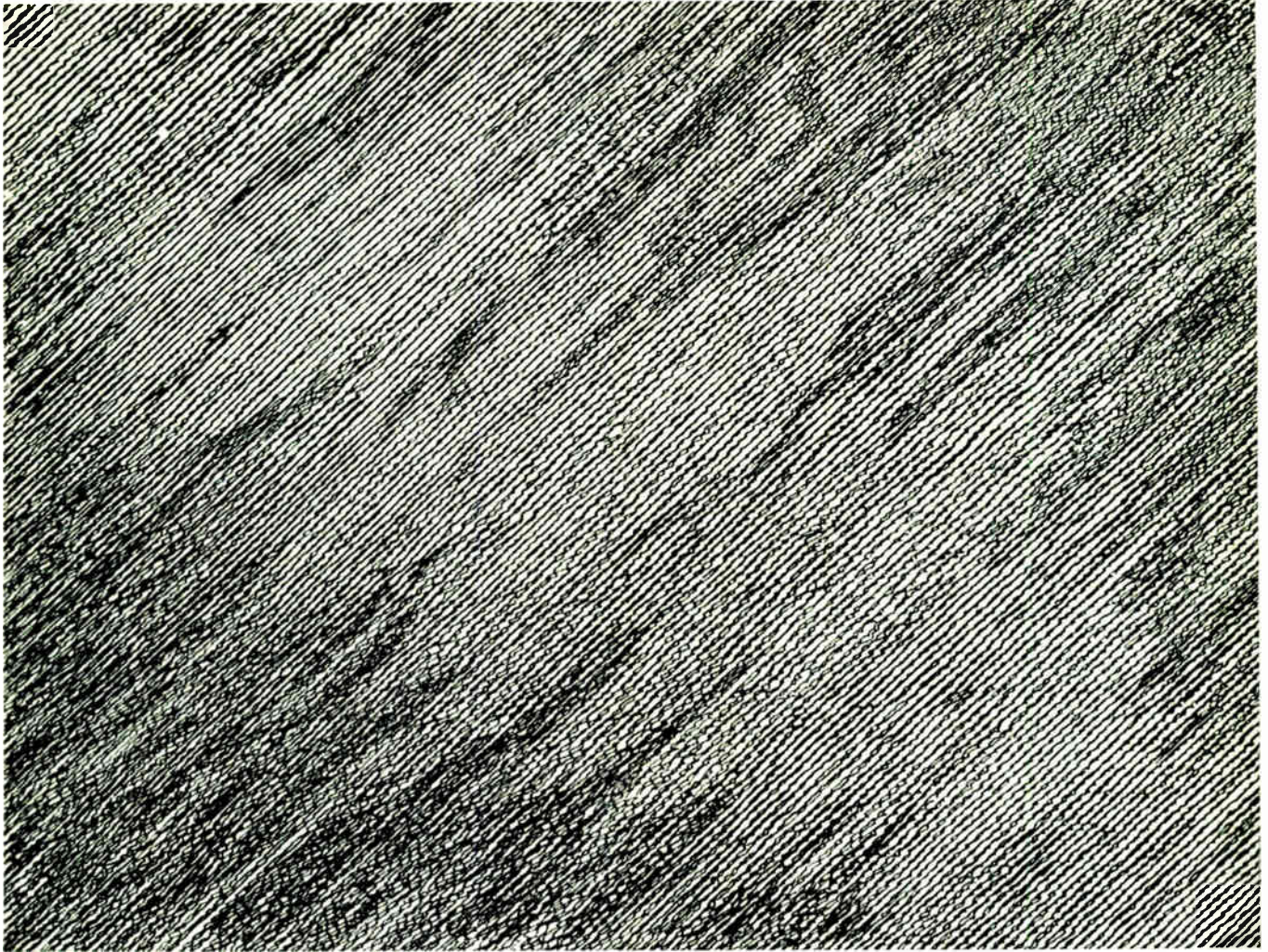

# **STOP PRESS. AT THE TIME OF GOING TO PRINT, UNION CARBIDE SOLID TANTALUM CAPACITORS HAD COMPLETED 4,000,000 CAPACITOR-HOURS IN TELSTAR WITHOUT FAILURE. KEMET MEANS RELIABILITY**

## **NOW 100 VOLT RATING**

*In May this year a range of solid tantalum capacitors rated at 100v was added to the Kemet J-Series.*



Production at Aycliffe Trading Estate, Co. Durham.

UNION CARBIDE LIMITED · KEMET DIVISION · 8 GRAFTON STREET · LONDON · W.1 · MAYFAIR 8100

## **KEMET J-SERIES** Comply with:—

US MIL-C-26655A UK DEF 5134-A, 1 EID & ARB release available

## **OTHER KEMET PRODUCTS**

Non-Polar Capacitors · 'C' Series solid tantalum Capacitors (for commercial applications) · Barium Getters · Semiconductor Silicon · Silicon Monoxide · Laser Maser Crystals · Alumina  
We will be happy to send you further information on any of these products.

*The terms KEMET and UNION CARBIDE are trademarks of UNION CARBIDE CORPORATION*



CRC/KB

*Theme...*

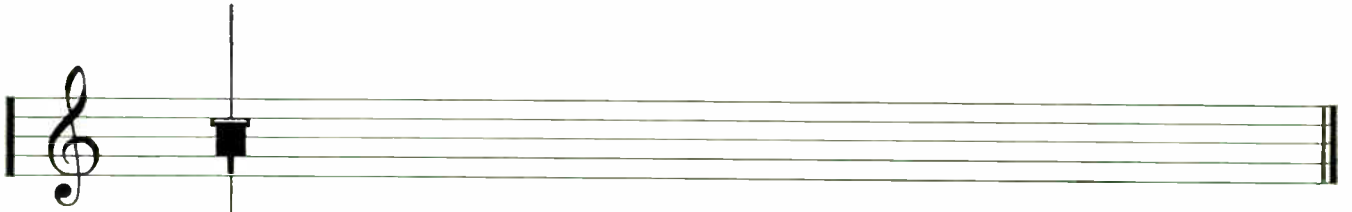

*and Variations*

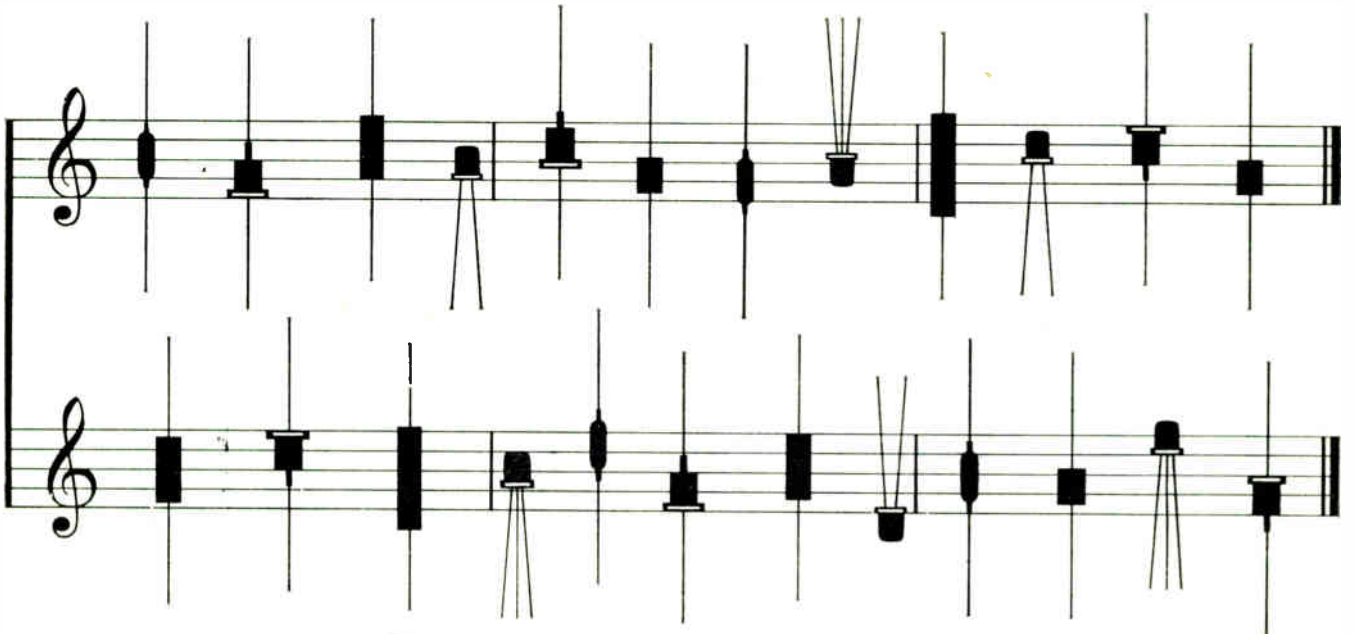

The silicon rectifier is our theme.

We've developed it in every conceivable way . . . conceivable, that is, at the time of writing. If you've got a job for a silicon rectifier which we cannot fill, we'll give the theme another twist. If anyone can do it, IR can.

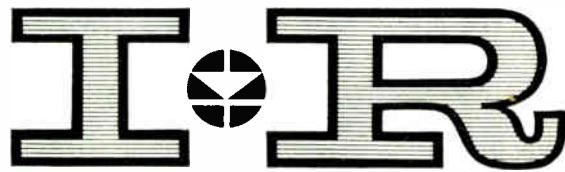

# INTERNATIONAL RECTIFIER

Details of any type of silicon rectifier, or advice on any particular application, will be provided on request.

*Immediate off-the-shelf delivery from I.R. distributors throughout the U.K.*

INTERNATIONAL RECTIFIER COMPANY (GREAT BRITAIN) LIMITED, HURST GREEN, OXTED, SURREY. OXTED 3215

Associate Company of International Rectifier Corporation U.S.A. and the Metal Industries Group, Great Britain



# WONDERFUL NEWS!

IN

## ELECTROLYTIC CAPACITORS

ALUMINIUM FOIL CAPACITORS FOR TRANSISTOR AND OTHER LOW VOLTAGE CIRCUITS



### TECHNICAL

CAP TOL—20%+100% of rated  
DISSIPATION FACTOR extremely low—less than 8% at 50 WVDC

D.C. LEAKAGE extremely low—less than 6 UA after 1 min applied WVDC

OPERATING TEMP. 65°C at rated WVDC

### ALL-MOULDED ENCAPSULATION

- ★ HERMETICALLY SEALED ALL-PLASTIC ENCASEMENT
- ★ ULTRA-SMALL SIZES WITH CAPACITIES TO 200  $\mu$ F
- ★ CLOSE TOLERANCE DIMENSIONS
- ★ LEAD SPACING TO  $\pm .015$ "
- ★ HIGH RELIABILITY BY CLOSE QUALITY CONTROL PROVEN IN THE EXACTING U.S. MARKET
- ★ SURPRISINGLY LOW COST
- ★ FAST DELIVERY

# SPSI

For full details write or phone:

**SPS**

**INTERNATIONAL LTD.**  
SHANNON · IRELAND  
TELEPHONE: SHANNON 245

<b>INDUSTRY'S</b>	<b>MOST</b>
<b>Flexible</b>	<b>FAILURE</b>
<b>ALARM</b>	<b>SYSTEM</b>
<i>is made by</i> <b>THORN</b>	

Designed for the widest possible industrial use, this extremely flexible system gives visible and audible indication both of the nature and the location of a fault in all types of production processes. It may be used with any flow failure or pressure sensitive switch, or any other device which will change the conditions of an electrical contact. The modular form of construction enables the equipment to be panel mounted, free standing, or mounted at angles to suit any viewing point. It can be added to at any time for moderate cost.

- Modular construction
- Primary fault indication
- Transient fault lock (manual reset)
- Signalled fault clearance
- Automatic or manual test facilities

*The substantial financial and technical resources of the Thorn Group are your assurance of the technical excellence and continued availability of all products associated with the Thorn symbol.*



**THORN ELECTRONICS LIMITED**  
105/109 Judd Street, London, W.C.1 (EUSon 4433)

**Thorn Electronics Limited**

For further information circle 250 on Service Card

## ARE YOU UP-TO-DATE WITH YOUR SOLDERING TECHNIQUE?



A new Adamin mains model is the C10L, shown on a Bench stand, which we also manufacture. This model is probably the smallest mains voltage model in the world. BIT DIAMETER, 3/32 in. LENGTH, 7 in. WEIGHT, 1/2 oz. (Less Flex). HEATS IN 30 seconds.

Brochures A & L33

post free from the sole proprietors:—

### LIGHT SOLDERING DEVELOPMENTS LTD.

28 SYDENHAM ROAD, CROYDON, SURREY. Telephone: CROYdon 8589

There is a large range of instruments (BIT sizes 1/32 in. to 13/32 in.) and accessories marketed under the names of . . .

### ADAMIN and LITESOLD

Get the brochures and see for yourself what others are using!

For further information circle 252 on Service Card

### PROMPT DELIVERY

Many Types  
Ex Stock



## PHIL-TROL SOLENOIDS

COMPLETE RANGE—MINIATURE TO POWER A.C. and D.C. Stocks maintained in power laminated core, mains voltage A.C. types and the smaller sizes in 6, 12, 24, 48, 115 and 230 volts, continuous, intermittent (25%) and impulse duty (6%) ratings. Push or pull, spring return and change-over switch models available. Send for leaflet No. 108a.

### PHILLIPS CONTROL (G.B.) LTD.

Dept. G.7  
Farnborough Road, Farnborough, Hants  
Telephone: Farnborough 1120. Grams & Cables: Philtrol, Farnborough, Hants

For further information circle 251 on Service Card

## KUHNKE

### UNIVERSAL-RELAY

For DC- and AC-operation

Low Price

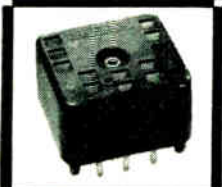
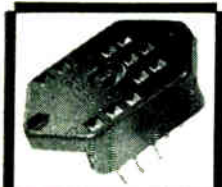

Stock Items

Max. 3 PDT contacts  
Max. contact rating:  
120 W / 150 VA resp.  
250 volts, 6 amps.

Solder terminals  
Slip-on terminals  
For printed circuitry  
Screw terminals

Dimensions: only 35 x 35 mm

H. Kuhnke, Ltd., 163, Stanwell Road,  
Ashford, Middlesex.

PHONE: ASHFORD 52798 TELEX: 21577

For further information circle 253 on Service Card



If you have not had a copy of this NEW Metway List of Cable Sockets, Connectors and Glands in metal and nylon, and Locknuts, Bushes, Plugs, etc., write now for List No. ME1/62D/IE.

METWAY · KEMP TOWN · BRIGHTON 7



# BURROUGHS NIXIE<sup>®</sup> INDICATOR TUBES



- wide range of types
- character sizes from 0.3" to 2"
- rectangular (space saving)
- ultra long life
- wide angle viewing
- low voltage
- also available: tube accessories
- driver modules
- complete readout assemblies

Send for your copy of 26 page catalogue:

## WALMORE ELECTRONICS LIMITED

11-15 Betterton Street, Drury Lane, London, WC2

Telephone: TEMple Bar 0201/5

For further information circle 255 on Service Card

# HALCO DIAZOPRINTERS



HALCO minor two hundred



HALCO minor 480



HALCO minor 750



HALCO major

## FOR PLAN COPYING

A system of 'unit construction' has been adopted in a new range of the well known Halco Diazoprinters, resulting in a more economical price structure. These machines use light sources ranging from 200-2000 Watts. A high output of photo copies using the Semi-dry Dyeline process can be maintained.



**NO FUMES—  
NO EXHAUST  
PIPES REQUIRED**

*Craftomen to Draughtomen*

**ROWSLEY WORKS, REDDISH, STOCKPORT**

Telephone: HEATON MOOR 2241/2,3

Branches at MANCHESTER · LONDON · NEWCASTLE · BIRMINGHAM · GLASGOW · LEEDS · BRISTOL · NOTTINGHAM

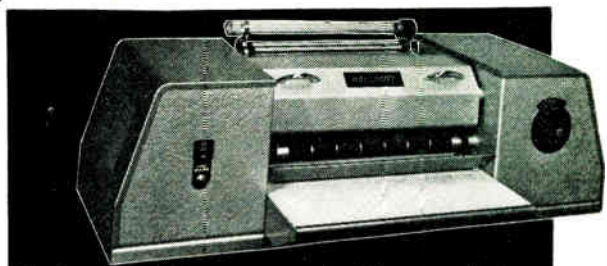

Halcodet document diazoprinter

## & DOCUMENTATION

**OXLEY  
DEVELOPMENTS  
CO. LTD**

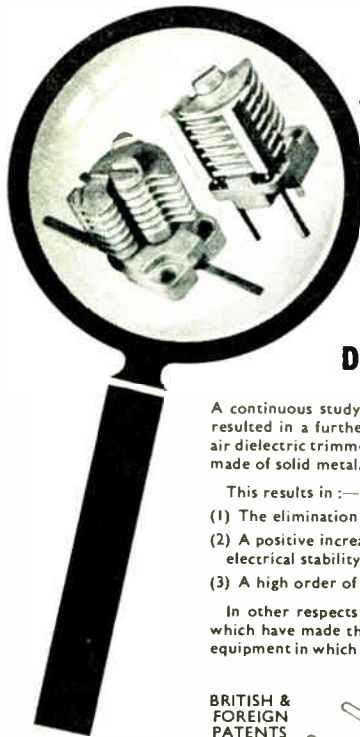

**OXLEY**

**SUBMINIATURE AIR  
DIELECTRIC TRIMMERS**

A continuous study in the laboratory and in the field has resulted in a further development in Oxley subminiature air dielectric trimmers, the rotor and the stator both being made of solid metal.

This results in:—

- (1) The elimination of practically all soldered joints.
- (2) A positive increase in mechanical rigidity and improved electrical stability.
- (3) A high order of consistency in capacity.

In other respects the trimmers retain all those facilities which have made them the inevitable choice of professional equipment in which reliability is the dominant requirement.

BRITISH &  
FOREIGN  
PATENTS

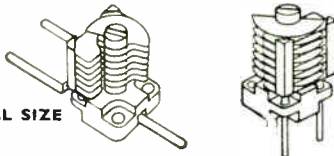

ACTUAL SIZE

Write for technical details of these and other Oxley products  
**OXLEY DEVELOPMENTS CO. LTD., ULVERSTON, LANCASHIRE**

**Tension Gauge**

*Kontaktor*



For checking and adjusting springs of all kinds; especially to adjust contact pressures on relay springs for automatic telephone stations, to check pressures and tensions on switches, brushes of motors, and in the production and service of Radios, TV, Record Changers, Tape Recorders, Cameras, Projectors, Calculators, Dial Indicators and gauges of all kinds.

	dia. of dial 36 mm	dia. of dial 72 mm
size 000	0.3-3g	size 5 50-500g
.. 00	0.6-6g	" 6 100-1000g
.. 0	2-15g	" 7 200-2000g
.. 1	3-30g	" 8 300-3000g
.. 2	5-50g	" 9 400-4000g
.. 3	10-100g	" 10 500-5000g
.. 4	20-250g	



**GEORG KARSTENS GMBH**  
7304 RUIT/Stuttgart - W. Germany  
Cables: Gekarstens Stuttgart-Telex 07-23 498

Mfrs. of Measuring Tools and Instruments - Cylindrical Grinders

For further information circle 257 on Service Card

**ULTRASONIC  
DELAY LINES**

C. F. Brockelsby, B.S.C., A.R.C.S. A.M.I.E.E.

J. S. Palfreeman: R. W. Gibson, B.S.C. (ENG.) I GRAD. I. MECH. E.:

**an invaluable new book**

Modern ultrasonic delay lines—capable of introducing delays up to several milliseconds—can act both as timing elements and as information storage devices. They find important applications in radar—for which they were first developed—in radio and television, electronic computers, pulse-forming networks correlation techniques and multi-channel communication systems, and even further afield in acoustic interferometry, etc.

In spite of many references to these devices in world technical literature, this is the first book specifically devoted to them. The authors, headed by C. F. Brockelsby, are members of a team who have been working on the subject for many years at the Mullard Research Laboratories. They write from a position of unique authority, and have included much original matter not to be found elsewhere.

Though the book is written mainly for engineers and physicists actively engaged in the subject, scientists and technologists in other fields will find it of the greatest value.

obtainable from leading booksellers

Published by **ILIFFE Books Ltd.** DORSET HOUSE STAMFORD STREET LONDON S.E.1

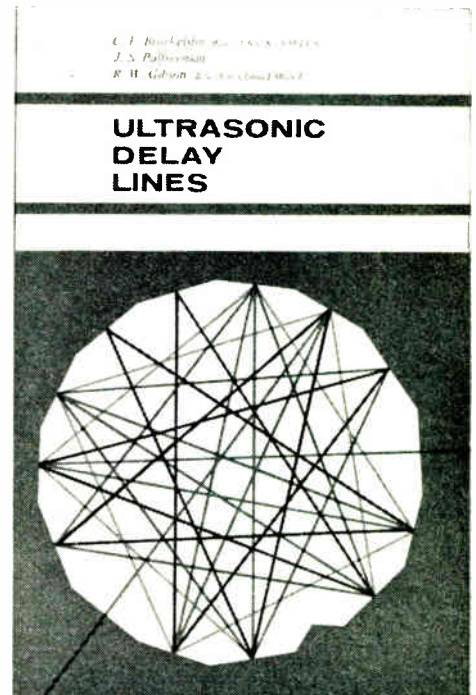

**65s net** by post 66s 3d

8½ ins. × 5½ ins. 297 pages

plus 8 pages of plates

# INDUSTRIAL ELECTRONICS

Press date for the November 1963 issue is  
first post 23rd October 1963

## CLASSIFIED ADVERTISEMENTS

Advertisement Rates. 6d. per word, minimum charge 6/-, each paragraph charged separately. Remittances payable to "Industrial Electronics", Dorset House, Stamford St., S.E.1. Series discount of 15% is allowed for 12 consecutive insertions.

Box Numbers are available at an additional charge of 2/- to defray cost of registration and postage. Replies should be addressed Box No. 0000, c/o "Industrial Electronics", Dorset House, Stamford Street, London, S.E.1.

Semi-Display advertisements with centralized lines £1/15/- per single column inch, Display advertisements £2/10/- per single column inch—no additional charge for Box Numbers. The Publishers are not responsible for clerical or printers' errors although every care is taken to avoid mistakes.

### FINANCIAL

#### FINANCIAL AND PROFESSIONAL HELP FOR YOUR BUSINESS

Long term loans from £10,000 upwards, together with professional advice from specialists in all fields of business administration. The service provided by Whitehead Enterprises Ltd. enables progressive businesses with a moderate record of profit to take advantage of growth opportunities while still retaining control.

For more details write to:  
Whitehead Enterprises Limited  
7 & 8 Chandos Street, London, W.1 [2033]

### SERVICES OFFERED

Precision Sheet Metal Work for the Radio & Electrical Trade. Chassis, Panels, Brackets, etc. Power Press Capacity up to 100 tons. Press brake capacity up to 105 tons 8ft. x 7/32in. All spray and stove finishes. A.I.D. approved. — The Kaymet Company, Kaymet Works, Sylvan Grove, London, S.E.15. Telephone: NEW Cross 6644. [2036]

### MISCELLANEOUS

#### PHOTO-ELECTRIC CONTROLS for industry

Send for catalogues

**HIRD-BROWN LIMITED**  
FLASH STREET, BOLTON

Telephone 27311 [2027]

#### Wanted

#### GERMANIUM

Surplus Lots

Also Metal Scrap

Box 5245 [2035]

### BOOKS WANTED

Wanted, issues of Electronic & Radio Engineer June 1959 and Industrial Electronics October 1962. Box 5244 [2034]

### BOOKS, ETC.

"ADVANCED Theory of Waveguides." By L. Lewin. Sets out various methods of treating problems arising in work on this complex subject. The author has selected for discussion a number of topics as representative of the field in which the centimetre-wave engineer is engaged, many of the examples being concerned with the rectangular waveguide, 30s net from all booksellers. By post 31s from Iliffe Books Ltd., Dorset House, Stamford Street, London, S.E.1.

"RADIO Designer's Handbook." (4th Edition.) Editor: F. Langford-Smith, B.Sc., B.E., Senior Member I.R.E.(U.S.A.), A.M.I.E.(Aust.). A comprehensive reference book, the work of ten authors and twenty-three collaborating engineers, containing a vast amount of data in a readily accessible form. The book is intended especially for those interested in the design and application of radio receivers or audio amplifiers. 55s net from all booksellers. By post 57s 9d from Iliffe Books Ltd., Dorset House, Stamford Street, S.E.1.

For further information circle 259 on Service Card

### Electronic Circuits and Instrumentation Systems

**J. J. STUDER**, Lecturer in Electrical Engineering, University of California, Berkeley

To build an understanding of modern complex electronic instrumentation systems, the author discusses topics such as signal transfer properties and modulation and demodulation. This material is of particular interest to engineers and scientists employing these systems; choice and operating methods of instrumentation are not stressed. 436 pages, 80s.

### Basic Electronics Second Edition

**R. G. KLOEFFLER**, Professor of Electrical Engineering, Kansas University

**M. W. HORRELL**, Vice-President in Charge of Manufacturing and Engineering, UNIVAC, New York

and **L. E. HARGRAVE, Jr.**, President of Business Research and Engineering Corporation, Ardmore, Pennsylvania

This revision of a text for the undergraduate student, whether majoring in electrical engineering or other engineering fields, presents a completely new approach to introductory electronics in comparison with the successful first edition. A concurrent coverage of vacuum tubes and transistors is featured, in a clear and direct fashion, with a minimum of mathematical apparatus. 653 pages, 80s.

**John Wiley · Interscience**

Glen House · Stag Place · London SW1

For further information circle 260 on Service Card

### CLEVELAND ELECTRONICS INC. OF AMERICA

#### "CLETRON" Deflection Components

$\frac{1}{2}$ " - 1" - 1 $\frac{1}{2}$ "

Vidicon Focus Coils.  
Vidicon Deflection Yokes.  
Vidicon Alignment Coils.  
Vidicon Deflection Assemblies (Yoke, Focus and Alignment Coil).  
Horizontal and Vertical Deflection Output Transformers.

3"

Image Orthicon Magnetic Deflection Yoke.  
Image Orthicon Focus Coil.  
Image Orthicon Alignment Coil.

4 $\frac{1}{2}$ "

Image Orthicon Deflection Assembly.

Some of the features that make "Cletron" products so popular throughout the U.S.A.:

Geometric Distortion less than 1%.  
Coils covered with Mu-Metal Shield.  
Available to Industrial, Reinforced and Military Specifications.  
Will operate Vidicon, Uvicon and Permachon Tubes.

Data Sheets, Literature and Prices from  
EXCLUSIVE U.K. DISTRIBUTORS:

**T. J. SAS & SON LTD. DEPT. I**

23 UPPER BROOK STREET, LONDON, W.1

Telex: 24508

Telephone: HYDe Park 0521

# NEW! CHARTS

## ON BOSCH METALLISED ELECTROSENSITIVE RECORDING PAPER

ULTRA SENSITIVE 15-20v  
ULTRA THIN · 0015

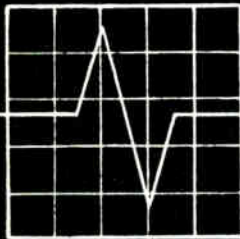
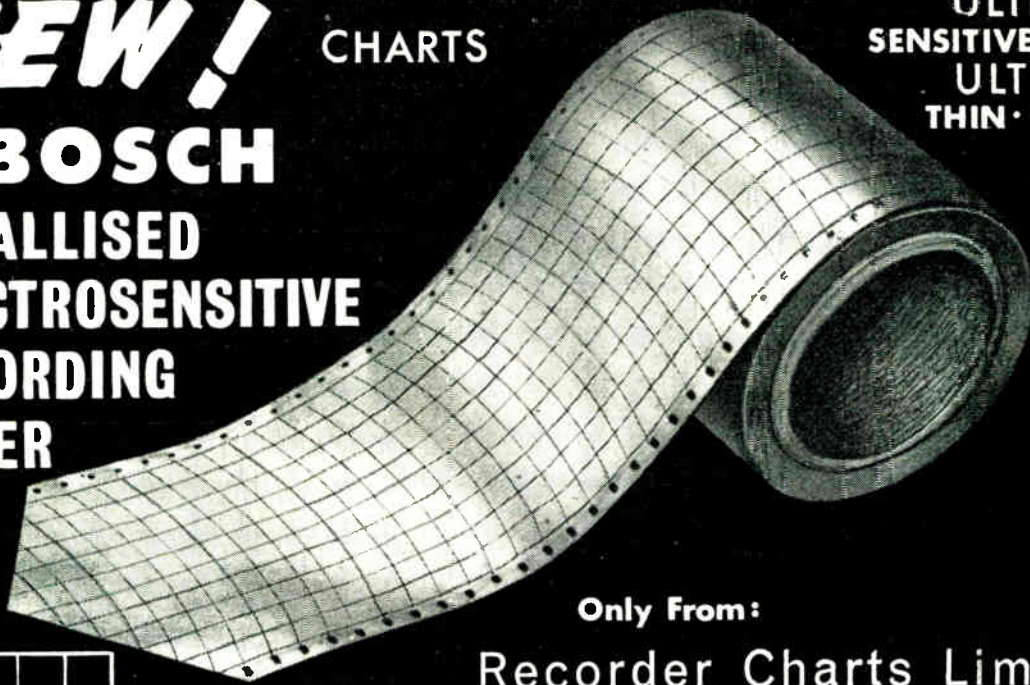

Only From:

**Recorder Charts Limited**

P. O. Box 774 · Clyde Vale · London · S. E. 23

Telephone: FORest Hill 9200    Telegrams: Verigraph London-SE23

### Index to Advertisers

Adcola Products Ltd. .... 36	Haldens ..... 45	R.C.A. (Gt. Britain) Ltd. .... 6
Advance Components Ltd. .... 19	Harwin Engineers Ltd. .... 11, 13	Recorder Charts Ltd. .... 48
A.E.I. Ltd. (Electronic Apparatus Division) .... 20, 21	Hughes International (U.K.) Ltd. .... 25	Reliance Controls Ltd. .... 2
Aircraft Marine Products Ltd. .... 15	Iliffe Books Ltd. .... 46	Sas, T. J., & Son Ltd. .... 47
Anglo-American Vulcanised Fibre Co. Ltd. .... 14	International Rectifier (Gt. Britain) Ltd. .... 42	Silentbloc Ltd. .... <i>Cover iii</i>
Appointments Vacant ..... 47	Karstens Georg GMBH ..... 46	Solartron Electronic Group Ltd. 38, 39
Atlas Instruments & Electronics ... 32	Kuhnke, H., Ltd. .... 44	SPS International Ltd. .... 43
Aveley Electric Ltd. .... 34	Light Soldering Developments Ltd. 44	Standard Telephones & Cables Ltd. 7, 8, 9
Brush Crystal Co. Ltd. .... 10	Metway Electrical Industries Ltd. ... 44	Telcon Metals Ltd. .... 37
Cannon Electric Co. Ltd. .... 22	M.O. Valve Ltd. .... 1	Thorn Electronics Ltd. .... 43
CIBA (A.R.L.) Ltd. .... 24	Mullard Ltd. .... <i>Cover ii</i> , 4, 5	Union Carbide Ltd. .... 41
Coutant Electronics Ltd. .... 17	Murex Ltd. .... 36	Varian AG ..... 29
E.A. Data-Processing Ltd. .... 30, 31	Oxley Developments Co. Ltd. .... 46	Walmore Electronics Ltd. .... 45
Electrosil Ltd. .... 16	Phillips Control (G.B.) Ltd. .... 44	Welwyn Electric Ltd. .... 23
Ericsson Telephones Ltd. .... 26	Phoenix Telephones Ltd. .... 18	Westinghouse Brake & Signal Co. Ltd. .... 12
Erie Resistor Ltd. .... <i>Cover iv</i>	Plannair Ltd. .... 3	Wiley, J., & Sons Ltd. .... 47
Ferranti Ltd. .... 35	Pullin, R. B., & Co. Ltd. .... 33	Wingrove & Rogers Ltd. .... 40



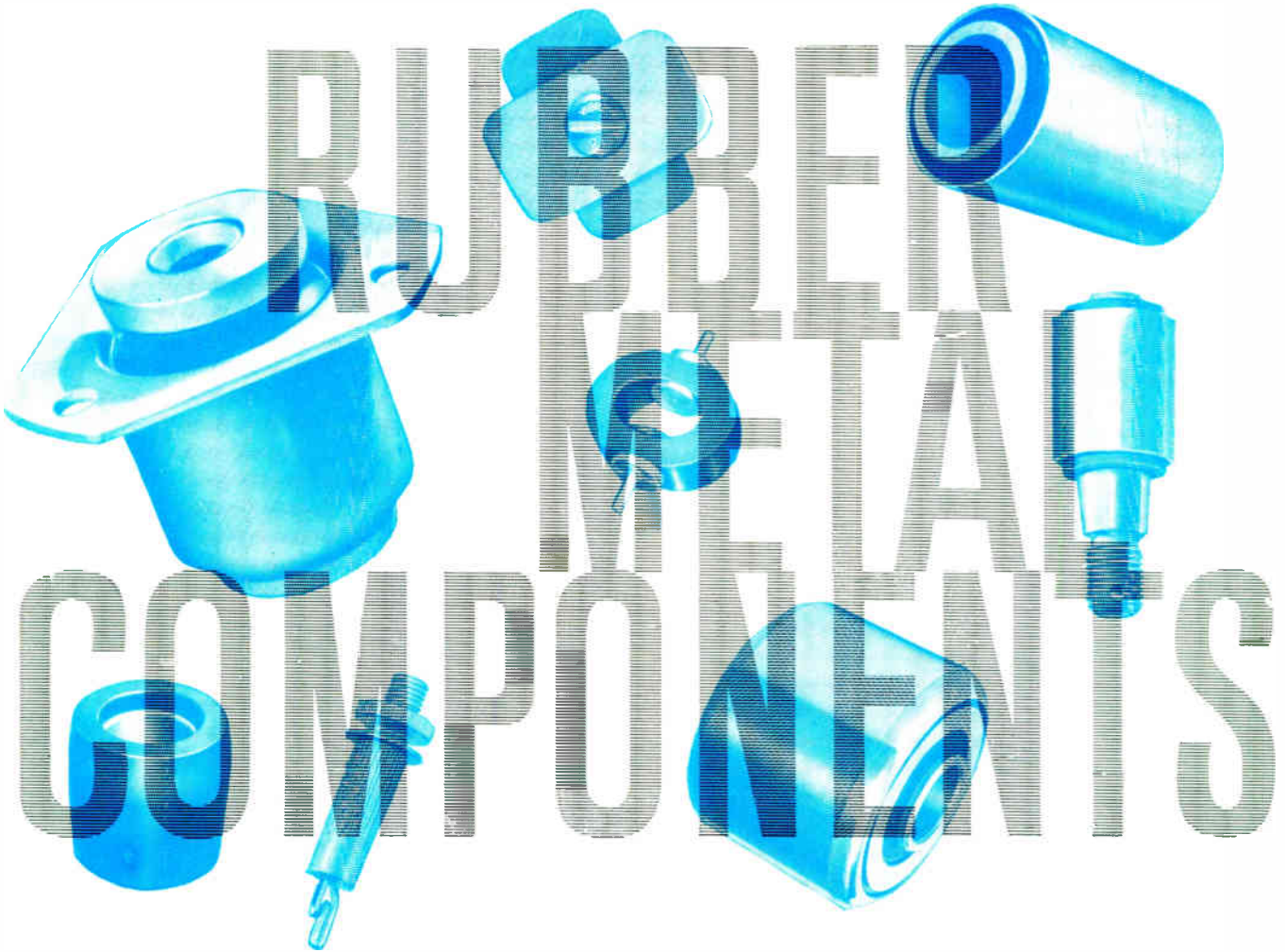

The range of Silentbloc products includes a wide variety of devices for noise and vibration reduction, efficient power transmission, instrument protection, power unit location, vehicle suspension and many other purposes in all branches of industry. Weight and power ranges provided for extend from light portable equipment to the heaviest industrial machinery.



*Come to us at the drawing-board stage*

ENDLESS EXTENSIBLE RUBBER BUSHES  
 "INTERLOCK" LOCATING PINS  
 DRIVING BELTS  
 FLEXIBLE COUPLINGS  
 FLEXIBLE BEARINGS  
 INSTRUMENT MOUNTINGS  
 "VIBREX" PANEL FASTENERS  
 MACHINERY MOUNTINGS  
 BALL JOINTS

# SILENTBLOC

ANTI-VIBRATION DEVICES

FOR ROAD AND RAIL TRACTION  
 INDUSTRY • MARINE APPLICATIONS  
 INSTRUMENTATION • ELECTRONICS

**SILENTBLOC LIMITED MANOR ROYAL CRAWLEY SUSSEX**

Telephone: Crawley 27733      Telegrams: Silentbloc Crawley

Andre Rubber Co. Ltd., is another Silentbloc Company.

Silentbloc products are also manufactured by Silentbloc (Australia) Pty. Ltd., Melbourne

Broadway S/115

For further information circle 202 on Service Card

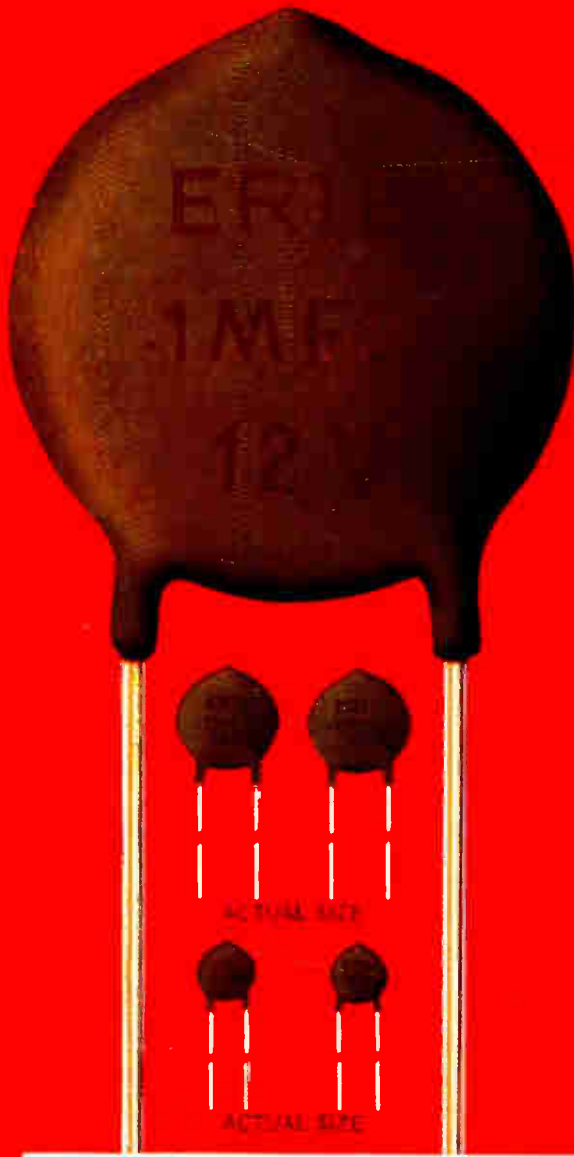

# Transcaps<sup>★</sup> Pat. App. for beat paper capacitors 4 ways!!!!

- 1 Transcaps are much smaller than paper capacitors of identical capacitance.
- 2 Transcaps — thin discs — are more conveniently shaped to fit into confined spaces.
- 3 Transcaps — with their parallel leads — are more speedily mounted, particularly to printed circuit boards.
- 4 Transcaps are superior — in stability and in reliability.

***There's always  
room for a  
Transcap<sup>★</sup>***

Transcap Style	Value $\mu\text{F}$	Volts Wkg d.c.	Transcap Style	Value $\mu\text{F}$	Volts Wkg d.c.	Transcap Style	Value $\mu\text{F}$	Volts Wkg d.c.
831/T/12V	0.010	12	831/T/3V	0.047	3	831/T/3V	0.100	3
831/T/12V	0.015	12	811/T/25V	0.047	25	811/T/12V	0.100	12
831/T/12V	0.020	12	831/T/3V	0.050	3	811/T/3V	0.250	3
831/T/12V	0.022	12	811/T/25V	0.050	25	811/T/3V	0.470	3
831/T/12V	0.030	12	831/T/3V	0.068	3	811/T/3V	0.500	3
831/T/12V	0.033	12	811/T/12V	0.068	12			

SOUTH DENES, GT YARMOUTH, NORFOLK  
Telephone: Great Yarmouth 4911

Factories  
Great Yarmouth and Tunbridge Wells, England;  
Trenton, Ont., Canada; Erie, Pa., U.S.A.

# ERIE

R E S I S T O R  
L I M I T E D

<sup>★</sup> Registered Trade Marks