

# Hobby Electronics



## SHARK!

**Cassette Decks And Tapes**  
*We've got it taped*

**Short Circuit Special**  
*Eight pages worth*

**Resistors**  
*Another inside story*

**Baby Alarm**  
*A peaceful project*

**Points Controller**  
*A new direction*

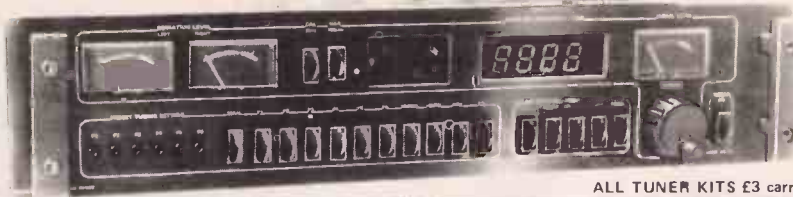
**Linear Scale Ohmmeter**  
*Ohm on the range*

# Tecknowledgey for sale.

## The Mark III FM Tuner

DIY Hi-Fi will never seem the same again. Ambit's Mark III tuner system is electrically & visually superior to all others. Some options available, but the illustrated version with reference series modules: £149.00 + £18.62 VAT

With Hyperfi Series modules £185.00 + £23.12



## Feature of the system

- \* Precision construction & design of all parts
- \* Time/frequency display
- \* State of the art performance with facilities for updates, using modular plug in systems.
- \* Deviation level calibrator for recording
- \* All usual tuner features

## Digital Dorchester All Band Broadcast Tuner: LW/MW/SW/SW/SW/FM stereo

A multiband superhet tuner, constructed using a single IC for RF/IF processing - but with all features you would expect of designs of far greater complexity. The FM section uses a three section (air gang) tuned FET tunerhead, with ceramic IF filters and interstimation mutes; AM employs a double balanced mixer input stage, with mechanical IF filters - plus a 8FO and MOSFET product detector for CW/SSB reception. Styled in a matching unit to the Mark III FM only tuner, employing the same degree of care in mechanical design to enable easy construction. MW/LW reception via a ferrite rod antenna.

Electronics only (PCB and all components thereon) £33.00 + £4.12 VAT  
 Complete with digital frequency readout/clock-timer hardware £99.00 + £12.37 VAT  
 Complete with MA1023 clock/timer module with dial scale £66.00 + £8.25 VAT  
 Hardware packages are available separately if you wish to house your own designs in a professional case structure. Please deduct the cost of electronics from complete prices.

## LW/MW/FM LCD Digital Frequency Display - July PW feature

Update your old radio, or build this into a new design. Or use it as a servicing aid - this low power unit with LCD display reads direct frequency in kHz/MHz, or with usual AM/FM IF offsets for received frequency.

Low power LCD means no RFI - 15-20mA at 9v even with the divide by 100 prescaler. FM resolution is 100kHz, AM 1kHz. Sensitivities better than 10mV  
 Complete kit £19.50 + £1.56 VAT. Built and tested version £24.00 + £1.92 VAT  
 Various other DFM systems described in our catalogue part 2 - including a one chip solution to providing digital display of FRG7 kHz dial, combined with clock/timers etc.



## PW SANDBANKS PI METAL LOCATOR

Maintaining our professional approach to home constructor kits, we offer the pulse induction 'Sandbanks'. Now with injection molded casing for greatly improved environmental sealing. £37.00 + £2.96vat.

## VHF MONITOR RX WITH PLESSEY IC

4/9 channel version of the PW design - but using standard 3rd OT crystals, and TOYO 8 pole crystal filter with matching transformers. Coil sets from our standard range to cover bands from 40 to 200MHz. Complete module kit £31.25 + £3.90vat.

## ETI - REMCON RADIO CONTROL

A tried and tested RC system with a full set of supporting hardware from a well known manufacturer. Please send for details - and watch our ads for further news of developments in RC products.

## Radio and Audio Modules : The biggest range/ best specs:

EF5801/3/4 6 stage varicap tunerheads with LO feed and various levels of sophistication. New 5804 include pin AGC loop 'on board'. 5801:£17.45+£2.18vat - 5803:£19.75+£2.47vat 5804:£24.95 +£3.18vat. Frequencies in 40-180MHz on approx.

EF5402 4 stage varicap with TDA1062, compact FET/Bipolar input stage, low noise, balanced mixer, pin agc, osumm output. A worthy successor to the 5400. £10.75+£1.34vat

The 5402 is available centred on a wide range of frequencies from 30MHz to 180MHz. Non standard units £14.75+£1.84 - 3 weeks.

8319 4 stage varicap tunerhead from Larsholt using MOSFET RF and mixer stages. New temperature compensated oscillator for wide ranges of ambient temperature £13.45+£1.68vat

7252 Complete Larsholt FM tuner less stereo decoder. £26.50+£3.31vat

7253 Stereo FM tuner from Larsholt with FET head. (as 7252)

944378 Hyperfi stereo decoder. The very best. £19.95+£2.19vat

911223 Pilot cancel stereo decoder, priced to make the MC1310 as obsolete as it now deserves to be. £12.50+£1.56vat

Inotec 1-A fully DC tuned and switched LW/MW/FM stereo tuner to interface with synthesiser control etc. A first! Details OA

## COMPONENTS for Radio and Audio ICs, HMOS etc.

The list is too long to attempt here, but AMBIT specializes in all types of semiconductor for radio reception, including devices operating from DC to 5GHz. New low cost SBL1 diode ring mixers (equiv case MD108 etc) - first with HMOS fets, now with a PCB for DC amplifier, and offset sense and protection relay for speakers. See catalogue and updates for most info, please send an SAE for information on anything you cannot find in catalogues.

Radio ICs	cost +vat	Stereo ICs	cost +vat	AF power ICs	cost +vat
CA3089E	1.94 24	MC1310P	1.50 19	LM380N	1.00 12
CA3189E	2.45 30	uA758	2.20 27	TBA810AS	1.09 14
HA1137W	2.20 27	CA3090A	2.75 34	TDA2002	1.95 24
SN76660	0.75 9	HA1196	3.95 49	TBA820M	0.75 9
TDA1090	3.35 42	HA11223	4.35 54		
TDA1083	1.95 24	KB4437	4.35 54		
TDA1220	1.40 17	KB2224	2.75 34		
SL6640	2.75 34				
MC3357	3.12 39				
HA1197W	1.40 17				
MC1496	1.25 16				
LM373/4	3.75 49				

from the general list:  
 LEDs: all colours and low prices  
 2SJ48/2SK134 HMOS  
 9.90 + £0.80 vat (Pair)  
 Signal fets/transistors and TOKO COILS & FILTERS!

OSTS: Remember all OSTS stocks are obtained from BS9000 approved sources - your assurance that all devices are very best first quality commercial types. Some LPSN TTL is presently in great demand, so please check by phone before ordering.

## TTL Standard AND LP Schottky

'N'	'LSN'	'N'	'LSN'	'N'	'LSN'	'N'	'LSN'	'N'	'LSN'	
7400	13	20	7455	35	24	74126	57	44	74185	134
7401	13	20	7460	17		74128	74		74188	275
7402	14	20	7463		124	74132	73	78	74190	115
7403	14	20	7470	28		74133		29	74191	
7404	14	24	7472	28		74136		40	74192	105
7405	18	26	7473	32	38	74138		60	74193	105
7406	38		7474	27	38	74139		60	74194	105
7407	38		7475	38	40	74141	56		74195	95
7408	17	24	7476	37	38	74142	265		74196	99
7409	17	24	7478		38	74143	312		74197	85
7410	15	24	7480	48		74144	312		74198	150
7411	20	24	7481	86		74145	65	97	74199	160
7412	17		7482	69		74147	175		74200	
7413	30		7483A		110	74148	109	191	74248	
7414	51		7484	97		74150	99	93	74249	
7415		24	7485	104	99	74151	64	84	74251	90
7416	30		7486	40	40	74153	64	54	74253	105
7417	30		7489	205	90	74154	96		74257	108
7420	16	24	7490	33	90	74155	54	110	74258	153
7421	29	24	7491	76	110	74156	80	110	74259	420
7422	24	24	7492	38	78	74157	67	55	74260	153
7423	27		7493	32	99	74158		60	74261	353
7425	27		7494	78		74159	210		74266	40
7426	36	27	7495A	65	99	74160	82	130	74273	124
7427	27	29	7496	58	120	74161	92	78	74275	312
7428	35	32	7497	185		74162	92	130	74279	52
7430	17	24	74100	119		74163	92	78	74283	120
7432	25	24	74104	63		74164	104	130	74290	95
7433	40	32	74105	62		74165	105		74291	95
7437	40	24	74107	32	38	74166			74295	120
7438	33	24	74109	63	38	74167	20		74298	100
7440	17	24	74110	54	54	74168			74324	157
7441	74		74111	68		74169		200	74325	242
7442	70	99	74112		38	74170	230	200	74326	237
7443	115		74113		38	74172	625		74327	237
7444	112		74114		38	74173	170		74352	100
7445	94		74116	198		74174	87	120	74353	100
7446	94		74118	83		74175	87	110	74362	715
7447	82	89	74119	119		74176	75		74365	49
7448	56	99	74120	115		74177	78		74366	49
7449		99	74121	25		74180	85		74367	43
7450	17		74122	46	57	74181	165	350	74368	49
7451	17		74123	48	73	74182	160		74373	77
7453	17		74124		137	74183		210	74374	77
7454	17		74125	38	44	74184	135		74375	60

## CD4000 CMOS

4000	17p	4059	563p	4522	149p
4001	17p	4060	115p	4527	157p
4002	17p	4063	109p	4528	102p
4006	109p	4065	53p	4529	141p
4007	18p	4067	400p	4530	90p
4008	80p	4068	25p	4531	141p
4009	58p	4069	20p	4532	125p
4010	58p	4070	20p	4534	614p
4011	17p	4071	20p	4536	380p
4012	17p	4072	20p	4538	150p
4013	55p	4073	20p	4539	110p
4014	95p	4074	20p	4541	141p
4016	52p	4075	90p	4543	174p
4017	80p	4077	20p	4549	399p
4018	80p	4078	20p	4553	440p
4019	60p	4081	20p	4554	153p
4020	93p	4082	20p	4556	77p
4021	82p	4085	82p	4557	386p
4022	90p	4086	82p	4558	117p
4023	17p	4089	150p	4559	388p
4024	76p	4093	50p	4560	218p
4025	17p	4094	190p	4561	65p
4026	180p	4095	100p	4562	530p
4027	55p	4097	372p	4566	159p
4028	72p	4098	110p	4568	281p
4029	100p	4099	122p	4569	303p
4030	58p	4160	90p	4572	25p
4031	250p	4161	90p	4580	600p
4032	100p	4162	90p	4581	319p
4033	145p	4163	90p	4582	164p
4034	200p	4174	100p	4583	84p
4035	120p	4175	95p	4584	63p
4036	250p	4194	95p	4585	100p
4037	100p	4501	23p		
4038	105p	4502	91p		
4039	250p	4503	69p		
4040	83p	4506	51p		
4041	90p	4507	55p		
4042	85p	4508	248p		
4043	85p	4510	99p		
4044	80p	4511	149p		
4045	150p	4512	98p		
4046	130p	4513	206p		
4047	99p	4514	260p		
4048	60p	4516	300p		
4049	55p	4518	125p		
4050	55p	4517	382p		
4051	65p	4518	103p		
4052	65p	4519	57p		
4053	85p	4520	109p		
4054	120p	4521	236p		
4055	135p				

## Micromarket

6800 series	8216	1.95	2114	£10
6800P	8224	3.50	2708	t
6820P	8228	4.78		
6850P	8251	6.25		
6810P	8255	5.40		
6852				
8080 series	2102	£1.70		
8080	2112	£3.40		
8212	2513	£7.54		
	4027	£5.78		

## MISC. LSI/Scalars/DVMs

NE555	30p	NE556	78p	NE558	180p	
LM3909	72p	95H90DC	320MHz	780p		
11C90DC	650MHz	£14.00				
ICM7216B1P	8 decade	10MHz	DFM/timer	with direct LED drive and all counter features	£19.82	
ICM7217A1B1	4 decade	programmable	cntr.		£9.50	
ICM7207	clock pulse	generator	IC		£4.95	
ICM7208	7 decade	counter/display	driver		£14.95	
ICM7106CP	LCD DVM	IC (3 1/2 digit)			£9.55	
ICM7106CPK	LCD DVM	KIT			£24.80	
ICM7107CP	LED DVM	IC			£9.55	
ICM7107CPK	LED DVM	KIT			£20.65	
SP8629	divide by	100/200MHz	scalar		£4.20	
MSL2318	divide by	100 to 175MHz	mm	divide by 10 to 45MHz	mm	£4.20

PLEASE REMEMBER TO ADD 8% VAT TO ITEMS LISTED UNDER OSTS

## LINEARS non-consumer

BIMOS	LM324N	71p	0.43" High Efficiency HP:
CA3130E	84p	LM339N	60p
CA3130T	90p	LM348N	186p
CA3140E	72p	LM3900N	60p
CA3140T	72p		

# Hobby Electronics

Vol. 1. No. 9

July 1979

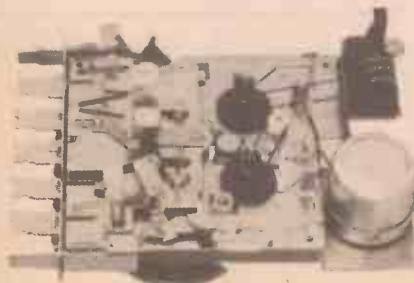
**Monitor** ..... 6

**Shark** ..... 9



Jaws the job

**Cassette Decks And Tapes** 13



We've got it taped

**HE Book Service** ..... 19  
Books you're bound to read

**Linear Scale Ohmmeter** .. 20



Ohm made test gear

**Binary Numbers** ..... 23

Computer language

**Market Place** ..... 26

Bargain basement

**Resistors** ..... 28



Ohm from Ohm

**Next month's HE** ..... 33

Coming soon

**Short Circuits Special** .... 35

Experiments galore

**Next Month's ETI** ..... 43

**Decibels** ..... 44

Some sound theory

**Points Controller** ..... 46



Get on the right track

**Into Linear ICs** ..... 49

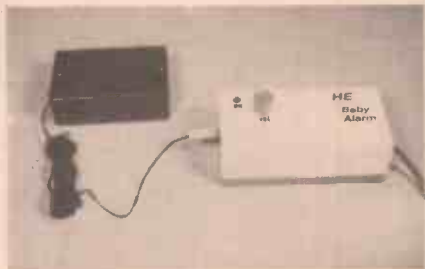
First of the series

**Kit Review** ..... 54



A bright spark?

**Baby Alarm** ..... 57



Wah-Wah amplifier

**SI Units** ..... 60

**Hobby Chit-Chat** ..... 64

Topical topics

**Specials** ..... 67

A new addition

**Letters** ..... 68

Much controversy

**Petition** ..... 70

**Hobbyprints** ..... 73

• Just rub 'em down

## Hobby Electronics

25-27 Oxford Street, London W1R 1RF  
01-434 1781

Published by Modmags Ltd,

Distributed by Argus Distribution Ltd,

Printed by QB Ltd, Colchester

Hobby Electronics is normally published  
on the second Friday of the month prior  
to the cover date

**Editor:** Halvor Moorshead

**Editorial Asst:** Richard Maybury

**Project Team:** Ray Marston, Steve Ramsa-  
hadeo, John Fitzgerald, Keith Brindley

**Production:** Diego Rincon, Peter Howells,  
Gail Armbrust.

**Technical Artists:** Paul Edwards, Tony  
Strakas

**Advertising:** Chris Surgenor, David Sinfield,  
Joy Cheshire, Sandie Neville

**Admin Staff:** Margaret Hewitt, Alan Carlton,  
Bren Goodwin, Kim Hamlin, Tim Salmon,  
Neville MacDonald, Tracey Campbell.

**Copyright.** All material in this publication is  
subject to world-wide copyright protection.  
Permission to reproduce printed circuit board  
patterns commercially or marketing kits of the  
projects must be sought from the Editor. All  
reasonable care is taken in the preparation of  
the magazine to ensure accuracy but Mod-  
mags cannot be held responsible for it legally.

- ACCESS
- BARCLAYCARD
- CASH
- CHEQUE

- FREEPOST ON ORDERS
- VAT INCLUSIVE PRICES
- ADD 30p P&P
- 24 HR TELEPHONE ANSWERING SERVICE

# GMT ELECTRONICS B

## Freepost Birmingham B19 1BR

TEL ORDERS WELCOME

### DIGITAL INTEGRATED CIRCUITS

4000 Buffered C-MOS - High Speed

5-15V 'B' Series, Up to 20MHz

HEF4000	14	HEF4046	100
HEF4001	14	HEF4047	87
HEF4002	14	HEF4048	28
HEF4006	95	HEF4050	28
HEF4007	14	HEF4051	69
HEF4008	80	HEF4052	72
HEF4011	14	HEF4053	72
HEF4012	14	HEF4056	37
HEF4013	32	HEF4067	380
HEF4014	14	HEF4068	16
HEF4015	60	HEF4069	14
HEF4016	35	HEF4070	14
HEF4017	55	HEF4071	14
HEF4018	65	HEF4072	16
HEF4019	46	HEF4073	16
HEF4020	88	HEF4075	16
HEF4021	85	HEF4076	85
HEF4022	87	HEF4077	14
HEF4023	14	HEF4078	16
HEF4024	45	HEF4081	16
HEF4025	14	HEF4082	16
HEF4027	32	HEF4085	64
HEF4028	52	HEF4086	64
HEF4029	60	HEF4093	60
HEF4030	46	HEF4094	175
HEF4031	200	HEF4104	166
HEF4035	110	HEF4502	91
HEF4040	68	HEF4506	571
HEF4041	75	HEF4508	81
HEF4042	54	HEF4510	70
HEF4043	79	HEF4511	110
HEF4044	84	HEF4512	98

### 7400 T.T.L.

N7400N	9	N7444N	83	N74122N	39	N74192N	60	N74LS28N	32	N74LS138N	85	N74LS253N	105
N7401N	11	N7445N	85	N74123N	37	N74194N	60	N74LS30N	16	N74LS139N	85	N74LS257N	104
N7402N	11	N7446AN	82	N74125N	32	N74195N	79	N74LS32N	24	N74LS153N	76	N74LS258N	107
N7403N	11	N7447AN	51	N74126N	32	N74198N	120	N74LS33N	32	N74LS154N	122	N74LS260N	26
N7404N	12	N7448AN	45	N74128N	74	N74199N	139	N74LS37N	24	N74LS155N	80	N74LS261N	300
N7405N	13	N7449N	26	N74129N	15	N74202N	160	N74LS38N	24	N74LS156N	80	N74LS266N	40
N7406N	25	N7451N	13	N74145N	60	N74279N	116	N74LS40N	22	N74LS157N	54	N74LS273N	130
N7407N	27	N7453N	15	N74147N	125	N74298N	200	N74LS42N	53	N74LS158N	60	N74LS283N	116
N7408N	13	N7454N	13	N74148N	63	N74365N	150	N74LS51N	22	N74LS160N	120	N74LS290N	90
N7409N	13	N7460N	13	N74150N	13	N74366N	150	N74LS54N	16	N74LS161N	78	N74LS293N	100
N7410N	11	N7470N	11	N74151N	26	N74377N	120	N74LS55N	22	N74LS162N	130	N74LS298N	100
N7411N	18	N7472N	22	N74153N	55	N74368N	150	N74LS57N	29	N74LS163N	78	N74LS324N	170
N7412N	23	N7473N	23	N74154N	96	N74LS73N	40	N74LS164N	90	N74LS164N	90	N74LS324N	170
N7413N	23	N7474N	23	N74155N	53	N74LS76N	33	N74LS164N	90	N74LS164N	90	N74LS324N	170
N7414N	46	N7475N	28	N74156N	48	N74LS78N	33	N74LS164N	90	N74LS164N	90	N74LS324N	170
N7415N	26	N7476N	26	N74157N	49	N74LS80N	33	N74LS164N	90	N74LS164N	90	N74LS324N	170
N7416N	23	N7480N	43	N74158N	54	N74LS85N	70	N74LS164N	90	N74LS164N	90	N74LS324N	170
N7417N	21	N7483N	63	N74160N	74	N74LS86N	33	N74LS164N	90	N74LS164N	90	N74LS324N	170
N7418N	26	N7485N	65	N74161N	74	N74LS89N	45	N74LS164N	90	N74LS164N	90	N74LS324N	170
N7419N	27	N7486N	74	N74162N	74	N74LS92N	70	N74LS164N	90	N74LS164N	90	N74LS324N	170
N7420N	28	N7488N	65	N74163N	74	N74LS93N	45	N74LS164N	90	N74LS164N	90	N74LS324N	170
N7421N	26	N7489N	30	N74164N	60	N74LS95N	65	N74LS164N	90	N74LS164N	90	N74LS324N	170
N7422N	22	N7491AN	33	N74165N	65	N74LS96N	116	N74LS164N	90	N74LS164N	90	N74LS324N	170
N7423N	21	N7492N	30	N74166N	61	N74LS97N	38	N74LS164N	90	N74LS164N	90	N74LS324N	170
N7424N	21	N7493N	31	N74167N	61	N74LS100N	23	N74LS164N	90	N74LS164N	90	N74LS324N	170
N7425N	21	N7494N	74	N74168N	62	N74LS101N	23	N74LS164N	90	N74LS164N	90	N74LS324N	170
N7426N	22	N7495AN	48	N74169N	63	N74LS102N	23	N74LS164N	90	N74LS164N	90	N74LS324N	170
N7427N	21	N7496N	46	N74170N	62	N74LS103N	38	N74LS164N	90	N74LS164N	90	N74LS324N	170
N7428N	21	N74100N	88	N74171N	63	N74LS104N	38	N74LS164N	90	N74LS164N	90	N74LS324N	170
N7429N	60	N74101N	25	N74172N	65	N74LS105N	24	N74LS164N	90	N74LS164N	90	N74LS324N	170
N7430N	12	N74102N	12	N74173N	111	N74LS106N	23	N74LS164N	90	N74LS164N	90	N74LS324N	170
N7431N	12	N74103N	48	N74174N	63	N74LS107N	38	N74LS164N	90	N74LS164N	90	N74LS324N	170
N7432N	21	N74104N	88	N74175N	62	N74LS108N	38	N74LS164N	90	N74LS164N	90	N74LS324N	170
N7433N	21	N74105N	88	N74176N	63	N74LS109N	38	N74LS164N	90	N74LS164N	90	N74LS324N	170
N7434N	60	N74106N	25	N74177N	65	N74LS110N	24	N74LS164N	90	N74LS164N	90	N74LS324N	170
N7435N	12	N74107N	25	N74178N	60	N74LS111N	24	N74LS164N	90	N74LS164N	90	N74LS324N	170
N7436N	12	N74108N	12	N74179N	165	N74LS112N	24	N74LS164N	90	N74LS164N	90	N74LS324N	170
N7437N	148	N74109N	148	N74180N	89	N74LS113N	38	N74LS164N	90	N74LS164N	90	N74LS324N	170
N7438N	79	N74110N	23	N74181N	165	N74LS114N	38	N74LS164N	90	N74LS164N	90	N74LS324N	170
N7439N	79	N74111N	23	N74182N	69	N74LS115N	38	N74LS164N	90	N74LS164N	90	N74LS324N	170
N7440N	79	N74112N	23	N74183N	69	N74LS116N	24	N74LS164N	90	N74LS164N	90	N74LS324N	170
N7441N	79	N74113N	23	N74184N	65	N74LS117N	24	N74LS164N	90	N74LS164N	90	N74LS324N	170
N7442N	79	N74114N	23	N74185N	65	N74LS118N	24	N74LS164N	90	N74LS164N	90	N74LS324N	170
N7443N	79	N74115N	23	N74186N	65	N74LS119N	24	N74LS164N	90	N74LS164N	90	N74LS324N	170
N7444N	79	N74116N	23	N74187N	65	N74LS120N	24	N74LS164N	90	N74LS164N	90	N74LS324N	170
N7445N	79	N74117N	23	N74188N	65	N74LS121N	24	N74LS164N	90	N74LS164N	90	N74LS324N	170
N7446AN	82	N74118N	23	N74189N	65	N74LS122N	24	N74LS164N	90	N74LS164N	90	N74LS324N	170
N7447AN	51	N74119N	23	N74190N	65	N74LS123N	24	N74LS164N	90	N74LS164N	90	N74LS324N	170
N7448AN	45	N74120N	23	N74191N	65	N74LS124N	24	N74LS164N	90	N74LS164N	90	N74LS324N	170
N7449N	26	N74121N	23	N74192N	60	N74LS125N	24	N74LS164N	90	N74LS164N	90	N74LS324N	170
N7451N	13	N74122N	23	N74193N	60	N74LS126N	24	N74LS164N	90	N74LS164N	90	N74LS324N	170
N7453N	15	N74123N	23	N74194N	60	N74LS127N	24	N74LS164N	90	N74LS164N	90	N74LS324N	170
N7454N	13	N74124N	23	N74195N	79	N74LS128N	24	N74LS164N	90	N74LS164N	90	N74LS324N	170
N7460N	13	N74125N	23	N74196N	61	N74LS129N	24	N74LS164N	90	N74LS164N	90	N74LS324N	170
N7470N	11	N74126N	23	N74197N	61	N74LS130N	24	N74LS164N	90	N74LS164N	90	N74LS324N	170
N7472N	22	N74127N	23	N74198N	120	N74LS131N	38	N74LS164N	90	N74LS164N	90	N74LS324N	170
N7473N	23	N74128N	74	N74199N	139	N74LS132N	38	N74LS164N	90	N74LS164N	90	N74LS324N	170
N7474N	23	N74129N	15	N74200N	160	N74LS133N	38	N74LS164N	90	N74LS164N	90	N74LS324N	170
N7475N	28	N74130N	74	N74201N	139	N74LS134N	38	N74LS164N	90	N74LS164N	90	N74LS324N	170
N7476N	26	N74131N	63	N74202N	160	N74LS135N	38	N74LS164N	90	N74LS164N	90	N74LS324N	170
N7478N	43	N74132N	63	N74203N	160	N74LS136N	38	N74LS164N	90	N74LS164N	90	N74LS324N	170
N7480N	63	N74133N	63	N74204N	160	N74LS137N	38	N74LS164N	90	N74LS164N	90	N74LS324N	170
N7483N	63	N74134N	63	N74205N	160	N74LS138N	38	N74LS164N	90	N74LS164N	90	N74LS324N	170
N7485N	65	N74135N	63	N74206N	160	N74LS139N	38	N74LS164N	90	N74LS164N	90	N74LS324N	170
N7486N	74	N74136N	63	N74207N	160	N74LS140N	38	N74LS164N	90	N74LS164N	90	N74LS324N	170
N7488N	65	N74137N	63	N74208N	160	N74LS141N	38	N74LS164N	90	N74LS164N	90	N74LS324N	170
N7489N	30	N74138N	63	N74209N	160	N74LS142N	38	N74LS164N	90	N74LS164N	90	N74LS324N	170
N7491AN	33	N74139N	63	N74210N	160	N74LS143N	38	N74LS164N	90	N74LS164N	90	N74LS324N	170
N7492N	30	N74140N	63	N74211N	160	N74LS144N	38	N74LS164N	90	N74LS164N	90	N74LS324N	170
N7493N	31	N74141N	63	N74212N	160	N74LS145N	38	N74LS164N	90	N74LS164N	90	N74LS324N	170
N7494N	74	N74142N	63	N74213N	160	N74LS146N	38	N74LS164N	90	N74LS164N	90	N74LS324N	170
N7495AN	48	N74143N	63	N74214N	160	N74LS147N	38	N74LS164N	90	N74LS164N	90	N74LS324N	170
N7496N	46	N74144N	63	N74215N	160	N74LS148N	38	N74LS164N	90	N74LS164N	90	N74LS324N	170
N74100N	88	N74145N	63	N74216N	160	N74LS149N	38	N74LS164N	90	N74LS164N	90	N74LS324N	170
N74101N	25	N74146N	63	N74217N	160	N74LS150N	38	N74LS164N	90	N74LS164N	90	N74LS324N	170
N74102N	12	N74147N	63	N74218N	160	N74LS151N	38	N74LS164N	90	N74LS164N	90	N74LS324N	170
N74103N	48	N74148N	63	N74219N	160	N74LS152N	38	N74LS164N	90	N74LS164N	90	N74LS324N	170
N74104N	88	N74149N	63	N74220N	160	N74LS153N	38	N74LS164N	90	N74LS164N	90	N74LS324N	170
N74105N	88	N74150N	63										



# Monitor



## HUBBLE BUBBLE

PCBs have always been a bit of a chore to make, hours spent over the kitchen sink, holes appearing in your clothes for days afterwards. The use of Ferric Chloride in washing up bowls has usually been a necessary evil.

PCB baths and etchers have been available for some time now, the cost, however, has always put them firmly into the professional end of the market. The Bubble etcher featured here is intended for hobby use and this is reflected in its price, £55 inc. VAT. The etcher has heating element built-in, which will warm the etchant to its optimum operational temperature of 45 C within 30 minutes. The tank holds 5 litres of fluid and will accept a board of up to 12 x 10 inches.

The average etching time for both single and double sided boards is an astonishing 4½ minutes. The bath features in-built pneumatics (for the bubbler) and full thermostatic control for the heating element. If you're interested in finding out about the etcher (Type PLBE-1210) contact Mega Electronics at 9, Radwinter Road, Saffron Walden, Essex CB11 3HU for more details.

## HEAVY METAL TAPE CASSETTES



At first glance it would seem tape technology is moving backwards, (the first tape recorders used metal wires for recording). This new tape from Scotch (3M) claim their new Metafine tape has vastly improved characteristics over the best Chrome tapes available. Apparently the best tapes *would* consist of pure metal, Scotch have come as close as possible with their new fine metal particle coating. To get the best from these tapes new heads have had to be designed, several manufacturers have already designed new decks for this new generation of TAPE. If you want to find out more details contact Scotch at 3M UK Ltd, 3M House, Berkshire, RG12 1JU.

## SHORT WAVE ALBUM



We actually received a phone call from Mitch Murray the other day (he's the songwriter that wrote 'Ballad of Bonnie and Clyde', 'The Night Chicago Died' etc, etc). Anyway apart from being an avid HE reader he is also a Short Wave enthusiast of some years standing.

He has produced and narrated an LP called Long Live Short Wave. The LP contains a wealth of information for anyone even remotely interested in SWL (Short Wave Listening) or amateur radio. Side one deals with the technical aspects of SWL, signal identification etc. Side two contains recordings from the major Short Wave transmitters around the world. The album also contains a short piece from Henry Hatch, one of the personalities of the short wave. The album costs £3.50 inclusive of world-wide post and packing. The address to send your order to is Trans Island Productions, Dept. P, PO Box 24, Douglas, Isle of Man, British Isles.

## MONITOR FOR MONITOR

Anyone interested in Citizens Band radio must promise to close their eyes and not read the next few paragraphs, this new product is definitely *not* for them.

This Short Wave monitor is primarily intended to warn radio control enthusiasts of sources of potential interference from those wicked CB operators, other nearby R/C users or even sunspot activity??? (We hear from reliable sources that the Sun has *not* got a Post Office licence to transmit on 27 MHz).

The monitor is a 3 band superhetrodyne receiver which can be continuously tuned over the entire 27 MHz band as well as receiving normal broadcasts on AM and FM. Sharp eyed readers will spot that the dial is marked not in MHz but in CB channels, now isn't that peculiar?

Chromatronics are marketing the monitor for £17.95 (inc VAT and P+P). If you can't obtain it through normal retail channels, try Chromatronics at:- Coachworks House, River Way, Harlow, Essex.



# News from the Electronics World

## CAP CHECK

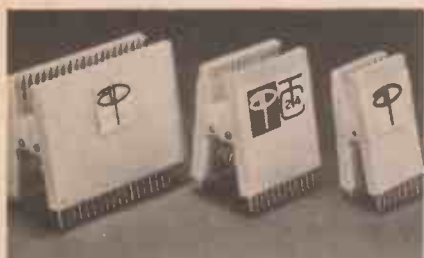


Capacitors, as you will appreciate are probably the most difficult of electronic components to check. Obviously if one goes short-circuit its easy enough to find with a multimeter but what happens if it ends up open-circuit or even worse out of tolerance?

The instrument featured here is a pocket-sized capacitance meter from Alcon Instruments. It's called the Varicap tester and will measure capacitance from just 1 or 2 pF to several thousand microfarads. The tester features an anti-parallex scale with a bright red pointer. The manufacturers claim it will handle all types of capacitor including polarised and non-polarised devices as well as Varicap and Varactor diodes. An LED is used to indicate accurately values above 3 µF by indicating the timing intervals between flashes of the LED.

The Varicap tester comes complete with instructions, leads, case and batteries. At £82.50 its not cheap but it is worthwhile if you are involved to any degree with servicing or fault-finding. Alcon can be reached at:- 19 Mulberry Walk, London SW3.

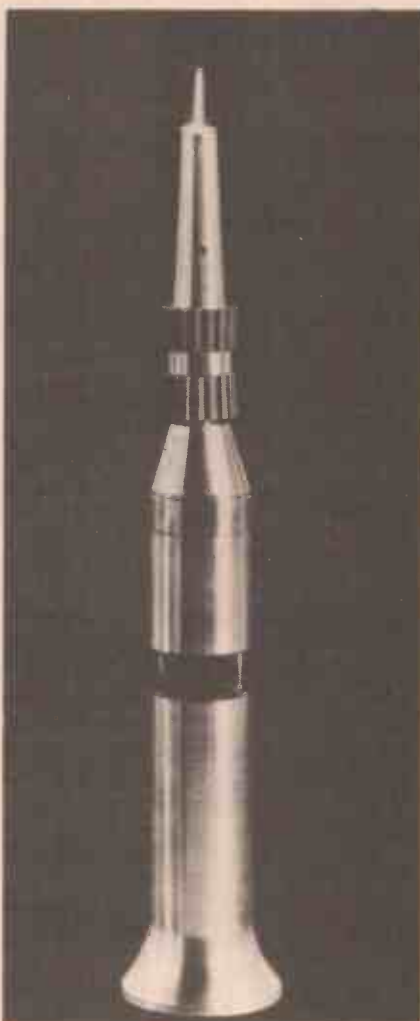
## CHIP CLIP



Another useful piece of test equipment, this time an IC Test Clip from Letrokit. The clip simply grips the IC on its lead pins with a 'comb' separating each of the legs. The connections are made by gold plated, phosphor-bronze wires that give a wiping/cleaning action every time the clip is used. Probes from test equipment can hang quite freely from the long terminal pins/connectors at the top of the test clip.

Letrokit are marketing a selection of clips conforming to popular pin-out configurations. (8, 14, and 16 DIP, DIL etc.) As an example the TC-14 (14 pin DIP) sells for about £2.95 which makes it an ideal investment for hobbyists and experimenters alike. Letrokit live at: Sutton Industrial Park, London Road, Earley, Reading, Berks RG6 1AZ.

## HOT ROD



This miniature-precision blowtorch is a bit of a novelty. It was originally designed for use in dental laboratories where craftsmen used it for exacting and delicate work. The "Miniflame" operates rather like one of those refillable gas lighters, using ordinary butane gas fuel.

Each charge lasts about one hour, the advantage being there is no bulky cylinder or cumbersome pipes to impede movement. The blowtorch, looking rather like an Apollo spacecraft, weighs in at just 130 grammes and is 180 mms long.

The flame, which reaches about 1600 C can be controlled by altering the gas pressure and air volume to give a wide range of flame sizes and shapes.

By using an optional Oxygen adaptor and miniature bottle of gas the flame temperature will soar to 2750 C. Obviously uses are very wide ranging, ideal for jewellers, soft soldering etc. (No not PCBs) Price is £17.62 for the basic tool and is available from Henri Picard & Frere Ltd. 357/359 Kennington Lane, London SE11 5HY.

## MAINS INTERFERENCE

We have had some information concerning one of our Short Circuits (Mains Interference Suppression May HE). The capacitors used in the filters should ideally be of the type designated Class X or Y to ensure complete safety. If you have any difficulty in obtaining these capacitors contact Mr. P. E. White at 22 York Road, Camberley, Surrey GU15 4HR.

## ERRATA

A couple of gremlins crept into our feature on 555 projects (May issue). The captions for figures 12 and 13 have become interchanged. On the Metronome circuit (formerly Fig. 13) C1 is 3.3µF, R2 is 2k2 and RV2 is 5k0. Sorry about that we really are trying you know. (Too true).

## HUP POWER

The university of Leeds have recently announced the development of a new material they claim will revolutionise the field of fuel cells.

Basically the fuel cell is a device that will either store or generate electricity very efficiently. The drawback until now has been their high cost and short life. This new material has been christened HUP (hydrogen uranyl phosphate). HUP is a semi-transparent solid consisting of layers of frozen acid. Apparently it has the property of being able to conduct protons. (We don't understand it either).

Apart from its use in fuel cells the Leeds group have built digital displays using HUP which turn from dark blue to yellow with the passage of a small current. Getting back to fuel cells another area of research has centred on the possibility of forming batteries directly onto PCBs.

HUP looks to become a major new development in electronics in the years to come and we at HE will be following its progress with interest.

## BANNED TOGETHER

Following our article in the June Issue on CB (Citizen Band radio) another organisation has been brought to our attention. They are the United Kingdom Citizens Band Campaign (UKCBC). Membership is £2.50 and we're told includes a regular newsletter, stickers etc. Their address is 32 Downbank Avenue, Barnehurst, Kent DA7 6RP.

## STOP PRESS

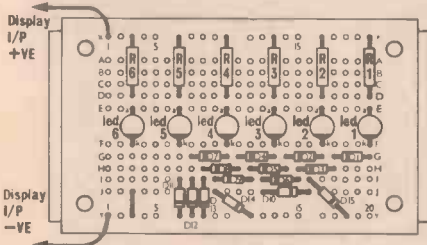
ONLY just made it, another CB club have just contacted us. They're only two weeks old and have already got nearly 100 members. Called the 10-4 Club, they have yet to find a permanent address, so we'll forward any enquiries, mark your envelopes 10-4 Club, c/o Hobby Electronics etc, etc. Meanwhile, if any other clubs/organisations dedicated to the legalisation of CB would like to get in touch with us we will be glad to hear from you.

# THREE FOR FREE FROM CSC

ELECTRONICS BY NUMBERS  
FREE PROJECTS  
No 1, No 2,  
& No 3.

## ELECTRONICS BY NUMBERS LED BAR GRAPH UNIVERSAL INDICATOR

Now using **EXPERIMENTOR BREADBOARDS** and following the instructions in "Electronics by numbers" ANYBODY can build electronic projects. Look at the diagram and select R1, this is a resistor with a value between 120 to 270 ohm. Plug it into holes X20 and D20, now take LED 1 and plug it into holes E20 and F20. Do the same with the Diodes e.g. plug D7 into holes G7 and G10.



## YOU WILL NEED

### EXP- ANY EXPERIMENTOR BREADBOARD

**D1 to D15** - Silicon Diodes (such as 1N914)  
**R1 to R6** - From 120-270 ohm resistors ¼ watt.  
**LED1 to LED6** - Light emitting diodes.

**LED BAR GRAPHS** are replacing analogue meters as voltage-level indicators in many instances.

This circuit uses the forward voltage drop of diodes to determine how many LEDs light up. Any type of diode can be used but you must use all the same type. For full working details of this circuit fill in the coupon. If you have already built the Two-transistor Radio and the Fish'n'cliks projects you will find that you can reuse the components from these projects to build other projects in the series.

FILL IN THE COUPON AND WE WILL SEND YOU FREE OF CHARGE FULL COPIES OF "ELECTRONICS BY NUMBERS" PROJECTS No 1, No 2 and No 3.

## PROTO-CLIP TEST CLIPS.

Brings IC leads up from crowded PC boards. Available plain or with cable with clips at one or both ends.



PC - 16 pin. £2.75.  
PC - 16 pin with cable. £6.00.  
PC - 16 with cable and 16 pin clips at both ends. £10.25.



Europe, Africa, Mid-East: CSC UK LTD.  
Unit 1, Shire Hill Industrial Estate,  
Saffron Walden, Essex CB11 3AQ.  
Telephone: SAFFRON WALDEN 21682.  
Telex: 817477.

## EXPERIMENTOR BREADBOARDS.

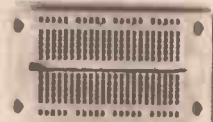
No soldering modular breadboards, simply plug components in and out of letter number identified nickel-silver contact holes. Start small and simply snap-lock boards together to build breadboard of any size.

All EXP Breadboards have two bus-bars as an integral part of the board, if you need more than 2 buses simply snap on 4 more bus-bars with the aid of an EXP.4B.

**EXP.325.** The ideal breadboard for 1 chip circuits.  
Accepts 8,14,16 and up to 22 pin IC's.  
**ONLY £1.60.**



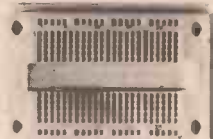
**EXP.350.** £3.15.  
270 contact points with two 20-point bus-bars.



**EXP. 300.**  
550 contacts with two 40-point bus-bars.  
**£5.75.**



**EXP. 650** for Micro-processors. **£3.60.**



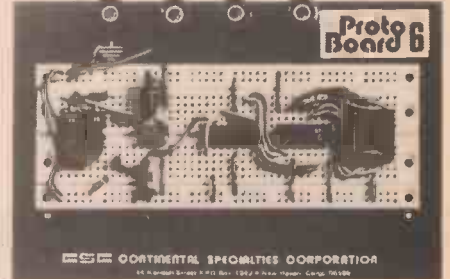
**EXP 4B.**  
More bus-bars.  
**£2.30.**



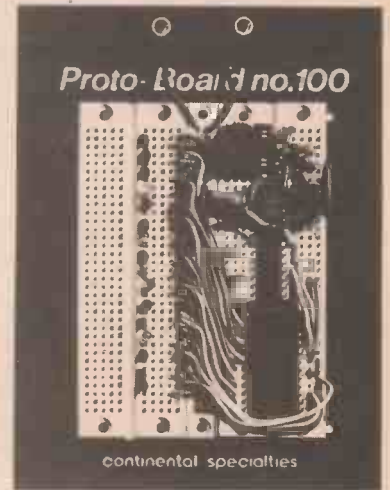
ALL EXP.300 Breadboards mix and match with 600 series.

## PROTO-BOARDS.

THE ULTIMATE IN BREADBOARDS FOR THE MINIMUM COST. TWO EASILY ASSEMBLED KITS.



PB.6 Kit, 630 contacts, four 5-way binding posts accepts up to six 14-pin Dips.  
**PROTO-BOARD 6 KIT. £9.20.**



PB.100 Kit complete with 760 contacts accepts up to ten 14-pin Dips, with two binding posts and sturdy base. Large capacity with Kit economy.  
**PROTO-BOARD 100 KIT £11.80.**

## HOW TO ORDER AND RECEIVE FREE COPY OF TWO-TRANSISTOR RADIO PROJECT, FISH'N'CLIKS AND LED BAR GRAPH.

CSC UK LTD. Unit 1, Shire Hill Industrial Estate, Saffron Walden, Essex CB11 3AQ.

It's easy. Give us your name and full postal address, in block capitals. Enclose cheque, postal order or credit card number and expiry date. OR telephone 0799 21682 and give us your Access, American Express or Barclaycard number and your order will be in the post that night.

EXPERIMENTOR BREADBOARDS.	CONTACT HOLES.	IC CAPACITY 14 PIN.DIP.	UNIT PRICE INCLUDING POSTAGE AND V.A.T.
EXP. 325	130	1	£ 2.53
EXP. 350	270	3	£ 4.21
EXP. 300	550	6	£ 7.29
EXP. 650	270	use with 0.6 pitch Dip's Bus-Bar Strip	£ 4.69
EXP. 4B.	Four 40 Point Bus-Bars		£ 3.29
TEST CLIPS			
PC. 16.			£ 3.78
PC.16-18.			£ 7.56
PC. 16-18 Dual Clip.			£12.15
PROTO-BOARDS.			
PB. 6.	630	6	£11.01
PB. 100.	760	10	£13.82

NAME .....  
ADDRESS .....

DEPT 147

FILL IN COUPON & RECEIVE FREE COPY OF  
ELECTRONICS BY NUMBERS PROJECTS Nos 1, 2 AND 3



# Shark!

**H.E. Shark game brings you the sun, surf and sand. All electronic; add absolutely no water!**

OVERTIRED, TENSE, NERVOUS HEADACHE? Then this is the game to really send you over the edge. Featuring fingertip control, it is the ideal toy for the squeamish, hydrophobics and non-swimmers. It takes the shark out of water and the mess out of being devoured.

The top panel has two columns of ten LEDs leading to a tropical island. One LED lights in each column to indicate the swimmers' progress towards the safety of the island. Two push buttons are mounted, one either side of a central LED which represents the shark's fin. The power switch, reset button and 'loose' alarm are mounted on the small front panel while a PCB accommodates most of the other components. The circuit is powered by a single PP7 nine volt battery. This was chosen as currents of up to about one hundred milliamps may be drawn by the circuit when all the LEDs are lit.

## A BIGGER SPLASH

To play, after pressing reset, each player must depress his pushbutton switch for as long as possible while the single 'shark's fin' LED remains lit. This causes his swimmer to appear and begin moving towards the island. Short depressions or failure to play at all will result in that swimmer moving only slowly or not at all. A depression while the LED is extinguished causes the swimmer to slip back towards the shark.

The winner of the game is the player whose swimmer first reaches the safety of the island when the 'lose' buzzer will sound for his opponent and both columns of LEDs will light, the highest indicating the winner.

## WHAT! NO CHIPS?

It has often been remarked that most electronic games can be reduced to one; find the 4017. It is true that this chip has been overused and we are pleased to say that this game is an outstanding exception. Featuring a hybrid mixture of analogue and digital circuit techniques it is based on the LM3914. This little known chip from National is a LED dot/bar bargraph display driver and comes in an eighteen pin DIL package. It is very simple to set up and use. LED display current and full scale range are programmable by selection of a couple of resistors and individual constant current outputs remove the need for limiting resistors and tedious LED selection which was necessary with previous devices of this type. CMOS analogue transmission gates are used to multiplex the two signals to the bargraph chip input. This keeps the unit's cost down without sacrificing performance or increasing circuit complexity too much. Any size and colour of LEDs may be used. We used miniature green for one column and red for the other with a yellow standard 0.2" LED for the shark fin. The driver chip sinks about ten milliamps through each LED.



The case for Shark was made from a Vero box, the artwork on the case makes it look very attractive.

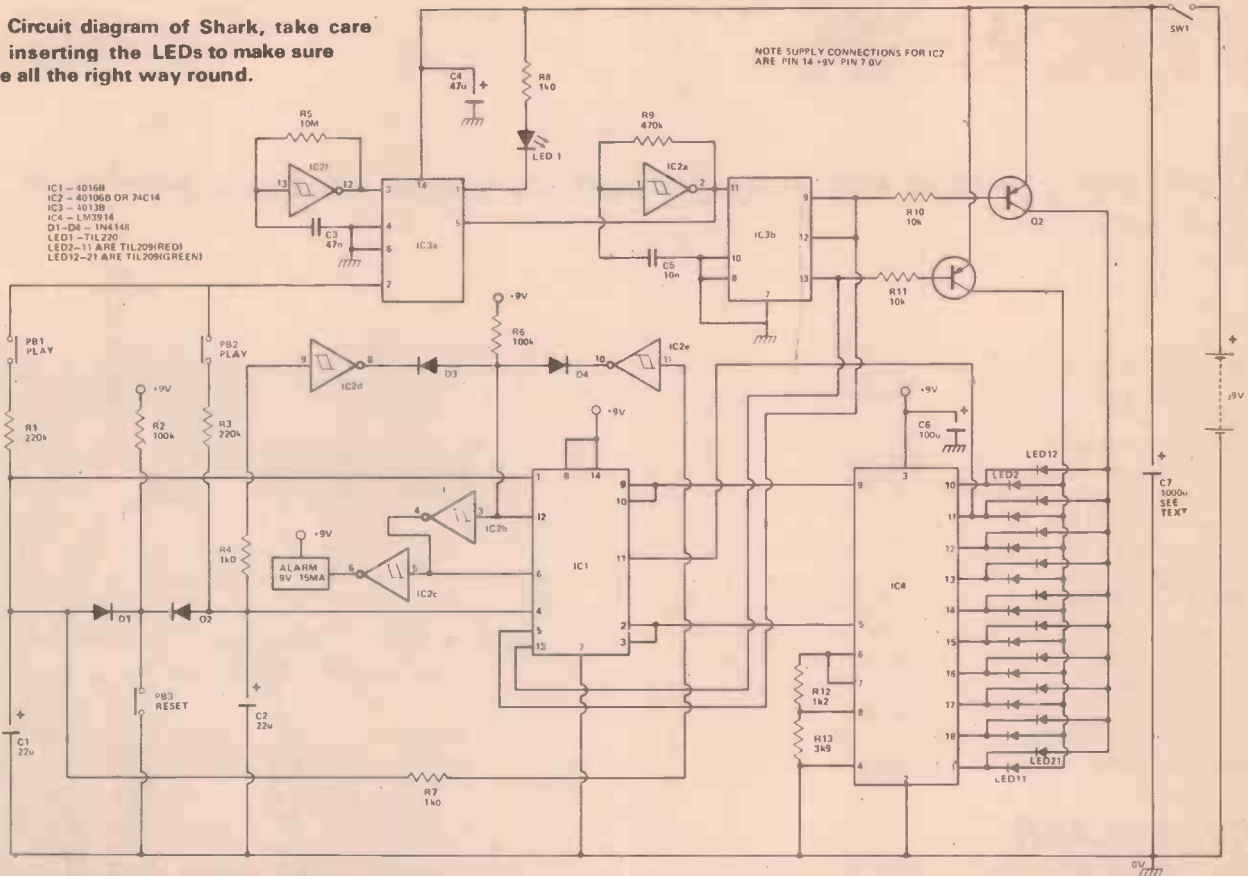
## CONSTRUCTION

Construction of the game is greatly simplified if our PCB is used. As the components are closely packed on the board, the PCB tracks have to be made quite thin, so take care when soldering that no excessive heat is applied to any section of the board.

Begin construction by inserting all vero-pins and links followed by IC holders, resistors, capacitors and semiconductors paying attention to the orientation of all polarised components. To allow more space on the PCB, C7 has been mounted off board beside the battery and is held in place by a sticky pad as shown in the internal photograph of the game. The solid state buzzer was glued into position against the front panel of the case.

To complete construction, mount the switches in

**Fig 1 Circuit diagram of Shark, take care when inserting the LEDs to make sure they're all the right way round.**

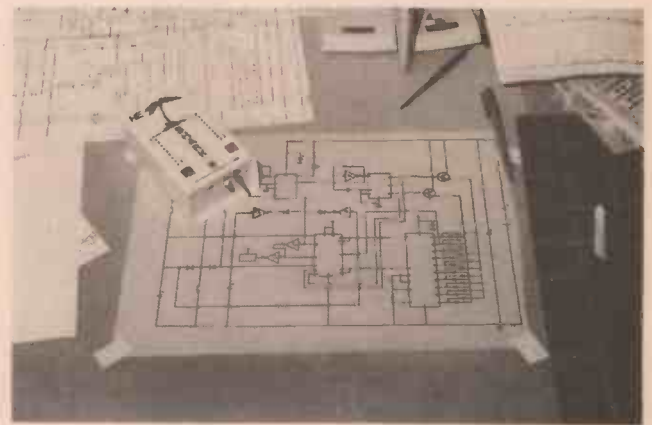


## How it Works

Each competitor's progress is represented by the charge on C1 or C2. These capacitors are initially discharged at the start of a game by depressing 'reset'. The 'shark's fin' LED is on when the Q output of IC3a is low. During this time the Q output (pin 2) is high and C1 or C2 can charge via R1 or R3 if the corresponding play button is depressed. If the switch remains closed when the output goes low then C1, C2 will discharge. To introduce a degree of chance into the game, the state of IC3a and the 'shark's fin' LED depends on the logic level from fast clock IC2a which is present at the data input (pin 5) during the rising edge of the slow clock signal from IC2f.

IC4 drives the LED displays in dot or bar format according to the state of two of the transmission gates in IC1. These are in turn controlled by the 'OR ed' outputs from IC2d and IC2e and the inverted signal from IC2b. When the voltage on C1 or C2 rises above the transition level of IC2d or IC2e, the display changes from dot to bar mode, one column of LEDs lights and the 'lose' alarm sounds indicating a completed game.

To conserve power and keep construction costs down, the input signals to IC4 from C1, C2 are multiplexed by transmission gates in IC1. These are controlled by the antiphase Q and Q signals from IC3b which also control the LED driver transistors Q1 and Q2. C6 helps to prevent possible oscillations at the output of IC4 while C7 smooths the whole supply and prevents false triggering of IC3.



## Buylines

The audible alarm used on the prototype was obtained from Progressive Radio, 31 Cheapside, Liverpool L2 2JD.  
The LM3914 Bargraph display driver should be available from Marshall's, Watford or Maplin.

position and insert all LEDs. It is wise at this point to confirm their polarity. For the Texas TIL 209 series the flat on the body denotes the cathode. Most of the interwiring is concentrated between the LEDs and the PCB so extreme care and attention should be exercised. Flying leads should be taken from the PCB to the case mounted components and the battery fitted. There are no adjustments to make and the circuit should work first time so switch on and swim for your life!



# STEVENSON

## Electronic Components

### REGULATORS

78L05 30p	7805 60p	79L05 70p	7912 80p
78L12 30p	7812 60p	79L12 70p	7915 80p
78L15 30p	7815 60p	7905 80p	LM723 35p

### HARDWARE

#### MINIATURE TRANSFORMERS

240 Volt Primary

Secondary rated at 100mA.

Available with secondaries of:

6-0-6, 9-0-9 and  
12-0-12. 92p. each.



### LOUDSPEAKERS

56mm dia. 8 ohms	70p
64mm dia. 8 ohms	75p
64mm dia. 64 ohms	75p
70mm dia. 8 ohms	100p
70mm dia. 80 ohms	110p



### TERMINALS

Rated at 10A. Accepts 4mm plug, black, blue, green, brown and red 22p

### SWITCHES

Subminiature toggle. Rated at 3A 250V.

SPDT 70p SPDT centre off 75p  
DPDT 80p DPDT centre off 95p

Standard toggle

SPST 34p DPDT 48p

Wavechange switches.

1P12W, 2P6W, 3P4W or 4P3W all 43p ea.

Miniature switches (non-locking)

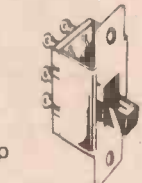
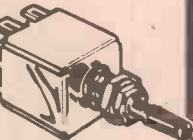
Push to make 15p Push to break 20p

Slide switches (DPDT)

Miniature 14p Standard 15p

### CONTROL KNOBS

Ideal for use on mixers etc. Push on type with black base and marked position line. Cap available in red, blue, green, grey, yellow and black. 14p



### TRANSISTORS

AC127 17p	BCY71 14p	ZTX109 14p
AC128 16p	BCY72 14p	ZTX300 16p
AC176 18p	BD131 35p	2N697 12p
AD161 38p	BD132 35p	3N1302 38p
AD162 38p	BD135 38p	2N2905 22p
BC107 8p	BD139 35p	2N2907 22p
BC108 8p	BD140 35p	2N3053 18p
BC109 8p	BF244B 36p	2N3055 50p
BC147 7p	BFY50 15p	2N3442 135p
BC148 7p	BFY51 15p	2N3702 8p
BC149 8p	BFY52 15p	2N3704 8p
BC148 9p	MJ2955 98p	2N3705 9p
BC177 14p	MPSA06 20p	2N3706 9p
BC178 14p	MPSA56 20p	2N3708 8p
BC179 14p	TIP29C 60p	2N3819 22p
BC182 10p	TIP30C 70p	2N3904 8p
BC182L 10p	TIP31C 65p	2N3905 8p
BC184 10p	TIP32C 80p	2N3906 8p
BC184L 10p	ZTX107 14p	2N4058 12p
BC212 10p	ZTX108 14p	2N5457 32p
BC212L 10p		2N5458 30p
BC214 10p		2N5459 32p
BC214L 10p		2N5777 50p
BC477 19p		
BC478 19p		
BC479 19p		
BC548 10p		
BCY70 14p		

### DIODES

1N914 3p	1N5401 13p
1N4001 4p	BZY88ser 8p
Full spec. product	
1N4148 £1.40/100. £11/1000	

### LINEAR

THIS IS ONLY A SELECTION!

CA3140 38p	LM301AN 26p	NE555 21p
LM318N 85p	NE556 50p	NE565 85p
LM324 45p	NE567 170p	SN76003 200p
LM339 45p	SN76013 140p	SN76023 140p
LM380 75p	SN76033 200p	SN76477 220p
LM382 120p	TDA800 70p	TDA1022 650p
LM1830 150p	ZN414 75p	
LM2900 50p		
LM3909 65p		
MC1496 60p		
MC1458 32p		

### CAPACITORS

#### TANTALUM BEAD

0.1, 0.15, 0.22, 0.33, 0.47, 0.68, 1 & 2.2uF @ 35V	each
4.7, 6.8, 10uF @ 25V	8p
22 @ 16V, 47 @ 6V, 100 @ 3V	13p
	16p

#### MYLAR FILM

0.001, 0.01, 0.022, 0.033, 0.047, 0.068, 0.1	3p
	4p

#### POLYESTER

Multilard C280 series	
0.01, 0.015, 0.022, 0.033, 0.047, 0.068, 0.1	5p
0.15, 0.22	7p
0.33, 0.47	10p
0.68	14p
1.0uF	17p

#### CERAMIC

Plate type 50V. Available in E12 series from 22pF to 1000pF and E6 series from 1500pF to 0.047uF

#### RADIAL LEAD ELECTROLYTIC

63V 0.47 1.0 2.2 4.7 10	5p
	7p
	13p
	20p
25V 10 22 33 47	5p
	8p
	10p
	15p
	23p

### CONNECTORS

#### JACK PLUGS AND SOCKETS

2.5mm screened	9p	13p	7p
3.5mm	9p	14p	8p
Standard	16p	30p	15p
Stereo	23p	36p	18p

#### DIN PLUGS AND SOCKETS

2pin	7p	7p	7p
3pin	11p	9p	14p
5pin 180°	11p	10p	14p
5pin 240°	13p	10p	16p

#### 1mm PLUGS AND SOCKETS

Suitable for low voltage circuits. Red & black. Plugs 6p each Sockets 7p each.

#### 4mm PLUGS AND SOCKETS

Available in blue, black, green, brown, red, white and yellow Plugs 11p each Sockets 12p each

#### PHONO PLUGS AND SOCKETS

Insulated plug in red or black	9p
Screened plug	13p
Single socket	7p Double socket 10p

### VERO

Size in.	0.1in	0.15in	Veropins
2.5 x 1	14p	13p	single sided
2.5 x 3.75	42p	40p	per 100
2.5 x 5	52p	50p	0.1in 35p
3.75 x 5	60p	60p	0.15in 40p
3.75 x 17	195p	180p	

### BOXES



Aluminium boxes with lid and screws

	Length	width	height	
AL1	3	2	1	48p
AL2	4	3	1	58p
AL3	4	3	2	65p
AL4	6	4	2	70p
AL5	6	4	3	85p
AL6	8	6	2	116p

### THYRISTORS

Plastic-cased Thyristors Texas

	4A	8A	12A
100V	36p	45p	62p
200V	42p	53p	68p
400V	51p	66p	86p

### TRIACS

Plastic-cased Triacs. Texas. All rated at 400V.

4A	70p	12A	90p	20A	185p
8A	80p	16A	95p	25A	215p

### CMOS

4018	55p	4050	25p
4023	12p	4066	35p
4024	40p	4068	18p
4001	12p	4026	90p
4002	12p	4027	30p
4007	12p	4028	48p
4011	12p	4029	50p
4013	28p	4040	65p
4015	50p	4042	50p
4016	30p	4046	90p
4017	48p	4049	25p

FULL DETAILS IN CATALOGUE!

### SKTS

Low profile by Texas



8 pin	8p	16 pin	11p	28 pin	22p
14 pin	10p	24 pin	18p	40 pin	32p
Soldercon pins		100	50p.	1000	370p

### OPTO

LED's	0.125in	0.2in	each	100+
Red	TIL209	TIL220	9p	8p
Green	TIL211	TIL221	13p	12p
Yellow	TIL213	TIL223	13p	12p
Clips	3p	3p		

DISPLAYS			
DL704	0.3 in CC	130p	120p
DL707	0.3 in CC	130p	120p
FND500	0.5 in CC	100p	80p

### RESISTORS

Carbon film resistors. High stability, low noise 5%.

E12 series. 4.7 ohms to 10M. Any mix	
each	100+
0.25W	1p
0.5W	1.5p
	1.2p
	1p

Special development packs consisting of 10 of each value from 4.7 ohms to 1 Meg-ohm (650 res) 0.5W £7.50. 0.25W £5.70.

#### METAL FILM RESISTORS

Very high stability, low noise rated at 1/2W 1%. Available from 51ohms to 330k in E24 series. Any mix.

0.25W	each	100+	1000+
	4p	3.5p	3.2p

PLEASE WRITE FOR YOUR FREE COPY OF OUR NEW 64 PAGE CATALOGUE OF COMPONENTS. CONTAINS OVER 2500 STOCK ITEMS.

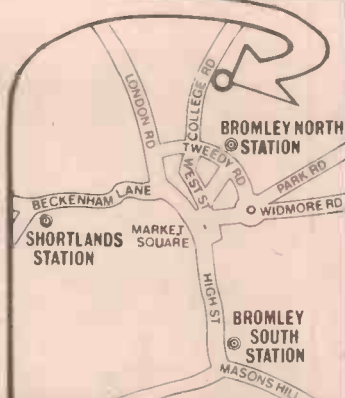


WHY NOT VISIT OUR

## NEW SHOP

We welcome callers at our new premises at the address below (5 mins. from High St.) We are open Mon - Sat, 9am - 6pm. Special offers available.

Express telephone order service. Orders received before 5pm. are shipped first class on that day. Contact our Sales Office now! Tel: 01-464 2951/5770.



ORDERS DESPATCHED BY RETURN POST

Quantity discounts on any mix TTL, CMOS, 74LS and Linear circuits: 100+ 10%, 1000+ 15%. Prices VAT inclusive. Please add 30p for carriage. All prices valid to April 1980. Official orders welcome.

BARCLAYCARD & ACCESS WELCOME.



12 Mail orders to: STEVENSON (Dept HE)

# 76 College Road, Bromley, Kent, England

# Cassette Decks & Tape

***Gordon King takes a look into the world of the Compact Cassette, the system, now a true entry into the Hi-Fi field, that has developed into a sophisticated audio medium in its own right.***

ONE AREA OF domestic-based electronics which has attained remarkably high optimization is that associated with the compact cassette medium. Current issue cassette decks partnered with the latest tapes are capable of a frequency response approaching 20 kHz and a net quality of reproduction which is not far short of a prestige record deck or FM tuner. The advantage of the cassette deck over such other programme signal sources is the ease at which programmes can be recorded from radio, disc and other sources in stereo at a cost of around 3p per minute.

This tight packing of information is achieved by the use of two pairs of stereo tracks, each a mere 0.6 mm wide, and a tape/head velocity of 4.75 cm/s. One stereo track pair is recorded along one half of the tape width and the other pair along the other half, the cassette as a whole usually being turned over to change from one pair to the other.

These constraints have over the years, since the introduction of the compact cassette medium by Philips way back in the fifties, encouraged a good deal of lateral thought by the designers, and it is to their utmost credit that today we are able to enjoy the hi-fi quality that the best machines offer. When the compact cassette was first launched the results were well below hi-fi standards: frequency response was little higher than about 8 kHz, wow and flutter were bad and signal-to-noise ratio and hence dynamic range were abysmal. It was not until the advent of the Dolby B noise reduction system (NRS) that the cassette deck started to take off in 'hi-fi' terms. Designed by Dr Ray Dolby, who also had much to do with early video recording, the system produces an integrated noise reduction of almost 10 dB, thereby putting 10 dB on the effective dynamic range. Other noise reduction systems have since been evolved, but that the Dolby system is a viable one is witnessed by the fact that pretty well every hi-fi deck today is equipped with the system!

The Dolby B NRS sparked off renewed design effort: record/replay heads were vastly improved to define the short wavelengths of the signals recorded on the tape, tapes themselves were improved, and are improving still, and the last traces of subjective W & F (Wow and Flutter) were eliminated from the tape transport

mechanisms. On top of all this, the electronic circuits and metering arrangements have been remarkably enhanced, and today we are even seeing the introduction of the microprocessor for machine control.

## ***RECORDING/REPLAY PROCESSES***

The tape is recorded merely by passing through the winding of the recording head a current corresponding to the amplified input signal. The head pole pieces are styled to form a narrow gap across which the changing magnetic field develops, and it is over this gap that the tape is caused to pass. The oxide layer is thus magnetized to the pattern of the audio signal.

For replay the tape is rewound and again caused to pass over the head pole pieces at the same speed as it was recorded. This time the magnetic lines of force linking the pole pieces induce an electromotive force into the winding which is a close replica of the original signal used to make the recording. This signal is amplified and eventually fed as current to the loudspeaker for reproduction.



***Above the Hitachi D560 cassette deck, this piece of Hi-Fi includes a fine bias control and fluorescent display.***

## THE NEED FOR BIAS

Although basically straightforward, a number of problems need to be resolved to secure a distortion-free rendering during replay. A primary one concerns the intrinsic non-linearity between the recording current and the output EMF of the magnetic tape itself. When a metal or oxide of metal is magnetised, the magnetism acquired fails to follow the magnetic force (and hence the current through the winding) applied to the material to produce the magnetism. The curious set of curves in Fig. 1 show what happens. Let us suppose that the tape

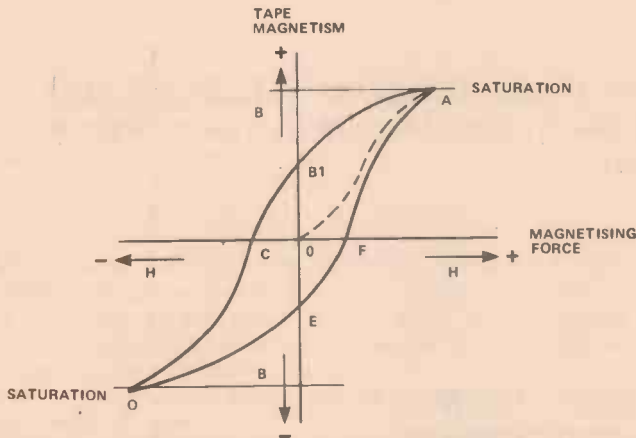


Fig. 1. Hysteresis loop of magnetism which is explained in the text.

starts in an unmagnetised state at origin O and that the magnetising force H is increased in a positive direction by current flowing in one direction through the winding then the magnetism B acquired by the tape increases rather non-linearly according to the broken-line curve OA. At point A the rise in magnetism B halts, even though H may be further increased. This is the saturation point of the tape, meaning that it is unable to accommodate any more magnetism.

If now the current through the winding is reversed H moves in a negative direction and the value B originally acquired by the tape is reduced along curve AB1. At point B1 H is zero, yet B has level B1. This represents the level of magnetism which has been acquired by the tape, called the remanent flux. To pull this flux back to zero and hence demagnetise the tape H needs to be increased further in the negative direction to point C on the curve.

The equivalent things happen to B in the opposite polarity as in curve CD, and a reversal of current in the positive direction brings the remanent flux to level E at zero H (opposite polarity), to the demagnetised state again at F, and up to saturation again over FA. The collection of curves is called the hysteresis diagram of the tape (that shown is not meant to be typical of any tape).

## KINKY DISTORTION

Let us now suppose that a sinewave signal is fed to the recording head and that the tape so recorded is replayed. Fig. 2a shows that, owing to the non-linearity between H and B, the replay signal will suffer bad distortion caused mainly by the 'kink' at the centre of the HB curve. This is

overcome by superimposing the recording signal on a much higher frequency (100 kHz) signal, called the high-frequency bias. When this is done the audio signal is lifted clear of the centre 'kink' so that it operates on the more linear parts, as shown in Fig. 2b.

The remaining non-linearity of the curve is responsible for third-order distortion which, at normal recording levels at middle frequencies, averages something less than 1%. However, if the recording level is so great that the tape closely approaches or, indeed, enters saturation then the distortion rises dramatically to 20% or more. This is what is likely to happen, especially at the higher frequencies as we shall see, when the recording level meters are running well into the red region.

Different tapes unfortunately require different values of HF bias current for the best results, and for this reason latter-day decks have provision for bias change and sometimes for fine adjustment. Basic ferric (Fe) tape requires less bias than chromium dioxide (Cr) tape. More recent high-energy cobalt-modified Fe tapes need about the same bias as Cr tapes, while the two-layer FeCr (ferrochrome) tapes call for a bias somewhere between the Fe and Cr requirements.

## THE NEED FOR EQUALISATION

Each time a half-cycle of signal current flows through the head winding a small magnet is formed on the tape oxide. For simplicity this is illustrated in Fig 3 with a squarewave signal. Thus for the positive half-cycles we get SN poles and for the negative half-cycles NS poles. The length of these magnets, of course, will depend not only on the tape speed, which is fixed, but also on the frequency of the signal. As the frequency is increased, so the length diminishes.

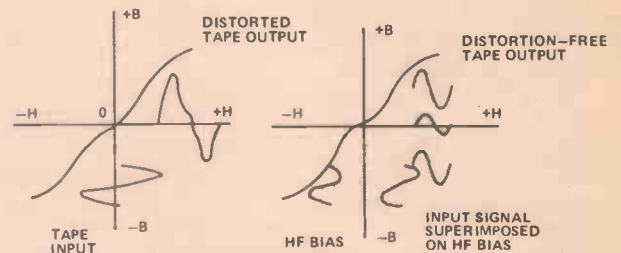
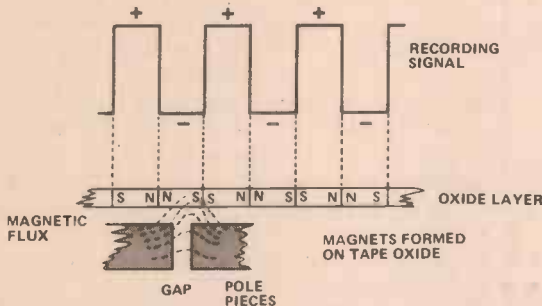


Fig. 2. (a) Showing how the 'kink' at the middle of the BH curve distorts the output signal, and (b) how by superimposing the recording signal on a high-frequency (bias) signal the distortion is eliminated.

During replay the EMF in the head winding increases with the increase in rate of change of the magnetic flux linking the pole pieces. This is on par with a simple dynamo whose output increases with increase in speed of the rotor. It follows, therefore, that the EMF will rise as the frequency of the signal increases. Doubling the frequency doubles the EMF, and since doubling the frequency is an octave and doubling the EMF is a 6dB increase, it is said that the head output rises at the rate of 6dB/octave. This is shown in Fig 4 where it is seen that this natural rate is modified at the LF and HF ends owing to losses.

To provide a 'flat' output during replay it is thus necessary to arrange for the replay amplifier to have a

response to inverse of that of Fig 4. That is, for the bass to be boosted at the rate of 6dB/octave. All cassette machines are equipped with this basic equalisation; but additional equalisation is required to compensate for the HF losses in particular, so that the response is boosted at the treble frequencies as it rolls off due to the losses.



**Fig.3.** For each half-cycle of recording signal, a small magnet is formed on the tape oxide. The magnet poles alternate with the positive and negative half-cycles as shown.

## FLAT RESPONSE

This is done in two parts: one by arranging for the recording signal to be treble boosted (pre-emphasis), and two, to check the rate of treble roll-off arising from the 6dB/octave bass boost. When these are handled correctly with respect to the tape formulation employed, the result is a response sensibly 'flat' up to, at least, 12 kHz, depending on the length of the gap in the replay head (note: gap length is defined as that distance between the faces of the head pole pieces).

The treble losses are partly attributable to what is called tape compression. If a tape is recorded at a constant level but at an increasing frequency, the magnetism acquired by the tape diminishes with frequency, so the output on replay falls. The compression takes effect earlier in the frequency spectrum as the level of the recording is increased. The onset of compression has much to do with the ability of the tape to retain high-frequency signals. This is called tape coercivity. Tapes of high coercivity, such as *Cr*, some *FeCr* formulations and cobalt-modified *Fe* formulations, retain the high-frequency, short wavelength signals more satisfactory than basic *Fe* tapes. They thus require less effective equalisation at the treble end. This equalisation is expressed as a time-constant which for basic *Fe* tape is 120uS and for *Cr*, *FeCr* and some of the cobalt-doped *Fe* tapes 70uS. Hence most machines are also equipped with an equalisation change switch providing these two time-constants (on many machines the 70uS requirement happens automatically when a *Cr* cassette is inserted).

## SIGNAL TO NOISE RATIO

The time-constant merely refers to the frequency where the boost or arrest in the basic 6dB/octave equalisation takes effect, which is equal to  $1/2\pi T$ , where the frequency is in Hz and the time-constant (T) is S. Thus 120uS corresponds to a turnover of 1,326 Hz and 70uS to 2,274 Hz. The net result works out to less effective

treble boost overall at 70uS than 120uS, which endows *Cr* and other 70uS tapes with a 3 to 4 dB S/N ratio advantage over basic *Fe* tapes. You can discern the drop in noise by switching to *Cr* when running a blank tape via an amplifier with its volume control well advanced.

The higher coercivity of the tape, the less tendency there is for it to demagnetise at the higher, very short wavelength signals. Running at 4.75 cm/s, the overall magnet length of a 10 kHz signal is a miniscule 4.7uM (tape speed divided by the frequency in Hz); but each magnet has a length of half this value, or 2.35uM, little wonder, then, that there is a tendency for demagnetisation with the poles so close together! The coercivity of basic *Fe* tape is around 300 oersteds (Oe) and *Cr* and high-energy tapes around 500 Oe.

Depending on the coercivity, the compression at HF is governed by the recording level, so when a frequency response plot is made of a cassette machine the level of the swept frequency is deliberately kept low (around 20 to 25 dB below peak recording level — corresponding to approximately -20VU on the meters). As the compression takes effect so the distortion rises, and it rises dramatically when the tape is running well into compression owing to the extremely bad non-linearity then obtaining (there being hardly any increase in output in spite of a large increase in recording current). The distortion is essentially 3rd-order, so the 3rd-harmonic caused by a signal of 333 Hz (a common test frequency) falls at 999 Hz, well within the passband. At higher frequencies the 3rd-harmonic eventually vanishes — for example, at 10 kHz the 3rd-harmonic is 30 kHz, which is too high to be passed by a cassette deck.

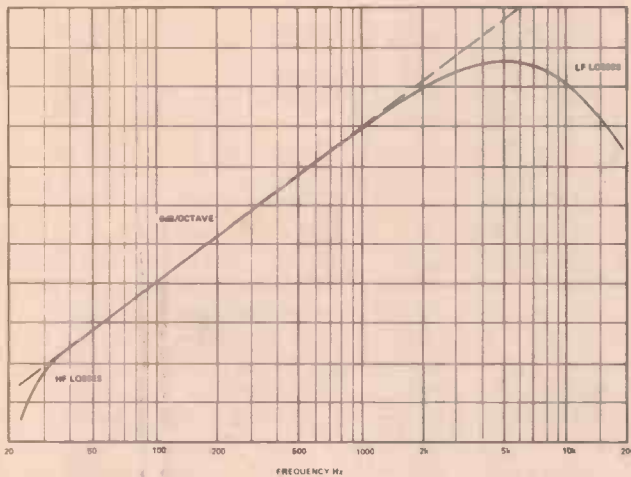
## CONSTRAINTS

Nevertheless, compression non-linearity at HF gives rise to intermodulation products which certainly do fall in the passband. A 3rd-order product arising from two signals at, say, 9 and 10kHz falls at  $(2 \times 9) - 10$ , or 8 kHz, while the 2nd-order falls at  $10 - 9$ , or 1 kHz, both well in the passband.

Much of the poor quality of cassette decks occurs as the result of over-recording the high-frequency music components, creating in-band intermodulation products which, unlike simple harmonic distortion of low-order, is singularly unmusical!

Some of the more expensive tapes allow recording to a higher level, but even with these tapes care needs to be taken over the recording level. It is a sad fact about ordinary VU meters that the peak value of a swiftly occurring music transient could be as much as 10dB above the indicated level. This is because the inertia of the meter prevents the pointer from accelerating anywhere near as fast as a fast-rising, short-duration signal component. The net result is that the transient has come and gone before the pointer barely has time to move! With complex, wide dynamic range classical music, therefore, it is desirable to peak several VUs below the red section for the best quality results. Some machines are equipped with much faster responding light emitting diodes for peak indication. If these complement the VU meters, it will often be found that the +3dB LED will flash at times when the VU meters are registering -6VU or less.

On the other hand, if the recording level is set too low



**Fig. 4.** From a constant recorded flux the replay head output rises at the rate of 6dB/octave. This is equalised by arranging for the replay amplifier to have an inverse response. Equalisation and record pre-emphasis are also used to combat the fall in treble output caused by HF losses.

the dynamic range will be impaired because the noise floor relative to the upper recording level will be too high (from first principles, dynamic range refers to the dB distance between the upper recording level and the noise floor). Without Dolby noise reduction, the noise floor is about 50dB (CCIR/ARM-weighted) below peak modulation level (on many machines corresponding to approximately +3VU — Dolby level) using Fe tape and about 54.5dB using Cr, FeCr and certain cobalt-modified Fe tapes requiring 70uS equalisation. With Dolby the effective dynamic range is increased by a further 10dB, yielding the hi-fi dynamic range of around 65dB.

## HOW DOLBY NOISE REDUCTION WORKS

If treble boost is applied to the recording signal the reproduction on replay will be treble heavy, which is fairly obvious. However, if during replay the treble is rolled-off by the same amount as it was boosted, then the frequency response integrity will be restored. The background noise detected by a listener depends on the noise power bandwidth of the replay channel. If the bandwidth is reduced, then the noise level falls. Thus by boosting the recording signal at the treble end, the bandwidth and hence the noise can be reduced during replay without impairing the overall frequency response from recording input replay output.

This scheme is known as pre-emphasis (the treble boost) and de-emphasis (the treble roll-off), and is adopted as a noise reducing artifice for both FM radio and gramophone records. The treble roll-off, of course, is tantamount to a reduction in bandwidth.

The amount of noise reduction possible by this scheme is limited by the amount of boost that can reasonably be applied to the treble. That is, the frequency at which the boost starts to take effect. If the treble boost occurs too early treble overload could well result unless the average recording level is reduced. This is one of the problems of the 75uS pre- and de-emphasis of the American FM standard. The UK standard is 50uS

so the start frequency of the treble boost (and cut) is higher. In America the tendency is towards Dolby FM noise reduction allied with 25uS pre- and de-emphasis to help solve the problem and enhance the S/N ratio on weak signals.

## DOLBY NOISE REDUCTION

The basic principle of DNR is similar to pre- and de-emphasis except that the amount of pre-emphasis is determined by the actual level of the recording signal at any instant. At low level where the noise is obviously more troublesome a greater treble boost is given than at higher level where the signal well outweighs the noise, anyway. In fact, at very high level (the Dolby reference level corresponding to a recording level of 200nWb/m and +3VU on most meters) there is no treble boost at all.

During replay the frequency response integrity is restored by a circuit which again monitors the signal level and sets the treble cut to correspond to the treble boost applied during recording. The encode and decode circuits need to be well matched in gain to avoid aggravation of intrinsic frequency response aberrations, and this requires the circuits to be adjusted for 'balance' on the type of tape which will be used with the machine. If the sensitivity of the tape used differs significantly from that with which the circuits were originally adjusted, then the Dolby circuits will fail to operate correctly — a point well worth bearing in mind!

## METAL PARTICLE TAPES

A new tape which will further improve the compact cassette medium is about to be launched. This uses as the coating pure iron particles instead of oxide particles, and as a result exhibits a coercivity (Oe) almost twice as high as Cr tape, (1,060 Oe instead of about 540 Oe), and a remanence of 2,600 gauss against about 1,550 gauss of ordinary high-energy tape. For the best results from such tape a greater HF bias current will be needed (also a higher erase field), and the recording amplifier will need to supply a greater recording current without over-loading. The record head, too, will need to deliver the higher magnetic force without running into saturation distortion. Already machines are being made which will do justice to the tape.

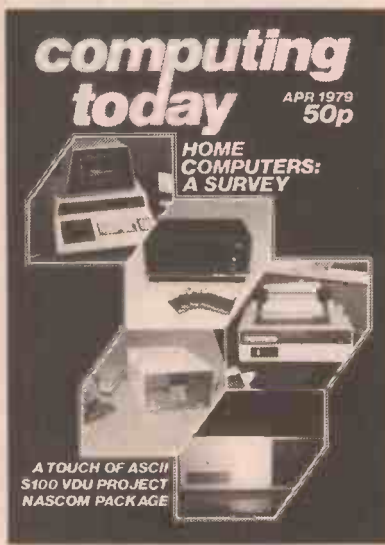


**One of the latest pieces of tape technology from Hitachi, this particular example features an inbuilt memory.**

## ERASE

As a final thought, magnetic tape is erased by the machine before recording by passing the erase head which yields a HF magnetic field (working from the HF bias oscillator), and the effect is that the tape coating is subjected to a number of decreasing hysteresis cycles as it passes the erase head, which reduces the remanent flux to zero, thereby fully demagnetising the tape. **HE**





First there was ETI, catering for the middle-range to advanced electronics enthusiast. Then there was HE which was aimed at the newcomer to the field. Now there is Computing Today from the

same stable. CT covers the area of small-business and amateur computing and deals with both software and hardware. CT's third issue (cover date of May) is out now — 50p at your newsagent.

# Books from the HE Book Service

**28 Tested Transistor Project** ..... £1.15  
Richard Torrens. The projects can be split down into simple building blocks which can be recombined for ideas of your own.

**Electronic Projects for Beginners** ..... £1.55  
F. G. Rayer. Divided into 'No Soldering Projects,' Radio and Audio Frequency, Power Supplies and Miscellaneous.

**Solid State Short Wave Receivers for Beginners** ..... £1.15  
R. A. Penfold. Several modern circuits which give a high level of performance even though only a few inexpensive components are used.

**Popular Electronic Projects** ..... £1.65  
R. A. Penfold. A collection of the most popular types of circuits and projects using modern, inexpensive and freely available components.



**Digital IC Equivalents and Pin Connections** ..... £2.70  
Adrian Michaels. Covers most popular types and gives details of packaging, families, functions, country of origin and manufacturer.

**How to Build your own Metal and Treasure Locators** ..... £1.20  
F. G. Rayer. Gives complete circuit and practical details for a number of simple metal locators using the BFO principle.

**Linear IC Equivalents and Pin Connections** ..... £2.95  
Adrian Michaels. Gives most essential data for popular devices.

**Projects in Opto Electronics** ..... £1.45  
R. A. Penfold. Covers projects using LED's, Infra-red transmitters and detectors, modulated light transmission and also photographic projects.

**52 Projects using IC 741** ..... £1.15  
Rudi and Uwe Redmet. Translated from an enormously successful German book with copious notes, data and circuitry.

**50 FET (Field Effect Transistor) Project** ..... £1.45  
F. G. Rayer. Contains something of interest for every class of enthusiast. Short Wave Listener, Radio Amateur, Experimenter or audio devotee.

**How to Build Advanced Short Wave Receivers** ..... £1.40  
R. A. Penfold. Full constructional details are given for a number of receivers plus circuits for add-ons such as Q-Multiplier, S-meter etc.

Note that all prices include postage and packing. Please make cheques etc. payable to Hobby Electronics Book Service (in Sterling only please) and send to:

**Hobby Electronics Book Service**  
P.O. Box 79  
Maidenhead, Berks.

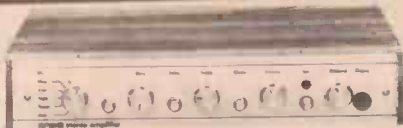
**Essential Theory for the Electronics Hobbyist** £1.45  
G. T. Rubaroe gives the hobbyist a background knowledge tailored to meet his specific needs.

**Beginners Guide to Building Electronic Projects** . £1.45  
R. A. Penfold. Covers component identification, tools, soldering, constructional methods and examples of simple projects are given.

**50 Projects using IC CA3130** ..... £1.15  
R. A. Penfold. Describes audio projects, RF project, Test Equipment, Household and miscellaneous circuits.

**IC 555 Project** ..... £1.65  
E. A. Parr. Circuits are given for the car, model railways, alarms and noise makers. Also covers the related devices 556, 558 and 559.

**50 Projects using Relays, SCR's and TRIAC's** £1.30  
F. G. Rayer. Gives tried and tested circuits for a whole variety of projects using these devices.



### 20 x 20 WATT STEREO AMPLIFIER

Viscount IV unit in teak simulate cabinet. Silver finish rotary controls and pushbuttons with matching fascia. Red mains indicator and stereo jack socket. Functions switch for mic, magnetic and crystal pickups, tape tuner and auxiliary. Rear panel features two mains outlets DIN speaker and input sockets plus fuse 20x20 watts RMS 40x40 watts peak. For use with 8 to 15 ohm speakers.

**£29.90**  
£2.50 p&p

### 30x30 WATT AMPLIFIER IN KIT FORM

For the experienced constructor complete in every detail, same facilities as Viscount IV, but with 30x30 output. 60x60 watts peak. For use with 4 15 ohms speakers.

**£29.00** + p&p £2.50

### SPECIAL OFFER

**30 x 30 WATT AMPLIFIER KIT** with BSR P200 belt drive deck and Shure M75 cartridge. **£55.00** + p&p £5.00

### EMI SPEAKER BARGAIN

Stereo pair 350 kit. System consists of 13" x 8" approx woofer with rolled surround, 2 1/2" approx. Audax tweeter, crossover components and circuit diagram. Frequency response 20 Hz to 20 KHz. Power handling 15 watts RMS 20 watts max. 8 ohm impedance.

**£14.95**  
Per stereo pair + £3.40 p&p



### BSR P200

Belt drive chassis turntable unit semi automatic, cueing device. **£24.95** p&p £2.55

A O.C. OLM 30 Mk III Magnetic Cartridge to suit. **£7.75**



**BSR** Manual single play record deck with auto return and cueing lever, fitted with stereo ceramic cartridge 2 speeds with 45 r.p.m. spindle adaptor ideally suited from home or disco use. **OUR PRICE £10.95** p&p £2.55

### GARRARD DECK MODEL CC 10A

Record changer with cueing device fitted with stereo ceramic cartridge ready to fit into your own plinth.

**£7.95** p&p £2.00 Size 12" x 8 1/2"



**SANYO** Nic/cad. battery, with mains charger equivalent in size and replaces 4 SP11 type cells. Size 3 1/2" x 1 1/4" x 2" approx.

**£7.50** p&p £1.50p



### BARGAIN FOR PERSONAL SHOPPERS ONLY Altone UA4 Stereo System

Features 8 watt total output. Full size BSR manual turntable with cueing and auto return. Socket for tape in and out and stereo headphones. **£34.95** complete with speakers.

**Micro Cassette Recorder** Pocket size—home or office use or when travelling. **£13.95**

**Battery operated fluorescent camping lamp.** Runs off 8 U2 batteries. **£4.50**

# Mullard

## AUDIO MODULES IN BARGAIN PACKS

### CURRENT CATALOGUE

PRICE **£25** AT OVER PER PACK

### SEE OUR PRICES

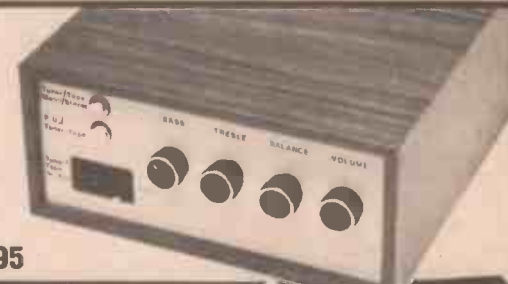
**1** PACK 1 2 x LP1173 10w RMS output power audio amp modules, + 1 LP1184/2 Stereo pre amp for ceramic and auxiliary input. **OUR PRICE p&p £1.00 £4.95**

**2** PACK 2 2 x LP1173 10w RMS output power audio amp modules, + 1 LP1184/2 Stereo pre amp for magnetic, ceramic and auxiliary inputs. **OUR PRICE p&p £1.00 £7.45**

AVAILABLE ALSO TO PURCHASERS OF THE 10 + 10 AMPLIFIER KIT.

### 10 + 10 AMPLIFIER KIT

An opportunity to buy a 10 watts per channel stereo amplifier kit which is suitable for use with a ceramic cartridge. The amplifier utilises proven Mullard modules and is available at a very competitive price. The amplifier kit comes complete with instructions and includes: a Mullard LP1183 stereo preamplifier module, two LP1173 power amplifiers with integral heatsinks, a power supply, Zobel networks, front and back mounting panels, a finished fascia panel, all control potentiometers (bass, treble, volume and balance), switches, input, output and headphone sockets, wire, and an easily assembled wrap around cabinet to house the finished unit. Size approximately 9 1/2" x 8 1/4" x 4" **p&p £2.05 £11.95**



ACCESSORIES ARE ONLY AVAILABLE TO THOSE CUSTOMERS WHEN BUYING OUR BARGAIN PACKS.

### ACCESSORIES

Suitable mains power supply parts, consisting of mains transformer, bridge rectifier, smoothing capacitor and set of rotary stereo controls for treble, bass, volume and balance. **£2.90** plus £1.50 p&p

**Two Way Speaker Kit** Comprising of two 8" x 5" approx. 4 ohm bass and two 3 1/2" 15 ohm mid-range tweeter with two cross-over capacitors. **£3.95** per stereo pair plus £1.50 p&p

### BARGAINS FOR PERSONAL SHOPPERS

LED 5 function men's digital watch stainless steel finish **£5.95**

LCD 5 function men's digital watch stainless steel finish **£6.95**

LCD 8 Function CHRONOGRAPH men's digital watch, stainless steel finish **£12.95**

POCKET CALCULATOR. With LED display, memory and percentage key **£2.95**

AM/FM DIGITAL CLOCK RADIO Accurate 4 Digit Electronic Clock with 1/2" LED display Buzzer and snooze timer **£11.95**

125 Watt Power Amp Module **£13.95**

Mains power supply for above unit **£3.50**

MULLARD Built power supply **£1.50**

OECCA 20w Stereo speaker kit comprising 2 8" approx. bass units - 2 3 1/2" approx. tweeter inc. crossovers **£20.00**

VIDEOMASTER Super Score TV Game with pistol mains operation **£14.95**

PORTABLE RADIO/CASSETTE RECORDER, AM/FM with clock LW, MW, SW, VHF mains/battery operation **£41.95**

VIDEOMASTER COLOUR SHOT TV GAME Choice of three games—Football, Tennis and Squash. Ready to play—one or two players. MAINS OPERATED. **OPPORTUNITY AT £9.95 ONLY**

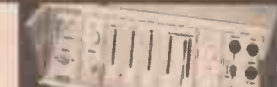
### 50 WATT MONO DISCO AMP

**£29.95** Size approx. 13 1/2" x 5 1/4" x 6 1/4" 50 watts rms, 100 watts peak output. Big features include two disc inputs, both for ceramic cartridges, tape input, and microphone input. Level mixing controls fitted with integral push-pull switches. Independent bass and treble controls and master volume.



### 70 & 100 WATT MONO DISC AMP

**£57** **£65** Size approx. 14" x 4" x 10 1/4" Brushed aluminium fascia and rotary controls. Five vertical slide controls, master volume, tape level, mic level, deck level, PLUS INTER DECK FADER for perfect graduated change from record deck No. 1 to No. 2, or vice versa. Pre fade level control (PFL) lets YOU hear next disc before loading it in. VU meter monitors output level. Output 100 watts RMS 200 watts peak. **70 watt £57** **140 watt peak p&p £4.00** **100 watt £65**



### For personal shoppers only DUO II SPEAKERS

Attractive teak finish modern design, incorporating 2 speaker units—8" approx. woofer and 2 1/2" approx. tweeter, 45 to 1800 Hz impedance 8 ohms. Power 15 watts RMS. **£17.00** Per stereo pair



### FOR PERSONAL SHOPPERS ONLY STEREO RADIOGRAM CABINET

Finished in a natural teak veneer with opening top. Easily modified to accommodate stereo equipment of your choice. **Price £10.95** Size approximately 47" x 15 1/2" x 15"

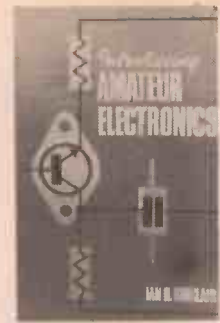


**325 EDGWARE ROAD, LONDON W2 21H HIGH STREET, ACTON W3 6NG**

ACTON: Mail Order only. No callers. ALL PRICES INCLUDE VAT AT 12 1/2% All items subject to availability. Price correct at 7/5/79 and subject to change without notice

Personal Shoppers EDGWARE ROAD LONDON W2 Tel: 01-723 8432. 9.30am-5.30pm. Closed all day Thursday ACTON: Mail Order only. No callers GOODS NOT DESPATCHED OUTSIDE UK

# Hobby Electronics Book Service



## POPULAR ELECTRONICS BOOKS

Sinclair, I. R., <i>Introducing Electronic Systems</i> .....	£1.80
Sinclair, I. R., <i>Introducing Amateur Electronics</i> .....	£1.55
Sinclair, I. R., <i>Electronic Fault Diagnosis</i> .....	£3.45
Sinclair, I. R., <i>Repairing Pocket Transistor Radios</i> .....	£2.50
Sinclair, I. R., <i>Oscilloscope In Use</i> .....	£3.00
Sinclair, I. R., <i>Understanding Electronic Components</i> .....	£4.00
Sinclair, I. R., <i>Understanding Electronic Circuits</i> .....	£4.00
Kitchen, H. T., <i>Handtools For Electronic Workshop</i> .....	£2.75
Kitchen, H. T., <i>Electronic Test Equipment</i> .....	£5.00
Capel, V., <i>How To Build Electronic Kits</i> .....	£2.20

## AUDIO

Earl, J., <i>Audio-Technicians Bench Manual</i> .....	£3.50
Earl, J., <i>Pickups and Loud Speakers</i> .....	£3.50
Earl, J., <i>Tuners and Amplifiers</i> .....	£3.00
Earl, J., <i>Cassette Tape Recorders</i> .....	£5.25
Earl, J., <i>ABC of Hi-Fi</i> .....	£4.25
Capel, V., <i>Microphones In Action</i> .....	£3.00
Capel, V., <i>Improving Your Hi-Fi</i> .....	£3.50
Capel, V., <i>Creative Tape Recording</i> .....	£4.00
Hellyer, H. W., <i>Tape Recorders</i> .....	£4.25
Sinclair, I. R., <i>Audio Amplifiers For Home Construction</i> .....	£2.75

## RADIO CONTROL

Aldridge, O., <i>Transistorised Radio Control For Models</i> .....	£3.50
Drake, J., <i>Radio Controlled Helicopter Models</i> .....	£3.95
Jeffries, C. R., <i>Radio Control For Model Yachts</i> .....	£1.85
Safford, E. L., <i>Radio Control Manual</i> .....	£2.45
Safford, E. L., <i>Advanced Radio Control</i> .....	£3.95

## COOKBOOKS

Tracton, K., <i>BASIC Cookbook</i> .....	£4.10
Lancaster, D., <i>TTL Cookbook</i> .....	£7.00
Lancaster, D., <i>RTL Cookbook</i> .....	£4.65
Lancaster, D., <i>CMOS Cookbook</i> .....	£8.20
Jong, W., <i>IC Op Amp Cookbook</i> .....	£10.00
Lancaster, D., <i>T.V. Typewriter Cookbook</i> .....	£7.75
Lancaster, D., <i>Cheap Video Cookbook</i> .....	£7.00
Jong, W., <i>IC Timer Cookbook</i> .....	£7.50
Lancaster, D., <i>Incredible Secret Money Machine (a how to cook book for setting up your computer or technical business)</i> .....	£4.95

## QUESTIONS AND ANSWERS

SIMPLE AND CONCISE ANSWERS TO MANY QUESTIONS WHICH PUZZLE THE BEGINNER.

Coker, A. J., <i>Q &amp; A On Electric Motors</i> .....	£1.50
Hellyer, H., <i>Q &amp; A On Radios and T.V.</i> .....	£1.50
Hibberd, R., <i>Q &amp; A On Integrated Circuits</i> .....	£1.50
Jackson, K., <i>Q &amp; A On Electricity</i> .....	£1.50
Brown, C., <i>Q &amp; A On Hi-Fi</i> .....	£1.50
Brown, C., <i>Q &amp; A On Transistors</i> .....	£1.50
Brown, C., <i>Q &amp; A On Electronics</i> .....	£1.50
Reddihough, J., <i>Q &amp; A On Colour T.V.</i> .....	£1.50
Miller, H., <i>Q &amp; A On Electric Wiring</i> .....	£1.50

## CONSTRUCTOR GUIDES

Graham, P., <i>Simple Circuit Building</i> .....	£2.45
Colwell, M., <i>Electronic Diagrams</i> .....	£2.45
Colwell, M., <i>Electronic Components</i> .....	£2.45
Colwell, M., <i>Printed Circuit Assembly</i> .....	£2.45
Ainslie, A., <i>Practical Electronic Project Building</i> .....	£2.45
Colwell, M., <i>Project Planning and Building</i> .....	£2.45

## BEGINNER'S GUIDE

Sinclair, I. R., <i>Beginner's Guide To Tape Recording</i> .....	£3.30
Sinclair, I. R., <i>Beginner's Guide To Integrated Circuits</i> .....	£3.10
Sinclair, I. R., <i>Beginner's Guide To Audio</i> .....	£3.10
King, G. J., <i>Beginner's Guide To Radio</i> .....	£3.10
King, G. J., <i>Beginner's Guide To Television</i> .....	£3.10
King, G. J., <i>Beginner's Guide To Colour T.V.</i> .....	£3.10
Gillou, F., <i>Beginner's Guide To Electric Wiring</i> .....	£3.10

## PROJECT BOOKS

Marston, R. M., <i>110 Cosmos Digital IC Projects For The Home Constructor</i> .....	£3.25
Marston, R. M., <i>110 Wave Form Projects For The Home Constructor</i> .....	£3.45
Marston, R. M., <i>110 Op Amp Projects For The Home Constructor</i> ..	£2.95
Marston, R. M., <i>110 Semiconductor Projects For The Home Constructor</i> ..	£3.45
Marston, R. M., <i>110 Thyristor/SCR Projects For The Home Constructor</i> ..	£2.95
Marston, R. M., <i>110 Electronic Alarm Projects For The Home Constructor</i> ..	£3.45
Marston, R. M., <i>110 Integrated Circuits Projects For The Home Constructor</i> ..	£3.45
Marston, R. M., <i>20 Solid State Projects For The Car and Garage</i> ..	£2.50
Marston, R. M., <i>20 Solid State Projects For The Home</i> .....	£2.50

Note that all prices include postage and packing. Please make cheques, etc. payable to Hobby Electronics Book Service (in sterling only please) and send to:

Hobby Electronics Book Service,  
P.O. Box 79,  
Maidenhead, Berks.

# Linear Scale Ohmmeter

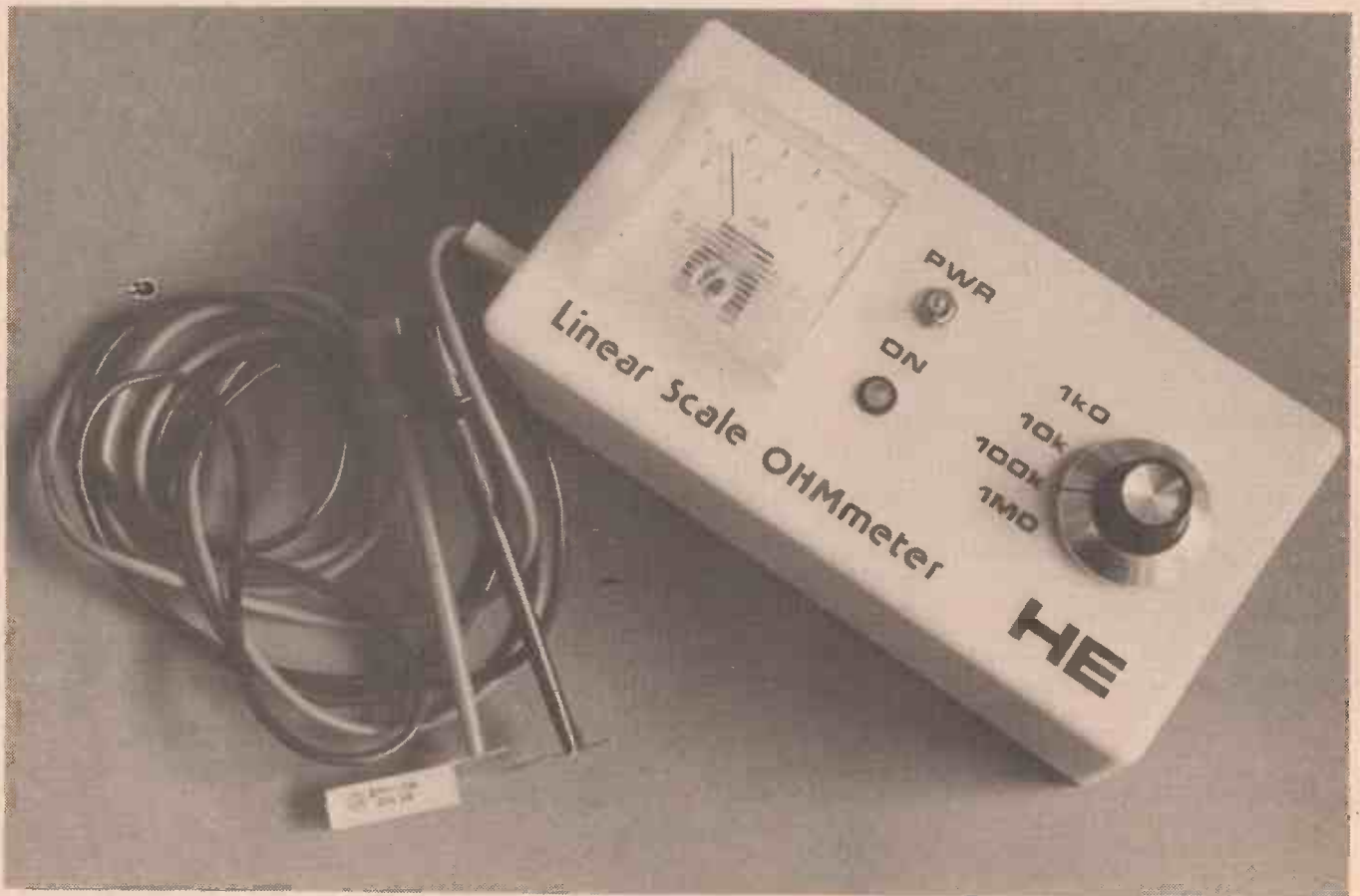
**HE's latest piece of test gear. An inexpensive unit that gives rapid and accurate readings of resistance from a few tens of ohms to one megohm.**

THE HE LINEAR SCALE OHMMETER is a simple and inexpensive semi-precision instrument that can be used to give rapid and accurate readings of resistance values from a few tens of ohms up to one megohm. The unit has four decade ranges covering 1k $\Omega$  to 1M $\Omega$  full scale, and has a basic full-scale accuracy of 2%.

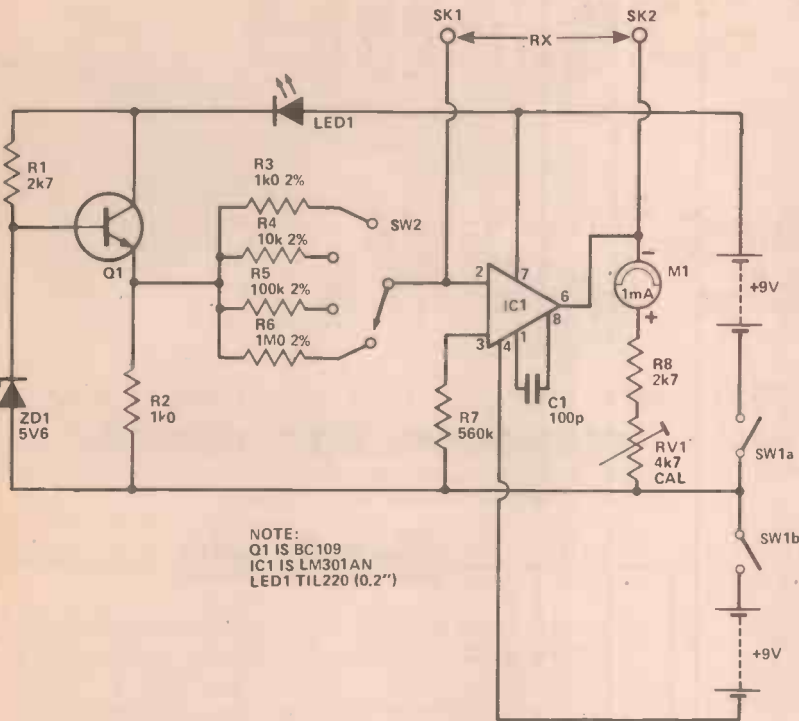
Conventional moving-coil ohmmeters have highly non-linear scales, which typically cover two to four decades of resistance value on a single scale. It is impossible to obtain accurate readings of resistance on such values. The HE ohmmeter, by contrast, gives resistance value readings on a linearly-calibrated scale of

a moving coil meter, and covers only a single decade of resistance on each switched range. The instrument thus inherently gives accurate readings of resistance.

Our linear scale ohmmeter can either be constructed as a completely self-contained unit, with its own built-in moving coil meter, as in the case of our prototype, or can be built as an add-on unit for use with an existing multimeter having a 1 mA DC current range. In the latter instance the unit can be built for a total cost of under £5, including the switches, PCB, and case, etc. That's not bad value for a semi-precision instrument, is it?



*Measuring a 12k resistor on the 100k range. The scale is very easy to read.*



NOTE:  
Q1 IS BC109  
IC1 IS LM301AN  
LED1 TIL220 (0.2")

Fig. 1 Circuit diagram of the HE Linear Scale Ohmmeter.

## Parts List

### RESISTORS

R1, 8	2k7
R2	1k0
R3	1k0 2%
R4	10k 2%
R5	100k 2%
R6	1M0 2%
R7	560k

### POTENTIOMETER

RV1 4k7 preset

### CAPACITORS

C1 100p polystyrene

### SEMICONDUCTORS

Q1 BC109  
ZD1 5V6 zener  
LED1 TIL220 (0.2in.)  
IC1 LM301AN

### MISCELLANEOUS

SW1 DPST  
SW2 4 pole 1 way  
M1 1mA meter  
Sk1, 2 2mm sockets  
2 PP3 batteries

### VEROCASE

65-2520J  
£5 (without meter)

## How It Works

The HE linear scale ohmmeter circuit is divided into two parts, and consists of a test voltage generator and a readout unit that indicates the value of the resistor under test. The test voltage generator section of the circuit comprises zener diode ZD1, transistor Q1, and resistors R1 and R2. The action of these components is such that a stable reference of about 5 volts is developed across R2, and this reference voltage is fed to the op-amp resistance-indicating circuit via range resistors R3 to R6.

The op-amp is wired as an inverting DC amplifier, with the 1 mA meter and R8-RV1 forming a voltmeter across its output, and with the op-amp gain determined by the relative values of ranging resistors R3 to R6 and by negative feedback resistor Rx. RV1 is adjusted so that the meter reads full scale when Rx has the same value as the selected range resistor, and under this condition the op-amp circuit has a voltage gain of precisely unity. Since the values of the reference voltage and the ranging resistors are fixed, the reading of the meter is directly proportional to the value of Rx, and the circuit thus functions as a linear-scale ohmmeter and has a full scale value equal to the value of the selected range resistor.

The op-amp in the IC1 position is a special device, the LM301 AN, used because its input bias currents are so small that they have negligible shunting effect on the range resistors, and the op-amp thus does not detract from the overall accuracy of the circuit.

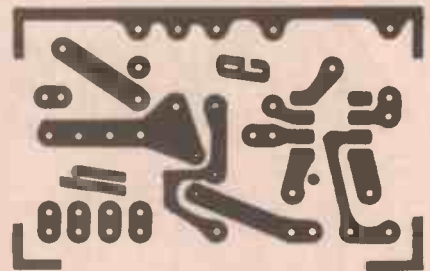


Fig.3 PCB foil pattern for the Linear Scale Ohmmeter.

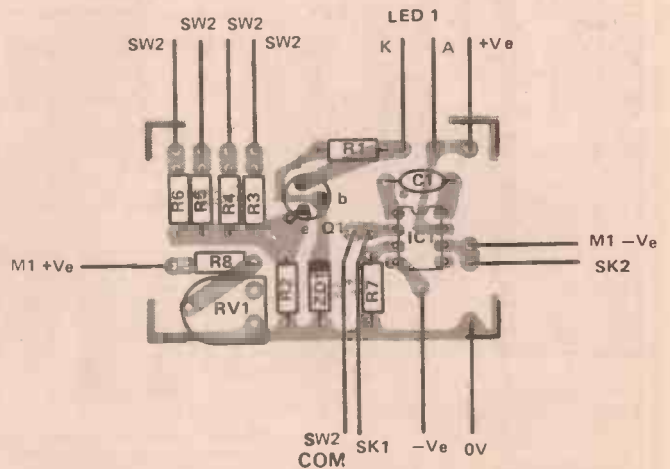


Fig.2 PCB overlay for the Ohmmeter, note the orientation of the IC, transistor and diode.

# Linear Scale Ohmmeter

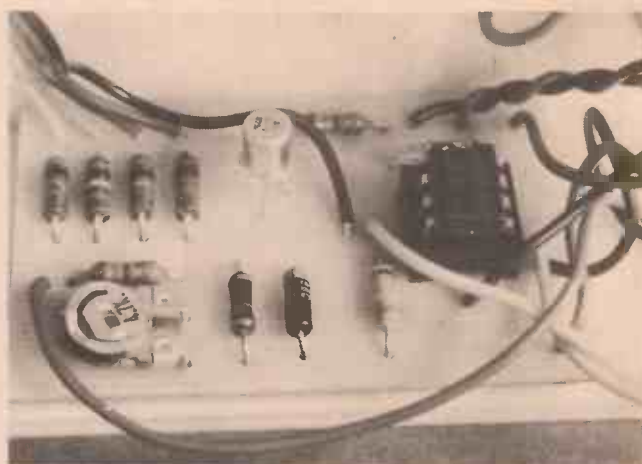
## CONSTRUCTION AND USE

Most of the circuit components are mounted on the PCB, and construction should present few problems. Note, however, that IC1 is not just the usual run-of-the-mill bipolar op-amp, so do NOT try using a 741 or similar device in this position. The overall accuracy of the completed instrument is determined by range resistors R3 to R6, so be sure to use high-accuracy (2% or better) components in these positions.

When the PCB assembly is finished, fit the board in a suitable case and complete the interwiring. Note that pin 2 of IC1 connects to the common terminal of SW2, and that resistors R3 to R6 connect to the four 'way' terminals of the switch. If you are making an add-on version of the circuit, fit a couple of 4mm panel terminals in place of meter M1, so that you can easily connect the unit to an external meter.

When construction is complete, switch the unit on and check that LED 1 lights up: if it doesn't, check that the LED is fitted in the correct polarity. When all is well, switch the unit to its 10k range, connect an accurate 10k test resistor across the Rx terminals, and adjust RV1 to give a precise full-scale reading on the meter. The calibration is then complete, and the unit is ready for use.

If you are using the circuit as an add-on unit with an external meter or multi-meter, note that the external meter must have a full scale range of 1 mA DC.



The PCB layout of the Ohmmeter, for accuracy over the entire range use only high stability resistors.

## Buylines

The only components likely to present any problems in this project are range resistors R3 to R6, which should ideally have accuracies of at least 2%. In case of difficulty suitable high-accuracy components can be obtained from Electrovalue Ltd, 24 St Judes Road, Englefield Green, Egham, Surrey TW20 0HB. Their catalogue is well worth obtaining in any case.

Largest range of quality components in the U.K. — over 8,000 types stocked

M

# Marshall's

A

Head Office and Mail Order to Dept. H.E.  
A. Marshall (London) Ltd.,  
Kingsgate House, Kingsgate Place,  
London, NW6 4TA. Tel: 01-624 0805  
Tlx. 21442

Retail sales: London: 40 Cricklewood Broadway, NW2 3ET. Tel: 01-452 0161/2. Also 325 Edgware Road, W2. Tel: 01-723 4242.  
Glasgow: 85 West Regent Street, G2 2QD. Tel: 041-332 4133 and Bristol: 108a Stokes Croft, Bristol. Tel. 0272-426801/2

TRANSISTORS (full range in catalogue)			P65		
2M696	N70	.39	2N1485	N70	2.20
2M697	N70	.31	2N1507	N70	.35
2M698	N70	.49	2N1524	P54	.60
2M699	N70	.58	2N1553	P66	1.50
2M706	N70	.30	2N1613	N70	.30
2M708A	N70	.30	2N1637	P70	.72
2M708	N70	.30	2N1638	P54	.70
2M710	N70	.30	2N1711	N70	.30
2M718A	N70	.54	2N1889	N70	.30
2M720A	N70	.85	AC126	P54	.48
2M721	P70	1.00	AC127	P54	.48
2M722	P70	.45	AC128	P54	.48
2M717	P70	.50	AC151	P54	.43
2M744	N70	.35	AC152	P54	.54
2M753	N70	.35	AC153	P54	.59
2M760	N70	.35	AC153K	P54	.59
2M869	P10	.35	AC176K	P54	.70
2M914	N70	.30	AC176	P54	.70
2M918	N70	.33	AC187	P54	.59
2M917	N65	.38	AC187K	P54	.85
2M919	N65	.48	AC188	P54	.54
2M929	N70	.37	AC188K	P54	.85
2M929A	N70	.37	AD136	P59	2.75
2K900	N70	.37	AD142	P66	1.45
2M900A	N70	.95	AD143	P66	1.45
2M1131	P70	.32	AD149	P66	2.65
2M1132	P70	.35	AD150	P66	3.10
2M1204	P70	1.55	AD161	P66	1.00
2M1302	N70	.80	AD162	P66	1.00
2M1303	P70	.80	AF106	P65	.80
2M1304	N70	.80	AF109	P65	.82
2M1305	P70	.80	AF114	P64	.70
2M1306	N70	1.00	AF115	P64	.70
2M1307	P70	1.00	AF116	P64	.70
2M1308	N70	1.10	AF117	P64	.70
2M1309	P70	1.10	AF118	P64	.70
2M1370	P70	.55	AF124	P70	.70
2M1420	N70	.55	AF125	P70	.70
2M1483	N70	1.83	AF126	P70	.70

LINEAR (see catalogue for full range)			P98		
CA3013	£1.85	SL610C	£2.75	SN76001R	£1.30
CA3014	£2.20	SL611C	£2.75	SN76003R	£3.08
CA3018	£0.75	SL612C	£2.75	SN76004R	£1.95
CA3018A	£1.10	SL620C	£3.85	SN76013R	£2.04
CA3020	£2.20	SL621C	£3.75	SN76013RD	£1.72
CA3020A	£2.50	SL622C	£3.25	SN76014R	£1.90
CA3021	£2.40	SL630C	£2.60	SN76023R	£2.05
CA3022	£2.20	SL640C	£4.40	SN76023R	£1.72
CA3023	£2.20	SL611C	£4.40	SN76033R	£3.08
CA3026	£0.70	SL701C	£2.50	SN76110R	£1.30
CA3028A	£0.90	CA3086F	£1.87	SN76115R	£1.65
CA3028B	£1.25	CA3089F	£2.90	SN76116R	£1.80

VALVES — MULLARD			P54		
Type	Price	£1.85	£2.43	PC201	£2.77
0167/802	£1.17	£1.95	£1.71	PC201	£1.77
6CC2	£1.38	6Y86/802	£1.17	PCF802	£1.77
6CC3	£1.31	6Y50	£2.87	PCF806	£1.77
6CC4	£1.51	6Z34	£2.14	PCN200	£2.84
6CC8	£2.15	PC86	£2.31	PC82	£1.51
6CF80	£1.51	PC88	£2.31	PC83	£1.80
6CH4	£2.75	PC97	£1.81	PC84	£1.87
6CL80	£1.71	PC90	£2.43	PC86	£1.76
6CL2	£1.71	PC94	£1.81	PC805/85	£1.80
6CL6	£1.78	PC85	£1.71	PD510	£4.40
6HR5	£1.17	PC99	£1.75	PL200	£2.25
6T83	£1.81	PC189	£2.15	PL36	£2.31
6T84	£1.82	PC190	£1.81	PL83	£2.87
6T86	£2.60	PC196	£1.77	PL84	£1.78
6T88	£1.30	PC199	£2.77	PL95	£1.46

### NEW 1979 CATALOGUE

48 pages containing largest range of quality components in the UK — Over 8,000 line items — 50p post paid or 40p to collect at any of our 4 branches.

### MAIL ORDER

All prices are VAT inc. Telephone Credit Card orders — minimum £10. Access and Barclaycard.



### TTL (see catalogue for full range)

74LS242R	£1.25	74LS270R	£1.30	74LS320R	£2.70	74LS379R	£1.25	SN74S40R	£0.77
74LS243R	£1.25	74LS275R	£3.20	74LS321R	£2.55	74LS380R	£0.44	SN74S44R	£0.77
74LS244R	£1.50	74LS279R	£0.58	74LS340R	£1.10	74LS390R	£0.90	SN74S56R	£0.77
74LS245R	£1.65	74LS280R	£1.65	74LS350R	£1.07	74LS393R	£0.90	SN74S112R	£1.70
74LS247R	£1.09	74LS283R	£1.20	74LS353R	£1.07	74LS396R	£1.50	SN74S114R	£1.70
74LS248R	£1.09	74LS289R	£3.74	74LS365R	£0.55	74LS398R	£1.90	SN74S140R	£0.77
74LS249R	£1.09	74LS290R	£1.00	74LS368R	£0.55	74LS399R	£1.45	SN74S157R	£2.95
74LS251R	£1.00	74LS293R	£1.00	74LS367R	£0.55	74LS400R	£0.90	SN74S188R	£2.70
74LS253R	£1.00	74LS296R	£1.35	74LS369R	£0.55	74LS470R	£1.90	SN74S189R	£1.81
74LS257R	£1.00	74LS299R	£1.35	74LS373R	£0.85	SN74S00R	£0.77	SN74S200R	£3.50
74LS258R	£1.00	74LS299R	£2.95	74LS374R	£0.85	SN74S03R	£0.77		
74LS259R	£1.55	74LS323R	£3.50	74LS375R	£0.66	SN74S04R	£0.84		
74LS261R	£3.25	74LS324R	£1.65	74LS377R	£1.30	SN74S10R	£0.77		
74LS266R	£0.44	74LS325R	£2.40	74LS378R	£1.00	SN74S20R	£0.77		

### POTENTIOMETERS-VOLUME CONTROLS

ROTARY POTENTIOMETERS. All standard 1/4" spindles

35p 1) SINGLE LESS SWITCH.  
Long spindle, double wiper available in following values.

75p 2) SINGLE SWITCHED.  
As above but with 2 Pole Switch 2 Amp 250V AC

### 95p 3) DUAL GANGED-STEREO

As above, but dual No Switch. All Log or Lin available in the following values:

5k 10k 25k  
50k 100k 250k  
500k 1Meg 2Meg

except type 1 not available in 1Meg value.



### COAXIAL CABLES

Z.41—U.H.F. (BANDS 1, V) 75 OHMS 18 p/m Z.45—V.H.F. (BANDS 1, 1.11) 750 OHMS 18 p/m

### V.H.F. FEEDER CABLES

Z.50—U.H.F./F.M. TWIN RIBBON FEEDER 300 OHMS 10p/m.

### MAINS CABLE

Z.31-2 CORE OVAL — 2 1/2 AMPS  
Z.25—FIGURE 8 RIB POLARISED 10p/m  
Z.23 STEREO SCREENED LEAD 14p/m  
Z.1/2,3 MICROPHONE SINGLE/TWIN 12p/19p/m  
Z.8 MULTICORE 12-WAY 50p/m

### TEST LEADS KIT PN90

Complete luxury kit — curly leads, long reach probes, banana plug, pin plug, Spade terminal and croc clip. PRICE £3.50/SET.



### SIGNAL INJECTOR. Model SE2508

Unusually stable trouble-shooter — for checking TV, Radio amp. etc. £5.30.



### TINNED COPPER WIRE

Available on 2oz. reels in the following gauges:

SWG	Price	SWG	Price	SWG	Price
18	£0.55	26	£0.40	32	£0.73
22	£0.55	30	£0.45	36	£0.80

### MULTICORE SOLDER — SAVBIT 1.2mm

Approx. 13.7 metres of size 12 Savbit Solder. Ideal for Radio, TV and similar work. £2.28

### CMOS (see catalogue for full range)

CD4000	£0.20	CD4012	£0.20	CD4021	£1.05	CD4031R	£2.25
CD4001B	£0.20	CD4013B	£0.52	CD4022B	£1.00	CD4034B	£2.46
CD4002	£1.18	CD4014	£1.00	CD4023B	£0.20	CD4035B	£1.30
CD4006	£0.25	CD4015	£0.79	CD4024B	£0.76	CD4037	£1.20
CD4007	£0.18	CD4016	£0.52	CD4025B	£0.20	CD4040	£1.12
CD4008B	£0.99	CD4017B	£1.05	CD4027B	£0.55	CD4041B	£0.86
CD4009	£0.58	CD4018B	£1.05	CD4028B	£0.60	CD4042B	£0.86
CD4010	£0.58	CD4019B	£0.52	CD4029B	£1.10	CD4043	£1.05
CD4011B	£0.52	CD4020B	£1.15	CD4030	£0.64	CD4044	£1.05

# Binary Numbers

***Machines find it the simplest language to understand, but binary numbers pose certain problems for mere mortals born with ten fingers. A. Lipson takes the guessing out of binary.***

THE PURPOSE of this article is to explain the nature and workings of the binary number system, as far as addition, and subtraction. An understanding of binary is essential to a clear appreciation of digital electronics, one of the most exciting fields of electronics and also to an appreciation of computer science.

## **FEAR NOT**

The fact that binary has been referred to as a 'number system' is nothing to be afraid of. It is no more difficult to understand than ordinary simple arithmetic, and, once a grasp of it has been obtained, is considerably easier to use.

Our number system is based on the number ten. This is an inherent property of the way in which we use numbers, normally. We use ten different symbols to represent different numbers. These symbols are 0, 1, 2, 3, 4, 5, 6, 7, 8, 9, and the way in which we write down larger numbers is dependent on the number ten. Counting one, two, three, etc., we simply use the symbols for these numbers *until we reach ten*.

At this point, we start to use combinations of two previously used symbols to represent the new numbers. The symbol used for the number ten is, as every knows, 10. This we interpret as meaning — one times ten, plus zero times one.

Another example of a 'compound number' is 34, which we interpret as meaning:— three times ten, plus four times one. His method works perfectly until we reach the number one hundred, or ten times ten. At this point we start using combinations of three symbols, because have used up all the possible combinations of only two symbols. At one thousand, or ten times ten times ten, we start using combinations of four symbols, and so on, the number of symbols used increasing by one at every power of ten. (That is, every time we reach a number that is ten multiplied by itself a number of times). Even higher numbers may make use of any number of symbols. e.g. 96,327, which we interpret as meaning nine times ten thousand, plus six times one thousand, plus three times one hundred, plus two times ten, plus seven times one. These, it will be seen, are all expressed as multiples of powers of ten. i.e.

$$\begin{aligned} 96,327 &= 90,000 + 6,000 + 300 + 20 + 7 \\ &= 9 \times 10 \times 10 \times 10 \times 10 \times 10 \\ &+ 6 \times 10 \times 10 \times 10 \\ &+ 3 \times 10 \times 10 \\ &+ 2 \times 10 \\ &+ 7 \times 1. \end{aligned}$$

(You may not hink that one is a power of ten, but in fact it is. That is a little beyond the scope of this article, however).

## **CONVENIENT BASE**

We can easily see that our normal number system is based on the number ten. Indeed, to most of us this system seems a natural one; but is it? The answer to this question is no. We use the number ten as the base of our system purely as a matter of convenience, and other bases are quite feasible. Take, for example, base three. In this system, a digit in the 'second column' of the number would indicate the number of threes present, rather than the number of tens, and only three symbols, 1, 2, and 2, would be necessary. Instead of counting 1, 2, 3, 4, 5, 6, 7, 8, 9, 10, 11, 12, we could count 1, 2, 10, 11, 12, 20, 21, 22, 100, 101, 102, 110, etc., and although we might be tempted to read the 110, for example, as one hundred and ten, or one times a hundred, plus one times ten, plus zero times one, we would be wrong to do so. In fact, it means one times nine (three times three) plus one times three, plus zero times one, and translated into normal notation, means twelve.

Obviously we have a marvellous chance to confuse people here. How are we to tell the difference between 110, base ten (normal) notation, meaning one hundred and ten, and 110, base three notation, meaning twelve? For that matter, why should not the 110 that we read be in base four, five, six, seven eight or nine, in which case it would mean twenty, thirty, forty-two, fifty-six, seventy-two or ninety, respectively? Well, it is generally agreed that in order to distinguish between bases, any number should have written, just to the right of itself, as a subscript, the number of the base in which it is written. An example should make this clearer. We will once again take the number 110. As a base three number, meaning twelve, it will be written as follows: 110<sub>THREE</sub>. If it were in base six, and meant one times thirty-six, plus one times six, plus zero times one, or forty-two, it would be written 110<sub>SIX</sub>.

Note: — When numbers are being written in base ten (normal) notation, the subscript is usually left out. This is because base ten is used so much mote than any other number base, and to add the subscript ten to every base ten number used would be a serious drain on the world's ink supplies.

Seriously, though, all this means in practice is that it is possible to recognise the base number of any collection of digits by looking at the subscript. If it doesn't

have a subscript, then it is a base ten number.

So what is binary? Binary is the number system using two as its base number. The first column from the right of a binary number indicates the number of 'ones' in it, the next indicates the number of 'two's' in it, the next, the number of 'fours', and so on, each column showing the number of various powers of two present.

### VOLTAGE MEANS NOTHING

It is immediately apparent that the binary number system will need only two symbols, and, in fact, the ones usually chosen are 0 and 1. It is this aspect of binary, in fact, which makes it of such use in digital electronics. Suppose we want to send a number along a piece of wire, in the form of an electrical signal. We could use morse code, but in a computer this is a little inconvenient, as morse code was not really invented with computers in mind, and is really one of the most illogical codes or cyphers ever invented. Another possible system would be to say that one volt means one, two volts means two, and so on, and then send an appropriate series of voltages along our piece of wire. Fine, some computers do work this way, but they tend to be a bit bulky and expensive, and are of relatively little use in simple arithmetic. The system most commonly used is one in which it is agreed that no voltage means 0, and some voltage means 1. We can then send numbers along the wire in binary form. This works very well. It is both easier and cheaper to design a computer to sense the difference between no voltage and some voltage than to design one to sense the difference between no voltage, 1 volt, 2 volts, 3 volts, etc.

### BILINGUAL MATHS

'Translation' of a number from binary to base ten is quite easily achieved. Consider the binary number of  $10011011101001_{TWO}$ , which, it must be admitted, looks pretty fearsome. There is, however, no need to be afraid of it. Just remember that the first column on the right is counting 'ones', the next 'twos', the third 'fours', the fourth, 'eights' and so on. The number as a whole may be seen to contain:—

A single one	=	1
No 2s		
No 4s		
One 8	=	8
No 16s		
One 32	=	32
One 64	=	64
One 128	=	128
No 256s		
One 512	=	512
One 1024	=	1024
No 2048s		
No 4096s		
One 8192	=	8192

Adding these together, we get 9961

which is the base ten equivalent of  $10011011101001_{TWO}$ .

Base ten-to-binary conversions may also be easily achieved. Let us re-convert 9961 to binary.

First, find the highest power of two (that is, the highest number in the series 1, 2, 4, 8, 16, 32, 64... where each number is twice the number before), that may be subtracted from 9961. We find that the highest

such number is 8192. Subtract 8192 from 9961 and write down a 1, thus:—

$$\begin{array}{r} 9961 \\ -8192 \\ \hline 1769 \end{array}$$

This gives us 1769. Halve the power of two which we subtracted from 9961, to give us 4096, and find how many times this new number can be subtracted from 1769. The answer is 0, so we write down a 0 next to the 1 which we already have, giving us 10. Halve 4096 and try to subtract the result from our 1769.

Again, 2048 cannot be subtracted from 1769, so write down another 0. Halve 2048, to get 1024, and try to subtract this from 1769. This time it can be subtracted once, leaving 745. Write down a 1 next to the 100 that we already have. Continue in this way, until you have subtracted 1 from what is left of your number. You will then find that the string of 1s and 0s that you have written down is  $10011011101001$ . Add to the suffix- $_{TWO}$  to this, and you have the binary equivalent of 9961!

Now try converting the following binary numbers into decimal:— a)  $1001101_{TWO}$   $11101_{TWO}$   $11111_{TWO}$   $10000001_{TWO}$ .

And the following decimal numbers into binary:—

b) 123 24 76 15.

(Answers at the end of the article)

### SPACIOUS BINARY

At this stage it becomes apparent why we don't usually use binary in everyday life. To write down any high number in binary takes far more space than writing it in decimal. Also, it is far harder to remember a large binary number than its equivalent decimal. If you don't believe me, look at the following:—

$$1453 \quad 10110101101_{TWO}$$

Don't look at them again. At the end of this article, find out which one you remember most easily.

### BINARY ADDITION

Binary addition, like most other aspects of binary arithmetic, becomes very simple once one is used to it. For easy explanation, we will compare decimal addition. Shown below are two problems in addition, one in decimal and one in binary.

+ 589	10001101
+ 234	+ 1011

The decimal addition we should all find easy. First we add the nine and the four, which comes to thirteen. This is greater than ten, the base number of the system that we are using, so we subtract ten from it, write down the three which is left, and "carry one" to the next column. Now we add 8 and 3, plus the one which we have carried, coming to twelve. Again, this is greater than ten, so we write down the 2, and carry one. Now we add two and five, and the one we have carried, giving 8. This is less than ten, so we just write it down. We have now written the answer to our problem:—823.

In binary, exactly the same system is used, with the single change that one is carried, not if the number is equal to our greater than ten, but is equal to or greater than two. Let us do the example.

### DOWN TO SOME WORK

First, we look at the two digits on the extreme right of each of the two numbers. They are both 1. One and one is two, but this is the base number of the system, and we subtract 2, leaving 0, and carry one to the next column.



# Binary Numbers

We add 0 and 1, and the one which we have just carried, and again they come to two, so we write down 0 and carry one again. The same happens in the next column, but in the column after that we find ourselves adding 1 and 1, plus the one which we are carrying, which altogether come to 3. Subtracting 2, we get 1, which we write down, and carry one. We continue in this way until we have added all the digits, and have obtained the answer, which is 10011000<sub>TWO</sub>.

Now try adding the following binary numbers. The answers are at the end of the article.

c)

$$\begin{array}{r} 10110_{TWO} \\ 100_{TWO} \end{array} \quad \begin{array}{r} 1111_{TWO} \\ 110_{TWO} \end{array} \quad \begin{array}{r} 1101_{TWO} \\ 1001_{TWO} \end{array} \quad \begin{array}{r} 10101_{TWO} \\ 11101_{TWO} \end{array}$$

As you might expect, binary subtraction is very similar to base ten subtraction. We will take as an example the case of subtracting 10101<sub>TWO</sub> from 11101<sub>TWO</sub>.

$$\begin{array}{r} 11101_{TWO} \\ -10101_{TWO} \end{array}$$

First we subtract the 1 on the extreme right of 10101<sub>TWO</sub> from that on the extreme right of 11101<sub>TWO</sub>. This obviously gives us 0, so we write this down and proceed to the next column, where we subtract 0 from 0, giving (you guessed it) 0. So far, so good. In the next column, we subtract 1 from 1, once again giving 0, and in the next column we subtract 0 from one, giving 1. In the last column, we subtract 1 from 1 and get 0. Thus we have our answer: 01000<sub>TWO</sub>. Numbers may not begin with a 0, so we remove this digit, and are left with 1000<sub>TWO</sub>. This answer may be easily checked by adding it to 10101<sub>TWO</sub>, and seeing if it comes to 11101<sub>TWO</sub>. In fact, as you may have noticed, we could have treated this subtraction like a decimal one, and obtained the same answer.

So where's the difference? The difference may be seen when a subtraction like 10<sub>TWO</sub> - 1<sub>TWO</sub> has to be solved. In the first column, we have to subtract 1 from 0, and this can only be done by 'borrowing' from the next column, that is, we say that we will add two to the digit we have in the first column, and then, to keep our quantities even, we will subtract the same amount from the next column. Okay, here goes. We take the 0, and add two, giving two. Now, subtract the 1, and write down the answer 1 in the space below. In the next column, we have 1, and nothing to subtract from it, but we borrowed two, remember? Well, two in the last column means 1 in this column, so we subtract 1 from our 1, to get 0. 10<sub>TWO</sub> minus 1<sub>TWO</sub>, therefore equals 1<sub>TWO</sub>. Now have a go at these.

d)

$$\begin{array}{r} 1101_{TWO} \\ -110_{TWO} \end{array} \quad \begin{array}{r} 222_{TWO} \\ -10_{TWO} \end{array} \quad \begin{array}{r} 1011_{TWO} \\ -101_{TWO} \end{array}$$

Okay, that's it. Not so bad, eh? Now how about the answers?

- a) 77, 29, 31, 129  
 b) 1111011<sub>TWO</sub>, 11000<sub>TWO</sub>, 1001100<sub>TWO</sub>, 1111<sub>TWO</sub>  
 c) 11010<sub>TWO</sub>, 10101<sub>TWO</sub>, 10110<sub>TWO</sub>, 110010<sub>TWO</sub>  
 d) 111<sub>TWO</sub>, 101<sub>TWO</sub>, 110<sub>TWO</sub>

Oh, and by the way, remember that binary number and the decimal number? Which do you remember most easily? I was afraid of that... Alright how many digits did each have? **HE**

## Car Audio

Manual  
MW/LW

Full medium and long wave tuning. Complete with speaker and mountings. Suitable for positive or negative chassis. Latest model.

**£9.95 + £1.00 Post**

Push-Button  
MW/LW

One LW, four MW buttons plus manual tuning. Complete with speaker and mountings. Latest model, negative chassis only.

**£15.60 + £1.00 Post**

Stereo FM/  
Cassette  
+ MW

Standard cassettes and FM in stereo plus medium wave. Tone and balance controls. Fast forward facility on tape. Adjustable shafts. Suitable for 4 or 8 ohm speakers (not supplied). This model is discounted elsewhere at £50 up.

**£39.95 + £1.00 Post**

Stereo  
Speaker Set

Suitable for above stereo unit. Good quality in surface mounted casing, 5W nominal, 8W peak.

**£3.95 (pair)**

+ 70p Post

Telescopic Car Antenna

Multi-section standard type, suitable for angled mounting with locking key.

**£1.60 + 30p Post**

## Metal Detectors

Treasure Tracer Mk III

The original Treasure Tracer. Sales exceed 7,000. 5-transistor circuit with Varicap tuning. Sensitive, stable BFO design. Built-in speaker and earphone. Fitted with Faraday shield. Kit supplied with pre-built search head.

Kit: £17.50 + £1.00 Post  
 Built: £22.50 + £1.00 Post

★ Induction Balance Model

Built with sensitivity up to 10in on single coin; fitted with speaker and meter; PP3 battery; 7in dia. search head. Telescopic stem. Excellent pin-pointing, positive reaction to non-ferrous, negative reaction to iron. This model's normal price is £39.95!

**£22.95 + £1.00 Post**

All goods guaranteed one year. 10-day money-back offer. Goods ex-stock at time of going to press. Callers by appointment only please. Send s.a.e. for illustrated leaflet.

**Minikits Electronics Ltd.**

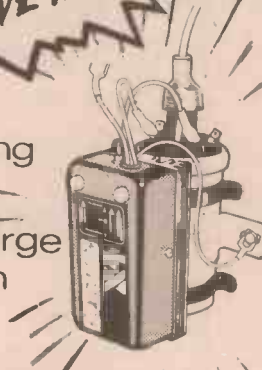
7 H Cleveland Road  
 S. Woodford  
 London E18 2AN

# The latest kit innovation!

## from Sparkrite

*Sparkrite - featured by Shaw Taylor in "DRIVE IN"*

the quickest fitting  
**CLIP ON**  
 capacitive discharge  
 electronic ignition  
 in KIT FORM



- Smoother running
- Instant all-weather starting
- Continual peak performance
- Longer coil/battery/plug life
- Improved acceleration/top speeds
- Optimum fuel consumption

Sparkrite X4 is a high performance, high quality capacitive discharge, electronic ignition system in kit form. Tried, tested, proven, reliable and complete. It can be assembled in two or three hours and fitted in 1/3 mins.

Because of the superb design of the Sparkrite circuit it completely eliminates problems of the contact breaker. There is no misfire due to contact breaker bounce which is eliminated electronically by a pulse suppression circuit which prevents the unit firing if the points bounce open at high R.P.M. Contact breaker burn is eliminated by reducing the current to about 1/50th of the norm. It will perform equally well with new, old, or even badly pitted points and is not dependent upon the dwell time of the contact breakers for recharging the system. Sparkrite incorporates a short circuit protected inverter which eliminates the problems of SCR lock on and, therefore, eliminates the possibility of blowing the transistors or the SCR. (Most capacitive discharge ignitions are not completely foolproof in this respect). The circuit incorporates a voltage regulated output for greatly improved cold starting. The circuit includes built in static timing light, systems function light, and security changeover switch. All kits fit vehicles with coil/distributor ignition up to 8 cylinders.

#### THE KIT COMPRISES EVERYTHING NEEDED

Die pressed epoxy coated case. Ready drilled, aluminium extruded base and heat sink, coil mounting clips, and accessories. Top quality 5 year guaranteed transformer and components, cables, connectors, P.C.B., nuts, bolts and silicon grease. Full instructions to assemble kit neg. or pos. earth and fully illustrated installation instructions.

NOTE - Vehicles with current impulse tachometers (Smiths code on dial RV1) will require a tachometer pulse slave unit. Price £3.85 inc. VAT, post & packing.

**Electronics Design Associates, Dept. HE 7**  
 82 Bath Street, Walsall WS1 3DE. Phone (0922) 614791

Name .....

Address .....

Phone your order with Access or Barclaycard

Including postage and packing UK only

QUANTITY REQ'D.

Send SAE if brochure only required.

X4 KIT £16.65 inc. VAT

TACHO PULSE SLAVE UNIT  
 £3.85 inc. VAT

I enclose cheque/PO's for

£

Cheque No. ....

Access or Barclaycard No. ....

# Hobby Electronics

## CLOCK RADIO



Size: 177mm x 90mm x 47mm.

You probably won't believe us as we're selling the goods but we're going to tell you anyway! We have *rejected* eight clock radios for Marketplace, they were all cheap enough but the quality was so poor that we couldn't have lent our name to them. However, we are now able to offer a portable LCD Clock Radio to you which meets our standards.

The clock is a 12-hour one with AM/PM indicated and a back light. The radio is Medium Wave and FM with very nice quality for a small speaker — for FM there's a telescopic aerial. The alarm can be either a 'beep-beep' type or the radio, there's also a snooze facility.

The case is sensibly rugged and is printed on the back with a World Time Zones map, a bit of a cheek really, especially as the time is relative to Japan!

We won't even mention the RRP — but just check on comparable prices — you'll find ours a bargain.

An example of this Clock Radio can be seen and examined at our Oxford Street offices.

# £20.50

(Inclusive of VAT and Postage)

To:

**CLOCK RADIO Offer,**  
**Hobby Electronics,**  
 25-27 Oxford Street, London W1R 1RF.

Please find enclosed my cheque/P.O. for £20.50 (payable to Hobby Electronics) for my Clock Radio.

Name .....

Address .....

**CLOCK RADIO**

Please allow 21 days for delivery UK only

# Marketplace

## DIGITAL ALARM CLOCK



Size: 100mm x 130mm x 60mm.

Over 10% of Electronics Today International's readers have purchased a digital alarm clock from offers in that magazine — the offer is now extended to Hobby Electronics readers. This is a first rate branded product at a price we don't think can be beaten.

The Hanimex HC-1100 is designed for mains operation only (240V/50Hz) with a 12 hour display, AM/PM and Alarm Set indicators incorporated in the large display. A switch on the top controls a Dim/Bright display function.

Setting up both the time and alarm is simplicity itself as buttons are provided for both fast and slow setting and there's no problem about knocking these accidentally as a 'locking switch is provided under the clock. A 9-minute 'snooze' switch is located at the top.

An example of this digital alarm clock can be seen and examined at our Oxford Street offices.

# £8.95

(Inclusive of VAT and Postage)

## LCD CHRONOGRAPH



We feel we've got to tell you carefully about this offer. Why? Because our price is so enormously lower than anywhere else you may suspect the quality.

The exact same watch is currently being offered by another magazine as a special at £24.95 — some of the discounters are selling it at £29.95 the price to HE readers for exactly the same watch is £12.95.

The display is LCD and shows the seconds as well as the hours — and minutes — press a button and you'll get the date and the day of the week.

Press another button for a couple of seconds and you have a highly accurate stopwatch with hundredths of a second displayed and giving the time up to an hour. There is a lap time facility as well — and of course a back light.

Our Chrono comes complete with a high grade adjustable metal strap and is fully guaranteed.

An example of this LCD Chronograph can be seen and examined at our Oxford Street offices.

# £12.95

(Inclusive of VAT and Postage)

To:  
DIGITAL Alarm Offer,  
Hobby Electronics,  
25-27 Oxford Street,  
London W1R 1RF.

Please find enclosed my cheque/P.O. for £8.95 (payable to Hobby Electronics) for my Digital Alarm Clock.

Name .....

Address .....

Please allow 21 days for delivery. UK only.

DIGITAL ALARM

To:  
LCD Chrono Offer,  
Hobby Electronics,  
25-27 Oxford Street, London W1R 1RF.

Please find enclosed my cheque/P.O. for £12.95 (payable to Hobby Electronics) for my LCD Chronograph.

Name .....

Address .....

Please allow 21 days for delivery. UK only.

LCD CHRONO

# Fixed Resistors

## The Inside Story.

*Fixed resistors are perhaps the most familiar of all electronic components. These colourful little tubes have a lot more to them than you think. Richard Maybury looks beneath the coloured bands to find out just what they're made of.*

FOLLOWING THE TREMENDOUS reaction to our feature on capacitors in the April Hobby (we discovered this from our recent reader survey) we thought it would be a good idea to do a follow up, this time on resistors. As with capacitors the subject has been pretty well covered in the past, so we're going to take a somewhat slanted look at how they work and what they're made of.

Most of you probably have a fair idea of how resistors work, mainly from countless analogies to water pipes

*Just a small selection of the many types of resistor available to the amateur market. This article is primarily concerned with fixed types although the variable resistor will be covered in a future feature.*

etc. So if you're like us and have vague notions of electricity dripping out of the ends of your household wiring, unless you keep the plug in, read on.

The first thing we have to accept are some basic principles of electricity, forget for the moment AC and DC and all those other things we are told electricity can be made to do. Consider for a moment the Trans-Atlantic telephone cables that were laid between Britain and America during the early years of this century. The electrons that were present at the British end of the cable when the cable was laid have yet to reach a quarter the way across in 1979. Quite a thought that, but when you



consider that an electron in a conductor rarely travels faster than one inch per minute. The HE calculator tells us it will take around 301 years for the poor old electron to cover the distance.

## ENERGETIC ELECTRONS

But you thought like us that electricity, like water flows, well it doesn't, not in the true sense. So looking at electricity like water can be a little misleading. Rather than water think of electricity as a line of billiard balls. By pushing the end one, all the balls move, virtually instantaneously, but the one you pushed has moved, very little. Electricity operates along similar lines (groan), it is a shift of electrons that makes a current flow, not all the electrons rushing down the conductor, so the overall effect happens very fast — at the speed of light in fact.

Getting back to resistance we can see that resistance is not only determined by the thickness of the wire (or pipe in the case of water) but by the amount of space the electrons have to move around in. Put in terms of billiard balls, the size of gaps between the balls and the amount of balls in the pipe or wire. (See Fig 1.)

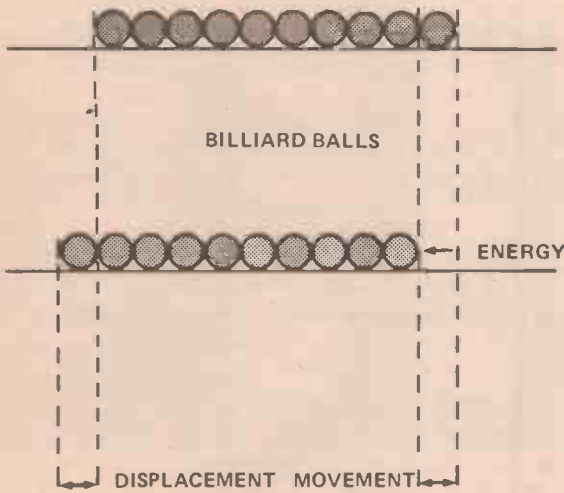


Fig. 1. (a) Using billiard balls as an analogy to electrons in a conductor it can be seen that a tight formation results in an easier movement of electrons.

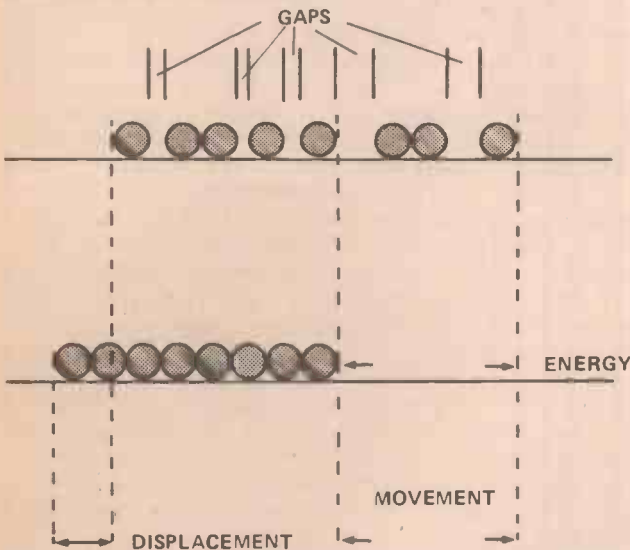


Fig. 1. (b) Loosely spaced electrons (billiard balls) result in a less efficient current flow — a resistor.

## RESISTANCE TO CHANGE

Certain materials, mainly metals have an abundance of 'free' electrons within their structure (plenty of billiard balls, close together). This means that if you attempt to cram a certain amount of electrons in one end of a conductor, (ie a metal wire) there's a good chance a similar amount will be dislodged at the other end. If we use a material with fewer 'free' electrons (ie a resistor) and try the same trick, because there are larger gaps between the electrons not so many will be shifted. The energy you used in pushing the electrons in at your end will be lost. In the case of electricity this 'lost' energy will cause the conductor to heat up, after all, all that wasted effort has to be accounted for.

So now with a bit of basic know-how under our belts and a few rumours dispelled we can start to take a look at what those little coloured tubes do and how they do it. It's probably a good idea to avoid referring to anything to do with atoms and things from now on, mainly because we don't understand them and they're not really needed once you understand the basic concepts.

## CARBON FILM RESISTORS

Probably the most frequently encountered type of resistor today is the Carbon Film resistor, a very descriptive name, quite simply using carbon or a Carbon-Boron mixture as the resistive material. Remember, to be resistive a material must make it difficult for the electrons to move within the material, carbon does just that under the right conditions.

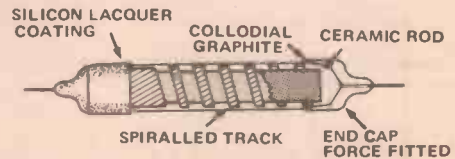


Fig.2. Cut-away diagram of a Carbon Film resistor showing the spiralled track.

The Carbon (or Carbon-Boron) mixture is deposited on a ceramic former, usually a tube or rod. A helical groove is then cut into the 'film' coating and what's left forms a spiral, resistive track wound along the length of the device. Terminations are made in a variety of ways, metal caps may be forced over the ends of the ceramic rod, contacting with the film. Leads are attached to the caps by soldering or spot welding. In some cases a metallic film is deposited on the ends of the rod and the terminations, wires, are tightly wrapped around the ends. The ends are then soldered in place and a suitable coating is applied to protect the component.

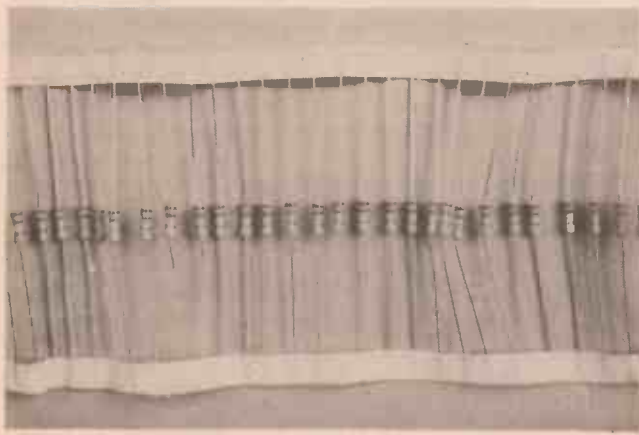
The Carbon Film resistor is manufactured by a process known as 'cracking' or Pyrolytic forming where a Hydrocarbon vapour at high temperature is deposited on to the ceramic rod producing a thin carbon film. Sometimes a Boron gas is introduced into the reaction chamber, the resulting Carbon Boron mixture produces a resistor with a superior temperature co-efficient over a fairly limited range.

The final coating for the component can be one of a variety of substances, numerous layers of varnish may be applied followed by a coat of paint. Some modern types are completely sealed in a coat of Silicon resin which is impervious to water as well as providing excellent mechanical and thermal protection. Other types are sealed in a ceramic or glass tube, or even in a plastic moulding in certain low-power applications.

## METAL FILM RESISTORS

Generally Metal-Film resistors look much the same as the carbon-film resistors. The Metal Film is deposited on a glass or ceramic by evaporating a metal or alloy in a vacuum. The metal condenses on the former, forming a hard dense film. Some manufacturers use a chemical deposition process to coat the former with a nickel alloy.

Metal-film resistors are mostly used in applications where reliability, close tolerance and high stability are required or controlled temperature characteristics are called for. Generally they are more expensive than the carbon film type of resistor but with rapidly increasing production over the past few years the price differential is becoming less significant.



Resistors on a Bandolier strip, this makes transport and storage of large quantities of resistors simple.

## METAL OXIDE RESISTORS

The Metal Oxide Film resistor is currently the most popular type of Metal Film resistor. The MOF resistor is formed on a glass or ceramic rod which is heated to red heat and a layer of Tin and Antimony Oxide is deposited upon the surface of the rod. The chemical reaction produces a hard glass-like oxide on the surface of the former. The oxide film is conductive and is inert to common chemicals. The resistance value required is obtained by cutting a helical groove in the film, along the former, (similar to carbon film resistors). General construction and terminations are again similar to other types of film resistor. The resistive spiral is usually coated in a flame-proof epoxy resin.

The particular characteristics of MOF resistors enables them to be made with wattage ratings of up to 7 watts in the standard axial-lead (tubular, with a wire at each end) type of construction. However, much higher power types are produced. Standard ratings above 1 watt are 2, 3, 5, and 7 watts, in axial-lead. Cylindrical styles and square-section power types can be obtained as 3, 4 and 10 watt rated.

Before we go on to look at the other types of resistors there are a couple of limited-usage film resistors we should consider. The first is the Thick Film resistor.

## THICK FILM RESISTORS

Thick Film resistors are a special type of film resistor. They are generally constructed by depositing the resistive material on a ceramic or Aluminium Oxide substrate. A portion of the film is then removed, according to a

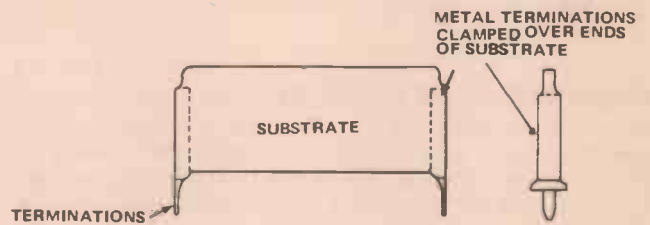
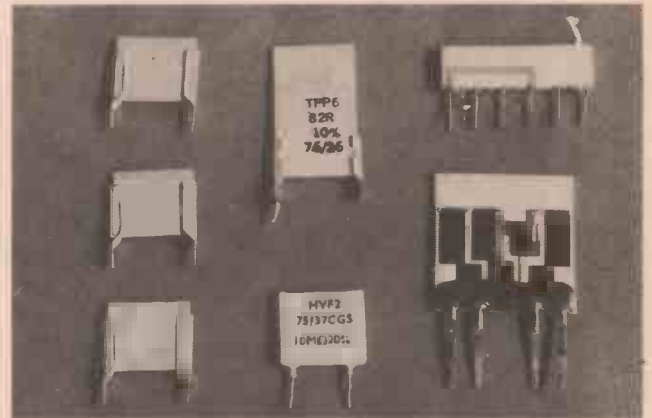


Fig.3. A Thick Film resistor, the body of the resistor, a ceramic substrate has the resistive material coated on its surface.

pre-determined pattern, to provide a resistive path between the terminals.

Some Thick Film resistors are obtainable as 'fusible resistors'. Should an overload occur and the resistor dissipates too much heat, the substrate cracks and an open circuit results, hopefully preventing any further damage. The Thick Film resistor occupies a minimum of space and can dissipate a considerable amount of power owing to their large surface area (up to 150°C).



A small selection do Thick Film resistors, the two-legged variety will crack under overload conditions.

## THIN FILM RESISTORS

The second type of 'obscure' film resistor is the Thin Film resistor. They are constructed in a similar way to the Thick Film but on a considerably smaller scale. They are primarily used in IC manufacture. Some thin film resistors are available in standard DIL packages as resistor networks, the main area of application for thin film resistors is in the field of digital electronics.

There are two types of resistor that have largely disappeared in recent years. The two in question are: Carbon Composition and Wirewound resistors. The Carbon Composition type has been superseded to a large extent by the Carbon and Metal film types. Both have proved to be considerably more reliable and now a great deal cheaper.

The second type is the Wirewound resistor, with the all-round reduction in power consumption for modern electronic equipment they tend to be found only in power supplies, multimeters and high-power applications. However, their continued use is assured (for the moment) as a suitable replacement has yet to be found.

As both of these types of resistor are still going to be found in electronic equipment for some time to come it is well worth taking a brief look at both of them.

## CARBON COMPOSITION RESISTORS

This type of resistor has been used extensively in the manufacture of radio and television sets since the valve era. Carbon resistors are manufactured in wattage ratings ranging from 0.1 watt to 2 watts and resistance values ranging from 10 ohms to 100 meg ohms. Tolerance for CC resistors is usually quoted as  $\pm 5\%$  or  $\pm 10\%$ , there is a range manufactured to 20% tolerance but their applications are somewhat limited with so many cheap high tolerance resistors available.

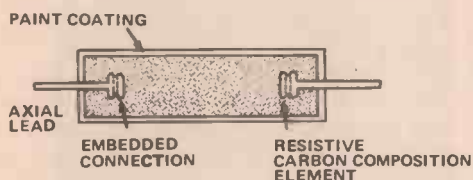
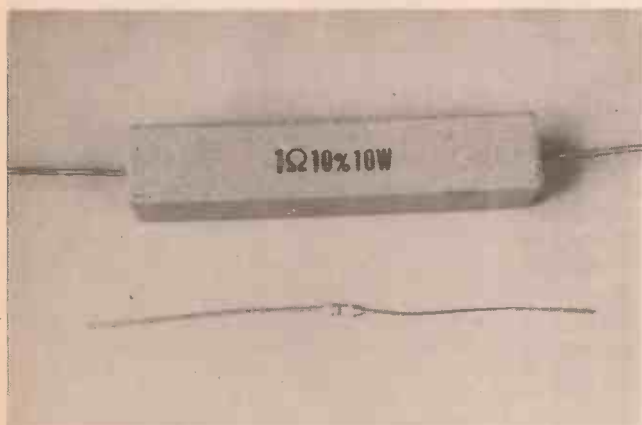


Fig.4. A cut-away diagram of a Carbon Composition resistor now largely superseded by Carbon and Metal Film devices.

There are three basic types of carbon composition resistor: uninsulated, insulated and filament or filament-coated. *Uninsulated type.* In this type, the resistive element consists of fine carbon particles mixed with a refractory filling, which is non-conducting, bonded together by a resin binder. The proportion of carbon particles to filler determines the resistance value. The mixture is compressed into shape, usually cylindrical, and fired in a kiln. The end connections are made by a variety of methods. In the first method, the ends of the composition rod are sprayed with metal, and wire leads soldered on to provide radial connections. The resistor is then painted and colour coded. This method was extensively used with 1 W and 2 W resistors. A second method, much more widely used now, involves



Little and Large, a 10-watt power type resistor next to its 1/4-watt little brother.

enlarging the ends of the connecting leads and moulding them directly into the carbon composition rod — this method is used extensively as it is adaptable to all wattage ratings and sizes of the resistor body. A third method is also employed. Pressed metal caps, usually having integral leads, are forced onto the ends of the carbon rod. These caps have radial leads and are particularly suited to printed circuit board mounting as

they may be plugged straight into mounting holes on the board without the necessity of preforming the leads as is required with axial lead components. These are also known as 'pluggable' types. Film resistors are also made in this style.

Uninsulated carbon composition resistors are generally smaller than the insulated types for a given wattage as their open construction permits good heat dissipation. There is the danger, however, that short circuits may occur to adjacent components, and for this reason the insulated type is preferred.

*Insulated Type.* This type has the composition element made in the same manner as just described, but it is then encapsulated in either a silicon lacquer, a thermoplastic moulding or epoxied into a ceramic tube. The first two generally employ a resistance element having embedded connections. The ends of the element are sprayed with metal and an end-cap having an integral lead is force-fitted over them. This assembly is then put inside the ceramic tube and the ends sealed with an epoxy or other compound. *Filament or Filament-coated Type.* With this type, carbon granules are dispersed, along with a filler, in a varnish which is then applied to the surface of a continuous glass or ceramic filament which is then baked. The resistance value depends on the length and mixture, the filament is cut into appropriate lengths and leads applied by one of the methods detailed above. It is usually encapsulated in an insulating compound as per the insulated style of resistor.

## WIRE-WOUND RESISTORS

In the final part of this article we take a look at Wire-wound resistors. This type of resistive device is probably the oldest electrical component there is, simply because wire itself is resistive, sometimes as much as 1 or 2 ohms per metre.

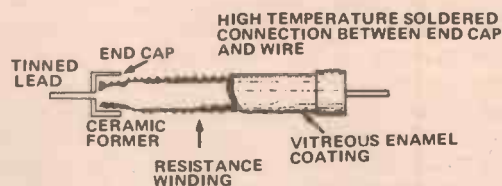


Fig.5. Inside the wire-wound resistor, nothing more than a coil of resistance wire, wound onto an insulating former.



A low resistance wirewound resistor, this type will often find application in power supplies and amplifier output stages.

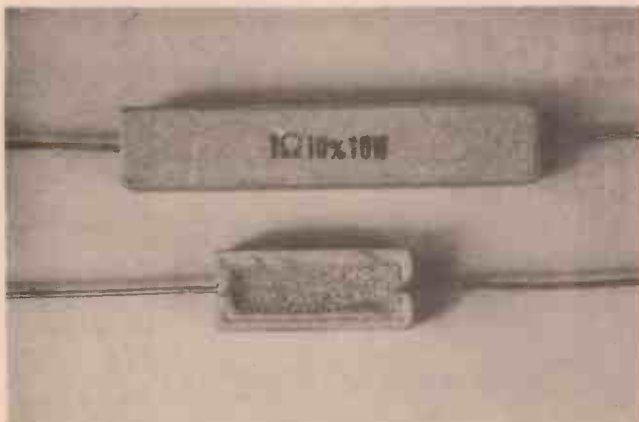
Obviously ordinary wire could be used, but so much would be needed to make only quite small value resistors. Realising the problem (never being slow on the uptake) the electrical industry has developed wire with a controlled resistance. The two most common types in use today are 'Eureka' and 'Constantan' wire; obviously there are many more but most if not all are based on one or more alloys of Nickel.



*Underneath the skin of a wirewound resistor, a ceramic former is used to aid heat dissipation and electrical insulation.*

Up till quite recently all resistors required to dissipate more than just a couple of watts were wirewound; with the improvement in Thick-Film technology they are now found mostly on high-power equipment.

The most commonly encountered type of wirewound usually consists of a coil of resistance wire wound onto a ceramic former, terminations are usually of the forced cap type with soldered leadouts. Because these resistors are expected to dissipate a fair amount of heat a 'stand-off' style is usually adopted, where the component will stand proud of the PCB etc and hopefully in a cooling airstream.

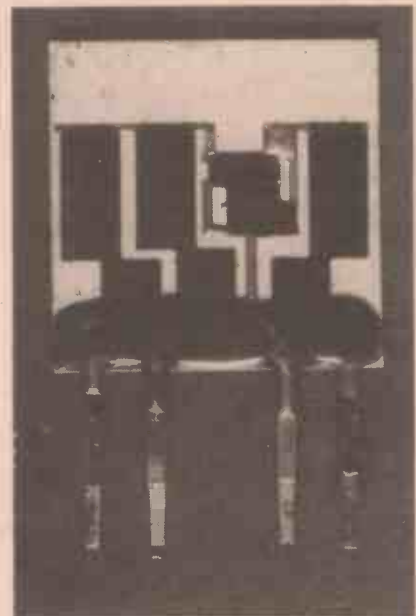


*Two types of high power resistor. The larger one is 10 watt rated whilst the smaller one will dissipate just 5 watts.*

Generally wire-wound resistors are manufactured to very high tolerances, ratings of 0.5-1% are not uncommon. This stability and accuracy finds application in high quality multi-meters where values not covered in the conventional resistance ranges can be tailor-made.

One possible drawback of wirewound resistors is

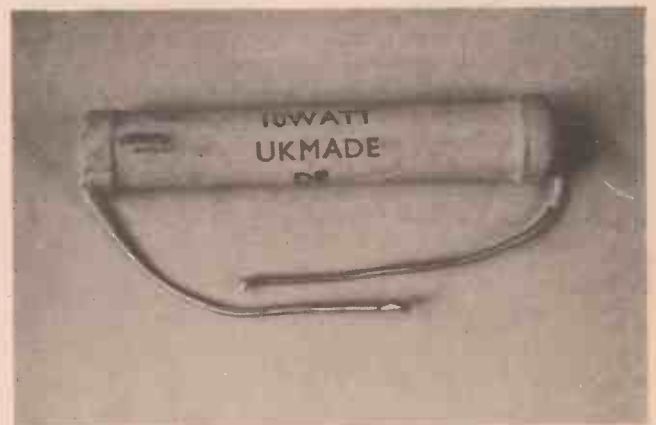
their ability to become inductive at high frequencies; this is easily overcome by winding the resistance coil in two



*A Thick Film composition resistor. Several resistive tracks are incorporated onto one substrate. This type of resistor is commonly found in applications where failure of one track will require the whole unit to be replaced. This particular specimen is used on the video output stages of a colour television receiver. One lead (second from the right) is the common and the other three connect to each of the other individual resistive tracks.*

layers or in two directions. This is commonly called a 'back to back' winding.

Well that's just about it, we've only just scratched at the surface of resistor. As you will have realised this article has not even mentioned variable resistors, and that includes LDRs, VDRs and thermistors, they're destined to be covered in an article in the very near future.



*A 10-watt wire-wound resistor. The ability of wire-wound resistors to be manufactured to high tolerances makes them ideal for inclusion in multimeters. Figures of around 0.5% are not uncommon.*

It's also fairly apparent the something needs to be written about component identification (even we're confused sometimes), both resistors and capacitors, so look out for an explanation of these heiroglyphics fairly soon.



# Hobby Electronics

Next  
Month

## SATELLITE POWER

Have you ever considered what a wasteful object the Sun is. All that energy going to waste when we're so short of it here on earth. This feature investigates the research that's currently being carried out into using orbital power stations to provide for our future needs.

## TOOLS



Back to basics. If you are still considering starting out into electronics for your hobby then do not miss this feature on tools, what to look for and what to avoid.

## COMPETITION



It's about time we had a competition, so keep an eye open for this one it's a real humdinger.

## INJECTOR/TRACER

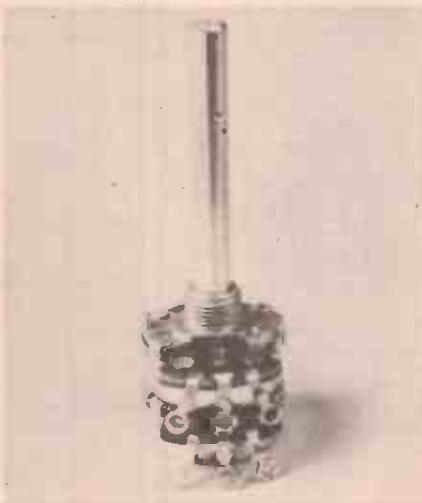
Another in our series of do-it-yourself test equipment. Anyone who has had to repair audio/radio equipment will testify to its usefulness. A very simple project taking only an hour or so to build but saving many hours of frustrating fault-finding.

## HOME SECURITY UNIT



Well, we couldn't call this project a mere burglar alarm. It boasts a 'panic button', fire alarm option and as a further bonus it will drive either a mechanical bell or the electronic siren we're incorporating into the design.

## VARIABLE RESISTORS



Concluding our short series on resistors. We take a look at all types of variable resistors, LDRs, VDRs, Thermistors and of course Potentiometers.

## CONSTANT VOLUME AMPLIFIER



This natty little unit is primarily intended for tape-recorder, and audio enthusiasts in general. It will accept a wide range of inputs and will preserve the 'dynamic range' of your recordings.

## LED TACHOMETER

We're quite proud of this project. It has a range of 0-10 000 RPM shown by the progressive illumination of 30 LEDs. (It won't cost as much as you think.) The circuitry is very advanced but not at the expense of cost or complexity, indeed it will still cost less than most commercial units.

## CLEVER DICK

Next month we're trying out a little experiment. Judging from the response to our Technical Query service it seems like a good idea to have some sort of agony column. Our resident technical expert will attempt to answer any questions or problems that may arise from your hobby. Obviously it doesn't have to be specifically about articles in HE, (it would be nice though, we're not that clever). We won't be entering into any personal correspondence, we can't afford the stamps. So mark your letters 'Clever Dick's Problem Page', and we'll see what we can do. (We know its a silly name, perhaps you can suggest a better one).

---

The August issue will be on sale July 13th

---

The items mentioned here are those planned but circumstances may affect the actual contents

TANTALUM		RADIAL ELECTROLYTICS		2200 40V		'MYLAR' Epoxy Dipped Polyester Capacitors	
1.5V	10	AT 50V	06	4700 6.3	.38	Standard values from 001	
2.2 35V	10	1.5V	06	TAB 2200 6.3V	1.72	rad through 47 nfd. 100	
3.3 35V	10	2.2 50/35V	06	TAG 4700 6.3V	1.99	V.O.C. 10%	
4.7 35V	10	3.3 50V	06			001: .0015, .0022, .0033, .0047;	
5.6 35V	10	4.7 50V	06			0068, .01, .015, .022, .033, .047;	
1.5 35V	10	10 16V	06			068, .1, .15, .22, .33, .47,	
1.5 35V	10	10 25V	06				
2.2 35V	10	10 50V	06				
3.3 35V	10	2.2 10V	05				
4.7 10V	12	2.2 16V	06				
4.7 25V	12	2.2 35V	07				
4.7 50V	12	3.3 16V	08				
6.8 35V	13	3.3 25V	07				
10 6.3V	12	4.7 16V	07				
10 16V	13	4.7 25V	08				
10 25V	15	47 63/50	.15				
10 35V	16	100 10V	06				
15 16V	15	100 16V	08				
15 25V	18	100 25V	09				
22 10V	15	100 50V	22				
22 16V	16	220 10V	09				
22 35V	26	220 16V	10				
33 10V	16	1.0 100 25V	10				
33 16V	24	330 10V	10				
33 25V	26	330 25V	19				
47 6.3V	16	470 6.3	09				
47 10V	18	470 16V	15				
47 16V	26	470 25V	21				
56 3V	16	470 50V	35				
56 3V	16	1000 16V	18				
100 3V	16	1000 25V	35				
100 6.3V	24	2200 6.3	24				
100 10V	26	2200 16V	38				
220 3V	24						

AXIAL ELECTROLYTICS		MULTILAYER POLYESTER CAPACITORS 5% Tolerance 7.5mm PCB	
1.5V	06	001	.06
2.2 10V	05	0015	.06
2.2 16V	06	0022	.06
2.2 35V	07	0033	.06
3.3 10V	08	0068	.06
3.3 16V	08	01	.06
3.3 25V	08	015	.06
4.7 10V	09	022	.07
4.7 16V	10	033	.07
4.7 25V	10	047	.07
6.8 10V	11	068	.08
6.8 16V	11	1	.10
6.8 25V	11	22 (100V)	.13
10 10V	12	47 (100V)	.22
10 16V	13	68 (100V)	.25
10 25V	13	100 (100V)	.28

Ceramic Capacitors EDPU 63V Stock Values (µf)	
1: 2.2, 3.3, 4.7, 5.6, 6.8, 8.2, 10, 12, 15, 18, 22, 27, 33, 39, 47, 56, 62, 100, 120, 150, 180, 220, 270, 330, 390, 470, 560, 680, 820, 1000, 2200, 3300, 4700, 10,000, 22,000.	
1.47µf 2% (Low K)	.03
56-100µf 2% (Low K)	.035
100-150µf 2% (Low K)	.055
180-820µf 10% (Med. K)	.03
1000-2200µf 10% (Med. K)	.04
3300-4700µf 10% (Med. K)	.05
10,000-20 + 80 40V	.035
22,000 20 + 80 40V	.06

**GREENWAY ELECTRONIC COMPONENTS** 62 MAYPOLE RD ASHURST WOOD EAST GRINSTEAD SX RH19 3RB. Tel: Forest Row (034-282) 3712




**DIGITAL 24 HOUR CLOCK**

- SILENT RUNNING
- LARGE ILLUMINATED NUMERALS

MECHANISM WITH ALARM £5.00 MECHANISM & CASE £6.99

THREE FOR £13.50 MECHANISMS 10 FOR £39. 100 FOR £300

● AC MAINS ● SIZE 6 3/4 x 2 3/4 x 2 3/4 Your receipt is a 2-year guarantee

**HENRY'S RADIO** 404 EDGWARE ROAD, LONDON W2 1ED 01-723 1008

EXPORT ENQUIRIES INVITED

**HENRY'S Radio** DELIVERY FROM STOCK

**ACE** COMPONENTS — Now over 1,000 types in stock!

KITS — See the new range of low-cost 'ELEKITS'.

SERVICE — 1st Class same day despatch.

QUALITY — All guaranteed products.

PRICES — Many reductions!

MAGAZINE PROJECTS — Trouble-free!

S.A.E. for list of HE projects

ACE MAILTRONIX LTD Dept. HE Tootal Street Wakefield, W. Yorkshire WF15 3JR

I enclose 30p\*, please send catalogue.

Name \_\_\_\_\_ Address \_\_\_\_\_

\*Refundable with future orders over £5.00.

Ref.	ELECTRONIC BOOKS	Price
126	Boys Book of Crystal Sets	25p
138	How to Make Aerials for TV (Band 1-2-3)	25p
160	Coil Design and Construction Manual	75p
196	AF — RF Reactance — Frequency Chart for Constructors	15p
200	Handbook of Practical Electronic Musical Novelties	50p
201	Practical Transistorised Novelties for Hi-Fi Enthusiasts	35p
202	Handbook of Integrated Circuits (IC's) Equivalents and Substitutes	100p
203	IC's and Transistor Gadgets Construction Handbook	60p
205	First Book of Hi-Fi Loudspeaker Enclosures	75p
206	Practical Transistor Circuits for Modern Test Equipment	60p
207	Practical Electronic Science Projects	75p
208	Practical Stereo and Quadrophony Handbook	75p
210	The Complete Car Radio Manual	100p
211	First Book of Diode Characteristics Equivalents and Substitutes	95p
213	Electronic Circuits for Model Railways (Reprinting)	100p
214	Audio Enthusiasts Handbook	85p
215	Shortwave Circuits and Gear for Experimenters and Radio Hams	85p
216	Electronic Gadgets and Games	100p
217	Solid State Power Supply Handbook	85p
218	Build Your Own Electronic Experimenters Laboratory	85p
219	Solid State Novelty Projects	85p
220	Build Your Own Solid State Hi-Fi and Audio Accessories	85p
221	28 Tested Transistor Projects	95p
222	Solid State Short Wave Receivers for Beginners	95p
223	50 Projects Using IC CA3130	95p
224	50 CMOS IC Projects	95p
225	A Practical Introduction to Digital IC's	95p
226	How to Build Advanced Short Wave Receivers	120p
227	Beginners Guide to Building Electronic Projects	125p
228	Essential Theory for the Electronics Hobbyist	125p
RCC	Resistor Colour Code Disc Calculator	10p
BP1	First Book of Transistor Equivalents and Substitutes	50p
BP2	Handbook of Radio, TV & Industrial & Transmitting Tube & Valve Equivalents	60p
BP6	Engineers and Machinists Reference Tables	50p
BP7	Radio and Electronic Colour Codes and Data Chart (Reprinting)	25p
BP11	Practical Transistor Novelty Circuits	40p
BP14	Second Book of Transistor Equivalents and Substitutes	110p
BP22	79 Electronic Novelty Circuits	75p
BP23	First Book of Practical Electronic Projects	75p
BP24	52 Projects Using IC 741	95p
BP25	How to Build Your Own Electronic and Quartz Controlled Watches & Clocks	85p
BP26	Radio Antenna Handbook for Long Distance Reception and Transmission	85p
BP27	Giant Chart of Radio Electronic Semiconductor and Logic Symbols	60p
BP28	Resistor Selection Handbook (International Edition)	60p
BP29	Major Solid State Audio Hi-Fi Construction Projects	85p
BP30	Two Transistor Electronic Projects	85p
BP31	Practical Electrical Re-Wiring and Repairs	85p
BP32	How to Build Your Own Metal and Treasure Locators	100p
BP33	Electronic Calculator Users Handbook	95p
BP34	Practical Repair and Renovation of Colour TVs (Reprinting)	95p
BP35	Handbook of IC Audio Pre-amplifier and Power Amplifier Construction (Reprinting)	95p
BP36	50 Circuits Using Germanium, Silicon and Zener Diodes	75p
BP37	50 Projects Using Relays, SCR's and TRIACS	110p
BP38	Fun and Games with your Electronic Calculator	75p
BP39	50 (FET) Field Effect Transistor Projects	125p
BP40	Digital IC Equivalents and Pin Connections	250p
BP41	Linear IC Equivalents and Pin Connections	275p
BP42	50 Simple L.E.D. Circuits	75p
BP43	How to Make Walkie-Talkies	125p
BP44	IC555 Projects	145p
BP45	Projects in Opto-Electronics	125p
BP46	Radio Circuits Using IC's	135p
BP47	Mobile Discotheque Handbook	135p
BP48	Electronic Projects for Beginners	135p
BP49	Popular Electronic Projects	145p
BP50	IC LM3900 Projects	135p
BP51	Electronic Music and Creative Tape Recording	125p
BP52	Long Distance Television Reception (TV-DX) For The Enthusiast	145p
BP53	Practical Electronic Calculations and Formulae	225p
BP54	Your Electronic Calculator and Your Money	135p
BP55	Radio Stations Guide	145p
TI	TTL Pin Configuration Guide	175p

**TECHNOMATIC LTD** 17 BURNLEY ROAD, LONDON NW10 1ED  
 (2 minutes from Dollis Hill Tube Station) (Ample parking space)  
 Telephone: 01-452 1500. Telex: 922800

**DIL SOCKETS**  
 8pin 12p  
 14pin 13p  
 16pin 14p

Large range of components available Send SAE

**ANTEX SOLDERING IRONS**  
 C-15W 390p  
 CX-17W 410p  
 CCN-15W 410p

**COPPERCLAD**  
 X-25W 410p  
 Spare bit 50p  
 Stand 170p

**VEROBOARDS**  
 01 Copperclad  
 2 1/2 x 5 62p  
 3 1/2 x 2 1/2 53p  
 3 1/2 x 3 1/2 62p  
 3 1/2 x 5 69p  
 3 1/2 x 7 240p

**POCKET MULTIMETERS**  
 KRT100 580p  
 (1000 ohms/V)  
 LT22 1360p  
 (20k ohms/V)  
 Test Lead Kit 160p  
 (Prods, Croc clips, bananas, Spades)  
 10 Test leads with Croc Clip at each end 110p

**EXPERIMENTER BREAD-BOARDS**  
 (No soldering, suitable for DIL ICs)  
 For 1 IC Circuit (up to 22pin) EXP325 180p  
 For up to 3x14pin DIL IC EXP350 360p  
 For up to 5x14pin DIL ICs EXP300 641p  
 IC Test Clips 14pin 285p  
 16pin 297p  
 Logic Probe 1900p

# Short Circuits Special

*This month we've decided to dig deep into our Short Circuits file. Here are sixteen Short Circuits to experiment with, it's up to you to find a use for them.*

## SIGNAL INJECTOR - TRACER

There are two extremely useful pieces of test gear for both the serviceman and the amateur constructor. These are a signal source and a signal tracer.

Faced with a transistor radio that doesn't work, what do you do? It is important that a logical approach is taken and although this may sound obvious, it is very, very easy to become diverted.

First check that the battery is not flat (for this accounts for about 50% of so called faults) and then check that a good contact is being made on the cut-out switch of the earpiece socket if one is fitted. Always check these first but assuming there is still no joy what do you do?

The volume control is easily located, contacts can generally be made to it quickly and it is an excellent place to start.

If you inject a signal of the slider of the volume control and it is heard at a decent level from the loudspeaker you can be fairly sure that nothing is wrong with the amplifier. If nothing is heard there is obviously something wrong and the field is immediately narrowed.

Assuming that the audio stage is working you can then inject and IF signal at the collector of the mixer stage — the same rules apply as before.

Alternatively you can take the 'signal detect' approach. If instead of injecting a signal at the volume control you can listen at the same point to establish that the radio is working satisfactorily up to a certain point.

The above is a super concise lesson in fault finding but it does illustrate the tremendous use that a signal injector and a signal tracer can be put to.

The project described here is for a combined device — it can inject

signals at RF IF and audio and can detect signals at the same frequencies assuming that they are high enough in level. The simplicity of circuit may lead you to doubt this claim but it does do all this.

The function switch, SW1, has

- No. 1 Off position
- No. 2 Trace Position
- No. 3 Inject Position

Position 1 merely disconnects the supply and the device is of course inoperative. As shown the function switch is in position 2 and in the trace mode.

One of the contacts is the common line and should be wired using a crocodile clip to the chassis of the equipment being investigated. The other connection is the probe.

This goes via DC blocking capacitor C1 whose working voltage should be high — if a 500 V working component is used the circuit can be used on valved equipment working at high voltages.

The signal is fed to Q1 which is

arranged as a common emitter amplifier but which is biased nearly to cut-off which creates deliberate distortion at the same time as amplifying the signal. Distortion in such a manner leads to the detection of RF signals and so whatever the frequency fed in, assuming it is modulated, and audio output will be heard. The collector load of Q1 is R2 and the output of this stage is fed to a further one of similar design, but the collector load here is represented by a high impedance magnetic earpiece in which the signals are heard.

On inject, SW1 is in position 3 and the output of Q2 is coupled to R4, acting as the collector load and also to C3 which feeds back to the base of Q1. The circuit, which was previously an amplifier, now becomes a multivibrator producing a square wave signal at approximately 1kHz and this is fed, again via C1, to the probe.

A square wave can be described as a fundamental frequency plus all its harmonics and so in addition to 1kHz there is an output at 2kHz, 3kHz etc., going right up into the

RF range. In fact, these are still a useable output at 30MHz.

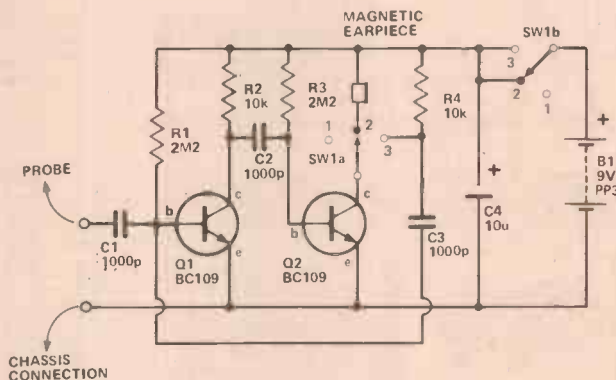
Holding the probe near the aerial will produce an output from a working radio as the injector is working as a very low power transmitter and an output at 1kHz will be heard from the loudspeaker.

High gain transistors are needed in order to hear really low signal sources and high frequency types are needed to handle the upper harmonics. A transistor incorporating both these qualities is the BC109 and is the one used here.

The current drain, both in the trace and inject mode is quite small and can be handled by a PP3 battery. SW1, the function switch, needs to be a 2-pole, 3-way rotary switch and these are very common.

Note that only high impedance magnetic earpieces are suitable, though 2000 ohms headphones can be used instead.

Once completed and used the signal injector/tracer will be found to be almost indispensable and for this reason it is worthwhile building the circuit carefully and neatly into a small chassis.



# Short Circuits

## MAGIC CANDLE

Electronic party tricks are always popular. The majority of people have very little understanding of electronics and even simple tricks can mystify them. This circuit, a "Magic Candle" uses only a handful of common components and can be built very quickly. However, as with many projects of this type, the ingenuity in building is probably more important than the circuitry, this however is left to the reader though some general tips are given later.

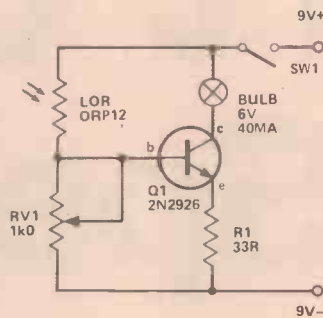
The idea of the "Magic Candle" is to demonstrate that lightbulbs can be lit by a match or cigarette lighter and can be snuffed in a similar way. The bulb should be the only item that is actually showing but it is important that the LDR — light dependant resistor — is very close by with the active face pointing at the bulb. When a match is struck and brought up to the bulb this causes light to fall on the LDR rather than the bulb. This causes the resistance of the LDR to fall considerably and since this forms a potential divider with RV1, which is coupled to the base of the trans-

istor, the voltage here rises and causes the transistor Q1 to conduct. This causes current to flow through the bulb which in turn lights up.

When the match is withdrawn the light from the bulb takes over as the source which keeps the resistance of the LDR low, and so the transistor will remain on and the bulb will stay alight. If now the bulb is "snuffed" by breaking the path of light between the bulb and the LDR, the bulb will go out and remain so until the light level once again reaches a sufficient brightness to turn the transistor on.

The use of a 6 V bulb is simple because these types are widely available and cheap and in order to prevent too high a voltage being applied the resistor R1 is connected in the emitter circuit. In the conducting stage there is only a tiny voltage drop across Q1 but about 3 V will be dropped across this resistor thus ensuring that the bulb is not overdriven.

Since the circuit will have to operate in widely differing light levels, it is necessary to control the sensitivity of the circuit and this is accomplished by RV1. In high



ambient light levels the value of RV1 should be low, this means that the transistor will remain switched off until the light level created by the match goes above this level. In low light levels the value of RV1 will be high.

RV1 can take the form of a miniature preset control which for normal uses can probably be left at some level found experimentally for general purpose use. It is not possible to give even an indication of this value as the resistance of light dependant resistors varies

considerably with the individual specimen.

The current drain is 40 mA which is rather heavy for a PP3 battery though one in good condition will work for a short period. The heavy current drain may be acceptable as the circuit is unlikely to be on for long periods and this battery has the advantage of being small in physical size and cheap. SW1, the on-off switch can take any convenient form, it may even be omitted, the circuit being switched off by removing the battery clips.

As we mentioned before the bulb should be the only thing that observers can see, all the other components being hidden in a small box on which the bulb is mounted. An LDR is about 5/8 in. in diameter though even this can be well disguised since the active surface is rather smaller and in any case not all of it has to be exposed, even a 1/4 in. diameter hole should be sufficient and this hole should be close to the bulb and pointing at it. It must of course be possible to easily interrupt the light path between the bulb and the LDR in order to "snuff" it.

## NOISE LIMITER

This circuit is particularly intended for those interested in DX-ing, that is, listening for distant radio stations. However, the same circuit has other uses such as reducing the scratch level on very old records (Note that this is not the normal type of scratch filter circuit normally associated with Hi-Fi equipment). It also has uses in PA equipment where it can limit the input to the final stages and prevent overload distortion; distortion will still be present when an overload occurs but it is not as objectionable as that usually produced.

The circuit is designed to take almost any audio input but the output will have all peaks above a certain level, which can be adjusted, eliminated. Anyone who has listened to a really weak radio signal will know the limitations imposed by the noise. At any one time there are literally thousands of thunderstorms taking place somewhere in the world and sensitive receivers will hear lightning a considerable distance away, often the level of noise is much higher than that of the radio signal that is wanted. Apart from lightning there is more local interference such as that produced by poorly suppressed motor cars or electric motors. With a powerful radio signal these are just not noticeable since the noise level is well below that of the radio signal but on distant stations the noise level all but buries the signal.

The circuit can either be wired into a receiver circuit or directly from a headphones socket in which

case the headphones are wired to this unit instead. If wired into a circuit permanently, RV1 should take the place of the normal volume control and the output should be control slider. An extra control plus a switch will also have to be mounted on the receiver front panel. The circuit can either be left in permanently as at most settings it will not affect the signal or it can be switched out.

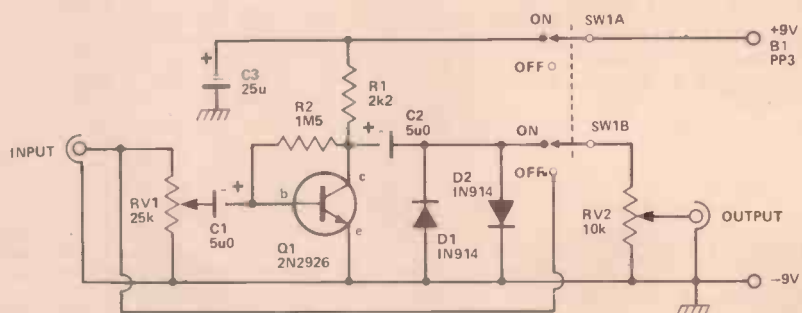
The output of the receiver, which as we have said can be from the volume control or the headphone socket, is taken to the input and amplified by Q1 which is connected in the common emitter mode. This transistor will considerably increase the audio level and this is applied via a DC blocking capacitor, C2 to the two silicon diodes D1 and D2. In the normal way these diodes will not have any bias voltage applied across them and so they will present a high resistance, and will not affect the output in any way. However, as soon as the output from the

amplifier exceeds about 0.6 V, the diodes will conduct and short the output to the negative line. Two diodes are needed, one connected each way around, so that both positive and negative going peaks are shorted out. The idea of the amplifier is to make sure that whatever the input level across RV1, it can be amplified so that at least 0.6 V can be applied across the diodes. Since RV1 is adjusted so that the level is always the same a volume control has been included in the circuit so that the output level can be controlled in the usual way; this is accomplished by RV2.

To limit the noise the input level is increased until the audio signal that is wanted is just distorting and then backed off slightly so that no distortion is heard on the peaks above that level will hardly be heard in the output as the peaks above the preset limit will be conducted to the negative line, RV2 is then adjusted as a normal volume control. If RV1 is adjusted well below the limiting level and RV2 is

adjusted for normal listening levels, the circuit has no effect. However, it is a simple matter to include SW1 which will bypass the circuit. The supply voltage can be taken from a battery as shown in the circuit, the current drain being very small, or from the receiver's supply. If this is transistor operated with 9 V then there will be no difficulty but if the receiver is a valved type or uses a supply potential higher than 9 V then a suitable dropping resistor from the HT supply rail will have to be included. The value will depend on the supply voltage but for 250 V a resistor in the order of 150k ohms will be about right; this should be connected between the HT line and the slider of SW1a.

The effect of the noise limiter is quite remarkable and by switching the circuit in and out it is possible to compare the results. The noise will still be there but not at an annoying level and the signal will be very, very much clearer.



# Short Circuits

## SOUND TRIGGERED FLASH

The introduction of inexpensive electronic flash guns has made possible a number of effects in photography. The duration of an electronically produced flash is of course very brief, normally about 1/500th of a second. If the camera shutter is left open in the dark or subdued light and the flash is made, it is the timing and duration of the flash which controls what is imprinted on the film rather than anything done by the camera.

Electronic flash guns are "fired" by making a switch and it can be seen that an electronic switch can do this job. If in turn this switch is activated by sound then some very interesting effects can be obtained. A champagne cork leaving the bottle is one idea but the various gimmicks are limited only by the imagination.

The circuit shown is completely solid state and instead of a relay being used, a SCR is employed. This is cheaper and for this function just as good.

The first stage of the circuit is an impedance convertor. A crystal

microphone is used. Normally these have rather poor quality but in this circuit we are not too interested in quality, we are only using it as a device for converting sound into an electrical pulse. Q1 is connected as a common collector stage; this has very high input impedance to correctly match the high impedance of the crystal microphone. The potentiometer RV1 is the emitter resistor and the sounds produced appear across this at a workable impedance. The output from this is fed to the conventional common emitter amplifier, Q2 with RV2, a preset pot, as the collector load.

The collector of this transistor is connected to the gate of the SCR via a resistor R3. For setting up the SCR is connected to a bulb, these two being across the battery supply.

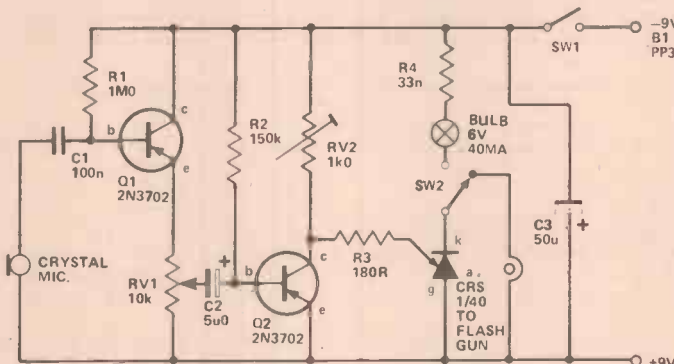
When a sound is produced it is amplified by Q1 and Q2 and this causes Q2 to draw rather more current at the peak of the sound. This reduces the voltage at the collector of the transistor and this is fed to the gate of the SCR. At the correct setting of RV1 this will cause the SCR to switch on and light will pass through the bulb. The bulb can be a 9 V type but as

these are hard to come by it can just as well be a 6 V type with a 33 ohm resistor in series.

The bulb is used for setting up only. To continually trigger the flash gun in order to find the correct settings will be wasteful, especially as the flash tube has a limited life. Once the correct settings have been found, SW2 can be made and the SCR applied across the flash gun terminals. There are two variables in the circuit, RV1 and RV2. RV2 will normally only require setting once.

With the slider of RV1 at about a quarter the way up the track from the positive line, RV2 should be set so that the SCR just triggers on the loudest sound that can be made near the microphone. When this is done RV1 should give control over a wide range of sounds and acts as the sensitivity control.

The circuit should be tested to obtain the correct level setting of RV1 before every shot is taken with the test bulb in series. Once the correct settings are obtained the switch can be made to the flash gun having first made sure that the SCR is not on at that point. The SCR will stay switched on until the supply voltage is removed and so it is necessary to switch off the circuit using SW1 before switching over.



## QUICK TRANSISTOR CHECKER

This very simple and inexpensive circuit is not designed to measure any transistor performance figures, but is intended for quick testing to show whether or not the test device is functional. The basic method of testing a transistor is to first connect a supply to its emitter and collector terminals and check that no significant current flows. If the

base terminal is then given a small forward bias, this will be amplified in the form of a large collector-emitter current.

This circuit is based on a CMOS quad 2 input NAND or NOR gate IC. Either type is suitable as each gate has its two inputs connected together so that it acts as an inverter. The first two inverters are

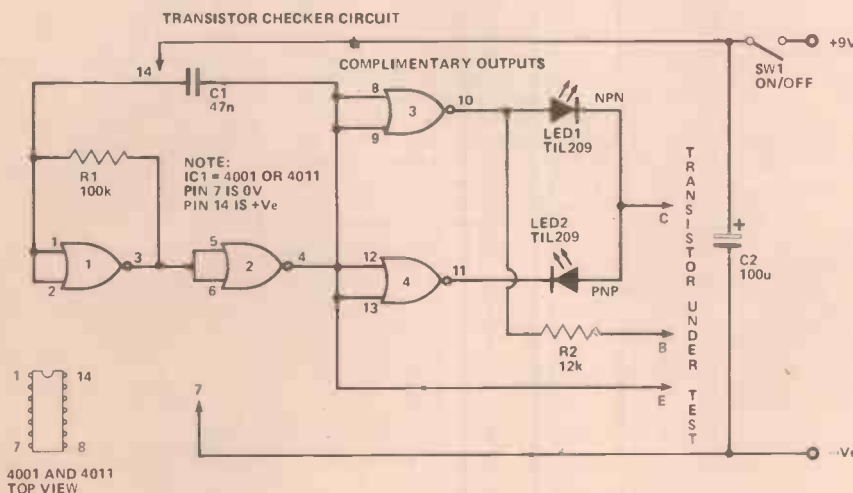
used in conjunction with R1 and C1 as a conventional CMOS oscillator operating at a frequency of a few hundred Hz. The other two inverters are connected in parallel, and fed from the output of the oscillator so that they provide a complementary output. In other words, one output will be positive and the other will be negative except during the brief periods when the outputs change state.

The collector and emitter of the transistor are fed from the outputs via D1 and D2, and the base is fed from one output via R2. If we

assume that an NPN device is being tested, when gate 2 output is positive and the other output is negative, the transistor will not be forward biased by R2 (it will be reverse biased in fact) and it should pass no significant collector current. If it is a short circuit device and does pass such a current, this will pass through D2 which will light up and indicate the fault. When the outputs are in the opposite states, the transistor will be forward biased by R2 and should conduct heavily, causing D1 to pass a current and light up. Failure of D1 to come on indicates an open circuit or very low gain device. PNP devices operate with the opposite polarity, and so when testing one of these it is D2 that should switch on, and D1 which should remain off.

### Summary

- One LED on = functional device, type (ie PNP/NPN) as indicated.
- Both LEDs on = short circuited device.
- No LEDs on = open circuit or very low gain device.
- Diode or rectifier testing (anode to collector, cathode to emitter).
- D1 on = functional device.
- D2 on = connected with wrong polarity.
- Both LEDs on = short circuited device.
- No LEDs on = open circuit device.



# Short Circuits

## TOUCH SWITCH

This touch switch is designed to provide on/off switching for 9 volt battery operated equipment having a current consumption of up to 100 mA. It has a single touch contact which is briefly touched in order to change from on to off or vice versa. The circuit is operated by stray pick-up of mains hum which is coupled to the input of gate 1 (which like the other three gates employed in the unit is connected to act as an inverter) via R1 when the input contact is touched. As IC1 is a CMOS device it has a very high input impedance, and the input signal will be capable of switching gate 1 input from one

logic state to the other. The input impedance of the circuit is so high that the reverse resistance of D1 is used to tie the input to earth under quiescent conditions, so as to prevent spurious operation. R1 acts as a low pass filter in conjunction with the input capacitance of the circuit, and this attenuates high frequency noise which may be present on the 50MHz mains signal.

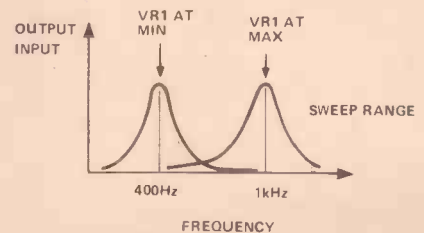
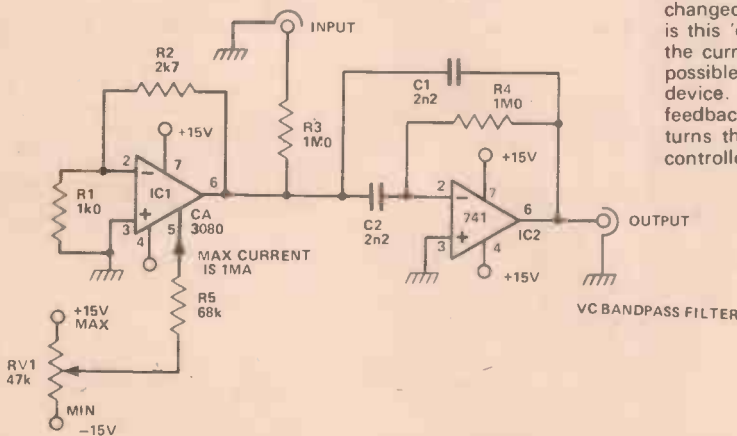
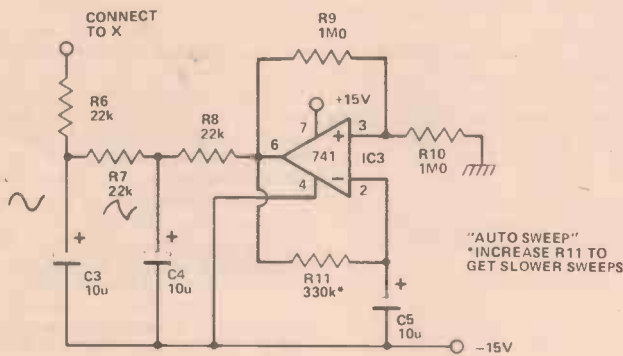
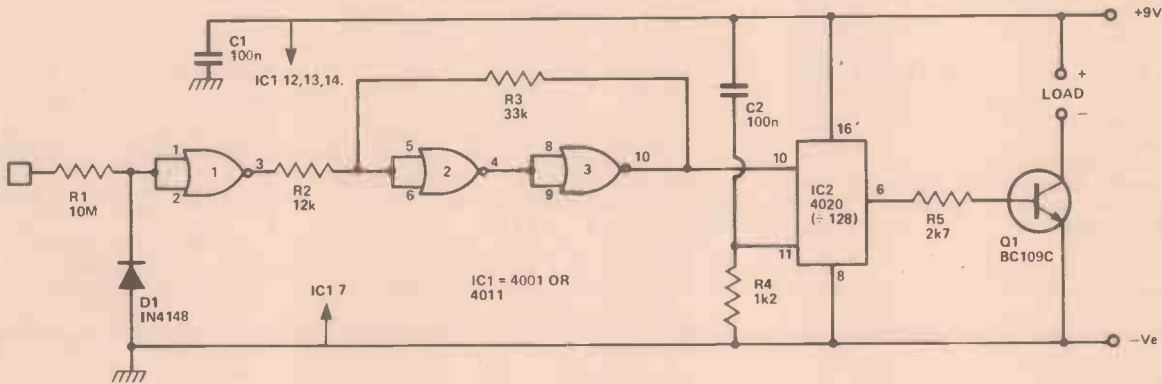
The output from gate 1 still contains significant noise products, and also has a rise time which is inadequate to drive the final stage of the circuit. This is overcome by using the trigger circuit based on gates 2 and 3. R3 tends to hold gate 2 input in the same state as gate 3 output, resis-

ting any change in logic state caused by gate 1 output due to the coupling through R2. This resistance to change is termed 'hysteresis'. R2 has a lower value than R3, and so gate 1 can operate the trigger circuit if its output signal is of adequate amplitude. The main 50Hz signal will be strong enough, but the noise spikes will not, and are thus eliminated from the output of the trigger. Once the output of the trigger does start to change state, the coupling through R3 provides a triggering action which ensures a rapid change.

IC2 is a 14 stage binary (divide by 2) counter, and Q1 is driven from the output of the seventh stage via current limit resistor R5.

C2 and R4 provide a positive reset pulse to the counter at switch on so that the outputs are all low, and Q1 is switched off. The controlled equipment forms the load for Q1, and obviously receives no significant power. If the touch contact is operated, a 50Hz signal is fed to IC2 and the 7th stage output changes state every 64 pulses. As this output goes high and low the load is switched on and off. In practice the contact is touched just until the unit switches to the desired state (which one tends to do automatically).

The unit consumes only about 1uA. in the "off" mode and approximately 3mA in the "on" state.



The CA3080 is an Operational Transconductance Amplifier. What this means is that it is an amplifier whose gain can be controlled. Thus the CA3080 finds lots of uses in circuits where something has to be varied electronically, one such example being a voltage controlled filter.

A bandpass filter is constructed using IC2, R4, C1, C2. This is known as a multiple feedback bandpass filter and normally there is another resistor which is connected from ground to the junction of the two capacitors. By varying this 'other' resistor, the resonant frequency of the filter can be changed. The CA3080 and R1, R2 is this 'other' resistor. By varying the current into pin 5 of IC1 it is possible to control the gain of the device. R1, R2 provides negative feedback around the IC and this turns the network into a current controlled resistor. By increasing

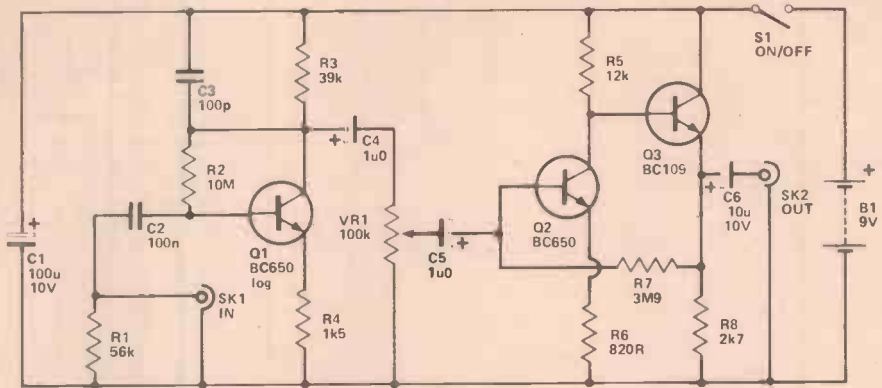
## VOLTAGE CONTROLLED FILTER USING A CA3080

the current, the effective resistance is reduced, which in turn alters the resonant frequency of the filter.

It is possible to provide a varying control current using the circuit involving IC3. This is a low frequency squarewave oscillator. The oscillation frequency is determined by C11, R5. The squarewave is heavily filtered by R6, R7, R8 and C3, C4, to produce a smoothly modulating current drive to IC1. This causes the centre frequency of the filter to be swept up and down. The autosweep can be used as an effect for electric guitar or for electronic music processing.

# Short Circuits

## TWO MICROPHONE PREAMPLIFIERS



Microphones provide only a minute output signal and cannot be used successfully with many items of equipment unless their output is augmented by a suitable preamplifier. For example, few stereo Hi-Fi amplifiers have an input that is an acceptable match for a microphone (a magnetic pickup input is unsuitable as it has RIAA equalisation with consequent bass boost and treble cut). Many simple makers have only high level inputs and require separate preamplifiers for use with low level sources.

The first preamplifier circuit shown here is for use with low impedance (200 or 600 ohms) dynamic microphones. Most electret type microphones have an integral source follower JFET buffer stage which gives a low output impedance, and these should also work well with this circuit. Low impedance microphones have an extremely small output voltage

which in normal use is unlikely to ever exceed 1 mV. RMS. This means that the preamplifier must have a high level of voltage gain and a very low noise input stage as well if a high signal to noise ratio is to be achieved. This circuit requires only about 200 µV. RMS at the input for an output level of 1 V. RMS, and the unweighted signal to noise ratio (input open circuit) is a little under -66 dB.

A common base input stage is used, and it is based on Q1 which is an ultra low noise - high gain device. Although the common base configuration is not often encountered in audio circuits it is ideal for this application as it gives the required low input impedance and high voltage gain. In order to obtain a really low noise level Q1 is operated at a collector current of only about 180 µA. C4 is an RF filter capacitor, and this reduces the risk of radio signals picked up

by the input wiring breaking through to the output. With high gain circuits such as this RF breakthrough is not an uncommon problem, and ideally the unit should be built into a metal case so that the circuit is screened from RF signal sources.

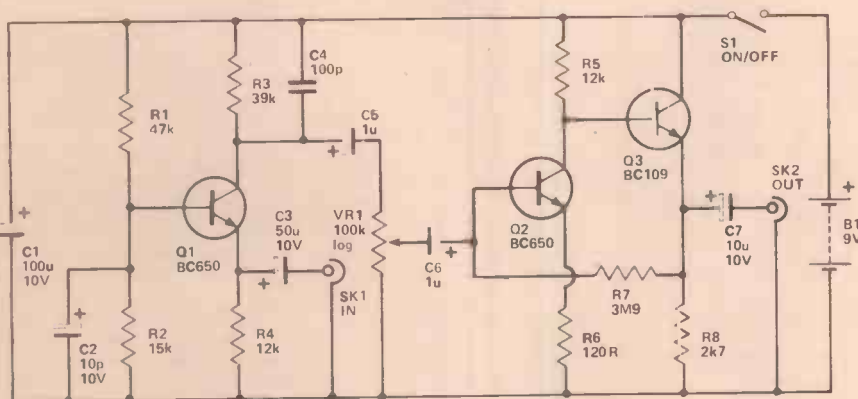
The output from Q1 collector is fed by way of gain control RV1 and coupling capacitors C5 and C6 to a two stage amplifier circuit. Q2 is a common emitter amplifier and it provides the additional voltage gain that is required. Q3 is used as an emitter follower output stage and gives the circuit a low output impedance. Power is obtained from a 9 volt battery supply and the current consumption is only about 3 mA.

Many dynamic and electret microphones have an integral step up transformer which gives increased output voltage, but the available output current is of

course decreased and so a preamplifier having a higher input impedance (usually 50k) is required. Although on the face of it there may seem to be no point in incurring the additional expense of the transformer plus the small loss of performance it inevitably gives, indirectly it gives improved performance. This is simply because a preamplifier designed to match the higher voltage, higher impedance signal tends to have superior performance to an equivalent circuit designed to match the direct output of the microphone.

The high impedance microphone preamplifier shown here requires an input level of approximately 5 mV. RMS for an output of 1 V RMS, and the unweighted signal to noise ratio (input short circuited) is well over -70dB. With reference to this output level. Apart from the input stage the circuit is virtually identical to the previous design, the only difference being that the emitter resistor for Q2 has been increased in value. This has been done because the circuit only needs to have a moderate amount of voltage gain, and the increased negative feedback produced by raising the value of the resistor gives the necessary reduction in voltage gain.

The input stage is again run at a fairly low collector current (about 250 µA.) in order to give a low noise level. Only a moderate voltage gain and medium input impedance are required from this stage, and so Q1 is employed in the common emitter mode with non-passed emitter resistor R4 being used to introduce negative feedback to give increased input impedance and reduced voltage gain. The input impedance to Q1 is actually somewhat higher than is required, and so R1 is used to shunt the input and reduce the input impedance to approximately the required figure of 50k.



# Short Circuits

## NANOAMP METER

It is not possible to accurately measure currents of a few microamps or less using an ordinary panel meter or multimeter. In order to make such measurements it is necessary to use an active circuit such as the one shown here. It can be built as a self-contained unit or used as part of an instrument requiring a highly sensitive current meter. The sensitivity is from 100 nA to 10 mA. FSD in six ranges; the higher ranges being included to permit calibration, and because many multimeters have very few low current ranges.

M1 is connected in a 1 V FSD voltmeter circuit which also uses R10 and R11. The latter is adjusted to give the unit the correct sensitivity. IC1 is an Op Amp connected in the non-inverting mode and having a DC voltage gain of about 100 times (set by feedback network R8-R1). C2 reduces the AC gain to only about unity so as to improve stability and immunity to stray pick-up. The non-inverting input of the IC1 is biased to the 0 V rail by whichever of the range res-

istors (R2-R7) is selected by SW1. In theory this gives zero output voltage and no meter deflection, but in practice it is necessary to compensate for small offset voltages using offset null control, RV1.

If an input current is connected to the unit, a voltage will be developed across the selected range resistor, this voltage being amplified to produce a positive meter deflection. With R2 switched into circuit, 10mA is needed to give full scale deflection of

M1, since 10mA will cause 10mV to be developed across R2 ( $E=I \times R, = 0.01 \text{ A} \times 1 \text{ ohm}, = 0.01 \text{ V}$  or 10 mV), and this will be amplified one hundred fold by IC1 to give one volt at the output. On successive ranges the range resistor is raised by a factor of ten, reducing by a factor of ten the current required at the input to develop 10mV and give full scale deflection of M1.

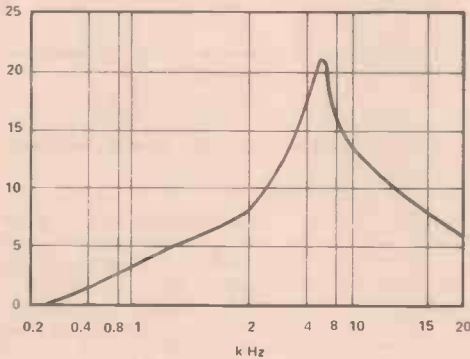
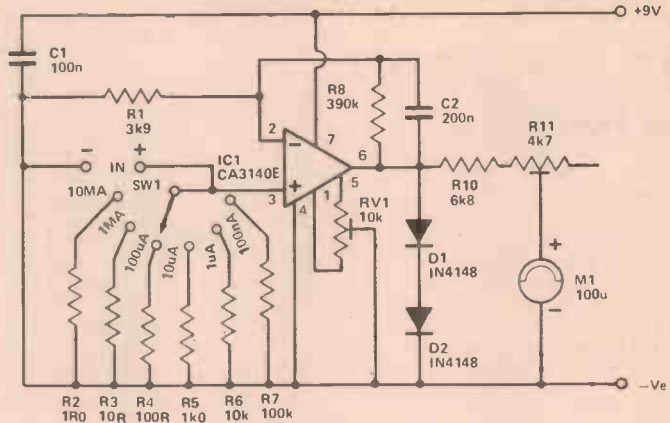
This arrangement relies on the amplifier having a very high input impedance so that it does not drop

a significant amount of input current, and this is achieved by using a FET input op amp having a typical input resistance of 1.5 million meg ohms. D1 and D2 prevent the output voltage of IC1 from exceeding more than about 1.3 volts, and they thus protect M1 against overloads.

When adjusting RV1 start with its slider at the pin 5 end of the track (there should be a strong deflection of M1), and then back it off just far enough to zero the meter, and no further.



R1 TO R7 ARE CLOSE TOLERANCE TYPES



THE FREQUENCY RESPONSE OF THE TREBLE BOOSTER

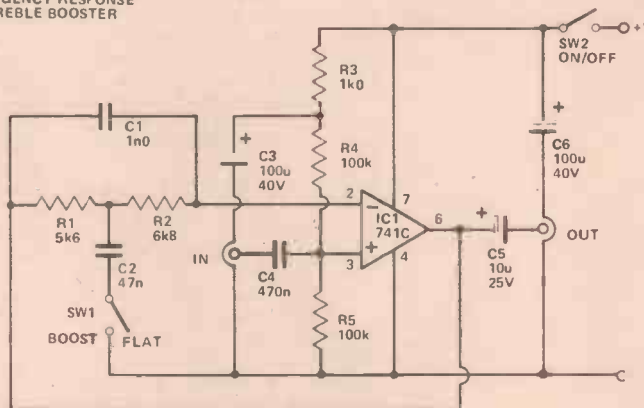
## TREBLE BOOSTER

A treble booster circuit can be used with an electric guitar (and also electronic instruments) to boost the higher order harmonics and give a more "brilliant" sound. A circuit of this type gives a fairly flat response at bass and most middle audio frequencies, with the upper-middle and lower treble frequencies being given a substantial amount of boost. It is normal to

give only a modest amount of emphasis to the upper-treble in order to give good stability and a low noise level, and this also prevents the output from sounding too harsh. The frequency response of this treble booster is shown in the accompanying graph.

The circuit is basically just an op. amp. (IC1) used in the non-inverting amplifier mode. The non-inverting input is biased by R4 and R5 via a decoupling network which is comprised of R3 and C3. C4 and C5 give DC blocking at the input and output respectively. With SW1 open there is virtually 100% negative feedback through R1, R2, and C1, giving the circuit unity gain and a flat response. Closing SW1 brings C2 into circuit, and this decouples some of the feedback through R1 and R2 at frequencies of more than a few hundred Hz, giving the required rising response. Feedback through C1 at high treble frequencies causes the response to fall away about 5.5kHz, and prevents the very high frequency harmonics from being excessively emphasised.

As the unit has unity gain at frequencies where boost is not applied it can simply be connected between the instrument and the amplifier.





# Short Circuits

## ELECTRONIC METHRONE WITH SYNTHESISED TICK TOCK

An electronic metronome needs three sections, a variable rate beat generator, a sound synthesiser to produce the tick tock noises and a small audio amplifier. First the beat generator, IC1. This circuit is a schmitt trigger and an 'integrator' all in one. The positive feedback via R1, 2 produces the schmitt action

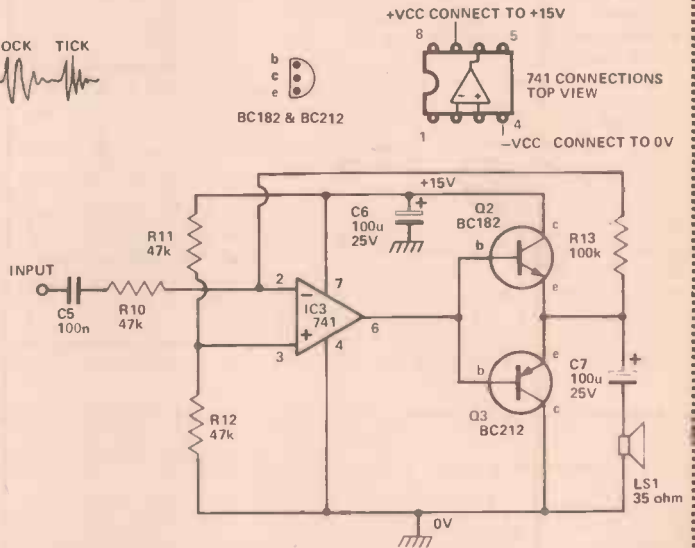
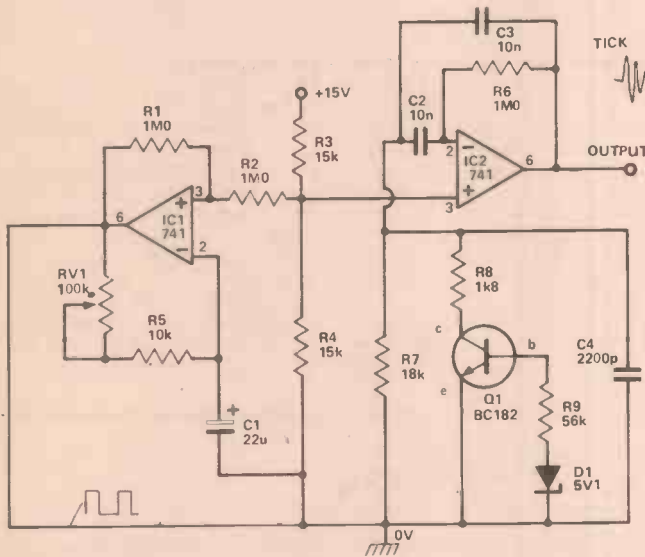
and the 'integrator' is made up of RV1, R5, C1. Imagine the output of IC1 is low at about +2 V. The non-inverting terminal of IC1 will then be at +4.75 V. The positive end of C1 will be discharged via RV1 plus R5 towards +2V, until it reaches +4.75 V. When this happens the schmitt trigger makes the

output of IC1 snap into its high state. Now the voltage on the non inverting terminal is +10.25 V and C1 is charged up towards this voltage. When this voltage is reached by C1 the schmitt trigger snaps back into its low state.

Thus square wave oscillations are produced, the frequency of which is determined by RV1, R5, C1. The square wave is fed into IC2 (via C4), which is a band-pass filter with a relatively high Q. The edges of the square wave 'excite' the filter which rings producing a percussive waveform. The pitch of the percussive waveforms is controlled by R7, 8 but R8 is only

turned on by Q1 when the output of IC1 is high. Therefore two percussive notes are produced, a low note when IC1 output is low and a higher note when IC1 output is high. This double pitch percussive waveform sounds just like a 'tick-tock' sound. If you want some really crazy sounds, try shorting out C4 or connecting a 5k pot across it!

The tick-tock waveform can then be fed into a small audio amplifier. IC3 is just such an amplifier. The gain is set by R13, R10. If more gain is required, then increase R13, if less, then decrease it.



## INSECT REPELLANT

The title of this circuit may at first appear to belong more in the pages of a biology or a chemistry book, but we are not joking. It is possible to make life uncomfortable for certain types of bugs using electronics. The theory is quite com-

plex though it is possible to give a rough outline of what happens.

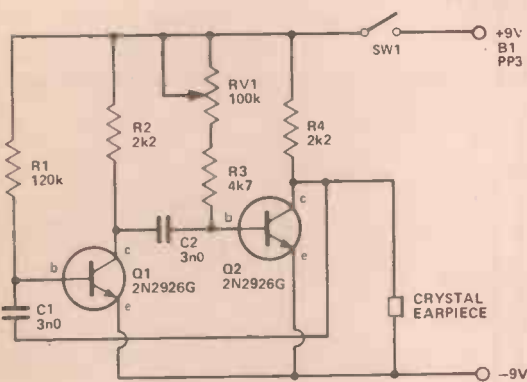
It seems that mosquitoes and other nasty insects only mate at certain times and except for these times the two sexes are most unfriendly, in fact they stay well away

from each other. It has also been reliably established that it is only the female of the species that actually bites. The third fact that we need to know is that the male mosquito (and this applies to other bugs as well) beats its wings at a slightly different rate than the female — this is one way that they identify each other. From these gems of information it will be seen that if one electronically simulates the sound of a male mosquito, the females will steer well clear. We are mentioning mosquitoes here but the same factors also apply to other bugs.

The circuit shown is a simple audio oscillator whose frequency of operation can be varied over a wide range, in fact from about 500Hz to 10kHz and this will take in the range of all the common bugs. The circuit is a straightforward multivibrator with RV1 altering the audio frequency. This produces a square wave which is applied across the small crystal earpiece connected between the collector of Q2 and the negative line. Crystal

earpieces have a very high impedance and it will in no way affect the operation of the circuit. Pretty well any transistors can be used in this simple circuit but if PNP types are used the battery supply should be reversed. The values of the capacitors are not too critical either and if others are used and it is found that the frequency range is not adequate, R1 can be altered to bring it back to the right sort of range. The current consumption is low at 2-3mA, this varies slightly with the frequency, but a PP3 battery will last quite a while; after all the unit will have to be left on for long periods. None of the components need be large and the unit can be built in a small box to fit into a jacket pocket with the components arranged so that the earpiece is external. The preset RV1 should be a small skeleton preset with a facility for adjusting from outside.

As to adjusting for the right frequency this is a matter of trial and error.



# Short Circuits

## CMOS LOGIC PROBE

A logic probe is a device which is used when testing digital circuits, and it shows the logic state at the selected test point. In common with most designs this one can indicate four input states, as follows:

1. Input high (logic 1).
2. Input low (logic 0).
3. Input pulsing.
4. Input floating.

The circuit uses the four 2 input NOR gates contained within the 4001 CMOS device, and is primarily intended for testing CMOS circuits. The probe derives its power from the supply of the circuit being tested. The first gate has its inputs tied together so that it

operates as an inverter, and it is biased by R1 so that roughly half the supply potential appears at its output. A similar voltage appears at the junction of R4 and R4, and so no significant voltage will be developed across D1 and D2 which are connected between this junction and gate 1 output. Thus under quiescent conditions, or if the probe is connected to a floating test point, neither D1a or D2 will light up. If the input is taken to a high logic point, gate 1 output will go low and switched on D1, giving a "high" indication. If the input is taken to a low test point, gate 1 output will go high and D2 will be

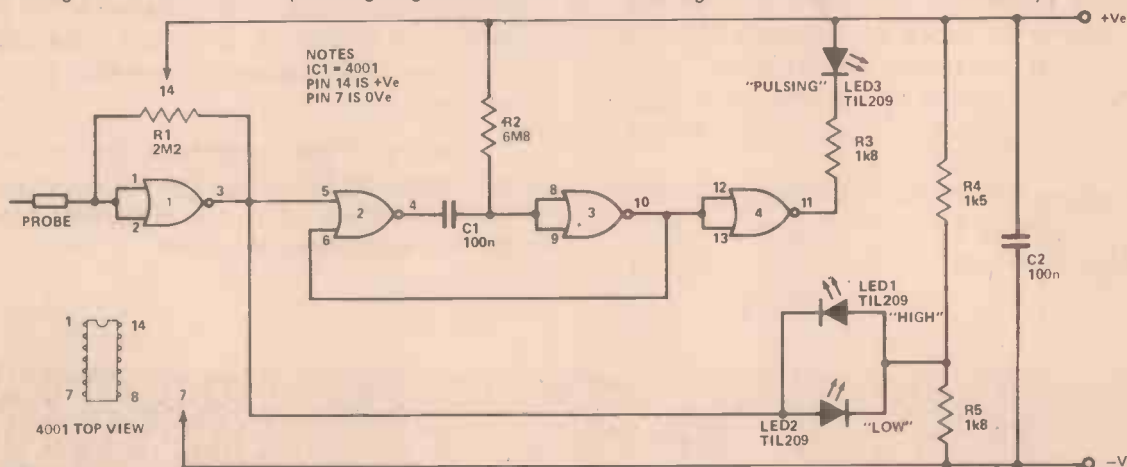
switched onto indicate the "low" input state.

A pulsed input will contain both logic states, causing both D1 and D2 to switch on alternately. However, if the mark space ratio of the input signal is very high this may result in one indicator lighting up very brightly while the other does not visibly glow at all. In order to give a more reliable indication of a pulsed input gates 2 to 4 are connected as buffered output monostable multivibrator. The purpose of this circuit is to produce an output pulse of predetermined length (about half a second in this case) whenever it receives a positive going input pulse.

The length of the input pulse has no significant effect on the

output pulse. D3 is connected at the output of the monostable, and is switched on for about half a second whenever the monostable is triggered, regardless of how brief the triggering input pulse happens to be. Therefore a pulsing input will be clearly indicated by D3 switching on.

The various outputs will be:  
 Floating input — all L.E.D.s off.  
 Logic 0 input — D2 switched on (D3 will briefly flash on).  
 Logic 1 input — D1 switched on.  
 Pulsing input — D3 switched on, or pulsing in the case of a low frequency input signal (one or both of the other indicators will switch on, showing if one input state predominates).

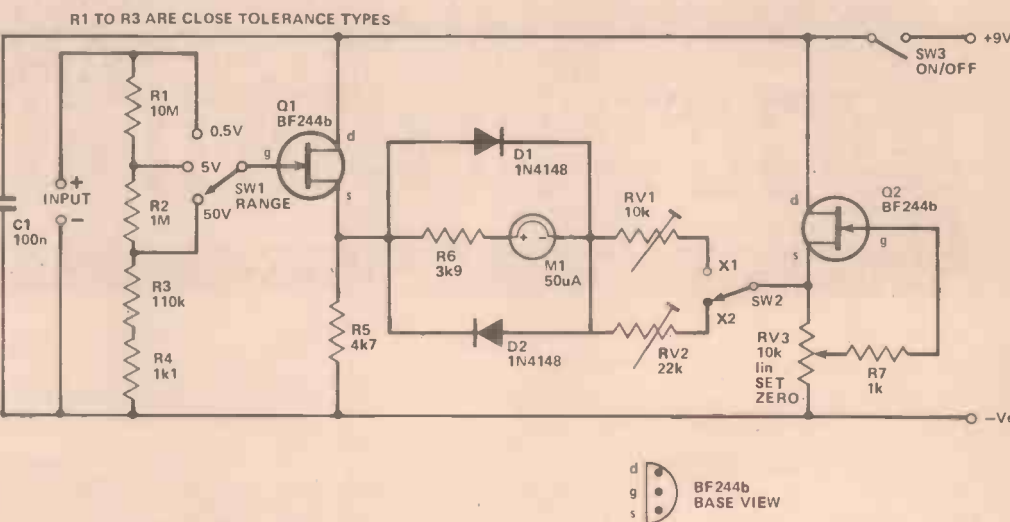


## FET VOLTMETER

Although an ordinary multimeter is suitable for most DC voltage measurements it can occasionally prove to be inadequate. This is the case when making measurements on high impedance circuits which cannot supply the current required to operate even a sensitive moving coil meter of the type normally employed in a multimeter. The loading effect of the meter then causes the voltage at the test point to substantially fall, giving a misleading reading.

The problem is overcome by this FET voltmeter circuit which has six ranges from 0.5 V to 100 V FSD with an input impedance of a little over 11 meg on all ranges. This gives a sensitivity of over 22 meg/V on the 0.5 V range dropping to a little over 110k/V on the 100 V range (most multimeters have a sensitivity of 20k/V).

A FET unity voltage gain buffer amplifier based on Q1 is used to give the necessary high input impedance, which is an inherent feature of a FET. A simple voltmeter circuit is fed from its output, and this has a FSD value of 0.5 V in the 'X1' position of SW2, or 1 V in its 'X2' position. R1 and R8 res-



pectively are adjusted to give the circuit the correct FSD values. There is a small quiescent output voltage from the buffer stage and so a bridge circuit is used to give zero quiescent voltage across the meter circuitry. To give good stability another source follower is used to form the other section of

the bridge and this results in no noticeable meter drift. RV1 is used to electrically zero the meter. D1 and D2 simply protect the meter movement against serious overloading.

An input attenuator can be used to reduce the basic sensitivity by a factor of 10 or 100, giving FSD

values of 0.5 V, 5 V, and 50 V with SW2 in the 'X1' position, or 1 V, 10 V and 100 V if it is set to the 'X2' position. The circuit does not have to be built as a complete instrument in its own right, and it makes an excellent add-on unit for any multimeter which has a 50 uA range.

What to look for In the August Issue: On sale July 6th

## STRING THING

To call this project an electronic piano would be an injustice. To call it a string ensemble likewise fails to explain all the mysteries and beauties awaiting the builder once this beast is activated. Yes it can be a piano. Yes it can play string sounds.

The designer (Tim Orr who also can be blamed or praised for the Transcendent 2000) wanted to call it a "Digital Multi-

Voice String Synthesising Keyboard Instrument". But we wouldn't let him. We couldn't think of a better title ourselves, but we still wouldn't let him. It's the way we are.

Being fitted with a CCD choraliser allows our String Thing to sound like several of 'em at once. Why not tune in and be amazed next month?



### BENCH AMPLIFIER

One for the workshop or table top. How many times have you been half-way through a project and needed to test something, somehow, somewhen. And that of course is exactly when it occurs to you that there is nothing around suitable.

A bench amp is worth its weight in soldering ten times over, and if you DON'T build this you will regret it.

### MICROSENSE

MPUs are definitely for you. Oh yes they are, don't give me that old line about them being all covered in mystery and incomprehension. MPUs are nice friendly little chips, and next month we've got the definitive article to prove it. Based on a book by John Miller Kirkpatrick it takes you through the subject from scratch in a thorough but light-hearted manner.

### LED AUDIO DISPLAY

A really lovely little design to amaze, astound and hypnotise the entire universe. This project takes the input from your hi-fi or TV or budgie and turns it into a dazzling and bemusing shifting pattern of light upon a LED matrix.

Build it any size you like it'll add a bit of visual spice to the hi-fi rack — or simply keep mother-in-law quiet while you nip off down the local.

# Decibels

*Have you ever wondered why the word Decibels seems to crop up everywhere, from audio units to TV signals, read on and find out*

LOOK UP THE REFERENCE BOOKS, and they'll tell you that Alexander Graham Bell invented the telephone. He did, true enough, but what he was *trying* to invent was a deaf-aid, and it just happened that the microphone and earpiece he came up with were a lot more suitable for a telephone than for the deaf. The point is that Bell was very interested in ears and hearing, which is how a unit called the bel came about. One tenth of a bel is called a decibel, and it's this unit whose name seems to crop up everywhere in electronics.

Why? Well, it happens that the end result of a lot of electronic gadgets is something you hear or see, and Bell's work on the telephone led to a very important discovery about the way we hear sounds. A telephone microphone converts sound waves into electrical signals. Now electrical signals are waves that we can measure, and even a hundred years ago we could measure the power of electrical signals, so that converting sound waves into electrical signals is a very convenient way of measuring the power of sound waves. Bell carried out some measurements, and made the rather surprising discovery that two sounds of the same pitch, one with twice as much power as the other, did not sound so very different to the ear. Quite certainly, one didn't sound twice as loud as the other.

## RING OF CONFIDENCE

It's not so surprising when we use modern equipment to make measurements on the sounds around us. The softest sound we can just hear (those of us of the generation before discos, that is); has a power of about one millionth of a millionth ( $10^{-12}$ ) of a watt on each square metre of surface. The loudest sound our ears can stand (Concorde at three yards, or a disco at 20 feet) sends out something like 10 watts per square metre. Now there's a huge ratio between these two quantities, some ten million millions, a darn sight more than the

ratio of sizes of an elephant to a flea, and no instrument can be devised which can handle the full range. How does the ear cope, then? The answer is that the output of signals which the ear sends to the brain isn't proportional to the power of the signals arriving at the ear, but to the logarithm of the sound power.

Remember your logs? The logarithm of ten is 1, the logarithm of 100 is 2, and the log of 1 000 is just 3. For these numbers which are powers of ten (ten multiplied by itself several times), the log is equal to the number of zeros which follow the 1.

The other feature of logs which made them so useful in the days before pocket calculators (that's given my age away!) is that multiplying and dividing numbers can be done simply by adding or subtracting the logs of the numbers. For example, the ratio  $1\ 000/10 = 100$  can be worked out by taking the logarithms 3 (log of 1 000) and 1 (log of 10), and subtracting, to give 2 (log of 100). You wouldn't use logs for such a simple one as that, but it did make more complicated multiplications and divisions a lot easier.

## LOGS AND WATTS

To measure how the ear reacts to sound, then, we take the log of a ratio of powers. We need two measurements of powers to form a ratio, though, so that we have to choose some standard to compare all other power measurement to. In electronics we take 1 mW (one milliwatt, which is one thousandth of a watt) as the standard power, though acoustical engineers sometimes use the threshold of hearing,  $10^{-12}$  W/square metre as their starting point. When someone says that a sound is 95 decibels, then, you need to know from which power level this is being measured.

When we measure some quantity of power, we find the ratio of that power to one milliwatt, then find the

### DECIBELS TO VOLTAGE GAIN

To use the table, split up the decibel figures into tens and units (100 is ten tens) look up the tens figure in the left-hand column, and the units figure in the top row. The intersection gives the voltage ratio which corresponds to the db figure. For example, 26 decibels is 19.9 times.

Units	1	2	3	4	5	6	7	8	9	10
Tens										
0	1.12	1.26	1.41	1.48	1.78	1.99	2.24	2.51	2.81	3.16
1	3.55	3.98	4.47	5.01	5.62	6.31	7.08	7.94	8.91	10.0
2	Numbers in this row are 10 times the numbers in the first row									
3	Numbers in this row are 100 times the numbers in the first row									
4	Numbers in this row are 100 times the numbers in the first row									
5	Numbers in this row are 100 times the numbers in the second row									
6	Numbers in this row are 1,000 times the numbers in the first row									
7	Numbers in this row are 1,000 times the numbers in the second row									
8	Numbers in this row are 10,000 times the numbers in the first row									
9	Numbers in this row are 10,000 times the numbers in the second row									
10	Numbers in this row are 100,000 times the numbers in the first row									

### VOLTAGE GAIN TO DECIBELS

To use the table, convert the gain to a number (less than ten) and power of ten. For example, a gain of 52,000 is  $5.2 \times 10,000$ , and a gain of 652 is  $6.52 \times 100$ . Look up each part of this number in the table, and add. For example, 5.2 is, from the table, 14.3, and 10,000 is 80db. Adding these gives 94.3 db. One place of decimals of voltage gain is enough, because the difference in decibels is very small.

Gain	0	.1	.2	.3	.4	.5	.6	.7	.8	.9
1	0	.82	1.48	2.28	2.92	3.52	4.08	4.60	5.125	5.66db
2	6.02	6.44	6.84	7.22	7.60	7.96	8.30	8.42	8.949	24db
3	9.54	9.82	10.1	10.4	10.6	10.9	11.1	11.4	11.611	8db
4	12.0	12.2	12.5	12.7	12.9	13.1	13.2	13.4	13.613	8db
5	13.9	14.0	14.3	14.5	14.6	14.8	14.9	15.1	15.315	4db
6	15.6	15.7	15.8	15.9	16.1	16.3	16.4	16.5	16.616	8db
7	16.9	17.0	17.1	17.3	17.4	17.5	17.6	17.7	17.817	9db
8	18.1	18.2	18.3	18.4	18.5	18.6	18.7	18.8	18.919	0db
9	19.1	19.2	19.3	19.4	19.5	19.5	19.6	19.7	19.819	9db
Powers of ten:										
10			20 db	10,000			80 db			
100			40 db	100,000			100 db			
1,000			60 db	1000,000			120 db			



# Points Switch

**Eliminate points motor burn-out on your model railway with this capacitor discharge points control unit. The device can control any number of points, and is an ideal companion for the HE Train speed controller.**

THE HE POINTS SWITCH is a push-button operated capacitor discharge unit that can operate an unlimited number of model railway point motors or solenoids. The unit was designed as a companion for the HE Train Speed Controller featured in our April issue, and is powered from the 16 volt AC output terminals of that unit. The points controller is, however, compatible with any model train speed controller (the Hornby 900, etc) that has an auxiliary AC output that will deliver approximately 16 volts at currents above 200 mA.

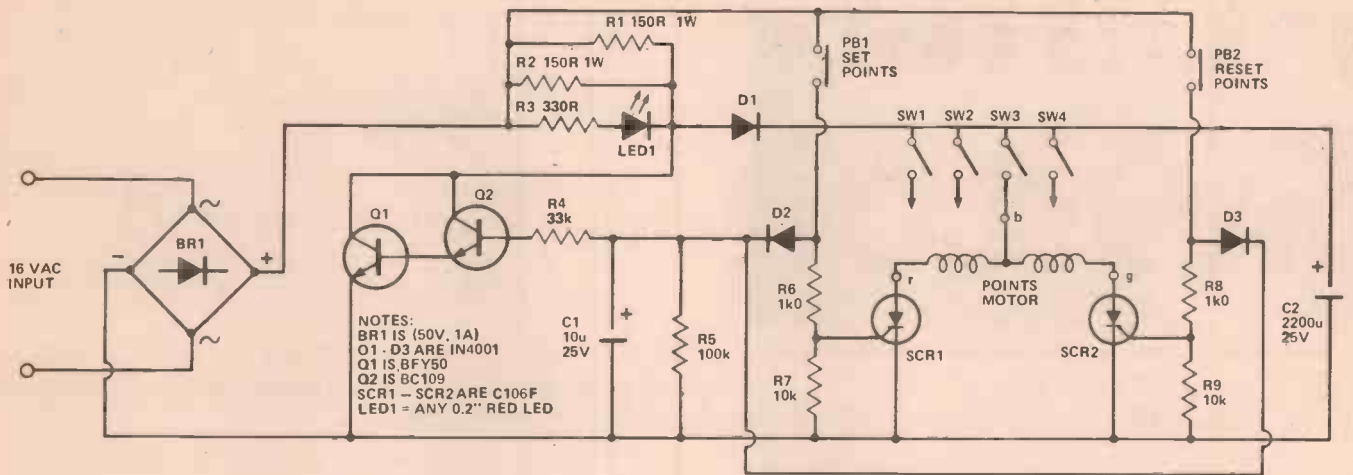
Conventional model railway points 'motors' consist of a simple double solenoid assembly that is activated by

direct connection across a high-current 12 to 16 volt AC or DC supply. The motors draw a few amps of current when they are activated, and are prone to burn out if they are connected to the supply for more than a few seconds.

The HE points controller eliminates the burn-out problem by activating the points motor via short pulse of heavy current that is obtained by discharging a high-value capacitor via one or other of two SCR's (silicon controlled rectifiers). The SCR's are activated via push-button switches. One of these is arranged to set the points motor to the SET position, and the other to the



*The finished product, a really neat project, fit to grace any model railway layout.*



NOTES:  
 BR1 IS (50V, 1A)  
 Q1 - D3 ARE IN4001  
 Q1 IS BFY50  
 Q2 IS BC109  
 SCR1 - SCR2 ARE C106F  
 LED1 = ANY 0.2" RED LED

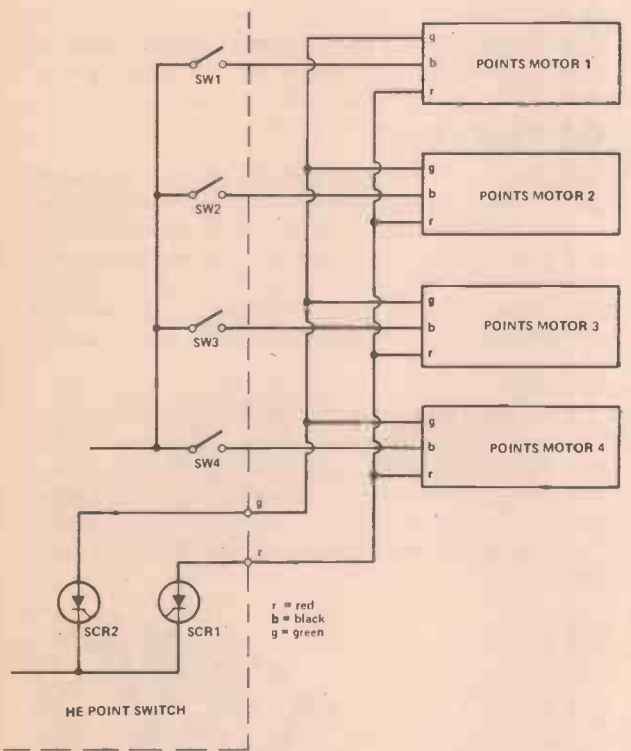


Fig. 1 Circuit diagram of the HE Points Controller.

RESET position. The unit can control any number of point motors via suitable selector switches.

The front panel of the controller holds a bank of numbered single pole changeover switches, which are used to select the required point motor, plus the two push-button SET and RESET switches. The front panel is also provided with a LED (light emitting diode) that indicates the state of readiness of the unit. A pause of about two seconds should be allowed between operations of the controller, and the LED illuminates brightly as soon as a point is operated to indicate that the unit is going through a recharging cycle, and dims or extinguishes when this cycle is complete and the unit is again ready for firing.

The 16 volt AC input connections are mounted on the rear of the unit, together with a bank of terminal connectors that facilitate connections to the point

## How it Works

The unit derives its 16 volts AC input from the auxiliary output of a train speed controller such as the Hornby 900, or the HE controller published in our April issue. This 16 volts AC is full-wave rectified by bridge rectifier BR1, and is used to charge capacitor C2 via the R1-R2-R3-LED 1 combination. LED 1 illuminates throughout the charging cycle, which typically takes a couple of seconds to complete.

When the charging cycle is complete and LED 1 is extinguished, a points motor can be selected by closing the appropriate one of the SW1 to SW4 selector switches. The selected motor can then be moved to the SET position by pressing PB1 and thus activating SCR1, or to the RESET position by pressing PB2 and activating SCR2. SCR1 and SCR2 are silicon controlled rectifiers, and act as self-latching solid state switches. They rapidly discharge C2 through the selected points motor whenever they are activated, and thus cause the points motor to operate.

A major problem with SCR's is to get them to turn off once they have gone into a self-latching mode. This can only be done by briefly reducing their anode currents to a near-zero value. In the HE Point Switch this turn-off action is facilitated by Q1-Q2 and the associated C1-R4-R5-D1-D2-D3 network.

Each time that an SCR is activated via PB1 or PB2, capacitor C1 is rapidly charged up via D2 or D3 and drives Q1 and Q2 to saturation via R4, thus pulling the LED 1-D1 junction down to near-zero volts for a typical period of one second or so. During this interval the selected SCR has time to fully discharge capacitor C2, so the SCR turns off automatically once C2 reaches its discharged state. At the end of the one second interval Q1 and Q2 also turn off as capacitor C1 discharges, at which point C2 is able to recharge via the R1-R2-R3-LED 1 network. The operating sequence is then complete.

# Points Switch



Inside the points switch, note the position of the thyristors

motors. Figure 1 illustrates the method of connecting the points motors to the unit. Note that the 'red' terminals of the motors are connected in parallel and taken to the anode of SCR1, and the 'green' terminals of the motors are connected in parallel and taken to the anode of SCR2. The 'black' terminal of each motor is taken to the positive terminal of C2 via its own single-pole on/off switch.

## CONSTRUCTION

Most of the circuit's electronic components are assembled on a single PCB, and construction here should present few problems so long as care is taken to ensure that all semiconductors and electrolytic capacitors are fitted in the correct polarity. If you are in doubt about the polarity of any component, cross-check the PCB layout against the circuit diagram.

The completed PCB can be fitted into any conveniently sized case (we used a unit from the Verocase range for our prototype), together with the two push button switches, the LED, and the points selector switches. Note that the unit can be fitted with any

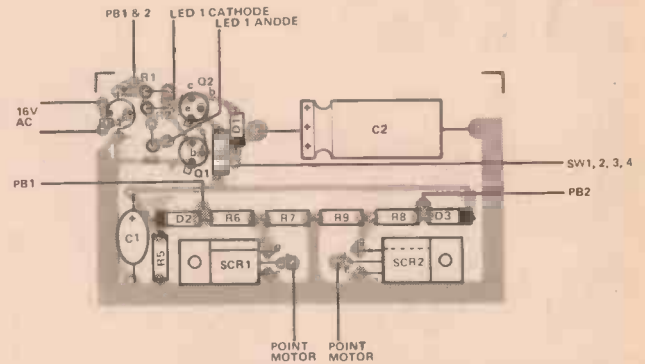


Fig.2 PCB overlay for the HE Points Switch, note position of polarised components.

number of point-selector switches, although we only used four on our prototype.

Finally, the two 16 volt AC input terminals can be fitted in place on the rear of the unit, together with a bank of terminal connectors to facilitate connections to the external point motors (see Fig 1).

## USING THE UNIT

The completed unit is very easy to use. Simply connect the input of the unit to a suitable 16 volt AC power source, such as the auxiliary output of the HE Train Controller, and connect the external points motors to the output of the unit as shown in Fig 1. When you want to operate a particular points motor, turn its selector switch on and then operate the appropriate SET or RESET button firmly (i.e., push, rather than stab at, the push button switch).

The unit's panel mounted LED illuminates as soon as a push button is operated, indicating that the unit's capacitor is no longer fully charged, but extinguishes again after about two seconds, showing that the unit is again ready for use. Remember to turn the selected points selector switch off after you have operated your points motor.

## Parts List

### RESISTORS

R1, 2	150R (1W)
R3	330R
R4	33k
R5	100k
R6, 8	1k $\Omega$
R7, 9	10k

### CAPACITORS

C1	10 $\mu$ 25v
C2	2200 $\mu$ 25v

### SEMICONDUCTORS

Q1	BFY50
Q2	BC109
D1-D3	1N4001
BR1	Bridge rec. 50v 1A
SCR1, 2	C106F
LED 1	0.2" LED

### MISCELLANEOUS

PCB	
SW1, 2, 3, 4	SPS7
PB1, 2	SP push-button
	Case to suit.
	Approximate cost £15.

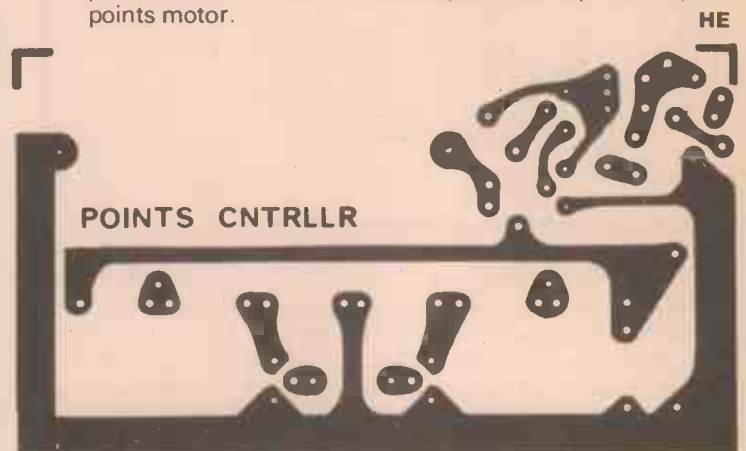


Fig.3. PCB foil pattern for the HE Points Controller. Use of a PCB is strongly recommended for a neat, trouble-free project.

## Buylines

All components used in this project are standard types, and are readily available from most of our advertisers. Bridge rectifier BR1 can be any 1 amp type with a voltage rating of 50 volts or greater.



# Into Linear ICs

## By Ian Sinclair

**Now that *Into Electronics* has finished, Ian Sinclair again puts pen to paper and tackles the awesome task of describing the habits of that family of ICs known as Linear ICs.**

IF YOU'RE JUST GETTING INTO THIS ELECTRONICS CAPER, perhaps you think that you'd better avoid ICs. Can't say we blame you — ICs are small, with lots of connecting pins laid out a bit too close for comfort, and the circuits which use ICs look strange in comparison to the more familiar circuits which use transistors. Just to make life a bit more difficult for the unfortunate beginner, books for beginners very often don't mention ICs at all, and books which do mention ICs seem to assume that you know all about them already.

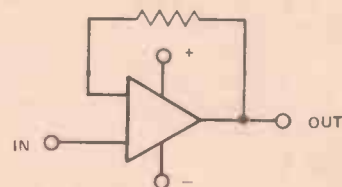
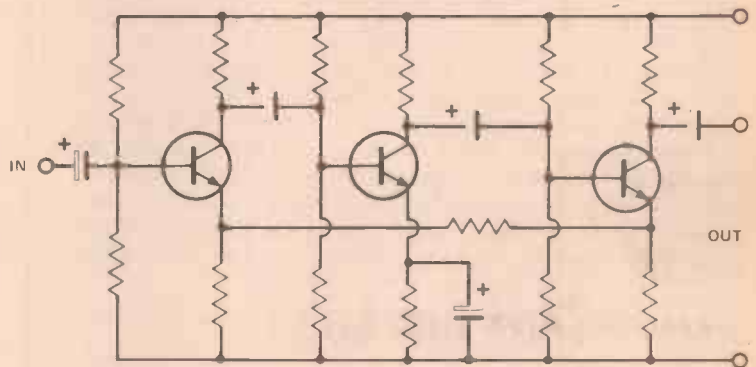
This series is designed to change all that. We're going to start off by introducing you to the types of IC which are classed as *linear* — and we'll explain what that means in a moment. Later — much later — we'll look at the other type of IC, the digital IC. In addition, the series will be built around practical work — we're not going to spend too much time on the theory of ICs. Reason is that what goes on inside an IC is not of so much interest as what goes on outside — it's not like a transistor circuit in which we can change any component we like. That doesn't mean we won't explain how the circuits work; we will, honest, but we won't explain the details of the circuits inside the ICs.

### IC THE DIFFERENCE

What is an IC anyway? The letters stand for Integrated Circuit, which doesn't tell you much more than the phrase 'silicon chip' which you read in the papers — and they usually manage to add an 'e' to silicon as if it were a furniture polish. What the IC means is that a complete electronic circuit can be made on a small piece of silicon as easily and as quickly as a single transistor. Transistors are made from thin silicon pieces, called wafers, measuring about 1.25 mm square, by a set of manufacturing processes which include heating in various gases and evaporation of silicon and metals. Now as it happens, we can make resistors and capacitors by the same processes in a different sequence, so by using shields (or *masks*) over the silicon we can control what sort of component we make on each part of the wafer. By evaporating metal, we can then make connections between different sections, so constructing a complete circuit.

What's the advantage? It's not just that the whole circuit is smaller to an incredible extent, though that can be handy. The big, big advantage is that all the connec-

tions are made during the manufacturing process. Let's explain that. Suppose we made up a 5 transistor circuit (Fig. 1a) using separate components — the name for a circuit made this way is *discrete* circuitry.



**Fig. 1. A transistor amplifier circuit (a) and an IC circuit (b) with the same performance.**

There are a lot of connections to make in this discrete circuit. Making each connection takes time, and each one is a possible source of trouble, like dry joints, mistakes, short circuits, the lot. Even if you get all of these connections right, there's a fair chance that one out of all these components may break down and fail at some time, and the more components you use, the greater the chance of at least one of them failing. An electronic circuit is like anything else — the more components it uses, the less reliable it is.

## PINNED DOWN

Now if we make the same circuit in integrated form, as an IC Fig. 1b, there's just one component — the IC. All the components which make up the circuit are there, but because they were made in one operation and at the same time, they behave with the reliability of one component. There are now fewer connections to make; in the example shown, we've replaced 21 components and 42 connections by two components, the IC and Resistors, and seven connections. That's a big improvement, and because the IC is a single component, it can be tested more easily and more quickly than would be possible if we had to test each component of a discrete circuit separately, then the whole circuit once it was assembled.

That's not all, either. The IC is produced by the same sort of factory methods as are used to make transistors, so that making one IC costs about as much, once we get production going, as making one transistor. Because of that, the IC is usually cheaper than the components it replaces. Just to complete the list of advantages, the IC is not so easily damaged by mechanical shock (he means they still work after you've dropped them, lad) as a complete circuit made from separate components.

Any snags about all this? Well, yes, there's one. If you make up your circuits from separate components, you can make any circuit you like. Using ICs, aren't you limited to what the manufacturers think is worth providing? The answer is yes and no! A readymade circuit is a bit of a restriction, but the types of circuits that are made as ICs are so designed that they can be used in a huge number of ways, making them practically as versatile as separate components, as you'll see when we get round to trying out some circuits. To keep prices low, ICs have to be made in very large quantities, so that an IC must be useful for a lot of applications so as to earn a bit of lolly for all the people who make it.

## LINEAR AND DIGITAL

So far, so good. Now we come to the two main types of IC. Apart from a few specialised ICs, they're all either linear ICs or digital ICs, so now we have to explain what the difference is. Any electronic circuit usually has an input and an output, and we put a signal into the input and take a signal from the output. If the output signal is a copy of the input signal then the circuit is a linear circuit, an amplifier in fact. Why linear? If we plot a graph of the output signal voltage against the input signal voltage, the graphs shown in Fig. 2, then the graph shape is a straight line for a linear circuit — and that's where the word *line*-ar comes from. When an amplifier is perfectly linear, the graph line plotted as we've just described, is perfectly straight, and the output signal is a perfect copy (though to a different scale) of the input signal.

ICs that are designed for use as amplifiers are linear ICs, each part of the circuit inside the IC is a linear amplifier. A few other types of ICs are also classed as linear ICs, even though their output signals look nothing like their input signals, just because they contain linear amplifier circuits. We'll be looking at one of these ICs, the 555 timer, later in this series.

## LINEAR ICs

How about digital ICs, then? Very briefly, because there's another series on digital ICs coming up, these ICs

use the same types of signals for both input and output, and what we are interested in is what combination of signals or sequence of signals we have. Much more of that later, in the next series but for now we're concerned only with linear ICs.

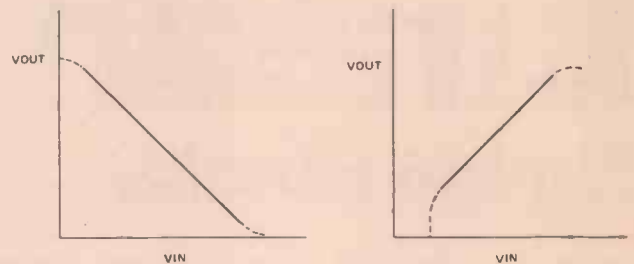


Fig. 2. Linear graphs (a) Inverting amplifier, (b) non-inverting amplifier. The graph lines usually bend noticeably at the ends, hence the use of bias to use only the straight portions.

## SHAPES AND SIZES

The first ICs were made quite a fair time ago; the idea was first hawked around in 1952, but it wasn't until silicon was being used on a large scale to make transistors that the first serious attempts to make ICs started. In those days of the late 50's, only fairly simple circuits, two or three transistors and a resistor or two, could be made, and these first ICs didn't need many connecting leads, very often only four or five. These were input, output, supply positive, supply negative and perhaps an additional feedback connection.

Now the silicon wafer slice, or chip, which is used for an IC is the same chip as we use for a transistor, and it will fit into the same size of can. As a result the first ICs were mounted in the same TO-5 cans as were used for most transistors at the time, but with a few more leadout wires added. Because the TO-5 can is a fairly large one (by transistor standards), it was possible to use up to 9 leadout wires from one TO-5 can, and most of the early ICs were so mounted. You can still get these TO-5 ICs, but it's not the most convenient method nowadays. The kind of 'Package' that's most often used nowadays is the rectangular block of plastic with a row of pins on either side. This is called the dual-in-line package (shortened to DIL or DIP), and all ICs are obtainable in this form. The actual silicon chip takes up only a small part of the block, and the plastic is simply a convenient way of protecting the IC chip and its leadout wires.



Fig. 3. An IC in a TO-5 can.

To make life simpler, a number of standard DIL packages are used, some with 8 pins, some with 14, some with 16. Larger pin numbers are used, but these numbers are the most common, particularly for linear circuits. The spacings of the pins are designed to fit a 2.5 mm grid (0.1" if you are unconverted), so that the distance between pins is always a multiple of 2.5 mm. The 8-pin, 14-pin and 16-pin types, for example, have the pins of each line set at 2.5 mm apart, and the lines 7.5 mm apart. Some of the bigger types of linear or digital ICs have the lines spaced 15 mm apart, but the spacing between pins on one line is always 2.5 mm.

Sometimes not all of the total number of pins in a DIL package are used, and in any case we need to know how the pins that *are* used are to be connected. To make it a bit easier, the pins are numbered, but the numbers aren't printed on the ICs — there isn't room. What is done is to mark the IC package so that we can find pin 1, and then go on from there to find all the others. Fig. 5 shows how the pins are numbered. The index mark is a notch at one end of the IC, or a small dot at pin 1, sometimes both. When the small dot is used, it locates pin 1; the notch shows which end of the IC has pin 1. Looking down on the IC, pins *down*, with the notch at 12 o'clock, pin 1 is always at around 11 o'clock. The pins are then numbered in sequence down one line and up the next one, with the last pin at the notch end of the IC, around 1 o'clock. A few ICs, incidentally, look as if they have a notch at each end — the correct one to use is the one which is more deeply cut into the plastic.

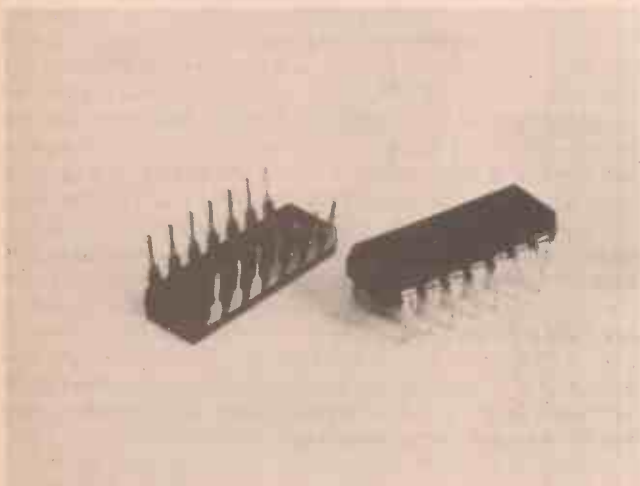


Fig. 4. Typical DIL packages.

## PRACTICALITIES

Let's be practical for a moment. If all of your construction has been with transistors up to date, you're going to notice a difference. Transistors have thin leadout wires which can be bent and shaped to suit your circuitboard. ICs have thicker, flattened pins, and the circuit board has to be shaped, with solder pads 2.5 mm apart in lines 7.5 mm apart, to take the IC *without* bending the pins. On most solderboards, this presents a few problems because with lines spaced only 2.5 mm apart, your soldering has to be pretty neat if you're to avoid shorting tracks together with the solder. It's a great advantage to have a soldering iron with a really small bit, and to use fine-gauge solder — more of this in Part 2.

## SYMBOLS

Good ol' fashioned transistor circuits use a symbol for each component and most of these symbols have been around for a long time. There aren't many standard symbols for linear ICs, mainly because so many linear ICs would need special symbols, and it takes longer these days to get a symbol accepted than it does to design and produce the IC! The symbol which is most often used is the triangle (Fig. 6) with input(S) at the flat end and output from the sharp end. This symbol is used to represent an amplifier, and since most linear ICs contain amplifiers or *are* amplifiers, it's the most useful thing to have a symbol for. Other linear ICs simply use a square or rectangular block symbol, with, input, output and power supply lines going in and out of the block. What goes on inside the IC then remains a mystery until we take a long hard look at the data sheet — and until you've finished this series it may remain a mystery even after you've seen the data sheet.

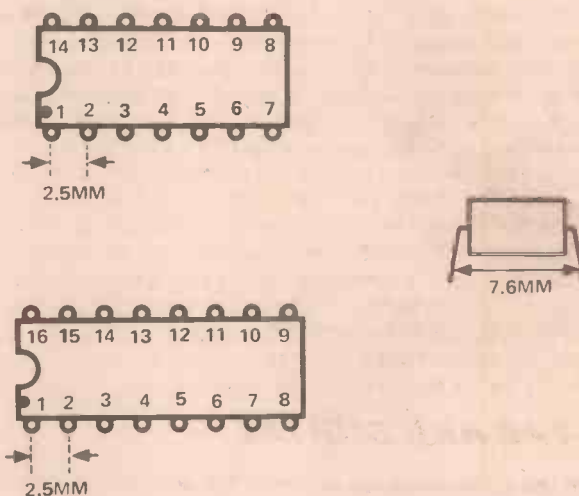


Fig. 5. The DIL numbering system.

One feature of the amplifier symbol needs a bit of explaining, though. A lot of IC amplifiers have two inputs, marked + and -. This has nothing to do with power supplies, but with feedback connections. Remember feedback? It means taking some of the output signal and connecting it back to the input of the amplifier. Feedback comes in two main types; positive, which increases gain and distortion, and causes amplifiers to oscillate; and negative which decreases gain and distortion and makes amplifiers more stable if we use it correctly. The + and - symbols at the input of the IC amplifier refer to feedback connections. A feedback connection from the output to the + input is a positive feedback connection, and a feedback connection from the output to the - input is a negative feedback connection. We can't get inside the IC, so we need some way of making these connections as and when we need them. We'll see how these two connections can be used later on when we look at the uses of the 741 IC amplifier chip.



## BIAS AND FEEDBACK

One feature of an IC amplifier which looks as if it might be a source of trouble is the fact that we can't make large-value IC capacitors — they would take up too much room on the chip. IC amplifiers are directly coupled, meaning that the collector of one transistor in the amplifier circuit is connected directly to the base of the next one. Now if you recall anything about coupling signals from one transistor to another, you'll remember that direct coupling is a very dodgy business indeed. To use a transistor as a linear amplifier, the bias current has to be correct. What amount is correct, then? It's the amount which ensures that a normal input signal will not cause any transistor to cut off (no current) or to bottom (when the collector voltage is almost zero and can't go lower). If the transistor cuts off, the collector voltage reaches supply voltage and can't go higher — result is no more amplification until the voltage drops again. If the transistor is allowed to bottom, the collector voltage gets down to about 0.2 V higher than the emitter voltage, and can't go lower; again this means no more amplification until the voltage can rise again. If any transistor in an amplifier cuts off or bottoms, then the amplification certainly isn't linear. We usually ensure correct bias by setting the current through each transistor so that with no signals at the input, the collector voltage of each transistor is about half-way between the supply voltage and the emitter voltage.

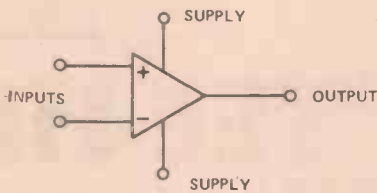


Fig. 6. Symbol for an amplifier IC.

## DC COUPLING

Now the dodgy business about direct coupling is that we can't bias each transistor in an amplifier separately by itself. If all the transistors are connected together, collector to base, without the use of capacitors to isolate the DC, then the collector voltage of one transistor is the base bias voltage for the next one, and the only way we can control all of this is to have the bias for the first transistor in the amplifier set correctly, and design the amplifier so that setting the first one will ensure that all the others are correct also.

The only way we can bias a linear IC, then, is by applying a steady bias voltage at an input terminal. We can't take the circuit apart to get to any of the transistors inside, we simply have to assume that the designer of the IC knew what he was doing (and they do, folks, they do) and arranged things so that with the correct bias on the input each stage of the IC would be correctly biased.

We can ensure that we have the correct bias for linear action by using negative-feedback bias. As we've seen, a signal fed back from the output of an amplifier to the + input is positive feedback, but a signal fed back to the - input gives negative feedback. A linear amplifier IC can be correctly biased by connecting a resistor to act as a

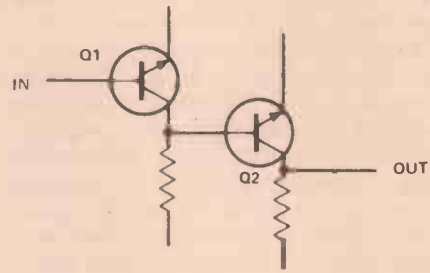


Fig. 7. Direct coupling — the base voltage of Q2 is equal to the collector voltage of Q1.

feedback path between the output and the — input terminal. This feeds back DC, and works only because the amplifier is completely direct-coupled.

How does it work? Let's take a look at a typical circuit (Fig. 8) which uses two separate batteries to operate a linear IC amplifier. Now using two batteries as this circuit does may look a bit complicated, but in fact it makes amplifier circuits a lot simpler, as we'll see later. In the diagram, the + input of the amplifier is connected to earth, which is also the return path for both batteries, and the output of the amplifier is connected through a resistor (any size, 10K to 10M) to the — input. This automatically sets the amplifier to the correct bias.

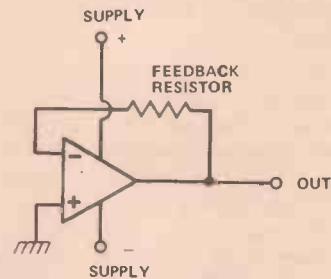


Fig. 8. Negative feedback bias — this is the bias system which is used for all linear amplifier circuits.

## HOW IT WORKS

Here's how it works. Remember that the circuit inside the linear IC is quite an elaborate one, containing a lot of transistors and with a very large voltage gain, 100 000 or more. In addition, the voltage that is amplified is not just the voltage at one input but the voltage *difference* between the inputs — if both of the inputs are at the same voltage there's nothing to amplify. We've shown the + input connected to earth, so unless the - input is also at earth voltage (give or take a bit, as we'll see), there will be some voltage difference between the inputs and this will be amplified to appear at the output. If the voltage at the + input is higher than the voltage at the - input, the output voltage goes high (to +9 V in the diagram) and if the voltage of the - input is higher than the voltage of the + input, the output voltage goes low (to -9 V in the diagram).

So far, so good, now we have to get back to the negative feedback. If we raise the voltage at the - input above earth voltage (which is the voltage of the + input), then the voltage at the output will drop below earth voltage. If we lower the voltage at the - input below earth voltage, then the output voltage will rise well

above earth voltage. The output voltage is free to swing either above or below earth voltage because we've used two power supplies in this example.

With the output connected to the  $-$  input, the only thing that can happen is for both the  $-$  input and the output to settle at earth voltage. Why? Imagine that the  $-$  input voltage rises to  $0.00001$  V above earth voltage. With a voltage gain of  $100\,000$ , and the usual inversion, this would cause an output voltage of  $-0.00001 \times 100\,000 = -1$  V. This amount of voltage at the output, connected back to the  $-$  input by a resistor, would whip the input voltage back to zero pretty smartly. Imagine it the other way round — that the  $-$  input voltage has dropped to  $-0.00001$  V. Once again, the combination of high gain and inversion produces a voltage, this time of  $+1.0$  volts, at the output, and the feedback ensures that the voltage drops back to zero again. If the  $-$  input voltage is exactly zero, the same as the voltage that the  $+$  input has been set to, then there's no difference between the input voltages, nothing to amplify, and the output voltage remains at zero — which is exactly halfway between the supply voltages, just the condition to ensure that the amplifier is correctly biased.

## INPUTS AND OUTPUTS

Why can't we just connect both inputs to earth? The reason, once again, is the very high voltage gain of the IC amplifier. The slightest voltage difference between the inputs, as small as  $10$  microvolts, will cause an output of a volt or so, and so and slight differences between the transistors inside the IC will cause a change of output voltage even with both inputs earthed. This sort of difference is called an offset. We can't, even in an IC make transistors which match each other perfectly, so that this offset always exists. Using negative feedback for bias solves this problem, because the feedback action compensates for the offset. If we absolutely insist on being able to earth both inputs, then some ICs have an offset adjustment so that the output can be set to zero volts (using the circuit of Fig. 9) with both inputs earthed. Later on in this series, we'll look at circuits which let us set bias correctly when only one battery supply is used.

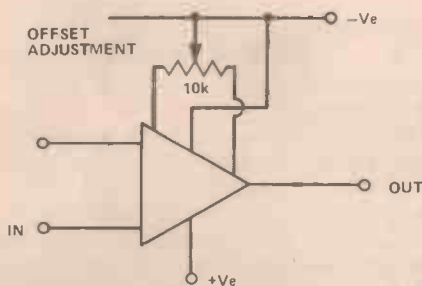


Fig. 9. Offset adjustment. The potentiometer can be adjusted to make the output voltage zero when both inputs are zero.

Finally, as far as this session is concerned, to matters practical. Reading about what ICs do is fine, but there's nothing like experimenting for yourself, and your understanding of what linear ICs do becomes a lot more complete when you've tried out some circuits and found out for yourself how they behave. There are going to be a lot of circuits shown in this series, and I wouldn't suggest that you tried out each and every one of them,

but at least one or two from each part of the series is about par for the course, keeping you up to date in the practical side of using ICs. One of the pleasant things about working with ICs is that you quite often don't need many other components — the bias circuit of Fig. 8 demonstrates that. On the other hand, if you want to show exactly what a circuit is doing, you need some way of testing it. If you have access to such goodies as signal generators and oscilloscopes, great — you can check out any of the circuits completely. If you don't run to this sort of laboratory equipment, then we'll try always to include circuits which can be tested with simpler methods, like cheap crystal microphones and earpieces, old loudspeakers, LEDs and the like. One really useful aid, though, is a decent voltmeter or multimeter with at least  $20\,000$  ohms per volt on its DC ranges. Come to think of it, it's time we had a multimeter offer from H.E.

Now the next thing is how to construct the circuits. You could, of course, solder up each one, spend a fortune on ICs, and end up with an awful lot of small bits of board, each with a different circuit on it. A much simpler way is to use one of these very useful devices, a solderless breadboard. This way there's no soldering problem, circuits can be assembled very quickly, taken apart afterwards, and the components re-used. We can even arrange our circuit diagrams (and we have, too) so that you can check each connection in the circuit — it's as near to electronics-by-numbers as you'll ever get. More about all that next month, and also about soldering and power supplies. We'll also take a brief look at how you can design a circuit layout for yourself — stay with us.

## TEE-HE!

### HOBBY ELECTRONICS TEE-SHIRTS

Join the He-men by sporting our cotton Tee-shirts. They're available in Large, Medium and Small, please specify which when ordering. All inclusive price is £2.00 from:

HE Tee-Shirts,  
Hobby Electronics,  
25-27 Oxford Street,  
London W1R 1RF.



# Kit Review

## Sparkrite Electronic Ignition

***Do you have trouble getting going in the morning? Do you lack that vital spark? The Sparkrite Capacitor Discharge ignition system might take care of all that. One for the motorist this month.***

GENERALLY, WHEN WE REVIEW A KIT we look at it from two directions. Firstly the electronics, is it easy to build, is anything missing and does it work? Secondly does it live up to the manufacturers claims and how well does it work? It's quite rare to find a kit that does well on both counts, this month's kit is the exception to that rule.

The kit in question is the Sparkrite X4 electronic ignition system. Not only did it just fall together in the building, it worked first time and believe it or not it actually has proved to be of benefit. A really practical, money saving kit.

When you open the box you're confronted with an assortment of neatly packaged plastic bags. One word of warning, before you open anything read the instructions first. Some very useful tips are given on soldering and component identification. Take notice of this section, particularly if you've never built a kit on this scale before. A nice touch was the inclusion of some solder, a generous coil, in fact quite sufficient for even the clumsiest of solderers.

### **BODY BUILDING**

Assembly of the kit was a dream. The kit was a roller tinned PCB for ease of soldering. From start to finish it took about two and a half hours and that wasn't hurrying. Everything fitted first time, although details of how to mount the transistor heat-sink were a little vague. A couple more pictures or diagrams in the instructions wouldn't come amiss.

One or two things to look out for, the mounting for the case/heatsink to the PCB uses an almighty pair of self-tapping screws, so arm yourself with the sturdiest, broad blade screwdriver you can find. (A short course in muscle-building might come in handy too). Watch out for the little sachet of Silicon grease, it's smeared on the transistors and heatsinks to ensure a good thermal joint. It's the sort of stuff that ends up everywhere, it even manages to adhere itself to things you haven't been near. It's a real pig to remove from clothing too so beware.

### **INSTALLATION**

Once assembled the type of installation has to be decided upon, provision is made for either clip-mounting on the ignition coil (if space allows). Or if room is at a premium and a more rigid fixing is required, it can be sited on the bulkhead. All the fixing brackets and screws are provided. Depending upon the type of car to be used a selection of spade terminals are also provided.

We opted for the clip-on type of fixing, it took only a



***Once assembled the device can be fitted in a matter of minutes.***



***What you get for your money, literally everything is there.***

couple of minutes to hook up (only four wires). Just in case something was wrong we left the switch on the unit in the 'off' position and gingerly turned on the ignition.

A quick sniff confirmed nothing was burning so using an insulated handled screwdriver the switch was moved into the 'conventional' position (after all the makers do warn of 'high voltage' and the switch is made of metal.

Yes we're all cowards). The car (a Vauxhall Viva) started after several attempts, quite usual for this particular specimen.

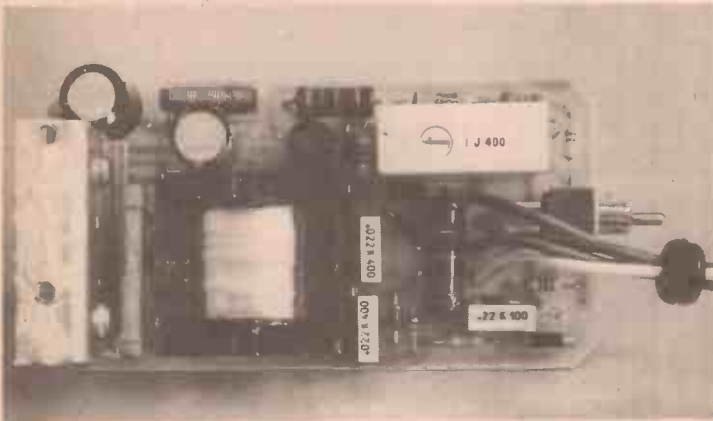
Judging all of this to be satisfactory the switch was then moved to the 'electronic' position, (without the aid of a screwdriver this time). The unit emitted a high pitched whine and the 'system function' lamp showed all was well. This time the car was started on the first attempt whilst still cold, most impressive, and it has remained consistently easy to start ever since.

## BRIGHT SPARK

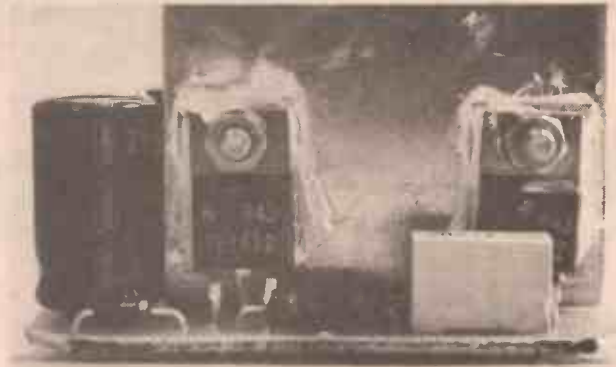
Over a period of a few days the petrol consumption of the car has fallen by a small but significant amount, not we suspect as a direct result of the unit's efficiency but as a by-product of the smoother running of the engine. But the overriding benefit been the improved starting from cold. In their literature Sparkrite recommend widening the spark-plug gap to improve efficiency further when using a weakened mixture.

Because the contact breakers only pass a light switching current (several amps are switched in a conventional system, hence the 'burning that eventually wears them out) the contact breakers should enjoy a greatly extended life.

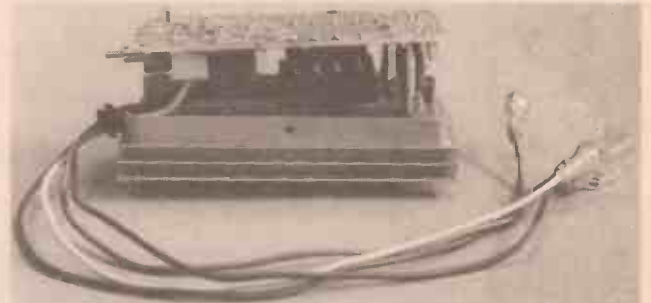
*When assembling the kit watch out for polarity-conscious components, particularly the transformer and thyristor.*



*Below. only four wires are needed to connect up the Sparkrite.*



*The transistor heat-sink is a little confusing to assemble, a minor criticism of the instruction booklet.*



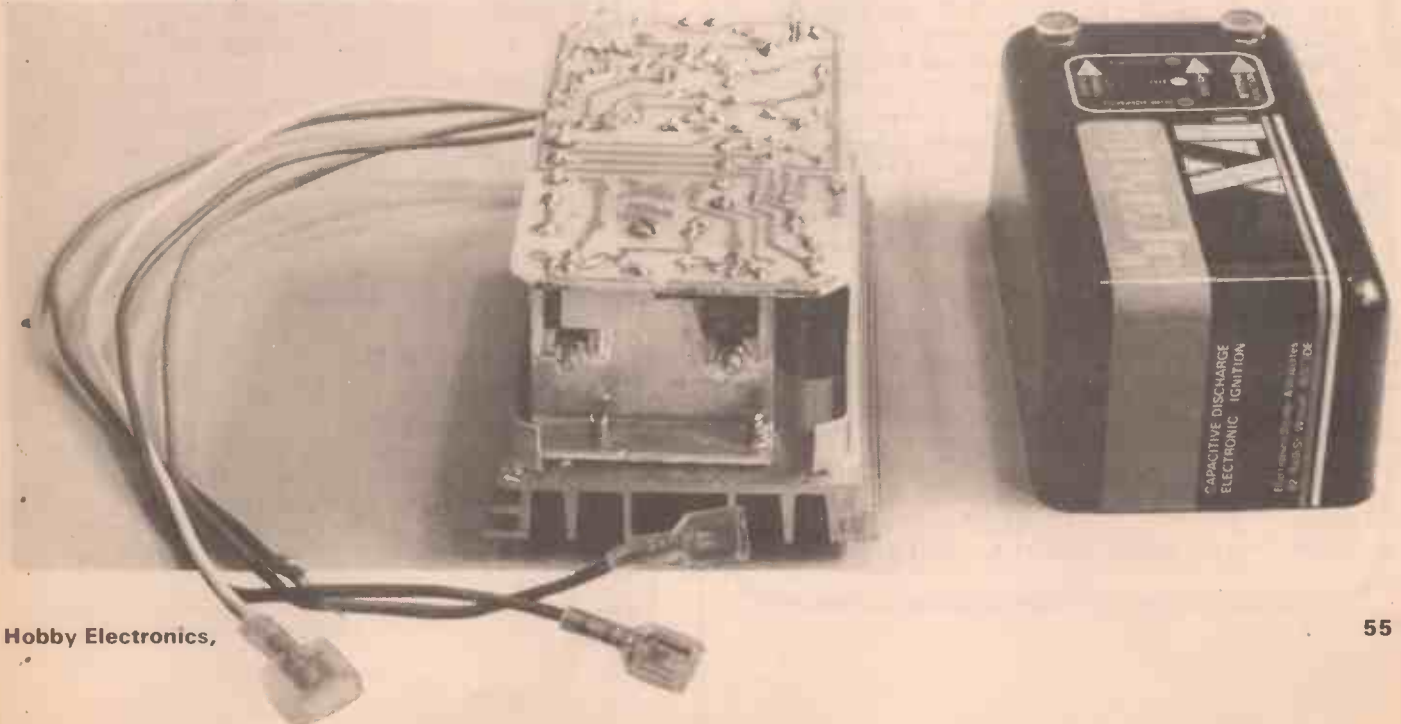
*Inside the Sparkrite X4, the roller tinned PCB is a delight to use.*

## TACHOMETERS

A couple of things to look out for, cars fitted with certain types of electronic tachometers may require the addition of a Pulse Slave Unit to ensure correct operation. A small increase in radio interference may also be experienced but Sparkrite explain how to overcome these maladies.

Criticisms? We would like to see a circuit diagram in with the instructions, and probably just as important some technical information. Dare we suggest a 'How It Works' section.

All in all a good kit and a worthwhile introduction into the world of automotive electronics. We must add that as a learning aid its potential is enormous, all it needs is that technical description. For £16.95 the kit is good value and we have no qualms in recommending it. **HE**



## 24 TUNE DOOR CHIMES

DOOR TUNES £18.50 inc. VAT

Waddingtons Videomaster announce a doorbell that doesn't go Brrring, Ding-Dong or BZZZZZ. Instead it plays 24 different classical and popular tunes. It will play the tune you select for your mood, the season or the visitor you are expecting to call. Door Tunes is not only great fun and a wonderful ice breaker, but is also very functionally and beautifully designed to enhance your home. These are something for Christmas, something for your continental visitors or your relations from the States and even something for the Queen. Door Tunes is easy to install and has separate controls for volume, tone and tempo.

## T. V. GAMES

PROGRAMMABLE - £31.86 inc. VAT  
COLOUR CARTRIDGE TV GAME

This TV Game can be compared to an audio cassette deck and is programmed to play a multitude of different games in COLOUR, using various plug in cartridges. At long last a TV game is available which will keep pace with improving technology by allowing you to extend your library of games with the purchase of additional cartridges, as new games are developed. Each cartridge contains up to ten different action games and the first cartridge containing ten sports games is included free with the console. Other cartridges are currently available to enable you to play such games as Grand Prix Motor Racing, Super Wipeout and Stunt Rider. Further cartridges are to be released later this year, including Tank Battle, Hunt The Sub, and Target. The console comes complete with two removable joystick player controls to enable you to move in all four directions (up/down/right/left) and built into these joystick controls are ball serve and target fire buttons. Other features include several difficulty option switches, automatic on screen digital scoring and colour coding on scores, bats and balls. Lifelike sounds transmitted through the TV's speaker, simulating the actual game being played. Manufactured by Waddingtons Videomaster and guaranteed for 1 year.



### EXTRA CARTRIDGES:

ROAD RACE - £9.58 inc. VAT. Grand Prix motor racing with gear changes, crash noises, etc.  
SUPER WIPEOUT - £9.90 inc. VAT. 10 different games of blasting obstacles off the screen.  
STUNT RIDER - £13.13 inc. VAT. Motorcycle speed trials, jumping obstacles, leaping various rows of up to 24 buses, etc.

### NON PROGRAMMABLE

6 Game - COLOURSCORE II - £14.50 inc. VAT.  
10 Game - COLOUR SPORTSWORLD - £24.30 inc. VAT.

A/C MAINS ADAPTOR - £3.13 inc. VAT.  
(Suitable for all three models above)

## CHESS COMPUTERS

ELECTRONIC CHESS BOARD TUTOR  
£19.75 inc. VAT

A special bulk purchase of these amazing chess teaching machines enables us to offer them at only £19.75, less than half recommended retail price. The electronic chess tutor is a simple battery operated machine that can actually teach anyone to play chess and improve their game right up to championship level. This machine is not only for total beginners but also for established players wanting to play better chess. Unit contains the electronic chessboard with 32 chess pieces, a 64 page explanatory booklet and a set of 32 progressive programme cards including 6 beginners cards, 18 check mate positions, 9 miniature games, 5 openings, 3 and game, 28 chess problems and 2 master games.

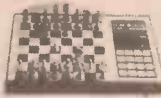


STAR CHESS - £59.50 inc. VAT  
PLAY CHESS AGAINST YOUR PARTNER  
using your own TV to display the board and pieces

Star Chess is a new absorbing TV game for two players, which will interest and excite all ages. The unit plugs into the aerial socket of your TV set and displays the board and excitement and interest to the game. For those who have never played Star Chess is a novel introduction to the classic game of chess. For the experienced chess player, there is a whole new dimension, of unpredictability and chance added in the strategy of the game. Not only can pieces be taken in conventional chess type moves, but each piece can also exchange rocket fire with its opponents. The unit comes complete with a free 18V mains adaptor, full instructions and twelve month guarantee.

CHESS CHALLENGER 7-£92.50 inc. VAT  
PLAY CHESS AGAINST THE COMPUTER

The stylish, compact, portable console can be set to play at seven different levels of ability from beginner to expert including "Mate in two" and "Chess by Mail". The computer will only make responses which obey international chess rules. Casting, or present and promoting a pawn are all included as part of the computer's programme. It is possible to enter any given problem from magazine or newspaper or alternatively establish your own board position and watch the computer react. The positions of all pieces can be verified by using the computer memory recall button. Price includes unit with wood grained housing and Stainion design chess pieces. Computer plays black or white and against itself and comes complete with a mains adaptor and 12 months' guarantee.



Other Chess Computers in our range include:  
Chess Champion - 6 level - £89.50 inc. vat  
Chess Challenger - 10 levels - £154.50 inc. VAT.  
Boris - Multi level + talking display - £178.50 inc. VAT.

## DRAUGHTS COMPUTERS

Checker Challenger - 2 level - £47.50 inc. VAT  
- 4 level - £86.50 inc. VAT

Play Draughts/Checkers Against The Computer



The draughts computer enables you to sharpen your skills, improve your game, and play whenever you want. The computer incorporates a sophisticated, reliable decision-making microprocessor as its brain. Its high level of thinking ability enables it to respond with its best counter moves like a skilled human opponent. You can select offence or defence and change playing difficulty levels at any time. Positions can be verified by computer memory recall. Machine does not permit illegal moves and can solve set problems. Computer comes complete with instructions, mains adaptor and a twelve months' guarantee.

FOR FREE BROCHURES—SEND S.A.E.

For free illustrated brochures and reviews on TV and chess games please send a stamped, addressed envelope and state which particular games you require information on. Callers welcome at our shop in Watling - demonstrations daily.  
Open from 9 a.m.-5.30 p.m. Mon.-Sat. (9 a.m.-1 p.m. Wed.)

To order by telephone please quote your name, address and Access/Ordercard number. VAT inc. included in all prices above—Postage and Packing FREE

AJD DIRECT SUPPLIES LIMITED

Dept. NE4, 102 Belgrave Road, Welling, Kent DA16 3QD. Tel. 01-303 9145 (day), 01-850 8652 (evenings)

# it's WAR!!



## ANOTHER WAR!!!

Yes once again we have stock coming out of our ears! Arrow have purchased the entire stock of a prominent mail order company and must clear space in our warehouse.

Cut out and mail whole coupon:

Insert no of packs required in box

1. Quarter Kilo weight mixed resistors, may incl. 1/4 to 2 watt/Wirewounds great variety **£1.00**

2. 100 Assorted Capacitors, may incl. Discs, Electrolytic/Myllars/Polys, etc. **£1.00**

3. Thyristor pack - 3 mixed S.C.Rs, may incl. 1/2-10 Amp @ 50 to 400 volt **£1.00**

4. Zener Pack, 15 assorted Zener diodes/regulators, may inc. 250mw to 5 watt, many voltages **£1.00**

5. Trimmer Capacitors, unique pack may incl. Variables, Presets, UHF/VHF/TV types 15 pcs **£1.00**

6. 20 Transistors, may incl. Germanium, silicon, NPN and PNP, Power, etc. **£1.00**

7. 20 Diodes, may incl. Signal, planar, gold bonded, rectifiers, etc. **£1.00**

8. Linear Integrated Circuits 9 pcs., may incl. 741s, 709s, 301s, DIL and T099. Great value **£1.00**

9. COSMOS pack, inc. 4011 plastic/ceramic DILs, 8 pieces for just **£1.00**

10. 10 Presets/Pots/Rectilinears, all sorts **£1.00**

**FREE.** Order all 10 packs, get a JUMBO SURPRISE PACK ABSOLUTELY FREE

OFFER IS LIMITED TO U.K. MAINLAND CUSTOMERS ONLY. PRICE INCLUDES VAT no more to pay, except POSTAGE 30p BUT **FREE** if you order over 5 packs.

(Your name and address)

To:

Please print clearly. Please give your postcode

**ARROW ELECTRONICS LIMITED**  
LEADER HOUSE  
COPTFOLD ROAD  
BRENTWOOD  
ESSEX CM14 4BN

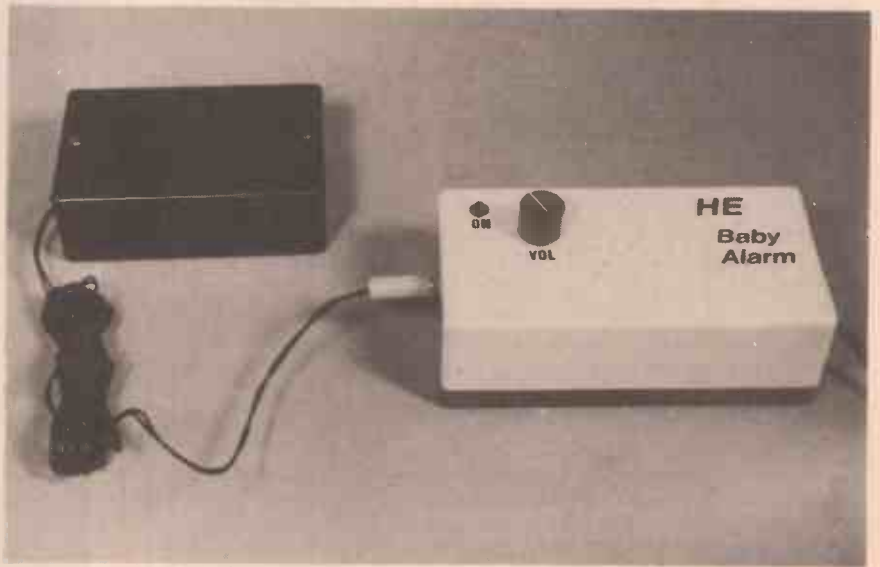
If you wish you may collect at our shop.

OUR 1979 PRICE LIST SUPPLEMENT IS NOW AVAILABLE. SEND LARGE STAMPED SELF-ADDRESSED ENVELOPE or if you are ordering packs tick box



# Baby Alarm

*An HE project for the loving parent. It's a mains powered audio system that lets you keep one ear on the kids while you do your own thing elsewhere.*



NO, A BABY ALARM IS NOT a pregnancy-detecting device. It is simply a gadget that lets the parent monitor the sounds of the babies room from the comfort of his or her own living area. It consists of a simple audio amplifier/speaker unit that's placed in the parents room, and a microphone unit, that is placed in the childs room: the two units are interconnected via a suitable length of 2-core lead.

The major problem with most commercial baby alarm units is that they are battery powered, and are thus very expensive to run if they are in regular use. The HE baby alarm, by contrast, is mains powered, and thus has near-zero running costs. It has a built-in LED (light emitting diode) to indicate that the system is switched on, and has a volume control to allow for varying levels of sound. The unit is designed around an LM380 audio power amplifier integrated circuit, which is capable of delivering 2 watts of output power.

The 'microphone' that is used with the unit can be any inexpensive speaker with an impedance in the range four to forty ohms: this speaker can be housed in a suitable case.

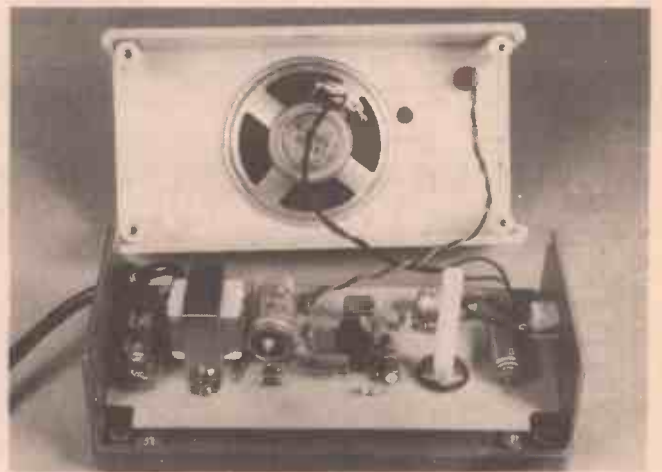
## CONSTRUCTION AND USE

Construction of the unit should present few problems, providing that you follow the PCB overlay with care and pay the usual attention to component polarities. We suggest that you assemble the PCB components in two distinct stages, as follows.

Start by assembling T1, FS1, D1, D2, and C1 on the PCB, taking care to check that the centre tap of the transformer goes to the position indicated on the overlay. Temporarily connect T1 to the mains via FS1, and check that a DC voltage reading of roughly 17 volts appears

across C1. When this check is OK, remove the mains connection and proceed with the rest of the construction. Note the positioning of volume control RV1 on the reverse side of the board, where three leads must be connected from its solder tags to the circuit board track.

When construction of the PCB is complete, fit the unit in a suitable case, together with the main speaker. Similarly, fit the remote 'microphone' speaker in a suitable case. The system is then ready for use, and the two units can be interconnected with a suitable length of 2-core wire.



*Inside the Baby Alarm, take particular care when building mains-powered equipment.*



Note when using the unit that, if the two units are placed an insufficient distance apart (less than a few yards), acoustic feedback or howl-round can cause the system to oscillate when RV1 is set to a high-gain position. This feedback can be heard as a loud howl coming from the output speaker, and should not be allowed to occur for more than a few seconds. **HE**

## How it Works

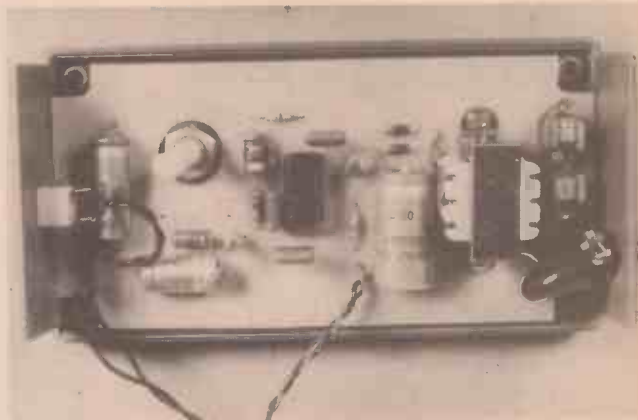
Parts T1, D1, D2 and C1 form a simple mains/DC power supply. T1 gives an output of 12 volts AC from a mains input. D1 and D2 rectify this to direct current and capacitor C1 smooths the supply. This provides an unregulated supply i.e. the output voltage will be reduced with the increasing current taken from it. However, as the rest of the circuit takes only about 25-30 mA there is no reason to suppose that the voltage should drop enough to stop the circuit from working correctly.

LED1 is used as an indicator to show that the circuit is on. The input speaker is a low impedance, transistor radio type speaker typically in the range 4-40 ohms, which acts as a microphone, picking up the baby's cries and is therefore placed in the nursery. The signal is amplified and matched to the input of IC1 by Q1 and its associated components, C2, 3, R2, RV1.

IC1 is an LM 380, which operates as a simple 2 watt integrated circuit amplifier which feeds the amplified signal to the output speaker. The sound from this speaker is quite loud enough so that you should hear baby's faintest cries.

According to manufacturer's specifications IC1 can sometimes develop high frequency oscillations at its output which can affect its lower frequency performance and so R4 and C8 are used to eliminate this whilst all audio frequencies pass through C9 to the output speaker.

C6 and 7 are decoupling capacitors, reducing mains hum which can often occur in such circuits.

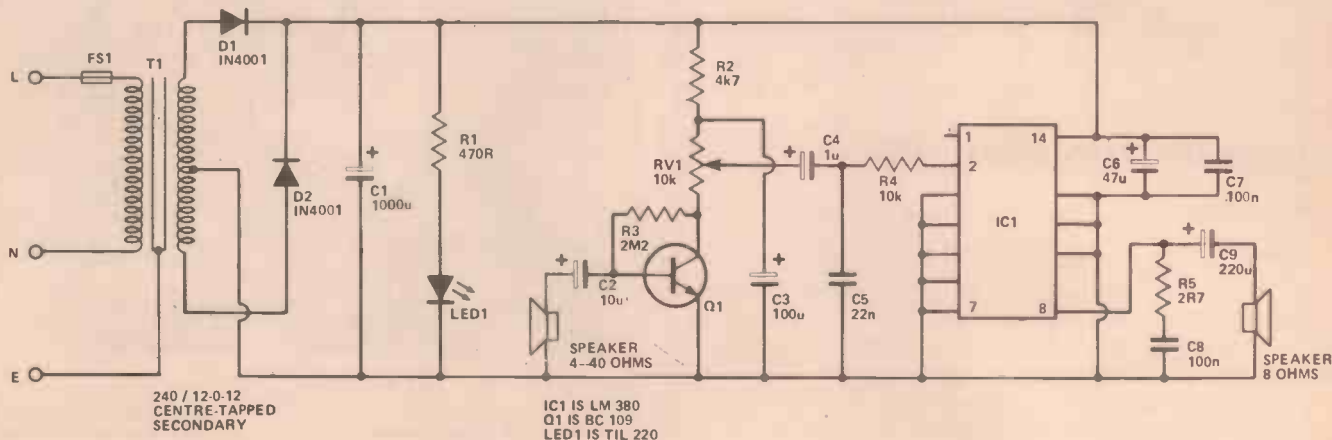


The Baby Alarm with its lid removed, using a PCB keeps interwiring to a minimum.

The HE Baby Alarm, it looks very neat in a Vero Box, as well as preventing tiny fingers from straying inside.

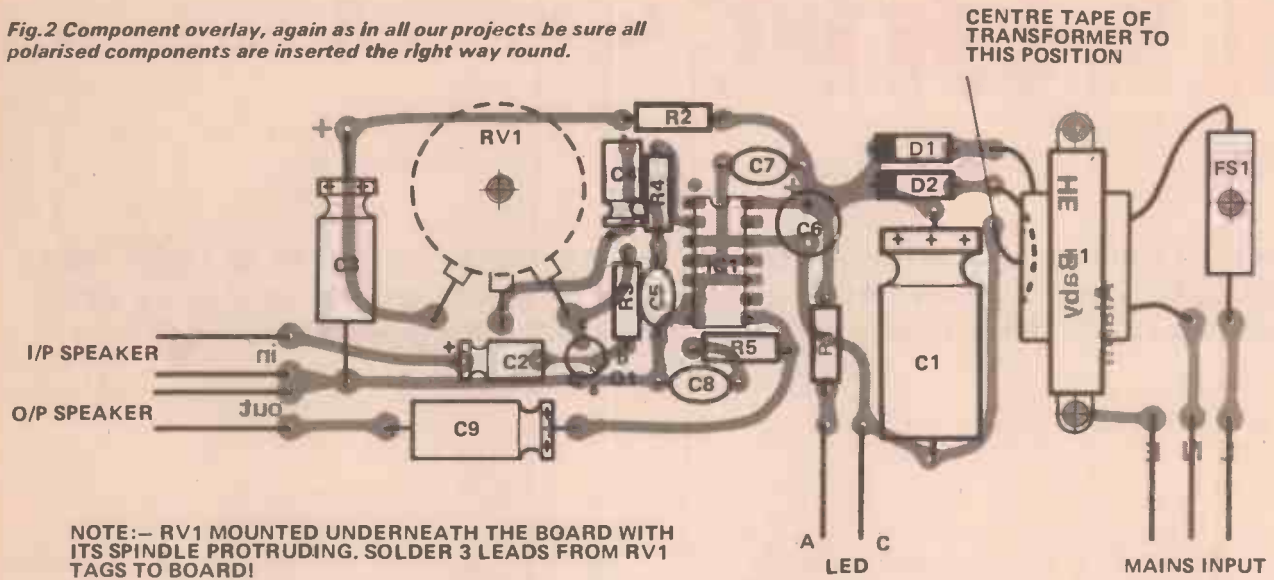


Fig.1 Circuit diagram for the HE Baby Alarm, using a mains power supply enables the unit to be left on for prolonged periods.



# Baby Alarm

Fig.2 Component overlay, again as in all our projects be sure all polarised components are inserted the right way round.



NOTE:- RV1 MOUNTED UNDERNEATH THE BOARD WITH ITS SPINDLE PROTRUDING. SOLDER 3 LEADS FROM RV1 TAGS TO BOARD!

## Parts List

### RESISTORS (All 1/4W 10%)

R1	470R
R2	4K7
R3	2M2
R4	10K
R5	2R7

### POTENTIOMETERS

RV1	10K Log
-----	---------

### CAPACITORS

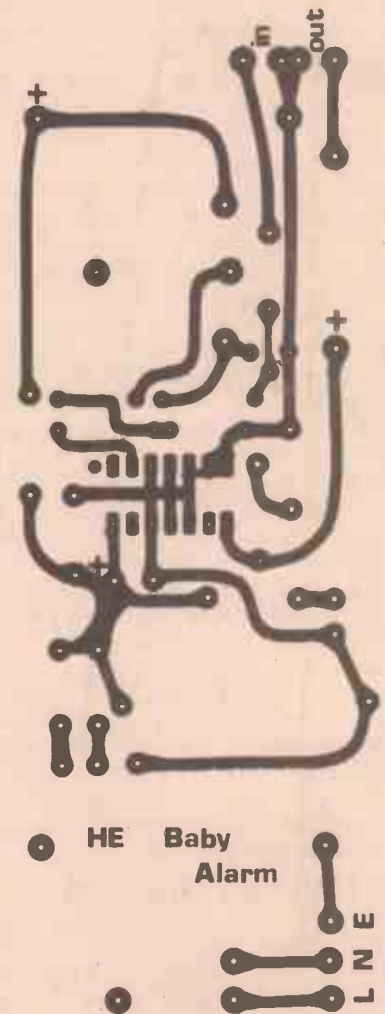
C1	1000u 25V
C2	10u 25V
C3	100u 25V
C4	1u0 25V
C5	22n Polyester
C6	47u 25V Tantalum
C7, 8	100n Polyester
C9	220u 25V

### SEMICONDUCTORS

IC1	LM380
Q1	BC109
D1, 2	1N4001
LED 1	TIL 220 or similar

### MISCELLANEOUS

T1 12-0-12V 100mA Input speaker 4-40 Ohms, Output speaker 8 Ohms, FS1 100mA +suitable holder.  
P.C.B. Case to suit  
Approximate cost £12.00



## Buylines

We can foresee no problems in obtaining any of the specified components for this project.

Fig.3 PCB foil pattern for the HE Baby Alarm, if you make your own PCB take particular care around the mains transformer area.

# S.I. Units

We've had quite a few letters recently asking about the use of SI units. We tend to use them more and more these days so it's as well to find out a little more about them. This article by Ian Sinclair will help you do just that.

WITHIN THE LAST TEN YEARS a major revolution in scientific measuring units has taken place, with hardly a ripple noticeable to the general public. The big change is to the use of a system of units which replaces many of the old measuring systems of the past incorporates new discoveries, deletes old mistakes and generally makes life simpler in all branches of science—including electronics. The new system is called the Systeme Internationale, SI for short. How did it come about?

Think for a moment what measuring anything, from the length of granny's clothes line to the resistance of a length of wire, means. When you measure anything you compare it with a standard, called a unit, and find how many units you have. This way, granny's clothes line gets compared to the standard metre, and the resistance of the length of wire gets compared to the standard ohm, so that you end up with a length in metres and a resistance in ohms. Not much to it, really, is there?

The trouble with measurement, though, is that we didn't start with a set of units for measuring everything. There wasn't much call for measuring voltage or current or resistance before electricity was discovered, so nobody ever thought of measuring units for these things. What has happened is that we've invented measuring units as the need arose, as new items needed to be measured. This business of making up new units as we went along, mainly over the last three hundred years or so, has served us well, but by the turn of this century had left a bit of a mess as far as measurement was concerned.

Why so? Well, it's all because measuring units affect each other, so that when you choose a couple of units, you automatically make others. If a whole set of units is designed at one time, they can be made to fit each other properly—but that didn't happen in the early days. The SI system is just such an attempt to design one complete set of units for measurement.

## NEW UNITS FOR OLD

Let's go back to basics to see why our measuring systems got into such a mess. A good illustration is the old Imperial units, inch, foot and yard. These are measurements of length—which are always the first measurements any civilisation has to find units for. Reason is, of course, that builders want to be able to make measurements of length. Ancient civilisations ran through a number of units like the cubit which are

practically forgotten now because they were never standardised—there never was a metal bar which everybody agreed was one cubit long. The real history of measurement has to start with units which are the same everywhere—and that's surprisingly difficult. The Imperial yard, for example, is the length of an arm span. To be more precise, it's the arm span of Henry VIII from breast bone to one finger tip. He needed the other arm for the wife, so the yard is shorter than it might have been. The foot is, so to speak, a well-trodden unit; and the inch was invented by King David I of Scotland.

In the first attempt at using an **average**, he decreed that the inch should be distance across the thumb, measuring the thumb widths of a small man, a medium man, and a large man. Quite democratic, when you think about it, but not really much more scientific. These measurements are all very well for rough work, but there's no reason why 36 Scotsmen's thumbs should equal half-a-King Henry, is there? Relationships like 12 inches to the foot and 36 inches to the yard only work if the units are fixed so as to be that way, and that took a long time.



$$\text{FORCE} = \frac{q1 \times q2}{d^2}$$

Fig. 1. Coulomb's law of 1784. For the first time, this established the relationship between the size of electric charges and the forces of attraction and repulsion between them.

## BAKERS DOZEN

By the middle of the eighteenth century, each country had its own sets of weights and measures, sometimes differing from one end of a country to the other. Phrases like 'a baker's dozen' remind us how imprecise these measures were. A baker's dozen was thirteen loaves, the number he had to supply to be sure that the weight of bread was at least the amount specified for twelve.

All this lack of precision was, of course, a handicap to

science, and yet in a curious way, a help. It was a handicap in the sense that the results of work in one part of the world might not apply in another place, because it was so difficult to ensure that the same weights and measures were used. It helped, surprisingly, because news of any discovery prompted dozens of other reservers to try out the same methods. In this way, each discovery was carefully checked, and, more important, relationships were formed which did not depend on what units of measurement were used. Just to take one example (though from the 19th century, rather than the 18th) Ohm's Law will always be  $V = RI$  no matter what units we choose for  $V$  and  $I$ , as long as the units of  $R$  are units of  $\frac{V}{I}$ . Even if all the units are chosen separately, the only effect on the law is to put a constant into it, like  $V = 1528RI$ —but it's still recognisably Ohm's Law.

That last point is important. The laws of Physics, which includes electrical and electronic laws, don't change according to what units of measurement we use. Life becomes much simpler, though, if all formulae are direct, with no number constants. In other words, it's easier to remember  $V = RI$  than  $V = 1528RI$ . When measuring units are just added, one by one, as they are needed, we can never achieve this simplicity. In fact, we could reasonably argue that it's impossible because we would have to know of everything that could be measured—and we have a bit of historical evidence for this view coming up.

PRACTICAL UNIT	EQUIVALENT IN ESU	EQUIVALENT IN EMU
Volt	1/300 ESU	10,000,000 EMU
Ampere	$3 \times 10^9$ ESU	1/10 EMU
Coulomb	$3 \times 10^9$ ESU	1/10 EMU
Henry	$\frac{1}{9 \times 10^{11}}$ ESU	$10^9$ EMU
Farad	$9 \times 10^{11}$ ESU	$10^{-9}$ EMU

### RELATIONSHIPS

Current:	$\frac{\text{EMU}}{\text{ESU}}$	= speed of light
Inductance:	$\frac{\text{ESU}}{\text{EMU}}$	= speed of light
Capitance:	$\frac{\text{EMU}}{\text{ESU}}$	= speed of light

Fig. 2. Some examples of the three sets of units which were all in use until recently. Students of A Level Physics were expected to know all three sets of units and how to convert from one to another.

### FRENCH RULERS

The French revolution started in 1789. We tend to remember it now as an example of the general rule that revolutions benefit very few and leave most people worse off, but the periods of dictatorship which followed the execution of the King and Queen did start off something of benefit to the rest of us. Dictators always seem to be obsessed by order—in more recent times both Hitler and Mussolini were fanatical about building

new motorways and about railways running to time. The aftermath of the French Revolution was an obsession with standardised weights and measures, culminating in what we know as the metric system.

The metric system was the first attempt to invent a **system** of weights and measures, the units are related to each other, and not just chosen at random. That way, with a bit of luck, your equations contain no awkward numbers. We often speak of the yard, foot measurement as the 'Imperial system' but in fact it's not a system at all, just a random set of units with no attempt to relate one to another.

Let's illustrate this a bit more clearly. The designers of the metric system decided to create units which would be constant, so that they could be re-checked at any time, unlike the arm-span of a dead King. For the standard of length, always the first and most important unit, they decided to use one ten-millionth of the diameter of the earth. Now this was a bit cheeky, really, because the diameter of the earth had only been measured approximately, and it's not constant—its a bit more round the equator than it is round the poles. At times of revolution, though, people tend to do rather cheeky things, and no-one working on the committee which made the decision wanted to stick his neck out—literally! As it happened, they were about 27% out,

### COULOMB'S LAW IN SI

$$F = \frac{q_1 q_2}{4\pi\epsilon_0 r^2}$$

$F$ — Force in Newtons  
 $q_1, q_2$ — charge in coulombs  
 $\epsilon_0$ — permittivity of free space in farads/metre  
 $r$ — distance between  $q_1$  and  $q_2$  in metres

Fig. 3. Coulomb's law in SI units. The quantity  $\epsilon_0$  is called the permittivity of free space, units Farads per metre. The idea behind this quantity is that even a vacuum allows radio waves to pass, behaving like a transmission line with capacitance an inductance per metre.

but this has never been important because they had standard metres made in the form of metal bars with scratches to show the distance of one metre. The present standard metre is the distance between two scratch marks on a platinum bar kept in a case at a constant temperature in the French Standards Laboratory, at Sèvres. Our own National Physical Laboratory has a copy, as do standards laboratories all over the world.

### RELATIONSHIPS

They may have let their revolutionary enthusiasm overcome common sense (it often does) in that case, but the committee made sound decisions all the rest of the way. They realised, for a start, that there were only a very few units which had to be standardised—the ones we call fundamental units. At that time, the fundamental units were those of length, mass and time. The need for units of electric current, light flux, temperature, and chemical equivalence hadn't hit them yet—that's the danger in trying to set up a system of units before you know of every quantity that can be measured. At the end of the 18th century the notion that light was measurable would have seemed, shall we say, a bit too revolutionary.

With the metre established, they then decided that all larger or smaller units should be powers of ten, such as 10, 100, 0.1, 0.01 and so on. After a few tries at making a decimal scale of time, they decided to retain

seconds, minutes and hours, but they were more successful with the third fundamental unit of mass, the gram. Now mass isn't an easy quantity to explain to anyone who hasn't been taught what Physics is about. Mass is a measure of quantity of material, not its size (that's volume) nor its weight (that's the force of gravity on it). Masses are compared on a balance, and any sort of standard can be used. The metric committee hit on the bright idea of taking as their standard of mass a cubic centimetre of pure water at 4°C—a standard which anyone in the world could duplicate.

Having settled the three fundamental units, all other units are derived from them, whatever they happen to be called, by combining the fundamental units in the right ways. The volume of anything, for example, is found by multiplying three lengths together, so that the units of volume are units of length multiplied together three times. That makes the volume units cubic centimetres or cm<sup>3</sup>. Similarly, speed is measured in centimetres per second (cms), acceleration in centimetres per (second)<sup>2</sup> or cms<sup>2</sup>, force in dynes. Dynes? No, its not a new fundamental unit. From Newton's Laws of 1666, we know that Force = Mass X Acceleration, so that the unit of force was a unit of mass multiplied by a unit of acceleration, grams X cms<sup>2</sup> — it's too much of a mouthful, so that the word dyne was used.

## POLITICAL CONSIDERATIONS

This was the first real system of scientific measurement, and it went hand-in-hand with a complete set of weights and measures for everyday use. The scientific measures were called the CGS system (meaning centimetre-gram-second), and they lasted until just a few years ago, when they were superceded at last by SI. What went wrong, and why did it take so long to sort it all out?

The answer is the same old problem—you can't really design a sensible system of units until you know everything you might have to measure. The members of the revolutionary committee thought they had it all licked, but they had, unfortunately, executed a few people who might have been able to tell them more about it all. The situation is pretty familiar, after all, our own parliament often makes decisions which affect the electronics industry, and yet these decisions are made by lawyers, teachers and good 'Party men' with little or no knowledge of electronics. They don't nowadays execute people who know better, just ignore them.

What the revolutionary committee could not have known was that current electricity, static electricity and magnetism were all part of the same thing. Nor, of course, could they have known that light was an electromagnetic wave, and that there was an absolute zero of temperature, colder than any temperature they could imagine. All these things were to come later, along with Joule's discovery that heat was just one other form of what we now call energy. These, however, were the things that with 50 years were to make the CGS system start to look rather foolish. Let's look at the electrical problems, since they affect electronics more than some of the others.

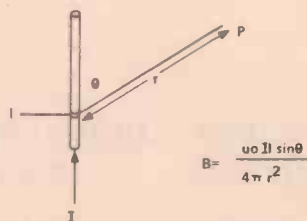
## COULOMBS CALCULATIONS

At the end of the 18th century, electrostatics was fairly well understood, measurements of magnetism well established, and current electricity just a curiosity. Ohm

was still a young man and Faraday had not started his remarkable career. As far as the CGS committee was concerned, static electricity, current electricity and magnetism were three separate, unrelated branches of electricity, which could use units derived from the CGS fundamental units.

For example, Coulomb had discovered in 1784 that the amount of force between two electrical charges, Q1 and Q2, obeyed the equation of Fig. 1. Now since the CGS system has units for force and for distance, this fixed the units of electrical charge as cm X √dynes written as cm.dyn<sup>1/2</sup>. Around the same time, measurements on long magnets showed that an almost identical law held for the magnetic 'poles'. Once again, the CGS system appeared able to cope.

Things started to go wrong when current electricity started to be more than a laboratory curiosity. By the early 19th century, researchers began to be quite certain of something they had suspected for a long time: that electrostatics, magnetism and current electricity were part of the same thing. By this time, 'practical' units, the familiar volt and ampere were in use for making measurements on electrical circuits. The discovery of a few more relationships then wrecked the structure of the CGS system.



B IS THE MAGNETIC STRENGTH AT POINT P  
 $u_0$  IS THE PERMEABILITY OF FREE SPACE, HENRIES/METRE  
 I IS THE LENGTH OF A SHORT PIECE OF WIRE  
 $\theta$  IS THE ANGLE BETWEEN THE WIRE AND A LINE DRAWN TO POINT P  
 I IS THE CURRENT IN AMPS  
 r IS THE DISTANCE FROM THE WIRE TO P

Fig. 4. The Biot-Savart law of magnetism. This law shows how much magnetic flux density, B, is caused by each bit of a wire carrying current. The quantity  $u_0$  is called permeability of free space. Once again, if space is thought of as a transmission line, permeability measure the inductance per metre.

## CHARGED SUBJECT

One discovery was that which we call electric current is the movement of electric charge, so that the units of current should be units of charge per second. The other vital discovery was that magnetism and electric current are related, so that electric current can be measured in terms of the units used to measure the strength of a magnet.

By now there were three sets of units for electrical measurements. For electrostatics, we used electrostatic units, ESU, and for magnetism the electromagnetic units, EMU. For electrical circuits, however, we used the practical units, Ampere and Volt, joined now by Ohms, Henries and Farads. All three sets of units were needed and used, and anyone seriously working in electricity had to learn all three and also the conversions between them. For example, an electrostatic volt was 300 practical volts, and a practical volt was 100 million electromagnetic volts. Just to make things more embar-

raising, the ratio between ESU and EMU was always related to the speed of light (Fig. 2).

Things were equally chaotic elsewhere, with one unit of energy (the Calorie) being used for heat, one in mechanics (the ERG) and another in electricity (the Joule). That sort of thing had been forgivable once, when heat, mechanics and electricity were thought of as completely un-related, but the work of Joule (1840 on) had shown that all forms of energy were equivalent, so that only one unit was needed. By the 1880's the need for a system of measurement was becoming rather pressing, but how could it be done?

## RATIONALISATION

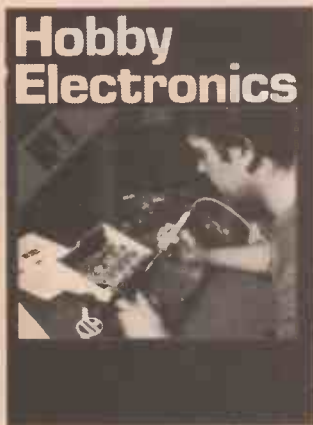
The answer was brilliantly provided by Georgi in 1904. He proposed that the whole system could be reversed without making really drastic changes if only two of the original fundamental units were changed, and a few more added. The changes were to the metre and kilogram instead of the centimetre and gram, keeping the second, and adding the ampere as a basic electrical unit. The system became known as the MKS or MKSA system (metre, kilogram, second, ampere), and gradually established itself until it was being almost exclusively used by electrical engineers. This took time, though, and the MKSA system was not being taught to engineers until the 1950's. Nobody really wanted to upset the established system, despite the fact that even at A level, students were having to learn three different sets of electrical units. Eventually, the lunacy of it all had some effect and an international committee which had been

considering a change of units came down at last in favour of the MKSA system.

That, in essence, is what we have now, re-named SI. The basic units are the metre, kilogram, second and ampere, along with the candela for light, the Kelvin for temperature and the mole for chemical quantity. At long last, there's only one set of quantities for electrical units and for energy (though they weakened a bit on light energy). Most equations are straightforward, with no conversions to remember, at the expense of a few new names to remember, like Newtons of force, Teslas of magnetism and Pascals of pressure. Nothing changes the law of physics, though, and the old business of the speed of light still appears. Coulomb's law of electric charge appears with a new constant  $\epsilon_0$  (Fig. 3), and the Biot-Savart law of magnetism with another new constant  $\mu$  (Fig. 4). The quantity  $\sqrt{\frac{1}{\epsilon_0 \mu}}$  is  $c$ , the speed of light, reminding us constantly that what we call radio waves are just one form of the family of electromagnetic waves of which light is another equally distinguished member.

## UNIFIED UNITS

The future? Well, it looks as if we've made it at last, with a set of units that hangs together properly. There are a few odds and ends to tidy up, but at last we've made the teaching of electrical engineering and Physics a lot simpler, without having to change the metric system. Mind you, if someone now discovers some relationship between gravitation and electricity . . . . !



## Are you missing out on something?

Take out  
a sub to  
HE today

To: Subscriptions  
Hobby Electronics  
P.O. Box 35  
Bridge Street,  
Hemel Hempstead,  
Herts

Name .....

Address .....

I would like a postal subscription to HE starting with the ..... issue. I enclose payment (£6.50 for UK and Eire, £7.50 elsewhere, £11.50 air mail).

# Hobby Chit~Chat

*HE project editor and chief designer Ray Marston takes the first of a monthly series of looks at the hobby scene.*

ELECTRONICS IS an intellectually stimulating yet intensely practical hobby. Through it, the hobbyist can learn to build, and eventually design, such diverse projects as audio systems, radios, home computers, music synthesizers, remote control systems, instrumentation and test gear circuits, as well as a variety of instruments and gadgets for use in the car, home and workshop. Leisure and hobby activities such as amateur archeology, treasure hunting, photography, model railroading, and slot car racing, can also benefit from a knowledge of electronics.

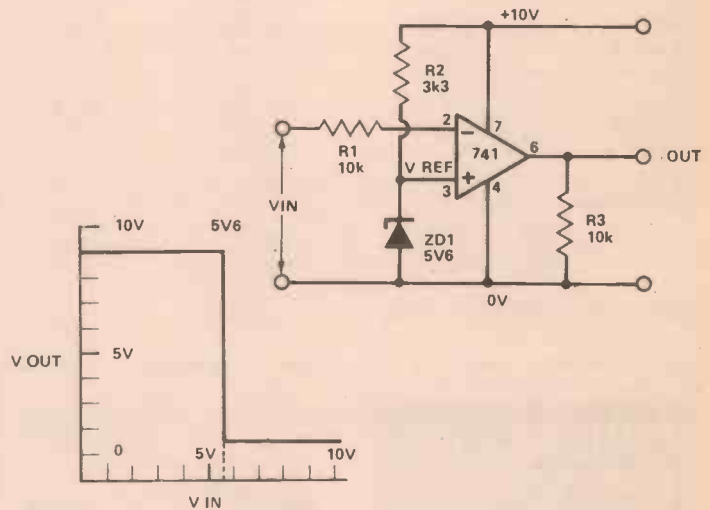
The intellectual stimulation of the hobby stems from its apparent complexity. Modern electronic circuits can usually be categorised as either linear or digital. Each category consists of a fairly large number of basic building 'blocks', and each block can be built using a variety of alternative 'technologies'. A small-signal linear amplifier can, for example, be built from either a bipolar transistor, a FET, an operational amplifier or a linear IC. There are in fact almost an unlimited number of possible permutations of circuit design.

The average hobbyist probably learns about his subject by starting off with an intensive and gruelling reading course of books and articles on electronics theory, from which he gains a grounding in the subject. Subsequently, he finds that his knowledge increases quite effortlessly through the virtually unconscious assimilation of additional information from casually read articles and from informal discussions with colleagues.

This new 'Hobby Chit Chat' feature is intended to be just such a 'casually read' article. It will, I hope, help the reader usefully but effortlessly to increase one's knowledge and thus enjoyment of the hobby. Each month we'll discuss one or more of the many aspects or facets of the hobby, with a view to stimulating, educating, and entertaining the reader. We start this month with a discussion of, and practical introduction to, that special breed of electronic circuits known as VOLTAGE COMPARATORS.

## VOLTAGE COMPARATORS

There are many occasions in electronics when it is desirable to have a circuit that abruptly changes its output state when an input voltage, or a quantity that can be represented by a voltage (such as a current, resistance, temperature, or light level, etc.), goes above or below a pre-set reference value. Circuits that perform this basic function are known as voltage comparators.



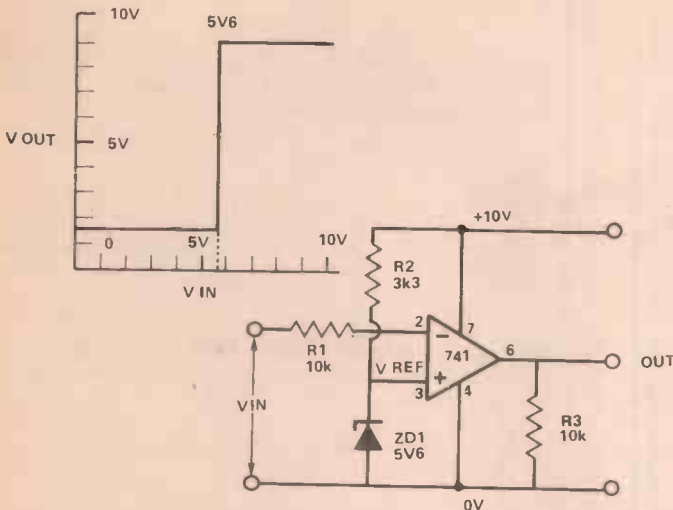
**Fig. 1. An Op-Amp Voltage Comparator circuit in which the output goes high when  $V_{in}$  is less than  $V_{ref}$ . The circuit functions as an under-voltage switch.**

Voltage comparators have plenty of practical applications in the hobby scene, apart from the obvious ones of over- and under-voltage switches. They can readily be made to activate relays, alarms, and other mechanisms when load currents or temperatures or light levels go outside of, or come within, pre-set limits, and have a stack of uses around the home and in the car.

The easiest way to make a voltage comparator is to use a 741 or other readily available operational amplifier in one or other of the configurations shown in Figures 1 and 2. The 741 op-amp has a typical basic or open-loop low frequency voltage gain of about 100 dB, or 100 000, so its output can be shifted from the high to the low state (or vice versa) by shifting the input voltage a mere 100  $\mu$ V or so above or below the reference voltage value. The op-amp can be powered from either single ended or split supply rails, and provides an output that typically swings to within a volt or so of its positive and negative (or zero) supply rail values.

The operation of the Fig 1 circuit is quite simple. The reference voltage,  $V_{ref}$ , is applied to the non-inverting input terminal (pin 3) of the op-amp via R2 and ZD1, and the test or input voltage is applied to the inverting input





**Fig. 2. An alternative voltage comparator in which the output goes high when  $V_{in}$  exceeds  $V_{ref}$ . This circuit functions as an over-voltage switch.**

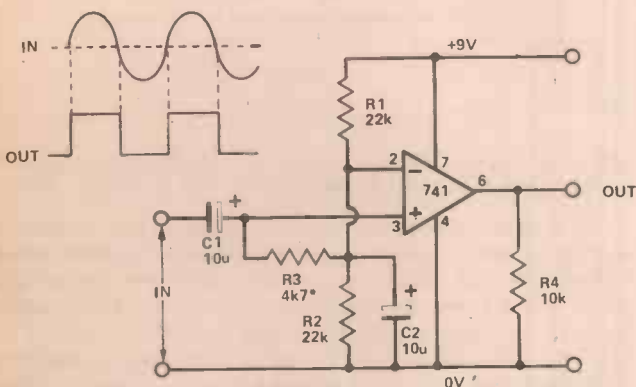
terminal (pin 2) via current-limiting resistor R1. The output of the op-amp is high or in positive saturation when  $V_{in}$  is below  $V_{ref}$ , but changes to the low or negative saturation level when  $V_{in}$  rises above  $V_{ref}$ . The circuit action can be reversed, so that the op-amp output is normally low but goes high when  $V_{in}$  exceeds  $V_{ref}$ , by transposing the pin 2 and pin 3 connections of the op-amp, as shown in Fig 2.

Note in the Fig 1 and Fig 2 circuits that  $V_{ref}$  can have any value that is more than a couple of volts above the negative (or zero) supply rail value, but at least a couple of volts below the positive supply rail value. The  $V_{in}$  value must not be allowed to exceed the positive supply rail voltage: for higher voltages, apply the voltage to the  $V_{in}$  terminal via a suitable voltage divider network.

## HOBBY APPLICATIONS

Figures 3 to 6 show a variety of ways of using voltage comparator circuits in hobby applications.

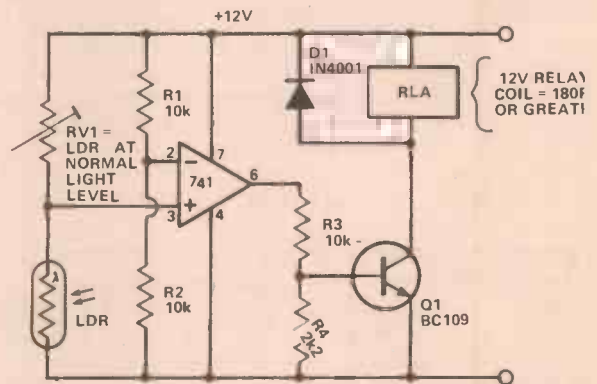
Figure 3 shows the circuit of a sensitive sine-square converter that can be operated from input signal amplitudes as low as a few tens of millivolts. The circuit produces a decent square wave output from sine wave inputs with frequencies up to a couple of kHz.



**Fig. 3. The sensitive Sine-Square converter needs only a few tens of mV input signal. The circuit produces a decent square wave output up to a couple of kHz.**

The circuit theory is quite simple. Voltage divider R1-R2 and capacitor C2 apply a decoupled reference voltage to pin 2 of the op-amp, and an almost identical but non-decoupled voltage is applied to pin 3 via R3. When a sine wave is fed to pin 3 via C1 it swings pin 3 above and below the pin 2 reference level, causing the op-amp output to transition at the 'zero voltage difference' cross-over points of the input waveform and produce a square wave at the output.

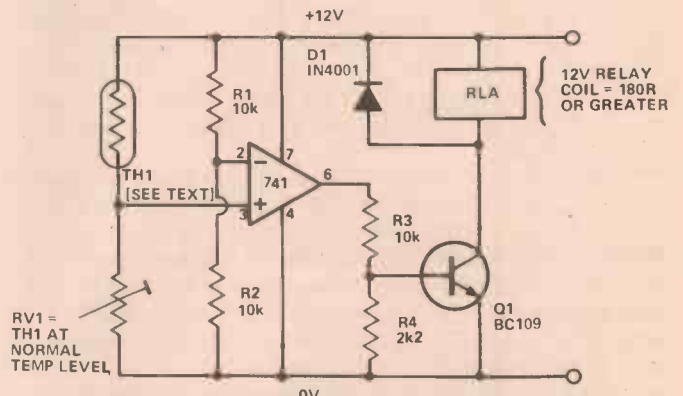
Note in the Fig 3 circuit that a slight offset occurs between the pin 2 and pin 3 voltages of the op-amp, due to a small volt drop that occurs across R3 as pin 3 draws current. This offset voltage limits the sensitivity of the circuit. The circuit sensitivity can be reduced, if required, by increasing the value of R3, up to a few tens or hundreds of kilohms.



**Fig. 4. A voltage comparator used as a light-sensitive switch. The relay turns on when the light intensity falls below a pre-set level. The action can be reversed so that the relay turns on when the light intensity goes above a pre-set level, by transposing the LDR and RV1.**

Fig 4 shows how a comparator can be used to make a very sensitive relay-output light-activated switch. The circuit action is such that the relay turns on when the light intensity falls below a pre-set level. The action can be reversed, so that the relay turns on when the light intensity goes above a pre-set level, by transposing LDR and RV1.

The LDR used in this circuit can be any cadmium sulphide photocell that presents a resistance in the range 5k to 100k at the required switching level. RV1 is chosen so that it can be set to the same value as the LDR resistance at the required trip level. The relay can be any 12 volt type that has a coil resistance of 180R or greater.



**Fig. 5. Temperature-Activated switch. The relay turns on when the temperature exceeds a pre-set level. The action can be reversed by transposing TH1 and RV1.**

Fig 5 shows how the above circuit can be adapted for use as a temperature-activated switch in which the relay turns on when the temperature exceeds a pre-set level. The action can be reversed by transposing TH1 and RV1. TH1 can be any negative temperature coefficient thermistor that presents a resistance in the range 5k to 100k at the required switching level. RV1 is chosen so that it can be set to the same value as the TH1 resistance at the required trip level.

For details on suitable LDR's, thermistors, and relays for use with the Fig 4 and 5 circuits, read through the catalogues of mail-order component suppliers (see ads in this and back issues for addresses).

Fig 6 shows the circuit of an over-current switch that turns the relay on when the load current exceeds a value pre-set by RV1. The value of Rx is chosen so that it develops roughly 100 mV at the required trip current level. The action of this circuit can be reversed, so that it acts as an under-current switch, by transposing the connections to pins 2 and 3 of the op-amp. The circuit can be used in this latter configuration as a lamp or load failure-indicator in cars or in test gear circuits, etc.

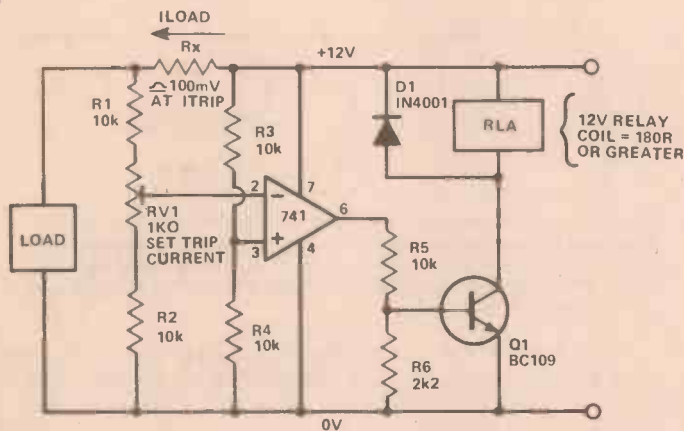


Fig. 6. An Over-Current switch. The relay turns on when the load current exceeds a pre-set value. By transposing connections to pins 2 and 3 on the Op-Amp the action is reversed.

## THROUGH THE WINDOW

The voltage comparator circuits that we've looked at so far give an output transition when the inputs go above or below a single reference voltage value. It's a fairly simple matter to interconnect a pair of voltage comparators so that an output transition is obtained when the inputs fall between, or go outside of, a pair of reference voltage levels. Fig 7 shows the basic circuit configuration, which is generally known as a window comparator or discriminator.

The action of the Fig 7 circuit is such that the output of the upper op-amp goes high when  $V_{in}$  exceeds the 6 volts  $V_{uL}$  'upper limit' reference value, and the output of the lower op-amp goes high when  $V_{in}$  is below the 4 volts  $V_{lL}$  'lower limit' reference value. By feeding the outputs of the two op-amps to R4 via the D1-D2 diode OR gate network, we get the situation where the final output is low when  $V_{in}$  is within the limits set by  $V_{lL}$  and  $V_{uL}$ , but goes high whenever the input goes outside these limits.

The action of the Fig 7 circuit can be reversed, so that its output goes high only when the input voltage is

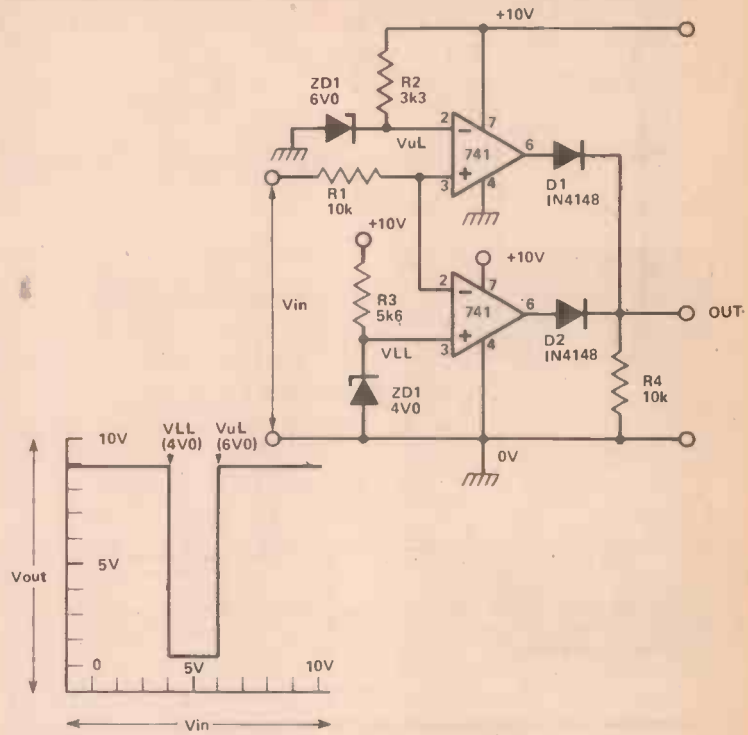


Fig. 8. An alternative Window Discriminator circuit in which the output goes high when  $V_{in}$  falls within the  $V_{lL}$  and  $V_{uL}$  limits.

within the 'window' limits, by taking the output signal via an additional transistor or op-amp inverter stage. Alternatively, the required action can be obtained by transposing the two reference voltages and taking the output via a diode AND gate, as shown in Figure 8.

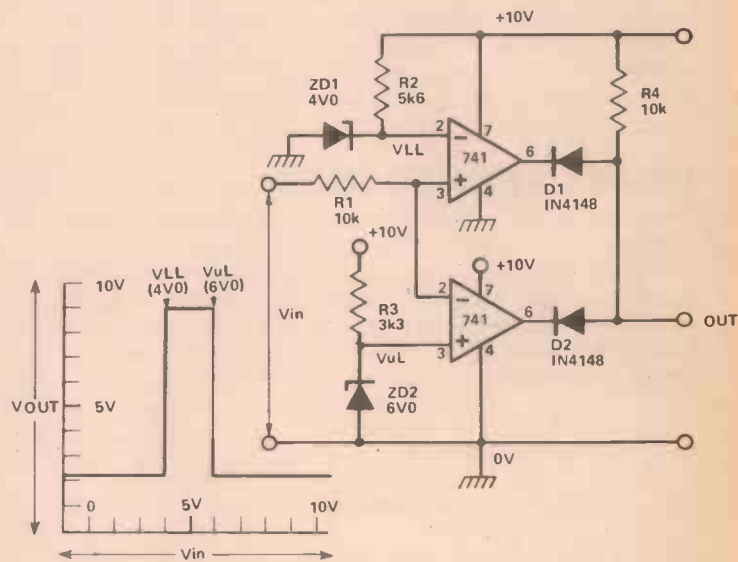


Fig. 7. A voltage Window comparator or Discriminator. The output goes high when  $V_{in}$  goes outside the  $V_{lL}$  and  $V_{uL}$  limits.

Window discriminators can readily be made to activate from any parameter that can be turned into a voltage, in just the same way as a voltage comparator circuit can. They can thus be used in a variety of ways around the house or in the car to sound alarms or activate relays when temperatures, voltages, currents or light levels go outside of a set of pre-set limits. Readers should have little difficulty in figuring out how to adapt the circuits to suit their own specific applications.

# SPECIALS



## TOP PROJECTS

Book 1 + 2: £2.50 + 25p P&P.

Master mixer, 100W guitar amp, low power laser, printmeter, transistor tester, mixer preamp., logic probe, Ni-Cad charger, loudhailer, 'scope calibrator, electronic ignition, car theft alarm, turn indicator canceller, brake light warning, LM3800 circuits, temperature alarm, aerial matcher, UHF-TV preamp., metal locator, four input mixer, IC power supply, rumble filter, IC tester, ignition timing light, 50W stereo amp. and many more.

Book 3: SOLD OUT!

Book 4: £1.00 + 25p P&P.

Sweet sixteen stereo amp., waa-waa, audio level meter, expander/compressor, car theft alarm, headlamp reminder, dual-tracking power supply, audio millivoltmeter, temperature meter, intruder alarm, touch switch, push-button dimmer, exposure meter, photo timer, electronic dice, high-power beacon, electronic one-armed bandit ...

Book 5: £1.00 + 25p P&P.

5W stereo amp., stage mixer, disco mixer, touch organ, audio limiter, infra-red intruder alarm, model train controller, reaction tester, headphone radio, STD timer, double dice, general purpose power supply, logic tester, power meter, digital voltmeter, universal timer, breakdown beacon, heart rate monitor, IB metal locator, temperature meter ...

Book 6: £1.00 + 25p P&P.

Graphic equaliser, 50/100W amp. modules, active crossover, flash trigger, "Star and Dot" game, burglar alarm, pink noise generator, sweep oscillator, marker generator; audio-visual metronome, LED dice, skeet game, lie detector, disco light show ...

Graphic Equaliser... Marker Generator  
Power Amplifier Modules... £2 Sound  
CCTV Camera... Headphone Adaptor  
LED Dice... Sound-Light Flash Trigger  
Expander-Compressor... Stereo

**ETI TOP PROJECTS**  
**NO 6** electronics today **£1**

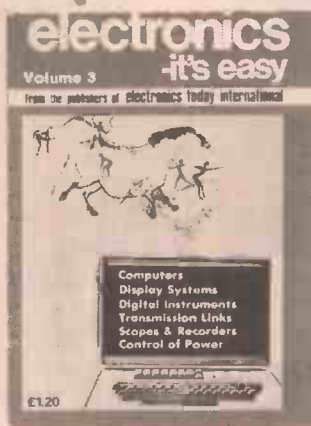
Alarm... Digital Thermometer  
Stars & Dots Logic Game... Lightshow  
Active Crossover... Hear and Tell Unit  
Pink Noise Generator... GSR Monitor  
Sweep Oscillator... Stereo Simulator



## ELECTRONICS TOMORROW

Comprised entirely of new material, the edition covers such diverse topics as Star Wars and Hi-Fi! The magazine contains projects for everyone — none of which have appeared in ETI — and a look at the future of MPUs, audio, calculators and video. How can you not read it?

75p + 25p P&P.



## ELECTRONICS — IT'S EASY

Books 1, 2 & 3.

Our successful beginners series came to an end some time ago now, and the whole series is available from us in reprint form. The three books between them contain all the information presented in the series (sometimes in more detail!) and together form an excellent starting point for anyone interested in learning the art of electronics.

£1.20 + 25p P&P each.

FROM THE PUBLISHERS OF  
ELECTRONICS TODAY INTERNATIONAL

## ETI CIRCUITS No 2

£1.50

## ETI CIRCUITS

Books 1 & 2.

Each volume contains over 150 circuits, mainly drawn from the best of our Tech-Tips. The circuits are indexed for rapid selection and an additional section is included which gives transistor specs, and plenty of other useful data. Sales of this publication have been phenomenal — hardly surprising when the circuits cost under 1p each!

£1.50 + 25p P&P each.

## ORDER FROM

Specials Modmags Ltd 25-27 Oxford Street London W1R 1RF

Postage and packing also refers to overseas. Send remittance in Sterling only.

Please mark the back of your cheque or PO with your name and address.

# from ETI

# Reader's Letters

Please send submissions for the letters page to: Hobby Electronics, 25-27 Oxford Street, London W1. Mark the envelope "Letters Page." Letters which are too long for publication will be suitably edited.

The response to our article 'Citizens Banned' has been so overwhelming it has prompted us to publish no less than three pages of letters. In order to print as many as possible we've even used a smaller type size, even so this represents only a small fraction of the letters we have received

Dear Sir

For many years I have been a Short wave listener, and have received a few QSL cards from parts of the world.

Some while ago, during 'skip' conditions, I copied the C.B. truckers in the USA on the 27MHz frequency. I found the language and terms used both novel and original compared to the dry talk of the hams.

One evening last July, as I was 'earholing' whilst working at my base, I was amazed to suddenly hear a CBer with a cockney accent. When he gave his 'rough 20' as Hackney, I realised that CB had arrived in England. I have since learnt that CB had been active in the country for about two years, and the equipment used was low powered hand held sets. But this follows the same pattern of how it started in the US.

I soon learnt that the breaker channel of One Four, 27.125MHz was the contact channel. The reason for this I believe was that early US rigs had 23-27 channels and 14 was the middle channel.

As the months passed I copied more local breakers on my receiver and gleaned much useful information about the CB scene. I wanted to get on channel, but how does one go about getting a rig? Well, even today if you take a walk along Edgware Road or Tottenham Court Road you will see you can purchase legally hand sets from 1/2 watt 1 channel to 2 watt 6 channels. Even a browse through the Exchange and Mart could put your 'ears on'.

For 3 weeks I worked with a small hand set, then I met another CBer and was given a contact from who I purchased a Sommerkamp rig. This unit has 40 channels AM 40 upper side band and 40 lower side band, and the same again on the high bands. A total of 240 channels. AM puts out about 4 1/4 watts and side band 12 watts.

The buddy that I purchased this rig from claims that he worked a guy in Boston USA on side band 'Barefoot'.

If 'Boots' or power amplifiers are used then it is easy to work the 'Skip'. One CBer I have worked told me that he works Australia with 300 'Whiskys'. Another breaker works the US often with 100 watts. In March this year, a few days before the end of the fishing season. I was at one of my club waters. I was sitting in my car drinking coffee after an uneventful morning in which my only success was in the drowning of a couple of worms. I switched on my rig and twiddled the knobs, I found a blank spot on upper side band and transmitted a CQ DX. After a few seconds stand by I copied an Italian breaker and my call sign was repeated. I spilt coffee in the surprise. His base was Milan and he was using 150 watt 'Boots' with preamp. All I had was my straight 12 watts.

One of the main topics of conversation on channel, is the question of when or will CB be legalised in this country. I personally think it will, but when? Well that I won't even try to guess.

Every time I put my 'ears on' I hear new breakers, the obvious give away is the new handles and the lack of knowledge of the language and the 10 code. So with the fast increase of new CBers, the Home Office will have to step up the number of busts. But to achieve this they would need to employ more manpower, plus a large warehouse to store the seized equipment. Many of the good buddies that have been busted, soon are back on channel with new rigs and new handles. One buddy that I know was back on the air within the hour of having his rig seized.

The only advice I can give to new breakers for keeping ones nose clean would be; No eyeballs with unknown breakers at venues arranged over the air. No transmitting from base 20s. If transmitting whilst static in your wheels use common sense and don't stay stationary too long. No Boots.

Some time ago I started a radio amateurs course with the intention

of taking the exam in the future. To continue this is, at the present the big question. The cost of legal equipment is expensive. Even compared to the price of blackmarket CB rigs. The UK regulations state that there are limitations as to what one can talk about on the air. As I said before the ham chat is dry and technical. To confirm this I have met a CBer who is a licenced Ham and he is fed up with the red tape attached to the licence. He also agrees that to attempt to have a chat on the 2 metre band is near impossible with the squeakers, whispers, whistlers, and Idi Amins. Surely this does not comply with the 'rules'. Perhaps if the home officers jumped on these persons I might consider continuing with my radio ham course. So until I see which way the wind blows: All the good numbers to you, Breaker break, Bye bye, I've gone.

Mack the Hack  
London

Dear Sirs,

With reference to your recent article 'Citizens Banned' in your magazine, I should like to say that after having been in the USA recently, and seeing the benefits of CB from 'first hand', I think it would be a good idea for it to be introduced in this country.

However, I feel that if we adopt a different waveband to that of the CBs in the USA the CB sets will be too expensive to get the large number of sets necessary to enable a worthwhile to be started.

If we did adopt the USA standard, obviously we would be free to purchase from the USA if necessary but hopefully the British made sets would be competitively priced to make such a move unnecessary.

A CB Supporter  
(Address withheld).

Dear H.E.,

Many thanks for your accurate and informative article on C.B. Radio, you certainly told it like it is!

It is to England's own shame (in a country where so much emphasis is placed on the right of the individual to liberty) that it has not yet seen fit to allocate to the general public a meagre 440kHz, that the normal C.B. band uses.

I have used C.B. both in the U.S.A. and U.K. and have made many friends and have yet to encounter unpleasantness or bad language. I wish I could say the same for the London Amateur Ham repeater 'LO' on the 2 metre F.M. band, just listen one day!

As regards the V.H.F. A.M. controversy and whilst I appreciate the merits of the former surely C.B. should be an international frequency so that it is possible to use the set in your car whilst on holiday in other countries. Half the challenge of C.B. is in "getting through," in adverse conditions and working surprisingly long-distances, with just 4 watts, in favourable conditions with V.H.F. the challenge is gone as communication is on a line or sight basis with no surprises in store.

Keep up the good work and how about an article on single side band C.B. (triple the distance, clearer signal, etc).

10-4,

Sidewinder

P.S. Please excuse the anonymity but I'm also paranoid about the fear of prosecution!!

Dear Sir,

I found your article on Citizens Band radio very informative and being strongly in favour of CB being legalised in this country I hope you are able to do a follow-up to this feature.

C. J. Harrison  
Surrey

Dear Sir,

I write in response to your article 'Citizens Banned' in the June Issue of your magazine. There are a number of points in the article which I feel are dangerously misleading.

Before getting too involved in technicalities, perhaps I should state my background and declare my (vested) interests in the subject. I am a professional communications engineer working in the broadcasting industry, and a radio controlled model aircraft enthusiast. In principle I am not opposed to a 'Citizens Band' type service being set up in this country, and willingly concede that many of the benefits advanced by its protagonists are perfectly valid.

I am however totally opposed to those people who illegally import and operate 27 MHz CB equipment in this country, as that band has already been set aside for other users and the consequences of interference are potentially very dangerous.

First of all, let me state that I am amazed that an apparently serious magazine can publish what amounts to six pages of incitement to commit a criminal offence, and dismiss legitimate licensed users of the band, and the effect of this equipment on them, in three or four lines!

Your statement that RC operators use 'two or three' of the 40 channels is just totally untrue. However RC channels are basically colour coded and do not totally coincide with CB channels, so there is room for confusion.

Most RC equipment in use today uses a digitally coded transmission amplitude modulated onto a carrier with a typical output of 1/2 to 1 watt. Channel bandwidth is basically 20 KHz due to the wider bandwidth required by a digital signal compared to speech. AM sets are now being slowly superseded by FM sets that have the twin advantages of better rejection of CB transmissions, and allow operation at 10 KHz spacing instead of 20 KHz relieving pressure on an already overcrowded band.

The following is a table of AM channel allocations with CB channels that will cause serious interference.

Colour	Frequency	CB channel (20 KHz bandwidth)
Brown/black	26.975	1, 2 & 3
Brown	26.995	3 & 4
Brown/red	27.025	5, 6 & 7
Red	27.045	7 & 8
Red/orange	27.075	9, 10 & 11
Orange	27.095	11 & 12
Orange/yellow	27.125	13, 14 & 15
Yellow	27.145	15 & 16
Yellow/green	27.175	17, 18 & 19
Green	27.195	19 & 20
Green/blue	27.225	21 & 22
Blue	27.255	25 & 26
Blue/violet	27.275	26, 27 & 28

A visit to any club operating in the London area at weekends will reveal a queue of at least three or four people on every channel. One of the main reasons for the present switch to FM is that the 10 KHz channel spacing possible with this mode of transmission relieves congestion by allowing more people to fly at once. That completely accounts for channels 1-28 and makes something of a mockery of your quoted 'two or three channels'.

Also bear in mind that to change channels on an RC set is not a flick of a switch operation, but usually requires removal of the aircraft's wings to gain access to the receiver to physically swap crystals, and that may be a soldering iron job!

Furthermore whilst a CBER can switch through channels until he finds a vacant one, the RC operator cannot hear the output from his receiver. At close proximity his transmitter will swamp out any interfering signal, and the first indication he may get that a channel is being used by a CBER down the road, is when his model goes haywire 400 feet up. Not very funny.

It is also worth bearing in mind the peculiar propagation characteristics of a 27 MHz signal. Most of it goes up into the sky, and very little goes out along the ground. You can go right round the world on 1 watt, but may need 25 watts to go 25 miles. In fact as a very rough rule of thumb you can count on a mile per watt ground range under average conditions. Thus a conscientious CBER may listen out on a channel and detect nothing unaware that a mile or less away someone is operating an RC model. However when he goes on the air with his (say) 4 watt Tx, that model will suffer very severe interference and it is only a question of time before someone gets hurt in this way. No I am not joking. Most model clubs operating in this area (say 7 or 8 with a typical membership of 60-70) reckon to lose at least one model and maybe three or four each weekend purely due to CB interference.

When someone is finally seriously injured or killed, you can bet your life it won't be the CBER who gets the blame, but the poor unfortunate who had just gone out for a quiet afternoon's flying. Many of my friends are seriously questioning whether it is worth carrying on

because they have been so badly frightened on occasions. Why should we be prevented from enjoying our legitimate pastime by these poachers? All this in spite of your alleged 'code of practice'.

In recent months an even more frightening twist has occurred, with what is no doubt a 'lunatic fringe' deliberately setting out to trace model flying groups, and deliberately crash models by jamming their transmissions. I have actually overheard them boasting of their prowess at this 'sport' at home in the evenings on my 27 MHz monitor.

Even if the Authorities were to do a complete about face and offer a VHF CB service, I do not believe that the present 27 MHz operators would dump their equipment and switch to the legitimate band. In fact judging from the many conversations I have overheard recently, the very attraction of CB is that it is illegal!

My own club has been approached by CB associations on more than one occasion, with requests for support for a VHF service; but I have never seen anywhere, neither in magazine articles nor in CB assoc. letters, a proposal that CBERs should first of all assist RC modellers in their endeavours to secure an alternative channel (preferably the internationally recognized 35.00 to 35.20 MHz band) in order to vacate 27 MHz for CB or whatever. I have no doubt that were the associations concerned offered 27 MHz, whatever its disadvantages, they would grab it with both hands and to hell with everyone else. In fact that's just about what has happened anyway.

However, before CBERs get too smug there are one or two points they should be aware of. Firstly rumours persist that 27 MHz will eventually become a 'Citizens Band' but that it will be FM only with AM and SSB strictly prohibited. Thus all those who have spent a lot of bread on illegally imported rigs could soon find themselves with a useless piece of expensive junk on their hands. It would be completely non-compatible with the majority of legitimate users. Further in view of the Post Office's almost complete failure to stay in control of the situation, many model clubs are equipping themselves with receivers and DF loops. Personally I would not like to see a war develop between CB and RC fraternities through what is, after all, a failure on the part of the Authorities to judge the mood of the people and act accordingly. However in the meantime I, like many of my colleagues, will have no qualms whatsoever in passing on to the relevant authorities any information which will help protect my heavy investment in 27 MHz gear, and just maybe save someone's life.

P. Christy, B.Sc.  
Middlesex

Dear Sirs,

I have been to the USA many times and used the CB network there. At all times I found it very useful in all aspects. Not only for knowing if there is a radar trap but as you state in your article, road conditions, reporting of accidents and keeping in touch with fellow travellers.

I have been on the "air" for some time and at all times found the CBERs very helpful here in London. As I see it, we could be of more use to everybody rather than a hindrance as in the States, we could choose channel nine for emergencies and this could be monitored by the police. Any problems either way could be conveyed. Whether we are correct in using the 27MHz band is a debatable question but as there is already equipment for this range obviously we will use it. I certainly have no objections to move up into 230MHz.

As you state 'Who owns the Air' we must have freedom of speech, and access to use it.

Breaker Break  
'BLUEBELL'

Dear Sirs,

I read with great interest your CB article. I am a field service engineer and spend most of my working life on the road. The CB would be of great value to me and other engineers saving time and money, avoiding traffic jams, and as you started saving, life and petrol now. It would be marvellous for invalids and make a change from Radio 1, 2, 3, 4. The ham radio people enjoy their freedom — so why not have a small piece of air space for CB without the dreaded RAE. I am interested in radio but I am one of the people that fear exams so I have no chance of getting a ham licence.

You can certainly put me down for a CB vote.

I hope something is done to legalise it without too much red tape, before it is too late.

Thank you for printing the CBA address. I hope to become a member shortly.

Thanking you,  
J. Steels

PS I read quite a lot of magazines and was delighted with the CB article. I have sent for 12 months subscription of HE. Great stuff, let's have lots more.

Dear Sir,

Congratulations on your courageous CB article!

In common with most radio amateurs I dislike any "piracy" but I am very much in favour of a legalised citizens band in this country as I feel sure that the many illegal operators would prefer to operate within the law, within a citizens band. There are many thousands of illegal operators in addition to the 20,000 odd (an estimated figure taken from Electronic Weekly) CBers. There is a huge European pirate network on 6.6 MHz which has been operating for many years. There are the Medium Wave pirate broadcasters who can be heard swapping records in the early hours. There are those who play with FM transmitters in the 88 to 108 MHz FM band and, worst of all, the foul mouthed characters who plague the 2-metre amateur radio repeater GB3LO and also, incidentally, can occasionally be heard jamming the police repeaters just outside the 2-metre amateur band. They have even jammed airport communications at Gatwick on one occasion. I believe that a CB band would provide a *legitimate* outlet for all these people.

I think the CBA idea of 230 MHz CB is a non-starter. Firstly, there is terrific pressure on PMR frequencies with a two year waiting list for a telephone service number in London for example. The argument that British manufacturers would have a lead is erroneous as 220 MHz equipment is already manufactured in Japan for the American amateur market. However, I like the coded signal idea and perhaps the CB pirates, on legalisation of a 27 MHz citizens band would be prepared to submit their equipment for incorporation of such a circuit, perhaps at the time of applying for a licence. I estimate that a £10 licence fee would enable the Home Office to have sufficient funds, say in the region of £15 to £30 million, to clear up and administer the frequency allocations in the U.K.

I am sure that model control enthusiasts can co-exist with 27MHz CB as they do in both the USA and Germany from my personal experience.

P. F. L. Clarke  
G3LST

Dear Sir,

Firstly, congrats, on being the first UK electronics mag to explain and show CB to everyone in such detail. The points you make are all valid but I would like to concentrate on several main points. First I don't think too much can be said about the benefit to old people, on the introduction of a well regulated CB system. I have seen for myself how well it works in the USA where many town and country dwellers, as well as motorists benefit from a superb communications system which helps in times of need or emergency. (Check out the 'ALERT' emergency radio teams that monitor channel 9.

The closed mind of the Home Office in their absolute refusal to even discuss the legalisation of CB is something we should not have to tolerate. However, with the advent of a new government things may get better and I urge all persons who are interested in seeing CB legalised in the UK to write to the Home Secretary stating their views.

One other point I should like to make, you mention the possible use of 230 MHz as a likely spot for CB. This is all very well but not at the expense of making CB prohibitively costly, especially to those who would benefit most. As a guide CB sets in the USA retail on average for £25-£60, and this is for high quality equipment.

Lastly, I do hope you will follow your fine article and perhaps keep us all informed of happenings in the CB controversy, how about a regular CB column. Well I'm going down now, so all the high numbers and breaker break.

'Speedbird 1'  
London Area.

Dear Sirs,

I would just like to congratulate you on your excellent article on citizen band radio in the June mag.

Everything about the article is just as the situation is in the UK at present, particularly the xample conversation. Rigs themselves are very easy to obtain if you know exactly who to ask, however prices do vary considerably being a lot dearer in the London area than up north. You were also correct in saying that there is a strict code of conduct as I have never heard any bad language on the air.

I'm writing this letter on behalf of many other readers so we'll wish you all the good numbers and please let's have more articles to get this thing legalised, catch you on the flip flop.

Radio Star	Captain Cutlass
Silver Surfer	Bulldog
Stampede	Seadog
Bluebird	

Dear Sirs,

Citizen band should not be "banned" from the UK because its advantages far outnumber its disadvantages, for instance, in the terrible arctic conditions we had last winter, would have been an ideal time for CB. If a motorist was trapped in a snowdrift, as so many were, he could have used his CB radio to let other operators know that he was there and save our overworked police and rescue forces a job of finding and digging out any stranded motorists.

The CB operator could also tell other motorists of such things as pileups, road blocks and diversions so that they could alter their plans before it was too late and so save further congestion, because the traffic reports on the radio do not always give sufficeint news of the traffic problems. In accidents, the CB operator could get in touch with any mobile ambulance, on the emergency band, so saving time by not having to search for a telephone that most likely has been vandalised, so **SAVING MANY LIVES.**

My colleagues below also feel the same as I do about citizen band radio.

Yours faithfully,

T. Baker	T. Goodly	R. Allen	S. Armstronge
P. Skilcher	S. Singly	A. Dobney	N. Smith
D. Gardener	N. Wood	R. Gratten	K. Coles
D. Cross	P. Penty	S. Webb	S. Bunton

Dear Sir,

Of course CB radio should be legalised in Britain as it is in the rest of Europe, most of the Free World and even some Soviet countries. Lives saved, convenience, friendship, are only a few of the benefits of a legalised CB system. Once legalised the various channels available can be selected for voice, radio control and pagers, providing the frequency security which the radio and modeler rightly needs and is entitled to.

In my opinion most of the DX problems with CB could be solved with a total banning of "burners". Most of the interference in the UK comes from Italy, apparently, where the legal power limit is 1 WATT ERP which I am sure would not cause skip. No ban these anti-social devices now by legalising a coded CB service now. Burners have no place in breaker land.

I do not operate CB as I have faith that in the new Government common sense will prevail and a coded CB system will be introduced soon.

In the meantime your good magazine could greatly assist the CB by having a monthly section on CB news and views your mag would be first to do this. Also you could, over the course of a few months, publish a blank page for a petition to Parliament, I know I could fill some number of them.

Thank you for your excellent feature on a vital topic, 10-4!

Yours faithfully,

Nigel Longbotham

**Your wish is our command**

**Two points seem to have arisen from the article. Number one. With only one (unprintable) exception no-one has actually condemned CB as a system. However, and this is the second, more important point, the present illegal network does interfere with legitimate users of 27 MHz.**

**Hobby Electronics in no way condones this interference. We want CB to be legalised as a basic personal freedom, but not at the expense of anyone else. Over the page you will see a two-page petition. (No, this is not a cheap way to fill a magazine.) We feel strongly enough to want you, the readers, to sign these forms and send them to us. We will then forward them to the Home Secretary to bring this situation to the attention of Her Majesty's Government.**

**We would like to make it perfectly clear to the many radio control modellers who wrote to us that we are *not* advocating a system that would interfere with their hobby. In fact it is in their interests to join with us in our campaign to get CB allocated a channel that would protect their quite considerable investments.**

# PETITION

## TO: THE HOME SECRETARY

We, the undersigned, hereby petition Her Majesty's Government to introduce legislation to permit the use of a radio system similar to that commonly referred to as "Citizens Band" as permitted in the majority of western democratic nations.

We appreciate that such a system would have to be allocated frequencies which would not interfere with existing users and that adequate control would have to be exercised to prevent misuse or abuse.

Note to signatories: We will feel unable to pass on any forms with anything other than legitimate signatures. If we suspect misuse we shall invalidate the entire form in order to maintain credibility.

1	.....	21	.....
2	.....	22	.....
3	.....	23	.....
4	.....	24	.....
5	.....	25	.....
6	.....	26	.....
7	.....	27	.....
8	.....	28	.....
9	.....	29	.....
10	.....	30	.....
11	.....	31	.....
12	.....	32	.....
13	.....	33	.....
14	.....	34	.....
15	.....	35	.....
16	.....	36	.....
17	.....	37	.....
18	.....	38	.....
19	.....	39	.....
20	.....	40	.....

41	71
42	72
43	73
44	74
45	75
46	76
47	77
48	78
49	79
50	80
51	81
52	82
53	83
54	84
55	85
56	86
57	87
58	88
59	89
60	90
61	91
62	92
63	93
64	94
65	95
66	96
67	97
68	98
69	99
70	100



# Hobbyprints

An easy, patented method of making PCBs for HE projects.

For some time it has been possible to buy acid resist rub-down pads and track — in fact we use them in the HE workshops and they work very well. HOBBYPRINTS take this idea a stage further — the complete PCB pattern is already on the sheet and can be rubbed down in seconds — and the patterns are nice and crisp, made from the original artwork, used for the prototype.

If you have the facilities for ultraviolet exposure, HOBBYPRINTS make excellent masters — being solid black on a translucent film. With this method you can use the HOBBYPRINTS time and time again!

HOBBYPRINTS are produced exclusively for HE, and the whole system is protected by patents 1445171 and 1445172. Each month we will be bringing out a new HOBBYPRINT, containing the patterns for each issue's projects.

**HOBBYPRINT A (November HE)**  
5 Watt stereo amplifier, Waa-Waa pedal, Bedside radio.

**HOBBYPRINT B (December HE)**  
Digital dice, Photon (2 copies), Metronome, Audio mixer.

**HOBBYPRINTS C (January HE)**  
Graphic Equiliser, Touch switch, Vari-Wiper, Flash Trigger.

**HOBBYPRINT D (February HE)**  
Short Wave Radio, Sine/Square generator, Scratch/Rumble filter, Car Alarm.

**HOBBYPRINT E (March HE)**  
Light Chaser, Photo Timer, Casanova's Candle, (2 copies), Tone Control (2 copies).

**HOBBYPRINT F (April HE)**  
Train controller, Cistern Alarm, Transistor Tester

**HOBBYPRINT G (May HE)**  
Parking meter timer, Digibell, Power supply, Sound effects unit

**HOBBYPRINT H (June HE)**  
GSR Monitor, Drill Speed controller, Envelope Generator.

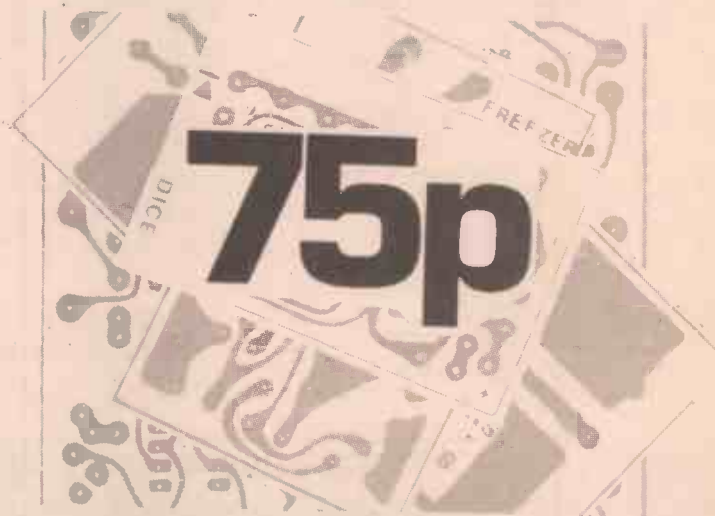
## ORDER TODAY

Send cheque or postal order (payable to Hobby Electronics) to:

**HOBBYPRINTS,  
HOBBY ELECTRONICS,  
145 CHARING CROSS ROAD  
LONDON W1.**

**75p INCLUSIVE OF VAT AND POSTAGE.**

Please mark the letter(s) of the HOBBYPRINTS on the outside of the envelope.



## How to use HOBBYPRINTS.

1. Clean the PCB as you would for any work giving it a rub down with fine sandpaper (we even supply this in the kit). A quick wipe over with lighter fuel will help to remove any grease marks.
2. Lay down the HOBBYPRINT and rub over with a soft pencil until the pattern is transferred to the board. Peel off the backing sheet carefully making sure that the resist has transferred. If you've been a bit careless there's even a 'repair kit' on the sheet to correct any breaks!
3. Cut the board to size and put it in the Ferric Chloride.
4. When etching is completed, wash the board and use the sandpaper or a scouring powder to remove the resist. The resist pattern is pretty hardy but is easily removed at the final stage.
5. All you've got to do now is drill the board. Time? Only about ten minutes from beginning to end plus etching time (15 minutes usually with a good acid).



## BARGAINS FOR THE ELECTRONIC HANDYMAN BRANDED LED DIGITAL ALARM CLOCKS



Returned to Service Department within guarantee period.

- (1) With alarm repeat — S.R.S.P. of £17.00 offered at £3.95 inc. VAT.
  - (2) With luxury lamp and repeat alarm as featured in most major U.K. Mail Order catalogues, S.R.S.P. £31.00 — offered at £6.95 inc. VAT.
  - (3) With integral luxury light and repeat alarm also as featured in most major U.K. Mail Order catalogues, S.R.S.P. of £32.00 — offered at £6.95 inc. VAT.
- These will be sold as received from our customers with the existing fault(s) and without guarantee.

Discounts available on large bulk purchases

**PRESCOTT CLOCK AND WATCH COMPANY LIMITED**  
Prescott House, Humber Road, London NW2 6ER

## AD INDEX

ACE	33
AJD DIRECT SUPPLIES	56
AMBIT	2
ARROW ELECTRONICS	56
S + R BREWSTER	45
C.S.C.	8
E.D.A.	26
GMT ELECTRONICS	4 & 5
GREENWAY ELECTRONICS	33
HENRYS	33 & 45
MAPLIN	76
MARSHALLS	22
METAC	75
MINIKITS	25
PRESCOTT CLOCK AND WATCH CO.	74
RAMAR	74
R.T.V.C.	44
STEVENSON	12
SWANLEY	74
TAMTRONIK	74
TECHNOMATIC	33

**SINCLAIR PRODUCTS PFM200** £49.48, case £3.24, adaptor £3.24, connector kit £10.58. Microvision TV UK model £89.95, mains adaptor £8.73. PDM35 £28.95, mains adaptor £3.19, case £3.18. DM350 £68.95. DM450 £97.98. DM235 £49.45, rechargeable battery £7.50, mains adaptor £3.70, case £8.45. Enterprise prog. calculator with accessories £22.95. Cambridge prog. calculator £12.13, prog. library £4.45, mains adaptor £3.20. CSC MAX100 freq meter £75.40.

**CALSCOPE** oscilloscopes. Send sae for data or see the Calscope advert in this magazine. Super 6 £174, Super 10 £238. **COMPUTER GAMES** Star chess £59. Chess challenger 7 £79. Checker challenger 4 £84. Checker challenger 2 £50. Atari videocomputer £138. Cartridges £13.45. **COMPONENTS** 1N4148 1.4p. 1N4002 2.9p. 741 15p, bc182b, bc183b, bc184b, bc212b, bc213b, bc214c 4.5p, resistors ¼W 5% E12 10R to 10M 1p, 0.8p for 50+ of one value. 16V electrolytics 5/1/2/5/10/22uf 5p, 100uf 6p, 1000uf 10p. 1 lb. FeCl<sub>3</sub> £1.13. dialo pen 79p. 40sq ins pcb 80p.

**TV GAMES** AY-3-8500 + kit £8.95. Rifle kit £4.95. AY-3-8610 + kit £15.70. Stunt cycle chip + kit £15.70. AY-3-8603 chip £8.90. **TRANSFORMERS** 6-0-6v 100ma 74p, 1½a £2.35. 6-3v 1½a £1.99. 9-0-9v 75ma 74p, 1a £2, 2a £2.60. 12-0-12v 100ma 90p, 1a £2.49. **IC AUDIO AMPS** with pcb. JC12 6W £1.60. JC20 10W £2.95.

**BATTERY ELIMINATORS** 3-way type 6/7½/9v 300 ma £2.95. 100ma radio type with press studs 9v £3.35. 9v+9v £4.50. Car convertor 12v input, output 4½/6/7½/9v 800ma £2.60.

**BATTERY ELIMINATOR KITS** send sae for data. 100ma radio types with press studs 4½v £1.40. 6v £1.40. 9v £1.40. 4½v+4½v £1.80. 6½v £1.80. 9+9v £1.80. Stabilized 8-way types 3/4½/6/7½/9/12/15/18v 100ma £2.80, 1Amp £6.40. Stabilized power kits 2-18v 100ma £2.80, 2-30v 1A £8.95. 2-30v 2a £10.95. 12v car convertor 6/7½/9v 1a £1.95.

**T-DEC AND CSC BREADBOARDS** s-dec £3.80, t-dec £4.02, u-deca £4.40, u-decb £6.73, 16 di adapters £2.17, exp 4b £2.48, exp300 £8.21, exp350 £3.40, exp325 £1.73. **HI-PAK AUDIO MODULES** 450 £23.51, AL60 £4.86, pa100 £16.95, spm80 £4.47, bml80 £6.95, stereo 30 £20.12, AL30 £3.95, PA12 £7.80, PS12 £1.39, MA60 £35.44.

## SWANLEY ELECTRONICS

Dept. HE, 32 Goldsai Rd., Swanley Kent.  
Post 30p extra. Prices include VAT. Official and overseas orders welcome. Lists 20p post free.

**Carbon Film Resistor Packs (5%).** 20 of each value, 10Ω, 18Ω, 47Ω, 82Ω, 180Ω, 220Ω, 270Ω, 330Ω, 390Ω, 470Ω, 1kΩ, 1.8kΩ, 3.3kΩ, 3.9kΩ, 4.7kΩ, 10kΩ, 15kΩ, 18kΩ, 22kΩ, 27kΩ, 33kΩ, 39kΩ, 47kΩ, 56kΩ, 68kΩ, 100kΩ, 220kΩ, 270kΩ, 470kΩ, 680kΩ (600 resistors) only £3. Silicon diodes (1N4148 specification) on bandolier for convenient storage, 1p each, 150 for £1, 1,000 for £5. Post free from D. Johnston, 12 Balgillo Road, Dundee DD5 3LU.

**INTRODUCTION TO MICROPROCESSORS AND COMPUTING.** 50 pages of diagrams and explanation to get you started. Price £2.30 + 45p postage.

**EDUCATIONAL DATA AND TECHNICAL SERVICES**  
59 Station Road, Cogenhoe, Northampton NN7 1LU

## PRINTED CIRCUITS and HARDWARE

Comprehensive range Constructors' Hardware and accessories.

Selected range of popular components  
Full range of HE printed circuit boards normally ex-stock, same day despatch at competitive prices  
P.C. Boards to individual designs  
Resist-coated epoxy glass laminate for the d.i.y. man with full processing instructions (no unusual chemicals required)

Affac range of etch resist transfers, and other drawing materials for p.c. boards

Send 15p for catalogue.

**RAMAR CONSTRUCTOR SERVICES**  
MASON'S ROAD  
STRATFORD-ON-AVON  
WARWICKS. Tel. 4879

## TAMTRONIK LTD. (DEPT. HE)

217 TOLL END ROAD, TIPTON  
WEST MIDLANDS DY4 0HW

TEL. 021-557 9144

## PRINTED CIRCUIT BOARDS and KITS FOR HE PROJECTS

Mag Issue	Project	Kit Ref	PCS	Kit	Kit Contents (See key)	KEY TO KIT CONTENTS	SPECIAL OFFERS
Nov 78	Bedside Radio	HO01	1.25	15.95	BEHL	A. Vero-board(s).	Plug-in mains PSU 3v/6v/9v/12v DC 300MA. Suitable for calculators, TV Games, etc. £2.99 100 x ¼W ½k resistors 30p 4 x ¼W 555 £1.00
	Stereo Amplifier	HO02	3.90	43.95	BEHL	B. Printed Circuit Board(s).	
	Was Was Padal	HO03	.90	6.90	BEHL	C. With Screen printed component layout.	
Dec 78	Push Button Dice	HO05	1.10	5.85	BEHL	D. Tag strip.	
	H.E. Mastroome	HO06	.85	6.40	BEHL	E. All Resistors, potentiometers, capacitors, semi-conductors.	
	Photo Phase	HO07	1.60	—	BEGN	F. As E but with exclusions. Please ask for details.	Pcbs and kits available from TAMTRONIK LTD. for projects from ETI and EVERYDAY ELECTRONICS. Send sae for free catalogue. Please quote project and kit reference number when details of a specific kit are required. sae.
	H.E. Mixer	HO08	3.25	23.35	BEGLH	G. Di and/or transistor sockets and/or soldercon pins.	
Jan 79	Graphic Equaliser	HO09	3.25	24.55	BEGLH	H. Hardware includes switches, knobs, lamps and holders, fuses and holders, plugs and sockets, microphones, transformers, speakers, meters, relays, terminal blocks, battery connectors, etc. BUT excludes nuts, bolts, washers, connecting wire, batteries and special miscellaneous items.	Tamtronik Ltd. reserves the right to change kit content without notice to incorporate current modifications or to make valid substitutions for temporarily unavailable components.
	Flash Trigger	HO10	1.10	13.15	BEHL	I. As H but with exclusions. Please ask for details.	
	Varisuper — Relay	HO11R	.90	7.30	BEHL	J. As H but including connecting wire.	
	Varisuper — SCR	HO11S	.90	4.10	BEHL	K. Suitable case(s).	
	Touch Switch	HO12	1.15	4.95	BEHL	L. Suitable case with screen printed fascia.	
Feb 79	Short Wave Radio	HO13	1.40	11.95	BEHL	M. Full kit to magazine specified standards.	The majority of kits advertised can be supplied from stock, however please allow 21 days delivery since demand on any kit is unpredictable.
	Sine/Square Wave Generator	HO14	1.95	25.95	BEHL	N. Kit with professional finish — incorporating all prime features including screen printed pcb and case where appropriate.	
	Scratch & Rubble Filter (Mosa)	HO15	1.45	14.40	BEHL		
	Scratch & Rubble Filter (Stora)	HO15S	2.90	18.45	BEHL		
	HE Car Alarm	HO16	1.20	8.35	BEHL		
Mar 79	Light Chaser	HO17	2.00	14.25	BEHL		
	Casaova's Candle	HO18	1.10	8.95	BEHL		
	Tone Control	HO19	1.00	8.80	BEGLH		
	Photographic Timer	HO20	1.25	9.95	BEGLH		
Apr 79	Model Train Controller	HO21	1.40	21.95	BEHL		
	Cistern Alarm	HO22	.80	2.20	BEHL		
	Transistor Gain Tester	HO23	.75	5.25	BEGLH		
May 79	Power Supply Unit	HO24	1.93	21.55	BEJ		
	Parking Meter Timer	HO25	.92	—	—		
	Diagnol	HO26	1.35	4.95	BEHL		
	White Noise Generator	HO27	1.67	14.95	BEHL		
Jun 79	CSR Monitor	HO28	1.05	10.10	BEHL		
	Envelope Generator	HO29	1.50	12.10	BEGLH		
	Drill Speed Controller	HO30	1.05	6.95	BEHL		

Photocopy of any of listed Projects 30p.

### THIS MONTH'S PROJECTS

	KIT REF.	PCB	KIT	KIT CONTENTS
HE Shark	HO31	2.00	22.95	BEHL
Points Controller	HO32	1.15	12.35	BEHL
Baby Alarm	HO33	1.45	13.60	BEHL

Kits can be supplied excluding pcb and/or case. Send sae for details naming kit and kit reference and free catalogue.

Trade and Educational enquiries welcome

PRICES INCLUDE  
VAT & P.&P.  
MINIMUM ORDER  
£3.00

Visit our shop at  
32 Market Place  
Great Bridge, Tipton  
West Midlands



**QUARTZ LCD  
5 Function**

Hours, mins., secs., month, date, auto calendar, back-light, quality metal bracelet.

**£6.65**

Guaranteed same day despatch.  
Very slim, only 6mm thick.



M1

**QUARTZ LCD  
7 Function**

Hours, mins., secs., month, date, auto calendar, back-light, seconds STOP WATCH.

**£9.65**

Guaranteed same day despatch.  
Very slim, only 6mm thick.



M2

**QUARTZ LCD  
11 Function SLIM CHRONO**

6 digit, 11 functions. Hours, mins., secs., day, date, day of week. 1/100th, 1/10th, secs., 10X secs., mins. Split and lap modes. Back-light, auto calendar. Only 8mm thick. Stainless steel bracelet and back. Adjustable bracelet.

Metac Price

**£12.65** Thousands sold!

Guaranteed same day despatch.



M3

**QUARTZ LCD  
ALARM 6 Function**

Hours, mins., secs., month, date, back-light, 24 hour ALARM. Adjustable stainless steel bracelet. Only 9mm thick.

**£12.65**

Guaranteed same day despatch.



M4

**QUARTZ LCD  
ALARM 7 Function**

Hours, mins., secs., day, date, alpha day, back-light, auto calendar. Adjustable stainless steel bracelet. Only 9mm thick.

**£18.65**

Guaranteed same day despatch.



M5

**QUARTZ LCD Alarm  
Chronograph with Dual  
Time Zone Facility**

Constant LCD display of hours and minutes, plus optional seconds or date display, plus day of the week and am/pm indication. Perpetual calendar, day, date, month and year 24 hour alarm with on/off indication. 1/10 second chronograph measuring net, lap and first and second place times. Dual time zone facility night light. Only 9mm thick.

**£24.65**



M6

**SOLAR QUARTZ LCD  
Chronograph with Alarm  
Time Zone Facility**

Constant LCD display of hours and minutes, plus optional seconds or date display, plus day of the week and am/pm indication. Perpetual calendar, day, date, month and year 24 hour alarm with on/off indication. 1/10 second chronograph measuring net, lap and first and second place times. Dual time zone facility night light. Only 9mm thick.

**£27.65**



M7

**QUARTZ LCD  
Alarm Chrono**

22 function, 6 digit. Hours, mins., secs., date, day of week, stopwatch, split time, alarm, second watch (dual time), back-light. FRONT BUTTON OPERATION.

**£22.65**

Guaranteed same day despatch.

METAC ★ PRICE



M8

**SOLAR QUARTZ LCD  
Chronograph**

6 digit, 11 function. Hours, mins., secs. 1/100, 1/10 secs., mins. Split and lap modules. Auto calendar and back light. Powered from solar panel with battery back-up.

**£14.95**



M9

**SEIKO Alarm Chrono**

LCD, hours, mins., secs., day of week, month, day and date, 24 hour Alarm, 12 hour chronograph, 1/10th secs., and lap time. Back light, stainless steel, HARDLEX glass.

List Price £130.00

METAC PRICE

**£105.00**



M10

**SEIKO Chronograph**

LCD, hours, mins., secs., day of week, month, day, date, 12 hour chronograph, 1/10th secs. and lap-time. Back light, stainless steel water resistant, HARDLEX glass.

List Price £85.00

METAC PRICE

**£68.00**



M11

**SOLAR QUARTZ LCD  
5 Function**

Genuine Solar. Solar panel with battery back-up. Back light and auto calendar. Hours, mins., secs., day, date. Quality metal bracelet.

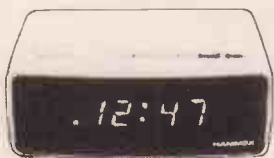
**£ 9.95**

Guaranteed same day despatch.



M12

**HANIMEX  
Electronic  
LED Alarm Clock**



Features and Specification: Hour/minute display. Large LED display with p.m. and alarm on indicator. 24 Hours alarm with on/off control. Display flashing for power loss indication. Repeatable 9-minute snooze. Display bright/dim modes control. Size: 5.15" x 3.93" x 2.36" (131mm x 11mm x 60mm). Weight: 1.43 lbs (0.65 kg).

**£8.65** Thousands sold!

Guaranteed same day despatch.

M13

**QUARTZ LCD  
Ladies Slim Bracelet**

5 function. Hours, mins., secs., day, date and back light and auto calendar. Elegant metal bracelet in silver or gold. State preference.

**£15.95**

Guaranteed same day despatch.



M14

**QUARTZ LCD  
Ladies 5 Function**

Only 25 x 20mm and 6mm thick. 5 function. Hours, mins., secs., day, date and back light and auto calendar. Elegant metal bracelet in silver or gold. State preference.

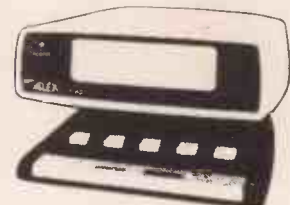
**£9.95**

Guaranteed same day despatch.



M15

**DIGITAL  
LED CLOCK**



Automatic brightness control. Weekend alarm cancel.

Features and Specification: Hour/minute display. Large LED display with p.m. and alarm on indicator. 24 Hours alarm with on/off control. Display flashing for power loss indicator. Repeatable 9-minute snooze. Automatic brightness control. Weekend alarm cancel.

**£10.95**

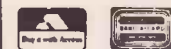
Guaranteed same day despatch.

M16

**HOW TO ORDER**

Payment can be made by sending cheque, postal order, Barclay, Access or American Express card numbers. Write your name, address and the order details clearly, enclose 30p for post and packing or the amount stated. We do not wait to clear your cheque before sending the goods so this will not delay delivery. All products carry 1 year guarantee and full money back 10 day reassurance. Battery fitting service is available at our shops. All prices include VAT.

Trade enquiries: Send for a complete list of trade prices - minimum order value £100.  
Telephone Orders: Credit card customers can telephone orders direct to Daventry or Edgware Rd., 24 hour phone service at both shops: 01-723 4753 03272-76545.



CALLERS WELCOME  
Shops open 9.30 - 6.00.

**Metac**

ELECTRONICS  
& TIME CENTRES

North & Midlands  
67 High Street, DAVENTRY  
Northamptonshire  
Telephone: 03272 76545

South of England  
327 Edgware Road  
LONDON W.2  
Telephone: (01) 723 4753



A quality range of British made electrical accessories plus a "How to" book. Do your own home electrical work with complete confidence. See cat. pages 129 to 134



This superb organ — build the first working section for just over £100. Full specification in our catalogue.



A range of highly attractive knobs is described in our catalogue. Our prices are attractive too!



Mobile amateur radio, TV and FM aeriels plus lots of accessories are described in our catalogue



A pulse width train controller for smooth slow running plus inertia braking and acceleration. Full construction details in our catalogue



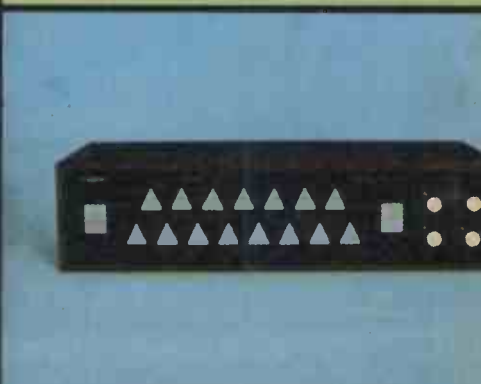
A wide range of disco accessories at marvellous prices. Our catalogue has all the



Add-on bass pedal unit for organs. Has excellent bass guitar stop for guitarists accompaniment. Specification in our catalogue



The 3800 synthesiser, build it yourself at a fraction of the cost of one ready-made with this specification. Full details in our catalogues.



Touch operated rhythm generator, the "Drumsette". Construction details 25p (L. MES49). Specification in our catalogue

# MAPLIN

**ELECTRONIC SUPPLIES LTD**  
 All mail to:-  
 P.O. Box 3, Rayleigh, Essex SS6 8LR.  
 Telephone: Southend (0702) 554155.  
 Shop: 284 London Road,  
 Westcliff-on-Sea, Essex.  
 (Closed on Monday).  
 Telephone: Southend (0702) 55400



A superb technical bookshop in your home! All you need is our catalogue. Post the coupon now!



An attractive mains alarm clock with radio switching function and battery back-up. Complete kit with case only £13.88 (incl. VAT & p&p) MA1023 module only (incl. VAT)



76

A massive new catalogue from Maplin that's even bigger and better than before. If you ever buy electronic components this is the one catalogue you must not be without. Over 280 pages — some in full colour — it's a comprehensive guide to electronic components with hundreds of photographs and illustrations and page after page of invaluable data.

Our bi-monthly newsletter contains guaranteed prices, special offers and all the latest news from Maplin.



A 63-key ASCII keyboard with 625-line TV interface. 4-page memory and microprocessor interface. Details in our catalogue

**Post this coupon now for your copy of our 1979-80 catalogue price 75p.**

Please send me a copy of your 280 page catalogue. I enclose 75p but understand that if I am not completely satisfied I may return the catalogue to you within 14 days and have my 75p refunded immediately. If you live outside U.K. send £1 or ten International Reply Coupons.

NAME \_\_\_\_\_

ADDRESS \_\_\_\_\_