

Hobby Electronics

March '79
40p

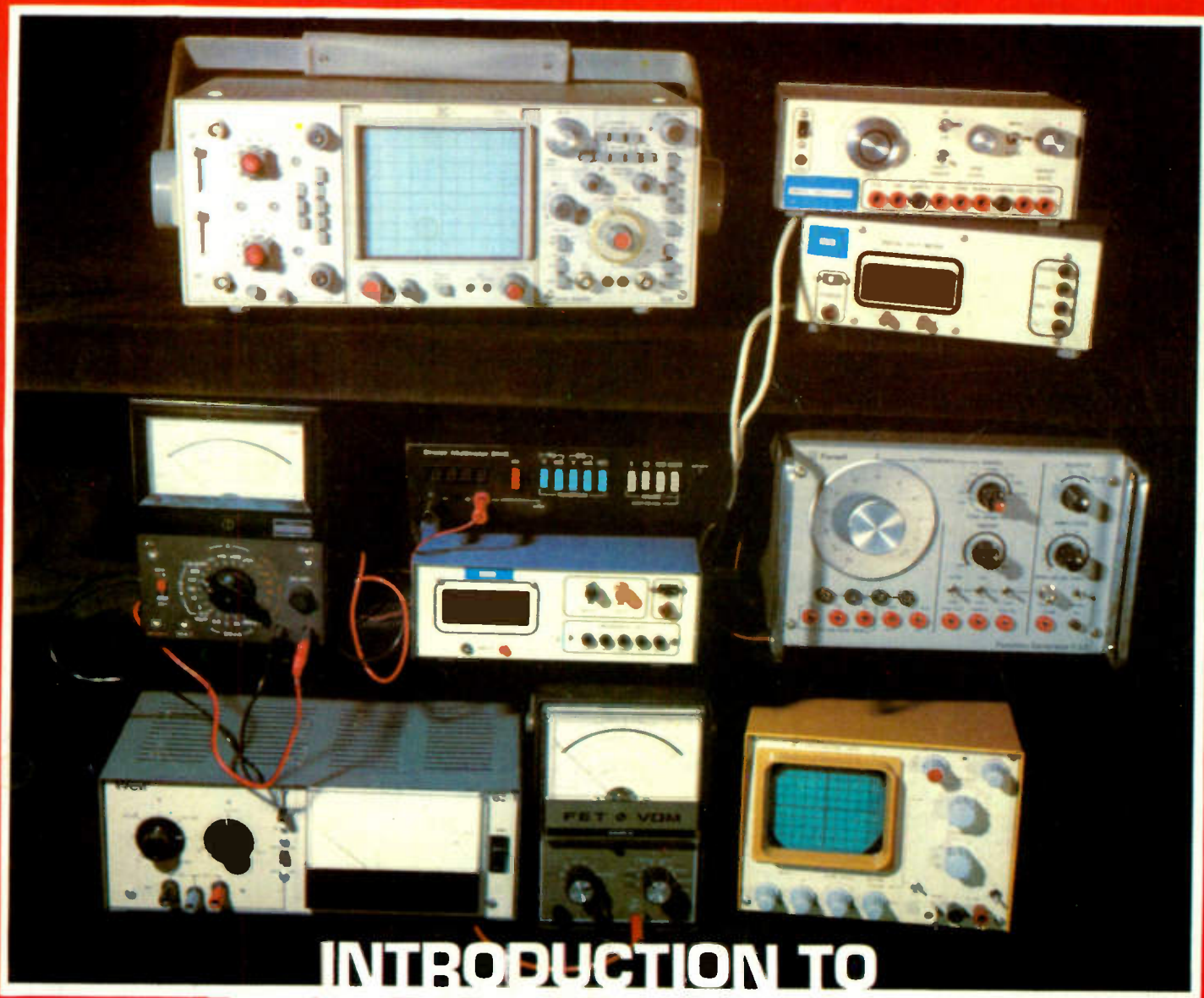

INTRODUCTION TO **TEST GEAR**

Light Chaser Project
Sequential light controller

Communications Satellites
The commercial aspect of the space race

10W Stereo Amp and Record Player
Offer — Under £20 (+P&P)

S.W. Receiving Aerials
How to listen to the world

Crossing Your Bridges
Electronic bridge circuits explained

Casanova's Candle
Timed light dimmer

Hobby Electronics

Vol. 1. No. 5

March 1979

Monitor 4	Marketplace 30	HE Book Service ... 32, 38, 73
News from the world of electronics	Bargains from us to you	Look out a good read
Light Chaser 7	Introduction to Test Gear .. 33	TV Shopping 45
		Price comparisons on-cable TV

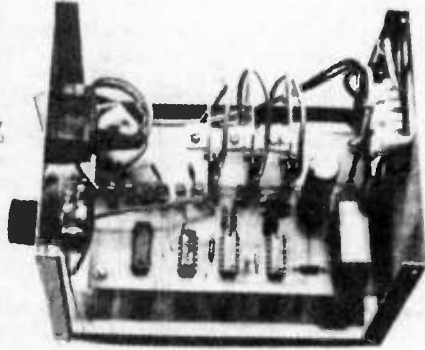

Sequential lighting project

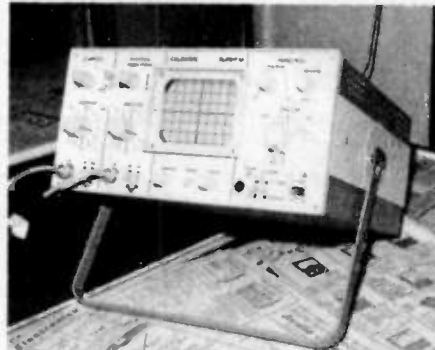

Our project team reviews the range

Photographic Timer Project 47



A neat, easy-to-build unit

Crossing Your Bridges ... 13

Wheatstone and all that

Casanova's Candle 16

A dim project

Short Circuits 19, 25, 32, 50, 68

Practical circuits for the inventive

How TV Signals are Propagated 21

From transmitter to aerial

Tone Control Project 27

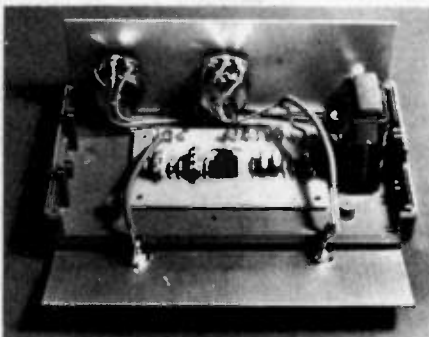

Up and down with the highs and lows

Stereo Record Player and Amp Offer 38

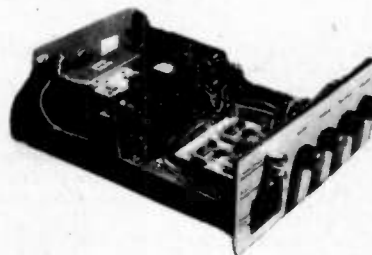

A bargain if ever there was one

Preview of April HE 40

Sneak look at next month's issue

SW Aerials 41

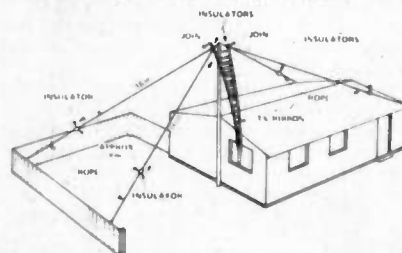

How to listen to the world

Into Electronics Part 5 ... 51

Our introductory series

Communications Satellites 63

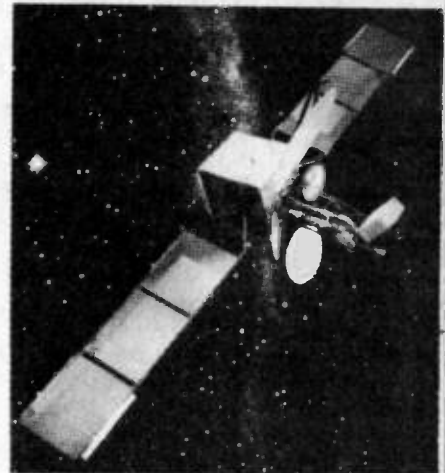

The commercial end of the space race

Interfering Waves 69

How signals add and subtract

Letters from our Readers . 72

What you think of us

Good Evans 74

Garry Evans look at model railways

Hobby Electronics
25-27 Oxford Street, London W1R 1RF
01-434 1781
Published by Modmags Ltd.
Distributed by Argus Distribution Ltd.
Printed by Q. B. Ltd, Colchester
Hobby Electronics is normally published on the second Friday of the month prior to the cover date

Editor: Halvor Moorshead
Editorial Staff: Richard Maybury, Ian Graham, Ray Marston, Steve Ramsahadeo, Diego Rincon, Pete Howells, Paul Edwards, Tony Strakas
Advertising: Chris Surgenor, David Sinfield, Joy Cheshire
Admin Staff: Margaret Hewitt, Alan Carlton, Bren Goodwin, Kim Hamlin, Tim Salmon, Cliff Bailey

Copyright. All material in this publication is subject to world-wide copyright protection. Permission to reproduce printed circuit board patterns commercially or marketing kits of the projects must be sought from the Editor. All reasonable care is taken in the preparation of the magazine to ensure accuracy but Modmags cannot be held responsible for it legally.

Monitor

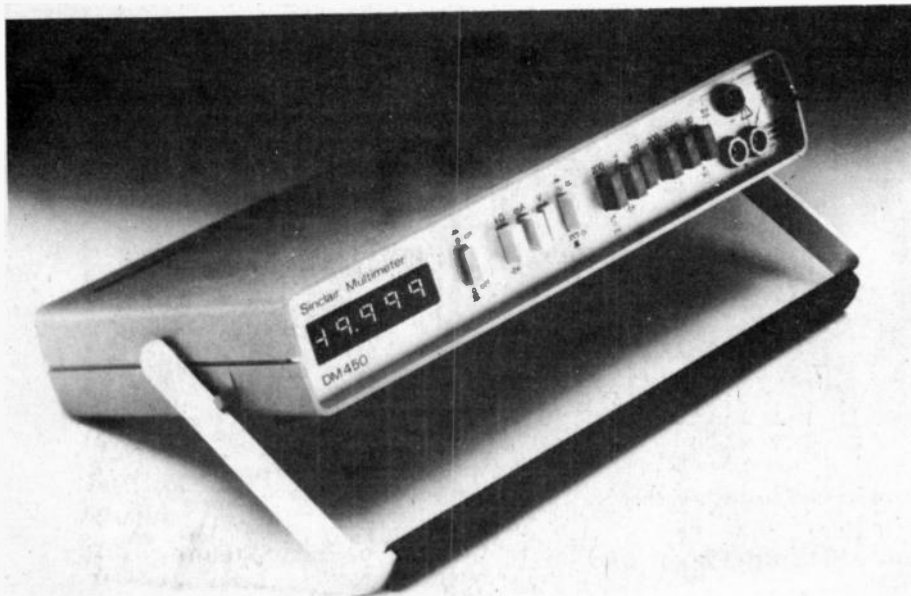

DM NECKWEAR

Sinclair Radionics have introduced two new digital multimeters — the DM 450 and the DM 350.

The DM 450 is a 4½ digit meter with a basic accuracy of 0.05% of reading. The DM 350 is a 3½ digit model with a basic accuracy of 0.1% of reading.

Both are five function meters with resolution of 100 µV, 1nA and 100 milliohms. They use high brightness, 8 mm LED displays of ultra-wide viewing angle with automatic

polarity and out-of-range indication. Each unit weighs 670 gms.

The meters are battery powered, but an AC adaptor is available for continuous operation. A rechargeable battery pack, a 30 kV high voltage probe and an eveready carrying case with neck strap (enabling the instruments to be used with both hands free) are available as accessories.

The DM 450 costs £99 + VAT, the DM 350 £69 + VAT.

Sinclair Radionics, London Road, St. Ives, Huntingdon, Cambs. PE17 4HJ.

SALTY DISPLAY

An Electrochromic Display (ECD), made by Sharp in Japan, is claimed to be clearer and more visible than conventional LCD units. The ECD, which is composed mainly of sodium chloride solution, will be mass-produced and marketed early this year.

VIDEODISC

RCA will shortly be marketing a new video disc system in America. The grooved disc, with one hour of recording time each side, revolves at 450 rpm and is 'read' by a diamond stylus.

In RCAs system, the disc is never touched by human hands. Disc and protective sleeve together are loaded into the player, which is compatible with any television. The empty sleeve can then be removed from the player, and is later used to retrieve the disc.

The initial selection of prerecorded programmes will cover 250 titles ranging from feature films to sports and educational programmes.

SEA WHERE YOU ARE

Texas Instruments have announced the introduction of an electronic navigation aid for sailing addicts.

The system, called Navigatronic, comprises a TI-58 programmable calculator, a marine navigation program library, a 12-24 V DC adaptor/charger and a marine navigation quick reference guide, all mounted in a brass-handled mahogany case. A 220 V AC adaptor/charger for shore use is also supplied.

The package is designed to meet the needs of racing, cruising and ocean crossing navigation. The calculator has up to 480 program steps and a solid state library of 30 programs is available at the touch of a key. These deal with coastal and celestial navigation, with sailing and tactical programs for the racing sailor.

If you don't believe you are where the system says you are, there is an additional diagnostic program to confirm correct operation of the calculator and library-calculator interface.

The TI Navigatronic package costs £149.95 (RRP incl. VAT). Texas Instruments Ltd., European Consumer Division, Manton Lane, Bedford, MK41 7PA.

COMPUTATEMP

A new range of hand-held digital thermometers from the British Rototherm Co. Ltd. combines microprocessor computing techniques with rugged construction for 'on site' use.

The new ITS range comprises four models, two to cover the range 0 C to 110 C and two to cover -35 C to 149 C.

The instruments are housed in high impact aluminium cases. A microprocessor computer measures the signal from the probe sensor, and the temperature, in either Fahrenheit or Centigrade, is shown on an 8 mm LED digital display.

More than 25 interchangeable probe/sensor heads are available to cope with measurement in liquids, gases, grains, chemicals, etc.

British Rototherm Co. Ltd., Kenfig Industrial Estate, Margam, Port Talbot, West Glamorgan SA13 2PW.

MATRIX TELLY

Matsushita have developed a pocket television with better resolution than any previous LCD type. The 2.4 inch screen consists of 57,600 elements arranged in a 240 by 240 matrix. Even though CMOS circuits are used, the set consumes 1.5 W.

BAZAAR

The first exhibition for electronics enthusiasts was held last November — we now have news of another to be held at Alexandra Palace in North London, on 28-30th June.

Called the 'Great British Electronics Bazaar', is being organised by a company well experienced in the exhibitions field.



News from the Electronics World

GAMES IN THE HAND

A new range of children's hand-held electronic games and microprocessor 'mini-computer' games area are being introduced by Sepctrum Marketing.

The children's games will complement the adult computer games Chess Challenger and Checker Challenger (draughts). The new microprocessor games, designed for children of five and above, rejoice in the names of 'Amaze-a-Tron', 'Zap', 'Digits' and 'Lil Genius'.

'Amaze-a-Tron' is a maze game for two players, 'Zap', an electronic missile game for two players, 'Digits', an electronic code game using numerals instead of the familiar coloured pegs, and 'Lil Genius' is an electronic calculator designed to teach children rudimentary arithmetic.

Not yet on the market are two riveting games from Mattel Electronics, called Battlear Galactica and Auto Race. The object of the space game is to move your spaceship (an LED) to avoid being hit by missiles from three enemy ships. In Auto Race, your job is to avoid obstacles as your car progresses along a road of LEDs at speeds from slow to impossible. The games are improved enormously by sound effects.

The four Spectrum games will retail at between £9 and £18. SEGIO, 113-115 Gloucester Road, London SW7 4TE.

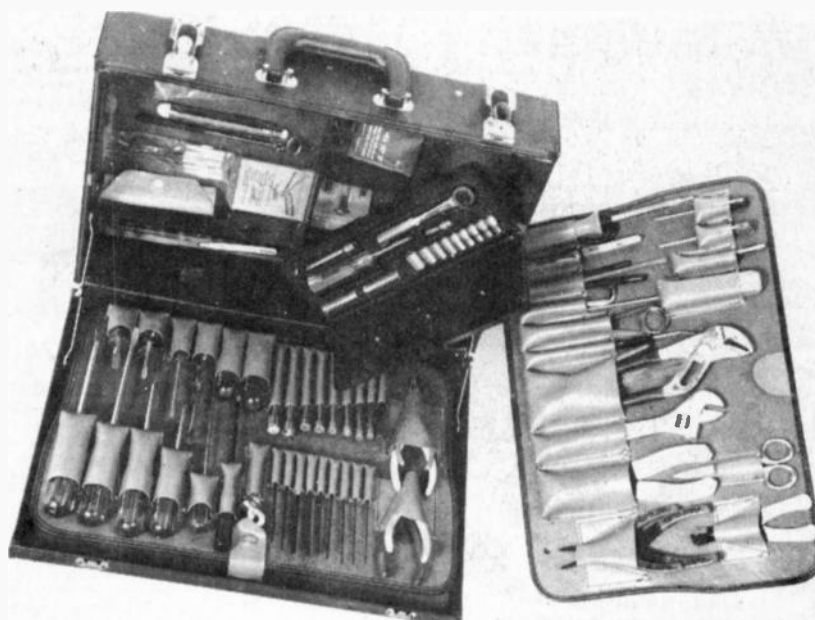
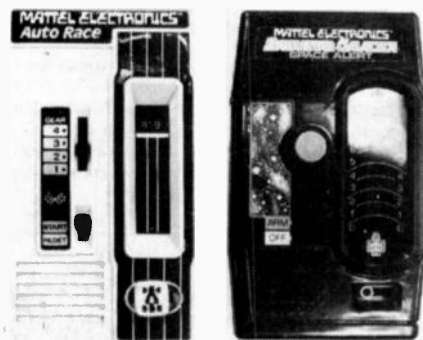

MINI-IRON

A new 6 V, 6 W soldering iron from Toolrange should make soldering eye-straining IC's a little easier. The sub-miniature Orysc PSU.6 comes complete with fused and isolated transformer, a coil spring rest and a sponge tray for tip clearing. The iron's slide-on nickel-plated tip is only 2.4 mm in diameter. The complete 'soldering station' costs £9.95 + VAT ex stock from Toolrange.

Toolrange can now also supply what they claim to be the world's best-selling tool mit, the JTK 17 from Jensen.

The kit is designed to be used for the maintenance of electronic equipment, communications, radar, computers and office machines of all minds. It is one of a range of Jensen tool kits and cases shortly to be available from Toolrange.

Toolrange Ltd., Upton Road, Reading RG3 4JA.

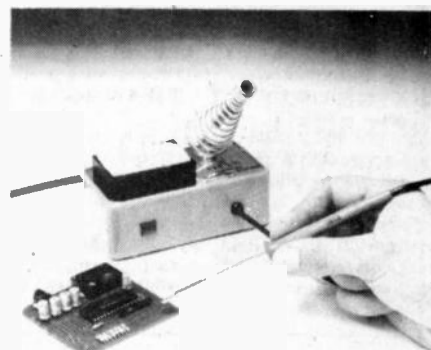

PANIC HERE

During the recent rush by housewives to stock up as a result of the road transport strike, we saw a lovely sign outside Direct Electronics at Manor Park in East London — 'Panic Buyers Welcome!'

MICRO TELLY

Sinclair Radionics are now producing a new Microvision pocket television. The new set receives all BBC and ITV channels. It weighs in at 20 oz. Powered by four penlight batteries, giving eight hours viewing time, the set has only two controls — on/off volume and tuning. Brightness and contrast

on the two inch screen are automatically adjusted.

Viewing the Microvision at reading distance gives a picture as bright and sharp as that of a full-sized set seen at 15 feet. The new set will be available for under £100.

Sinclair Radionics, London Road, St. Ives, Huntingdon, Cambs. PE17 4HJ.

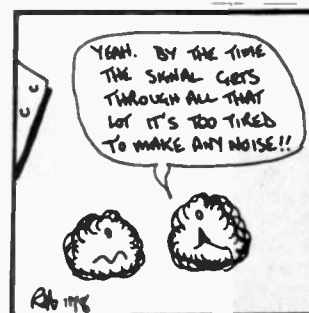
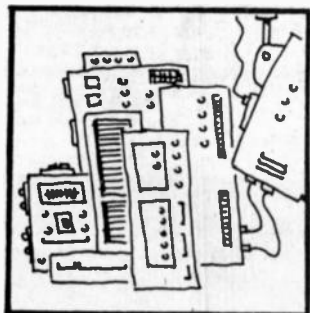

PRINTED CIRCUITS

and

HARDWARE

Comprehensive range Constructors' Hardware and accessories.

Selected range of popular components. Full range of HE printed circuit boards, normally ex-stock, same day despatch at competitive prices. P.C. Boards to individual designs. Resist-coated epoxy glass laminate for the d.i.y. man with full processing instructions (no. unguual chemicals required).

Alfac range of etch resist transfers, and other drawing materials for p.c. boards.

Send 15p for catalogue.

RAMAR CONSTRUCTOR SERVICES

MASONS ROAD
STRATFORD-ON-AVON
WARWICKS. Tel. 4879

ETCH RESIST TRANSFER KIT SIZE 1:1

Complete kit 13 sheets 6in x 4½in £2.50 with all symbols for direct application to P.C. board. Individual sheets 25p each. (1) Mixed Symbols (2) Lines 0.05 (3) Pads (4) Fish Plates and Connectors (5) 4 Lead and 3 Lead and Pads (6) DILS (7) BENDS 90° and 130° (8) 8-10-12 T.O.S. Cans (9) Edge Connectors 0.15 (10) Edge Connectors 0.1 (11) Lines 0.02 (12) Bends 0.02 (13) Quad in Line.

FRONT AND REAR PANEL TRANSFER SIGNS

All standard symbols and wording. Over 250 symbols, signs and words. Also available in reverse for perspex, etc. Choice of colours, red, blue, black, or white. Size of sheet 12in x 9in. Price £1.

GRAPHIC TRANSFERS WITH SPACER ACCESSORIES

Available also in reverse lettering, colours red, blue, black or white. Each sheet 12in. x 9in contains capitals, lower case and numerals ½in kit or ¼in kit. £1 complete. State size.

All orders dispatched promptly.

All post paid

Ex U.K. add 50p for air mail
Shop and Trade enquiries welcome
Special Transfers made to order

E. R. NICHOLLS
P.C.B. TRANSFERS
Dept. HE

46 LOWFIELD ROAD
STOCKPORT, CHES.061-480 2179

TIMETRON Recommended by TEMPUS

Until TEMPUS have re-established their business we will be pleased to supply you from the superb range of

QUALITY CASIO PRODUCTS

A well-known consumer magazine has published a report on digital watches which supports our opinion that CASIO and SEIKO are probably the best watches in the world with CASIO offering unbeatable value for money.

NEW CASIO 46CS-27B

Almost certainly the slimmest and most sophisticated alarm/chronograph watch available today. liquid crystal display of hours, minutes, seconds, day. And with day, date, month and year perpetual calendar.

- Optional 12-hour clock (with am/pm indicators) or 24-hour display
- 24-hour alarm setting
- Optional hourly chimes
- Chronograph measures in units of 1/100 seconds in six hours.
- Net, lap and 1st and 2nd place times.
- All stainless steel case only 7.8mm thick
- Mineral glass face
- Water resistant to 100ft.
- ± 10 seconds/month
- R.R.P. £89.95



£74.95

CASIO CHRONOGRAPH

45CS-22B. Similar functions to the above watch but without the alarm and chime. (R.R.P. £69.95) £54.95.
CASIO SPORTS WATCHES. LCD. 6 digits. 1/100 second stopwatch, net lap and 1st and 2nd place times. Time and calendar display. F-100 resin case, strap (£24.95) £19.95

£20S-14B. S/S encased, bracelet (£44.95) £34.95

NEW CASIO CARD WATCH THE INCREDIBLE MQ-11



Microcomputer Quartz Sensor Touch keys LC Display of hours, minutes, seconds, am/pm, full calendar display of day, date and every Sunday. Also digital date, month, year. And day, Sundays. Three date memories. Two independent alarms with hold and display fac. Countdown alarm/timer, or Time Memory (24 hr.), or 1/10 sec stopwatch.

Will display any monthly calendar from 1901 to 2099. Memories and displays three optional important dates. Calculator with Sensor Touch keys, full memory, %, °, K. Battery life approx. 1 year. 3/16 x 2½ x 3½ inches. Leatherette wallet with window (£34.95) An incredible £29.95.

NEW CASIO CQ-82

LCD calculating alarm clock with snooze facility.



6 digit LC Display of time with nightlight. Four alarms, one with snooze facility. Calculator with %, °, K. Long battery life, compact size (£24.95)

£19.95

CQ-81. Calculating alarm clock now only £14.95

PQ-7. Alarm clock, alarm/timer, stopwatch. Now £17.95

NEW CASIO AQ-2000

Calculating alarm clock with stopwatch and calendar £24.95

ST-24. Card Time Calculator, stopwatch, 2 alarm-timers £19.95

NEW LCD calculators with full memory, %, °, K. Most have battery saving APO (Automatic Power-Off).
LC-79. Sensor touch Mini Card with APO. A very rigid 1/16 x 2½ x 3½ins. Beautifully styled. Pouch £15.95

LC-841. APO Rigid ½ x 2½ x 4½ in Pouch £12.95

NEW HL series. Two AA batteries last 6,000 - 10,000 hours.

HL-801 8 digits £9.95, HL-101 (10) £12.95, HL-121 £19.95.

LCD SCIENTIFIC CALCULATORS. FX-48 £19.95

FX-2500 £21.95, FX-3100 £25.95, FX-8000 £29.95.

Most CASIO products in stock. Send 15p for brochures.

Prices include VAT, P. & P. Send cheque, P.O. or phone your Access or Barclaycard to:

TIMETRON

Det. HE, Beaumont Suite
164-167 East Road
Cambridge CB1 1DB
Telephone 0223 67503

Callers welcome by appointment

BUILD THE TREASURE TRACER MK III

METAL
LOCATOR



AS SEEN
ON BBC-1
& BBC-2
TV

- Genuine 5 silicon transistor circuit, does not need a transistor radio to operate.
- Incorporates unique varicap tuning for extra stability.
- Search head fitted with Faraday screen to eliminate capacitive effects.
- Loudspeaker or earphone operation (both supplied).
- Britain's best selling metal locator kit, 4,000 already sold.
- Kit can be built in two hours using only soldering iron, screwdriver, pliers and side-cutters.
- Excellent sensitivity and stability.
- Kit absolutely complete including drilled, tinned, fibreglass p.c. board with components sited printed on.
- Complete after sales service.
- Weighs only 22oz.; handle knocks down to 17" for transport.

Send stamped, self-addressed envelope for literature.

Complete kit with pre-built search coil **£15.95**
Plus £1.20 P&P
Plus £1.37 VAT (8%)

Built, tested and Guaranteed **£20.95**
Plus £1.20 P&P
Plus £1.77 VAT (8%)

MINIKITS ELECTRONICS,
6d Cleveland Road, South Woodford,
LONDON E18 2AN
(Mail order only)

Light Chaser

Rid your home of moths and give yourself a perpetual headache with the disco effects unit.

A LIGHT CHASER is a mechanical, or in this case, electronic, gadget which controls three or more sets of lights arranged in a chain. These are flashed on, one at a time in sequence, to create an illusion of movement. Such devices can be seen at fairgrounds, on advertising signs and in shop windows. Here is a design that is simple and cheap to build, and suitable for any of these applications.

DESIGN FEATURES

We have seen many designs for light chasers ranging from three relays switched sequentially by a motor and cam follower contacts to elaborate phase control circuits. We chose to opt for a happy medium retaining features like easily adjustable rate and zero crossing switching but still being simple and cheap to build.

To reduce cost, we decided against using an isolation transformer. Because of this, the *entire* circuit is at mains potential and should therefore be treated with due respect. By using a series capacitor which costs about £1.00, we save a power transformer (£3.00) and three pulse transformers (about £1.50 each), resulting in a £5-£6 saving.

EXPANSION

The unit can be expanded beyond three channels if desired by moving the reset line of IC4 (pin 15) from the fourth output to the $(n+1)$ th, where n is the desired number of channels. The sequence in which the pins on IC4 go high is 3, 2, 4, 7, 10, 1, 5, 6, 9 and 11. Therefore for a six-channel unit pin 5 will be connected to pin 15. The output stage consisting of the NAND gate, transistors, capacitor and TRIAC will of course have to be duplicated for each additional channel.

The unit is described is suitable for about 1000W per channel but if additional heatsinks are used this could be raised to the 15A limit of the triacs or, if different triac are used (e.g. the TIC 2460 (16 A 400 V PIV) even higher currents can be handled.

CONSTRUCTION

The PC board should be assembled with the aid of the overlay in FIG. 2. Ensure that the diodes, capacitors and transistors are oriented correctly. The transistors shown on the overlay are plastic types and can be identified by the fact that the base lead is bent so that the three leads form a triangle. If the three leads are in line the transistors should be inserted facing in the opposite direction.

The CMOS ICs should be inserted last ensuring that the pins are not handled more than necessary and that pins 7 and 14 (the power supply rails) are soldered first.

The heatsinks and the triacs used depends on the intended load. We used about 2500 square mm of



The case used for the light chaser (see text), note the position of the three output sockets.

aluminium on each triac, and found this to be satisfactory for about 1000 W per channel. The tabs of the triacs are live and separate heatsinks, insulated from earth, should be used or the triacs should be insulated from the heatsink.

We mounted our prototype into a simple aluminium box (type N 6x6x3in available from H. L. Smith 287 Edgware Road, London W2 for £3.25 inc PP and VAT) with an external rate potentiometer and three three-pin sockets. If an external potentiometer is not required a trim potentiometer can be mounted on the board. To adjust this potentiometer an insulated trimming tool must be used. The unit can be wired according to FIG. 2 taking care with insulation as many points are at 240 V.

WARNING

The circuit described here does not use an isolation transformer and therefore all sections of the circuit must be considered dangerous.

If the unit does not work when switched on, disconnect the mains and then, using a separate dc power supply, apply 10 V across C2. Now add a 50 Hz AC signal of 12-32 V onto the normal active-neutral input. In this way the control circuitry can be safely checked up to the triacs.

Light Chaser

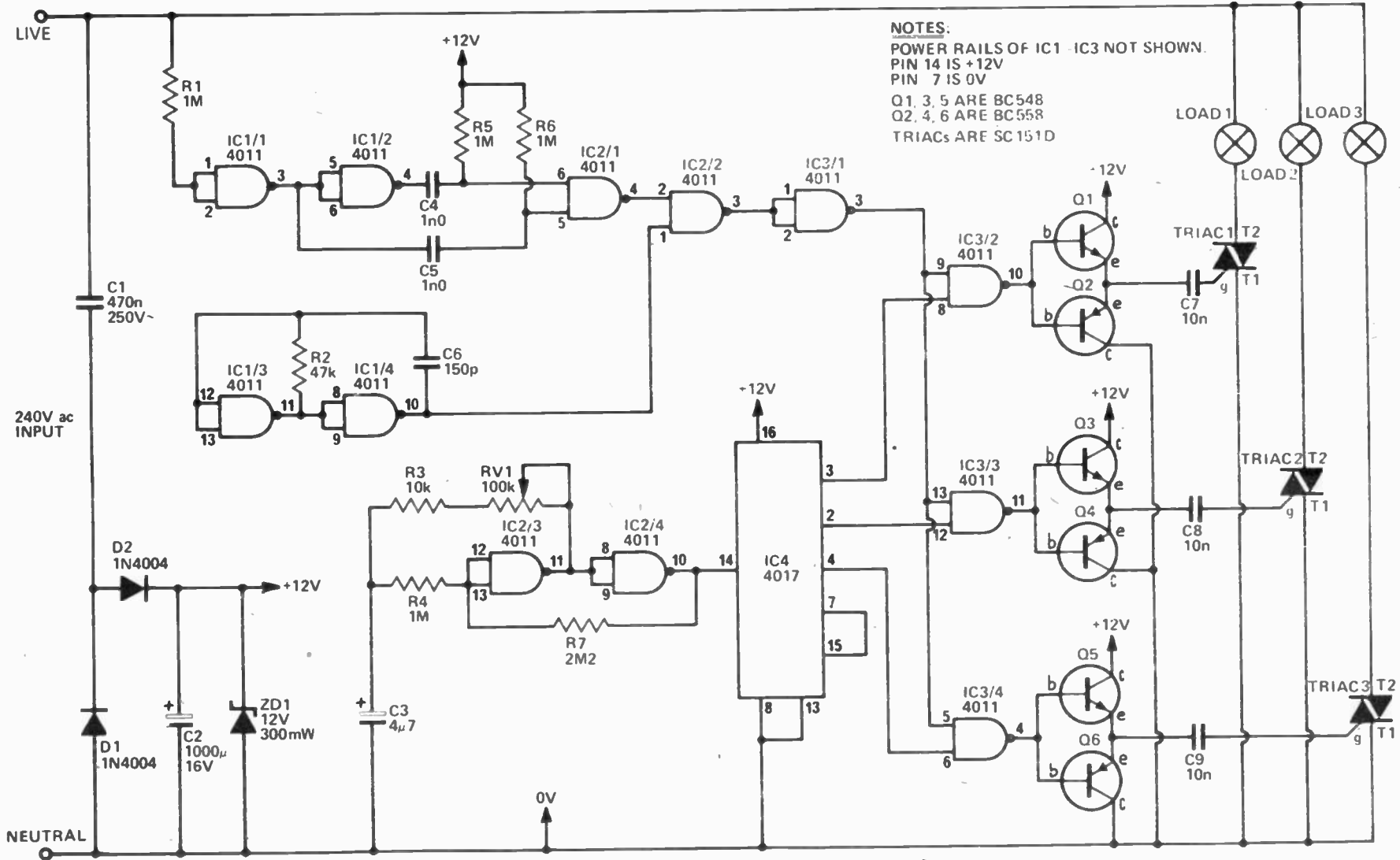

Fig. 1. The circuit diagram of the complete chaser.

How it Works

A light chaser consists of three or more AC switches which are turned on, one at a time, in sequence. To make this explanation simpler, we have separated the circuit into several sections.

POWER SUPPLY

The 240 VAC is reduced to the 12 VDC required to operate the control circuitry by the use of a series capacitor C1, the diodes D1 and D2, the smoothing capacitor C2, and is then regulated by zener diode ZD1.

SYNCHRONIZATION GENERATOR

The input to IC1/1 is connected to the 240 VAC supply via the 1 M resistor R1. The value of this resistor, combined with the effects of the protection diodes inside the IC, prevent damage to the IC. The output of this device is a 50 Hz square wave which is synchronized with the mains. IC1/2 is used to invert this square wave and then the RC networks R5/C4 and R6/C5 are used to generate negative pulses on the two inputs of IC2/1 on each zero crossing of the 50 Hz signal – i.e. 100 pulses per second. The width of these pulses is about 0.5 ms.

HIGH FREQUENCY OSCILLATOR

This is formed by IC1/3 and IC1/4, and runs at about 80 kHz. Its output is gated with the synchronizing pulses by IC2/2; this results in 600 μ s long bursts of 80 kHz at the start of each half cycle.

LOW FREQUENCY OSCILLATOR

This is formed by IC2/3 and IC2/4 and its frequency is variable by RV1 from 1 Hz to 10 Hz. We have used this form of oscillator in preference to that used for the high frequency oscillator to prevent reverse biasing the tantalum capacitor.

COUNTER

This is IC4 which is normally a divide-by-ten counter with ten decoded outputs which go high in sequence. By connecting the fourth output back to the reset, a divide-by-three is formed. This IC is clocked by the low frequency oscillator.

DRIVER & OUTPUT STAGES

There are three identical output stages consisting of a two input NAND gate, a two transistor buffer, a series capacitor and a Triac. The function of the gate is to direct the high frequency tone bursts onto the appropriate triac gate. The counter IC4 selects the required gate.

GENERAL

The use of a short tone burst at the start of each half cycle is intended to minimise RFI as the Triac can only switch on at this point. This does, however, limit its use to incandescent loads. For use on fluorescent loads C4 and C5 can be increased to 10 n.

The fact that we have not used an isolation transformer reduces the cost, but it does mean that the complete circuit must be considered live! We did not use a fuse in the prototype, but one can be used if required in the live input lead. Ensure that the fuse used will protect the Triac.

Pin-out of the TIC 246 TRIAC.

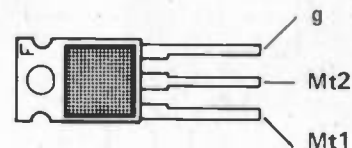

PCB foil pattern for the light chaser.

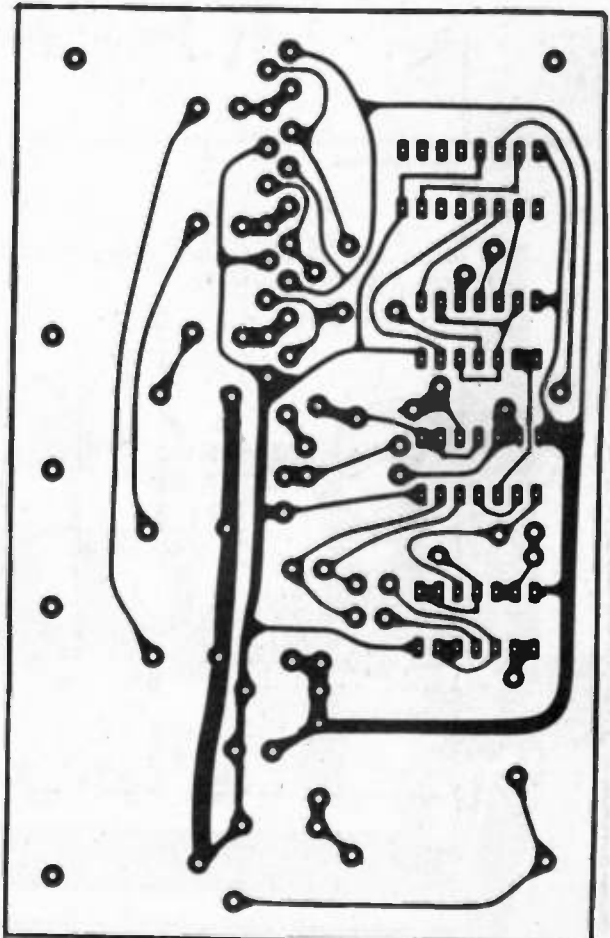

Light Chaser

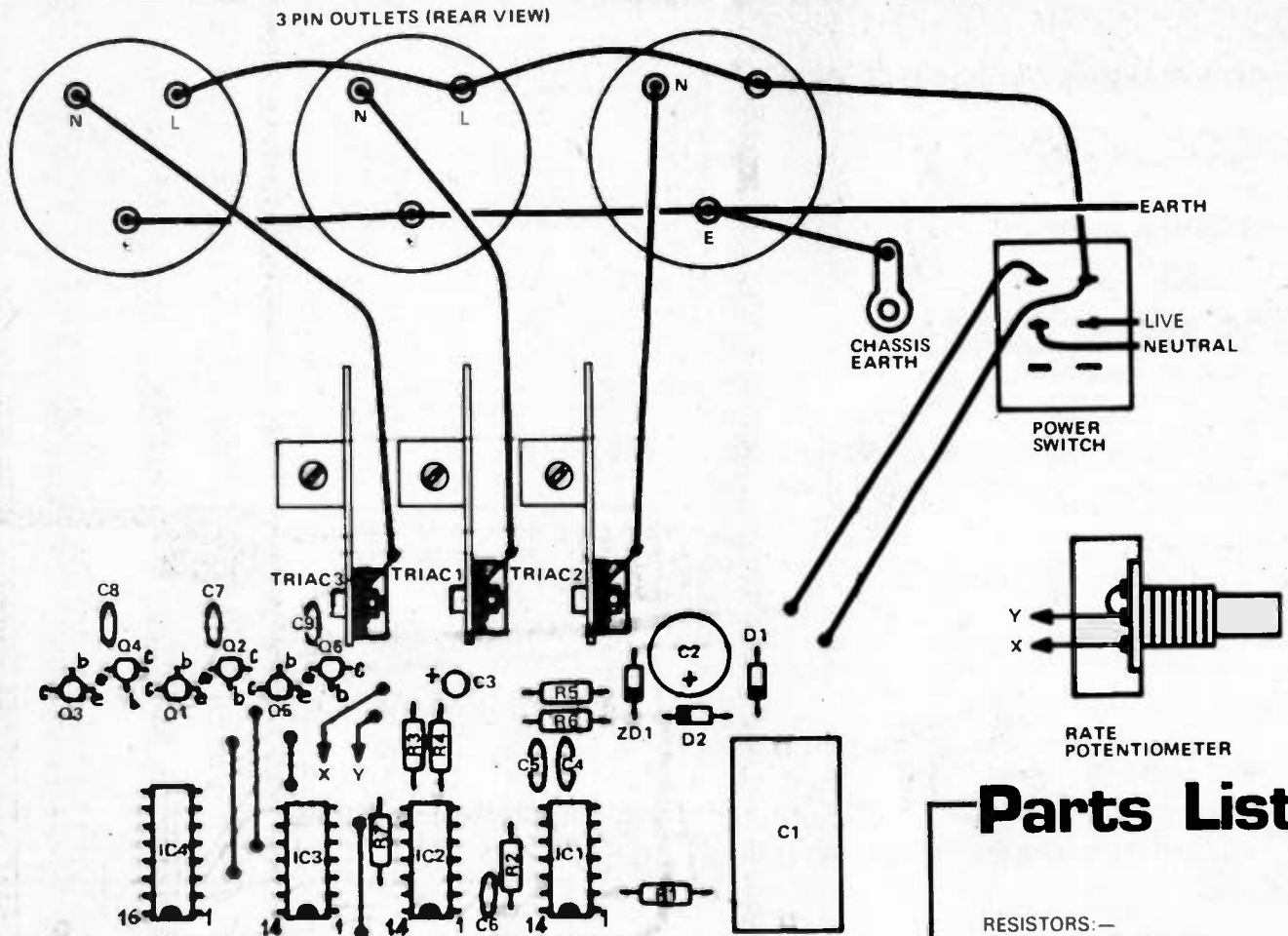

Fig. 2. The component overlay and wiring diagram. Ensure that the chassis is well earthed.

Parts List

RESISTORS:—

	all ½W, 5%
R1	1M
R2	47k
R3	10k
R4-R6	1M
R7	2M2

POTENTIOMETER

RV1	100k lin (trim or rotary)
-----	---------------------------

CAPACITORS:—

C1	470n 250VAC
C2	1000µ 16V
C3	4µ7 25V tantalum
C4, 5	1n0 polyester
C6	150p ceramic
C7-C9	10n polyester

SEMICONDUCTORS:—

IC1-IC3	4011 (CMOS)
IC4	4017 (CMOS)
Q1, 3, 5	BC548
Q2, 4, 6	BC558
D1, 2	1N4004
ZD1	12V, 400mW
TRIAC 1-3	TIC 246D (16A 400V PIV)

MISCELLANEOUS

Metal box to suit (see text)
 Three 3-pin power outlets
 Power switch
 3-core flex and plug
 PCB to pattern

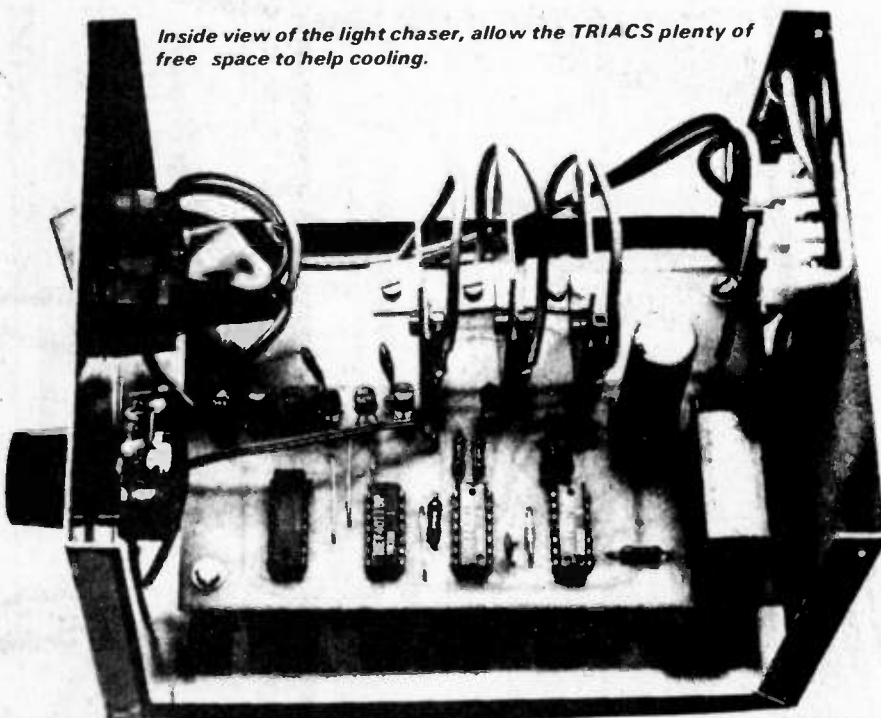

Inside view of the light chaser, allow the TRIACS plenty of free space to help cooling.

STEVENSON

Electronic Components

LOUDSPEAKERS

56mm dia. 8ohms	70p
64mm dia. 8 ohms	75p
64mm dia. 64 ohms	75p
70mm dia. 8 ohms	100p
70mm dia. 80 ohms	110p

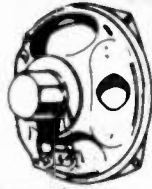

PLUGS AND SOCKETS

1mm plugs and sockets suitable for low voltage circuits. Available in red or black. Plugs 6p each. Sockets 7p each.

4mm plugs and sockets. Available in black, blue, green, brown, red, white and yellow. Plugs 11p each. Sockets 12p each.



Jack plugs and sockets

	unscreened plug	screened plug	socket
2.5mm	9p	13p	7p
3.5mm	9p	14p	8p
Standard	16p	30p	15p
Stereo	23p	36p	18p

Din plugs and sockets

	plug	socket
2 pin speaker	7p	7p
3 pin	11p	9p
5 pin 180°	11p	10p
5 pin 240°	13p	10p

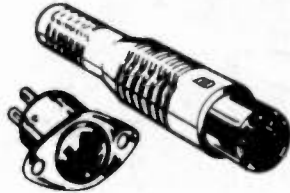

CABLES

Connecting wire Available in packs of 8 metres (one metre of each colour) or packs of forty metres (five metres each colour).

	single	standard
Eight Metre pack	16p	16p
Forty Metre pack	76p	70p

Screened Cable
Single screened 8p
twin individually screened 11p

Ribbon cable
10 way 58p metre
20 way 100p metre

ALUMINIUM BOXES

Boxes complete with lid and screws.



	Length	width	height	
AL1	3	2	1	48p
AL2	4	3	1½	58p
AL3	4	3	2	65p
AL4	6	4	2	70p
AL5	6	4	3	85p
AL6	8	6	2	116p

We now have an express telephone order service. We guarantee that all orders received before 5pm. are shipped first class on that day. Contact our Sales Office now! Telephone: 01-464 2951/5770.

ORDERS
DESPATCHED
BY RETURN
POST

Quantity discounts on any mix TTL, CMOS, 74LS and Linear circuits: 25+ 10%. 100+ 15%. Prices VAT inc. Please add 30p for carriage. All prices valid to 30th April 1979. Official orders welcome.

BARCLAYCARD AND ACCESS WELCOME.



Mail orders to: STEVENSON (Dept HE)

236 High St, Bromley, Kent, BR1 1PQ, England

TRANSISTORS

AC127	17p	BCY71	14p	ZTX109	14p
AC128	16p	BCY72	14p	ZTX300	16p
AC176	18p	BD131	35p	2N697	12p
AD161	38p	BD132	35p	3N1302	38p
AD162	38p	BD135	38p	2N2905	22p
BC107	8p	BD139	35p	2N2907	22p
BC108	8p	BD140	35p	2N3053	18p
BC109	8p	BF244B	36p	2N3055	50p
BC147	7p	BFY50	15p	2N3442	135p
BC148	7p	BFY51	15p	2N3702	8p
BC149	8p	BFY52	15p	2N3705	9p
BC158	9p	MJ2955	98p	2N3706	9p
BC177	14p	MPSA06	20p	2N3707	9p
BC178	14p	MPSA56	20p	2N3708	8p
BC179	14p	TIP29C	60p	2N3819	22p
BC182	10p	TIP30C	70p	2N3904	8p
BC182L	10p	TIP31C	65p	2N3905	8p
BC184	10p	TIP32C	80p	2N4058	12p
BC184L	10p	ZTX107	14p	2N4547	32p
BC212	10p	ZTX108	14p	2N5458	30p
BC212L	10p			2N5459	32p
BC214	10p			2N5777	50p
BC214	10p	1N914	4p		
BC477	19p	1N4001	4p	1N4148	3p
BC478	19p	1N4002	4p	1N5401	13p
BC479	19p	1N4004	5p	1N5402	15p
BC548	10p	1N4006	6p	1N5404	16p
BCY70	14p			1N5406	18p

DIODES

BZY88 series 2V7 to 33V 8p each.

74LS

LS00	16p	LS95	65p
LS01	16p	LS123	56p
LS02	16p	LS125	40p
LS03	16p	LS126	40p
LS04	16p	LS132	60p
LS08	16p	LS136	36p
LS10	16p	LS138	54p
LS13	30p	LS139	50p
LS14	70p	LS151	50p
LS20	16p	LS153	50p
LS30	16p	LS155	80p
LS32	24p	LS156	80p
LS37	26p	LS157	45p
LS40	22p	LS164	90p
LS42	53p	LS174	60p
LS47	70p	LS175	60p
LS48	48p	LS190	80p
LS54	16p	LS192	70p
LS73	29p	LS193	70p
LS74	29p	LS196	80p
LS75	44p	LS251	60p
LS76	35p	LS257	55p
LS78	35p	LS258	55p
LS83	60p	LS266	40p
LS85	70p	LS283	60p
LS86	33p	LS290	55p
LS90	45p	LS365	45p
LS93	45p	LS366	45p
		LS367	45p
		LS386	35p
		LS670	180p

LINEAR

A SELECTION ONLY!
DETAILS IN CATALOGUE.

709	25p	LM324	50p	NE556	60p
741	22p	LM339	50p	NE565	120p
747	50p	LM380	75p	NE567	170p
748	30p	LM382	120p	SN76003	200p
CA3046	55p	LM1830	150p	SN76013	140p
CA3080	70p	LM3900	50p	SN76023	140p
CA3130	90p	LM3909	60p	SN76033	200p
CA3140	70p	MC1496	60p	TBA800	70p
LM301AN	28p	MC1458	35p	TDA1022	650p
LM318N	125p	NE555	25p	ZN414	75p

OPTO

LEDs	0.125in.	0.2in.	
Red	TIL209	TIL220	9p
Green	TIL211	TIL221	13p
Yellow	TIL213	TIL223	13p
Clips			3p

DISPLAYS

DL704	0.3 in CC	130p
DL707	0.3 in CA	130p
FND500	0.5 in CC	100p



RESISTORS

Carbon film resistors.
High stability, low noise 5%.

E12 series. 4.7ohms to 10M. Any mix:

	each	100+	1000+
0.25W	1p	0.9p	0.8p
0.5W	1.5p	1.2p	1p

Special development packs consisting of 10 of each value from 4.7 ohms to 1 Megohm (650 res.)
0.5W £7.50. 0.25W £5.70

CAPACITORS

HERE ARE JUST
A FEW OF THE
CAPACITORS STOCKED

TANTALUM BEAD

	each
0.1, 0.15, 0.22, 0.33, 0.47, 0.68, 1 & 2.2uF @ 35V	9p
4.7, 6.8, 10uF @ 25V	13p
22 @ 16V, 47 @ 6V, 100 @ 3V	16p

MYLAR FILM

0.001, 0.01, 0.022, 0.033, 0.047	3p
0.068, 0.1	4p

RADIAL LEAD ELECTROLYTIC

63V	0.47	1.0	2.2	4.7	10	5p
			22	33	47	7p
			220			20p
25V	10	22	33	47		5p
						8p
					470	10p
						15p
						23p
10V	220					5p
						9p
						13p
			2200			23p

TTL

7400	12p	7493	34p
7401	12p	7494	52p
7402	12p	7495	52p
7404	12p	7496	50p
7408	14p	74121	25p
7410	12p	74122	33p
7413	25p	74123	40p
7414	48p	74125	35p
7420	12p	74126	35p
7427	24p	74132	50p
7430	12p	74141	56p
7442	43p	74148	90p
7447	55p	74150	70p
7448	58p	74151	50p
7454	14p	74156	52p
7473	25p	74157	52p
7474	25p	74164	70p
7475	32p	74165	70p
7476	28p	74170	125p
7485	70p	74174	68p
7489	145p	74177	58p
7490	32p	74190	72p
7492	35p	74191	72p
		74192	64p
		74193	64p
		74196	55p
		74197	55p

CMOS

FULL DETAILS
IN CATALOGUE

4001	15p	4029	60p
4002	15p	4040	68p
4007	15p	4042	54p
4011	15p	4046	100p
4013	35p	4049	28p
4015	60p	4050	28p
4016	35p	4066	40p
4017	55p	4068	20p
4018	65p	4069	16p
4023	15p	4071	16p
4024	45p	4075	16p
4026	95p	4093	48p
4027	35p	4510	70p
4028	52p	4511	70p
		4518	70p
		4520	65p

SKTS

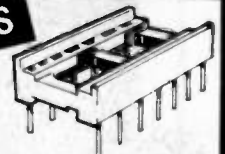

Low profile by Texas

8 pin	10p	24 pin	24p
14 pin	12p	28 pin	28p
16 pin	13p	40 pin	40p

Soldercon pins: 100: 50p
1000: 370p

FOR YOUR
COPY OF OUR
40 PAGE
CATALOGUE
OF COMPONENTS,
SEND
LARGE S.A.E.

STEVENSON



computing today

50p

From February 16th COMPUTING TODAY goes out on its own. CT will deal with all aspects of computing projects, features, there're all here, and only 50 pence. An excellent follow-up if you've been reading the series on BASIC and programming in HE.

TANGERINE- ONE BOARD VDU

TANGERINE the sweet alternative to seven segment-displays. Don't be pipped at the post, we've got under the skin of this really versatile one-board VDU.

MICRO- BIOLOGY

Continuing the series with an almost indecently intimate look at the good old 6800 MPU.

SOFTSPOT

This very popular feature continues to bring you the very lat-

INTRODUCING BASIC

Probably the most widely used 'High Level Language' today. You may forget FORTRAN, even criticise COBOL but never be

without BASIC.

The language of MPUs will be explained as you have never seen it before.

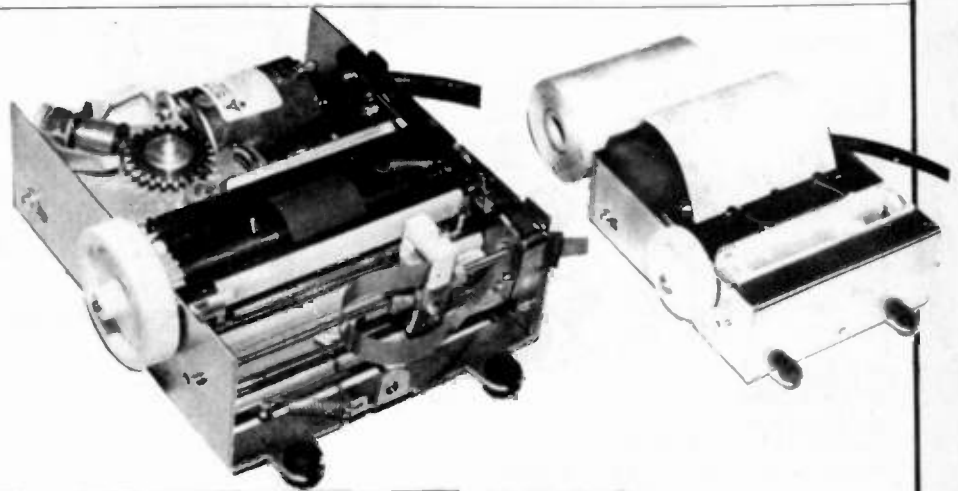

S100 PRINTER

Hard up for hard copy? Tired of losing those valuable programme listings? Then this is for you. This printer uses the almost universal S100 bus format, low cost mechanics and readily available electronics. It will represent a substantial saving over commercial units.

TRITON EXPANSION

Add another 8K of RAM to your TRITON and it will now have the

capacity to thank you personally. Details of mother board and plug-in RAM cards are given in this follow up to the phenomenally successful TRITON series.

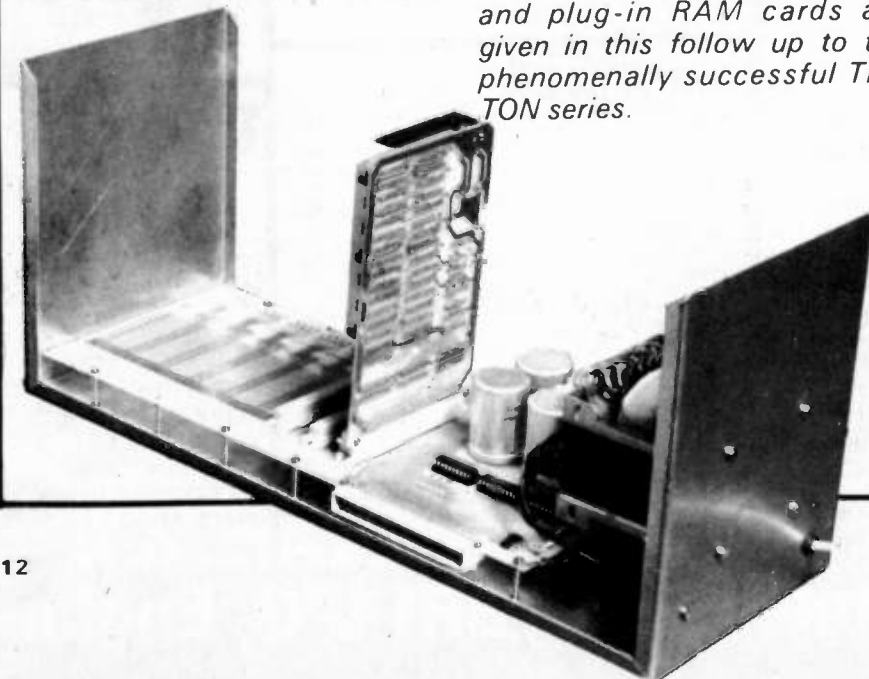

STOMPER

Do you dislike insects? Are you a conservationist? Well this program allows you to stamp on insects without damaging the environment, they even give a satisfying SPLAT when you crush them. Good fun for software Arachnophobiacs.

Crossing Your Bridges

One of the principle circuits used in measurement today is the Bridge, yet it is by no means new. K. T. Wilson explains.

ONE OF THE FUNNY (peculiar) things about electronics is the way so many of the circuits that we use turn out to have been invented long before electronics, as we know it, started. How much effect, do you think, would the work of an electrical engineer who lived between 1802 and 1875 have on modern electronics circuits? He died more than a hundred years ago yet Sir Charles Wheatstone gave his name to one of the most important measuring circuits which we use. What's more important, the principle that he used has led to a huge variety of measuring circuits being devised, all of which are still in use.

WHEATSTONE

The Wheatstone bridge is, of course, the circuit for which Sir Charles is remembered — let's jog our memories a bit on this one. Suppose we have two resistors in series, R1 and R2, and E volts across the two, then across R2, the voltage is $E \times R2 / R1 + R2$.

For example, if the resistors are 3k3 and 6k8 across 9 V, then the voltage across the 3k3 is $9 \times 3.3 / 3.3 + 6.8$ which is 2.94 V. Prove it? Dead easy, using a bit of Ohm-sweet Ohm! (Fig. 1)

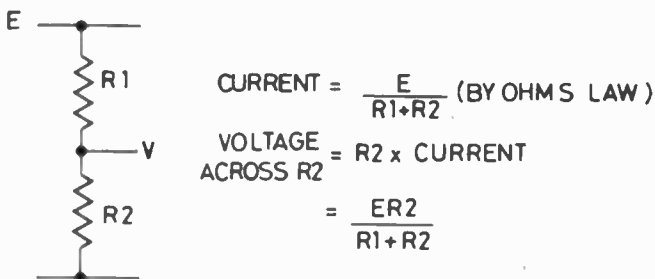
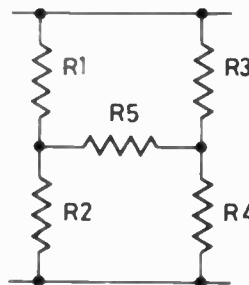

Fig. 1. The potential divider.

Now suppose that we have two of these circuits, potential dividers we call them, one with R1 and R2, the other with two other resistors R3 and R4. Connect them both to the same supply voltage and build a bridge across. A bridge? Yes, a resistor connected across the joins, as shown in Fig. 2 — it bridges across between the potential dividers. Problem — how much current flows through this resistor? Well, if you take any old values of resistors, it's quite a difficult problem, one that will give sleepless nights even to most experts. It's easy to solve by a useful fiddle called Thévenin's Theorem, but very



THERE IS NO CURRENT THROUGH R5 IF

$$\frac{R1}{R2} = \frac{R3}{R4}$$

OR $\frac{R1}{R3} = \frac{R2}{R4}$

Fig. 2. The bridge circuit.

tedious by any other methods (see OST Rules OK in the February issue of HE).

There is, however, one set of resistance values for which this puzzle clicks into place very easily. These are the values for which the current across the bridge resistor is zero, nil, nothing at all. That condition comes about when the other four resistors in the circuit have values which give $R1/R2 = R3/R4$. If, for example, R1 is 1k and R2 is 100R, giving a 10:1 ratio, then the ratio R3/R4 must also be 10:1 if no current is to roll across the bridge. If R4 = 3k3, for example, then R3 must be 33k to give that 10:1 ratio.

BALANCING YOUR BRIDGES

Now Wheatstone didn't come across this by accident. He was working as a consultant for the Post Office, who wanted a method of measuring the resistance of telegraph lines. How do we use Wheatstone's circuit to measure resistance? Easy, just make one of the pairs of resistors a variable. Suppose we redraw the circuit of Fig. 2 so that it appears as Fig. 3, with RV1 a linear

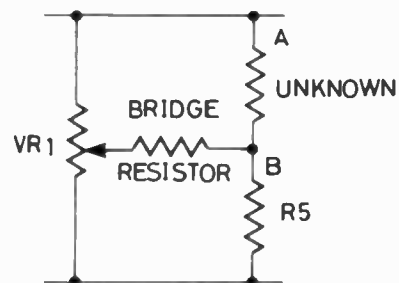

Fig. 3. Using the bridge circuit for measurement.

potentiometer. The makers of these pots will obligingly supply dials which read the ratio of the resistances each side of the slider, from 0.1 through 1 (middle of the track) to 10. Now to measure a resistance value, all we have to do is to connect the unknown resistance at A and B, either way round, adjust the pot until no current flows across the bridge and read the dial of the pot. In this condition with no current flowing across the bridge, we say that the bridge is *balanced*. The amount of the unknown resistance between A and B is equal to the value of R_s multiplied by the potentiometer ratio. For example, if $R_s = 10k$, and the potentiometer ratio is 0.33, then the unknown resistance must be $10k \times 0.33 = 3k3$.

DETECTING THE BALANCE

Easy enough, but how do we tell when there's no current flowing across the bridge resistor? One simple way is to replace the bridge resistor by a current meter, preferably a centre-zero type, and watch it. We can use any old current meter as long as it's reasonably sensitive. It doesn't have to be a precision instrument, it doesn't have to have any scale, as long as that zero position is marked. Meters, even low quality meters, are expensive items, though, so a better scheme is to use electronic methods. There's no reason why we should have to use DC to operate the bridge, so if we use AC at some convenient frequency, say 400 Hz, then we can make use of audio amplifiers to detect the balance. Why choose 400 Hz? Well we want a frequency which is high enough to be easily amplified, with smallish values of coupling capacitors, well above the frequency of mains hum, but low enough so that we don't run into trouble with signal leaking away through stray capacitance. In addition, if we want to use earphones or a loudspeaker to detect when we've reached the balance point, 400 Hz is a frequency to which the human ear is particularly sensitive.

We can use an ordinary voltage amplifier, provided we remember that the input connections have to be to the resistors of the bridge and not to a common earth connection. This way, any AC voltage difference between the two ends of the bridge is amplified and can be detected by an earphone, loudspeaker, or rectifier/meter combination as shown in Fig. 4. Even more useful is the arrangement called a differential amplifier which, as the name suggests, amplifies the voltage difference between the two ends of the bridge. We can use an

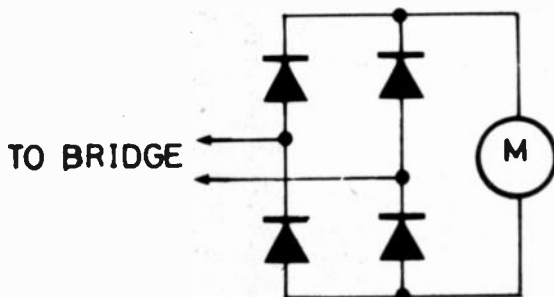

Fig. 4. A rectifier/meter arrangement for reading balance on an AC bridge. This is useful only if an amplifier is used between the bridge output and the detector, because the forward voltage of the diodes will limit the sensitivity of the detector.

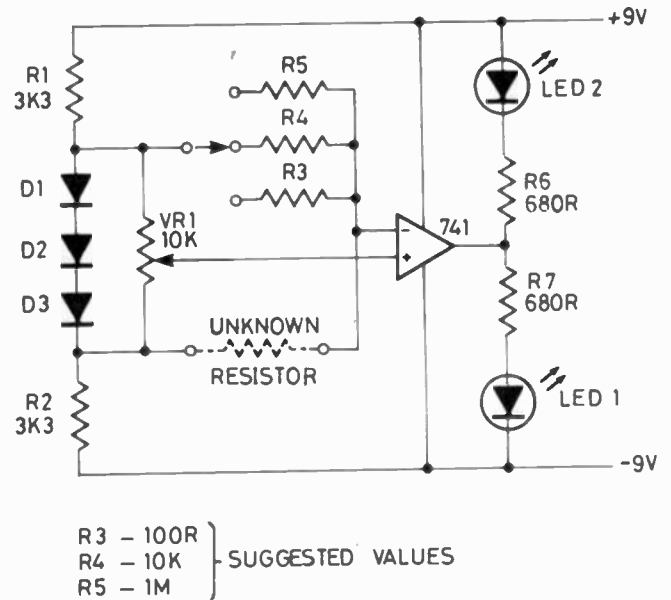

Fig. 5. A sensitive DC bridge using an op amp and LEDs for balance indication.

operational amplifier for this job, but we have to remember that the operational amplifier has to be correctly biased. If we use AC for the bridge that's easy, but if we want to avoid using a built-in signal generator and make use of the fact that an op amp like the 741 is fully DC coupled, then we run into a slight complication. We must make sure that the voltage across the whole bridge circuit is small, and that it lies about midway between voltage and earth. The reason is that the inputs to the 741 have to be around this mid-voltage, the circuit simply won't work if the inputs are near supply voltage or zero voltage because the circuits inside the IC aren't correctly biased then. Fig. 5 shows a useful bridge circuit which uses DC, with a 741 and a pair of LEDs to indicate balance. With the arrangement shown, LED1 will light if the potentiometer setting is too high, and LED2 will light up if the potentiometer setting is too low. When the setting is just right and the bridge balanced, both LEDs will glow.

LESSER KNOWN BRIDGE

Mr Wheatstone's bridge therefore is a quick and simple method of making resistance measurements without using costly meters — provided we have some standard value resistors that we can use as R_4 (in Fig. 2). If we can switch in different values of R_4 , then the measuring range of the bridge can be very great.

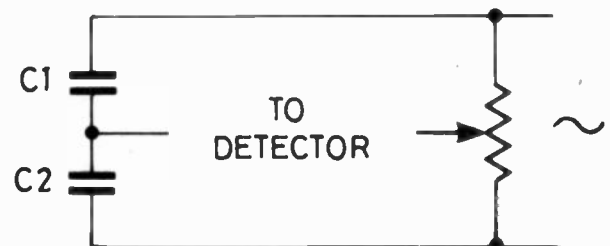

Fig. 6. The De Sauty bridge circuit.

Crossing Your Bridges

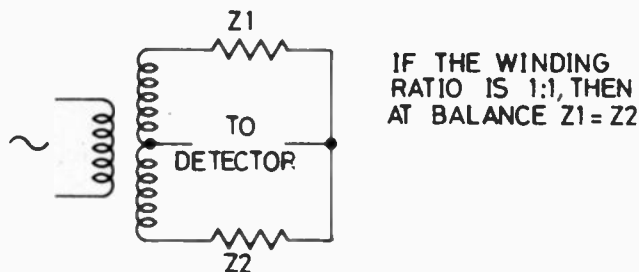
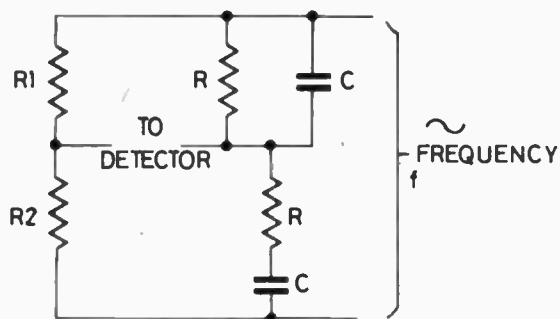

Fig. 7. Transformer-arm bridge principle.

The usefulness of the bridge idea doesn't end there, though, because dozens of people took up the principle of the bridge from where Wheatstone left off. Cast your eyes over Fig. 6, which is a bridge circuit called the *De Sauty* bridge after its inventor. In this particular version, the two fixed resistors of the Wheatstone bridge are replaced by capacitors, but the ratio potentiometer is unchanged. It won't work on DC, of course, but any sort of AC supply, sine wave, square wave, over a wide range of frequencies, will operate the bridge. As usual, RV1 is operated until the signal output from the amplifier is as low as possible, then the ratio is read from the potentiometer dial. The value of the unknown capacitance is found by multiplying the ratio value by the capacitance of the standard, C1. Sharp-eyed readers will have noticed that this capacitor is not in the same place in the circuit of the bridge as the unknown resistors was in the Wheatstone bridge. That's because capacitors don't behave like resistors — the greater the value of capacitance, the less it hinders the flow of current. Many commercial bridge designs use a bridge which is a combination of the Wheatstone and the *De Sauty* so that both capacitor and resistor values can be measured with the same instrument.

That's just scratching the surface as far as bridges are concerned. Among the dozens of bridge circuits we can count the *Owen* bridge, for finding the inductance and the resistance of a coil. This is a type of bridge which is a bit more awkward to use, because there are two adjustments that are needed for balance and they both have to be correct for balance. One, of course, is for inductance and the other for resistance. This two-adjustment business is usually found when inductors are measured and it also has to be used when we take measurements on capacitors which may be leaky, such as electrolytics.



IF $R2 = 2R1$, THEN AT BALANCE $f = \frac{1}{2\pi CR}$

Fig. 8. The *Wien* bridge circuit.

Looking at just a few more examples of what Charles Wheatstone started, there is the *Maxwell* bridge for inductance, the *Hey* bridge for large inductors, the *Schering* bridge for capacitors, and the *Felici* bridge for measuring the mutual inductance of transformer windings.

BRIDGE RECTIFIERS

Oddly enough, one of the bridge circuits that is most used these days in commercial bridges has no special name. It's the transformer bridge, and the principle is shown in Fig. 7. The transformer is specially wound, with the secondary windings perfectly matched and balanced to earth so that the signals, at audio frequency, are perfectly in antiphase. For zero output from the AC detector, the two impedances (resistors, inductors or capacitors) must be exactly identical. To use this system as it stands, of course, we would have to be able to balance any unknown with an exactly equal standard, so what is done is to make the transformer ratio variable, by winding the transformer in the same way as we wind a potentiometer, with a sliding contact. We can then go back to the familiar method of having a standard and a ratio once again. This alas, is not a bridge for the constructor because of the need for a very specially wound transformer.

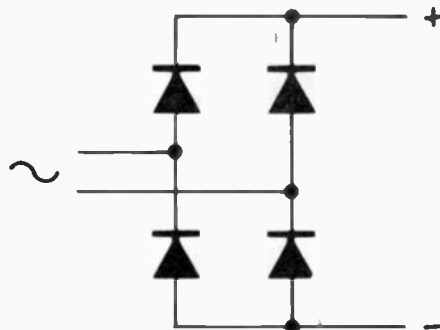

Fig. 9. Modern method of drawing the full-wave 'bridge' rectifier circuit.

Just for a glimpse of a different sort of application, there's the *Wien* bridge, which has the interesting characteristic that it is balanced at one frequency only. This is the bridge circuit that is used in so many audio oscillator circuits, in the form shown in Fig. 8. The feedback is exactly in phase only for the frequency: $f = 1 / 2\pi RC$ so that this is the frequency of oscillation.

Just to round off, there is the arrangement of rectifier diodes that we know as a *bridge rectifier*. It's certainly the same shape as a bridge circuit, but it's hardly in the same league as the real bridges, whose aim is to have zero current passing across the bridge. We wouldn't be happy about a "bridge" rectifier if no current crossed the bridge, because that's the load, just where we want the current! It's not a true bridge circuit, in fact, despite the shape, because current is not free to flow in the two arms, since the diodes in each arm are connected to prevent current flowing right through the arm. Perhaps we shall avoid confusion in future by drawing this full-wave rectifier circuit in the modern form (Fig. 9) rather than in the traditional diamond shape.

HE

Casanova's Candle

If Casanova were alive today he would have certainly approved of this project, history however does not record whether or not he could solder.

IT WOULD SEEM that almost every electronics manufacturer has at one time or another produced some kind of light dimmer. In general they all fulfill the same need, that is to vary the intensity of an incandescent lamp (a normal light bulb to you and me) over the whole range of brightness. Our dimmer has the added capability of being able to reduce the brightness of a lamp over the greater part of its range, over a period that can be from just one or two minutes to nearly one hour. At this point it's probably unnecessary to explain the title, however the unit could just as easily be used as a child's bedroom lamp, or indeed a reading lamp for any bedroom.

THE LIGHT FANTASTIC

Because only two wires protrude from the average light switch, certain constraints are placed upon the design, it is almost impossible to get the light to dim from full intensity for reasons that will become apparent later (see How It Works).

The final design managed to achieve a gradual reduction in brightness from about half-brightness to almost zero: using the components specified this will take about forty minutes.



The type of switch used is unimportant, it must, however be of the double pole changeover type.

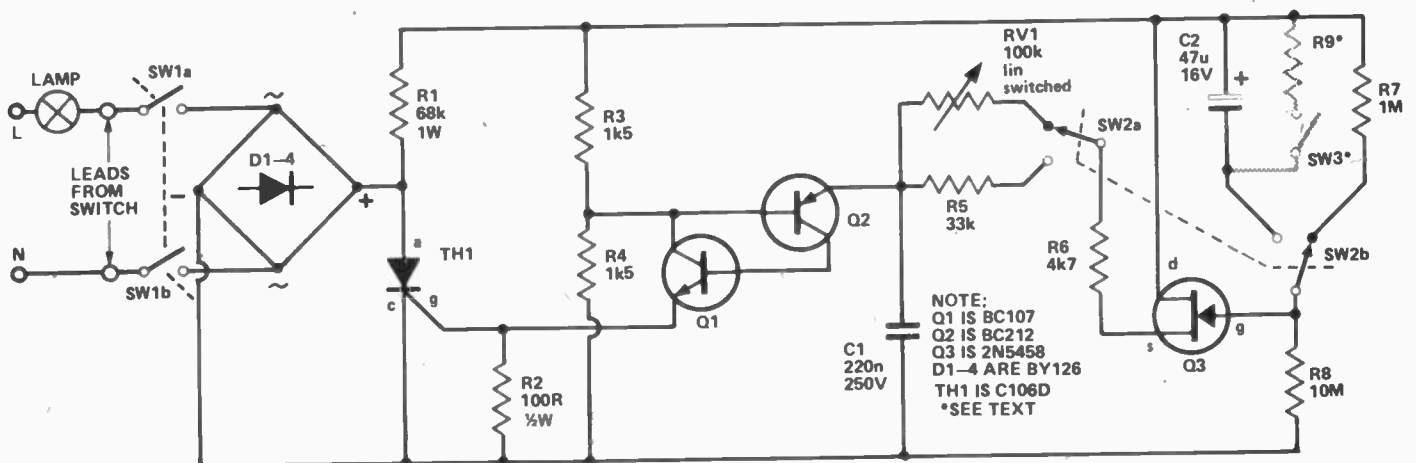

Fig. 1. Circuit of Casanova's Candle. See text for notes on discharge switch SW3.

CONSTRUCTION

For ease of construction the unit is mounted on a shaped one-piece PCB. It is suggested that the board be cut to size and the central hole and cut-outs be completed before any etching is done.

The whole assembly relies upon the pot to mount the unit so care should be taken when soldering the pot to ensure a rigid joint between the pot and the board. Mounting the rest of the components should present no problems.

The Thyristor should be left slightly clear of the board to prevent any heat build-up.

The dimmer assembly is mounted on a blank MK switch plate. The hole for the pot and the slot for the switch should be drilled and filed with great care as the switch plate is made from an extremely brittle type of plastic and does not take too kindly to abuse.

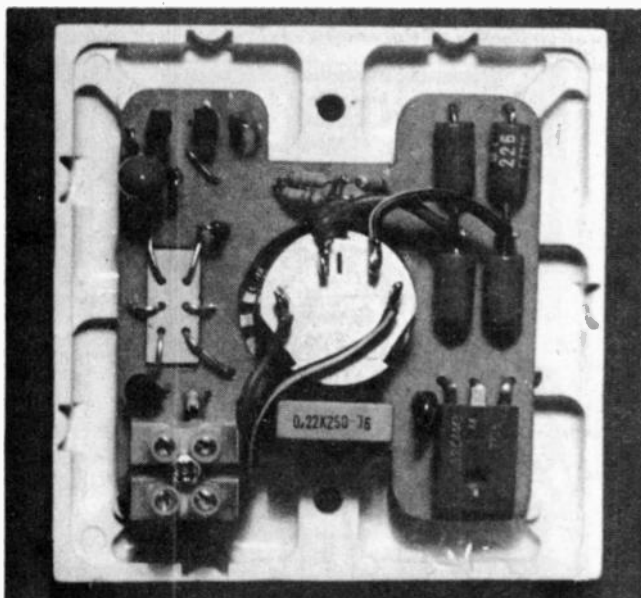

Note the cut-outs on the PCB, these are to clear the lugs on the mounting box.



How Fast Do You Work?

You may find that a discharge switch across C2 via R9 might be needed as the discharge time of C2 is somewhat prolonged. This however was not found to be necessary on the prototype.

Fitting The Unit

The unit will, with luck, replace the existing switch directly but in case your switches are of the older type

How it Works

This dimmer works in rather unconventional way, most dimmers on the market use a TRIAC to switch both half cycles of the mains, this however was not practical for this application as the circuit requires a low voltage DC rail. To this end it was decided to use a fullwave bridge rectifier circuit with a Thyristor across its "DC" output, this will switch both half cycles and give a progressive reduction over the whole range.

The method used to "fire" the Thyristor relies on the fact that at the output of the bridge appears two full-wave rectified levels 180 degrees out of phase with one another. The upper path (+ve) is presented to a CR network, comprising, C1, RV1, and R6 (at this point the FET can be regarded as short circuit). This will effectively put the upper path out of phase with the lower path at the base of Q2, if the voltage at this point rises above 0.6V relative to the base, the transistor will conduct, Q1 will also be switched on, thus firing the Thyristor.

The action of the Thyristor firing is to put a virtual short circuit across the bridge, this will cause the lamp to extinguish, the degree of triggering will be related to the brightness of the lamp.

The transistors Q1 and Q2 can be regarded as a comparator, that is comparing the degree of phase shift between the junction of R3 and R4 with the delayed, out of phase signal on the emitter of Q2. So far so good.

The delay circuitry comprises Q3 and the CR network C2, R8, the switch SW2 is used to switch the delay circuit in and out. As was said earlier the FET should be regarded as a purely resistive device, the degree of resistance being determined by the CR network. Upon being switched in the pot RV1 is removed from circuit and replaced by R5 which will give approximately half-brightness until the CR network starts to charge.

The need for a DC rail will now become apparent, as it would all but disappear when the lamp was at full brightness, leaving nothing to provide the charging current for the CR network. C2, R8.

The resistor R7 is used to keep the FET Q3 conducting during it's normal operation so it becomes a virtual short circuit.

If for any reason the time taken to dim the lamp is either too long (or too short) the value of R8 can be changed to suit (C2 can be altered, but its physical size may prove to be a limitation).

you may find it necessary to sink in a mounting box (also available from MK) into your wall.

Finally a safety point, using the values suggested the lamp will never completely extinguish, so in theory at least it can never be left in the "auto" position accidentally. Lastly don't forget that mains electricity is potentially fatal stuff to play around with, we would hate to lose any of your readers. **HE**

Parts List

RESISTORS

R1	68k 1W
R2	100R ½W
R3	1k5
R4	1k5
R5	33k
R6	4k7
R7	1M
RB	10M
R9	470R (see text)
RV1	100k Lin. switched
(R3-R9 all ¼W, 5%)	

CAPACITORS

C1	220n 250V Polyester
C2	47u 16V Tantalum

SEMICONDUCTORS

Q1	BC107 or BC10B
Q2	BC212
Q3	2N545B FET
TH1	C106D
D1-D4	BY126

Miscellaneous:

SW2 Miniature slide or rocker switch (double pole, changeover)
Blank MK switchplate.
Terminal block
Wall box (see text)
PCB

APPROXIMATE COST £5-£6.

Note that R1 and R2 need to be of a higher wattage than normal but these and the semiconductors are all available from the larger mail order companies. The thyristor is not particularly critical and most 400 V, 2 A devices will do although the leadouts may vary. The bridge rectifier is made up from common rectifier diodes but other 400 V, 1 A components can be used.

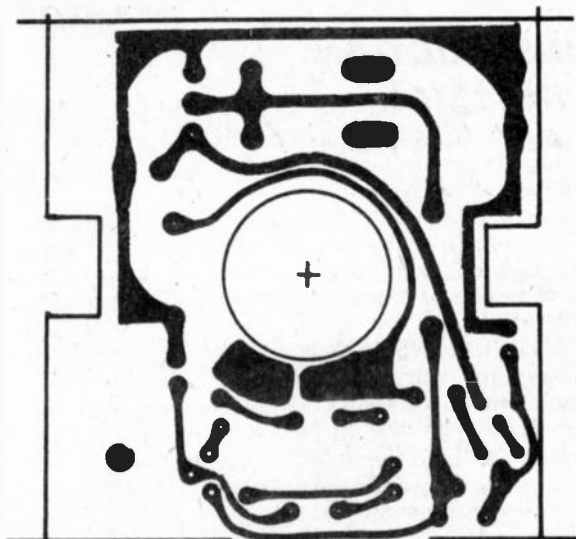

Fig. 2. PCB foil pattern, the pot RV1 and switch SW2 are mounted on the foil side of the board.

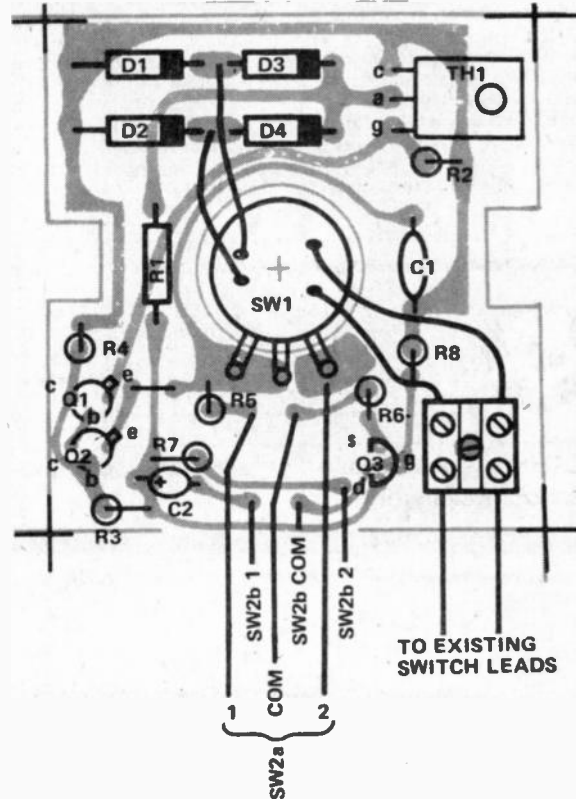
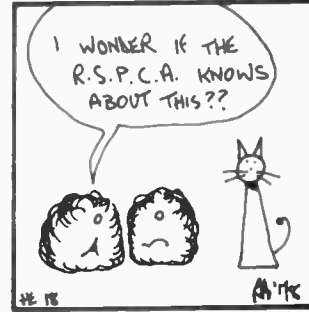
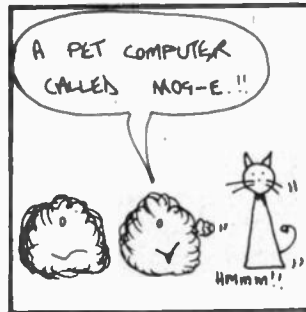
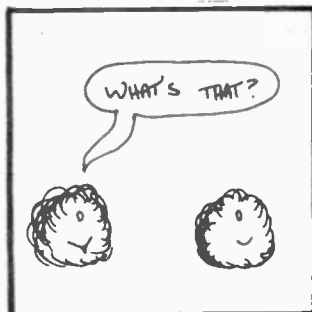
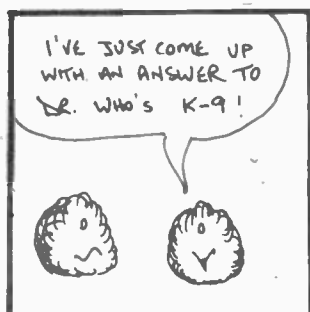

Fig. 3. Component overlay, note the position of the terminal block, and connections to the switch SW1.



Short Circuit

PRECISION HALF-WAVE RECTIFIER

By putting a diode in the feedback loop of an op amp, a precision rectifier can be constructed. Normally a diode will need to be forward biased by 0.6V before it will start conducting, so if you want to half wave rectify a low signal sine-wave (say 0.1 V peak-to-peak) it is almost impossible to do it with just a diode.

However, by using an op amp it is possible to get this diode to drop to below 1 mV in most applications. Referring to the circuit, imagine V_{in} goes positive; then the output of the op amp will swing negative to such an extent that D2 will be properly biased and will draw current through the feedback resistor Rfb. In fact the op amp adjusts its output such that the voltage at pin 2 is virtually at 0 V (virtual earth). Thus the output voltage: $V_{OUT} = V_{in} \times R_{fb} / R_{in}$ which is just like a normal op amp.

FOR POSITIVE INPUTS, VOLTAGE GAIN = $- V_{out}/V_{in} = R_{fb}/R_{in}$

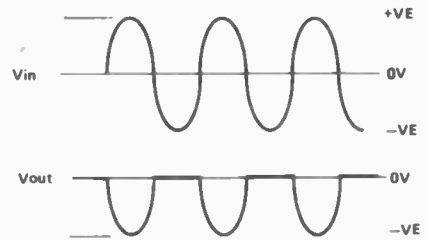
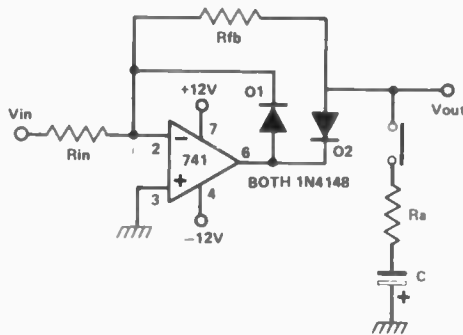

The diode D2 doesn't seem to have affected things and this is true for positive inputs even as low as a few millivolts.

Now when V_{in} goes negative, the output of the op amp swings positive, D1 conducts and maintains a virtual earth condition and D2 is reverse biased. So, now the output is just Rfb connected to effectively 0V. What this means is

that there is only an output voltage (negative) for positive going inputs; when the input goes negative, the output is zero. That is, the input signal has been precisely half wave rectified.

Now, if the R_A , C network is connected to V_{out} , the half wave rectifier can be turned into a negative envelope follower. When V_{out} goes negative C is charged via

R_A ; V_{out} is unaffected whilst C is being charged. When V_{out} returns towards 0V, C discharges through R_A and Rfb. If C and R_A are correctly selected then a contour of the envelope of the signal will be produced at V_{out} . For an envelope attack time of 1 millisecond (1 kHz), with an envelope release time of 100 milliseconds, make Rin and Rfb 100k, R_A 1k and C 1uf.



LITESOLD

AT HOME SOLDERING

LC18 - 18 watts for all general electronic and small model work.



LC12 - 12 watts, slimmer, with smaller bits for fine work.



New LITESOLD 'L' Series irons are ideal for model and electronic hobbies. Designed to meet latest safety standards, they have fully enclosed heating elements, 3-core screw-connected mains leads, and a non-roll GRP handle shaped for comfort and safety.

24 different interchangeable copper bits, in chromium or long-life iron finishes, fit right over the heating elements for maximum efficiency.

Use the No. 3 spring stand for extra safety and convenience. Fitted with non-slip base, wiping sponge, and holds spare bits.

Available direct, or ask at your hobby shop.

Mail Order Prices (including postage and packaging, 8% VAT.)

	Copper Bit	L/L Bit
LC18 (State 12v, 24v or 240v)	£4.50	£4.98
Spare Bits 1.6mm, 2.4mm, 3.2mm, 4.7mm each	£0.62	£1.09
LA12 (state 6v, 12v, 24v or 240v)	£4.48	£4.96
Spare Bits 1.2mm, 1.6mm, 2.4mm, 3.2mm	£0.55	£1.03
No.3 Spring Stand	£3.19	
Special Offer Sets		
LC18 Iron, Stand and 4 spare Bits	£8.97	£11.11
LA12 Iron, Stand and 4 spare Bits	£8.72	£10.86

Light Soldering Developments Ltd.

97-99 Gloucester Road, Croydon, Surrey CRO 2DN. England.
Telephone 01-689-0574 Telex 8811945

Hobbyprints

An easy, patented method of making PCBs for HE projects.

For some time it has been possible to buy acid resist rub-down pads and track — in fact we use them in the HE workshops and they work very well. HOBBYPRINTS take this idea a stage further — the complete PCB pattern is already on the sheet and can be rubbed down in seconds — and the patterns are nice and crisp, made from the original artwork, used for the prototype.

If you have the facilities for ultraviolet exposure, HOBBYPRINTS make excellent masters — being solid black on a translucent film. With this method you can use the HOBBYPRINTS time and time again!

HOBBYPRINTS are produced exclusively for HE, and the whole system is protected by patents 1445171 and 1445172. Each month we will be bringing out a new HOBBYPRINT, containing the patterns for each issue's projects.

We're sorry for the delays in sending off the Hobbyprints, we'll be sending them out as soon as possible.



HOBBYPRINT A (November HE)
5 Watt stereo amplifier, Waa-Waa pedal, Bedside radio.

HOBBYPRINT B (December HE)
Digital dice, Photon (2 copies), Metronome, Audio mixer.

HOBBYPRINTS C (January HE)
Graphic Equaliser, Touch switch, Vari-Wiper, Flash Trigger.

HOBBYPRINT D (February HE)
Short Wave Radio, Sine/Square generator, Scratch/Rumble filter, Car Alarm.

HOBBYPRINT E (March HE)
Light Chaser, Photo Timer, Casanova's Candle, (2 copies), Tone Control (2 copies).

How to use HOBBYPRINTS.

1. Clean the PCB as you would for any work giving it a rub down with fine sandpaper (we even supply this in the kit). A quick wipe over with lighter fuel will help to remove any grease marks.
2. Lay down the HOBBYPRINT and rub over with a soft pencil until the pattern is transferred to the board. Peel off the backing sheet carefully making sure that the resist has transferred. If you've been a bit careless there's even a 'repair kit' on the sheet to correct any breaks!
3. Cut the board to size and put it in the Ferric Chloride.
4. When etching is completed, wash the board and use the sandpaper or a scouring powder to remove the resist. The resist pattern is pretty hardy but is easily removed at the final stage.
5. All you've got to do now is drill the board. Time? Only about ten minutes from beginning to end plus etching time (15 minutes usually with a good acid).

ORDER TODAY

Send cheque or postal order (payable to Hobby Electronics) to:

**HOBBYPRINTS,
HOBBY ELECTRONICS,
25-27, OXFORD STREET,
LONDON W1R 1RF.**

75p INCLUSIVE OF VAT AND POSTAGE.

Please mark the letter(s) of the HOBBYPRINTS on the outside of the envelope.



TV Signal Propagation

Point your TV aerial at the nearest transmitter and switch on your set. Nine times out of ten the picture's perfect. Gordon King explains how the signal reaches your television and why, sometimes, it doesn't.

IF YOU ARE standing up in a small boat on the sea your distance from the visible horizon would be about 3 miles. If you are 200 feet up on a cliff the distance would be about 17 miles. It is a fundamental law of physics that light travels in straight lines (if it didn't we shouldn't be able to discern detail). Because the surface of the Earth is curved it follows that the greater our elevation, the farther we can see. The horizon distance in miles can be approximated by multiplying the height in feet by 1.5 and then finding the square root of the result.

Light is a part of the electromagnetic wave family, as are radio waves; but radio waves differ from light in that they have a longer wavelength. The wavelength of visible light ranges from about 0.00039mm (deep violet) to about 0.00064mm (deep red). After this comes infra-red and then radio waves from about 0.00077mm upwards to 6,000mm or more. 405-line TV occupies Bands I and III (Band II is used by FM radio) whose wavelengths respectively range from about 4.5 to 7.2 metres and 1.4 to 1.7 metres. 625-line TV (including colour of course) occupies Bands IV and V whose wavelengths respectively are about 516 to 628 mm and 351 to 483 mm. Band I embraces channels 1 to 5, Band III channels 6 to 13, Band IV channels 21 to 34 and Band V channels 39 to 68.

The speed at which light and radio waves travel is close to 300 metres each millionth of a second. The frequency of a wave of given length can thus be discovered merely by dividing 300 by the wavelength, the answer then being in millions (denoted by the capital M for mega) of cycles per second (denoted by Hz), or MHz.

The frequencies corresponding to the wavelengths of TV Bands I and III are called very high frequencies (VHF for short), while the frequencies corresponding to the wavelengths in Bands IV and V are called ultra high frequencies (UHF). VHF extends from 30 to 300 MHz and UHF from 300 to 3000 MHz. The wavelength of the vision signal of Channel 3 works out to 5.286m (56.75 MHz), that of Channel 10 1.5m (199.75 MHz), that of Channel 27 507mm (591.25 MHz) and that of Channel 52 417mm (719.25 MHz).

HOT ROCKS

We shall see in a subsequent feature that the size of the aerial conductors are related to the signal

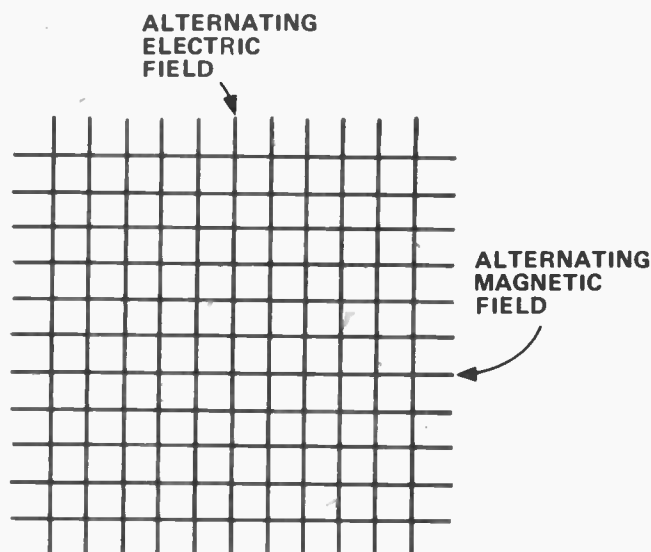

Fig. 1. Elementary impression of electromagnetic wave front advancing out of the page, showing the alternating electric and magnetic fields at right-angles to each other. The plane of polarization is in line with the electric field, vertical in this illustration.

wavelength and hence the frequency. The exercise right now is to get some idea of how the TV signals are propagated through space; but before they can be dispatched into space they must first be generated. They commence life as fairly low power oscillations of accurately controlled frequency established by a quartz crystal enclosed in a constant-temperature oven. They are then passed through frequency multiplying and power amplifying stages to endow them with the required transmitting frequency and power, and ultimately matched to the transmitting aerial. At some stage during these processes the information is modulated upon the radio-frequency (RF) signal which, for the 625-line TV system, is amplitude modulation (AM) for vision and frequency modulation (FM) for sound.

The aerial is tuned to the range of frequencies used by the transmitter which is achieved by altering the dimensions of the conductors or slots of which the aerial is

composed. When an RF signal is fed to an aerial which is correctly tuned and matched the signal is radiated into space in rather the same way as light is radiated from the top of a lighthouse, the main difference being that the radio waves are invisible.

In clear space and properly matched to the transmitter the aerial represents an impedance or resistance, which is called the radiation resistance. Signal current thus flows from the transmitter into the aerial and hence into space! Just how this happens is complex; but from a strictly elementary viewpoint the RF signal can be regarded as yielding self-supporting energy in space. Part of the energy is electric and part magnetic. Hence the term electromagnetic wave. The electric and magnetic fields as they are called work at right-angles to each other, and if it were possible to see an electromagnetic wave *advancing* out of this page the two fields would be related as shown in Fig. 1.

The polarity of both fields changes continuously at a rate corresponding to the frequency of the signal, and it is the interaction of the changing polarities which keeps the signal going as a coherent whole as it travels at the speed of light through space. Radiation from an omnidirectional aerial (an aerial which is designed to radiate equally from all angles round it) takes the form of an expanding sphere of signal field of diminishing intensity, just as the intensity of light diminishes with distance.

For many TV purposes, however, both the transmitting and receiving aerials are designed for directionality, the first to concentrate the radiation in a specific direction or directions, and the second to discriminate against unwanted signals arriving from directions other than that of the wanted signal. The optical analogy is the reflector or lens. We shall see soon that TV signals can be reflected, refracted and diffracted just like light.

TRANSVERSE ROPE TRICK

The direction of wave travel is perpendicular to the fields which are responsible for it; that is, the direction is at right-angles to the electric and magnetic fields. It is for this reason that an electromagnetic wave is called a transverse wave. An easily visualised transverse wave is that which is caused to run along a rope when one end is jerked sharply sideways. A distinction is a sound wave which is called a longitudinal wave because the molecules of the air or other medium through which it passes travel to and fro in a path which is parallel to the direction of propagation.

Under free-space conditions the signal intensity diminishes as the inverse square of the distance. This merely means that each time the distance is doubled the signal field falls by a factor of four. Under practical conditions, though, other factors come into play, such as topography, proximity of other aerials and buildings and tropospheric refraction. However, before looking at these things we should understand why it is that some TV aerials have their conductors or element vertically disposed while others have them horizontally disposed.

A radio wave is said to have a specific polarization, vertical when the lines of electrical field are vertical (as in Fig. 1) and horizontal when the lines of electric field are horizontal. In order for a conductor type aerial to extract the maximum of energy from a passing radio wave it must be set up to correspond to the polarization of the wave. This is because the signal induced into the aerial results from the changing magnetic field cutting through

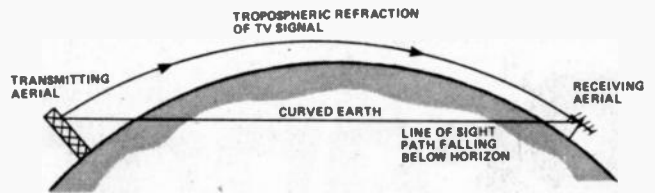

Fig. 2. Owing to tropospheric refraction, a TV signal is propagated over a distance greater than the optical line-of-sight distance. There is also a degree of diffraction of signal over the curves surfaces of the Earth.

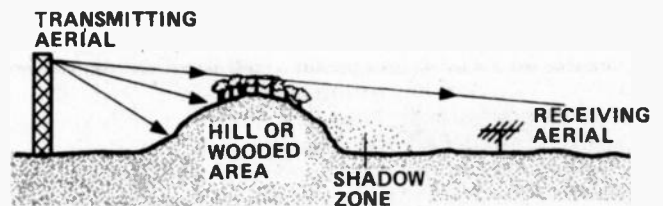

Fig. 3. A hill or heavily wooded area can obstruct UHF signals as shown.

the conductor (the dynamo principle). A slot aerial, on the other hand, needs to be set up in line with the magnetic field because such an aerial responds to the electric field. Some radio signals are slant polarized, notably the signals from some FM radio stations, so as to provide a reasonable response to both horizontal and vertical aerials, the latter which may be used with portable sets and car radios.

VHF and UHF signals, particularly the latter which are used for 625-line TV in Bands IV and V, are little affected by the ionosphere, which are 'electrified' or ionised layers surrounding the Earth, and thus pass straight through into outer space. To avoid this loss the radiation at high angles from TV transmitting aerials is deliberately curtailed. Long, medium and short wave signals, though, are considerably influenced by the ionosphere; they are reflected back to Earth by the layers which act rather like a large mirror in the sky, and for this reason are able to cover far greater distances than VHF and UHF signals, depending upon the time of day or night and the prevailing refractive index of the ionosphere.

The radiation of VHF and UHF signals from the top of a TV aerial is akin to the radiation of light from the top of a lighthouse. The waves travel in straight lines which means that the distance over which they may be received is significantly influenced by the respective heights of the transmitting and receiving aerials. We have seen that for light the horizon distance in miles approximates the square root of 1.5 times the height in feet. The radio horizon distance for VHF and UHF signals is a little greater, approximating in miles the square root of 2 times the height in feet.

TV Signal Propagation

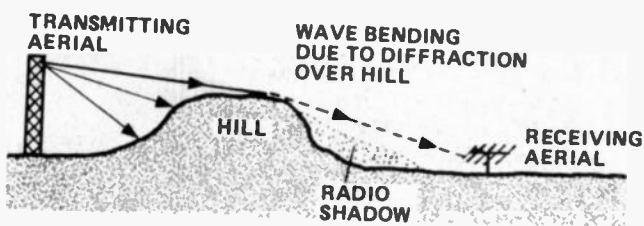

Fig. 4. It is sometimes possible to receive TV signals at the far side of a hill owing to diffraction over the surface of the hill; but a shadow zone is always present close to the foot of the hill.

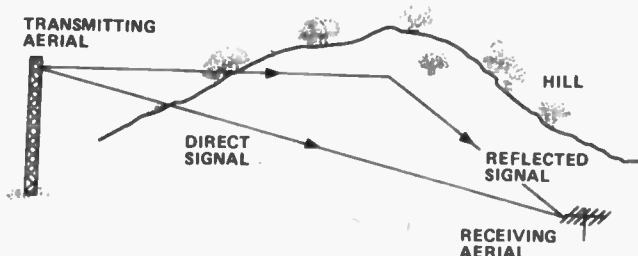

Fig. 5. Because a reflected TV signal has a longer path than the direct signal it arrives a fraction of a second after the direct signal at the receiving aerial and produces a ghost image on the screen as described in the text.

This is because the local layer of the Earth's atmosphere, called the troposphere, refracts the waves, causing them to curve slightly so that they hug the surface of the Earth over a greater distance than close-to-Earth light rays. There is also a degree of diffraction over the surface of the Earth which further extends the distance.

Some TV transmitting aerials have an elevation of 1,000 feet, so from the top of such an aerial the radio horizon distance would be about 45 miles. If the receiving aerial has an elevation of 50 feet then this would have a radio horizon distance around 10 miles, giving a total radio distance between the tops of the two aerials of about 55 miles, as shown in Fig 2. At distances in excess of this the reception would start to deteriorate; it would be variable and inconsistent because the signal field at the receiving aerial would be relying on tropospheric conditions, which can change significantly with changes in air pressure and weather.

LOW PRESSURE TV

Enthusiasts interested in long-distance reception at VHF and UHF exploit abnormal tropospheric conditions. When the tropospheric propagation deviates from the norm the radio distance increases owing to the change in refractive index of the troposphere, which is caused by temperature inversion effects (e.g., a change to increasing temperature after a certain height). The signal then tends to be 'ducted' through the troposphere over quite considerable distances. This sort of propagation is more likely to happen during a spell of anticyclonic weather, especially when the pressure just starts to fall after a prolonged spell of high pressure and hence

settled weather conditions. If you want to try your hand at receiving distant TV stations, keep your eye on the household barometer and tune over the TV bands at the start of a pressure decline following a high pressure period.

The very short wavelengths of visible light make it impossible for it to penetrate obstacles such as hills, buildings, walls, etc. in its path. The light thus casts a deep shadow behind the obstacle. Radio waves are more accommodating owing to their greater wavelengths. However, with reducing wavelength, and hence increasing frequency, radio waves tend to behave more and more like light rays. At the higher UHF channels even a wall can attenuate the signal arriving at the aerial if it is indoors. This is why it is always best to use a well elevated outside aerial for UHF television, especially at distances of 15 miles or more from a powerful station.

It is possible for a viewer to be located only a few miles from a high-channel UHF transmitter and yet be unable to obtain good reception from it. This can happen if a hill or wooded area obstructs the path between the transmitting and receiving aerials, as shown in Fig. 3. It may then be necessary to turn the aerial to a more distant transmitter, probably one with a lower channel number, to achieve reasonable reception. The screening effect of hills, etc. is less dramatic on the longer wavelength VHF channels because the far side of the hill may not be in total shadow owing to diffraction of the signal over the hill, as shown in Fig 4. However, if you are unhappily located close to the foot of the far side of a hill you could well be in a heavy shadow zone, even on the VHF channels, making it necessary to site the aerial at the top of the hill and feed signal down to the set through low-loss coaxial cable, probably *via* a preamplifier placed as close as possible to the aerial. There are quite a few viewers in hilly areas who need to do this.

Like light, VHF and UHF signals can also be reflected. While a shiny surface or mirror is required for good reflection of light, any object which is large compared with the wavelength can reflect TV signals. This can be troublesome because the receiving aerial will respond first to the direct signal and then a fraction of a second later to the reflected signal. The reflected signal, of course, always takes a little longer to reach the aerial than the direct signal owing to its greater distance of travel, as shown in Fig 5.

DOUBLE VISION

If the path length of the reflected signal is, say, 1.5 km greater than the direct signal, the reflected signal will arrive at the aerial $5\mu\text{s}$ (5 millionths of a second) after the direct signal. This may not seem very significant; but it is because the scanning spot which traces out the picture on the TV screen takes only about $52\mu\text{s}$ (625-line system) to travel from left to right to make a full line. Thus if the width of the screen is, say, 500mm the spot would have travelled 48mm when the reflected signal arrives. The result is a ghost display of the original image displaced by 48mm to the right.

Owing to the phasing of the reflected signal the ghost may appear in positive or negative form, and multiple ghosts result from multiple reflections. In severe cases the line synchronising of the TV can be disturbed. The only real solution to this problem is to employ a highly directional aerial which can be orientated for maximum discrimination of the reflected signal or signals, as we shall see in a later feature.

HE

EMI SPEAKER BARGAIN

Stereo pair 350 Wt. System consists of 13" x 8" approx. woofer with rolled surround; 2 1/2" approx. Audax tweeter, crossover components and circuit diagram. Frequency response 20 Hz to 20 KHz. Power handling 15 watts RMS 20 watts max. 8 ohm impedance.

£14.95 Per stereo pair + £3.40 p&p.

★ As above but complete with all woodwork in kit form, finished in simulated teak veneer, with instructions. Size approx 20" x 11" x 9 1/2" **£28.00** Per stereo pair + £5.00 p&p.



BSR Manual single play record deck with auto-return and cueing lever, fitted with stereo ceramic cartridge 2 speeds with 45 r.p.m. spindle adaptor ideally suited from home or disco use. **OUR PRICE £10.95** p&p £2.55

TURNTABLE BARGAINS FOR PERSONAL SHOPPERS

GARRARD 86SB Deck **£26.95** | GARRARD SP25 MKIV Deck with Shure head **£25.95**
Plinth and cover for BSR decks **£6.00**

BARGAINS FOR PERSONAL SHOPPERS

PORTABLE STEREO RADIO CASSETTE RECORDER UNREPEATABLE



MW, LW, SW and Stereo VHF. 6 watts output Battery/Mains operation. **160 16 VOLT MAINS TRANSFORMER, 2 1/2 amp** **£69.95**

Garrard Record auto deck on plinth with stereo cartridge ready wired **£18.95**

LED 5 function men's digital watch stainless steel finish **£5.95**

LCD 5 function men's digital watch stainless steel finish **£6.95**

LCO 8 Function CHRONOGRAPH men's digital watch, stainless steel finish **£13.95**

Battery/Mains Cassette Recorder with built-in Mic. **£12.95**

AM/FM DIGITAL CLOCK RADIO Accurate 4 Digit Electronic Clock with 1/2" LED display. Buzzer and snooze timer. **£11.95**



125 Watt Power Amp Module **£13.95**

Mains power supply for above unit. **£3.50**

MUSIC CENTRE CABINET with hinged smoke acrylic top, finished in natural teak veneers. size 30 1/2" x 14 1/2" x 7 1/2" approx. **£5.95**

MULLARD Built power supply **£1.50**

OECCA DC 1000 Stereo Cassette P.C.B. complete with switch oscillator coils and tape heads. **£2.95**

DECCA 20w Stereo speaker kit comprising 2 8" approx. bass units + 2 3 1/2" approx. tweeter inc. crossovers **£20.00**

VIDEOMASTER Super Score TV Game with pistol mains operation **£14.95**

PORTABLE RADIO/CASSETTE RECORDER, AM/FM with clock. LW, MW, SW, VHF mains/battery operation. **£41.95**

7" TAPE TRANSPORT Mechanism—a selection of models from **£8.95**

SANYO Nic/cad. battery, with mains charger equivalent in size and replaces 4 SP11 type batts. Size 3 3/4" x 1 1/4" x 2" approx. **£7.50** p&p £1.50p



AM/FM STEREO TUNER AMPLIFIER CHASSIS COMPLETE WITH DECODER Ready built. Designed in a slim form for compact, modern installation. Rotary Controls Vol On/Off, Bass, Treble, Balance. Push Buttons for Gram, Tape, VHF, MW, LW. Power Output 5 watts per channel Sine at 2% THD into 15 Ohm 7 watts speech and music. Tape Sensitivity Playback 400mV/30K OHM for max output Record 200mV/50K output available from 25KHz. (150mV/100K) deviation FM signal Frequency Range (Audio) 50Hz to 17KHz within ±1dB Radio FM sensitivity for 3dB below limiting better than 10 uV AM sensitivity for 20dB S/N MW 350 uV/Metre LW 1mV/Metre Size approx length 16" x height 2 3/4" x depth 4 1/4" **£19.95** p&p £2.50

Mullard

AUDIO MODULES IN BARGAIN PACKS

CURRENT CATALOGUE PRICE & AT OVER **25** PER PACK

SEE OUR PRICES

1 PACK 1. 2 x LP1173 10w. RMS output power audio amp modules, + 1 LP1182/2 Stereo pre amp for ceramic and auxiliary input. **OUR PRICE £4.95** p&p £1.00

2 PACK 2. 2 x LP1173 10w. RMS output power audio amp modules + 1 LP1184/2 Stereo pre amp for magnetic, ceramic and auxiliary inputs. **OUR PRICE £7.45** p&p £1.00

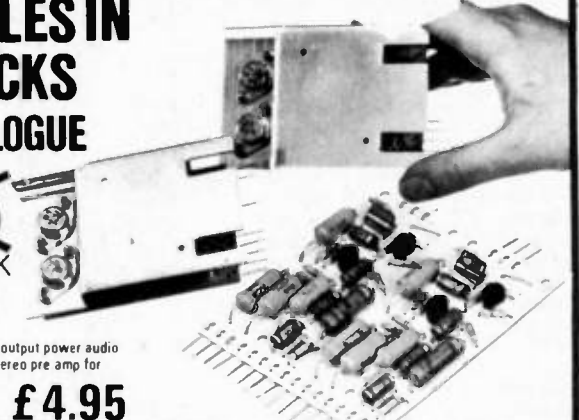

ACCESSORIES

Suitable power supply parts including mains transformer, rectifier, smoothing and output capacitors **£1.95** p&p

Recommended set of rotary stereo controls comprising BASS, TREBLE, VOLUME and BALANCE. **p&p 50p 95p**

★ FOR PERSONAL SHOPPERS ONLY

GARRARD BARGAIN

LIST PRICE ~~£98.00~~
OUR PRICE **£39.95**

86 SB MKII. Belt drive, 2 speed turntable module with plinth and cover.



20 x 20 WATT STEREO AMPLIFIER

Viscount IV unit in teak simulate cabinet. Silver fascia with aluminium rotary controls/pushbuttons, red mains indicator and stereo jack socket. Functions switch for mic, magnetic and crystal pickups, tape tuner and auxiliary. Rear panel features two mains outlets DIN speaker and input sockets plus fuse 20x20 watts RMS 40x40 watts peak. For use with 8 to 15 ohm speakers. **£29.90** + £2.50 p&p

SPECIAL OFFER FOR PERSONAL SHOPPERS ONLY

FREE: 4 dimensional stereo sound adaptor, when purchasing the 20x20 Viscount amplifier.

30x30 WATT AMPLIFIER IN KIT FORM

For the experienced constructor complete in every detail, same facilities as Viscount IV, but with 30x30 output. 60:60 watts peak. For use with 4-15 ohms speakers. £23.00 without cabinet. £29.00 complete with cabinet. p&p £2.50 in each case.

£23.00 + £2.50 (NOTE Cabinet not available separately.) **£29.00** + £2.50 complete with cabinet

SPECIAL OFFER Complete with case

30x30 WATT AMPLIFIER IN KIT WITH SPEAKERS

2 Goodman compact 12" bass woofers with cropped size 14,000 Gauss magnet. 30 watt RMS handling + 3 1/4" approx. tweeters and crossovers. **£49.00** + p&p £4.00

BUILT AND READY TO PLAY

30x30 Viscount. Available fully built and tested. **39.00** + p&p £2.50



323 EDGWARE ROAD, LONDON W2
21H HIGH STREET, ACTON W3 6NG

ALL PRICES INCLUDE VAT AT 12 1/2%

All items subject to availability. Price correct at 15.12.78 and subject to change without notice. As at press date (25/1/79) there are delays on all postal items due to the road and rail industrial disputes.

50 WATT MONO DISCO AMP

£29.95

P&P £2.50

Size approx. 13 1/2" x 5 1/2" x 6 1/2"

50 watts rms, 100 watts peak output. Big features include two disc inputs, both for ceramic cartridges, tape input and microphone input. Level mixing controls fitted with integral push-pull switches. Independent bass and treble controls and master volume. **SPECIAL OFFER** The above 50 watt amp plus 4 Goodmans Type 8P 8" speakers. Package price **£45.00** + £4.00 P&P

70 & 100 WATT MONO DISCO AM

Size approx. 14" x 4" x 10 1/2"

Brushed aluminium fascia and rotary controls

Five vertical slide controls: master volume, tape level, mic level, deck level, PLUS INTER DECK FADER

for perfect graduated change from record deck No. 1 to No. 2, or vice versa. Pre fade level control

(PFL) lets YOU hear next disc before fading

140 watt peak

it in. VU meter monitors output level. p & p £4.00

Output 100 watts RMS 200 watts peak. **100 watt £65**

STEREO CASSETTE TAPE DECK ASSEMBLY

Consisting of ready built tape transport system/mechanism mated to the electronics

Unit is ready built for installing into cabinet of own choice

Features include pause control, solenoid assisted auto-stop, 3 digit tape counter, belt driven balanced fly wheel by DC motor with electronic speed control, twin VU meters

Specification Power Output, more than 0.5v, mc -65dB 10K, DIN -47dB 100K

Track-2 channel stereo record play back. Tape speed 4.8cm/sec. Freq response 50 1200 Hz signal to noise ratio 42dB Recording system AC bias Erasing system AC erase Bias freq. 57KHz. Compatible for both normal and chrome dioxide tapes. Size of mechanism only 4 1/2" x 6 1/2" x 11 1/4" approx. included a moulded top plate as illustrated

13 1/2" x 9 1/2" approx. with circuit diagram **£25.00** P&P £2.50

Opt extras Mains transformer to suite **£2.50** + £1 p & p



555 I.C. PROJECTS

Short Circuits

THE 555 IC is one of the most useful devices to the electronics hobbyist, and three examples of its use in the astable (oscillator) mode are given here.

Electronic Doorbuzzer.

This design provides a novel doorbuzzer signal which starts at a low pitch and gradually rises in frequency.

The normal method of oscillation for the 555 is for the timing capacitor (C2) to charge up two thirds of $V+$ via two timing resistors (R1 and R2). The IC is then triggered and C2 is discharged through R2 and an internal transistor of the 555. The IC resets when the charge voltage drops to one third of $V+$, with the discharge transistor switching off and C2 commencing to charge up to the trigger potential once again.

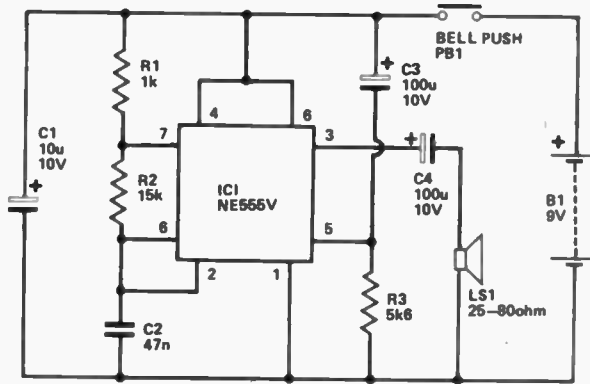

This particular circuit does not oscillate in precisely this basic way, since the network comprised of R3 and C3 is used to shunt the potential divider (within the IC) which

sets the trigger voltage. When SW1 is initially closed, C3 will be discharged and the trigger voltage will be raised. This increases the charge and discharge times of C2,

and reduces the frequency of operation. C3 is quickly charged through R3 though and after about one or two seconds the trigger voltage will have fallen to a level set by R3 and the integral potential divider. R3 pulls the trigger voltage below its normal level, reducing the charge and discharge times of C2 and causing an increase in the operating frequency. Thus, as C3 charges up, the output frequency is swept upwards, producing a novel and effective signal.

The main output at pin 3 of the 555 goes high during the charge period, and low during the discharge period, producing a rectangular waveform of low enough impedance to drive a speaker with up to a few hundred milliwatts of signal.

Continuity Tester.

A common failing of simple continuity tester circuits is that they will give an indication of continuity between the test prods when there may actually be a resistance of a few hundred ohms or more. This is often of no importance, but it can sometimes give misleading results. This simple design can be adjusted so that it will not respond to resistances of more than a few ohms.

The circuit is basically just a standard 555 astable operating at a frequency of about 800 Hz and feeding a high impedance speaker. However, reset terminal pin 4 is tied to the negative supply rail by R3, and this blocks the astable action. Pin 4 must be taken positive by about 0.5V, or more in order to produce an audio output.

RV1 is adjusted so that with the

rest prods shorted together there is only just sufficient voltage at pin 4 to enable oscillation to take place. Therefore, with genuine continuity between the test prods the unit will produce an audio output, but with a resistance of more than about 7 or 8 ohms in circuit, the voltage at pin 4 will be inadequate due to the voltage drop across this resistance. RV1 is fed from a stabilised supply provided by R4 and D1 so that minor variations in the supply voltage do not necessitate readjustment of RV1. Occasional readjustment of RV1 may still be needed if this is very critically adjusted for optimum discrimination.

Note that the circuit will consume power when the test prods are not connected together (about 6 mA.), and so on/off switch SW1 is required.

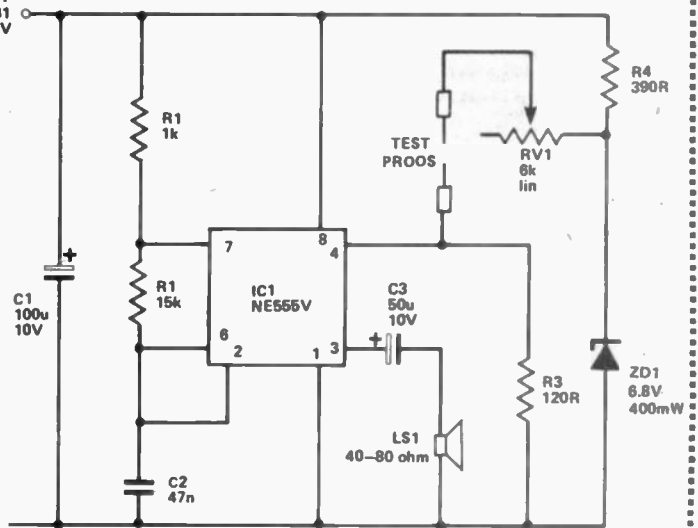

Simple Timer.

This general purpose timer gives an audible alarm so predetermined time after the unit is switched on. With the specified values the time is variable from about 30 seconds to 5 minutes, but this can be altered to suit individual requirements.

When the unit is switched on using SW1, C1 begins to charge via R1 and RV1. Initially the voltage at the inverting (-) input of IC1 will be higher than that appearing at the non-inverting (+) input, and so IC1 output will assume a very low voltage. As C1 charges up, the voltage fed to the inverting input gradually falls until it starts to go below the voltage at the non-inverting input. IC1 output then begins to rise in voltage and due to coupling through R4 this increases the voltage at the non-inverting input. This causes a further increase in output voltage, and a regenerative action takes place which causes IC1 output to rapidly swing to almost the full positive supply potential.

The 555 is used to generate the

alarm signal using a circuit which is basically the same as the continuity tester circuit described above. However, the reset terminal is, of course, controlled by the output of IC1 rather than by the test prods and potential divider circuit.

The charge rate of C1 and thus the length of the timing interval can

be altered by changing the resistance of RV1. The time delay is approx. $1.4 CR$ (with C in μF , R in Meg., and the time in seconds), but due to the high tolerances of the timing components it is impossible to obtain highly predictable results. R3 has therefore been included so that the trigger voltage of the

circuit can be varied, and by trial and error R3 can be adjusted to give the appropriate timing range.

When the unit is switched off, SW1 discharges C1 through current limiting resistor R7 so that the unit is ready to start a new timing run almost immediately.

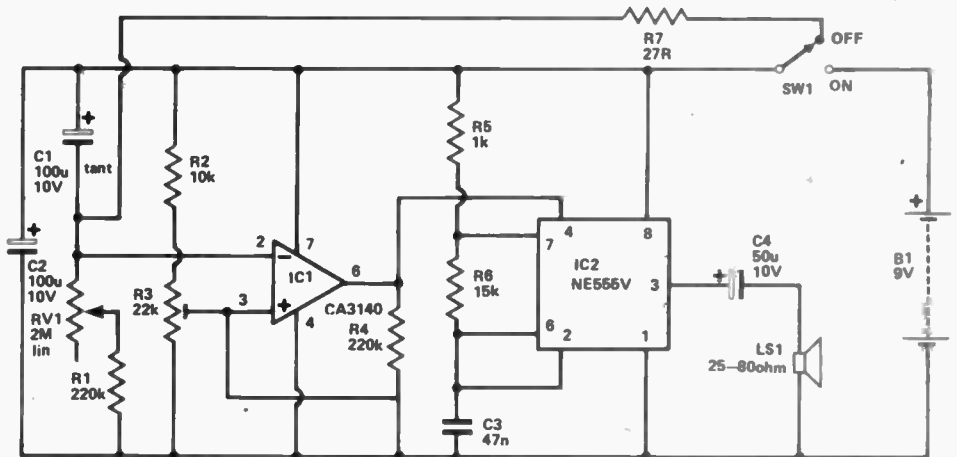

The latest kit innovation!

from **Sparkrite**

Sparkrite featured by Shaw Taylor in "DRIVE IN"

the quickest fitting
CLIP ON
capacitive discharge
electronic ignition
in KIT FORM

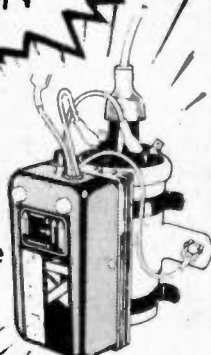

- Smoother running
- Instant all-weather starting
- Continual peak performance
- Longer coil/battery/plug life
- Improved acceleration/top speeds
- Optimum fuel consumption

Sparkrite X4 is a high performance, high quality capacitive discharge, electronic ignition system in kit form. Tried, tested, proven, reliable and complete. It can be assembled in two or three hours and fitted in 1/3 mins. Because of the superb design of the Sparkrite circuit it completely eliminates problems of the contact breaker. There is no misfire due to contact breaker bounce which is eliminated electronically by a pulse suppression circuit which prevents the unit firing if the points bounce open at high R.P.M. Contact breaker burn is eliminated by reducing the current to about 1/50th of the norm. It will perform equally well with new, old, or even badly pitted points and is not dependent upon the dwell time of the contact breakers for recharging the system. Sparkrite incorporates a short circuit protected inverter which eliminates the problems of SCR lock on and, therefore, eliminates the possibility of blowing the transistors or the SCR. (Most capacitive discharge ignitions are not completely foolproof in this respect). The circuit incorporates a voltage regulated output for greatly improved cold starting. The circuit includes built in static timing light, systems function light, and security changeover switch. All kits fit vehicles with coil/distributor ignition up to 8 cylinders.

THE KIT COMPRISES EVERYTHING NEEDED

Die pressed epoxy coated case. Ready drilled, aluminium extruded base and heat sink, coil mounting clips, and accessories. Top quality 5 year guaranteed transformer and components, cables, connectors, P.C.B., nuts, bolts and silicon grease. Full instructions to assemble kit neg. or pos. earth and fully illustrated installation instructions.

NOTE - Vehicles with current impulse tachometers (Smiths code on dial RV1) will require a tachometer pulse slave unit. Price £3.85 inc. VAT, post & packing.

Electronics Design Associates, Dept. HE5
82 Bath Street, Walsall WS1 3DE. Phone: (9) 614791

Name _____

Address _____

Phone your order with Access or Barclaycard

Send SAE if brochure only required.

Including postage and packing UK only

QUANTITY REQD.

X4 KIT £16.65 inc. VAT

TACHO PULSE SLAVE UNIT
£3.85 inc. VAT

I enclose cheque/PD's for

£

Cheque No. _____

Access or Barclaycard No. _____

BULK PURCHASE - EXCLUSIVE TO HENRY'S
ALLOWS US TO SELL AT SUCH FANTASTIC PRICES!

QUALITY ITEMS
Compare performance and specification with units costing 3 times as much!

AS USED IN **BRAUN**
DIGITAL CLOCKS

DIGITAL
24 HOUR
CLOCK

WITH
BUILT IN
ALARM

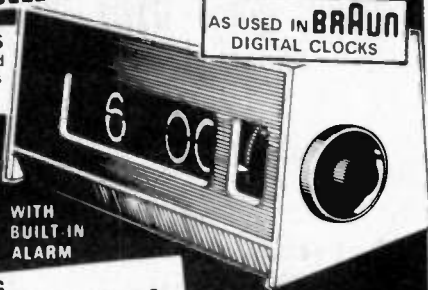

- SILENT RUNNING
- LARGE ILLUMINATED NUMERALS
- AC MAINS ● SIZE 6 1/2 x 2 1/4 x 2 1/4

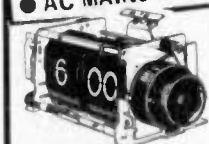

MECHANISM ONLY



Assemble it in an evening!
MECHANISM & CASE
Inc. assembly instructions



Modern Styling
COMPLETE UNIT

£5.00

£6.99

£7.99

THREE FOR £23

THREE FOR £13.50

THREE FOR £20

POST & VAT INCLUSIVE

Send cheque, P.O. / M.O. for the correct amount which includes VAT and P & P or pay by Access/Barclaycard. Send name / card number (if applicable) and address to:

HENRY'S RADIO
404 EDGWARE ROAD,
LONDON W2 1ED

EXPORT ENQUIRIES INVITED

AVAILABLE ONLY FROM

HENRY'S
Radio



DELIVERY FROM STOCK

ACE

TOPS THE PACK!

ACE MAILTRONIX LTD
Dept. HE5, Bath Street
Walsall, W. Yorkshire, WF15 8JR

COMPONENTS - Now over 1,000 types in stock.
KITS - See the new range of low-cost 'ELEKITS'.
MODULES - New ready-built functions.
SERVICE - 1st Class same day despatch.
QUALITY - All guaranteed products.
PRICES - Many reductions!
MAGAZINE PROJECTS - Trouble-free!

Look

Our 2nd edition illustrated catalogue is now available. The much increased range shows many welcome price reductions.

FABULOUS
HOURS OF PLEASURE
'ELEKITS'
EASY BUILD INTRODUCTION
TO ELECTRONICS

The new range of easy build kits complete with simple to follow instructions. Battery powered (not supplied). With case.

- * BURGLAR ALARM
- * ROULETTE
- * BICYCLE SOUND FLASHER
- * MINI ORGAN
- * SIREN
- * BLINKER
- * TIME SWITCH

Many others in preparation - included in full ACE catalogue - send S.A.E. for free brochure of kit range.



Name _____
Address _____

* Refundable with future orders over £5.00.

Tone Control

The trouble with old or cheap audio equipment is that it sounds old or cheap. This tone control unit won't turn a steam radio into hi-fi, but it will help to cut the tinny top and boost the missing bass.

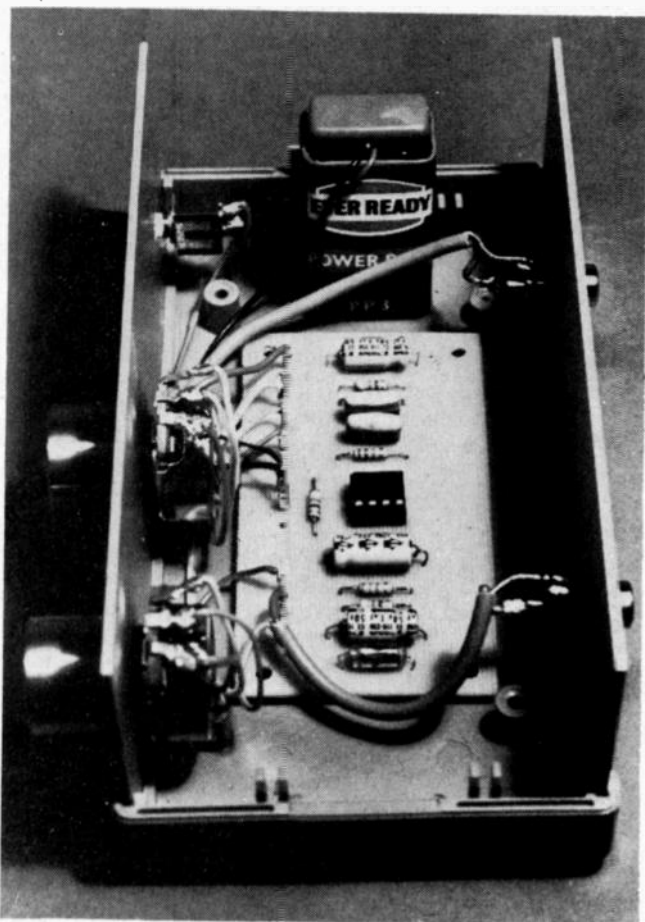

This add-on control circuit can be used to improve the audio quality of any old or inexpensive radio, amplifier, or record player, etc. The circuit is designed around an operational amplifier which is powered from single-

ended supply rails. These supply rails can have any value in the range 9 V to 18 V.

The tone control circuit can either be built as an independent general-purpose accessory, as in the case of our prototype, or can simply be built into existing audio or radio equipment and powered from the equipment's own power supply rails.

CONSTRUCTION AND USE

Construction of the unit should present no problems at all, providing care is taken to ensure that the i.c. and the electrolytic capacitors are fitted the right way round. If you intend to build the circuit into existing equipment, omit switch SW1 and take the top of R1 to the positive supply rail of the equipment, after first checking that the supply rail is in the 9 V to 18 V range.

If you are fitting the unit into existing equipment, place it in a position where it handles low-level audio signals. In a radio, place it between the detector and power amplifier stages, and in an audio system place it between the pick-up or pre-amp and the main amplifier stages.

Below: the full size PCB foil pattern

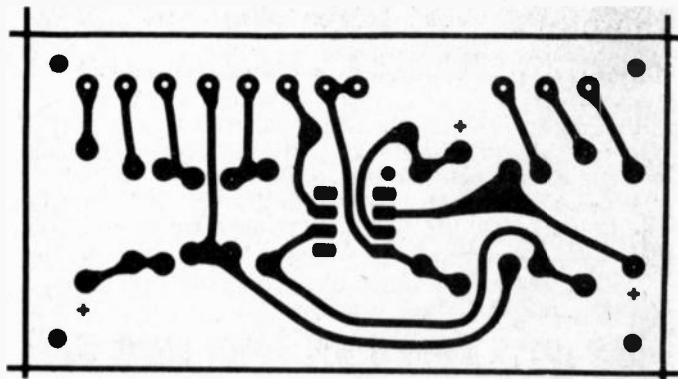

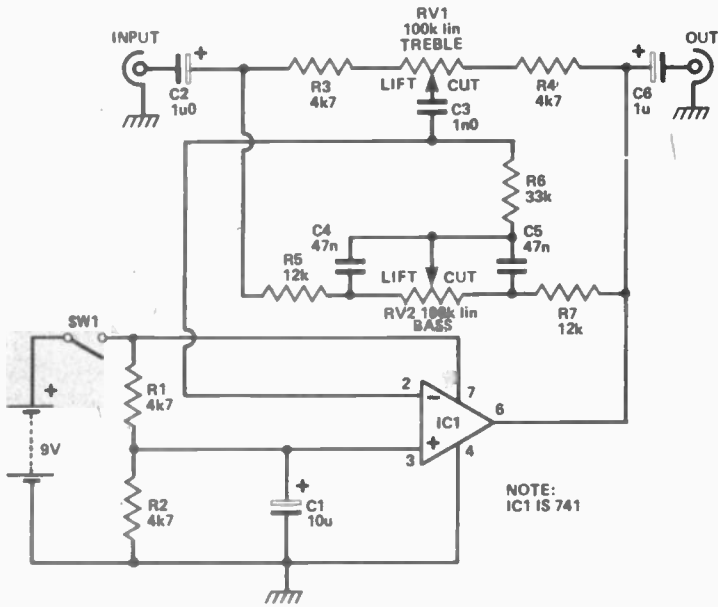

Fig. 1. Circuit diagram of the tone control unit.

How it Works

The integrated circuit used in this design is a type-741 general purpose operational amplifier. Most op-amp circuits are powered from split supply rails, but in our circuit we get away with using only a single-ended supply by biasing input pin 3 at half-supply voltage via potential-divider R1-R2 and decoupling this pin via C1.

The op-amp is wired as an inverting amplifier with a frequency-selective tone control networks in its feedback and input paths. These networks provide usable lift and cut ranges of plus and minus dB respectively.

The operating theory of the tone-control network is fairly involved. Look first at the treble control section. When RV1 is in its LIFT position, R3 is effectively in series with the input signal and RV1 and R4 are in the op-amps feedback path at high frequencies, so the high frequency gain is large, but when RV1 is in its CUT position R3 and RV1 are in series with the input and R4 is in the feedback path, so the high frequency gain is low. C3 determines the high frequency turnover or lift and cut points of the circuit.

Look now at the BASS control section. When RV2 is in the LIFT position C4 is shorted out, so R5 is effectively in series with the input and RV2 and R7 are in the feedback path, so the low-frequency gain is high. Note, however, that in this mode RV2 is shunted by C5, so the gain falls off as frequency increases. When RV2 is in the CUT position C5 is effectively shorted out, so R5 and RV2 are in series with the input and R7 is in the feedback path, so the low-frequency gain is low. Note in this case, however, that RV2 is then shunted by C4, so the gain rises as frequency increases.

The composite range of performance of the complete tone control network is illustrated in the graph.

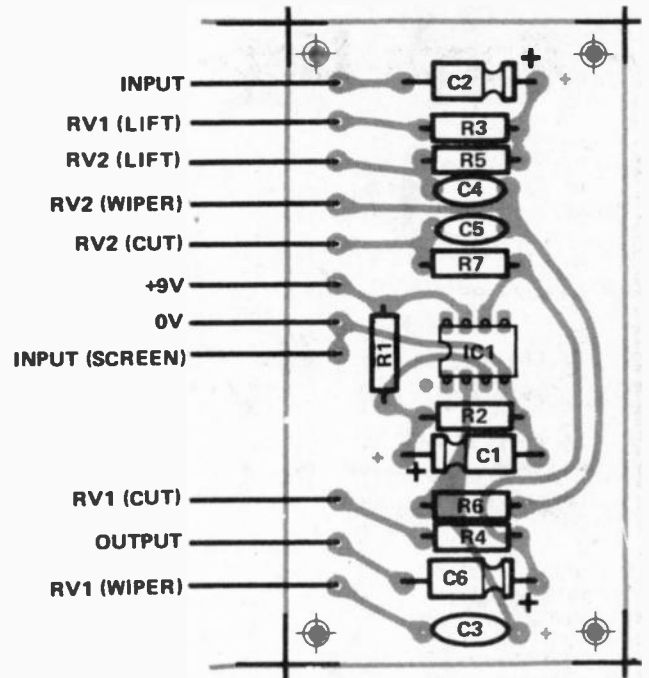

Fig. 2. How to position the components on the PCB.

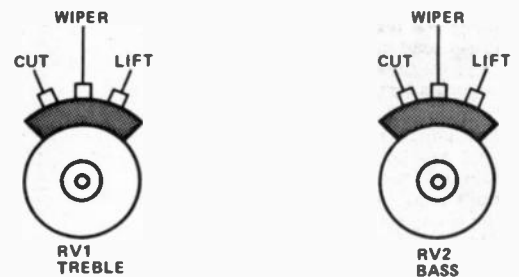
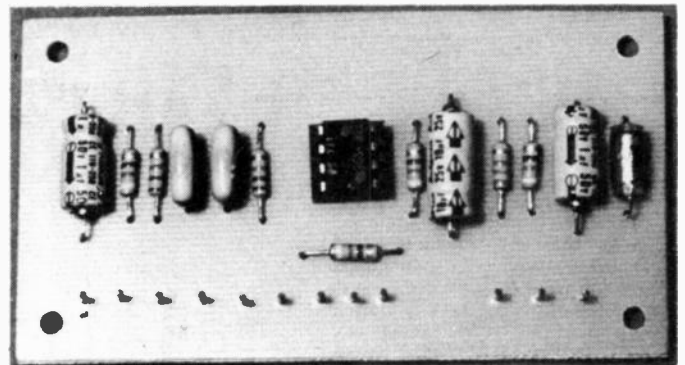

Fig. 3. Rear view of the two control pots.

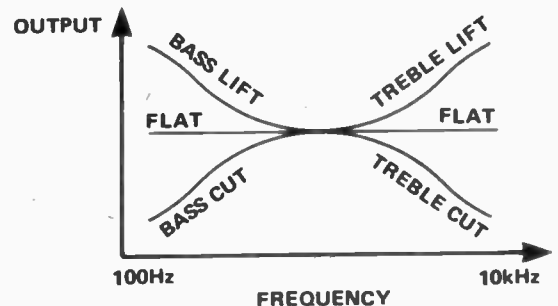

Fig. 4. Composite performance graph of the tone control circuit. The range of LIFT and CUT is + 16 db.

Parts List

RESISTORS

R1, R2, R3, R4,	4k7
R5, R7,	12k
R6,	33k

CAPACITORS

C1	10u	elect
C2, C6	1u	elect
C3,	1n	polystyrene
C4, C5	47n	polystyrene

POTENTIOMETERS

RV1, RV2	100K	Lin
----------	------	-----

SEMICONDUCTORS

IC1	741
-----	-----

MISCELLANEOUS

DPST min. toggle
2 off phono sockets
8 pin DIL socket
9 V PP Battery 3
foil pattern for PCB.
Vero box to suit.

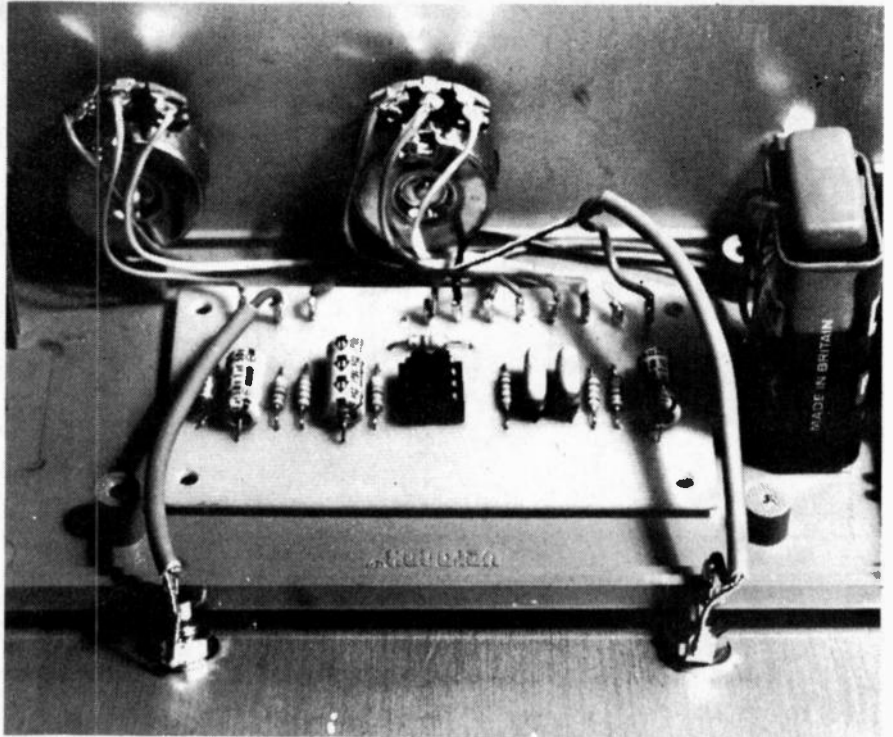

Short Circuit

NOISE LIMITER

This circuit is particularly intended for those interested in DX-ing, that is, listening for distant radio stations. However, the same circuit has other uses such as reducing the scratch level on very old records (note that this is not the normal type of scratch filter circuit normally associated with Hi-Fi equipment). It also has uses in PA equipment where it can limit the input to the final stages and prevent overload distortion; distortion will still be present when an overload occurs but it is not as objectionable as that usually produced.

The circuit is designed to take almost any audio input but the output will have all peaks above a certain level, which can be adjusted, eliminated.

The circuit can either be wired into a receiver circuit or directly from a headphone socket in which case the headphones are wired to this unit instead. If wired into a circuit permanently, RV1 should take the place of the normal volume control and the output should be wired to the point which was previously connected to the volume control slider. An extra control plus a switch will also have to be mounted on the receiver front panel. The circuit can either be left in permanently as at most settings it will not affect the signal or it can be switched.

The output of the receiver, which as we have said can be from the volume control or the headphone socket, is taken to the input and amplified by Q1 which is connected in the common emitter

mode. This transistor will considerably increase the audio level and this is applied via a DC blocking capacitor, C2 to the two silicon diodes D1 and D2. In the normal way these diodes will not have any bias voltage applied across them and so they will present a high resistance, and will not affect the output in any way. However, as soon as the output from the amplifier exceeds about 0.6V, the diodes will conduct and short the output to the negative line. Two diodes are needed, one connected each way around, so that both positive and negative going peaks are shorted out. The idea of the amplifier is to make sure that whatever the input level across RV1, it can be amplified so that at

least 0.6 V can be applied across the diodes. Since RV1 is adjusted so that the level is always the same a volume control has been included in the circuit so that the output level can be controlled in the usual way; this is accomplished by RV2.

To limit the noise the input level is increased until the audio signal that is wanted is just distorting and then backed off slightly so that no distortion is heard on the peaks of the audio part of the signal. This will then mean that any audio peaks above that level will hardly be heard in the output as the peaks above the preset limit will be conducted to the negative line, RV2 is then adjusted as a normal volume control. If RV1 is adjusted well below the limiting level and RV2 is

adjusted for normal listening levels, the circuit has no effect. However, it is a simple matter to include SW1 which will bypass the circuit. The supply voltage can be taken from a battery as shown in the circuit, the current drain being very small, or from the receiver's supply. If this is transistor operated with 9 V then there will be no difficulty but if the receiver uses a supply potential higher than 9 V then a suitable dropping resistor will have to be included.

The effect of the noise limiter is quite remarkable and by switching the circuit in and out it is possible to compare the results. The noise will still be there but not at an annoying level and the signal will be very, very much clearer.

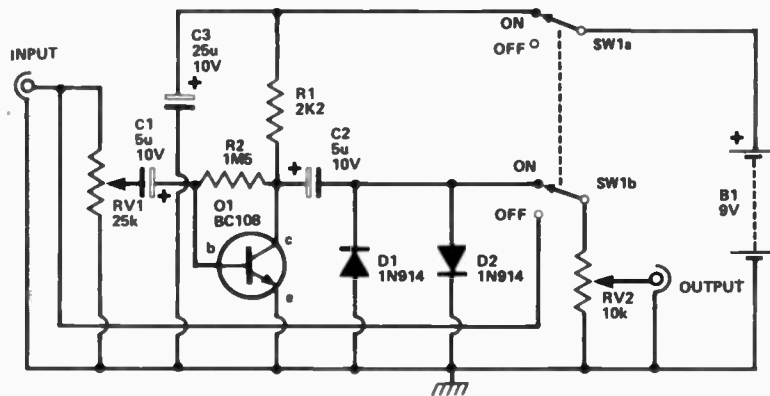

OUR RANGE OF PRODUCTS ARE NOW INDIVIDUALLY AND ATTRACTIVELY PACKAGED

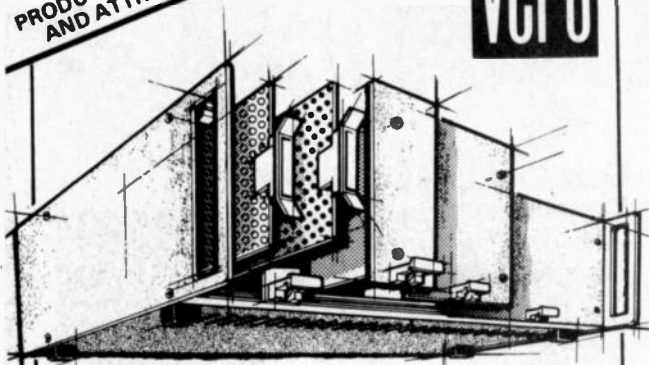

Our new catalogue lists a card frame system that's ideal for all your module projects — they used it in the ET1 System 68 Computer. And we've got circuit boards, accessories, cases and boxes — everything you need to give your equipment the quality you demand. Send 25p to cover post and packing and the catalogue's yours.

VERO ELECTRONICS LTD. RETAIL DEPT.
Industrial Estate, Chandlers Ford, Hants. SO5 3ZR
Telephone Chandlers Ford (04215) 2956

SINCLAIR PRODUCTS*

Microvision TV UK model £89.95, PDM35 £27.25, mains adaptor £3.24, case £3.25, DM350 £87.50, DM450 £98.90, DM235 £49.48 Rechargeable battery £7.50. Mains adaptor £3.70, Enterprise prog calculator £21.99, Cambridge prog calculator £13.13, prog library £3.65, mains adaptor £3.20.

COMPONENTS

Send see for full list: 10 Fac1 £1.05, Dalo pen 73p, 60 sq ms pcb 85p, Laminated cutter 78p, Small drill 28p, ZN414 £1.05, Pcb and za parts for radio £3.88, Case £1, IN4148 1.4p, IN4002 2.8p, 723 28p, 741 18p, NE555 23p, BC182B, BC183B, BC184B, BC212B, BC213B, BC214C 4.8p, Plastic equips BC107 4.8p, BC109 6p, 1/4w 5% E12 resistors 10R to 10M 1p, 0.5p for 50+ of one value Electrolytics 16v 5/11/2/5/10/22mf 8p, 100mf 6p, 1000mf 10p, 1500mf (PC) 3.4p, 10v 2mf 1.7p, 1000mf 8.1p, 2200mf 8p, Polyesters 250v 015 088, 1mf 1 1/2p, Ceramics 50v E5 22pf to 47n 2p, Polystyrenes 83v E12 10pf to 10n 3p, Zeners 400mW E24 2v 7 to 33v 7p.

TV GAMES KITS

Send see for data AY-3-8500 + kit £8.95, Rifle kit £4.95, AY-3-8500 + kit £2.50, Stunt cycle chip + kit £10.90, Racing car chip + kit £17.00.

TRANSFORMERS

6-0-6V 100ma 74p, 1 1/2 £2.38, 6 3V 1 1/2 £1.88, 9-0-9V 75ma 74p, 1a £2, 2a £2.80, 12-0-12V 100ma 90p, 1a £2.48.

IC AUDIO AMPS

With pcb JC12 6W £1.80, JC20 10W £2.88. Send see for data

BATTERY ELIMINATORS

3-way type 6.75 9V 300ma £2.98, 100ma radio type with press-studs, 9V £3.35, 9V+9V £4.80, Stabilized type 3 6.75 9V 400ma £5.30, 12V car converters 3 4 1/2 6.75 7.9V 800ma £2.98.

BATTERY ELIMINATOR KITS

Send see for data, 1000ma radio types with press-studs 4 1/2V £1.40, 6V £1.40, 9V £1.40, 4 1/2+4 1/2V £1.80, 6+6V £1.80, 9+9V £1.80, Stabilized 8-way type 3 4 1/2 6.75 7.9V 12/15 18V 100ma £2.88, 1 Amp £5.40, Stabilized power kits 2-18V 100ma £3.88, 2-30V 1A £6.95, 2-30V 2A £10.95, Car converter 6 7 1/2 9V 1A £1.35.

T-DECS AND CSC

BREADBOARDS
S-Dec £3.17, T Dec £4.02, OeCA £4.40, DeCB £6.73, 16 di adaptor £2.14, EXP300 £6.21, EXP350 £3.40, EXP650 £3.88, EXP48 £2.48.

BI-PAK AUDIO MODULES

S450 £23.81, AL60 £4.88, PA100 £16.58, SPM80 £4.47, BMT80 £5.95 Stereo 30 £20.12.

SWANLEY ELECTRONICS

(Dept HE), 32 Goswell Rd., Swanley, Kent.
Postage 30p extra Prices include VAT

Hobby Electronics

CLOCK RADIO



Size: 177mm x 90mm x 47mm.

You probably won't believe us as we're selling the goods but we're going to tell you anyway! We have *rejected* eight clock radios for Marketplace, they were all cheap enough but the quality was so poor that we couldn't have lent our name to them. However, we are now able to offer a portable LCD Clock Radio to you which meets our standards.

The clock is a 12-hour one with AM/PM indicated and a back light. The radio is Medium Wave and FM with very nice quality for a small speaker — for FM there's a telescopic aerial. The alarm can be either a 'beep-beep' type or the radio, there's also a snooze facility.

The case is sensibly rugged and is printed on the back with a World Time Zones map, a bit of a cheek really, especially as the time is relative to Japan!

We won't even mention the RRP — but just check on comparable prices — you'll find ours a bargain.

An example of this Clock Radio can be seen and examined at our Oxford Street offices.

£20.50

(Inclusive of VAT and Postage)

To:
CLOCK RADIO Offer,
Hobby Electronics,
25-27 Oxford Street, London W1R 1RF.

Please find enclosed my cheque/P.O. for £20.50 (payable to Hobby Electronics) for my Clock Radio.

Name

Address

Please allow 21 days for delivery.

CLOCK RADIO

"All 'OUSAABOUT THAT, THEN, GUYS 'N' GALS!?'
"CLUNK - CLUNK EVERY TRIP....!"

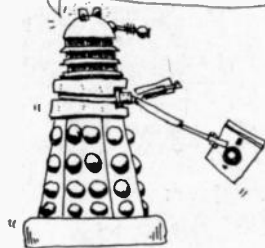

"UH, AND THIS IS OUR NEW MAGNETIC DISC PLAYER....."



Marketplace

DIGITAL ALARM CLOCK

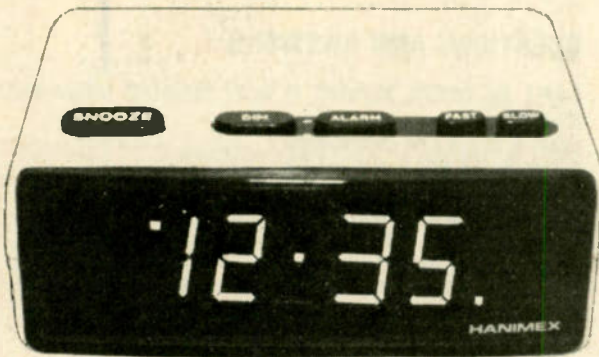

Size: 100mm x 130mm x 60mm.

Over 10% of Electronics Today International's readers have purchased a digital alarm clock from offers in that magazine — the offer is now extended to Hobby Electronics readers. This is a first rate branded product at a price we don't think can be beaten.

The Hanimex HC-1100 is designed for mains operation only (240V/50Hz) with a 12 hour display, AM / PM and Alarm Set indicators incorporated in the large display. A switch on the top controls a Dim/Bright display function.

Setting up both the time and alarm is simplicity itself as buttons are provided for both fast and slow setting and there's no problem about knocking these accidentally as a 'locking switch' is provided under the clock. A 9-minute/snooze switch is located at the top.

An example of this digital alarm clock can be seen and examined at our Oxford Street offices.

£8.95

(Inclusive of VAT and Postage)

LCD CHRONOGRAPH

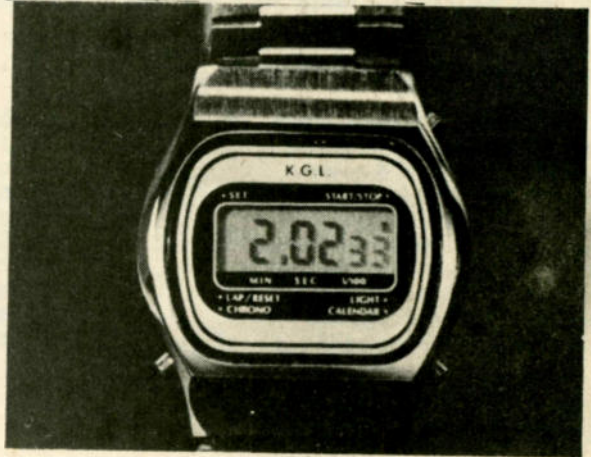

We feel we've got to tell you carefully about this offer which we're introducing for the first time. Why? Because our price is so enormously lower than anywhere else you may suspect the quality.

The exact same watch is currently being offered by another magazine as a special at £24.95 — some of the discounters are selling it at £29.95 the price to HE readers for exactly the same watch is £12.95.

The display is LCD and shows the seconds as well as the hours — and minutes — press a button and you'll get the date and the day of the week.

Press another button for a couple of seconds and you have a highly accurate stopwatch with hundredths of a second displayed and giving the time up to an hour. There is a lap time facility as well — and of course a back light.

Our Chrono comes complete with a high grade adjustable metal strap and is fully guaranteed.

An example of this LCD Chronograph can be seen and examined at our Oxford Street offices.

£12.95

(Inclusive of VAT and Postage)

To:
DIGITAL Alarm Offer,
Hobby Electronics,
25-27 Oxford Street,
London W1R 1RF.

Please find enclosed my cheque/P.O. for £8.95 (payable to Hobby Electronics) for my Digital Alarm Clock.

Name

Address

Please allow 21 days for delivery.

To:
LCD Chrono Offer,
Hobby Electronics,
25-27 Oxford Street, London W1R 1RF.

Please find enclosed my cheque/P.O. for £12.95 (payable to Hobby Electronics) for my LCD Chronograph.

Name

Address

Please allow 21 days for delivery.

DIGITAL ALARM

LCD CHRONO

Hobby Electronics Book Service

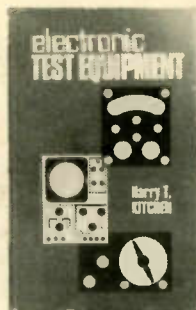

POPULAR ELECTRONICS BOOKS

Sinclair, I. R., <i>Introducing Electronic Systems</i>	£1.80
Sinclair, I. R., <i>Introducing Amateur Electronics</i>	£1.55
Sinclair, I. R., <i>Electronic Fault Diagnosis</i>	£3.45
Sinclair, I. R., <i>Repairing Pocket Transistor Radios</i>	£2.50
Sinclair, I. R., <i>Oscilloscope In Use</i>	£3.00
Sinclair, I. R., <i>Understanding Electronic Components</i>	£4.00
Sinclair, I. R., <i>Understanding Electronic Circuits</i>	£4.00
Kitchen, H. T., <i>Handtools For Electronic Workshop</i>	£2.75
Kitchen, H. T., <i>Electronic Test Equipment</i>	£5.00
Capel, V., <i>How To Build Electronic Kits</i>	£2.20

QUESTIONS AND ANSWERS

SIMPLE AND CONCISE ANSWERS TO MANY QUESTIONS WHICH PUZZLE THE BEGINNER.

Coker, A. J., <i>Q & A On Electric Motors</i>	£1.50
Hellyer, H., <i>Q & A On Radios and T.V.</i>	£1.50
Hibberd, R., <i>Q & A On Integrated Circuits</i>	£1.50
Jackson, K., <i>Q & A On Electricity</i>	£1.50
Brown, C., <i>Q & A On Hi-Fi</i>	£1.50
Brown, C., <i>Q & A On Transistors</i>	£1.50
Brown, C., <i>Q & A On Electronics</i>	£1.50
Reddihough, J., <i>Q & A On Colour T.V.</i>	£1.50
Miller, H., <i>Q & A On Electric Wiring</i>	£1.50

AUDIO

Capel, V., <i>Public Address Handbook</i>	£3.50
Earl, J., <i>Audio Technicians Bench Manual</i>	£3.50
Earl, J., <i>Pickups and Loud Speakers</i>	£3.50
Earl, J., <i>Tuners and Amplifiers</i>	£3.00
Earl, J., <i>Cassette Tape Recorders</i>	£5.25
Earl, J., <i>ABC of Hi-Fi</i>	£4.25
Capel, V., <i>Microphones In Action</i>	£3.00
Capel, V., <i>Improving Your Hi-Fi</i>	£3.50
Capel, V., <i>Creative Tape Recording</i>	£4.00
Hellyer, H. W., <i>Tape Recorders</i>	£4.25
Sinclair, I. R., <i>Audio Amplifiers For Home Construction</i>	£2.75

CONSTRUCTOR GUIDES

Graham, P., <i>Simple Circuit Building</i>	£2.45
Colwell, M., <i>Electronic Diagrams</i>	£2.45
Colwell, M., <i>Electronic Components</i>	£2.45
Colwell, M., <i>Printed Circuit Assembly</i>	£2.45
Ainslie, A., <i>Practical Electronic Project Building</i>	£2.45
Colwell, M., <i>Project Planning and Building</i>	£2.45

RADIO CONTROL

Aldridge, D., <i>Transistorised Radio Control For Models</i>	£3.50
Drake, J., <i>Radio Controlled Helicopter Models</i>	£3.95
Jeffries, C. R., <i>Radio Control For Model Yachts</i>	£1.85
Safford, E. L., <i>Radio Control Manual</i>	£2.45
Safford, E. L., <i>Advanced Radio Control</i>	£3.95
Wareing, R. H., <i>Simple Single Channel Radio Control</i>	£1.95

BEGINNER'S GUIDE

Sinclair, I. R., <i>Beginner's Guide To Tape Recording</i>	£3.30
Sinclair, I. R., <i>Beginner's Guide To Integrated Circuits</i>	£3.10
Sinclair, I. R., <i>Beginner's Guide To Audio</i>	£3.10
King, G. J., <i>Beginner's Guide To Radio</i>	£3.10
King, G. J., <i>Beginner's Guide To Television</i>	£3.10
King, G. J., <i>Beginner's Guide To Colour T.V.</i>	£3.10
Guilou, F., <i>Beginner's Guide To Electric Wiring</i>	£3.10

COOKBOOKS

Tracton, K., <i>BASIC Cookbook</i>	£4.10
Lancaster, D., <i>TTL Cookbook</i>	£7.00
Lancaster, D., <i>RTL Cookbook</i>	£4.65
Lancaster, D., <i>CMOS Cookbook</i>	£8.20
Jong, W., <i>IC Op Amp Cookbook</i>	£10.00
Lancaster, D., <i>T.V. Typewriter Cookbook</i>	£7.75
Lancaster, D., <i>Cheap Video Cookbook</i>	£7.00
Jong, W., <i>IC Timer Cookbook</i>	£7.50
Lancaster, D., <i>Incredible Secret Money Machine (a how to cook book for setting up your computer or technical business)</i>	£4.95

PROJECT BOOKS

Marston, R. M., <i>110 Cosmos Digital IC Projects For The Home Constructor</i>	£3.25
Marston, R. M., <i>110 Wave Form Projects For The Home Constructor</i>	£3.45
Marston, R. M., <i>110 Op Amp Projects For The Home Constructor</i>	£2.95
Marston, R. M., <i>110 Semiconductor Projects For The Home Constructor</i>	£3.45
Marston, R. M., <i>110 Thyristor/SCR Projects For The Home Constructor</i>	£2.95
Marston, R. M., <i>110 Electronic Alarm Projects For The Home Constructor</i>	£3.45
Marston, R. M., <i>110 Integrated Circuits Projects For The Home Constructor</i>	£3.45
Marston, R. M., <i>20 Solid State Projects For The Car and Garage</i>	£2.50
Marston, R. M., <i>20 Solid State Projects For The Home</i>	£2.50

Note that all prices include postage and packing. Please make cheques, etc. payable to Hobby Electronics Book Service (In sterling only please) and send to:

Hobby Electronics Book Service,
P.O. Box 79,
Maidenhead, Berks.

An Introduction to Test Gear

If you're going to get seriously involved with electronics, you're going to have to buy or build some kind of electronic test equipment. HE's project team describe what types of test gear you need.

ANY HE READER seriously intending to test, troubleshoot, modify, design or experiment with electronics projects will need some kind of test gear (electronic test equipment). The types of test gear you will need depends on how seriously involved you are with electronics, what your particular fields of interest are, and how much spare cash you have to buy or build that test gear. In the next few pages we introduce you to some of the types of test gear that are available, and give advice on the types of gear you actually need.

MULTIMETERS

One of the most basic types of test you can carry out on an electronic circuit is to measure a voltage or current. The type of instrument you need to carry out this test is a multi-range multi-function meter, or multimeter. These instruments enable you to measure, via a range switch and a pair of probes, a wide range of AC and DC voltages and currents: most instruments also have a facility for measuring resistance values, and a few have a facility for measuring capacitance values as well.

Multimeters come in three general classes, as follows:

ANALOGUE MULTIMETERS are relatively simple instruments of electrical (rather than electronic) design



A small analogue multimeter. This sort of device should sell for around £10 or under.



A display of test gear such as you find at many retail shops.

and have a moving-pointer type of readout indicator (either a moving coil or a taught-band suspension meter) in which the pointer deflection is proportional to (an analogue of) the parameter being measured. An important quality of this type of meter is its *sensitivity* or its loading effect on the electronic circuit that it is being used to test: Sensitivity is specified in terms of thousands of ohms per volt, or k/volt: For general electronics work, a meter sensitivity of at least 20k/volt is required. Good quality analogue multimeters are provided with some kind of overload protection, so that the instrument doesn't vaporise when you connect it to a thousand volts when its controls are set to measure only one volt full scale deflection.

ELECTRONIC MULTIMETERS are souped up versions of the analogue type: They have a built-in electronic amplifier to improve the basic instrument sensitivity and give improved (sometimes) overload protec-



◀ The Avometer is the Rolls-Royce of electronic multimeters. The model 8, pictured left, carries a price tag of over £100.

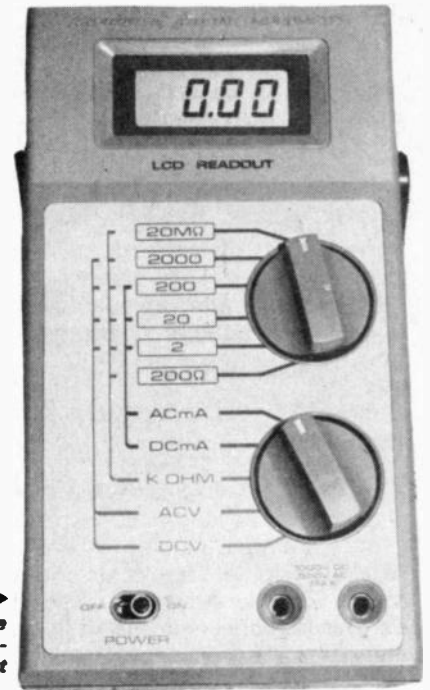

▶ The digital multimeter on the right uses a liquid crystal display (LCD) and costs about £50.

tion, but use the same type of moving-pointer readout indicator as the normal analogue multimeter.

DIGITAL MULTIMETERS are 'all electronic' instruments: they use sophisticated electronic circuitry to convert the magnitude of the parameter under test into a numeric value which is displayed directly on a digital readout unit. These instruments have very good sensitivity. They also have a high degree of overload protection; you can, for example, set them to their 100mV range and then connect them straight across a 500 volt power line without doing any serious damage, which is why we at HE use them!

WHAT TO BUY? If you are just starting in electronics and expect to stay interested in the subject for some time, you are bound to need *at least* one multimeter. Start by buying a reasonable quality analogue instru-

ment with a sensitivity of at least 20k/volt and with some kind of overload protection. At a later date you may find it worth while to build or buy an electronic or digital multimeter.

WAVEFORM GENERATORS

Most electronic circuits are concerned with processing waveforms in one way or another: Hi-Fi circuits are concerned with amplifying waveforms with a minimum of distortion: filters are concerned with imparting a kind of frequency distortion to incoming signals: A waveform generator of some kind is thus needed when testing most types of electronic circuit.

Waveform generators are usually classified either by the type of waveform they generate (sine, square, triangle, pulse, etc.), by the area off frequency coverage of the generator (AF, LF, RF, VHF, etc.), or by the

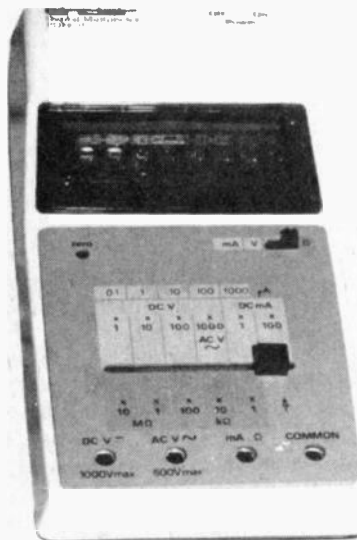

A brace of digital multimeters from Sinclair. Both have light emitting diode (LED) displays. The PDM 35 (left) sells at about £30, the DM235 (right) at about £50.

technique used in generating the waveform (R-C or L-C oscillator, or function generator, etc.). The better known types of waveform generator are as follows.

AF or LF SINE or SINE/SQUARE GENERATORS produce waveforms from below 20 Hz up to at least 20 kHz (AF types) or 100 kHz (LF types). The basic sine wave is usually produced from an oscillator that uses an R-C (Twin-T or Wien) tuning network and the resulting waveform is usually reasonably pure and typically has a harmonic distortion content of less than 0.5% at the normal test frequency of 1 kHz.

These generators invariably incorporate some kind of amplitude stabilisation circuitry, so that the mean output amplitude of the signal is constant at all frequency settings:

In spite of this amplitude stabilisation circuitry, most R-C generators suffer from a phenomenon known as 'bounce', in which the amplitude varies in an unstable manner as the frequency control is altered, but then settles down as frequency stability is obtained.

It is a simple matter to convert a sine wave into a square wave, so many AF and LF generators have a facility for generating either a sine or a square waveform, either simultaneously via individual outlets, or alternatively via a mode selector switch.

A good quality sine/square generator is an essential piece of equipment to anyone interested in designing or experimenting with AF or LF amplifiers or filters, and the

keen reader is advised to build or buy one at the earliest opportunity.

FUNCTION GENERATORS usually produce a basic triangle wave, which is then modified into a sine form by special circuitry: They also produce a square wave. Often, these waveforms can be subjected to amplitude and/or frequency-modulation, either via external control terminals or via a built-in auxiliary generator. A major attraction of most function generators is that they cover a very wide frequency spectrum, typically from less than 0.1 Hz to above 100 kHz. A second attraction is that they do not suffer from amplitude 'bounce' as their operating frequency is altered. The only real disadvantage of most function generators is that their sine wave outputs have perceptible distortion (typically between 0.5% and 2%), and they are thus not suitable for distortion testing Hi-Fi amplifiers.

Function generators are nice instruments to own, but are not needed by the average electronics novice: When the novice blooms into an amateur, however, he (or she) may find it worth while building one of these instruments.

PULSE GENERATORS produce waveforms suitable for testing digital electronic circuits. They are usually provided with two built-in variable pulse generator networks (one giving a *delay* pulse and the other an *output* pulse) which can be triggered either via an external signal or via a built-in variable-frequency square-wave generator.

A pulse generator is not needed by the average novice, but is an essential item to any keen amateur interested in designing or experimenting with digital circuitry: Pulse generators make good do-it-yourself projects.

RF and VHF GENERATORS produce high-frequency basic (but often highly distorted) sine waves for testing radios, TV's, etc: The generated waveform can usually be subjected to amplitude and/or frequency modulation, either via external signals or via a built-in modulation generator.

These generators are essential items to anyone interested in servicing, repairing, or designing radios or TV's: if you need one, buy it rather than build it: DIY versions are difficult to construct, and very difficult to calibrate.

VARIABLE POWER SUPPLIES

Variable power supplies enable you to power an experimental circuit via the mains, rather than from batteries, and usually give a regulated output that is variable from zero up to at least 20 volts, at currents up to at least 1 amp: All good designs have some form of overload protection, so that the instrument does not disintegrate when you place that accidental short across its output.

Some designs of variable power supply provide only a single output (e.g., 0-20 V): Others provide either a split output (e.g., 0 to ± 20 V), or have two independent outputs (e.g., $2 \times 0-20$ V). The split-output type of power supply is ideal for powering experimental op-amp (operational amplifier) circuits.

A decent variable power supply is an essential item to any amateur interested in experimenting with electronic circuitry. DIY power supplies are easy projects to build.



This signal generator will produce frequencies in the range 120kHz to 500 MHz for a price of around £60.



The power supply above is available in kit form (see last month's issue) and costs about £40.

OSCILLOSCOPES AND ACCESSORIES

An oscilloscope is an instrument that lets you look at an actual waveform appearing in any part of a circuit. The instrument has a small TV-type of screen which has its face covered with a graduated scale or *graticule* which is marked in both the horizontal and vertical axis. The instrument also has a number of front panel controls which are calibrated in relation to the graticule scales. Thus, it is possible to display an unknown waveform on the 'scope and know, merely by looking at its shape and its relationship to the graticule and control settings, that it is (for example) a 15 kHz distorted sine wave with a peak-to-peak amplitude of 2.7 volts.

An oscilloscope is probably the most useful (but most expensive) instrument in any electronics workshop or laboratory. 'Scopes come in a variety of types, and can be used with a variety of accessories. The most important ones are as follows:

BASIC (SINGLE TRACE) OSCILLOSCOPES have a 'Y amplifier', which has its controls graduated in relationship to the vertical scale of the tube graticule, and an 'X amplifier' or *timebase*, which has its controls graduated in relationship to the horizontal scale of the graticule. Modern 'scopes use a *triggered timebase*, which provides the X axis with meaningful calibration: Older 'scopes have a *free-running timebase*, which gives almost meaningless calibration to the X axis.

One of the most important parameters of a 'scope is its bandwidth, or frequency-display capability. Old fashioned 'scopes could handle AC-coupled inputs only and had typical bandwidths extending from 20 Hz up to about 1 MHz. Modern 'scopes are DC coupled and have bandwidths that extend down to zero at the low end and up to about 5 MHz on low-priced 'scopes, or 15-25 MHz on medium priced 'scopes, or 100-225 MHz on high-priced 'scopes.

DUAL TRACE OSCILLOSCOPES are capable of displaying two waveforms at the same time. This is useful, for example, if you want to look simultaneously at the input and the output waveforms of a circuit. These 'scopes have two calibrated and independent Y amplifiers, which provide the display drive. The final display is either obtained from a special *dual beam* tube, or more commonly, from a single-beam tube that has its beam electronically chopped to provide the illusion of two independent beams.

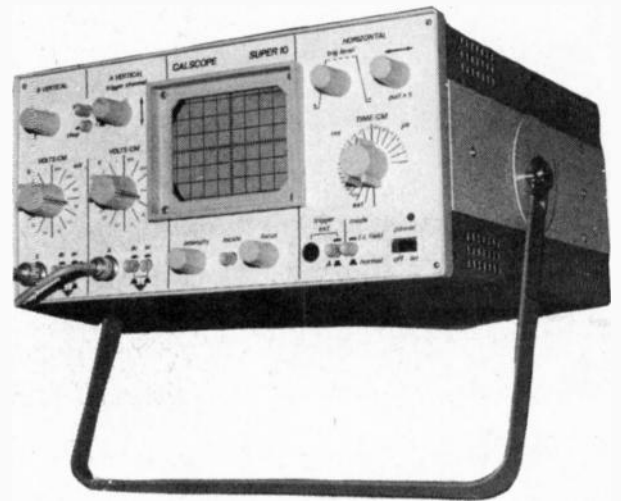
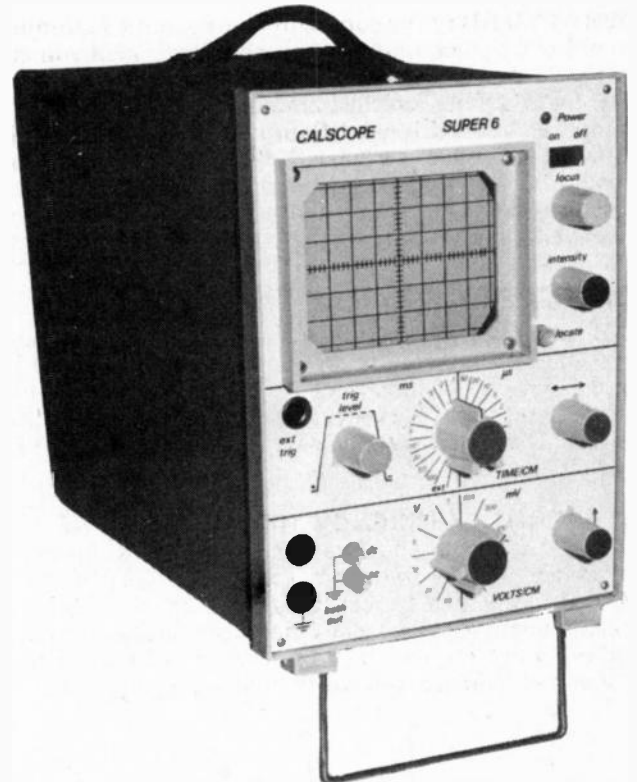

OSCILLOSCOPE TRACE DOUBLERS are add-on devices or accessories that can be used to give a single-trace 'scope a dual-trace capability.

DUAL SWEEP (DUAL TIMEBASE) OSCILLOSCOPES are provided with two timebases, which can be used independently, alternately, or with one triggering the other. These 'scopes can let you do fancy things, such as look at a one microsecond wide pulse superimposed on a 1 kHz square wave and occurring 470uS after the leading edge of the square wave. (Not many amateurs need this facility.)

OSCILLOSCOPE CALIBRATORS are fairly simple accessories that enable the owner to measure and adjust the calibration accuracy of the Y and/or X axis of an oscilloscope.

WHAT TO BUY? A 'scope is the most useful instrument in any electronics workshop or laboratory, so if you can get one, do so. A single-beam single-timebase instrument is adequate for most amateur uses. Ideally, the Y amplifier should have DC-coupling, with an upper bandwidth limit of at least 3 MHz, and the timebase should be the triggered type: On the other hand, any 'scope is better than none at all, and good 'scopes tend to be rather expensive.

MISCELLANEOUS TEST GEAR

C-R and LCR BRIDGES are specialised instruments that let you measure the precise values of resistors (R), capacitors (C), or inductors (L). They are nice instruments to own, but are only rarely used or needed by the novice. They are, nevertheless, fairly easy and interesting projects to build.

ANALOGUE FREQUENCY METERS look similar to a normal multimeter, but are designed only to measure frequency. Typical frequency coverage is 100 Hz to 1 MHz full scale, and typical accuracy is 2% or 3% of full scale. Sometimes these instruments are designed as DIY add-on units for use in conjunction with a normal multimeter, and are well worth building in this form.

DIGITAL FREQUENCY METERS give a direct read-out of frequency from a few Hz up to tens or hundreds of MHz, with a typical accuracy of .001% or better. They are very useful instruments for the serious experimenter or designer, but are fairly expensive to buy or build.

DISTORTION FACTOR METERS are specialised instruments for rapidly measuring the distortion content of audio-frequency waveforms. They are only essential instruments for the serious Hi-Fi designer and experimenter, but are fairly easy projects to build.

ANALOGUE VOLT/MILLIVOLT METERS are multi-range electronic instruments with typical full-scale range coverage extending from 1 mV to 1000 V AC and/or DC. They are particularly useful for measuring low-level signals in audio amplifiers, etc., and are popular DIY projects.

STARTING A WORKSHOP

If you are going to take electronics seriously, you're going to need some test gear. So what do you need? Our advice is to take the following four steps, and then progress from there:

1. The first instrument you will have to get, and one that you will always need, is a decent multimeter. Buy, rather than build one, and make sure it has a sensitivity of at least 20 k/volt, and has some kind of overload protection.
2. The next item to acquire is a waveform generator. If your field of interest is audio or LF, build yourself a decent sine/square generator. If you're a radio or TV buff, buy yourself an RF or VHF generator. If you only like digital circuits, build a pulse generator.
3. Build or buy a decent variable power supply. This is an essential item to anyone interested in designing or experimenting with electronic circuits.
4. Whatever your field of interest, try at some time to acquire an oscilloscope of some kind, no matter how tatty it is: These instruments add a whole new dimension to the field of hobby electronics. **HE**

Our thanks to Audio Electronics of Edgware Road, London for allowing us to use their showroom and stock as photographic studio and models for this article.



Top left: A single beam oscilloscope like this will cost around £150.

Above left: A dual beam oscilloscope with a price tag of £340.

Above: An LED frequency counter for about £60, and a prescaler (which divides the input frequency by 10) for about £40.

Right: A wider ranging frequency counter; this one goes for about £80.



New Books from the HE Book Service

28 Tested Transistor Project

Richard Torrens. The projects can be split down into simple building blocks which can be recombined for ideas of your own.

Electronic Projects for Beginners

F. G. Rayer. Divided into 'No Soldering Projects,' Radio and Audio Frequency, Power Supplies and Miscellaneous.

Solid State Short Wave Receivers for Beginners

R. A. Penfold. Several modern circuits which give a high level of performance even though only a few inexpensive components are used.

Linear IC Equivalents and Pin Connections

Adrian Michaels. Gives most essential data for popular devices.

Popular Electronic Projects

R. A. Penfold. A collection of the most popular types of circuits and projects using modern, inexpensive and freely available components.

Projects in Opto Electronics

R. A. Penfold. Covers projects using LED's, Infra-red transmitters and detectors, modulated light transmission and also photographic projects.

52 Projects using IC 741

Rudi and Uwe Redmet. Translated from an enormously successful German book with copious notes, data and circuitry.

50 FET (Field Effect Transistor) Project

F. G. Rayer. Contains something of interest for every class of enthusiast. Short Wave Listener, Radio Amateur, Experimenter or audio devotee.

How to Build Advanced Short Wave Receivers

R. A. Penfold. Full constructional details are given for a number of receivers plus circuits for add-ons such as Q-Multiplier, S-meter etc.

Note that all prices include postage and packing. Please make cheques etc. payable to Hobby Electronics Book Service (in Sterling only please) and send to:

Hobby Electronics Book Service
P.O. Box 79
Maidenhead, Berks.



Digital IC Equivalents and Pin Connections

Adrian Michaels. Covers most popular types and gives details of packaging, families, functions, country of origin and manufacturer.

How to Build your own Metal and Treasure Locators

F. G. Rayer. Gives complete circuit and practical details for a number of simple metal locators using the BFO principle.

Essential Theory for the Electronics Hobbyist

G. T. Rubaroe gives the hobbyist a background knowledge tailored to meet his specific needs.

Beginners Guide to Building Electronic Projects

R. A. Penfold. Covers component identification, tools, soldering, constructional methods and examples of simple projects are given.

50 Projects using IC CA3130

R. A. Penfold. Describes audio projects, RF project, Test Equipment, Household and miscellaneous circuits.

IC 555 Project

E. A. Parr. Circuits are given for the car, model railways, alarms and noise makers. Also covers the related devices 556, 558 and 559.

50 Projects using Relays, SCR's and TRIAC's

F. G. Rayer. Gives tried and tested circuits for a whole variety of projects using these devices.

Hobby Electronics

10W Stereo

and

Record Player

THIS OFFER FROM RT-VC is exclusive to HE Readers and comprises a 10W per channel stereo amplifier modular kit (complete with a cabinet, supplied as a flat pack) and a BSR P207 turntable unit (fitted with a ceramic cartridge)

Construction is straightforward. The pre-amplifier and power amplifier boards are Mullard LP1183 and LP1173 modules, respectively. The boards are ready-made and have only to be connected to the power supply and controls.

Wiring diagrams supplied with the kit are clear. The mains transformer with the kit which we built had to be modified. 27 turns had to be taken off the secondary winding to reduce the induced voltage to the maximum rating of the power amplifiers (24V). It's not as difficult as it sounds. But now the good news — RT-VC will be supplying a transformer which does not need any modification.

The only piece of hardware not supplied is a chassis base plate. RT-VC suggest that the front and rear panels should be joined by a chipboard base, covered with aluminium foil. In fact we used an aluminium panel as we happened to have one exactly the right size. Whatever you use, make sure it does not foul the twin DIN

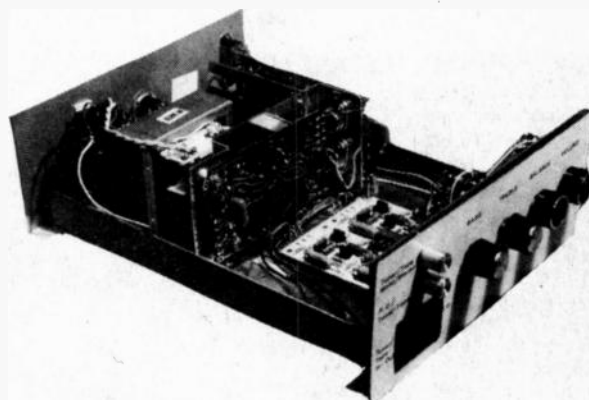

The amplifier that we built from a prototype kit — it worked first time! Detailed assembly instructions are supplied.

Reader Offer

Amp layer

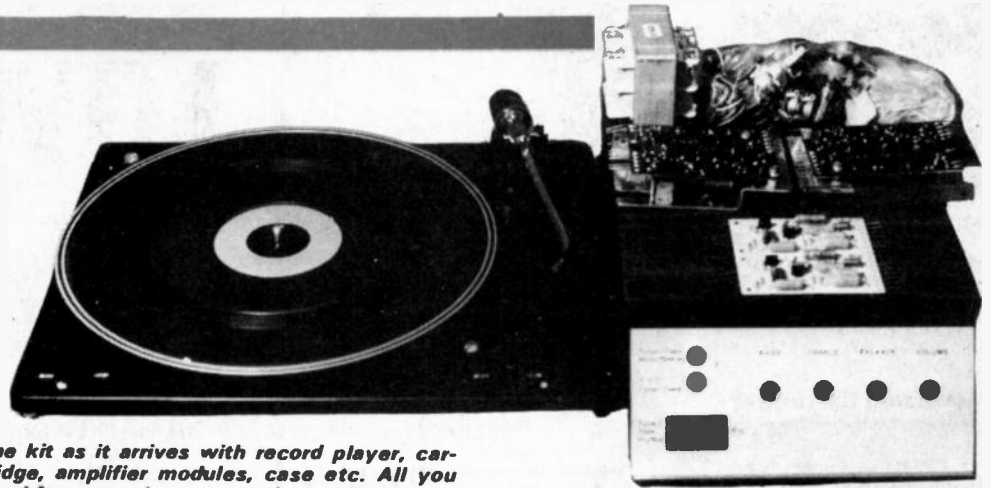

The kit as it arrives with record player, cartridge, amplifier modules, case etc. All you need for a complete system is speakers and a piece of chipboard.

socket on the front panel.

A suggested layout of the modules on the base plate is given in the instructions but we changed this a bit to that shown in photographs. This has the advantage that the heatsinks on the main amplifier boards shield the mains transformer and cut down any hum. If you vary it further make certain that the preamp board is kept well away from the transformer.

FIRST TIME!

HE readers may be surprised to hear us admit that often things we build don't work first time — this unit did, adding to the pleasure of building it! All you need to add to make a complete system are speakers, a plinth and cover for the record player and audio leads. The inexpensive price may make you wonder about the quality — but have no fears — it's good! The modules are high quality types and the power supply is man-enough to enable them to be operated at their best.

We thoroughly recommend this kit and consider it one of the best value offers we've ever been able to arrange, either in HE or our sister magazine ETI.



The kit, as offered here, will soon be available elsewhere but at £24.95. Hobby Electronics has made special arrangements with RT-VC for a superb introductory price of:

£19.95

Plus £2.55 Postage

Orders can only be accepted for despatch to UK addresses. Please allow 28 days for delivery and more if the transport and postal difficulties are continuing. Offer expires March 31st 1979.

Please send orders direct to RT-VC, not to Hobby Electronics. The address below is mail order only

To: Hobby Electronics Offer
RT-VC
21H High Street,
Acton, London W3 6NG

Please find enclosed my cheque/P.O. for £22.50 (£19.95 plus £2.55 postage payable to RT-VC) for a 10W Stereo Amp and BSR Record player.

Name

Address

UK only. Please allow 28 days for delivery. Offer expires March 31st 1979.

**Next
Month**

Hobby Electronics

Model Train Controller



We've just bought ourselves a rather nice model railway layout for the HE workshop — not because we enjoy playing with it (though we do) but for next month's main project — a model train speed controller which we believe will give better performance — especially at low speeds — at lower cost than many commercial units.

In our sister magazine ETI we were surprised to find out how popular model train projects were, so we're entering the field as well.

The Telephone System

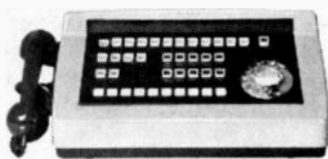

We originally hoped to carry this feature in this issue of HE but all's well for next month. Lots of exciting things are happening in the telephone field as electronics begins to take over from the relays and uniselectors that dominate the system today.

555 Circuits



A selection of excellent circuits taken from the book 'IC 555 Projects' by EA Parr, published by Babam's. The 555, if you didn't know, is a very cheap, beautifully versatile IC which is essentially a timer has all types of trigger and reset facilities which make it a truly attractive device.

Cistern Overflow Alarm

Not a complex project — or an expensive one — but it could save you masses of trouble. The unit is battery operated and can be largely forgotten about — until it warns you of trouble.

Capacitors

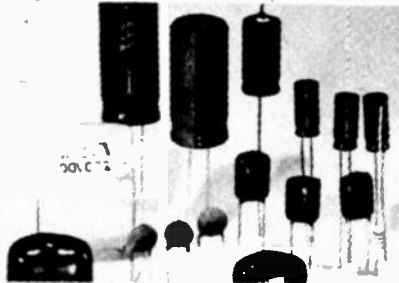

For the newcomer to electronics, capacitors are the most confusing components; they come in a variety of forms that make transistors seem simple. We've come up with a feature that should explain the essentials which aren't too difficult, just rarely explained properly.

Transistor Tester

A straightforward project to enable you to sort out the good from the bad and will quickly work its way through the bargain packs of miscellaneous semiconductors.

Tailoring White Noise

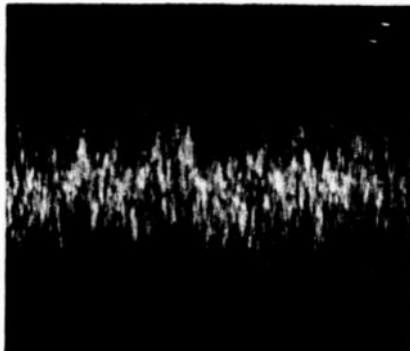

We've have good fun with this one! White noise is just a 'ssh' which is easy enough to generate electronically. However, we've added a few other components to tailor the sound to simulate a variety of events: waves, waterfalls, jet engine, rain and whistling wind.

Electronics Warfare — a Selective Digest



Like it or not, the largest growth area of electronics is in the military field. If there is ever a major conflict between the major powers, the winner will without doubt be the one best able to wage electronic warfare (EW). Most of this work is secret but we've collected together from our files various snippets which make fascinating reading.

How TV Aerials Work



A follow-on article from this month's 'TV Propagation' feature which goes over the theory and practice of TV antennae.

THE APRIL ISSUE WILL BE ON SALE ON MARCH 9th

The items mentioned here are those planned for the next issue but circumstances may affect the actual content.

SW Aerials

The traditional long wire receiving aerial for short wave enthusiasts is cheap and easy to set up. There are alternatives, though . . .

SALES OF GOOD QUALITY 'general coverage' receivers with tuning ranges that cover the HF spectrum from 3 MHz to 30 MHz have boomed in recent years, bringing about an upsurge of interest in shortwave listening.

The price of receivers with good 'slow' tuning rates, dial readout to 5 kHz or better, excellent sensitivity and selectivity as well as good stability has decreased to the point where many enthusiasts can afford a 'communications quality' receiver.

However there remains a problem with aerials to suit such wide frequency coverage.

WHEN DOES LONG MEAN LONG?

No discussion or description of wide coverage receiving aerials is complete without mention of the ubiquitous 'long wire'. The time-honoured long wire is simply what it says — any 'random' length of wire that it is possible to erect in a given space. Theoretically it is 'long' when its length is one wavelength or more at the lowest frequency of interest.

No matter, modern receivers are sufficiently sensitive that they only need a whisker of an aerial to pull in plenty of stations at good strength. It's for the weak ones that you need the big aerial.

A typical long wire installation is illustrated in Fig. 1. The actual height and length depend entirely on your circumstances. A piece of 50mm by 100 mm post is painted and bolted to a fence post or other support, as far from your receiver installation as you can reasonably manage. A pulley, obtainable at almost any hardware store, is fixed to the top and a loop of good quality hemp rope threaded through it, before erection.

An egg or strain insulator is attached to one end of the aerial which is also tied. The other end of the aerial is erected near the receiver installation. An insulator is also attached at this end and the lead-in taken down from it to the receiver installation. The aerial is then supported from this end by tying it off to a chimney, as illustrated.

Having one end of the aerial higher than the other is of little consequence. It'll still work!

The lead-in should be taken in such that it clears the house guttering and may be fed through a ventilator opening or over a window sill — whatever is convenient. Avoid running it for any distance clamped to a wall or parallel to metal guttering, pipes, or wiring. The more direct the better.

Once your long wire is up, you're ready to go! The end of the lead-in can simply be attached directly to the aerial terminal of your receiver.

'VEE HAVE WAYS OF TUNING IN'

A wideband 'inverted-vee' style of aerial is illustrated in Fig. 2. This works extremely well across the range from about 5 MHz up to 30 MHz and uses ordinary TV ribbon for a feedline. However, a balun or an aerial tuner is necessary. A balun is simple but an aerial tuner will give better results.

Good signals will be picked up by this aerial right down to 2 MHz but at these low frequencies there's no substitute for size and different aerials, designed to operate in these regions, usually provide better performance.

Beggars can't be choosers though, in many circumstances!

Construction is quite simple. Again, a 4m or 6m length of 50 x 100 mm post, painted, is erected against a suitable support — shown here as the side of a house. A fence or garage is just as good.

If you can attach a length of aluminium pipe to a chimney mount or to your house gable — well and good. Just get the centre up as high as you reasonably can.

Each leg of the inverted-vee should be six metres long. However, they can be shorter — whatever you can fit, but the performance at low frequencies suffers.

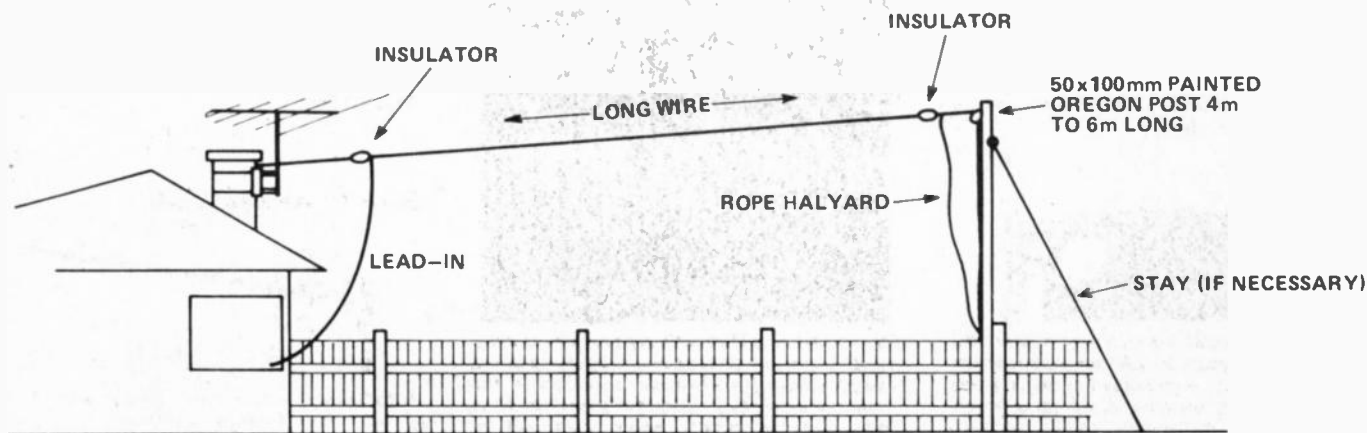

Fig. 1. Cheap and relatively simple — the long wire aerial.

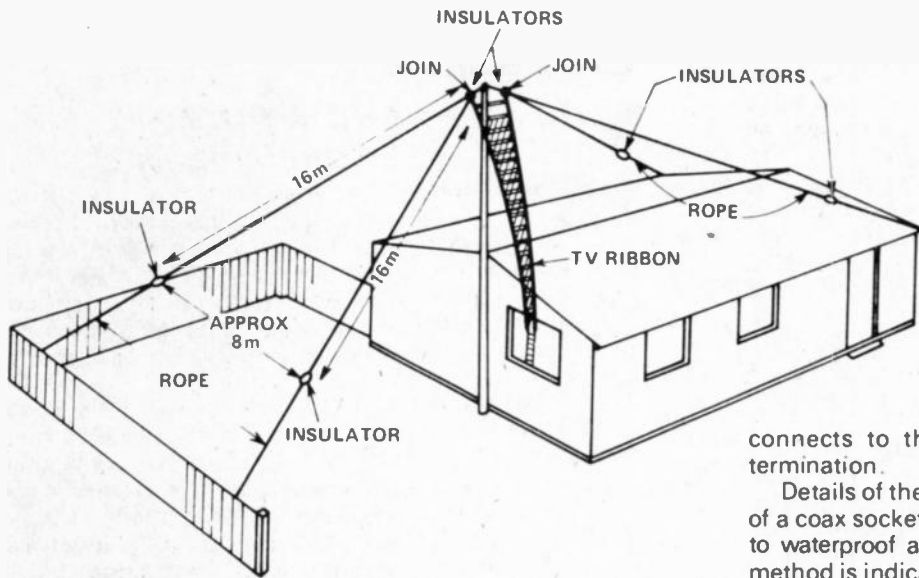

Fig. 2. The 'inverted-vee' aerial (wideband version).

SAY IT WITH RIBBON

The TV ribbon is connected where the opposite legs of the aerial join at the apex. Support the ribbon with standard screw-in TV ribbon insulator standoffs.

Each leg should be individually tensioned with the rope strainers indicated in Fig. 2. Large screw-eyes, obtainable from most hardware stores, screwed into the supports, as illustrated, serve as excellent anchor points and allow the rope to be tightened using an appropriate slip knot (a round turn and two half half-hitches is excellent).

Balun and aerial tuner construction, whichever you choose to suit the inverted-vee aerial, will be described in a future article.

STRAIGHT UP

The familiar groundplane aerial, much used in commercial VHF two-way communications systems as base-station aeriels becomes somewhat cumbersome at the frequencies that interest hams and shortwave listeners, although they are manageable above 14 MHz.

Loaded verticals, short verticals and other forms of the vertical aerial are popular for a variety of reasons, one good one being they have a low impedance, unbalanced feedpoint which suits most receivers on the market today.

If the *actual* ground is utilised as the ground plane for a HF groundplane aerial, a series of vertical elements can be connected in parallel at the feedpoint to provide a wideband vertical aerial system — which can give an excellent account of itself.

Such an aerial is illustrated in Fig. 3.

Five elements, of different lengths, are arranged in a fan supported from a rope bearer. They are all brought down to a termination which is supported on the top of a piece of pipe which has been driven into the ground.

The joining of the bottom of all the elements at the terminal provides the feedpoint connection. The centre conductor of the 50 ohm coaxial feedline connects to this point and the outer conductor, or braid, of the coax

connects to the earth via the pipe supporting the termination.

Details of the termination are shown in Fig. 4. The use of a coax socket is recommended as it is a simple matter to waterproof a coax connector; however, an alternative method is indicated. Waterproofing of the coax plug and cable will ensure that it has a long useful life. The aerial dimensions indicated in Fig. 3 need not be strictly adhered to — some latitude is possible.

BEAR WITH US

Construction is easy if you follow this procedure: lay out the bearer rope first. Insert the insulator ties at intervals of two or three metres as indicated. Attach the insulators that go at the top of each element to these points on the bearer ropes using short lengths of rope or wire. These will have to be subsequently adjusted, so don't tie the insulators on permanently yet.

Next, lay out all the elements, using the lengths as a guide and allow at least one metre at the termination end of each wire so that they can be individually tightened from the termination and when the aerial is erected.

Hoist the bearer rope into position and adjust the termination ends of the elements so that they come together with the termination insulator about 300 mm above the ground.

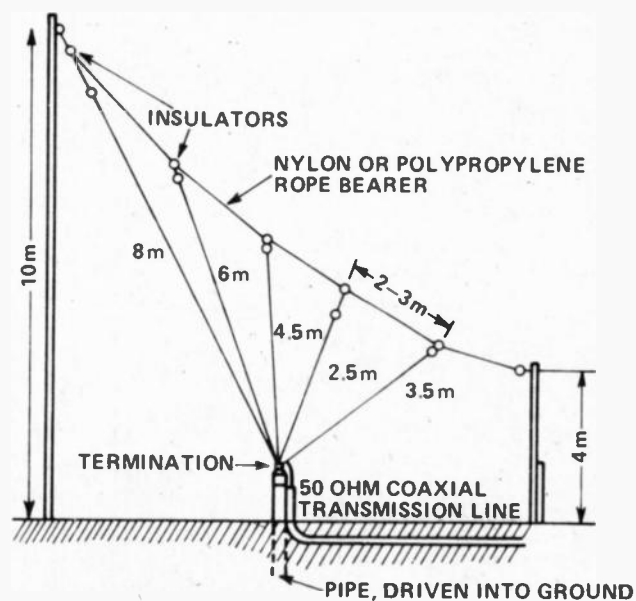

Fig. 3. A broadband version of the HF groundplane aerial.

Drive the pipe into the ground below this point. Finish everything off as illustrated in Fig. 4. If using a coax socket for the coax connection, mount it on a small aluminium or galvanised steel plate which is mounted to the pipe via a long bolt passed through the pipe, as illustrated.

If you wish, the coax may be buried. However it is advisable to pass it through some flexible plastic conduit and bury the whole assembly. This will prevent damage to the cable (from enthusiastic or ignorant gardeners, dogs, small brothers etc) as well as reducing moisture seepage.

If you want the ultimate in performance, a series of ground wires can be buried about 200-300 mm below the soil surface radiating out from the pipe for a distance of six to ten metres. They should all be connected together at the centre and bonded to the pipe.

However, keeping the area surrounding the pipe well-watered should satisfy most requirements.

BICONICAL MONOPOLE

Yes I know it sounds funny — looks funny too (except to the dyed-in-the-wool enthusiast!) but this aerial really performs as is attested by the fact that many professional and military receiving installations throughout the world use them.

The biconical aerial is mentioned in all the classic textbooks — so I won't go into it here. Suffice to say that it will readily cover a 4:1 bandwidth and has a low impedance, unbalanced feed. Low frequency perfor-

mance is reduced of course but it still works sufficiently well to provide reasonable signals well below the low frequency design limit.

FOUR GUYS AND A POLE

A biconical monopole suitable for home-construction (for the enthusiastic!) is illustrated in Fig. 5. A central pole has two cross-arms located low down around which is passed a length of rope. Twelve wires run from the top termination to the bottom termination, all wires being connected together at the termination points. The four wires which pass over the ends of the cross-arms are arranged to act as guys so that the whole assembly is self-supporting.

The most practical height for the central pole is about six metres, although if you can manage something higher, so much the better. The cross-arms are located about 40% of the pole height above the ground. Each cross-arm is about 40% of the pole height long.

Dimensions are given in Fig. 6 for a biconical monopole that will cover the 7 to 30 MHz range.

Specific construction details are left up to the individual constructor. However, the following points should be noted.

TYING AND TENSIONING

All the wires should be insulated from the pole and cross-arms. wooden cross-arms are recommended (paint them though). Nylon or polypropylene rope is recommended to go around between the ends of the cross-arms to support the eight wires not used as the guys. Simply tie them with short lengths of wire to the rope to secure them, after tensioning.

All the wires should be joined together at the top and bottom terminations. The bottom termination is the feedpoint. An arrangement similar to that in Fig. 4 should be used to connect the coax feedline. A good ground stake should be used, or better still a ground radial system, as previously described.

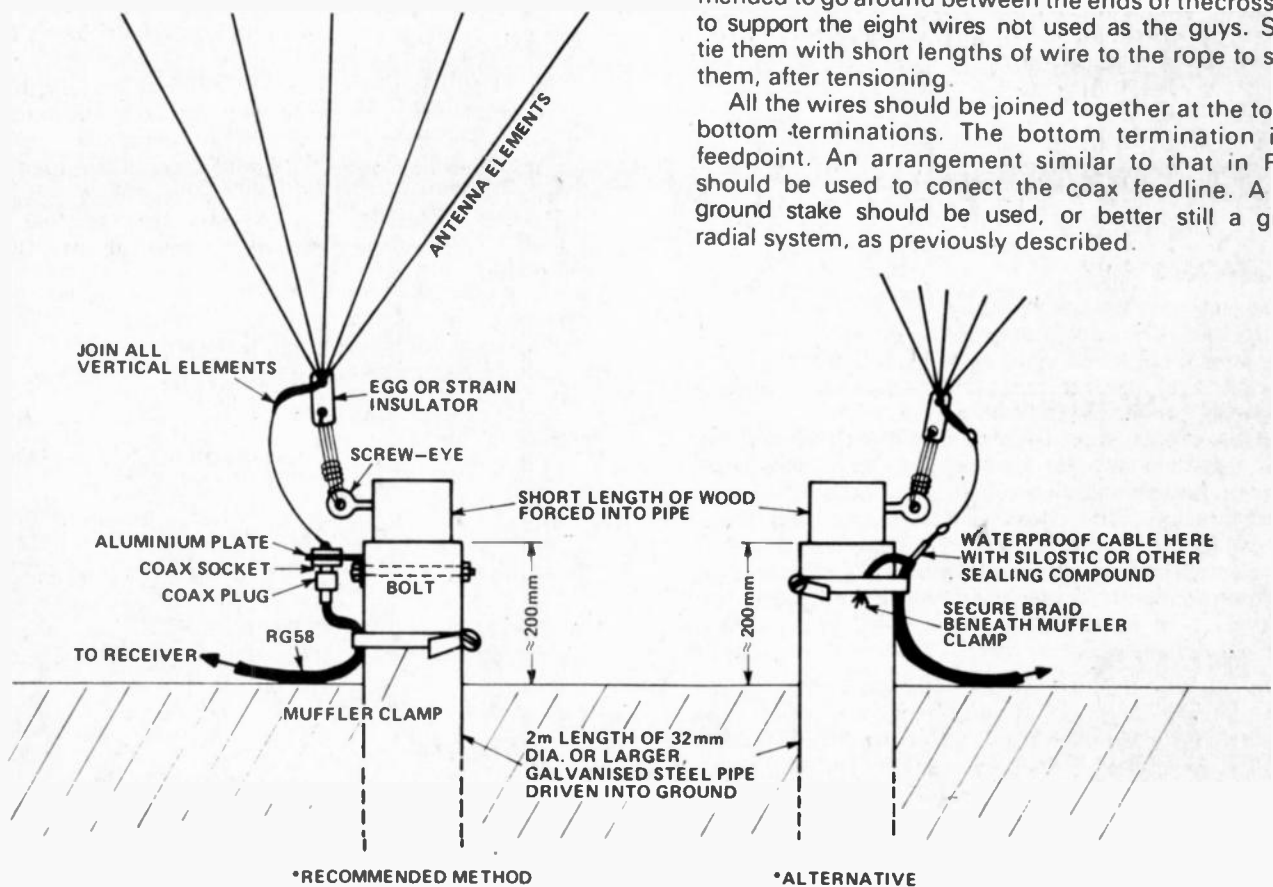

Fig. 4. Two methods of terminating the broadband ground-plane.

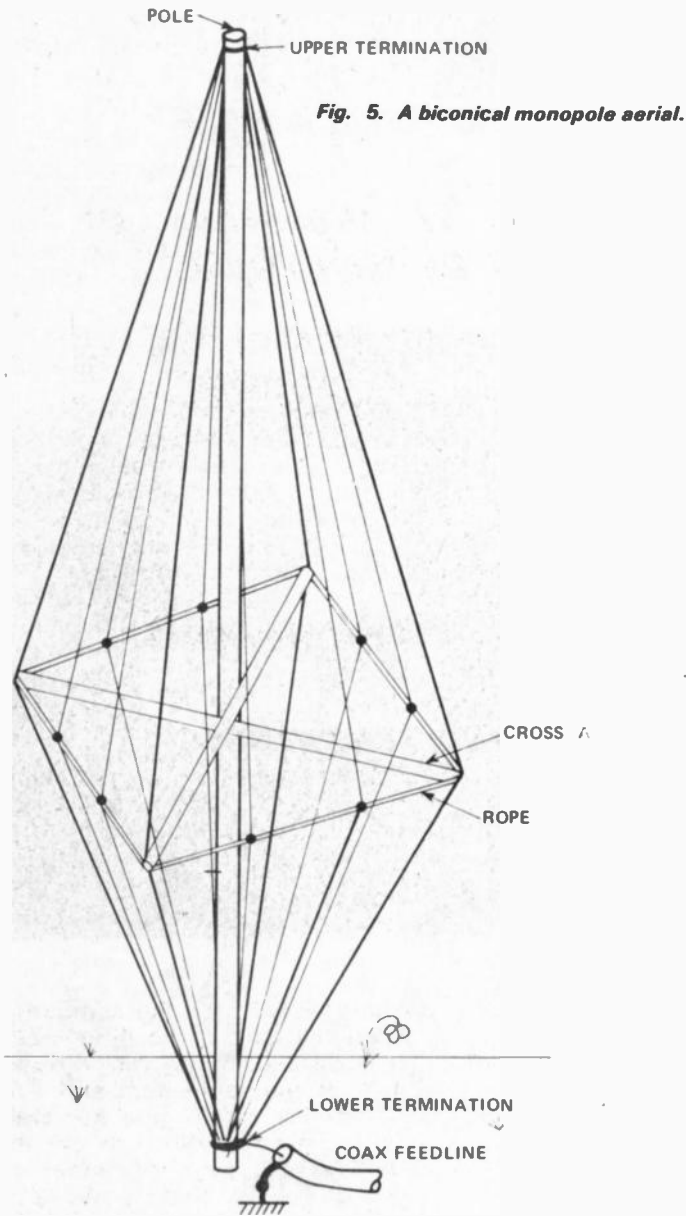

Fig. 5. A biconical monopole aerial.

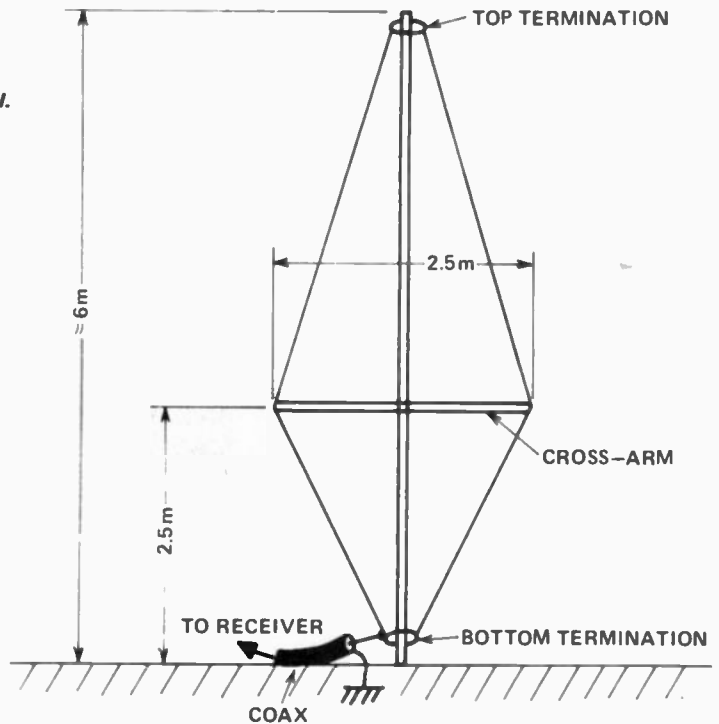

Fig. 6. Dimensions for the biconical monopole.

Both types creep considerably under strain and the tension will have to be adjusted periodically, but this is only a small chore.

FAIL-SAFE

The insulators illustrated are available in porcelain, nylon and glass. The nylon type egg insulator is usually the least expensive — but they do have one drawback. After some time in use, the tension of the wire causes the nylon to creep or remould itself and the wire literally pulls itself through the insulator. This may cause the insulator to fail completely. It isn't so much of a disaster however as the aerial wire and support rope are loped through one another and the aerial won't fall down — an advantage of the egg insulator. Periodic inspection and replacement will obviate any problems here.

Good luck and good listening!

HE

INSULATOR HINTS

The aerials described call for the use of insulators at various critical points to insulate the aerial elements from any support or tension rope.

There are two types generally available, the 'egg' insulator and the 'strain' insulator — both illustrated in Fig. 7. Using them is very simple. However, the rope, or aerial wire must be firmly secured where it ties on to the insulator.

GET KNOTTED

Where heavy, standard wire is used, simply wrapping the wire around itself a number of times is usually sufficient. If flexible hookup wire, such as 7/0026 or 10/010 PVC covered, is used then it will have to be knotted to be properly secured. Usually a number of half-hitches following several turns through the insulator eye are sufficient.

Nylon and propylene rope, while cheap and water repellent, deteriorate under the ultra-violet light from the sun and weaken considerably with time. Frequent inspection will indicate when replacement is necessary.

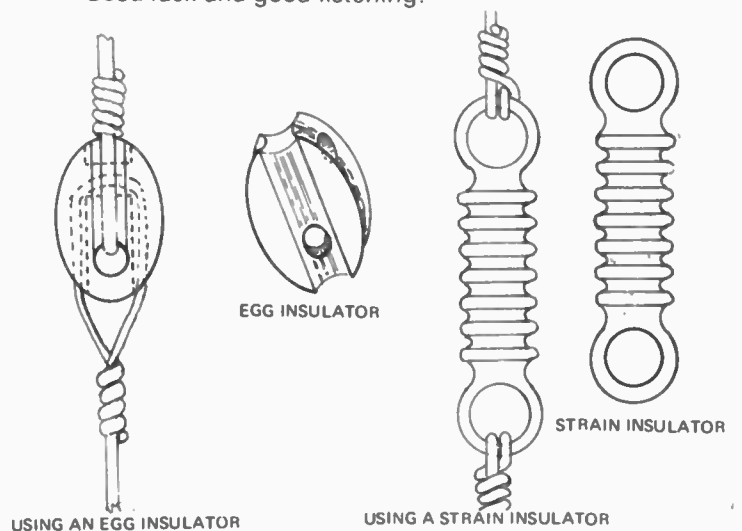

Fig. 7. Two types of aerial insulator and how to attach them.

TV Shopping

A revolutionary new TV service gives tens of thousands of housewives up-to-the-minute news of shop prices. By James Gold.

FOR 68,000 FAMILIES in the New York area and thousands more in various other American towns, grocery and drug shopping is as close as their television sets.

Subscribers of Cablevision, the pay-television service that comes into the home via cable rather than over the air waves, can sit back with their shopping lists and price 64 different items offered by 14 different supermarkets. At the same time — the service is broadcast from 4.30 pm continuously until 10.15 am the next day — shoppers can price 70 frequently prescribed drugs at 10 major drug stores.

The television surveys aren't advertisements, such as those shoppers pore over in the daily newspaper in an effort to save money on their food bills. And this fact makes the televised surveys distinctly advantageous. For the newspaper ads merely feature the prices of items each supermarket or drug store wishes to feature. And that leaves unanswered the question of which store has the best prices *overall*.

Both surveys are provided under contract with Cablevision by Vector Enterprises, a California-based company that was started three years ago by four computer experts.

PRICE CHECK

In the case of the supermarket price survey in the New York area, each Monday four women who live nearby and are employed by Vector, go to the stores, gather the prices and telephone them three thousand miles away to California. An operator there feeds the prices into a computer that tabulates and stores them. In the evening a computer operated by Reuters News Service in Manhattan calls Vector's computer and takes the data which is then transmitted to Cablevision and sent out along the cable to its subscribers.



A viewer studies the latest prices.

If it sounds complicated, it really isn't. The whole thing — after the surveys are completed — only takes a few seconds of whirring and blinking.

Each separate supermarket item and its price are shown on the screen for 20 seconds and after all have been shown individually, the totals are given for produce, meat, groceries and sundries. A grand total, computed to include the quantities of each item likely to be consumed by a family of four, is also given. Among the items surveyed are ground beef, stew beef, most kinds of steak, three kinds of roasts, beef, liver, bacon, whole frying chicken, two kinds of fish, apples, bananas, melons, tomatoes, potatoes, coffee, spaghetti, cereal, bleach, tissues, eggs, kidney beans and the cheapest brand of detergent on hand.

SAVE IT!

Why is the service being offered?

"It's not so much that we are being crusaders," said Alan Krause, pro-

gramme director for the company, "although I look at the differences that show up among the various stores for the same item and I'm shocked. We really give our customers the opportunity to get an objective and fair assessment of what's on sale . . . before they have left the house and committed themselves by entering a particular store."

"Money is very tight everywhere," he added. "People are happy to save even a few dollars over the period of a week."

CUMULATIVE

The supermarket survey has been shown on Cablevision since the end of 1975 and a look at the cumulative cost of the 148-item market basket over the period provides an interesting look at the pricing of various chains.

From December 29th 1975 to June 7th, 1976 . . . 24 weeks . . . the most expensive and the cheapest were separated by a difference of 17

per cent overall, or \$454.55 (about £200) for all the items.

But some shoppers aren't all that interested in overall savings as the difference between many of the stores over a long period are not that great. They're more interested in saving on an item by item basis. They like to plan a shopping day, leaving a certain amount to be spent at one store with a special price on one product before going to another bargain elsewhere.

Many viewers say that they have made substantial savings, using both the newspaper advertisements and the television lists in conjunction.

A woman in Massapequa, a suburb about 40 miles east of New York City, said that she had shopped at the same supermarkets for fifteen years—until she began keeping close tabs on the survey. "Then I realised that they weren't the cheapest by any means," she said. "I didn't switch over to another store completely, though. Because after looking at the surveys for a few weeks, I could see a pattern in pricing begin to emerge and I saw that some of the items it carried were cheaper. Now I shop at three or four stores, all nearby. The extra time travelling is worth it."

There are some who complain.

Ernest Barbella, vice president of A & P on Long Island, has disputed the results of the survey that places them 12th out of 14 stores. "I know our price structure and there is no way we are 17 per cent higher than many other stores listed. I could believe one or two per cent because not all stores are the same."

A spokesman for Grand Union said that "it was no use commenting" because the surveys were not "scientifically conducted." The spokesman pointed out that inconsistencies in the survey make for big differences such as stores which might stock large and high quality items which must invariably cost more. "Some goods you wouldn't want to serve your family, no matter how much you could save," he said.

USEFUL INFORMATION

According to Russel Smith, president of Vector, the firm that conducts the surveys, consumers are left to draw their own conclusions from the data they see on their television screens. He also said that his firm never intended the survey as a guide to

quality.

But Mr Smith said he believed the information was useful and that the survey had proved popular. The service is already being offered in Los Angeles and on two stations in San Diego and will soon begin in Honolulu, Hawaii, Dover and Oakland, New Jersey and in Manhattan.

Since many markets already accept orders by phone and deliver them the possibilities for the future are intriguing indeed. Combined with the telephone, shopping may be only as difficult as sitting in an easy chair before the television with an extension nearby.

This is seen as a potential saviour for the elderly, bed-ridden and disabled in particular, and for very busy housewives and professional women who don't have the time to spend in the market but wish to retain some control over how much they spend and what they buy.

"Eventually what we are hoping for is to show the actual product on the shelf, allowing the customer to shop by television by merely pressing a button when she sees what she wants," said Krause. "That, however, is a bit far off. But not as far as you would think . . ."

HE

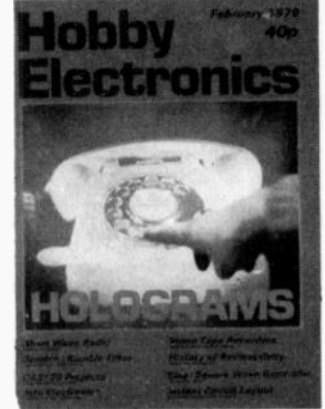
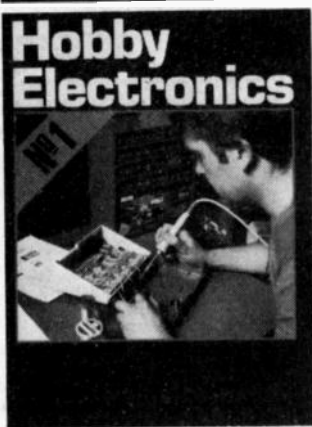

Are you missing out on something?

Take out
a sub to
HE today

To: Subscriptions
Hobby Electronics
P.O. Box 35
Bridge Street,
Hemel Hempstead,
Herts

I would like a postal subscription to HE starting with the . . . issue. I enclose payment (£6.50 for UK and Eire, £7.50 elsewhere, £11.50 air mail).

Name

Address

Photographic Timer

This project should appeal to the photo enthusiast. Use it to do your enlarger timing.

OUR PHOTOGRAPHIC TIMER is a useful project with some unusual features. It has two fully variable ranges, covering 0.9 seconds to 10 seconds and 9 seconds to 100 seconds. The unit has a relay output for turning the enlarger on and off, and is battery powered. Timing periods are initiated by pressing a start switch, and either end automatically at the end of the pre-set timing period, or they can be aborted part way through the timing period by pressing a RESET switch.

POWER SAVING

The most unusual feature of the timer is that it consumes power only during the actual timing period. This feature makes it legitimate to use a battery power supply, which in turn increases the unit's versatility by making it fully portable and suitable for use as a general-purpose short — period timer. The unit has a built-in LED (light-emitting diode) that illuminates during the timing periods.

CONSTRUCTION

Most of the circuit is built on a PCB, and construction should present no problems if you follow the overlay with care. Be sure to fit the two diodes, the two electrolytic capacitors, the LED and the IC the right way round. Take extra care when doing the interwiring, especially to SW1.

If you wish to use the relay output socket we recommend, a $\frac{3}{4}$ in diameter hole must be punched to house the socket. We used a Q-max metal punch for this purpose (available from most tool shops): this punch needs a pilot hole of $\frac{5}{16}$ in.

When the construction is complete, double-check all wiring and then give the unit a functional check. Connect the battery supply, press the START switch, and check that the relay and LED operate and turn off again automatically at the end of a pre-set period. The maximum timing period can be pre-set to precisely 10 seconds on range 1 via RV2, and to 100 seconds on range R via RV3.

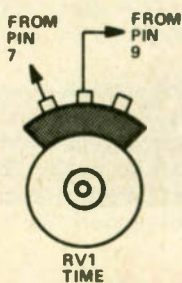

How to wire the 'TIME' pot and the 'TIME SET' switch.

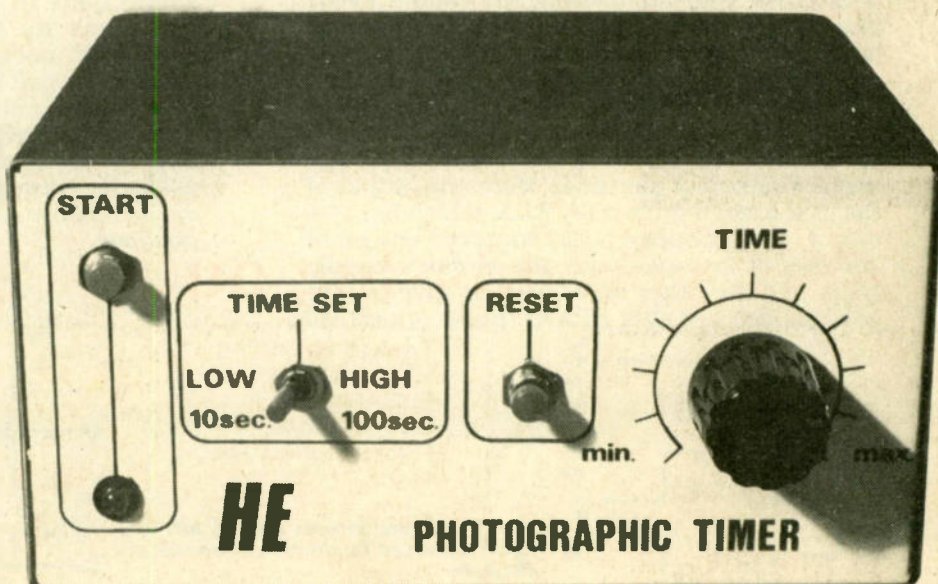
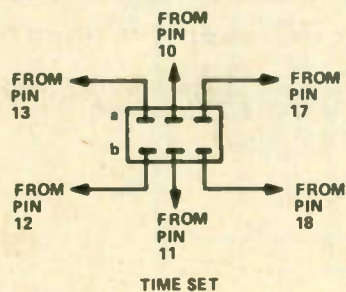

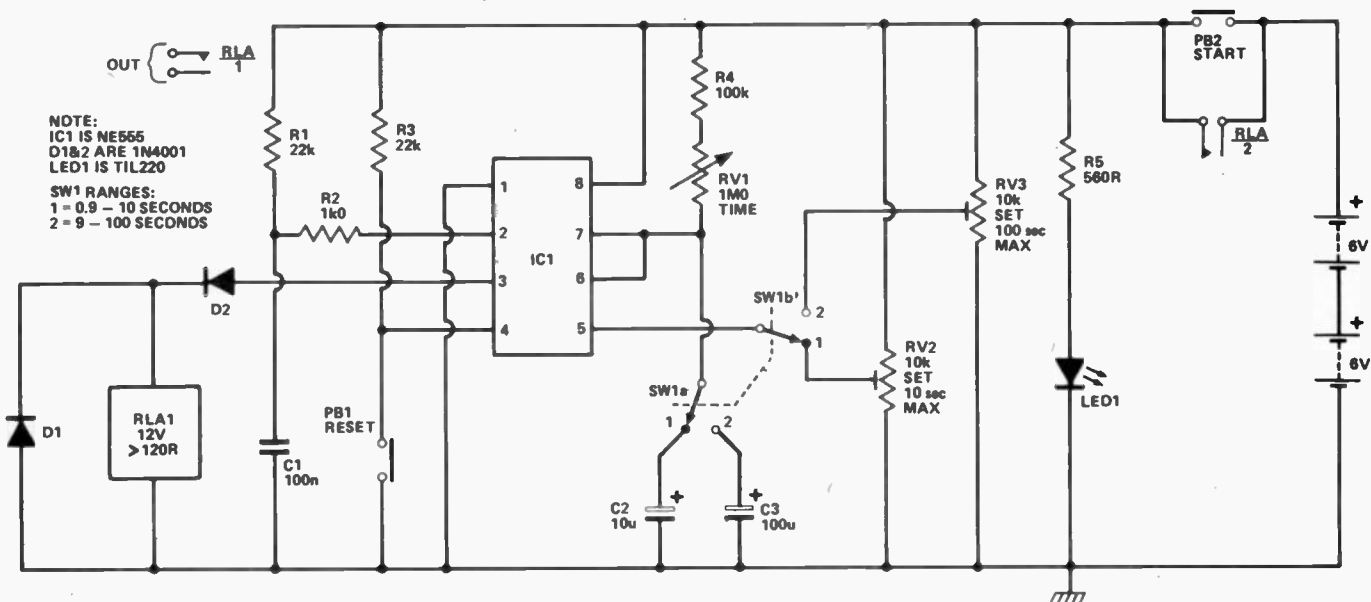

The circuit diagram for the timer.

How it Works

The photographic timer is designed around a simple and inexpensive IC known as the 555 timer. Fig. 1 shows the circuit and waveforms of a simple manually-triggered timer built around this IC. Here, trigger pins 2 and 4 are normally held high by Ra and Rb, and output pin 3 is low. When a brief negative-going trigger pulse is applied to pin 2 of the IC, via the push-button PBa, a timing period is initiated and the pin 3 output terminal immediately goes high and C1 starts to charge towards the positive supply rail voltage via Rc.

After a delay determined by the values of Ca and Rc, the Ca voltage reaches 2/3 of the supply voltage value, and at this point a switching action is initiated within the IC in which output pin 3 switches rapidly to zero volts and Ca is discharged, thus completing the timing cycle. Note that the timing cycle can be aborted part way through, if required, by applying a negative-going pulse (by briefly closing PB2) to pin 4 of the IC.

Our photographic timer is a modified version of the basic Fig. 1 circuit. Look now at the full circuit diagram of our timer. Here, the output of the IC is used to drive relay RLA, which has two sets of N.O. (normally-open) contacts: one set of contacts is in series with the circuit's supply leads, and the other set is used to give output control. The circuit's START pulse is derived

from the positive supply line via R1 and C1, and the timing periods are determined by the values of C2-C3-RV1-RV3-R4, which can be switch-selected via SW1.

The timer operation is initiated by momentarily closing PB2 and thereby briefly connecting the positive supply to the circuit. At the instant that the supply is connected, C1 is discharged: Consequently, trigger pin 2 is held negative relative to the supply line at this instant, and a timing cycle is immediately initiated: As the timing cycle is initiated relay RLA operates and contacts RLA/2 close and bypass switch PB2, thus maintaining the supply connection to the circuit once PB2 is released. At the end of the timing cycle RLA turns off and contacts RLA/2 open, thus breaking the supply connections to the circuit. The circuit thus consumes no current when it is in the STANDBY mode.

Pre-set pots RV2 and RV3 are switch-selected to connect to modulation pin 5 of the IC, and enable timing periods to be varied over a limited range to compensate for variations in the actual values if electrolytic capacitors C2 and C3 and to enable precise maximum timing periods to be obtained.

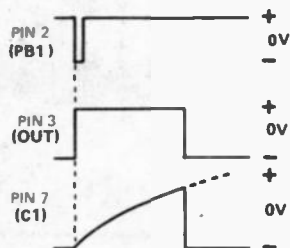
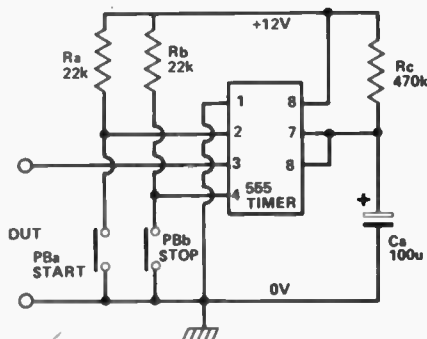
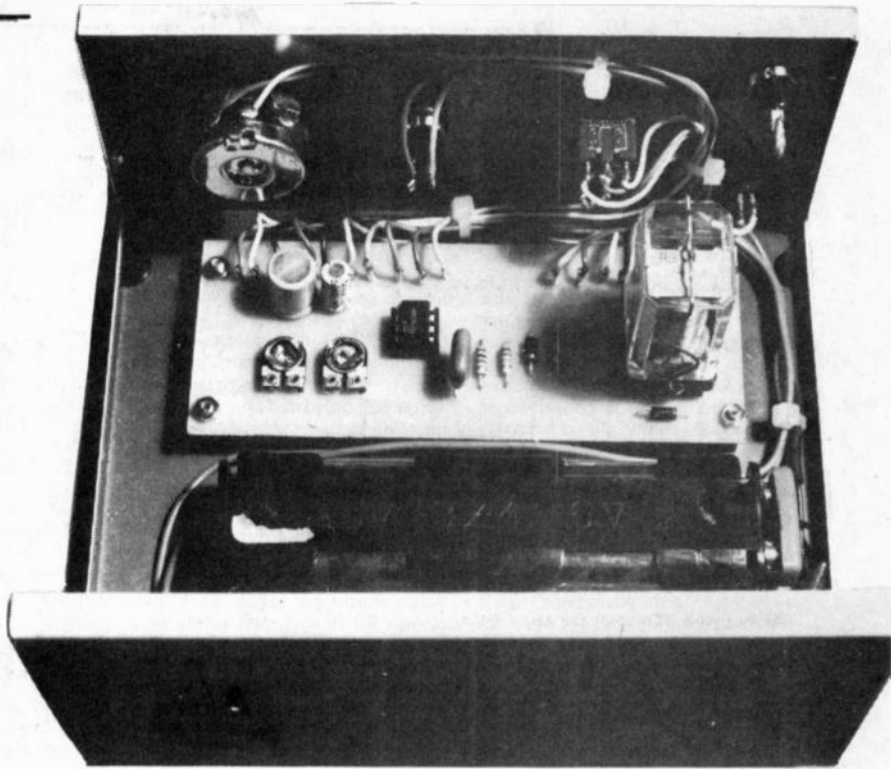
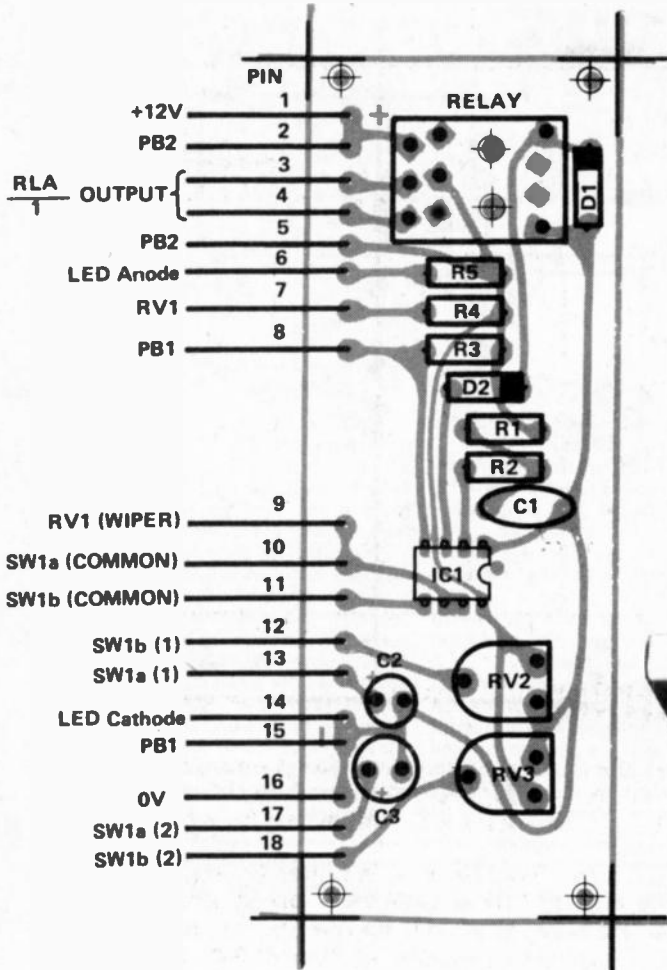

Fig. 1. The waveforms on the left are those produced by the simple circuit on the right.



Photographic Timer



Above left: The overlay for the PCB.

Above right: Inside the box.

Below left: The PCB with components in place.

Below right: The PCB foil pattern show full size

Parts List

RESISTORS (All 5%, 1/4W)

R1	22k
R2	1k
R3	22k
R4	100k
R5	560R

CAPACITORS

C1	100n (0.1uF) polyester, mylar etc.
C2	10u 16V electrolytic, PCB mounting
C3	100u 16V electrolytic, PCB mounting

POTENTIOMETER

RV1	1MO linear, rotary
-----	--------------------

SEMICONDUCTORS

IC1	555 (NE555)
D1, D2	1N4001 silicon diode
LED1	TIL 220

MISCELLANEOUS

SW1	Miniature toggle, two pole, two way
PB1, PB2	Push button switches, push-to-make
Relay	12V coil with minimum resistance of 120R, sub miniature type with at least two 'normally open' contacts (change-over contacts will contain a normally open pair)
PCB	Pattern as shown
	Bulgin mains plug and socket, 2-off HP7 4 section battery holders, 8-off HP7 battery. Case to suit.

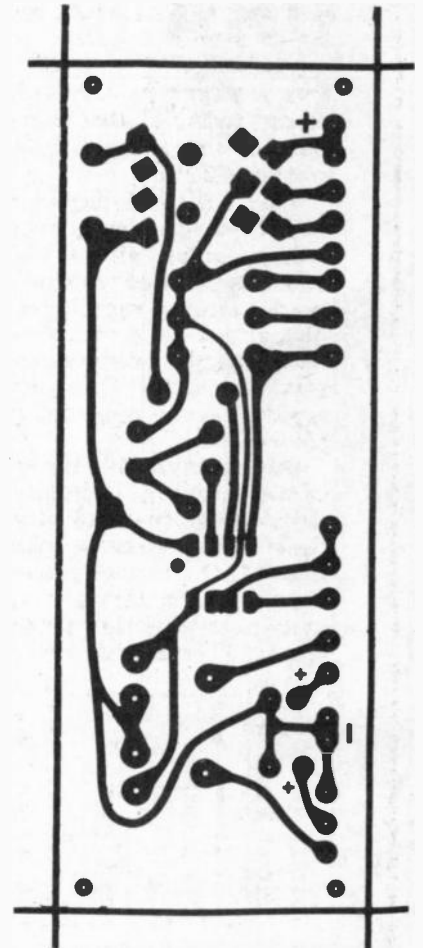
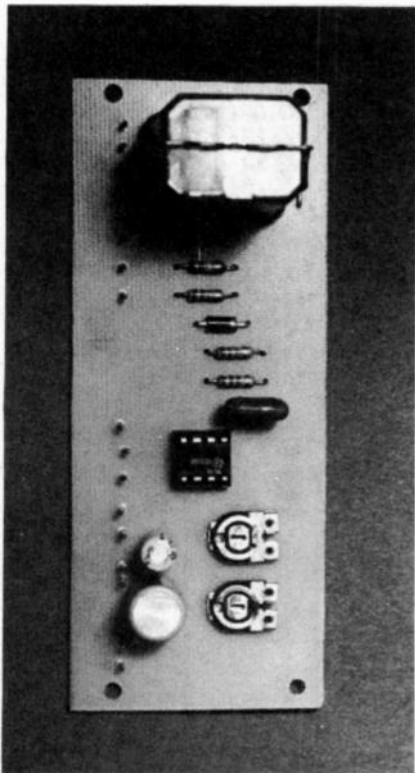

Short Circuit

LIE DETECTOR

It is well known that a person perspires under tension; what is less well known is that this effect is a gradual one and that a small amount of perspiration takes place, especially in the palms of the hands, even under slight pressure. In the normal course of events this is rarely noticed but this effect can be shown electronically.

When a person is embarrassed or tells a lie there is a very small, but noticeable, increase in the sweat on the palms of the hands. Perspiration is reasonably conductive; holding the probes of a test-meter in the hands will show a resistance reading, albeit at a high level. It will therefore be seen that by measuring the resistance across a person's hands that we shall be able to see an indication of whether they are telling the truth or not. Let us say straight away that this test is far from perfect and it has little serious use but it does illustrate an interesting phenomenon and makes for a little experimenting.

The change in the body resistance is quite small when shown as a percentage — about 5 or 10 per cent and showing this change directly on a meter leaves something to be desired. For this reason we make use first of a transistor to "amplify" the resistance and secondly we place this in a bridge circuit. When this is in balance the meter will only read changes in the resistance.

When the probes are held, one in each hand, the body resistance, in conjunction with R2, provides the bias for the transistor. The body resistance varies enormously from person to person as well as with their emotional state but a typical value could be taken as 100 k ohms. R2 is included solely as a safety resistor and will prevent damage to the device if the probes are touched directly together. The current passing through this transistor and through R1 will depend upon the value of the resistance between the collector and emitter.

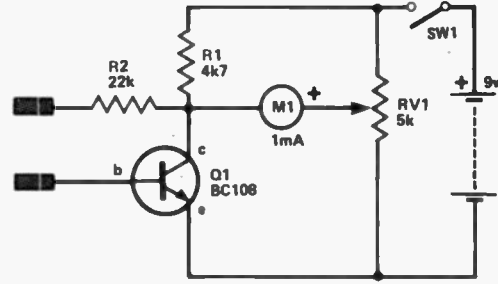

As the current varies, so will the voltage at the collector.

For setting up the circuit the probes should be held in the hands. This will give a particular voltage and RV1 is adjusted so that the voltage at the slider is the same as that at the collector of the transistor. As the voltages are the same, no current will be flowing through the meter coil and no reading will be registered.

If the body resistance now falls, Q1 will conduct more and the voltage at the collector also falls and a reading will be shown on the meter, the size of the deflection will indicate by how much the body resistance has fallen.

Although the probes are held in the hand, there is no danger as only a 9V battery is being used. RV1 will have to be adjusted for each individual and even for each set of readings with the same person.

The effect is quite remarkable and also surprisingly rapid; within a very short while (one or two seconds) the meter will show a deflection. There may be a small amount of wandering of the needle but this will be small compared to normal readings.

As we have said, the results should not be taken too seriously but very definite readings are given when the person being tested is under stress.

ASTRA-PAK

92 GOOSTONE ROAD, WHYTELEAF, SURREY CR3 0EB

GRAND SALE

All prices include VAT Add 25p for P & P (Extra for overseas). Send SAE for complete Special Offers list Where more than one price appears, overall quantity prices apply to groups of devices of the same type (74 and 74LS cannot be mixed)

7400 SERIES		74LS00 SERIES		7400 SERIES		74LS00 SERIES		7400 SERIES		74LS00 SERIES		CMOS		1+ 25+ 100+		1+ 25+ 100+		1+ 25+ 100+		LINEARS		
1+	25+	100+	1+	25+	100+	1+	25+	100+	1+	25+	100+	1+	25+	100+	1+	25+	100+	1+	25+	100+		
7400	.08	.078	.07	.185	.14	.13	7490	.30	.28	.26	74167	2.20	2.08	1.88	4000	13	11	10	4072	14	13	.30
7401	.11	.108	.10	.185	.14	.13	7491	.60	.56	.52	74168				4001	13	12	11	4073	14	13	.30
7402	.11	.106	.10	.185	.14	.13	7492	.30	.28	.26	74169				4002	13	12	11	4074	14	13	.30
7403	.11	.106	.10	.185	.14	.13	7493	.28	.26	.23	74170	1.20	1.10	1.00	4003	70	62	50	4075	14	13	.30
7404	.11	.106	.10	.18	.16	.135	7494	.50	.46	.42	74171	3.60	3.58	3.60	4004	90	82	70	4076	14	13	.30
7405	.12	.115	.11	.18	.16	.135	7495	.50	.46	.42	74172	.80	.84	.80	4005	32	28	27	4077	30	26	.72
7406	.22	.21	.20				7496	.48	.42	.38	74174	.84	.80	.80	4006	32	28	27	4078	14	13	.30
7407	.22	.21	.20				7497	1.80	1.70	1.65	74175	.88	.84	.81	4007	32	28	27	4079	14	13	.30
7408	.13	.128	.12	.185	.14	.13	74100	.90	.72	.68	74176	.88	.84	.81	4008	32	28	27	4080	14	13	.30
7409	.13	.128	.12	.18	.16	.135	74104	.40	.36	.34	74177	.88	.82	.81	4009	120	100	100	4081	14	13	.30
7410	.11	.106	.10	.185	.14	.13	74105	.37	.34	.32	74178	.90	.80	.78	4010	14	13	12	4082	14	13	.30
7411	.17	.16	.15	.18	.16	.135	74107	.22	.20	.18	74179	1.08	1.00	.95	4011	14	13	12	4083	14	13	.30
7412	.14	.138	.13	.16	.15	.135	74109	.28	.26	.24	74180	.90	.70	.82	4012	13	12	11	4084	14	13	.30
7413	.23	.21	.20	.28	.26	.24	74110	.36	.34	.32	74181	1.16	.96	.80	4013	30	25	22	4085	1.20	1.00	1.00
7414	.48	.43	.40	.68	.67	.60	74111	.58	.52	.50	74182	.82	.67	.44	4014	48	32	30	4086	1.48	1.20	1.00
7415				.18	.16	.135	74112				74184	1.28	1.08	1.00	4015	90	82	70	4087	1.48	1.20	1.00
7416	.22	.20	.18				74113	.28	.26	.24	74185	7.50	6.90	6.70	4016	32	28	27	4088	3.00	2.60	2.60
7417	.22	.20	.18				74114				74187	2.60	2.40	2.28	4017	30	25	22	4089	1.90	1.70	1.50
7420	.11	.106	.10	.185	.14	.13	74116	1.10	.90	.86	74190	.80	.80	.86	4018	30	25	22	4090	1.90	1.70	1.50
7421	.22	.21	.20	.18	.16	.135	74118	.78	.78	.72	74191	.68	.68	.66	4019	30	25	22	4091	1.90	1.70	1.50
7422	.17	.168	.16	.18	.16	.135	74119	1.10	.90	.86	74192	.82	.82	.82	4020	30	25	22	4092	1.90	1.70	1.50
7423	.20	.19	.18				74120	.90	.76	.74	74193	.80	.80	.86	4021	30	25	22	4093	1.90	1.70	1.50
7425	.20	.19	.18				74121	.21	.21	.20	74194	.88	.80	.86	4022	30	25	22	4094	1.90	1.70	1.50
7426	.21	.20	.19	.18	.16	.135	74122	.32	.29	.27	74195	.88	.80	.86	4023	13	12	11	4095	1.90	1.70	1.50
7427	.21	.20	.19	.18	.16	.135	74123	.38	.35	.32	74196	.88	.80	.86	4024	30	25	22	4096	1.90	1.70	1.50
7428				.18	.17	.16	74124	1.80	1.50	1.42	74198	.88	.80	.86	4025	30	25	22	4097	1.90	1.70	1.50
7430	.11	.106	.10	.185	.14	.13	74125	.32	.30	.28	74199	.88	.80	.86	4026	30	25	22	4098	1.90	1.70	1.50
7432	.21	.20	.19	.23	.20	.18	74126	.32	.30	.28	74197	.60	.44	.40	4027	30	25	22	4099	1.90	1.70	1.50
7433	.30	.27	.26				74128	.80	.85	.82	74198	.96	.86	.78	4028	30	25	22	4100	1.90	1.70	1.50
7437	.20	.19	.18	.24	.21	.185	74130	.40	.38	.32	74199	.90	.80	.85	4029	32	28	27	4101	1.90	1.70	1.50
7438	.20	.19	.18	.24	.21	.185	74132	.47	.44	.42	74201	1.20	1.00	.88	4030	32	28	27	4102	1.90	1.70	1.50
7440	.12	.118	.11	.18	.16	.15	74134	.32	.30	.28	74247				4031	1.80	1.60	1.48	4103	1.90	1.70	1.50
7441	.48	.45	.43				74135	.82	.88	.88	74248				4032	30	25	22	4104	1.90	1.70	1.50
7442	.40	.38	.34	.60	.44	.40	74136	.82	.48	.48	74249				4033	30	25	22	4105	1.90	1.70	1.50
7443	.85	.80	.87				74137	.74	.88	.88	74251	1.00	.82	.74	4034	30	25	22	4106	1.90	1.70	1.50
7444	.64	.60	.56				74138				74257				4035	30	25	22	4107	1.90	1.70	1.50
7445	.53	.50	.48				74139				74258				4036	30	25	22	4108	1.90	1.70	1.50
7446	.55	.52	.50				74141	.52	.48	.48	74266				4037	30	25	22	4109	1.90	1.70	1.50
7447	.50	.44	.40	.87	.60	.56	74142	1.85	1.78	1.68	74273	1.90	1.70	1.65	4038	30	25	22	4110	1.90	1.70	1.50
7448	.55	.50	.48	.82	.73	.65	74143	2.30	2.10	2.00	74279	1.10	.90	.82	4039	30	25	22	4111	1.90	1.70	1.50
7449				.87	.80	.66	74144	2.30	2.10	2.00	74283	1.80	1.30	1.20	4040	30	25	22	4112	1.90	1.70	1.50
7450	.12	.118	.11				74145	.85	.80	.88	74284	3.50	3.20	3.00	4041	30	25	22	4113	1.90	1.70	1.50
7451	.12	.118	.11	.16	.16	.135	74147	1.00	.92	.88	74289				4042	30	25	22	4114	1.90	1.70	1.50
7453	.12	.118	.11				74148	.84	.78	.78	74290				4043	30	25	22	4115	1.90	1.70	1.50
7454	.12	.118	.11	.185	.14	.13	74150	.80	.86	.80	74293	1.20	1.00	.80	4044	30	25	22	4116	1.90	1.70	1.50
7455	.12	.118	.11	.18	.16	.135	74151	.46	.41	.38	74296	1.80	1.65	1.40	4045	30	25	22	4117	1.90	1.70	1.50
7470	.28	.23	.21				74153	.48	.41	.38	74352				4046	30	25	22	4118	1.90	1.70	1.50
7472	.22	.20	.18				74154	.78	.68	.60	74353				4047	30	25	22	4119	1.90	1.70	1.50
7473	.23	.21	.20	.26	.23	.21	74155	.80	.44	.44	74356				4048	30	25	22	4120	1.90	1.70	1.50
7474	.23	.21	.20	.26	.23	.21	74157	.48	.40	.38	74366				4049	30	25	22	4121	1.90	1.70	1.50
7475	.28	.28	.26	.40	.38	.32	74158	.36	.82	.82	74367	1.10	.85	.70	4050	30	25	22	4122	1.90	1.70	1.50
7476	.28	.24	.23	.29	.23	.21	74159	1.85	1.80	1.70	74368				4051	30	25	22	4123	1.90	1.70	1.50
7478				.28	.26	.23	74160	.87	.82	.88	74385				4052	30	25	22	4124	1.90	1.70	1.50
7480	.40	.38	.34				74161	.50	.44	.40	74390	1.70	1.40	1.25	4053	30	25	22	4125	1.90	1.70	1.50
7483	.52	.48	.48	.56	.55	.52	74162	.87	.82	.88	74393	1.78	1.48	1.25	4054	30	25	22	4126	1.90	1.70	1.50
7484	.84	.80	.77				74163	.87	.82	.88	74670				4055	30	25	22	4127	1.90	1.70	1.50
7485	.82	.88	.86	.87	.80	.66	74164	.87	.82	.88					4056	30	25	22	4128	1.90	1.70	1.50
7486	.22	.20	.18	.28	.28	.23	74165	.87	.82	.88					4057	30	25	22	4129	1.90	1.70	1.50
7489	1.38	1.26	1.18				74166	.70	.84	.88					4058	30	25	22	4130	1.90	1.70	1.50

Mixed prices apply for quantity discount

Into Electronics

by Ian Sinclair

Part 5

Oscillators are probably the most used and least understood of all circuit building blocks, get to know and love them in this the fifth part of Into Electronics.

POSITIVE FEEDBACK is the process of taking some of the signal at the output of an amplifier and connecting it back, in phase, to the input. How much effect this has depends on how much of the signal is fed back. Small amounts of positive feedback (as we call this) can increase the gain of an amplifier and also increase the input impedance. A simple example of this use of positive feedback is the circuit of Fig. 5.1. This is an emitter-follower (see earlier parts) with a capacitor feeding signals back from the emitter to the base. Because the voltage gain of an emitter-follower is always less than unity this has no effect on the gain of the whole circuit, but it does make the input impedance for signals very much higher than that of the unaltered emitter follower. This use of positive feedback is called **bootstrapping**. The name comes from the (US) inventor of the circuit who remarked that "it looks a bit like pulling yourself up with your own bootstraps." A two-stage bootstrap circuit with a very high input resistance is shown in Fig. 5.2.

The bootstrap circuit is stable because there is unity

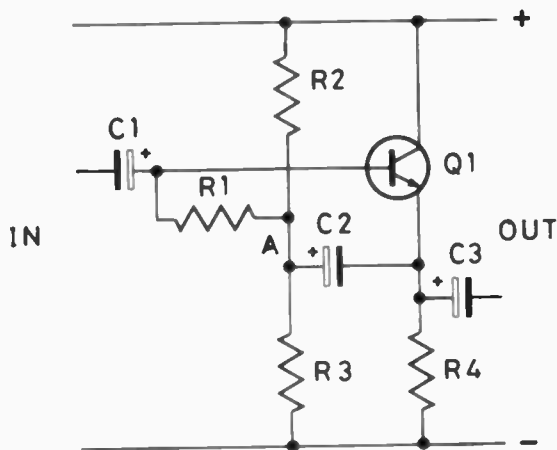

Fig. 5.1 A bootstrapped emitter-follower. The voltage at point A changes in phase with the input voltage, so that practically no signal current flows through R1. The effect is similar to that of having a very large value of R1 for signals only.

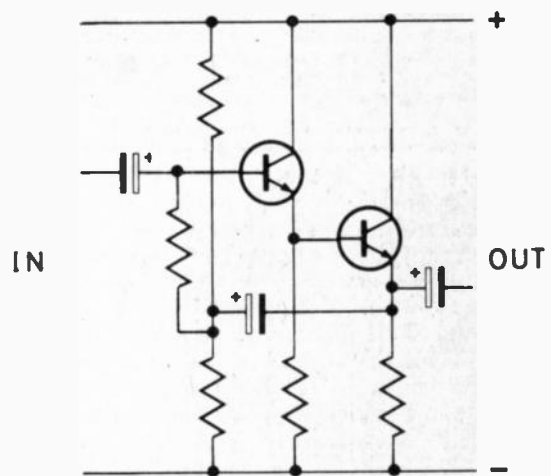

Fig. 5.2 A two-stage bootstrapped circuit with a very high input resistance of several megohms.

(or slightly less than unity) gain in the amplifier that is bootstrapped. If we attempt to use positive feedback in an amplifier which has voltage gain, then we run into difficulties because the amount of feedback has to be very carefully controlled. Any change in the gain of the amplifier or in component values may be enough to make the circuit unstable so that the amplifier oscillates. For this reason, positive feedback, other than bootstrapping, is seldom used in amplifier circuits.

The main use of positive feedback, then, is to make amplifier circuits into oscillators. There are two kinds of oscillators, the sine-wave type, in which the amount of positive feedback is controlled so as to give a sinewave with a good wave-shape; the other sort is the aperiodic type in which the positive feedback is allowed to run wild. This second type of oscillator uses so much positive feedback that it spends most of its working life with the transistors either bottomed or cut-off. Because it's simpler, we'll look at this type first.



THE WILD ONES

Take a look at the circuit in Fig. 5.3. It's a simple two-transistor amplifier, and the output signal will be in phase with the input signal but greatly amplified. Now make the dotted connection and there is a positive feedback loop. This is 100% positive feedback; all the signal at the output is connected back to the input and it converts a simple two stage amplifier into an oscillator of a type called the **astable multivibrator**. The word astable means 'not stable', and that's a good description. The positive feedback is so effective that the circuit cannot exist for more than a few nanoseconds with both transistors conducting. It's an important circuit, so let's go over the action carefully.

When the circuit is switched on, the voltages at the collectors and also at the bases of the two transistors will start to rise. Because of the inevitable slight differences between transistors, one will conduct before the other, so that its collector voltage will start to fall again. Let's say that it's Q1 that is conducting — then the voltage at the collector of Q1 is falling and the capacitor coupling through C1 will cause the voltage at the base of Q2 to drop as well. A drop of voltage at the base of Q2 will cause the collector voltage of Q2 to rise and this rise of voltage is coupled by C2 to the base of Q1 to rise and this rise of voltage is coupled by C2 to the base of Q1, completing the positive feedback loop and making the voltages change very, very quickly. The whole process is over in a matter of nanoseconds, and it ends with Q1 conducting fully, its collector voltage bottomed at about 0.2 V, and Q2 cut off with its base voltage at about -5.3 V. Why -5.3 V, you ask, very reasonably? Well, it's like this: suppose that the base of Q2 was about to conduct, at around 0.5 V when all this happened. The collector voltage of Q1 changes from 6 V (not conducting) down to about 0.2 V (bottomed). That's a drop of 5.8 V. Now a capacitor will couple a voltage change like this, so that the voltage at the base of Q2 also drops by 5.8 V, from 0.5 V to -5.3 V, making pretty sure that Q2 is shut off. Meantime, the connection of R2 to the +6 V line makes equally sure that Q1 stays fully conducting. Once it gets into this connection, there's no more positive feedback, because there's no more amplification when one transistor is bottomed and the other cut-off. It would stick like this for good if it were not for one important point: the base of Q2 is connected to the +6 V line through R2.

Since there's a voltage difference across R2 (+6 V at one end, and -5.3 V at the other), current flows. Where? Into the capacitor C1, that's where, so that C1 charges up. The voltage of one plate of this capacitor is held at about 0.2 V by the collector voltage of Q1; the voltage of the other plate now rises in the shape of an exponential curve (Fig. 5.4C) from -5.3 V. Left alone, it would eventually get to +6 V in the usual time of about four time constants ($4 \times R2 \times C1$). It's not left alone, though. When the voltage at the base of Q2 reaches about 0.5 V, Q2 starts to conduct and one again the positive feedback loop takes control.

Once the positive feedback loop takes control, the circuit goes wild again. Q2 is forced into full conduction, Q1 is shut off within a few nanoseconds. The same performance as before now happens as C2 charges, allowing the voltage at the base of Q1 to rise from about -5.3 V until Q1 can start to conduct again . . . and there we go again. Fig. 5.4 shows the waveforms, comparing

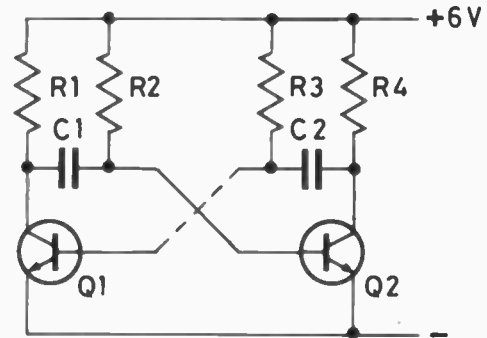

Fig. 5.3 The astable circuit. Try this out with the following values: $R1, R4 = 3k\Omega$, $R2, R3 = 33k\Omega$, $C1, C2 = 0.02\mu F$. Use an oscilloscope to examine the output waveform.

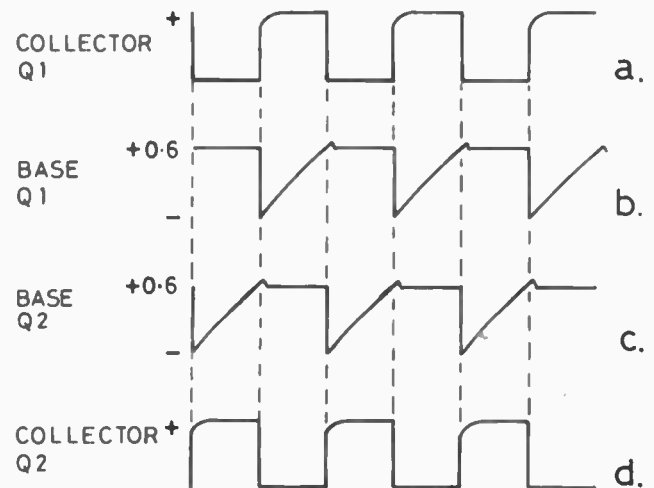

Fig. 5.4 Astable waveforms — these have been drawn to the same time-scale, with the vertical dotted lines linking changes which take place at the same time.

the graphs so that you can see what is happening at each electrode at the same time. Notice, by the way, that when one base is being driven negative, the other is being driven positive. The base voltage cannot, however, greatly exceed around 0.6 V because of the current that can flow between the base and the emitter of the transistor. The base-emitter junction effectively acts as a short circuit, preventing the base voltage from rising above about 0.6 V.

In a circuit of this type, the positive feedback is just a way of ensuring that the circuit flips over from one stage to the other very quickly. The real control is exercised by the time constants $R2.C1$ and $R3.C2$. If these are identical, both parts of the wave take equal times. The total wave-time for a complete cycle is given by $0.7(R2.C1 + R3.C2)$. If the two time constants are not equal, then the wave is not symmetrical, but there's a limit to the mark-space ratio (on/off ratio) that we can get by altering the time constants.

PULSE PROBLEMS

Problems? Well, the simple circuit can suffer from sticking if the bias resistors R2, R3 are either too low (around 1 k) or too high (220 k or more). Sticking means that both transistors are bottomed or cut-off together, so that oscillation will not start. The remedy is to keep to sensible values of bias resistors. Next problem — a poor

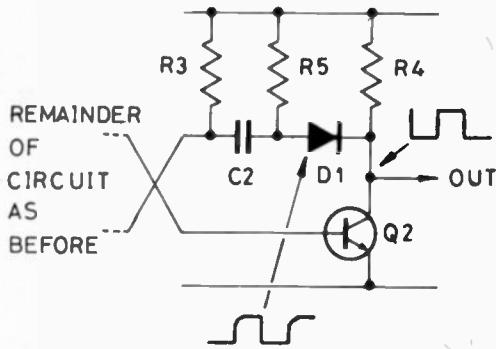

Fig. 5.5 A modification to give a better shaped wave at the collector of Q2

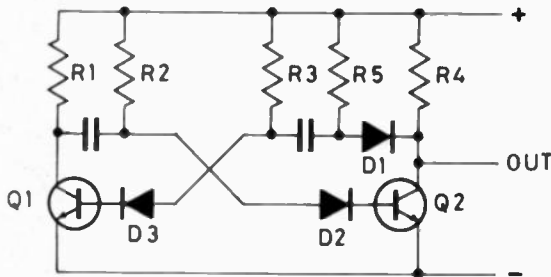

Fig. 5.6 Astable circuit with the modifications mentioned in the text.

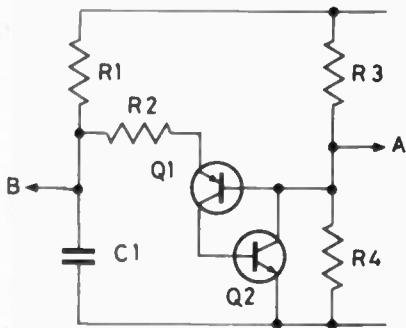

Fig. 5.7 Serial astable circuit. Try this out with the following values: $R1 = 33\text{ k}$, $C1 = 0.02\mu\text{F}$, $R3 = R4 = 10\text{ k}$, $R2 = 100\text{ R}$, Q1 2N905, Q2 2N2219.

wave-shape at the collector of each transistor. The cause is the time needed to charge the coupling capacitor. Looking at the collector of Q2; when Q2 cuts off, C2 has to charge from about 0.2 V up to +6 V through R4. One plate of C2 is held at about 0.5 V by the base of Q1, the other has to reach +6 V, and current must flow through R4, which takes time (a time constant of $C2 \cdot R4$). This makes the rising part of the wave at the collector of Q2 rather slow. The remedy is to add a resistor and a diode as shown in Fig. 5.5 at the collector of Q2. Now when Q2 cuts off, the voltage can rise quickly at the collector by R5, and can take its time. When the collector voltage of Q2 drops, of course, the action is quite normal because the diode now conducts.

Last problem — in the simple circuit, the frequency varies rather a lot when we change the voltage, and the theory says it shouldn't. When theory and practice disagree like this, there's usually something wrong with the practice! In this case it's the base-emitter junction of the transistors breaking down so that the base voltage cannot go as negative as the signal (through the capaci-

tor) is trying to force it. The remedy is simple — a silicon diode connected into each base lead, using a type which can stand the reverse voltage rather better than the base-emitter junction of the transistor.

THE SERIAL ASTABLE

Got your breath back? Fig. 5.7 shows quite a different type of astable, a *serial* type. This circuit also uses two transistors, but the type of action is quite different. Instead of switching so that the transistors conduct alternately, this circuit works so that we have either both transistors conducting together or both cut off. The output is a series of short negative pulses, and there is only one time constant. One transistor is a PNP type, the other an NPN. It all works like this:

When the circuit is switched on, C1 is uncharged and will take some time to charge through R1. As a result, the emitter voltage of Q1 is still low by the time its base voltage has reached the level set by R3 and R4 (a voltage equal to half of supply voltage when $R3 = R4$). Now this ensures that Q1 is not conducting, because a PNP transistor conducts only when its emitter voltage is more positive than its base voltage (or its base voltage more negative than its emitter voltage, if you like it that way round). No current flows through Q1, then, and there's no base current flowing into Q2 either to switch that one on.

As C1 charges up, though, the voltage at the emitter of Q1 will become higher than the voltage at the base of Q1. When this happens, Q1 conducts, current flows into the base of Q2, so that Q2 conducts and its collector voltage drops right down to about 0.2 V. The base of Q1 is connected to the collector of Q2 to complete the positive feedback loop, though, so that Q1 is now well and truly conducting, with C1 now discharging like mad through R2 and the base-emitter junction of Q1 will drop until it's too low to keep current flowing through Q1. When that happens, there's no current flowing into the base of Q2, so that it shuts off. The collector voltage of Q2 then rises, bringing the base voltage of Q1 with it, up to the value set by R3 and R4. Q1 now has its base at the voltage set by R3 and R4, and the emitter of Q1 is at a low voltage, so that Q1 is cut off. C1 now starts to charge again through R1, and the whole cycle repeats.

The waveforms at various parts of the circuit are shown in Fig. 5.8. The output at point A consists of short-duration negative-going pulses, and of near-sawtooth waves at B. The circuit is economical in components and takes very little current from the supply because when both transistors do conduct most of the current is supplied by the charged capacitor C1.

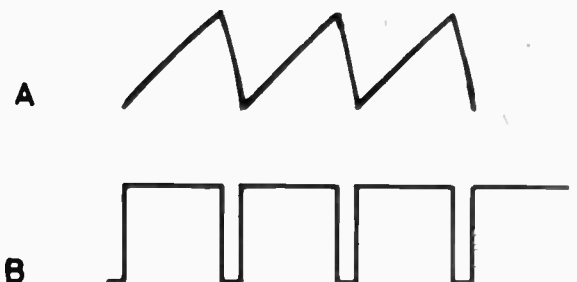

Fig. 5.8 Serial astable waveforms.

THE HALF-TIME TYPE

The kind of **Multivibrator** which we've just described is the **astable**, which cannot stay in any stable state but has to oscillate continuously. There's a related circuit, the **monostable**, which has one stable state. Fig. 5.9 shows one type of monostable. R3 keeps the base of Q2 conducting, at a voltage of around 0.5 V to 0.6 V. With the base passing current, the collector voltage of Q2 is low because of the current through R4, and so the base of Q1, which is connected to the collector of Q2 through resistor R5 is also at a low voltage. When a collector voltage bottoms, it can go to a voltage of about 0.2 V, less than the 0.5 V, or so that is needed to make a base conduct, so that Q1 is quite definitely not conducting. There's nothing in the circuit itself, no charging capacitors, to change this so that the circuit can remain in this state (Q1 off, Q2 on) until the cows come home.

The cows come home when a short positive pulse is fed through C1 and D1 to the base of Q1. Only a small change of voltage is needed to make Q1 start to conduct, then the old positive feedback loop takes over, ending up with Q2 off (base negative) and Q1 held on with current flowing through R5. The diode D1 isolates the base of Q1 from any negative pulse which would otherwise turn off Q1 before the end of the timing period. What timing? Oh yes, there's a timing action as C2 charges up because of the current flowing through R3. During this time the collector voltage of Q2 is high, and the collector voltage of Q1 is low. When the base voltage of Q2 reaches a level of about 0.5 V (in a time of about $0.7 - C3.R3$, Q2 conducts and the positive feedback ensures a quick snap back to the original conditions. There it remains, waiting again for the next trigger pulse.

The monostable is ideal for generating short pulses at long intervals, the job which cannot be done by using very unequal time constants in an astable multivibrator. The trigger pulses can be obtained from the square wave of the astable by using a differentiating circuit, as shown in Fig. 5.11.

SYNCHRONISE YOUR PULSES

One of the many useful points about an astable is that it's rather unstable. Now for many purposes that's about as useful as a lead life-jacket, because so many oscillators have to be very stable. Stable in this respect means that the frequency can be set and will not thereafter change when temperature changes or as components slowly change value. The oscillator that sets the frequency of a radio or TV transmitter must, for example,

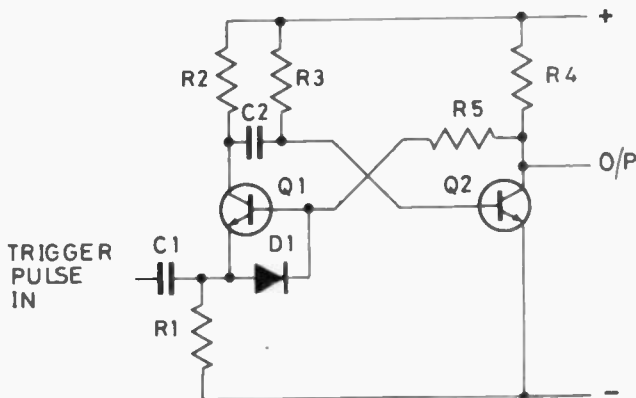

Fig. 5.9. A monostable circuit.

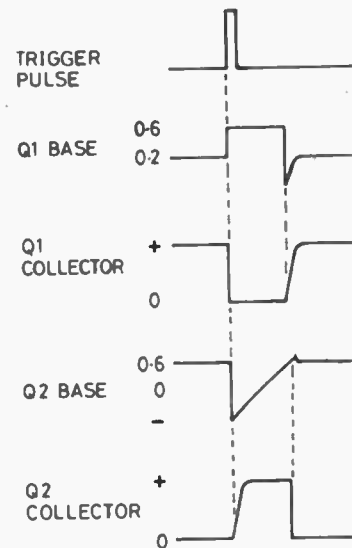

Fig. 5.10 Monostable waveforms.

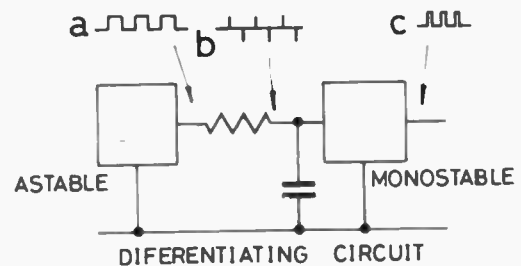

Fig. 5.11 A monostable connected to an astable. The differentiating circuit converts the square wave into a set of pulses. The diode at the input of the monostable circuit selects only the positive pulses to trigger the monostable. The time of the monostable pulse (its pulse-width) is decided by the values of C2, R3 in Fig. 5.9.

be particularly stable so that the transmitter is always at its correct frequency. The oscillator of an electronic watch has to be stable so that the time can be held accurate to within a few seconds a month. We wouldn't use a plain astable for either of these jobs, but the instability of the astable is useful to us nevertheless. Take a problem — how do you generate a square wave with exactly the mains frequency, but which will keep going when the mains supply stops? You can generate a 50 Hz wave using an astable but the frequency will change — unless it's synchronised. Synchronisation means forcing an oscillator to run at the frequency of a wave that is fed into it. If we feed a wave, say a 3 V, 50 HZ sine wave from a transformer into the base of one transistor of an astable running at some frequency between 40 Hz and 60 Hz, then the astable will be forced to run at 50 Hz. There's not much choice about it. If the frequency of the astable is higher or lower than the synchronising frequency, then at some time or other there will be a 50 Hz positive peak of the synchronising signal at the base of the transistor when that transistor is just about to switch on (Fig. 5.12). The synchronising signal ensures that the transistor switches at that

continued on page 57

SPECIALS



TOP PROJECTS

Book 1 + 2: £2.50 + 25p P&P.

Master mixer, 100W guitar amp., low power laser, printmeter, transistor tester, mixer preamp., logic probe, Ni-Cad charger, loudhailer, 'scope calibrator, electronic ignition, car theft alarm, turn indicator canceller, brake light warning, LM3800 circuits, temperature alarm, aerial matcher, UHF-TV preamp., metal locator, four input mixer, IC power supply, rumble filter, IC tester, ignition timing light, 50W stereo amp. and many more.

Book 3: SOLD OUT!

Book 4: £1.00 + 25p P&P.

Sweet sixteen stereo amp., waa-waa, audio level meter, expander/compressor, car theft alarm, headlamp reminder, dual-tracking power supply, audio millivoltmeter, temperature meter, intruder alarm, touch switch, push-button dimmer, exposure meter, photo timer, electronic dice, high-power beacon, electronic one-armed bandit ...

Book 5: £1.00 + 25p P&P.

5W stereo amp., stage mixer, disco mixer, touch organ, audio limiter, infra-red intruder alarm, model train controller, reaction tester, headphone radio, STD timer, double dice, general purpose power supply, logic tester, power meter, digital voltmeter, universal timer, breakdown beacon, heart rate monitor, IB metal locator, temperature meter ...

Book 6: £1.00 + 25p P&P.

Graphic equaliser, 50/100W amp. modules, active crossover, flash trigger, "Star and Dot" game, burglar alarm, pink noise generator, sweep oscillator, marker generator, audio-visual metronome, LED dice, skeet game, lie detector, disco light show ...

Graphic Equaliser...Marker Generator
Power Amplifier Modules...£2 Sound
CCTV Camera...Headphone Adapter
LED Dice...Sound-Light Flash Trigger
Expander-Compressor...Skeet Game
Rumble Filter...
ETI TOP PROJECTS
NO 6 electronics today £1
...Witchhater
Burglar Alarm...Digital Thermometer
Stars & Dots Logic Game...Lightshow
Active Crossover...Near and Tell Unit
Pink Noise Generator...GSM Monitor
Sweep Oscillator...Stereo Simulator

ELECTRONICS TOMORROW

Comprised entirely of new material, the edition covers such diverse topics as Star Wars and Hi-Fi! The magazine contains projects for everyone — none of which have appeared in ETI — and a look at the future of MPUs, audio, calculators and video. How can you not read it?

75p + 25p P&P.

ETI CIRCUITS

Books 1 & 2.

Each volume contains over 150 circuits, mainly drawn from the best of our Tech-Tips. The circuits are indexed for rapid selection and an additional section is included which gives transistor specs, and plenty of other useful data. Sales of this publication have been phenomenal — hardly surprising when the circuits cost under 1p each!

£1.50 + 25p P&P each.



TRANSDUCERS IN MEASUREMENT AND CONTROL

This book is rather an unusual reprint from the pages of ETI. The series appeared a couple of years ago in the magazine, and was so highly thought of by the University of New England that they have republished the series splendidly for use as a standard textbook. Written by Peter Sydenham, M.E., Ph.D., M.Inst.M.C., F.I.I.C.A., this publication covers practically every type of transducer and deals with equipment and techniques not covered in any other book. Enquiries from educational authorities, universities and colleges for bulk supply of this publication are welcomed: these should be addressed to H. W. Moorshead, Editor.

£3.00 + 25p P&P.

TRANSDUCERS IN MEASUREMENT AND CONTROL

by PETER H SYDENHAM
M.E., Ph.D., M. Inst. M.C., F.I.I.C.A.



FROM THE PUBLISHERS OF
ELECTRONICS TODAY INTERNATIONAL

ETI CIRCUITS No 2

£1.50

ELECTRONICS — IT'S EASY Books 1, 2 & 3.

Our successful beginners series came to an end some time ago now, and the whole series is available from us in reprint form. The three books between them contain all the information presented in the series (sometimes in more detail!) and together form an excellent starting point for anyone interested in learning the art of electronics.

£1.20 + 25p P&P each.

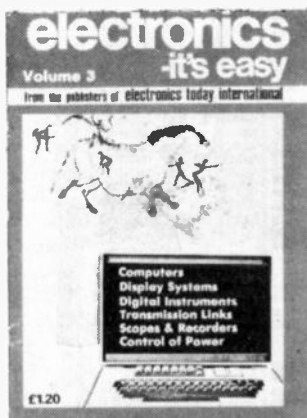

ORDER FROM

Specials
Modmags Ltd
25-27 Oxford Street
London W1R 1RF

Postage and packing also refers to overseas. Send remittance in Sterling only.

Please mark the back of your cheque pr PO with your name and address.

from ETI

OSCILLOSCOPE

WITH FULL INSTRUCTION MANUAL

FEATURES

- Response: DC to 5MHz.
- Sensitivity: 100MV to 50V/division.
- Fully calibrated time-base circuit and automatic blanking.
- 100% solid state
- utilising 13 transistors, 1 FET and 1 specially designed time-base module.
- Stabilised power supplies and active sync circuits.
- Rugged construction together with portability.
- Inexpensive — excellent value and performance.

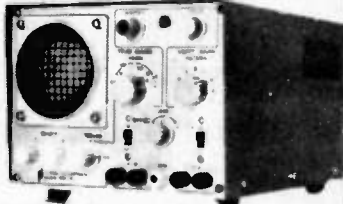

FROM STOCK
£83.25
Add VAT **£6.66**
Carriage **£1.50**
EXPORT ADD £5.00

FULL INSTRUCTION & OPERATING MANUAL

SPECIFICATIONS

ELECTRICAL DATA

VERTICAL AXIS (Y)

Deflection Sensitivity — 100mV/division
Bandwidth (between 3dB points) — DC — 5MHz
Input Attenuator — (calibrated) — 9 steps D1, B2, 0.5, 1, 2, 5, 10, 20, 50V/div
Input Impedance — 1 Meg/40pF in shunt
Input Voltage — Max — 500V P-P

HORIZONTAL AXIS (X)

Deflection Sensitivity — 0.400mV/division
Bandwidth (between 3dB points) — 1 Hz — 350KHz
Gain Control — Continuous: when time base in EXT position
Input Impedance — 1 Meg/40pF in shunt
Input Voltage — Max — 500V P-P

TIME BASE

Sweep Range (calibrated) — 100ns/div to 10 sec/div
In 5 steps

Time Control — Variable between steps — includes time axis calibration position
Blanking — Internal — on all ranges

SYNCHRONISATION

Selection — Internal, external
Synchronisation Level — Continuous from positive to negative

POWER SUPPLY

Input Voltage — 115-220V AC, 10% at 50/60Hz

Power Consumption — 10W

CRT DATA

— 3" round display single beam
— Maximum high voltage — 750V
— Fitted with 10 sections blue filter gratings

PHYSICAL DATA

Dimensions — 15cm (h) x 20.5cm (w) x 28cm (d)
Weight — 3.8Kg (approx.)
Case — Steel, epoxy encapsulated
Colour — Light blue
Front Panel — Anodized aluminium, epoxy printing

Also at 248 Tottenham Court Road, London, W.1.
301 Edgware Road, London, W.2



Henry's
RADIO

All mail to: Henry's Radio
404 Edgware Rd. London W2
PHONE (01)723 1008 ENGLAND

the MIGHTY MIDGETS

MINIATURE SOLDERING IRONS AND ACCESSORIES

	RETAIL PRICE each inc. v. a. t.	POSTAGE extra.
18 WATT IRON inc. No.20 BIT	£3.78	22p
SPARE BITS	44p	—
STANDS	£3.25	65p
SOLDER: SAVBIT 20'	52p	9p
" " 10'	26p	4p
LOWMELT 10'	65p	9p
1/2 C. DESOLDERING BIT	88p	9p

BIT No.19 (1.5 mm) No.20 (3 mm)
SIZES: No.21 (4.5 mm) No.22 (6 mm)



From your Local Dealer or Direct from Manufacturers

S&R BREWSTER LTD
86-88 Union St. Plymouth PL1 3HG
Tel: 0752 65011 TRADE ENQUIRIES WELCOME

Marshall's Electronics

A. Marshall (London) Ltd., Dept: HE. Head Office mail order: Kingsgate House, Kingsgate Place, NW6 4TA. Tel: 01-624 0805
Retail Sales London: 40-42 Cricklewood Broadway, NW2 3ET. Tel: 01-452 0161/2. Telex: 21492. London: 325 Edgware Road, W2. Tel: 01-723 4242.
Glasgow: 85 West Regent Street, G2 2OD. Tel: 041-332 4133. Bristol: 1 Straits Parade, Fishponds Road, B516 2LX. Tel: 0272 654201.

TRANSISTORS				T.T.L.				LINEAR				TRIACS																																																																																																																																																																																																																																																																																																																																																																																																																																																																																																																																																																																																																																																																																																																																																																																																																																																																																																																						
Part No.	Price	Part No.	Price	Part No.	Price	Part No.	Price	Part No.	Price	Part No.	Price	Part No.	Price	Part No.	Price																																																																																																																																																																																																																																																																																																																																																																																																																																																																																																																																																																																																																																																																																																																																																																																																																																																																																																																			
2K2219	0.38	40362	0.55	8C183	0.12	8BY39	0.55	SN7400M	0.17	SN7407N	0.22	SN7475W	0.60	SN74119N	1.40	CA3045	0.77	LM7812CN	0.85	CA308E	2.90	LM7815CN	0.85	CA3130	1.06	LM7824CN	0.85	CA3140	1.04	LM7805KC	1.56	LM307AM	0.40	LM7812KC	1.56	LM307B	0.30	LM7815KC	1.56	LM308A	1.20	LM7824KC	1.56	LM309C	1.95	LM7805CZ	0.30	LM317L	3.35	LM7812CZ	0.30	LM318A	2.45	LM7815CZ	0.30	LM3201-5	1.86	LM7824CZ	0.30	LM3201-12	1.86	LM7805CZ	0.33	LM3201-15	1.86	LM7805CZ	0.65	LM3201-24	1.86	LM7805CZ	1.98	LM3202	0.75	LM7805CZ	4.50	LM339A	0.60	LM7805CZ	1.00	LM3401-5	0.88	LM7805CZ	1.75	LM3401-12	0.88	LM7805CZ	1.00	LM3401-15	0.88	LM7805CZ	4.95	LM3401-24	0.88	LM7805CZ	3.08	LM348N	0.95	LM78013N	2.04	LM377B	1.80	LM78013N	1.72	LM378N	2.40	LM78023N	2.05	LM3785	4.25	LM78023N	1.72	LM3795	4.25	LM78033N	3.08	LM380N	1.04	LM78053N	1.58	LM381AN	2.70	LM78660N	0.87	LM723C	1.45	LM78660N	0.99	LM741C	0.50	SO41P	1.35	LM741C	0.50	SO42P	1.35	LM741C	0.50	SO43P	1.35	LM741C	0.50	SO44P	1.35	LM741C	0.50	SO45P	1.35	LM741C	0.50	SO46P	1.35	LM741C	0.50	SO47P	1.35	LM741C	0.50	SO48P	1.35	LM741C	0.50	SO49P	1.35	LM741C	0.50	SO50P	1.35	LM741C	0.50	SO51P	1.35	LM741C	0.50	SO52P	1.35	LM741C	0.50	SO53P	1.35	LM741C	0.50	SO54P	1.35	LM741C	0.50	SO55P	1.35	LM741C	0.50	SO56P	1.35	LM741C	0.50	SO57P	1.35	LM741C	0.50	SO58P	1.35	LM741C	0.50	SO59P	1.35	LM741C	0.50	SO60P	1.35	LM741C	0.50	SO61P	1.35	LM741C	0.50	SO62P	1.35	LM741C	0.50	SO63P	1.35	LM741C	0.50	SO64P	1.35	LM741C	0.50	SO65P	1.35	LM741C	0.50	SO66P	1.35	LM741C	0.50	SO67P	1.35	LM741C	0.50	SO68P	1.35	LM741C	0.50	SO69P	1.35	LM741C	0.50	SO70P	1.35	LM741C	0.50	SO71P	1.35	LM741C	0.50	SO72P	1.35	LM741C	0.50	SO73P	1.35	LM741C	0.50	SO74P	1.35	LM741C	0.50	SO75P	1.35	LM741C	0.50	SO76P	1.35	LM741C	0.50	SO77P	1.35	LM741C	0.50	SO78P	1.35	LM741C	0.50	SO79P	1.35	LM741C	0.50	SO80P	1.35	LM741C	0.50	SO81P	1.35	LM741C	0.50	SO82P	1.35	LM741C	0.50	SO83P	1.35	LM741C	0.50	SO84P	1.35	LM741C	0.50	SO85P	1.35	LM741C	0.50	SO86P	1.35	LM741C	0.50	SO87P	1.35	LM741C	0.50	SO88P	1.35	LM741C	0.50	SO89P	1.35	LM741C	0.50	SO90P	1.35	LM741C	0.50	SO91P	1.35	LM741C	0.50	SO92P	1.35	LM741C	0.50	SO93P	1.35	LM741C	0.50	SO94P	1.35	LM741C	0.50	SO95P	1.35	LM741C	0.50	SO96P	1.35	LM741C	0.50	SO97P	1.35	LM741C	0.50	SO98P	1.35	LM741C	0.50	SO99P	1.35	LM741C	0.50	SO00P	1.35	LM741C	0.50	SO01P	1.35	LM741C	0.50	SO02P	1.35	LM741C	0.50	SO03P	1.35	LM741C	0.50	SO04P	1.35	LM741C	0.50	SO05P	1.35	LM741C	0.50	SO06P	1.35	LM741C	0.50	SO07P	1.35	LM741C	0.50	SO08P	1.35	LM741C	0.50	SO09P	1.35	LM741C	0.50	SO10P	1.35	LM741C	0.50	SO11P	1.35	LM741C	0.50	SO12P	1.35	LM741C	0.50	SO13P	1.35	LM741C	0.50	SO14P	1.35	LM741C	0.50	SO15P	1.35	LM741C	0.50	SO16P	1.35	LM741C	0.50	SO17P	1.35	LM741C	0.50	SO18P	1.35	LM741C	0.50	SO19P	1.35	LM741C	0.50	SO20P	1.35	LM741C	0.50	SO21P	1.35	LM741C	0.50	SO22P	1.35	LM741C	0.50	SO23P	1.35	LM741C	0.50	SO24P	1.35	LM741C	0.50	SO25P	1.35	LM741C	0.50	SO26P	1.35	LM741C	0.50	SO27P	1.35	LM741C	0.50	SO28P	1.35	LM741C	0.50	SO29P	1.35	LM741C	0.50	SO30P	1.35	LM741C	0.50	SO31P	1.35	LM741C	0.50	SO32P	1.35	LM741C	0.50	SO33P	1.35	LM741C	0.50	SO34P	1.35	LM741C	0.50	SO35P	1.35	LM741C	0.50	SO36P	1.35	LM741C	0.50	SO37P	1.35	LM741C	0.50	SO38P	1.35	LM741C	0.50	SO39P	1.35	LM741C	0.50	SO40P	1.35	LM741C	0.50	SO41P	1.35	LM741C	0.50	SO42P	1.35	LM741C	0.50	SO43P	1.35	LM741C	0.50	SO44P	1.35	LM741C	0.50	SO45P	1.35	LM741C	0.50	SO46P	1.35	LM741C	0.50	SO47P	1.35	LM741C	0.50	SO48P	1.35	LM741C	0.50	SO49P	1.35	LM741C	0.50	SO50P	1.35	LM741C	0.50	SO51P	1.35	LM741C	0.50	SO52P	1.35	LM741C	0.50	SO53P	1.35	LM741C	0.50	SO54P	1.35	LM741C	0.50	SO55P	1.35	LM741C	0.50	SO56P	1.35	LM741C	0.50	SO57P	1.35	LM741C	0.50	SO58P	1.35	LM741C	0.50	SO59P	1.35	LM741C	0.50	SO60P	1.35	LM741C	0.50	SO61P	1.35	LM741C	0.50	SO62P	1.35	LM741C	0.50	SO63P	1.35	LM741C	0.50	SO64P	1.35	LM741C	0.50	SO65P	1.35	LM741C	0.50	SO66P	1.35	LM741C	0.50	SO67P	1.35	LM741C	0.50	SO68P	1.35	LM741C	0.50	SO69P	1.35	LM741C	0.50	SO70P	1.35	LM741C	0.50	SO71P	1.35	LM741C	0.50	SO72P	1.35	LM741C	0.50	SO73P	1.35	LM741C	0.50	SO74P	1.35	LM741C	0.50	SO75P	1.35	LM741C	0.50	SO76P	1.35	LM741C	0.50	SO77P	1.35	LM741C	0.50	SO78P	1.35	LM741C	0.50	SO79P	1.35	LM741C	0.50	SO80P	1.35	LM741C	0.50	SO81P	1.35	LM741C	0.50	SO82P	1.35	LM741C	0.50	SO83P	1.35	LM741C	0.50	SO84P	1.35	LM741C	0.50	SO85P	1.35	LM741C	0.50	SO86P	1.35	LM741C	0.50	SO87P	1.35	LM741C	0.50	SO88P	1.35	LM741C	0.50	SO89P	1.35	LM741C	0.50	SO90P	1.35	LM741C	0.50	SO91P	1.35	LM741C	0.50	SO92P	1.35	LM741C	0.50	SO93P	1.35	LM741C	0.50	SO94P	1.35	LM741C	0.50	SO95P	1.35	LM741C	0.50	SO96P	1.35	LM741C	0.50	SO97P	1.35	LM741C	0.50	SO98P	1.35	LM741C	0.50	SO99P	1.35	LM741C	0.50	SO00P	1.35	LM741C	0.50	SO01P	1.35	LM741C	0.50	SO02P	1.35	LM741C	0.50	SO03P	1.35	LM741C	0.50	SO04P	1.35	LM741C	0.50	SO05P	1.35	LM741C	0.50	SO06P	1.35	LM741C	0.50	SO07P	1.35	LM741C	0.50	SO08P	1.35	LM741C	0.50	SO09P	1.35	LM741C	0.50	SO10P	1.35	LM741C	0.50	SO11P	1.35	LM741C	0.50	SO12P	1.35	LM741C	0.50	SO13P	1.35	LM741C	0.50	SO14P	1.35	LM741C	0.50	SO15P	1.35	LM741C	0.50	SO16P	1.35	LM741C	0.50	SO17P	1.35	LM741C	0.50	SO18P	1.35	LM741C	0.50	SO19P	1.35	LM741C	0.50	SO20P	1.35	LM741C	0.50	SO21P	1.35	LM741C	0.50	SO22P	1.35	LM741C	0.50	SO23P	1.35	LM741C	0.50	SO24P	1.35	LM741C	0.50	SO25P	1.35	LM741C	0.50	SO26P	1.35	LM741C	0.50	SO27P	1.35	LM741C	0.50	SO28P	1.35	LM741C	0.50	SO29P	1.35	LM741C	0.50	SO30P	1.35	LM741C	0.50	SO31P	1.35	LM741C	0.50	SO32P	1.35	LM741C	0.50	SO33P

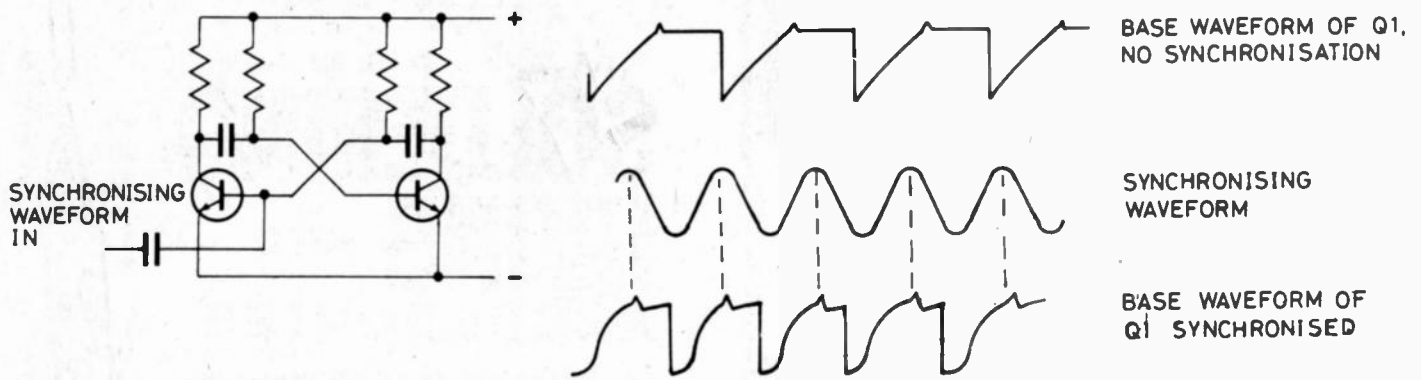

Fig. 5.12 Synchronisation of an astable. In this example, the astable is forced to run at the frequency of the sync. wave, but the astable can be made to run at lower frequencies, half a third a quarter etc., of the sync. wave.

moment, and the next positive peak of the synchronising signal will ensure that the same happens again, and so on. The astable is synchronised, it runs at the same frequency as the synchronising signal.

A monostable will do even better, because it gives one output pulse for each synchronising pulse, no more, no less — this is called triggered operation. The difference between the two is that the monostable does not run unless it is triggered, the astable keeps running, though its speed may not be correct when the synchronising pulses are missing.

SWEEPING UP

The square wave from an astable can be used to generate another important waveform, the timebase or linear sweep. As the name 'timebase' suggests, this is a waveform which is used for timing operations, particularly in oscilloscopes and in digital voltmeters. A simple timebase makes use of the charging and discharging of a capacitor through a resistor. If we put in a square wave at the input of the R-C circuit shown in Fig. 5.13 (an **Integrator**), then the voltage signal across the capacitor is a sloping waveform; it's the exponential charge and discharge curve. Now if we could make the resistor a large value for the upward slope and a small value for the downward slope we would get the type of sweep waveform we need, with a slow steady rise and a rapid-fall of voltage. Say no more, we have the circuit in Fig. 5.14.

When the transistor is cut off by the negative part of the input wave, C charges through R, giving the slow rising part of the sweep wave. The positive part of the input wave then makes the transistor conduct, the

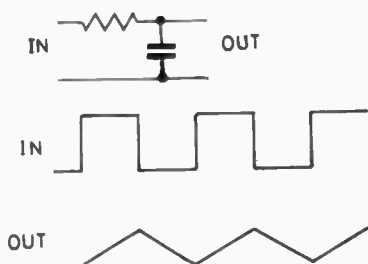

Fig. 5.13 Integrating circuit and waveforms.

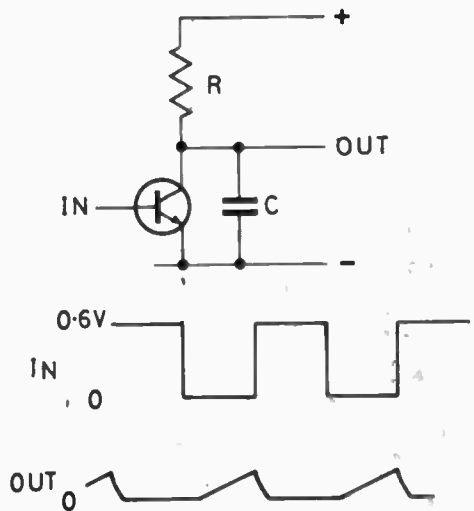

Fig. 5.14 A simple timebase circuit, with waveforms. The amplitude of the output sawtooth depends on the value of time-constant CR compared with the period of the square-wave. For a good wave-shape, CR should be much greater than the period of the square-wave.

collector-emitter part of the transistor has a low resistance that discharges C rapidly and the result is a sweep waveform. It's not perfect, but it's a start, and various improvements aimed at keeping the charging current through the resistance constant during the time of the sweep result in the good linear sweeps that we use for oscilloscope timebases. Take a look at the circuit of Fig. 5.15 for example, which uses a PNP transistor to control the current into C1. If you have time, construct this circuit and have a look at the waveform.

SINES OF THE TIMES

We've spent a lot of time on square-wave generators like astables, but what about sine-waves? Nowadays, the types of circuit that we use have less need of sinewaves, but we still need to generate waves of perfect sine shape for a lot of uses, not least the carrier waves of radio transmitters. A sinewave oscillator, like any other oscillator, uses an amplifying circuit along with positive feedback, but it needs two other important features.

One is some sort of automatic limiting action, so that the feedback does not simply whack the amplifier between the cut-off and bottomed states as happens in the astable circuits. The other requirement is a circuit that will control the frequency and shape of the sine-wave.



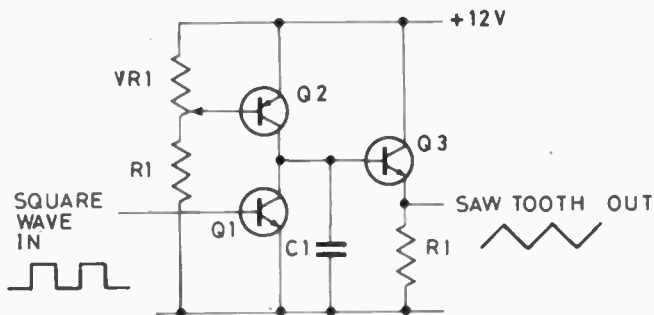

Fig. 5.15 A timebase circuit which gives a more linear shape of sweep when smaller values of time constant are used. The current through Q2 is set by the bias on its base, and is constant for most of the sweep. Try the following values: RV1 5 k; R1 47 k; C1, 0.1 μ F; R2 1 k Ω ; Q2 2N2905; Q1, Q3 2N2219.

That excellent circuit, the **tuned circuit**, does a lot of what we want. A tuned circuit, such as the parallel connection of an inductor and a capacitor, responds only to frequencies very near to its resonant frequency of about $1/2\pi\sqrt{LC}$.

The type of response, as far as a parallel circuit is concerned, is its resistance to signals, which is maximum at the frequency of resonance and very small for signals at other frequencies. If we use a parallel tuned circuit as the load of an amplifier which has a little bit of positive feedback, then there will be enough amplifier gain for oscillation to start only at the frequency to which the parallel tuned circuit is tuned. The transistor itself will prevent the oscillation amplitude from becoming too great if we can arrange it so that the transistor runs out of gain when the amplitude of the oscillation becomes too large. This happens when the collector voltage is low, or if the bias is reduced. Both of these methods of controlling the amplitude would cause a distorted signal but for two things. One is that the amount of positive feedback is kept small, so that a reduction of gain stops or reduces the amplitude of oscillation rather than allowing a large and distorted signal to be generated. The other point is that the tuned circuit itself will sort out a distorted wave, and extract a well-shaped sine-wave from it.

A sinewave oscillator circuit is shown in Fig. 5.16. This is a type called a **Colpitts** oscillator, and its trademark is the signal potential divider using two capacitors. These two capacitors are connected across the inductor L, and arranged so that a fraction of the output signal is fed back to the emitter of the transistor. This is positive feedback, because if the base voltage is held steady, then a rise in the emitter voltage causes less bias voltage between base and emitter, so less base current, therefore less collector current, and so causes a rise of collector voltage. To make sure that the base voltage remains steady, a capacitor C3 must be connected as shown. Without this capacitor, the base voltage can follow the emitter voltage at high frequencies so that oscillation does not occur. The tuned circuit for this oscillator consists of L, with the capacitors C1 and C2 in series with each other (but connected in parallel with L).

Oscillators that use inductors and capacitors are useful for generating radio frequency waves, particularly if we need to alter the frequency. Using a variable capacitor as part of the tuned circuit lets us do just that, making the oscillator a VFO, (variable frequency oscillator).

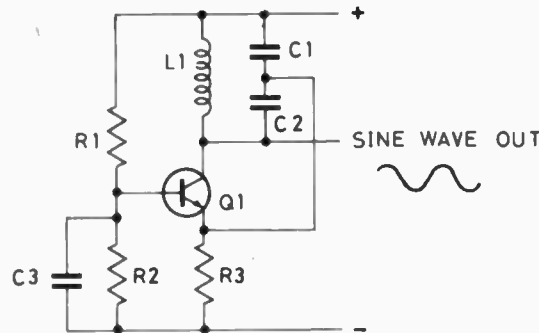

Fig. 5.16 One form of the Colpitts oscillator.

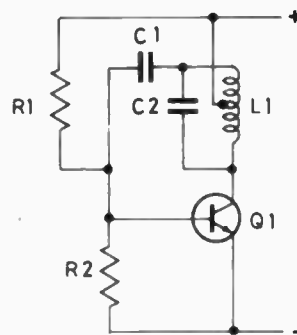

Fig. 5.17 One form of the Hartley oscillator, which uses a tapped coil.

The Colpitts oscillator is not ideal from this point of view because both plates of the variable capacitor would have a signal voltage on them. This makes adjustment rather difficult, because a variable capacitor is constructed with one set of plates connected to the central shaft. If this set of plates is connected to a signal voltage, then touching the control (tuning) knob will change the frequency of the oscillator even before the control is adjusted, because the capacitance between your hand and the capacitor plates is now part of the tuned circuit. When variable tuning is needed, other circuits which allow the moving plates of the tuning capacitor to be earthed are more suitable. The **Hartley** oscillator circuit is of this type, and is shown in Fig. 5.17.

THE CRYSTAL OSCILLATOR

Sinewave oscillators which use LC tuned circuits are useful, but their frequency can be altered by small changes of supply voltage and by changes of temperature. For generating sinewaves of very precise frequency, something better than the LC circuit is needed, and that something is the quartz crystal. Quartz crystals are just what the name says they are — crystals of Quartz (silicon oxide). The quartz is carefully cut to shape, and opposite faces are coated with silver so that wire contacts can be soldered in place. With this done, the crystal will now behave like a tuned circuit. At one particular frequency, depending on the size and shape of the crystal, the crystal can resonate to a frequency applied to its connections, vibrating mechanically at that frequency. At this resonant frequency, the crystal behaves like an LC circuit, but one with values of L and C that we could not possibly obtain when we use ordinary components. The usefulness of a tuned circuit for generating a good shape of sinewave is measured by a figure called the **Q factor**. A conventional LC tuned

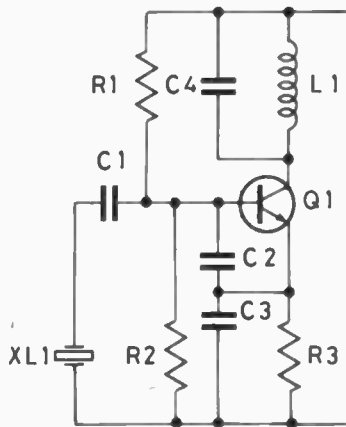

Fig. 5.18 A crystal oscillator, one of a large number of possible circuits.

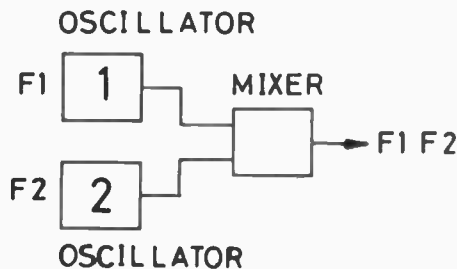

Fig. 5.19 Principle of the beat-frequency oscillator (BFO)

circuit might have a Q factor of 150 with luck, but a quartz crystal can notch up a Q figure of 30 000. This makes crystal oscillators the natural choice when a very precise value of frequency has to be generated and when the oscillator frequency must be unaffected by charges in other components. Quartz crystals are therefore used in digital watches, radio transmitters, frequency meters and in any other application which needs a fixed frequency.

A typical crystal oscillator is shown in Fig. 5.18. The oscillator is of the Colpitts variety, but the frequency is controlled almost entirely by the crystal, so that the output frequency is much more stable than that of any LC Colpitts circuit.

HOW LOW CAN YOU GET?

We have a pretty satisfactory set of circuits for generating sinewaves at radio frequencies, but we run into problems if we try to use the same circuits to generate lower frequencies, audio frequencies, for example with a range of 20 Hz to 20 kHz. LC oscillators are of very little use because a very large value of inductance will be needed for the low frequencies, and the values of capacitance will also have to be large, ruling out the use of the usual 500 pF variable capacitor as a method of tuning.

There are two ways around this problem. One is the use of the beat-frequency oscillator (BFO). This type of circuit uses two oscillators, both working at radio frequencies of several hundred kHz. The output signals at frequencies f_1 and f_2 are fed into a mixer stage which produces (surprise, surprise) a mixture of signal frequencies including the difference frequency $f_1 - f_2$ and the sum $f_1 + f_2$. Now if the frequencies f_1 and f_2 are close, such as 320 kHz and 325 kHz, then the difference frequency is low, 5 kHz in this example, and

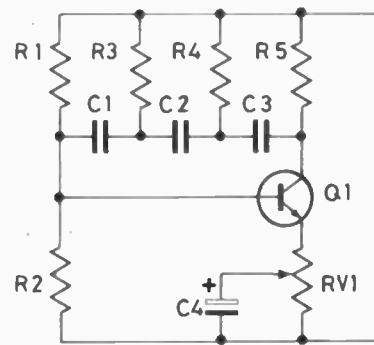

Fig. 5.20 Basic phase-shift oscillator. This circuit is often seen in print, but it seldom oscillates because the gain of the transistor is usually too low to overcome the losses in the CR network.

can easily be separated from all the other signal frequencies. The BFO is a simple way of generating low frequency sinewaves, but if its performance is to be good then both of its oscillators must be very stable. A frequency change of 10 Hz, may be noticeable in a 320 kHz oscillator, but it does make rather a lot of difference when the difference frequency is only 20 Hz. The BFO circuit is still used, in metal detectors for example, but not so much now as a generator of low frequency sine waves.

BEAT THIS!

The modern method of generating low frequency signals is the RC oscillator, so let's have a look at these. Like any other oscillator, the RC type consists of an amplifier, a positive feedback connection, a frequency selective circuit (tuned circuit) and a method of stabilising the amplitude. The trouble with frequency selective circuit which use resistors and capacitors only is that they are not nearly so selective as the LC circuits. The Q factor which measures how good they are at selecting a frequency is only around 2 to 6 (compare LC at about 50 to 150, crystals 5000 upwards). Because of this, we can't rely on the RC circuits to keep a sinewave looking like a sinewave, and every RC oscillator needs some other method of adjusting the feedback so that the oscillator is just oscillating with an amplitude that stops well short of bottoming or cutting off the transistor.

Figure 5.20 shows a phase-shift RC oscillator — probably the simplest type. It's possible to make this type of oscillator using only one transistor, but the results are rather unpredictable, and as often as not the circuit totally refuses to oscillate. The circuit shown in Fig. 5.21 is a bit more reliable. Q2 is an emitter follower (with unity gain) and Q1 is a common-emitter amplifier, load R4 which provides voltage gain. The phase-shift network is R1, C1, R2, C2, R3, C3 three lots of RC time constants. Each of these RC time constants has two effects on a sine wave — it reduces the amplitude and it phase shifts the current wave relative to the voltage wave. If the total phase shift in the three sections is 180° , then the sinewave of current into the base of Q1 is 180° out of phase with the voltage wave at the collector of Q2. For a sinewave, a 180° phase shift has the same effect as inverting the wave, so that the feedback through this network is positive. The circuit will oscillate if the gain of Q2 is just slightly more than the losses through the RC network (not forgetting RV1) and Q1. We have to adjust the gain in this simple circuit by

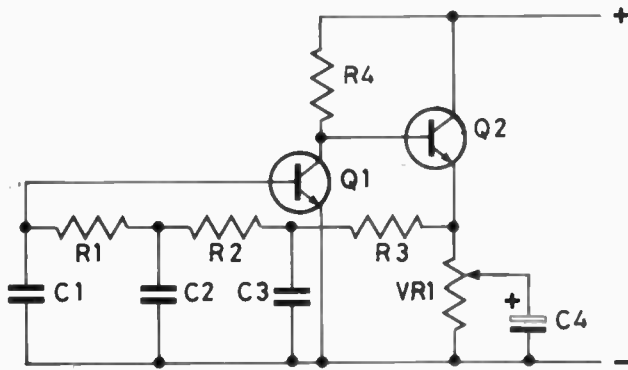

Fig. 5.21 A more reliable phase-shift circuit. Try this with the following values: $R1=R2=R3=15\text{ k}$, $C1=C2=C3=0.01\text{ }\mu\text{F}$, $R4=3\text{ k}$, $RV1=1\text{ k}$, $C4=10\text{ }\mu\text{F}$, $Q1, Q2=2N2219$. $RV1$ is used to adjust the gain so that the circuit is just oscillating. The DC voltage at the emitter of $Q2$ should be about 1.5 V, if it is much too low or too high, adjust the value of $R4$.

setting $RV1$, which provides a bit of negative feedback. If $RV1$ is set so that the circuit is only just oscillating, the shape of the sinewave that it produces can be quite good.

The phase-shift circuit isn't used much, however, because it is rather difficult to provide variation of the frequency (too many quantities to change) and also because there are other networks which are more selective. Really well-shaped sinewaves are produced only if the amplifier has its gain automatically controlled.

A BRIDGE TOO FAR?

Figure 5.22 shows the circuit of a **Wein-bridge oscillator**. This circuit calls for an amplifier with two inputs so that both negative — and positive feedback loops can be connected. This, of course, can be as simple as using a transistor base as one input and the emitter of the same transistor as the other, but to avoid cluttering up the diagram, the amplifier is shown as a triangle with negative feedback going to the input marked — and positive feedback to the input marked +. The Wein bridge is actually the network consisting of $C1, R1, C2, R2$, connected as shown. The action of this circuit is that it has zero phase shift at one frequency, when $f = 1/2\pi CR$ (with $C = C1 = C2$ and $R = R1 = R2$) (where f is the frequency of oscillation.)

With the Wein bridge circuit connected into the positive feedback loop, there is positive feedback only when the phase shift of the network is zero, which is at the frequency f_0 . As usual, the sinewave shape is good only if the amplifier gain can be controlled so that it just compensates for the losses in the network; this requires a gain of about 3 times. The easiest way of providing the gain and regulating it is to make the amplifier a high-gain type and arrange $R3$ and $R4$ so that the negative feedback adjusts and controls the gain. One commonly-used method is to use a thermistor for $R4$ and a resistor with twice the thermistor resistance for $R3$. Twice what resistance? Well, we use a thermistor which will run at a temperature which is a bit above room temperature when signals current passes through it, and we pick the value of resistance it will have at this temperature. When the circuit is switched on at first, the oscillations quickly build up to full amplitude, but the current through the thermistor heats up the tiny element until the resistance drops, adjusting the gain of the amplifier, and reducing

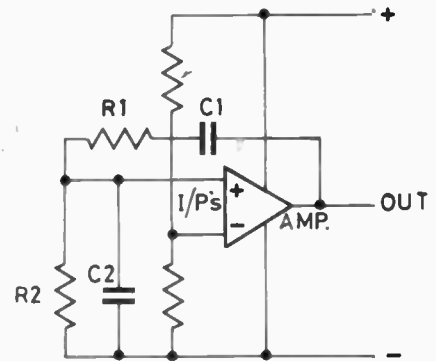

Fig. 5.22 Wein-bridge oscillator showing both feedback paths.

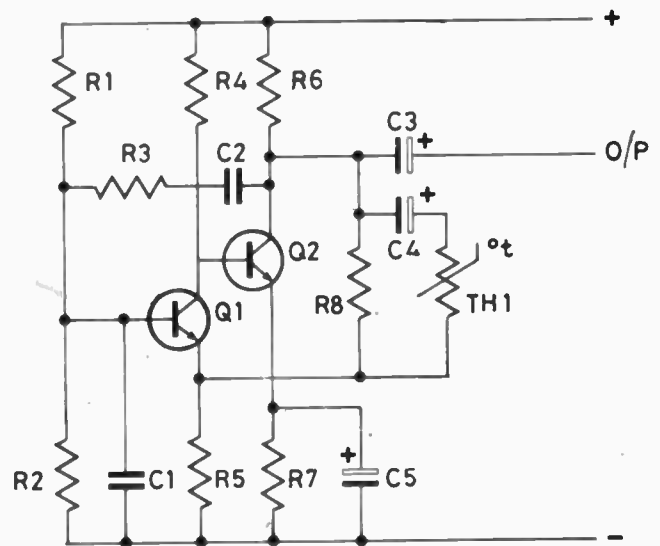

Fig. 5.23 A complete Wein-bridge oscillator. The Wein bridge components are $C2, R3, C1, R2$ in the positive feedback loop, and the negative feedback is through the thermistor (in parallel with the bias resistor $R8$) to the emitter of $Q1$.

the amplitude of oscillation. Too small an amplitude, of course, will allow the thermistor to cool, raising its resistance, decreasing the negative feedback and increasing the gain so that the amplitude can build up. This negative feedback loop then controls the gain of the amplifier to ensure that the waveshape remains good and the amplitude constant.

Another method that is used to control the gain of the amplifier is to rectify the signal output and use the rectified signal to provide bias for a FET, using the source-drain connections of the FET as the resistor $R4$. This method is not affected by the temperature of the air surrounding a thermistor, so that it is a better method of stabilisation.

Well that wasn't too bad was it, next month we take our first cautious steps into the wonderful world of Digits.

HE



STEREO DYNAMIC RANGE CONTROLLER CP-DR1

'Noise-free' Cassette Recordings (with an additional 30 db dynamic range); signal expansion (to recover lost dynamics) and compression (for listening in noisy environments) are all achievable with the **Magnum CP-DR1**.

If you wish to avoid point-to-point wiring, use the newly-announced **CP-MPC4** interconnection board and build your system within the hour. We can provide any suitable pots, etc that you may require. The **CP-MPC4** also has provision for a **CP-TM1** if you wish to monitor signal levels.

CP-DR1 — £41.40 incl. (U.K.) £43.40 incl. (Export)
CP-MPC4 — £8.86 incl. (U.K.) £8.86 incl. (Export)

Also available: Pre-amplifiers, Power Amplifiers, Filters, Peak Programme Monitors, Active Crossovers, Stereo Function Modules, Power Supplies, plus all pots., switches, etc.

MAGNUM AUDIO Ltd.

DEPT. ET2, 13 HAZELBURY CRESCENT
 LUTON, BEDS, LU1 1DF
 TEL: 0582 28887

SEND LARGE S.A.E. FOR DETAILS

MAINS OPERATED

ELECTRONIC DIGITAL ALARM CLOCK

IMMEDIATE DELIVERY

£8.95

INCL. V.A.T. POST PAID

THREE FOR £26.00 POST FREE

E.T.I. RECOMMEND THIS MODEL

- Hanimex HC-1100
- Large Bright LED display
- White case with red display on black background
- Adjustable dim / bright control
- Silent operation, all electronic
- Space age technology L.S.I. circuitry
- Alarm and 9 minute snooze repeater
- P.M. indicator
- Hour and minute display
- Size 100mm x 130mm x 60mm high
- Fully guaranteed

BARCLAY ACCESS

Just phone in number



HENRY'S
RADIO

HENRY'S RADIO
404 Edgware Rd. London W2
PHONE (01) 723 1008 ENGLAND

HANIMEX Electronic LED Alarm Clock

Same as ET1 offer
Thousands sold

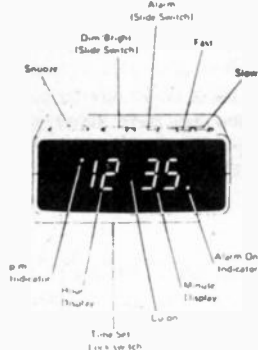

Feature and Specification

- Hour / minute display
 - Large LED display with p.m. and alarm on indicator
 - 24 Hours alarm with on-off control
 - Display flashing for power loss indication
 - Repeatable 9-minute snooze
 - Display bright / dim modes control
- Size 5 15 x 3 93 x 2 36 (131mm x 100mm x 60mm)
 Weight: 1 43 lbs (0 65 kg)

Guaranteed same day despatch

£8.65

LADIES LCD

Only 25 x 20 mm and 6 mm thick. 5 functions: hours, mins, secs, day, date. + back light and auto cal. Elegant metal bracelet in silver or gold. State preference.



£9.95

Guaranteed same day despatch

5 FUNCTION LCD

Hours, mins, secs, month, date, auto calendar, back-light, quality metal bracelet.



£7.65

Guaranteed same day despatch Very slim, only 6mm thick.

THOUSANDS SOLD 11 FUNCTION SLIM CHRONO

6 digit 11 functions

- Hour, mins, secs.
 - Day, date, day of week.
 - 1/100, 1/10, secs, 10 x secs, mins.
 - Split and lap modes.
 - Back light, auto calendar.
 - Only 8 mm thick.
- This same watch is being sold for £22.00 in newspaper and magazine special offer ads.



Metac Price
£12.65

Guaranteed same day despatch

All products carry full 12 months guarantee. Please add 30p p&p with all orders. All prices include VAT.

Shops open 9.30 to 6.00 daily.

Trade enquiries welcome. **Delivery:** One week. Except where same day delivery is stated.

ALARM CHRONOGRAPH WITH DUAL TIME ZONE FACILITY

- Constant LCD display of hours and minutes, plus optional seconds or date display, plus day of the week and am/pm indication
- Perpetual calendar: day, date, month and year
- 24-hour alarm with on/off indication
- 1 / 10 second chronograph measuring net, lap and first and second place times
- Dual time zone facility



£27.95

PLEASE NOTE

All our products carry full money back 10-day reassurance. Watches are despatched by **FIRST-CLASS POST**. They are fitted with new batteries, and include guarantee and instructions. Battery fitting service is available at our shops for no extra charge. We stock most watch batteries and this service is available to all. Metac have been selling electronic watches probably longer than anyone else in the UK. We take care of your watch not just this year but next year and the years after that.

Telephone Special
24-hour phone service
Credit-card customers are welcome to buy by phone—simply phone D1 723 4753 with your credit card number to place your order

METAC Electronics & Time Centre
67 HIGH STREET
DAVENTRY, NORTHANTS
Tel. (032 72) 76545

327 EDGWARE ROAD
LONDON W2
Tel. (01) 723 4753

Barclay & Access welcome
Phone or Send Card Number with order



electronics today

international

What to look for in the April issue: On sale March 2nd

Amp Survey

Build-it-yourself hi-fi continues to flourish, and new designs appear almost daily. Power amplifiers are a favourite in the field, and their numbers, by now, are legion.

Unfortunately there is no way for the home constructor to 'listen in' to a module before he builds it, and thus he is left to fall back on the spec. sheets. Fine if you like it, rotten if you don't.

Next month we're surveying the field, giving full details of all the models we can find, and putting the market leaders against top quality commercial equipment to find out how they sound.

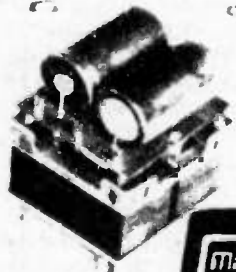
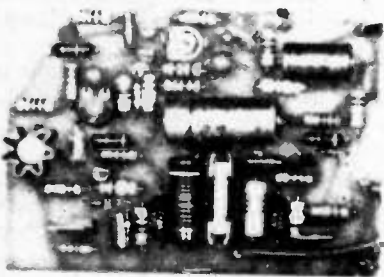

MAINS SEEKER

So you are about to drill the living room wall to hang up those shelves you promised the wife 7 years ago. Black & Decker in hand you advance to the plaster. Wait a minute there a mains socket right beneath.

Doubt sets in — to drill or not to drill — that is the question. Which way do the wires run? Will you black out the entire Universe if you try it? How can you find those wires?

Simple really — just read ETI next month when we have a neat little project to show you exactly where the mains-wires lie!

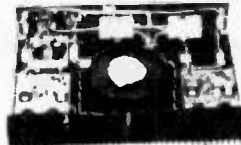

OCTAVE SHIFTER

A superb little circuit to add that instant 'jump' to guitar playing. Operated by a footswitch the effect has a unique sound all its own — not to be missed — no strings attached to this one.

3080

Well ten of them anyway The 3080 is a much under-rated device, and next month's IETs circuit man Tim Orr hopes to put that right with ten ways to use device, all comprehensively explained to help you design the other 3070 circuits yourself.

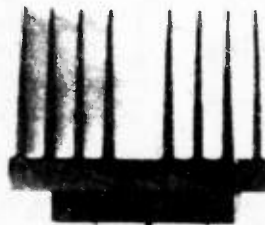

AMBUSH

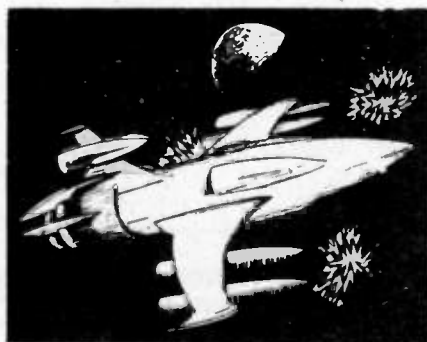

Your starship crashes through the void — running between the lines of enemy dreadnoughts to deliver medical supplies to the seiged plant of Tora. In order to preserve energy your ship has no weapons, only its shields and its speed.

Missiles can appear from any direction, and to destroy them you must actuate your shields at the precise moment of impact, thereby conserving power and allowing the engines to keep you moving at Warp Factor 20.

Can you make it through the Ambush and make Capt. Kirk look a cissy?

New Look For Communications Satellites

The latest Intelsat V series of satellites promises greater capacity through the use of advanced technology. Brian Dance reports.

IF ONE PICKS UP a telephone and makes an intercontinental call, the chances are that it will be connected through one of the satellites stationed over the India, Pacific or Atlantic oceans. The demand for international telecommunications has increased enormously during the past few years and increasingly sophisticated satellites have been placed in orbit to provide more and more channels. Most of the satellites currently in use are cylindrical in shape with solar cells on the outside of the body, but future trends are stretched arms so that all of the solar cells are directed towards the sun. These new look satellites will provide even more channels of communication than their predecessors.

About 80% of satellite traffic is for telephone use. Although long distance television signals produce quite an impact in millions of homes, television accounts for only about 2% of the use of global satellite communications. About 15% of the traffic is for data and message transmission. Apart from international communications, satellites are now used for communications across a single country such as Canada, Nigeria, Indonesia, etc. Satellites are used for conveying television signals to remote areas and it is rather interesting to note that the earth station which received more occasional television transmission in 1975 was any other earth station was at Manaus — a Brazilian rubber port about 1 400 km up the river Amazon!

HISTORY

A regular inter-continental telephone service was first introduced from London to New York in 1927 using a 60 kHz transmitter, but the first trans-Atlantic cable became available in 1956 with 48 speech circuits and provided much better quality and reliability. Reflections from the moon were used to provide a speech link across the U.S.A. in 1956, but our natural satellite is a poor reflector of radio waves and is too far away for low noise wide band signals.

The first artificial communications satellite, Echo 1, was a balloon about 30 m in diameter which was launched in 1960. Its aluminised surface reflected both radio waves and light very well; it formed a very bright object in the sky which has probably been seen by more people than any other man made object. Echo 1 orbited the earth in about two hours and acted as a passive

reflector of radio waves so that it could be used to relay signals between Europe and the U.S.A. Echo 2 was rather similar, but the first television transmissions between the U.S.A. and Europe were carried by Telstar 1 in 1962; this satellite had its own transmitter operating on 4170 MHz with a power of 2.25 W. the power being provided by 3 600 solar cells.

These and similar satellites had the severe disadvantage that they were visible from any earth station only for a short time — about 20 minutes in the case of Telstar 1 — and had to be followed across the sky by the earth station aeriels. Complex systems using as many as 50 satellites were proposed so that continuous communications could be maintained, but each earth station would have required at least two aeriels so that one could follow the satellite whilst the other searched for the next satellite coming above the horizon.

A much better system was proposed as long ago as 1929 in which satellites in circular orbits 36 000 km above the equator are used; such satellites have orbital periods of about 24 hours, so they can be made to appear stationary from a point on the earth. The early rockets did not have enough power to place a satellite in one of these geosynchronous orbits. In addition, it took time to develop the technology required to enable the satellites to be manoeuvred in orbit, etc. Satcom 1 was the first geosynchronous satellite launched in 1963, but all modern communications satellites are geosynchronous.

The International Telecommunications Satellite Organisation (INTELSAT) was founded in Washington in 1964 to provide telephone and television communications to all users on a non-discriminatory commercial basis. INTELSAT owns the satellites and leases circuits to numerous countries, but the earth stations are normally owned by the telecommunications authorities in the countries concerned.

The INTELSAT satellites launched up to the present time are known as the I, II, III, IV and IVA series, whilst a new type V series is planned for this year. The first INTELSAT I ('Early Bird') could carry only 240 telephone conversations and could communicate with only two earth stations at any time. INTELSAT II ('Blue Bird') had the same capacity, but could operate with several ground stations simultaneously.



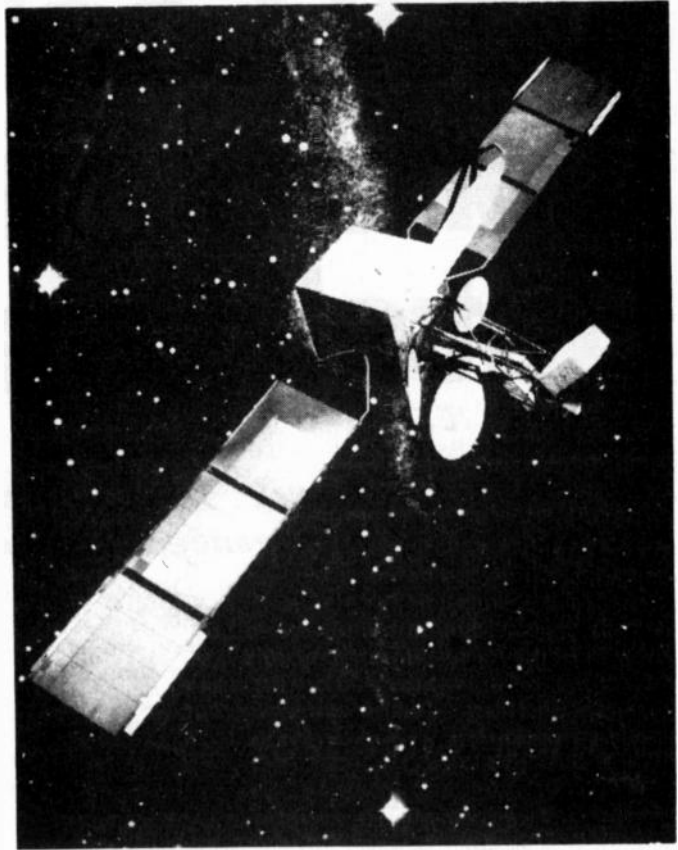
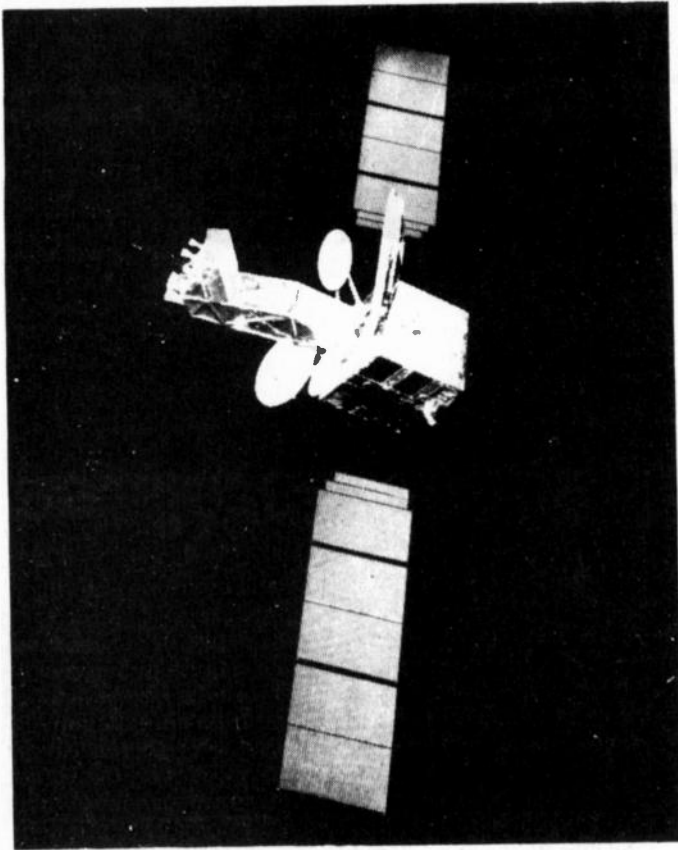

Figs 1 and 2. These two models show the outstretched solar arrays of the Intelsat V satellite.

The INTELSAT III, IV and IVA vehicles have bodies which are spinning for optimum stability, the rate of spin being of the order of 1 revolution per second. The aeriols are placed on a 'de-spun' shelf so that they point in a constant direction. Special lubricants are required for the bearings in the high vacuum of space which can operate over a wide temperature range. Failures occurred in over half of the INTELSAT III spacecraft, but a much greater proportion of the INTELSAT IV and IVA craft have provided the desired performance.

The aeriols of the INTELSAT IV satellites include 'global' beams for covering the largest possible area of the earth (including remote islands) and spot beam antennae which provide a 4.5° beam for optimum communication with areas where the traffic density is very high. Each successive type of satellite provides more channels of communication. The main improvement in the IVA-series is the use of directional aeriols for the east and west beams so that the same frequencies can be used in both of these beams without mutual interference.

INTELSAT V

One of the main disadvantages of the cylindrical spin-stabilised craft is that only a small proportion of the solar cells on the cylindrical body are facing the sun at any one time. Thus the available power is much smaller than that which could be obtained from a satellite with a similar number of cells which all face the sun. The new INTELSAT V vehicles will therefore employ three axis body stabilisation with the solar cells on extendible arms

which can be rotated so that all of the cells face the sun at all times. This type of system can provide about three times the power per square meter of solar cells than in a spinning satellite. The new satellites will use the 11 GHz and 14 GHz bands for communications as well as the 4 GHz and 6 GHz bands used by the existing INTELSAT craft.

The contract for the supply of INTELSAT V vehicles was awarded to Aeronutronic Ford (now Ford Aerospace and Communications Corporation) in September 1976 at a cost of \$236 million for seven satellites with options on a further eight. Each INTELSAT V craft will have a capacity of about 12 000 telephone channels and 2 colour television channels. The first will be placed over the Atlantic to cater for the very heavy traffic in that region. The second will be a spare for the first, whilst the third is scheduled for the Indian Ocean (including Australian use). It is hoped to use the NASA space shuttles to launch some of these craft, since this should reduce the cost from about \$25 million to \$15 million. All seven craft are due for launching by May 1981.

The INTELSAT V Atlantic satellites will employ space diversity with shaped beams to the east and west so that Europe and Africa are covered by the east beam and North and South America by the west beam. Thus the 500 MHz wide frequency band will be used twice, as in the current IVA craft. In addition, INTELSAT V will re-use the frequency spectrum a second time for the Northern Hemisphere where the traffic demand is heavy. This will be accomplished by polarising these additional beams perpendicularly to the normal beams. The simultaneous use of polarisation and directional isolation is one of the major technical challenges of INTELSAT V.

Communications Satellites

TABLE 1. Frequencies used for satellite communications.

From earth station to satellite (GHz)	From satellite to earth station (GHz)
5.925 — 6.425	3.7 — 4.2
12.5 — 12.75	10.7 — 10.95
14.0 — 14.5	11.2 — 11.45
27.5 — 31.0	17.7 — 21.20

FREQUENCIES

The current INTELSAT system employs frequencies in the 6 GHz band for transmission from the earth stations, whilst the satellites transmit in the 4 GHz band. These frequencies and other likely to be used are shown in Table 1.

The bandwidth at the lower frequencies is 500 MHz, but, there is a 3.5 GHz bandwidth in the 19 and 29 GHz bands for the up and down links respectively. In general the use of the bands is shared with terrestrial services and there is a limit to the power which can be used to avoid interference. However, the frequencies of 19.7—21.2 GHz and 29.5—31.0 GHz are to be reserved exclusively for down and up satellite links respectively. The maximum permitted power in the 4 GHz band is —152 dBW/m²/4 kHz at arrival angles of less than 5° rising to —142 dBW/m²/4 kHz at arrival angles of 25° or more. These values are 2 dB higher in the 11 GHz band, whilst in the shared part of the 20 GHz band it is increased by a further 11 dB, but the latter is specified for a 1 MHz rather than a 4 kHz bandwidth.

The greater available bandwidth and reduced chances of interference makes the use of the higher frequency bands very attractive, but one of the most fundamental obstacles to the use of frequencies above 10 GHz for satellite communications is the degradation of the signal by heavy rain in the vicinity of the receiving station. Rain and precipitation in the atmosphere not only attenuate the signal from a satellite, but cause depolarisation, increased noise and increased interference between terrestrial and satellite systems. Even when 4 GHz signals were being received from the early Telstar satellite, it was noted that the noise level increased when the receiving station was near heavy rain. The effects of rain can be overcome by the use of diversity techniques with switching between two or more receiving stations, but this is obviously expensive. The use of high transmitter power also helps to reduce the effects of rain.

Telemetry and command signals are transmitted to the satellites within the communications band, but outside the communications channels themselves. The INTELSAT IV spacecraft have 223 command channels.

POSITIONAL CONTROL

Gravitational fields due to the sun, moon, etc. and variations in the earth's gravitational field cause small movements in the position of a geosynchronous satellite. Solar radiation pressure also produces a small effect which accumulates with time. The drift in the orbit inclination out of the equatorial plane is about 0.8° per

year in the case of small inclinations. If uncorrected, the would cause the satellite to move progressively around in a figure of eight. In addition, a satellite is accelerated towards two stable points at 75°E and 105°W due to the non-uniformity of the earth's gravitational field.

When a satellite has moved from its desired position by a certain amount, small thruster jets operated by command signals from the earth cause it to return to the desired position. The gas jets used consist of a mixture of nitrogen and hydrogen obtained by admitting liquid hydrazine into a reaction chamber containing a catalyst which causes the liquid to separate into its two constituent elements. Jets can also be used to keep the aerals on the de-spun shelf of existing satellites pointing towards the earth with an accuracy of 0.1°; the reference direction may be obtained by an infra-red sensor detecting radiation from the earth and from the sun.

Although the use of geosynchronous satellites gives rise to the problems discussed, it brings many advantages, such as no Doppler shift of the signal frequency, few thermal stress cycles, low radiation environment, low magnetic fields, etc. The earth subtends an angle of about 18° at a geosynchronous satellite; a global beam from the satellite will cover about 4/10 of the earth's surface, so ground stations can be linked over great circle distances of up to 17 000 km.

POWER LEVELS

The variation of the signal power level at various points is extremely large. Let us trace the levels which are typical for a television signal being relayed from one amplifier in an earth transmitting station to the output of the amplifier of an earth receiving station.

The signal comes into the transmitter power amplifier at a level of around 1 mW, but is amplified to a level of a few hundred watts before it is fed to the aerial at the centre of one of the giant 30 metre diameter dish aerals. This dish provides an effective gain of about a million by concentrating the power into a narrow beam; a power of a few hundred megawatts would be required to achieve the same signal level at the satellite if this power were radiated equally in all directions. This signal is attenuated by a factor of about 10²⁰ during its journey to the satellite, so it arrives at a level of a few picowatts. The satellite aerial provides a gain approaching one hundred and the satellite receiver amplifier a gain of about 100 000, so the signal leaves the receiver at a level of about 10 μW.

Power levels in the circuits from the satellite back to earth are of the order of one million times lower than those in the up path in many cases. The 10 μW signal from the satellite receiver is amplified to a level of about 10 W and fed to an aerial with a directional gain of about 50; the effective power radiated by the satellite is thus around 500 W. This suffers a loss of the order of 10²⁰ in the down path, so it arrives at the ground station receiving aerial at a level of about 5 attowatts (1 attowatt = 10⁻¹⁸W). However, the enormous receiving dish provides a gain of about a million to bring the signal level up to around 5 pW; without such a dish, the signal would be lost in noise. The signal is then amplified in the ground station receiver system so that its power level is brought up to about the 1 mW level (similar to the level at which it arrived at the power amplifier of the ground station transmitter at the start of the cycle).

It is difficult to fully appreciate the enormous range of



power levels involved. This range is some 10^{26} times or 260dB between the effective power radiated from the transmitting aerial of the earth station and the effective power level at the aerial of the receiving earth station.

SATELLITE REPEATERS

A satellite repeater accepts the incoming signal, amplifies it, changes its frequency for the new band and amplifies the power level for re-transmission. Frequency modulation is normally employed for simplicity in both the up and down links, the modulation being identical in each case. In the Intelsat IV craft, the band is divided by a filter into 12 channels of 36 MHz each with a 40 MHz spacing of the centre frequencies.

The incoming signal in the 5.932 to 6.418 GHz region is fed to a tunnel diode amplifier operating at the signal frequency. It is then converted into a 2225 MHz signal for broadband amplification before being converted into a 4 GHz signal which is passed to a travelling wave tube for power amplification. These tubes offer efficiencies of about 30% and require a high voltage supply. There is a four fold redundancy in the electronic systems of a satellite to ensure reliability is high.

Tunnel diode amplifiers are simple and light in weight, but other amplifiers can be used in the receiver circuits of satellites. For example, the European Orbital Test Satellite (OTS) uses a parametric amplifier operating in the 11 and 14 GHz bands instead of a tunnel diode. It seems likely that gallium arsenide (GaAs) field effect transistors will replace tunnel diodes and possibly even travelling wave tubes at frequencies of up to at least 14 GHz.

EARTH STATIONS

The design of earth station equipment is very different from that of the circuits in the satellite, since the weight and size of the ground station aerial can be far greater than that of the satellite system. In addition, ample power is readily available at earth stations. The carrier power required from a satellite is approximately inversely proportional to the gain of the earth station aerial in the receiving direction (G_r) and directly proportional to the earth station noise temperature (T_s). Thus the factor G_r/T_s can be used as the figure of merit for an earth station which is conveniently expressed as $101 \log_{10} (G_r/T_s)$ dB/°K. This figure of merit is an important parameter of an earth station, since it determines the traffic handling capability. The figure of merit is usually measured by pointing the aerial at a distant radio star so that the noise level may be compared with that of other aerials using the same star. This method is most satisfactory for large aerials, but the moon may be used for smaller 10 meter diameter dishes. For small aerials of up to 8 m diameter, it is more convenient to obtain the figure of merit from the noise temperature and gain.

All standard earth stations in the INTELSAT network must have a high figure of merit, namely 40.7 dB/°K. An aerial of at least 26 m diameter is required to obtain this figure, but a 30 m dish is normally used to give more flexibility in the positioning of low noise receivers by using longer wave guides with higher losses. The total weight of a '5th generation' standard aerial for INTELSAT use is about 300 000kg and the overall height some 28m.

The satellites are not quite stationary. A fixed antenna is unsatisfactory, since the aerial beam angle is narrow (about 0.2° at 6 GHz for a 30 m aerial). A servo system is

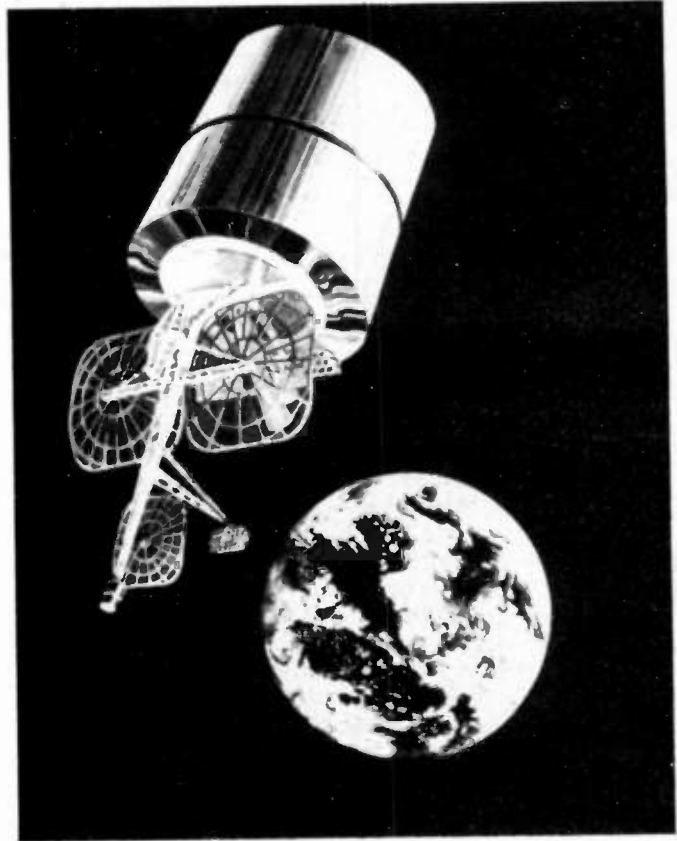

Fig 3. The antennas of the Intelsat III and IV satellites are 'de-spun' on a shelf.

usually used to control the movement of the aerial, the error signal being obtained by using a beacon signal emitted by the satellite. Most aerials are fully steerable and can be moved to operate with any satellite.

EARTH STATION RECEIVERS

Some of the very early earth station receivers employed master amplifiers in the first stage, but these amplifiers cannot operate over the wide bandwidth used in the INTELSAT system. A very low noise amplifier is essential to handle a low power signal over a 500 MHz bandwidth.

Parametric amplifiers cooled to about 15° K are usually employed. Such an amplifier can provide a gain of some 30dB with an effective noise temperature of about 15° K. It may be followed with a tunnel diode amplifier giving a gain of about 10 dB or with a travelling wave tube amplifier. Continuously operating cryogenic cooling devices using gaseous helium have been developed in which the helium is re-circulated in a closed system.

Although the receiver noise temperature is about 15° K by losses in the feeders, by 15° K by side lobe pick-up and by 25° K by atmospheric absorption. Thus the total effective noise temperature is about 70° K.

Each earth station receives a carrier from every other earth station with which it wishes to communicate. The number of carriers sent from stations is reduced to a minimum by using a single carrier for conveying signals to various destinations. Thus the number of transmitted carriers is lower than the number of signals received by various stations.

Communications Satellites

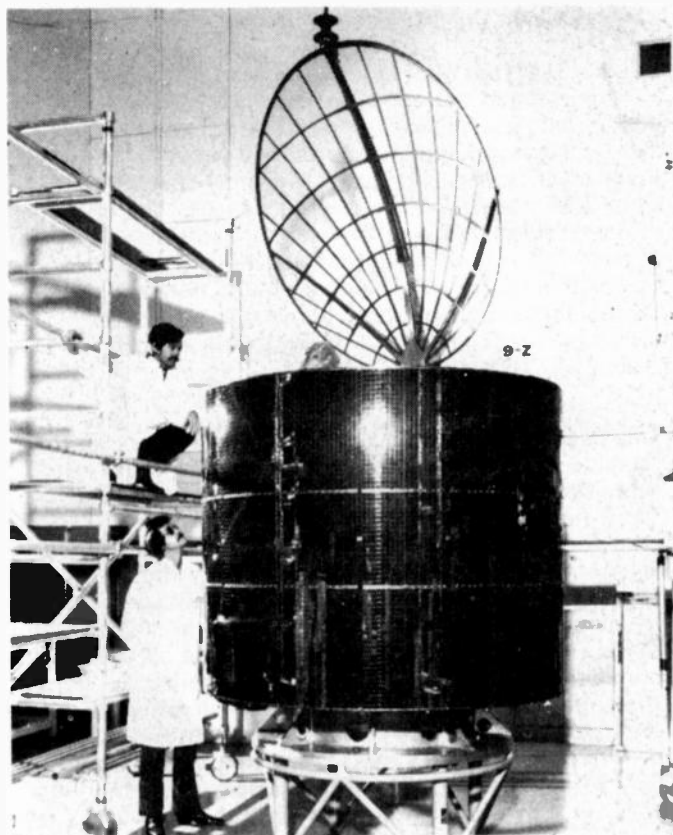

Fig 4. Intelsat satellites are not small, as can be seen here. The use of the Space Shuttle will reduce launch costs tremendously.

EARTH STATION TRANSMITTERS

The power required from an earth station transmitter depends on the aerial gain, on the geographical position and on the gain of the satellite system. The latter will depend on whether global or spot antennae are being employed and on the number of channels available. The required power can be obtained at the earth station by using narrow band transmitters (some tens of MHz) using klystrons or a wide band transmitter using travelling wave tubes (500 MHz bandwidth). If klystrons are used, each carrier is amplified to a suitable level in a separate transmitter and the outputs of the transmitters are combined before the signals are fed to the aerial. This arrangement is used mainly in stations operating with relatively few carriers. The initial cost and the

running costs are fairly small with klystrons, but long breaks are required to change frequencies.

Large stations operating with many carriers favour travelling wave tubes. The carriers are combined at low power and then are amplified by the wide band transmitter before being passed to the aerial. The non-linearity of the travelling wave tube produces some intermodulation products at the output and these must be limited by operating the tube some 10 dB below its capability to prevent interference with other signals. Travelling wave tubes are more expensive and less efficient than klystrons in these circuits, but their wide band capability is very convenient.

DOMESTIC SATELLITES

THERE is a rapidly growing demand for communications via 'domestic' satellites across a single country. Signals from satellites used for this purpose can be concentrated within the boundaries of a nation so smaller earth station aerials can be employed than for international communications where the beam energy must be more widely dispersed. For example, 10 m diameter antennae give G/T_s values of around 31 dB/°K, whilst 10 m antennae of G/T_2 about 26dB/°K are being delivered in the USA for receiving only television signals. Antennas of 2 to 3 m in diameter with a figure of merit of 14 to 20 dB/°K can be used in remote areas for providing 12 voice channels for emergency use or on oil drilling rigs, etc.

Telephone companies cannot charge such high rates for inland calls as they do for international calls, so the viability of domestic satellites is more severely limited by costs than that of international communications systems. However, domestic systems are now well established in countries such as Canada whose Telesat system provides television and voice communication throughout the country, the USSR (mainly television), the USA, which has three systems provided by three different companies and various other countries.

Some countries, such as Spain and Mexico, have leased INTELSAT circuits for their domestic use, but the charges are high enough to make it more economical for most large countries to have their own system. In some cases a group of countries close together can jointly own a system.

COMPARISON WITH CABLES

Satellite communication links are generally cheaper than long distance cables operating under the ocean, but the cables have a minimum expected life of 25 years against 7 for a satellite. It is uneconomic to connect remote

TABLE II. The INTELSAT satellites

	First launch	Height cm	Mass in orbit (kg)	Power (W)	Capacity (Voice circuits)	Effective Bandwidth (MHz)	Design life (yr)	Cost per circuit per year (US dollars)
INTELSAT I	1965	59.6	38	42	50	240	1.5	32,000
INTELSAT II	1967	76.3	86	80	130	240	3	11,000
INTELSAT III	1968	104	152	120	500	1200	5	2,000
INTELSAT IV	1971	531	700	420	500	4000	7	1,200
INTELSAT IVA	1975	590	790	500	800	6000	7	1,100
INTELSAT V	1979	1570	1570	1200	2300	12000	7	800

Communications Satellites

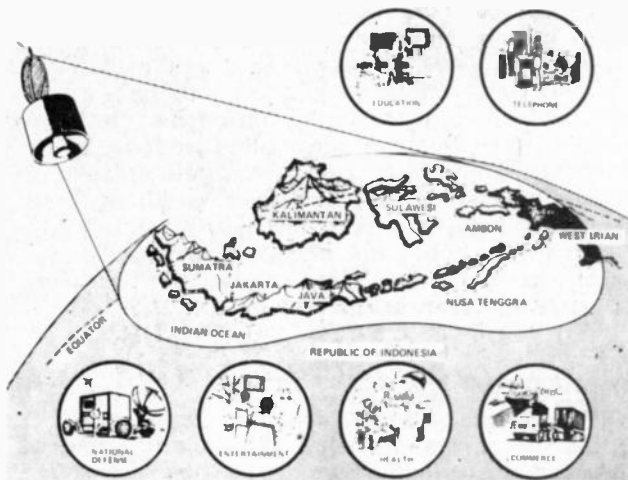

Fig 5. Satellite Communication is ideal for areas such as Indonesia.

islands by cable, so satellite or radio links are used. Satellites are essential for carrying high bandwidth signals (like television) over intercontinental distances. The new TAT-6 cable laid across the Atlantic can carry 4 000 voice channels, but satellites of the IVA series can carry 6 000 speech channels and some domestic satellites even more. Cables may be more vulnerable to enemy attack and communications are vital in war.

A peculiarity of a satellite link arises from the fact that the signal must travel rather over 36 000 km to the satellite and a similar distance back to the earth. Thus there is a delay of about a quarter of a second before the signal reaches its destination and a delay of at least half a second before any response reaches the sender. If a signal received by a satellite was transmitted to another satellite before being returned to earth, the delay of a second or so before any response could be returned to a person might be unacceptable in ordinary telephone conversations. The longest delay on sub-oceanic cables is about 1/16 second.

CONCLUSIONS

Satellite communications are one of the most useful products of the huge investment in space technology. They have radically changed the pattern of world communications and confer outstanding benefits on the lives of ordinary people. It seems likely that satellites able to handle 100 000 telephone circuits will be developed without any great increase in the satellite mass. Improvements in frequency re-use, 3 axis body stabilisation, high efficiency solar cells, on board switching, hybrid modulators, etc. will provide great improvements. The life of satellites is partly limited by the life of the batteries used to provide power when the vehicle is eclipsed by the earth, but new nickel-hydrogen cells are showing great promise for this application. HE

Short Circuit

SIMPLE AMPLIFIER

The term amplifier covers a very wide range from a one transistor preamp to an ultra sophisticated high power Hi-Fi system. There is no doubt that the latter is much more pleasant to listen to but for many applications high quality is of little importance and simplicity is required. There is little doubt that the circuit shown here is very simple. The output is in the order 250 mW — which is quite sufficient for most purposes and is comparable to that of the average transistor radio. The distortion level is rather high, being about 5%.

The amplifier is also reasonably sensitive and will give full output with an input of about 50 mV. Input impedance is about 50 k. A simple tone control is included though as since this is an active control, rather than a passive one, the range is quite sufficient.

The slider from the volume control is connected to the base of Q1 via a DC blocking capacitor. Q1 is connected as a pretty conventional common emitter amplifier with R2 providing the base bias and R3 acting as the collector load. This stage is directly connected to the second transistor which is a PNP type. In this way the current passing through Q1 provides the bias

for the second transistor. Because of the values used, the output of the second transistor is connected directly to the speech coil of the loudspeaker. This is not normally good practice since the standing current in the output transistor continually biases the coil either slightly in or out from its usual operating point. However if a large speaker is used, as it should be, this has very little effect and since we are not aiming at Hi-Fi, it does not matter.

The tone control comprises C2 and RV2 which are connected between the collector and base of Q1. At high resistance settings of RV2 this has little effect but on minimum settings the 100 n feeds back the high frequencies out of phase, thus cancelling them.

For this circuit to work properly R3 must be selected with great care. The value shown here of 39 ohms is only a typical one and although it may be used for initial setting up to ensure the circuit is operating, the value should be found by experiment. If it is too low there will be severe distortion at the higher volume settings. If it is too high the current drain will be excessive even though the quality of reproduction will be good.

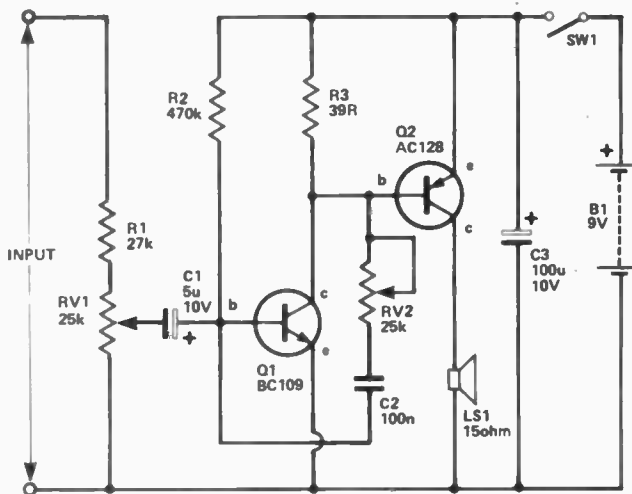

There are two ways of finding the value. Without a multimeter the value should be selected as being the lowest which is compatible with good quality. If a multimeter is available this should be wired in series with the supply voltage and R3 should be selected so that the quiescent current, this is the current flowing with no input signal, is reading 20 mA.

It is very important that Q2 is

fitted with a heatsink as it will get very hot and will probably run away without it.

The speaker impedance is not all that critical and in the prototype speakers with an impedance as low as 8 ohms and as high as 80 ohms all worked, well although changing the speaker impedance will also necessitate a change in the value of R3.

Interfering Waves

Electromagnetic waves, be they radio or light, are everywhere and keep bumping into each other. Here we look at the problems this causes — and the benefits we can derive from the effect.

SOMEBODY ONCE SAID that he would have great difficulty in describing an elephant but he could recognise one if it walked into the room. Waves are a bit like that — we know a water wave when we see one, but it's difficult to describe what's going on, and it's even more difficult when the wave is invisible (like sound) or if it's a wave that doesn't need any material to move in (like light or radio waves).

Well, let's have a go. A wave is an oscillation of something which can spread from one place to another. A water wave is a lot of oscillating water, and the oscillation of each drop of water in the wave is what makes the next drop oscillate, and so on. A sound wave is an oscillation of air pressure, and an oscillation of pressure in one place causes an oscillation of the pressure further away. An electromagnetic wave, the kind we call light or radio waves, is an oscillation of something less substantial, voltage and magnetism. Neither voltage nor magnetism is a material, so that electro-magnetic waves, unlike the others we have mentioned, don't need any material to spread from one place to another.

Now the important point about waves is that the oscillation spreads out in all directions from its starting point with a definite speed. Sound waves move at about 330 metres per second in air, electromagnetic waves at about 300 million metres per second in a vacuum, and everything in the path of the wave will be affected in some way. A sound wave, for example, hits materials and makes them vibrate. An electromagnetic wave doesn't make the whole material vibrate, just its electrons, but the action is similar. In each case, the wave that strikes a material causes an oscillation which is a copy of the oscillation that caused the wave in the first place.

Because a wave is an oscillation, though, we can get some interesting effects when two (or more) waves meet. Each wave tries to cause the material, at the place where it strikes, to oscillate but where two waves meet they're trying to make the same bit of material oscillate. Now two sound waves, for example, can't cause a bit of air to have two different amounts of pressure at the same time, and two radio waves can't cause the same piece of air to have two different voltages at the same time. So what happens? What you might expect, in fact. The

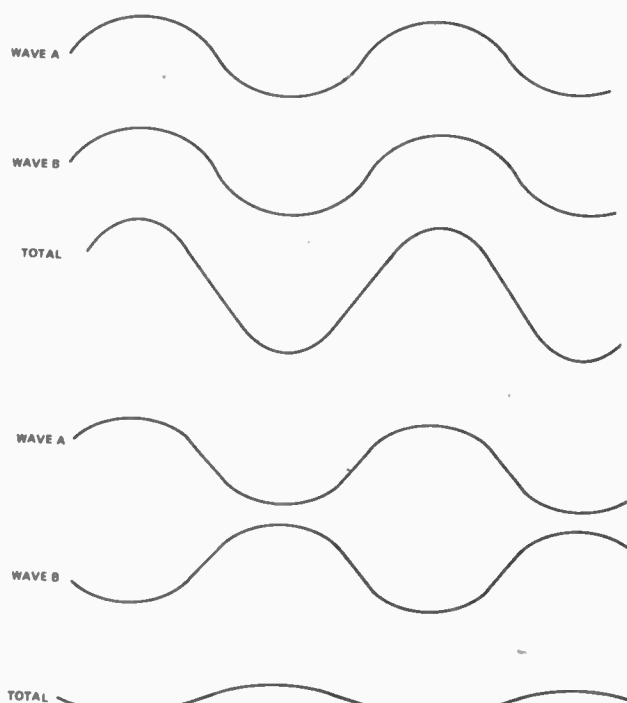

Fig. 1. Wave interference. (a) Adding in phase, constructive interference. (b) Adding in antiphase, destructive interference.

amount (or *amplitude*) of the oscillation is just equal to the sum of the amplitudes of the two waves.

Now this raises an interesting point. Suppose two waves meet, and their peaks line up exactly at the place where they meet (Fig. 1a). From what we know of waves, the amplitude of the oscillation at the place where the waves meet should be the sum of the wave amplitudes, a greater amount of wave. On the other hand, though, if, at the place where the waves meet, the peak of one wave always coincides with the dip (or trough) of the other (Fig. 1b), we would expect the result to be no wave at all. Does it happen?

INTERFERENCE

It does, and the effect is called interference. Waves which add as in Fig. 1a are said to be in phase, adding constructively; waves which add as in Fig. 1b are in



antiphase, adding destructively. The interference of sound waves causes the sounds we hear to appear different in different parts of a room. Try this for yourself; if you can hear the whistle from the old telly, shift your head from side to side and notice how the intensity of the whistle changes. This interference effect causes headaches for the designers of concert halls, public address systems and loudspeaker cabinets.

Interference also affects electromagnetic waves, but not always so obviously. Three hundred years ago it was a bit difficult to believe that light was a wave. Had anyone ever seen two beams of light hit a screen and cause darkness where they overlapped? No one had, and it was a long time before the reasons were understood; in fact many people believed that light could not be a wave.

Reason one is that the wavelength of light, the distance from one peak of the wave to the next, is very small, about a ten-thousandth of a millimetre. The other reason is that light consists of short bursts of waves, not a continuous stream, and that when two light sources send out beams of light the bursts are never in step, so that any interference effects last only for less than the time of a wave burst — and that's not a long time, less than a nanosecond. The technical term for this is that the light sources are *incoherent*.

THE LUXEMBOURG EFFECT

Radio waves have a much longer wavelength (and so a lower frequency) than light waves; that's the main difference between the two. They're both electromagnetic waves, they both travel at the same speed, but the interference of radio waves with each other is so obvious that we have to do something about it. In the earliest days of radio the problem hardly existed — there were so few transmitters, the range so short, the equipment was so unreliable anyhow. What was the problem? Well, in the 1920's it became known as the *Luxembourg Effect*, when that well-known transmitter started broadcasting in English. In the UK, Radio Luxembourg transmissions could be picked up, but they were plagued by alternate fading and 'blasting'. One minute you had to turn the volume control right up to hear anything at all, the next minute you had to turn it right down again to stop it blasting your ears out. Sounds familiar, doesn't it? The Luxembourg effect is caused by the interference of radio waves — both from the same transmitter, at the same frequency, sometimes in phase, sometimes in antiphase.

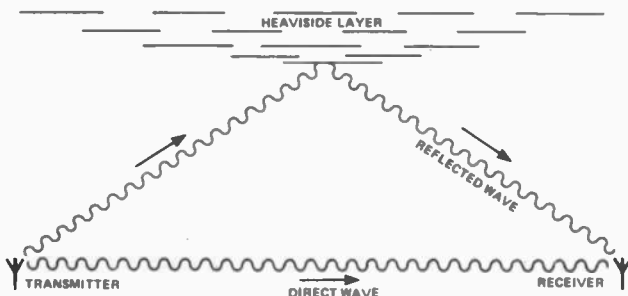

Fig. 2. How reflected waves interfere with the direct wave.

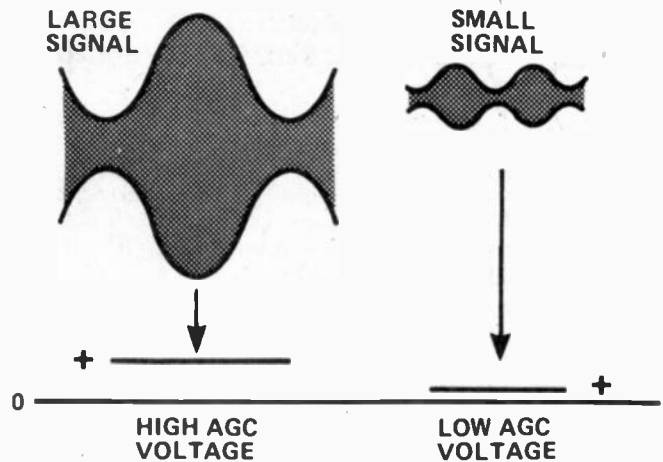
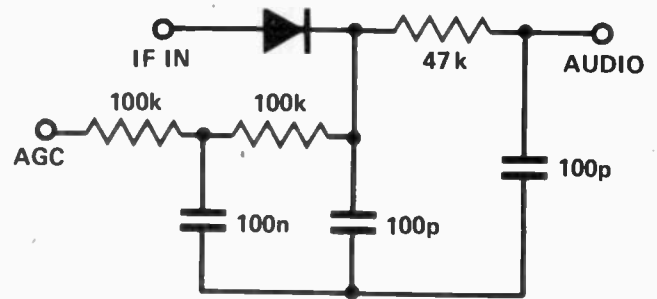

Fig. 3. An AGC circuit and its effect.

Way back in the 1880's, Oliver Heaviside, an electrical engineer who was probably the least understood genius of the last century, had predicted that the action of the Sun's rays on the 'outer edge of the earth's atmosphere, 50 to 150 km up, would create a layer of ions, atoms broken into pieces, which would reflect electromagnetic waves. Since no one at the time was really sure that electromagnetic waves existed (they had been predicted mathematically by Clark Maxwell in 1864), and because Heaviside didn't particularly care if anyone understood him or not, this idea of his didn't exactly make front page news. It rang a very loud bell, however, when the Luxembourg effect was noticed, because it explained why there should be two lots of waves interfering at the receiver.

There is, in fact, more than one layer of ions at the edge of the atmosphere. One layer is called the Heaviside Layer (see Fig. 2.) which is about 50-90 km above the earth, another is named after Appleton, the US pioneer of measurements in the upper atmosphere. These layers are constantly shifting, affected by the action of the sun and the stirring effect of the movement of the earth beneath them. When a radio transmitter sends out a wave, some of the wave hugs the earth's surface, some reflects from one or more of these layers which act like a huge mirror in the sky. The result at the receiver is a set of waves which have travelled different distances from the same transmitter.

Travelling different distances means that some waves will arrive in phase, some in antiphase. Waves that arrive in phase will reinforce, causing a large amount of signal

Interfering Waves

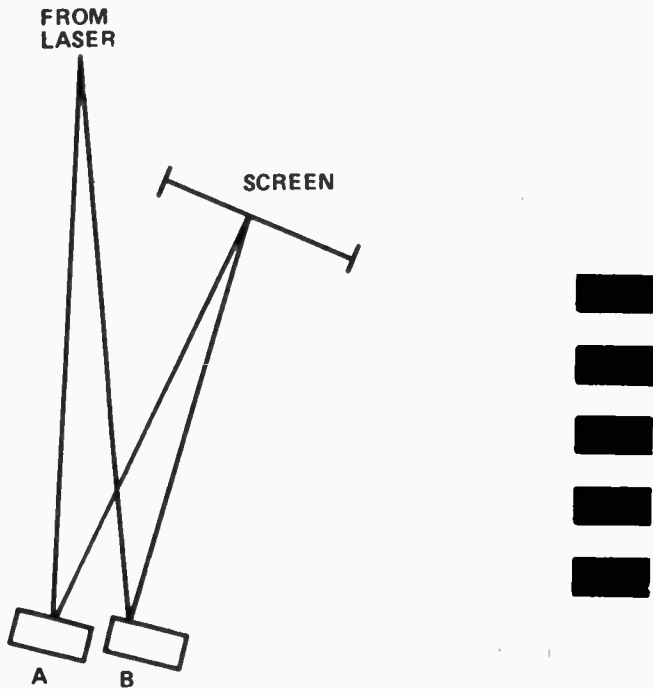

Fig. 4. Laser interferometry (a) set-up, (b) fringe pattern.

which can overload the first stages of a radio. Waves arriving in antiphase cause cancellation, so that the signal is weak or missing altogether. Because the reflecting layers are constantly on the move, reception is never steady, so that the Luxembourg effect is, in fact, heard on every medium-to-long distance radio transmission.

You've never heard it? That's because we've devised an ingenious fiddle for counteracting it. Instead of sitting by the receiver alternatively turning the volume up or down, we use a circuit which does this automatically. At the detector of an AM radio, the signal is rectified by a diode. As well as the audio signal, we get a DC voltage at this point, and the size of the DC voltage is equal to the peak voltage of the carrier wave. When the input waves cancel, this DC voltage sinks to zero, when the waves reinforce, the DC voltage rises. (See Fig. 3).

We use this voltage to control the amplification, or gain, of the radio signal amplifiers of the radio, so that the gain is turned down when the voltage is high, and turned up when the DC signal is low. The result is that the signal from the detector is almost constant, though you can hear the noise that is picked up increase noticeably when the signal fades (listen for it on a car radio as you drive under some high voltage lines). This system is called AGC (automatic gain control) and it's used on practically all receivers. TV receivers, incidentally, suffer from wave interference effects even if they're near the transmitter, because the waves reflect from aircraft, large vans or other large moving objects to cause just the same problems, though, oddly enough, the Heaviside

layer and its relatives cause no bother because the high-frequency waves we use for TV broadcasting pass right through these layers.

MAKING USE OF THE PROBLEM

Strangely enough, this wave interference caper can be turned to some very good uses. One is for very precise speed measurement; it's a system called *Doppler Radar*. A beam of radio waves is sent out towards a moving object. The waves that return interfere with the waves that are being sent out, causing the usual reinforcement and cancellation. The rate at which this reinforcement and cancellation takes place depends on how fast the target is moving, and can be computed directly, so that the speed of an object can be measured with no contact between the moving object and the measuring instruments. This system is used for radar speed meters and for aircraft altitude meters.

The most precise measurements of distance can be made using the principle of wave interference. Light rays do not normally interfere, because of this incoherence problem we have with light, unless both rays are obtained from the same part of a light source. That very modern light-source, the *laser*, gives out light beams which stay coherent for a long time. It's possible, therefore, to produce interference between two laser beams, and it's possible to make use of one laser beam to produce very precise measurements of distance or angle.

Figure 4 shows the kind of equipment that is needed. The light from a laser beam is split, so that one ray is reflected from one object, and another from a second object. If the two rays are allowed to meet on a screen, the interference causes a pattern looking like a set of dark and light bands. Each complete pair of bands represents a difference of one light wavelength in the distance the light has had to travel along the two different paths. Now move one of the objects and the bands will move. If the reflection is at about 90° , a movement of half-a-wavelength of light will cause the band pattern to shift by a complete pair (dark and light) of bands. For green light, a half-a-wavelength is about 2.5×10^{-7} m: less than a thousandth of a millimetre. It's a very sensitive and precise measurement and we can easily detect a shift of much less than a complete pair of bands, so that much smaller changes of position can be measured.

This type of measurement, called *interferometry*, is used for computer control of machine tools. You want to turn 0.01 mm from a piece of steel on a lathe? You set up the laser interferometer, and the computer that controls the lathe, then dial the amount. The tool is racked towards the work, turning starts, and the computer counts the number of bands that go past a photocell used in place of our screen in Fig. 4. When the right number of bands has been counted out, the tool is retracted, the lathe stops, and the machine is ready for the next job.

Need we add that similar methods are used for measuring the thickness of metal and semiconductor films which make up integrated circuits? It just shows, even interference can have its uses.

Reader's Letters

Please send submissions for the letters page to: Hobby Electronics, 25-27 Oxford Street, London W1. Mark the envelope "Letters Page." Letters which are too long for publication will be suitably edited.

Cartoons

Dear Sir,

Unless there is a drastic improvement in your new magazine I for one, will not be a regular reader.

Please omit the stupid cartoons and use the space for circuits and more circuits. That is what people buy the magazine for. Comics come a lot cheaper!

Oh yes. Cut out computer programming etc, there are specialised publications for this.

R. V. Aldridge,
Bucks.

We need criticism, after all no one is perfect, but we feel your comments are a little harsh, particularly with regards computing. This is a subject of importance to everyone, and will be even more so in the future. Cartoons may at first seem a little frivolous but a little comic relief is what separates us from text books, and we all know how dull some of those can be.

Oscilloscope

Dear Sir,

I have been enjoying the last few editions of 'HE'. Returning to electronics as I am after a long gap (my last project was a valve amp!) I find myself both fascinated (and bemused) by the possibilities offered by integration techniques.

What I would like to ask or suggest is a project based around an oscilloscope, even a teaching series. A scope would provide an insight into the functioning of many circuits making fast learning much easier.

J. Harrison,
Middlesex.

As you are probably aware a 'scope is an invaluable asset to anyone interested in electronics, but cost and calibration of a home-built unit put against the cost of a commercial device makes it impractical. However we're bearing your suggestion in mind.

Abbreviations

Dear Sir,

I have become a regular subscriber to your magazine and I must congratulate you on the standard of your publication.

I am the Head of Science Dept. in a secondary school and among other things conduct a course in electronics. I am trying to persuade my pupils to regularly take HE to complement their course, and we find 'Introduction to Electronics' and the various projects a great help to us.

We as you know live in a world of abbreviations and I find that my pupils are bewildered by the mass

of abbreviations that appear in print, even your publication, which you admit is aimed amongst others at newcomers.

I hope you will give favourable consideration to my suggestion and look forward to receiving any comments from you.

R. J. Armstrong,
Lincs.

We are grateful for your comments, something along the lines you suggest may well be dealt with in a future issue.

Great Stuff

Dear ETI team,

I think your "Hobby Electronics" magazine is absolutely brilliant. If I had asked you to write an electronics mag just to suit me, you couldn't have done better. I hope that everyone else who has bought the mag is as pleased with it as I am and that you will keep on publishing 'HE' for many millenniums to come.

A. Capaldi
Herts.

Flash Trigger

Dear Sir,

I am writing to apply for the position of proof-reader (part time) on your editorial staff.

The realisation of your need for this was noticed while studying the article "Flash Trigger" in your January issue (for I am a keen amateur photographer) where reconciling resistance numbers in the "How it works" panel on page 60 with the drawings on page 61 proved an excellent intellectual pastime over Christmas.

If I may have your attention for a few moments longer, I would dispute your use of "nanofarads". For many years we have managed with the prefixes Micro and Pico units in which we could think. If, sir, you buy litres of petrol and fill the tyres with air at Newtons/sq mm before driving to an inn to sink some litres, then you are entitled to use SI units.

V. L. Malempre,
Surrey.

We are genuinely sorry about the mix-up on the parts list, the list for the prototype got mixed up with the revised one for the article. As a rule you can always rely on the circuit diagram to be correct. As for the use of SI units, you yourself admit to using older types of prefixes for many years. Many of our readers are new to electronics, schools and colleges teach in SI units, so who are we to add confusion, particularly as the SI units are to become standard.

AD INDEX

ACE	26
AMBIT	2
ASTRA-PAK	50
BREWSTER	56
E.D.A.	26
HENRY'S	26, 56, 61
LIGHT SOLDERING DEVELOPMENTS	19
MAGNUM AUDIO	61
MAPLIN COVER	Back Cover
MARSHALLS	56
METAC	61
MINIKITS	6
NICHOLLS	6
RAMAR	6
RT-VC	24
STEVENSON	11
SWANLEY	30
TAMTRONIK	73
TIMETRON	6
VERO	30

COMPUTING BOOKS for beginners: A Fast Introduction To Computing £3.95; Home Computers 2¹⁰ Questions and Answers Volume 1 Hardware £6.50; Volume 2 Software £5.95; A Beginners Glossary And Guide £5.45. All post free. Industrial Training Press, Dept. HE1, 3 Ringwood Way, Winchmore Hill, London N21 2RA.

HOBBY ELECTRONICS BOOK SERVICE

30% Discount on Selected Titles

We have been able to acquire a large selection of books — originally published in the US — and are able to offer these at 30% off the regular price. Note that all prices include postage.

	Regular Price	HE Offer Price
	(inc. Post)	(inc. Post)
Gilbert, J.	£4.20	£2.94
Crowhurst, N.	£1.90	£1.33
Smith, D.	£1.90	£1.33
Ash, J.	£2.30	£1.61
Mandz, M.	£2.20	£1.54
Hallmark, C.	£2.00	£1.54
Stapleton, G. F.	£1.90	£1.33
Heiseman, D.	£3.70	£2.69
Wells, B.	£1.90	£1.33
Kyle, J.	£2.20	£1.54
Ashe, J.	£4.40	£3.08
Weis	£2.50	£1.75
Turner, R.	£2.10	£1.45
Brown, R. M.	£1.40	£0.98
Darr, J.	£1.70	£1.19
Brown, R.	£2.10	£1.45
Green, W.	£2.10	£1.45
Seissons, K.	£1.60	£1.12
Salm, W.	£2.00	£1.40
Margolis, A.	£1.90	£1.33
Clifford, M.	£2.10	£1.45
Wells, B.	£4.00	£2.80
Gaddis, B.	£1.90	£1.33
Shunaman, F.	£2.10	£1.45
Horowitz, M.	£2.70	£1.89
Goodman, H. L.	£2.20	£1.54
Swearer, H.	£1.90	£1.33
Klein, B.	£2.00	£1.40
Sands, L. G.	£1.70	£1.19
Steckler, L.	£1.70	£1.19
Green, W.	£2.60	£1.82
Green, W.	£2.10	£1.45
Swearer, H.	£2.20	£1.54
Fox, R. W.	£2.10	£1.45
Tuite, D.	£2.60	£1.82
TAB Staff	£2.10	£1.45
Goddis, B.		
Cunningham, J.	£1.80	£1.26
Wanninger, A.	£1.80	£1.26
Saunders, A. C.	£1.70	£1.19
Saunders, A. C.	£1.70	£1.19
Everest, F.	£1.70	£1.19
Seissons, K.	£2.30	£1.61
Carr, J.	£1.80	£1.26
Carr, J.	£3.80	£2.26
Carson, K.	£2.20	£1.54
Clifford, M.	£6.50	£4.55
Clifford, M.	£3.90	£2.73
Advanced Applications of the Pocket Calculator		
Basic Audio Systems		
Basic Electronic Problems Solved		
Handbook of IC Circuit Projects		
Electronic Puzzles and Games		
Electronic Measurement Simplified		
Beginners Guide to Computer Logic		
Build Your Own Working Robot		
Fire and Theft Security Systems		
Electronics Unravelled		
Electronics Self Taught With Experiments		
How to Repair Musical Instrument Amplifiers		
125 One Transistor Projects		
104 Easy Projects For The Electronics Gadgeteer		
New Ways To Diagnose Electronic Troubles		
Sixty Four Hobby Projects For Home and Car		
Solid State Projects For The Experimenter		
Stereo-Quad Hi-Fi Principles and Projects		
Tape Recording For Fun and Profit		
10 Minute Test Techniques For P.C. Servicing		
Test Instruments For Electronics		
Transistor Circuit Guidebook		
Troubleshooting Solid State Amplifiers		
How To Test Instruments In Electronic Servicing		
How To Troubleshoot And Repair Electronic Test Equipment		
Indexed Guide To Modern Electronic Circuits		
Installing and Servicing Electronic Protective Systems		
Introduction To Medical Electronics		
Mobile Radio Handbook		
Simple Transistor Projects For Hobbyists		
RTTY Handbook		
Protected Test Equipment You Can Build		
Pulse Switching Circuits		
Protected TRIAC/SCR Projects For The Experimenter		
Practical Circuit Design For The Experimenter		
Popular Tube / Transistor Substitution Guide		
Troubleshooting Solid State Wave Generating and Shaping Circuits		
Understanding and Using The VOM and VTM		
Using Electronic Testers For Car Tune Up		
Working With The Oscilloscope		
Working With Semiconductors		
Acoustic Techniques For The Home and Studio		
Amateur FM Conversion Construction Projects		
FM / Stereo / Quad Receiver Servicing Manual		
Op Amp Circuit Design and Application		
Simplified Computer Programming		
Modern Electronic Maths		
Modern Guide To Digital Logic		

All prices include postage. Please make cheques payable to HE Book Service (in sterling only please) and send to: Hobby Electronics Book Service, P.O. Box 79, Maidenhead, Berks.

TAMTRONIK LTD. (DEPT. HE)

217 TOLL END ROAD, TIPTON
WEST MIDLANDS DY4 0HW

TEL. 021-557 9144

PRINTED CIRCUIT BOARDS and KITS FOR HE PROJECTS

Mag Issue	Project	Kit Ref	PCB	Kit	Kit Contents (See key)
Nov 78	Bedside Radio	H001	95	13.09	BEHL
	Stereo Amplifier	H002	3.45	38.26	BEHL
	Waa Waa Pedal	H003	80	5.70	BEH
	Digital Clock	H004	—	18.80	EH
Dec 78	Push Button Oice	H005	79	4.75	BEHL
	H.E. Metronome	H006	61	5.26	BEHL
	Phonon Phone	H007	1.40	7.58	BEGH
	H.E. Mixer	H008	2.95	20.69	BEGML
Jan 79	Graphic Equaliser	H009	2.95	21.31	BEGML
	Flash Trigger	H010	95	9.72	BEHL
	Variwiper — Relay	H011R	80	6.15	BEH
	Variwiper — SCR	H011S	75	3.34	BEH
	Touch Switch	H012	95	4.03	BEH
Feb 79	Short Wave Radio	H013	1.25	10.15	BFH
	Sine/Square Wave Generator	H014	1.60	22.41	BEHL
	Scratch & Rumble Filter (Mono)	H015	1.25	12.31	BEHL
	Scratch & Rumble Filter (Stereo)	H015S	2.50	15.82	BEHL
	HE Car Alarm	H016	1.10	7.12	BEHL

Photocopy of any of above Projects 30p.

Kits can be supplied excluding pcb and/or case. Send sae for details naming kit and kit reference and free catalogue.

Trade and Educational enquiries welcome

Hobby Electronics, March 1979

KEY TO KIT CONTENTS

A	Vero board(s)
B	Printed Circuit Board(s)
C	With Screen printed component layout
D	Tape strip
E	All Resistors, potentiometers, capacitors, semi-conductors
F	As E but with exclusions. Please ask for details.
G	Di and/or transistor sockets and/or soldercon pins
H	Hardware includes switches, knobs, lamps and holders, fuses and holders, plugs and sockets, microphones, transformers, speakers, meters, relays, terminal blocks, battery connectors, etc
J	BUT excludes nuts, bolts, washers, connecting wire, batteries and special miscellaneous items
K	As H but with exclusions. Please ask for details
L	As H but including connecting wire
M	Suitable case(s)
N	Suitable case with screen printed facia
P	Full kit to magazine specified standards
	Kit with professional finish — incorporating all prime features including screen printed pcb and case where appropriate

SPECIAL OFFERS

Plug-in mains PSU 3v/6v/9v/12v DC 300MA.
Suitable for calculators, TV Games, etc. £2.99
100 x 1/4W 1k resistors 30p
4 x HE 555 £1.00

Pcbs and kits available from TAMTRONIK LTD. for projects from ETI and EVERYDAY ELECTRONICS. Send sae for free catalogue. Please quote project and kit reference number when details of a specific kit are required, sae.

Tamtronik Ltd. reserves the right to change kit content without notice to incorporate current modifications or to make valid substitutions for temporarily unavailable components.

The majority of kits advertised can be supplied from stock, however please allow 21 days delivery since demand on any kit is unpredictable.

SOLDERING IRONS & ACCESSORIES

SRB 18 watt iron, incl. No. 2D bit	£3.78	Spare bits	44p
Stand	£3.25	BIT SIZES	
Solder - Saubit 20ft	52p	No. 19 (1.5mm), No. 2D (3 mm), No. 21 (4.5mm), No. 21 (6mm).	
L.c. Desoldering bit	£1.00		

"IDEAL FOR THE HOME CONSTRUCTOR"

Visit our shop at Telephone or Letter

P. & P. 30p
Prices include VAT

32 Market Place
Great Bridge, Tipton
West Midlands



Good Evans

We recently checked around amongst HE staff: all but one still has the model railway they were given as youngsters. That includes our reporter Gary Evans.

ONE OF THE nice things about having electronics for a hobby is that you get double your value for money. How? you ask. Well my reasoning goes like this.

Electronics is probably not going to be your only hobby, for most people will have two, if not more hobbies. Further, because just about everything we do in life has some aspect in which electronics can be involved, we can combine our hobbies, the money spent on electronics being saved by not having to buy ready-made equipment to suit our other interest. Whether you are a fisherman, photographer, motorist or model railway fanatic, do-it-yourself electronics can save you money.

Taking the last group in my list above, response to projects published in HE's sister magazine, ETI, in the past has shown that there is a considerable interest in the role that electronics can play in making a model train setup more fun to use. For example the provision of a means to simulate inertia and braking of a real train rather than the abrupt start/stop of conventional controllers.

The manufacturers of model railway equipment have not been slow to realise that electronics can considerably enhance their equipment either. The Zero 1 from Hornby is an example of the latest generation of model train controllers.

The Zero 1 features a central control unit with a speed control lever and a calculator style keyboard to the right of it. The keyboard allows any one of 16 trains to be "dialed up" and controlled by the Zero 1. Each of the trains must have a special module inserted between its power pick up point from the rails and its motor. Each of these train modules can be coded to a number between one and sixteen. When the corresponding number is punched in on the main unit, the train will recognise its own special code and feed power to its motor. None of the other trains on the track will move as they will ignore the code.

The Zero 1 offers four levels of inertia which can be selected for different trains as required; slow acceleration for a heavy goods train, fast for a HST. The Master Control unit should be available towards the end of this year (just in time for Christmas) while a little later further units will be added to the system.

The first addition will be slave units that with the master controller will allow up to three trains on the track to be individually controlled at any one time. Keyboard control of points, signals and other electrical accessories is also planned, again all by special codes sent down the track; no need for additional wiring. Lastly Hornby plan to add a sound effects unit to the system.

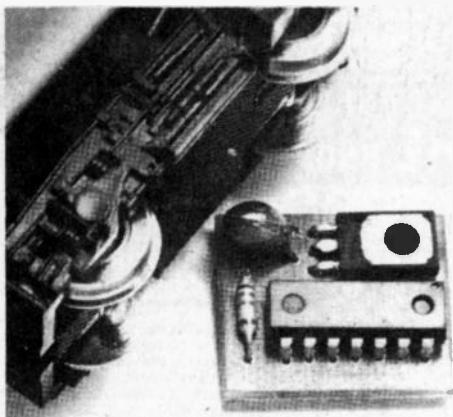

The locomotive module which Hornby say can be fitted to almost all 'OO' and 'HO' engines. This involves cutting one wire between the pickups and the motor. The 'chips' are coded by the user.

The diagram on the left shows a conventional model layout where control is carried out by moving trains from section to section, each section being electrically isolated from the next but all being connected to the central controller. A lot of wires!

Conventional system

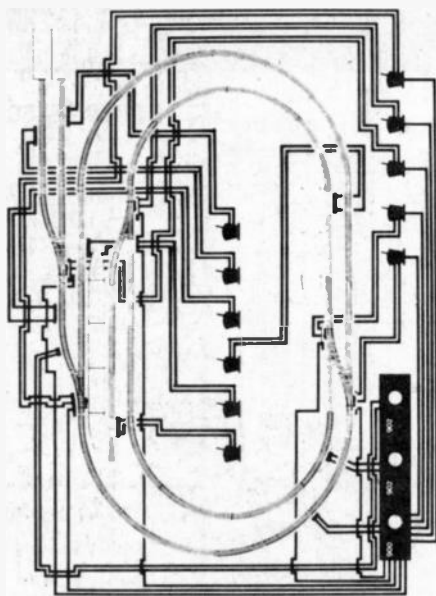

ZERO 1-only 2 wires

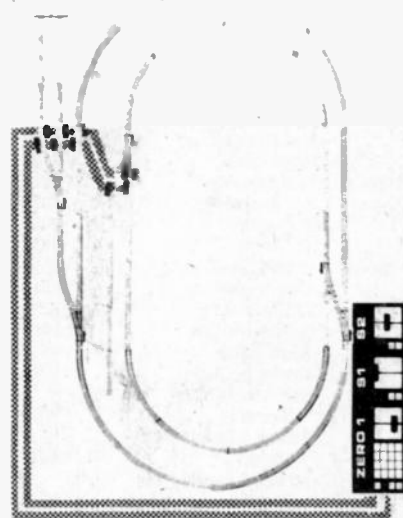

The Zero 1 system on the right requires only two wires to the track, the train to be energised being selected by a special code that is passed down the track. Note also that points, signals etc. can also be controlled by these codes, greatly simplifying the layout.



Hobby Electronics

RESISTOR COLOUR CODE

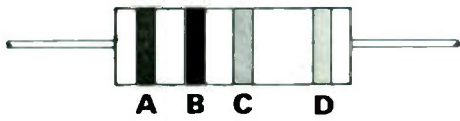

	A and B	C
BLACK	0	-- ohms
BROWN	1	-- 0 ohms
RED	2	- k -
ORANGE	3	-- k
YELLOW	4	-- 0 k
GREEN	5	- M -
BLUE	6	-- M
VIOLET	7	
GREY	8	
WHITE	9	

D (tolerance)	
NONE	20%
SILVER	10%
GOLD	5%
RED	2%
BROWN	1%

CAPACITOR COLOUR CODE

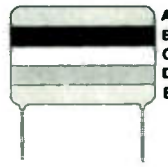

C	D (tolerance)
BLACK	20%
WHITE	10%
GREEN	5%

E (voltage)	
RED	250 V

A and B: As for resistors.

EXAMPLES:

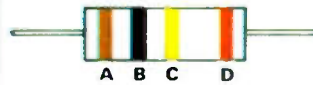

A = 1, B = 0, C = -- 0 k, so value is 100 k; D = accuracy = 2%

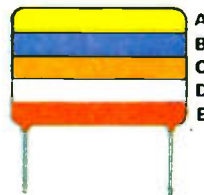

A = 4, B = 7, C = -- n, so value is 47 n; D = accuracy = 10%; E = voltage = 250 V

BRITISH STANDARD COMPONENT MARKINGS

M (pronounced mega) means multiply by 1 000 000,
 k (pronounced kilo) means multiply by 1 000,
 m (pronounced milli) means divide by 1 000,
 u (pronounced micro) means divide by 1 000 000,
 n (pronounced nano) means divide by 1 000 000 000 and
 p (pronounced pico) means divide by 1 000 000 000 000.

So when we write 10 mV, we mean (10 / 1000) V, or 0.01 V. Note: it is usual to leave the "F" and "ohm" out altogether when writing, but as we rarely talk about resistances less than one ohm or capacitances greater than one farad, this does not cause too much confusion.

Examples: 10 uV = (10 / 1 000 000) V = 0.000 001 V; 330 R = 330 ohms (R is used for ohms when no multiplier is needed); 10 k = 10 000 ohms; 3.9 mV = 0.003 9 volts; 3.9 u = 0.000 003 9 farads.

Now, at some stage, someone decided to jazz up the system by putting the suffix in place of the decimal point, so that: 4k3 is 4 300 ohms and 4u9 is 0.000 004 9 farads.

Also, in case one of the digits got lost, it was decided that there should always be at least three numbers or letters in the value, so: 5k is written 5k0, et cetera.

Examples: 3M0 = 3 M ohms = 3 000 000 ohms; 4n5 = 4.5 nF = 0.000 000 004 5 farads.

INTEGRATED CIRCUIT NUMBERS

TTL:



Example: DM 74121

CMOS:

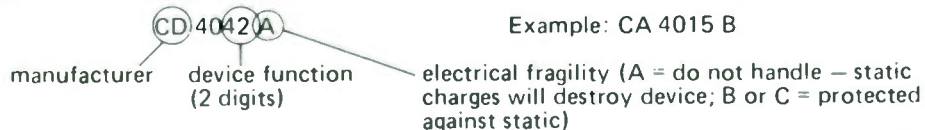

Example: CA 4015 B

OTHER TYPES:



Examples: LM 309, CA 3011, NE 555



A quality range of British made electrical accessories plus a 'How to' book. Do your own home electrical work with complete confidence. See cat. pages 129 to 134.



This superb organ — build the first working section for just over £100. Full specifications in our catalogue.

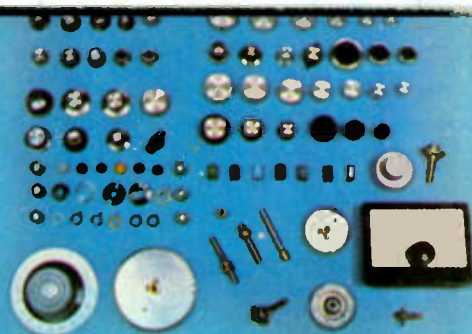

A range of highly attractive knobs is described in our catalogue. Our prices are very attractive too!



Most amateur radio, TV and FM aerials plus lots of accessories are described in our catalogue.



A pulse width modulator for smooth slow running plus inertia braking and acceleration. Full construction details in our catalogue.



A wide range of disco accessories at marvellous prices. Our catalogue has all the details.



Add on bass pedal unit for organs. Has excellent bass guitar stop for guitarists accompaniment. Specification in our catalogue.



The 3800 synthesiser — build it yourself at a fraction of the cost of one ready-made with this specification. Full details in our catalogues.



Touch operated rhythm generator — the Drumsette — Construction details 25p (Leaflet ME549). Specification in our catalogue.

MAPLIN

ELECTRONIC SUPPLIES LTD

All mail to:—

P.O. Box 3, Rayleigh, Essex SS6 8LR.
Telephone: Southend (0702) 554155.

Shop: 284 London Road,
Westcliff-on-Sea, Essex.
(Closed on Monday).

Telephone: Southend (0702) 554155.



A superb technical bookshop in your home! All you need is our catalogue. Post the coupon now!



An accurate alarm clock with radio switched function and battery back up. Complete set with case only £11.99 (incl. VAT & p&h). MK1023 module only £9.47 (incl. VAT).

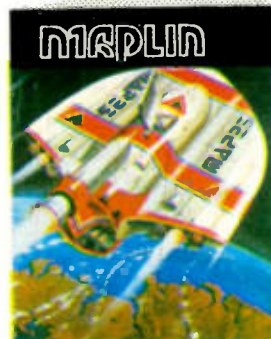

A massive new Catalogue from Maplin that's even bigger and better than before. If you ever buy electronic components, this is the one catalogue you must not be without. Over 280 pages — some in full colour — it's a comprehensive guide to electronic components with hundreds of photographs and illustrations and page after page of invaluable data.

Our bi-monthly newsletter contains guaranteed prices, special offers and all the latest news from Maplin.



A 63 key ASCII keyboard with 625 line TV interface, 4 page memory and microprocessor interface. Details in our catalogue.

Post this coupon now for your copy of our 1979-80 catalogue price 75p.

Please send me a copy of your 280 page catalogue as soon as it is published (8th Jan 1979). I enclose 75p but understand that if I am not completely satisfied I may return the catalogue to you within 14 days and have my 75p refunded immediately. If you live outside U.K. send £1 or ten International Reply Coupons.

NAME _____

ADDRESS _____

HE379