

5th JULY 1961

VOL. 132

NUMBER 3421

THE ORIGINAL
'DO-IT-YOURSELF'
MAGAZINE

HOBBIES *weekly*

FOR ALL
HOME CRAFTSMEN

Instructions for making . . .

Also in this issue:

INTERCOM SYSTEM
BY LOUDSPEAKER

COLLECTOR'S CLUB

MAKING YOUR
OWN JEWELLERY

PLANS FOR MAKING
A HOBBY HORSE

FRAMING YOUR
PHOTOGRAPHS

A FOLD-AWAY
IRONING BOARD

ETC. ETC.

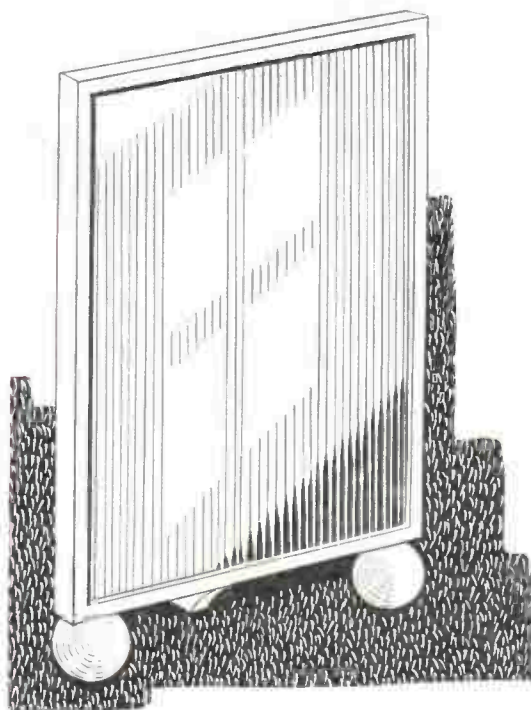

A MODERN FIRESCREEN



Up-to-the-minute ideas

Practical designs

Pleasant and profitable things to make

World Radio History

5^D

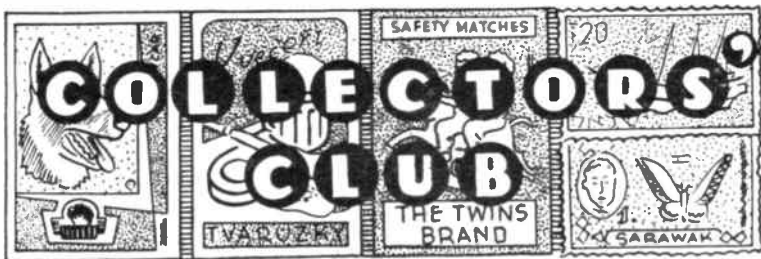

ABOUT 1857 an officer of the 2nd Battalion of the Coldstream Guards presented his men with a pet monkey named 'Jennie'.

The drummers had charge of the pet, and the rascals delighted in making her drunk. Smearing with blackball and pipeclay, she would appear on parade, convulsing the officers and men by her extraordinary antics.

REGIMENTAL PET 'JENNIE'

When the battalion was in Dublin the bare feet of the Irish street boys afforded her particular delight, and she lost no opportunity in darting at them, to their great terror.

Jennie turned up at all the field-days on the 'Fifteen Acres', trotting beside the drum-major, and though she didn't care a straw for the rifle-firing, the artillery seemed to annoy her tremendously.

At length she upset the gravity of the

men so much that orders were given not to allow her to accompany the battalion to Phoenix Park. So she was fastened up next field-day. But, gnawing the cord through, she arrived on parade as the commanding officer was mounting his charger.

Imitation is said to be the sincerest form of flattery. But the gallant colonel didn't take it that way when Jennie vaulted on to the back of a large Newfoundland dog, and went careering across the ground amid a shout of laughter which even military discipline could not suppress.

In vain the astonished dog tried to dislodge its passenger, which clung to his long coat, giving many a sharp tug and sly pinch. The Newfoundland finally settled matters by rolling on the gravel, and Jennie went home a sadder and wiser monkey.

For that escapade she got a long 'C.B.' Some time after, having hidden money and torn up some valuable papers, the Coldstreams decided that she was 'one of the Queen's bad bargains', and accordingly sold her.

'Rajah' the elephant

The Englishman's first impulse, on

going out to India, is to shoot something. Some officers of the 25th King's Own Scottish Borderers captured a baby elephant, after killing its mother, just before the outbreak of the Mutiny.

Giving him the imposing name of 'Rajah', the regiment adopted him. The ladies worked a wonderful saddle-cloth for the new pet, covering it with the honours and emblems of the 25th, embroidered in gold.

The 1st Battalion came home in 1856, and 'Rajah' came with it, causing considerable astonishment as they marched through country places where circuses were rare.

An Austrian Commemorative

IN accordance with a long-standing tradition, a special postage stamp was issued in Austria last December to commemorate the Day of the Postage Stamp.

Featured on the design is a trial impression taken from the original plate in the course of the engraving process. The trial impression, which is being examined through a magnifying glass, shows the 3-50S denomination of the 1959 Hunting Series.

It is the purpose of such proof to tell the engraver how far the required shading and accentuation has already been achieved on the original printing plate. The importance of the trial impressions appears from the fact that the engraver, in the course of his work, may only further accentuate the lines and dots. Any subsequent reduction of line depth, on the contrary, would jeopardize the good quality of printing, and detract from the beauty of the engraving. On checking a trial impression with the aid of a magnifying glass, — which scene is depicted on this special postage stamp — the viewer can easily discern the tracing of the lines. It is for the engraver to determine from the outset in the light of his experience, and guided by his deliberation, the right spacing between the dots and lines, so that in the end the shading and accentuation achieved on the tiny stamp will create the same impression as the artist's drawing.

CAN WE HELP?

BILL Robinson of 35 Hartley St., Cairns, N.Q., Australia, wishes to make a Lord's Prayer Tablet from Hobbies design No. 5 Special, for his church, and wonders whether any reader can help him in his quest for this particular design. He is also interested in the Easter Cross design No. 1069, and any readers who can help should communicate direct with Mr Robinson.

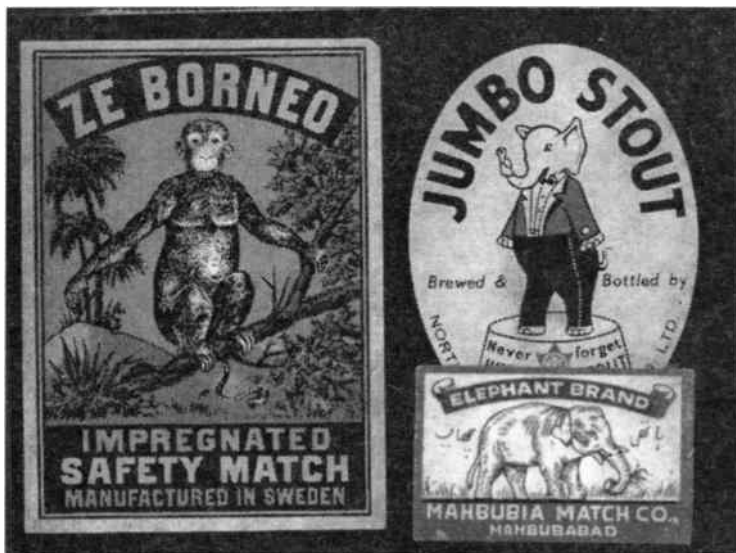

For the Handyman

MAKE MODERN FIRESCREENS

The completed firescreen may be stained and varnished or french polished. High gloss enamel will give an attractive finish if the wood is first prepared by filling the grain. It can be further enhanced by applying a large Decorette transfer. Hobbies Ltd can now supply the new large size (8½ in. wide by 12 in. deep), which costs 4s. 4½d. (postage extra). Suitable designs are Nos. 195C and 195E. The wooden balls cost 1s. 6d. each (postage 6d.) from Dereham, Norfolk. (M.h.)

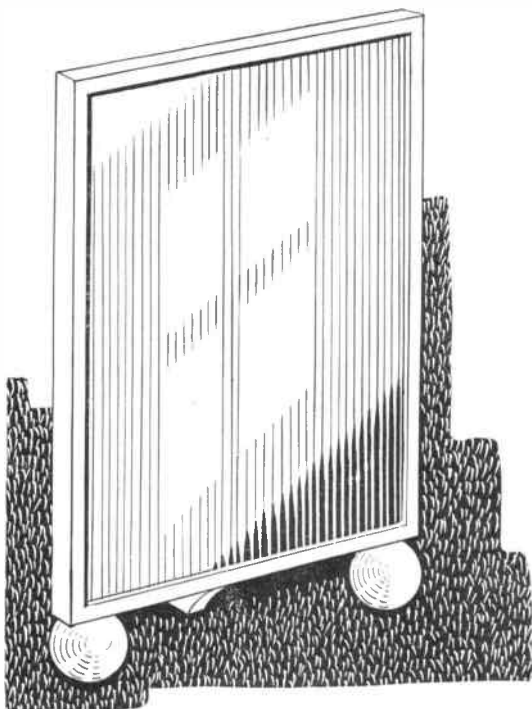

First the framing material must be rebated to take the backing piece. When the rebate has been planed in satisfactorily the corners are then mitred and glued together as in Fig. 2. Pin each corner to provide a really strong joint.

THIS framed firescreen is made up from 1½ in. by ¾ in. stripwood, rebated and mitred at the corners. It is a most attractive style, and can be left plain or decorated with transfers. These are inexpensive to buy and easy to fix.

The diagrams in Fig. 1 give the main measurements, and these will be suitable for most fireplaces. The backing piece is of ¼ in. faced plywood, and the framing of wood to suit.

The feet consist of two Hobbies 3 in. diameter wooden balls. They are bored to take ¾ in. diameter round rod as shown in Fig. 3. The round rod is also let into the framing. Groove the rod to allow air and excess glue to escape.

The back stay is 1 in. thick, and is cut to the shape shown in Fig. 4. The squares should be enlarged to 1 in., and the shape carefully drawn in. Cut out this shape with your fretsaw. Glue the back-stay in position as shown in the side view.

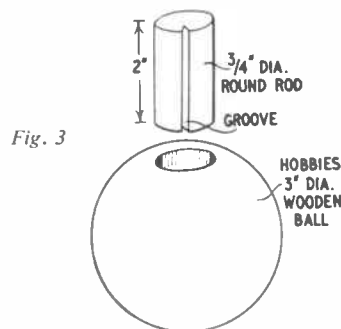

Fig. 3

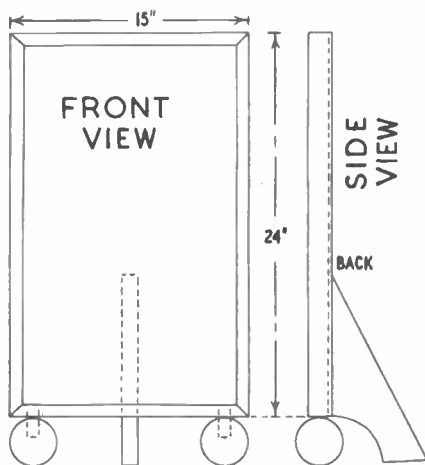

Fig. 1

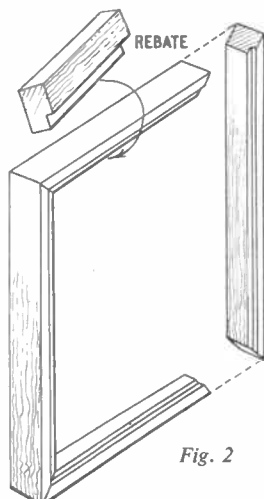
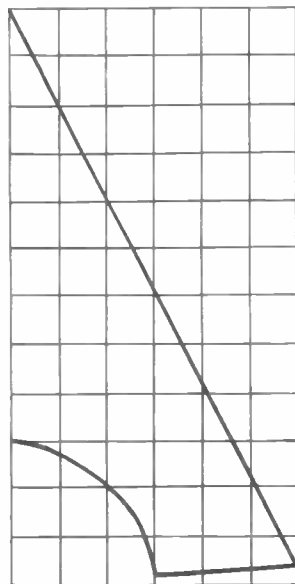
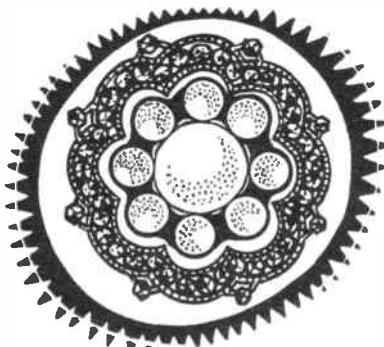

Fig. 2

Fig. 4





Hand-Made JEWELLERY

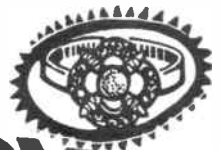

VERY few pieces of jewellery can be made without recourse to soldering. For this reason, and also because the beginner usually needs a fair amount of practice in order to become really skilled at soldering, this operation will be dealt with first.

Joints in precious metals are nearly always made by *hard* soldering, using for solder an alloy of the metal being worked. Thus, silver solder for silver, gold solder for gold, and so on. The strongest joint is made when the solder has a melting point only slightly below the melting point of the metal being worked. But, the closer these two melting points, the greater the risk of damaging or even melting the work when it is heated to the point where the solder becomes molten and fills the joint.

A range of solders is available — hard, medium, and easy — for silver, for platinum, and for every gold alloy, i.e.

9 ct., 18 ct., etc. The hard variety has in each case the highest melting point. The main reason for using a range of solders is seen in the case where successive soldering operations must be done very close to each other, and where the solder of previously soldered joints must not be re-melted for fear of the parts shifting.

SOLDERING AND JUMP RINGS

In this case one can begin by using a hard solder and finish with an easy grade.

For practice work and first projects the easy grade solder is all that you will need.

Non-precious hard solders — brass spelter for example — should not be used for jewellery. The proper solder makes an invisible join on the finished job, and this means that any job of which you are particularly proud could be sent to the Assay Office for hall marking.

Before attempting any soldering, it pays to practice with the blowpipe. The French blowpipe is the easiest to master. Gas is supplied via the adjustable tap, the other inlet taking a tube with mouthpiece, or connected to a small bellows or compressed air supply.

Turn on until a small flare of gas comes from the nozzle. Blow gently in the mouthpiece; then harder, noting the different types of flame produced. Now turn on a little more gas, and repeat the procedure. Fig. 1 shows the effects obtained.

With a $\frac{1}{2}$ in. square of thin copper on the charcoal block the amount and the area of heat of each flame can be clearly judged. Let the very tip of the blue flame touch the metal in each case.

With the spirit lamp and mouth blowpipe all but the larger and fiercer flames can be produced. Control of air is of course the same, but instead of turning down the gas, move the tip of

the blowpipe further into the flame; instead of turning up the gas, move the tip out of the flame (Fig. 2).

Making grains from jump rings

As your first real jewellery projects will be in silver, here is an exercise, the results of which will not be wasted. Wind a few inches of standard (sterling) silver wire of about 22 S.W.G. tightly round a $\frac{1}{2}$ in. dia. steel or brass rod, keeping the wire quite taut and the coils touching each other. Slide the wire off the rod, and with a fine blade in the jeweller's saw cut through all the coils in one straight line. You will now have a number of identical jump rings, and will appreciate the variations possible with formers of different sizes — round, oval, or square in section — and wires of different gauges.

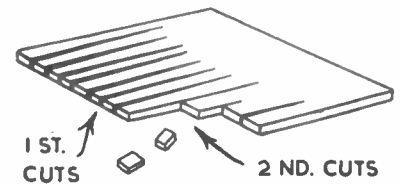

Fig. 4

Jump rings as such have obvious uses, but they also enable you to make grains in batches of exact size.

Put a few drops of water on a slate — a piece of ordinary roofing slate will do — and rub the borax cone on it until a thin creamy paste results. Lay several jump rings on the slate, coat them with the borax flux, using a small brush, then lay them on the charcoal block or the soft asbestos sheet.

Direct a fairly small, fierce flame on each ring in turn, until it melts and spins into a shining globe. As soon as this happens, remove the flame. You will soon be able to judge from the colour of the silver the exact point at which it will melt — a very important piece of knowledge.

During heating, silver becomes coated with a dark, frequently black oxide, which must be removed before any soldering — or, in the later stages of a piece of work, polishing — is attempted. A solution of sulphuric acid, made up of one part concentrated acid added to

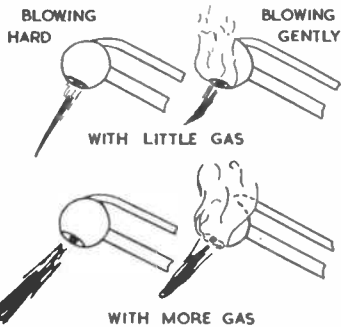

FIG. 1. USING FRENCH BLOWPIPE

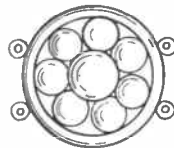

FIG. 3.

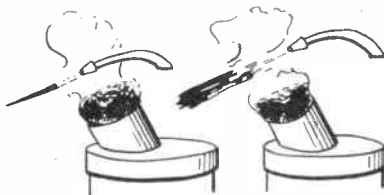

FIG. 2. CONTROL OF SPIRIT FLAME

eight parts of water, is the best pickle for silver. Always add the acid to water — never the reverse — or have the chemist do it for you.

This pickle can conveniently be kept in a glass or pyrex bowl. If pyrex is used, the solution can safely be warmed in order to speed up its action.

It is a good idea gently to warm the silver grains with a soft flame before tipping them off the charcoal block and into the acid: they will then become pickled almost instantaneously. But beware of splashes of hot acid. When properly pickled, silver has a pure white and pearly appearance. The grains must be thoroughly rinsed before storing in suitable containers according to size. Make as many of them as you please; they have more uses than is at first apparent.

Fig. 3 shows a silver bracelet, necklace or ear-ring motif. This ring and grain motif is shown actual size. The units can be made almost any size you wish, or, in the case of a bracelet or necklace, the sizes can be graduated. They are an excellent exercise in soldering. If you spoil one, melt it into a blob and make another; in jewellery, literally nothing is wasted.

To make units of the size shown in Fig. 3, use 18 S.W.G. wire for the outside ring. Make as many of these rings as you will need by the method described for making jump rings, winding the wire round a former of about $\frac{1}{8}$ in. dia. To close the sawn jumping, hold with two pairs of flat-nosed pliers from which the serrations have been removed, or, better still, to the jaws of which brass inserts have been soldered. Then twist the ring sideways until the ends meet.

With creamy borax and a small brush, coat the joins, working the flux between the butted ends. Also flux the inside of the ring, where the grains will be soldered. This is to prevent oxidation. Cut a thin sheet of Johnson Matthey's 'Easiflow' silver solder as shown in Fig. 4 to produce small snippets or *paillons*. Some of these should be dropped on the borax slate and fluxed. Carefully lay one on the join of each ring. With a ring on the charcoal block or asbestos, apply a very small gentle flame until the borax has risen, and subsided, without displacing the solder. Continue heating the ring, playing the flame for a few moments either side of the join, until red heat shows and you touch the solder

with the flame tip. The metal being already hot enough to receive it, the solder should melt immediately.

It is important to remember that solder runs when molten to the hottest part, so both sides of any join should be about the same temperature.

Having made enough rings in the gauges and sizes you need, and soldered their joins, next melt grains of such a size that they exactly fill the space. A little guess work and one or two trials will soon establish the size of grains, and you can then manufacture all you need, and pickle them ready for soldering. All places to be soldered must be in actual contact when the grains are in position.

Flux and very small *paillons* of solder can now be applied to the joins indicated in Fig. 3. Warm the whole unit very slowly on the charcoal with a fairly large but gentle flame, and continue heating, keeping the flame moving over the work until the whole thing gradually assumes the temperature at which every *paillon* of solder will melt and flush almost instantaneously into every join.

(P.W.)

(This project will be concluded in the next article)

MUSEUMS IN MATCHBOXES

A MATCHBOX museum is an attractive way of showing off a collection of small objects. It can be used in many ways, and offers great scope for your ingenuity. Each of the 'showcases' is a matchbox tray, which is covered with a piece of transparent wrapping foil gummed round the sides of the tray after the exhibit has been mounted.

Making model ships small enough to place in matchboxes may sound difficult,

but in fact is quite easy, for the small scale of the models means that the details are reduced to simple basic

By A. Liston

shapes. The model destroyer (A) illustrates this. First, a suitable background is painted on card, and gummed in place.

The hull is made from scraps of $\frac{1}{8}$ in. thick balsa wood. All the fittings are small blocks of balsa or rounded pieces of matchstick, and the masts and gun barrels are broom bristles. Using transparent adhesive, the pieces are put in place with a pair of tweezers, the only other tool needed being a sharp knife or razor blade. The emulsion paint finish is applied with a small water-colour brush.

Another unusual idea is to make a

model of part of a room in a matchbox. It is usually best to start with your own home. The one shown at B uses small odds and ends such as cardboard bookshelves with the 'books' painted on a strip of card. The lamp is a small cork on a matchstick with a button base, and the table is a plastic cap with pin legs. Other details are of painted cardboard. The wall colours and patterns are copied on the inside walls of the matchbox, too.

Nature exhibits

A nature section containing twigs and seeds can form part of your museum. Choose sturdy twigs with small offshoots if possible. Before gluing the specimen in place, paint a leaf of the appropriate tree on a piece of card, and gum it inside the tray. An example is shown at C. Small fir cones, acorns, and beech-nuts, sycamore seeds, and chest-nuts are other suitable exhibits. It is best not to include real leaves or berries, as these will, of course, wither and spoil the appearance of your showcase.

Another attractive nature exhibit is sea-shells (D). Use part of a coloured picture postcard as a background, which is gummed inside the matchbox. Make a beach by coating the floor of the box with gum, and sprinkling sand on it, then glue the shells in place with clear cement.

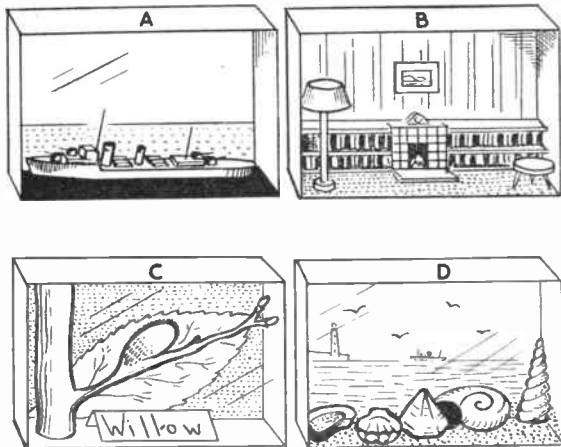

LOUDSPEAKING INTERCOM

AN inter-communications system, such as is used in large offices or shops, can be rigged up between rooms in a house, or between house and workshop. It will provide quite a lot of amusement, in addition to its more practical uses.

It is assumed that an existing amplifier will be used — this item may be of the kind employed for record playing, or for a microphone. It may be battery or mains operated, or using a transistor circuit. Some radio receivers equipped with pick-up sockets will also be suitable. The equipment, whatever its type, should give a fairly high degree of amplification, to permit easy loud-speaker communication in both directions. Normally, any amplifier intended for use with a microphone will be satisfactory.

Very simple AC/DC mains-operated amplifiers, which draw high tension current directly from the mains, are not recommended. With these, the communication circuit can be alive at mains voltage, if the amplifier is not connected with its chassis to mains neutral.

be any ordinary 3-valve or similar item, as explained.

The arrangement in Fig. 1 will provide high impedance input and output. This is suitable for high-impedance speakers or other reproducers.

Another means of providing input and

to make do with an earphone unit at one end of the circuit. But for easy loud-speaker conversation both ways, loud-speakers will be most satisfactory.

For best results, the speakers should be enclosed in small cabinets. Small cases to stand on the desk, or elsewhere, will be convenient.

By 'Radio Mech'

output circuits with a common earth is shown in Fig. 2. The output circuit will be the usual speaker transformer, one secondary lead being returned to chassis. For input, a second, similar transformer is used. The secondary of this transformer is wired to the amplifier input sockets. The primary provides input and earth points, as shown.

The circuit in Fig. 2 is for low-impedance speakers; that is, moving coil loudspeakers, without additional transformers. Usually, the existing output transformer and speaker can be re-

Switching circuit

As there is only one unit each end, and one amplifier, each unit has to act alternately as microphone and loud-speaker. This is arranged by wiring a 2-pole 2-way switch, as in Fig. 3. When the circuit is completed to the right-hand contacts, the local unit (loudspeaker or earphone) is connected to the amplifier input, and the distant unit is operated from the amplifier output. The person at the local unit can thus talk, his voice being heard at the distant point. When he has finished, he turns the switch to 'listen' and connections are then changed over, so that the person at the distant unit can talk, his voice being reproduced in the local loudspeaker.

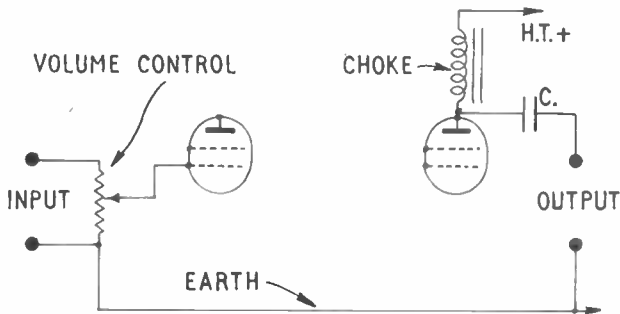

Fig. 1—Condenser coupled output circuit

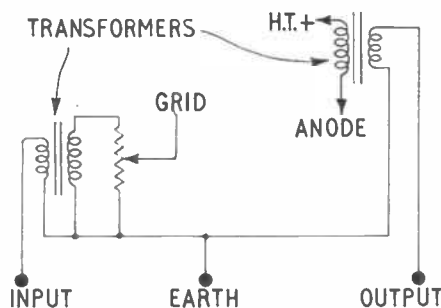

Fig. 2—Low impedance circuit

New output circuit

Amplifiers normally have one input socket connected to the chassis, earth line, and H.T. negative, as in Fig. 1. To simplify wiring between 'local' and 'distant' stations in the intercom system, an output with one earthed connection is also required. One way of obtaining this is to use the coupling condenser 'C' from the output valve anode. This condenser should best be of 1mfd or 2mfd capacity, but smaller condensers will work. For a transistor amplifier, a low voltage condenser is suitable. For battery amplifiers, use a 150V. to 250V. condenser. For mains equipment, a 500V. condenser is needed.

No special component is required as choke, as the primary of the existing speaker transformer will be satisfactory. Fig. 1 shows input and output circuits only, of course, and the full amplifier can

be maintained at the amplifier. For the input circuit and distant unit, an additional loudspeaker, with transformer, will be required.

Local and distant units

Very good results can be expected when small, permanent magnet loudspeakers are used for both local and distant stations. Ordinary 2/3 ohm speakers, with 3½ in. or similar cones, will do very well.

The loudspeakers have to work as microphones, as well as in the usual way, and if a very large speaker is used, reproduction of the voice will be rather lacking in treble, or higher frequencies.

It is quite in order to use dissimilar reproducers for local and distant positions, provided each is coupled to the high or low impedance circuit, as required. For example, it might be decided

Commercially-made equipment often has a spring-loaded switch, so that the local operator holds it down while talking, and releases it to listen. But any ordinary type of 2-way switch will do almost as well. The person at the local station must remember that the whole circuit is under his control, so he must always return the switch to 'listen' when he is not actually speaking, so that the person at the distant unit can be heard. Spring-loaded switches can be obtained from radio component suppliers. Old type switches can sometimes be converted by adding a spring. If these are used, arrange connections so that the switch is in the 'listen' position, except when held.

Means of working

The circuit in Fig. 3 may be used exactly as shown, with a mains amplifier.

The amplifier is then left running continuously, during periods when communication is expected. The local unit is at 'listen', so if the distant person wishes to call, he merely speaks into his unit. The local station operator then turns the switch to 'talk' and replies.

If the local operator wishes to start the conversation, he puts the switch to 'talk' and calls, then returns the switch to 'listen' to await the reply.

With battery-operated equipment, the running costs of leaving the amplifier on are no longer negligible. The person at the local unit can always call the distant

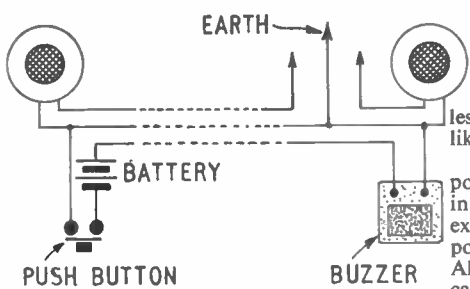

Fig. 4—Buzzer to call local unit

If the extension line has to run near house mains wiring, which may be concealed in walls, etc, a mains hum may be heard, when speaking from the distant unit. This is very much less likely with a low-impedance circuit like that in Fig. 2.

A little hum is usually of small importance, bearing in mind the purposes in view. If hum is objectionably loud, the extension line should be tried in other positions, possibly clear of mains wiring. Alternatively, a co-axial or screened line can be used, with the outer braiding con-

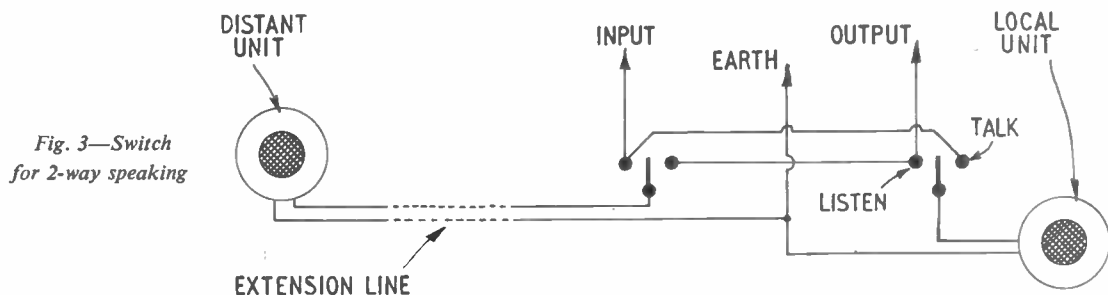

Fig. 3—Switch for 2-way speaking

person, by switching on the amplifier, turning his switch to 'talk', and calling. But when the amplifier is off, the distant person needs some means of signalling the local operator, if he wishes to start a call.

A simple means of doing this is shown in Fig. 4. The earth return is used as one lead for a buzzer or bell circuit. If the local operator wishes to start a conversation, he merely switches on, and calls as described. But if the distant person wishes to start, he operates the push button switch, to sound the buzzer. The local operator then switches on the amplifier, and waits for the distant person to speak.

In practice, the way of working is very simple, and will normally cause no confusion or difficulty.

Another method of working is for the local unit to have a second 2-way switch. When this switch is in its normal position, the circuit is as in Fig. 3. But when the switch is moved to 'standby' the local loudspeaker is connected directly to the two leads of the extension line. A push-button, battery and buzzer are fitted at the distant end of the line, and connected to it. When the button is up, these items have no effect on 2-way speaking. But when the button is depressed the buzzer feeds interrupted current to the speakers, so that the local unit sounds loudly, thus calling its operator. This method requires only two leads between stations, instead of the three leads in Fig. 4.

Extension line

Practically any 2-wire conductor, such as twin flex, will do for the line between units. For 2/3 ohm circuits, thin bell wire should not be used if leads will be more than 20 ft. or so long, or volume will be reduced. Ordinary twin flex is adequate for 50 to 100 ft.

nected to earth. The cost of this kind of wire will be somewhat greater.

To avoid hum or other troubles, the switch in Fig. 3 should be near the amplifier, and connected with screened wire. The best method is to have amplifier, switch, and a small loudspeaker all in one cabinet, to provide a complete unit.

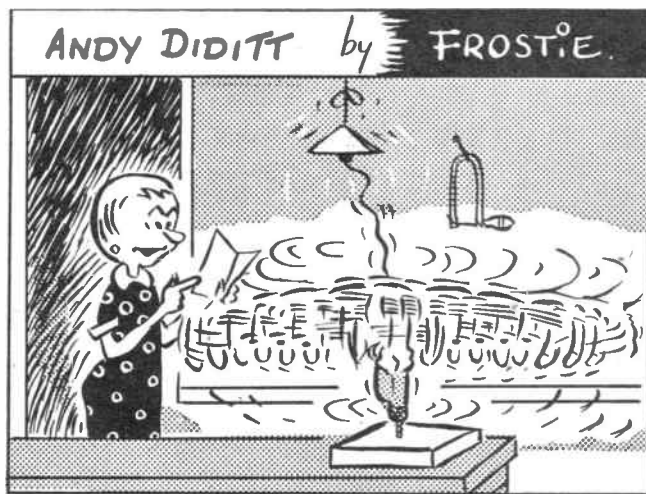

"ACCORDING TO THE INSTRUCTIONS,— IT'S THE DRILL THAT'S SUPPOSED TO GO ROUND, NOT YOU, ANDY!"

1 HOUR + UNDER $7\frac{1}{6}$ D = "The V"

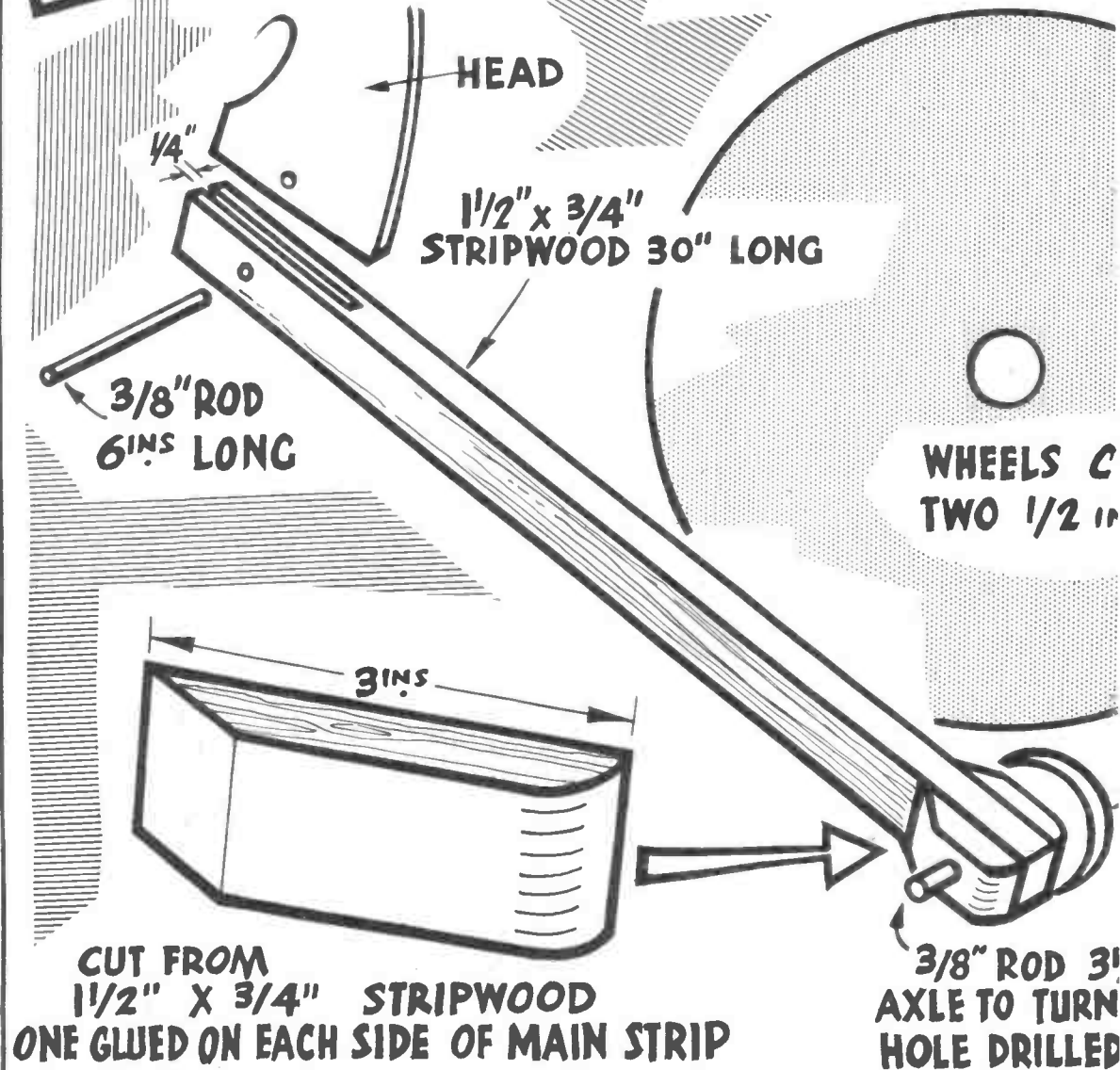

Winner"

HOBBY HORSE



UT

GLUE TO
AXLE

1/2" LONG
FREELY IN
THRO' STRIPWOOD

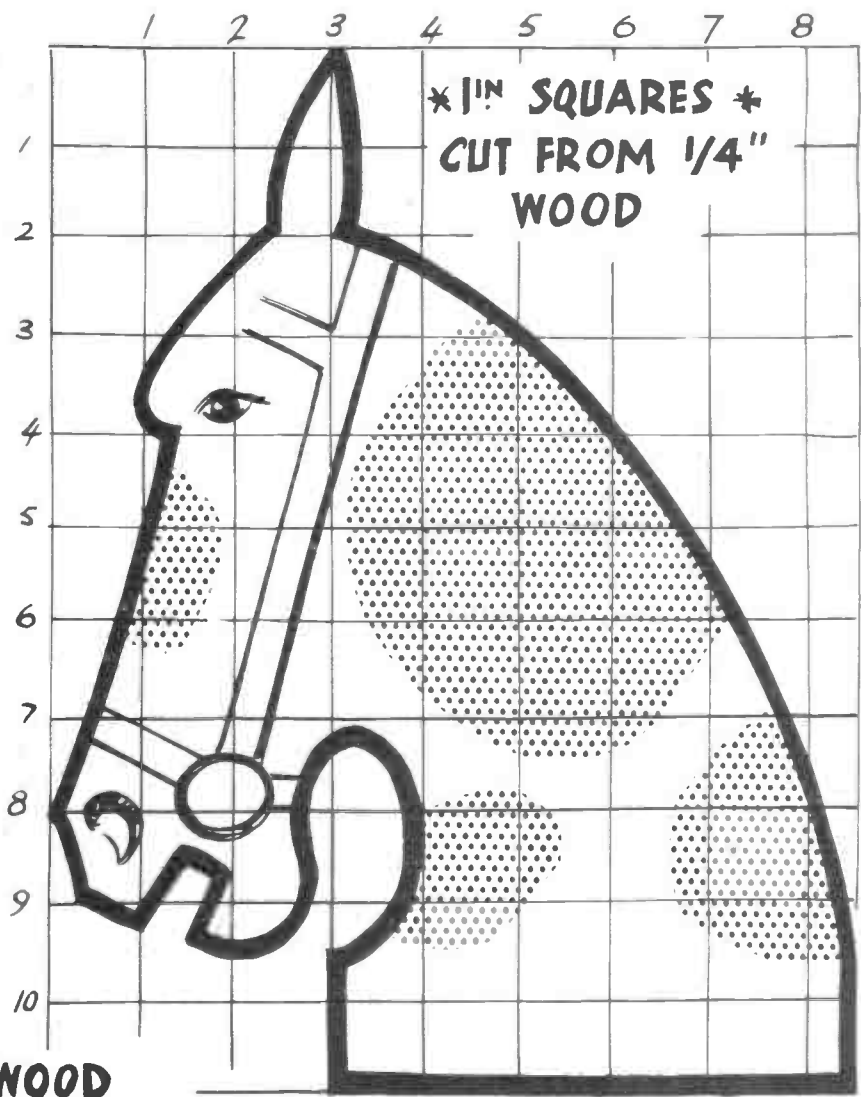

FRAMING YOUR PRINTS

A SIMPLE and inexpensive way of framing your special photographs is by the use of passe-partout binding. A roll of this strip will be sufficient for framing a dozen or more pictures of sizes up to 8 in. by 10 in.

Passe-partout is obtainable in a wide variety of colours, some of which have a finish that resembles wood or metal. The colour used depends largely on the picture itself and the room in which it will stand or be hung.

By K. Baxter

As a general rule portraits look best with a black binding. Landscapes or action pictures will frequently benefit from a brighter colour, depending on their dramatic content. Woodgrain strip is very suitable for warm sepia toned prints; metal finish blends well with cold tones.

If the mounted picture is to be permanently framed no backing card is necessary. A sheet of picture-glass, or of one of the glass substitutes now available, is cut to the exact size of the mount. Two strips of passe-partout for the sides and two for the top and bottom are then cut from the roll of binding. Each of these should be slightly longer than the required finished length. The picture-glass makes a useful and reliable measure, and while dry the strip will not adhere to it.

Moisten the gummed surface of one of the side strips with a sponge or small paint brush. Press the strip firmly along the edge of the glass so that approximately half its width is attached. Then place the mounted picture in position and press the other half of the strip on to the back of it. Cut each end of the strip to form a mitre, and repeat the procedure for each of the remaining sides.

Various types of hangers are available, but for the method of framing described above stick-on ones are recommended. These are quite efficient and will not damage the mount.

Alternative method

An alternative method of framing, using a backing card, enables the photograph to be changed without marking the one being removed in any way.

Cut out a piece of card the same size as the mounted photograph. Then, if metal hangers are being used, attach these to the card and cover the part that



Attaching passe-partout strip

would come into contact with the mount with a piece of passe-partout binding, or similar adhesive strip. This will reinforce the strength of the backing card and, in turn, that of the hangers.

Next, place the mount on the backing card, the glass in position on top of this and attach the passe-partout in the normal way.

A thin piece of wire fixed between the two hangers makes a good 'cord'. It will remain permanently out of sight and is not subject to stretching like ordinary picture cord.

Pictures that are to stand on a shelf or similar flat surface should be framed using a backing card. A supporting strut is then attached to this card.

For this you will require a piece of flexible cardboard about two-thirds the height of the framed picture and one-third its width. Trim to the shape shown in Fig. 1. Then, with a penknife, lightly score the strut across its width at the base of the circle so that a crease can be formed at this point. Strengthen the back of the crease with gummed tape.

The circular section of the strut is then

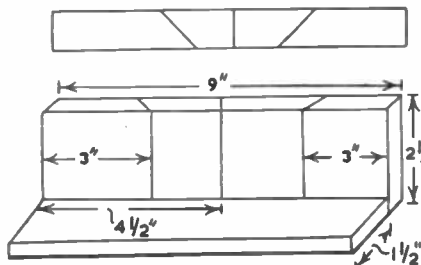

Fig. 2

glued securely to the backing card. Finally, a short piece of cotton tape is stuck to the card and to the inside of the strut. The tape should be long enough to allow the strut to project at an angle of approximately 45°.

For a neat finish, cover the backing card and strut with coloured paper that will match, or provide a contrast to, the passe-partout binding.

Wooden frames

For those once-in-a-lifetime pictures, and for complete protection from dust and damp, wooden framing may be preferred. Choose moulding that will complement your picture without detracting from it.

Plain moulding, obtainable in various shades of gold, silver and the like, will generally be found most suitable. A strong subject will look well in a strong

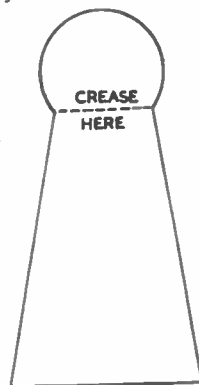

Fig. 1

frame of 1 in. moulding. High key pictures, such as those of children, respond admirably to a light frame of a pastel shade. Remember, however, to select a colour that is in harmony with the room in which the picture will be placed.

Picture framing is a fairly simple operation and the only difficulty likely to be encountered is in preparing the mitre joints. For really satisfactory joints a jig or mitre block is essential. If much of this work is undertaken, Hobbies No. 1 Mitre Cutting Tool and Corner Cramp would be a good investment.

A suitable block can be made in a matter of minutes from two pieces of softwood or chipboard. You will require one piece 9 in. by 2 1/2 in. by 1 in., and one 9 in. by 1 1/2 in. by 1 in. They are glued together and screwed from the back for extra strength.

● Continued on page 220

YOU'LL CLICK WITH ONE OF THESE ILFORD CAMERAS



49'8

Sporti 4

For black-and-white and glowing colour prints too. The Sporti 4 can be set for sunny or cloudy days, has snappy modern styling, eye-level viewfinder, press-button release. Takes 12 pictures on 127 size roll film.

SELOCHROME PAN
Famous Ilford film, the best for black-and-white work all year round.



ILFACOLOR
Fabulous new film for colour enprints. Fits all popular camera sizes.



77'7

Sporti

Takes black-and-white and colour prints. Accurate focus with a quick guide to settings for Close-ups, Groups and Views when you're shooting in a hurry. Plus Sunny/Cloudy aperture settings. Eye-level viewfinder, press-button release. Takes 12 pictures on 120 size roll film.

ILFORD famous in black-and-white * **fabulous in colour**

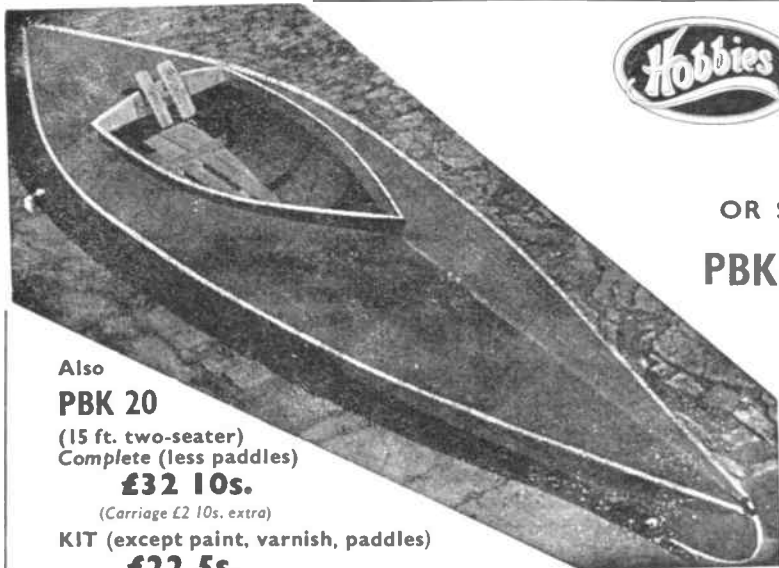

CANOEES

FULLY FINISHED CRAFT
OR SPECIALLY PREPARED KITS

PBK 10 (11 ft. single-seater, as illustrated)
Complete (less paddles)

£24 5s.

(Carriage £2 extra)

KIT (except paint, varnish, paddles)

£15 10s.

(Carriage 15s. extra)

Double-bladed paddles

47s. 6d.

(Carriage 2s. 6d. extra)

Also

PBK 20

(15 ft. two-seater)
Complete (less paddles)

£32 10s.

(Carriage £2 10s. extra)

KIT (except paint, varnish, paddles)

£22 5s.

(Carriage 20s. extra)

Easy payments available.

Send for Agreement Form.

HOBBIES LTD (Dept. 99), Dereham, Norfolk

'Playing Trains' for Puzzle Fans

AN engine driver may be required to solve difficult problems when he is called upon to shunt railway trucks. He may encounter all kinds of tricky situations and, at the same time, he must act with reasonable haste, and not consume large quantities of expensive fuel. You can experience the dilemma of an engine driver on such occasions when you try to solve these two puzzles.

Fig. 1 illustrates, in diagrammatic form, an area of railway track with two trucks, an engine, and a short tunnel. The engine driver must shunt the black

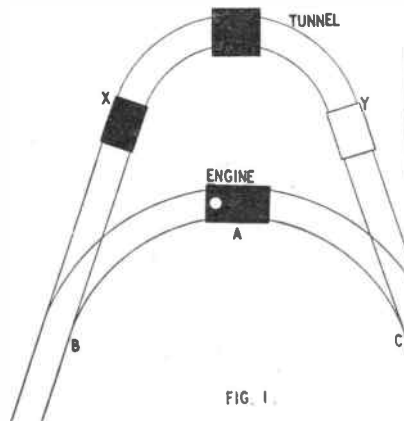

FIG. 1

truck to Y and the white truck to X, and return his engine to its starting place, but he is inconvenienced by the fact that the engine has a tall smoke stack and is unable to pass through the tunnel. How is the problem solved in the minimum number of moves?

Puzzles of this sort are easier to solve if you begin by making a simple model. Copy the track layout on to a sheet of drawing paper, fashion a strip of cardboard into a low tunnel, and use draughtsmen to represent the 'black' and 'white' trucks. A stack of two draughtsmen will serve as an engine.

Fig. 2 shows the arrangement for a more complicated puzzle. Note the different plan of the track, which you may again copy on to paper. Employ the same cardboard tunnel, but this time stacks of two draughtsmen must be used to represent the black and white trucks. A single counter will symbolize the engine. Once again you are asked to change the relative positions of the trucks, and bring the engine back to its starting place. However, now it is the trucks which are too tall to pass under the tunnel. Only the engine is low enough to do this. You can only count

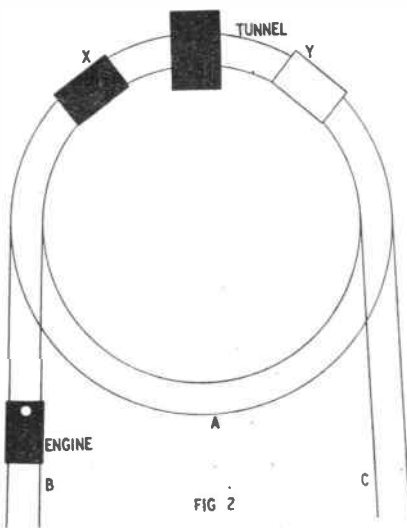

FIG. 2

your solution as successful if it involves the minimum number of possible moves.

Solutions

Do not read on unless you have attempted both the puzzles. Here is the answer to the first. The engine advances from A to B, then it reverses and pushes the black truck into the tunnel. Now the engine moves forward to B, then reverses past A on to the straight track at C. Again the engine runs forward, and

pushes the white truck up against black. Both trucks and the engine are connected together, and the short train is pulled back to C. The trucks are pushed along to A, where the black truck is uncoupled and left behind, while the engine drags the white truck back to C. The white truck is pushed up to the tunnel where it is uncoupled, and then shunted over to X. Finally the engine comes back for the black truck, and pushes it up to Y before returning to its starting point at A.

Now for the solution to the second problem. The engine advances, and is coupled to the black truck at X before reversing and dragging the truck across to Y. The black truck is pushed down to C, where it is left behind. The engine reverses again, and is coupled to the white truck at A, where it is left behind. After this the engine travels round the loop, through the tunnel, and proceeds down to C, where it is connected with the black truck. When the engine reverses again, it drags the black truck to Y, then pushes black up against the white truck, at A, to which black is then coupled. The little train is pulled to Y, then pushed to C, where the white truck is released, before the engine pulls the black truck to Y, leaves the black truck there, and continues onwards, round the loop, through the tunnel, and back to the stretch of line at Y. The engine advances to C, picks up the white truck, drags white to Y, and finally pushes the white truck to X before returning to its starting position at B. (A.E.W.)

● Continued from page 218

FRAMING YOUR PRINTS

A 45° saw-cut is made 3 in. in from each end of the upright section. A third cut is made through the centre of the upright (see Fig. 2).

Measure the four sides of the picture and mark out along the inside of the rebate. Place the moulding in position on the base of the mitre block and press it firmly against the upright. It is then a simple matter to cut the mitres.

Glue and pin each of the joints. To eliminate any risk of splitting the wood, it is advisable to drill small holes to receive the pins.

Cramp the frame together until the glue has set. If cramps are not available

use angle pieces. Place one outside each corner and hold in position with a piece of string passed round the complete frame. Check that the sides of the frame are at right angles to each other before finally tightening and tying the string. Remove any surplus glue with a damp cloth.

When the frame is ready for use slip the picture-glass in place, allowing a clearance of $\frac{1}{16}$ in., then the picture and lastly the backing. Fix firmly in position with veneer pins.

To ensure complete dust-proofing, the back of the picture is covered with brown paper, gummed along the edges.

Mitre-cutting Tools — see facing page

LET 'Plasticine'
 ★ **HELP YOU DO-IT-YOURSELF** Regd. Trade Mark
 Special Trial Offer. We will send 4 lb. 'Plasticine' (any colour) with booklet 'Plasticine Modelling for Amateurs' Post free: 10/- U.K. only.
 Harbutt's Plasticine Ltd, Bathampton, Bath

No. 1 MITRE-CUTTING TOOL AND CORNER CRAMP
 Will cut mitres on moulding and similar work up to 4 ins. wide. (post free) **55/-**

WOOD MITRE BOX
 Made of selected hardwood. Size 9 ins. long. (postage 1/6) **5/6**

WOOD MITRE BLOCK
 Made of selected hardwood. Size 9 ins. long. (postage 1/-) **3/-**

HOBBIES LTD (DEPT. 99), DEREHAM, NORFOLK



The **STRONGEST** handy glue

STILL ONLY

1/2 a large tube

Completely new 54 page Edition
WHERE'S THAT CAR FROM?
 Price 1/- (Postage 4d.)
 Of all Booksellers
 or
RALEIGH PRESS, Exmouth, Devon

GET YOUR FREE COPY of "Write for Profit", the most interesting little book you've ever read. For beginner or experienced. — **WRITERS' RING (HW), 5 Edmund Street, Birmingham, 3.**

BUILD your own electric guitar in one hour. Screwdriver only required. Thin line cutaway full-size body. Reinforced neck; built-in Vox pick-up and controls, 9 gns., plus 5/- carriage or 20/- and eight payments of 23/-. — **Musiland, 88 Broadway, Bexleyheath, Kent.**

PROFITABLE LEISURE. Learn to draw/paint flowers, birds, doodles, etc. Waiting markets. Profitable. Fascinating. Exciting. Booklet, specimens, free. — **Popular Art Services (HW), Clun, Shropshire.**

100 DIFFERENT stamps free! Request 4d. upwards discount approvals. — **Bush, 53 Newlyn Way, Parkstone, Dorset.**

 Add an air of distinction to your dining table on those 'special' occasions with these decorative

GALLEON CANDLESTICKS

Kit No. 3306 **5s. 8d. (pair)**

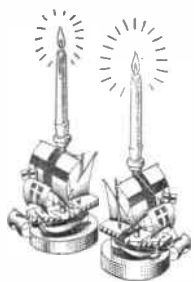

Easily made with a fretsaw and a few simple tools. Kit contains design and instructions and all materials (except candles). Kit to make a pair costs 5/8 (by post 1/6 extra) from:

HOBBIES LTD (Dept. 99), DEREHAM, NORFOLK

LEARN RADIO & T/V SERVICING for your OWN BUSINESS/HOBBY

● by a new exciting no-maths system, using practical equipment recently introduced to this country
 FREE Brochure from:—

RADIOSTRUCTOR
 DEPT. G81, READING, BERKS. 5/7/61

LEARN RADIO & ELECTRONICS the NEW Practical Way! Very latest system of experimenting with and building radio apparatus — "as you learn". FREE Brochure from: Dept. H.W.10, Radiostructor, 40 Russell Street, Reading, Berks.

EARN EXTRA MONEY with your sewing machine by making cushion covers. Regular work guaranteed. Apply Dept. 28, Arnold Company, 10 Shelley Road, Worthing, Sussex.

50 MIXED stamps 5/-. Try our 6d. in 3/- discount approvals. — **E. C. F. Townsend, 92 Tenby Road, Edgware, Middx.**

BUYING OR SELLING?
 Classified advertisements on this page are accepted at a cost of 6d. per word prepaid. Use of a Box No. is 1/- extra. Send P.O. with advertisement to **Hobbies Weekly**, Advert. Dept., Dereham, Norfolk. Rates for display advertising on application.

FOLD-AWAY IRONING BOARD

THIS handy ironing board will be welcome in most homes. It is ready for use in a flash, and can be stowed away just as quickly. Teenage daughters will love it; it provides the perfect answer for a quick iron-over of their frocks before they set off for a dance or a date with the boy friend.

Most rooms will have an odd corner where the board can be fixed. It need not be fixed to a wall as shown, but could be screwed to the back of a convenient door.

At first glance, you may assume that you could simplify the construction. You may think along the lines that if the board is made of a length that equals its height from the floor, the foldback mechanism will work without the bracket pieces, and may be simply hinged at the one point.

Don't be tempted. For one thing you will need a board or ironing surface as long as possible. If you key up this length with the height of the board from the floor, you will probably find you have to stand on a box to iron comfortably.

The more important point, however, is that of the leg position. It must be set well back from the bull-nosed front of the board. Otherwise, the practice of semi-draping part of the garment to be pressed over the bull-nosed front will be impossible. And then you will meet trouble from the ladies of the house!

Immediately you set back this leg you find that its length must be shortened to

allow it to fold back without fouling the wall.

Proceed, therefore, in this way. Determine what length of board you would prefer combined with the comfortable height from the floor. Then, remembering that you will be setting

By Ed. Capper

back the leg, say 9 in., make the bracket length (the one to which the leg is hinged), 10 in., which will give you 1 in. to play with, and ensure that the board does not scrape on to the floor when it is being folded back.

Make the leg from 2 in. \times $\frac{1}{2}$ in. wood, and screw it together with cross supports to the shape of a letter A as shown. This will serve two purposes. The two feet ends of the leg will have a wider base than the top end, and will therefore stand more firmly on the floor. Secondly, it will allow for any error you may make over the leg height, for as can be seen in the drawing, the bottom leg support, positioned about 6 in. up from the base of the legs, forms a gap. When the unit is put in its fold-back position, this gap will clear the actual iron stand end of the board.

The board itself is made from a

length of $\frac{1}{2}$ in. plywood. It is a good idea to drill six holes through it, in two rows of three. This will provide an air inlet beneath the board which will eliminate any tendency for the plywood to warp due to a build up of steam percolating from semi-damp garments. Not that there is any real danger from warping. The writer built such a board ten years ago, using only $\frac{3}{8}$ in. thick plywood, and it is still in use, without any sign of warping.

The board is best padded with one or two layers of old flannelette, and finished with a final layer of cotton material. It is pulled taut and held in place with white upholstery pins. You can, if you prefer, buy a top cover for the board.

The bracket over the leg should be screwed to the ironing board with good stout screws at least 3 in. long. Or you could augment its hold with angle brackets, although these do look clumsy. The leg should be hinged to this bracket with a pair of single leaf hinges.

The built-in iron stand is, of course, optional, but in practice you will find it most convenient to have the iron always at hand. The first procedure is to fit to the wall a bracket piece of 1 in. thick wood, about 8 in. in depth, and of a length that corresponds to the width of the ironing board. If you are fitting the unit to a door, it is still best to fit such a bracket piece although, of course, you won't have any plugging to do.

To this bracket piece the iron stand is screwed at right angles along the top edge. Here again, this should be of 1 in. thick wood, around 6 in. wide. This piece must be more fully supported by fitting angle brackets underneath, or ordinary shelf brackets as shown in the drawing.

Site these shelf brackets as near as possible to the edges of the bracket screwed to the wall, so as to allow room for a pair of hinges also to be fitted underneath. These hinges could be of the double-leaf variety, for extra support. Finally, surround the iron stand piece with $\frac{3}{8}$ in. quarter moulding, and then cut a piece of asbestos to fit into the shallow recess formed.

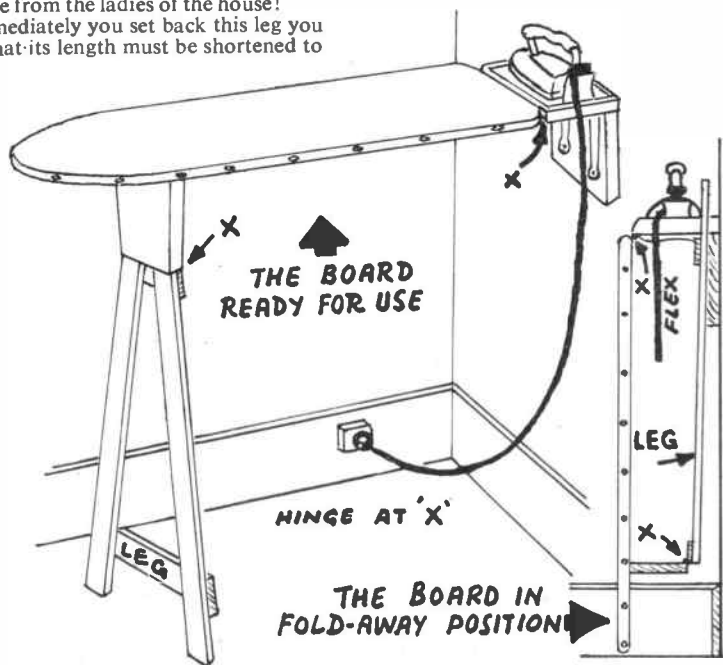

 ★ A free design for making a very ★
 ★ popular Scots money box will be ★
 ★ given with next week's issue. ★
 ★ Make sure of your copy. ★
 ★ ★

Decorative 'Bird' Overlays

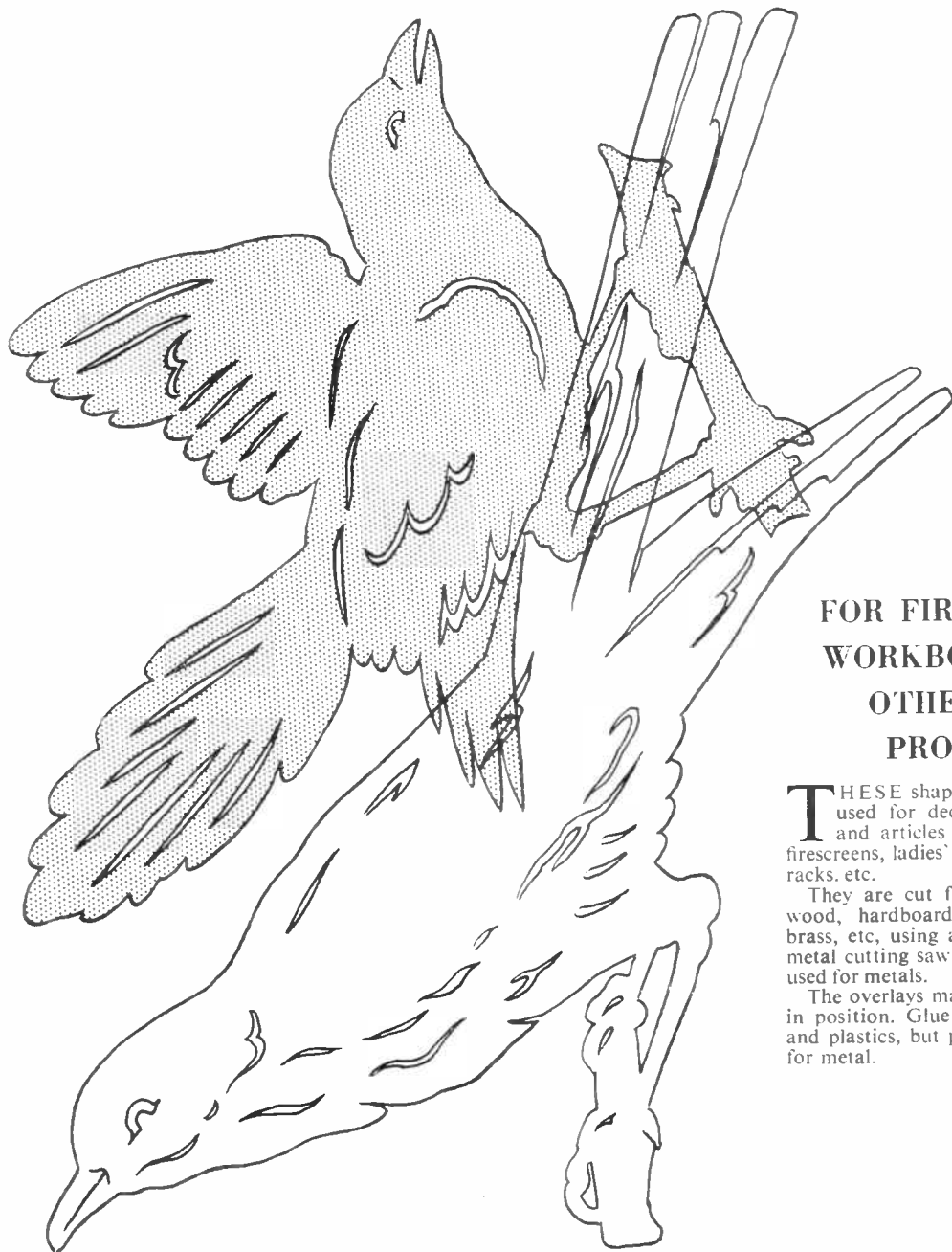

FOR FIRESCREENS WORKBOXES AND OTHER GIFT PROJECTS

THESE shapes are intended to be used for decoration on novelties and articles of furniture such as firescreens, ladies' workboxes, magazine racks, etc.

They are cut from thin wood, plywood, hardboard, Perspex, Waverite, brass, etc, using a Hobbies fretsaw. A metal cutting saw should, of course, be used for metals.

The overlays may be pinned or glued in position. Glue is suitable for wood and plastics, but pins are more reliable for metal. (M.p.)



WOODWORKING LATHES FOR THE KEEN AMATEUR

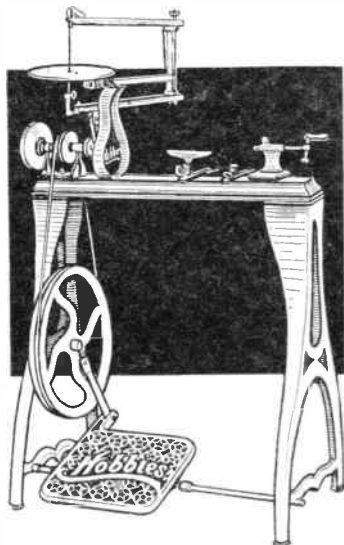

The 'Companion'

The 'Companion' Treadle Lathe. A marvellous combination for the amateur. Obtainable with or without fretsaw attachment shown. The larger driving wheel has two grooves of varying depths to give a change of speed. The headstock is provided with a 2 in. faceplate, a spur centre, and a screw centre for turning cups. It has also a solid emery wheel. The tailstock has a screw feed centre. The lathe is 14 in. between centres and is provided with two rests, designs, saws, etc. The fretsawing attachment is secured to the lathe bed by one bolt, and can be put on or taken off as desired. It is fitted with 19 in. arms and an 8 in. diameter tilting table. A well illustrated book on Wood Turning is included with each lathe.

Cash Price: £15 3s. 6d. (as illustrated) or without fretsaw £11 5s. 0d.

Easy Payments: £3 17s. 6d. down, and 6 monthly payments of £2 1s. 6d.

Without fretsaw, £2 17s. 6d. down and 6 monthly payments of £1 10s. 9d.

The 'Hobbies' Lathe. This lathe has similar features to the 'Companion' but is built for larger work. It stands 6 in. higher, and the distance between centres is 20 in.

Cash Price: £17 7s. 6d. complete. Without fretsaw £13 9s. 0d.

Easy Payments: £4 7s. 6d. down and 6 monthly payments of £2 7s. 8d.

Without fretsaw £3 7s. 6d. down and 6 monthly payments of £1 17s. 0d.

Handy Bench Lathe. This machine is similar to the 'Companion' Treadle Lathe but without the legs, treadle, etc. The headstock spindle has two small 'V' groove pulleys for drive by $\frac{3}{8}$ in. diameter round leather belt. The balance wheel is similarly grooved, so that three speeds are thus provided. An emery wheel, a spur centre and a screw centre are also included. Two centres obtainable.

Cash Price: (14 in. between centres) £6 5s. 0d.

Easy Payments: £1 12s. 6d. down and 6 monthly payments of 17s.

20 in. between centres model, Cash Price: £6 12s. 6d. Or easy payments: £1 15s. 0d. down and 6 monthly payments of 17s. 11d.

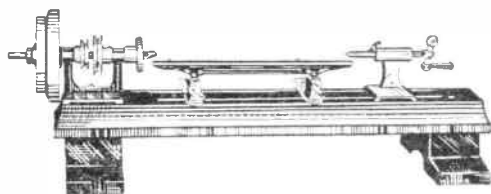

Handy Bench Lathe

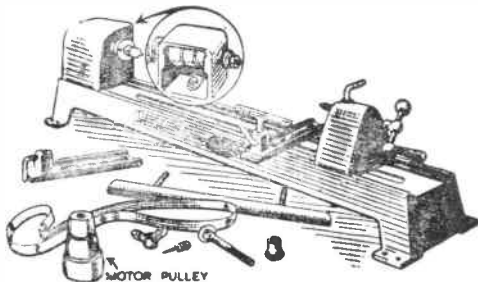

Mark II Bench Lathe

On the Mark II Bench Lathe the keen handyman can turn his own stool legs, table lamps, wheels, and 101 things in wood. Unlike some 'cheap' lathes with bed made from steel rods or angle iron, the Mark II is built as a lathe should be built. It has a solid cast bed 32 in. long, machined its entire length. Specification: 22 in. between centres. Height of centres $2\frac{1}{2}$ in. A three-step pulley in conjunction with a similar three-step motor pulley gives speeds of 1,065, 1,420, and 1,890 R.P.M. Drive from motor (*motor not included*) is by $\frac{3}{4}$ in. flat belt provided.

Cash Price: £12 19s. 6d. Easy Payments: £3 5s. 0d. down and 6 monthly payments of £1 15s. 8d.

EASY PAYMENTS. A machine can be dispatched carriage paid after the initial down payment, and subject to the completion of a simple form of agreement. It is impossible for us to allow this system to apply in any part of Ireland, or anywhere outside Great Britain. Agreement forms are obtainable at any Hobbies branch, or you can do the business through the post with Head Office at Dereham, sending your instalments there.

HOBBIES LTD (DEPT. 99) DEREHAM NORFOLK