

1st MARCH 1961

VOL. 131

NUMBER 3403

THE ORIGINAL
'DO-IT-YOURSELF'
MAGAZINE

HOBBIES *weekly*

FOR ALL
HOME CRAFTSMEN

*Full
instructions
for making . . .*

Also in this issue:

GLASS PANELS
FOR STAIRS

COLLECTORS' CLUB

AN 'EXPLODING
STOCK CAR

TOY THEATRE
FOR A PUPPET

MODEL AND
POWERED SHIPS

NOVELTIES FROM
CLOTHES PEGS

THIS MONTH IN
THE GARDEN

ETC. ETC.



MODERN-STYLE SIDEBOARD



Up-to-the-minute ideas

Practical designs

Pleasant and profitable things to make

5^D



MEN and women from all ranks of the Army are shown on the world's stamps, labels, and cards.

No rank has had such a variety of names as that of 'private'. Man-at-arms, centinel, sentry, common soldier, trooper — they all mean 'private'.

Field-Marschals were unknown in the British Army until 1736. But long before that date there were feldmarschalls in Germany and veldtmaarschalks in Holland.

In Oliver Cromwell's army there were three grades of generals — Captain-general, lieutenant-general, and sergeant-major-general. But James II altered all that. He made the captain-general a 'general' and the sergeant-major-general a 'major-general'.

Before the 1914-18 War there were brigadier-generals in command of cavalry, artillery, and infantry brigades. But after that war the title reverted to brigadier.

The French word 'colonne' means a column, hence a colonel is the officer who originally marched at the head of a column of men.

Before about the middle of the eighteenth century, colonels 'owned' their regiments. That is why the French called him 'Colonel-Propriétaire'.

Now look at your illustrations depicting many of the uniforms worn by men and women of the army — see if you can form a complete army from field-marshal to private.

THE introduction of this new value £1 postage stamp which fulfils a long-felt need in the Turks and Caicos Islands completes the current definitive issue. The existing denominations of the definitive issue, which was first released on 25th November 1957, are as follows: 1d. 1½d., 2d., 2½d., 3d., 4d., 5d., 6d., 8d., 1s. 0d., 1s. 6d., 2s. 0d., 5s. 0d., and 10s. 0d.

NEW ISSUES GUIDE: A NEW £1 STAMP

The new value £1 stamp has been printed by Messrs Harrison & Sons Ltd. by the photogravure process in a horizontal format size 40 mm. by 30½ mm. in sheets of sixty stamps. The design, which has been adapted by the printers from a sketch by Mrs Shirley Hurd, the winner of a local competition, includes a medallion portrait of Her Majesty the Queen, and features a pelican against a background showing salinas and a salt heap. The medallion and vignette are in dark brown, contained in a deep red border.

The salinas are the ponds originally built during the seventeenth century (1678 onwards) for the production of salt by solar evaporation, which still

A LETTER FROM IVAN

Ivan Powis, of 85 Walsall Road, near Stone Cross, West Bromwich, Staffs., requests a pen friend aged about seven or eight years old. Incidentally, Ivan himself is seven-and-a-half, and for this tender age has written a very nice letter. So if there are any other youthful readers of our magazine who would like a pen friend, they should write to Ivan, who stipulates that it must be in English 'because I do not know any other language'.



today remains the major industry of the Islands. The Pelican (Pelecanus) Waterfowl, which is a familiar sight on the salinas at dawn when the salt workers commence their daily task, has a rough, harsh plumage and a short rounded tail. The red hook which terminates the bill, combined with the resting position of the bill on the breast, is said to be the origin of the fable that the pelican feeds its young with blood from its own breast.

This attractive stamp may be interpreted as representing the importance of the salt industry to the Turks and Caicos Islands.

STAMP TABLE

MAKE a stamp top table. It is easy if you have a table with a glass top.

Cut out a thin sheet of paper the size of the table top. Hinge your stamps to this sheet. Remove the glass and place the sheet of stamps on the table top and cover it with the glass. You can arrange the stamps in countries, series or designs.

If you have a small table without glass, you could use a clear plastic cover. Get some thin acetate plastic, cut it to fit the table top, and proceed as with glass.

An identification card may be included with your stamps to answer the questions which your friends will ask when they see this novel idea carried out.



Illustrated on front page

A CONTEMPORARY SIDEBOARD

THIS type of furniture looks well in the modern home. The shape of the sideboard is not only sleek and streamlined, but extremely functional. The sliding doors allow easy access to the interior of the upper portion, and the lower shelf provides a generous surface for plates, bottles, glasses etc., not in immediate use during mealtime.

The design allows for easy modification to suit individual needs. For instance the cupboard may be subdivided into smaller partitions and the back rails may be altered in shape or even omitted

altogether. The layout is such that sizes may be altered without affecting the general construction.

The side and front views in Fig. 1 show the important measurements. The total height is approximately 35 in. and the overall width 50 in. Note that the bottom shelf is strengthened by three battens which are set back so as to be hidden from view.

The first step in construction is to make up the cupboard portion as seen in Fig. 2. It can be made from $\frac{1}{2}$ in. or $\frac{3}{4}$ in. plywood or from $\frac{3}{4}$ in. boards 6 in. wide.

facing of laminated plastic, in such as Waverite. Fix $\frac{1}{4}$ in. square stripwood to form grooves or use special grooved moulding as shown in the details in Fig. 2.

Construction of the bottom shelf is seen in Fig. 3. Make it from $\frac{1}{2}$ in. plywood or from $\frac{1}{2}$ in. boards butted together. In either case the shelf will be strengthened by battens of $\frac{3}{4}$ in. by 2 in. wood glued and screwed underneath. The back rails are both cut from $\frac{3}{4}$ in. wood 3 in. wide. They are glued and screwed in position as indicated in Fig. 1.

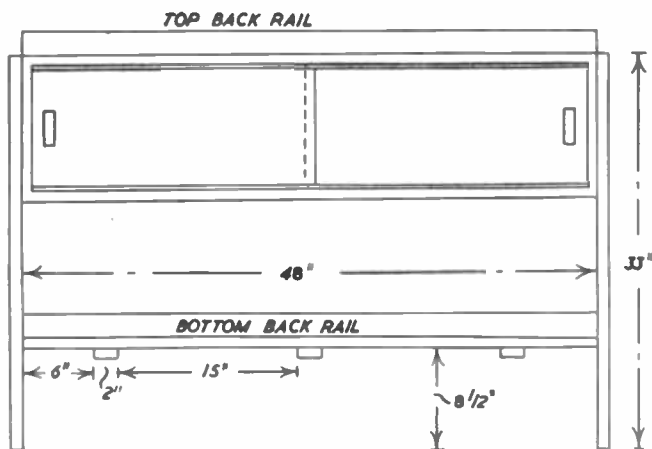

FRONT VIEW Fig. 1

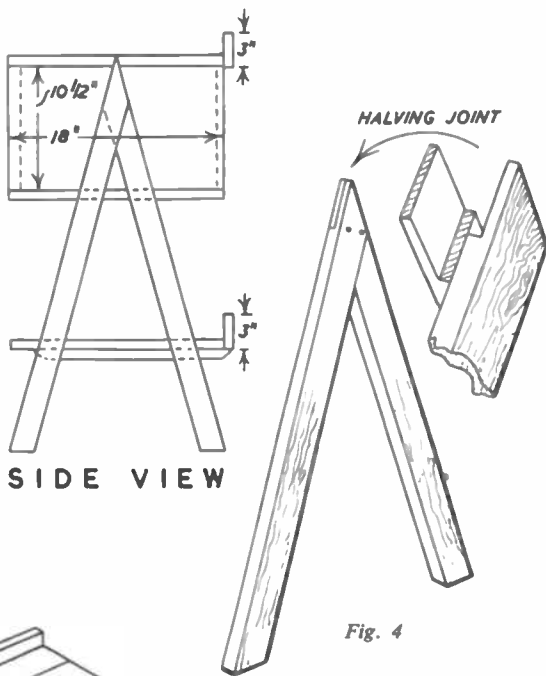
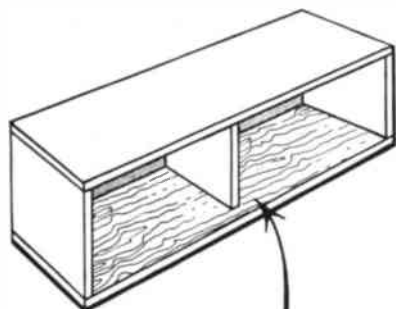
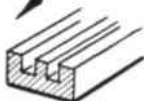

Fig. 4



STRIPWOOD

Fig. 2



GROOVED MOULDING

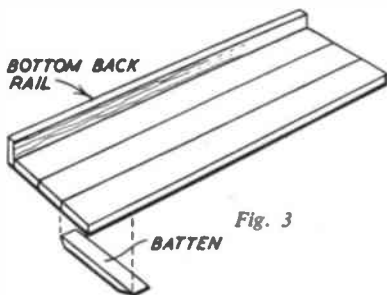

Fig. 3

The middle partition is set back to allow for the sliding doors. The back fits between top, bottom and sides.

The sliding doors should be of $\frac{1}{2}$ in. hardboard or of $\frac{1}{2}$ in. wallboard with a

The legs are 1 in. thick and 2 in. wide. Cut four pieces 34 in. long and halve them together in pairs as shown in Fig. 4. Splay the legs to the same width as the cupboard (18 in.) and use glue and screws for fixing.

All parts must be thoroughly cleaned with glasspaper and the grain filled before attempting to stain, polish or paint. The success of the finish will depend largely upon this preparatory work.

An excellent finish can be obtained by french polishing. It is not at all difficult and is well worth a try. Alternatives are wax polish, varnish or high gloss enamel. (M.h.)



GLASS STAIR PANELS

★★★★★★★★★★★★★★★★★★★★★
 ★ Gordon Whiting, who is starring ★
 ★ as Detective-Sergeant Trotter in ★
 ★ 'The Mousetrap', which is now ★
 ★ in its ninth year at the Amba- ★
 ★ sadors Theatre, London. ★
 ★★★★★★★★★★★★★★★★★★★★★★

MAYBE you are one of the many thousands who have been entertained by the Agatha Christie thriller 'The Mousetrap', now in the ninth year of its record-breaking run at the Ambassadors Theatre, London.

What you perhaps didn't know is that Gordon Whiting, who plays the part of Detective-Sergeant Trotter, is a keen do-it-yourselfer. The photograph of him was



taken in his well-planned workshop, where I spent a pleasant hour with him talking shop, writes Ed Capper. Note the way he drills a long hole and keeps it on course with a square set in the vice. By keeping the drill in line with the edge of the square you just can't go wrong. It's a useful tip to remember . . .

'I'll tell you a job I do like to see in the home, and that is the replacing of the banister rails on the staircase with hard-board sheets — or better still, glass', said Gordon.

We agreed that this work has a functional value as well as adding dignity to the smallest hall. For there is nothing more frustrating to the housewife than the tiresome job of trying to remove the accumulated fluff and dust that gathers in the acute angle at the bottom of the stair rails.

Gordon continued: 'I know you don't use ordinary glass, but the toughened variety.' He showed me a handful of leaflets he had gathered from his local dealer. Certainly there was a great variety of designed glass to satisfy even the most fastidious. You can get these leaflets from your dealer and, of course, any other advice you need. We also agreed that plain glass should not be used as the finished effect would be that of an oversized window frame in the hall.

The biggest snag you will encounter is in finding the correct angle to which the ends of the glass must be cut. Two methods can be employed; either make a template from thick card or hardboard before the banister rails are removed or call in your glass dealer and have him measure and cut the glass ready for fixing. If you are measuring it yourself do not allow for the glass to be a tight fit but rather have it cut at least $\frac{1}{4}$ in. smaller all round than the space it is to occupy.

The fixing of the glass is comparatively easy provided great care is taken. As shown in the sketch, the glass is held within a framework of quarter-round moulding, probably the $\frac{1}{4}$ in. size. The moulding is shown at 'A' and it is tacked to the woodwork with 1 in. long panel pins. One side of the moulding frame is first fitted, then the glass held in position whilst the other side of the moulding is fixed. Needless to say the nailing must be done carefully, a small tack-hammer being ideal for the job.

It is optional whether you use one sheet of glass to enclose the balustrade or two separate sections, as seen in the photograph. This shows the excellent job made by Mrs F. Thomas of Bristol and gives a good idea of the very pleasant effect that can be obtained in a small hall.

It will not always be possible to pur-

AN 'EXPLODING' STOCK CAR

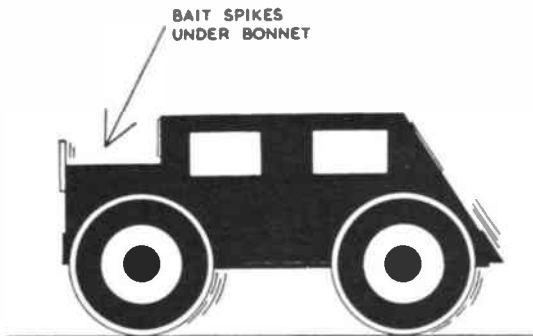

A SEEMINGLY innocent little toy motorcar will 'explode' and overturn when it is pushed along the floor, and made to collide with an obstacle such as a book or the wall. Its surprising and unpredictable antics will be a great source of interest and amusement to a boy.

The mechanical part of the toy, which is hidden beneath the motorcar's bodywork, is a common mousetrap with a somewhat weakened spring. To construct the car you will need, in addition to the mousetrap, a set of four model wheels, some nails and drawing pins, and a sheet of thin stiff cardboard. The wheels, which may be up to $1\frac{1}{2}$ in. in diameter, can be bought at your local hobbies or handicraft shop.

Only a brief examination of the mousetrap will be required for you to see how the spring may be weakened.

Pull out the 'free' side of the 'snapper', and use manual pressure to adjust the tension of the spring. The resulting arrangement will render the mousetrap harmless to the fingers of a child. Use a clean, new mousetrap. Paint the wooden

By A. E. Ward

part black before you attach the wheels to the little 'carriage', using cobbler's nails. The wheels should not project beyond the ends of the mousetrap. Impale a small cork or wooden bead upon the bare bait spikes of the trap, as an additional measure of safety.

Copy the pattern for the bodywork of the vehicle upon thin stiff cardboard,

using a ruler and pencil. Score along the lines shown dotted in the diagram and cut out the shape with sharp scissors. Fold down the back, sides, and bonnet of the motorcar, and glue the tabs in their proper places to form the sturdy motor body illustrated. It will be a good idea to measure the dimensions of your mousetrap before you commence constructing the toy, as some traps might be too large or small to suit the measurements shown upon the car body pattern, and you may have to adjust the dimensions accordingly. Use gummed coloured papers to make the blue bumpers and yellow windows. Cut out the shapes as suggested by the illustrations, and stick the simple windows and bumpers in position. Press a pair of drawing pins into the front of the bonnet, to serve as headlights and, as a final humorous touch, glue little cut-out red letter 'L plates' upon the bumpers.

Your toy stock car will now be ready for its rather rough trials. 'Set' the mousetrap and place the body of the motorcar upon the carriage. The cardboard shell should fit snugly upon the wooden mousetrap base. The protected bait spikes must lie beneath the bonnet of the car. Test the toy by running it against a wall. As soon as it strikes the obstacle, the inertia of the bait spikes will carry them forward, and the trap will be sprung. Suddenly the top of the car will shoot upwards and the shock of the activated trap will probably cause the carriage to turn upon its side. To make the car turn a somersault on contact with the wall, place the carriage 'upside down' before fitting the car body upon it.

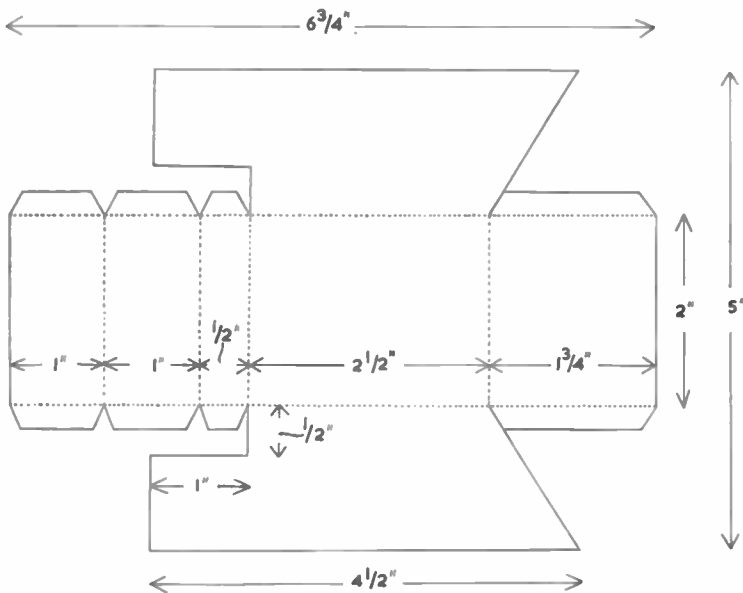

ANSWERS TO QUIZ (see page 381)

1. Venetian. 2. A claw hammer. 3. A Queen Closer, a brick so cut making two closers as shown. It is used at the end of a course (or row) of brickwork, next to what is called a quoin header brick. 4. Walling of rough, uncut stones, not laid in regular rows. 5. Barefaced Tongue.

TOY THEATRE FOR A PUPPET

MR TAPTOE is a colourful clown puppet who performs an amusing tap-dance in his own little theatre. By operating a simple mechanism at the side of the stage he will dance to any music from Bach to Rock!

A youngster will enjoy making the puppet dance. An older child can provide further movement and play-value by operating strings attached to the puppet's arms and by making scenery cards and stage 'props'.

The theatre front and sides, 1, are cut and folded from one piece of strong cardboard. Top and bottom pieces, 2 and 3, are of $\frac{1}{4}$ in. wood, piece 2 having an opening cut as shown. Form the front and sides around top and bottom of theatre, securing with glue and small nails. Add the 'foot-light' strip, 6, along the bottom edge of cut-out stage.

By
T. S.
Richmond

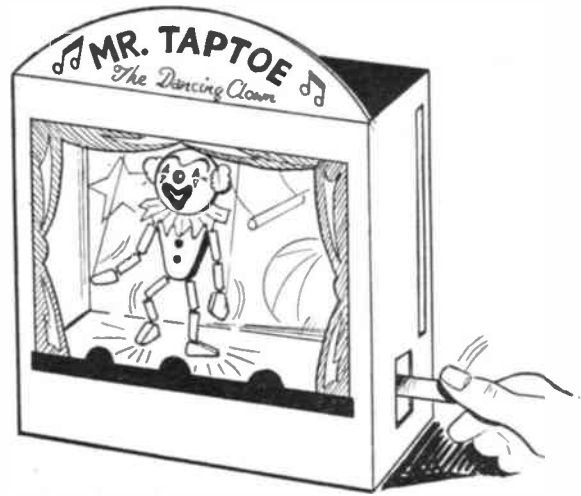

Cut piece 4 from $\frac{1}{8}$ in. plywood, making certain that the outside grain of wood is across the width as indicated by the arrow. Piece 5 is a $2\frac{1}{2}$ in. square block built up of layers of wood. Screw or glue and nail to one end of piece 4. The 'flicker' round rod has a slot so that it can be glued securely to the other end of the 'stage', and should be tapered and

smoothly rounded with glasspaper. This assembly is then placed inside the theatre, making certain it comes level with bottom edge of the front opening and that the rod protrudes through the slot made for it in the side of the theatre. Secure the block 5 to the bottom of piece 3.

The theatre back (not shown) is cut to fit the inside dimensions and glued in place after decorating. Scenery cards may be made, using magazine illustrations or by hand-painting, for insertion in slots between the sides and back. Cover the theatre with fancy papers or colourful plastic material. Paint curtains red and 'foot-lights' black. If a 'clown' puppet is adopted as illustrated, then the wording 'Mr Taptoe' may be neatly printed on card or paper and pasted above the stage.

The puppet is built up of individual pieces. Head, A — a ping-pong ball; body, B — $\frac{1}{4}$ in. thick softwood; limbs, C and D — short lengths of $\frac{1}{4}$ in. diameter rod. Hands are of $\frac{1}{4}$ in. thick wood. Feet, $\frac{1}{4}$ in. wood, suitably shaped with fretsaw and glasspaper. Each moving part is joined with a short piece of black thread inserted in cement-filled pin-holes. 'Clown' features are painted on the ping-pong ball; and cotton-wool is used for hair.

Suspend the puppet from the support brace, 8, centred above platform. Adjust its height so that the feet rest flat but lightly on the platform. The round bar 9, with strings to the hands may be assembled for the usual manipulation of string puppets if desired. You may wish to create other puppets, painting in suitable features and adding such items as a grass skirt for a 'hula-hula dancer'.

Flick the control bar to vibrate the platform which makes your puppet tap-dance.

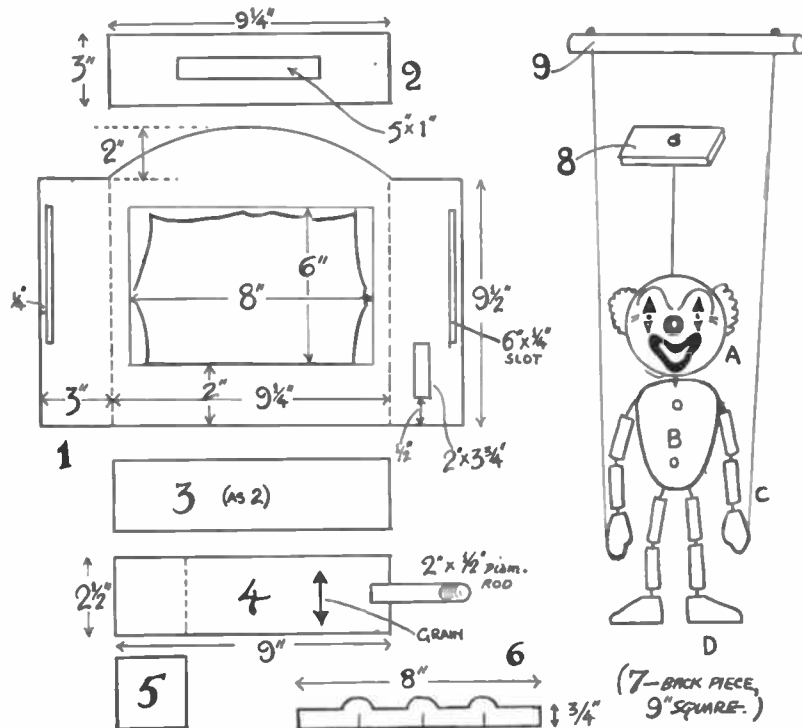

Mainly for Modellers



LUGGERS—2

By 'Whipstaff'

WE now continue with the deck layout and add the deck fittings. No. 1 is the companionway leading to the cuddy. It is made from a small block of wood cut to the size shown. The cover is made from

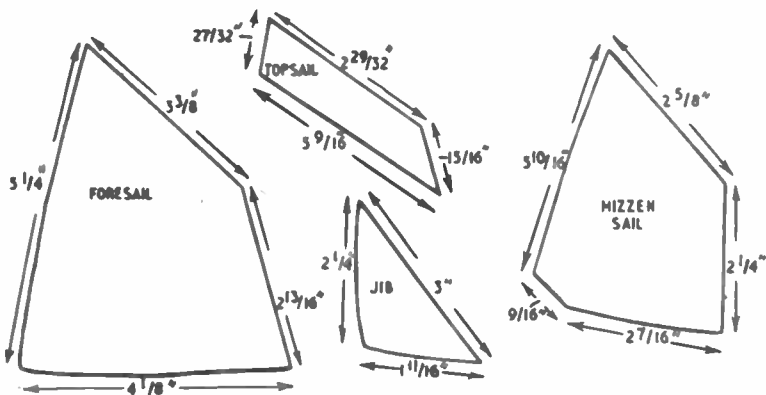

Bristol board, and the panelled effect is obtained by overlays of thin veneer, for which Bristol board can again be used. The whole is then painted brown.

Aft of the companionway is the stack pipe from the boiler (2). This is made from stout wire, and painted black.

No. 3 is the pipe from the stove, also made from stout wire. To the upper part was added a blob of plastic wood which, when hardened, was given a final shaping with a small file, and painted black. If you have no wire of suitable thickness use bamboo dowel.

No. 4 is the crutch upon which the foremast rests when lowered. This is made of stout wire with 'U' piece soldered on top. If you use plastic solder with a Britinol blowlamp, these small fittings can be made quite easily. An alternative is to make the wire a little longer, and bend over the end to enclose the base of the 'U' piece, and secure with a spot of balsam cement or liquid solder.

The pump is shown at No. 5. In this small scale it is made from a piece $\frac{1}{8}$ in. dowel, the handle being fashioned from a pin, painted black.

The hatches (6), are made from $\frac{1}{2}$ in. timber and sanded down to $\frac{3}{32}$ in. thick. The panelling is again made from thin veneer or Bristol board and painted brown. Where these fittings are made of wood and veneer they can, instead of being painted brown, be stained oak or mahogany, and varnished as in actual practice.

We now come to the most interesting of our small deck items, No. 7, which is the steam capstan, and at this scale we can make it in some detail. If you have a lathe, turn the capstan, and add the whelps in thin wood. Otherwise it can be turned with a file by mounting a piece of $\frac{1}{8}$ in. dowel in your hand drill, holding the drill in the bench vice. Or it can be filed freehand on a length of dowel, and afterwards cut off.

The top of the capstan, forming a winch, is cut from $\frac{1}{4}$ in. wood, and two tiny beads are added to complete the winch unit. This part is then glued on top of the turned capstan.

No. 8 is the cover to the 'Scottie', the slot in the deck through which the foremast passes to the tabernacle. In our model this covering board is made of $\frac{1}{2}$ in. wood with a $\frac{1}{2}$ in. hole to come over the hole drilled to glue in the foremast.

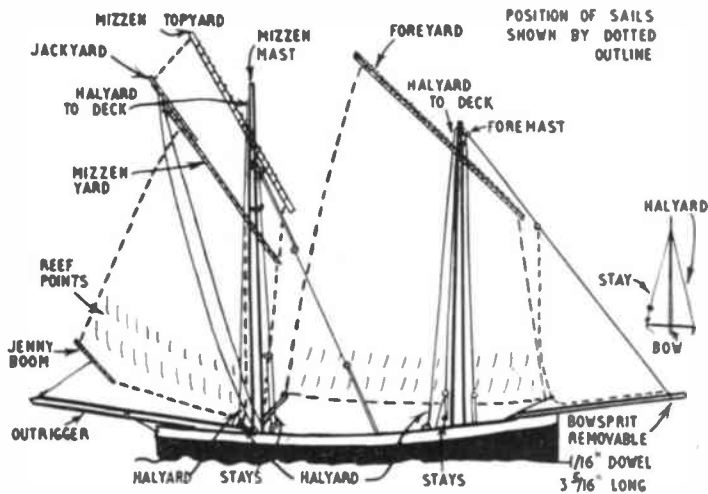

STAYS ON PORT SIDE

HALYARD ON STARBOARD SIDE

The outrigger (No. 9) is made from $\frac{1}{8}$ in. dowel $3\frac{1}{2}$ in. long and glued in position. In actual practice this is secured and held down by a clamp or collar, which is capable of being removed. In the model this is represented by a $\frac{1}{8}$ in. strip of Bristol board, painted black.

The tiller (No. 10) in the model is made from a collar of thin plywood, with the actual tiller made from a $1\frac{1}{2}$ in. length of bamboo dowel bent to shape and glued into the collar. The collar is fitted on top of the rudder and glued in position.

The binnacle is not shown in our model. In these vessels it was a small box, not a fixture, and was lashed to the foot of the mizzen in rough weather. Owing to its small size it is better left out of a model of this scale.

The painting of the model is simple. The inside and outside of the bulwarks are brown and below the bulwarks the hull is black.

In the plan the bulwark pieces are cut slightly long to allow for trimming. This will allow for slight individual variations in carving the hull.

The masts and spars required are as follows:

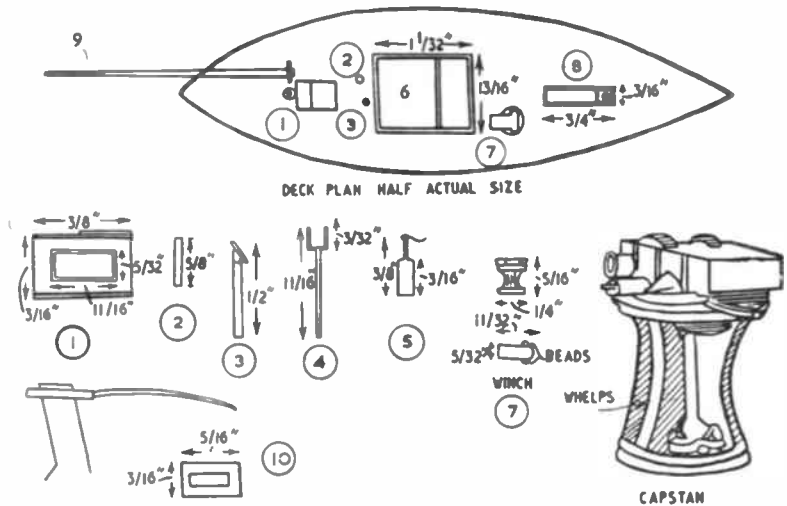

Foremast $\frac{1}{8}$ in. dowel $4\frac{7}{8}$ in. long; mizzen mast $\frac{1}{8}$ in. dowel $5\frac{1}{2}$ in. long (this includes $\frac{1}{8}$ in. deck to be glued in holes drilled in the deck to receive the masts). The spars are made from $\frac{1}{8}$ in. dowel;

foreyard $3\frac{1}{2}$ in. long; mizzen yard $2\frac{3}{4}$ in.; mizzen topyard $2\frac{3}{4}$ in.; boom $3\frac{1}{2}$ in.; jackyard 1 in.; and jenny boom $\frac{3}{4}$ in.

The shape of the sails, together with the sizes, is given in the sketch, and although parchment or paper could be used, I suggest you use fine lawn, such as is used for ladies' handkerchiefs. The small size of the prototype in this case allows for the sails to be made of this fine fabric without appearing out of scale. The hems can be fastened down with balsa cement, unless you can persuade one of the ladies of the family to machine narrow hems with a fine stitch. Weathering the sails has been covered in a previous article.

The main rigging is also shown for this size model, and small plastic blocks can be purchased or tiny beads used and painted black.

As in the sketch of the finished ship a suitable stand is made to mount the model on.

Making Stamp Gum

I SHOULD like to know how to gum paper so that on dampening it becomes adhesive — it is a mixture like that used on postage stamps which I need. (D.G.B. — Winchester.)

A GUM suitable for your purpose can be made with gum arabic (about 4 parts); glycerin (about 1 part); water (about 1 part or just sufficient when the ingredients are warmed to form a thin paste). This, when applied to the paper, should dry fairly quickly, but when moistened becomes adhesive again. A few trials will indicate the most suitable proportions.

A FUNNY FACE-MAKING TOY

YOUNG children love toys which make them laugh, and comic faces are always a great source of merriment. From time to time an old-

fashioned plaything, with which an endless variety of humorous faces may be made, appears in the toyshops. The object is in the form of a profile drawing, showing a man's head, hair, eye and neck, but minus a proper forehead, nose, mouth and chin. Where those vital features should be is a loose piece of a very fine metal chain secured between the sketched hair and the top of the neck. When the picture is shaken or tapped the loop of chain assumes the outlines of absurd and funny faces.

Copy the looking-glass shape on to stout cardboard or thin plywood and cut out the form with sharp scissors or a fretsaw. Paint the whole shape a light colour and then paint the partial profile upon the circular part and decorate the handle with simple designs. Use two or three bright colours, but keep your art work bold and simple.

Bore small holes at points A and B. Acquire a short length of fine chain and secure it in place between the two holes. You may do this by fixing the ends of the chain beneath the toy, using little pieces of coloured Sellotape. Let the chain be loose enough to produce a fairly large nose and chin when it is bent to suggest the profile of a face. Gently shake your completed toy, or tap it with your finger, and observe the countless weird and subtle faces that it will produce. (A.E.W.)

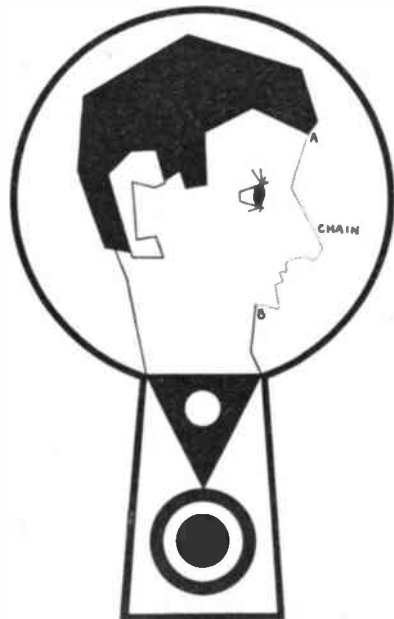

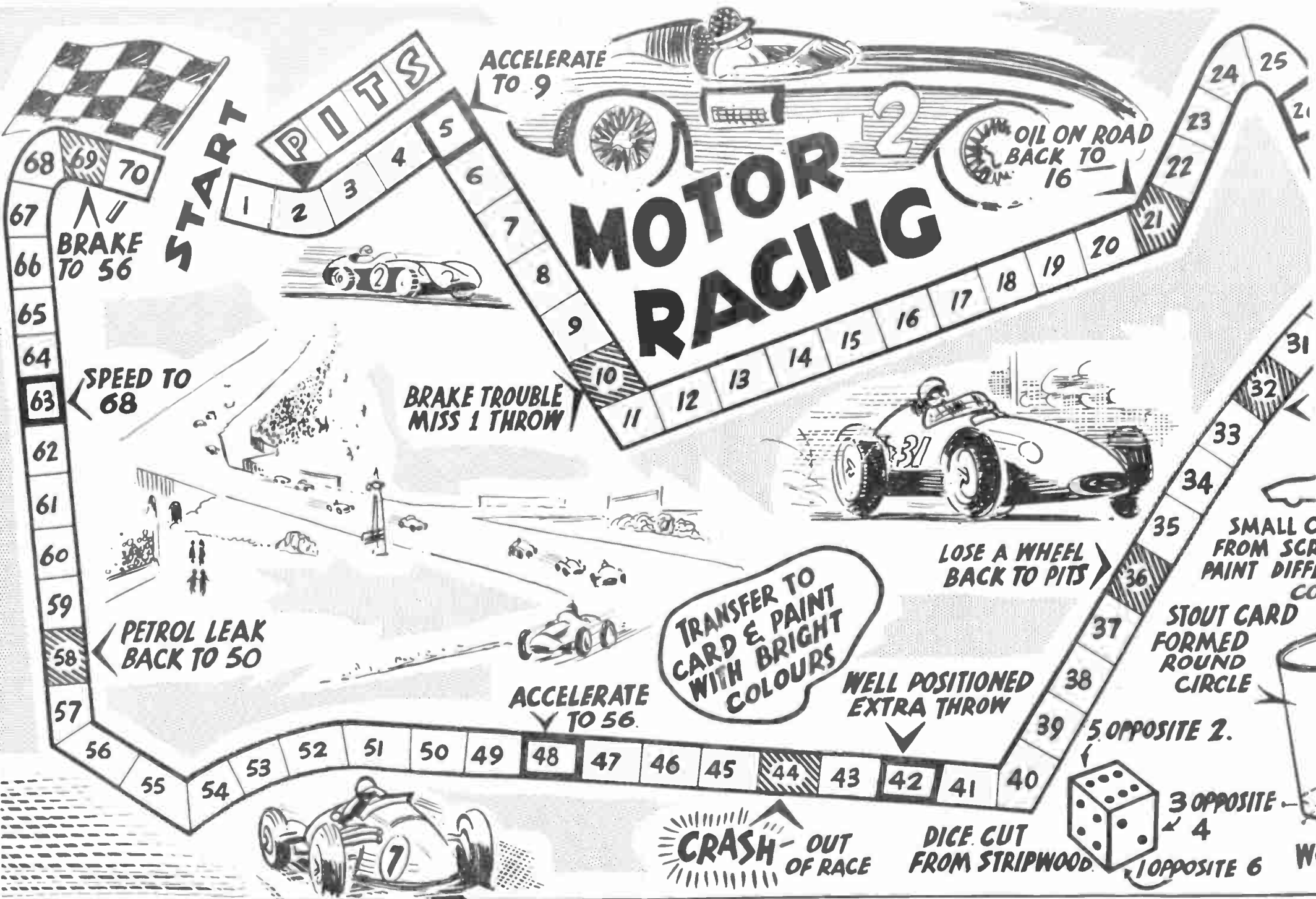

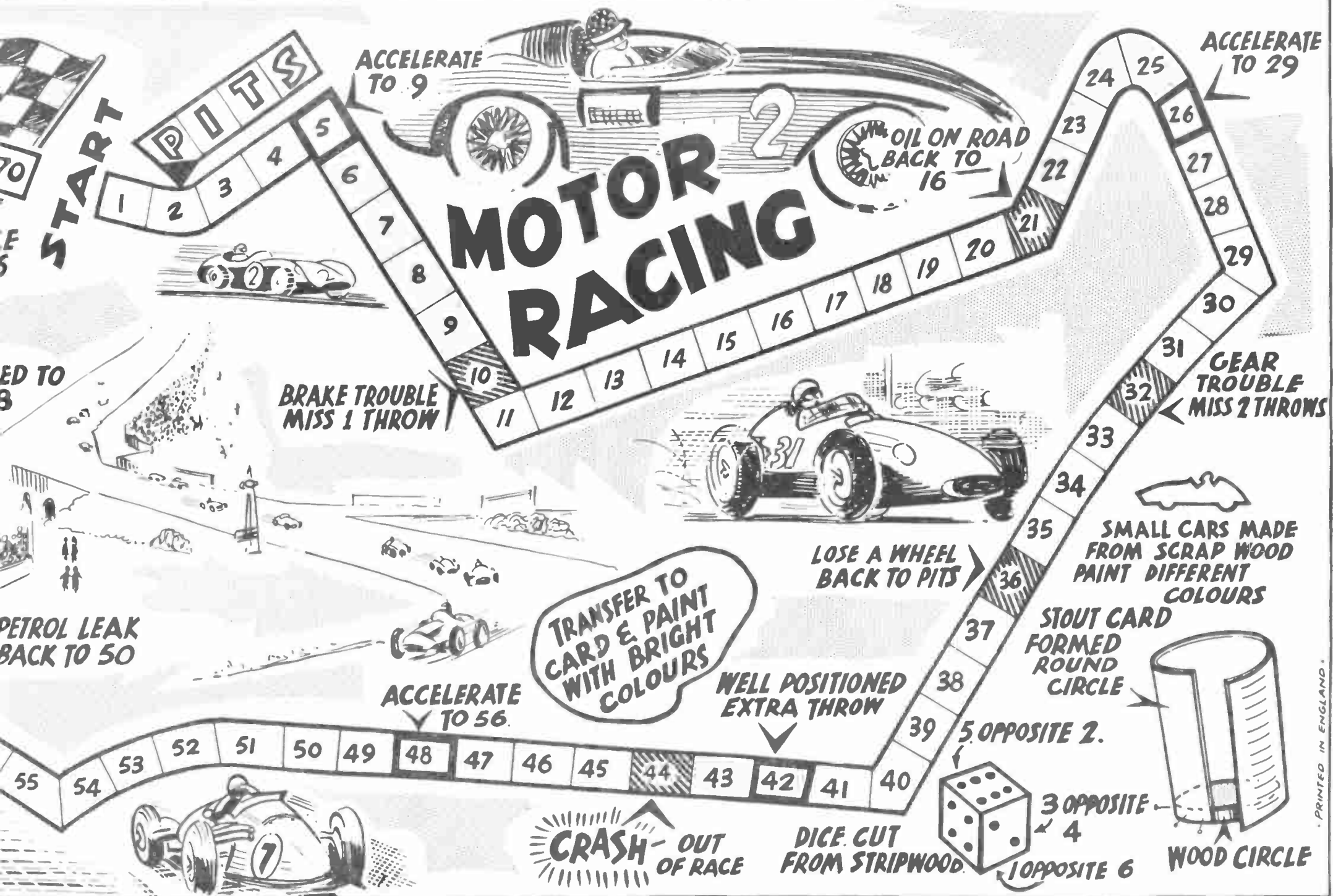

Made from paper

Battery-driven Model Boats

MODEL boats of every kind may be made up from thick glued paper which is sold in the shops and stores in rolls of 1 in., 2 in., 3 in. and 4 in. widths in brown and other colours, at a few pence per roll according to the width.

large enough to cover the overall dimensions of the finished model, mark out these shapes.

Cut out the block of wood quite roughly to the plan, end and side elevations and then proceed to carve neatly, finishing off with glasspaper. This wood mould or former must now be painted in order to give it a really smooth and non-porous surface, which is essential for the next stage — making up the paper hull on the hull former.

Working from amidships, cover part of the hull former with wet tissue paper so that it holds to the shape of the former temporarily and prevents the first layer of gummed strip from adhering to the mould. Now lay over this wet tissue $\frac{1}{4}$ in. wide strips of well moistened tape, overlapping each other by about half the width of the tape (Fig. 2). When this section is completed, proceed in the same manner, with a layer of wet tissue followed by overlapping strips of gummed strip. At the bow and stern it will be found that the strips of tape will not lie parallel to one another, but this will not matter, just carry on and ensure that the whole of the former is covered. The bow, stern or bottom may be stiffened where necessary by additional pieces of gummed strip.

shell required, i.e. No. 1 Plates overlapping for steamer hull — No. 2 Planks edge to edge for carvel hull — No. 3 Planks overlapping for clinker-built hull.

A wooden deck must be made and the former made for the hull may be used as a template to mark out the plan of the deck on a suitable piece of wood which must then be cut to plan (Fig. 3). Cut out a hole in the deck to enable the power plant, stern tube and rudder

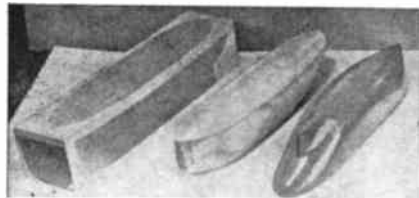

Fig. 1. Shaping the hull



Fig. 2. Application of gummed strip

The basis of model making with this medium is to build up the glued tape after thoroughly moistening layer upon layer so that it assumes a board like substance in any ply desired. When the tape is bone dry after moistening, it will be rather hard and will need a very sharp knife to cut it into shape. In the heavier weights of laminated materials it would have to be sawn.

Models may also be based on a former made up from wood which acts as a master shape about which to model the moistened tape. The shape of the former and its make up and method of over-laying the moistened tape is illustrated. Numerous models of boats, aircraft and trucks may be made up along these lines. Inexpensive boats and aeroplanes may be purchased and they provide ready-made formers for model making. First class and elegant working models of many kinds may be produced in this way.

An example for a first attempt is a model tug-boat. First a mould or former for the hull is made. As many hulls as required may be shaped from this former. Fig. 1 illustrates how the former or original mould is made up from wood. The top, of course, is the plan, front side the side elevation and the end, the end elevation. On a block of wood

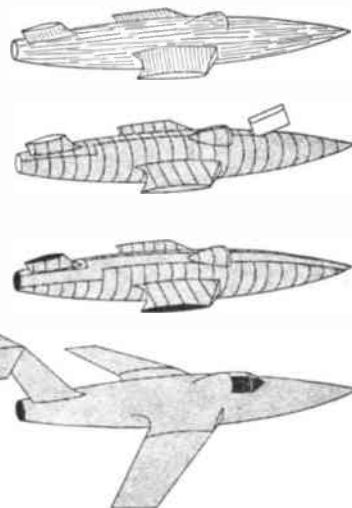

Fig. 4. Constructing a model jet plane

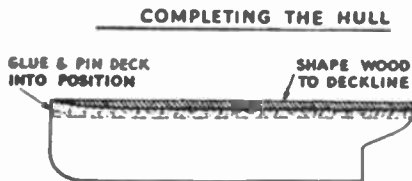

Fig. 3

After the initial layer of gummed tape is practically dry, trim off the edges of the tape at the deck line and carefully ease the hull shape off the former. If a small part of the shape has stuck to the former, use a piece of fairly stiff paper between the hull former and the hull shape to separate the two. Dust the hull former with french chalk to prevent any subsequent tendency for the hull shape to stick to the former. Replace the hull shape on the former. Build up layers of tape at an angle until the required strength for the size of the hull is reached. (It is suggested that four separate layers of tape or strips are sufficient for a hull some 18 inches long). Again trim off the excess tape at the deck line. The final layer of tape should be laid according to the type of hull

post, etc. to be subsequently fitted. Pin and glue the deck into position and when the glue is hard, shape off the portion of the deck above the curve of the deck line.

The methods described lend themselves to many aspects of model making — for example, a funnel. Use a tube of the diameter required and wind this round with tape taking the necessary precaution to avoid tape adhesion. Subsequent layers of tape should be built up and when dry will form a very strong tube. To fit a stern tube in a paper hull, plastic wood can be built up inside the hull around the stern tube to hold it securely in position.

Painting and varnishing treatment will be necessary both for finish, additional waterproofing qualities and general appearance.

The same general method is followed

● Continued on page 389

DO IT WITH DOWELLING

DOWELLING rod, costing only a few coppers a foot, is an ideal material for making simple and inexpensive household fittings. Here are some ideas for easily-made articles.

A MAGAZINE RACK to fit beneath a coffee table (shown in Fig. 1) has two sides of $\frac{3}{4}$ in. dowel rod, $\frac{1}{2}$ in. longer than the distance between the legs at the height chosen. The spars are of $\frac{1}{2}$ in. dowelling inserted in holes in the side pieces at 2 in. intervals. Two $\frac{3}{4}$ in. holes drilled on the hidden side of the front legs, and screws inserted from the back in the rear pair of legs, hold the rack in place with a minimum of visible alteration.

A LIGHT AND PORTABLE BOOK-SHELF consists of lengths of $\frac{3}{4}$ in. dowelling between end pieces of $\frac{3}{4}$ in. thick wood, tapering from 12 in. at the base to 6 in. at the top. The distance between the dowels depends on the size of the books, which should fit between the pairs of dowels at an angle as

shown in Fig. 2. One dowel of each pair should be 1 in. higher than the other for books of standard paperback size. Supports similar to the ends should be placed at 15 in. intervals.

AN ELEGANT STANDARD LAMP is made by inserting three 4 ft. lengths of $\frac{3}{4}$ in. dowelling in a heavy wooden base.

By A. Liston

The dowels pass through holes in a round or triangular spacer of 7 in. diameter half way up the lamp, and they are glued into holes in a 4 in. round capping piece of 1 in. thick wood. A white plastic lampholder is screwed to this, and the flex led down the centre of the lamp through holes drilled in the top piece and central spacer. A torpedo switch can be incorporated in the upper part of the flex.

A SPACE-SAVING AIRING RACK FOR

dishcloths, etc. in the kitchenette (shown in Fig. 4) is made by fixing 1 ft. lengths of $\frac{3}{4}$ in. dowelling to a 1 in. by 1 in. strip of wood at 3 in. intervals. The ends of the strip are cut at an angle, and it is fixed to the wall obliquely, so that the ends of the strip are horizontal.

AN ATTRACTIVE WINDOW GARDEN effect is obtained by adding a white enamelled 'fence' to the window sill. The uprights are 7 in. lengths of $\frac{3}{4}$ in. dowelling glued in place at 6 in. intervals to an upper and lower rail of 1 in. by 1 in. wood. The holes in the rails are drilled at an angle so that the dowels slope outwards. Small hooks and eyes hold the 'fence' in position at each end.

THE POT STAND shown in Fig. 6 uses three 4 ft. lengths of $\frac{3}{4}$ in. dowelling and five triangles of $\frac{1}{2}$ in. thick chipboard, spaced at 1 ft. intervals. The triangular pieces have holes drilled to take the dowels 1 in. from each corner. The lowest triangle has 15 in. sides, the next 13 in. sides, then 11 in., 9 in., and finally 7 in. sides. The sizes can be altered to suit personal needs, but the shelf sizes must diminish regularly by 2 in. Holes drilled in the dowelling take headless nails to act as pins to support the shelves, which are glued in place. Assemble the stand by threading the shelves over one dowel first, then pass the other two dowels down through the shelves from the top.

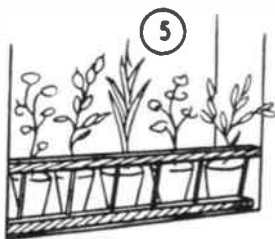
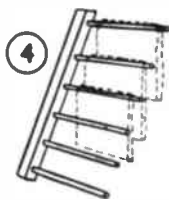
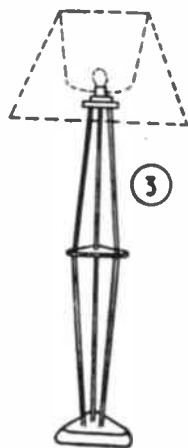
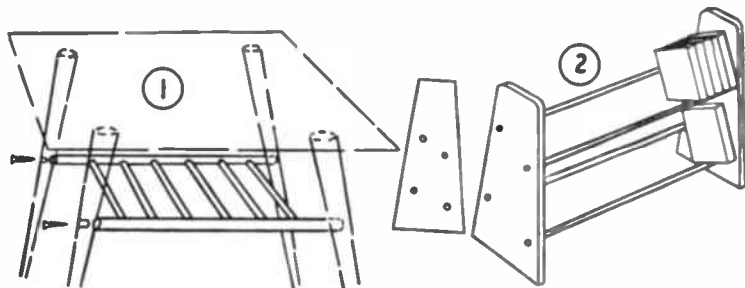

• Continued from page 388

PAPER BOATS

in the make-up of various types of aircraft models.

The influencing factor in each case will be the former or wooden mould previously prepared for the work. The use of suitable toy aircraft is often quite satisfactory.

The illustrations in Fig. 4 show the former or mould which has been completely covered with gummed strip first overlaid and finally neatly stuck with the covering strips side by side in the full width for finish. The work is then cut as shown and the two halves are rejoined with gummed strip. The first layers of tape should be overlapped in both directions in order to provide the necessary strength.

The rings and tail are made up from thick paper or thin card suitably cut and stuck in the appropriate places of the aircraft model. The final painting and varnishing with any other decorative work will complete the model.

(F.T.D.)

NOVELTIES FROM CLOTHES PEGS

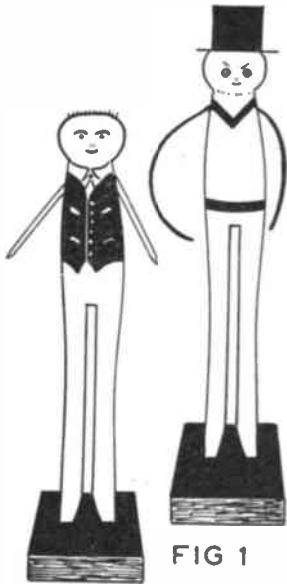

FIG 1

A FEW common clothes pegs can be used for making some new novelties to amuse the children. With only a minimum of preparation they can be adapted to make turned legs for tables and chairs for dolls' houses.

Fig. 1 shows two peg men, the treatment being a little different in each case. In the one on the left a small hole was made in each shoulder for the insertion of a cocktail stick arm, fixed in position with glue. The clothing is added in water colours with facial details in Indian ink. The other peg man has flexible arms made from a single pipe cleaner. A small hole is drilled right through the shoulder and the pipe cleaner inserted and bent as desired. A small disc of paper is stuck to the top of the peg for a hat brim and on top of this is a cork hat. The figures are fixed into a small base by drilling suitable holes and gluing in the legs. You may also use modelling clay for this purpose if shaped appropriately.

A little more preparation is required for the furniture construction and to

make this perfectly clear we would refer you to Fig. 2. Here you will see that A has had one leg removed from the top of the notch, providing a small rebate for a flat piece of plywood. B shows a peg cut a little above the notch and is longer than C which has been trimmed off at the top of the notch. The reason for these different treatments will be apparent.

By H. Mann

In Fig. 3 we have a chair where two legs are cut for the rear as shown in Fig. 2A, while the two front legs are cut as in Fig. 2C. A small piece of plywood makes the seat and all you have to do is to glue the parts together as shown, adding a stretcher at the rear which is made from one of the cut off legs.

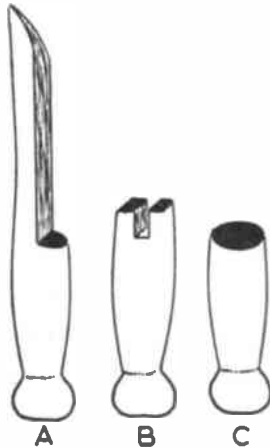

FIG 2

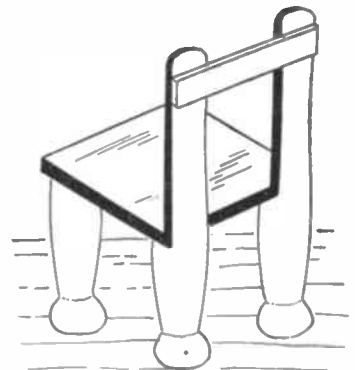

FIG 3

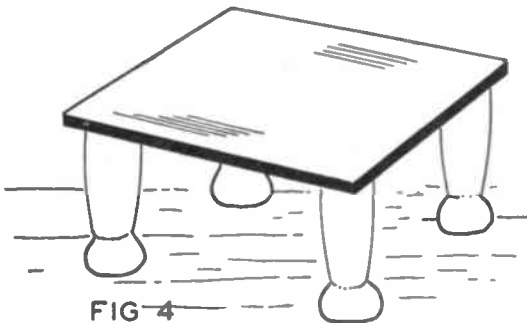

FIG 4

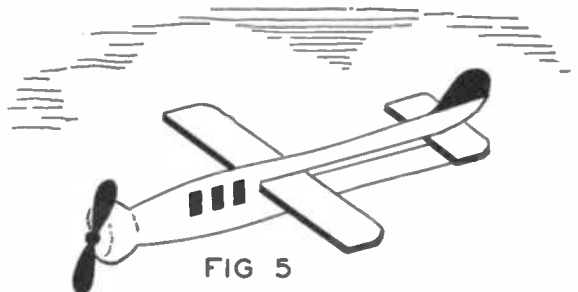

FIG 5



BOYS- AVIATION OFFERS YOU ADVENTURE!

A world of wonder opens wide when you enter the world of aviation. For a career connected with the aircraft of today is more than a career—it's high adventure. An adventure that can bring you close to the top secret research, the exciting trials and tests that will help man to conquer outer space in the aircraft of tomorrow. *You* can become one of the select band of skilled engineers whose work is devoted to every aspect of modern flight. From test rockets and guided weapons to the latest radar tracking techniques, from new fuels for rocket propulsion to plasma jet investigations, electronic research and experiments on metal fatigue at high speeds, from these and a host of other stimulating subjects *you* can select the field in which to specialise as an engineer with the Ministry of Aviation; an engineer in a fine, well-paid career, with good holidays, doing an important job.



each dealing with a specific branch of activity. Candidates should be 16-19, according to the level of entry and type of apprenticeship concerned. Apprenticeships normally last five years. OPEN COMPETITIONS for 'O' and 'A' level candidates will be held shortly. Interviews will be held in early summer; U.K. travelling expenses exceeding 7s. 6d. will be paid.

Complete the coupon below, and post it off NOW. The application form which you will receive must be returned not later than March 17, 1961.

To: Mr. W. N. Robinson, C.B.E., Ministry of Aviation,
Gower Street, London, W.C.1

Please send me details and application form for the forthcoming student apprenticeship entrance competitions to be held by the Ministry of Aviation. Please tick whether 'O' or 'A' level application form required.

NAME _____ 'O' LEVEL
 'A' LEVEL

ADDRESS _____

No. 3

SEIZE THIS OPPORTUNITY

to join us AS AN APPRENTICE. Vacancies exist for entry to various categories of apprenticeship,



MARCH

THESE NOTES REFER CHIEFLY TO MIDLAND GARDENS — DUE ALLOWANCE SHOULD BE MADE FOR CHANGE OF LATITUDE.

WITH improving weather an effort should be made to fork over herbaceous borders, rose beds, etc. Try to finish before the middle of the month when time will be required for seed sowing. Quite a number of shrubs can be pruned this month, notably the roses. Tie in climbing roses, cutting back laterals to two or three

buds. Hybrid musks should be arched and pegged down and the laterals lightly pruned.

Cut buddleia back hard to encourage new vigorous growth. As a guide to pruning, remember that those flowering on new wood should be pruned in the spring. All prunings should be gathered up and burnt.

In the cold greenhouse

Sow seeds of half-hardy annuals.
Stir soil around lettuces.
Remove decaying leaves.
Ventilate well except during frosts.

COMPOSTS FOR SEED SOWING AND POTTING

Seed Sowing — 2 parts (by bulk) loam (sifted through $\frac{1}{2}$ in. sieve). 1 part peat (horticultural grade), 1 part coarse sand (approx. $\frac{1}{2}$ in. particles). Add to each bushel of the mixture: $1\frac{1}{2}$ oz. superphosphate and $\frac{3}{4}$ oz. chalk.

No. 1 for plants in pots or boxes — 7 parts loam, 3 parts peat, 2 parts coarse river sand. Add to each bushel of the mixture: $1\frac{1}{2}$ oz. hoof and horn meal, $1\frac{1}{2}$ oz. superphosphate, $\frac{3}{4}$ oz. sulphate of potash, $\frac{3}{4}$ oz. chalk.

No. 1 and No. 3 Composts — Add double and treble the amounts of fertilizers as given for No. 1, excepting the chalk, which will remain the same for all three. These composts are for potting on.

All loam should, of course, be sterilized, but excellent results may be obtained from using good garden soil. The peat is, of course, essential. (M.H.)

SOME JOBS TO GET ON WITH

Tie in raspberries and top dress with compost or manure.

Plant new strawberry beds.

Plant last of fruit trees and shrubs.

Trench and sow early peas.

Make main outdoor sowings of vegetables.

Sow — cabbage, leeks, sprouts, broad beans, broccoli, turnips, parsnips, and carrots — all outside during latter half of month.

Sow radish and lettuce under cloches.

Put out onion sets.

Sow first potatoes according to locality.

Sow first hardy annuals.

Sow half-hardy annuals under cloches.

In the warm greenhouse

Start begonias and gloxinias.

Sow tomatoes, cucumbers, and coles.

Sow seeds of bedding plants for early displays.

Take cuttings of dahlias, fuchsias, and chrysanthemums as they become available.

Inspect cacti and repot last years seedlings if becoming crowded.

Pot up cuttings already rooted.

In the cool greenhouse

Pot up boxed cuttings.

Sow seeds of annual bedding plants.

Start begonias and gloxinias.

Sow tomatoes.

Repot overwintered plants.

AN 'EYESIGHT TEST' TO PUZZLE YOUR FRIENDS

IF you wrote out the complete alphabet in printed capital letters and held a mirror along the top of each letter in turn you would discover that nine letters will not appear upside down when they are reflected. These are the letters B, C, D, E, H, I, K, O, and X. Words like 'CHEEK', 'BOXED', and 'BEDDED', if printed in capital letters, will not appear inverted if reflected in the manner described.

A quick study of these nine letters will reveal that they are symmetrical in structure from top to bottom. You may employ this principle in arranging a curious optical illusion which you can present as an eyesight test for the amusement and bewilderment of your friends.

Prepare three postcards as 'test cards'. Number these, 'one', 'two', and 'three', then tidily print the following

words across them in letters $\frac{1}{2}$ in. high.

Card 1 CODE BOOK

Card 2 MAGIC MAN

Card 3 CHOICE READING

Note that the words upon card 1, and the first word upon card 3 are composed of the reversible letters. When you hold a lady's handbag mirror against the upper edges of the words on card 1 the reflection will still be readable as 'Code Book'. Hold the mirror against the words 'Magic Man' on card 2, and the letters will appear upside down and unreadable. The words 'Choice' and 'Reading' upon card 3 will appear upright and reversed, respectively.

Your presentation of the effect as a genuine eyesight test may be along these lines. Suggest to your friend that his eyesight may be failing, and offer to help

him by giving him a free eyesight test. Show card 1, and suggest him to close his right eye and open his left eye to read the reflected words when you hold the mirror against the card. He will probably not be surprised when the words appear perfectly normal.

Give a satisfied nod and proceed to offer him the second card. Ask him to view the reflection with his right eye only. He will remark that the words appear upside down. Look a little concerned, and say that, as a clinching test, he had better gaze at card 3 with both his eyes open. He will tell you that the right-hand word is upside down. Ask him if the left-hand word seems upright. When he gives an affirmative, put away the cards quickly, and suggest that he should consult an oculist at once!

(A.E.W.)



A NEW RANGE OF JOHNSON DO-IT-YOURSELF OUTFITS

Here's excitement! The new Johnson range of "Do-it-yourself" outfits makes it so easy to develop and print your films at home.

These outfits contain everything you need. They range from sets for the beginner, to outfits for the more advanced enthusiast. And full instructions go with every outfit. Prices from £1-17-6 to £5-12-6.

JOHNSONS
OF HENDON LTD

FOR CONFIDENCE
IN PHOTOGRAPHY



MOSAICRY

The New Craft!

By the simple method of sticking colourful marble chips to a design already drawn on a base board, you can have in your contemporary home, the most modern of pictures — an arresting piece of stone Mosaic work.

The attractively-boxed kits include everything you need including a frame and instructions, and cost 13s. 11d. (size 12 in. by 7 in.) and 19s. 11d. (18 in. by 11 in.). Available now from most craft shops and departmental stores. Illustrated Folder (F19) and Stockists address from: 'B' Department.

"ATLAS" Handicrafts
SPRING ALLEY, MANCHESTER 4

MANY MODELS from ONE TIN!



Pyruma, plastic and ready to use from its tin, can be fashioned into the widest variety of models imaginable. Buildings for your model railway set, houses, ship models, animals and figures, ashtrays and plaques — all of which when set or baked to stone-hardness can be finished in natural colours. Get the Pyruma Model Instruction book — see Coup-in, and start making things like those shown below

SANKEY'S PYRUMA PLASTIC CEMENT



Made by amateur modellers, this signal cabin and light-house show how with Pyruma you can get the effects of tiles, wood, brickwork, chimney pots, concrete — and even the rocks of the sea. The book offered below tells you how. Pyruma is obtainable from your local Ironmonger, Hardware Store or Art Material dealer.

POST THIS BOOKLET COUPON TO-DAY

To J. H. SANKEY & SON, LTD (Dept. HW),
ILFORD, ESSEX

Enclose P.O. 6d. (not stamps) for a copy of Pyruma Modelling Instruction Booklet, post free to:

NAME _____

ADDRESS _____

(BLOCK LETTERS PLEASE)

MUSICAL MOVEMENTS CHEAPER THAN EVER

Ballerina movements only 19/9 post free. Send for illustrated catalogue of movements and kit.

SWISSCROSS LTD (Dept. HW2)
202 TULSE HILL, LONDON, S.W.2

Completely new 54 page Edition
WHERE'S THAT CAR FROM?

Price 1/- (Postage 4d.)

Of all Booksellers

or

RALEIGH PRESS, Exmouth, Devon

50 MIXED stamps 5/-. Try our 6d. in 3/- discount approvals—E. C. F. Townsend
92 Tenby Road, Edgware, Middx.

LEARN RADIO & ELECTRONICS the NEW Practical Way! Very latest system of experimenting with and building radio apparatus — 'as you learn'. FREE Brochure from: Dept. H.W.10, Radiotractor, 40 Russell Street Reading, Berks.

100 DIFFERENT stamps free! Request 4d. upwards discount approvals. — Bush,
51 Newlyn Way, Parkstone, Dorset.

Starline CHINESE LACQUER

THE SAFE PAINT FOR HOUSE & NURSERY FURNITURE

"GLOBE-KING"

WORLD-FAMOUS KITS AND RECEIVERS

for the Radio Amateur and S.W. Listener. Catalogue Free, enclose stamp for postage. Kits from 79/6 obtainable at your dealers or direct from sole manufacturers

JOHNSONS (Radio)
ST. MARTINS GATE — WORCESTER

WORKERS with sewing machines required for making cushion covers. Regular work guaranteed. Apply enclosing s.a.e., Dept. 28, Arnold Trading, 10 Shelley Road, Worthing, Sussex.

PROFIT AND PLEASURE is obtainable from WRITING (typewriter unnecessary) or ARTISTRY. Send for free fascinating bumper package 'PROFITABLE LEISURE'. — Writers' & Artists' Ring (HW), 5 Edmund Street, Birmingham.

PROFITABLE LEISURE. Learn to draw/paint flowers, birds, doodles, etc. Waiting markets. Profitable. Fascinating. Exciting. Beginner's work can sell. Booklet free. Popular Designs (HW), Clun, Shropshire.

LEARN

RADIO & T/V SERVICING for your OWN BUSINESS/HOBBY

● by a new exciting no-maths system, using practical equipment recently introduced to this country.

FREE Brochure from:—

RADIOSTRUCTOR

DEPT. G81, READING, BERKS.

1/3/61

BUYING OR SELLING?

Classified advertisements on this page are accepted at a cost of 6d. per word prepaid. Use of a Box No. is 1/- extra. Send P.O. with advertisement to *Hobbies Weekly*, Advert. Dept., Dereham, Norfolk. Rates for display advertising on application.



It won't move!

CERTOFIX liquid glue can cope with all general repairs. It unites wood, glass, metal and almost all substances. It is clean in use; its joints are stronger than the materials it unites.

Sold at all
Woolworth Stores

CERTOFIX

WILL Really FIX IT!

THE 'MARVEL' BENCH MOTOR- DRIVEN SAW

To meet modern needs. Just plug in and switch on from any house lighting point. For either A.C. or D.C. mains. With 230/250 volt motor, flex, switch, etc.

£12 5 0

Easy Payments
Available

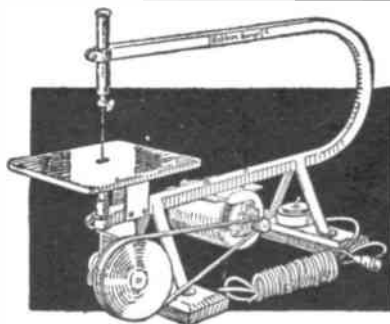

HOBBIES LTD (Dept. 99), DEREHAM, NORFOLK

APPARATUS & CHEMICALS

For your experiments. Let us help you equip a
HOME LABORATORY

Beakers, Crucibles, Flasks, Funnels,
Gas Jars, Test Tubes, etc.

Booklets:
(including postage)

'Experiments' 1/3
'Formulae' 1/3
'Home Chemistry' 2/11
New edition

Send 4d. Stamp for latest PRICE LIST

A. N. BECK & SONS (Dept. H.W.)
60 Stoke Newington High Street, London, N.16



THE PERCY POTATO NOVELTY

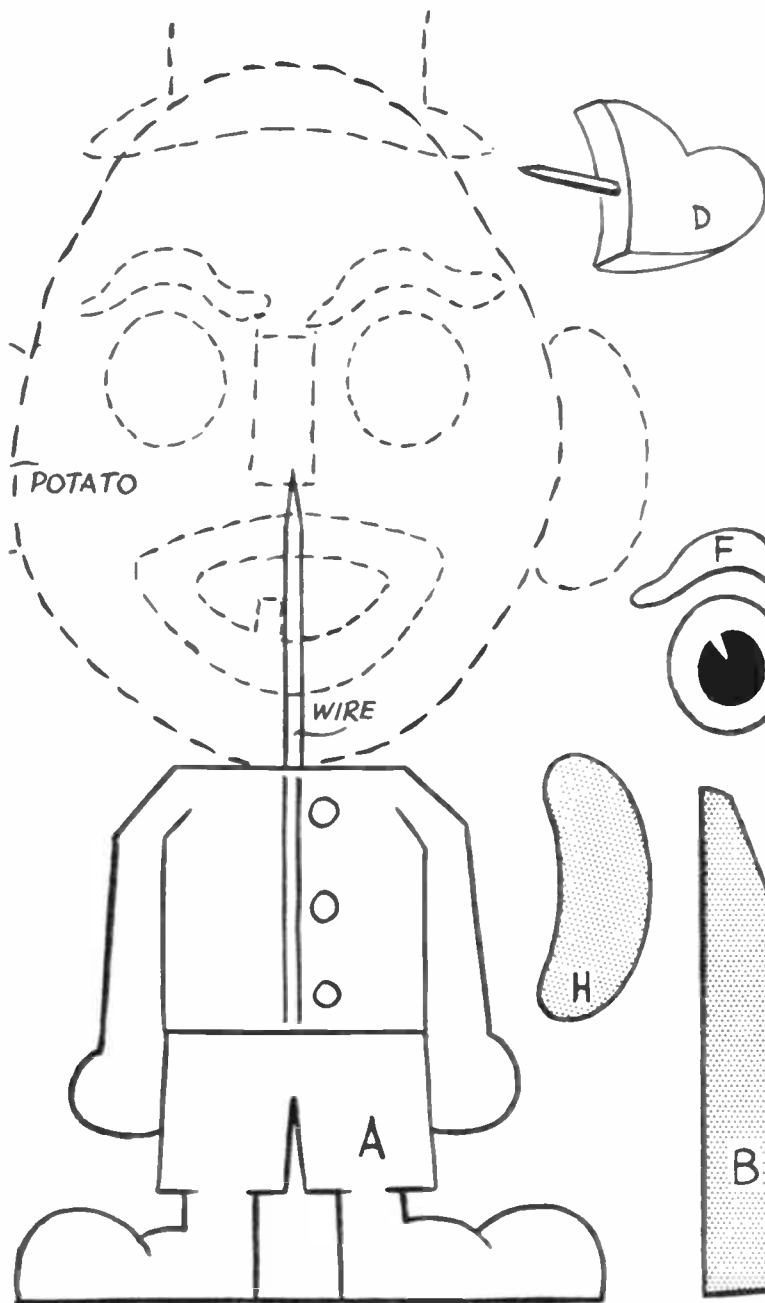

THIS novelty is easily cut with a fretsaw. Cut one of A and one of B from $\frac{1}{4}$ in. wood. Glue B to the back of A and paint up in bright colours. Push a spike made of wire into the neck, as shown, and push a potato on the spike.

The mouth C, nose D, hat E, eyebrows F, eyes G, and ears H are also cut from $\frac{1}{4}$ in. plywood. Into each piece insert a piece of wire, or a panel pin. The pins are then pushed into the potato in the appropriate positions. All pieces are cleaned up and painted. (M.p.)



CHARMING MUSICAL BOXES



**MUSICAL
SWISS CHURCH**
No. 3364. Holds about 30 cigarettes.
10/6 (post 1/6)



**ILLUMINATED MUSICAL
SWISS CHURCH**
No. 256 Special. Full kit contains
materials, paint, glue, electrical
fittings, etc.
25/- (post 1/2)



**TWO-STOREY
MUSICAL SWISS CHALET**
No. 255 Special
Kit contains materials,
paint, glue, etc. (post 1/9) **19/11**



**SWISS CHALET MUSICAL
CIGARETTE BOX. No. 3152**
Kit for chalet **7/11** (post 1/3)

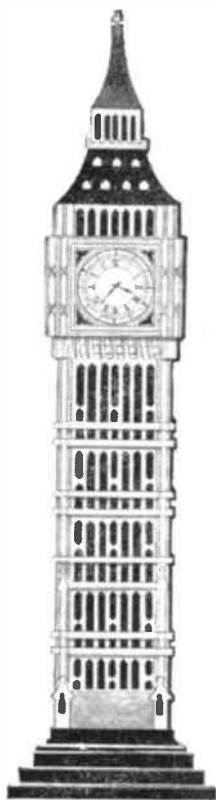

'BIGBEN' CIGARETTE BOX
No. 3324
Model of this famous London landmark
stands 16½ in. high.
14/3 (post 1/6)

WILLOW PATTERN BOX
No. 3284
For cigarettes, trinkets, etc.
9/3 (post 1/6)



**OLD WOMAN
WHO LIVED
IN A SHOE
MUSICAL BOX**
No. 259 Special. For
cigarettes or trinkets.
24/- (post 1/9)



GRAND PIANO
No. 3250. Kit to make
includes wood, hinges, printed
keyboard, etc.
12/6 (post 1/6)



**TREASURE CHEST
MUSICAL TRINKET BOX**
No. 3312
Charming reproduction of a pirate's
treasure chest. **15/-** (post 1/6)

Kits and Musical Movements from
all Hobbies branches or direct
by post from

**HOBBIES LTD, Dept. 99
DEREHAM, NORFOLK**

SWISS MUSICAL MOVEMENTS

Choice of 27 Tunes
(One Tune per Movement)
Westminster Chimes
Kiss Me Honey-Honey
The Knick-Knack Song
Anniversary Song
Jingle Bells
O My Papa
Blue Danube
Vienna, City of my Dreams
The Harry Lime Theme
from 'The Third Man'
Brahms' Lullaby
Parade of the Wooden Soldiers
Auf Wiedersehen
(Till We Meet Again)
Church Bells Air
The Bridge on the River Kwai
(Col. Bogy)

On the Street where you Live
Ave Maria de Gounod
Happy Wanderer
Silent Night
Lime Light
Moulin Rouge
Greensleeves
Tales from the Vienna Woods
Home Sweet Home
Swedish Rhapsody
Bells of St. Mary's
Blue Bells of Scotland
Irish Eyes are Smiling

Price 14/11

(post 6d.)