

HOBBIES WEEKLY

NOVEMBER 12th 1958

VOL. 127

NUMBER 3289

IN THIS ISSUE

	Page
'Twin' Board and Easel	97
An Occasional Table	99
Fascinating Fungi	100
Solution to Jig Quiz-No. 10	101
A Camera Enlarger	102
Patterns for The Boys' Brigade Badge Overlay	104
A 'New-Way' Toast Rack	106
3-D Pictures	108
The Wilds of 'Dooneland'	110
X-Ray Yourself	110
Patterns for Old-Time Locomotive	111



All correspondence should be addressed to the Editor, Hobbies Weekly, Dereham, Norfolk

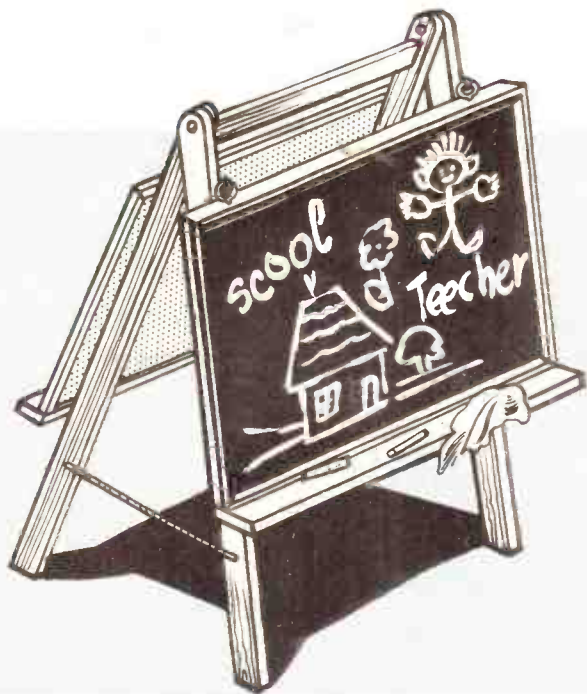

*A two-in-one
Gift for
two children*

BOARD AND EASEL

THERE should be no quarrels over the use of the blackboard if the 'twin' is made up for the family. Two children can play comfortably at 'schools' without interfering with each other.

It is a dual purpose board; not only a blackboard, but an easel for water-colour painting. The blackboard is simply reversed to present a plain surface to which paper may be pinned for water-colour or crayon work.

The boards are hung on hooks and are easily removed for reversing, whilst the easel folds flat for easy storage.

FULL INSTRUCTIONS FOR MAKING

97

**FOR ALL HOME CRAFTSMEN
Over 60 years of 'Do-it-Yourself'**

World Radio History

4¹/₂

MAKING THE 'TWIN' BOARD AND EASEL

Measurements are indicated in the diagrams, but these can be altered as required. The construction allows for plenty of latitude in size of wood and main dimensions.

Commence construction by making up the two boards. Use $\frac{1}{2}$ in. plywood 24ins. by 18ins. and frame with Hobbies No. 11 contemporary picture with moulding mitred as shown in Fig. 1. Cut the mitres with tenon saw and mitre block and glue to the board. Strengthen with pins or screws and allow to dry thoroughly. The blackboards will thus be framed, but the backs will be plain.

Two coats of black

The boards should be painted with Hobbies Blackboard Black. Rub down with fine glasspaper and apply the first coat. Allow to dry, rub down again and then apply a second coat. This will give a surface suitable for chalk, etc. The reverse side of the boards and the moulding should be stained and varnished.

The easel consists of four legs (A), one cross piece (B) and two ledges (C). The legs (A) are pivoted by means of bolts at the top as shown in Fig. 1 and Fig. 3, and the cross piece (B) is tenoned into pieces (A). Make sure that the mortise and tenon joints are a good fit before gluing.

The ledges (C) are fixed to the legs (A) by means of brackets as shown in Fig. 2. Screw the brackets to the ledges (C) and then to the legs (A). Ledges will be approximately 24ins. long by 4ins. deep by 1in. thick. Drill the legs (A) to take two pieces of cord as shown in the inset diagram (Fig. 1), and knot the ends as indicated.

The boards are hung on cup hooks fixed into the legs. Large screw eyes are inserted into the top edge of the boards as shown in Fig. 1.

Materials available

To finish off the easel, rub down with glasspaper and give two or three coats of brush polish. This will give a golden effect which can be further enhanced by a coat of clear varnish.

Blackboard Black and moulding can be obtained from Hobbies Ltd., Dereham, Norfolk. Blackboard Black costs 1/3, postage and packing 9d., and the No. 11 moulding costs 1/6 per 3ft. length, postage and packing 1/6 for any quantity. (M.h.)

Fig. 1

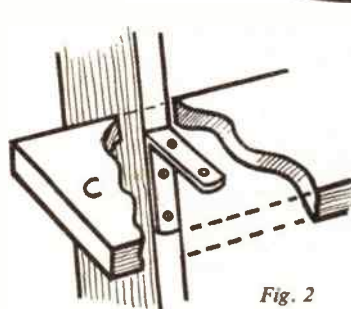
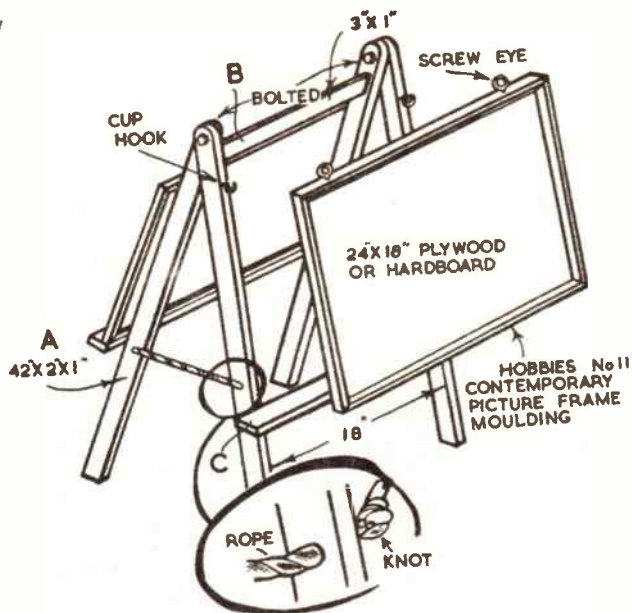
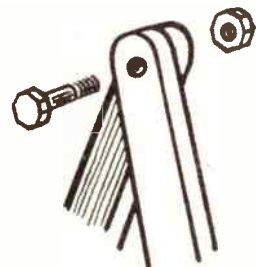

Fig. 2



SHOWING HOW TOPS OF LEGS ARE BOLTED

Fig. 3

HAPPY THOUGHT — LUCKY LAD!



THE young lad pictured here is lucky indeed to have such a clever and thoughtful grandad as Mr J. Buxton of 70 Wigston Road, Plaistow, E.13, who made this magnificent model for him from Hobbies Design No. 248 Spcl. It measures nearly 3ft. long by 2ft.

3ins. wide, and all the outside walls, small towers, etc. are interlocking so that it can be taken apart for storage.

The cost of kit is 54/- and the design and instructions separately cost 2/6 (post 2d.) from Hobbies branches, or from Hobbies Ltd, Dereham, Norfolk.

FASCINATING FUNGI



A bracket fungus on a birch trunk

like the 'flower' of an ordinary plant. The real fungus consists of a network of threads, called 'mycelium', below ground, intermingling with the decaying matter on which the fungus lives. In order to produce and distribute the spores (equivalent to seeds) the so-called fruiting body is thrown up, and it is this that appears above ground. It consists typically of a stem and a cap, the underside of which usually carries a large number of flat 'gills', radiating from the centre like the spokes of a wheel. These are the gill fungi. The pore fungi have, instead of gills, a spongy mass of pores underneath. It is the gills or pores that produce the millions of spores of the fungus; these are dust-like particles often of a characteristic colour. If the cap of a fungus is cut away from the stem and laid on a sheet of white paper overnight, gills or pores downwards, a 'spore pattern' can often be produced.

deaths due to fungus eating. Most of the others that are not considered as edible are either unpalatable or may cause temporary sickness and unpleasant effects. However, this article is not about eating fungi and it cannot be emphasised too strongly that no collected fungus should be eaten unless the collector is absolutely certain of its identity, and this may not always be

By P. R. Chapman

WHEN Autumn comes, although the brilliance of our Summer flowers is no more, the woods and fields can still yield interest for the careful searcher. Then the fungi are to be found, and although most of them have not the colour of the flowering plants, they can form a most interesting study.

Probably most people consider that there are two classes of fungi, mushrooms which are good to eat, and toadstools which are poisonous. They probably also realise that moulds and mildew are fungi, but these are usually considered as just 'nasty' and not to be encouraged!

The group of plants included in the fungi is immense, many of them, such as the moulds and mildew already mentioned, together with various 'rusts' and 'smuts', causing diseases in garden plants and crops, being very small or microscopic, and we are not concerned with them here. All fungi are characterised by their lack of chlorophyll which enables other plants to manufacture their food from water and carbon dioxide in the presence of sunlight. Since fungi are unable to do this, they must behave as parasites, living on other plants or animals, alive or dead, and since they do not require sunlight, they are able to exist in total darkness. Here we are going to consider the conspicuous, larger fungi of field and woodland, and they are, indeed, a fascinating subject for study.

The conspicuous part of the fungus that we see, appearing so mysteriously from a bed of leaves or grass is rather

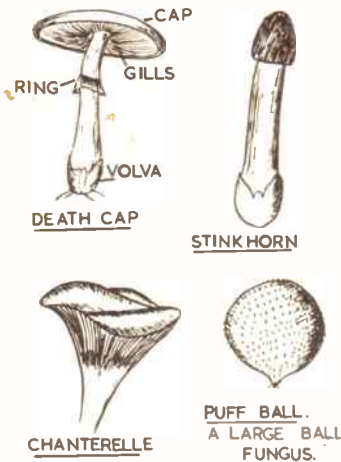

easy. There are various so-called 'rules' to determine whether or not a fungus is 'poisonous', but these are all based on fancy and are completely unreliable. The deadliest fungus and the common mushroom both behave in the same way towards most of these 'tests', except when eaten!

The Death Cap

Since the deadly always has a fascination of its own, let us start with the one already mentioned. This is the 'Death Cap', *Amanita phalloides*. It is about the same size as the common mushroom, but has white gills, together with a frilly ring on the stem and a cup at the base (volva); the mushroom possesses only the ring and has dark gills. The top of the cap is usually a yellowish green colour, but like many fungi is rather variable. It is to be found in woods, not pine woods, in Autumn, and although it is fairly common, it occurs in definite localities and is not widespread. As already stated, this fungus is deadly to us, although slugs, snails and sometimes rabbits appear to suffer no ill effects from eating it. Since its effects do not show themselves until about twenty-four hours after it has been eaten, the poison having then been assimilated by the body, little can be done. Usually death occurs after about three days of intense suffering, but should the results not be fatal, several weeks of illness followed by a long convalescence are almost inevitable.

Fly Agaric

The other two deadly poisonous fungi are also Amanitas, but are quite rare. An Amanita which is also very well-known, if only in illustrations to childrens' books, is *Amanita muscaria*, sometimes called 'Fly Agaric' (due to its reputed effectiveness as a fly killer). This has a bright red cap, covered with

A few words to clarify the position of 'poisonous' fungi may not be out of place. Of course, as everyone knows, the cultivated and the field mushroom are edible and pleasant to eat, but there are many other kinds, considered as 'toadstools' (the division into mushrooms and toadstools has no scientific meaning) that are even better and, although hardly ever eaten here, are quite common in Continental markets. Amongst our larger fungi there are only three species that are really deadly and only one of these is at all common. It is this that is responsible for the majority of

many small greyish scales, and is one of the most conspicuous of fungi, being often seen in Autumn in birch and pine woods. Like many Amanitas, it is 'poisonous' but not deadly, except, perhaps, in rare cases. However, its appearance is so distinctive that it is impossible to confuse it with a mushroom. All Amanitas are characterised by possessing both a ring, the remains of the covering of the young fungus, and a volva, which is a kind of cup out of which the stem appears to grow. The latter is easily overlooked unless one searches carefully at the base of the stem.

The common mushroom possesses a ring but no volva, and, as is well-known, it is found growing in fields, not in woods as the poisonous species already mentioned. The cultivated mushroom sold in shops is related, but not quite the same.

Honey Tuft

A common fungus often seen growing at the base of trees is the Honey Tuft. This has a golden brown cap and is quite attractive, being also edible, although not considered a delicacy. It is, however a violent destroyer of trees, attacking the roots and eventually killing them. The mycelium of this fungus when embedded in wood often causes the latter to become luminous in the dark.

One of the most prized fungi on the Continent for eating is the Chanterelle. This is different in shape from the mushroom, since the gills appear to run down the stem, the whole fungus being somewhat trumpet shaped. It is a bright yellow colour, and the crushed fungus has an apricot-like smell.

An Ink Cap fungus may sometimes be found in the garden or on the compost heap, particularly where horse manure has been tipped. This starts as a small

conical cap, which opens out umbrella fashion, and after about two days begins to disintegrate into a black ink-like fluid, containing the spores. In its young stage it is edible.

Stinkhorn

Bracket fungi can often be seen growing on the trunks of trees, especially elm and birch, in which they cause a

appears above ground. This is white and leathery, and if removed and kept, it will burst open and the fungus emerge. If taken home, however, be sure to keep it at the bottom of the garden and not in the house, unless you want to be extremely unpopular! The Stinkhorn is quite harmless, although it is doubtful if anyone would want to taste it.

In this article we have only been able



Amanita Muscaria (fly agaric)

rotting of the wood. These are pore fungi, but the cap is woody rather than fleshy. They are usually stemless and look just like brackets.

A mention must be made of the Stinkhorn fungus, which is usually discovered by its smell! This is of quite a different shape from the others, as can be seen from the sketch. The black slimy covering to the cap, which is responsible for most of the odour of rotting flesh, is attractive to flies, who eat it and distribute the spores it contains. Before developing into the mature fungus, an odourless, egg-like structure

to mention a few of the more easily recognised of the countless number of fungi to be found in our fields and woods. Many others are often more difficult to identify, but for those who wish to delve more deeply into the subject, there are a few books available. There is an excellent one in the Observer series and a more technical one may be obtained from the London Natural History Museum. If collected for further study, fungi are best carried in a basket with layers of newspaper between specimens. They do not keep well, and should be examined as soon as possible.

Solution to last week's Jig-Quiz - No. 10

The aeroplane featured in our Jig-Quiz last week is the De Havilland Dove light transport. It is powered by two De Havilland Gipsy Queen 70 engines and has a maximum cruising speed of 202 m.p.h. The Series 5 and 6 are powered with Gipsy Queen 70 Mk. 2 engines.

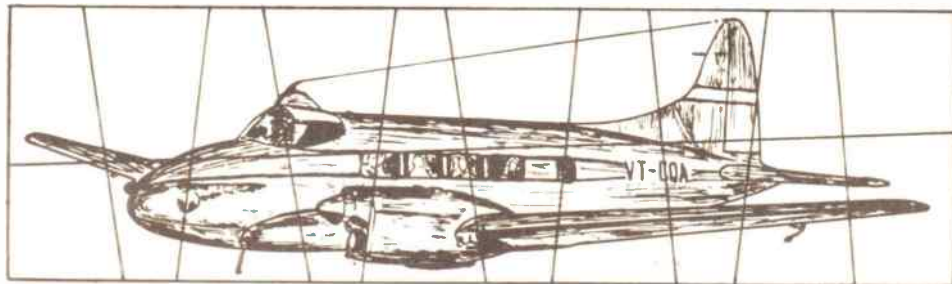

Made for a few shillings

A CAMERA ENLARGER

THE enlarger described here is very easily made, indeed, and the total cost is only a few shillings. It is of horizontal type, which greatly simplifies building. No bellows, focusing mechanism or lens need be bought or made, because a camera takes the place of these.

The photographer will, of course, already have a camera, and this will be suitable unless it is of the very inexpensive type with no means of adjusting the focus. The camera is not altered in any way, and using it for enlarging will not cause damage to the lens, shutter or other parts.

If a box camera or other fixed-focus camera is used for taking shots, then a new lens and focusing tube can be added to the lamphouse unit, so that the enlarger is complete in itself.

The lamphouse is a large tin container, with lid, and should be at least 4ins. in diameter and 6ins. long. About 5ins. in diameter and 7ins. or 8ins. long would do very well, but tins much shorter than about 6ins. will bring the lamp too near the negative. No ventilation is provided, because the lamp is only on for a minute or so when actually making an enlargement.

Wooden pieces

A distance piece cut from wood $\frac{3}{8}$ in. or 1in. thick is required, to increase the distance between negative and camera lens, and for $2\frac{1}{2}$ in. by $2\frac{1}{2}$ in. negatives this has a cut-out $2\frac{1}{8}$ ins. by $2\frac{1}{8}$ ins., as in Fig. 1. (This item may be cut from thin wood if a new lens and focusing tube are to be used instead of the camera.)

A further square of 3-ply with a similar cut-out is also necessary, as shown in Fig. 1. Both pieces are cut to suit the diameter of the tin lamphouse — that is 5ins. by 5ins. for a canister 5ins. in diameter.

By F. G. Rayer

If the camera provides $2\frac{1}{2}$ in. by $3\frac{1}{2}$ in. negatives, the cut-out in both squares should be about $2\frac{1}{2}$ ins. by $3\frac{1}{2}$ ins. With other sizes, the dimensions of the aperture are similarly adjusted to suit.

The wooden baseboard is as wide as the diameter of the lamphouse, and long

enough to take lamphouse and camera. A spacing strip to go between lamphouse front and distance piece is also required. It should be just thick enough to allow the carrier glasses, with negative, to slip into position.

Assembling

Fig. 2 shows how the parts are arranged. The two pieces of wood shown in Fig. 1 are nailed or screwed together, with the spacing strip between them. The bottom is then cut out of the tin container, leaving a flange roughly $\frac{1}{2}$ in. wide all round. Four holes are made in this flange, to take small screws.

A piece of opal glass is fixed inside the lamphouse front, as in Fig. 2. Photographic dealers stock this glass for use in ordinary vertical enlargers of the type

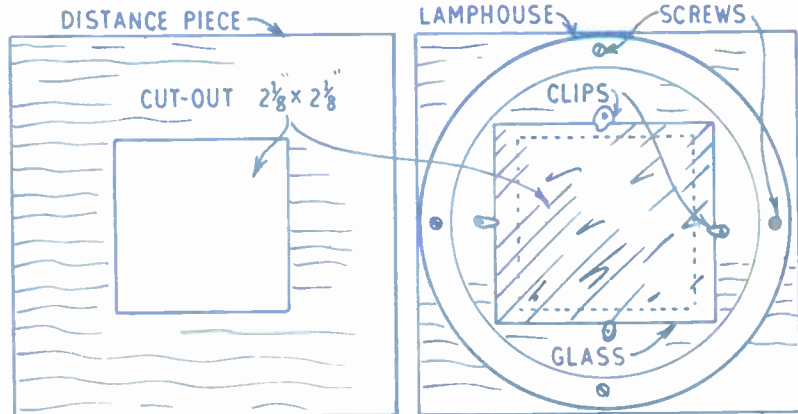

Fig. 1 — Distance piece and lamphouse front

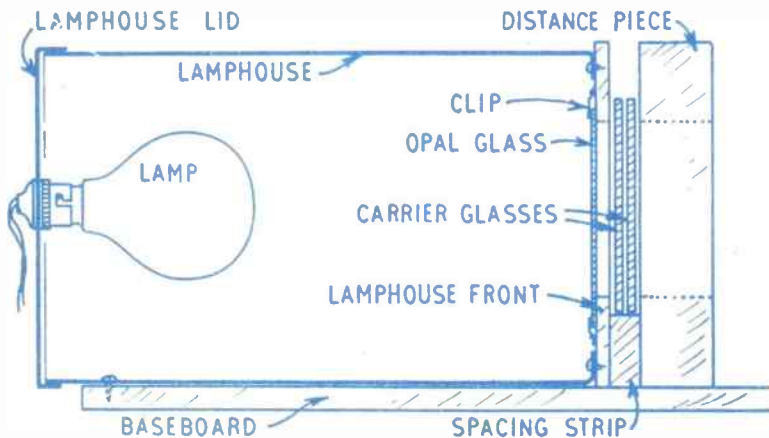

Fig. 2 — Lamphouse and carrier

without condenser illumination, and it may be square, rectangular or circular. It must completely cover the opening, and it is held by four small clips cut from tin and held by small screws, as in Fig. 1.

The lamphouse should now be secured to the lamphouse front, four small screws being used. Two screws are then driven up through the baseboard into the distance piece. A further screw holds the lid end of the lamphouse to the baseboard. The canister top projects slightly, so that the lid can be put on.

An insulated lampholder is fitted in a hole cut in the centre of the lid. A length of good quality twin flex is taken to the holder, a lead through switch being included near the enlarger. Current may be drawn from an adaptor inserted in a lighting fitting.

Satisfactory enlargements are possible

with a 60 or 100 watt pearl lamp, but an opal lamp of the type sold for use in enlargers is better, as it gives more even illumination. After inserting the lamp in its holder, the lid is pushed on the lamphouse.

Negative carrier

The negative to be enlarged must be held flat, emulsion side towards the lens, and this is most easily done by placing it between two carrier glasses. Any clean glass, free from defects, will be satisfactory. Dirt or dust on the glasses or negative will cause corresponding white marks on the finished enlargements.

wood may be required under the camera, to raise it sufficiently. These pieces should afterwards be screwed down in suitable positions. There is no real need to fix the camera, provided it rests firmly in place, but with some models a $\frac{1}{2}$ in. bolt can be passed through a hole in the baseboard and inserted in the camera tripod bush.

The easel

A vertical easel suitable for half-plate enlargements is shown in Fig. 3. Other sizes can be provided for by making a frame to suit. That is, with a 6ins. by 8ins. cut-out for whole-plate enlarge-

negative should appear on the easel. The front cell or other focusing control of the camera is adjusted to secure a sharp image.

If a greater degree of enlargement is required, the easel is moved a few inches farther from the camera, and focusing adjusted to compensate.

To secure a bright image, and simplify focusing, the camera aperture should be opened as far as possible. It is usual, however, to stop down to about $f5.6$ or $f8$ when making the print, to improve definition.

To make an enlargement, switch off the lamp, and place a sheet of bromide

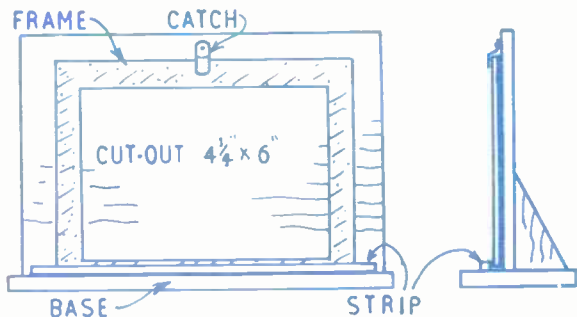

Fig. 3—Half-plate easel

The glasses, with negative between them, rest in the space between lamphouse front and distance piece, as in Fig. 2. When doing upright enlargements, the negative is placed with one side edge uppermost. For views, the negative is inserted upside down.

Camera position

The camera shutter must be set open. If the shutter has a 'T' setting, this is easily done. If there is only a 'B' setting, for brief time, then a cable release with time lock should be inserted in the cable socket, to hold the shutter open.

With the usual 7.5cm. lens, as fitted to 2 $\frac{1}{2}$ ins. square cameras, a distance piece about 1in. thick will permit enlargements from postcard size up to whole plate. If smaller enlargements are required, the back of the camera must be moved away from the negative. This can be done by cutting a further distance piece, with aperture, and placing it between the first distance piece and the back of the camera. In the event of larger prints being wanted, the camera must be a trifle nearer the negative, and thinner wood must then be used for the distance piece.

The camera must not contain a film, and its back is opened out of the way. It is then placed flush against the distance piece, so that the opening in the back of the camera agrees with that in the distance piece. One or two pieces of

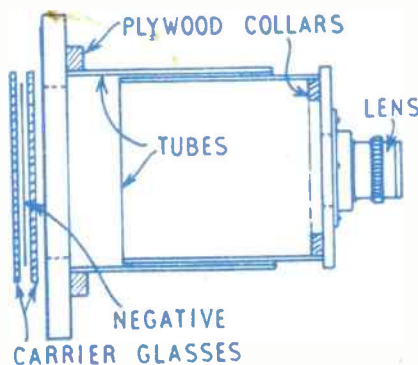

Fig. 4—Lens with tube

ments, or 3ins. by 5ins. for postcards.

For sizes up to half-plate, the easel may be 8ins. by 6ins. A narrow strip keeps the bottom of the removable frame in position, a small catch fashioned from sheet metal being pivoted to hold the top, as shown. Two wooden angle pieces hold the easel to the base.

Making enlargements

A piece of white paper is inserted in the easel, which should be placed about 12ins. from the camera lens. The room light is switched off, and the enlarger lamp turned on, when an image of the

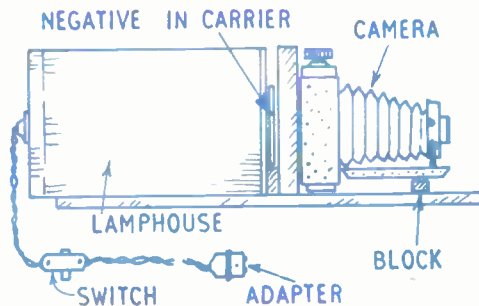

Fig. 5—Complete enlarger using camera

paper in the easel, sensitive side towards the camera. Switch on the lamp for the exposure, timing this with a watch or clock with seconds-hand. Switch off when the time has elapsed, and develop the print for about 45 seconds, rinse briefly in clean water, and transfer to a fixing bath for about 10 minutes. All enlargements are afterwards washed for at least 30 minutes in running water. The correct exposure time can be found with test strips, or small pieces of bromide paper. A very weak picture shows that the exposure was too short, while a black dark print indicates it was too long.

New lens

If a new lens is to be used, one of about 3 $\frac{1}{2}$ in. focal length is usual for 2 $\frac{1}{2}$ in. by 2 $\frac{1}{2}$ in. negatives, with 4 $\frac{1}{2}$ ins. for 2 $\frac{1}{2}$ in. by 3 $\frac{1}{2}$ in. negatives. The cheaper enlarging lenses have an aperture of about $f6.3$, with a sliding stop for $f8$ or $f11$. More expensive lenses are of $f4.5$ or larger aperture, with adjustable iris.

Enlarging lenses have a flange, and can be screwed to a small panel, as in Fig. 4. The panel is fitted to a tube which is a sliding fit in a second tube fixed to the front of the enlarger, as shown. The tubes must be matt black inside. The sliding tube is moved in or out as necessary to focus the image on the easel.

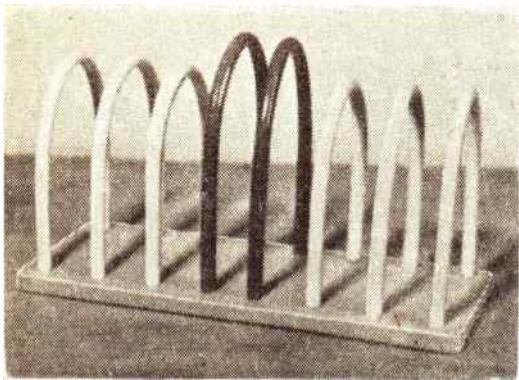

A 'NEW-WAY' TOAST RACK

By S.H.L.

BY taking advantage of some of the newer plastic materials we can make a decided improvement to canework products, and here we describe how to make a simple toast rack, which not only looks bright, but is also easily cleaned.

You may buy ready-prepared bases already drilled, but it is not a difficult matter to make one of these from a piece of scrap plywood. The one shown is made from $\frac{3}{8}$ in. plywood measuring $6\frac{1}{2}$ ins. by $3\frac{1}{2}$ ins., slightly rounded at the corners and having holes bored along each side $\frac{1}{2}$ in. from the edges. As revealed in Fig. 1 the holes are drilled $\frac{1}{2}$ in. apart except for those at the centre which are $\frac{3}{4}$ in. apart and required for the handles. While this size may be considered rather large, holding six slices of toast, by slight modification, the size can be adjusted to make a smaller rack. The holes in the base should be $\frac{1}{2}$ in. in diameter.

Having drilled the holes and smoothed off with glasspaper a piece of plastic, self-adhesive material is applied to the base. 1ft. of this material costs a little over a shilling, and will be sufficient for several toast racks or similar projects. Measure the amount of plastic material required very carefully, allowing for the thickness of the plywood and at least $\frac{1}{2}$ in. extra for turning on to the underside. Reference to Figs. 2a and 2b will show how we deal with the corners.

The protective backing of the plastic is peeled away and laid on the table with the adhesive surface uppermost. Place the base on this when the material will adhere and on turning over, a clean duster should be rubbed all over and at one edge. Rub this edge with the duster, folding over the plastic to the underside. Cut at the edges as shown in Fig. 2a with a pair of scissors, turning the resulting strip round on to the side and finally trimming away the remaining waste — as indicated by the shaded portion — which may be thrown away. Both long sides should be similarly

treated, finally folding over the balance at the ends after making a neat mitre as shown in Fig. 2b. Note that you must also allow for the thickness of the base before making the mitre.

We have now covered the base, obscuring the holes, but a little pressure with the duster will soon reveal their

FIG 1



FIG 2A

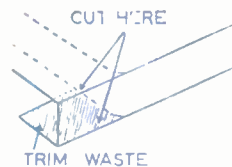
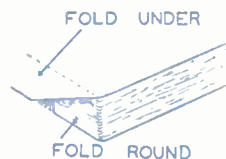

FIG 2B



positions, and it is an easy matter to make ready for adding the cane by inserting a pricker or the end of the scissors blade.

You will require number 15 gauge cane for making the divisions, and you will find that this is rather larger in diameter than $\frac{1}{2}$ in., the size of the holes, but will squeeze in when wetted, giving a tight fit. You will also require some plastic tubing to fit the cane, and obtainable at the crafts shop. In the sample shown in our illustration, blue plastic was used for the handles, white for the other divisions and the base also had a covering of blue plastic material.

While you may make any modification you like to the size and shape, or colouring, you will find that the lengths of cane are best cut $7\frac{1}{2}$ ins. long, with the plastic tubing cut to correspond, but less twice the thickness of the base. This allows for free cane only to fit into the holes, leaving the exact amount of plastic tubing. Canes for the handle(s) should be at least 1 in. longer, so that they stand above the other divisions. Cut off the number of canes required, rub the sharp edges of the ends on glass-prep to permit easy insertion into the

small holes, and place in a bowl of clean cold water, where they should remain until quite pliable, perhaps, a matter of fifteen minutes.

Take a piece of cane and after shaking off excess water, push through a length of plastic tubing, so that each end of the cane remains bare, this portion being equal to the thickness of the base. Insert one end of the cane into a hole, bend over towards the corresponding hole on the other side and force into position. If you have followed the foregoing instructions, rubbing the cane ends as directed, you will find that the cane squeezes into the holes with a tight fit, eliminating the necessity for glue. At this stage you should see that the fitted cane is nicely rounded and vertical for any adjustments can be made while it

remains in the pliable condition. Viewing from the side will reveal whether the division is also at right angles to the base.

The work should proceed from one end to the other, and do not forget to fit the differently coloured handles in the centre where proposed. A final examination will reveal any minor defects which should be corrected before leaving the cane to dry. If the canes are accurately measured when cutting to length, there should be no need whatever to make any corrections, because of unequal heights of the divisions.

All manner of cane projects may be made in this fashion, including flower pot baskets, fruit bowls, bread baskets and the like.

Follow the **FLUXITE** way to Easy Soldering



No. 11 Keeping the bit hot

When on a long job place bit just outside heating flame and occasionally apply **FLUXITE**. This will help prevent it from detinning. Don't dip the bit into the tin of **FLUXITE**—put a little aside in a spare tin lid for the purpose.

FLUXITE is the household word for a flux that is famous throughout the world for its absolute reliability. In factory, workshop and in the home **FLUXITE** has become indispensable. It has no equal. It has been the choice of Government works, leading manufacturers, engineers and mechanics for over 40 years.

FLUXITE
SIMPLIFIES ALL SOLDERING

FLUXITE Limited, Bermondsey St., London, S.E.1
GM.61



**The world's
strongest
glues**

STILL ONLY

1/2

A LARGE TUBE

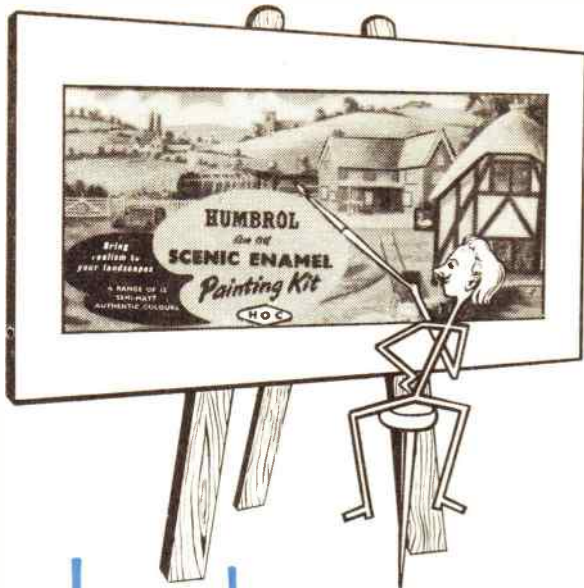

**Landscapes
really come to
life**

With each stroke of your brush, landscapes — model air stations — railway layouts — backgrounds, etc., take on true authenticity.

This brand new kit contains 12 authentic matt colours specially produced for finishing landscapes. Black, Concrete, Earth, Wood, Foliage Green, Grass Green, Yellow Brick, Red Brick, Tarmac, Slate, Stone, Tile.

The enamel is of the jellied type and needs no stirring — cannot spill, and gives a realistic finish. The Kit also includes mixing palettes and a high quality artist's brush. Ask your local model shop for full details of the laboratory tested H.O.C. range of handicraft products. Remember they are . . .

**SPECIALLY PRODUCED FOR
THE WORLD'S MODELLERS**



12/11

The Humber Oil Company Ltd.
Marfleet, Hull, England

3-D PICTURES

Described by

A. Liston

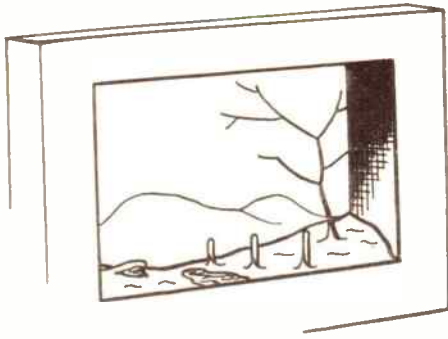

ATTRACTIVE three-dimensional pictures make an unusual wall decoration and are easy to construct.

For the frame all that is required is a cardboard backing, several thicknesses of cardboard surround to make a depth of about $\frac{3}{4}$ in., a piece of glass and some passe-partout tape.

The backing and surrounds are first glued together and left to dry (Fig. 1). The scene itself is built up in the hollow of the frame. The method is the same for all scenes, and the following instructions are for a simple but effective snow scene. First, mix some proprietary plaster filler (such as Alabastine) to a thick paste, and with a knife blade, model the foreground as shown in Fig. 2, heaping it to one side and to the back, and tapering it towards the front edge of the cardboard surround. While the plaster is still wet, insert a small twig in it for a tree.

Add three smaller twigs or painted matchsticks for a fence, one or two small stones half-covered with plaster, a strip of slightly crumpled cellophane for ice, and the scene is complete.

The background should be kept simple — here, plain pink or blue with distant hills in pale grey would look best. The sides of the scene should be painted, too, or thinly coated with plaster to conceal the edges of the cardboard, then painted.

After the plaster has dried, the glass is held in position with passe-partout tape.

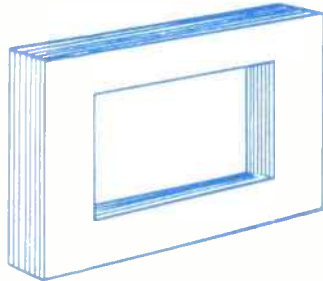

Fig. 1

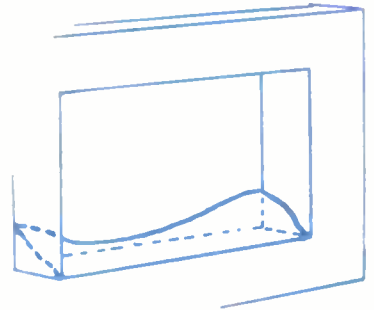
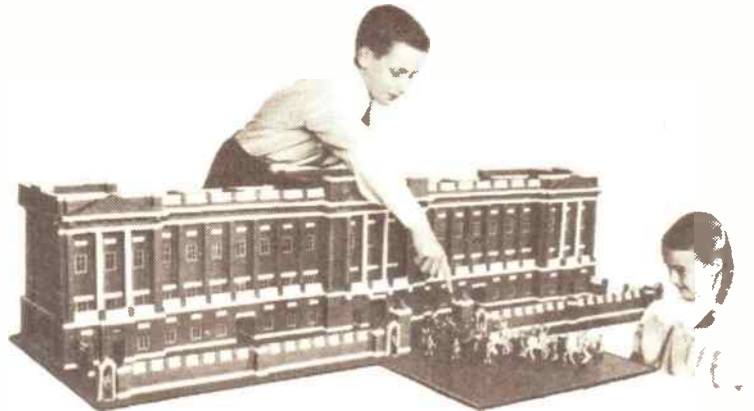

Fig. 2

American buys 'The Palace'

THIS large to-scale model of Buckingham Palace is built of 13,611 Minibrix, interlocking rubber building bricks. The model weighs 205 lbs., is 5ft. 7ins. long, 2ft. high, and cost £300. This replica was a highlight of this year's International Toy Fair, New York. It was there that Sir Charles Colston, head of the Colston Group of Companies which includes Minibrix, was asked by an American woman to send her a similar model.



BUYING OR SELLING?

Classified advertisements on this page are accepted at a cost of 6d. per word prepaid. Use of a Box No. is 1/- extra. Send P.O. with advertisement to *Hobbies Weekly*, Advert. Dept., Dereham, Norfolk. Rates for display advertising on application.

'PAINTSPRAYING' HANDBOOK. Covers Car, Industrial & Flock Spraying, 3/6, post 4d. Catalogue of our Cellulose and Paints and all Allied Sundries 3d. — Leonard Brooks Ltd., 81 Oak Road, Harold Wood, Essex.

BECOME CHIROPODIST MASSEUR. Postal Schools, (Dept. 27), 48A Abbey Street, Accrington.

100 DIFFERENT stamps free! Request 3d. upwards, discount approvals. — Bush, 53 Newlyn Way, Parkstone, Dorset.

MAKE A MUSICAL BOX for as little as 21/-. New kits and tunes available. Movements 13/- post free. Please send 3d. stamp for free illustrated catalogue. — The Swisscross Co., Dept. B., 202 Tulse Hill, London, S.W.2.

STAMPS FREE — Empire Packet including Pictorials and Victorians with approvals. Robert J. Peck, 7A Kemp Road, Bournemouth.

CLUB PRINTING AND DUPLICATING. Samples and prices 3d. — Bernard Salmon, 107 Shearer Road, Buckland, Portsmouth.

PENNY A STAMP! That is our price! Large commemoratives, pictorials. Empire packet free! — Marton Stamps, Marton, Winsford, Cheshire.

FULLY TRANSISTORIZED

The VOXETAPETAPE RECORDER

NOW a brand new EXPENSIVELY TRANSISTORIZED tape recorder and play back machine AT EVERYBODY'S PRICE. Complete outfit ready to record and play back. £11. 19. 6., carr. 5/-



No more to buy. Records anything — music, outdoor sound effects, sing-songs, parties. Ideal reporters, dictating, etc. Permanent recordings or tape can be used again and again. Further 3 in. spools obtained anywhere. With standard batteries (cost 1/8d. — months of normal use) you can record outdoors — anywhere! Perfect reproduction. Portable. Written guarantee. Or sent for £4, bal. 18 ftly, payts. 10/10d. **LISTS. GUITARS, WATCHES, RINGS, CABINETS, JEWELLERY, etc. TERMS.**

Headquarter & General Supplies Ltd. (HOBW/37) 196-200 Coldharbour Lane Loughboro Junc., London, S.E.5. Open Sat.

MUSICAL MOVEMENTS. The largest selection of tunes in England. — Richardson & Forder, 5 Chapel Place, London, N.17.

10,000 FORMULAS. Trade secrets, recipes, processes. Remarkable 900 page book. Only few available. Money back guarantee. 27/6 p. pd. — S. P. Ltd., 28(H.B.) Dean Road, London, N.W.2.

Completely new 54 page Edition
WHERE'S THAT CAR FROM ?
Price 1/- (Postage 4d.)
Of all Booksellers
or
RALEIGH PRESS, Exmouth, Devon

SAVE THIRTY SHILLINGS !
ELECTRIC DRILL ACCESSORY KITS

Sanding Discs — Backing Pad — Lambswool Bonnet — Grinding, Buffing and Wire Wheels with Arbor — Masonry Drill and Wallplugs — 3 Drills for wood — 3 Drills for Metal — Postage Paid — 24/6 — (Usually 54/6) — Lists Free.
BARKERS, 70 WEST STREET, LEEDS 1

THE RIGHT ANGLE IS DEXION. — Saves time and money on every job. Right for Brackets, shelves, racks, ladders, tables, trolleys, sea-folding, etc. Send for details. — Pithers, 36 Mortimer Street, London, W.1.

OLYMPIC Games stamp and 10 beautiful Pictorials free! Five Continents represented. Send 3d. postage requesting bargain approvals. — Greenwood (HA), 9 Moor View Road, Sheffield 8.

MEN-WOMEN with spare time, required for new simple weaving work. For details send S.A.E. — (Dept. 4) Weava Products, 10 Shelley Road, Worthing.



with



Hobbies kits for novel musical boxes are extremely popular for making up as gifts and for sale. Kits include materials and full instructions for making with a few simple tools. Musical movements are extra. Make your choice of tune from list below.

GET A KIT NOW!



Kit No. 3152 **7/11** (post 1/3)

SWISS CHALET. Lift the lid to offer a cigarette and it plays a tune. Fit with Musical Movement No. 1.



Kit No. 3222 **11/6** (post 1/6)

MUSICAL TAVERN. A savings box which plays a tune when you insert a coin. Fit with Musical Movement No. 2.

- Fit your box with one of these tunes
- No. 1 Movement, 15/6 (post 6d.)
 - C Swedish Rhapsody
 - D Silent Night
 - E Brahms' Lullaby
 - Y Anniversary Waltz
 - No. 2 Movement, 16/9 (post 6d.)
 - R Happy Wanderer
 - S Teddy Bears' Picnic



Kit No. 3250 **12/6** (post 1/6)

GRAND PIANO. Kit includes printed keyboard. Fit with Musical Movement No. 1.

Other models detailed in free Booklet

To Hobbies Ltd., Dept. 992, Dereham, Norfolk.
Please send free copy of Profitable Leisure and items detailed.

Kit No.....
Musical Movement.....
Name.....
Address.....
P.O. for..... enclosed

THE WILDS OF 'DOONELAND'

DARTMOOR is a district famed as a tourist ground. It is a land of beauty, its charms are unique, a region of moors and tors, of silvery streams, deep leafy lanes, of open spaces and clean sweet winds.

Devon is a name to stir all hearts. "What is it?" asks a well-known writer "that sends a thrill through you as you draw near to Exeter, and see the crimson squares of ploughland glowing in the afternoon sun on the hillside? Partly, I think, that you are now in the land of girt John Ridd, and famous men whose exploits charmed your boyhood days, for any ground is holy ground which brings us back to our boyhood."

There is truth in this view-point, for the very thought that the tourist is treading soil linked with famous people adds zest to a tour in this county from whence so many excellent things come, such as cider, Cornish pasties, good literature, good fishing, and delights of many kinds. Its literary associations are as varied as its landscapes. Charles Kingsley, R. D. Blackmore, Eden Phillpotts, Rev. Baring-Gould, Henry Williamson, among the more modern writers. Gay, John Ford, and Nicholas Rowe, of a more distant date, have produced books with a Devon background.

North Devon is particularly connected with Blackmore's immortal book *Lorna Doone*. Here lies the countryside where the drama of John Ridd and the beautiful Lorna was played amid romantic scenery — wild, with purple hills, russet moors, by-ways, valleys, hills and tors, and remarkable verdure. A summer holiday spent here is seldom forgotten! Gazing on this wonderful country it is not surprising that John Ridd, on his return from a visit to London and crowded streets, "thanked God for the sight of it again".

Ponies and deer

Exmoor ponies and wild red deer graze on the heathery slopes and expanses of fern and ling — unspoiled enough to please the most exacting of Nature-lovers.

Dartmoor is wilder than Exmoor. Its curious granite tors, its legends, its prehistoric relics, all mark it as a region different from any other part of England. Its deep tree-filled valleys are a feature of this country of tors and solitude where the silvery Dart winds on its rocky way down the folds of narrow glens, with waters gurgling among black rocks.

Dartmoor is the background of many of Eden Phillpotts' novels. Among present day writers he is pre-eminent as

the depicter of the rural characters of Devon. He invested the moors and tiny hamlets and woody combs with fascinating charm.

Other literary associations linked with Dartmoor are books by the Rev. S. Baring-Gould, John Oxenham, Sir Walter Besant, Edgar Wallace and other well-known writers who have used the Dartmoor country with the moors for a setting investing the story or 'thriller' with romance and popularity. Then Salcombe, a delightful little town with marvellous trees and exotic flowers has figured in stories by John Masefield and others.

The 'Doone' Church

The little moorland village of Oare, just over the Somerset border, is the next step, for no admirer of Blackmore would dream of returning from Exmoor without a pause at the tiny church that

figures in the book of *Lorna Doone*, where John and Lorna plighted their troth. It is a tiny edifice, shrouded in foliage in summer, with a low chancel and square tower — a building quite in harmony with the romantic episodes told in the book. Here, at a time when the lilacs were blooming in clusters of purple and white, scenting the spring-time air, the final act in the drama of John Ridd was played — the shooting of the winsome bride by the jealous rival, and the energetic action of the bridegroom, who with fury and sudden heartbreak, hastened to settle old scores at last with the wicked Carver Doone.

If your imagination takes wings as you tramp across the wilds of 'Doone-land', then surely you will meet with one of the outlaws on horseback, or glimpse Sir Ensor lurking amid the bracken. If one possesses a spark of imagination, then 'Vile Glen Doone' should stir the most sluggish mind. (A.S.)

You can X-ray Yourself!

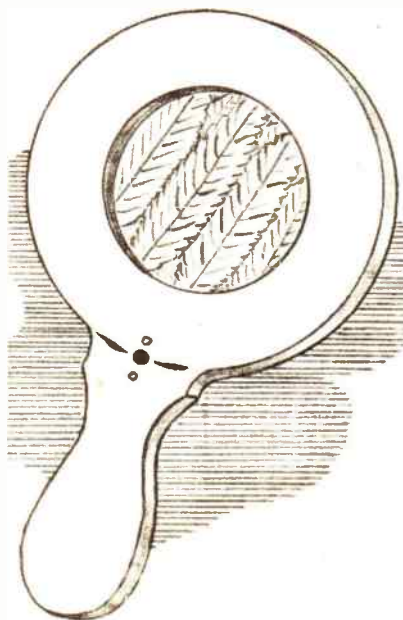

All you need is some cardboard, some glue and some chicken feathers. The last-named can easily be obtained from your local poultry dealer or from neighbours who keep chickens. Be fussy in choosing the feathers. You will need about six nice downy specimens with the threads undamaged. Also, smooth out any gaps in the delicate edges.

Cut from cardboard two 'hand-mirror' shapes as shown in the drawing. If this is too difficult for you, cut two simple squares of about 4ins. each side, and cut out a 3in. diameter circle in the centre.

Smooth the feathers

Take one of the shapes and across the centre hole place neatly the feathers. To keep them in position, put a minute portion of glue on the feather tips where they overlap the hole. Finally, glue the other shape over the first shape to form the unit shown in the drawing. You must aim at arranging the feathers in an orderly manner, so that the whole of the cut circle is filled with smooth down and with the minimum of open spaces.

To use the X-ray unit, hold up your hand in front of an electric light bulb. All you see is a silhouette. But place the unit between your eyes and your hand and close to the latter. You will now see your hand as an X-ray picture — the bones in black outlines, the flesh semi-transparent and so on. (E.C.)

YOU don't need a lot of money to construct a simple X-ray machine. It can be made with odd materials lying around the house.

OLD-TIME LOCOMOTIVE

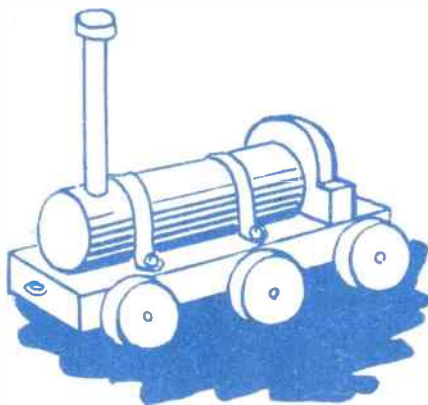

MAKE this little toy from odd pieces of wood and round rod. Suitably painted and packed in a polythene bag it would be an attractive present for Christmas.

Cut the chassis (A) from $\frac{1}{2}$ in. wood and the piece (B) from $\frac{1}{4}$ in. The boiler (E) is a piece of 1 in. diameter round rod and the chimney (C) is $\frac{3}{16}$ in. round rod. Slightly flatten the underside of (E) and glue to (A). Secure from underneath with two nails or screws. Drill a hole in (E) to take the chimney (C). Glue the cap (D), cut from $\frac{1}{4}$ in. wood, to the top of (C).

Now glue piece (B) to (E) and add six wheels (F) cut from $\frac{1}{4}$ in. wood. Pivot them to (A) by means of round-head screws. These wheels may be cut from plywood if desired.

Finish off by adding two straps of $\frac{1}{4}$ in. wide brass strip or cardboard, securing them by screws. They should go over the boiler and are screwed to piece (A).

Paint in bright colours and add a screweye at the front for attaching a cord. (M.p.)

