

HOBBIES WEEKLY

JUNE 4th 1958

VOL. 126

NUMBER 3266

IN THIS ISSUE

	Page
Handsome Cabinet for Records, Books, etc.	129
The Tavern in Veneers	130
Collectors' Club	131
Passé Partout Pictures	132
More Shots Per Film	134
Weather Novelty	135
Learn to Swim—6	136
Flowering Cacti	137
Wine-making Calendar	138
Mainly for Modellers	140
Is this Your Problem?	142
Pattern for 'Swan' Toothbrush Rack	143



All correspondence should be addressed to the Editor, Hobbies Weekly, Dereham, Norfolk

★ FREE design inside

THIS handsome cabinet can be utilised for the storing of records and books, or as an ordinary cabinet. It has contemporary legs, and nicely finished would make an admirable piece of furniture for any room in the house.

There are two storage compartments, which in turn are divided by partitions. These partitions are optional or can be increased in number if desired, as will be later explained. The doors pull downwards and are supported by cabinet stays.

Construction is mainly from ½in. timber and plywood, and the project is suitable for finishing by staining and polishing or with a coloured lacquer.

Make up the carcass of the cabinet as shown in Fig. 1. The necessary measurements of the various parts are given in the front and side views on the design sheet. If working from a Hobbies kit in which standard size ½in. panels are included, remember when cutting the top and bottom that the waste wood is used for the corner pieces B. Therefore, before commencing to cut, mark out the top

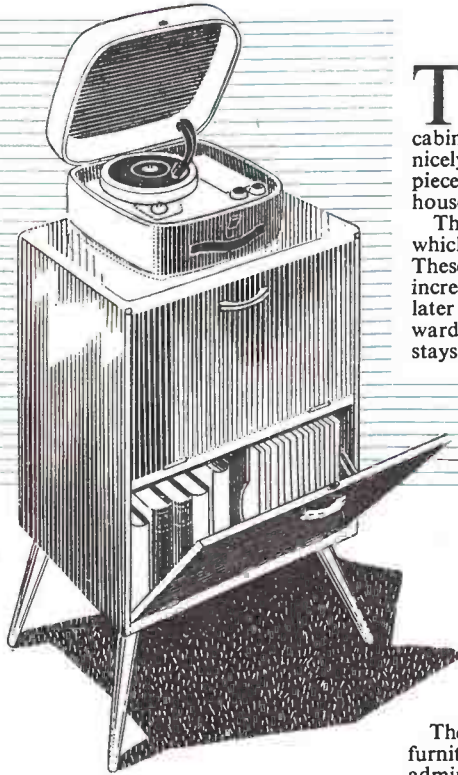

HANDSOME CABINET

(FOR RECORDS, BOOKS, etc)

The overall height of this piece of furniture is 34ins., which makes it admirably suited for manipulating a record player or gramophone placed on top.

(pieces C and D), the bottom (C and D) shelf pieces (E), and corner pieces (B) (eight required). Fig. 2. shows how the wood should be laid out for economical cutting. The sides (pieces A) are cut from ½in. plywood.

FOR ALL HOME CRAFTSMEN
Over 60 years of 'Do-it-Yourself'

4¹/₂¹/₂

Before assembling the carcass, insert the ball portion of a ball catch in the front edge (underneath) of the top C and the shelf E, centrally and as near the edge as practicable. Incidentally, it will be noted from the layout that there is a gap between the pieces E. This does not serve any definite purpose, but will

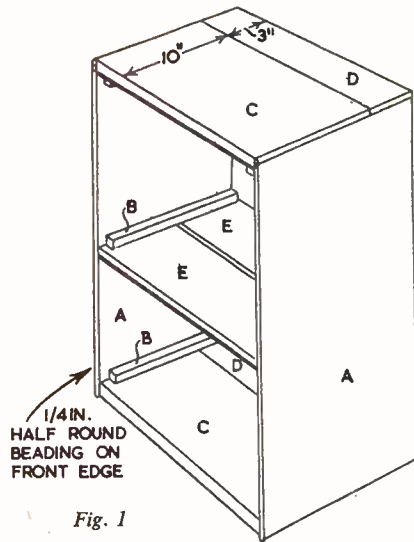

Fig. 1

economise on wood as the pieces E are cut from a standard 6in. panel.

Assemble the top, back and sides etc, using glue and panel pins, the holes of which will later be filled with plastic wood or filler. Note that the sides are $\frac{1}{2}$ in. down from the top to allow for the addition of quarter-round beading. Pieces B are added for strengthening at the corners. The back, cut from $\frac{1}{2}$ in. ply, measures 17ins. by 23 $\frac{1}{2}$ ins. and goes between the sides, top and bottom, being screwed in place to pieces B.

The two doors are made up as shown on the design sheet. Make up the frames, consisting of 1in. by $\frac{1}{2}$ in. stripwood halved together and covered with $\frac{1}{2}$ in. plywood as shown in the details. The frames are screwed together and the plywood is glued in place.

The doors can now be hinged, the top to shelf E and the lower one to the bottom C, using two pairs of 1 $\frac{1}{2}$ in. brass hinges which will be recessed to fit flush. Fix the two handles (Hobbies No. 711) to the doors near the top edges.

Now close the doors and locate the exact positions of the matching halves of the ball catches before screwing these in position.

The cabinet stays are fixed according to the detail on the design sheet. Note that a small plate of $\frac{1}{2}$ in. ply must be glued to the side to provide thickness for screwing the metal plate of the stay in

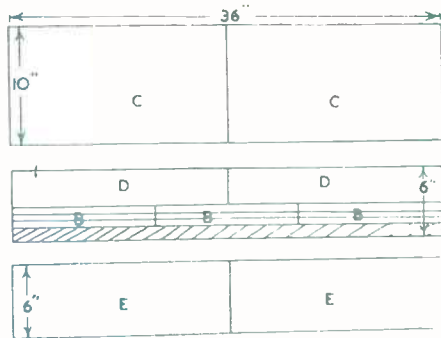

Fig. 2

position.

The partitions consist of the waste portions from the plywood panels, and they are held in position by $\frac{1}{4}$ in. square stripwood. The makeup of these partitions is shown in Fig. 3. The lower partition will, of course, be only 10 $\frac{1}{2}$ ins. high. Further partitions, if required, can be similarly made up from hardboard or plywood and $\frac{1}{4}$ in. square stripwood.

Beading ($\frac{1}{4}$ in. quarter-round) is now glued along the top of the sides and $\frac{1}{2}$ in. half-round beading is glued along the front edges of the sides.

The legs are Hobbies No. 580 contemporary style (10in.). They can be slightly splayed as shown by the side view. These legs screw into wooden blocks which are in turn screwed to the

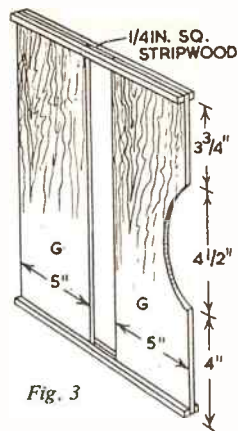

Fig. 3

bottom of the cabinet, making fixing quite easy.

Finish is left to the choice of the worker. In all cases the wood should be well cleaned and filled before polishing or painting, in order to get a superior result.

Hobbies Kit No. 3266 for making this elegant cabinet contains all wood, beading, legs, catches, handles, stays, etc. Price 65/- from branches, etc, or Hobbies Ltd, Dereham, Norfolk (post free)

The Tavern in Veneers



WE are always pleased to learn of readers' experiences in the making up of our various designs, especially when an improvement upon the original is claimed by an enthusiastic hobbyist.

Mr. G. Beardwell of 186, Whalebone Lane South, Dagenham, Essex, writes to inform us of the method he adopted in making up the Musical Tavern (Design No. 3222).

In the first instance the box structure of the model tavern was constructed from plywood in accordance with the instruc-

tions, and then, recognising how well this design lent itself to the use of veneers, Mr. Beardwell cut out and applied all overlays as in knife marquetry. Readers will probably be interested to hear the details of the finish he gave to what must have resulted in a most charming model.

All dark pieces (such as the half-timbering) were cut from very dark veneer and the intervening spaces representing white plaster were completed with white inlaid veneer. Grey veneer was used for the windows and brown for the window surrounds.

The roof was covered with Zebrano veneer, applied lengthwise, and all window sills ($\frac{1}{4}$ stripwood) were painted green. The pieces under the roof were painted a lighter green and the chimneys were painted grey. Grass green paint was applied to the base.

Kit No. 3222 for making the Musical Tavern, a savings box which plays a tune when you insert a coin, costs 11/6 from branches or by post from Hobbies Ltd, Dereham, Norfolk. Musical movements are 18/3 extra.

CIGARETTE cards were first issued in 1876. By 1938 about 9,000 different sets had been issued by tobacco firms throughout the world covering almost every subject of human interest. Gradually the cigarette companies ceased to insert cards in their products and the card field was taken over by confectioners.

Card collecting today remains an interesting yet expensive hobby. Many sets are still quite common. Beginners can build up a fine collection easily and inexpensively.

But collectors should always be on watch for the following scarce sets.

Anstie: 50 Racing Scenes (1922) cat. 40/- set; 50 scout series (1923) — 30/- set.

Ardash: MP45 Photocards, Group N — 30/- set; LP54 Real Photos, Series 12 — 40/- set.

British American Tobacco: LP36 Modern Beauties, 9th — 30/- set; 25 Prehistoric Animals — 15/- set; 25 Warriors of All Nations — 12/6 set.

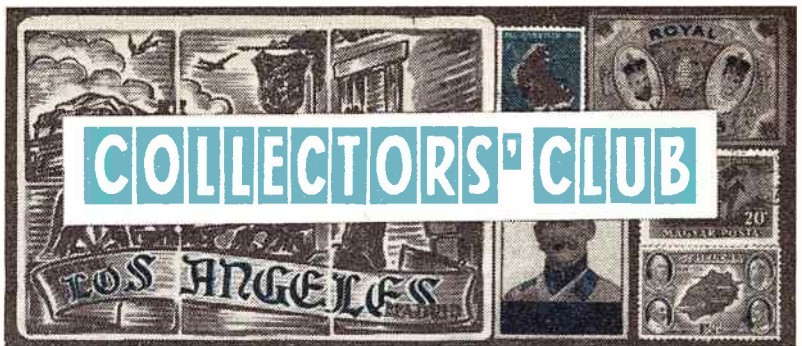

Lambert and Butler: 40 Arms of K. and Q. of England — 60/- set.

Ogden: 50 Orders of Chivalry — £5 set.

Player: 50 Celebrated Bridges (1903) — 70/- set; 50 Cities of the World (1901) — £8 set.

Wills: 60 Coronation Series (1902) — £8 set; 50 Medals (1906) — £7 set; 50 Sports of all Nations (1900) — £5 set.

Beano Ltd: 50 Modern Aircraft; 50 Wonders of Modern Transport — printed in Blue and Black; 50 This Age of Speed (1) Aeroplanes, (2) Buses and Trams; 50 Conquest of Space.

Chix Confectionery: 96 Radio and Television Stars.

A.B.C. Cinemas: 10 Water Sports; 10 Journey to the Moon; 10 Travel of the Future; 10 Sea Exploration.

Few enthusiasts have a complete collection of every set. Most collectors are constantly on watch for scarce items.

CIGARETTE CARDS—By R.L.C.

Perhaps these cards are purchased from dealers or obtained through exchange with fellow collectors, or found in antique shops. This constant pursuit for perfection is the lifeblood of card collecting. And a by-product of the vast correspondence involved is the number of close friendships that are cultivated.

The subject of 'cartophily', or card collecting, has appeared frequently in the press and has been featured by the B.B.C. Not that it has reached the commercialized state of philately — confectioners still insert cards in their products to promote sales — not as items for collectors. But the hobby has shown a steady, healthy growth.

So if you seek fresh fields of hobby adventure why not become a 'cartophilist'?

 ★ Next week's issue will contain ★
 ★ details for making a working model ★
 ★ of a 1904 Darracq veteran car. ★
 ★ MAKE SURE OF YOUR ★
 ★ COPY ★
 ★ *****



Carreras: L25 British Costumes — 52/- set; P27 British Prime Ministers — 25/- set; 27 Famous Women — 40/- set; 140 Raemakers War Cartoons — 60/- set; 50 Women on War Work — 50/- set.

Churchman: 25 Cathedrals and Churches — 50/- set; 50 East Suffolk Churches — 35/- set; 50 West Suffolk Churches — 40/- set

Coudens: 60 Holiday Resorts, E. Anglia — 40/- set.

Gallagher: 100 Birds Nests and Eggs — 70/- set; 100 Boy Scouts — £5 set; 100 The Great War — £6 set

Hill: 40 Famous Cricketers (1923) 60/- set.

The value of a collection depends on the state of the cards — soiled specimens, even rarities, are practically worthless — so include only those in spotless condition.

When selling cards remember that dealers buy at a percentage of the catalogue price, usually offering about a sixth of the catalogue quotation for 'perfect' sets. And this also applies to stamps, labels, coins, etc.

The following list of trade cards now being issued by confectioners and cinema proprietors should prove useful.

Ace High Confectionery: 25 Wonders of the Universe.

PASSE PARTOUT PICTURES

ONE of the cheapest methods of picture framing is undoubtedly that of binding with passe partout and with a little care you can quickly produce really attractive results. The materials are very easy to handle, consisting of cardboard for the backing, pastel paper for overmounts, hangers and the binding, while you only need scissors as tools. The binding is now made in a wide variety of attractive colours to suit any picture, a roll costing 1/3, and ivory white is now an extremely popular colour for any tint of overmount. Of course, glass forms the usual protective cover but there is also a substitute for this, easily cut to size with scissors and named Neerglass — a clear plastic material similar to celluloid and most suitable for lightweight pictures, or where there is any danger of the glass breaking.

are made in white, cream, pale green, pale brick and neutral shades, a large sheet costing about sixpence at any artists' materials shop. When buying such paper ask for it to be rolled, for if folded the creases would spoil the appearance of your mount. Margins are a

and the backing. But observe that the aperture in the overmount must be cut at least 1/4 in. smaller in both dimensions than the actual size of the picture. You must also mark out carefully, centring this aperture with even borders, and above all, see that the corners are true, using a set square for accuracy. After preparation of the overmount, the picture may be attached by a few touches of paste, using the smallest possible amount for too much will certainly cause a cockle. If the mounting paper is very thin it may be better to omit fixing the picture in this way.

By S. Longbottom

matter for personal taste but it is always better to have an equal width at the top and sides but the lower border should be almost twice as broad. And often when dealing with horizontal pictures you may make the top border a little wider than the sides.

If a 2 in. border is selected remember to add 4 ins. to the width of the picture and 6 ins. to the depth to determine the overall size of the overmount, the glass

There is another interesting method of making overmounts to reveal a deckle, or torn edge to the inside of the aperture. Reference to Fig. 1 will show how this is achieved. Mark out the rectangle for the aperture as before, but cutting from corner to corner diagonally. Fold back each triangular section thus made, crease and gently tear away the waste.

FIG 1

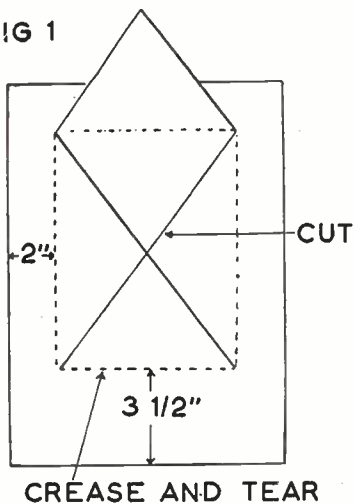

The size of the glass is governed by the size of the picture, plus any increase arising from the introduction of an overmount. Many small pictures may be bound without a mount, so that the glass, backing and picture are of equal size. This being so, it might well be asked why we should go to the trouble of making mounts which are something more than merely ornamental. It will be appreciated that if we wish a picture to be seen at its best, we must endeavour to isolate it from its immediate surroundings so that there are no conflicting distractions. When a picture is surrounded by a border of this description the eyes are held within the frame and concentration is directed solely to the picture.

You must first decide whether or not the picture warrants a mount and then a suitable colour for same. Pastel papers

FIG 3

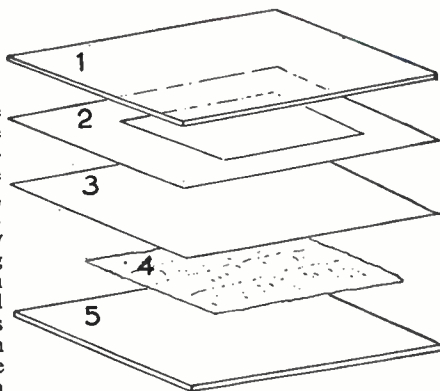
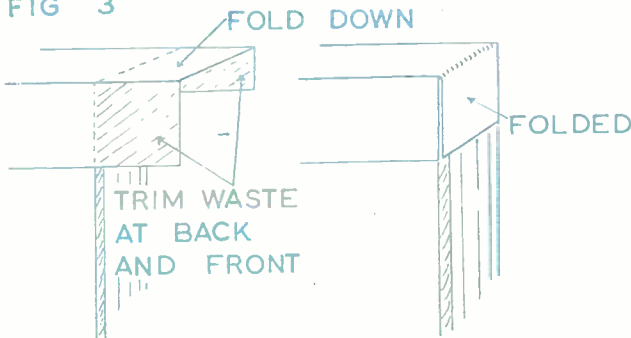

- 1 GLASS
- 2 OVERMOUNT
- 3 PICTURE
- 4 NEWSPAPER
- 5 BACKING

FIG 2

Needless to say, all pencil lines must be erased before proceeding to bind with the passe partout tape.

The cardboard backing should be made to the exact measurements of the mount, and fitted with ring hangers for a cord. These hangers are composed of a ring and a flexible flange, the latter being pushed through a slot and opened out. Hangers should be arranged so that they are about 2 ins. from the top and 1 1/2 ins. from the sides. Mark such positions, make a tiny slit with the penknife point and the flanges will push through quite easily. A small piece of passe partout should be gummed over the flanges to keep in position. It may be mentioned that pictures lay flatter to the wall when the hangers are placed nearer to the top, and when binding together do not forget that the hangers must be at the top. There is nothing more annoying to find that backing has been fixed upside down, and there is no remedy except to strip the binding away for a new start.

Glass will be cut to accurate size by most plumbers and again, must be equal in size to the dimensions of the overmount and backing. But do make certain that the glass is thoroughly clean on the inside surface before sealing on with the passe partout binding. Here again, specks of dust or fingermarks cannot be removed from the inside once binding has been completed.

Now for the operation of binding.

Take the various parts together as prepared, plus a little packing in the form of two pieces of newspaper about the size of the picture — that is, smaller than the overmount. The purpose of this packing is twofold, to prevent the hangers marking the picture and to counteract any tendency for the backing to bend outwards in the centre. You may omit the packing if the picture is already mounted on cardboard. You will observe that this small amount of packing will keep a thin picture, and overmount, in close contact with the glass. Fig. 2 shows the positions of the various parts.

Beware of dust

Assemble the parts as shown, make sure there are no dust specks about, the backing is correct way up, when a bulldog clip, or spring clothes peg, is placed on two opposite sides. The clips will keep the parts firm while the other sides are bound.

You will find a newspaper most useful in helping to maintain a perfectly straight border. First rule a thick pencil line about $\frac{1}{4}$ in. from and parallel with a printed column line of a newspaper. The glass is placed to the pencil line, while the passe partout is laid so that it is in perfect alignment with the printed line. Measure off two strips of tape from the roll to fit the two sides we are about to bind, plus $\frac{1}{2}$ in. extra. Now you must decide on the actual width of the binding which is to show on the face of the glass, and for a large picture a $\frac{1}{4}$ in. border is generally accepted as suitable. To achieve this it is a good plan to lay the binding face downwards on the table, making a light score on the gummed side with the back of a knife. Do not use too much pressure or you will cut through the binding. Now make a crease by folding. You may test the binding on glass before damping and attaching. See that the binding is in alignment with the printed column line as shown in Fig. 3, leaving $\frac{1}{4}$ in. overlap at each end. Press firmly on to the glass with a clean duster — particularly if white binding is being used — and turn over the picture for attaching to the backing. Take hold of the binding about the centre of the side, applying a little pressure with the free hand to the backing so that it is in firm contact with the glass, working towards one end, then similarly with the other half, finally

FIG 4

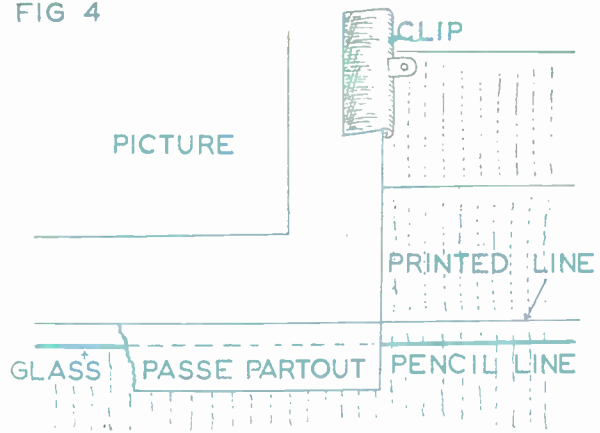

smoothing down with the duster. Now trim the surplus portion remaining at each end as shown in Fig. 4, slotting with scissors and folding down the small pieces for protection.

The other two sides are now similarly treated after removal of the clips, but here the binding should be measured to fit exactly, scored as before, then mitred at each corner. You may mitre either before or after fixing to the glass and for a really neat job you are recommended to use a set square. It may be mentioned that if it should happen that the binding is warped in any way, or a little out of alignment, it is possible to trim to a straight line. Lay a straight edge on the binding, making a clean cut to correct with a sharp knife or razor blade and the waste will strip off quite easily. Always

allow the binding to dry thoroughly before attempting to hang the picture, using a short cord if you prefer it to be unseen.

The foregoing deals with the straightforward method of binding pictures with one colour of passe partout tape, but there are several modifications if you wish to experiment. For example, two colours of tape may be used, one laid with $\frac{1}{4}$ in. showing on the face of the glass, and the second overlaid on this but leaving $\frac{1}{4}$ in. showing. Such work calls for care in laying but is well worth the trouble provided the colour combinations are suitable, black and white being a good example. Brown or sepia toned pictures often call for similarly coloured passe partout and this is another point to observe when buying your binding.



MORE SHOTS PER FILM

THE increasing cost of roll films probably accounts for the fact that the type of camera taking 12 or 16 shots, instead of 8, is more popular than in previous years. Contact prints from these smaller negatives can be satisfactory, and if enlargements are made the smaller size is almost no disadvantage. If an 8-on camera is modified to take 12 shots, 4 exposures are gained, at no extra cost. The saving with 16 shots is greater, virtually reducing film costs to half.

Some cameras, especially of modern design, have an internal mask, so that 8, 12 or 16 shots can be taken at will. This method can easily be copied, with

being screened off a little at each end.

The mask

This comes between lens and film, near the latter. With some cameras it can be cut from card, blacked with Indian ink, and fitted just in front of the aperture across which the film is wound, but with the usual folding camera it will need to be cut from thin metal and placed between camera and film.

Such a mask, for 16 shots, is shown in Fig. 1. It can be cut from flat tin, blackened by heating to red heat, or by soaking in vinegar. Shiny metal must not be used, or reflections will spoil results.

The mask must be exactly the correct

With some cameras, the film will lie in the same plane as before, when the mask is in position. If so, this is best. With others, the film will be farther from the lens by the thickness of the mask itself.

By F. G. Rayer

In theory, this minutely upsets focus. In practice, it is difficult to find any actual loss of sharpness, as the change in distance is only one hundredth of an inch or so.

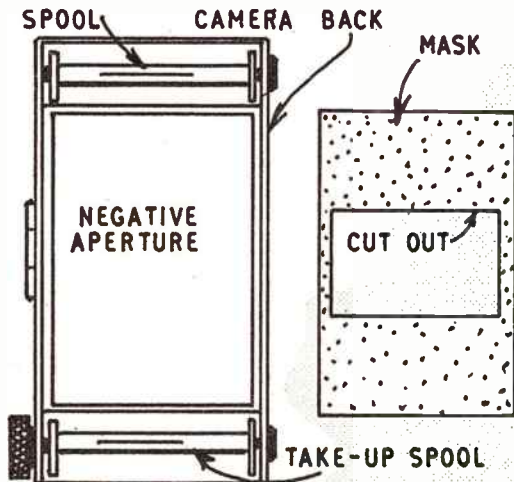

Fig. 1—How the mask is shaped

any camera normally giving only 8 shots. The modification will have to be in three steps: (1) making and fitting the internal mask, (2) arranging so that the film can be wound on in 12 or 16 steps, instead of 8, (3) marking the smaller field of view on the viewfinder.

These will be dealt with in order. It is first worth noting the usual negative sizes, however. With 8 shots on 120 or 620 film, each is about 3½ ins. by 2½ ins. This is reduced to about 2½ ins. square for 12 shots, and 2¼ ins. by 1½ ins. for 16. The exact size is liable to vary a little from camera to camera, and is not important.

When the mask is made, it gives the smaller picture area in the centre of the lens field, where definition is best. The full width of the film is used, as before, but the negative is reduced in length by

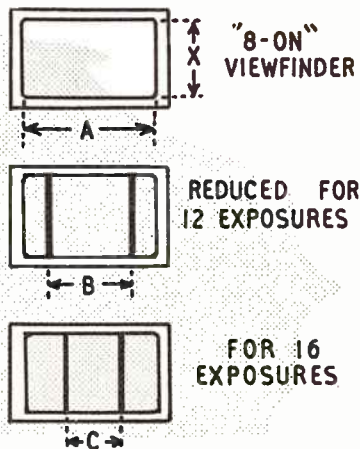
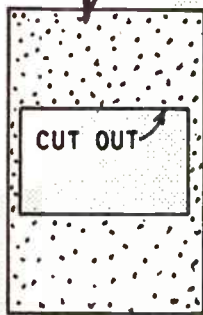

Fig. 3—Modifying the viewfinder



Fig. 2—Position of new window

dimensions, slightly overlapping the camera aperture so that no light escapes round it. It is a good plan to make a trial mask with thin card, afterwards copying this when it is correct. All rough edges must be smoothed away, or the film will be scratched during winding.

The mask, if correctly cut, will be held in place by the film, and can be removed at any time, if 8 shots are wanted again. In some cameras it will prove easier to cut two separate strips of metal, bending a little flange which will enable them to clip on one at each end of the camera aperture. There is no reason why two masks should not be made, allowing 8, 12 or 16 shots at will.

Winding the Film

The old window will only show the film numbers from 1 to 8, but one of several methods can now be employed instead. There is no real need to modify the camera, if one of the two following systems is used.

(1) The film may be wound on to a spare spool, in total darkness, so that 1 to 16 numbers will become visible in the usual 1 to 8 camera window. To do this, the backing paper is threaded

through the spare spool slot, as usual, and the paper and film wound on to this spool, keeping it taut. When the free end of the film itself is felt, it must be stuck to the backing paper. This is done by having a piece of adhesive tape ready. Winding then continues until all the backing paper is on the spare spool. The film is inserted in the camera in the usual way. The number 16 will appear first, the numbers descending as shots are taken. The new numbering thus shows the exposures remaining, not those taken, and this is no disadvantage.

(2) An old backing paper, spool, and developed film may be inserted in the camera in the usual way, and the number of times the winder has to be rotated, to wind from one number on the 1 to 8 series to the next, is noted. With the usual 120 spool, this will be $1\frac{1}{2}$ revolutions of the winder. Every *odd* numbered shot is then made by winding one of the numbers 1 to 8 into the window. Every *even* shot is made by guesswork — that is, giving the winder about $\frac{1}{2}$ to 1 revolution only. The shots may be a little unevenly spaced on the film, but this is no real disadvantage, and any errors are corrected every second shot, when a number appears in the window. It is necessary to remember that the winder has to be rotated a trifle less each time, as the movement of the film makes the take-up spool wind on an increasing diameter. However, the method is a very simple and successful one, as a film can be inserted at once. A trial or two with an old film and backing paper will show if any serious mistakes are being made, as the camera can be open, to observe the positions of the numbers.

Modifying the Camera

The foregoing methods are only suitable for 16 shots instead of 8. If the camera is old, or 12 shots are wanted, then a new window can be made, so that the 1 to 12 numbers can be seen.

This window will have to be in the centre of the camera, as shown in Fig. 2, and need only be about $\frac{1}{4}$ in. in diameter. A $\frac{1}{4}$ in. drill, used with light pressure, will do this. If a spring plate is fitted inside to keep the film flat, the hole must be continued through this, and any rough edges smoothed away.

For ortho films, a red window is necessary. A piece of thin red celluloid can be cemented over the aperture, inside, for this purpose. With pan films, dark green is required, or a sliding metal flap to keep the light off the window. The best thing, here, is to copy the arrangement adopted in the window already present — e.g., red or green window, as the case may be, with flap or cover, if used. A cover is not required for ortho films with a red window, or panchromatic films, with a dark green

window, or if the camera is kept in a light proof carrying case. Should too much light pass into the camera, a round black mark will appear on the film. This gives a round light mark on enlargement or contact print, and usually indicates that the camera is being carried in the sun, or that direct sunshine falls on the viewing window, during winding.

If a new window is desired for 16 shots, it should be to the left, where the 1 to 16 numbers appear on the film.

The Viewfinder

The final step in the modification is to show the smaller angle of view on the viewfinder. This can usually be done by sticking on two tiny slips of paper or adhesive tape, or by ruling two thin lines with paint.

Fig. 3 shows the front of the usual

fixed or folding optical viewfinder for eye-level use. As the width of the film is unchanged, the distance 'X' remains the same. The distance 'A' is, however, for 8 shots. It thus has to be reduced to 'B', for 12 shots, or 'C', for 16 shots.

For 12 shots, distance 'A' is measured and divided into 13. Two-thirteenths are then masked off at each side of the finder.

For 16 shots, distance 'A' is divided into 4, one-quarter being masked off at each side of the viewfinder.

If thin lines are drawn on the finder window, it can still be used for 8 shots as well, and this method is used in most dual-size cameras. If the finder is an open type, with no glass, the reduced angle of view can be shown by two thin wires soldered across; or a small metal mask can be cut, with suitable aperture, and clipped in place.

WEATHER NOVELTY

BLUE—
IT'S FINE



PINK—
IT'S WET

MOTHER will surely appreciate a novelty which will tell her what weather to expect on her washing day.

First, make up the simple model shown in the drawing. The base is a piece of $\frac{1}{4}$ in. plywood, 8 ins. by 3 ins. The two line posts facing each other from opposite corners are made from $\frac{1}{4}$ in. dowelling. Glue them into a drilled hole in the base-board.

The lady is a suitable illustration cut from a magazine and mounted on stiff cardboard. Most likely you will be able to draw the figure and paint it yourself. Her legs are fitted into slots across two blocks of wood, to represent feet. Glue the feet to the baseboard, in a position so that her outstretched hands come level with the length of twine that has been drawn across between the line posts.

With your paint-box, decorate the baseboard as shown with approximately half as crazy paving and the other as grass. Make some cut-out flowers from cardboard and glue in place border.

The washing on the line is the weather indicator. It is treated beforehand, as explained below, so that if its colour is bluish, it will be fine and dry; if change-

able, wet weather is approaching the washing will turn a lilac-pinkish colour. If very wet and stormy, the colour changes to very pink.

This is how you make and prepare the 'washing'. Get your chemist to make up the following solution: Cobalt chloride, $\frac{1}{2}$ oz.; Sodium chloride, $\frac{1}{2}$ oz.; Calcium chloride, 40 grains; Gum arabic, $\frac{1}{2}$ oz.; Water, 2-2 $\frac{1}{2}$ ozs.

Shake the solution well to see that all the crystals have been dissolved. Pour a small quantity into a clean, shallow tray and immerse pieces of unused blotting paper. Allow each piece to remain floating for five minutes, then hang up to dry by pinning one corner. When thoroughly dry, cut up the blotting paper into shapes of shirts, stockings, etc.

Drape them over the line and keep in place with pegs made from balsa wood. If you have to stick any on to the line be sure and stick only along the top edge. Do not paste it all over.

You will probably think of other ideas in which to incorporate the weather paper. Cut-outs of a girl, with her dress as a piece of special paper, or dogs with ribbons and many similar ideas can be used, for cards or calendars to send to your friends. (E.C.)

FLOATING



THE ability to float is not essential for a swimmer, but it gives a pleasant relaxation and added confidence in the water. The human body is only slightly less dense than fresh water, which means that when floating without any movements of limbs, only a small part of the body can be above the surface, and this, naturally, needs to include the mouth. Women and children can float more easily than the heavier boned men, but there are only a very few men who are physically unable to do so. In sea water, floating is much easier for everybody.

The chief obstacle to floating is muscular tenseness. To float successfully you must learn to relax completely. Assuming that you are now able to swim, you can start learning to float anywhere in the bath, but if you are not over confident, start at a depth where you can stand. Push off gently from the side of the bath, on your back, and extend your hands above your head. Lie as still and relaxed as you can and take a deep breath. When you breathe out, do so quickly and breathe in again quickly; this is to give you maximum buoyancy. Your head should rest back on the water with just your face above the surface. You should now feel your feet coming to the surface. If they will not do so, raise your hands very slightly out of the water; since the body balances about the lower part of the chest, this will force the arms down and the legs up. Do not, however, expect to succeed at the first attempt. If you are exceptionally buoyant, you may be able to float with your hands by your sides, but this is not easy in fresh water.

If you learn to float in fresh water, you will be surprised to find later on how much easier it is in the sea, but the ability to float in fresh water should be your aim.

Diving

Now, lastly, we will deal with simple diving. We start with the sitting dive. Sit on the edge of the bath with your feet on the rail and bend over with your hands pointing towards the water, thumbs together, with your head between your arms and close to your knees, which

should be apart (Fig. 1). Gradually bend further over until you topple, keeping your head between your arms (Fig. 2). As you topple, straighten your body and push with your feet, so that you enter the water cleanly (Fig. 3), and remain in the glide position until you come to the surface, which you can easily do, if you feel that you are going too deep, by tilting your hands upwards and raising your head.

4. When your arms have just passed your sides and without a pause, fling them forwards and upwards, at the same time jumping upwards and outwards (Fig. 7).

5. Drop your head between your arms and thus you should turn over in the air to enter the water head first, with your body in a straight line (Fig. 8).

At first you will probably make a horrible splash, owing to not keeping

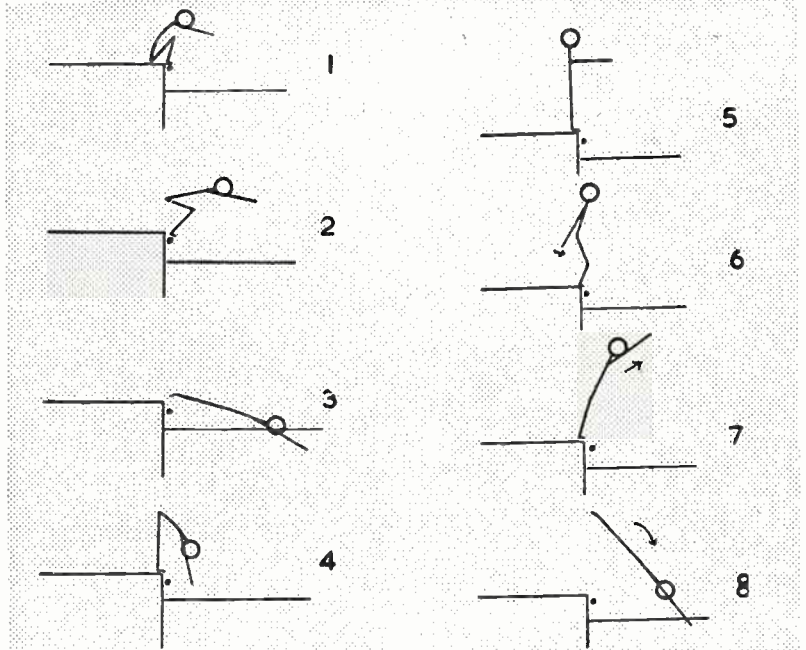

When you are able to do this easily, try the same thing but now standing on the edge (this is best practised at the deep end of the bath). Stand with your toes curled over the edge and bend over as far as you can, again with your hands together, thumbs inwards and head between your arms (Fig. 4). Continue to lean until you topple, and as you straighten your body, push hard with your feet. Keep your eyes open and aim to go as deep as you can.

The final stage in our elementary diving is a plain header from the side.

1. Stand as before, but this time up straight.

2. Raise your arms to shoulder level and pointing to the front, whilst looking straight ahead, not at the water (Fig. 5).

3. Sweep your arms down beyond your sides and at the same time bend your knees slightly (Fig. 6).

your body in a straight line, but the best way to correct this is to imagine that you have to kick your legs over a small obstacle at the edge, and that your arms will make a hole in the water through which your whole body must pass. This plain header is all that is necessary to establish your prestige with onlookers, and it can easily be performed from a springboard if you wish and when you feel confident to do so.

Fancy springboard and higher diving are out of the scope of this series, and, as already stated, is a separate subject, having little to do with true swimming, but, if you are interested, you should be able to base your practice on what you have already learnt. However, much practice and patience are necessary in order to become an expert diver, and it will not aid your swimming! (P.R.C.)

Page 137 missing

Page 138 missing

FREE PICTORIAL packet with approvals. 3d. postage.—Allcock, 74 Tynyparc, Rhiwbina, Cardiff.

ROYS STAMP SERVICE—Beginners and Juniors specially catered for. Send 3d. stamp requesting details and trial.—23 Adria Road, Birmingham 11.

EARN 100% PROFIT selling fancy jewellery. List of cheapest wholesale prices from—Cole, 37 College Avenue, Maidenhead.

SAN-MARINO 1956 OLYMPIC GAMES. This lovely mint sports set offered. Absolutely Free to approval applicants enclosing 3d. postage.—Yulwontmor Stamps (Dept. H7), 29 Layton Avenue, Mansfield, Notts.

CZECHOSLOVAKIA—Set of nine pictorials given free with approvals.—Kimberley, 27a Toddington Road, Luton.

ORIENTAL BUTTERFLIES—Exotic colourful wings on paper bodies specially mounted in cellophane. Ideal for art and decorative work. Dozen different 7/6. 3 doz. 21/—Doris Gardiner, 43 Woodlark Road, Cambridge.

100 DIFFERENT stamps free! Request 4d. upwards, discount approvals. — Bush, 53 Newlyn Way, Parkstone, Dorset.

WHEELS (Hardwood and Rubber Tyred Metal), Cot, Pram and Doll's Tyre Fittings and Papers, Beads, Transfers, Prints and other accessories. Stamp for new lists. (Trade supplied.) New address — JOYDEN CO., 91 Peplins Way, Brookmans Park, Herts.

GREAT FURNITURE SALE!
THREE-IN-ONE
★ **WRITING BUREAU**
★ **BOOKCASE**
★ **RECORD CABINET**



ONLY £319.6
CABINETS ETC. 102-1

Magnificent ultra-modern space saving item of furniture designed for 3 essential purposes. Holds 200/300 Records (upright in perfect condition). Incorporates a spacious Bookcase. Drop-front desk closes when not in use. Numerous compartments provided to contain papers, etc. Superbly made, beautifully sand-polished 100% hard wood. Doors Compoo read, 42" x 24". Don't miss. Flat top takes Radio or Gram.

Complete transmitting and Receiving apparatus for two persons.
From a few yards to a mile. Normal telephone strength. No batteries or electricity — it just works! Send 12/11, post 2/1. Ready for use in 5 mins. Lists, Binoculars, Watches, Tents, Terms. Headquarter & General Supplies Ltd. (HOBV/14) 196-200 Coldharbour Lane Loughboro Junc., London, S.E.5 Open Sat



'PAINTSPRAYING' HANDBOOK. Covers Car, Industrial & Flock Spraying. 3/6, post 4d. Catalogue of our Cellulose and Paints and all Allied Sundries 3d. — Leonard Brooks Ltd., 81 Oak Road, Harold Wood, Essex.

MODELS. You can make lasting stone-hard models with Sankey's Pyruma Plastic Cement. Supplied in tins by Ironmongers, Hardwaremen and Builders' Merchants. Ask for instruction leaflet.

KUKLOS ANNUAL. Indispensable cyclists' handbook. Tours, resthouses, money-saving hints. 3/- post free. — Burrow, Publishers, 2 Imperial House, Cheltenham.

MAKE A MUSICAL BOX for as little as £21/6. New kits and tunes available. Movements 14/9 post free. Please send 3d. stamp for free illustrated catalogue. — The Swisscross Co., Dept. B., 202 Tulse Hill, London, S.W.2.

STAMPS FREE — Empire Packet including SPictorials and Victorians with approvals. — Robert J. Peck, 7A Kemp Road, Bournemouth.

BECOME CHIROPODIST MASSEUR. BPostal Schools, (Dept. 27) 48A Abbey Street, Accrington.

STOP SMOKING in 3 days or money back. Safe, pleasant, permanent. The only scientific way. **No Will Power necessary.** 'Conquered the habit in 2 1/2 days'.—F.C. 'Within 2 days I was free from the tobacco habit'.—W.G. 'Was a smoker for 2 years and broke the habit in 2 days'.—F.N. 'I used to smoke 20 a day . . . now I have no desire to smoke'.—J.M. Recommended by 'Health and Efficiency Magazine'. Complete course 7/6 (or \$1.00 bill). Details 3d. stamp. Sent under plain cover. **NATURE REMEDIES**, 28 (H/180) Dean Road, London, N.W.2. Established 1928

APPARATUS & CHEMICALS

For your experiments. Let us help you equip a **HOME LABORATORY**

Beakers, Crucibles, Flasks, Funnels, Gas Jars, Test Tubes, etc.

Booklets: (including postage)

- 'Experiments' 1/2
 - 'Formulas' 1/2
 - 'Home Chemistry' 2/10
- New edition



Send 3d. Stamp for latest **PRICE LIST**

A. N. BECK & SONS (Dept. H.W.)
60 Stoke Newington High Street, London, N.16

HEAR ALL CONTINENTS
With **H.A.C. Short-Wave Receivers**

Suppliers for over 18 years of Radio S-W Receivers of quality.

One-Valve Kit, Price 25/- Two-Valve Kit, Price 50/-
Improved designs with Danco coils. All kits complete with all components, accessories and full instructions. Before ordering, call and inspect a demonstration receiver, or send stamped addressed envelope for descriptive catalogue.

'H.A.C.' Short-Wave Products (Dept. 22), 11 Old Bond Street, London, W.1

HARDHITTING ACCURATE

Webley AIR PISTOLS

AIR RIFLES · ACCESSORIES

Write for Catalogue

WEBLEY & SCOTT Ltd., 166 WEAMAN ST., BIRMINGHAM, ENGLAND

MAKE YOUR OWN

GUITAR

Kit 3209

All wood (including partly shaped neck) full-size plan, six strings, etc.

59/11

(Note reduced prices)

UKULELE

Kit No. 3260

Contains all wood, wire, strings, etc., for full-size instrument

24/6

To Hobbies Ltd., Dept 99, Dereham, Norfolk. Please send Kit No.

P.O. for enclosed

Name.....

Address.....

.....



Overall Length 36 1/2"

As shown on TV. Thousands of satisfied customers. Make your own first-class instrument.



From branches, etc., or post free

MAINLY *for* MODELLERS

IN the present series we are going to consider the correct types of dead-eyes and methods of erecting shrouds and we will start with the period that is so popular with our readers, the days of the galleon.

For the 15th and 16th centuries the heart shaped deadeye is the correct one to use for erecting the shrouds.

I have in an earlier article described how to make your own deadeyes of this type and we will now consider how they can be attached to the shrouds and to the hull in authentic manner.

For the beginner, undoubtedly the

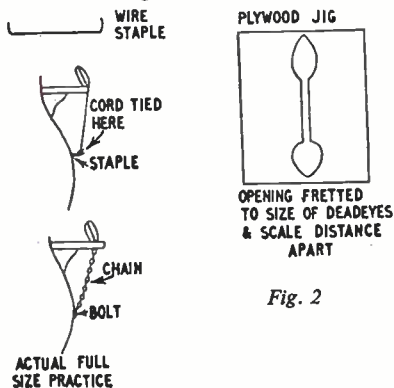

Fig. 1

best method is to build up the shrouds on a card or piece of plywood as described previously and then reeve the lower deadeyes into lengths of cord allowing plenty for tying.

A jig is now made as in Fig. 2. This will hold your deadeyes whilst you reeve through the lanyards. Having done this erect your shrouds by securing them to the top of the mast, under the top (crows nest).

You will now need some staples made from thin piano wire, or when this is not readily available, office wire paper clips. They are made slightly less in length than the channel they are to go under. Tap them in place in the hull, starting the holes with a fine bradawl, and leaving them about $\frac{3}{16}$ in. 'proud'. Now taking the first shroud forward take hold of the cord of the lower deadeye and pass through the staple tying it as tight as possible, following through each one in turn until all on both sides of the model are fastened.

Now tap home flush with the hull, do not tap one right home, but tap home each one around the hull gently a little

at a time until all are flush with the hull, you will now find all your rigging lines very taut and shipshape, and if you have followed the above instructions your masts will be in correct alignment.

And now to the copying of the actual methods of the period for the modeller who likes everything authentic. The extra trouble is well worth while.

The first necessity is some very fine chain. This can sometimes be obtained from old jewellery or even purchased from a jewellery supply house. On large scale models use $\frac{1}{16}$ in. and even sometimes on $\frac{1}{32}$ in. to the scale. I know model en-

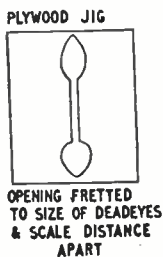

Fig. 2



Fig. 3

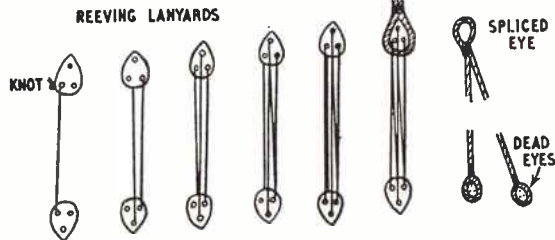

Fig. 4—Follow through, straight cords outside, crossed cords inboard (deck side).

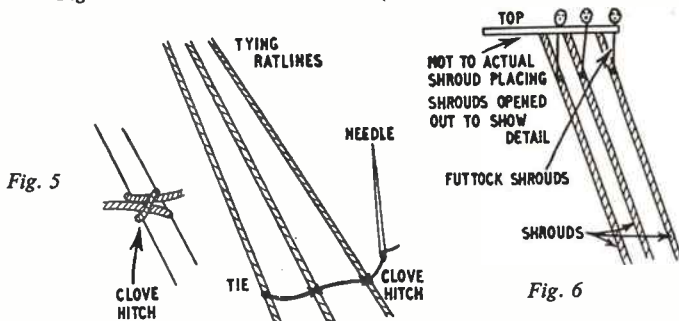

Fig. 6

thusiasts who make their own small chains link by link.

In Fig. 3, we have the correct method of seizing the deadeyes on the shrouds and also the seizing of the lower deadeyes.

Now you can build up the shrouds as before or you can follow full scale practice as follows. In this case your ratlines (or ladders) are not added until the shrouds are erected on the model.

The shrouds are erected in pairs and on most of our Hobbies models the mast tops or crows nests must not be added until the shrouds are in position.

A length of cord is cut allowing sufficient length for the particular shrouds, an eye is spliced in the head as

FITTINGS FOR SHROUDS—1

By 'Whipstaff'

Fig. 4, which also shows the deadeyes in place. When each pair is made from your full-sized drawing, they are slipped over the masthead in the following order (the same order for each mast), first starboard pair, first port pair, second starboard pair, second port pair, and so on, until all are in place.

The next operation is to reeve your lanyards. These must be as taut as you can get them (see Fig. 5).

When this is complete you can start on the ratlines. You will find this tedious at first but after you have completed one model in this manner you will get quicker with it and I do not think you will return to the glued on 'ladder'.

It is helpful to use a needle, and start as in Fig. 5 by securing the end of the cord to the outside shroud. Do not forget that the scale of your ratline cord must be about half the thickness or diameter of the shroud cord. Tie cord to each shroud in turn with a *clove hitch* and remember, for an authentic appearance, each step of the ratlines must sag slightly, as with the weight of the men climbing the rigging.

●Continued on page 142

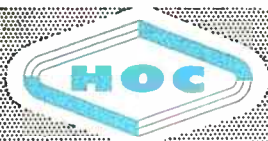

makes you an expert... *easily!*

It's not difficult to be an expert with the BRITFIX/HUMBROL combination... tried to the qualities which the Handyman needs... tested to the requirements of the do-it-yourself man. And—more than ever—produced to give that 'professional' look... That's the way with H.O.C.—you can see-it-yourself when you do-it-yourself!

FOR WORKING IN WOOD OR PLASTICS . . .

Humbrol Art Oil Enamel, a 4-hour lacquer enamel which dries with a brilliant finish. Is most suitable for the handyman about the house, being ideal for touching up all decorative household and workshop utensils.



BRITFIX TISSUE PASTE.
A specially prepared paste for aeroplane tissue providing exceptional adhesion and non-staining qualities.



BRITFIX CEMENT.
The finest all-purpose adhesive made. Transparent, water and heat proof, BRITFIX CEMENT combines rapid drying with the utmost tenacity.

BRITFIX PLASTIC POLYSTYRENE CEMENT.
A high quality polystyrene adhesive, combining quick drying with excellent adhesion. An ideal companion to Enamel

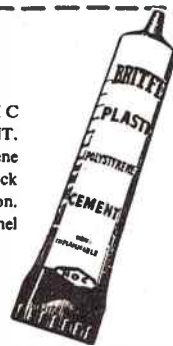

BRITFIX COLOUR DOPES, fast drying, clean and bright, smooth and easy to work with.



HUMBROL INTERMIXABLE PAINTING KIT.
Humbrol Art Oil Enamel Kit-6 intermixable colours in capsule form. An economical method of application for the Handicraft Worker.



the choice of the expert!

Send to-day for **FREE Humbrol Colour Card,**

THE HUMBER OIL CO. LTD., MARFLEET, HULL.

Fretwork pattern

'SWAN' TOOTHBRUSH RACK

USE your fretsaw to cut out this pleasing rack for the bathroom. The markings on the wings and head can be cut out or painted on later. If cut, they should be drilled first to take the saw.

The pieces (A) and (B) are cut from $\frac{1}{4}$ in. wood or plywood and the tenon of (B) is glued into the mortise of (A) as seen by the detail.

Clean up with glass paper and paint the whole rack white. Leave to dry, rub down lightly with fine glass paper and give a final coat.

Hang the rack to the bathroom wall by means of a brass bracket eye screwed to the back. (M.p.)

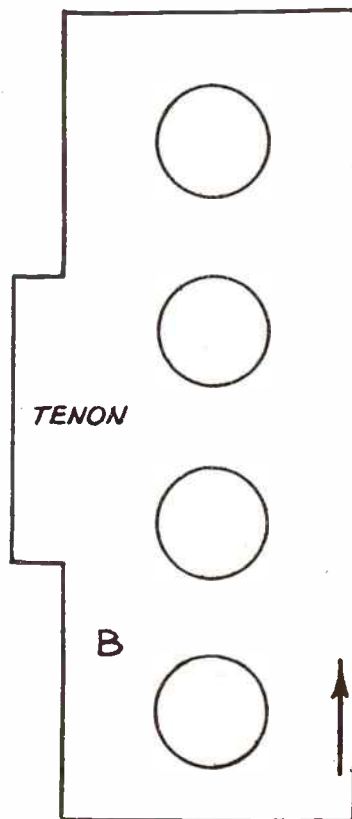
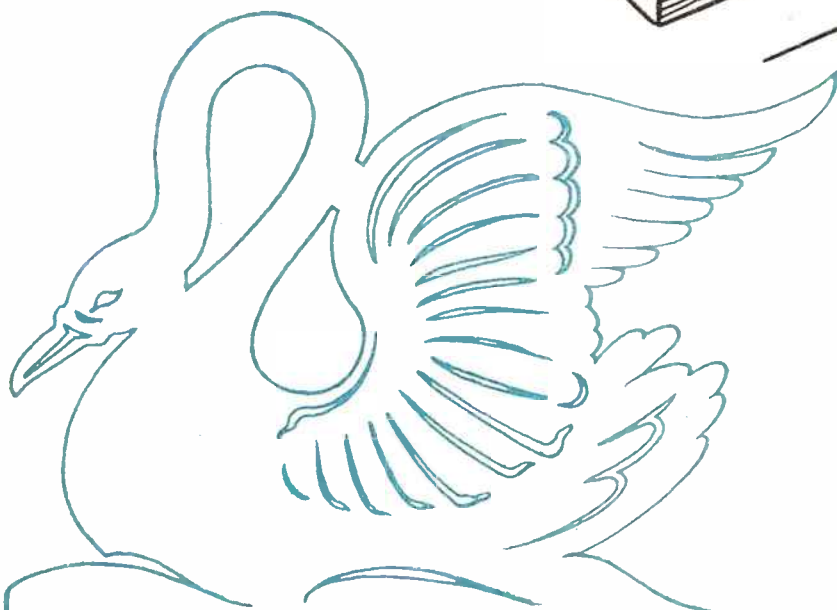
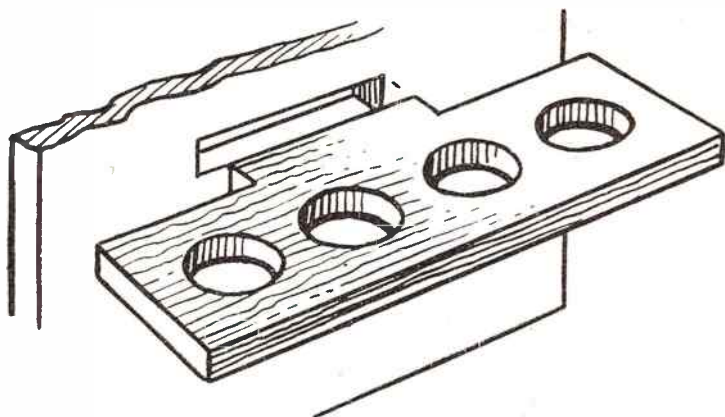

This model farm cost less than 2/6

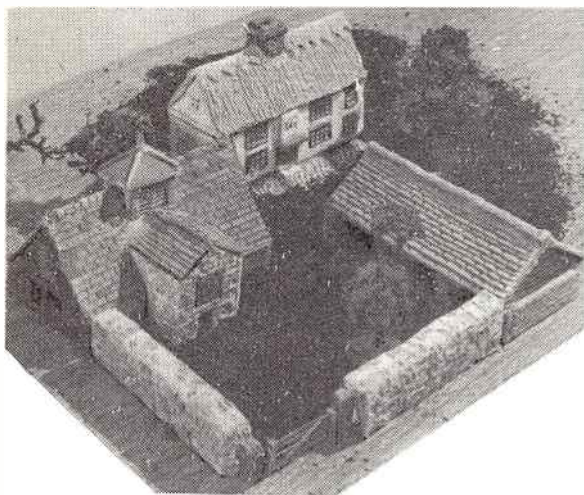

It was made from a half-crown tin of Sankey's PYRUMA — farmhouse, barn, implement shed, walls and gate — and there was still plenty of this grand modelling material left to build many more farm features, by simple methods described in the Instruction Book (see Coupon below). PYRUMA, plastic and ready-for-use, becomes stone hard after drying or baking, and can be painted in natural colours. For permanent modelling —

MAKE IT AND BAKE IT IN



Obtainable from your local Ironmonger or Hardwareman and many Art Material dealers. Ideal for making —

Model Railway Buildings and Accessories. Harbours. Ship Models. Airport Buildings and Features. Houses. Bookends. Ashtrays. Animals and Figures. Plaques, etc.

Post this Coupon today for your Instruction Book.

J.H. SANKEY & SON, L^{TD}

Established over a century
Dept. H, ILFORD, ESSEX

Please send ILLUSTRATED INSTRUCTION BOOK with full colour pages on Pyruma Modelling.

Enclosed Postal Order value 6d. (not stamps)

NAME (Block letters)

ADDRESS

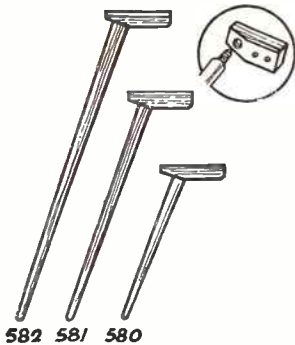

You Can Make a Modern Table in One Evening with these legs



FOR ALL CONTEMPORARY FURNITURE

A coffee table, TV table, footstool, etc. . . . all can be made in quick time with these Contemporary style legs. Beautifully turned in Scandinavian beech, they can be left in their natural colour, or stained. Each leg is threaded at one end to screw into a hardwood block (see inset) which, in turn, is screwed to the underside of a piece of plywood or suitable material which forms the table top. Simple . . . and a perfect job. The legs are obtainable in three sizes:—10 ins. 2/3 each, 15 ins. 2/6 each and 20 ins. 3/- each. Postage on 3 or 4 legs 1/6 extra. Legs from branches or:

HOBBIES LTD, Dept 99, Dereham, Norfolk

For wood, card, plastic, leather, metal, etc.

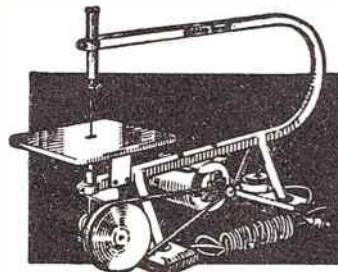

£12 - 5 - 0

TREADLE OR MOTOR FRETSAWS

Whatever the handyman or craftsman is cutting or making, one of Hobbies Fretmachines will help with the job. For toy making, fretwork, model making, it provides easy and speedy cutting in all kinds of material. A pleasure to use, a factory for output, a lifetime of service.

Obtainable at any Hobbies Branch or good class ironmonger or hardware stores. Or carriage paid U.K. from:

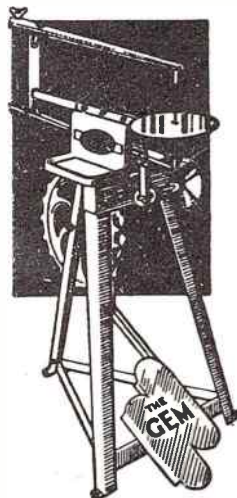

£5 - 17 - 6

HOBBIES LIMITED, DEREHAM, NORFOLK

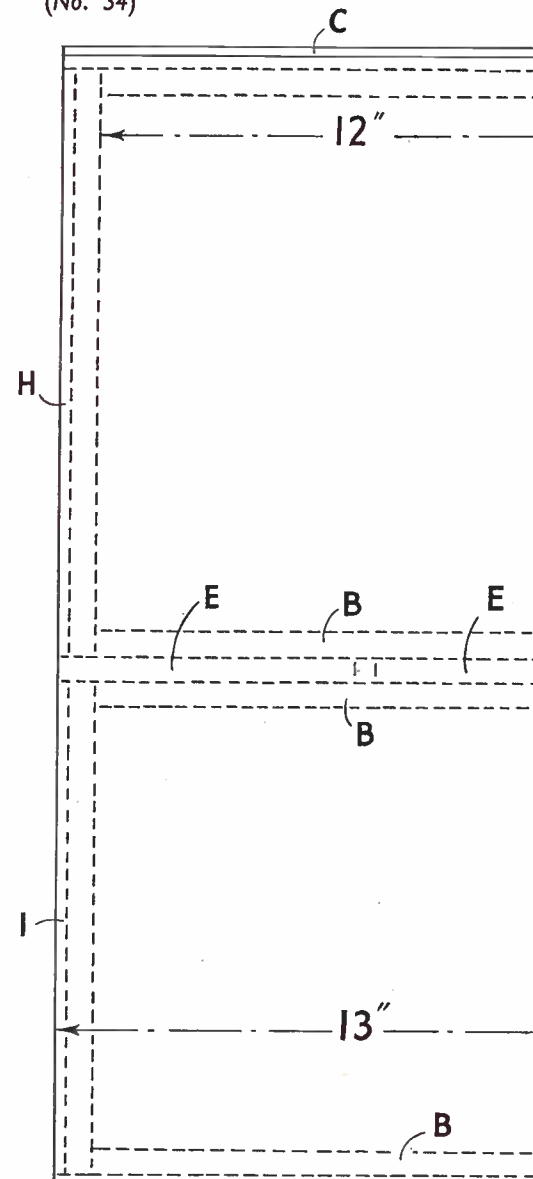
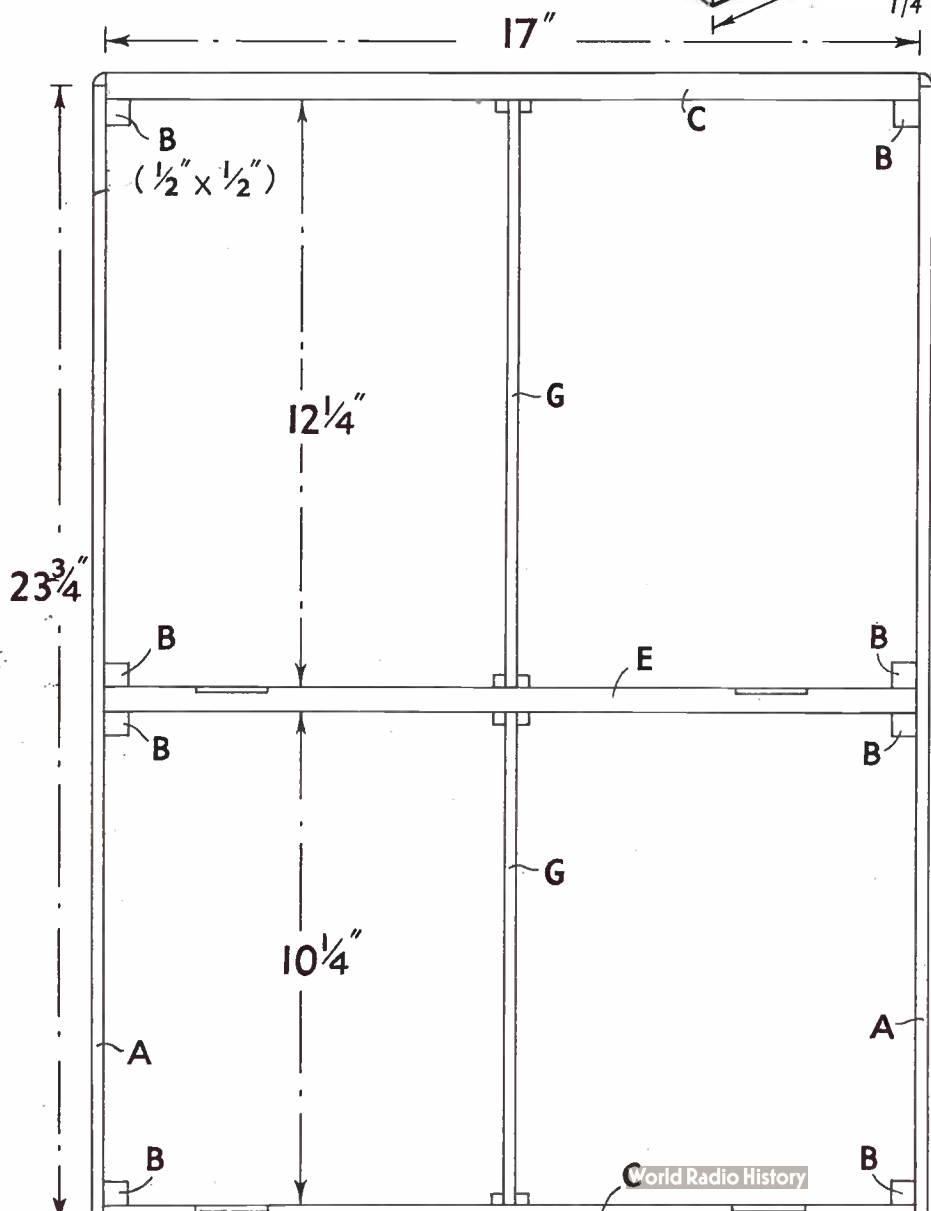
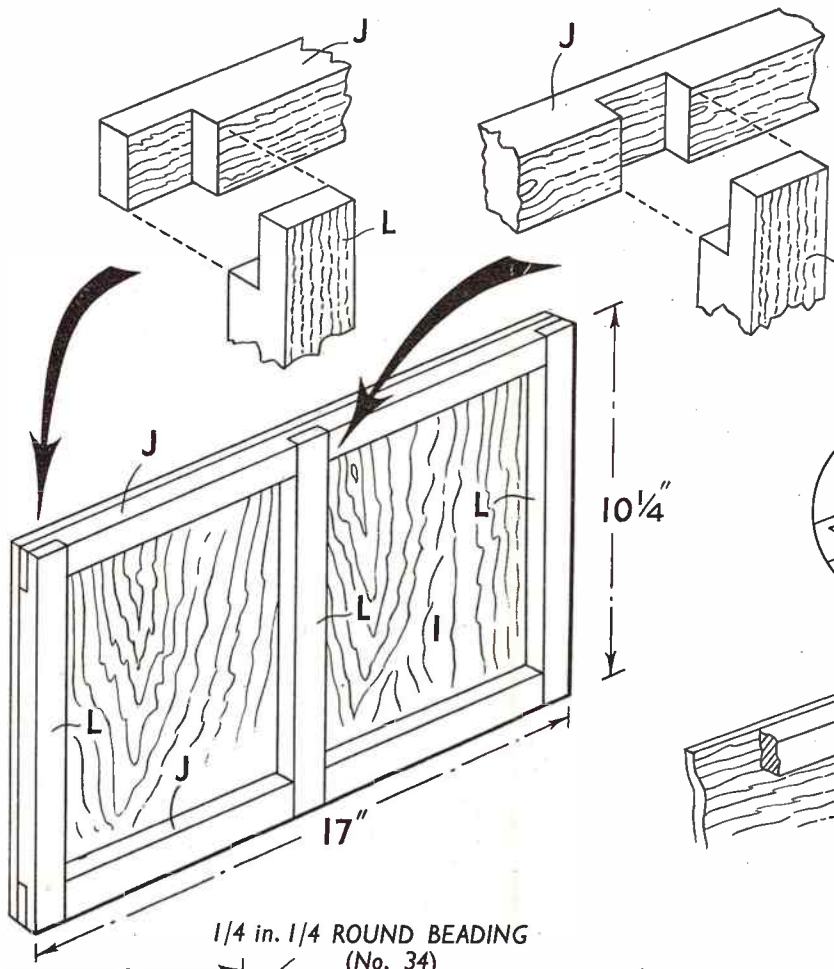
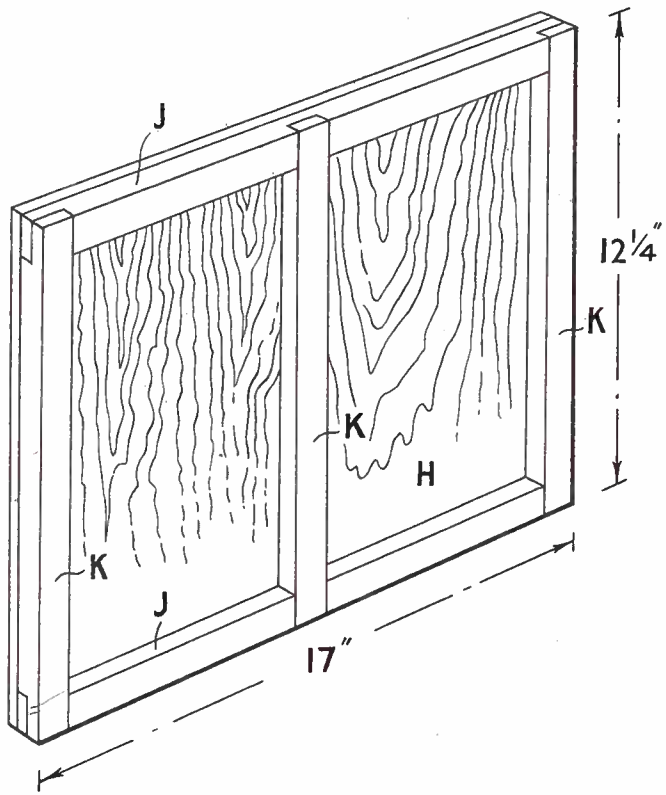

RECORD CABINET AND BOOKCASE

Size — 34 ins. high. 20½ ins. wide. 13½ ins. deep.

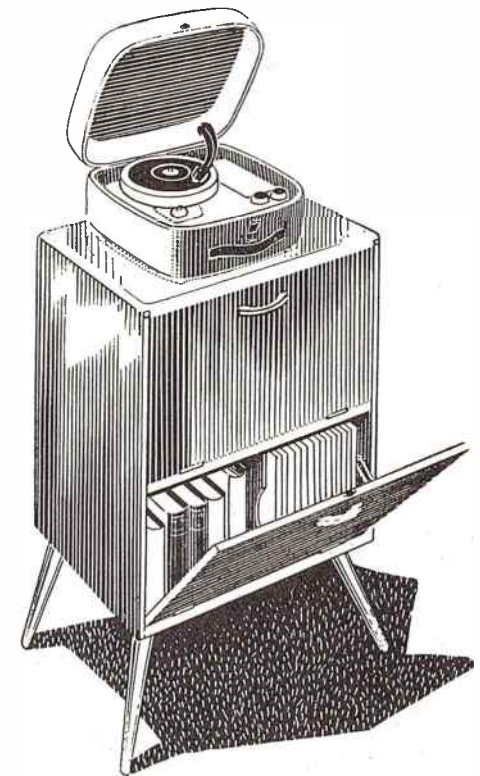
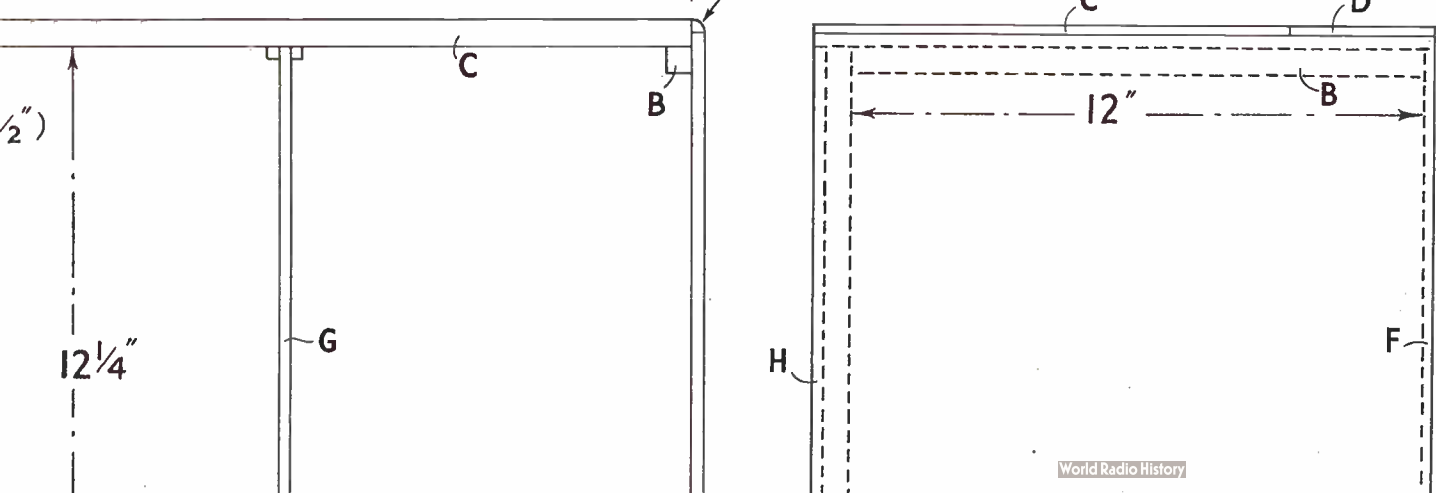
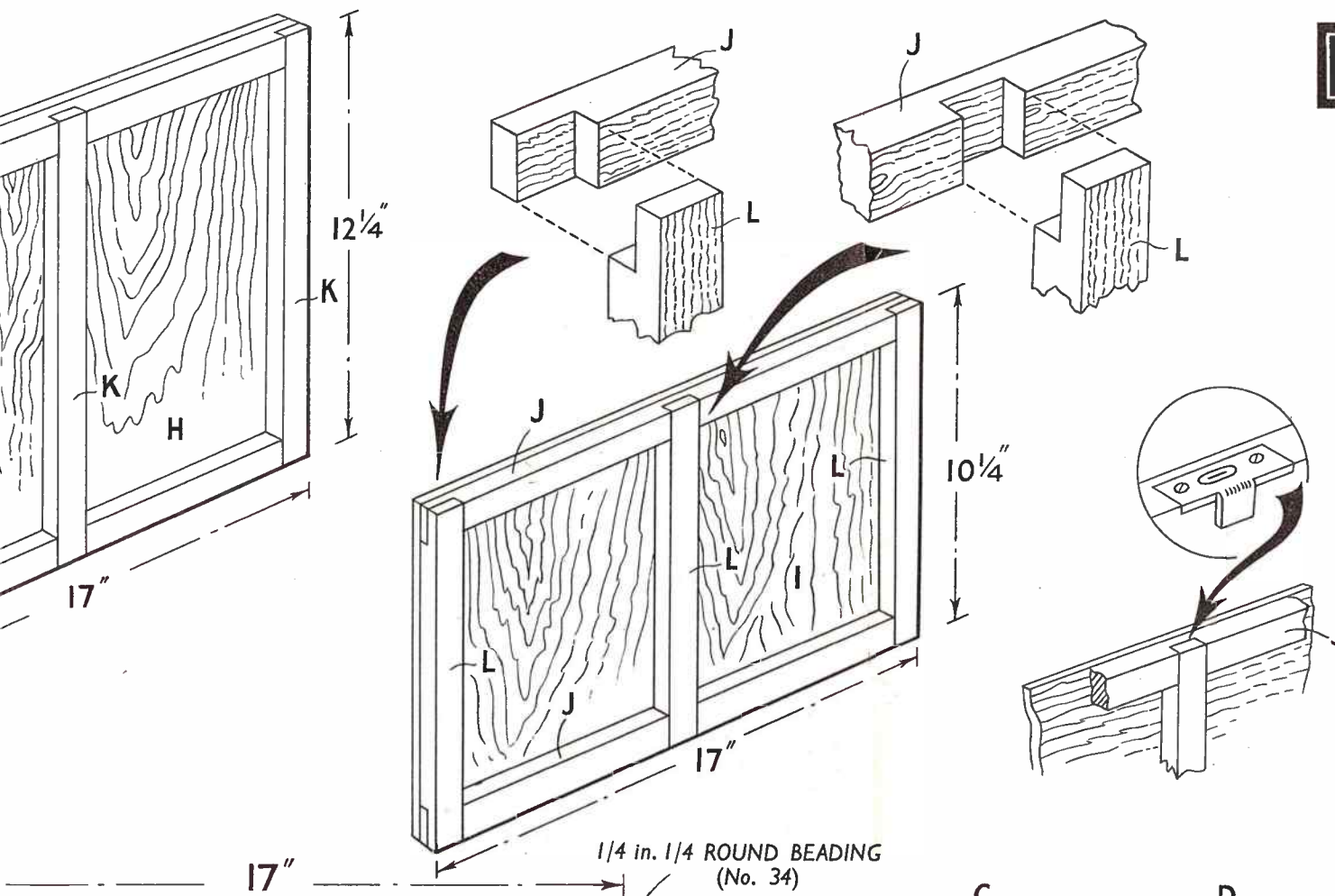

A KIT OF MATERIALS FOR MAKING THIS DESIGN IS SUPPLIED BY HOBBIES LIMITED, DEREHAM, NORFOLK. PRICE ON APPLICATION.



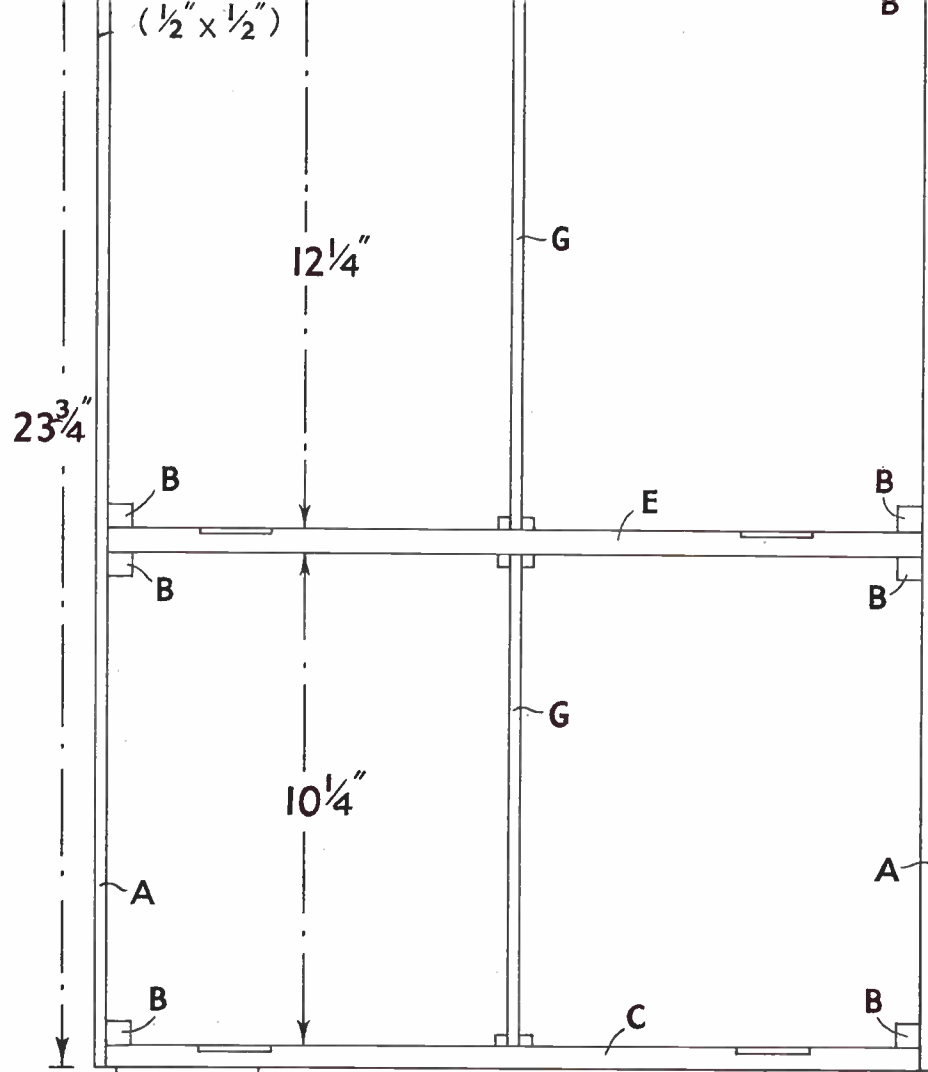

FRONT VIEW

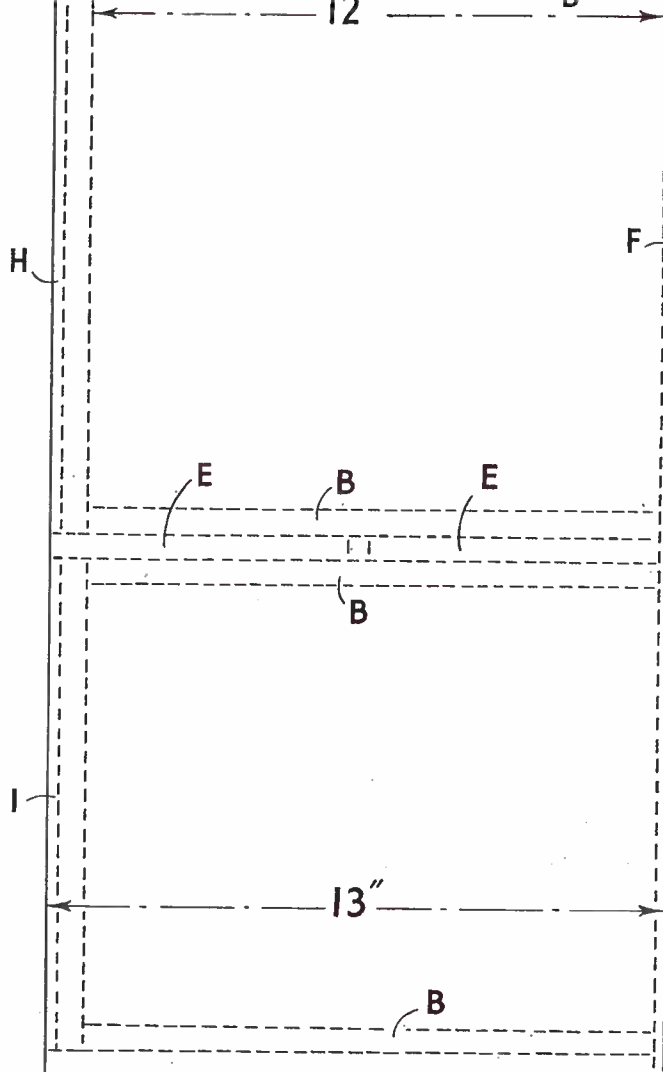

SIDE VIEW

HOBBIES No. 580 LEG.

A KIT OF MATERIALS FOR THIS DESIGN IS SUPPLIED BY HOBBIES LIMITED, DEREHAM. PRICE ON APPLICATION.

Use **CASCAMIT** 'One Shot' Resin Glue

for all Model Making

- Mixed & use cold ● Waterproof
- Gap-filling and non-staining

Stocked by: Ironmongers, Builders

Manufactured by: LEICESTER, LOVELL & CO. LTD. NORTON

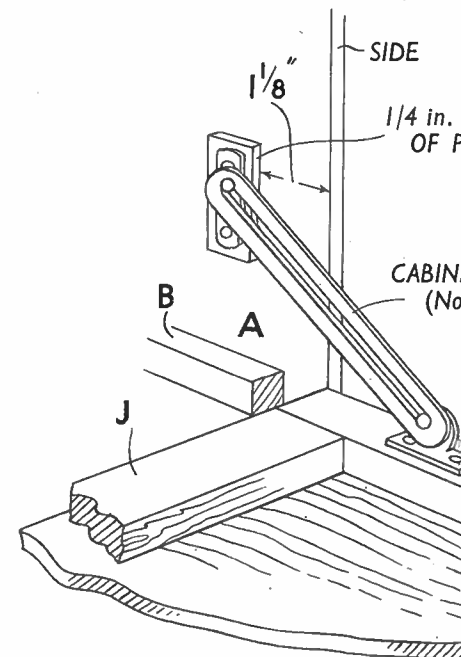

PRINTED IN ENGLAND

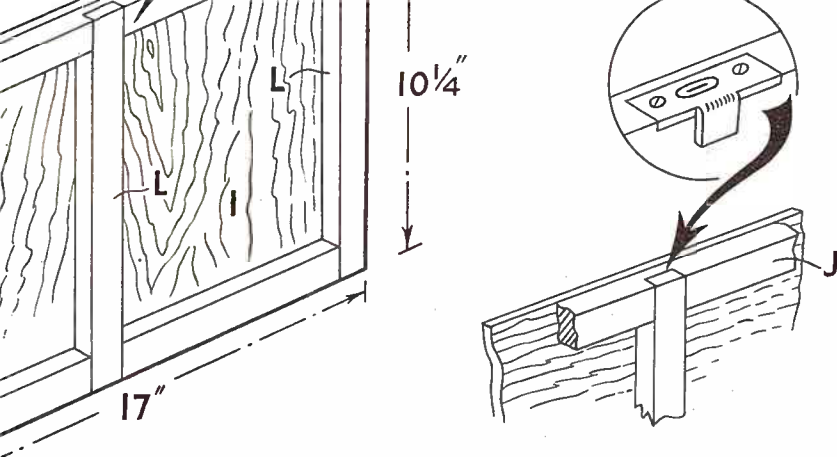

1/4 in. 1/4 ROUND BEADING
(No. 34)

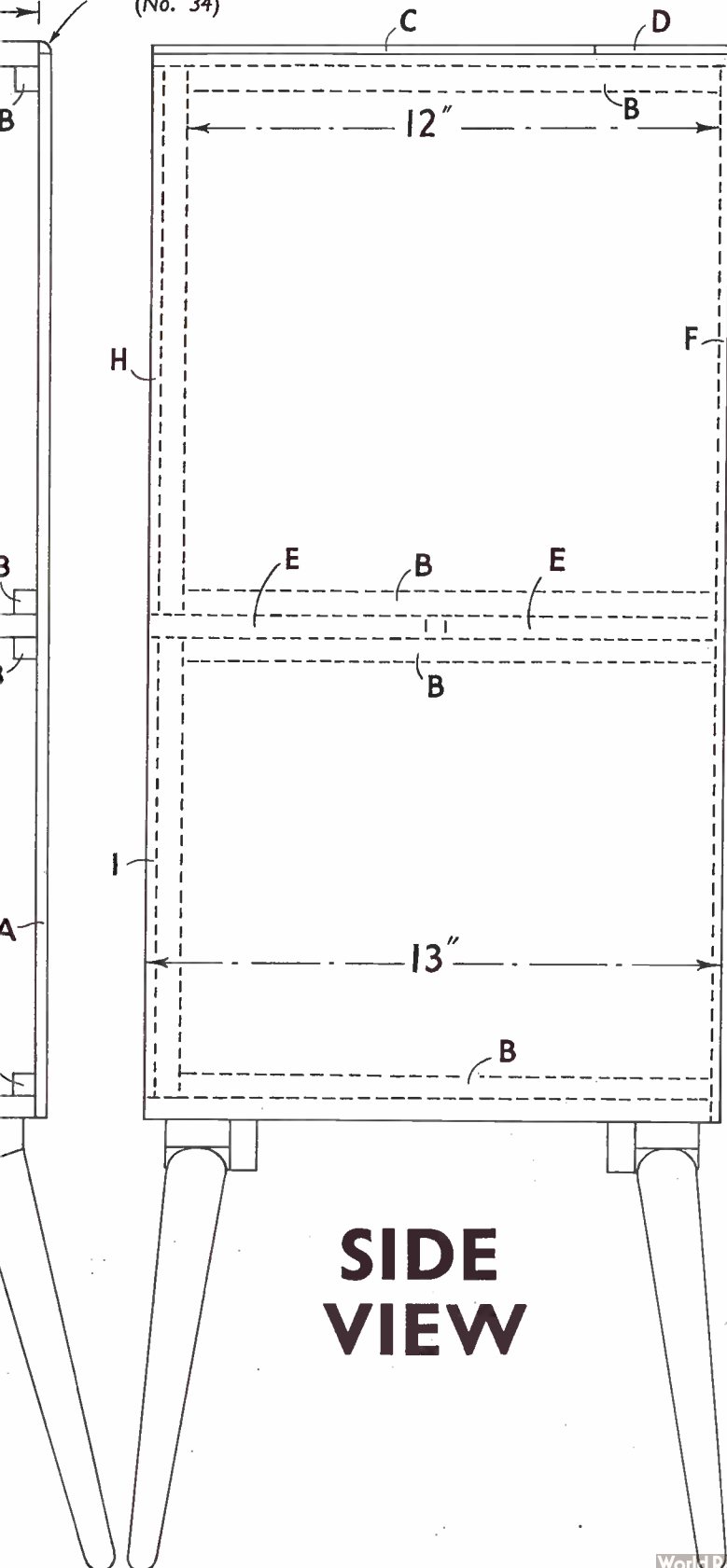

SIDE VIEW

A KIT OF MATERIALS FOR MAKING THIS DESIGN IS SUPPLIED BY HOBBIES LIMITED, DEREHAM, NORFOLK. PRICE ON APPLICATION

Use **CASCAMITE** 'One Shot' Resin Glue for all Model Making



- Mixed & use cold
- Waterproof type
- Gap-filling and non-staining

Obtainable in: 3 1/2-oz.; 7-oz. and 18-oz tins.

Stocked by: Ironmongers, Builders' Merchants, etc.

Manufactured by: **LEICESTER, LOVELL & CO. LTD.** North Baddesley, Southampton

