

HOBBIES WEEKLY

IN THIS ISSUE

	Page
Child's Cot	385
Use Cramps as Vices	386
Make a Perpetual Calendar	387
Small Boat Sea Fishing	388
Books to Read	389
Hobbies Crossword No. 3	389
Stamp Collector's Corner	390
A Handy Tea Caddy	390
Container for Plants	391
Photographing Small Objects	392
Modern Lounge Table	393
With Rod and Line	394
Is This Your Problem?	396
Patterns for a Tea Caddy	399



MARCH 13th 1957

VOL. 123

NUMBER 3202

★ *FREE design for a*

CHILD'S COT

THE handyman should experience no trouble in making this drop-side cot, which is a worth-while project for the family man, who can make quite a successful job of this design and save himself money.

The cot is full size (4ft. by 2ft.) thus providing a bed for baby for quite a long time. There is a lift-out webbing mattress and the sides are hinged at two corners. On removing the metal rods the whole thing folds up for flat storage. Hobbies kit includes all the wood necessary, the dropside fittings and webbing.

Make a start by constructing the two ends, which are identical. They consist of frames in which are inserted dowelling, and their layout and appropriate measurements are shown in the top left-hand corner of the design sheet. Dowels (G) are let into rails (B) to a depth of ½ in., and pieces (B) are let into the uprights (A) as shown in detail on

**WITH
DROP SIDE**



**MAKE IT YOURSELF
— AND SAVE MONEY**

the design sheet. Note that all joints should be glued and the sides cramped up until this is dry.

The hinged side and the drop side differ only in the lengths of the rails. Rails (C) of the hinged side measure 3ft. 9½ ins. and rails (D) are 3ft. 9 ins. This allows ½ in. clearance at each end for the operation of the drop side. These sides are made in similar manner to the ends, with the addition of the panels (E).

The detail on the design sheet shows

how one side is hinged to the ends and Figs. 1, 2 and 3 indicate the working and fixing of the dropside fittings. Holes are, of course, bored in rails (D) to take the steel rods.

The making of the mattress frame from 1½ ins. square wood is also shown in detail on the design sheet. Note that pieces (H) and (I) are halved together, giving a flush fitting. Pieces (I) are placed on top and this section should

● **Continued on page 386**

All correspondence should be addressed to The Editor, Hobbies Weekly, Dereham, Norfolk

*For Modellers, Fretworkers
and Home Craftsmen*

4½^D

PAGE 385

Handy for model makers

USE CRAMPS AS VICES

THE model maker without a permanent workshop is often handicapped by the lack of a suitable small vice. Whilst you cannot screw a vice to the kitchen table, you can at least make use of two light cramps of the kind shown in Fig. 1.

You will probably have one or two of these amongst your tools, but if not, they are quite inexpensive to buy. Hobbies can supply you with 2½ins. all-steel light cramps for only 1/7 each.

The cramps are placed on the table as shown in Fig. 2. To prevent the table being marked, small packing pieces should be placed between the cramps and the table.

To hold small pieces for shaping, gluing or painting, a piece of wood can be used as packing and adjusted so as to leave the work in a convenient position.

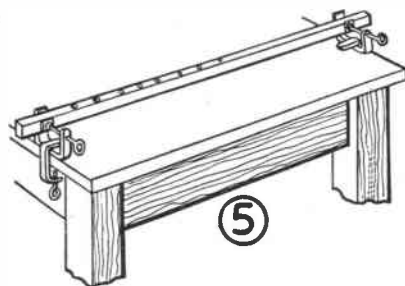
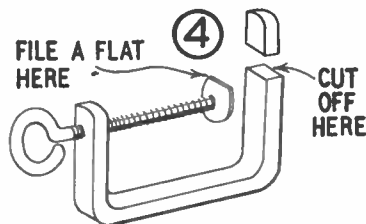
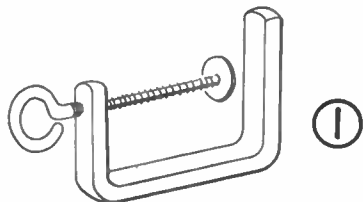

Continued from page 385

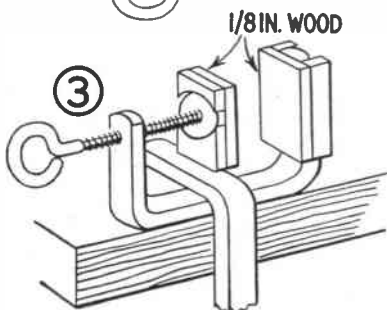
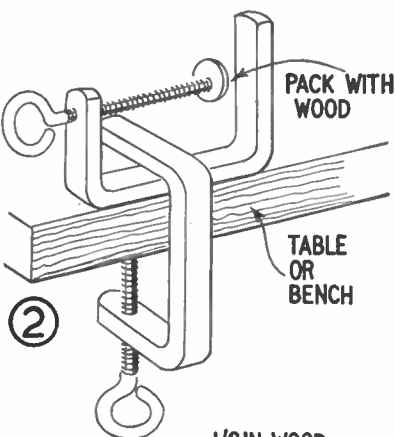

Child's Dropside Cot

also be pinned as well as glued. The ends of pieces (H) are cut ¼in. on the underside to drop into ¼in. slots in rails (B). This gives rigidity to the construction. Webbing is interwoven and tacked to the top or sides of the frame. Make sure it is taut before tacking.

The tops of uprights (A) can be nicely rounded and the top rails (C), (D) and (B) smoothed off.

Finish can be by staining and varnishing, and the addition of nursery transfers on the insides of the panels will give much pleasure to the young occupant. Rubber tyred castors fitted to the legs will also facilitate moving the cot around.

Delightful transfer designs are obtainable from Hobbies Ltd., Dereham and branches, who also can provide rubber-tyred castors for 4/- a set of four.

KIT OF MATERIALS

Kit No. 3202 contains all the necessary wood (including panels) webbing, dropside fittings, etc. Obtainable from branches, or carriage free from Hobbies Ltd., Dereham, Norfolk, price 63/8. Dropside fittings can be supplied separately, price 7/- a set.



Fig. 1

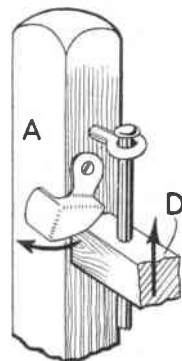

Fig. 2

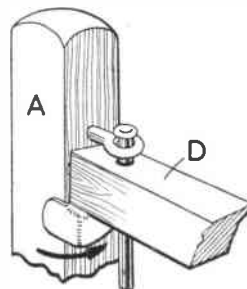

Fig. 3

MAKE A PERPETUAL CALENDAR

HERE is an easy way to make a perpetual calendar for hanging on a wall or standing on a desk. The front is made from a piece of veneered plywood, with thin card discs for the dates, and cardboard for the backing. The corners are rounded to prevent scratching of other furniture.

The front is cut from plywood measuring $7\frac{3}{8}$ ins. by $5\frac{1}{8}$ ins., as shown in Fig. 1, and the windows cut out. Use a fine drill and fretsaw for this purpose. The area shown by the picture may be fretted with a small design, but the following description allows for a picture to be attached, without any necessity for cutting out.

We now require three thin white card discs for lettering the months and numbering the dates. These discs should be the thickness of a postcard, one with a diameter of $4\frac{1}{8}$ ins. and two with

diameters of 2 ins. Lettering and numbering the discs is the next task. Reference to Fig. 1 shows the position of the discs by dotted lines and here is a simple way of determining the exact positions for the months and numbers. Stick a pin through the centre of the larger disc, centring on the back of the wood until the circumference is just below the window opening. Lightly pencil in the shape of the opening, turn the disc, marking in the next window which adjoins the tip of the last. This process is repeated until twelve oblongs — one for each month — have been made on the disc. Alternatively, set your compasses to a radius of 1 in., arcing the circumference all the way round. By joining the two neighbouring arcs a straight line is produced on which to print in the months. You may adopt a similar method for the smaller discs, but

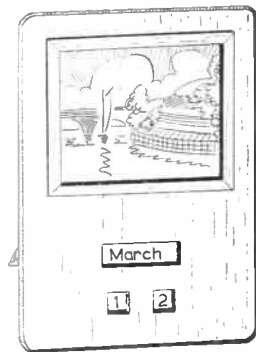

Draw a centre line down the inside on this backing piece, carefully marking the points for the holes as shown in Fig. 3. Correct measuring is essential or the months and dates will be out of register with the windows. Pierce the holes with a fine pricker, so that a small countersunk screw may pass through to the knobs at the back.

At this stage it is well to consider the provision of a support for the calendar in the form of a leg, made from cardboard. This leg should be made to hinge by scoring with a blunt knife, reinforced with a piece of gumstrip, then glued to the back, so that it does not foul the holes already pierced. You may also attach a small loop of tape for hanging purposes.

Now make a small hole in the centre of the large disc, place on the inside of the backing to coincide with the hole there, and passing a screw through both for insertion into a small wooden knob. The knobs may be made from $\frac{3}{8}$ in. dowel rod about $\frac{1}{2}$ in. in length, rounded off at the outer edge.

With the three discs in position and fastened to the back, now supplied with a leg and hanger, we may make the final test to determine that the months and dates are in perfect register with the window openings.

A photograph or picture can be glued to the front and given a frame of strip-wood.

All that now remains is the fixing of the back to the front to complete the calendar. Coat the strips of cardboard attached to the inside of the back with glue, thinly and evenly spread. If you have made the earlier tests, everything should fit in position, if not this must be done before final gluing. Test as already mentioned, making small pencil marks on the back of the plywood front where the back should fit. When the glue has been applied it only remains for the back to be fitted to these guide marks. After gluing, leave the calendar with a little pressure on the edges, so that the strips will be firmly bonded. This can be done with the use of short battens. (S.H.L.)

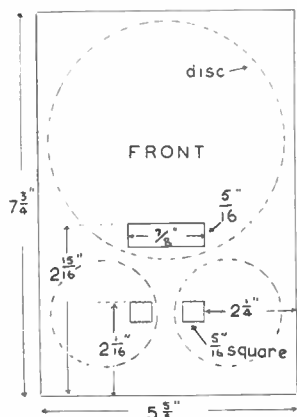

Fig. 1

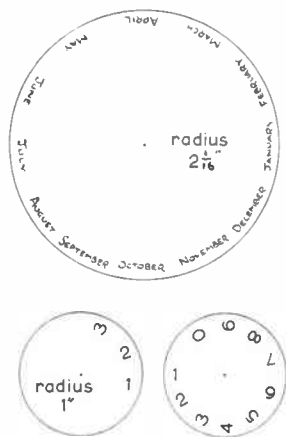

Fig. 2

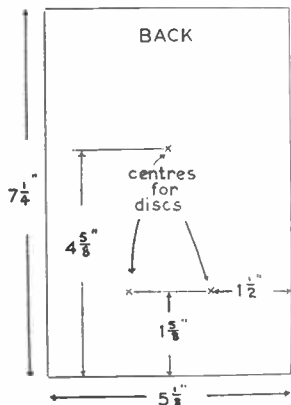

Fig. 3

using the compasses at a fraction over $\frac{1}{2}$ in.

Either write in the letters and numbers in indian ink, or use ready printed ones from a discarded calendar or diary of suitable size. On completion, the discs should appear as shown in Fig. 2. Now test for accuracy as already suggested.

We now require a piece of good quality cardboard, measuring $7\frac{1}{8}$ ins. by $5\frac{1}{8}$ ins. for the back, slightly less in area, therefore, than the front. The mechanism lies within the two parts, calling for the addition of some spacers in the form of strips of cardboard $\frac{1}{4}$ in. wide glued all the way round the edge of the back, giving the appearance of a shallow tray.

gut it is attached to is laced with a couple of coloured beads.

Mackerel move swiftly and constantly, and you will usually catch several at once when you are lucky enough to pass through a shoal. Gulls circling over a spot indicate their presence. Fixed spots cannot be mapped for this lively fish.

Pollack Fishing

This can fill a gap between seasons. Where I am writing they abound in the late spring months before the mackerel arrive. To catch the pollack your boat should be slowly moving, so that the line is kept just clear of the sea-bed, and a little knowledge of the sea-bed around harbour entrances or rocks where pollack feed will save much loss of gear. Even with such knowledge I have found it to necessitate more renewal of gear than other types of fishing.

I usually use a length of gut resembling

a long paternoster but constructed entirely with gut, with the hooks laced with bright feathers. The line should terminate with a very light weight, while both this tackle and the mackerel tackle, previously described, should have swivels to ensure a smooth passage through the water.

On one occasion I landed twelve pollack simultaneously. They were all large fish and took some handling.

The tackle described can often catch early mackerel and occasional bass, but an alternative bait is a rubber eel of a colour suitable to the environment. In this case the remainder of the line should be as for mackerel fishing but with a lighter lead.

Moonlit nights

In general, the hours around sunrise and sunset are the best for all the fishing I have described, though in the case of ground fishing a moonlit night often

provides a mixed bag with emphasis on larger fish such as congers. A small outboard motor or sail, with the tackle adapted just a little to compensate for the increase in speed, will double the catch when mackerel fishing.

Return the small ones

I am not advocating greed and waste, but giving advice that will ensure a constant small supply which will capture the interest of your family. Above all, you should be fair and return the immature fish to the sea at once, unless it is maimed in such a way as to render its destruction a kindness.

Be a friend to the local fisherman and repay his advice with truthful stories of any success. He will probably laugh, but try your advice all the same, and the general effect will be to provide you with an increased confidence and interest that will broaden your circle of friends and your whole outlook.

Books to Read

Electronics for Everyone

by Monroe Upton

edited by W. E. J. Farvis, B.Sc.,
A.M.I.E.E.

DESPITE its technical title this proves to be a delightful book dealing simply but in great detail with the fascinating story of this electronic age, from the early groping struggles of the great 'electricians' to the latest marvels of colour television, radar, high-fidelity reproduction and all the remaining applications of electrical energy. As one reads, one is gradually led without effort from the elementary to the advanced stages, and it is, therefore, an excellent volume for all classes — the casual reader, the enthusiast or the student with serious thoughts of a career in the electronic field.

Published by Faber and Faber Ltd.,
24 Russell Square, London, W.C.1—
Price 21/-.

Model Engineering Practice

by F. J. Camm

MODEL engineering practice must not be confused with model making. Whereas there are many books dealing with the making of models, this latest volume from the prolific pen of this acknowledged expert is, we believe, the first work to deal solely with model engineering practice. From the construction and equipping of the workshop to the various processes such as filing, drilling, pattern making, casting, etc., all aspects of the model engineer's craft are fully dealt with in lucid style supported by numerous illustrations.

Published by George Newnes Ltd.,
Tower House, Southampton St., Strand,
London, W.C.2—Price 17/6.

British Boxers - First Series

by Trevor Hilton

THIS compact little volume is the first of a series of Beverley Sport-lives to be published, and if subsequent issues reach the standard of the opening number, then lovers of sport will have

little room for complaint. Here are action-crammed details of the lives of Dai Dower, Joe Erskine, Peter Waterman and Dick Richardson, backed by illustrations and boxing statistics, and not the least attractive feature is a complete setting out of the rules of the British Boxing Board of Control.

Published by Beverley Books, 29 Regent Street, London, S.W.1—Price 2/-.

Hobbies Crossword No. 3

Note: Figures in parentheses denote the number of letters in the words required.

ACROSS:

- Eternally among several (4).
- Your account maybe (7).
- Grand enough to be in the picture (4).
- Spoken, not written (4).
- Brittle yet shaky (7).
- Here is the difference financially speaking (4).
- Before (3).
- Naval gang of old (5).
- Take counsel (7).
- This mistake has been noted though (7).

- Imitation gem (5).
- Court girl (3).
- Entry in traditional style (4).
- The qualities that make something what it is (7).
- Natural wig? (4).
- Logical change for ogre (4).
- They must keep up to scratch in order to make an impression (7).
- Sure sorry it seems (4).

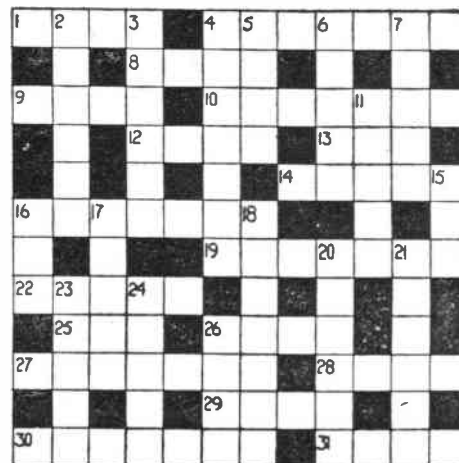

★ ★ ★ ★ ★ ★ ★ ★ ★ ★ ★ ★ ★ ★ ★ ★
★ SOLUTION WILL BE ★
★ GIVEN NEXT WEEK ★
★ ★ ★ ★ ★ ★ ★ ★ ★ ★ ★ ★ ★ ★ ★ ★

DOWN:

- A masculine woman? (6).
- Shifts (6).
- Obvious (7).
- No doubt you've heard this before (4).
- Cut off in several places (5).
- Story giants (5).
- Build (5).
- One plus one (3).
- Explosive hat (3).
- Some attempt at least (5).
- Doubleless you have had some dealings with them (7).
- But for him, there'd be no such thing as a book worm (6).
- He's only interested in seeing fair play (6).
- Such seats may be quite an advantage (5).
- Some people can remove theirs (5).
- Care for the maple tree (4).



Stamp Collector's Corner

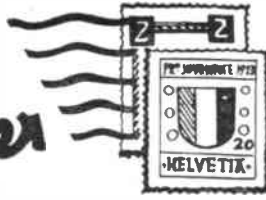

ISSUES OF FINLANDIA By R. Cantwell

FINLAND'S courageous stand against overwhelming odds during the late war won world admiration. Since then this land of honest men and brave women has made great progress. From 1154 to 1809 Finland formed part of the kingdom of Sweden, then became a Grand Duchy of Russia.

Russian stamps introduced in 1856 were exchanged for those of the Provisional Government. Finland became a republic on 17th July, 1919.

Idleness is unknown in this country where women are engaged in almost every branch of work. The many industries include agriculture, lumbering, paper and pulp, iron and mechanical works, textiles, leather, rubber, fur and chemicals. The merchant marine totals some 300 vessels of nearly 600,000 tons. The country's economy is based upon the co-operative system which has worked throughout Finland for forty years with marked success.

The Evangelical Lutheran Church is the state religion, but there is religious tolerance and free worship. There are three universities, one in Helsinki, the capital (formerly Helsingfors) and two in Turku.

Stamps for page one of 'Finlandia' may be easily and cheaply obtained. 1875, 25 penni blue (2d. used). 1917, 5 penni green (1d.). 1946, Red Cross. Designs: trawling, butter making, harvesting, logging (set, 1/7 used). 1947, 10 mark black — ploughing (3d. used). 1949, 9 mark brown — trees and papermill (8d. used). 1949, 50th anniversary of Finnish Co-operative Movement — 15 mark green (9d. used). 1932, Red Cross — University Library, Helsinki, St. Nicholas Cathedral, Houses of Parliament (set, 6/9 used). 1940, 300th anniversary of Helsinki University — 2 mark blue (8d. used).

Sleighting and skiing are favourite sports. The sleighs consist of a wooden framework, supported on runners and are about 9ft. long. The guiding pole is about 18ft., slightly tapered and over heavy. At one end is a round metal knob, at the other a sort of lance-head. When the reindeer misbehaves or slackens speed, they get a sharp tap on the back with the knob. Football is popular and regular athletic contests are held throughout the country.

1945, Sports Fund issue — wrestling,

vaulting, running, skiing, throwing the javelin (set, 2/10 used). 1947, National Sports Festival — 10 mark blue (8d. used). 1951, 15th Olympic Games, Helsinki — diving, football, stadium (set, 2/6 used).

The Finns are skilful hunters and famed for the dexterity with which they capture or kill wild animals. Bear and

knitted three knots, and told the buyer that when he untied the first he would have a good gale; when the second was untied he would have a strong wind; and when the third, a severe tempest.

Their Christianity is tinged with ancient superstition. They owe much of their present intelligence to the Finns, to whom they are not related.

1943, Charity issue — 50 penni + 5 penni green — Laplander (4d. used).

Finland's future is unpredictable. But main events are bound to receive postal



reindeer hunting still goes on, but mostly among the rich.

1953, Charity issue — 15 mark brown bear, 25 mark elk (1/9 used).

At one time, the Lapps of Northern Finland drove a profitable trade by the sale of winds. After being paid, they

commemoration. Philatelists should prepare for Part II of 'Finlandia' by aluming Part I now. And, by the way, the early issues contain numerous printers' errors, some are rare, many uncatalogued. So look out for them. You may be lucky!

A Handy Tea Caddy

A TEA caddy makes a useful wedding or birthday gift, and is more personal if it is something made by the donor. If attention is paid to detail, it will be equal to any shop-bought article.

The box is made from two sides (A) 4ins. wide and two sides (B) 3½ins. wide. The bottom (C) is 3½ins. square and goes between the sides as shown in the diagram at the top of the pattern page. All parts are cut from ¼in. wood.

The lid comprises two pieces of ¼in. wood glued together. Piece (D) is 4ins. square and piece (E) 3½ins. square. A knob is formed by gluing a Hobbies No. 15 ball foot in position as shown.

The overlay is cut from ¼in. wood and glued to side (A). Clean up with glass-paper and stain or paint as desired. The inside of the box should be lined with metallic paper glued or pasted in position. (M.p.)



See page 399 for full-size patterns

CONTAINER FOR PLANTS

By
H.C.K.

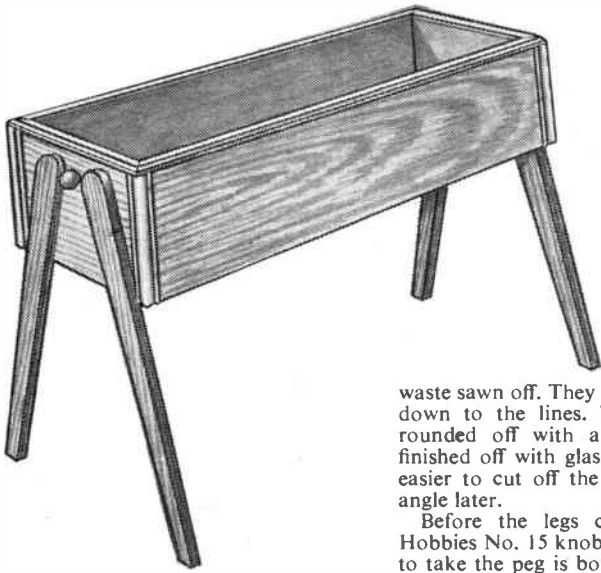

THE popularity of indoor plants is growing steadily, and most people have either a few pot plants or cacti in their homes. The window sill often has to serve for accommodation, but this cold spot is not the best place for delicate plants.

The indoor plant holder shown here will be a suitable home for them and enable them to be used as part of the furnishing scheme. The holder is very simple to make but, when finished, has an appearance of quality.

The Box Section

The sides and ends can be cut conveniently from one Hobbies Furniture Panel (No. S8), which is 36ins. by 10ins. by $\frac{1}{2}$ in. The pieces are cut to size and the edges trued up (see Fig. 1). As the corners are to be covered later, it is only necessary to butt joint and nail or screw them as shown in Fig. 2.

To support the bottom of the box, lengths of $\frac{1}{2}$ in. by $\frac{1}{2}$ in. stripwood are mitred round the insides of the sides and ends at their lower edges. They should be glued and screwed in place. The bottom is cut from $\frac{3}{4}$ in. solid wood or plywood, and is screwed to the $\frac{1}{2}$ in. by $\frac{1}{2}$ in. strips. This part of the work is detailed in Fig. 3.

Four pieces of Hobbies No. 301 corner moulding are now cut to the exact height of the box sides. These corner pieces are fixed with glue and fine panel pins. To finish off the top edge, Hobbies No. 21 moulding is used. This is mitred round the top, so that the thicker edge lies flush with the inside surface of the box. Once again, glue and panel pins are used for fixing.

Four 15 $\frac{1}{2}$ in. pieces of 1 $\frac{1}{2}$ in. by $\frac{1}{2}$ in. wood are shaped as shown in Fig. 4. The tapers are marked out and most of the

waste sawn off. They can then be planed down to the lines. The top ends are rounded off with a coping saw and finished off with glasspaper. It is much easier to cut off the lower ends at an angle later.

Before the legs can be fixed, the Hobbies No. 15 knobs are fitted. A hole to take the peg is bored in each end of the box. As will be seen in Fig. 4, its centre is 1in. from the top and, of course, midway across the width. A little glue spread evenly on each peg will hold it.

Fixing the Legs

The positioning of the legs is quite simple. At the top they rest against the knobs, while lower down they butt against the corner moulding. This is

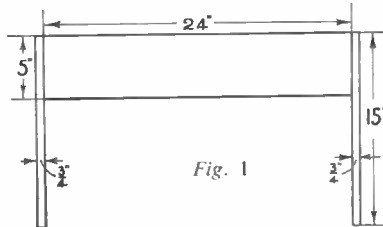

Fig. 1

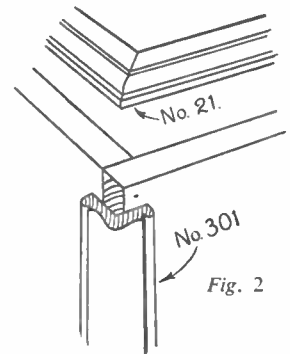

Fig. 2

made quite clear in Fig. 4. Having laid each in place, its position is marked lightly in pencil. Holes for screws to hold them are then drilled in the box ends and countersunk on the inside. The legs are now fixed by using two 1in. by No. 8 screws for each, from inside the box.

The angles at the bottoms of the legs are marked by standing the plant holder on its feet and drawing lines parallel with the floor. When these have been sawn to the line, the sharp edges are removed with a file.

It is advisable to take off the legs for

Points to note

Photographing Small Objects

TAKING photographs of small articles is an entertaining and useful pastime for the cold days when outdoor camera work has less appeal.

The chief trouble in most cases is to get a clear picture at close quarters. Few ordinary cameras are capable of being focused on subjects nearer than about 6ft., and this is not close enough to give an image of satisfactory size on the film, but most instruments can be adapted for use at closer range. All that is needed is a supplementary lens which can be slipped over the camera lens to alter the focal length.

Such supplementary lenses can be bought at photographic stores, but a much cheaper plan is to acquire a few discarded spectacle lenses. It does not matter if these are chipped at the edges, and most opticians are able to supply several for a shilling or so, since chipped edges preclude using the lenses for spectacles.

The lenses should then be mounted in pill boxes with the bottom removed, so that they can be tried out on the camera. Layers of gummed tape wound round the inside of the box will ensure that the supplementary lens fits snugly over the camera lens.

The next operation is to determine the effect of the additional lens, by examining the image thrown on the film. A focusing screen of some kind is needed for the test, and a simple idea is to remove the back of the camera and place a sheet of ground glass in the position normally occupied by the film.



Medals and coins should be photographed under a strong sidelighting to emphasize the relief design.

Alternatively, a strip of translucent paper, the same width as the camera film and at least 1ft. long, may be wound on an empty film spool and loaded into the instrument. If the paper strip is then carried through the camera to the opposite spool, like a real film, it will serve as a focusing screen on which the picture thrown by the lens can be seen when the back of the camera is shielded from direct light.

The temporary focusing screen will enable the effect of the supplementary lens to be noted, showing just how close to the subject the camera can be placed without putting the subject out of focus.

Many small objects are best photographed flat on the table, with the camera directed from above. A tripod with a ball and socket head will enable this to be done, the tripod legs being kept telescoped or only partly extended, so that the distance between the camera and the subject is not excessive.

Focusing on the temporary screen will be facilitated if the object being photographed is temporarily replaced with a lighted pocket torch. This will enable pin-sharp definition to be obtained, the torch then being removed and the object itself put in its place.

The background and lighting call for special care. Such things as coins and brassware are best photographed against a contrasting background and should be

lighted from one side only to show up the modulation. Coins usually photograph best when laid on a piece of black velvet. Medals, too, are best photographed in that way.

By A. Gaunt

On the other hand, small models require more even illumination if the details are not to be hidden by heavy shadows. They are most satisfactorily photographed in a shady place out-of-doors, or in-doors near a large window but not in direct sunlight. When they have to be taken by artificial light, some form of reflector should be placed on the shadow side, to throw back some of the light and prevent harsh results. The reflector need only be a large white card, but it will much improve the results.

An ordinary electric table lamp will serve as the illuminant, and there is no need to use specially high-powered photographic lamps in this work. The smaller degree of lighting from a standard 40 watt or 60 watt lamp can be offset by increasing the duration of the exposure, and there is no difficulty about this, the subjects being stationary.

It is essential to avoid all camera-shake while the picture is being taken, however. A cable release for the shutter (one with a lock for the trigger) is almost essential.

Another necessity is to reduce the lens aperture, as a supplementary lens made from a spectacle lens will not give good definition at full aperture.

The factors governing the length of the exposure (stop, light brilliance, distance of light from subject, and speed of film) are so widely variable that no definite exposure times can be quoted. Experiments must be made, but for the first attempts the basis may be taken to be 5 sec. at $f/16$ on medium speed film.

As a trial, three exposures may be made — 5 sec., 15 sec., and 60 sec. In many cases it will be found that one of these gives a satisfactory result, slight errors being taken care of by the latitude of the film. The series will also provide a standard for subsequent photographing of small objects, provided the main conditions of lens stop and lighting are not varied.

The film should be developed along normal lines, care being taken to avoid over-development, since that fault gives harsh negatives and clogs the highlights.



Small objects such as horse brasses are usually best photographed flat on a table with the camera directed vertically downwards.

MODERN LOUNGE TABLE

DESIGNED to carry magazines on the lower shelf, with a drawer for knick-knacks, the end rails enable this modern looking table to be lifted easily from place to place.

The basic structure is from $\frac{3}{4}$ in. ply. It is suggested that if oak or walnut finish is required, veneer-faced ply of the appropriate kind should be used, the veneer faces to show in the final assembly. A mahogany table would call for mahogany ply throughout.

Top and bottom panels are identical. These are assembled with the two ends to form a perfectly true 'box', the four corner joints being accurately mitred, glued and pinned. Drive the pins down below the surface of the wood with a nail set. The small holes remaining on the upper side of the table will subsequently be covered by the end rails and do not have to be filled.

The partition can then be cut and slid into place. Note that this fits into a $\frac{1}{2}$ in. deep groove cut in the underside of the top but is only pinned and glued through from the bottom. It must be assembled absolutely true otherwise the drawer will not fit properly.

Rather than work to given dimensions check the *actual* height and width required for the drawer from the assembly so far. Dimensions may vary on individual assemblies just enough to affect the drawer sizes shown. The drawer should be a really snug fit and slide easily right through. Keep the drawer construction quite simple and fit a carved 'pull' at each end so that it can be withdrawn from either side.

The end rails fitted to the table are cut from $1\frac{1}{2}$ in. by $\frac{1}{2}$ in. basic stock, trimmed as shown in one of the detail sketches. It is sufficient to glue these in place if

you use a modern synthetic resin adhesive and clamp up well during setting. However, additional pinning or screwing may be thought worthwhile.

The outer edges of the rails are well rounded and finished perfectly smooth

By R. H. Warring

with glasspaper. If you aim to have these in a contrasting colour, finish these to colour and fill and stain the rest of the table before fitting.

The legs are cut from $\frac{3}{4}$ in. ply, marked out to the dimensions shown. A separate detail drawing is given of the leg assembly. A mounting block is secured to the top of each leg, this block being cut from 7ins. by 2ins. by $1\frac{1}{2}$ ins. to the dimensions shown. The angled face gives the necessary rake to the legs to ensure that they come level with the table edge, mounted 4ins. in at the top. The pair of legs - when cut and assembled - should be checked that they conform in this respect, and top and bottom edges then chamfered off as required.

The leg pair is assembled with a rail gluing into the mounting blocks. The table assembly then sits on top, being glued down to the legs and mounting blocks but the length of the rail also secured with screws (from the underside). Care must be taken in choosing the screw lengths so that the points do not break through the lower surface of the table proper.

Finishing is largely a matter of choice. All the ply edges can be left square and covered with appropriate veneer, either in a matching or a contrasting colour, or smoothed and the edges lightly rounded off. Either method is equally effective, if done neatly. All the exposed surfaces of the table and drawer should, of course, be filled and sanded, followed by staining and polishing, or clear lacquering to a gloss finish.

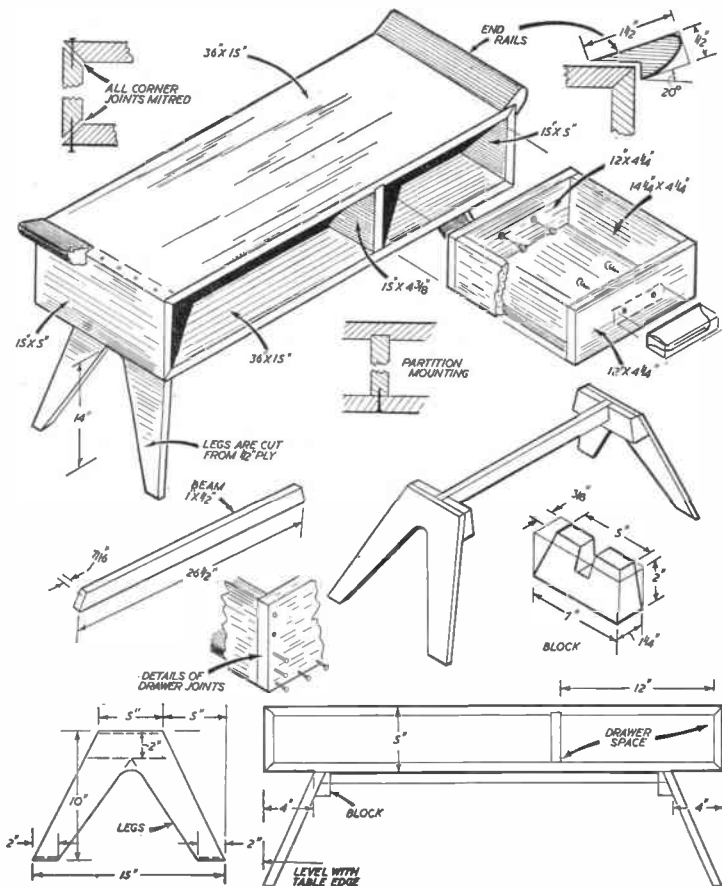

☆☆☆☆☆☆☆☆☆☆
 ☆ Details for making your own canoe ☆
 ☆ —the PBK14 Mk 2—will be given ☆
 ☆ in next week's issue. Simpler and ☆
 ☆ a little cheaper to build than the ☆
 ☆ original PBK 14, it is "capable of ☆
 ☆ going anywhere wet" says P. W. ☆
 ☆ Blandford, the designer. ☆
 ☆☆☆☆☆☆☆☆☆☆☆



AS spring approaches trout fishers will be thinking of 'speckled beauties', of the sport to come, and of trouty waters that are to be explored. The prospects of testing the possibilities of a river, beck, burn, or loch, hitherto unvisited, are always intriguing and fascinating. To wander, rod in hand, by distant trout haunts, is, indeed, something worth the anticipation as a new season draws nigh.

In Britain we are richly endowed with beautiful streams, many of them well stocked with brownies, and in some cases, rainbows. The Ordnance Survey maps are scribbled with winding blue-lined tracings denoting the courses of delectable fishings. Studying such O.S. Sheets — we like those with a scale of One Inch to One Mile — is ever attractive. What thoughts are conjured up — what visions flash to the mind! How we would love to try that stream or this, especially in those parts of the country as yet unexplored by us!

We dally with Glorious Devon, with Somerset, Wild Wales, Derbyshire, Yorkshire, the Border Country and Lake District, and, if we are ambitious, Bonnie Scotland and even the Outer Isles. How do we make our choice? It all depends upon our fancy, plus time for fishing, length of holidays, distance, luck in possessing good friends in the right quarters, and, not least, upon the state of one's bank balance!

The choice is wide and varied, so much so that we may become a trifle bewildered by the numerous possibilities. North, south and west the map shows the symbols of streams containing the beautiful sporting fish we covet.

In the West

The charms, trouty and scenic, of the West Country, are a byword amongst ardent troutists. The very names of the many desirable waters ring like music in one's ears — Exe, Barle, Sheardown Water, Bale Water, Mole, Bray, Badgworthy Water — where Kingsley's hero went a-fishing for loaches — East and West Lyn, Otter, Teign, Tamar, Taw and Torridge, Dart and its tributaries. Glorious are the hill streams which flow sparkling like champagne down the wooded combs, bubbling over the mossy rocks, and loitering in deep,

rock-shaded pools — all framed in a most picturesque setting of hill, moor, and woodland. Badgworthy Water, previously mentioned, is a good example of the smaller West Country stream, as it rollicks down from the Exmoor heights to link up with the Lyn at Malmsmead, gathering unto itself many lesser waters issuing from the combs that lie to the west.

Derwent and Dove

Happy is the angler after trout who pitches his tent at Withypool on the banks of the Barle, perhaps one of the most favoured haunts of trout fly-fishers in Somerset and North Devon. There is Winsford, too, that charming village with its Thatched Inn, interesting cottages, and low stone bridges which cross the twining river. The trouting in the Exe here is very attractive. Close by is Exton, where the Exe is joined by the Quarre; Exford, in the heart of the moors, is equally delightful.

It is difficult to imagine anything more delightful in river scenery than the Dart between Totnes and Dartmouth, with many resorts where the angler may get good fishing. From Launceston the Tamar may be exploited, and the Taw and Torridge are not far away. Then there are dozens of small tributary streams feeding the bigger rivers, all affording a chance for the roving troutist to test his skill.

One can imagine a Derbyshire angler, who knows the waters of his native county, saying: 'Yes! West Country streams are grand — but what about our Peakland waters? Are they not beautiful as well as fishful?' As a born native of that beloved county the writer can reply emphatically: 'They are that!'

One thinks of the lovely Derwent born in the wild hills beyond the Derwent Valley reservoirs. Along its course through Bamford Dale, Baslow, Darley Dale, and the Matlocks, it flows with many ins and outs amid scenes which, in places, rise almost to the sublime.

There is good fishing still to be had at such resorts as Rowsley (Peacock Hotel) and Darley Dale; also at Baslow where the Peacock Hotel has water available for guests (note: there are two hotels named the Peacock, one at Baslow, the other at Rowsley). At

BEST SPOTS FOR TROUT

By A. Sharp

Matlock there is some trout-fishing by day ticket (Matlock U.D.C.) and the hotels are The Boathouse and Crown.

Much of the trout-fishing on the Derwent, it should be pointed out, is in the hands of clubs and private owners. Its chief tributary is the Wye, another charming stream, excellently stocked with rainbow and brown trout. The stretch where romantic Haddon Hall nestles on the verdant banks forms a delightful pastoral and river scene. Anglers staying at the hotel at Rowsley (Peacock) may enjoy miles of pleasant fishing, fly only.

Derwent, though beautiful, takes second place to the far-famed Dove, of immortal memory. Wandering troutists will go a long way to find a river more attractive in England than Cotton's 'Princess of Rivers'. The banks of Dove are linked with memories and associations of Izaak Walton and Charles Cotton. Its superb scenery, its grand fishing, and its literary connections lift this stream above all others. Hotels on the banks which have fishing available include the Charles Cotton Hotel at Hartington; the Pack Horse at Crowdecote; the New Inns Hotel at Alsop-en-le-Dale; and the Izaak Walton at Ilam, near Ashbourne.

Yorkshire's Claim

After reading the above we can anticipate a Yorkshire trout-angler holding a brief for his own county of lovely rivers and fine moorland scenery. He will sing praises of Wharfe, Swale, Yore, Costa, Rye, Pickering Beck, etc. The larger streams in their upper and middle reaches have the charms of hills and dales; deep waterfalls, and rushing cascades. Visitors to Bolton Abbey, Ilkley, Richmond, and Wensleydale will certainly support the just claims of the county of broad acres. And visiting anglers will not be disappointed.

As to fishing resorts we may mention Grassington on the Wharfe; Appletreewick, Ilkley, the Yore at Coverbridge, and the tributary Cover, with fishing for guests at the local inn. Wensley, Hawes, and Askrigg are other resorts. The Swale at Richmond and higher up the dale affords trouting, and there are numerous small becks at Muker and Keld with free fishing.



A FASCINATING HOBBY made Simple & Successful by means of this BOOK

Lampshade making can give endless fun, beautify your home and delight your friends. There are 83 practical and easy-to-follow illustrations and ideas to show how to do it.

Published by C. Arthur Pearson Ltd., Tower House Southampton Street, Strand, London, or obtainable from

SAMUEL JONES & CO. LTD.

8/6



SAMUEL JONES & CO. LTD.
Obtainable from all Booksellers or by requisition

When you want it
to stay put



USE CERTOFIX

CERTOFIX really fixes
This super liquid glue copes with all general repairs. With wood, glass, metal and most other materials, CERTOFIX makes a joint stronger than the substances it unites.

make it immovable with Certofix

Sold at all Woolworth Stores

NEW! THE PRACTICAL WAY of learning RADIO · TELEVISION · ELECTRONICS

AMATEUR S.W. RADIO · MECHANICS · PHOTOGRAPHY · CARPENTRY, etc., etc.

NEW—Experimental outfits and lesson manuals sent on enrolment remain the student's property. Tutor allotted to each student for personal tuition throughout the course.

In radio and television courses, specially prepared components are supplied which teach the basic electronic circuits (amplifiers, oscillators, detectors, etc.) and lead by easy stages, to the complete design and servicing of modern radio and T/V equipment.

THESE PRACTICAL COURSES ARE IDEAL AND MAY BE YOURS FOR MODERATE COST

Fill-in the coupon to-day for a free Brochure. There is no obligation whatsoever.

Courses with equipment enable you to design, construct and service

2-stage radio equipment
3-stage T.R.F. circuits · Television equipment · Workshop Test Panel
Oscilloscope · 5 valve 3-waveband superhet circuit

SUBJECTS INCLUDE:— Radio · Electronics · Television Equipment
Mechanics · Chemistry · Photography · Electricity · Woodwork
Electrical Wiring · Draughtsmanship · Art · Short Wave Radio
Oscilloscope · also many other Home Study Courses w.thout equipment.

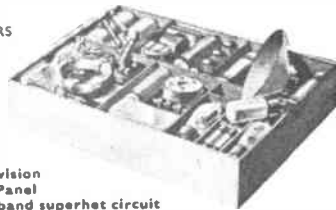

EMI INSTITUTES

Associated with H.M.V.,
Marconiphone, etc., etc.
The only Home Study
College run by a
World-wide industrial
organisation.

COURSES FROM 15/- PER MONTH

E.M.I. INSTITUTES, Dept. 31X, London W.4

NAME _____

ADDRESS _____

Subject of interest _____ AGE _____
(if under 21)

(We shall not worry you with callers) 13 3/57 IC85

Replies to Readers Is this YOUR Problem?

Making Rudd Blocks

I WANT to make some rudd blocks, and in my younger days can remember making some, using venetian red and plaster of Paris. Can you give me the proportions of red to plaster and where can I obtain the venetian red, or can you tell me how to make rudd? (J.D.—Carlisle).

THERE seem to be no definite details regarding the ratio of plaster to colour in making rudd blocks, but a little experiment should speedily decide that. Mix 1 measure of plaster of Paris to 3 measures of Venetian red together intimately in the dry state, and add water to make a consistency of thick cream. If block is too soft, add more plaster and vice versa until the hardness is satisfactory. Only enough plaster to make the blocks easy to handle is necessary. Venetian red, sometimes sold as red ochre, should be obtainable at any oil and colour shop or, perhaps, ironmongers. It is a cheap and common pigment.

Repairing Tent Canvas

I HAVE a tent which has suffered considerably in the high winds. The bottom of the walls are holed where the brass rings have pulled out, and the ridge is ripped in several places. Will ordinary calico be satisfactory for repairs or should a waterproof material be used? (A.H.—St. Albans).

IF the bottom of the walls are badly torn, it will be advisable to replace with new material, either good quality tent duck or canvas — not calico. Any camping stores or reliable outfitters will be able to supply this to your requirements, and the necessary rings, etc. Otherwise, where the bottom of the walls are only holed, they may be patched with canvas. Cut your patch a good bit bigger than the hole that it has to cover, and cut away the ragged edges of the tear. Turn in a hem all round the outside patch and press this down heavily so that it lies tightly to the canvas to which it is to be hemmed with waxed thread. When this has been done neatly, the edges of the tear should be sewn on to the patch with a neat herringbone stitch. Press all again, driving the wax into the thread holes. Renew the peg rings. Any small holes not demanding a patch can be carefully darned with a herringbone stitch of waxed thread, and afterwards well pressed. Secure rings with firm strong

stitches and oversew any places where the threads have become worn. As regards the ridge, cut your canvas patch larger than the hole to be mended. Lay it over and hem round neatly, cross-stitching the edges of the hole to the patch, afterwards giving the mend a good pressing with a flat-iron if possible.

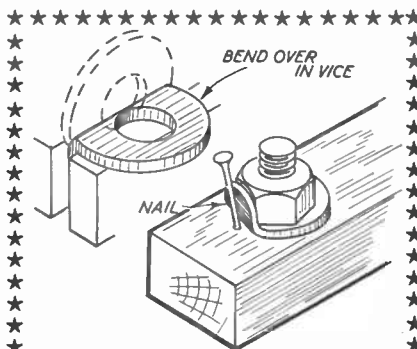

TO LOCK NUTS

THE sketch shows a positive method of locking a nut on a bolt used to hold a wooden member. A washer will have to be used under the nut, in any case. If one side of the washer is bent up into a tab the nut, after tightening, is securely locked by driving in a nail close up against the tab. (R.H.W.)

White Stain on Wood

HOW can I remove a white stain on a table top which I believe has been sprayed with a cellulose.

AS ordinary methods have failed to remove the white stain, try the following. Dampen a clean fluffless rag with methyl acetone, and rub the spot gently until the stain disappears. If the stain is deep enough, this treatment may remove the cellulose as well, but if so, go over the surface afterwards with brush-on cellulose varnish, very carefully.

Hardening Plasticine Models

I HAVE made a Plasticine model for exhibition purposes, and wish to know how to harden this. (J.W.—Darlington).

AS there is no way of hardening Plasticine we suggest you treat your model as is generally done when the

model has to be kept for exhibition purposes. Paint the Plasticine model with two thin coats of white shellac polish. This is quite cheap and can be obtained from any paint shop. When the shellac is quite dry, give one or more coats of ordinary decorator's paint. This treatment gives a hard surface, and the model can then be handled with little fear of damage. For permanent models there is a self-hardening material called Plastone.

Fixing Panels

I HAVE made a sideboard, using mahogany plywood in the side panels. I made the mistake of fixing the panels to the framework by screws, covering the heads with plastic woodfiller. This looks unsightly and the solid 'blobs' show up badly against the grain of the wood. What can I use which will imitate the grain of the wood and which will take french polish satisfactorily? (E.G.—Lakenheath)

FOR future guidance in fixing panels, employ panel pins and punch down, then fill the tiny holes with coloured stopping. In your present case, any attempt to disguise the screw heads is likely to prove a failure. Instead, glue and pin over the lines of holes a suitable strip of moulding, previously stained to match the wood of the panels. You must level off the blobs of stopping previously made, quite level with the panels, and scrape off all polish where the moulding is to come.

Film Tank Apron

CAN you supply information about constructing an apron for a 3½ in. Kodak film tank? I have every part complete excepting the apron and I am told I cannot now purchase one as it is out of date. I should also welcome instructions for use of film tank as it is quite a time since I used one. (J.H.—Colwyn Bay).

THE usual apron consists of a piece of celluloid or other material, with raised lips along each edge, so that developer can flow over the film. It might possibly be made from an old film, the lips being made with a heated tool. Film tanks are loaded in darkness. If you use a developer such as Azol, you will find each film listed, with the time required. Mix the developer with water as explained (e.g., 1:40) and ascertain the temperature with a thermometer. Then develop for the time listed. The developer is then poured out and the film washed with one or two changes of water. Fixer is then poured in and left for about 15 minutes, after which the film may be examined in daylight. After fixing, wash the film for 60 minutes in running water, or with 12 changes of clean water at five-minute intervals.

DON'T SAY GLUE SAY UHU

- Sticks in seconds ● Colourless
- Waterproof ● Holds for keeps
- Heat resistant

USE

UHU GLUE FOR ALL REPAIRS

Obtainable Everywhere Including:

F.W. WOOLWORTH & CO. LTD.

GENUINE Swiss Musical Movements. The best and largest selection of tunes in the country, lowest prices 16/3 each. Genuine Thorens Movements, 22/9 each. All guaranteed. P & P. 9d. extra on all orders. — Richardson & Forder, HW, 5 Chapel Place, White Hart Lane, London, N.17.

WHEELS (Hardwood and Rubber Tyred Metal), Cot, Pram and Doll's House Fittings and Papers. Beads, Transfers, Prints and other accessories. Stamp for new lists. (Trade supplied.) New address — JOYDEN CO., 91 Peplins Way, Brookmans Park, Herts.

100 DIFFERENT stamps free! Request 4d. upwards discount approvals. — Bush, 53 Newlyn Way, Parkstone, Dorset.

SWISS MUSICAL MOVEMENTS. Before you buy send 2d. stamp for our illustrated brochure — Metwood Accessories (Dept. HW), Church St., Wolverton, Bucks. (Trade enquiries invited.)

* GREAT CAMPING OFFER * RIDGE TENT SENT FOR 4/-



Complete. Ideal cyclists, campers. Length 7' 3" sleeping base x 4' 6" wide x 3' 6" high x 12" walls, all approx. Weight 3 1/2 lb. Cash 55/-, or 4/- deposit and 6/- monthly. WITH FLYSHEET 83/6, or 9/3 deposit and 9/9 monthly. Both carriage 2/6. LISTS OTHER EQUIPMENT. TENTS, CLOTHING, ETC., TERMS.

BRAND NEW U.S.A. OFFICER'S SLEEPING BAG

MADE IN THE U.S.A. These are a gen. American issue, not to be confused with spurious imitations on the market. Real 100% wool inner zipped down the front, with an additional free waterproof outer, you can sleep in the open. Comfortable, warm, rolls into easy carrying pack. 29/11, post etc. 2/6. LISTS, TENTS, TERMS.



WITH FREE OUTER

29/11
Post etc. 2/6

HEADQUARTER & GENERAL SUPPLIES LTD.
(HOBW/50), 196-200 Coldharbour Lane
Loughboro Junction, London, S.E.5
Open all day Saturday. 1 p.m. Wednesday.

STAMPS FREE — Empire Packet including Pictorials and Victorians with approvals. — Robert J. Peck, 7A Kemp Road, Bournemouth.

EARN it as you do it — we provide practical equipment combined with instruction in Radio, Television, Electricity, Mechanics, Chemistry, Photography, etc. — Write for full details to E.M.I. Institutes, Dept. HW47, London, W.4

To stamp collectors:—

100 FLAGS (FREE)

Printed in full colours, gummed and perforated just like stamps, these are ideal for illustrating your stamp album. Complete sheet of 100 different will be sent to you quite free if you enclose 2 1/2d. stamp and ask for a selection of stamps on approval (without approvals: — 9d.)

Don't delay, rush your order to—

G.E. MOAT (Dept. HF) 133 Beedell Ave., WESTCLIFF, Essex

AMERICAN PUBLICATIONS. Deltacraft Hard Bound Library — 'Getting the Most out of Your Lathe', 'Your Drill Press', 'Practical Finishing Methods' 10/- each inc. postage. Year's subscription 'Homecraftsman' 16/6; 'Homecraft' 18/-. Send for complete catalogue. — Willen Ltd. (Dept. 57), 9 Drapers' Gardens, London, E.C.2.

MODELS. You can make lasting stone-hard Models with Sankey's Pyrama Plastic Cement. Supplied in tins by Ironmongers, Hardwaremen and Builders' Merchants. Ask for instruction leaflet.

'PAINTSPRAYING' HANDBOOK. Covers Car, Industrial & Flock Spraying, 3/6, post 4d. Catalogue of our Cellulose and Paints and all Allied Sundries 2 1/2d. — Leonard Brooks Ltd., 81 Oak Road, Harold Wood, Essex.

10,000 FORMULAS. Trade secrets, recipes, processes. Remarkable 900 page book. Only few available. Money back guarantee. 27/6 p. pd. — S. P. Ltd., 28(H.B.) Dean Road, London, N.W.2.

STOP SMOKING!! Quick guaranteed remedy. Free testing sample!! — Triumph Remedies (H), Exeter.

KUKLOS ANNUAL. Indispensable cyclist's handbook. Tours, resthouses, money-saving hints, 2/10, post free. — Burrow, Publishers, 2 Imperial House, Cheltenham.

WATCH AND CLOCK REPAIR OUTFIT



The complete Outfit for cleaning and repairing. Comprises: Illustrated explanatory booklet, eye-glass, tweezers, screwdrivers, oil, dusting powder, oils, also illustrated catalogue, tools and materials.

Plus P. & P. 1/- extra. C.O.D. if required.

The above with additional luminous compounds, jewellers' rouge, dial brush, jewels.

Plus P. & P. 1/- extra. C.O.D. if required.

12/9

21/-

ASSEMBLE YOUR OWN JEWELLERY

Selection of unset earrings, pendants, rings, brooches and stones, etc. at fraction of cost.

Send S.A.E. now for big illustrated free catalogue. Money back guarantee.

THE BOLSTER INSTRUMENT CO. (Dept. HD6)
GOVETT AVENUE, SHEPPERTON, MDDX.



MANCHESTER

10 Piccadilly
(Phone CENTRAL 1787)

BIRMINGHAM

100a Dale End, Birmingham 4

SHEFFIELD

4 St. Paul's Parade

LEEDS

10 Queen Victoria Street

HULL

10 Paragon Square

(Phone 32959)

SOUTHAMPTON

134 High St. (Below Bar)

BRISTOL

30 Narrow Wine Street

NEWCASTLE

42 Dean Street

Head Office & Factories—HOBBIES LTD, DEREHAM, NORFOLK

NEW LOW PRICES FOR

DOWELS

CLEAN SMOOTH TIMBER
BEECH/BIRCH

5/16" x 36" 37/-

3/8" x 36" 47/3

1/2" x 36" 146/-

per 1,000 running feet delivered (30 miles radius of London)

VARIOUS DISCOUNTS FOR QUANTITIES

LURALDA LTD IBEX HOUSE
MINORIES LONDON EC3

Royal 1852

MAKE A RADIO

NO SOLDERING—Only a screwdriver and pliers required. All kits complete with easy to follow building instructions.

WINNER crystal set, 12/6 post free.

CONQUEROR 1-valve set, 22/6; valve and batteries 15/6 extra.

FREE! Send stamped addressed envelope for complete list of 10 kits

BLANCHARD'S RADIO

(Dept. H6), 13 GAINFORD GARDENS, MANCHESTER, 10

HEAR ALL CONTINENTS With H.A.C. Short-Wave Receivers

Suppliers for over 18 years of Radio S-W Receivers of quality.

One-Valve Kit, Price 25/-

Two-Valve Kit, Price 50/-

Improved designs with Denco coils. All kits complete with all components, accessories and full instructions. Before ordering, call and inspect a demonstration receiver, or send stamped addressed envelope for descriptive catalogue.

"H.A.C." Short-Wave Products (Dept. 22), 11 Old Bond Street, London, W.1

See page 390

Patterns for a Tea Caddy

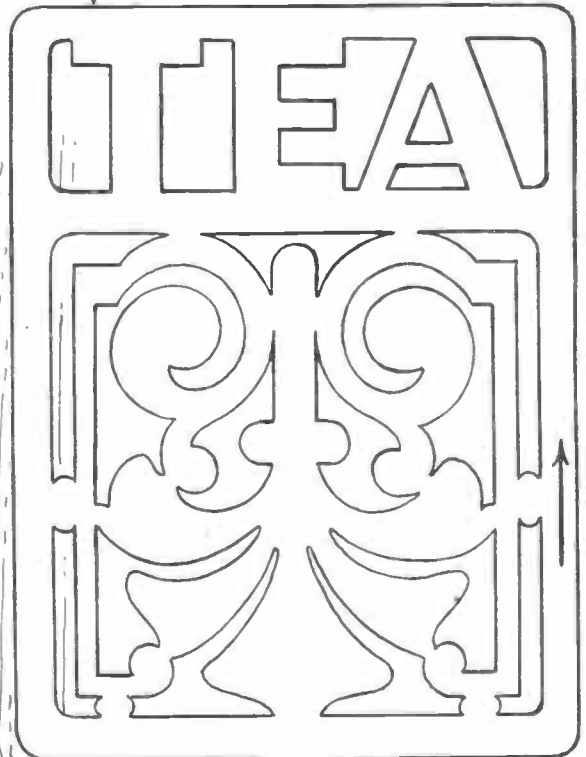
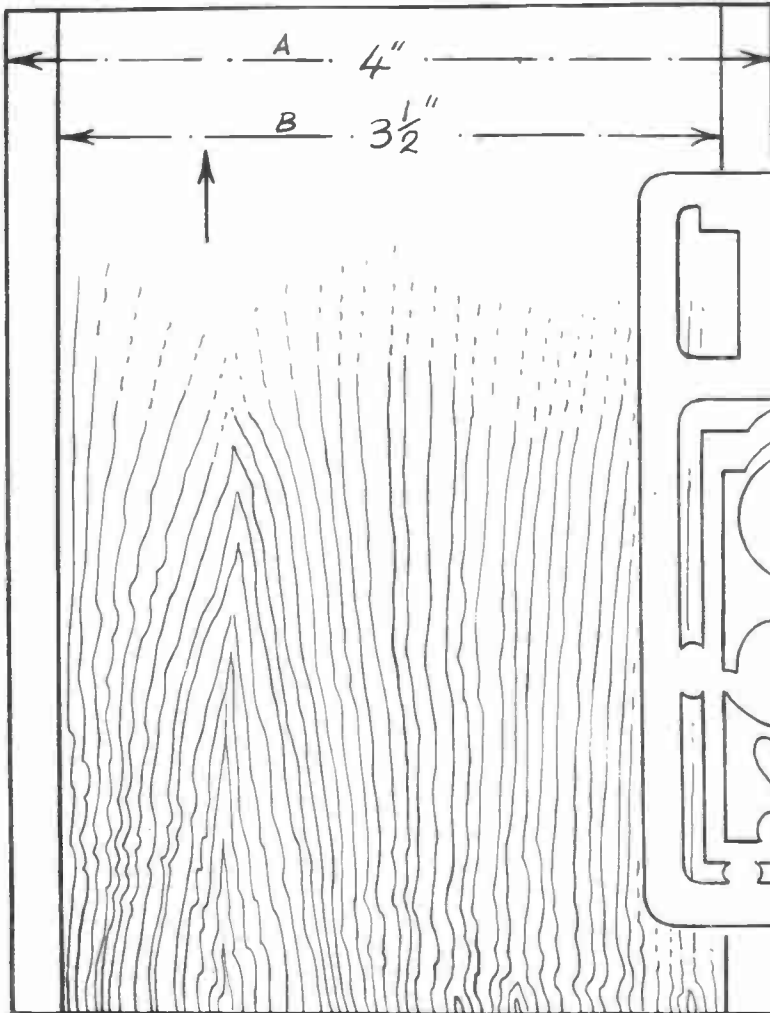
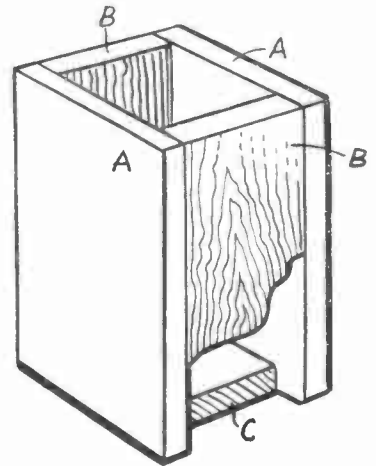
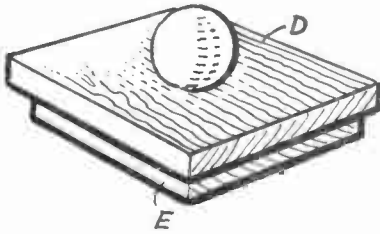

Make Leisure a Pleasure with

Some of our
Kits which can
be made up as
GRAND GIFTS

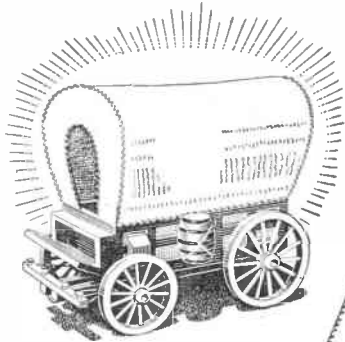

24/6 'Covered Wagon'
Kit No. 3156

**NOVEL,
PRACTICAL
ELECTRIC
LIGHTS**



23/11 'Yacht' Kit No. 3110



6/9 'Bird' Vase Holders
Kit No. 3140
(for a pair, including vases)



3/6 'Windmill' Egg Timer
Kit No. 3118

**CHARMING
DESIGNS
WHICH WILL
DELIGHT
EVERY
HOUSEWIFE**

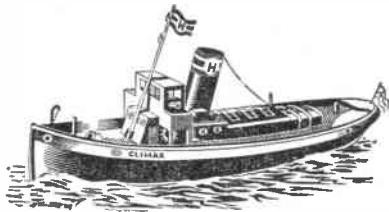

Electric Tug 'Climax' Kit No. 251 Special
(including motor and propeller unit) **52/6**

**— AND
THRILLING
JOBS FOR
THE BOYS**



45/- Cruiser 'Crusader' Kit No. 3154
(including motor and propeller unit)

To Hobbies Ltd, Dept. 99, Dereham, Norfolk

Please send kit marked X (all post free)

- | | | |
|--|--|---|
| <input type="checkbox"/> Covered Wagon
No. 3156, 24/6 | <input type="checkbox"/> Egg Timer
No. 3118, 3/6 | <input type="checkbox"/> Tug 'Climax'
No. 251 Spl., 52/6 |
| <input type="checkbox"/> Yacht Light
No. 3110, 23/11 | <input type="checkbox"/> Vase Holders
No. 3140, 6/9 | <input type="checkbox"/> Cruiser 'Crusader'
No. 3154, 45/- |

NAME

ADDRESS

P.O. enclosed for

**From Branches,
Stockists etc, or fill
in coupon for one
of these fine kits**

TODAY

A CHILD'S DROPSIDE COT (COLLAPSIBLE)

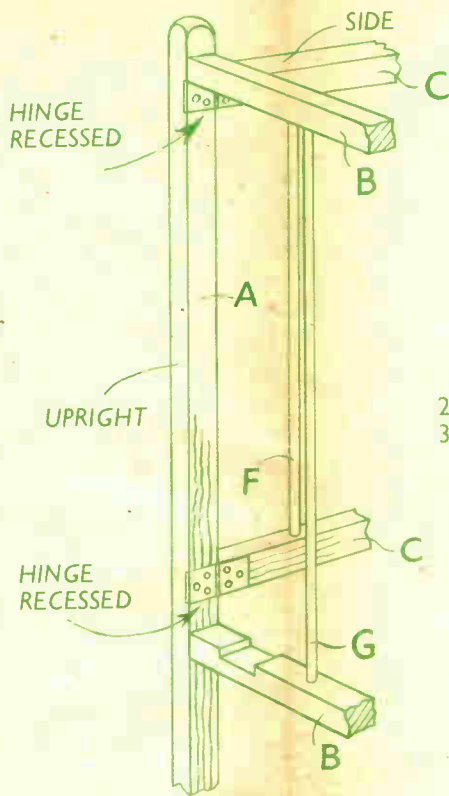

SIZE
4 ft. LONG
24½ ins. WIDE
39 ins. HIGH



1¼ ins. SQUARE

AN EASY JOB FOR THE HOME HANDYMAN

A KIT OF MATERIALS IS SUPPLIED BY HOBBIES LTD., DEREHAM, NORFOLK
Price on application

Use



Croid AERO

IT'S DESIGNED FOR THE JOB

This pure hot animal glue of great strength needs no mixing or preparation. The Home Outfit consists of 8 oz. tin Croid Aero Glue — Hot Water Container — Handy Brush — 4 — complete.

AVAILABLE FROM ALL BRANCHES OF HOBBIES LTD

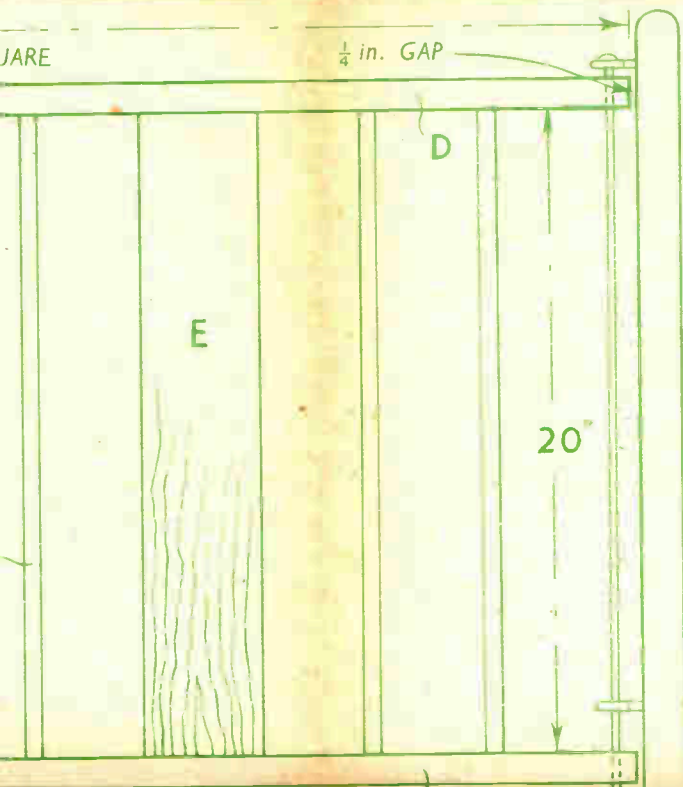

2
20

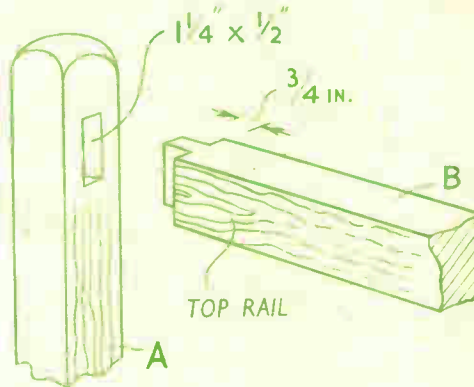

SHOWING HOW RAILS ARE TENONED INTO UPRIGHTS.

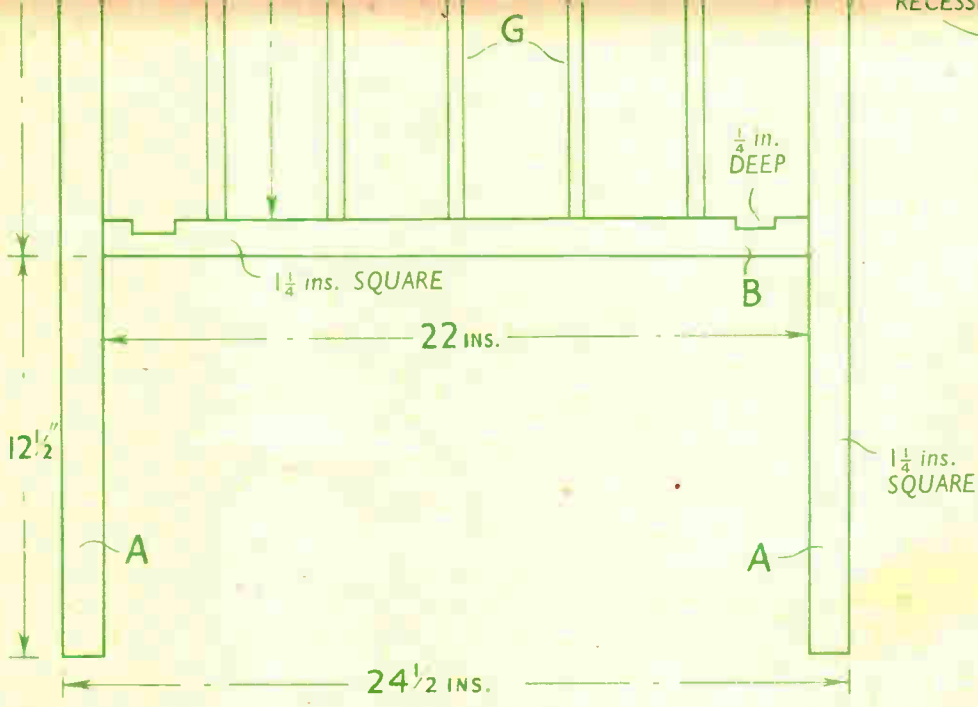

**AN
EASY
JOB FOR
HOME
HANDY**

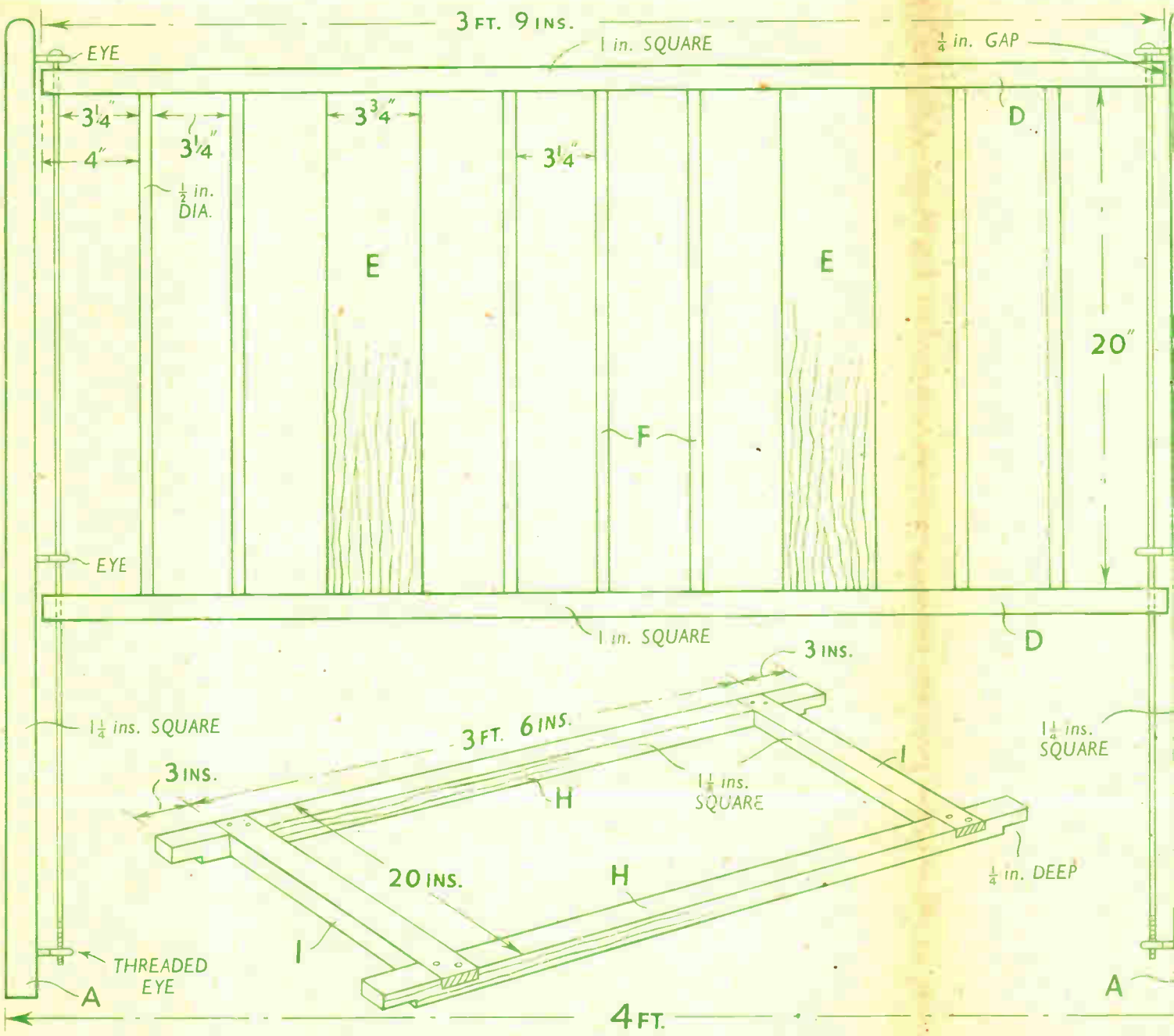

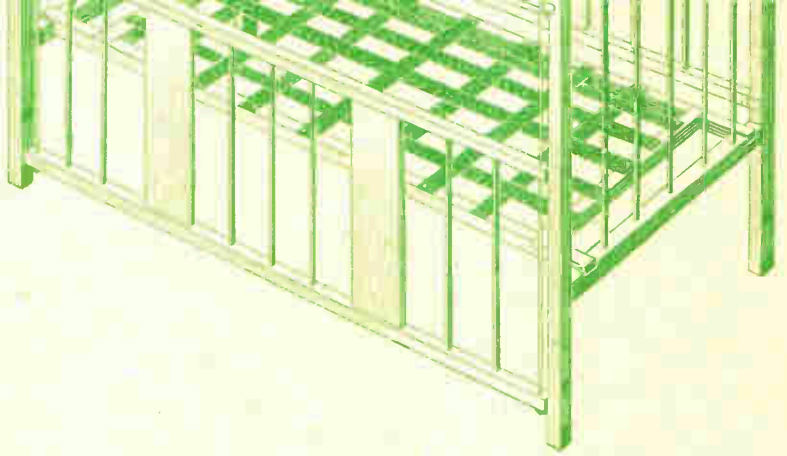
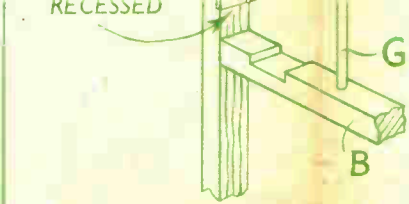

AN EASY JOB FOR THE HOME HANDYMAN

1 1/4 ins. SQUARE

A KIT OF MATERIALS IS SUPPLIED BY HOBBIES LTD., DEREHAM, NORFOLK
Price on application

Use



Croid AERO

IT'S DESIGNED FOR THE JOB

This pure hot animal glue of great strength needs no mixing or preparation. The Home Outfit consists of 8 oz. tin Croid Aero Glue -- Hot Water Container -- Handy Brush -- 4- complete.

AVAILABLE FROM ALL BRANCHES OF HOBBIES LTD

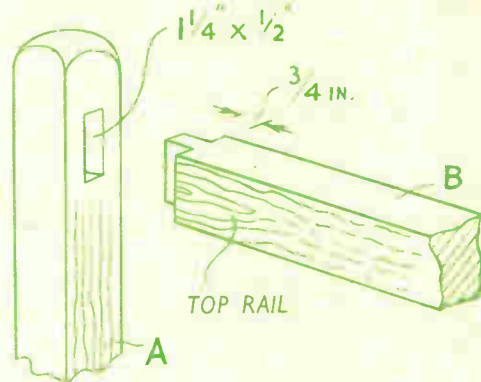
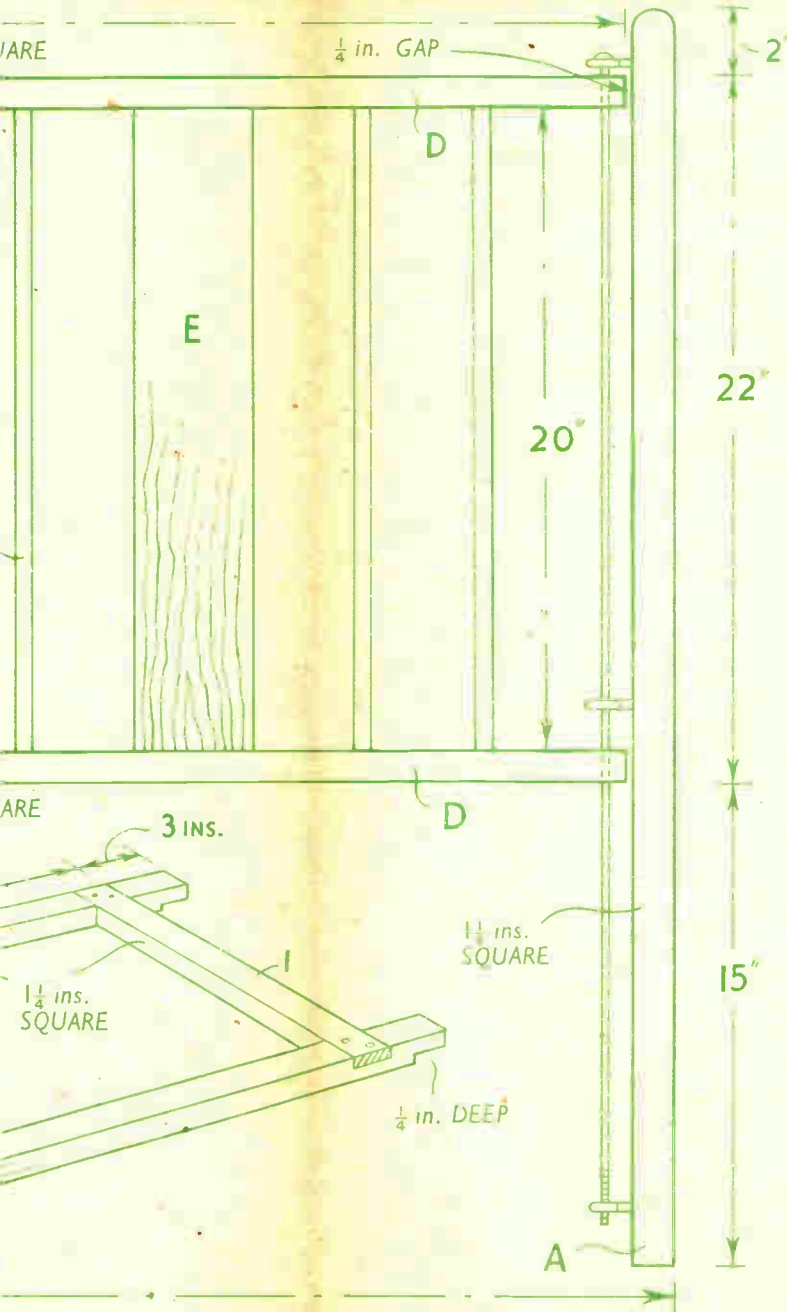

SHOWING HOW RAILS ARE TENONED INTO UPRIGHTS.

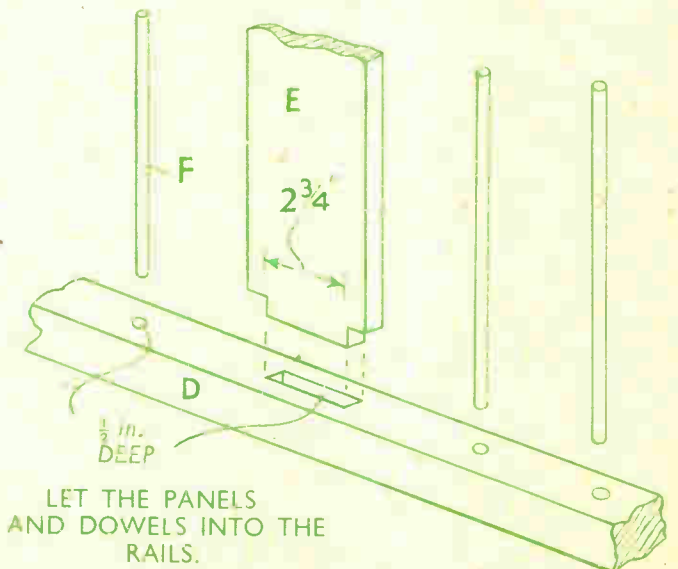

LET THE PANELS AND DOWELS INTO THE RAILS.

PRINTED IN ENGLAND.