

HOBBIES WEEKLY

IN THIS ISSUE

	Page
Soiled Linen Basket	289
Crinoline Bookmarkers	290
A Trick Pack	291
Make a Realistic Fort	292
Eliminating those Blemishes	294
Work Bench with Several Uses	295
Patterns for Scale Model Horse	296
The Shipmodeller's Corner	298
An Accumulator Charger	301
Patterns for Bookmarkers	303



AUGUST 8th 1956

VOL. 122

NUMBER 3171

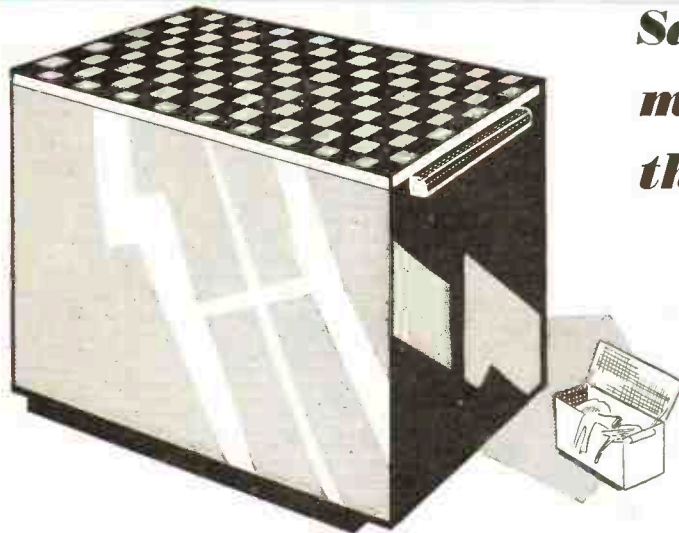

*Save yourselves
money by making
this for the home*

The two centre-rails (D) are also tenoned in position, but stub tenons are made as shown in Fig. 4. They should be quite short, about $\frac{1}{2}$ in. will be sufficient.

When all tenons and mortises have been cut they should be cleaned up and glued in position. Wipe off excess glue before it is dry and clamp up where necessary.

The bottom of the basket rests on the lower rails and is cut at the corners to fit as shown in Fig. 5. It need not be fixed in position. Holes for ventilation should be drilled at intervals as shown in

SOILED LINEN BASKET

DESIGNED for economic use of hardboard and simplicity of construction, this linen basket is an ideal project for the handyman. The mortise and tenon joints are well within the scope of the average woodworker and the hardboard is simply pinned over the completed framework to give a neat and easy to clean appearance.

As a seat and linen basket it serves two useful purposes and when painted to

match the bathroom it will be equal to any shop-bought article.

The framework is made from $1\frac{1}{2}$ in. square material to the measurements shown in Fig. 1. Make allowance, when marking up the rails, for the tenons as shown in Fig. 2. They are mortised into the upright pieces (A) and are mitred to fit. Measurements of the tenons are shown in detail and the section in Fig. 3 shows the tenons mitred at the centre.

Fig. 5. Alternatively, pegboard could be used for this piece.

THE DIAGRAMS ARE OVERLEAF

Hardboard $\frac{3}{8}$ in. or $\frac{1}{2}$ in. thick is now cut and fitted round the sides as shown in Fig. 6, using panel pins for fixing. Drive them slightly under the surface to allow for filling before painting.

All correspondence should be addressed to The Editor, Hobbies Weekly, Dereham, Norfolk

For Modellers, Fretworkers
and Home Craftsmen

4 $\frac{1}{2}$ ^D

PAGE 289

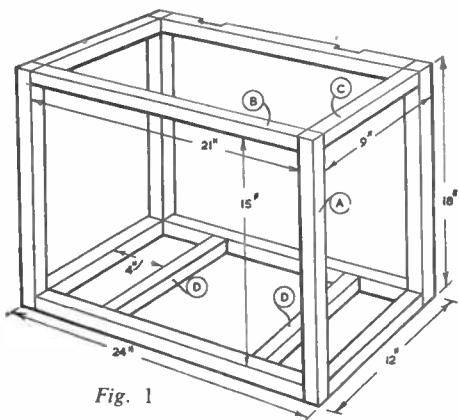

Fig. 1

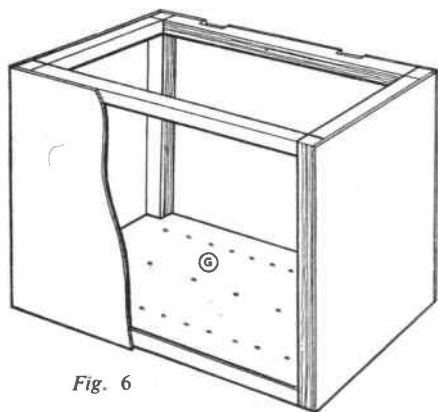

Fig. 6

The lid is made from 3in. by 3/4in. material halved together as shown in Fig. 7. Secure the joints with glue and countersunk screws. The lid is covered with 3/8in. hardboard, taking it flush to the edges as shown. Provision must be made for 1 1/2in. to 2in. butt hinges, which should be let in as shown in Figs. 6 and 7. Lid stays can be added as in Fig. 8, or a special cabinet stay used.

Cutting the handles

The handles are cut from 1 1/2in. square wood to the length shown in Fig. 9. They are cut away underneath as indicated by the section. This cut-away portion will stop short about 1in. from the ends. Note that most of the cutting away will be done with a chisel or gouge.

The plinth around the base is made up as shown in Fig. 10. It is made from 3/4in. thick material and screwed together, using countersunk screws. It is fixed to the cross-rails (D) by means of screws let in as shown in the inset diagram.

After assembly, the whole cabinet is cleaned up and given a white undercoat. Rub down again before applying the finishing coats of high-gloss enamel. (M.h.)

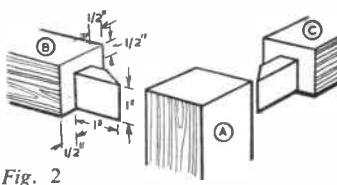

Fig. 2

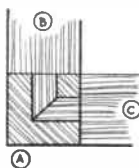

Fig. 3

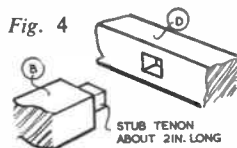

Fig. 4

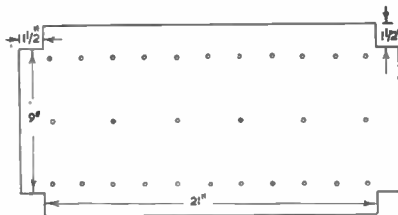

Fig. 5



Fig. 9

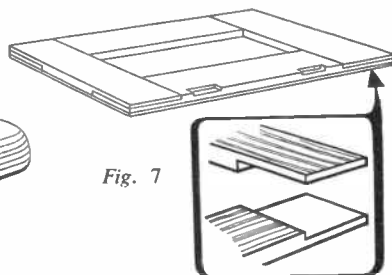

Fig. 7



Fig. 8

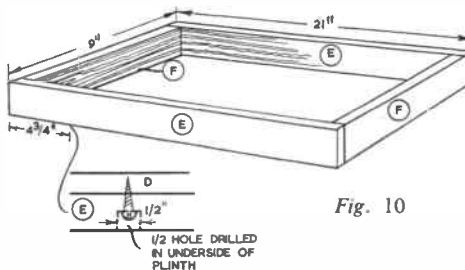
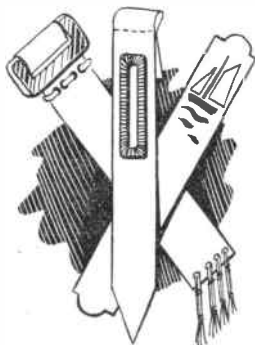

Fig. 10

CRINOTHENE BOOKMARKERS



USE odd pieces of pastel-coloured Crinothene to make these attractive book-markers. They make ideal small gifts and it will be handy to have one or two about the house.

The design (A) is cut and bent round at the top and stitched with coloured silk. The piece (B) is cut from card and is also stitched in place. It can later be covered with silk, using a buttonhole stitch.

Design (D) is threaded through the wooden shape (C) and bound with plastic thonging. The end is decorated with silk tied in place.

The other three designs are cut to suitable shapes and decorated by painting or by cutting away with a sharp knife to give a stencil effect. Oil paints should be used to give the best effect on the Crinothene. (M.p.)

Patterns on page 303

Make these at home

A TRICK PACK . . .

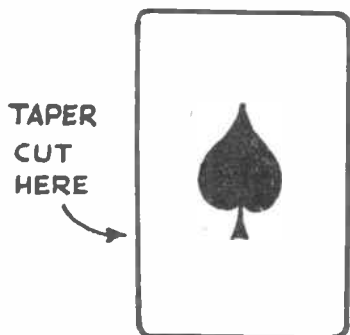

AMATEURS who perform tricks with cards should as a general rule avoid tricks which call for a high degree of manipulative skill. Better a simple trick neatly performed than an elaborate one badly bungled. Indeed, there are plenty of simple tricks with cards which depend entirely upon some such subtlety as an arranged pack or a cunningly faked pack.

The doctored pack

One of the most useful of faked packs is the so-called tapered pack. This is an ordinary pack which has been doctored by cutting a tiny tapered slice from the side of each card with a razor blade. The cutting should be done along the edge of a steel rule and the taper should run from $\frac{1}{8}$ in. to nothing. It is advisable not to treat an old pack in this

returned with its broad end among the tapered ends of the pack. If the pack is now nicely squared up it will be easy for the performer to cut at the chosen card, bringing it to the bottom of the pack — ready to be produced in any entertaining manner he knows.

He can, for instance, pick up the pack with the faces towards him, revealing the chosen card. He can then pick out half a dozen cards at random, including the chosen one, asking if the chosen card is one of them. On receiving confirmation of the fact he can ask his

helper to shuffle the six cards and hold them in a fan while thinking of the chosen card. He can then slowly draw the chosen card from the fan as though guided by mysterious thought impulses.

Nearly every trick of the 'choose a card' variety can be done with the tapered pack and the keen amateur can think out many ways of revealing those chosen cards. They must never be tossed casually and baldly on to the table. An artistic ending to every trick, even the simplest, is the aim of every really entertaining performer.

. . . and The Magic Doll

TRICKS in which things are produced apparently from nowhere have a fascination all their own. In the present trick a cardboard cylinder is shown to be perfectly empty. It is so empty that the performer allows the audience to see right through it.

After the cylinder has been shown it is stood aside in full view while the performer displays a few small sheets of tissue paper of various colours. He at once begins to tear up the paper and drop the pieces into the cylinder. On raising the cylinder a moment later a pretty doll, dressed in bright paper clothes, is seen.

and thought a most elaborate doll can be built up, and if the paper clothes are properly designed to stand out a little from the body the effect will be much improved. An idea of what should be aimed at is shown in the sketch.

The doll is easily pushed into the outer cylinder head first, the clothes

HERE'S MAGIC FOR YOU!

By R. W. Wood

way. A better job will result from the use of crisp new cards. Each one must be cut individually while lying flat on a smooth piece of thick card.

It will be seen that when a pack of this kind is stacked with all the tapered ends together it will appear quite normal, but when a card is reversed its broad end will protrude very slightly beyond the tapered ends. This will hardly be noticeable to the eye, but easily detected by touch.

To use the pack for the discovery of a chosen card, shuffle it, fan it out and have a card selected. While the card is being noted, casually turn the pack round. The chosen card will then be

Especially for the children

This attractive trick is specially suitable for children, and the performer who can tell some kind of story as he performs it will find his efforts well rewarded.

A handy size for the cylinder is $3\frac{1}{2}$ ins. diameter by 10 ins. long. It should be made of stout cardboard, stained dead black inside with indian ink and ornamented on the outside with bright fancy paper. The doll that is later produced is actually nothing but another cardboard cylinder which fits snugly within the first cylinder, but which tapers to about $2\frac{3}{4}$ ins. diameter. This inner cylinder should be about $9\frac{1}{2}$ ins. long. Inside it is also stained dead black.

Making the Doll

The doll is built up around this cylinder by pasting on paper clothes and painting on the face and hair. A hat should be added to complete the dress. This is contrived by pasting a rim of cardboard around the cylinder about $\frac{1}{2}$ in. from the tapered end. With care

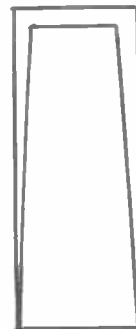

SECTION OF CYLINDER



THE MAGIC DOLL

pressing up close against the body. Viewed from one end the cylinder looks perfectly empty, for the tapered tube is taken for the inside of the empty cylinder.

On raising the cylinder the performer pushes down the inner cylinder with his thumb and the torn pieces of paper are, of course, hidden within the body of the doll. If the doll is produced on a tray there is no danger of the torn paper being exposed when it is put aside in readiness for the next trick.

For a few shillings . . .

MAKE A REALISTIC FORT

THIS model fort is constructed almost entirely out of hardboard, and total cost should not exceed ten shillings — a very reasonable figure in view of its overall size. Working time to complete should be about twelve to fifteen hours, exclusive of painting. All the hardboard parts will

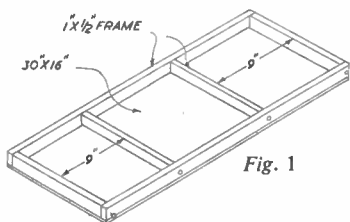

Fig. 1

The two side pieces are then cut from hardboard sheet, as per the layout shown in Fig. 2. The notches are cut out by making vertical saw cuts, scoring along the bottom line and then breaking out the piece. If necessary, clean up with a file or glasspaper, although a slightly rough appearance is quite acceptable. The slits in the towers are formed by drilling at each end with a 3/8 in. diameter drill, cutting the slot between them with a small saw and then opening up with a 1/8 in. warding file. Alternatively, the notches along the tops of the walls and towers and the tower slits can be fretted out. To save time in marking out, one side can be finished completely and then used to mark out the other side.

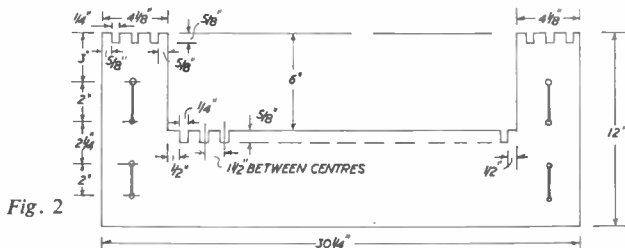

Fig. 2

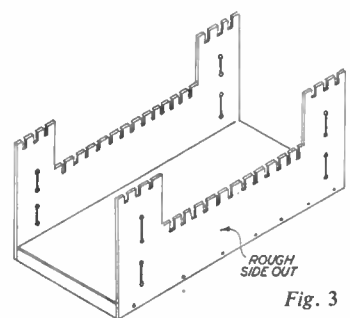

Fig. 3

come out of a 4ft. by 4ft. panel, with some to spare. Approximately 11ft. of 1in. by 3/8 in. or similar section is required for bracing the base, which should represent the only other expenditure apart from glue and panel pins.

Assembling the Base

The first part to build is the base, which is a 30in. by 16in. panel of hardboard, braced with a 1in. by 3/8 in. frame as shown in Fig. 1. Frame members are attached by gluing and pinning, a synthetic resin glue being recommended (e.g., Casco One-Shot powder mixture). Assemble the base with the shiny side of the hardboard uppermost.

When finished, the two sides are fastened to the base, as in Fig. 3. The rough surfaces of the hardboard should face outwards to simulate a stone surface. Secure with glue and panel pins spaced at about 3in. intervals.

The 'north' and 'south' ends differ in layout and are detailed in Fig. 4. Again these are cut from hardboard, using the same technique as previously. Finish the extreme edges perfectly true and square and fasten to each end of the base. Tower joints are glued and should be reinforced in places with pins. The best method of fitting the pins is to drill through the facing piece of hardboard and then position the pin carefully and drive home. Two or three pins in each

tower will provide sufficient support. The joint can be strengthened by running a fillet of glue down the joint line on the inside, balsa cement being excellent for this purpose.

The remaining parts of the towers are then cut to the patterns shown in Fig. 5.

By R. H. Warring

Note that two off each pattern are required, but arranged so that when assembled, the rough side of the hardboard is facing outwards. No slits are cut in these tower faces.

The two side 'galleries' are simply strips of hardboard 28ins. by 2ins. These locate in the slots cut in the longer tower pieces and should be assembled together, i.e., the galleries slipped into the tower slots, the whole lot offered up, positioned and glued in place. Hold the tower faces with two or three pins as before.

The 'north' end gallery is a piece of hardboard 10ins. by 2ins., which rests on the protruding ends of the side galleries, glued down and supported at the middle with a 3 1/4 in. by 2 in. upright of hard-

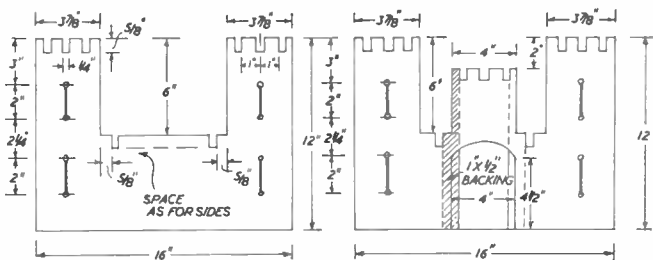

Fig. 4

board or, preferably, 3/8 in. to 1/2 in. thick material. In the latter case the gallery can be pinned down to the upright, as well as glued. After the gallery is properly fitted the two 'north' towers can be completed by the addition of the smaller faces, which need only gluing on (Fig. 6).

The 'south' end is somewhat different in that it incorporates an additional false tower with the main doorway and has no gallery running from side to side. Instead, two shorter but wider galleries are erected, cut from hardboard to 6ins. by 3 3/4 ins. Before these are fitted, however, erect the 1in. by 3/8 in. (frame stock) main doorway supports, first marking out and trimming to fit and

then gluing and screwing to the hardboard. The short gallery pieces are then either trimmed to fit against these door frames or the frames slotted to accommodate the gallery and thus offer more positive support. The inner ends of the galleries (inside the towers) rest on and are glued down to the projecting side galleries, as before. The outer cor-

ners of the galleries are supported with wooden posts, these details being shown in Fig. 7. The remaining sides of the 'south' towers have doorway cut-outs and are simply glued in place. A smaller gallery cut from hardboard is erected on the false tower, as shown, pinning and gluing down to the trimmed door frames. This carries the 'windlass' for operating the drawbridge and the 'free' corners should be tapered and rounded off, so as not to mask off the galleries immediately below. $3\frac{3}{8}$ in. square 'floors' are cemented and pinned into each tower at a suitable height, e.g., $1\frac{1}{2}$ ins. below the top edge.

3 $\frac{3}{8}$ ins. fitted with two wedge-shape pieces cut from the frame stock and the lower edge feathered to produce a smooth ramp leading up to the base height. It can conveniently be mounted on small hinges, or alternatively, strips of tape glued on in place of conventional hinges and performing the same function. It is drawn upwards by two strings or model

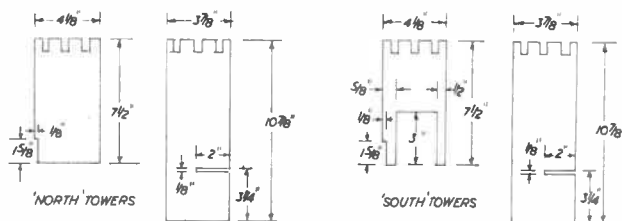

Fig. 5

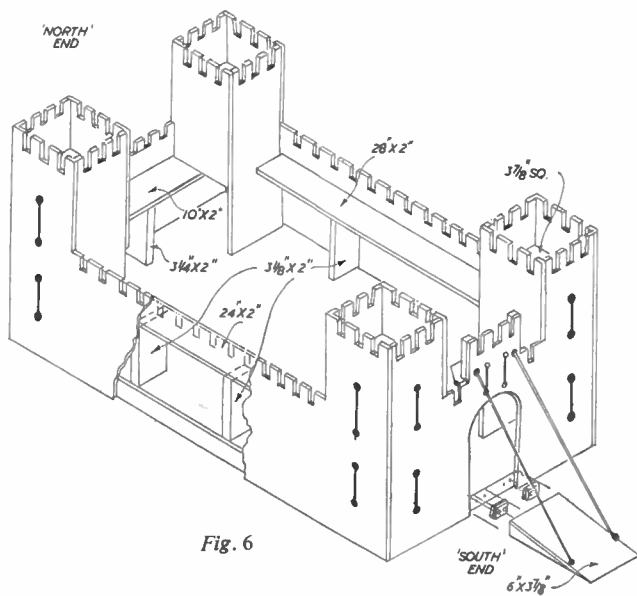

Fig. 6

ners of the galleries are supported with wooden posts, these details being shown in Fig. 7.

The 'Windlass'

The remaining sides of the 'south' towers have doorway cut-outs and are simply glued in place. A smaller gallery cut from hardboard is erected on the false tower, as shown, pinning and gluing down to the trimmed door frames. This carries the 'windlass' for operating the drawbridge and the 'free' corners should be tapered and rounded off, so as not to mask off the galleries immediately below. $3\frac{3}{8}$ in. square 'floors' are cemented and pinned into each tower at a suitable height, e.g., $1\frac{1}{2}$ ins. below the top edge.

The drawbridge is a piece 6 ins. by chains passing through holes drilled in the false tower side-members and terminating on a cotton reel. This cotton reel is mounted on a short length of dowel glued into a hole drilled in the hardboard platform behind the tower, and should either be a friction fit on the dowel, or the hole in the cotton reel packed tight with scrap wood to prevent the reel unwinding under the weight of the drawbridge. Material removed in forming the entrance cut-out in the 'south' end can be cut vertically down the centre and fastened back with small hinges (or tape hinges) to provide working doors in addition to the drawbridge.

Whatever further refinements are then added is mainly a matter of personal choice. The tower faces and walls should be painted light grey and then 'lined'

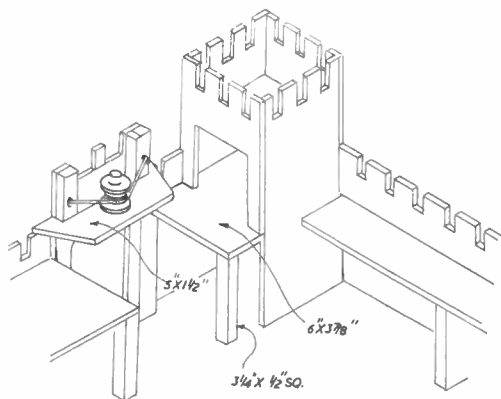

Fig. 7

properly strung on thread, so that they can be raised and lowered. Inside the fort itself there is plenty of scope for building sheds and offices, with a sentry box near the main gate, and so on. In fact, having completed the main assembly you can profitably add a similar amount of working time on details which will make your ten shilling fort even more expensive looking.

* * * * *

THAT'S THE SPIRIT!

METHYLATED spirit has many general uses. Here are a few.

A drop of meths poured on a screw which has rusted in position will often loosen it sufficiently to be turned.

Add about a tablespoonful of meths to the water used for cleaning windows. It removes grime and stains, promotes a brilliant polish and helps to keep down insects.

Mixed with whiting it is probably the finest and safest silver cleaner.

Tender feet may be hardened with a spoonful of alum dissolved in a wineglassful of meths; apply night and morning. When wearing new shoes for the first time, rub the feet with methylated spirit and prevent blistered feet. (R.L.C.)

* * * * *

Eliminating those Blemishes

A FEW minutes careful inspection of an exposed and developed film can reveal many an unsuspected camera fault. A film that shows white spots on its emulsion can almost certainly be ascribed to a dusty camera interior.

The minute spots of dust settle upon the sensitized surface of the film prior to exposure and result in that part of the emulsion being unexposed on development. These spots appear in the positive prints as black spots.

The cure is obvious, and it is always very good practice to thoroughly clean the camera interior with a non-fluffy cloth at every film change, and also to wipe the fresh roll-film to remove any dust before inserting it into the camera.



A scratched film caused by sand and grit

Straight lines and scratches running vertically down the film indicate the presence of sand or grit within the camera. This trouble can be avoided with a little forethought and care. Do not, under any circumstances, change your films on a sandy beach. To do so, almost invariably deposits a few sand grains within the camera, where they can do much harm, not only to the surface of the film, but very possibly to the shutter mechanism.

Flare spots or streaks of fogging across the surface of the film can be caused by pin-holes in the bellows, and in the case of box cameras, through light-leakage occurring at a damaged corner of the camera, or, perhaps, at the moveable portion where the film is inserted.

Pinholes generally make a round

shape flare spot or patch with radiating shafts of fogging on the negative, and in bad cases can cause a complete fogging of the entire emulsion.

Where pinholes occur in the bellows the trouble can sometimes be very baffling, for some exposures are entirely free from fogging, whilst others are defective. If a careful note is taken of the exposures, it will usually be found that the flare marks occur at certain focal distances, that is, at a certain point on the distance or focusing scale. The explanation here is, that in all probability the pinhole which invariably occurs in the crease of the bellows is covered when the bellows are only partially extended, and so does not cause any tell-tale light leakage until the bellows are more fully extended.

Pinholes and extraneous light leakages are rather difficult to trace, and probably the best and simplest way is to place a lighted electric light bulb within the camera in a dark room and the fault will be quickly found.

One of the best repair mediums to use is the old fashioned black Court Plaster which is still obtainable at many chemists. The adhesive side of the plaster should be slightly moistened with the tongue, and after waiting a few seconds to become tacky it is then applied to the faulty part of the camera and well pressed into position. This material is ideal for bellow repairs, as it is extremely flexible, non-cracking and strongly adhesive.

Faulty seams and corners of box cameras should be repaired from the inside as well as the outside, as these cameras due to their somewhat bulky nature tend to receive a fairly rough usage.

Light leakages in the movable back of the camera are often caused through strained and weakened fixing clips. These should be carefully adjusted, so that they hold the back of the camera in tight contact with the rest of the body.

Most camera backs have a thin metal light trap incorporated in their construction. This often takes the form of mating metal channels, and should these be slightly bent or distorted, then a light leakage is bound to occur at that point. They should be carefully rectified with a pair of small pliers. On some older models of folding hand-cameras,

the movable back is provided with light seals of red plush or velour. In time this wears thin, or if the camera has been stored away a considerable time, it is liable to be attacked by moth grubs. In this case the old material should be carefully removed with a sharp knife, and replaced.

~~~~~  
*By E. S. Brown*  
~~~~~

With box cameras, the interior is invariably constructed of light metal, which is coated with a dead matt black finish. Should any of this paint become badly scratched or, perhaps, flake away, then a series of light reflections will occur upon exposure and badly fog the film. Any scratches should be retouched with photographic black matt paint. Where extensive flaking has occurred, it is best to completely smooth the surface with fine glasspaper, and give two thin coats of the paint.

A punctured or cracked film winding window is an almost certain cause of fogged and degraded negatives. Quite a good repair can be effected by cementing with cellulose adhesive, a small patch of dark red Cellophane on the inside of the window. If the damage is serious, how-



Effect of dust spots

ever, a complete repair should be made by removing the damaged window and replacing with ruby coloured celluloid or plastic sheeting.

When using a folding hand camera, always make sure that the stays supporting the platform are fully extended and locked into position, otherwise the lens will not be parallel to the surface of the film and so cause an aberration upon exposure. A spot of oil should be applied to the linkages of the stays, and any surplus immediately removed with a clean cloth.

The focusing scales of most folding hand cameras are divided into a series of

● **Continued on page 295**



By A. F. Taylor

IT is not difficult to make a very useful little work bench which can be easily moved from place to place as required. The one described does not take up much room, and may be used for a variety of purposes. The top is hinged so that it can be swung over when not required as a bench and used for sawing logs or other lengths of wood. The top is quite suitable to stand on or if this is too high it may be swung over and the half-way shelf used instead. Also with the top lowered it can be used as a garden seat.

Any type of wood is suitable, depending on how much it will be used and the nature of the intended work. It is an advantage, however, to make the bench top from a sound piece of hardwood to withstand any rough usage.

It is advisable to get a piece of hardwood in one piece for the top, otherwise you must join two pieces, preferably with a dowel joint, so that it is 24ins. long, 10ins. wide and $\frac{3}{4}$ in. thick. Each end is strengthened with a bar 12 $\frac{1}{2}$ ins. long, 2ins. wide and $\frac{1}{2}$ in. thick glued and screwed on the underside, and projecting 2 $\frac{1}{2}$ ins. at the back. On to this part the hinge is fixed so that the top is free to swing right over and hang down out of the way when sawing logs, etc.

The legs are made from 1 $\frac{1}{2}$ ins. square material, but if you want a very substantial bench you may increase these to 2ins. square. The height may be varied to suit your special needs, but for general work 24ins. will be found suitable.

Each pair of end legs are joined together by a bar at the centre with a mortise and tenon joint, so that they are 10ins. apart on the outside (Fig. 1). With a $\frac{3}{4}$ in. tenon the bars must be cut 8 $\frac{1}{2}$ ins. long and of the same material as the legs. For very heavy work the joint can go right through, using a dowel for extra security.

When the glue has thoroughly set, the two pairs of legs can be joined together with the central plank 24ins. long, 7ins. wide and from $\frac{1}{2}$ in. to $\frac{3}{4}$ in.

Work Bench with Several Uses

thick, which is screwed to the end bars. Then the 'V' pieces can be cut and fixed, and these may also be 1 $\frac{1}{2}$ ins. square or slightly thinner. If the ends are cut at the correct angle to fit snugly, they will only need gluing and screwing to make a satisfactory job.

Now lay the top carefully on the legs so that the two hinges can be fixed.

Ordinary hinges cannot be used, as these would not allow the top to swing right over. A very effective substitute is shown in Fig. 2. A steel 'ell' plate is securely fixed to each back leg with two screws and the hinge joint obtained with a substantial round-headed screw fixed through the end hole of the plate and into the projection of the top bar.

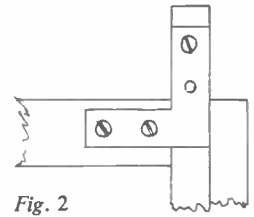
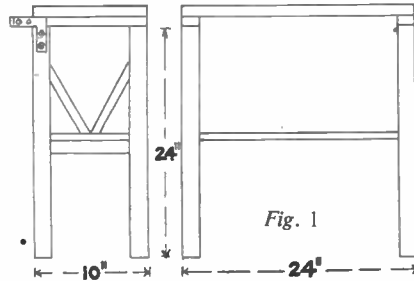

Continued from page 294

Know Your Camera

focal distances from near-subjects to infinity. The lower readings are really critical, especially with a large f aperture, and a misjudgment of a foot or so either way, can throw the subject completely out of focus. As we progress further along the scale towards infinity, the focus becomes less critical, and a slight under or over estimate of distance is of little importance.

A simple and efficient gauge is shown in Fig. 1. The eye-piece (A) is constructed from a 3ins. length of $\frac{1}{4}$ in. internal diameter brass tube. The scale plate (B) is of approximately 2ins. radius and constructed from $\frac{1}{8}$ in. thick brass. It is secured by cutting a slot in the brass tube equal in length to the scale-plate and soldering into position. The indicator (C) is cut from $\frac{1}{8}$ in. thick brass and secured with a rivet. The indicator should be quite free to move under its own weight.

The scales are computed by measuring out a series of distances on the ground in conformity with those shown on your camera scale. Each set of distances are indicated by sticking pegs or staves in the ground. The gauge is then held close

to the eye and pointed at the *ground-level* of each respective peg. At each reading the indicator will rest on a particular part of the scale-plate, and the distance is then scribed on the plate with a sharp instrument.

To use the gauge, focus the sighting tube so that its angle of incidence is at *ground-level* of the subject. Press the indicator to the scale-plate with a finger, then remove from the eye and take the reading given. It should be mentioned that this type of gauge is only suitable for taking readings on approximately level ground.

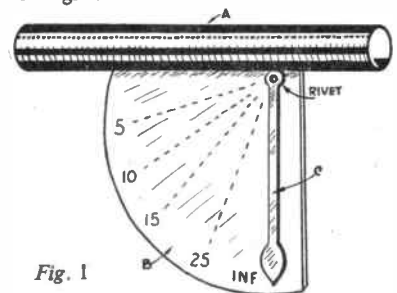

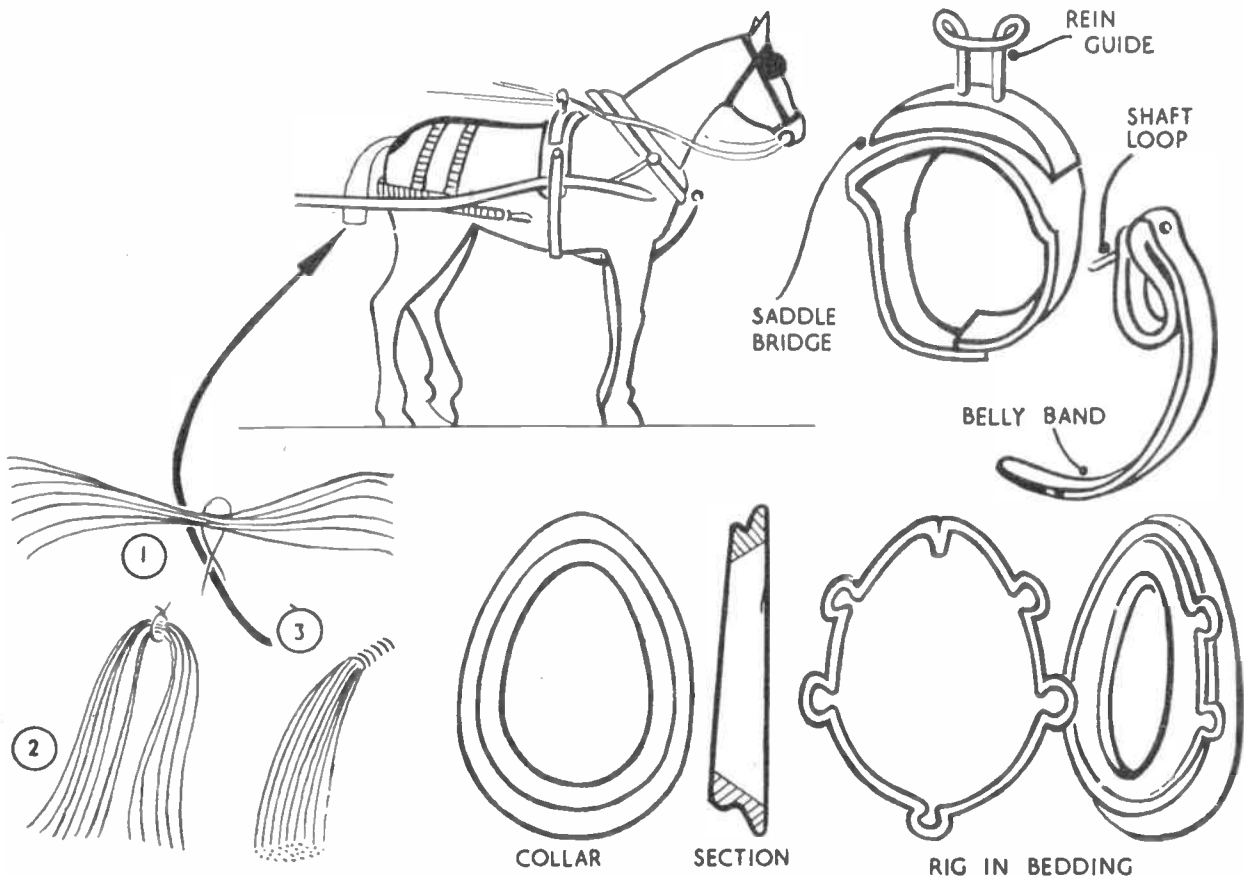

THIS horse is intended for use with models such as stage coaches, cabs or caravans. It can be enlarged or diminished by the square method, modifying the thickness of wood accordingly.

Glue the left and right sides on either side of the centre piece and fix the shoulder pieces (A) in position. Allow the glue to dry and then shape with a penknife or modelling knife. The tail is made from hair and glued into a hole as shown.

The collar is shaped from wood, the rein guide, etc., from wire, and the remainder from thin leather strips.

(M.h.)

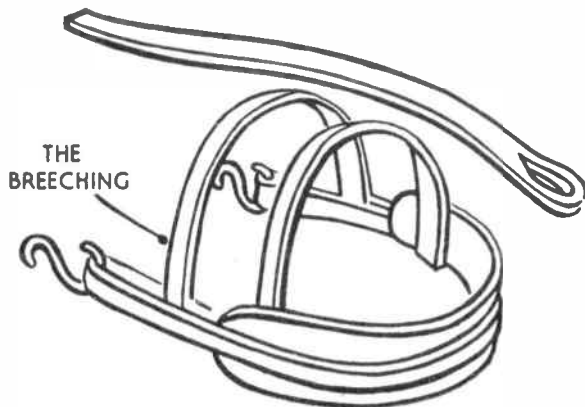

SCALE MODEL HORSE

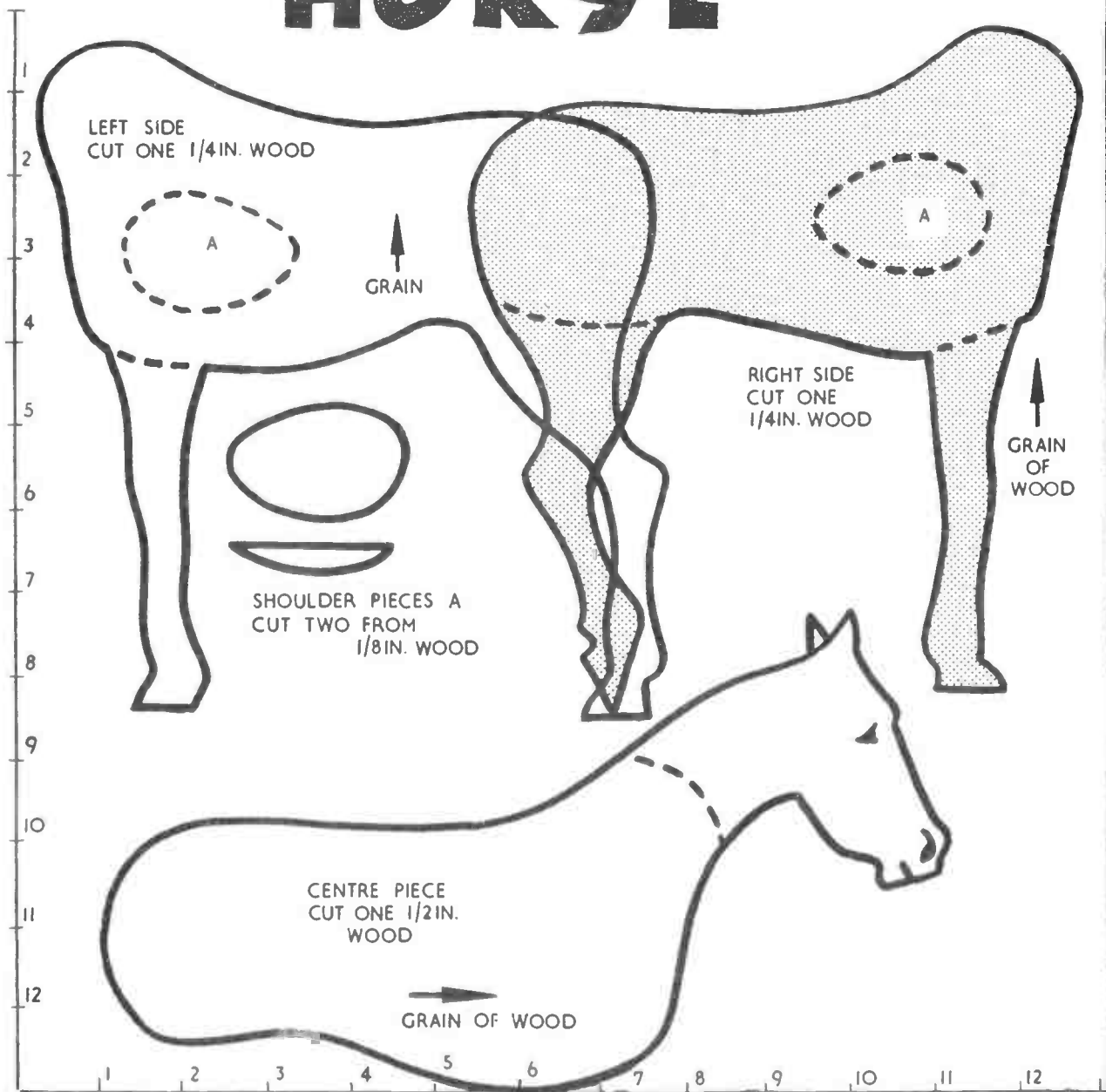

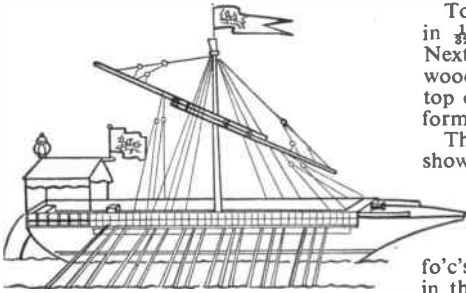

The SHIPMODELLER'S Corner

IN designing this model, I have based my re-construction on a drawing in an early work on naval architecture, supplemented by a study of various authorities and our present knowledge of the ships of the period. With these miniature models we can have quite a large fleet of historical interest and a constant source of pleasure.

Venice and Genoa were maritime powers of the Middle Ages, and our little model represents one of the smaller galleys or galliot of this period.

They were rigged with a lateen sail, but this is not shown on our model. The sailors of these vessels were not skilled in tacking and unless the wind was directly astern, they preferred to trust to their oars.

To make this model, first cut part (A) in $\frac{1}{32}$ in. wood. This is the main deck. Next cut out (B) and (C), both in $\frac{1}{4}$ in. wood. These are glued together, (B) on top of (C) and (A) on top of (B), to form the hull.

The bow and stern are shaped as shown in Figs. 1 and 2. If the part (D) is cut out at this stage it can be used as a template in shaping the stern.

Next cut out part (E), the fo'c'sle, and drill a $\frac{1}{8}$ in. hole $\frac{1}{8}$ in. deep in the exact centre of one long side for the gun; this side will be the front of the fo'c'sle. This part is now glued on as marked on the deck drawing, leaving a space on either side to accommodate the bulwarks.

The stern seat and sternboard are next cut and glued into position.

The bulwarks are cut from $\frac{1}{8}$ in. wood. In my model I used boxwood stringing, and the vertical lines were cut in with a small model saw. The heavy black line is the upper wale. This is a length of Hobbies rigging cord, stretched taut and fixed in position with balsa cement.

In these vessels the deck beams protruded outwards from the side of the hull and formed a fulcrum for the oars, to which they were secured by leather thongs as in Fig. 4.

Fig. 5. Use a thin flat file $\frac{1}{16}$ in. thick for this work, the thin edge being the right size.

Next cut two strips of veneer to the size of part (I) and glue into position down one side of each part (H). Now file the spaces between the deck beams back to the edge of part (I), as in Fig. 6, which shows the finished assembly glued to the hull level with the top of (B).

The lower wale is now fitted. Again

VENETIAN GALLEY

By 'Whipstaff'

use the rigging cord, drawn taut and cemented in position. There is also a strip of ornamental beading directly underneath the deck beams. For this again use rigging cord (Fig. 7). The centre wale is not added until the oars are in position.

Next cut two bulwarks for the beak-head deck from $\frac{1}{8}$ in. wood and glue in position. They do not follow the line of the beak exactly as will be seen from the dotted line on the deck plan. A small gun is filed to shape and glued into the hole drilled in the front of the fo'c'sle. A

All parts here are drawn to half scale

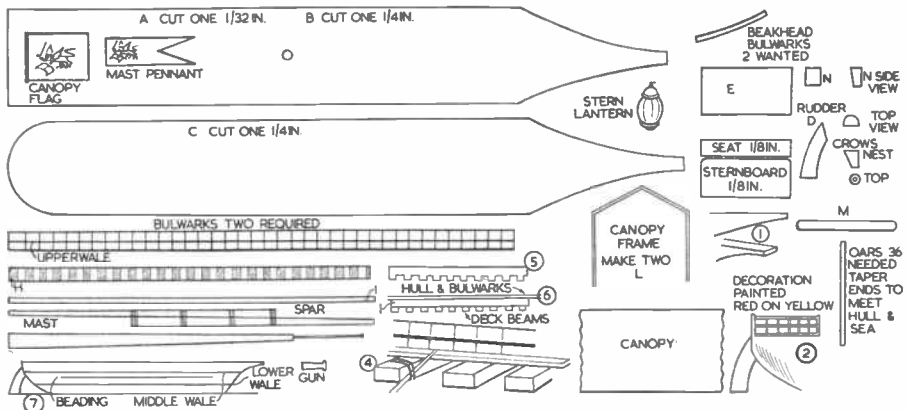

This model also depicts one of the first introductions of the gun to the ship's armament, one being placed in the bow of the galley. In fact, in this type of vessel the fighting power was always concentrated in the front of the ship.

To obtain this effect in so small a model the following method should be used.

Cut two pieces of part (H) and file the shaded portions half-way through; boxwood again is the best material for the purpose. This gives two strips as at

piece of thin black knitting needle serves well for this.

The next addition is the canopy at the stern. Cut a wood former to the shape of the inside line of (L) and bend thin wire around this to form the two canopy

● Continued on page 302

Wolf Cub ELECTRIC DRILL AT ONLY £5.17.6

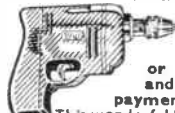

or 8/- deposit
and 6 monthly
payments of 20/6d.

This wonderful Electric Drill is also the power unit for ALL Cub equipment. Drilling capacity: Mild Steel, 1/2"; Hard Wood, 3/8"; with 210 watts input on full load. Complete with 1/2" three-jaw chuck and Allen key and 5ft. of cable. TV Suppressed. State Voltage. ALSO Sanding & Polishing Kit (drill, discs, etc.). Cash Price: £6. 19. 6 or 22/- deposit and 6 monthly payments of 22/-
Send for illustrated Brochure

CHILTON ELECTRIC HAIR CLIPPER 5/- DOWN



Keep short hairstyles smartly trimmed yourself with the Chilton. Gives the professional comb-and-scissors action. Slip comb off and use to tidy neck hair. Useful for children's hair, also for men too busy to visit barber. Plugs into lampholder. Complete with plug. A.C. only, 210/250v. £4.14.6 cash or 5/- deposit and 6 monthly payments of 16/6. 12 months guarantee. ALSO hand clippers 16/-.
Send for list of other Bargains.

BARGAIN DISTRIBUTORS (Dept 124), 5 Silver Street, Luton

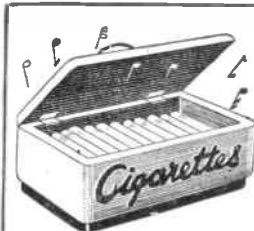

Musical Cigarette Box
It plays when you lift the lid. Full kit to make box only 4/10. Musical movements to fit, 18/10.

Hobbies have hundreds of designs and kits from which, with a few simple tools, it is easy to make novelties like those illustrated.

Get Hobbies 1957 Handbook (2/- from newsgents, etc. or by post 2/3) and this will show you how to really enjoy your hobby

**To Hobbies Ltd., Dept. 99,
Dereham, Norfolk.**

Please send items marked thus: X
 Musical Cigarette Box, Kit No. 3106 - 4/10
 List of musical movements available at 18/10
 Hobbies 1957 Handbook, 2/3 post free.

Name
Address

STOP SMOKING

Any Man or Woman in the World May Now Stop Smoking
Quick and Sure

To Prove It. A Free Trial Package Sent Sealed To All Who Write

If you want to stop smoking, this should be just the thing you need. Simply send your name and address to Mr. Brian Hussey, Dept. HD/14, The Triumph Remedies, Exeter, and he will send, absolutely free of charge, a trial package of our remedy to show how it is used and how it will quickly conquer the habit of smoking, also full directions how to use it, free advice, and everything needed to aid you in overcoming the habit quickly and certainly. No matter what else you have tried or how many times you have failed, this time you will succeed. Please send name and address now—as this free offer may never appear again.

IT'S EASY WHEN YOU KNOW HOW!

It's easier with—



Just one wipe and - zoom - every single speck and bit of fluff suddenly isn't there. Use it after sand-papery (that's a dusty job) and use it before each coat because

it is dust and fluff BEFORE painting that makes all those unsightly nibs and blobs, not dust after the paint is put on.

YOU CAN GET A SMOOTH PROFESSIONAL FINISH WITH DIS-TACCY. From your ironmonger or paint retailer.

PRICE 1/6 Postage 2½d.

A. D. TACK RAGS & ADHESIVE DUSTERS LIMITED
ST JOHNS ST., KATES HILL, DUDLEY, WORCS. TEL. 4816

Classified advertisements are accepted at a cost of 6d. per word prepaid. Send P.O. with advertisement to Advertisement Dept., Hobbies Weekly, Dereham, Norfolk

LEARN it as you do it—we provide practical equipment combined with instruction in Radio, Television, Electricity, Mechanics, Chemistry, Photography, etc.—Write for full details to E.M.I. Institutes, Dept. HW47, London, W.4.

MONACO WEDDING. Short set free to all sending for my approvals.—C. S. Berry (Dept. H.), 32 Cross Whitehouse Row, Leeds, 10, Yorks.

MAGIC Catalogue and 'Shocking Letter' Trick, 1/-.—DeHempsey, 363 Sandycroft, Kew, Surrey.

'PAINTSPRAYING' HANDBOOK (1954 Ed.), Covers Car, Industrial & Flock Spraying 3/6, post free, including catalogue of our Cellulose and Synthetic Paints and all Allied Sundries and Plant Hire.—Leonard Brooks Ltd., 81 Oak Road, Harold Wood, Essex

PLYWOOD; large sizes, 14 lbs. 10/- delivered (Express) C.W.O.—H. Leader (1920), Gosford St., Middlesbrough.

100 Different Stamps free! Request ½d. upwards discount approvals.—Bush, 53 Newlyn Way, Parkstone, Dorset.

Stick to
SECCOTINE
—it sticks Regd.
everything!
1/- PER TUBE

KEEP A TUBE IN THE HOME
Sole Manufacturers:
McCaw, Stevenson & Orr Ltd., Belfast

GENUINE Swiss Musical Movements. The best and largest selection of tunes in the country, lowest prices 16/3 each. Genuine Thorens Movements, 22/9 each. All guaranteed. P. & P. 9d. extra on all orders.—Richardson & Forder, HW, 5 Chapel Place, White Hart Lane, London, N.1.

MODEL RAILWAY MAGIC. The beginner's book 2/6. 'Making a baseboard' 6d. Bargain list 4d.—Southgate Hobby Shop, 1 The Broadway, London, N.14.

SWISS MUSICAL MOVEMENTS. Before you buy send 2d. stamp for our illustrated brochure.—Metwood Accessories (Dept. HW), Church St., Wolverton, Bucks. (Trade enquiries invited.)

● I MUST GET

... the EXTRAORDINARY Home-Made GADGETS MAGAZINE ... EVERY MONTH it fully describes OVER FIFTY ingenious gadgets, devices and novelties I CAN MAKE to keep or sell. I'll send 1/3 NOW for the latest de-luxe issue to:

Home-Made GADGETS MAGAZINE
(26) Kingsbury, London, N.W.9
● 7/- pays for 6 months & LUCKY KEY CHAIN ●

Dress in a 'near to life' Davy Crockett Hat, Jacket, Leg Dress, all with fringes, and an adjustable belt. Our special secret-waterproofed material to withstand Prairie storms. Hat is real Fur Fabric. Just send 2/6 for post & pack. If satis. 5 monthly payts. 4/6. Cash 19/11 complete. Ages 4 to 9 and 10 to 13. STATE AGE. DAVY CROCKETT TENTS 21/-, post, etc. 1/6.

BOYS! Be a real DAVY CROCKETT



COMPLETE 4-PIECE OUTFIT
+ NO DEPOSIT!

Includes FREE HAT

GERMAN PRISMEX BINOCULARS
8 LENSES × 50 mm.

New Coated Lenses
Brighter Viewing
Widest Angle
NO DEPOSIT

Latest Prismex Binocular giving widest angle of 50 mm. Blooming increases light intake. Day and night use, sports, and long distant viewing. 5½" × 6½" Bending Bar eye adjustment, with centre focus. 3-D view. Lightweight. 79/6 with case and leather slings or send 2/6 for pack., post, etc., then 18 fortnightly payments of 4/11. Lists, Terms.

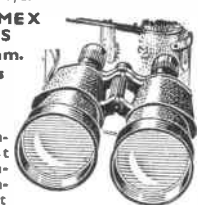

Headquarter & General Supplies Ltd. (8HOBW/19), 196-200 Coldharbour Lane, Loughboro Junc., London, S.E.5. Open Sat.

STAMPS FREE—Empire Packet including Pictorials and Victorians with approvals.—Robert J. Peck, 7A Kemp Road, Bournemouth

Make Leisure a Pleasure with

Some of our
Kits which can
be made up as
GRAND GIFTS

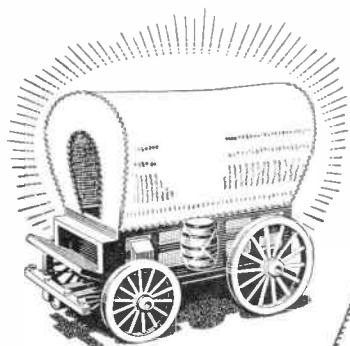

24/6 'Covered Wagon'
Kit No. 3156

**NOVEL,
PRACTICAL
ELECTRIC
LIGHTS**

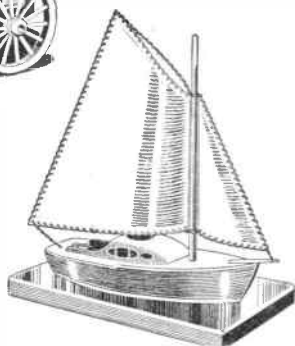

23/11 'Yacht' Kit No. 3110



6/9 'Bird' Vase Holders
Kit No. 3140
(for a pair, including vases)



3/6 'Windmill' Egg Timer
Kit No. 3118

**CHARMING
DESIGNS
WHICH WILL
DELIGHT
EVERY
HOUSEWIFE**



Electric Tug 'Climax' Kit No. 251 Special **52/6**
(including motor and propeller unit)

**— AND
THRILLING
JOBS FOR
THE BOYS**

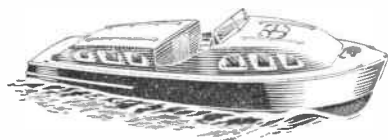

45/- Cruiser 'Crusader' Kit No. 3154
(including motor and propeller unit)

To Hobbies Ltd, Dept. 99, Dereham, Norfolk

Please send kit marked X (all post free)

- Covered Wagon
No. 3156, 24/6
- Yacht Light
No. 3110, 23/11

- Egg Timer
No. 3118, 3/6
- Vase Holders
No. 3140, 6/9

- Tug 'Climax'
No. 251 Spl., 52/6
- Cruiser 'Crusader'
No. 3154, 45/-

NAME

ADDRESS

P.O. enclosed for

**From Branches,
Stockists etc, or fill
in coupon for one
of these fine kits
TODAY**

Reliable and cheap

AN ACCUMULATOR CHARGER

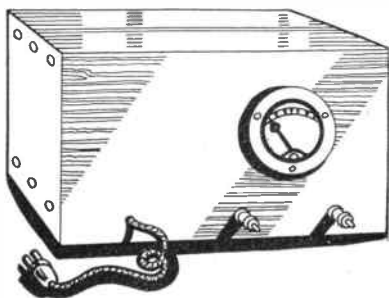

By F. G. Rayer

A CHARGER to deal with any type of battery up to about 12 V can be constructed at quite low cost, the actual parts required being very much cheaper than the cost of a ready-made charger. The circuit described here is a reliable one, and with average components and ordinary use it can be expected to function for years without breakdown. The actual cost of the current drawn from the mains when

(e.g., through the night) will be of great benefit when a vehicle is normally difficult to start because the accumulator is somewhat run down.

Circuit and Parts

The circuit is shown in Fig. 1, and only three items are necessary — a transformer to reduce the voltage, a rectifier to change the alternating current to direct current, and a meter to show the charging rate. These items are best purchased to suit the *maximum* output from the charger which will be required. For example, if batteries of more than 6 V will never be charged, it is pointless to use a 12 V transformer or rectifier, especially as the cost of these components depends directly upon the voltage and current they will handle. As an example of this, a small 6 V charger could be built for less than £1, whereas a large one for rapid charging of larger batteries might cost three or four times this sum.

As an aid to selecting suitable components, the following points will help. The

two when necessary. A 1 amp. rectifier will thus do well, as a rule.

Once the rectifier has been decided upon, the mains transformer can be obtained to suit. It will require a 1 amp. secondary for a 1 amp. rectifier, and so on. To compensate for voltage drop and the fact that charged cells will rise in voltage, the secondary should give at least 50 per cent more voltage than the voltage of the largest battery to be charged. That is, 9 V for a 6 V battery, or 18 V for a 12 V battery.

It is very helpful to use a transformer with several tappings on the secondary, so that a range of voltages can be selected. The same charger will then be able to deal with any type of battery up to the maximum figure. Such components are easily purchased. It may also be possible to use a radio or model transformer, if to hand.

Only the meter remains to be mentioned, and one reading 0-1, 0-2, or 0-5 amps. will do well. Ex-service R.F. (radio frequency) thermo-couple meters are not suitable for such purposes, but

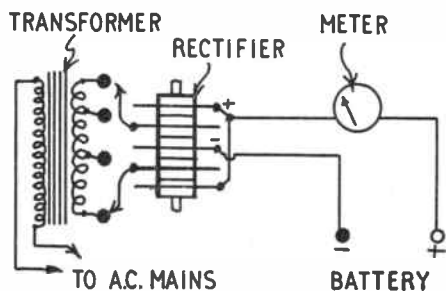

Fig. 1—Circuit

charging an accumulator is almost negligible. In addition to the eventual saving from this, there is also the added convenience of not needing to carry the battery to a shop to be charged.

Full details about the correct methods of charging will be given in another article, but it is worthwhile noting here some of the purposes to which such a charger can be put. For example, the accumulators used with some models may, with advantage, be charged at home, as may the accumulator used in some types of portable and battery receiver. Motor-cycle and car batteries can also be charged, and when it is possible to draw current from a near-by socket, there is no need to remove the battery from the vehicle, which is a great convenience. Occasional charging

voltage rating of the rectifier should be equal to, or greater than, the voltage of the largest battery to be handled, e.g., a 6 V rectifier for 2 V, 4 V or 6 V, or a 12 V or 15 V rectifier for any battery up to 12 V.

The *current* rating of the rectifier is again equal to, or greater than, the maximum current required. A 1 amp. rating will do for model, radio, and motor-cycle batteries. For car batteries 2 amps. is better. A 1 amp. rectifier would charge the latter just as well, but take twice as long as the 2 amp. rectifier.

When charging at home, a low rating is not much disadvantage, as it is easy to leave the charger operating for a day or

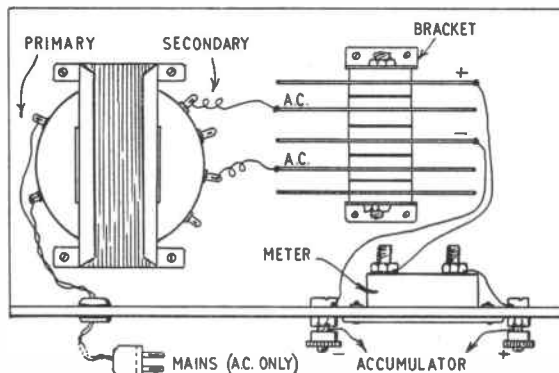

Fig. 2—Complete wiring plan

any type of D.C. ammeter, charging meter, or shunted moving-coil milliammeter is satisfactory.

Simple Wiring

All connections are shown in Fig. 2, and the parts are mounted upon a wooden base and panel, 3-ply being satisfactory for the latter. The dimensions will depend to some extent upon the parts, but 5ins. by 7ins. will in each case normally be ample.

A suitable length of twin-flex, with mains plug or adapter, is taken to the transformer primary. If several tags are fitted here, for 200-250 V, then the correct tags are chosen to suit the house

voltage. If a 3-pin outlet is available, with Earth socket, 3-core flex may be used, the Earth lead (large pin) being connected to transformer core and one secondary tag.

Positive and negative on the rectifier may be marked by the usual signs, or by red and black. Some manufacturers place the positive tag in the centre, instead of the negative one, as in Fig. 2. The actual markings should, therefore, be followed.

The 'A.C.' tags may be marked green, or with a symbol like 'S'. Two short lengths of flex are taken from these tags, to join to the transformer secondary tags. Two terminals complete wiring, the meter being in series with one.

Correct Polarity

It is absolutely essential that the correct polarity, both for rectifier and accumulator, be observed, or damage to rectifier, meter, or battery will arise. If desired, this can be guarded against to some extent by including a 1, 2 or 5 amp. fuse in one lead, or by using 1, 2 or 5 amp. fuse wire for the connection between meter and positive terminal.

The rectifier is best mounted with fins vertical, and two metal brackets can be made to accomplish this. In Fig. 2, a full-wave type with 4 tags is shown, and this is most efficient.

If a half-wave rectifier with only two tags is to hand, it can be used instead. To do this, wire one secondary tag to negative on rectifier, and the other secondary tag to negative accumulator terminal. The positive rectifier tag is

then connected to the meter, as in Fig. 2.

If a transformer without secondary tappings is to hand, and gives too high a voltage, a resistance may be added as in Fig. 3, to reduce the current and voltage. It may be wound with 26 S.W.G. iron or resistance wire, about 2ft. usually being sufficient. A metal strip can be clamped in place when the correct position (or resistance) has been found.

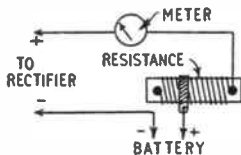

Fig. 3

If this method is used and the charging rate is too high for a small battery, as shown by the meter, then the resistance is increased. On the other hand, if the rate is too low, the resistance is reduced. Adjustable resistances of various kinds can also be purchased, some for panel operation with a knob. With these, the knob is simply turned until the charging rate is suitable for the battery.

Containing Case

To protect the components and avoid possible shocks from touching the mains or primary tags on the transformer, a case made from thin wood will be necessary. This can best be made with top, back and sides permanently fitted

together, base and panel forming bottom and front, when secured in place by small screws. Some measure of ventilation is required, and rows of holes in sides and back will provide this.

Charging

The accumulator is joined to the two output terminals, not forgetting that polarity must be observed. When the mains plug is inserted, the meter pointer should move. If it does not, the circuit is interrupted somewhere — most probably through dirty accumulator terminals.

If the meter pointer tries to move in the wrong direction, then the two connections going to it must be reversed, and the pointer will move over the scale correctly.

If the charging rate is too low, the resistance (Fig. 3) is reduced in value, or the transformer secondary tappings are changed to apply a slightly higher voltage to the rectifier. If the rate is excessive, the voltage is reduced by selecting other tappings, or the resistance value is increased. For a 2 V battery, about 4 V will be necessary; with 6 or 7 V for a 4 V battery, and 8 V to 10 V or so for a 6 V battery.

After a time, as the battery begins to charge up, the meter pointer will fall back a little, but this can be disregarded. Most batteries have a maximum charging rate marked on them, and this must not be exceeded. For example, a radio battery of average size would have a maximum rate of 1½ amps. Any lower rate than this maximum figure is satisfactory.

● Continued from page 298

Venetian Galley

frames. Cement into holes drilled in the deck. Piece (M) is cut from ½ in. box-wood and glued in place to form the top bar of the canopy, while the canopy itself can be cut from thin material, or even paper and cemented on top of the framework. The two seats (N) are cut and shaped and glued in position on the deck up against the front canopy supports to complete the deck assembly.

The base, 9 ins. by 4½ ins., is painted blue and covered with Cellophane. Glue

in position and allow to wrinkle very slightly.

The hull is painted and glued on to the centre line of the base, brown below the lower wale and red between the lower wale and the lower edge of the bulwarks, leaving the deck beams natural wood colour. The bulwarks are painted yellow. The lower wale is also painted yellow, the beading under the deck beams gold, the middle wale yellow and the upper wale gold.

The next stage is to make the oars. These must all be exactly alike and, therefore, a jig should be made. This consists of a piece of thin metal or stout tin, with a ¼ in. hole drilled through the centre and mounted on a cotton reel. The oars are cut from bamboo and roughly shaped, then gently tapped through the

hole in the jig. This results in thirty-six pieces of bamboo dowel all exactly the same diameter, from which to make the oars.

Cut the oars 1½ ins. long and, using tweezers, cement into position on the model. The oars are set up in threes, one oar to each deck beam and one beam between each set of three. The upper end of each oar is glued to the top edge of (B). The top wale (rigging cord) is now added along the top of the oars.

The canopy is painted crimson (or red) with gold markings, and the tops of the seats are patterned in red and white squares.

The mast and spar for the lateen sail can be made from the illustration. The spar is in two parts, lashed together. With the flags painted, and the simple rigging of the period added, the little model is complete.

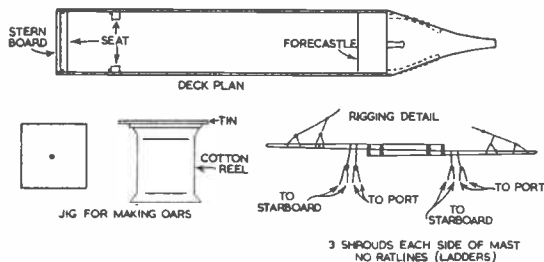

Next week's free Design will be for a Decorative Cover for your 'Radio Times'—an ideal choice for a gift.

See page 290

Patterns for Bookmarkers

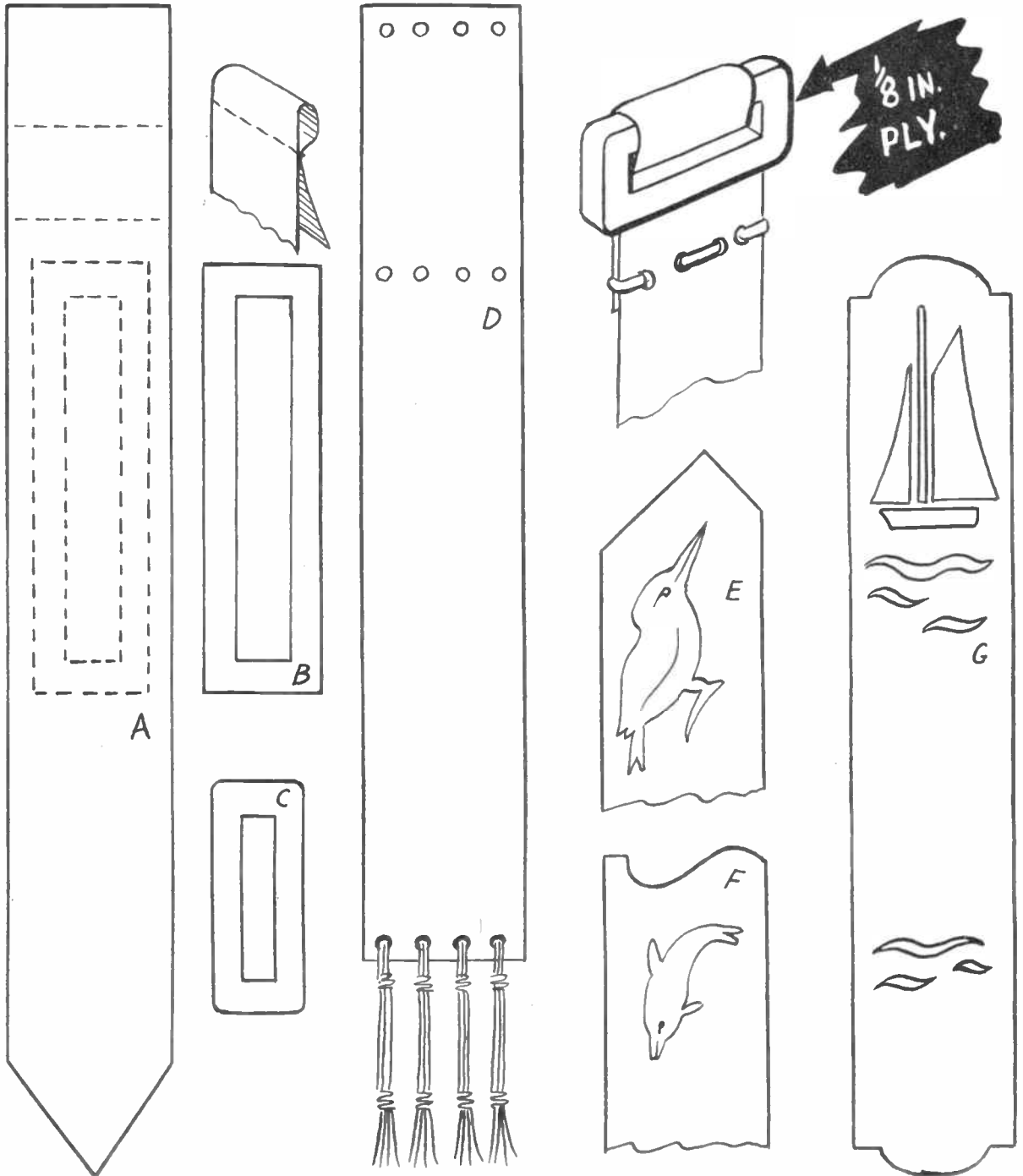

When you want it
to stay put



USE CERTOFIX

CERTOFIX really fixes
This super liquid glue copes with all general repairs. With wood, glass, metal and most other materials, CERTOFIX makes a joint stronger than the substance it unites.

make it immovable with Certofix
Sold at all Woolworth Stores

NEW!

**THE PRACTICAL WAY
of learning RADIO
TELEVISION · ELECTRONICS**

- Beginners Radio Course ●
- Advanced Radio ●
- Short Wave Technique ●
- Lesson Manuals ●

Experimental work includes construction of Basic Oscillators, Amplifiers, Deflectors, Power Units, 1, 2 and Multivalve TRF and Superhet receivers.



COMPLETE EXPERIMENTAL COURSES IN RADIO ENGINEERING and SERVICING

An entirely new series of courses designed to teach Radio, Television and Electronics more quickly and thoroughly than any other method. Specially prepared sets of radio parts are supplied and with these we teach you, in your own home, the working of fundamental electronic circuits and bring you easily to the point when you can construct and service radio receivers, etc. Whether you are a student for an examination; starting a new hobby; intent upon a career in industry; or running your own business — these Practical Courses are ideal and may be yours at very moderate cost. With these outfits, which you receive upon enrolment and which remain your property, you are instructed how to build basic Electronic Circuits (Amplifiers, Oscillators, Power Units, etc.) leading to designing, testing and servicing of complete Radio and Television Receivers.

COURSES FROM 15/- PER MONTH

POST THIS COUPON TODAY

To E.M.I. Institutes,
Dept. 31 Grove Park Road, London, W.4.
Please send me your FREE book on Practical Courses

NAME

ADDRESS

Aug. 8 LC74

**EMI
INSTITUTES**

associated with
"His Master's Voice,"
Marconiphone,
Columbia, etc.

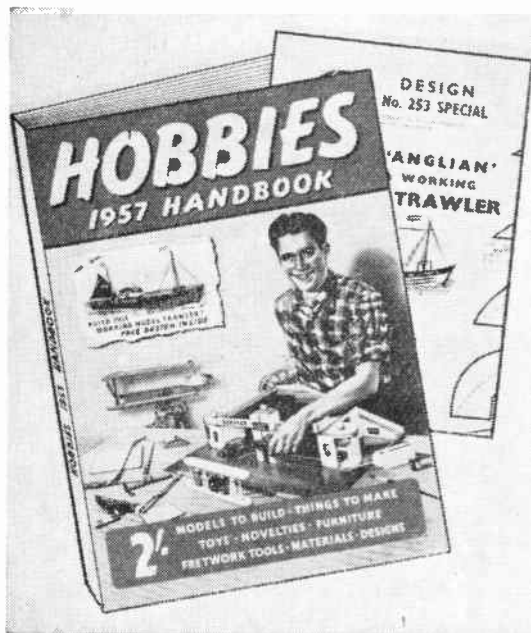

A BARGAIN FOR ALL

Get a copy now from Hobbies branches, stockists or newsagents
Only 2/- or post free 2/3 (See coupon)

On Sale NOW! GRAND NEW EDITION

Hobbies 1957 Handbook has many outstanding features
including

FREE DESIGN for a grand working model trawler

Toy-making articles

Furniture projects for the home and garden

Marquetry - Fretwork and hundreds of ideas
for the modeller and handyman

152 pages crammed with interest and features

To Hobbies Ltd., Dept. 99 Dereham, Norfolk

Please send copy/copies of Hobbies 1957 Handbook
(P.O. 2,3 each)

Name

Address