

HOBBIES WEEKLY

IN THIS ISSUE

Attractive Case for Barometer and Clock	33
Single Seater Scout—S.E.5a	34
Dark Slide Reducing Frame and a Variable Safelight	36
Make Your Own Bird Cages	37
Easy Experiments with Gases	38
Fixing Wall Electric Fires	39
A Useful Bow Saw	40
Christmas Tree Decorations	41
Hints for Match Anglers	42
Simple Bead Loom	42
Replies to Readers	44
Baffling Reels	44
A Useful Log Box for Your Fireside	47



OCTOBER 26th 1955

VOL. 121

NUMBER 3130

Made from this week's
★FREE Design
**ATTRACTIVE
CASE FOR
BAROMETER
AND CLOCK**

INTENDED primarily to contain a barometer, the case illustrated would also admirably suit a clock fitting, while one of each—a barometer and a clock—would make a perfect pair for the sideboard or mantelpiece.

Hobbies Ltd. can supply both the barometer and the clock for fitting into these cases. The aneroid barometer is a beautiful instrument in a heavily chromiamed case and with distinctive lettering and figuring on the face which makes for easy reading. It costs 39/6.

The clock, which costs 29/11, is made by a famous English manufacturer with a big reputation, and has a reliable 30-hour movement with alarm. A 12-month guarantee covers all defects in material and manufacture. It has a polished brass bezel with convex glass, and here again the figuring is very clear and distinctive.

If it is intended to use the clock

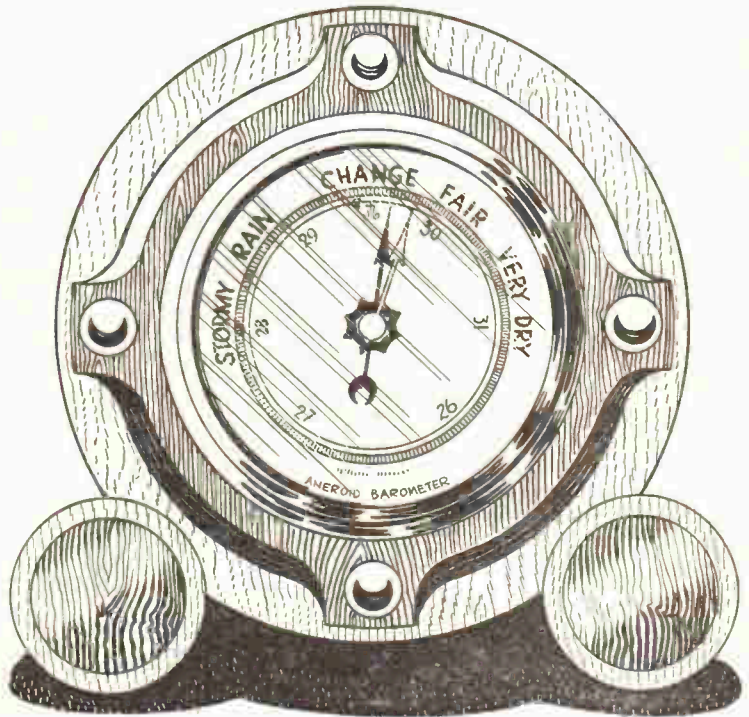

TWO WILL MAKE A PERFECT PAIR

movement in this design it will be noticed that one or two slight adjustments in cutting, etc., will have to be made, but they are quite simple and fully explained in the instructions.

The first step is to trace the various

pieces on to the appropriate thicknesses of wood, and cut them out with the fretsaw. Piece 1 forms the main structure of the case, and to this is glued piece 2 which has previously been shaped

●Continued on page 39

All correspondence should be addressed to The Editor, Hobbies Weekly, Dereham, Norfolk

For Modellers, Fretworkers
and Home Craftsmen

World Radio History



Famous fighter aircraft—No. 2

Single Seater Scout—S.E.5a

ARRIVING in France in the early part of 1917, the S.E.5a shared, with the Sopwith Camel, the distinction of being the most famous single-seater fighter of World War I. It was the aeroplane that did most to obtain aerial supremacy over the Germans.

Designed by the Royal Aircraft Factory at Farnborough, its speed, at first, was 105 m.p.h. Much later, with

victories), Captain Albert Ball (43 victories), Major Mannock (73 victories) and Colonel Bishop (72 victories), flew the S.E. with great success.

The letters S.E. stood for Scouting Experimental, and a full size S.E.5a may still be seen today in the Air Section, Science Museum, Kensington.

All the plans in this series are drawn to a scale of 1/72nd, or 6ft. to the inch.

purchased, or they can be made from short lengths of $\frac{1}{8}$ in. dowel (see Fig. 4). The propeller may be made from thin card or sheet metal.

Remember, if you are using balsa wood, to rub a good coat of clear dope into the wood (before the final assembly) and when dry it should be rubbed down with fine glasspaper. This will give it a good surface to take the paint.

The tools have already been described in Number One of this series and will serve for all the models.

Construction

Reference should be made to Number One of this series for the general methods of preparing the fuselage, the wings and the tail units.

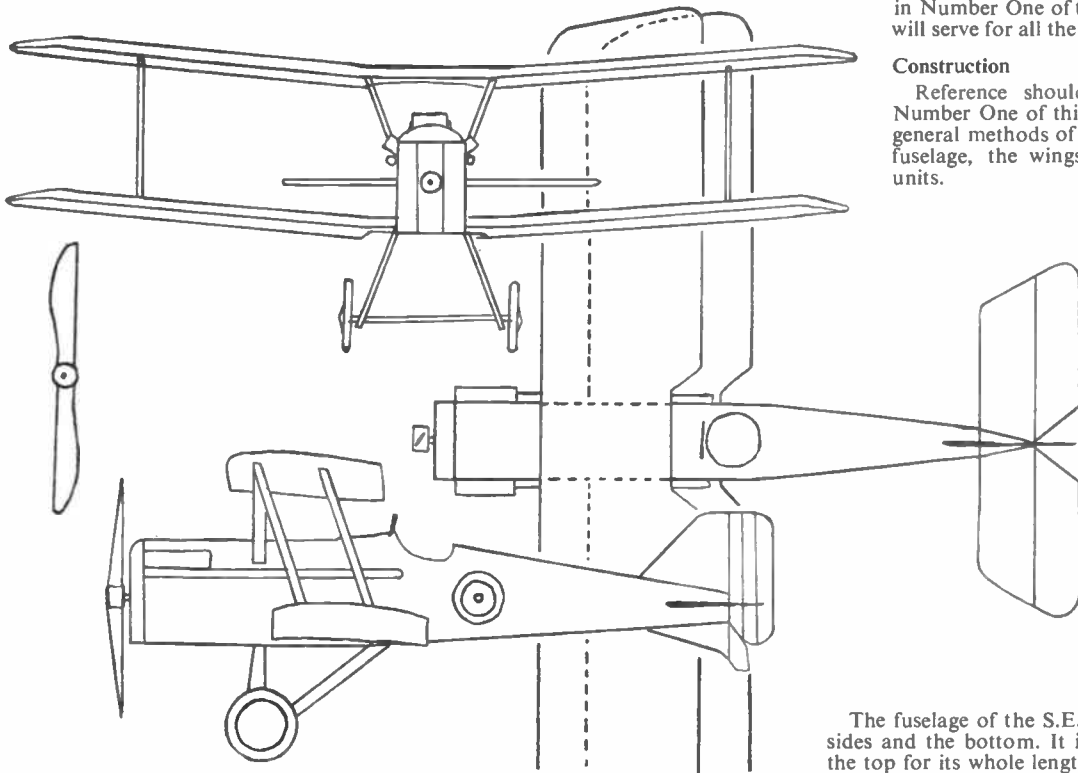

the 240-h.p. Hispano-Suiza engine, the S.E. had a top speed of 125-135 m.p.h. and was a match for any fighter that the Germans produced. Though not as manoeuvrable as the Sopwith Camel, it was pleasant to fly and of very strong construction. It could outdive any German fighter, thus enabling the pilot to break off combat when this was thought necessary. Its armament consisted of a single Vickers machine gun firing forward through the propeller, and a Lewis machine gun fixed on the top wing, fitted to a special mounting, which permitted the gun to be pulled down and thus fired vertically.

Many famous fighter pilots, including four V.C.'s, Major McCudden (57

Materials

A block of balsa $2\frac{1}{2}$ ins. by $\frac{7}{8}$ in. by $\frac{1}{8}$ in. for the fuselage; a sheet of balsa $4\frac{1}{2}$ ins. by 2 ins. by $\frac{3}{8}$ in. for the wings. For the tail units a sheet of balsa 3 ins. by 2 ins. by $\frac{1}{8}$ in.; for the struts (interplane, centre-section and undercarriage), thin sheet metal from coffee, biscuit or other food tins will be found extremely useful and should be cut with thin-nosed metal cutters or a pair of old scissors. Some of these tins are painted on the outside, and if the various parts are marked out on the painted side, they will show up clearly. Wheels are $\frac{3}{8}$ in. diameter and can be purchased at most model shops. Tricky parts such as Lewis and Vickers machine guns can be

The fuselage of the S.E. is flat on the sides and the bottom. It is rounded on the top for its whole length (see Fig. 1). In front of the cockpit is a small hump which houses the Vickers machine gun, on the left-hand side.

The wings are straightforward, but they have a pronounced dihedral (see Fig. 2). Where the dihedral starts it is best to make a shallow cut with a razor blade across the wing before bending, gently, over a candle flame.

Assembly

The tail plane is also straightforward and the rudder is best made in one piece with the tail-skid arrangement beneath the fuselage (see Fig. 3).

For the mounting of the Lewis gun see Fig. 4.

Reference should be made to Number One of this series. It is advisable to glue

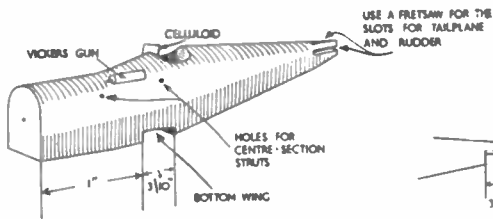

Fig. 1

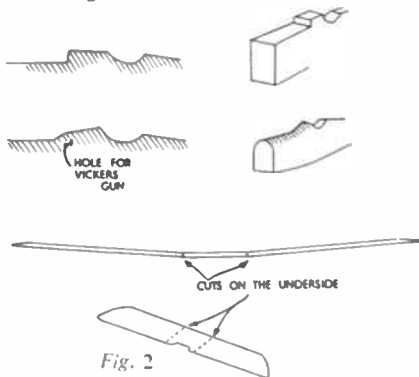

Fig. 2

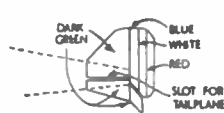
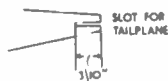
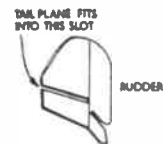

Fig. 3



MAGAZINE: CUT FROM MODEL BALSA

Fig. 4

SHORT PIECE OF FUSE WIRE TO REPRESENT BARREL
THIS END IS TAPERED TO FIT INTO HOLE IN HUMP

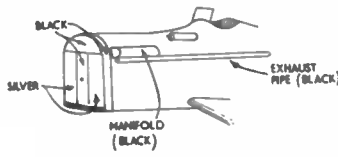

Fig. 5

CENTRE SECTION STRUT
INTERPLANE STRUT
4 REQUIRED

UNDERCARRIAGE
2 REQUIRED

Note: To save space these illustrations have been made half scale

the Vickers gun in place as soon as the bottom wing is in place. The top wing should rest 3/10in. above the fuselage. The track of the undercarriage should be 7/10in. For details of the exhaust pipes and manifolds, see Fig. 5.

Painting

The S.E.5a was painted dark green on all upper surfaces of the wings, on the fuselage and on its underside and on the upper surfaces of the tail-plane and on the rudder, in front of the red, white and blue markings. The under surfaces of

the wings and tail-plane were painted cream. Interplane and centre-section struts were varnished. For this yellow ochre poster colour, with a touch of Seccotine, can be used or even orange coloured dope is suitable. The undercarriage was black. The wheel discs may be any colour. The propeller was often grey, or it may be painted the same colour as the struts. The rudder was red, white and blue with red at the end. (Poster colour is excellent for this.)

The usual red, white and blue circles or cockades were used on both wings

and on the sides of the fuselage. Excellent transfers may be purchased from model shops.

See Fig. 5 for details of painting the nose of the fuselage.

Take care with your painting. All surfaces should be free from finger marks and should be smooth. It is best to paint individual pieces, such as exhaust pipes, manifolds, and the red, white and blue of the rudder first. The exhaust pipes and manifolds can be fitted when the whole model has been painted. (D.G.N.)

Repelling the Invaders

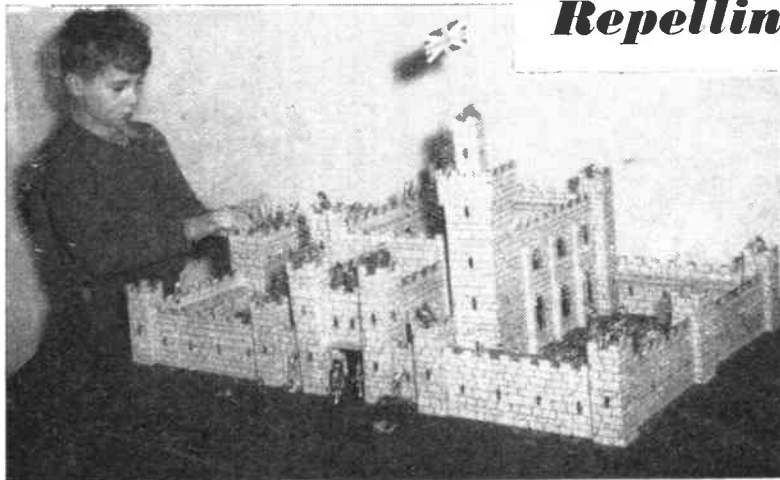

A young lad is re-arranging his defences in order to meet an impending enemy attack. Soon the invaders will be swarming round with whoops of frenzy. Crack will go the rifles—and another bad'un will bite the dust.

This delightful model fort was constructed by Mr. A. Payne, of Ashford, Paulton, Nr. Bristol, from Hobbies Design and kit No. 248 Special, costing 51/3. It is nearly 3ft. long by over 2ft. wide.

Hobbies also have smaller model fort kits, No. 2494 (14/9) and No. 2706 (31/11). They are featured among the hundreds of other kits in Hobbies 1956 Handbook, price 2/- from newsagents, Hobbies stockists or branches, or 2/3 post free from Hobbies Ltd., Dereham, Norfolk.

Dark Slide Reducing Frame . . .

PHOTOGRAPHIC plates are fairly expensive, even by modern standards, so if a smaller and consequently cheaper plate can be used for any job, it is always worth while.

Lesser plates than those intended can always be worked in a slide by employing an adapter. If used edge to edge the loss of picture area with some smaller plates is curiously unnoticeable, and, of

hold the smaller plate firmly in position in conjunction with the force of the spring from the underside. The pieces only hold the extreme corners of the plate and so the whole area is available for picture-making.

To load the plate into the frame and the frame into the holder two clips are required. This because the smaller plate is not secure till the whole frame is in the slide and the pressure of the spring from behind is felt.

The clip is simply a piece of tin bent

with a shorter top arm to go over the frame and a longer under arm to hold the plate. The frame is completed by a coat of matt black.

In practice the inside rectangle must be cut to a very easy $3\frac{1}{2}$ ins. by $2\frac{1}{2}$ ins., as plates are seldom accurate in dimensions and some latitude is necessary. Of course, too loose fitting must be avoided. For good fitting also, it must be seen that the corners are quite clear of stray solder which can easily prevent good sitting in of the plate. (H.A.R.)

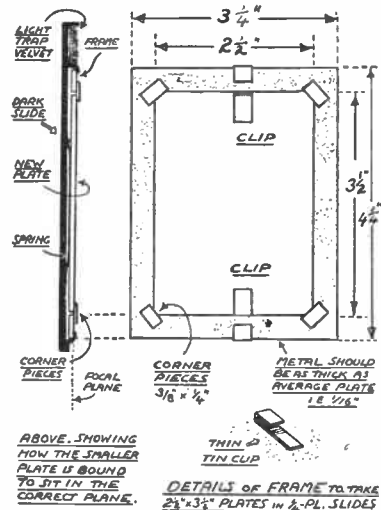

. . . and a Variable Safelight

PHOTOGRAPHERS can make a variable safelight from an empty tin about 6ins. in diameter, 10ins. deep, usually obtainable from a sweet shop for a matter of a few pence.

A hole 1in. in diameter is made in the centre of the bottom for a lampholder. If you have no suitable drill the best method is to stand a brick inside the tin, using a punch or sharp screwdriver to cut out the hole. When the full circle has been punched, the waste will push away but leave a jagged edge. This should be smoothed off with a file.

Two cardboard discs with four holes as shown in Fig. 2 are required to hold the coloured screens. The diameter of these discs is a little less than that of the tin lid. Mark lines through the centre at right angles, so that the four holes, not more than $1\frac{1}{2}$ ins. in diameter, are equally spaced. These holes may be cut out with a sharp scriber or perforated with a needle and the waste pushed

recommended for this gadget. Bromide papers may be printed in an orange light and the screen suggested is a Micro 5 filter. Contact papers may be printed under a green light, so for this a Micro 3 filter may be chosen.

For the development of films, ruby red is required and here a piece of the red paper from printing paper packets will prove suitable. All the filters are obtainable at any photographic shop, but if any coloured celluloid is available, it will serve the same purpose. The fourth hole should be left uncovered to allow a clear light for inspection purposes. The screens mentioned are liable to damage easily, so as a means of protection, a piece of clear celluloid should be placed at each side. Alternatively, you may use some old negative material from which the emulsion has been removed. This is done by soaking the films in warm water to which some ordinary household bleach has been

course, if enlargements are to be made later, the smaller-sized negative does not matter in the least.

Reduction in size is more effective in some combinations than in others, but using $3\frac{1}{2}$ ins. by $2\frac{1}{2}$ ins. plates in $\frac{1}{4}$ -plate slides is ideal, for here the loss of area is not very obvious, but the reduction in cost is considerable, $\frac{1}{4}$ -plates running up to 7/6 a dozen, while $3\frac{1}{2}$ ins. by $2\frac{1}{2}$ ins. work out to about 4/8 a dozen.

It is essential that the smaller plate shall lie in exactly the same plane as that of the plate normally used, and here is where some adapters fall down, for they are anything but precise in this important matter.

It was in search of some method by which $3\frac{1}{2}$ ins. by $2\frac{1}{2}$ ins. plates could be used through one of my $\frac{1}{4}$ -plate cameras that I evolved a reducing frame which by its very make-up forces the new plate to lie in the correct focal plane. Indeed, it cannot do anything else.

The frame is cut from zinc the thickness of a standard plate, i.e. $\frac{1}{16}$ in. Outside dimensions are $4\frac{1}{2}$ ins. by $3\frac{1}{2}$ ins. ($\frac{1}{4}$ -plate) and the inside $3\frac{1}{2}$ ins. by $2\frac{1}{2}$ ins.

Straddling the inner corners are four thin pieces of tin soldered on very flatly and filed down to wafer thinness. These

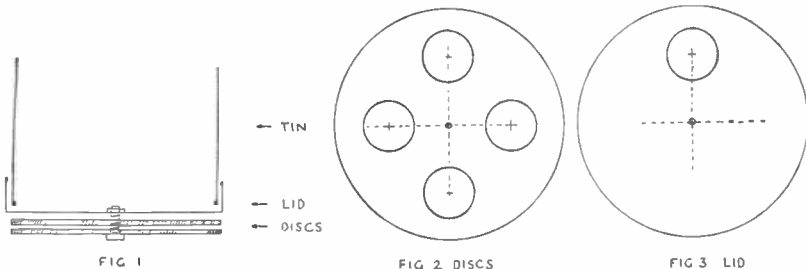

away, smoothing the edges. A hole is also required in the centre for bolt. Drill this with the discs in position on the tin lid, so that the centres register correctly. Another hole is scribed on the tin lid while the pieces are held in position (see Fig. 3).

The screens are now fixed in position between the two discs, using adhesive tape to hold in place, then gluing the discs together. Ilford gelatine filters are made in various colours and are

added.

When the screens and protective pieces have been attached to the discs, apply glue to fasten both together, leaving under a heavy weight until dry. This revolving disc is then attached to the tin lid with a small nut and bolt, using a spring washer on the inside to prevent loosening. The assembly of the parts is shown in Fig. 1, and a 15 watt pearl lamp should be used for lighting. (S.H.L.)

MAKE YOUR BIRD CAGES

Says K. Packer

YOU can make your own bird cages quite easily, and apart from the cost being considerably less, you have the satisfaction and pleasure that goes with making something with your own hands.

First of all it is necessary to design the shape and size of the cage. Here is a tremendous outlet for your imagination and ingenuity, as the flow of ideas which come to mind are never ending. After you have settled on the design, the next step will be to estimate the material required. This consists only of wire rod and punched bar, plus soldering equipment.

Materials Needed

The wire rod is made in two thicknesses, namely 14 S.W.G. and 16 S.W.G. The former, which is the thinner, is mostly used for canary cages, and the latter for budgies. This rod is purchased in 4ft. lengths, ready tinned, so no cleaning is required. The punched bar is also made in two sizes. In one the holes are set at $\frac{1}{2}$ in. centres and the other at $\frac{3}{4}$ in. centres. Again, the former bar is used with the thinnest rods and the latter with the stouter. These bars are also ready tinned and bought in lengths of 4ft.

It now becomes an easy matter to work out how many rods you will need, and as there are approximately 14 rods to the lb., you can determine how many pounds to buy. The amount of punched bar required is measured and bought in single lengths. The price of wire rod is 1/6 per lb. and punched bar 6d. per length. Materials can be obtained at most pet stores.

Bending the Rod

Having a sketch, with design and measurements, at hand, bend into position the first wire rod. The bending of this first rod is very important and must be done carefully, checking all measurements when finished. The actual forming of the rods will be detailed at a further stage. When you are satisfied that the rod is the correct shape and size, lay it on a piece of ply and fix it down with small staples, so that there is no fear of it being disturbed in any way. This rod, once fixed, then acts as a template and the remaining rods are bent up into position and checked against it.

Cut your punched bar to the required lengths. The number of pieces needed along each side of the cage is dependent on the shape and individual choice. Three lengths of bar on all four sides,

one at the very base, another 3ins. above and one near the top is preferable. This helps to keep the rods nicely spaced and allows for easier building (see Fig. 1).

Getting back to the rods. They can easily be bent in a number of ways. A simple wooden jig could be made first and all the wires bent to it. The curves can be formed around anything handy with the right diameter. But in all cases

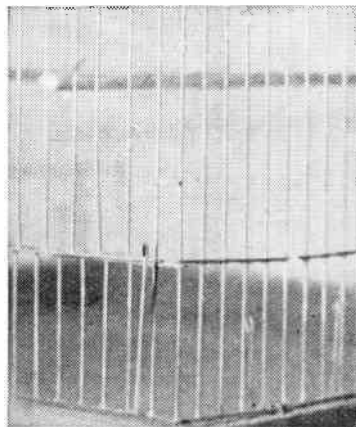

Fig. 1—Positioning of the punched bars

of bending allow for the amount of spring in the wire; that is why it was stressed earlier about making a good template.

When you start erecting the cage, form the basic structure first. If it is rectangular cut six long pieces of punched bar and six short pieces. By taking two of the ready bent wires to use as the extreme ends of the cage and threading on the twelve pieces of bar and soldering in position, you now have the shape of the cage to work to. Take a third wire, thread it through the centre holes of the cage and solder. This will give added strength while you continue to fix the remaining wires.

Hinging the Door

The gable ends of the cage present no problem. Usually they consist merely of straight pieces of wire cut to length and soldered in position.

Now to form the door, or doors as the case may be. (A study of Fig. 2 will be helpful here.) Mark out on the cage exactly where you are having the door. Cut two pieces of wire, a little longer than the width of the door required and

bend the ends to form hooks. Hook these on to one of the bars of the cage and then close the hooks. These then act as hinges. Space these out to the height of the door on the sketch and solder them to the bars of the cage. You now have the door formed. It is preferable to put the bottom rail of the door very slightly above the punched bar. The punched bar then acts as the bottom ledge of the door frame. Solder another wire above the top rail of the door to form the door frame. Bend up a little catch from cuttings and solder this on (as in Fig. 2) and cut through the bars between the door and the frames. The ends of the rods where cut can be filed smooth.

Feeding Pots

To fix the seed and water pots, two clips are needed for each. These consist of short pieces of wire with one end bent over to form a small loop. This prevents the bird from injuring itself. The other end is bent at right-angles. These clips are then soldered to the cage. The best

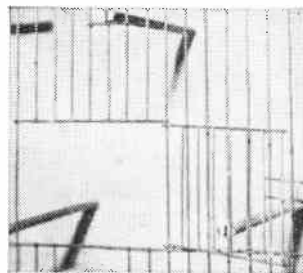

Fig. 2—Hinging the doors

position is the lowest punched bar. The distance between the clips is dependent on the size of pots. These pots have flanges on each side which slip behind these clips, making them easily removable.

A piece of wire can be shaped to a handle and fixed to the top of the cage, making it easily portable, while oval wood perches can be added as indicated in the illustrations.

The base and tray can be made of wood or metal and fixed to the cage; the former with staples and the latter with solder.

All soldering can be done with an electric iron or the small type of blow-torch. Flux should be wiped off the bars before painting and a special bird cage paint which is free from lead compounds and so non-poisonous must be used.

Easy Experiments with Gases

IN a previous article for beginners facts about and interesting experiments with oxygen were given. Many gases other than oxygen are known and some of them play an unsuspected part in our lives. Gases and liquids seem very different, but let us see what we can find out about the commonest liquid of all—water.

Attach two copper wires to a twin cell battery, as shown in Fig. 1. The wires should be the rubber-covered type and scraped bare only at the battery ends and at the parts which lie within the test tubes. The test tube ends of the wires are wound on to two carbon rods removed from an old battery.

Add Acid

Partly fill the bowl with water. We are going to pass an electric current through the water and to make this easier a little dilute sulphuric acid must be stirred into the water—just enough to turn a blue litmus paper red when it is dipped into it. You can buy the acid

but the spill bursts into flame again, showing the gas to be oxygen.

Repeat this process with the other tube, but this time use a lighted spill. A slight pop will be heard and the gas will burn. This gas is hydrogen.

This experiment shows us that water is made up of two gases—a rather startling fact when we think of water as a liquid!

Most of us have blown soap bubbles—and probably been disappointed that they did not rise right up into the sky and disappear, instead of drifting awhile and then coming down to earth. Place some granulated zinc in a test tube provided with a cork and glass delivery tube, as shown in Fig. 2. Pour in a little dilute sulphuric acid and press in the cork. Bubbles of hydrogen will appear. Attach the end of the delivery tube by means of rubber tubing to a clay pipe, and dip the latter into soap suds. Your hydrogen-filled soap bubbles will now shoot up into the sky and disappear. This shows hydrogen to be

Some will stick to the wet sides of the tube. Part fill a tumbler with water and sink the open end of the tube about $\frac{1}{2}$ in. below the surface. Hold the tube in position by fastening it with plastic tape to the edge of the tumbler.

Iron Rusts

During the next day or two the iron will rust and the water will begin to rise in the tube. After a few more days it will rise no more. You will see that the air has diminished by about one fifth its original volume. Close the tube with a finger, lift the tube out of the water, and invert it. Light a spill, remove your finger from the tube and plunge in the lighted spill. The flame will instantly go out and the gas in the tube will not take fire.

As this gas neither supports burning nor burns itself it can be neither oxygen nor hydrogen. It is, in fact, nitrogen. We know also that nitrogen makes up about four-fifths of the volume of the air. The other fifth is oxygen and in the tube was removed because it combined with the wet iron to form rust. Thus only one fifth of the air is of any direct use to us, but that large proportion of nitrogen is equally necessary to dilute the oxygen. Were we to breathe pure oxygen for any length of time we should develop enormous appetites in order to supply waste for the oxygen to burn up, become feverish and eventually die of exhaustion.

Finger Nail Test

Nitrogen and hydrogen combine together to form ammonia, familiar to us all as household ammonia. Ammonia is a gas. What we call household ammonia is a solution of the gas in water. Ammonia and water combine in the solution to form ammonium hydroxide—an alkali—so that household ammonia is really ammonium hydroxide.

To show that it is an alkali we can make use of red litmus paper, which turns blue when in contact with an alkali. Ammonia gas is always being given off its solution, so that if you wet the red litmus paper and hold it in the neck of the bottle, the ammonia gas will combine with the water in the litmus paper and form ammonium hydroxide there. The paper instantly turns blue.

It is a startling fact that you can produce ammonia from your finger nails! Place a few small nail clippings in a dry test tube. Just cover them with powdered quicklime (calcium oxide), add a few drops of water and heat the

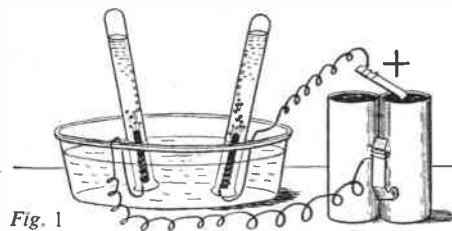

Fig. 1—Proving that water is composed of two gases

Fig 2—Soap bubbles which really go up!

Fig. 1

ready diluted to ten per cent strength from your pharmacist.

Lower the two test tubes into the acidified water so that they fill completely, leaving no air in them. Insert a wired carbon rod into each and bring the tubes into a more or less upright position so as to stand against the bowl edge. The mouths of the tubes must not be lifted above the water surface in the process or air will enter and spoil the experiment.

Gas Bubbles

You will now see minute gas bubbles rising from the carbon rods. Over the next few hours the gases will collect at the top of each tube. When about $\frac{1}{2}$ in. or so have collected, remove the carbon rod from the tube connected to the positive pole of the battery, keeping the mouth of the tube below the surface. Close the tube mouth with your finger. Light a spill and blow it out, so as to leave a glowing end. Remove the tube from the water, invert it, remove your finger and immediately plunge in the glowing spill. The gas will not take fire,

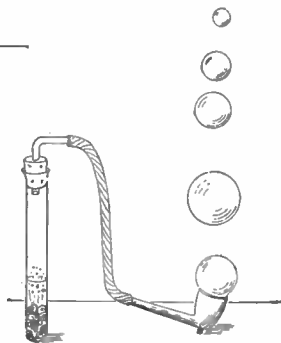

Fig. 2

much lighter than air. Because of this it has been used to fill airships.

We have learned that oxygen helps burning and that hydrogen will itself burn, showing them to be very chemically active gases. We need oxygen from the air to burn up waste matter from the blood circulating through our lungs, and hydrogen and oxygen in the form of water to dissolve waste solids from our blood. We also need another gas. Let us see where it is and find out something about it.

Take a long test tube. Fill it with water and empty it again. Drop in some iron filings and shake out the surplus.

Fixing Wall Electric Fires

By P. W. Blandford

THE ordinary open grate so often fitted in bedrooms is so rarely used that it is better covered. The modern practice of using electric fires for the brief periods when heat is needed in the room is much more convenient. However, a loose electric fire and its trailing flex can be a nuisance and even dangerous. An electric fire fixed to the wall or in a panel covering the old fireplace is the real solution, and this is something which the home handyman can tackle himself.

In some rooms, particularly in old houses, the fireplace and chimney provide ventilation for the room. If the fireplace is closed in a room where there is little other ventilation via doors or windows, a few holes, about $\frac{1}{4}$ in., should be drilled at the top and bottom of the asbestos.

If a fire is to be fitted to a wall

of asbestos. If there are holes in the top and bottom of the box, air will circulate, keeping the box cool and passing the warm air into the room.

Make the box with asbestos sheets on a wood frame (F). Have the depth sufficient to give the fire about 1in. clearance from the back. While this type of mounting can be merely finished by painting, it looks best if covered with tiles. If that is to be done, the box sizes should be arranged to suit the tiles.

With ordinary tiles of the traditional type, it is usually possible to get narrow ones with rounded edges. A suitable adhesive may be bought from a builders' merchant and the pattern built-up (G). Any adhesive on the surface should be wiped off before it sets.

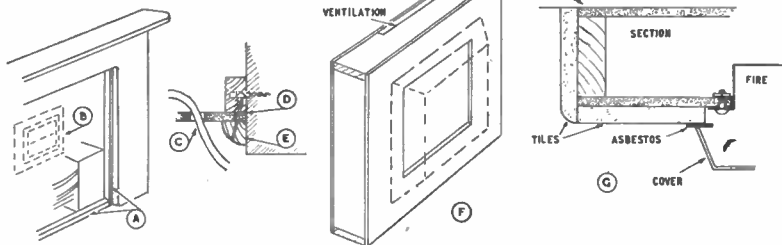

Electric fire units sold for mounting in this way are usually designed to bolt to the panel with the main unit projecting slightly through an oblong hole in the panel, then the fitting is encased by a frame which covers the assembly. Fires may be one or two unit. Usually the two-unit one has a switch for reducing it to one unit, and this is the best choice for the average bedroom.

instead of into a panel covering a fireplace, it should be mounted in a shallow box, to keep it away from the wall. Modern electric fires of this type are designed so that they throw the maximum amount of heat forward. Very little heat is lost behind them, but to protect the wall there should be a sheet

Use Asbestos

A neat and cheap way to mount an electric fire in a panel to cover an open fireplace is to use a sheet of asbestos. Arrange wood strips on the inside of the surround (A). If it is an old-fashioned grate that comes near the front of the surround, the asbestos may have to touch it in places and be supported by blocks elsewhere. Screw the blocks or strips to the surround, which may have to be plugged if there are no convenient joints which can be used for fixing.

Shape the asbestos sheet and try it in place. Mark out the opening. To clear the old grate this may have to be fairly high, but a high position for the fire is preferable in any case (B). Bolt the fire in place and try the assembly. The mains lead may pass through a hole in the side of the asbestos to a nearby plug (C).

Screw the asbestos to the wood strips (D) and cover the screw heads with half-round moulding (E) fixed with panel pins. If the fire chosen is fairly bright it will look best if the asbestos is enamelled black or a dark colour to match the rest of the room.

Plastic Tiles

There are several plastic tiles available now. These are generally smaller than traditional tiles, and in some cases there are ornamental strips and special shapes available, for building up patterns. Each make has its own adhesive. If this is used, there should be no trouble in fixing plastic tiles.

The tiles should not get very hot, but to protect them the frame of the fire could be screwed down on to a narrow asbestos border, which should be painted with a heat-resisting enamel.

Continued from page 33

Barometer - Clock Case

between the four corners to the section shown on the design sheet. Now glue pieces 3 to piece 1 and then pieces 4 to pieces 3, centrally, of course.

KIT FOR 6/6

For making this case we can supply a kit (No. 3130) containing all wood &c., for 6/6, at branches or post free from Hobbies Ltd., Dereham, Norfolk.

The strut at the back (piece 5) is now glued and screwed to the centre of the back of piece 1, and the buttons glued to the four corners, again making sure that they are centred accurately.

If the clock movement is to be incorporated, the radii of pieces 1 and 2 must be extended to approximately 2ins. in order to take the barrel, which has a larger circumference than that of the barometer. The strut will also need to be

slightly altered in this case to fit the back. In addition, cut a ring of stiff cardboard to fit inside the flange on the back of the clock in order to ensure a tight fit in the case. Incidentally, if a piece of $\frac{1}{4}$ in. fretwood is available this would be more suitable than cardboard. A $\frac{1}{4}$ in. notch will also have to be cut in the top centre of piece 1 to allow movement of the alarm stop pin.

When cleaning up before applying the finish, make sure that this is done carefully in the interior of the case to obviate any particles, etc., fouling the mechanism of the clock. Finish can consist of staining and then polishing or varnishing, or using a clear wax—depending on the choice of the worker, and the type of furniture it is intended to match.

Either or both of these instruments would make excellent Christmas gifts. Why not get on with making one right away—and let this year's present be a delightfully personal one.

Make it Yourself

USEFUL BOW SAW

THOUGH not an absolutely essential tool like the handsaw and chisel, for curved sawing in thick wood the bow saw has no equal. For round and oval table tops, curved legs and such work generally, it is speedier than the keyhole or coping saw, and does the job ever so much better. As it is easily made from a small piece of hardwood, oak or mahogany, for example, and need cost little, as blades are reasonably cheap, why not make one yourself?

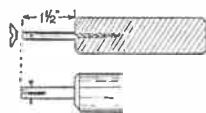

Fig. 2

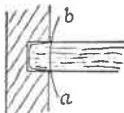

Fig. 3

Fig. 1 shows the completed saw. The wood should be $\frac{3}{4}$ in. thick, and a piece 2 $\frac{1}{2}$ ins. wide and about 15ins. long, will do the job. Cut this into three equal strips, two of which will serve for the sides and the other for the cross rail. Cut the side strips to the length indicated, and at the spot where the cross rail will come, chisel out a mortise for its reception. These should be $\frac{1}{4}$ in. wide, and as long as necessary for the tenon at the ends of the rail. Make the mortises $\frac{3}{8}$ in. in depth.

Notches for Cord

At $\frac{1}{4}$ in. from the tops cut out the notches for the tensioning cord to the shape shown, and rasp and glasspaper to smoothness the sharp edges where the cord passes round. At $\frac{3}{8}$ in. from the bottoms of the sides, drill holes so as to enable the pins, to which the saw blade is afterwards fitted, to slip easily through. As it is most desirable for these holes to go straight through, drill them half-way one side, and complete the hole from the opposite side. Mark the centres for the holes accurately, of course. Finish off the sides by rounding off both top and bottom ends.

The pins to hold the saw blade can be made from a pair of stout 2 $\frac{1}{2}$ ins. to 3ins. screws. For a handle, a 4ins. length of round wood rod (piece off a broomstick if you like) is used. Partly drive one screw in the centre, as at Fig. 2, and cut off the head, leaving the shank projecting about 1 $\frac{1}{2}$ ins. At $\frac{1}{4}$ in. from the ends of this drill a hole through, large enough to take a 1in. wire nail. At rightangles to the hole cut a slot down the shank with a hacksaw, deep enough to let in the saw blade until the hole in it

By *W. J. Ellson*

is in alignment with the hole drilled through the shank. Fig. 2 should make this quite clear.

The second screw is driven in a small wooden cupboard knob, and similarly treated to make the second pin. Pass both pins through their respective holes in the sides. Now fit a 12ins. saw blade, holding the blade in position by the insertion, each end, of a small nail through pins and blade, and draw the sides apart until the blade is fully extended. Measure between the sides. This will give the length of the cross rail, less tenons.

Cut the rail to its length, plus $\frac{1}{4}$ in. extra at each end for the tenons. These are $\frac{1}{4}$ in. thick, to suit the mortises, of course. The shoulders of the tenons should then be slightly curved, as indicated by the arc (a-b) in Fig. 3. The

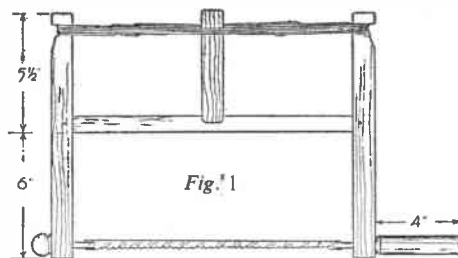

Fig. 1

tenons should be sloped down a little, and the ends rounded off a bit, as in the drawing, to provide a sufficiently loose joint that will permit of just enough movement for tensioning. Fix the rail across, holding it in place with single pins through each side.

For tensioning, about 6yds. of strong cords will be required. For straining the cord, a slip of thin fretwood, $\frac{3}{4}$ in. wide and 6ins. long, will also be needed. Wind the cord eight times across the sides of the saw, and tie the ends. Push the strainer between the cords and turn until the saw blade is tensioned sufficiently, then let the strainer rest against the cross rail.

A 12ins. saw blade can be bought from any tool shop and you now have, at little cost, a really worthwhile addition to the workshop.

● Continued from page 38

Experiments with Gases

tube. Hold a wet red litmus paper over the mouth of the tube. The paper will turn blue! Remove the tube from the flame and smell at its mouth. You will note ammonia, modified somewhat by other fumes being given off.

Those Smells!

Ammonia was first made by this method, using horn, and the solution of the gas was called very suitably 'spirit of hartshorn'. Nowadays it is manufactured from one of the products of coal distillation.

Bad eggs and cooking cabbage have one thing in common—the smell. This smell is chemically the same, too. It is caused by the gas hydrogen sulphide. This gas is colourless, but, as we now know well, by no means odourless! An easy way to prepare a small quantity is to cut a pea-sized piece of wax from a candle and to heat this with a little flowers of sulphur in a dry test tube—but do it outside, or the family will complain. The gas is soon evolved.

Now is the time to answer a domestic question. Why does silver blacken?

Take a silver coin (dated before 1947, for those minted since then contain no silver), wet it and hold it at the mouth of the test tube. It will blacken. The silver has reacted with the hydrogen

sulphide to form black silver sulphide. Both fresh eggs and the air contain enough hydrogen sulphide to bring about this change in time.

You may sometimes have noticed a sharp pungent smell when you poke the cinders of a dying fire. This is due to the presence of the gas sulphur dioxide, formed by the heating of those brassy looking particles often seen in coal; they consist of iron pyrites or iron disulphide. Sulphur dioxide is needed to make sulphuric acid, and the gas is sometimes obtained for the purpose by heating iron pyrites.

Bleaching Agent

Sulphur dioxide has another important use. Delicate materials such as straw, wool and silk which would be injured by other methods are bleached by sulphur dioxide without harm. We can make the gas by placing some sodium bisulphite in a clean jam jar and pouring vinegar over it. Hang some delicately tinted flowers in the jar and close the latter with a sheet of cardboard. In half-an-hour or so you will find the flowers are white, but quite uninjured.

By means of these few simple tests a good deal about the part gases play in our lives has been revealed. (L.A.F.)

Gay and inexpensive

Christmas Tree Decorations

By Donald Fraser



Clown in the Fry's Milk Punch advertisement

IT is never too early to start making simple and inexpensive ornaments for your Christmas tree. It will bring the spirit of Yuletide much closer and will help the long dark evenings to pass more quickly.

You will need a pair of scissors, a pot

of paste, some thin cardboard (cereal cartons are excellent for this); a ball of coloured string, and a little imagination. Should you want to make a really finished job of your decorations, then add a small bottle of clear varnish and a brush to your list. This will make them stand out more and is well worth the trouble.

Plenty of Material

The magazine pages are crowded with colourful illustrations and advertisements. From many of these you can choose most of your material. Many of the figures and objects in these pictures are just the right size for a Christmas tree decoration. Go carefully through the magazines and pick out the little subjects which appeal to you most. It is better to have more and smaller decorations, than larger and fewer.

As you come across the type of thing which appeals to you, cut it out roughly from the magazine and paste it on your sheet of cardboard. You will find that you can dovetail them in with one another, as it does not matter, at this stage, how they are mounted. If you are



Santa Claus in the Wolsey grip-top advertisement

using a cereal carton for your backing, paste your decorations on to the coloured side so that the back will be plain white. This adds to the effectiveness of your tree, as when the little figures swing around the wrong way, it will give the appearance of snow.

When you have filled up your sheet of cardboard, carefully cut them out, leaving a little square piece at the top (see illustrations) in which to pierce a hole. Through this put your coloured string for hanging. Should you want to make a more permanent job of these paper cut-outs, then they should be glued on to thin wood and cut out with a fretsaw. In this case the backs of the figures should be painted white.

One last word of advice—concerning colours. Reds, naturally, should predominate. Avoid as much as possible solid greens, dark browns or any drab colours. Yellows always show up well against the dark green background of the tree, but the more gold and silver subjects you can find, the more your tree will sparkle.

(This appears to be an excellent opportunity for younger readers especially to get in plenty of practice with their fretsaws. And while on the topic of Christmas, don't forget that a Hobbies Fretwork Outfit makes the perfect gift. Write for fully illustrated booklet—Editor.)



Method of dovetailing figures before cutting out

Hints for Match Anglers

By Arthur Sharp

TO hope for the best results when match fishing, likely tactics should be thought out beforehand. To lay plans it is necessary to know, first, the kinds of fish available in the water pegged for the contest; secondly, the average depth and type of water—fast, slow, or medium; thirdly, the condition of the water, low and bright, or stained as the result of showers, or high and muddy following a storm of heavy rain upriver. Such variations of water affect one's chances, and the competitor must adjust his tackle, baits, and methods accordingly.

Speed is a great factor. To facilitate this, see that you have all your essential needs close at hand. Fix the keep-net handy to your peg and seat-basket, or your stance if standing or kneeling to your task, in order that you drop your fish into it without having to move far. Obviate hauling the keep-net out of the water each time you land a fish, for this wastes time, and is liable to disturb the swim, and so scare off the fish into deep water or into your neighbour's 'pitch'.

If your keep-net is low owing to a steepish bank, it is a good idea to add a sort of muslin funnel—or a short length of tubular netting—to the top ring of the net; you can then slide your captures down this 'chute' to their temporary prison without disturbing the net and making undue commotion.

Always use the best baits, and as fresh as possible. This also applies to ground bait. Worms and maggots must be lively; 'weary' baits are not attractive to fish. Throw your ground bait in the swim sparingly and without undue splashing.

For match fishing maggots, or gentles if you prefer their other name, take some baiting as hook baits. Use the bigger ones for the hook; the smaller ones can be scattered in the swim from time to time. Coloured and uncoloured maggots may be included in the kit at a contest, ready for a change-over if you feel this would be helpful. If the water is

'pea-soupy' then worms will probably be most effective. If chub are in the swim, use a tiny cube of cheese paste. Breadcrust cubes are tempting to roach. Creedwheat and stewed barley are also attractive at times. In a match of limited duration it is advisable to take a choice of varied baits.

Light tackle for match fishing. The lighter you fish the better your chances. You just cannot afford to use clumsy and heavy tackle. Don't waste your breath in grousing about your particular swim—make the best of it. Don't keep your eye on your neighbours' activities—you may well miss a bite. Keep several spare casts made up with hooks of different sizes. Carry your box of split shot in a handy pocket to facilitate quick changing over from light to heavier tackle.

And a final note: When returning the catch after the weigh-in don't just sling the fish back into the water. Place them in your landing-net, lower it into the swim and allow the captives to go free. Then you are not liable to injure them.

Weave Novelties on this

SIMPLE BEAD LOOM

ON the easily-made bead loom described here, you can weave quite enchanting little gifts, which look and are expensive to buy. The gifts are very cheap to make, like the loom itself.

All the materials needed for the loom are:—a wooden box (no lid is necessary) measuring about 12ins. long, 9ins. wide and 2ins. deep; glasspaper; penknife; and enamel paint.

First glasspaper the box until both the inside and outside are quite smooth. This is absolutely essential for efficient weaving, so a little patience is necessary.

When this is finished, enamel the box on the outside any colour you choose, but leave the inside unpainted so that the warp may show clearly.

Be accurate

Now take a ruler, and placing it perfectly straight over the top edges of the box, make pencil marks for notches to be cut to take the warp. Leave 2ins. at either side of the box clear of notches. The pencil marks must be accurately made and should be about $\frac{1}{8}$ in. apart. Cut the notches with a sharp penknife about $\frac{1}{8}$ in. in depth.

The loom is now ready for the threading. The materials required for

this are:—button-hole twist (for warp) and adhesive tape or drawing pins. Wind the button-hole twist round the loom into the notches at each end in order. Secure the twist at the start and again at the finish with adhesive tape or drawing pins on the outside of the loom. The warping is now complete.

Threading Beads

Weaving the beads is a simple matter. The materials required are:—beads, 1 packet of bead needles and button-hole twist. Thread a needle with a good length of twist and tie the end of this to the first thread of the warp. Do not cut the twist too close to the knot but leave a long length after tying. Now thread as many beads on to the needle and thread as the width of the weaving requires for the first line and, with the left hand, push the threaded beads up from underneath the warp—one bead between each thread. Keeping the beads in this position, draw the needle and thread through the beads as far as it will go. Then turn the needle round and back through the beads but this time over the warp. This locks the beads to the warp.

The first line is now finished. Continue weaving in this way until you have

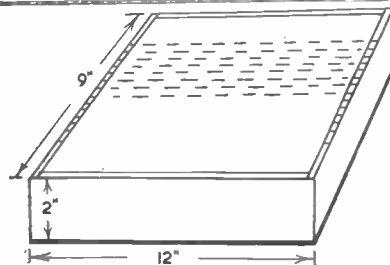

The warping placed in notches

completed sufficient rows to meet your requirements. Knot on more thread when that in the needle becomes used up but keep the knot hidden on the lower side of the weaving.

To finish off cut the warp threads across underneath the loom in the middle, remove weaving from the loom, and tie the ends of the warp threads together to secure.

A few of the countless articles which may be made easily and quickly are:—belts, napkin rings, teapot mats, wine-glass mats, necklaces, bracelets, purses and bags. (D.M.D.)

YOU CAN MAKE XMAS CRACKERS

We can supply all materials and filling for this interesting and profitable occupation. Beginners—our special Learner Pack contains enough materials to make two dozen crackers complete with easy step-by-step instructions, only 5/-. Full sample range of fillings 2/- refundable. Lists free.

GAIETY CARNIVAL NOVELTIES
Amen Corner, TOOTING, S.W.17

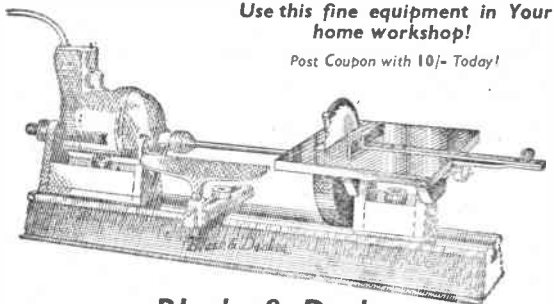

Use this fine equipment in Your home workshop!

Post Coupon with 10/- Today!

Black & Decker DRILL, LATHE & SAW

Start a home workshop with this famous Black & Decker DRILL, LATHE & SAW outfit. Enjoy the thrill of using this fine equipment. Outfit consists of $\frac{1}{2}$ in. Electric Drill complete with drills and Polishing equipment in fitted tool-box, B & D wood turning Lathe and Sawbench attachment with 5 in. circular saw.

How to Get This Outfit

All you have to do to get immediate delivery is to send coupon with first instalment of 10/-. 48 further weekly payments of 10/- complete purchase. Post Coupon NOW!

10/-

49 weekly payments of 10/- or £21/5/6 cash

To NEW TRADING HOUSE

Dept. O.E. 14, Primrose Hill Mill, Preston, Lancs.

Send - one BLACK & DECKER DRILL, LATHE & SAW Outfit, I enclose 10/- and will send 48 further weekly payments of 10/- under your H.P. scheme.

Signed.....

Please PRINT name and address in margin

7^D SPEEDFIX
SELF-ADHESIVE Tape
All sizes from 6" a roll

STOP SMOKING

Any Man or Woman in the World May Now Stop Smoking Quick and Sure

To Prove It. A Free Trial Package Sent Sealed To All Who Write

If you want to stop smoking, this should be just the thing you need. Simply send your name and address to Mr Brian Hussey, Dept. HD/5, The Triumph Remedies, Exeter, and he will send, absolutely free of charge, a trial package of our remedy to show how it is used and how it will quickly conquer the habit of smoking, also full directions how to use it, free advice, and everything needed to aid you in overcoming the habit quickly and certainly. No matter what else you have tried or how many times you have failed, this time you will succeed. Please send name and address now—as this free offer may never appear again.

Conduct real experiments

WITH A

LOTT'S CHEMISTRY SET



Not just a toy but the real thing in miniature, a LOTT'S Chemistry Set provides an absorbing and instructive hobby for youngsters with a scientific bent.

It contains real chemicals and apparatus with full detailed instructions for carrying out many fascinating experiments. Spare apparatus for converting your set into a student's laboratory also available. Sets from 12/3 per box.

Stocked by all branches of
HOBBIES LTD
and Toy shops everywhere
Enquire for list

Model Railway Enthusiasts!

Ask to see

LOTT'S TOY STONE BUILDING BRICKS

for true-to-scale trackside buildings.

Price from 6/11 to 57/6

You simply pour out these

NOVELTIES

with NEW LIQUID PLASTIC

Here's the hobby to make your spare time pay dividends. You simply choose your mould and pour out beautiful castings. We supply everything, including instructions. Wonderful results achieved - wonderfully quickly! Start right away - no training needed. Send 2½d. stamp for exciting book and market details. No obligation.

QUALITY PLASTICS LTD.

DEPT. H.18, BRENTWOOD, ESSEX



YOU CAN BECOME A HANDICRAFTS INSTRUCTOR

EXPERIENCE NOT ESSENTIAL

Men who enjoy making things in wood or metal can turn their hobby into a permanent and interesting Career. Short hours, long holidays and security in a job you would really enjoy, can be yours if you become a Handicrafts instructor. Let us send details of the easiest and quickest way to get the necessary qualification.

We guarantee "NO PASS—NO FEE"

If you would like to know about our unique method of preparing you for one of these appointments, write today, and we will send you our informative 144 page Handbook—free and without obligation. Mark your letters "Handicrafts Instructor".

**BRITISH INSTITUTE OF
ENGINEERING TECHNOLOGY**

595 College House, Wright's Lane
Kensington, London, W.8

BIET

Replies to Readers

Is this YOUR Problem?

Flower Bowls from Records

HOW can I make useful articles out of old gramophone records? (L.M.—Wisbech).

ONE method is to make them into flower bowls. This can be done by using any bowl-shaped object of suitable size, laying the record flat on the bowl and then heating both until the record warms sufficiently to droop over the bowl. Leave to cool, then remove the record. Another suggestion is to make the discs into stands by affixing them to suitable central supports, which could either be turned or be made of fretwork. A further idea is to turn out the centre part of one disc, to surround a mirror and back them by a second disc. The two discs could be held together by screws, round-headed paper clips, or by an adhesive. Mostly it is a matter for individual ingenuity to secure the results you desire.

Stamp Gum

I SHOULD like to know how to gum paper so that on damping it becomes adhesive—it is a mixture like that used on postage stamps which I need. (D.G.B.—Winchester).

A GUM suitable for your purpose can be made with gum arabic (about 4 parts); glycerin (about 1 part); water (about 1 part or just sufficient when the ingredients are warmed, to form a thin paste). This, when applied to the paper, should dry fairly quickly, but when moistened becomes adhesive again. A few trials will indicate the most suitable proportions.

Ant Destroyer

PLEASE tell me how to get rid of ants in the house. (D.M.—Dundee).

ANTS are partial to honey, and it is customary to use this mixed with various arsenic compounds, but these are erratic in effect and we do not quote them. Thallium sulphate works where arsenic fails, and in America complete extermination has been effected in three to four weeks. The mixture used consisted of:—water, 1 pint; sugar, 1 pound; thallium sulphate, 27 grains; honey, 3 ounces.

The mixture is brought to the boil and stirred well. After cooling, small portions are left about the ants' haunts on watch glasses or old saucers. Like arsenic, thallium sulphate is extremely poisonous, hence the mixture should be

boiled in an old enamel pan or glass beaker. The pan should not be used again for food. Thallium sulphate costs about 5/3 for 10 grams (rather more than one-third of an ounce), and may be obtained from The British Drug Houses Ltd., B.D.H. Laboratory Chemicals Group, Poole, Dorset. The order must be signed by the purchaser, giving his full name, address and must state his trade, business or profession, and the purpose for which the thallium sulphate is required.

Repairing Plastic Cape

PLEASE tell me how I can repair a torn plastic waterproof cape. (D.G.—Carlisle).

A TEMPORARY repair can be made to a plastic cape with a self-adhesive tape. Most of the plastic cape

☆☆☆ WORTH NOTING ☆☆☆

Cleaning Pewter

IN cleaning pewter ordinary surface grease can be removed by washing with a detergent. If, however, you wish to remove the discoloration due to ageing, then more drastic treatment will be needed. For example—by brushing or rubbing with pumice powder moistened with a detergent solution or water, followed by polishing with rottenstone and water or with plate powder or rouge.

materials can be welded as follows:—lay the two edges together with a slight overlap and cover with a cloth. Press with the edge of a hot soldering iron or flat-iron. Experiment with a scrap piece or an unimportant corner to get the right heat. The correct heat will soften the two surfaces so that they join together. Most of the common adhesives will not join plastics. Welding is best, but as an alternative you could use Surridge's Titebond.

HERES MAGIC FOR YOU!

Baffling Reels

FIVE reels of black cotton are stacked in the way illustrated on a small tray on the magician's table. A little to one side is a reel of white cotton and an empty paper tube.

The performer shows the tube to be quite empty. He then holds it upright on the tray, dropping the black reels in one by one. The reels fit just neatly and easily into the tube. Finally the white reel is picked up and the performer calls special attention to the fact that it is placed in last and is, therefore, on top of the black reels within the tube.

After muttering the magic words 'Abracadabra—pass!' the performer slowly raises the tube. The stack of reels is exposed—with the white reel at the bottom. The empty tube is tossed aside, then tube, reels and tray are passed round for examination. There is no clue as to how the white reel found its way to the bottom of the stack.

But now for the simple secret. An extra white reel is used, but this is hidden behind the stacked black reels when the trick begins. After showing the empty tube the performer stands it upright over this white reel. As the black reels fall into the tube they stack themselves on to the white reel. Now the other white reel is dropped on top of the stack. Thus there is a white reel at the top and a white reel at the bottom of the stack, quite unknown to the audience.

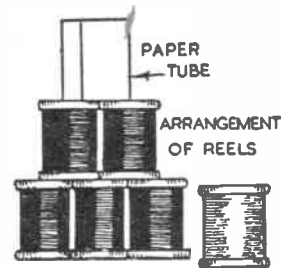

By R. W. Wood

When raising the tube it is gripped at the top so that the top white reel is taken away with it. While the audience are looking with surprise at the white reel at the bottom, the performer allows the hidden reel to slip quietly out of the tube into a pocket formed from a part of the table cloth pinned up behind the table.

If the performer is working on a small table, such as a card table, a small fancy cloth can be used. Most magicians use a black cloth with a length of gold fringe sewn around the edge. A cloth of this kind adds a nice magical touch and it can be carried among the magical gear for use when working on small stages in clubs, concert halls, and so on.



29/11 POST ETC 1/6

A romantic ten thousand miles an hour trip to the Moon. Adventure galore for brave young pioneers to rush through space and be first on the Moon. Attractive coloured wind, rain, and element resisting material. Silver tipped. With Aerial. Large enough for the Scientist, Pilot, Radio

operator and 1 crew. Stands indoors or outdoors. A bargain complete 29/11, post etc. 1/6.

THE NEW INTERPLANETARY SPACE SUIT



SENT 2/6 CASH 29/11 POST 1/3 FOR PRICE 29/11 ETC.

Be an Interplanetary Commando. Wear this metallic blue Space Suit and pressure helmet. Be the first Earth Man to Jupiter. Can also be worn over outdoor clothing, guaranteed waterproof. For boys aged 4 to 10. Waisted and adjustable, visor on helmet. Lightning flashes on breast panel. Attractively boxed. Sent for 2/6 deposit and 5/- monthly. LISTS, Clothing, Watches, TERMS.

HEADQUARTER & GENERAL SUPPLIES LTD.

Dept. HOBW/75, 196/200, Coldharbour Lane, Loughborough Junction, London, S.E.5. Open all Saturday 1 p.m. Wednesday.

TELEPHONE PARTS

Telephone Handset Mouldings—P.O. Type—12/6 per set.

Single Pin, 2-way plugs—4/6 each.

Set of Transmitter Parts—10/6.

Set of Receiver Parts—10/6 each.

Tinsel Flexible Cords—tagged each end, 4ft. 6ins. long—8d. each.

Various type Relays; Induction Coils; Choke Coils; Condensers, etc.—Price on application with stamped addressed envelope.

'ONLY' COMPONENTS LTD., Llanerch-y-Mor, Holywell, Flintshire

ENFIELD EASIFIND

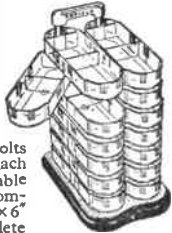

A unit of 14 Transparent Plastic Trays each 7 1/2" x 2 1/2" x 1" deep, swivelling outwards for easy access. Ideal storage for nuts, bolts and all small parts. Each tray supplied with 1 movable partition providing 28 compartments for only 8 1/2" x 6" bench space. Complete Unit 49/6

Cash with order or C.O.D. (Carriage paid). Callers welcome at each branch.

Write today:—ENFIELD TYRE COMPANY, 123-5 Baker St., Enfield, Middx. Enfield 2982 Branches: 1058, Christchurch Road, Bournemouth and Castle Lane, Market Street, Torquay.

A GRAND BOOK FOR ALL THE FAMILY. The "Kaylee Year Book of Bright Ideas". A really helpful guide to home planning, decoration, Hobbies, toys, etc. Showing famous Kaylee Transfers in brilliant colours, and most effective uses. From "Hobbies" stockists or direct.

KAYLEE TRANSFERS Postage 3d. LTD. (HW), Long Eaton, Nottingham.

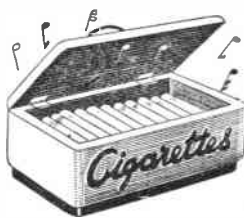

Musical Cigarette Box
It plays when you lift the lid. Full kit to make 4/9, musical movements to fit, 17/11 (ask for tune titles available).

Hobbies have hundreds of designs and kits from which, with a few simple tools, it is easy to make toys, colourful galleons, musical novelties like those illustrated, lovely models, and a host of other delightful things.

Get Hobbies 1956 Handbook (2/- from newsagents, etc., or by post 2/3) and this will show you how to really enjoy your hobby

To Hobbies Ltd., Dept. 991, Dereham, Norfolk.

Please send free 20-page booklet and items marked thus: X

- Musical Cigarette Box, Kit.No. 3106 - 4/9
- List of musical movements available at 17/11
- Hobbies 1956 Handbook, 2/3 post free.

Name

Address



with **BRICKPLAYER**

Brickplayer Kit 3 25s. 6d.
Brickplayer Kit 4 47s. 6d.

Kit 3A converting Kit 3 into Kit 4 .. 25s. 6d.

Brickplayer Farm Kit 56s. 6d.

2000 Bricks Box 53s. 6d.

Extra Bricks, Roofing and Cement in low-priced packs.

Windows and Doors obtainable singly.

BRICK AND MORTAR BUILDING KIT AND ACCESSORIES

The Brickplayer Kit contains miniature bricks in all required shapes, mortar, roofing, plastic windows and doors, plans and instruction booklet. All models are architect designed to 'O' gauge scale.

Buildings can be permanent or dismantled by merely soaking in water and the bricks used again and again. If your dealer cannot supply, write for leaflet and address of nearest stockist to:

J. W. SPEAR & SONS LIMITED

Dept. 'HW', Enfield, Middlesex

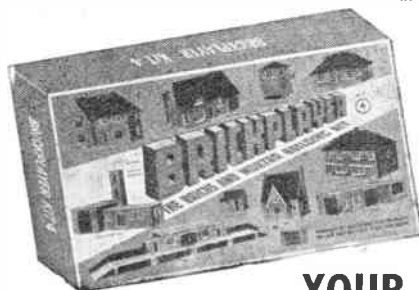

YOUR IDEAL XMAS GIFT

ELECTRIC PAINT SPRAYER

For 4/- deposit



Cash 75/-. Or 4/- deposit and 6 monthly payments of 13/6

Paint easily, evenly, twice as fast with the Burgess Electric Sprayer. Sprays paint, varnish, etc. Complete with sturdy glass container, flex, nozzles for ceiling spraying and extra nozzle discs for different liquids. A.C. mains - state your actual voltage. Fully guaranteed. Also Horvell Electric Paint Stripper 30/- cash, or 4/- deposit and 3 monthly payments of 10/-. Leafflets free



BATHROOM SCALE BARGAIN

★ FOR ONLY 5/-

★ and 6 monthly payments of 13/- (or Cash Price 69/6) WATCH YOUR WEIGHT every day with this streamlined Bathroom Scale. Magnified dial easy to read. Weighs accurately from 1lb. to 20st. Lovely white enamel finish. Non-slip plastic mat. All mechanism enclosed. 2 years' guarantee. Cash 69/6, or 5/- dep. and 6 monthly payments of 13/-.

BARGAIN DISTRIBUTORS
(Dept. 124), 5 Silver Street, Luton

PHILISHAVE

14 DAYS' FREE TRIAL

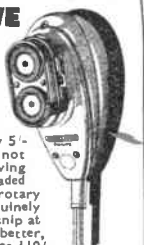

Try the wonderful Philishave Electric Dry Shaver FREE for 14 days. Send only 5/- deposit (returnable if not satisfied). Two shaving heads with two 6-bladed cutters have unique rotary action which genuinely shaves - doesn't just snip at the hairs. Result - better, quicker shave. Operates 110/250 volts. A.C./D.C. £7.9.1 cash less your deposit. Or 5/- deposit can be first payment, followed by 8 monthly payments of £1. 12 months' guarantee. Brochure of this & other shavers free.

Wolf Cub ELECTRIC DRILL AT

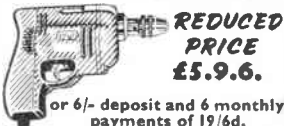

REDUCED PRICE £5.9.6.

or 6/- deposit and 6 monthly payments of 19/6d.

This wonderful Electric Drill is also the power unit for ALL CB equipment. Drilling capacity: Mild Steel, 1/4"; Hard Wood, 1 1/2"; with 210 watts input on full load. Complete with 1/4" three-jaw chuck and Allen key and 5ft. of cable. TV Suppressed. State Voltage. ALSO Sanding & Polishing Kit (drill, discs, etc.). Cash Price: £6. 10. 6 or 19/- deposit and 6 monthly payments of 21/-.

Send for Illustrated Brochure of Wolf Cub equipment.

NEW! EXPERIMENTAL KITS

LEARN THE PRACTICAL WAY

Here is home study of the most effective kind under expert tutors.

There is no better way of studying for an examination, starting a new hobby or for a career in industry.

These special courses comprise the most modern methods of postal tuition, combined with a Practical Kit of parts (which remains your property).

COURSES FROM 15/- A MONTH

COURSES WITH PRACTICAL EQUIPMENT INCLUDE: Radio, Television, Mechanics, Electricity, Chemistry, Photography, Carpentry; also Draughtsmanship, Commercial Art, Amateur S.W. Radio, Languages, etc.

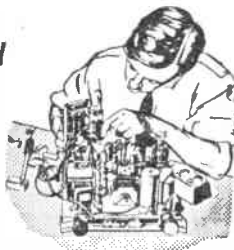

POST THIS COUPON TODAY

For FREE brochure write: E.M.I. INSTITUTES, Dept. 31X, Grove Park Road, London, W.4.

SUBJECT(S) OF INTEREST _____

NAME _____

ADDRESS _____

26/10/55

IC51A

E.M.I. INSTITUTES

The only Postal College which is part of a world-wide Industrial Organisation

HEAR ALL CONTINENTS With H.A.C. Short-Wave Receivers

Suppliers for over 18 years of Radio S-W Receivers of quality.

One-Valve Kit, Price 25/- Two-Valve Kit, Price 50/-

Improved designs with Denco coils. All kits complete with all components, accessories and full instructions. Before ordering, call and inspect a demonstration receiver, or send stamped addressed envelope for descriptive catalogue.

"H.A.C." Short-Wave Products (Dept. 22), 11 Old Bond Street, London, W.1

TOY CASTING MOULDS. Soldiers, sailors, Airmen, etc. 1,000 varieties from 3/- each. Rubber moulding compound for flexible moulds, granulated ready for use, 8/6 per lb. Aluminium moulds for plaster work. S.A.E. for list. Catalogue 9d.—F. W. Nuthall, 69 St. Mark's Road, Hanwell, London, W.7.

PLYWOOD — HARDBOARD — at amazing low prices. Send S.A.E. for samples and prices to — N. Gerver, 10 Mare Street, Hackney, London, E.8.

'PAINTSPRAYING' HANDBOOK (1954 Ed.). Covers Car, Industrial & Flock Spraying. 3/6, post free, including catalogue of our Cellulose and Synthetic Paints and all Allied Sundries and Plant Hire.—Leonard Brooks Ltd., 81 Oak Road, Harold Wood, Essex.

STAMPS FREE — Empire Packet including Robert Jackson and Victorians with approvals.—Richard J. Peck, 7A Kemp Road, Bournemouth.

SWISS MUSICAL Mechanism for cigarette boxes, etc., 16/6 post free. S.A.E. for illustration and list of tunes available.—Dept. HW., Metwood Accessories, Church St., Wolverton, Bucks. (Trade supplied.)

MAGIC Jumping Card and wonderful Catalogue 1/-.—DeHempsey, 363 Sandycombe, Kew Gardens, Surrey.

THE 'ROYAL CHARLES'

is the latest design in Hobbies wide range of models of famous old-time galleons. Obtain your design FREE with

HOBBIES 1956 HANDBOOK

Now on sale (2/-) at newsagents, etc., or 2/3 post free from Hobbies Ltd., Dept. 991, Dereham, Norfolk

MODELS. You can make lasting stone-hard models with Sankey's Pyruma Plastic Cement. Supplied in tins by Ironmongers, Hardwaremen and Builders' Merchants. Ask for instruction leaflet.

AMERICAN MAGAZINE Subscriptions. One Year Popular Mechanics 30/-. Popular Science 43/-. Homecraftsman 16/6. Homecraft 18/-. Deltagram 10/6. Free booklet quoting others.—Willen Ltd. (Dept. 57), 101 Fleet St., London, E.C.4.

STOP SMOKING!! Quick Guaranteed remedy. S'free Testing Sample!!—Triumph Remedies (H3), Exeter.

BUILD your own T/V and learn about its operation, maintenance and servicing. Qualified engineer-tutor available whilst you are learning and building. Free Brochure from—E.M.I. Institutes, Dept. HW.58, London, W.4. (Associated with H.M.V.)

GENUINE Swiss Musical Movements. Owing to large purchase now reduced to 14/6 each. Genuine Thorens Movements, all guaranteed, 19/3 each. P. & P. 9d. extra on all orders.—Richardson & Forder, 5 Chapel Place, White Hart Lane, London, N.17.

PLYWOOD: large sizes, 14 lbs. 10/- delivered (Express) C.W.O.—H. Leader (1920), Gosford St., Middlesbrough.

DO-IT-YOURSELF BOOKS. List free.—S.P. Ltd., 28 (H) Dean Road, London, N.W.2

100 DIFFERENT stamps free! Request 1d. upwards discount approvals.—Bush, 53 Newlyn Way, Parkstone, Dorset.

STAMPS FREE!! Twenty unused (2 1/2d.).—S.G. H. Barnett, Limington, Somerset.

THE Mysterious Letter and The Elusive Cross. 10 piece and five piece puzzles in lovely coloured plastics. Absorbing! Fascinating! Send 2/6 P.O. now!—Tenmay Mfg. Co., 96 Devonshire Rd., Bolton.

AUSTRALIA 1947 Newcastle. Fine historic complete set, free to approval applicants enclosing postage.—Yulwontmor Stamps (Dept. H5), 29 Layton Avenue, Mansfield.

50 STAMPS free to all approval applicants enclosing 2 1/2d. stamp.—Cliffe West (Z), 61 Wynyard Road, Sheffield, 6.

'PROFITABLE HOBBIES', America's leading monthly. Year's subscription 28/6, specimen 3/6. Full list American magazines free.—Hobson, 79 Southbrook Road Exeter.

A Useful Log Box for Your Fireside

★ *Make it yourself from these easy-to-follow details*

CUT the sides and ends from 1in. thick wood to the measurements shown. The sides are winged and let into the ends. They are secured by screws. Fillets are screwed round the inside and a loose floor of $\frac{1}{2}$ in. wood laid in position on these.

Cut the handles from 2in. thick wood and make them about 4ins. by 2ins., hollowing out a portion for the fingers. Finish off by staining and polishing.

(M.p.)

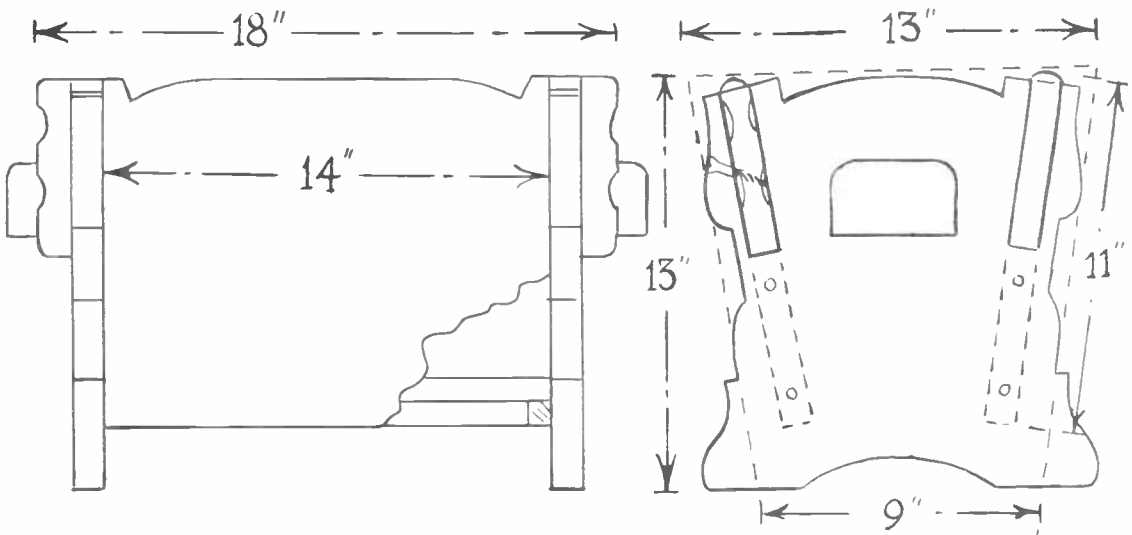
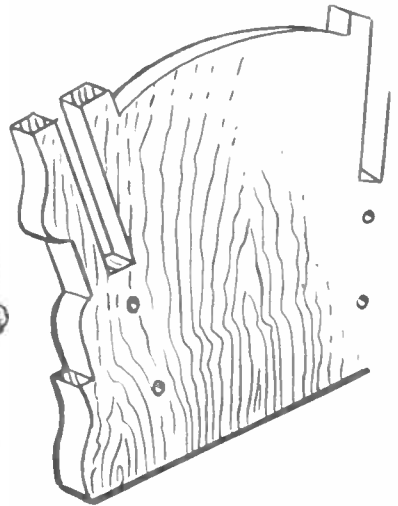
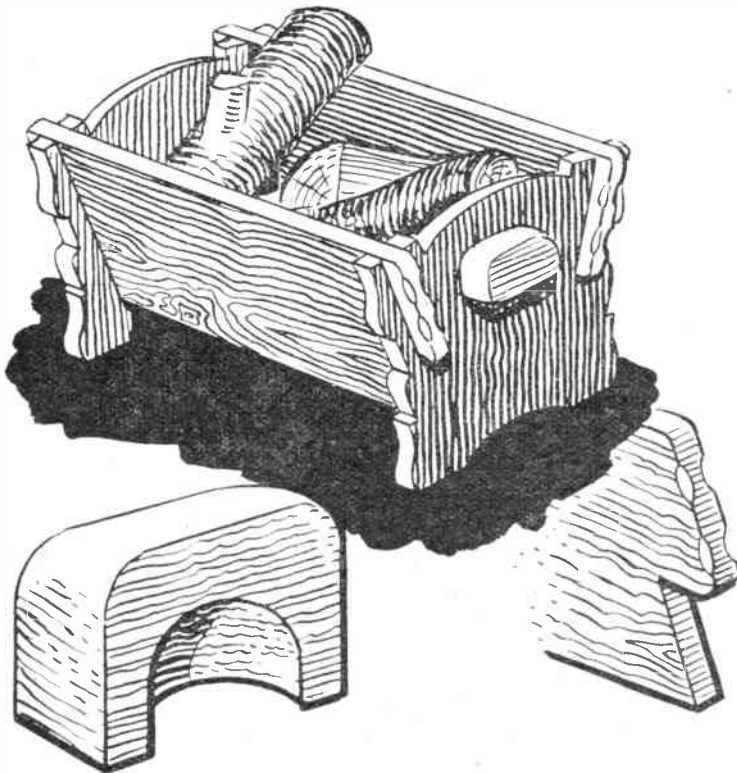



THIS IS THE TOOL I'VE BEEN LOOKING FOR

says *W. P. Matthew,*
the T/V handyman

IT'S THE REVOLUTIONARY NEW **SURFORM**

'SURFORM IS A TOOL THAT OUGHT TO GO INTO EVERY HANDYMAN'S TOOL KIT. IT DOES A LOT OF JOBS ON A LOT OF MATERIALS -- AND IT DOES THEM QUICKLY AND WELL.'

SURFORM is the nearest approach yet to a general-purpose hand-surfacing tool. It smooths down rough wood like a plane. On red deal, for example, it works twelve times faster than a rasp. On convex curves, it's easier than a spokeshave.

But that's only part of the story. You can use SURFORM on rubber, leather, plastics, "Formica," "Warerite," plywood, hardboard, fibre, non-ferrous metals, and mild steel too. On all these materials it works faster than any other surfacing tool, and gives a fine finish.

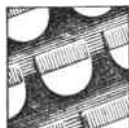

THE SECRET'S IN THE CUTTING STRIP

SURFORM has 500 tough razor-sharp teeth set in a hardened and



tempered carbon steel cutting strip which is a patented product of Firth Brown Tools Ltd. of Sheffield. These teeth really cut the material instead of just tearing it away. And they can't get clogged up, because in front of each tooth is a hole through which the cuttings pass.



SURFORM 'Plane' Type 17/6.

'File' type 12/6.

Replacement for the long-lasting cutting strip 3/6, from your local ironmonger or hardware store. If you have any difficulty, write to us and we'll tell you the name of your nearest stockist.

Manufactured by SIMMONDS AEROCESSORIES LTD.
TREForest · PONTYPRIDD · GLAMORGAN
A MEMBER OF THE FIRTH CLEVELAND GROUP



"SURFORM"

REGD. TRADE MARK

CRC 55U

SIZE—7 $\frac{1}{4}$ ins.
WIDE OVERALL

THIS RADIUS TO BE
EXTENDED TO 2ins.
IF USED FOR
CLOCK.

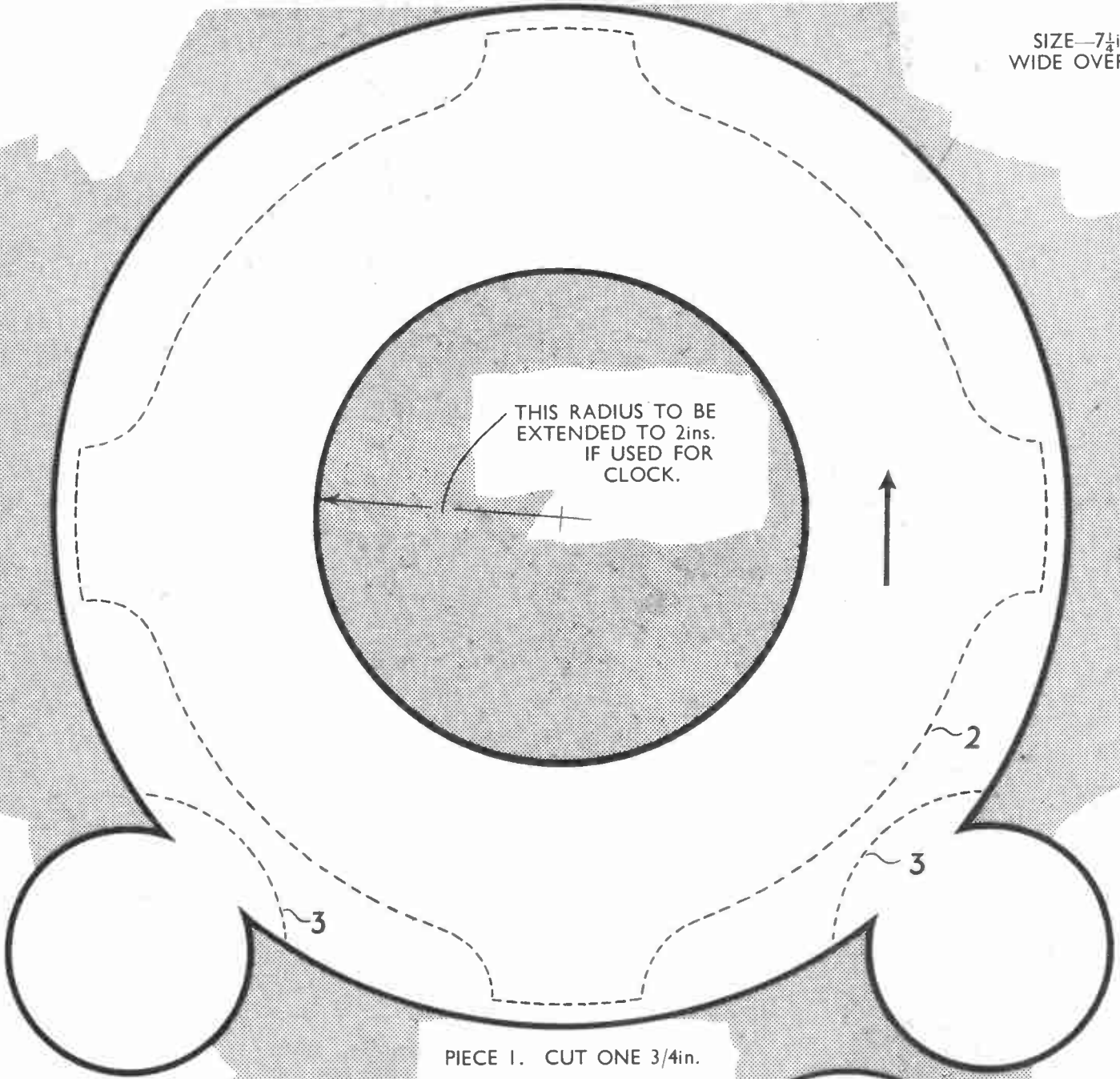

PIECE 1. CUT ONE 3/4in.

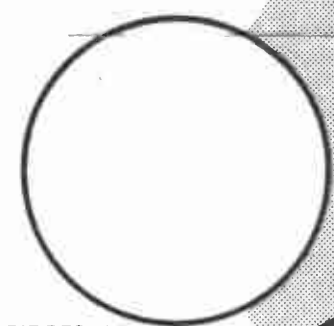

PIECES 4.
CUT TWO 1/2in.

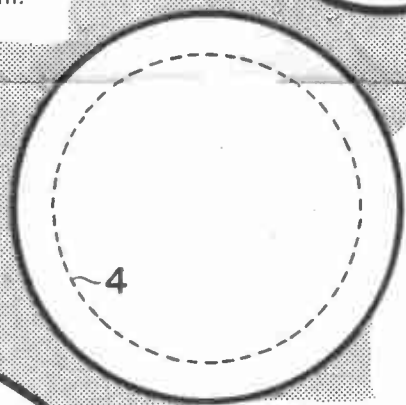

PIECES 3.
CUT TWO 1/2in.

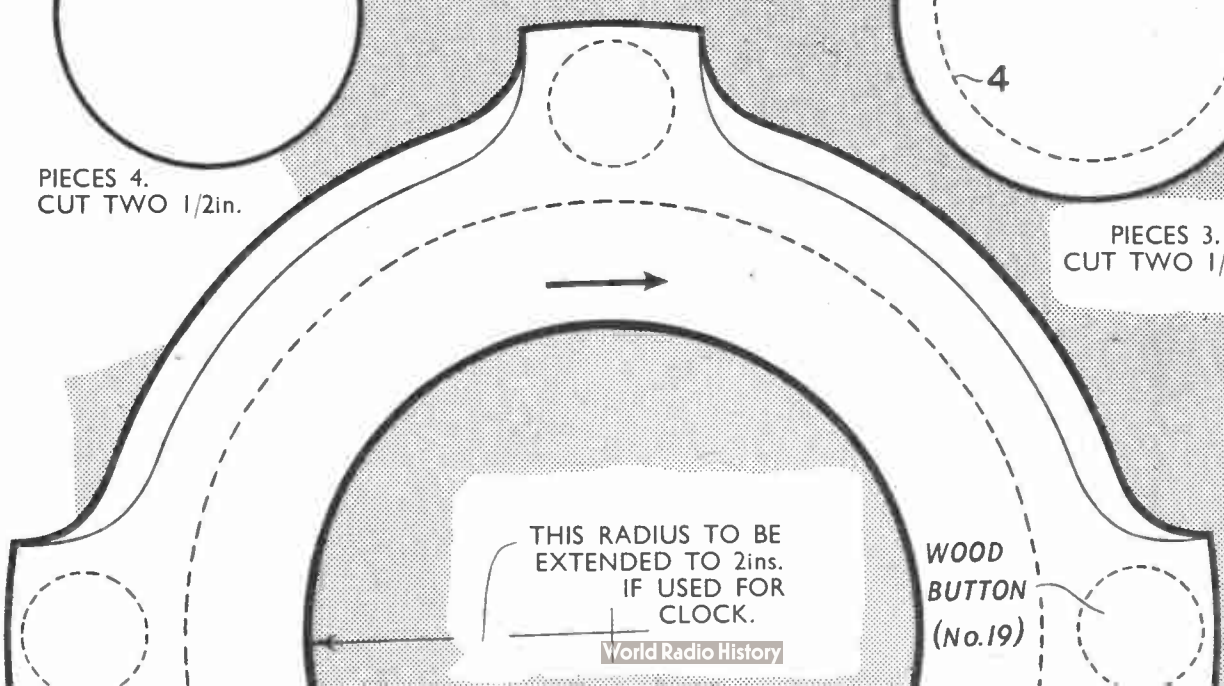

THIS RADIUS TO BE
EXTENDED TO 2ins.
IF USED FOR
CLOCK.

WOOD
BUTTON
(No.19)

SIZE—7½ins.
WIDE OVERALL.

AN ATTRACTIVE
BAROMETER OR CLOCK CASE

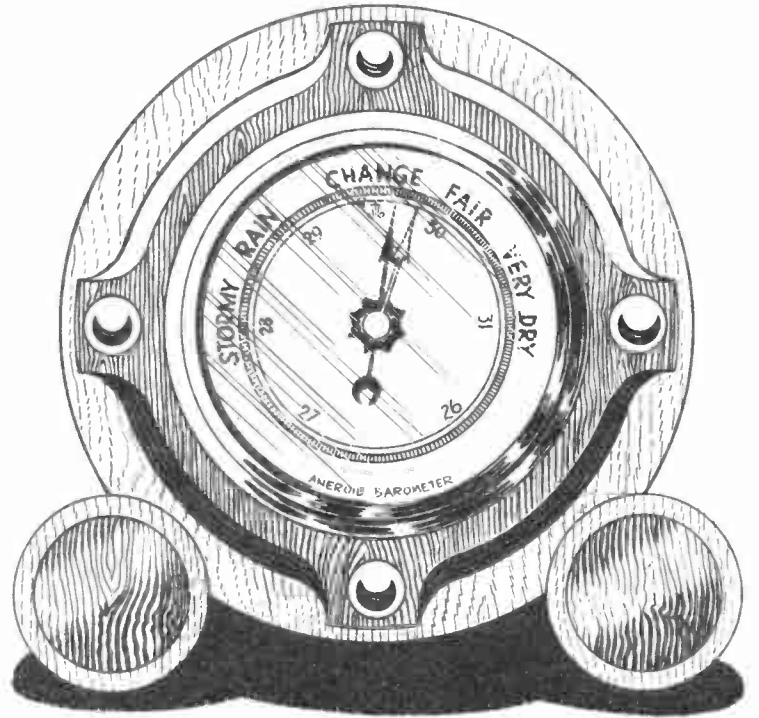

Note—
BAROMETER
OR
CLOCK CAN
BE OBTAINED
SEPARATELY.

Materials required

- WOOD** One piece 10ins. x 9ins. x ¾in.
One piece 10ins. x 7ins. x ½in.
Four wood buttons (Hobbies No. 19)
One 1 ¼in. countersunk screw

A complete kit of the above materials can be obtained from
HOBBIES LTD., DEREHAM, NORFOLK

Did You Know

. . . That details of hundreds of designs and kits, chosen from among the best of those produced during the past few years, are given in . . .

**HOBBIES Annual
HANDBOOK**

In addition, there is an extensive editorial section full of "how-to-make" articles, a large **FREE** Design, and a comprehensive catalogue of tools and materials.

The Handbook is published each year, and is obtainable from newsagents or Hobbies stockists and Branches, or by post from Hobbies Ltd., Dereham, Norfolk.

TO BE
TO 2ins.
ED FOR
OCK.



2

3

¾in.

4

PIECES 3.
CUT TWO ½in.

WOOD
BUTTON
(No.19)

2

1

THE ARROWS
INDICATE
DIRECTION
OF
GRAIN OF WOOD.

PIECE 1. CUT ONE 3/4in.

PIECES 4.
CUT TWO 1/2in.

PIECES 3.
CUT TWO 1/2in.

THIS RADIUS TO BE
EXTENDED TO 2ins.
IF USED FOR
CLOCK.

WOOD
BUTTON
(No.19)

SECTION

PIECE 2.
CUT ONE 1/2in.

SECTION

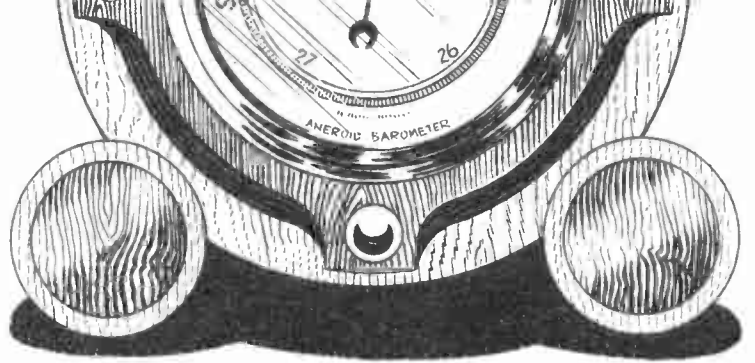

Note—
BAROMETER
OR
CLOCK CAN
BE OBTAINED
SEPARATELY.

Materials required

- WOOD** One piece 10ins. x 9ins. x 3/4in.
One piece 10ins. x 7ins. x 1/2in.
Four wood buttons (Hobbies No. 19)
One 1 1/4in. countersunk screw

A complete kit of the above materials can be obtained from
HOBBIES LTD., DEREHAM, NORFOLK

Did You Know

. . . That details of hundreds of designs and kits, chosen from among the best of those produced during the past few years, are given in . . .

HOBBIES Annual HANDBOOK

In addition, there is an extensive editorial section full of "how-to-make" articles, a large FREE Design, and a comprehensive catalogue of tools and materials.

The Handbook is published each year, and is obtainable from newsagents or Hobbies stockists and Branches, or by post from Hobbies Ltd., Dereham, Norfolk.

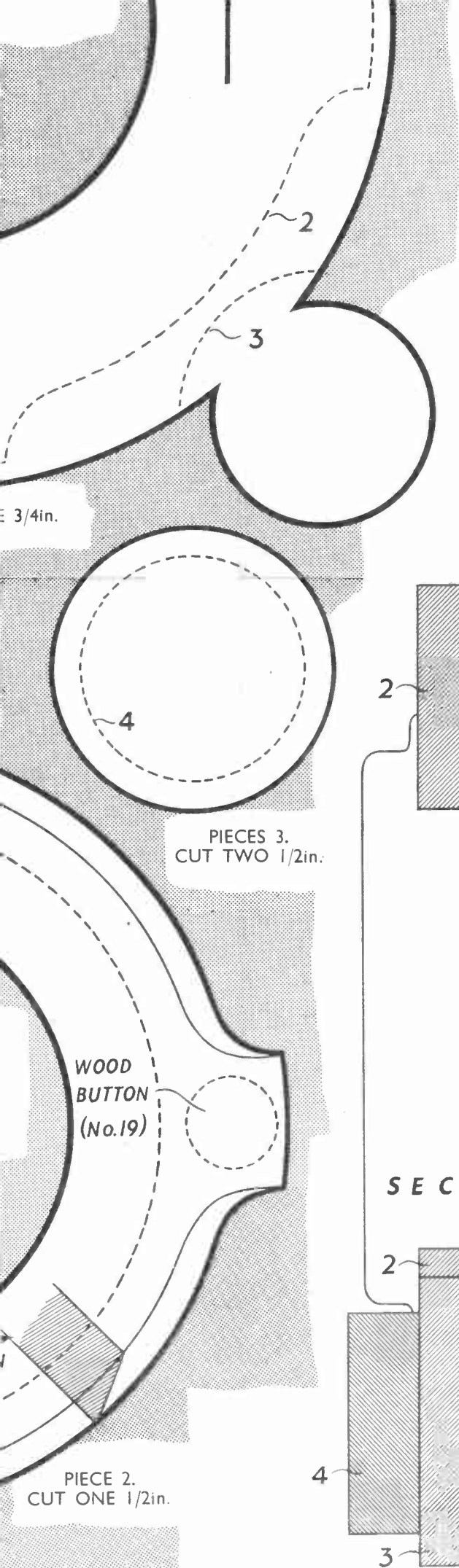

THE ARROWS INDICATE DIRECTION OF GRAIN OF WOOD.

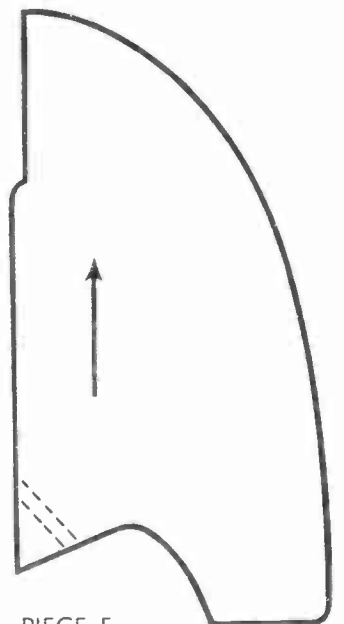

PIECE 5. CUT ONE 3/4in.

PRINTED IN ENGLAND.