

HOBBIES WEEKLY

IN THIS ISSUE

	Page
Amateur Boat Building -	1
A Handy Shopping Reminder -	3
A Filing and Storage Cabinet -	4
Curing Those Draughty Windows -	5
A Useful Egg Server -	6
Some Random Recipes -	7
Seven-year-old Margaret Sets a Challenge -	8
An Improvised Marking-Gauge -	8
Trouting Advice For Beginners -	9
Holding Thin Wood -	10
Replies of Interest -	12
Patterns for the Egg Server -	15



APRIL 6th 1955

VOL. 120

NUMBER 3101

The first article in a new series on AMATEUR BOAT BUILDING

By R. H. Warring

TRADITIONALLY, every Briton has a love of the sea and ships. The nearest most of us come to expressing that love is an occasional trip in a pleasure boat, with just a temporary feeling of 'belonging' to that particular craft. How casual we try to

This is the First Issue of
a new volume

appear, too, about embarking and disembarking—as if we had been doing that sort of thing for years. And if we are allowed to take over the tiller or the wheel for a while, then that voyage will always be remembered.

Now let us take our interest in boats a little further. You do not have to live by the seaside to have access to suitable stretches of water. Rivers and inland waterways provide some of the finest—and safest—areas for yachting and boating. All you need is a small craft of your own. Leave her at moorings and travel down at week-ends, or trail her behind (or on top of) the family car. It will take a little time to learn to handle her properly, but it will be fun 'finding out'. Take reasonable precautions and boating will be as safe as any other

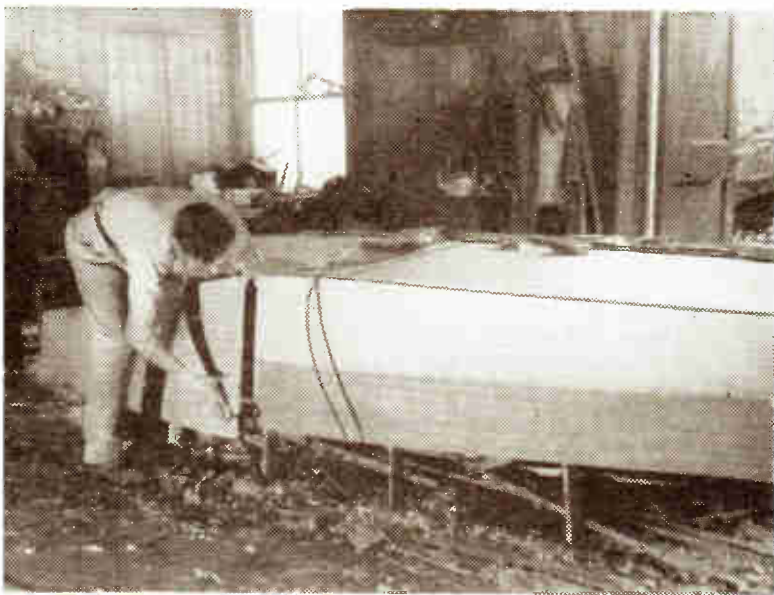

The author at work on a 13 ft. outboard run-about, built complete with motor, for about £100.

sport. Go about it the right way and you will also find that *it need not be very expensive*. Once you have got your boat, keeping her in good trim is largely a

matter of *work*, not money. Do the work yourself and your cash outlay will be kept down to a minimum.

All right, but that still has not got you

All correspondence should be addressed to The Editor, Hobbies Weekly, Dereham, Norfolk

For Modellers, Fretworkers
and Home Craftsmen



a boat. What about the cost of that in the first place? Well, we can't avoid spending money here, but remember again that at least half, and often more, of the total cost of a new boat is the cost of labour. We can save that, anyway, by building her ourselves.

Kits Available

Building a small craft is not all that difficult. Almost anyone with a reasonable skill in handling carpentry tools can tackle such a job with confidence—provided he starts with the right kind of design. It was because of the high cost of finished boats after the war that many designers turned to developing plans suitable for the amateur builder, avoiding difficult constructional features and at the same time retaining all the desirable features of comparable 'professional' jobs. A number of firms co-operated by producing kits of parts for these various craft—pre-fabricated to a large extent in that frames are already assembled, stem pieces already shaped, bevels already formed on longitudinal members, and so on.

Today the manufacture of pre-fabricated boat-kits is quite a business in this country. In the United States it is even bigger. Amateur boat-builders in America can buy a kit of parts from any one of a dozen or more firms, the largest 'kit' being for a 35ft. long ocean-going cabin cruiser! Over here, something like half-a-dozen firms specialise in kits ranging from small dinghies which can be rowed, sailed or powered by a small outboard motor, up to 20ft. cruisers for inboard motors.

Buying a kit of parts is very little

will hardly be worth it in the long run. The kit manufacturers know more about materials than you do for a start. Hence you are automatically guaranteed first-class materials throughout the kit. Also quite a bit of the harder work is ready done on these materials. Having had experience of both methods—starting from scratch with just a plan, and starting with a pre-fabricated kit—the writer would now plump for a kit every time!

The size and type of boat you build will largely be influenced by the amount of money you can afford to spend. The cheapest type of boat is a pram dinghy—generally about 6 to 8ft. long and suitable for rowing, sail or outboard motor. A good dinghy of this type can carry four adults with safety—or possibly three in comfort, for sailing. Materials for the boat will only cost about £15. You will need about another £6 for a sail, if you want a sailing version, and about another £25 for a new outboard engine, if you want to go the whole hog. You can start with a £15 outlay—and end up with a safe boat which you can at least row. The 'extras' you can add later on.

which will give you scope for further development.

In price, the next step from a small pram dinghy is a small sailing boat, or a larger dinghy with a conventional (pointed) bow. These run up to 14ft.

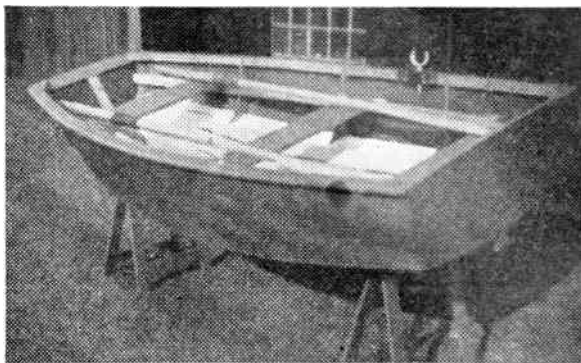

The 'Yachting World' pram dinghy—a four-seater for rowing or motoring. Can also be sailed and is easy and inexpensive to build

long or more. Around this size you have a handy four-seater, still small enough to trail, but sturdy enough to take to sea in good weather. A small cabin cruiser will bring your material costs up to £100, exclusive of engine, which will have to be something to consider for the future.

Settle for the job which appears most useful for your purpose, limiting a first attempt to a simple, straightforward design. The table gives you some idea of

the costs involved. You, individually, need not have to find all that amount for boat ownership is something that can well be shared. You will want help in building here anyway, and so a club group is an ideal organisation to tackle such a project. Each member of the group shares in the cost and for a matter of only a pound or so the whole cost can be covered.

One of the most popular of such 'group' projects is the Y.W.

Cadet—a two-seater sailing craft 10ft. 6in long. Cost of materials about £30, plus another £20, say, for sails and rigging. Literally hundreds of Cadets have been built in school carpentry classes by boys, cadet or scout units—and she is just the sort of job to teach you how to sail.

Name	Length	Beam	Type of Craft	Price of Kit of Parts	Extras to Buy	Building Time (Hours)
Cockle	6ft. 6ins.	3ft. 6ins.	Pram Dinghy	£12 10 0	Oars, Glue, Screws, Varnish—say £5	15-20
Bell Dinghy	10ft. 3ins.	4ft. 2ins.	Fishing Dinghy	£22 15 0	Oars, Fittings, etc.—£5 Outboard (optional) £29-£30	15-25
Y-W Utility	7ft. 9ins.	3ft. 11ins.	Pram Dinghy	£15-£20	Sails £6 Motor £25	35-50
Bungey	9ft. 0ins.	4ft. 0ins.	Sailing Dinghy	£20-£25	Sails £9	60
Cadet	10ft. 7ins.	4ft. 2ins.	Racing Dinghy	£30	Fittings £10 Sails £12-£18	60-70
Guppy	12ft. 0ins.	4ft. 10ins.	Outboard Runabout	£45	Fittings £5 Outboard £25-£45	100
Heron	11ft. 3ins.	4ft. 6ins.	General Purpose Dinghy	£40	Sails £12-£20 Outboard £25-£45	100

dearer than purchasing all the materials in bulk yourself. And, of course, you lose the pre-fabricating done by the kit manufacturers. They keep their costs down by purchasing materials at trade prices, eliminating wastage and tooling up to produce a hundred or so kits at a time.

You may be tempted to save a pound or two by starting from scratch, but it

Of course, you could make a boat more cheaply. You could probably knock up a canoe for about £10 or an indifferent 'fair weather' river craft for about the same price.

This series of articles, however, is intended for those of you wishing to go about the job of becoming a boat owner by starting with a 'real' boat

A Handy Shopping Reminder

By W. J. Ellson

THE making of this handy shopping reminder will help the housewife in her shopping expeditions and avoid those annoying lapses of memory, which result in articles being forgotten. It is easily made, and can be suspended from a hook in the kitchen, where a tick can be marked against items required as

together. The suspension tab in the rear panel should have a hole bored through, as shown in the diagram.

From thin white card cut a piece as at B (the same outside dimensions as the

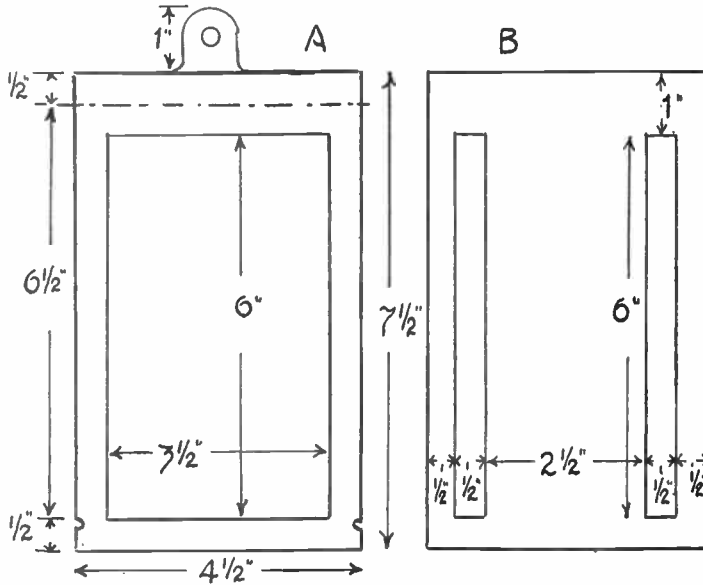
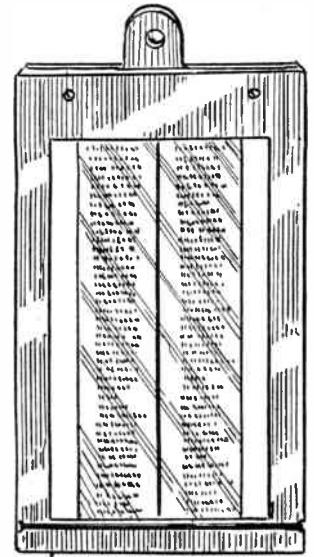

Fig. 1.

their need becomes apparent. Then, slipped into the shopping basket, it can be referred to at the counter.

Cut from Plywood

Good quality plywood, $\frac{3}{8}$ in. thick, will serve for making the article. From this material cut two panels to dimensions given in Fig. 1 (A), one panel being without the suspension tab at the top. This will be the upper one when both are hinged together. From it, cut out the 'window' as shown, and in both, at $\frac{3}{8}$ in. from the bottom, cut a nick on each side edge. This is to hold an elastic band, which will keep the panels

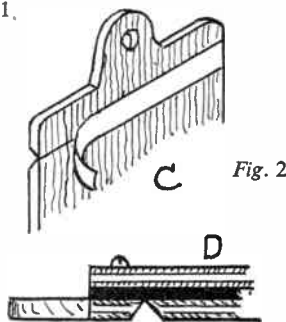

Fig. 2

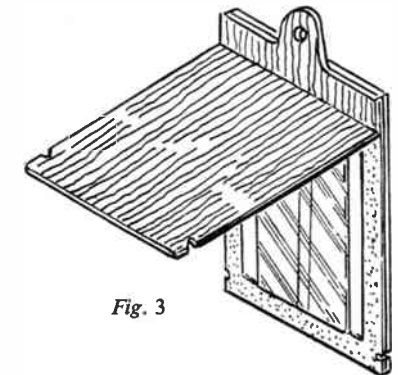

Fig. 3

upper panels). Mark accurately on this the two elongated openings shown, and cut them out with a sharp knife, using a straight-edge. This is now glued to the back of the upper panel. Apply glue to the panel, then press the card on and

lay under a weight (a heavy book will do) until the glue is set hard. On this panel the names of articles commonly used in the kitchen should be neatly written or printed. A helpful list is included in this article. This can be amended, naturally, to suit individual needs.

Now take the rear panel, and where indicated by the dash and dot line in A, saw across. Bevel off the sawn edges to

● Continued on page 5

NAME LIST

Currants	Ginger	Nutmegs	Bacon
Raisins	Cloves	Curry	Castor Sugar
Arrowroot	Cereals	Jam	Icing Sugar
Tea	Rice	Marmalade	Sweets
Sugar	Sago	Honey	Biscuits
Milk	Semolina	Vanilla	Candies
Flour	Tapioca	Almond	Matches
Salt	Prunes	Lemon	Cakes
Pepper	Custard Powder	Margarine	Eggs
Mustard	Coffee	Lard	Peel
Vinegar	Cocoa	Cornflour	Coconut
Pickling Spice	Baking Powder	Jelly	Sultanas

A Filing and Storage Cabinet

By A. Fraser

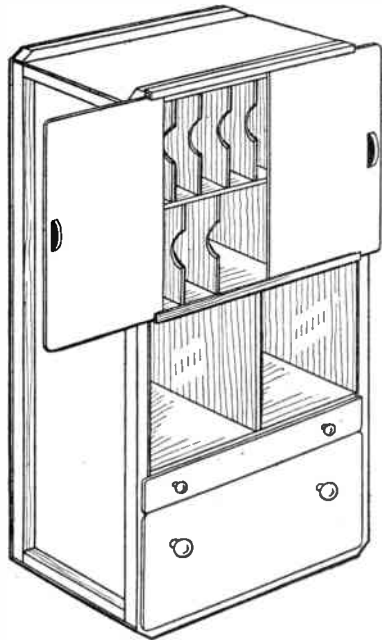

width of the board, while the sides can be 56½ ins.

Next, make the top and bottom. These will be similar board 14 ins. wide by 24 ins. long. (The length, again, can be altered to suit individual needs.) Along each long side, 1 in. square stripwood is nailed. Each spar should be chamfered off at each end, just to improve appearances. When finished, top and bottom can be nailed on to the sides by driving nails through the board into the frame spars of the sides.

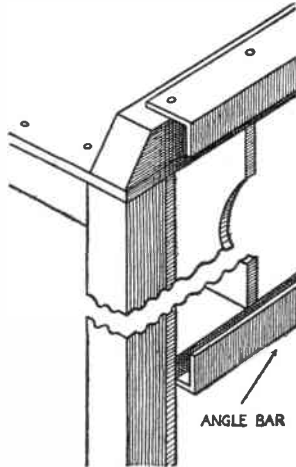

Fig. 1

The back can then be sawn out, again from plywood or hardboard. If the measurements of this particular cabinet are being followed, then the back board should be 24 ins. wide. The length should be calculated to enable the back to reach up to and cover the spars on top and bottom. This means 58½ ins. plus 2 ins. (spars) plus two thicknesses of plywood (whatever the thickness is).

Fix the back into place by driving nails through it into the stripwood on the sides, top and bottom. When done, saw off the corners to the level of the chamfers on the top and bottom spars.

Attention may now be given to the two rows of vertical compartments. The shelves that hold the partitions can be made first. These should be of ¾ in. board. (½ in. would also do). They will be 22 ins. wide and 14 ins. from back to front or whatever the depth of the cabinet is. Each shelf should be put in to leave compartments 12 ins. deep. They are fixed in simply by nailing through

the sides of the cabinet. Before this is done, however, means must be established for sliding in or retaining the partitions.

The partitions are of ¼ in. plywood and grooves could be made in the shelves for them to slide in. Or stripwood could be nailed on the shelves to make raised grooves. However, the simplest method is to drive fine panel pins through the shelves into the bottom edges of the partitions. Although the latter are only ¼ in. thick, it is not at all difficult to accomplish this. In any case, thicker partitions could be used, thus facilitating the fixing.

The actual dimensions of the partitions will, naturally, be decided by the method of fixing chosen. However, when sawing them out, saw a triangular or semi-circular portion out of the front edge. It will be found a great help when

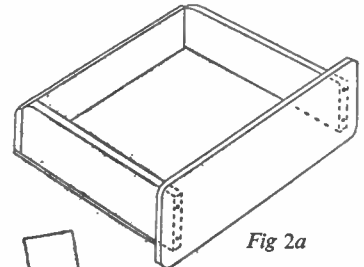

Fig. 2a

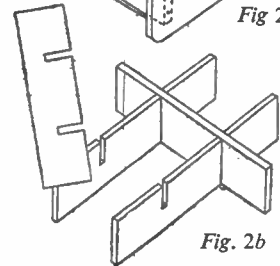

Fig. 2b

removing tightly-packed papers from the compartment, as the hand can grasp hold of the papers, which are then easily withdrawn.

The top half of the cabinet is completed by the provision of two sliding doors or shutters. These are indispensable if the menace of dust is to be combated. The simplest way of accomplishing the above is to screw lengths of angle-bar (½ in. by ½ in.) along the width of the cabinet, as shown in the illustrations.

The angle-bar should project a little more than ¼ in. to provide sufficient room for the doors to slide along. The doors should be of ¼ in. plywood, each 12 ins. wide (i.e. if the cabinet is 24 ins.

● Continued on page 6

THE accumulation of material in connection with one's hobby or work soon becomes a major problem. The necessity, also, for constant reference to notes, data, etc., and, when doing practical work, to know the resting place of particular items, makes it desirable to have some systematic method of storage. The cabinet described in this article should help to solve your storage problem.

How to start

Its chief claim is that it is serviceable and fulfils the purpose for which it was designed. Moreover, it has the added advantages that it can be built quickly (a great recommendation when one is busy), and very cheaply. Simplicity of construction was aimed at, throughout.

When making the cabinet, it is best to start with the sides. These should be of plywood ¼ in. or more thick. Hardboard would do just as well. The size of each side is 58½ ins. high by 14 ins. wide. (These measurements, of course, can be altered to suit particular requirements.) A frame is put round all sides, and this should be 1 in. by 1 in. stripwood. This not only strengthens the board, but also serves as fixing areas for back, top and bottom. The stripwood need not be mitred, and can be nailed in position. The top and bottom spar can be the full

Curing those Draughty Windows

By A. F. Taylor

EVEN with the very best sash windows there is always a certain amount of draught where the frames meet at the centre. Besides this serious defect there is always the possibility that on a windy day the frame will rattle, and when this happens with a bedroom window it can be most annoying.

Trying to cure the rattle by putting in a wedge only opens the gap more and lets in extra draught. With the aid of a simple little gadget, however, all this can be put right.

Window Cleaner too

It is easy to make and is very efficient in use. Not only does it keep out all draught but it completely stops any rattle. In addition to these virtues it also acts as a window cleaner for the bottom panes and by fitting another gadget the top panes can also be cleaned when the window is opened or closed.

Let us start with the draught excluder and rattle preventer first, the details of which are clearly shown in Fig. 1. A strip of thin rubber about 2ins. wide is fixed tightly on to the underside of the top sash. In order to be effective it must extend across the entire width of the window and the edge fit closely to the glass. Don't forget, cut nicks in the rubber strip just large enough to fit the wooden bars you encounter across the width of the window.

A bar of wood about 1½ins. wide and ¼in. thick screwed into the sash bar holds the rubber strip tightly against the gap between the two sash bars. Several countersunk screws will be needed to

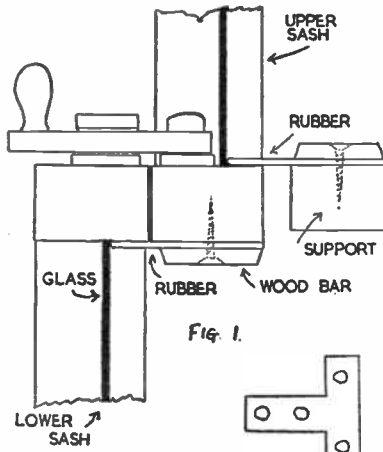

Fig. 1.

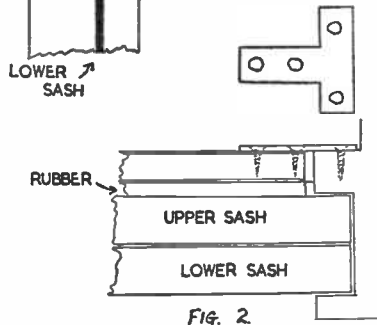

Fig. 2.

make a good fit all along the bar, especially if it is a wide window.

Cleaning the bottom panes of the window is accomplished by opening either the top or bottom sash. This allows the rubber to slide up and down

the glass and wipe off any rain or dust from the outside of the window.

While being a labour-saver on all windows it is extremely useful on upstairs ones which may otherwise be awkward to reach.

The gadget which can be made for the upper sash is for cleaning only, but is well worth the trouble and time taken to make it. It differs from the draught excluder in not being screwed to the outer window frame. Therefore, it does not move when the sash is opened or closed.

In order to hold the rubber securely it is necessary to fix a fairly substantial support right across the window. The actual size for the support will, of course, depend on the width of the window. One about 1½ins. wide by 1in. thick should be sufficient in most cases.

Fix with Brackets

Brackets will have to be screwed to each end to fix the support to the window frame. Brass or iron brackets will serve this purpose and Fig. 2 shows how they are fitted. A little modification may be necessary on some windows but no difficulty should be found in dealing with this. As with the other fittings the strip of rubber is held down securely with a wooden bar 1½ins. wide, ¼in. thick and extending across the sash to cover all the glass.

To preserve the woodwork give it a coat of undercoating and a coat or two of paint to match the existing colour.

After a shower of rain the sashes can be raised and lowered once or twice, which will remove all moisture and dirt and leave the glass quite clean.

● Continued from page 3

Handy Shopping Reminder

45 degrees, place both pieces together again and across the joint at the back glue a strip of calico or similar strong, but thin material, as shown at C in Fig. 2. Leave for an hour or two for the adhesive to fix the joint firmly. Now give the edges of both parts of the article a thorough rub over with fine glasspaper, slightly rounding them. The vertical edges of the panel opening would also benefit with a little bevelling, which can be most conveniently done at this stage.

The shopping reminder, when completed, can be left in the plain wood—after all it is a utility article. But if a finish is preferred it should be done

before both parts are connected together. A stain and varnish application or coat of lacquer would improve its appearance. Care should be taken to avoid soiling the cardboard when painting. In fact, it might be safer to apply any finish before gluing the card to the panel.

Cut a strip of clear Cellophane, wide enough to cover the exposed part of the cardboard, and fold over to the back, as in Fig. 3. There it is stuck down to the card with a touch of glue and will protect the 'named' part of the card against stains and finger marks. Complete the work of construction by fixing both parts together at the top with a

pair of small brass round-headed screws. The side detail (D) in Fig. 2) shows this method of attachment, the card sandwiched between being indicated in full black.

Make sure that the rear panel of the shopping reminder can be opened out easily and not stick. Then stretch a strong rubber band across to keep both parts closed. A sheet of writing paper is inserted, and ticks marked in with a pencil, on those parts of it exposed in the long openings in the card, opposite the names of the articles. The paper is changed, of course, after a shopping tour. An economical idea here is to insert a folded sheet of paper. This can be refolded each time in such manner as to expose a clean portion in the openings, and will last for several occasions.

A Useful Egg Server

Full-size patterns are on page 15

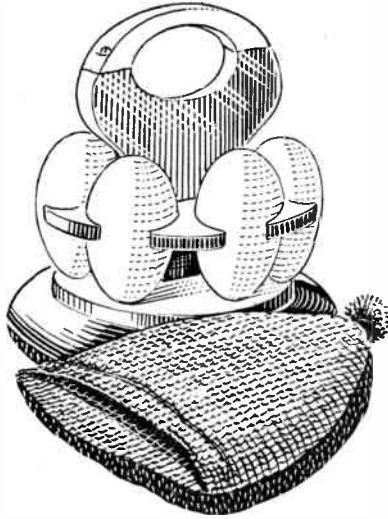

THIS server or stand is intended for table use. Made up from wood and painted in a pastel shade, with a gleaming plastic handle, it will look most attractive on any breakfast table. A large cosy can be knitted and placed over the whole thing to keep the eggs hot.

Cutting

Commence by tracing the patterns and transferring to wood. Piece (A), the thick line, is cut from $\frac{1}{2}$ in. wood and

piece (B), the thin line, from $\frac{1}{4}$ in. The other two pieces, forming the base, are circles of wood with a rectangle, or mortise as it is called, cut from the centre. It is not possible to show these full size, but enough is shown for you to take the radii of the circles. The larger circle (C) is cut from $\frac{1}{2}$ in. wood and (D) from $\frac{1}{4}$ in.

Assembly

All the parts are glued together and the exact method is shown in the illustration Fig. 1. The narrow portion of piece (A) is put through the mortise in piece (B). Pieces (C) and (D) are now glued together and piece (A) is glued into these.

Finishing

After cleaning up with glasspaper give two or three coats of plastic enamel paint. Give a light rub with fine glasspaper between coats when the paint is quite hard.

The cream or black plastic handle, No. 711 can be obtained from Hobbies

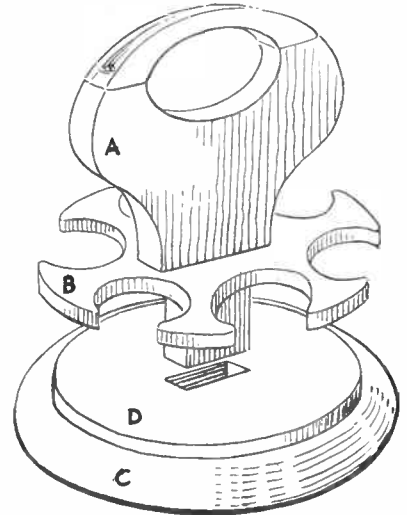

Fig. 1

Ltd., Dereham, Norfolk, price 6d., postage extra. Screw in place as shown in Fig. 1. Try to persuade the lady of the house to knit a smart cosy as suggested previously. (M.p.)

● Continued from page 4

Filing and Storage Cabinet

wide). The height is determined by measuring, when the rails have been screwed on. A small knob or handle can be fitted to the outer side of each door to facilitate opening. These can be secured by countersunk screws through the back of the door.

The top and bottom edges of the doors should be rounded and smoothed, and the doors should run easily along.

The compartment below this is a double one. It is 16ins. deep and divided in two by a vertical partition made of any plywood or board available, and fixed by panel pins through upper and lower shelves. Incidentally, these compartments are very handy for filing magazines. The bottom shelf of this compartment, by the way, is $\frac{1}{2}$ in. or $\frac{3}{4}$ in. board, fastened by nails through the sides of the cabinet, like all the other shelves.

We are now left with the two bottom drawers—one shallow and one deep. The relative depths depend on one's particular needs. In the writer's case, the top drawer is only 3ins. deep and is

divided into numerous compartments in order to store small items of different kinds, such as screws, nuts, washers, and various radio odds and ends. It is extremely useful in keeping parts in an organized and readily-accessible state.

The lower drawer is exceptionally deep and provides a store-place for bigger and awkwardly-shaped things, and becomes a sort of miscellaneous junk box.

Before making the drawers, a pair of rails must be inserted in the sides of the cabinet on which the top drawer can run. This can be 1in. square stripwood fixed, like the shelves, by nails through the cabinet sides.

The base of the drawers is of plywood ($\frac{1}{2}$ in. or thicker), the sides of $\frac{3}{4}$ in. or $\frac{1}{2}$ in. thick board. The back and front can be of $\frac{1}{2}$ in. or $\frac{3}{4}$ in. plywood. The base is nailed to the sides, while the back and front are fixed with a combination of nails and glue. Triangular fillets can be used to strengthen junction of back and front with the base.

The front projects about $\frac{1}{2}$ in. all

round, and it can be rounded off to make it look better. (See illustrations.)

The compartments in the shallow drawer can be made of any suitable ply, or plain board. An old box from the grocer's will provide admirable material. The number of compartments must be decided by the individual, but they are best made as in the drawings. Slots are cut half-way down one piece and half-way up the other cross-piece. The two pieces then slip into each other, being brought level with each other, and at right-angles. A partition system producing nine compartments is shown. These can be assembled and glued and pushed into the drawer, again being glued to the sides and bottom.

Knobs are attached to the drawers when completed. It need hardly be said that the drawers should be a loose fit and so work freely. Remember also that the fronts of the doors should have no gap between them when closed, otherwise a piece of stripwood will have to be joined across between the ends of the rails supporting the top drawer.

To finish the cabinet, rub down with glasspaper and give two or three coats of some chosen paint.

Some Random Recipes

As past articles have shown, the home chemist can produce many useful products and solve tricky practical problems by a file of recipes—not to mention make pocket money by the sale of his products. In this article will be found further formulas of interest.

SOLIDIFIED METHYLATED SPIRIT

Campers who use pressure stoves often find the carrying of methylated spirit in bottles an inconvenience owing to the risk of breakage or leakage. It is not generally known that methylated spirit can easily be turned into a solid form by dissolving soap in the hot spirit. The proportions are:

Meths.	50 c.c.
Soap	1.5 grams

The soap should be in the form of shavings and must be allowed to dry in a warm place until it crumbles easily between the fingers. Place the meths. and soap in a flask attached to a reversed condenser (Fig. 1) and boil on the water-bath until the soap has dissolved.

The hot solution is poured into moulds made of lengths of about $\frac{1}{2}$ in. bore glass tubing closed at the lower ends with corks as shown in Fig. 2. Cork the top of each tube as soon as filled and let them stand a few hours.

The solution will solidify to waxy rods, which can easily be pushed out of the tubes and cut to convenient lengths. A small press lid tin makes a convenient container in which to take them to camp. For use, simply cut off a few pieces and light them in the meths. cup of the stove.

CAMP FIRELIGHTERS

Where there are birch trees on the camp site, firelighters are ready to hand. If you examine a birch tree you will find tissue-thin strips of bark curling off the main bark. Gather a handful of these and light it under your cone of sticks. It will blaze vigorously and soon get your fire going.

In the absence of birch trees it is useful to have a few ready-made firelighters. You will want an odourless product so as not to impart a smell to food or clothing in your pack. Such a product consists of:

Rosin	1 part
Sawdust	1 part

both by weight. Melt the rosin and stir in the sawdust. Matchboxes make convenient moulds. Fill the hot mixture into them and allow to solidify.

DELUSTRING ALUMINIUM

A matt silver finish gives a novel and suitable appearance to some aluminium articles. This can be obtained by using

the following solution:

Sodium hydroxide	1 ounce
Water	9 fluid ounces

Place the sodium hydroxide in the cold water and stir occasionally until it has dissolved. If the article is small, place it in the solution and leave it there until copious gas bubbles appear on the article. Remove and rinse it thoroughly in water.

To treat larger articles, dip a wad of woolly asbestos in the solution and liberally coat the article. Two minutes is usually long enough for the delustring, after which rinse thoroughly. Repeat the operation if not sufficiently matted.

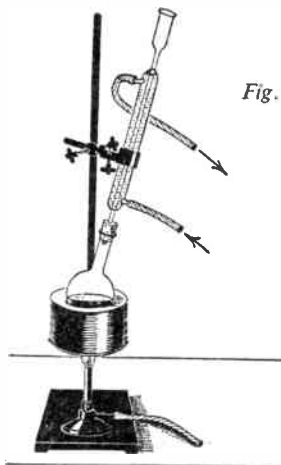

Fig. 1

The solution should be kept off the skin, for it dissolves the outer layers, imparting a slippery feeling. If any gets on your hands, rinse them and then swab with vinegar until the slippery feeling has gone. The solution may be stored for future use in a rubber stoppered bottle. Glass stoppers stick fast and corks are corroded.

PURIFYING STABLE AIR

Ammonia fumes are troublesome in stables and give, as those who work with horses know, an unpleasant smell to the clothing. Accumulator acid diluted with three times its volume of water is the answer to this. Soak wood shavings in the liquid, drain them thoroughly until they are damp but do not drip, fill a basket with them and hang the basket from the stable roof.

The acid will react with the ammonia, forming odourless ammonium sulphate. When the smell of ammonia appears again it is a sign that the acid has been entirely used up. A fresh lot of shavings should then be prepared and the old thrown away.

NON-METALLIC CASTING COMPOSITION

This composition has the advantages of being cheap and requiring only a low-working temperature. It is especially suited to taking impressions of small objects, such as medals. Needed for this are:

Sulphur	40 grams
Iodine crystals	0.1 gram

Heat the sulphur slowly in a crucible until it has just melted, stir in the iodine and raise the temperature to 180 degrees Centigrade. Let the composition cool to 120 degrees and then pour into the mould.

LOW-TEMPERATURE CASTING ALLOY

Where a metal casting composition is desired for medals and similar small articles, the following formula gives a hard non-brittle product:

Bismuth	6 parts
Tin	3 parts
Lead	13 parts

All parts are by weight. First melt the tin, add the lead and when it has melted, add the bismuth and stir with a wooden rod until an even melt results. Pour off into the mould.

NON-ELECTRIC COPPER PLATING

Every home chemist knows that a penknife blade dipped in copper sulphate solution takes on a copper coating and that, despite its thinness, it is surprisingly hard to remove. A slight

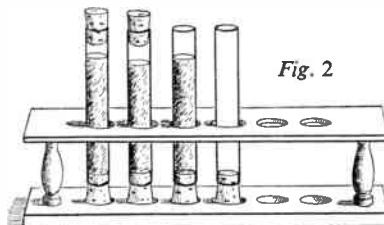

Fig. 2

modification of the method gives a durable copper plating to iron and steel articles. Two solutions are needed:

Solution A:

Hydrochloric acid	1 fluid ounce
Water	3 fluid ounces

Stir the acid into the water.

Solution B:

Copper sulphate	1 ounce
Water	3 fluid ounces.

Heat the water, dissolve the copper sulphate in it and allow to cool.

First polish the article mirror-bright, brush it with hot washing-soda solution, and rinse it in water. Do not touch the article with the fingers, or a grease film will interfere with the plating.

Add enough of solution B to solution A to give it a pale blue colour. Enter the article and leave it a few minutes. Then add more solution B, so as to give a full blue tint to the plating bath. Leave the article in the solution for half an hour.

Remove and rinse in washing-soda solution, then in water. Buff up with precipitated chalk applied with a damp cloth. Finally polish with a soft cloth.

Her galleon won a cup

Seven-year-old Margaret Sets a Challenge



The four successful winners, as they appeared on T.V. Children's Newsreel. From left to right, Margaret Adams, David Nation, David Adams and Allan Harold

MANY among the thousands of modellers who have made galleons from the kits supplied by Hobbies Ltd. of Dereham, Norfolk, must have viewed with interest the news film featured recently on television. This was taken on the occasion of the second exhibition and challenge cup competition of the Hornsey Ship Modelling Club.

Members of the club, which includes two girl enthusiasts, were seen in various stages of modelling their ships. In the junior section of the competition a model of the popular miniature galleon 'Bonaventure', the kit for which costs only 5/11, gained second prize for little Margaret Adams, who is only seven years old.

Only seven years old—and a girl at that! There's a challenge for you.

Incidentally, it should be stated that Margaret was beaten only by her brother David, who has reached the ripe age of nine!

Other galleon models which were featured in the television film included the 'Santa Maria', the ship in which Columbus undertook his hazardous journey across the Atlantic (price 20/2), and the 'Mayflower', which took the Pilgrim Fathers from Plymouth to North America in 1620 (price 18/5).

Why not follow the example of this go-ahead ship modelling club at Hornsey? Its 20 young members meet every Saturday afternoon, and their efforts are guided by two instructors and the principal, Mr. H. L. Adams. Get together, pool your knowledge, and models of which you can be proud will result.

The Editor of Hobbies Weekly will be pleased to help with advice on the formation of such a club. Write to him at Dereham, Norfolk.

(Photographs by courtesy of Owen Richards)



Margaret Adams, age 7, proudly displays her cup and prize-winning galleon 'Bonaventure'

COMING ATTRACTION

We shall shortly be publishing details for making a grand semi-scale model yacht. This model is 14" long, easy to build, and very fast. It will be just the thing for the summer holidays

Watch for further details

An Improvised Marking-Gauge

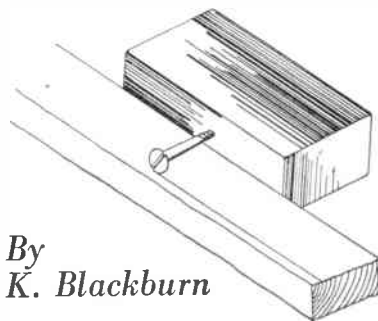

By
K. Blackburn

IF you haven't got a marking-gauge, this handy little substitute can be made in a few moments. Although it has a limited range, it will be found adequate for small work.

The countersunk-head screw should be twice the length of the maximum gauge-setting you will be likely to need. Thus, a 3in. screw will be needed to gauge up to 1½ins., while a 2in. screw will be long enough to gauge up to a distance of 1in.

Hardwood should be used for the stock, as it provides a firmer grip for the screw. A piece 4ins. long, 2ins. wide, and 1½ins. thick is big enough to be held comfortably. The sharp edges should be removed with glasspaper.

The turning of the screw when setting the gauge will eventually enlarge the hole, so that the screw is able to move when the gauge is in use. When this happens, the screw should be moved further along the wood to a new position.

If a lot of measuring is done, it is a good idea to make several of these gauges, leaving them set permanently to the most frequently used measurements, say, ½in., ¾in., 1in., 1½ins. and 1¾ins.

There is no reason why two screws should not be driven into one edge. The stock is raised at one end when the gauge is in use to lift one screw clear of the wood. This is particularly useful in the marking of mortises and tenons.

Trouting Advice for Beginners

By Arthur Sharp

TROUT prefer clear, swift streams, with pebbly and gravelly bottoms, and a fair amount of weed. The beginner should expect to find trout lurking in 'dubs' and swirly holes beneath cascades; in pools below the mill-weirs; in eddies behind stones and rocks and turfs; basins where the water eddies leisurely; junctions where tributary streams join the main current; pools under trees; below bridges; shady spots around old tree-roots; under shelving banks, and below hatches.

Where to fish often depends upon the condition of the water. An extra foot or two, as following a rainstorm, makes all the difference. In a high water, in spots where the fish lie when the water is low, will often be such a riot of unruly and seething swirls and tumult, that it is impossible for trout to feed there until more normal conditions prevail.

Helpful Tips

Use as short a line as possible in trouting, with the exception, perhaps, of river minnow-fishing.

Long distance casting may be spectacular, but does not help to catch fish—more trout are lost than won, by indulging in long and fancy casting.

When you see a trout rise, crawl up to within casting distance, draw out the line from the reel, and measure in your mind's eye, the distance to several feet above the fish, by making a few false casts in the air. After this preliminary effort, cast with the utmost delicacy. Bring up your rod-top as the fly comes down with the current, and try to avoid any 'drag' on the line, which will cause disturbance of the water. There being no response, let the fly float 2yds. or 3yds. beyond the spot where the fish rose, before lifting the line from the water, in order not to scare the trout. Then dry out the fly by swishing it gently to and fro in the air before making a fresh cast. This is the general procedure when fishing with the dry fly, and a certain amount of skill is called for.

When using the 'wet' fly it is usual to cast the lure a little higher up than the spot where you think a trout may be lying, or where you have seen a movement, letting it float down just under the surface. It is better to cast the fly so that it pitches on the edge of a ring made by a rising trout rather than into the centre of it. There is then less chance of the fish spotting the gut.

When fishing 'wet' fly, cast the lure across stream, and allow the flies—supposing you have two or more droppers on the cast—to come round and down with the current, moving the

rod top gently up and down meanwhile. Whilst fishing up-water as much as possible, it is as well to remember that many trout have been caught by floating the flies down-stream.

A trout comes smartly from below and breaks the surface as it seizes the fly; a quick turn of the wrist will then suffice to hook him. In fishing a smallish stream you will find that many trout will be lying at the head and tail of a pool, few in the centre.

Trout usually lie head facing upstream. It is advisable, therefore, to approach from behind the fish. Keep under cover whenever possible, and when wading, keep below your quarry.

Not all trout take up feeding positions facing the down-coming current. For instance, in a weir-hole below a mill, where the water pours through the mill-race to rush into the pool with much ado of swirling waters, we know that big fish will be stationed heads facing downstream in places just off the edge of the sweeping current, where a sort of backwash carries all kinds of odds and ends, edible trifles and so on, in a retrograde direction. Lying alert in such a backwash or under-current, a trout can pick up an easy living without having to exert himself overmuch.

I have in mind such a trout haunt where the water rushes with some force through a low arch below an old mill, to swirl and 'boil' in a deepish pool. The action of the current causes a backwash to eddy under the bank. A trout always lies there, head facing downstream as the river runs, yet actually with his nose meeting an under-current that brings all manner of titbits right to his mouth. If a trout is caught there one day, another quickly takes his place.

With Dry Fly

A dry fly can be fished, not only when a 'rise' is on and you can see the fish coming to the surface, but also when few trout are breaking the water. This is worth remembering. In dry fly fishing have the lure well oiled, so that it keeps afloat.

Don't be discouraged if reward does not speedily come your way. Probably, for a time, until you get the knack of it, you may 'put down' more trout than you actually induce to sample your fly. Be patient and carry on. When you have netted a fish, proceed further up-stream and keep an alert eye open for another rising trout, and try your luck again.

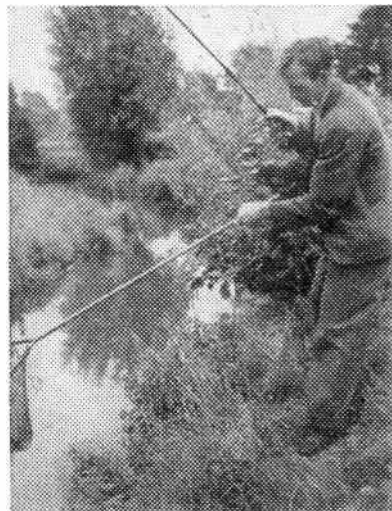

Landing a fish

Playing the Fish

To hook a fish and 'yank' it out of the pool in one prodigious haul, would be so 'tame' that the attraction of the pastime would be soon gone. Fortunately, with the fine tackle used for fly-fishing it is impossible to do this without taking a big risk of losing a hooked trout. It would be simply absurd. Rough and ready methods do not pay.

When you have hooked the fish, play him carefully, more particularly if he is of any size. Don't pull on him, and don't attempt to haul him out of the water. Let him run, keeping only the pressure of the rod-top to bear upon him—always keep the rod-top up. Give the fish line if he demands it, but check him if he is heading into weeds or other entanglements.

A golden rule is—lead the struggling fish downstream; he will the sooner become exhausted. It is then an easy matter to draw him towards the landing-net.

In trout-fishing success depends largely on knowing, under prevailing conditions, what places to fish; what fly to use; about where to place it; and how to manage your fish when hooked.

Do not neglect the advertisement pages of Hobbies Weekly. They are always worth your attention.

P. W. Blandford explains some methods of HOLDING THIN WOOD

WHEN thin pieces of wood have to be planed on their edges the ordinary vice and bench stop may not provide sufficient steadiness. A long strip held for only part of its length in a vice will bend and twist, while a narrow piece will not stand unaided against the stop on the top of the bench.

Boards which would be too high to stand, even with supports, on the bench top may be held against the side of the bench, with one end in the vice, or held in a notched piece of wood, while the lower edge is supported on pegs (A). The notched piece of wood should be

support. The cam is a piece of wood, about the same thickness as the support (C), cut so that as it turns it presses against the wood being held, pivoting on a screw.

Another idea is a pair of cams. These are circles of wood with screws put through a little way off centre (D). Within reason the larger the circles the better the grip. They are arranged so that the pressure of planing tends to tighten the grip. For very long work a pair of cams may be used to support the part of the job furthest from the block and cam (B).

Cams have to be screwed to the bench, but a very effective support is a V-shaped block of wood, with dowels to fit into holes in the bench (E). The exact size of the block is not important, but the notch should be cut to a deep V with perpendicular sides, so that the thin

wood will be held upright. A piece of oak or elm about 1½ ins. thick will hold thin wood up to about 5 ins. wide. The dowels should be near the ends of the V, otherwise the action of planing may lift the device slightly. To resist this it is an advantage if the dowels are parallel in the direction of planing, but set at an angle to the bench top (F). Drill the block, then use this in position as a jig for drilling the bench top.

An ingenious device carries the V-shaped block a step further, by pivoting the two sides so that as the work presses into the V, the sides of the device also grip the wood (G). The action of planing tightens the grip, but a pull-back releases the work. One size is shown (H), which will suit the general woodworker. The pieces are 1½ ins. thick, so that each of the tongues is ¾ in. thick. The dowels are ¾ in. Any close-grained hardwood, such as beech or birch, may be used. The dowels are fixed in the blocks and rotate in the holes in the bench. This size is intended to hold wood up to ¾ in. thick. The greatest thickness which can be held is governed by the space between the bulges around the dowels.

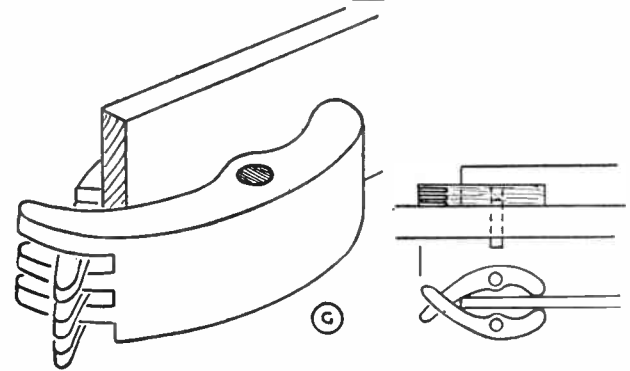
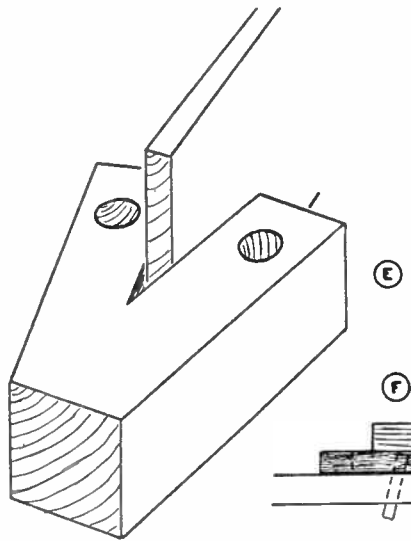
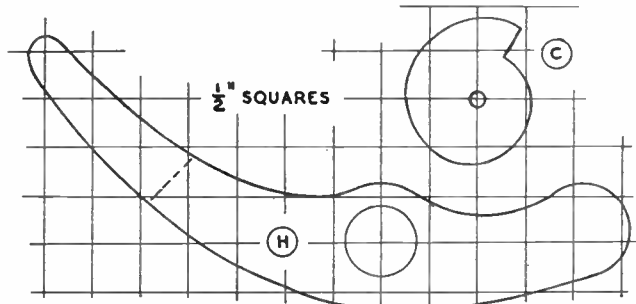
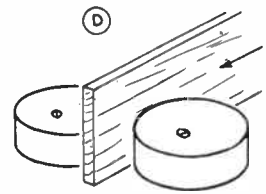
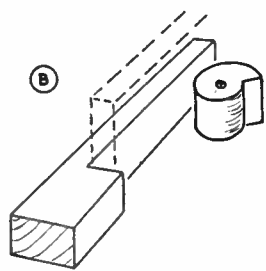
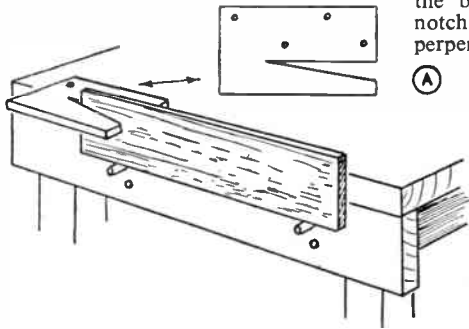

fairly thick plywood and the notch cut to an acute angle.

Where a number of strips have to be planed on their edges it is worth while making up a special jig. This consists of a notched block and a cam (B). The block serves as a stop as well as a

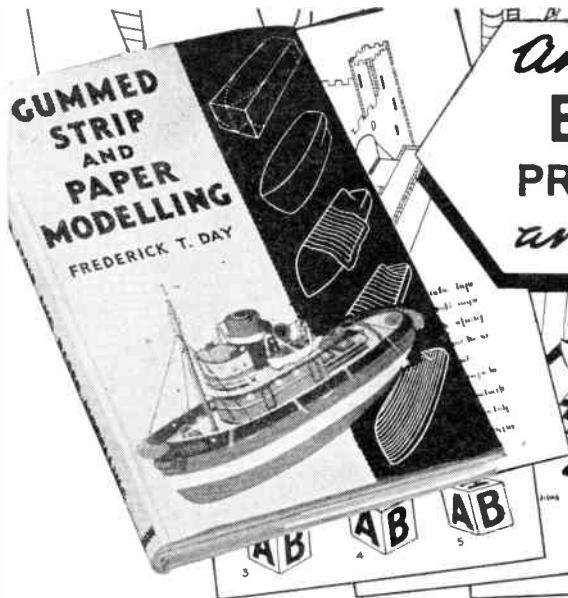

An inspiration to
EVERY MODELLER
 PRACTICAL · INGENIOUS
 and CRAMMED WITH IDEAS

Make your own ships, aeroplanes, puppets and models of many kinds. Ideal for mending, making and many other things too.

7/6

SAMUEL JONES & CO. LTD
 STATIONERY MILL, CAMBERWELL, LONDON, S.E.5
 GRAMS: NONCURLING, PECK, LONDON TELEPHONE: RODNEY. 2346

Published by Newnes Educational Publishing Co. Ltd., or obtainable from **Samuel Jones & Co. Ltd.**

'JUST PUBLISHED'

How to Make

MARQUETRY PICTURES

By J. C. ANDERSON



Containing many instructive drawings, plus twelve art pages illustrating the importance of tone contrast, natural markings of veneers, grain direction, etc. Various methods are described and, for the benefit of beginners, the making of a picture is illustrated stage by stage. The creative side of the craft is also dealt with and there is much to interest experienced marquetry enthusiasts. This book shows how photographs can be used as a basis for attractive marquetry work; it also includes many useful hints on handling and cutting veneers.

82 PAGES NUMEROUS DRAWINGS & 12 ART PLATES

price **4s 6d** postage 3d

PERCIVAL MARSHALL & CO LTD
 19 - 20 Noel Street, London W1



Quick...
 the
Savlon!

Keen-edged tools are good tools. But one slip can mean a nasty cut. Even a 'clean' cut may have dirt in it. So keep the Savlon near at hand in the workshop.

action extends over the whole range of bacteria likely to infect cuts, burns or scalds.

Get a tube of quick-healing Savlon from your chemist today, price 2/6d.

Savlon is a new healing anti-septic cream in a handy tube. It does three jobs: cleans dirt away from cuts, soothes pain, fights germs. Its germ-killing

Savlon 
 HELPS NATURE HEAL

Savlon is the Trade mark of Imperial Chemical (Pharmaceuticals) Ltd., a subsidiary company of I.O.I. Ltd. SAV. 19

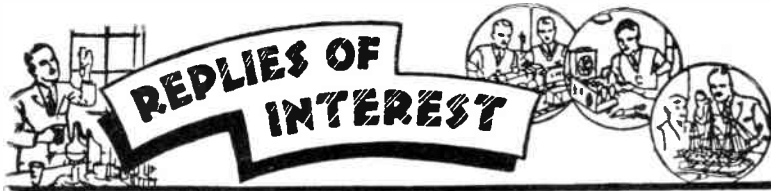

Query About Metal Rectifiers

CAN you give me any information about all-wave metal rectifiers? I need one for a model train 12 V 1 amp., and cannot procure one. Do you know where these are obtainable, or if not, is it possible to make one? (F.G.—Rothwell.)

METAL rectifiers may be purchased in three types. A full-wave type with four tags is best. The A.C. tags are wired to the transformer secondary, and the positive and negatives go to the model. Bridge types have three tags and require a transformer with a centre-tapped winding giving twice the required output voltage. The rectifier A.C. tags are wired to each end of the secondary; the model is fed from the secondary centre-tap and centre tag of rectifier. Finally, ½-wave rectifiers have two tags only, and are merely wired in series with one lead from the transformer secondary. A supplier of rectifiers of these types is Radio Supply Co., 32 The Calls, Leeds, 2. It is not feasible to make such rectifiers at home.

'Brush' Polish

PLEASE give me an explanation of 'brush' polish, as I am not familiar with the process. (L.T.—Malmesbury).

'BRUSH' polish is the name given to a form of varnish, usually containing shellac, which is brushed on to the wood. It is used for work which would be difficult to french polish or where that finish is not required.

SHEFFIELD EXHIBITION

The fifth exhibition of hobbies and crafts, organised by the Sheffield Society of Aeromodellers, will be held at the Central Technical School, Leopold Street, from April 13th to 16th inclusive. Competition sections include those for galleons, power boats, model cars and aircraft, and among the awards will be the Hobbies Trophy for any article or model made from a Hobbies kit.

Turning Ivory

IS it possible for me to turn a number of ivory billiard balls in a lathe, to make ashtrays? (A.J.C.—Norwich).

IVORY can be sawn, drilled and turned in a lathe in a similar way to, and with tools as used, for brass. Probably the best way to chuck the balls would be to mount them in a recess in a block of wood or metal fixed to the lathe faceplate, and held therein by means of the usual clamps or faceplate 'dogs'. Another method is to chuck a piece of hardwood, bore it out to a shade under the diameter of the ball,

and then after applying some hot resin to the bore, press the ball into it, and let the resin set hard. An economical way is, of course, to cut the ball asunder, to form two halves, from which to turn the ash trays, in which case the 'back centre' can be brought against the work, at least until most of the turning is completed.

Rebuilding a Door-step

I WISH to rebuild a front door-step which is badly worn, but should like to do so with a tile-red concrete. Is this possible? If so, could you please give me some advice on what to use for colouring the concrete? (J.G.—Newfoundpool.)

TO rebuild your door-step, chip the step over to provide a key for the concrete. A mixture of 1 cement to 3 of sand will do nicely if not too thick, but if the amount to be made good is quite a lot in thickness, it would be better to build it up partly first, then apply a finishing coat over all. Colouring matter for concrete can be bought at most oil shops and builders' merchants.

HANDLING AND USE OF WOODWORK TOOLS

Squaring a Line Round

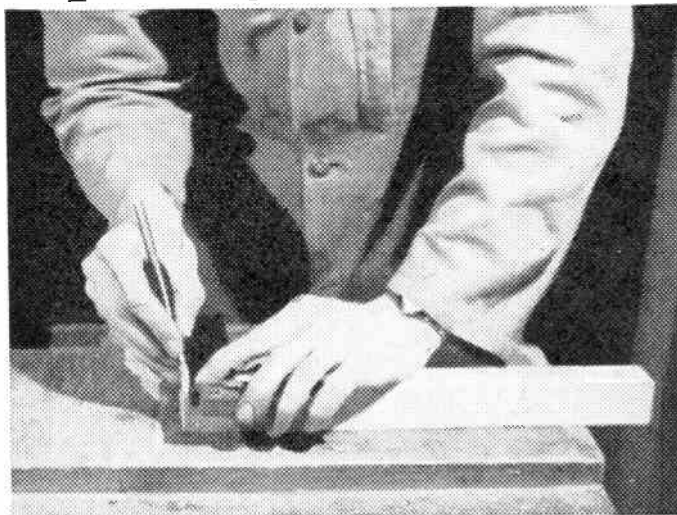

WHEN squaring a line round a piece of wood it is most important that the stock (or handle) of the try-square be pressed against the side or edge which has been tested for true, i.e. the face side or face edge. If this is done, the line will meet exactly on the last corner.

Note how the thumb and three fingers squeeze the wood and try-square into close contact, while the forefinger holds down the blade. In the photograph the face edge is on the side

opposite to the body, so the stock of the try-square presses against that edge.

If the face edge were on the side nearer to the body, the try-square would be reversed, and the thumb would squeeze the stock while the three fingers would grip the wood. Always use the full length of the stock if the length of the wood permits it, otherwise the try-square may tilt.

When squaring across the edge of a narrow piece of wood, hold it in the vice to prevent it tipping. (K.B.)

YOU MAKE THE BRICKS

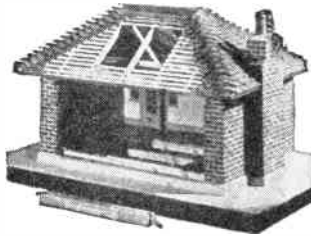

TO BUILD THE HOUSE this simple way—

Just a simple wood mould with a tape or paper strip base—and there's your home-made brickworks, ready to supply you with "Pyruma" bricks for building houses, walls, farm buildings, model railway stations, etc. Just one of the ways of modelling in Sankey's "Pyruma" plastic cement explained more fully in the Instruction Book offered below. Other and simpler ways of modelling are also described, showing how to make many useful, permanent stone-hard objects which can be painted in colour, from



Pyruma is ready for use from its airtight tin—to be modelled while plastic. It dries or bakes to stone hardness and, after treatment as instructed, can then be painted or enamelled. Pyruma is ideal for modelling Houses, Railway and Airport Buildings, Farms, Docks, Figures and for making Ashtrays, Bookends, Plaques, Dolls Furniture, Relief Maps, Animals, etc.

Sankey's, PYRUMA and TILUMA are inexpensive and obtainable in air-tight tins from Ironmongers, Art Material Dealers, Hobbies Shops, etc.

POST THE COUPON TO-DAY

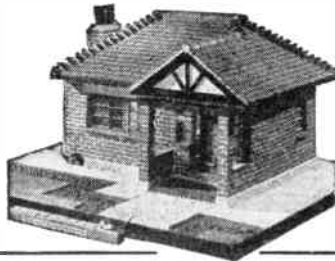

To: **J.H. SANKEY & SON, LTD.**

Ltd. 1857

Dept. H.W., ILFORD, ESSEX.

Enclosed 4d. In stamps for PYRUMA MODELLING INSTRUCTION BOOK addressed to:

NAME (Block letters).....

ADDRESS.....

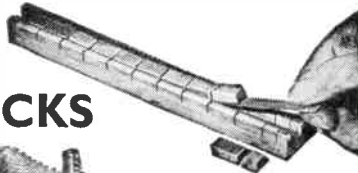

A really superior finish!
... FOR 101 JOBS

Easy to apply and quick to dry, these inexpensive lacquers have many uses. They will impart a rich and lustrous finish to models, picture frames, lamp standards, wicker chairs, work baskets, those unsightly water or gas pipes, etc. Fine for dance shoes too!

Be sure to ask by name for
CROWN SILVER LACQUER AND GUINEA GOLD LACQUER



Obtainable only from

WOOLWORTHS

ELECTRIC PAINT STRIPPER

4/-
DEPOSIT
3 monthly payments of 10/-
Cash price 30/-

Old paint peels off like magic with the Horvell electric paint stripper. Easy, even strokes remove paint, varnish, etc. Four-sided blade for angles and corners. A.C./D.C. mains - state voltage. P & P 1/-. Extra flex 1/- a yard. Send for leaflet

ELECTRIC PAINT SPRAYER

For 5/- deposit

Cash 75/-. Or 5/- deposit and 6 monthly payments of 13/6

Paint easily, evenly, twice as fast with the Burgess Electric Sprayer. Sprays paint, varnish, etc. Complete with sturdy glass container, flex, nozzles for ceiling spraying and extra nozzle discs for different liquids. A.C. mains - state voltage. Guaranteed. Supplied with 96 page booklet. Leaflet free

ROLLS RAZOR

ONLY 3/6 deposit

and 8 monthly payments of 7/-

This famous Razor is now offered on easy terms. Each set contains sharpening mechanism (strop and hone) to keep the blade keenly edged for years. The most economical safety razor yet made. Cash price 53/3, or terms as above. Also in leather pouch with spare blade 79/6, or 5/- down and 8 payments of 10/6.

PHILISHAVE

14 DAYS' FREE TRIAL

Try the wonderful Philishave Electric Dry Shaver FREE for 14 days. Send only 5/- deposit (returnable if not satisfied). Two shaving heads with two 6-bladed cutters have unique rotary action which genuinely shaves - doesn't just snip at the hairs. Result - better quicker shave. Operates on 110/250 volts. A.C./D.C. 27.9.3 cash less your deposit. Or 5/- deposit can be first payment after trial, followed by 8 monthly payments of £1. 12 months' guarantee.

Brochure of this and other shavers free.
BARGAIN DISTRIBUTORS
(Dept. 124), 5 Silver Street, Luton

The Model Railway Club

MODEL RAILWAY EXHIBITION

WORKING MODEL RAILWAYS AND TRAMS · LOCOMOTIVES · COACHES WAGONS · SIGNALS · STATIONS RAILWAY MODELS OF ALL KINDS

Model Steam Passenger-Hauling Engines

ADMISSION 2/6 Children under 14 1/3
Special terms for parties of 12 or more:
Apply to The Model Railway Club,
60 Howard Road, South Norwood, S.E.25.

Easter Week
Tuesday APRIL 12—Saturday APRIL 16
Tuesday 12 noon to 9 p.m.
Other days 10.30 a.m. to 9 p.m.

Central Hall
Westminster, S.W.1

50 FREE STAMPS, to all applicants enclosing 2½d. stamp and requesting approvals. Various other free gifts given.—Beeze, 116 Newton Rd., Mumbles, Swansea.

APPROVALS—25 a 1d. upwards. Customers write "Good condition, excellent value".—Jeffreys, 2 Bay View, Craigavon, Port Talbot.

'SHIPS in Bottles and Electric Light Bulbs'. Plans and instructions 3/-. Toy plans included FREE.—W. Phillips, 47a Linden Gardens, Chiswick, W.4.

AMATEUR woodworkers—why not turn your hobby into substantial income? S.A.E. for full particulars.—Goodwood Crafts, Cross Street, Leamington Spa.

PERFORATION gauge and 50 stamps, free to all approval applicants enclosing 2½d. stamp. Cliffe West (H3), 61 Wynyard Road, Sheffield, 6.

A GRAND BOOK FOR ALL THE FAMILY. The "Kaylee Year Book of Bright Ideas". A really helpful guide to home planning, decoration, Hobbies, toys, etc. Showing famous Kaylee Transfers in brilliant colours, and most effective uses. From "Hobbies" stockists 1/- or direct.
KAYLEE TRANSFERS Postage 3d.
LTD., (HW) Long Eaton Nottingham.

BRITISH Colonials, all periods, bargain prices. One country or mixed selections on approval. Discount allowed.—L. Newell, 6 St. Mary Road, Walthamstow, E.17.

100 DIFFERENT stamps free! ½d. upwards approvals.—Bush, 53 Newlyn Way, Parkstone, Dorset.

AMAZING discounts off all approvals. See for yourself. Details from—Walker, Daggons, Everton, Lynton, Hants.

MOTORISTS—Decorators, washing down? Use the new nylon sponge for best results. 2/9 post paid to—King, 75 Summerhill Road, Tottenham, London, N.15.

CASTING moulds for lead soldiers, animals, etc.—Illustrated catalogue 4d. Sample mould 6/-.—C. F. Rhead, Wayside, Botesdale, Diss, Norfolk.

VENTRILOQUISM—Lifesize cheeky boy's head, new, ideal beginner, £2/5/-.—Brighton, 285 Rectory Road, Pitsea, Essex.

MAKE your own greenhouse. Size 8ft. 6ins. by 6ft. wide. Complete kit of accurately machined timber. Yours for 42/- deposit. Cash price £13.10.0. Write for details to—Garden-Craft (Newark) Sutton-on-Trent, Newark.

TRANSFER Graining Paper—Oaks, Walnuts, Samples, 1/-; Complete range, 3/-; Roll, 16/10.—H. Decano Co., 20 Clarendon Rd., Jersey.

Micromodels
MODEL MAKING IN CARD

SET TR I
4 MDLS. 2/6

SET ARC XXI

Send stamped addressed envelope for Illustrated List of 100 Models, Authentic, Architectural, Mechanical, Railway, Maritime, Aero, etc. etc.

MICROMODELS LTD.
3 (H) Racquet Court, Fleet St., London E.C.4

£5 to £20 weekly earned at home running, your own Mail Order business. Complete Course 5/6.—Courses, 28(HB) Dean Road, London, N.W.2.

KUKLOS ANNUAL. Indispensable cyclist's handbook. Tours, resthouses, money-saving hints, 2/10, post free.—Burrow, Publishers 2 Imperial House, Cheltenham.

STAMPS FREE—Empire Packet including Pictorials and Victorians with approvals.—Robert J. Peck, 7A Kemp Road, Bournemouth.

BUILD your own T/V and learn about its operation, maintenance and servicing. Qualified engineer-tutor available whilst you are learning and building. Free Brochure from—E.M.I. Institutes, Dept. HW.58, London, W.4. (Associated with H.M.V.)

MAKE A RADIO SET

... with a screwdriver and pliers. No soldering. Building instructions included.
CRYSTAL SET, 11/- post free
1-VALVE SET, 33/- including valve
2-VALVE SET, 58/6 including valves
Building instructions only, 7½d. (3 2½d. stamps)

BLANCHARD'S RADIO (H10)
13, GAINFORD GARDENS, MANCHESTER, 10

* GREAT CAMPING OFFER *

RIDGE TENT SENT FOR 4/-
BRAND NEW de luxe Para. Tent. All colours. Complete. Ideal Cyclists, Campers. Length 7 ft. 3 in. sleeping base x 4 ft. 6 in. wide x 3 ft. 6 in. high x 12 in. walls, all approx. Weight 3¼ lb. £2.15s. or 4/- deposit and 6/- monthly. With fly-sheet £4.2s. 6d. or 10/- deposit and 9/9 monthly. Both carr. 1/6. Lists of other models. Terms. Send now for this really wonderful offer.



"I strongly recommend this VERY LATEST O.G. lens x 40mm GERMAN PRISMEX BINOCULAR"



Says Our Director

POPULAR SQUAT MODEL made of lightweight material. METAL COMPASS INSET IN BENDING BAR EYE ADJUSTMENT enables quick reading of bearing of view. LUMINOUS TIPPED, VERY LATEST IMPROVEMENT. Size 3½" x 4½". Genuine day and night powerful prismex lenses give 3-D clarity. Centre focus. Case, etc. Send only 2/6 pack. & reg. 7 days approval. If satisfactory send 5/6, then pay 8 payments 7/6 within 8 months. Cash Price 59/6. Lists, Terms.
Headquarter & General Supplies Ltd.
HOBBY 46, 196/200 Coldharbour Lane, Loughboro Junc., London, S.E.5. Open Sat., 1 p.m. Wed.

'PAINTSPRAYING' HANDBOOK (1954 Ed.). Covers Car, Industrial & Flock Spraying. 3/6, post free, including catalogue of our Cellulose and Synthetic Paints and all Allied Sundries and Plant Hire.—Leonard Brooks Ltd., 81 Oak Road, Harold Wood, Essex.

PLYWOOD—HARDBOARD—at amazing low prices. Send S.A.E. for samples and prices to—N. Gerver, 10 Mare Street, Hackney, London, E.8.

RUBBER MOULDS for plaster casting sample 3/11. Trade supplied. S.A.E.—Burleigh Supplies, 13 Burleigh Street, Hull.

EVERY CAR THAT PASSES—YOU WILL FIND THE INDEX MARK ALPHABETICALLY ARRANGED IN WHERE'S THAT CAR FROM?

Price 9d.

from all Booksellers or from the Publishers (1½d. postage)

RALEIGH PRESS, EXMOUTH

ULSTER HANDICRAFTS. Downshire Place, Great Victoria Street, Belfast, supply craftworkers with Stanley tools, Handicrafts, Marquetry, Veneers, Aerolite, Musical Movements, Lamp Frames, Paints, etc.

SWISS MUSICAL Mechanisms for cigarette boxes, etc., 18/- post free. S.A.E. for illustration and list of tunes available.—Dept. HW, Metwood Accessories, Church St., Wolverton, Bucks. (Trade supplied.)

Patterns for the Egg Server

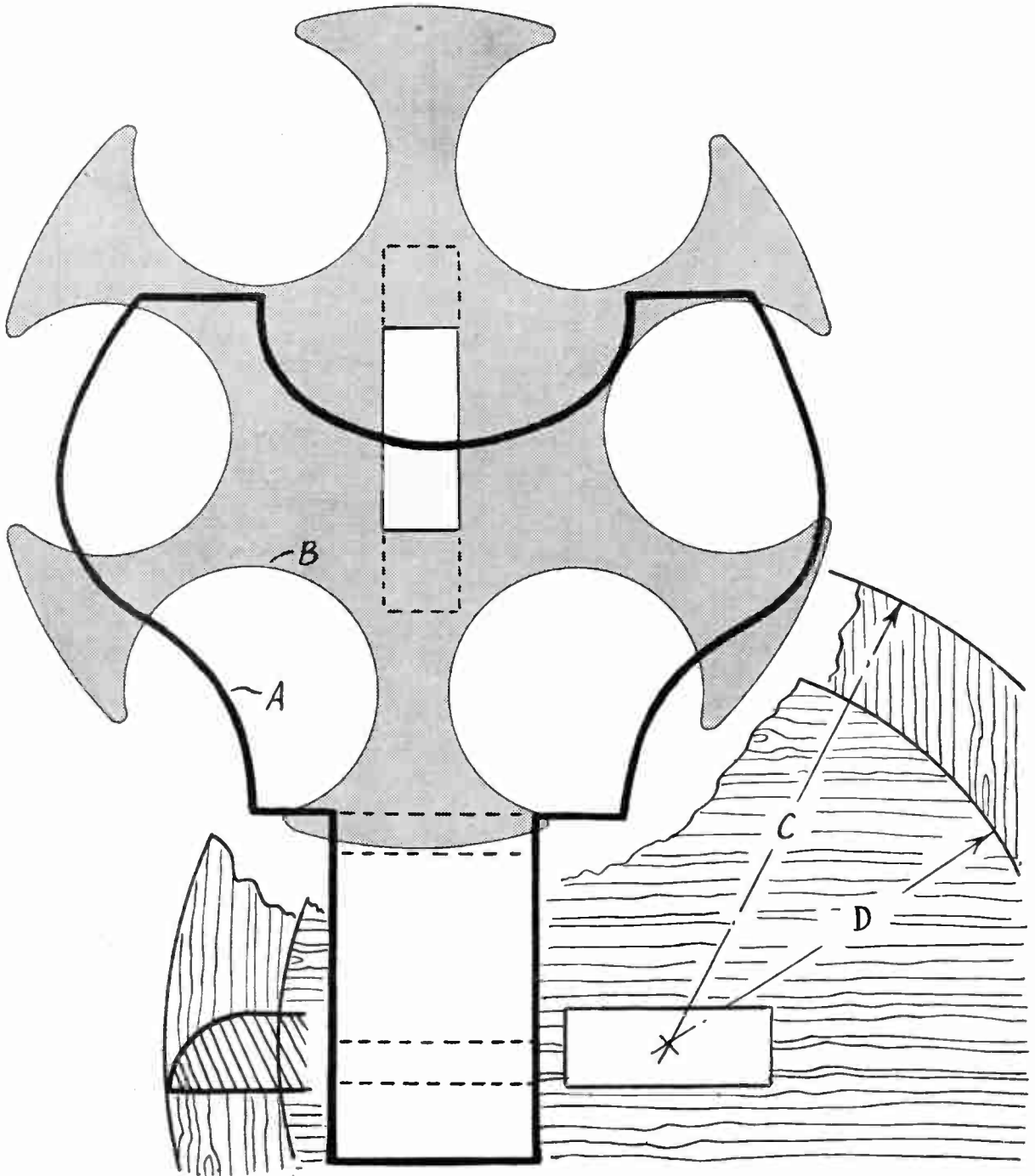

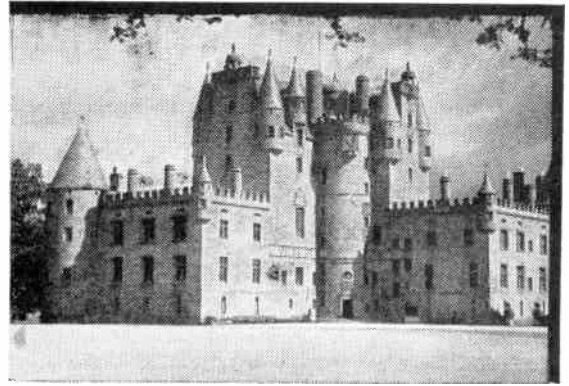
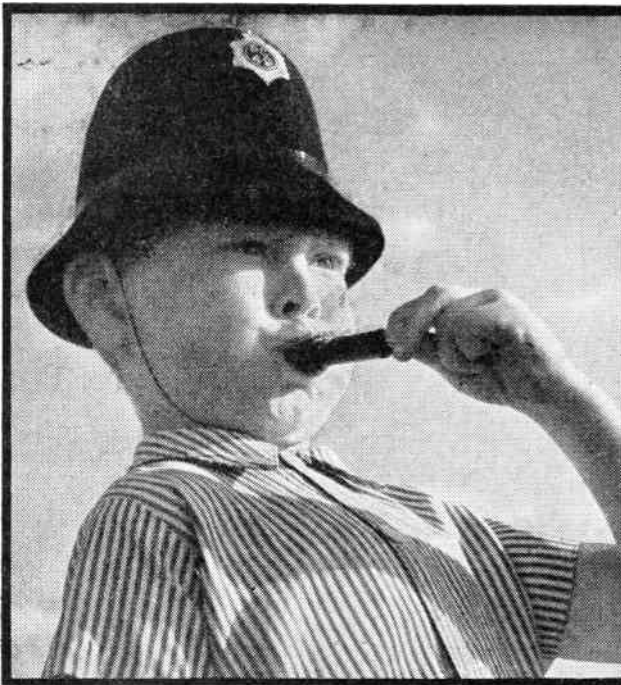

Glamis Castle

"Come-along-a-me"

But it was the camera which arrested *him*. And a very happy picture it makes—one which will never be forgotten.

Make sure of a well-packed album of exciting Faces and Places by using Ilford films. They fit all popular cameras and you'll get a good picture every time.

ILFORD FILMS FOR FACES AND PLACES

POWER BOAT PLANS

Hours of pleasure lie in store for you when you start to build your model Power Boat. The plans listed below all provide full-size templates and each model can be adapted to suit most types of drive.

"WALTON" CRUISER

(as illustrated below)

A modern motor cruiser with streamlined hull. Length 23in. "Bread-and-butter" construction. Plan price 7/6

"DAYTONA" CRUISER

A smart and racy American style cruiser which can be powered by either Diesel or Electric drive. Length 33in. Plan price 12/6

"COASTAL" CRUISER

A typical modern sea-going type of cruiser. Easily built in Balsa wood on the rib-and-plank principle. Length 17in. Plan price 3/- Plan and Kit 24/6

"DIXIE" SPEEDBOAT

A fascinating little runabout which will give excellent results when powered by any of the smaller Electric motors. Length 12in. Plan price 2/6

Postage 6d. per plan

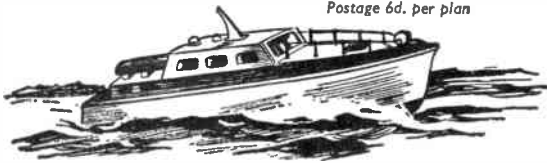

MODEL CRAFT LTD

77 (F), GROSVENOR ROAD, LONDON, S.W.1

NEW! EXPERIMENTAL KITS

LEARN THE PRACTICAL WAY

Here is home study of the most effective kind under expert tutors. There is no better way of studying for an examination, starting a new hobby or for a career in industry. These special courses comprise the most modern methods of postal tuition, combined with a Practical Kit of parts (which remains your property).

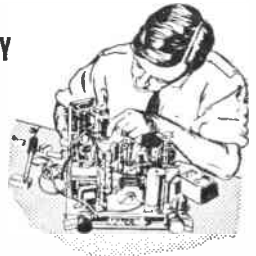

COURSES FROM 15/- A MONTH

COURSES WITH PRACTICAL EQUIPMENT INCLUDE: Radio, Television, Mechanics, Electricity, Chemistry, Photography, Carpentry; also Draughtsmanship, Commercial Art, Amateur S.W. Radio, Languages, etc.

POST THIS COUPON TODAY

For FREE brochure write: E.M.I. INSTITUTES, Dept. 31X, Grove Park Road, London, W.4.

SUBJECT(S) OF INTEREST _____

NAME _____

ADDRESS _____

6/4/55 _____

IC51A

**E.M.I.
INSTITUTES**

The only Postal
College which is
part of a world-wide
Industrial Organisation