

Hobbies

WEEKLY

CONTENTS

	Page
Air Rifle Target	- - 353
Sunken Garden	- - 355
Handy Kitchen Unit	- - 356
Artist's Paint Box	- - 357
Screen Grid Three	- - 358
Readers' Problems	- - 359
Home Punch Ball	- - 360
Garden Tool Shed	- - 361
Home Chemistry	- - 363
Building Bricks	- - 364
Stamp Collecting	- - 365

MODEL FIRE ENGINE
DESIGN SHEET

March 7th, 1951

Price Fourpence

Vol. III No. 2888

A SIMPLE ELECTRIC AIR RIFLE TARGET

MANY boys living in the city are denied the joy of having a 'pot-shot' with an airgun because of the difficulty of ricocheting bullets in such thickly populated areas. In the country, of course, things are different. Sparrows abound in the farmyards, eating valuable corn, and the farmers are only too pleased to be rid of them.

Even so, the little 'safety' target shown here will be very useful for practise shots. It will entirely eliminate the danger of 'ricochets', and obviate the necessity for paying for an occasional broken window or dead chicken.

The Bullet Catcher

The sketches on these pages show

how to make a bullet catcher which will answer the purpose of both city and country dweller admirably. It will take two targets at once, so when two are shooting, each can use a target and compare scores afterwards.

Targets for 25yds. distance are usually about 6ins. square, with an actual target area of 4 $\frac{3}{4}$ ins. diameter. The targets can be bought from most local ironmongers, who usually stock guns and their accessories. Small drawing pins should be used for fixing to the front of the box.

The box is designed to hang on a wall or shed and is made up of $\frac{1}{2}$ in. wood. The kind of wood does not really matter and the choice is, therefore, left to the

reader. It is possible that a box from the grocer may be adapted to suit.

The section in Fig. 1 and the cut-away view in Fig. 2 show enough of the construction to enable you to commence work. The front piece measures 16 $\frac{1}{2}$ ins. long and is 9ins. wide. An opening 13 $\frac{1}{2}$ ins. by 5 $\frac{1}{2}$ ins. is cut in with a fretsaw. Mark out the opening, drill a hole in one corner and insert the fretsaw blade in the normal manner.

Constructing the Box

For the main part of the box two pieces 16 $\frac{1}{2}$ ins. by 8ins. and two 8ins. square are butted together, as shown.

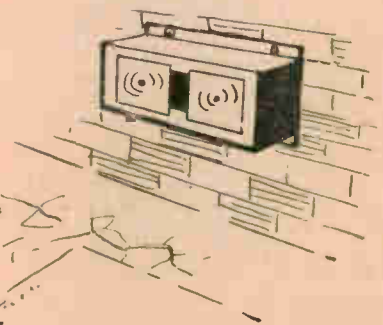
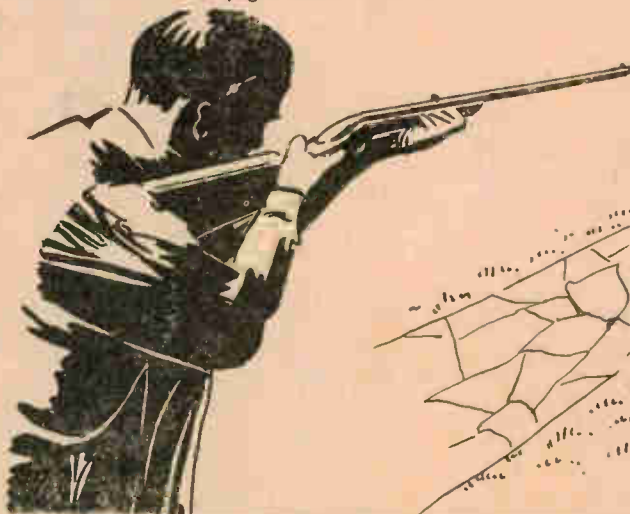

A safe target arrangement for the amateur rifleman in the garden

All correspondence should be addressed to The Editor, Hobbies Weekly, Dereham, Norfolk.

Screws should be used in preference to glue or nails for fixing, since the box will have to stand the weather as well as a good deal of knocking about. The cut-out front can now be screwed securely in place and the back cut out.

You will see in the diagrams that the back is not shaped, but is simply a piece of $\frac{1}{2}$ in. wood measuring $16\frac{1}{2}$ ins. by 11 ins. You could, of course, make up the width of 11 ins. by using two narrower boards.

The Armoured Interior

The 'armour' inside consists of a piece of $\frac{1}{4}$ in. sheet metal bent round so as to cover the bottom, back and top. The sides are not so important since they will not take the direct force of the

To use, you simply pin two targets over the opening and firing side by side, make your allotted number of shots and compare scores.

Bear in mind that the measurements need not be strictly adhered to, since the size of wood obtainable may vary. Decide what material you will use and then decide on the measurements required.

An Electric Indicator Bell

Since it is often difficult to see when the 'bull' is hit, it will add considerably to the enjoyment of the shooting if you have something to tell you definitely

head screws, as shown in Figs. 3 and 4. You will see that contact is made by the bullet striking the metal spring strip which momentarily touches the round-head screw. The wires can be led out through the top and bottom to the battery and bulb holder. It is advisable to use rubber covered wire, as this would be less likely to 'short'. Ordinary pocket-lamp batteries will suffice and will last a considerable time with 3.5 volt bulbs, since the current will only be used intermittently.

A Bell Indicator

A more simple method of indication is by means of a bell. The general con-

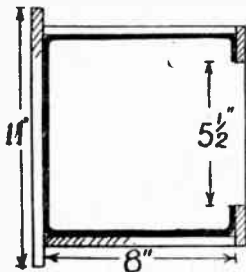

Fig. 1—End section

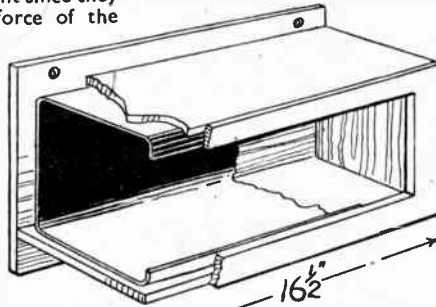

Fig. 2—Cut-away view

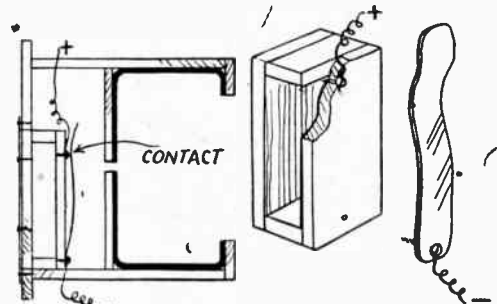

Fig. 3—Electrical connections

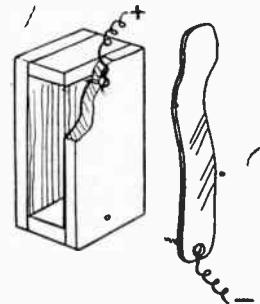

Fig. 4—Spring contact

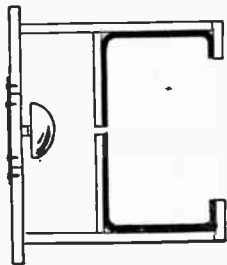

Fig. 5—Indicator bell

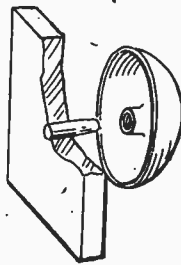

Fig. 6—Bell fitting

when a 'bull' is scored.

We have shown a modification of the original box so that an electrical indicator can be incorporated. The general measurements of the box will remain the same. You will notice in Fig. 3 that the metal sheet does not go so far back, but that a space is left for the connecting gadget to be fixed behind. First you must bore holes in the metal exactly behind the 'bulls' in the targets. Make the holes slightly larger than the black bull of the target.

struction is shown in Figs. 5 and 6. The holes in the metal allow the bullet to strike the bell when a bull is scored. The bells are tops of old bicycle bells which are pushed on to a dowel let into a piece of wood, as shown.

The cut-away view in Fig. 6 indicates how this is done. The square of wood is cut from the back itself and fixed back in position by means of a strip of metal, as shown.

The completed box should be given two coats of outside paint to withstand the weather.

bullet, but they could also be covered with similar material if desired.

There is no need to fix the main sheet of 'armour', but the ends will need to be screwed in place. Your local iron-monger should be able to supply you with the metal and will probably have it bent to shape for a small extra charge.

To Hang and Use

To hang up the box you will need to bore two holes in the back. Alternatively you could obtain two suitable hangers and fix in place with screws. The hangers can be purchased locally for a few pence.

Paint Box—(Continued from page 357)

Four small metal corner pieces are tacked on to the lid to hold the cards in position for painting. It is best to cut away the wood so that these are flush to enable the case to close nicely.

Now in conclusion a word or two about materials would probably be welcomed by the budding artist. It will be found cheapest in the end to always buy the best of everything. Get artists colours and not students, which are coarser in texture and often fade rather badly. The actual colours chosen will

The Connections

As you are using two separate targets you will need a separate connecting and wiring scheme for each. For each target a spring switch is made, as shown in Fig. 4. A box of $\frac{1}{2}$ in. wood is made up as shown. The measurements are not critical, but it should fit into the back, as indicated in Fig. 3.

Two holes of the same dimensions as the small boxes must be cut in the back before assembling the main box. The connecting boxes are held in place by a strip of metal or wood screwed to the boxes and the back, see Fig. 3.

The wires run from the two round-

depend on the type of work to be done but the following list will form a useful foundation.

Yellow ochre, gamboge, cobalt, ultramarine, viridian, burnt sienna, light red, crimson, Payne's grey and Vandyke brown. With the following useful additions practically anything could be tackled—Aureolin, cadmium yellow, Naples yellow, chrome orange, scarlet lake, brown madder, brown ochre, Prussian blue, emerald green, olive green, terre verte, mauve, Chinese

The Backboard

In the event of no suitable wall being available you might construct a large backboard of rough boards held together by battens. The size of the board depends largely upon the accuracy of your aim, but one about 2ft. by 3ft. should be large enough. It should be fixed to posts at a convenient height and the bullet catcher hung, as on a wall.

Just one word of warning when enjoying yourself with a gun, always keep the muzzle pointed upwards or downwards whether loaded or unloaded. Never get into the bad habit of swinging it round in wild circles. (363)

white, neutral tint.

Brushes should be of sable and three will be sufficient in sizes 3, 5 and 8. The best pencils for light sketching in are grade B.

Whatmans water-colour paper or board 'not' surface is, undoubtedly, the best to use, but there are now quite an assortment of other makes on the market which are nearly as good.

To complete the kit put in a small piece of sponge, india rubber, some blotting paper and some pieces of clean rag. (372)

Ornamental work can easily be undertaken to make A SUNKEN GARDEN

CEMENT work is often considered too bare and harsh for garden work, but it is not realized by many how decorative and suitable it can be for certain purposes. In the front of the house, where the area is too small for a lawn, a sunken garden made of cement is ideal.

It is advisable to make a sketch to fit the space available. Wooden boards are used for the moulds to hold the cement until it has set, so straight lines predominating in the design will make for easier building. Small portions of curved wall can be incorporated, and these are useful as a foil to the straightness of the main lines and can be used to break up any great length of straight wall. A plan of a pleasing formation such as seen in the photograph is shown in Fig. 1.

Preparation

In preparing the site, determine how much below ground the base is to be. The soil is marked out slightly larger than the actual measurements of the plan, to allow for the wooden moulds — of the walls which hold back the earth. The soil is dug out to the depth of the garden, plus the thickness of the base, plus an allowance for broken rubble or ashes on which the base is laid.

Do not disturb the soil to an unnecessary depth as a hard firm base is required, and soil newly dug is apt to sink after a time. The foundation of rubble should be well rolled in.

Wooden boards are sunk in at the outside limits of the base, and levelled up at a height which allows an average thickness to the base of 1½ ins. of cement. It should nowhere be less than 1 in. In

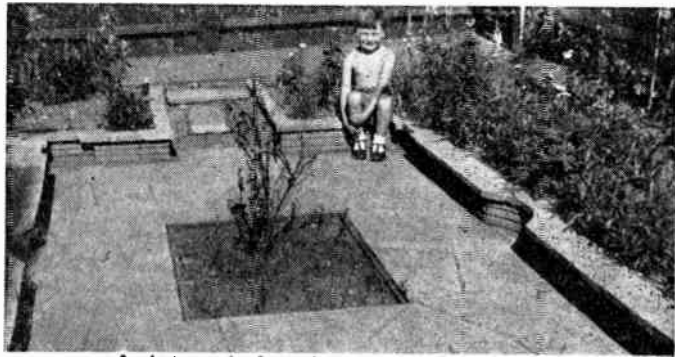

A photograph of a sunken garden made of cement

thickness. If a flower bed is to be left in the middle of the base, boards limiting the size of the bed must also be fixed, then the area in between is ready to receive the cement.

Base Work

The boards may be of any wood which will make a straight edge to hold in the cement; old fence palings serve the purpose well. This base is the largest surface of the sunken garden; it must be marked out. When the cement has set but before it has hardened, indentations can be made.

If the end of a stick is drawn across in different directions, with more or less pressure according to how firm the cement has set, a series of lines is obtained which breaks up the bare area and gives the impressions of stones laid side by side. The width of the breaks is controlled by the different widths of sticks,

Cut the lines as the work proceeds as soon as the cement is firm enough.

Do not leave the lines until the end, unless it is a small area, as by that time the first section may be too hard for marking, and with a square area or one more than about four feet wide it may be impossible to reach the centre to cut the lines, while the cement is still soft.

Fig. 2 represents (on left) a section of the wall with wood mould removed and wall marked out. To the right the wood strips erected ready to receive cement. If very long, small strips of wood can be tacked across top to give support. Dotted lines represent where the curved section will be placed and this will be done last. The two completed and hardened straight sections will give firm supports for erecting strips of linoleum.

Note on the completed section on the left, the crossed lines which are made in the cement before hardening. They can be made with a knife and are to give a better grip when the next section is joined on, and on top the 'tiles' will stick better.

The walls are made in sections, each section being marked out as soon as firm enough. On the straight sections being completed, the curved parts are filled in. When building the moulds for the walls, fix the boards lightly.

Bricks on the outside are sufficient to prevent the boards bulging out, and strips of wood across the top and pieces lightly tacked at the end will be sufficient to prevent the boards falling in. The boards can then be dismantled easily without damage to the cement.

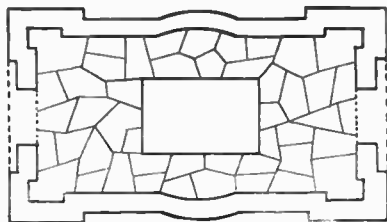

Fig. 1—A simple plan with slight curves

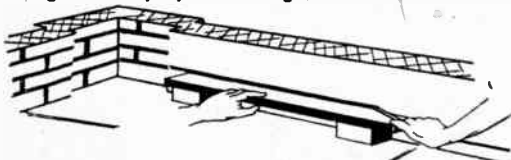

Fig. 3—Wood strip to mark lines



Fig. 5—Six shapes in mould with dotted lines representing cut

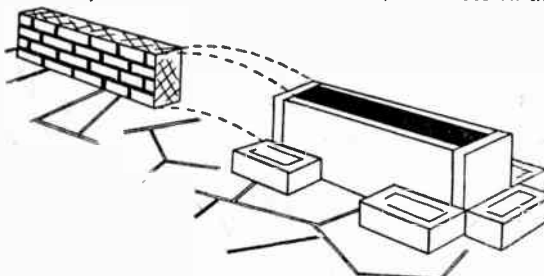

Fig. 2—Constructional details of the wall



Fig. 4—The frame for moulding, with front edge screwed on

and the depth is made by pressure or repetition over the same line.

A straight edge of wood may be used as a ruler, but pressure on this must be avoided. Lines too deep are not advisable as they will weaken the area as a whole.

How the home handyman can make a simple HANDY KITCHEN UNIT

OCCASIONALLY it happens that there is need for a re-arrangement of shelving in the kitchen. Perhaps you have had a change of furniture which leaves an awkward shelf in the wrong position.

Perhaps—and here is the best reason for the construction of one of these units—there is an annoying little shelf which seems to collect all the odd bottles, tins and packets so necessary to

shelves which will neatly contain a good selection of odds and ends, and an upper cabinet with a sliding door which is useful to keep the family boot-blackening materials in.

It may be used for shaving gear by those who are obliged to shave in the kitchen! There is nothing to prevent the fitting of sliding doors to all the shelves, with the necessary modification of the runners for the two mid-shelves.

The unit has no back, and is planted on the wall in a suitable position, fixed with a ledging strip underneath the lower shelf and two iron angle brackets inside the top, screwed into wall plugs.

Actual overall measurements will depend upon the size of the boxes obtained. The wood of the average packing case is of varied quality, and it is advisable to finish the unit in a good hard gloss paint after suitable priming. The sliding door should be made a good free fit to allow for the paint. See that the paint has hardened before use, or the door may stick in the grooves.

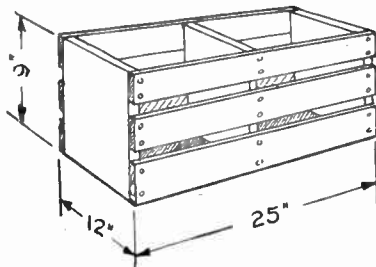
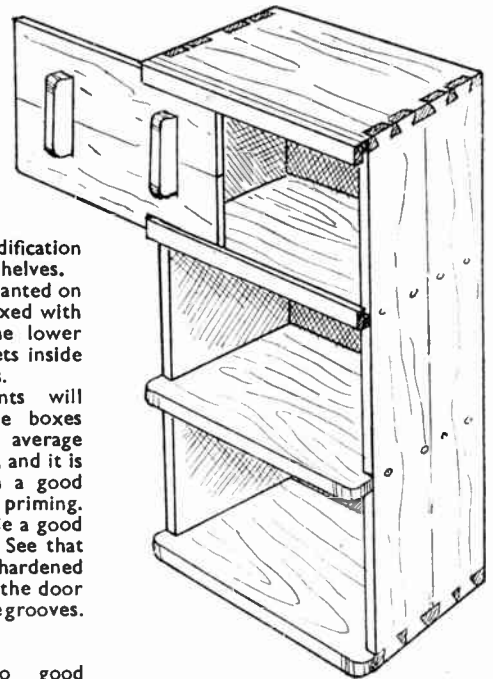

Fig. 1—Typical fruit box—two required

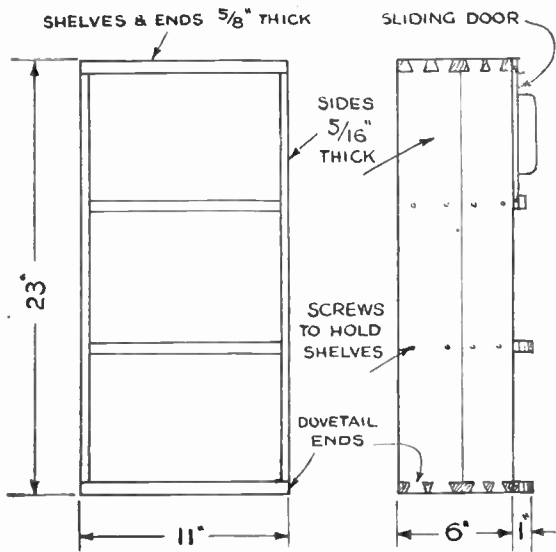

Fig. 2—Front and side view: sliding door not shown

Material

Obtain two good boxes of the approximate size shown in Fig. 1. Try and get those with solid ends of about $\frac{1}{4}$ in. material, and avoid those with battened and nailed ends, as they make for unsightly shelves.

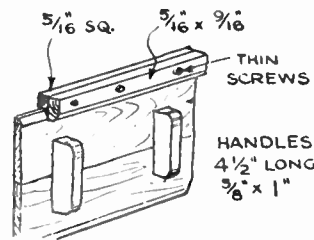

Fig. 3—The door with batten handle

nailed. Select the best pieces of wood from the lot.

Construction

Cut the top to 11ins. by 6ins., and the bottom to 11ins. by 7ins. The two mid shelves are shorter by the thickness of the sides.

The sides are matched up from the thinner pieces of wood. Two pieces about 3ins. wide should be planed down to make a side 6ins. wide. The top and bottom ends should, preferably, be dovetailed to the sides but they may be screwed or nailed if a quick job is required. Fix in the mid shelves equally spaced between the ends.

The two lower shelves project 1in. to the front and have rounded corners.

Sliding Door

A piece of plywood $\frac{1}{4}$ in. thick will make a better door, but two pieces fixed by the handles, as shown in the drawing, will serve well. Cut the door $\frac{1}{4}$ in. wider than the space between the shelf and the top, so that it will not fall inside, and screw on the runners, leaving plenty of slack for the door to slide easily. Needless to say all these parts must be planed and glasspapered quite smooth.

(352)

a kitchen, but which for long have left an impression of straggling untidiness.

The unit provides two very useful

One box may provide sufficient material if it is free of unsound knots and no splits occur when extracting the

An Inexpensive Camera Stand

An inexpensive but extremely useful camera stand can be made from a Hobbies cramp and a 2ins. by $\frac{1}{2}$ in. gutter bolt and nut.

Cut off the head of the bolt, and drill and tap the top and side of the cramp, as at Fig. A., to take the bolt. Pieces of felt placed at the points shown in Fig. A. will ensure that damage to furniture is avoided when the stand is used in such ways as those shown in Figs. B. & C.

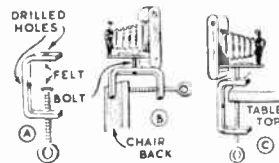

Readers may well make for themselves this complete ARTIST'S PAINT BOX

THERE can hardly be a more pleasant hobby for the fine sunny days than to get out into the open air with paper and colours and to paint some of the scenery around us. Why not make the most of this Festival of Britain Year and capture the ever-changing beauty of our countryside?

Wherever we live, be it busy city street or the heart of the country, there is always something to interest the true artist. The person who can paint reasonably well need never be idle, nor should he find it difficult to dispose of the results of his labour.

Water-colour drawings suitably mounted and, perhaps, framed, form admirable gifts, and it is even possible that there will be quite a ready sale for most of the work. People are always willing to purchase good paintings, and at the present time they are considered a very good investment.

A Holdall

The handy painting box described in this article was designed to meet the needs of such an artist. It contains all the materials necessary for a day's sketching out and is complete in itself. The box is easily made, it is light in weight and very compact.

There is ample space for a good assortment of colours, a place for pencils and brushes, rubber, mixing palette, water container and other sundries. In the lid, which also acts as an easel, there is plenty of room for half-a-dozen prepared water-colour boards.

Mahogany is the wood generally used for making commercial painting boxes,

and if you can use this it will make a really first class job. Walnut is a second choice, but there are many other hardwoods that are suitable, and this includes plywood which will make a quite serviceable box.

Size

A very useful size to make the paintings is quarter imperial or 15ins. by 11ins., and the box has been designed to hold this size. The box could be made smaller if desired, but sketches which are much smaller are liable to cramp the style and are not to be recommended.

The outside measurements of the box are 16ins. long, 12ins. wide and 2½ins. deep when closed, the lid being 1in. deep and the bottom part 1½ins. deep. For the top and bottom thin plywood is used, and this is cut to the exact outside measurements, the case and lid then being built up on them.

The sides are made up of wood having a thickness of ¾in., and where extra strength is needed, such as the hinge sides and also the handle bar, the thickness is increased to 1in.

For the case cut two strips 16ins. long, 1½ins. wide and ½in. thick, and two strips 11ins. long, 1½ins. wide and ¾in. thick. Glue firmly and tack on to the ply base with fine panel pins, also carefully secure the corners with panel pins. Small corner blocks can be added if thought necessary.

The Lid

The construction of the lid differs slightly from the case; only three sides being glued to the ply panel. The fourth side which, when the case is open for use, is at the top, and is hinged to the ply for inserting the water-colour boards.

Cut two strips 16ins. long and ¾in. wide, one being ½in. thick and the other ¾in. The two short sides are 11½ins. long, ¾in. wide and ¾in. thick. Glue and pin the three sides firmly to the ply, while the hinged strip can be fixed with a strip of tape glued on the entire length.

The case can now be glasspapered smooth, a pair of strong brass hinges fitted and a strong but light handle screwed or bolted on to the base of the case.

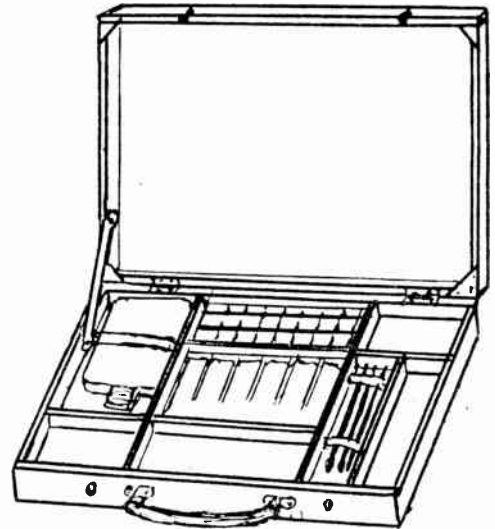

Raised Lid

In order to keep the easel lid in a convenient position for painting, a strut is fitted to the left-hand corner near the water container. It is very simple and is just a strip of brass about ¾in. wide with a hole in each end. One end is screwed to the side of the case and the other end is adjustable and slips over one of several small round-head screws fixed in the side of the lid. By moving from one to the other the correct angle can be obtained for easy painting.

Two small catches and screw eyes fitted on either side of the handle keep the case securely closed for carrying.

The inside fittings can now be put in position and thin strips of about ¼in. thickness are quite sufficient for the job.

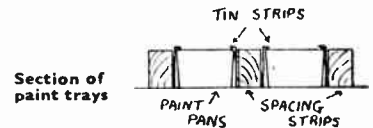

The exact positions and placing of the partitions must be left to the artist, as individual requirements may vary considerably. It may happen that you already have a good colour box and wish to fit this in the box, or you may decide to have more or less than the twenty-four colours as shown.

The colours are obtained in half-pans which usually measure ¾in. by ¾in. and they are here arranged in three rows of eight. The rows are kept in position by strips of tin bent over slightly, as shown in the sketch.

Brushes and pencils are held in their positions by two strips of elastic and the water container could also be secured in a like manner.

(Continued foot of page 354)

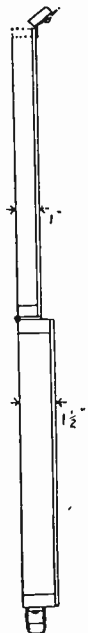
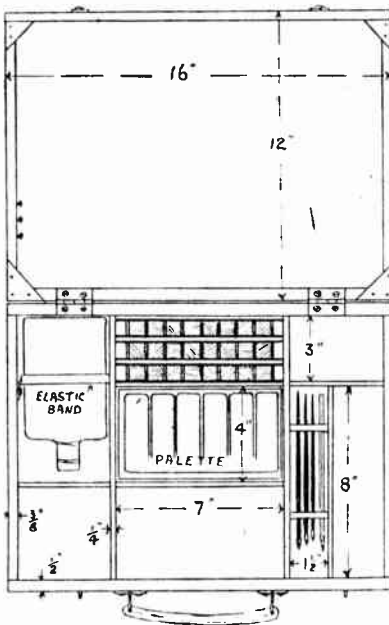

The amateur radio enthusiast should make this SCREEN GRID THREE

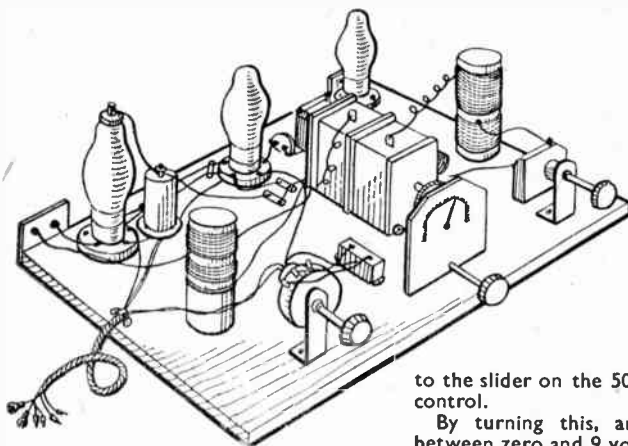

THE constructor who has built some of the 3-valve circuits employing only one tuned circuit will probably like to go a step further and make a receiver with a high frequency stage. With the latter, two tuned circuits are used, thus considerably increasing selectivity (sharpness of tuning). Both coils are tuned simultaneously to the same wavelength by a 2-gang condenser (which resembles two ordinary single tuning condensers on a common spindle).

Circuit Explanations

In order that the operation of the

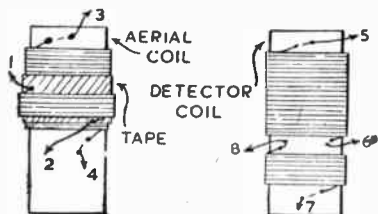

Fig. 2—The tuning coils

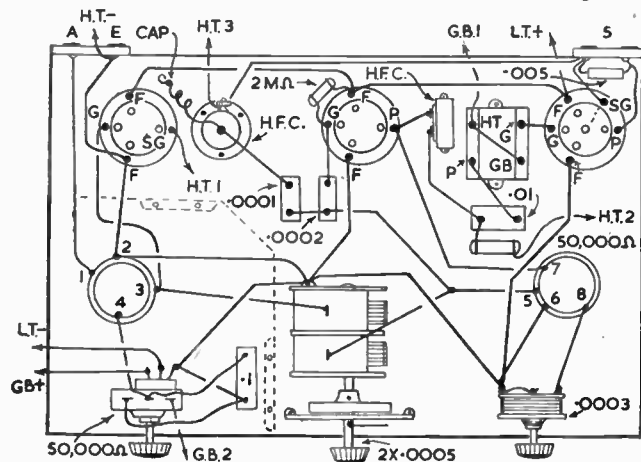

Fig. 3—Complete wiring diagram

circuit can be understood, the builder should examine Fig. 1. The first coil is tuned by one section of the gang condenser, the aerial being coupled by the small winding between points 1 and 2. To control volume, the bottom end of the tuning coil (3 and 4) is taken

to the slider on the 50,000 ohm volume control.

By turning this, any value of bias between zero and 9 volts can be applied to the valve, through the coil. This adjusts the degree of amplification provided by the valve, and consequently the volume. The bottom end of the coil

This assures sufficiently sharp tuning for all ordinary purposes, with ample speaker volume on a good selection of stations.

Winding the Coils

It is essential that the tuned section of each be exactly the same, so the tubes must be of the same diameter. Also employ the same gauge wire for each coil, and put on the same number of turns. The coils are shown in Fig. 2, and the tuned section of each is between points 3 and 4, with the aerial coil, and points 5 and 6, with the detector coil. With a 1in. diameter tube and 32 S.W.G. enamelled wire, 90 turns, closely side by side, are used. With a 1½in. tube, use only 80 turns on each coil.

Bind two or three layers of thick insulating tape round the bottom of the aerial coil winding. On this put 35 turns, side by side, as shown.

With the detector coil, leave a ¼in. space, then put on 50 turns, side by side,

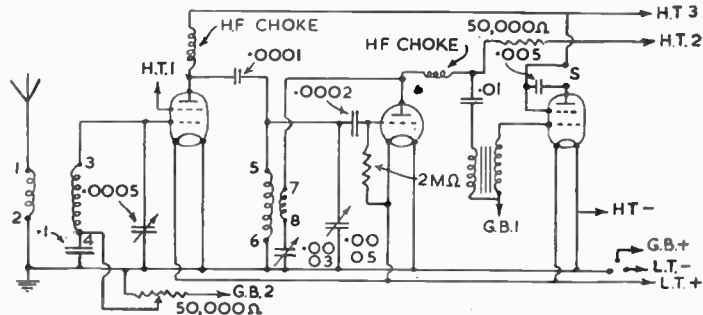

Fig. 1—Theoretical circuit of the receiver

is by-passed to the earth line by a .1 mfd. condenser to allow it to tune correctly.

The amplified signal cannot pass the H.F. Choke, instead going to the detector coil (5 to 6). The latter is tuned to the same wavelength as the first coil, and has reaction

applied through the small winding between points 7 and 8. After detection, the signals, now converted to audio-frequency, are further amplified by a transformer drive, is screwed down centrally. The knobs should project over the front edge of the baseboard, so that the receiver can be placed in a cabinet from the back. The control spindles will then project through clearance holes, and the tuning dial come opposite a suitable cut-out.

below the other winding, as illustrated.

All turns throughout must be in the same direction, and the ends can be made secure by passing them through pairs of small holes drilled in the formers. In the case of the winding between points 1 and 2 this is not possible, and the ends may be secured by binding with cotton, or with additional pieces of tape. Leave all the ends a few inches long to reach the various parts. The coils can be mounted by pushing them on discs of wood screwed to the baseboard.

Base and Parts

The simplest form of construction is to use a baseboard ¼in. thick and about 7ins. by 12ins. Screw down the parts in the positions shown in Fig. 3. The two outer controls are mounted on brackets. The tuning condenser, with reduction drive, is screwed down centrally. The knobs should project over the front edge of the baseboard, so that the receiver can be placed in a cabinet from the back. The control spindles will then project through clearance holes, and the tuning dial come opposite a suitable cut-out.

Two 4-pin holders are used, and one

5-pin, for the output valve, which is near the speaker sockets. The high frequency valve will have a top cap, and this is connected through a short flexible lead to the first H.F. choke. The latter should be a good one, preferably of the type employed for high frequency coupling.

The second choke is only for reaction purposes, and is not critical. The coupling transformer may be of ordinary type, or that especially intended for coupling in this way, if the latter is to hand.

The volume control is a 50,000 ohm one, with internal 3-point switch. This enables both low tension and grid bias batteries to be switched off, and the latter is necessary, here, or the battery would run down through the volume control element even when the set was not in use.

Wiring Details

Any insulated wire of about 22 S.W.G. or so can be used, and flex is employed for the battery leads. If the wiring diagram is followed, no difficulty should arise. Keep all leads short and direct, especially those going to the tuning coils.

The coils themselves should be kept well apart on the baseboard, otherwise coupling between them will cause uncontrollable oscillation. The gang condenser will normally provide some measure of screening between the coils. If it is very small, and oscillation arises, it will be necessary to erect a metal screen in the position shown by the dotted line. This may consist of zinc, aluminium or similar metal, and can be mounted by bending a flange and screwing to the baseboard. It must be connected to the earth socket by a short

lead. Where required, notches can be cut for leads to pass under it.

Valves to Use

Any screen grid, detector and output valves in good condition are satisfactory. In the left-hand holder, S.G. types such as the VS24 can be used, or high frequency pentodes such as the 210VPT (4-pin). For detector (centre holder) a HL2 or similar type is used. For output, a tetrode or pentode such as the 220HPT. (In the latter case, a triode can be used, with no alteration of wiring, but will provide slightly less amplification).

Up to 9 volts can be applied to GB2. GB1 will require about 4.5 to 6 volts, according to type of valve. HT1 will require about 48 to 72 volts, according to valve. HT2 will require about 60 to 108 volts, with 120 volts, for preference, for HT3. (These voltages can be adjusted to note the difference in reception resulting).

For maximum results, both tuned circuits must gang correctly together. To assure this, tune to some weak station with the plates of the tuning condenser almost fully opened, and with the usual aerial and earth connected. Now adjust the small trimming screws on the gang condenser sections, carefully re-tuning, if necessary at the same time, until maximum volume has been obtained. Both circuits should then tune simultaneously together.

Experimenting

If a .0003 mfd. pre-set condenser is used instead of the .0001 condenser, it can be adjusted to provide various degrees of coupling, and volume or selectivity can be further increased, if desired, according to how it is set.

Transformer coupling is also possible between H.F. valve and detector. To do this, put an additional winding on the detector coil, just as shown on the aerial coil in Fig. 2. Take the H.F. valve cap to point 1 on this new winding, and point 2 to H.T. positive. The H.F. choke and associated .0001 mfd. condenser are now not required. When properly arranged, this form of coupling can be very satisfactory.

The H.F. valves mentioned were of the type known as variable-mu ('mu' means 'amplification'). This means they can receive any value of grid bias without distortion. Old valves, such as the 215SG types, though otherwise excellent, cannot be used in this way. Therefore, if such a valve is to hand, it will be necessary to omit the volume control and .1 mfd. condenser, instead taking point 4 on the coil directly to the earth line of the set. An ordinary small switch can then be used for on/off switching of the low tension battery, there now being no need to switch the GB positive lead as well.

If it is desired to simplify matters and use ordinary transformer coupling between detector and output valve, omit the .01 condenser and 50,000 ohm resistor. Take 'P' on transformer to the H.F. choke, and H.T. to about 60 volts on the H.T. battery. Take G.B. terminal to the grid bias battery, about 4.5 volts. The grid lead to terminal 'G' remains unchanged.

With a very long aerial it is desirable to connect a small condenser in lead going to point 1, or the aerial coil may not be able to tune correctly with the detector coil, with consequent loss in volume. Normally, however, good results should be obtained at once.

Readers' Problems—

Transformer Alteration

I HAVE a small transformer which operates on 230-250 volts—50 cycles A.C. driving an electric train set. I should like to alter it so that I could use it on my mains supply which is 230-250 volts 30 cycles A.C. (S.S.—Chesterfield).

FOR a supply averaging 240 volts, 50 cycles, 1,920 turns per sq. in. of core cross-sectional area will be employed. For use on 30 cycles, the number of turns will require to be increased to 2,340 per sq. in. To avoid complete re-winding it might be possible to add approximately 400 turns to the primary, assuring these extra turns are in the same direction as the existing primary, and well insulated from the secondary and core stampings. It is also desirable to add turns to the secondary at the rate of 2 for each volt of the model driven (e.g. 12 volt train, add 24 turns). In the event of the cross-sectional area of the transformer core not being 1 sq. in., determine its actual area by measurement and multiplication, and multiply 2,340 by the figure obtained to find the number of turns required on the particular core size in question. A

core suitable for 240 v. at 50 cycles will have a reactance suitable for 190 v. at 30 cycles. If re-winding is to be avoided, a power resistor or lamp to drop 50 volts could be included in series with the primary, extra secondary turns being added to the transformer to increase the output if the model is sluggish.

Solving Interference

I HAVE constructed a crystal set and find there is too much interference all the time. Is there any way to cure this? (L.F.—Oakenshaw).

YOUR trouble is caused by lack of selectivity, and this is a fault inherent in all crystal set circuits. However, as a rule it should be possible to receive at least one station free from interference. If your aerial is very long, it may be reduced, or a condenser of about .0001 to .0002 mfd. connected in series with the lead-in to the receiver. (If available, a pre-set or variable condenser is best here, as the capacity can then be adjusted to the most suitable value). If the receiver uses a slide-coil tuning arrangement, in some

circumstances tuning may be sharpened by connecting a variable or fixed condenser (maximum capacity .0005 mfd.) in parallel with the winding (e.g. from aerial to earth). Unfortunately most arrangements serving to sharpen tuning, reduce volume.

Commutator Construction

I AM making a three-pole motor of the pronged type, and do not quite know how to connect up. Should I have three brushes? I have only two, with three-segment commutator. (E.B.—Shooters Hill).

YOU should use a commutator with three segments, and two brushes only are required. Wind each pole of the armature in the same direction, looking at it from the outside end. The beginning of each winding should now be connected to the end of the winding next to it. When this is done all round, there will be three double ends, and one of these is connected, in orderly sequence, to each commutator segment. The commutator should be turned a little one way or the other in relation to the armature poles as necessary, to obtain the best running position.

Keep fit by making and using A HOME PUNCH BALL

PUNCHING a heavy bag for a few minutes every day is a simple and cheap way of keeping fit. But for real enjoyment in this way there is nothing to beat the springy punch ball. The effects of the punching can be better judged, and if you should get off balance when close to the ball you will find that it can 'retaliate'—sometimes rather painfully!

Contrary to what is generally believed, the punch ball is not a piece of equipment intended solely for the would-be boxer. Whatever may be the owner's favourite sport, he will find that the ball teaches quickness, balance, and co-ordination of hand and eye, three factors that are of prime importance in any athletic game.

The Ball

It is possible to buy the actual ball which is inflated in much the same way as a football. This will give the most satisfactory results if it can be fastened to the top of a sprung standard, but the fellow who wants to do the entire job from scratch can easily do so.

A piece of 1in. thick wood is taken, and a circle of 1in. radius is cut from it. A hole 1in. in diameter is cut from the centre of this, and eight thin holes are made with a gimlet in the $\frac{1}{2}$ in. rim remaining, these holes being spaced at equal distances apart.

The column is a length of 1in. diameter ash or similar dowelling, 4ft. in length. It fits up through the hole in the previously prepared disc, which is glued to it, so that its top face is at 11ins. from the extreme top of the column.

Wire Supports

Four fairly long lengths of springy galvanized wire are needed. One end of each piece fits in one of the holes in the collar and goes up to the top of the column, across it, and down to the hole directly opposite to the one from which it started. The object of these wires is to form a pear-shaped outline about 8ins. across at the widest part. Drawing (A) gives a sectional side view of the top of the column, showing one such wire in position.

The wire outline will not be found to hold its shape very well, but this is soon

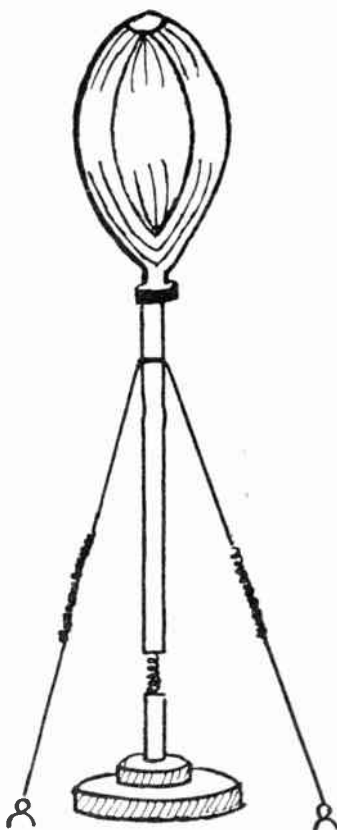

remedied. The end of each wire should be bent sharply at right-angles, so that it is firmly anchored underneath the collar, and the wires should be hammered down firmly (and, if necessary, stapled) at the head of the column. Strands of thin wire can then be tied horizontally to connect the main wires and hold them in place.

The main wires divide the shape of the ball into eight panels. Using a brown paper pattern as a guide, eight panels shaped as at (B) are cut from some good

quality canvas, being made rather wider than required to allow for hemming. These panels can then be stitched to the main wire framework with stout thread, but at this stage the panels should be sewn only half-way up the height of the ball.

Stuffing

Kapok, hair or similar material can be used as stuffing. This should not be packed too tightly, but should be worked into place so that the ball keeps its proper pear shape. As the filling is worked up the ball, the seams of the canvas covering are sewn to the frame. When sewn, the ball will resemble drawing (C).

To prevent the wire frame working through its covering, some thin cotton wadding should be wrapped round the ball and may be held in place, temporarily, by a few stitches. A large piece of leatherette or similar material is tacked through its centre to the top of the column, and is then smoothed down over the ball, pleated as necessary, and tacked to the top of the disc.

The Base

Work can then be started on the base.

Two 1in. thick discs are needed for this, one having a diameter of 9ins. and the other of 4ins. The larger disc should be made up in two halves, and in each portion a series of 1in. diameter holes can be bored to a depth of $\frac{1}{2}$ in. Five such holes will be sufficient on each half-portion (see drawing (D)).

The smaller disc has a 1in. diameter hole bored in its centre, into which a 4ins. length of 1in. dowelling is glued. The two halves of the lower disc are glued and cramped together, while the smaller disc is glued and screwed to the centre of it (see sectional view at (E)).

Weighted Base

To give extra stability to the base, some scrap lead can be melted down and poured into the holes on the underside of the larger disc. The molten lead will char the wood and the weights will tend to fall out, but when each piece of lead has set, a hole can be knocked through it with a large nail, and it can then be held in place by a screw.

The column is fastened to the base by a short length of stout bed spring. It may be possible to pare down the dowel on both column and base so that the

(Continued foot of page 365)

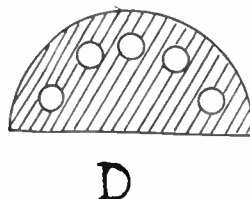
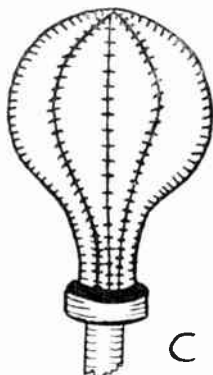
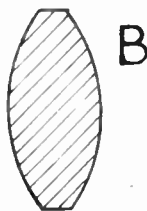
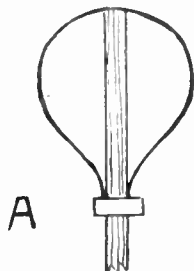

Now is the time to consider the erection of A GARDEN TOOL SHED

A TOOL shed is a desirable feature in any garden, but, unfortunately, its construction calls for a considerable amount of timber. Every handyman knows how difficult it is, nowadays, to get hold of wood in any quantity.

If the garden walls are of reasonable height, however, it is possible to build a shed in one of the corners. Such a building can be quite large, but is economical, as it requires less than half of the timber needed for a shed of comparable size built in the open.

In the details given below definite sizes have been suggested, but these can be varied as necessary to suit individual requirements.

Framework

Two frames will be needed, both being made up of 2 ins. square material. The long side frame measures 7ft. long by 6ft. 6ins. high, outside measurements. All corners are secured by bridge joints which, as can be seen from drawing (A), closely resembles the mortise and tenon joint. Before assembly, each joint should be brushed with red lead, and to make it more secure, a hole is drilled through it and it is pinned with a length of hardwood dowelling.

Two intermediate uprights are also fitted, these having their inside edges at 2ft. 6ins. apart and being central as regards the length of the frame. To enclose the window opening two 2ft. 8ins. long crossbars are housed into

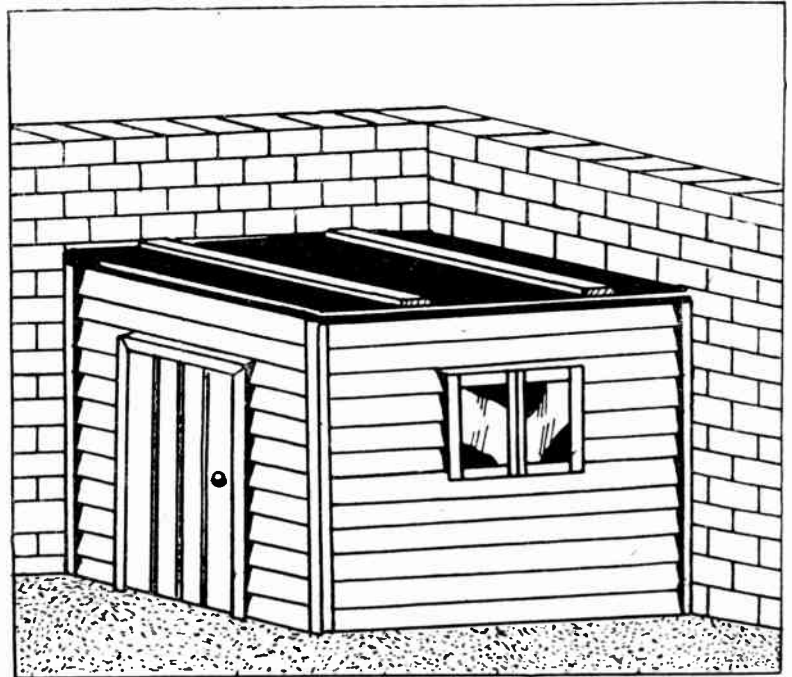

these uprights, these last having their bottom edges at 4ft. 1in. and 5ft. 7ins. from the bottom of the frame. Drawing (B) shows the type of joint used for

fitting these bars, while (C) shows the main dimensions of the long frame.

The end frame is made in much the same way, but has outside measurements of 4ft. 6ins. by 6ft. 6ins. This frame carries the door opening, the size and position of which is clearly shown at (D), and it also has two short horizontal rails that hold the door uprights at their correct distances from the outside uprights.

When completed, both frames should be taken to the site for erection.

Erection

If the shed is being erected on a concrete foundation, the frames can be stood directly on this, but if it is an earth site, the soil must be levelled, all weeds, grass, etc., removed, and the frames stood on a few odd bricks. This will allow of free ventilation underneath the shed and thus prevent rot setting in in the floorboards.

For subsequent dismantling if it is ever necessary, the meeting edges of the two frames can be bolted together, sinking the bolt-heads well into the wood to avoid interference with the weatherboarding. The end of each frame that butts against a wall will need to be screwed to

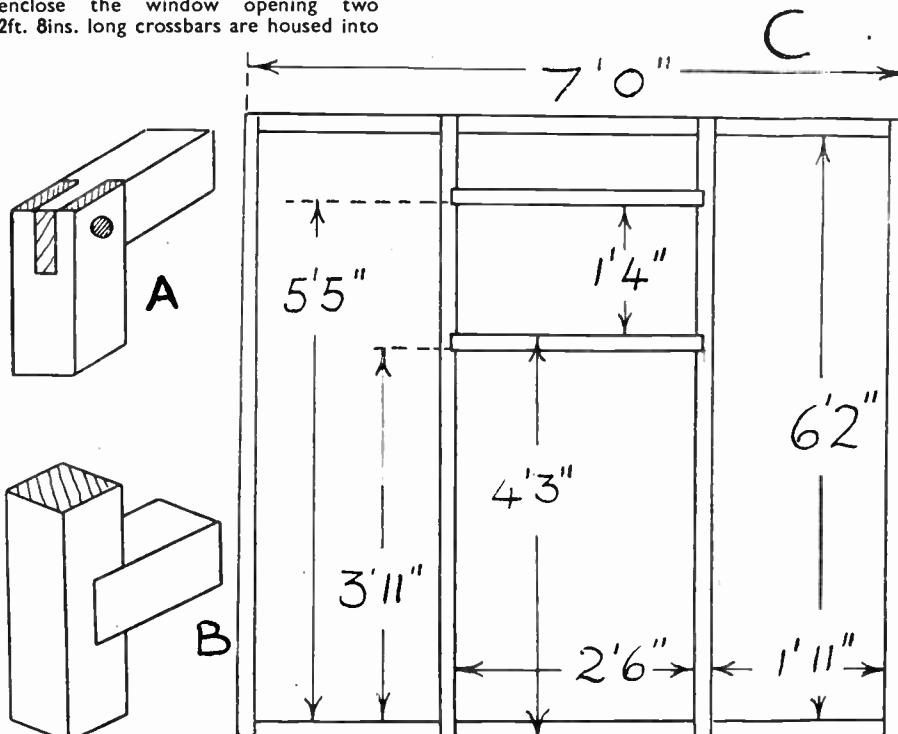

wooden plugs set in the wall. The holes for these plugs are cut with a hammer and brick chisel, the plugs are put in place, and a little cement is run in round them. When the cement has dried the projecting parts of the plugs

which may be chamfered on one edge to make a simple moulding. This moulding is nailed into place with its inside edge flush with the inside edges of the window opening, the bottom edge of the rail of the door frame, and the inside edges of the two uprights of the latter, but extending only to the height of the door frame rail. It will be seen that where this moulding is applied it makes a rebate on the framework.

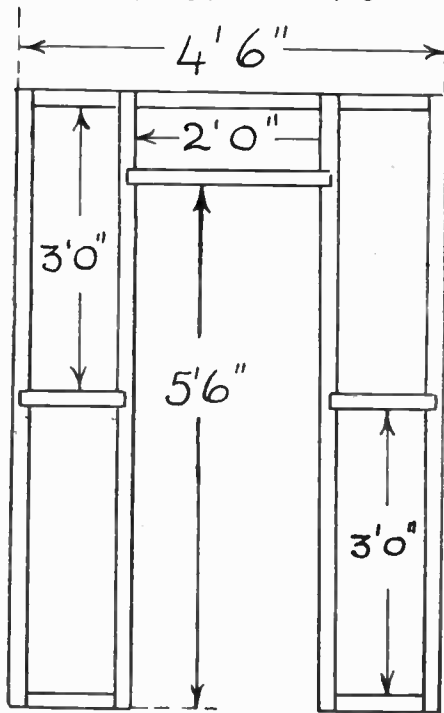

D

can be sawn off and the wood rasped down to the level of the wall surface.

The window and door openings must then be framed with 1 in. by 1/2 in. strip,

Two 2 ins. square rails should be fastened to the walls to act as roof supports. The top edges of these should be level with the top rails of the two

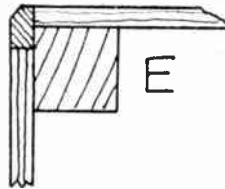

E

frames, and they will have to be screwed to wooden plugs let into the walls.

The roof itself should, preferably, be of grooved and tongued boarding, and is simply nailed on to the rails. It should be allowed to slightly overhang the sides of the shed, and should be covered with roofing felt. The joints in the felt should be covered with small wooden battens, as shown on the drawing of the finished shed.

The Door

Grooved and tongued boarding can also be used for the door, which measures 5ft. 6ins. by 2ft. Lengths of boarding are cramped together to make up the desired width, and are nailed on to three horizontal rails of 3ins. by 1in. The door is hung so that the rails are on the inside of the shed.

If desired, the window glass can be cut to size and fixed permanently into place, but it will be more satisfactory to make two rebated frameworks. Wood 1 in. wide by 3/4 in. thick (carrying a rebate 1/4 in. wide and deep on one edge) will be found most suitable for this. As there are no intermediate bars, ordinary halved joints may be used on the corners. Each framework has outside measurements of 1ft. 3ins. long by 1ft. 4ins. high.

Sheds of this type are not normally fitted with a floor, though one may easily be fitted if desired.

Weatherproofing

To make the shed completely weather-proof it is advisable to seal the joints between the uprights and the wall with some thin mortar. Similarly, the small gap along the back of the roof caused by the rough surfaces of the brickwork can be closed by a thin strip of zinc bent at rightangles, one arm of the angle-piece resting on the felt and the other against the brickwork. (373)

Sunken Garden—(Continued from page 355)

This is done when the cement is firm enough to stand on its own. With a stick, or blunt end of a pencil and a straight piece of wood, the wall is then marked out in the form of stones in layers. The horizontal lines are first marked the entire length of the section, the vertical

lines are added after, according to the desired size of the 'stones'.

Curved walls are made in a similar manner except that a bendable material must be used for the side of the wall. Strips of old linoleum will do, but they must be well supported on the outside

as they tend to bulge under the weight of the cement. A perfect curve is not necessary as such imperfections are lost when the surface is cut into small stones.

If a piece of curved wood is not available for cutting the lines across, short straight pieces can be used, taking care not to dig the ends into the cement.

A nice finish to the top of the wall is obtained by making separate slabs of cement, wider than the wall itself, so that they jut out slightly. These slabs can be made by making a mould of a base plank, a fixed strip of wood running the length of one side of the plank, and a similar strip but detachable on the other side. The ends too will of course be built up to hold the cement.

If a smooth finish is required, the cement is used fairly wet. There should be no small stones in the sand. When firm, this long strip of cement can be cut across with a knife while in the mould; finally before absolutely hard the movable strip is taken away and the slabs separated.

For the top of the curved wall, pieces will be cut out narrower one end than the other. The slabs when hard are cemented on top of the walls, the gaps in between being filled in with very liquid cement. (293)

Our Advertisement pages are always worth studying

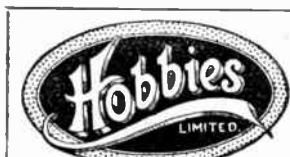

BRANCHES LONDON

78a New Oxford St., W.C.1
(Phone MUSEum 2975)
87 Old Broad Street, E.C.2
(LONDON Wall 4375)
117 Walworth Road, S.E.17

GLASGOW

326 Argyle Street
(Phone CENTral 5042)

Head Office & Factories—HOBBIES LTD., DEREHAM, NORFOLK

MANCHESTER

10 Piccadilly
(Phone CENTral 1787)

BIRMINGHAM

14 Bull Ring

SHEFFIELD

4 St. Paul's Parade

LEEDS

10 Queen Victoria Street
(Phone 28639)

HULL

10 Paragon Square

SOUTHAMPTON

25 Bernard Street

BRISTOL

30 Narrow Wine Street
(Phone 23744)

Experiments with cobalt chloride in our series of HOME CHEMISTRY

THE mention of cobalt chloride conjures up the idea of sympathetic inks. The interest of cobalt chloride for the home chemist, however, need not finish there, for many cobalt compounds can be made with simple apparatus and common chemicals. Those dealt with in this article are some of the rarer ones and, therefore, doubly interesting.

A Beautiful Compound

Cobalt mercuric thiocyanate is an unusual and beautifully coloured compound. To prepare it mix solutions of cobalt chloride and mercuric chloride, then add ammonium thiocyanate solution. Unless the solutions are strong nothing happens immediately, but on standing a splendid royal blue crystalline precipitate forms. Set the solution aside overnight so that the precipitation may complete itself. Then wash it by decantation several times, preferably with hot water.

Pigments

Cobalt salts when heated with salts of some metals form brightly coloured substances of complex composition. These are known as cobaltites and are used as pigments. Rinman's green, for instance, you can prepare by mixing solutions of zinc sulphate and cobalt chloride and then adding sodium carbonate solution.

Filter the precipitate, wash it on the filter, and dry it in the oven. If you now heat this strongly in a crucible carbon dioxide and water will be given off and the pigment will be left in the crucible.

Cobalt blue or Thénard's blue is another of these cobaltites. To prepare it, mix cobalt chloride and alum solutions and precipitate with sodium carbonate. Then filter, wash, dry and heat it in a crucible. Both of these pigments make good oil or water colours.

Cobalt Yellow

Another brightly coloured cobalt compound is potassium cobaltinitrite, which is also known as cobalt yellow. To prepare it, add acetic acid to cobalt chloride solution until the mixture smells strongly of the acid. Now add potassium nitrite solution.

Either at once or on standing, a brilliant yellow crystalline precipitate of potassium cobaltinitrite is formed. Filter, wash and dry it in the usual way. This reaction serves as a useful test for cobalt or potassium, but as ammonium forms a similar compound, it should be used only as a confirmatory test.

If you have the use of a rough balance, such as a cheap photographer's dispensing balance, you can make up a solution of sodium cobaltinitrite, which is soluble in water and can hence be used as a test solution for potassium or

ammonium. Dissolve 5 grams of sodium nitrite and 3 grams of cobalt nitrate in 15 ccs. of warm water.

When they have dissolved, add 1 cc. of glacial acetic acid. On adding a few ccs. of this solution to a potassium or ammonium salt solution, yellow precipitates of the cobaltinitrites are formed.

Salts

When solutions of cobalt salts are mixed with ammonium salts and ammonium hydroxide and exposed to the air, they absorb oxygen, forming complex compounds known as cobaltamines. Over two thousand of these are known. One which is simple to prepare is rosecobaltic chloride. First pre-

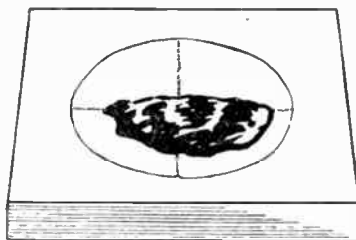

Drying a precipitate

cipitate cobalt hydroxide by mixing hot solutions of cobalt chloride and sodium hydroxide.

Wash the pink precipitate well on the filter and dissolve it in a solution of ammonium chloride to which enough

ammonium hydroxide has been added to give it a strong smell. In a day or two the solution will have become violet-red in colour. Now add hydrochloric acid and some methylated spirit. A heavy red crystalline precipitate of rosecobaltic chloride is formed.

Drying

Filter and wash it with a little hydrochloric acid and then with a little cold water. Open out the filter paper and put it on a clean porous tile or brick, as shown and leave it to dry at room temperature—not in the oven, for heat decomposes it.

A beautiful pink salt of cobalt is the oxalate. This is insoluble in water and so is made by adding to cobalt chloride solution a solution of an oxalate, such as the common laboratory reagent ammonium oxalate. Pink cobalt oxalate is precipitated. Wash this well on the filter and then dry it in the oven.

Stock

Reserve half of the cobalt oxalate for your chemical stock. Put the rest into a crucible and heat it strongly with a bunsen flame, leaving off the crucible lid. The oxalate gives off carbon dioxide and water. When all action has ceased and the crucible contents are red hot, allow the whole to cool. You will find a black powder has been formed. This is one of the oxides of cobalt and has the re-sounding name of cobaltoso-cobaltic oxide!

A Queer Hobby

WHEN in 1897, the American mariner Captain Joshua Slocum, who was the first man to sail single-handed round the world in a small yacht, called at Pretoria during a spell in South Africa on his way home, he met and dined with the famous President Kruger. The President was much interested in Slocum's feat, but was so bold as to tell him the world was flat! The old sailor, halfway on his journey round the globe, laughed to himself, but said nothing, but Kruger believed he was right. Nor has he been the only South African to hold this out-dated belief. In many of the flat parts of the country

people still cling to the notion that the earth is laid out flat. Inspired by President Kruger's example is one such person, Mr. E. Venter, who himself subscribes to the view of what Rudyard Kipling called the 'geoplanarians'. A resident of Bloemfontein, he has made himself a hobby out of this strange belief, for he collects literature of all kinds—books, tracts, propaganda pamphlets, which set out to prove that the earth is flat. His collection is an impressive one, containing many weird arguments in favour of a flat earth. But obviously Mr. Venter and his fellow-believers are not sailors or airmen! (280)

Odd wood can be cut and shaped for children's BUILDING BRICKS

HUNDREDS of interesting models can be built with the simple and inexpensive set of wooden bricks described below. It will give hours of delight to any boy or girl who is fond of 'making things'.

The materials needed are few, and it is possible to make the set in an evening or two. For the bricks, the writer used two wooden ends of an apple box, costing 3d. A similar one should readily be obtainable from your greengrocer.

The Bricks

Remove the two ends (12ins. by 10ins. by $\frac{3}{4}$ in.), and glasspaper them all over until quite smooth. Then, from one of these pieces, cut twelve lengths, 10ins. by 1in.; and, from the other, six lengths, 10ins. by 1in. Each of the twelve lengths should be cut into 2in. bricks, and each of the six into 1in. bricks. You will then have sixty 2in., and sixty 1in. bricks.

All the bricks should now be given a white undercoating, and, standing on end, allowed to dry. Then apply white paint or enamel.

Roof and Chimney

The roof is formed of two wooden pieces, each 8ins. by 4ins. by $\frac{1}{4}$ in. They

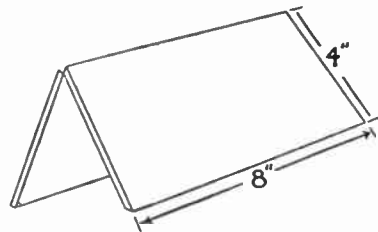

Fig. 1—The roof

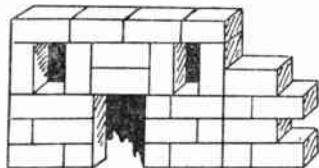

Fig. 4—Making doors and windows

should be fastened together with two small hinges (Fig. 1).

Model Making Building Bricks

Cut another 2in. brick for the chimney, and remove a V-shaped portion, to enable it to rest on the roof, when opened to cover a building (Fig. 2). This chimney and roof are to be painted red.

When dry, dip an artist's brush into Indian ink, and draw lines to represent tiles and bricks.

Three pieces of thick cardboard will be found useful for making floors and ceilings for the buildings. Convenient

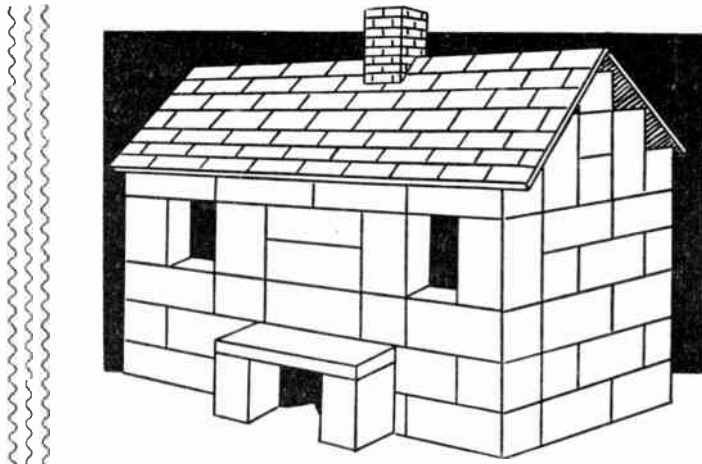

sizes are—5ins. by 5ins., 4ins. by 4ins., and 3ins. by 3ins.

Making the Box

A compact box in which to keep the building bricks can easily be constructed. Two strips 10 $\frac{5}{8}$ ins. by 2 $\frac{1}{2}$ ins. by $\frac{1}{4}$ in., nailed to two more strips 12 $\frac{1}{4}$ ins. by 2 $\frac{1}{2}$ ins. by $\frac{1}{4}$ in. form the sides; while the bottom and top portions measure

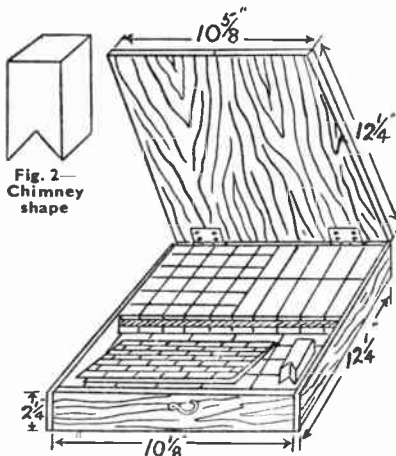

Fig. 3—A suitable container

12 $\frac{1}{4}$ ins. by 10 $\frac{5}{8}$ ins. by $\frac{1}{4}$ in. The top part, forming the lid, should be hinged.

DESIGN FOR MODEL FIRE ENGINE

Materials for making the Model Fire Engine from this week's design, (No. 2888) are available price 6/- from Hobbies Branches; or 6/10 post free from Hobbies Ltd., Dereham, Norfolk.

A strip 10 $\frac{5}{8}$ ins. by $\frac{1}{4}$ in. by $\frac{1}{4}$ in., nailed about half way across the box, will keep the bricks neatly together, leaving a space for the roof, ceilings and floors, and chimney. Fix a small hook at the front of the box to fasten the lid securely (Fig. 3).

Doors and Windows

A method of making doors and windows is shown in Fig. 4. For quick assembly, ready-made doors can readily be made with two bricks, each 1 $\frac{1}{2}$ ins. by 1in. by $\frac{3}{4}$ in., over which is nailed another piece 3ins. by $\frac{3}{4}$ in. by $\frac{1}{4}$ in. Windows are similarly formed with two bricks, each 1 $\frac{1}{2}$ ins. by 1in. by $\frac{3}{4}$ in., under and over which are attached pieces each measuring 3ins. by $\frac{3}{4}$ in. by $\frac{1}{4}$ in. (Fig. 5).

If these ready-made doors and windows are to be included, obviously the box

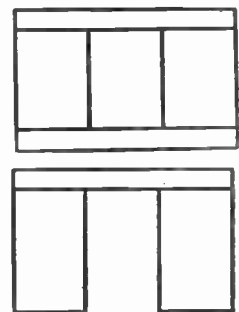

Fig. 5—Window and door construction

will have to be enlarged proportionately.

The interior of a building can be illuminated by placing in it a small electric lamp in a holder, to which is attached a piece of flex connected with a cycle lamp battery.

With this set of bricks a large number of fascinating models can be built—houses, shops, castles, fortresses, towers, and a host of other objects of absorbing interest to young and old alike. (362)



ON SELLING STAMPS

WE all know that stamp collecting can be a rather expensive matter if one is going to procure all those stamps one wants (excluding, of course, the really rare ones, which would be impossible except for a millionaire). But suppose one considered those stamps as rare if they cost over £10, even then it would be a matter of greater expense than the majority can manage.

Now what is the best way of setting about buying lots of stamps? To buy each separately would add very much to the cost and also it would waste an enormous amount of time.

A much better manner would be to buy them by countries or even by collections, but by doing so we should be bound to gather a great number of duplicates in quite a short time. It is these duplicates that one wants to consider selling. What is the best way of getting rid of them so as to recover some of the money expended on making a good collection?

Three Methods

There are three main methods and each has its special merits. The three ways are, first the sale of single stamps, second the sale of the duplicates as a collection and third by circulation in an exchange club. Suppose we take these methods in turn and consider which will suit what we have for disposal.

The first—single stamps. Well, this method would provide the best return of money, but the disadvantage is this, you will not be able to find a buyer for all your stamps very quickly. Valuable stamps will always find a ready sale at a reasonable price, say, about a quarter to a half of the catalogue price for a good specimen. But the trouble is that it is not the valuable stamps that we want to sell.

The price just mentioned was that which was averaged for stamps at an auction the writer attended recently. Common stamps, say, those of less than 10/- catalogue value, cannot be sold singly at the usual auction.

The only suggestion that one could offer for the sale of those would be to mount them on a sheet of cardboard,

price them and to ask some shopkeeper to put them on sale in his shop. They should only be priced at from a tenth to a quarter of the catalogue value, the higher amount for the more fashionable, such as the British Colonials which are in good condition.

Shopkeeper's Profits

Naturally the shopkeeper will want paying for his trouble. He will most likely ask for a proportion of the takings, and he may or he may not look after the stamps. If for example he exposes them in the sun, then it will spoil quite a lot and they will not then sell. More common stamps should be made up into packets and sold in the same way; that is to ask the shopkeeper to dispose of them.

If the duplicates are mounted in a collection and sold in this way, then you could expect to get a higher price. But there is, of course, quite a lot of work involved, and these days few people have time to spare.

If you do decide to make up a collection of the duplicates, then decide how many stamps you are going to put in the finished collection and buy an album to fit. It is quite unwise to think that a large album with only a few stamps will fetch a big price. A smaller but a better filled album is much more pleasing.

Display

Since you have decided to make a collection, then the stamps must be mounted properly, and in the correct order. That is, as they were issued, with certain spaces left so anyone who purchases will be able to add to the collection as they wish. A mounted collection of, say, 2,000 will fetch very much more than the same stamps placed in an envelope and sealed down.

Unless you know the value of the collection, then it is better to send the stamps to an auctioneer for disposal. Quite a number of people will see them and then they will decide how much they want it and bid against one another for it. In any case it is not likely to go for a very low price, as if it is an exceptional bargain, then others will want it and the price will go up. Just now collections are

making very good prices indeed, particularly if there are a few desirable stamps among the others.

Possibly owing to having some friends or relations in some quarter of the globe, you have a great number of stamps from this region. Then you could make up a collection of stamps from this country and sell as a one-country collection. Again the best way being to send them to an auction.

The Auctions

One disadvantage of sending stamps to an auction is the wait before they are put up for sale. Naturally the auctioneer will require a little while to make up his catalogue, which is something like ten or twelve weeks. But you do learn what the approximate value is and you can place a reserve on the stamps and so avoid their being sold too cheaply.

Exchange Clubs

The third suggestion was by means of an exchange club. Now if you join one of these, this is briefly what happens. You mount the stamps that you have for disposal in a book—frequently these are sold by the club—and you write the price that you want for each stamp above and send the book to the club secretary.

He makes up a parcel of all the books that he has and sends them out to, say, Mr. A, with a list of addresses, so that Mr. A when he has seen them, sends the parcel to Mr. B and so on. Mr. A takes out the stamps that he wants and writes his name in the vacant spaces and sends the money to the club secretary. Mr. B does the same.

Then after the books have gone the round and come back to the secretary, he calculates what amount if any is due to each member and sends this, less a certain percentage which he keeps for expenses. Here again only the good specimens are saleable.

Most clubs are seeking new members, so if you have any fairly good stamps for sale at a fair price, there is no reason why they should not bring back some of the money that has been spent on making a collection.

Punch Ball—(Continued from page 360)

ends of the spring will grip tightly. Alternatively, the ends of the springs can be stapled down on to the dowels, but whichever method is adopted, it is essential that the spring should be perfectly secure.

A simple metal or wooden collar is fitted round the column a few inches below the punch ball, and to the ends of

this, two side guys are fitted. Each guy can consist of two pieces of stout cord connected by a length of spring in the middle. The lower end of each guy will have to be fastened to a small screw-fitting in the floor, but before finally connecting the guy, it will be necessary to adjust the tension so that the ball is properly sprung.

This completes the ball, but a final hint is advisable.

Although a definite length has been given for the column, do not hesitate to cut a piece from it if the ball is found to be too high. The centre of the ball should be at a position where it gets the full benefit of a 'straight left'. (374)



For 101 jobs for the home

**CUTTING CARD
WOOD, LEATHER
SHEET METAL
COMPOSITION
SLATE, HORN, etc.**

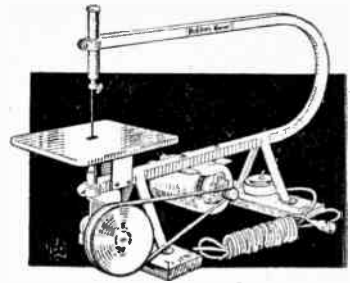

The real craftsman and handyman knows the greatest joy in his work with a fretmachine. It is easy running, strong and rigid—halves his labour and doubles his output. Hands are free to manipulate the work. The frame allows a sweep of from 17ins. behind the saw for large work. Prices range from 70/- to £10 and details are obtainable from all ironmongers and stores. See them at Hobbies own Branches in London, Glasgow, Manchester, Birmingham, Sheffield, Leeds, Hull, Southampton, Bristol. Or write for free illustrated list to Hobbies Ltd., Dereham.

For Toy making Model making Fretwork

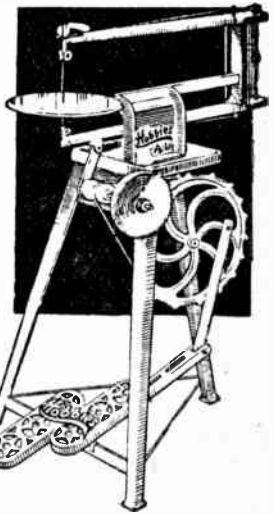

HOBBIES MOTOR AND TREADLE FRETSAWS

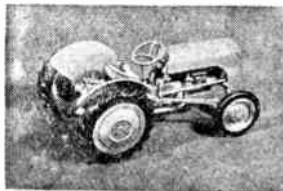

MAIL ORDER HOUSE, BEDFORD SQUARE, SIDMOUTH, DEVON

BOYS!!! BOYS!!!
With the aid of our amazing assembly outfit you can quickly and easily assemble this superb scale model of the famous 'Ferguson' Tractor. All parts supplied in finished state. All Plastic construction, real rubber trakgrip tyres. Can be dismantled and re-assembled with ease. Send P.O. today for 8/- post free.

MURRAY HILL & CO. (Dept. H.)
SQUARE, SIDMOUTH, DEVON

PEDAL MOTOR CAR

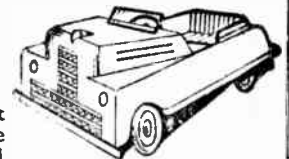

This new simplified chart enables any amateur to make a strong smart modern Pedal Car suitable for children 2 to 5 years. Complete plan and instructions **2/6** post free

Wheels and other parts for Pedal Cars and Dolls Houses available. Send stamped addressed envelope for list.

ZIMPLAN 88 WARE ROAD
HODDESDON, HERTS



THE BOLSTER HOME WATCH AND CLOCK REPAIR OUTFIT

These precision jewellers instruments include watchmaker's magnifying eyeglass, finest watch tweezers, set watchmaker's screwdrivers, watch and clock oil, oilers, dusting powder, clock brush, plus illustrated instructional manual for the amateur. In container 12/6 post free.

Senior Outfit includes everything above, plus watch jewels luminous compounds, dial renewer, jewellers rouge, explanatory book. Price 21/- post free.

BOLSTER INSTRUMENT Co. (Dept. H.W.), 5a Station Parade, Ashford, Middx.

MODEL RAILWAY CLUB EXHIBITION

EASTER WEEK, TUES MAR. 27th to SAT. MAR. 31st

The work of members of the Model Railway Club, over 3,000 models of locomotives, coaches, wagons, signals and working tracks. Free rides behind real steam engines.

CENTRAL HALL, WESTMINSTER

Tuesday 2 p.m. to 9 p.m. Thereafter 11 a.m. to 9 p.m.

Admission—Adults 2/6 Children under 14 1/-
SPECIAL TERMS FOR ORGANIZED PARTIES on application to:

R. C. PANTON, 162a STRAND, LONDON, W.C.2

YOU CAN BECOME A HANDICRAFTS INSTRUCTOR

EXPERIENCE NOT ESSENTIAL

Men who enjoy making things in wood or metal can turn their hobby into a permanent and interesting Career. Short hours, long holidays, and security in a job you would really enjoy, can be yours if you become a Handicrafts Instructor. Let us send details of the easiest and quickest way to get the necessary qualification.

**We definitely guarantee
"NO PASS—NO FEE"**

If you would like to know about our unique method of preparing you for one of these appointments, write today, and we will send you our informative 176 page Handbook—free and without obligation. Mark your letters "Handicrafts Instructor".

**BRITISH INSTITUTE OF
ENGINEERING TECHNOLOGY**

595 Shakespeare House
Stratford Place, London, W.1

BIET

new MARK II BENCH SAW

Introducing the vastly improved Mark II version of the popular Masco Bench Saw—best of the old features retained, but note new points gained from world-wide use by purchasers.

1. Solid base to avoid distortion.
2. Improved rise, fall and tilting adjustments with strengthened fixing lug.
3. Saw table strongly ribbed, size 11ins. by 5½ins.
4. Protractor Quadrant Angle Guide.
5. Thicker 6in. diameter saw blade to prevent flexing under side pressure
6. Adjustable fence of improved design with positive locating device.
7. Phosphor bronze bearings.
8. Ground Spindle.
9. Stouter three point mounting.

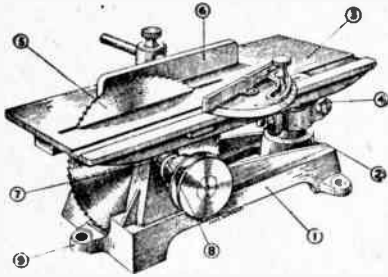

Note also that direction of saw, now clockwise to take advantage of greater length of table and provide greater protection as saw now working behind the pillar supporting the table instead of in front of it.

What users say: '... a very compact job'.
 '... a cabinet maker ... will do ... a lot of work normally ... have to do by hand'.
 '... the saw a great help ... will rebate groove-cut small tenons ...'
 '... I am pleased with it ... it will save a lot of time ...'

EASY PAYMENT TERMS 2S/- Deposit with order and six monthly payments of 17/6. No references or guarantors required.

POST FREE DELIVERY

£6 . 6 . 0

MODEL ACCESSORIES SUPPLY CO.

The Aerodrome, Billington Road, Stanbridge, Nr. Leighton Buzzard, Beds.

EXTRA CASH IN SPARE TIME

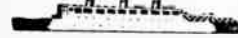

A fascinating way of earning extra cash in spare time from odd pieces of lead. Small Outlay—Large Profits. Sample mould 3/6d. Casting moulds, deep-cut and ordinary type Aeroplanes, Soldiers, Farm and Wild Animals, Cars, etc. Stamped envelope for full list Illustrated Catalogue 9d.

MASTERCRAFT MOULDS
 69, ST. MARKS ROAD, HANWELL, LONDON, W.7

the strong point of every hobby...



Aero Glue. The strongest glue in the world.
Universal Glue. Cold glue ready for use from tube or tin.
Waterproof Cement. Specially prepared for balsa wood.
Whyte Paste. For paperwork and photo-mounting, etc.

CROID LTD., IMPERIAL HOUSE, KINGSWAY, LONDON, W.C.2

TO CELEBRATE THE 10th BIRTHDAY OF THE A.T.C.



GIVE YOURSELF THIS GRAND BOOKLET

This year the Air Training Corps is 10 years old, and what a great start it has given to thousands of young men who are now playing a leading part in the Royal Air Force. You, too, will find that the A.T.C. has a place for you if you are keen, healthy and ambitious.

Send coupon now for this 12-page illustrated booklet that tells you all about the A.T.C.

TO: R.A.F. HOME COMMAND (H.S.30)
 WHITE WALTHAM, BERKS.

NAME _____

ADDRESS _____

AGE _____

There's a place *for You* in the **A.T.C.**

FOR FACES & PLACES



ILFORD

SELOCHROME

FILM



RAWLPLUG PRODUCTS

**INDISPENSABLE
IN THE WORKSHOP
HANDY IN THE HOME**



DUROFIX

The indispensable adhesive for instant use on crockery, glass, wood, metal, celluloid and the thousand and one things handled by the hobbies enthusiast. Instant drying, insulating, water-proof and heatproof. Durofix is grand for repairs to electrical, sports and leather goods. Tubes 9d. and 1/3d. Tins 2/9d. and 7/6d.



DUROGLUE

UNDILUTED ANIMAL GLUE OF INCOMPARABLE STRENGTH

Ready for instant use for the many purposes for which an extra strong glue is needed. Wood, cloth, fabric, felt, leather and any greaseless surface can be stuck with Duroglue. Tubes 6d. and 1/- Tins 2/3d. and 3/9d.



PLASTIC WOOD

APPLIED LIKE PUTTY, DRIES LIKE WOOD

Can be cut, sanded, polished & painted like wood. Will take nails and screws like wood. It does not blister, crack or decay. Rawlplug Plastic Wood is actually the best quality product of its kind on the market. Tubes 10d Tins 2/- & 5/-.



TILE CEMENT

Rawlplug Tile Cement is a liquid cement possessing

very strong adhesive qualities. For replacing tiles to walls, floors, fireplaces, hearth, curbs, etc., in kitchens, lavatories, bathrooms, halls, bedrooms, reception rooms, etc. 2/3d. per tin.



SHARPENER

efficient Tool with a great number of uses. Hardwood Handle, polished and varnished with Sharpening Stone of medium grading. Use water, or a thin clear oil if stone cuts too rapidly. For cleaning stone—wash with paraffin. 2/- each.



SCRAPER

finish without chatter or scratching. Easy-grip handle made solid with blade carrier in seasoned hardwood, polished and varnished. Total length approx. 6". Fitted renewable 2 1/4" Cadmium Plated Steel Blade, with cutting edge ground like a razor. 3/- each.



FUSE WIRE

BE PREPARED FOR BLOWN FUSES

A useful card carrying 3 gauges of fuse wire (3 amp. for lighting, 10 amp. for heating and 15 amp. for power). Directions for use are printed on the card which is punched for easy hanging near the fuse box. 3d. per card.

RAWLPLUG FIXING DEVICES & TOOLS

Whatever your fixing problems, there's a Rawlplug Device that will solve it for you—easily and quickly. Rawlplugs make neat and absolutely firm fixings in any material from plaster or brick to stone or slate, with a size for every screw from No. 3 up to 4" coach screws. Raw plug Tools are easy to use and ensure a perfect hole without damage to surrounding surfaces. Other Rawlplug Devices include Rawbolts for heavy duty fixings, Rawanchors and Toggle Bolts for thin or hollow materials and Rawclips for instant fixing of conduits and cables to girders—a device in fact for every need.

Rawlplug fixing devices and products can be obtained from Ironmongers, Hardware Dealers, Stores or Model Makers Suppliers.

THE RAWLPLUG COMPANY LTD. LONDON. S.W.7.

Printed by BALDING & MANSELL, LTD., London and Wisbech, and Published for the Proprietors, HOBBIES LTD., by HORACE MARSHALL & SON, LTD., Temple House, Tallis Street, E.C.4. Sole Agents for Australia and New Zealand Gorden & Gotch (A'sia) Ltd. For South Africa: Central News Agency Ltd. Registered for transmission by Canadian Magazine Post.

Hobbies

WEEKLY

CONTENTS

	Page
Tea Trolley - - -	369
Microscopic Sillies -	370
Simple Home Repairs	371
Revolving Cabinet -	372
Stencil Letters - - -	373
Table Skittle Game -	374
Shaving Mirror - - -	375
Small Table Mats - -	376
Washday Gadgets - -	377
Cycle Overhaul - - -	377
Lampshade for 1/- -	378
Plaster Plaques - - -	379
Ferret Hutch - - -	380
Home Chemistry - - -	381

March 14th, 1951

Price Fourpence

Vol. III No. 2889

A TEA TROLLEY FOR THE GARDEN

A DINING-ROOM service wagon can be made into quite a beautiful piece of furniture, but this is not possible with the tea trolley designed solely for garden use. An elegant finish, small rubber castors, and so on, would be sadly out of place at the picnic tea.

This is not to say that a garden trolley can be made in a slipshod manner from any odds and ends of material. The more familiar design must be modified to suit the new requirements, but the underlying principles of the design must be sound.

For the wagon described below it is suggested that ash, beech or elm be used. The timber must be of reasonably good quality without too high a percentage of knots, for the work is neither stained nor painted. This is not intended as an economy measure, but a natural wood finish is more in keeping with the design, and none of the untreated woods mentioned will come to any great harm if they are left exposed to the weather for a few days.

The four legs are of $1\frac{1}{2}$ ins. square material, the two back legs being 2ft. and the front legs 1ft. $10\frac{1}{2}$ ins. long. In what is to be the outside edge of each front leg a slot $4\frac{1}{2}$ ins. long by $\frac{3}{4}$ in. deep is taken out with the tenon saw, while on two

adjacent faces of each leg a $\frac{1}{2}$ in. diameter hole is bored. These holes have their centres at 2 ins. from the top of the leg. Before drilling the holes the legs should be arranged in pairs to ensure that they are drilled on the proper faces.

These holes must be drilled to such a depth that they meet in the centre of the thickness of the legs. They are intended for lengths of dowel (shown shaded

black on the perspective sketch) that 'tie' the parts of the framework together.

Two narrow frameworks are made by gluing a 1ft. 5 ins. length of $\frac{1}{2}$ in. diameter dowel between the holes on the front and back pairs of legs. Before being glued into place the end of each dowel

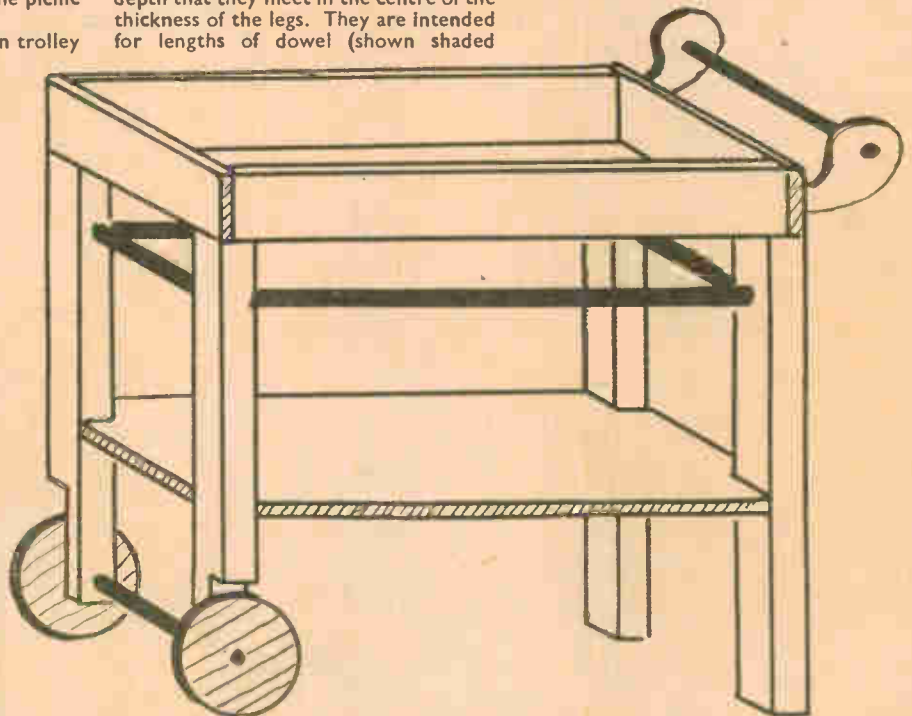

All correspondence should be addressed to The Editor, Hobbies Weekly, Dereham, Norfolk.

must be cut across at an angle to 45 degrees, so that the long side dowels, when similarly treated, will be able to fit correctly into the leg. Drawing (A) shows the front pair of legs at this stage.

When the glue on these two frameworks has dried the long side dowels (2ft. 5ins. long) can be glued into place. At this stage the framework will not be

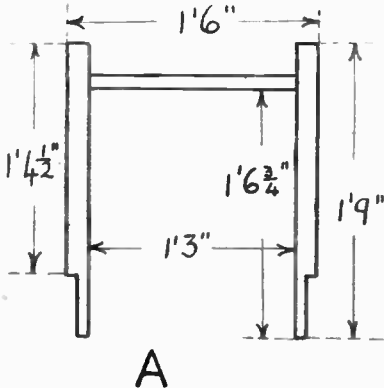

A

particularly strong, and to prevent it sagging, the front legs should be, temporarily, supported on 3ins. thick blocks.

Bottom Shelf

The next step is to fix the bottom shelf. This measures 27ins. by 15ins., and may be of 1/2 in. plywood or 1/2 in. solid timber; in the latter case boards will need to be glue-jointed together to obtain the required width. A rectangle 1 1/2 ins. square is cut from each corner so that it can be housed round the legs, and it is fixed into place so that its lower edge is at 9ins. from the bottom of the back legs.

Special fittings are available to simplify the fixing. Each fitting has two screw-holes bored in a thin metal plate,

the end of which carries a screw-thread. One such fitting is screwed in to each of the two inside faces of each leg, then screws are driven up through the holes in the plate into the under-side of the shelf. A plan of this arrangement is given at (B).

Wood of 1/2 in. thickness is used for the top tray. The sides of this are 3ins. deep and they are assembled with ordinary screwed butt joints to make a framework measuring 27ins. by 15ins. These joints, and all screwed work in the construction, should be fastened with flat-head brass screws, countersunk so that they are flush with the surface of the wood.

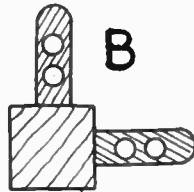

B

Three 1in. wide by 1/2 in. thick strips are then screwed between the long sides of the framework, level with the bottom edge. Two of these strips butt against the inside edge of the long sides, while the third is midway between them. The tray is then fastened on top of the legs, using a 2in. screw at each corner.

Eleven short strips of 1in. by 1/2 in. are then screwed down on top of the longitudinal strips on the inside of the tray, these being spaced at equal distances apart. Drawing (C) gives a plan of the completed top tray as viewed from beneath.

Handle

The handle is the next item to be fixed. End brackets for this are cut from

1/2 in. thick wood to the shape shown at drawing (D). This drawing has been covered with a gridded framework to make the outline easy to follow, each small square of the grid having sides that must be assumed to be 1/4 in. long. At the position indicated, a 1/2 in. diameter hole is drilled in each bracket, and a 1ft. length of dowelling is glued between these. The assembled fitting is then screwed to the back rail of the top tray, being set in the centre of the length of it.

The wheels are simply circles of 1/2 in. thick wood, and are 5ins. in diameter. A 1/2 in. diameter hole is bored through

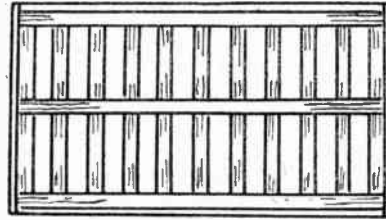

C

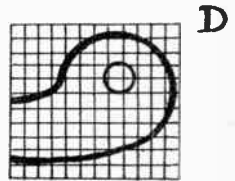

D

the centre of each, while similar holes are bored in the half-thicknesses of the front legs, the centres for these holes being at 1in. from the bottom of the tongue.

Axles

Dowelling is used for the axle, but it should be slightly eased with coarse glasspaper at the points where it passes through the holes. The axle should have an overall length of 1ft. 9 1/2 ins. Its end is glued into one of the wheels (flush with its outer surface), it is threaded through the holes, and the second wheel is then glued into place. The glue should be given a good chance to set before the wheels are tried out. Apart from a thorough glasspapering, this completes the work on the trolley. (375)

Making Microscopic Slides

FOR the amateur naturalist there are few more fascinating branches of his craft than microscopic work. Even if one is not the possessor of a microscope there are now a number of cheaper instruments available which serve almost the same purpose at a far less expensive outlay.

The making of slides, with the infinite variety, saves extra expense, while at the same time being interesting and satisfying. They are simply made, and at little cost.

The Slides

The slides themselves can be bought or cut from plate glass or from old negative camera plates from which the negative is removed by washing in hot soda and water. They should measure 3ins. by 1in.; this is the size of normal slides.

Besides these there will also be required a solution of balsam and chloroform, small glass setting rings, a

small earthenware tile, and brunswick black varnish.

Little is needed in the way of instruments, but some pointed steel knitting needles will be useful for setting some of the subjects; and also a small pair of forceps, clean razor blades, test tubes, and watch glasses. Some subjects will require to be dyed, and for this violet methyl is generally used.

Mounting the Subjects

More opaque subjects require to be soaked in turpentine for a few days to make them more transparent. Those which can be mounted dry are dealt with thus. In the centre of the slide let fall a drop of balsam, and work this to a small circle of the liquid. Place the slide on the earthenware tile which has already been slightly warmed.

Make a ring of the varnish round the balsam, and the heat will soften this in readiness for the setting ring to be put in place. When this is placed over the subject, which is put carefully in position

in the spot of balsam, press it gently and firmly so that all the air is excluded at the same time. The plate may then be allowed to cool.

Opaque Subjects

Soak these for a few days in turpentine, then wash in clean water. If they require to be dyed, place them for a minute or two in the methyl. Place the balsam on the slide, put the subject in position, press on the setting slip, and varnish it into position round the edge.

When dealing with moist subjects, such as the part of a small insect, the whole can be soaked for a few days in liquor potasse, and the part desired can then be worked away and washed in clean water. Dry them on blotting paper, and they can then be mounted as explained before.

Variety of Slides

The field from which subjects can be chosen is almost without limit. Sections

(Continued foot of page 371)

How the handyman can easily undertake SIMPLE HOME REPAIRS

In these days of rising prices, the ordinary man is compelled to economise as best he can. One way of saving money is to do your own household repairs. The only tools necessary are those the handyman already has in his possession, a pair of pliers, wrench, screwdriver and file. Here are a few simple hints on how to undertake some of these minor jobs about the home.

A Dripping Tap

If the tap drips continuously, it follows that the rubber washer in the tap has worn out and requires to be renewed. To fix a new washer in the tap, first unscrew the cover (see Fig. 1) to reveal nut (A), which should be turned anti-clockwise until the top of the tap is disconnected from the bottom half. All that remains to be done is to

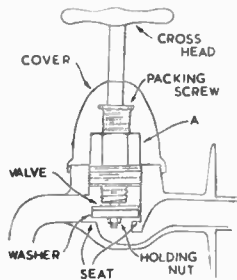

Fig. 1—Tap section

unscrew the lock nut which secures the old washer, take

screws to fix the new tap to the pipe board.

The Overflowing Cistern

Another common domestic problem is the overflowing lavatory cistern, or it may be the cold water storage tank. Both cistern and storage tank are fed through a ball-cock. Fig. 2 shows how, by means of the ball-cock, the flow of water is automatically shut off when the cistern or tank is full. As the level of the water rises, the floating copper ball moves upward, and the lever slides the cartridge along until the rubber washer presses against the face of the ball-cock, and so stops the inflow of water.

Like a tap washer, the ball-cock washer eventually wears out, and fails to shut off all the water, and so the water rises to the overflow pipe, and runs over outside. The rubber washer can be renewed just as easily as the tap washer. First, give the stop-cock and the ball-cock a quarter turn so that the stop-cock is lying at right angles to the pipe. The water can no longer flow through the

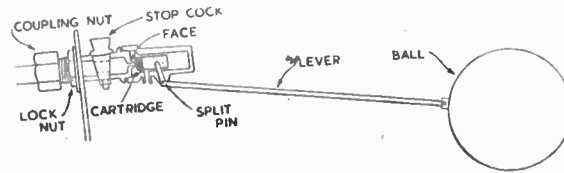

Fig. 2—A cistern ball valve

Before assembling the ball-cock, you should file the face a little to ensure a good contact between the face and the washer.

File the outside of the cartridge and the split pin in order to cut down friction and prevent sticking.

Assemble the ball-cock, making sure that the short lever arm is in the slit in the cartridge. Turn on the stop-cock. If the water still rises up to the overflow pipe, bend the lever arm slightly downwards to lower the ball.

Sometimes the copper ball develops a leak, because of water corrosion, and fails to float. When this happens, turn off the water. Unscrew the ball from the lever (see Fig. 2). Buy a new ball of the same size from a plumber. Screw on the new ball, and turn on the water.

A Choked Sink

It needs no mechanical skill to clear a choked sink. Unscrew the small trap screw, underneath the U-shaped bend in the waste pipe, remembering, of course, before unscrewing, to put a pail under-



Fig. 3 Washer details

off the old washer, and put on the new one, purchasable in any ironmonger's or plumber's shop. Finally, screw on the lock nut, and assemble the tap.

Fitting a New Tap

Perhaps you may wish to fit a new tap. The procedure is quite easy. Turn off the water, unscrew the two screws holding the old tap to the pipe board, and then turn the whole tap anti-clockwise until it is disconnected from the pipe.

A short threaded piece of pipe will be seen sticking out from the back of the new tap. This piece must be screwed into the water pipe connection, but before this is done, give the threads a coating of paint to ensure watertightness. After screwing the tap to the water pipe connection, use chromium

ball-cock. Take out the split pin to enable the lever to be withdrawn.

It will be seen from the diagram that the 'shell', containing the cartridge, is screwed to the part of the ball-cock, made up of the stop-cock and the face. Unscrew the 'shell', and take out the cartridge. Fig. 3 shows how the cartridge is constructed. Unscrew the part of the cartridge, marked (A) in the diagram, and take out the old washer. A new washer must now be made.

Obtain a piece of rubber $\frac{1}{16}$ in. thick. (A piece of old rubber mat will do, or if this is not available, a plumber can be asked for some sheet rubber). Cut it to the same size as the bore of part (A) press it into the open end of that part. Screw the two parts of the cartridge together.

neath the bend to catch the water from the sink.

Make a small hook on the end of a long piece of wire. Poke the wire through the hole from which the trap screw has been removed. Push the wire in both directions, and give it a twist now and again in an attempt to hook the obstruction.

If the sink is still choked after the trap screw is replaced, bore a hole in the waste pipe just before it enters the outside wall. Through this hole, poke the wire in both directions, again giving the wire an occasional twist. The obstruction, usually a number of small pieces of cloth, will be hooked on the end of the wire, and taken out. After the sink is cleared, plug the hole up with a piece of wood. (383)

Microscopic Slides—(Continued from page 370)

of twigs and stems can be sliced quite easily with a razor blade, and have a wide variety of patterns through them. A multitude of creatures found in every garden provide many, many subjects: the earthworm, the common fly, spiders, ants, beetles, wasps and bees, larvae. The legs, tongues, antennae, eye, stomach, palate, and other parts are all very suitable for mounting.

In the case of creatures with a hard shell or outer covering, work the inner parts away before mounting if the whole

is being dealt with. The eggs of various creatures are very beautiful, and the cast-off skin of some creatures makes an excellent mount. Hairs from the bodies of insects are very fine, and also the wings of flying creatures.

Vegetables and Creatures

Portions can be cut from all the common household vegetables for mounting, as well as from the fruits of wild plants and trees. Sections can also be shaved from the roots of plants.

Sections of the seeds of plants are easily shaved, and make particularly good specimens.

Only a few of the more common subjects have been mentioned here, but it will be seen that the variety is endless. It is not until this interesting and simple branch of the naturalist's art has been tried that it is realised what a world of beauty lies hidden from the ordinary eye, a beauty which can only be seen on the microscope slide. (365)

A novel and practical article is this small REVOLVING CABINET

THIS novelty cabinet with a rotating or turntable shelf was produced originally to hold four bottles of ink. Each bottle was of a different colour and the selector knob on top coloured accordingly. Rotating this knob brought that ink bottle to the front of the cabinet for easy removal.

Obviously this little cabinet has numerous other applications as a dispenser—either for the table to house the

condiment set, in the office or study for inks or paints, or even in the workshop. The one described takes four small sized ink bottles which have a base diameter of slightly less than $1\frac{1}{2}$ ins. For other containers or bottles the dimensions can be altered accordingly.

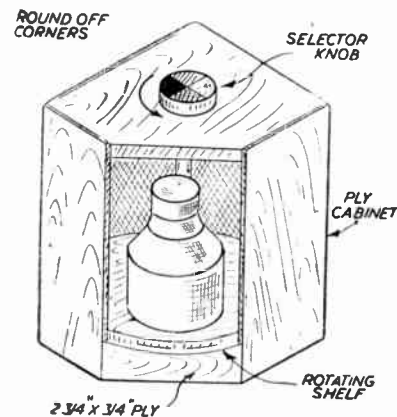

Fig. 1 - General view

into a piece of tin which is turned over, as shown, and pressed into the base wood. The top of the dowel projects through a $\frac{1}{2}$ in. diameter hole in the top of the cabinet and is then capped with a small hardwood disc or button.

Dowel, discs and button are assembled as an integral unit and glued together, remembering that the knob can only be added after the main assembly is located within the cabinet. The cabinet, in fact, will have to be built

centre of the base. The corner joints of the side can be backed up with triangular stock, if desired, glued in place. These should be cut to exactly 3 ins. length, three being required. These will be quite hidden and are not shown in the drawings.

Rotating Shelf

At this stage the rotating shelf assembly should be added, when the top can be slid into place. Glue and pin or

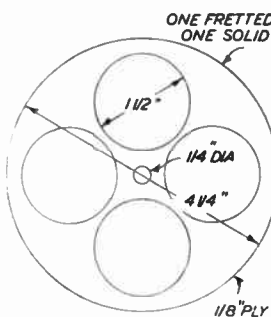

Fig. 2 - The circle shelf

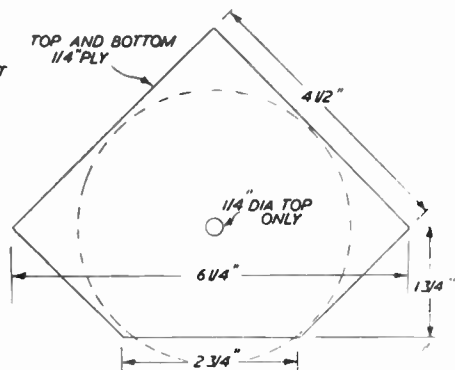

Fig. 3 - Plan of base and top

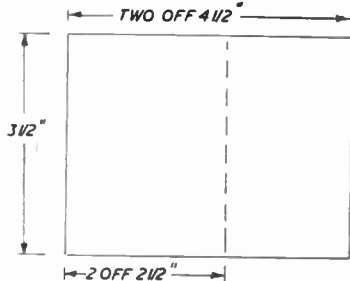

Fig. 4 - The sides

The rotating shelf is made from two pieces of ply, cut to circular outline—Fig. 2. One disc is again fretted out with four circular holes, each $1\frac{1}{2}$ ins. diameter. When the discs are glued together these holes form a well to hold the ink bottles in place. A $\frac{1}{2}$ in. diameter hole is drilled through the centre of each disc to take the dowel spindle.

Assembly

The rotating shelf assembly is shown in Fig. 5. The $3\frac{1}{2}$ in. length of $\frac{1}{2}$ in. dowel fits flush with the bottom of the assembled discs. This dowel is drilled out to take a gramophone needle which is a force fit. Assembled in the cabinet, this needle point rests in a 'dimple' punched

up around this main assembly.

The cabinet top and bottom are cut from $\frac{1}{4}$ in. ply to the dimensions shown. Only the top is drilled out with a $\frac{1}{2}$ in. diameter hole at the centre of one diagonal.

The sides are cut from $\frac{1}{8}$ in. ply, two wide and two narrow. All the sides are $3\frac{1}{2}$ ins. high. Assemble the four sides on the base, gluing and pinning or bradding. Add also the tinplate bearing at the

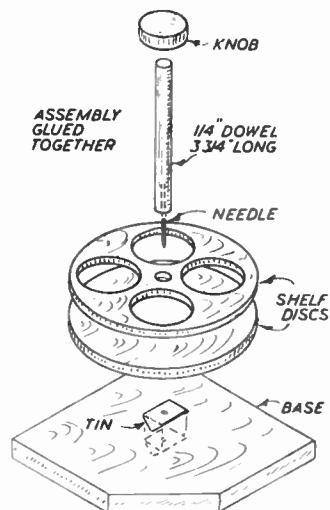
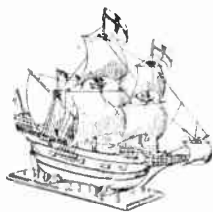

Fig. 5 - The shelf assembly

brad the top to the sides and the main assembly is complete. Add the selector knob and a small piece of $\frac{1}{8}$ in. ply across the bottom of the open face of the cabinet, bradding to the base. The height of this piece— $\frac{3}{4}$ in.—should be such that it will just clear the bottom of the rotating shelf which protrudes slightly through the cabinet opening.

Finally round off all corners of the assembly and stain and finish to taste. Mark off the selector knob in the appropriate colours or code letters, and the job is complete. (390)



Do you make Model Galleons?

From time to time we have published in these pages pattern sheets for all the most popular ships of history—'Santa Maria', 'H.M.S. Bounty', 'Ark Royal', 'Cutty Sark', etc.—and kits were provided so attractive models could be made. Readers may be interested to know all these designs and kits are still available from any Hobbies Branch, or an illustrated leaflet of them can be obtained free on request to Hobbies Ltd., Dereham, Norfolk.

A correct and simple way of forming STENCIL LETTERS

CORRECTLY proportioned lettering is often one of the most difficult things for the amateur craftsman to achieve. The 'straight-line' letters—E, F, L, T and so on—are generally easy enough, but 'W' and 'M' tend to complicate the issue. And when it comes to curved letters, commonsense proportions seldom work out satisfactorily. The letter 'S' and the figures '3', '5' and '8' are particular offenders in this respect.

The answer is that you must have a planned alphabet to follow. A style of lettering and numerals which are correctly proportioned, both individually and with respect to one another. Preferably, too, this alphabet should be capable of simple construction, using

only straight lines and circular arcs to complete all the letter forms.

The simple styling chosen does exactly this and construction has been reduced to the simplest form possible. To assist in spacing, all letters are made the same width—with the exception of 'l' and 'S' and all layout dimensions related to the *height* of the lettering.

The thickness of all the strokes is also uniform— $\frac{1}{8}$ th of the height—and spacing between adjacent letters should also be made $\frac{1}{8}$ th of the height. You can, therefore, plan out the exact *length* of lettering and adjust proportions accordingly, remembering that certain letter combinations, e.g. AV, WA will have a slightly less overall width than purely block letters adjacent to one another.

All the letters and numerals shown are compounded purely of straight lines and circular arcs and construction of each should be perfectly clear from the diagram. There are no 'tricky' letters, 'S', the most difficult of them all, is made up simply of four intersecting arcs, the overall width of the letter 'S' being reduced somewhat to make it conform in styling to the remainder of the alphabet. The appearance of each one of the letters is clear and attractive.

For straightforward lettering, whether it be a house name or number, or a simple notice, the outline is constructed in pencil. Preferably, then, the outline should be ruled in with a ruling pen and ink compasses in the paint in which the lettering is to be made. The paint should be thinned down well to make it flow freely. For such lettering cellulose paint or 'dope' is highly recommended. Once the outline has been completed the letters themselves can be blocked in with a small brush, working right up to the original outlines. This avoids the somewhat ragged edge common with hand painting to pencil guide lines.

Alternatively, of course, stencils may be prepared of individual letters and used either with brush painting or spray. Care is needed when using stencils to hold them in place absolutely flat against the surface to be painted, otherwise colour will tend to 'creep' under the stencil and spoil the outline.

Made from some reasonably stout semi-flexible material, it is a good plan to stick stencils in place, if extreme accuracy of finish is required. This means cutting the actual width of the stencils down to the barest minimum so that the stencils themselves may be closely spaced to form the complete wording.

The other plan is to draw out the complete lettering on to a piece of stout drawing paper and cut the stencil from this, using it only once rather than construct a complete set of stencil letters for repeated use. Making a complete stencil takes very little more time than drawing on the outline lettering on the work itself.

Once the stencil lettering has been drawn out on paper, the letters should be cut out with a razor blade or sharp modelling knife, leaving a number of bridges where required to hold centre portions of the letters in place. For temporary attachment to the work, rubber gum is strongly recommended. This should be smoothed over the back of the stencil, when the whole can be pressed and stuck in place. Excess gum can be rubbed off.

After spraying or painting, the stencil should be removed before the paint has properly dried, otherwise it may tend to pull up the edges of the lettering. Rubber gum remaining on the work can then be rubbed off clean when the work has finally dried. (391)

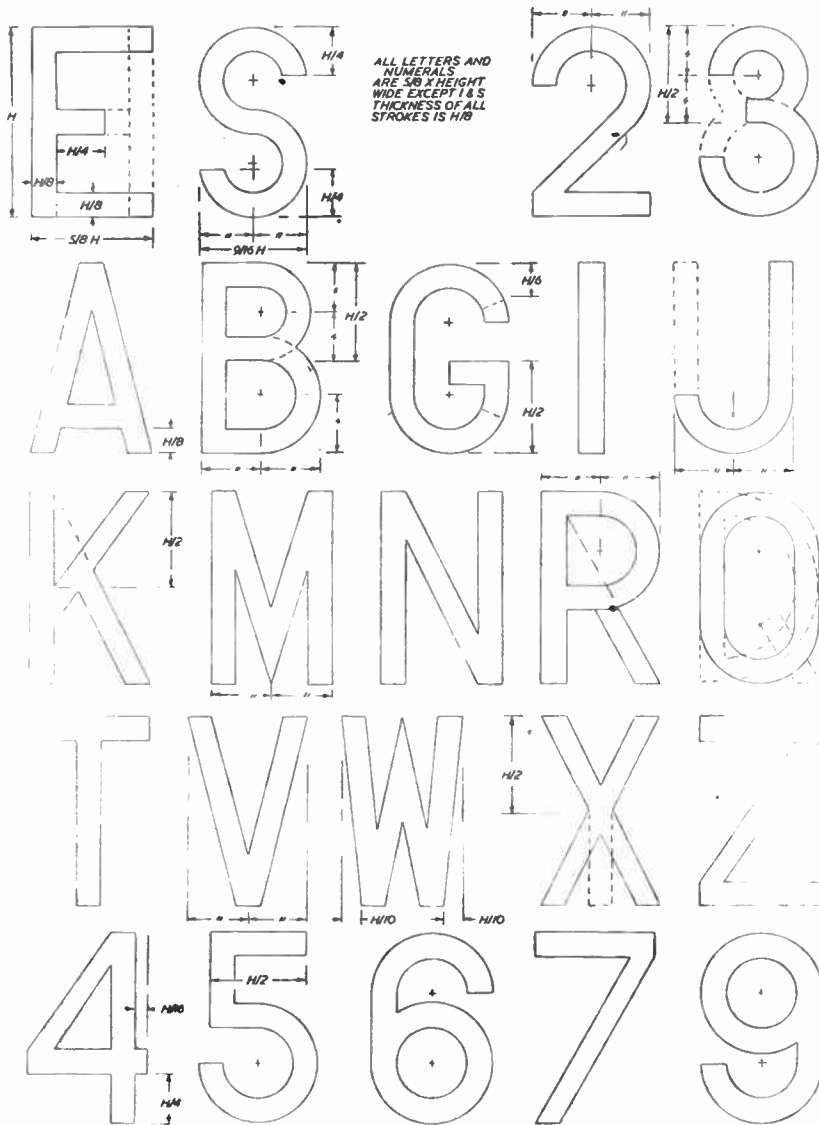

A few 'bits and pieces' can form a novel TABLE SKITTLE GAME

HERE is a good table game that can be made up simply and cheaply from a few pieces of odd wood.

As illustrated in the sketch, it consists of a pole or standard, to the top of which is hung a cord with a wooden ball attached. The pole is supported by a firm base consisting of two pieces of flat wood which are made to fit into each other crossways, being held in the middle by the pole which passes through each piece.

At the extreme ends of these base strips there are hinged the cut-out figures, so arranged that by the swing of the ball they collapse on contact with it.

The Game

It will be found very difficult to knock down more than two of the figures with one swing of the ball, but with care and practise, it should be possible to lay all four figures flat with one 'shot'. It is purely a matter of constant practise, and judging each swing and noticing the distance the ball comes each time in relation to the figures.

There is thus a certain amount of skill required in the game, and it should, therefore, create much amusement amongst a crowd of players.

At Fig. 1 in the diagram we show exactly how the base is made, and further explanation is hardly necessary. It will be noted, too, from this diagram, how the pole and base are easily taken apart for storing compactly in a long shallow box. Wood $\frac{1}{4}$ in. thick should be sufficient for the strips of the base and for their cross pieces at the ends and each side of the pole.

If the pole is made more than 15ins. long, then it would be necessary to use a heavier wood, say, $\frac{3}{8}$ in. or even $\frac{1}{2}$ in. thick for the base strips, etc.

Cross Strips

Piece (A) in Fig. 1 has two cross strips which hold the piece (B) centrally in place until the pole is inserted, when the base will be found to be quite rigid for playing.

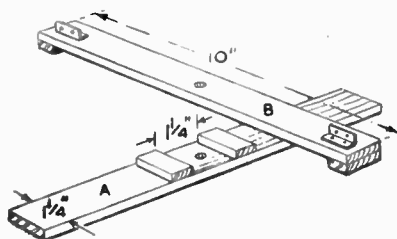
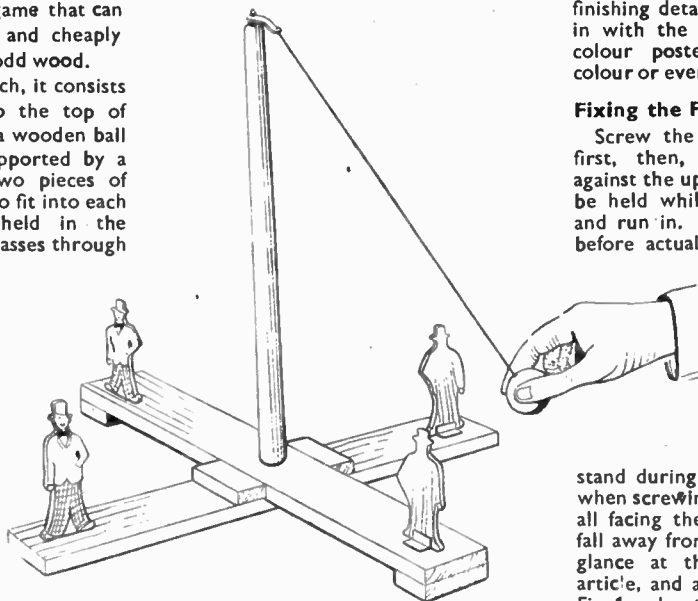

Fig. 1—Base board frame



The enlarged diagram, Fig. 2, shows how the cut-out figures are held upright by the hinges.

The diagram, Fig. 3, shows the swivel arrangement for the top of the pole. A piece of stout brass about $1\frac{1}{2}$ ins. long is bent up, as shown, and a hole drilled at both ends. A thin wire nail about $\frac{3}{8}$ in. long is then inserted in the end of the pole with the bent metal strip running smoothly on it between two glass beads which have in turn been threaded on the nail. The beads afford perfectly smooth running and allow the brass strip to swing easily when the cord and ball are attached.

The Figures

It only remains now to make the four cut-out figures. Each figure measures 5ins. high by $2\frac{1}{2}$ ins. wide, and on a piece of paper this size, rule off the half inches, as shown at Fig. 4. Through the squares draw the outline and the interior work and finally thicken up the outline and rub out the lines of the squares.

The figure can now be transferred to the four pieces of wood, $\frac{3}{8}$ in. or $\frac{1}{2}$ in. thick, by means of carbon paper and a sharp pointed pencil. The outline should be cut round with a fine fretsaw and the edges cleaned with glasspaper. The

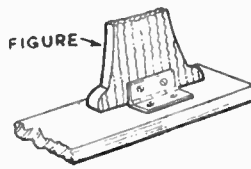

Fig. 2—Hinging

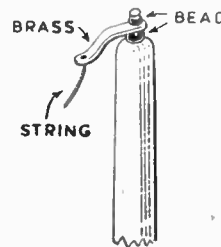

Fig. 3—Pillar top



Fig. 4—Figure shape

finishing details of the figure can be put in with the brush, using either water colour poster paint, ordinary water colour or even oil paint or enamel.

Fixing the Figures

Screw the hinges to the base strips first, then, by standing the figures against the upturned flap, the former can be held while the screws are inserted and run in. It should be remembered, before actually screwing the figures to hinges, to slightly chamfer the extreme flat lower edge of each, so that they lean ever so slightly forward.

By doing this the figures will remain upright in spite of any joggling or unexpected movement of the whole stand during play. Care must be taken when screwing on the hinges to get them all facing the right way, so the figures fall away from each other as it were. A glance at the sketch of the finished article, and also at the pair of hinges in Fig. 1 makes this all clear.

A good finish for the base would be two coats of enamel or oil paint, while the pole could be simply varnished over. For the pole a length of dowel rod $\frac{3}{8}$ in. or $\frac{1}{2}$ in. diameter and from 12ins. to 15ins. long is best. This should be tapered gently towards the top, as shown, and rounded off and made smooth where the bead rests. Make the pole quite smooth with fine glasspaper before adding the varnish.

Designs are given free with every other issue but not with back numbers of Hobbies

Useful shelf and drawer fitted to this modern SHAVING MIRROR

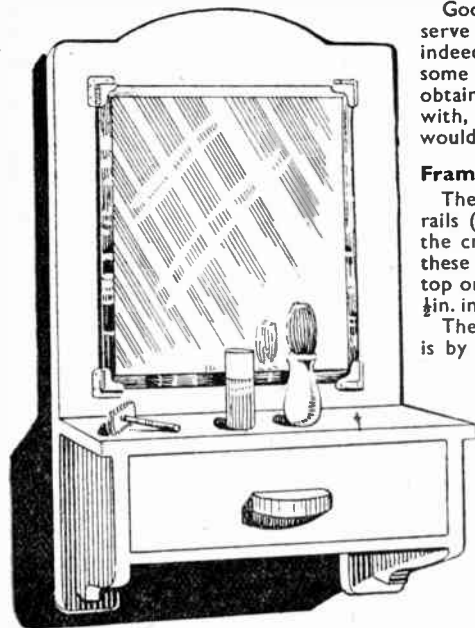

WE give a sketch here of a very useful modern type of bathroom fitment. In addition to a good mirror of useable proportions, it has a handy little drawer for keeping shaving utensils in, instead of having them lying about. The home craftsman should be able to make a good job in the making of the fitment, as it is of simple and easy construction, and when painted or enamelled white or cream, should make a handsome addition to the bathroom or the bedroom, come to that.

The Back

In Fig. 1 we see the main back frame of the article with all the necessary measurements for the spacing of the rails, etc. Fig. 2 shows a side view, giving the shape of the side brackets supporting the shelf and drawer.

Just the ordinary set of household tools, including, of course, the most useful fret-work handframe, will be found adequate for the make-up of the frame and its drawer.

CUTTING LIST

A	2	16ins.	by	1 1/2ins.	by	1/2in.
B	1	10ins.	by	1 1/2ins.	by	1/2in.
C	1	10ins.	by	1 1/2ins.	by	1/2in.
D	1	10ins.	by	2 1/2ins.	by	1/2in.
E	2	4 1/2ins.	by	4ins.	by	1/2in.
F	1	8 1/2ins.	by	4ins.	by	1/2in.
G	1	10ins.	by	4ins.	by	1/2in.
H	2	8 1/2ins.	by	2 1/2ins.	by	1/2in.
I	2	3 1/2ins.	by	2 1/2ins.	by	1/2in.
J	1	8 1/2ins.	by	3 1/2ins.	by	1/2in.
K	1	8 1/2ins.	by	2 1/2ins.	by	1/2in.
L	1	2ins.	by	1in.	by	1/2in.

Good straight grained deal would serve to make up the frame, and, indeed, all parts of the fitment, but if some higher quality wood could be obtained, then a better fitting frame with, perhaps, a smoother surface, would result.

Framework

The frame consists of two upright rails (A), which are tied together with the cross rails (B), (C) and (D), and all these rails, with the exception of the top one (D), are 1 1/2ins. wide, and all are 1/2in. in thickness.

The method of connecting up the rails is by the halving joint, shown in detail in Fig. 3. This joint is very simple to make but it forms a very strong holding when properly made and glued up and screwed. A small-tooth tenon saw will be found most useful for cutting down across the grain preliminary to disposing of the unwanted wood.

The top or pediment rail (D) is shown shaped to give character above the mirror, the arc of the curve being struck from a point 5ins. down from the top edge of the 2 1/2ins. wide rail, and central, of course. Set out the tenons and their mortises carefully with the square, marking in good pencil line ready for the saw.

A 1/2in. chisel will be found very helpful for cleaning out the wood between the cross cuts.

The curve on rail (D) will be cut, of course, with the fretsaw.

The side view, Fig. 2, shows the end grain of the halvings of the cross rails.

When the frame has been put together it should be levelled and glasspapered up smooth. The two brackets (E) are next made and each measures

4 1/2ins. by 4ins. The simple shaping at the bottom of the pieces can be gauged from the measurements given in Fig. 2. Clean up the cut edge with glasspaper but do not round off the edges or a neat effect will be lost.

Shelf

The rail (F) will next be marked out and cut, and as there are two methods of fixing it to the brackets, a choice must be made before actually cutting the length of the shelf. It may just butt simply against the brackets and be screwed to them with countersunk screws, or the ends may be housed about 1/8in. into grooves made in the brackets.

The length, therefore, of the shelf will be made 1/2in. longer in the latter case to allow for this housing process. The length will be 8 1/2ins. in the one case and 8 3/4ins. in the case of the housings. The lower extremity of each bracket will be set up 1/2in. from the tail of rail (A), and they will be set in from the outer edge of them 1/2in. Glue the brackets firmly to the uprights and run in some countersunk brass screws from the back of the frame.

Now fit in the shelf (F) and put in some screws through rail (C) into the back edge. The top (G) of the box is another plain square-cut piece 10ins. by 4ins., the side and front edges being neatly rounded over and glasspapered up smooth. It is glued to rail (C), and screws are put through from the back. A screw can also be added each end of the top to go into the top of the bracket.

The Drawer

The construction of this is simple and is easily explained in the detail Fig. 4.

The inner front and the back of the drawer is 1/2in. thick, while the outer front (K) might be 1/2in. thick and glued and screwed to the inner front, the screws being of such length that their

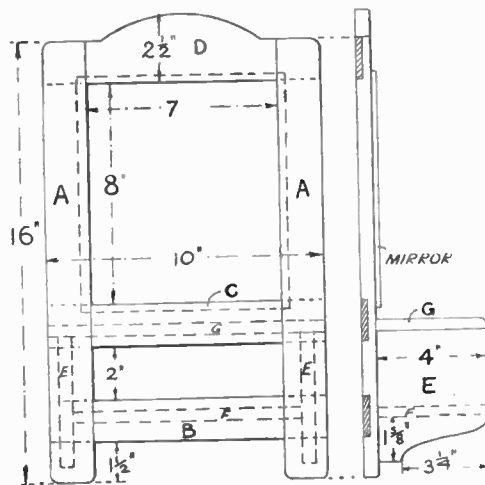

Fig. 1—The back frame

Fig. 2—Side view

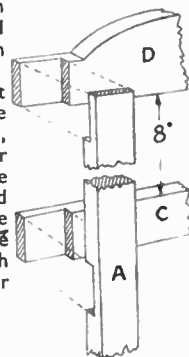

Fig. 3 Rail joints

(Continued foot of page 380)

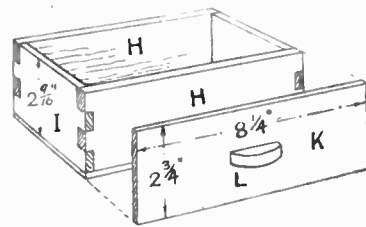

Fig. 4—Drawer construction

How to convert balsa into suitable SMALL TABLE MATS

BALSA wood is an excellent insulating material, readily obtainable and very easy to work. It is excellent for table mats, but suffers from the defect that the wood is so soft that edges are readily dented and spoiled.

The design shown utilises balsa mats edged with laminated hardwood strips. This not only serves the purpose of protecting the edges but adds a pleasing decorative effect. Nor does the wood bending involved present any special difficulties.

Start by cutting the mats themselves

with hardwood stock. Three laminations of $\frac{1}{4}$ in. by $\frac{1}{16}$ in. hardwood are recommended, preferably birch or spruce for ease of bending. A very pleasing effect is given by making the middle strip of the three of contrasting colour—choosing a dark wood, for example, to go with two spruce strips. Alternatively, use three spruce strips and dye one beforehand with waterproof dye.

Three 30 in. lengths of $\frac{1}{4}$ in. by $\frac{1}{16}$ in. material will be adequate for each of the mat sizes shown. Again we would advise a waterproof cement rather than

strip on top, all three strips then being assembled one on top of the other on a convenient surface.

Cement and Pin

Then coat around the edge of the mat with cement and start by pinning the strips to the centre of one side, stepping them, as shown. A pin can be forced through $\frac{1}{4}$ in. by $\frac{1}{16}$ in. material without damage.

To bend the strips in place, simply work round from this initial point, forcing the strips around the curve. The strips will bend quite satisfactorily without any other treatment unless cross-grained, when there may be a tendency to split. Force the strips right round the edge of the mat back to the starting point and make off each strip as a butt joint at its respective stepped position. Hold with another pin or a clamp, or just a rubber band around the mat.

At least twelve hours should be allowed for the cement to set when the mat can be handled again. Simply

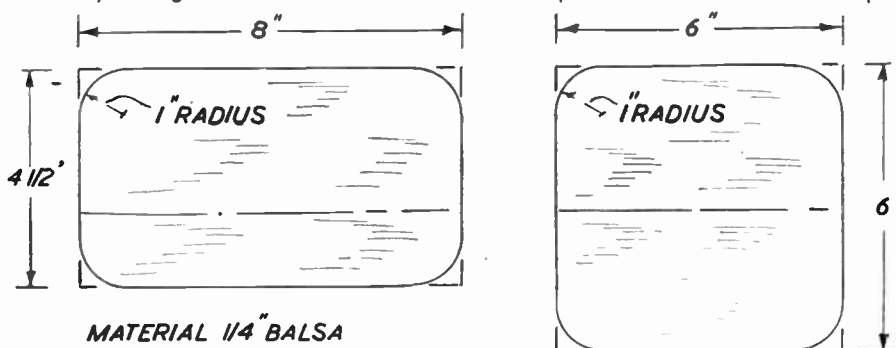

Fig. 1—Two suitable sizes

from $\frac{1}{4}$ in. balsa sheet. Two recommended sizes are shown. All corners are rounded off with a 1 in. radius. Usually balsa is obtainable in widths of 3 ins. Thus to get the full width required two pieces must be joined together. An ordinary butt joint is quite adequate, using balsa cement. This will give a strong waterproof joint—stronger, in fact, than the wood itself if carefully made.

Drying time with balsa cement is only a matter of minutes.

Having completed a set of balsa mats in this way, each must now be edged

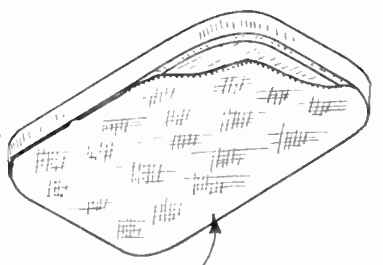

Fig. 3—The covered underside

normal glue. The type of slow-drying balsa cement is excellent. Coat all along one strip, lay the second strip on this, add more cement and lay the third

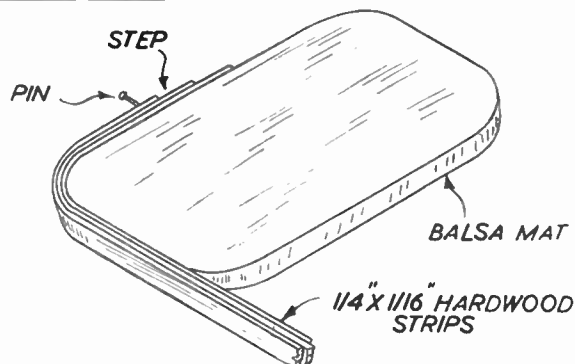

Fig. 4 Edging strips

glasspaper down smooth and treat the edges with stain or polish, as desired. Balsa will not take a satisfactory polish or respond to stain evenly unless previously treated with grain filler. Actually it will not suffer if left untreated, and if good clean wood was chosen initially, it will look quite attractive plain.

Undermat

The final stage is to cement or glue a strip of baize or similar material to the underside of each mat to provide a non-scratch surface. A suitable stand can then be made out of ply to hold the complete set which, besides being as attractive as most on the market, will, probably, be more effective as heat insulators. (389)

Your Letters are Welcome

WE are always glad to answer letters of readers, to solve their problems and to offer suggestions, but readers should remember to add their full name and address or include a stamped addressed envelope, as it may be impossible to print their replies in these pages in our usual 'Replies of Interest' section. Letters should be clearly written and explain fully the nature of the query.

Housewives will be delighted if you make them SOME WASHDAY GADGETS

THERE are many little gadgets that can be made and ideas adopted in order to make the work of wash day so much easier.

Probably the greatest nuisance is the everlasting dirty linen line. Smuts from nearby chimneys fall on the line and then rain comes and washes it all in, making a nasty mess which cannot be properly cleaned. If the line is made to take in after use, this would not happen.

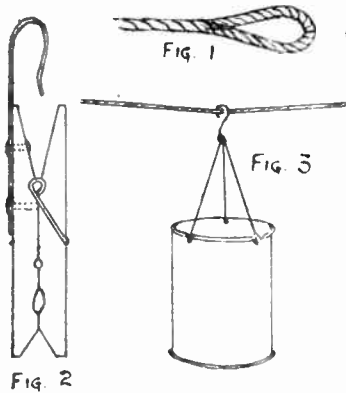

The best method to adopt here is to make a loop in each end of the line proper, as shown in Fig. 1, the line being only long enough to go between the posts. On each end is fastened a short

length of rope connected to the line loop by means of a toggle, which is a short piece of dowel rod having a groove cut round its centre. It, therefore, takes only a matter of seconds to unhook and take in the line after use.

Another way with dirty lines is to hang the clothes so that they do not touch the line at all. Clothes pegs fitted with a clip, as shown in Fig. 2, is the easy solution to this problem.

Cut a strip of springy brass or alu-

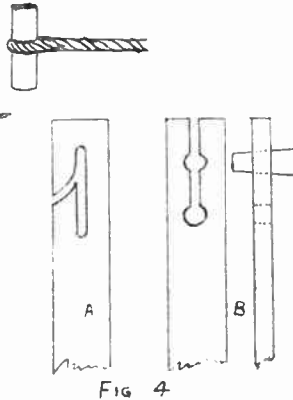

minium $3\frac{1}{2}$ ins. long and $\frac{3}{8}$ in. wide and fasten on to one side of the peg with two rivets. Bend the top over to form a springy hook to fit the linen line.

The clothes are gripped in the lower

end of the peg and, therefore, there is no need for them to ever touch the line and get dirty marks on them.

Another very useful gadget is a container for the clothes pegs that is always near and handy for pegging out. It is awkward to hold a handful of clothes and sufficient pegs to hang them with, but with the aid of a container, such as that illustrated in Fig. 3, which can be hung on the line near at hand, the job is made easy. It can be made from a tin or small wooden box suspended with three wires and a hook to slip over the line.

Prop Fitting

The prop can sometimes be a nuisance, especially on a windy day, on account of the 'V' at the top not being deep enough to hold the line securely. By using a carefully designed prop this difficulty can be overcome and Fig. 4 shows two such improvements.

Although (A) is very simple and does not look satisfactory, it will be found that the line enters easily, but is much more difficult to get out again, especially if the inlet curve is kept just wide enough for the line.

The second prop (B) is made by first drilling two holes and then cutting the slot just a little narrower than the holes. A plug is made to fit in the top hole and is inserted after the line is in position, thus making it quite impossible to come out, however strong the wind. (355)

Overhaul your Cycle

NOW comes the time to start thinking of the days ahead when cycle touring at week-ends and holiday periods will be possible again. This form of pastime is one of the most carefree, economical, enjoyable and health-giving ways of spending leisure hours and holidays. Thousands have discovered this fact, and each year more thousands join the great brotherhood of the road.

To newcomers one would say that, to ensure the greatest pleasure from cycle touring much depends upon your 'steed'. Remember, a machine that may be quite suitable for everyday riding around home or to and from business, is not necessarily a satisfactory mount for a long-distance run, when you have to carry a certain amount of luggage.

The essentials of a touring machine are briefly: Comfort; reliability; suitable gearing; bearings that run freely but without shake; and a chain that provides a smooth silent drive. All these attributes are to be found in any well-known manufacturer's products, and it only requires careful thought and common-sense in selecting a good type

of standard tourer. Above all, it must be in faultless mechanical condition before you set off on any sizable tour.

Obtain a machine that is light and rigid; an all-steel, sturdily built lightweight with variable gear, and a comfortable saddle fits the requirements of the tourist. Some cyclists still remain faithful to the fixed gear, and this has certain advantages for riding to and from business in a town or city; but for touring where you may have to face stiff gradients, hill-climbs, and often meet head winds at times, the variable gear is a great boon.

When mentioning 'lightweight' machines one refers to those types having a small rigid frame and light wheels, fitted with flat or upturned handlebars, a comfy saddle, tyres of a medium width, and a variable gear, and not to the 'racing' 'lightweight' with dropped handlebars, a hard, unyielding saddle, and a fixed gear. There is all the difference between them, although designed somewhat on similar lines.

Remember, too, in selecting a mount, to take into consideration your height and weight. Do not buy a machine without first inspecting it thoroughly,

and sitting on it. Unless you can reach the ground with the forepart of both feet, the machine is too big for you, and therefore undesirable.

Your Old Machine

Perhaps you already possess a good machine that has served you well, and is good enough for another season, but looks a trifle shabby. As we all need to be very economical in these days, it is worth thinking about. By all means renovate the machine.

Look well to the bearings and make sure they are not badly worn. The brakes, too, must be carefully inspected and readjusted. The wheel-chain should be examined, and if necessary replaced with a new one; otherwise correctly adjust it for tension, so that there is no visible 'sag' when the machine is at rest.

You can well give the machine a 'new look' by enamelling it with a good lacquer, first scraping off any old enamel that is in a bad condition; if you have a blow-lamp and know how to use it, careful heating with a soft flame will help to get the old enamel off, then scour smooth with emery cloth, and wash

(Continued foot of page 378)

How the handyman can easily make A LAMPSHADE FOR 1/-

As most readers know, the average lampshade has a limited life, heat from the lamp and household dust, both playing a part in its ultimate deterioration. When a new shade does become necessary, it can be a simple and most inexpensive business to provide a new one. The wire frame is not included in the total cost above, as this is almost everlasting.

For making the shade above, one sheet of white cartridge paper is required, price about 5d., with 2yds. of narrow braid, 4d., and about 3d. of castor oil. With these materials to hand, work on making the shade can commence. It is a pleasant job, just the thing to fill in the evening, with something worthwhile to show for your labour.

Shade Pattern

A pattern for the shade must be drawn out first. This is shown at Fig. 1. On a sheet of paper, draw line (A), the small diameter of the shade, below this line (B), the large diameter, both lines being separated by a distance equal to the depth of the shade. Connect these lines at each end, then extend them until they meet at the centre line.

At this point press in a drawing pin or stout domestic pin. Wind a length of string round the pin and tie. Then extend the string to one end of line (A) and tie a pencil to it. Hold the pencil vertical and swing it to the opposite end of the line, leaving a curve, as shown.

Repeat this on line (B) below. To get a satisfactory and firm curve, it is necessary for the string to be drawn quite taut and the pencil held truly upright. A long strip of wood can be used in place of the string, if preferred, with a hole through the top end to drop over the pin, and two holes lower down, at the required distance, to reach lines (A) and (B), for the point of the pencil to enter. The latter method is really the best.

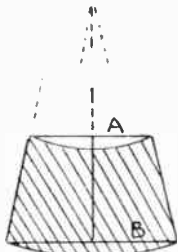

Fig. 1 - Shape pattern

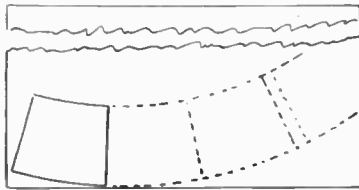

Fig. 2 - Repetition work

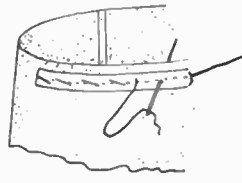
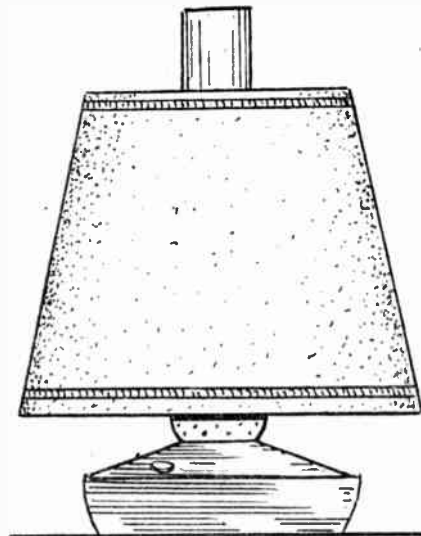

Fig. 3 - Stitching



The complete pattern, shown shaded in the diagram, is now cut carefully out. On a flat table spread out the cartridge paper, and on it, at about the spot shown in Fig. 2, lay the pattern and lightly pencil round it to the paper.

Remove the pattern, and lay it against that already drawn and repeat, about $3\frac{1}{2}$ times will be enough, as shown by the dotted outlines. The actual length of paper will be about $3\frac{1}{4}$ times the pattern, but allow a little more.

Shaping

If the sheet of paper is not large enough to lay out the full pattern, then it must be divided, but that need present no difficulty. Now cut out the complete pattern and bend it round the wire frame of the shade, letting it come down below the wire about $\frac{1}{2}$ in. Pencil mark here, allow $\frac{1}{2}$ in. for joining the edges together, and cut away the surplus. Join the ends together with a strong cement

or liquid glue, and press down to ensure complete adhesion.

Lay a sheet or two of common newspaper on the table and place the shade upon it. Press down at the centre, but avoid the curved sides, as these must not, on any account be creased, or the shape of the whole will be damaged. Provide a clean piece of white rag, drop the castor oil on the paper shade and rub well all over. Do a piece at a time until the whole outer surface has been treated, then repeat the treatment on the inside of the shade.

Assembly

Now leave it to dry, which will take but a short while. This process leaves the paper translucent, just the right condition for a lampshade.

Place the shade over the frame, and fix it there with three or four stitches of thread, evenly spaced round the ring. Now, with a strong thread ready, place the narrow braid on the shade, just over the wire ring of the frame inside, and there stitch through and round the wire. Stitches about $\frac{1}{2}$ in. long will serve, and the job should be neatly done. For the top of the shade, the braid can be just stitched round and will probably keep the shade circular without anything else.

It will be helpful, however, should the reader have in his possession a few feet of thin iron wire, to sandwich the wire between the braid and the lampshade, as in detail sketch, Fig. 3, and to stitch through, with the stitches crossing the wire during the process to keep it in place.

This does ensure a firmer shape. If not quite satisfactory a little manipulation with the fingers will improve the curve, but it usually happens that the wire assumes a reasonably correct circle during the stitching operation; owing, probably, to the bending it receives from the fingers.

This completes the shade, and the effect when the light shines through is most pleasing, a pearly glow resulting, restful to the eyes. Take care of the pattern, then when a new shade is wanted, it can be used again. Though the drawings for this article are designed mainly for a shade to suit a lamp of the 'Aladdin' type, it is quite easy to amend them, as may be necessary, to suit the electric current as well. (367)

Cycle Overhaul—(Continued from page 377)

clean with petrol. Give one coat of enamel, leave to dry hard, and give another coat, and afterwards, if you like, give the whole a thin coat of 'finish'. After the job is done, and has hardened thoroughly, wash down with cold water, using a window leather, before taking out the machine again.

During a complete renovation, strip the cycle as much as you can—chain, wheels, brakes, handlebars, etc.—and wash out all bearings, and chain with paraffin, drying off all surplus. When re-assembling the parts be sure to get everything carefully in position and correctly adjusted; you cannot be too

particular about this, as so much depend upon it. Worn tyres should be replaced with new. Test brakes by applying them hard, and then trying to push the machine along; this will be impossible if the brakes have been properly adjusted and rendered efficient. (360)

Simple instructions for making plaster PLAQUES FROM LINO-CUTS

HERE is a novel method of making wall-plaques, either for yourself, as gifts, or for sale. Your mould is fashioned from an ordinary lino-cut and the plaque, itself, is cast from plaster of Paris or a similar medium.

A suitably sized piece of lino for quite a large mould should cost you no more than a few pence. Do not use ordinary household linoleum, unless you can lay your hands on some of exceptionally good quality. For our purpose it is best to obtain thick brown lino from an art-stockists. This has been expressly manufactured for the purpose of lino-cutting. A stout piece of this linoleum will provide you with a mould capable of reproducing scores of plaques. The additional outlay of a few pence will be well worthwhile, you see.

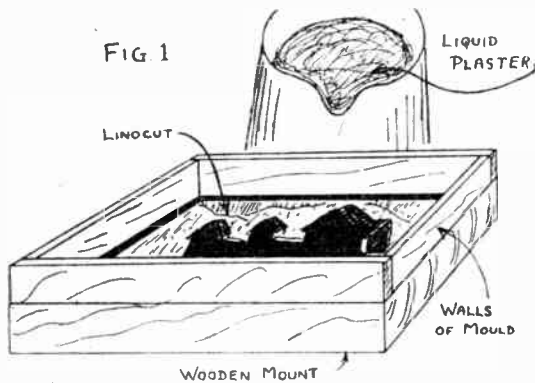

Decide on the size and external shape of your plaque and cut the piece of lino to shape, accordingly. The plaque may be square, rectangular, hexagonal, circular, etc. Make the edges as clean and sharp as you possibly can, using fine glasspaper to finish off with, if necessary.

Choosing the Design

Now you must choose a suitable design. Do not be too ambitious to begin with. A simple motif, devoid of intricate detail, is far better to commence with until you have mastered the reasonably simple technique which is necessary.

If you are not a good artist (and how many of us really are!) trace any suitable pattern or design and transfer this outline to the surface of the lino. If ordinary pencil marks do not show up plainly enough, give the lino a brushing of white poster paint, allow to dry, and then draw on this.

A Decision

You must decide whether you wish the pattern, when cast in plaster, to appear in relief or below the surface of the finished plaque. For most purposes you will probably find it best to cut away the actual design and leave the

background untouched. When a cast is taken the pattern will then be standing in relief above the background.

The technique involved in cutting your mould is similar to that employed for making an ordinary lino-cut. The usual lino-cutters and gouges are used. For the purpose of a mould, however, it is necessary to eliminate all rough gouge marks where the lino has been removed. A certain amount of glasspapering can be done to the surface of the finished cast, but you will find that time spent in making the mould as smooth as possible will be really time saved, especially if you propose casting dozens of these plaques.

When satisfied with your lino-mould it should be glued to a smooth slab of wood that is 1in. or so larger all round than the external dimensions of the lino. Place under pressure until the glue has dried.

Now to build the walls of the mould. If your plaque is to have straight sides you will find that this can most effectively be accomplished by planing up strips of wood and tacking these into position, as shown in Fig. 1. The larger your plaque is the thicker should be the finished cast.

You can regulate this thickness by making the walls of the mould the necessary depth before securing them to the wooden block.

WIRE HANGER TO BE SUBMERGED IN THE WET PLASTER



FIG 2

**Tell your friends
they can now get
copies of Hobbies
from any newsagent**



If the plaque is to have circular sides you will find it best to either bend a strip of thin metal or stout cardboard to form the walls of the mould or else build a bank of modelling clay round the outer edge of the lino-cut.

Just the inside of the mould, to ensure its perfect freedom from scraps of lino, and then brush it over with a thin film of oil to make it easier to withdraw the completed cast.

The Cast

The actual cast can be made in plaster of Paris, dental plaster, or one of the proprietary brands of modelling media which simulate the effect of marble when hardened off. Plaster of Paris is as good as anything for your first few trial casts. It should be mixed with water to the consistency of thick cream and then gently poured into the mould.

This form of plaster will set reasonably hard within ten or fifteen minutes. Before it has quite hardened off it is a good plan to push a small wire hanger into the back of the plaque (see Fig. 2). This will obviate the need for any messy fiddling, afterwards. Upright the mould, shake the cast carefully free from the lino-cut, and then put aside in a warm dry spot to harden off completely.

Finishing the Plaque

Smooth the face of the plaque with fine glasspaper wherever necessary. Some may prefer the plaque in this natural state, others will wish to paint the completed work. A coating of size should be applied to the plaster to seal the pores, and then poster paints or art enamels, etc., may be used for the finishing touches. Clear varnish will impart a nice glossy surface if water colours are employed. (397)

Here is the proper way to construct A FERRET HUTCH

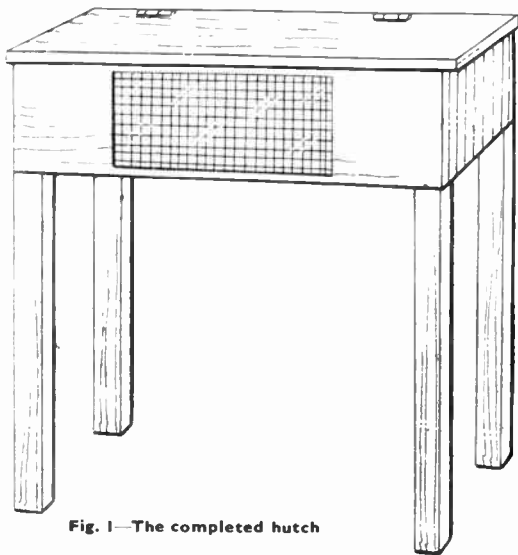

Fig. 1—The completed hutch

The width of the hutch is 4ft., the length from front to back 1½ft., and the height 1ft. An area covering the whole of the height of the front, except for 1in. at top and bottom, should be sawn out to leave 1ft. still enclosed at either end of the hutch. In this is nailed a piece of wire netting which then covers the front of the living quarters (see Fig. 1).

The Interior

The interior is then divided into three by fastening into position two struts inside which run from front to back at the point where the wire adjoins the wood. They are not completely rectangular pieces, as a

rear edge of the hutch.

The Separate Quarters

The compartment on the one end is the animals' closet. It should have most of its floor space sawn out, and a piece of wire netting nailed in its place. It must be kept bare so that they will see the difference between it and the other two compartments.

The living room, in the middle, may have a sprinkling of straw on the floor; and food should be put in this space at feeding-time. The space at the other end, which is the 'bedroom', should have a good bed of wood shavings.

It is essential that the whole hutch should be kept clean at all times, with particular attention to the closet. This must be swilled with water every day, and the contents washed out through the wire netting (see Fig. 3).

Mount It On Legs

When the hutch is complete mount it

A SIMPLE ferret hutch, which has plenty of room in which the animals can exercise, can be made from ordinary ½in. board. It stands on four legs, and has separate compartments which will tend to keep the ferrets tidy and clean in their habits.

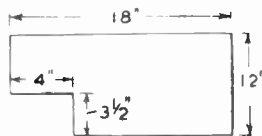

Fig. 2—Division pieces

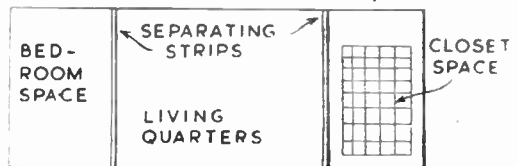

Fig. 3—Plan of the compartments

Lay-out of the Hutch

The complete hutch is divided into three compartments, the normal living-space, the sleeping quarters, and a small piece with, for the most part, a wire floor, which serves as the animals' closet.

small hole is sawn away to allow the animals access from one compartment to another (see Fig. 2). When the interior is complete in this respect, construct the roof so that it overlaps the whole by 1in. all the way round. Cover it with a piece of waterproofed tarpaulin so that the rain runs off, and hinge it to the top

on legs about 5ft. tall. This will enable it to be cleaned easily without stooping. It should be kept in a position where there is no draught, as ferrets are prone to many minor ailments. The normal diet is bread and milk, with a rat or some rabbit flesh twice a week. (343)

Shaving Mirror—(Continued from page 375)

points will not project through the front. The pieces (H) and the ends (I) are lock-jointed together, as shown, this type of joint if properly cut and fitted, being excellent for any such drawer construction.

The floor, shown as (J) measures 8½ins. by 3½ins. and may consist of a

piece of ½in. plywood. It is pinned or screwed direct to the edges of pieces (H) and (I). Note in the drawer diagram that the main front (K) comes down and hides the front edge of the floor. It may be of help to the worker to say that when cutting the projections of the lock joints, to always cut along on the outside of the lines so that when the joint is glued and knocked together, a firm and perfectly rigid joint is assured.

Again, before attaching the front (K), thoroughly glass-paper the front (H) the floor edge and make a good level surface before gluing on the front. A simple

handle can be shaped up with the fret-saw and the edges well glasspapered to make for safe handling.

The Mirror

A bevelled edge mirror measuring 8½ins. by 7½ins. would be ideal to suit the size frame shown. If a bevelled mirror cannot be obtained then a plain piece would serve the purpose, the sharp edges being rubbed down with a grit stone or carborundum slip dipped in oil. Specially made chromium-plated clips can be bought for fixing the mirrors and these are screwed to the framing after the mirror has been put accurately in place. Two or more brass or chromium-plated hanging plates are screwed to the back of the frame for fixing to the wall, rawlplugs being let into the walls for the screws.

The cutting list of wood required for this Bathroom fitment as given here will be found very useful when draughting out and cutting the several pieces.



BRANCHES

LONDON
78a New Oxford St., W.C.1
(Phone MUSEum 2975)
87 Old Broad Street, E.C.2
(LONDON Wall 4375)
117 Walworth Road, S.E.17

GLASGOW
326 Argyle Street
(Phone CENTral 5042)

Head Office & Factories—HOBBIES LTD., DEREHAM, NORFOLK

MANCHESTER
10 Piccadilly
(Phone CENTral 1787)

BIRMINGHAM
14 Bull Ring

SHEFFIELD
4 St. Paul's Parade

LEEDS
10 Queen Victoria Street
(Phone 28639)

HULL
10 Paragon Square

SOUTHAMPTON
25 Bernard Street

BRISTOL
30 Narrow Wine Street
(Phone 23744)

Experiments with Cream of Tartar in our series of HOME CHEMISTRY

NO need to look far for the raw material for these experiments!

Cream of tartar is known to chemists by the name potassium hydrogen tartrate, and is prepared by purifying the crude tartar which is deposited during the fermentation of wine. Besides being helpful to the housewife in her baking, it is used in medicine, certain metal working processes, in dyeing and for preparing tartaric acid.

Heat a little in a dry tube. It chars and gives a smell resembling burnt sugar. The charring indicates it contains combined carbon, and hence is an organic compound. Pour dilute hydrochloric acid on to the residue in the tube. It will effervesce, and if you pass the evolved gas into lime water it will turn it milky. This indicates a carbonate has been formed. We can use this reaction to make pure potassium carbonate.

boiling solution (solubility at the boiling point, one part in fifteen).

We can avoid these inconveniences by converting it into Rochelle salt which is very soluble in water, and only differs from cream of tartar in being potassium sodium tartrate instead of potassium hydrogen tartrate.

Washing Soda

Make a solution of sodium carbonate (washing soda) in boiling water and add solid cream of tartar to it in small portions. It will effervesce and give off carbon dioxide. Let each portion dissolve before adding more, removing a drop each time with a clean glass rod and testing it with red litmus paper.

When only a faint blue colour is imparted to the litmus paper, the solution is neutral and the reaction complete. You now have your stock solution of Rochelle salt.

after a few moments, and you can hasten it by scratching the sides of the vessel with a glass rod. Calcium tartrate occurs naturally in senna leaves.

Lead tartrate may be made in a similar way, using lead acetate instead of calcium chloride. This, too, is a white crystalline precipitate, which you can filter off, wash and dry for your chemical stock.

Copper tartrate is a pale greenish-blue powder, insoluble in water. To prepare it mix copper sulphate and Rochelle salt solutions, wash on the filter and dry it.

A Rare Compound

From copper tartrate we can prepare a rather rare and very beautiful compound. This is basic copper potassium salicylate. Make a strong solution of potassium hydroxide by dissolving this alkali in about twice its bulk of water. Dissolve in it enough copper tartrate to produce a deep blue solution.

Now take about five times the bulk of salicylic acid as you did of copper tartrate. Stir the acid into the solution. It will dissolve. Almost immediately a green precipitate forms which is the basic copper potassium salicylate. Let the solution stand half-an-hour, then decant off the clear liquor and pour the green precipitate on to a clean porous brick or tile to drain.

In an hour or so the compound will be left almost dry, as a brilliant green crystalline powder. To purify it, dissolve it in the smallest possible amount of warm water, and leave it to crystallise overnight. Remove and drain the crystals.

Finally, if you dissolve some of this in cold water and add barium chloride solution, a dull green precipitate of the rare compound basic copper barium salicylate forms, which you can wash on the filter and dry.

These last two compounds are rare not in the money sense, but in being seldom prepared. Indeed, most chemists never handle them in the whole of their scientific careers.

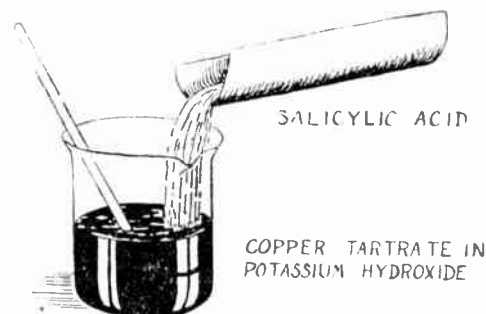

Fig. 1—Making a rare compound

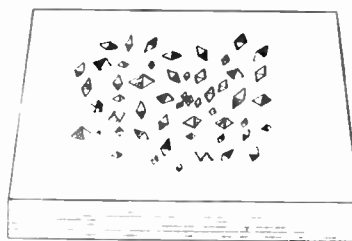

Fig. 2—Crystals on a porous tile

Half fill a crucible with cream of tartar and heat until the action has ceased. Stir up the charred product with several lots of water until you have removed it all from the crucible. You now have a solution of potassium carbonate mixed with carbon. Filter the solution from the suspended carbon and evaporate to dryness.

No Crystals

Do not attempt to produce crystals, for this is difficult, owing to this salt being highly deliquescent. Scrape out as much as you can from the evaporating basin and keep the specimen in a tightly corked bottle. The small portion which is left adhering to the basin will soon show you how deliquescent potassium carbonate is. Leave it aside while you carry on with the other experiments. When you return to it you will find the dry solid has become an oily liquid.

Cream of tartar, being a tartrate, gives us the means of preparing other tartrates. As most of these are insoluble in water we can prepare them by precipitating them from solutions. But as cream of tartar is only slightly soluble in cold water (one part in two hundred of water) this means we must either use large quantities of cold solution or else use a

characteristic tartrate—and one which is much used as a test for tartrates—is calcium tartrate. Take some of the Rochelle salt solution and add to it calcium chloride solution. A white crystalline precipitate of calcium tartrate falls, which you can filter off, wash on the filter and dry in a cool oven.

Natural Tartrate

If your solutions are dilute, the precipitate will not appear at once, but

Your Screwdriver

Next to a hammer, a screwdriver is probably the most used tool—and often gets the least thought or attention. But even the most haphazard among us find ourselves faced with a job of re-conditioning when, after using the screwdriver as a jemmy or a chisel, we find the shaft bent and the blade burred or notched.

Straightening the shaft is usually a simple enough job, but repairing the blade needs a little more care. First, use a fine file across the end so as to make a smooth, blunt edge. Then file parallel sides down each face. Take care not to form a sharp, chisel-like edge, as the blade will then be easily

damaged again, and may also tend to slip out of the notches of the screws.

Glasspaper

Where a plane has not left the surface of the wood as smooth as one would have liked, it is usual to put the final finish on it with glasspaper. If the work is to be varnished or french-polished, remember to rub along the grain of the wood, as scratches left on the surface will show through.

For the best results it is advisable to use a block to hold the glasspaper absolutely flat. They can be purchased in different sizes, and are quite cheap. It saves time, too, to buy refills ready cut to fit the blocks.

MISCELLANEOUS ADVERTISEMENTS

The advertisements are inserted at the rate of 3d. per word prepaid. Name and address are counted, but initials or groups, such as E.P.S. or £1/11/6 are accepted as one word. Postal Order and Stamps must accompany the order and advertisements will be inserted in the earliest issue. Announcements of freework goods or those shown in Hobbies Handbook are not accepted. Orders can be sent either to Hobbies Weekly, Advert. Dept., Dereham, Norfolk, or Temple House, Temple Avenue, London, E.C.4

MAKE money—our books 'Spare Time Pounds' and 'Deal in Stamps' will show you how. 2/9 each, post paid.—King, 63 Crabble Hill, Dover.

PERSONAL—the fascinating magazine for all hobbyists. Crammed with pen friend addresses, personal advertisements, hobby announcements, etc. Specimen, 1/.—Woolf's Publicity, 142 Mile End Road, London, E.1.

PENNY Black on stamp of Mexico, catalogued, 2/6, free. Request approvals, enclosing postage.—Hubert Rajski, 211d Thornes Road, Wakefield.

STAMPS FREE! Twenty unused (2½d.).—G. H. Barnett, Limington, Somerset.

ALL printing requirements at keenest prices. Distribution/publicity services available for authors, businessmen, hobbyists. State requirements.—Scrivener Press, 142 Mile End Road, London, E.1.

STAMPS free. Wonderful offer. Approvals from ½d.—Walker, 13 Broom Rd., Hale, Cheshire.

MATCHBOX radio. With the aid of our instructions, you can build a complete radio set in a matchbox, using parts purchased from your radio dealer. The set incorporates medium wave inductor with station selector switch, long wave loading coil, and crystal-valve radar detector. Powered entirely by the incoming signal, no batteries are required. Full instructions, drawings and theoretical circuit diagram. Price 3/., post free.—Swift Radio (H), 137 Cotham Brow, Bristol, 6. Mail order only.

50 GOOD stamps free, mainly pictorials. Send for approvals, enclosing 2½d.—Junior or medium.—Beeze, 116 Newton Rd., Mumbles, Swansea.

FREE Bahawalpur, Colonial discount approvals. Weddings. (Not abroad).—Bishop, 40 Marine Parade, Hythe, Kent.

INTRODUCTIONS. Pen friends, companionship or marriage.—V.C.C., 34 Honeywell Road, London, S.W.11.

GAIN confidence, personality. Be successful. Learn the secrets of hypnotism, personal magnetism and auto-suggestion. New methods enable you to develop these amazing sciences quickly and easily. Complete course by expert, 5/., post free.—R. Hainsworth (Dept. H.), 34 Beamsley Rd., Frizinghall, Bradford, Yorks.

ATTENTION. Quality duplicating at lowest prices. No extra charge, simple diagrams. Send for details, samples, price lists. Prices and service beat all competitors.—N.S.S., Gorleston.

IF you have nothing to occupy your leisure, why not try something interesting and profitable? Experience is not required in leathercraft. Send S.A.E. for our brochure, free of obligation.—Leathaweave (Dist. 37), 2 Tudor Rd., Leicester.

START earning money at home, whole or spare time, making up fancy leather and felt goods. Material provided. Write for rates of pay, etc.—Grange Co., 2 Curzon Street, Leicester.

STAMPS. 25—18. 50—2d., etc. Approval books. Free gift.—Pavely, 12 Leeder Close, Coventry.

LEARN Perspex modelling the practical way, by making the toast rack, cigarette/trinket box, brooches and bracelets featured in our latest course. (Details, 6d.). Instructional course, 29/11.—Plastics Home Products, 18 St. Mary's Road, London, N.9.

FREE—stamps catalogued 5/- to applicants for ½d. approvals.—Cox, 17 Stoneleigh Park Road, Ewell.

MAKE money! Ply outfits, 3/-, 5/- and 10/- parcels.—Mayco (D), 117 Station Rd., Sutton Coldfield.

WORLD stamps—1,000 different, 10/-, 1,000 unsorted, 5/-. Free pictorials with approvals.—Robert J. Peck, 7A Kemp Road, Bourne-mouth, Hants.

BEAUTIFUL interior decorating for walls, ceilings, etc., in mottle roughcast, etc. can be obtained by using 20th Century Plastic in all pastel shades, price 9/6 per 6lbs. (delivered). Sample, 1/6.—20th Century Products (1), 99 Kings Cross Road, London, W.C.1.

9.5 Film Library, Projectors, Films, for sale. Stamp for lists.—Wayland, 223 Longley Road, Tooting, London.

FRANCE 8 free. 2½d. stamp for approvals.—D. Bailey, 72 Marshfield Road, Gooles, Yorks.

NEW Zealand stamps free. 15 different. Send 3d. postage and request approvals.—Crutchfield, 11 West Court Street, Brompton, Chatham.

AMERICAN Magazines post free for one year. Popular Mechanics, 32/-; Popular Science, 28/6; Mechanix Illustrated, 22/6; Popular Homecraft, 18/-. Stamp for full list of others.—Willen Ltd. (Dept. 57), 101 Fleet Street, London, E.C.4.

PLYWOOD and Timber Offcuts for sale at very cheap prices. Veneered Oak Plywood panels, etc., Japanese Oak. Bumper list, 1d. S.A.E.—Dept. 'H' JDD. Storage, 71 Northcross Road, S.E.22. Tel. BR1Xton 741.

MAKE your own Jig-saw Puzzles. Fine Art Pictures, various reproductions and sizes. Also suitable for framing. Stamp for full list.—Joyden Toy Co., 193 Chase Side, London, N.14.

MAGICIANS Tricks, crazy cut-outs, only 1/3; parcels, 5/6. An evening's entertainment. Lists, 3d.—De Hempsey, 363 Sandycombe, Kew Gardens, Surrey.

HARDWOOD Ball Beads, ¼in. diameter, suitable for children's counting frames, etc. 5/3 per hundred, plus 1/9 P.T.—Joyden Toy Co., 193 Chase Side, London, N.14.

ATTRACTIVE Pictorial Stamps on approval.—G. Smith, P.T.S. 95 Ocean Road, South Shields.

MADE big money, so can you. Enclose envelope.—H. Wamstecker, Box 34, Wynberg, Cape, Africa.

CV102 Crystal diode. New, guaranteed, 3/6, postage 2½d. Fixing brackets, 3d. Recommended for 'Hobbies' crystal set; wiring instructions for reliable set. Send stamp for lists, including copper wires, enamelled, silk, cotton covered; B.A. screws, nuts, washers, headphones, radio publications, Paxolin type tubes, ebonite and bakelite panels, rods, etc.—P.R.S., 33 Bourne Gardens, London, E.4.

BE Taller. Quickly! Safely! Privately! No Appliances—no tablets—no dieting. Details, 6d. stamp.—Malcolm Ross, Height Specialist, BCM/HYTE, London, W.C.1.

MODELS. You can make lasting stone-hard models with Sankey's Pyruma Plastic Cement. Supplied in tins by Ironmongers, Hardwaremen and Builders' Merchants. Ask for instruction leaflet.

TRANSFERS for decorating toys, trays, furniture, fancy goods. List and samples, 3d. Flowers, pixies, dogs, nursery rhymes.—H. Axon Harrison, Jersey.

PRESSED Metal Wheels. 1½ins., 1/3; 2ins., 1/9 per dozen. Or in stove enamel finish, red, green or blue at 6d. per dozen extra. Tax included. Post paid.—The Joyden Toy Co., 193 Chase Side, London, N.14.

DOLL'S House fittings and papers; send S.A.E. for list. Doll's House plan, special; send 2/6. Trade supplied.—Zimplan, 88 Ware Road, Hoddesdon.

LORRY Kits, 4 mm. and 7 mm. scale. Also large range of spare parts from which to build to your own design. Send for fully illustrated catalogue—price 1/-.—Wilson's Lories Ltd., 6 Gt. Winchester Street, London, E.C.2.

BLUSHING, shyness, nerves, self-consciousness, B fears, ended. Details under plain cover, 1d.—Stebbing Treatment, 28 (HB) Dean Road, London, N.W.2.

BE Taller in 14 days or money back. Details, 1d.—Stebbings System, 28 (HB) Dean Road, London, N.W.2.

HARDWOOD Wheels. 2ins., 1/-; 3ins., 2/- per set of four. Tax included. Post paid. Other sizes available.—The Joyden Toy Co., 193 Chase Side, London, N.14.

£5 to £20 weekly earned at home, running your Town Mail Order business. Details, 1d.—Stebbing Publications Ltd. (HB), Naphill, High Wycombe.

STAMP Albums, Outfits, accessories, etc. Lists, 3d.—R. Hawkins (Dept. L.2), 247 Rocherhiche New Road, S.E.16.

PLYWOOD Offcut parcels, nothing under 12 x 12 x ½ in., 15 sq. ft. parcels, 7/6, post paid. Immediate despatch.—Breezecraft Limited, 113 High Street, Staines. 3461/2.

100,000 Government surplus bargains. 170 ohm variable resistances in bakelite case with knob, 9d. each, post 3d.; 5-way junction boxes in bakelite case (approx 2ins. dia.), 9d. each, post 3d.; strong elastic cord, multi-core, ¼in. dia., 10yds for 3/6, post 9d.; aluminium rivets, approx. 1lb. assorted, 2/6, post 6d.; 12 volt drills (work from car battery), 10 amps, with ¼th capacity chuck, 19/6, post 1/6. Hundreds of other bargains. Send 3d. stamp for illustrated list.—Milligan's, 24 Harford Street, Liverpool, 3.

USE spare time for profitable homework. Making fancy goods. Write for free booklet.—(Area 544), 54 Southgate Street, Leicester.

HOME Watch and Clock Repair Outfit. Includes watchmaker's magnifying eyeglass, tweezers, screwdrivers, oils, oil brush, dusting powder, plus illustrated explanatory book. Watch and clock repairing simplified. In container, 12/9 inclusive.—D. Bolster (Dept. H), 5a Station Parade, Ashford, Middx.

(Continued foot of page 383)

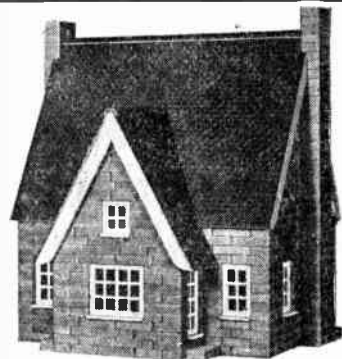

YOU can build this INN

WITH BRICKPLAYER

BRICK & MORTAR BUILDING KIT

It enables you to build Garages, Houses, Railway Stations, Signal Boxes, or from your own imagination. All railway models will fit 'O' gauge scale. Buildings can be permanent, or dismantled by merely soaking in water and the bricks used again and again.

BRICKPLAYER KITS AT 26/6 AND 49/6 ARE AVAILABLE FROM GOOD TOYSHOPS, HOBBY SHOPS, AND DEPARTMENTAL STORES.

ACCESSORY PACKS

No.	Contents	Price
100	100 Full size Bricks	2/9
101	52 ½-Bricks and 72 ¼-Bricks	2/9
102	Gable and Peak Bricks	2/9
111	Capping and Roof Tiling	2/3
112	Concrete Roofing	2/3
114	Bag of Brickplayer Cement	1/3
115	Roofing Cement	7d.
8107	2 Bay Windows with 31 Splay Bricks	3/9

METAL WINDOW AND DOOR FRAMES

F1	F2	F3	F4	F6	F8	F10
8½d.	6½d.	7½d.	5d.	4d.	6d.	7½d.

8108 Sheets of Glazing, 1½" x 6" (Plastic) 1½d.

If your dealer cannot supply, write for address of nearest stockist to:

J. W. SPEAR & SONS LTD.
(Dept. H) ENFIELD MIDDLESEX

YOU CAN BECOME A HANDICRAFTS INSTRUCTOR

EXPERIENCE NOT ESSENTIAL

Men who enjoy making things in wood or metal can turn their hobby into a permanent and interesting Career. Short hours, long holidays, and security in a job you would really enjoy, can be yours if you become a Handicrafts instructor. Let us send details of the easiest and quickest way to get the necessary qualification.

**We definitely guarantee
"NO PASS—NO FEE"**

If you would like to know about our unique method of preparing you for one of these appointments, write today, and we will send you our informative 176 page Handbook—free and without obligation. Mark your letters "Handicrafts Instructor".

BRITISH INSTITUTE OF ENGINEERING TECHNOLOGY

595 Shakespeare House
Stratford Place, London, W.1

BIET



Swann-Morton CRAFT TOOL

The perfect, razor-sharp utility tool for modellers in Balsa Wood, also for Biologists, Students, Commercial Artists, Photographers, etc. 2 interchangeable blade shapes.

Handle and two blades 2/- post free. Spare blades six for 2/6 post free. Send P.O. to

FAMILY PRODUCTS
92-94 BRADFIELDRD.
SHEFFIELD 6.

Trade enquiries invited

EVERY CAR THAT PASSES YOU WILL FIND THE INDEX MARK ALPHABETICALLY ARRANGED IN WHERE'S THAT CAR FROM ?

Price 6/-
from all Booksellers or from the Publishers (1d. postage)

RALEIGH PRESS, EXMOUTH

WEBLEY AIR PISTOLS

Marvellously accurate for target practice. No licence required to purchase for use on enclosed premises.

Senior Mark I
Junior Mark I
Write for List. WEBLEY & SCOTT LTD.
166 WEAMAN STREET, BIRMINGHAM, ENG.



MAIL ORDER HOUSE, BEDFORD SQUARE, SIDMOUTH, DEVON

BOYS!!! BOYS!!!
With the aid of our amazing assembly outfit you can quickly and easily assemble this superb scale model of the famous 'Ferguson' Tractor. All parts supplied in finished state. All Plastic construction, real rubber trackgrip tyres. Can be dismantled and re-assembled with ease. Send P.O. today for 8/- post free.
MURRAY HILL & CO. (Dept. H.)
MURRAY HILL & CO. (Dept. H.)
MURRAY HILL & CO. (Dept. H.)
MURRAY HILL & CO. (Dept. H.)

Miscellaneous Advertisements—(Continued from page 382)

PLYWOOD Offcuts. Birch and Gabbon in various thicknesses. Handy sized parcels for the cabinet, toy, model maker, and all handicrafts. Parcels made up in £1 and 10/- lots. Carriage paid. Send P.O. to Reeves, Plywood and Timber Merchant, 33 Front Street, Monkseaton, Whitley Bay. Tel. W.B. 4677. Parcels are now despatched on day of receiving order.

PERSPEX Flat Sheets, sizes cut to shape. Corrugated Perspex. Aluminium Sheets. Plastics.—Henry Moat & Son Ltd., Atom Works, Newcastle, 1.

LOOK! All at 3/-. Metal Die Cast Moulds for Toy making. Soldiers, Planes, Sailors, Ships and Farm Yard Stock, etc. All new lines. Pick where you like, 3/- each mould. New illustrated Catalogue price 6d., post free.—Robin Hood Moulds (Dept. H), 140 Hollings Road, Bradford, Yorks.

LAMP SHADE making. Send 6d. for comprehensive catalogue giving full details of this interesting, profitable and instructional hobby.—Crescent Plastics Ltd., Dept. F., 14a Crescent Road, Manchester, 8.

CASCO GLUE

will see you through!



CASCO Cold Water Glue has superseded the old fashioned glue kettle. Whatever your gluing problems may be—new work, or repairs—Casco is an absolute necessity. Casco is easy to mix, no heating is required; 1-lb. dry powder makes 3-lbs. liquid glue solution. Casco sets quickly, is highly resistant to heat and moisture. For permanent wood joints, gluing wood to metal, plastics, cork and asbestos, etc., Casco strength is exceptional. It is economical to use, too, and available in all quantities. A versatile moisture resistant glue for: Joiners, Builders, Decorators, Handicraftsmen and Home users.

DISTRIBUTORS:

Gt. Britain: Charles Cleeve & Co. Ltd.,
45 Gt. Peter Street, London, S.W.1

Eire: Waller & Willis Ltd., 60 Middle Abbey St., Dublin.
M. J. Galligan, 16 Oliver Plunkett St., Cork.

FREE SAMPLE supplied on request to manufacturers (Dept. HW)

LEICESTER LOVELL & CO. LTD.

NORTH BADDESLEY, SOUTHAMPTON

SHIPS
GALLEONS
LOCOS
HISTORIC &
ARCHITECTURAL
SUBJECTS
ENGINEERING
MOVING
TOYS
ETC.

Micromodels

TRADE MARK

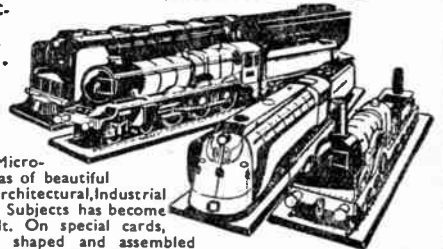

Assembling Micro-model replicas of beautiful Mechanical, Architectural, Industrial and Maritime Subjects has become a serious cult. On special cards, units readily shaped and assembled models authentic in every detail. Cost a few pence, often sell for guineas. Send 1d. stamp for Illustrated Descriptive Catalogue.
MICROMODELS LTD., 6 (H) Racquet Court, London, E.C.4



TOOL CLIPS

All Steel. A boon in the workshop and home. For small, handled tools and articles. 1½" diameter.

6d. Each. Post 2½d.

HOBBIES LTD., DEREHAM
or Hobbies Branches and Ironmongers everywhere

EARN £5 to £20 weekly dealing in stamps, Booklets, testimonials. 1d.—M. Stebbing, Terry, Naphill, High Wycombe.

HOMEWORKERS required, either sex, light assembly. Part or full time. S.A.E.—Esprey, Box 18, 41 Wade Street, Lichfield.

LAY your own solid or ply Parquet floors, over existing wood floors. Materials supplied complete with instructions. Wall Panelling, polishes, etc. Call or write.—New-Een (H), 101 Kings Cross Road, London, W.C.1.

STUDY
AT
HOME

IN YOUR
SPARE
TIME

THE BENNETT COLLEGE

*will set you on the right
course for success*

You make sure of planned progress in the career of your choice when you let the most progressive, most successful Correspondence College in the world coach you through the post. By friendly, individual training we equip you with the specialized knowledge you must have for a well-paid key position. Make the first move TODAY—post the coupon below!

ALL TEXT BOOKS ARE FREE! We send as many volumes as subject chosen demands, they become your property.



IS YOUR CAREER HERE? IF NOT, WRITE FOR FREE ADVICE

- | | | |
|----------------------|----------------------|----------------------|
| Accountancy Exams. | Engineering. | Radio Service En- |
| Agriculture | All branches. Sub- | gineering |
| Applied Mechanics | jects and Exams. | Radio (Short Wave) |
| Auctioneers and | General Certificate | Road Making and |
| Estate Agents | of Education | Maintenance |
| Aviation (Engineer- | Examinations | Sanitation |
| ing and Wireless) | General Education | School Attendance |
| Blue Prints | G.P.O. Eng. Dept. | Officer |
| Boilers | Heating and Vent- | Secretarial Exams. |
| Book-keeping. Ac- | ilating | Sheet Metal Work |
| countancy, and | Institute of Muni- | Shipbuilding |
| Modern Business | cipal Engineers | Shorthand (Pitman's) |
| Methods | Journalism | Short Story Writing |
| Builders' Quantities | Languages | Speaking in Public |
| Building, Archite- | Mathematics | Structural Engineer- |
| cture, and Clerk of | Metallurgy | ing |
| Works (A.R.I.B.A. | Mining. All Subjects | Surveying (R.I.C.S. |
| Exams.) | Mining. Electrical | Exams.) |
| Carpentry and | Engineering | Teachers of Handi- |
| Joinery | Motor Engineering | crafts |
| Chemistry | Naval Architecture | Telecommuni- |
| Civil Engineering | Plastics | cations (City and |
| Civil Service | Plumbing | Guilds) |
| All Commercial | Police, Special | Television |
| Subjects | Course | Transport Inst. |
| Commercial Art | Preceptors, | Examinations |
| Common Prelim. | College of | Viewers, Gaugers |
| E.J.E.B. | Press Tool Work | Inspectors |
| Concrete and Struc- | Pumps and Pumping | Weights and Mea- |
| tural Engineering | Machinery | sures Inspectors |
| Diesel Engines | Quantity Surveying | Wireless Telegraphy |
| Draughtsmanship. | —Inst. of Quantity | and Telephony |
| Electrical or | Surveyors Exams. | Works Managers |
| Mechanical | | |

COUPON. CUT THIS OUT

IF YOU ATTEND TO THIS NOW
IT MAY MAKE A WONDERFUL
DIFFERENCE TO YOUR FUTURE.



To Dept. 62
THE BENNETT COLLEGE LTD.
SHEFFIELD

Please send me (free of charge)

Particulars of..... (Cross out line
which does not
apply.)

Your private advice

about

PLEASE WRITE IN BLOCK LETTERS

Name

Address

The acid-free cored solder for every handyman

This new, non-resin cored solder is an indispensable addition to every home workshop, replacing stick solder and fluid and paste fluxes. It contains two cores of Arax Flux, a flux so fast that Arax Multicore Solder can even be used for soldering blued spring steel without pre-cleaning. Flux continuity is assured, there is no waste, and no extra flux is required. The flux residue can be easily washed off with water.



SIZE 8 CARTON 5/- EACH



A COMPLETE RANGE OF MULTICORE
SOLDERS IN THIS SINGLE HANDY KIT
The Multicore 2/- Solder Kit contains
two specifications of Arax Multicore
for metal soldering and two specifica-
tions of Erin Multicore for electrical
and radio work.

MULTICORE SOLDERS LTD.,
MELLIER HOUSE, ALBEMARLE ST., LONDON, W.1. REGent 1411



“Like my rabbits...?”

Can't see them? What do you think I'm holding? Sure, they're the rabbits — Service language for presents for the folks at home. When we got that big rise in pay I decided I'd do the folks proud . . . can send Mum home a bit extra, too. Not bad for a Seaman Boy, eh? I certainly landed lucky when I got into the Navy . . .”

BOYS AGED 15-16 years 3 months can enter the Seaman Branch of the Royal Navy. Higher pay — better prospects than ever. The Navy needs the right Boys NOW.

Make the ROYAL NAVY your career

WRITE TODAY for FREE booklet to: D.N.R., Dept. Y/37,
Admiralty, London, S.W.1. (Applications from U.K. only.)

Name

Address

Age

Hobbies

WEEKLY

CONTENTS

	Page
Telephone Table - -	385
Modelling with Matches	387
Easter Novelties - -	388
Club Championship Board -	389
Alarm Clock Door Bell	390
Handpainted Firescreen	391
First Aid Cabinet - -	392
Short Ladder - - -	393
Improve your Photography -	394
Plastic Letter Rack -	395
Universal Test Meter -	396
Shipmodellers' Corner	397
MODEL TRAM DESIGN SHEET	

March 21st, 1951

Price Fourpence

Vol. III No. 2890

MAKING A MODERN TELEPHONE TABLE

PRIMARILY this useful and novel table for telephone, small radio or similar fitment was designed with the idea of incorporating a tipping drawer as a wastepaper basket which was completely hidden when not actually required. As a table for the telephone, however, the main use for the drawer has been to accommodate directories—the ideal and obvious place for them!

Construction is quite straightforward. Top and bottom are identical in size, 15ins. by 9ins. cut from $\frac{3}{4}$ in. material. The two side pieces are cut from $\frac{3}{4}$ in. ply, one side purely rectangular in shape 16 $\frac{1}{2}$ ins. by 7 $\frac{1}{2}$ ins., the other the same length but tapering from 6ins. to 3 $\frac{1}{2}$ ins. This taper cut is to give clearance for the drawer in the tipped position, so it can be removed from the assembly by sliding out sideways.

Base, top and side pieces are erected

first, making sure that the assembly is square. Triangular bracing blocks are used inside at the top and outside at the bottom, joints being glued and also screwed or nailed. A facing piece of 1in. by $\frac{1}{2}$ in. material, 15ins. long is secured under one long edge of the top, as shown.

The Tipping Drawer

Construction of the tipping drawer is shown in a separate sketch, where all relevant dimensions are given. Suggested material thickness is $\frac{3}{4}$ in., with plain butt joints at the corners again reinforced with triangular stock. Small screws or nails should again be used as well as glue.

A 2in. strip of material is secured to the top of the sloping back of the drawer to act as a stop. This, by striking the 1in. by $\frac{1}{2}$ in. strip under the top of the table prevents the drawer being pulled out or tipped too far.

To the bottom of the drawer, close up to the vertical face, is screwed a length of $\frac{1}{2}$ in. dowel. A $\frac{1}{2}$ in. groove, $\frac{1}{2}$ in. deep is cut in the base to accommodate this dowel, as shown. The drawer rocks about this point—the dowel resting in the base groove. Normally its own weight is sufficient to hold it closed.

A drawer pull or a simple rectangular block of wood is attached to the vertical face of the drawer as a grip for tilting. Tilted forward to its fullest extent the

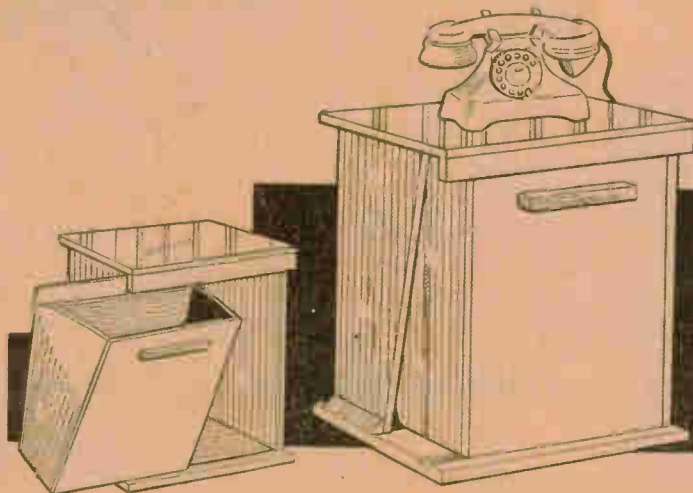

All correspondence should be addressed to The Editor, Hobbies Weekly, Dereham, Norfolk.

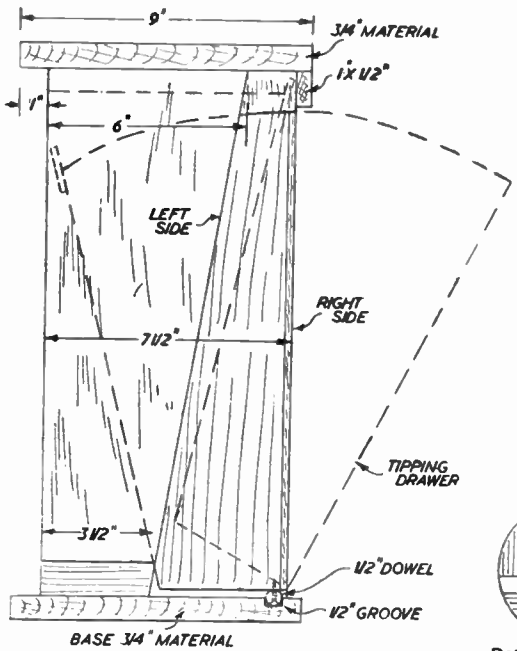

Side elevation

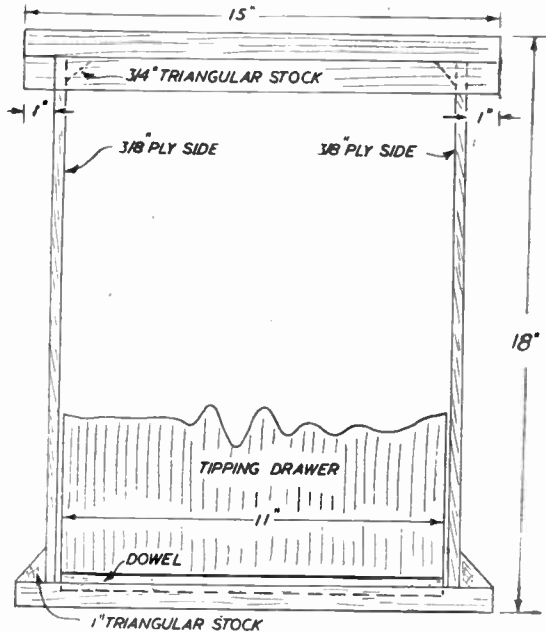

Front elevation

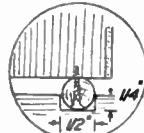

Details of hinge

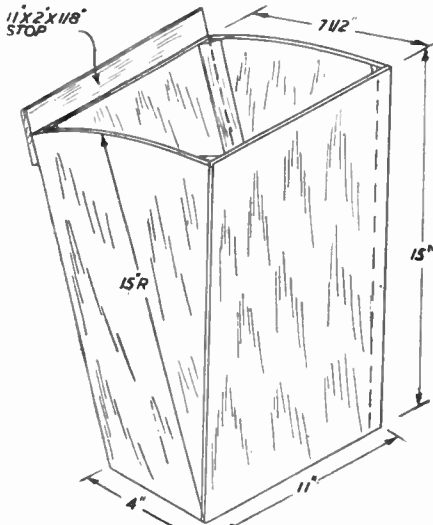

The tipping drawer

rear face of the drawer comes in front of the taper edge of the left hand side and the drawer can be removed entirely by sliding out.

Drawer and table can be finished according to taste, painted or stained and polished. Instead of a polished top, a fitted mirror or plain glass top adds greatly to the attractiveness of the finished article.

Where the tipping drawer is to be used purely as a waste-paper holder, there is one suggested modification to the design which can be incorporated. Space is not now of such importance and the bottom of the drawer can be brought to a point. In other words, the drawer can be

laid out so that the sloping face joins the vertical face at the point, this also being the attachment point for the dowel.

Only a very small clearance is then needed to slide clear and so the left hand side can be made 7 ins. wide and untapered. This is largely a matter of taste. (370)

A London Man's Queer Hobby

A LONDON man, Mr. G. C. Nash, has a hobby that is both satisfying and quite inexpensive. He collects the catalogues of the kind that are sent out gratis by commercial firms of all kinds. Over the many years he has been collecting, Mr. Nash has built up an amazing array of free catalogues describing every kind of goods and merchandise. Some are dull lists and brochures, some highly-coloured leaflets, others are well-produced booklets, and a few are even beautifully bound and illustrated books. Pride of place in Mr. Nash's collection goes to catalogues that offer queer merchandise of a type not usually found in shops, and those whose make-up is done artistically and attractively. Es-

pecially interesting are the detailed catalogues of firms who supply magicians and conjurers with all their props and trick apparatus, and also the lurid seed catalogues with over-optimistic pictures and descriptions of flowers and vegetables that are claimed to result if the seeds are sown. Catalogues are offered all over the world almost daily, yet it is surprising how rare the hobby of collecting specimen ones is. Mr. Nash's collection is unique. One of the biggest catalogues comes every year from a large American mail-order firm: it weighs about 4 lbs., is a thick, bound book illustrating almost every kind of tool and household appliance, and is sent free to hundreds of thousands of homes in the U.S.A. (280)

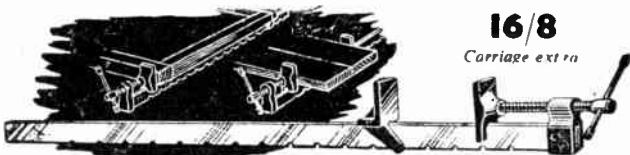

16/8

STRONG STEEL BAR CRAMPS

A strong well-made tool for the carpenter and handyman. Takes work up to 36 ins. long. Easily adjusted to varying lengths as a sash cramp or for wide boards. Strong steel bar with square edges for rigidity.

At Ho-bies Branches or from
HOBBIES LIMITED · DEREHAM · NORFOLK

You can spend many interesting hours MODELLING WITH MATCHES

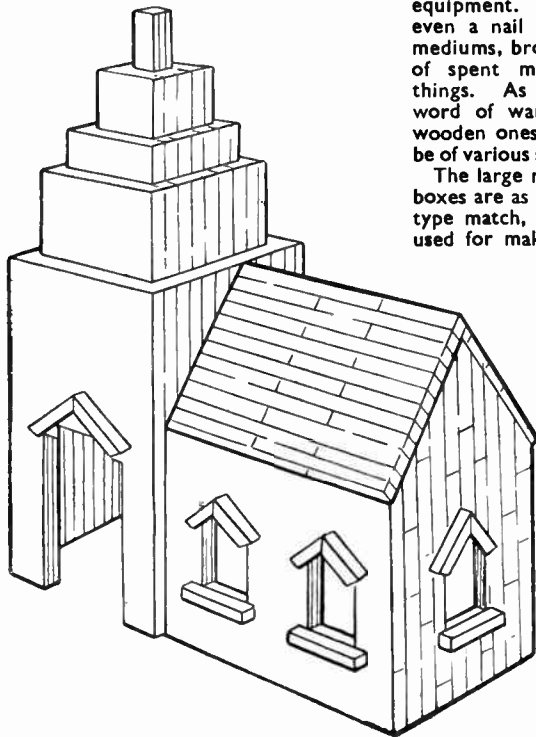

equipment. A pen knife, a small file, even a nail file, glue or tube sticking mediums, brown paper, and a great pile of spent matches, are the essential things. As for the spent matches, a word of warning. They must be all wooden ones, of course, and they must be of various sizes.

The large matches which fit into large boxes are as necessary as the usual small type match, for the larger matches are used for making beams, principals, and other things for the inside of models such as buildings. Indeed, they can form the frames round which the other things are built. It must be obvious that instead of matches, small pieces of wood can be used for this framework, but that is but defeating the whole idea of this type of modelling. One might as well use clay or plasticine for modelling a steel engine. The end might look all right, but the true modeller would look askance at such a composite affair.

Buildings are Best

Scale drawings of anything in this number, of engines, aeroplanes or other things can become for you, the drawing by which you work. The only thing is that you must substitute matches for tin, steel, brass or metals of other kinds. The best things for this type of modelling, however, are well known buildings. If you live near Westminster Abbey or St. Paul's Cathedral, The Houses of Parliament, you can make models of these. If you run to lighthouses you can make a whole collection of them. If you are in the west country there are many things there. The various cathedrals, many a town hall, or in the Midlands, the cottage of Anne Hathaway, Shakespeare's birthplace, the Memorial Theatre, are suitable subjects.

You see, the match modeller is also something of a collector. He makes a model of this, perfects it, then looks round for fresh fields to conquer. In his room he has his models which are a source of enjoyment to his friends and family as to himself. Why? Why should such models be capable of giving more enjoyment than other types? For this simple reason, that most models, engines, ships, aeroplanes, racing cars, are working models which are seldom effective when not used for one's self.

Things to Know

There are a few things to be understood in this type of work, just as there are about other things. The matches to be used for joints have to be cut into 'joints'. That is half or less of the ends of the matches are cut away so that they fit together exactly as the join in a cabinet. Then some match ends must be pared away so that they can fit into holes bored into other matches. Especially does this apply to the larger ones which are used for holding the rest in place.

Like every other type of model known to man, to work in this field, it is better to start with a small ambition and work up. Indeed, I know one man who has made wonderful models in this field who started years ago by making doll's furniture for his child. With the aid of spent matches, he made small chairs, beds, tables, suites of furniture for the doll's house. They were so small that few would care to inspect them so closely.

But after he had made progress, then the first set were thought to be unworthy and a later set, built to scale, with many points about them incredible to those who do not know how, are a source of deep astonishment to the casual inspection.

What types of models are possible in this type of work? There is no limit. You can get any model in this issue, and with spent matches make it. Indeed, this is one of the advantages.

TO the unknowing to model anything from matches might sound the height of foolishness. Not live matches, of course, but spent ones. Yet, to those who realise, here is a field wide enough for the beginner and the expert to work in. Nor is this type of modelling just for the one field alone. The modeller who makes an engine, generally sticks to that type of model all his life. Another whose hobby is aeroplane modelling often does nothing else. With spent match modelling one can work in any field.

The Possibilities

Aeroplanes to scale, engines to correct proportions, ships or canoes, are all possibilities for the spent match worker. Not that these are the best things for such an enthusiast to tackle. Being a wood medium, the best results seem to be obtained by modelling buildings and similar things, but just as the one who models engines loves to have them to scale, indeed, must have them to scale to obtain the most satisfaction, so must the one who makes his models with spent matches.

In this field of modelling one need not have expensive tools. If such can be afforded, all the better. They are for those with the cash. But the youth with limited pocket money can do work quite as thrilling, just as enthralling, as the one who works with expensive

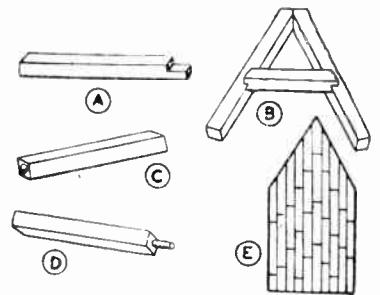

Principles of construction. A—End joints. B—Usual construction for a roof, and for the side or end of a building. C—The tiny hole in the end of a match into which the dwell on D can be fitted. E—Method of fitting matches in sections.

So match models do not work! Indeed they do! One does not mean that match models of ships will sail. They might but that is doubtful. One is not asserting that match engines will run. That is asking too much. Such match models are but the forerunners of the later working models to be made. No! No! The working models which are made from spent matches are of quite a different type. Westminster Abbey, for instance. What is that? How in the name of all that is wonderful, can one make a working model of Westminster Abbey?

Just as with Liverpool, Exeter, Truro,

(Continued foot of page 388)

The children will be thrilled by these EASTER NOVELTIES

HERE are a few suggestions for novelties for the children at Easter. They are easily and quickly made and will provide some good fun. The novelties include Mr. Cockerel and Mrs. Hen, and as many baby chickens as one cares to make. Amusement at breakfast time is provided by putting features on real eggs and making little hats for them.

The chicken family are all made the same way, so a description of the

cockerel will suffice for all. Sketch on stiff paper or thin card, the shape of the chicken with the base in between, as shown in the illustration. Cut round the complete outline. By bending up and right over at lines (AA) and (BB), and by bending lines (CC) and (DD) so that the two sides of the chicken coincide, a base is formed, the lines (CC) and (DD) meeting at (XX). Cover the whole inner surface with seccotine, stick the two sides together and press down the base. If desired, a thicker piece of card can be stuck under the base to make a firmer stand. When set, a coat of paint is added. This should be kept simple. Poster paint is good as it is opaque and obtainable in very bright colours. It can also be used almost dry. Too much water will tend to make the surface cockle.

The real eggs for the Easter breakfast can be decorated with faces. For this, pencil, crayon or indian ink can be used. Water colour will wash off when the eggs are boiled. Hats can be added quite simply. A circle of stiff paper, cut to fit over the top of the egg, will make a brim. Add a short tube, the same circumference as the inner circle of the brim, and a top hat is obtained. Stick the tube to the brim by means of the ties. Turn the

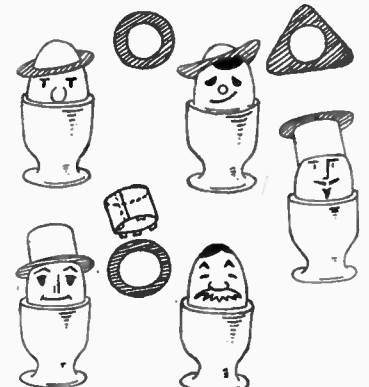

These sketches give some ideas for decorating real eggs—complete with hats

top hat upside down and the result is a chef's hat. Cut out a triangular piece and curl up the straight edges and a period hat is obtained.

All kinds of ideas crop up in the making, which add to the fun. A frilled collar could be set between the egg and the egg cup. Two paper legs could be made to hang over the edge of the cup in front, like Humpty Dumpty on the wall—and, no doubt, the children themselves will think out a few more ideas to try out at a later date. (405)

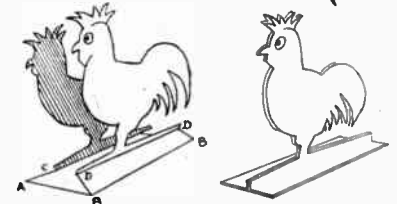

The method of folding and sticking the chickens. For added strength a thicker piece of card can be stuck under the base

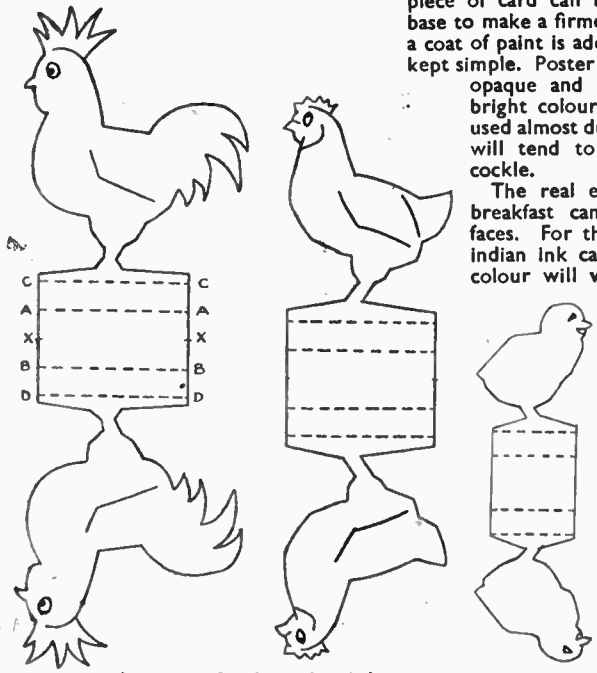

Simple cut-outs for the cockerel, hen and baby chick

Modelling with Matches—(Continued from page 387)

Norwich or Chester Cathedrals. Such buildings are the ideal in this field. The buildings are marked out to whatever scale the modeller desires. This can be done by first buying a photograph of the building desired, and by laying the paper flat on the modelling table, fill it with matches stuck to the portion of the photograph chosen. When these are glued down, the part is turned over and the same process repeated, except, it ought to be remembered that the model will be stronger if the matches are reversed, that is, glue your matches

upright on the outside, and horizontally inside. But such buildings require windows, and here the modeller can give vent to his ambition.

He should make such windows of glass, stained glass pieces are often readily obtainable from many sources. He can fix lighting inside with tiny bulbs here and there, even to the lighting in scale of special lighting sets in such buildings. And, of course, as our Cathedrals have services and choirs, by modelling the choir entering in procession, dressed to the part, the Clergy, and Bishop following, by the aid of a small pick-up from the radiogram a hymn record such as 'Onward Christian Soldiers' or Christmas, or Easter hymns, lends a touch of realism to such models, which in this sense 'work' as much as does a car or an engine with something, which is missing from the latter working models.

Nor is this type of modelling wholly a

dead loss. If one is money minded, a profit can be gained. Many a local Parish Church will gladly engage such a working model for sales of work, exhibitions, and other affairs, either at a fee or on a percentage basis. I know one man with a match model of Strasbourg Cathedral who has made a few hundred pounds in this way from Roman Catholic Churches.

Strangely enough the general public assume that match modelling is harder, infinitely harder than other modelling, whereas it only requires greater patience. Once you get the idea of putting your matches both sides of the photograph parts, and the joints, which are the usual wood joints on a tiny scale, there is no reason why you should not only have a field of great pleasure to work in, but a field to bring good cash return. As was said at the beginning, Make it with Matches. We feel sure you will never regret it if you do. (381)

SILVER POLISH

A good polish for silver is to mix a few crystals of sodium thio-sulphate in as little water as possible, so that you have a strong solution. Rub the tarnished silver with it, and the stain is easily removed.

Incite more competition by making a CLUB CHAMPIONSHIP BOARD

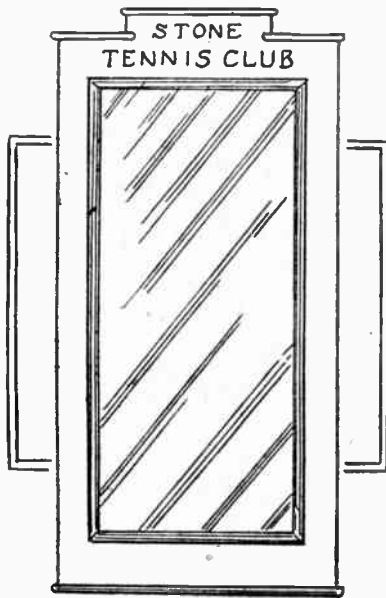

PROBABLY the best method of inciting club competition is to inscribe the names of the annual champions on a framed board for all to see and emulate if possible. This, I believe, is already done by many clubs, and proves highly productive of good play. A very simple design of board will suffice, and most clubs can find a wood-working member able to make one.

The design given to head this article would look quite well made in oak, or if that is not obtainable, deal would serve well enough, as the design shows practically no awkward end grain. It could be enamelled or painted, and need present no difficulty to make.

Fig. 1 shows the parts of the frame; wood $\frac{3}{4}$ in. thick being recommended, to make a substantial article. The dimensions given, especially the width, can, of course, be amended if thought desirable, to suit the club's requirements. The corner joints are of mortise and tenon kind, and entering the sides about 1 in., not right through, as in

detail (A) in Fig. 2. Make the joints a close fit, and well glued.

At the top and bottom, strips of $\frac{1}{2}$ in. wood are glued and pinned along. These overhang the front by $\frac{1}{2}$ in., also the ends. The outer pieces on the top should be cut away $\frac{1}{2}$ in. where they join the centre wider part, so that they extend that distance across at each inner end. This is explained at (B) Fig. 2, and will be noticed in the view of the completed board.

Providing a Rebate

To provide a rebate for the glass and backboard, a few feet of moulding of the type shown at (C) can be mitred round the opening. This particular moulding is suggested on account not only of its suitability for the job, but its neat appearance. Rebated moulding of this type, however, sometimes puzzles the amateur how to estimate the correct lengths for accurate fitting.

A simple method is to cut off a 1 in. length of the moulding, place over the edge of the opening, as at (F) in Fig. 3, and slide it along the whole four sides, keeping a pencil pressed against its outer edge. This will give the exact length of each of the four pieces, and ensure their correct lengths for mitring the corners.

Next Best Thing

If the moulding mentioned is not obtainable, the next best thing is to plane up a few feet of quarter-round moulding, $\frac{3}{8}$ in. section, as at (D) or you may be able to purchase a few feet already prepared, and save trouble. This should be mitred round, as in sectional detail (E), letting it stand slightly above the surface to break the monotony of flatness.

A sheet of stout glass should now be provided, also a backboard. This latter part should be moderately stout, say, $\frac{1}{2}$ in. or $\frac{3}{4}$ in. plywood. Cut it to fit the rebate, and to keep it in place, and the same time ensure its easy removal for adding fresh names to the championship list, a few metal clips should be fitted. These can usually be bought or just as easily cut from sheet metal, making them about 1 in. long and $\frac{3}{8}$ in. wide, with a hole drilled at the wide end for fixing with screws.

Place glass and board in position, and at the spots where the clips are considered necessary, chisel out curved recesses, as at (G) Fig. 3, for them to lie in, and just deep enough for the clips to press firmly enough on the backboard, and keep it in place. Be sure the recesses are long enough to allow the clips to swing clear of the board. For a board of the dimensions given in this article, six such clips may be sufficient, one at top and bottom, and two each side.

Finishing

If the board is of oak, it could well be left plain, after glasspapering, of course; staining and varnishing it is just a matter of choice. A deal board could be painted, but a glossy surface, such as can be obtained by enamelling, is much to be preferred. A final coat of good quality hard gloss paint can also be recommended, but for this a suitable undercoat is necessary to give solidity or body to the colour.

A sheet of quality white cardboard or paper will be needed, on which the names of the champions can be inscribed. This can be backed with a sheet or two of common newspaper before the backboard is placed over it. A brass glass plate should also be screwed to the top of the frame for hanging it to the wall.

In fact a second glass plate, this time at the bottom of the frame, would not be amiss, as it would prevent it being pushed to one side should anyone press up against it.

Take Care with the Name

Complete the board by having the name of the club neatly inscribed at the top, and if no member is sufficiently versed in the art of sign writing to do the job, well do not spoil the ship for a ha'p'orth of tar with a botched job, but have it done professionally, the trifling expense being more than worth it.

No cutting list is really necessary for this article, as adhering to the dimensions given, a 30 in. length of $\frac{3}{4}$ in. thick board will provide the materials for the frame, plus 7 ft. of moulding, and a panel of plywood for the back measuring 10 ins. by 26 ins. (393)

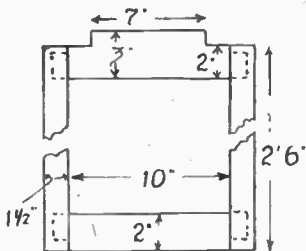

Fig. 1—Parts of the frame

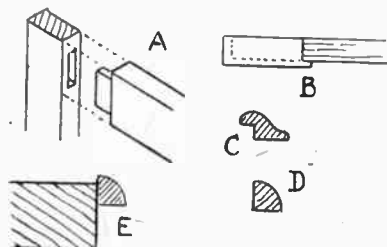

Fig. 2—Details of joints and moulding

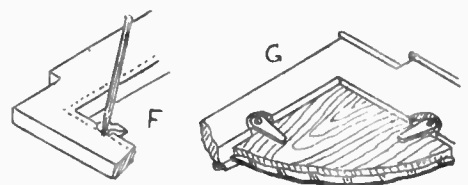

Fig. 3—Fixing the back

Cheap to make and to run is this ALARM CLOCK DOOR BELL

THE reader who is attracted to novel forms of door bells should find the subject of this article interesting. It works entirely off its own power and is not dependent on an electric supply of some sort. Its construction does not call for much skill, and it has the added advantage that the cost can be very small or it may be made from the scrap box for nothing.

If made carefully from good materials it will prove a very efficient piece of apparatus and be equal to some of the best door bells on the market.

The Mechanism

The main mechanism consists of the alarm side of an old drum alarm clock. In the majority of cases when an alarm clock fails to function as such it will be found that the breakdown is on the going side of the clock. This part of the clock is ticking away all day and soon wears out, whereas the alarm is only called on to work once during the day.

It should not be much trouble to get an old alarm clock movement. There are probably few households that have not at least one lying around somewhere that has seen better days. If not, a watchmaker would be glad to get rid of one, in many cases just for the asking, or if a charge was made it should not be much.

The sketch shows a good example of an old type alarm movement with a medium size bell—the larger this is the better. You might even be able to get one having two bells, and would fit into our scheme quite well.

Having got the clock, take it out of the case, remove the hands and the dial. Then take the movement to pieces, and at this point it would be a good idea to clean the parts that are wanted with either petrol or paraffin oil. These will include the two plates, alarm main wheel with mainspring, inter scape wheel and pallets with hammer.

In some alarm clocks there is an extra wheel between the main and scape wheels which allows the alarm to run for a much longer time with one winding. Now put the parts together and tighten up the nuts.

On the plate nearest to the dial will be found a steel strip spring, the end of which engages with the hammer tail wire. This is not wanted and can be either removed or bent back so as to be out of the way of the hammer wire.

Different Spring

Instead of this spring we shall have to make another of similar type to fix on to the back plate, as shown in the sketch, and we will call this the ringing spring. It can be made from a strip of springy brass or a piece of the broken spring from the going side of the clock. Drill a hole in one end for fastening to the

plate with one of the nuts, and the other end is bent over so as to make contact with the hammer tail wire. This keeps the bell from ringing until the button is pressed.

Make sure that this spring passes over the hole in the plates, as this is where the press button rod is fixed. Open out both holes to take a length of brass or steel rod—a knitting needle would answer for this.

On one end of the wire solder a small washer or nut to prevent it from slipping out and also to allow a larger bearing surface on the spring. The other end of the wire has the press button attached to it, but we must wait until the movement has been fixed to the door before cutting it to length.

Next the movement is screwed on to a block of wood about 4ins. square and ½in. thick—the actual sizes will depend on the clock used. The block should be

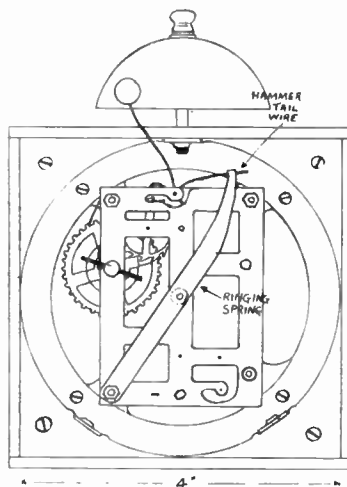

round the movement to keep the dust out and make it look neat and attractive. Quite thin wood can be used for this purpose, anything between ¼in. and ½in. will do nicely and it can be plywood for added strength if desired.

Cutting the Sides

Cut the two sides to just fit the block of wood, while the top and bottom pieces will be a little larger so as to overlap. The width of the case is shown in the sketch as 3ins. but the actual size will depend on the type of clock used. Allow just enough room for the winding key to turn easily.

Glue and pin the pieces firmly to the block; corner pieces can be used to strengthen if thought necessary. Glue a

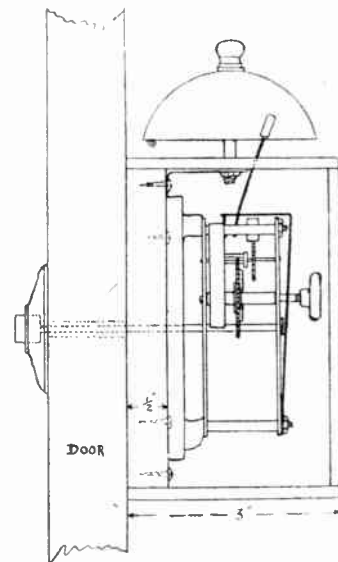

These drawings show clearly the layout and construction

slightly larger than the dial plate of the clock, while the size of the bell will determine the thickness. It is only necessary to keep the bell clear of the door.

Drill a hole in the centre of the block large enough for the press rod to slide through—it does not matter how large it is. Now drill three or four holes in the dial plate and screw it to the block; also drill four holes in the corners of the block and countersink them for fixing to the door.

We can now make a light casing to fit

narrow fillet of wood round the inside of the case near to the back and make a door to fit.

The movement and case can now be screwed to the door, but before doing so, drill a hole to take the press wire. An old electric bell press button was used, the spring being removed, a small hole drilled through the casing and then fastened to the door over the hole already drilled there.

Drill the back of the press button to take the wire. Make it so that it is a tight fit and has to be pressed on. The length of the wire must be adjusted so that when the button is pressed in, it just releases the tail of the ringing spring from the hammer tail wire and allows the alarm to run.

The woodwork can be stained or painted to match the existing woodwork of the door. Give all moving parts a spot of oil, and finally do not forget to wind up the spring each day. (396)

BURNS AND SCORCH MARKS

To remove burns or scorch marks from a cloth, rub with half an onion till the mark disappears.

You will enjoy making this HANDPAINTED FIRESCREEN

A HANDPAINTED glass firescreen is an attractive addition to any room. The firescreen illustrated in the accompanying diagrams is easy and inexpensive to make because the main part of the framework consists of an old picture frame.

There is no need to fight shy of this particular how-to-make because you happen to be an indifferent artist. The colourful galleon design, shown in Fig. 1, can easily be enlarged to the size required by ruling out a squared grid on to a large sheet of paper and then carefully copying in each section of the outline.

Trick of the Trade

As to the actual handpainting of this galleon motif on a pane of glass. Well, between ourselves, there is a little crick-of-the-trade that will make the job no more difficult than colouring the printed design in one of your children's painting-books.

First, scout around the home and see if you can unearth an old picture-frame of suitable dimensions to mask the



Fig. 1—The galleon design

frame and to cut a completely new side to take its place.

Either copy the curved outline of the top, shown in Fig. 2, or design a suitable ornamentation for yourself. Cut round the outline with coping-saw or bow-saw and clean up with spokeshave or file and glasspaper. Drill three holes for the finger-grip and either file or chisel to the finished shape.

If you intend to stain and polish the firescreen you must choose timber for the new top that will match the existing woodwork. This question of matching will not apply if you are going to have a painted finish. It is a simple matter to camouflage different types of wood under a coat or two of paint.

Fig. 3 shows two alternative designs for the feet of your screen. The size of the feet may have to be adjusted to suit the overall size of the screen. Obviously, small feet on a large screen would be most unserviceable. But in the main the sizes given in Fig. 3 will be found suitable enough for the average-sized firescreen.

Sketch the outline of the feet on to a piece of wood of the correct thickness, and with a coping-saw or a bow-saw, remove the necessary waste-wood. Clean the roughly-sawn edges up with a spokeshave and glasspaper, and then mark out and cut a simple housing joint in the top of each foot. The bottom of the frame must then be glued and screwed (from the underside of the feet) into this housing joint.

Paint or Stain?

The actual construction of your firescreen is now complete. Give the woodwork a final rub down with fine glasspaper and then decide whether to paint or stain and polish it. A painted job will require a flat coat of priming on first and then a final top-coat of hard-gloss or enamel paint. Alternatively,

stain the screen to the required shade, using water or spirit stain, and when dry, brush on a coat or two of white polish or varnish.

As already mentioned, it is a fairly simple matter to enlarge the galleon design at Fig. 1. Use a large sheet of white or brown paper and make the outline rather heavy with charcoal or black crayon, etc. Now place this sheet of paper under the glass and secure it in position with a dab of glue at each corner.

With any odds and ends of ordinary household paint or enamel, carefully paint over the outline showing through the glass. You will soon find that it is absolutely child's play to execute an attractive design on glass in this manner.

A Background

When the handpainted decoration has been completed, remove the pattern from the back of the glass, clean off the glue at the corners, and cut a large sheet of coloured paper or card to size, so that it may serve as a background to the painted design.

You may, if you like, use frosted glass for the panel of the firescreen. It will still be possible to see the outline of your design through the pane, and although the actual painting may be rather more difficult because of the uneven surface of the glass, the fire-

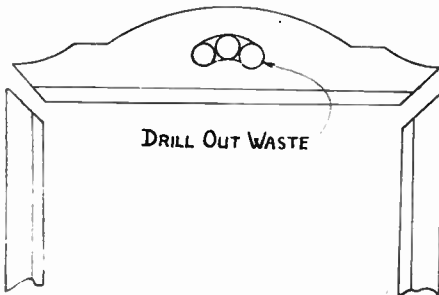

Fig. 2—The top of the screen

front of the fireplace where it is proposed to be used. It does not matter if it happens to be in a rather dilapidated condition. Even if the glass is broken this can easily be renewed. If the loft or lumber-room fails to disgorge a suitable picture-frame have a look round among the second-hand shops. You should be able to pick up a serviceable frame quite cheaply.

Once you have acquired a frame, remove the tacks at the back and lift the pane of glass out. If the woodwork is in a shabby condition clean off all previous paint or stain, using either a paint-stripping solvent or coarse glasspaper. Use a fine glasspaper to produce a smooth finish on the bare wood.

You must now decide whether some form of ornamentation, incorporating a practical little handle, is required at the top of the firescreen. There is no reason why you should not leave the frame as it is, of course. If you would like to give your screen the form of handle shown in Fig. 2 it will be necessary to remove one of the shorter sides of the

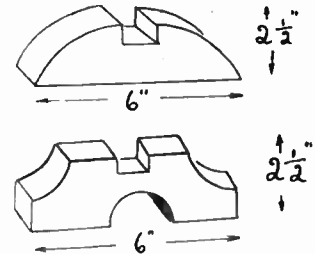

Fig. 3—Alternative designs for the feet

screen will be opaque enough to enable you to dispense with a coloured card backing.

There are, of course, other ways of decorating your firescreen. One method would be to choose a colourful picture and place it inside the frame in the normal manner. This would obviate the necessity for painting the screen. An attractive effect can also be obtained by stretching a piece of embroidered canvas inside the aperture of the frame and tacking it carefully into place. (385)

DYNAMO TIP

If the tread on a cycle dynamo gets broken or lost, the screw on terminal knob of a L.T. accumulator is quite satisfactory.

An unusual but convenient FIRST AID CABINET

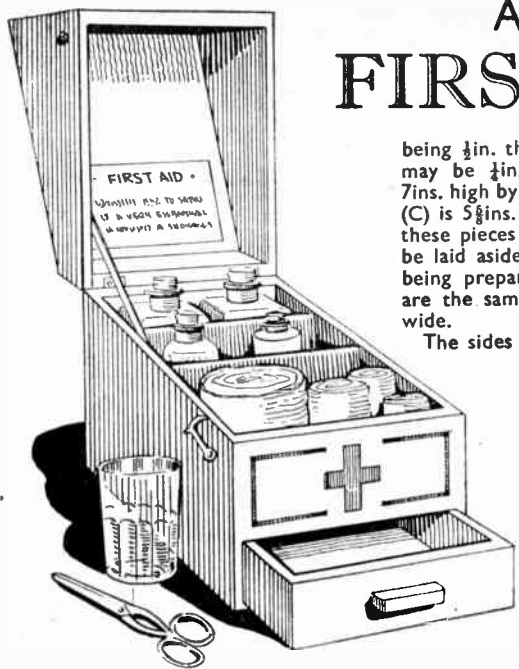

being $\frac{1}{2}$ in. thick, while the other pieces may be $\frac{1}{4}$ in. The back (B) measures 7 ins. high by $6\frac{1}{2}$ ins. wide, while the front (C) is $5\frac{1}{8}$ ins. high by $6\frac{1}{2}$ ins. wide. Both these pieces when cut and cleaned may be laid aside while the top and base is being prepared. The latter pieces (A) are the same size, 10 ins. long by 7 ins. wide.

The sides (D) measure 10 ins. long by 7 ins. wide and these may be glued to the floor, flush at the sides, as Fig. 1, then the back (B) and the front (C) can be fitted and fixed in between them. Note in fixing (C) that it must be put in flush with the top surface of the sides which will leave an opening in the lower front for the passage of the drawer, see Figs. 1 and 2.

The top member is next glued on and fret pins driven in to strengthen the joints. The box is thus complete, and all sides should be cleaned up with glasspaper. Rub the joints of the box well down to leave fine clean glued joints.

Forming the Lid

When the above has been done set up a measurement of 4 ins. from the bottom

severed, rub each cut face down on a sheet of glasspaper which has previously been glued to a perfectly flat and even piece of backing board. A pair of $\frac{1}{2}$ in. brass hinges should now be procured and recessed into the back, as shown in Fig. 2. The recesses can be cut down neatly with the fretsaw and the waste wood cleaned out either with a $\frac{1}{4}$ in. chisel or a sharp pointed pocket knife.

Ensure a Close Joint

With care in the fixing of the hinges it should be possible to ensure a perfectly close joint between the lid and the box. There are two partitions in the box, shown as (E) and (F) in Fig. 2. The back one (E) should stand clear $1\frac{1}{2}$ ins. from the inside back of the box and wood $\frac{1}{2}$ in. or $\frac{3}{4}$ in. thick should answer for both partitions.

The front partition should stand away $2\frac{1}{2}$ ins. from its neighbour. Glue and a few $\frac{1}{2}$ in. fine wire nails should form a good fixing for the partitions. Now cut a piece of $\frac{1}{2}$ in. wood $6\frac{1}{2}$ ins. long and $1\frac{1}{2}$ ins. wide as a bearer for the floor (G), this bearer, shown as (G1) in Fig. 2, is glued to the front face of partition (F).

The floor (G) is a piece of $\frac{1}{2}$ in. stuff cut $6\frac{1}{2}$ ins. long and $4\frac{1}{2}$ ins. wide, and it should rest on the bearer (G1) and come flush with its under surface level with the opening in the front of the box. The sectional diagram, Fig. 2, plainly shows its proper position.

To hold the floor firmly to the front (C) of the box, a piece of $\frac{1}{2}$ in. quarter-round beading should be glued in the angle, as seen at (H) in the section.

The Drawer

The neat little drawer to fit the cabinet is clearly shown in the details in Fig. 3. All parts here may be of $\frac{1}{2}$ in. wood excepting the floor (I) which might be of $\frac{1}{4}$ in. stuff. The drawer might be made up to the measurements given but it will be a good plan to check the exact width and depth from the actual made-up box before any marking out or cutting is commenced.

Note how the main front (K) takes up the full open space at the front, and how

(Continued foot of page 396)

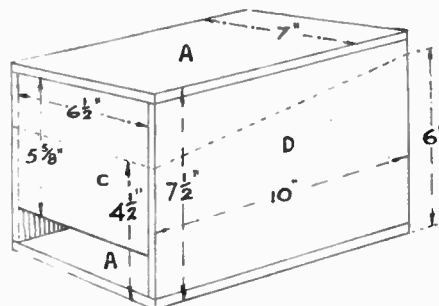

Fig. 1—The main dimensions

with space immediately in front for smaller bottles.

Then to the front of these again sufficient room for rolls of bandages, lint, etc., is provided and for the ever necessary pair of scissors. Below the front compartment there is a useful little drawer for smaller articles and instruments.

It will be noted from the sketch that the lid is hinged along the back of the box, and that a tape or small-link chain is included for holding it in a safe position, while two hooks and eyes are fixed to the side of the cabinet to hold the lid tightly to prevent dust from entering the box.

The construction of the cabinet may be clearly understood from diagrams, Figs. 1 and 2. The front and back pieces of the box are thicker than the rest,

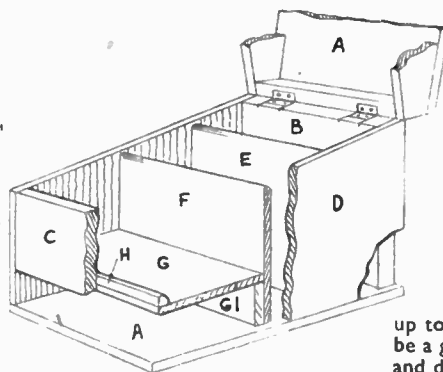

Fig. 2—Showing details of the interior

of the base at the front, and a measurement of 6 ins. at the back of the box, as seen in Fig. 1. Connect up with a line, as shown dotted in this diagram. Do this on both side faces, and then run the line across the back of the box and one across the front of the box so as to make a continuous line all round.

Now grip the larger or bottom section of the box in the bench vice, adding just sufficient pressure to hold it rigid without collapsing the box. Then with a small-tooth tenon saw commence to saw carefully along the line, keeping an eye each side of the box meanwhile to ensure that the guide lines are being strictly followed.

When the two parts have been thus

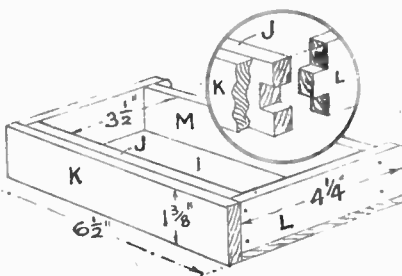

Fig. 3—Layout of the drawer

Anyone handy with tools can make this SHORT LADDER

A SHORT ladder, one about 6ft. long, such as that shown in our illustration Fig. 1, may be found useful for many household jobs and especially round about spring cleaning time. The width of the ladder at the bottom is about 14ins., while at the top there is a wall board 18ins. long and 5ins. wide to distribute the pressure on the wall.

The general arrangement of the parts of the ladder are shown in Fig. 1, while in Fig. 2 a detail of one side is shown, with dotted lines set across, giving the angles to which the steps themselves will be

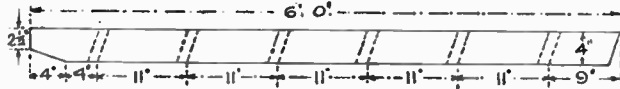

Fig. 2—Detail of one side

fixed. Deal wood may be used throughout 1in. thick, and for the sides two pieces will be wanted 6ft. long by 4ins. wide.

The proper angle at which to cut the top where it fits on to the board is shown in Fig. 2, the measurements given being set out on one piece of the wood and cut and smoothed up, then this piece laid on the second piece and so marked ready for cutting. After cutting each side piece alike, round off the top outer points, as in the detail Fig. 3.

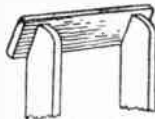

Fig. 3—The top

The Two Methods

Now there are two distinct ways of making the steps, and before further progress can be made, it must be decided which of the two methods are going to be carried out.

The treads of the steps may rest upon bearers or fillets of wood screwed to the sides, and be nailed or screwed to them, or they may be let into or housed into the sides. This latter method being shown in Fig. 4.

If the fillets of wood are to be used, cut off twelve pieces 5ins. long by 1½ins. to 2ins. wide by ¾in. or 1in. thick. The grain of these pieces run lengthways, of course, for strength sake. Fix them as Fig. 5 shows, and trim off neatly each end to the angle of the sides with the tenon saw. The spacing of the steps must be plotted out to the measurements given in Fig. 2, the bearers being placed under the dotted lines given.

Bore two holes in each bearer and countersink the holes and screw them on securely. Care must be taken in preparing the second side to get all the bearers in the proper positions and exactly opposite those already fixed. The two sides should be placed together and the positions of all the steps and

bearers ticked off in pencil across each side. There should thus be a right and a left hand side made up complete and ready for the treads to be nailed on. For the treads cut off six pieces 12½ins. long and 5ins. wide and smooth up the cut ends and round off slightly one edge—the front.

It only remains now to lay the steps on the bearers and bore holes slightly sloping, as shown in the circle in detail Fig. 5, and drive in two long nails to each end.

The top board is shown in Fig. 6 and is 18ins. long and 5ins. wide. Bore the holes in a slightly sloping manner and fix with long nails or screws. If it is decided to house the steps into the sides, a small-tooth tenon saw should be used

in making the cuts ¼in. deep, the interior waste wood being cleaned away with a chisel.

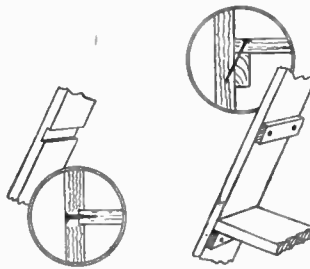

Figs. 4 and 5—Two methods of fixing the treads

Be sure and get the cleaned-out surface smooth, so that the steps will fit closely and evenly. Place all the treads in one of the sides, gently tapping them home with a mallet, and then place on the second side, holding a square piece of wood over where the treads come before using the mallet again. Bore and countersink two holes for each end of the

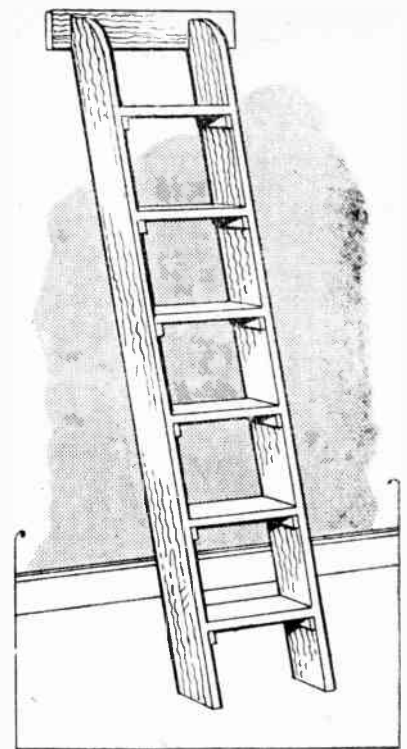

Fig. 1—The completed ladder, showing the general arrangement of the parts

treads and drive in stout nails.

Stiffening the Steps

The board at the top will be fixed as previously mentioned, and to stiffen up the steps, some may decide, in fact, it is to be strongly recommended, that an iron rod be placed beneath the top step and the lowermost step, as in Fig. 7. To do this, bore a ¼in. hole so that it comes immediately under the step, then pass

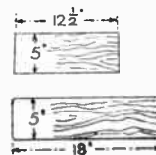

Fig. 6—Tread and top board measurements

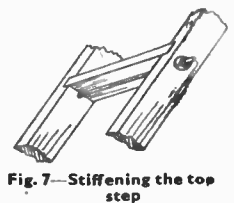

Fig. 7—Stiffening the top step

through a piece of ¼in. iron rod which has been previously tapped at both ends to take nuts for screwing up and thus holding the steps well together.

Put on an iron washer next to the wood, and after adding the nuts, file away the projecting ends of the rod and make all smooth. If it is decided to paint the woodwork, a coat of red lead priming should first be given, any knots that should occur in the wood being first given a coat of knotting varnish. Finish off with two coats of paint. Do not, however, paint the immediate treads of the steps, as this would be inclined to make them slippery.

Designs are given free with every other issue but not with back numbers of Hobbies

This article will help you to IMPROVE YOUR PHOTOGRAPHY

DOUBTLESS there have been many thousands of resolutions made and broken this year—some before they could possibly have been put into practice. Anyway, this is not concerned so much with the making of resolutions as with the good which might be derived from the thought behind the suggested idea of resolving to do something that will definitely lead to improvement or, inversely, to refrain from doing that 'something' if by so doing one can avoid a certain number of errors or mistakes.

Visit an Exhibition

You will remember that it has often been suggested in these articles that amateur photographers should, whenever possible, pay a visit to a photographic exhibition. There is an extraordinary amount of benefit to be gained by seeing the work of others, and competitive work at that. You can, by using your own judgment and comparing one print with another, learn a lot and very soon find yourself criticising some of the exhibits.

In other words, picking out faults or errors which in your estimation rather spoil the print. If the opportunity presents itself of being accompanied by an experienced photographer, you will, undoubtedly, be given many illustrations of real practical value to yourself, and, incidentally, it is possible that he may be able to demonstrate that some of your criticisms are not so justified as you may think.

Commonplace

A short time ago I was invited to visit an exhibition of photographs entered for a Town Corporation Photographic Competition. The rules were drawn up in the usual manner and to encourage as many entries as possible, there were few restrictions and a goodly array of prizes. The exhibition was well arranged in a good hall and every entry exhibited. But, and this is what so often happens in these competitions, so many folk had taken the same scene or object that those particular subjects became commonplace and failed to catch the judge's eye.

The prints that secured the big prizes were those which displayed originality, good technique and careful manipulation; characteristics which absolutely commanded attention as compared with the majority of other entries.

Let us apply this lesson or idea of exhibitions to our work of last year. Get every one of your prints and negatives and display them in a room and in such a manner that they can each be very carefully scrutinised. Then invite some of your friends to come along and, if possible, include two or three whom you know do all their own processing,

including picture-making, i.e. enlarging. Invite criticisms and do not take offence at what may be said. One friend may suggest that you ought to have done 'so and so', while another one would disagree about this or that object being in the attempt.

It is just likely that an argument will be started as to the rights and wrongs of the use of such and such a gadget for securing certain effects. Take all that may be said in good part. Remember, you are getting the other chaps' ideas and points of view and you cannot possibly help getting a few valuable tips; but this does not mean that you have got to sink your own pet theories. If you find that one of these is being challenged by your friends, then it is up to you to hit back and to draw from their experiences something that conclusively proves that you are on the wrong track. Only then is it time for you to accept their opinions and to modify your own.

Word of Warning

A word of warning is advisable at this point. You may find that some of the criticisms are too severe. They are destructive rather than constructive and you feel very depressed and disappointed. Even your own personal feeling about some of the results is by no means good because you are convinced that you could have made a better job,—if.

Yes, that is so. There is no doubt that most results would be improved 'IF' we could take the shot again but do not be discouraged by any arguments that may be put forward. Every amateur makes failures and produces dud results. Rather let us all learn something from those mistakes.

Now that you have managed to collect all or most of your prints from the year's collection of negatives, I would most earnestly ask you to arrange them in some sort of order in an album. This may sound like another big expense in connection with a hobby which is, perhaps, not the only one and one on which you may not wish to spend too much. Well, the author does not advocate spending unless there is a jolly good return for the money assured.

There is a good return if the album is used methodically. Dates of the taking, the name of the place, the brand of film and, in fact, every little bit of data that you can rake up about the exposure should be mentioned on the back of the print or very close to it in the album.

Albums are expensive if you intend to purchase a first class one, but if it is not possible to get a ready-made one at a price to suit the pocket, I would suggest making one on the following lines:—In the industrial section of any town you can usually find a stationer specialising in office equipment, and included in this will be found various forms of loose-leaf

covers, some made of very stiff card, others not so stiff and still others of more or less flimsy but fairly substantial material. These covers are provided with some sort of mechanical device for holding the leaves firmly in position. Sometimes it is a strong clip or grip. Other forms consist of two or three hinged rings fixed to a metal bar on one of the covers. The ring divides so as to allow a perforated sheet to fall into position on the ring. Instead of rings, other sets of covers are provided with metal pillars which again are for use with perforated sheets. From these descriptions of a few types of covers you will have gathered what is in mind.

The paper restrictions make it very difficult to obtain good quality sheets suitable for use as album sheets, but first try some of the photographic dealers in your neighbourhood. If unsuccessful, then you must fall back on a temporary measure and secure some fairly thick good class writing sheets from the stationer or some artists' sheets from the Artists' shop. A good make is Whatman's and this can be obtained in fairly large sheets so as to enable you to cut to the size of the covers.

If you can get covers about 12ins. by 10ins. do so, but if not, then somewhere about 10ins. by 8ins. should answer satisfactorily. Anyone with a leather punching machine can make the necessary holes in the sheets and these must, of course, coincide with the pillars or rings of the covers. The total cost of such an album should be only a few shillings, including a number of sheets, and with such a book you will be able to retain for many years your results of 1950 and possibly another year or two.

Fastening the Prints

If the prints are pasted or fastened with corners on the left-hand page of the opening, the data, to which reference was made earlier on in this article, could be written on the right-hand page and opposite the print.

Some few years ago the author went on a most enjoyable holiday with a party of friends. Each day he made a brief report of any outstanding happening and on returning home he got a loose-leaf book, similar to that described. He pasted a whole collection of 'snaps' on the one side of each sheet and on the other side wrote a complete and humorous account of the holiday. You can do this, and you will be surprised how interesting that record will become as the years pass on.

There is another piece of advice which I endeavour to pass on to all my amateur friends and which I invariably include in photographic talks or lectures. It is this:—If you have a print which you feel is really good both pictorially and

(Continued foot of page 395)

A few odd pieces can make an attractive PLASTIC LETTER RACK

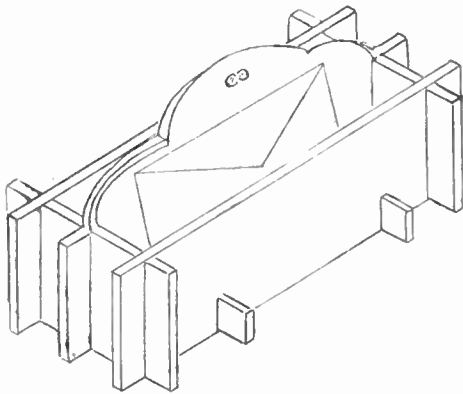

LOOSE envelopes and postcards tend to stray in the desk or office bureau. This delightful and cheap-to-make Perspex model is designed to keep them all together, and ready for use.

The holder is portable and very strong, the material is durable and will not break if dropped, but the construction of the model requires careful and patient craftsmanship.

Pieces Needed

You will need one piece of Perspex 7ins. long and 5ins. wide, two pieces 7ins. long and 2ins. wide, two more 3½ins. long and ½in. wide. All the pieces are 3mm. thick. Buy machine-cut plastic, ready trued-up, so as to save yourself a great deal of draw filing in the first place. Then cover each piece with gummed white paper, and trim the edges to the contour of the Perspex.

The model is built up on the principle of long cross-halved joints, as shown in Fig. 1. Set out the central piece of the holder, the one 7ins. by 5ins., and carefully fretsaw along the curves. Then cut out the two holes with a No. 8 drill, and file them with a 3in. half-round

smooth file, to make the finger-and-thumb grip of the model.

There are four slots, each 3mm. wide for the cross-halved joints in this central piece. The outside slots are 1in. long from the base edge, but the inside ones are ½in. long from the same line. Now set out the slots on the two pieces 7ins. by 2ins. in exactly the same way.

The best way to remove the waste plastic in these slots is to drill a hole at the end of the slot with a No. 32 drill, and then fretsaw slightly inside the shoulder lines of the slot. True-up the shape of the slot with a needle file, and a 3in. flat file.

Remember these slots on the long pieces are removed from the base edge upwards.

Now the slots made on the short cross pieces 3½ins. by 2ins. are cut from the upper edges downwards, as shown in Fig. 1. They must correspond in length exactly with the slots already shaped in the 7in. lengths of Perspex.

When all the cross-halved joints are completed, assemble the pieces for a trial fit. After corrections have been made, dismantle the model, smooth all cut edges with No. 1 and No. 00 glasspaper, and then wash off the white paper gummed to the plastic.

Now all that remains is to fuse these pieces together to make a permanent fitting. To do this, brush the inside faces

of the slots with a No. 3 new Reeves paint brush charged with concentrated (glacial) acetic acid. First, fuse the short cross pieces to the long central piece of the model. Then fuse the other parts, and leave the model for twenty-four hours. At the end of this time the fusion will be complete, and the model ready for finishing.

Polishing

The very fascinating cut-glass finish effect can be obtained by rubbing all faces with a piece of old sock wet with Silvo. When the Silvo has dried as a white film of powder on the plastic, rub it away very vigorously with some clean silk.

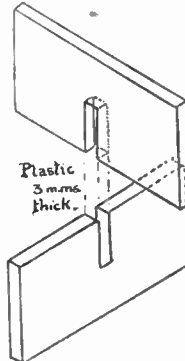

Fig. 1—Type of joints

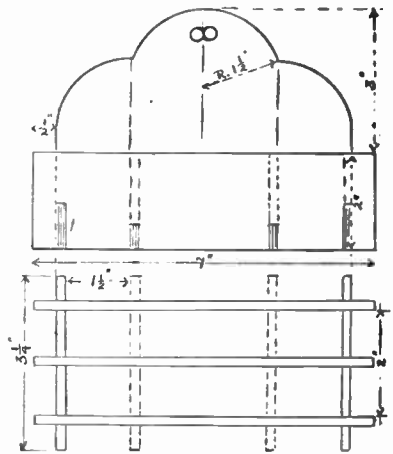

Fig. 2—Plan and side view

Your finished model will never fail to draw admiration from those who see you use it. (384)

Improve Your Photography—(Continued from page 394)

technically, and you like to show it to your friends who in turn are inclined to compliment you on the result, why not make an enlargement of it? If you have not got an enlarger, send the negative to a good class dealer or professional photographer for him to make a 12ins. by 10ins. or a 10ins. by 8ins. print. Mount it yourself so that it will fit any frame that may be out of use temporarily, and hang the picture on the wall of a room which is in constant use by you. Now, if you can live with that framed picture for, say, four or five weeks, it is good, but if each time it catches your eye you seem to feel that it is lacking in something, then there is something wrong with it and it is up to you to find the fault.

Now what is the purport of this business of visiting Exhibitions; making

an exhibition of your own prints and inviting criticisms; placing all your 1950 results in an album with a lot of data accompanying each print; and having an enlargement made and framed and after a few weeks removing it from the dining room wall?

Here is the answer to your query. You have a camera and have evinced a certain amount of interest in the hobby of photography, and, let us assume, are fairly pleased with the results so far attained. But you are not quite sure whether they are really all right. You somehow feel that you would like to have a little more advice and to be shown where you are not doing the right thing.

Yes, it was the same about your cricket, tennis or golf. You felt fairly confident—but. And it was that 'but'

that caused you to go to the Professional and have a lesson and that lesson improved your play so much that you enjoyed the game 100 per cent. more than you used to.

Do not be Haphazard

Do not treat your camera work haphazardly. Try to take a deeper interest in the hobby by more concentration before making an exposure. And above all else do make a special effort to see what other fellows are producing. The keen amateur photographer sees much more on his jaunts into the country and when on holiday than the chap who is without a camera. And he can live those happy days over and over again, in fact, every time that album is opened. (392)

The instruments are easily obtainable for this UNIVERSAL TEST METER

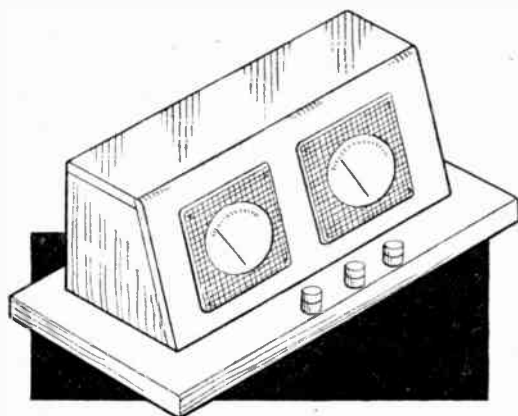

THIS simple stand, comprising voltmeter and ammeter, forms a very useful accessory for the hobbyist. The instruments themselves can now be obtained very cheaply from most stores specialising in surplus goods; a reliable accurate ammeter or voltmeter not costing more than a few shillings each.

Choose a popular range according to the type of electrical measurement you are most likely to have to carry out. A voltmeter reading from 0.5 volts will cover most possibilities where ordinary dry battery power is used (except, of course, radio high tension batteries). A similar range for the ammeter—0.5 amps—also covers most useful needs.

The two instruments are housed side by side on the sloping face of a small cabinet. Construction is shown in the diagrams. Material thickness is relatively unimportant, $\frac{1}{4}$ in. plywood or similar being quite satisfactory and makes a robust unit. The base could be of slightly thicker material.

All joints are simple butt joints, assembled with small screws or panel pins. The top is fitted last when the whole can be sanded down perfectly smooth and the corners and edges rounded off.

Two circles of $2\frac{1}{4}$ in. diameter are fretted out of the front panel to accommodate the instruments. These are then located by small screws through each of the four corner holes into the front face of the cabinet. Wiring to the three front terminals is simple, the centre terminal being the common negative.

Whilst the actual wiring is not shown on the assembly drawings, it is recommended that three holes be drilled in the base under the main body of the cabinet and the wires fed through these in grooves cut in the underside of the base to the terminals themselves. This will make for a neater job than external wiring.

To the terminals should be attached a three lead flex or cord with the free ends appropriately marked with tags. One tag, the wire going to the centre terminal, will be marked '-VE', the other terminals simply 'AMPS' and 'VOLTS', respectively. One has only then to select the appropriate two leads for test readings. All the leads being together, it is a matter of seconds only to obtain readings in both 'volts' and 'amps'. In the normal way several minutes

could be wasted in connecting up the two instruments separately.

Home electricians might care to extend the use of this instrument by coupling up various shunts and series resistances to extend the range of the original voltmeter and ammeter. A whole row of terminals could then be used corresponding, say, to 0.1 amp, 0.5 amps, 0.10 amps, and so on, and similarly for the voltmeter. It is relatively simple to calculate the values of the resistances involved and work out the appropriate wiring. All this can be accommodated within the cabinet itself. (369)

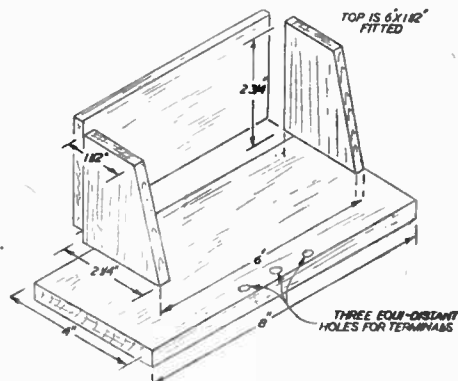

Dimensions of the cabinet

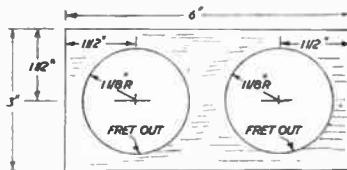

FRONT FROM $\frac{1}{4}$ " MATERIAL

Details of the front panel

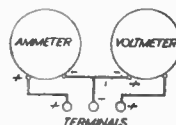

First Aid Cabinet—(continued from page 392)

the false front (J) goes inside it with the sides (L) of the drawer nailed to it. It would be well if the lock joint, shown in the circled diagram in Fig. 3, were introduced here, as a much stronger connection would result. It means only a little more careful marking and cutting and is well worth the extra time

and trouble it would take.

Note, too, how the back (M) of the drawer stands in a little way from the back ends of the sides. This is done again for strength, the small nails having plenty of surrounding wood to support them. Note the position of the floor in relation to the back (J) and the sides.

A simple block handle may be made for the drawer, as shown in the sketch, and glued on, and with a screw run through from the inside. Rub all surfaces down on the glasspaper board, referred to previously, to get a true and even fit.

The matter of finish to the cabinet is largely one of individual taste, but it

seems generally recognized that any first-aid cabinet should be painted white. This being so, we suggest that the outside surfaces be given a final cleaning with fine glasspaper and a coat of lead priming paint put on.

When this has hardened rub it down again with fine paper and then add one or two coats of white paint or enamel. The closing edges of the lid and box should be coated, but the inside of the box should not be painted at all. It might, perhaps, be varnished. The cross and border lines on the front above the drawer should be painted bright red. A pair of hooks and eyes should be added.

**The Advertisements in
Hobbies are always
worth your attention**



The SHIPMODELLER'S Corner



ALTHOUGH the accession of Elizabeth to the throne in 1558 A.D. resulted in increased activity in the designing and building of ships of war, there is a great shortage of accurate details of individual ships.

Contemporary pictures are practically non-existent and we have only such details as a mere statement of tonnage and the number of men forming the crew.

Our best source of information lies in a series of manuscripts described by Samuel Pepys as 'Fragments of Ancient Shipwrightry' which, while the draughts and plans do not represent any particular ship, gives accurate details of the designs, methods of construction and decoration in vogue at this period.

These draughts show that the vessels were 'galleon' built, with long beam, fore-castle well back from the stem.

In most warships the upper works consisted of fore-castle, quarter-deck and poop and in the largest vessels, fore-castle, half-deck, quarter-deck and poop.

The 'sheer' line, that is the upward curve of the hull towards the bow and stern, was very marked, but it is not generally known that this 'sheer' affected the exterior appearance of the hull only; it was defined by the wales that ran along the outside of the hull and which added strength to the hull.

This is easily understood when we consider that if the sheer line of a ship of this period were followed by the line of the decks, the stern decks would have been at an angle of slope impossible to stand upon.

'Tumble-home' was also very marked, due to the upper decks being narrower than the hull at the waterline, this was due to the desire to obtain stability, especially when working the guns.

At times the upper decks amidships were cut half the breadth of the hull at waterline level amidships.

Early in this 16th century portholes were invented and the bulkheads shutting off the upper decks from the waist were also pierced for small guns, thus allowing the gunners to 'rake' the waist when boarded by an enemy crew.

The waist of a galleon was often devoid of bulwarks and during battle it was the custom to protect the waist with 'pavasses' either of thin plank painted with armorial bearings, or of canvas (two bolts of canvas 3½ft. deep) gally painted in red, yellow, green and white.

Bowsprits at this period were not placed on the centre line of the hull, but towards the starboard side, about the width of the foremast off centre.

Another custom was the fitting of 'Sheerhooks', heavy steel sickles, at the ends of the yard-arms; the purpose of

this custom was the cutting of enemy rigging when grappled alongside an opposing vessel.

Most large warships carried three ship's boats, stowed on chocks in the waist.

Heraldic designs on sails, which artists depicting ships of this period

Some Notes on Elizabethan Warships

By 'Whipstaff'

seem to delight in died out of use as far as Royal ships were concerned, by the end of the 16th century, and figure-heads, when used, were usually confined to the Dragon or Lion. It is unlikely that the 'Golden Hind' for example, ever carried the 'Hind' figurehead so often shown on models made to represent this famous vessel.

The colouring of the period was carried out above the main wale in geometrical designs mainly using the Tudor colours of white and green, red was also popular.

During Elizabeth's reign yellow, purple and to a much less extent blue were also used.

The stern usually carried the Royal Arms painted in full Heraldic colours, occasionally also carved in relief. Painted designs in general followed the designs used in the internal decoration of houses of the period and when they were not simple geometrical designs, represented panels, arches and pillars. Below the main wale to the water-

line on the hull proper was not painted, but 'paled' with a mixture of oil, turpentine and resin. Below the waterline was usually white.

All wales were painted black.

We have Sir Walter Raleigh as authority for the information that at this period separate top-masts were introduced, thus enabling the top-mast to be 'struck' or lowered.

He also mentions the introduction of bonnets, drabbers, and studding sails, the introduction of 'weighing the anchor' by capstan and the introduction of chain-pumps.

To obtain extra realism why not arm your little model in the customary manner of the period? Namely, in large ships like the 'Ark Royal', the lower gun deck would be armed with 'culverins', the main gun deck with demi-culverins, and the waist and upper works with sakers.

If the size of your model allows it without being overscale, you can include swivel guns on the rails.

In a later article guns of this period, how to model them to scale and mount them will be dealt with fully.

Another item on which many models of this period fail is in the dead-eyes, most are rigged with round dead-eyes with one hole in the centre, the correct dead-eye of the period, which can be made in several ways, was heart-shaped, with three holes. Methods of making and setting up will be dealt with in the near future.

In these few notes designed to help you to obtain more realism in your model, there is nothing that even the beginner cannot use to improve his little ship, none of the suggested improvements are difficult to obtain, only requiring a few home-made tools and patience.

MODEL TRAMCAR DESIGN

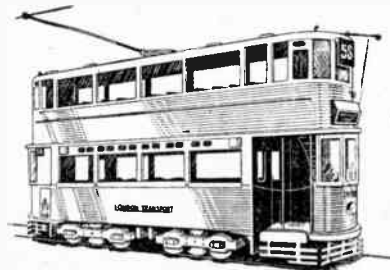

The necessary material for making the model tramcar from this week's design sheet (No. 246 Special) consisting of standard wood panels, with sufficient wire, stripwood and round wood rod, etc. is obtainable for 12/6 including tax, from any Hobbies Branches or Stockists, or by post direct for 13/4 from Hobbies Ltd., Dereham, Norfolk.

BE TALLER

I Guarantee to increase your height in 12 days or return your money. New gland and spinal discovery increases height 2 to 5 inches.

I have gained 4½ inches in height and feel fresher first thing in the morning. My weight increased from 9-stone 4-lb. to 10-stone 3½-lb.—P. D., Witham. Since taking your Course I have increased in stature from 5 feet 1 inch to 5 feet 4 inches, a matter of 3 inches.—H.G., Chesterfield. 'My increase is 2 inches and I really do feel ALIVE'.—E.T.

Guaranteed harmless. Full Course 10/- post free, Air Mail 14/-. Details free for 1d. stamp. Sent under plain cover.

J. H. MORLEY

(H/83), TERRY HOUSE, NAPHILL, HIGH WYCOMBE, ENGLAND
Established 1936

IT'S New - but ANYONE CAN DO IT!



WRITE TODAY FOR YOUR KIT

PRINT YOUR OWN PHOTOGRAPHS ON SCARVES, TIES, HANDKERCHIEFS, GREETINGS CARDS, ETC. ETC.

With the YANKEE PHOTO KIT it's easy to make up to 150 perfect permanent prints from your own negatives on cloth, paper, cards and almost any surface. Simple and easy. Cannot harm fabric or negative. Send today for kit with complete instructions.

6/-

Y.P.K. PRODUCTS COMPANY (Post 4d)
Major Size 8/6
688 Christchurch Road, Boscombe 3, Hants.

YOU CAN BECOME A HANDICRAFTS INSTRUCTOR

EXPERIENCE NOT ESSENTIAL

Men who enjoy making things in wood or metal can turn their hobby into a permanent and interesting Career. Short hours, long holidays, and security in a job you would really enjoy, can be yours if you become a Handicrafts instructor. Let us send details of the easiest and quickest way to get the necessary qualification.

We definitely guarantee "NO PASS - NO FEE"

If you would like to know about our unique method of preparing you for one of these appointments, write today, and we will send you our informative 176 page Handbook—free and without obligation. Mark your letters "Handicrafts Instructor"

BRITISH INSTITUTE OF ENGINEERING TECHNOLOGY

595 Shakespeare House
Stratford Place, London, W.1

BIET

'THE MODEL RAILWAY CONSTRUCTOR'

If you are interested in the fascinating hobby of model railways you must read this leading monthly magazine. Every issue full of constructional articles and photographs. Send to-day for a specimen copy (1/2 post free) to—

'VELMEAD' (Dept. 6) CHURCH CROOKHAM, Hants.



MAIL ORDER HOUSE, BEDFORD SQUARE, SIDMOUTH, DEVON

BOYS!!! BOYS!!!

With the aid of our amazing assembly outfit you can quickly and easily assemble this superb scale model of the famous 'Ferguson' Tractor. All parts supplied in finished state. All Plastic construction, real rubber trackgrip tyres. Can be dismantled and re-assembled with ease. Send P.O. today for 8/- post free.

MURRAY HILL & CO. (Dept. H.),



MANCHESTER
10 Piccadilly
(Phone CENTral 1787)

BIRMINGHAM
14 Bull Ring

SHEFFIELD
4 St. Paul's Parade

LEEDS
10 Queen Victoria Street
(Phone 28639)

HULL
10 Paragon Square

SOUTHAMPTON
25 Bernard Street

BRISTOL
30 Narrow Wine Street
(Phone 23744)

BRANCHES

LONDON
78a New Oxford St., W.C.1
(Phone MUSEum 2975)
87 Old Broad Street, E.C.2
(LONDON Wall 4375)
117 Walworth Road, S.E.17

GLASGOW
326 Argyle Street
(Phone CENTral 5042)

Head Office & Factories—HOBBIES LTD., DEREHAM NORFOLK



FILM STRIPS
Presenting
THE MOST AMAZING STORY EVER FILMED

ROCKETSHIP X-M EXPEDITION MOON

LONG SUPER STRIP FILMS 2/6 each
PART I "Journey into the unknown"
PART II "On the other world"

THIS CINE VUWER

GIVES PERFECT CINEMA SCREEN PICTORIZATION FOR ALL STRIP FILMS 2/6



ABOVE FILMS AND VUWER 7/6
VUWER ONLY 2/6
FILMS ONLY 2/6 each
Post and packing 6d.

FILM STRIPS
EDLESBORO
NR. DUNSTABLE

STOP SMOKING

You can overcome the smoking habit in 3 days, or money back. Safe, pleasant, permanent. The only scientific way. No Will Power necessary. "Conquered the habit in 2½ days. Am delighted".—F.C. "Within 2 days I was free from the tobacco habit".—W.G. "Was a smoker for 2 years and broke the habit in 2 days".—F.N. "I haven't smoked a cigarette for 5 weeks".—J.E. "I used to smoke 20 a day . . . now I have no desire to smoke".—J.M. Recommended by "Health and Efficiency Magazine". Complete course 6/6. Details 1d. stamp. Sent under plain cover.—**STEBBING'S, 28 (H/98), Dean Road, London. N.W.2. Established 1928.**

MONEY-MAKING BOOKS

114 WAYS TO BE YOUR OWN BOSS—114 Tested ways of earning a second income at home with little or no capital 5/6

MONEY FROM MAIL ORDER—How to start and run a Mail Order business at home and earn pounds weekly 5/6

HOW I WRITE AND SELL THRILLERS—By the author of 73 successful thrillers 4/6

Catalogue of Money Making Books free.

STEBBING PUBLICATIONS LTD., 28 (H/98) Dean Road, London N.W.2. Established 1928.

THE BOLSTER HOME WATCH AND CLOCK REPAIR OUTFIT

These precision jewellers instruments include watchmaker's magnifying eyeglass, finest watch tweezers, set watchmaker's screwdrivers, watch and clock oil, oilers, dusting powder, clock brush, plus illustrated instructional manual for the amateur. In container 12/6 post free.

Senior Outfit includes everything above, plus watch jewels luminous compounds, dial renewer, jewellers rouge, explanatory book. Price 21/- post free.

BOLSTER INSTRUMENT Co., (Dept. H.W.), 3a Station Parade, Ashford, Middx



HOBBIES BRITISH FRETSAW BLADES

YELLOW LABEL 1/2 per doz. 13/6 gross

BLUE LABEL 1 1/2 per doz. 10/6 gross

From Hobbies Branches or by post (2½d. extra) from Hobbies Ltd., Dereham, Norfolk.



**FOR A
REAL
Professional
'FINISH'**

'FINISH' is the true test of craftsmanship. It's easy to impart a real professional 'finish' to woodwork and furniture you make at home with "COLRON" WOOD DYE—the finest strain for all practical purposes.

One coat of "COLRON" is all that is required to emphasise the natural beauty of the wood grain. No smears—no "overlaps"—no trouble. Leave from two to three hours, burnish with rough dry cloth and you have a perfect base for french polishing or for waxing with "RONUK" FLOOR POLISH.

COLRON WOOD DYES

12 SHADES—ALL SIZES

Write for colour guide and full details to:

RONUK LTD. (Dept. 62) Portslade, Sussex



**Model
Yacht
Plans**

The "KESTREL"

Hull length 24in. A thoroughbred racer. The plans include a description of the bread and butter method of hull construction employed and detailed information about the 'Braine' steering gear. *post free 6/-*

The "GULL"

Hull length 18in. This is the design for beginners to get the hang of the game. Later on you will go on to something more ambitious with valuable experience behind you. *post free 4/-*

The "MERLIN"

Hull length 36in. An M.Y.A 'class' boat. A fine powerful boat with race winning performance and a high degree of controlability. *post free 9/-*

The International 'M' class Racing Yacht "OSPREY"

Hull length 50in. A boat right up in the top flight of competition performance. High standards of skill are called for in construction but it is a thoroughly rewarding task. *post free 14/-*

Modelcraft complete list for 1951 costs 1/- *post free or from your modelshop. It gives details of over 600 plans, planbooks, kits and accessories and contains a 1/- refund voucher for use in purchasing Modelcraft goods.*

MODEL CRAFT LTD.
77 (F) GROSVENOR ROAD, LONDON, S.W.1

JOHNSON

**PHOTOGRAPHIC
COMPETITIONS**

1951

For amateurs only. Separate classes for experts and novices.

Any camera may be used. No entrance fee. Merely attach a label from any Johnson chemical product.

Eighty-six prizes to be won. Value in cash

£130



Fullest details in leaflet, obtainable from your dealer, or by post from Johnsons of Hendon. Closing date for the Spring Competition is

30th APRIL

JOHNSONS OF HENDON LTD.
335 HENDON WAY, LONDON, N.W.4



"KARLENITE"

PLASTIC MARBLE

The entirely new Art Stone for casting Bookends, Ashtrays, Wall Vases, Statuettes, etc. 'KARLENITE' sets granite-hard with scintillating crystalline structure which very closely resembles marble or alabaster. It is enormously strong, highly resistant to heat, and impervious to water. Literally any type of natural 'veining' can be simulated in any colour and a wide range of pigments is available for this purpose.

MAKE YOUR OWN

FLEXIBLE MOULDS

with 'Elastomould' Synthetic Rubber Solution. By means of this simple technique, you can easily prepare permanent elastic moulds for repetition casting, plaques, bookends, etc., in quantities of thousands.

'Elastomould' will faithfully reproduce even the most minute details of ornamentation and surface texture.

It is incredibly simple to use, and moulds can be prepared from any type of pattern including Wood, Metal, Plaster, Stone, Glass, Ivory, etc.

Such moulds are ideally suitable for casting in Plaster, Cement and Karlenite.

Start your Own Business. Send 1s. for full details of this easy, fascinating and profitable hobby.

MONEY REFUNDED TO BONA FIDE ENQUIRERS

Dept. H.3, Karlana Art Stone Company, Ltd.,
55 Deansgate Arcade, Deansgate, Manchester, 3.

For wood,
card,
plastic,
leather,
metal etc.



TREADLE OR MOTOR FRETSAWS

Whatever the handyman or craftsman is cutting or making, one of Hobbies Fretmachines will help with the job. For toy making, fretwork, model making, it provides easy and speedy cutting in all kinds of material. A pleasure to use, a factory for output, a lifetime of service.

From 70/- to £10
Ask to try one at any Hobbies Branch or good class ironmonger or hardware stores. Or free illustrated leaflets on request to:

HOBBIES LIMITED, DEREHAM, NORFOLK

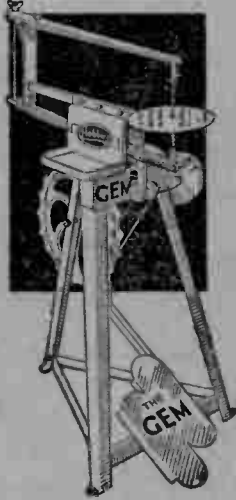

One plastic material
MAKES MANY PERMANENT

MODELS

and utility objects, from simple instructions in illustrated Booklet—please read below.



ONLY 4^d
IN STAMPS
BRINGS BOOK

... showing how such models as those above, and many others, can be made, without skill or special tools, from Sankey's PYRUMA Plastic Cement. Ready for immediate use in its plastic state, Pyruma sets or bakes to stone-hardness, and can be painted or enamelled in all colours according to instructions.

Pyruma is inexpensive, and easily obtainable in tins from Ironmongers, Art Material Dealers and Hobbies Shops. Send 4d. in stamps for illustrated Instruction Book.



J.H. SANKEY & SON, L^{TD}

ILFORD

Est. 1877

ESSEX

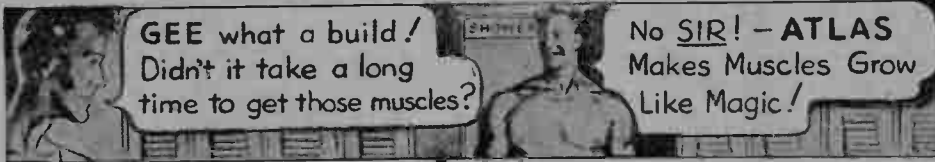

CHARLES ATLAS
twice won
the title
"The most
perfectly
Developed
Man"

Will You Give Me 7 Days to PROVE I Can Make YOU a New Man?

DO you want big, smashing, sledge-hammer muscles all over your body? Husky, broad shoulders? A deep, powerful chest? All the pep and vigour of a "hard as nails" athlete?

Give me just 7 days—one short week. That's all I need to give you the PROOF that I can make you a New Man—give you a real he-man build and glowing health that resists sickness, ends pimples, constipation and other troubles.

Once I was a soft, skinny, 7-stone weakling. Then I discovered "Dynamic-Tension". It gave me the body that twice won for me the title "The World's Most Perfectly Developed Man!" and what my amazing system did for me—it can do for YOU, too.

Send for 48-page FREE Book

Make me PROVE in just 7 days that I CAN give you the big, smashing muscles—powerful shoulders—deep chest—and glowing, all round health you have always wanted. Take the first step TO-DAY. Post the coupon for YOUR Free copy of "Everlasting Health and Strength". Do it NOW! Address to CHARLES ATLAS (Dept. 102/Q), 2, Dean Street, London, W.1.



I want the proof that your system of "Dynamic-Tension" will make me a New Man. Send me your book, Everlasting Health and Strength FREE and details of your amazing 7-day Trial Offer.

CHARLES ATLAS (Dept. 102/Q), 2, Dean Street, London, W.1.

Name

(Please print or write clearly)

Address

Hobbies

WEEKLY

CONTENTS

	Page
Block Toys in Wood	- 401
A Sliding Towel Rack	- 402
Lawns and their Making	403
Useful Pencil Box	- 404
Bricklaying for	
Beginners	- 405
Bedside Lamp & Clock	407
For Cyclist and Hiker	408
Realism in Model Work	408
Sturdy Garden Seat	- 409
Books to Read	- 410
'P.O.P.' is Here Again	411
Stamp Collecting	- 412
Block Toy Patterns	- 415

March 28th, 1951

Price Fourpence

Vol. III No. 2891

HOW TO MAKE SMALL BLOCK TOYS IN WOOD

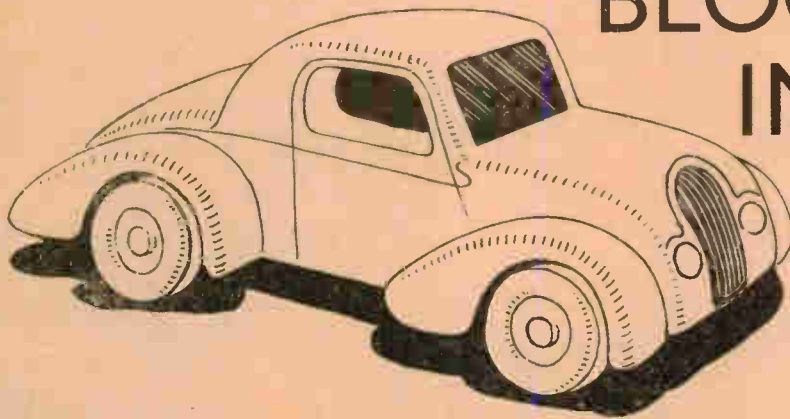

can be very quickly marked on to the wood. Do not forget to keep the pencil sharp during this operation. Fig. 2 shows the mudguards being glued in place. The construction of all three vehicles is exactly the same.

Shaping

The next step is to round off all the edges to give a more streamlined appearance. This can best be done with a small rasp, but a sharp penknife will do almost as well. Having roughly rounded the edges you can now clean them up thoroughly with glasspaper. Fig. 3 shows how the body and mudguards will look after shaping.

Painting

First give one coat of flat undercoat and then apply two thin coats of glossy enamel. The colours will, naturally, be bright; say, red or bright

HERE is a suggestion for our fretwork enthusiasts who have small children with birthdays during the summer months. Simple cars are made up in block form so that they are easily assembled and painted. The shapes are designed to represent the real thing, without a great deal of intricate cutting or the addition of a lot of details.

These sturdy little toys are really intended for rough usage, and they are highly suitable, therefore, for the youngsters to pull about in the garden.

If you will turn to page 415 you will see three complete outlines—a saloon car, a tradesman's van and a two-seater coupé. The positions of the mudguards are dotted on in each case, and you will also notice that the same mudguards are suitable for each of the three designs. When marking the shapes on to wood remember that the grain of the wood must run in the direction shown by the arrows.

Cutting Out the Parts]

The wood suggested is odd] in.] stuff.

The body of each car is made up of three pieces as shown in Fig. 1. The car we have chosen as an example is the two-

Full size patterns on
page 415

seater, and the shape is carefully traced on to the wood three times. Two pieces will have the window openings cut out and the third piece can be solid for the sake of strength.

These three pieces are glued together and placed under a weight for a time until the glue has hardened. The mudguards are also cut from $\frac{1}{2}$ in. wood. We suggest that a template be cut from card for each mudguard, and then any number

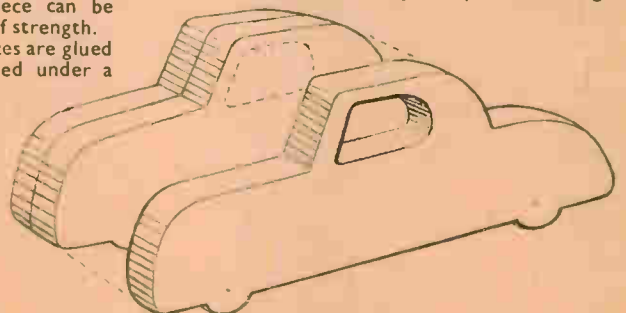

Fig. 1—How the bodies are made up

All correspondence should be addressed to The Editor, Hobbies Weekly, Dereham, Norfolk

blue, and you could also introduce two shades of the same colour on each vehicle. Allow each coat to dry thoroughly before applying the next. This is absolutely essential with toys that are handled frequently.

The inside of the side windows and the windscreen can be painted black, while the radiator could be black with silver lines marked on. If you wish to add further detail you could paint on the door handles and headlamps. Alternatively,

the headlamps could be small circles of card cut out with scissors. Do not add too much detail, however, or the character of the cars will be destroyed. They are not intended to be models but merely sturdy toys.

The Wheels

To save expense the wheels could be cut from $\frac{1}{4}$ in. wood and the edges rounded off with a rasp. Many workers, however, are not keen on cutting their

own wheels because of the difficulty in getting them perfectly round. Suitable bakelite wheels, $1\frac{1}{4}$ ins. diameter, are supplied by Hobbies Ltd. and cost 9d. per set of four. Postage and packing is, of course, extra. This will amount to 2 $\frac{1}{2}$ d. per set.

Since the body is quite solid we suggest that you use fairly long screws—about 1in.—which will hold the wheels securely in place. (403)

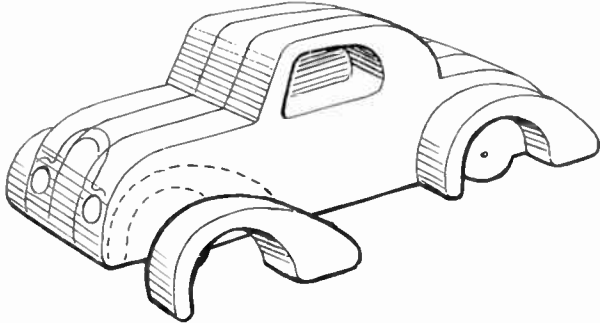

Fig. 2—Mudguards being glued into place

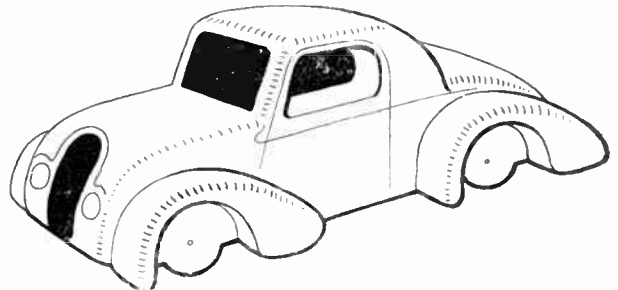
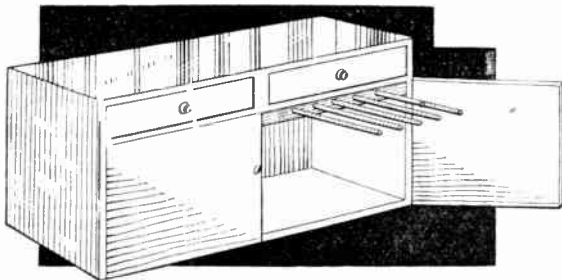

Fig. 3—How body and mudguards look after shaping



A Sliding Towel Rack

THIS useful fitment can be proportioned to fit any size of kitchen cabinet, choosing the dimensions to suit the space available. Towels or drying cloths are hung on the dowel arms, the whole unit capable of being pulled out or pushed in, as required. Towels or cloths stored in this way air better and dry quicker, and with the door shut everything is out of sight.

Construction is simple. One or both 'door spaces' of the cabinet can be used. Two lengths of channel are built up, as shown, exactly to fit the length of the available space inside the cabinet. 1in. by $\frac{1}{2}$ in. and $\frac{3}{4}$ in. by $\frac{1}{2}$ in. stock is used for this, screwed and glued together and also screwed in place. Use countersunk wood-screws throughout.

tongued to fit the grooves in the fixed channel sections with $\frac{1}{8}$ in. clearance for smooth operation. From the bottom of each of these carriers mark off a line $\frac{3}{4}$ in. and punch centre holes at approximately 2in. spacing. Drill $\frac{1}{2}$ in. to take

the dowels. The assembly of this unit is obvious from the diagram. The dowels should all be glued in place.

The length of the dowels must be arranged so that there is adequate clearance for the door to close with the rack fully closed. A spacing of about 7ins. between the two carriers provides a stable support. A suitable stop can be fitted at the extreme outer edge of each channel section to prevent the whole carrier being completely withdrawn. (371)

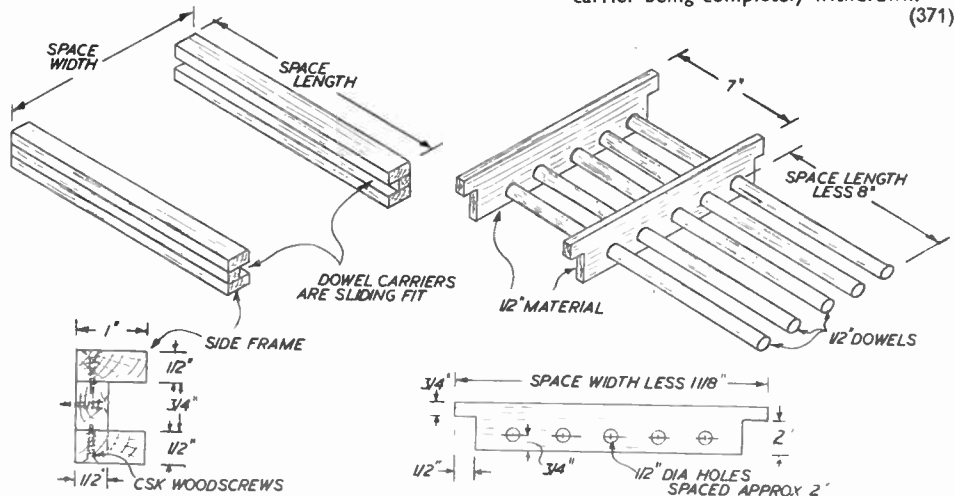

Showing construction of channels and dowel carriers

Hints for the handyman-gardener on LAWNS AND THEIR MAKING

It generally falls to the lot of the home handyman to tend the household lawns, and now is the time when these attractive features of domestic life should receive attention.

If you do not possess a lawn but are desirous of making one, it is much better to prepare the ground and set seed than lay sods taken from elsewhere. Sodds seldom 'root' consistently, and it is difficult to get them to present a perfectly flat surface, for if the underlying ground is hard they will not catch on, while when it is soft the turfs sink, causing uneven depressions.

Before setting seed, the ground should be dug for about 1ft. in depth. Large lumps must be completely broken down and all stones and weeds removed. Sowing is best in showery weather, although with a hose the ground can be artificially moistened. Never attempt the sowing at very dry, windy times as grass seed is light and easily blows away. In any case, high wind makes even distribution—which is essential—almost impossible.

Peg Out the Ground

About 1oz. to 2ozs. of seed must be used for every square yard of ground and it is really a good idea to peg the area out with strings to ensure that equal distribution is being obtained.

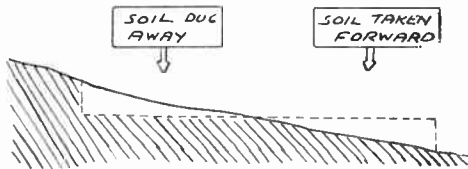

Fig. 3—Leveling a sloping lawn

To prevent ruining the prepared ground, perform the sowing standing on a plank to distribute your weight, and when the seed is down, cover only with the finest layer of soil, otherwise germination may not take place. Actually, grass seed need be no more than $\frac{1}{2}$ in. below the surface and it will be found that this thin covering can be secured by raking gently in two opposing directions.

Use a Light Roller

When the new shoots are about 1in. high, a very light roller can be used with advantage over the surface, but no cutting should be attempted till shoots are in the neighbourhood of 2ins. Up to this period the new lawn must be kept under continual observation, and weeds or coarse blades that may appear must be ruthlessly pulled out. Any stones that were missed in the first preparation should also be removed—in fact get rid of anything that looks as though it

might be going to cause an inequality in the final sward. All this can be done without causing damage to the ground if you always work from the weight-distributing plank.

The Use of Turf

If for some special reason you are desirous of laying your new lawn with turves, the main thing is to get these as large as possible (little bits of grass are

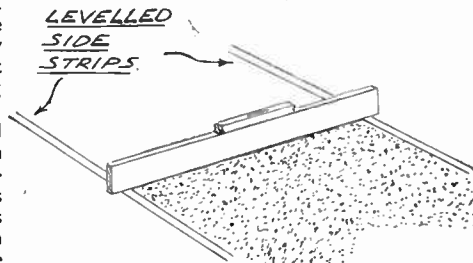

Fig. 1—Leveling a new lawn

useless) and cut with perfectly straight edges so that each will sit tight up to its neighbour. A handy size of turf is 3ft. by 1ft.

Once laid, the area should be given a tamping with a wooden 'beater' of some considerable area. This will ensure everything being as flat as possible, but, as pointed out, a perfectly even surface with loose sods is not easy to obtain unless the condition of the new rect-

men do when laying a concrete surface. Two persons, if possible, should work the length, which is taken slowly forward from end to end of the area being prepared, pushing unwanted soil before it. With this straight-edge depressions are easily detected and can be filled up with surplus soil from other parts.

Make Side Strips

For very accurate use of this method, two levelled-up side strips should be put down (as shown in Fig. 1) along

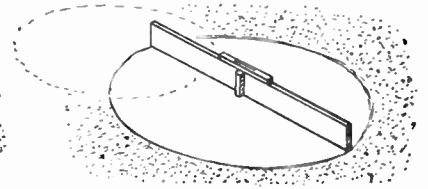

Fig. 2—The rotating plank method

which the ends of the plank can slide. It is good, too, to have a spirit level temporarily fixed to the top edge of the wood at the mid point for continual reference.

Some lawns, by the very nature of the land, have to slope, and then this plank method cannot be used in its entirety, but it is generally possible to get a horizontal line in one direction, and this should be aimed for.

Another way to get a level surface with a long plank is to put a strong pivot of wood in the centre, sink this in and then rotate the length as in Fig. 2, which gives a complete circle of plank. When one circle is finished the plank is moved on to an overlapping area, and so on till the whole area is completely traversed—the holes made by the pivot being carefully filled.

The Sloping Lawn

In the case of a sloping lawn that you wish to level, this can be effected (see Fig. 3) by working from a centre line, digging out the ground from the raised portion and carrying it forward to the depressed end—allowing for sinkage here.

Excessive moisture in a lawn is bad as it makes for heaviness and mud. Grass flourishes best in firm but porous, airy soil. Drainage can be effected in bad cases by using the standard agricultural drainpipe. These are bought in quite small sections 12ins. long by 3ins. diameter, and are laid 12ins. to 18ins. below the ground, and sloping at 1in. in every 10ft. to some point where the water coming into the pipe-line formed can readily drain away. It is no good having nowhere for the water to go.

Agricultural drain pipes are not

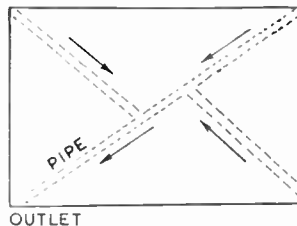

OUTLET



Fig. 4—Draining

angles and undersoil is ideal. Once laid, the turves should be kept freely watered until they root.

The laying of turves for a new lawn, although it is not the best method, has some advantages. The lawn is rough-finished from the start, and if you are able to get your own turves in the country instead of buying, it is not so costly as seed-setting.

In the preparation of any ground for lawn-making, the question of levelling is of the utmost importance, while drainage should not be overlooked. One of the best ways of levelling with loose soil is to use a long plank on edge, as road-

(Continued foot of page 404)

Any youngster would be pleased to have this USEFUL PENCIL BOX

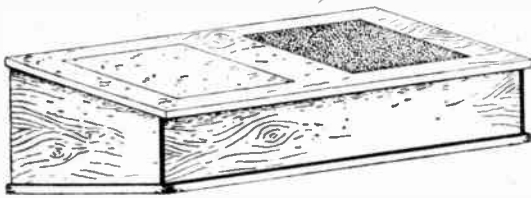

Fig. 1—The completed box

THE pencil box indicated in Fig. 1, and the same box with cover removed in Fig. 2, is just the thing to make either for yourself, or for your young brother or sister. The box lid is provided with a piece of emery cloth on which the pencil can be sharpened, as indicated in Fig. 2.

Also a piece of blotting paper is fixed on the lid which is useful for cleaning the pen nib, or rubbing the pencil point over to clean off any powdered lead after sharpening on the emery cloth. The box is quite simple to make from good sound pieces of $\frac{3}{8}$ in. plywood, and all the parts are fixed together with glue.

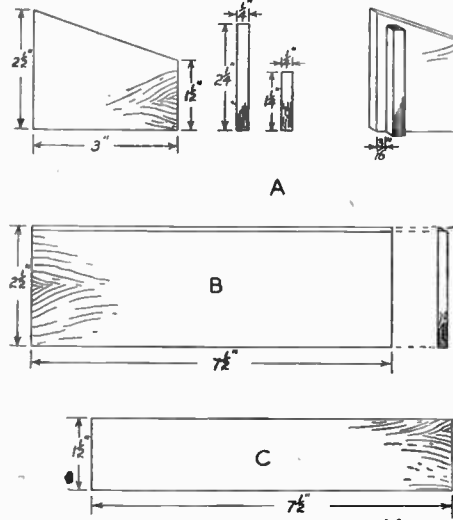

Fig. 3—Details of the sides, back and front

Commence on the sides, details of which are given in (A) Fig. 3. Cut two pieces 3 ins. long by $2\frac{1}{2}$ ins., tapering the top edge down to $1\frac{1}{2}$ ins., as clearly indicated. Cut two pieces $2\frac{1}{2}$ ins. by $\frac{1}{2}$ in., and two pieces $1\frac{1}{2}$ ins. by $\frac{1}{2}$ in., and glue

one of each on the sides $\frac{1}{8}$ in. from the edges, as clearly shown in (A) Fig. 3. The back is indicated in (B) Fig. 3, and consists of a piece of plywood $7\frac{1}{2}$ ins. long by $2\frac{1}{2}$ ins. wide.

The top edge of this piece is tapered off to the slope of the side pieces,

and this is easily done with a file and glasspaper.

The Front

The front for the box is simply a piece of plywood cut $7\frac{1}{2}$ ins. long by $1\frac{1}{2}$ ins. wide, as indicated in (C) Fig. 3. The parts thus cut are well smoothed up with glasspaper, and then fixed together with glue and allowed to set hard, after which all surplus glue showing can be carefully scraped off.

The Bottom

The bottom for the box is indicated in (D) Fig. 4, and simply consists of a piece of plywood cut carefully to size $8\frac{1}{2}$ ins. by $3\frac{1}{2}$ ins. Well smooth up the piece when cut, and glue it in position with an overlap of the edges $\frac{1}{8}$ in. all round.

Details of the box lid top are given in (E) and (F) Fig. 4. Cut a piece of plywood

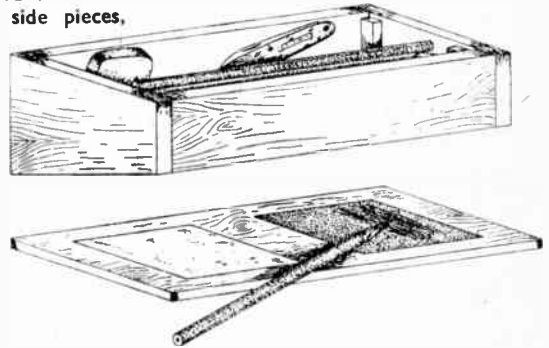

Fig. 2—The box with the lid off

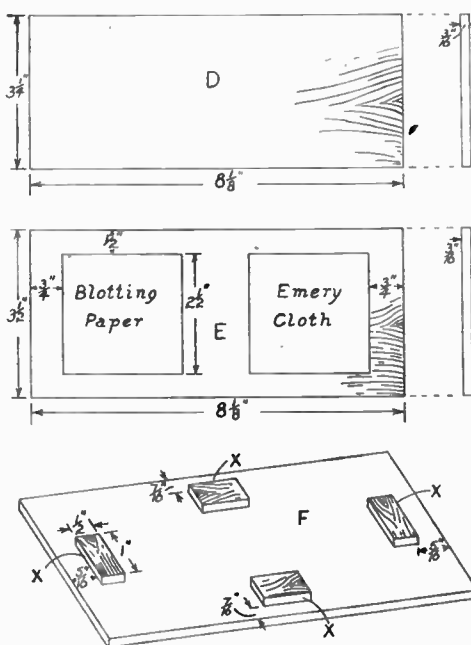

Fig. 4—Dimensions for the top and bottom

$8\frac{1}{2}$ ins. by $3\frac{1}{2}$ ins., as indicated in (E) Fig. 4, and the positions of the blotting paper and emery cloth are also indicated. The blotting paper and emery cloth are fixed by a little glue applied along the edges.

Next cut four pieces of plywood $1\frac{1}{2}$ in. by $\frac{1}{2}$ in., and carefully glue them on the underside of the lid, in the positions shown in (F) Fig. 4. The edges of the pieces marked (X) in view (F) Fig. 4, are carefully filed until the lid fits nicely in position on the box top.

The box can now be finished off by applying a coat of stain. (376)

Lawns and Their Making—(Continued from page 403)

cemented together, but merely laid end to end, and the trench in which they lie must be filled with light soil, not heavy impervious clay. With small lawns one pipe taken diagonally across with a branch to each corner will generally do all that is required (Fig. 4). Bigger lawns need more considered treatment.

Where a lawn is already in existence, the best way to get it into trim is by the consistent use of a good mowing machine—if possible with roller attached. Mounds can be removed by turning back the turf, digging out the unwanted soil and replacing the turf. Small hollows are best filled by continual

dusting with sand till the desired level is reached—the turf not being disturbed.

Worms are sometimes a real nuisance as they keep the ground too loose and throw up unsightly casts. The trouble can be well dealt with in Spring by the use of a worm killer, as February to the end of May is a breeding season. (402)

Here is some helpful advice on BRICKLAYING FOR BEGINNERS

THE building of a low wall is well within the scope of the average handyman provided his effort is guided along the right lines. Such a wall can be put to many uses, decorative and otherwise, especially in the garden.

The First Step

Mark out the position of the wall and dig a trench 12ins. deep, 15ins. wide and, if possible, about 1ft. longer than the intended length of the wall. Ram the

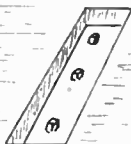

Fig. 1—The foundation trench

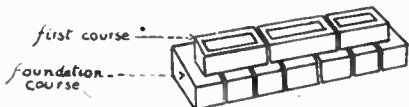

Fig. 2—The foundation and first courses

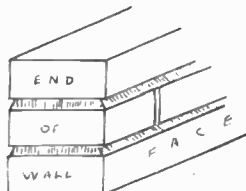

Fig. 5—Pointing the joints

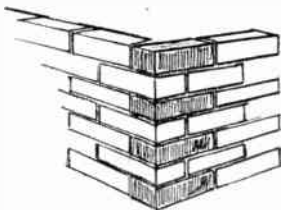

Fig. 6—Building up a corner

bottom of the trench until it is hard and firm. On to this will go a 4in. layer of concrete.

Along the middle of the trench drive in wooden pegs 3ft. apart, leaving 4ins. of each peg above the ground (Fig. 1). Put a piece of deal boarding across the first two pegs and test with a spirit level. In this way adjust the pegs all along the trench so that their tops are all perfectly level.

Mixing the Concrete

A suitable mixture is:

- 1 bucketful of cement.
- 2 bucketfuls of clean sharp sand.
- 3 bucketfuls of gravel.

Use a wooden or stone base for the mixing. First tip the gravel into a heap. Over this put the sand and finally, the cement. The easiest way to do the mixing is to shovel the heap over into another heap and then shovel it back again. Keep this up until the mixing is complete.

Now sprinkle with water from a watering can and repeat the mixing process until there are no dry 'pockets' of material left in the heap.

Tip the cement mixture into the

trench and use a piece of boarding to level it off flush with the tops of the wooden pegs.

Making Cement Mortar for the Wall

Cement mortar is preferable to lime mortar in that it is easier to mix and cleaner to use.

The mixture:

- 1 part cement.
- 5 parts clean sharp sand.

Mix in the same way as for the foundation concrete until the whole mass is the consistency of cream.

Laying the Foundation Course

The foundation course is the layer of bricks placed immediately on to the concrete base. In this particular case the course is one brick wide and one brick high. Spread a ½in. thickness of mortar on the concrete base and on this lay the bricks crossways to the run of the wall



Fig. 3—Essential arrangement

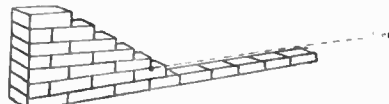

Fig. 4—Ends of wall built first

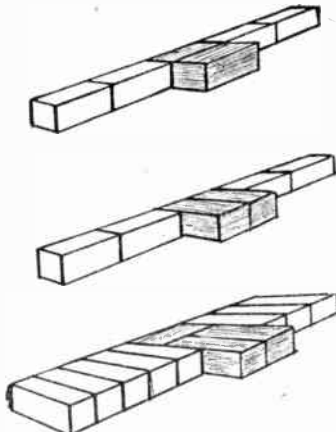

Fig. 7—How courses are built up when strengthening a wall with piers

straight edge and spirit level to level up the foundation course and, where necessary, use the handle of the trowel to tap the bricks into place. Now test the face of the bricks with the straight edge so that the whole course is squared up.

The Wall Itself

Fig. 3 shows the essential arrangement; each brick overlaps the joint immediately above and below it. This overlapping is a 'stretching bond' or a 'chimney bond'.

To do this start all odd numbered courses with a whole brick and all even numbered courses with a half-brick.

The layer of mortar between each course, and the dab of mortar at the end

of each brick should be a ¼in. thick. Wet the bricks beforehand to make a strong union. Firstly build the ends of the wall up to six courses, and then work to the middle of the wall (Fig. 4).

Cutting Bricks in Half

To cut a brick in half use a broad chisel called a bolster. Scratch the brick on each side. Place the chisel on the scratch on each side in turn and give it a blow with a hammer. A heavy blow with the hammer will now break the brick in half. These half bricks are called brickbats.

Building Up the Wall

Fasten a length of string to two nails, or better still, use proper bricklayer's 'pins'. Push the nails into a mortar joint so that the line is taut and at the level of the first course (Fig. 4). This course is now completed and the line moved up to

the level of the next one.

When the sixth course has been completed start on the ends again. Build them up to the required height (ten to twelve courses) and then build up the middle portion again.

Pointing the Joints

Where the face of a wall is exposed to the weather it must be treated so that water cannot lodge in the joints.

Put the trowel flat against the top of a joint, pressing the mortar in at the top and flush with the brick at the bottom. Fig. 5 shows the final effect.

Where a face is not so exposed the joints are given a flush finish. The mortar is pressed tightly into the joint and the surplus scraped off level with the bricks.

This type of wall can be used for the building of a coal-bunker and so on. Fig. 6 clearly shows how the corners are made.

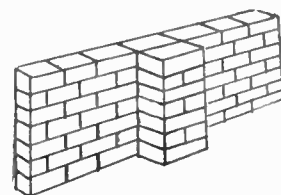

Fig. 8—A completed pier

Building a Higher Wall

If this type of half-brick wall is to be built higher than ten to twelve courses, it must be strengthened by means of piers built at regular intervals along its length.

This time the base is made of a 6in. depth of concrete and the trench must be

widened wherever a pier is to be built. Fig. 7 shows the arrangement of the bricks for the foundation courses and for the odd and even numbered courses. The completed pier is shown in Fig. 8.

The 9in. Wall

Dig the trench 30ins. wide and lay a

The Nine-Inch Wall

Perspective View
of courses

Plan of courses

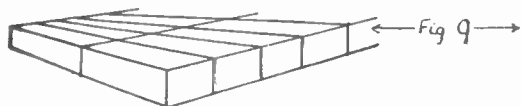

Fig. 9—Foundation course

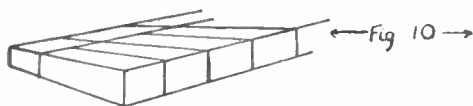

Fig. 10—Second foundation course

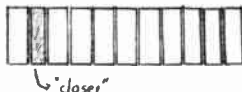
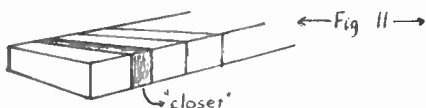

Fig. 11—First course

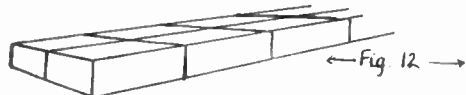

Fig. 12—Second course

6in. layer of concrete.

First foundation course—two bricks wide (Fig. 9).

Second foundation course—a brick and a half wide (Fig. 10).

First course and all odd numbers—Fig. 11.

The shaded brick is only 2½ins. wide and is called a 'closer'. The closers are used to make the headers fall across the joints between the stretchers.

Second course and all even numbers—Fig. 12.

The finished wall is illustrated in Fig. 13.

The Plumb Rule

The plumb rule is used to make sure that the ends and the face of the wall are vertical.

The easiest way is to hold the rule against the bricks with the left foot and left hand. With the trowel handle tap in protruding bricks until the metal bob hangs exactly in the centre of the hole and the cord lies just in front of the groove. (382)

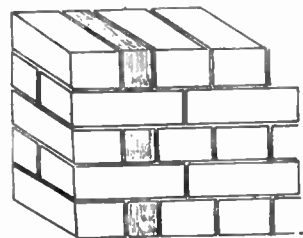

Fig. 13—The finished wall

The Work of a Craftsman

FROM Mr. T. Smith, of 7 Station Avenue, Eastfield Estate, Bolton (Lancs.) comes this picture of 24 of the models he has made during the past few years—mostly from Hobbies patterns.

Among them we notice a model of St. Paul's, The Coronation Chair, the ½d. Galleon, the Santa Maria, two locos—the Gt. Northern Pacific type nearest camera, and the old-timer 'North Star' on the left—a stage coach, and numerous of our fretwork designs.

Mr. Smith has certainly been busy, but he has something to show for his labours. And something to be proud of, too, for, as far as we can see from the photograph, the models are extremely well made.



You should find it easy to make this BEDSIDE LAMP AND CLOCK

A CLOCK in the bedroom is really only partly fulfilling its purpose if there is no light in a handy position for seeing it. It is generally during the dark hours that we want to refer to it and then a light of some sort is essential.

The subject of this article is a combined bedside reading lamp and clock that fulfils these requirements. It is quite an attractive piece of furniture designed on modern lines and should find a ready appeal.

The switch mounted on the baseboard in front of the clock makes operation quite simple. It is well within reach when lying in bed and the clock is adjustable to any angle.

The lamp has been designed to work off the mains but it could be easily adapted for use with batteries if desired.

Which Wood

The choice of wood is rather important, and a hardwood such as oak or walnut is to be preferred. Even if the woodwork is to be painted with one of the modern lacquer finishes a hardwood should be used if possible.

Three separate pieces of wood make up the base and have a total thickness of 1 in. The top one, which is 8 ins. long, 5 ins. wide and $\frac{1}{2}$ in. thick could be made of plywood but a solid piece of wood would look better. For the middle section cut a piece 8 $\frac{1}{2}$ ins. long, 5 $\frac{1}{2}$ ins. wide and $\frac{1}{2}$ in. thick, and this could be cut with the grain across the width to give variation to the design. This centre section has a 4 in. square hole cut in the centre to allow room for the switch and all the necessary wiring.

Cut a piece of $\frac{1}{2}$ in. thick wood 9 ins. long and 6 ins. wide for the third section which is screwed in position when the wiring has been connected up.

Next cut the two supporting bars from wood 1 in. square. Allowing for the piece let into the baseboard $\frac{1}{2}$ in. and into the top bar $\frac{1}{2}$ in., the total length will be 6 $\frac{1}{2}$ ins. Cut two square holes right through the top two sections of the baseboard to just fit these supports—there must be a clear space of 5 ins. between them.

One of the supporting bars is hollowed out for the wiring to pass down, and the best way of doing this is to use two pieces of $\frac{1}{2}$ in. wood for this side instead of one square piece. Cut the grooves large enough to take twin flex and then glue together.

The Clock Panel

Before we can fix the supports into position the clock panel must be made. It consists of a piece of wood 5 ins. long, 4 ins. wide and $\frac{1}{2}$ in. thick, and in the centre a hole is cut of sufficient size to fit the clock. No definite information can be given regarding this, as it entirely

depends on the clock used and must be left to the reader's discretion.

This bedside combination was designed to take the popular little time-piece now made with dials of such diverse shapes and sizes. The movement behind the dial is contained in a drum having a diameter of about 2 $\frac{1}{2}$ ins. and this is the size to be cut out of the panel. A fairly tight fit is usually sufficient to hold the clock in position, but you must use your own discretion regarding the fixing.

It may be that you already possess a clock mounted in a wood panel that can be cut to the necessary size to fit between the supporting bars. Another idea is for the clock panel to have a slight sink cut in the centre to fit a pocket watch, which is suspended on a neat little hook.

Two pivots must now be fitted to the clock panel in order to make it adjustable to any angle. In the centre of each end drill a hole about $\frac{3}{8}$ in. deep to take a length of $\frac{1}{4}$ in. dowel rod. Make it a fairly tight fit and glue in position, leaving a piece projecting about $\frac{1}{4}$ in.

The two supports have holes drilled to receive these dowel pivots 2 $\frac{1}{2}$ ins. up from the baseboard. Make them a movable fit, but at the same time they must be fairly tight, or the clock may swing over by itself.

Now is the time to fit the clock panel into the supports and then glue these firmly into the baseboard. At the same

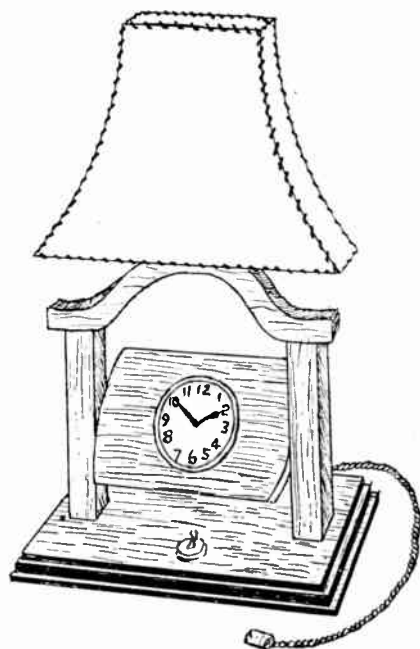

time the two top sections of the baseboard can be glued together.

The Top Bar

The curved top bar which supports the electric light holder can now be cut and fitted to the side bars. Like one of the side bars it is best made in two halves, so that a groove may be cut to take the flex from the holder.

A piece of wood 8 ins. long, 3 ins. wide and $\frac{1}{2}$ in. thick will cut one side, then lay it on another piece of wood and cut a similar piece. Cut a mortise in each end to fit the tenons on the side supports before cutting out the grooves for the wires. Quite shallow grooves will be sufficient to take the flex, and this must be placed in position before fastening the two halves together with glue.

Cut a block of wood 2 ins. diameter and $\frac{3}{4}$ in. thick and glue to the centre of the top to screw the lamp holder on to. Drill a $\frac{1}{2}$ in. hole in the centre for the wires to come through.

Before the final finishing, mark and cut the hole for the switch. A small tumbler switch of the wireless type capable of carrying a current of 3 amps. will do nicely.

Glasspaper all quite smooth and finish either with french polish or one of the modern lacquers chosen to match the existing furnishings.

Take a little time and care over wiring up and leave no loose strands of flex when connecting to the holder and switch, especially if you are going to work off the mains.

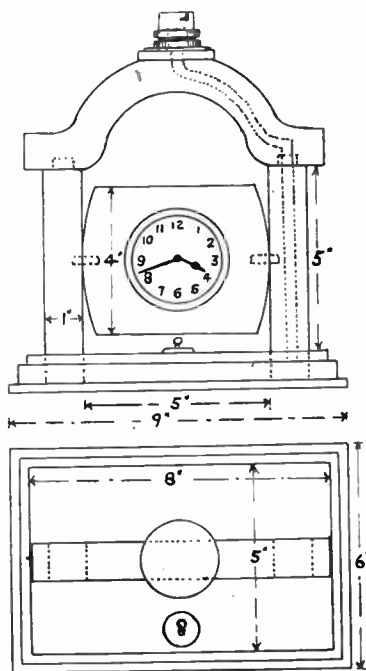

General dimensions

An interesting hobby FOR CYCLIST AND HIKER

WHEN out cycling or hiking there is no more interesting side hobby—if you have a bent in that direction—than the making up of a naturalist's book of specimens. The pastime need not be very arduous, but the collector's satisfaction in getting a new leaf here or a good specimen there is great—so why not give it a try?

The big book in which you keep your collection will, of course, be left at home, but something in which to store the specimens temporarily must be taken with you on the run. Flowers and leaves wither quickly if carried in the hand or if they are exposed for too long periods to a hot sun or drying wind, so the 'something' must be efficient.

A Container

A tin box with a tight-fitting lid and some damp moss in is quite serviceable, or an old book can be used, placing the items between the pages. The latter is all right for leaves, but not very satisfactory for bulky flowers, etc. which, apart from anything else, require care in pressing and which may be spoilt by the first incorrect pressure. In these cases a box is better—and this can be quite shallow, and need not take up too much room.

For a general plant collection the best specimens are those which exhibit a leaf and flower together, and the ideal time to collect is just before the flower is full out. Back home, if you have not time to deal with the specimens at once, it is best to put them in water.

The pressing of a specimen needs some little care if it is to be done properly. It is, of course, the squeezing of all the moisture and sap from the stems and petals without destroying the outlines.

Good pressing can only be done fairly slowly. Trying to rush the job only ruins things. Required is some good stiff cartridge paper (which can now be obtained again). The specimens are taken from the water and drained, and the first one laid on the first sheet of paper. Carefully arrange how you want the petals and parts to go and then place another sheet of paper on top. On this sheet can be adjusted a second

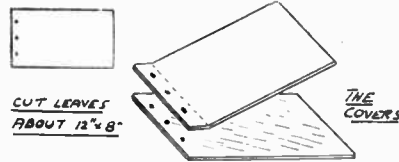

COMPLETED ALBUM



Details of the album

specimen. When several layers have thus been made up, place the block on some firm surface where it will not be interfered with, place a board on top, and a weight on this.

Examined after a day, it will be found that only partial pressing has taken place. Carefully remove the specimens, dry out the cartridge papers and restack with a slightly heavier weight. This process may have to be repeated a number of times (according to the type of specimens) before full pressing and drying has taken place.

Mounting

When ready, the specimens must be

mounted in the album that is to be their permanent home. At one time, 'news-paper cutting' books could be obtained fairly cheaply, and made excellent albums for botanical specimens, but now it is best to make your own book, and no handyman will find this difficult.

Making an Album

Cut several sheets of strong paper of medium wrapping-paper thickness and some pleasing colour. Such papers can be obtained now at most stationers or printers. The size should be about 12ins. by 8ins. At the same time, cut two rectangles of card the same size for the cover and back.

At about 1½ins. in from the end of each card, score a line with the tip of something blunt, so that the card will bend here without cracking. Now punch three holes in the flap so formed, and also a single hole at the other end to take a fastening tape.

The leaves now are given holes at the ends corresponding with those in the cards, and the album is made up by putting the leaves between the cards and lacing up with a leather or other boot lace. At the further end two tabs are put on and these are tied together in an easily released bow when the book is closed. An album made thus is really loose-leaved and can be built up to almost any size.

Holding the Specimens

Adhesive paper is the best thing to use for holding the specimens in position and below each should go a neat strip of paper bearing the name. Once pressed and dried, handle specimens only by tweezers or by sliding a thin knife underneath them. (401)

Realism in Model Work

THE writer has just been examining some very well made ship models, ancient and modern, and without wishing to be unkind, cannot help remarking that even the model trawlers appear to have golden chains, silver metalwork, and maple dance hall floors for decks.

When shipping lines commission a model they like to have the newness of their ship emphasised. In the case of a model trawler, however, the model-maker would do well to paint on some realistic red rust, etc. and begrime the funnels.

The same applies to models of all descriptions. For example, the underside of a concrete railway tunnel is always black from the smoke of trains. In any length of fencing, it will add to the

realism of your model if one or two of the posts or rails are shown broken or otherwise out of place. In model houses where a lot of windows are shown, it will look more natural if appropriate ones are shown cracked, broken, patched or boarded up. In real life many rain gutters are kinked. Again, if one is to include a road in a model, a study of the real thing will soon show that the surface of the road is often marked by patches of oil from standing cars, etc. Sufficient has been shown to emphasise my point.

Old-time ship models should be treated to look antique, in other words, to look as if they were contemporary models. Tins of 'antique' medium are sold, but for a few pence the writer could make far more antique medium than he could ever possibly hope to use

in a double life-time. All that is necessary is a little soot from the chimney (only a little!) mixed with paste (either ordinary flour and water paste, or the proprietary makes). This stuff is dabbed on the model with an old brush, working it well in the crevices. After a minute, it is wiped off again with two or three changes of rag.

It is as well to practice on a spare piece of wood first, and, in any case, do not attempt to cover the whole of the ship at once. One should attempt to wipe off in the same way as decorators 'grain' varnished doors, etc. The effect should be of age, not of dirt. As a matter of fact, it is the soot in the air that gradually deposits upon a genuine old model and gives it an antique effect, so this mixture of soot and paste closely approximates Nature's own way. (102)

There will be satisfaction in making this STURDY GARDEN SEAT

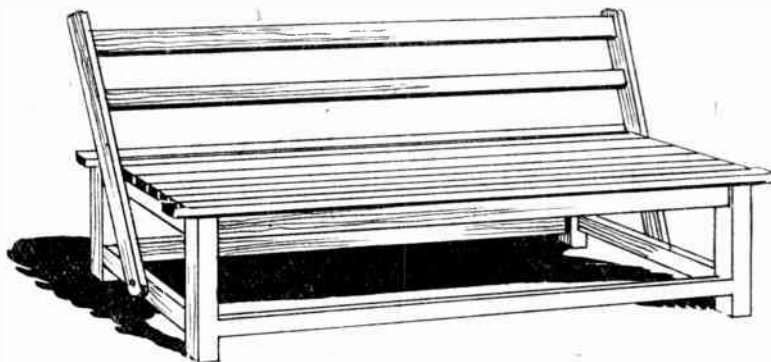

Fig. 1 - The completed seat

A GOOD garden seat is almost a necessity to a garden and lawn of any reasonable size. The seat shown in Fig. 1 is so constructed that the back rest is adjustable, being pivoted to a lower side rail so that it can be swung back to suit the direction of the sun. Thus, the full benefit of the sunshine can be felt regardless of what position the seat takes on lawn or garden.

The seat shown in our illustration can be made from white wood. A good straight-grained deal, finished with paint, or even creosote, would make quite a

serviceable job and be of attractive appearance.

The constructional work is simple, comprising nothing more than a few simple mortise and tenon joints. These joints, however, need to be carefully set out before the work of chiselling is proceeded with, and here again a set of good tools is needed if clean joints are to be made. All the joints so made should be securely doweled to make them more resistant to weather conditions.

The End Frames

The two end frames of the seat should be made first, and for these you require four pieces of 2½ in. square wood 17 ins. long for the legs. For the bottom rails, two pieces 20 ins. long by 2½ ins. by 1½ ins. are required, and for the top rails two pieces 20 ins. long by 3 ins. by 1½ ins. are needed. These latter rails are slightly hollowed towards their middle, as shown in Fig. 2, to make the

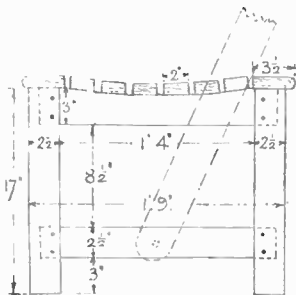

Fig. 2.

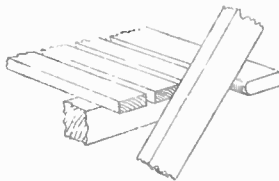

Fig. 4

seat comfortable. This shaping, however, is not compulsory, as cushions are frequently used for such a hard seat.

The joints can now be marked out, and it will be noticed that the tenons on the top rails are on one edge of the wood and extend to half their thickness. The tenons on the bottom rails are one-third the thickness of the wood, and the ends are mitred so that the two tenons

fit together in the mortises which meet in the legs (see enlarged details at Fig. 3).

Mark out the mortises on the legs to correspond with their respective tenons. It will be noticed from Fig. 3 that the upper mortises are made open at the top, these joints being hidden and sufficiently covered by the seating boards, as Fig. 2 shows. In this diagram is shown, too, the lengths between the shoulders on the rails. The joints can now be cut out very carefully with the tenon saw, and mallet and chisel for the mortises. Most of the wood in the latter can be cleaned out by using a brace and bit of the required size and using the chisel for clearing away.

It is advisable to trim out the mortises on the other sides of the legs, which receive the front rails, at the same time. These are exactly the same in size and shape as the others.

The next job is to fit the frames together. With a ¼ in. twist bit bore two holes through each joint for the dowels, which may consist of ¼ in. round rod pointed at the end and smeared with a mixture of glue and paint to resist the weather.

Cut the ends of the dowels off flush with the frame and clean up with the plane.

Front and Back Rails

Two top and two bottom rails are now required to fit between the legs along the front and back of the seat.

The top rails are each 3 ft. 11 ins. by 3 ins. by 1½ ins., and the lower rails 3 ft. 11 ins. by 2½ ins. by 1½ ins. The tenons can then be marked out on the ends of these rails similar in size and shape to those on the end rails, the distance between the shoulders this time being 3 ft. 7 ins. The lower rail tenons must be mitred as before to fit in the mortises.

When all the joints have been cut and fitted, the tenons can be painted and the dowels driven through the legs into them as explained before.

The next job is to fix the top slats on the assembled frame. For these obtain two pieces of wood 4 ft. 3½ ins. long by 3½ ins. by 1 in. for the outside slats (see Fig. 2) and six pieces, each 4 ft. by 2 ins. by 1 in., for the intermediate ones. One edge of each outside slat must be rounded with a smoothing plane, and it is advisable to glasspaper the corners off the remaining slats to remove any splinters, etc.

The best way to fix the slats to the frame is shown in Fig. 6. A hole is bored through the wood where the screws are to go and the tops are then countersunk deeply. The screws are then

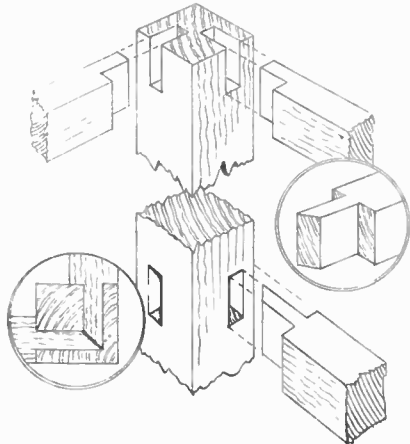

Fig. 3

Fig. 5

Fig. 6

(Continued at foot of page 411)

Books to Read!

A review of interesting books for craftsmen which have been recently published. Obtainable through newsgents or book-sellers or direct from the publishers mentioned.

Concrete, Stone & Brickwork

by Noel D. Green

THE home handyman who wishes to undertake successfully a variety of outdoor constructional work in concrete, stone or brick, should secure a copy of this latest addition to the Home Mechanic Series. Introductory chapters explain the various types of concrete mixes and the methods of mixing, and simple instructions are given for the types of work that can make so much difference to a garden—laying crazy paving, constructing garden edging, paths, balustrade columns, bird baths and aquariums. Chapters for the more ambitious worker are also included, and give practical instruction for the construction of reinforced structures such as fences, coal bunkers, garages and greenhouses. Masonry and brickwork are thoroughly dealt with in the final chapters.

Published by Newnes and Pearson Ltd., Southampton Street, Strand, London, W.C.2—Price 5/-

Your Children's Crafts

Edited by E. Sheila MacEwan

THERE are many books on children's crafts, but this is one with a difference. It is planned throughout for children old enough to read instructions and follow simple diagrams for themselves, and avoids, as far as possible, the manner of the school textbook. Then again, it is not just another book on how to make something useful. The crafts—hand and glove puppets, modelling and carving, paper model making, print making, wooden toy making and weaving—are described rather as a media of artistic expression, and to encourage children to use, in an imaginative way, odds and ends of materials ready to hand.

Published by The Sylvan Press Ltd., 24 Museum Street, London, W.C.1—Price 9/6

Make Your Own 'O' Gauge Motor

by E. F. Carter

THERE can be few railway modellers who have not read something from the pen of Mr. Carter, and few who have not profited from such reading. This latest book will prove a valuable asset to those of our readers who own 'O' gauge layouts, for are not numbers of us often deterred from constructing another

locomotive body, simply because we cannot afford to buy the motor it will need before it can take its place among the rest of our locos? By following the instructions in the book, a sturdy and reliable unit can be made for a fraction of the cost of a manufactured one, and for the man who contemplates putting a new loco on his layout, the book will be a profitable investment. For anyone faced with the problem of completing a number of locos to build up his stock, the book is indispensable.

Published by Percival Marshall & Co. Ltd., 23 Gt. Queen Street, London, W.C.2—Price 3/6

Pewter Relief Modelling

By Zita Dundas

FOR anyone wishing to acquaint themselves with the craft of relief modelling in pewter, Miss Dundas' book can be recommended. Pewter work in a general sense is, of course, a highly specialised craft calling for skilled technical training, but pewter relief work in itself is a handicraft which requires few tools and can be practised by anyone. The book is easy to understand and well illustrated, and the illustrations include a number of designs which should offer no difficulty to the beginner.

Published by Vawser & Wiles (London) Ltd., 356/358 Kilburn Road, London, N.W.6—Price 2/6

Home Carpentry

By W. A. G. Bradman

HERE is a book for the amateur woodworker, a book which sets out to provide a concise instruction course of real worth to the beginner. The chapters deal with such things as the tool kit, woodwork joints (explained stage-by-stage in text and pictures), fittings, cabinet drawers and doors, veneering, and staining and polishing. In addition, there is a section on six things to make.

Published by W. & G. Foyle Ltd., 119/125 Charing Cross Road, London, W.C.2—Price 2/6

Rope Splicing

By P. W. Blandford

IN this book an attempt has been made to gather descriptions of all kinds of rope splices into one volume—

and a very handy volume it thus turns out to be. For while there are many excellent books on knotting and general ropework, and which include splicing in their contents, they cannot hope to treat the subject as fully as one devoted solely to splicing. So that the reader who wants to know about this particular subject alone cannot do better than secure a copy of Mr. Blandford's book. It is comprehensively illustrated, and altogether good value for money.

Published by Brown, Son & Ferguson Ltd., 52/58 Darnley Street, Glasgow—Price 3/6

Modern Furniture Projects

By W. A. G. Bradman

FOR the amateur woodworker who is setting up home, or who needs additional pieces, this is a book that can be wholeheartedly recommended. It is assumed, of course, that the reader has the essential pieces, and the articles concentrated upon are, for the most part, of the smaller variety such as stools, lounge tables, etc.; but larger pieces are not altogether neglected, and there are drawings and instructions for making divans, a sideboard, etc. A chapter on joints caters specially for the reader of limited woodworking experience, and he need not fear that the subsequent designs will be too difficult for him. The designs themselves are modern, pleasing to look at—and useful.

Published by Herbert Jenkins Ltd., 3 Duke of York Street, London, S.W.1—Price 7/6

Aeromodeller Annual 1950

Compiled by D. J. Laidlaw-Dixon; edited by D. A. Russell, M.I.Mech.E.

ONCE again comes this now old friend to mark the passing of another aeromodelling year. It gives, as usual, a detailed review of the year's aeromodelling throughout the world in theory and practice, and is full of useful data and authoritative articles produced by the staff and contributors of the Aeromodeller. The popular plans section has been not only retained, but enlarged, and several new countries are represented. In all, the annual offers sound value for money to all who make and fly model aircraft.

Published by the Model Aeronautical Press Ltd., Allen House, Newark Street, Leicester—Price 7/6

Bedside Lamp and Clock—(Continued from page 407)

Leave a sufficient length of flex to connect to the source of supply; about 2yds. is usually enough but this will depend on individual requirements.

The bottom board can now be fixed on with a few $\frac{1}{2}$ in. screws, and if desired a piece of thin felt can be glued on to prevent scratching the furniture.

Choice of shade is left to the reader; there is an endless variety on the market now, or it is not a difficult job to make one. (388)

Good news for amateur photographers— 'P.O.P.' IS HERE AGAIN

Printing-out photographic paper, generally called P.O.P., is back on the market after its long absence due to the war. This is excellent news for the amateur camera man, for making prints with this kind of paper is very easy, no darkened or semi-darkened room being necessary as with bromide or gaslight papers. Also, when watching a P.O.P. print come into being there is an interest that seems absent with other developing papers.

With the daylight paper, the negative is placed in the frame with a sheet of the material behind, exposure to daylight then being made. The frame must not be placed in the full sun, and the making of the print is quite a leisurely job. After the frame has been out for a little time take it into the greater shade of, say, a doorway, undo half the back and gently lift the paper from the negative. At once you will see that the picture has arrived, though as yet it may not be dark enough.

The Correct Depth

The picture has, of course, been produced by the action of the sunlight through the negative and the longer it is left in the light the darker it will go. The correct depth to aim at is just a little deeper than you require the final picture to be, as the print will lighten in the 'fixer', some brands more than others.

Although there is an almost irresistible urge to get a really good long peep at your latest snapshot, do not keep the half back up for too long, as the light in the doorway may be brighter than you had imagined and the paper will start to darken all over, which will spoil the sheet. After just a very brief look, therefore, close the half back down carefully, re-clip and, if necessary, place the frame back in the sun. With a little practice you will be able to get the desired depth of printing without too

many inspections.

Having completed the printing, remove the sheet and put it in the envelope in which the paper arrived (and which is quite light-tight) till you are ready to do the fixing. The usual thing is to print quite a number of negatives and then fix the prints altogether. However, try with single prints at first until you get your hand in.

The Two Types

Printing-out papers all give a brown picture and there are two types of the material, the 'ordinary' and 'self-toning'. Both are 'fixed' by placing in hypo, but whereas the 'self-toning' turns to a rich sepia in plain hypo, the 'ordinary' has to be placed first in a 'toning bath' to get the same effect. Treatment with hypo will certainly fix the ordinary papers without the toning solution, but the final colour is not too nice, being reddish and devoid of the rich depth of true sepia.

If there are special instructions necessary for the using of any particular brand of P.O.P. these are usually enclosed in the packet, but generally the prints are first rinsed in plain water for a few minutes and put straight into hypo which has been made up to a strength of roughly 1oz. of the hypo crystals to 10ozs. of water. In here the prints slowly change to a deeper and deeper sepia, at the same time slightly lightening. Ten minutes in this bath is sufficient, and then the prints are washed for half-an-hour in running water. That the water must be running over the prints is important.

The 'ordinary' type of paper is first rinsed and then placed in the 'toner' which can be bought in small packets from any dealer. The prints stay here for about 5 minutes, being kept on the move and in a shady place, and are then put in a hypo solution as before.

Printing-out papers can be dried

naturally by laying out on clear blotting paper, but the glossy types 'glaze' exceptionally well; that is, they can be given a super high gloss by placing face down on a sheet of glass when wet. The prints are taken straight from the washing water and put quickly on to the glass. A piece of clean blotting paper is then placed over their backs and they are pressed into tight contact with the smooth surface, either with a squeegee roller or by pulling some flat edge (e.g. a ruler) over the blotting paper which is firmly held meanwhile so that the prints do not slip. The aim is to expel all air from between the print and glass.

The glass is now put on one side, and as the prints dry they peel off with a depth of gloss that is quite impossible by straight drying. Should they stick at all it is because the glass has not been absolutely clean. Stuck prints, however, can be soaked off, and reglazed when the glass has been given another polish. French chalk makes an excellent grease-removing and polishing agent.

Unfixed Prints

P.O.P. is useful also to the photographer who mainly uses gaslight or other developing papers, as it allows him to see in a few moments what he has really got on his negative. In fact, some years ago it was much used by professional photographers for 'proofs'. While unfixed P.O.P. prints cannot be looked at for too long in daylight without browning in, they can be examined for any length of time by artificial light without damage.

One final point. The best P.O.P. prints are obtained from fairly strong, contrasty negatives, and these can be obtained by developing the film for a rather longer time than usual. A little experimenting will soon show you the best class of negative for this extremely handy paper. (400)

Sturdy Garden Seat—(Continued from page 409)

driven in and the heads filled with putty or other suitable filling. This covering prevents the screws from rusting. Two screws driven in each end of each slat is sufficient if a piece of odd wood is screwed across the middle of the slats on the underneath side to make everything rigid. Screw the two outside slats on first, and notice in Fig. 4 that they are 1½ ins. longer than the seat at each end—to receive the back rest. The intermediate slats must also be longer than the top rails of the seat frame, but level with the edges of the legs. These slats are spaced out carefully between the front and rear wide slats.

Making the Back Rest

For the back rest, obtain two side uprights about 3ft. 3ins. long by 3ins. by

1½ ins., and two horizontal rails 4ft. 3ins. by 1½ ins. Mark out the mortise and tenon joints as shown in Fig. 5. The tenons are ¼rd the thickness of the rail and pass right through the uprights. Cut these and fix them as before, by gluing and painting and then dowelling. It is better to round the ends of the uprights and plane all the corners off before fixing together as above. Next obtain two 4ins. by ½ in. bolts, with nuts and washers complete, then put the back rest in position so that the bottom of the uprights fit the lower rails of the frames as in Fig. 2. First, however, bore holes centrally in the rails to receive the bolts. The back rest should move freely against the slats of the seat. Any clearance needed can be arranged by adding washers on the bolts.

The completed seat may be oiled, painted or creosoted, the bottom of the legs being coated with tar, or thoroughly saturated with the creosote.

HOBBIES BRANCHES

LONDON, 78a New Oxford St., W.C.1
87 Old Broad Street, E.C.2
117 Walworth Road, S.E.17
GLASGOW, 326 Argyle Street
MANCHESTER, 10 Piccadilly
BIRMINGHAM, 14 Bull Ring
SHEFFIELD, 4 St. Paul's Parade
LEEDS, 10 Queen Victoria Street
HULL, 10 Paragon Square
SOUTHAMPTON, 25 Bernard Street
BRISTOL, 30 Narrow Wine Street



MARCH MEMORIES

It would appear that the merry month of March is an important one for philatelic commemoratives, either births or deaths. If we go through the diary we find that on March 3rd Alexander Graham Bell was born. You can see his portrait on either the 10c. of the United States set of famous inventors issued in 1940 or else on the 4c. Canadian stamp which was issued in 1947 to commemorate the centenary of his birth in 1847 in Edinburgh. He went to Canada from Scotland when he was twenty-three. He became professor of vocal physiology at Boston University and specialized in teaching the deaf and making aids for those who had difficulty in hearing, and it was from his researches into this that he developed his idea for a telephone which he invented in 1876. It is for this invention that we mainly remember him. He died in 1922.

On March 6th, 1945, Cologne was captured. We do not suggest that this is a birthday, of course, but it is quite a

1938, which shows Masaryk holding up a small child in a very happy mood.

On March 12th, 1925, Sun Yat Sen died in Peking, he was born in 1867 and was the founder and first President of the Chinese Republic as well as the first graduate in medicine at Hong Kong in 1892. He played a large part in the revolution of 1911, and the next year he was elected President of the Southern Provinces, but soon resigned. His portrait first appears on the 1912 set. Then he appears on the stamps of 1931 and 1938 and then each succeeding year from 1941, so that you should not have any difficulty in finding a good picture.

Karl Marx

On March 14th, 1883, Karl Marx died and was buried in London. He was born in Prussia and went to the University, where he became the editor of a paper which was suppressed. This was in 1843, the same year in which he was married and went to Paris where he did much work on Socialism. Later, he founded

commemorated on the stamps of Norway by a set of four issued in 1928 showing his portrait and also his signature.

The 'G's

The last three of the month's commemoratives are all 'G's—Goethe, Goya and the Duke of Gloucester. Goethe died in 1832, and his portrait appears on the two values 3 pf. and 25 pf. of the 1926 issue of famous Germans. Born in 1749, Johann Wolfgang Goethe studied at Leipzig and at Strassburg, and many of the plays he wrote met with immediate success. His most noted, 'Faust', was published in 1831. He was a scientist of no mean standing but this is completely overshadowed by his fame as a writer.

Goya was born on March 30th, 1746, and studied art for a time at Saragossa. He later went to Madrid, and at the age of 19 he was travelling with a troupe of bullfighters into Italy. There he again took up art and later became the Court painter in Spain. As could be expected from his intimate knowledge of bull



Canadian 4c. stamp showing portrait of Alexander Graham Bell



Russian stamp with picture of Karl Marx and his grave in Highgate cemetery



Goya pictured on a Spanish stamp



Portraits of The Duke and Duchess of Gloucester on an Australian 2d. stamp issued in 1945

notable date, and Cologne Cathedral appears on the 1923 German stamp of 10,000 mark value. The cathedral is the most noted building in the city, but we must not forget that it is also an important manufacturing town, cotton and woollen goods, scent, machinery, and chemicals being the chief products. It was the headquarters of the British Army of Occupation from 1918 to 1926.

Masaryk

Thomas Masaryk was born on March 7th, 1850, and his portrait appears on many of the Czechoslovakian stamps. He founded the progressive Czech Party in 1889, and strongly opposed the pro-German influence in Austria, so that he had to leave his country when the 1914 war broke out. But after the war he became the first President of Czechoslovakia. Many and varied are his portraits, the most pleasing being, undoubtedly, the child welfare stamp of

the Communist League and in 1848 issued the Communist Manifesto. He was banished from Germany and came to London, where he lived in great poverty. The 50th anniversary of his death was commemorated by Russia in 1933. She issued three stamps, showing respectively: a view of Treves, his birth place, on the lowest value, with a small medallion portrait of Marx; a picture of Karl Marx's grave in Highgate cemetery (middle value); a portrait of Karl Marx (highest value).

The 20th of the month is the anniversary of the birth of Henrik Ibsen, who was born in 1828. He was a Norwegian playwright and poet whose works can be divided into three groups—first, historical dramas, mostly in verse; secondly, poetical fantastic plays of which 'Peer Gynt' is probably the best known; and thirdly, satirical dramas written in prose dealing with social conduct. He died in 1906, and is

fighting, his etchings on this subject were masterly. His portrait and three of his paintings appear on the 1930 set from Spain. He died in 1828, aged 82.

March 31st is the birthday of the Duke of Gloucester, who was born in 1900, the third son of H.M. King George V. In 1935, he married Lady Alice Montague Scott, his portrait, together with that of the Duchess, is on the 1945 issue of Australia during the time that he was Governor-General.

Newfoundland has always been noted for the portrait stamps that she has produced, and on the 1911 set the Duke of Gloucester appears on the 6c. stamp. (399)

FAKE PHOTOGRAPHY

To make a 'moonlight' scene, under-expose a negative of a daylight view and then overprint.

MISCELLANEOUS ADVERTISEMENTS

BE Taller. Quickly! Safely! Privately! No Appliances—no tablets—no dieting. Details, 6d. stamp.—Malcolm Ross, Height Specialist, BCM/HYTE, London, W.C.1.

MODELS. You can make lasting stone-hard models with Sankey's Pyruma Plastic Cement. Supplied in tins by Ironmongers, Hardwaremen and Builders' Merchants. Ask for instruction leaflet.

TRANSFERS for decorating toys, trays, furniture, fancy goods. List and samples, 3d. Flowers, pixies, dogs, nursery rhymes.—H. Axon Harrison, Jersey.

LEARN Shorthand by April 28th (1 hour's study nightly). 1st lesson, 2½d. stamp.—Duttons (Dept. HB), 92 Gt. Russell St., London, W.C.1.

RUBBER Tyred Metal Disc Wheels finished in red, green or blue enamel. 2ins., 2½; 3ins., 3½ per set of four. Post paid. Other sizes available up to 9ins.—The Joyden Toy Co., 193 Chase Side, London, N.14.

DOLL'S House fittings and papers; send S.A.E. for list. Doll's house plan special; send 2/6. Trade supplied.—Zimplan, 88 Ware Road, Hoddesdon.

LORRY Kits, 4 mm. and 7 mm. scale. Also large range of spare parts from which to build to your own design. Send for fully illustrated catalogue, price 1/—Wilson's Lorries Ltd., 6 Gt. Winchester Street, London, E.C.2.

BLUSHING, shyness, nerves, self-consciousness, fears, ended. Details under plain cover, 1d.—Stebbing Treatment, 28 (HB) Dean Road, London, N.W.2.

WHEELS for Toys, and other accessories. Full lists will be sent on application to—The Joyden Toy Co., 193 Chase Side, London, N.14.

100,000 Government surplus bargains. Gear units, containing numerous useful gear wheels, 2/6, post 6d.; indicator lights (red) for standard screw bulbs, 6d., post 3d.; ammeters, moving iron, 0-25 amps., 5/-, post 6d.; special sample parcel of assorted switches, junction and fuse boxes, resistances, etc., packed in useful wooden box, 6/6, including post. Send 3d. stamp for full list of other bargains.—Milligan's, 24 Harford Street, Brownlow Hill, Liverpool.

PLYWOOD Offcuts. Birch and Gaboon in various thicknesses. Handy sized parcels for the cabinet, toy, model maker, and all handicrafts. Parcels made up in £1 and 10/- lots. Carriage paid. Send P.O. to Reeves, Plywood and Timber Merchant, 33 Front Street, Monkseaton, Whitley Bay, Tel. W.B. 4677. Parcels are now despatched on day of receiving order.

BE Taller in 14 days or money back. Details, B1d.—Stebbing System, 28 (HB) Dean Road, London, N.W.2.

£5 to £20 weekly earned at home, running your own Mail Order business. Details, 1d.—Stebbing Publications Ltd. (HB), Naphill, High Wycombe.

AMERICAN Magazines post free for one year. Popular Mechanics, 32/-; Popular Science, 28/6; Mechanix Illustrated, 22/6; Popular Homecraft, 18/-; stamp for full list of others.—Willen Ltd. (Dept. 57), 101 Fleet Street, London, E.C.4.

PLYWOOD and Timber Offcuts for sale at very cheap prices. Veneered Oak plywood panels, etc., Japanese Oak. Bumper list, 1d. S.A.E.—Dept. 'H' JDD, Storage, 71 Northcross Road, S.E.22. Tel.: BRixton 7441.

STAMPS free. Wonderful offer. Approvals from 3d.—Walker, 13 Broom Rd., Hale, Cheshire.

2/6 South Africa Stamp free. Stamp brings pictorial approvals.—G. Smith, P.T.S., 95 Ocean Road, South Shields.

CV102 Crystal diode. New, guaranteed, 3/6, postage 2½d. Fixing brackets, 3d. Recommended for 'Hobbies' crystal set; wiring instructions for reliable set. Send stamp for lists, including copper wires, enamelled, silk, cotton covered; B.A. screws, nuts, washers; headphones, radio publications; Paxolin type tubes, ebonite and bakelite panels, rods, etc.—P.R.S., 33 Bourne Gardens, London, E.4.

MECHANICAL Wood Toymaker—a new book with 158 illustrations and patterns, 2/6. Lead Toy Casting slush and gravity, with 128 illustrations and catalogue of moulds, 2/6.—G. F. Rhead, 2 Waldegrave Park, Twickenham.

PLYWOOD Offcut parcels, nothing under 12 x 12 x ¼ in., 15 sq. ft. parcels, 7/6, post paid. Immediate despatch.—Breeze Craft Limited, 113 High Street, Staines, 3461/2.

LEARN Self-defence quickly or money back. Details of Wharton Course, 1d.—Stebbing Publications (H), 28 Dean Road, London, N.W.2.

LAY your own solid or ply Parquet floors, over existing wood floors. Materials supplied complete with instructions. Wall panelling, polishes, etc. Call or write—New-Een (H), 101 King's Cross Road, London, W.C.1.

STAMP Albums, Outfits, accessories, etc. Lists, 3d.—R. Hawkins (Dept. L2), 267 Rotherhithe New Road, S.E.16.

UTSE spare time on profitable homework, making fancy goods. Write for free booklet.—(Area 544), 54 Southgate Street, Leicester.

HARDWOOD Ball Beads, ¾ in. diameter, suitable for children's counting frames, etc. 5/3 per hundred, plus 1/9 P.T.—Joyden Toy Co., 193 Chase Side, London, N.14.

HOME Watch and Clock Repair Outfit. Includes watchmaker's magnifying eyeglass, tweezers, screwdrivers, oilers, oil, brush, dusting powder, plus illustrated explanatory book. Watch and clock repairing simplified. In container, 12/9 inclusive.—D. Bolster (Dept. H), 5a Station Parade, Ashford, Middx.

HOMEWORKERS required, either sex, light Assembly. Part or full time. S.A.E.—Esprey, Box 18, 41 Wade Street, Lichfield.

LOVELY? Then write Secretary U.C.C., L5B.B. Hay St., Braughing, Herts. Genuine. Est. 1905.

LOOK! All at 3/-. Metal Die Cast Moulds for toy making. Soldiers, planes, sailors, ships and farm-yard stock, etc. All new lines. Pick where you like, 3/- each mould. New illustrated Catalogue, price 6d., post free.—Robin Hood Moulds (Dept. H), 140 Hollings Road, Bradford, Yorks.

IMADE big money, so can you. Enclose envelope.—H. Wamsteker, Box 34, Wynberg, Cape, Africa.

START earning money at home, whole or spare time, making up fancy leather and felt goods. Material provided. Write for rates of pay, etc.—Grange Co., 2 Curzon Street, Leicester.

STAMPS. 25—1d. 50—2d., etc. Approva Sbooks. Free gift.—Pavely, 12 Leeder Close, Coventry.

LEARN Perspex modelling the practical way, by making the toast rack, cigarette/trinket box, brooches and bracelets featured in our latest course. (Details, 6d.). Instructional course, 29/11.—Plastics Home Products, 18 St. Mary's Road, London, N.9.

BEAUTIFUL interior decorating for walls, ceilings, etc. in mottle roughcast, etc., can be obtained by using 20th Century Plastic. In all pastel shades, price 9/6 per 6lbs. (delivered). Sample, 1/6.—20th Century Products (1), 99 King's Cross Road, London, W.C.1.

NEW Zealand 6 free. 2½d. stamp for approvals.—D. Bailey, 72 Marshfield Road, Goole, Yorks.

NEW Zealand stamps free. 15 different. Send 3d. postage and request approvals.—Crutchfield, 11 West Court Street, Brompton, Chatham.

50 GOOD stamps free, mainly pictorial. Send for approvals, enclosing 2½d. Junior or medium.—Beeze, 116 Newton Rd., Mumbles, Swansea.

MAKE dioramas. Fascinating, profitable. Design and instructions, 3/6.—BCM/EASIPLAN, London, W.C.1.

MATCHBOX radio. With the aid of our instructions, you can build a complete radio set in a matchbox, using parts purchased from your radio dealer. The set incorporates medium wave inductor with station selector switch, long wave loading coil, and crystal-valve radar detector. Powered entirely by the incoming signal, no batteries are required. Full instructions, drawings, and theoretical circuit diagram. Price 3/-. post free.—Swift Radio (H), 137 Cotham Brow, Bristol 6. Mail order only.

FREE stamps value 1/-. Pick your own. Send 2½d. for approvals, stamps from 3d. each, large Pictorials, Diamonds, Triangulars, etc. Space fillers of 12s a penny. Liberal discounts.—Carless, 10 Henderson Road, Eastney, Portsmouth.

MAKE your own Jig-saw Puzzles. Fine Art Pictures, various reproductions and sizes. Also suitable for framing. Stamp for full list.—Joyden Toy Co., 193 Chase Side, London, N.14.

FOR sale—Hornby clockwork engine Royal Scot, length 16ins., four coaches, six wagons, thirty-six rails, points, turn-table. All good condition, scarcely used. Post paid, £5.—Mrs. Peacock, 30 High Street, Halstead, Essex.

HAVE you got your Junero Riveting Jig yet? From all hobby shops or post free from—Junero Ltd., Stirling Corner, Boreham Wood, Herts.

LUMINOUS Paint. 2/- per tin. Box No. 44, Hobbies Weekly, Dereham, Norfolk.

STAMPS free—Empire packet including Pictorials and Victorians free to approval applicants.—Robert J. Peck, 7A Kemp Road, Bourne-mouth, Hants.

MAKE magic X-ray mirrors. You see through, but they can't see you. This amazing device is an ordinary mirror one side, but you can see through the other side. Complete process and directions for making these novel X-ray mirrors, 10/-. Complete lead toy making course, 6/3. How to grow dwarf trees, full instructions, 2/6. Spare-time pounds, how to profit from your free hours, 2/9. Deal in stamps, explains the profitable stamp trade, 2/9. All American magazines available by subscription, single copy or library. Big list of books on approval, details from—Herga Limited, 394 Waverley House, Hastings.

STAMP collectors. Two giant Pictorials free to applicants for progressive discount approvals. Postal business only.—Willson Tillyer, 279 London Road, Rainham, Gillingham, Kent.

STAMPS FREE!! Twenty unused (2½d.).—S.G. H. Barnett, Limington, Somerset.

HUNDREDS of tested money makers. Complete book, 2/6, post paid. Business secrets, formulas, mail order, ideas, etc., no fees or catches. Money returned if dissatisfied.—H.W., 98 Mayplace Road East, Barnehurst, Kent.

NO catch, absolutely free. Large 2/6 South Africa stamp. Request approvals, enclose 3d. postage.—N. H. Dargue, 36a Gray Avenue, Murton, Co Durham.

TELEVISION Constructors Manual, 3/9. Build an inexpensive receiver with this practical handbook.—Blackshaw, BCM/HADOR, London, W.C.1.

BEGINNERS. New beautifully illustrated Balbum, 100 stamps and mounts, 3/-. 200—4/-, 500—6/-, 1,000—10/-. All different, World, Pictorials, Mint.—W. Hewison, 16 Westwood, Scarborough.

FREE. 8 scarce old Latvia stamps. Request approvals. Enclose 3d. postage.—N. H. Dargue, 36b Gray Avenue, Murton, Co Durham.

STAMP magnifier and 500 different World Stamps, 4/-.—H. Whitchy, Godshill, Fordling-bridge, Hants.

INTRODUCTIONS. Pen friends, companionship or marriage.—V.C.C., 34 Honeywell Road, London, S.W.11.

IF you have nothing to occupy your leisure, why not try something interesting and profitable? Experience is not required in leathercraft. Send S.A.E. for our brochure, free of obligation.—Leathaweave (Dist. 37), 2 Tudor Rd., Leicester.

FREE perforation gauge to all applicants for our approvals. Ideal for beginners and medium collectors. Send S.A.E. for trial selection.—Alan Archer, 14 Brookfield Avenue, Stenson Road, Derby.

BOHEMIA Red Cross stamp (cat. 9d.) and others free. Request approvals. Enclose 3d. postage.—N. H. Dargue, 36c Gray Avenue, Murton, Co Durham.

PERFORATION gauge free. Send 2/6 for either 100 different British Colonials or 100 large Pictorials.—Selby, 66 Donnington Road, London, N.W.10.

PERSONS are wanted for spare time work, making up fancy goods at home. Experience unnecessary. Write for details.—Dept. 918, Universal Products, 5 Cornhill, Lincoln.

WANTED Design No. 2039.—E. Lodge 9 Grove Road, Ash Vale, Aldershot, Hants.

SPACE fillers from 3 a 1d. upwards.—Jeffreys, S2-Bay View, Craigavon, Port Talbot.

YOU CAN BECOME A HANDICRAFTS INSTRUCTOR

EXPERIENCE NOT ESSENTIAL

Men who enjoy making things in wood or metal can turn their hobby into a permanent and interesting Career. Short hours, long holidays, and security in a job you would really enjoy, can be yours if you become a Handicrafts instructor. Let us send details of the easiest and quickest way to get the necessary qualification.

**We definitely guarantee
"NO PASS—NO FEE"**

If you would like to know about our unique method of preparing you for one of these appointments, write today, and we will send you our informative 176 page Handbook—free and without obligation. Mark your letters "Handicrafts Instructor".

**BRITISH INSTITUTE OF
ENGINEERING TECHNOLOGY**

BIET

595 Shakespeare House
Stratford Place, London, W.1



BRITFIX BALSA CEMENT

★ The ideal transparent cement for Balsa Ply Wood, Hard Woods, and Plastics, combining rapid drying with utmost tenacity.

Remember
**STICK BY
BRITFIX**

8oz. Tube 6d.
1oz. Tube 9d.
2½oz. Tube 1/3

THE HUMBER OIL CO. LTD., HULL

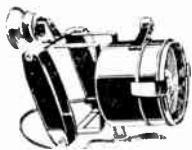

R.A.F. SIGNALLING LAMPS

For day or night use. New Ex-W.D. 12v. 4½in. lamp, adaptable to voltage. Morse trigger, view finder, polished mirror reflector, 6½ft. rubber flex and plug. In strong wooden box 10½ x 8 x 7½ins. leather carrying handle. Adaptable as car, motorcycle, spot lamp, stage or studio spot light.

Post 1/6 **14/9**

Complete Two-Way TELEPHONE SETS

No Battery Required—Sound Powered, New Ex-W.D. in original cartons. Microphone can be used as earphone, and earphone as microphone. Ideal as extension speaker or earphone for radio, intercom. for offices, kitchen, restaurant.

Post 1/6 **15/6** each

Illustrated catalogue free



PRIDE & CLARKE LTD.,

(P.W.) STOCKWELL ROAD, LONDON, S.W.9. BRI 6251

**EVERY CAR THAT PASSES
YOU WILL FIND THE INDEX MARK
ALPHABETICALLY ARRANGED IN
WHERE'S THAT CAR FROM ?**

Price 6d.

from all Booksellers or from the Publishers (1d. postage)

RALEIGH PRESS, EXMOUTH

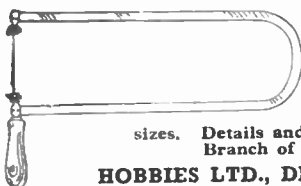

FRETWORK HANDFRAMES

—for the fretworker, model maker and handyman. Made by Hobbies. In various sizes. Details and prices on application at any Branch of Hobbies Ltd. or

HOBBIES LTD., DEREHAM, NORFOLK

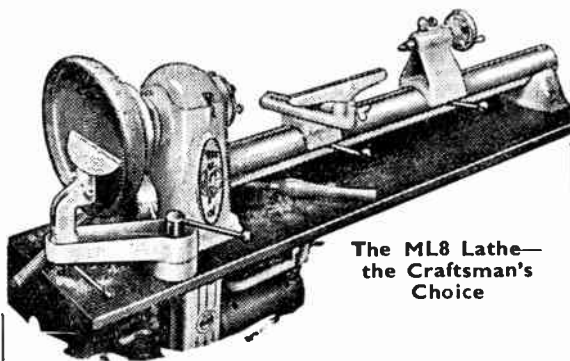

The ML8 Lathe—the Craftsman's Choice

MYFORD

For both the home craftsman and the professional expert, the ML8 Woodworking Lathe (8" swing x 30") incorporates the most modern, up-to-date features.

Extra attachments enable sawing, grooving, planing, rebating, sanding, grinding, polishing, metal and plastic turning. The illustration shows a mahogany bowl being turned on the Rear Turning Attachment.

The ML8 Lathe (also available on steel cabinet stand) is sold through all leading Tool Merchants.

Myford Engineering Co., Ltd.
Beston - Nottingham

STOP SMOKING

You can overcome the smoking habit in 3 days or money back. Safe, pleasant, permanent. The only scientific way. No Will Power necessary. "Conquered the habit in 2½ days. Am delighted".—F.C. "Within 2 days I was free from the tobacco habit".—W.G. "Was a smoker for 2 years and broke the habit in 2 days".—F.N. "I haven't smoked a cigarette for 5 weeks".—J.E. "I used to smoke 20 a day... now I have no desire to smoke".—J.M. Recommended by "Health and Efficiency Magazine". Complete course 6/6. Details 1d. stamp. Sent under plain cover.—**STEBBINGS, 28 (H/99), Dean Road, London, N.W.2. Established 1928.**

MONEY-MAKING BOOKS

114 WAYS TO BE YOUR OWN BOSS—114 Tested ways of earning a second income at home with little or no capital 5/6
MONEY FROM MAIL ORDER—How to start and run a Mail Order business at home and earn pounds weekly 5/6
HOW I WRITE AND SELL THRILLERS—By the author of 73 successful thrillers 4/6
Catalogue of Money Making Books free.
STEBBING PUBLICATIONS LTD., 28 (H/99) Dean Road, London, N.W.2. Established 1928.

SHIPS
GALLEONS
LOCOS
HISTORIC &
ARCHITECTURAL
SUBJECTS
ENGINEERING
MOVING
TOYS
ETC.

Micromodels

TRADE MARK

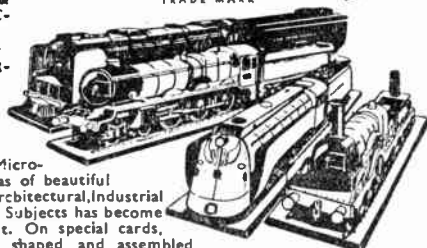

Assembling Micro-model replicas of beautiful Mechanical, Architectural, Industrial and Maritime Subjects has become a serious cult. On special cards, units readily shaped and assembled models authentic in every detail. Cost a few pence, often sell for guineas. Send 1d. stamp for Illustrated Descriptive Catalogue.
MICROMODELS LTD., 6 (H) Racquet Court, London, E.C.4

SMALL BLOCK TOY PATTERNS

See Front Page

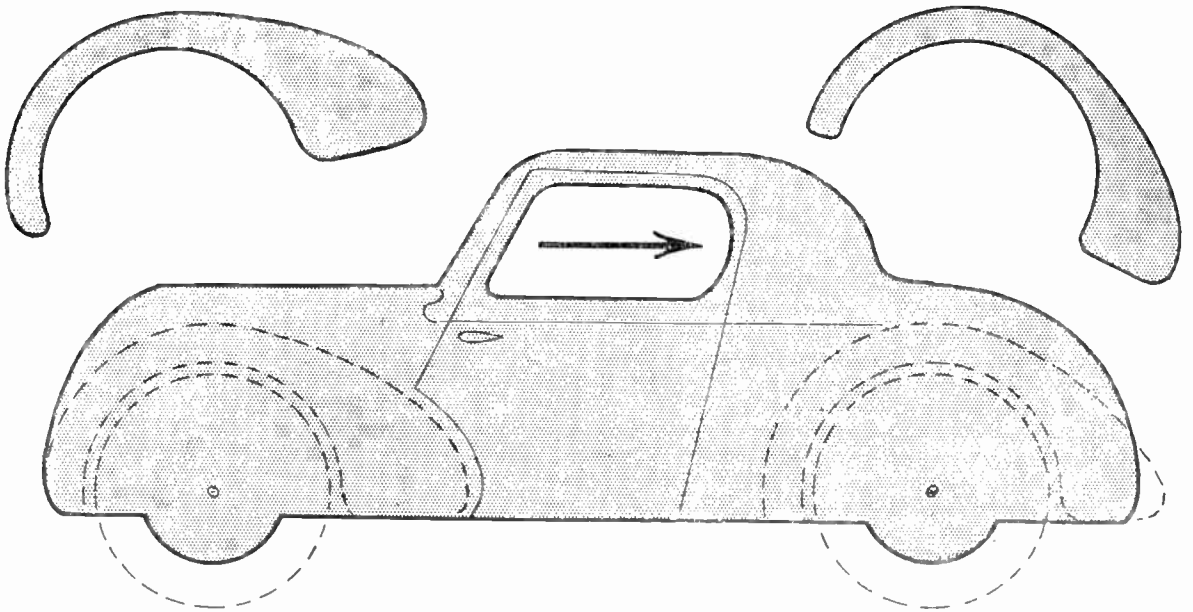
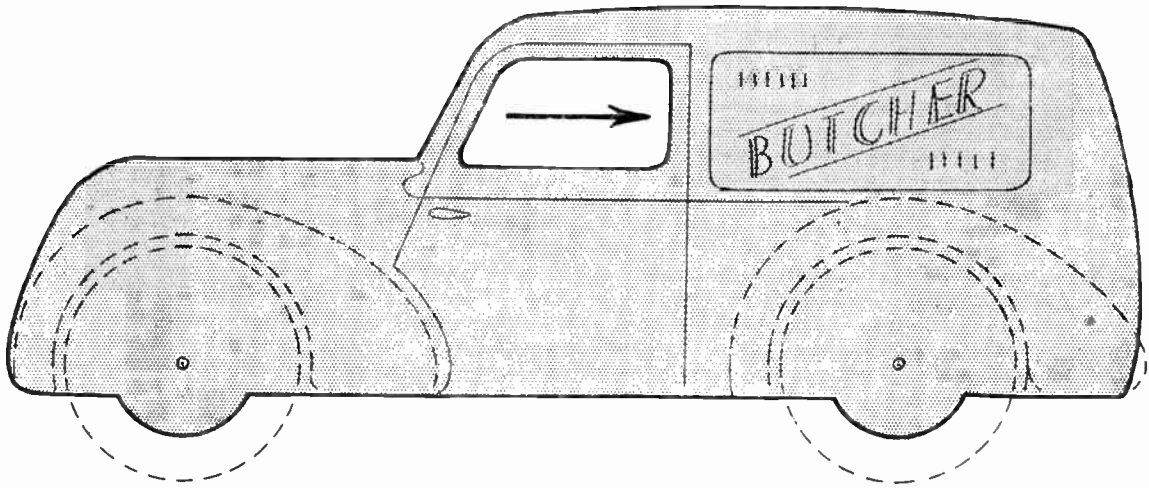
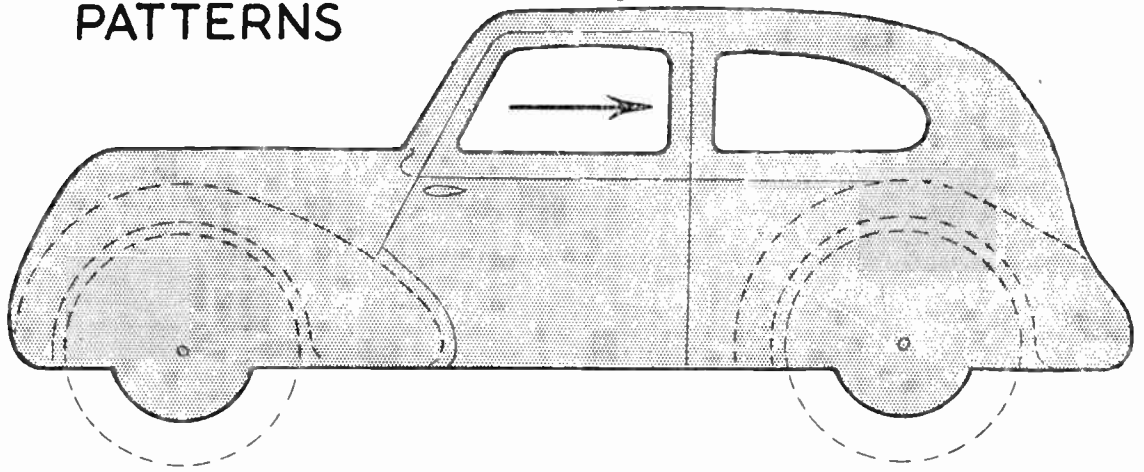

STUDY
AT
HOME

IN YOUR
SPARE
TIME

THE BENNETT COLLEGE

*will set you on the right
course for success*

You make sure of planned progress in the career of your choice when you let the most progressive, most successful Correspondence College in the world coach you through the post. By friendly, individual training we equip you with the specialized knowledge you must have for a well-paid key position.
Make the first move TODAY—post the coupon below!

ALL TEXT BOOKS ARE FREE! We send as many volumes as subject chosen demands, they become your property.



IS YOUR CAREER HERE? IF NOT, WRITE FOR FREE ADVICE

Accountancy Exams.
Agriculture
Applied Mechanics
Auctioneers and Estate Agents
Aviation (Engineering and Wireless)
Blue Prints
Boilers
Book-keeping, Accountancy, and Modern Business Methods
Builders' Quantities
Building, Architecture, and Clerk of Works (A.R.I.B.A. Exams.)
Carpentry and Joinery
Chemistry
Civil Engineering
Civil Service
All Commercial Subjects
Commercial Art
Common Prelim. E.J.E.B.
Concrete and Structural Engineering
Diesel Engines
Draughtsmanship. Electrical or Mechanical

Engineering. All branches. Subjects and Exams.
General Certificate of Education Examinations
General Education G.P.O. Eng. Dept.
Heating and Ventilating
Institute of Municipal Engineers
Journalism
Languages
Mathematics
Metallurgy
Mining. All Subjects
Mining. Electrical Engineering
Motor Engineering
Naval Architecture
Plastics
Play Writing
Plumbing
Police, Special Course
Preceptors, College of
Press Tool Work
Pumps and Pumping Machinery
Quantity Surveying—Inst. of Quantity Surveyors Exams.

Radio Service Engineering
Radio (Short Wave)
Road Making and Maintenance
Salesmanship
Sanitation
School Attendance Officer
Secretarial Exams.
Sheet Metal Work
Shipbuilding
Shorthand (Pitman's)
Short Story Writing
Speaking in Public
Structural Engineering
Surveying (R.I.C.S. Exams.)
Teachers of Handicrafts
Telecommunications (City and Guilds)
Television
Transport Inst. Examinations
Viewers, Gaugers
Inspectors
Weights and Measures Inspectors
Wireless Telegraphy and Telephony
Works Managers

COUPON. CUT THIS OUT

IF YOU ATTEND TO THIS NOW
IT MAY MAKE A WONDERFUL
DIFFERENCE TO YOUR FUTURE.

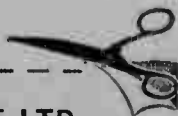

To DEPT. 62
THE BENNETT COLLEGE LTD.
SHEFFIELD

Please send me (free of charge)

Particulars of.....
Your private advice
about.....
(Cross out line which does not apply.)

PLEASE WRITE IN BLOCK LETTERS

Name.....

Address.....

CASCO

COLD water GLUES



supersede this

CASCO Glues are easily and quickly prepared for use, no heat being required. CASCO Glues comply with MODERN BRITISH STANDARDS SPECIFICATION requirements, ensuring outstanding strength and durability.
CASCO Glue, Grade "A" is the world-famous Cascin Cold Water Glue manufactured in Great Britain, Australia, U.S.A., Argentina and Scandinavian countries.
Conforms to British Standards Specification 1444 Type A.

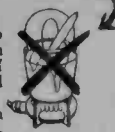

Stocked by Ironmongers, Builders' Merchants, Hardware Stores, etc.

DISTRIBUTORS:

Gt. Britain: Charles Cleeve & Co. Ltd.
45 Gt. Peter St., London, S.W.1.
Ire: Waller & Willis Ltd.
60 Middle Abbey St., Dublin
M. J. Galligan, 16 Oliver Plunkett St., Cork



FREE! Send for literature and Free Sample to the manufacturers
LEICESTER, LOVELL & CO. LTD.
(Dept. HW) NORTH BADDESLEY, SOUTHAMPTON



BROOK
Cub
FRACTIONAL H.P.
MOTOR

THE ECONOMICAL
FRACTIONAL

Standard Motor without feet

For every purpose in the
small home workshop
use a BROOK "CUB" 1/4 h.p.
motor. Single or split phase.
Electric motors from 0.25
to 200 H.P.



IMPRESS WORKS Huddersfield

I.H.M.150