

THE ARROWS INDICATE DIRECTION OF GRAIN OF WOOD.

SUPPLEMENT TO HOBBIES No. 2862.

DOLL'S ROCKING CRADLE

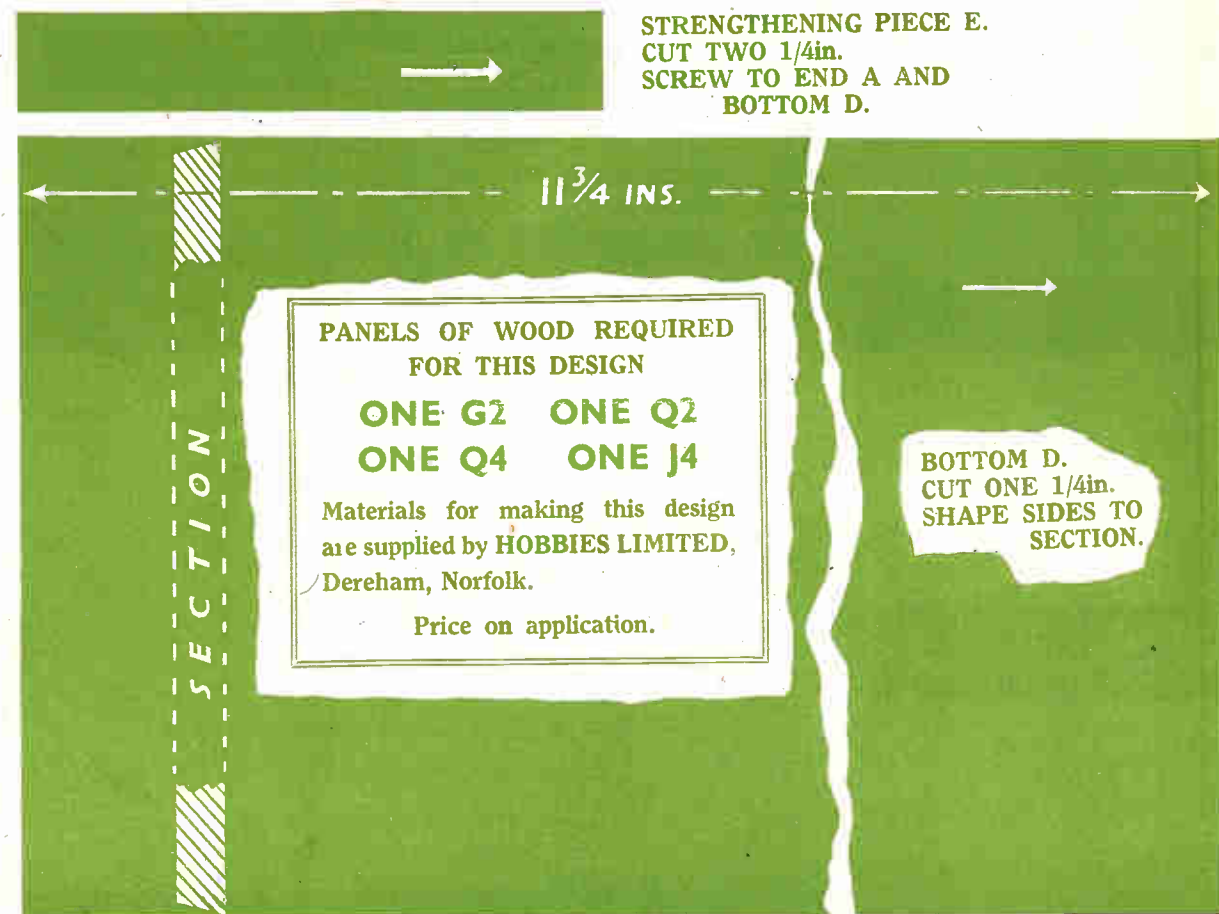
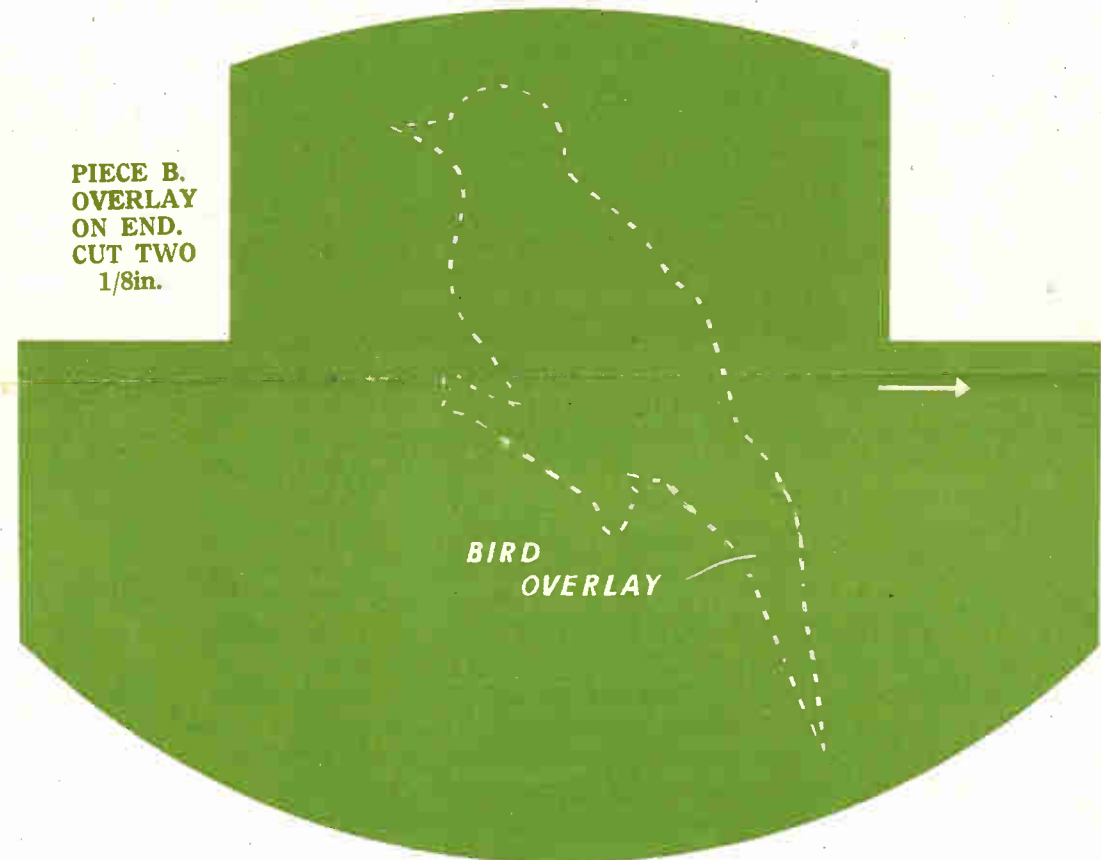
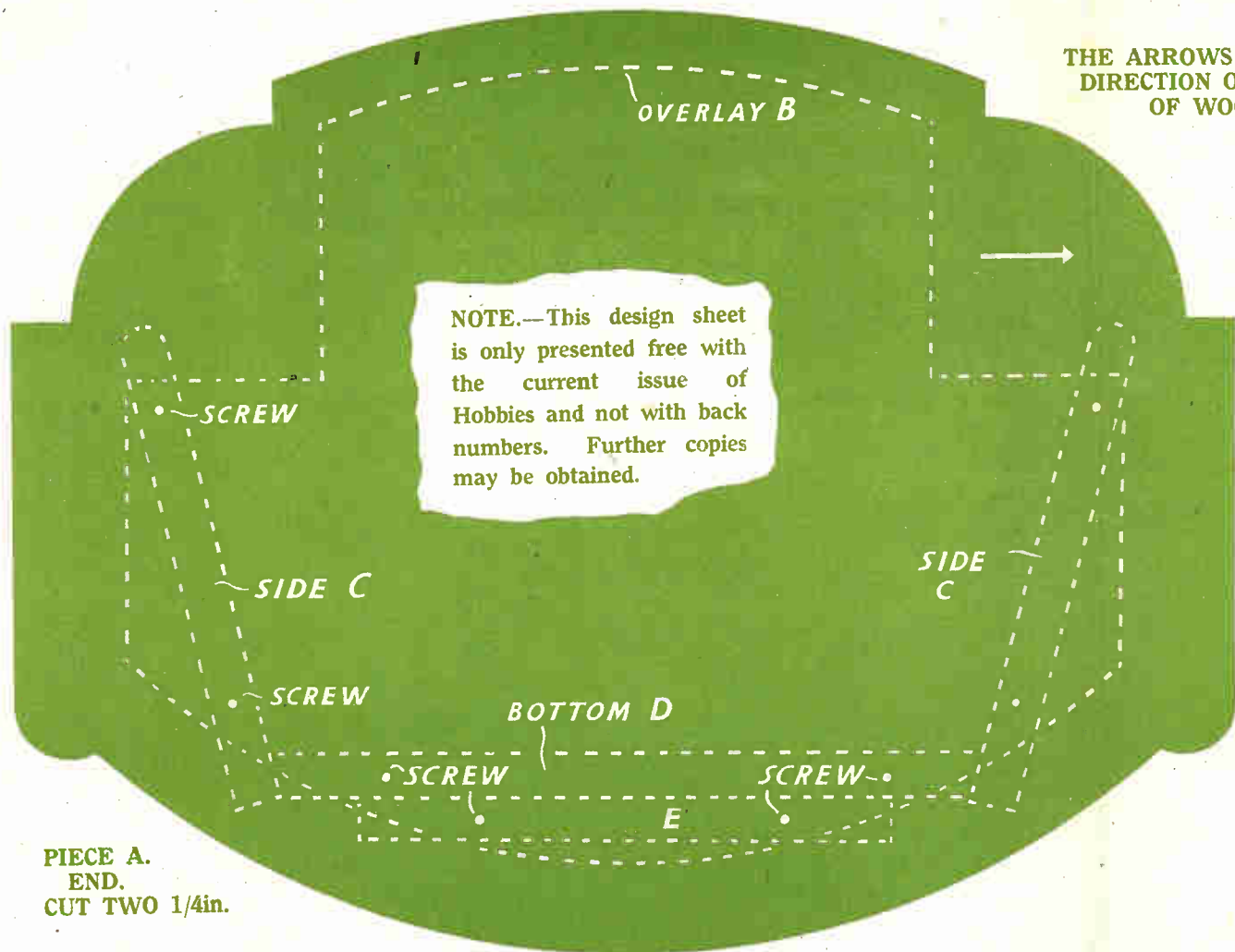
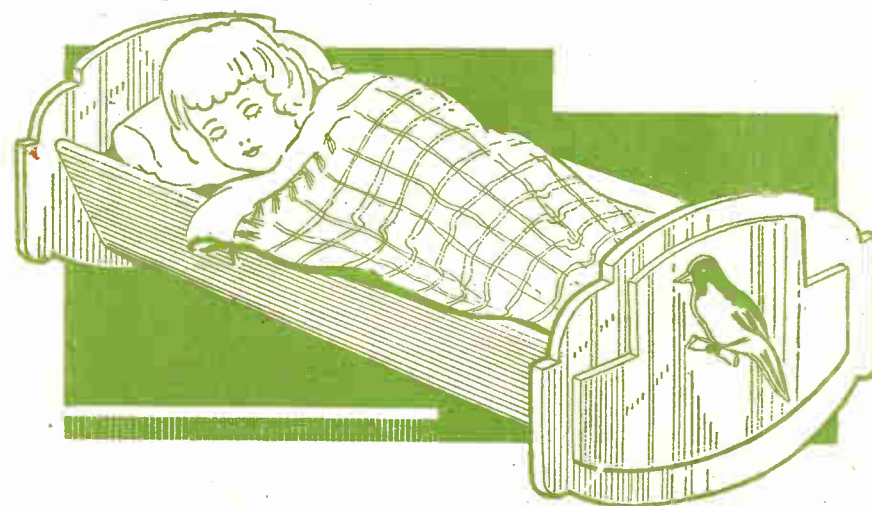

THIS novelty is just the type of article to appeal to any little lady with a doll. The cradle is easily completed in thin wood 1/8in. and 1/4in. thick, and the inside measurement is 11 3/4ins. which is quite large enough to take a reasonable size doll.

The construction is straightforward, can be carried out with a fretsaw and the usual few tools and the whole thing can, of course, be left in its natural state or painted one of the colours usually found in a nursery. There is no need to paste the patterns to the wood, for they can be easily copied off through carbon paper or traced off in the usual way.

Two ends are required 1/4in. thick and between them the floor is added. This is a plain 1/8in. piece 11 3/4ins. long and 4ins. wide with the long edges slightly chamfered to allow the sides to slope. The exact position of the floor and the sides is indicated by the dotted lines on the pattern at the ends. This position can be indicated by drilling small holes through the ends to give the screw holes where shown on the pattern.

It is imperative, of course, that the two sides and the floor be exactly the same length and this should be tested before final fitting.

The sides and floor make a trough and all are glued between the ends and afterwards screwed in from the outside. Actual positions should be marked in pencil before fixing this undertaking. The screws should be thin shank and countersunk, so they do not project above the surface of the end.

The floor is stiffened by little fillet pieces (E), again shown by the dotted lines on the pattern at the end. These fillets are glued and screwed first to the end itself and then upwards into the floor.

All the screw heads are covered by the overlay on the end cut from 1/8in. wood. This is a simple outline and when cleaned is glued in place 3/8in. down from the top edge and central between the sides.

On the face of this main overlay there is the bird overlay also cut from 1/8in. wood. Cut one for each end but do not glue in position until the rest of the article has been painted. Clean everything with glasspaper and stain or paint according to taste. The inside can well be a light blue with a darker shade of blue for all outside surfaces.

A suggested colour for the bird is shown with the pattern and can be carried out in either flat or enamel surfaces. The edges of the wood are of course, treated the same colour as the face. Let the bird overlay dry thoroughly before gluing on and remember to scrape the paint on the end part to make the glue hold.

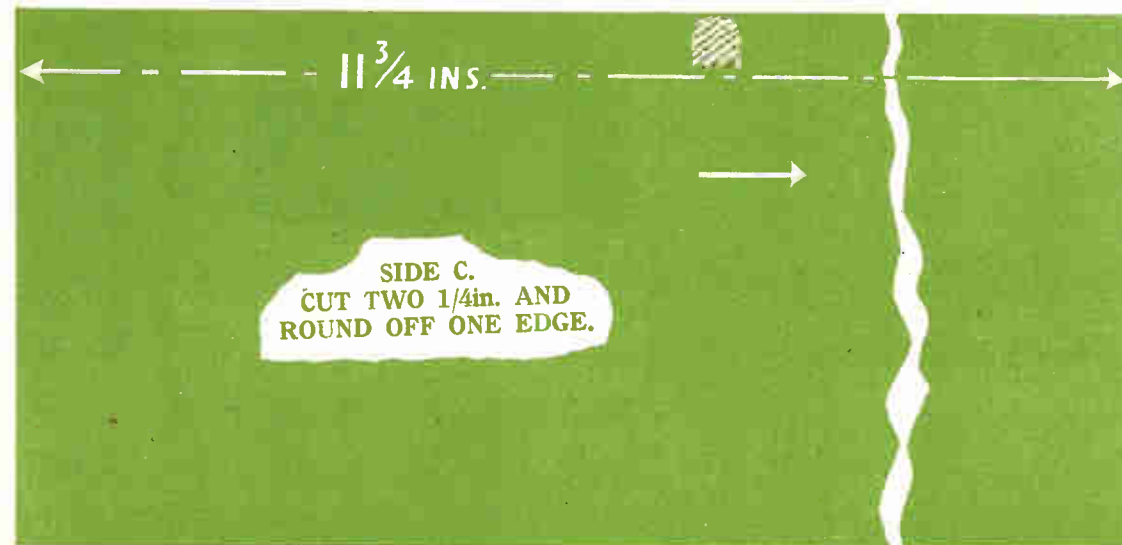

DISCS GLUED TO FEET OF HORSES. CUT EIGHT 1/4in.

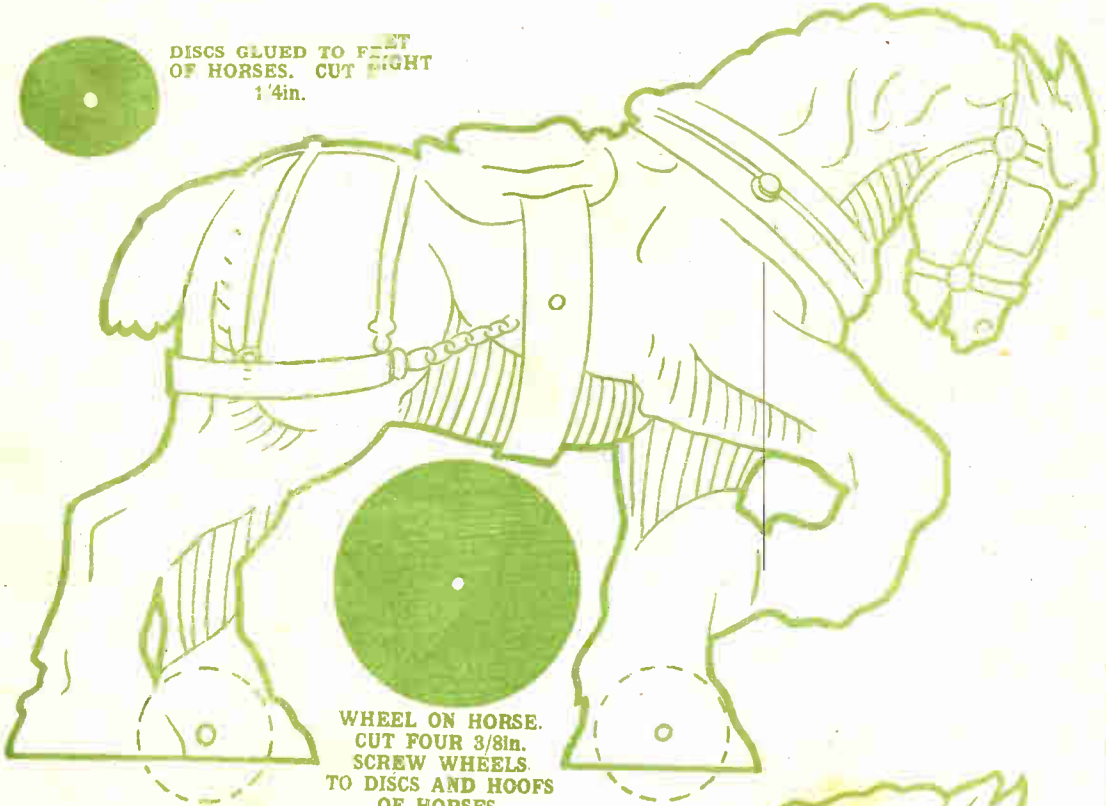

WHEEL ON HORSE. CUT FOUR 3/8in. SCREW WHEELS TO DISCS AND HOOFES OF HORSES.

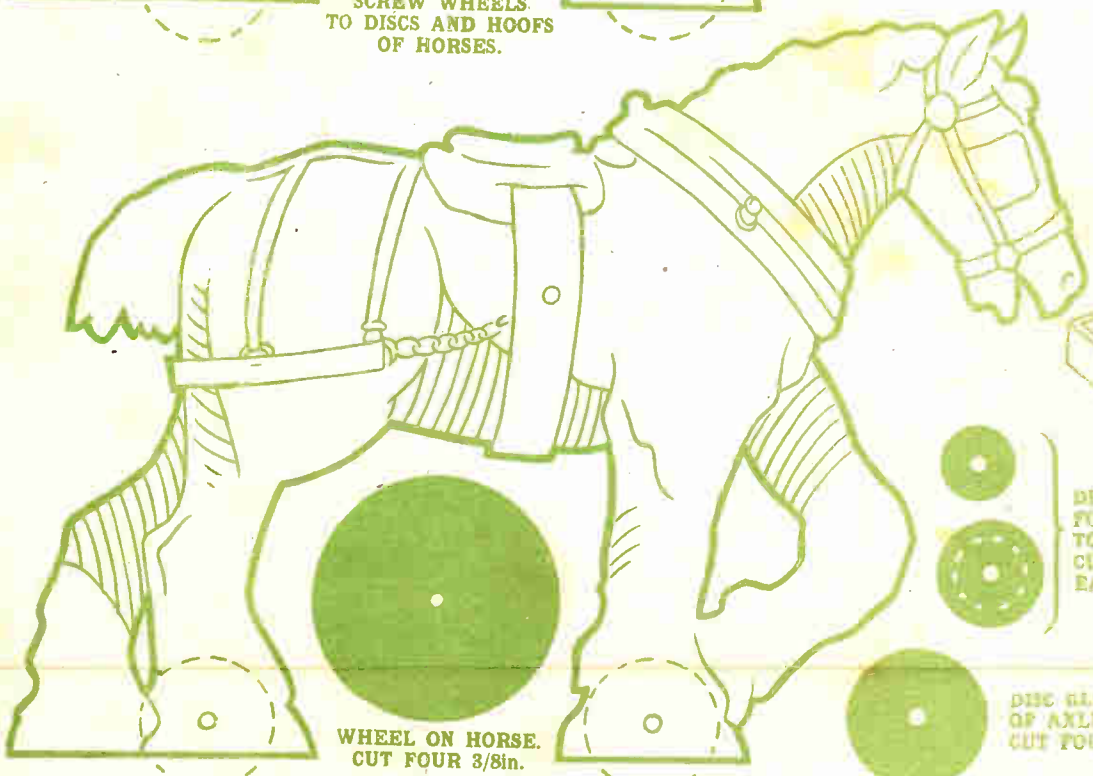

WHEEL ON HORSE. CUT FOUR 3/8in.

THE ARROWS INDICATE THE DIRECTION OF GRAIN OF WOOD.

SUPPLEMENT TO HOBBIES No. 2854.

TOY TIMBER WAGON DRAWN BY TWO HORSES

LENGTH ABOUT 24ins.



NOTE:--This design sheet is only presented free with the current issue of Hobbies and not with back numbers. Further copies may be obtained.

PANELS OF WOOD REQUIRED FOR THIS DESIGN.

THREE GD6
ONE LD6
ONE G4 ONE G2

Materials for making this design are supplied by HOBBIES LIMITED, Dereham, Norfolk. Price on application.

DROP PIN. MAKE FOUR FROM STOUT WIRE.

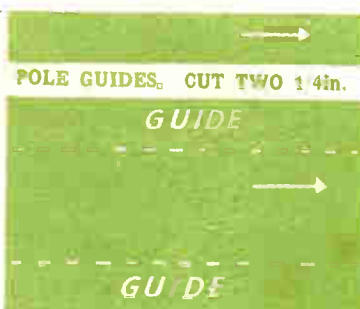

POLE GUIDES. CUT TWO 1/4in.



AXLE BAR CUT TWO 3/8in.

SHOWING HOW STRAPS ARE ANGLED UP.



REAR POLE BEARER. CUT ONE 1/8in.

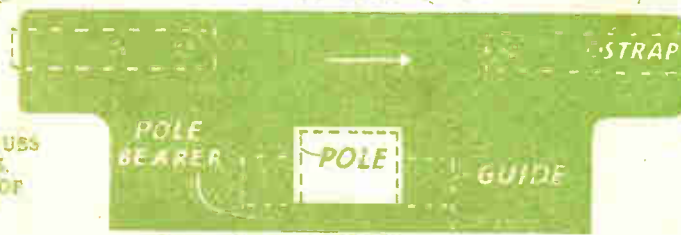

REAR TIMBER BEARER. CUT ONE 3/8in.

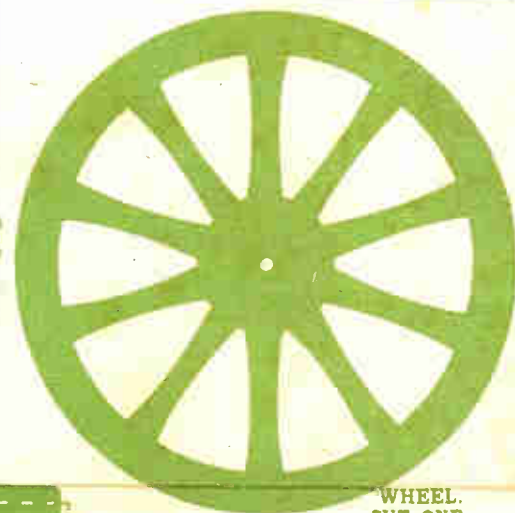

WHEEL. CUT ONE 3/8in.

DISCS FORMING HUBS TO WHEELS. CUT FOUR OF EACH 1/8in.

DISC GLUED TO END OF AXLE BAR. CUT FOUR 1/4in.



FRONT TIMBER BEARER. CUT ONE 2/8in.



WHEEL. CUT ONE 3/8in.



WHEEL. CUT ONE 3/8in.



WHEEL. CUT ONE 3/8in.

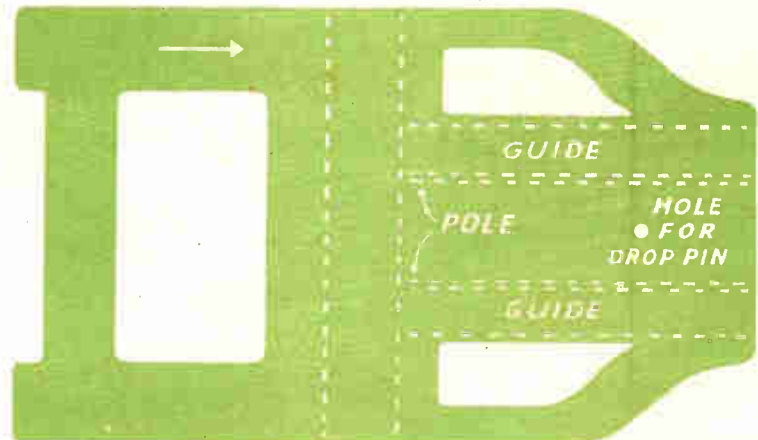

REAR UNDERCARRIAGE. CUT ONE 3/8in.

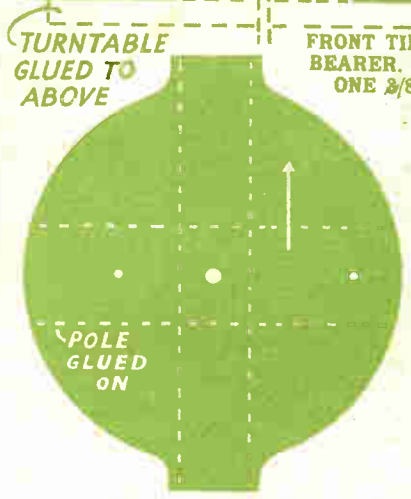

TURNTABLE. CUT ONE 1/8in.



FRONT UNDERCARRIAGE. CUT ONE 3/8in.

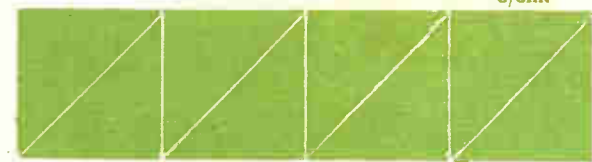

GLUED STIFFENING BLOCKS BETWEEN UNDERCARRIAGES AND AXLES. CUT THE EIGHT BLOCKS FROM THE ONE PIECE AS SHOWN 3/8in THICK.

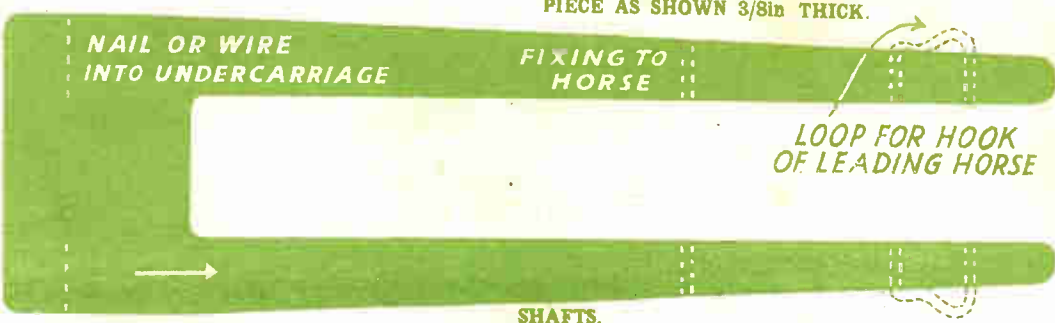

SHAFTS. CUT ONE 3/8in.



POLE CONNECTING FRONT AND REAR WHEEL CARRIAGES. CUT ONE 3/8in.

A novelty pull-along painted model TOY TIMBER WAGON

THIS novelty toy can be cut from wood $\frac{1}{8}$ in., $\frac{1}{4}$ in., and $\frac{3}{8}$ in. thick. The main part of the toy is in the thickest stuff, $\frac{3}{8}$ in., thus making a solid and usable piece of work for any youngster. There is very little cutting in it, and when completed, the whole thing should be painted in bright colours to attract the owner. Patterns are shown full size and can be marked direct to the wood by means of carbon paper or taking a tracing.

It is not advisable to paste the paper down as you then have the design sheet to which to refer. Each pattern shows by dotted lines where adjoining pieces are to be fixed, and the construction is quite straightforward. Cut all parts with the fretsaw, clean up with glass-paper, and then fit together.

Two Wheel Units

The two sets of wheels are made as complete units, and held by the long pole bar coming between. This is pivoted on a pin at the front end, allowing for turning. The detail of the front under-

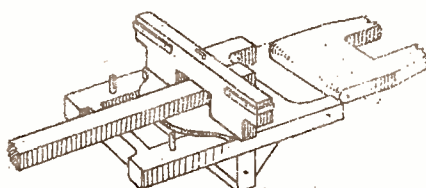

Fig. 1—Detail of undercarriage

carriage portion at Fig. 1 clearly shows its construction. On the top of the chassis portion itself is the circular turntable left loose. On this turntable a timber bearer is glued across in line with the projecting pieces on the table itself. This part, of course, is glued on edge with the aperture on the underside to allow the pole bar to come in.

This pole bar can be glued to the turntable later, and the whole thing is held on a pivot made by a piece of stiff wire run through the centre holes previously drilled. The wire can be flattened out or turned over at each end. Note the two screws which are left projecting about $\frac{1}{2}$ in. on the top of the undercarriage. This is to prevent the pole turning too far and so binding on to the wheels. On the underside of the carriage, the axle bar is glued on edge. In the right-angle formed each

side of it, the triangular blocks for stiffening are also glued as can clearly be seen in Fig. 1.

Undercarriage

The rear undercarriage unit is shown at Fig. 2. It is built very much the same as the other, except that there is no turntable, and all parts are glued firm. The rear timber bearer has an aperture cut to take the pole, and is glued across at right angles to the undercarriage itself. To provide a channel for the pole, the bearer piece is glued in place, and then on the top of it two guide strips are glued at the edges.

The under work of the wheels is the same as in the front, with the stiffening blocks added in the corners as before. Note the detail showing the metal strips. These can be of tin or Juneero strip bent to form a stirrup, and fixed with short nails on to the projecting ends of the timber bearers themselves.

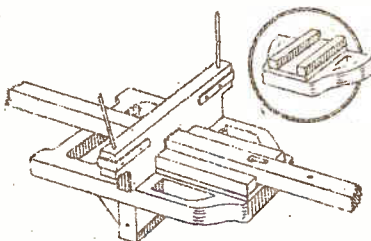

Fig. 2—Rear undercarriage unit

They are in reality put there to bind the wood and prevent breakage. A fairly thick headless nail is driven into these bearer pieces to act as stops when the tree trunks are actually in place. You can see them in position in the finished drawing.

The long bar is fitted with three holes, the front one forms the pivot on the front carriage, the other two are for alternative positions for the rear pin. This pin can be a nail dropped through the pole, the guide, and the undercarriage.

Wheels

The four wheels are cut to the pattern shown, and on the outside of each, two discs are fixed forming the hubs. A circular disc $\frac{3}{8}$ in. in diameter is also cut, and then glued to the end of the axle bar. The wheels are finally screwed on

with round-head screws.

The horses are simple in outline and are purposely made with thickened legs to provide strength. Cut the wood to the outline shown, and then fix to the wheels, a detail of which is shown at Fig. 3. Here again, a small disc $\frac{3}{8}$ in. in diameter is glued each side of the 'hoof' to provide a thickness on to which the actual wheels can revolve. The round-head screws holding the wheels in place should not be longer than $\frac{3}{8}$ in., or they will be liable to meet and bind together.

Painting

The horses, of course, should be painted before the wheels are fitted, and the lines shown on the patterns indicate what should be carried out in paint. Give the whole wood a coat of flat grey first, and allow it to harden in before adding whatever colour you are making the animals. They can be brown with the leatherwork traces, etc., a darker brown, or lined out with black. If you wish, the wood itself can be carved and shaped to give an even more realistic

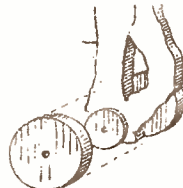

Fig. 3—Horse wheels

effect to the animals.

The shafts holding the rear horse in place are plain pieces held in position by a nail or wire run into the undercarriage at the point indicated by the dotted line. At the front end of the shaft, a little wire staple is added to make a loop for the reins to the leading horse. The rear horse is fixed between the shafts by another nail or screw driven through into the 'body' to form a pivot. This nail is put in $1\frac{1}{2}$ ins. back from the front end of the shaft, through the edge of the wood. Bore a hole carefully so the material does not split.

The front wheels can be painted a bright red or black, and you can complete the toy by adding two or three fairly substantial 'twigs' of timber in imitation of the actual trees. They should be held down by small chain or thick string, in imitation of rope.

LETTER RACK

PANELS OF WOOD REQUIRED FOR THIS DESIGN

TWO H3

Materials for making this design are supplied by
HOBBIES LIMITED, Dereham, Norfolk.

Price on application.

INSTRUCTIONS.

CUT ONE OF EACH PART 3/16in. THICK:

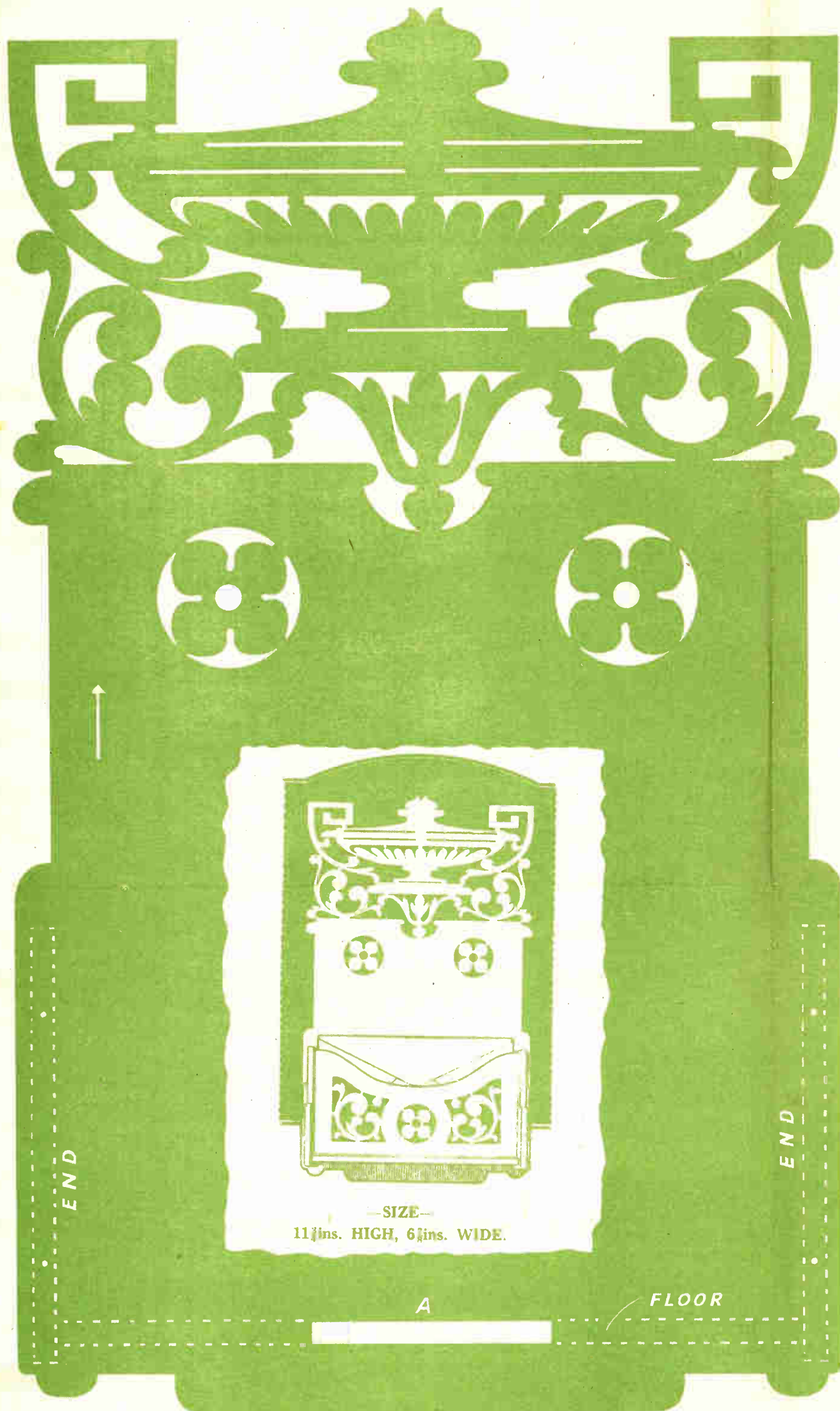

NOTE.—This design sheet is only presented free with the current issue of Hobbies and not with back numbers. Further copies may be obtained.

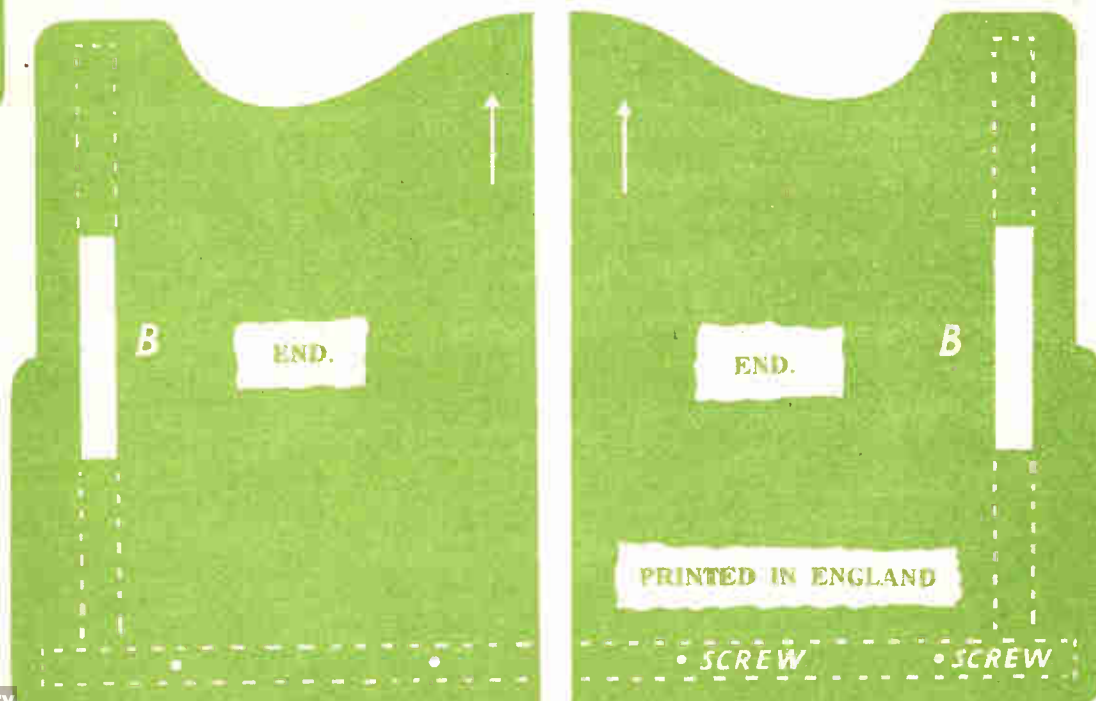

A Wall Letter Rack

THIS is quite a straightforward piece of work, the design incorporated being of the Grecian Urn characteristics. It should appeal to the beginner because there is not a great deal of work involved, although at the same time it must be carefully undertaken to preserve the balance and the gracefulness of the curves. There are only five parts to cut, the letter pocket comprising four of them, and all being fixed to the main back.

Paste Patterns to Wood

The patterns containing the fretted work should be pasted to the wood. All the parts being in $\frac{3}{8}$ in. material, cut them out as usual with the fretsaw and clean up with glasspaper, being careful in cutting the mortise and tenon joints at (A) and (B) to get a good fit.

Keep the fretsaw slightly on the inside of the slot and slightly on the outside of the projecting tenon piece. These mortise and tenons should fit together with hand pressure only, and if the parts have to be cleaned with glasspaper, be careful not to taper off the pieces either to make the wood thinner or to shorten the actual length. The making of a good tenon joint is one of the points that judges watch in competitions, and whilst it is not the easiest thing to do, it is perfectly straightforward with a little care and attention.

Having cut the three parts of the pocket, cleaned them up and temporarily fitted the ends, the whole part can be put together. The two ends are fitted on to the front at the joint (B), with a small portion of tenon projecting beyond. The floor comes between the two ends but projects slightly beyond the front which stands on it. The dotted lines on the various patterns clearly indicate where the adjoining pieces are to come.

If you are proposing to back up the fretted front of this, now is the time to do it, before fitting the pockets in place. A piece of fancy paper will make a suitable background, or, of course, you can obtain the special linen cloth or linen-faced paper which will add to the appearance. Cut it the shape of the inside of the front, and glue it securely and flat close to the fretted work.

Fixing the Pocket

The whole pocket is fixed to the back through the tenon (A), and fine fretnails or screws can be driven in from behind to stiffen the whole thing if necessary. Glue, of course, is added to the edges, in any case.

In order to hang the letter pocket, two little brass wall brackets must be added at right angles to the sides, near the top, or you can make a small hole in the main back between the two circular rosettes, to take a nail on which the whole thing will fit.

MODEL DIESEL TRACTOR
 — AS MADE BY —
 INTERNATIONAL HARVESTER COMPANY

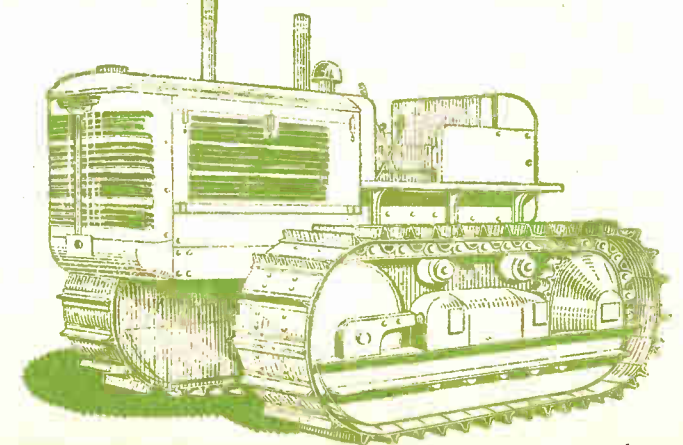

THE ARROWS INDICATE DIRECTION OF GRAIN OF WOOD.
 TRACK LINK. MAKE 52 FROM CARD AND GLUE THEM TO PIECE BB. FOUR LINKS WILL HAVE TO BE TRIMMED OFF INTO ANGLES AT *

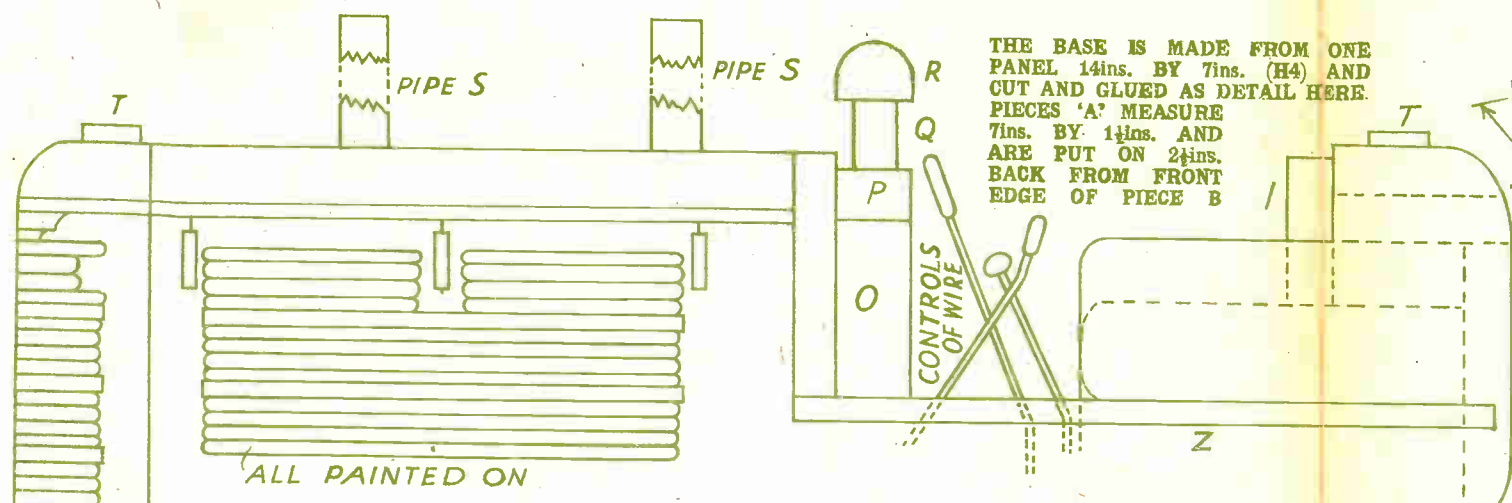

THE BASE IS MADE FROM ONE PANEL 14INS. BY 7INS. (H4) AND CUT AND GLUED AS DETAIL HERE. PIECES 'A' MEASURE 7INS. BY 1 1/4INS. AND ARE PUT ON 2 1/4INS. BACK FROM FRONT EDGE OF PIECE B

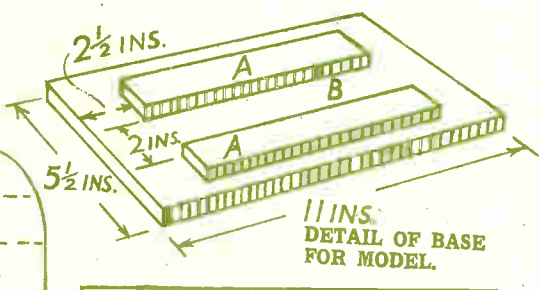

PANELS OF WOOD REQUIRED FOR THIS DESIGN.
THREE #4, ONE #4, TWO #2 ONE PPM
 Materials for making this design are supplied by HOBBIES LIMITED, Dereham, Norfolk. Price on application.

CARD IS NOT SUPPLIED WITH WOOD.

NOTE.—This design sheet is only presented free with the current issue of Hobbies and not with back numbers. Further copies may be obtained.

FULL SIZE SIDE VIEW OF TRACTOR.

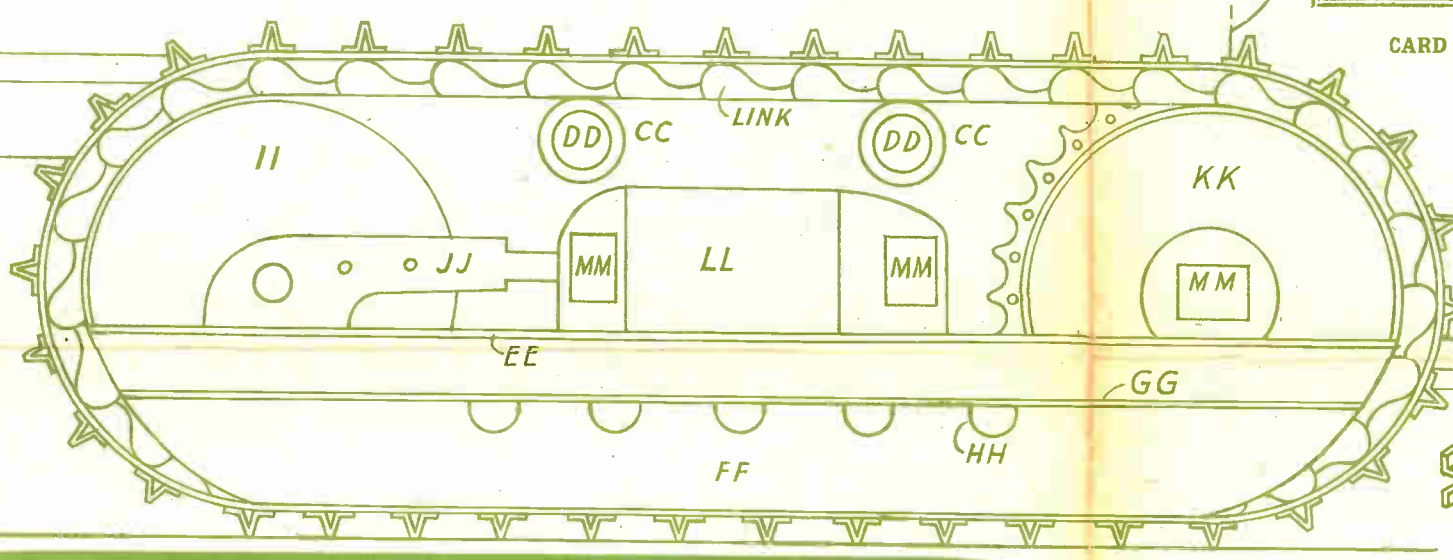

SHOWING HOW CARD IS ANGLED UP TO FORM THE SHOES.



OVERLAY ON JJ. CUT TWO THIN WOOD

PIECE JJ. CUT TWO 1/8in.

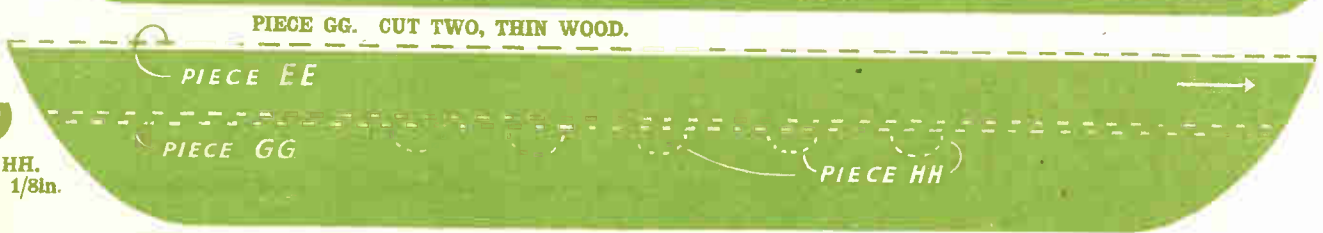
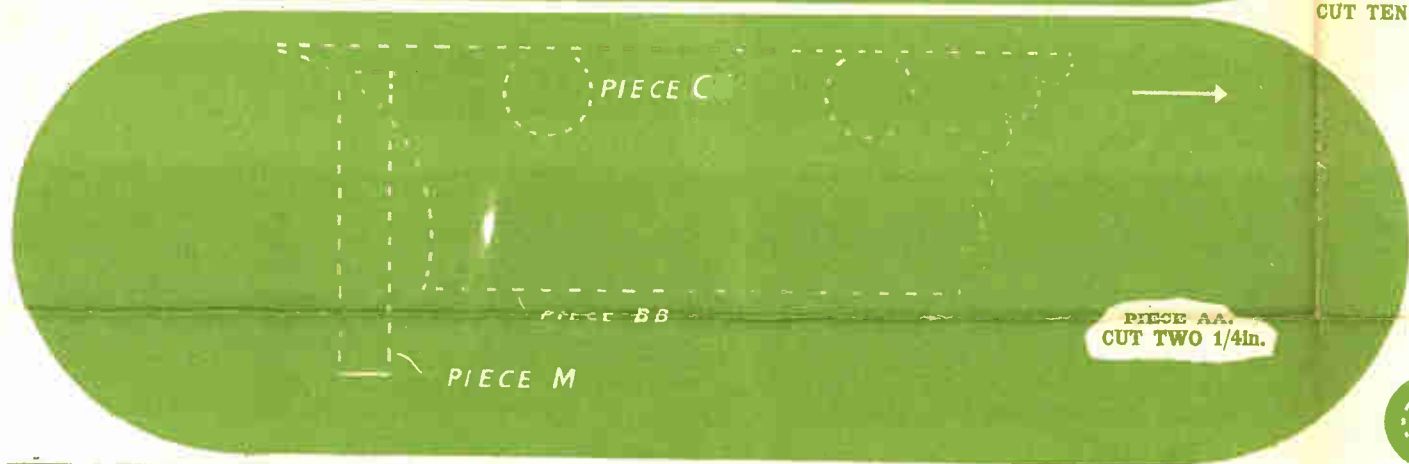
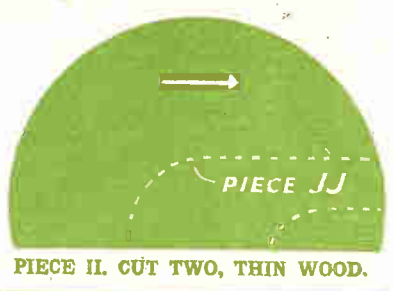
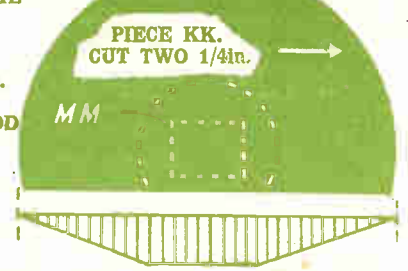

PIECE FF. CUT TWO THIN WOOD.

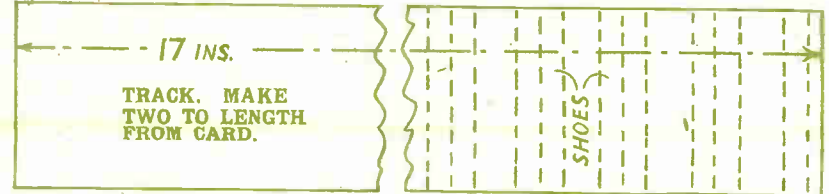

THERE ARE 76 TRACK SHOES MADE FROM STOUT CARD. THESE ARE BENT UP AND GLUED TO THE TRACK AS SHOWN BY THE DOTTED LINES.

PIECE DD. CUT FOUR THIN WOOD.

PIECE CC. CUT FOUR 1/4in.

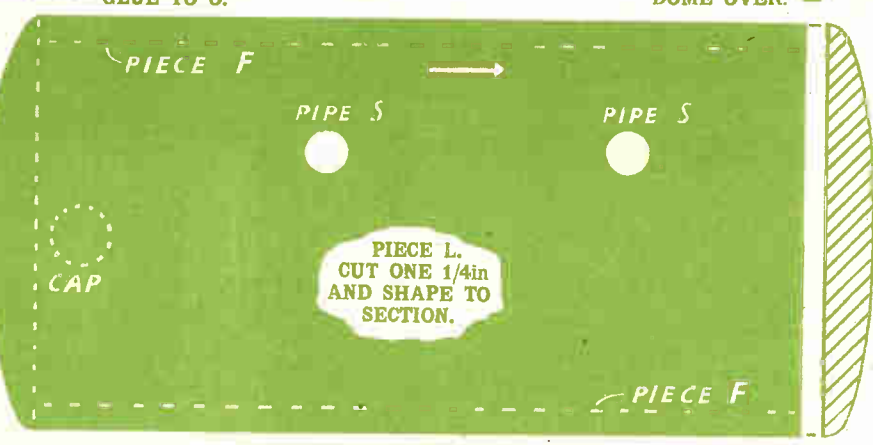
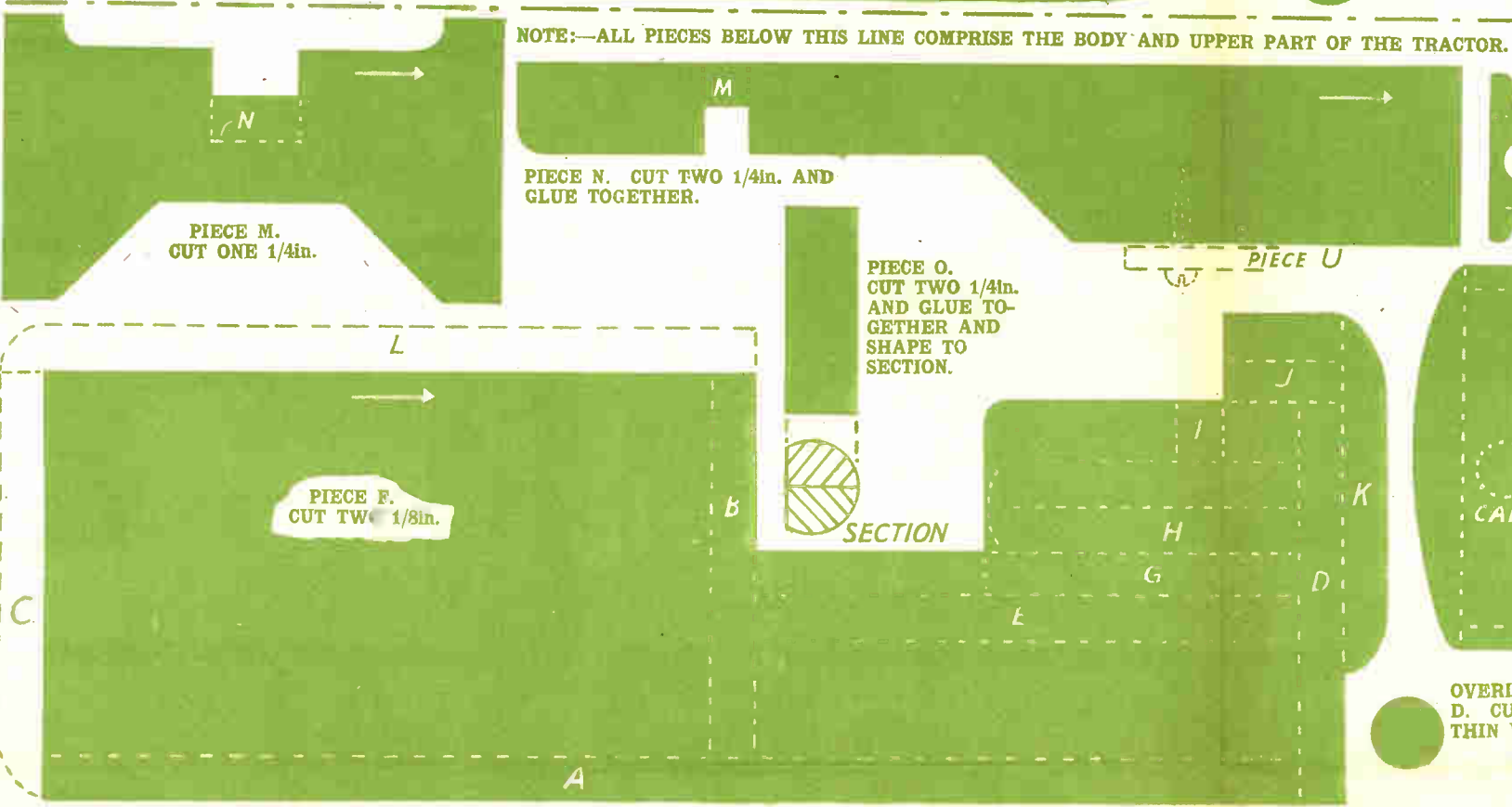

OVERLAY ON D. CUT ONE THIN WOOD.

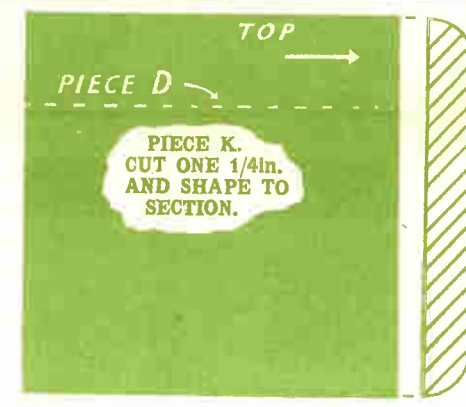

PIECE X. CUT ONE 1/8in.
 PIPES S. CUT TWO 1/4in. ROD.

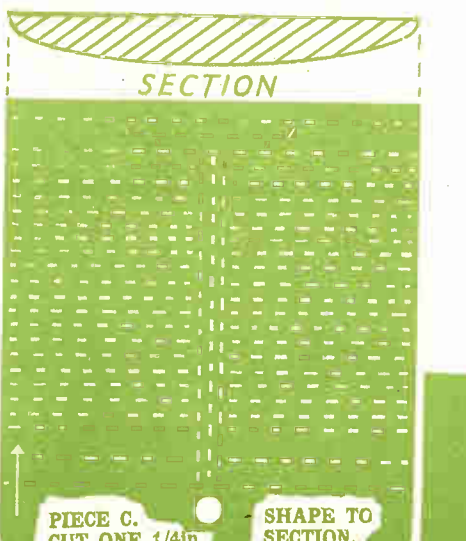
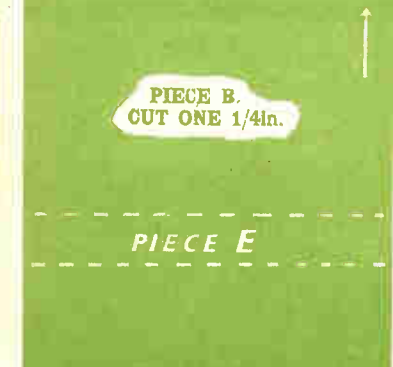
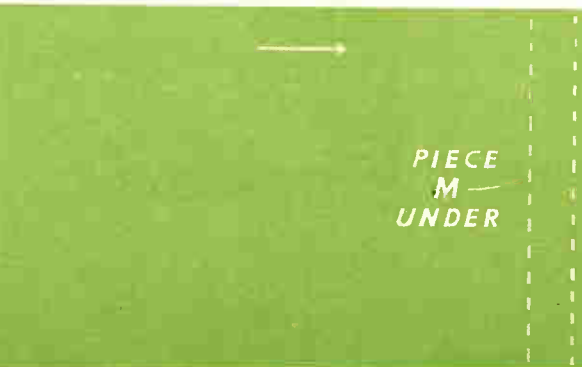
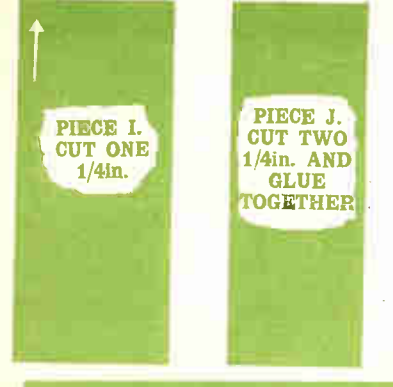

AN EXHIBITION MODEL DIESEL TRACTOR

THIS tractor is one of those solid-looking diesel engine driven machines largely used on big work with bulldozers, or for tree felling, in road making, building operations, forestry work, etc. The model made is as realistic as possible on such a small scale, and the work of making should only be undertaken by those experienced in this type of construction.

Apart from the cutting out of the parts in wood, building must be undertaken carefully, the shaping done as shown, and the whole thing finished with paint to make it finally realistic. The model stands on a base, and is, of course, for exhibition purposes, as the tracks or wheels do not revolve. Before starting, make a close study of the drawings herewith, and the lettered patterns on the sheet.

Order of Assembly

The parts can be put together in alphabetical order, and the position of many of them is indicated by dotted lines on other pieces to which they join. The work is virtually in two units, the body of the tractor being built first, and then the track portion added with the chassis underneath. The patterns need not be pasted to the wood, but should be marked out carefully. Cut out the parts

as you go along, shape them and glue them solidly in position according to these instructions.

Take the body of the machine first. The floor (A) has a centre partition (B) glued upon it, and then the ends (C) and (D) glued upright. The sectional view at Fig. 1 shows this clearly. The various portions forming the driver's seat and floor (E, G, H, I and J) are added between. Their position is indicated clearly by the dotted lines on pattern (F). These two pieces (F) are the sides between which all these interior pieces and the ends are glued.

Note that part (H) is two pieces glued together, shaped to form the seat. The two pieces (J) are glued between the sides, but (I) is glued on edge in front of them on the seat itself. The back end of the body piece is (K). The top of the engine casing (L) is glued on flush with the back end which provides the rounded shape for the front. The whole front of the body is now rounded, as can be seen in the picture of the finished model. Shaping is done at top and bottom, as well as sides. The drawing at Fig. 2 is a useful guide in making up, and three shows finished parts.

Undercarriage

The undercarriage portion is made by ends (M) and (N) being halved together

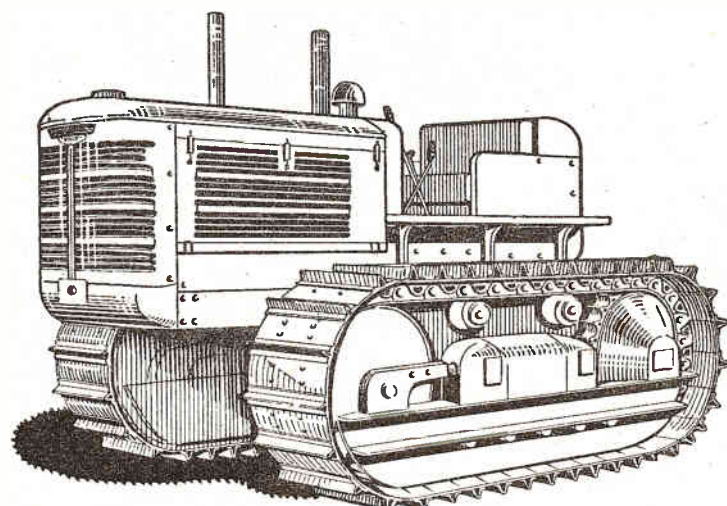

(see Fig. 4). The completed body beds down into this chassis portion, and is there glued in place, the back end of (N) fitting to piece (D) which drops below the floor. The various pieces as additions to the top of the engine (O to T) are shown in Fig. 5 and also in Fig. 2. Cut and shape the parts carefully before gluing in place in the positions indicated. The parts (U to Y) are at the back end of the body, and are put together carefully (see Fig. 6). When this unit is completed, the upright pieces (Y) are glued to the back end of (D), as shown by the dotted lines on the pattern of that part.

The pattern of the part (Z) is for a shelf piece which forms the step immediately below the driver's entrance.

It is glued on at rightangles and three bracket pieces under (Z) are glued each side. One is in the centre, and the other two $\frac{1}{4}$ in. inwards from each end. The position of these shelves is seen on the side view on the sheet.

Tractor Portion

Now turn to the formation of the tractor and wheels, and study the full-size side view on the sheet in conjunction with the picture of the finished shapes at Fig. 7. The building is straightforward when you have cut out and shaped the parts, commencing with the foundation pieces (AA) and (BB) (see Fig. 8). The piece (EE) beds in flat between the wheel portions projecting outwards. $\frac{1}{8}$ in. below this is (GG) also glued on edge, as indicated on the pattern of (FF).

Make the part (KK) a cone shape with its rectangular capping piece (MM) glued over. Add the other pieces as shown in the positions indicated. The track links of which 52 are required, are cut from card and glued to the face of the main part (BB). Notice where these links disappear on the underside at the point marked (X), they must be cut smaller to fade away.

The track portion is a piece of card 17 ins. long, 1 in. wide. Glue it round the outside of the body work (see Figs. 7 and 8), a distance of $\frac{1}{4}$ in. from the body of the engine portion. When fixed, the shoes are glued on. Each of these is cut from a piece of card 1 in. long and $\frac{1}{8}$ in. wide. Fold it to the angle shown in the detail on the sheet, then carefully glue each shoe with $\frac{1}{8}$ in. between along the card track. Mark their position first with pencil and see they are firmly in place. Fitting these 76 track shoes requires patience and care, although there is nothing difficult in their fitting.

The Track

The completed track portion is finally glued on to the ends of (M) (see Fig. 4), the exact position being noted from the side view on the pattern sheet. It may, however, be as well to paint the model as two complete units—before the tractor sides are glued on.

This painting is, indeed, the next job. Give the model a clean-up and then a coat of flat grey paint to allow to harden in. The finished coat is of red for the main body work, brown for the tractor portions and, of course, the various lining up in black. The picture of the finished model helps in this respect. Details of the base are shown on the sheet, and the tractor can be stood on this for exhibition purposes.

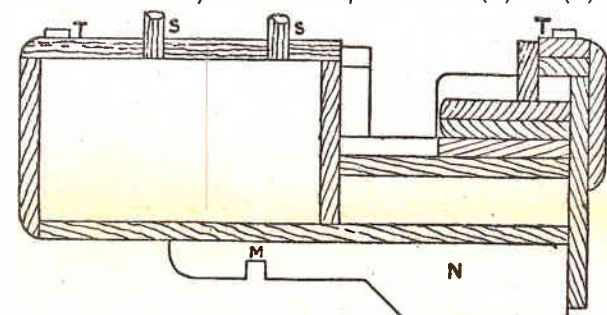

Fig. 1—Sectional view of main parts, and outline indicating position of tractor portion

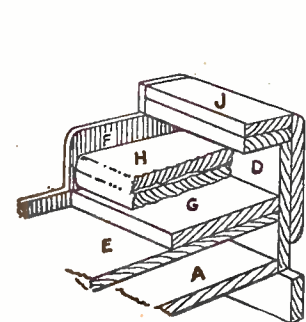

Fig. 2—Cut-away detail of seat and back

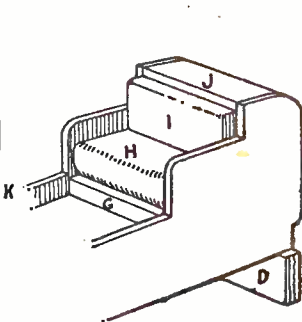

Fig. 3—Seat portion completed

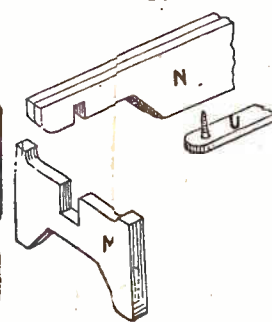

Fig. 4—The under chassis and its pivot screw

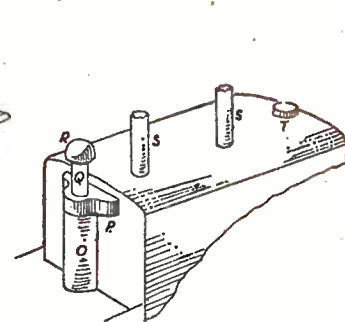

Fig. 5—Dash view of engine with top vents

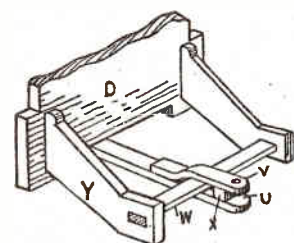

Fig. 6—Rear portion with trailer bar

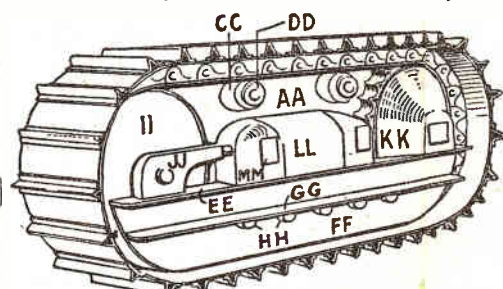

Fig. 7—Lettered parts which make the tractor complete

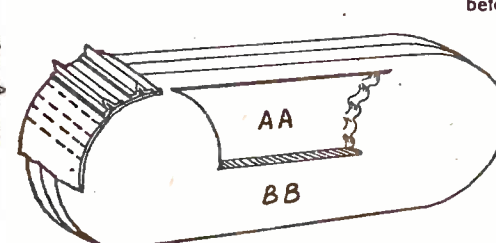
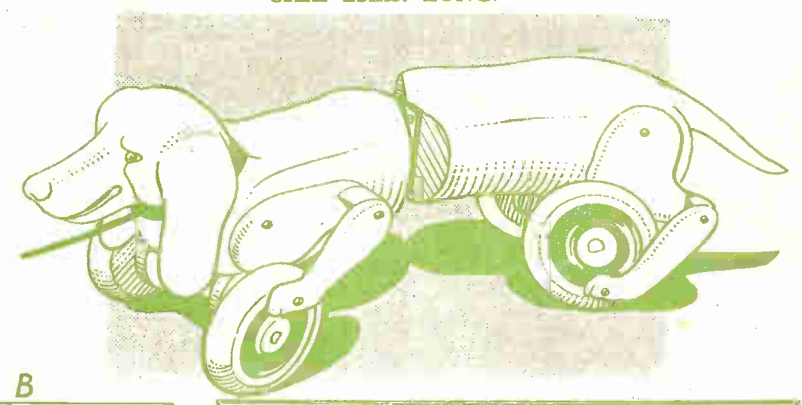

Fig. 8—The two foundation parts of wheels

SUPPLEMENT TO HOBBIES No. 2834.

THE WALKING DOG

A PULL-ALONG WORKING TOY
SIZE 13ins. LONG.



THE ARROWS INDICATE THE DIRECTION OF GRAIN OF WOOD.

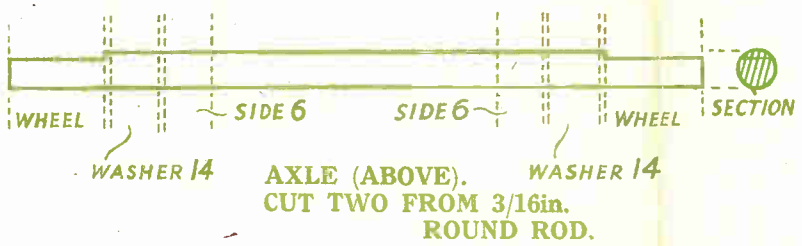

AXLE (ABOVE).
CUT TWO FROM 3/16in.
ROUND ROD.

NOTE.— This design sheet is only presented free with the current issue of Hobbies and not with back numbers. Further copies may be obtained.

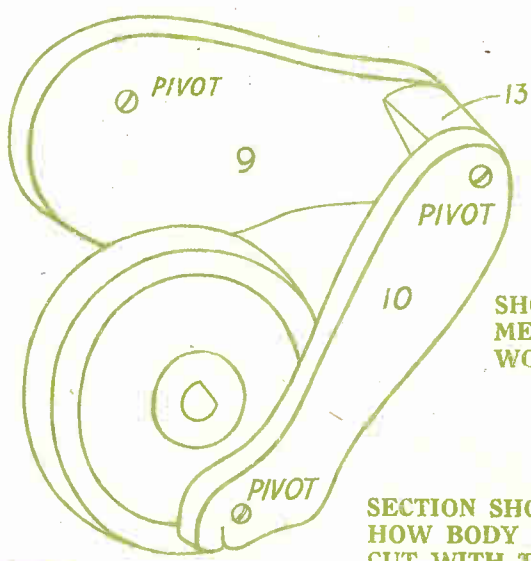

SHOWING METHOD OF FIXING WORKING PARTS.

SECTION SHOWING HOW BODY IS CUT WITH TENON SAW FROM A to B AFTER PIECES 1 to 7 HAVE BEEN GLUED TOGETHER.

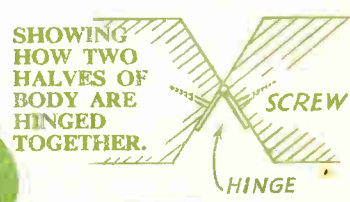
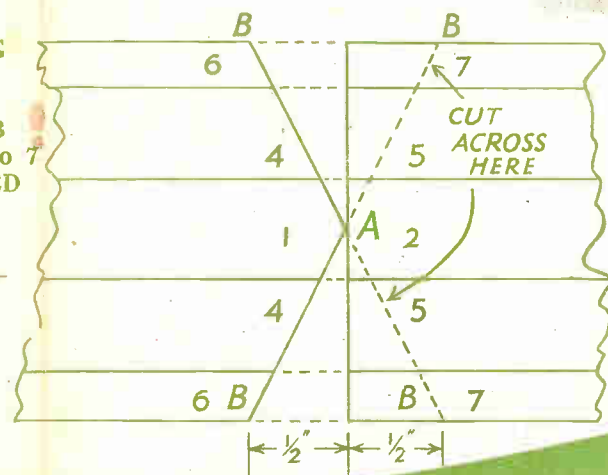

PANELS OF WOOD REQUIRED FOR THIS DESIGN

THREE ND8 ONE H4

Materials for making this design are supplied by HOBBIES LIMITED, Dereham, Norfolk. Price on application.

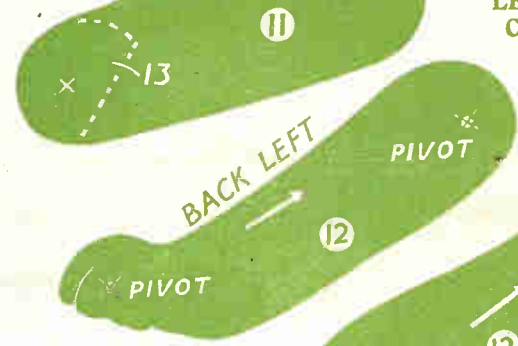
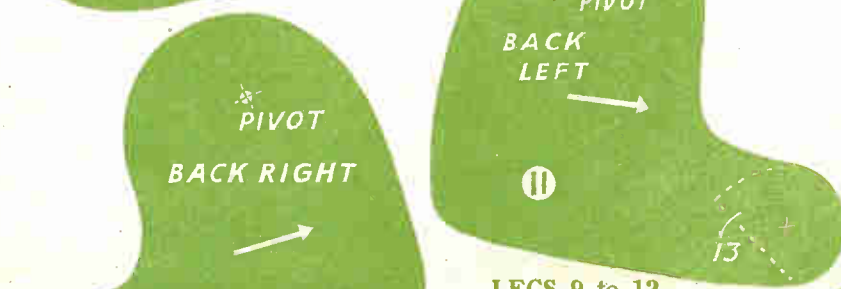
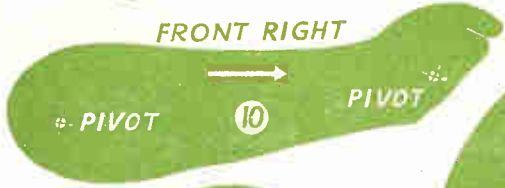
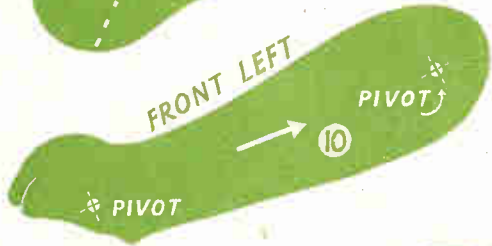
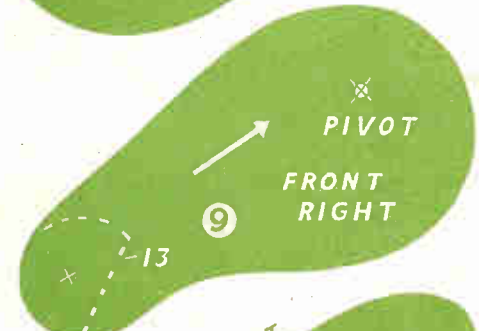
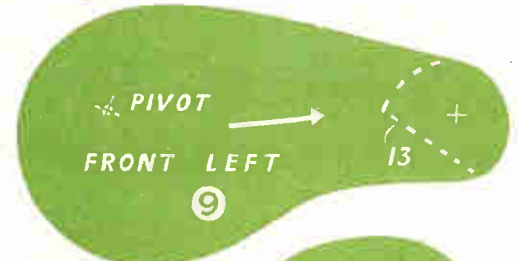

LEGS 9 to 12. CUT ONE OF EACH PART SHOWN 1/4in.

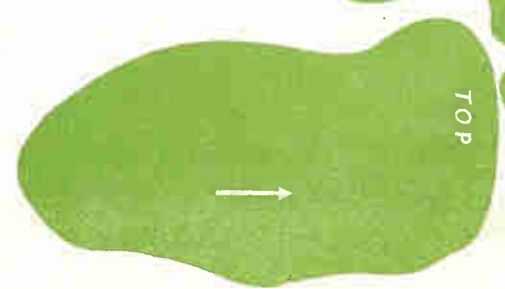
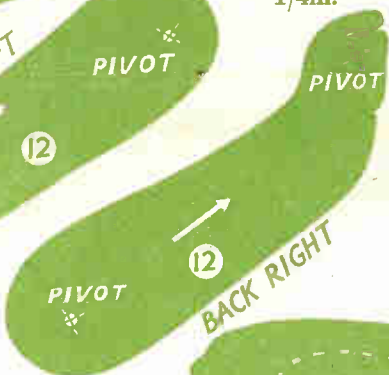
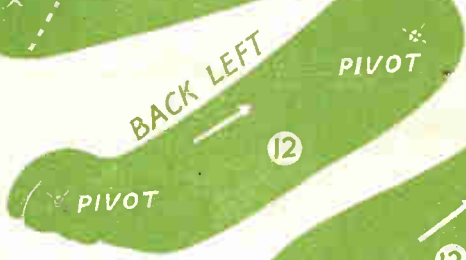

EARS 8. CUT TWO 1/4in.



TAIL 3. CUT ONE 1/2in.

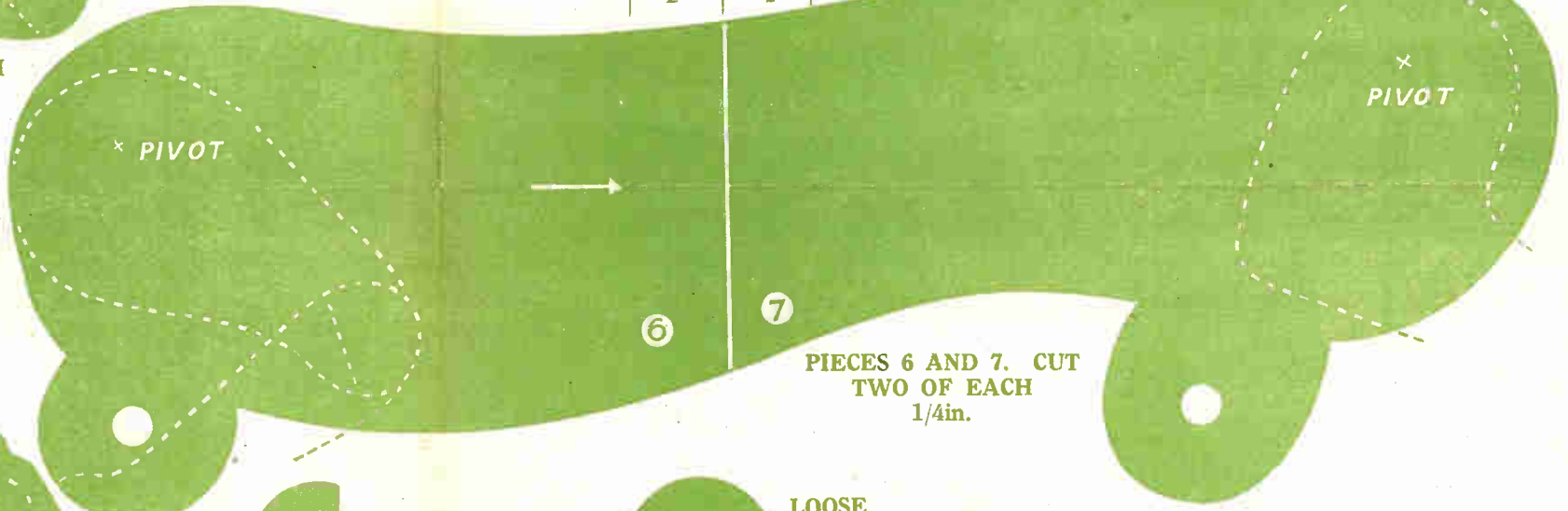

PIECES 6 AND 7. CUT TWO OF EACH 1/4in.

PIECES 13. CUT FOUR 1/2in.

LOOSE WASHERS 14. CUT FOUR 1/4in.

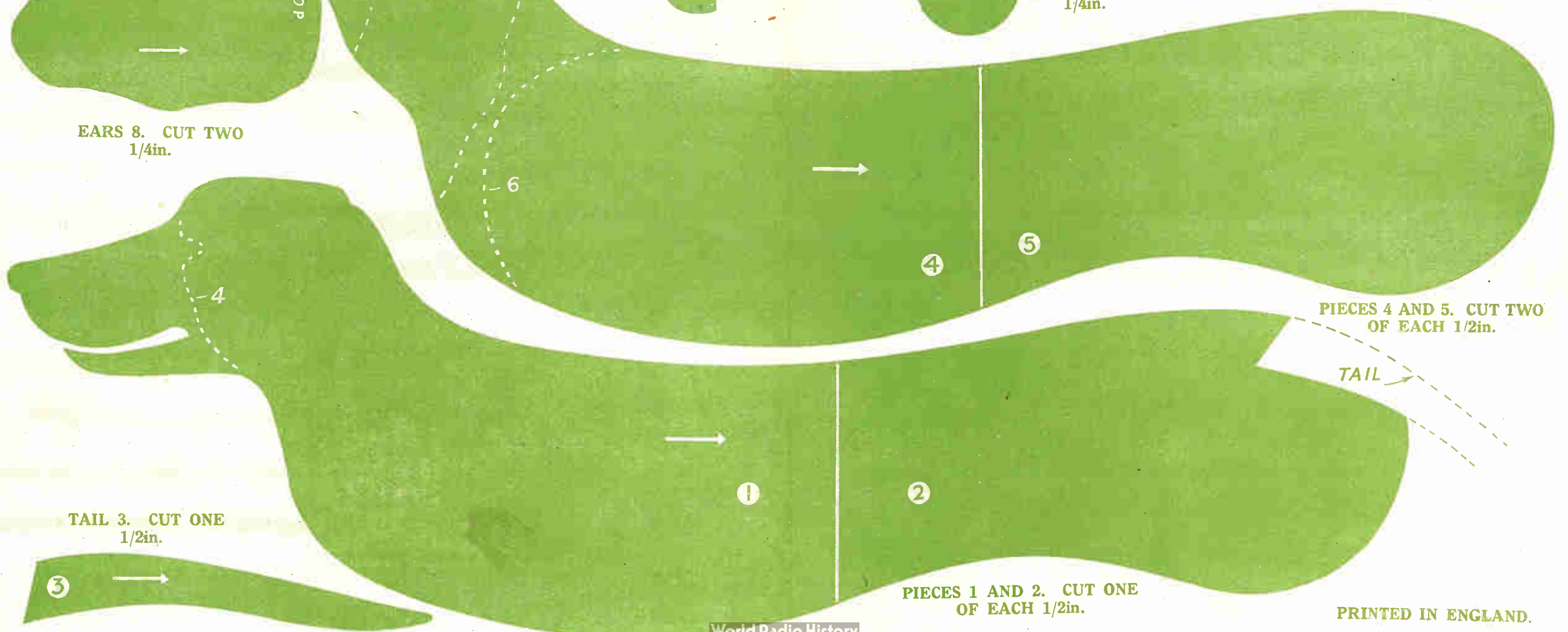

PIECES 1 AND 2. CUT ONE OF EACH 1/2in.

PIECES 4 AND 5. CUT TWO OF EACH 1/2in.

How to use our patterns to make THE WALKING DOG TOY

THIS quaint novelty is an amusing toy of useful size, simple to make from odd pieces of wood and four wheels, or the complete kit of parts provided. The model is a solid piece of work, hinged in the middle, and fitted with movable legs pivoting on wheels. When the toy is pulled along, therefore, the legs move quite realistically and the dog can be turned around or moved about by means of its hinged centre portion.

All parts are shown full size, and

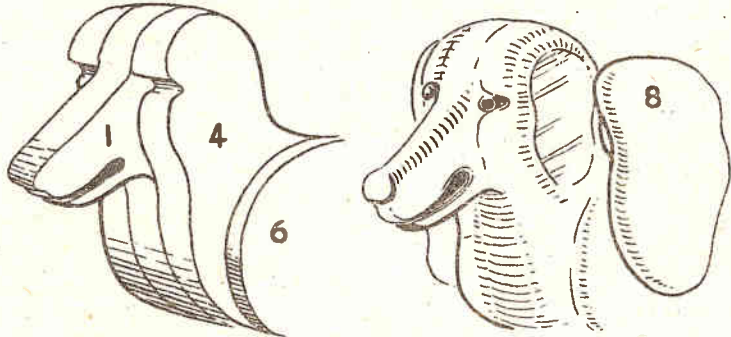

The block of the head before and after shaping

apart from cutting out with the fretsaw, there is just the gluing and pivoting together, and shaping up the body. The dog is of the typical dachshund type, and the shaping of it is, consequently, quite straightforward.

The actual patterns can be pasted down if you wish, or you can mark them direct on to the wood. They are cut out to shape with the fretsaw, glued together, and then shaped as a solid block so far as the body is concerned.

Shaping

This shaping can be done with a penknife because the wood is soft, and finished off to the appropriate lines with glasspaper. There are one or two points to watch in consideration, but the whole job is really quite simple.

The outline of piece (1) and (2) is cut first in its entirety, and then sawn through the straight line in the centre of the body. The outline of (4) and (5) is then cut in the same way, but of this, two pieces are required. These two parts are glued one each side of the centre portion (1) and (2). Before finally gluing on one rear portion (5), however, cut and glue in the tail (3).

This is cut as a separate piece of wood in order to get the grain running the long way and so reducing the likelihood of breakage. Outside these come the parts (6) and (7), forming the actual outside of the body. The position of the various pivot holes, etc., should be clearly marked on the outside parts, and the holes for the axle rods bored.

It is a good plan, by the way, to bore these holes before the actual shape of the outline is cut. This will prevent the wood splitting. The holes can be bored with a bradawl or brace and bit, but must be sufficiently large to allow $\frac{1}{8}$ in. dowel rod

axle to move smoothly and loosely in it. You now have two complete parts forming solid blocks for the dog's body, and shaping can be undertaken.

Body Movement

Before doing this, however, the inner ends of the blocks must be cut to an angle towards the middle. Mark the lines shown as (BB) on the section across the top and on the underside. A line is drawn down the side of the body $\frac{1}{2}$ in. from the end, and then the line drawn across the top connecting it to the

the projecting lugs on the outside portion of the body. It must turn in these smoothly. Outside the legs is fitted a loose washer (14), and then outside these is glued on the wheel itself. The holes in the wheels as provided will have to be enlarged to fit the axle, and here is a good plan which will ensure a rigid fit.

Cut the central holes with a fretsaw, but do not make them a complete circle. On one side have a flat piece, then you can just file a flat shelf on to the end of the axle rods to fit in tightly. You can see this in the diagram of the axle and of the working movement. This flat portion provides an anchorage when glued in the wheel. These wheels are, of course, fixed to the ends of the axle rods, but do not press them tight up against the loose washers. Allow the parts to move easily.

Having fitted the wheels, you can screw on the foot portion. In doing this, get the foot on one side at the bottom of the wheel, and on the other side of the animal at the top. The fixing is near the edge of the wheel, but must allow clearance of the foot from the ground. The whole of this mechanism should be tested, but not fixed until after the parts have been painted.

Painting the Model

Paint the body first with two coats of brown, and also paint the leg movement. The wheels need only be varnished or given a brush polish. The two parts of the dog are finally fitted together by a $1\frac{1}{2}$ in. hinge. It is screwed into the same portion of each side, as shown in the detail on the section in the drawing. The weight of the dog when complete,

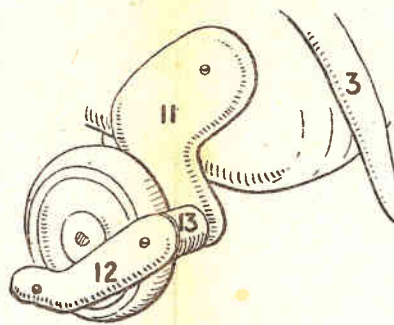

Mechanism of the hind leg

centre point of the end itself. Cut this across right through the block, taking care to keep the tenon saw upright. You will then have the two ends of the body coming to a point centrally to take the hinge later.

The body should be nicely rounded off, and the drawing of the head shown here, clearly indicates the curved effect required. Pay some attention to this work to get a nicely balanced animal with the sharp pointed nose, sunken eyes, and the long drooping ears. The ears can also be glued on if you wish, or can be left until you have tested the moving parts.

Leg Mechanism

The working of the leg movement is shown in the detail on the other side, and the actual shaping of the parts is shown here. Here again it is worth boring the pivot holes with a fretwork drill before you cut the outline of the part. The patterns, of course, are put on with the arrow running the length of the grain to provide strength. The part (No. 13) is $\frac{1}{2}$ in. thick, and in each case is glued to the knee end of the thigh.

You can see its place by the dotted lines on the parts concerned. Glue firmly. The actual thigh piece is, of course, pivoted to the main body. The lower leg is pivoted to (13). Near the toes the pivot runs through into the flat rim portion of the wheel. All these pivots are made by the round head brass screws provided with the kit, and the parts, of course, must work loosely in each case.

The Axle

The axle rod is a $3\frac{1}{2}$ in. length of $\frac{3}{16}$ in. dowel rod. Smooth it and fit it through

should be sufficient to move the legs when the wheels are turned. For this reason, ensure that no paint gets into the pivot holes, and that all joints work easily.

You can add a narrow strip of leather for the collar, and fit a small eyelet beneath it in the chest to provide the pulling string. The mouth, of course, should be painted slightly inside with a little silver edge for the lips. The nose pad at the extreme front is black, and the eyes can be made more realistic by putting in the end of a match-stick or even a round-headed nail.

SUPPLEMENT TO Hobbies No. 2878.

MODEL OF AN ARTICULATED TRANSPORTER

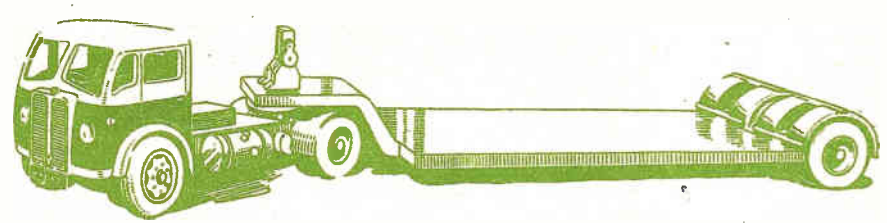

PIECE 1 CUT ONE 1/8in. SCREW FROM INSIDE

PIECE 2 CUT ONE 1/8in.

PIECE 3 CUT TWO 3/16in.

PETROL TANK 4 CUT ONE 1/8in. AND TWO 3/16in. GLUE TOGETHER AND ROUND OFF. SCREW TO 1

PIECES 5 CUT TWO 1/4in.

SEAT 9 CUT TWO 1/8in.

SEAT BLOCK 8 CUT TWO 1/4in.

STEERING COLUMN 12 CUT ONE FROM 1/8in. DIA. ROUND ROD.

SEAT BACK 10 CUT TWO 1/8in. CHAMFER BOTTOM EDGE.

STEERING WHEEL 13 CUT ONE FROM CARD, USING BROKEN RAZOR BLADE.

SKETCH OF COMPLETED PETROL TANK.

PAPER STRIP
1/8in. ROUND ROD
GAUGE (PAINT ON)

BONNET 7 CUT THREE 1/4in. AND GLUE TOGETHER.

FLOOR 6 CUT ONE 1/8in.

SHOWING HOW BONNET IS ROUNDED OFF AFTER GLUING.

PIECE 11 CUT ONE 1/4in. SHAPE TO SECTION.

PANELS OF WOOD REQUIRED FOR THIS DESIGN

ONE G2 ONE Q2 ONE Q3 ONE Q4

Materials for making this design are supplied by Hobbies Limited, Dereham, Norfolk. Price on application.

SIZE 14 1/2 ins. LONG. 3 ins. HIGH.

The arrows indicate the direction of grain of wood.

NOTE.—This design sheet is only presented free with the current issue of Hobbies and not with back numbers. Further copies may be obtained.

FRONT 14 CUT ONE 3/16in. SHAPE TO SECTION.

SECTION

BACK OF CAB 15 CUT ONE 1/8in. CHAMFER BOTTOM EDGES TO SECTION.

SECTION

SIDES 16 CUT TWO 1/8in. SHAPE TO SECTION

PAINT ON

ROOF 17 CUT ONE 1/4in. SHAPE TO SECTION.

Note. The cab will be shaped AFTER gluing together. The sections shown are intended to be a guide for the final shaping.

FRONT MUDGUARD 19 CUT TWO 1/8in. ROUND OFF OUTSIDE EDGE AND GLUE TO 16

RADIATOR 20 CUT ONE 1/4in.

RADIATOR CAP. CUT ONE FROM 1/8in. ROUND ROD.

HEADLAMP 21 CUT TWO 1/8in. SHAPE SLIGHTLY TO FIT SLOPE OF FRONT. GLUE IN PLACE AFTER CAB HAS BEEN COMPLETED.

PIECE 23 CUT ONE FROM CARD.

PIECE 24 CUT ONE 1/4in. GLUE TO 23

PIECE 25 CUT ONE 1/4in. ROUND TO SECTION. GLUE TO 2

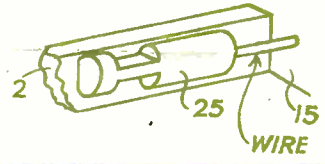

SIDELAMP 22 MAKE TWO FROM 1/8in. ROUND ROD AND SMALL FRET PIN WITH HEAD CUT OFF.

PIECE 23 CUT ONE FROM CARD.

POSITION OF FRONT WHEELS

PIECE 18 CUT ONE 1/8in.

PIECE 27 CUT SIX 3/16in.

PIECE 29 CUT TWO 1/8in.

STARTING HANDLE. MAKE ONE FROM WIRE.

PIECE 30 CUT TWO 1/8in.

PIECE 31 CUT TWO FROM THIN CARD.

TURNTABLE 33 CUT ONE 1/8in.

PIECE 34 CUT TWO 1/8in.

WASHER 35 CUT TWO 1/8in.

PIECE 49 CUT FOUR 1/8in.

PIECE 48 CUT FOUR 1/8in.

PIECE 47 CUT FOUR 3/16in.

PIECE 50 CUT FOUR 1/8in.

FRONT AXLE 26 CUT ONE 1/4in.

PIECE 52 CUT FOUR 1/8in.

PIECE 53 CUT FOUR 1/8in.

PIECE 55 CUT SIX FROM 1/8in. ROUND ROD.

TRAILER MUDGUARDS 54 CUT FOUR FROM CARD.

FRONT WHEEL. MAKE TWO.

PIECE 32 CUT TWO 1/8in.

TWIN REAR WHEELS. MAKE TWO.

PIECE 28 CUT FOUR 1/8in.

3/4 IN. COUNTER-SUNK SCREW

PIECE 41 CUT TWO 1/8in.

PIECE 43 CUT ONE 1/8in.

TRAILER WHEELS. MAKE FOUR.

PIECE 46 CUT ONE FROM CARD.

PIECE 43 CUT ONE 1/8in.

PIECE 40 CUT ONE FROM CARD.

PIECE 42

MUDGUARD OVER TWIN REAR WHEELS OF TRACTOR. CUT TWO FROM THIN CARD. GLUE TO PIECE 3

PIECE 37 CUT ONE 1/4in. GLUE BETWEEN PIECES 36

PIECE 42 CUT ONE 1/8in.

PIECE 36 CUT TWO 1/4in.

REAR No. PLATE. CUT ONE FROM CARD.

FRONT No. PLATE. CUT ONE FROM CARD.

PIECE 39 CUT TWO 1/4in. GLUE ON OUTSIDE OF PIECES 36

PIECES 44 & 45 CUT TWO 44 and ONE 45 FROM 1/8in. WOOD.

SPEED RESTRICTION SIGN. CUT ONE FROM CARD. GLUE TO NEAR SIDE TRAILER MUDGUARD.

CRANE CUT OUT AND PASTE TO REAR OF TRAILER MUDGUARD.

PRINTED IN ENGLAND.

MODEL ARTICULATED TRANSPORTER

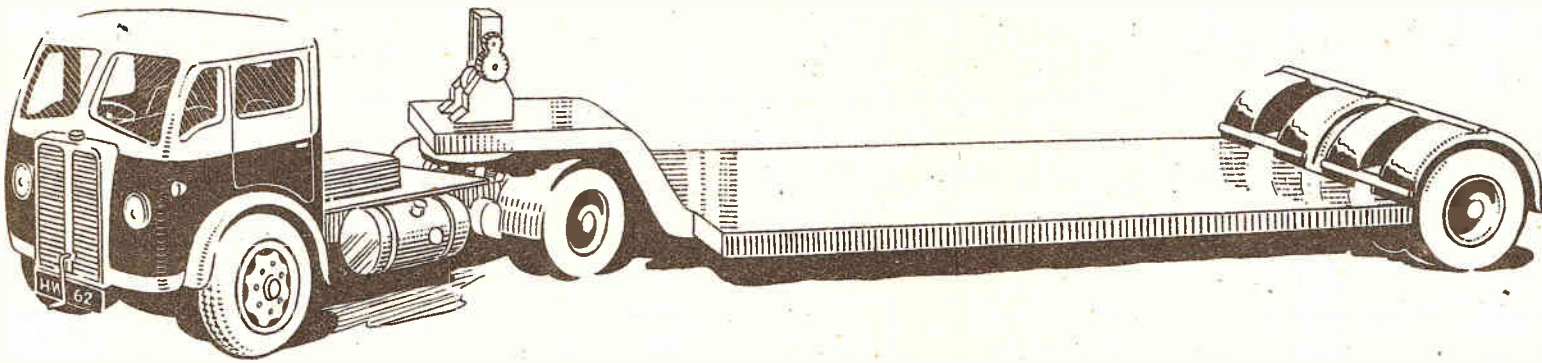

THIS striking little model is a reproduction of one of the outsize articulated transporters used for exceptional pieces of machinery. The size of the actual transporter can be gathered when you realise it is 14½ ins. long and incorporates no less than four wheels on its tail and six on the tractor portion of the front.

It is built by specialists in this type of work—Cranes (Dereham) Ltd., who supply this and other types of large trailer for export all over the world. The model, for which patterns are provided on the other side, is 14½ ins. long, and when completed and painted, is a pleasing replica of the actual article.

Its construction, however, is not to be recommended to the beginner unless he is conversant with reading patterns, and is nimble and able enough to work out constructional detail. This does not mean there is anything really difficult about it, but a complete study of parts and constructional detail must be made before beginning. The kit of wood provides the necessary material, apart from screws, glue, nails and odds and ends.

Sequence of Construction

The construction is according to the numerical order of the patterns. Study their position one with another, and particularly note where parts have to be chamfered or shaped. The model is in two units and can be built in that order. The cab and front tractor portion is pivoted on to the rear trailer by means of a stub pin. The model is, of course, finished with paint and as you proceed with its construction you must remember this and not fit on any pieces

angle of the seat back to allow the slope, and also the angle of the hole containing the steering wheel. The side view of piece 11 is shown shaded, giving the chamfer also. The wheel can be a tiny metal one or cut from card and fitted on the end of the steering column with a tiny nail. The complete unit is fitted centrally on the chassis with the front edge flush (see Fig. 2).

The Cabin

Now build the cabin from parts 14 to 18. Note the top of 14 projects slightly beyond 16 at the upper portion, and the way part 18 is stepped into the front. When this part 14 is fixed, it is shaped down to form the same curve as the side (16). The whole of this cab has to be rounded off, but before doing this, add the mudguard shaped and glued. All edges of the cab are rounded nicely (see Fig. 4) with Cellophane put behind the side windows, and the inside painted before the roof is finally added.

The front windows of transparent material are cut correctly to the two apertures. Glue a tiny angle of card or thin wood in the corners (see inset Fig. 4), and then tip the edges of the material and the corners with glue and set in place. Note in Fig. 4 also the tiny piece of thin card to form the back face of the mudguards. The lamps 21, 22 can be cut, and if necessary painted, or can be left to fix in place until later. Completion of the floor of this unit is carried on with pieces 23, 24, the rear view at Fig. 5 giving helpful details. Note the addition of Pump portions (25) which are glued on this side only, connecting with the back of the cab.

The back end of this chassis is open to allow the turntable upon which

with their top. 37 and 38 are glued between these girder pieces 36, which extend at the tail as seen. The floor covering the chassis is a piece of card (piece 40). Note the extension to bins at the rear of this pattern, and mark out accordingly before cutting. The narrow piece of card is glued over 37, carried down the slope and then glued along the chassis pieces 38 and 39.

Mounted on the front end (37) is the cable winch from parts 41 to 46. The various cog wheels are painted silver and the gear teething painted on the edge with black lines close to each other across the width. A short length of cord or thick thread can be wound round the drum (46) to indicate cabling, if you wish. Assemble these parts as Fig. 9 and then glue central to the part 40, as shown on the dotted lines of pattern.

Immediately on the underside of this front end is the turntable portion seen in Fig. 6. The two parts 34 are glued by the tenon into the table itself, and the washers 35 fit between them and the chassis pieces 1 and 2. It is advisable to bore holes through all pieces when assembled, to ensure they come opposite each other.

The pin running through must work loosely through pieces 34, in order there may be a certain amount of up and down play for the tractor. The turntable itself works loosely on a stub pin into the trailer portion and allows the horizontal turning required. Fit these pieces carefully to ensure accuracy, and even movement.

Mudguards

The fitting of the mudguards of the rear end can be done as complete units. They are in the end, glued in place on to

rounded cup of that part. The construction of the various wheels is given by sectional details on the sheet. A single disc is cut through the centre of which is driven the long thin screw. Around this screw is added the raised hub portion, and to form the thickness of the tyre a collar of wood is glued on. This collar should be shaped in section before being added, and then the plain disc portion is also rounded to complete the illusion of the tyre.

Where a double tyre is required, it merely means the solid back wheel is glued on to the front one and the whole lot screwed in place. The screw head is always covered by a disc cap which, of course, cannot be added until the wheels are fitted. The rear wheels of the trailer are shown at Fig. 11, and here the assembly is added.

Making the Wheels

The wheels are made and the washer glued to each as shown. Run a long screw through the outer wheel and disc, then through the chassis part and finally drive it into the second wheel. Make sure the hole in the chassis is large enough to allow the screw being used, to revolve quite freely. The pair of wheels then will revolve together, each pair being fixed to the chassis, as seen in Fig. 11. In this detail, too, you have a clear view of how the number plate, mileage plate and name plate are added. One of the mudguard assemblies is also shown lifted away for clarity.

Make sure now that all parts are clean and correct and paint the model over first with grey and then finally with the finished colours. The main parts can be red or a dark brown, with tyres grey, wings and mudguards, oil

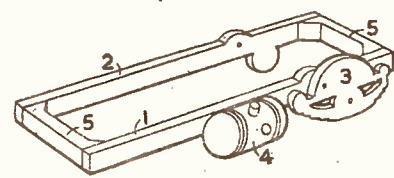

Fig. 1—Front chassis

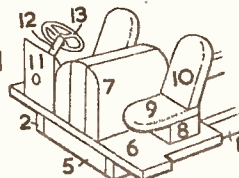

Fig. 2—Cabin interior

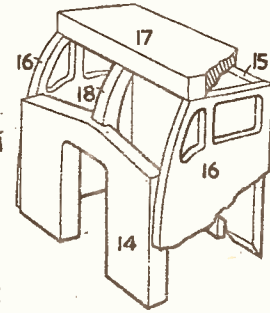

Fig. 3—Cabin cover parts

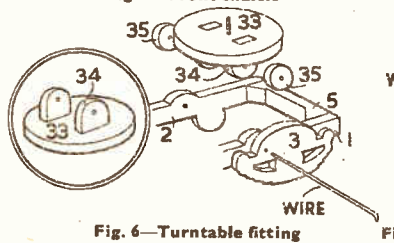

Fig. 4—Shaped cabin

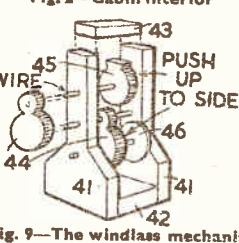

Fig. 5—The tractor chassis

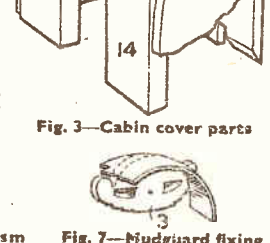

Fig. 6—Turntable fitting

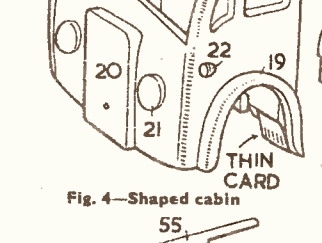

Fig. 7—Mudguard fixing

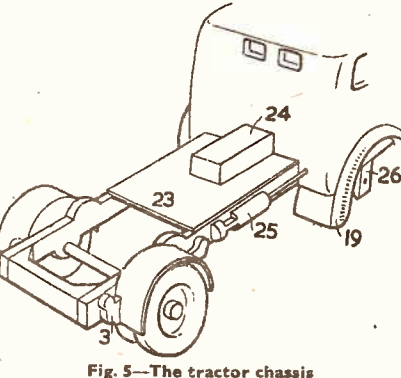

Fig. 8—Chassis of trailer portion

finally which prevent you painting behind. This applies, for instance, to the inside of the cab, behind the wheels, etc.

Mark the patterns off on to the wood accurately, cut them out with the fretsaw and put their number in pencil on the reverse side. Build up as far as possible as you go along, according to numerical order. Start with the chassis of the front portion, a detail of which is shown at Fig. 1. Before you make the framework of parts 1, 2 and 5, you must screw on the rounded petrol tank (No. 4), because otherwise you will not be able to get at the inside. Note the position of the spring pieces (3) as indicated by the dotted lines on the pattern of piece 2. Although not provided for on the design sheet, it is as well to add an axle piece between the two drop sides.

At the front end of this chassis, the cab is next built. Engine, steering and seating are put together as a complete unit (see Fig. 2). Build these on part 6, shaping each one carefully. Note the

the actual trailer part is later pinned. The turntable is shown in Fig. 6, although the actual turntable itself is not fitted to the chassis until later, then it is added by the long wire pin driven through the hole indicated in the patterns concerned. To complete this tractor unit, add the back mudguards by gluing the shaped card shown over the top of the spring leaves already fitted to the side of the chassis (see Fig. 7).

Chassis Assembly

Now turn to the trailer chassis assembly seen in Fig. 8. Notice the flat parts (39) glued on edge to 36 and flush

the chassis girder (36) but this should not be done until the wheels and all their axles have been added. The mudguards can be made up in two pairs (see Fig. 10) from parts 52 to 55. Note the recessed portion in pieces 55 which form distance pieces between the framers (52).

The mudguard cover is, of course, of card glued on to the shaping portions before the cross strips 55 are added. Round these cross strips nicely, and see that when they are laid in place on the chassis girder (36) they rest in the

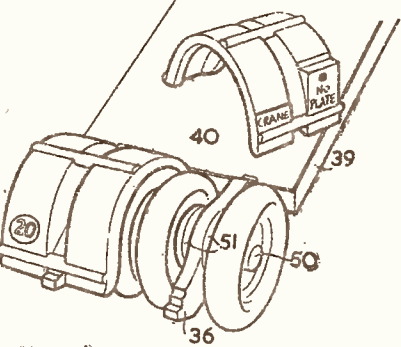

Fig. 9—The windlass mechanism

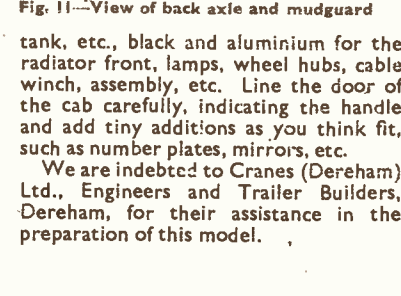

Fig. 10—Rear mudguards

Fig. 11—View of back axle and mudguard

tank, etc., black and aluminium for the radiator front, lamps, wheel hubs, cable winch, assembly, etc. Line the door of the cab carefully, indicating the handle and add tiny additions as you think fit, such as number plates, mirrors, etc.

We are indebted to Cranes (Dereham) Ltd., Engineers and Trailer Builders, Dereham, for their assistance in the preparation of this model.

THE TIGER

A MECHANICAL WORKING TOY

—SIZE—
LENGTH 8½ins. HEIGHT 5½ins.

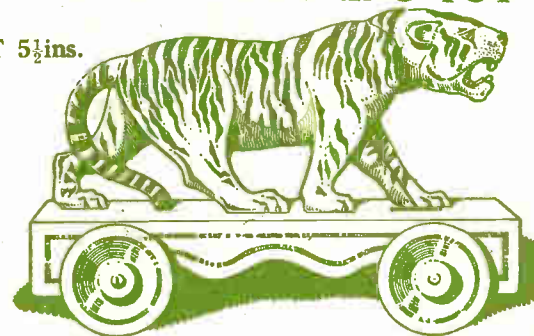
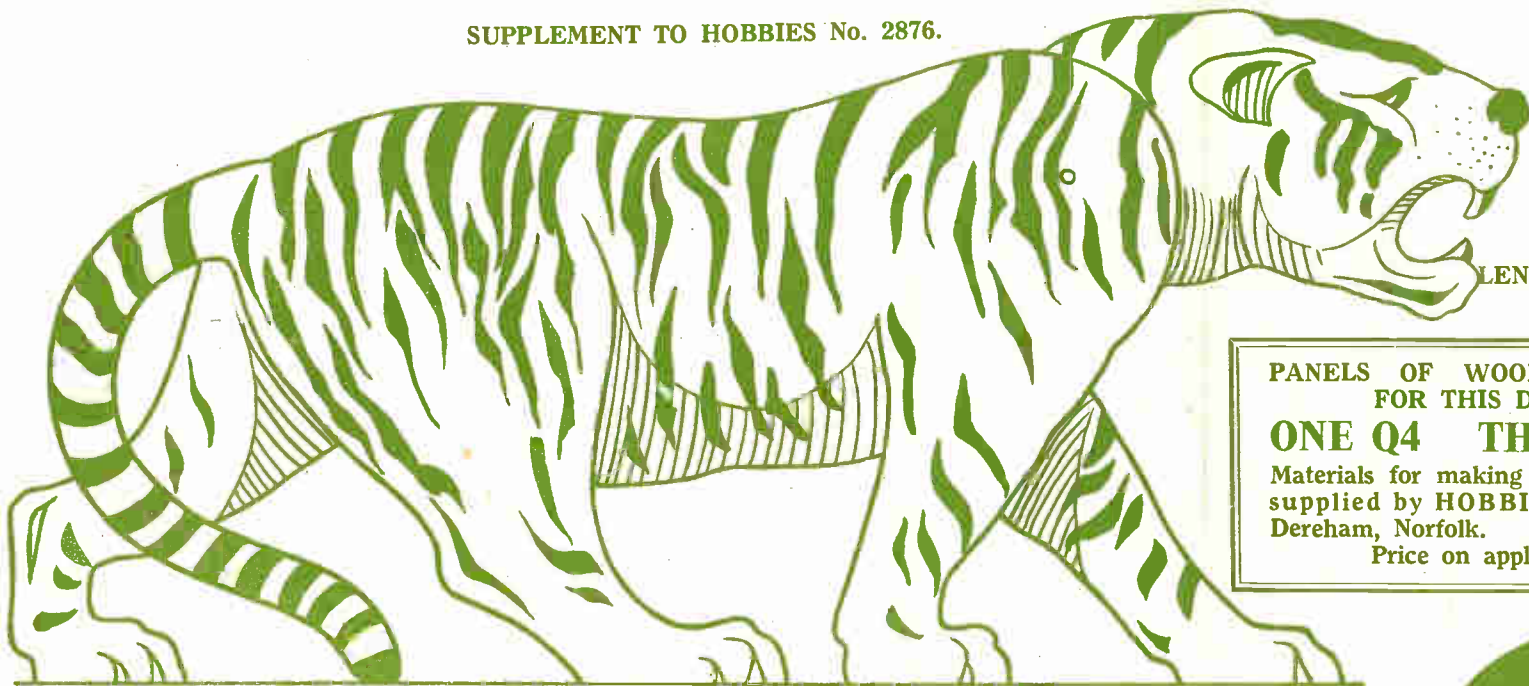

PANELS OF WOOD REQUIRED FOR THIS DESIGN
ONE Q4 THREE GD6

Materials for making this design are supplied by HOBBIES LIMITED, Dereham, Norfolk.
Price on application.

SIDE VIEW OF TIGER SHOWING HOW TO PAINT IN THE STRIPES, ETC.

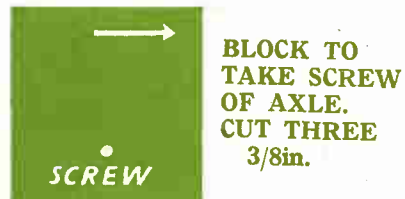

NOTE.—This design sheet is only presented free with the current issue of Hobbies and not with back numbers. Further copies may be obtained.

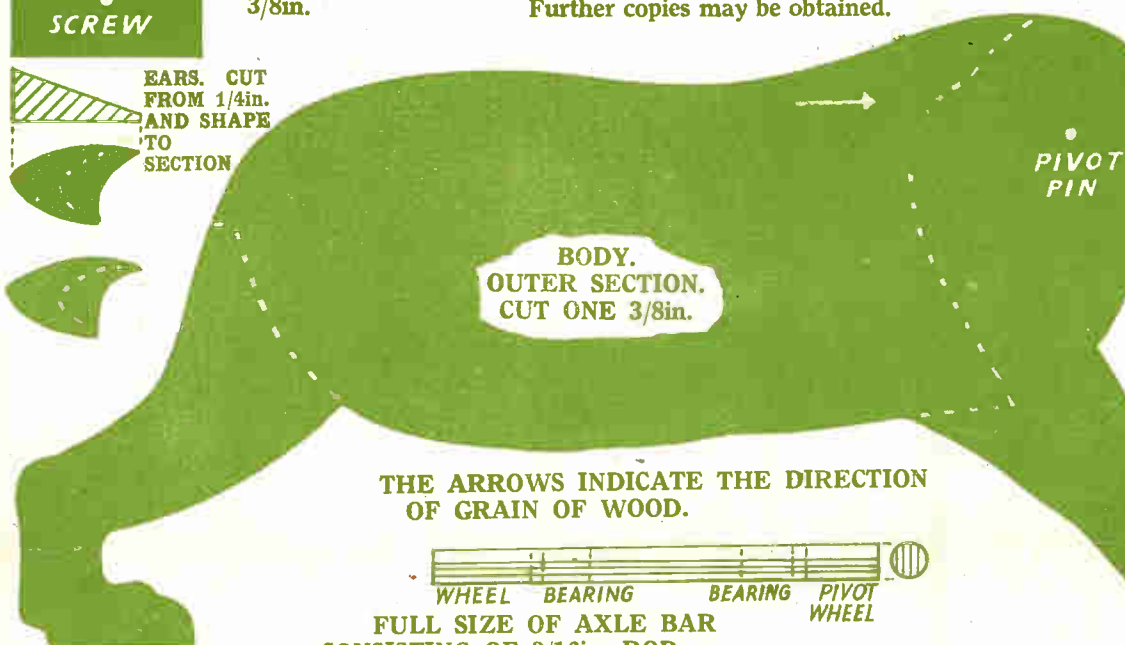

THE ARROWS INDICATE THE DIRECTION OF GRAIN OF WOOD.

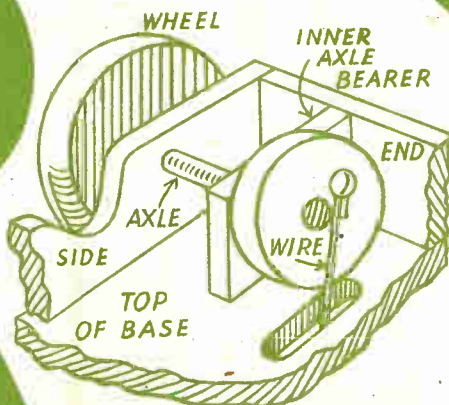

DETAIL SHOWING WORKING MECHANISM INSIDE THE BASE. VIEW FROM THE UNDERSIDE.

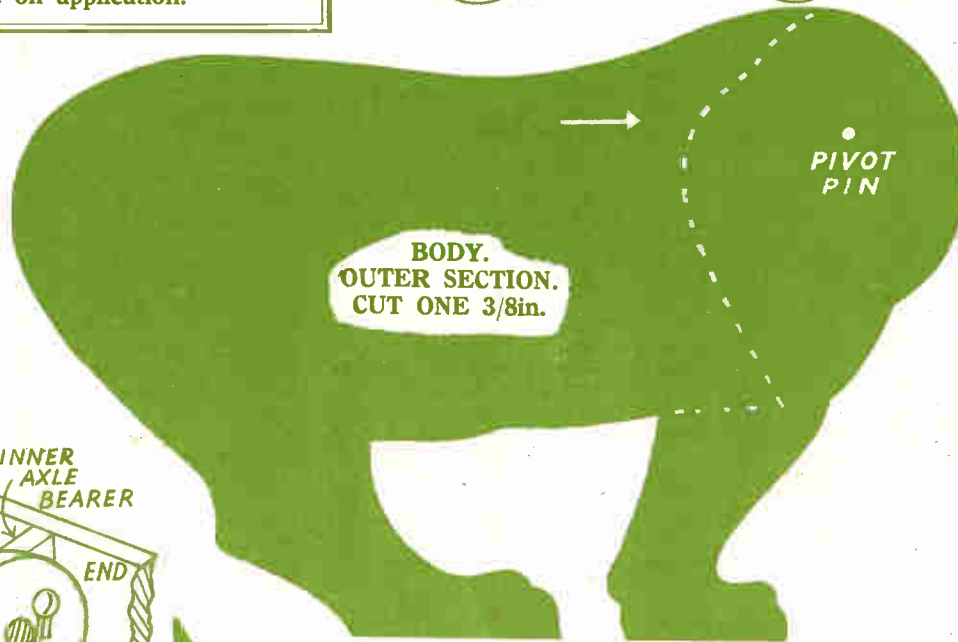

HEAD. CUT ONE 3/8in.

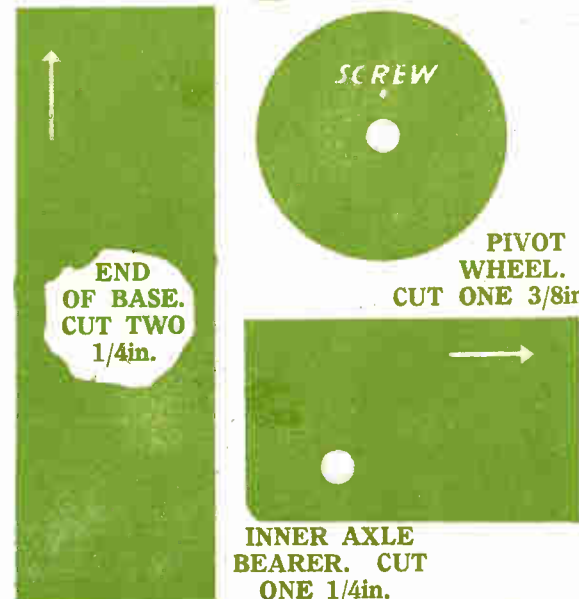
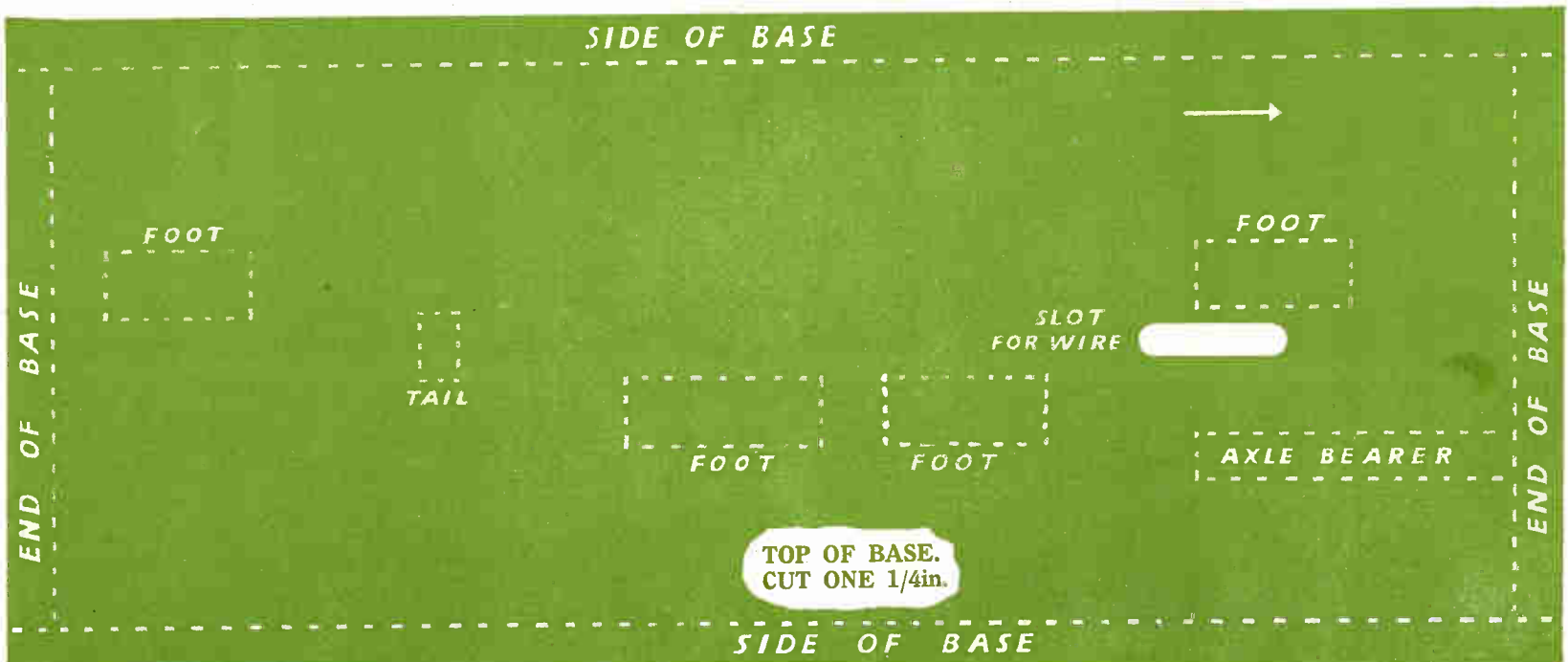
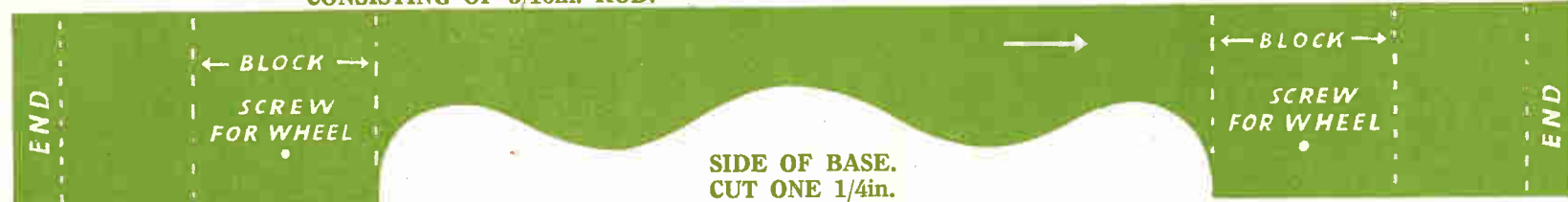

SCREW INTO WHEEL

FULL SIZE OF WIRE REQUIRED FOR MECHANISM.

SCREW EYE

MECHANICAL TIGER TOY

THIS is another of the easily constructed pull-along toys, cut from thin wood, painted and completed from the full size patterns on the other side. These pattern parts can be pasted to the wood, or the outlines traced through carbon paper or ordinary tracing paper. If the paper itself is pasted down it will, of course, later have to be cleaned off with glasspaper.

As the tiger is pulled along, the head nods up and down by means of a simple mechanical contrivance. A piece of stiff wire is fixed to one of the wheels and to the inner end of the neck, so that as the wheels revolve they actuate the up and down motion of the head.

Foundation Parts

The whole thing stands on a base which is the first preparation to undertake. This baseboard is a plain rectangle, and on the underside of it are glued the two ends between the two sides. In one of the sides, a hole is bored to take the axle, but in all others the wheels are screwed straight on.

The side with the axle hole must be fixed with this hole at the same end as the slot for the wire. Behind the other three wheel positions—indicated by a screw hole—a block of $\frac{1}{2}$ in. wood is glued to provide the substance for the screw itself. The hole provided for the movable wheel on its axle, leads to the eccentric movement of the wheel on the opposite side. An underneath view of this corner is shown in detail. The axle bearer is glued firmly to the end at the position shown and, of course, to the underside of the base.

Axle Running

A hole in this inner axle must come immediately in line with the one in the side. The axle is then put through both the bearer and the side, and should be smoothed so it revolves with a minimum of friction. At one end of this axle rod the wheel is glued on, and at the other, the pivot wheel is fixed. A good method of ensuring the wheels do not revolve on the axle is to drive in a small sliver of razor blade to go right across the axle and into the main wheels.

To give additional strength to the whole base, little blocking pieces can be glued in the corners. You can now proceed with the construction of the actual animal. The two outer sections of the body are cut from $\frac{1}{2}$ in. wood and

between them is glued the middle section. Get these in alignment, so the outer edge is the same, a position which is indicated by the dotted lines on the patterns of the outer body.

Ensure that the bottom of the four feet are level, so they will stand flat to the base. If they do not, rub the whole thing on a piece of glasspaper fixed to the workbench and rub down until the required result is obtained. The head piece is independent, and must be cleaned with glasspaper to make it slightly thinner, so it works easily between the outer body portions.

Carved Animal

The animal body itself is now $1\frac{1}{2}$ ins. thick, and if you wish, the parts can be rounded off to make them more realistic. The underside of the body can be rounded inwards to make the legs stand out a little more. The tail can also be rounded and slightly tapering, but the end of it should be left square finally to glue on to the base itself.

To return to the mechanism of the head and wheel, you must prepare the piece of wire to the length and shape shown. Turn one end to an eye in one direction, and then twist the opposite end to a similar eyelet, but at right-angles to the other. The whole thing completed, should be $\frac{1}{2}$ ins. long to ensure the satisfactory working. Use a long pin or a piece of stiff wire to make the pivot for the head. It is driven through the two sides, and the head itself, exactly at a point indicated on the patterns.

Drive it through all parts carefully, and then run a pencil mark on the side of the head, indicating where it comes in relation to the body. This will make it easier when you extract the pin and want to replace it.

Mechanism

A tiny screweye is fixed into the back of the head portion at the point indicated on the pattern, and this is threaded on one end of the wire. Take the wire through the slot in the base and fix the outside of the pivot wheel by means of the small screw, as you can see in the detail. Now put the animal's head in place, push the pin through and test that the mechanism is running satisfactorily.

The other three wheels are now fitted on to the base by means of $\frac{1}{2}$ in. round-headed screws, keeping in line so all four wheels rest level when in use.

It may be that some added weight is required to the base to ensure that the wheels grip the floor sufficiently to revolve. If so, then it is a simple matter to add a strip of lead in the corners under the base. The lead-covered electric cabling will do nicely for the purpose.

Again test the running parts, holding the body and head in place, then take the body away, so the whole thing can be painted. The wheels can be left in the natural state, but the base can be black with a green ground. Before undertaking the final coat, it is as well to give a first coat of grey to allow it to soak in hard before applying the final bright enamel.

Of course, all parts must be thoroughly clean and smoothed down with glasspaper, and it is a good plan to take the wheels off while the painting is being done. In painting the base, you can add the line effect of the panelling which you can see in the finished drawing, but if this cannot be undertaken neatly, it is better to leave the side plain.

Painting

The body of the animal can be painted natural colours, a light brown being given the whole body, with a deeper colour of shadow on the underside, and chocolate or black striped effect. The full size drawing on the sheet is a useful guide for this painting. Before painting finally, add the ears, which are cut from tiny pieces of wood shaped as shown to a taper, and then glued in the position indicated. Add the eye, nose and mouth, painting the inside of the mouth.

Take the pin out so the head can be painted independently to ensure that when you have added the paint it still moves satisfactorily between the two side portions. When the paint is thoroughly hard, the whole body is glued on to the base at the position indicated, and a final test made with the head in place.

If you find the toy does not act as it should, it is probably because not enough weight is given to the base, and some more can be added. This, of course, largely depends on the surface of the material upon which the toy is used. It will act better on a carpet, for instance, than on a smooth table, but a little manipulation to ensure smooth running can easily bring about the desired effect. For pulling, a piece of string is fixed to an eyelet or staple driven into the front end of the face near the top.

SUPPLEMENT TO HOBBIES No 2874.
INLAID SERVIETTE RINGS AND PRESENTATION BOX

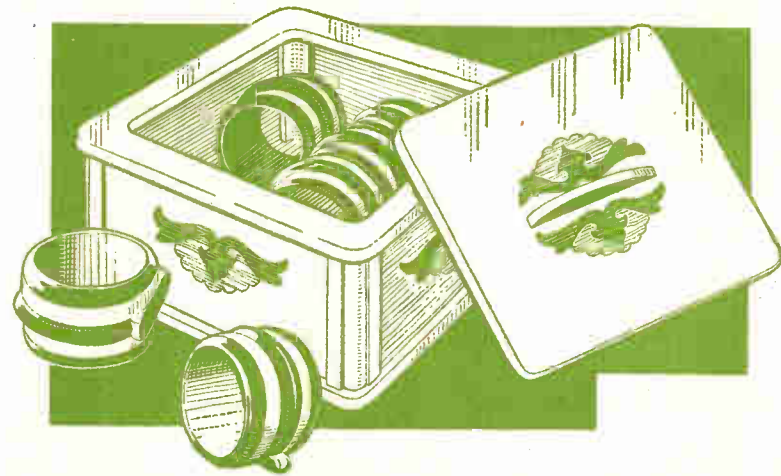

NOTE.—This design sheet is only presented free with the current issue of Hobbies and not with back numbers. Further copies may be obtained.

PIECE A. THE BASE. CUT ONE 1/4in.

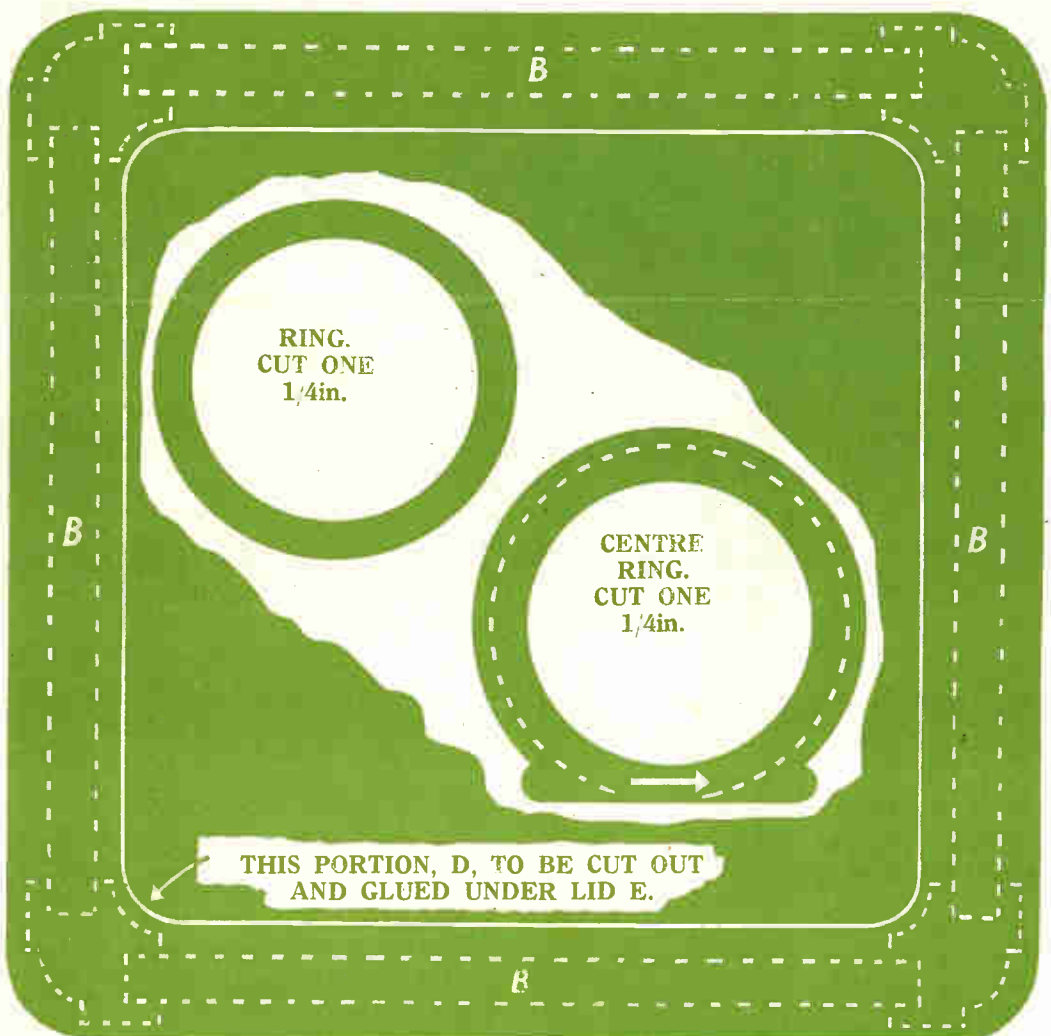

RING. CUT ONE 1/4in.

CENTRE RING. CUT ONE 1/4in.

THIS PORTION, D, TO BE CUT OUT AND GLUED UNDER LID E.

PIECE C. TOP. CUT ONE 1/4in.

NOTE. WHEN CUTTING SIDES B, ALLOW 1/6in ON EACH END FOR TRIMMING. SIDE B, AND MOULDING SHOULD FIT SNUGLY UNDER RIM OF TOP C, AS SHOWN BY DOTTED LINES.

THE ARROWS INDICATE THE DIRECTION OF GRAIN OF WOOD.

SIZE OF BOX 5 3/8ins. SQUARE.

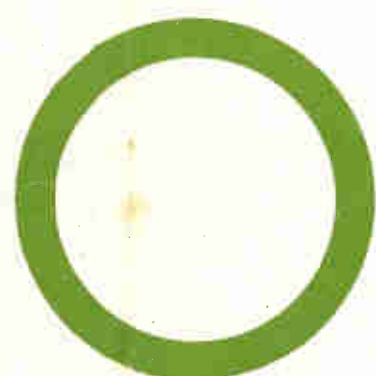
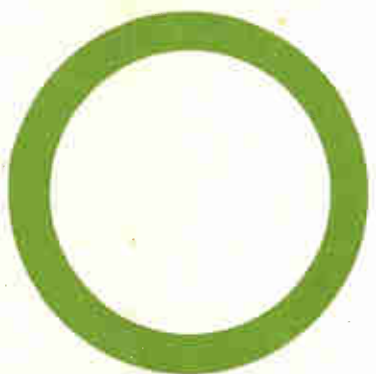
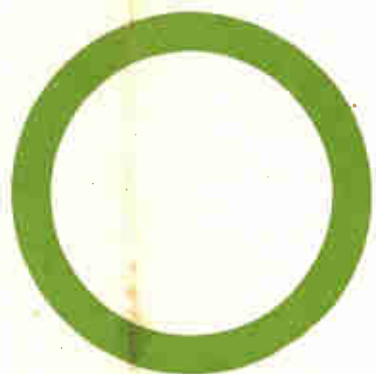

RINGS. CUT ONE OF EACH 1/4in.

PARTS SHOWN ARE FOR ONE SERVIETTE RING ONLY. ENOUGH WOOD IS SUPPLIED TO MAKE SIX.

HANDLE F. CUT ONE 1/4in. GLUE TO E.

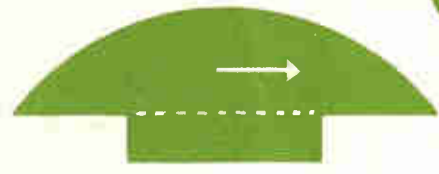

PANELS OF WOOD REQUIRED FOR THIS DESIGN
FIVE Q4
Materials for making this design are supplied by HOBBIES LIMITED, Dereham, Norfolk.
Price on application.



HANDLE F DRILL HERE

INLAY DECORATION. TO BE CUT OUT, STAINED AND GLUED BACK INTO PLACE.

LID E. CUT ONE 1/4in.



SIDE B. CUT ONE 1/4in.



SIDE B. CUT ONE 1/4in.



SIDE B. CUT ONE 1/4in.



SIDE B. CUT ONE 1/4in.

SERVIETTE RINGS AND BOX

THE articles which can be made from the patterns illustrated on the other side, form an ideal presentation gift set for any friends at any time. They are suitable for weddings, Christmas or birthday, with equal appeal, and are simple to make, as well as attractive in appearance. The wood used is $\frac{1}{4}$ in. thick throughout, and as the patterns are all simple, there is really no need to paste them down to the wood. They can be easily traced off or measured up with ruler, square and pencil.

The construction, too, incorporates a simple idea of inlaid panel work which is very distinctive and attractive. At the same time, this can be omitted if so

Incorporating the inlaid motif suggested on these sides and the lid, here is the way it can be undertaken and, of course, the work must be done before the parts are glued together. Use a fine fretsaw blade, and make as tiny a drill hole as possible at the point indicated on the lid pattern.

Go carefully round the cutting line, returning to the drill hole so that the upper part of the pattern falls out, then cut the second shaded portion, taking great care not to run the saw into the wood away from the design line, because every cut will show.

Staining

The two parts so cut out, are then

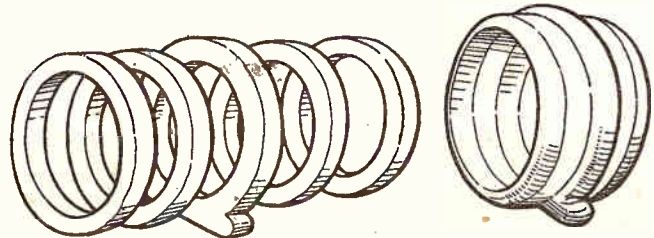

The plain cut rings before shaping

Shaped and glued together

desired, with the sides and lid left plain. Another alternative, of course, is the addition of a simple transfer put on. The box is made to hold six serviette rings, and wood sufficient for them all is contained in the kit provided.

Simple Cornering

It also includes the special grooved moulding which makes the construction of the box simple. This moulding is shaped at the corners, but has a groove just deep enough to take the $\frac{1}{4}$ in. wood of the sides. In construction, remember to get all edges perfectly straight, and all similar parts of a like size. The four sides of the box, for instance, must fit into the grooves evenly, and the whole lot have a square edge, top and bottom to ensure fitting between the base and lid portion without any gaping.

The base is a plain $\frac{1}{4}$ in. piece, and on it are glued the four sides. If you are

stained before they are returned to their former place and glued in position. A contrasting colour should be provided in each case, but the same pattern on each side should be the same colour throughout. Brown or green or even red ink can be used, and the little part is dipped in it for a short time, and then hung to dry before being returned to its original position in the side with the addition of glue on its edges to fix it.

Gluing

When all four sides are complete, glue them into the corner grooved moulding, then glue the whole thing down squarely on the base. To get the bottom edge flat, rub the box frame on a sheet of glasspaper laid flat on the bench. If thought fit, one or two screws can be added from the underside into the sides, but if so, their heads should be countersunk below the surface of the wood.

The rim (C) is the part which is added to the top edge of the moulding and sides. In cutting out this part, notice that the inside portion of wood is required to glue to the underside of the lid. Make a drill hole, therefore, at one of the corner curves and keep to the cutting line right through, until you return to the starting point. The piece which then comes out is the same size as the hole it leaves, and thus forms a stop piece if glued to the underside of the top. The lid piece has a similar overlay pattern as the sides, and the addition of a simple handle tenoned in at (F).

The whole box is complete and will look brighter if you give it one or two coats of clear varnish. The inside of the box, too, can be stained or coloured if you so desire.

Serviette Rings

The composition of the serviette rings is shown in the detail here. A centre ring is cut, and the outer edge rounded nicely with glasspaper. Four more rings slightly smaller are then cut, and the outer edge of the outer two is also rounded. The circles can be marked out with pencil compasses instead of pasting down the patterns, the radii required being shown in the drawings.

Now stain the centre ring and the two outer ones with their curved edges. Dip in colour and leave for sufficient time for the stain to soak well in. Hang up to dry, and then glue them together with the other two. The centre ring, as you see, should project beyond the outer ones, and the whole thing can be given a glossy coat of varnish finally. If this varnish soaks in, then give it two or three more until it remains dry.

The inside of the ring can well be coloured with enamel or paint or, of course, if you have a very dark stain, black or brown, this may be used so the inside of the ring does not show the length of the stained parts. The half dozen rings made, will stand neatly in the box and make a very attractive presentation either as a gift to a friend, or for a Sale of Work.

OUTER SIDE OF CHAIR. CUT THE TWO FRETTED PARTS FROM 3/16in. WOOD AND GLUE THEM TO THE INNER 1/8in. SIDES.

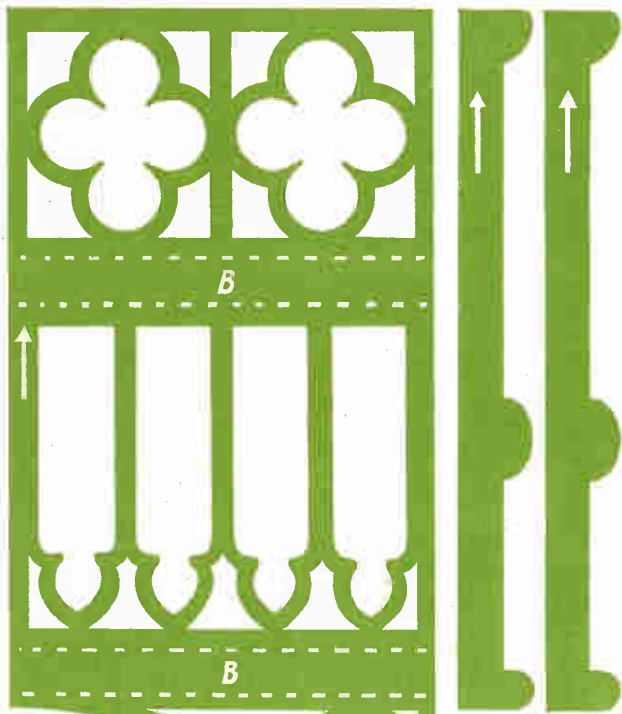
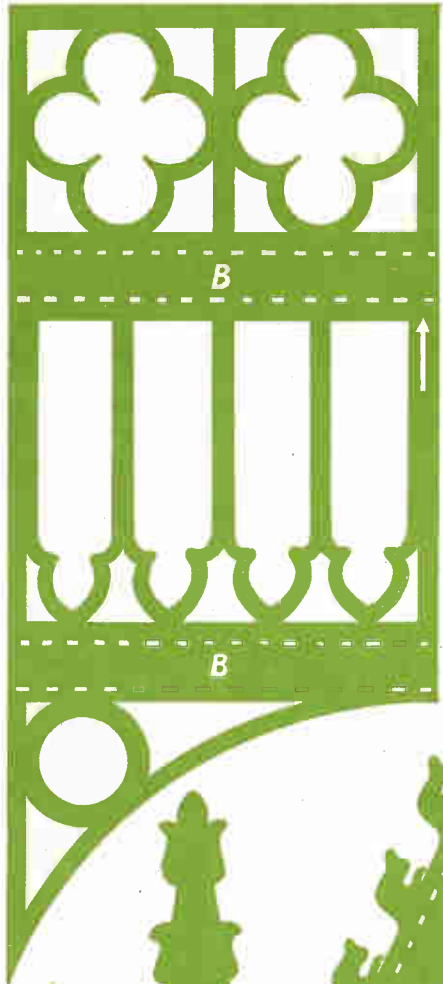

THE ARROWS INDICATE THE DIRECTION OF GRAIN OF WOOD.



OVERLAY STRIPS. TO BE GLUED ON OUTER SIDES OF CHAIR AT B. CUT THE FOUR FROM 1/8in.

ARM RESTS. GLUE TWO PIECES OF 3/16in. WOOD TOGETHER AND CUT THE ARM RESTS FROM THE 3/8in. WOOD.

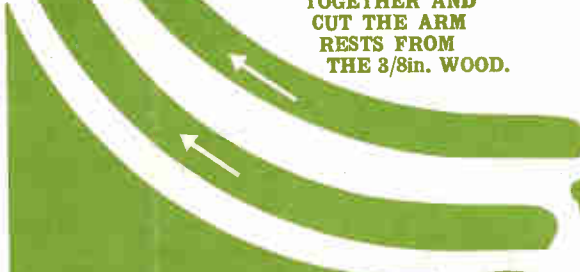

UPRIGHTS ON FRONT EDGES OF SIDES. GLUE TWO PIECES OF 3/16in. WOOD TOGETHER AND CUT THE UPRIGHTS FROM THE 3/8in. WOOD.

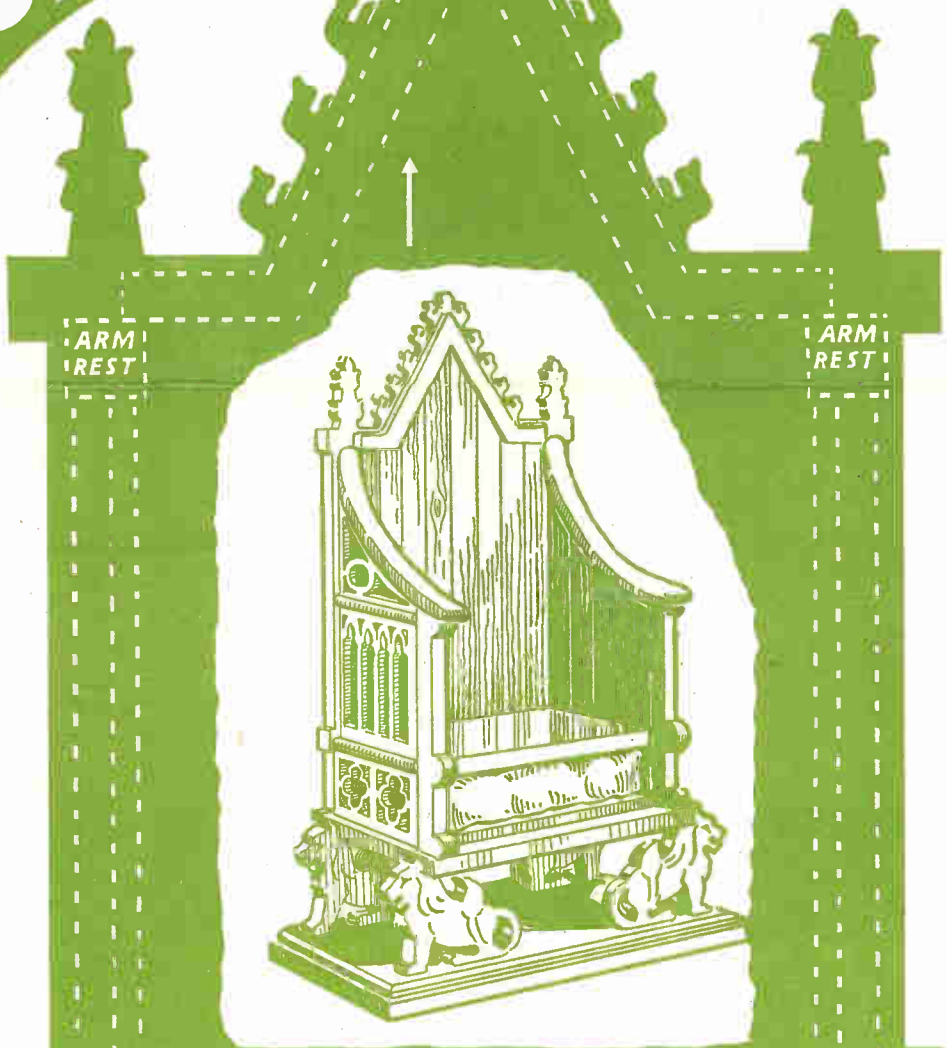

INNER SIDE OF CHAIR. CUT TWO 1/8in. TWO PIECES OF 1/8in. WOOD MAY BE PINNED TOGETHER AND THE OUTLINE CUT AT ONE OPERATION IF DESIRED. GLUE THE OUTER SIDES TO THESE PIECES.

SUPPLEMENT TO HOBBIES No. 2872.

MODEL OF THE **CORONATION CHAIR**

HEIGHT 10 1/2ins. WIDTH 6ins.

PANELS OF WOOD REQUIRED FOR THIS DESIGN

ONE H4 ONE H3 ONE G2

Materials for making this design are supplied by **HOBBIES LIMITED**, Dereham, Norfolk. Price on application.

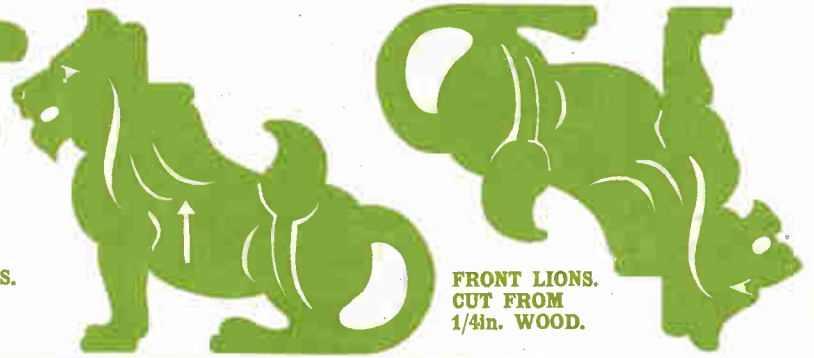

SECTION ON ARM RESTS.

FRONT LIONS. CUT FROM 1/4in. WOOD.

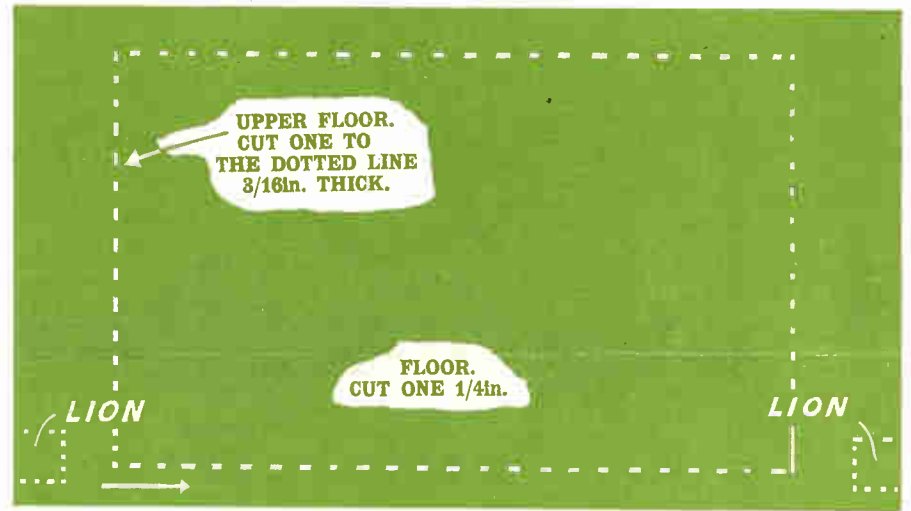

UPPER FLOOR. CUT ONE TO THE DOTTED LINE 3/16in. THICK.

FLOOR. CUT ONE 1/4in.

LION

LION

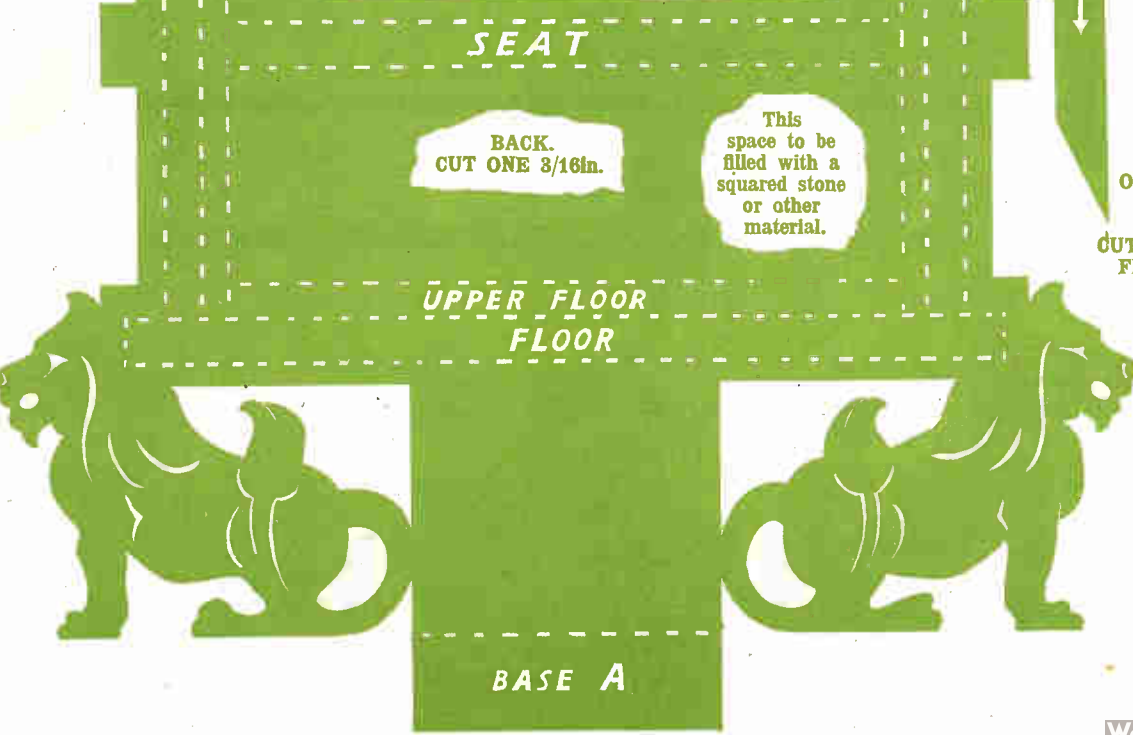

BACK. CUT ONE 3/16in.

This space to be filled with a squared stone or other material.

UPPER FLOOR FLOOR

BASE A

OVERLAY. TOP OF CHAIR. CUT THE TWO FROM 1/8in. WOOD.

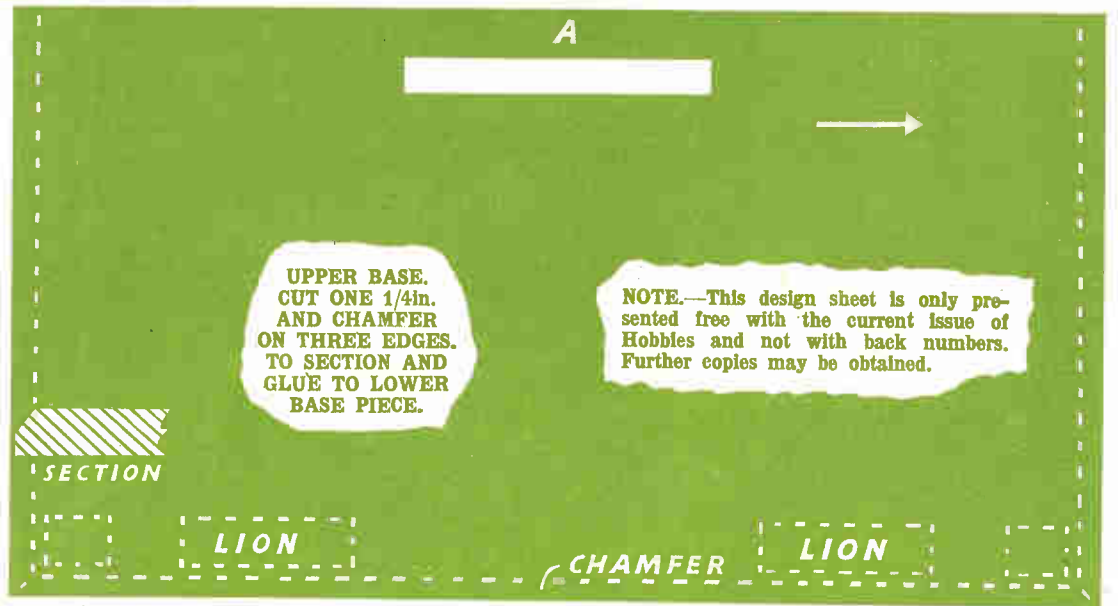

UPPER BASE. CUT ONE 1/4in. AND CHAMFER ON THREE EDGES. TO SECTION AND GLUE TO LOWER BASE PIECE.

NOTE.—This design sheet is only presented free with the current issue of Hobbies and not with back numbers. Further copies may be obtained.

SECTION

LION

CHAMFER

LION

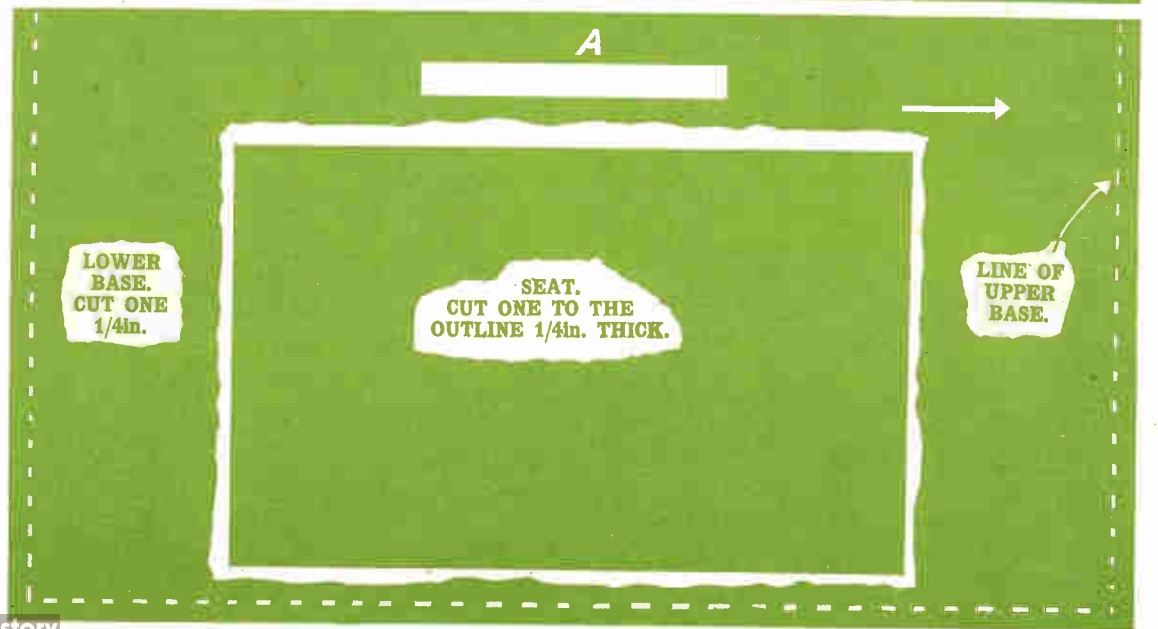

LOWER BASE. CUT ONE 1/4in.

SEAT. CUT ONE TO THE OUTLINE 1/4in. THICK.

LINE OF UPPER BASE.

How to make our small model of THE CORONATION CHAIR

MOST people know of the historical Coronation Chair used for the crowning of Kings in Westminster Abbey, and the model shown here is a replica of it, easily made in wood from the patterns printed on the other side. The Chair is of solid wood, supported by four metal lions at each bottom corner.

Beneath the seat is the famous Coronation Stone brought from Scone in Perthshire to Westminster Abbey by Edward I in 1296, where it still serves its historic purpose. Now for the making of our model.

Thin Wood

The wood used in the construction is $\frac{1}{8}$ in., $\frac{3}{16}$ in. and $\frac{1}{4}$ in. thick, and one each of the Hobbies panels is sufficient for all of it. The finished model, of course, should not be painted, but will be stained a suitable dark shade in keeping with the antiquity of the actual Chair. The patterns are shown full size, and should be copied off to the wood.

In the case of the fretted patterns, of course, these can be stuck down with paste, but then the outline of the back should be redrawn on to the wood direct so you may still have the actual design pattern sheet to which to refer. This is rather essential because the dotted lines on the pattern of the back are most helpful in measuring off distances, showing positions of the various pieces concerned. All the parts can be cut first, but in doing so test out sizes where necessary. For instance, the seat and the upper floor are both alike with an exactly similar length to fit between the sides.

Base Fixing

The long tenon on the back (at A) must be cut to fit through the slots in the two pieces, and these in turn must be glued together coincident with each other so the tenon itself will slide through with hand pressure and without undue forcing. Note, too, that the pattern of the upper floor is shown dotted, but will have to be cut as a separate piece. It is $3\frac{1}{2}$ ins. long and $2\frac{1}{2}$ ins. wide.

You can build the whole thing up from the base, or if you prefer, make the actual chair portion as a complete unit,

and then fit it into the base itself finally. This base is composed of two pieces—the lower one which is a solid part except for the slot at (A), and the upper one which is slightly smaller. The upper base is glued to the lower one with both back edges in line. This allows a slight projection of the lower portion, whilst the upper edge of the top base will be chamfered slightly according to the shaded section shown.

The back can be fitted through the slot (A), care being taken that the flat edge of the lions rests snugly on the

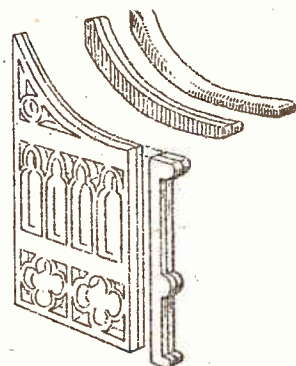

How the sides and arm rests are made

floor. The two front lions can be put in now by gluing them to the upper base to face outwards in the position shown by the dotted lines on the pattern.

Before finally gluing in, however, have the floor piece ready and see that it fits into the right-angle cut at the back of each lion's head. The back edge of the floor, of course, is glued to the back itself, and fitted there $1\frac{1}{2}$ ins. upwards from the base. Each side of the Chair is composed of two pieces, one fretted and one plain, and the detail herewith shows the construction of the whole side.

Inner Side

The fretted piece is glued to a similar part cut to outline only to form the inner side. To ensure this similarity, the parts can be pinned together when the outer edge is cut round as one piece. After cleaning, glue the two parts together.

On the front edge, a solid upright is

formed, again by gluing two pieces of $\frac{3}{16}$ in. wood and cutting to the shape shown. Notice that this complete thickness is a little wider than the actual seat, and so will project slightly on each edge. At the top, the shaped arm rest is fitted. Glue two pieces of $\frac{3}{16}$ in. wood together, and then cut to the outline shown, afterwards rounding them off to make a shapely curved portion. If, of course, you have a solid $\frac{3}{16}$ in. piece of wood, it will save the trouble of gluing the two together in every case.

The Arm Rest

The detail here shows the two pieces of the arm glued, and then how it is shaped. Here again there will be an overlap on each side. The two sides should be completed, and are then glued to the back with the upper floor at the bottom, and the seat portion $1\frac{1}{2}$ ins. above it. Glue the parts securely to the back and ensure that they are at right-angles all round.

An ornamental top is provided by the angular overlay, cut in two pieces and glued flat to join at the apex. On each side there is also a rounded bead. These strips are cut from $\frac{1}{8}$ in. wood and then glasspapered half-round so they can be glued two on each of the sides at the position marked (B) on the pattern, and as can be seen in the picture of the finished Chair.

Stained Finish

The actual construction is now complete, and the finished work should be finally cleaned and stained. Get the whole of the model dark, with the appearance of weatherbeaten oak, and do not attempt to add a polished or painted finish. The space between the seat and upper floor should be filled with something to represent the stone mentioned at the beginning.

Possibly a piece of natural rock stone or limestone could be roughly shaped and slipped into the aperture provided. It should not be more than $1\frac{1}{2}$ in. thick and $3\frac{1}{2}$ ins. long. The baseboard, of course, can be coloured flat or polished black, and the carving of the lions can be made more shapely with a penknife or small file. These lions actually are metal, and can be stained much darker or even painted a flat metal colour.

SUPPLEMENT TO HOBBIES No. 2870.
THE WALTZING CAT
MECHANICAL PULL ALONG TOY

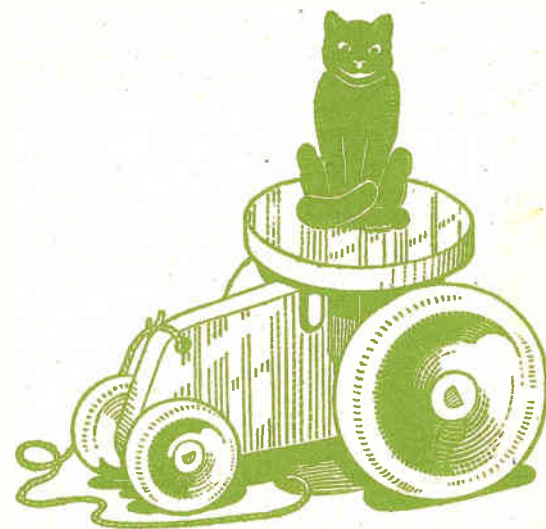

SIZE 9½ins. HIGH, 7½ins. LONG.

PANELS OF WOOD REQUIRED FOR THIS DESIGN
TWO ND 8 ONE G 4
 Materials for making this design are supplied by HOBBIES LIMITED, Dereham, Norfolk.
 Price on application.

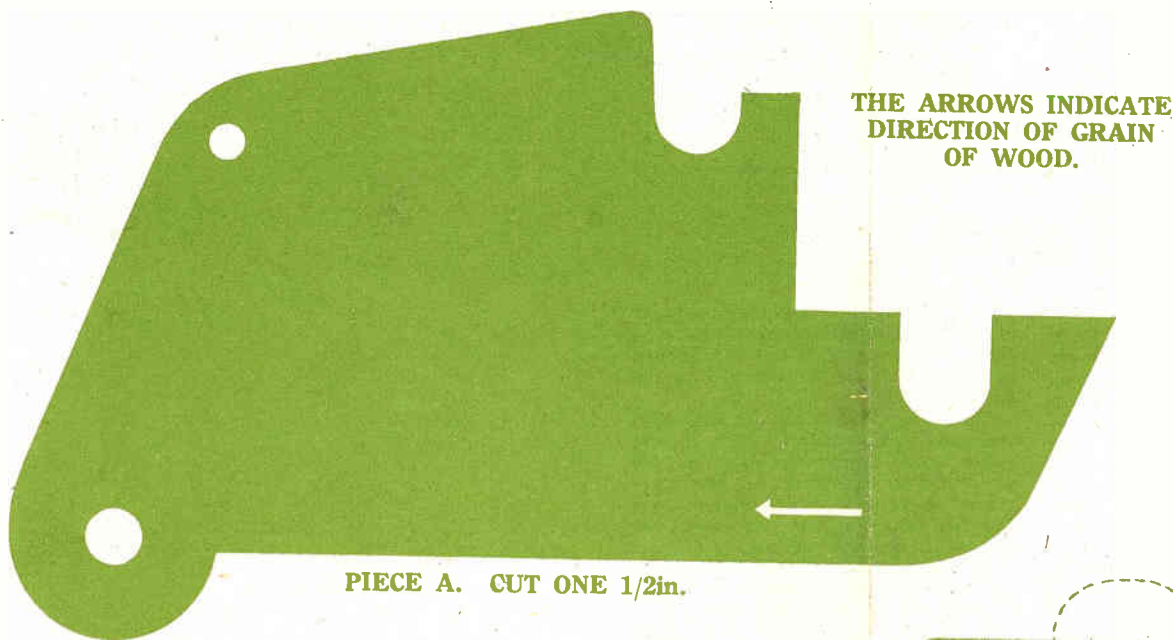

THE ARROWS INDICATE DIRECTION OF GRAIN OF WOOD.

PIECE A. CUT ONE 1/2in.

WASHERS J. CUT ONE OF EACH 1/4in. AND GLUE TO AXLE AND 4in. WHEELS.

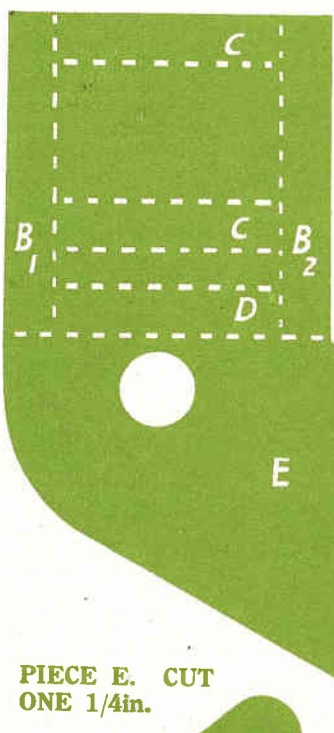

PIECE E. CUT ONE 1/4in.

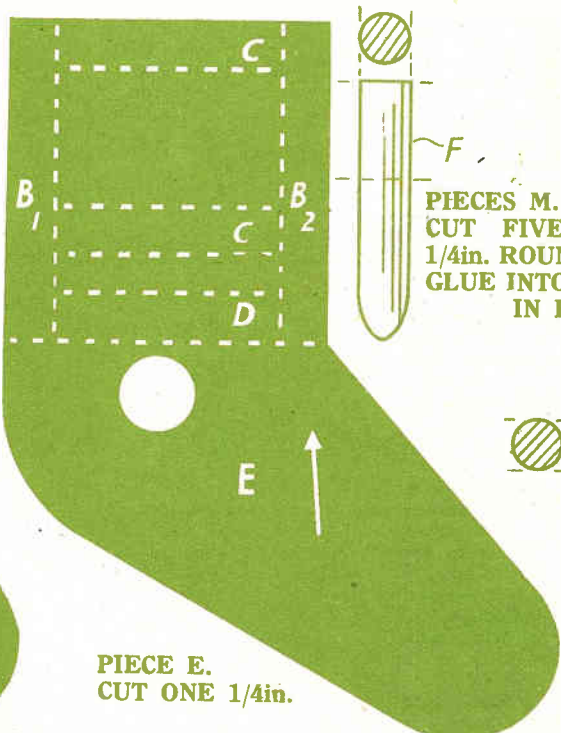

PIECE E. CUT ONE 1/4in.



4" WHEEL

PIECE K. CUT ONE FROM 1/4in. ROUND ROD. A HOLE MUST BE BORED IN ONE OF THE LARGE WHEELS AND PIECE K WEDGED IN TIGHTLY.

PIECES M. CUT FIVE FROM 1/4in. ROUND ROD. GLUE INTO HOLES IN F.

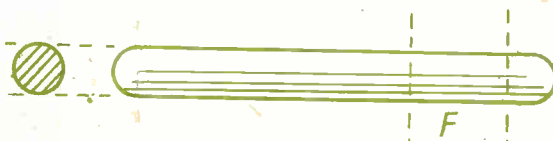

SPINDLE L., CUT ONE FROM 1/4in. ROUND ROD. ROUND OFF THE ENDS AND GLUE INTO CENTRE HOLE OF DISC F.



FRONT AXLE N. CUT ONE FROM 1/4in. ROUND ROD.

NOTE.—This design sheet is only presented free with the current issue of Hobbies and not with back numbers. Further copies may be obtained.



CUT THIS OVERLAY FROM 1/4in. WOOD. ROUND OFF AND GLUE TO CAT.

THE CAT. CUT ONE 1/2in. AND PAINT BLACK.

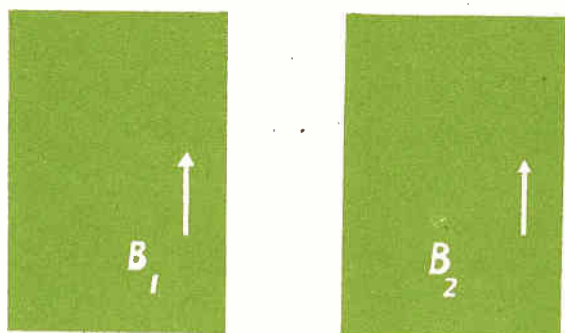
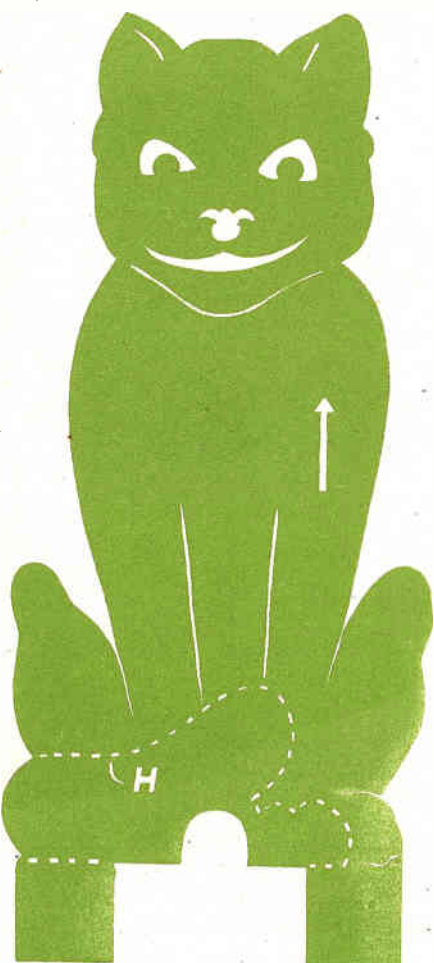

PIECES B. CUT ONE OF EACH 1/4in.

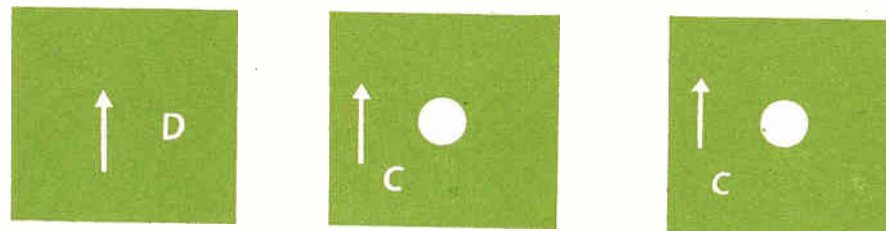

PIECES C AND D. CUT ONE OF EACH 1/4in.



LOOSE WASHERS I. CUT ONE OF EACH 1/2in.

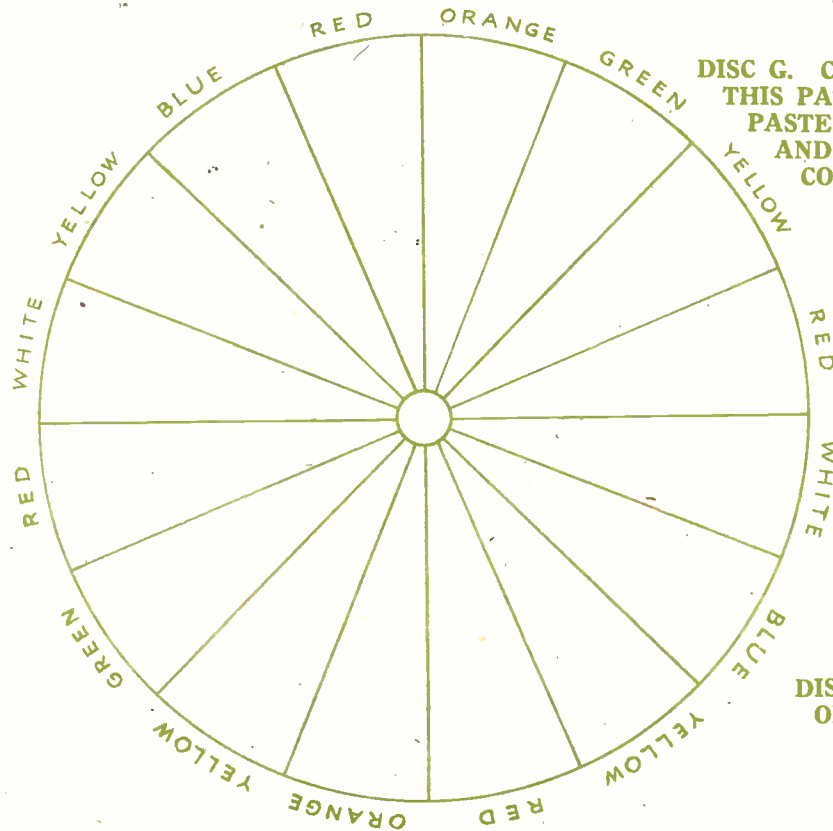

DISC G. CUT OUT THIS PATTERN, PASTE TO CARD AND COLOUR.

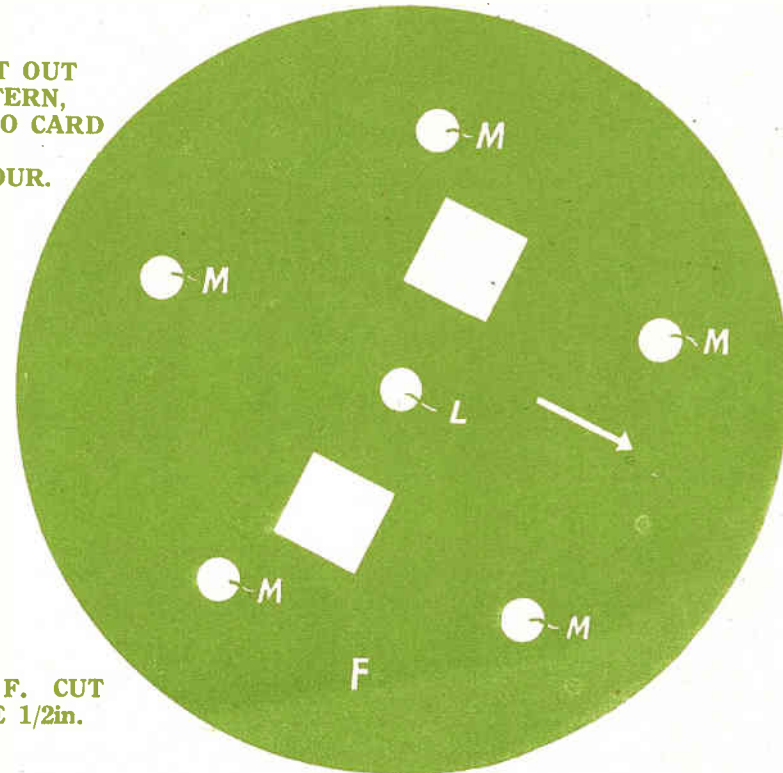

DISC F. CUT ONE 1/2in.

PRINTED IN ENGLAND.

The Waltzing Cat Toy—

THIS novel mechanical toy is simple to construct with the fretsaw and a few tools, and when completed, is made attractive by colourful painting, such as appeals to any youngster. The parts required are few, and the details herewith show the general construction of the mechanism. When the toy is pulled along, the black cat sitting on the top platform, waltzes round and round.

If you prefer, you can also add a coloured card disc which further adds to the attractiveness. Indeed, there are several alternatives. You can omit the cat altogether and prepare a variety of

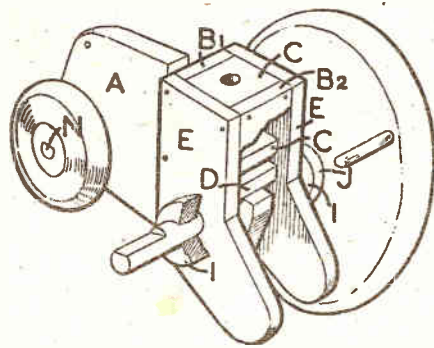

discs in colour. These discs, as they revolve, blend into all sorts of shades as different ones are added.

A pattern for one is shown where various shades are depicted. As this revolves, it alters the overall colouring according to the speed of turning. Apart from this type of disc, you can have one with just quarter colours on it, or rings of colour extending from the centre, or a whirl-shaped line, all of which make variety and popularity.

Wood $\frac{1}{4}$ in. and $\frac{1}{8}$ in. thick is required in the construction, with $\frac{1}{8}$ in. and $\frac{3}{16}$ in. dowel rod for axles, spindles, etc. The parts shown by the pattern should be redrawn on to the wood, and then can be cut with the fretsaw, taking care to get all edges straight and smooth. Clean the parts before fitting together. The building can be in the sequence of the lettered parts, commencing with the

main portion of $\frac{1}{4}$ in. stuff at (A).

The box portion which you can see in the cut-away view at Fig. 1 must be made up in the sequence shown. The drop pieces at the back, by the way, are to prevent the toy toppling over if it happens to tip. When making the box of (B), (C), (D) and (E), complete it with the exception of the front portion (B1). The position of the inside pieces (C) and (D) are marked on the pattern of (E). The central hole in (C) should be bored through the two parts at one operation to ensure the hole being in the same position. There is no hole in (D) as the spindle in the revolving top rests upon this piece.

Get the box together (apart from B1), adding small fretnails if you think advisable, to hold the inside parts. The piece (B1) is now glued and screwed to the straight upright edge of piece (A), and then the rest of the partly

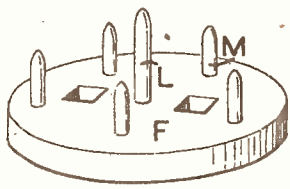

constructed box can be put to it and finally glued in place with (D) resting on the projecting bracket of (A) (see Fig. 1).

This should bring the axle holes in all three pieces in line, and the main axle itself can then be fitted. This is a $4\frac{1}{2}$ in. length of $\frac{3}{16}$ in. rod, and the position of the various parts is indicated by the dotted lines. The rod turns loosely in the main framework, with the wheels and washers glued on. Each end of the axle is flattened down a little, which will allow a wedge to be fixed in to prevent it turning in the wheel itself.

Bore the holes on the small side in the wheels, and glue on firmly. Before this, of course, you must have added the $\frac{1}{8}$ in. loose washer and the fixed washer (J) which is glued to axle and wheel. In one of the wheels only a $1\frac{1}{2}$ in. spindle is fitted to project inwards. A hole is bored through the wheel about $\frac{1}{4}$ in. from the rim.

This position is important, and is clearly shown by the dotted indication on the spindle pattern. It can also be seen in the detail at Fig. 1. Get this spindle glued firmly.

The front wheels (2ins. in diameter) are glued at the end of a $1\frac{1}{2}$ in. spindle which works loosely through the hole previously bored in part (A). There is a space between the inside of the wheel and the part (A), but this allows for turning the toy when pulling.

An upside-down picture of the revolving top platform is given at Fig. 2. Cut the holes (M), then glue in the $2\frac{3}{4}$ in. spindle (L). This projects $1\frac{1}{2}$ ins. above the centre, with the other end projecting about $\frac{1}{4}$ in. and similarly rounded off. You should test out the mechanism now by putting this long spindle (L) into the hole in the top of the toy and seeing it engages when the main wheel turns.

The platform spindle should revolve loosely in the top so that when the toy is pulled along it will revolve freely and at quite good speed when the article is in motion. As there is only one wheel spindle, the top can revolve independently of the rate at which the wheel is turning.

The cat has a small overlay (H) on the front at the foot, and when the part is cut from $\frac{1}{4}$ in. wood you may like to carve it with penknife or other cutting tool, roughly to the shape of a cat itself. The stub joints at the bottom, fit into the holes of the platform but are not glued in place. It should be possible to stand the cat in place with hand pressure only.

The whole thing is complete so far as construction is concerned, and painting can now be undertaken. Use poster paint or bright enamels after having put one coat of flat paint on first to body in the wood. Bright reds and yellows should be introduced, although, of course, the cat itself is black with appropriate colouring for eyes, nose, mouth, etc.

If you have your own particular type of cat, you could probably copy this more or less realistically. The kit provided by Hobbies contains not only the wood, but the necessary wheels and spindle rod for all parts.

SUPPLEMENT TO HOBBIES No. 2868.

TOY CARAVAN

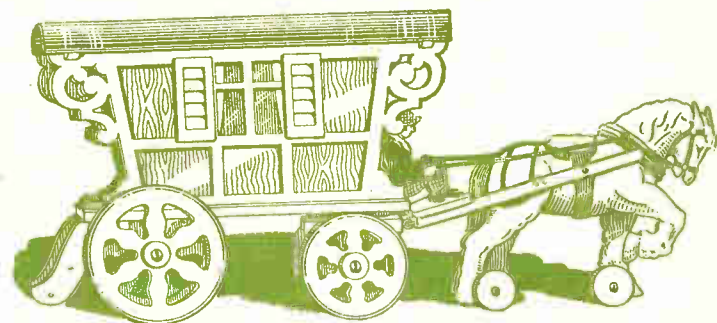

PANELS OF WOOD REQUIRED FOR THIS DESIGN
ONE H4 ONE G4 ONE G3
THREE GD6
 Materials for making this design are supplied by HOBBIES LIMITED, Dereham, Norfolk. Price on application.

SIZE
 14ins. LONG,
 6ins. HIGH.

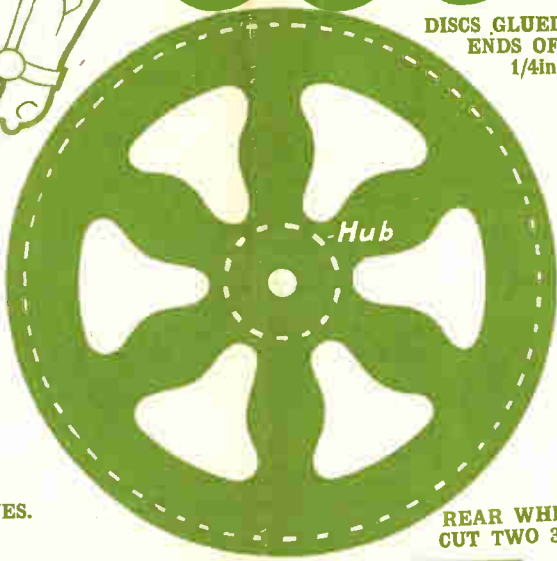
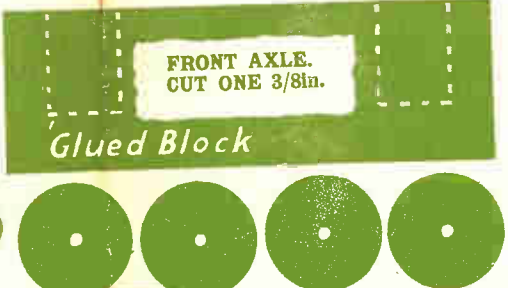
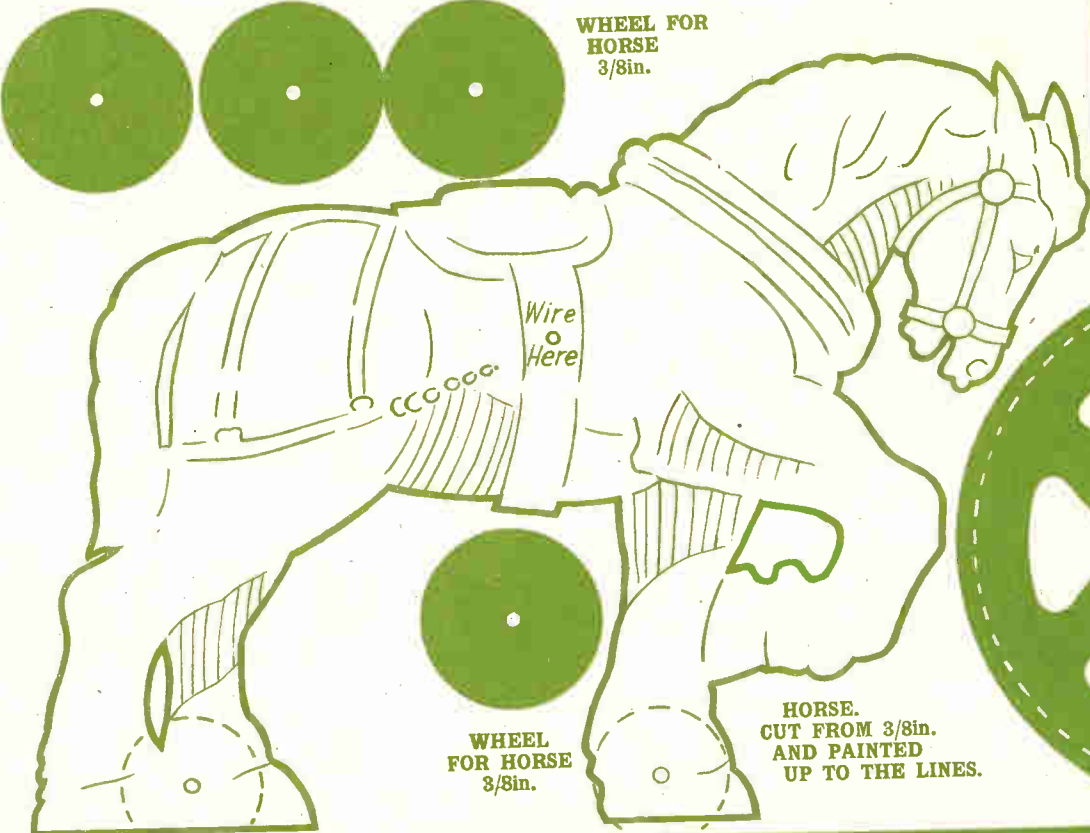

REAR WHEEL.
 CUT TWO 3/8in.

8 1/4"
 4 1/2"
 ROOF
 MADE FROM
 STOUT CARD.

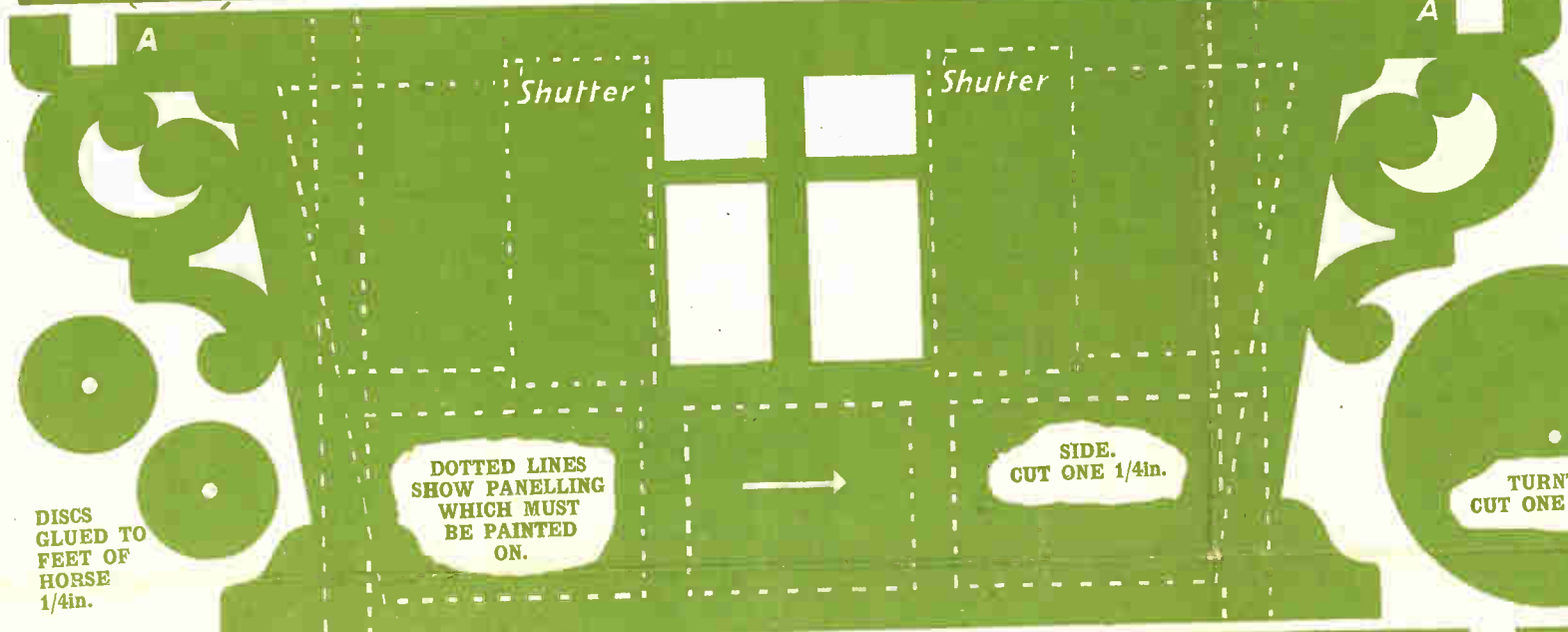

SIDE.
 CUT ONE 1/4in.



FRONT
 WHEEL.
 CUT TWO
 3/8in.

DISCS
 GLUED TO
 FEET OF
 HORSE
 1/4in.

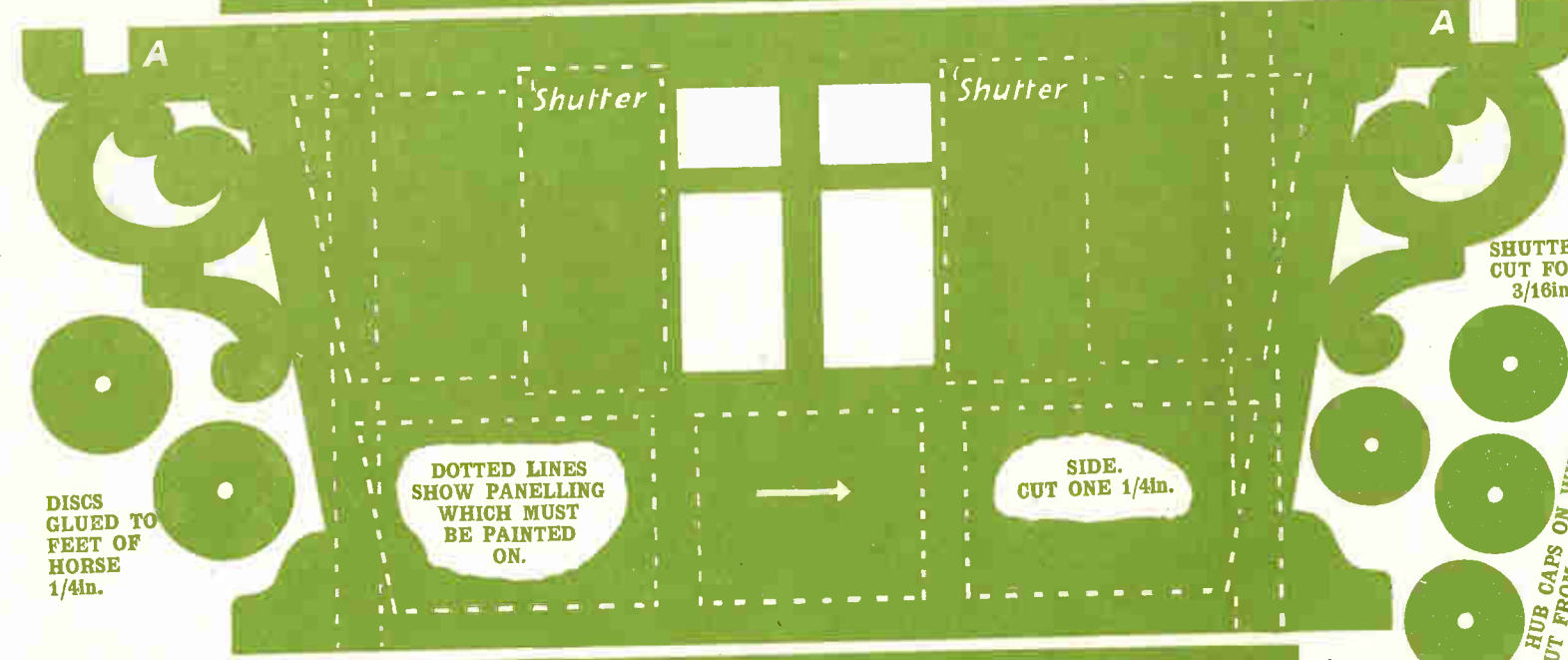

SIDE.
 CUT ONE 1/4in.

DISCS
 GLUED TO
 FEET OF
 HORSE
 1/4in.



TURNTABLE.
 CUT ONE 3/16in.

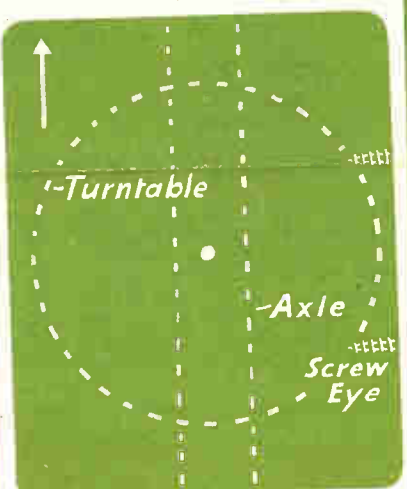

FRONT AXLE SUPPORT.
 CUT ONE 3/8in.



STEPS. SIDE.
 CUT TWO 1/4in.



SHUTTER.
 CUT FOUR
 3/16in.



Paint



GLUED
 BLOCK.
 CUT EIGHT
 3/8in.



TAILBOARD.
 CUT ONE 3/16in.



BACK
 STEPS.
 CUT
 THREE
 3/16in.

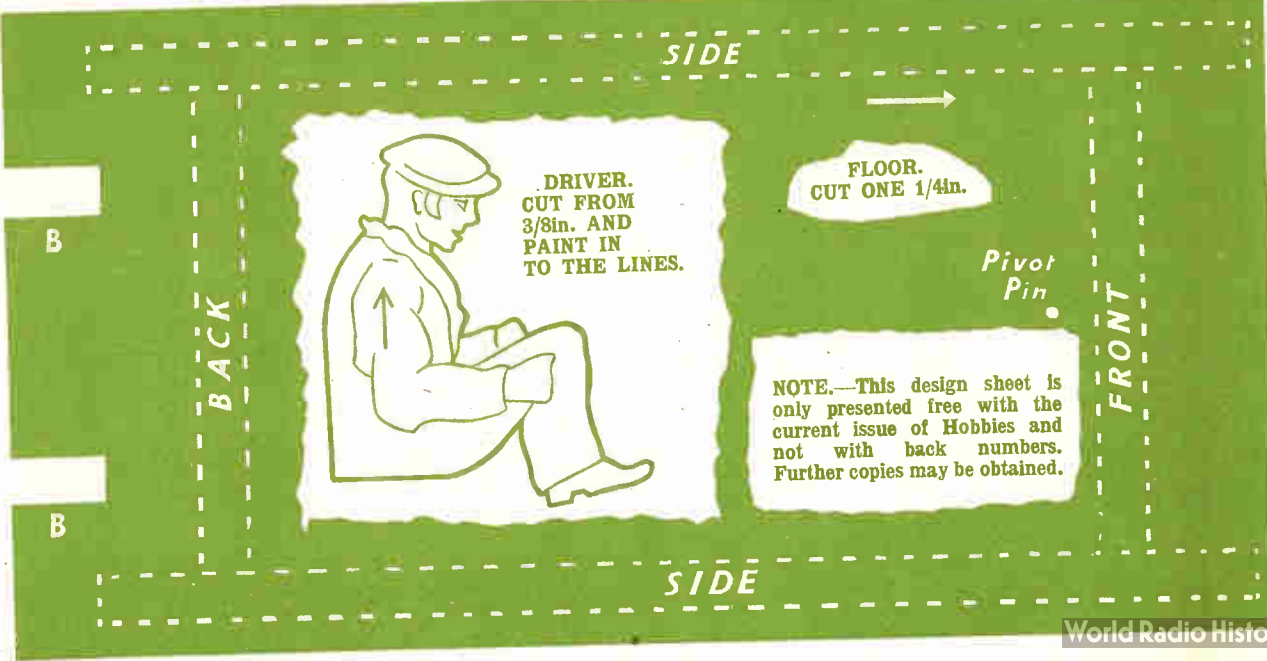

DRIVER.
 CUT FROM
 3/8in. AND
 PAINT IN
 TO THE LINES.

FLOOR.
 CUT ONE 1/4in.

BACK

FRONT

SIDE

NOTE.—This design sheet is only presented free with the current issue of Hobbies and not with back numbers. Further copies may be obtained.



BACK AXLE.
 CUT ONE 3/8in.

Glued Block

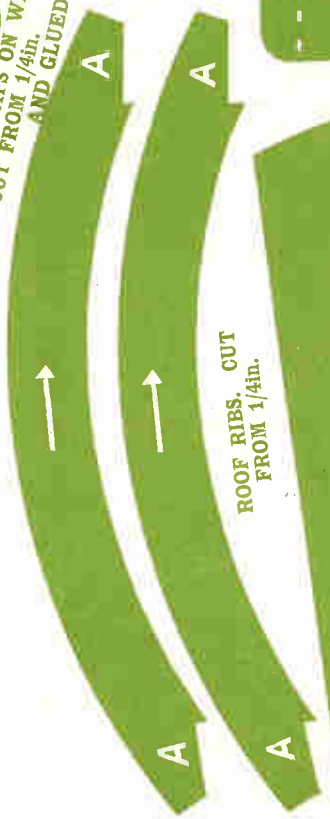

ROOF RIBS. CUT
 FROM 1/4in.

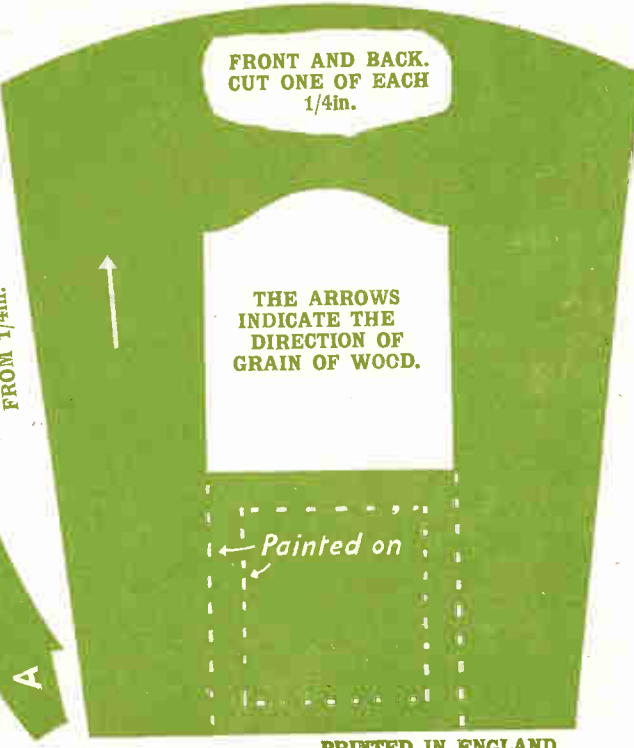

FRONT AND BACK.
 CUT ONE OF EACH
 1/4in.

THE ARROWS
 INDICATE THE
 DIRECTION OF
 GRAIN OF WOOD.

Painted on

THE toy caravan illustrated on the other side, can be completed from the patterns provided, with the help of these instructions. To have the sheet for reference, it is advisable to trace off the patterns direct on to the wood of the thickness suggested, the cutting out is done with the fretsaw, and the construction is straightforward. The finished article should be painted in bright colours.

The patterns themselves show the outline of the part to be cut, and also dotted lines indicating where other parts adjoin. These positions must be measured and marked out, and care taken to get a strong joint in every case, so the toy will stand up to the rough handling it is likely to receive.

Main Body

The main body of the caravan is built first as a complete unit. Cut the floor, two sides and two ends. The half door opening shown on the pattern of the front and back, should be cut in the back only. Fit this back and front between the two sides, setting it inwards just over $\frac{1}{2}$ in., as shown by the dotted lines on the patterns concerned. This four-piece frame is glued together firmly and

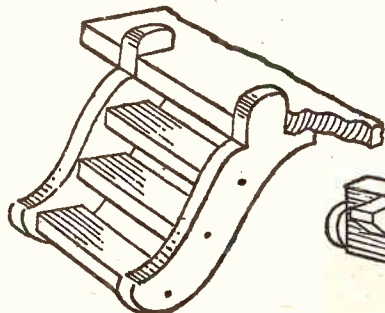

Fig. 1—The back steps

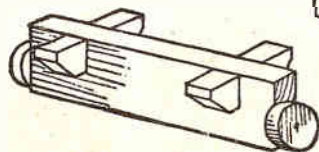

Fig. 2—The back axle

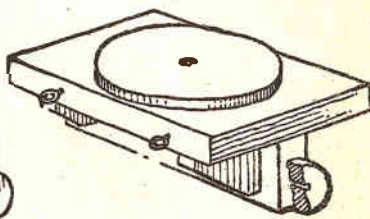

Fig. 3—Front turntable

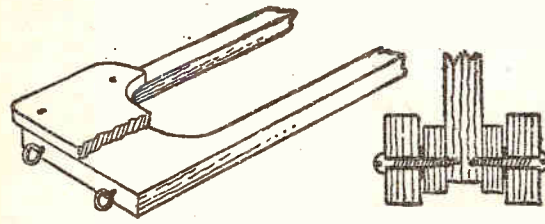

Fig. 4—Shafts and fixing eyes

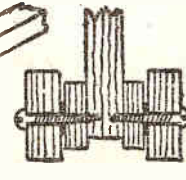

Fig. 5—Section of small wheel fixing

fillet pieces can be added inside in the corners.

As the sides slope outwards the angle at the bottom must be cleaned down to be flat. You could do this by taking the whole glued frame and rubbing it with a circular movement on a piece of flat glasspaper. Stiffening pieces forming the roof ribs are also cut and let into the extension of the sides at the point (A).

the wheels.

For the forward wheels you will need a movable portion such as shown in Fig. 3. The circular disc of turntable is glued to the front axle support. Now fit this piece underneath the floor with its centre point $1\frac{1}{2}$ ins. from the front. Have a flat-headed screw countersunk into the wood, but long enough to drive well into the floor and so serve as a

pivot. A good plan is to add a blocking piece inside the van into which the screw will turn. If possible, too, add a thin metal washer between the turntable and the floor, to reduce friction.

The axle bar is next built in the same manner as the other. It is glued across the front axle support as two angle blocks on each side, and the disc for the wheel pin on each end (see Fig. 3). Two tiny screw hooks are added to the front edge to link up with the shafts which can next be made (see Fig. 4). The tail-board is glued to overlap slightly each side, and the screweyes added to coincide with the others in the turntable portion.

The Horse

The horse is cut to the outline shown. If you prefer to have one made thicker, you can glue two pieces of $\frac{3}{8}$ in. wood together. There is still room for the $\frac{1}{2}$ in. board between the shafts. This thicker outline will give you the opportunity of carving and shaping the animal to make it more realistic. If you cut the two in this way, remember to get the right action for the legs, so that the two offside ones are cut on one board, and the two nearside ones are cut in the other. Note the position of the hole for the pivot pin which goes through the shafts both sides as well as the horse itself. A fairly stout pin with its ends turned over, will serve. Do not, how-

which the screw holding the wheels themselves can be driven. If you are using a double thickness of wood for the horse, the discs can be omitted. Here again, a thin washer between wheel and main body, will help in easy running. Have round-headed screws so that the parts can be taken off for painting.

The wheels of the caravan are simply circular discs cut with fancy spokes added on to the axle discs with screws, and if possible, washers between. The figure of the driver is cut to the outline shown, and after painting, is glued on the front of the caravan.

Painting

The rest of the work after cleaning, consists of painting. This should be done carefully to make a bright attractive finish. The markings of the horse can be painted on, the shutters, doors and windows can be indicated by lining if you follow the style shown on the picture of the finished article. There is no overlay to the sides, but the thick black lines would frame this up quite well. The shutter portion, too, is painted on in a contrasting colour from the caravan itself.

Paint the inside, add curtains to windows and doors, then glue on the roof. That part, too, should also be painted, possibly a dark brown or black.

The harness and trappings of the horse can be either painted, or better still,

added in thin strips of American cloth or very thin leather for realism. The reins, of course, run from the bit to the hands of the driver. As the wood throughout may be absorbent, the best plan is to give a complete coat of matt light paint to fill up the grain, then add a second one of the colour desired.



FRETWORK DESIGN No. 245 SPECIAL

SUPPLEMENT TO HOBBIES No. 2868.
Oct. 4, 1950.

— MODEL OF — FLORENCE NIGHTINGALE CARRIAGE

SIZE: 8 1/2 ins. LONG.
7 ins. HIGH.

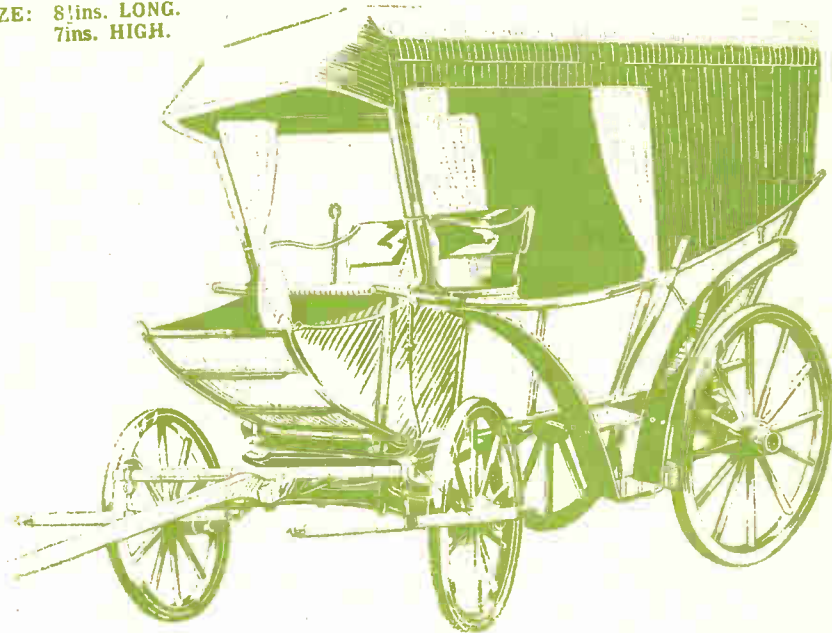

FLOOR (1) CUT ONE
1 1/4 in. SHAPE TO
SECTION.

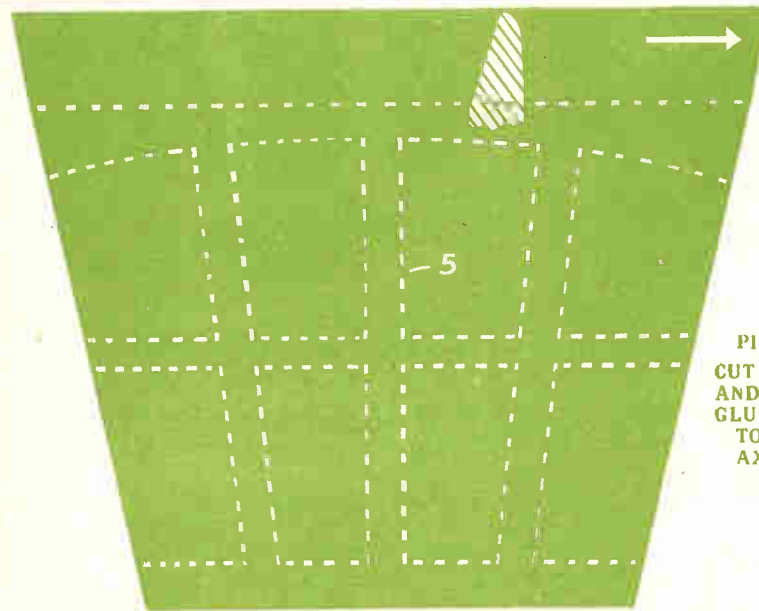

BACK (4)
CUT ONE 1 1/4 in.
SHAPE TO SECTION.

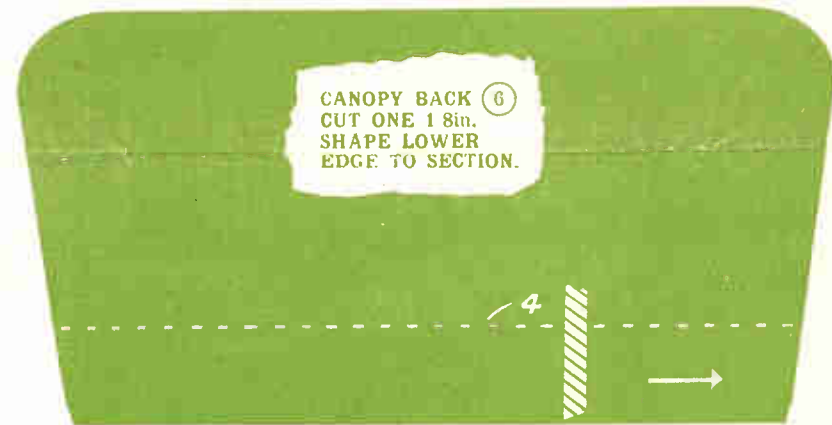

CANOPY BACK (6)
CUT ONE 1 8 in.
SHAPE LOWER
EDGE TO SECTION.



HOOD CROSS MEMBER (7) CUT TWO 1 8 in.



FRONT UPRIGHT (8) CUT TWO 1 8 in.

REAR UPRIGHT (9) CUT TWO 1 8 in.

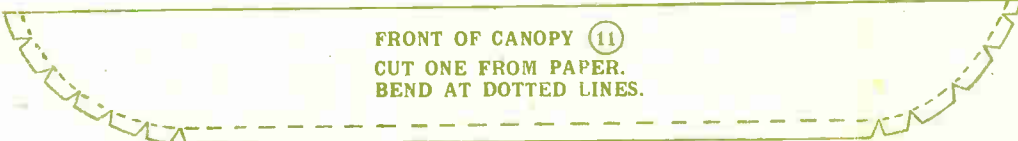

FRONT OF CANOPY (11)
CUT ONE FROM PAPER.
BEND AT DOTTED LINES.



DRIVER'S SEAT (20)
CUT ONE 1 8 in. AND ROUND OFF
FRONT EDGE TO
SECTION.



SEAT BACK (22) CUT ONE FROM
THIN WOOD OR CARD. BIND TO WIRE
STAYS (23) WITH THREAD.



PIECE (21) CUT
TWO AND GLUE
UNDER SEAT TO 3.

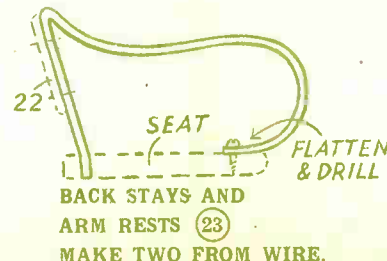

SEAT
BACK STAYS AND
ARM RESTS (23)
MAKE TWO FROM WIRE.

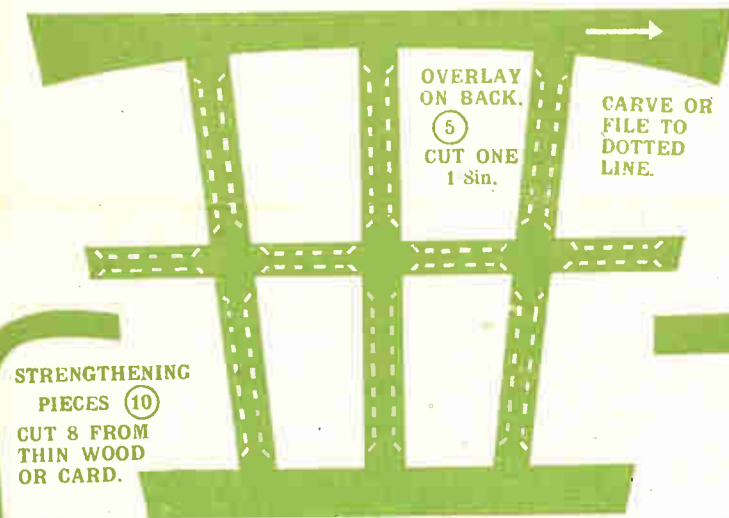

OVERLAY
ON BACK.
(5)
CUT ONE
1 8 in.

CARVE OR
FILE TO
DOTTED
LINE.

STRENGTHENING
PIECES (10)
CUT 8 FROM
THIN WOOD
OR CARD.

PIECE (12) CUT TWO 1 8 in.

PIECES 13, 14 AND 15.
CUT ONE OF EACH
1 8 in.

PIECE (19) CUT TWO
1 1/4 in.

HANDLES (24) CUT
TWO 1 8 in. GLUE TO 2.

PIECE (17) MAKE TWO
FROM WIRE.

PIECE (18) BEND TWO
FROM WIRE.

PIECE (16)
MAKE TWO FROM
WIRE. FLATTEN
ONE END AND
DRILL AS
SHOWN



DRAWBAR. CUT ONE 1 1/4 in. AND ROUND OFF.

PIECE (33)
CUT TWO FROM WIRE.

YOKE (34) CUT TWO 1 8 in.
AND ROUND OFF.

MUDGUARDS (39) CUT TWO FROM THIN CARD.

PANELS OF WOOD REQUIRED
FOR THIS DESIGN
**TWO Q4 THREE Q2
TWO P.P.M.**

Materials for making this design are supplied by HOBBIES LIMITED,
Dereham, Norfolk.
Price on application.

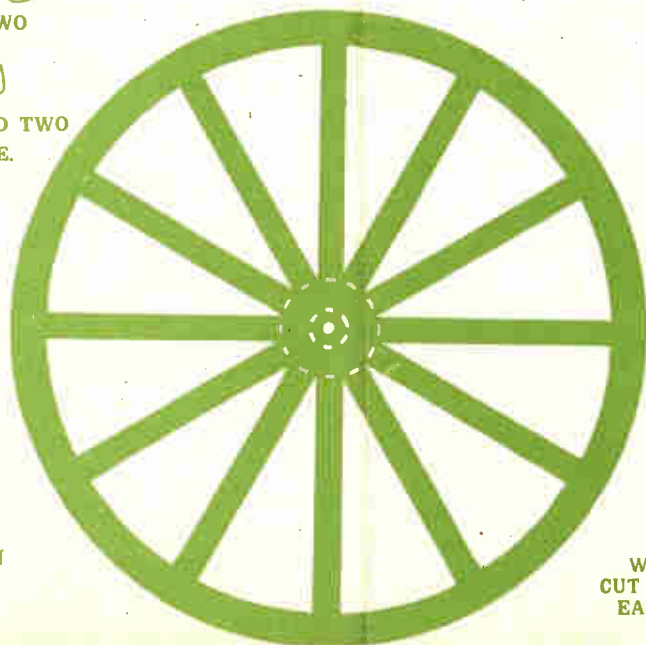

REAR
WHEELS.
CUT ONE OF
EACH 1 8 in.

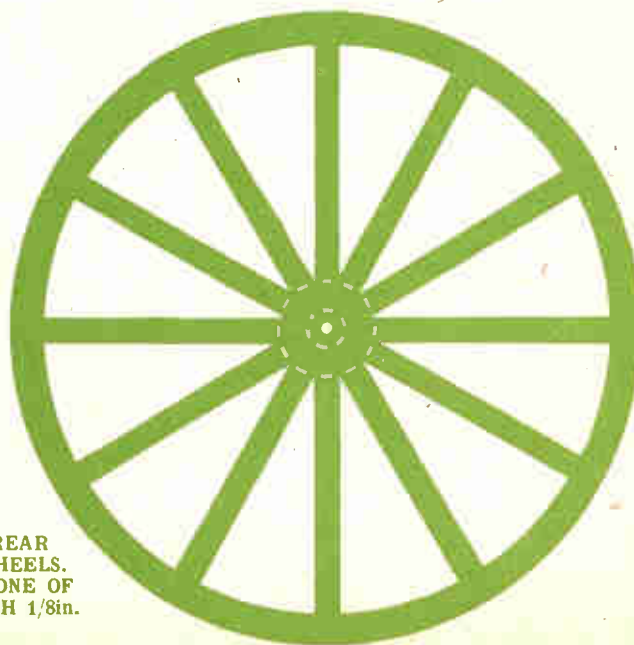

FRONT
WHEELS.
CUT ONE OF
EACH 1 8 in.

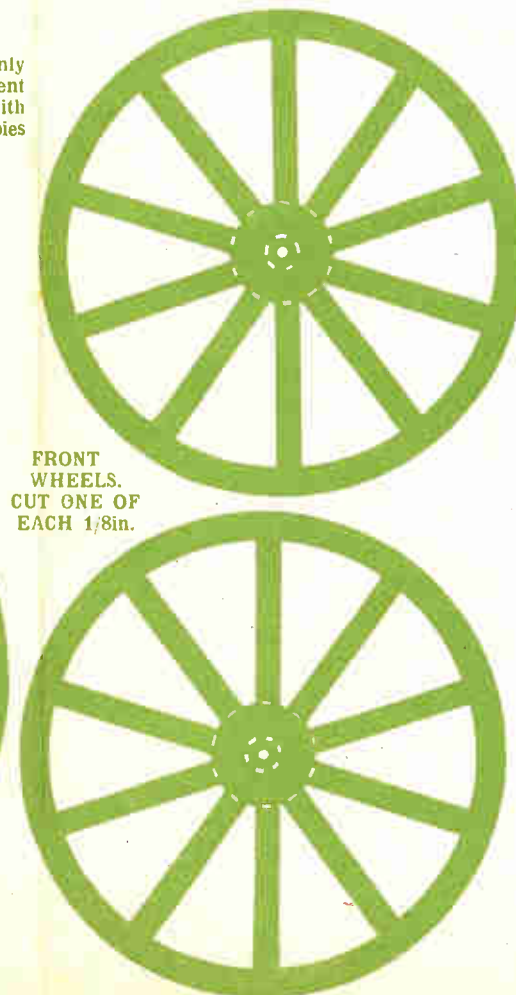

INNER HUB (40)
CUT FOUR 1 8 in.

OUTER HUB (41)
CUT FOUR 1 8 in.

HUB CAP (42) CUT
FOUR 1 8 in.

THIS IS THE CARRIAGE
USED BY
FLORENCE NIGHTINGALE
(LADY WITH THE LAMP,
DURING THE CRIMEA WAR,
1854-1856.

A COPY OF
THE CARD
HUNG ON THE
ACTUAL CARRIAGE.
CUT OUT AND PASTE
TO CARD.

PRINTED IN ENGLAND.

Constructional details for the Florence Nightingale Coach

THE historical model which can be built from the patterns shown the other side, and Hobbies kit and material, is a novel piece of work which can be undertaken by those experienced in this class of craftsmanship. The coach was the flimsy horse-drawn affair used by Florence Nightingale during the Crimean war, and the original is now proudly possessed by St. Thomas's Hospital, London, to whom we are indebted for details from which the preparation of this model was made. Pictures of the original from the Picture Post Library were also helpful.

The model itself is only 8 1/2 ins. long and is built of thin material to the pattern shown. The construction will require a certain amount of patience and knowledge of model making, apart from the use of the fretsaw for cutting, and the usual small tools for putting together. The parts shown are numbered in accordance with their constructional need, and the patterns shown should be marked direct on to the wood through carbon paper or by means of tracing paper.

Great care must be taken for accuracy, not only in the outlines, but in the shaping where shown, or the chamfering as indicated by the shaded sectional drawings and adjoining parts by dotted lines on the patterns concerned. A study of the sheet in conjunction with the drawings, should be made after reading these details, and speed should not be attempted in putting the parts together.

Commencing with the floor, note the back edge and two sides are chamfered to slope downwards. This must be carefully done in order that the sides and back themselves may slope outwards when fitted. The framework of the sides (2) is covered on the inside with very thin wood or card. The wood is the thin plywood provided in the kit, but card can be used if preferred.

Note that the side overlay should be glued at the front edge first, and that the opposite end will then project a little beyond the solid side itself. Cut out the back and glue on it the overlay (5), shaping something like the spokes of a wheel to reduce the thickness. This

shaping is cut according to the dotted lines, but, of course, does not pass right through the overall thickness.

Have the completed back ready before you fit in the sides, because this will help when gluing in place to keep the whole solid frame at the right angle, and the whole rigid. A cut-away view at Fig. 1 shows this, where you can also see the canopy back (6) glued to the sloping edge at the top of the main back.

The canopy itself is merely a stiff paper covering supported on cross framework. These supports are shown in Fig. 2 and the direction of grain should be noted in parts 7, 8 and 9. 7 and 8 form the top and side, and then a strengthening piece (10) is added round the angle each side to stiffen up (see Fig. 2). The base of Part 8 is glued on the similarly shaped projecting piece on the side. The rear upright (9) is dealt with in the same way. A study of the side and front view will help right through the construction.

Before the canopy is put on, the inside must be painted, and it is also advisable to add the seat. For this purpose, the paper can be omitted until later, care being taken not to damage the supports in the meantime.

At Fig. 3 are details of the front projecting portion forming the space for the driver's feet. The end pieces are of wire, fitted to the side, and then the space filled in with paper (it was leather in the original), and the cross struts added to the front at 13, 14 and 15. At right angles to the side, the wire (16) is fixed and the support given to its bottom end by part 19.

Where possible the end of the wires concerned should be flattened and held with a pin, or the ends turned at a point and driven into the wood. In gluing the paper behind the cross strips 13, 14 and 15, leave pin loose, so it can go inside the sides of the carriage and be glued to the floor.

The driver's seat is shown at Fig. 4 and is made of an end framework of wire, fitted to the seat portion (rounded at the front). The back (22) is fitted to the wire near the top by boring tiny holes in the wood and holding the part in place with strong thread drawn through and tied out of sight. Note the two

rests (21) which are glued to the main sides of the coach and support the seat. The chamfer on the top edge is necessary for the seat to lie flat and level.

Fig. 5 shows the fixed parts of the chassis. Part 25 is let in at the point shown by the dotted lines on piece 27, below which in turn, comes the axle portion 26. Note the pivot hole in the front end of the main arm (27) which is fitted under the floor (1) at the front end where shown. A long pin or piece of wire will hold this. Put the pin in place through the holes to give you the position in which the back end can be glued under the floor.

The pin is not finally fixed because the movable front chassis portion comes between this part (27) and the floor, and is pivoted in also. The drawing at Fig. 6 shows the construction of this front undercarriage built very similarly to the other. It pivots on the same pin, and at the front end a draw bar (35) is also pivoted. This draw bar is rounded and fitted with a cross pin so it can be lifted and raised when not in use. The yoke

portions are shown in the inside Fig. 6 as well as the method of fitting with wire and card to hang from the carriage portion.

At Fig. 7 you have the wire construction of the brake which is on the outside of the coach, blocks of wood being fitted on as brake blocks. The lever fits into a card or thin wooden ratchet (36), glued to the side of the framework. Fig. 7 gives you the two views showing how the handle lever should work both brakes by means of the under-floor rod which passes through the two support pieces (37).

Mudguards are

made of stiff card, bent as seen in Fig. 8 and held in place with short support wires. The steps (see Fig. 8) are completed of wire with card, the top of the wire being pointed for driving into the underside of the floor.

Each wheel is composed of a single piece of 1/4 in. wood, the spokes being rounded carefully. On the inside of each, the disc (40) is glued, and on the outside of each, the two parts 41 and 42 are also glued (see Fig. 9). Notice these last two have a small circular hole taken out of the centre to form a hollow hub and to allow the long fixing screw to be put through the wheel itself, leaving the hollow ends outwards. The holes for these fixing screws, by the way, should be bored before the circular disc is cut.

The wheels are screwed on to the axles formed by part 25. To give these a more solid bearing, little discs are formed by gluing on edge the tiny segments (27a) as seen in Fig. 10.

The paper canopy covering can be finally added of fairly stiff paper such as cartridge, or very thin card. It is curved

over the top, drooping slightly each side. Towards the rear end, the side is covered in with stiff paper to form a complete hood, but from there to the front, the model is open, apart from hanging 'curtains'. These can be of any light material draped back. They were, of course, originally intended for drawing to enclose the whole compartment. The front of the canopy is shown to a pattern (11), and the scalloped portion provides tabs which can be bent to form the rounded ends.

Having cleaned all parts, painting can be undertaken. The canopy hood should be glossy black. All framing and wheels are painted black, with red/gold, gold/red lining. Shafts and all iron work, of course, are also painted black. The interior trimming was of khaki cloth with seats black. The main panels of the coach were varnished woven wickerwork in its natural colour, and this could probably be painted on very carefully with straw coloured lines. The front and foremost panel are painted black.

A suitable panel of particulars is printed on the sheet. It can be glued to card or wood and stood by the model when on exhibition.



A worker on the actual coach undertaking renovations

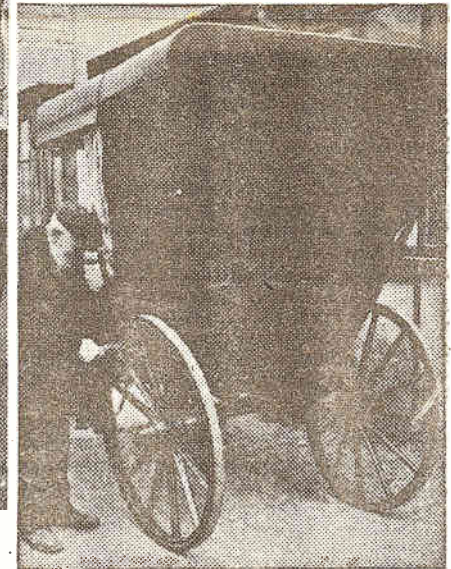

A rear photograph of the actual coach

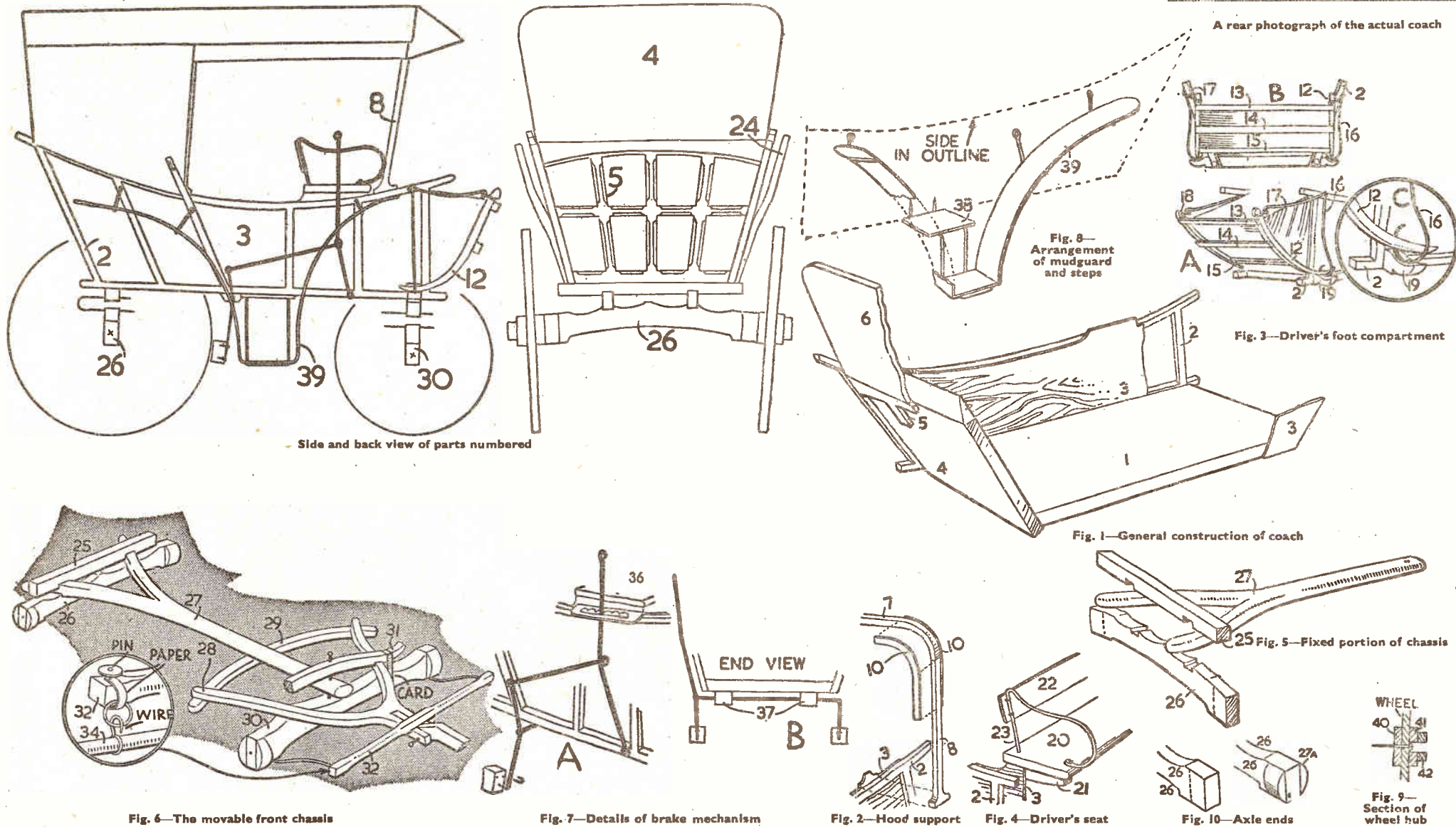

THE ARROWS INDICATE THE DIRECTION OF GRAIN OF WOOD.

SUPPLEMENT TO HOBBIES No. 286A.

OLD ENGLISH WEATHER HOUSE

SIZE:—WIDTH 8ins. HEIGHT 8½ins.



PANELS OF WOOD REQUIRED FOR THIS DESIGN
ONE K3 ONE H3
 Materials for making this design are supplied by HOBBIES LIMITED, Dereham, Norfolk.
 Price on application.

Note:—WOOD ¼ in. USED THROUGHOUT

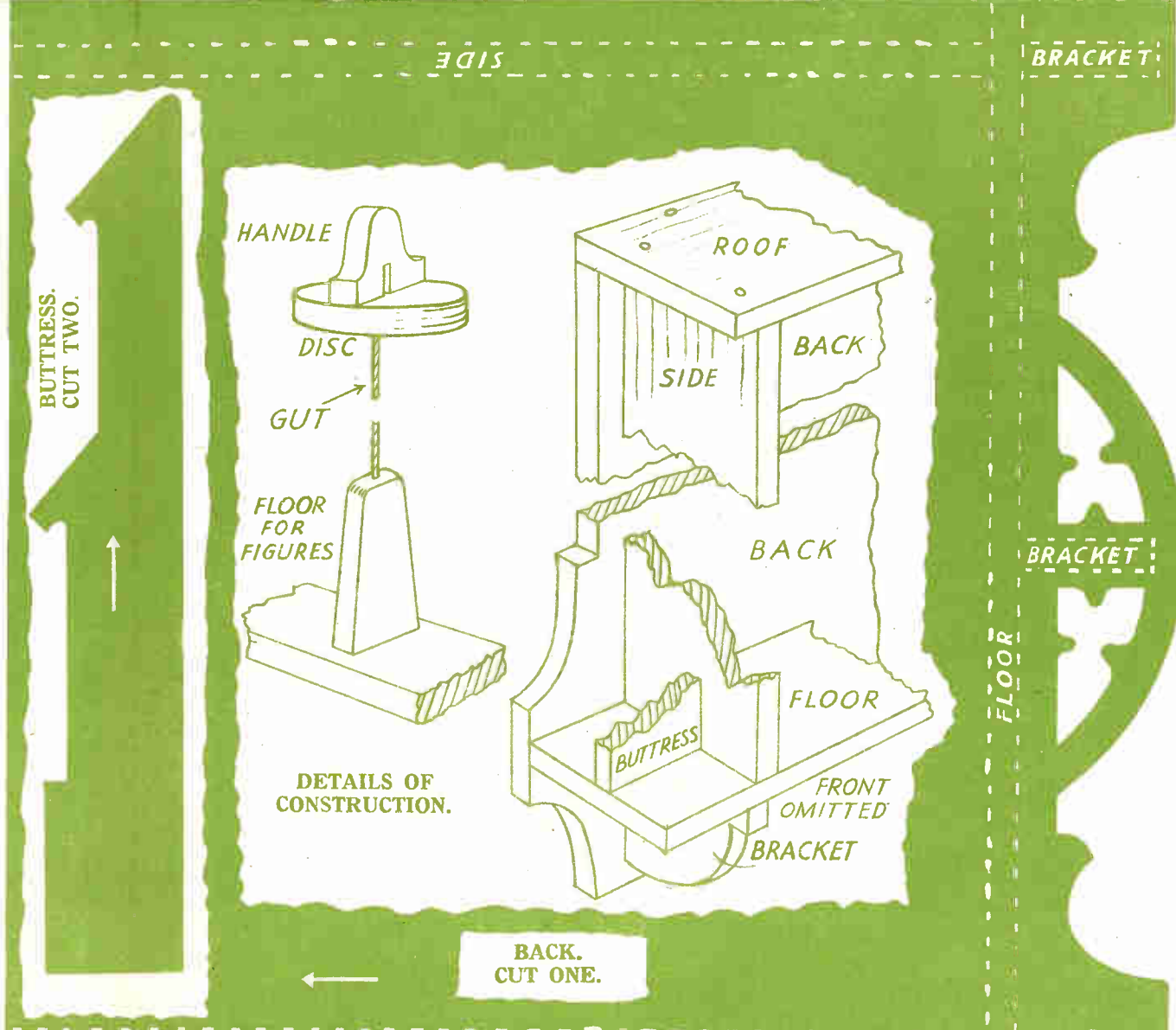
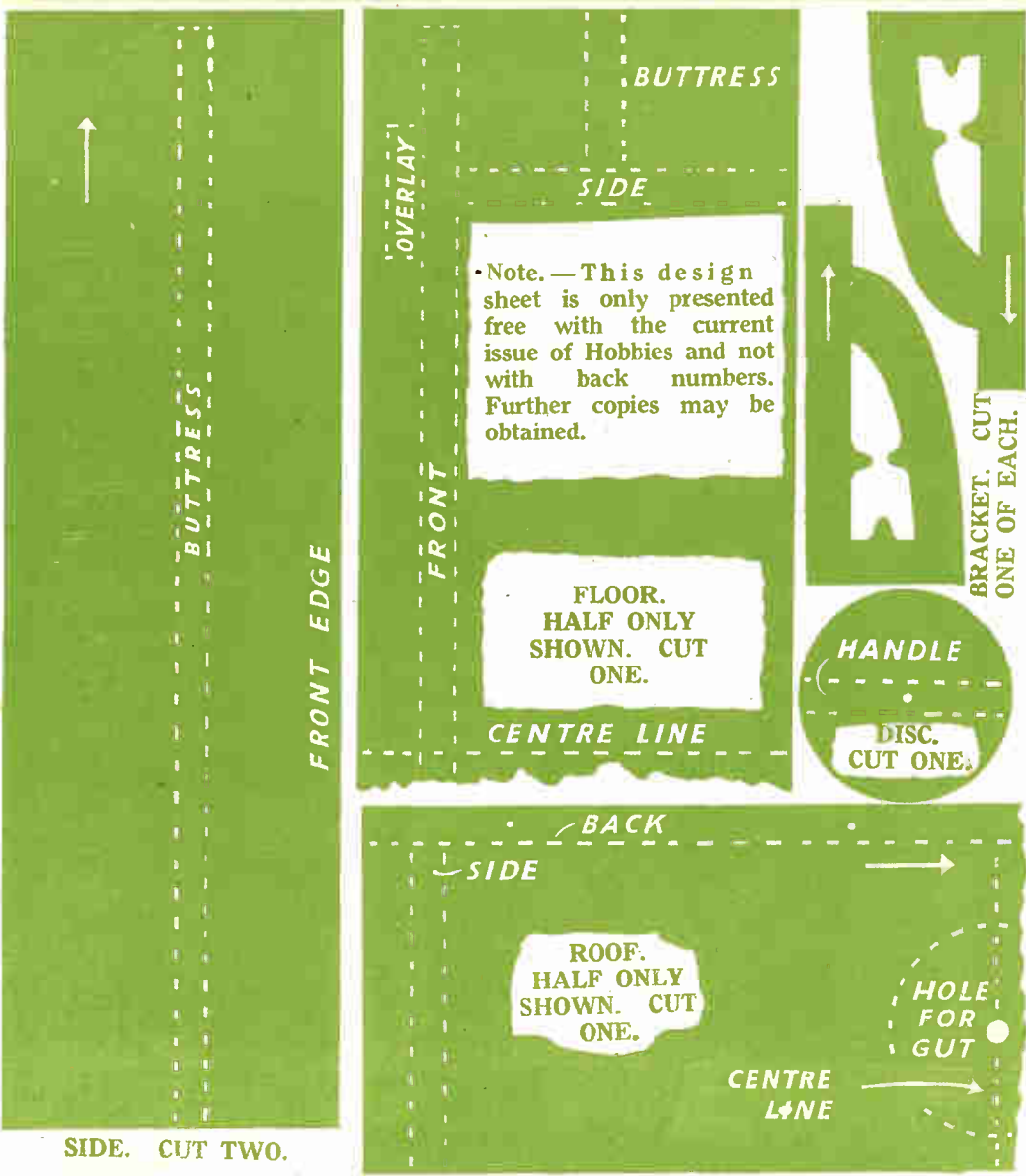
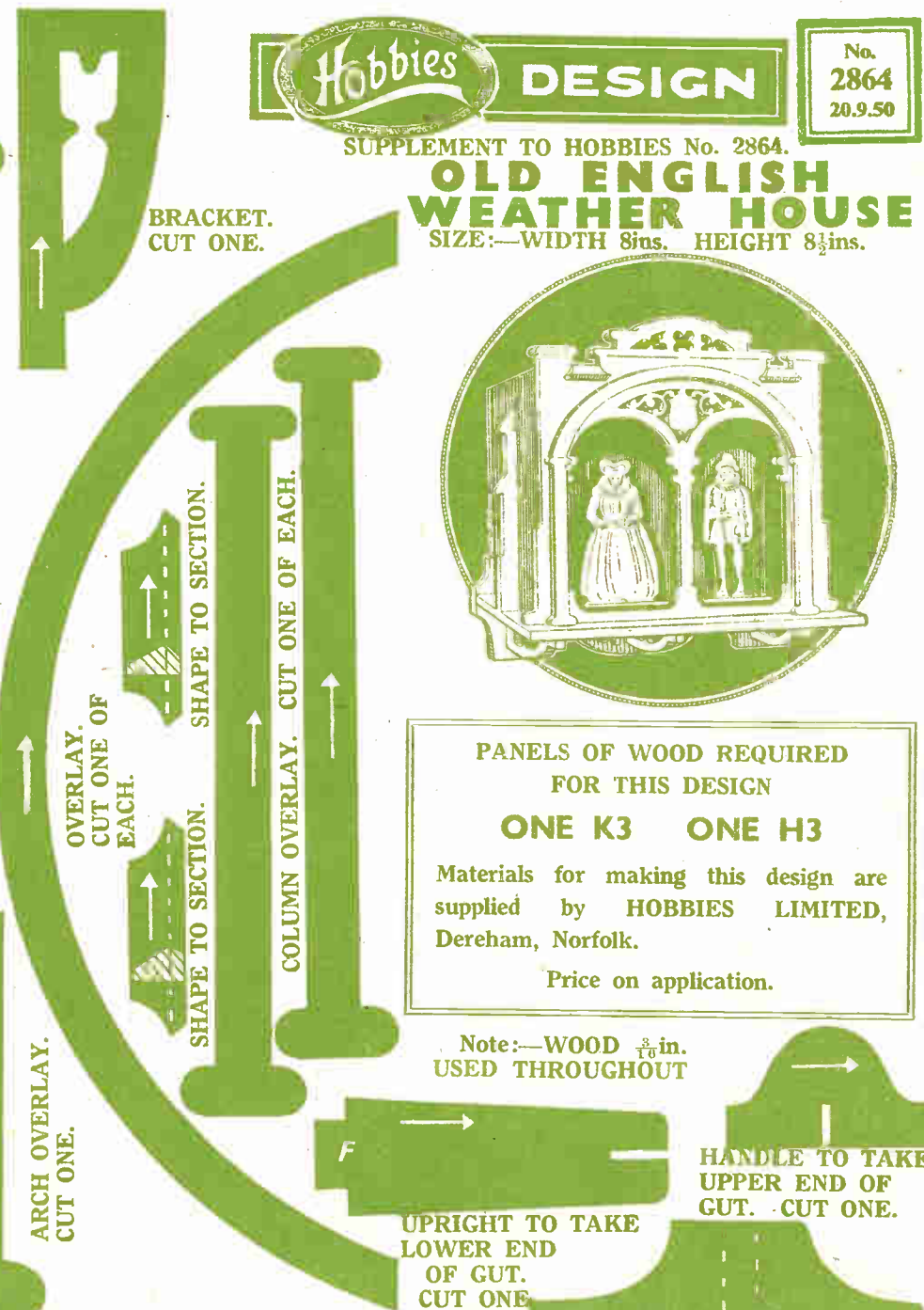

FLOOR FOR MOVING FIGURES. CUT ONE.

Note.—This design sheet is only presented free with the current issue of Hobbies and not with back numbers. Further copies may be obtained.

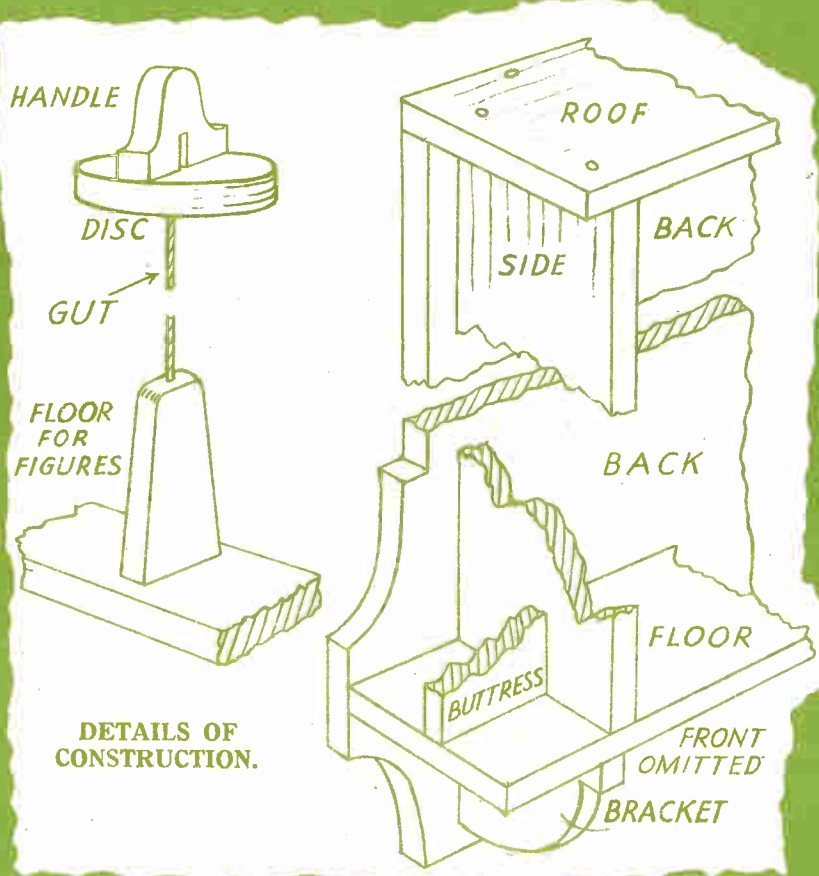

DETAILS OF CONSTRUCTION.

OLD-TIME WEATHERHOUSE

THE Old English Weatherhouse illustrated on the other side, is one of those novelties comparatively easy to make, and always popular. The whole thing acts on a hygroscopic principle, the humidity of the air affecting the piece of gut by which the actual figures are hung.

This gut stretches and contracts according to the atmosphere, and in doing so turns slightly. If this action is connected to the figures, when the gut turns in one direction, the appropriate figure comes either in or out of the house, then the weather alters and the gut contracts, then it turns the opposite direction and the other figure makes its appearance. In the kit of wood supplied, there is also a piece of gut suitable for the purpose, or you can obtain any short length of the fairly thick gut as used in a tennis racket. The thicker and more pliable it is, the better.

The article is designed on the Old English style, with typical Elizabethan figures and a frontage suggestive of the castle effect with shields incorporated into the arch decoration.

All the parts shown are cut from $\frac{3}{8}$ in. wood, and if you do not want to paste the actual patterns down, they can be traced off in the usual way or put through carbon paper. Notice that in the case of the floor and roof, half only is shown, but it is quite a simple matter to measure up the distance each side of the centre line given, and mark this out on to the board. All the parts are straightforward to cut with the fretsaw, and are afterwards cleaned with glass-paper.

The general construction is of a box effect, with two open archways in the front. Various dotted lines on the patterns indicate the position of the adjoining pieces, and these should be carefully measured and marked off to make it easier for putting the whole thing together.

You can build upwards from the back, having marked off thereon the position in which the floor and sides are to come. Run pencil lines along to indicate these positions, and note the side is set inwards $\frac{1}{2}$ in. from the edges of the back. You could immediately fix the three fancy

brackets which go into the rightangle under the floor, as this will serve to help to keep the whole thing rigid.

The roof portion can be fitted, and it is screwed into position so it can be removable for adjustment if necessary later. Notice that the roof extends to the edges of the back, and therefore overlaps the sides about $\frac{1}{2}$ in., as you can see by the constructional detail shown in the pattern of the back.

The front can next be cut, but before finally fitting, should have the various overlays glued on. These overlays consist of the column on each side of the door and the arc of the archway above. Notice the way of the grain and hold the wood close to the fretsaw to prevent breaking. If you have a piece of $\frac{1}{8}$ in. plywood this would probably serve the purpose better, being less likely to snap.

It is probably best also to test and fit the interior figures before finally gluing on the front portion. The two figures are cut from the waste wood where shown, and the markings of the folds of the dress, features, etc. are cut in with a sharp knife or a V-tool. These figures, of course, should be slightly rounded at the edges to make them more realistic, and those who are clever with the paint brush can colour the parts appropriate to the period.

A detail is given also showing how the gut is fitted to the platform holding the figures. This floor is first fitted with the usual upright which is glued firmly into the mortise at (F). On the top of the upright, you can bore a hole with a fretwork drill about $\frac{1}{2}$ in. downwards to take the end of the gut.

The gut will, of course, have to be squeezed into this, and glued there, but if you do not think you can make a satisfactory joint like this, then cut a slot in the end as shown in the pattern. You can glue this end of the gut in place, remembering to let it come from the centre of the upright in order that the floor may swing flat.

The actual length of the gut required is a matter of adjustment, and you must first make the disc and little handle (see details) which holds the top end. This disc and spindle rests on the roof, the gut passing through a hole previously cut at the point shown. A hole is bored

through the disc, and then a slot again put into the handle portion in which the gut itself is glued. Now you can regulate the height in order to cut the gut the right length before fixing.

The floor holding the figures must be $\frac{1}{2}$ in. above the floor of the actual article and, of course, before it is finally swung into place, the two figures themselves are fitted on at (D) and (E). There may be a slight difference in the actual weight of these two figures, causing the floor to tilt one side. This must be overcome by adding a tiny piece of lead behind the figure or even a further support of wood will get the desired result.

Having the figures and floor in place, thread the gut through the hole in the roof and adjust for length before gluing into the disc and handle as previously mentioned. The gut, of course, should be quite taut and straight, and the disc turned as required to keep the two figures level inside the house. Then when you see how the weather affects them, you can turn the disc to get them satisfactory.

When you first put it in, the dampness or dryness may have already affected the gut so that the platform should have the figure out. This actual first position of the figures themselves is only a matter of trial and error, and the changes in the weather will soon show you how they are affected.

Ornamentation to the outside is provided by simple additions. A buttress piece just for effect is glued to the side half way between back and front, then a tiny shaped overlay of imitation stonework is also added above and each side of the arch where the drop portion comes in the front.

These two small ornamental overlays are cut to the outline, and then have to be shaped up at the front for imitation stonework. The lower edge is chamfered sharply upwards for about $\frac{1}{8}$ in. and then the wood is tapered towards the back at the top. The shaded section on the pattern shows this clearly as an imaginary end view.

The whole article can be stained and given a coat of varnish or polish, or have the wood left in its natural state. Be careful, of course, not to let any colour or stain on to the gut.

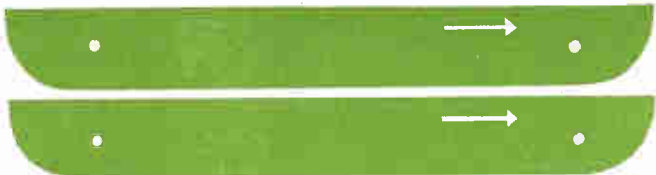

STRENGTHENING FILLETS FOR FLOOR. CUT FROM 1/4in. WOOD, AND GLUE TO ENDS AS SHOWN BY THE DOTTED LINES.

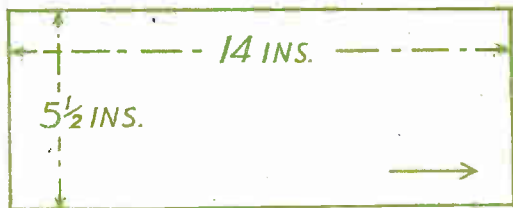

FLOOR. CUT ONE TO THE MEASUREMENTS GIVEN 1/4in. THICK.



No. 2860
23.8.50

SUPPLEMENT TO HOBBIES No. 2860.

TABLE NEWSPAPER RACK

PANELS OF WOOD REQUIRED FOR THIS DESIGN

TWO J4 ONE H4 ONE J3

Materials for making this design are supplied by HOBBIES LTD., Dereham, Norfolk
Prices on application

—SIZE OF STAND—

LENGTH—14 3/4 ins.
WIDTH—6 1/2 ins.
HEIGHT—7 1/2 ins.



SIDE. HALF ONLY SHOWN. CUT TWO COMPLETE SIDES 1/4in. THICK. ONE SIDE ONLY NEED HAVE THE FRETTED WORK INCLUDED.



LEFT HALF OF FRETTED PANEL. THIS TO BE PASTED DOWN TO THE WOOD TO CORRESPOND WITH THE RIGHT HAND HALF OF DESIGN.



NOTE.—This design sheet is only presented free with the current issue of Hobbies and not with back numbers. Further copies may be obtained.

END. CUT TWO 1/4in. GLUE THE OVERLAYS ON WITH EQUAL MARGIN ALL ROUND

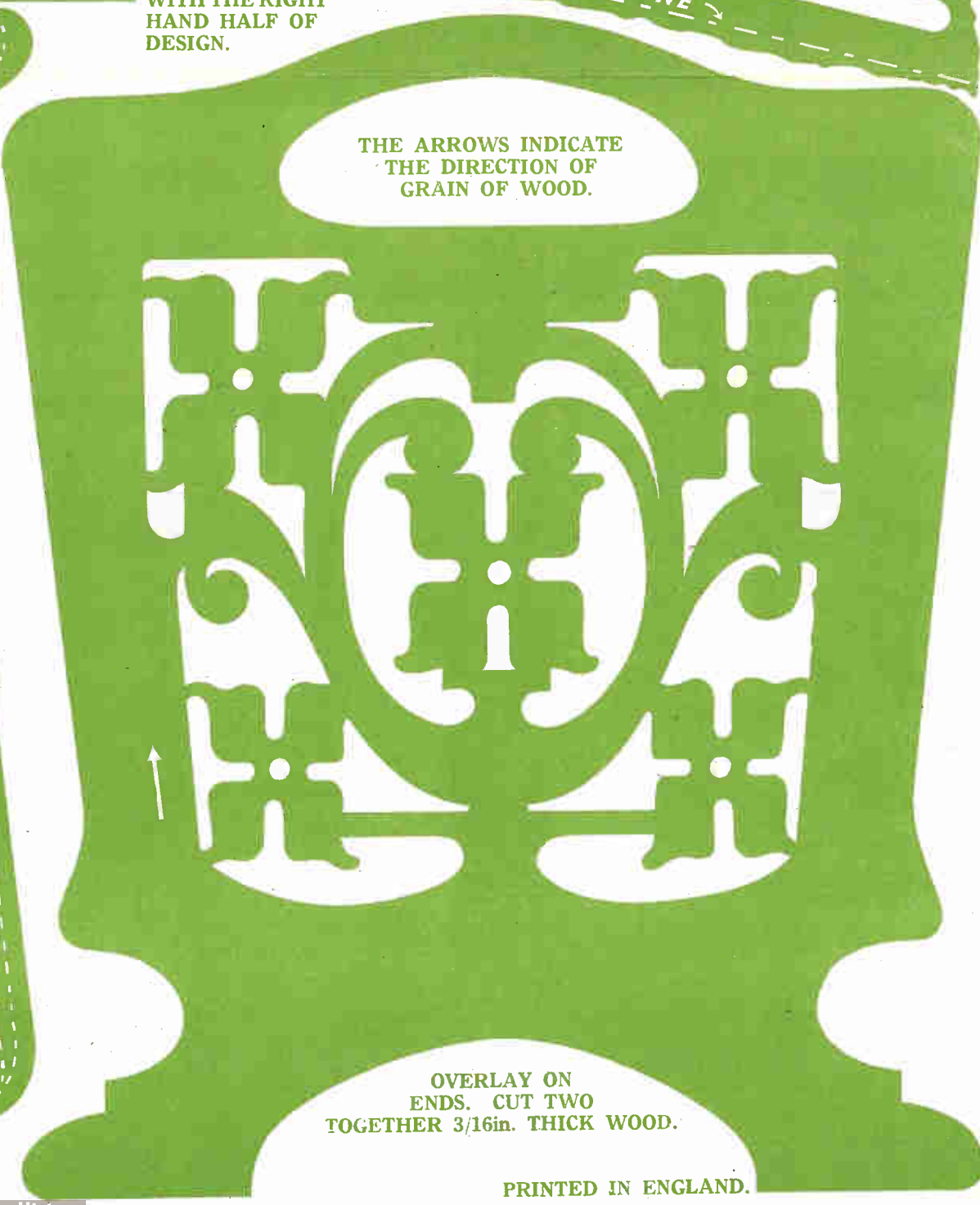

OVERLAY ON ENDS. CUT TWO TOGETHER 3/16in. THICK WOOD.

PRINTED IN ENGLAND.

Patterns for making a Table NEWSPAPER STAND

THE patterns shown on the other side are cut from $\frac{1}{4}$ in. and $\frac{3}{8}$ in. wood as stated. Some duplication of them will be required first, as there has not been room to get all of them on the sheet. Note the pattern of the side of which half only is given. Paste this part to the wood, keeping one edge in line with the actual edge of the board. This will save one complete sawcut.

This pattern, however, is half only. The other portion of the pattern is shown in the top right-hand corner. Cut the paper down the centre line marked, and then paste this pattern by the side of the other one with the two centre lines together and the long straight edge of the pattern extending along the edge of the wood to be a continuation of the previous paper pasted down.

Pattern Details

This second portion of the pattern includes the fretted work, but the outline must, of course, be completed with pencil marks. Mark off the end across the wood 7 ins. from the centre line to complete the rectangle. On this end line, carefully mark out the tenon (A), projecting $\frac{1}{4}$ in. and being $2\frac{1}{2}$ ins. wide—that is, $1\frac{1}{2}$ ins. from each edge.

You now have the outline and pattern of one complete side, of which two are required. You can either have both these sides fretted, or if you prefer, leave the second one plain. If you are having it exactly like the first with its fretwork panel, then, of course, you must trace off the design and reproduce it on the second piece of wood. A second tracing will have to be taken of the overlay on the end, as two of these

parts also are required.

The two sides are tenoned into the ends at (A). Note that the bottom edge of the sides must be chamfered slightly to stand flat to the floor, whilst the opposite edge—the upper one—is rounded to the shaded section shown.

The Floor

When the sides and ends are in place, fit the floor. Both its long edges are rounded, and they project beyond the upright sides when the part is in place. You can glue them to the sides and then add strengthening fillets to the inside of the ends. This is shown by the dotted lines on the patterns of the ends themselves.

The two fretted overlays cut from $\frac{3}{8}$ in. wood—or $\frac{1}{2}$ in. if you prefer, and have the boards—are cut, cleaned and glued on the ends. The bottom edge is in line with the bottom edge of the main end, but the outline is about $\frac{1}{4}$ in. smaller all round the other edges. You see this again by the dotted lines on the pattern of the end.

Hints on Finishing

If you are proposing to stain or colour the stand, it should be done before this final overlay is glued on. Or, of course, you can stain the end much darker where it will be behind the fretted overlay, to help to show it up.

Hand holes are cut in the ends, and you can make these smoother for handling by rounding the edges if you desire. One point to watch when you are constructing the whole thing, is that the four feet rest firmly and flat on the table. Be sure the parts do not wring at all whilst they are being fitted together.

NOTE.—This design sheet is only presented free with the current issue of Hobbies and not with back numbers. Further copies may be obtained.

SUPPLEMENT TO HOBBIES No. 2858.

THE "GALLEON" TEA TRAY



SIZE:—14ins. BY 8½ins.

PANELS OF WOOD REQUIRED FOR THIS DESIGN
ONE J4 TWO G4
ONE H2 ONE G2
 Materials for making this design are supplied by **HOBBIES LIMITED**, Dereham, Norfolk. Price on application.

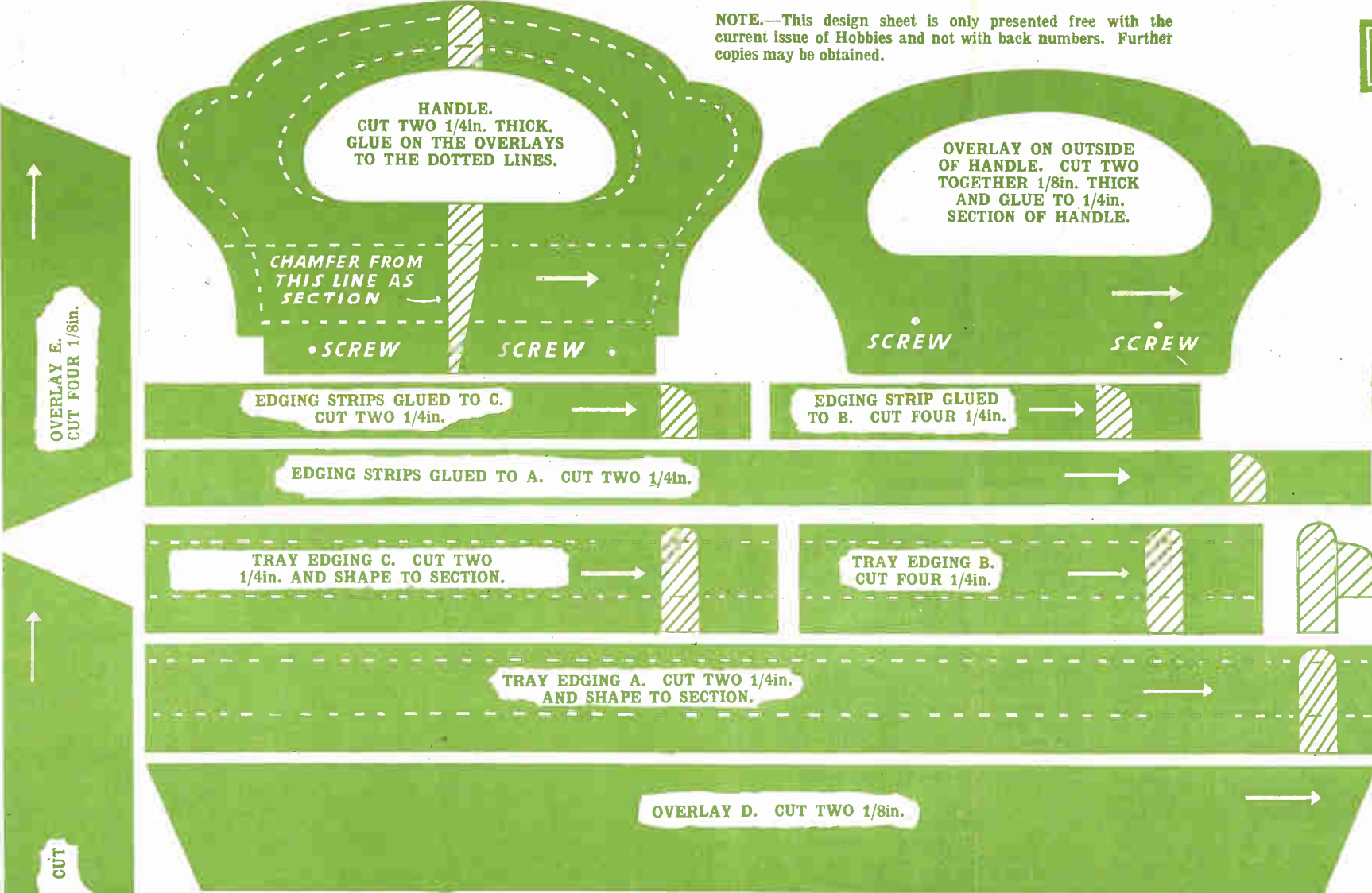

THE ARROWS INDICATE THE DIRECTION OF GRAIN OF WOOD.

MAIN BACK. CUT ONE 1/4in. WOOD. DOTTED LINES SHOW POSITION OF EDGING STRIPS AND OVERLAYS.

PRINTED IN ENGLAND.

GALLEON TEA TRAY

THE patterns on the other side, provide the opportunity of building a useful practical tray in a variety of ways. It is intended for the service of comparatively small articles like a couple of cups of tea or two or three glasses for drinks, being only 12 $\frac{3}{4}$ ins. long and 8 $\frac{1}{2}$ ins. wide over all. The patterns provided, give the opportunity of several ways of completing it.

As shown now, the tray has a glass top which covers a striking and picturesque overlay of a galleon which essentially incorporates an amount of fretwork

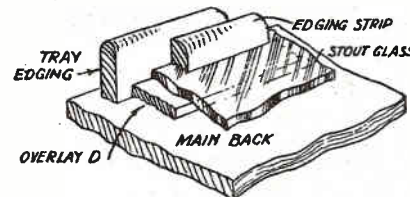

Fig. 1—Cut-away view of rim

cutting. An alternative style is to omit this galleon, and to have a simpler decorative centre piece for a more formal part. Or again, you can omit the glass altogether, and have the tray as a plain wooden article.

If, however, you are wanting to make a really attractive piece of work, then you cannot do better than follow out the original suggestion of a galleon picture under glass. The wood provided is sufficient for all parts, and the construction is straightforward. The design of the galleon should be cut out in paper, and pasted on to $\frac{1}{8}$ in. wood, but apart from that, there is no need to paste the paper down as the measurements can be taken from the pattern sheet direct on to the boards.

Constructional Details

The two details here, show helpful constructional views, and a study of them with the patterns, should make the construction straightforward. The principal point is in getting the angles by which the framework of the tray are fitted. These are in the ordinary 45 or 60 degrees, and accordingly must be marked off with care.

Cutting them is best done, too, with a small tenon saw, both the tool and the wood being held firmly. As there are

four parts angled at each end of the tray, it is essential to get them correct, and if only one is cut badly, then the frame will not fit together as nicely as it should. For that reason, careful marking out is essential. Lay the pattern sheet on the wood with a piece of carbon paper between it, and mark through with a ruler exactly on the cutting line.

How to Cut

When you come to the actual cutting, keep the sawblade slightly on the outside of the line, so that the cut itself may not be inside the pencil marking provided. Moreover, if you cut the parts too small, you cannot get them to fit, whereas if they are slightly too long, you can always take off a piece more satisfactorily.

The flat overlays (D, E and F) should be cut out first, and framed up round the edge of the base. Test them before finally gluing in place, and note that they are set inwards equidistant all the way round. The exact position is indicated by the dotted line on the base itself, but checking must be done with the actual parts.

Outside this flat overlay is the upright edging with its rounded top. These are the parts (A, B and C). To get the ends correct, stand the edging piece upright close to the overlay previously glued to the board. If the end is overlapping the angle of this flat piece, then you can mark on the upright strip the actual angle required for cutting to a suitable mitre. Having cut one end, the part is stood in place again, and the opposite end marked and cut in a similar way.

Any duplicates of this part can be treated similarly, testing out each one as you go along, to see it fits in place. Cut and glue (A) in position on each of the long sides, and then build round the end strips (B) and (C) between. Ensure good close joints, and finally glue upright and behind the flat overlays as you see in Fig. 1.

The Glass Base

A piece of 21oz. glass is required, and this can probably be obtained from a local glazier. It is slightly under 10 $\frac{1}{4}$ ins. long and just under 5 $\frac{3}{4}$ ins. wide. Have it cut scant rather than fit too tightly. The actual shape can be traced off in the

dotted lines or from the overlay in place, and should be taken to the glazier for cutting.

This glass is held in place by quarter-round edging strips. Various lengths are required, and here again the ends must be cut carefully to the angle to fit. They are glued above the glass, but before doing so you must, of course, fit in the galleon overlay or whatever decoration you are adding.

The Galleon Decoration

Remember, too, to colour the base of the tray as you wish. If the galleon is in whitewood, it will stand out attractively with the baseboard lacquer black. The galleon can be more attractively painted in its appropriate colours with a blue or a brown hull, tan sails and a coloured pennant. Glue the overlay of the galleon in place, and then lay the glass on the overlay framework. Glue the edging strips along, and if you wish, add one or two thin headless fretnails from the outside tray edging. All parts should have been cleaned before the glass was put in, in case of dust getting beneath.

There only remains the two handles,

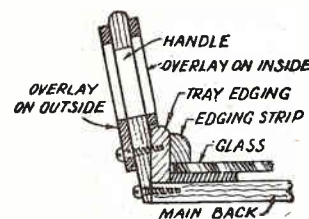

Fig. 2—Section of handle

and a section of these is given at Fig. 2. The main portion is $\frac{1}{4}$ in. thick, and on the inside a short overlay is added. A longer overlay is put on the outside. Notice that the straight line of the opening of the hand grip comes the same all through the three pieces, so that the upper and end edges can be rounded for comfort in handling.

To make the handle lean outwards, a long chamfer as shown by the section is made on the inside edge. Then the handle is glued in place centrally on the ends, and four screws driven in—two into the base and two through into the tray edging (see Fig. 2).

Waterline Model of the 'HISPANIOLA'

THIS is another one of those interesting ships of history of which we have produced quite a number, and all of which have proved popular. It is, of course, the ship that was made famous in Robert Louis Stevenson's famous story, *Treasure Island*, and which has now gained further popularity by the film of the same name. It was, indeed, due to the assistance of the producers of the film, R.K.O. Walt-Disney British Productions Ltd., that much of the detail of the model has been possible.

The *Hispaniola*, you remember, is merely mentioned in the story, but by making a model such as this, you can visualise the ship in which Squire Trelawney sailed with Jim Hawkins and the shipload of scoundrels. The adventures with Long John Silver stumping about with Israel Hands in attendance, is the more realistic by having the actual model on view.

Building and Painting

The work demands a certain amount of patience, and one must not be in a hurry to complete the model. The gluing of certain parts must be allowed to harden before the next can be added, and in painting, a great deal of care must be taken to get lines and colours correct. The kit of material provides all that is necessary, and the patterns on the other

is a similar piece at the stern, which is shown by the section as also slightly tapered. Part 6 goes above this to slope downwards towards the centre. These stern pieces overlap slightly, as shown at Fig. 2A, and when finally glued, the whole is filed to a flat surface sloping inwards and downwards (see Fig. 2B).

The stern overlay No. 7 is cut from thin wood or card, and is then glued round. It can be held in place with thin cord passing round the step of No. 6 until the glue has set. When fixed, the strip (8 and 9) is glued along as the bulwark just overlapping the stern itself. You can either cut or paint the rails and doors of the bulwark as indicated. Note the deck line on the pattern of the bulwark as the strip runs upwards towards the bow. Glue the bulwarks firmly, adding small freenails here and there, which can be withdrawn after the glue has set, or have their heads nipped off. The perspective view in Fig. 3 illustrates the detail at the stern.

At the Bow

The fitting of the bow parts 10 to 15 is shown in Fig. 4. The figurehead No. 10 is glued in the slot of the hull, and then the end of the bulwark strip drawn round to it and glued there. The piece 12 forms a platform in front of 4, and on this is 13 and 14, forming the

model. A view of the foredeck given at Fig. 5, shows the formation of the pieces 23 and 24 in place, and the black and white painting round the lower portion of the mast itself. Part 25 is merely a flat hatch glued just aft the mast hole.

These mast holes, remember, should be bored at a slight angle to provide the rake for the masts themselves. The hole in the deck is cut to make the mast slope slightly backwards—but only very slightly. On the well deck there is the main mast hole, with its rails round (24) and the gun placed just behind. This gun is shown in detail at Fig. 7. A hollow hatch framework (29) is glued flat to the deck, and on this the two little shaped boats are glued keel downwards. The shape of the boats themselves is shown in the section, and must be carefully made and shaped before fixing.

Stern Window

There is a side window at the stern, as you can see in the picture of the finished model. This is composed of parts 20, 21 and 22, a detail of which is seen at Fig. 8. The outline of part 20 is shown dotted, on the bulwark pattern, to indicate position. On it is glued the rounded piece 22, which is sandwiched between two similarly rounded pieces 21.

ments are given in Fig. 9. A detail of the fitting of the join is given in one case, and follows through for all positions. The shrouds and ratlines run from each top strip downwards and are held in dead eyes. Those by the bulwarks are fixed to channels. These channels are strips of wood (34) glued on edge. They are pierced with a small hole as indicated to take the cords of the shrouds carried to the hull underneath. A detail at Fig. 10 shows the construction clearly. Remember to glue these channels very firmly, as they have to take the strain of the lines.

The larger dead eyes are supplied in the kit, but the smaller ones can be easily made from small dowelling grooved and cut off as required. Cord is provided which goes to the points shown, being glued in the riggings and held to the deck with tiny wire staples. Masts, of course, should taper upwards, and a little capping piece added at the top of each.

Sail Diagram

It is impossible to give either measurements or shapes of the sails in the space on this instruction sheet, so we have prepared a larger special supplement sheet for them. Here they are shown

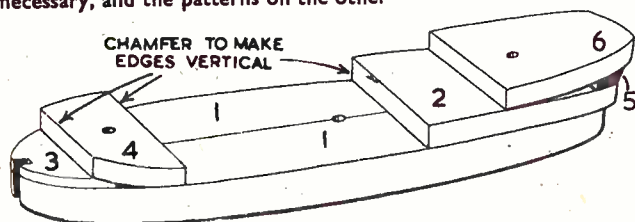

Fig. 1—The parts forming the hull and decks

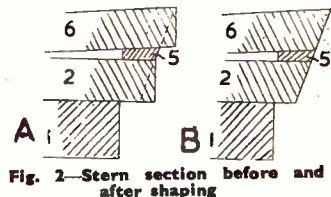

Fig. 2—Stern section before and after shaping

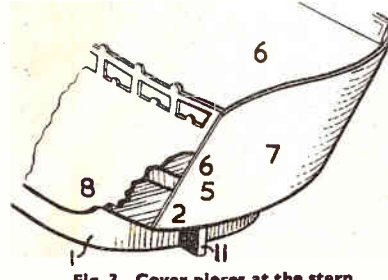

Fig. 3—Cover pieces at the stern

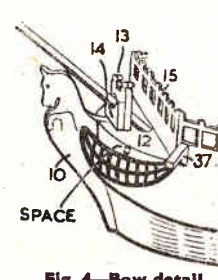

Fig. 4—Bow detail

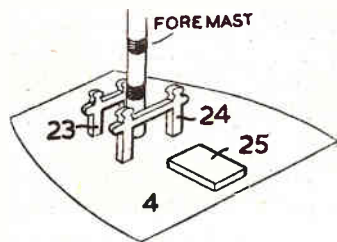

Fig. 5—Mast setting and hatch

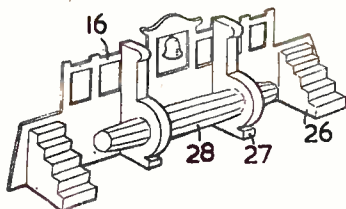

Fig. 6—Rails, ball and winch complete

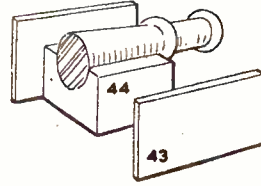

Fig. 7—Cannon detail

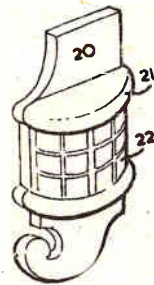

Fig. 8—Stern window

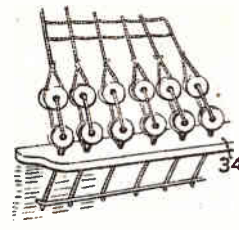

Fig. 10—Channels and deadeyes

side are shown full size. They should be marked down direct to the wood through carbon paper, and carefully lined in in pencil before cutting is undertaken.

If you are using the kit provided, certain parts need to be joined in their length, owing to the narrowness of the boards supplied. In that kit, too, the plywood is provided in two pieces, and also needs joining when fixed. If you have material full size in some odd wood, then you can quite well utilise it and save yourself the trouble of joining as mentioned here.

Read through these instructions first, and get an idea of how the thing is put together in conjunction with the details shown. Parts are numbered numerically as they can be built up, and dotted lines on various parts show the adjoining position of other pieces. All parts can be cut with the fretsaw, and are fixed together with thin glue after having been tested in place for accuracy.

The Hull

The main portion is the hull (part 1), a piece of 1/4 in. thick wood. The two pieces in the kit are glued together side by side, and then the whole cut to the shape shown 4 ins. wide and 13 1/2 ins. long. Note the opening at the bow to take the figurehead piece, and at the stern to take the rudder. This hull has the adjoining pieces added to it (parts 2 to 6), as shown in the detail at Fig. 1. Refer to the pattern of the hull to see where these pieces overlap, and how they are added.

Part 3, for instance, is glued to the front and 1/4 in. of its surface is tapered slightly so that part 4 lies at an angle to rest on the deck at its back edge. Part 5

step for the bowsprit. This bowsprit is a tapering rod 3 1/2 ins. long. The inboard end is cut at an angle to rest on piece 14 and pass through piece 13 (see Fig. 4). The outer end of the bowsprit is a piece of stiff wire which can be added now or left until the standing rigging lines are added. By the way, piece 12 is formed of two 1/4 in. pieces glued together, but if you have an odd piece of 1/2 in. wood, then you can do it from a single part.

The various upright cross pieces forming the fronts to the various decks are next added—16, 17 and 18, and they are shown in the details herewith. Much of the work can be indicated by painting, but the experienced worker can quite well cut out apertures, rails, etc. Fig. 6 shows piece 16 completed. The fancy steps are added each end, and the cross windlass pieces of 27 and 28. Piece 28 is first rounded after tapering towards each end, and then made octagonal as shown by the section shape. Glue this into the two pieces at 27 and then fix the whole lot to the front of piece 16 (see Fig. 6).

The front of the other various raised decks are treated in the same way with steps added to piece 17 and to piece 18. Piece 17 stands on the main deck in front of part 2, and part 18 is in front of the stern deck (6). Note on part 18 there is a doorway painted. Behind this door piece 19 is to be added, cut as an arc glued in place and then rounded to the shape of the door arch.

Deck Parts

Now comes the formation of the various parts on the deck. These are, of course, quite small, but must be made shapely and correct because they give so much additional character to the whole

A tiny lantern can be raised on wire fixed above the stern slope, seen in the finished model picture, whilst a wheel and other incidentals are added as indicated. Note particularly at the bow, the projecting cathead (37). This is a shaped bracket piece glued on edge with the longer surface at right-angles to the hull. It is seen in Fig. 4.

This completes the main hull, and it will probably be advisable to paint now. Poster paint can be used, and a coat of white or cream should be put on first and allowed to soak in before the second and final colour is added. The actual colouring is immaterial because there seem to be no authentic details of this.

Ships of that period would probably be between the gay colours of the earlier galleon models, and the severe black and white types of the Trafalgar period. The deck, of course, can be natural oak planks, with the other woodwork in darker oak. Lines should be done very fine in black—possibly Indian ink—and the stern details, figurehead, etc., would be represented in gold.

Masts and Rigging

Of the masts, three sets are required, and these with the standing line measure-

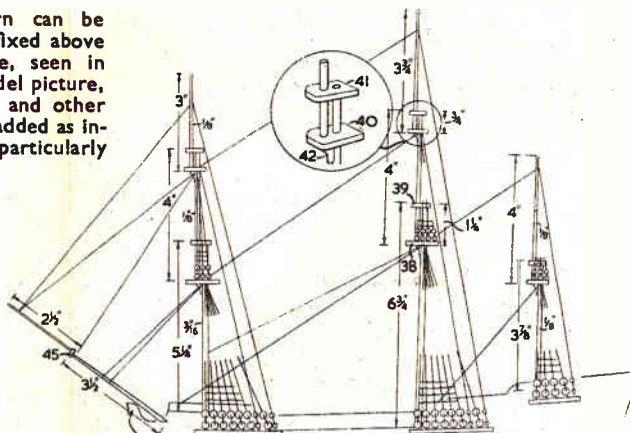

Fig. 9—The standing rigging and masts

full size and lettered with a complete diagram as to where they are placed. This diagram is obtainable for 6d. from Hobbies. The sails are made from the parchment included in the kit. Spars are cut from dowel tapering towards each end.

Sails are glued on along the top, bellied out and then held in place by running lines passing to the deck or to each other, as can be seen in the picture of the finished model. Little spots of ceiling wax can indicate tiny pulley blocks, or joining lines and fixings. The whole model is glued to a baseboard. Material in the kit is provided for this 1/4 in. thick, but you can add another.

The baseboard measures 16 by 6 and here again, two parts of the narrow board are glued together to form this width, unless you have a single board the size needed.

SUPPLEMENT TO HOBBIES No. 2848.

HORSE RACING

AN EXCITING GAME TO MAKE UP

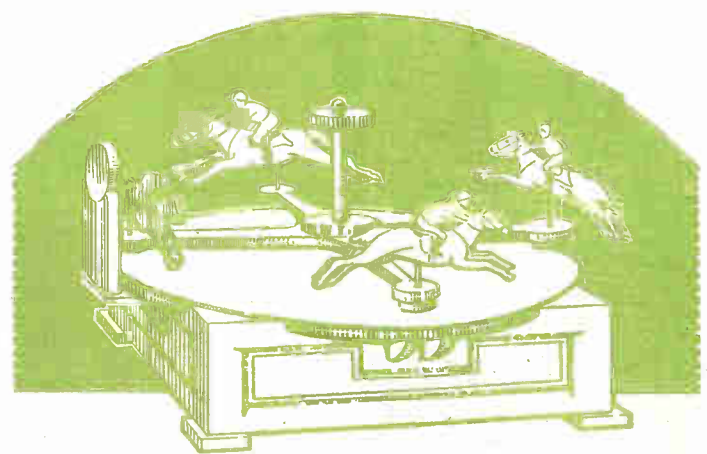

CORNER FEET. CUT FOUR 3/16in.



MOVING ARMS FIXED TO SPINDLE. CUT ONE OF EACH 3/16in. AND GLUE BETWEEN DISCS K. See detail.

WINNING POST. CUT ONE 3/16in.

WINNING POST. BASE CUT ONE 3/16in.

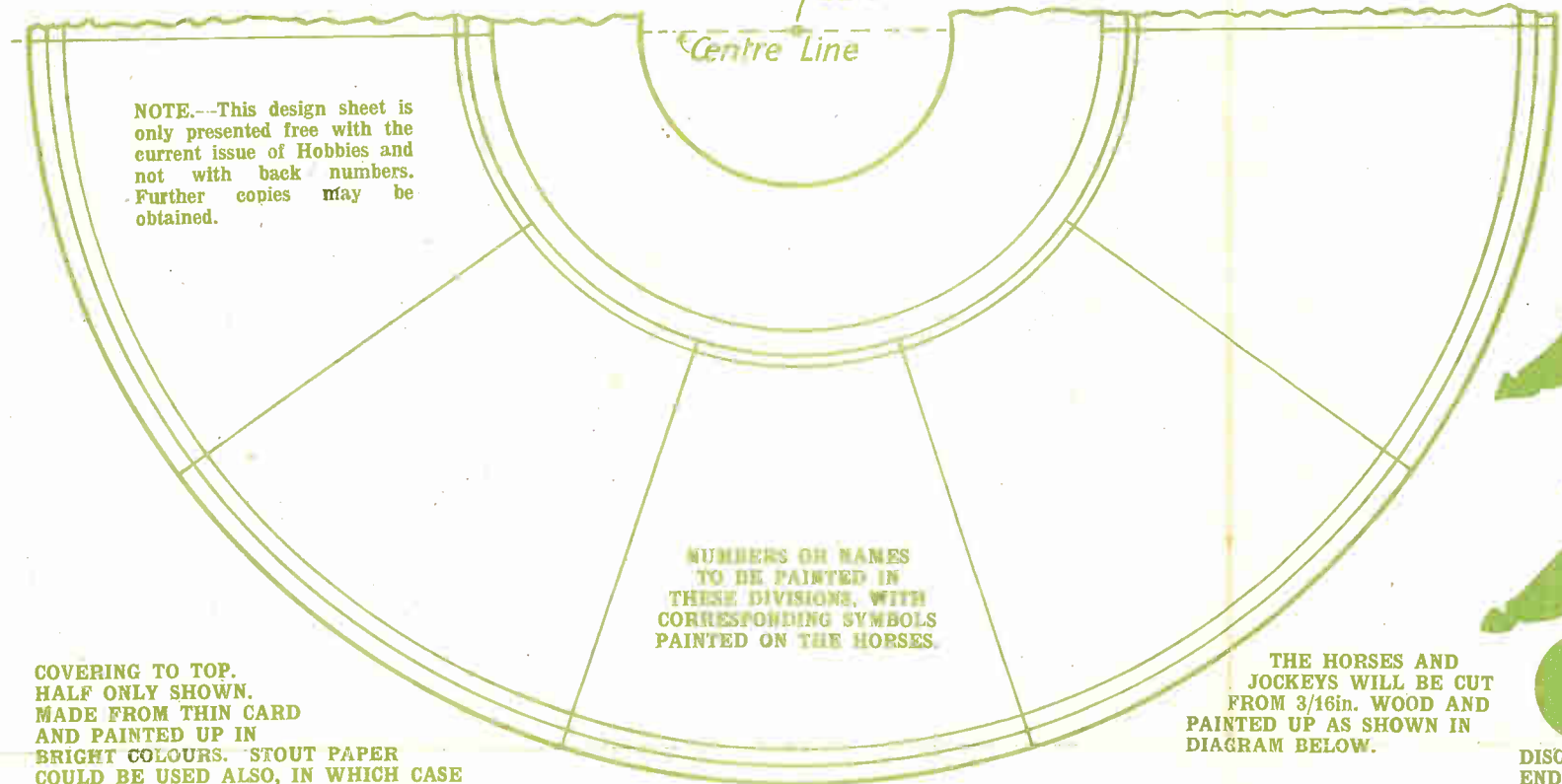

NOTE.--This design sheet is only presented free with the current issue of Hobbies and not with back numbers. Further copies may be obtained.

NUMBERS OR NAMES TO BE PAINTED IN THESE DIVISIONS, WITH CORRESPONDING SYMBOLS PAINTED ON THE HORSES.

COVERING TO TOP. HALF ONLY SHOWN. MADE FROM THIN CARD AND PAINTED UP IN BRIGHT COLOURS. STOUT PAPER COULD BE USED ALSO, IN WHICH CASE IT SHOULD BE GLUED TO THE WOOD.

—SIZE—
8ins. BY 8 1/2ins.
BY 4 1/2ins. HIGH.

SPACING BLOCK FOR BASE OF POST. CUT ONE 3/16in.



DISCS GLUED TO SPINDLE. CUT TWO 3/16in.

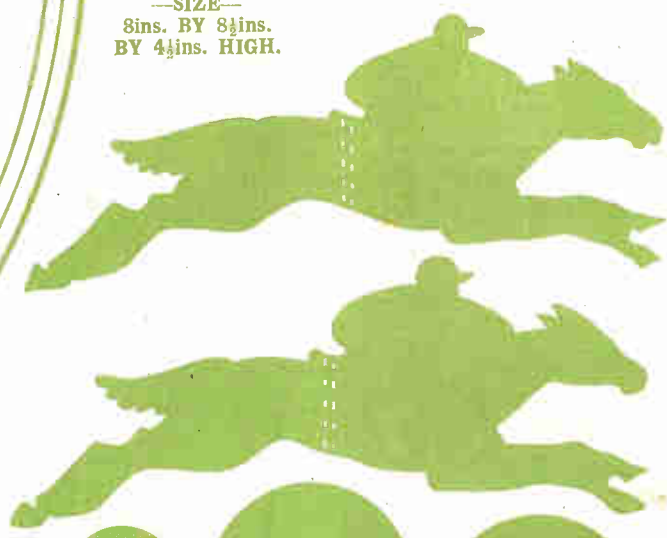
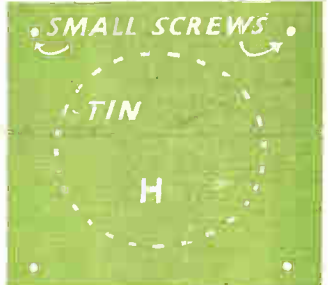

DISC L
DISC GLUED TO ENDS OF ARMS. CUT FOUR 3/16in.

DISC J
DISC GLUED TO SPINDLE. CUT TWO 3/16in.

DISC I
DISC GLUED TO FLOOR. CUT ONE 3/16in.

PANELS OF WOOD REQUIRED FOR THIS DESIGN
TWO H3 ONE G3
Materials for making this design are supplied by HOBBIES LIMITED, Dereham, Norfolk.
Price on application.

LINE OF CARD OR PAPER OVERLAY

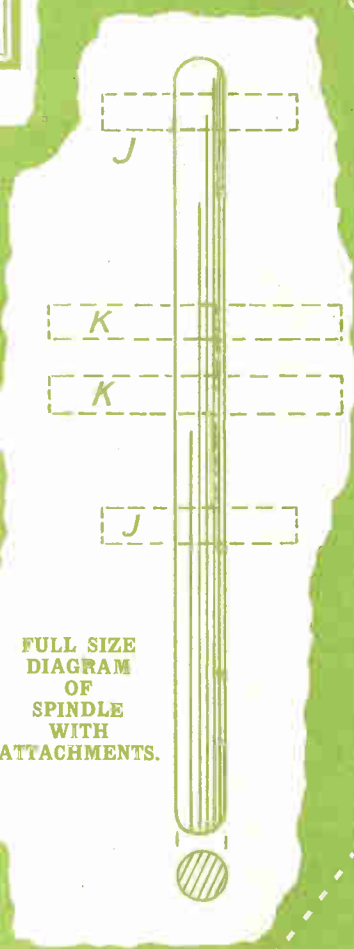

FULL SIZE DIAGRAM OF SPINDLE WITH ATTACHMENTS.

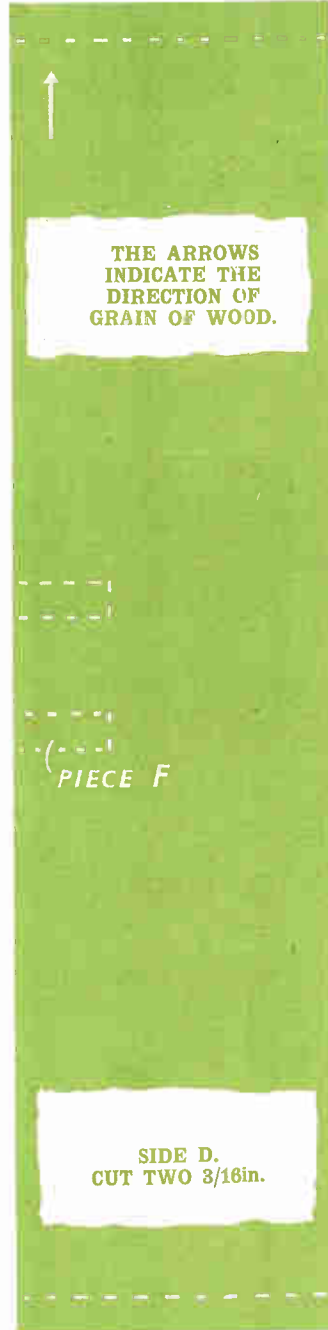

THE ARROWS INDICATE THE DIRECTION OF GRAIN OF WOOD.

SIDE D. CUT TWO 3/16in.

SIDE E. CUT TWO 3/16in.

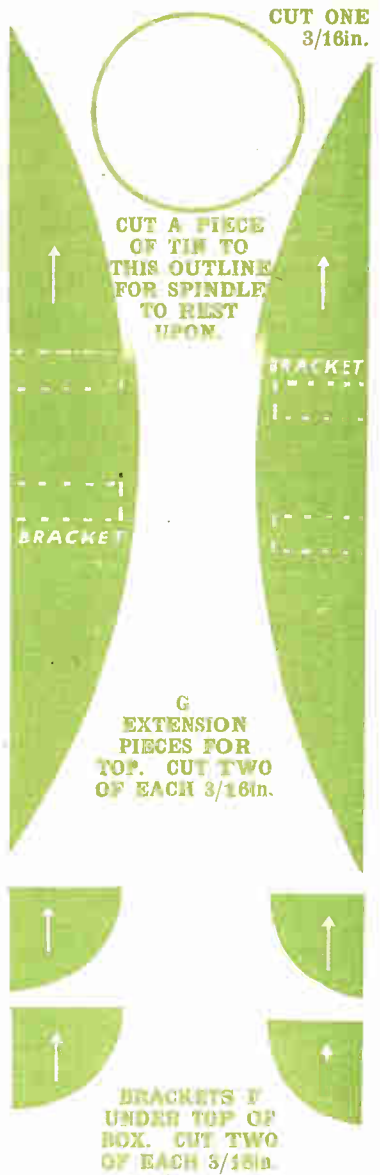

CUT ONE 3/16in.
CUT A PIECE OF TIN TO THIS OUTLINE FOR SPINDLE TO REST UPON.

G EXTENSION PIECES FOR TOP. CUT TWO OF EACH 3/16in.

BRACKETS B UNDER TOP OF BOX. CUT TWO OF EACH 3/16in.

A--TOP OF BOX. CUT ONE 3/16in. ALSO
B--FLOOR OF BOX. CUT ONE 3/16in.



PIECE H SCREWED TO UNDERSIDE OF FLOOR



SHOWING THE MARKINGS ON HORSE AND JOCKEY.

MECHANICAL RACE GAME

THIS novelty is just one of the things to make up particularly for Christmas, but also forming a pleasing game for any time. As can be seen from the illustration, the horses are mounted on a circular table and spin past the winning post on one side. By twirling the knurled handle at the top of the spindle, the horses gallop round until they gradually come to rest. By painting the jockeys in suitable colours, stakes can be laid, the one coming nearest the winning post being obviously the winner.

Marking the Patterns

The patterns provided should be marked out direct on to the wood, either through carbon paper or by tracing paper. The parts are cut with the fretsaw, glued together according to these instructions, and then the finished toy painted in bright colours. There is nothing difficult in the construction but, of course, care must be taken to see that all parts are properly cut, cleaned and joined together as they should be. Wood is provided in the kit for all the parts, and there is a length of wire intended to mount the horses in their respective positions.

The main portion of the game is the box base. This is composed of a top,

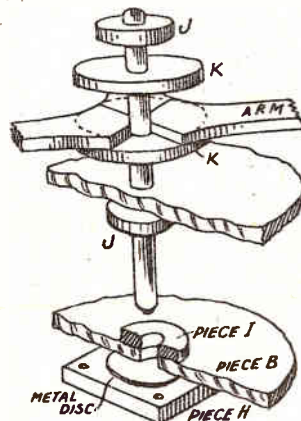

Fig. 1—Cut-away view showing spindle

bottom and four sides. The four sides butt together and are then glued on to the base. A hole is bored through both top and bottom for the $\frac{1}{4}$ in. diameter spindle, and one must be sure that the hole in these parts is opposite to ensure

the spindle itself being upright. To prevent the spindle falling through, and also to provide a suitable pivot, an additional part is fixed beneath. This is the piece (H), and before it is screwed under the central hole, a circular or square disc of thin metal is fitted between as you see in Fig. 1.

Two discs are added inside the box, one on the bottom (I) and one on the underside of the top (J). The holes through these are all in line, and the spindle must revolve smoothly, but not too loosely in them. It will be as well also to stiffen up the inside corners of the box by adding little blocking pieces from waste wood.

Circular Top

To make the top of the box circular, four segments of wood are glued on in line with the top, and halfway along each edge. They are supported beneath by a pair of brackets (F) set centrally but about $\frac{1}{4}$ in. apart. They can be seen in the picture of the finished game. On one side, however, an additional piece is provided to form a stand for the winning post. Between these two angle pieces (F) is the spacing block glued $\frac{1}{8}$ in. below the underside of the top (part G). This is shown in the underview at Fig. 2.

The space between is occupied by the winning post base into which the winning post itself is glued by the tenon (M). This post and its base can be made into a complete unit, but need not be glued into the space under the top. It will thus be like the whole of the top movement detachable when the game is not in use. The circular top having been formed, a piece of card 8in. in diameter can be cut and glued on. The actual shape of half of it is shown as a pattern with divisions and rims which can be painted on in bright colours.

Fitting the Spindle

Next you can fit in the spindle. This is a $\frac{1}{4}$ in. length of $\frac{1}{8}$ in. dowel rod with nicely smoothed surface. Round off both ends and on the bottom drive in a round-headed small nail or even a large pin. This will provide a suitable pivot to act on the metal disc in the base, thus ensuring smooth running when the spindle is turned.

Now prepare the four arms and the horses themselves. To provide strength, the arms are cut with the grain running longways, and then all are fitted between two central circular discs (K).

Get these arms, of course, at right-angles to each other. On the outer end a further small circular disc (L) is added on the underside.

The wire holding the horses can now be driven through, but the horses themselves need not be added until later. A $1\frac{1}{2}$ in. length of stiff wire is sufficient for each arm. Bend about $\frac{1}{4}$ in. at a right-angle, then drive the straight piece through the centre of the disc and main portion of the arm itself, leaving 1in. projecting above. Now take the completed arms and pass the top of the spindle through them. Glue the disc and arms in place on the spindle so that the underside of (K) is $1\frac{1}{2}$ in. from the top. This will leave about $\frac{1}{4}$ in. or $\frac{3}{8}$ in. between the arms and the top of the table when the spindle is put in place. The exact distance of these pieces is shown dotted on the full-size drawing of the spindle on the sheet.

Near the top of the spindle itself, a further disc (J) is securely glued. The outer edge of this disc can well be provided with a number of upright grooves to form a knurled surface providing a better grip for the finger and thumb when turning. Get the whole of these moving parts to run smoothly and finally add the horses to the top of the wire supports previously fitted.

Markings

A suggestion for the markings of the horse and jockey is shown, and the parts should be painted before finally fixing in place. Bore a hole for the wire carefully through the thickness of the horse, and

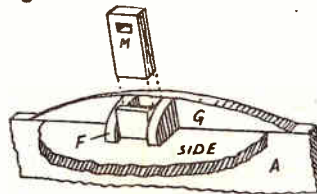

Fig. 2—The winning post socket

add a spot of glue to grip finally in position.

On the underside of the box at each corner, a small square foot is added. It should be glued with a projection of about $\frac{1}{4}$ in. on two sides, rather than in line with the edge of the box itself.

The toy should be painted in bright enamel or with poster paint, covered with clear varnish.

SUPPLEMENT TO HOBBIES No. 2846.

'O' GAUGE RAILWAY "GOODS SHED"

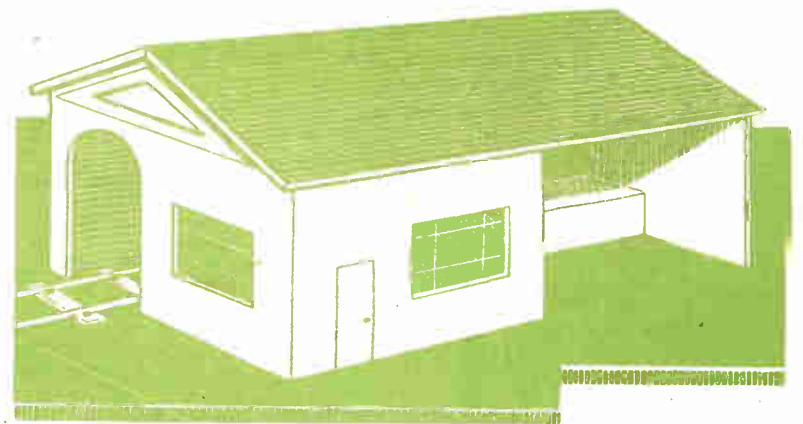

LIST OF PLAIN PIECES REQUIRED.

- No. 4. CUT ONE 3/16in. 5 1/2in. x 4 1/2in.
- No. 6. CUT ONE 3/16in. 11 1/2in. x 4 1/2in.
- No. 7. CUT TWO 3/16in. 12in. x 4 1/2in.
(THESE PIECES FORM THE
ROOF AND MUST BE
CHAMFERED TOGETHER AT
THE RIDGE).
- No. 9. CUT ONE 3/16in. 5 1/4in. x 1 1/2in.
- No. 10. CUT TWO 3/16in. 5 1/4in. x 1 1/2in.

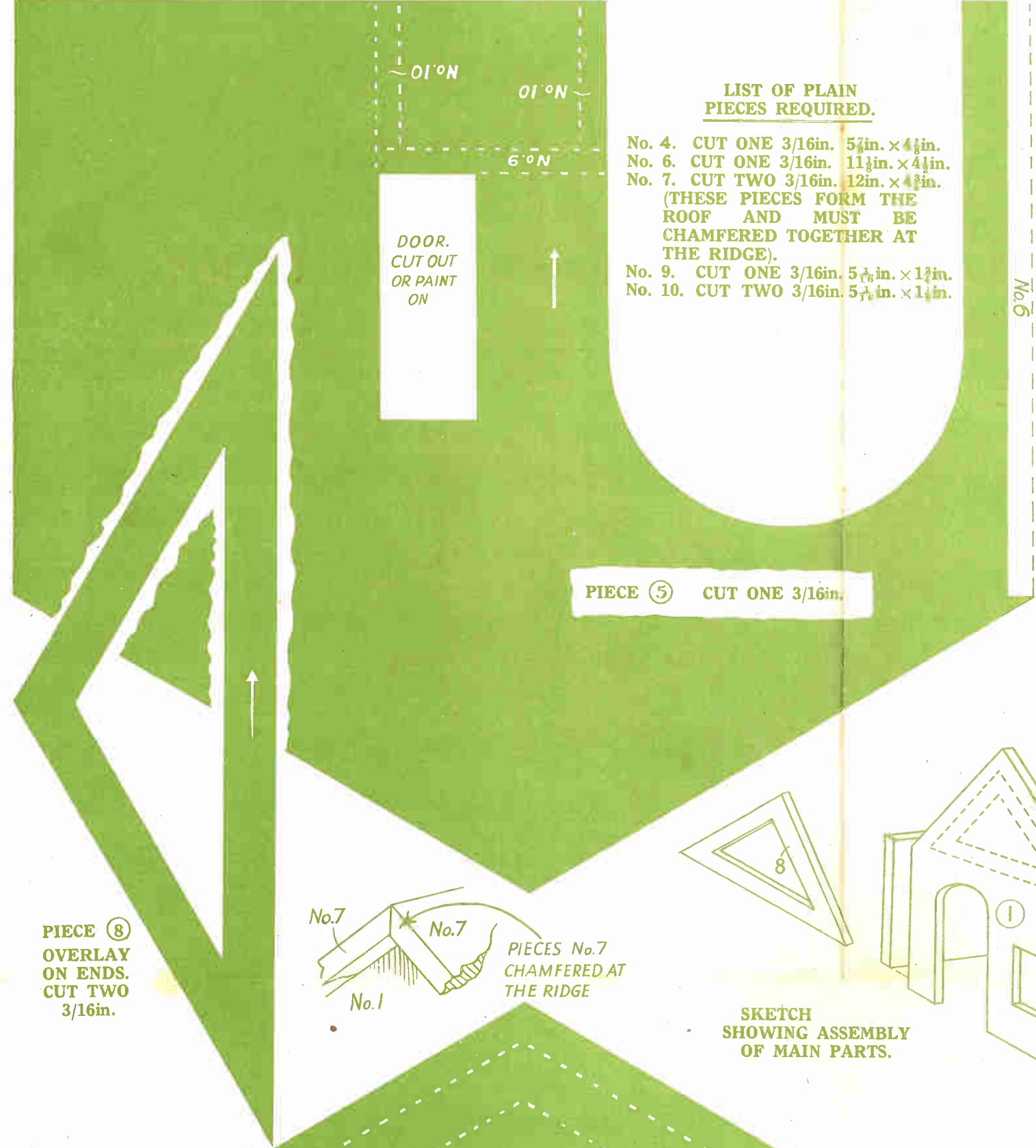

PIECE ⑤ CUT ONE 3/16in.

PIECE ⑧
OVERLAY
ON ENDS.
CUT TWO
3/16in.



PIECES No.7
CHAMFERED AT
THE RIDGE

THE ARROWS INDICATE
DIRECTION OF GRAIN
OF WOOD.

SIZE—12ins. LONG.
7 1/2ins. WIDE.

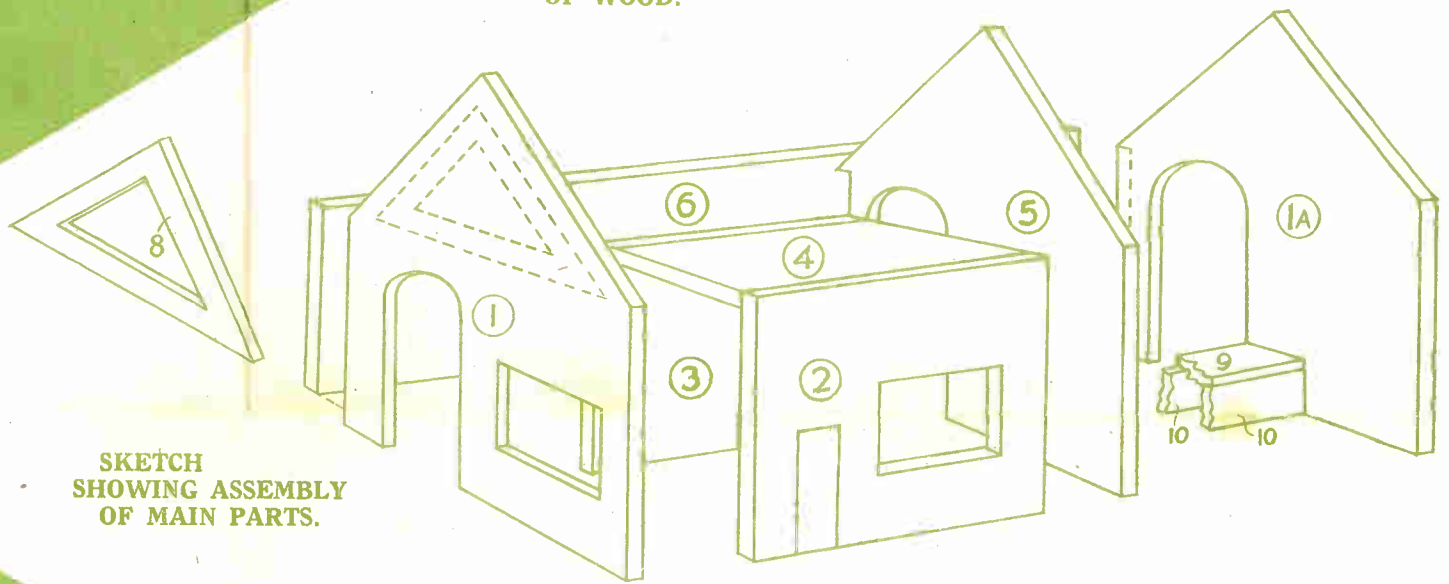

SKETCH
SHOWING ASSEMBLY
OF MAIN PARTS.

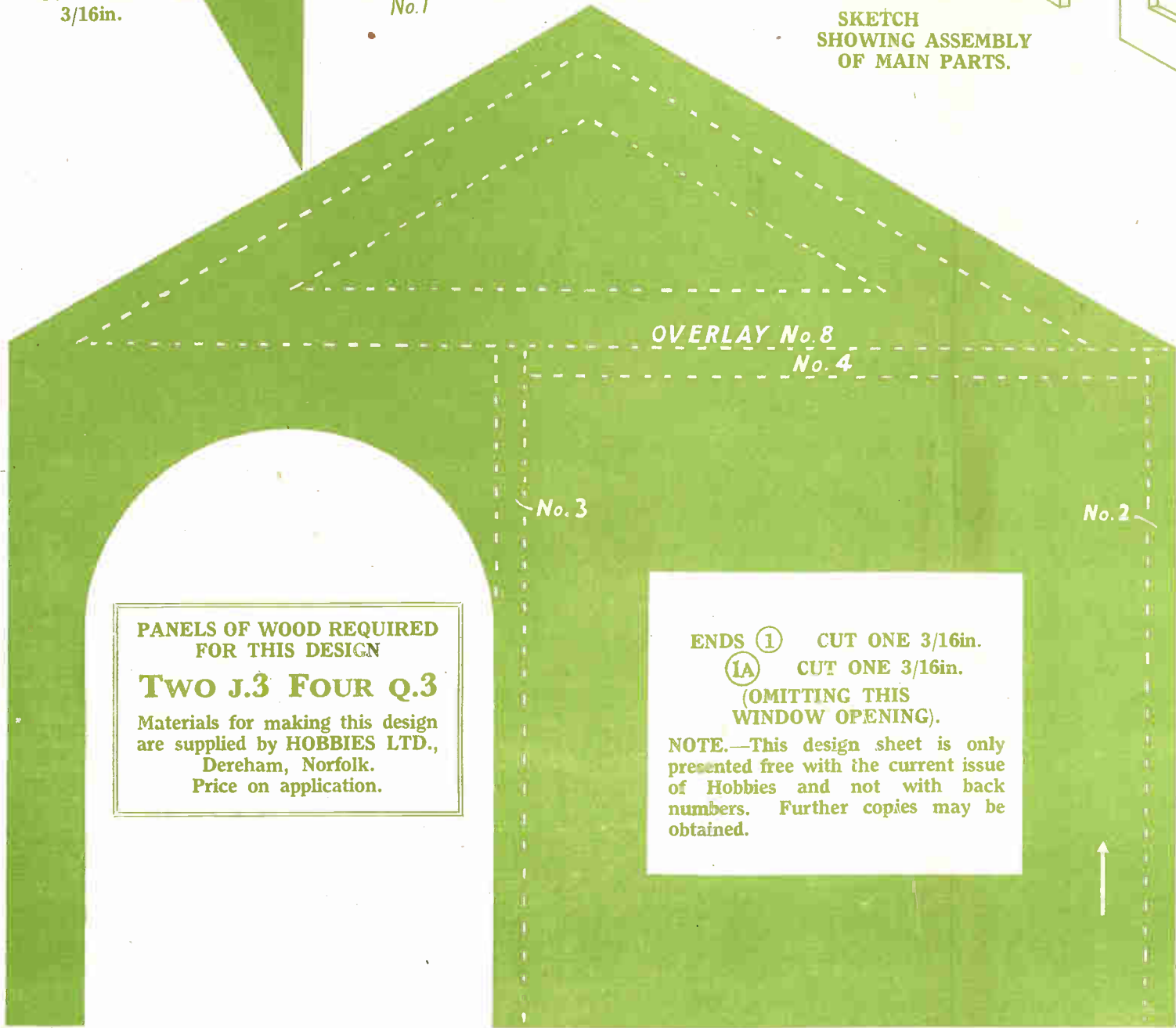

**PANELS OF WOOD REQUIRED
FOR THIS DESIGN**
Two J.3 Four Q.3
Materials for making this design
are supplied by HOBBIES LTD.,
Dereham, Norfolk.
Price on application.

ENDS ① CUT ONE 3/16in.
①A CUT ONE 3/16in.
(OMITTING THIS
WINDOW OPENING).

NOTE.—This design sheet is only
presented free with the current issue
of Hobbies and not with back
numbers. Further copies may be
obtained.

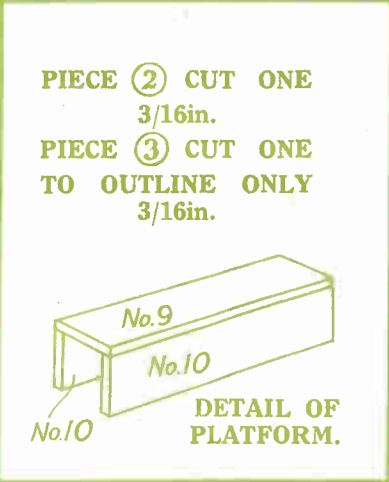

PIECE ② CUT ONE
3/16in.
PIECE ③ CUT ONE
TO OUTLINE ONLY
3/16in.

DETAIL OF
PLATFORM.

DOOR.
CUT OUT OR
PAINT ON

PRINTED IN ENGLAND.

O-GAUGE GOODS SHED

THE drawings on the other side provide for the building of a typical goods shed suitable for an O-gauge railway layout. Most of the parts are drawn full-size and can be transferred direct to the wood in pencil. You can lay the patterns down on to the board, prick through the corners, take away the pattern and connect up the holes with pencil marks.

Do all marking out with ruler and square, and test dimensions in every case. Some of the parts are plain pieces, and a list of these rectangles is shown. It is not advisable to cut all parts out at once, but to do so as they are being needed for building. In this way, you can check off dimensions on the actual material being built, to ensure a good fit.

The Walls

The constructional detail drawing shows the position of the various pieces, and makes the whole thing quite clear. The two ends are the same outline, and with door arch, but only one of them has a window opening. Parts 2, 3 and 4 form a three-sided box with the piece at the top (No. 4) glued between the two sides.

Part 3 is a plain outline only, but part 2 has a window and door cut from it. The sawcut to the top should be made so the part taken out can be used again for the door itself. It can be later hung in place with a narrow strip of tape glued inside to form the hinge. The pieces 2, 3, and 4 are glued together, and then the whole thing fitted to the inside of the end No. 1. Check up that the bottom edge of all these pieces are level, and with a square, to ensure a rightangle at all joints.

The Back

The partition wall (5) is next added, being glued to the end of 2, 3, and 4. Notice that this part is $\frac{1}{8}$ in. narrower than the actual ends (1), leaving a little overhang on the top. Before fitting in place, cut out part 6 which forms the main back and is 11 $\frac{1}{2}$ ins. long and 4 $\frac{1}{2}$ ins. wide. Test this piece in place, stand it on the inside of the end wall, and see that

part 5 butts close up to it, still having its other edge in line with the front wall of part 2. Again, the bottom edge of all parts must be level.

The end (No. 5) and the long wall (No. 6) can now be glued in place, which will allow you to fit on the back wall (1a). Between this back wall and the centre partition piece 5, there is a little goods platform, which you can see broken away in the drawing, and the construction of which is shown in the detail of pattern part 3.

Platform

This platform consists of three plain pieces (Nos. 9 and 10) and before cutting them the length shown, measure the distance between the two walls to ensure a good fit. This space should be 5 $\frac{1}{2}$ ins. but there may have been a little variation, and checking up with a ruler will ensure the platform when put together fits snugly between the two walls. You can, if you wish, add little blocking pieces inside this platform part, to help to glue it to the end walls for strength. These little corner blocks should also be added, if you wish, to the inside of the main part of the building (2, 3, and 4).

The Roof

The whole model is made the more solid by adding the two roof slopes. These are 12 ins. long and 4 $\frac{1}{2}$ ins. wide, to allow an overlap all round. At the top where they meet, both edges have to be chamfered to form the ridge, and a detail of this is shown on the sheet. The ends of the building are decorated by a hollow triangle (part 8). Glue on the ends $\frac{1}{2}$ in. away from the roof. These parts should not be glued, of course, until the main walls have been papered or painted.

The construction is now complete. Add the windows by fitting the transparent material provided in the kit. Paint across the material an imitation framework, and also paint the door for panels. The building itself, of course, is covered with suitable brickpaper or painted in the usual way, and in keeping with the other parts of this layout.

SUPPLEMENT TO HOBBIES No. 2844.

FERN POT HOLDER

DESIGNED TO TAKE A 4 IN. POT

NOTE.—This design sheet is only presented free with the current issue of Hobbies and not with back numbers. Further copies may be obtained.

The arrows indicate the direction of grain of wood.

PANELS OF WOOD REQUIRED FOR THIS DESIGN
THREE H3
Materials for making this design are supplied by HOBBIES LIMITED, Dereham, Norfolk.
Price on application.

FLOOR. CUT TWO PIECES AS SHOWN 3/16in. AND GLUE TOGETHER. SCREW ON CROSS FILLETS TO GIVE ADDITIONAL STRENGTH.



—SIZE—
10 1/2 ins. LONG.
5 1/2 ins. WIDE.
4 1/2 ins. HIGH.

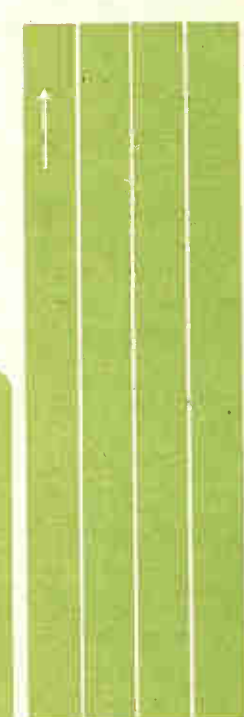

STIFFENING FILLETS UNDER TOP. CUT ONE OF EACH 3/16in.

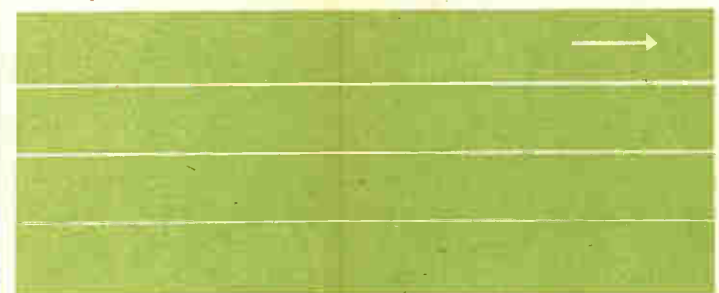

FLOOR SUPPORTS. CUT ONE OF EACH 3/16in.



END. CUT TWO 3/16in. THE FRETTED DECORATION ON THESE ENDS IS OPTIONAL.

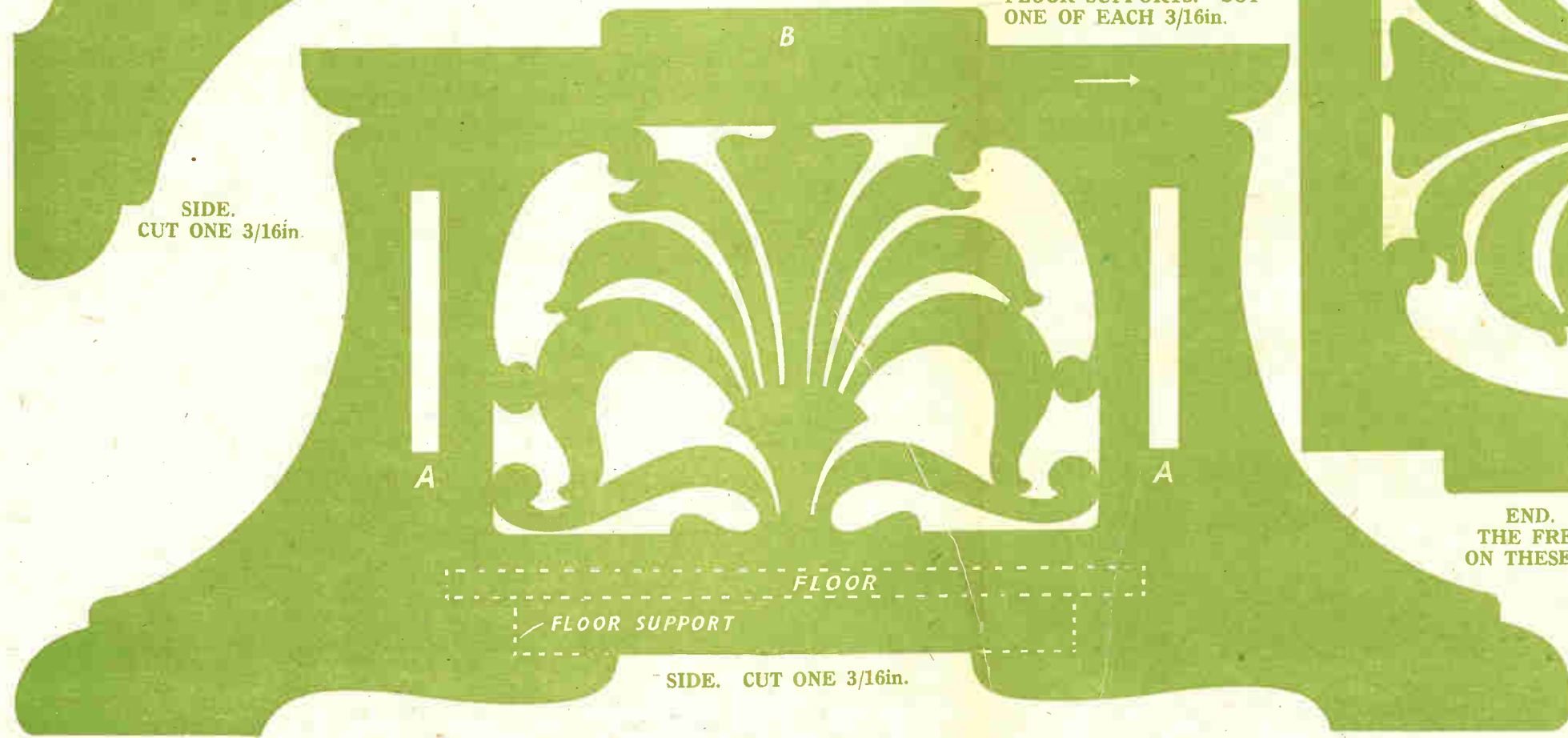

CROSS FILLET ON FLOOR. CUT TWO 3/16in. TO LENGTH. PRINTED IN ENGLAND.

A FERN POT HOLDER

THE design provides for a typical piece of fretwork which can be undertaken by anybody used to handling the fretsaw. The fancy decoration in the sides calls for the usual care in cutting to see that the design is balanced, and with the curves flowing as easily as they do in the actual patterns. Linking pieces where one part adjoins another closely, should be cut very carefully to see that the sawblade goes neither too far nor stops short. These link pieces should be the same right through, and it is one of the points which judges in any exhibition pieces.

All one Thickness

The whole of the work is cut from $\frac{3}{8}$ in. wood, and as usual, the kit of planed boards provides sufficient for all parts. If you do not wish to cut the fretwork in all four sides, you can, as suggested on the sheet, omit it from two of them. There is also the possibility of lining the inside of the box with some suitable material so that you cannot see the interior. Almost any veneer type of paper will do, although it is not advisable to get a fancy 'flowery' type which would detract from the beauty of the whole stand.

The upright sides to the box are cut in two pairs, and if you have a machine you will probably like to pin two boards together and do the operation in one. In such cases you must take particular care to see that the saw maintains an upright cut or you will find the pattern on the under-part will be substantially different from that of the upper, and entail some amount of filing to make it similar.

Pattern to Wood

In most cases, the pattern should be pasted to the wood, taking care that there are no air bubbles or creases. It will mean that you should clean this paper pattern off afterwards, but this is not necessary entirely if these parts are placed with the paper inside the box. It will be essential to clean the paper away at the corners where it would be seen, in any case. There are two long sides, each of which contains two mortises at (A). The other two sides are shorter and bear the projecting tenons at (A).

See they fit nicely and firmly together. The length of the tenon allows for projection through the wood, but this will not be at all unsightly. Make the

mortise and tenon joints to fit comfortably with hand pressure. Do not have the mortises so small that the tenons have to be forced home hard. If you do you will break the narrow neck of wood across the grain and do considerable damage.

Marking for Joints

Having cut and cleaned the four parts, test them together and then mark the position with a pencil on the inside to show where the actual joints come. They can thus be replaced in the same position after having been taken apart for final cleaning. The position of the floor should also be indicated, and that of the support strip which is glued along each side to hold it. Their actual place is indicated by the dotted line on the patterns. Mark it off with a pencil line, and also glue the floor supports in place. Be sure to get them level with each other so that when the floor is laid in position, it rests evenly on all of them.

Floor Stiffener

The floor itself is stiffened across the grain with a cross fillet $\frac{1}{4}$ ins. long and $\frac{1}{4}$ in. wide. These two strips are glued to the top of the floor $\frac{1}{4}$ in. inwards from one edge. Not only do they thus stiffen the wood itself, but provide a support for the flower pot and raise it to allow the air to get underneath to the plant.

The four sides and floor having been put together, the top is the next and final piece. It is mortised on to the tenons of the sides at (B), and in order to stiffen it up there are also the strip fillets glued just beneath. These are $3\frac{1}{2}$ ins. long and glued on edge to the sides in line with the bottom of the mortise opening. They thus provide an increased surface for the glue, which can be applied to them as well as to the edge of the box framework itself.

By the way, in cutting these tenons in the top, it is advisable to do them and test their accuracy before cutting out the centre circle for the pot. This provides a more substantial piece of wood to work on, and so reduces the likelihood of breakage if the operation is done in the reverse order.

The whole stand is now complete, and should rest firmly on its four feet without any 'wobble'. If you have decided to add interior lining to the fretted sides, this must have been glued on before the top is fitted.

SUPPLEMENT TO HOBBIES No. 284
TWO NOVELTY SWING TOYS

INSTRUCTIONS.
BOTH TOYS ARE CUT FROM 3/16in. WOOD THROUGHOUT. CUT ONE OF EACH PART SHOWN. THE WHITE LINES ON THE BIRDS AND WINGS ARE FOR GUIDES WHEN PAINTING.

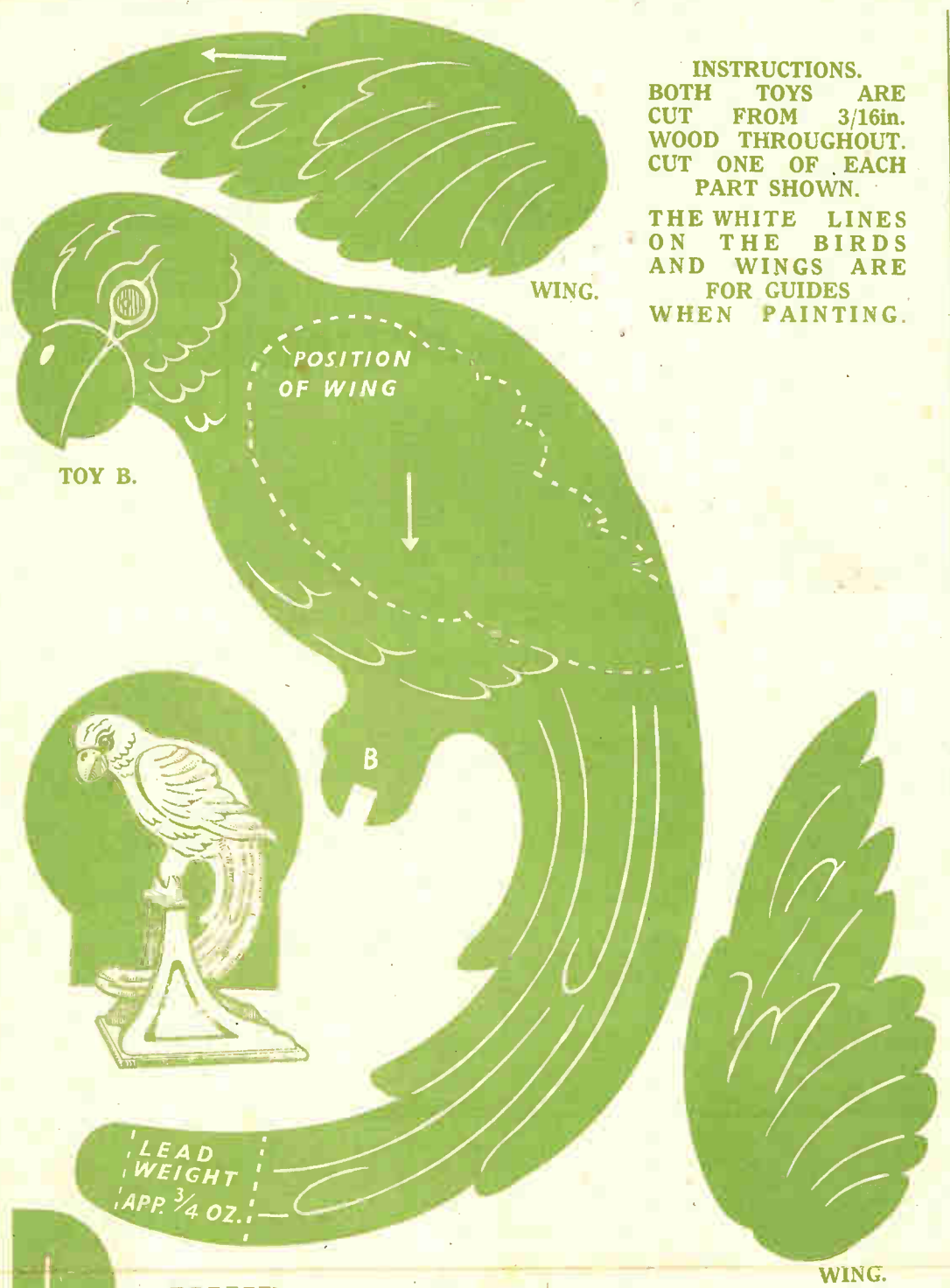

HEIGHT OF TOYS WHEN MADE UP
A, 7ins. AND B, 9ins.

THE ARROWS INDICATE THE DIRECTION OF GRAIN OF WOOD.

PANELS OF WOOD REQUIRED FOR THIS DESIGN SIX G3
Materials for making this design are supplied by HOBBIES LIMITED, Dereham, Norfolk. Price on application.

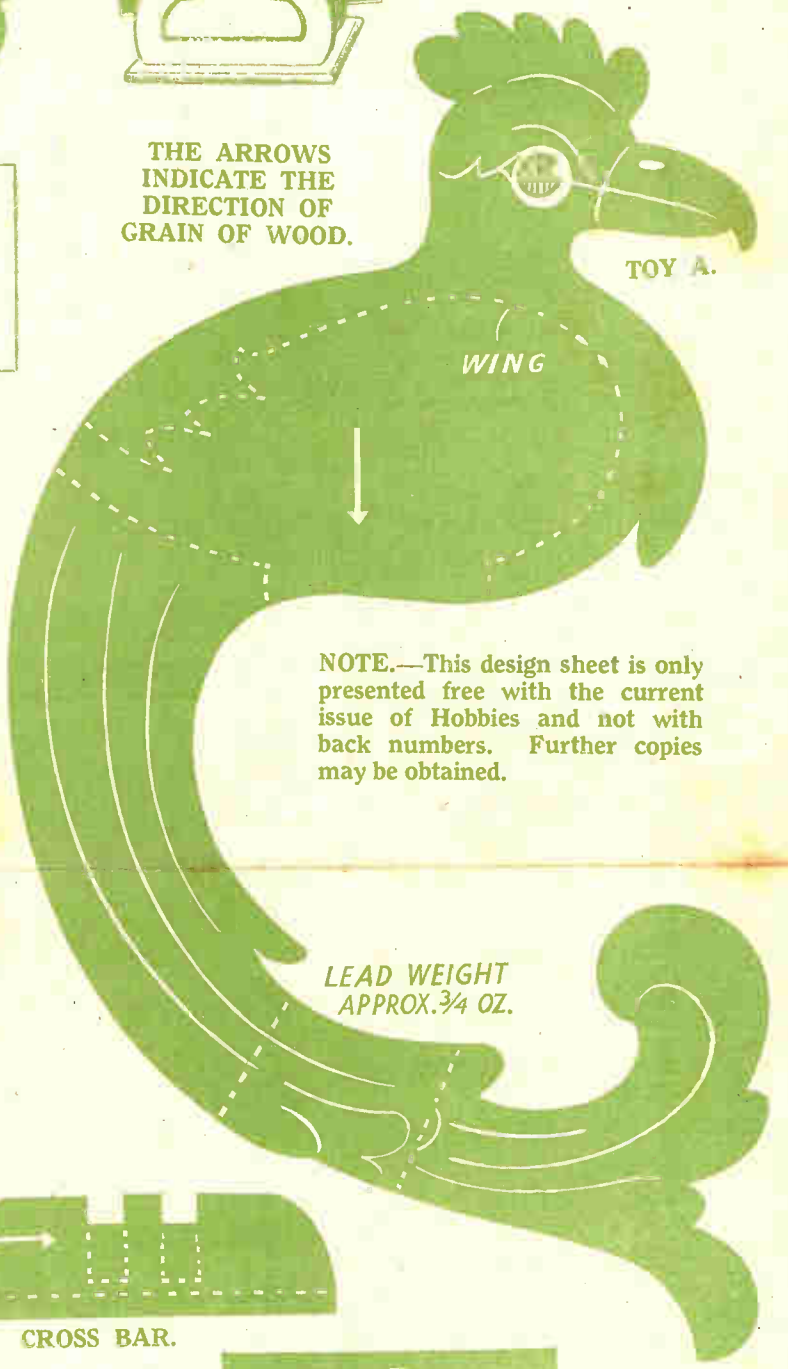

NOTE.—This design sheet is only presented free with the current issue of Hobbies and not with back numbers. Further copies may be obtained.

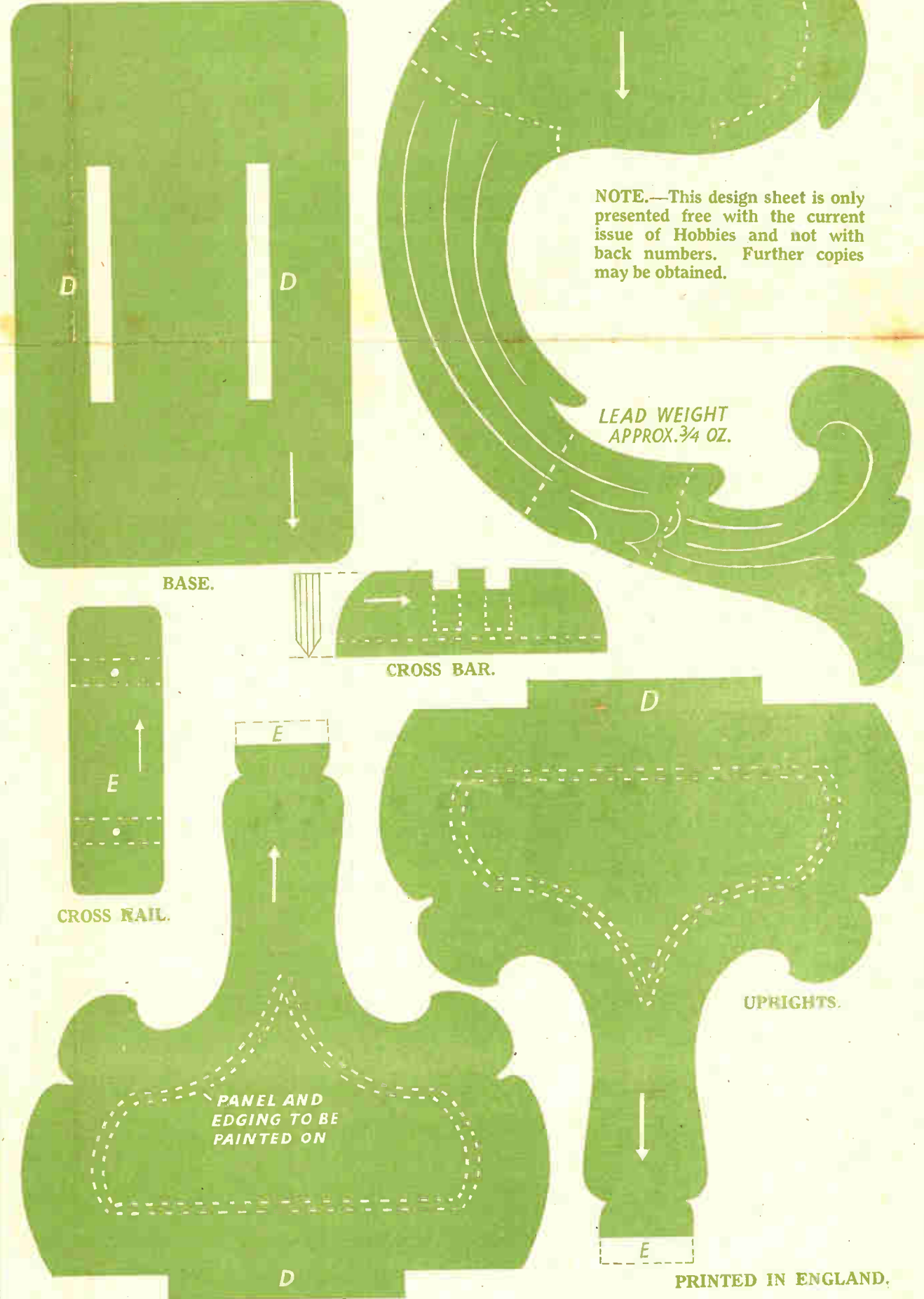
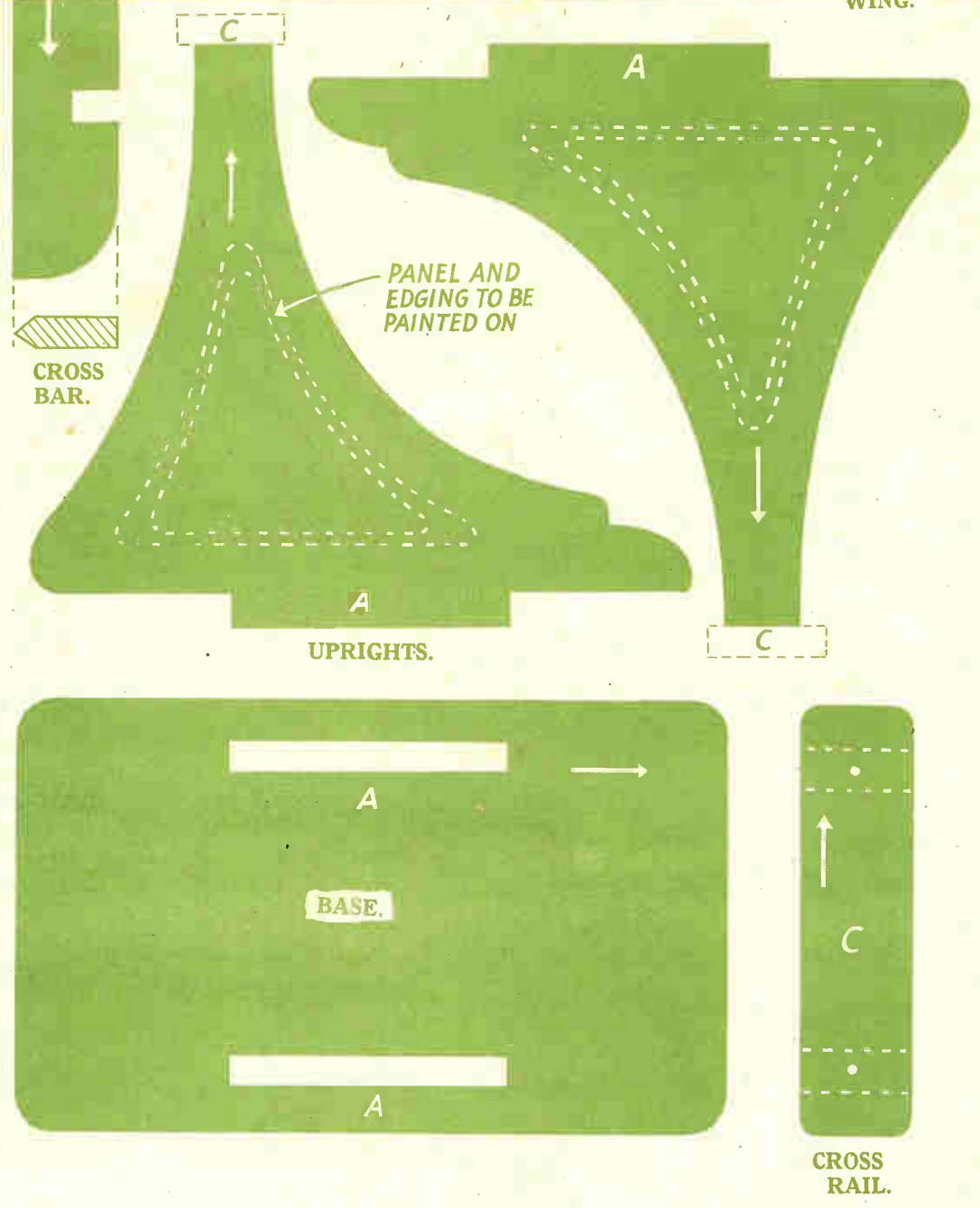

PRINTED IN ENGLAND.

TWO SWING TOYS

THE two swing toys shown on the other side, are the sort of little novelty to be made from odd pieces of wood $\frac{3}{8}$ in. thick, and when painted, make quite pleasing little toys for young friends or even to sell. The kit of wood provides panels sufficient to make both of them. As you may be likely to undertake making several, a good plan is to trace off the actual panels through to the wood itself. This can be done by means of carbon paper between the wood and the pattern, or by tracing the outline off on tracing paper, turning it over and then duplicating it on to the board.

The only work involved is with the fretsaw, and the few usual tools, and there is no elaborate jointing to be done beyond that shown in the base. Each is built the same, being a swinging bird which rests on a platform and swings between the two uprights. The actual momentum is created by a small piece of lead being fixed towards the base of the bird, cut out and so balanced that the whole thing swings.

Suitable Weight

This piece of lead can be taken from an ordinary piece of electric cabling or, of course, a thin strip of ordinary builder's lead itself. It does not have to weigh more than about $\frac{1}{2}$ oz. If you get a piece $1\frac{1}{2}$ ins. long and about $\frac{1}{2}$ in. wide, it can be nipped round the wood and holds itself in place there. If the weight is too much, or it is not properly balanced, it could be moved about, and if necessary a slight piece pared off with a knife or file until the correct swing is obtained.

The actual swing is provided for by a sharp edge cut to the bracket holding the bird itself. This is shown in the crossbar of each pattern, where you see the section shows the edge being chamfered to a sharp point. This long

sharp edge rests on the flat platform between the two uprights, and so forms the rocking base for the whole thing.

General Construction

Now for construction. Two uprights are tenoned into the base at points shown. Across the top a flat platform rail is fitted. It is glued to project beneath at each end, and a small fret nail or gramophone needle can be driven in for further strength. The birds themselves have a long centre body piece as the main part. On each side of this, the wing feather portion is added. Its position is shown by the dotted lines on the main part, and to secure the proper balance it is essential the pieces be glued in this position.

In the case of the parrot, the 'claws' fit over the upright crossbar by halving joint at (B). In the case of the other one, the fixing is a little different. The wings have an extension piece into which a halving joint provides the fitting for the crossbar at (F).

Glue on the wings first, making sure that the slots are in line, then you can slide the crossbar between them with its sharp edge projecting below. Trial and error with the lead temporarily added, will prove the balance to be correct.

Painting

The finished toys can be painted in bright enamel. The stands can be black and the birds follow the lines indicated in the black and white drawings. It is probably best to give the whole thing a coat of flat paint first, to provide the filler for the wood. Afterwards bright enamel should be used and allowed to harden before the toy is again handled. Blues, greys, yellows and reds can be introduced to make gay foliage for the birds themselves, with the features of the beak, eyes, talons, etc., lined on in black.

SUPPLEMENT TO HOBBIES No. 2840.

A MEDAL CASE

SIZE OF INTERIOR OF CASE—
9 1/2 ins. by 7 ins.

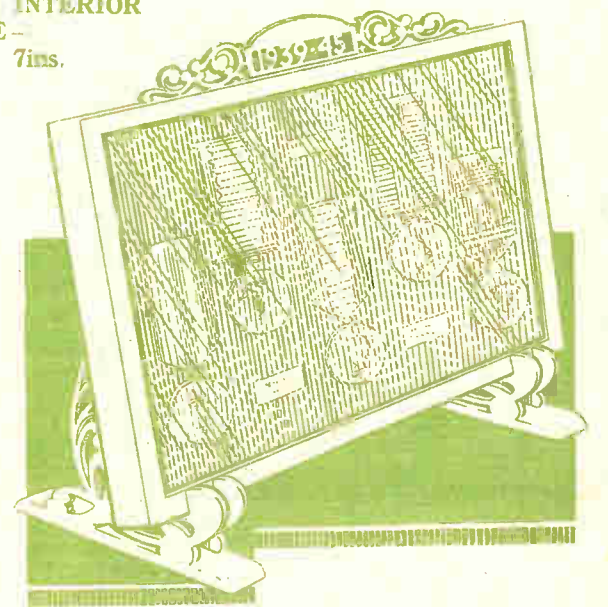

SMALL PIECE OF 1/4 in. WOOD
GLUED TO I TO FORM HYPHEN
BETWEEN DATES.



(I) BACKING TO PEDIMENT C.
CUT ONE 1/8 in.

THE ARROWS INDICATE
DIRECTION OF GRAIN
OF WOOD.



PEDIMENT (C). CUT ONE 1/4 in.

NOTE.—This design sheet is only presented free with the current issue of Hobbies and not with back numbers. Further copies may be obtained



SECTION THROUGH CASE SHOWING PARTS LETTERED.

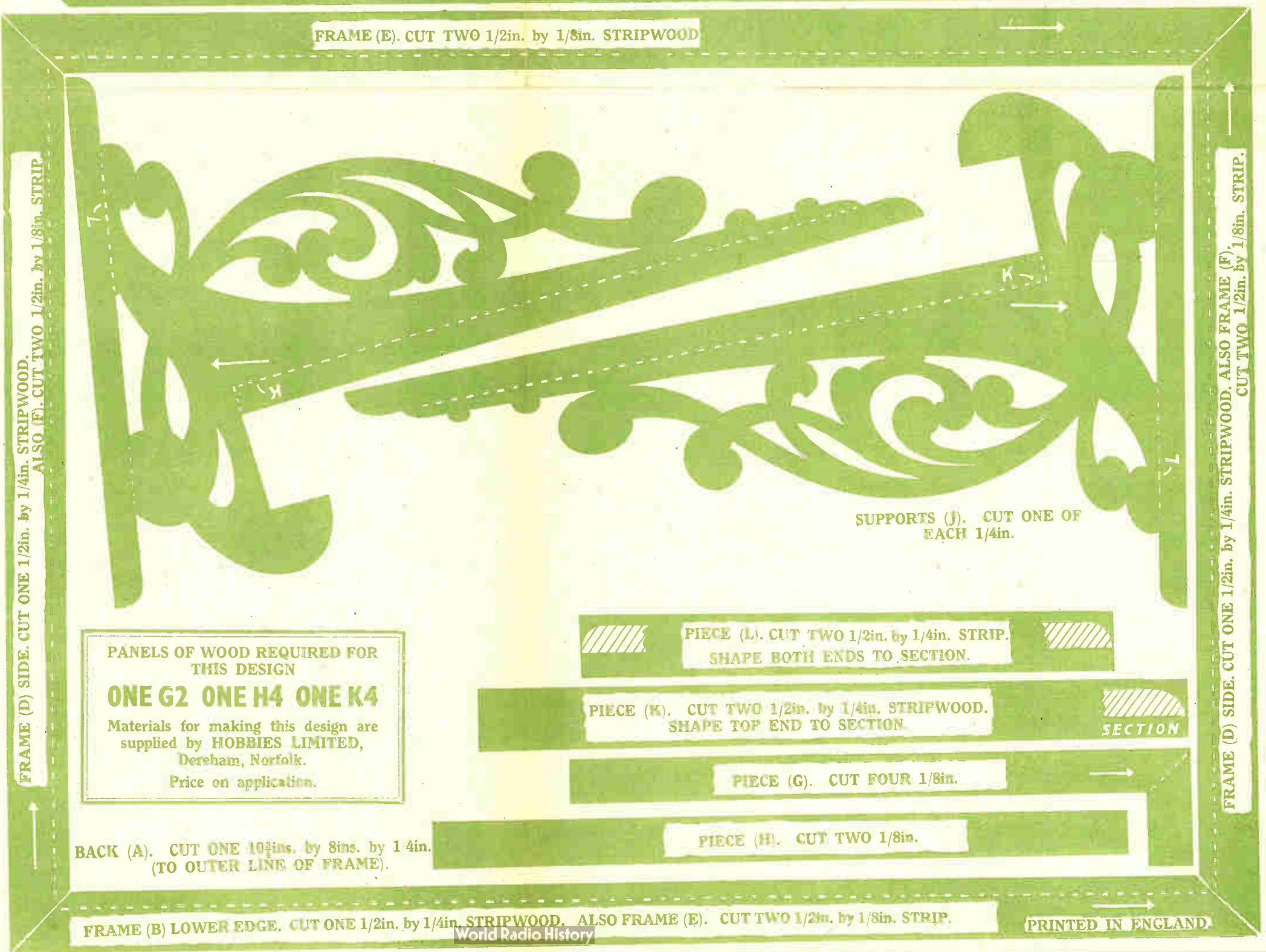

FRAME (E). CUT TWO 1/2 in. by 1/8 in. STRIPWOOD

FRAME (D) SIDE. CUT ONE 1/2 in. by 1/4 in. STRIPWOOD. ALSO (E). CUT TWO 1/2 in. by 1/8 in. STRIP.

FRAME (D) SIDE. CUT ONE 1/2 in. by 1/4 in. STRIPWOOD. ALSO FRAME (F). ALSO FRAME (E). CUT TWO 1/2 in. by 1/8 in. STRIP.

SUPPORTS (J). CUT ONE OF EACH 1/4 in.

PANELS OF WOOD REQUIRED FOR THIS DESIGN
ONE G2 ONE H4 ONE K4
Materials for making this design are supplied by HOBBIES LIMITED, Dereham, Norfolk.
Price on application.

PIECE (L). CUT TWO 1/2 in. by 1/4 in. STRIP. SHAPE BOTH ENDS TO SECTION.

PIECE (K). CUT TWO 1/2 in. by 1/4 in. STRIPWOOD. SHAPE TOP END TO SECTION

PIECE (G). CUT FOUR 1/8 in.

PIECE (H). CUT TWO 1/8 in.

BACK (A). CUT ONE 10 1/2 ins. by 8 ins. by 1/4 in. (TO OUTER LINE OF FRAME).

FRAME (B) LOWER EDGE. CUT ONE 1/2 in. by 1/4 in. STRIPWOOD. ALSO FRAME (E). CUT TWO 1/2 in. by 1/8 in. STRIP.

PRINTED IN ENGLAND.

HOW TO MAKE A MEDAL CABINET

QUITE a number of those who served in the Forces during the war, or who had relatives or friends doing the same, will be glad of the opportunity of making a glass-fronted case in which to attractively display the service medals awarded for the various campaigns.

The opportunity is provided by the patterns on the opposite side, and the kit of wood provides all the necessary boards from which the parts can be cut. Beyond the wood there is, of course, the piece of $\frac{1}{2}$ in. glass, and the backing of velvet or thick baize on which the medals can be hung.

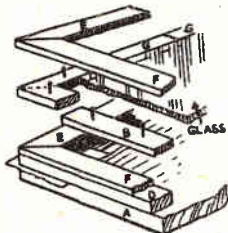

Fig. 1—The layers of the frame

The display case is made in two units, one being the glass-fronted frame itself, and the other the two fretted feet pieces which hold it at the correct angle for display. To save space, some of the patterns have been printed over each other, and reference to these should be made in conjunction with the details herewith.

Main Back

The main back is a solid piece of $\frac{1}{2}$ in. wood 10 $\frac{1}{2}$ ins. long and 8ins. wide. Around the edge of this is fitted the narrow strip frame parts (B), (C) and (D). This is not glued in place, but merely at its mitred corners. Lay the

strips on the backboard to ensure correct size, and when gluing the corners put in a piece of thin paper to prevent the glue running on to the backboard (A). You can see this piece in the detail at Fig. 1.

Three pieces of this frame are merely $\frac{1}{2}$ in. wide strips $\frac{1}{2}$ in. thick. The piece (C), however, provides the ornamental pediment with its fretted addition, and the date tablet. Behind this date panel a piece of thin backing is added, and on to this the tiny part which forms the hyphen between the dates 1939 and 1945. If you wish, a piece of card can be used, the size of (I) instead of the $\frac{1}{2}$ in. wood.

Glass Holder

To form the rebate for the glass, a framework of $\frac{1}{2}$ in. wood is now glued on. This consists of the parts (G) and (H), and their position is shown in Fig. 1. Notice the angle of (G) goes round the corner, and so when glued, helps to bind the mitred framework beneath. In addition to glue, you can add $\frac{1}{2}$ in. fret pins if you desire.

This frame, of course, is glued with the outer edges flush to the other parts so there may be a little rebate on which the glass will rest. The glass, by the way, must be 10ins. by 7ins. scant. If it is cut full, it will not fit in. In any case, check the measurements carefully before ordering the glass.

Front Frame

To hold this glass in place from the front, you have a further frame composed of the parts (E) and (F), which are $\frac{1}{2}$ in. wide and $\frac{1}{2}$ in. thick. Glue them again flush with the outer edge but, of course, with the inner edge over the glass to hold it in place. When the frame is complete, it will be possible to screw it to the main backing with $\frac{1}{2}$ in. screws through the back. You can see one in the section drawing on the sheet.

Before screwing up, a piece of velvet

must be glued to the back to come inside the framework. Ensure it is the right size in order to allow the framework to be screwed down finally.

Now we can turn to the two stands which provide the sloping holder for the frame. These are cut throughout from $\frac{1}{2}$ in. wood and a duplicate pair is needed. Get the grain of the wood running in the direction of the arrow, to provide strength, and cut each pair of uprights correctly to the pattern. Each two uprights are held slightly apart by the $\frac{1}{2}$ in. strips (L) and (K) (see Fig. 2).

The bottom strip (L) is glued between the feet of the supports, and each end afterwards rounded to the shape of the fretted piece. The part (K) is glued between the long backs of the upright in the position shown by the dotted line on the pattern. One end of this piece (K)



Fig. 2—Stand construction

comes in line with the shelf. This allows a portion of the top to project slightly. You can thus round it off to be in line with the fretted side of the support itself.

Glue each two-piece support carefully, and ensure that the bottom edges are flat to provide an upright and rigid stand. The whole frame, of course, rests in the shelf portion provided, which you can see enlarged in Fig. 2. The usual staining and polishing or just plain varnishing can be undertaken to complete the whole work.

SUPPLEMENT TO HOBBIES No. 2838.

PAIR OF BOOK ENDS

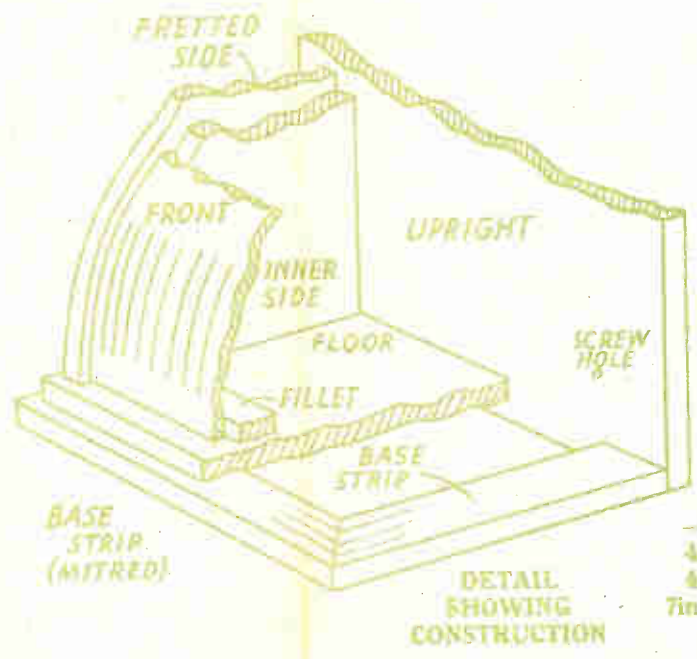

—SIZE—
4ins. BY
4ins. BY
7ins. HIGH.

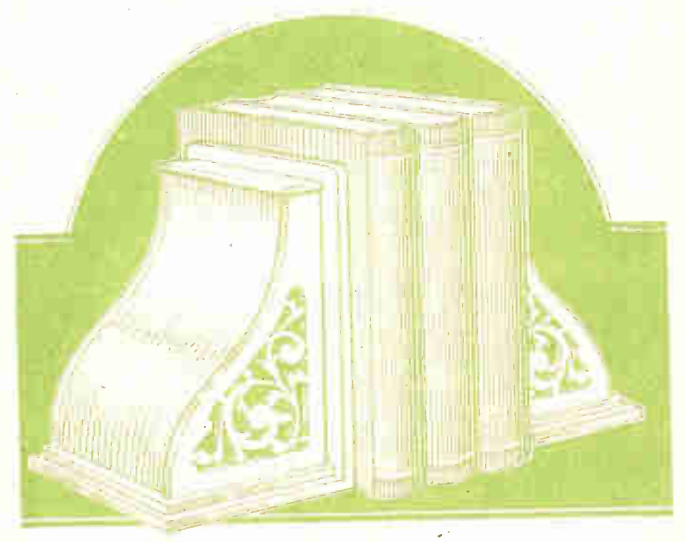

SECTION
TOP. CUT TWO 1/4in. AND ROUND OFF FRONT AND END EDGES TO SECTION.

STIFFENING FILLET GLUED UNDER TOP TO SUPPORT CURVED FRONT. CUT TWO 1/4in.

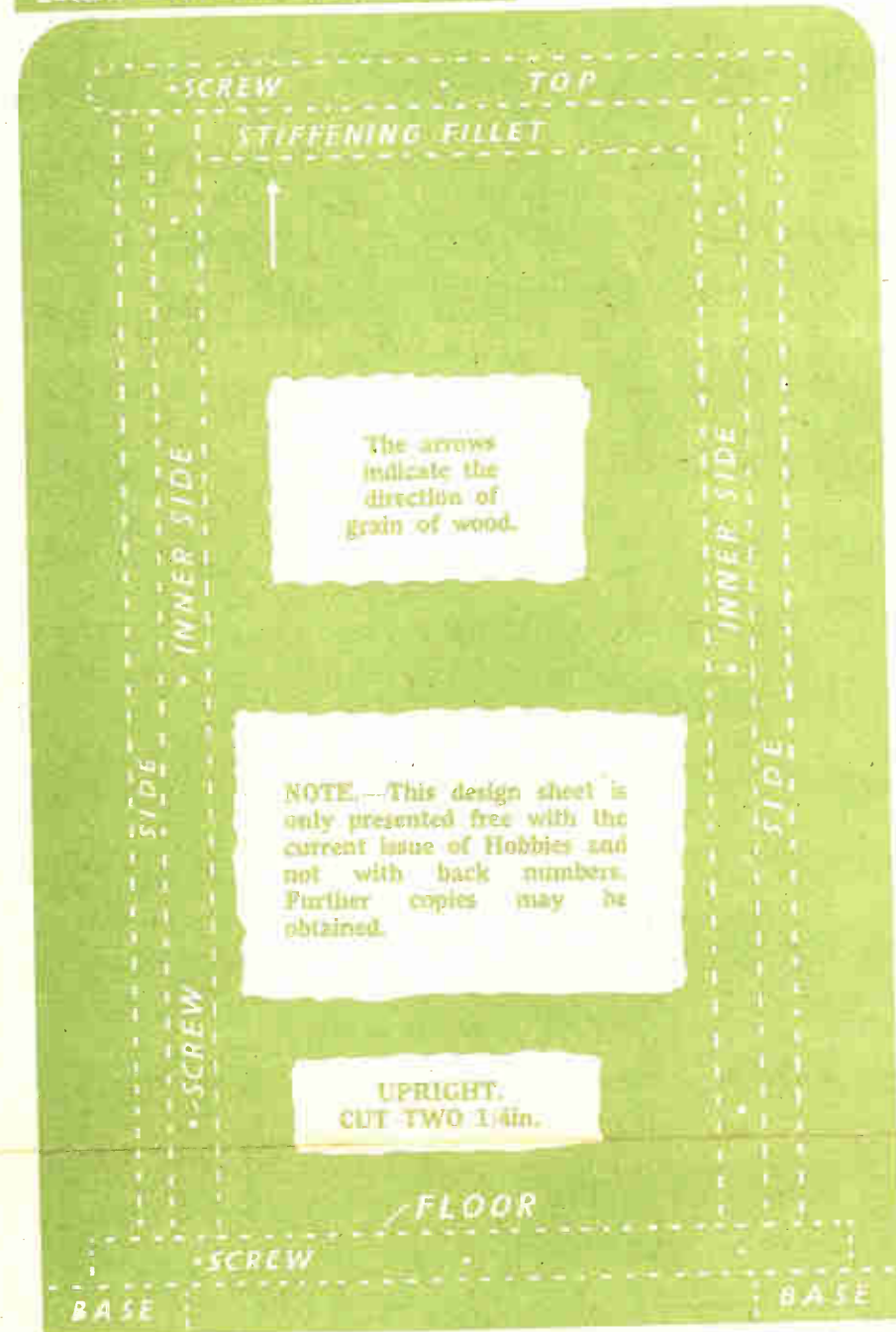

STIFFENING FILLET GLUED TO FLOOR TO SUPPORT CURVED FRONT. CUT TWO 1/4in.

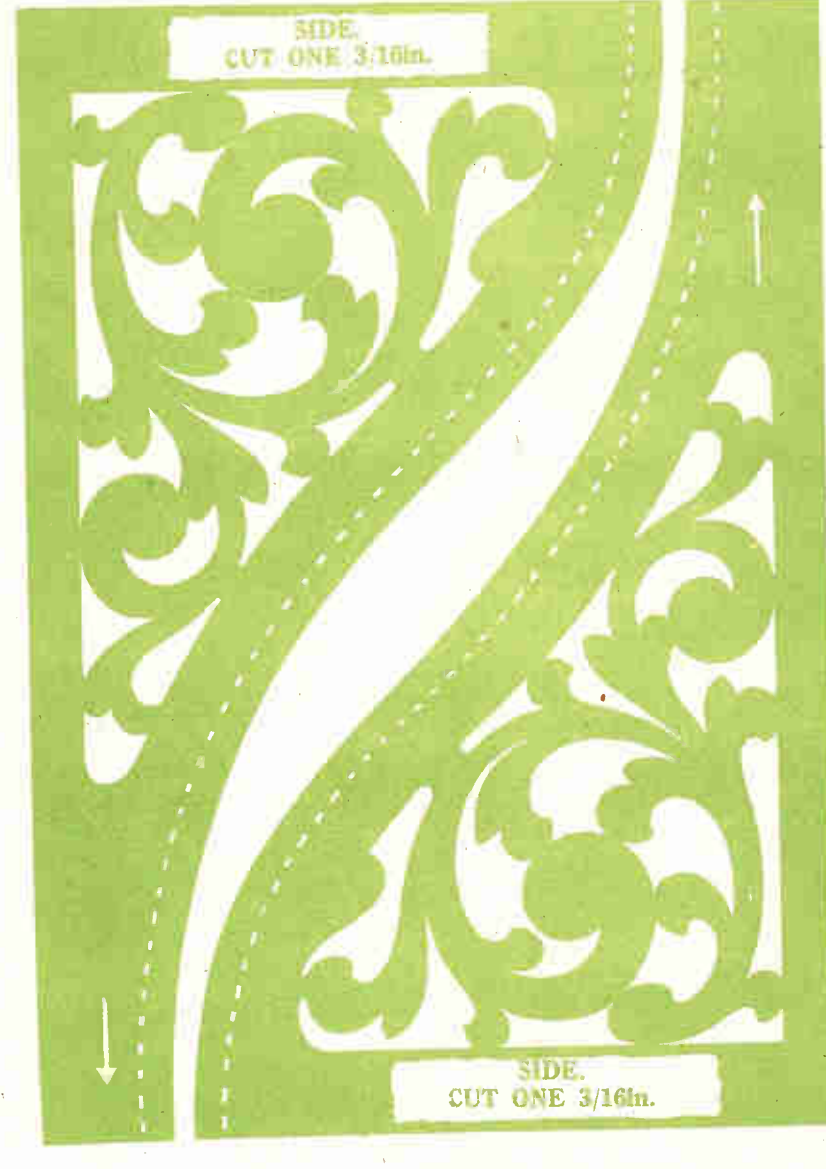
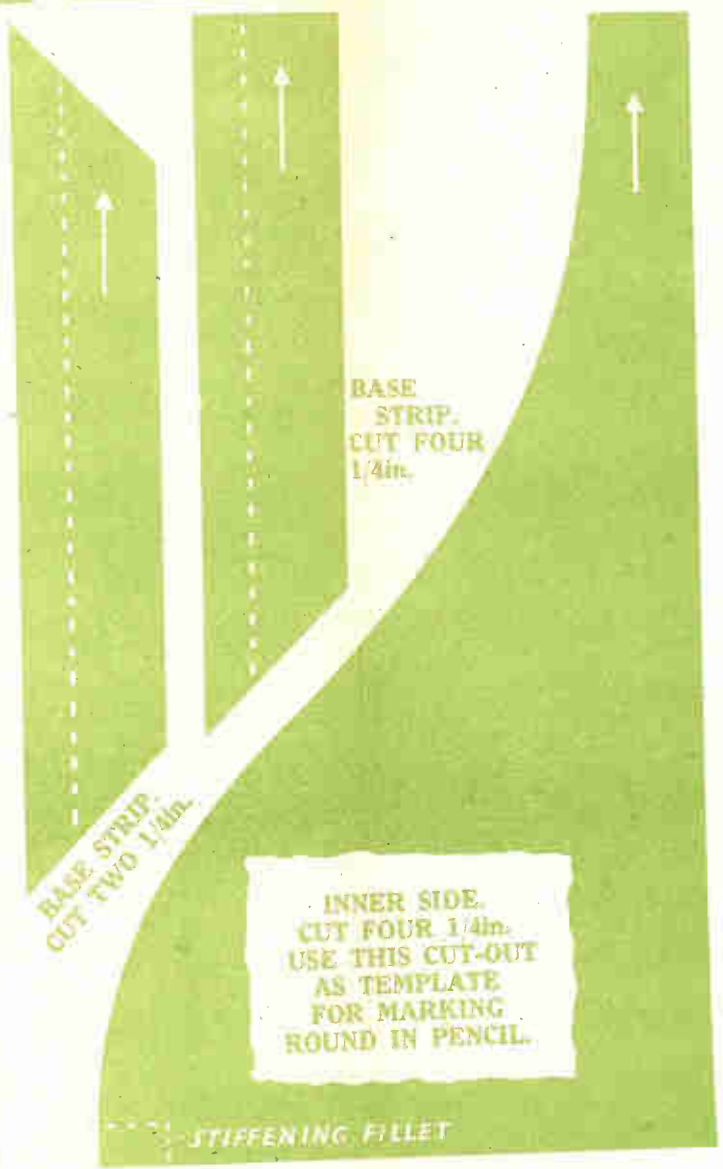
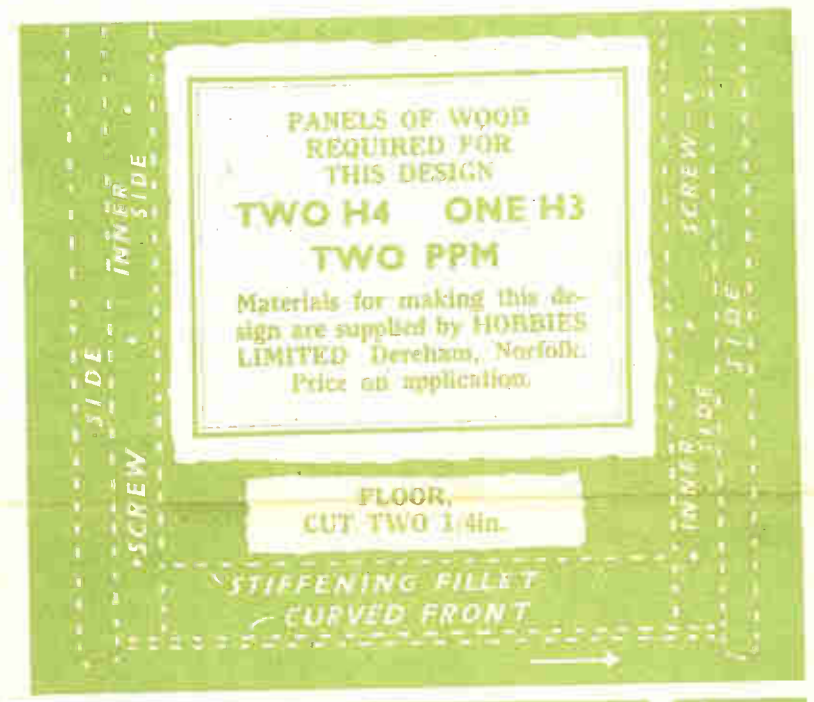
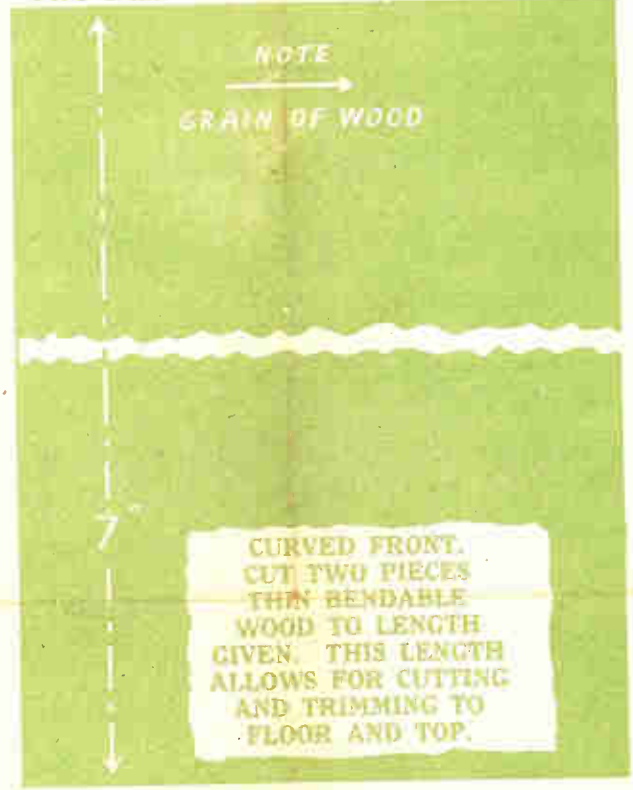

A PAIR OF BOOK ENDS

PATTERNS are provided full size on the other side for making an attractive, shapely bookend. A kit of wood supplied provides the necessary material for a pair. The patterns themselves should be marked on to the wood direct, and not pasted down except in the case of the one containing the fretted design.

Lay the paper pattern over the wood, and prick through the corners. Take the paper away and link up the pin holes with a hard pencil line, then check all parts with a pair of dividers to ensure accuracy. Note that the pattern of the curved front is shown shortened. It is 7ins. long in its full length, and the grain of the wood should run cross-ways. Dotted lines on various patterns indicate adjoining positions, and the screw holes indicated, should be made with an awl so they are obvious when the time comes to put the screws in place.

Base Weighting

The cutaway drawing of one of the ends plainly indicates the construction. The article in wood is, of course, fairly light, and possibly to provide sufficient weight to hold it satisfactorily, you could put pieces of lead or lead shot or something equally heavy, in this interior. The lead could be tacked down and the shot contained in a suitable tin also fixed to the floor. The parts are cut with a fretsaw, taking care to get straight lines correctly so they can be glued up satisfactorily when butted to any adjoining piece.

First of all make the framework of the base—a three-sided piece to be glued at rightangles to the upright back. The two front parts of the strip are mitred, but the back end is square. When these parts are cut, glue them to the floor

piece. The back edge of the floor must come level with the straight edge of the base strips, and the framework will then project slightly on three sides.

Fretted Sides

The whole of the base can now be glued to the upright. Use a square to ensure the rightangle is correct, and add a few fine screws if you think necessary, at the positions shown. On the inside of these fretted sides, is glued the inner side piece. One each is fitted, and then a stiffening fillet glued across on the floor and at the top. Have these fillets ready before gluing the inner side, and test out for their equal length to ensure a correct fitting. One fillet can be seen in the cutaway drawing, the other comes between the sides at the top, and as indicated by the dotted lines on the pattern of the main upright.

The inner sides being set back slightly, provide a foundation on which the shaped ends or front can be fitted. This curved front is of thin plywood 7ins. long, and just wide enough to fit between the main sides. Test its width before fitting in position. Lay it along the curve of the inner side, and cut off the top end level with the top itself.

Wood Finish

Put in this top platform piece before adding the front, shaping it rounded on three sides before gluing to the top of the main sides themselves. As shown, it projects slightly each way. If you are going to weight the bookend, remember to add this inside before you finally fix the curved front. The whole part can be stained and given a coat of polish or varnish, and if you wish, some baize or similar cloth can be glued to the underside to prevent the likelihood of scratching the table when in use.

THE ARROWS INDICATE THE DIRECTION OF GRAIN OF WOOD.

SUPPLEMENT TO HOBBIES No. 2836.

'O' GAUGE ENGINE SHED

DOUBLE TRACK. LENGTH 12ins. (TWO 6in. UNITS)

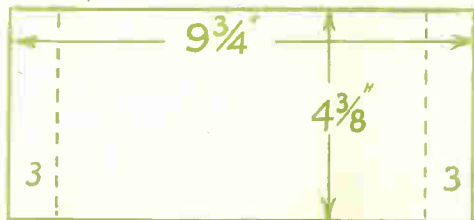
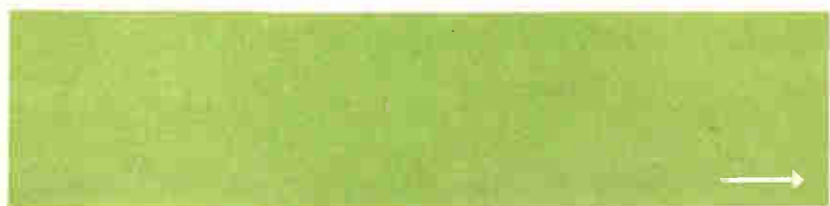
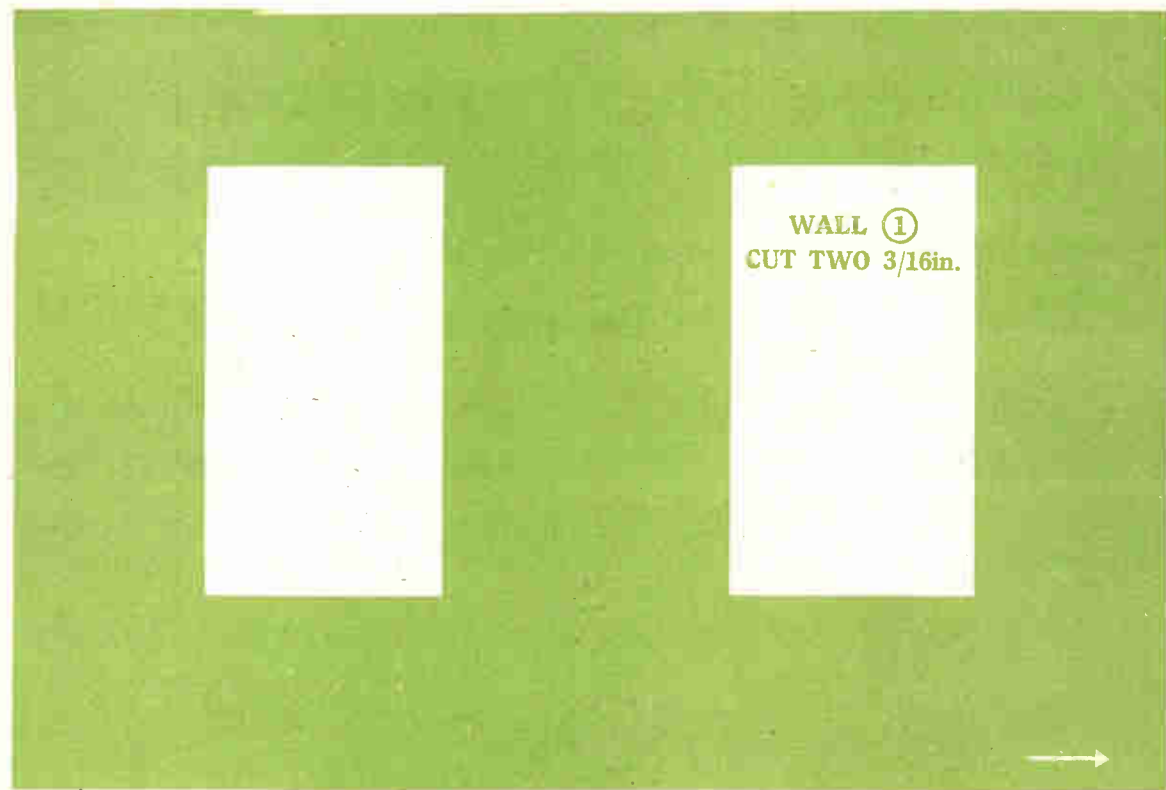
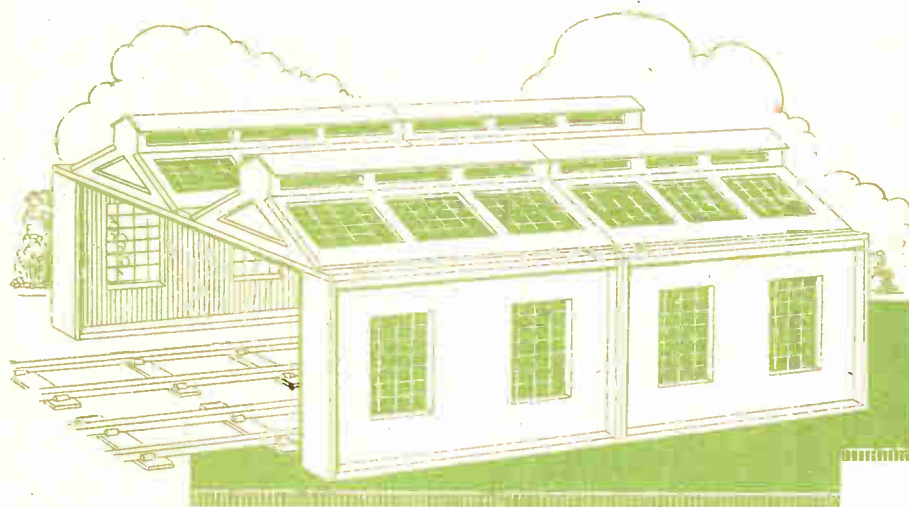

DOORS. CUT ONE 1/8in. AND DIVIDE AS SHOWN. IT IS NOT ABSOLUTELY NECESSARY TO PROVIDE DOORS FOR THE SHED, BUT ENOUGH WOOD FOR THEM IS INCLUDED IN THE PARCEL.

NOTE.—This design sheet is only presented free with the current issue of Hobbies and not with back numbers. Further copies may be obtained.

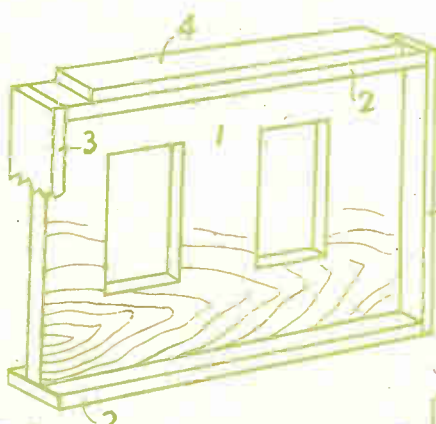

NOTE.—THE ENGINE SHED IS MADE OF TWO SEPARATE UNITS, EACH OPEN AT ONE END, WITH END ⑬ AND DOORS ⑭ (IF REQUIRED) IN PLACE. THE OPEN ENDS ARE SIMPLY STOOD TOGETHER TO FORM ONE LONG SHED. PARTS FOR ONE UNIT ONLY ARE SHOWN, BUT ENOUGH MATERIAL IS PROVIDED FOR TWO.

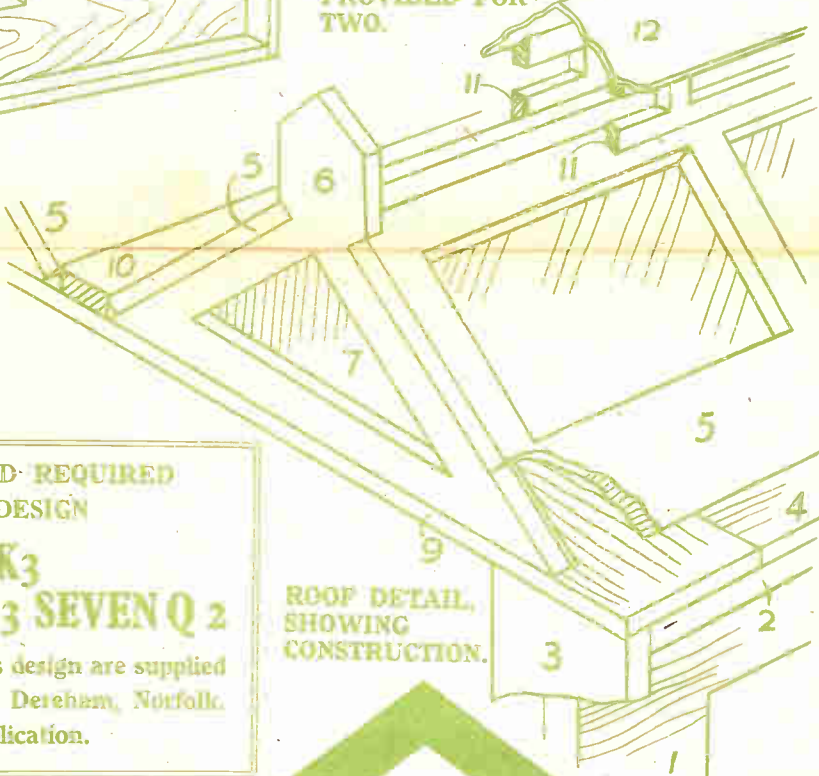

PANELS OF WOOD REQUIRED FOR THIS DESIGN

ONE K₃
ONE H₂ ONE Q₃ SEVEN Q₂

Materials for making this design are supplied by HOBBIES LIMITED, Dereham, Norfolk. Price on application.

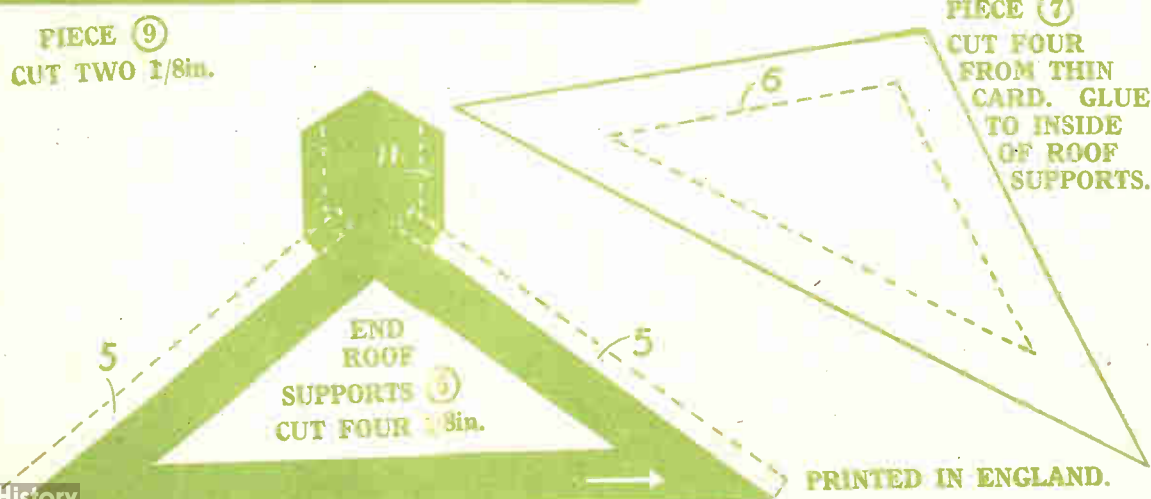
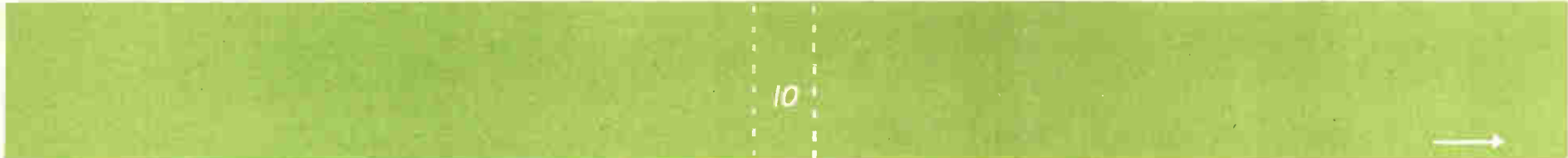

O-GAUGE ENGINE SHED

THIS typical Engine Shed is built to accommodate the O-gauge models, and has been planned so the units shown can be extended to receive larger or a greater number of engines as required. The kit of wood provided allows for the building of the whole of the shed shown here, but this in turn is built in two complete units standing close up as you can see at the central buttresses.

As illustrated, it is open-ended, but provision is made for doors at one end. The other end can be stood against a wall as a terminal shed, or you can add a sheet of stiff card to fill it in. Without the doors, the shed can be easily taken apart if the roof portion is merely laid on top of the walls and not fixed. If the doors are added, the structure will become more solid as a complete article. As shown, the shed is 12ins. long, and will accommodate a double track of the ordinary O-gauge.

With or Without Doors

Before commencing, it is necessary to decide whether the parts are to be made as a complete whole with doors, or as previously mentioned, to be in separate pieces which can be taken down for storage when required. The wood used is $\frac{3}{8}$ in. and $\frac{1}{2}$ in. thick and patterns are marked in numerical order according to the sections of their building. Two details are also shown on the pattern sheet, which almost clearly explain their position to each other. In most cases, too, a dotted line is drawn on the patterns to indicate where an adjoining piece is to be fixed. In the kit, transparent material is provided for the windows. There is also sufficient card for the complete back of the shed, and the long strip needed to form the folded ridge of the ventilators. Four small hinges are included for the doors at one end.

Commence with the construction of the walls first, two of which will be required for each unit. As most parts

are butted together, it is essential for perfectly straight edges to be obtained in the cutting to give the glue a full grip. Even so, small screws or nails can also be driven through because they will be covered later with paint or paper. Put the wall upright centrally between the flat pieces (No. 2) and then on the ends add parts (3). On the top is part (4), which you will note is set back 1in. from each end. This is to allow the cross span of the roof (No. 9) to lie flat and snug in position. To make the shed shown, you require four sides of these complete walls so far mentioned.

The Roof

Next proceed with the making of the roof unit which is a double span built on the cross girders (No. 9). First of all, however, prepare the sloping roof pieces (No. 5). The ends are formed by (No. 6) on the inside of which a triangle of thin card is added, coming flush with all its edges. Glue the card to overlap first, and then with a sharp penknife cut it in line with the edge of the wood to ensure a similar outline to both. When these ends are complete, you can glue on the sloping roof pieces (5). The 'glass' of the roof can have been added before fixing the part, so you can put it in position later. The transparent material is cut about 1 $\frac{1}{2}$ ins. long and about 2ins. wide.

Do not glue one strip the whole length, because supporting frames are added to the under angle of the roof by the parts (8). These come at the two positions shown by the dotted lines on the pattern piece (9). The completed roof (5) is glued on to the support of (6), and is shouldered in the corner for strength. No chamfering of these edges is needed. To get the position of these roof pieces you should first of all glue the long strip (10) to the end cross strips (9).

This piece (10) comes midway as you see on the pattern of (9), and indicates where the long roof parts will fit. This position provides certain projection of

the girder (part 9) which, as you can see by the detail, is made to fit into the top of the wall between (3) and (4). The ventilator portion of the roof is added by gluing pieces (11) upright along the whole length, and coming between the end roof supports (6). In this case, the top and bottom edge will have to be chamfered as shown by the section on the drawing of part (11).

Ventilator Card

The final covering of the ventilator piece is made by a strip of card (part 12). This is 6 $\frac{1}{2}$ ins. long, 1 $\frac{1}{4}$ ins. wide and the point of a knife should be run down the centre to score the card sufficiently for it to be bent to a clean angle the whole length. Windows of the transparent material can, of course, have been previously added to the inside walls of the shed, or can now be put in place. Cement the transparent material on firmly, and then paint with narrow white lines the framework between the panes.

The whole model can be finished by painting, or can be covered with brick and tile paper if you prefer. Probably the best way is to have a roughcast stone effect by having that type of paper glued over the whole of the outside. Or you can use a cream for the walls, slate colour for the roof and, say, a brown for the projecting buttresses of the walls, etc. The inside should also receive attention in the same way.

Hinged Doors

If you are having the units removable, then the work is finished, but if you are making it a wholly rigid piece of work, then you can hinge the doors at one end and glue on a sheet of card at the back end. If doors are fitted, it is advisable to glue a piece of wood under the roof girder to form a stop. The doors, of course, should open outwards, and fit snugly to each other, being provided with a small wire catch for holding together when closed.

SUPPLEMENT TO HOBBIES No. 2832.

A PAIR OF BELLOWS

SIZE:
ABOUT 17ins. LONG.
7½ins. WIDE.

NOTE. — This design sheet is only presented free with the current issue of 'Hobbies' and not with back numbers. Further copies may be obtained.

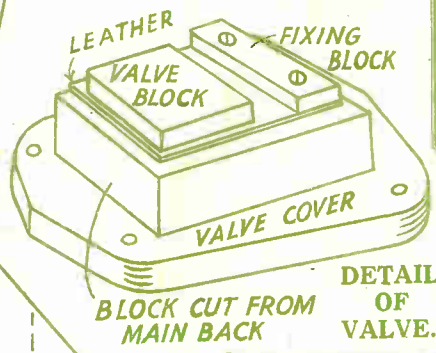

DETAIL OF VALVE.

PANELS OF WOOD REQUIRED FOR THIS DESIGN
THREE MD8 THREE LD6 ONE J4
Materials for making this design are supplied by HOBBIES LIMITED, Dereham, Norfolk. Price on application.

The arrows indicate the direction of grain of wood.

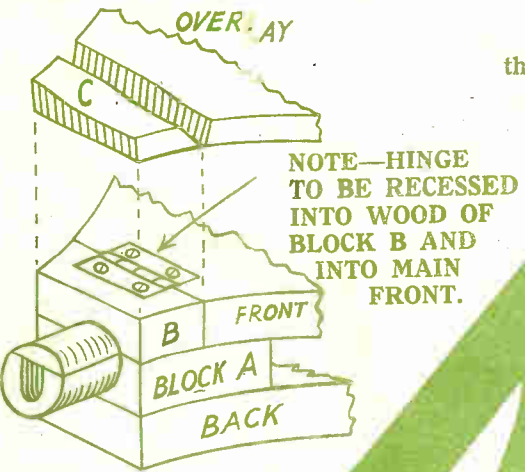

NOTE—HINGE TO BE RECESSED INTO WOOD OF BLOCK B AND INTO MAIN FRONT.

PUT NOZZLE ON HERE
DETAIL OF NOZZLE END OF BELLOWS.

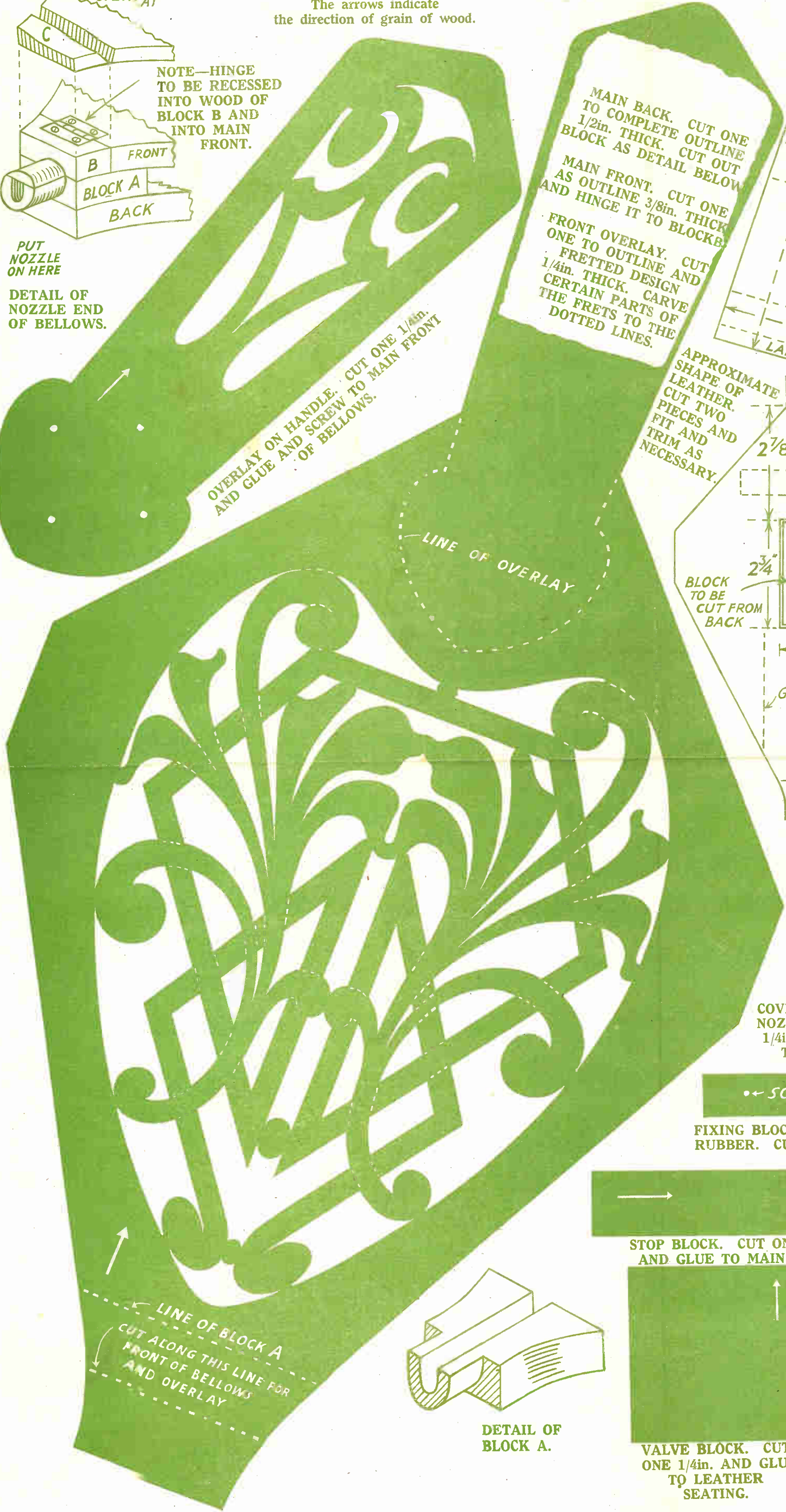

OVERLAY ON HANDLE. CUT ONE 1/4in. AND GLUE AND SCREW TO MAIN FRONT OF BELLOWS.

MAIN BACK. CUT ONE TO COMPLETE OUTLINE 1/2in. THICK. CUT OUT BLOCK AS DETAIL BELOW

MAIN FRONT. CUT ONE AS OUTLINE 3/8in. THICK AND HINGE IT TO BLOCK B

FRONT OVERLAY. CUT ONE TO OUTLINE AND FRETTED DESIGN 1/4in. THICK. CARVE CERTAIN PARTS OF THE FRETS TO THE DOTTED LINES.

APPROXIMATE SHAPE OF LEATHER. CUT TWO PIECES AND FIT AND TRIM AS NECESSARY.

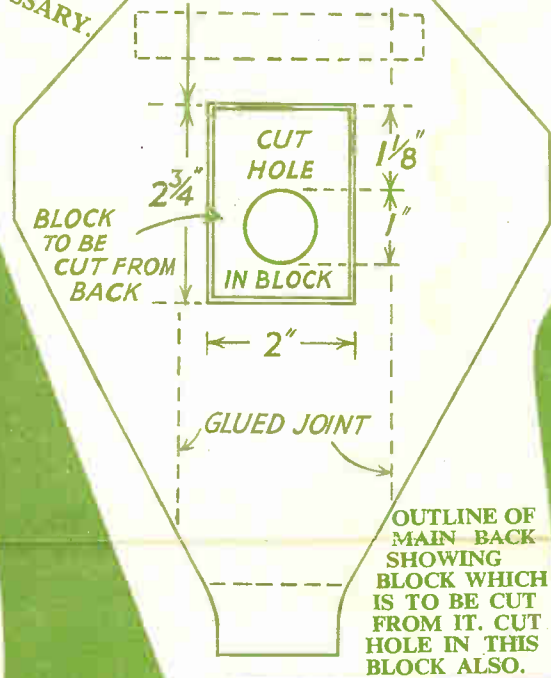
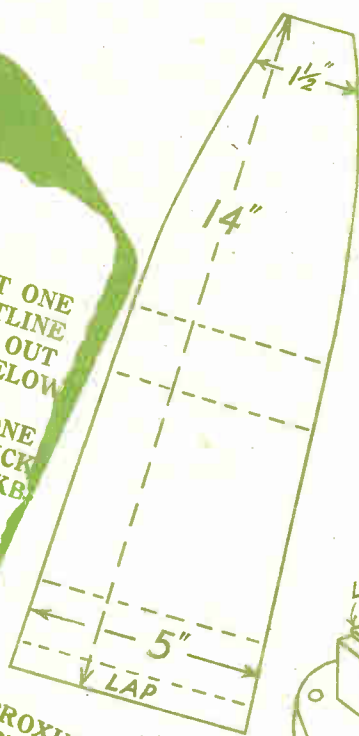

COVER PLATE FOR NOZZLE. CUT ONE 1/4in. AND SHAPE TO SECTION.

FIXING BLOCK TO VALVE RUBBER. CUT ONE 1/4in.

STOP BLOCK. CUT ONE 1/2in. AND GLUE TO MAIN BACK.



VALVE BLOCK. CUT ONE 1/4in. AND GLUE TO LEATHER SEATING.

LOWER END OF OVERLAY SHOWING HOW IT IS CHAMFERED TO MEET THE CHAMFER ON MAIN OVERLAY.

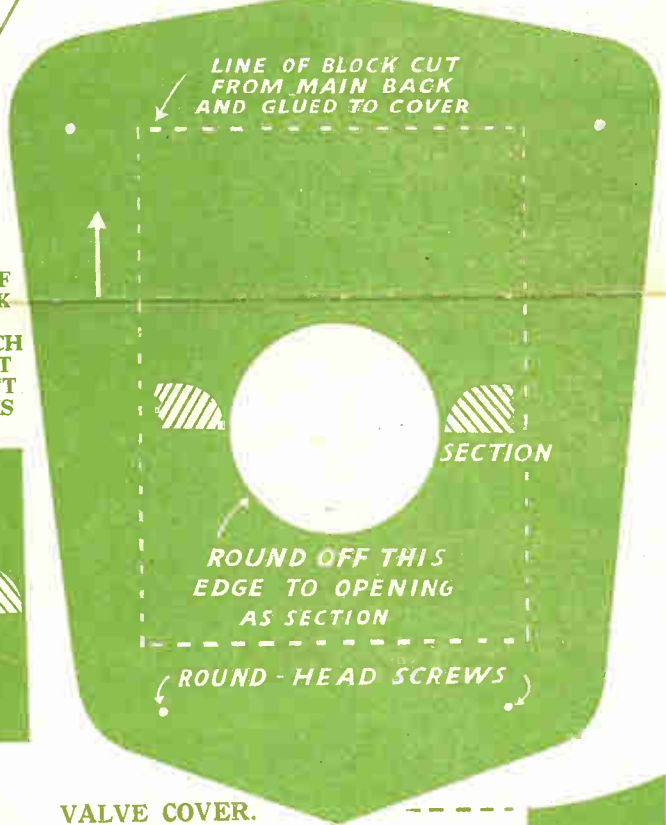

VALVE COVER. CUT ONE 1/4in. AND SCREW TO MAIN BACK.

BLOCK B. CUT ONE 3/8in. AND SHAPE TO THE SHADED SECTION.

BLOCK A. CUT ONE 1/2in. AND CUT IN THE GROOVE AND SHAPE TO THE SHADED SECTION.

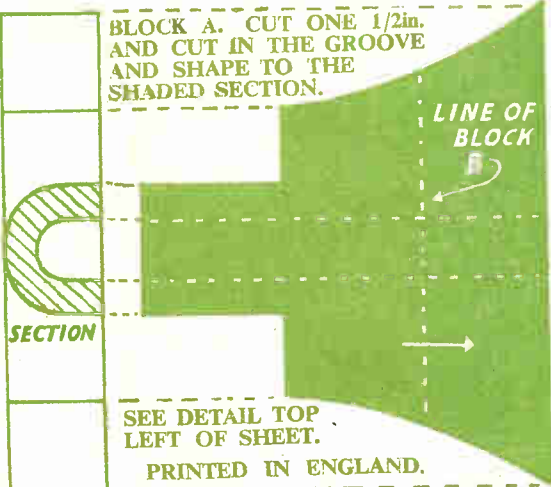

SEE DETAIL TOP LEFT OF SHEET. PRINTED IN ENGLAND.

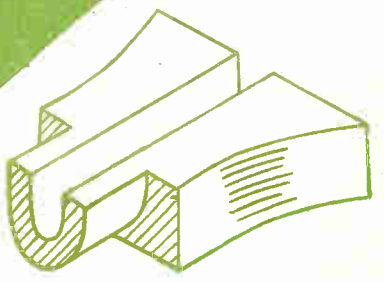

DETAIL OF BLOCK A.

Instructions and patterns for MAKING A PAIR OF BELLOWS

THE pair of bellows, illustrated on the other side, can be made from the kit of wood provided, in conjunction with the patterns. Apart from the actual fretted portion, the other patterns need not be pasted down, but can be traced out direct to the wood through carbon paper or by means of tracing paper.

The parts are cut with the fretsaw and fitted together with glue. Apart from the wood, you will require a single hinge 1 in. or 1½ in. wide, with countersunk screws, and three pieces of soft leather. Two of these form the bellows portion, and the third is the small piece inside forming the valve.

Back and Front

Cut the parts to the shape, and clean them with glasspaper before gluing together. Note that one pattern is made to serve the three shapes for the back, the front, and the overlay. The back is cut from ½ in. wood to the complete outline shown. The front is similarly cut to the outline, but is ¾ in. shorter at the narrower end, being cut across where indicated by the dotted line. The overlay from ½ in. material includes the fretted decoration of the pattern, although this, too, can be omitted if you prefer the plain board.

When cutting the back, you will also have to cut from it a hole 2 in. by 2½ in. at the position indicated by the small diagrammatic outline. Cut this block out with a fairly coarse fretsaw, as it has to be replaced later. From the centre of this block, too, a 1 in. diameter hole must be either bored or cut with the fretsaw to form an air inlet.

The Valve Part

This complete block is glued to the valve cover piece so the whole thing can be screwed on the back of the bellows as a shield type overlay. The centre hole of this valve cover piece is rounded, as shown by the section. The block which came from the back forms the foundation of the valve itself, and the detail shown indicates its construction.

A small piece of very soft leather 1½ in. by 2½ in. is fixed to the back of the block with a strip of ½ in. wood and two screws. At the other end of the leather is glued on the valve block. This is

simply a piece of wood to form a weight to prevent the leather being forced away. Thus, when the air comes in through the hole, the leather is blown out, but the air cannot escape again because the weight of the block holds the material flat against the hole. This whole valve can, of course, be built but need not be screwed on to the back at present.

When the back is cleaned, the nozzle end must be made, and the detail in the top lefthand corner clearly illustrates this. The block (A) of ½ in. wood has a

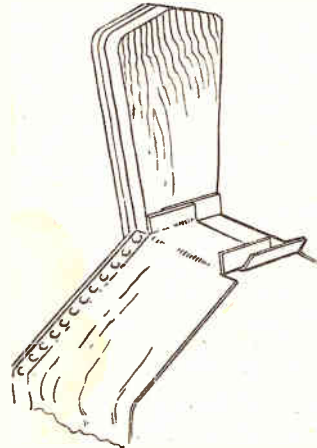

How the side strips fit the handle

groove cut in it its whole length. This is ½ in. wide, and should be rounded. If you can drill a hole straight through, so much the better. Glue block (A) with the rounded portion projecting beyond the end of the back. Above this, the block (B) is glued. It must be cut to the shape shown in the detail, and fixed to (A) to form a complete nozzle pipe.

Cover Plate

Over all of this is fitted the cover plate, the central hole of which should be tested to be the same as the diameter of the blocks before being actually cut. The nozzle itself will still project ½ in. beyond the cover plate, and if you have a suitable tube of brass or other metal, it can quite well be fitted over to form a good finish. Behind block (B) comes the front of

the bellows, and it is hinged there as shown. Let the hinge well into the wood so that the two pieces of the overlay are bedded flat. The overlay goes on the front of the bellows, the bottom end in line with the knuckle of the hinge. Notice that this bottom edge must be chamfered to a slight section. A piece forming the lower end of the overlay is also glued on (part C). This also has to have its edge chamfered to allow the front to open satisfactorily without binding on the overlay itself.

A Stop Block

Before hinging on the front finally, glue to the inside of the back the stop block shown. Its position is indicated by the dotted lines on the diagram of the main back outline. It comes about ½ in. above the valve block, and is glued on edge there to prevent the two pieces of the back and front closing together too much. The valve cover piece can now be fitted on to the back. It should be screwed there to be removable in case the valve fails to work at any time. A fretted piece of overlay on the handle adds to the attractiveness of the front.

Edging Material

The approximate shape of the two pieces of leather which form the sides of the bellows is given. Cut it a little larger than shown, to allow trimming afterwards. The material should be soft to allow for bending, and it is held in place by a row of round-headed brass upholsterer's nails, set close together along the edges of the back and front.

Commence nailing from the nozzle end, with the narrowest part of the leather. The other end, of course, will come between the handles, and cut to allow for an overlap to the piece coming up inside the handle, as shown on the detail. Glue securely here to prevent any air escaping.

Each of these strips is bent along its central length, half of it glued to the inside of the handle, and the other half to the joined portion of the sides. The overlap of this leather is shown in the detail herewith, and the small strip on the inside of the handle is detailed at (A).

The whole work can be stained and polished as usual, or oiled or varnished, or even painted if your wood is not suitable for the other processes.

MODEL OF THE UNION-CASTLE LINE ROYAL MAIL SHIP "PRETORIA CASTLE"
 THE LINER IS 749 FEET LONG AND ITS GROSS TONNAGE 28,705.

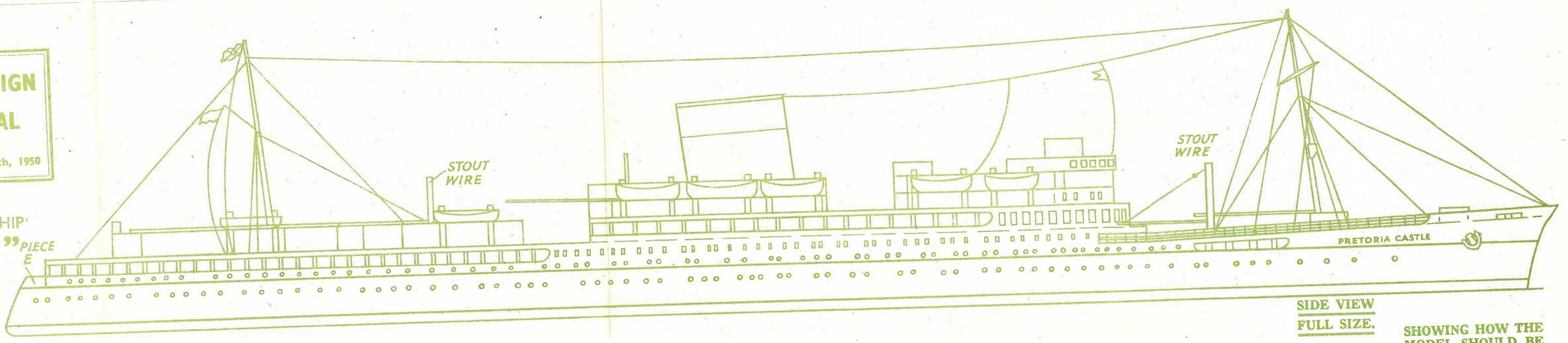

SIDE VIEW FULL SIZE. SHOWING HOW THE MODEL SHOULD BE PAINTED UP.

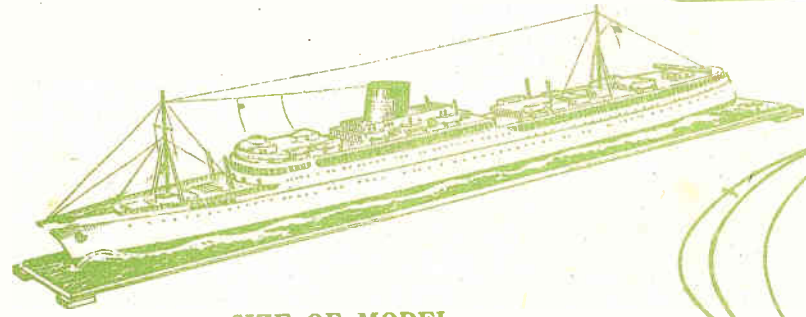

SIZE OF MODEL NOT INCLUDING BASE
 15 1/2 ins. LONG. 3 ins. HIGH.

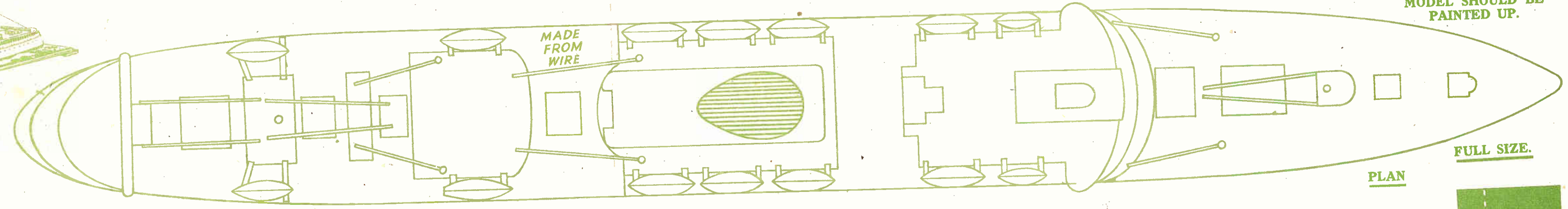

PLAN FULL SIZE.

NOTE.—This design sheet is only presented free with the current issue of Hobbies and not with back numbers. Further copies may be obtained.

The arrows indicate direction of grain of wood.

PANELS OF WOOD REQUIRED FOR THIS DESIGN
 ONE MD8- ONE H4 ONE G3 ONE LD6 (BASE)
 Materials for making this design are supplied by HOBBIES LIMITED, Dereham, Norfolk. Price on application.

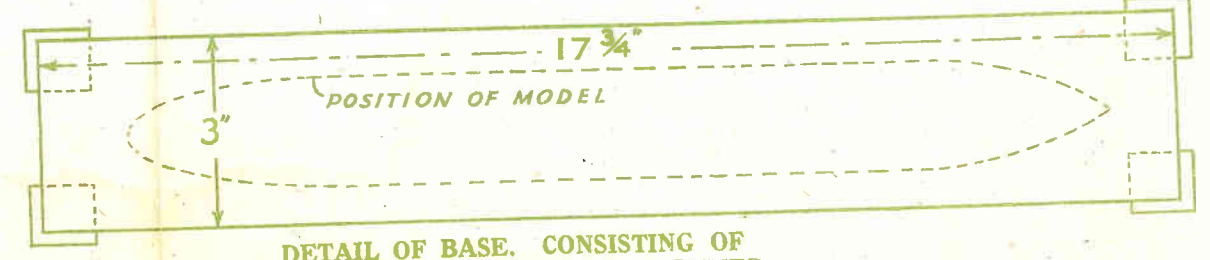

DETAIL OF BASE. CONSISTING OF ONE PANEL OF WOOD LD6, TRIMMED AND SHAPED, AND CORNER FEET.

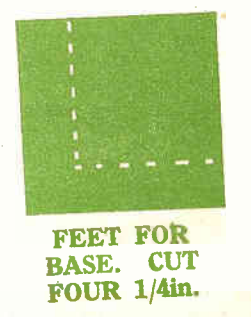
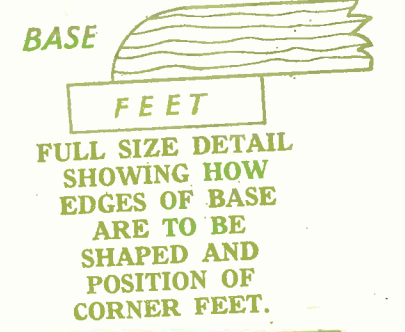

FEET FOR BASE. CUT FOUR 1/4 in.

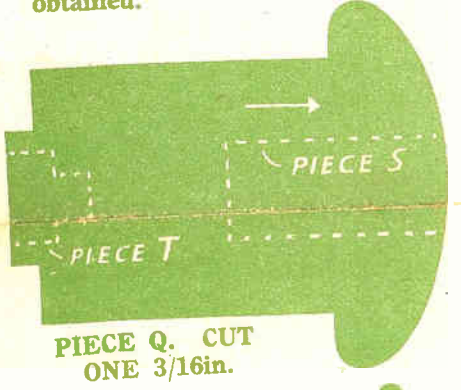

PIECE Q. CUT ONE 3/16 in.



PIECE R. CUT ONE 3/16 in.



PIECE S. CUT ONE 3/16 in.



PIECE O. CUT ONE 3/16 in.

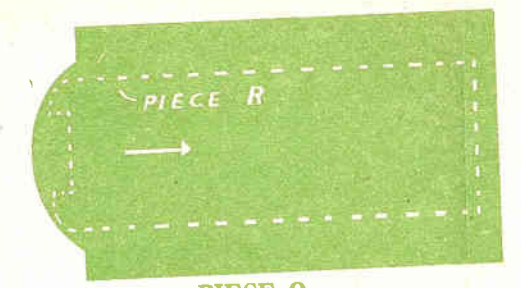

PIECE P. CUT ONE 3/16 in.

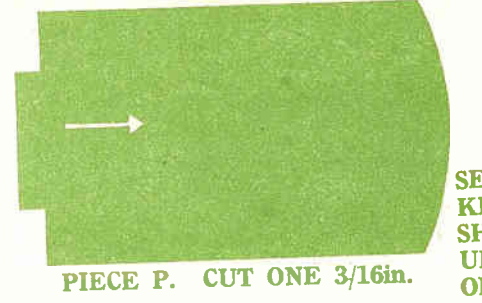

PIECE T. CUT ONE 3/16 in.

PIECE U. CUT ONE 3/16 in.

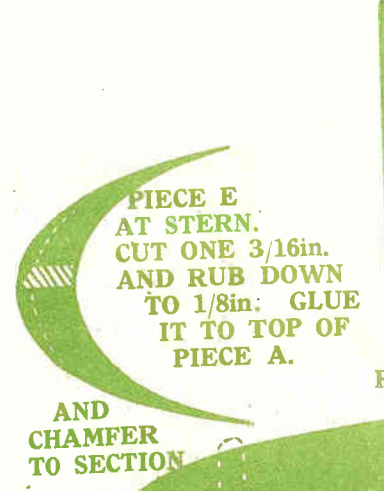

PIECE E AT STERN. CUT ONE 3/16 in. AND RUB DOWN TO 1/8 in. GLUE IT TO TOP OF PIECE A.

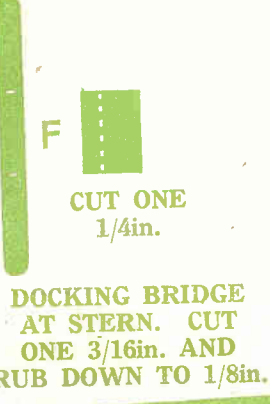

PIECE F. CUT ONE 1/4 in.



PIECE G. CUT ONE 1/4 in.



PIECE H. CUT ONE 1/4 in.

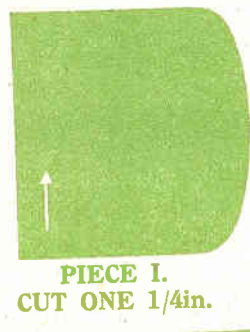

PIECE I. CUT ONE 1/4 in.



PIECE K. CUT ONE THICK CARD.



PIECE L. CUT ONE THICK CARD.



PIECE M. CUT ONE 1/4 in.



PIECE N. CUT ONE 3/16 in. THICK.

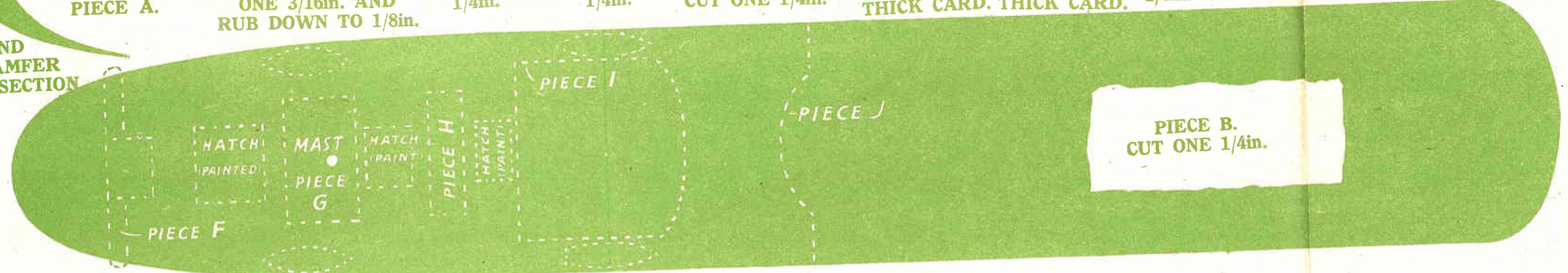

PIECE B. CUT ONE 1/4 in.

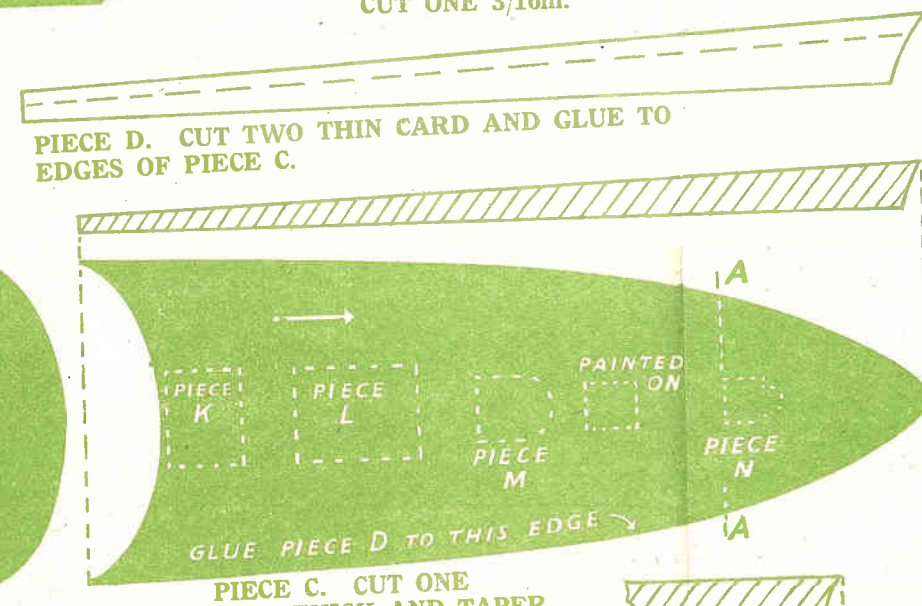

PIECE C. CUT ONE 1/4 in. THICK AND TAPER TO SECTION ABOVE.

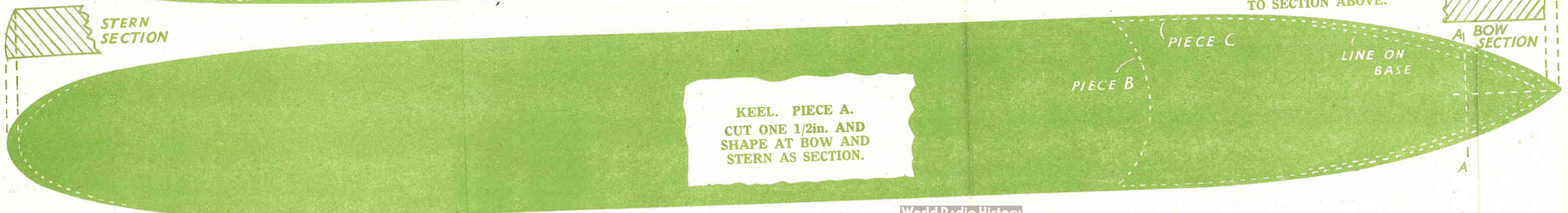

KEEL. PIECE A. CUT ONE 1/2 in. AND SHAPE AT BOW AND STERN AS SECTION.

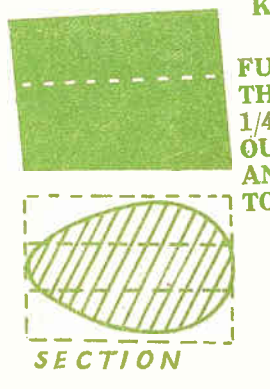

FUNNEL. CUT THREE PIECES OF 1/4 in. WOOD TO OUTLINE GIVEN AND SHAPE UP TO SECTION.



SECTION THROUGH KEEL ON LINE A.A. SHOWING HOW THE UPPER SIDE, MADE OF CARD, IS GLUED TO PIECE C, TO COME FLUSH WITH KEEL. PIECE A.



BOAT DAVITS. CUT TWENTY-FOUR 1/16 in.



BOAT DAVITS. CUT FOUR 3/16 in.

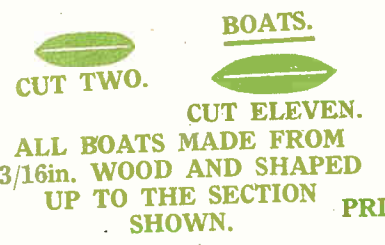

BOATS. CUT TWO. CUT ELEVEN. ALL BOATS MADE FROM 3/16 in. WOOD AND SHAPED UP TO THE SECTION SHOWN.

SPARE WOOD FROM THE G3 PANEL TO BE USED HERE, AND RUBBED DOWN ON GLASSPAPER TO ABOUT 1/16 in.

SECTION PRINTED IN ENGLAND.

MODEL of the PRETORIA CASTLE

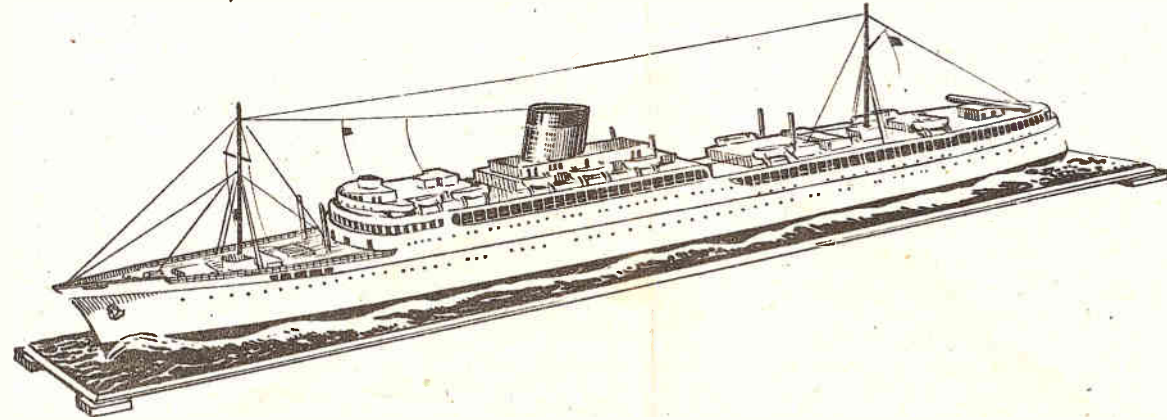

THE patterns on the reverse side enable the model maker to make up a waterline model of one of the latest and most popular modern liners engaged in the South African Royal Mail service. This is the Pretoria Castle, which was launched in 1947—incidentally by radio telephony from Pretoria 6,000 miles away from the actual spot. The boat is 749ft. over all, with a gross tonnage of 28,705, being one of the most recent of the well-known Castle ships renowned for the England—South Africa service.

The waterline model we can make is almost 16ins. long and 3ins. high. All the necessary parts are shown full size on the sheet, and the kit provides the necessary panels of wood from which they can be cut. Construction is straightforward, the outline of the shaping is done with penknife or chisel, followed by glass-paper to get a final smooth surface and necessary curves. Care and attention must be paid throughout the building, and patience given to the tiny parts which have to be added.

Order of Construction

Study the side view and plan so you may realise where each part is to come. The pieces are lettered in alphabetical order according to their construction. Piece (B) goes upon (A), and piece (C) upon (B), etc. Dotted lines on each part indicate where adjoining pieces are to be fixed. The actual pattern should not be pasted, but the outlines marked off on to the wood and tested out for position and size before being finally glued in place.

The hull itself is of the 1/2in. piece (A) on which is glued the two parts (B) and (C). Notice that (B) is set back a little inwards from the stern so that the front curve comes in line with the dotted position on piece (A). Piece (B) closes up to it from the bow but overlays at the front slightly to form the flare of the hull.

Piece (C) is slightly smaller at the front than the hull itself. This allows the thin card forming the bulwark to be glued on, and yet come flush outside with the rest of the hull. Notice, too, that the thickness of (C) tapers to 1/2in. towards the back, so that piece (B) stands above it at that point. The whole bow slopes slightly inwards and measurements with the side view should be checked off.

The stern has also the tiny piece (E) fitted behind (B). This is chamfered to the section shown by the shaded part, and is seen also in the side view detail.

The various upper decks are now added, the position being shown by the dotted line in each case. Follow them through in numerical order, and also study the perspective detail here of the funnel portion and the bridge.

Masts are made of wire and derrick pillars of the same material. Thin wire or fine cord runs from masts to the deck at various points, and the aerial from funnel to mast has a lead down in two places. Notice the shape of the funnel by the shaded portion on the deck plan. The derricks are hung by a spot of solder.

Boats and Davits

Boats are 'hung' with a spot of glue on to the underside of the davits, which are glued along as shown. The boats themselves are shaped to the usual water curve, and have a sloping top indicative of the canvas covering forming an arch down the centre. Derricks, mast, etc., and fixing staples to hold the lines are driven into the appropriate deck after a

receptive hole has been made.

You will probably find it advisable to paint the main portion of the model before the mast derricks and lines are added. The hull itself is a blue-grey above a red waterline extending upwards as far as the full length of port-

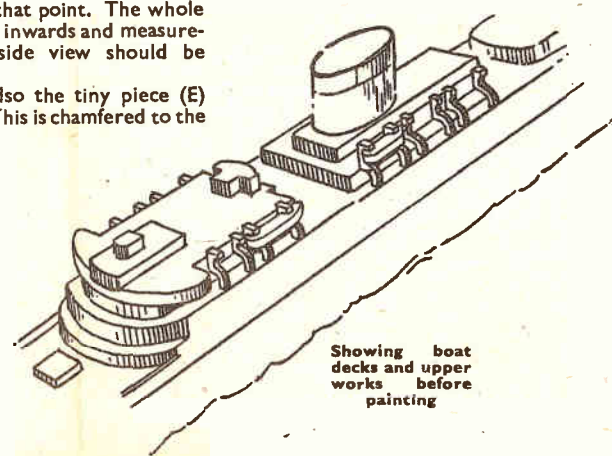

holes. The deck is a natural wood with all superstructure painted white, the windows are painted blue. The funnel is red up to the line shown, with the part above it in black. Port-holes also are black, as well as any doors or companion openings on the decks.

Baseboard

The baseboard is formed of a single panel of wood 17 1/2ins. long, 3ins. wide. To lift it slightly, add four tiny 1in. square pieces to overlap, as shown in the diagram. The baseboard should be provided with an imitation sea by having plastic wood or glue and sawdust or even Plasticine or putty put on it.

Make it reasonably smooth for the sea, and paint it blue, flecked with white for wave effect. There should, of course, be a slight bow wave towards the front of the boat, and a stern wash behind.

SUPPLEMENT TO HOBBIES No. 2828.

TOY TELEPHONE MONEY BOX

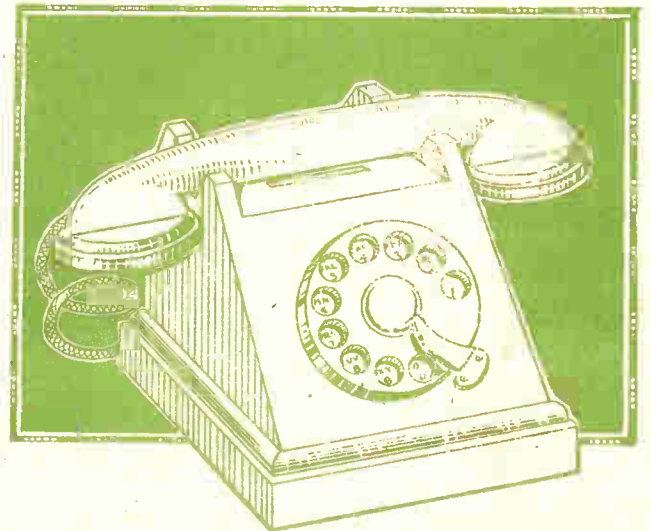

SIZE:—7½ins. WIDE, 4½ins. DEEP AND 4½ins. HIGH.

PANELS OF WOOD REQUIRED FOR THIS DESIGN
THREE G3 TWO G4
 Materials for making this design are supplied by HOBBIES LIMITED, Dereham, Norfolk.
 Price on application.



RECEIVER HANDLE. CUT TWO 1 ¼in. AND GLUE TOGETHER. SHAPE TO SECTION.

NOTE.—This design sheet is only presented free with the current issue of Hobbies and not with back numbers. Further copies may be obtained.

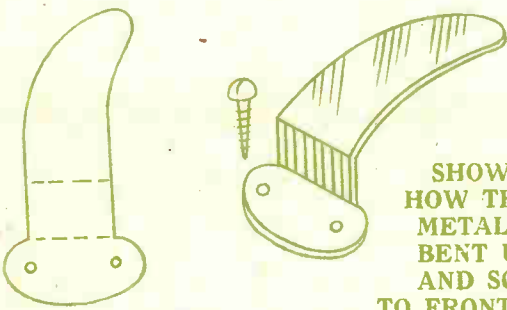

SHOWING HOW THE METAL IS BENT UP AND SCREWED TO FRONT OVER-LAPPING MOVING OUTSIDE DIAL.

CUT ONE PIECE BRASS OR TIN TO SHAPE.

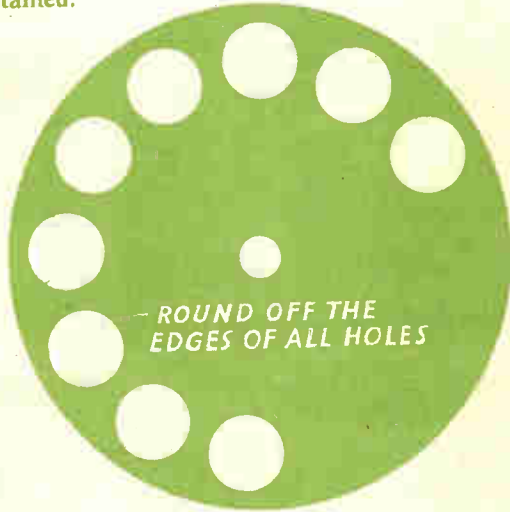

OUTSIDE DIAL. CUT ONE 3 16in.



INSIDE DIAL. CUT ONE 3 16in.

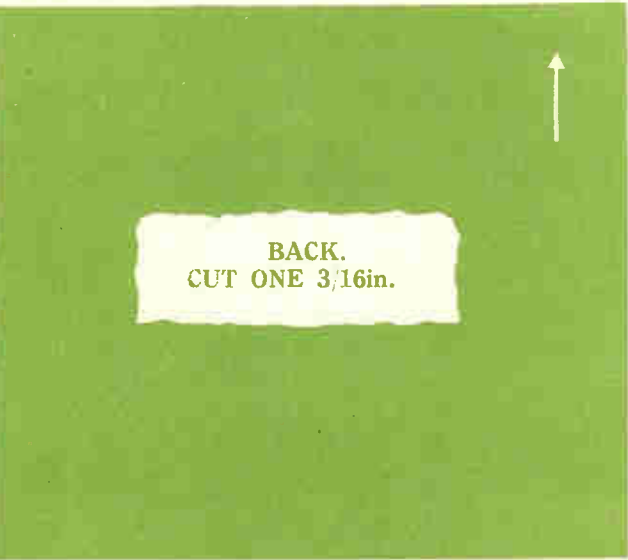

BACK. CUT ONE 3 16in.

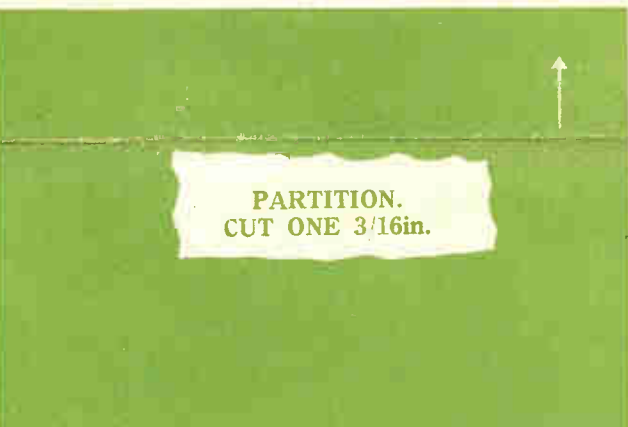

PARTITION. CUT ONE 3 16in.

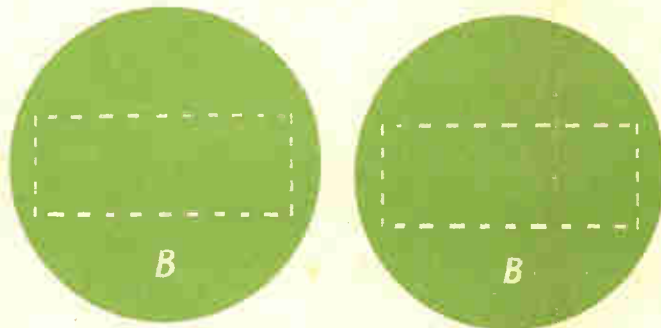

DISC AT END OF RECEIVER. CUT ONE OF EACH 3 16in. GLUE DISCS A AND B TOGETHER.

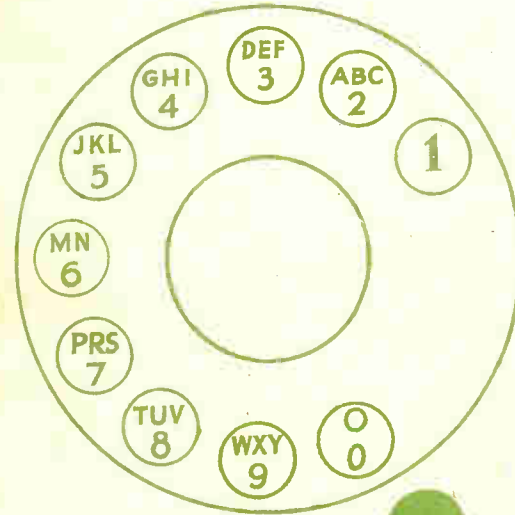

PAPER DIAL TO BE CUT ROUND AND GLUED TO FRONT (see front).



TOP. CUT ONE 3 16in.



DISC AT END OF RECEIVER. CUT ONE 3 16in.

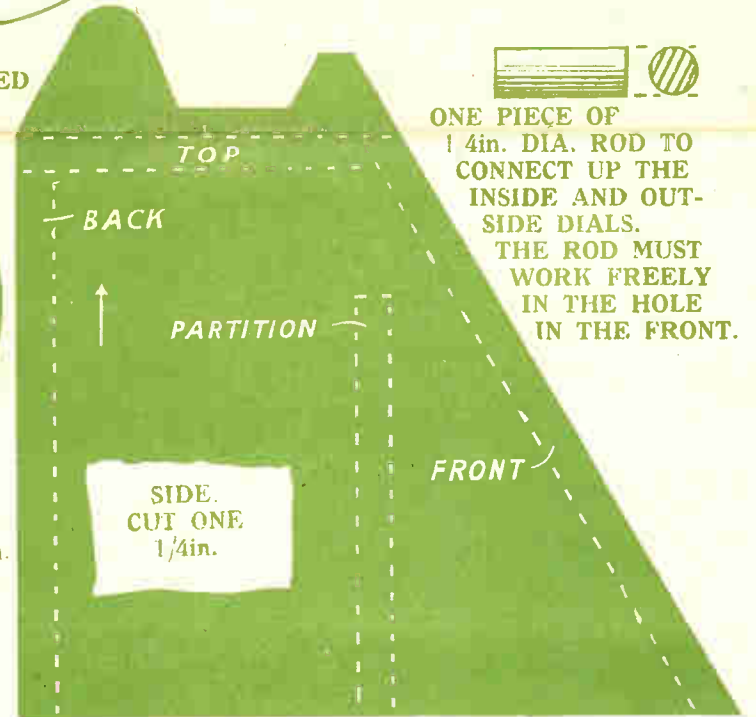

SIDE. CUT ONE 1 ¼in.

ONE PIECE OF 1 ¼in. DIA. ROD TO CONNECT UP THE INSIDE AND OUTSIDE DIALS. THE ROD MUST WORK FREELY IN THE HOLE IN THE FRONT.

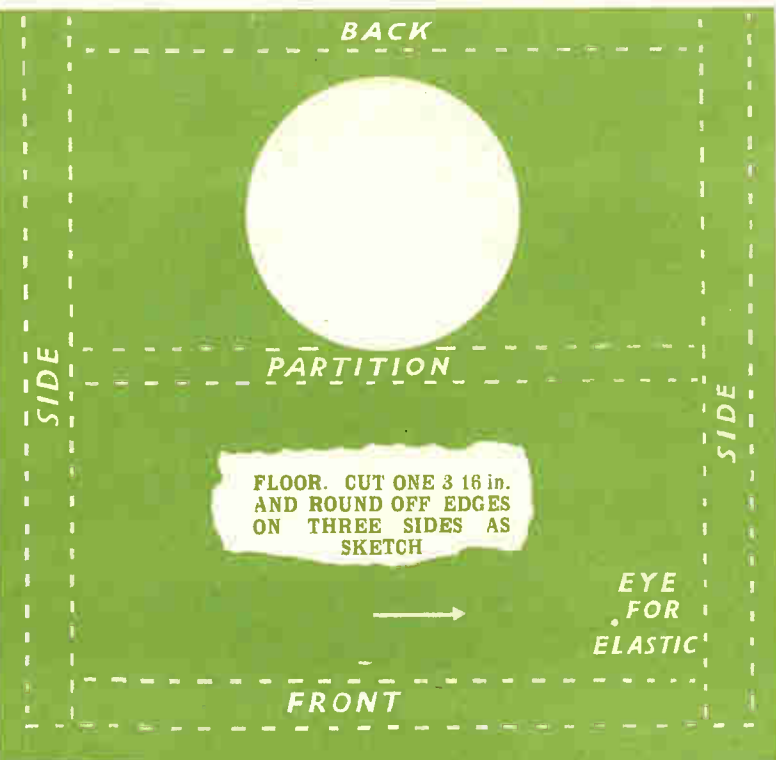

FLOOR. CUT ONE 3 16 in. AND ROUND OFF EDGES ON THREE SIDES AS SKETCH

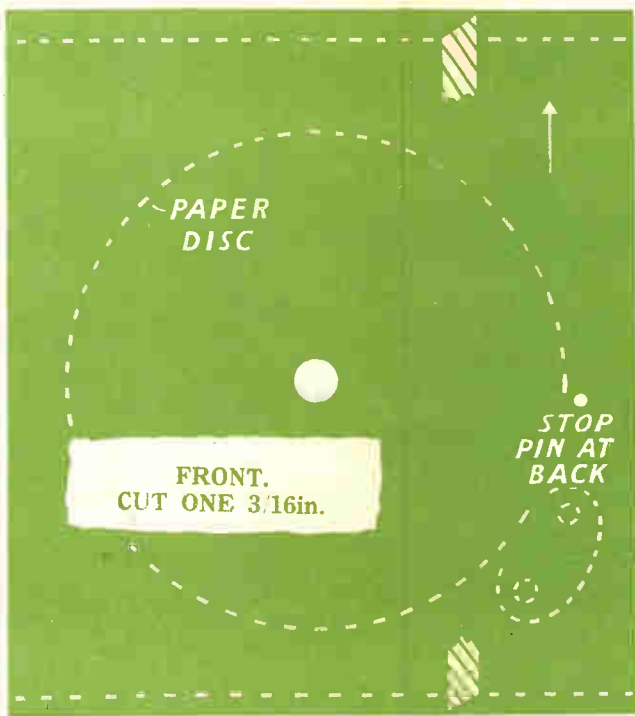

FRONT. CUT ONE 3 16in.



DISC AT END OF RECEIVER. CUT ONE 3 16in.



BASE. FRONT. CUT ONE 1 ¼in.



BASE. BACK. CUT ONE 1 ¼in.



BASE. SIDE. CUT ONE 1 ¼in.



BASE. CUT ONE 1 ¼in.

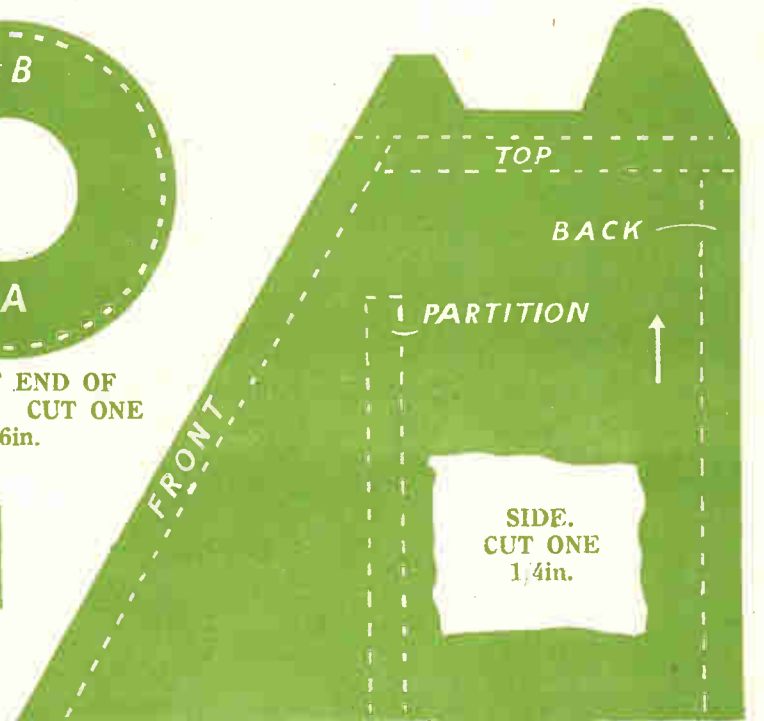

SIDE. CUT ONE 1 ¼in.

PRINTED IN ENGLAND.

MODEL TELEPHONE MONEY BOX

THIS little mechanical novelty can be made from the kit provided, and patterns set out on the reverse of this sheet. Mark the parts direct on to the wood by means of tracing paper or carbon paper, cut them out with the fretsaw and then build to form the completed article. The dialling is mechanically operated, the dial itself returning to its original position after use.

The receiver when lifted reveals a slot in the top, forming an aperture for the money box beneath. If you prefer, of course, the model can be made as a

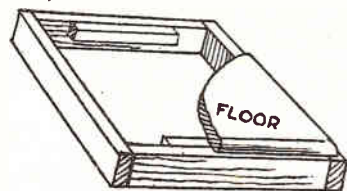

working toy only, and the money box part of it omitted. If this is being done, you should omit the coin slot in the top of the circular opening—for the extraction of the coins—underneath.

The Base

The base portion is a hollow framework with the floor glued upon the edge of the four narrow uprights strips which you see in Fig. 1. The size of the floor is slightly less than the framework of these strips which project beyond it. Underneath you can stiffen with little blocking pieces to make a rigid base. On the top of this floor will be glued the two sides, the front and the back, and the centre partition. They cannot, however, all be put in at once, but should be cut, tested and cleaned first.

Erect the floor and ensure that the front will lie over the top of its edges and the back fit between the parts. Both edges of the front will have to be chamfered so it can bed down on the floor and come in line with the top later. The angle of chamfer is shown. In

the centre a hole is drilled to take the disc rod. Note also the position of the pin which forms the stop behind the front. It is important to drill this through so you can place the pin in from behind. Mark also the position of the curved metal piece which you see in the picture of the finished model.

The Mechanism

The mechanism on the back of the front is shown at Fig. 2. The inside disc has three screws driven in, and then the disc itself is glued on the length of $\frac{1}{4}$ in. rod indicated. Glue this securely, and then see that the rod moves smoothly in the front. Holding the inside disc with the projecting lug against the stop screw previously fixed, put on the front disc. Before doing this, however, you must have the front cleaned, and glue on the paper dial with its lettered and numbered

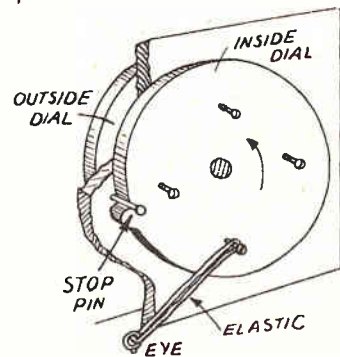

Fig. 2—Back view of front showing dialling movement

circles. The exact position can be seen from the picture of the finished model.

This paper is glued to the front, and then the disc is finally put over the dowel rod, and glued on it, making sure that the circles in the movable disc will come opposite the names on the front itself when the inside dial comes to rest against the stop pin. The part is held there by a short length of elastic—an elastic band will do—held at one end by an eye driven into the floor, and at the

other end by the screw on the revolving disc. These parts should be fitted and tried before you add the inside partition. This partition is merely an upright piece glued between the sides, and on the floor $1\frac{1}{2}$ ins. inwards from the front.

The circle cut from the floor is, of course, to replace and cover over on the outside with a piece of paper. This provides access to the interior compartment when the money is to be extracted. The back fits between the two sides, and the top rests above it. The dotted lines in the patterns of the sides show you the position. One end of this top has to be chamfered, and you

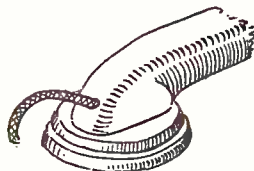

Fig. 3—The receiver shape

will notice that the slot for the coin is nearer the front edge than the back.

Receiver

One end of the receiver is given at Fig. 3. It is made from two pieces $\frac{1}{4}$ in. glued together, and then the outside edge shaped as shown by the section. Smooth the whole part off nicely for handling, then glue on the flat end ear and mouth piece. Each consists of two discs of wood (A and B) glued together, and then glued centrally over the hand piece. A length of cord fairly thick and coloured is used to connect the receiver to the instrument. The cord can disappear into the base through a hole in the back edge, the other end being fitted into a hole at the mouth-piece end of the receiver.

The whole model should be painted a glossy black, care being taken that the lettering remains in white, whilst the moving disc itself can be painted aluminium or silver.