

# Hobbies

## WEEKLY

August 25th, 1943

Price Twopence

Vol. 96. No. 2497

## How to make standing or wall-type RABBIT HUTCHES

AS rabbit breeding is popular at present, a simple design of hutch should be welcome. Rabbits do not need an elaborate house to live in, and breed; they seem to do equally well in the plainest form of

hutch, made perhaps from a grocery box. New wood is not necessary and if a few second-hand boards, preferably of the tongued and grooved variety, can be got they will be equally suitable.

A few hints as to suitable sizes may be helpful. Those given in Fig. 1 are intended for small and medium breeds, such as Dutch, Angoras and Chinchillas, etc. A breeding hutch is, of course, larger than one

intended for a single rabbit.

Dimensions given in Fig. 1 will be suitable for single rabbits of large breeds such as Flemish or breeding Dutch. If required for breeding Angoras, or Chinchillas, the width can be increased to 3 ft., if for Flemish, 4ft.

The single hutch, Fig. 3, if required for breeding, should be increased to 2ft. 6ins. to 3ft. for small and medium breeds and 6ins. higher if for the latter kind.

These dimensions, however, need not be adhered to too strictly if a box, or boxes, are available which can be made into suitable hutches without much trouble, or, if the wood to build them happens to be in small supply. Stick to them, however, if sufficient wood is available as fairly commodious hutches are easier to keep clean and more healthy for the rabbits.

Two designs of hutches are shown, one capable of housing two pairs of breeding rabbits, and one of smaller size where a single rabbit only is kept, or a pair of the smallest breed.

The large hutch, Fig. 1 (a front elevation) will be dealt with first. It is a double tier hutch, but can be made high enough to accommodate three tiers if desired, but as this would make rather a tall con-

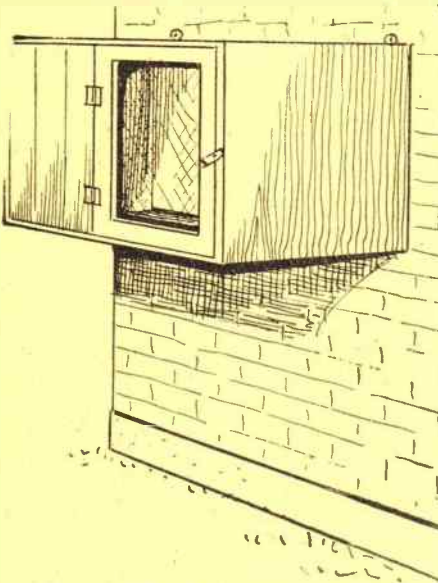
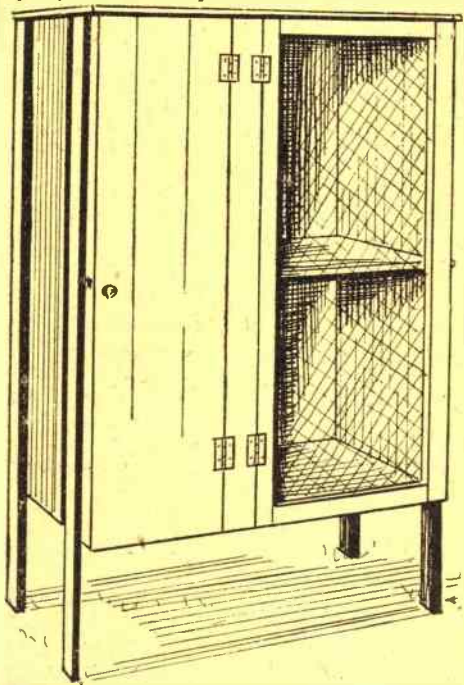

cern, the height of each tier might be reduced to 1ft. 6ins., making with the legs, a total height of 5ft. 6ins.

Fig. 2 shows a detail of the simple construction. Cut the boards to length, enough of them to make up the width given. Lay them together and fix with lin. sq. battens at the top, bottom, and middle, the latter to support the mid division.

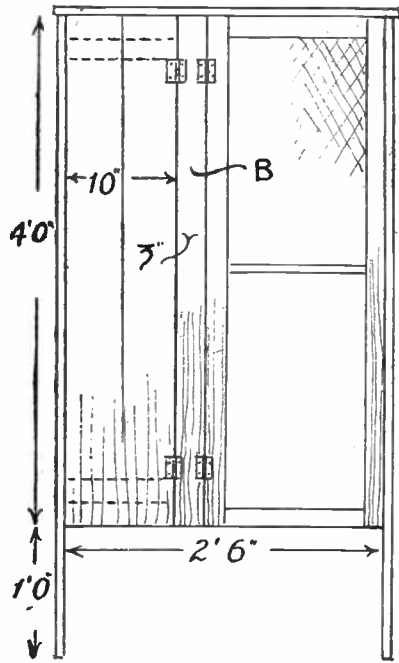

Fig. 1—Front elevation with dimensions

These battens, except the top one, run the full width of the sides. The top batten is 2ins. short of the front, to make room for a cross bar, A of 2in. wide wood. Now cut the bottom and division boards to length, noting that the bottom is the full width of the hutch and the division the width between the sides. The cross bar, A, is the same length as the division piece.

Nail all these parts strongly together adding a few screws to strengthen the whole. Cut the boards for the back of the hutch and nail these across. The battens for the legs are cut 3ins. wide and as long as the hutches are high, plus about 1ft. for the leg

extension underneath. Nail these to the sides.

Now cut the boards for the top of the hutch, making these long and wide enough to overlap ends and front lin. This completes the carcass.

The front consists of two doors, hinged to a vertical batten, B. Cut this piece and nail it to the hutches, 10ins. away from the left-hand side.

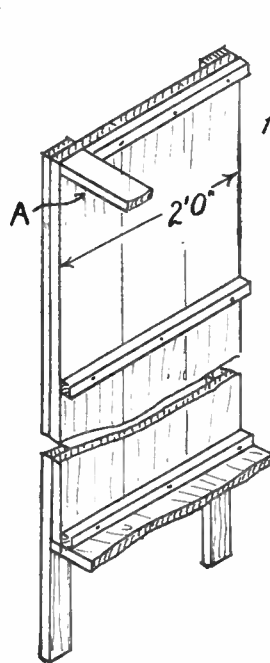

Fig. 2—Inside detail of framework

The left-side door consists of a board, or boards to the required width and length, nailed to battens at the back to keep all together, the position of the battens being shown by dotted lines.

Keep these battens about lin. short of the left side to clear the side of the hutch. Hinge the door to B with a pair of 1½in. back flap iron hinges or 2in. butt hinges.

The righthand door is a frame of 2in. wide battens, fixed together with a simple halved joint at the corners. Make these joints strong, however, with glue and nails or the door will tend to drop to one side in time. This also is hinged to B, just like the other.

On the inside of the door tack across some ½in. mesh wire netting. The top of the hutch will be much improved, so far as keeping out the wet is concerned, by covering with roofing felt or a piece of oilcloth. Finish the hutch with a coat of creosote, inside and out.

The small hutch is constructed in much the same way as the large one.

A front elevation is given in Fig. 3, showing dimensions. Fig. 4 shows a detail of construction.

The sides and ends are nailed together, with lin. sq. battens in the corners, like a box, in fact, and then the back nailed across. Cut two 7in. lengths of the batten, and nail these inside at top and bottom, far enough from the front edges to allow a board, or two, to be nailed to them and lie in flush with the outside. This closes up about one third of the front.

The door is made of 2in. battens, halved at the corners, and hinged to the boarded-up part with 1½in. iron back flap hinges. A wooden button will supply a fastener. Cover the inside of the door with wire netting, and creosote the whole.

As a hutch of this kind will perhaps be hung on a wall, or side of an outhouse or shed, fix a pair of strong wall plates to it at the back and screw plug it in place. A piece of felt, or oilcloth, should, if possible, be tacked across the top to keep out the rain.

#### Roof Covering

See that this covering is fixed down firmly with proper large-headed roofing felt nails. Otherwise the wind is likely to strip it in an exposed place. The edges of the covering are best turned over to the sides and nailed there. It is as well to tar the roof covering to prevent rain seeping through in the winter.

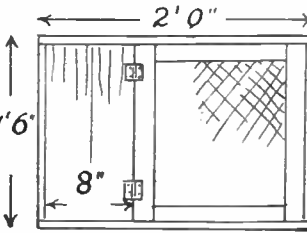

Fig. 3—Front of wall-type hutch

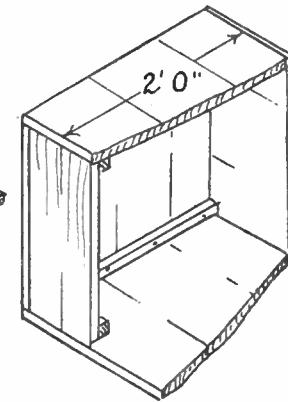

Fig. 4—Details of construction

WITH so much interest in navigation, the science of the stars is more and more to the fore, particularly among Air Cadets and those following the Air Service. The Astronomie Spherical Stellar Chart is exactly what its name suggests, and provides excellent opportunity for the model maker to complete for himself a sphere illustrating the heavens. In this way the distortion of the ordinary planisphere is avoided, and a number of interesting results can be obtained.

Not only can you learn to read the stars, but it can be used to tell times of sunrise and sunset, tell the time by the stars and how ships and planes are navigated by the stars.

The parts are clearly printed on a very large sheet of stiff paper which is cut out according to the complete instructions to form the shaped chart of the heavens. C. J. Grimwood, B.Sc., is the cartographer of the Astronomie Chart, which is published for 1/6 by George Allen & Unwin Ltd., Museum Street, London, W.C.

#### Solution to Last Week's Cross-Word

C	Y	C	L	O	M	E	T	E	R
E	A	U	A	L	O				
A	S	P	I	R	I	N	L	A	
S	T	E	M	S	L	O	I	D	
S	E	P	L	I	P				
I	R	K	F	A	N	G	S		
S	D	T	O	N	G	U	E	S	
T	A	G	U	D	L	A			
Y	A	R	N	C	L	I	P		
G	E	T	A	S	K				

# An interesting collection can be staged in this SMALL PICTURE GALLERY

A GOOD use can be made of some of the many fine photos and pictures in the newspapers and periodicals, by framing them for exhibition in a model picture gallery. Photos of famous war celebrities will be likely to be most favoured just now, and why not a "Rogues" gallery for Hitler and his gang?

The gallery can be, of course, almost any size in reason, the dimensions given in Fig. 1 being merely suggestive.

For this gallery, deal  $\frac{3}{8}$  in. thick is recommended. Only a small piece is required, and a board of  $\frac{1}{2}$  in. planed matchboarding, which will be  $\frac{3}{8}$  in. actual thickness, would serve nicely for all parts. Cut the sides and ends and nail them together, adding glue to the joints to strengthen them.

## Pediment and Back

It will be noticed that the ends have sloping tops. This provides a piece each end, rising above the top side, to which the pediment can be fixed. This is a strip of the wood cut to the shape shown, and glued and nailed across.

The back of the gallery is a sheet of stout cardboard, glued over, with a few small nails added to help hold it in place until the glue is hard.

The double doors (one shown in Fig. 2) are large enough to completely cover the front. Make these of the same thickness wood and fix together with a halved joint at the corners.

What will be the inside faces, are covered with stout cardboard, like the back of the gallery. The doors are now fitted to the front with a pair of small brass hinges each side.

A simple catch to prevent the doors swinging open when the gallery is closed, is shown at Fig. 3. It is

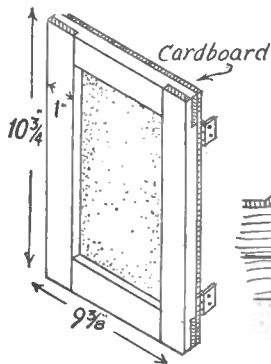

Fig. 2—The hinged door

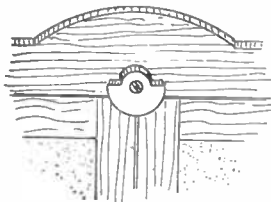

Fig. 3—Holding the frame

practically self explanatory, being a lin. dia. disc of fretwood, with part of one half cut away, as shown.

It is fitted to the pediment with a single screw, so arranged that when in the position shown it closes down on the doors and keeps them shut, and when turned half round, releases them. No catch need be fitted at the bottom of the doors.

The interior of the gallery and inside faces of the doors, should be covered with a coloured paper of some kind, or a grey wrapping paper could be used.

It does not matter much, as long as a suitable background for the picture is provided. The floor of the gallery could be similarly treated or just varnished. The latter treatment could also be applied to the outside of the gallery.

The lettering "National Picture Gallery" is optional, it adds a touch of realism, that is all, but after all, realism in a model is desirable.

An easy way to do it is to paste

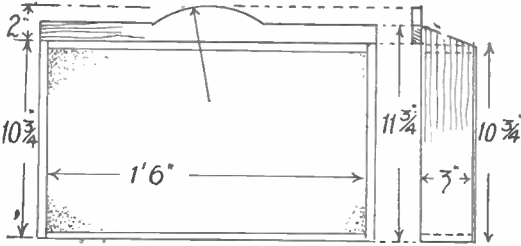

Fig. 1—Front and side view with dimensions

white paper over the pediment, or part of it, and to put the letters in in coloured ink. Unless readers can do a neat job of lettering, however, it would be wiser to omit it.

Suitable frames for the pictures will be required and they can easily be cut from some stiff cardboard. If the cardboard is plain it will be advisable first to paste some brown paper over, or other suitable colour available.

For the size of gallery illustrated, the frames will be cut to about the dimensions given in Fig. 4 and hung either vertically or horizontally. Some variations can however, be

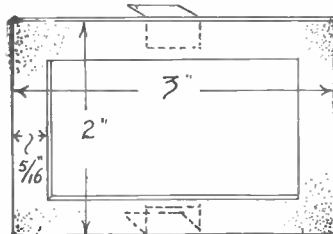
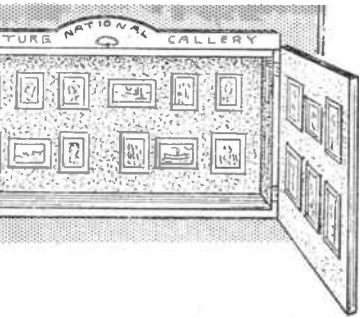

Fig. 4—The picture gallery frame



allowed so that the pictures will not all be the same size—usually they are not in any picture gallery.

When cutting the cardboard, it will be safer to cut out the opening first, then the outer lines. Readers are usually tempted to reverse this procedure, then, if a slip occurs the may frame be spoilt. If the outer edges are cut to a slight bevel the result looks neater.

## Fitting the Picture

Cut the picture out of the paper, and lay the frame over it shifting the frame about until the best result is achieved. Then gum the back face of the frame, lay over the picture and rub gently down.

Cut a piece of plain paper about the same size as the picture and gum that over it to the back. Gum need only be applied to the frame part, not all over.

Then trim the outer edges of both picture and paper backing to the frame. The cut edges of the frames by the way, are best blacked or rubbed over with a brown crayon, they look much neater.

The completed pictures are "hung" on the walls and doors of the gallery with philatelist's stamp mounts, as in Fig. 4, or small pieces of gummed paper if such mounts are not handy.

Just fold the mounts double, stick half to the back of the picture (one at top and bottom) damp the other half and press the picture flat to the walls of the gallery.

A pleasing variation of frame is shown at Fig. 5. Dimensions can be the same size as Fig. 4. Copy the

(Continued foot of next page)

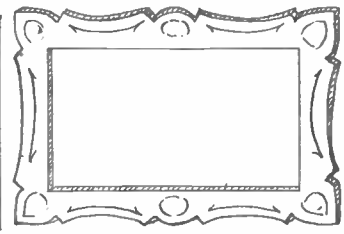

Fig. 5—A more decorative frame

# Prepare now for the time when you will require FRUIT STORAGE TRAYS

THE time will soon come round again when the storage of fruit and vegetables must be taken into consideration. Now is the time, while the light evenings are here to make up a few useful trays as shown in the sketch on this page.

By making these trays interlocking means the saving of space and they may be piled up one above the other and made to stand firm when loaded with produce, and the great benefit too by making them as shown, is that a free circulation of air is always guaranteed.

While the greater number of trays should be made as shown in the sketch Fig. 1, one or two at least should have solid sides so they may be taken into the garden or orchard and the fruit gathered ready for transferring to the more open trays.

## Size and Style

A solid-sided tray is shown in the larger diagram, in Fig. 2 and it will at once be obvious how useful this type of tray would be while gathering in the store.

A convenient size of tray may be made up from Hobbies Standard panels of wood, and it is intended here to show how these may be used to the best advantage with very little extra cutting and no waste. The size of tray suggested is 19ins. long by 11ins. wide, and the two standard size panels of Hobbies wood to be adapted are LD6 and ND8. The former is 18ins. long, 3ins. wide and  $\frac{1}{2}$ in. in thickness, the latter 11ins. by 5ins. by  $\frac{1}{4}$ in.

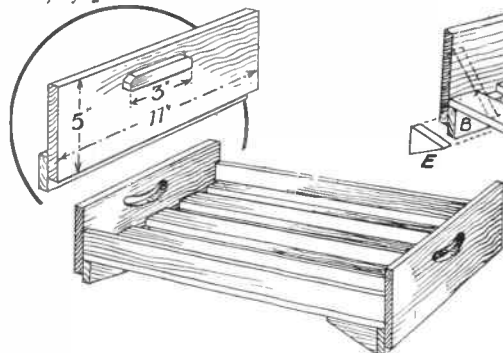

Fig. 2—Shows construction and two types of handgrips

The construction is simple, and a glance at Fig. 3 shows clearly how the end rails are arranged and the seats fixed lengthways on battens nailed to them. The marking and cutting must be carefully and accurately done so that the trays when made up in numbers will fit easily into each other.

## Tray Ends

Each end of a tray consists of an uncut complete ND8 panel, and to this is screwed a ledge of  $\frac{1}{4}$ in. thick wood 1 $\frac{1}{2}$ ins. wide, that is one ND8 panel divided up and cut into three parts as B in Fig. 4.

In the top diagram in Fig. 2 one end is shown with ledge attached, this latter lapping on to the end a distance of  $\frac{1}{2}$ in. A solid block handle is shown also nailed on.

## A Hand Hole

If a cut-out hand-hole is preferred, then this can be about 4ins. long, and care must be taken in setting this out to keep it 1 $\frac{1}{2}$ ins. down from the top edge of the board so it clears the batten of these trays fitting immediately on top. Cut the openings with a coarse fretsaw and glasspaper the edges so that they do not cut the hands.

The slots C to be nailed lengthways are  $\frac{3}{8}$ in. thick and two may be got by sawing down the middle a LD6 standard panel.

Thus, each slot will be nearly 1 $\frac{1}{2}$ ins.

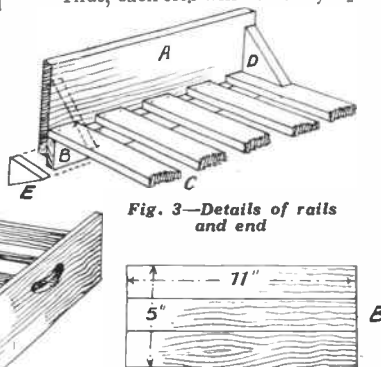

Fig. 3—Details of rails and end

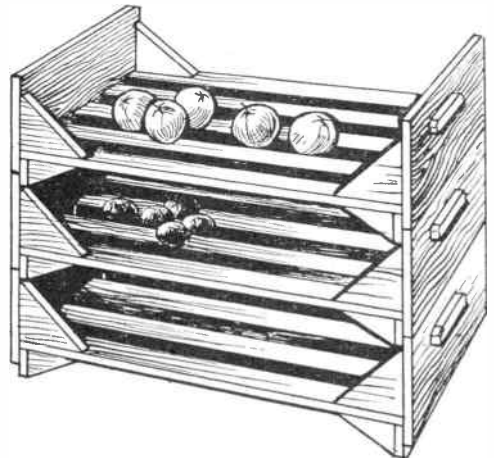

Fig. 1—Three trays in use

wide, and after nailing on one each end of the end rail and flush with its outer edge (see Fig. 3) the remaining three slots can be spaced out about  $\frac{7}{8}$ in. apart. Nail or screw them rigidly to the battens—screws for preference.

Some stiffening block will be required and they will be put on as D in Fig. 3. One panel LD6 can be divided up as shown at D in Fig. 4 for making sufficient angle blocks for a set of three trays. They should be nailed with long wire nails to the end rails and to the outermost slots.

## A Railed Tray

In making the tray shown in Fig. 2 these blocks will be replaced by rails about 1 $\frac{1}{2}$ ins. wide. Smaller blocks, E, Fig. 3 may be cut from an LD6 panel as outlined at E Fig. 4 and put beneath the slots at each end.

Do not use glue in the fixing of any of the parts as the likelihood of dampness from the fruit may cause the pieces to come apart.

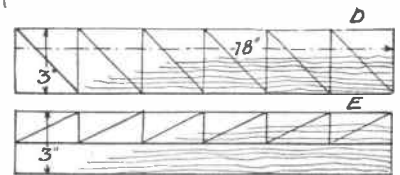

Fig. 4—An economical method of cutting out the wood from standard panels

## Picture Gallery—(Continued from previous page)

outline and cut out with scissors to the shape.

These frames should be coloured yellow, with crayon, to simulate gold, the markings being put in either with brown crayon or pencil. Colour the edges to match.

While these frames can be used like

the plain ones, for newspaper illustrations they are better occupied with coloured pictures, such as can be got from cigarettes and picture postcards. Other varieties of frame can be added.

Nothing has been said about titles for the pictures, so here are two suggestions. One is to allow a small

strip of white card to the bottom of each frame, when cutting it out, say  $\frac{1}{4}$ in. wide and 1 $\frac{1}{2}$ ins. long on which the title can be written or neatly printed.

The other is to gum a similar size strip of paper to the bottom of the frame for the same purpose.

# What every woodworker should know about HINGES AND HINGING

WE recently gave readers a few helpful hints on the process of gluing. Another normally simple procedure which is so often badly undertaken is that of hinging, and these few details will probably be helpful. So often the beginner light-heartedly takes a pair of hinges, screws them on to a door of a cabinet or something of that sort, and then finds trouble.

First the door won't fit, then it

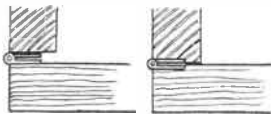

Fig. 1—Wrong and right method.

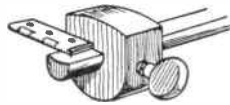

Fig. 2—Gauge measurement.

fits at one end and not the other. Again the hinges are taken off and replaced, and the whole thing looks badly misshapen without even a sign of fitting at all.

As in all other processes there is a procedure which should be undertaken carefully and correctly. Generally, the trouble is that measurements are not made to ensure the correct fitting, whilst the necessary rebate is just hacked away instead of being cleaned with a chisel.

In many fretwork articles, of course, the hinges are so thin that they can be fitted direct to the wood without being let in at all. If there is any need for a rebate to allow the sinking, then it can probably be undertaken with a file to smooth down the surface to take the hinge plate. In normal woodwork, however, where 1½ in. or larger hinges are used, a definite rebate must be made into the wood to take the thickness of the metal concerned.

## Points to Note

The width of the hinge as well as the thickness of it, therefore, is of paramount importance, for unless you get the hinge properly let in, you will have an unsightly gap, or else a badly fitting result.

If you look at Fig. 1 you will see in the first drawing the result merely of hinging on the outside of the wood. This allows a gap between the two parts which in turn throws the door or whatever it is, out of its correct

position. In the second drawing at Fig. 1 you will see the difference made by letting the plates of the hinges into the parts concerned.

The centre of the knuckle of the hinge, you will notice, too, is in line with the outer edges of the wood. This allows the part to open and close correctly. If the knuckle, on the other hand, projects a long way—say, in the case of a door—that door is going to be thrown wide open and allow a space between the two parts.

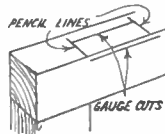

Fig. 3—Marking out

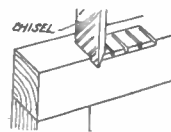

Fig. 5—Chiselling out

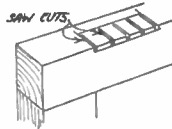

Fig. 4—The first cuts

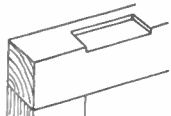

Fig. 6—The finished recess

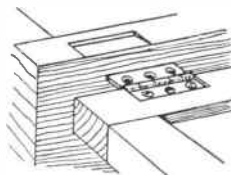
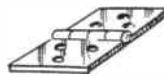

Fig. 7—The Hinge plate in place



BUTT



FLAP

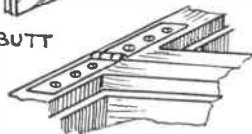

STRAP



LINK PLATE FIXING



RULE JOINT STAY

Fig. 8—The common butt hinge, with a number of more uncommon types

Whereas, of course, even when opened, a door and its jamb or stile should be as close as possible together.

To ensure the correct recessing you should measure the hinge across its width as shown in Fig. 2 with a gauge. This is then drawn along the edge of the piece of wood concerned (see Fig. 3) and the actual length marked on with pencil cuts. The depth of the recessed portion is the thickness of the hinge plate, and can also be marked on with a gauge or with a pencil against the finger.

Next come the sawcuts, the number depending on the width of the chisel you are proposing to use. In Fig. 4 you have the sawcuts let in and you will notice that the two end ones have the outside against the line of the extent of the hinge.

At Figs. 5 and 6 the completion of the work is shown, the chisel goes straight down and bores out the wood cut with the saw. Then it is laid flat into the recess and the whole thing cleaned up as in Fig. 6. Having done this, you can lay the hinge in place as at Fig. 7 and you will have a satisfactory joint.

When you are ready for the fixing, the position of the screws should be marked with the hinge laid in place. Run a little circle round the hole, take away the hinge and then prick a position centrally with an awl.

Normally, of course, you are using a pair of hinges, and it is advisable to test the hanging temporarily before driving the screws in place. Put, say, the centre screw in each plate in position, and then test that with the door or swinging portion works properly. If this is so, drive in the remaining screws, testing after each one to see that there is no undue binding.

In cutting out the recess, be careful not to go too deep. If you do, the hinge plate will be held to the wood and when the door is shut there will be undue strain upon them or else the whole thing will bind badly.

The hinges for a door are the same type as those for a box, except that

in this case the width of the plate is narrower as the hinge is often fixed on the edge or thickness of the wood concerned. In fitting hinges as a lid to a box also remember to put some stay between the two.

## A Holding Chain

If the lid is allowed to fall right back, then obviously the hinge is apt to pull the screws and split the wood. A piece of light chain or even fancy ribbon or cord can be fixed with a screw to the underside of the lid and

to the inside of the box. The length of this is just sufficient to allow the lid to fall slightly back beyond the perpendicular.

The hinges dealt with are the ordinary type called butts, and an ironmonger will best know them by this name. For other occasions, however, there are other kinds required and some of them are shown in the diagram at Fig. 8.

#### A Variety of Types

The Flap hinge is a general type mainly used for kitchen tables and larger pieces which have a greater width than used in conjunction with butts. A Strap hinge is used for a writing desk and similar types whilst the Rule Joint Stay is the one serving the purpose of a hinge and a support at the same time. This is a combination of the chain and hinge mentioned before, and is commonly seen in radiogram lids, gramophone lids,

desk drops and so on.

The Link Plate Hinge is made in various forms for different kinds of tables. In this, as you see, there is no knuckle standing above the surface of the hinge plate itself, which is the essential on such articles as card tables, etc. The way in which this hinge is fixed is also shown with the side of it recessed into each portion of the table.

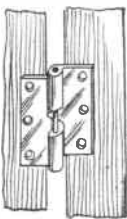

Fig. 9—The Skew

There are occasions also when a hinge is required to lift a door as well as open it, and for this it is necessary to have the Skew Hinges shown at Fig. 9. If a door opens on to a room where there is a carpet surrounded by a stained edge, the door must be lifted so it does not drag on the carpet.

To do this, the knuckle of the hinge has its centre portion cut at an angle. When the door is closed the hinge is in the normal position, but as it opens one portion gradually arises on the central pivot, passing through the knuckle.

#### Good Results

The method of fixing all these hinges may vary slightly in actual process. The principal requirements in each of them is to measure and mark positions, thicknesses, dimensions, etc. carefully, and to cut out any recesses clean and shapely.

It is always a sign of good workmanship if a pair of hinges can be fitted neatly, and readers of Hobbies should make a point of finishing their work in a craftsman like way so that even an expert looking at this particular point could find no fault.

Before undertaking your first fixing you should try experimentally on rough boards.

## Something simple and new for you in this small NOVEL RAILWAY PUZZLE

HERE is a snappy little puzzle that will while away many odd moments and is very interesting to make. The board represents a locomotive depot in which there are six turntables and five engines, and it is desired to change the positions of the engines R and G (this being the problem).

Moves are made by sliding the "locos" about on the "rails" and twisting them into other lines at the turntables if desired. No engine can stand on a length of line between the turning points, each move being from turntable to turntable.

When a solution has been found, further interest can be obtained by seeing what is the smallest number of moves in which the transfer can be effected.

#### The Board

The board is made up of three layers (A) the base, (B) a rectangle that gives the channels in which the pegs of the pieces slide and (C) a top layer that gives the wider channels in which the pieces actually move. The part (A) is of any 1/4 in. material (preferably plywood) 5 in. by 3 in.

The second layer (B) is also of 1/4 in. material, but is made into three pieces (as in the bottom sketch), by cutting along the inside rectangles shown in the lower left-hand figure. The rectangles so formed are then taken down a little with a small plane or glasspaper till when laid together a 1/4 in. channel is secured round the centre pieces (as in the right-hand sketch).

The top layer (C) (also 1/4 in. thick) needs rather more careful cutting. Mark out first the centre lines (dotted) to the dimensions shown, then at the intersection of each, scribe a 1 in. diameter circle and join these by 1/4 in. channels. When scribed out, cut with a fretsaw along the heavy lines (middle figure) which will give three separate sections as (1), (2) and (3).

Smooth all the parts and assemble as shown in the upper diagrams, using 3/16 in. screws of small diameter, filling any protruding points if necessary.

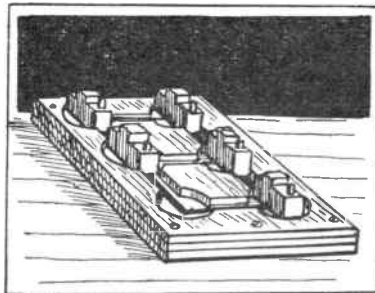

Care must be taken to get the channels on the two layers agreeing, but high precision is really not necessary.

Finally come the pieces—the engines—which are 7/8 in. long, 1/4 in. wide and 3/8 in. high. They can be cut as figure (E) merely to represent an engine, or they can be shaped in a more elaborate way as (D).

#### A Peg Slider

In any case, each must be fitted with a little peg (a) 1/4 in. long, in the mid centre to allow the part to slide in the narrower channel. It is simply a short length of wood, as from a match, glued into a small hole bored in underside of the engine.

The main point about the pieces is that they must slide equally well in all the channels and twist equally well at all the turntables, but a little application of glasspaper will soon effect this if not obtained in the first assembling.

The two of the engines that have to be interchanged are painted red and green but the others are left plain, also the letters "R" and "G" are painted at the two end positions to show how the board is set out and the engines to be transferred.

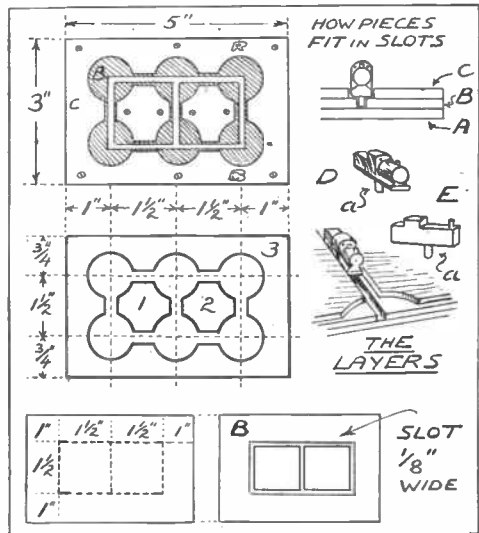

# Topics of various interest are discussed in THE EDITOR'S NOTES

**M**ANY of our models were included in the annual exhibition held at the Miners Welfare Institute, Pinxton, recently, where there were over 500 exhibits. They included the King George V Battleship, the Canopus Flying Boat, and the Cruiser Ajax. This model engineering exhibition is of great regular interest in the district and is an outstanding event showing the wonderful ability of its members.

\* \* \*

**B**EFORE our bombers and fighters go over foreign countries a great deal of work has to be done in selection of suitable targets. Much studying of maps, books and pictures has to be undertaken. Moreover, before a Commando Raid or an Army landing a great deal of literary reconnaissance must be made to ensure a thorough knowledge of towns, streets, buildings, parks, etc. Guides, maps, foreign directories, trade catalogues, etc. have all some use in the war effort, and the Ministry of Economic Welfare appeals to readers who may have literature of the continent of Europe. Such literature may contain information of vital importance and assistance and if any reader can assist he should send the books, or papers or maps or directories to Room 629, Ministry of Economic Welfare, Lansdowne House, Berkeley Square, London, W.1.

\* \* \*

**A** NUMBER of more or less stationary service units have formed small Hobbies Centres, and much interest and spare time occupation is afforded by our designs. The miniature models are perhaps the most popular and many thousands of planes and ships must have been made from an odd piece of wood and a jack knife.

\* \* \*

**I**HAVE received an appeal for helpful books to build up a reference library of handicrafts from Sgt. G. Webster of the Army Educational Corps., writing from Whitby, Yorks. Any reader who can spare back Handbooks or even copies of Hobbies, as well as other magazines and annuals likely to be useful should send them to the Sergeant addressed to 52 A.A. S.T.R. R.A. where they will be gratefully received and usefully applied.

\* \* \*

**M**Y overseas mailbag does not produce so many letters as in pre-war times naturally, but I still have a surprisingly large correspondence from ardent workers in

many parts of the world. I'm sure you will be delighted, as I was, with this recent effort which came from A. O. Abita, who lives in the Opopo Division of Nigeria. If his English is weak his spelling, like his enthusiasm, is strong. He writes, "I hope you'll receive my letter with pure delight and would never wonder

who I am. I beg to understand that your 'League' is one of the best in England. Therefore I have this fair chance to pen you for the latest catalogue of pen friends. I would have written you for a long time, but due to the war deprived me from doing so. I hope to hear from you at the earliest convenience."

## NOVEL NAPKIN RING

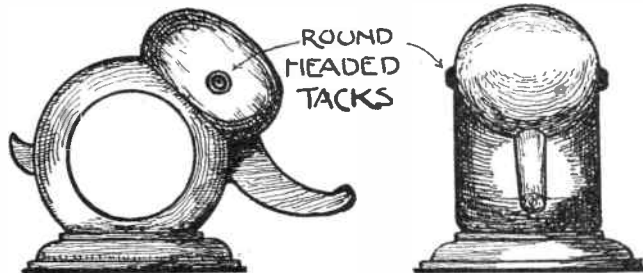

**T**HE advantage of this piece of work is that it can be made from scraps of hardwood which might otherwise be wasted. The use of a lathe is essential for the turning. A well-selected variety of wood is maple or birch for the ring and head, gum or cedar for the beak and mahogany or walnut for the base.

The base to most of homeworkers would be a simple face plate job on the lathe. If the size is too small for your face plate the wood may be glued to a larger disc of soft pine with a piece of thick paper separating the two pieces.

### Without a Lathe

Where one has no foot lathe, cut out the disc for the base piece with a paring chisel and whittle out the shape of the moulding as shown in the drawing of the base at Fig. 10 then finish the moulded edge with glass-paper.

The rough wood for the body is 2ins. by 2½ins. by 2½ins. as shown at Fig. 9. The block should be bored with a 1½in. auger. If you have no large bit at hand, bore several small holes to fill the opening and pare out with a gouge. The inside of the hole should in each case be glasspapered smooth and then fitted with a 6in. pine core.

Take out the core and finish the shaping on the outside of ring as shown at Fig. 3 with a chisel.

This pine core is again fitted snugly enough into the ring so it will form a hand grip while the body is being whittled and glasspapered out as shown at Fig. 4.

The two sides of the body which are to be flattened are shown by dotted lines at Fig. 3. This work may be done with the saw or the plane.

The head is a simple part as shown at Figs. 5 and 6. It can be turned or whittled out with a knife. The circle on the underside should be made to fit in with the flat cut on the top of the body.

### Appendages

The tail and beak (as shown at Figs. 7 and 8) are cut from ¾in. thick wood. All these parts should be glasspapered perfectly smooth and assembled with strong glue.

Any of the standard finishes for hardwood may be used to complete this article. In any case, the finish should be one that brings out the natural beauty of the wood. A bright colour paint should be used if made for a child.

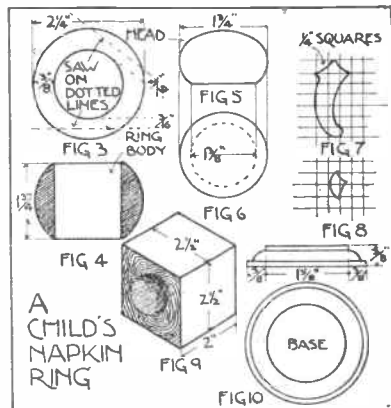

# Useful things to know about TYPES OF FUSE WIRE

AS every amateur electrician knows, a fuse is what could be termed the "safety valve" of an electrical circuit. It is mainly a fine wire of suitable gauge and strength serving to "carry" the normal current of the circuit only.

It is when the current flowing through the conductors rises above the carrying capacity of the fuse-wire (due to an overload, short-circuit, etc.) that the wire melts and breaks, thereby cutting off the supply of current at the meter-box where the fuse holder is situated.

## Wall Boxes

In the case of large buildings, the fuse carrier may be only one of a series in a wall box situated some distance from the meter itself, and it may have a number indicating the particular room it serves to supply with current.

The wire itself is often held in place by screw terminals provided in a porcelain fuse-carrier, the latter being kept in position by metal sockets fixed upon a suitable porcelain base or slab.

In respect to ordinary small domestic meters, the fuse is usually connected to a base having a bakelite knob which, after twisting, can be drawn out, this action alone serving to "switch off" the current at the mains. If the wire is broken, the knob is screwed off and the porcelain fuse-wire carried withdrawn so a new wire can be fitted.

## Wire to Use

Now, there are different types of fuse wires and the proper type must always be used. Instructions are usually embossed on the carrier bases, telling where the fuse wire is threaded and giving the specifications of the wire to use.

The usual rules for fuses is that when the working current does not exceed 10 amps., the fuse-wire must necessarily be of such capacity as to melt at not more than twice the working current of the smallest cable it protects.

## Lead or Copper

The wires for small currents, such as the currents flowing in sub-circuits in lighting installations, normally consists of a lead alloy. When, however, a current is known to exceed 10 amps., a copper wire, or a special cartridge fuse, is used.

Therefore, in order to ascertain the correct types of fuse-wire to use in various cases, the following table of fuse-wires will be found extremely helpful:—

No.	Thickness of wire. (S.W.G.)	Lead alloy. (Lead 75% ; Tin 25%) Approx. fusing current in Amperes.	Tinned copper. Approx. fusing current in Amperes.	Pure tin. Approx. fusing current in Amperes.
16			106	26
18			108	17
20	9-42		70	11
22	6-46		48	7
24	4-50		33-4	5
26	3-33		24-7	4
28	2-48		18-4	3
30	1-90		14-0	2
32			11-5	1-75
34			9-04	1-50
36			6-79	.75
38			4-76	
40			3-41	

It is a wrong thing to make use of any sort of wire, such as the strands from a piece of electric light flexible cord, aerial wire, etc. That kind of wire will, of course, serve to connect the "break" in the circuit, but in the case of a short-circuit, all lighted lamps in the house are liable to be fused.

Obtain only the right stuff and keep it in a safe, handy place, such as in the mains meter box. Small coils of the fuse-wire can be, in fact, coiled into a groove (provided for the purpose) at the underside of the bakelite knobs on most domestic fuse-carriers.

## For Models

Although not really what it is intended for, this wire also comes, in useful in small model making. It can be used for instance as hand-rails round the decks of ships or for shrouds in model galleons.

It is easily bent and turned, but if any strain is to be put upon it then a slight spot of solder should be added here and there.

## Three Helpful Hints

WHAT is a "flasher bulb?" As few people can tell what it is—beyond the fact that it must flash!—right away, or at all, the true answer is that a flasher bulb is an ingenious affair which, screwed into a lighting decoration set, will cause the miniature lights to flash on and off continually.

EXCELLENT springs for door locks can be made from the old-fashioned type of "ribs" used in ladies' corsets. These ribs are flat lengths of springy steel, easily bent to shape; any lock springs made from them are strong and lasting. The new type of flattened-spring ribs (made from coils of wire) are, of course, unsuitable. One can, by the way, make use of old alarm clock springs.

HAVE you an old copy of Hobbies Handbook? By means of the 9in. rule printed along the edge of the inside back cover, a handy, lasting, useful measuring stick can be made. Cut out the strip with the scissors and glue it upon a piece of wood the same length and width; the thickness should be about 1/4in. The strip of wood could be planed to be a wedge in section; the inch divisions should be at the sharp edge of the stick.

## PYRUMA FOR

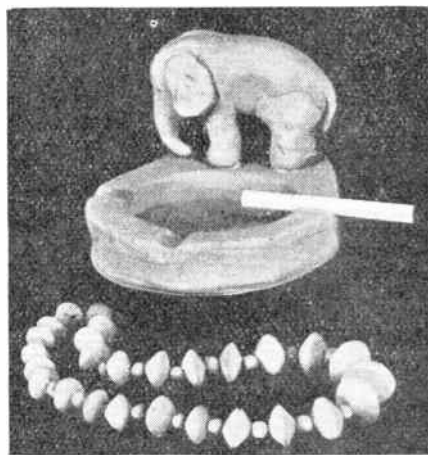

## MODELLING

Permanent, stone hard models from plastic medium, ready for use. Military Relief Maps, Surgical Models, School work and home crafts. Just make and bake, then paint.

PYRUMA in tins, 2 lb. 1/3, 4 lb. 2/3, 7 lb. 3/6.  
Tiluma Jointing Cement in 1/2 lb. tins, - 1/9.

From local ironmongers, Hobbies Shops, Bassett-Lowke Depots and Art Material Dealers. Instruction Sheet from

**J.H. SANKEY & SON, LTD.**

ILFORD ESSEX

Head Office: Aldwych House, London, W.C.2