

# Hi Fi

1960

## YEAR BOOK

Including Tape & Tape Recording  
and . . . Cine Sound Supplement

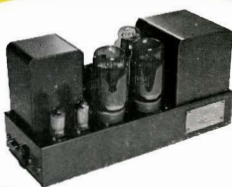

# QUAD

*For the closest approach to the original sound*

ACOUSTICAL MANUFACTURING CO. LTD. HUNTINGDON, HUNTS

**PICKUPS • MOTORS • TUNERS • SPEAKERS •  
AMPLIFIERS • MICROPHONES • RECORDERS**

10/6

# Hi-Fi Year Book

————— 1960 Edition —————

*Editor* - - MILES HENSLOW



*Published by*

MILES HENSLOW PUBLICATIONS LIMITED,  
99 MORTIMER STREET - - LONDON, W.1



# INDEX

	<i>Page</i>
<b>Introduction</b>	
The Hi-Fi Scene, 1960 .. .. .	3
<b>Home Construction</b>	
Pictorial feature .. .. .	11
<b>Constructors' Kits</b> .. <i>DIRECTORY</i> .. .. .	19
<b>Motor Units</b>	
Introduction and .. .. .	<i>DIRECTORY</i> 25
<b>Pickups and Arms</b> .. .. .	<i>DIRECTORY</i> 29
<b>Pickup Accessories</b> .. .. .	<i>DIRECTORY</i> 37
<b>Pre-amplifiers and Amplifiers</b>	
An Introduction by <i>George Tillet</i> .. .. .	39
<i>DIRECTORY</i> .. .. .	45
<b>Radio Tuners, an introduction</b> .. .. .	73
<i>DIRECTORY</i> .. .. .	75
<b>FM Service Areas Map</b> .. .. .	82
<b>Loudspeakers</b>	
An introduction .. .. .	83
<b>Speaker Drive Units</b> .. .. .	<i>DIRECTORY</i> 85
<b>Speaker Enclosures</b> .. .. .	<i>DIRECTORY</i> 98
<b>Crossover Units, an introduction</b> .. .. .	112
<i>DIRECTORY</i> .. .. .	113
<b>Tape Recorders, an introduction</b> .. .. .	115
<b>Tape Recorders</b> .. .. . <i>DIRECTORIES</i>	
Professional and Semi-Professional .. .. .	117
Decks, General Purpose and Semi-professional .. .. .	121
General Purpose and Domestic Recorders .. .. .	124
Battery Operated Portables .. .. .	142
Tape Amplifiers and Mixer Units .. .. .	144
Tape Accessories and Components .. .. .	152
<b>Magnetic Tape, an introduction</b> .. .. .	157
<i>DIRECTORY</i> .. .. .	157
<b>Microphones and Mixers</b>	
An introduction by <i>John Borwick</i> .. .. .	159
<i>DIRECTORY</i> .. .. .	167
<b>Cine Sound, an introduction</b> .. .. .	173
<b>Cine Sound Equipment</b> .. .. .	<i>DIRECTORY</i> 175
<b>Unclassified Equipment (too late for Directory Inclusion)</b> .. .. .	185
<b>Hi-Fi Dealers</b> .. .. .	<i>DIRECTORY</i> 189
<b>Advertisers' Index</b> .. .. .	195

# THE HI-FI SCENE—1960

by Stanley Kelly

FOUR years ago, in the first edition of the “Hi-Fi Year Book”, we stated what at that time were the minimal requirements for high fidelity reproduction of speech and music. Those basic requirements have in no way been lessened during the past four years, and the advent of stereophonic disc reproduction, which was then a pious hope, has placed extra requirements on particular sections of the equipment—particularly the pickup, the loudspeaker, and room acoustic conditions. It has also brought about a minor revolution in recording techniques.

## Recording Techniques

Although the major record companies were producing stereo masters as early as 1954, the general monophonic recording techniques involved the use of multiple microphones with complex fading and mixing techniques in order to obtain the best “picture” of the sound scene. On the initial stereo recordings the same techniques were followed. These were not entirely satisfactory, and the best of present day stereo recordings are made with a single set of microphones and the stereo “picture” is obtained by actual movement and disposition of the artists concerned.

Experimental stereo transmissions have been undertaken by the BBC, using separate carrier frequencies, and at least two compatible stereo transmission systems using one “carrier” only have been demonstrated. By “compatible” we mean a system in which the listener using a normal monophonic receiver obtains optimum results, whilst a receiver equipped with the necessary stereo adaptor can obtain the full benefit of stereo transmission and reception.

## Studio Acoustics

With modern studios, the acoustics are so arranged that the amount of reflected sound (and thus reverberation) is optimum for the class of music being performed. The use of echo rooms, especially with stereo, is now frowned upon. The best microphones today, together with their associated amplifiers, are

equalised to give a flat response from below 30 c/s to an upper limit of approximately 20,000 c/s. The signal to noise ratio of the microphones and associated equipment is such that a dynamic range in excess of 60 dB can be comfortably accepted and some masters are now produced with a total dynamic range in excess of 70 dB; that is, a power ratio of 10,000,000 : 1, and is almost the limit of dynamic range of a modern symphony orchestra. The dynamic range of broadcast transmissions is somewhat less. Even with the very high powers involved, the total distortion due to microphone, amplifiers and recording (or, in the case of radio transmission, modulating) amplifiers, is of the order of 0.05 to 0.1%.

## Three Channels

In most recording studios, three channel recording systems are used. By these means, optimum stereo information is obtained from the two outer channels (and some judicious mixing of the centre channel) whilst the centre channel gives adequate information for monophonic recording. Some master tape recordings have been produced and are currently being used in studios with as many as eight separate channels in order that the recording engineer shall have complete mastery over all acoustic and other problems in the studio. On gimmick records, certain types of pops, this is a very material advantage; it is generally considered to be a mixed blessing in the recording of large scale symphonic works, opera, chorals, etc., and for the recording of small ensembles, soloists, it can be considered a complete waste of at least five tracks!

Without exception, all modern recordings are initially produced on type. The modern studio recorder has a response of at least 30 to 16,000 c/s  $\pm$  1 dB, and in some equipments the high frequency response is extended to 20 Kc/s for a loss of only — 2 dB. This is for a dynamic range in excess of 60 dB. The total harmonic distortion of the equipment is of the order of 0.15% maximum, and

wow and flutter are sufficiently low as to be neglected.

The response quoted above includes the microphones, the pre-amplifiers, and the necessary recording pre-emphasis curves; it assumes that the master tape will be played back through an amplifier corrected to either C.C.I.R. or N.A.R.T.B. characteristics. The CCIR Curve is that adopted by the European broadcast and recording studios, whilst the NARTB is the one used in the United States. Under normal working conditions the CCIR response is to be preferred from the point of view of signal to noise ratio and intermodulation distortion.

### **The Master tape**

Depending on the soloist's, conductor's, and/or artists manager's conception of a particular work, the theoretical "flat" characteristic can be, and often is, modified in order that the aesthetically most satisfying recreation will be obtained.

When the performance as recorded on the master tape is accepted, gramophone disc masters are then produced from the tape. Again, the masters may be recorded to CCIR or NARTB characteristics, and at this stage it should be noted that the present day high fidelity amplifier usually has only one L.P. recording characteristic, the difference between NARTB and CCIR easily being taken care of by a slight adjustment of the bass and treble controls. It can also be said in parenthesis that the difference between these two recording characteristics are considerably less than the difference between two equally "good" loudspeaker systems of different make.

### **Frequency Response**

In the case of monaural record pressings, these can be considered to have a flat frequency response from 30 to about 18,000 c/s, and a total distortion content (with the exception of tracing distortion, of which more anon) throughout the whole recording and reproducing chain of less than 1%.

In the case of stereo records, the frequency response is not quite as good, extending usually from 30 c/s to about 12,000 c/s, but because of the added realism due to the stereo information, the high frequency loss is not often noticed, although it can be detected by direct A-B switching from monaural to stereo where the records have been made from the same tape. This should be compared with the sound channel of a modern television receiver (using a  $7 \times 4$  in. elliptical loudspeaker), which extends from

approximately 250 to 3,000 c/s  $\pm$  15 dB and distortion usually in excess of 20%!

Not all records are 100% perfect, and the proportion of really satisfactory stereo records is considerably less than that of mono, but the percentage of "listenable" records issued today is considerably greater than that obtainable only four years ago. In the case of radio transmissions, the frequency modulation system (FM) which now covers the majority of the United Kingdom is capable of giving results at least as good as the best disc. Unfortunately this does not often happen, and it is feared that the BBC are sometimes guilty of deliberately degrading the frequency range of their transmissions in order to mask the distortion due to long telephone lines. Taking all factors into consideration, one can say that 95% of all distortions heard in reproducing equipment have originated in that equipment and not in the recording or transmitting side.

### **Reproducing Equipment**

The basic equipment required for high fidelity reproduction consists of a loud-speaker(s), amplifier(s), pickup, gramophone turntable, FM tuner, and, for the enthusiast, a tape recorder. A necessary adjunct to the above equipment is a comfortable easy chair and a warm, well proportioned listening room. The difficulty in the majority of cases is to persuade the distaff side of the house that the latter is really necessary! With modern furnishing schemes much of the matronly opposition to the "wireless" which the enthusiast strewed half way round the room is fast disappearing.

Most hi-fi enthusiasts form their equipment around a record collection, which ultimately accounts for the major capital investment. It is therefore most important to store the records correctly, to keep them scrupulously clean and to use the best possible pickup, operating under optimum conditions.

### **Turntables**

The turntable should be of "transcription" quality, without automatic stop and it should most certainly not, repeat not, be a record changer. The turntable itself should be heavy, well balanced and have substantial bearings. The drive should be automatically disconnected when the motor is switched off, in order to avoid "flats" on the rubber idler, which could introduce wow and flutter. In order to reduce the possibility of the idler being left engaged when the equipment is switched off, the motor itself should be connected to the live side of the mains

rather than through the amplifier main ON/OFF switch. If, additionally, a small pilot light is wired across the motor input terminals, the user will have ample warning that the motor is not switched off.

There has been a tendency to reduce the power of the main driving motor in recent years, and this is to be deprecated. Sufficient power must be available even with the heaviest turntables to ensure that there is not the slightest sign of speed variation on heavily modulated passages. The majority of prime movers are shaded pole motors, which do not run synchronously with the power supply frequency, and for a musical purist who is sensitive to absolute pitch, some form of speed control may be advisable. (But in the writer's experience not even the best orchestras are absolutely on pitch at the end of a concert, so this may be a question of which comes first, the chicken or the egg.)

### Pickups

Without doubt the pickup is the most important single item of equipment. Its excellence to a large extent determine one's enjoyment, and also to a large extent the life of the record. We will repeat the homily from our first edition of "Hi-Fi Year Book, 1956": "one cannot advise too strongly—save pennies on the amplifiers, use only a two speaker instead of a three speaker system, but whatever else you save on, buy the best possible pickup and if at all possible, invest in a diamond stylus". The majority of the modern gramophile's woes can usually be traced to one or other of various pickup faults.

In the case of stereo records, because of the relatively short life of a sapphire stylus, a diamond should be considered a "must". Because the geometric distortion of 45/45 stereo disc is greater than that occasioned by normal lateral single channel recordings, the radius of the point should be reduced con-

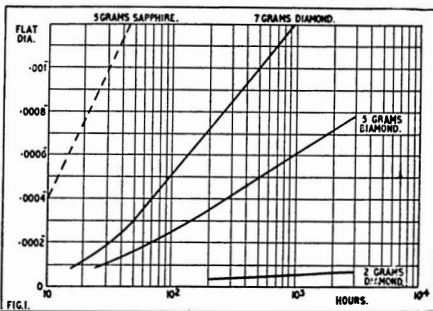

FIG. 1. Playing life of 0.001" stylus

siderably. This results in increased pressure loading for a given playing weight and hence increased wear, both of the stylus and the gramophone record.

Graph, Fig. 1, shows the life of an L.P. stylus (0.001 inch radius) for different playing weights. It is plotted in terms of "flat" diameter against time. With wide range high fidelity equipment, distortion is apparent when the "flat" diameter approaches 0.0004 in., and record wear becomes noticeable when the "flat" diameter is greater than 0.0007 in. It will be seen that with a sapphire stylus even at 5 grams playing weight the life is a few hours only, whilst the diamond should certainly be replaced before 2,000 playing hours. If the playing weight could be reduced to 2 grams, the life of the diamond stylus would be practically infinite.

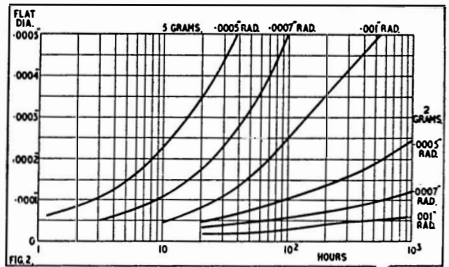

FIG. 2 shows the same story for stereo diamonds. For the best possible stereo results a half-thou diamond is mandatory. Unfortunately, a large quantity of stereo records have been pressed in the United States (and, be it whispered, a few in this country) in which the bottom radius of the groove has approached 0.0005 in. (half a thou). This may have been due to polishing the masters or stamper or one of a dozen other things, but the important point to remember is that when the groove radius approaches this value, the half thou stylus skates along the relatively rough bottom of the groove, giving increased distortion and noise. Additionally, a relatively large percentage of early L.P. mono's were also produced with the bottom groove radius of the order of half a thou. For this reason, a "compatible" point of 0.0007 in. radius has been advocated. It has the advantage of eliminating distortion due to skating in the bottom of the groove and increasing both the stylus life and hence the record life, but it has the very material disadvantage that with the best high fidelity equipment the increased distortion can be heard.

The effect of the "flat" worn on each side of the stylus tip is twofold; firstly, when the



flat becomes appreciable it tends to shave off the corners of the high frequency modulation on the record; and, secondly, when the dimension of the flat becomes comparable to a wavelength, harmonic distortion (principally 3rd and 5th) is introduced. This distortion is a function only of the ratio of the width of the flat of the stylus to the wavelength of the recorded tone, and becomes severe before there is appreciable attenuation of the fundamental caused by record wear. It is only noticeable at high frequencies, but if there is a low frequency tone recorded at the same time, intermodulation products will most certainly be apparent. With stereo recordings the maximum "flat" size before the distortion becomes apparent is of the order of 3/10ths of a thou. The stylus life for different radii and playing weights can readily be obtained from graph Fig. 2.

### Types of Pickup

There are three major types of pickup: (1) Crystal, (2) Ceramic, which are characterised by a relatively high output voltage, a corrected frequency response and medium to high playing weights, and (3) Magnetic units, which have a low output, extremely wide frequency response, low playing weight, but require high gain corrected amplifiers. Without exception, crystal cartridges are used on moderately priced equipment where the added sensitivity results in considerable savings in pre-amplifier cost, and certainly, including stereo, the majority of pickups used today are crystal. But it can be asserted without any fear of contradiction that the best magnetic stereo cartridges are infinitely superior to the best crystal ones.

Although no new monaural pickups have appeared on the market in the last 18 months, the lessons learned on designing lightweight stereo pickups could now be applied to monaural pickup design, resulting in infinitesimally low playing weights as compared with even two years ago. There is no reason why monaural pickups playing at less than 1 gram should not be produced immediately, and stereo pickups playing at this weight can be available during the middle of 1961.

### New Pickup Arms

All too often the pickup arm is considered a rather necessary evil, rather than part of the integral pickup design. Fortunately, this omission is now being repaired and a number of excellent arms have made their appearance in the last 12 months. Without exception these have mass counterbalancing instead of springs, have a relatively low moment of

inertia, and are dynamically balanced, vertically and laterally. Some of the units are, in addition, counterbalanced to offset side thrust, and whilst none are cheap, they can be recommended as a sound investment in helping to preserve one's gramophone records.

Even with a superlative cartridge and tone arm, unless the unit is mounted so that the pedestal is exactly vertical, considerable side thrust could be generated due to the action of gravity on the mass of the pickup head forming a couple and giving a lateral thrust. This sideways thrust can approximate to 50% of the playing weight of the pickup and is a frequent cause of non-tracking, resulting in rattles and distortion even if the pickup does not actually jump grooves on heavily modulated passages. Where the motor, turntable and pickup arm are obtained as a complete unit it can generally be assumed that the pedestal will be perpendicular to the turntable, but after the system has been installed it should always be checked that this is fact.

### Tracing Distortion

Although modern records and pickups have a combined excellent frequency response and dynamic range, the limiting factor today is tracing distortion. This tracing distortion is due to the geometry of the system, and even though individually the recording chain and the reproducing chain are distortionless, due to the fact that the recording stylus and the reproducing stylus are not of the same shape, this particular form of distortion (tracing distortion) shows itself when heavily modulated high frequency passages occur.

It can be minimised by increasing the groove velocity, by increasing the rotational speed of the record, or by increasing its diameter. The distortion can also be lowered by reducing the stylus radius. Reducing the radius of the stylus from one thou to half a thou gives not only a measurable reduction in tracing distortion but also can be very plainly heard. As mentioned above, it is unfortunate that a large number of early L.P's have been pressed with the bottom groove radius in excess of half a thou, so this desirable feature cannot be used.

Experimental diamond styli, have, however, been produced in which the tip instead of being spherical is oval, with the major diameter across the record groove approximately 0.7 thou, and the minor diameter parallel to the groove 0.3 thou. Using this type of stylus, the tracing distortion on monaural records is reduced to almost

negligible proportions, whilst on stereo records tracing distortion is reduced to approximately that of the best monaural discs. It should be noted, however, that with a stylus of this form the maximum playing weight is of the order of one gram.

Because of the increased stylus tip/record groove compliance with smaller tip diameters, the high frequency resonance for a given stylus mass is reduced, so that replacing a one thou point with, say, a 0.7 or 0.5 thou point, whilst effectively reducing tracing distortion, will reduce the high frequency response somewhat. The answer here is obviously to design the pickup with a reduced stylus mass in order that the accepted frequency response be obtained.

### Harmonic Distortion

Mono records which are laterally modulated are substantially push-pull devices, and assuming that the stylus point makes contact with the groove at all times, even harmonics are cancelled out leaving only odd harmonics as the distortion component. In the case of 45/45 stereo recording, these consist of two hill and dale systems juxtaposed 90° to each other. The hill and dale modulation can be considered as a single ended system generating both even and odd harmonics and, for a given set of conditions (recorded frequency, modulation depth, groove velocity and tip radius) the individual components and the sum of the harmonics are considerably greater than lateral monophonic recording. It is for this reason that the stylus radius was reduced in size. It should be noted that to give the same overall distortion under otherwise identical conditions a stylus radius of approximately 0.3 thou. should be used for stereo when compared with a stylus radius of one thou. for mono.

### Loudspeakers

In the past there have been many arguments as to the optimum distribution of sound from the loudspeaker. One school of thought popularly termed the "Voigt" school thinks of the loudspeaker as being the open window of the listening room, the listening room itself being suspended in the optimum part of the concert hall. For monophonic reproduction this gives very good results. It does, however, add the characteristics of the listening room to those of the concert hall, and where the loudspeaker is placed in a corner of the listening room in order to obtain optimum bass performance, a maximum number of eigentones in the room will be excited, and it is these eigentones (that is, modal resonances

associated with the room dimensions) that give local colour to the reproduction.

The other school of thought, headed by Cecil Watts, contends that the recording or the initial performance should have a minimum of ambience or studio colouration and should be reproduced through an omnidirectional loudspeaker; this should then give the impression of the orchestra performing in one's own room. If the speaker is carefully placed, the excitation of eigentones will be at a minimum. A variation on this system is provided by the *Quad Electrostatic* and the *Wharfedale SFB3*, which act as "doublet" sources. That is, the radiation from the rear of the loudspeaker cone (instead of being absorbed as an infinite baffle or reversed in phase to augment the sound from the front of the cone in vented enclosures), is fed into the room. This arrangement completely eliminates colouration due to enclosure resonances, etc., and also reduces eigentone colouration, but the bass response, particularly below a critical frequency determined by the physical size of the baffle, is somewhat reduced.

### Speakers for Stereo

The advent of stereo has brought all these problems very much to the fore, and there are now at least as many schools of thought as to the correct type of loudspeaker and layout as there are loudspeaker manufacturers. Generally, omnidirectional loudspeakers give best stereo in large rooms, whilst loudspeakers in which the high frequency units are "beamed" towards the centre of the room give slightly better stereo information in small rooms.

In the case of omnidirectional loudspeakers, unless the high frequencies are increased by a few dB, "presence" is reduced, whilst with "forward facing" loudspeakers the stereo "position" tends to be brought forward. For optimum results, similar speakers, or at least speakers by the same maker, should be used, although quite acceptable results can be obtained by using completely dissimilar types of loudspeaker unit. In some of the cheaper equipment a common bass unit is used, the mid and upper frequencies being then separated into two small loudspeakers. Again, one of the high frequency speakers may be combined with the common bass unit, whilst this is an economical method of achieving stereo information it cannot in any sense of the term be considered high fidelity.

With the large scale introduction of stereo reproduction in the home, the accent has been on smaller and smaller loudspeakers. This is

understandable because no housewife likes her living room cluttered up with odd boxes which to her seem unessential. A lot of "hoo-ha" has been expounded in the United States on how it is possible to obtain identical results with small enclosures (say, 2 cu. ft.) as with the older accepted enclosures of 9 to 12 cu. ft. At first sight this is nonsense. It does, however, make some sense if one is prepared to accept a reduced overall efficiency of the loudspeaker system in proportion to the reduction in volume of the cabinet.

The enclosure generally acts as a stiffness which tends to oppose the motions of the loudspeaker diaphragm. The smaller the enclosure the greater the stiffness and, for a given loudspeaker with lower input, the smaller is the diaphragm motion. At the same time, the stiffness resonates with the mass of the cone at some low frequency, and reducing the volume of the enclosure increases this resonant frequency.

As an example, a 12 cu. ft. enclosure with a particular 12 inch loudspeaker may resonate at 30 c/s, whilst reducing the enclosure to 2 cu. ft. will increase the resonant frequency to about 100 c/s. It must also be remembered that below the resonant frequency the response falls off anything from 12 dB to 24 dB per octave, depending on the constants of the system. The way to overcome this anomaly is to increase the mass of the cone proportionate to the reduction in volume of the enclosure, and loudspeakers can be and have been made which will give a flat response down to 30 c/s with only 2 cu. ft. of enclosure, but the price paid is a considerably reduced sensitivity and increased cost because of the very much larger magnet which has to be fitted to the loudspeaker to keep the overall efficiency of the system usable.

### Pre-Amplifiers

The pre-amplifier used is necessarily conditioned by the pickup, and when checking the sensitivity of the pre-amplifier it should be remembered that a pickup having a nominal output of, say 4 mV per cm per sec. will give a maximum output of approximately 70 mV on the heaviest modulated passages on L.P. records and 120 to 140 mV on 78's. One must therefore not fall into the fallacy of specifying a pre-amplifier sensitivity which will fully load the power amplifier to its maximum output on the nominal voltage loading of the pickup cartridge. At the same time, the tendency towards a pre-amplifier that has inadequate sensitivity must be discouraged because of the possibility of hum when the gain control is turned to maximum.

Separate bass and treble tone controls, each giving a variation of 10 to 15 dB lift and cut at, say, 100 and 10,000 c/s should be considered a "must", whilst a steep cutting variable high pass filter is a nice accessory if one contemplates playing 78 r.p.m. records. For newcomers to the art this is not absolutely essential, because many of the best 78 discs have now been re-issued in L.P. form and the recording companies have taken great pains to reduce the surface noise as much as possible.

A small observation at this point: If the pickup and loudspeakers are really smooth and flat to, say, 16 Kc/s, the "needle scratch" or hiss is not only not objectionable, but is usually unnoticeable. This is because the needle hiss familiar to all of us who played 78 r.p.m. records is actually the colouration of a wide band of frequencies by the pickup and loudspeaker resonances, and if these resonances occur in the 3 to 9 Kc/s region, this background is rendered very much more prominent and can become objectionable.

### Power Amplifiers

In terms of performance, the modern power amplifier is the most nearly perfect link in the whole chain of reproduction equipment. Most amplifiers today claim a frequency response in excess of 20 to 20,000 c/s, and a total harmonic distortion of less than 0.1%. This distortion is specified at an arbitrary output (the nominal maximum) and at a frequency of either 400 or 1,000 c/s. In the early days of high fidelity, this formed the basic claim for the amplifier's performance, and if distortion was measured at, say, 30 c/s and 15,000 c/s, it would generally be found that the rated distortion figures would be exceeded by a factor of anything up to times 50; and with quite a lot of manufactures it was impossible to get more than 20% of the rated power output at these frequencies. Fortunately, with improved techniques, especially with regard to output transformers, this defect is becoming less and less serious, and all of the better class of power amplifiers fully meet their rated specification in terms of distortion and power output over a frequency band of at least 30 to 15,000 c/s.

With the average domestic listening room and speakers of normal efficiency (5%) fitted into enclosures of, say, 4 to 6 cu. ft., about 15 watts maximum power can be considered satisfactory for monophonic reproduction. A power amplifier using a pair of KT 66's or equivalent will more than meet the specification. For stereophonic reproduction about 8 watts per channel will be

adequate, and can be obtained from amplifiers using a pair of *EL 84*'s in push-pull in each channel.

It will generally be found that one tends to reproduce stereo at a higher average level than mono, and also that one tends to reproduce twin speaker mono at a higher level than when replayed from a single speaker. With twin speaker systems, one also notices that the background noise, hiss, rumble, etc., tend to become disassociated from the music as a whole.

### FM Tuners

Now that the major portion of the United Kingdom is completely covered by FM transmission, the old bugbears of medium wave radio reception with its whistles, monkey clatter, and other venial forms of interference, which completely mitigated against any high frequency reception, are now a thing of the past. The first FM tuners were clever pieces of engineering, generally based on radar practice, but suffered from drift and, sometimes, particular types of distortion.

The best modern FM tuners are completely blame-free in these respects, and in the case of good local transmissions, where landlines are not employed, the results are sometimes superior to the best reproduced disc. This is due to efficient automatic frequency control, very effective limiting, linear demodulator and correct de-emphasis networks.

Where possible, if economics allow, it is better to purchase an FM tuner with its own built-in power supply because even with modern amplifiers there is sometimes a tendency towards very low frequency instability which, whilst it cannot be heard as the normal L.F. "motor-boating", does give a muddy reproduction.

### Tape Recorders

The sale of tape recorders in the last few years has been phenomenal. Of course, the majority of sales have been in the lower price brackets, and rumour has it that they are being bought principally by the teenagers to record the "Top Ten" from the radio without having to buy the records, much to the chagrin of the record manufacturers.

To the serious hi-fi enthusiast, this type of equipment is not very interesting, and to obtain results equal to a modern L.P. record a minimum tape speed of  $7\frac{1}{2}$  inches per sec. is necessary. Separate record and replay heads should be used, and the replay head gap should have a maximum dimension of 3 microns.

In general,  $3\frac{3}{4}$  i/s give results considerably inferior in terms of signal to noise ratio, if the frequency response is extended to approach that of a modern disc; whilst the  $1\frac{1}{2}$  i/s speed may be of use in office dictating machines but cannot be considered as a medium for hi-fi entertainment.

### Wow and Flutter

Wow and flutter are the most serious problems with the popular priced decks, and it is unfortunate that money and effort that could have been expended in the form of closer tolerances and better workmanship for a simple mechanism (with concomitant improved performance of wow and flutter, reliability, etc.) have been sacrificed for gimmicks in the form of instantaneous reverse mechanisms and all the other advertising blurbs we have been regaled with. The extra head used for the "reverse" track could easily be used as a direct monitor head with its own replay amplifier which could have been underwritten by the saving in cost of the materials for these complex switching systems. Fortunately, at least one British manufacturer has seen the light of day and produced a resoundingly simple deck at a reasonable cost which does exactly what a tape transport mechanism should do—namely, pull the tape past the head at a perfectly constant, smooth, speed.

### Stereo Machines

Stereophonic recorders are coming more and more on to the market, but, apart from dubbing stereo discs on to tape, one cannot see very much use for these recorders in the average household. The advent of stereo broadcasting will, of course, completely alter the complexion of this picture.

Here a word of caution should be added. The recording companies and the holders of copyright works have issued firm and plain warning on the unauthorised re-recording of their works and notice should be taken of these warnings!

The advent of extended and double play tape is a mixed blessing, especially with double play tape where the dangers of "print through" are considerable. Experiments performed over the last six months by the author of recording at 3 dB below saturation on double play tape showed "print through" appearing between — 25 and — 40 dB with different makes of tape. The print through was apparently maximum in the mid-upper frequencies and even though the tape is periodically re-spooled, once the print through (which usually takes 24 to 72 hours



to reach maximum) takes place there is nothing one can do to eradicate it without destroying the recording.

### Microphones

For average domestic recording (at  $3\frac{1}{2}$  inches per sec.) a medium priced crystal microphone is more than adequate, whilst at  $7\frac{1}{2}$  i/s the better class crystal microphones will do justice to the majority of recorders. The usual peak in the 5 to 8 Kc/s region of the microphone may introduce a little sibilant distortion but especially when the record/replay head has become worn with attendant loss of high frequency response, this added pre-emphasis may be of advantage.

At present, all crystal microphones available on the British market are pressure types, with the result that the microphone responds not only to the initial sound source, but also to all the reverberations as well (which are plentiful and usually of high amplitude in a domestic living room). Using a directional microphone, such as a ribbon, or cardioid, enables considerable control over recording conditions to be obtained with quite simple apparatus, and especially with the recording of piano music, is to be preferred to a simple pressure microphone. For outdoors, extreme care must be taken of the ribbon microphone not only because of its sensitivity to wind noise, but also because of the possibility of physical damage if a high wind blows directly on to the fragile aluminium ribbon, which is usually only 1 or 2 microns (less than 1/10th of a thou) thick.

### Summing up

*To summarise:* The equipment should be considered as an integrated whole and even though bought piecemeal, commencing with basic mono equipment and adding units as finances permit to give finally a complete stereo system, each section of the equipment should be considered in relation to the rest, it being remembered that the strength of a chain is only that of its weakest link; and it is foolish to pay £120 for the first loudspeaker and only 55s. for the pickup. The following are considered to be the minimal requirements:

The amplifier should have a basic minimum of 7 watts per channel, whilst a power output in excess of 20 watts can be considered a luxury. The frequency response should be flat from 30 to 15,000 c/s at the rated power output when fed into the loudspeakers it is

intended to work with. Under these conditions the total harmonic distortion at any frequency should not exceed 0.5%, and the total intermodulation distortion (at 30 and 10,000 c/s) should not exceed 2%.

The pre-amplifier should have adequate sensitivity for the pickup used, should have facilities for pickup, tape and radio inputs, with correct equalisation and preset level controls for each of them. Its frequency response should be at least that of the main power amplifier and the maximum distortion introduced by the pre-amplifier at an output sufficient to drive the power amplifier to maximum level should not exceed 0.05%.

The pickup should have a response flat from below 30 c/s to above 16 Kc/s. Its low frequency resonance (and this in part is determined by the tone arm constants) should be an absolute minimum of 18 Kc/s. The stylus should be diamond. For monophonic reproduction the tip radius should be 0.8 to one thou, and for stereo reproduction should be 0.5 to 0.65 thou.

The loudspeaker main bass resonance should be below 50 c/s and preferably below 35 c/s. The high frequency response should be flat and smooth to at least 15 Kc/s and the beam width at 10 Kc/s should be at least 90°.

The overall distortion of the system is difficult to assess. The pickup, when driven from a test record at maximum velocities should not generate more than 2% distortion in the low frequency band, although because of tracing distortion at the high frequency end it is difficult to assess realistic values. The total intermodulation content with a 30 c/s and 2,000 c/s tone at a maximum velocity of 12 cm per sec. should be less than 5%. In the case of the loudspeakers, the principal distortions are likely to occur below the lower resonant frequency, and in the case of some cone speakers, due to break-up and intermodulation in the 8-11 Kc/s region. Quantitative figures of distortion are rather startling, being anything up to 15 or 20%, but because of their transient nature the ideal way of specifying the speaker is in listening fatigue. When comparing two speakers, which apparently sound equally good, the one with which one tires sooner is the inferior of the two.

It should be remembered that all this equipment and all the thought that has gone into it is only a means to an end, and that end is the recreation of the original music for one's enjoyment.

# HOME CONSTRUCTION

**T**HERE is a “boom” in the Do-it-Yourself corner of Hi-Fi. In fact, so many people are doing-it-themselves that one might well ask “who is buying what?” The answer to that, of course, is that only one in every few hundred enthusiasts are home constructors, no matter what the subject—from dressmaking to carpentry; and the boom in Hi-Fi construction is only another pointer to the overall growth of interest in high fidelity sound reproduction.

In the early days of radio, as the longbeards amongst us will remember, *all wireless sets were home-built*. Those days were indeed the very beginning of home construction in electronics.

The end of World War I provided the first real pool of Government Surplus equipment, from which thousands of early radio receivers were built, and which formed the basis of a million “junk boxes” throughout the world. There is, by the way, no intended slur in that

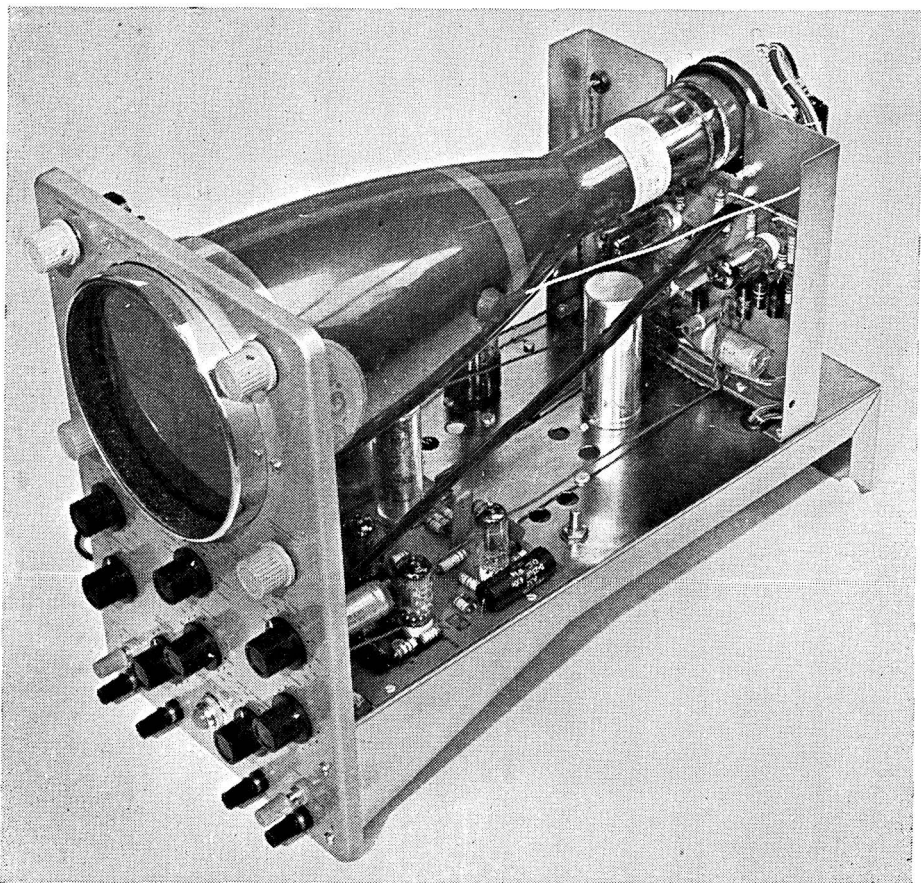

*Once the exception in service departments: now quite common on the home workbench.*

expression. The Americans call it a "parts box"; but whatever its name, it is an essential piece of background for all home construction. More about it later!

### Electronics and World War 2

World War 2 was fought very largely with the aid of electronics, and in consequence the three fighting services trained many thousands of men to operate and service electronic equipment. Once again, Government Surplus provided a bargain-hunter's treasure store; and demobilisation let loose a new army of home constructors who were able to turn their wartime experience to useful account, making almost everything that needed a valve, a meter, or a cathode ray tube. And it was very largely from this new influx of do-it-yourself enthusiasts that the

recent upsurge in home-built hi-fi began. It is an infectious habit; and, once caught, the baccillus rarely dies! It is safe to say that many old-timers who built some of the first cat's-whisker and crystal radio receivers are still hard at work with pliers, wire and solder, building anything from deaf aids to electronic organs or computers.

### Modern electronics are simple

Many potential home constructors are put off by the apparently over-complex circuitry which prevails today. This, as it happens, is by no means the barrier that it appears to be; and the numerous constructional features which are published monthly in such magazines as *Hi-Fi News*, or *Radio Constructor*, are excellent bridges over the barrier. There is, however, yet another introduction to the



Four do-it-yourself kits are now available for 'scope construction, from **Cossor, Jason and Heathkit**. Here are the bits and pieces, as the postman delivers them. Check carefully!

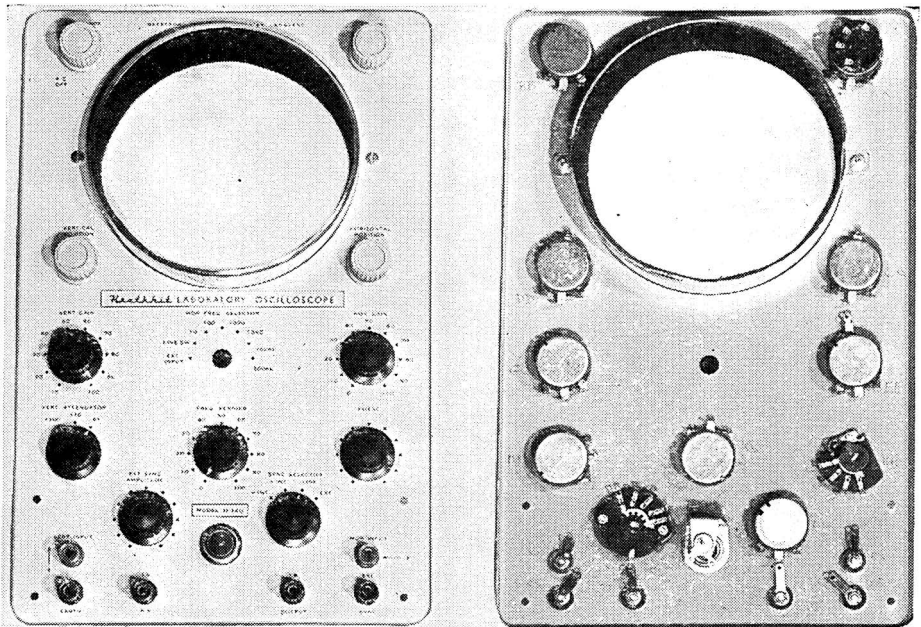

*Mechanical assembly comes first. Orient all components as outlined in diagrams. To save work and mistakes, write the diagram numbers of components in soft pencil on the chassis; for example, "VR1 : SW2" etc. It may help to add the tag numbers as well. To get a better working picture of the whole job, it often pays to hold all mechanical assemblies together for study, rather than plough blindly on, stage by stage.*

hobby, which not only takes care of the above difficulties, but which goes so much further that *anyone* who can solder, and who can follow instructions, can build up electronic equipment ranging from simple radio sets to quite complicated test gear—and with little more than a talking knowledge of electronics.

Home construction can, in fact, be grouped into three neat sections. (1) Step-by-step construction from complete kits, as just referred to, and which an intelligent child can tackle successfully. (2) Construction of apparatus, as published in monthly journals and handbooks, from circuitry, photographs and point-to-point wiring diagrams. (3) Construction which begins from original design.

There are three firms in the U.K. who have specialised in category (1). Of these, **Cossor** market several kits of test gear as part of their far greater manufacturing programme. **Jason** are now marketing a wide range of equipment in kit form, and also supply the same equipment ready-built if required. **Heathkit** concentrate entirely upon kits. The term "kits", as used in this article, means the complete A-to-Z outfit, from the

smallest shake-proof washer to the steel cabinet, plus a detailed set of instructions which make it unnecessary even to refer to a circuit diagram. However, although this form of home construction enables the complete novice to build something that will "work first time when switched on", it must not be sneered at on account of its simplicity. On the contrary, the constructor who is really keen to understand what he is doing, and who wishes to learn something as he goes along, can make these "kit" jobs the perfect basis for self-instruction.

Whereas the man who merely wants to build something that will work "as advertised" can, if he wishes, complete the job with nothing more than concentration; so can the would-be learner follow the circuit diagram, inking in step by step as he works. From this he can discover for himself the art of placing components, the logical way to wire-up, the relationship between circuit drawing and chassis, and above all the instinctive outline of what-is-what, and why. An introduction to home construction via category (1) cannot but be a good thing. Those who find it easy-going and interesting



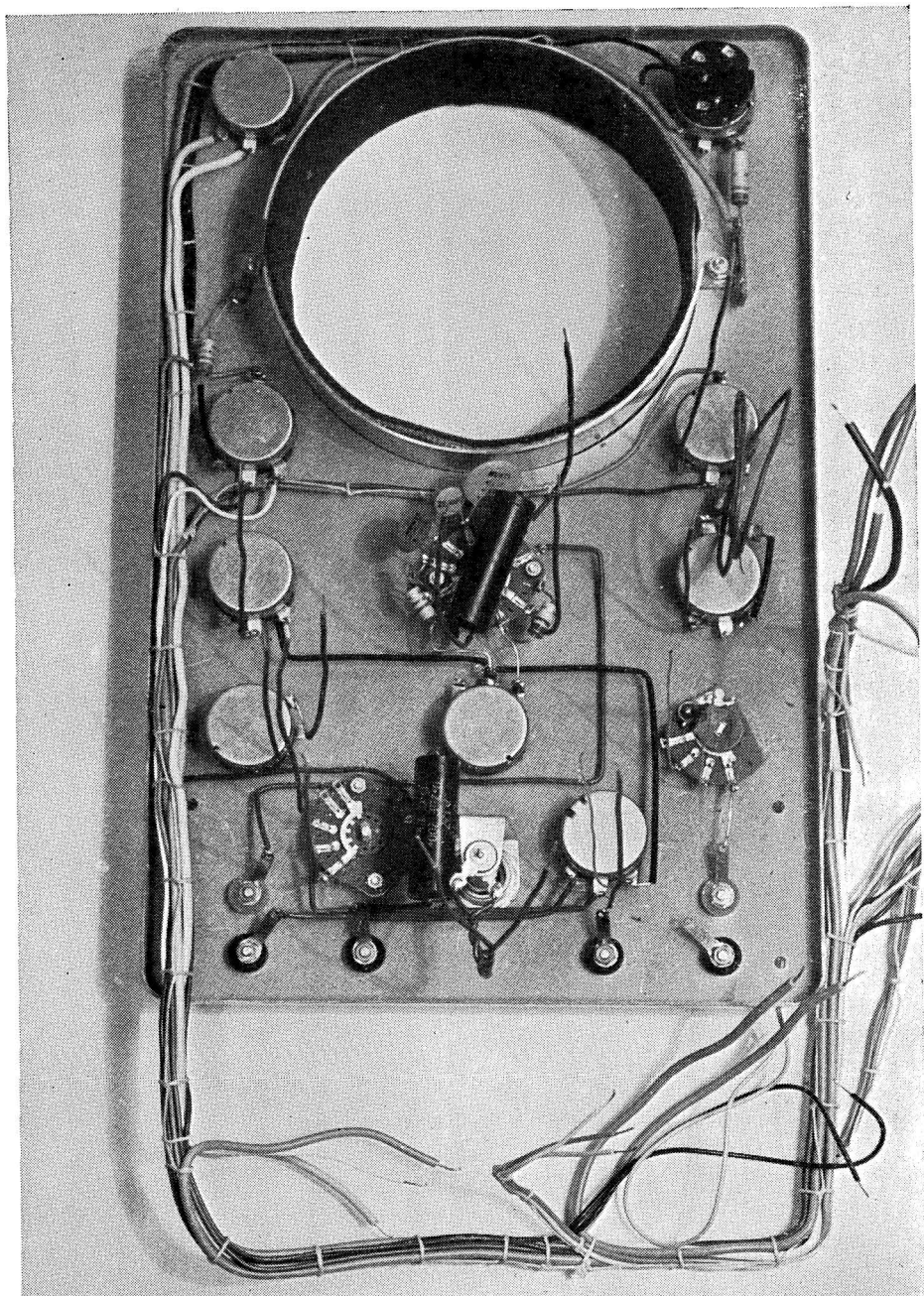

*It takes longer to wire neatly, and although the equipment will work no better for such kindness, the results are far more satisfying—even though the handiwork is hidden when once the metal case is screwed home. There is no point in rushing any job unnecessarily; and neat work, which demands more thought, is conducive to better all round workmanship. Instead of running a wire blindly from A to B, route it tidily, and with an eye to what comes next.*

will soon step into category (2). Those who wish to go further can do no better than write to **Mullard Ltd.** for the books of circuits that they publish, and for the new circuitry that they issue from time to time.

The theme of the picture story which has been selected to illustrate this article is "step-by-step" construction; but it also provides a good guide for more advanced work. The item chosen was the *Heathkit Oscilloscope*. For the purpose of progressive photography, the various main stages in the instruction book were not strictly followed. For example, all possible screw-and-bolt work was completed as one stage, and followed by basic chassis wiring as the next stage. Printed circuit boards were tackled next, then the assembly of sections and the final wiring. Up to the time of writing, at any rate, no kit instructions pay any attention to the refinements of neat wiring. From the point of view of getting a thing to work, and as simply and quickly as possible, there is nothing to be gained by this. Indeed, many people who are too lazy to attempt neat and tidy wiring will quote the excuse that "there is less chance of introducing unwanted capacity effects between wires".

The writer holds rather a different view on this subject: namely, that an intelligently wired piece of electronic equipment will not produce any ill effects; and that it is surely best to make the tidiest possible job of anything one builds—even if a steel cover is destined to hide it from view for evermore. But a possibly more important point in favour of neat wiring layout is that it makes one *think*—and is therefore the very finest form of training for anything else that may follow.

Quite obviously there would not be room in the average kit instruction book to cover all the details necessary for exhibition quality wiring: nor would the beginner thank the designer for including so much irritating detail; but an hour of study, as one proceeds with the first kit job, will yield plenty of good lessons. For example: the instruction "*Fit a 3-inch length of wire . . .*" will occur many times. Instead of fitting it blindly, study the drawings (if necessary holding the bits together) and see where the length of wire has to go. Usually, the specified length has been given to go from A to B, with adequate provision for stripping the ends and easy routing. It may be necessary to increase the length if any attempt at neat layout is envisaged.

Also, when connecting up various lengths of wire to a printed plate, it can be a good idea

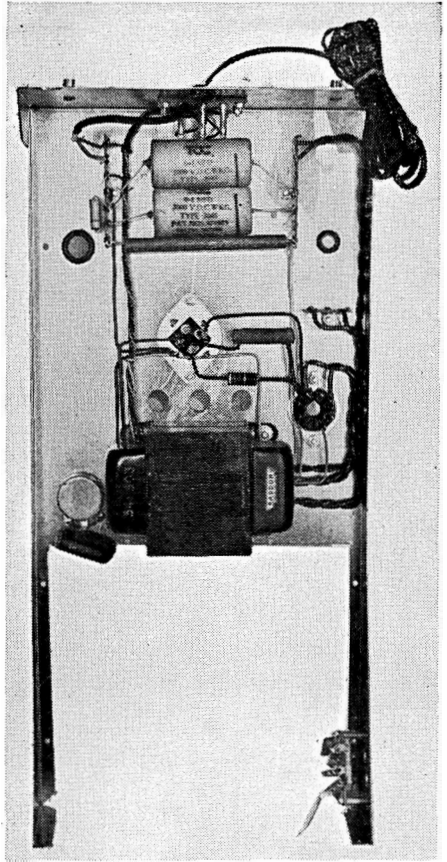

*Here is another example of tidy wiring. More important, though not visible, is that all sleeving is stripped neatly back, and all wire ends are hooked with long-nose pliers, tinned with solder, and crimped home. Result—no dry joints!*

to review the result when all are in place. Often it will be found that by moving one over another, and re-shuffling generally, an ugly tangle of wires can be resolved into a most pleasing pattern. Having reshuffled, then tick the step off as "done", and only then solder!

#### **Where good soldering pays**

Remember, that almost nothing is "final", provided that soldering has been done intelligently. Even the offending wire can be taken off and replaced. But (especially for complete beginners) when "making a disconnection" always put a cross against the item which has been disturbed, and *re-tick only when it has been replaced.*

The above observations deserve a special short paragraph to qualify them. Even in

the interests of tidiness, do not run wires of extravagant length, or route them in obviously impossible patterns. As a rule, anything from half-an-inch to two inches will make all the difference between a professional looking job, and a tangle that no self-respecting starling would consider twice as the basis for a nest.

Mention was made earlier about the "junk box". One of the writer's objections to the extreme efficiency of kit purveyors is their apparent meanness in expendable bits and bobs. Often, if the kit calls for 24 nuts and shakeproof washers, precisely that quantity will be provided—with not one over to replace the item that rolls on to the floor, through the knot-hole. This is not parsimony,

of course, but the result of mechanical sorting and counting; and if one argues that the odd spare part should be included, the manufacturer's very reasonable retort would be: "Where do we stop? What about a spare valveholder to replace the one that will have solder poured into it? Or the spare resistor . . ."

The answer is, of course, start a "junk box". Indeed, as these lines are written Jason are already preparing a basic kit of *necessary spares*, which they intend to market for a few shillings. This will contain a small stock of all the items normally lost or needed at awkward moments—washers, screws, nuts, sleeving, crocodile clips, tinned wire, tag strips, etc. All would-be constructors should

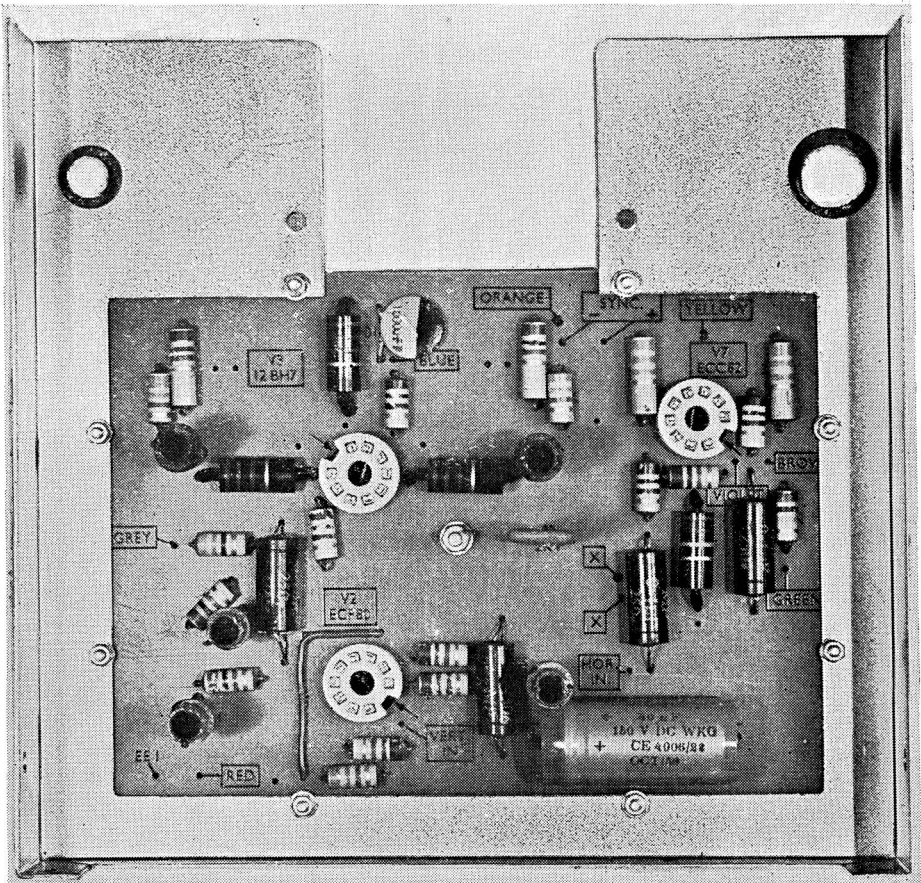

*The assembly of printed circuit boards requires special care. Scrape all terminal leads of components with side-cutter blades and bend them for insertion through holes. Press them into position and bend the wires against the circuit lines to which they will be soldered. Clip off excess wires and press home so that the components are seated snugly and firmly. Use a hot iron, solder quickly and decisively. Do not let it "fry!"*

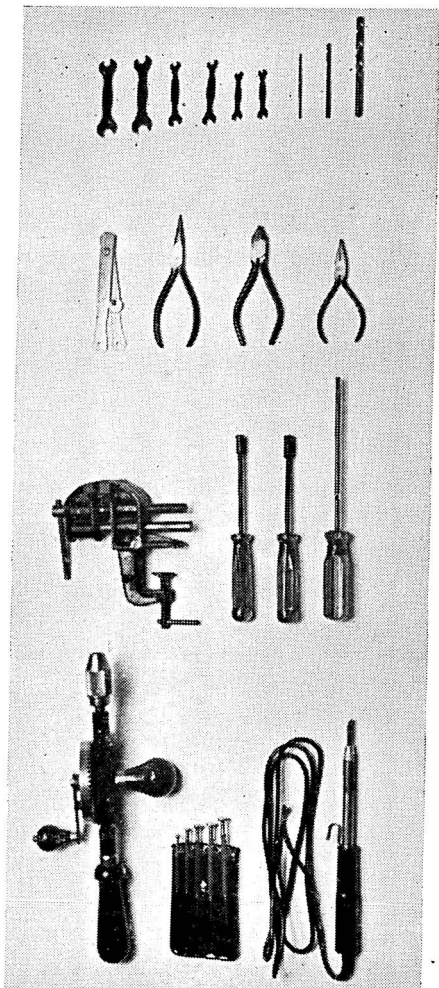
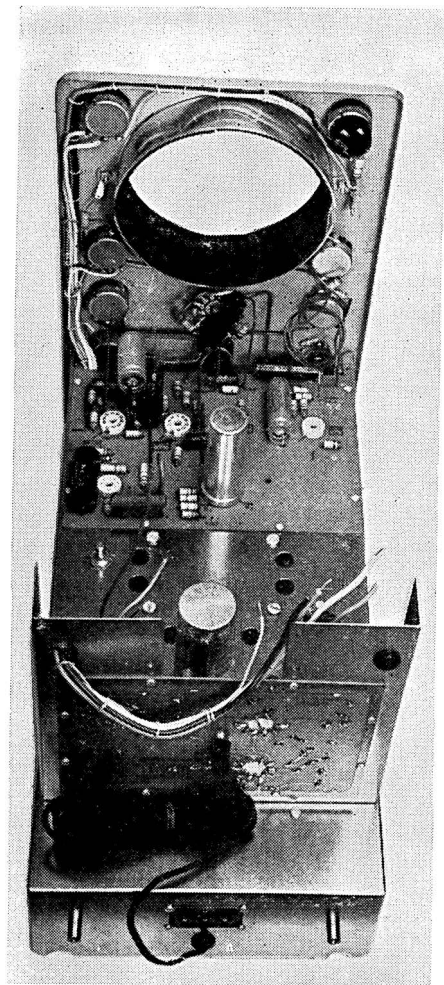

**Left: Nearly finished! Right: the tools for the job:** 25 watt Solon iron (24s.): Stanley hand drill (29/6d.): Set of small screwdrivers (5/6d.): Small vice (9/6d.): 2008 Stanley driver (5/3d.): 4BA and 6BA box spanners (each 4/9d.): 4-inch flat-nosed pliers 13043, (5/6d.): 4½-inch side-cutters 21123, (11/10d.): 5-inch long-nosed pliers 23107, (10/1d.): Bib wire-stripper (3/6d.): Clearance drills for 6BA, 4BA and ¼-inch (5/6d. the lot): Set of 6 Terry BA spanners (2/6d.): Postage 2/-.

forearm themselves with such a basic kit of bits. They should then add to it such items as resistors and capacitors most often used. Above all, before beginning any work at all, they should acquire a proper set of tools. A complete set is listed above.

Finally, and of absolute importance, those without soldering experience should spend two or three evenings doing nothing else—practising on all manner of components. For example, wafer switches, tag-strips, valve-holders, resistors and capacitors. Three

or four wire terminations at a single tag can cause hours of trouble-hunting if one of them is not electrically connected. Make it a rule to scrape the wires of capacitors and resistors between the lightly gripped blades of the side-cutters (this removes wax and film); and “tin” each one.

A booklet, “How to Solder” is in course of preparation (price 2/6d.) and will shortly be announced in the columns of “Hi-Fi News”. This small and well illustrated publication, which shows the fingers of an expert at work



in explanatory photographs, will undoubtedly save much home-built equipment many rail journeys between home and service depot!

Two useful suppliers to note, for readers who are remote from well-stocked shops, are (for the tools listed) **Buck & Ryan Ltd.**, 310/312 Euston Road, London, N.W.1, and (for selected components) **H. L. Smith & Co. Ltd.**, 287/289 Edgware Road, London, W.2. Before beginning to build, make sure that (a) everything quoted in a published com-

ponents list is available or (b) that it is in your possession. The best procedure, in cases of doubt, is to copy out the list and to send it to a supplier, such as H. L. Smith, with a request to supply or suggest alternatives—if possible sending the complete instruction booklet. The reason for this advice is that many items quoted by a designer are hard to get, and there are often much more easily obtainable substitutes—just as good, if not better, and often much cheaper.

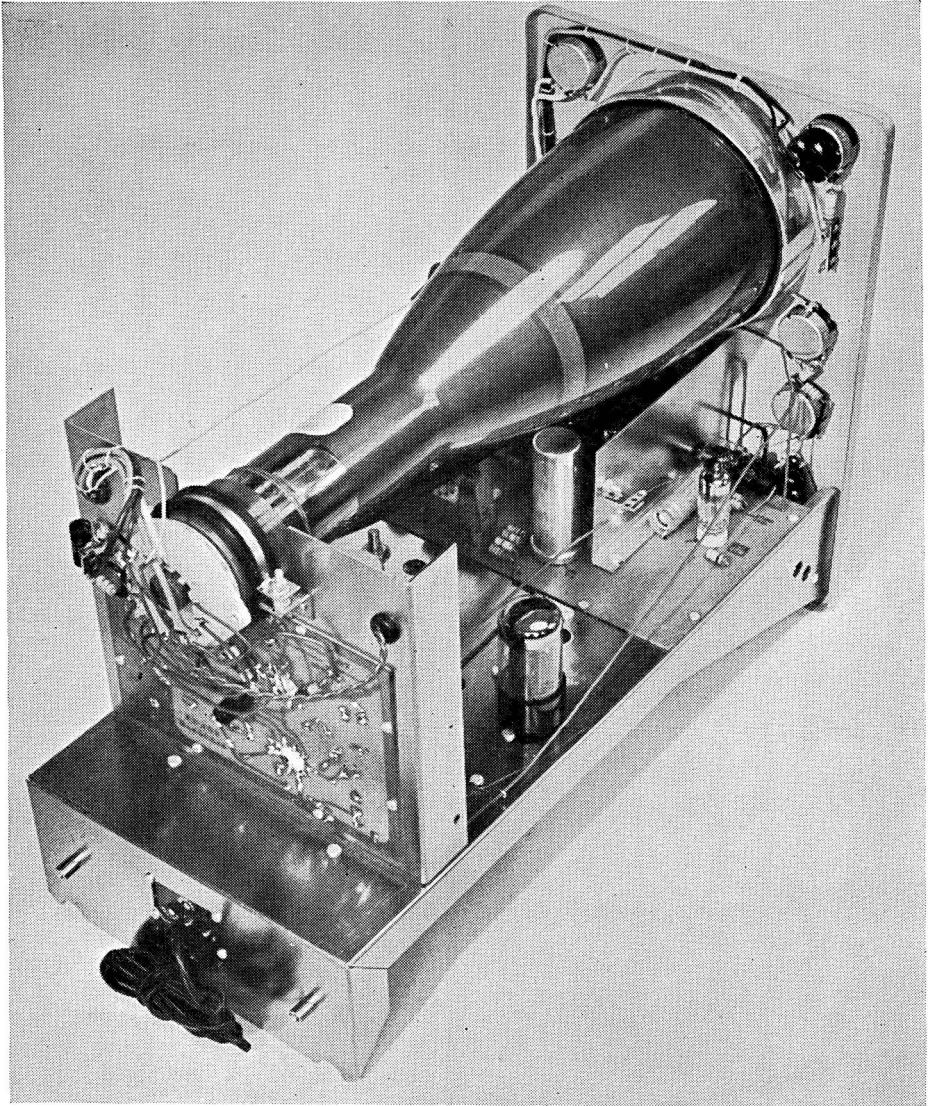

*Finished and ready for its case—but beginners should first try something more simple.*

# DIRECTORY OF CONSTRUCTIONAL KITS

**Altobass Ltd.**, Percy Road, Aylestone Park, Leicester. Tel.: Leicester 31616. Cables: Altobass, Leicester.

**Altobass Stereo 44 Amplifier.** Inputs: pickup, radio, tape, sensitivity 130 mV. Frequency response 20-20,000 c/s  $\pm 1$  dB H & N - 70 dB. Distortion 2.5% at 4 watts (1.5% at 3 watts). Separation better than 40 dB at 1,000 c/s. 4 watts each channel, 8 watts monaural. Output impedance 4, 8, or 16 ohms. Size  $11\frac{1}{2} \times 4\frac{3}{4} \times 9$  ins. Price £18 18s.



*Altobass Stereo 44 amplifier*



**Cossor Instruments Ltd.**, Cossor House, Highbury Grove, London, N.5. Tel.: Canonbury 1234. Cables: Cossor, London.

**1044K.** Valve voltmeter kit. Ranges A.C. volts 1.5, 5, 15, 50, 150, 500 and 1,500 volts R.M.S., full scale; 4, 14, 40, 140, 400, 1,400 and 4,000 volts peak-to-peak, full scale. D.C. volts 1.5, 5, 15, 50, 150, 500 and 1,500 volts full scale. Ohms 1, 10, 100, 1,000, 10K, 100K, 1 Megohm. Measures 0.1 ohm to 1,000 Megohms with internal battery. Size  $9\frac{1}{2} \times 5 \times 4\frac{3}{4}$  ins. Price £15 12s. 6d. Assembled £22 5s.



*Cossor 1044K valve voltmeter*

**1045K.** Single-beam Oscilloscope kit. Printed circuits. 4-inch tube. Y amplifier sensitivity 50 mV/cm, response 5 c/s to 3 Mc/s (30% down), rise-time 0.12 microsec. X amplifier sensitivity 0.75 V/cm, response 2 c/s to 275 Kc/s (30% down), rise time 1.4 microsec. Intensity modulation. 1 volt calibration source built in. Size  $14\frac{3}{4} \times 9 \times 18\frac{1}{4}$  ins. Weight 18 lb. Price £35. Assembled £45 2s. 6d.



*Cossor 1071K Double-beam oscilloscope*

**1071K.** Double-beam Oscilloscope kit. Printed circuits. 4-inch tube. Two Y channels, each sensitivities 0.5, 1.5, 5, 15 and 50 V/cm, response D.C. to 3 Mc/s (30% down), rise time 0.12 microsec. Pre-amplifier on Y giving sensitivities down to 5 mV/cm. X amplifier sensitivity 0.5 V/cm, response 0.5 c/s to 300 Kc/s (30% down), rise time 1.2 microsec. Intensity modulation. 10V, 1V and 10 mV calibration built in. Size  $15 \times 9 \times 18\frac{1}{4}$  ins. Weight  $20\frac{1}{2}$  lb. Price £49 17s. 6d. Assembled £60 10s.

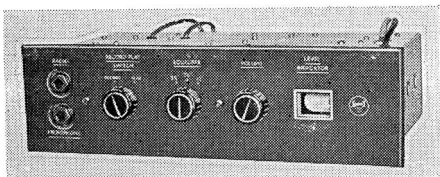

*Denco Type "C" tape pre-amp.*

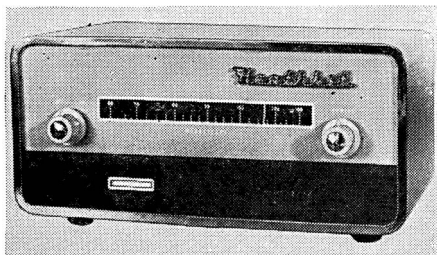

*Heathkit FM Tuner*

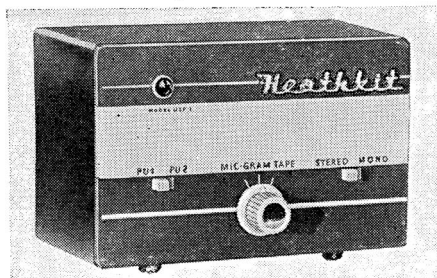

*Heathkit USP-1 booster amplifier*

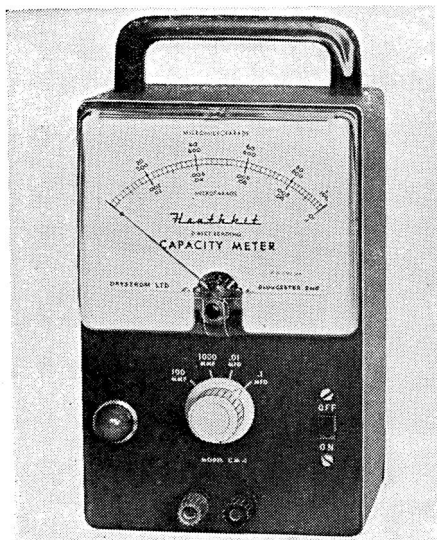

*Heathkit CM-1U capacity meter*

**Denco Distributors Ltd.**, 115 Fleet Street, London, E.C.4. Tel.: Fleet Street 5812. Cables: Dendistib, Fleet, London.

**Type C Tape pre-amplifier.** To Mullard design (see Tape Amplifier Section). Price £11 15s., power supply unit £2 15s. extra.

**HF/TR3.** Tape amplifier. To Mullard design (see Tape Amplifier Section). Price, with power supply unit, £12 15s.



**D.G.C. Ltd.**, 41 High Street, Camberley, Surrey.

**Oakhurst Doric Speaker Enclosure.** To house a single Goodmans Axiette 8 in. speaker. Cabinet available in whitewood or veneered finish. Size 30 × 11½ × 11½ ins. Price in kit form: £8 whitewood, £11 10s. veneered. Assembled: £10 10s. whitewood, £14 14s. veneered. 10% reduction when ordering stereo pair.



**Heathkit.** Manufactured by Daystrom Ltd., 900 Southgate Street, Gloucester, England.

**S-88.** Stereo amplifier kit. 8 watts per channel. Distortion 0.1%. Stability better than 10 dB. Response 30-20,000 c/s ± 2 dB. Inputs: pickup 20 mV, radio 200 mV, tape 400 mV. Push-button sel., bass, treble, filter, balance and reversing switch. Size 13½ × 5½ × 9½ ins. Price £25 5s. 6d. High sensitivity (4 mV) model S-88B £1 10s. extra.

**S-33.** Stereo amplifier kit. 3 watts per channel. Distortion 0.3%. Input 100 mV at 1 Megohm. Bass, treble, balance, volume. Price £11 8s.

**USC-1.** Stereo pre-amplifier. Inputs: pickup 1, 3-4 mV 50 K; pickup 2, 150 mV 1 megohm; tape 1, 2.5 mV 80 K CCIR, tape 2, 150 mV 100K; radio 150 mV; mic. 3 mV 1 megohm; aux., 4-150 mV 1 megohm. Controls: bass, treble, rumble filter, variable low pass filter, balance, volume, function, channel reverse. Power required: 250v 10 mA, 6.3v 1.5 amps. Output voltage 1.3 volts RMS. Price £17 19s. 6d.

**USP-1.** Booster amplifier. Suitable for stereo and monaural sources of low sensitivity, e.g. pickups, tape heads or microphones. Input sensitivity 2-20 mV. Output adjustable from 20 mV to 2 volts. Maximum gain 100. Power requirements 180-250 volts, 3-5 mA: 6.3 volts 0.5 amps. Price £5 19s. 6d.

**SSU-1.** Speaker system kit. Comprises 8 in. and 4 in. matched drive units, and ducted-port bass reflex cabinet. Response 40-16,000 c/s  $\pm$  5 dB, crossover frequency 3,000 c/s. Imp. 15 ohms. Size 23  $\times$  11 $\frac{1}{2}$   $\times$  11 $\frac{1}{2}$  ins. Price complete £11 16s., without legs, £10 9s.

**V-7A.** Valve Voltmeter Kit. Printed circuit. Measures A.C. volts (0-1.5, 5, 15, 50, 150, 500, 1,500) R.M.S., A.C. volts (0-4, 14, 40, 140, 400, 1,400, 4,000). Peak-to-peak, D.C. volts (0-1.5, 5, 15, 50, 150, 500, 1,500). Ohms (with 10 ohms centre)  $\times$  1, 10, 100, 1,000, 10K, 100K, 1 Meg. 0.1 ohms to 1,000 Megohms with internal battery. Input resistance 11 Megohms. Meter 200 micro-amps. Full scale deflection. Accuracy  $\pm$  3% full scale. Price £13.

**MGP-1.** Power supply unit. 200, 250, 270V 120 mA; 6.3V, 2.5A. Price £4 9s.

**OS-1.** Service oscilloscope kit. 2 $\frac{3}{4}$ -in. C.R. tube. Printed circuit. Vertical bandwidth 10 c/s to 2.5 Mc/s. Built-in calibrator. "Y" sensitivity 10 mV R.M.S. per cm. "X" sensitivity 1v R.M.S. per cm. Price £18 19s. 6d.

**O-12U.** General purpose oscilloscope Kit. 5 in. flat face C.R. tube. Printed circuits. Vertical bandwidth 3 c/s to 5 Mc/s. Built-in 1 volt calibrator. "Y" sensitivity 10 mV R.M.S. per cm. "X" sensitivity 0.12v R.M.S. per cm. Phasing control. Z-axis modulation. Price £34 15s.

**S-3U.** Electronic Switch (oscilloscope trace doubler). Converts a single beam oscilloscope to double beam. Switching rates 150, 500, 1,500, 5,000 and 15,000 c/s. Signal frequency response 0-100 Kc/s  $\pm$  1 dB. Signal input range 0.1 to 1.8 volts R.M.S. Price £9 18s. 6d.

**CM-1U.** Direct-reading capacitance meter. Uses a 4 $\frac{1}{2}$  in. meter with four ranges as follows: 100 picofarads, 1,000 picofarads, 0.01 microfarads and 0.1 microfarads. Price £14 10s.

**C-3U.** Resistance/capacitance bridge. Self-contained and powered. Capacitance range 0.00001 to 1,000 microfarads. Resistance range 100 ohms to 5 megohms. Power factor and leakage also indicated. Polarising voltages available from 5 to 450 volts. Price £7 19s. 6d.

**AV-3U.** Audio valve millivoltmeter. Measures voltages as low as 1 mV to a maximum of 300 volts at high impedance in 10 ranges.



*Heathkit S-88 stereo amplifier*

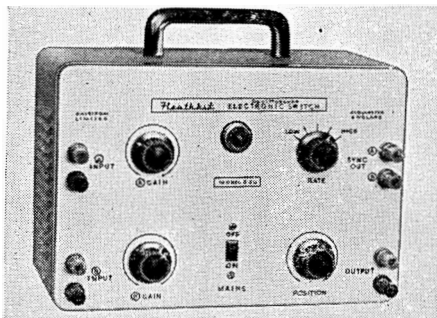

*Heathkit S-3U Electronic switch*

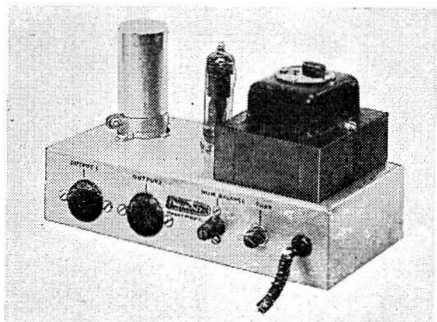

*Heathkit MGP-1 power unit*

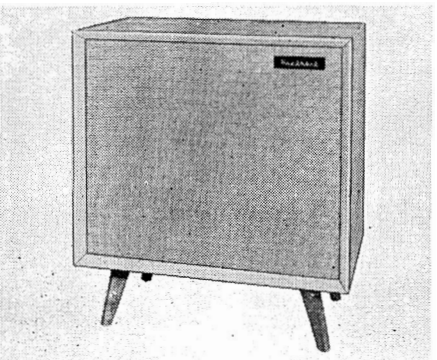

*Heathkit Cotswold speaker system*



Heathkit AG-9U Audio generator



Jason Audio generator AG10

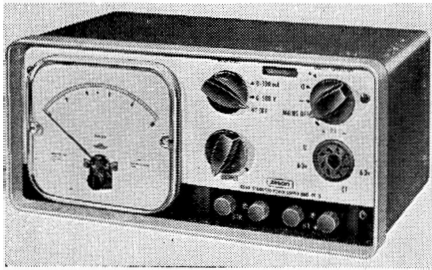

Jason PP 10 M stabilised power pack

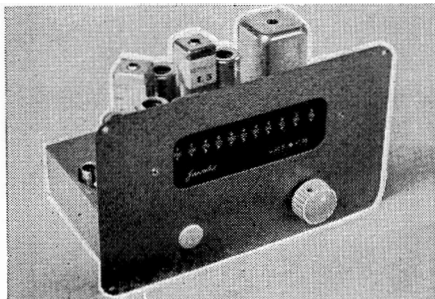

Jason FMT 1 FMT Tuner

Frequency range 10-400,000 c/s. Uses a  $4\frac{1}{2}$  in. meter. Cathode follower output. Price £13 18s. 6d.

**309-CU.** RF probe. Extends the range of a valve voltmeter to 100 Mc/s. Uses a printed circuit board. Price £1 5s. 6d.

**AW-1U.** Audio wattmeter. Uses external loads or the following internal loads: 3, 8, 15 and 500 ohms. 5 power ranges from 0.5 mW to 50 watts.  $4\frac{1}{2}$  in. meter calibrated in watts and dB. Price £13 18s. 6d.

**AG-9U.** Audio signal generator. Range 10 c/s to 100 Kc/s. Distortion less than 0.1% from 20 c/s to 20 Kc/s. Decade switching over 8 voltage ranges from 3 mV to 10 volts monitored. Uses  $4\frac{1}{2}$  in. meter. Price £19 3s.

**FM tuner.** Comprises model FMT-4U tuner unit and FMA-4U IF strip and power supply. Flywheel tuning, thermometer tuning indicator, three IF stages with two limiters, printed circuit board and pre-aligned coils. Tuning range 88-108 Mc/s. Sensitivity 2.5 microvolts for 20 dB quieting. Price £13 12s. 6d. (for both units).

**Cotswold.** High fidelity three-way loud-speaker. Drive units are 12 in. bass, 8 × 5 ins. elliptical, and pressure tweeter. Range 30-20,000 c/s. Two volume controls. Celotex lined enclosure. In white wood ready cut and drilled. Dimensions 26 × 23 × 14 $\frac{1}{2}$  ins. Price complete with crossover unit, etc. £19 18s. 6d.

**Chepstow.** Cabinet for hi-fi equipment. Space available for FM tuner, amplifier and record player. Dimensions 34 × 32 $\frac{3}{4}$  × 18 ins. Price £10 10s.

**Gloucester.** Cabinet for hi-fi equipment. Space available to house records, tapes, etc. Mk. 1 accommodates tape deck or record player, FM tuner, and stereo amplifier. Mk. II accommodates both tape deck and record player, FM tuner and stereo amplifier. Dimensions: length 46 $\frac{3}{8}$ , height 30, depth 21 ins. Price Mk. I £15 18s. 6d., Mk. 2 £17 8s. 6d.



**Jason Motor and Electronic Co.,** 3/4 Gt. Chapel Street, London, W.1. Tel.: Gerrard 0273/4.

**F.M.T.1 Standard F.M. tuner kit.** The original kit has been built successfully by many thousands of constructors. 4 valves only are used, giving an aerial sensitivity of better than 100 microvolts. A Ratio detector is combined with a limiter for low distortion and good noise rejection. Price without



valves and power supply £5 5s. Power Pack kit £2 1s. 9d.

**F.M.T.2.** This is the same unit as the F.M.T.1. but built into a shelf mounting case. Price, less valves, but with power supply £7 3s.

**F.M.T.3.** A fringe FM tuner with automatic frequency control. Two limiters combat the effects of aeroplane flutter and car interference. Price with case but less seven valves required, £8 5s.

**J.S.A.2.** Three watt amplifier kit. Three watts per channel are available from this simple kit which gives good results from such stereo pickups as the *Ronette* and *Acos*. 18 dB of feed-back is applied to the pentode section of the first amplifier which is an EFC80 while the triode section is used in the tone control circuit. Stereo balance control gives 5 dB variation each way. Price £13 19s. including all valves.

**JSP2.** Stereo pre-amplifier. A new design which will be available shortly features sufficient gain for tape heads and low output magnetic pickups. The output voltage of 2v is sufficient to drive any type of power amplifier. There is a built-in steep cut rumble filter. Price with five valves required £13 19s.

### Test Instrument Kits

**EM10 Valve Voltmeter.** The heart of this instrument is a four valve bridge circuit which was first published in *Wireless World*. The feed-back employed reduces the gain to unity but results in a very high input impedance low errors, and very small zero drift. Attention has been given to the diode probe circuits so that an accuracy of 3% is maintained on the lowest ranges. The input resistance on the 1, 5 and 10 volt D.C. ranges is extremely high being above 1,000 M ohm and on other ranges is 100 M ohm. The performance of this kit is as good as the most expensive valve voltmeter and considerably better than any other kit. A large clear 4½ in. scale meter completes this unit which is mounted in the standard case measuring 11½ in. x 5½ in. x 6½ in. deep. A cast surround protects the front of the instrument. Price £18 10s. Kit £23 built.

**AG10 Audio Generator.** A capacity tuned Wien bridge covers from 10 c/s to 100 Kc/s with excellent stability and low distortion while the output is held constant within 1 dB. Output impedance is 600 ohm from a

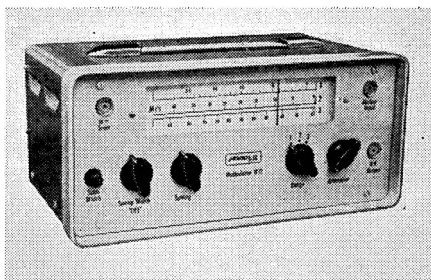

*Jason W11 Wobbulator*

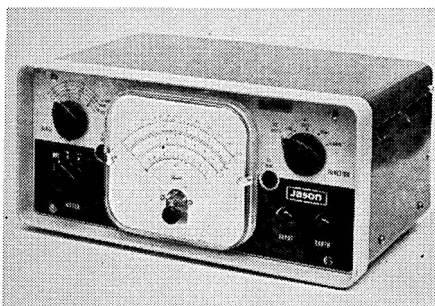

*Jason EM10 Valve Voltmeter*

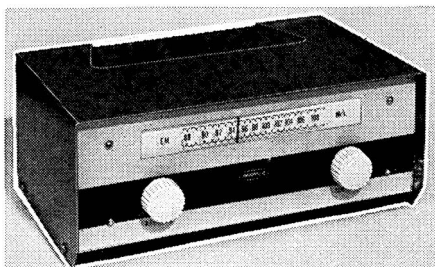

*Jason FM Tuner, FMT 3*

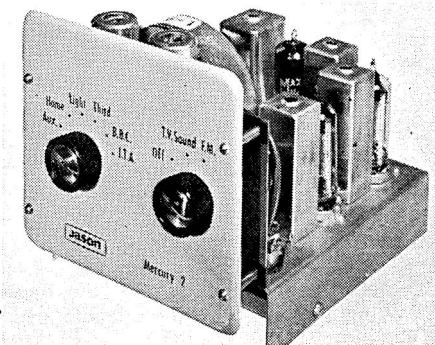

*Jason Mercury 2 FM/TV Tuner (see page 185)*

cathode follower and the Attenuator uses resistors of 1% accuracy. The rise time on square waves is better than 2 microseconds. Price kit £14 5s. Built £17 10s.

**AA10 Audio Attenuator.** Nine slide switches give the following attenuation. 40 dB, 20 dB, 20 dB, 10 dB, 10 dB, 5 dB, 2 dB, 2 dB, 1 dB, while the tenth switch allows the addition of a 600 ohm termination resistor. Resistors of 1% accuracy are used. The case measures 13 in. long  $\times$  2½ in. wide  $\times$  1 in. high. Price kit £6. Built £7 15s.

**CC10 Crystal Controlled Calibrator.** The exact frequency of a generator may be found by connecting the output to this crystal calibrator when the self-contained audio section and loudspeaker allow marker pips to be heard directly. These marker pips are generated at 10 Mc/s, 1 Mc/s, 100 Kc/s and 10 Kc/s so that generators in the range of 10 Kc/s to 250 Mc/s may be checked. The basic accuracy of .01% comes from a 1 Mc/s crystal oscillator. Price kit £16 19s. Built £21.

**P.P.10M Stabilized Power Packs.** (240v at 80mA) and **P.P.20M** (300v at 175 mA). A cascode amplifier feeds a series regulator valve giving a low output impedance of less than 1 ohm which is maintained over the voltage range of 250-350v in the case of the P.P.20M and 250-300 in the case of the P.P.10M. Prices P.P.20M kit £22 10s. Built £27 15s. P.P.10M kit £19. Built £23 15s.

**OG10 Oscilloscope.** This simple but excellent 2½ in. Oscilloscope has a sensitivity of 10 mV/cm with a bandwidth of 2 c/s-2 Mc/s. Sweep linearity is good and push-pull amplifiers are used on both X and Y. Price kit £22 10s.

**OG20 Oscilloscope.** A 1 in. ray tube gives a remarkably detailed indication. The time base covers from 30 c/s to 10 Kc/s while the amplifier has a sensitivity of 25 mV/cm and a bandwidth of 10 c/s to 50 Kc/s. Provisional price £12 19s.

**W11 Wobbulator.** This unit used in conjunction with the Oscilloscope OG10 or OG20 allows frequency response curves to be shown. It is suitable for all IF and RF alignment in TV and radio tuners. 50 c/s sine wave is used for scanning while the return trace is blanked to provide a reference base line. Price kit £14 19s. Built £19 19s.

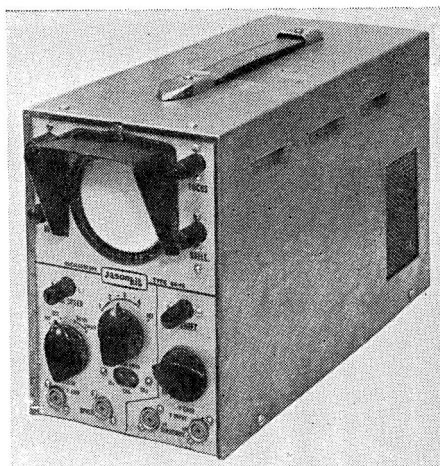

*Jason OG10 Oscilloscope*



*Jason CC10 Crystal Calibrator*



*Jason JTV2 TV sound tuner (see page 185)*

**H. L. Smith & Co. Ltd.,** 287/289 Edgware Road, London, W.2. Tel.: Paddington 5891/7595.

See Amplifier Section for details of the following kits:

**Cooper-Smith Mk.II Control Unit.**

**Cooper-Smith B.P.1. Amplifier.**

**Prodigy Combined Amplifier and Control Unit.**

**Cooper-Smith Stereo Control Unit.**

**Cooper-Smith Stereo Amplifier.**

# DIRECTORY OF MOTOR UNITS

IT may seem strange, at first sight, that there is so little annual change in the development and production of record playing units. However, upon reflection it is not surprising, because it is a very specialised corner of the industry, and those manufacturers who have been serving it for many years have established their products on the market, and are well able to cater for the rising demand. The Transcription Motor Unit is in many cases the "luxury product" from a factory whose main business is the production of many thousands of record changers each year.

## Accumulated 'Know-how'

It is because of the huge plant involved, and the years of accumulated 'know-how', that some of our British-made and world famous Transcription Units were originally able to emerge to meet the very exacting demands of a relatively few hi-fi customers. The styling of the record changer varies from year to year, taking in modifications as required. The transcription unit, which requires no frills or decorations, has merely to efface itself when the lid is closed on it, and to deliver its selected r.p.m. accurately and with an absolute minimum of wow, flutter and rumble. Any gadgets added to it would displease 100 users for every one they pleased.

Provisions for different record speeds are probably the only serious annual headache for the manufacturer of Transcription Units. In the whirligig days of 78 r.p.m. the scene

was comparatively tranquil, even if rumbly; but as hi-fi as we now know it was still in the future, motors were (generally speaking) just motors. The coming of the lp and ep discs simultaneously put the cat among two sets of pigeons. Three speeds were required, involving complications, and a far higher degree of smoothness was demanded from the more complicated product. But now, barely ten years after this revolution, there seems to be a good case for reverting to the single-speed Transcription Unit. Stanley Kelly remarked in this introductory note last year that some enterprising manufacturer might produce a two-speed-only turntable. Arnold Sugden has done so, with the new *Connoisseur* unit, and there is no doubt that his enterprise will be well rewarded. The next logical step would seem to be the 33½ r.p.m. unit—with the very considerable reduction in production costs that would follow, and the not unlikely improvement in performance that would result from reduced mechanical complications.

## High Quality Single-speed Unit?

There must be a very large and growing number of hi-fi enthusiasts who are even less interested in 45 r.p.m. discs than they are in 78's. For the customer who wants the lot, there are the established 3-speed models. For the newcomer, a single-speed transcription unit of high quality and reasonable price would surely be most welcome.

---

**Collaro Limited**, Ripple Works, By-Pass Road, Barking, Essex. Tel.: Rippleway 5533. Cables: Korllaro Telex, Barking.

**Transcription Unit, Model 4T200.** Four speeds. Complete with pickup arm and "Studio" TX88 head with turnover cartridge.



Collaro 4T200

Plays discs up to 16-in. diameter. Price £14 1s. 6d. (U.K. purchase tax £4 11s. 6d.)

**Transcription Unit Model 4TR200**, specification as for 4T200 but without the arm and pickup. Price £10 10s. (U.K. purchase tax £3 8s. 3d.)

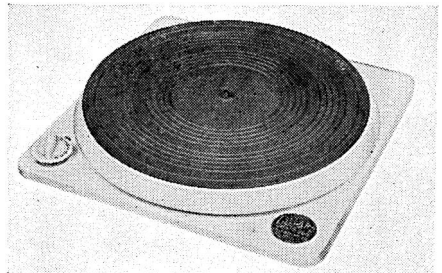

Collaro 4TR200



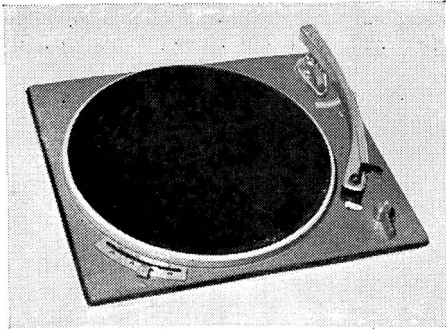

*Goldring-Lenco GL60*

**Garrard Engineering & Manufacturing Co. Ltd., Swindon, Wiltshire, England. Tel.: Swindon 5381. Cables: Garrard, Swindon.**

**Model 301 Transcription Motor.** Three speeds. Variable speed adjustment. Price £16 17s. 6d. (U.K. purchase tax £5 9s. 9d.)

**Stroboscopic Turntable,** extra cost, £1 3s. 6d. (U.K. purchase tax 7s. 7d.)

**Garrard 4HF.** Four speed record player complete with pickup arm. 12-in. pressed steel turntable. Rheostat speed control  $\pm 3\%$ . Automatic stop may be disconnected. Price with GC8 cartridge £13 19s. (U.K. purchase tax £4 10s. 9d.), with GMC5 cartridge £20 1s. 3d. (plus £6 10s. 6d.)



**Goldring Manufacturing Co. (Great Britain) Ltd., 486/488 High Road, Leytonstone, London, E.11. Tel.: Leytonstone 8343.**

**Lenco Transcription Unit GL58.** Infinitely variable speed adjustment with preselected stops for 16, 33 $\frac{1}{3}$ , 45, and 78 r.p.m. Groove location arm lowers pickup on to record as on/off is operated. Fitted with G.60 arm. Price £15 (U.K. purchase tax £4 17s. 6d.)

**Lenco Transcription Unit GL60.** Non-ferrous turntable, weight 8 lb. Infinitely

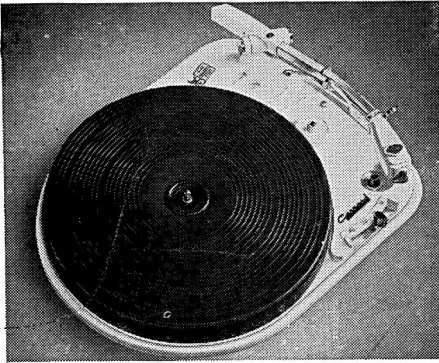

*Garrard 4HF*

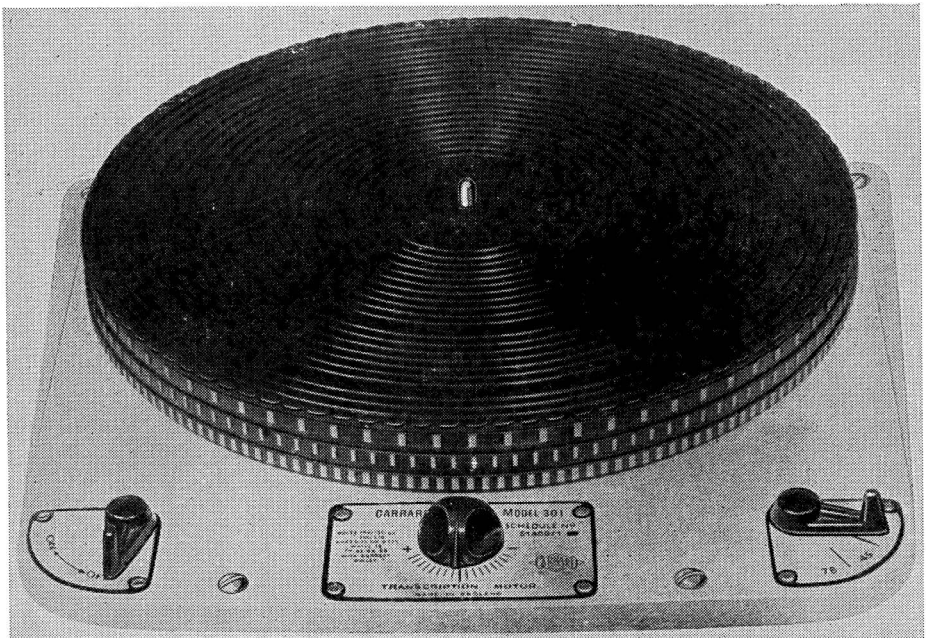

*Garrard 301 Transcription Unit with Stroboscopic turntable*

variable speed adjustment. Groove location arm. Massive centre spindle on nylon thrust bearing. Fitted with G.60 arm. Price £20 17s. (U.K. purchase tax £6 15s. 6d.)



**Philips Electrical Limited**, Century House, Shaftesbury Avenue, W.C.2. Tel.: Gerrard 7777. Cables: Phillamps.

**AG2005. High Fidelity Record Player.** Three speeds,  $33\frac{1}{3}$ , 45 and 78 r.p.m. Built-in stroboscopic indicator and speed control. Price £17 17s. 8d. (U.K. purchase tax £5 14s. 10d.)



**A. R. Sugden & Co. (Engineers) Ltd.**, Market Street, Brighouse, Yorkshire. Tel.: Brighouse 2142. Cables: Connoisseur, Brighouse.

**Connoisseur 2 speed stereo transcription motor.** Operates at  $33\frac{1}{3}$  and 45 r.p.m. fixed speeds. Full 12-in. turntable of non-ferrous material. All bearings are adjustable throughout the life of the unit. Synchronous motor. Price £12 10s. (U.K. purchase tax £4 3s. 1d.)

**Connoisseur Transcription Motor Type B.** Similar to the original model, but incorporating a large stroboscopic disc beneath the turntable, viewed through a mirror with an internal light source. Precision ground revolving shafts run in nylon graphite bear-

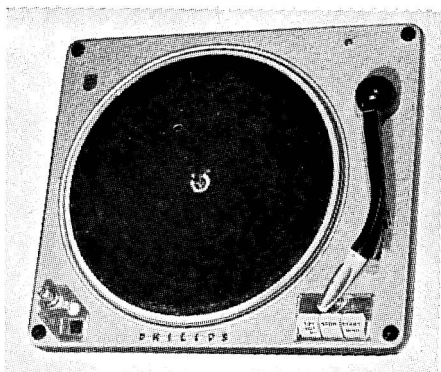

*Philips AG 2005*



*Connoisseur Type B Transcription motor*

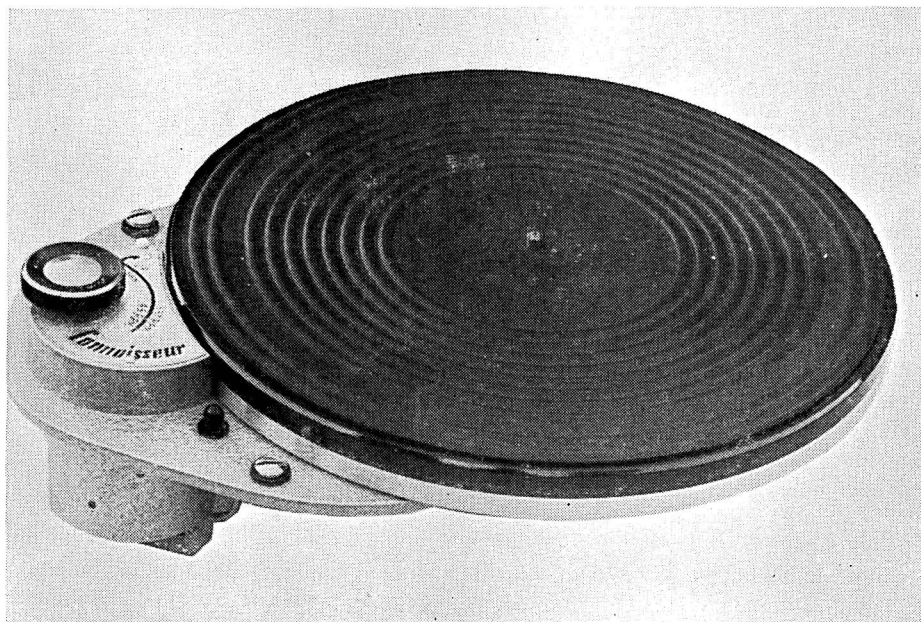

*Connoisseur 2-speed Stereo Transcription Unit*

ings, which are adjustable to maintain full accuracy throughout the life of the unit. Price £20 10s. (U.K. purchase tax £7 6s. 1d.)

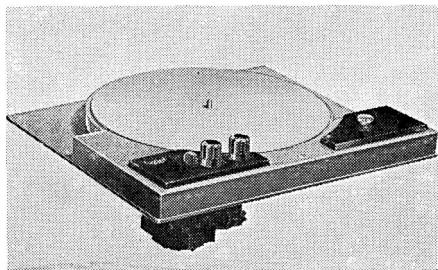

Woollett 3-speed Motor unit

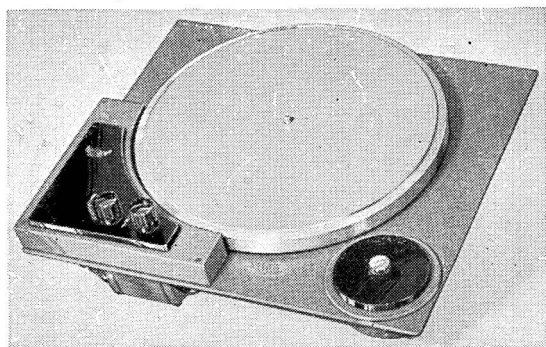

**3-speed Transcription Motor Unit**, fitted with accessory container. Price £17 17s. (U.K. purchase tax £7 2s. 5d.)

**4-speed Transcription Motor Unit**, with variable speed adjustment providing 8% variations on 78 and 3% on 16 $\frac{2}{3}$ , 33 $\frac{1}{3}$  and 45 r.p.m. Will accommodate any pickup on baseplate. Price as 3-speed model.

*Woollett 4-speed motor unit with speed adjustment.*

**Thorens.** Distributed in the U.K. by Technical Suppliers Ltd., Hudson House, 63 Goldhawk Road, London, W.12. Tel.: Shepherds Bush 2581, 4797. Cables: Teknika, London.

**Thorens TD124 Transcription Turntable.** Four speeds with "OFF" position of selector switch between each speed. Eddy current speed control  $\pm 3\%$ . Built-in stroboscope for four speeds at 50 and 60 c/s. Price £40 17s. (U.K. purchase tax £13 15s.)



**Woollett Sound & Wireless Equipment.** Distributed by Gramophone Equipment Manufacturers, Wells Park Road, London, S.E.26. Tel.: Forest Hill 2527.



Thorens TD 124 Transcription Turntable

# DIRECTORY OF PICKUPS AND ARMS

★ In the abridged specifications of this directory, the following abbreviations are used for economy of space: **S.r.u.**—Stylus can be replaced by user; **D.p.**—Downward pressure of stylus; **Cms**—Centimetres per second. ■ Denotes Stereo Equipment

**Bang & Olufsen**, Struer, Denmark. Sole U.K. importers: Aveley Electric Ltd., Ayrton Road, South Ockendon, Essex. Tel.: South Ockendon 3444.

**Orthophonic** balanced 8-pole variable reluctance pickup. Available as single stylus or dual stylus. Sapphire or diamond. Output voltage l.p. 100 mV; 78 200 mV. Range 20-16,000 c/s. D.p. l.p. 5-7 gm.; 78 9-12 gm. Load imp. 10-100 K. Price from £1 (U.K. purchase tax 6s. 11d.) single sapphire to £3 8s. 2d. (£1 2s. 8d.) dual diamond.

■ **Stereodyne 11** stereo magnetic pickup. Stylus 0.7 thou diamond. Output voltage 7 mV per channel at 5 cm/sec. Channel separation > 22 dB. Range 30-15,000 c/s  $\pm$  2 dB. D.p. 2-4 gm. Rec. load 47,000 ohms or higher. Price £7 7s.

■ **ST/L Arm and moving iron** stereo pickup complete. Diamond stylus 0.7 thou. Load imp. 47,000 ohms per channel. Output voltage 1.4 mV per channel. Range 30-15,000 c/s  $\pm$  2 dB. D.p. 3 gm. Price £13 7s. 9d. (U.K. purchase tax £4 9s. 3d.)

★

**Burne-Jones & Company Ltd.**, 18 Brunswick Road, Sutton, Surrey. Tel.: Vigilant 5050. Cables: Burjomag, Sutton.

■ **B.J. Stereo Cartridge**. Non-magnetic. Diamond stylus approx.  $\frac{1}{2}$  thou. Output voltage 200 mV. Range 30-12,000 c/s. D.p. 4-7 gm. Load imp. 2 Megohms. Price £3 0s. 0d. (U.K. purchase tax 19s. 3d.)

■ **B.J.-ELAC 210**. Magnetic stereo cartridge. Diamond stylus 0.5-0.7 thou. Output voltage 20 mV for 10 cm/sec. Range 30-15,000 c/s + 6 - 3 dB. D.p. 4-6 gm. Load imp. 1,500 ohms. Price £13 3s. 9d. (U.K. purchase tax £4 4s. 8d.)

■ **B.J.-ELAC 310**. Magnetic stereo cartridge. Diamond stylus 0.5-0.6 thou. Output voltage 15 mV for 10 cm/sec. Crosstalk better than 25 dB at 1,000 c/s, and 14 dB at 15 Kc/s. Range 30-15,000 c/s  $\pm$  2 dB. D.p. 3-6 gm. Load imp. 1,500 ohms. Price £16 12s. 6d. (U.K. purchase tax £5 6s. 8d.)

**B.J. Tan/11 arm**. Designed to overcome "tracking error". Total tracking error less

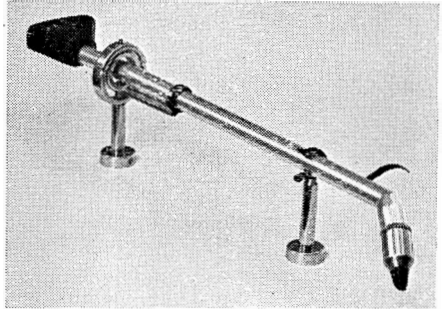

*B. & O. ST/L arm and Stereodyne pickup*

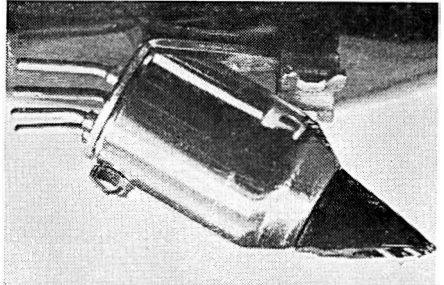

*B. & O. Stereodyne moving iron pickup*

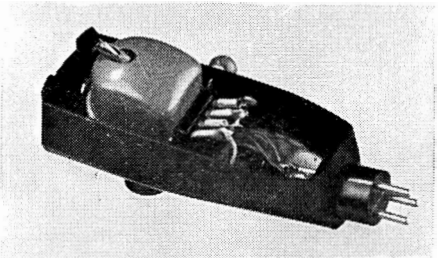

*B.J.-Elac 310 Stereo*

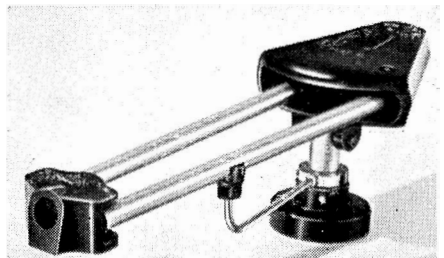

*B.J. TAN/11 arm*

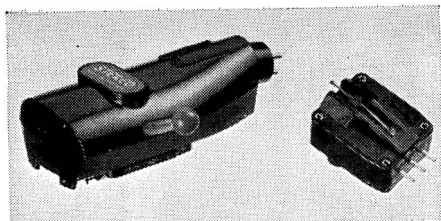

*B.J. Head and Stereo cartridge*

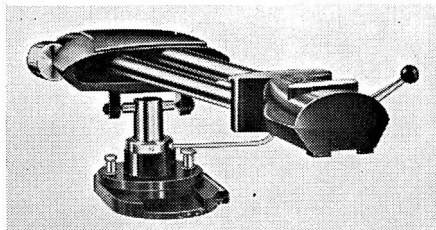

*B.J. Super 90 arm*

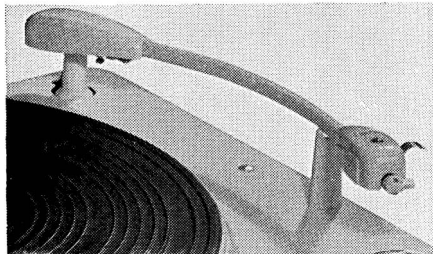

*Collaro Transcription arm*

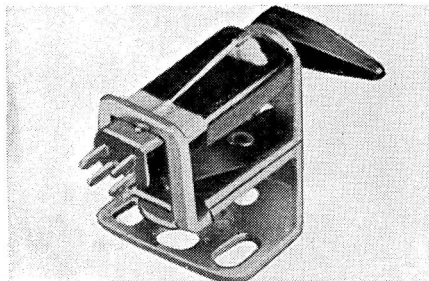

*Collaro Stereo Type C*

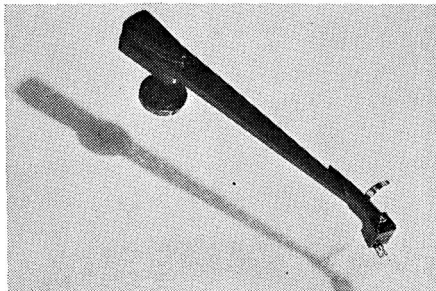

*Acos Black Shadow*

than 1 degree. Height adjustable. Price £3 3s. (U.K. purchase tax £1 0s. 3d.)

**B.J. Super 90 Mk II pickup arm.** Two models. 12 in. and 16 in. Price (including two plug-in-shells to carry standard cartridges) Super 90/12 in. £11 11s. (U.K. purchase tax £3 14s. 2d.); Super 90/16 in. £12 5s. (U.K. purchase tax £3 18s. 8d.)

**B.J. plug-in shell** for holding cartridges. Price 17s. 3d. (U.K. purchase tax 5s. 9d.)



**Collaro Ltd.,** Ripple Works, By-pass Road, Barking, Essex. Tel.: Rippleway 5533. Cables: Korllaro. Telex: Barking 28748.

**Studio O.** Turnover crystal cartridge. Output voltage 200 mV. Range 50-10,000 c/s  $\pm$  5 dB. D.p. 8 gm. Price with two sapphire styli £1 10s. (U.K. purchase tax 9s. 9d.)

**Studio TX88.** Turnover crystal cartridge. Output voltage l.p. 125 mV/cm/sec. at 1 Kc/s. Range 30-18,000 c/s. Load imp. 1 megohm. Price with two sapphire styli £1 15s. (U.K. purchase tax 11s. 8d.)

■ **"Studio" Stereophonic "Type C".** Turnover ceramic cartridge. Output voltage 50 mV. Price £2 5s. (U.K. purchase tax 14s. 8d.)

■ **Studio stereophonic Type R.** Turnover crystal cartridge. Output voltage 110 mV per channel  $\pm$  10 dB. D.p. 6 gm. Price including two sapphire styli £3 (U.K. purchase tax 19s. 6d.)

**Studio transcription arm** to play up to 16-in. records, suitable for turnover type cartridges. Price complete with "Transcription" cartridge £3 17s. 6d. (U.K. purchase tax £1 5s. 10d.)



**Cosmocord Ltd.,** Eleanor Cross Road, Waltham Cross, Herts. Tel.: Waltham Cross 5206. Cables Cosmocord, Waltham Cross.

**Acos GP65-1.** Turnover crystal cartridge. Output voltage l.p. 160 mV/cm/sec. Range 40-12,000 c/s, substantially flat. D.p. 8-10 gm. Load imp. 2 Megohms. Price £1 10s. (U.K. purchase tax 11s. 7d.). Diamonds available.

**Acos GP65-3.** High output version.

**Acos "The Black Shadow."** Complete arm and slide-on l.p. head. Output voltage l.p. 30 mV/cm/sec. Range 40-16,000 c/s  $\pm$  3 dB. D.p. 4-6 gm. Load imp. 100K ohms or



higher. Diamond stylus fitted. Price complete £4 17s. 2d. (U.K. purchase tax £1 17s. 6d.). 78 heads available.

**Acos GP67-1.** Turnover crystal cartridge. Output voltage 200 mV. Load imp. 2 Megohms. Range 30-14,000 c/s. D.p. 5-7 gm. Price 18s. (U.K. purchase tax 5s. 9d.)

■ **Acostereo 71-5.** L.p. only.  $\frac{1}{2}$  thou. stylus. Output voltage 140 mV. Load imp. 2 Megohms. Range 40-12,000 c/s. D.p. 3-4 gm. Price with diamond £2 (U.K. purchase tax 12s. 10d.)

■ **Acostereo 73-1.** Turnover crystal stereo/standard. Output voltage l.p. 150 mV. Load imp. 2 Megohms. Range 40-12,000 c/s. D.p. 3-4 gm. Price with sapphire £2 (U.K. purchase tax 12s. 10d.), diamond £3 7s. (U.K. purchase tax £1 1s. 6d.)

**Acopoise.** Pickup arm suitable for stereo cartridges. Recommended playing weight 4 gm. Price £1 18s. 6d. (U.K. purchase tax 12s.)

**Acos Hi-Light.** Ultra lightweight adjustable arm for stereo and mono. Plug-in heads. Sapphire styli 0.5 thou. Load imp. 2 Megohms. Output voltage 16 mV (mono), 30 mV (stereo). Range 20-20,000 c/s  $\pm$  3 dB. D.p. 1 gm (mono), 2 gm (stereo). Price with both heads £14 6s. 2d. (U.K. purchase tax £4 1s. 10d.)



**Decca Radio & Television,** Ingate Place, Queenstown Road, London, S.W.8. Tel.: Macaulay 6677.

■ **Decca fss.** Magnetic stereo pickup with slide on head. Diamond 0.5 thou stylus. Output 1.4 mV/cm/sec. r.m.s. per channel stereo 1 mV/cm/sec. mono. Response within  $\pm$  1 dB of R.I.A.A. characteristic. D.p. 3.5 gm. Load imp. 50,000 ohms. Price £15 18s. (U.K. purchase tax £5 2s.)

Also available: other heads, with 1 thou diamond for mono L.P.'s; with 2 $\frac{1}{2}$  thou diamond for 78's. Price (each) £8 5s. 9d. (U.K. purchase tax £2 13s. 3d.)



**Electronic Reproducers Ltd.,** Porters Wood, Valley Road, St. Albans, Herts. Tel.: St. Albans 50555. Cables: Saphobear, St. Albans.

**E.R.60.** Stereo ceramic cartridge. Turnover. Output voltage 140 mV. Range 40-12,000 c/s. D.p. 5-6 gm. Load imp. 1

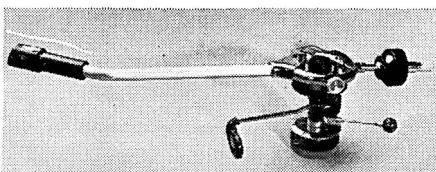

*Prototype Acos Hi-Light pickup arm*

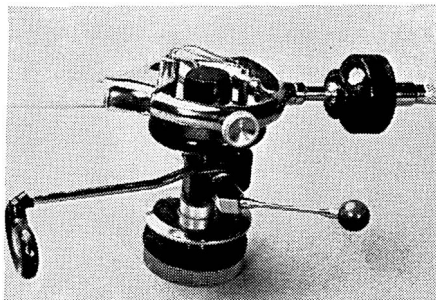

*Detail of Hi-Light Pivot*

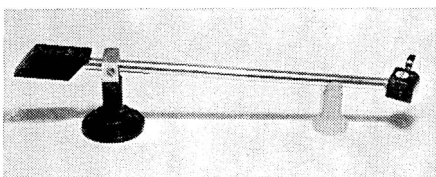

*Decca FFSS Stereo pickup*

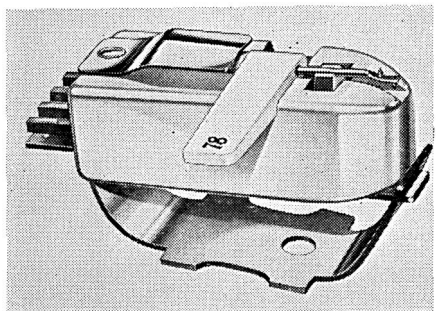

*E.R. 61 Crystal Stereo cartridge*

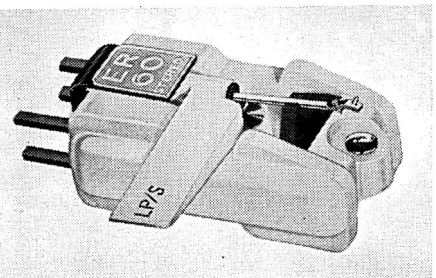

*E.R.60 Ceramic Stereo cartridge*

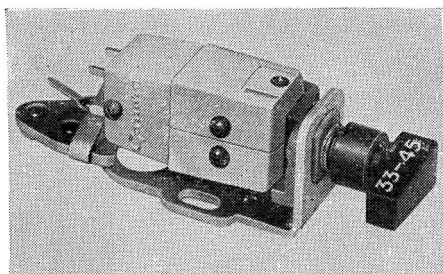

Garrard G.M.C.5 cartridge

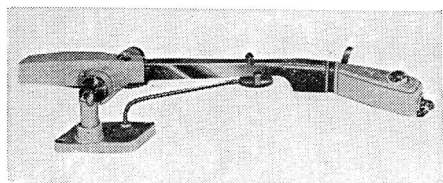

Garrard "TPA 12" pickup arm

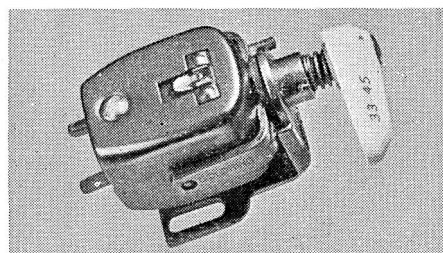

Goldring "600" cartridge

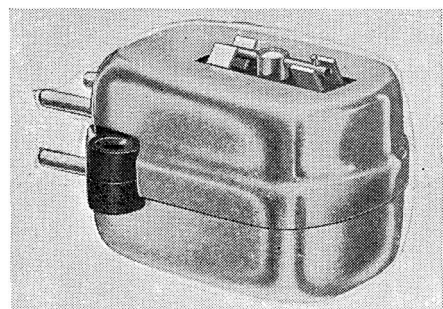

Goldring "700" stereo cartridge

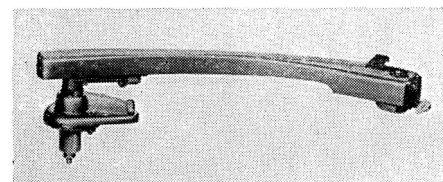

Goldring G60 pickup arm

megohm. Price £1 15s. 3d. with sapphire. (U.K. purchase tax 11s. 4d.). Diamond stylus available.

**E.R.61.** Stereo crystal cartridge. Turnover. Output voltage 170 mV. Other details as above. Price not yet available.



**Expert Gramophones Ltd.,** 39-41 New Oxford Street, London, W.C.1. Tel.: Covent Garden 2156.

**Pickup and arm.** Hard steel-pointed pivots for vertical and horizontal movements. Adjustments for tracking and stylus pressure. Moving coil pickup head. Also sold as separate plug-in head. Diamond styli for l.p. and 78, also thorn for 78. Output voltages l.p. 60 mV; 78, 80 mV (both at transformer secondary). Range 30-20,000 c/s  $\pm$  1 dB (diamond stylus). D.p. adjustable down to 3 gm. Load impedance 10 ohms (pickup only), transformer secondary impedance 250,000 ohms. Price, complete with diamond, £11 5s. (U.K. purchase tax £3 15s. 10d.); thorn £9 2s. (U.K. purchase tax £3 1s. 4d.); transformer £4 8s. Head supplied separately.



**The Garrard Engineering & Manufacturing Co. Ltd.,** Newcastle Street, Swindon, Wilts. Tel.: Swindon 5381. Cables: Garrard, Swindon. Telex: 44-271.

**G.M.C.5.** turnover moving coil cartridge. Separate coils attached to each stylus. Fitted with diamond l.p. and sapphire 78 styli. Output voltages with TP.1 transformer l.p. 0.008v; 78 0.03v. Range 20-16,000 c/s. D.p. 5 gm. Load imp. 0.5 Megohm min. across transformer. Price, inc. transformer £6 17s. (U.K. purchase tax £2 4s. 6d.)

**TPA.12** Transcription pickup arm with plug-in moulding to take almost all makes of cartridge. Price £3 7s. 6d. (U.K. purchase tax £1 2s.)



**Goldring Manufacturing Co. (Great Britain) Ltd.,** 486/488 High Road, Leytonstone, E.11. Tel.: Leytonstone 8343. Cables: Echovox London.

**"600."** Variable reluctance turnover cartridge  $\frac{1}{2}$  in. centre, mounting holes s.r.u. Diamond stylus for l.p. sapphire for 78. Output voltage 3.2 mV/cm/sec. Range



20-21,000 c/s  $\pm$  2 dB. D.p. 7 gm. Load imp. 68,000 ohms. Price £8 8s. (U.K. purchase tax £2 14s. 7d.)

“580.” Variable reluctance turnover cartridge. Diamond stylus for l.p. sapphire for 78. Output voltage 3.2 mV. Range 20-18,000 c/s. D.p. 6-7 gm. Load imp. 68,000 ohms. Price £4 4s. (U.K. purchase tax £1 7s. 4d.)

■“700.” Magnetic cartridge for stereo. Diamond stylus  $\frac{1}{2}$  thou. Output voltage 1 mV. Range 30-12 Kc/s. D.p. 4 gm. Load imp. 50,000 ohms per channel. Price £7 7s. (U.K. purchase tax £2 7s. 9d.)

■G60. Transcription arm wired for stereo. Incorporates new slide-in head that will accommodate most cartridges. Height adjustable and d.p. variable from 2 gm upwards. Price £3 (U.K. purchase tax 19s. 6d.)

TR.1 and TR.2 transcription pickup arms. TR.1 12 in., TR.2 16 in. Counter-balance weight adjustment from 2-12 gm. Adjustable height, ball races throughout. Price, TR.1, £8 8s. (U.K. purchase tax £2 14s. 7d.); TR.2, £9 9s. (U.K. purchase tax £3 1s. 5d.)

★

H. J. Leak & Co. Ltd., 57/59 Brunel Road, East Acton, London, W.3. Tel.: Shepherds Bush 1173. Cables: Sinusoidal, Ealux, London.

Dynamic pickup Mk. II. Moving coil, interchangeable heads, both with diamond stylus. Output voltages l.p. and 78, 8 mV (at transformer secondary). Range 40-20,000 c/s  $\pm$  1 dB. D.p. l.p. 3 gm, 78, 5 gm. Load imp. 50,000-100,000 ohms. Price, with two heads, £16 (U.K. purchase tax £5 19s. 9d.)

★

The Long Playing Record Library Ltd., Squires Gate, Station Approach, Blackpool.

Mackie “Delta” parallel tracking arm. Designed to eliminate tracking error. Side pressure less than 0.1 gm. Groove cueing scale and pickup lowering device. Total moving mass 35-40 gm. depending on cartridge used. Takes all standard cartridges and Decca ffs to special order. Height above turntable 3 in. Price £14 14s.

★

The Lowther Manufacturing Co., Lowther House, St. Mark's Road, Bromley, Kent. Tel.: Ravensbourne 5225. Cables: Lowther, Bromley.

L.P. pickup. Moving coil fixed head.

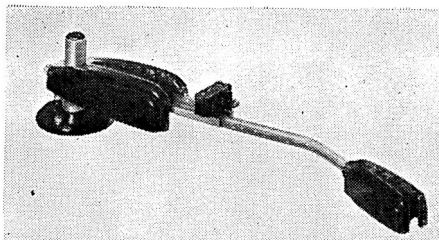

*Goldring TR.2 pickup arm*

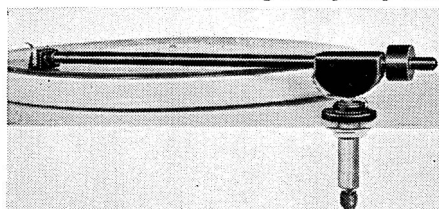

*Leak Dynamic arm and head*

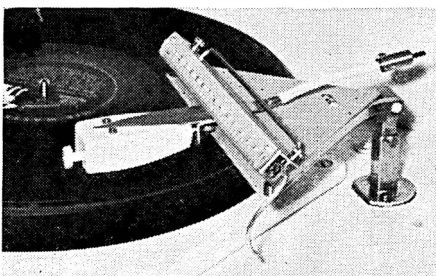

*Mackie “Delta” arm*

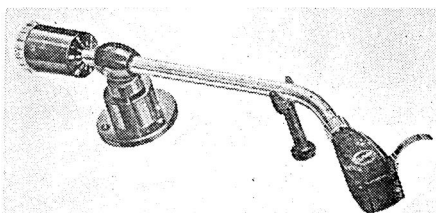

*Ortofon SSM 212 pickup arm*

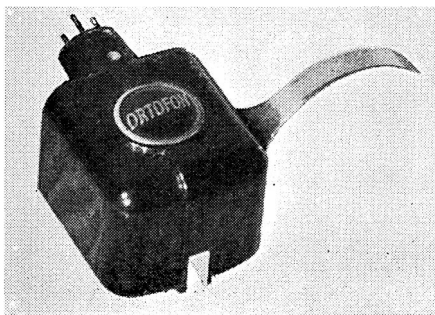

*Ortofon Type C mono head*

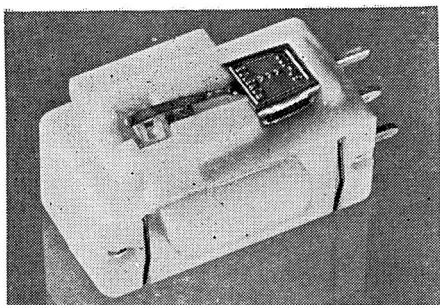

Ronette Binofluid BF40

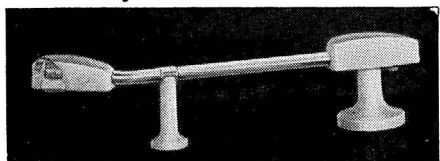

Ronette arm and pickup

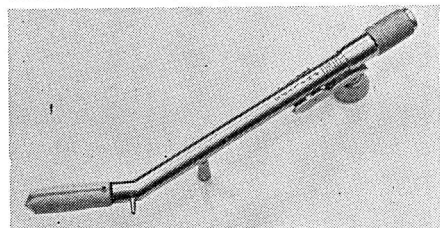

Philips NG.5400/S

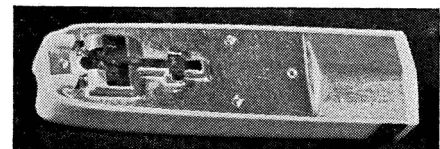

Philips AG.3060 stereo cartridge

Output voltage 10 mV. Range 20-20,000 c/s  $\pm$  2 dB. D.p. 4-6 gm. Imp. 25 ohms. Price with sapphire stylus £5 10s. (U.K. purchase tax £2 3s. 10d.); with diamond stylus £12 10s. (U.K. purchase tax £4 19s. 9d.)

**78 pickup.** Moving coil fixed head. Output voltage 18 mV. Range 20-20,000 c/s  $\pm$  2 dB. D.p. 6 gm. Imp. 25 ohms. Price, same as for L.P.

■ **In preparation:** a stereo moving-coil.



**Ortofon**, Fonofilm Industri A/S. Copenhagen. Distributed in the U.K. by Technical Suppliers Ltd., Hudson House, 63 Goldhawk Road, London, W.12. Tel.: Shepherds Bush 2581. Cables: Teknika, London.

**Type A.** Moving coil. Exchangeable

head with vertical coils. Diamond stylus. Output voltage l.p. 0.5 mV/cm/sec. Range 20-20,000 c/s  $\pm$  2 dB. D.p. 5-6 gm. Load imp. 2 ohms (transformer required). Price £7 5s. (U.K. purchase tax £2 8s. 11d.)

**Type C.** Moving coil as above. Diamond stylus. Output voltage l.p. 0.3 mV/cm/sec. Range linear 20-20,000 c/s. D.p. 3-5 gm. Load imp. 2 ohms (transformer required). Price £13 (U.K. purchase tax £4 7s. 8d.)

**Transformer** for use with above pickups. Price £2 7s. 6d.

■ **Type SCG.** Magnetic stereo pickup. Diamond stylus approx. 0.7 thou. Output voltage 0.5 mV. Range 20-20,000 c/s. D.p. 3-5 gm. Load imp. 2.5 ohms. Price £24 (U.K. purchase tax £8 1s. 9d.)

**SK 212.** Pickup arm with adjustable playing weight. Price £4 15s. (U.K. purchase tax £1 12s.)

■ **SSM212.** Pickup arm for stereo cartridges. Playing weight adjustable from 0 to 12 gm. Price £10 (U.K. purchase tax £3 7s. 4d.)



**Philips Electrical Limited**, Century House, Shaftesbury Avenue, W.C.2. Tel.: Gerrard 7777. Cables: Phillamps.

**AG.3025.** Crystal head fitted with diamond stylus. Output voltage approx. 0.5v. Load imp. 470,000 ohms. Price £3 0s. 6d. (U.K. purchase tax 19s. 6d.)

**NG.5400 Magnetodynamic.** Arm and moving magnet l.p. head fitted with diamond stylus. Output voltage approx. 25 mV. Range substantially linear 20-20,000 c/s. D.p. 0-10 gm. Load imp. 68,000-100,000 ohms. Price complete £14 6s. 2d. (U.K. purchase tax £4 11s. 10d.)

■ **AG.3301.** Crystal stereo pickup cartridge with turnover head. Sapphire styli. Output voltage 120 mV per channel. Load imp. 470,000 ohms per channel. Price £1 6s. 6d. (U.K. purchase tax 8s.)

■ **AG.3060.** Crystal stereo pickup. Diamond stylus. Output voltage 120 mV per channel. D.p. 4-6 gm. Load imp. 470,000 ohms per channel. Price £3 3s. 7d. (U.K. purchase tax £1 0s. 5d.) Sapphire AG. 3063 version also available.

■ **NG.5400/S.** Transcription arm fitted with crystal stereo pickup (Type AG 3060). Micrometer adjustment of playing weight and height variable. Diamond stylus. Output voltage 0.5v per channel. Range 30-12,000 c/s. D.p. 4-6 gm. Load imp.  $\frac{1}{2}$  Megohm per channel. Price £11 18s. 6d. (U.K. purchase tax £3 16s. 6d.)

**Ronette.** Sole U.K. Importers: Trianon Electric Ltd., 3 Violet Hill, St. John's Wood, London, N.W.8. Tel.: Maida Vale 2255.

**TX88.** Turnover crystal cartridge. Low effective mass. Output voltage 1 p. 125 mV/cm/sec. at 1 Kc/s. Response 50-20,000 c/s. Load impedance 1 Megohm. Clip in styli for easy replacement. Price with two sapphire styli £1 15s. (U.K. purchase tax 13s. 6d.)

**OV.** Stereo/OV turnover crystal cartridge. Sapphire styli. Output voltage 160 mV. Range 50-12,000 c/s. D.p. 5 gm. Load imp. 1 Megohm. Price £3 (U.K. purchase tax 19s. 6d.)

**Binofluid BF40.** Crystal stereo cartridge. Details as above. Price £2 10s. (U.K. purchase tax 16s. 3d.)

**Fonofluid/Binofluid.** Arm and stereo pickup complete. Sapphire stylus. Output voltage 160 mV. Range 50-12,000 c/s. Load imp. 1 Megohm. Price £6 (U.K. purchase tax £1 19s.)

**Ronette 105 & 106.** Stereo cartridge. Crystal turnover head. Sapphire styli. Load imp. 1 Megohm. Output voltage: Type 105, 250 mV; Type 106, 580 mV. Range 30-12,000 c/s. D.p. 5 gm. Price £3 (U.K. purchase tax 19s. 6d.) Diamond styli £1 1s. 6d. extra (U.K. purchase tax 7s. 6d.)

★

**F. & H. Schumann, GmbH.** Sole U.K. importers: G. A. Stanley Palmer Ltd., Maxwell House, Arundel Street, London, W.C.2. Tel.: Temple Bar 3721/3.

A range of crystal pickups, including the Schumann-Merula stereo cartridge Type STK490.

★

**Shure Brothers Inc.** U.K. distributors: J. W. Maunder, 95 Hayes Lane, Beckenham, Kent. Tel.: Beckenham 7413.

**M7D stereo dynetic cartridge.** Moving magnet. Diamond stylus 0.7 thou. Load imp. 47,000 ohms. Output voltage 5 mV. Range 20-15,000 c/s. D.p. 5 gm. Price not yet available.

**M3D stereo professional dynetic cartridge.** Moving magnet. Diamond stylus 0.7 thou. Load imp. 47,000 ohms. Output voltage 5 mV. Range 20-15,000 c/s  $\pm$  3 dB. D.p. 3-4 gm. Price not yet available.

**M212 studio stereo dynetic pickup.** Complete unit with moving magnet head. Dia-

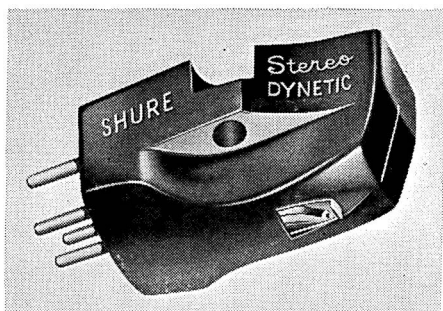

*Shure M7D Stereo Dynetic cartridge*

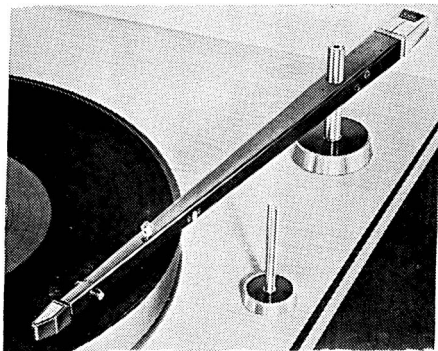

*Shure M212 Stereo Dynetic pickup*

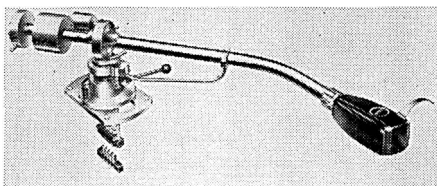

*S.M.E. 3009 pickup arm*

mond stylus 0.7 thou. Load imp. 47,000 ohms. Output voltage 4.5 mV. Range 20-20,000 c/s  $\pm$  2.5 dB. D.p. 1.5-2.5 gm. Price not yet available.

★

**S.M.E. Ltd.,** Steyning, Sussex. Tel.: Steyning 2228.

**3009 precision pickup arm.** Suitable for stereo or mono heads. Height and playing weight adjustable. Tone arm length (pivot to stylus) 9 ins. Foolproof arm lowering device. Four conductors plus screen. Price £18 15s. (U.K. purchase tax £6 5s.)

**3012 precision pickup arm.** Details as above. Tone arm length 12 in. Price £20 12s. 6d. (U.K. purchase tax £6 17s. 6d.)

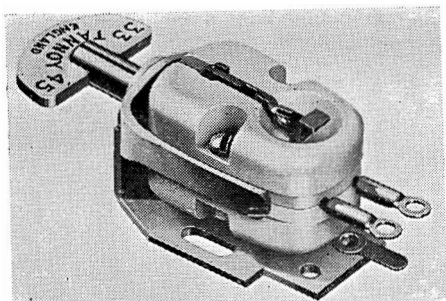

*Tannoy Variluctance cartridge*

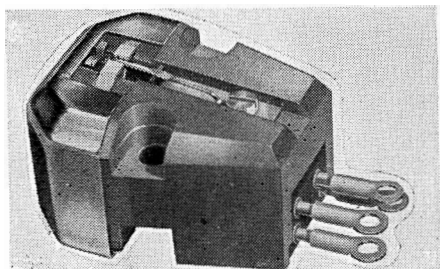

*Tannoy Vari-Twin Mk II*

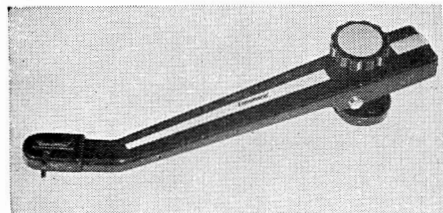

*Connoisseur Stereo CS1*

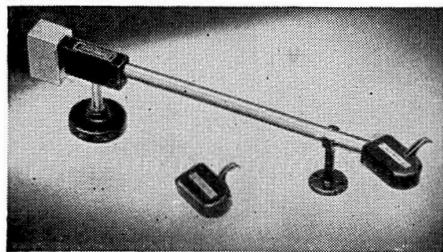

*Connoisseur Super Lightweight Mk. II*

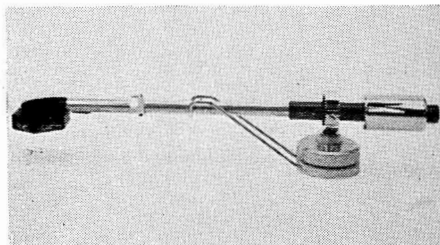

*Woollett pickup arm and head*

**A. R. Sugden & Co. (Engineering) Ltd.,** Market Street, Brighouse, Yorkshire. Tel.: Brighouse 2142. Cables: Connoisseur, Brighouse.

**Connoisseur Super Lightweight Pickup Mk. III.** Suitable for monaural and stereo heads. Height adjustable. Heads available: Mk. II monaural, magnetic, with choice of 1, 2.8, 3.5 thou. stylus; stereo ceramic with 0.5 thou. diamond stylus. Price arm only £3 (U.K. purchase tax 19s. 11d.)

■ **Connoisseur stereophonic Pickup Arm CS1.** Also suitable for monaural heads. Height adjustable. Pickup lifting device fitted. Price arm only £3 15s. (U.K. purchase tax £1 4s. 11d.), complete with stereo head £9 15s. (U.K. purchase tax £3 4s. 10d.)

■ **Connoisseur Stereo Head.** Ceramic cantilever system. Diamond stylus 0.0005/6 ins. radius. Output voltage 20 mV. Load imp. 50,000 ohms. Range 20-16,000 c/s  $\pm$  2 dB. Channel separation 20/25 dB. D.p. 3 $\frac{1}{4}$  gm. Price £6 (U.K. purchase tax £1 19s. 11d.)



**Tannoy Products Ltd.,** West Norwood, London, S.E.27. Tel.: Gipsy Hill 1131. Cables: Tannoy, London.

**Variluctance turnover cartridge.** S.r.u. Output voltages: l.p. 10-12 mV; 78 18-20 mV. Range 20-16,000 c/s  $\pm$  2 dB. D.p. 5-6 gm. Load imp. 50,000 ohms. Price, with 2 diamonds £12 (U.K. purchase tax £4 17s.); with 1 diamond and 1 sapphire £9 10s. (U.K. purchase tax £3 16s); with 2 sapphires £7 (U.K. purchase tax £2 16s. 7d.)

Single stylus version of Variluctance for l.p. also available. Price with diamond £6 15s. (U.K. purchase tax £2 14s. 7d.)

■ **Vari-twin Mk. II.** Magnetic stereo cartridge. Balance 4-pole system. Diamond stylus 0.5 thou. Output voltage 7 mV per channel. Range 30-15,000 c/s  $\pm$  1.5 dB. D.p. 4 gm. Load imp. 100,000 ohms. Inductance 350 mH. Price £9 19s. (U.K. purchase tax £3 7s.).



**Woollett Sound & Wireless Equipment,** Wells Park Road, London, S.E.26. Tel.: Forest 2527.

■ **Stereo Pickup.** Arm and moving-coil pickup complete. Diamond stylus 0.7 thou. Output voltage approx. 5 mV. D.p. 4 gm. Load imp. 100,000 ohms. Price £21 (U.K. purchase tax £4 13s. 1d.)

**Single Channel Pickup.** Arm and moving-coil pickup complete, or available with interchangeable heads. Diamond stylus. Output voltage: l.p. 10 mV; 78 8 mV. D.p. 4 gm. Range 20-18,000 c/s. Load imp. 100,000 ohms. Price £15 0s. 8d. (U.K. purchase tax £3 16s. 6d.)

## ACCESSORIES

**Auriol (Guildford) Ltd.**, 63 Shepherds Lane, Guildford, Surrey. Tel.: Guildford 66712.

**Auriol Pickup Control.** This unit eliminates accidental damage to the record by the stylus, the control provides air cushioned lowering and positive vertical lifting and lowering of the stylus. The supporting arm is serrated and calibrated for accurate positioning of the stylus at any pre-selected position within 1-2 microgrooves. Three cursors are provided to mark starting positions and an indexing clip is supplied to suit any specified pickup arm. U.K. price £3 3s., inc. purchase tax. Export price £2 15s.

**Auriol Pickup Control Mk. II.** This is dimensionally similar to the above but the arm will swing clear of the turntable to allow its use with the Autochanger/Manual player units. U.K. price £4 0s. 6d., inc. purchase tax. Export price £3 7s. 6d.



**Burne-Jones & Co. Ltd.**, 18 Brunswick Road, Sutton, Surrey. Tel.: Vigilant 5050. Cables: Burjomag, Sutton.

**Counterweight Unit.** The addition of this unit to a B.J. pickup arm permits speed and accuracy in weight compensation. The unit may be attached with or without standard weights supplied, and produces a total point pressure variation of approximately 4 gm. Price 12s. (U.K. purchase tax 3s. 11d.)

**B.J./Acos Adaptor.** This has been designed to accommodate Acos slide-on heads to the B.J. range of arms and those arms using standard 3-pin plug-in head fixing. Price 10s. (U.K. purchase tax 3s. 3d.)

**Alignment Protractor.** For measuring the tracking accuracy of all pickup assemblies. Made in plastic ivoryine. Price 7s.



**Cosmocord Ltd.**, Eleanor Cross Road, Waltham Cross, Herts. Tel.: Waltham Cross 25206.

**Acos Changer Dust Bug.** Developed in conjunction with Cecil Watts. Clips on to changer arms. Price 17s. 6d. (U.K. purchase tax 5s. 8d.)



**The Garrard Engineering & Manfg. Co. Ltd.**, Newcastle Street, Swindon, Wilts. Tel.: Swindon 5381. Cables: Garrard, Swindon.

**S.P.G.2.** Stylus pressure gauge, also includes a spirit level for checking the level of the turntable. Price 19s. 3d. (U.K. purchase tax 6s. 4d.)



*Auriol pickup control*

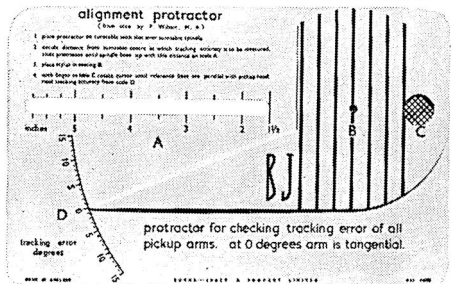

*B.J. alignment protractor*

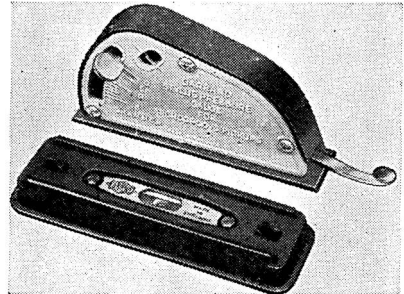

*Garrard S.P.G.2*



*The Rimington Clendisc and Fredorec*

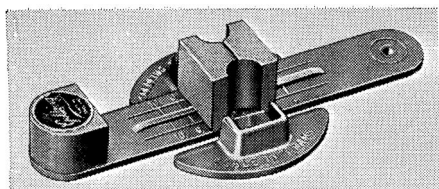

*The Goldring STB1*

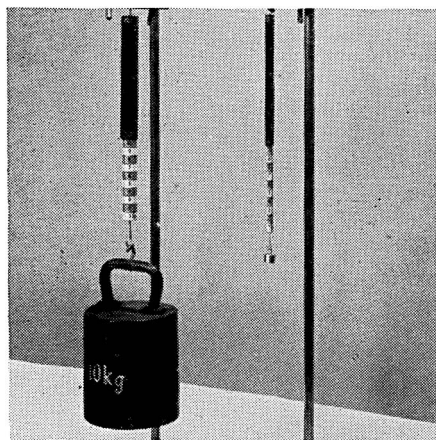

*Two examples of the Maey spring balance*

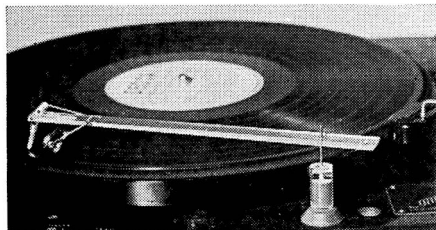

*The Dust Bug*

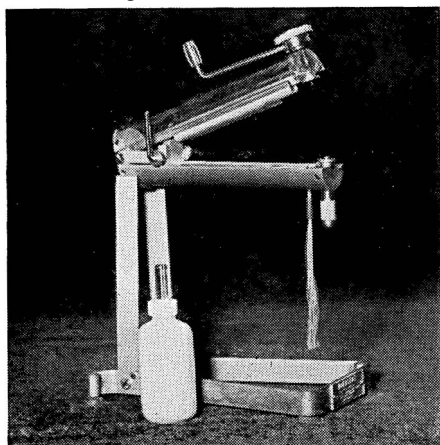

*The Parastat*

**Goldring Manufacturing Co. (Great Britain) Ltd.**, 486/488 High Road, Leytonstone, E.11. Tel.: Leytonstone 8343. Cables: Echovox, London.

**Anti-static Cleaning Pad.** Removes dust from records and is fitted with a detachable brush for keeping stylus clean. Price 4s. 6d. (U.K. purchase tax 1s. 6d.)

**STB.1.** Stylus balance, a simple yet accurate gauge which operates at record level. Stylus pressure is read directly in grams off the calibrated scale. Price 3s. 6d. (U.K. purchase tax 1s. 2d.)



**The Metro-Sound Manufacturing Co. Ltd.**, 19a Buckingham Road, London, N.1. Tel.: Clissold 8506. Cables: Metrosound, London.

**Stylometer.** 4-digit counter for recording the number of playings. Price, single unit, £2 5s., double unit £4.



**Rimington van Wyck Ltd.**, 42 Cranbourn Street, London, W.C.2. Tel.: Gerrard 1171.

**Clendisc.** An anti-static cleaner and preserver for all l.p. records, also suitable for 78s. Price 3s. 9d. and 6s.

**Fredorec.** A cleaning pad for removing dirt from all records. When used with Clendisc forms a perfect combination for record care. Price inc. purchase tax 3s. 4d.



**M. Tietze**, 25 Castellain Road, London, W.9. Tel.: Cunningham 2846.

**Maey Spring Balances.** A range of spring balances from 1 gm full scale up to 10 Kg. Prices from £1 9s. 6d. to £3 5s.



**Cecil E. Watts Ltd.**, Darby House, Sunbury-on-Thames, Middx.

**The "Dust Bug."** Claimed to be the most efficient method of removing all static and dust from records as they are played. Instantly fitted, suitable for all types of records. Record quality is improved, surface noise and wear reduced. Price 17s. 6d. (U.K. purchase tax 7s.) Note: A model suitable for use on autochangers is produced in co-operation with Cosmocord Ltd.

**The "Parastat."** For cleaning both sides of an l.p. disc simultaneously and making it inert to all static charges. Principally for trade use. Price Mk. II £18 10s. (U.K. purchase tax £6 3s. 4d.)

# AMPLIFIERS AND PRE-AMPLIFIERS

by George Tillet

THE trend towards integrated or self-contained amplifiers which was so noticeable a year or so ago is continuing, though it is only fair to say that the larger separate units are still holding their own. The picture is of course, quite different in America where, as far back as last March, more than 90% of all amplifiers sold were integrated units. In this country many people prefer to mount their hi-fi equipment in some sort of cabinet, thus nullifying some of the advantages of the free-standing type of presentation. Indeed, as pointed out in a recent leaflet: "*to mount some amplifiers in a cabinet it is often necessary to remove part of the decoration which contributed to the original attractiveness*".

Again, there is the question of ventilation. An amplifier dissipates a considerable amount of heat, and in many installations it is a definite advantage if the main units which contain the power supply and output stages can be mounted on the floor of the cabinet where they can receive maximum ventilation.

## Mono on the way out

Few purely monophonic amplifiers were made these days—in fact I do not know of any new single channel amplifier produced for well over a year. Manufacturers are taking the view that the minority who do not want stereo now will certainly do so later. This is often a question of economics, as there must be very few Hi-Fi enthusiasts or music lovers who are not convinced of the tremendous potentialities of stereo. True, there are a few unfortunates who have to be a little careful how and when to introduce the second speaker to the domestic scene—but that is another story!

As far as the general public is concerned, the initial response to stereo sound was, I believe, disappointing. This was due to the poor quality of most of the early crystal

pickups, the bad stereo and worse sound from some of the cheaper stereo radiograms, and the incredibly poor demonstrations given by many radio dealers who knew little about sound reproduction and cared less. Not all dealers place their loudspeakers among the washing machines and refrigerators, of course, and those who have fitted up a reasonable demonstration room have found their efforts well repaid. There will be an even greater interest from the general public when the BBC commence regular stereo transmissions—although what sort of noise will emerge from two giant-size 5-inch speakers (spaced about 15 inches apart in some of the cheaper sets) doesn't bear thinking about . . .

## The "Fi" has suffered

Let us not forget that many elaborate looking amplifiers sold as "*H-Fi*" are not what they should be either; and the advent of stereo, with the need for fitting two amplifiers into the space previously occupied by one, *plus* the necessity of keeping the cost down, did mean that some sacrifices had to be made. In some cases this meant that such features as low-pass filters, slope controls and pre-set input controls and rumble filters had to be dropped. This was bad enough, but one or two firms—in an attempt to keep the number of valves to an absolute minimum—succeeded in increasing the distortion several times higher than the equivalent single channel amplifier. Here they probably acted on the assumption that "you can get away with anything with stereo" (some speaker makers still appear to think so; especially in America where, if we believe the advertisements, the smaller the speaker system the better!).

However, the position is improving, and now that the stereo honeymoon is over and the trains and racing cars no longer race across the drawing room carpet, so listeners



are becoming more discriminating. It cannot be repeated too often that the same

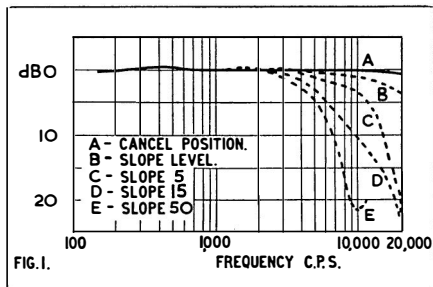

Fig. 1. Quad 22, showing effect of slope control at 5 Kc/s.

high standards which apply to ordinary Hi-Fi must also apply to stereo Hi-Fi. It is not possible to compromise with any link in the chain without affecting the result; and in the long run a really good single channel installation will give more lasting satisfaction than a poor quality stereo set-up.

#### Four Classifications

At the moment Hi-Fi amplifiers can be roughly divided into four groups as follows: (a) Self-contained, with ECL82 triode-pentode output stages giving 7 to 8 watts per channel. Price £28 to £40: (b) As above but with EL84 output stages giving some 10 to 12 watts per channel. Usually having high gain to permit direct operation from tape heads. Price £40 to £55: (c) Similar to B but with separate pre-amplifier or control unit, some having two power amplifiers to facilitate conversions. Price £45 to £60: (d) As above but capable of giving power outputs in excess of 15 watts per channel. Price from £45 upwards. The division is based mainly on power output and price, but it will be found that one or two amplifiers in the first section have many refinements normally associated with the larger amplifiers. The price categories refer to complete assembled amplifiers, and at least four firms (Altbass, Heathkit, Jason and Pye) are supplying equipment in kit form showing a saving of 25% to 40%.

#### A Revolution Awaited

Since 1945, when Harold Leak changed basic amplifier circuitry with the famous 'Point one', amplifier design has been far from static. Audio engineers such as Williamson, Baxandall, Ferguson of Mullard, Hafter and Keroes with the Ultra-Linear output stage, have all made a great contribution; but we are still waiting for really revolutionary improvements such as a practical trans-

formerless output stage. I say "practical" because such circuits have appeared regularly for more than 20 years but they either stipulate a high impedance speaker or they use a number of valves in parallel which consume an incredible amount of current!

#### The Opening for Transistors

Transistors with their low impedance are particularly suitable for this type of circuit, and a number of transistor portables use single-end push-pull output stages directly coupled to the speaker, which is usually of about 30 to 40 ohms impedance. Thus it is not unlikely that we will see transistors used in transformerless amplifiers in the not too distant future. The overwhelming majority of power amplifiers follow the conventional pattern of pentode stage, connected to a

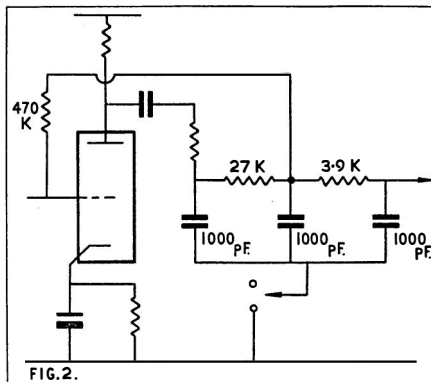
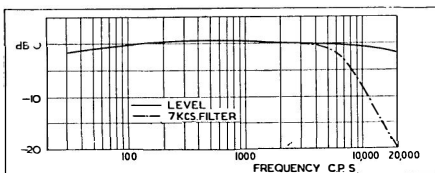

Fig. 2. Filter circuit of Beam-Echo SPA21.

Fig. 3. Effect of 7 Kc/s filter of Beam Echo SPA21.



cathode-coupled phase-splitter and an Ultra-Linear output circuit, using either EL84's or EL34's. Notable exceptions are the Pye Mozart with single end EL34's, and the Beam-Echo SPA21 which has a low-loading circuit with pentode connected EL84's.

Much ingenuity has been exercised in the design of control units or pre-amplifiers, and in particular many of the latest amplifiers feature remarkably efficient filter circuits. For the initiated it must be explained that much of the unpleasant distortion caused by record imperfections, bad radio trans-

missions, pickup deficiencies, tape hiss, etc., can be removed or at least minimised by restricting the higher frequencies. We cannot do this effectively with the ordinary treble controls because they normally operate from the middle of the scale at around 1,000 c/s; so not only would we remove the distortion, but most of the programme as well—a classic case of throwing out the baby with the bath water! Hence we have to use a special type of tone control called a filter which will attenuate the frequencies above 5 or 7 Kc/s without affecting the middle of the scale.

This is not quite as simple as it may appear, because if the attenuation is too sharp, or if there is a significant rise in frequency before the cut-off point, then transient 'ringing' or mutilation will occur which may even sound worse than the original distortion. So it is easy to see that the upper frequencies must be removed gradually, whilst preserving as much as possible of the musical values, and without introducing appreciable further distortion in the process.

### Filter Types

There are many varieties of filter in common use, including simple switched types cutting at about 7 Kc/s, those providing a choice of cut-off frequencies, variable types which attenuate progressively between 4 and 12 Kc/s, and switch filters combined with a slope control which varies the actual rate of attenuation. This latter method is used in the *Acoustical Quad 2* and *22*, and the rate of attenuation can be varied up to 35dB per octave from any selected frequency between 5 and 10 Kc/s.

Fig. 4. Filter circuit of Emisonic 555.

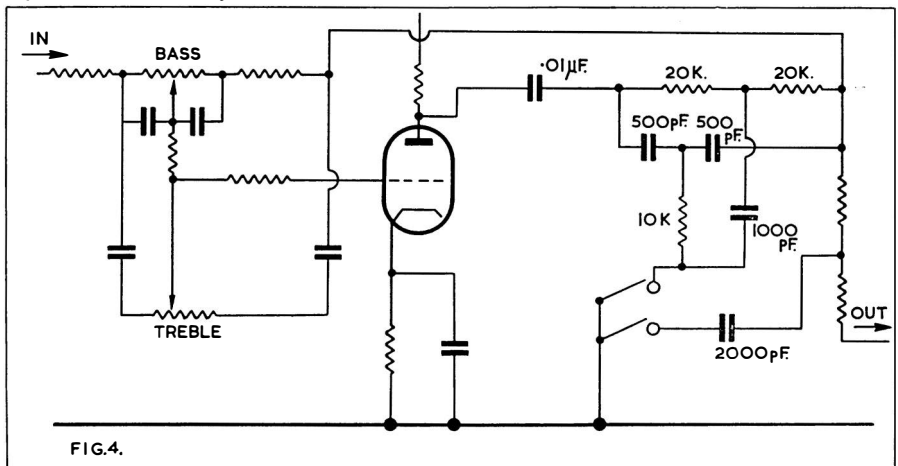

FIG.4.

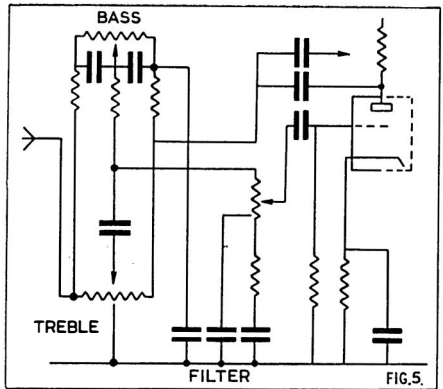

Fig. 5. Filter circuit of the Rogers HG88.

Fig. 1 shows the action of the slope control with the filter set to 5 Kc/s. The *Leak Varislope* series—including the new *Stereo Varislope* unit—also provide similar facilities although a 'bridged T' circuit is used instead of the tuned inductance method of the *Quad* amplifiers. An example of a comparatively simple circuit giving a single cut-off frequency of 7 Kc/s is shown in fig. 2. This is the *Beam-Echo SPA21*; and as the response curves shows, the rate of attenuation is about 12dB per octave (Fig. 3).

### The Unusual Emisonic Circuit

A more unusual circuit is used by the *Emisonic 555* (Fig. 4). This is a straight forward 'Bridged T' arrangement, but it is ingeniously combined with the Baxandall tone control system. The cut-off frequency is 7 Kc/s with an attenuation approaching 35dB per octave. Another example is provided by the *Rogers HG88* (Fig. 5). Here the filter

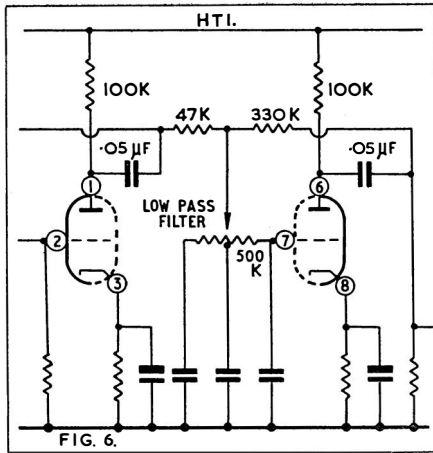

FIG. 6. Heathkit USC-1 filter circuit.

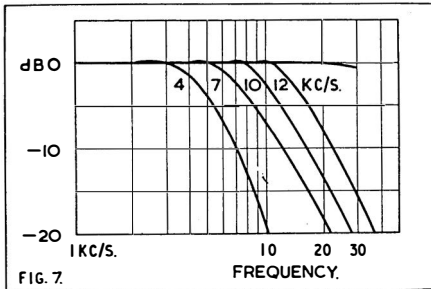

FIG. 7. Characteristics of Heathkit USC-1 filter.

control is continuously variable and is in the grid circuit of the tone control stage. The attenuation is about 14dB per octave between 5 and 15 Kc/s. Fig. 6 shows the filter circuit of the latest *Heathkit* control unit model USC-1. This is also a variable type and, like the *Rogers*, uses a special tapped control but it is connected in a separate feedback loop. As can be seen from fig. 7, the cut-off rate is approximately 18dB per octave.

Yet another circuit involving a Baxandall tone control system is shown in fig. 8. This is used by the new *Rogers Master* control unit and has some rather unusual features. The feedback loop X not only includes the filter but the cathode follower stage as well (V2). VRI is a slope control and SI is the filter switch giving a choice of 3 cut-off frequencies between 5, 7, and 9 Kc/s. This is used in the J2 Mk.III and gives a choice of two turn-over points at 6 and 9 Kc/s, as shown in fig. 9. The circuit is not unlike that of the *Beam-Echo SPA21*, but the attenuation is rather more gradual at 10dB per octave (see fig. 10).

The Baxandall tone control system as originally devised (Ref. *Wireless World*, Nov. 1952), provides no gain, as the amplification of the associated valve is entirely used as negative feedback, which is still appreciable even when both bass and treble controls are set for maximum lift. This means that the basic distortion of the system is extremely low—virtually unmeasurable in fact. However it is possible to decrease the feedback loop by 6 to 10dB or so without appreciably

FIG. 8. Filter circuit of the new *Rogers Master* control unit.

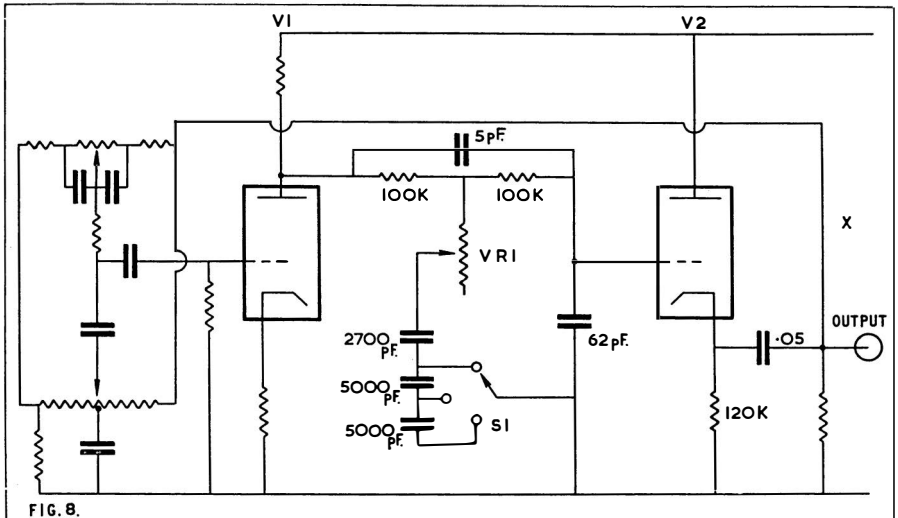

FIG. 8.

affecting the distortion, and thus to produce a gain of 2 or 3 which is very often worthwhile. This is effected in the *Pye 'Mozart'* and *Heathkit S88B* by changing the resistor and capacity values, and in the *Leak "point one"* stereo control unit by introducing what amounts to a parallel circuit.

Not long ago, high pass or rumble filters were regarded as almost a luxury as they were rarely required; in fact it was felt that the right way to deal with the problem of rumble was to buy a transcription motor. But stereo pickups with their inherent response to vibrations in the vertical direction have changed the situation entirely. I would go as far as to say that even the best transcription motor will produce an audible amount of rumble if used with a low output stereo pickup. Whether it is enough to be objectionable depends on the characteristics and size of the room, the response of the speakers to the lower frequencies, and also to the listening level.

Much can be done in this respect by mounting the pickup and motor as detailed by Gilbert Briggs and Ralph West in their recent articles; but I am convinced that an efficient rumble filter in the amplifier is most desirable. Ringing is not a problem at low frequencies, so our ideal filter should attenuate as sharply as possible below about 30 to 40 c/s. One of the best types is the "bridged T", as used in the "*Emisonic*" 399. Fig. 11 shows the extremely steep rate of attenuation. Fig. 12 shows a feedback type of filter used by the *Heathkit USC-I*. Here the cut-off rate is 18dB per octave below 50 c/s. A choice of 3 cut-off frequencies is provided by the new *Rogers Master* control unit—20, 60 and 120 c/s. The latter position is presumably intended for use with the cheaper record changers. Actually, many rumble filters which really consist of a simple series capacitor to attenuate from 100 c/s or even higher, and are thus open to serious objections (throwing out the baby again!).

### Problems of High-gain Amplifiers

Higher gain amplifiers have brought problems of hum and noise, and at least two—the *Jason J2 Mk.III* and the *Pye Mozart* use a DC supply for the heaters of the first stages (ECC83 triodes in both cases). Copper screens are used on the mains transformers of most self-contained amplifiers in order to restrict the stray field, and a common dodge is to reduce the heater voltage of the first stage so as to improve the signal-noise ratio. Metal rectifiers are being used in a number of amplifiers, particularly where their small size

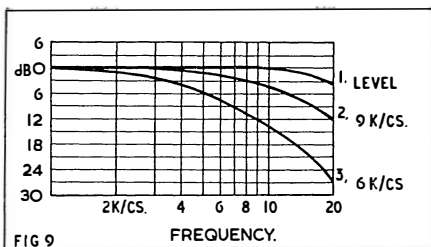

Fig. 9. Filter characteristics of the *Jason J2 Mk.III*.

is an advantage. These contact-cooled rectifiers are likely to be superceded by the new silicon types which are even smaller. Not only are they less than one fifteenth the size of an equivalent valve, but the voltage drop (and the temperature rise) is negligible. They can even be mounted in the wiring! Fig. 13 shows a typical example made by IRC, compared with a threepenny bit.

### The American Scene

And now for a very brief look at the American scene. Elaborate, high powered amplifiers are still the order of the day, although one or two small units boasting of but 6 or 8 watts have appeared. These are intended for

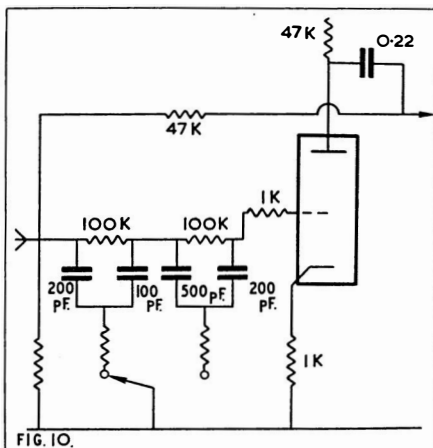

Fig. 10. Two position filter of *Jason Mk.III*

beginners, and most Americans go for outfits giving 40 to 100 watts or more. Apropos this question of power ratings, there still appears to be a certain amount of confusion over the method used, in spite of efforts by the *Heath* company, the *Institute of High Fidelity Manufacturers* and other organisations to establish a standard. One British amplifier, which is rated here at a mere 12 watts per channel, is advertised in America

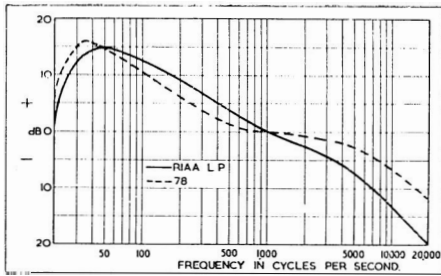
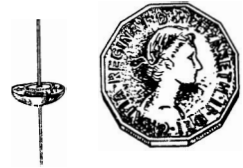

Fig. 11. Emisonic 399, showing action of rumble filter.

as a 50 watt model ! In other words the *rms* power output is multiplied by two in order to give a peak power figure. At present much publicity is being given to 3 channel stereo; but it must be said right away that the term is misleading, because what it amounts to is plain two channel stereo, plus the addition of a centre channel made up of a mixture of channel 1 and channel 2. This is advertised as "giving extra realism" and "removing that hole in the middle", etc., etc. The truth is that three genuine channels are better than two; in fact the more the merrier; but after the second channel further additions will produce smaller and smaller improvements, as might be expected. But what about the synthetic 3rd channel idea? Is it worthwhile? Reports from America confirm my own experiments, which indicate that if the speakers have to be positioned a long way apart, then a centre speaker *could* prove useful to iron out that "hole-in-the-middle" effect. But it will not give results as good as can be obtained from two correctly positioned speaker systems. The signal fed to the centre speaker must be at a lower level than that of the other two, and it is possible that a speaker of lower

efficiency can be used successfully. Some of the more expensive amplifiers have a separate output stage, complete with volume and tone controls; whilst others derive the centre

Fig. 13. Typical example of silicon rectifier.



channel from the outputs of the other two. Simply connecting a speaker from one output to the other would not work, because this would produce a *difference* signal instead of a *sum* signal; and in theory at any rate it would be inoperative on monophonic signals.

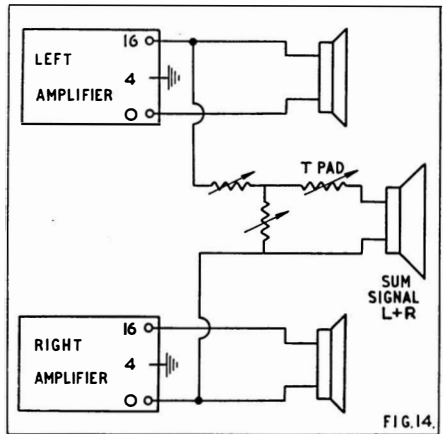

Fig. 14. Method used to obtain sum signal for a 3rd channel.

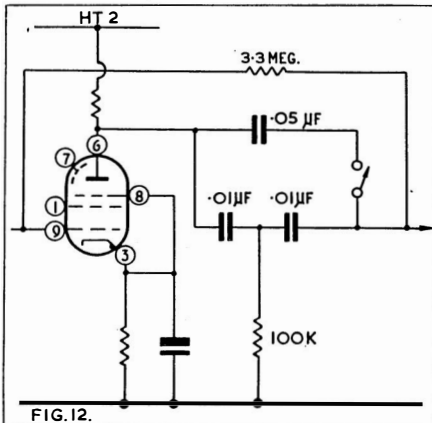

Fig. 12. Heathkit USC-1 rumble filter.

One method of obtaining the composite signal as used by *Knight, Pilot* and many others is shown in fig. 14. The centre taps of the output transformers are earthed, thus permitting a *sum* signal to be fed to the centre speaker. One *Pilot* model which uses this idea (the 30 watt "Model 240") also features an electronic cross-over which enables the bass to be fed to one channel and treble to the other for monophonic use. During the last few months there has been a marked increase in the amount of Japanese Hi-Fi equipment on the American market. Most of the amplifiers appear to be beautifully styled and have first-rate specifications. One of them gives a total output of 30 watts, uses 23 valves plus 4 germanium diodes, and covers the short, medium and FM bands. No doubt we shall be seeing such equipment soon, and may even be writing about it next year!

# DIRECTORY OF AMPLIFIERS & CONTROL UNITS

★ The following abbreviations are used in this directory section: H.D.—Harmonic Distortion; <—less than; H and N—Hum and Noise; P.a.t.—Power supplies available for tuner; R.M.S.—root mean square; N.L.—Noise level; Sel.—Selector switch; ■—Stereo equipment.

**Acoustical Manufacturing Co. Ltd.,** St. Peter's Road, Huntingdon, Hunts. Tel.: H'don 361 and 574. Cables: Acoustical.

**Quad II Q.C. II Control Unit.** Inputs: radio/tape 100 mV; mic. 1.5 mV; gram. to suit pickup. Treble, bass, vol. and on/off, filter slope. Switch filter 5, 7, 10 Kc/s and "out." Tape record socket, switched playback socket. H.D. <0.1%. H and N — 70 dB. Size  $10\frac{1}{2} \times 3\frac{1}{2} \times 6\frac{1}{2}$  ins. To operate with Quad II power amp or similar. Price £19 10s.

■ **Quad 22 Control unit.** Inputs: Radio/tape 70 mV at 100 K; mic. 1.5 mV at 100 K; pickup dependent on adaptor unit used, Vol. and on/off bass, treble, filter slope, filter switch 5, 7, and 10 Kc/s. Push-button selection of channels, mono/stereo, and record equalisation. H.D. <0.02% H and N — 70 dB total, P.a.t. 330v 35 mA each tuner, 6.3v 3 amps. Size  $10\frac{1}{2} \times 3\frac{1}{2} \times 6$  ins. Price to be advised. To operate with QUAD II amplifiers. Price £25.

**Quad II Amplifier.** 15 watts. Total 3rd harmonic and higher. <0.1% at 12 watts. Input for spec. output 1.4v. R.M.S. for 15 watts. Response 20-20,000 c/s.  $\pm 0.2$  dB; 10-50,000  $\pm 0.5$  dB. Feedback incorporated in original ultra-linear arrangement. N.L. — 80 dB at 15 watts. Out. imp. 7 and 15 ohms. Output KT66's. Original combined anode/screen current circuit. Size  $12\frac{1}{2} \times 4\frac{3}{4} \times 6\frac{1}{2}$  ins. To operate with QCII or Q22 control units. Price £22 10s.

★ **A.E.I. Sound Equipment Ltd.,** Crown House, Aldwych, London, W.C.2. Tel.: Temple Bar 8040. Cables: Soundequi, Estrand, London.

**Hi-Fi Control Unit Mk. 1.** Inputs: Mic. 5 mV; tapehead 5 mV; pickup 6 and 250 mV; Equalised tape 180 mV; radio 180 mV. 8-position sel., filter, bass, treble, volume and on/off. H.D. <0.05%. H. and N. — 86 dB. Size  $10\frac{1}{2} \times 3\frac{3}{8} \times 5\frac{1}{2}$  ins. Price £17 10s. To operate with BTH Hi-Fi Amplifier, or similar.

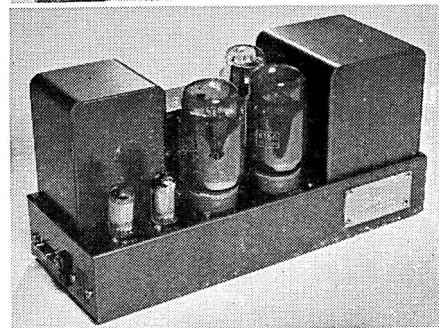
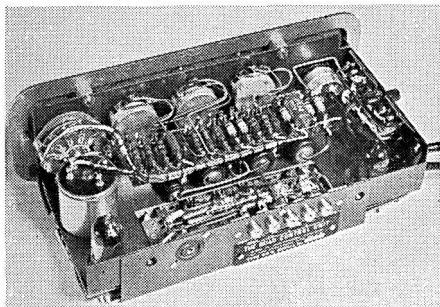
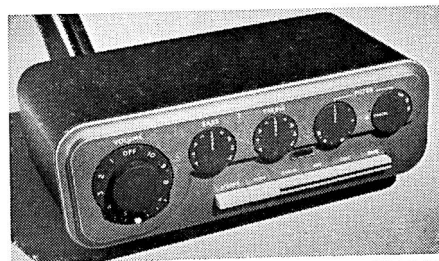

*Quad QC.II control unit  
Below, with the cover removed*

*Quad 22 stereo control unit  
Below, Quad II power amplifier*

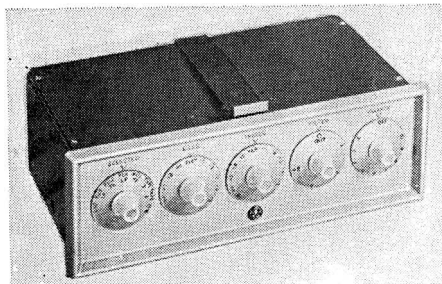

*A.E.I. Mk I control unit*

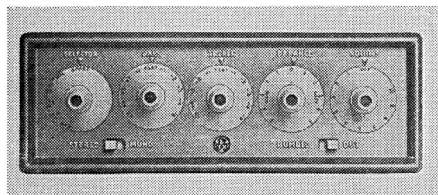

*A.E.I. stereo control unit*

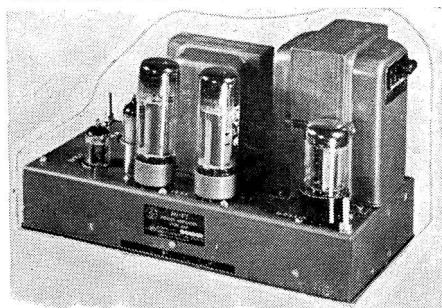

*A.E.I. Mk I power amplifier*

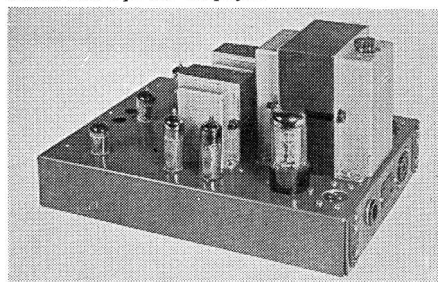

*A.E.I. stereo power amplifier*



*Altobass 510 control unit*

**Hi-Fi Power Amplifier Mk. 1.** 20 watts nominal, 30 watts peak. Dist. <0.05%. Input for 20 watts 100 mV. Response 20-20,000 c/s  $\pm$  1 dB. Feedback 24 dB. N.L. - 80 dB. Out. imp. 4, 8 and 15 ohms. Output EL34's. Ultra-linear. Size  $10\frac{3}{4} \times 5\frac{1}{2} \times 6\frac{3}{4}$  ins. Price £24 10s. To operate with BTH Hi-Fi Pre-amp. or as a pair with BTH Stereo Control Unit.

■ **Stereo Hi-Fi control unit.** Inputs: stereo and mono pickup, stereo tape, radio, mic. spare. 6 position sel. bass, treble, balance, vol., on/off. Rumble filter. H.D. less than 0.05% at 10 watts. H. and N. -85 dB. P.a.t. 400v 30 mA, 6.3v 3 amps. Size  $10\frac{1}{4} \times 5\frac{1}{2} \times 3\frac{5}{16}$  ins. To operate with B.T.H. stereo amplifier or two mono amplifiers. Price £24 9s.

■ **Stereo Power Amplifier.** 10 watts each channel, 15 watts max. Dist. less than 0.05% at 10 watts. Input for spec. output 100 mV. Response 20-20,000 c/s  $\pm$  1 dB. 24 dB feedback. N.L. -90 dB relative to 10 watts. Out. imp. 4, 8, and 16 ohms. Output EL84's ultra-linear. Size  $12\frac{3}{4} \times 10 \times 7\frac{3}{8}$  ins. To operate with B.T.H. stereo control unit or similar. Price £27.



**Airmec Limited,** High Wycombe, Bucks. Tel.: High Wycombe 2501.

■ **Airmec Stereo Amplifier and Control Unit.** 10 watts per channel. Distortion <0.2%. Response 20-20,000 c/s  $\pm$  0.5 dB. H. and N. -70 dB. Out. imp. 3.75 and 15 ohms. Inputs: pickup 1 20 mV at 100 K, pickup 2 400 mV at 1 M ohm, tape and radio 100 mV at 220 K. Selector switch, bass, treble, volume. P.a.t. 320v at 60 mA, 6.3 volts at 4 amps. Chassis size  $16\frac{1}{2} \times 15\frac{1}{4} \times 7\frac{1}{2}$  ins. 5-inch long control spindles. Price £33 10s.



**Altobass Ltd.,** Percy Road, Aylestone Park, Leicester. Tel.: Leicester 31616. Cables: Altobass, Leicester.

“**High Fidelity 510**” Control Unit. Inputs: tape/radio 100 mV; P/U (l.p.) 50 mV; P/U (78) 60 mV; mic. 10 mV. 5 pos. sel., treble, bass, vol. and on/off. Tape replay socket. H.D. 0.15%. H and N - 64 dB mic.; -71 dB on other inputs. Size  $10 \times 3\frac{1}{2} \times 4\frac{1}{4}$  ins. Price £8 8s. Sold only with 510 power amp.

“**High Fidelity 510**” Amplifier. 10 watts nom., 11 watts max. Dist. 0.1% (10 watts. at 400 c/s). Input for spec. output 40 mV. Response 15-20,000 c/s  $\pm$  0.6 dB. Feed-



back -20.5 dB. N.L. -78 dB relative to 10 watts. Out. imp. 3.75 or 15 ohms. Output EL84's. Ultra-linear. Size  $13\frac{1}{2} \times 5\frac{1}{2} \times 5\frac{3}{4}$  ins. Price £15 15s.

**Altobass Seventy Control Unit.** Inputs: Pickup 4 and 50 mV; Radio 250 mV; Tape 5 and 250 mV; Aux. 50 mV. 6-position sel., bass, treble, volume and on/off, switched high pass filter 100 c/s, switched low pass filter 5.5 Kc/s. H.D. 0.015%. H and N Tape -52 dB, others -56dB. Size  $10\frac{3}{8} \times 4 \times 4\frac{1}{2}$  ins. Price £16 16s. To operate with Altobass 510.

■ **Altobass Stereo 70 Control Unit.** Inputs: pickup 4 mV; radio 220 mV; tape 3 mV; mic. 5 mV; aux. 100 mV. 5-position sel., bass, treble, volume, function switch and on/off. H.D. 0.015%. H and N -54 dB. Rumble filter. Size  $13\frac{1}{2} \times 7 \times 3\frac{1}{2}$  ins. Price £24 3s. To operate with Altobass Twin Twelve.

■ **Altobass Twin-Twelve Stereo Amplifier.** 10 watts each channel, 12 watts max. Dist. 0.1% at 10 watts. Input for spec. output 150 mV. Response 20-20,000 c/s  $\pm 0.5$  dB. 20 dB feedback. N.L. -78 dB relative to 10 watts. Out. imp. 4, 8, and 16 ohms. Output EL84's. Ultra-linear. Size  $14\frac{1}{2} \times 7 \times 6\frac{3}{4}$  ins. Price £30 9s. To operate with Altobass Stereo 70 Control Unit.

■ **Altobass Twin II Amplifier and Control Unit.** Inputs: 200 mV for 2 watts per channel. 3-position sel., dual-concentric volume and frequency controls with on/off switch. H and N -56 dB referred to 2 watts. Size: Main amp.  $9 \times 6 \times 5\frac{1}{2}$  ins., Control Unit  $5 \times 3 \times 4\frac{1}{2}$  ins. Price £16 16s. complete.

■ **Stereo 44 Amplifier Kit**—See Kits Section.



**Armstrong Wireless & Television Co.,** Warlters Road, Holloway, N.7. Tel.: North 3213/4.

**Mk. II Control Unit.** Inputs: radio 80 mV; tape 80 mV; mic. 4 mV; gram. (4) 8-1200 mV. 4 pos. input switch; 6 pos. equaliser; treble, bass, vol. and on/off; 6 pos. switched filter. Switched tape input. H.D. 0.05% at 1,000 c/s at 180 mV. H and N better than -60 dB. Rumble filter. P.a.t. 320v at 35 mA; 6.3 at 2A. Size  $5\frac{1}{2} \times 9\frac{3}{4} \times 5\frac{1}{2}$  ins. To operate with A10 Mk. II power amp. Price £10 10s.

■ **PCU 21 Stereo Control Unit.** Inputs: Radio 180 mV, Tape 500 mV, Gram 1,000 and 280 mV, and 180 mV stereo, 3-position sel., function, bass, treble, balance, volume. H.D. 0.5%. H and N -66 dB. Size  $13 \times 4\frac{1}{2} \times 2\frac{1}{2}$  ins. Price £9 15s. To operate with amplifier A6.

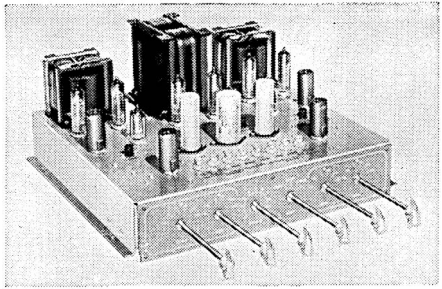

*Airmec combined stereo amplifier*

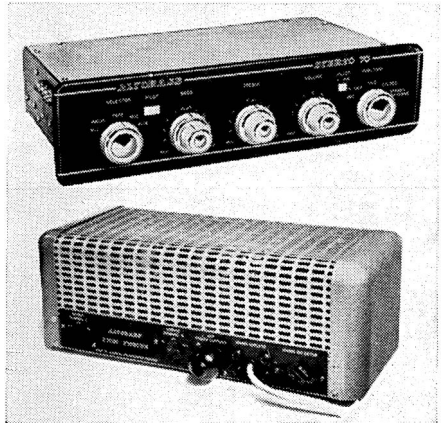

*Altobass Stereo 70 C/U and Twin 12 amp.*



*Altobass Seventy control unit*

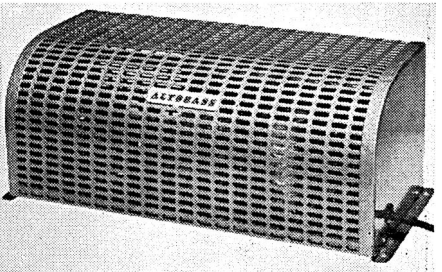

*Altobass 510 amplifier*

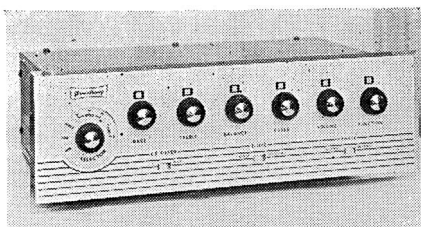

*Armstrong PCU 27 Stereo control unit*

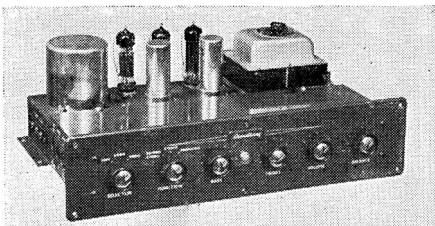

*Armstrong PCU 21 C/U and A6 amplifier*

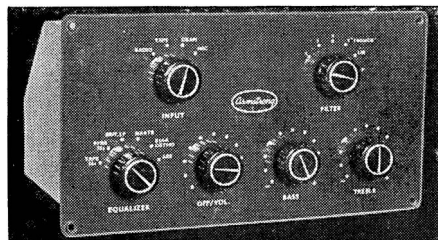

*Armstrong A10 Mk II C/U and amplifier*

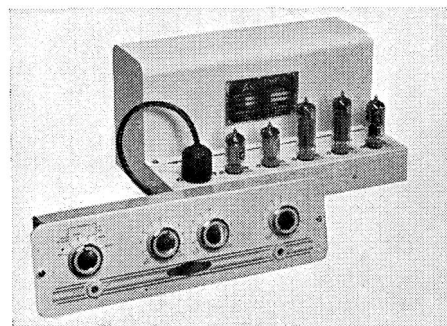

*Astronic A1332 control unit and A1333 amp.*

**RF125T. Tuner/Control Unit.** Inputs: radio, gram. 1.1 volts or 280 mV. Tuning, volume, bass, treble, wave change, on/off. Size  $15 \times 9\frac{3}{4} \times 9\frac{1}{4}$  ins. Price £22 10s. (U.K. purchase tax £7 4s. 4d.)

**A10 Mk. II.** 10 watts nominal, 20 watts max. Dist. 0.1%. Input for spec. output 400 mV for 10 watts. Response 15-30,000 c/s  $\pm 1$  dB. Feedback 28 dB. N.L. better than - 80 dB. Out. imp. 1, 3,  $7\frac{1}{2}$  and 15 ohms. Output EL34's. Ultra-linear. Size  $14 \times 8\frac{1}{2} \times 6\frac{1}{2}$  ins. To operate with Mk. II control unit. Price £21 10s.

**A6.** 6 watts. Dist. 0.5%. Input for spec. output 700 mV. Response 15-35,000 c/s  $\pm 2$  dB. Feedback 14 dB. N.L. - 70 dB. Out. imp. 3,  $7\frac{1}{2}$ , and 15 ohms. Output ECL82's. Size  $13 \times 3\frac{1}{2} \times 5$  ins. Price £9 17s. 6d. To operate with PCU21 Control Unit.

■ **PCU27 Stereo Control Unit.** Inputs: Auxiliary 2 mV. Microphone 2 mV. Radio 80 mV; Gram 1 80 mV, Gram 2 7 mV; Gram 3 3.5 mV; Tape 1 130 mV; Tape 2 2 mV. 8 position sel., bass, treble, balance controls, filter switch, slope switch, rumble filter, vol. phase, function. Tape outputs, stereo and mono. H.D. less than 0.1%. H and N - 62 dB. Power supplies required H.T. 300 volts at 8 mA. L.T. 6.3 volts at 2 amps. Size of front panel  $14\frac{1}{2} \times 4\frac{1}{2}$  ins. To operate with A10 amplifiers. Price £26 10s.



**Associated Electronic Engineers Ltd.,** 10 Dalston Gardens, Stanmore, Middx. Tel.: Wordsworth 4474/5/6. Cables: Astronic, Stanmore.

**Astronic A1332 Control Unit.** Inputs; mic. 20 mV; gram. A.E.S., FFRR, NARTB 10-20 mV; radio/tape 220 mV. 6 pos. sel., treble, bass, vol. and on/off, gram. input attenuator. Tape record and playback socket. H and N - 70 dB. Size  $12 \times 3\frac{3}{8} \times 1\frac{1}{2}$  ins. To operate with A1333 power amp. Price £9 10s. 6d.

**Astronic A1432 Control Unit.** Inputs: mic. 20 mV; radio 120 mV; P/U 4 mV or 20 mV; tape (C.C.I.R.) 1-2 mV. 6 pos. sel. (3 record equal.), treble, bass, vol. on/off. Filter 5, 7, 10 Kc/s. Slope 6-30 dB/octave. Loudness - 18 dB max. Presence + 6 dB, 2-3 Kc/s. Rumble filter. Variable P/U attenuator. Socket for direct replay from tape head. H.D. not measurable. H and N - 65 dB. Size  $11\frac{1}{2} \times 3\frac{1}{2} \times 5\frac{1}{4}$  ins. To operate

with A1333 or A1440 amplifiers. Price £21 19s.

**Astronic A1333 Amplifier.** 10 watts nom., 13 watts max. Dist. 0.1% at 10 watts. Input for spec. output 0.33v R.M.S. Response 20-20,000 c/s  $\pm$  0.5 dB. Feedback 18 dB N.L. — 72 dB. Out. imp.  $3\frac{3}{4}$ ,  $7\frac{1}{2}$  and 15 ohms. Output N709's or EL84's. Ultra-linear. Size  $11\frac{1}{2} \times 6\frac{1}{4} \times 6$  ins. To operate with A1332 control unit. Price £18 19s. 6d.

■ **Astronic A1434 Stereo Control Unit.** Inputs, single channel: tape 1-2 mV; l.p. (Int.) 4 mV; radio 120 mV; mic. 20 mV; aux. 120 mV. Stereo inputs for tape, P/U and radio same sensitivities. 8 pos. sel., bass, treble, vol., on/off, rumble filter, presence switch, channel balance (pre-set). Dist. negligible. H and N — 65 dB. Size  $11\frac{1}{2} \times 3\frac{3}{4} \times 6$  ins. To operate with amplifiers A1333 Mk. I and Mk. II or A1440. Price £22 5s.

■ **Astronic A1444. Combined Stereo Unit.** 4 watts. Dist. 2%. Inputs: radio, tape and L.P. discs. 150 mV; 78 discs. 350 mV. 4-position sel., bass, treble, volume and on/off. Out. imp. 3 and 15 ohms. Size  $11\frac{1}{2} \times 8\frac{3}{4} \times 3\frac{3}{4}$  ins. Price £24 3s.

**Atlas A1440.** 20 watts nominal, 35 watts max. Dist. 0.1%. Input for spec. output 0.25 volts. Response 20-20,000 c/s  $\pm$  5 dB. Feedback 30 dB. N.L. — 85dB. Out. imp.  $3\frac{3}{4}$ ,  $7\frac{1}{2}$  and 15 ohms. Output EL34's. Ultra-linear. Size  $13 \times 7\frac{1}{4} \times 8\frac{1}{2}$  ins. Price £37 16s. To operate with amplifiers A1332, A1432, and A1434.



**Beam-Echo Ltd.,** 13 South Molton Street, London, W.1. Tel.: Mayfair 1039. Cables: Hibeam, London.

**Avantic DL7 Control Unit.** Inputs: P.U.1 4-6 mV; P.U.2 40-60 mV; P.U.3 55 mV; tuner 1:100 mV; tuner 2:500 mV; aux. 1:2 mV; aux. 2:20 mV; tape 100 mV. 8 pos. sel., treble, bass, vol. and on/off, loudness. Switched filter 5, 10 and 20 Kc/s. 3-pos. monitor/record switch. Tape record and playback sockets. H.D. <0.1% for 200 mV and <0.2% for 2.0v. H and N, radio and tape — 64 dB; pickup — 53 to — 56 dB; aux. 1 — 45 dB. Roll-off freq. 40 c/s. Slope 12 dB/octave. P.a.t. 200v at 30 mA, 6.3v at 2.5A. Size  $11 \times 4 \times 7$  ins. Price £22.

**Avantic DL7-35 Amplifier.** 35 watts r.m.s. continuous. Dist. 0.05% at 20 watts. Input for spec. output 250 mV for 27 watts. Response 5-30,000 c/s  $\pm$  0 dB, 2-100,000 c/s  $\pm$  1 dB. 30 dB feedback. H and N — 89 dB

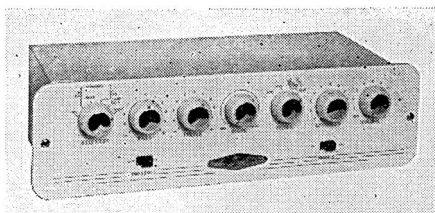

*Astronic A1432 control unit*

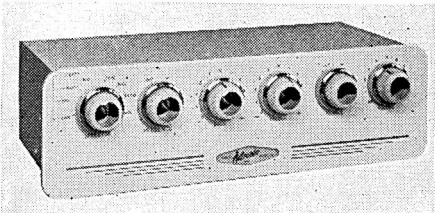

*Astronic A1434 stereo control unit*

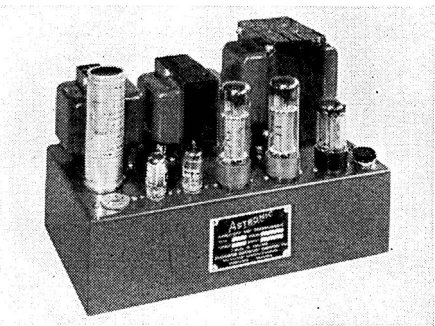

*Astronic Atlas A1440 amplifier*



*Astronic A1444 complete stereo amplifier*

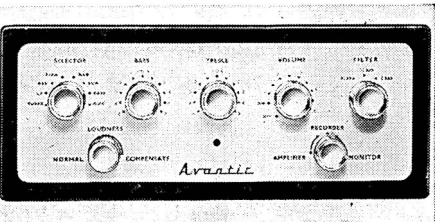

*Avantic DL7-35 control unit*

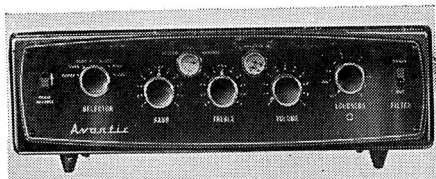

*Avantic SPA21 integrated stereo amplifier*

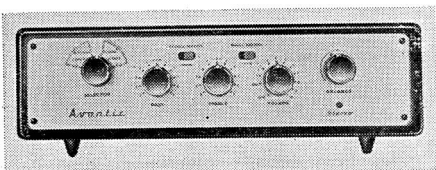

*Avantic SPA11 integrated stereo amplifier*

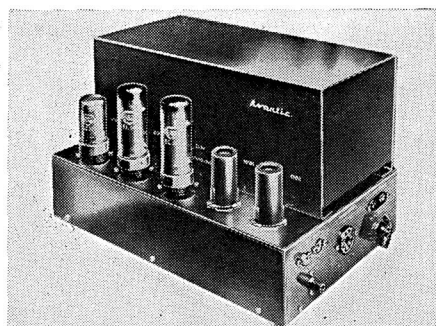

*Avantic DL7-35 amplifier*



*B.K. Partners P.205 stereo control unit*

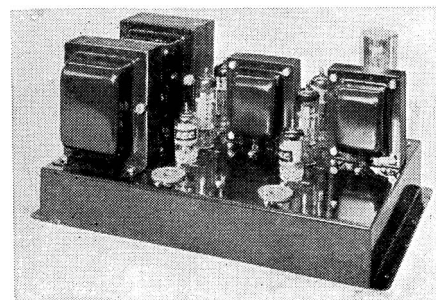

*B.K. Partners A205 stereo amplifier*

relative to 20 watts. Out. imp. 4, 8, and 16 ohms. Output EL34's. Size  $14\frac{1}{2} \times 9 \times 8\frac{1}{2}$  ins. To operate with Avantic SP21/2 pre-amplifier. Price £31 10s.

■ **Avantic SP21. Stereo Control Unit.** Inputs: tuner 100 and 250 mV; tape 100 mV; pickup 5 and 50 mV; aux. 250 mV. 6 position sel., bass, treble, volume, loudness, function switch, filter. Rumble filter. Size  $15 \times 9 \times 4$  ins. Price £28 10s. To operate with Avantic DL7-35.

■ **Avantic SP21/2. Stereo Control Unit.** Inputs: tuner 100 and 250 mV; tape 4 mV aux. 250 mV; pickup 4-6 and 40-60 mV. 6 position sel., bass, treble, balance, vol., loudness 7.5 Kc/s filter, phase reverse, stereo reverse. H and N — 60 dB. P.a.t. To operate with Avantic DL7-35 amplifiers.

■ **Avantic SPA21. Integrated Stereo Amplifier.** Inputs: tuner 100 and 250 mV; tape 3.5 and 250 mV; pickup 5 and 50 mV. 6 position sel., bass, treble, vol., loudness, balance, switched 7.5 Kc/s filter, phase reverse and stereo reverse. H and N — 60 dB. Output 12 watts per channel. Dist. 0.2% at 10 watts. Response 40-15,000 c/s. 20 dB feedback. Out. imp. 4, 8, and 16 ohms. Output EL84's. Size  $14\frac{1}{2} \times 14 \times 4$  ins. Price not yet available.

■ **Avantic SPA11. Integrated Stereo Amplifier.** Inputs: pickup 0.6v; tuner 100 mV; tape 100 mV. Response 40-15,000 c/s  $\pm 1$  dB. Dist. less than 1% at 7 watts. N.L. — 70 dB relative to 7 watts. Out. imp. 4, 8, or 16 ohms. Output ECL82's. Size  $14\frac{1}{2} \times 8\frac{3}{4} \times 4$  ins. Price not yet available.

■ **STEP11 Stereo Pre-amplifier.** Enables the SPA11 to be used with low sensitivity stereo pickups. Size  $7\frac{3}{8} \times 4\frac{3}{8} \times 2\frac{1}{2}$  ins. Price £6 16s. 6d.



**B.K. Partners Ltd.,** 229 Regent Street, London, W.1. Tel.: Regent 7363.

**Audio Plan Control Unit.** Inputs for P/U and radio. 5 pos. sel. (4 record equal). H.D. 0.25%. H and N — 75 dB. Panel size  $9\frac{1}{2} \times 3\frac{3}{4}$  ins. To operate with Audio Plan power amp.

**Audio Plan Amplifier Mk. I.** 6 watts nom., 8.5 watts peak. Dist. 0.25%. Input for spec. output 40 mV. Response linear 30-100,000 c/s at 3 watts. N.L. — 75 dB. Out. imp. 3 and 15 ohms. Output ECL82's. Size  $11\frac{1}{2} \times 4 \times 4\frac{1}{2}$  ins. Price with control unit £18.

**Audio Plan Amplifier Mk. II.** As Mk. I, but with aux. power for tuners, etc., H.T. at

30 mA and 6.3v at 2A L.T. Price with control unit £19 15s.

■**P205 Stereo Pre-amplifier.** Inputs: tape 2 mV; pickup 3 and 120 mV; radio 120 mV; mic. 20 mV; Aux. 120 mV. 8-position sel., treble, bass, presence. H and N — 65 dB. Rumble filter. P.a.t. 230 volts, 35 mA. Size  $11\frac{1}{2} \times 3\frac{1}{2} \times 6$  ins. To operate with amplifier A205. Price complete £42 10s.

■**A205 Twin Channel Amplifier.** 5 watts per channel, 7 watts peak. Dist. <0.2%. Input for 5 watts 300 mV. Response 30-25,000 c/s  $\pm 1$  dB. Feedback 15 dB. N.L. — 70 dB. Out. imp.  $3\frac{3}{4}$ ,  $7\frac{1}{2}$  and 15 ohms. Output ECL82's. Ultra-linear. Size  $12 \times 8 \times 6$  ins. Price £42 10s. See P.205 above.



**Cape Electrophonics Ltd.,** 43-45 Shirley High Street, Southampton. Tel.: Southampton 74251,

**Cape Audio System.** Based on M/S control unit and VL2 amplifier. Interchangeable additive units covering all monaural and stereo applications for radio, gramophone, tape and microphone.

■**Cape VLP/MS. Stereo/Monaural Pre-amplifier.** Sel., treble, bass, vol., balance controls. To operate with Cape VL2 amplifier. Price not yet available.

**Cape VL1 Amplifier.** 25 watts nom. approx. 40 watts max. Dist. at 1,000 c/s. 0.03% at 15 watts, 0.1% at 25 watts. Over range 50-10,000 c/s, 0.1% total at 15 watts. Input for 15 watts output, 0.8v R.M.S. Response 10-80,000 c/s  $\pm 0.5$  dB. Feedback external loop 20 dB. N.L. — 85 dB at 25 watts. Out. imp. 3.5, 7 and 15 ohms. Output KT66's. Ultra-regulated. Choke regulated power supply. P.a.t. 430v at 75 mA, 6.3v at 4A. Output and driver stages balanced by direct coupled feedback. Size  $15\frac{3}{4} \times 8\frac{1}{2} \times 7$  ins. Price £30.

**Cape VL2. Power Amplifier.** 20 watts nominal. Output KT88's. To operate with Cape VLP/MS control unit. Price not yet available.

**Cape Sub-amplifiers.** Range includes **Model A:** straight single stage amplifier with gain of 100 pentode-connected, or 30 triode-connected. Price £3 10s. **Model B:** single stage tape or gram. correction amplifier. Price £4. **Model C:** single stage amplifier for ribbon or moving coil microphone with Partridge transformer matching 15, 30, 300 or 600 ohms balanced line. Price £6 10s. **Model D:** simple two stage "no compromise" pre-amplifier without tone control or filter.

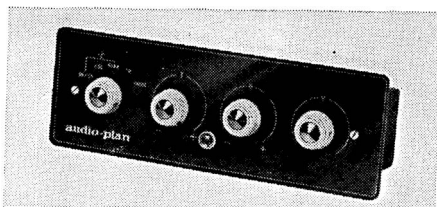

*B.K. Audio control unit*

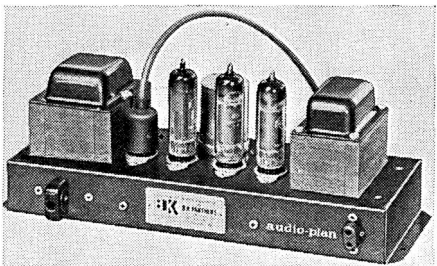

*B.K. Partners "Audio Plan" amplifier*

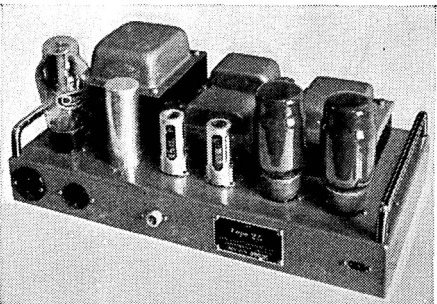

*Cape VLP Mk 2 control unit and VL1 amplifier*

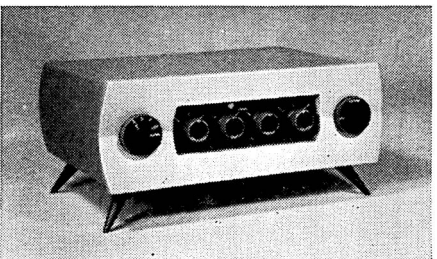

*Chapman 305 stereo control unit*

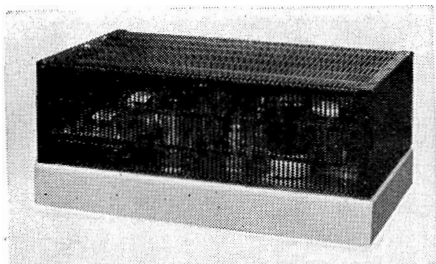

*Chapman 305 stereo amplifier*

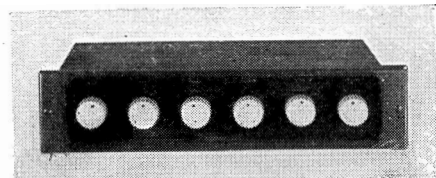

*Chapman 205 C/U control unit*

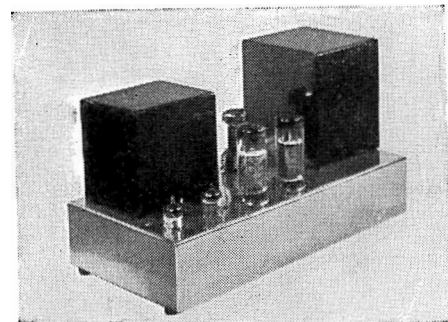

*Chapman 205 amplifier*

Sel. l.p.  $7\frac{1}{2}$  i/s tape, radio. Vol. control. Price £7 10s. **Model E:** as type B with additional stage, giving output of up to 1 volt. Price £6 15s. **Model F:** straight two stage unit, low noise, for boosting output from stereo pickup or tape head. Price £6. **Model G:** twin two stage corrected stereo amplifier for coupling pickup or tape head to pre-amplifier. Output up to 1 volt. Price £10 10s. Any three switched characteristics added to above models at additional cost of £1.



**C. T. Chapman (Reproducers) Ltd.**, Chapel Lane, High Wycombe, Bucks. Tel.: H.W. 2474.

**Chapman 205CU Control Unit.** 6 inputs from 1.5 mV-100 mV. 6 pos. sel., treble, bass, loudness. 3 pos. roll off, 5, 10 and 20 Kc/s. Tape record and playback jacks. H.D. <0.1%. H and N radio - 64 dB.

P/U - 54 dB. Rumble filter, better than 12 dB per octave below 35 c/s. Size  $12 \times 2 \times 6$  ins. To operate with power amp 205 or Williamson power amplifier. Price £12.

**Chapman 205 Amplifier.** 20 watts from 30-20,000 c/s. Dist. <0.05% at 20 watts. Response 2-100,000 c/s  $\pm 1$  dB. Feedback 30 dB. N.L. - 89 dB at 20 watts. Out. imp. 15 ohms. Output EL34's. Ultra-linear. To operate with 205CU. Price £34.

■ **Chapman 305 Stereo Control Unit.** Inputs: Pickup and tape 4.5 mV; radio 100 mV; Aux. 100 mV. 4 position sel., bass, treble, volume, balance, filter. H.D. <0.1%. H and N - 50 dB. Rumble filter. Size  $12 \times 4\frac{1}{2} \times 6\frac{1}{2}$  ins. Price £18 18s. To operate with 305 amplifier or  $2 \times 205$  amplifiers.

■ **Chapman 305 Stereo Amplifier.** 8 watts per channel, 15 watts peak. Dist. <0.1%. Input for spec. output 350 mV. Response 30-20,000 c/s  $\pm 0.2$  dB. Feedback 10 dB. N.L. - 80 dB. Out. imp. 3 and 15 ohms. Output EL84's. Ultra-linear. Size  $12 \times 7 \times 5$  ins. Price £21. To operate with 305 pre-amplifier.

**Chapman 105 Combined Control Unit and Amplifier.** 10 watts nominal, 20 watts peak. Inputs: pickup 10 and 50 mV; radio and tape 100 mV. Selector, bass, treble, filter, loudness control, volume and on/off. Rumble filter. Dist. <0.1%. Response 30-20,000 c/s  $\pm 0.2$  dB. N.L. - 80 dB. Out. imp. 3 and 15 ohms. Output EL84's. Ultra-linear. Size  $12 \times 4\frac{1}{2} \times 8\frac{1}{2}$  ins. Price £29 18s.



**Expert Gramophones Ltd.**, 39-41 New Oxford Street, London, W.C.1. Tel.: Covent Garden 2156.

**Expert Control Unit.** Input P/U, tape, radio, all 20 mV. 3 pos. sel., vol., bass, treble filter-variable slope. Tape input socket. H.D. <0.1%. H and N - 60 dB. Attenuation introduced below 20 c/s. P.a.t. from power amp. Size  $12 \times 3\frac{1}{2} \times 6$  ins. To operate with Expert "Master" and "Standard" or any similar power amp. Price £18.

**Expert "Standard" Amplifier.** 12 watts nom., 14 watts max. Dist. 0.1%. Input for spec. output 200 mV. Response 20-25,000 c/s  $\pm 0.5$  dB. Feedback 30 dB. N.L. - 80 dB at 8 watts. Out. imp. 15 ohms. Output EL84's. Ultra-linear. Size  $12 \times 9 \times 6\frac{1}{2}$  ins. To operate with Expert control unit or similar. Price £23.



**Expert "Master" Amplifier.** 20 watts nom., 26 watts max. Dist. 0.07%. Input for spec. output 200 mV. Response 20-30,000 c/s  $\pm$  0.5 dB. Feedback 30 dB. N.L. — 85 dB at 20 watts. Out. imp. 15 ohms. Output EL34's. Ultra-linear. Size 12  $\times$  9  $\times$  7 $\frac{1}{2}$  ins. To operate with Expert control unit or any similar. Price £35.

■ **Expert "Standard" Stereo Amplifier.** 10 watts per channel. Dist. 0.1% at 10 watts. Input for spec. output 200 mV. Response 30-20,000 c/s  $\pm$  1 dB. 28 dB feedback. N.L. — 80 dB ref. 8 watts. Out. imp. 15 ohms. Output ECL82's. Size 12  $\times$  9  $\times$  6 $\frac{1}{2}$  ins. To operate with stereo Mk. I control unit. Price £23.

■ **Expert Stereo Mk. I Control Unit.** Inputs (6) 250 mV sensitivity. Switched bass, treble, function controls. H.D. less than 0.1%. P.a.t. Size 12  $\times$  3 $\frac{1}{2}$   $\times$  3 ins. To operate with "Standard" stereo amplifier. Price £18.



**General Electric Co. Ltd.,** Magnet House, Kingsway, W.C.2. Tel.: Temple Bar 8000. Cables: Polyphase, London.

**BCS2417A. Control Unit.** Inputs: pickup 5-15,000 mV, radio 300 mV, tape 7.5 mV. 6 position sel., vol., treble, bass, presence. Size 7 $\frac{1}{2}$   $\times$  6 $\frac{1}{2}$   $\times$  5 $\frac{1}{8}$  ins. To operate with BCS2418A amplifier. Price £11 11s.

**G.E.C. BCS2418A Amplifier.** 12 watts nom. Dist. <0.5% at 12 watts. Input for spec. output 120 mV. Response 20-20,000 c/s  $\pm$  1 dB. Feedback 22 dB overall. Out. imp. 15 ohms (or 1, 2 or 3 3-5 ohms speakers). Output N709's. Size 14  $\times$  7 $\frac{3}{4}$   $\times$  6 $\frac{1}{2}$  ins. To operate with BCS2417A. Price £17 17s.



**Goodsell Ltd.,** 40 Gardner Street, Brighton. Tel.: Brighton 26735.

**Golden PFA Control Unit.** Inputs: pickup 5-7 mV; mic. 5 mV; radio 80 mV. 4 pos. sel., treble, bass, vol. Separate "roll-off" and "turnover" facilities covering all known equalising characteristics. Switched filter 5, 7, 9, 13 Kc/s and "out." Spec. dependent on amp. used. Size 11  $\times$  9  $\times$  3 $\frac{1}{2}$  ins. To operate with all Goodsell amplifiers. Price £20.

■ **Stereo I Control Unit.** Inputs: pickup 7 mV stereo; radio 150 mV. Selector switch, vol., bass, treble and on/off. H.D. 0.1%. Size 7  $\times$  6  $\times$  4 ins. Price £16 15s.

■ **Stereo II Control Unit.** Inputs: pickup 7 mV stereo; radio 150 mV; tape 3 mV. Selector switch, vol., bass, treble, on/off.

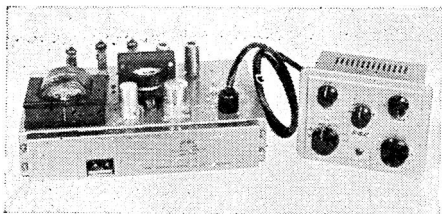

*G.E.C. control unit and amplifier*

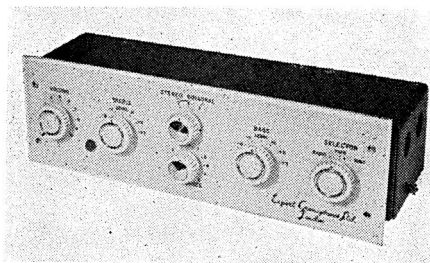

*Expert Stereo control unit*



*Expert Standard Stereo amplifier*

H.D. 0.1%. Size 13  $\times$  7 $\frac{1}{2}$   $\times$  3 $\frac{3}{4}$  ins. Price £27 15s.

■ **Stereo III Control Unit.** Inputs: pickup 60 mV, radio and tape 100 mV. Push-button selector, ganged bass, treble, volume controls. H and N — 65 dB. To operate with Goodsell "Mullard" stereo amplifier. Price not yet available.

■ **MA8 Stereo Amplifier.** 3.5 watts per channel. Dist. 0.4%. Input for spec. output 1.5 volts. Response 30-30,000 c/s. Feedback 25 dB. N.L. — 70 dB. Out. imp. 3 and 15 ohms. Output EL84's Ultra-linear. Size 14  $\times$  6  $\times$  6 ins. Price £17. To operate with Stereo I or Stereo II Control Unit.

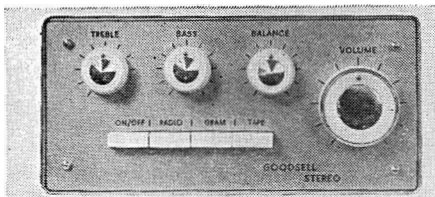

*Goodsell Stereo III control unit*

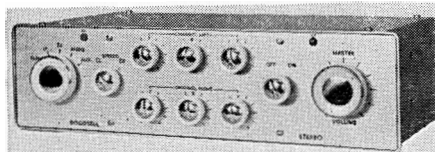

*Goodsell Stereo II control unit*

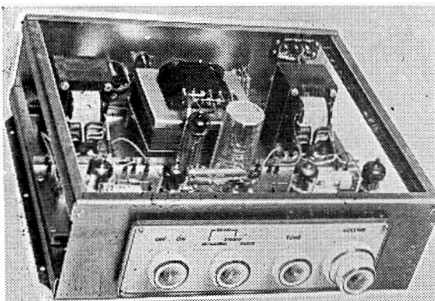

*Goodsell Stereo Mk. I*

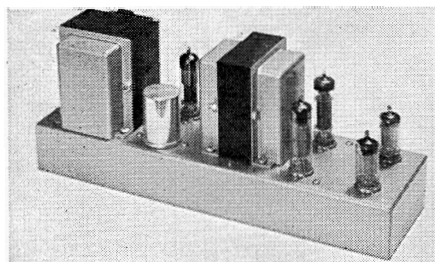

*Goodsell MA10 amplifier*

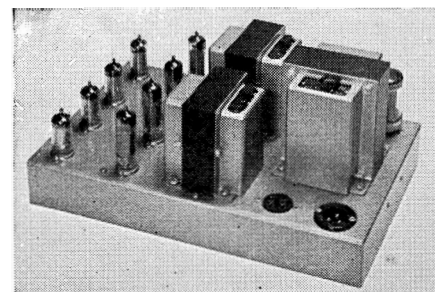

*Goodsell MA20 Stereo amplifier*

**MA10 Amplifier.** 10 watts. Dist. 0.1%. Input for spec. output 1.5 volts. Response 30-30,000 c/s  $\pm$  0.5 dB. Feedback 22 dB. N.L. — 70 dB. Out. imp. 3 or 15 ohms. Output EL84's. Ultra-linear. Size 14  $\times$  5  $\times$  6 ins. Price £18. To operate with Stereo I or Stereo II Control Units.

**GW25 Amplifier.** 20 watts. Dist. 0.1%. Input for spec. output 1.5v. Response 20-100,000 c/s. Feedback 20 dB. N.L. better than — 75 dB. Out. imp. 3, 8 and 15 ohms. Output KT66's. Ultra-linear. Size 14  $\times$  10  $\times$  7 ins. Weight 35 lb. To operate with PFA control unit. Price £27 10s.

**Golden GW50 "Williamson" Amplifier Mk. II.** 40 watts. Dist. <0.1%. Input for spec. output 1.5v. Response 20-100,000 c/s  $\pm$  2 dB. Feedback 20 dB. N.L. — 75 dB. Out. imp. 3 or 8 or 15 ohms. Output KT88's. Size 17  $\times$  11 $\frac{1}{2}$   $\times$  8 $\frac{3}{4}$  ins. Weight 54 lb. To operate with PFA control unit. Price from £40 10s.

■ **MA20 Stereo Amplifier.** 10 watts per channel. Details as MA10 above. Price £32 5s.

■ **"Mullard" Stereo Control Unit.** Details as per Mullard 2-valve design. To operate with Goodsell "Mullard" amplifier. Price £16 15s.

■ **"Mullard" Stereo Amplifier.** 7 watts per channel. Details as per Mullard design. To operate with Stereo III or "Mullard" control unit. Price £17 to £19 10s.



The Gramophone Company Ltd., Hayes, Middx. Tel.: Southall 2468. Cables: Jabberment, London.

■ **E.M.I. Stereoscope 555. Integrated Stereo Amplifier.** Inputs: pickup 2 mV magnetic; 60 mV crystal, tape 3 and 150 mV; microphone 2 and 20 mV, tuner 150 mV. 7 position sel. for each channel. Bass, treble, vol., loudness, scratch filters, rumble filter. Cathode ray tube for balance and level checking. Mixing of two channels for recording purposes. 10 watts per channel, 12.5 max. H.D. less than 0.1%. Response 20-20,000 c/s  $\pm$  1 dB at 5 watts. Crosstalk — 50 dB at 1 Kc/s, — 30 dB at 20 c/s and 20 Kc/s. H and N — 80 dB. 34 dB feedback. Output EL84's. Size 14  $\times$  4  $\times$  13 $\frac{3}{4}$  ins. Price £63 3s.

■ **E.M.I. Stereoscope 556. Stereo Control Unit.** Inputs: as 555, plus an extra magnetic pickup pair at 2 mV. Other facilities as 555. Cathode follower output rated from 200 mV

to 6 volts, adjustable by preset controls in each channel. Size  $14 \times 4 \times 9$  ins. To operate with Type 600 stereo amplifier. Price to be announced.

■ **E.M.I. 600. Stereo Amplifier.** 30 watts per channel, 35 watts peak. Dist. less than 0.1% at 30 watts. Input for spec. output 500 mV. Response 10-30,000 c/s  $\pm 0.5$  dB. 34 dB feedback. N.L. - 80 dB. Damping factor greater than 30. Output EL34's. Size  $16\frac{1}{2} \times 10\frac{1}{2} \times 6$  ins. To operate with Type 556 stereo control unit. Price to be announced.

“**Orthotone**” **STD/448 Control Unit.** Inputs: pickup 10 mV; radio and tape 40 mV; mic. 5 mV. 6-position sel., bass, treble, filter, slope, vol. H.D.  $<0.1\%$ . H and N - 65 dB. Size  $11\frac{3}{4} \times 4\frac{5}{8} \times 7$  ins. Price £19 19s. To operate with STD/373 amplifier. Self powered. Cathode follower output.

“**Orthotone**” **STD/399 Stereo Control Unit.** Inputs: pickup 3 mV; radio and tape 35 mV. 4-position sel., bass, treble, balance, volume, function switch. H.D.  $<0.1\%$ . H and N - 60 dB. Rumble filter. Size  $11\frac{3}{4} \times 4\frac{5}{8} \times 7$  ins. Price £22 1s. To operate with STD/381, and STD/373 amplifiers.

■ “**Orthotone**” **STD/444 Combined Stereo Amplifier and Control Unit.** Inputs: pickup, radio, and aux. 300 mV. 6-position sel., bass, treble, balance, vol. 2.5 watts per channel. Dist. 0.3%. Out. imp. 15 ohms H and N - 60 dB. Size  $11\frac{3}{4} \times 4\frac{5}{8} \times 10$  ins. Price £27 6s.

■ “**Orthotone**” **STD/381 Stereo Amplifier.** 10 watts per channel. Dist. 0.1%. Input for spec. output 200 mV. Response 30-20,000 c/s  $\pm 1$  dB. Feedback 26 dB. N.L. - 80 dB. Out. imp. 4, 8, and 16 ohms. Output EL84's. Ultra-linear. Size  $8\frac{1}{2} \times 13 \times 6$  ins. Price £29 8s. To operate with STD/399 Control Unit.

“**Orthotone**” **STD/373 Amplifier.** 25 watts. Dist. 0.1%. Input for spec. output 160 mV. Response 20-20,000 c/s  $\pm 1$  dB. Feedback 28 dB. N.L. - 76 dB. Out. imp. 4, 8, and 16 ohms. Output EL34's. Ultra-linear. Size  $11 \times 9 \times 6\frac{1}{2}$  ins. Price £25 4s. To operate with STD/448 and STD/399 Control Units.

★

**Grampian Reproducers Ltd.,** Hanworth Trading Estate, Feltham, Middx. Tel.: Feltham 2657/8/9. Cables: Reamp, Feltham.

**Grampian 582 Control Unit.** Inputs: pickup 15 mV; radio 200 mV; tape 500 mV.

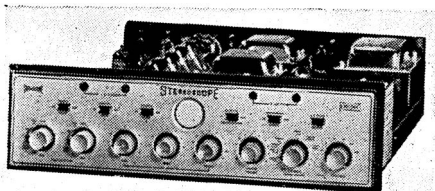

*E.M.I. Stereoscope 555*

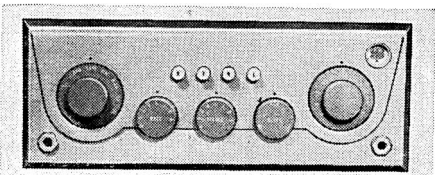

*Orthotone STD/448 control unit*

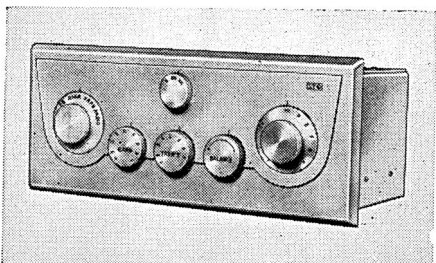

*Orthotone STD/399 stereo control unit*

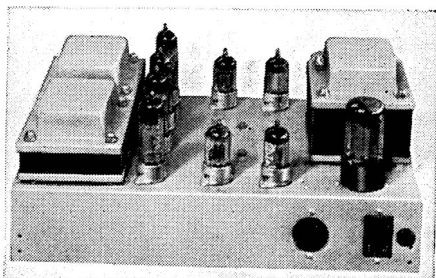

*Orthotone STD/381 stereo amplifier*

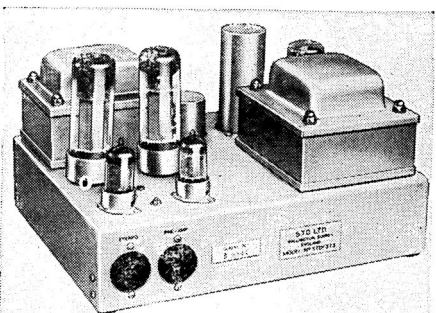

*Orthotone STD/373 amplifier*

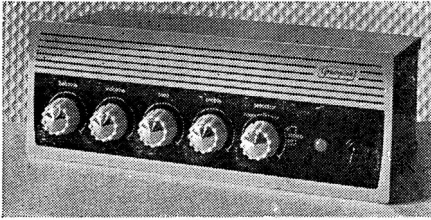

*Grampian stereo control unit*

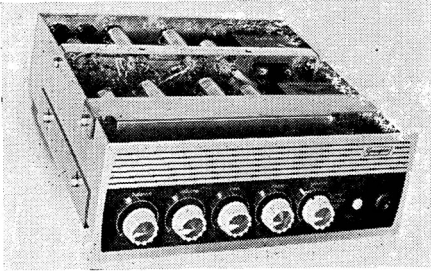

*Grampian 590 combined stereo amplifier*

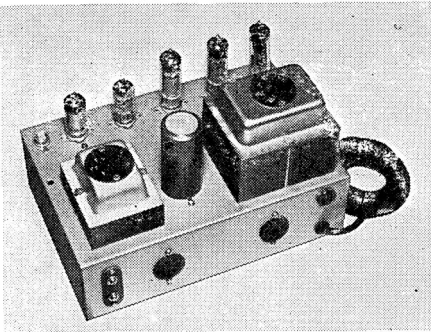

*Grampian 10-15 amplifier*



*Kolster Brandes PHA30 power amplifier*

Selector switch, bass, treble, vol. Size  $10\frac{1}{4} \times 4 \times 5\frac{1}{2}$  ins. Price £14. To operate with "Ten Fifteen" Amplifier.

**Grampian 580 Control Unit.** Similar to 582, but for crystal pickups. Sensitivity 600 mV, radio 500 mV. Price £8 5s.

**Grampian 10-15 Amplifier.** 10 watts nom., 15 watts peak. Dist. 0.1% at 10 watts. Input for spec. output 50 mV. Response 30-20,000 c/s  $\pm 1$  dB. Feedback 20 dB. N.L. - 65 dB below full output. Out. imp. 4, 8, 15 ohms. Output EL84's. Ultra-linear. Size  $11 \times 7\frac{1}{2} \times 6\frac{1}{2}$  ins. To operate with "580" and/or "582" control unit. Price £18.

■ **Grampian 590 series.** Stereo Control Unit with single channel amplifier and provision for adding a second amplifier for stereo. 7 watts per channel, 10 watts peak. Dist. 1%. H and N - 60 dB. Inputs: pickup 0.5v at 1 Megohm, tuner and tape 1v at 0.5 Megohm. Sel. switch, balance, bass, treble. Out. imp. 4 and 15 ohms. Size: chassis  $10\frac{7}{8} \times 3\frac{7}{8} \times 13$  ins., wood surround  $12\frac{1}{4} \times 5\frac{3}{4} \times 13$  ins. Price 590/1 (control unit and one 584 amplifier) £21 10s., 590/2 (control unit and two 584 amplifiers) £32, 584 amplifier £10, wood surround £3.



**Jason Motor & Electronic Co.,** 3/4 Gt. Chapel Street, London, W.1. Tel.: Gerrard 0273/4.

**J10 Combined Control Unit and Power Amplifier.** Inputs: mic. 1 mV; tape 0.5V; radio 0.5V; P/U 1.0v and crystal P/U. 6 pos. sel., treble, bass, vol. P.a.t. 270v at 10 mA, 6.3v at .3A. Output 10 watts nom., 15 watts max. Dist. 0.1%. Response 30-30,000 c/s  $\pm 2$  dB. N.L. better than 55 dB (mic. input). Out imp. 15 ohms (other imps. to order). Output EL84's. Ultra-linear. Size  $15 \times 8\frac{1}{4} \times 4\frac{3}{8}$  ins. Price £22 10s.

■ **J2-10. Integrated Stereo Amplifier, Mk. III.** Inputs: pickup 3 mV and 60 mV; tape 1.5 mV; radio 60 mV; mic. 5 mV. 5 position sel. switch; bass, treble vol., balance, function, 9 Kc/s and 6 Kc/s filter. H.D. less than 0.1%. H and N - 55 dB. Rumble filter. 10 watts per channel, 15 watts max. 18 dB feedback. Out. imp. 4, 8, 15 ohms. Output EL84's. Size  $15 \times 4\frac{3}{8} \times 12$  ins. Price £37 10s.



**Kolster Brandes Ltd.,** Footscray, Sidcup, Kent. Tel.: Footscray 3333. Cables: Matchtone, Sidcup.

■ **PHC20. Stereo Control Unit.** Inputs: pickup 10 mV; radio 100 mV; tape 100 mV;

mic. 1 mV. Push-button sel., bass, treble, vol., balance and function. H.D. less than 0.1%. H and N — 48 dB. Rumble filter 30 c/s. P.s.r. 250v 5 mA, 6.3v 0.5 amps. Size  $13\frac{1}{4} \times 5 \times 9$  ins. To operate with PHA30 amplifier. Price £23 2s.

■ **PHA30. Power Amplifier.** 12 watts nominal, 16 watts max. Dist. <0.1% at 12 watts. Input for spec. output 200 mV. Response 10-30,000 c/s  $\pm 1$  dB. 30 dB feedback. N.L. — 80 dB. Out. imp. 3.75, 8 and 15 ohms. Output EL84's. Size  $11\frac{1}{2} \times 6\frac{1}{2} \times 10\frac{1}{4}$  ins. To operate with PHC20 stereo control unit. Price £22 1s.



**H. J. Leak & Co. Ltd.,** 57-59 Brunel Road, East Acton, London, W.3. Tel.: Shepherds Bush 1173. Cables: Sinusoidal, Ealux, London.

“**Point One Plus**” Control Unit. Inputs: tape 50 mV or mic. 4 mV; tuner 50 mV; P/U 9.5 mV. 6 pos. sel., 4 record equal, treble, bass, vol., mains on/off. Switch filter 4, 6 and 9 Kc/s. Input level control for P/U, tuner. Tape record and replay sockets on front and rear. H.D. <0.01%. H and N — 66 dB. Size  $11\frac{1}{2} \times 4\frac{7}{8} \times 5$  ins. To operate with TL/12 Plus, TL/25 Plus or TL/50 Plus amplifier. Price £12 12s.

“**Vari-slope III**” Control Unit. Inputs: tape 50 mV or mic. 4 mV; tuner 45 mV; pickup I 9 mV; pickup II 9 mV. 6 pos. sel. and change-over switch for pickup I/pickup II. Treble, bass, vol., mains on/off. Switched low pass filter 5, 7, and 9 Kc/s plus Vari-slope controls. Rumble filter cut in. Input level controls for tuner, pickup I, pickup II. Tape input sockets on front and back panels. H.D. <0.01%. H and N — 66 dB. P.a.t. on TL/12 plus power amp. Size  $11\frac{1}{2} \times 4\frac{7}{8} \times 5$  ins. To operate with TL/12 Plus, TL/25 Plus, and TL/50 Plus amp. Price £15 15s.

“**Point One**” TL/12 Plus Amplifier. 12 watts. Dist. 0.1%. Input for spec. output 125 mV. Response 20-20,000 c/s  $\pm 0.25$  dB. Feedback 26 dB. N.L. — 84 dB. Out. imp. 4, 8 and 16 ohms. Output EL84's. Ultra-linear. Size  $10 \times 8 \times 6$  ins. To operate with Vari-slope III or Point One Plus control units. Price £18 18s.

“**Point One**” TL/25 Plus Amplifier. 25 watts. Dist. 0.1%. Input for spec. output 125 mV. Response 20-20,000 c/s  $\pm 0.25$  dB. Feedback 26 dB. N.L. — 83 dB. Out. imp. 4, 8 and 16 ohms (other imps. to order). Output EL34's. Ultra-linear.

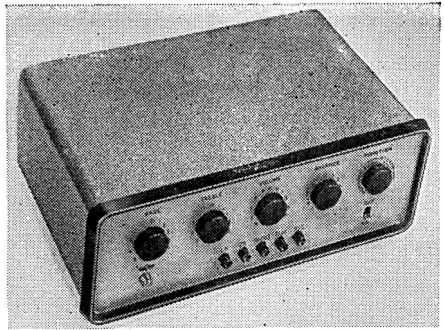

*Kolster Brandes PHC20 control unit*



*Jason J2-10 Mk. III integrated stereo amp.*



*Leak "Point One Stereo" control unit*



*Leak Vari-slope III control unit*

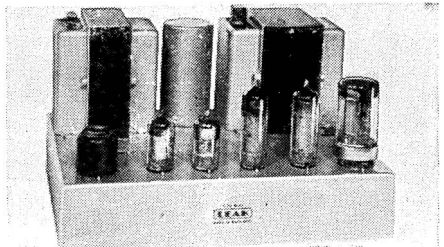

*Leak TL/12 plus amplifier*

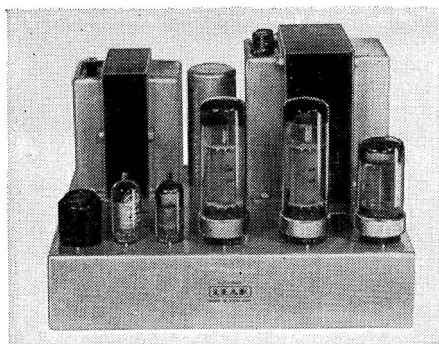

Leak TL/25 plus amplifier

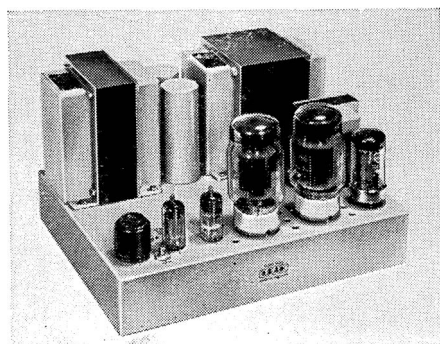

Leak TL/50 plus amplifier



Leak "Point One" Stereo 20 amplifier

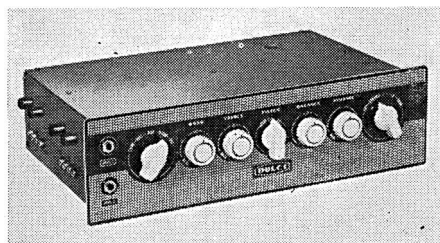

Lee-Dulci Stereo Eight control unit

Size  $10 \times 8 \times 6\frac{3}{4}$  ins. To operate with Vari-slope III or Point One Plus control units. Price £25 4s.

**"Point One" TL/50 Plus Amplifier.** 50 watts. Dist. 0.1%. Input for spec. output 125 mV. Response 20-20,000 c/s  $\pm 0.25$  dB. Feedback 26 dB. N.L. - 84 dB. Out. imp. 4, 8 and 16 ohms (other imps. to order). Output KT88's. Ultra-linear. Size  $11\frac{1}{2} \times 9 \times 6\frac{3}{4}$  ins. To operate with Vari-slope III or Point One Plus control units. Price £33 12s.

**Varislope Stereo Control Unit.** Inputs: Pickup I 3.5 mV or 35 mV; pickup II 3.5 mV or 350 mV; tape 3 mV; tuner 50 mV or 250 mV; mic. 2 mV; extra 50 mV or 1V (all mono and stereo), sel. switch. Bass, treble, vol., on/off. Switched low pass filter 4, 6, 9 kc/s plus Varislope control. Rumble filter cut/in. Balance control. H and N - 55 dB. Size  $11\frac{1}{2} \times 4\frac{1}{2} \times 6\frac{1}{2}$  ins. To operate with any Leak amplifiers. Price £25.

**"Point One Stereo" Control Unit.** Twin channel inputs for P/U, 5 mV; tuner 50mV, tape recorder 50 mV; tape head 4 mV; mic. 3.5 mV. Stereo/monaural and rumble switches, balance, treble, bass, vol., mains on/off. Input level controls. Tape sockets for recording. H.D. 0.01% on each channel H and N - 66 dB. To operate with "Point One" Stereo 20 amplifier. Price £21.

**"Point One" Stereo 20 Amplifier.** 11 watts each channel. Dist. 0.1% on each channel. Input for spec. output 125 mV. Response 20-20,000 c/s. Feedback 24 dB. N.L. - 80 dB. Out. imp. 4, 8 and 16 ohms. Output EL84's. Ultra-linear. To operate with "Point One Stereo" or "Varislope Stereo" control units. Price £30 9s.

**"Point One" Stereo 50 Amplifier.** 25 watts each channel. Price £42.



**Lee Products (G.B.) Ltd.,** Elpico House, Longford Street, London, N.W.1. Tel.: Euston 5754. Cables: Leprod, London.

**DPA10 Control Unit.** Inputs: pickup 6 mV; tape 100 mV; microphone 1.5 mV; radio 100 and 300 mV. 6-position sel., bass, treble, volume and on/off. H.D. <0.1%. H and N - 45 dB. Size  $11\frac{1}{4} \times 3 \times 5\frac{1}{4}$  ins. Price £7 7s. To operate with DPA10 amplifier.

**DPA10 Power Amplifier.** 15 watts nominal. Dist. 0.3%. Input for 10 watts 40 mV. Response 30-15,000 c/s  $\pm 1$  dB. Feedback 26 dB. N.L. - 75 dB. Out. imp. 3-16 ohms. Output EL84's. Ultra-linear. Size  $11\frac{1}{4} \times 6 \times 5\frac{1}{2}$  ins. Price £12 12s. To operate with DPA10 Control Unit, Stereo Two, or Stereo Eight.



■“Stereo Two” Control Unit. Inputs: radio and tape 100 mV; pickup adjustable 50 mV to 2 volts. 6-position sel., bass, treble, volume, balance. H.D. <0.1%. H and N — 60 dB. Size  $12\frac{1}{2} \times 3\frac{1}{4} \times 5$  ins. Price £9 9s. To operate with two DPA10, or SP44 amplifiers.

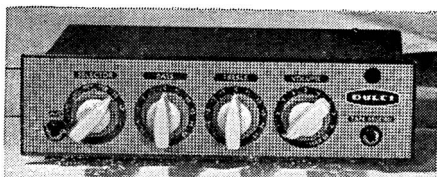

*Lee-Dulci DPA10 control unit*

■“Stereo Eight” Control Units. Inputs: mic. and tape 3 mV; radio 100 mV; pickup 4 to 100 mV; tape 100 mV; aux. 50 mV to 2 volts. 6-position sel., bass, treble, filter, balance, function. H.D. <0.1%. H and N — 50 dB. Rumble filter. Size  $14\frac{1}{4} \times 4 \times 9\frac{3}{8}$  ins. Price £23 2s. To operate with two DPA10, or SP44 amplifiers.

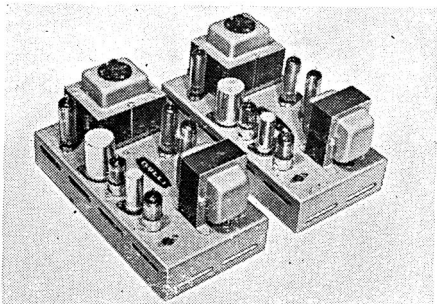

*Matched pair of Lee-Dulci DPA10/2 amps.*

■SP44 Stereo Amplifier. 4 watts per channel. Dist. <1%. Input for 3 watts, 65 mV. Response 40-25,000 c/s  $\pm 1$  dB. Feedback 20 dB. N.L. — 72 dB. Out. imp. 3 and 15 ohms. Output EL84's. Size  $11\frac{1}{2} \times 6 \times 5\frac{1}{2}$  ins. Price £12 12s. To operate with “Stereo Two”, or “Stereo Eight”.

GA4 Combined Amplifier and Control Unit. 4 watts. Dist. <1%. Input for spec. output 40 mV. Response 40-18,000 c/s  $\pm 2$  dB. Feedback 20 dB. N.L. — 65 dB. Out. imp. 3 and 15 ohms. Output EL84. Size: Amplifier  $14 \times 4\frac{1}{2} \times 5$  ins., Control Unit  $6 \times 4 \times 4$  ins. Price £9 9s. complete.

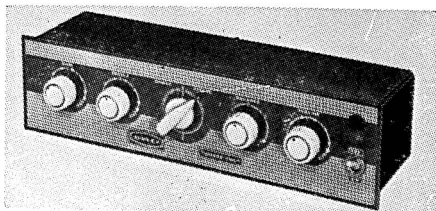

*Lee-Dulci Stereo Two control unit*



Lowther Manufacturing Co., Lowther House, St. Mark's Road, Bromley, Kent. Tel.: Ravensbourne 5225. Cables: Lowther, Bromley.

Lowther No. 2 Control Unit. Inputs: mic 45 mV; P/U 45 mV; radio 100 mV. 4 pos. sel., treble, bass, vol., on/off. Mic./tape input socket. H.D. 0.1% on 1v R.M.S. H and N — 60 dB. Size  $10\frac{1}{2} \times 3 \times 3\frac{1}{2}$  ins. To operate with LL15, LL26 and similar power amp. Price £10 10s.

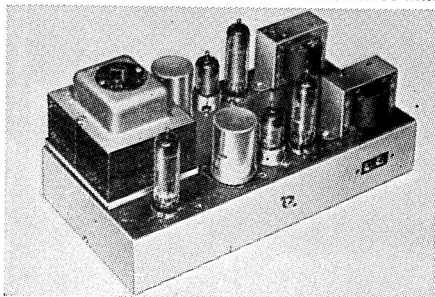

*Lee-Dulci SP44 Stereo amplifier*

Master Control Unit Mk. II. Inputs: mic., P/U and tape head 3 mV; radio, tape and aux. 100 mV. 6 pos. sel., 5 pos. record equal, treble, bass, vol., on/off. Low pass filter. 18 dB per octave. 35 down to 4 Kc/s. Socket for direct connection to tape playback head. H.D. <0.1%. H and N — 90 dB. Size  $10\frac{1}{2} \times 5\frac{1}{2} \times 7\frac{1}{2}$  ins. To operate with LL15, LL26 and similar power amp. Price £24.

Lowther LL15 Amplifier. 15 watts. Dist. <0.1%. Input for spec. output .75v. Response 30-30,000 c/s  $\pm 1$  dB. Feedback 22 dB. N.L. — 80 dB. Out. imp. 16 ohms with adjustment. Output EL34's. “Low-



*Lowther Master Control Unit Mk. II*



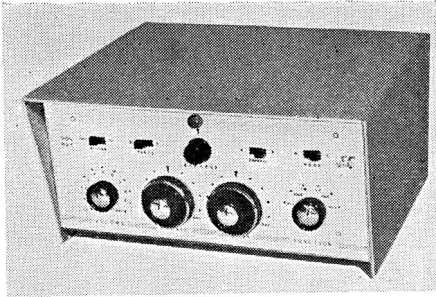

*Lowther S.C.U. stereo control unit*

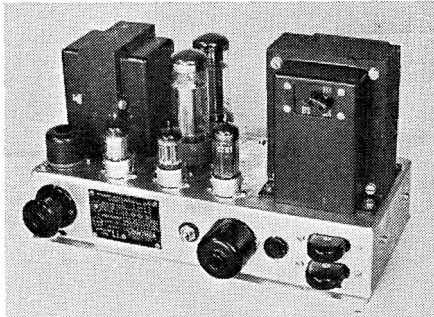

*Lowther LL16 amplifier*

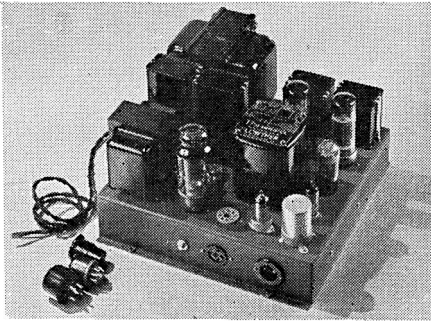

*Lowther LL26 amplifier*

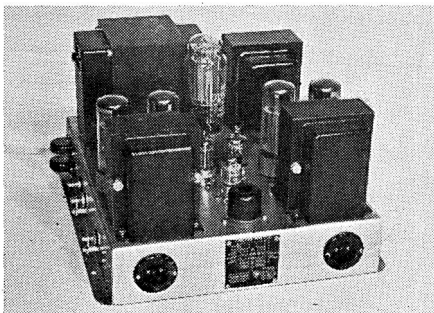

*Lowther LL15S stereo amplifier*

ther Linear" (screen and anode feedback). P.a.t. Size  $12 \times 9 \times 6\frac{1}{2}$  ins. To operate with MCUII, MCUIV. or control unit No. 2. Price £27 10s.

**Lowther LL26 Amplifier.** 26 watts. Dist.  $<0.1\%$ . Input for spec. output 0.75v. Response 20-60,000 c/s  $\pm 1$  dB. Feedback 22 dB. N.L. - 90 dB. Out. imp. 16 ohms with adjustment. Output EL34's. "Lowther Linear." P.a.t. Size  $12 \times 12 \times 8\frac{1}{2}$  ins. To operate with MCUII, MCUIV. or control unit No. 2. Price £47.

**Lowther-Murray Transistor or "Matching" Unit No. 1.** Inputs: 5 mV. 5-50 ohms. On/off battery switch only. Imp. matching transistor pre-amp forward gain 100-1. Dist. not measurable at normal output. No hum/noise. Size approx.  $3\frac{1}{2} \times 3\frac{1}{2} \times 6$  ins. To operate with any power amp. Price £9 9s.

**Lowther-Murray Transistor or "Matching" Unit No. 2.** Spec. as for No. 1 but gain 45-1. Size  $3\frac{1}{2} \times 3\frac{1}{2} \times 3\frac{1}{2}$  ins. To operate with any power amp. Price £6 6s.

**Lowther-Murray Transistor or "Matching" Unit No. 3.** Inputs 5 mV, low imp. 5-50 ohms. Imp. matching transistor control unit with corrections for connection to normal "Radio" position. 4 pos. sel. off, R.I.A.A., frr 78, mic. H.D. nil. H and N no hum, less noise than record or radio background. Size approx.  $3\frac{1}{2} \times 3\frac{1}{2} \times 6$  ins. To operate with any power amp. Price £12 12s.

■ **Lowther S.C.U. Stereo Control Unit.** Input as for Master Control Unit Mk.IV. Tape input sockets. H.D. 0.1%. Dual low pass filters. Dual output balanced and balance controls between channels. Size as M.C.U. Mk. IV. To operate with LL15S power amp. Price £40.

■ **Lowther LL15S Stereo Amplifier.** 15 watts output on each channel. Dist. 1%. Input for spec. output 0.75v. Response 20-40,000 c/s  $\pm 1$  dB. N.L. - 80 dB. Out. imp. 7.5 or 15 ohms. Output EL34. "Lowther Linear." Size  $11 \times 10 \times 8$  ins. To operate with SCU control unit. Price £47.

■ **Lowther LL8S Stereo Amplifier.** 8 watts per channel. Dist.  $<0.1\%$ . Input for spec. output 0.75 volts. Response 25-20,000 c/s  $\pm 1$  dB. Feedback 22 dB. N.L. - 85 dB. Output EL84's. Size  $11 \times 10 \times 8$  ins. Price £35.



**Pamphonic Reproducers Ltd.,** 17 Stratton Street, W.1. Tel.: Grosvenor 1926.

**1004 Self-contained Control Unit and Power Amp.** Separate controls for bass,

treble, volume and loudness (contour), and input selection. Plug-in gram, attenuation. 10 watts. Dist. at 1,000 c.p.s., 0.5% at 10 watts. Input voltage for spec. output mic. 2.5 mV; tape/radio 100 mV; P/U 12-15 mV. Response substantially flat 50-50,000 c/s. Feedback 20 dB. N.L. mic. — 53 dB, P/U — 54 dB. Out. imp. 3.5 and 15 ohms. Output 6 BW6's. Ultra-linear. Price £26 5s.

**1002B Control Unit.** Inputs: mic. 2-3 mV, radio/tape 60 mV; P/U 6-8 mV. Push-button sel. 9 pos. (6 gram.). Cut off filter 4, 7, 12 Kc/s and "out." Terminals for tape input. H and N 60 dB below 0.5v. P.a.t. Size  $10\frac{1}{2} \times 4\frac{1}{4} \times 7\frac{1}{4}$  ins. To operate with 2001 power amp. Price £25 4s.

**2001A Control Unit.** Inputs: 3-120 mV depending on input. 6 pos. sel. Pre-set level control for tape/radio. Cut-off filter at 4, 7, 12 Kc/s and "out." Loudness control. Tape input sockets. H and N 60 dB below 0.5v. P.a.t. To operate with 2001 power amp. Price £12 12s.

**2001 Amplifier.** 25 watts. Dist. at 1,000 c/s, 0.05% at 15 watts. Input for spec. output 0.5 v. Response substantially flat 2-100,000 c/s. Feedback 28 dB. N.L. 90 dB below full output. Out. imp. 3.75, 6.6, 10, and 15 ohms. Output KT66's. Ultra-linear. To operate with 2001A or 1002B control units. Price £29 8s.

■ **3000 Stereo Amplifier.** 7.5 watts per channel. Dist. 0.5%. Inputs: radio 1 volt; tape 0.5 volts; pickup crystal stereo. Response. 50-15,000 c/s. Feedback 20 dB. N.L. — 57 dB. Out. imp. 15 ohms each channel. Ultra-linear. Size  $14 \times 9\frac{3}{4} \times 4\frac{1}{2}$  ins. Price £31 10s.

■ **3001 Integrated Stereo Amplifier.** Inputs: pickup 4-6 mV and 150 mV; tape or radio 400 mV and 1 volt. Bass, treble, balance controls. Dist. 0.5% at 6 watts. H and N — 60 dB. 7.5 watts per channel. Out. imp. 15 ohms. Response 40-20,000 c/s  $\pm 1$  dB. Crosstalk better than 60 dB. Output ECL82's. Size  $13 \times 10\frac{1}{4} \times 4\frac{1}{4}$  ins. Price £35.



**Period High Fidelity Ltd.,** 28 South Street, London, W.1. Tel.: Grosvenor 4686.

■ **Saville Double Six.** Integrated stereo amplifier. Inputs: pickup 5 and 100 mV; tape 4 mV and 100 mV; radio 100 mV. 6 position sel., bass, treble, balance, vol. controls. H.D. <0.5%. H and N better than 40 dB. P.a.t. 230v at 40 mA; 6.3v 2.5 amps. 6 watts per channel, 9 watts max.

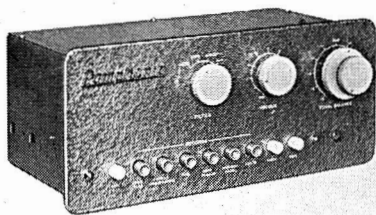

*Pamphonic 1002B control unit*



*Pamphonic 1004 integrated amplifier*



*Pamphonic 3000 stereo amplifier*



*Pamphonic 3001 integrated stereo amplifier*

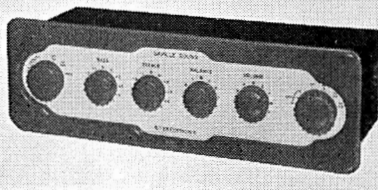

*Saville stereo control unit*

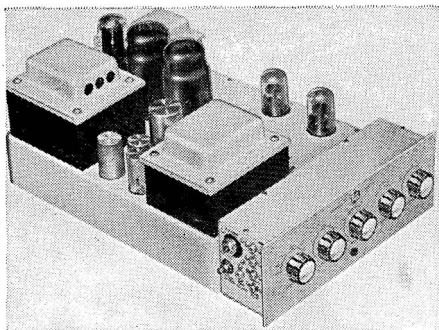

*Pye Proctor control unit and Provost amplifier*

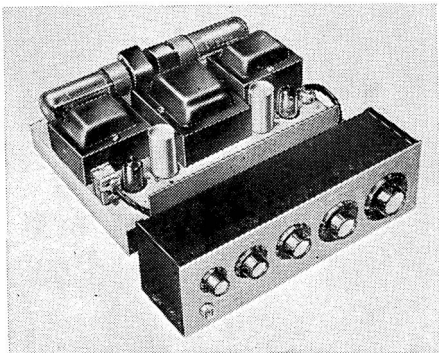

*Pye Stereo Mozart combined amplifier*

Response 30-20,000 c/s  $\pm$  1 dB. 12 dB feedback. Out. imp. 15 ohms or to order. Output ECL83's ultra-linear. Size 13  $\times$  8  $\times$  3 $\frac{1}{2}$  ins. Price £33 12s.

■ **Saville Stereo Control Unit.** Inputs: pickup 5 and 50mV; radio 50 mV; tape 3 mV. Selector switch, bass, treble, vol., balance. H.D. 0.1%. H and N - 60 dB. Size 11  $\times$  5  $\times$  6 $\frac{1}{4}$  ins. Price £15. To operate with Saville Twenty or Seven amplifiers.

■ **Saville Stereo Seven Amplifier.** 7 watts per channel, 15 watts max. Dist. 0.2%. Input for spec. output 3 volts. Response 35-20,000 c/s. Feedback 15 dB. N.L. 75 dB. Out. imp. 15 ohms, or to order. Output ECL82's. Ultra-linear. Size 11 $\frac{1}{2}$   $\times$  7 $\frac{3}{4}$   $\times$  6 ins. Price £33. To operate with Saville Stereo Control Unit.

**Saville Twenty Amplifier.** 20 watts nominal, 30 watts peak. Dist. 0.1%. Input for spec. output 3 volts. Response 35-30,000 c/s. Feedback 20 dB. N.L. - 85 dB. Out. imp. 15 ohms, or to order. Output EL34's. Ultra-linear. Size 11 $\frac{1}{2}$   $\times$  7 $\frac{3}{4}$   $\times$  8 ins. Price £27. To operate with Saville Stereo Control Unit.

■ **Saville 12P. Stereo Control Unit.** Inputs: pickup 4 and 50 mV; tape 3 and 50 mV; radio 50 mV. 6 position sel., bass, treble, balance, vol. controls. H.D. less than 0.1%. H and N better than -50 dB. Rumble filter. P.a.t. 300v at 40 mA; 6.3v at 2.5 amps. Size 13  $\times$  4 $\frac{1}{2}$   $\times$  3 $\frac{3}{4}$  ins. To operate with Saville Double Twelve stereo amplifier. Price see below.

■ **Saville Double Twelve. Stereo Amplifier.** 12 watts per channel, 21 watts peak. Dist. less than 0.1% at 10 watts. Input for spec. output 200 mV. Response 30-20,000 c/s  $\pm$  1 dB at 10 watts. 18 dB feedback. N.L. - 65 dB. Out. Imp. 15 ohms or to order. Output EL84's. Size 11 $\frac{1}{2}$   $\times$  8  $\times$  6 ins. To operate with Saville 12P stereo control unit. Price complete with control unit £51 9s.



**Pye Limited.,** 65 Fairview Road, London, S.W.16. Tel.: Pollards 9441/2. Cables: Faramarine Souphone, London.

**HF10 Mozart Self-contained Control Unit and Power Amplifier.** Inputs: tape 100 mV; radio 100 mV; P/U 15, 10 and 10 mV on each of the 3 curves at 1,000 c/s. special compensation for all makes of P/Us. 5 pos. sel., treble, bass, vol., mains on/off, filter at 4, 7, 12 Kc/s and out. Tape replay socket. H.D. 0.3% at 1,000 c/s and 9 watts. H and N main amp. - 70 dB; tape, radio - 60 dB; P/U - 55 dB. Output 10 watts nom. Response 3-70,000 c/s  $\pm$  3 dB. Feedback 3 main loops over output stage - 5, 8 and 14 dB. Out. imp. 4, 8 and 15 ohms. Output 1 EL34. Integrated single ended ultra-linear. Size 10 $\frac{1}{2}$   $\times$  3 $\frac{1}{2}$   $\times$  5 $\frac{1}{2}$  ins. Price £23 2s. Also available in metal case for shelf mounting. HF10M £24 13s. 6d. and mounted in cabinet with provision for motor HFP1 £33 12s.

**Proctor HF25A Control Unit.** HF25AW in cabinet. Inputs: tape 120 mV; radio 120 mV; mic. 3 mV; P/U max. sens. 8 mV dependent on P/U compensator used. 7 pos. sel. (4 gram.), treble, bass, vol. and on/off. Switched filter 4, 7 and 12 Kc/s and "out." Tape input socket. H and N - 60 dB on 0.5v. Size 10 $\frac{3}{4}$   $\times$  4  $\times$  4 ins. To operate with HF25 power amp. Price HF25A £12 12s.; HF25AW £17 6s. 6d.

**Provost HF25 Amplifier.** 25 watts nom., 30 watts max. Dist. 0.3% at 25 watts, 3.0% at 30 watts. Input for spec. output

0.5v. Response 2-160 Kc/s  $\pm$  3 dB. Feedback 26 dB. Variable poss. feedback by means of manual control. N.L. - 90 dB at 25 watts. Out. imp. 3.75, 6.6, 15 and 60 ohms. Output KT66's. Ultra-linear. Size  $13\frac{1}{2} \times 10 \times 7$  ins. To operate with HF25A control unit. Price £29 8s.

■ **Mozart Stereo Amplifier and Control Unit. HFS20.** Inputs: Pickup 7 mV; radio and tape 100 mV. Vol., bass, treble, balance, on/off, selector switch. H and N - 58 dB. 9 watts per channel nominal, 10 watts max. Dist. 0.3%. Response 10-50,000 c/s  $\pm$  2 dB. Feedback 27 dB. Out. imp. 4, 8, and 15 ohms. Output EL34. Size  $4 \times 10\frac{1}{2} \times 11$  ins. Price Chassis £35, in metal case £36 15s., in Lowboy cabinet £46 15s.



**Rogers Development (Electronics) Ltd.,** 4-14 Barmeston Road, Catford, S.E.6. Tel.: Hither Green 7424/4340. Cables: Rodevco, London, S.E.6.

**RD Cadet Control Unit.** Prov. spec. inputs: tape 200 mV; radio 200 mV; P/U1 comp. 60 mV; PU/1 flat 18 mV; P/U2 comp. 360 mV; P/U2 flat 220 mV. 6 pos. sel., treble, bass, vol. on/off. Tape record and replay sockets. Size  $8\frac{1}{2} \times 5\frac{1}{8} \times 2\frac{1}{2}$  ins. To operate with RD Cadet amplifier. Price £7.

**RD Junior Mk. II Control Unit.** Inputs: tape 20 mV; radio 50 mV; mic. 5 mV; P/U1 5-9 mV; P/U2 40-75 mV. 7 pos. sel. (4 record equal.), treble, bass, vol. on/off. Switched filter 4, 5, 7, 9 and 20 Kc/s. Tape record and replay sockets. Size  $8\frac{1}{2} \times 5\frac{1}{8} \times 4\frac{7}{8}$  ins. To operate with RD Junior Amplifier. Price £11.

**RD Cadet Amplifier.** Prov. spec. 5 watts nom., 6 watts max. Intermod. Dist. 3.5% at 4 watts (100 c/s and 6,000 c/s mixed 4 to 1). Input voltage for spec. output 600 mV. Response 30-20,000 c/s  $\pm$  0.25 dB. Feedback 14 dB  $\pm$  1 dB, 30-20,000 c/s. N.L. - 72 dB below 5 watts. P.a.t. 230v at 35 mA, 6.3v at 2 A. Out. imp. 15 or 3.75 ohms. Output ECL83's. Ultra-linear. Size  $11 \times 4\frac{1}{2} \times 4\frac{1}{2}$  ins. To operate with RD Cadet control unit. Price £10 10s.

**RD Senior Mk. II Amplifier.** 20 watts nom., 36 watts peak. Dist. 0.1% at 15 watts. Input for spec. output 1.4v for 20 watts. Response 25-20,000 c/s  $\pm$  0.25 dB. Feedback 25 dB (2 loop). N.L. - 95 dB below 20 watt. Out. imp. 3.75, 7.5 and 15 ohms. P.a.t. 425v at 40 mA, 6.3v at 2 A. Output EL34's. Ultra-linear. Size  $13 \times 8 \times 8$  ins.

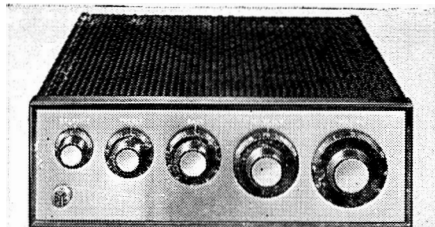

*Pye Mozart HF10M*

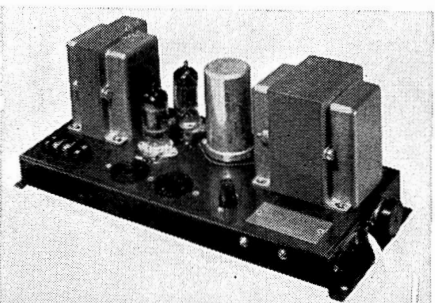

*Rogers RD Minor control unit and amplifier*

To operate with RD Senior Mk. IV control unit. Price £28.

**RD Senior Control Unit Mk. IV.** Inputs: radio/mic. 2 mV; radio 100 mV; tape 50 mV; P/U 8-10 mV. 7 pos. sel. (4 record equal.), treble, bass vol. and on/off. Switched filter 5, 7 and 9 Kc/s. Filter slope control 5-30 dB per octave. Tape record 1.5v and replay socket (flat or C.C.I.R. at  $7\frac{1}{2}$  i/s). Rumble filter fixed 12-15 dB fall off below 25 c/s. Size  $10\frac{1}{2} \times 5 \times 2\frac{7}{8}$  ins. To operate with RD Senior Mk. II power amp. Price £13 10s.

**RD Junior Amplifier.** 10-12 watts nom., 14 watts max. Dist. at 1,000 c/s. 0.12% at 10 watts. Input for spec. output 600 mV. R.M.S. for 10 watts. Response 20-30,000 c/s  $\pm$  0.25 dB. Feedback 20 dB. N.L. - 85 dB below 10 watts. P.a.t. 285v at 40 mA, 6.3v at 2.5 A. Out. imp. 2-3, 6-8, 12-16 ohms.

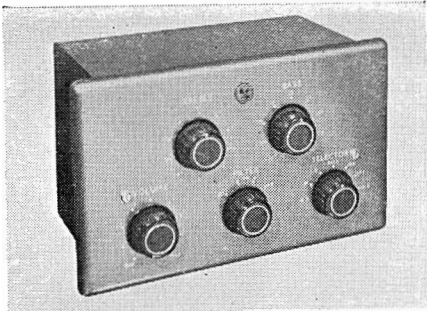

Rogers RD Junior control unit

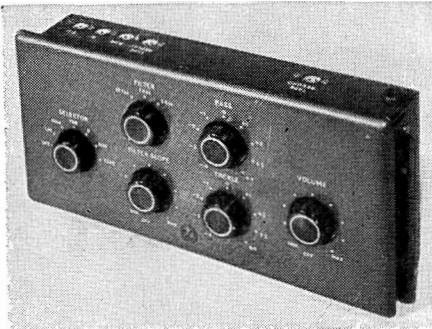

Rogers RD Senior control unit

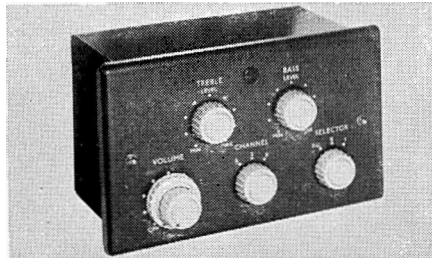

Rogers RD Cadet Stereo control unit



Rogers RD Junior Stereo control unit

Output EL84's. Ultra-linear. Size  $11 \times 6 \times 5\frac{1}{2}$  ins. For Junior II control unit. Price £17.

■RD Cadet Stereo Control Unit. Inputs: pickup 50 mV; radio and tape 100 mV. Bass, treble, vol., function switch, selector switch. Size  $8\frac{1}{2} \times 5\frac{1}{2} \times 4\frac{7}{8}$  ins. Price £12. To operate with two RD Cadet, Junior, or Senior II amplifiers.

■RD Junior Mk. II. Stereo Control Unit. Inputs: pickup 5-10 and 100-200 mV; tape 4 and 50 mV; radio 50 mV. Push-button sel., bass, treble, balance, filter controls. Response 25-20,000 c/s  $\pm 1$  dB. Crosstalk - 40 dB. Size  $8\frac{1}{2} \times 5\frac{1}{2} \times 5\frac{3}{8}$  ins. To operate with RD Junior stereo amplifier. Price £18.

■RD Junior. Stereo Amplifier. 12 watts per channel, 18 watts max. Dist. 0.2% at 12 watts. Input for spec. output 750 mV. Response 20-20,000 c/s  $\pm 0.25$  dB. 20 dB feedback. N.L. - 85 dB. Out. imp. 4, 8 or 16 ohms. Output EL84's. Size  $14 \times 8 \times 5\frac{3}{8}$  ins. To operate with RD Junior Mk. II stereo control unit. Price £28 10s.

■RD Stereo Adaptor. Designed to couple together two single channel Control Units for stereo operation. Provides ganged vol. control, and function switch. Price £2 10s.

■HG88. Combined stereo amplifier and control unit, 8 watts per channel. Dist. 0.5%. H and N - 55-60 dB. Response 30-60 dB. Response 30-20,000 c/s  $\pm 1$  dB. Inputs: pickup 4, 10, 60 and 150 mV at 60K and 1 Megohm, radio and aux. 40 mV, tape 4 mV, mic. 3 mV. Sel. switch, bass, treble, balance, filter, and precision volume control. Out. imp. 3.75 or 15 ohms. Size  $15\frac{1}{2} \times 10\frac{1}{2} \times 7$  ins. Price complete in case £40.



Shirley Laboratories Ltd., 3 Prospect Place, Worthing, Sussex. Tel.: Worthing 30536.

Jupiter 3B/1-15E Self-contained Control Unit and Power Amplifier. Inputs: radio, tape, P/U 78 and L.P. Output 15 watts nom. 25 watts max. Input approx. 10 mV for 15 watts. Treble, bass, vol. Response 45-35,000 c/s  $\pm 1$  dB. N.L. - 80 dB. Dist. 0.2% at 10 watts and 1,000 c/s. Out. imp. 15 ohms or as requested. Output EL84. P.a.t. 250v at 35 mA, 6.3v at 2 A. Size  $10 \times 7 \times 6\frac{1}{2}$  ins. Price £23 2s.

Jupiter 3B/1-30E Self-contained Control Unit and Power Amplifier. Spec. as for 3B/1-15E except output 30 watts nom., 45 watts max. Response 28-35,000 c/s  $\pm 1$  dB. Output EL34's. Price £33 12s.

■ **PA 4/86 Stereo Control Unit.** Inputs: pickup 3 and 50 mV; radio 100 mV; tape 3 mV and 0.5 volts, selector switch, bass, treble, volume, balance. H.D. 0.1%. H and N — 58 dB. Price £21 1s. To operate with SF/10 amplifier, or two SB/7-30.

SB/7-30s Amplifier. 20 watts nominal, 35 watts max. Dist. 0.1%. Input for spec. output 2.5 volts. Response 34-40,000 c/s  $\pm$  0.3 dB. N.L. — 80 dB. Out. imp. 15 ohms. Output EL34. Ultra-linear. Size 11  $\times$  7 $\frac{1}{2}$   $\times$  8 ins. Price £29 8s. 28 watt version £32 11s. To operate with PA 4/86 Control Unit.

**Jupiter SB1-15F Combined Amplifier and Control Unit.** Input 2 mV minimum. Dist. 0.2%. 14 watts nominal, 23 watts max. Response 45-35,000 c/s  $\pm$  1 dB. N.L. — 80 dB. Out. imp. 100 ohms line or to order. Size 10  $\times$  7  $\times$  6 $\frac{1}{2}$  ins. Price £23 2s.

■ **SF/10 Combined Stereo Amplifier and Control Unit.** 12 watts per channel, 18 watts peak. Dist. 0.1%. Control Unit similar details to PA 4/86 above. Price complete £45 3s.

■ **2SB/10. Integrated Stereo Amplifier.** Inputs: magnetic and crystal pickup; tape direct from high impedance head and from tape recorder; radio. Sel. switch, bass, treble, volume, balance controls. 7 watts per channel. Output ECL82's. Price £45 3s.

■ **2SB/12. Integrated Stereo Amplifier.** 12 watts per channel, 20 watts peak. Output EL84's. Other details as 2SB/10. Price £48 6s.

■ **2SB/50. Integrated Stereo Amplifier.** 25 watts per channel, 40 watts peak. Output KT88's. Response 35-35,000 c/s  $\pm$  1 dB at 25 watts. Dist. 0.05% at 25 watts. Other details as 2SB/10. Price £84.



**H. L. Smith & Co. Ltd.,** 287/289 Edgware Road, London, W.2. Tel.: Paddington 5891/7595.

**Cooper-Smith Mk. II Control Unit.** Inputs: radio 100 mV; P/U 3 mV; mic. 1.5 mV; tape 100 mV. 6 pos. sel. (3 record equal.), treble, bass, vol. on/off. Switch filter 6, 8 and 10 Kc/s. Co-axial tape replay switch. H.D. 0.1% or less at 1,000 c/s. H and N — 80 dB. Rumble filter 12 dB cut at 30 c/s. Size 10  $\times$  3 $\frac{1}{2}$   $\times$  6 $\frac{1}{2}$  ins. To operate with B.P.I. power amp. Price kit £7 17s. 6d. Assembled and tested £10 17s. 6d.

**Cooper-Smith B.P.I.** 10 watts nom., 12 watts max. Dist. 0.15% or better at 10 watts.

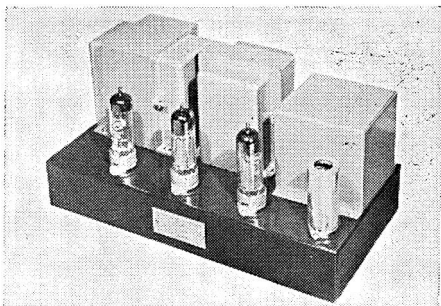

*Rogers RD Junior amplifier*

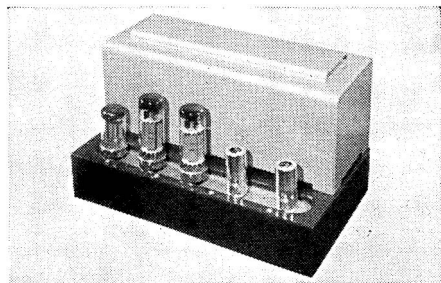

*Rogers RD Senior amplifier*

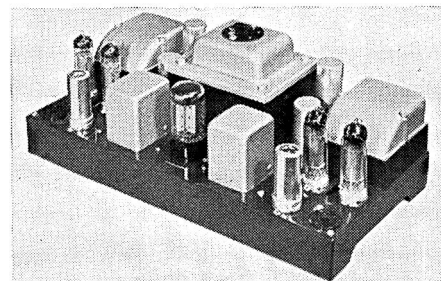

*Rogers RD Junior stereo amplifier*

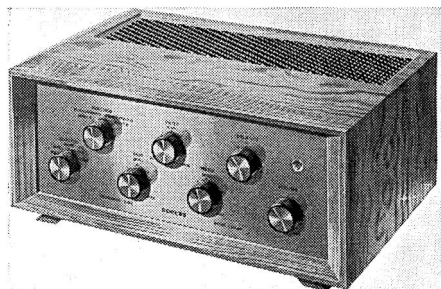

*Rogers HG88 integrated stereo amplifier*



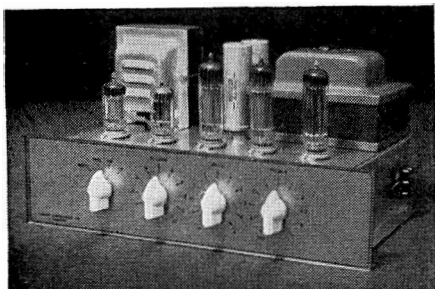

*Shirley Jupiter amplifier*

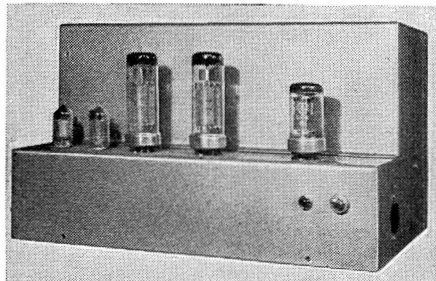

*Shirley Mullard 20-watt amplifier*

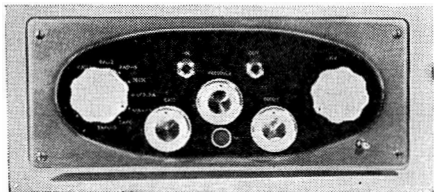

*Sound Sales Mk. III control unit*

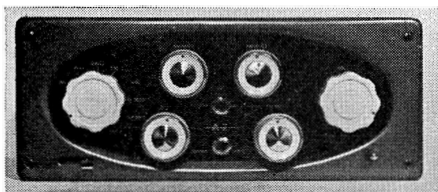

*Sound Sales A-Z Twin Twenty control unit*

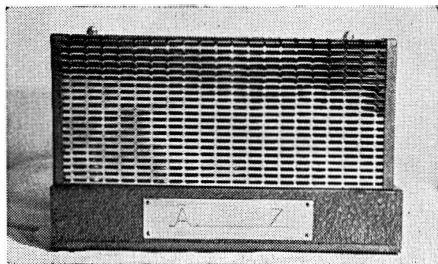

*Sound Sales A-Z Senior Mk. II amplifier*

Input for spec. output approx. 1.9 V. Response 20-30,000 c/s  $\pm$  1 dB. Feedback 18 dB. N.L. 90 dB below max. output. Out. imp. 3.75 and 15 ohms. Output 6BQ5's or EL84's. Ultra-linear. Size 12  $\times$  7  $\times$  7  $\frac{1}{2}$  ins. To operate with Cooper-Smith Mk. II control unit. Price kit £12 5s. Assembled and tested £14 5s.

**"Prodigy" Combined Amplifier and Control Unit.** Inputs: pickup 8 mV; radio and tape 100 mV, 6 watts, 9 watts max. Dist. 0.2%. Response 30-25,000 c/s  $\pm$  1 dB. Feedback 15 dB. N.L. - 70 dB. Out. imp. 3  $\frac{3}{4}$ , 7  $\frac{1}{2}$ , and 15 ohms. Output ECL82's. Ultra-linear. Size 10  $\frac{1}{2}$   $\times$  7  $\times$  5  $\frac{1}{2}$  ins. Price Kit £12 10s. Assembled and tested £15 15s.

■ **Cooper-Smith Stereo Control Unit.** Inputs: pickup 3 mV; tape 100 mV; radio 100 mV. 4 position sel., bass, treble, vol., balance. H.D. 0.15%. H and N - 60 dB. Size 10  $\frac{1}{2}$   $\times$  4  $\frac{1}{2}$   $\times$  3  $\frac{1}{2}$  ins. To operate with Cooper-Smith stereo amplifier. Price Kit £12 12s. Assembled and tested £15.

■ **Cooper-Smith Stereo Amplifier.** 6 watts per channel, 9 watts peak. Dist. 0.2% at 6 watts. Input for spec. output 800 mV. Response 40-25,000 c/s at 6 watts. 15 dB feedback. N.L. - 80 dB. Out. imp. 3.75, 7.5, 15 ohms. Output ECL82's. Size 12  $\times$  7  $\times$  6  $\frac{1}{4}$  ins. To operate with Cooper-Smith stereo control unit. Price Kit £13 13s. Assembled and tested £16.



**Sound Sales Ltd.,** Works and Acoustic Laboratories, West Street, Farnham, Surrey. Tel.: Farnham 6461-2-3. Cables: Sounsense.

**A-Z Wide Range Control Unit Mk. III.** Inputs: pickups 5 and 50 mV; radio 50 mV; mic. 1 mV. 8-position sel., bass, treble, presence. H.D. 0.06%. H and N - 80 dB. Rumble filter. P.a.t. 250v at 40 mA. Size 11  $\frac{1}{4}$   $\times$  4  $\frac{3}{8}$   $\times$  5  $\frac{1}{2}$  ins. To operate with Mk. III Amplifier, and not sold separately.

**A-Z Mk. III Amplifier.** 10 watts nominal, 13.5 watts max. Dist. 0.06%. Input for 10 watts - 18 dB ref. 1 volt. Response 12-27,000 c/s  $\pm$  1 dB. Feedback 22 dB. N.L. - 80 dB. Out. imp. 3, 6, 15, and 30 ohms. Output EL84's. Ultra-linear. Size 10  $\frac{1}{4}$   $\times$  7  $\frac{1}{2}$   $\times$  6 ins. To operate with Mk. III Control Unit. Price complete £25. Amplifier only £17.

■ **A-Z Twin Twenty Stereo Control Unit.** Inputs: pickup 5 mV and 100 mV; radio 3 at 30 mV; tape 14 and 125 mV; mic. 1.4 mV. 11-position sel., balance, bass,



treble, Filter. Size  $11\frac{1}{4} \times 4\frac{3}{8} \times 9\frac{1}{2}$  ins. Price £20.

■ **A-Z Wide Range Stereo Control Unit.** Details as for Twin Twenty above but with additional Transistor stage to increase sensitivity to 0.80 mV for pickup, and 80 mV for P/U and tape head. Size  $11\frac{1}{4} \times 4\frac{3}{8} \times 9\frac{1}{2}$  ins. Price £26.

■ **A-Z Twin Twenty Stereo Amplifier.** 10 watts per channel, 13.5 watts peak. Dist. .08%. Input for spec. output 0.1 volts. per channel. Response 20-20,000 c/s flat. N.L. - 80 dB. Out. imp. 3, 8, and 15 ohms. Output EL84's. Ultra-linear. Size  $12\frac{1}{2} \times 10 \times 6\frac{1}{2}$  ins. Price £30. To operate with Twin Twenty Control Unit, or A-Z Wide Range Control Unit.

■ **A-Z Stereo Convertor.** Inputs: pickup 45 and 70 mV; radio 3 inputs at 45 mV; tape 45 and 55 mV. 8-position sel., bass, treble, presence, volume, balance. Rumble filter. Size  $11\frac{1}{4} \times 4\frac{3}{8} \times 5\frac{1}{2}$  ins. Price £17 10s. Designed to operate with any existing amplifiers for conversion to stereo. Supplied less power pack, with 1 Mk. III Amplifier at £34.

**A-Z Senior Control Unit** with transistor input. Inputs: mic. 1 mV; radio 100 mV; tape 250 mV; tape 1 mV (from head) C.C.I.R. and N.A.R.T.B.; P/U variable 1-100 mV. 11 pos. sel. (5 record equal.), treble, bass, vol., presence control, switched filter, 2 pos. and out combined with variable slope. Tape recording in all positions, also jacks for portable recorders. Specially designed for use with M.C. pickups or tape-head without necessity of transformers. Size  $11 \times 4\frac{1}{2} \times 6$  ins. Sold only with A-Z Senior power amp.

**Tri-Channel Control Unit** with transistor input. Inputs: mic. 1 mV; radio 100 mV; tape (from recorder) 250 mV; tape (from head, C.C.I.R. and N.A.R.T.B.) 1 mV; P/U variable 1-100 mV. 11 pos. sel. (5 record equal.). Presence, middle channel response; treble, top channel response; bass, bass channel response. Infinitely variable electronic crossover system, controlling 3 separate amplifying channels to appropriate speakers via master vol. control. Switched filter. Tape recording in all positions also jacks for portable recorders. H and N better than - 80 dB. Dist. not measurable at normal output. Size  $11\frac{1}{4} \times 4\frac{3}{8} \times 6$  ins. Sold only with Tri-channel amp. and speaker enclosure.

**Tri-Channel Amplifier Mk. V.** Bass 20-30 watts, mid channel 8-12 watts, treble channel 4 watts. Total undistorted output approx.

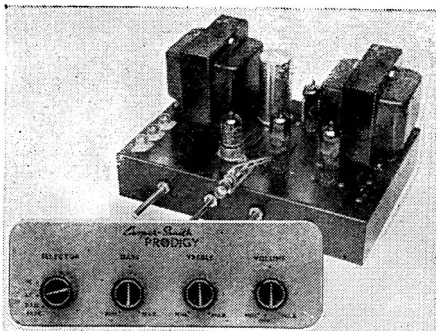

*Cooper-Smith Prodigy control unit and amp.*

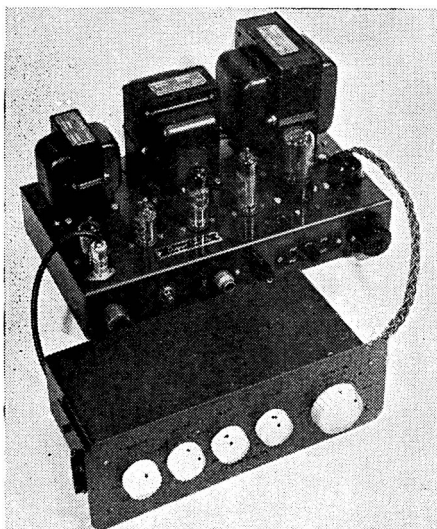

*Cooper-Smith control unit and amplifier*

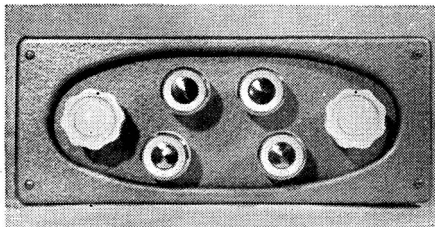

*Sound Sales Tri-Channel control unit*

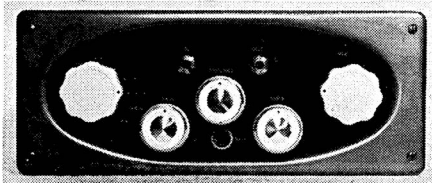

*Sound Sales A-Z stereo convertor*

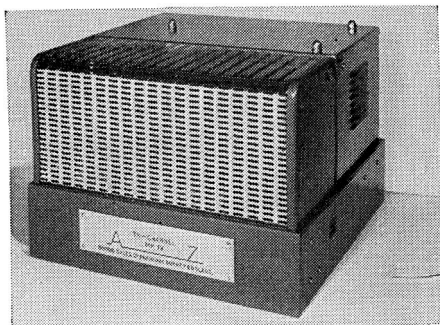

*Sound Sales Tri-Channel amplifier*

45 watts. Dist. 0.05%. Response infinitely variable on 3 channels. N.L. better than - 80 dB. Output LN309, EL84, EL34. Ultra-linear. Size 18 × 10 × 8½ ins. Price complete with control unit and tri-channel speaker enclosure £125.

■ **Tri-channel Stereo Control Unit and Tri-channel Stereo Amplifier.** Designed for stereophonic or monaural reproduction using 2 Tri-channel main amps. and 2 labyrinth speakers. Stereo to monaural changeover switch, giving parallel or stereo connection. Price complete with control unit, 2 amps and 2 speaker systems £300.

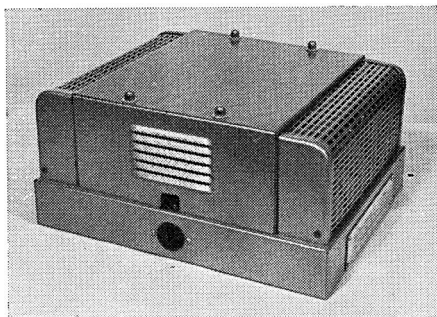

*Sound Sales Twin Twenty stereo amplifier*

**A-Z Senior Mk. II Amplifier.** 20 watts nom. 30 watts max. Dist. 0.05% at 20 watts. Response flat 10-30,000 c/s. Feedback 25 dB. N.L. - 80 dB at 20 watts. Out. imp. 3, 6, 15 or 30 ohms. Output EL34's. Ultra-linear. Size 14½ × 8½ × 8½ ins. Price complete with A-Z Senior control unit £42.



**Specto Ltd.,** Vale Road, Windsor, Berks. Tel.: Windsor 1241/2. Cables: Specto, Windsor.

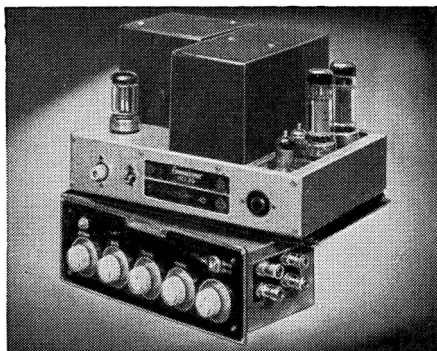

*Connoisseur HQ20 control unit and amplifier*

**Spectone 5-15 "Eton" Combined Control Unit and Amplifier.** 3 pos. sel. Plug-in equalisers for crystal P/U's. 10 watts nom. 15 watts max. Dist. better than 0.3% at 10 watts. Input for spec. output 500 mV. Response 20-20,000 c/s ± 0.5 dB. Feedback - 26 dB. N.L. - 73 dB on 10 watts. Out. imp. 15 ohms. Output EL84's. Size 14 × 7 × 8½ ins. Price £18 18s.

**Eton Pre-amp.** Available for low output P/U's, etc. Input 40 mV for 500 mV output. H.D. better than 0.1%. H and N - 73 dB. Size 6½ × 3½ × 1½ ins. Price £4 4s.

**Spectone 5-15 "Windsor" Control Unit.** Inputs: radio 100 mV; P/U 50 mV; aux. 10 mV. 4 pos. sel., treble, bass, vol. and on/off. H.D. better than 0.15% on all inputs for 40 mV output. H and N - 54 dB on mic. - 73 dB others. Size 10 × 5 × 3 ins. Sold only with the Windsor power amp.

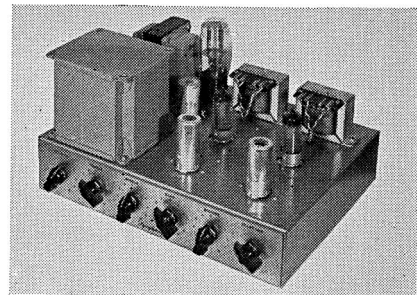

*Symphony stereo integrated amplifier*

**Spectone 5-15 "Windsor" Amplifier.** 10 watts nom., 15 watts max. Dist. better than 0.3% at 10 watts. Input for spec. output 40 mV. Response 20-20,000 c/s ± 0.5% dB. Feedback - 26 dB. N.L. - 73 dB on 10 watts. Out. imp. 15 ohms. Output EL84's. Size 14 × 7 × 8½ ins. Price with control unit £24 17s. 6d.

**A. R. Sugden & Co. (Engineers) Ltd.**, Market Street, Brighouse, Yorks. Tel.: Brighouse 2142. Cables: Connoisseur, Brighouse.

**Connoisseur HQ20 Control Unit.** Inputs: radio, tape and P/U 10 mV. 5 pos. record char. switch, treble, bass, vol. Steep slope filter, 5, 7 and 9 Kc/s. Tape input sockets. H.D. at 1,000 c/s better than 0.1% at 20 watts. H and N with amp 75 dB down on 20 watts. 30 c/s rumble filter. Size  $11\frac{1}{2} \times 4 \times 4\frac{3}{4}$  ins. To operate with HQ20 power amp. Price £16.

**Connoisseur HQ20 Amplifier.** 20 watts nom., 30 watts max. Dist. better than 0.1% at 20 watts. Input for spec. output 300 mV. Response 20-50,000 c/s  $\pm 0.5$  dB. N.L. - 85 dB at 20 watts. Out imp. 15 ohms. Output EL34's. Ultra-linear. Size  $12 \times 8\frac{1}{2} \times 7\frac{1}{2}$  ins. Sold only with control unit. Price £31 10s.

■ **Connoisseur Stereo S66 Control Unit.** Inputs: pickup 6 mV; radio and tape 100 mV. 5-position sel., treble switch, vol., channel switch. H.D.  $<0.1\%$ . H and N - 60 dB. Rumble filter. Size  $10\frac{3}{4} \times 3\frac{1}{2} \times 5\frac{1}{2}$  ins. Price £16 10s. To operate with Stereo S66 Amplifier, or two HQ20.

■ **Connoisseur Stereo S66 Amplifier.** 6 watts per channel, 7.5 watts max. Dist.  $<0.3\%$ . Input for spec. output 250 mV. Response 30-20,000 c/s  $\pm 1$  dB. Feedback 20 dB. N.L. - 70 dB. Out. imp. 3.5 or 15 ohms. Output ECL82's. Ultra-linear. Size  $11\frac{1}{2} \times 5\frac{1}{2} \times 6\frac{3}{4}$  ins. Price £24 10s. To operate with Stereo S66 Control Unit.



**Symphony Amplifiers Ltd.**, 16 Kings College Road, London, N.W.3. Tel.: Primrose 3314/5.

**Symphony No. 1 Amplifier Mk. 3.** 4 watts, 5 watts max. Dist. less than 0.6%. Input for spec. output 140 mV. Response 30-30,000 c/s  $\pm 1$  dB. 24 dB feedback. N.L. - 80 dB. Out. imp. 3 or 15 ohms to order. Output 6V6's. Size  $13\frac{1}{2} \times 6 \times 6$  ins. Price £12 12s.

**Symphony No. 2 Amplifier Mk. 4.** 8 watts, 10 watts max. Dist. less than 0.2% at 6 watts. Input for spec. output 130 mV. Response 20-20,000 c/s  $\pm 1$  dB. 26 dB feedback. N.L. - 85 dB. Out. imp. 3, 7.5, and 15 ohms. Output 6L6's (triode strapped). Size  $12 \times 7 \times 9\frac{1}{2}$  ins. Price £18 18s.

■ **Symphony Stereo Amplifier.** 5 watts per channel. Dist. 0.3%. Input for spec. output 130 mV. Response 30-30,000 c/s  $\pm 1$  dB. 24 dB feedback. N.L. - 85 dB. Out. imp. 15 ohms. Output 6BW6's. Size  $12 \times 7 \times 9\frac{1}{2}$  ins. Price £19 19s.



*Tansley-Howard Archon SP31*

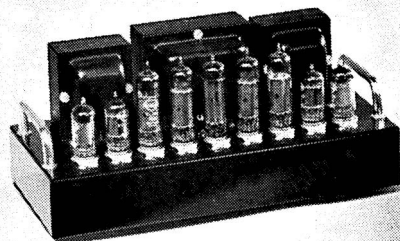

*Tansley-Howard Archon SL101*

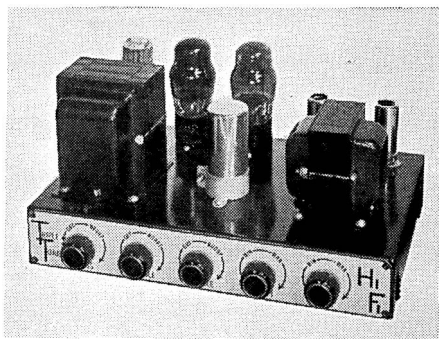

*Tripletone Hi-Fi Major*

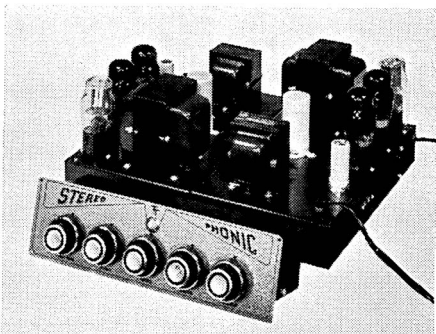

*Tripletone Stereo 12-12*

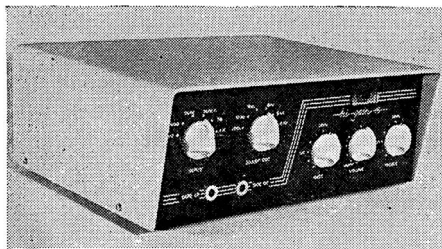

*Tannoy Hi-Gain 15 combined amplifier*

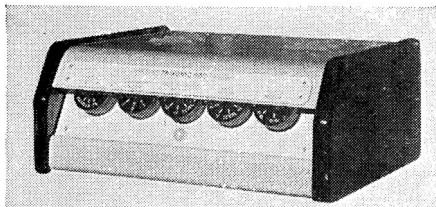

*Trixonic combined control unit and amplifier*

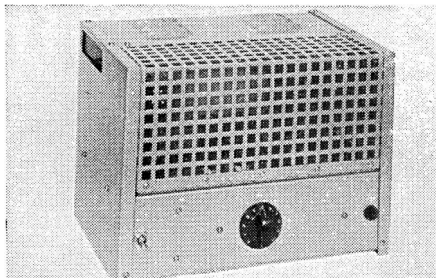

*Westrex 2192 amplifier*

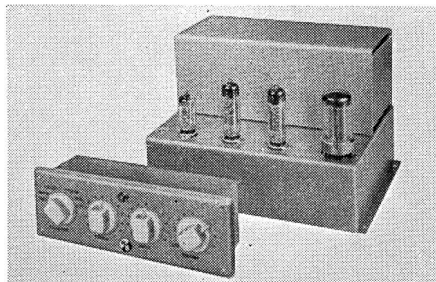

*Stentorian WB12 control unit and amplifier*

**Tannoy Products Ltd.**, West Norwood, London, S.E.27. Tel.: Gipsy Hill 1131. Cables: Tannoy, London.

**"Hi-Gain 15" Combined Amplifier and Control Unit.** Inputs: pickup 5 and 10 mV; radio 100 mV; tape 4 and 100 mV; mic. 4 mV. Selector switch, vol., bass, treble, filter. 10 watts nominal, 15 watts peak. Intermod. 1%. Response 30-20,000 c/s. Out. imp. 4, 8, and 16 ohms. H and N — 40

dB. Size  $12\frac{1}{2} \times 4\frac{1}{2} \times 9\frac{1}{2}$  ins. Price free standing £42, and for panel-mounting £39 18s.



**Tansley-Howard Ltd.**, 95 Kensal Road, London, W.10. Tel.: Ladbroke 7195.

■ **Archon SP31. Stereo Control Unit.** Inputs: pickup 1, 7 or 70 mV variable, 2, 7 mV; tape 60 mV; radio 60 mV variable. Sel. balance, treble, bass, filter controls. H.D. 0.05%. H and N — 61 dB. Rumble filter. Size  $12 \times 6 \times 2\frac{3}{8}$  ins. To operate with SP31 stereo amplifier. Price £20 9s. 6d.

■ **Archon SL101. Stereo Amplifier.** 10 watts per channel. Dist. 0.2% at 10 watts. Input for spec. output 200 mV. Response 3-50,000 c/s  $\pm 1$  dB. 22 dB feedback. N.L. — 80 dB. Out. imp. 3, 7, and 15 ohms. Output EL84's. Size  $12 \times 6 \times 5\frac{1}{2}$  ins. To operate with SC31 stereo control unit. Price £29 8s.



**Tripletone Manufacturing Co. Ltd.**, 241A The Broadway, Wimbledon, S.W.19. Tel.: Liberty 1189.

**Hi-Fi Major. Integrated Amplifier.** Inputs: high imp. pickup or microphone. 12 watts, 15 watts max. Dist. 0.15%. Response 15-20,000 c/s  $\pm 1.5$  dB. 20 dB feedback. N.L. — 80 dB. Out. imp. 2-3 or 15 ohms. Output 6V6's. Size  $12 \times 7 \times 6\frac{1}{2}$  ins. Price £15 18s. 9d.

■ **Stereo 12-12. Stereo Control Unit and Amplifier Combination.** Inputs: pickup, radio, microphone 100 mV. Sel., bass, middle, treble, vol. controls. H.D. 0.15%. H and N — 80 dB. P.a.t. 300v 50 mA, 6.3v. 12 watts per channel, 15 watts max. Response 15-20,000 c/s  $\pm 1.5\%$ . 20 dB feedback. Out. imp. 2-3 or 15 ohms. Output 6V6's. Size: Control unit  $11 \times 3\frac{1}{2} \times 2\frac{1}{2}$  ins., amplifier  $12 \times 7 \times 6\frac{1}{2}$  ins. (two required). Price £33 19s. 6d. (three units).



**Trix Electrical Company Limited**, 1-5 Maple Place, London, W.1. Tel.: Museum 5817. Cables: Trixradio, Wesdo, London.

**Trixonic T800 Combined Control Unit and Power Amp.** Inputs: LP 4 mV; 78 12 mV; radio/tape 100 mV. 3 pos. sel., treble, bass, loudness control (additional bass and treble boost given at low vol. levels). 4 pos. pickup equalisation plug fitted. Tape input socket. H.D. at 1,000 c/s. <0.5% at 6 watts. H and N better than — 60 dB. Rumble filter 18 dB octave below 30 c/s. P.a.t. 270v at 20 mA, 6.3v at 1 A. 8 watts nom., 12 watts max. Response 30-15,000 c/s  $\pm 1.5$  dB at 6 watts,

Triple-loop feedback. Out. imp. 3, 8 and 15 ohms. Output EL84's. Size  $12\frac{1}{2} \times 9\frac{1}{2} \times 5$  ins. Price £33 12s.

■ **Trixette XT202. Integrated Stereo Amplifier.** Inputs: pickup, tape, tuner, 50/100 mV. 6 position sel., bass, treble, balance, vol. H.D. less than 0.5%. H and N - 60 dB. Switched rumble filter. 3.75 watts per channel. Out. imp. 3, 8, and 15 ohms. Output EL84's. Size  $11\frac{1}{2} \times 4\frac{1}{2} \times 7\frac{1}{2}$  ins. Price £23 2s.



**Wellington Acoustic Laboratories Ltd.,** Farnham, Surrey. Tel.: Farnham 6461/4961.

**WAL Gain.** Impedance matching transistor pre-amp, battery operated (3,000-hour life). Noise and distortion too low to measure, gain better than 100. Suitable for use with low output P/U or for direct connection to tape head. For use with any amplifier. Size  $3\frac{3}{8} \times 2\frac{1}{8} \times 2\frac{1}{8}$  ins. Price £5.

■ **Stereo WAL Gain.** Transistorised stereo pre-amplifier. To match pickups at 50,000 or 3,500 ohms. Battery life 1,000 hours. Size  $7 \times 2\frac{1}{2} \times 2\frac{1}{2}$  ins. Price £7 10s.



**Westrex Company Ltd.,** Coles Green Road, London, N.W.2. Tel.: Gladstone 5401/8. Cables: Westelcol, Norphone, London.

**2192 Amplifier.** 30 watts. Dist. 0.1%. Size  $12 \times 9 \times 8\frac{1}{2}$  ins. Designed primarily for use with the Westrex 2241 Loudspeaker Assembly. Price £49.



**Whiteley Electrical Radio Co. Ltd.,** Victoria Street, Mansfield, Notts. Tel.: Mansfield 1762/3/4/5. Cables: Whitebon, Mansfield.

**Stentorian WB12 Standard Control Unit.** Inputs 50 mV. 6 pos. sel. (3 gram.), treble, bass, vol. Tape/Radio input socket. H and N - 70 dB at 10 watts. P.a.t. 250v at 50 mA, 6.3v at 1.5 A. Size  $9 \times 3\frac{3}{8} \times 3\frac{3}{8}$  ins. To operate with WB12 power amp. Price £9.

**Stentorian WB12 Major Control Unit.** Inputs: mic. 2.5 mV; P/U 10 mV; radio 100 mV; tape 100 mV; aux. 50 mV. 9 pos. sel. (4 record equal), treble, bass, vol. on/off switched filter at 5.7 and 11 Kc/s; filter slope. Tape input socket. H.D. 0.3%. H and N - 70 dB. Size  $11\frac{3}{8} \times 4\frac{1}{2} \times 4$  ins. To operate with WB12 power amp. Price £19 10s.

**WB12 Amplifier.** 12 watts nom., 15 watts max. Dist. at 1,000 c/s. 0.12%. Response 20-20,000 c/s  $\pm$  0.15 dB. Feedback 25 dB. N.L. - 80 dB at 10 watts. Out. imp. 3 and

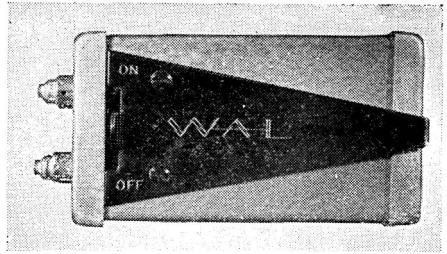

*WAL Gain*

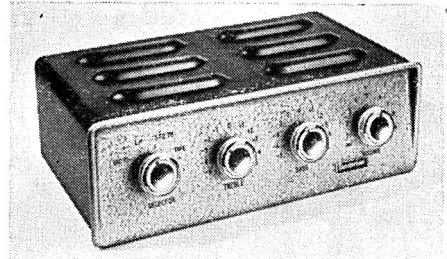

*Stentorian WB combined amplifier*

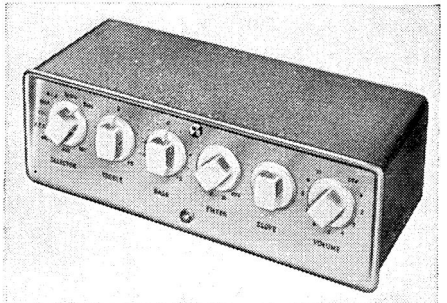

*Stentorian WB12 Major control unit*



*W & N combined stereo amplifier*

15 ohms. Output EL84's. Ultra-linear. Size  $10\frac{3}{8} \times 8 \times 7$  ins. To operate with WB Major or Standard control units. Price £18 10s.

■ **WB Stereo Control Unit.** Inputs: pickup 2.5 and 100 mV; radio and tape 50 mV. Selector switch, bass, treble. H.D. 0.2%. H and N - 70 dB. Size  $11\frac{3}{8} \times 4 \times 7\frac{1}{2}$  ins.



*W & N Audiomaster control unit*

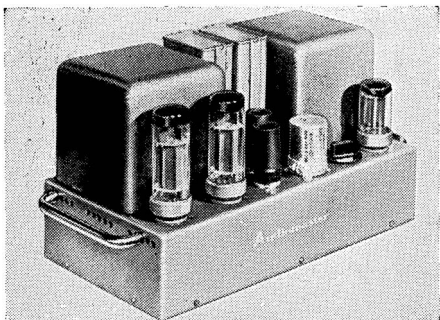

*W & N Audiomaster amplifier*

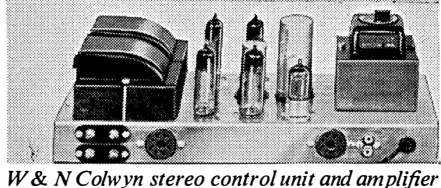

*W & N Colwyn stereo control unit and amplifier*

Price £22 15s. To operate with WB8S, or two WB12.

■**WB8S Stereo Amplifier.** 6-8 watts per channel. Dist. 0.2%. Input for spec. output 650 mV. Response 40-15,000 c/s  $\pm$  0.5 dB. Feedback 20 dB. N.L. - 60 dB. Out. imp. 3 and 15 ohms. Output ECL82's. Ultra-linear. Size  $10\frac{7}{8} \times 6\frac{1}{4} \times 10\frac{1}{2}$  ins. Price £23 15s. To operate with WB Stereo Control Unit.

**WB8 Combined Amplifier and Control Unit.** 6 watts, 8 watts max. Dist. 0.3%. Inputs:

pickup 100 mV; radio and tape 50 mV. Response 30-20,000 c/s  $\pm$  2.5 dB. Feedback 15 dB. N.L. - 60 dB. Out. imp. 3 and 15 ohms. Output ECL82's. Ultra-linear. Size  $11\frac{3}{4} \times 7\frac{1}{2} \times 4$  ins. Price £19 19s.



**W & N Electronics Ltd.,** 80/82 Uxbridge Road, London, W.13. Tel.: Ealing 4774. Cables: Wanamp.

**Audiomaster. Control Unit.** Inputs: pickup from 8 mV; tape 1.8 mV; mic. 1 mV; tuner 50 and 200 mV; aux. from 2 mV. 10 position sel., 1 treble, bass, loudness, filter slope. Dist. 0.1%. Size  $13\frac{3}{4} \times 5\frac{3}{8} \times 8$  ins. To operate with Audiomaster 25 watt amplifier. Price on application.

**Audiomaster. Amplifier.** 25 watts. Dist. 0.1% at 25 watts. Input for spec. output 250 mV. Response 15-30,000 c/s  $\pm$  1 dB. 25 dB feedback. N.L. - 90 dB. Out. imp. 4, 8, or 16 ohms. Output EL34's. Size  $12 \times 6\frac{3}{4} \times 8\frac{1}{4}$  ins. To operate with Audiomaster Conway or monaural control unit. Price on application.

■**Audiomaster Brecon. Integrated Stereo Amplifier.** Inputs: pickup 4 mV; tape 5 mV; mic. 3 mV; tuner 100 mV. 8 position sel., treble, bass, balance controls. 8 watts per channel. H.D. 0.5% at 6 watts. Response 40-15,000 c/s  $\pm$  2 dB. 15 dB feedback. Output ECL82's. Size  $14 \times 5 \times 13$  ins., in wooden cabinet. Price £33 15s.

■**Audiomaster Colwyn. Stereo Control Unit.** Inputs: pickup 4 and 80 mV; tape 5 mV; mic. 3 mV; tuner from 100 mV. 8 position selector, bass, treble, balance controls. Output 2 volts and 250 mV. Size  $14\frac{1}{2} \times 5 \times 6\frac{1}{2}$  ins. To operate with Audiomaster Colwyn stereo amplifier. Price about £20.

■**Audiomaster Colwyn. Stereo Amplifier.** 15 watts per channel. H.D. 0.3% at 15 watts. Response 30-20,000 c/s. Input for spec. output 1.5v. 20 dB feedback. Out. imp. 8 or 16 ohms. Output EL84's. Size  $7 \times 13\frac{1}{2} \times 5\frac{1}{2}$  ins. To operate with Audiomaster Colwyn stereo control unit. Price about £20.

■**Audiomaster Conway. Stereo Control Unit.** Inputs: pickup 3 and 750 mV; tape 5 mV; tuner 300 mV or 1 volt, aux., from 300 mV. 11 position sel., bass, treble, balance, filters. Output 250 mV. Size  $14\frac{1}{2} \times 5 \times 7\frac{1}{2}$  ins. To operate with two Audiomaster 25 watt amplifiers. Price £28 10s., with two power amplifiers £87 10s.

# RADIO TUNERS

## An Introduction

**L**OOKING back over a year of development does not show up any remarkable changes in the section of the industry devoted to radio tuners; and this is not surprising, because there has been no great change in the technique of broadcast transmissions during that period. What is most interesting, however, is the very big development that has taken place in this corner of the industry during the past four years. A glance at *Hi-Fi Year Book* for 1956, and a comparative glance at the following eight pages is most revealing. Four years ago, approximately two dozen radio tuners were listed, and these were made by thirteen manufacturers. Forty-seven models are now listed.

The increase is of course due to the spreading of the BBC's network of FM transmitters across Great Britain. When the 1956 *Year Book* was published there were 10 such stations. Today there are 18, and between them they cover approximately 97.2% of the population. In slightly lesser degree, the increase is also due to the desire of high fidelity enthusiasts to broaden the compass of their good listening. Many—and one could perhaps say “most”—newcomers to high fidelity have been awakened to its possibilities through experience with discs. It was, after all, the disc lover who paved the way for all this now universal search for better and better realism in sound reproduction.

### The fine Quality of FM.

When the cult (as it was) began, the quality of radio broadcasts was certainly not such as to win the attention of the listener who thought in terms of “sound”. But in the past four or five years such tremendous strides have been made—and notably by the BBC—that the best FM broadcasts of live performances can leave even the best lp discs standing at the post.

Thus it is, therefore, that the man in search of high quality sound reproduction—

the man who has outlaid perhaps £150 on disc playing equipment and speakers—has looked for alternative programme material to enjoy with his installation, and has added a radio tuner to the chain. And, today, the serious buyer of high fidelity equipment almost automatically includes a radio tuner in his budget.

### The Tuners

So much for the outline of the story; and now for the equipment itself. A few years ago, when the radio tuner began to demand the attention of the high fidelity enthusiast, amplifiers were mainly being built to cater for the disc user. It naturally took some time for the trend of events to become obvious, and it therefore took manufacturers even more time to adjust their products to suit the trend. The result was the appearance of numerous tuners on the market—some of them self-powered, and some of them designed to draw power from amplifiers—but with all too little advice available for the people who wanted to buy them.

It was, in fact, extremely difficult to advise potential buyers about the products they had in mind, because very few people seemed to know what they wanted; and, more important, whether what they wanted would work satisfactorily with what they already owned. Today, however, nearly all that is a thing of the past.

The trend, at the moment, seems to be in favour of the self-powered tuner; and in general this appears to be a good thing, because all tuners made in the U.K., and for sale in the home market, need only be plugged into the mains. Their audio outputs are such that one and all will satisfactorily drive almost every amplifier combination, and their connection therefore demands nothing more complicated than a plug of suitable type to mate with the socket provided on the amplifier's control unit.



This observation does not decry the non-powered tuners which are in several cases made specially by amplifier manufacturers to work with (and to draw their power supplies from) amplifiers from the same factory. In these cases the manufacturer has planned his products as units in a complete chain, and the purchaser may be sure that they will work well together. *Acoustical* are an example in this field. Power outlets are provided on the Quad control unit for driving one or two tuner units, and two types of Quad tuner are available—one FM and the other AM. And the three units (control unit, and both tuners) have also been designed, externally, to match each other in appearance.

### **A place for AM Tuners**

While there is no question whatsoever about the superior quality of FM broadcast programmes, over AM broadcasts (given good conditions) the advantages of using AM programme material through high fidelity equipment should not be overlooked. In many households one sees the radio set in use for Continental stations, and the “hi-fi set-up” reserved for the BBC and discs. It is easy to see how this state of affairs has developed. FM was the bait, and the quality of FM quite reasonably associated itself in users’ minds with disc quality sound. The FM unit took its place in the “hi-fi-corner”

of the household, and for many months, in many cases, *the radio* was unused. Then, gradually, interested listeners began to look farther afield than the three British services (Home, Light, and Third), and *the radio* was once more switched on, albeit with apologies for the shocking sound it produced.

But “the shocking sound” need not be half so shocking if it is given half a fair chance to justify itself. Remember that a well designed AM tuner has only to deliver its audio signal to the pre-amplifier or control unit. After that, the good circuitry of the control unit and amplifier, and the good design of the speaker, will together produce a quality of AM reproduction that is beyond the scope of most “radios” now in use.

### **Stereo Still to Come**

At the time of writing this introductory note, nothing startling has occurred to suggest that anyone should delay the purchase of a tuner (AM, FM, or AM/FM) because of impending stereo broadcast developments. The magic word “multiplex”, much heard on the Continents of Europe and America, has yet to appear in British catalogues. Stereo by radio, as a regular feature, is definitely on its way; but at the moment it is too early for any consideration in the planning of high-fidelity installations.

# DIRECTORY OF RADIO TUNERS

★ In the abridged specifications of these directory entries the following abbreviations have been used: P.s.n.—Power supply needed; A.F.C.—Automatic frequency control.

**Acoustical Manufacturing Co. Ltd.**, St. Peter's Road, Huntingdon, Hunts. Tel.: Huntingdon 361 and 574. Cables: Acoustical.

**F.M. Tuner.** Variable tuning. Range 87.5-108 Mc/s. Special double neon display ind. P.s.n. 330v at 27 mA; 6.3v at 1.85 amps. Size  $10\frac{1}{2} \times 3\frac{1}{2} \times 6$  ins. Price £21 (U.K. purchase tax £7 17s. 6d.)

**A.M. Tuner.** Variable tuning, DM 70 ind. P.s.n. 330v at 20 mA; 6.3v at 1.2 amps. Size  $10\frac{1}{2} \times 3\frac{1}{2} \times 6$  ins. Price £21 (U.K. purchase tax £9 9s.)

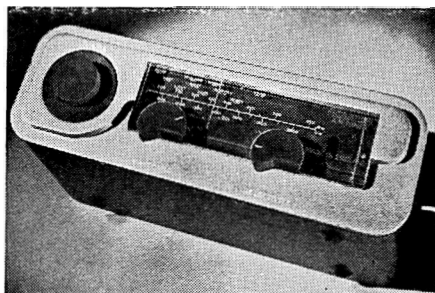

*Quad AM tuner*

★

**Armstrong Wireless & Television Co.**, Warlters Road, Holloway, London, N.7. Tel.: North 3213/4.

**A.M./F.M. Tuner ST3.** Variable tuning. Range 87-108 Mc/s, 187-570 and 1,053-2,000 metres. A.F.C. Ratio disc. Magic eye ind. Self-powered. Size  $13\frac{1}{2} \times 7\frac{3}{4} \times 8\frac{1}{2}$  ins. Price £20 13s. 4d. (U.K. purchase tax £6 12s. 8d.)

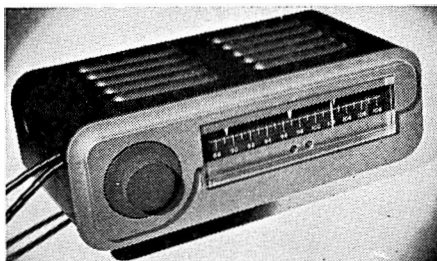

*Quad FM tuner*

**BS 125T.** A.M. Tuner/Control Unit combined. Bandsread tuning on 11, 13, 16, 19, 25, and 31 metre bands. General coverage 15-43, 43-150, 190-550 metres. Magic eye ind. P.s.n. 250v 30 mA; 6.3v 2.6 amps. Size  $15 \times 9\frac{3}{4} \times 9\frac{1}{4}$  ins. Price £31 10s. (U.K. purchase tax £10 2s.)

**RF 125T.** Home market version of above, covering 13-550 metres in four bands, plus Long Waveband.

**F.M. Tuner T4.** Free tuned. Range 87-108 Mc/s. A.F.C. Balanced ratio det. Self-powered. Preset vol. control. Size  $8\frac{1}{2} \times 7\frac{1}{2} \times 3\frac{3}{4}$  ins. Price £15 2s. (U.K. purchase tax £4 17s.)

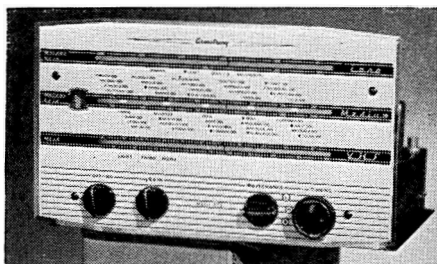

*Armstrong AM/FM ST3*

★

**Beam-Echo Ltd.**, 13 South Molton Street, London, W.1. Tel.: Mayfair 1039. Cables: Hibeam, London.

**Avantic BM 611.** A.M./F.M. Tuner, variable tuning. Range 88-108 Mc/s, 545-1,600 Kc/s. A.F.C. Foster-Seeley disc. Magic eye ind. Self-powered. Size  $14\frac{1}{2} \times 10 \times 4\frac{1}{2}$  ins. Price £29 8s. (U.K. purchase tax £10 12s. 3d.)

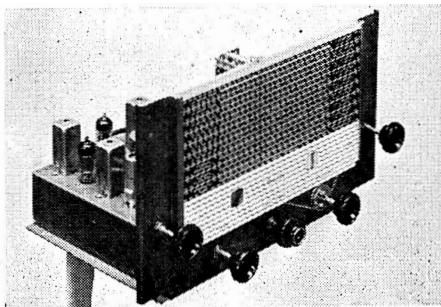

*Armstrong RF 125T*

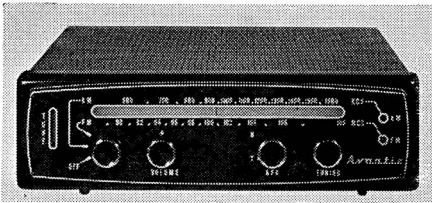

*Beam-Echo Avantic A.M./F.M. tuner*

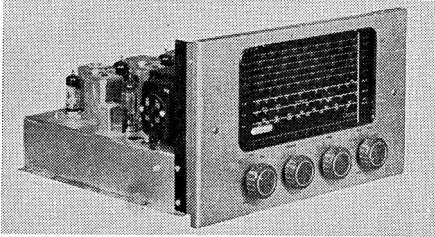

*Chapman S6BS/FM*

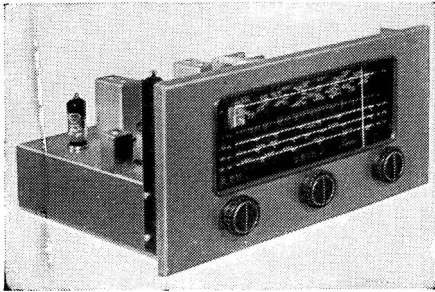

*Chapman S5E/FM*

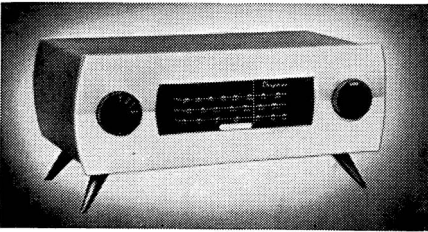

*Chapman FM95*

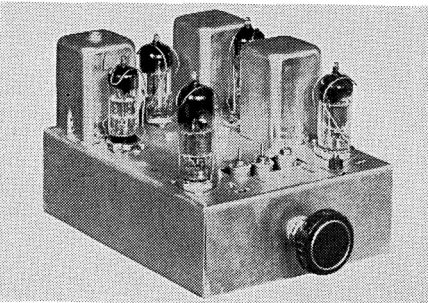

*Chapman FM90 switched tuner*

**C. T. Chapman (Reproducers) Ltd.**, Chapel Lane, High Wycombe, Bucks. Tel.: High Wycombe 2474.

**F.M. Tuner FM90.** Switched, 4 positions. Range 87.5-100 Mc/s. A.F.C. ratio disc. P.s.n. 250v at 40 mA; 6.3v at 2A. Size  $5 \times 4\frac{1}{2} \times 6\frac{1}{2}$  ins. Price £14 9s. (U.K. purchase tax £5 1s.)

**F.M. Tuner FM91.** Free tuned. Range 87.5-100 Mc/s or 88-108 Mc/s A.F.C. Wide band ratio det. Bright Line tuning ind. P.s.n. 250v at 40 mA; 6.3v at 2A or self-powered. Size  $12 \times 4\frac{1}{8} \times 6\frac{1}{2}$  ins. Price £17 6s. 8d. (U.K. purchase tax £6 1s. 4d.) Self-powered £20 5s. 7d. (£7 1s. 11d.)

**FM95 A.M./F.M. Tuner.** Variable tuning. Range 87.5-100 Mc/s, 195-550 and 800-2,000 metres. A.F.C. Ratio det. EM84 ind. P.s.n. 250v at 30 mA; 6.3v 2 amps. Size  $12 \times 4\frac{1}{8} \times 8\frac{1}{2}$  ins. Price £20 1s. 9d. (U.K. purchase tax £7 0s. 9d.) Self-powered version £23 1s. (£8 1s. 6d.)

**A.M./F.M. Tuner S5E/FM.** Free tuned Range (F.M.) 87.5-100 Mc/s or 88-108 Mc/s; (A.M.) 12.5-37, 35-100, 90-250, 190-550 metres. Ratio det. plus limiter. Magic eye tuning ind. P.s.n. 200/250v at 40/50 mA or self-powered.  $13\frac{1}{2} \times 6\frac{1}{2} \times 9$  ins. Price £25 3s. 8d. (U.K. purchase tax £8 16s. 4d.) Self-powered £28 3s. (£9 17s.)

**A.M./F.M. Tuner S5/FM.** Free tuned. Range (F.M.) 87.5-100 Mc/s; (A.M.) 16-50, 195-550, 800-2,000 metres. Ratio det. plus limiter. Magic eye tuning ind. P.s.n. 200/250v at 40/50 mA or self-powered.  $13\frac{1}{2} \times 6\frac{1}{2} \times 9$  ins. Price as S5E/FM above.

**A.M./F.M. S6BS/FM.** Free tuned. Range (F.M.) 87.7-108 Mc/s; (A.M.) 6 band-spreads: 11, 13, 16, 19, 25, and 31 metres; also 15-43, 43-140, 175-570 metres wide band ratio det. Magic eye ind. Self-powered. Size  $13\frac{3}{8} \times 13 \times 8\frac{1}{2}$  ins. Price £50 (U.K. purchase tax £17 10s.)

**A.M. Tuner S6E.** Free tuned. Range 12.5-37, 35-100, 90-250, 190-550 metres. Otherwise similar to the S6BS. Size  $13 \times 11 \times 8\frac{1}{2}$  ins. Price £22 9s. 10d. (U.K. purchase tax £7 17s. 8d.) or £27 powered (£9 9s.)

**A.M. Tuner S6BS.** Free tuned. Range 6 bandspread ranges: 11, 13, 16, 19, 25 and 31 metres, also 13-43, 43-140, 175-570 metres. Magic eye ind. P.s.n. 250v at 30/40 mA; 6.3v at 1.5A, or self-powered. Size  $13\frac{3}{8} \times 11 \times 8\frac{1}{2}$  ins. Price £32 19s. 2d. (U.K. purchase tax £11 10s. 10d.) or £37 8s. 2d. self-powered (U.K. purchase tax £13 1s. 10d.)

**C.Q. Audio Ltd.**, No. 3 Factory, Bush Fair, Tye Green, Harlow, Essex. Tel.: Harlow 24566.

**F.M. Tuner.** Free tuned. Range 88-108 Mc/s. A.F.C. Foster-Seeley disc. Self-powered. Size  $10\frac{1}{4} \times 4 \times 6$  ins. Price £19 4s. (U.K. purchase tax £7 15s.)



**EAP (Tape Recorders) Ltd.**, Bridge Close, Oldchurch Road, Romford, Essex. Tel.: Romford 62366-7.

**Elizabethan F.M. Tuner.** Manual tuning (permeability). Range 85-105 Mc/s. Foster-Seeley disc. Self-powered. Size  $8 \times 2\frac{1}{2} \times 8$  ins. Price £11 19s. 4d. (U.K. purchase tax £4 0s. 8d.)



**General Electric Co. Ltd.**, Magnet House, Kingsway, W.C.2. Tel.: Temple Bar 8000. Cables: Polyphase, London.

**F.M. Tuner BCS1352A.** Switched. Range 88-98 Mc/s. A.F.C. Temperature compensated Foster-Seeley. P.s.n. 150v at 25 mA; 6.3v at 1.8A. Size  $8 \times 4\frac{1}{2} \times 6$  ins. Price £20 8s. 10d. (U.K. purchase tax £6 11s. 2d.) Power unit available. Price £6 17s. 6d.



**Goodsell Ltd.**, Gardner Street, Brighton, Sussex. Tel.: Brighton 26735.

**F.M. Tuner FMT701.** Manual tuning (permeability). Range 85-100 Mc/s. Ratio det. Magic eye ind. P.s.n. 250v at 20 mA. Price £10 10s. (U.K. purchase tax £3 8s. 3d.)



**Grampian Reproducers Ltd.**, 19 Hanworth Trading Estate, Feltham, Middx. Tel.: Feltham 2657. Cables: Reamp, Feltham.

**F.M. Tuner 571.** Free tuned. Range 85-98 Mc/s. Ratio det. Magic eye ind. P.s.n. 300v at 35/40 mA, 6.3v at 2.5 amps. Size  $10\frac{1}{4} \times 5\frac{1}{2} \times 6\frac{1}{2}$  ins. Price £17 10s. (U.K. purchase tax £5 17s. 11d.)



**Jason Motor & Electronic Co.**, 3/4 Gt. Chapel Street, London, W.1. Tel.: Gerrard 0273/4.

**F.M. Tuner FMT3.** Variable tuning. Range 88-108 Mc/s. A.F.C. Foster-Seeley disc. Self-powered. Size  $11\frac{1}{4} \times 6\frac{5}{8} \times 4\frac{3}{8}$  ins. Better than  $5\mu\text{V}$  for 40 dB quieting. Price £17 5s. (U.K. purchase tax £5 10s. 8d.)

**JTV/2 F.M. and A.M./TV Sound Tuner.** Switched turret tuning. Automatic frequency control. Range 88-96 Mc/s, plus all Television channels. Discriminator. Self-powered.



*CQ Audio FM*

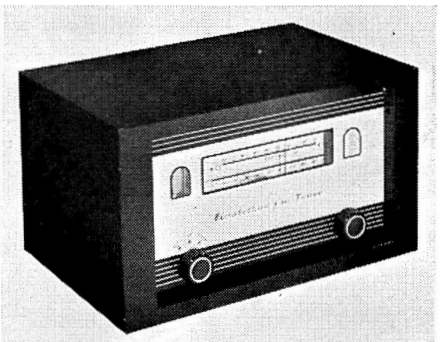

*Elizabethan FM tuner*

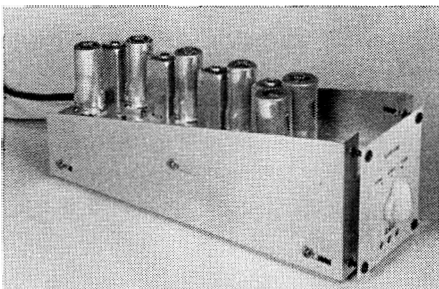

*G.E.C. BCS 1352A*

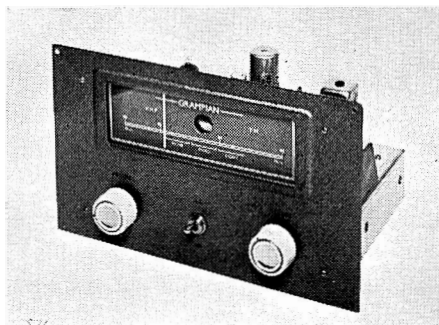

*Grampian FM 571*

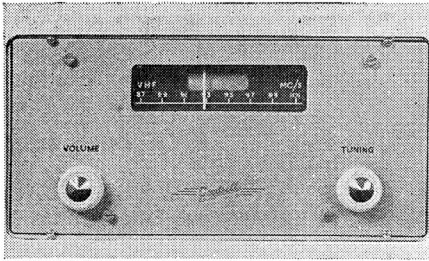

*Goodsell FMT701*

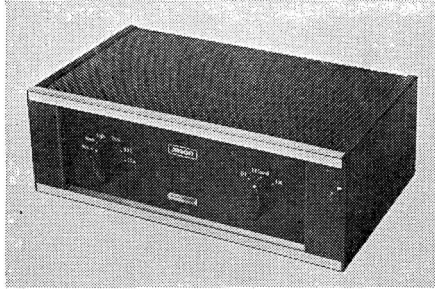

*Jason JTV 2*

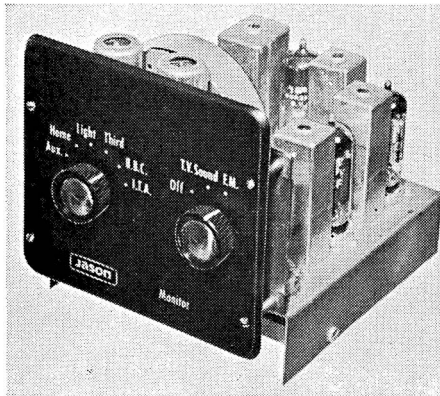

*Jason Monitor*

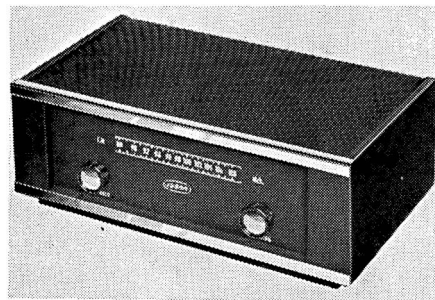

*Jason FMT 3*

Size  $11\frac{1}{4} \times 7\frac{1}{2} \times 4\frac{3}{8}$  ins.  $10\mu\text{V}$  for 40 dB quieting. Price £19 4s. (U.K. purchase tax £6 3s. 3d.)

**Monitor.** F.M. and A.M./TV Sound Tuner. Switched tuning. A.F.C. Range 40-212 Mc/s. Foster-Seeley disc. P.s.n. 230v at 35 mA; 6.3v at 1.5A. Size  $5 \times 5\frac{1}{2} \times 7$  ins. Price £15 (U.K. purchase tax £4 16s. 3d.)



**H. J. Leak & Co. Ltd.,** 57/59 Brunel Road, East Acton, London, W.3. Tel.: Shepherds Bush 1173. Cables: Sinusoidal, Ealux, London.

**F.M. Tuner, Trough-Line 11.** Variable tuning. Range 88-108 Mc/s. A.F.C. giving tuning stability from the instant of switching on. Foster-Seeley disc. Magic eye ind. Self-powered. Size  $10\frac{1}{2} \times 3\frac{3}{4} \times 7\frac{3}{4}$  ins. Price £25 (U.K. purchase tax £8 15s.)



**Lee Products (Great Britain) Ltd.,** Elpico House, Longford Street, London, N.W.1. Tel.: Euston 5754. Cables: Leprod, London.

**F.M. Tuner FMT/2.** Variable tuning. Range 88-100 Mc/s. A.F.C. Foster-Seeley disc. Self-powered. Cathode follower output. Size  $12\frac{1}{4} \times 3\frac{1}{4} \times 9\frac{3}{4}$  ins. Price £18 13s. 6d. (U.K. purchase tax £5 19s. 10d.)

**A.M./F.M. Tuner H3S.** Variable tuning. Range 87-101 Mc/s, 187-540 and 1,100-1,900 metres. Ratio det. Self-powered. Size  $12 \times 7\frac{3}{4} \times 9\frac{3}{4}$  ins. Price £21 (U.K. purchase tax £6 16s. 6d.) Note: includes twin audio amplifiers 4 watts per channel.

**A.M./F.M. Tuner H4T/2.** Variable tuning. Range 87-101 Mc/s, 16-50, 187-540, and 1,100-1, 900 metres. Ratiomet. Magic eye ind. Self-powered. Size  $12\frac{1}{2} \times 6\frac{1}{4} \times 10$  ins. Price £19 10s. (U.K. purchase tax £6 5s. 2d.)



**The Lowther Manufacturing Co.,** Lowther House, St. Mark's Road, Bromley, Kent. Tel.: Ravensbourne 5225. Cables: Lowther, Bromley.

**F.M. Tuner Mk. III.** Twin gang tuning, horizontal scale. Range 87.5-100 Mc/s. A.F.C. Foster-Seeley disc. Press button ind. 50 c/s injection. Self-powered. Size  $13\frac{1}{4} \times 5\frac{1}{2} \times 5$  ins. Price £24 10s. (U.K. purchase tax £8 2s. 11d.)

**F.M. Tuner Mk. V.** Variable tuning. Range 87.5-100 Mc/s. A.F.C. Foster-Seeley disc. Press button ind. P.s.n. 250v 30 mA; 6.3v 2 amps. Size  $10\frac{1}{4} \times 4\frac{3}{4} \times 7$  ins. Price £22 (U.K. purchase tax £7 6s. 4d.)

**A.M. and F.M. Tuner D/VHF.** Switched tuning. FM on band 2 plus AM on bands 1 and 3. Crystal control A.F.C. Foster-Seeley disc. P.s.n. 250v at 30 mA; 6.3v at 2.5A. Size  $10\frac{1}{2} \times 4\frac{1}{2} \times 6$  ins. Price to be announced.

**A.M. and F.M. Tuner Lowther double output.** Switched tuning. FM on band 2 plus AM on bands 1 and 3. Crystal control A.F.C. Foster-Seeley disc. P.s.n. 250v at 40 mA; 6.3v at 3A. Size  $10\frac{1}{2} \times 4\frac{1}{2} \times 6$  ins. Incorporates Time multiplex and double drive. Price to be announced.



**Pamphonic Reproducers Ltd.,** 17 Stratton Street, London, W.1. Tel.: Grosvenor 1926.

**640 F.M. Tuner.** Variable tuning. Range 86-103 Mc/s. Ratio sel. Magic eye ind. P.s.n. 200v at 30 mA, 6.3v at 2 amps. Size (panel)  $9\frac{3}{8} \times 3\frac{3}{4}$  ins. Price £15 (U.K. purchase tax £4 16s. 3d.)

**645 F.M./A.M. Tuner.** Switched F.M., variable A.M. Range (F.M.) 86-103 Mc/s. (A.M.) 185-565 metres. A.F.C. Foster-Seeley disc. Magic eye ind. Sensitivity F.M.,  $15\mu\text{v}$  for 40 dB quieting. Self-powered. Size  $13 \times 10\frac{1}{2} \times 4\frac{1}{2}$  ins. Price £21 13s. 2d. (U.K. purchase tax £6 19s. 1d.)



**Period High Fidelity Ltd.,** 28 South Street, London, W.1. Tel.: Grosvenor 4686.

**Saville F.M. Tuner.** Variable tuning. Magic eye ind. Cathode follower output. Price £24 (U.K. purchase tax £10 16s.)



**Pye Ltd.,** 65 Fairview Road, London, S.W.16. Tel.: Pollards 9441/2. Cables: Faramarine, Souphone, London.

**A.M./F.M. Tuner.** Variable tuning. Range (F.M.) 87-108 Mc/s. (A.M.) 190-550 metres. A.F.C. Foster-Seeley disc. Magic eye ind. Self powered. Size  $10\frac{1}{2} \times 3\frac{3}{8} \times 5$  ins. Price not yet available.

**A.M./F.M. Tuner, HFT.111 W.** Permeability tuning. Range (F.M.) 87.1 100 Mc/s. (A.M.) 183-564; 956-1,910 metres. Foster-Seeley disc. Magic eye ind. Self-powered. Size  $15 \times 8\frac{3}{4} \times 9$  ins. Price in walnut case with aerial £26 9s. 9d. (U.K. purchase tax £8 10s. 3d.)

**F.M. Tuner Mozart HFT.108.** Variable tuning. Range 88-108 Mc/s. A.F.C. Foster-Seeley disc. Self-powered. Size  $10\frac{1}{2} \times 3\frac{3}{8} \times 5$  ins. Price £16 13s. (U.K. purchase tax £5 7s.) chassis only or in metal case £18 3s. 3d. (U.K. purchase tax £5 16s. 9d.)

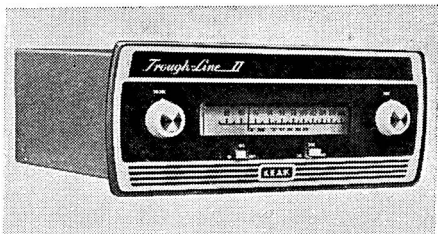

*Leak Trough-Line II*

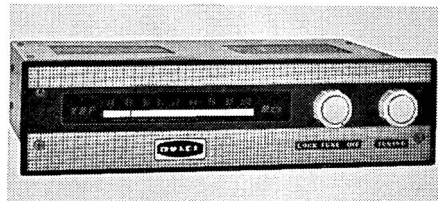

*Lee-Dulci FMT2*

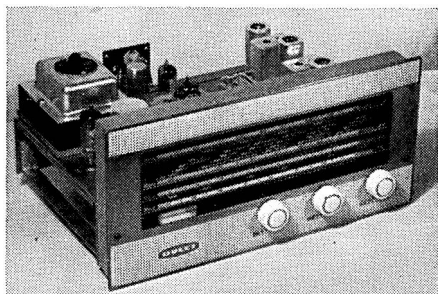

*Dulci HAT/2*

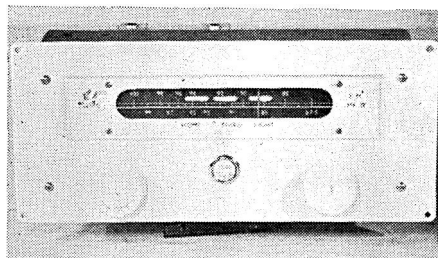

*Lowther Mk. IV*

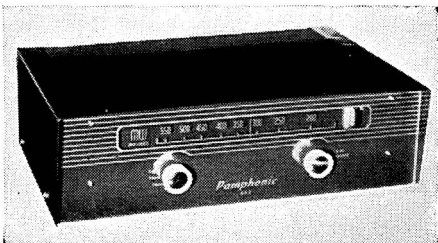

*Pamphonic 645 FM/AM tuner*



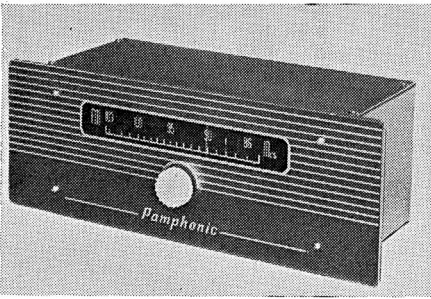

*Pamphonic 640 FM tuner*

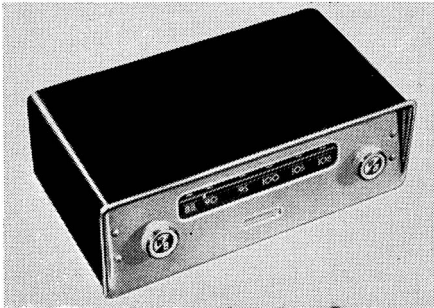

*W/B Stentorian F.M. tuner*

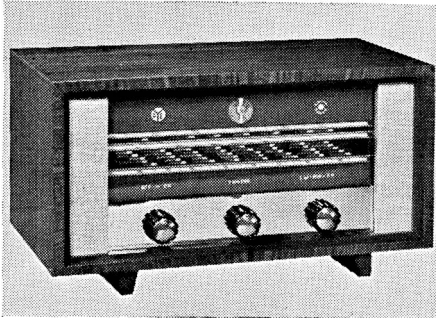

*Pye FM/AM tuner*

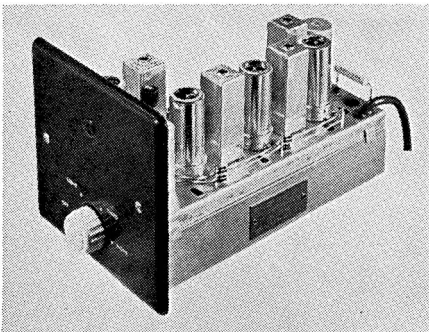

*Rogers RD Junior Switched FM tuner*

**Rogers Developments (Electronics) Ltd.,**  
 "Rodevco Works," 4-14 Barmeston Road,  
 Catford, S.E.6. Tel.: Hither Green 7244/  
 4340. Cables: Rodevco, London.

**R.D. Junior F.M. Tuner.** Variable inductance tuning. Range 87-107.5 Mc/s. A.F.C. Foster-Seeley disc. Tuning ind. centre-zero meter (optional extra). Sensitivity for full limiting,  $10\mu\text{v}$ . P.s.n. 270v at 38 mA, 6.3v at 2.3 A or self-powered. Size  $9 \times 5\frac{3}{8} \times 8\frac{3}{8}$  ins. Price £16 11s. (U.K. purchase tax £5 12s. 11d.) Self-powered £18 5s. 6d. (U.K. purchase tax £6 4s. 9d.) Also available to match HG88 amplifier with case £24 4s. 6d. (U.K. purchase tax £8 5s. 6d.)

**F.M. Tuner R.D. Junior Switched.** Switched tuning. Range 87-96 Mc/s. A.F.C. Foster-Seeley disc. P.s.n. 250v 35 mA; 6.3v 1.7 amps. Size  $9 \times 5\frac{3}{8} \times 5\frac{3}{8}$  ins. Price £11 5s. (U.K. purchase tax £3 16s. 10d.) Also available to match HG88 amplifier without case £11 18s. (U.K. purchase tax £4 1s. 3d.)



**Shirley Laboratories Ltd.,** 3 Prospect Place,  
 Worthing, Sussex. Tel.: Worthing 30536.

**F.M. Tuner R/6.** Variable tuning. Standard range. Ratio det. Magic eye ind. P.s.n. 200-300v 30 mA; 6.3v 2.5 amps. Price £27 10s.



**Sound Sales Ltd.,** Works and Acoustic Laboratories, West Street, Farnham, Surrey. Tel.: Farnham 6461/2/3. Cables: Sounsense, Farnham.

**A-Z F.M. Synchrolock Unit Mk. IV 108.** Variable twin gang tuning. Range 75.8-108 Mc/s. A.F.C. Foster-Seeley disc. Magic eye ind. Self-powered. Size  $11\frac{1}{8} \times 4\frac{1}{2} \times 6\frac{1}{2}$  ins. Price £22 (U.K. purchase tax £8 9s. 5d.)



**Symphony Amplifiers Ltd.** (Distributors Northern Radio Services (London) Ltd.),

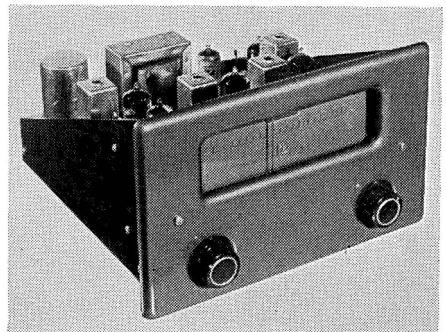

*Rogers RD Junior FM tuner*

16 Kings College Road, London, N.W.3.  
Telephone: Primrose 3314/5.

**F.M. Tuner Symphony No. 1.** Variable tuning. Range 87-101 Mc/s. Ratio det. P.s.n. 250v at 40 mA; 6.3v at 1.5A. Size  $9 \times 6 \times 6$  ins. Price £11 1s. 10d. (U.K. purchase tax £3 12s. 2d.) Power pack available. Price £3 7s. 6d. Magic eye available. Price £1.

**A.M./F.M. Tuner Symphony No. 2.** Manual tuning. Range 87-101 Mc/s, 16-50, 187-550, and 800-2,000 metres. Ratio det. Self-powered. Size  $13\frac{1}{2} \times 8\frac{1}{2} \times 7\frac{1}{2}$  ins. Price £18 2s. 3d. (U.K. purchase tax £5 17s. 9d.) Magic eye available. Price £1.

**A.M./F.M. VHF/TV. Tuner Symphony** Switched tuning. Home, Light and Third on band 2, T.V. on bands 1 and 3. A.F.C. Foster-Seeley disc. P.s.n. 200v at 45 mA; 6.3v at 2A. Size  $5 \times 5 \times 8$  ins. Price £15 (U.K. purchase tax £4 16s. 3d.)



**Technical Suppliers Ltd.,** Hudson House, 63 Goldhawk Road, London, W.12. Tel.: Shepherds Bush 2581/4794.

**F.M. Tuner Mk. III International Model.** Variable permeability tuning. Range 88-108 Mc/s. Ratio det. Magic eye ind. Self-powered. Size  $10\frac{5}{8} \times 7 \times 5\frac{5}{8}$  ins. Price £13 13s. (U.K. purchase tax £4 7s. 6d.)



**Whiteley Electrical Radio Co. Ltd.,** Victoria Street, Mansfield, Nottinghamshire. Tel.: Mansfield 1762-5. Cables: Whitebon, Mansfield.

**W/B Stentorian F.M. Tuner Mk. II.** Variable permeability tuning. Range 88-108 Mc/s. Foster-Seeley disc. P.s.n. 200-240v at 45 mA, 6.3v at 2 amps. Size  $11\frac{1}{2} \times 4 \times 7\frac{1}{2}$  ins. Price £16 2s. 5d. (U.K. purchase tax £6 19s. 7d.)

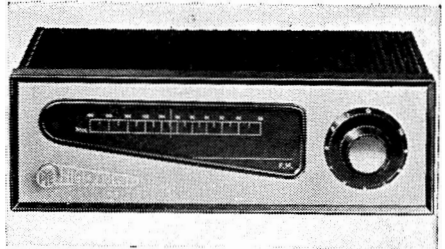

*Pye Mozart HFT 108*

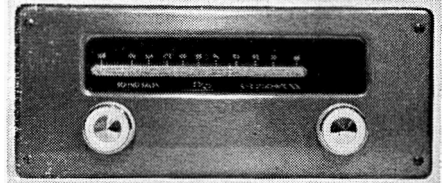

*Sound Sales Syncrolock Mk. IV*

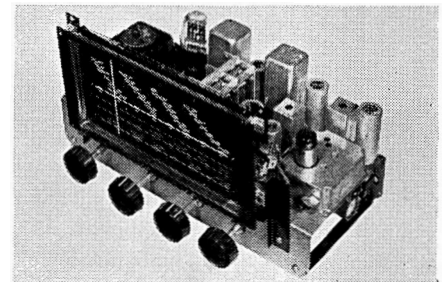

*Symphony AM/FM Tuner No. 2*

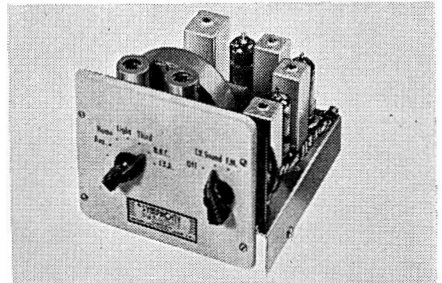

*Symphony TV/FM Switched tuner*

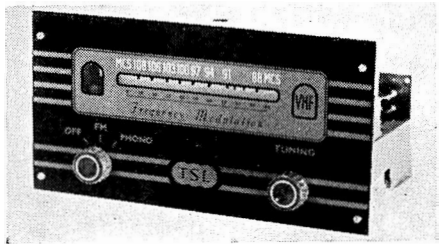

*T.S.L. F.M. tuner, Mk. III*



*Rogers RD Junior tuner in matching cabinet*

# APPROXIMATE COVERAGE OF THE BBC'S VHF SERVICE (August 1959)

Nominal limits  
of satisfactory  
reception (250  $\mu$ V/m)

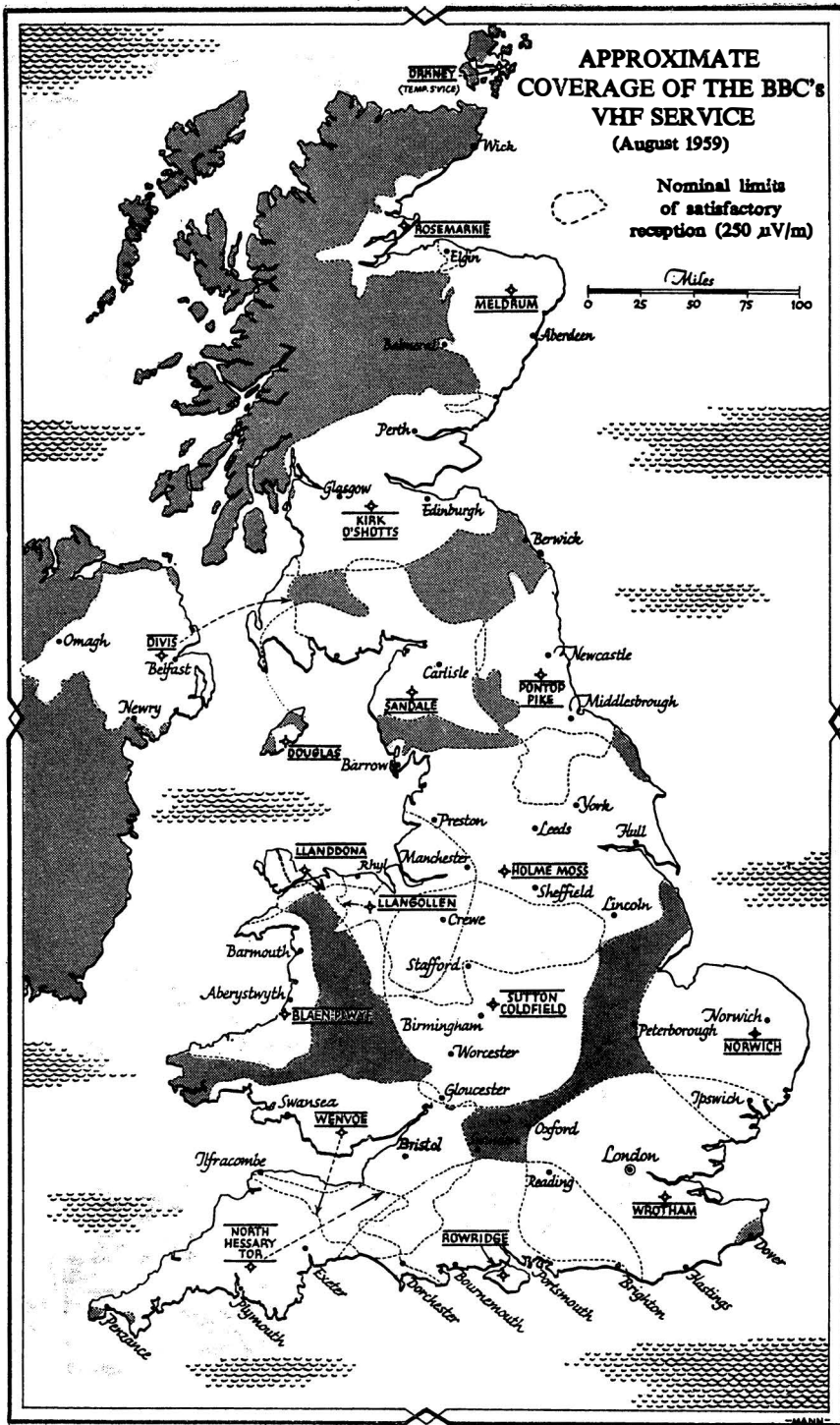

# LOUDSPEAKERS

## An Introduction

ONE of the surprising facts about speaker development and evolution over the past few years is that the electrostatic has not become more of a challenge from more quarters. When Peter Walker of *Acoustical*, introduced the first full-range electrostatic—the “Quad”—in the Spring of 1956, it was thought by many that this would be only the first of a number to appear. Indeed, at almost the same time as the “Quad” made its pre-production debut, two other well-known speaker manufacturers demonstrated their own versions of electrostatics, and it was confidently assumed that at least one of these would go into production. But, here we are, some four years older, and the Quad still holds the field—alone and unchallenged, apparently as popular as ever (if not more so) and enjoying a steady and well-deserved production.

### The Effects of Stereo

Needless to say, much has happened behind the scenes in speaker factories, and much is still going on; but there has been nothing dramatic to report during the last twelve months. It is probable that the impact of stereo has very greatly affected the speaker market and, as a direct result, has altered the trends of design as well. Certainly it is true to say that fewer large speakers are in demand today than would have been the case if stereo had not “arrived”. Both price and available floor space have dictated this. A good speaker is an expensive item and on grounds of cost it has often become a matter of choice between one very good one, for “mono”, or two reasonably good ones for “stereo”. And more or less the same decisions have often had to be made on grounds of size, for whereas a medium-sized room could be arranged to accommodate one big speaker, two big ones would have been out of the question.

This problem of “going stereo” was not at first as widely considered as many others which have long since been overcome;

although it is only fair to recall that many reliable voices—notably that of Cecil Watts—made the point, very early in the months preceding the stereo impact, that stereo and “hi-fi” should not be confused, and that the two could only be combined by the creation of a second reproducing channel every bit as good as that required for the accepted “mono” standard of high fidelity. It was, in fact, Cecil Watts who built and demonstrated (privately to a few friends) the first loudspeaker specially designed to provide twin-channel reproduction of really high quality from a single enclosure.

### Column Speakers

A similar device in many ways has recently been marketed by Lowther under the name “Acousta-Twin”; and it is likely that we shall see more such devices in the future. It is surprising that there have not been others already.

Column speakers have much to commend them when it comes to floor space, and many versions of these are now available. Two of the least known in this category are those designed by J. Somerset Murray and Dr. Dutton, respectively. Of the former not much can be said (except of their excellence) because they are not in general production, and are only available, hand made, to special order. Of the latter, it is expected that a lot more may be heard of them in the near future, because E.M.I. have decided to manufacture them for general sale. Originally designed for studio work, the prototypes stand 50 inches high, on castors, and measure about 14 inches across by 17 inches deep. Their most interesting feature is that they carry their own amplifiers in the base.

There are still many sound enthusiasts who hold the view that stereo is not the answer to their quest for high quality sound reproduction, and they maintain that one really good channel provides them with all they require. With reservations, this view must be respected.

The position has not altered. Two mediocre channels cannot provide anything like the quality of one good channel. Stereo as a “gimmick” is not even an apparent bargain at the expense of overall quality. For some genuine music lovers one channel is definitely good enough, because they obtain all the satisfaction they need from that one channel. But it can never be true to say that *good stereo* is not better than good mono. Given really good equipment, and good programme material, the advantages of stereo have not even to be argued: they are too immediately apparent.

### **Planning and Buying**

It is around this point that the genuine enthusiast must frame his plans, and with particular foresight when considering his loudspeaker requirements. There are now many medium-sized speakers available, ideal for twin channel listening of good average quality. The following pages describe and illustrate them. The newcomer to the scene should realise that, since the advent of stereo, several of the beliefs that were translated into “musts” in pre-stereo days have been

debunked. For example, it was even held that the two separate amplifiers (before stereo models were made) must be a pigeon pair; and it was certainly regarded as unthinkable to use two speakers that were not as two peas from a pod.

### **The Matched Pair**

The desirability of a perfectly matched pair of speakers is, of course, still important as an ultimate aim; but there is a very good case for buying one top grade speaker for mono—particularly one with an excellent bass response, and buying the second channel speaker from the cheaper price bracket against the day when the budget will allow for the addition of the other half. This, for many enthusiasts, could be a better proposition than the immediate purchase of two similar units, neither of which quite measured up to the standards really looked for; and such experimenters may well like to prove or to disprove, for their own satisfaction, the theory that one good bass + good treble unit, working with one good treble unit on the second channel, will provide all the useful stereo information that is needed !

# SPEAKERS & ENCLOSURES—Directory

● This directory is divided into two parts. **Part 1** deals with the range of drive units which, by makers' specifications, are within the Hi-Fi classification. **Part 2** deals with complete enclosures. These, as a general rule, embody the drive units of Part 1. For economy of space the following abbreviations are used: **v.c.i.**—voice coil impedance; **r.c.f.**—recommended crossover frequency (and in Part 2) **Rec.**—recommended units; Height by Width by Depth are the order of printed dimensions.

## PART I—DRIVE UNITS

**A.E.I. Sound Equipment Ltd.**, Crown House, Aldwych, London, W.C.2. Tel.: Temple Bar 8040. Cables: Soundequi, Estrand, London.

**B.T.H. 12A.** 12 in. Paper cone. Fabric surround. Voice coil  $1\frac{3}{4}$  in. Gap flux 14,400 gauss. Total flux 122,000 maxwells. H.C. 18 watts. v.c.i. 15 ohms. F.R. 50-10,000 c/s. Price £14.

**B.T.H. 12B.** 12 in. Paper cone. Foam surround. Voice coil  $1\frac{3}{4}$  in. Gap flux 14,400 gauss. Total flux 122,000 maxwells. H.C. 12 watts. v.c.i. 15 ohms. F.R. 40-10,000 c/s. Price £14 14s.

**B.T.H. DC12 Dual Concentric.** 12 in. Paper cone. Fabric surround. Voice coils (L.F.)  $1\frac{3}{4}$  in. (H.F.) 1.56 in. Gap flux (L.F.) 10,000 gauss (H.F.) 13,000 gauss. Total flux (L.F.) 85,000 maxwells (H.F.) 49,000 maxwells. H.C. 15 watts. v.c.i. 15 ohms. F.R. 50-14,000 c/s. Built-in crossover 1,500 c/s. Price £25.

**B.T.H. 18A.** 18 in. Paper cone. Fabric surround. Voice coil  $2\frac{1}{2}$  in. Gap flux 15,000 gauss. Total flux 376,000 maxwells. H.C. 40 watts. v.c.i. 10 ohms. F.R. 30-9,000 c/s. r.c.f. 500 c/s. Price £41.

**B.T.H. 18B.** Details as above, but Felt surround. R.F. 20-9,000 c/s.

**B.T.H. 18C.** 18 in. Paper cone. Fabric surround. Voice coil  $2\frac{1}{2}$  in. Gap flux 11,800 gauss. Total flux 215,000 maxwells. H.C. 30 watts. v.c.i. 10 ohms. F.R. 30-9,000 c/s. r.c.f. 500 c/s. Price £25 10s.

**B.T.H. K10A.** Dual Concentric. 18 in. Paper cone. Felt surround. Voice coils (L.F.)  $2\frac{1}{2}$  in. (H.F.) 1.56 in. Gap flux (L.F.) 14,300 (H.F.) 16,700 gauss. Total flux (L.F.) 285,000 (H.F.) 63,000 maxwells. H.C. 25 watts. v.c.i. 10 ohms. F.R. 30-17,000 c/s. Separate filter unit. 1,700 c/s. Price £48.



*BTH Type 18A*

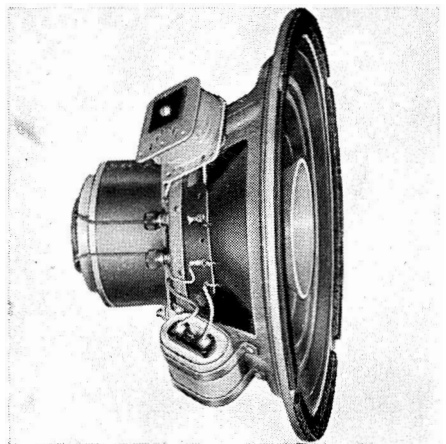

*BTH Type DC12*



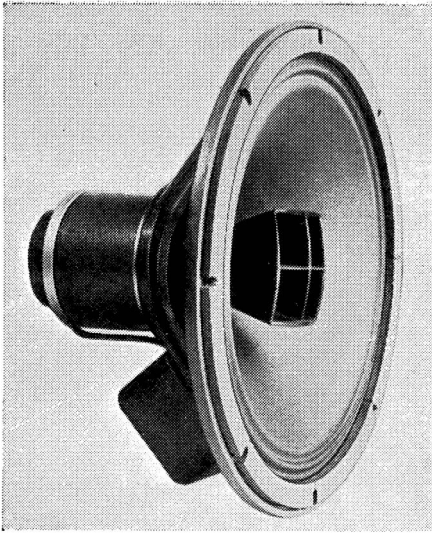

*Altobass 2000*

**Richard Allen Radio Ltd.**, Baffle House, Taylor Street, Batley. Tel.: Batley 1123/1308/4033. Cables: Acoustics Batley.

**Golden Eight.** 8 in. Paper cone and surround. Voice coil 1 in. Gap flux 12,000 gauss. Total flux 48,000 maxwells. H.C. 5 watts. v.c.i. 15 ohms. F.R. 60-10,000 c/s. Price £2 10s. (U.K. purchase tax 16s. 1d.)

**Bronze Twelve.** 12 in. Paper cone. Foam surround. Voice coil 2 in. Gap flux 12,500

gauss. Total flux 162,000 maxwells. H.C. 12 watts. v.c.i. 15 ohms. F.R. 25-5,000 c/s. r.c.f. 1,100 c/s. Price £9 9s.

**Golden Ten.** 10 in. Paper cone. Foam surround. Voice coil 1½ in. Gap flux 14,000 gauss. Total flux 82,000 maxwells. H.C. 10 watts. v.c.i. 15 ohms. F.R. 40-5,000 or 40-9,000 c/s. r.c.f. 5,000 c/s. Price £5 12s. (U.K. purchase tax £1 15s. 11d.)

**Bronze Ten.** 10 in. Paper cone. Foam surround. Voice coil 1½ in. Gap flux 12,500 gauss. Total flux 73,000 maxwells. H.C. 8 watts. v.c.i. 15 ohms. F.R. 40-5,000 or 40-9,000 c/s. Price £4 17s. (U.K. purchase tax £1 11s. 2d.)

**Golden Twelve.** 12 in. Paper cone. Foam surround. Voice coil 2 in. Gap flux 14,000 gauss. Total flux 182,000 maxwells. H.C. 15 watts. v.c.i. 15 ohms. F.R. 25-15,000 c/s. r.c.f. 1,100 c/s. Price £12 12s.

**410T. Tweeter.** 4 in. Paper cone and surround. Voice coil ½ in. Gap flux 10,000 gauss. Total flux 15,000 maxwells. H.C. 3 watts. v.c.i. 15 ohms. F.R. 2,000-17,000 c/s. r.c.f. 5,000 c/s. Price £1 5s. (U.K. purchase tax 8s.)



**Altobass Ltd.**, Percy Road, Aylestone Park, Leicester. Tel.: Leicester 31616. Cables: Altobass, Leicester.

**2000.** Dual Concentric. 12 in. Moulded paper cone, corrugated surround (L.F.). Duralumin pressure tweeter. Voice coil 1½

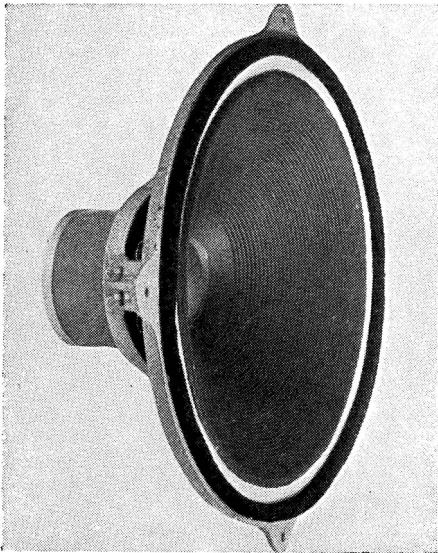

*Bakers Selhurst 15-in/CS Auditorium*

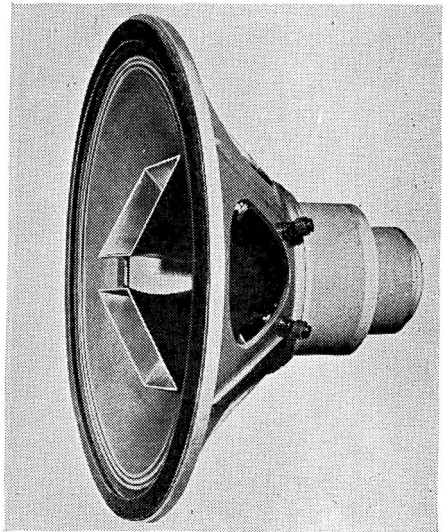

*BTH K10A Dual Concentric*

in. (L.F.), 1 in. (H.F.). Gap flux (L.F.) 8,000 (H.F.) 13,000 gauss. Total flux (L.F.) 90,000 (H.F.) 50,000 maxwells. H.C. 10 watts. v.c.i. 10 ohms. F.R. 30-20,000 c/s. Built-in crossover at 1,200 c/s. Price £17 17s.



**Bakers "Selhurst" Radio**, 24 Dingwall Road, Croydon, Surrey. Tel.: Croydon 2271.

**Junior de-luxe** 8 in. fibre cone, bakelised apex. Foam surround. Voice coil 1 in. Gap flux 18,000 gauss. H.C. 8 watts. v.c.i. 15 ohms. F.R. 35-20,000 c/s. Price £7 10s.

**Junior Special.** Spec. as for Junior de-luxe, but with aluminium voice coil and drive giving increased response and peak handling capacity. Price £8 5s.

**12-in. de-luxe** fibre curvilinear cone, bakelised apex. Foam surround. Voice coil 1½ in. Gap flux 15,000 gauss. H.C. 15 watts. v.c.i. 3 or 15 ohms. F.R. 20-17,000 c/s. Price £9 10s.

**12-in. Ultra de-luxe** fibre curvilinear cone, bakelised apex. Foam surround. Voice coil 1½ in. Gap flux 17,000 gauss. Peak H.C. 20 watts. v.c.i. 15 ohms. F.R. 18-20,000 c/s. Price £15 15s.

**Ultra Twelve** 12-in. fibre curvilinear cone, bakelised apex. Foam surround. Voice coil 1½ in. Gap flux 17,000 gauss. Aluminium voice coil and drive. H.C. 20 watts v.c.i. 15 ohms. F.R. 20-25,000 c/s. Price £17 10s.

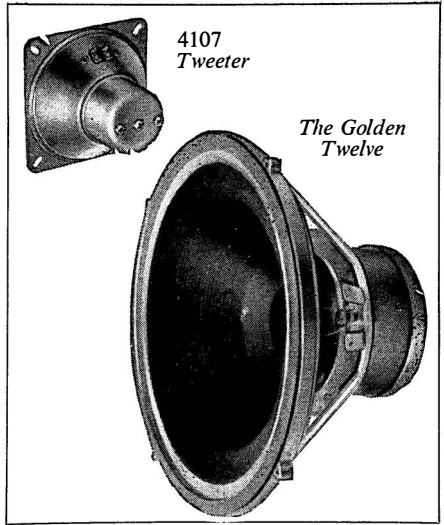

*Richard Allen Drive Units*

**15-in./CS Auditorium.** Fibre cone, bakelised apex. Foam surround. Voice coil 2 in. Gap flux 17,000 gauss. H.C. 15 watts. v.c.i. 8 or 15 ohms. F.R. 20-13,000 c/s. r.c.f. 5,000 c/s. Price £18.

**Ultrasonic** 3¼-in. bakelised cone. Foam surround. Voice coil 1 in. (aluminium). Gap flux 18,000 gauss. H.C. 12 watts above 1,000 c/s. v.c.i. 15 ohms. F.R. 1,000-25,000 c/s. r.c.f. 1,600 or 3,000 c/s or by 3µF condenser. Price £7 10s.

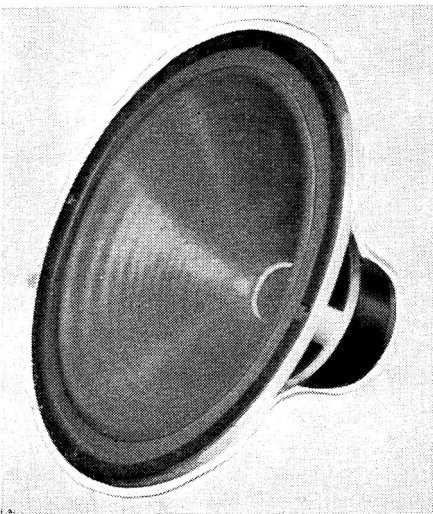

[ *Duode 12D*

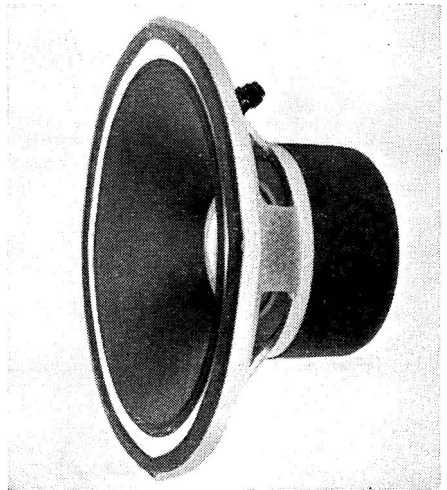

*Fane H.D. 121A*

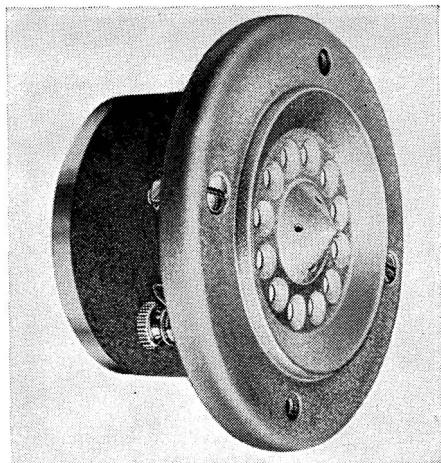

*Fane 301 H.F. Unit*

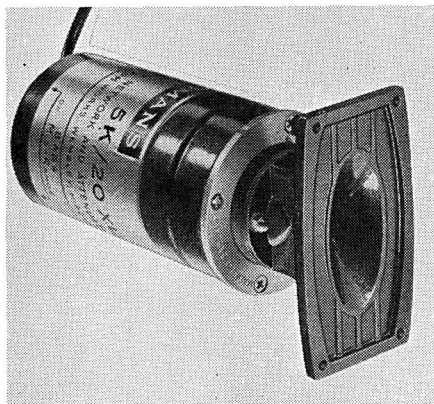

*Goodmans Trebax 5K/20XL*

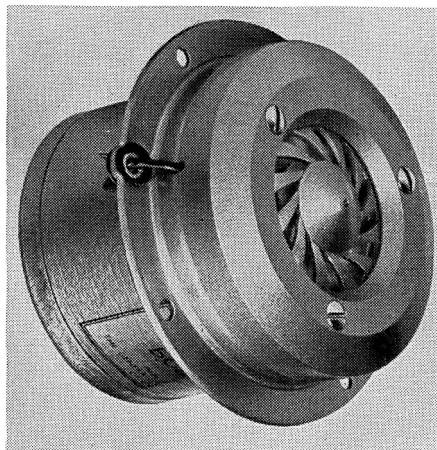

*G.E.C. High Flux Presence Unit*

**Duode Ltd., 24 Dingwall Road, Croydon.**

**Duode 12E.** 12-in. Linen moulded cone. Foamed plastic surround. Voice coil 1.5 in. Gap flux 17,000 gauss. Total flux 190,000 lines. H.C. 30-15 watts. v.c.i. 15-8-5 ohms. F.R. 20-16,000 c/s. Price £15.

**Duode 12D.** 12-in. Linen moulded cone. Foamed plastic surround. Voice coil 1.5 in. Gap flux 14,500 gauss. Total flux 130,000 lines. H.C. 15 watts. v.c.i. 30-15-8-5 ohms. F.R. 20-16,000 c/s. Price £12.



**Fane Acoustics Ltd., 1 Wellington Street, Batley, Yorks. Tel.: Batley 1578. Cables: Fane, Batley.**

**Fane H.D. 121.** 12 in. Paper cone. Foam surround. Voice coil 2 in. Gap flux 12,000 gauss. Total flux 160,000 maxwells. H.C. 20 watts. v.c.i. 15 ohms. F.R. 30-5,000 c/s. r.c.f. 2,000 c/s. Price £9.

**Fane H.D. 121A.** Details as above, but aluminium voice coil. F.R. 30-10,000 c/s. r.c.f. 5,000 c/s. Price £9 9s.

**Fane 301 High Frequency Unit.** Aluminium cone. Voice coil  $\frac{3}{4}$  in. Gap flux 17,000 gauss. H.C. 12 watts. v.c.i. 15 ohms. F.R. 1,500-17,000 c/s. r.c.f. 2,000 c/s. Price £3 15s.



**General Electric Co. Ltd., Magnet House, Kingsway, W.C.2. Tel.: Temple Bar 8000. Cables: Polyphase, London.**

**Metal Cone Speaker.** BCS1851. 8 in. metal cone. Plastic surround. Voice coil 1 in. Gap flux 13,500 gauss. H.C. 12 watts. v.c.i. 4 ohms. F.R. 30-20,000 c/s. r.c.f. 1,500 c/s. Price £7 3s. 10d. including power bracket (U.K. purchase tax £2 6s. 2d.)

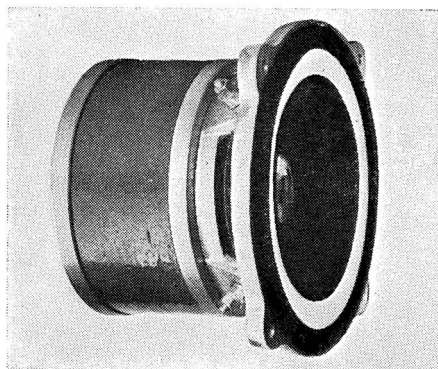

*Bakers Selhurst Ultrasonic*

**BCS1852 Presence Unit.** Miniature metallised pressure diaphragm. Surround integral with diaphragm. Overall dia.  $1\frac{5}{8}$  in. Voice coil  $\frac{3}{4}$  in. Gap flux 10,500 gauss. Total flux 26,000 maxwells. H.C. 5 watts max. v.c.i. 15 ohms. F.R. 1,000-15,000 c/s. Price £3 19s. 6d. including condenser and mounting components.

**BCS 1853. High Flux Presence Unit.** Miniature metallised diaphragm. H.C. 12 watts max. v.c.i. 15 ohms. F.R. 1,500-13,000 level. r.c.f. 1,500 c/s. Price £6 10s.



**Goodmans Industries Ltd., Axiom Works, Wembley, Middx. Tel.: Wembley 1200, Cables: Goodaxiom, Wembley.**

**Axiette.** 8-in. Paper cone. Plastic treated surround. Voice coil 1 in. Gap flux 15,000 gauss. H.C. 6 watts. v.c.i. 3 ohms or 15 ohms. F.R. 40-15,000 c/s. Price £5 (U.K. purchase tax £1 12s. 1d.)

**Triaxiette.** 8 in. Paper cone. Plastic treated surround. Main voice coil 3 in. H.F. 1 in. Total flux 178,000 maxwells. H.C. 10 watts. v.c.i. 15 ohms. F.R. 40-20,000 c/s. Price £10 4s. 3d. (U.K. purchase tax £3 5s. 9d.)

**Axiom 80.**  $9\frac{1}{2}$  in. Paper cone, free edge surround. Voice coil 1 in. Gap flux 17,000 gauss. Total flux 62,600 maxwells. H.C. 6 watts. v.c.i. 15 ohms. F.R. 20-20,000 c/s. Price £17 10s. (U.K. purchase tax £5 12s. 4d.)

**Axiom 60.** 12 in. Paper cone. Paper surround. Voice coil  $1\frac{1}{2}$  in. Gap flux 14,000 gauss. Total flux 158,000 maxwells. H.C. 15 watts. v.c.i. 15 ohms. F.R. up to 7,000 c/s. r.c.f. 950 c/s. when used as bass speaker in multi-speaker systems. Price £9 12s. 9d.



*Goodmans Triaxiette*

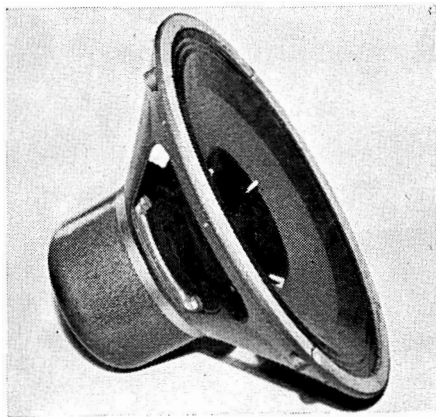

*Goodmans Axiom 300*

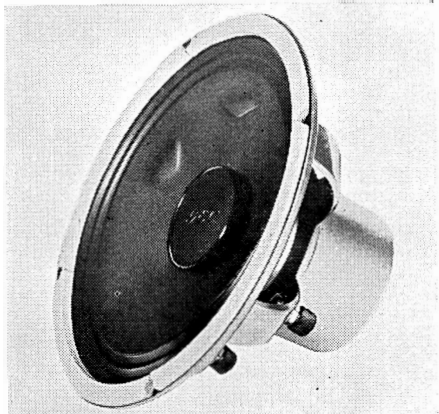

*G.E.C. Metal Cone*

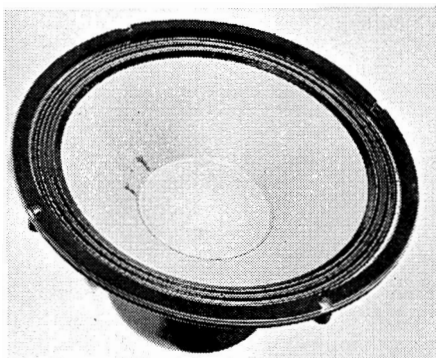

*Goodmans Axiom 112*

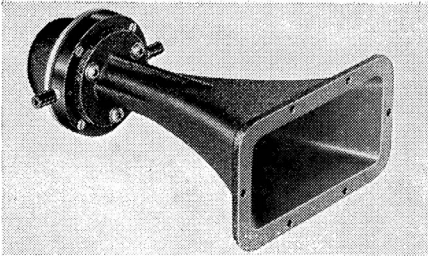

*Goodmans Midax 650*

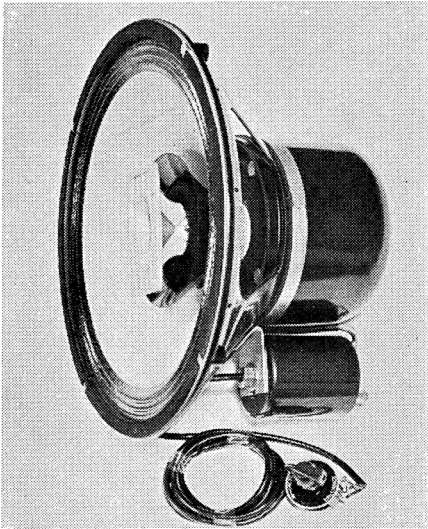

*Goodmans Triaxiom 12/20*

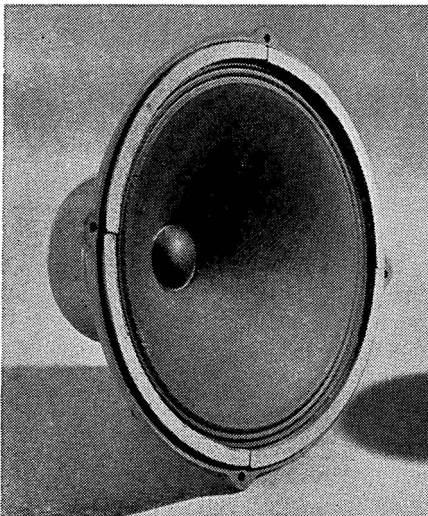

*Grampian 1255/15*

**Audiom 70.** 12 in. Paper cone. Paper surround. Voice coil  $1\frac{1}{2}$  in. Gap flux 17,500 gauss. Total flux 195,000 maxwells. H.C. 20 watts. v.c.i. 15 ohms. F.R. up to 7,000 c/s. r.c.f. 950 c/s when used as bass speaker in multi-speaker systems. Price £15 2s.

**Axiom 110.** 10 in. Paper cone. Plastic treated surround. Voice coil 1 in. Gap flux 12,000 gauss. H.C. 10 watts. v.c.i. 15 ohms. F.R. 40-15,000 c/s. Price £3 15s. 9d. (U.K. purchase tax £1 4s. 3d.)

**Axiom 112.** 10 in. Paper cone. Plastic treated surround. Voice coil 1 in. Gap flux 16,000 gauss. H.C. 12 watts. v.c.i. 15 ohms. F.R. 40-15,000 c/s. Price £6 8s. 8d. (U.K. purchase tax £2 1s. 4d.)

**Axiom 300.** 12 in. Twin diaphragm, paper cone. Plastic treated surround. Voice coil  $1\frac{1}{2}$  in. Gap flux 14,000 gauss. Total flux 158,000 maxwells. H.C. 15 watts. v.c.i. 15 ohms. F.R. 30-16,000 c/s. Built-in mechanical crossover network at 5,000 c/s. Price £11 5s. 9d.

**Axiom 400.** 12 in. Twin diaphragm, paper cone. Plastic treated surround. Voice coil  $1\frac{1}{2}$  in. Gap flux 17,500 gauss. Total flux 195,000 maxwells. H.C. 20 watts. v.c.i. 15 ohms. F.R. 30-16,000 c/s. Built-in mechanical crossover network at 5,000 c/s. Price £16 1s.

**Audiom 80.** 15 in. Paper cone. Paper surround. Voice coil 2 in. (5 cms). Gap flux 14,500 gauss. Total flux 215,000 maxwells. H.C. 25 watts. v.c.i. 15 ohms. F.R. up to 7,000 c/s. 950 c/s when used as bass speaker in multi-speaker systems. Price £22 10s.

**Triaxiom 12/20.** 12 in. Paper cone. Plastic treated surround. Main voice coil  $1\frac{1}{2}$  in. H.F. 1 in. Gap flux 16,000 gauss. Total flux 185,000 maxwells. H.C. 20 watts. v.c.i. 15 ohms. F.R. 30-20,000 c/s. Price £25.

**Trebax.** Horn-loaded pressure tweeter. Aluminium diaphragm. Voice coil 1 in. H.C. suitable for inclusion in systems of up to 25 watts. v.c.i. 15 ohms at 10 Kc/s. F.R. 2,500-20,000 c/s. r.c.f. 5 Kc/s. Price £6 4s.

**Trebax 5K/20XL.** Horn loaded pressure tweeter. Built in L/C crossover (5,000 c/s) and attenuator. H.C. 10 watts. Dispersion angle  $90^\circ$ . Price £7.

**Midax 650.** Horn loaded pressure unit. Resin impregnated linen diaphragm. Voice coil  $1\frac{1}{2}$  in. H.C. suitable for systems up to 25 watts. v.c.i. 15 ohms. F.R. 650-8,000 c/s. r.c.f. 950 and 5,000 c/s. Price £9 10s.



**Gramplan Reproducers Ltd.,** Hanworth Trading Estate, Middx. Tel.: Feltham 2657/8/9. Cables: Reamp, Feltham.

**Gramplan 1255/15.** 12 in. Paper impregnated cone and surround. Voice coil  $1\frac{1}{2}$  in. Gap flux 14,500 gauss. Total flux 130,500 maxwells. H.C. 10 watts. v.c.i. 15 ohms. F.R. 35-15,000 c/s. Price £9.



**The Lowther Manufacturing Co.,** Lowther House, St. Mark's Road, Bromley, Kent. Tel.: Ravensbourne 5225. Cables: Lowther, Bromley.

**P.M.6.** 6 in. Selected paper cone. Plastic surround. Voice coil 39 mm. Gap flux 17,500 gauss. Total flux 196,000 maxwells. H.C. 6 watts. v.c.i. 15 ohms. F.R. 20-18,000 c/s. Price £18 18s.

**P.M.2. Mk. I.** 6 in. Selected paper cone. Plastic surround. Voice coil 39 mm. Gap flux 21,000 lines per sq. cm. Total flux 281,000 maxwells. H.C. 6 watts. v.c.i. 15 ohms. F.R. 20-20,000 c/s. Price £30.

**P.M.2 Mk. II.** 6 in. Selected paper cone. Plastic foam surround. Voice coil 39 mm. Gap flux 23,000 gauss. Total flux 350,000 maxwells. H.C. 6 watts. v.c.i. 15 ohms. F.R. 22-20,000 c/s. Price £40.

**P.M.3.** 6 in. Selected paper cone. Plastic surround. Voice coil 39 mm. Gap flux 22,000 gauss. Total flux 307,750 maxwells. H.C. 6 watts. v.c.i. 15 ohms. F.R. 20-20,000 c/s. Not sold separately from enclosure type T.P.1.

**P.M.4.** 6 in. Selected paper cone. Plastic surround. Voice coil 39 mm. Gap flux 24,500 gauss. Total flux 385,000 maxwells. H.C. 6 watts. v.c.i. 15 ohms. F.R. 20-25,000 c/s. Price £48.



**Philips Electrical Ltd.,** Century House, Shaftesbury Avenue, W.C.2. Tel.: Gerrard 7777. Cables: Phillamps, London.

**9710.** 8 in. Paper cone. Corrugated surrounds. Voice coil 1 in. Gap flux 8,000 gauss. Total flux 97,000 maxwells. H.C. 10 watts. v.c.i. 7 ohms. F.R. 40-10,000 c/s. r.c.f. 500-1,000 c/s. Price £4 7s. 6d. (U.K. purchase tax £1 8s.)

**9710M.** 8 in. Dual cone. Paper corrugated surround. Voice coil 1 in. Gap flux 8,000 gauss. Total flux 97,000 maxwells. H.C. 10 watts. v.c.i. 7 ohms. F.R. 40-18,000 c/s. r.c.f. 500-1,000 c/s. Price £4 15s. 5d. (U.K. purchase tax £1 10s. 7d.)

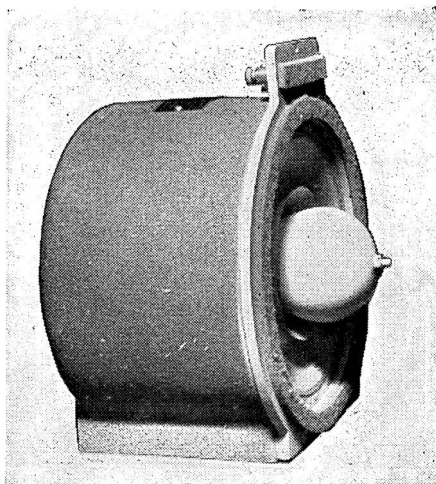

*Lowther P.M.3*

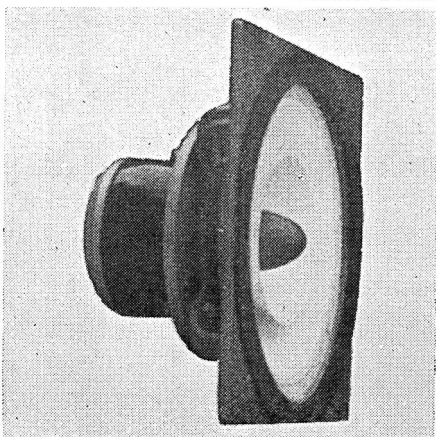

*Lowther P.M.6*

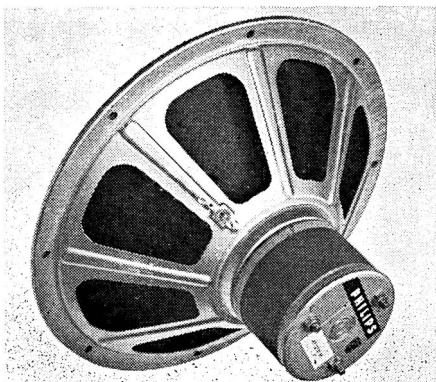

*Philips AD5200M*



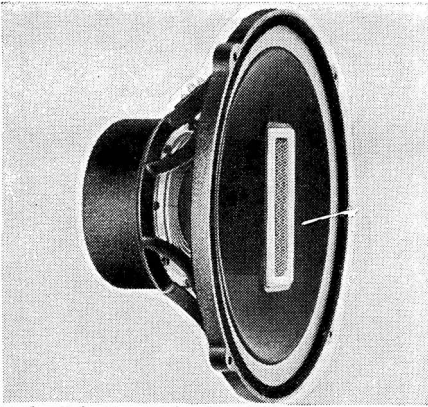

*Rola Celestion Colaudio 1550*

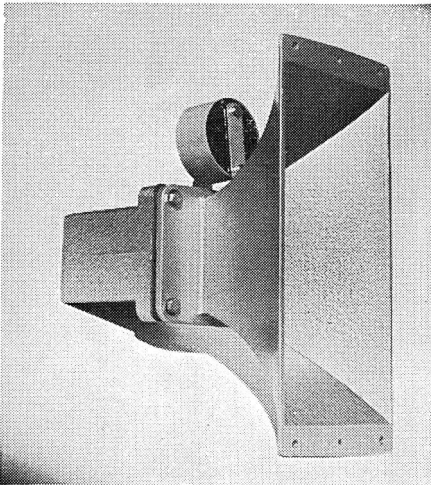

*Kelly Ribbon Mk. II*

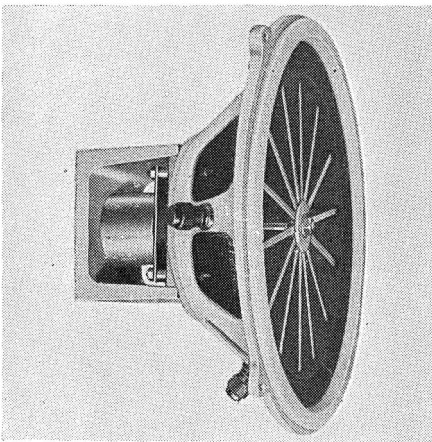

*Sound Sales Auditorium*

**9762.** 12 in. Paper cone. Corrugated surround. Voice coil  $1\frac{1}{2}$  in. Gap flux 11,000 gauss. Total flux 134,000 maxwells. H.C. 20 watts. Price £10.

**AD5200M.** 12 in. Dual cone. Paper. Corrugated surround. Voice coil  $1\frac{1}{2}$  in. Gap flux 11,000 gauss. Total flux 134,000 maxwells. H.C. 20 watts. Price £10 10s.



**Rola Celestion Ltd.,** Ferry Works, Thames Ditton, Surrey. Tel.: Emberbrook 3402-6.

**Colaudio 1550.** 15 in. Paper cone. Foam surround. Voice coils (L.F.) 3 in. (H.F.)  $\frac{3}{4}$  in. Gap flux (L.F.) 12,500 (H.F.) 14,500 gauss. Total flux (L.F.) 290,000 (H.F.) 73,500 maxwells. H.C. 25 watts. v.c.i. 15 ohms. F.R. 30-15,000 c/s. For use with 3K50 coupling unit. Price £32 10s. Coupling unit £2 19s. 6d.



**Romagna Reproducers Ltd.,** 2 Sarnesfield Road, Enfield, Middx. Tel.: Enfield 8717.

**Kelly Ribbon H.F. Speaker Mk. 2.** Horn loaded. Ribbon dimensions  $6 \times 1$  cms. H.C. 10 watts. v.c.i. 15 ohms through transformer supplied. F.R. 2,000-20,000 c/s. r.c.f. 2,000 c/s. Price £10 10s.

**L.F. Driver Mk. 1.** 12 in. Metal cone. Free edge. Voice coil 2 in. Gap flux 14,000 gauss. Total flux 250,000 maxwells. H.C. 25 watts. v.c.i. 15 ohms. F.R. 35-2,000 c/s. r.c.f. 2,000 c/s. Price £14 14s.

**L.F. Driver Mk. 2.** 12 in. Metal cone. Free edge. Voice coil 4 in. Gap flux 12,500 gauss. Total flux 650,000 maxwells. H.C. 25 watts. v.c.i. 15 ohms. F.R. 20-2,000 c/s. r.c.f. 2,000 c/s. Price £25 4s.



**Sound Sales Ltd.,** Works and Acoustic Laboratories, West Street, Farnham, Surrey, England. Tel.: Farnham 6461/2/3. Cables: Sounsense.

**Dual Suspension Auditorium.** Models A and B. 12 in. paper cone. Very flexible velvet surround plus dual suspension spider. Voice coil working in 0.06 in. by  $\frac{1}{2}$  in. deep gap, maximum effective travel  $\frac{3}{8}$  in. Gap flux 10,600 gauss. Total flux 95,000 maxwells. H.C. 12 watts in suitable enclosure. v.c.i. model A 15 ohms; model B 3 ohms. F.R. 30-13,500 c/s with suitable mounting. r.c.f. about 3,000 c/s. Price £9 13s. 4d.

**Tannoy Products Ltd.,** West Norwood, London, S.E.27. Tel.: Gipsy Hill 1131. Cables: Tannoy, London.

**12-in. Low Frequency Unit.** Moulded fibre cone. Plastic treated surround. Voice coil 2 in. Gap flux 10,000 gauss. H.C. 15 watts. v.c.i. 15 ohms. F.R. 35-4,000 c/s. r.c.f. 1,700 c/s. Price £14 14s.

**15-in. Low Frequency Unit.** Moulded fibre cone. Plastic treated surround. Voice coil 2 in. Gap flux 12,000 gauss. H.C. 25 watts. v.c.i. 15 ohms. F.R. 30-3,000 c/s. r.c.f. 1,000 c/s. Price £21 10s.

**Direct radiator.** 12 in. moulded fibre cone. Plastic treated surround. Voice coil 2 in. Gap flux 14,000 gauss. H.C. 15 watts. v.c.i. 20 ohms. F.R. 40-16,000 c/s. Price £14 14s.

**High Frequency Speaker Unit.** Horn loaded plastic coated light alloy diaphragm. Voice coil 2 in. Gap flux 15,000 gauss. H.C. 20 watts above 1,000 c/s. v.c.i. 15 ohms. F.R. 1,000-20,000 c/s. r.c.f. 1,000 c/s. Price £18.

**Monitor "Twelve".** 12 in. Moulded fibre cone. Plastic treated surround. Voice coils (H.F. and L.F.) 2 in. Gap flux (L.F.) 11,500 (H.F.) 15,000 gauss. H.C. 30 watts. F.R. 25-20,000 c/s. r.c.f. 1,700 c/s. Price £30 15s.

**Monitor "Fifteen".** 15 in. Moulded fibre cone. Plastic treated surround. Voice coils (L.F. and H.F.) 2 in. Gap flux (L.F.) 13,500 (H.F.) 18,000 gauss. H.C. 50 watts. F.R. 23-20,000 c/s. r.c.f. 1,000 c/s. Price £37 10s.



**Technical Suppliers Ltd.,** Hudson House, 63 Goldhawk Road, London, W.12. Tel.: Shepherds Bush 2581/4794.

**TSL-Lorenz. LP. 215.** 8 in. Reinforced paper cone. Permaflex surround. Voice coil 1 in. H.C. 8 watts, peak load 12 watts. v.c.i. 4.5 ohms. F.R. 35-12,000 c/s. Price £4 19s. 6d. (U.K. purchase tax £1 12s.)

**LP. 312-2.** 12 in. Reinforced ribbed paper cone. Permaflex surround. Voice coil 1½ in. H.C. 25 watts. (Peak rating in suitable enclosure 40 watts.) v.c.i. 15 ohms. F.R. 20 to above 17,000 with 2 type LPH 65 treble speakers in a fitted bridge assembly. r.c.f. 3,000-5,000 c/s. Price £14 19s. 6d.

**TSL-Lorenz Tweeter LPH 65.** 2½ in. Special plastic cone. Plastic surround. Voice coil ½ in. H.C. 2 watts (H.F. only). v.c.i. 5.5 ohms. F.R. 2,000 to above 17,000 c/s. r.c.f. 3,000-5,000 c/s. Price £1 8s. 6d. (U.K. purchase tax 9s. 2d.)

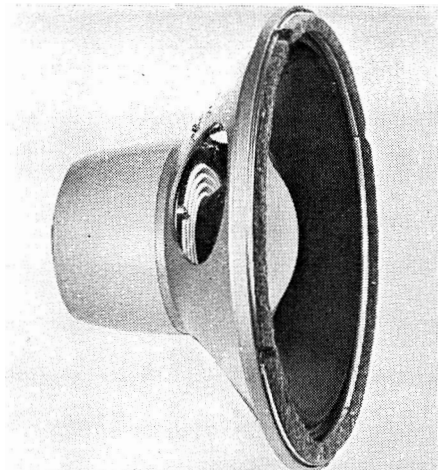

*Tannoy Monitor "Twelve"*

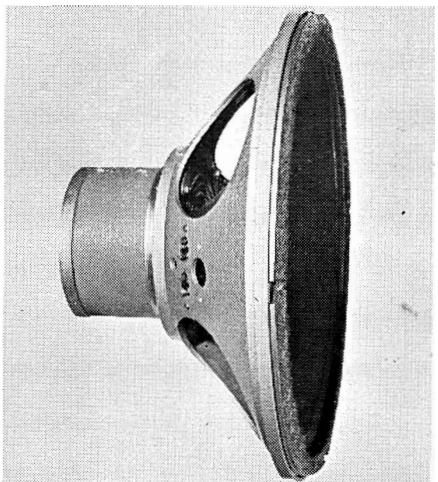

*Tannoy 12-in. L.F. Unit*

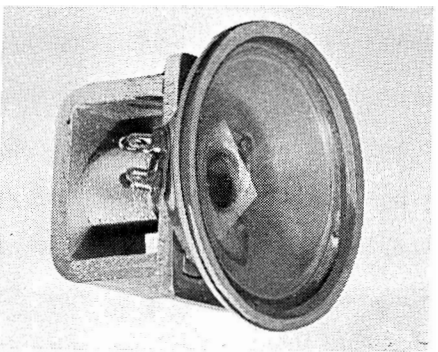

*TSL-Lorenz LPH 65 Tweeter*

**Vitavox Ltd.,** Westmoreland Road, London, N.W.9. Tel.: Colindale 8671. Cables: Vitavox, Hyde, London.

**Duplex Coaxial DU 120.** 12 in. and 3 in. Paper and polyester film cones and surround. Voice coil (L.F.) 1.75 in. (H.F.) 0.65 in. Gap flux (L.F.) 14,000 (H.F.) 12,000 gauss. Total flux (L.F.) 160,000 (H.F.) 15,000 maxwells. H.C. 15 watts. v.c.i. 15 ohms. F.R. 40-15,000 c/s nominal. Price £19 10s.

**AK.120.** 12 in. Paper cone. Paper surround. Voice coil 1.78 in. Gap flux 14,000 gauss. Total flux 160,000 maxwells. H.C. 15 watts. v.c.i. 15 ohms. F.R. 40-12,000 c/s. r.c.f. 1,000 c/s. Price £14.

**K15/40.** 15 in. Paper cone. Paper surround. Voice coil 2.25 in. Gap flux 14,000 gauss. Total flux 260,000 maxwells. H.C. 40 watts. v.c.i. 15 ohms. F.R. 40-10,000 c/s. r.c.f. 500 c/s. Price £25.

★

**Westrex Co. Ltd.,** Coles Green Road, London, N.W.2. Tel.: Gladstone 5401/8, Cables: Westcol, Norphone, London.

**20/80 Low Frequency Unit.** 15 in. Paper cone with damped surround and spider. Voice coil 3 in. of edgewound copper ribbon. Gap flux 13,200 gauss. v.c.i. 16 ohms. H.C. 30 watts. F.R. up to 800 c/s. r.c.f. 675 c/s. Price £33 15s.

**High Frequency Unit,** with acoustilens coupling unit. Horn loaded. Alloy dome on 3 in. voice coil of edgewound aluminium ribbon. Gap flux 17,500 gauss. H.C. above 500 c/s up to 30 watts. F.R. 500 to over

15,000 c/s. r.c.f. 675 c/s. Speaker includes horn and acoustic lens giving necessary dispersion. Price complete with horn and lens £69 17s.

★

**Wharfedale Wireless Works Ltd.,** Idle, Bradford. Tel.: Idle 1235-6. Cables: Wharfedel, Idle, Bradford.

**8-in. Bronze/FS/AL.** Paper cone. Foam plastic surround. Voice coil 1 in. (aluminium). Gap flux 10,500 gauss. Total flux 41,500 maxwells. H.C. 4 watts. v.c.i. 2-3 ohms or 10-15 ohms. F.R. 40-12,000 c/s. Price £3 5s. (U.K. purchase tax £1 1s. 7d.)

**Super 8.** 8 in. Paper cone. Surround, paper corrugations. Voice coil 1 in. Gap flux 14,500 gauss. Total flux 60,000 maxwells. H.C. 6 watts. v.c.i. 2-3 or 12-15 ohms. F.R. 60-12,000 c/s. r.c.f. 1,000 c/s. Price £4 10s. (U.K. purchase tax £1 9s. 11d.)

**Super 8/FS.** 8 in. Paper cone. Foam plastic surround. Voice coil 1 in. Gap flux 14,500 gauss. Total flux 60,000 maxwells. H.C. 5 watts. v.c.i. 2-3 or 12-15 ohms. F.R. 40-12,000 c/s. Price £5 (U.K. purchase tax £1 13s. 3d.)

**Super 8/FS/AL.** 8 in. Paper cone. Foam plastic surround. Aluminium voice coil 1 in. Gap flux 14,500 gauss. Total flux 60,000 maxwells. H.C. 4 watts. v.c.i. 2-3 or 10-15 ohms. F.R. 40-14,000 c/s. Price £5 5s. (U.K. purchase tax £1 14s. 11d.)

**10-in. Bronze/FSB.** Paper cone with bakelised apex. Foam plastic surround. Voice coil 1 in. Gap flux 10,500 gauss.

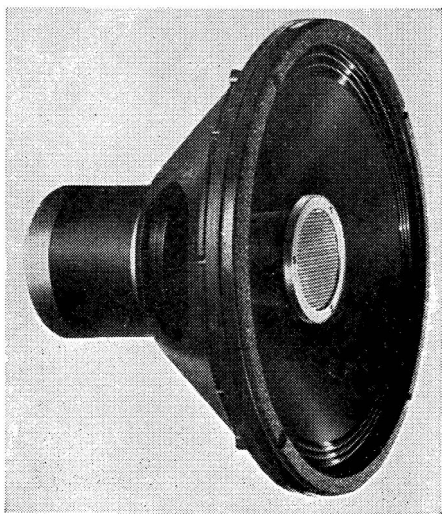

*Vitavox DU120 Duplex*

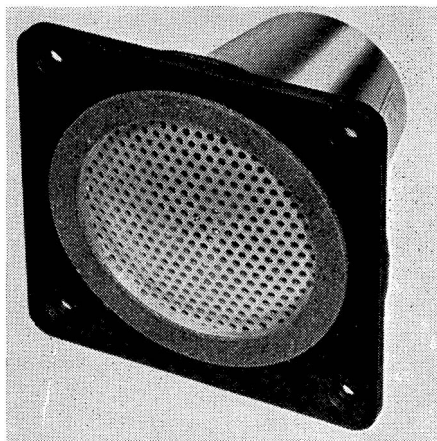

*Vitavox TR30 direct radiator moving coil treble unit with polyester film diaphragm sealed at rear, built-in capacitor. Price £6 10s.*

Total flux 41,500 maxwells. H.C. 6 watts. v.c.i. 2-3 or 12-15 ohms. F.R. 30-10,000 c/s. Price £3 19s. 6d. (U.K. purchase tax £1 6s. 5d.)

**Golden/FSB.** 10 in. Paper cone with bakelised apex. Foam plastic surround. Voice coil 1 in. Gap flux 14,500 gauss. Total flux 60,000 maxwells. H.C. 8 watts. v.c.i. 2-3 or 12-15 ohms. F.R. 30-12,000 c/s. Price £6 5s. (U.K. purchase tax £2 1s. 7d.)

**W10/FSB.** 10 in. Paper cone with bakelised apex and aluminium dome. Foam plastic surround. Voice coil 1 in. Gap flux 16,000 gauss. Total flux 84,000 maxwells. H.C. 10 watts. v.c.i. 2-3 or 12-15 ohms. F.R. 30-14,000 c/s. Price £9 7s. 6d. (U.K. purchase tax £3 2s. 4d.)

**W12/FS.** 12 in. Paper cone with bakelised apex. Foam plastic surround. Voice coil 1½ in. Gap flux 13,000 gauss. Total flux 145,000 maxwells. H.C. 15 watts. v.c.i. 12-15 ohms. F.R. 25-5,000 c/s. Price £10 5s.

**Super 12/FS/AL.** 12 in. Paper cone with bakelised apex. Foam plastic surround. Voice coil 1½ in. (aluminium). Gap flux 17,000 gauss. Total flux 190,000 maxwells. H.C. 15 watts. v.c.i. 12-15 ohms. F.R. 30-14,000 c/s. Price £17 10s.

**W 15/FS.** 15 in. Paper cone. Foam plastic surround. Voice coil 2 in. Gap flux 13,500 gauss. Total flux 180,000 maxwells. H.C. 15 watts. v.c.i. 12-15 ohms. F.R. 25-20,000 c/s. r.c.f. 800 c/s. Price £17 10s.

**Super 3.** 3 in. Bakelised paper cone with aluminium dome. Foam plastic surround. Voice coil 1 in. (aluminium). Gap flux 14,500 gauss. Total flux 60,000 maxwells.

H.C. 6 watts above 1,000 c/s. v.c.i. 2-3 or 8-15 ohms. F.R. 3,000-20,000 c/s. r.c.f. 4,000 c/s. Price £5. (U.K. purchase tax £1 13s. 3d.)

**8/145.** 8 in. Paper cone. Foam surround. Voicecoil 1 in. (aluminium). Gap flux 14,500 gauss. Total flux 60,000 maxwells. H.C. 4 watts. v.c.i. 2-3 or 10-15 ohms. F.R. 40-14,000 c/s. Price £5 5s. (U.K. purchase tax £1 14s. 11d.)

**Coaxial 12.** (L.F.) 12 in. (H.F.) 2 in. Paper cone. Foam surround. Voice coils (L.F.) 1½ in. (H.F.) 1 in. Gap flux (L.F.) 14,000 (H.F.) 13,200 gauss. Total flux (L.F.) 155,000 (H.F.) 44,000 maxwells. H.C. 15 watts. v.c.i. 12-15 ohms only. F.R. 25-20,000 c/s. Price £25.



**Messrs. Whiteley Electrical Radio Co. Ltd.,** Victoria Street, Mansfield, Notts. Tel: Mansfield 1762-5. Cables: Whitebon, Mansfield.

**Stentorian HF.812.** 8 in. Composite (paper and cambric) cone. Cambric surround. Voice coil 1 in. Gap flux 12,000 gauss. Total flux 47,400 maxwells. H.C. 5 watts. v.c.i. universal (3, 7.5 and 15 ohms). F.R. 50-12,000 c/s. Price £2 19s. 6d. (U.K. purchase tax £1 4s.)

**H.F.816.** 8 in. Composite (paper and cambric) cone. Cambric surround. Voice coil 1 in. Gap flux 16,000 gauss. Total flux 63,000 maxwells. H.C. 6 watts. v.c.i. universal 3 ohms, 7.5 ohms and 15 ohms.

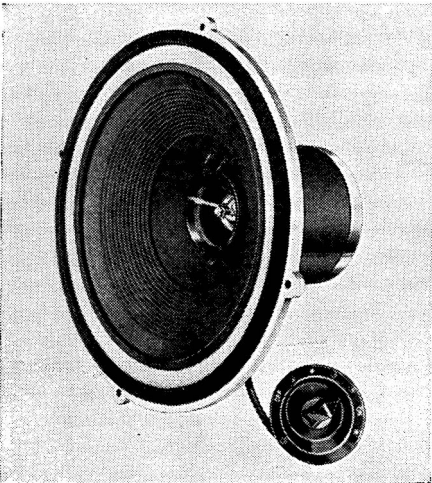

*Wharfedale Coaxial 12*

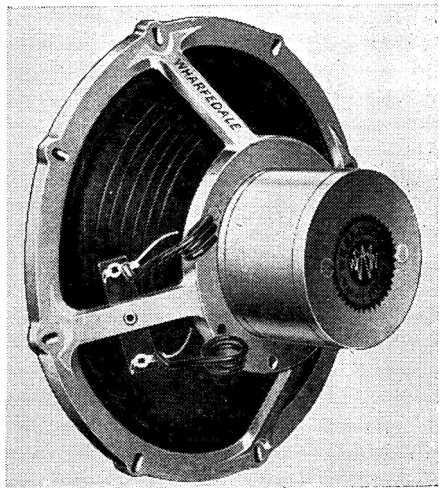

*Wharfedale Super 8*

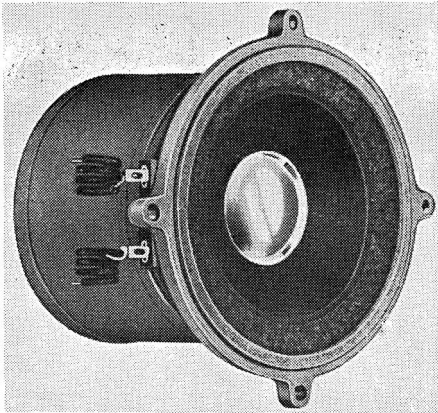

*Wharfedale Super 3*

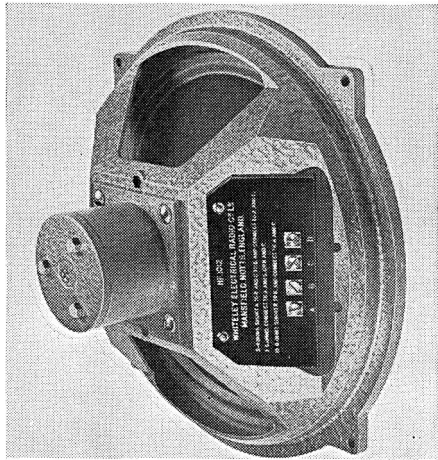

*Whiteley H.F. 1012 10-in.*

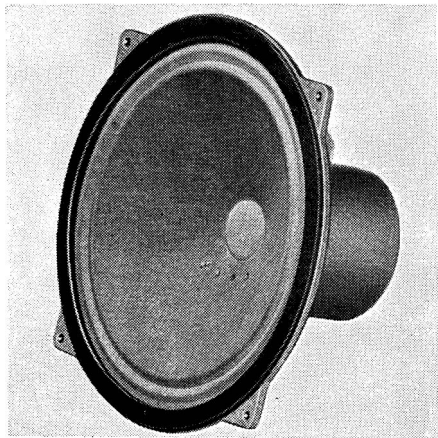

*Whiteley H.F. 816 8-in.*

F.R. 50-14,000 c/s. Price £4 17s. 7d. (U.K. purchase tax £1 19s. 5d.)

**H.F.817.** 8 in. Paper cone. Cambric surround. Voice coil 1 in. Gap flux 17,000 gauss. Total flux 67,000 maxwells. H.C. 10 watts in cabinet. v.c.i. 15 ohms. F.R. 60-22,000 c/s. Price £8 2s. (U.K. purchase tax £3 5s. 6d.)

**HF.912.** 9 in. Composite (paper and cambric) cone. Cambric surround. Voice coil 1 in. Gap flux 12,000 gauss. Total flux 47,400 maxwells. H.C. 7 watts. v.c.i. universal (3, 7.5 and 15 ohms). F.R. 40-13,000 c/s. Price £3 3s. (U.K. purchase tax £1 5s. 6d.)

**HF.1012.** 10 in. Composite (paper and cambric) cone. Cambric surround. Voice coil 1 in. Gap flux 12,000 gauss. Total flux 47,400 maxwells. H.C. 10 watts. v.c.i. universal 3 ohms, 7.5 ohms and 15 ohms. F.R. 30-14,000 c/s. Price £3 11s. (U.K. purchase tax £1 8s. 9d.)

**HF.1016.** 10 in. Composite (paper and cambric) cone. Cambric surround. Voice coil 1 in. Gap flux 16,000 gauss. Total flux 63,000 maxwells. H.C. 10 watts. v.c.i. 3, 7.5 and 15 ohms. F.R. 30-15,000 c/s. Price £5 13s. 11d. (U.K. purchase tax £2 6s. 1d.)

**10-in. Concentric Duplex.** Composite (paper and cambric) cone. Cambric surround. Voice coil 1 in. Gap flux (L.F.) 12,000 (H.F.) 13,000 gauss. Total flux 47,400 maxwells. H.C. 10 watts. v.c.i. 15 ohms. F.R. 30-14,000 c/s. r.c.f. 3,000 c/s built-in. Price £9 3s. 9d. (U.K. purchase tax £3 14s. 3d.)

**HF.1214.** 12 in. Composite (paper and cambric) cone. Cambric surround. Voice coil 1.5 in. Gap flux 14,000 gauss. Total flux 106,000 maxwells. H.C. 15 watts. v.c.i. 15 ohms. F.R. 25-14,000 c/s. r.c.f. 1,500-3,000 c/s. Price £9 15s. 6d.

**12-in. Concentric Duplex.** Composite (paper and cambric) cone. Cambric surround. Voice coil 1½ in. Gap flux (L.F.) 14,000 (H.F.) 17,000 gauss. Total flux 220,000 maxwells. H.C. 15 watts. v.c.i. 15 ohms. F.R. 25-17,000 c/s. r.c.f. 3,000 c/s. built-in. Price £25.

**15-in. Concentric Duplex.** Composite (paper and cambric) cone. Cambric surround. Voice coil 2 in. Gap flux (L.F.) 14,000 (H.F.) 17,000 gauss. Total flux 350,000 maxwells. H.C. 25 watts. v.c.i. 15 ohms. F.R. 20-18,000 c/s. r.c.f. 3,000 c/s built-in. Price £40 3s.

**HF.1514.** 15 in. Composite (paper and cambric) cone. Cambric surround. Voice coil 2 in. Gap flux 14,000 gauss. Total flux 178,000 maxwells. H.C. 25 watts. v.c.i. 15 ohms. F.R. 25-5,000 c/s. r.c.f. 1,500-3,000 c/s. Price £24 10s.

**T.10 Tweeter.** Aluminium cone and surround. Voice coil 1 in. Gap flux 14,000 gauss. Total flux 44,000 maxwells. H.C. 5 watts. v.c.i. 15 ohms. F.R. 2,000-14,000 c/s. r.c.f. 3,000 c/s. Price £4 4s.

**T.12. Tweeter.** Aluminium cone and surround. Voice coil 1.5 in. Gap flux 17,000 gauss. Total flux 110,000 maxwells. H.C. 12 watts. v.c.i. 15 ohms. F.R. 2,000-17,000 c/s. r.c.f. 3,000 c/s. Price £12 12s.

**T.816.** 8 in. Paper cone and surround. Voice coil 1 in. Gap flux 16,000 gauss. Total flux 63,000 maxwells. H.C. 15 watts. v.c.i. 15 ohms. F.R. 1,500 to 17,000 c/s. r.c.f. 1,500 c/s. Price £4 12s. 7d. (U.K. purchase tax £1 17s. 5d.)

**T.359.** 3½ in. Paper cone and surround. Voice coil 0.625 in. Gap flux 9,000 gauss. Total flux 14,900 maxwells. H.C. 15 watts with crossover. v.c.i. 5 or 15 ohms. F.R. 3,000-17,000 c/s. r.c.f. 3,000 c/s. Price £1 4s. 11d. (U.K. purchase tax 10s. 1d.)



#### Acoustic Resistance Units

**Goodmans Industries Ltd.,** Axiom Works, Wembley, Middx. Tel.: Wembley 1200. Cables: Goodaxiom, Wembley.

**ARU Units.** These units combine both reflex port and acoustic resistance in one complete unit. The port area and resistance are calculated to suit a particular cabinet volume and speaker cone resonance, thus being usable with a variety of cabinet designs and driving units. Price £2 15s. 3d. to £4 4s.

### ELECTROSTATIC SPEAKERS

**Acoustical Manufacturing Co. Ltd.,** St. Peter's Road, Huntingdon, Hunts. Tel.: Huntingdon 361 and 574. Cables: Acoustical.

**Quad Electrostatic Loudspeaker.** Full range doublet covering 45 c/s to 18 Kc/s. Attenuation outside band asymptotic to 18 dB/8ve. Total integrated radiation at max. output equivalent to 95 phons in rooms of up to 5,000 cu. ft. with average reverberation. Dispersion approx. 70 deg. horizontal; 15 deg. vertical. Impedance 30-15 ohms, 40 c/s to 8 Kc/s falling above 8 Kc/s. Designed for use with standard Quad II Amplifier or equivalent. Suitable for AC supplies 100-120 or 200-250v. 50-60 c/s. Free standing unit requires no enclosure or cabinet. Weight 35 lb. Price £52 complete.

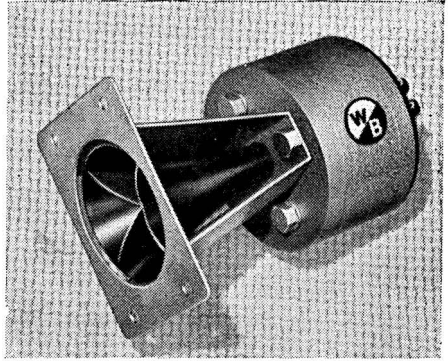

*Whiteley T12 tweeter*

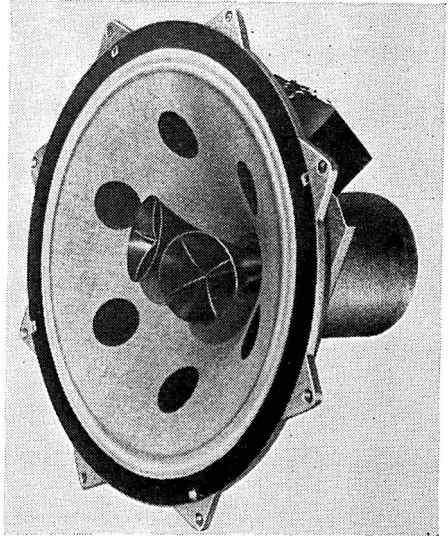

*Whiteley 15-in. Concentric Duplex*

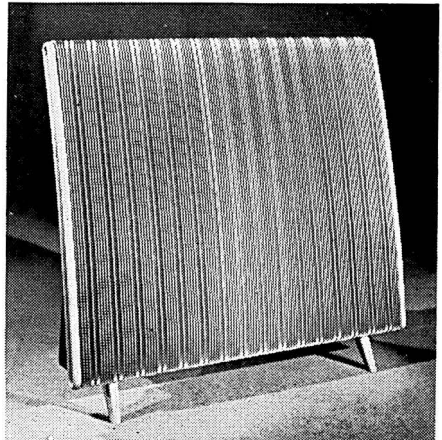

*Quad Electrostatic Loudspeaker*



## SPEAKERS, PART 2 — ENCLOSURES

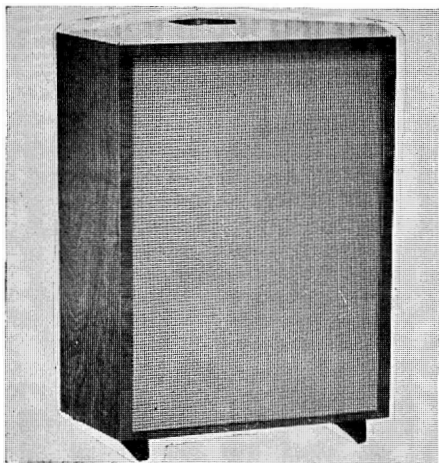

*Richard Allan Duchess*

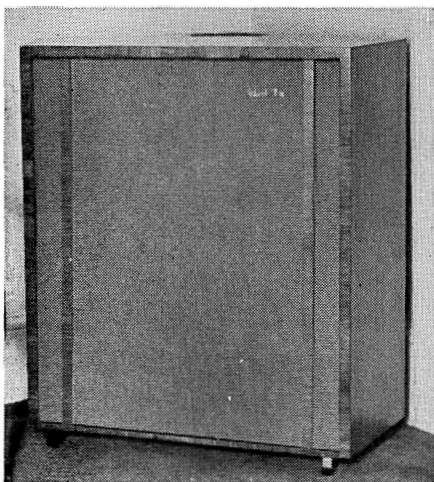

*Richard Allan Empress*

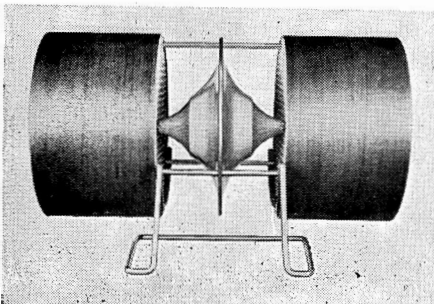

*Burne-Jones Treble Twin*

**Richard Allan Radio Ltd.**, Baffle House, Taylor Street, Batley, Yorks. Tel.: Batley 1123/1308/4033. Cables: Acoustics, Batley.

**Princess.** Reflex forward facing unit. Designed for corner location. One 8 in. drive unit. Rec. Golden Eight. Response 60-10,000 c/s. Size 28 × 20 × 12 ins. Weight 28 lb. Price £11 11s.

**Duchess.** Reflex unit designed for corner location. Upward facing tweeter, forward base. Two drive units. 10 in. bass and 4 in. tweeter. Rec. Golden Ten and 410T. Crossover CN.104. Response 40-17,000 c/s. Size 30 × 25 × 17 ins. Weight 48 lb. Price £15 15s.

**Empress.** Reflex unit designed for corner location. Upward facing tweeter, forward bass and middle units. Three drive units. 12, 8 and 4 ins. Rec. Golden Twelve, 812F, and 410T. Crossover CN.1284. Response 25-17,000 c/s. Size 33 × 31 × 21 ins. Weight 72 lb. Price (complete) £37 16s. (without units) £17 17s.



**Bakers "Selhurst" Radio**, 24 Dingwall Road, Croydon, Surrey. Tel.: Croydon 2271/2.

A range of phase-inverter enclosures for single and multi-speaker systems. Prices on application.



**Bang & Olufsen**, Struer, Denmark. Sole U.K. Importers: Avey Electric Ltd., Ayrton Road, South Ockendon, Essex. Tel.: South Ockendon 3444.

**B & O Toroidal Tweeter.** Omni-directional. Comprising 2 moving coil units facing inwards on to a double cone reflector. Response: 2,000-20,000 c/s. Series capacitor incorporated. Size 4½ ins. high, 3 in. diameter. Price £6 14s. 5d.



**Beam-Echo Ltd.**, 13 South Molton Street, London, W.1. Tel.: Mayfair 1039. Cables: Hibeam, London. Showrooms and Sales Office, 8 Eccleston Street, S.W.1. Tel.: Sloane 0695-7.

**Avantic L 20.** Forward facing reflex enclosure, dual throated ports for corner placing. Three drive units, 12 in. bass, mid-range unit and pressure H.F. unit. Crossover at 400 and 4,000 c/s. Response 20-20,000 c/s. Size 36 × 25 × 18 ins. Price (complete) £47 5s.

**Avantic SL12-21.** Vented enclosure forward facing. Two drive units, 12 in., 3 in. pressure unit. Crossover at 2,000 c/s, built in. Response 40-17,000 c/s. Size  $38 \times 18\frac{7}{8} \times 15\frac{7}{8}$  ins. Price £23 2s.

**Avantic SL71.** Vented enclosure forward facing. Two drive units,  $10 \times 6$  ins. elliptical and  $2\frac{1}{2}$  in. H.F. Response 80-12,000 c/s. Size  $36 \times 12\frac{1}{2} \times 9\frac{3}{4}$  ins., including legs. Price £17 17s.



**B.K. Partners Ltd.,** 229 Regent Street, London, W.1. Tel.: Regent 7363.

**L.P.R. 103.** Reflex with acoustic filter. Two drive units, with h.f. upward and l.f. direct radiation. Rec. Wharfedale Bronze 10/FSB and Wharfedale Super 3 tweeter. Crossover through 2 mfd filter condenser and level control. Response 35-18,000 c/s. Size  $29\frac{1}{2} \times 20 \times 11$  ins. (at base). Price (with rec. units) £24 19s. 8d. (U.K. purchase tax £3 11s. 8d.); without units, £12 8s. 6d.

**AP.10 and AP.12.** Audio Plan speaker unit. Forward facing reflex, designed to accept 12 or 10 in. units with resonance below 40 c/s, also some H.F. units. Rec. Tannoy 12 in. dual concentric Vitavox DU.120; Wharfedale W.12/FS, Super 12, Bronze 10, etc. Size  $24 \times 18 \times 18\frac{1}{2}$  ins. Weight 42 lb. Price of cabinet only £16 19s. 6d.

**Eight 1 Four.** Reflex with "Acoustiflex". Forward facing L.F. unit, upward facing H.F. unit. Two drive units, 8 in. bass, 4 in. treble. Rec. B-K 812/4 assembly with crossover. Response 40-16,000 c/s. Size  $14\frac{1}{2} \times 11 \times 24$  ins. Price (complete) £13 16s. 4d. (without units) £8 10s.

**Twelve 2 Four.** Reflex with "Acoustiflex". Forward facing with H.F. units at 45 degrees. Three drive units. Phillips Dual Cone 12 in., and two 4 in. H.F. units. Crossover included. Response 40-16,000 c/s. Size  $24 \times 29 \times 12$  ins. including  $4\frac{1}{2}$  in. legs. Price £26 10s.

Note: The above is a Sidewall version. There is also a corner version, size  $33\frac{1}{2} \times 27 \times 12$  ins., including legs. Price £28 10s.



**Brearcliffe Ltd.,** Hill Road Works, Beacon Hill, Hindhead, Surrey. Tel.: Hindhead 543.

**Brearcliffe 12, type KD.** Reflex. One drive unit up to 12 ins. Size  $32 \times 14 \times 13$  ins. including  $5\frac{1}{2}$ -in. legs. Weight 35 lbs. Price, cabinet only, £12 12s.

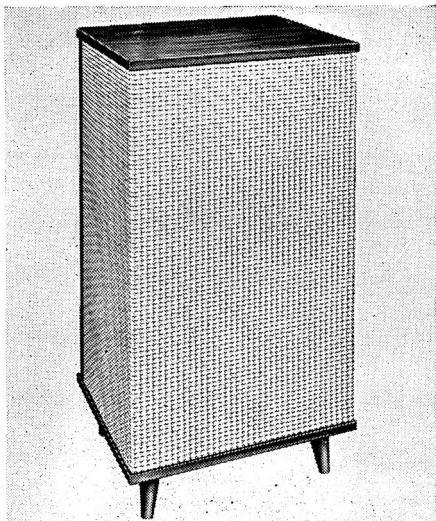

*Beam Echo Avantic SL12-21*

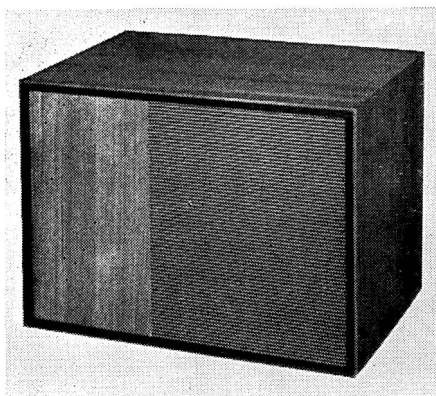

*BK Partners AP10*

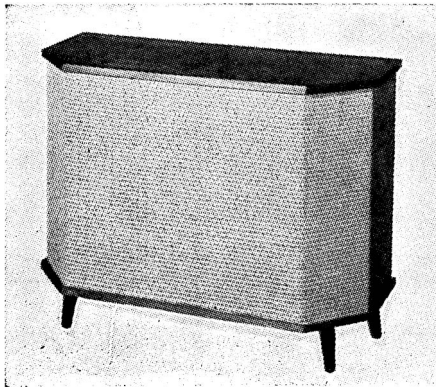

*BK Partners Twelve 2 Four*

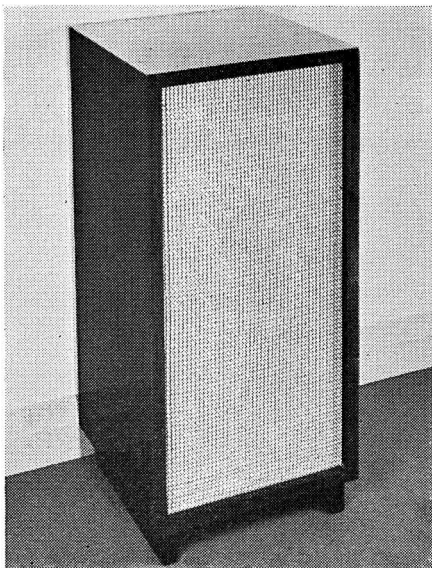

*Burne-Jones Sonetta*

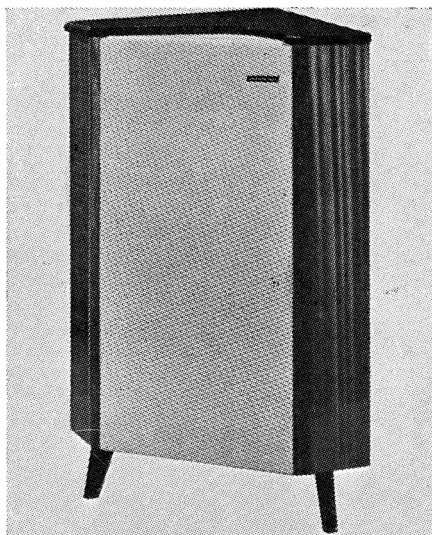

*"Brearcliffe" Enclosure*

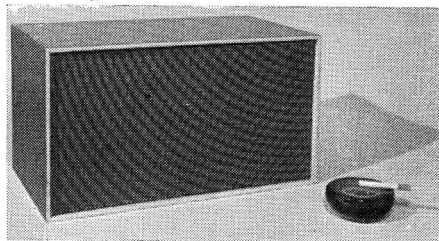

*CQ Audio Junior Enclosure*

**Brearcliffe 15, type KD.** Free standing reflex. One drive unit up to 15 ins. Size  $39 \times 19 \times 18$  ins. including  $5\frac{1}{2}$ -in. legs. Weight 45 lbs. Price, cabinet only, £15 15s.



**Burne-Jones & Co., Ltd.,** 18 Brunswick Road, Sutton, Surrey. Tel.: Vigilant 5050. Cables: Burjomag, Sutton.

**B.J. Sonetta.** Reflex column. Two drive units. 9 in. and 4 in. Crossover and balance control included. Response 35-18,000 c/s. Size  $26 \times 12 \times 12$  ins. Price £12 7s. 6d. (U.K. purchase tax £3 19s. 5d.)

**B.J. Top "C" Tweeter.** Horn loaded omni-directional. To stand on top of all reproducers. Response 1,000-18,000 c/s rec. for use with all enclosures. Complete with built-in crossover and balance control. Price £3 15s. (U.K. purchase tax £1 4s. 1d.) Reg. design.

**B.J. Treble 20.** Omni-directional multi-horn. One 4 in. unit. Crossover built in. Response 1,000-18,000 c/s. Size  $6 \times 5$  ins. Weight  $1\frac{1}{2}$  lb. Price £5 5s. (U.K. purchase tax £1 13s. 9d.) Reg. design.

**B.J. Treble Twin.** Omni-directional horn. Two 4 in. drive units. Crossover included. Response 900-18,000 c/s. Size  $9 \times 4\frac{3}{4} \times 6$  ins. Weight 2 lb. Price £7 2s. 9d. (U.K. purchase tax £2 5s. 10d.) Reg. design.



**C.Q. Audio Ltd.,** No. 3 Factory, Bush Fair, Tye Green, Harlow, Essex. Tel.: Harlow 24566.

**Senior "CQ".** Controlled "Q" reflex. Forward facing—upright or free standing—table model. Wide range  $9 \times 5$  in. elliptical, and 4 in. extended range tweeter. Crossover at 5,000 c/s. Response 35-17,000 c/s. Size  $22 \times 12 \times 13$  ins. Price £12 14s. 6d. (U.K. purchase tax £4 5s. 9d.)

**CQ Junior Enclosure.** Controlled "Q" reflex. Forward facing bookshelf model. One drive unit. Response 45-14,000 c/s. Size  $17 \times 10\frac{1}{2} \times 9\frac{1}{2}$  ins. Price £9 14s. (U.K. purchase tax £3 5s. 4d.)

**CQ Q-Flex.** Flexing wall reflex kit for home constructors. Upward facing units with H.F. deflector. Three drive units, one  $9 \times 5$  ins., and two 4 ins. Response 40-17,000 c/s. Size  $34 \times 17\frac{1}{2} \times 13\frac{1}{2}$  ins. Price,

enclosure only £7 7s. Speakers £5 4s. 8d.  
(U.K. purchase tax £1 15s. 4d.)



**Daystrom Ltd.,** Bristol Road, Gloucester.

Cotswold totally enclosed forward facing.  
(See Kits section.)



**Expert Gramophones Ltd.,** 39/41 New Oxford  
Street, London, W.C.1. Tel.: Covent Garden  
2156.

**Acoustic Column.** Elongated reflex. Vertically  
mounted 12 in. bass unit and 3 in.  
tweeter. Rec. Goodmans Audiom 60 and  
Wharfedale Super 3 tweeter. Response 35-  
18,000 c/s. Size 44 × 14 × 14 ins. Price  
(complete) £42. Alternative version available.  
Price £33.

**"All Range."** Corner reflex. Vertically  
mounted 12 in. unit: horizontally mounted  
8 in. unit. Rec. Baker 12 in. and Philips  
9710 M. Size 42 × 30 × 23 ins. Price  
(complete) £65.

**Master speaker.** Corner reflex. 15 in. dual  
concentric unit, vertically mounted with  
reflector. 90° distribution. Rec. unit 15 in.  
Tannoy dual concentric. Crossover 1,000 c/s.  
Response 28-20,000 c/s. Size 60 × 34 × 24  
ins. Price (complete) £110.



**Fane Acoustics Ltd.,** 1 Wellington Street,  
Batley, Yorks. Tel.: Batley 1578. Cables:  
Fane, Batley.

**Trio.** Cabinet-baffle, forward facing. Three  
drive units. 12 in., 8 in., and H.F. unit.  
Fane units rec. Crossover included. Re-  
sponse 40-17,000 c/s. Size 24½ × 24 ×  
8½ ins. Weight 13 lb. Price £17 10s.

**Quartet.** Cabinet-baffle, forward facing.  
Four drive units. 12 in., 8 in., and two H.F.  
units. Size 25½ × 25½ × 8¾ ins. Weight  
32 lb. Price £35. Cabinet only not supplied.



**General Electric Co., Ltd.,** Magnet House,  
Kingsway, London, W.C.2. Tel.: Temple  
Bar 8000. Cables: Polyphase, London.

**Periphonic Cabinet.** Model BCS 1869.  
Double-pipe loaded with periphonic L.S.  
coupling unit, forward facing. Two metal-  
cone type units 8 in. nominal, with 4 presence  
units, 2 front and one each side. Special  
crossover network and auto-transformers for  
15 ohms input. Response 30-15,000 c/s.

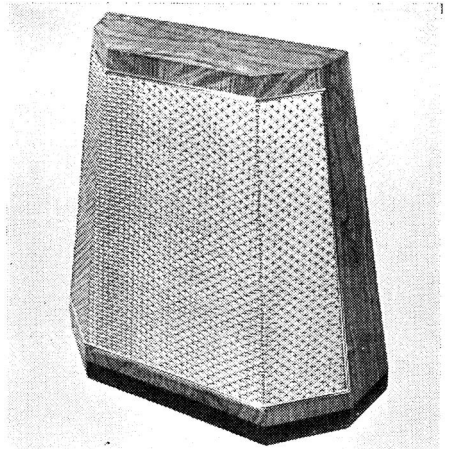

*Fane Quartet*

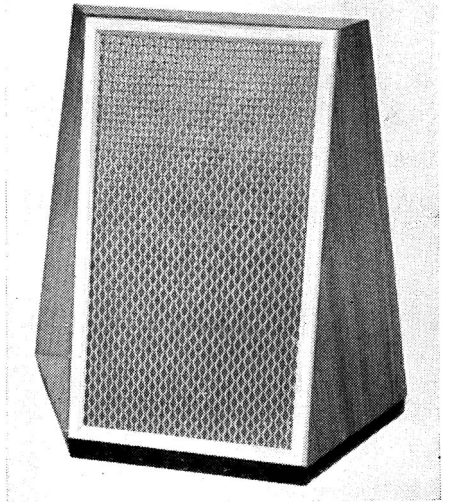

*Fane Trio*

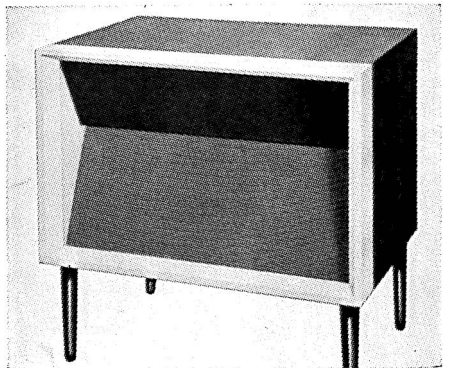

*G.E.C. Baby Periphonic*

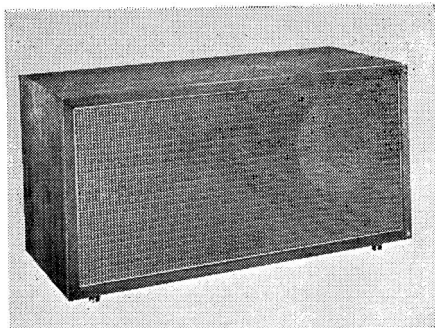

*G.E.C. BCS 1873*

Size 42 × 15 × 36 ins. Price complete, less metal cone units £98.

**Baby Periphonic BCS 1870.** Periphonic coupling, forward facing. Two metal cone 8 in. bass units with two presence units. Response 40-15,000 c/s. Size 21 × 22 × 14 $\frac{3}{4}$  ins. Weight 42 lb. Price, cabinet only £13.

**Octagonal Periphonic BCS 1872.** Periphonic with pipe loading. Forward facing. Two metal cone 8 in. bass, and one or two presence units. Response 30-15,000 c/s. Size 30 × 20 × 14 $\frac{1}{2}$  ins. Weight 38 lb. Price cabinet only £17 10s.

**Bookcase Loudspeaker BCS 1873.** Tuned pipe reflex, forward facing. Two drive units, 8 inch metal cone and BCS 1852 presence unit. Crossover 1,500 c/s. Response 40-15,000 c/s. Size 24 × 12 × 10 ins. Price without units £10 10s., complete £28 16s.

**Slender Periphonic BCS 1874.** Tuned pipe reflex, forward facing. Two 8 in. metal cones, plus one or two high flux presence units. Size 24 × 33 × 10 ins. Price £49 15s. 6d. (one H.F. unit), £56 5s. 6d. (two H.F. units).



**Goodmans Industries Ltd.,** Axiom Works, Wembley, Middlesex, England. Tel.: Wembley 1200. Cables: Goodaxiom, Wembley.

**Stereophonic Bowl Unit S.23.** Contains special 6 in. drive unit, and filter. Response with filter 300-15,000 c/s. Size 6 $\frac{3}{8}$  × 8 $\frac{1}{2}$  ins. Price £17 6s. 6d. Without filter £8 8s.

**AL100. Bookcase Loudspeaker,** forward facing. ARU loaded. One 12 in. drive unit. 40-15,000 c/s. Size 24 × 11 $\frac{1}{2}$  × 14 $\frac{1}{2}$  ins. Price £23 10s. complete.

**AL120. Bookcase Loudspeaker,** forward facing. Baffle ARU loaded. One 12 in. unit, Triaxiom 12/20. Crossover at 5,000 c/s built in. Size 24 × 11 $\frac{1}{2}$  × 14 $\frac{1}{4}$  ins. Price £29 10s. complete.



**The Gramophone Company Ltd.,** Hayes, Middx. Tel.: Southall 2468. Cables: Jabberment, London.

**"Orthotone" STD/418.** Reflex bookshelf speaker. One 8 in. drive unit. Rec. Goodmans "Axiette". Response 60-15,000 c/s. Size 13 × 23 × 12 ins. Price without unit £10 10s. Legs £1 15s. extra.

**"Orthotone" STD/415.** Octagonal reflex enclosure. Forward-facing 1 or 2 8 in. drive units. Rec. Goodmans "Axiette" or G.E.C. Metal Cone with Presence Unit. Response

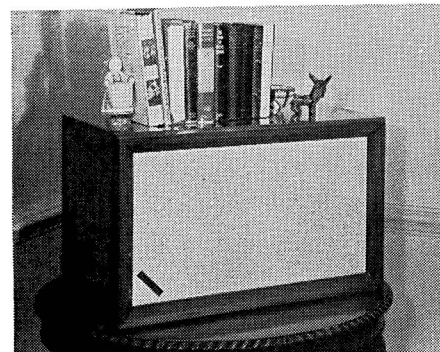

*Goodmans AL 100*



*Goodmans Stereophonic Bowl*

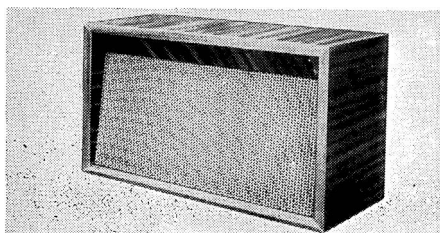

*Orthotone STD/418*



30-15,000 c/s. Size 30 × 20 × 15 ins.  
Price, without units £19 19s.

“Orthotone” STD/417. Octagonal Enclosure. Forward facing. Two drive units. 12 in. and tweeter. Size 35 × 24½ × 15 ins. Price, without units £26 5s.



**Grampian Reproducers Ltd.**, Hanworth, Trading Estate, Feltham, Middlesex, England. Tel.: Feltham 2657. Cables: Reamp Feltham.

**Grampian WS9.** Totally enclosed, forward facing. Fitted with 9 inch drive unit. Handling capacity 7 watts. Size 23 × 12 × 12 ins. Shaped for corner or wall position. Price £11 2s. 6d. (U.K. purchase tax £3 15s.), legs extra £1 2s. 6d.

**Grampian CE12.** Forward facing reflex, shaped for corner or wall position. One 12 in. unit. Grampian rec. 1255/15. Size 29 × 18 × 12½ in. Price (complete), £24 10s.



**Lektra Products**, 118 Gordon Road, London, W.13.

**Gazelle.** Reflex corner kit. One 8 or 10 in. unit, and one tweeter. Size 30 × 23½ × 12½ in. Weight 20 lb. Price £6 6s. Assembled £9.

**Mayfair.** Reflex corner kit. One 10 or 12 in. unit, and one tweeter. Size 36 × 28 × 16½ ins. Weight 30 lb. Price £9 9s. Assembled £13 2s. 6d.



**Lockwood & Co. (Woodworkers) Ltd.**, 67 Lowlands Road, Harrow, Middlesex, England. Tel.: Byron 3704.

**LE.1.** Reflex, forward facing. Suitable for 15 in. dual concentric unit, or 3-way combination. Size 44 × 24 × 17½ ins. Concealed castors. Price £38 10s.

**LE.2, 3, and 4.** These have a similar outward appearance and design to the LE.1 above, but are progressively smaller in dimension and price, and are suitable for smaller speaker systems. The smallest LE.4, is 27½ × 17½ × 12½ ins. Price £15 15s.



**Lowther Manufacturing Co.**, Lowther House, St. Mark's Road, Bromley, Kent, England. Tel.: Ravensbourne 5225. Cables: Lowther, Bromley.

**Corner Reproducer TP1.** Folded bass horn/direct h.f. horn type. One specially designed

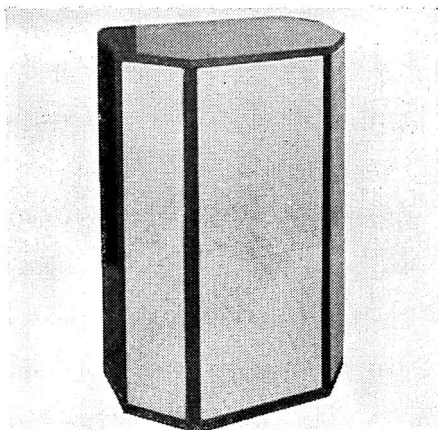

*Orthophonic STD/415*



*Grampian WS9*

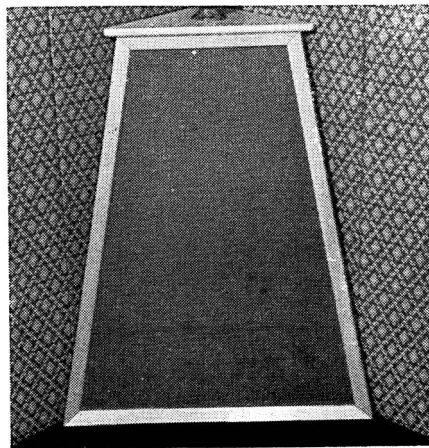

*Lektra Gazelle*



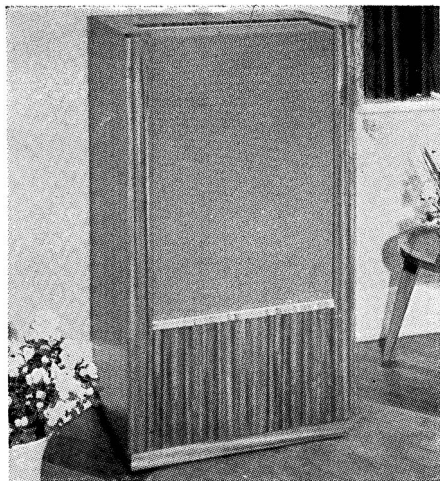

*Lockwood LE1 reflex*

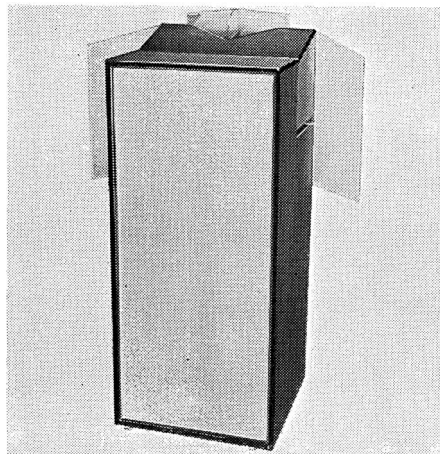

*Lowther Acousta-twin*

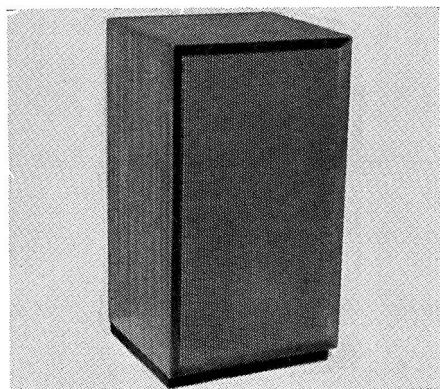

*Lowther Acousta cabinet*

6 in. pressure unit PM3. Acoustical crossover. Response 40-20,000 c/s. Size 47 × 32 × 31 ins. from corner. Weight 70 lb. Price of standard Model A £96. Model B £106.

**Acousta Cabinet.** Models FH/V, FH/H. Folded horn type, forward facing, with rear folded horn. Vertical on plinth, or horizontal on 12 in. legs. One unit, 6 in. or 8 in. Rec. Lowther PM6. Response 60-17,000 c/s. Size 34½ × 18½ × 17 ins. Weight 60 lb. Price without unit £18 18s., walnut, oak, mahogany.

This enclosure is also available in a "Do-it-yourself" kit form. Price £14 14s. ex works.

**Audiovector.** Compound horn. 180 deg. compound upward facing mid- and high-frequency horn with rear folded horn. One 8 in. unit. Range 30-20,000 c/s. Size approx. 26 × 30 × 18 ins. Price approx. £50.

**Acousta-twin.** Dual folded horn. Side facing and rear folded horn system for monaural and stereo reproduction. Two PM6 8 in. drive units. Acoustic crossover. Response 30-18,000 c/s. Dimensions 44 × 18 × 18 ins. Price £30 enclosure only, £67 16s. complete.



**M.S.S. Recording Co. Ltd.**, Colnbrook, Bucks., England. Tel.: Colnbrook 2431. Cables: Emesco.

**Model LSX/1.** Reflex forward facing. Cabinet on walnut pedestal. One 8 in. unit. Response 40-15,000 c/s. Size 34 × 17 × 10½ ins. Price £25.



**Musicraft**, 13 King Street, Richmond, Surrey. Tel.: Richmond 6798.

**F.E.H. Enclosure.** Folded exponential horn type, forward facing. Two units, 8 in. and 3 in. Rec. Goodmans "Axiette" and Wharfedale Super 3. Crossover 4/5,000 c/s. Response 30-17,000 c/s. Size 36 × 20 × 20 ins. Price (complete) £40 19s.



**Pamphonic Reproducers Ltd.**, 17 Stratton Street, London, W.1. Tel.: Grosvenor 1926.

**Victor Senior.** Two units. Bass, 15 in., treble 6 in. elliptical. Response 30-15,000 c/s. Crossover 1,000 c/s. Price £45.

**Victor Junior.** Two units. Bass 12 in., treble 6 in. elliptical. Response 35-12,000 c/s. Price £30.

**S.1 Stereo.** Cabinet type, forward facing. Elliptical 10 × 6 in. concentric cone unit.

Size 15 × 12 × 11 ins. Price £10 12s. 5d.  
(U.K. purchase tax £3 8s.)



**Pye Limited**, 65 Fairview Road, London, S.W.16. Tel.: Pollards 9441/2. Cables: Faramarine Souphone, London.

**Mozart Minor HF.8BS** Distributed vent reflex. Two drive units, 12 in. bass and 10 × 6 ins. elliptical. Crossover included. Response 60-14,000 c/s. Size 28 × 12½ × 8½ ins. Price £15 15s. complete.

**Mozart Companion HF.10 BS.** Folded duct bookcase loudspeaker. Two drive units. 8 in. bass and 4 in. H.F. Crossover frequency 7,000 c/s. Response 60-15,000 c/s ± 4 dB. Size 11½ × 25 × 10½ ins. Weight 22½ lb. Price £21. Legs £2 2s. extra.

**Mozart Major HF.15 SMT.** Folded labyrinth with forward facing units. One 12-in. and one 4-in. with built-in crossover. Response 45-17,000 c/s. Size 33½ × 17 × 13¼ ins. Weight 54 lb. Price £28 7s.

**De-Luxe HF.25 SCA.** Reflex corner speaker, forward facing. With A.R.U. Three drive units. 15 in., 8 × 6 in. elliptical, and 4 in. tweeter. Crossovers 1,500 and 7,000 c/s. Size 38½ × 28 × 19 ins. Weight 90 lb. Price £57 15s.



**Record Housing**, Brook Road, London, N.22. Tel.: Bowes Park 7487.

**Viking.** Reflex forward facing. Three drive units. 8 or 10-in. plus tweeter. Response 50-15,000 c/s. Size 32 × 19 × 12 ins. including 6-in. legs. Price, cabinet only, £10 10s.

**Capriol.** Reflex forward facing. Three drive units. 12-in. plus Goodmans Trebax and Midax recommended. Response 30-16,000 c/s. Size 30 × 16 × 16 ins. Price, cabinet only, £13 19s.



**Rogers Developments (Electrical) Ltd.**, 4-14 Barmeston Road, Catford, London, S.E.6. Tel.: Hither Green 7424/4340. Cables: Rodevco, London, S.E.6.

**1284.** 3-way column speaker. Three drive units. 12, 8 and 4 ins. Crossovers included. Response 35-17,000 c/s adjustable. Size 37 × 15 × 14 ins. Price £28 10s.

**84.** 2-way damped reflex loudspeaker system. Two drive units, 8 in. and 4 in. with adjustable vol. control. Impedance 5 ohms. Response 45-15,000 c/s. Size 28 × 12 × 12 ins. Price inc. purchase tax £18 18s.

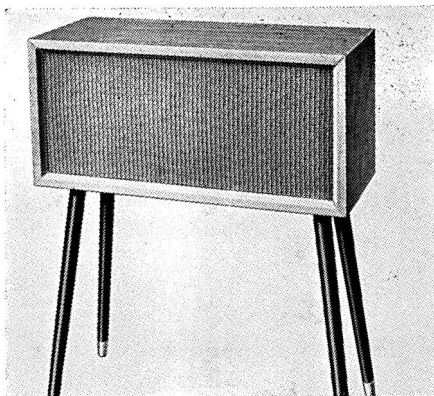

*Pye Mozart HF10BS*

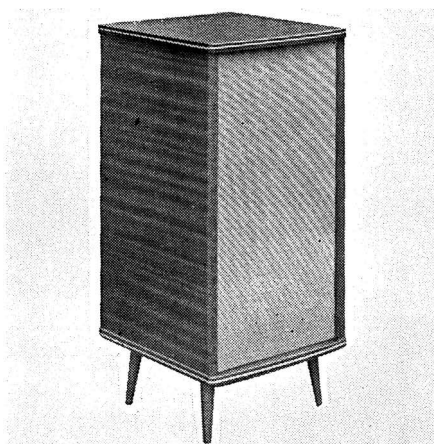

*Record Housing Capriol*

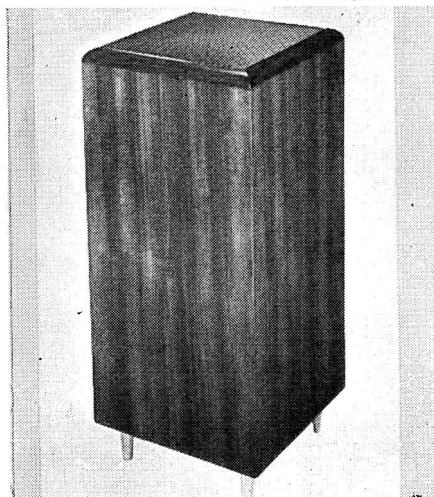

*Rogers 84 2 speaker system*

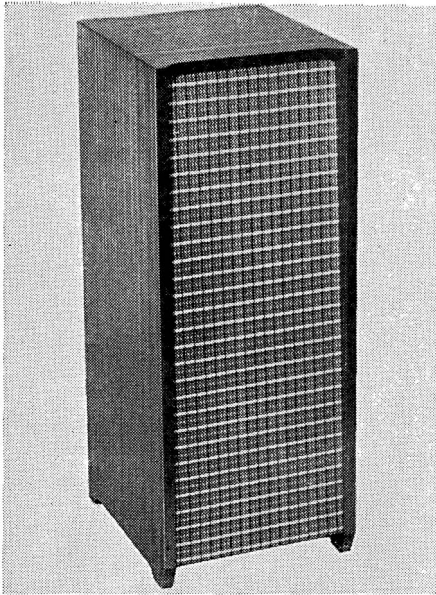

*Soundcraft Stanley*

**Romagna Reproducers**, 2 Sarnesfield Road, Enfield, Middx. Tel.: Enfield 8717.

**Mk. 1. Reproducer.** Reflex forward facing. Flat for mid-wall mounting. Two drive units, Kelly Mk. 1 bass unit and Mk. 2 ribbon. Crossover included. Response 35-20,000 c/s. Size 30 × 25 × 12 ins. Weight 55 lbs. Price complete £42.

**The Soundcraft Co.**, 1 Stanley Road, Bromley, Kent. Tel.: Ravensbourne 5673.

**Stanley.** Forward facing folded horn. One 8-in. drive unit. Size 31½ × 12 × 13¾ ins. Price, cabinet only, £13 13s.

**Langdon.** Forward facing folded horn. One 8-inch drive unit. Size 33 × 15 × 16 ins. Price, cabinet only, £17 17s.

**Westminster.** Forward facing folded horn. Two drive units—8-in. or 12-in. and tweeter. Size 37½ × 19 × 17½ ins. Price, cabinet only, £27 6s.



**Sound Sales Ltd.**, Works and Acoustic Laboratories, West Street, Farnham, Surrey. England. Tel.: Farnham 6461. Cables: Sounsense.

**Phase Inverter Speaker.** Model A, 15 ohms. Model B, 3 ohms. Reflex type. Ported cabinet for forward facing, inc. treble diffuser. 12 watt handling. 12 in. Sound Sales dual suspension auditorium unit. Response 30-13,500 c/s. Size 29 × 14 × 18½ ins. Weight 44 lb. Price £20 10s. complete.

**Tri-Channel Mk. 5.** Special labyrinth construction, reflex. Distribution over 90° arc. Three 12 in. Sound Sales Auditorium units, and one electrostatic tweeter. Response 25-27,000 c/s when used with associated amplifiers. (This equipment is sold com-

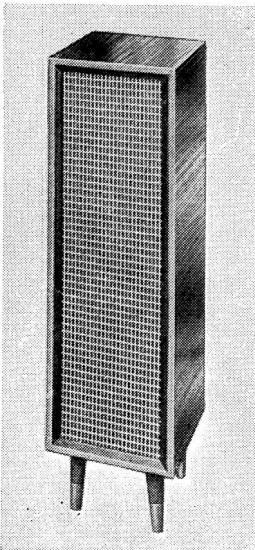

*Beam-Echo  
Avantix SL71*

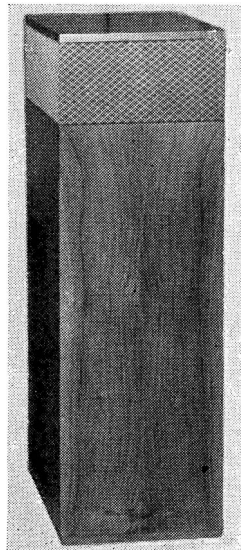

*Expert Gramophones  
Acoustic Column*

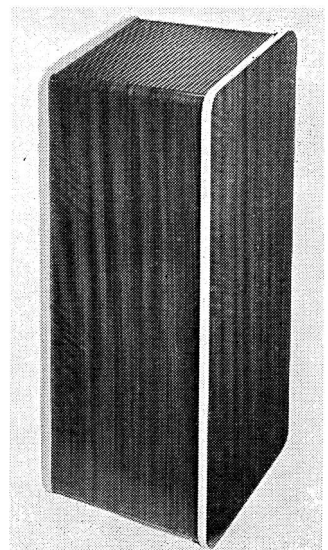

*Rogers Development 1284 3-way  
system*

plete. Refer to amplifier section.) Size 43 × 31 × 35 ins. Weight 202 lb. Price, including amplifiers and tone control unit, complete, £125.



**Symphony Amplifiers Ltd.**, 16 Kings College Road, London, N.W.3. Tel.: Primrose 3314/5.

**Symphony Column.** One 8-inch drive unit facing vertically. Rec. Wharfedale Column 8/145. Response approx. 30-16,000 c/s. Size 60 × 13 × 13 ins. Weight 50 lbs. Price, cabinet only, £13 13s.

**Symphony Bass Reflex Cabinets.** A range of forward facing systems to take 8, 10 or 12-in. units. Price, ready built, £10 10s. to £11 10s. Also available in kit form.



**Tannoy Products Ltd.**, West Norwood, London, S.E.27. Tel.: Gipsy Hill 1131. Cables: Tannoy, London.

**Chatsworth II.** Aperiodic enclosure for corner placing. One monitor 12 drive unit. Size 36½ × 20 × 12¾ ins. 4-in. legs. Price £49 15s.

**Canterbury.** Reflex, with forward facing unit, dual throated ports, for corner placing. One 12 in. dual concentric unit, or direct radiator. Size 37 × 25 × 17 ins. Price, with dual concentric, £57 15s.; with direct radiator, £43 15s.

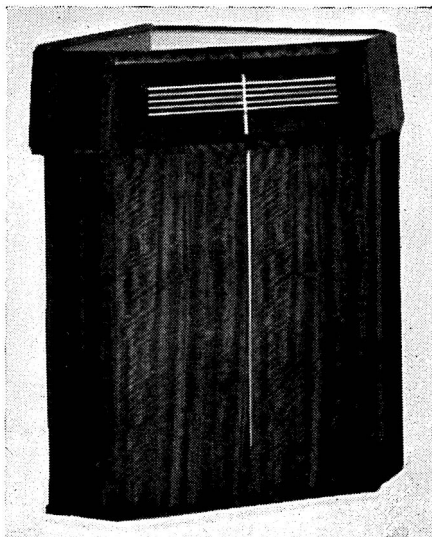

*Vitavox "Klipschorn"*

**Lansdown.** Reflex. Forward facing unit, dual throated ports, for side wall placing. One 12 in. dual concentric unit. Response 30-20,000 c/s. Size 32 × 36 × 17 ins. Price £75.

**York.** Reflex. Forward facing unit, dual throated ports, for corner placing. 12 in. or 15 in. dual concentric unit. Response

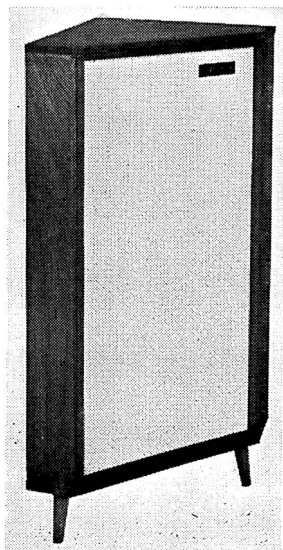

*Tannoy Products  
Chatsworth II*

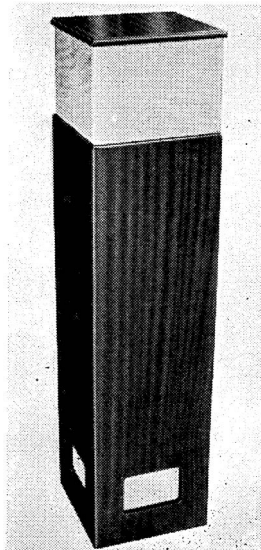

*Whiteley Electrical  
Stentorian WB Column*

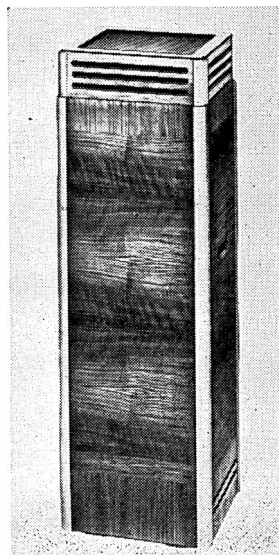

*Wharfedale Wireless  
Column eight*

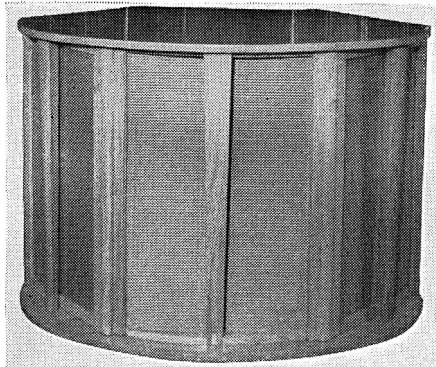

*Sound Sales Tri- Channel MK5*



*Wal Duo-Reflex*

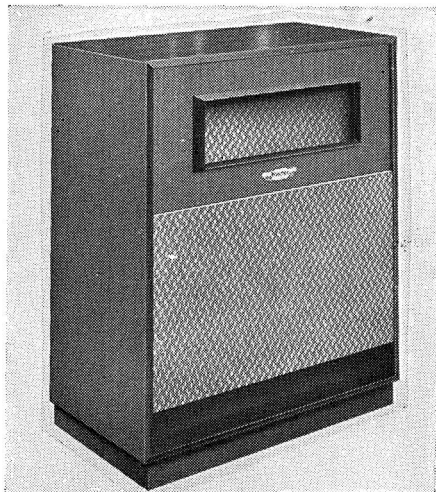

*Westrex Acoustilens 20/80*

35-20,000 c/s. Size  $45\frac{1}{2} \times 32 \times 22\frac{1}{2}$  ins. Price, with 12 in. unit, £66; with 15 in. £75.

**G.R.F. Folded horn.** Rear horn loaded, forward facing unit, for corner. One 15 in. dual concentric unit. Response 20-20,000 c/s. Size  $48 \times 38 \times 29$  ins. Price £122.

**Guy R. Fountain Autograph.** Folded horn. Front and rear horn-loaded unit, forward facing for corner placing. 15 in. dual concentric unit. Response 20-20,000 c/s. Size  $58\frac{1}{2} \times 43 \times 26\frac{1}{2}$  ins. Price £165.



**Tele-clinic (Sales & Service) Ltd.,** 36 Brick Street, Warrington, Lancs. Tel.: Warrington 33179.

**"Normanda."** Free standing reflex type with folded horn midrange unit. Three speakers, 12 in. bass, midrange pressure unit and  $2\frac{1}{2}$  in. tweeter. Crossover 1,000 c/s. Size  $33 \times 26 \times 18$  ins. 3 in. pedestal. Weight 110 lb. Price £63.



**Trix Electrical Co. Ltd.,** 1-5 Maple Place, London, W.1. Tel.: Museum 5817. Cables: Trixadio, Wesdo, London.

**Triple Unit Assembly,** comprises 12 in. bass reproducer,  $6 \times 4$  in. elliptical and 4 in. tweeter mounted in corner console cabinet. Response 40-12,000 c/s. Size  $22 \times 16$  ins.  $\times 32$  ins. high. Price, complete £28 7s.



**Vitavox Ltd.,** Westmoreland Road, London, N.W.9. Tel.: Colindale 8671. Cables: Vitavox, Hyde, London.

**Vitavox Hallmark.** Forward facing reflex, with port underneath. One 12 inch unit. Rec. Vitavox DU120 or AK120. Size Model 351:  $27\frac{1}{2} \times 20 \times 16\frac{1}{2}$  ins. Available as horizontal (Lowboy) or vertical (Tallboy) system. Price complete, £42 in Walnut or Oak; £45 in Teak.

**Klipschorn.** Double channel horn. Folded L.F. horn, forward facing H.F. horn. 2 drive units: 15 in. L.F., pressure type H.F. Crossover at 500 c/s. Response 30-15,000 c/s. Size  $50 \times 30 \times 27$  ins. Weight 210 lb. Price, with specified units, £165.



**Wellington Acoustic Laboratories Ltd.,** Farnham, Surrey. Tel.: Farnham 6461/4961.

**WAL Duo-Reflex Speaker.** Forward facing reflex enclosure. Incorporating 12 in. bass unit with foam surround and H.F. pressure tweeter. Built-in crossover unit. Response



30-13,500 c/s. Size 33 × 18 × 14 ins. Weight 55 lb. Price £27. Available as a matched pair for stereo £52.



**Westrex Company Ltd.**, Coles Green Road, London, N.W.2. Tel.: Gladstone 5401/8. Cables: Westelcol, Norphone, London.

**Acoustilens 20/80 High Fidelity System.** Large reinforced 1 in. ply reflex housing own (15 in.) 20/80 low frequency unit and horn loaded high frequency unit with acoustic lens. Crossover 675 c/s. Response below 30 c/s.—above 15,000 c/s. Size 44 × 33 × 19½ ins. Weight approx. 160 lb. Price, complete with units and crossover, £169.

**2241.** High efficiency 2-way loudspeaker of unusually large handling capacity. Incorporates Westrex 20/80 L.F. and Westrex H.F. Acoustilens Units. Price on application.



**Wharfedale Wireless Works Ltd.**, Idle, Bradford. Tel.: Idle 1235-6. Cables: Wharfedel, Idle, Bradford.

**RJ-8.** Damped reflex. Forward facing. One 8 in. drive unit. Rec. Super 8/FS/AL; 8 in. Bronze FS/AL. Response 60-14,000 c/s. Size 24½ × 11 × 10½ ins. Weight 16½ lb. Price, without unit, £11 10s.

**PST/8.** Damped reflex, forward facing. One 8 in. drive unit. Rec. Super 8/FS/AL or 8 in. Bronze FS/AL. Response 60-14,000 c/s. Size 24 × 12 × 12 ins. Weight 17 lb. Price, without unit £7 10s. whitewood, or £10 10s. veneered and polished.

**Column Eight.** Reflex column with acoustic filter and conical diffuser for upward facing 8 in. unit. Rec. 8/145, Super 8/FS/AL or 8 in. Bronze FS/AL. Response 40-14,000 c/s, depending on unit. Size 44 × 14 × 12 ins. Weight 34½ lb. Price, without unit £21 15s.

**AF/12.** Reflex with acoustic filter, forward facing. One 12 in. drive unit. Rec. Coaxial 12, Super 12/FS/AL, W12/FS. Response 30-20,000 c/s with Coaxial 12. Size 36½ × 23 × 14¼ ins. Weight 61 lb. Price £24 10s. (Whitewood £20).

**AF/10.** Forward facing reflex with acoustic filter. One 10 in. unit. Rec. 10 in. Bronze/FSB, Golden/FSB, W10/FSB. Response 40-10,000 or 14,000 c/s depending on unit fitted. Size 30 × 17 × 10½ ins. Weight 35 lb. Price, without units, £15 15s.

**SFB/3.** Sandfilled baffle. 3 drive units. 12 and 10 in. units facing forwards. 3 in.

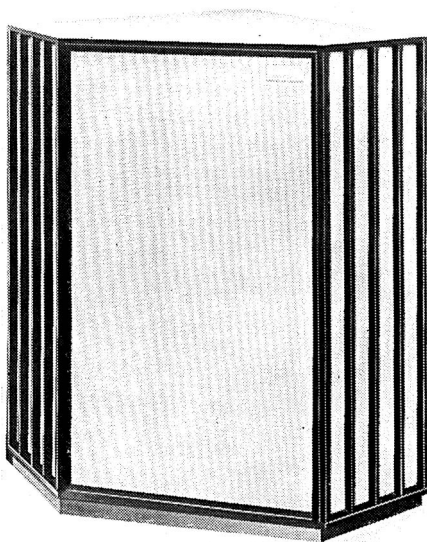

*Tannoy G.R.F.*



*Vitavox Hallmark*

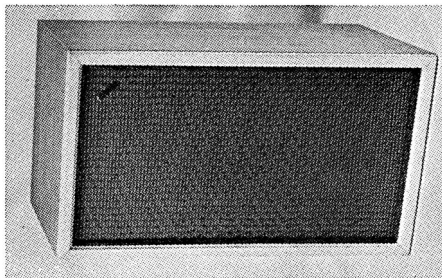

*Wharfedale W2*



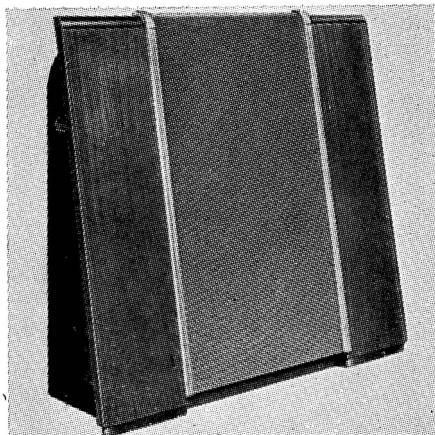

*Wharfedale SFB/3*

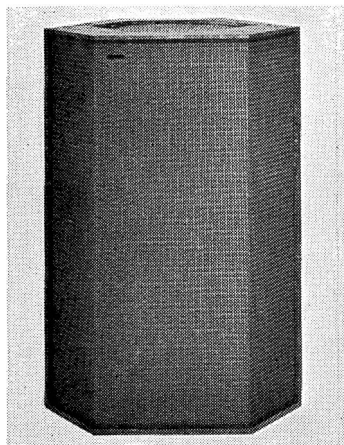

*Wharfedale W4*

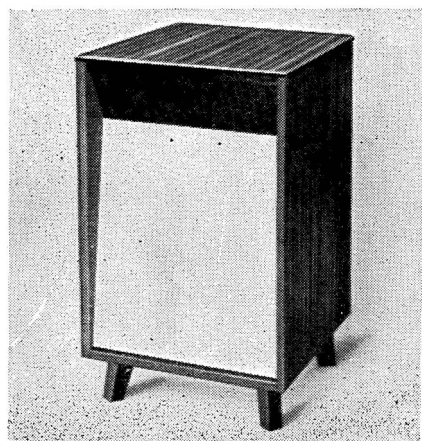

*Stentorian "Prelude" Major*

H.F. unit facing upwards for omni-directional treble distribution. Response 30-20,000 c/s. Size 34 × 31 × 12 ins. Weight 64 lb. Price, with units, £39 10s. (not sold separately).

**"Omni-directional"** 3-speaker corner system. Sand-filled reflex enclosure, bass unit facing forward, separate mid range and treble unit facing upward. 15 in., 8 in., and 3 in. units. Rec. W15/FS, Super 8/FS, Super 3. Response 20-20,000 c/s. Size 48 × 34 ins. Weight 160 lb. Price, with specified units, £73 10s.; sandfilled panel only, £31; twin treble cabinet, £8 15s.

**Super 3 Cabinet.** Open baffle, facing upward to house 1 Super 3. Crossover 5,000 c/s. Response 5,000-20,000 c/s. Size 8 × 6 × 5 ins. Weight 1½ lb. less unit. Price £4 10s. (for 8/15 ohm speakers); £5 (for 2/3 ohm speakers).

**W2.** Two-speaker system, incorporating WLS/12 and Super 5 with vol. control. Crossover 1,000 c/s. Size 23½ × 14 × 12 ins. Price, veneered, complete £29 10s.

**W3.** Three-speaker system, incorporating WLS/12, a 5-in. Bronze, and Super 3. Separate vol. controls for the two H.F. units. Crossover 1,000 c/s. Size 28 × 14 × 12 ins. Price veneered, complete £39 10s.

**W4.** Four-speaker system, incorporating WLS/12, two 5 in. Bronze, and Super 3. H.F. units are arranged for omni-directional radiation and have independent mid and treble vol. controls. Size 35 × 24 × 12 ins. Price veneered, complete £49 10s.



**Whiteley Electrical Radio Co. Ltd.,** Victoria Street, Mansfield, Notts. Tel.: Mansfield 1762/3/4/5. Cables: Whitebon, Mansfield.

**Stentorian Corner Console.** Infinite baffle. One 8 in. unit. Rec. HF812. Response 50-12,000 c/s. Size 26 × 17 × 7½ ins. Price, with specified unit, £8 9s. 6d. (U.K. purchase tax £1 4s.); without unit, £5 10s.

**Stentorian Junior Console.** Bass reflex for corner position. 1 or 2 drive units. Rec. HF816 or HF1012 with T10 tweeter, if required. Crossover 3,000 c/s. Response HF816, 50-14,000 c/s; HF1012 and T10 30-14,000 c/s. Size 33 × 22½ × 28½ ins. Price, with HF816, £14 6s. 7d. (U.K. purchase tax, £1 19s. 5d.); with HF1012 and T10, £18 14s. (U.K. purchase tax £1 8s. 9d.); without units, £9 9s.

**Stentorian Senior Corner Console.** Bass reflex for corner position. 10 in. or 12 in. drive unit with tweeter, if required. Cross-

over 3,000 c/s. Response with HF1012 and T10 30-14,000 c/s; with HF1214 and T12 25-17,000 c/s. Size 35 × 30 × 19 ins. Price, with HF1012 and T10, £20 16s. (U.K. purchase tax £1 8s. 9d.); with HF1214 and T12, £36 8s. 6d.; without units, £11 11s.

**Stentorian "Prelude."** Bass reflex for corner position. One 8 in. or 10 in. unit with provision for tweeter. Rec. HF812, HF816, or HF1012 and T10. Crossover at 3,000 c/s. Response depending on unit used. Size 33 × 21 × 17 ins. Weight 23½ lb. Price, without units, £10 10s. Model also available for free standing, otherwise as above. Size 33 × 19 × 19½ ins. Weight 27½ lb. Price £11 11s.

**Stentorian Sloping Dual Front.** Tweeter housing, reversible, either forward or rear facing. One 8 in. unit. Rec. T816. Response 1,000-17,000 c/s. Size 13 × 10½ × 7½ ins. Price, with unit, £8 10s. 1d. (U.K. purchase tax £1 17s. 5d.); without unit, £3 17s. 6d.

**Stentorian Prelude Major.** Reflex, forward facing. One or two 10 or 12 in. drive units. Rec. HF1214 and T10. Response 30-17,000 c/s. Size 35 × 20 × 33 ins. Price (complete), £45; without units £25.

**Stentorian Prelude Horn Loaded.** Folded horn, forward facing. One 8 in. drive unit. Rec. HF817. Response 60-22,000 c/s. Size 35 × 10½ × 16½ ins. Price (complete) £27 2s. (U.K. purchase tax £3 5s. 6d.) Price, without units, £19.

**Stentorian Junior Column.** Reflex upward facing omni-directional. One 6 in. unit. Rec. HF610. Response 100-11,000 c/s. Size 36 × 9 × 9 ins. Price (complete) £11 17s. 7d. (U.K. purchase tax 15s. 5d.) Price, without unit, £9 16s. 6d.

**Stentorian Senior Column.** Reflex upward facing omni-directional. One 8 in. unit. Rec. HF816. Response 60-14,000 c/s. Size 57 × 13½ × 13½ ins. Price (complete) £23 15s. 7d. (U.K. purchase tax £1 19s. 5d.) Price, without unit, £18 18s.

**Stentorian Sterereo.** Infinite baffle. Corner speaker, forward facing. Two drive units 8 in. and 5 in. Rec. HF812 or HF810 with S.510. Crossover 1,500 c/s. Response 100-12,000 c/s. Size 22 × 12½ × 10 ins. Price (complete) £13 0s. 8d. (U.K. purchase tax, £1 11s. 7d.) Price, without units, £7 10s. *Note: All units for the above may be supplied separately.*

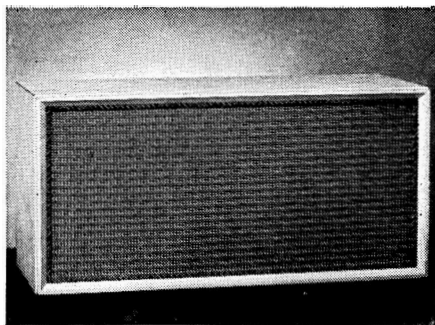

*Wharfedale PST/8*

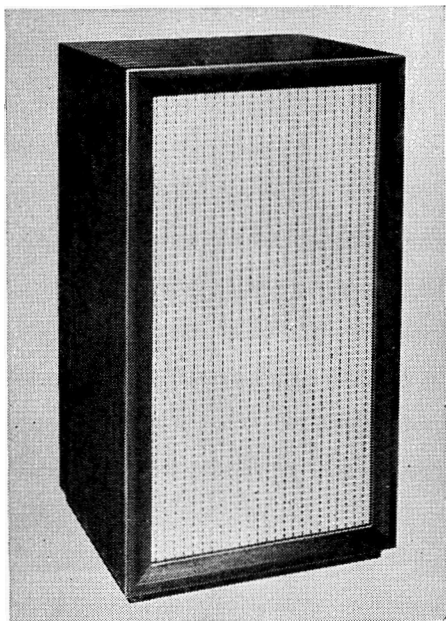

*Stentorian "Prelude" Horn Loaded*

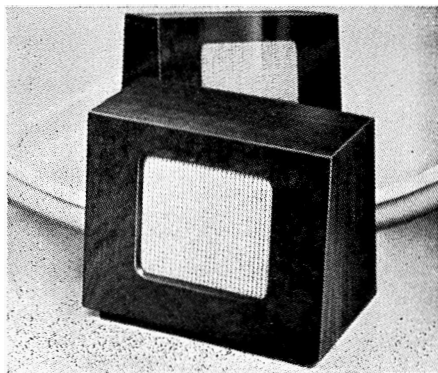

*Stentorian Sloping Dual Front*

# LOUDSPEAKER CROSSOVER UNITS

## — AN INTRODUCTION —

**L** OUDSPEAKER manufacturers have known for many years that the difficulties in constructing a wide-range speaker are somewhat easier of solution if two or more drive units are employed. The low frequency vibrations are best handled by a “soggy” cone and suspension, and are radiated most effectively by a large area diaphragm. For best high frequency response, by contrast, the system has to be light, and small in size to obviate out-of-phase effects and too directional a radiation pattern.

### Two-way Speakers

It was based on these conflicting requirements that the first two-way loudspeaker systems were evolved, and by clever design the low and high frequency units (“woofer” and “tweeter”) could be made complementary so that each made up for the “calculated” deficiencies of the other. Generally an electronic filter network would be incorporated to apportion the two halves of the frequency spectrum to the two speakers. The response curve of this network is arranged so that the high and low frequency halves each fall to half of their maximum value at a selected “crossover” frequency. Many two-way loudspeaker systems are co-axial, that is to say the small HF unit is mounted on the central axis of the LF unit. This has the advantage of localising the full frequency band to make all sounds appear to come from the same point in space, but the precise distance of the tweeter in front of the main cone is found to be fairly critical both from the phase point of view and its obstacle effect. We have said that electronic crossovers are generally included, but systems do exist in which acoustical or mechanical crossing over is arranged for.

One is often asked whether a single cone

loudspeaker—9, 10, 12, or 15 inch—can be improved by the addition of a tweeter, and the reply must usually take the form of “it all depends . . .”. In a case where the existing speaker has a substantial and extended bass response, and lacks only in the extreme top frequencies—due to (a) its own failure to reproduce top frequencies, (b) its method of mounting, e.g. upward facing as in a column enclosure, or (c) its being too directional—then a suitable tweeter may make all the difference.

The various free-standing tweeters offered (see under the appropriate Directory Section) are often sold with a series capacitor built in. The value of this is usually 4 or 10 microfarads, and it is designed simply to protect the tweeter movement from low frequency signals. The tweeters which require mounting on a baffle (or are sometimes mounted on the expanded metal grille of the main speaker) will not usually possess such a capacitor. In the latter case, therefore, and perhaps in the former, it will be necessary to employ an appropriate crossover network.

### When choosing a crossover unit

When choosing a crossover unit (*vide* the examples listed in this section) it will be found that a number of actual crossover frequencies are specified. In the simple case we have been considering, of adding a tweeter, a fairly high frequency in the region of 5,000 c/s will be best, although a slightly lower value may be chosen if the HF unit’s response is specified as going much below 5,000 c/s.

Another feature of crossover units is the actual steepness with which the response curves fall away from the normal level. In the so-called  $\frac{1}{4}$ -section units, a single capacitor

and choke combination produces a crossover slope falling at the rate of 6 dB per octave. This design will be good enough for many types of speakers, but there are situations where a steeper attenuation of the unwanted frequencies to HF and LF units is required, e.g. where the bass unit's HF performance is known to include distortion or marked resonances, or the tweeter must be protected from large amplitude LF signals. In such cases a half-section network will be recom-

mended, consisting of two capacitors and chokes, giving a 12 dB per octave slope.

Finally, it must be remembered that the sensitivities of the two speakers (or three in a three-way system) may be unequal. If, to take the more usual case, the tweeter is more sensitive than the woofer, it will be as well to include one of the 50 ohm volume controls specially made for the purpose in series with the tweeter to allow their outputs to be balanced.

## DIRECTORY OF CROSSOVER UNITS

**Richard Allan Radio Ltd.**, "Baffle House," Taylor Street, Batley. Tel.: Batley 1123/1308/4033. Cables: Acoustics, Batley.

**CN.104 Crossover Unit.** A two-way half-section parallel network. Crossover frequency 5,000 c/s. All terminations 15 ohms. Price £2 2s.

**CN.1284. Crossover Unit.** A three-way crossover with main crossover operating from half wave parallel network and subsidiary crossover capacity fed. Crossover frequencies 1,100 and 5,000 c/s. All terminations 15 ohms. Price £6 5s.



**Goodmans Industries Ltd.**, Axiom Works, Wembley. Middx. Tel.: Wembley 1200. Cables: Goodaxiom, Wembley.

**X0/5000-Crossover Unit.** A two-way half-section crossover network, operating at 5,000 c/s. All terminations 15 ohms. Price £1 19s.

**X0/950-Crossover Unit.** A two-way half-section, crossover network, operating at 950 c/s. All terminations 15 ohms. Price £5 5s. 8d.

**X0/950/5000. Crossover Network.** A multiple crossover network comprising four half-section L.C. filters. Crossover frequencies are 950 c/s and 5,000 c/s. All attenuation rates are 12 dB/octave. All terminations 15 ohms. Price £7 0s. 6d.



**Romagna Reproducers**, 2 Sarnesfield Road, Enfield, Middlesex. Tel.: Enfield 8717.

**CO/1/15. Crossover Network.** 3 Kc crossover frequency for 15 ohm loudspeakers and

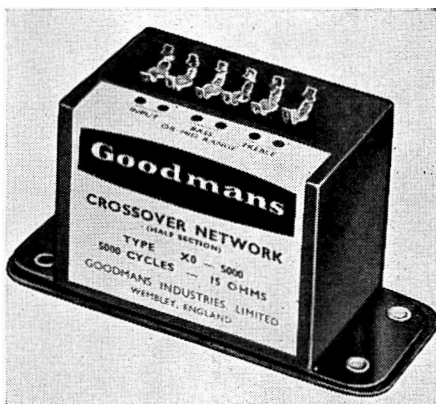

*Goodmans XO-5000 crossover unit*

amplifiers. Balance control fitted,  $\frac{1}{2}$  section networks giving 12 dB/octave cut-off. Maximum insertion loss 1 dB in pass band. Potted in cast aluminium case. Price £3 3s.

**CO/1/3.5. Crossover Network.** As CO/1/15, but with 3.5/5 ohm impedance. Price £3 3s.

**CO/2/15. Crossover Network.** As CO/1/15, but with 1,500 c/s crossover frequency. Price £3 3s.

**CO/2/3.5. Crossover Network.** As CO/2/15, but with 3.5/5 ohm impedance. Price £3 3s.

**CO/BK. Crossover Network.**  $\frac{1}{4}$ -section network. Coil is tapped to give two values of crossover—1,500 c/s and 3 Kc, and can be switched out of circuit. Price £1 11s. 6d.

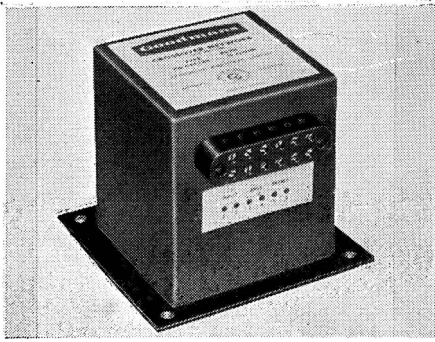

*Goodmans XO/950 crossover unit*

**Technical Suppliers Ltd.,** Hudson House, 63 Goldhawk Road, London, W.12. Tel.: Shepherds Bush 2581/4794.

**HP1 Crossover Unit.** A  $\frac{1}{4}$ -section crossover specially designed for use with TSL Lorenz LP312-2 speaker system, crossover at 5,000 c/s. Price £2 2s.



**Westrex Co. Ltd.,** Coles Green Road, London, N.W.2. Tel.: Gladstone 5401/8. Cables: Westelcol, Norphone, London.

**Dividing Network.** Constant impedance parallel network, using two L-type filter sections, low and high pass, crossover at 675 c/s. For any impedance 16-24 ohms. Price £13 10s.



**Wharfedale Wireless Works Ltd.,** Idle, Bradford, Yorks. Tel.: Idle 1235-6. Cables: Wharfedel, Idle, Bradford.

**Loudspeaker Separators.**  $\frac{1}{4}$ -section type. Operating at 1,000 or 3,000 c/s. 8 units available to cover from 2-16 ohms impedance. Slope 6 dB/octave. Size  $7 \times 4 \times 3\frac{1}{2}$  ins. Weight  $2-2\frac{1}{2}$  lb. Max. input 30 watts. Price from £2 11s. to £4 17s. 6d. depending on type.

**HS/CR3/2.**  $\frac{1}{2}$ -section 3-way separator unit with crossover at 800 and 5,000 c/s. Max. input 30 watts. Slope 12 dB/octave. Size  $9 \times 6 \times 5$  ins. Weight  $6\frac{1}{2}$  lb. 2 models. 2-6 ohms. Price £11; 7-16 ohms, Price £8 10s. Also available with crossover at 400 and 5,000 c/s. 7-16 ohms only. Price £10.

**WMT1 Matching Transformer.** Auto transformer for matching 10-16 ohms or 7-9 ohms speakers to sets with 2-5 ohms output or vice versa. Response 20-15,000 c/s  $\pm 1$  dB. Handling capacity 15 watts. Can also match speakers of different imps. to crossover unit in 2 or 3 speaker systems. Size  $2\frac{7}{8} \times 2\frac{3}{4} \times 2\frac{3}{4}$  ins. Weight  $12\frac{1}{2}$  oz. Price 13s. 6d.

**Stereo Truqual.** Ganged twin vol. control. L-pad type attenuators for stereo speakers. 6 positions. Price £1 10s.



**Whiteley Electrical Radio Co. Ltd.,** Victoria Street, Mansfield, Notts. Tel.: Mansfield 1762-5. Cables: Whitebon, Mansfield.

**CX 500. Crossover Unit.** A two-way half-section crossover network operating at 500 c/s. All terminations 15 ohms. Price £1 6s.

**CX 1500. Crossover Unit.** As CX 500, but operating at 1,500 c/s. Price £1 18s. 3d.

**CX 3000. Crossover Unit.** As CX 1,500, but operating at 3,000 c/s. Price £1 10s.

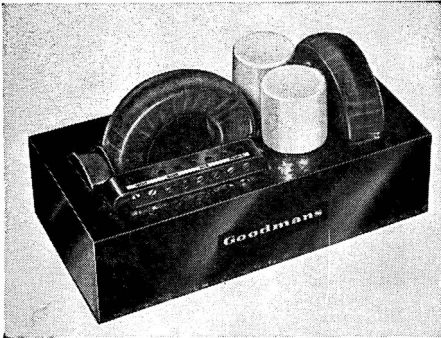

*Goodmans XO900/5000 crossover*

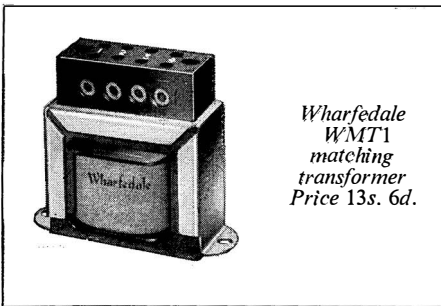

*Wharfedale WMT1 matching transformer  
Price 13s. 6d.*

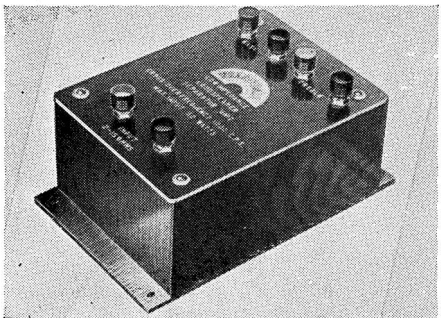

*Wharfedale  $\frac{1}{2}$  section crossover*

# TAPE RECORDERS

## An Introduction

IT was to be expected that this "Tape" section of the Year Book would provide evidence of greatly increased activity during the past year, but the following forty-two pages seem to prove the point—often raised editorially in *Hi-Fi News* and *The Tape Recorder*—that "Tape" is now rapidly establishing itself as one of the most popular forms of home entertainment. Readers who have followed the changing pattern of events, as reflected in the directory sections of *Hi-Fi Year Book*, will have noted that the number of items covering tape recorders of all types, plus tape accessories, have increased to this 42-page listing from a mere 2-page section that accommodated them five years ago. As a glance at the entries will show, the bulk of the increase is made up of recorders in the domestic and general purpose category; but a new and very important development is shown in the field of small recorders, notably those of the portable, battery-operated types.

### Home Entertainment

The most interesting feature of all this expansion in the industry is that tape recorders (as used in the home) are creating a new form of home entertainment, and that they are *not* competing with gramophones as players of recorded music. The fact that they are potentially able to do this is quite another matter. There are, so far, comparatively no supplies of tape records on the market, of a type and price that would make their adoption by the public possible.

Looking westwards, towards the United States of America, we see the makings of quite a different picture. There, it seems, the big business interests have decided that tape records have a good commercial future; and over the past twelve months the main interest in tape appears to have been concentrated upon the development of tape cassettes as a means of purveying recorded music. As this edition of the Year Book is completed, there is news of at least three types of tape cassette

—and, of course, a resultant hesitancy on the part of everyone to predict which of them, if any, is likely to emerge as the standard. One school of thought favours the standard  $\frac{1}{4}$ -inch tape, recorded as stereo on four tracks, and with a playing speed of either  $3\frac{3}{4}$  i/s or  $1\frac{1}{8}$  i/s. The other school favours the adoption of narrow gauge tape ( $\frac{7}{16}$ " wide), recorded for stereo on two tracks, and with a playing speed of  $1\frac{7}{8}$  i/s. In either case, a form of cassette player is envisaged, somewhat on the lines of a record changer, so that anything up to six hours of recorded music is available at the press of a button. This, of course, is not intended to rank as "hi-fi" music reproduction—even in the U.S.A., where the standards of high fidelity are somewhat relaxed in comparison with those of the U.K.

It should be emphasised, however, that the above remark does not deny the possibility of  $3\frac{3}{4}$  i/s becoming a practicable speed for good quality reproduction from tape. Five years ago it was still held that a tape speed of 15 i/s was the minimum tolerable for sound of top quality. A few years earlier, tapes were running at 30 i/s. Today, already, it is quite true to say that some tape recorders of really good design can produce a far better sound from tape at  $3\frac{3}{4}$  i/s than is tolerated by innumerable people from cheap disc players. This could not have been said 18 months ago; and it is surely a significant sign that the day is not far off for tape to become a challenge to disc for at least the shorter popular numbers.

### Tape and Hi-Fi

All the above has little to do with the "hi-fi" enthusiast, however; and the purpose of this survey is an attempt to put "tape" into the picture, as we see it today. The only connection between the *Domestic* type of tape recorder and the "hi-fi set-up" is that many owners of both will naturally use them together on occasion, both for recording and for replay; and there is no doubt that, in



terms of entertainment, such a combination is well worthwhile. The position of the tape recorder in relation to good quality reproduction of sound remains unaltered in principle, although it is now true to say that some of the better quality General Purpose/Domestic recorders will produce tapes that are worthy of replay on good equipment.

The sound enthusiast who wishes to make tape reproduction measure up to the same high standards as other programme material *must* use good tape electronics. This point has been made so often that it seems almost an insult to keep on repeating it; but there are so many pitfalls for the newcomer that the experienced reader will doubtless excuse the repetition. As mentioned above, a good quality domestic recorder—and certainly tapes made on a good quality recorder—will provide good entertainment with high fidelity reproducing equipment; but the addition of the average tape recorder to carefully selected “hi-fi” gear can only be likened to using a portable disc player in place of the high grade pickup and pre-amplifier.

The logical way to add tape facilities to the high fidelity chain is to buy a good tape deck and to equip it with really high quality electronics, tailored to match the individual

tape heads of the deck. If only tape replays are required, there are now numerous pre-amplifiers fitted with “tape” input points, and which cater for the relatively low output from the replay head. In which case it is usually sufficient to connect the two by way of a suitably screened lead. If “*record*” facilities are also required, then it is advisable to install a separate “record” amplifier, which will include the bias oscillator. Such units are now also readily available, and are listed in the following directory sections.

Some tape recorders—and notably those of good quality—have been designed for use with external electronics, and are provided with a suitable take-off point, so that the necessarily cramped electronics of the average portable can be by-passed. Such instruments provide the best answer for the person who requires a tape recorder, as such, for everyday use but who also wishes to use it to best advantage with his other apparatus. This is a half-way measure which can produce very satisfactory results, and which has the great advantage of economy. Nevertheless, for the user who requires tape facilities as a built-in part of his high fidelity chain, the professional or semi-professional deck, plus well designed electronics, is the only real answer.

# DIRECTORY OF TAPE RECORDERS

\* The abbreviations used for the specifications in this directory are as follows: F.R.—frequency response; i/s—inches per second; P.s.n.—Power supply needed; <, better than; M.E.—Magic eye; W.&F.—Wow and flutter; S-N—signal to noise ratio ■—Stereo equipment

## PROFESSIONAL and SEMI-PROFESSIONAL

**Ampex.** U.K. distributors, Rank Cintel Ltd., Worsley Bridge Road, London, S.E.26. Tel.: Hither Green 4600. Cables: Televisor, London.

**Ampex 300 Series.** Prof. recorders. One to eight tracks. Speeds 15 and  $7\frac{1}{2}$  i/s. 3 motors. 14-in. spools up to 1-in. wide. F.R. 15 i/s, 30-15,000 c/s;  $7\frac{1}{2}$  i/s, 40-10,000 c/s, both  $\pm 2$  dB. Large scale V.U. meter. H and N — 60 dB full track, — 55 dB multi-track. W. and F. less than 0.1% at 15 i/s. Prices on application.

**Ampex 351.** Prof. recorder in console, portable or rack-mounted form. Full or half track. Speeds 15 and  $7\frac{1}{2}$  i/s, or  $7\frac{1}{2}$  and  $3\frac{3}{4}$  i/s. 3 motors.  $10\frac{1}{2}$ -in. N.A.B. spools. F.r.: 15 i/s, 30-15,000 c/s;  $7\frac{1}{2}$  i/s, 40-10,000 c/s;  $3\frac{3}{4}$  i/s, 50-7,500 c/s, all  $\pm 2$  dB. Large scale V.U. meter. H and N — 70 dB full track, — 65 dB half track at 15 i/s. W. and F. less than 0.15% at 15 i/s. Size (console) 48 × 24 × 28 ins. Weight 168 lb. Price (15 and  $7\frac{1}{2}$  i/s), £687 portable, £703 console. Stereo version available (Ampex 351-2), £930.

**Ampex 352.** Prof. recorder in console or rack-mounted form. Full or half track, or stereo. Speeds 15 and  $7\frac{1}{2}$  i/s. 3 motors.  $10\frac{1}{2}$ -in. N.A.B. spools. F.r.: 15 i/s, 30-15,000 c/s;  $7\frac{1}{2}$  i/s, 40-10,000 c/s, both  $\pm 2$  dB. H and N — 70 dB full track, — 65 dB half track. W. and F. less than 0.15% at 15 i/s. Size (console) 35 × 24 × 24 ins. Weight 109 lb. Price, £521 mono, £648 stereo. Console cabinet, £50 extra.

**Ampex 601.** Prof. portable recorder. Speed  $7\frac{1}{2}$  i/s. One motor. 7-in. spools. F.r.: 40-10,000 c/s  $\pm 2$  dB. Large scale V.U. meter. H and N — 55 dB full track, — 50 dB half track. W. and F. less than 0.17%. Size  $16\frac{1}{2}$  ×  $13\frac{3}{4}$  × 8 ins. Weight 28 lb. Price £295.

**Ampex 601-2.** Stereo version of Ampex 601. Size  $24\frac{1}{2}$  × 13 × 8 ins. Weight 42 lb. Price £486.

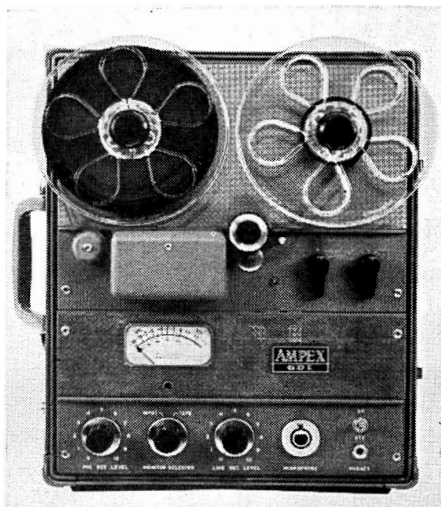

*Ampex 601 portable recorder*

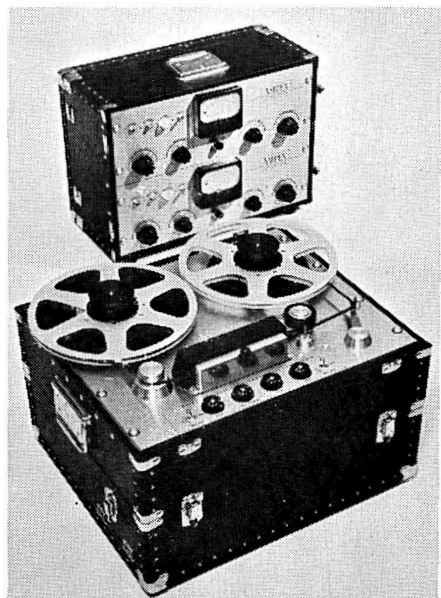

*Ampex 351-2 portable stereo*

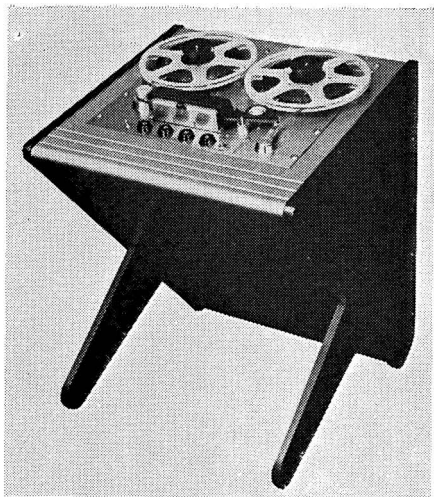

*Ampex 352 console*



*EMI TR52 stereo portable*

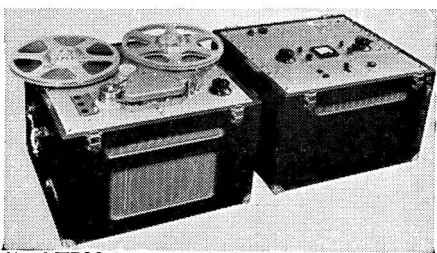

*EMI TR90 in transportable form*

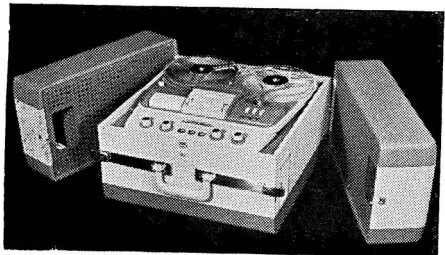

*Grundig TK60 stereo portable*

**EMI Sales & Service Ltd.**, Hayes, Middx. Tel.: Southall 2468. Cables: Emiservice, London.

■ **TR52.** Prof. portable stereo/mono recorder. Speed  $7\frac{1}{2}$  and  $3\frac{3}{4}$  i/s. One motor. 7-in. spools. F.r.:  $7\frac{1}{2}$  i/s, 50-10,000 c/s;  $3\frac{3}{4}$  i/s, 50-6,000 c/s, both  $\pm 2$  dB. W. and F. less than 0.25% at  $7\frac{1}{2}$  i/s. Crosstalk — 45 dB. V.U. meter. Size  $20 \times 17\frac{1}{2} \times 13\frac{1}{2}$  ins. Weight 80 lb. Price £245.

**E.M.I. Model TR90.** Prof. recorder for rack mounting or as a console on transportable trolley, 30 and 15 i/s or 15 and  $7\frac{1}{2}$  or  $7\frac{1}{2}$  and  $3\frac{3}{4}$  i/s. 4 motors. 10½-in. spools. F.r.: 15 i/s, 50-15,000 c/s;  $7\frac{1}{2}$  i/s, 50-10,000 c/s;  $3\frac{3}{4}$  i/s, 50-6,000 c/s. All  $\pm 2$  dB. V.U. meter level ind. or peak programme meter. Size (transportable version) 2 cases  $14\frac{1}{2} \times 20 \times 16\frac{1}{2}$  ins. Weight 80 and 58 lb. Price, from £588.

**BTR2/AM.** Prof. console recorder. Speeds 15 and  $7\frac{1}{2}$  i/s. 11½-in. European and N.A.B. spools. F.r.: 15 i/s, 50-15,000 c/s;  $7\frac{1}{2}$  i/s, 50-10,000 c/s, both  $\pm 2$  dB. H and N better than — 58 dB. W. and F. less than 0.15%. V.U. meter. Variable speed spooling. Auto-following. Size  $31\frac{1}{2} \times 28\frac{3}{8} \times 42\frac{3}{4}$  ins. Weight 558 lb. Price £1,260.



**Grundig (Great Britain) Ltd.**, 39/41 New Oxford Street, London, W.C.1. Tel.: Covent Garden 2995.

**TK60.** Semi-prof. mono/stereo portable recorder. Speeds  $7\frac{1}{2}$  and  $3\frac{3}{4}$  i/s. One motor. 7-in. spools. F.r.:  $7\frac{1}{2}$  i/s, 50-15,000 c/s;  $3\frac{3}{4}$  i/s, 50-10,000 c/s, both  $\pm 3$  dB. M.E. level ind. H and N — 40 dB. W. and F. less than 0.2% at  $7\frac{1}{2}$  i/s. Outlet from pre-amp. Stereo/mono recording and playback. Detachable loudspeakers. Size  $27 \times 17\frac{1}{2} \times 12$  ins. Weight 54 lb. Price £134 8s.



**Leavers-Rich Equipment Ltd.**, 78b Hampstead Road, London, N.W.1. Tel.: Euston 1481. Cables: Leemag, London.

**Model E. No. ER141K.** Prof. reproducer console. 15 and  $7\frac{1}{2}$  i/s. 3 motors. 11½-in. spools. F.r.: 15 i/s, 50-15,000 c/s;  $7\frac{1}{2}$  i/s, 50-10,000 c/s, both  $\pm 2$  dB on C.C.I.R. test tape. Size  $30 \times 22 \times 36\frac{1}{2}$  ins. Weight 162 lb. Price £460.

**Model E. No. E141R.** Complete rack mounting prof. recorder. 15 and  $7\frac{1}{2}$  i/s. 3 motors. 11½-in. spools. F.r.: 15 i/s, 50-15,000 c/s;  $7\frac{1}{2}$  i/s, 50-10,000 c/s, both  $\pm 2$  dB. V.U. level meter. Size  $19 \times 17\frac{1}{2} \times 9$  ins. Weight 50 lb. Price £435.

**Model E. No. E121P.** Prof. portable recorder. Spec. as for E141R. In two cases,  $20 \times 17 \times 11\frac{1}{2}$  ins. and  $15 \times 18 \times 10$  ins. Weight 79 lb. Price £550.

**Model E. No. E141K.** Prof. network recorder console. Spec. as for E141R. Size  $30 \times 22 \times 36\frac{1}{2}$  ins. Weight 185 lb. (approx.). Price £565.

**Model C. Model C621P.** Prof. portable recorder. 15 i/s. 3 motors.  $9\frac{1}{2}$ -in. spools. F.r.: 50-15,000 c/s  $\pm 2$  dB. V.U. level meter. Size  $13 \times 18 \times 10$  ins. Weight 73 lb. P.s.n. 12v battery or auxiliary mains unit. Price £450.

**Model DB. No. DB221P.** Prof. portable recorder. Spec. as for C621P but in two cases,  $13 \times 18 \times 10$  ins. and  $16 \times 20 \times 11\frac{1}{2}$  ins. Total weight 74 lb. P.s.n. as C621P. Price £500.

**Model CS. No. CS621P.** Syncropulse recorder, for magnetic recording in sync. with cameras, etc. Spec. as for C621P. In two cases both  $13 \times 18 \times 10$  ins. Total weight 73 lb. P.s.n. as C621P. Price £550.

■ **Model E. No. ED 142P.** Complete portable dual channel recorder. 3 motors. 15 and  $7\frac{1}{2}$  i/s. Monitoring off tape, separate V.U. Meter, unit amp. L.R. and H.R. Mic. or line inputs.  $11\frac{1}{2}$ -in. spools. Response at 15 i/s, 50-15,000 c/s  $\pm 2$  dB. Size 2 cases  $16 \times 20 \times 11$  ins. Total weight 80 lb. Price £655. Console version, £715.

★

**M.S.S. Recording Co. Ltd.,** Colnbrook, Bucks. Tel.: Colnbrook 2431. Cables: Emesco.

**Model CMR/DE.** G.P. recorder.  $7\frac{1}{2}$  and  $3\frac{3}{4}$  i/s, 3 motors.  $8\frac{1}{4}$ -in. spools. F.r.:  $3\frac{3}{4}$  i/s, 100-7,500 c/s.  $\pm 3$  dB;  $7\frac{1}{2}$  i/s, 60-10,000 c/s.  $\pm 5$  dB; flat 100-7,000 c/s. Level meter. Size  $36 \times 28 \times 18$  ins. Weight 110 lb. Price £140; F.M. tuner available at an extra £25.

★

**Multimusic Ltd.,** Mayland Avenue, Hemel Hempstead, Herts. Tel.: Boxmoor 3636. Cables: Multimusic, Hemel Hempstead.

**Reflectograph Model A.** Semi-prof. recorder chassis, suitable for rack mounting or fitting in carrying case. Speeds  $7\frac{1}{2}$  and  $3\frac{3}{4}$  i/s. 3 motors.  $8\frac{1}{4}$ -in. spools. F.r.:  $7\frac{1}{2}$  i/s, 50-10,000 c/s;  $3\frac{3}{4}$  i/s, 40-7,500 c/s, both  $\pm 2$  dB. Level meter. H and N — 50 dB. W. and F. less than 0.2%. Outlet from pre-amp. Size  $20 \times 16 \times 10$  ins. Weight 50 lb. (approx.). Price £99 15s.

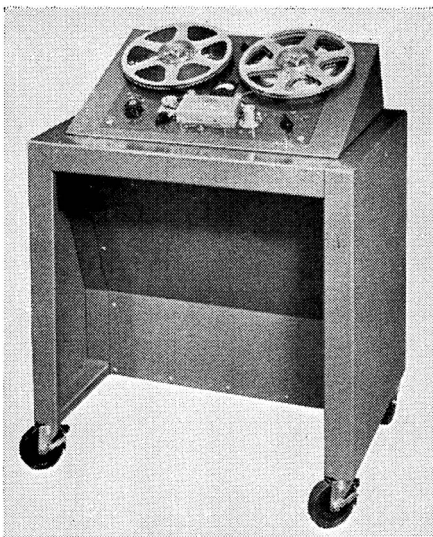

*Leevers-Rich Model No. E141K*

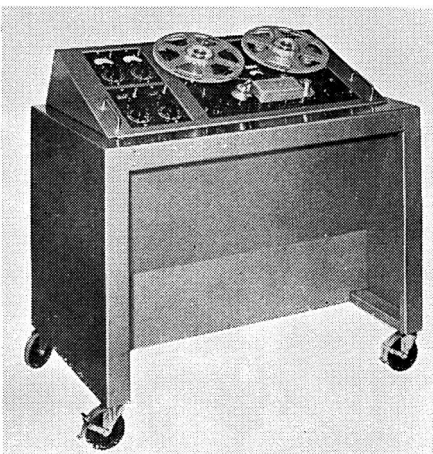

*Leevers-Rich ED142K stereo*

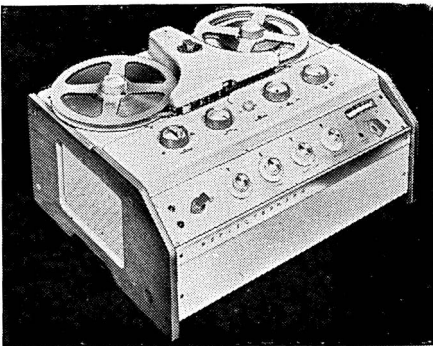

*Reflectograph Model A*

**Telefunken** – Sole U.K. distributors, **Welmec Corporation Ltd.**, 147 Strand, London, W.C.2. Tel.: Temple Bar 3357. Cables: Welmcors London.

**In Preparation**

**M.24** small studio recorder.



**Timbra** – Sole U.K. distributors, **Technical Suppliers Ltd.**, Hudson House, 63 Goldhawk Road, London, W.12. Tel.: Shepherds Bush 2581. Cables: Teknika, London.

**Timbra.** Semi-prof. portable recorder. Speeds  $3\frac{3}{4}$  and  $1\frac{7}{8}$  i/s. 3 motors. 7-in. spools, vertically stacked. M.E. level ind. H and N – 60 dB. W. and F. 0.05%. Mixing, monitoring. Size  $13 \times 11\frac{1}{2} \times 7$  ins. Weight 28 lb. Price £93 9s.



**Vortexion Ltd.**, 257/263 The Broadway, Wimbledon, London, S.W.19. Tel.: Liberty 6242/3. Cables: Vortex, Wimbledon.

**Model WVA.** Complete semi-pro. portable recorder 15 and  $7\frac{1}{2}$  i/s or  $7\frac{1}{2}$  and  $3\frac{3}{4}$  i/s. Wright and Weaire deck. 3 motors.  $8\frac{1}{2}$ -in. spools. F.r.: 30-17,000 c/s  $\pm 3$  dB at 15 i/s; 30-15,000 c/s  $\pm 3$  dB at  $7\frac{1}{2}$  i/s. S-N <50dB unweighted. W. and F., <0.2%. Meter level ind. ■Provision for fitting stereo head with direct connection. Loads 7uV mic. Weight 49 lb. Price £93 13s. (£5 extra for 15 i/s).

**Model WVB.** Spec. as for WVA, but with extra monitor head and amplifier. Echo facilities. ■Provision for fitting of stereo head. Price £110 3s. (£5 extra for 15 i/s).

**WVC.** Spec. as for WVA with provision for 4 watts per channel. Stereo output. Price £150.

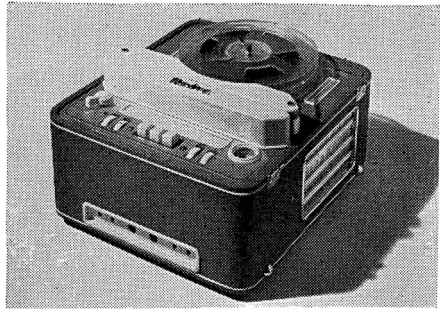

*Timbra semi-professional portable*

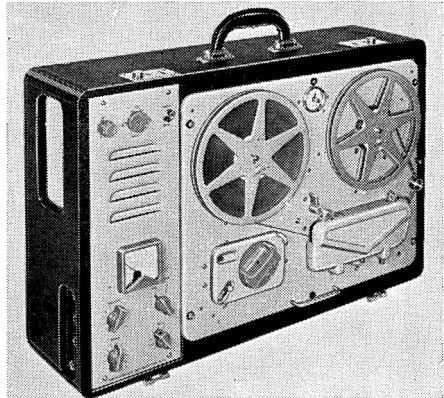

*Vortexion WVA semi-professional portable*

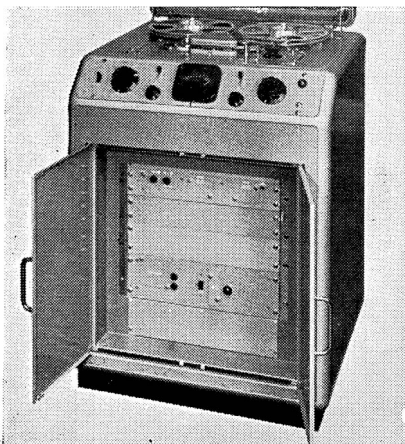

*EMI TR90 In console form*

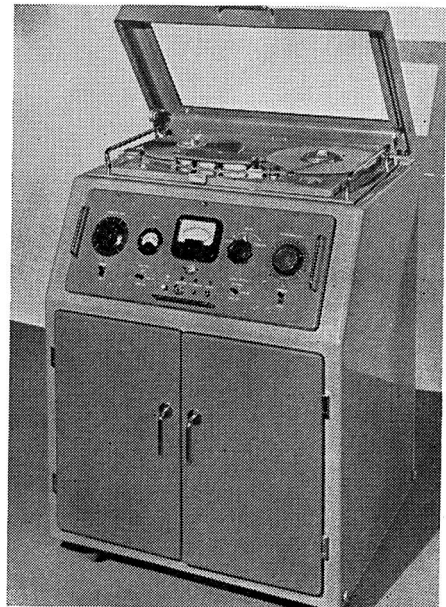

*EMI BTR2/AM console*

## DECKS—GENERAL PURPOSE and SEMI-PROFESSIONAL

**Birmingham Sound Reproducers Ltd.**, Monarch Works, Powke Lane, Old Hill, Staffs. Tel.: Cradley Heath 69272

**B.S.R. Monardeck TD1.** G.P. deck.  $3\frac{3}{4}$  i/s. One motor.  $5\frac{1}{2}$ -in spools. F.r.: with good amplifier equalisation 30-10,000 c/s  $\pm 3$  dB. 2 heads. W & F., 0.35% RMS. Size  $13 \times 8\frac{1}{2}$  ins. Price £12 12s.



**Bradmatic Ltd.**, Station Road, Aston, Birmingham, 6. Tel.: East 2881-2. Cables: Bradmatic, Birmingham.

**Bradmaster.** Models 5B, 5CS, 5CD, 5D Semi-prof. tape deck.  $7\frac{1}{2}$  and  $3\frac{3}{4}$  i/s. 3 motors. Model 5B 7-in. spools; 5CS and 5CL  $9\frac{3}{8}$ -in. spools; 5D  $10\frac{1}{2}$ -in. N.A.B. spools. F.r.:  $7\frac{1}{2}$  i/s, 40-15,000 c/s;  $3\frac{3}{4}$  i/s, 40-7,500 c/s, both  $\pm 4$  dB (dependent on amp. used). Size and weight dependent on model. Price 5B £42; 5CS £45 10s.; 5CL £47 10s.; 5D £50. ■ Available with full track or stereophonic heads to special order. Prices on application.

**Model 5DF.** Semi-prof. tape deck. 15 and  $7\frac{1}{2}$  i/s. 3 motors.  $10\frac{1}{2}$ -in. N.A.B. spools. F.r. 15 i/s, 30-18,000 c/s;  $7\frac{1}{2}$  i/s, 30-15,000 c/s, both  $\pm 2$  dB. W. & F., 0.1% at 15 i/s. Variable spooling control. Size  $20 \times 14\frac{1}{2}$  ins. Weight 20 lb. Price £62.



**Brenell Engineering Co. Ltd.**, 1a Doughty Street, London, W.C.1. Tel.: Holborn 7358.

**Mark 5.** G.P. tape deck. 15,  $7\frac{1}{2}$ ,  $3\frac{3}{4}$  and  $1\frac{1}{8}$  i/s. 3 motors.  $8\frac{1}{4}$  in. spools. W. and F.  $<0.2\%$  at  $7\frac{1}{2}$  i/s. accommodates up to four heads. Size  $15 \times 11\frac{1}{2} \times 5$  ins. Weight 16 lb. Price £29 8s.



**Collaro Ltd.**, Ripple Works, By-Pass Road, Barking, Essex. Tel.: Rippleway 5533. Cables: Kabarro. Telex, Barking.

**Collaro Mk. IV.** G.P. tape deck. 15,  $7\frac{1}{2}$  and  $3\frac{3}{4}$  i/s  $\pm 3$  dB with record/playback equalisation, 4 heads. W. and F., better than 0.15% at  $7\frac{1}{2}$  i/s. Direct use of second track without removing the spools. Size  $14\frac{1}{2} \times 11\frac{1}{2}$  ins. Weight 17 lb. Price £25.

**Collaro Studio.** G.P. tape deck  $7\frac{1}{2}$ ,  $3\frac{3}{4}$  and  $1\frac{1}{8}$  i/s. 3 motors. 7 or  $5\frac{1}{4}$ -in. spools. F.r.; 30-10,000 c/s at  $7\frac{1}{2}$  with record/playback equalisation 2 heads. Price £17 10s.

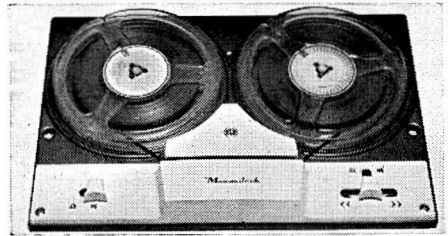

*B.S.R. Monardeck TD1*

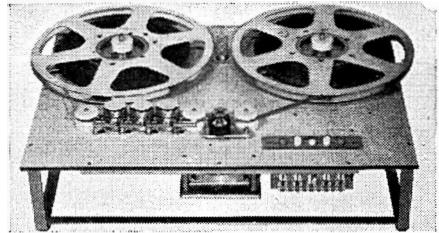

*Bradmatic Model 5D*

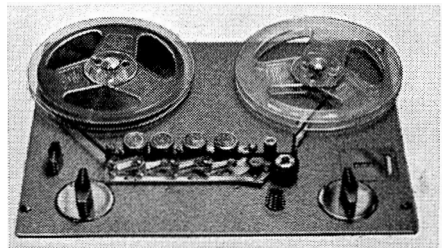

*Brenell Mk. 5*

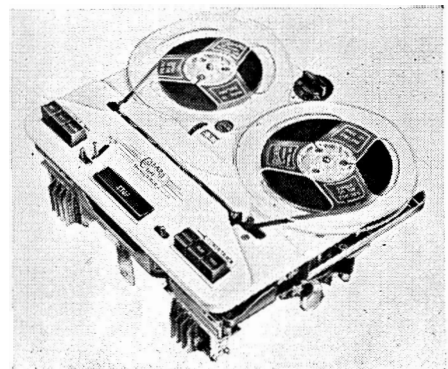

*Collaro Mk. IV*



**Garrard Engineering & Manufacturing Co. Ltd.**, Newcastle Street, Swindon, Wilts. Tel.: Swindon 5381. Cables: Telex 44-271.

**Garrard Magazine Tape Deck.**  $3\frac{3}{4}$  i/s. One motor. 4-in. spools or magazine. F.R. to 10,000 c/s. W. and F. 0.2%. No threading or spilling of tape. Size  $12\frac{1}{4} \times 8 \times 3\frac{1}{4}$  ins. Price not announced.



**Gramdeck.** U.K. distributors, **Andrew Merryfield Ltd.**, 29/31 Wright's Lane, Kensington, London, W.8. Tel.: Western 3603. Cables: Technology, Kens., London.

**Gramdeck.** Head and drive mechanism for attachment to gramophone turntable. Speeds  $7\frac{1}{2}$ , 4.3, 3.2 and 1.6 i/s for the standard disc speeds.  $5\frac{3}{4}$ -in. spools. F.R. 60-10,000 c/s  $\pm 3$  dB at  $7\frac{1}{2}$  i/s. W. and F. 0.15%. Size  $13\frac{1}{2} \times 6$  ins. Weight approx. 2 lb. Price including transistor pre-amplifier £13 12s.



**Grundig (Great Britain) Ltd.**, 39/41 New Oxford Street, London, W.C.1. Tel.: Covent Garden 2995.

■ **TM60.** G.P. tape deck for monaural and stereo use. Includes all pre-amplifier circuitry.  $7\frac{1}{2}$  and  $3\frac{3}{4}$  i/s. One motor. 7-in. spools. F.R.  $7\frac{1}{2}$  i/s, 50-15,000 c/s;  $3\frac{3}{4}$  i/s, 50-10,000 c/s, both  $\pm 3$  dB.M.E. level ind. H. & N. -40 dB. W. and F. less than 0.2% at  $7\frac{1}{2}$  i/s. Size  $14 \times 11\frac{3}{4} \times 8\frac{5}{8}$  ins. Weight 24 lb. Stereo/mono recording and playback through suitable output stages and loudspeakers. Price £94 10s.



**Harting** - Sole U.K. distributors, **Technical Suppliers Ltd.**, Hudson House, 63 Goldhawk Road, London, W.12. Tel.: Shepherds Bush 2581, 4794. Cables: Teknika, London.

■ **Harting HM5SD.** G.P. tape deck for monaural and stereophonic use.  $7\frac{1}{2}$  and  $3\frac{3}{4}$  i/s. One motor. 7-in. spools. F.R.: 30-20,000 c/s  $\pm 2$  dB at  $7\frac{1}{2}$  i/s; 30-16,000 c/s  $\pm 2$  dB at  $3\frac{3}{4}$  i/s. W. and F. <0.1%. Size  $15 \times 12 \times 6$  ins. Weight 19 lb. Price £44 2s.



**Modern Techniques**, Wedmore Street, London N.19. Tel.: Archway 3114.

**Motek K10.** G.P. tape deck.  $7\frac{1}{2}$ ,  $3\frac{3}{4}$ ,  $1\frac{7}{8}$  i/s. 3 motors. 7-in. spools. F.R.: approx 40-12,000 c/s at  $7\frac{1}{2}$  depending on amplifier used. W. and F. <0.2% at  $7\frac{1}{2}$  i/s. 2 heads. High imp. record head. Size  $15\frac{1}{4} \times 10\frac{3}{4}$  ins. Price £22 1s.

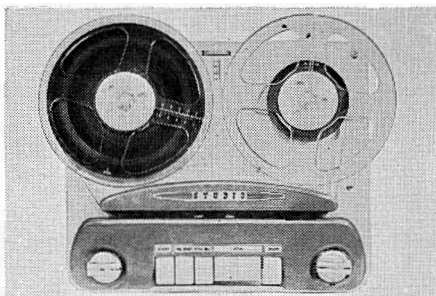

*Collaro Studio*

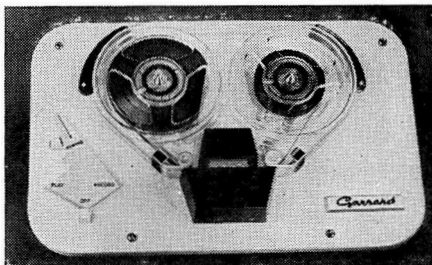

*Garrard Magazine deck*

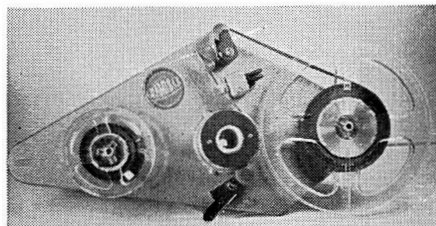

*The Gramdeck*

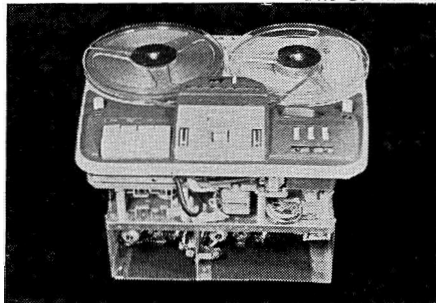

*Grundig Stereo TM60*

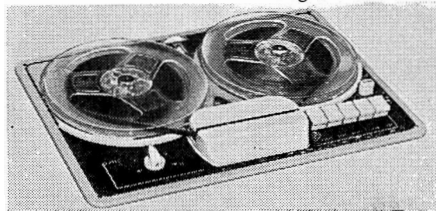

*Motek K10*

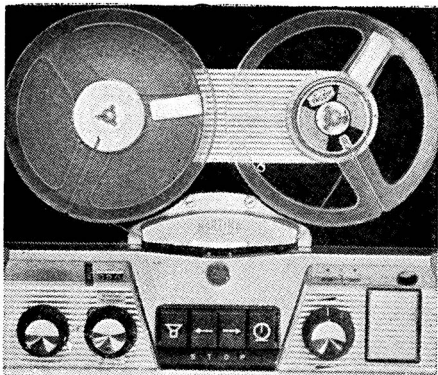

*Harting HM5SD*

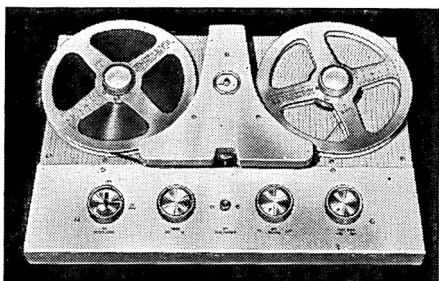

*Multimusic 2-speed*

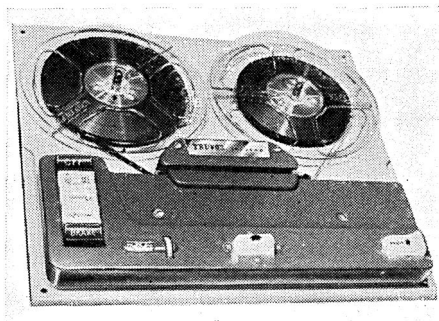

*Truvox Mk. VI 2-speed*

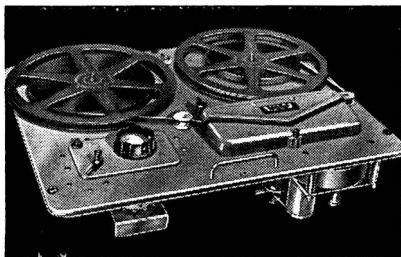

*Wearite deck*

**Mowbray Engineers Ltd.**, Mowbray Drive, Layton, Blackpool. Tel.: 31323. Cables: Safex, Blackpool.

**Stanley Minor.** G.P. tape deck.  $3\frac{3}{4}$  i/s. One motor.  $5\frac{1}{2}$ -in. spools. Size  $8\frac{3}{4} \times 13 \times 4\frac{1}{2}$  ins. Price not yet available.

**Stanley Major.** G.P. tape deck.  $7\frac{1}{2}$ ,  $3\frac{3}{4}$  and  $1\frac{1}{8}$  i/s. 3 motors. 7-in. spools. Size  $15\frac{1}{4} \times 11\frac{3}{4} \times 5$  ins. Price not yet available.



**Multimusic Ltd.**, Maylands Avenue, Hemel Hempstead, Herts. Tel.: Boxmoor 3636. Cables: Multimusic.

**Multimusic.** Semi-prof. tape deck. Speeds  $7\frac{1}{2}$  and  $3\frac{3}{4}$  i/s. 3 motors.  $8\frac{1}{4}$ -in. spools. Provision for two or four tracks. Standard 19-in. width for rack mounting. Price on application.



**Tape Recorders (Electronics) Ltd.**, 784-788 High Road, Tottenham, London, N.17. Tel.: Tottenham 0811. Cables: Taperec, London.

**Sound 333.** Miniature tape deck  $2\frac{1}{2}$  i/s. One motor.  $4\frac{1}{4}$ -in. spools. Push button control. Size  $10 \times 8 \times 3\frac{3}{4}$  ins. Price £15.



**Truvox Ltd.**, Neasden Lane, London, N.W.10. Tel.: Gladstone 6455. Cables: Truvoxeng.

**Mark IV.** G.P. tape deck.  $7\frac{1}{2}$  and  $3\frac{3}{4}$  i/s. 3 motors. 7-in. spools. F.r.: 50-12,000 c/s at  $7\frac{1}{2}$  i/s. 100-7,000 c/s at  $3\frac{3}{4}$  i/s, both  $\pm 3$  dB. W. and F., 0.2% at  $7\frac{1}{2}$  i/s. Size  $14\frac{1}{2} \times 12\frac{3}{4} \times 7\frac{1}{2}$  ins. Weight  $14\frac{1}{2}$  lb. Price £27 6s. with timing scale; £30 9s. with 3-digit counter.

**Mark VI.** G.P. tape deck. Pause control. Auto speed change. F.r.: 30-15,000 c/s at  $7\frac{1}{2}$ ; 30-9,000 c/s at  $3\frac{3}{4}$  i/s. Size  $14\frac{1}{4} \times 13 \times 4\frac{3}{4}$ . Weight  $13\frac{3}{4}$  lb. Price £26 5s. ■ Fitted with stereo head. £38 17s.



**Wright & Weaire Ltd.**, 131 Sloane Street, London, S.W.1. Tel.: Sloane 2214. Cables: Writewea, Knights.

**Wearite Models 4A, 4B, 4C.** Semi-prof. tape deck.  $3\frac{3}{4}$  and  $7\frac{1}{2}$  i/s. Also available  $7\frac{1}{2}$  and 15 i/s, 4AH, 4BH, 4CH. 3 motors.  $8\frac{1}{4}$ -in. spools. W. and F., 0.2% at  $7\frac{1}{2}$  i/s. Size  $16\frac{1}{2} \times 13 \times 7$  ins. Weight 18 lb. 4A standard monaural record/replay. Price £36 10s. 4AH £41 10s. 4B monaural record/replay plus monitor head. Price £41 10s. 4BH, £46 10s. 4C Industrial dual track. Price £46 10s. 4CH, £51 10s.

■ **Models 4SN, 4SH.** Monaural record replay plus stereo replay. Price, 4SN, £43 17s.; 4SH, £48 17s.

## GENERAL PURPOSE and DOMESTIC RECORDERS



*The Alba Duchess*

**Abbey Radiogram Manufacturing Co.,** 813 Green Lanes, London, N.21. Tel.: Laburnum 7315.

**Sovereign.** G.P. Portable. Collaro Mk. IV deck. F.R. 15 i/s, 50-15,000 c/s  $\pm$  3 dB;  $7\frac{1}{2}$  i/s, 50-12,000 c/s;  $3\frac{3}{4}$  i/s, 50-7,000 c/s  $\pm$  3 dB. W and F, 0.15%. M.E. level ind. Monitoring of input signal through speaker. Mixing of inputs. Screw-in legs available. Size,  $18\frac{1}{2} \times 13\frac{3}{4} \times 9\frac{1}{2}$  ins. Weight 38 lbs. Price, with tape and mic., £50 8s. Legs £2 2s.



**Alba (Radio & Television) Ltd.,** Tabernacle Street, London, E.C.2. Tel.: Clerkenwell 1322.

**Duchess Model R.59.** G.P. portable. Monardeck.  $3\frac{3}{4}$  i/s. F.R. 60-7,000 c/s. W & F 0.2%. Twin neon level ind. Outlet from pre-amp. Size  $14 \times 12 \times 6\frac{1}{2}$  ins. Weight 20 lbs. Price £28 7s.



**Apparatus & Instrument Co. Ltd.,** Aico House, 36 Grove Road, Hounslow, Middx. Tel.: Hounslow 7231/2.

**Selectophone.** G.P. portable.  $7\frac{7}{8}$ ,  $4\frac{9}{10}$  and  $3\frac{3}{8}$  i/s corresponding with a capstan speed of 78, 45 and  $33\frac{1}{3}$  r/m. One motor. A 35 mm strip of tape is housed in a cassette shaped like a book. There are 70 tracks on each tape, transfer is automatic. 3 lengths of tape are available. A. gives 70-150 mins; B. 120-278 mins; C. 155-360 mins. depending on speed used. F.R.  $7\frac{7}{8}$  i/s, 40-12,000 c/s  $\pm$  2 dB. A turntable and pickup are available that plug directly into the recorder. Straight through amp. M.E. level ind. Size,  $16\frac{1}{2} \times 11\frac{3}{4} \times 6\frac{1}{2}$  ins. Weight 30 lbs. Price, with tape A, £79 16s.

**Mobile I.** G.P. portable.  $1\frac{7}{8}$  and  $3\frac{3}{4}$  i/s. One motor. 7-in. spools. F.R.  $1\frac{7}{8}$  i/s, 50-8,000 c/s;  $3\frac{3}{4}$  i/s, 50-14,000 c/s. M.E. level ind. Outlet from pre-amp. Size  $15 \times 12 \times 7$  ins. Weight  $26\frac{1}{2}$  lbs. Price, with tape and mic. £59 17s.



**Audio Amplifiers Limited,** No. 3 Factory, Bush Fair, Tye Green, Harlow, Essex. Tel.: Harlow 24566.

**Crown.** G.P. portable. Collaro Studio-deck. F.R.  $7\frac{1}{2}$  i/s, 50-14,000 c/s;  $3\frac{3}{4}$  i/s, 50-9,000 c/s;  $1\frac{7}{8}$  i/s, 50-6,000 c/s, all  $\pm$  3 dB. Bar

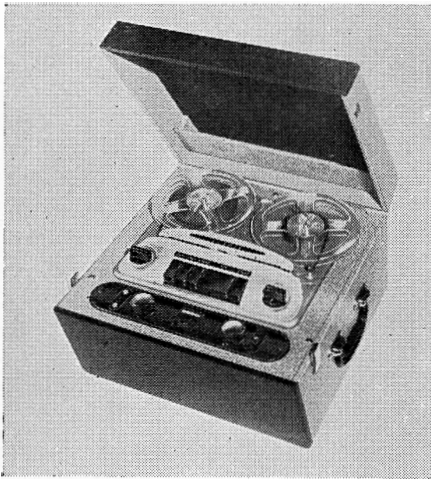

*Audio Amplifier Crown*



*Brenell Three Star*

type level ind. H & N - 40 dB. W & F 0.15% at 7½ i/s. Hi-fi outlet at 100 mV. Superimposing, and tone control. 4 watts output. Size 16½ × 9 × 6 ins. Price, with tape and mic. £40 19s.



**Birmingham Electronic Products Ltd.**, 1 Lodge Road, Birmingham 18. Tel.: Northern 9382.

**Norfield.** G.P. Consolette/portable. Motek deck. F.R. 7½ i/s, 40-16,000 c/s; 3¾ i/s, 40-10,000 c/s; 1⅝ i/s, 40-6,000 c/s. M.E. level ind. H & N - 50 dB. W & F 0.25% at 7½ i/s. Outlet from pre-amp.. Size 17¾ × 16 × 9½ ins. Weight 29 lbs. Price, complete with legs £52 10s.



**Brenell Engineering Co. Ltd.**, 1a Doughty Street, London, W.C.1. Tel.: Holborn 7358.

■ **Three Star.** G.P. portable recorder. 7½, 3¾ and 1⅞ i/s. 1 motor. 7-in. spools. F.R. 7½ i/s, 60,10,000 c/s ± 3 dB; 3¾ i/s, 60-6,000 c/s ± 3 dB; 1⅞ i/s, 60-3,000 c/s ± 3 dB. S-N, < - 40 dB. W and F, < 0.2% at 7½ i/s. M.E. level ind. Outlet from pre-amp. stage. Straight through amplifier. Adaptable for Stereo. Headphone monitoring. Size 15 × 15 × 7 ins. Weight 30 lbs. Price, with tape and mic., £60 18s.

■ **Three Star Stereo.** Portable stereo recorder, 7½, 3¾ and 1⅞ i/s. 7-in. spools. Level ind. in each channel. Twin built-in loudspeakers. Bass and treble controls. Straight through amp. Performance details as Three Star. Weight 40 lbs. Price £93 9s. or £99 15s. with two microphones.

■ **Mk. 5.** G.P. portable. 15, 7½, 3¾ and 1⅞ i/s. Three motors. 8¼-in. spools. F.R. 15 i/s, 50-16,000 c/s; 7½ i/s, 60-12,000 c/s; 3¾ i/s, 60-7,000 c/s; 1⅞ i/s, 60-4,000 c/s. All ± 3 dB. M.E. level ind. (Meter available.) H & N - 45 dB. W & F. 0.1% at 15 i/s. Hi-fi outlet at 200 mV. Straight through amp. Switched frequency correction. Pause control and monitoring. Size 18 × 18 × 8 ins. Weight 43 lbs. Price £67 4s., with meter £72 9s.

■ **Mk. 5 Stereophonic.** G.P. recorder. Rack mounted. General details as Mk. 5. Records and replays stereo or half-track mono. Alternatively records on one track whilst replaying on other. Price £99 12s.

■ **Brenell Stereo record and replay.** Mk. 5 deck, 15, 7½, 3¾ and 1⅞ i/s. Two Mk. 5 amps. F.R. as Mk. 5 portable. Mounted in special rack 17½ × 16½ × 11 ins. Weight 43 lbs. No speakers. Price £93 16s.

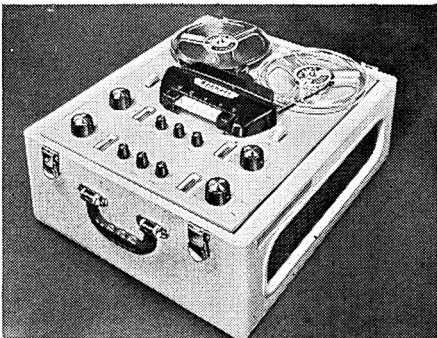

*Brenell Three Star stereo*

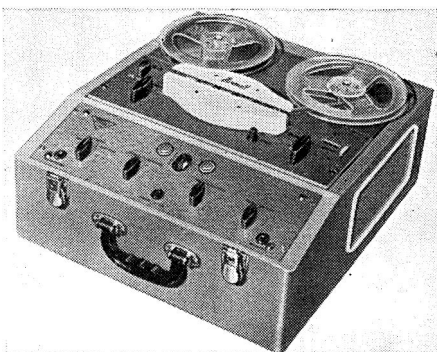

*Brenell Mk. 5 portable*



*Abbey Sovereign*

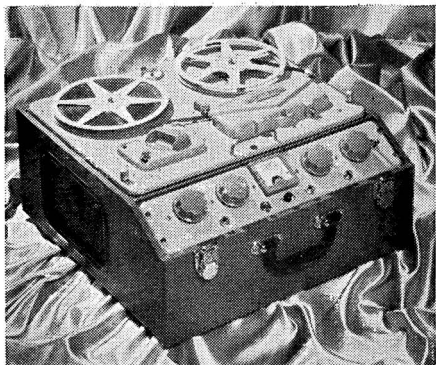

*Ferrograph Model 4A/N*

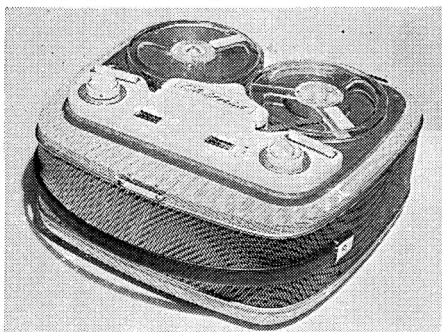

*Chitnis KM22*

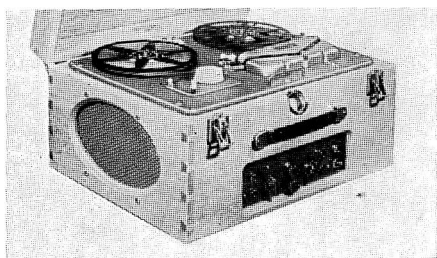

*Clarke & Smith STR/4*

**British Ferrograph Recorder Co. Ltd.**, 131 Sloane Street, S.W.1. Tel.: Sloane 1510. Cables: Britferro, Knights.

**Ferrograph 4A/N and 4A/H.** Complete portable recorder. Any two adjacent speeds from  $1\frac{7}{8}$  to 15 i/s. 3 motors.  $8\frac{1}{4}$ -in spools. F.R. 15 i/s, 40-15,000 c/s  $\pm 2$  dB;  $7\frac{1}{2}$  i/s 40-12,000 c/s  $\pm 3$  dB, 50-10,000 c/s  $\pm 2$  dB;  $3\frac{3}{4}$  i/s, 50-6,000 c/s  $\pm 3$  dB. Sustained peak signal level meter. Space under the head cover for additional plug-in head for monitoring, lower track working stereo playback or American dual stereo standard. Size  $18\frac{1}{2} \times 17\frac{1}{2} \times 9\frac{3}{4}$  ins. Weight 50 lb. Prices, 4 A/N ( $7\frac{1}{2}$  and  $3\frac{3}{4}$  i/s) £85 1s.; 4 A/H (15 and  $7\frac{1}{2}$  i/s) £90 6s.

■ **Ferrograph 4 S/N and 4 S/H** as models 4 A/N and 4 A/H, but with stereo replay heads fitted. With the Stereo-ad unit suitable for the replay of stereo tapes. Prices, 4 SN £92 8s., 4 SH £97 13s.

■ **Ferrograph Stereo 808.** A complete 2-channel recorder/reproducer. For tape speeds of  $3\frac{3}{4}$  i/s and  $7\frac{1}{2}$  i/s. Switched input meter enables levels of both channels to be balanced. Output of each channel on playback approx. 3 volts across 5,000 ohms. Can also be used for monaural record/replay. Price £110 5s.



**Chitnis Electronics Ltd.**, 1 Long Acre, London, W.C.2. Tel.: Covent Garden 2052. Cables: Tadsinhal, Souphone, London.

**Chitnis KM22.** G.P. portable.  $3\frac{3}{4}$ ,  $1\frac{7}{8}$  i/s. One motor.  $5\frac{3}{8}$ -in. spools. F.R.  $3\frac{3}{4}$  i/s, 30-16,000 c/s;  $1\frac{7}{8}$  i/s, 30-10,000 c/s, both  $\pm 3$  dB. M.E. level ind. Weight  $19\frac{1}{2}$  lbs. W & F 0.12% at  $3\frac{3}{4}$  i/s. Size  $14 \times 12\frac{1}{2} \times 8$  ins. Outlet from pre-amp. Price, with dynamic mic., £56 14s.

**Chitnis KM33.** G.P. portable. Four track version of the above. Price £65 2s.



**Clarke and Smith Manufacturing Co. Ltd.**, Melbourne Works, Wallington, Surrey. Tel.: Wallington 9252-3. Cables: Electronic, Wallington.

**Model CTR/4.** G.P. portable. Collaro Mk. IV deck. F.R. 15 i/s, 50-16,000 c/s;  $7\frac{1}{2}$  i/s, 50-12,500 c/s;  $3\frac{3}{4}$  i/s, 50-7,000 c/s. S-N < -45 dB. M.E. level ind. 6 watts output. Monitoring by headphones. Power supply available to power mixer unit or FM tuner. Stout wooden case. Size  $10 \times 18\frac{1}{2} \times 15\frac{1}{2}$  ins. Weight 48 lbs. Price, with tape and mic., £68 5s.

**Model STR/4.** G.P. portable. Wright and Weaire deck. F.R.  $7\frac{1}{2}$  i/s, 50-11,000 c/s  $\pm 3$  dB;  $3\frac{3}{4}$  i/s, 50-5,000 c/s  $\pm 3$  dB. S-N, -50 dB. M.E. level ind.  $4\frac{1}{2}$  watts output. Monitoring by headphones. Oak case. Size  $18 \times 14\frac{1}{2} \times 10$  ins. Weight 48 lbs. Price, with tape and mic., £93 9s.



**Cossor Radio & Television Ltd.**, 71 Endell Street, London, W.C.2. Tel.: Gerrard 2931.

**CR1601.** G.P. portable. Speeds  $7\frac{1}{2}$ ,  $3\frac{3}{4}$  and  $1\frac{7}{8}$  i/s. 7-in. spools. F.R.  $7\frac{1}{2}$  i/s, 50-20,000 c/s;  $3\frac{3}{4}$  i/s, 50-15,000 c/s;  $1\frac{7}{8}$  i/s, 50-7,000 c/s. M.E. level ind. H. & N. better than -40 db. W. and F. less than 0.2% at  $7\frac{1}{2}$  i/s. Monitoring, superimposing, tone and pause controls. Size  $16\frac{1}{2} \times 14\frac{1}{4} \times 7\frac{3}{4}$  ins. Weight 30 lb.

Price with tape and moving coil microphone £61 19s.

**CR1602.** G.P. portable. Speed  $3\frac{3}{4}$  i/s. 7-in. spools. F.R. 40-14,000 c/s. M.E. level ind. H. & N. —40 dB. W. and F. 0.3%. Four track recording/playback. Monitoring, superimposing, tone and pause controls. Size  $15\frac{1}{4} \times 12\frac{1}{2} \times 6\frac{3}{4}$  ins. Weight 19 lb. Price with tape and crystal mic. £38 17s.



**Connaught (Tape Recorder) Ltd.,** 1 Kings House, 396 Kings Road, London, S.W.3. Tel.: Flaxman 6575/6.

**Console.** G.P. recorder. Harting deck. F.R.: 30-16,000 c/s  $\pm 2$  dB at  $3\frac{3}{4}$  i/s. M.E. bar type level ind. Outlet from pre-amp stage. 10 watts output. Mounted in a pressure controlled cabinet housing 12 in. drive unit and 2 tweeters. 5 inputs. Price, with tape and moving coil mic., £125.

**Tape-o-gram.** Details as Console plus provision for AM/FM radio and four-speed gram. 15, and 9-in. speakers plus two tweeters. Size  $22 \times 56 \times 45$  ins. Price, with moving coil mic., £210.

**Tape-o-gram Stereo.** Complete stereo system including AM/FM radio, fourspeed gram. Price £350.



**Direct TV Replacements Ltd.,** 138 Lewisham Way, New Cross, S.E.14. Tel.: Tideway 6666.

**Chelsea.** G.P. portable. Collaro Studio Deck. Price, with tape and microphone, £44 2s.



**E.A.P. (Tape Recorders) Ltd.,** Bridge Close, Oldchurch Road, Romford, Essex. Tel.: Romford 62366-7. Cables: Elizabethan, Romford.

**Elizabethan Avon.** G.P. portable. B.S.R. Monardeck. F.R. 60-10,000 c/s. M.E. level ind. H & N —40 dB. Two inputs, two outputs. Tone control, mixing and superimposing. Size  $14 \times 7\frac{1}{2} \times 10\frac{1}{2}$  ins. Weight  $16\frac{1}{2}$  lbs. Price with tape and mic. £28 7s.

**Elizabethan Princess.** G.P. Portable. Motek deck. F.R.  $7\frac{1}{2}$  i/s, 60-12,000 c/s;  $3\frac{3}{4}$  i/s, 60-8,500 c/s;  $1\frac{7}{8}$  i/s, 60-6,000 c/s. M.E. level ind. H & N —40 dB. W & F better than 0.2% at  $7\frac{1}{2}$  i/s. Mixing, superimposing and monitoring. Size  $14 \times 11\frac{1}{2} \times 6\frac{3}{4}$  ins. Weight 23 lbs. Price, with tape and mic., £40 19s.

**Elizabethan Major.** G.P. portable. Collaro Studio deck. F.R.  $7\frac{1}{2}$  i/s, to 20,000 c/s;  $3\frac{3}{4}$  i/s, to 14,000 c/s;  $1\frac{7}{8}$  i/s, to 7,000 c/s, all

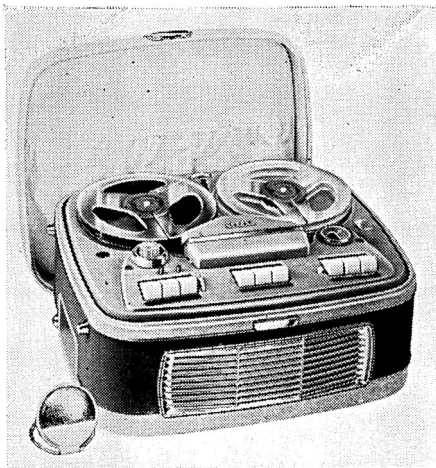

*Connaught CR1601*



*Connaught Console*

$\pm 3$  dB. Level meter. H & N —45 dB. W & F 0.15% at  $3\frac{3}{4}$  i/s. 6 watts push-pull outlet. 10  $\times$  6 in. speaker plus tweeter. Size  $15\frac{1}{2} \times 16\frac{3}{4} \times 9$  ins. Weight 32 lbs. Price, with tape, £68 5s.



**Electric Audio Reproducers Ltd.,** The Square, Isleworth, Middx. Tel.: Isleworth 6256. Cables: Eargram, Isleworth, Hounslow.

**Bantam.** G.P. portable. B.S.R. Monardeck. F.R. 60-9,000 c/s for 6 dB down. Twin neon level ind. Outlet from pre-amp. Size  $10\frac{3}{4} \times 15\frac{1}{2} \times 6\frac{3}{4}$  ins. Weight 19 lbs. Price £29 8s.





*Elizabethan Princess*

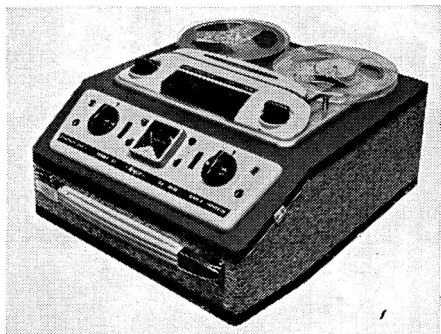

*Elizabethan Major*

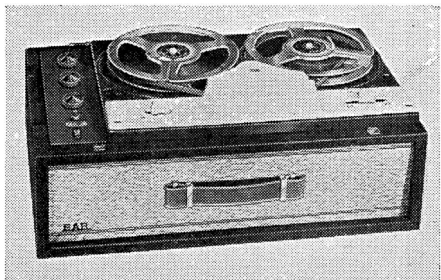

*E.A.R. Bantam*



*Ferguson 441 TR*

**Ferguson Radio Corporation Ltd.**, Thorn House, Upper St. Martin's Lane, London, W.C.2. Tel.: Temple Bar 2444. Cables: Eleclampo, Lesquare, London.

**441TR.** G.P. portable. B.S.R. Monardeck. F.R. 40-10,000 c/s  $\pm$  5 dB. M.E. level ind. H & N - 45 dB. W & F better than 0.2%. Outlet from pre-amp. Size 14 $\frac{3}{4}$   $\times$  12 $\frac{1}{4}$   $\times$  6 $\frac{1}{4}$  ins. Weight 15 $\frac{1}{2}$  lbs. Price £29 8s.



**Fidelity Radio Ltd.**, 11/13 Blechynden Street, London, W.11. Tel.: Park 4239/1321.

**Argyll.** G.P. portable. B.S.R. Monardeck. F.R. 60-10,000 c/s. H & N - 50 dB. W & F 0.4%. M.E. level ind. Two inputs, mixing, superimposing and monitoring. Size 17  $\times$  13 $\frac{1}{2}$   $\times$  7 $\frac{1}{4}$  ins. Weight 21 lbs. Price with tape and mic. £30 9s.



**The Gramophone Company Ltd.**, Hayes, Middx. Tel.: Southall 2468. Cables: Jabberment, London.

**D.S.R.1.** G.P. portable. Speeds 7 $\frac{1}{2}$  and 3 $\frac{3}{4}$  i/s. Three motors, 7-in. spools. F.R. 7 $\frac{1}{2}$  i/s, 50-10,000 c/s; 3 $\frac{3}{4}$  i/s, 50-8,000 c/s. M.E. level ind. H & N - 45 dB. W & F less than 0.3%. Outlet from pre-amp. Three heads. Separate record and playback amplifiers. Size 17 $\frac{1}{2}$   $\times$  14 $\frac{3}{4}$   $\times$  8 ins. Weight 33 lbs. Price £50.



**Grundig (Gt. Britain) Ltd.**, Newlands Park, Sydenham, S.E.26. Tel.: Sydenham 2211. Showroom: 39-41 New Oxford Street, W.C.1. Cables: Grundig, London. Telex: 22054.

**TK20.** G.P. portable recorder. 3 $\frac{3}{4}$  i/s. One motor. 5 $\frac{1}{2}$ -in. spools. F.R. 60-10,000 c/s  $\pm$  5 - 4 dB. S-N < - 45 dB. W and F, <  $\pm$  0.2%. Bar type M.E. level ind. Output from pre-amp. stage. Auto stop at end of tape. Size 13 $\frac{3}{4}$   $\times$  12 $\frac{1}{2}$   $\times$  7 ins. Weight 20 lbs. Price, with tape and mic., £54 12s.

**TK25.** G.P. portable recorder. 3 $\frac{3}{4}$  and 1 $\frac{7}{8}$  i/s. One motor. 5 $\frac{1}{2}$ -in. spools. F.R. 3 $\frac{3}{4}$  i/s. 60-15,000 c/s  $\pm$  3 dB; 1 $\frac{7}{8}$  i/s, 60-8,000 c/s  $\pm$  3 dB. S-N, < - 45 dB. W and F., 3 $\frac{3}{4}$  i/s, <  $\pm$  0.25%, 1 $\frac{7}{8}$  i/s, < 0.4%. Bar type M.E. level ind. Output from pre-amp. stage. Input fading control. Superimposing. Size 14  $\times$  12 $\frac{1}{2}$   $\times$  7 $\frac{1}{2}$  ins. Weight 25 lbs. Price, with tape. £65 2s.

**TK30.** G.P. portable. 7 $\frac{1}{2}$  and 3 $\frac{3}{4}$  i/s. One motor. 7-in. spools. F.R. 7 $\frac{1}{2}$  i/s, 50-15,000 c/s  $\pm$  3 dB; 3 $\frac{3}{4}$  i/s, 50-10,000 c/s  $\pm$  3 dB.

S-N, < -43 dB. W and F,  $7\frac{1}{2}$  i/s, < 0.2%;  $3\frac{3}{4}$  i/s, <  $\pm 0.25\%$ . Bar type M.E. level ind. Output from pre-amp. stage. Superimposing. Autostop at end of tape. Remote control facilities. Size  $18 \times 18 \times 11\frac{1}{2}$  ins. Weight 31 lbs. Price, with tape, £75 12s.

**TK35.** G.P. portable.  $7\frac{1}{2}$ ,  $3\frac{3}{4}$  and  $1\frac{7}{8}$  i/s. One motor. 7-in. spools. F.R.  $7\frac{1}{2}$  i/s, 50-18,000 c/s  $\pm 3$  dB;  $3\frac{3}{4}$  i/s, 50-14,000 c/s  $\pm 3$  dB;  $1\frac{7}{8}$  i/s, 100-8,000 c/s  $\pm 3$  dB. S-N, < -43 dB. W and F,  $7\frac{1}{2}$  i/s <  $\pm 0.2\%$ ,  $3\frac{3}{4}$  i/s - 0.25%,  $1\frac{7}{8}$  i/s - 0.4%. Output from pre-amp. stage. Superimposing, autostop, remote control facilities. Bar type M.E. level ind. Size  $17 \times 16\frac{3}{4} \times 9\frac{1}{2}$  ins. Weight 34 lbs. Price, with tape, £86 2s.

**TM20.** Deck mechanism with pre-amp. stage.  $3\frac{3}{4}$  i/s. One motor.  $5\frac{1}{2}$ -in. spools. F.R. 60-10,000 c/s + 5 - 4 dB. S-N, -45 dB. W and F,  $\pm 0.2\%$ . Bar type M.E. level ind. Size  $12\frac{1}{2} \times 9\frac{1}{2} \times 6$  ins. Price £46 4s.

**TK55.** G.P. portable with stereo playback. Speeds  $7\frac{1}{2}$ ,  $3\frac{3}{4}$  and  $1\frac{7}{8}$  i/s. One motor. 7-in. spools. F.R.  $7\frac{1}{2}$  i/s, 50-15,000 c/s;  $3\frac{3}{4}$  i/s, 50-10,000 c/s;  $1\frac{7}{8}$  i/s, 100-6,000 c/s, all  $\pm 3$  dB. M.E. level ind. H & N -43 dB. W & F less than 0.2% at  $7\frac{1}{2}$  i/s. Mono recording, mono/stereo playback. Size  $17 \times 16\frac{3}{4} \times 9\frac{1}{2}$  ins. Weight  $34\frac{1}{2}$  lbs. Price £96 12s.



**Hatfield Radio**, 28 Stroud Green Road, London, N.4. Tel.: Archway 1593.

**Viking.** G.P. portable. Motek deck. F.R.  $7\frac{1}{2}$  i/s, 50-11,000 c/s  $\pm 3$  dB. S-N, < -45 dB. M.E. level ind. Outlet from pre-amp. stage. Superimposing. Monitoring by headphones from erase head. Size  $16 \times 14\frac{1}{2} \times 8$  ins. Weight 34 lbs. Price, with tape and mic., £48 6s.



**Kurland Recording Systems Ltd.**, 9/11 Tilly's Lane, High Street, Staines, Middx. Tel.: Staines 52788.

**TR7M.** G.P. portable. Collaro Mk. IV deck. F.R. 15 i/s, 40-15,000 c/s;  $7\frac{1}{2}$  i/s, 50-12,000 c/s;  $3\frac{3}{4}$  i/s, 50-9,000 c/s; S-N -40 dB. W and F, < 0.1%. M.E. level ind. Built in mixer. Size  $15\frac{1}{4} \times 15\frac{1}{4} \times 7\frac{1}{4}$  ins. Weight 35 lbs. Price, with tape and mic., £58 16s.

**Konsollette.** G.P. portable. Collaro Studio deck. M.E. level ind. W & F 0.15% at  $3\frac{3}{4}$  i/s. Superimposing. Size  $13\frac{1}{2} \times 14\frac{1}{2} \times 7$  ins. Weight 24 lbs. Price £39 18s.



*Fidelity Argyll*



*Gramophone Co. D.S.R.1*

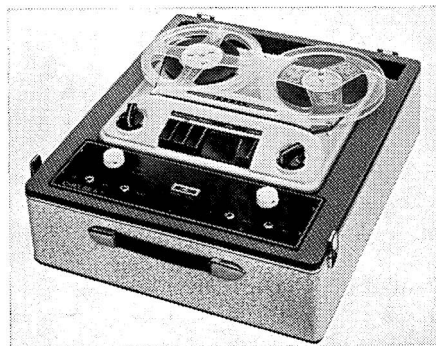

*Chelsea G.P. portable*



*Grundig TK35*

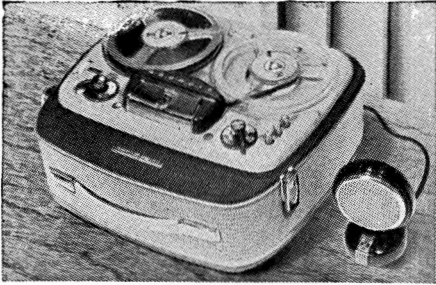

*Grundig TK20*

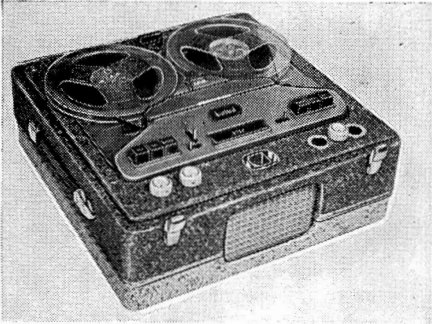

*Kurland TR7M*

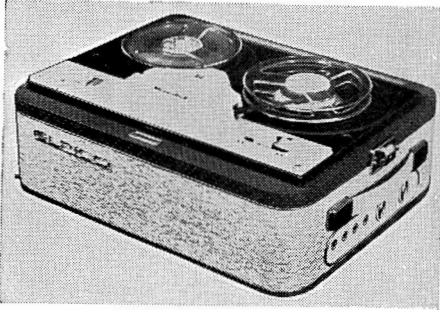

*Elpic TR/400*

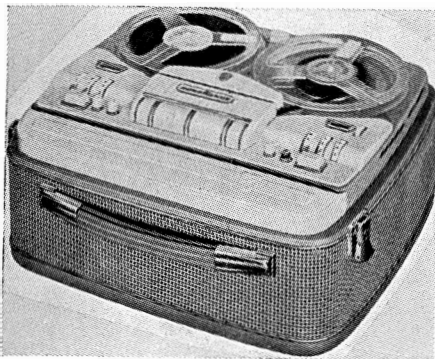

*Normende Titan*

**Lee Products (G.B.) Ltd.**, Elpico House, Longford Street, London, N.W.1. Tel.: Euston 5754. Cables: Leprod, London, N.W.1.

**Elpico TR/400.** G.P. portable. B.S.R. Monardeck. F.R. 80-8,000 c/s. M.E. level ind. H & N - 40 dB. W & F less than 0.4%. Size  $13\frac{3}{4} \times 11\frac{1}{4} \times 6$  ins. Weight 17 lbs. Price, with tape, and mic. £27 6s.

**Elpico/Geloso G.256.** Miniature G.P. portable. Speed  $1\frac{7}{8}$  i/s. One motor.  $3\frac{1}{4}$ -in. spools. F.R. 80,6-000 c/s. DM70 level ind. H & N - 40 dB. W & F 0.3%. Size  $10 \times 5\frac{1}{2} \times 4$  ins. Weight  $6\frac{1}{2}$  lbs. Price £27 16s. 6d.



**Magnafon Record Co.** Sole distributors: Market Developments, 221 Bishopsgate, London, E.C.2. Tel.: Bishopsgate 9415.

**Magnafon TR60.** G.P. portable. Speeds  $7\frac{1}{2}$ ,  $3\frac{3}{4}$ ,  $1\frac{7}{8}$  i/s. Three motors. 7-inch spools. F.R.  $7\frac{1}{2}$  i/s, 40-12,000 c/s;  $3\frac{3}{4}$  i/s, 40-8,000 c/s;  $1\frac{7}{8}$  i/s, 40-5,000 c/s, all  $\pm 3$  dB. M.E. level ind. H & N - 45 dB. W & F 0.2%. Mixing, Superimposing, Outlet from pre-amp. Size  $15\frac{1}{2} \times 16\frac{1}{2} \times 7\frac{1}{2}$  ins. Weight 28 lbs. Price £51 9s. Legs £2 2s. extra.



**Murphy Radio Ltd.**, Welwyn Garden City, Herts. Tel.: Welwyn Garden 3434.

**TR1.** G.P. portable. Garrard magazine loading deck. M.E. level ind. Two inputs, outlet from pre-amp. Size  $12\frac{3}{4} \times 10\frac{1}{4} \times 7\frac{1}{2}$  ins. Weight 21 lb. Price £29 18s. 6d.



**Normende, Bremen.** U.K. Distributors: **TAK Continental Importers**, Stone, Staffs. Tel.: Stone 260.

**Normende Titan.** G.P. portable.  $7\frac{1}{2}$  and  $3\frac{3}{4}$  i/s. 3 motors. 7-in. spools. F.R.  $7\frac{1}{2}$ , 50-18,000 c/s;  $3\frac{3}{4}$ , 50-13,000 c/s. Bar type M.E. level ind. Size  $16\frac{1}{2} \times 8 \times 15$  ins. Weight 33 lbs. Price, with tape and mic., £91 9s.



**P.a.R. Electronics**, 7 Avery Row, London, W.1. Tel.: Mayfair 9910.

**Allegro.** G.P. portable. Collaro Studio deck. F.R. 40-12,000 c/s  $\pm 3$  dB at  $7\frac{1}{2}$  i/s. M.E. level ind. W. and F. less than 0.15%. Superimposing, bass and treble controls. Size  $15 \times 15\frac{1}{2} \times 9$  ins. Weight 24 lb. Price with tape and crystal microphone £40 19s.

**Philips Electrical Ltd.,** Century House, Shaftesbury Avenue, London, W.C.2. Tel.: Gerrard 7777. Cables: Phillamps, London.

**EL3536.** G.P. Stereo Recorder. Speeds:  $7\frac{1}{2}$ ,  $3\frac{3}{4}$ , and  $1\frac{7}{8}$  i/s. F.R.:  $7\frac{1}{2}$ , 50-20,000 c/s;  $3\frac{3}{4}$ , 50-15,000 c/s;  $1\frac{7}{8}$ , 50-7,000 c/s. 7 in. spools. M.E. level ind. 4 track stereo/mono. recording and playback. Size  $20\frac{1}{2} \times 15\frac{3}{4} \times 11\frac{3}{8}$  in. Weight 43 lbs. Price £96 12s.

**EL3542.** G.P. 4 track recorder. Speeds:  $7\frac{1}{2}$ ,  $3\frac{3}{4}$  and  $1\frac{7}{8}$  i/s. F.R.:  $7\frac{1}{2}$ , 50-20,000 c/s;  $3\frac{3}{4}$ , 50-15,000 c/s;  $1\frac{7}{8}$ , 50-7,000 c/s. 7 in. spools. M.E. level ind. 4 track mono. record/playback. Size  $15\frac{1}{2} \times 13 \times 6\frac{3}{4}$  ins. Weight 30 lbs. Price £61 19s.



**Phillips & Bonson Ltd.,** Imperial House, Dominion Street, Moorgate, London, E.C.2. Tel.: Monarch 5481.

**President.** G.P. portable using the Truvox Mk. IV deck. Straight through amp. head-phone monitoring. M.E. level ind. Size  $22 \times 14 \times 9$  ins. Weight 35 lbs. Price, with timing scale, £57 15s. De Luxe model with 3 digit counter £65 2s.



**Portogram Radio Electrical Industries Ltd.,** Audio Works, Paxton Road, Tottenham, London, N.17. Tel.: Tottenham 7683.

**Monotape.** G.P. portable. B.S.R. Monar-deck. F.R. 50-9,000 c/s  $\pm 3$  dB. M.E. level ind. H & N — 50 dB. W & F less than 0.2%. Tone control, and outlet from pre-amp. Size  $14 \times 12\frac{1}{4} \times 8$  ins. Weight 19 lbs. Price with tape and mic. £30 9s.

**Portotape.** G.P. portable. Collaro Studio deck. F.R.  $7\frac{1}{2}$  i/s, 50-12,000 c/s;  $3\frac{3}{4}$  i/s, 50-9,000 c/s;  $1\frac{7}{8}$  i/s, 50-7,000 c/s, all  $\pm 3$  dB. M.E. level ind. H & N  $\pm 50$  dB. W & F 0.15%. Tone control, and outlet from pre-amp. Size  $17\frac{1}{2} \times 16 \times 9\frac{3}{4}$  ins. Weight 36 lbs. Price with tape and mic., £40 19s.



**Radio Gramophone Development Co. Ltd.,** Eastern Avenue West, Romford, Essex. Tel.: Romford 45991.

**RGD Mk. 107.** G.P. portable.  $7\frac{1}{2}$  and  $3\frac{3}{4}$  i/s. One motor. 7-in. spools. F.R.: 30-18,000 c/s at  $7\frac{1}{2}$  i/s; 40-13,000 c/s at



*Murphy TR1*



*P.a.R. Allegro*



*Magnafon TR60*



*Philips EL3542*

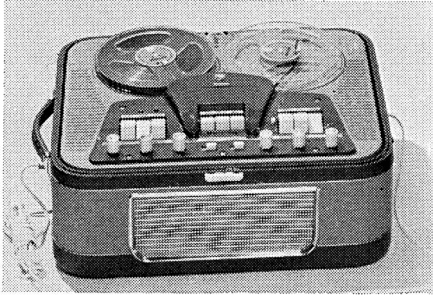

*Philips EL3536*

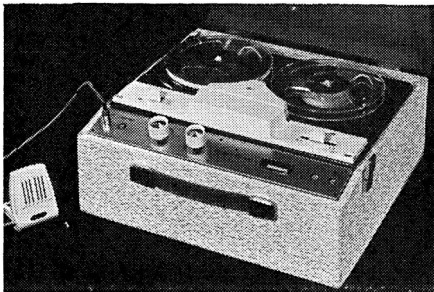

*Regentone RG20*



*RGD Mk. 104*

$3\frac{3}{4}$  i/s. S-N, - 45 dB, W. and F. 0.3% at  $3\frac{3}{4}$ , 0.1% at  $7\frac{1}{2}$ . Direct connection to replay head. Connection for remote control. M.E. level ind. 4 watts output. Straight through amp. Size  $16\frac{1}{2} \times 13 \times 8$  ins. Weight 29 lb. Price £72 9s.

**RGD Mk. 103.** G.P. portable. Motek deck. F.R.  $7\frac{1}{2}$  i/s, 60-10,000 c/s;  $3\frac{3}{4}$  i/s, 60-6,000 c/s;  $1\frac{7}{8}$  i/s, 60-3,500 c/s, all  $\pm 6$  dB. S & N - 45 dB. W & F 0.2% at  $7\frac{1}{2}$  i/s. Neon level ind. Size  $17 \times 14 \times 7\frac{1}{2}$  ins. Weight 24 lbs. Price with tape and crystal microphone, £51 9s.

**RGD Mk. 104.** G.P. portable. B.S.R. Monardeck. F.R. 60-8,000 c/s. S & N - 40 dB. W & F 0.4%. Neon level ind. Size  $13 \times 14\frac{1}{2} \times 7$  ins. Weight 14 lbs. approx. Price with tape and crystal microphone, £28 7s.



**Recording Devices' Ltd.**, 44 Southern Row, Kensington, London, W.10. Tel.: Ladbroke 4775.

**Mannequin.** G.P. portable. B.S.R. Monardeck. F.R. 80-9,000 c/s. M.E. level ind. H & N - 40 dB. W & F 0.45%. Mixing, superimposing. Size  $13 \times 11 \times 6$  ins. Weight 17 lbs. Price £28 2s.

**Stuzzi Tricorder.** G.P. portable. Speeds  $3\frac{3}{4}$ ,  $1\frac{7}{8}$  and  $\frac{1}{8}$  i/s. One motor.  $5\frac{3}{4}$  spools. F.R.  $3\frac{3}{4}$  i/s, 40-16,000 c/s;  $1\frac{7}{8}$  i/s, 40-8,000 c/s;  $\frac{1}{8}$  i/s, 40-4,000 c/s. M.E. level ind. H & N - 45 dB. W & F 0.25%. Mixing, Variable Superimposing, Monitoring, and remote control. Size  $13 \times 10 \times 6$  ins. Weight 18 lbs. Price £78 15s.



*RGD Mk. 107*



**Reps. (Tape Recorders) Ltd.,** 118 Park Road North, South Acton, London, W.3. Tel.: Acorn 4141.

**R.20.** G.P. portable. Collaro Mk. IV deck. F.R. 15 i/s, 40-17,000 c/s;  $7\frac{1}{2}$  i/s, 50-10,000 c/s;  $3\frac{3}{4}$  i/s, 60-6,000 c/s all  $\pm 3$  dB. Meter level ind. Size  $16\frac{1}{2} \times 16 \times 9\frac{3}{4}$  ins. Weight 41 lbs. Price, with crystal mic., stand and spool of tape, £65 2s.

**R.30,** as above, but with 2 in. meter level ind. Price £69 6s.

**R.40.** G.P. portable. Collaro Mk. IV deck. F.R. 15 i/s, 40-20,000 c/s;  $7\frac{1}{2}$  i/s, 50-12,000 c/s;  $3\frac{3}{4}$  i/s, 60-6,000 c/s. 10 W peak output. M.E. level ind. Size  $16\frac{1}{2} \times 9\frac{3}{4} \times 16$  ins. Weight 42 lbs. Price, with tape and crystal mic., £73 10s.

**R.10.** G.P. portable. Collaro Studio deck. Level meter. Size  $14 \times 15 \times 9$  ins. Weight 30 lbs. Price with tape, crystal microphone and stand, £58 11s. 6d.



**Regentone Radio & Television Ltd.,** Eastern Avenue West, Romford, Essex. Tel.: 45991.

**RG20.** G.P. portable. B.S.R. Monardeck. Twin neon level ind. F.R. 60-8,000 c/s. S & N - 40 dB. W & F 0.4%. Size  $13 \times 14\frac{1}{2} \times 7$  ins. Weight 19 lbs. Price with tape and crystal microphone, £29 8s.

**RT51.** G.P. portable. Motek deck. Twin neon level ind. F.R.  $7\frac{1}{2}$  i/s, 60-10,000 c/s;  $3\frac{3}{4}$  i/s, 60-6,000 c/s;  $1\frac{7}{8}$  i/s, 60-3,500 c/s, all  $\pm 6$  dB. S & N - 45 dB. W & F 0.2% at  $7\frac{1}{2}$  i/s. Size  $17 \times 14 \times 7\frac{1}{2}$  ins. Weight 24 lbs. Price, with tape and crystal microphone, £51 9s.

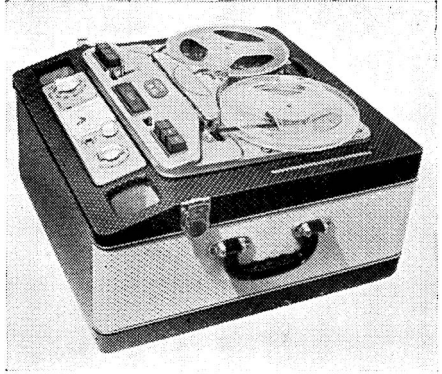

*Reps R30*



*Stuzzi Tricorder*



*Recording Devices Mannequin*



*Saba*





*Perth Clarissa*

**Perth Radios Ltd.,** Marten House, 39-47 East Road, London, N.1. Tel.: Clerkenwell 2413.

**Clarissa Mk. 1.** G.P. portable. Collaro Studio deck. F.R. to 10,000 c/s. M.E. level ind. Tone control. 3 watts output. Size 18 × 13 × 7 ins. Weight 23 lbs. Price, with tape and crystal microphone, £44 2s.

**Clarissa Mk. 2.** G.P. portable. Collaro Studio deck. F.R. 40-12,000 c/s ± 3 dB. W & F 0.15% at 3½ i/s. Mixing, superimposing, bass and treble controls. HF and LF speakers. Size 18 × 13 × 7 ins. Weight 26 lbs. This recorder is in preparation. Release date to be announced.

**Perth-Saja.** Two versions of this general purpose portable recorder are currently imported, the Standard and the Twin de Luxe. Features are large speakers, superimposing, position indicator. Prices from £47 5s. to £68 15s. 6d.



**Henri Selmer & Co. Ltd.,** 114 Charing Cross Road, London, W.C.2. Tel.: Temple Bar 5432. Cables: Selmatone, West, Cent.

**Saba.** G.P. portable. 7½ and 3¾ i/s. 2 motors. 7-in. spools. F.R. 7½ i/s, 30-20,000 c/s; 3¾ i/s, 40-16,000 c/s. W and F, 7½ i/s ± 0.2%; 3¾ i/s ± 0.4%. Bar type M.E. level ind. Automatic stop and reversal at end of tape. Straight through amp. Outlet from pre-amp. stage. Superimposing. Provision for remote control. Size 17½ × 8½ × 17½ ins. Weight 37½ lbs. Price, £82 19s.



**Simon Equipment Ltd.,** 48 George Street, London, W.1. Tel.: Welbeck 2371. Cables: Simsale, London.

**Simon SP/4.** Automatic. Complete semi-prof. portable 7½ and 3¾ i/s. 1 synchronous motor. 7-in. spools. F.R. 7½ i/s, 30-15,000 c/s ± 3 dB. ref. 1,000 c/s, 3¾ i/s, 30-7,000 c/s ± 3 dB. M.E. level ind. S-N, < - 52 dB. Ref. to 10W output. W and F, < 0.2% peak to peak. Automatic reversal at end of tape, 3 way mixing. Monitoring, push-pull oscillator. 10 watts output, 0.5% distortion. Independent tone controls. Provision for remote control. Size 16½ × 14¾ × 10½ ins. Weight 48 lbs. Price, with tape, £99 15s.

**Minstrelle.** G.P. table model. Garrard magazine loading deck. 4-in. spools or magazines. M.E. level ind. Mixing, straight through amplifier. Built-in mic. Size 18½ × 11½ × 8 ins. Weight 27½ lbs. Price £40 19s.

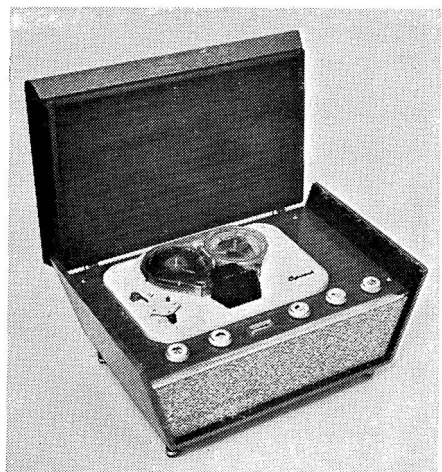

*Simon Minstrelle*

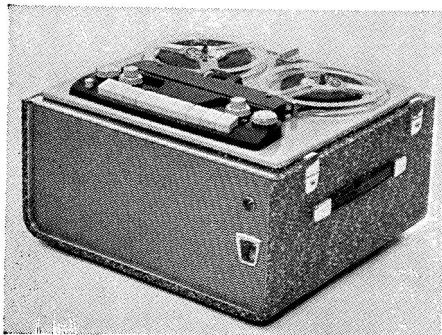

*Simon SP/4*

**Specto Ltd.,** Vale Road, Windsor, Berks.  
Tel.: Windsor 1241/2. Cables: Specto,  
Windsor.

**Spectone 151.** G.P. portable. Collaro Mk. IV deck. F.R. 15 i/s, 30-16,000 c/s (to C.C.I.R. spec.); 7½ i/s, 30-12,000 c/s (to C.C.I.R. spec.); 3¾ i/s, 40-6,000 c/s, all ± 3 dB. Level meter. Size 18½ × 16 × 11¾ ins. Weight 50 lbs. Price, with mic., £79 16s.

**Spectone 161.** G.P. portable. Collaro Mk. IV deck. F.R. 15 i/s, 50-16,000 c/s; 7½ i/s, 50-12,000 c/s; 3¾ i/s, 50-8,000 c/s. M.E. level ind. Mixing. Superimposing. Outlet from pre-amp. stage. S-N < -45 dB below full peak output. W & F, 0.15%. Size 15½ × 15½ × 8¼ ins. Weight 36 lbs. Price, with mic., £51 9s.

**Spectone 171.** G.P. portable. Garrard magazine loading deck. 4-in. spools or magazines. M.E. level ind. F.R. 50-10,000 c/s ± 3 dB. H & N - 45 dB. W & F 0.2%. Mixing, superimposing, outlet from pre-amp. Size 12¼ × 14¾ × 6¾ ins. Weight 21 lbs. Price £40 19s.

■ **Spectone 123.** Complete stereophonic and single track reproducer. 3 motors. 7½ i/s. Provision is made for fitting a transcription motor and FM tuner. 7-in. spools. Response C.C.I.R. spec. 50-12,000 c/s ± 1.5 dB. Size 44 × 25 × 34½ ins. Price £210.

■ **Spectone 129.** Complete reproducer. 3 motors. 7½ i/s. 7-in. spools. Facilities: ½ track record and replay plus twin track replay for stereo. Complete mixing on 3 input channels. Size 32½ × 22¾ × 22½ ins. Price £183 15s.



**Stella Radio & Television Co. Ltd.,** Astra House, 121/3 Shaftesbury Avenue, London, W.C.2. Tel.: Gerrard 7086.

**ST451.** G.P. portable. 3¾ i/s. One motor. 5 in. spools. F.r.: 50-10,000 c/s. M.E. level ind. Mixing. Straight through amp. Output from pre-amp. stage. Size 13¾ × 12½ × 7 ins. Weight 21 lb. Price, with tape and crystal mic., £42. 3 digit counter extra.

**ST450.** G.P. portable. 7½, 3¾ and 1¾ i/s. One motor. 2-in. spools. F.r.: 50-18,000 c/s at 7½; 50-12,000 c/s at 3¾; 50-6,000 c/s at 1¾ i/s. M.E. level ind. Mixing. Output from pre-amp. stage. Monitoring by headphones. Automatic stop at end of tape. Size 16½ × 14 × 8 ins. Weight 30 lb. Price, with tape and moving coil mic., £66 3s.



*Spectone 171*



*Spectone 161*

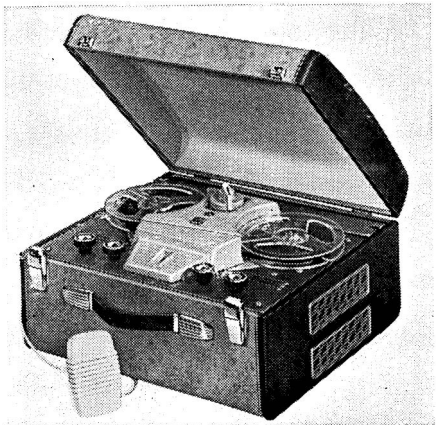

*Stella Model ST451*

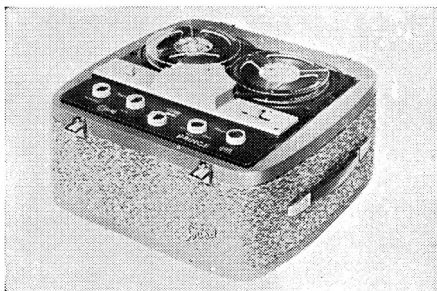

*Sound Prince*



*Sound Studio*

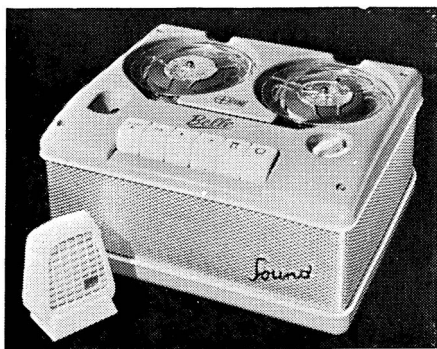

*Sound Belle 333*



*Harting HM8*

**John Street (Manufacturers) Ltd.**, Falcon Works, 71-73 Beacon Road, Lewisham, London, S.E.13. Tel.: Lee Green 3391.

**TR2.** G.P. portable. B.S.R. Monardeck. F.R. 60-10,000 c/s. M.E. level ind. Size 14 × 12 × 7 ins. Weight 19 lbs. Price, with tape, spare reel and mic., £25 4s.



**Symphony Amplifiers Ltd.**, 16 Kings College Road, London, N.W.3. Tel.: Primrose 3314.

**Symphony.** G.P. table recorder. Truvox Mk. VI deck with Truvox type K amplifier. 7½ and 3¾ i/s. F.R. to C.C.I.R. spec. ± 3 dB. S-N, - 45 dB at 4 watts. W and F < 0.2%. M.E. level ind. Output from pre-amp. stage. Available in either portable or table cabinet. Price £54 12s.



**Tape Recorders (Electronics) Ltd.**, 784-788 High Road, Tottenham, London, N.17. Tel.: Tottenham 0811-3. Cables: Taprec, London.

**Sound Belle 333.** G.P. miniature recorder. 2½ i/s avge. One motor. 4½-in. spools. M.E. level ind. Straight-through amp. Output from pre-amp. stage. Size 10 × 8 × 5 ins. Weight 11 lbs. Price, with L.P. tape and crystal mic., £27 6s.

**Sound 555.** G.P. portable. Collaro deck. F.R. 15 i/s, 90-14,000 c/s ± 3 dB; 7½ i/s, 90-11,000 c/s ± 3 dB; 3¾ i/s, 90-5,500 c/s ± 3 dB. W and F, < 0.1%. M.E. level ind. Output from pre-amp stage. Size 19½ × 13 × 9 ins. Weight 35 lbs. Price, with l.p. tape, stethoset for monitoring and dynamic mic., £68 5s.

**Sound Prince.** G.P. portable. B.S.R. Monardeck. F.R. 90-8,000 c/s ± 3 dB. M.E. level ind. H & N - 50 dB. W & F 0.4%. Mixing, superimposing, outlet from pre-amp. Size 15¾ × 14¾ × 7½ ins. Weight 18 lbs. Price £35 14s.

**Sound Studio.** G.P. portable. Collaro Studio deck. F.R. 60-12,000 c/s ± 3 dB at 7½ i/s. H & N - 50 dB. W & F 0.15% at 3¾ i/s. Mixing, superimposing, straight through amplifier. Size 15¾ × 14¾ × 7½ ins. Weight 32 lbs. Price £44 2s.



**Taplin-Hirst & Co.**, 66 Winstanley Road, London, S.W.11. Tel.: Battersea 4907.

**Balmoral TH9.** G.P. portable. Motek K.10 deck. F.R. 40-14,000 c/s ± 3 dB at

7½ i/s. M.E. level ind. H & N - 43 dB. W & F 0.15% at 7½ i/s. Separate record and playback amplifiers. Size 15¼ × 14 × 7½ ins. Weight 27 lbs. Price, with tape and mic., £47 5s.



**Technical Suppliers Ltd.**, Hudson House, 63 Goldhawk Road, London, W.12. Tel.: Shepherds Bush 2581 and 4794. Cables: Teknika, London.

**Vedette.** G.P. portable. Speeds 7½ and 3¾ i/s. One motor. 5¾-in. spools. F.R. 7½ i/s, 40-13,000 c/s; 3¾ i/s, 50-10,000 c/s, both ± 3 dB. M.E. level ind. H & N - 55 dB. W & F 0.12%. Size 11½ × 13 × 6 ins. Weight 22½ lbs. Price £30 19s. 6d.

**Elektron EMG 9/2.** G.P. portable. 3¾ i/s. One motor. 5¾-in. spools, F.R. 30-16,000 c/s ± 3 dB. S-N, < - 50 dB. W and F, < 0.12%. M.E. level ind. Size 13 × 10½ × 6½ ins. Weight 17½ lbs. Price, with tape and mic., £49 17s. 6d.

**Elektron 9M/4K.** G.P. portable. Four track 3¾ i/s. One motor. 5¾-in. spools. F.R. 30-16,000 c/s ± 3 dB. M.E. level ind. H & N - 60 dB. W & F 0.1%. Four track mono record and playback. Outlet from pre-amp. Size 13 × 10½ × 6 ins. Weight 17 lbs. Price £61 19s.

■ **Elektron 9S/4K.** G.P. portable. Stereo version of 9M/4K. Price £65 2s.

**Elektron EMG 94/2.** G.P. portable. Speeds 3¾ and 1⅞ i/s. One motor. 5¾-in. spools. F.R. 3¾ i/s, 30-16,000 c/s; 1⅞ i/s, 40-12,000 c/s, both ± 3 dB. H & N - 50 dB. W & F 0.12%. M.E. level ind. Size 13 × 10½ × 6½ ins. Weight 17½ lbs. Price, with tape, £57 15s.

**Harting HM8.** G.P. portable. Four track. Speeds 7½ and 3¾ i/s. One motor. 7-in. spools. F.R. 7½ i/s, 30-20,000 c/s; 3¾ i/s, 30-16,000 c/s, both ± 2 dB. H & N - 55 dB. W & F 0.06%. M.E. level ind. Stereo/mono record and playback. Two speakers. Outlet from pre-amp. Size 12¾ × 15½ × 8½ ins. Weight 37½ lbs. Price £90 6s.

**Korting MK128.** G.P. portable. Four track 3¾ i/s. One motor. 7-in. spools. F.R. 30-16,000 c/s ± 2 dB. H & M - 55 dB. W & F 0.08%. M.E. level ind. Stereo/mono record and playback. Two speakers. Outlet from pre-amp. Size 12¾ × 17½ × 7½ ins. Weight 32½ lbs. Price £71 8s.

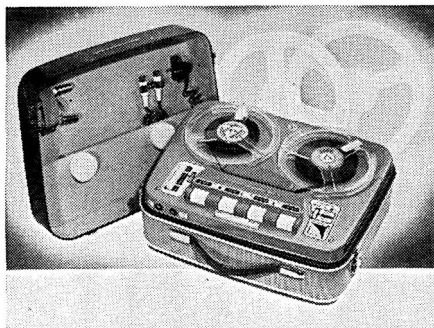

*Korting Mk. 128*

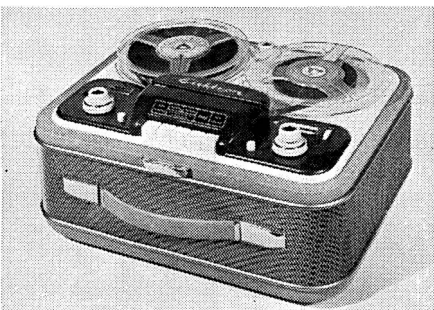

*Elektron 9S/4K stereo*

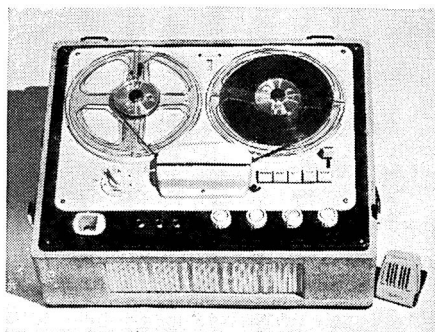

*Taplin-Hurst TH9*

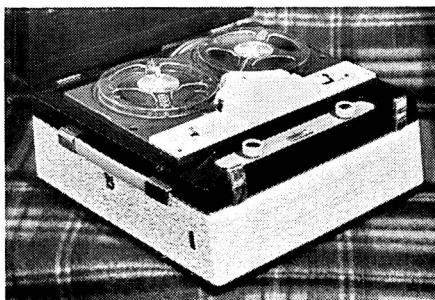

*John Street Falcon TR2*



*Telefunken 75K15*



*Telefunken 85T stereo*



*Telefunken 85KL*

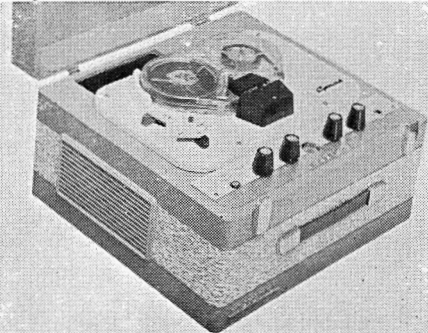

*Trix Comet*

**Telefunken**—Sole U.K. distributors, **Welmecc Corporation Ltd.**, 147 Strand, London, W.C.2. Tel.: Temple Bar 3357. Cables: **Welmecor**, London.

**Magnetophon 75K15.** G.P. portable.  $3\frac{3}{4}$  and  $1\frac{7}{8}$  i/s. One motor.  $5\frac{3}{8}$ -in. spools. F.r.: 60-16,000 c/s  $\pm 3$  dB at  $3\frac{3}{4}$  i/s; 60-9,000 c/s  $\pm 3$  dB at  $1\frac{7}{8}$  i/s. W. and F. 0.4% at  $3\frac{3}{4}$  i/s. S-N, > 40 dB. Fluorescent bar level ind. Automatic stop at end of tape by foils. Connections for synchronised control of automatic slide projector with Telechron I universal unit available as an extra. Connection for remote control. Output from pre-amp. stage. Size  $6\frac{1}{2} \times 12\frac{1}{2} \times 12\frac{1}{2}$  ins. Weight 21 lb. Price, with tape, £54 12s.

**Magnetophon 75T15.** A table model with no carrying case or loudspeaker, but a power stage with output of 2.5 watts 4.5 ohms. Size  $5\frac{1}{2} \times 9\frac{1}{4} \times 12\frac{1}{4}$  ins. Weight  $16\frac{1}{2}$  lb. Price £47 5s.

**Magnetophon 85KL.** G.P. portable.  $7\frac{1}{2}$  and  $3\frac{3}{4}$  i/s. One motor. 7-in. spools. F.r.: 30-20,000 c/s  $\pm 3$  dB at  $7\frac{1}{2}$  i/s; 30-15,000 c/s  $\pm 3$  dB at  $3\frac{3}{4}$  i/s. S-N, > 50 dB. W. and F.  $< \pm 0.2\%$  at  $7\frac{1}{2}$  i/s;  $< \pm 0.4\%$  at  $3\frac{3}{4}$  i/s. M.E. level ind. Outlet from pre-amp. stage. Straight through amp. 6 watts output. Superimposing. Automatic stop at end of tape by foils. Monitoring by earphones. Provision for remote stop/start. Built-in splicing device. Size  $7\frac{3}{4} \times 17\frac{3}{4} \times 16\frac{1}{4}$  ins. Weight 33 lb. Price £82 19s.

**Magnetophon 85T.** Table version. No carrying case, output stage or loudspeakers. Output from pre-amp. 1.2-2 volts. Price £66 3s.

**Magnetophon 76K.** G.P. portable. Four track. Speeds  $3\frac{3}{4}$  and  $1\frac{7}{8}$  i/s.  $5\frac{3}{8}$ -in. spools. F.R.  $3\frac{3}{4}$  i/s, 30-16,000 c/s;  $1\frac{7}{8}$  i/s, 30-9,000 c/s. M.E. level ind. Auto tape stop. Remote control. Outlet from pre-amp. Superimposing by monitoring both tracks. Size  $12\frac{1}{2} \times 12\frac{1}{2} \times 6\frac{1}{4}$  ins. Weight 21 lbs. Price £67 4s.

★

**Trix Electrical Co.**, 1-5 Maple Place, London, W.1. Tel.: Museum 5817.

**Companion.** G.P. portable. B.S.R. Monardeck. F.R. 40-10,000 c/s. M.E. level

ind. Superimposing. Straight through amplifier. Size  $14\frac{1}{4} \times 13\frac{1}{2} \times 9$  ins. Weight 21 lb. Price £30 9s.

**Comet.** G.P. portable. Garrard magazine loading deck. F.R. 40-10,000 c/s. M.E. level ind. Superimposing, mixing. Straight through amplifier. Size  $14\frac{1}{4} \times 13\frac{1}{2} \times 9$  ins. Weight  $32\frac{1}{2}$  lb. Price £36 15s.

**Everest.** G.P. portable. Collaro Studio deck. F.R.  $7\frac{1}{2}$  i/s, 40-12,000 c/s;  $3\frac{3}{4}$  i/s, 60-10,000 c/s;  $1\frac{7}{8}$  i/s, 100-6,000 c/s. M.E. level ind. Superimposing, mixing. Straight through amplifier. Size  $16\frac{1}{4} \times 15\frac{1}{2} \times 9$  ins. Weight  $32\frac{1}{2}$  lb. Price £51 9s.



**Truvox Ltd.**, Neasden Lane, London, N.W.10. Tel.: Gladstone 6455. Cables: Truvoxeng.

**R.6.** G.P. portable. Truvox Mk. 6. deck. F.R. 30-15,000 c/s  $\pm 3$  dB at  $7\frac{1}{2}$  i/s. Pause control. Price £57 15s.

**R.7.** G.P. portable. Speeds  $7\frac{1}{2}$  and  $3\frac{3}{4}$  i/s. Three motors. 7-in. spools. W & F 0.2%. Tracks in both directions. Outlet from replay head. Size  $15 \times 13 \times 11$  ins. Weight 37 lbs. Price approx. £78 15s.

**Melody.** G.P. portable.  $3\frac{3}{4}$  i/s. 4-in. spools. M.E. level ind. Straight through amplifier. Size  $11 \times 9 \times 5$  ins. Weight 11 lbs. Price with tape and mic., £36.

**Harmony.** G.P. portable.  $3\frac{3}{4}$  i/s. 5-in. spools. M.E. level ind. Straight through amplifier. Size  $12 \times 9 \times 5\frac{3}{4}$  ins. Weight  $13\frac{1}{4}$  lbs. Price, with tape and mic., £44.



**Tutor-Tape Co.**, 70 Brewer Street, London, W.1. Tel.: Gerrard 3376. Cables: Tutape, London.

**Tutor de Luxe.** G.P. portable. Collaro Mk. IV deck. M.E. level ind. Mixing, superimposing. Straight through amplifier. Size  $15\frac{1}{4} \times 17\frac{1}{2} \times 7\frac{1}{2}$  ins. Weight 36 lbs. Price with tape and crystal mic., £61 19s.

Also available Tutor type C. Price £54 12s.



**Uher** - Sole U.K. distributors, **Tedex (London) Ltd.**, 2/4 Great Eastern Street, London, E.C.2. Tel.: Bishopsgate 8719.

**Uher 500.** G.P. portable. Speed  $3\frac{3}{4}$  i/s. One motor. 5-in. spools. F.R. 50-15,000 c/s. M.E. level ind. H. & N. -45 dB. W. and F. 0.2%. Outlet from pre-amp. Size  $12\frac{1}{4} \times$



*Truvox R.7*



*Truvox R.6*

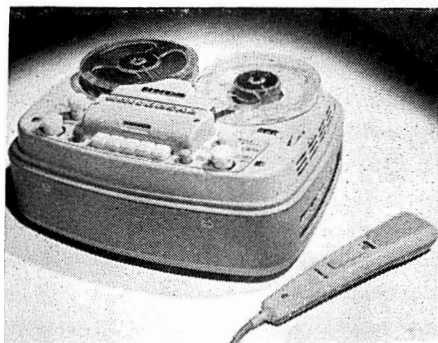

*Uher Universal*



*The Tutor Tape "Tutor"*





*Veritone Venus de luxe*



*Volmar Vectis*



*Walter "505"*

$10\frac{1}{2} \times 6$  ins. Weight 14 lb. Price £51 9s. Two-speed version also available (Uher 502) price £61 19s.

**Uher 720.** G.P. portable. Speeds  $7\frac{1}{2}$  and  $3\frac{3}{4}$  i/s. One motor. 7-in. spools. F.R.  $7\frac{1}{2}$  i/s, 40-20,000 c/s;  $3\frac{3}{4}$  i/s, 40-16,000 c/s. M.E. level ind. H. & N. 45 dB. W. and F. 0.1% at  $7\frac{1}{2}$  i/s. Outlet from pre-amp. Size  $15\frac{3}{8} \times 14\frac{1}{4} \times 8\frac{1}{4}$  ins. Weight  $26\frac{1}{2}$  lb. Price £78 15s.

Three-speed version also available (**Uher 730**) price £99 15s. Version with stereo playback (**Uher 750**) price £99 15s.

**Uher Universal.** G.P. portable. Speeds  $3\frac{3}{4}$ ,  $1\frac{7}{8}$  and  $1\frac{1}{8}$  i/s. One motor. 5-in. spools. F.R.  $3\frac{3}{4}$  i/s, 40-16,000 c/s;  $1\frac{7}{8}$  i/s, 40-8,000 c/s;  $1\frac{1}{8}$  i/s, 40-4,000 c/s. M.E. level ind. H. & N. —45 dB. W. and F. 0.3%. Outlet from pre-amp, remote control, synchronising. Size  $12\frac{1}{4} \times 9\frac{3}{8} \times 5\frac{3}{8}$  ins. Weight 17 lb. Price £82 19s.

★ **Uher Stereo 3.** G.P. portable. Four track stereo recording and playback. Speeds  $7\frac{1}{2}$ ,  $3\frac{3}{4}$ ,  $1\frac{7}{8}$  i/s. One motor. 7-in. spools. F.R.  $7\frac{1}{2}$  i/s, 40-20,000 c/s;  $3\frac{3}{4}$  i/s, 40-16,000 c/s;  $1\frac{7}{8}$  i/s, 40-9,000 c/s. M.E. level ind. H. & N. —45 dB. W. and F. 0.1% at  $7\frac{1}{2}$  i/s. Outlet from pre-amp. Stereo/mono recording. Size  $16\frac{1}{4} \times 15\frac{1}{4} \times 4\frac{1}{4}$  ins. Weight 31 lb. Price £108 3s.

★

**Veritone Ltd.**, Avenue Parade, London, N.21. Tel.: Laburnum 6641/2.

**Venus de luxe.** G.P. portable. Collaro Studio deck. Four speeds—15,  $7\frac{1}{2}$ ,  $3\frac{3}{4}$  and  $1\frac{7}{8}$  i/s. F.R. within  $\pm 3$  dB C.C.I.R. M.E. level ind. Comparator monitoring, mixing, superimposing, echo effect. Straight through amplifier, bass and treble tone controls. Size  $17\frac{1}{4} \times 15\frac{1}{2} \times 7\frac{1}{2}$  ins. Weight 33 lb. Price £69 6s.

**Venus Console.** G.P. recorder. Collaro deck. Spec. as for portable provision for in-built FM tuner. Size  $24\frac{3}{4} \times 17 \times 29$  ins. (inc. legs  $17\frac{1}{2}$  ins.). Weight 50 lbs. Price £75 12s.

★

**Volmar Limited**, 141 High Street, Brentford, Middx. Tel.: Isleworth 1161. Cables: Volmar, Brentford, Hounslow.

**Vega.** G.P. portable. Garrard magazine loading deck. F.R. 60-7,000 c/s  $\pm 3$  dB. M.E. level ind. Size  $13\frac{1}{2} \times 11 \times 7\frac{3}{8}$  ins. Weight 21 lb. Price with taps and mic. £35 14s.

**Vectis.** G.P. portable. Collaro Studio deck. F.R. 100-10,000 c/s  $\pm 7\frac{1}{2}$  i/s. M.E. level ind. Size  $15\frac{1}{2} \times 13 \times 8\frac{1}{2}$  ins. Weight 26 lb. Price with tape and mic. £37 16s.

★

**Walter Instruments Ltd.**, Garth Road, Morden, Surrey. Tel.: Derwent 4421. Cables: Walinst, Morden.

"101" Miniature portable recorder.  $3\frac{3}{4}$  i/s. One motor. 5-in. spools. F.R. 60-7,000 c/s. S-N, —35 dB. W. and F.

0.35%. M.E. level ind. Size  $11\frac{3}{4} \times 11 \times 6\frac{1}{2}$  ins. Weight 17 lb. Price, with tape and crystal mic., £30 9s.

**"303" De Luxe.** G.P. portable recorder.  $7\frac{1}{2}$  and  $3\frac{3}{4}$  i/s. One motor. 7-in. spools. F.R.  $7\frac{1}{2}$  i/s, 40-12,000 c/s;  $3\frac{3}{4}$  i/s, 35-7,000 c/s. S-N, — 40 dB. W. and F., 0.35% at  $3\frac{3}{4}$  i/s. M.E. level ind. Outlet from pre-amp. stage, telephone attachment, provision for cine strob., provision for cine strob., Size  $14 \times 11 \times 8\frac{1}{2}$  ins. Weight  $19\frac{1}{2}$  lb. Price, with tape and crystal mic., £44 2s.

**"505"** G.P. portable recorder.  $7\frac{1}{2}$  and  $3\frac{3}{4}$  i/s. One motor. 7-in. spools. F.R.  $7\frac{1}{2}$  i/s, 40-14,000 c/s;  $3\frac{3}{4}$  i/s, 40-7,000 c/s. S-N, — 40 dB. W. and F., 0.2% at  $7\frac{1}{2}$ ; 0.35% at  $3\frac{3}{4}$  i/s. M.E. level ind. Superimposing. Provision for cine strob., straight-through amp. Telephone attachment. Outlet from pre-amp. stage. Size  $16\frac{1}{2} \times 12\frac{1}{2} \times 8$  ins. Weight 23 lb. Price, with tape and crystal mic., £59 17s.

**"1000"** G.P. Console recorder. Walter Mk. II deck.  $7\frac{1}{2}$  and  $3\frac{3}{4}$  i/s. One motor. 7-in. spools. F.R. 40-14,000 c/s at  $7\frac{1}{2}$  i/s. S-N, <— 50 dB. W. and F., 0.2% at  $7\frac{1}{2}$  i/s. 10 watts output. M.E. level ind. Straight through amplifier. Provision for fitting of FM tuner. 5 replay speakers. Size  $33 \times 41 \times 17$  ins. Walnut veneer finish. Price, with tape and mic., £136 10s.

★

**Winston Electronics Ltd.**, Govett Avenue, Shepperton, Middx. Tel.: Walton 6321. Cables: Winston, Shepperton.

**Thoroughbred.** G.P. portable recorder. Collaro Mk. IV deck. F.R. 15 i/s 50-16,000 c/s;  $7\frac{1}{2}$  i/s, 50-12,000 c/s;  $3\frac{3}{4}$  i/s, 50-7,000 c/s. W. and F., 0.1%. M.E. level ind. Mixing. 3 loudspeakers. Output from pre-amp. stage. Size  $17 \times 15\frac{1}{2} \times 9\frac{1}{2}$  ins. Weight 48 lb. Price, with tape and mic., £61 19s.

★

**Wyndor Recording Co. Ltd.**, (inc. Magnetic Recording Co.) 2 Bellevue Road, Friern Barnet, London, N.11. Tel.: Enterprise 2226/7. Cables: Wyndreco.

**Victor.** G.P. portable. Collaro Studio deck. F.R.  $7\frac{1}{2}$  i/s, 50-15,000 c/s;  $3\frac{3}{4}$  i/s, 50-9,000 c/s;  $1\frac{3}{8}$  i/s, 50-5,000 c/s. M.E. level ind. H. & N. — 40 dB. W. and F. less than 0.1%. Mixing. Speaker in detachable lid. Size  $14\frac{1}{2} \times 12\frac{3}{8} \times 9$  ins. Weight 29 lb. Price with tape and mic., £47 5s.

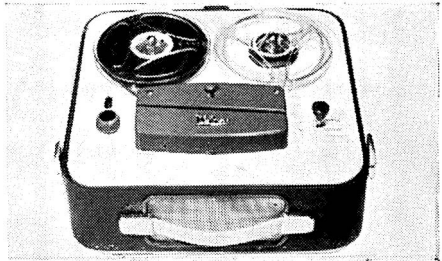

Walter "101"

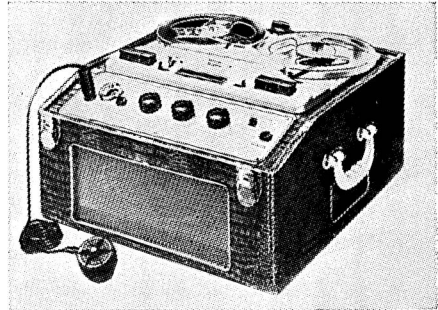

Winstone "Thoroughbred"



Wyndor Victor

**Viscount Console.** G.P. free-standing. Harting deck. F.R. 50-12,000 c/s  $\pm 3$  dB at 15 i/s. M.E. level ind. H. & N. — 40 dB. W. & F. less than 0.15%. Monitoring. Size  $21 \times 16\frac{1}{4} \times 16\frac{1}{2}$  ins. Height including stand 30 ins. Weight 42 lb. Price £60 18s., or £63 according to finish.

## BATTERY OPERATED PORTABLES

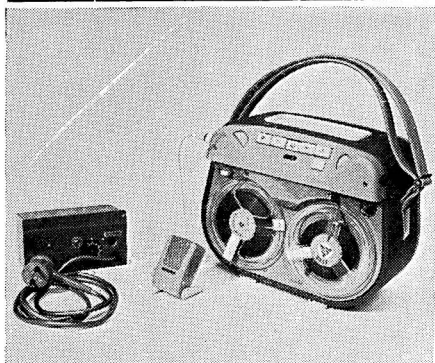

*Butoba MT 4*

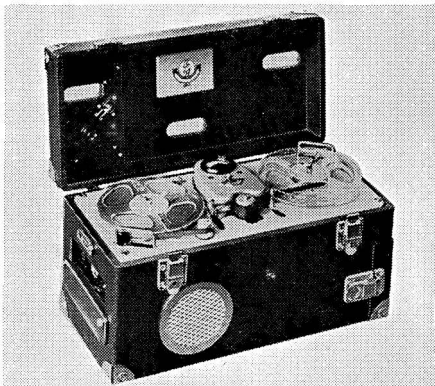

*E.M.I. L2/TA*



*Steelman Transitaape*

**Butoba** – Sole U.K. distributors, **Denham & Morley Ltd.**, Denmore House, 175 Cleveland Street, London, W.1. Tel.: Euston 3656. Cables: Denmorl, Wesdo, London.

**Butoba MT4.** Transistorised battery portable. Speeds  $3\frac{3}{4}$  and  $1\frac{7}{8}$  i/s. M.E. level ind. Two motors. F.R.  $3\frac{3}{4}$  i/s, 50-13,000 c/s;  $1\frac{7}{8}$  i/s, 60-5,000 c/s. H. & N. — 40 dB. Battery life 20-40 hours. Eight 1.5v batteries. Size  $12 \times 9\frac{1}{2} \times 6$  ins. Weight including batteries, 12 lb. Price £72 9s.



**Thomas A. Edison Ltd.**, Victoria House, Southampton Row, London, W.C.1. Telephone: Holborn 9988. Cables: Edison-gram. Westcent, London.

**Mohawk Midgetape 400.** Transistorised battery portable. Speed  $1\frac{7}{8}$  i/s. F.R. 150-5,000 c/s. H. & N. — 42 dB. W. and F. less than 0.7%. Special tape cartridge and T50 Mercury battery. Battery life 50 hours. Size  $8\frac{1}{2} \times 3\frac{7}{8} \times 1\frac{7}{8}$  ins. Weight 3 lb. Price with transistorised speaker, microphone and battery, £129 10s.



**EMI Sales & Service Ltd.**, Hayes, Middx. Tel.: Southall 2468. Cables: Emiservice, London.

**E.M.I. L2/TA.** Transistorised professional battery portable. Speed  $7\frac{1}{2}$  i/s. One motor. F.R. 50-10,000 c/s  $\pm 3$  dB. H. & N. — 44 dB. W. and F. 0.25%. Level meter. Eight 1.5v cells or rechargeable units of equivalent size. Full track recording and playback. Size  $14\frac{1}{2} \times 6\frac{3}{4} \times 8$  ins. Weight  $17\frac{1}{2}$  lb. Price £124.



**Fi-Cord Ltd.**, 40a Dover Street, London, W.1. Tel.: Hyde Park 3448. Cables: Fi-Cord London.

**Mark 1A.** Transistorised battery portable.  $7\frac{1}{2}$  and  $1\frac{7}{8}$  i/s. One motor.  $3\frac{1}{4}$ -in. spools. F.R. 50-12,000 c/s  $\pm 3$  dB at  $7\frac{1}{2}$  i/s. W. and F. 0.4%. S-N, — 35 dB. M.E. bar type level ind. Outlet from pre-amp, stage. Rechargeable batteries, price includes a charger. Mic. incorporates stop/start switch. Battery life,  $1\frac{1}{2}$ -2 hrs. at  $7\frac{1}{2}$  i/s; 3-3 $\frac{1}{2}$  hrs. at  $1\frac{7}{8}$  i/s. Size  $9\frac{5}{8} \times 5 \times 2\frac{3}{4}$  ins. Weight  $4\frac{1}{2}$  lb. Price, with tape, batteries and mic., £61 19s.



**GBC Electronic Industries Ltd.**, 121/123 Edgware Road, Marble Arch, London, W.2. Tel.: Ambassador 2872.

**Clarion-Transitaape.** Transistorised battery portable. Speed  $3\frac{3}{4}$  i/s. Four 1.5v batteries.

internal speaker. Size  $9\frac{1}{2} \times 5 \times 3\frac{5}{8}$  ins. Weight 5 lb. Price with tape and microphone, £26 5s. Mains converter available, £4 4s.



**Grundig (Great Britain) Ltd.**, 39/41 New Oxford Street, London, W.C.1. Tel.: Covent Garden 2995.

**Cub.** Transistorised battery portable. Mean speed  $3\frac{3}{4}$  i/s. One motor. 3-in. spools. F.R. 150-5,000 c/s  $\pm$  dB approx. H. & N. — 40 dB. W. & F. 0.2%. Four 1.5v cells and one 3v cell. Battery life 10-15 hours. Size  $11 \times 6\frac{3}{4} \times 3\frac{1}{2}$  ins. Weight  $5\frac{1}{2}$  lb. including batteries. Price £27 6s. Mains converter available, £7 7s.



**Livingston Laboratories Ltd.**, Retcar Street, London, N.19. Tel.: Archway 6251.

**Nagra IIIB.** Prof. battery portable recorder. 15,  $7\frac{1}{2}$  and  $3\frac{3}{4}$  i/s. One motor. 5-in. spools, or 7-in. with lid open. F.R. 30-15,000 c/s  $\pm$  1 dB at 15 i/s; 30-12,000 c/s  $\pm$  1.5 dB at  $7\frac{1}{2}$  i/s; 50-7,000 c/s  $\pm$  3 dB at  $3\frac{3}{4}$  i/s. S-N — 51 dB at  $7\frac{1}{2}$  i/s. 52dB at  $7\frac{1}{2}$  i/s. W. and F. 0.2% at  $7\frac{1}{2}$  i/s. Meter level ind. Batteries, twelve 1.5v torch batteries, life approx. 20 hours. On alkaline accumulators, approx. 70 hours' life. Mixing on the 3 inputs. 3 heads. Monitor speaker, outlet from pre-amp. stage. Size  $8\frac{3}{4} \times 12\frac{1}{2} \times 4\frac{1}{4}$  ins. Weight approx.  $15\frac{1}{2}$  lb. Price £270.



**Steelman — Sole U.K. Distributors, Telec Tronic Ltd.**, 46/47 Frith Street, London, W.1. Tel.:

**Steelman.** Transistorised battery portable. Speeds  $3\frac{3}{4}$  and  $1\frac{7}{8}$  i/s. 3-in. spools. F.R. 150-7,500 c/s. Neon level ind. Thirteen 1.5v batteries. Battery life 50 hours (motor), 300 hours (amplifier). Size  $9\frac{3}{4} \times 6\frac{1}{2} \times 2\frac{7}{8}$  ins. Weight  $6\frac{1}{2}$  lb. without batteries. Price £57 15s.



**Stuzzi — Sole U.K. distributors, Recording Devices**, 95 Villiers Road, London, N.W.2. Tel.: Willesden 6678.

**Stuzzi Magnette.** Battery portable.  $3\frac{3}{4}$  and  $1\frac{7}{8}$  i/s. 2 motors. 4-in. spools. F.R. 40-9,000 c/s at  $3\frac{3}{4}$  i/s; 80-4,500 c/s at  $1\frac{7}{8}$  i/s. W. and F. 0.25% at  $3\frac{3}{4}$  i/s; 0.35% at  $1\frac{7}{8}$  i/s. S-N, — 45 dB. M.E. bar type, level ind. Outlet from pre-amp. stage. Powered by four standard torch batteries; life, 30-100 hours depending on type of use. Battery indicators. Size  $11 \times 4\frac{1}{2} \times 8$  ins. Weight 8 lb. Price, with tape and mic., £72 10s.

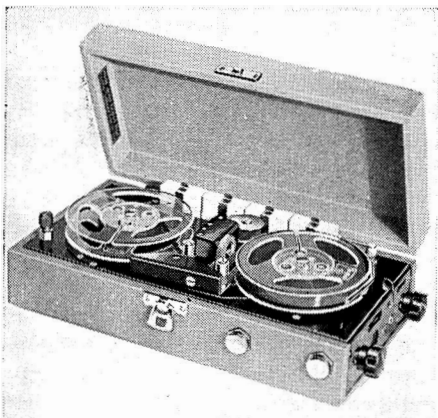

*Fi-Cord Mk. 1A*

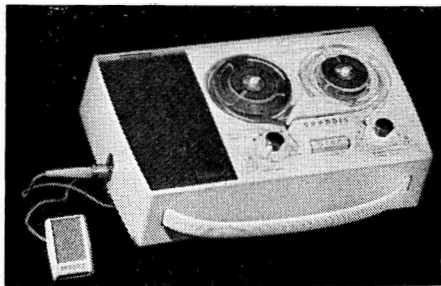

*Grundig Cub*

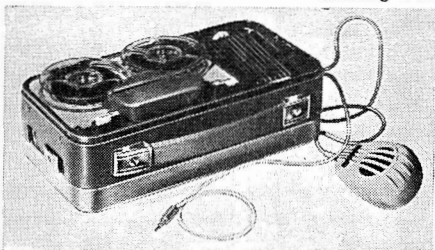

*G.B.C. Clarion*

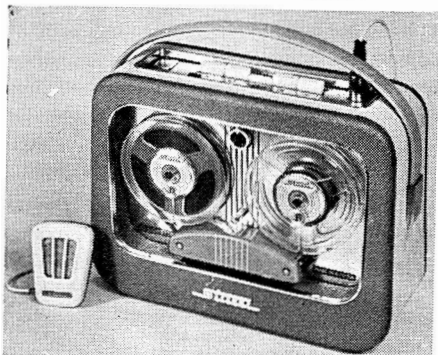

*Stuzzi Magnette 671B*

## TAPE AMPLIFIERS AND MIXER UNITS

**A.E.I. Sound Equipment Ltd.**, Crown House, Aldwych, London, W.C.2. Tel.: Temple Bar 8040. Cables: Soundequi, Lesquare, London.

**In preparation:** 4 channel electronic mixer unit primarily for low impedance microphones. Cathode follower output.



**Ampex.** U.K. distributors, Rank Cintel Ltd., Worsley Bridge Road, London, S.E.26. Tel.: Hither Green 4600. Cables: Telesvisor, London.

**Ampex 620 Speaker/amplifier.** Comprises 8-in. drive unit in special enclosure. Acoustically flat from 60 to 10,000 c/s. The built-in amplifier has 10 watts output. F.R. 20-20,000 c/s  $\pm$  0.5 dB. Price £88.



**Associated Electronic Engineers Ltd.**, 10 Dalston Gardens, Stanmore, Middx. Tel.: Wordsworth 4474/5/6. Cables: Astronic, Stanmore.

**Astronic A.1446.** 6 channel electronic mixer unit. Designed for 5 low impedance sources each 10/30 ohms, 0.5 mV; 1 high impedance source 250K ohms, 0.2 volts. There are four output sockets supplying 0.7 volts into 600 ohms. A master Gain fader is incorporated, and each channel has an indicator lamp to show which sources have been faded up. A.C. mains required. Size 9  $\times$  11  $\times$  8½ ins. Price £58 10s.



**Beam-Echo Ltd.**, 13 South Molton Street, London, W.1. Tel.: Mayfair 1039. Cables: Hibeam, London.

■**STEP21.** Stereo tape pre-amplifier. Provides equalisation and gain to enable

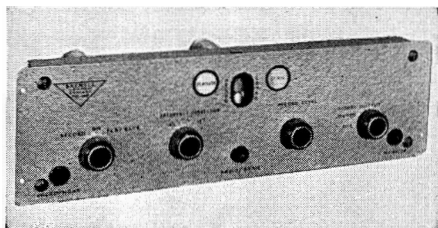

*Brenell TP2*

Avantic amplifiers type SPA11 and SP21 to operate direct from a medium or high impedance tape head. Size 7¾  $\times$  4¾  $\times$  2½ ins. Price £6 16s. 6d.



**Brenell Engineering Co. Ltd.**, 1A Doughty Street, London, W.C.1. Tel.: Chancery 5809/Holborn 7358.

**Mk.5 Record/playback amplifier.** Inputs: mic. 2.5 mV, radio/gram 250 mV, both high impedance. Outputs: 200 mV at 50,000 ohms, and 4 watts into 15 ohms for direct connection to loudspeaker. Headphone monitoring. M.E. level ind. or meter if required. Price £24. Meter, £5 5s. extra.

**Brenell Mixer Unit.** 3 channel unit. For best results high impedance sources such as crystal microphones and pickups are recommended. There are 4 sockets for jack plugs for the three inputs and the output lead, each input having a volume control. Price £2 18s.



**Cape Electrophonics Ltd.**, 43-45 Shirley High Street, Southampton. Tel.: Southampton 74251.

**Cape VLT/2.** Tape recording/replay amplifier suitable for operation with a variety of tape decks. Self-powered. To operate with VLP/MS and VL2 or other suitable amplifiers. Price to be announced.

See also Amplifiers Section for tape head amplifiers.



**Dektron**, 2 Westbourne Road, Weymouth, Dorset. Tel.: Weymouth 1987.

**Dektron Mixer/fader.** Pocket 3-channel mixer. Coaxial input and output sockets as

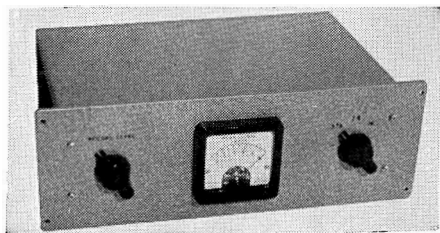

*Cape VLT*

standard, jack sockets if required. Price £1 19s. 6d.

**Dektron Monitor.** Transistorised unit to provide monitoring or act as pre-amplifier. Powered by 2 torch cells. Price £5 5s.



**Denco Distributors Ltd.,** 115 Fleet Street, London, E.C.4. Tel.: Fleet Street 5812.

**HF/G2P.** Tape pre-amplifier. Inputs: mic. 2.5 mV, radio/pickup 300 mV. F.R. 50-10,000 c/s  $\pm$  3.5 dB, equalised for  $3\frac{3}{4}$  i/s. Output 250 mV. Size  $12 \times 9\frac{1}{2} \times 5\frac{1}{2}$  ins. Weight 5 lb. To operate with Garrard magazine loading deck. Price £14.

**HF/G2A.** Tape amplifier. Details as HF/G2P plus 2.5 watts audio output into 3,  $7\frac{1}{2}$  or 15 ohms. Price £15.

**HF/TR3.** Tape amplifier. Inputs: mic. 2.5 mV, radio/pickup 300 mV. F.R. 35-16,000 c/s  $\pm$  3 dB at 15 i/s. Equalisation available for 15,  $7\frac{1}{2}$  and  $3\frac{3}{4}$  i/s or  $7\frac{1}{2}$ ,  $3\frac{3}{4}$  and  $1\frac{1}{8}$  i/s. 3 watts output into 3,  $7\frac{1}{2}$  or 15 ohms. To Mullard design, suitable for Brenell, Collaro, Motek, Truvox and Wearite decks. Price, with separate power unit, £16 10s. Also available in kit form.

**Type C Tape Pre-amplifier.** Inputs: mic. 0.5 mV, radio/pickup 250 mV. F.R. 30-17,000 c/s  $\pm$  3 dB at 15 i/s. Equalisation available for 15,  $7\frac{1}{2}$  and  $3\frac{3}{4}$  i/s or  $7\frac{1}{2}$ ,  $3\frac{3}{4}$  and  $1\frac{1}{8}$  i/s. 250 mV audio output. To Mullard design, suitable for Brenell, Collaro, Motek, Truvox and Wearite decks. Price, with separate power unit, £16 10s. Also available in kit form.



**Grundig (Gt. Britain) Ltd.,** Newlands Park, Sydenham, S.E.26. Tel.: Sydenham 2211. Showroom: 39-41 New Oxford Street, London, W.C.1. Tel.: Covent Garden 2995. Cables: Grundig London. Telex 22054.

**G.M.U.3.** Four channel mixer and pre-amp. Inputs: Mic. 1, 1.2 mV, 100 K ohms; Mic. 2, 4 mV, 100 K ohms. Polarised 100v D.C. Mic. 3 as Mic. 2. Channel (radio/

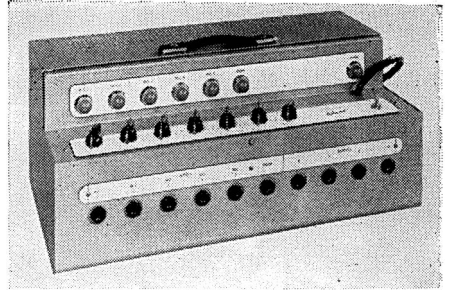

*Astronic A.1446*

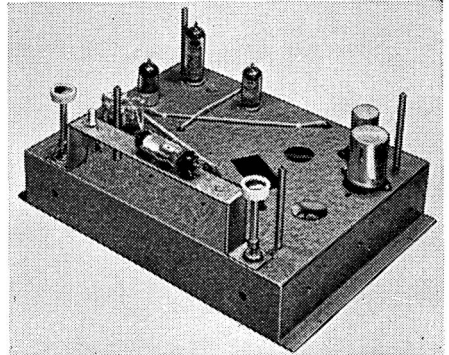

*Denco HF/G2D*

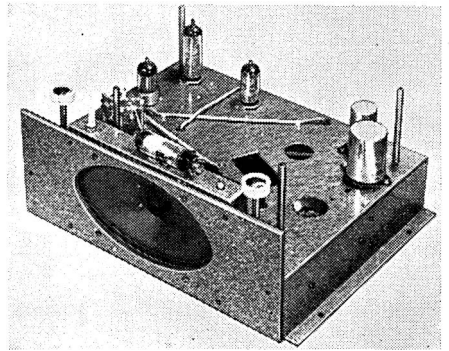

*Denco HF/G2A*

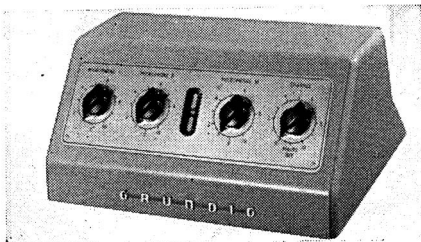

*Grundig G.M.U.3*

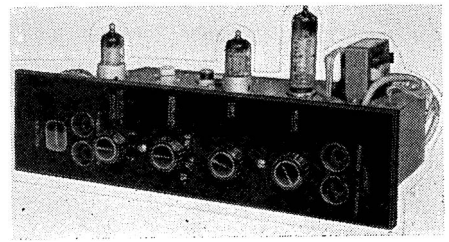

*Denco HF/TR3*



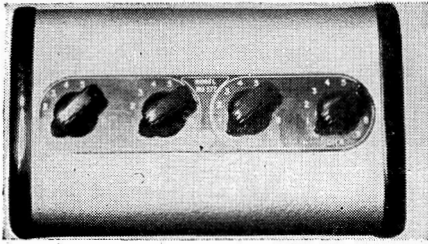

*Lustraphone MU577*

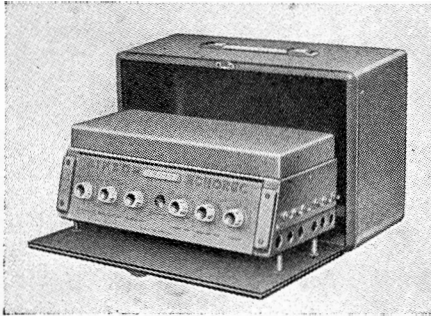

*Binson Echorec*

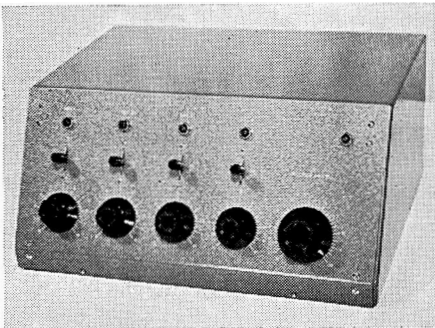

*MSS 4M2 4-Channel Mixer*

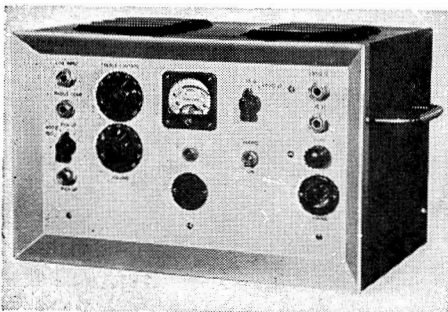

*MSS RA 50 recording amplifier*

P.U.). 300 mV, 500 K ohms. Out. imp. approx. 1,000 ohms. Magic eye level ind. Output level 65 mV. Mains-powered. Price £16 16s.



**Jason Motor & Electronic Co.,** 3/4 Gt. Chapel Street, London, W.1. Tel.: Gerrard 0273/4.

**J.S.M./1.** Record and replay tape unit. Recording input 100 mV. Push-pull oscillator. Variable bias control. Magic-eye indicator. Replay amplifier produces 0.5 volts from 7 mV programme peak. Size  $15 \times 8\frac{1}{4} \times 4\frac{3}{8}$  ins. Price £37 10s.



**The Lowther Manufacturing Co.,** St. Mark's Road, Bromley, Kent. Tel.: Ravensbourne 5225. Cables: Lowther, Bromley.

**Tape Unit, Type R.P.B., No. 1.** Tape Record unit for bias voltage and record level metered control with playback pre-amp, for direct head connection. Switch to allow meter setting of bias voltage to suit head or tape. P.s.n. 250v at 30 mA; 6.3v at 3 amps. Price £25.

**Companion Supply Unit No. 2.** H.T. and L.T. power supply suitable to power radio tuners. Preamp and tape bias amplifier. Output 250v at 40 mA, 6.3v at 3 A. Price £5 10s.



**Lustraphone Ltd.,** St. George's Works, Regents Park Road, London, N.W.1. Tel.: Primrose 8844. Cables: Lustraphon London.

**M.U.577.** Transistor mixer unit. Inputs: 1 and 2 are unbalanced and are suitable for low imp. mics. (line or high imps. to order). 2 and 3 are high imp. and suitable for radio or P/U. Output is balanced to match that from 1 and 2. F.r. substantially flat 50-14,000 c/s. Power by mercury cell with 1,000 hours life. Alternative input and output impedances to specification. Price, standard model, £22.

A range of transistorised power amplifiers, 10 watts and 15 watts, and complete public address systems. Details on application.



**Modern Electrics (Retail Ltd.),** 164 Charing Cross Road, London, W.C.2. Tel.: Covent Garden 1703. Cables: Modcharex, London.

**Binson Echorec.** Pre-amplifier and magnetic recording unit enabling echoes and other effects to be achieved. Three channels are included and the timing of echoes is variable. Operation from AC mains. Price £147 complete.

**M.S.S. Recording Co., Ltd.**, Colnbrook, Bucks. Tel.: Colnbrook 2431. Cables: Emesco.

**4 M 2 or 2 ML.** Microphone mixing and control unit. Up to 4 mics. or line, P/U and 2 mics. Microphone switching and level control. Output sockets for 600 ohm line and headphone monitor. 4 input sockets. H.D. at 1 mW 1,000 c/s. tone, is 0.25%. H and N at normal output level on 1 mW signal to noise ratio 60 dB. Size  $14\frac{1}{2} \times 12 \times 7$  ins. Price £50.

**RA/50.** Amplifier for recording and playback. 50 watts. Dist. 2.5% at 50 watts. Input for spec. output 1v. Response 30-15,000 c/s.  $\pm 2$  dB. Feedback 12 dB. N.L. — 80 dB at full output. Out. imp. RA50/1 1,800 ohms; RA50/2 200 ohms; RA50/3 15 ohms. Output EL37's. Size  $19 \times 14 \times 8$  ins. Power available for pre-amp. Price £70.



**Penco Products**, 36 Coniston Road, Kings Langley, Herts. Tel.: Kings Langley 3134. Cables: Penco, Kings Langley.

**Epigram Mix/3.** 3 channel unit. Incorporates 3 transistors and is designed for 2 low impedance 15/30 ohms and one high impedance input. Power derived from 4 volt Mercury Cell. Output is high impedance. Price £19 19s.

**Epigram Mix/35.** Details as above except that 5 transistors are included giving extra gain, e.g. to by-pass input stage of recorder. Price £26 5s. Specials to order.



**Philips Electrical Ltd.**, Century House, Shaftesbury Avenue, London, W.C.2. Tel.: Gerrard 7777. Cables: Phillamps, London.

**Philips ET.1039.** A channel unit. Each input is designed for a microphone of 50/600 ohms impedance and includes a transformer. The output voltage is approximately 90 mV and is cathode follower. A master gain control is included and mains supply is required. Size  $12 \times 6\frac{1}{2} \times 3$  ins. Price £36.

**Philips EL.3989.** 4 channel unit. Incorporating 4 separate potentiometers. Price £4 4s.



**Rank Cintel Ltd.**, Worsley Bridge Road, London, S.E.26. Tel.: Hither Green 4600. Cables: Televisor, London.

**Cintel Microphone Amplifier.** Transistorised unit. Input imp. 200 ohms with attenuator from 0 to 70 dB in 10 dB steps.



*Jason J.S.M.1 Tape Unit*

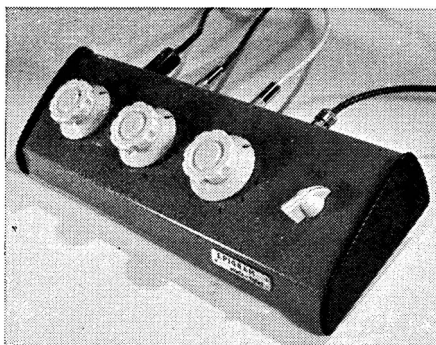

*Penco Products Mix/39*

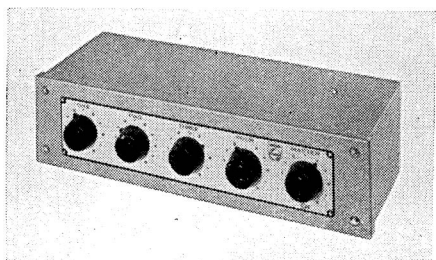

*Philips ET1039 Mixer*

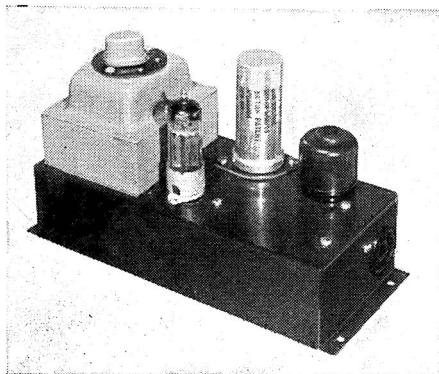

*Rogers Power Pack*

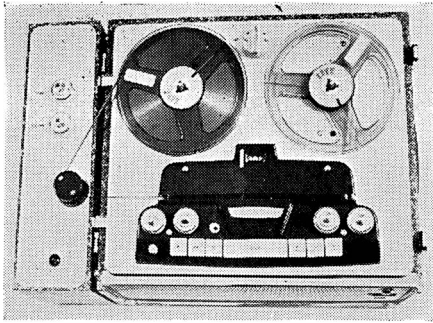

*Simon SP/4 Stereo adaptor*

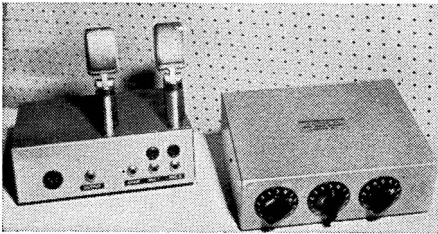

*Sound News Production Unimixer*

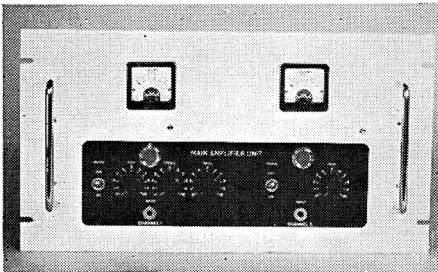

*Shirley double channel tape amplifier*

F.R. 30-15,000 c/s  $\pm$  1 dB. Distortion less than 0.2%. Normal output 0 dBm, maximum output  $\times$  16 dBm. Output imp. 600 ohms. Price not yet available.

**Cintel Line Amplifier.** Transistorised unit. Input and output imp. 600 ohms. F.R. 30-15,000 c/s  $\pm$  1 dB. Distortion less than 0.2%. Normal output + 14 dBm, maximum output + 26 dBm. Price not yet available.

**Cintel Transistor 5 Pre-amplifier.** 4-position inputs selector formic., pickup, tape, radio, all rated 20 mV. Stepped bass and treble controls. 7 kc/s low pass filter. H.D. less than 0.1%. Size 9  $\times$  2½  $\times$  3 ins. To operate with Cintel Transistor 5W Amplifier. Price not yet available.

**Cintel Transistor 5W Amplifier.** Output 5.5 watts max, Distortion less than 0.1%.

Input for spec. output 250 mV. F.R. 30-50,000 c/s  $\pm$  1 dB. 26 dB feedback. H and N — 80 dB. Size 7  $\times$  4  $\times$  4 ins. To operate with Cintel Transistor 5 Pre-amplifier. Price not yet available.

**Cintel Transistor 15 Pre-amplifier.** 4-position input selector for mic., pickup, tape, radio, all rated 60 mV. Stepped bass and treble controls. 7 kc/s low pass filter. H.D. less than 0.1%. Size 9  $\times$  2½  $\times$  3 ins. To operate with Cintel Transistor 15W Amplifier. Price not yet available.

**Cintel Transistor 15 W Amplifier.** Output 15 watts max. Distortion less than 0.3%. Input for spec. output 700 mV. F.R. 30-70,000 c/s  $\pm$  1 dB. 26 dB feedback. H and N — 80 dB. Size 8  $\times$  5  $\times$  5 ins. To operate with Cintel Transistor 15 Pre-amplifier. Price not yet available.



**Rogers Developments (Electronics) Ltd.,** "Rodevco Works," 4-14 Barmeston Road, Catford, S.E.6. Tel.: Hither Green 7424. Cables: Rodevco, London.

**General Purpose Power Pack, Model A.** Suitable for tape units and radio tuners. Output 250v at 45 mA, 6.3v at 2.5A. Size 7½  $\times$  3  $\times$  5 ins. Price £4 5s.

**Model C** for switched FM unit. Price £4.



**Henri Selmer & Co. Ltd.,** 114 Charing Cross Road, London, W.C.2. Tel.: Temple Bar 5432. Cables: Selmatone, Westcent, London.

**Saba Regiemixer 100.** 4-channel unit, comprising sliding controls and volume pre-set adjustment in each channel. Input sensitivity 0.05 mV on first three channels at 1,000 ohms, 350 mV at 500 K on fourth channel. F.R. 20-20,000 c/s. H and N — 65 dB. Inter-channel crosstalk — 65 dB. Output 60 mV max. into 15,000 ohms. 3 transistors type TF65. Size 8½  $\times$  6½  $\times$  3½ ins. Weight 2¼ lb. approx. Price £18 18s.



**Shirley Laboratories Ltd.,** 3 Prospect Place, Worthing, Sussex. Tel.: Worthing 30536.

**TW/PA2.** Recording amplifier for use with high quality power amplifier. Inputs: 1.5 mV. and 60 mV. Bias and erase oscillator. Full corrections. Valve voltmeter modulations level ind. For use with Wearite tape deck, can be supplied to order for any deck. Size 10  $\times$  5½  $\times$  5¼ ins. P.s.n. from main amp. or power pack can be supplied at £6 16s. 6d. Price £31 10s.

**TWA/15.** Tape amplifier for use with most tape decks, also for use with pickup or radio. Inputs: 1-1.5 mV and 40 mV. Output: 15 watts, 20 watts peak. F.r.: as recorder 50-12,000 c/s; as reproducing and gram amp. 20-40,000 c/s. Bass and treble boost and cut. H and N 85 dB down. Valve-Voltmeter level ind. power supply on separate chassis. Price £47 5s.

■ **TWA/1515.** Complete stereo record and replay amplifier. Output 15 watts continuous, 25 watts peak on each channel. Inputs: 1.5 mV and 50 mV. Bass and treble boost and cut. Level indicated by separate sustained peak-reading valve volt-meters. Power supply and oscillator on separate chassis. F.r.: 40-30,000 as ordinary amp.; 40-15,000 as recording amp. Size: control unit 23 × 7½ × 7 ins. Power unit 10 × 8 × 7½ ins. Price £100 16s.

■ **TW/PA22.** A two-channel version of the TW/PA2. Price on application.

★

**Simon Equipment Ltd.,** 48 George Street, London, W.1. Tel: Welbeck 2371. Cables: Simsale, London.

■ **SP/4 Stereo Adaptor.** For use with Simon SP/4 tape recorder, providing replay of stereo pre-recorded tapes. Consists of two units, a stereo pre-amplifier feeding 330 mV at 50,000 ohms for the right-hand channel (through SP/4) and 1v at 1,000 ohms for the left-hand channel. The latter is reproduced through the second unit, a 10 watt amplifier and loudspeaker housed in a cabinet identical in size to the SP/4. Price £51 9s.

★

**Sound News Productions,** 10 Clifford Street, New Bond Street, London, W.1.

**Unimixer 1.** 3 channel unit. Channels 1 and 2 have duplicate sockets for low or high impedance microphones—30 ohms or 400 K ohms. Recommended load impedance not less than 500 K ohms. Price £9 9s.

**Unimixer 2.** 3 channel unit. Inputs as above but high impedance is 5 M ohms in channels 1 and 2. Power supply needed 200/300 volts D.C. at 5 mA, 6.3v at 0.3 amps. Special connectors available to obtain power supplies direct from Ferrograph or Vortexion recorders without any alteration. Price £15 15s.

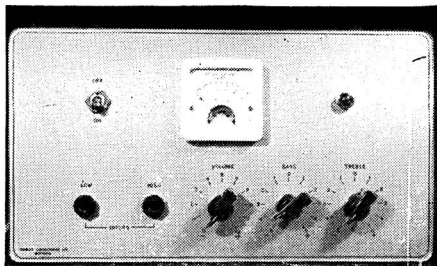

*Shirley TWA/15*

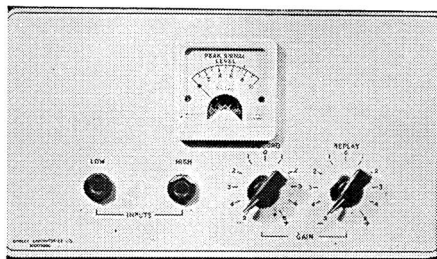

*Shirley TW/PA22*

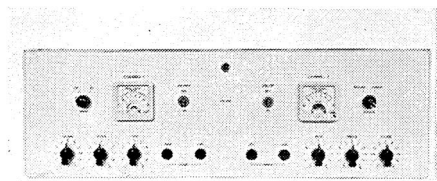

*Shirley TWA/1515*

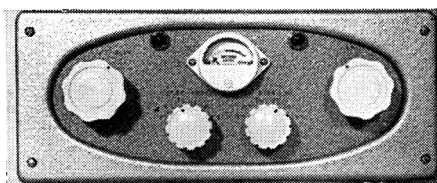

*Sound Sales A-Z Precord*

**Sound Sales Ltd.,** Works and Acoustic Laboratories, West Street, Farnham, Surrey. Tel.: Farnham 6461-2-3. Cables: Sounsense.

**A-Z General Purpose Power Pack** for supplying additional units beyond the scope of the main amplifier. Output 250v at 35 mA, 6.3v at 2 A. Size 11¼ × 4½ × 4½ ins. Price £5 10s.

**A-Z Precord Unit.** Designed for use with Wearite or Truvox tape deck. Self-powered. Inputs: mic. or radio/pickup. Sel. switch for record and replay. Green and red ind. lights give add. visual check. Calibrated recording



*Spectone Mixer*



*TSL Universal Mixer*



*Masterlink M2A*

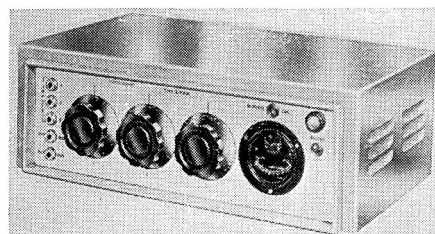

*Vortexion 3-way Mixer*

level indicator. Equalisation for  $3\frac{2}{3}$ ,  $7\frac{1}{2}$  and 15 i.p.s. C.C.I.R. and N.A.R.T.B. characteristics. Variable bias control. Record level gain control. Size  $11\frac{1}{4} \times 9\frac{1}{2} \times 4\frac{3}{4}$  ins. Price £30.



**Specto Ltd.**, Vale Road, Windsor, Berks. Tel.: Windsor 1241. Cables: Specto, Windsor.

**Spectone Electronic Mixer.** 142 and 142A. Inputs: radio 100 mV; mic. 1.5 mV; P.U.1 6 mV; P.U.2 50 mV. Output 0.5v. P.U.1 can be used as second mic. input. F.r.: radio 20-20,000 c/s.  $\pm 0.5$  dB; mic. 25-20,000 c/s.  $\pm 0.5$  dB. H and N P/U — 53 dB. P.s.n. model 142, 200-300v at 5 mA; 6.3v at 1.2 amps. Model 142A, self-powered. Size panel  $12\frac{1}{4} \times 5\frac{1}{4}$  ins. Casing  $11\frac{1}{4} \times 4\frac{1}{4} \times 4\frac{1}{4}$  ins. Price: 142, £17 17s.; 142A, £22 1s.



**Technical Suppliers Ltd.**, Hudson House, 63 Goldhawk Road, London, W.12. Tel.: Shepherds Bush 2581/4794. Cables: Teknica London.

**3 channel mixer unit.** Designed for high impedance inputs. Jack plug sockets fitted. Size  $4\frac{1}{4} \times 3\frac{1}{8} \times 4\frac{1}{2}$  ins. Price £2 2s.



**Tele-Radio (1943) Ltd.**, 189 Edgware Road, London, W.2. Tel.: Paddington 4455.

**Masterlink M2A.** Tape pre-amp originally for Wearite series of deck, suitable for Reflectograph, Collaro and Brenell decks. 2 units, pre-amp and oscillator and separate power supply. Switched inputs for mic., 1.2 mV and radio/P.U., 100 mV. Meter indicates bias, rec. signal, P/B signal. F.r.: 30-20,000 c/s.  $\pm 1$  dB. Oscillator cut-out facility for deck connection. Switched equalisation for  $3\frac{2}{3}$ ,  $7\frac{1}{2}$  and 15 i.p.s. Low imp. output approx. 200 mV. C.C.I.R. adjustment pre-set. Size  $12 \times 6 \times 8$  ins. Price £28 7s.



**Truvox Ltd.**, Neasden Lane, London, N.W.10. Tel.: Gladstone 6455. Cables: Truvoxeng.

**Type K Recording Amplifier.** Inputs: 1 megohm at 1-2 mV;  $\frac{1}{2}$  megohm at 0.5v. Vol. and on/off. Record/replay switch. Tone control. High imp. output. H and N — 45 dB. Output 4 watts. Primarily for Truvox tape deck. Price £19 19s.

**Type K Mk. 2 Recording Amplifier.** Similar to Type K but with playback into 3 or 15 ohm loudspeakers. Power available for bias and erase. Price £19 19s.

**Vortexion Ltd.**, 257/263 The Broadway, Wimbledon. Tel.: Liberty 6242/3. Cables: Vortexion, Wimble, London.

**3-channel Prof. Mixer.** Built-in mu-metal shielded input transformer, hermetically sealed controls, screened mains transformer. Output 1m/watt, 600 ohm balanced or unbalanced. Peak programme meter calibrated zero level + 12 to  $\pm 20$  dB. Size  $18\frac{1}{4} \times 10\frac{1}{4} \times 6$  ins. Price on request.

**4-channel Prof. Mixer.** For 30-50 ohm mic. balanced line or other imps. to order, heavy mu-metal shielded transformers, hermetically sealed controls. Outputs  $\frac{1}{2}$  v on more than 20,000 ohms or 600 ohm, 1 mV. Has own screened power pack for AC mains. Size  $18\frac{1}{4} \times 10\frac{1}{4} \times 6$  ins. Price £40 8s. 6d. 600 ohm output extra. Similar 12 way is also available.

**2MGT.15W.** Combined 4-channel mixer and 10/15 watts power amplifier. Distortion 0.1%. F.R. 2-20,000 c/s  $\pm 1$  dB. 24 dB feedback. H and N — 80 dB. Out. imp. 4, 8, and 15 ohms. Size  $18 \times 6 \times 9\frac{1}{2}$  ins. Price £49.

**S/30/50.** Combined 3-channel mixer and 35/200 watts power amplifier. Distortion 0.2%. F.R. 30-20,000 c/s  $\pm 1$  dB. 22 dB feedback. H and N — 85 dB. Out. imp. 4, 8, and 15 ohms. Size  $18\frac{1}{2} \times 10\frac{1}{2} \times 9\frac{1}{2}$  ins. Price £59.

**S/120/200.** 140/200 watts power amplifier. Distortion 0.2%. Input for spec. output 0.775v into 600 ohms. F.R. 30-20,000 c/s  $\pm 1$  dB. 24 dB feedback. H and N — 95 dB. Out. imp. 110 or 220 volt line. Size  $19 \times 12\frac{1}{4} \times 12$  ins. To operate with Vortexion 4-channel mixer or 3-channel plus P.P.M., etc. Price £112.



**W & N Electronics Ltd.**, 80/82 Uxbridge Road, London, W.13. Tel.: Ealing 4774.

**Audiomaster Monaural.** Tape amplifier. Equalisation for 15,  $7\frac{1}{2}$  and  $3\frac{3}{4}$  i/s. Separate playback channel for monitoring heads. Oscilloscope level ind. Size  $8 \times 5\frac{1}{2} \times 8$  ins. Suitable for Wearite and other decks. Price £26 14s.

■ **Audiomaster Stereo.** Tape amplifier. Equalisation for  $7\frac{1}{2}$  and  $3\frac{3}{4}$  i/s. No playback facilities. Oscilloscope level ind. Size  $8 \times 5\frac{1}{2} \times 8$  ins. Suitable for Harting and other decks. Price £33 15s.



*Vortexion S/30/50 mixer and amplifier*

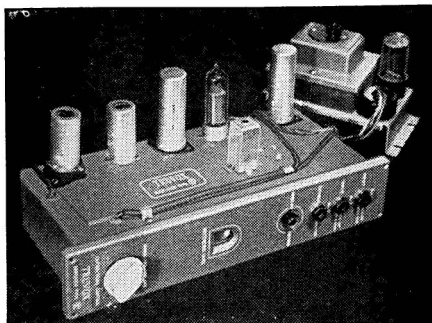

*Truvox Type K recording amplifier*

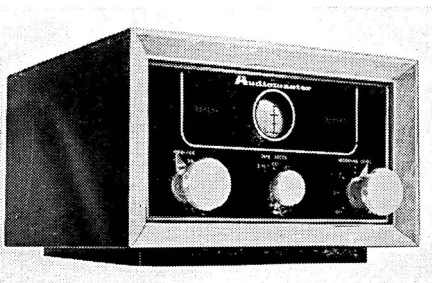

*Audiomaster Monaural tape amplifier*

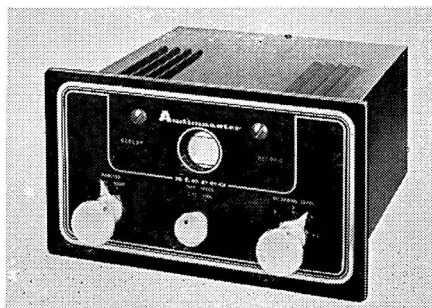

*Audiomaster Stereo tape amplifier*



## TAPE ACCESSORIES and COMPONENTS

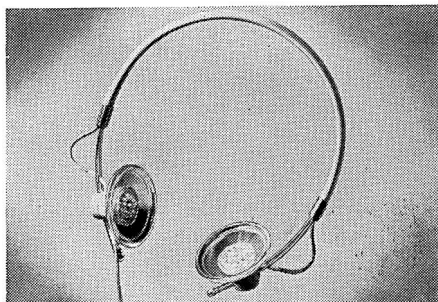

AKG lightweight headphones, type K50, have a frequency response from 30-20,000 c/s and 800 ohms impedance. Available from Politechna (London) Ltd., 357 Euston Road, N.W.1. Price: £8 4s. 6d.

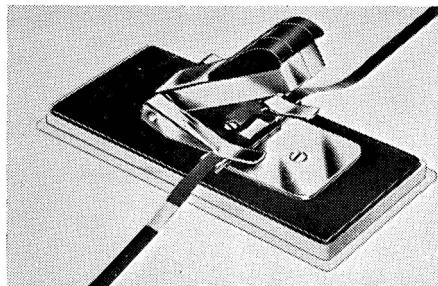

An ingenious tape splicer which makes a double cut without the use of scissors or razor blade is now available from Wilmex Limited, 131 Sloane Street, London, S.W.1. It is the Irish SP3.

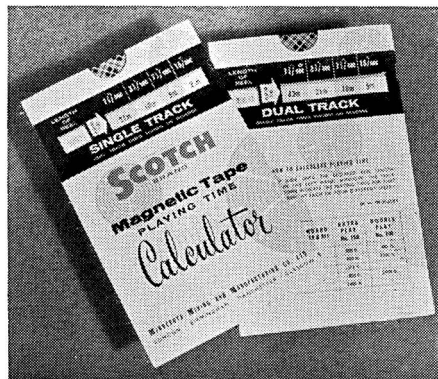

Offered as a free gift by the Minnesota Mining and Manufacturing Co., 3M House, Wigmore Street, London, W.1., is this useful calculator, which tells at a glance the playing times to be obtained from all the popular tape speeds and sizes of spool.

**Beam-Echo Ltd.** 13 South Molton Street, London, W.1. Tel.: Mayfair 1039. Cables: Hibeam, London.

**Stereo Tape Heads.** A range of four units as follows: (1) Erase, (2) record, (3) playback, (4) record/playback. Response of replay head 40-12,000 c/s at  $7\frac{1}{2}$  i/s. Price £7 10s. each.



**Bogen of West Germany.** U.K. distributors, Gopalco Ltd., 1 Long Acre, London, W.C.2. Tel.: Covent Garden 2052. Cables: Tadsinhal, Souphone, London.

A range of two-track and four-track heads comprising two symmetrical windings and a pair of laminated semi-circular cords. These are embedded in plastic and enclosed in a screening case. Gap width just under 0.00004 ins.

**Type UK 100.** Two-track monaural record/playback head. Price £3 3s.

**Type UL 110.** Erase head for the above. Price £1 1s.

**Type UK 200.** Two-track stereo record/playback head. Price £10 10s.

**Type UL 210.** Erase head for the above. Price £5 5s.

**Type UK 205.** Four-track stereo or monaural record/playback head. Price £10 10s.

**Type UL 215.** Erase head for the above. Price £5 5s.



**Bradmatic Ltd.,** Station Road, Aston, Birmingham, 6. Tel.: East 2881/2. Cables: Bradmatic, Birmingham.

A range of twin track high impedance sound heads, single hole fixing, pole pieces are cylindrically ground flush with caps. Screening cans available.

**Type 5 RP.** Combined record/replay head 0.0004 in. gap. Price £3 5s.

**Type 6 RP.** Super fidelity record/replay head 0.0002 in. gap. Price £3 15s.

**Type 5R.** Record only 0.0007 in. gap. Price £3 5s.

**Type 5E.** Erase head. Price £3 5s.

Full track versions of the above are also available.

■ **Type ST-RP.** Stereo record/replay head. Price with screen can, without fixing stem, £6.

■ **Type 2 TK-RPC.** Stereo record/replay head, super fidelity. Price £17 10s.

**S. G. Brown Ltd.**, Shakespeare Street, Watford, Herts. Tel.: Watford 27241. Cables: Sidbournix, Watford.

A range of headphones suitable for recording and dictating equipment, e.g. lightweight miniature model. Price £3 5s.



**Cinesmith Products**, Britannic Works, Regent Street, Barnsley. Tel.: Barnsley 4445.

**Cinesmith Depolariser.** For demagnetising record/playback heads in situ. Consists of a plastic moulding with polepiece and push-button switch. Price £1 15s.



**Cosmocord Ltd.**, Eleanor Cross Road, Waltham Cross, Herts. Tel.: Waltham Cross 25206.

**Acos telephone adaptor.** Allows recording or amplification of two-way telephone conversations by feeding into mic. or radio input of tape recorder. Price £1 1s.



**Dektron**, 2 Westbourne Road, Weymouth, Dorset. Tel.: Weymouth 1987.

**Telecon pickup.** For placing behind telephone (no actual connection) when telephone conversations are to be recorded or amplified. Price £1 7s. 6d.



**EAP (Tape Recorders) Ltd.**, Bridge Close, Oldchurch Road, Romford, Essex. Tel.: Romford 62366/7.

**Elizabethan Stethoset Headphones.** Lightweight, high impedance. Price £3 13s. 6d.

**Elizabethan Radio/P.U. Connecting Lead.** 3 yards of low loss screened cable fitted with British Standard jack plug and coaxial plug. Price 15s.

Telephone adaptor. Price £2 2s.



**EMI Sales & Service Ltd.**, Blyth Road, Hayes, Middx. Tel.: Southall 2468. Cables: Emiservice, London. Telex: 2-2417.

**Emitape Jointing Compound.** AP35 for C.A. base tape. AP77 for P.V.C. base tape. A jointing fluid for making permanent welded joints in magnetic tape. Price 7s. 6d. per bottle.

**Emitape Jointing Tape.** AP103. Adhesive jointing tape for simple and quick splicing and editing of magnetic tape. Price 7s. 6d. per reel.

**Emitape P.V.C. Editing and Marker Tapes.** A range of six coloured tapes to enable colour code reference to be inserted in a

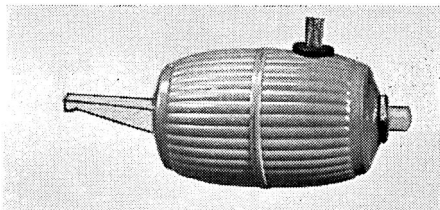

*Cinesmith Depolariser*

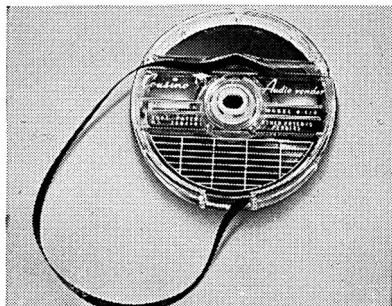

*Philips electrical continuous tape cassette contains 200 ft. of double sided tape. Price: £5.*

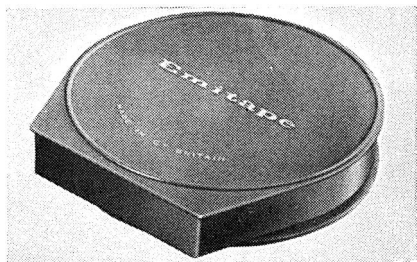

*E.M.I. plastic tape container*



*E.M.I. tape accessories*

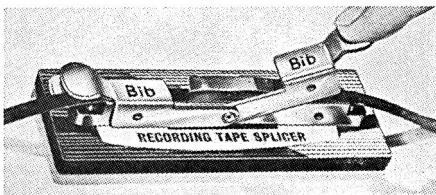

*Multicore "Bib" splicer*

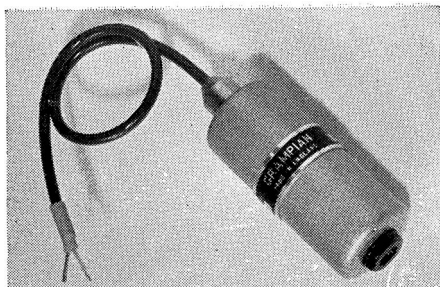

*Grampian G.7 matching unit*

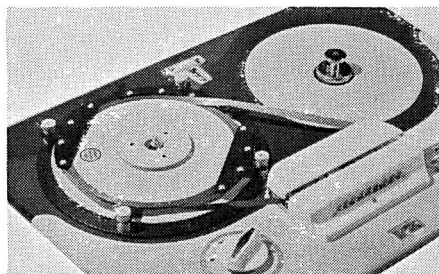

*Guy's Brittape*

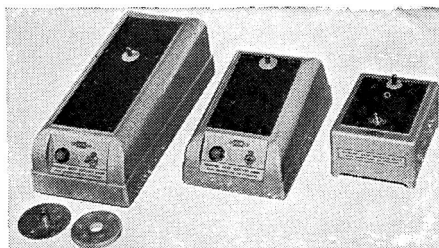

*Leavers-Rich LeeRaser*

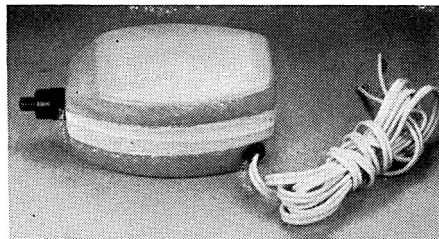

*Osmabet "Instant" Bulk Eraser*



*Romagna Tape Splicing block*

reel of recorded tape for quick editing and indexing purposes. AP38/1 white; AP38/2 red; AP38/3 yellow; AP38/4 blue; AP38/5 orange; AP38/6 green. Price 4s. 6d. per reel.

**Emitape Plastic Tape Spools** in cartons, all standard sizes available. Price: 3 in. and 3½ in. 3s.; 5 in. and 5½ in. 4s. 6d.; 7 in. 5s.

**Emitape Joining Block and Cutter.** Type AP 46. For splicing and editing tape. The tape location channel gives perfect alignment to the tape and the cutter is of non-magnetic material. Price 17s. 6d.

**Emitape Non-magnetic Scissors.** Type AP39. Made of non-ferrous metal, the scissors may be used for splicing magnetic tape without risk of magnetising, so ensuring a completely noiseless join. Price 16s.



**Grampian Reproducers Ltd.,** Hanworth Trading Estate, Feltham, Middx. Tel.: Feltham 2657. Cables: Reamp, Feltham.

**Grampian G.7.** Matching units, consisting of double wound transformer in a Mu-metal case with jack socket on the primary and a screened lead on the secondary. Dimensions 3½ × 1¼ ins. diameter. Versions available for matching 15/30 ohms, 600 ohms and 50,000 ohms or greater. Price £3 5s.



**Guy's Calculating Machines Ltd.,** Truro Road, Wood Green, London, N.22. Tel.: Bowes Park 2258. Cables: Guycalc, London.

**Brittape.** Endless tape cassette providing up to 200 ft. of constantly repeating tape. Effective length of tape may be doubled by "Möbius" loop. Price £6 6s.



**Harvey Electronics Ltd.,** 273 Farnborough Road, Farnborough, Hants. Tel.: Farnborough 1120. Cables: Harvelec, Farnborough, Hants.

A range of bulk erasers for 200-250v or 100-130v mains, 40-60 c/s. Smallest model will take 3¼ to 5-in. spools of ¼-in. tape, and the largest 3¼ to 12-in. spools of 1-in. tape. Prices, from £6 5s. to £15 10s.



**Leavers-Rich Equipment Ltd.,** 78b Hampstead Road, London, N.W.1. Tel.: Euston 1481. Cables: Leemag, London.

**LeeRaser.** Junior ER30A; Standard ER31B; Senior ER32B. Ultra rapid demagnetisers for spools of tape and accessories. Price £6 5s.; £9 10s.; £15.

**Metro-Sound Manufacturing Co. Ltd.**, 19a Buckingham Road, London, N.1. Tel.: Clissold 8506. Cables: Metrosound, London.

**Klenzatape.** Cleaning outfit for removing oxide deposits, dirt, etc., from tape heads in situ. Comprises a length of brushed velvet rubber-backed cleaning tape, two 3-in. spools and a bottle of cleaning fluid. Price 12s. 6d.

**Metro-Tabs.** Set of coloured identifying tabs for affixing to recording tape. Visible on the wound spool and may be catalogued on the folder supplied. Price 3s. 11d.



**Multicore Solders Ltd.**, Multicore Works, Hemel Hempstead, Herts. Tel.: Boxmoor 3636.

**The "Bib" Tape Splicer.** This splicer enables the tape to be jointed easily and to be edited to the accuracy of a syllable. Supplied complete with razor cutter and mounted on flock-covered panel. Price 18s. 6d.



**Osmabet Ltd.**, 2 Median Road, Lower Clapton Road, London, E.5. Tel.: Amhurst 7829.

**"Instant" Bulk Eraser.** Operates from A.C. mains to provide rapid and complete eraser of tapes prior to making quality recordings. Price £1 7s. 6d.



**Romagna Reproducers** - U.K. distributors, **K. H. Williman & Co. Ltd.**, 29 The Highway, Sutton, Surrey. Tel.: Melville 1491.

**Romagna Editing Block.** Accurately machined from aluminium and designed to grip the edges of the tape. Diagonal or vertical cuts using razor blade. Price 7s. 6d.



**Simon Equipment Ltd.**, 48 George Street, London, W.1. Tel.: Welbeck 2371. Cables: Simsale, London.

**Simon Remote Control Unit.** Operates with Simon SP/4 recorder to give start, stop and track change from up to 25 feet distance. Price complete with cable and plug £3 3s.

**Stethoscope Head Set.** Operates from ext. L/S socket for monitoring. Price with plug £2 12s. 6d.



**Tape Recorders (Electronics) Ltd.**, 784/788 High Road, Tottenham, London, N.17. Tel.: Tottenham 0811. Cables: Taperec.

**Sound Stethoset.** Lightweight headphones. Impedance 50 ohms. Weight 1½ oz. Price complete with lead and screened plug £2 10s.

**Sound Splicer CM6.** Incorporates strong plastic blades for rapid editing of tapes. Spare blades and guides available. Price £1 12s. 6d.

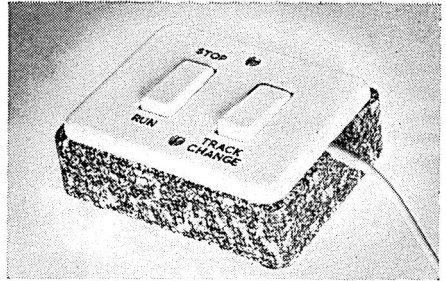

*Simon Remote Control*

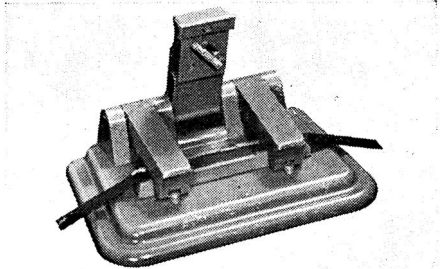

*The Sound tape splicer*

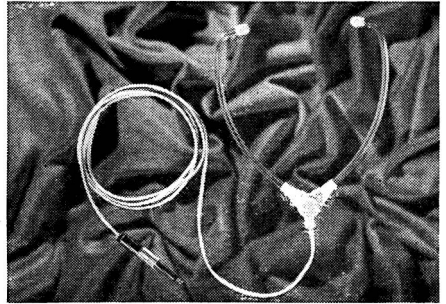

*Sound Stethoset*



*Truvox TR2049 Stereo Head*

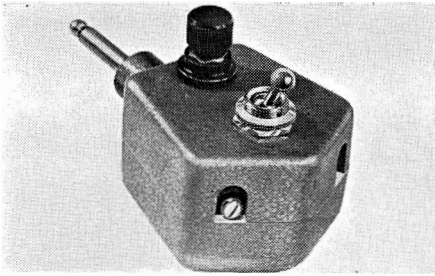

*Truvox Radio Jack*

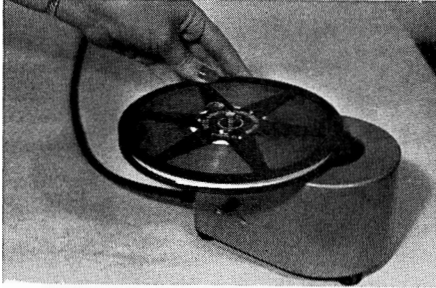

*WAL Tape eraser*

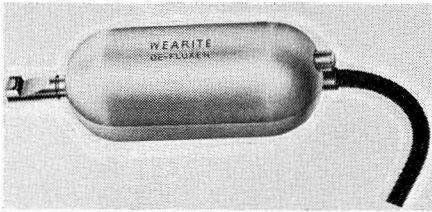

*Wearite Defluxer*

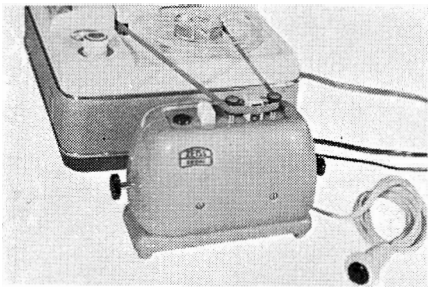

*Zeiss Ikon Diatrakt*

**Truvox Ltd.**, Neasden Lane, London, N.W.10. Tel.: Gladstone 6455. Cables: Truvoxeng.

■ **TR2049. Stereophonic Head.** Stacked heads with safety gap for  $\frac{1}{4}$  in. tape. Azimuth adjustment incorporated—will directly replace Truvox  $\frac{1}{2}$ -track heads. Response 50-15,000 c/s  $\pm$  3 dB with suitable amp. Impedance 50,000 ohms at 10 Kc/s. Cross talk better than 45 dB. Price £10 16s.

**Telephone attachment**, for recording 2-way telephone conversations. Price £2 2s.

**Stethoset**, for use with any recorder with low imp. output socket. Price £3 3s.

**A.M. Radio Jacks.** Price Standard (M.W. only) £2 10s. (U.K. purchase tax 18s. 4d.).



**Walter Instruments Ltd.**, Garth Road, Morden, Surrey. Tel.: Derwent 4421. Cables: Walinst, Morden, Surrey.

**Walter Telephone Attachment.** For use with Walter 303 and 505 tape recorders for recording two-way telephone conversations. Price £3 3s.

**Walter Cine Stroboscope.** For use with Walter 303 and 505 tape recorders for providing synchronised sound with any motor driven cine projector. Price £8 8s.

**Walter Featherweight Headphones.** Price £2 12s 6d.



**Wellington Acoustic Laboratories Ltd.**, Farnham, Surrey. Tel.: Farnham 6461/4961.

**WAL Tape Eraser.** A mains operated tape demagnetiser, accommodates from 5 to 10 in. reels, push button operated. Erases both tracks in a few seconds. Available for 200-250v. 50 c/s. or 110-125v, 60 c/s. Price £7 18s. 6d.



**Wright & Weaire Ltd.**, 131 Sloane Street, London, S.W.1. Tel.: Sloane 2214. Cables: Writwea, Knights.

**Wearite Defluxer.** For depolarising heads of tape recorders and players. It ensures maximum signal/noise ratio from any tape recorder and protects recorded tapes from cumulative background noise and the gradual attenuation of the higher frequencies. Price £2 10s.



**Wyndson Recording Co. Ltd.**, 2 Bellevue Road, Friern Barnet, London, N.11. Tel.: Enterprise 2226. Cables: Wyndreco.

**Wyndson Telephone Adaptor.** Stick-on unit, adheres to telephone base for recording two-way telephone conversations. Price with screened lead and jack plug, £1 9s. 6d.



**Zeiss Ikon A.G.** U.K. distributors, **Peeling & Komlosy Ltd.**, 181 Victoria Street, Dunstable, Beds. Tel.: Dunstable 1357.

**Zeiss Ikon Diatrakt Serial 38.4000.** Enables tape recorder to operate an automatic slide projector in sync. Switching signal is recorded on lower track, leaving upper track for commentary, etc. Price £21.

# DIRECTORY OF MAGNETIC TAPE

## An Introduction

THIS is the first time that a directory of magnetic recording tapes has been included in "Hi-Fi Year Book", and it may be that a word of explanation is called for. At a professional level there is little or no experimenting with tapes at all. When the most suitable—and durable—type is decided upon by a professional user, he adjusts the bias, etc., for optimum results, and that as far as he is concerned is that. In the case of domestic tape recorders, it can be taken that things are less cut and dried; all the same, most tape recorder manufacturers will include a spool of a certain brand of tape as an "included accessory", and will recommend this particular brand for use with their machines.

### Use recommended brand

It must be admitted too that departures from the recommended type of tape—without due thought or re-adjustment of bias values—generally lead to disappointing results. Amongst the troubles that can arise are poor high frequency response, poor dynamic range, and failure to erase previous recordings completely. Even when one keeps to the recommended brand of tape, buying new spools can be quite a puzzle now that some manufacturers market such a variety of tape

types. It is the function of this directory section to indicate the main features of the recording tapes available, as a general guide to intending purchasers.

The first item in each entry is the type of base employed. The most popularly-priced tapes employ an acetate base, with P.V.C. sometimes being offered as a super grade which has better handling and winding characteristics. Polyester bases, which are referred to also by a number of proprietary names including "Melinex" and "Mylar", are generally associated with the thinner tapes.

### Long Play tapes

Secondly we have indicated the thickness of the tape, and although fractional differences do occur it is fair to look upon these thicknesses as follows:—Standard Play 0.002 in.; Long Play 0.0015 in.; Double Play 0.001 in. No one will be surprised if, for a given base material, the tensile strength and resistance to "print through" are less on the thinner types than they are on Standard Play, but the dictates of economy will often outweigh these considerations, and for message tapes and recordings "in the field" the longer playing times of Long Play and Double Play tapes are becoming increasingly popular.

**Agfa A. G. Leverkusen, W. Germany.**  
**Agfa Ltd.,** 27 Regent Street, London, S.W.1.  
Tel.: Regent 8581.

**Agfa Magnetoband PE31.** Pre-stressed polyester. Long play. Spool sizes: 3, 5, 5½, 7-in. Price: 9s., £1 8s., £1 15s., £2 10s.

**Agfa Magnetoband PE41.** Pre-stressed polyester. Double play. Spool sizes: 3, 5½, 7-in. Price: 14s., £3, £4.



**Electro-Techno-Dynamics,** 101 Leadenhall Street, London, E.C.3. Tel.: Avenue 6982.

**Ferrodynamic Brand 5.** Acetate. Spool sizes: 5, 7 (1,200 ft.), 7-in (1,800 ft.). Price: 16s., £1 5s., £1 15s.; Mylar Dupont. Spool sizes: 5, 7 (1,800 ft.), 7-in. (2,400 ft.). Price: £1 17s. 6d., £2 6s., £3 5s.



**E.M.I. Sales & Service Ltd.,** Blyth Road, Hayes, Middx. Tel.: Southall 2468. Cables: Jabberment, London.

'44'. Cellulose acetate. Standard play. Spool sizes: 3½, 5, 5½, 7, 8½, 10½-in. Price: 6s. 9d., 18s., £1 4s. 6d., £1 10s., £3 6s.

'77'. P.V.C. Professional grade. Standard play. Spool sizes: 5, 5½, 7, 8½, 10½, 11-in. Price: £1 10s., £1 15s. 6d., £2 8s., £3 13s. 6d., £5 4s. 9d., £6.

'88'. P.V.C. Standard play. Spool sizes: 3, 3½, 5, 5½, 7, 8½, 10½, 11-in. Price: 7s. 6d., 7s. 6d., £1 1s., £1 8s., £1 15s., £2 17s. 6d., £3 18s. 9d., £4 11s.

'99'. P.V.C. Long play. Spool sizes: 3, 3½, 5, 5½, 7, 8½, 10½-in. Price: 9s. 6d., 9s. 6d., £1 8s., £1 15s., £2 10s., £3 12s. 6d., £5 10s.

'100'. Polyester. Double play. Spool sizes: 3½, 5, 7-in., Garrard magazine. Price: 17s., £2 5s., £4, £1 19s. 6d.



**Gavaert Ltd.,** Great West Road, Brentford, Middx. Tel.: Isleworth 2131. Cables: Artoveg, Brentford-Hounslow.



**Gevasoner Type M.** Cellulose triacetate. Standard play. Spool sizes: 5, 6, 7-in. Price: 16s., £1, £1 7s.

**Gevasoner Type LR.** Cellulose triacetate. Long play. Spool sizes: 3, 5, 6, 7-in. Price: 7s., £1 8s., £1 12s., £2 10s.

★

**F. A. Hughes & Co. Ltd.,** 4 Stanhope Gate, London, W.1. Tel.: Hyde Park 6080. Cables: Distancing Audley London.

**BASF LGS52.** P.V.C. Standard play. Spool sizes: 3, 4, 5, 5½, 7-in. Price: 8s., 13s. 6d., £1 1s., £1 8s., £1 15s.

**BASF LGS35.** P.V.C. Long play. Spool sizes: 3, 4, 4½, 5, 5½, 7-in. Price: 9s., 14s. 6d., £1 1s., £1 8s., £1 15s., £2 10s.

**BASF LGS26.** P.V.C. Double play. Spool sizes, 3, 4, 5, 5½, 7-in. Price: 14s., £1 5s., £2 2s., £2 12s. 6d., £3 17s. 6d.

**BASF LGS55.** P.V.C. Editing Sound tape. May be written on. Spool size: 4¼-in. Price: £1 5s.

★

**Lee Products (Great Britain) Ltd.**—(Concessionaires of Audio Devices Inc., U.S.A.), Elpico House, Longford Street, London, N.W.1. Tel.: Euston 5754. Cables: Leprod, London.

**Audiotape.** A range of 8 grades and thicknesses for amateur and professional use. Spool sizes: 3, 3½, 4, 5, 5½, 7-in.

★

**Minnesota Mining and Manufacturing Company,** 3M House, Wigmore Street, London, W.1. Tel.: Hunter 5522. Cables: Minnesota, London.

**Scotch 111.** Acetate. Standard play. Spool sizes: 3½, 5, 5½, 7, 10½-in. Price: 6s. 9d., 18s., £1 4s. 6d., £1 10s., £3 6s.

**Scotch 311.** P.V.C. Standard play. Spool sizes: 3½, 5, 5½, 7, 10½-in. Price: 7s. 6d., £1 1s., £1 8s., £1 15s., £3 18s. 9d.

**Scotch 150.** Polyester. Long play. Spool sizes: 3½, 5, 5½, 7, 8½, 10½-in. Price: 9s. 6d., £1 8s., £1 15s., £2 10s., £3 12s. 6d., £5 10s.

**Scotch 200.** Polyester. Double play. Spool sizes: 3½, 5, 7-in. Price: 17s., £2 5s., £4.

★

**MSS Recording Company Ltd.,** Colnbrook Bucks. Tel.: Colnbrook 2431.

**MSS Standard.** Spool sizes: 3, 4, 5, 5½, 7, 8½-in. Price: 5s. 6d., 10s., £1, £1 7s. 6d., £1 15s., £2 10s.

**MSS Long Play.** Spool sizes: 3, 4, 5, 5½, 7, 8½-in. Price: 8s. 6d., 14s. 6d., £1 8s., £1 15s., £2 10s., £3 10s.

**MSS Double Play.** Spool sizes: 3, 5, 5½, 7-in. Price: 10s. 6d., £2 5s., £3 10s., £4.

**MSS Supergrade.** Standard play. Spool size: 7-in. Price: £2 18s. 6d.

★

**Philips Electrical Ltd.,** Century House, Shaftesbury Avenue, London, W.C.2. Tel.: Gerrard 7777. Cables: Phillamps, London.

**Philips Standard Play.** P.V.C. Spool sizes: 4, 5, 5½, 7-in. Price: 13s. 6d., £1 1s., £1 8s., £1 15s.

**Philips Long Play.** P.V.C. Spool sizes: 3, 4, 5, 5½, 7-in. Price: 9s., 18s., £1 8s., £1 15s., £2 10s.

**Philips Double Play.** P.V.C. Spool sizes: 3, 4, 5, 5½, 7-in. Price: 14s., £1 5s., £2 2s., £2 12s. 6d., £3 7s. 6d.

★

**Tape Recorders (Electronics) Ltd.,** 784/788 High Road, Tottenham, London, N.17. Tel.: Tottenham 0811.

**Sonocolor W.H.S.** P.V.C. Standard play. Spool sizes: 3, 3½, 4, 4½, 5, 5½, 7, 9½-in. Price: 7s. 6d., 8s., 13s. 6d., 16s. 6d., £1 1s., £1 8s., £1 15s., £3 15s.

**Sonocolor W.S.M.** P.V.C. Long play. Spool sizes: 3, 3½, 4, 4½, 5, 5½, 7, 9½-in. Price: 9s. 6d., 14s. 6d., 16s. 6d., £1 0s. 6d., £1 8s., £1 15s., £2 10s., £5 5s.

**Sonocolor W.D.T.** P.V.C. Double play. Spool sizes, 3, 3½, 4, 4½, 5, 5½, 7-in. Price: 14s. 14s. 6d., £1 5s., £1 11s. 6d., £2 2s., £2 12s. 6d., £3 17s. 6d.

★

**Telefunken.**—Sole U.K. distributors, **Welmec Corporation Ltd.,** 147/148 Strand, London, W.C.2. Tel.: Temple Bar 3357. Cables: Welmcor, London.

**Telefunken Long Play.** P.V.C. Spool sizes: 5, 5½, 7-in. Price: £1 8s., £1 15s., £2 10s.

**Telefunken Double Play.** P.V.C. Spool sizes: 5, 5½, 7-in. Price: £2, £2 10s., £3 15s.

★

**Wilmex Ltd.**—(Concessionaires of Orr Industries Inc., U.S.A.), 131 Sloane Street, London, S.W.1. Tel.: Sloane 0621. Cables: Wilmexco, London.

**Irish 195.** Acetate. Standard play. Spool sizes: 5, 5½, 7-in. Price: 17s., £1 3s., £1 7s. 6d.

**Irish 211.** Acetate. Standard play. Spool sizes: 5, 7-in. Price: £1 1s., £1 15s.

**Irish 601.** Mylar. Long play. Spool sizes: 3, 5, 5½, 7-in. Price: 9s., £1 8s., £1 15s., £2 10s.

**Irish 724.** Tensilised Mylar. Double play. Spool sizes: 3, 4, 5, 5½, 7-in. Price: 13s. 9d., £1 5s., £2 5s., £2 12s. 6d., £4.

# MICROPHONES AND MIXERS

by John Borwick

**L**OW and medium priced tape recorders in the domestic category will usually have a microphone included in the price. We can assume that the makers have matched the electrical properties of microphone and recorder, but we won't be surprised if a fairly inexpensive microphone is the rule. In contrast to this, professional machines never are listed with a stipulated microphone, for it is assumed that anyone who will go to the expense of a professional grade recorder will wish to make recordings—whether of simple or complex material—that are fully up to the capabilities of the recorder. This may mean

choosing a different microphone for some recordings than others.

It is hoped in this article to assist both kinds of users, by offering suggestions on how low-priced microphones may be used to best advantage, and, at the other end of the scale, to describe the main performance details of the various microphone types and something of the art of placing microphones. The properties and behaviour of mixer units will also be discussed.

## Microphones and barometers compared

With a few exceptions that we shall come to later, most microphones are activated by



*It often pays to set up the microphones in their approximate positions before the musicians assemble (BBC photo)*

the pressure in the air. That is they may be compared to a barometer, but are designed to be much more sensitive. For example, if a microphone were bobbed up and down like a yo-yo the alternating air pressure due to the continually changing altitude (of a few feet only) would produce an output voltage. So it is in the path of a sound wave. The pressure is oscillating above and below normal, with the result that the microphone's light diaphragm is alternately pressed and released. The amount of power in the sound wave (to which the loudness is related) affects the degree of the alternating force on the diaphragm, and the rate of the air vibrations (to which the musical pitch is related) decides the cycles per second, i.e., the frequency of the diaphragm's movements.

In essence, the microphone is an electrical generator and its output takes the form of an alternating current which imitates in strength and frequency the air vibrations. It might be as well to say a few words at this point on the subject of microphone sensitivity, or in other words the voltage we can expect for a given pressure. The standard usually referred to for pressure is about one millionth of atmospheric pressure, i.e., one microbar, and corresponds to a force of 1 dyne per square centimetre. Typically, pressures of this order generate voltages in the region of 1 millivolt.

### Microphone sensitivity

The voltage output of a microphone is generally expressed in dB with reference to 1 volt, so that 1 millivolt, for example would be written as -60 dB. Hence, written out in long hand so to speak, a microphone whose sensitivity is given as -60 dB produces "one thousandth of a volt for a pressure of one dyne per square centimetre". In practice, conversational speech at a distance of about one foot gives sound pressures of about

The above method of rating the sensitivity is best suited to the high impedance microphones, crystal and condenser. For low impedance microphones, ribbon and moving coil, where this rating is less helpful due to the variations in impedance that occur and the usual insertion of a step up transformer, a power rating is often resorted to instead of the voltage rating. This states the output power in dB with reference to 1 milliwatt, for a given pressure—say 1 dyne/cm<sup>2</sup>, as before. The typical range of microphone sensitivities is set out in Table 1.

### Crystal microphones

Nine times out of ten, the microphone given as an accessory with inexpensive tape recorders is a crystal or piezo-electric type.

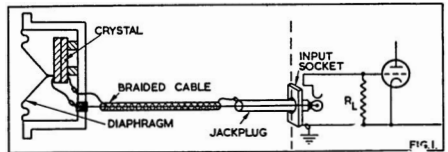

This type is simple to manufacture, and therefore cheap, and produces a strong output voltage suitable for connecting directly to the grid of the recording pre-amplifier valve . . . all features which recommend it for the machines in question. Crystal microphones also have the advantage of being extremely robust and light in weight. They may be obtained as lapel or button-hole microphones, to leave both hands free where necessary, and are not particularly prone

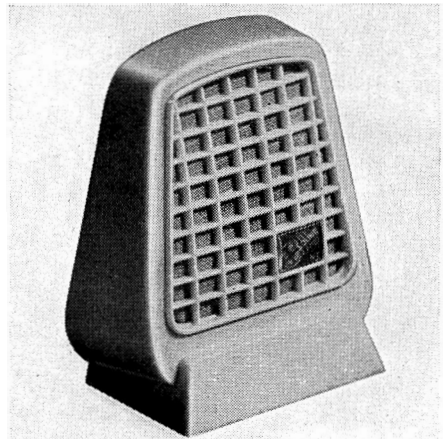

*Crystal microphones are very often the "included accessory" on low-priced tape recorders, and may be housed in a moulded plastic case as the Sound M.1 shown here.*

Type	Rel. 1 volt for 1 dyne/cm <sup>2</sup>	Rel. 1 milli- watt for 1 dyne/cm <sup>2</sup>
Crystal	-46 to -65	—
Condenser	-50 to -60	—
Moving Coil	—	-65 to -86
Ribbon	—	-74 to -83

10 dynes/cm<sup>2</sup>, and speaking very close to a microphone results in 100 dynes/cm<sup>2</sup>, so that our typical microphone would generate voltages of 0.01v and 0.1v respectively.

to pickup hum from stray magnetic or AC fields.

They have a reputation for being subject to temperature and humidity, but this need not present much of a problem in ordinary circumstances. However, it does rule out crystal microphones for tropical use, and makes it desirable to keep them from direct sunlight, etc. It must be admitted too that there is a limit to the recording quality—as represented by the frequency response—with crystal microphones of the high sensitivity variety here discussed. They do not usually respond to frequencies much beyond 7,000 to 9,000 cycles per second, and tend to exhibit a peak in output somewhere in the region of 4,000 c/s.

### O.K. for speech

For speech recordings, especially when it is the meaning rather than the fidelity of reproduction that interests us, as in note-taking etc., this is by no means a disadvantage. In music recording, however, a superior frequency response is necessary if the instruments are to be clearly differentiated and not made to sound strident.

### Connecting cables

The normal connector for crystal microphones consists of a coaxial cable (see fig. 1). The central "live" wire runs from a terminal or small plate on one face of the crystal via the tip of the jack plug or other form of coaxial plug to the grid of the first valve. The outer braid makes contact with the opposite face of the crystal element, and ultimately connects on to the sleeve or shaft of the plug, and the tape recorder chassis.

An examination of the electrical circuit formed by a crystal microphone and its cable (fig. 2) shows the twin importance of limiting the length of the cable itself, and of maintaining a high value of input impedance.

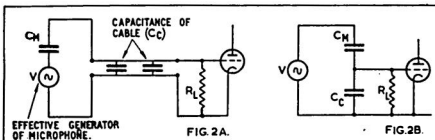
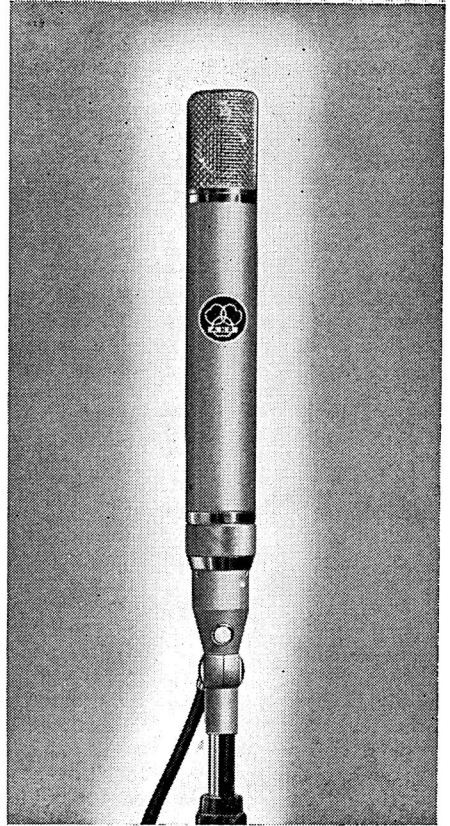

Fig. 2 the equivalent circuit of the cable.

The capacitance of the cable—which increases with each additional foot of length—is effectively in parallel with that of the crystal itself, and produces a drop in overall output level. The input impedance of the recorder is effectively that of the grid resistor, and this component should have a high value—in the



The A.K.G. condenser microphone type C.12 has a built-in amplifier to transform the head high impedance down to line impedance.

order of megohms—if the low frequency response is not to suffer.

### Condenser microphones

Many of the above remarks apply equally to another microphone type, namely the condenser. These are sometimes the standard accessory on continental recorders, e.g., *Grundig*, and also present a high, capacitive output impedance. The connecting lead has to be of low capacity cable and restricted in length, and there is a further complication. The active element or capsule of condenser microphones depends for its action on the mechanical modulation of the charging current drawn from a D.C. supply. It is necessary, therefore, to employ a multi-core cable to carry 100 volts or so D.C. to the microphone (generally supplied from the H.T. line in the recorder).

Related to the domestic condenser types (but costing some twenty times as much!)

are the professional condenser or electrostatic microphones. These invariably include a built-in amplifier which transforms the high impedance down to a suitable line impedance (200-600 ohms) for connection to the recorder. One model popular in broadcasting and recording studios is the *A.K.G. C.12*, which has a technical performance approaching that of the best amplifiers and recorders available.

### Moving coil microphones

Moving coil microphones are not confined to any price bracket, but are designed and manufactured in a wide range of types. At one end of the scale are very inexpensive models whose quality of reproduction is not very different from that of an equivalently priced crystal, and at the other we have professional moving coils used as hand microphones, etc. in broadcasting or recording circles.

Robustness is again a strong point in favour of moving coil types. They do not have the crystal's dislike of high temperatures or humidity, and are to be found in all parts of the world. The quality of the reproduction is pretty well in direct ratio to the cost, as we might expect, and it is also a fact that the sensitivity of the top quality types is a good bit less than that of the common or garden ones. The reason for this is that a flat response over an extended range of frequencies can be obtained only by damping out and otherwise suppressing the tendency to

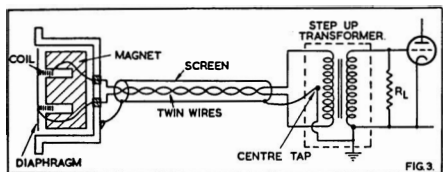

**Fig. 3.** Usual form of connection between a moving coil microphone and the tape recorder.

resonate of the diaphragm itself and the various air cavities, etc. formed inside the microphone's case. This brings down the overall output voltage for a given pressure and tends to rocket the price since the damping acoustic networks will often require to be adjusted individually by hand.

### The transformer

The impedance of the coil itself is commonly between 20 and 50 ohms. This makes a choice of connections possible. Either the ends of the coil may each be taken to the two "live" leads in a twin coaxial cable, and thence to a transformer inside or near the tape recorder (see fig. 4); or a step up or line



*The Lustraphone VR 64 ribbon microphone is an example which has 3 switched values of output impedance*

transformer may be built into the microphone inserted between the coil and output terminals. In the former case, quite long lengths of cable may be employed up to 100 feet or more. There is a risk of hum induction, of course, but the balanced type of connection helps to minimise this since any induced voltage will be equal in the two arms and tend to cancel out. As an added precaution, the screen connector is earthed.

When there is a built-in transformer, stepping up the impedance to some value such as 50,000 ohms for use into a high impedance recorder socket, the difficulties of hum pick up are somewhat increased. When a so-called line transformer is employed, to give an impedance of 600 ohms, long cables may safely be used.

### Ribbon microphones

The ribbon microphone has established itself as a high quality instrument, and in the best examples is capable of superlative performance. The frequency response, for example, may be typically 30-15,000 c/s plus or minus 5dB. Since they both rely on the electromagnetic principle, most of the above remarks on the electrical matching of moving coil microphones apply equally to ribbon microphones, but there are two main differences. One of these is a minor matter, but the other is extremely important.

The first point is that the impedance of the foil ribbon itself is a fraction of 1 ohm only, and a built-in transformer becomes virtually a necessity. Whether this steps up the impedance to 20, 600, or 50,000 ohms, or some intermediary value, varies from one model to another (indeed some ribbon microphones are arranged to present a choice of output impedances).

**Pressure gradient**

However, the most unique feature of the majority of ribbon microphones is that the ribbon is open to the atmosphere on both faces, and therefore responds not to the instantaneous pressure on one side, but to the difference in pressure obtaining on these faces (see fig. 4). This is referred to as

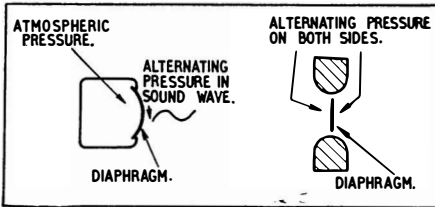

Fig. 4—(a) Pressure-operated microphone; (b) Pressure gradient microphone

pressure gradient operation, as distinct from pressure operation of a diaphragm microphone, such as the crystals and moving coils so far considered, and a good analogy is an ordinary spirit level.

**Spirit level compared**

Placing a spirit level on a gradient produces a maximum deflection of the bubble when the level is parallel with the slope. Turning the level through an angle reduces the deflection progressively, until, when the level is at right angles to the slope, the deflection falls to zero. The pressure gradient operated ribbon microphone is found to exhibit identical properties. It produces a maximum response to sounds arriving on its axis, but is increasingly insensitive to oblique sounds, and does not respond at all to sounds

arriving at the side. The resultant figure-of-eight polar response is in striking contrast to that of a pressure operated microphone (see fig. 5). The latter tends to respond equally to sounds from all directions, except that its physical size makes it present an obstacle to very short wave sounds arriving from behind, and therefore reduces the output at appropriately high frequencies.

The fact that so many ribbon microphones are pressure gradient operated, and therefore possess a bi-directional characteristic, has caused many people to suppose that this type of polar response is peculiar to ribbons, but this is not the case. Pressure-operated ribbon microphones *do* exist, and pressure gradient crystals and moving coils have been constructed.

**Microphone technique**

The technique of using "circle" and "figure of eight" microphones is quite different. The non-directional nature of the former tends to call for a fairly close microphone position to be taken up. The reason for this is two-fold. Firstly, the microphone does not discriminate against extraneous noises in any way, and a close balance will often be necessary to maintain the level of wanted to unwanted sound.

Examples of this would be the recording of a commentary in a noisy room or sports arena, etc., or a Public Address set-up in which the speech or music picked up by the microphone was being relayed over loud-speakers. Any sizeable spill-over of loud-speaker sound on to the microphone will trigger off acoustic feedback, and the close technique may be the only way to minimise this. A further example is encountered in recording musical groups, where unduly loud instruments such as the drums may be properly balanced only by adopting a close microphone for the weaker players.

**Reverberation**

The second factor making a close position usual with pressure microphones is the reverberant sound in the room or hall. This

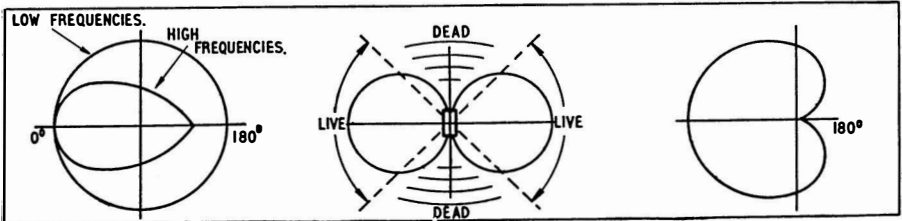

Fig 5—Field response of microphones: (a) Pressure; (b) Pressure gradient and (c) Cardioid



type of microphone picks up all the reflected sound going, and can easily produce too live sounding a recording for the purpose in hand. Also, there is a tendency for the ambient sound—at least in fairly small rooms—to consist predominately of the bass frequencies, and makes it more than ever desirable to preserve a reasonable balance between the direct sound picked up by the microphone and the reflected sound.

#### Advantages

It is in these finer points of microphone balance that a directional microphone such

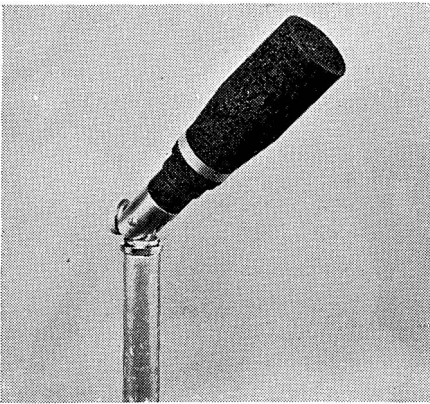

*The S. T. & C. type 4105 is a moving coil microphone with a cardioid characteristic. Its front-to-back ratio is 15-20 dB*

as the figure of eight type is seen to have many advantages. In the first place, it picks up roughly one third only of the reverberant sound, and a proportionately more distant position may be taken up *vis-a-vis* the pressure type. Then, the “dead” angles of the microphone are extremely useful for attenuating the signal derived from extraneous or over-enthusiastic sound sources. Even the simple question of avoiding the reflection of sound from an adjacent wall is made simpler when the microphone can be orientated to place the wall “in the dead”.

#### Musical balance

In subtle musical balances, and in recording drama, where the exact relative perspectives of the different actors and sound effects, etc. have to be carefully engineered, a figure-of-eight microphone will often allow a much more straightforward layout than a pressure

type. In the case of the latter, it is often found necessary to space the performers out to such a degree that they feel detached.

#### The cardioid pattern

There is a third basic polar characteristic for microphones, namely the cardioid, which has a wide frontal angle of pickup, but is “dead” to sounds arriving at the back. The design of a cardioid microphone involves combining the principles of pressure and pressure gradient operation, and it follows from this added complication that cardioid microphones are not amongst the cheapest available. Examples in the Directory include moving coil types, and the *S.T. & C 4033*, which comprises moving coil and ribbon movements in a single case.

#### Condenser cardioids

The cardioid microphones used widely in professional studios are condenser types, made in Germany or Austria. In some cases they may be arranged to produce a choice of polar characteristics by suitable switching of the plate voltage. No less than nine different characteristics are provided on the *C.12*, for example, switched remotely by the operator.

The cardioid pattern has the same 3.1 ratio of attenuation of ambient sound as the figure-of-eight, relative to a circle, and is equally effective in achieving a satisfactory balance

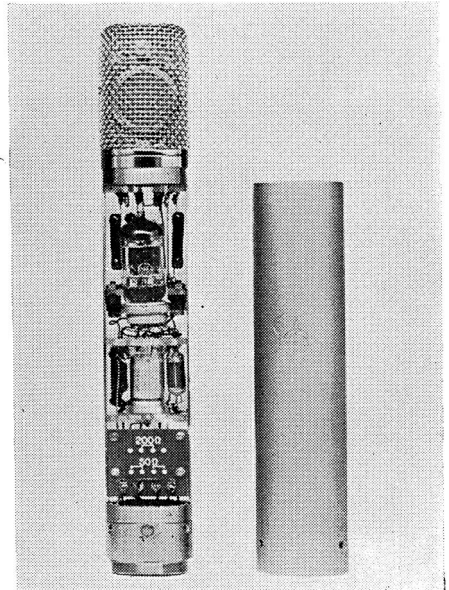

*The A.K.G. C.12 (whose built-in amplifier is seen here) has 9 switchable directional patterns*

of musical ensembles, speech/sound effects, etc. The cardioid recommends itself, too, for Public Address and Stage Presentations of all kinds. Here the wide frontal angle makes it better than the figure of eight, and the suppression of audience and/or pit orchestra makes it better than the circle.

In case it may be thought from the foregoing that there is nothing to be gained from trying different angles with a pressure microphone, it is again pointed out that a

fairly steep rise in high frequency response is found on a line at right angles to the diaphragm. This can give extra hard or brilliant quality, when required, or an oblique angle may be used to take the edge "off" the Sounds. For example in recording speech, it is important to try the effect of talking at various angles *across* the microphone to discover the angle which just avoids blasting, and emphasis of sibilants, without blurring.

## THE USE OF MIXER UNITS

When two or more input sources are used, it is necessary to provide some means of "rolling over" from one to another, or mixing. In an ideal mixer it should be possible to move smoothly through every possible combination of levels—rather like mixing Hot and Cold water supplies through a mixer tap—and this calls for two basic properties. First, the attenuation or loss of each individual control should alter evenly from its highest to its lowest value without perceptible breaks or jumps. Secondly, the programme volume on any given channel should remain constant at any setting regardless of the conditions of the other channels. It must be admitted here that these conditions are

achieved only on the professional and semi-professional units. However, the greater flexibility obtained from using a mixer makes even the cheapest examples worth considering, as understanding their limitations makes it possible to overcome them to a fair degree.

### Simple mixers

The simple mixer of fig. 7, for example, is what is technically known as a 3-channel, parallel-connected system and is "passive", i.e. possesses no amplification. It does not meet our second condition, viz.: independence of controls. The full load as "seen" by channel 1 comprises the amplifier input impedance, with the other channels in

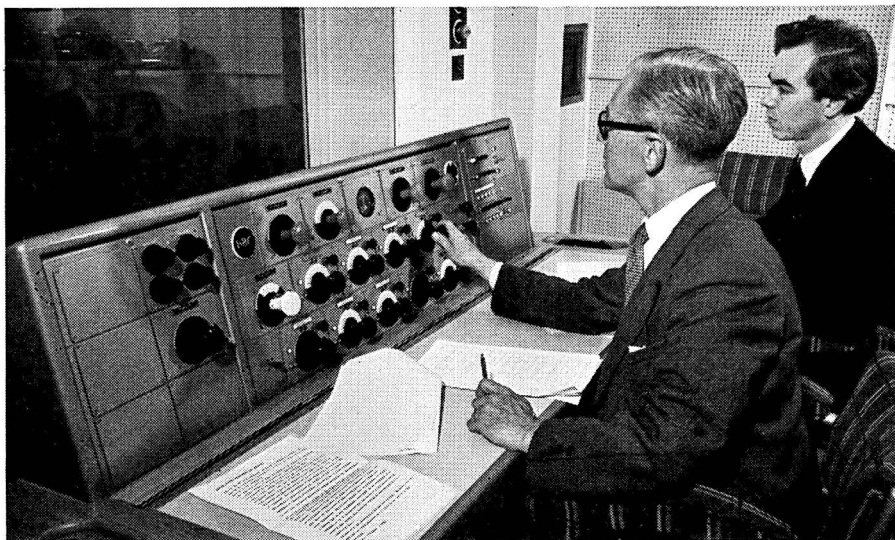
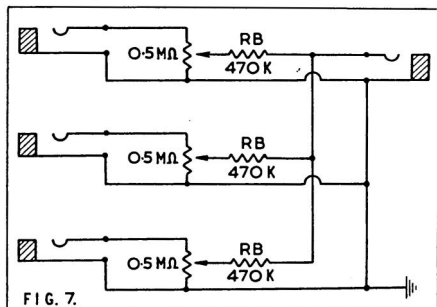

Fig. 6—Mixer consoles are an essential feature of professional studios, but quite professional results may be obtained from simple mixers (BBC photo)

parallel, and this will vary during mixing. The insertion of the "padding out" or "building out" resistors  $R_b$  will reduce these fluctuations at the expense of a fixed insertion loss. In the case where  $R_b$  equals the source impedance of the microphones and also equals the volume controls, this insertion loss



is 6, 9.5 and 12 dB for 2, 3 and 4 channels respectively. The additional loss on fading in extra sources is a few dB only, and one can, with practice, operate this type of mixer quite smoothly by holding single channels just below the maximum setting, and moving these fully clockwise with one hand at the same time as extra channels are faded in with the other.

#### More elaborate mixers

The use of standard carbon-track volume controls in this type of passive mixer does, however, set a severe limit to the accuracy with which intermediary settings can be gauged or returned to—errors of a few dB can easily creep in—and the mixing noise generated is often high. The latter aspect is all the more serious since e.m.f.'s generated at this point in the circuit are subjected to the full amplification of the system.

Two remedies suggest themselves, both of which are incorporated in professional mixers, and one or other in medium-priced amateur equipment. These remedies are (a) to use relatively noise-free and reliable

stud-by-stud variable attenuators in place of carbon pots, and (b) to insert a pre-amplifier in each channel prior to the faders.

Needless to say, each of these improvements involves considerable extra expense, but they are obligatory if recordings of professional standard are to be achieved. The stud-by-stud potentiometer consists of spring-loaded contacts on the rotor which pass over polished studs between which are wired fixed resistors. The values of these resistors are graduated so as to introduce a known small decrease (say 1.5dB from stud to stud, and in the more elegant professional faders the resistance is altered simultaneously in series and shunt arms so as to present a constant impedance overall. This obviates completely the fluctuations in level previously mentioned as being a feature of simple mixers.

Introducing pre-amplifiers in each channel makes it possible to isolate the channels completely. It will be appreciated that the design of microphone pre-amplifiers is of unusual difficulty. Quiet notes from a flute at 60 feet distance are a full 90dB down on loud trumpets 1 foot from the microphone, and since the gain control follows the amplifier the latter must be able to cope with this wide range of inputs and yet produce negligible noise and overload distortion. Mains hum introduced at this stage is particularly bothersome, and the transistorised mixers now available are designed to lay this bogey once and for all.

Operating a mixer is more art than science, but the amateur—whose time is his own—can patiently rehearse the various operations until they approach perfection. To mix artistically, however, whether it be the combined balance of microphones grouped in a theatre or concert hall or the inputs from disc, tape, and microphone, it is essential to monitor the mixed programme continuously. Headphones may be used for this, but are sometimes misleading, and a high fidelity loud-speaker in a room sound-proofed from the studio, is clearly conducive to better results.

# DIRECTORY OF MICROPHONES

★In these abridged specifications, the following abbreviations are used: **Source imp.**—microphone source impedance. **Rec. load imp.**—recommended load impedance, and Sensitivity is given in dB with reference to 1 volt/dyne/cm<sup>2</sup>, unless otherwise stated.

**AKG (Akustische und Kino-Geräte Ges. m.b.H.)** Sole U.K. agents, **Politechna (London) Ltd.**, 3 Percy Street, London, W.1. Tel.: Langham 6236. Cables: Polindust, London.

**D9.** Moving coil. Response 80-10,000 c/s. Source imp. 200 ohms and 50 K ohms. Fitted with collapsible stand and 5 ft. screened cable. Price £4 19s.

**D11.** Moving coil with cardioid directional pattern. Response 80-12,000 c/s. Source imp. 200 ohms or 50 K ohms. Fitted with screw-on table stand and 5 ft. screened cable. Price £5 6s. (low imp.) and £5 12s. (high imp.).

**D19.** Moving coil with cardioid directional pattern and bass cut switch. Response 40-16,000 c/s. Source imp. 200 ohms or 50 K ohms. Price £19 10s. (low imp.) and £22 (high imp.).

**D88.** Moving coil stereo microphone. Response 80-15,000 c/s. Source imp. 200 ohms each channel or 50 K ohms with transformer. Sensitivity -75 dB low imp., -52 dB high imp. Double cardioid for stereo, broad cardioid for mono. Price £17 10s. low impedance, £19 10s. high impedance.

**D12.** Moving coil with cardioid directional pattern. Response 40-12,000 c/s  $\pm$  4 dB. Front to back ratio 15 dB. Sensitivity -77 dB. Source imp. 60 ohms, or to order. Price £34.

**C12.** Professional condenser. Sel. switch gives choice of 9 polar characteristics. Response 30-15,000 c/s  $\pm$  3 dB. Sensitivity -60 dB. Source imp. 50 and 250 ohms. Price £185.

The full range of A.K.G. professional and domestic microphones and accessories is available. Details on request.

★

**Bang & Olufsen, Struer, Denmark.** Sole U.K. Importers: Aveley Electric Ltd., Ayron Road, South Ockendon, Essex. Tel.: South Ockendon 3444.

**BM3.** Ribbon. Response: music 20-14,000 c/s  $\pm$  2.5 dB, speech bass cut below 1,000 c/s (2 position switch). Impedance 50 ohms. Price £14 10s.

**BM4.** As BM3 with variable output impedance, 50, 250, and 40,000 ohms. Price £16.

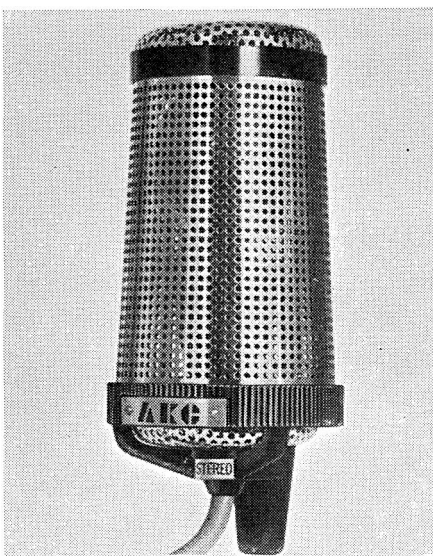

*AKG D88 moving coil stereo*

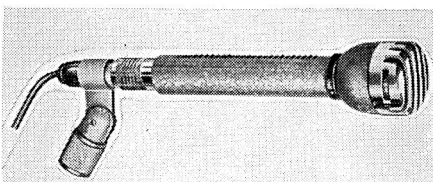

*AKG D19 moving coil*

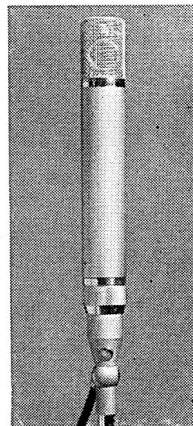
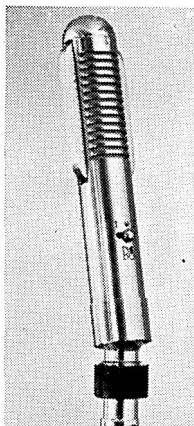

*Left: B & O Ribbon microphone. Right: AKG C12 condenser*



*Acos Mic. 40 ceramic*

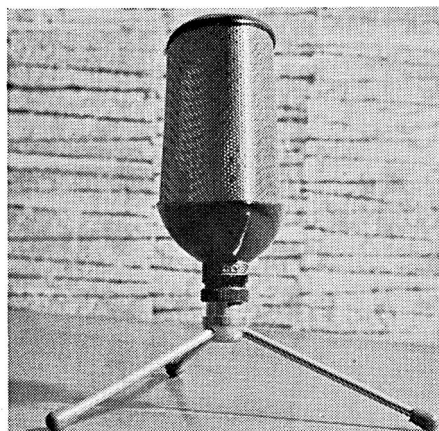

*Acos Stereo Mic. 44*

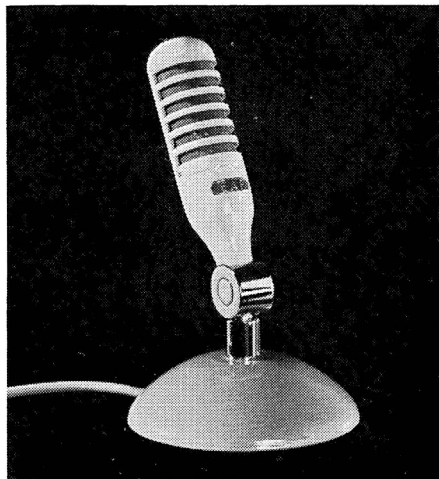

*E.A.P. Elizabethan Ribbon*

**Stereophonic Microphone Assembly.** Comprises two B & O ribbon microphones, plus stereophonic baffle assembly. Price £36 10s., with type BM3. £39 10s., with type BM4.



**Collaro Ltd.,** Ripple Works, By-Pass Road, Barking, Essex. Tel.: Ripplway 5533. Cables: Korllaro-Telex-Barking 28748.

**Studio Crystal.** Response 50-10,000 c/s. Sensitivity 1.8 mV/U.B. Source imp. 1,500 P.F. Rec. load imp. 5 megohm. 6-ft. cable. Tel. jack plug. Price £2 5s.



**Cosmocord Limited,** Eleanor Cross Road, Waltham Cross, Herts. Tel.: Waltham Cross 5206. Cables: Cosmocord, Waltham Cross.

**Acos Mic. 39-1.** Crystal. Response 40-15,000 c/s  $\pm$  6 dB. Sensitivity — 60 dB. Source imp. equals capacity of 800 pF. Rec. load imp. not less than 4.7 megohm. 8-ft. cable. Desk or floor stand, adaptor available. Price £3 3s.

**Acos Mic. 40.** Ceramic. Response 30-6,000 c/s. Sensitivity — 60 dB. Source imp. 2-5 megohms. Price £2.

**Acos Mic. 45.** Crystal. Response 30-6,000 c/s. Sensitivity — 50 dB. Source imp. 2-5 megohms. Price £2.

**Acos Stereo Mic. 44.** Crystal velocity. Response 50-6,000 c/s substantially flat or rising 6 dB per octave. Sensitivity — 62 dB, or — 50 dB rising. Source imp. 2-5 megohms. Price £6.



**E.A.P. (Tape Recorders) Ltd.,** Bridge Close, Oldchurch Road, Romford, Essex. Tel.: Romford 62366. Cable address: Elizabethan, Romford.

**Elizabethan.** Ribbon. Response 50-12,000 c/s. Sensitivity — 56 dB. Source imp. 50,000 ohms. Built in transformer. Price £7 17s. 6d.



**Film Industries Ltd.,** 90 Belsize Lane, N.W.3. Tel.: Hampstead 9632/3. Cables: Troosound, London.

**M.7.** Moving coil. Response 60-9,000 c/s. Source imp. 20 ohms. 6-ft. twin screened cable standard, other lengths if required. Table, desk and floor stands available. Price £6 5s.

**M.8.** Ribbon Response 35-13,000  $\pm$  3 dB. Standard source imp. 30 ohms with inbuilt transformer. Other impedances up to 57 K/ohms available 12-ft. twin screened cable standard, other lengths if required. Table, desk and floor stands available. Price £8 15s.

**General Electric Co. Ltd.**, Magnet House, Kingsway, London, W.C.2. Tel.: Temple Bar 8000. Cables: Polyphase, London.

**Studio Ribbon. BCS2373 and BCS2372S.** Response 50-14,000 c/s  $\pm$  1.5 dB. Sensitivity - 90 dB at 15-30 ohms, -89 dB at 250-300 ohms. Line transformer built in. Price £19 19s.

**BCS2249A.** Floor stand suitable for above mics. **BCS2246A** table stand. **BCS2255** "Boom" studio stand.

**BCS2378.** Ribbon. Response 50-8,000 c/s  $\pm$  2.5 dB. Impedance 30 ohms. Includes rotary ON/OFF switch, transformer, and length of screened cable. Price £10 5s.

**BCS2384.** Moving coil. Response substantially flat 200-10,000 c/s. Impedance 25-30 ohms. Price £8 18s. 6d.



**Grampian Reproducers Ltd.**, Hanworth Trading Estate, Feltham, Middx. Tel.: Feltham 2657/8. Cables: Reamp, Feltham.

**DP4/H.** Moving coil. Response 50-15,000 c/s. Sensitivity - 52 dB, - 70 dB, - 86 dB, for high, medium and low impedance. 50,000, 600, and 25 ohms. Tubular case. Price, including holder and lead. High or medium impedance £9 6s. 6d., Low impedance £8 6s. 6d.



**Lustraphone Ltd.**, St. Georges Works, Regents Park Road, N.W.1. Tel.: Primrose 8844. Cables: Lustraphon, London.

**LX55** Crystal. Response 30-8,000 c/s. High source imp. 9-ft. cable. Price £2 10s.

**Lustrette LD/61 Series.** Moving coil. Response 70-12,000 c/s. Source imp. low, line and high. Built-in trans. when required. 9-ft. cable. Price £3 7s. 6d.

**Master C51.** Moving coil. Response 50-8,000 c/s. Source imp. low, line and high. Built-in trans. for line and high. 3-pin moulded mic. plug. Stand as required. Price, low, £5 5s.; line and high, £5 15s. 6d.

**Master C48 and C48/S with Switch.** Moving coil. Response 50-8,000 c/s. Source imp. 20 ohms. 3-pin moulded mic. plug. 6-ft. cable. Price C48, £6 6s.; C48/S £7 7s.

**Hand Pencil LVF/H59.** Moving coil. Response 150-14,000 c/s. Source imp. low, line and high. Built-in trans. for line and high. 20-ft. cable for low and line. 9-ft. for high. Price £8 8s.

**Full-Vision LFV/59.** Moving coil. Response 150-14,000 c/s. Source imp. low, line and high. Built-in trans. for line and high. 20-ft. cable with low and line. 9-ft. with high. Stand as required. Price £8 18s. 6d.

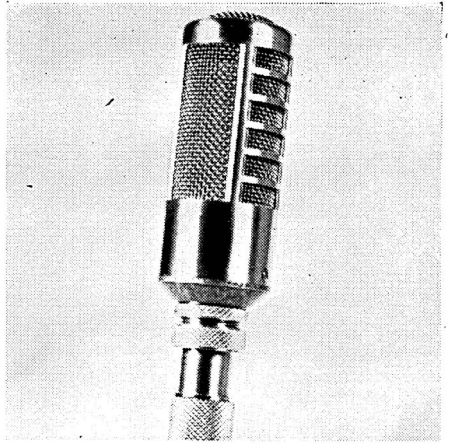

*Film Industries M.8 ribbon*

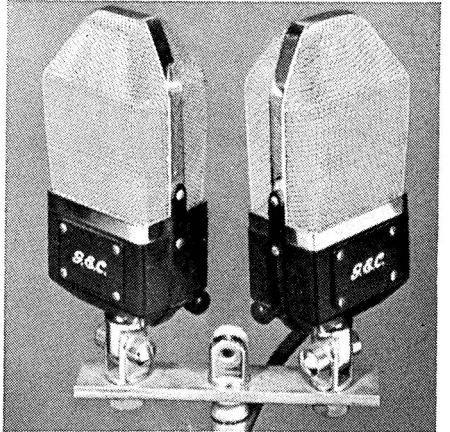

*Two G.E.C. Studio ribbon mics. mounted experimentally for stereo recording*



*Grampian DP4/H moving coil*





*Lustraphone LD/66*

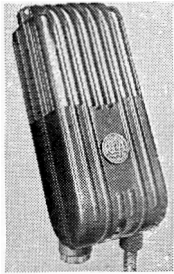

*Left: RCA  
Varacoustic LMI  
6203 C ribbon*

*Right: Lustra-  
phone Stereomic  
VR/65 ribbon*

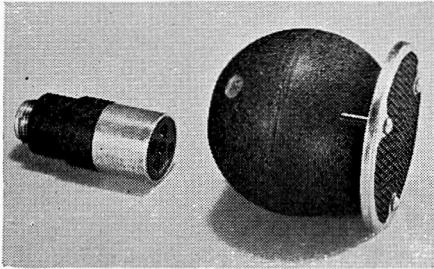

*STC 4021 moving coil*

**Lavalier LV/59.** Neck halter moving coil. Response 150-14,000 c/s. Low, line and high imp. Price £8 18s. 6d.

**LD/66.** Moving coil. Response 70-12,000 c/s. Sensitivity — 88, — 75, and — 52 dB, for low, line and high imp., respectively. Price £4 2s. 6d., low imp. £4 12s. 6d., line and high imp.

**Tubular Hand TH59/SB.** Moving coil with switch. Response 150-14,000 c/s. Sensitivity — 88 dB at 25 ohms, — 75 dB at 600 ohms, and — 54 dB at 50,000 ohms. Transformer as required. Price £8 18s. 6d.

**Studio VR/53.** Ribbon velocity. Response substantially flat to 14,000 c/s. Source imp. low, line and high. Built-in trans. 3-pin moulded mic. plug. 6-ft. cable. Stand as required. Price £9 19s. 6d.

**Ribbonette VR/64.** Ribbon. Response, substantially maintained up to 13,000 c/s. Source imp. low, line and high. Built-in transformer. 20-ft. cable for low and line. 9-ft. for high. Table base. Price £7 17s. 6d.

**Stereomic VR/65.** Dual head ribbon. Response 50-13,000 c/s. Sensitivity Stereo — 90 dB at 20 ohms. Source imp. 2 × 20 ohms or 2 × 300 ohms. Internal transformer. Price £31 10s.

**Lapel Mic. LP/62.** Electro-Magnetic. Response, substantially maintained up to 6,000 c/s. Source imp. 30 and 1,000 ohms. 6-ft. cable. Price £3 7s. 6d.

**Chest Harness DI59/B.S.** Moving coil. Response, substantially flat from 150-14,000 c/s. Source imp., low, line, high. 6-ft. cable. Price £11 11s.

**Velodyne VC52/THSB.** Noise cancelling moving coil with switch. Response rising to 1,700 c/s, flat to 3,500 c/s then falling. Source imp. 25 ohms or as required. Transformer as necessary. Price £8 18s. 6d.



**RCA Great Britain Limited,** Lincoln Way, Windmill Road, Sunbury-on-Thames, Middlesex. Tel.: Sunbury-on-Thames 3101. Cables: RCA, London. Telex: 28608.

**Varacoustic LMI. 6203C.** Ribbon. Response 60-10,000 c/s. Source imp. 50, 250 and 600 ohms. 30-ft., 2-conductor shielded cable. Stand as required.

**LMI. 6204C.** Ribbon. Response 60-10,000 c/s. Source imp. 40,000 ohms. 30-ft., 2-conductor shielded cable. Stand as required.



**Reslosound Ltd.,** Spring Gardens, Romford, Essex. Tel.: Romford 9087.

A range of semi-prof. and domestic microphones, including moving coils and ribbons. The latter are available in bi-directional or cardioid models, and a range of matching impedances is included. The base fitting incorporates the matching transformer and muting switches may be fitted if required. Details on application.



**Romagna Reproducers,** 2 Sarnesfield Road, Enfield, Middx. Tel.: Enfield 8717.

**HMC/1.** Crystal. Response 80-8,000 c/s. Sensitivity — 54 dB. Source imp. 2,000 p.f. Price £1 5s.

**HMM/1.** Dynamic. Response 60-10,000 c/s. Sensitivity — 60 dB. Source imp. inductive, 10,000 ohms at 1,000 c/s. Price £1 19s. 6d.

**HMR/1.** Ribbon. Response 35-12,000 c/s. Sensitivity — 60 dB. Source imp. 10,000 ohms at 1,000 c/s. Price £2 19s. 6d.



**Ronette,** Sole U.K. Importers: Trianon-Electric Limited, 3 Violet Hill, London, N.W.8. Tel.: Maida Vale 2255.

**Ronette.** 19 different crystal microphones. Response according to type from 50-10,000 c/s to 20-16,000 c/s. Source imp. 200 ohms. Rec. load imp. 5 megohms. Supplied with or without transformers. 9-ft. cable. Price range from £2 10s. to £17 10s. Desk stand DS5 £1 7s. 6d.



**Shure Brothers Inc.,** U.K. distributor J. W. Maunder, 95 Hayes Lane, Beckenham, Kent. Tel.: Beckenham 7413.

**55S Small Unidyne.** Moving coil. Response 50-15,000 c/s. Sensitivity — 57 dB at high impedance. Sourceimps. 35-50, 150-250 ohms, and high. Switched transformer built in. Price to be advised.



**Simon Equipment Ltd.,** 48 George Street, Portman Square, W.1. Tel.: Welbeck 2371. Cables: Simsale, London.

**Cadenza Ribbon.** Response 50-12,000 c/s. Sensitivity, high impedance — 58 dB, low impedance — 93 dB, or with suitable line transformer — 58 dB. Source imp. 30 ohms and 80 K/ohms. Price £8 18s. 6d.; with tripod desk stand and 11-ft. cable £10 10s.

**Cadenza Crystal.** Response 30-8,000 c/s. Sensitivity — 47 dB. Optimum load 10 megohms. Minimum load 1 megohm. Price £3 13s. 6d.



**Standard Telephones & Cables Ltd.,** Connaught House, Aldwych, London, W.C.2. Tel.: Holborn 8765. Telex: London 202385. Cables: Relay, London.

**4021.** Spherical omnidirectional moving coil. Flat response 30-15,000 c/s. Impedance 30 ohms. Sensitivity — 80 dB. Price £21.

**4032.** Moving coil hand microphone. Flat response 30-10,000 c/s. Impedance 30 ohms. Sensitivity — 78 dB. Windshield available. Price £18.

**4033.** Cardioid microphone. Moving coil and ribbon elements which can be used individually or in combination. Flat response 30-10,000 c/s. Impedance 50 ohms.



*Shure Bros. 55S Small Unidyne*

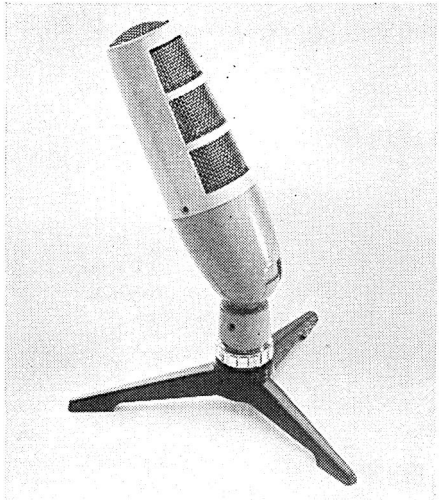

*The Simon Cadenza*

Sensitivity — 80 dB. Front to back ratio 15 to 20 dB. Price £46 10s.

**4035.** Moving coil. As 4032 above, but for stand mounting. Price £18 10s.

**4037.** Moving coil unobtrusive "Pencil" microphone. Flat response 30-15,000 c/s. Impedance 30 ohms. Sensitivity — 84 dB. Price £20.

**4038.** Studio ribbon microphone. Accurate figure-of-eight polar response. Flat response 30-15,000 c/s. Impedance 30 ohms. Sensitivity — 85 dB. Non-linear distortion 0.1%. Controlled transient response. Price £38 10s.

**4104.** Commentator's lip microphone. High degree of noise cancellation. Flat res-

ponse 70-10,000 c/s. Impedance 30 ohms. Output — 82 dB ref. 1v for 10 dynes/cm<sup>2</sup>. Price £75.

**4105.** Cardioid moving coil. Flat response 60-10,000 c/s. Impedance 30 ohms. Sensitivity — 82 dB. Front to back ratio 15 to 20 dB. Price £20.



**Tape Recorders (Electronics) Ltd.,** 784-8 High Road, Tottenham, London, N.17. Tel.: Tottenham 0811. Cables: Taperec, London.

**Sound M1.** Crystal hand mic. Response 20-16,000 c/s ± 15 dB. Rec. load imp. 1-5 megohm. 8-ft. screened cable and screened jack plug. Price £2 15s.

**Sound M2.** Moving coil. Impedance from built-in transformer 80,000 ohms. 8-ft. screened cable and screened jack plug. Price £5 12s. 6d.



**Technical Suppliers Ltd.,** Hudson House, 63 Goldhawk Road, Shepherds Bush, London, W.12. Tel.: Shepherds Bush 2581/4794. Cables: Teknika, London.

**M.1.** Dual impedance moving coil. Response 60-13,000 c/s. Sensitivity — 72 dB at 200 ohms, — 52 dB at 50,000 ohms. Built-in transformer. Price £4 4s.

**S.2.** Stereo dual impedance moving coil. Response 50-15,000 c/s. Sensitivity — 75 dB at 200 ohms, — 52 dB at 50,000 ohms. Built-in transformer. Price £19 19s.



**Trix Electrical Company Limited,** 1-5 Maple Place, London, W.1. Tel.: Museum 5817. Cables: Trixadio, Wesdo, London.

**G7871.** 3 models A, B, C. Moving coil. Response 50-8,000 c/s. Source imp. 30 ohms. G7871/A 18-ft. cable. G7871/B no cable, 2-pin plug. G7871/C 18-ft. cable, 3-pin locking type plug. Stand as required. Price A £7 10s.; B £8 8s.; C £9 9s.

**G7822.** 2 models B, C. Ribbon. Response 50-10,000 c/s. Source imp. 30 ohms. G7822/B 2-pin plug, no cable. G7822/C 18-ft. cable, 3-pin locking type plug. Stand as required. Price B £12 10s.; C £11.

Various types of floor and desk stands available, also flexible stems and hand grips.



**Vitavox Limited,** Westmoreland Road, London, N.W.9. Tel.: Colindale 8671. Cables: Vitavox, Hyde, London.

**B50.** Moving coil. Response 60-8,000 c/s. Sensitivity — 85 dB. Source imp. 25 ohms. 6-ft. cable. Price £6 10s.

**B51.** Crystal. Response 60-8,000 c/s. Sensitivity — 50 dB. Source imp. 1 megohm. 6-ft. cable. Price £5 10s.



*S.T. & Co. Type 4038 ribbon*

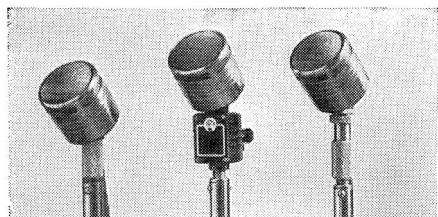

*Trix G7871 Models A, B and C*

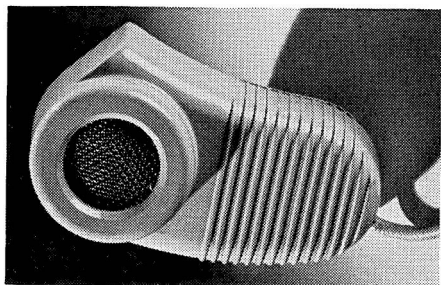

*Vitavox B52 moving coil*

**B52.** Moving coil. Response 60-8,000 c/s. Sensitivity — 85 dB. Source imp. 600/100,000 ohms. Built-in transformer. 6-ft. cable. Price £7 10s.

**Type A.** Moving coil. Response 60-8,000 c/s. Sensitivity — 82 dB. Source imp. 25 ohms. Rec. load imp. 25 ohms. Desk, table or pedestal stands. Price £9 9s.

# CINE SOUND

## An Introduction

**T**HE inclusion of a section on **Cine Sound** is a natural development of this annual reference book. Ever since the adoption of 'tape' by the audio enthusiast, there has been a steadily increasing interest in the coupling of tape and cine; and there is already a demand for good quality sound by those whose hobby is primarily cine, but who have become interested in audio matters as a result of their search for "the missing half".

### The Ingredients for Quality

Using the term "*Audio*" intentionally here, to cover the far wider field than that implied by the term "*hi-fi*", the amateur cine enthusiast has a large selection of recording equipment to choose from, as will be seen in the other sections of this book which deal with tape, recorders, microphones, mixers, etc. The field is considerably narrowed for the enthusiast whose aims are "*hi-fi*"—and by that we mean high fidelity reproduction of both the visual and the aural. It is an inescapable fact that there are no short cuts to really high quality sound; and the same applies to high quality movies. Both depend basically upon fine detail. Each demands that its own apparatus shall not fall below certain limitations. It is probably fair to state that *Hi-Fi Sound* and 16 mm cine are bracketed in this respect, and that 8 mm cine and *audio* are well paired. The expert will appreciate the distinction very readily: the newcomer should be made aware of it at the earliest possible moment.

### The Two Speeds

In terms of sound, the would-be purchaser of an 8 mm cine outfit must realise that he is limited to a quality of sound that is available at a tape speed of  $3\frac{3}{4}$  i/s. In order to step up to  $7\frac{1}{2}$  i/s sound quality, he must think in terms of 16 mm film.

In terms of pictures, the difference between 8 mm and 16 mm is approximately  $\times 4\frac{1}{2}$  the available definition, because the available area of photographic emulsion in an 8 mm

frame is under one quarter of that in a 16 mm frame. In terms of results, this rules out 8 mm cine for any serious work.

Far from damning 8 mm cine, however, the above statement will show the newcomer precisely which way to think. If he is in search of moving pictures, plus sound, that will provide him with good, average, everyday home entertainment—then he will be spending unnecessarily on 16 mm, and he can save himself money on the sound equipment too. On the other hand, if he intends "to go in for cine" (as opposed to making family and holiday movies), and if he is interested in making the type of pictures that demand fine detail—such as scenery and distant shots, then he should think in terms of sound equipment that is on a par with the 16 mm film equipment which he will need. As a final word for the uncertain, it should be said that 16 mm movie equipment, properly understood and handled, can produce sound films in the very highest class—more than adequate for the most particular amateur, and quite suitable for medium-sized halls and audiences. It is used almost exclusively for all TV work and industrial filming, both in black and white and colour.

### Marriage of Sound and Pictures

There are three ways of marrying sound and film. First, *optical sound*, which is beyond the limitations of 8 mm. Second, *magnetic sound on film*, which can be used with both film gauges. Third, *magnetic sound on tape*, with projector and tape recorder synchronised. Though the first of these systems will not be discussed here, it is mentioned briefly for the benefit of those who have it in mind to "go the whole way". It entails the initial making of a master sound track by magnetic recording; and this is either dubbed from a tape recording of good quality or, preferably, made direct on to 16 mm sprocketed magnetic film, as manufactured by EMI Ltd. The master copy of the cine film and the master sound track are then run together, mechanically locked in synchrony; and while

the film is printed, the output from the magnetic sound track is simultaneously photographed along the edge of the copy in the form of an optical track.

### **Magnetic Striping**

The second method involves "Striping" the film, and it is the most commonly used method for all but the most professional requirements which demand optical tracks. The quality from striped film can be very high, and it is used in conjunction with optical tracks for cinema work. Black-and-white films can be striped before they are exposed, so that the amateur can add his sound track immediately he receives his film from the processing station. Colour films, which have an anti-halation backing, cannot always be pre-striped. The stripe can be added to double perforated 16 mm film in the form of an "edge stripe", or as a "full stripe" down the wider area available on a single perforated (or "B-winding") film. It can also be added to a film which already carries an optical track, thus making it possible to add a second language commentary. A magnetic stripe can also be added to the edge of 8 mm films.

There are already several makes of 16 mm projectors with facilities for reproducing both optical and magnetic tracks, and most of these include a magnetic recording channel as well. 8 mm projectors with *record/replay* magnetic facilities are also available. Some projectors with "record" facilities provide two input points—for "line" and microphone—so that commentary or mixed input from several sources can be transferred to the magnetic stripe as the film is projected. Attachments are also available for projectors which have no built-in sound equipment. These attachments make it possible to use striped film.

It is of interest to note that film striping includes an additional "balancing stripe"

along the opposite edge of 16 mm film; and although this is only provided to maintain a physical spooling balance, it is available for the experimenter who has ideas for adding stereo sound to his movies!

It should also be noted here that, although such apparatus is still in the very high price bracket, there are now 16 mm cameras available with in-built recording heads. These, when used with the pre-striped film mentioned in an earlier paragraph, enable the sound track to be made while the film is being shot.

### **Tape Couplers**

The third method of marrying sound and film (either 16 or 8 mm) offers the amateur a far wider choice of equipment, and a great saving in cash; and it also gives him a very free hand in terms of technique, depending upon the degree of synchrony that he requires, and his ability to stabilise the running speeds of his tape recorder and projector. On the one hand, by tailoring his commentary, effects and musical background so that a reasonable amount of drift is tolerable, he can add sound to his film programmes by merely running tape recorder and projector side-by-side, and without any synchronising device. On the other hand, by means of a "tape coupler", he can hold his projector and recorder in fairly close synchronisation for recording and subsequent replays. As a middle course, there are various devices on the market which enable him to keep a fairly tight control of speed by the stroboscope effect.

### **Study the Directory**

Details of all the best known and currently available cine sound equipment, including cameras and projectors, are given in the following Directory Section, together with their prices and the addresses of the manufacturers or agents.

# DIRECTORY of CINE SOUND EQUIPMENT

**Note:** This Directory Section is as complete as careful and searching enquiries from overseas manufacturers and British Agents have made it possible. It will be appreciated if these and other manufacturers and agents will keep the Editorial Department of "Hi Fi Year Book" constantly posted with data and pictures, so as to ensure their inclusion in our next edition. Abbreviations used in the following text include: **fs**: es; **hs**=full, edge and half stripe. **f/r**=forward and reverse. **s/p**=still pictures. **fps**=frames per second. **sps**=suitable power supplies.

## ★ CAMERAS

**Neville Brown & Co. Ltd.**, 77 Newman Street, London, W.1. Tel.: Langham 7161. Cables: Nebrofoto, London.

**Bauer 88 ES.** 8 mm. Cine Camera. Lens; Schneider Xenoplan 1:1.9/13 mm. in focusing mount. Running speeds: 8, 16, 24, 48 f.p.s. Coupled exposure meter. Single pictures, synchro-running equipment for synchronised sound and picture shots. Weight 2 lb. 13 oz. Price £86 3s. (U.K. purchase tax £13 1s.)

**Bauer S Sound Coupler** for coupling 88ES camera to tape recorder. Price £45 4s. 6d.

**Bauer 88 DS.** As 88 ES, but with three lens turret head. Requires S coupler as above for synchronous recording. Price £107 (U.K. purchase tax £17 7s. 9d.)

★

**Rank Precision Industries Ltd.**, Gaumont-Kalee Division Studio, Woodger Road, Shepherds Bush, London, W.12. Tel.: Shepherds Bush 2050. Cables: Rankprest, London.

**Arriflex 16 mm.** Camera with Magnetic Stripe Equipment.

**Camera.** Mirror Reflex System. × 10 eyepiece magnifier. Rotating 3-lens turret, off-set design positions lenses with divergent optical axes. Lenses available: 12.5 mm, 16 mm, 20 mm, 25 mm. Lenses used on Arriflex

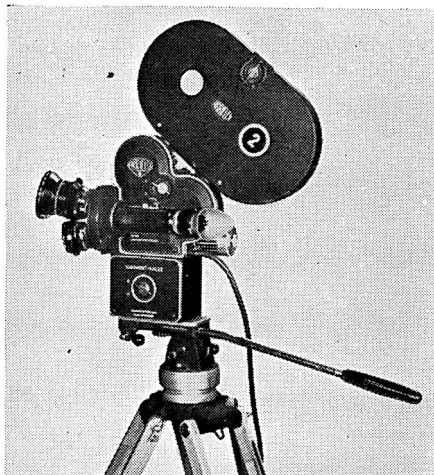

*Arriflex 16 mm camera*

35 mm camera can be employed on 16 mm Arriflex, with focal lengths ranging from 28 mm to 125 mm: extreme telephoto 200 to 600 mm. Loading: Standard 50 ft. and 100 ft. spools. Accessory magazines permit use of 200 ft. and 400 ft. spools. Transport: vertical twin claw with registration pin. Drives 8v DC motor with f/r switch. Rheostat provides speeds of 8 fps to 48 fps. Synchronous motor available for sound recording. **sps**: 8v DC from glass-wool lead or steel battery or 6v battery: up to 24 fps with standard motor. Synchronous motor requires AC. Weight with 3 lenses, 6½ lb. Battery 4½ lb. approx. Price, without lenses £461 5s.

**Sound attachment:** Camera requires modification to accept magnetic head. When fitted enables synchronised recordings to be made on 100 mil f/s on non-emulsion side, winding B films only. Sync. distance 28 frames. Recordings not affected in processing. Sound head can be removed from camera if required. Weight 5 lb. 8 oz. The sound attachment requires **1691 amplifier** for operation. Monitor output: direct and on playback. Operates on 7.5v battery. Two inputs with sensitivity of approx. 0.1 mV and 0.003 mV. Amplifier signal/noise better than 60 dB in normal conditions. Price: Amplifier and sound attachment, £565.

**Type 1830.** Portable Magnetic Recording Unit. Separate unit capable of accepting up to 400 ft. recordings on separate magnetic film with 100 mil f/s. Input sensitivity and signal/noise ratio identical to stripe attachment. Drive: synchronous motor with coupling to camera. Weight with case, 4 lb. 12 oz. Price £225.



## PROJECTORS

### 8 mm Magnetic Stripe Projectors

**D.W. (Cine Equipment) Limited**, 14-18 Ham Yard, Piccadilly, London, W.1. Tel.: Gerrard 7491.

**CirseSound, 8 mm.** Sps 110 to 240v AC. Lamp; 8v 50 watt A1/185. Amplifier output; 3 watts. Speaker; Philips Bi-phonic 8 in. Capacity; 400 ft. Speeds; 16 and 24 fps. Separate motor for sound head, s/p. Weight 45 lb. with case. Lens f 1.3 20 mm. Price £169 10s.



### 8 mm Projectors with Built-in Couplers.

**Johnsons of Hendon**, Hendon Way, London, N.W.4. Tel.: Hendon 7671. Cables: Bromide London.

**Eumig P.8.M. Imperial.** Sps 110 to 240v AC. Lamp; 12v 100 watt A1/186. Capacity; 400 ft. Variable speeds. Lens; 20 mm fl.4. Built in coupler suitable for any tape recorder working at  $3\frac{3}{4}$  in. per second. f/r. s/p. Power rewind. Price £45.



**Luminos Limited**, 1 Belsize Crescent, Hampstead, London. Tel.: Swiss Cottage 3399. Cables: Luminos, London.

**Noris Synchroner 100.** sps 110 to 240v AC. Lamp; 12v 100 watts A1/186. s/p. Power

rewind, cable release for editing punch marks. Lens; 20 mm Plankar. Built-in tape coupler suitable for any type of tape recorder with speeds of  $3\frac{3}{4}$  or  $7\frac{1}{2}$  i/s. Single connection between projector and recorder. Price £55. With 17 mm lens, £59.



### 16 mm Optical Projectors

**Simplex Ampro Ltd.**, 167-169 Wardour Street, London, W.1. Tel.: Gerrard 2911. Cables: Stafilm Newdo.

**E.B. New Educational.** sps direct from 200 to 250v AC or DC when using mains voltage lamp up to 1,000 watts. Through resistance unit 7105 with 110/115v A1/9 lamp up to 1,000 watts. Amplifier; AC/DC metal rectifier push-pull output, maximum output 6/8 watts. Two stage feed back-tone control. Speaker; 8 in. 15 ohm in lift off case. Automatic loop former. Capacity; 2,000 ft. Speeds; variable rheostat 16 to 24 fps. Automatic rewind. Lubrication control through central oil well. Weight 33 lb. Price £183.

**Model EDL. De Luxe Educational.** As above but fitted with still picture clutch and f/r. Price £197 10s. Additional 10 in. speaker for New Educational: £9.

**Simplex Ampro Mark II.** sps 110v AC or 200/250v AC when mains transformer 7102 is used. Lamp; 110v 750 watts A1/9 or



*Bauer 88 ES camera*

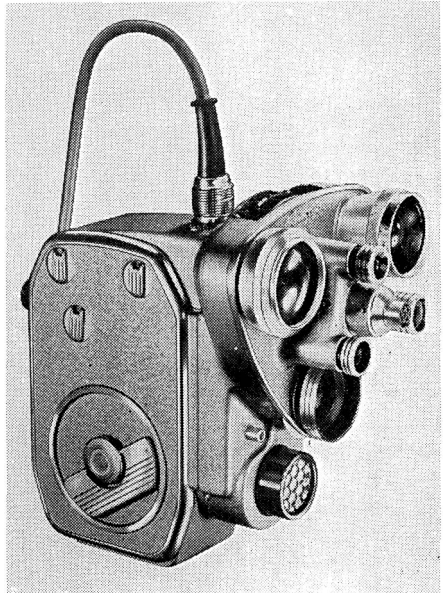

*Bauer 88 DS camera*

110v 1,000 watts A1/58. Amplifier out 15 watts push-pull. Separate microphone input cuts photocell. Capacity; 2,000 ft. Speeds; 16 and 24 fps. Speaker; 15 ohm 12 in. permanent magnet type in separate case. f/r. Weight 46 lb. Speaker 31 lb. Price £252 10s. Mains Transformer £22.



**Rank Precision Industries Ltd.**, Cine and Photographic Division, Mitcheldean, Gloucestershire. Tel.: Drybrook 421. Cables: Rankprecin Mitcheldean, Telex.

**Model 631 S.** sps 110v 50/60 cycles AC or 200/250v AC in conjunction with transformer. Lamp: 750 watts 100v A1/53 L.B. & H. or 1,000 watts A1/91 optional. Amplifier: 17-watt output, printed circuit. Independent base and treble controls. Speaker: 12 in. in separate case. Capacity: 2,000 ft. Speeds: 18 and 24 fps. f/r. s/p, variable aperture, for wide screen. Weight; projector 34½ lb. Speaker; 23½ lb. Power rewind. Price £246. Transformer, £18.

**Model 631 Compact.** Identical to Model 631 but with built-in detachable 6-in. speaker. Weight 37 lb. Price £219. Transformer, £18.

**Model 636.** sps 200/250v 50/60 cycles AC or DC. Lamp: Mains voltage 750 watts A1/53HV or 1,000 watts A1/91 optional. Amplifier output 8/10 watts. Printed circuit. Speaker 8 in. in separate case. Capacity: 2,000 ft. Speeds: 18 and 24 fps. f/r. f/p. Variable aperture. Power rewind. Weight 34½ lb. Price £221 10s.

**Model 636 S.** As above but supplied with 12-in. separate speaker. Price £239 13s.

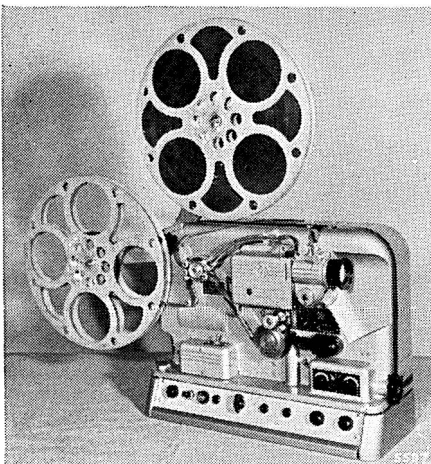

BTH 451 16 mm Projector

**Model 636 C.** As above but with 6-in. speaker built into the projector case. Price £214 10s.



**A.E.I. Sound Equipment Ltd.**, Crown House, Aldwych, London, W.C.2. Tel.: Temple Bar 8040. Cables: Soundequi Estrand.

**B.T.H. 450.** sps 110/120v AC or 200/250v with transformer. Lamp: 115v A1/9 750 watts adaptable to 250 watts high pressure mercury vapour lamp. Amplifier 30-watt output. Output impedance 7.5 ohms. Speaker: 12 in. 15-watt. Capacity: 2,000 ft. Speeds: 16 or 24 fps. f/r. Power rewind. Weight: projector in case 41 lb. Speaker 23 lb. Transformer 22 lb. Price £260.

**B.T.H. Model 452.** sps 200 to 250v AC. Lamp: mains voltage 750 watts A1/9. Amplifier output 10 watts. Speaker: 10 in. Capacity: 2,000 ft. Speeds: 16 to 24 fps. Power rewind. Lubrication: oil reservoir for mechanism grease pack ball-bearings. Price £215.



**Cinetechnic Ltd.**, 169 Oldfield Lane, Greenford, Middx. Tel.: Waxlow 1011. Cables: Cintec.

**Debie D16 Optical Sound Projectors.** Inter-convertable system of single mechanism with any of three different amplifiers. The following features are common to all models: sps 110v 50 cycles or with 1,000 watt transformer for 200/250v AC. Lamp: 110v 750 watts A1/52. Capacity: 2,000 ft. Speeds: 16 and 24 fps. No power rewind. Lubrication: automatic invisible oil feed by screw pump. Progressive rotary main switch providing intermediate lamp loading of 650 watts.

**D.16 Uni-compact.** Single case model. Amplifier output: 8 watts. Speaker: 8 in. Weight 58 lb. Price £276.

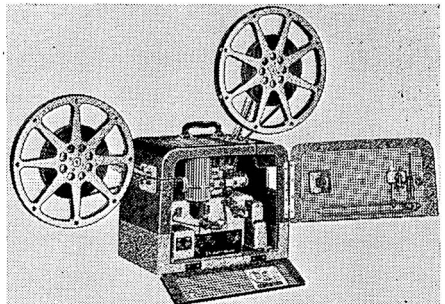

Bell & Howell Filmsound Models 631, 636, 640, etc.

## SOUND PROJECTORS — 16 MM

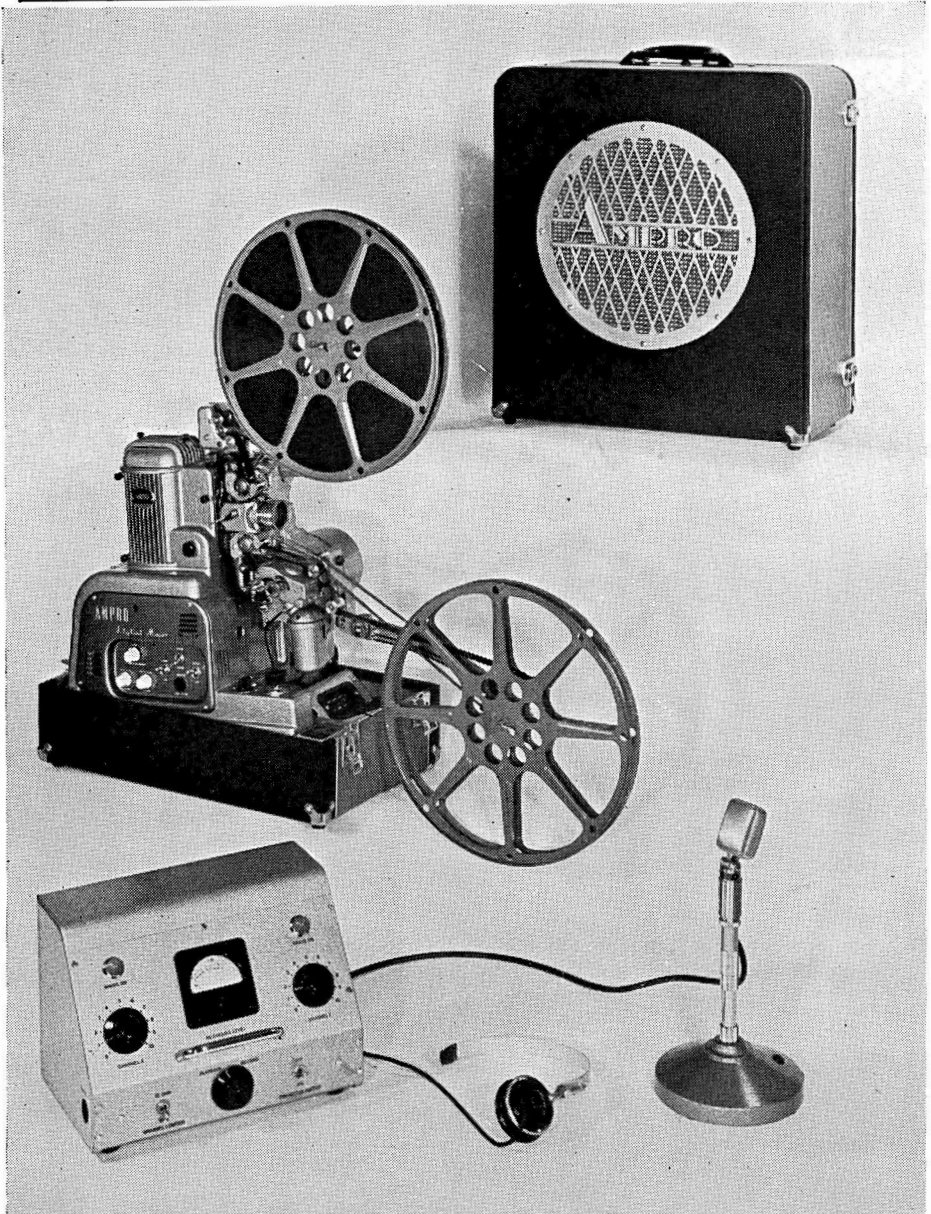

● The choice of sound projectors for 16 mm film is still very limited, but the quality of the available equipment is generally of a high standard. It may be grouped into three types: Optical only; Optical/Magnetic, with recording facilities on to magnetic stripe; Optical with magnetic playback facilities. Illustrated above is the Ampro Mk. III, with speaker, mixer, microphone and monitor headphone. Full details will be found in the directory section

**D.16 Duo-compact.** Two case model with 12 in. speaker. Amplifier output: 8 watts. Weight 80 lb. Price £305.

**D.16 Standard.** Two case model with 12 in. speaker. Amplifier output: 15 watts. Weight 80 lb. Price £340.

**D.16 Professional.** Two case model with 12 in. speaker. Amplifier output: 25 watts. Weight 102 lb. Price £440.



**RCA (Great Britain) Ltd.,** - Lincoln Way, Windmill Road, Sunbury-on-Thames, Middx. Tel.: Sunbury-on-Thames 3101. Cables: RCA London, Telex.

**RCA Hollywood.** sps 100/125v AC and 210/250v AC 50 or 60 cycles. Lamp: 110v 750 watts A1/9 or 1,000 watts A1/58, if external transformer is used. Mains voltage 750 watts A1/9HV or mains voltage 100 watts A1/58HV without need of external transformer. Amplifier output: 15 watts push-pull output. Separate bass and treble control. Speeds: 16 and 24 fps. f/r. Speaker: 15 ohm 12 in. high flux in separate case. Capacity: 2,000 ft. Weight: Projector 46 lb. Speaker: 21 lb. Price £252. Transformer, £19 10s.



#### 16 mm Optical Magnetic Projectors

**Simplex Ampro Ltd.** Address on page 176.

**Ampro Major Mark III.** sps 110v 50/60 cycles AC or 200/250 v AC in conjunction with transformer. Lamp: 110v 750 watts A1/9 or 1,000 watts A1/59 optional. Amplifier output: 15 watts max. push pull. Separate mic input and photocell input. Speaker: 12 in. Audium 60. Capacity: 2,000 ft. Speeds: 16 and 24 fps. f/r. s/p. Weight: Projector 46 lb. Speaker 31 lb. Console unit incorporating

mixer and DB meter. Cons: 29 lb. Trans: 29 lb. Remote control. Three channel input. Records and plays back es, hs, fs. Separate base and treble control. Optical tracks can be transposed to hs. Price £420. Reslo Ribbon Microphone, £11 5s. Single head set £1 17s. 6d. Additional pre-amplifier required for magnetic play back when console is not used, £17 12s. 9d. 7106 Transformer, £18.



**Rank Precision Industries Ltd.** Address on page 177.

**Bell & Howell Model 640.** sps 110v 50/60 cycles AC or 200/250v in conjunction with transformer. Lamp: 110v 750 watts A1/53 or 1,000 watts A1/91 optional. Amplifier output: 16/18 watts. Speaker: 12 in. in separate case. Capacity: 2,000 ft. Speeds: 18 and 24 fps. f/r. f/p. Variable aperture plate for wide screen. Power rewind. Records on es, hs, fs. Interchangeable head for twin track recording. Separate base and treble control. Modulation in flashing neon. Separate volume control for magnetic and optical allowing simultaneous reply. Power rewind. Weight: Projector 34½ lb. Speaker: 23½ lb. Price £348. Transformer, £18.



**A.E.I. Sound Equipment Ltd.** Address on page 177.

**B.T.H. 451.** sps 200/250v AC. Lamp: 110v 750 watts A1/9 or 1,000 watts optional. Amplifier output: 30 watts. Output impedance 7.5 ohms. Speaker: 12 in. high flux permanent magnet 15 watts. Linking lead available

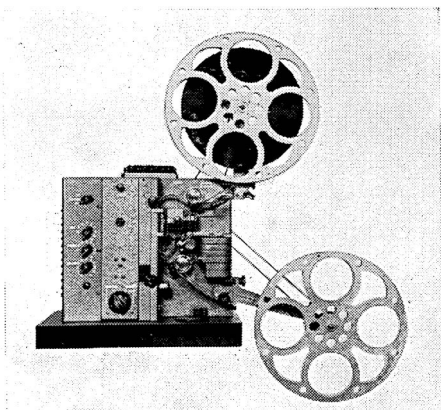

*RCA Hollywood Constellation*

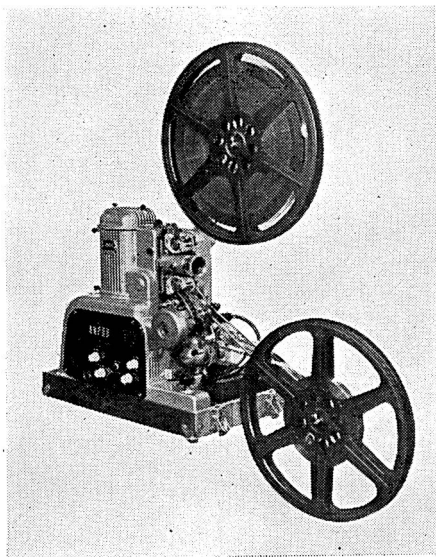

*Ampro New Educational*

for connection to second speaker when full output required. Capacity: 2,000 ft. Speeds 16 and 24 fps. s/p. f/r. Records on es, hs, fs. Separate base and treble control. Modulation indicator. Separate volume control for magnetic and optical allowing simultaneous replay. Optical tracks can be recorded on hs on the same film. Weight: Projector 42 lb. Speaker: 23 lb. Mains unit rectifier 22 lb. Price £375.



**Cinetech Ltd.** *Address on page 177.*

**Debie D.16 Magnetic Projector.** Any Debie optical sound projector can be converted to magnetic sound by addition of the magnetic sound equipment. Pre-amplifier unit type RP, hooks on to the normal amplifier. Inputs from microphone, disc and film. Volume indicator meter. Separate input volume control. Separate tone controls on play-back. Warning light indicator for "amplifier on" and recording. Magnetic sound head panel. Suitable for fs and hs. Three magnetic heads for recording, playing and monitoring/erasing, monitoring through head set is from the recorded track. Conversion of any optical model to magnetic can be carried out usually by the owner. Price: Conversion to Magnetic Record/Playback, £160. Conversion to Magnetic Playback only, £90.

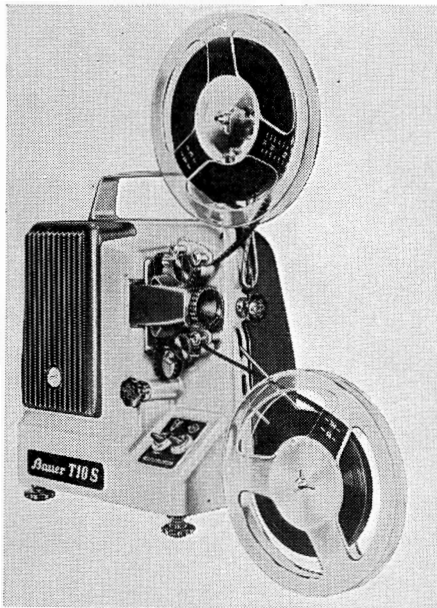

*Bauer T.10 S Projector*

**RCA (Great Britain) Ltd.** *Address on page 179.*

**RCA Hollywood Constellation.** sps 105/125v AC and 210/250v AC 50 or 60 cycles. Lamp: 110v 750 watts A1/9 or 110v 1,000 watts A1/58 if external transformer is used. Mains voltage 750 watts A1/9HV or mains voltage 1,000 A1/58HV without need of external transformer. Amplifier output: 15 watts push-pull. Separate bass and treble controls. Two input sockets with mixer controls. Monitoring socket. Records on es, ls and fs. Transfers optical tracks to magnetic. Simultaneous reply of optical or magnetic. Electronic recording — Neon glow - tube indicator. Speaker: 15 ohm 12-in. permanent magnetic in separate case. Capacity: 2,000 ft. Weight: Projector 46 lb. Speaker: 21 lb. Supplied with crystal hand mic. Price £356. Transformer, £19 10s.



#### **16 mm Optical Sound Projectors with Magnetic-Playback Facilities**

● These projectors are each modified versions of standard optical machines the specifications of which have been described under "optical sound projectors".

**Simplex Ampro Ltd.** *Address on page 176*

**Simplex Ampro Major Mark IV.** Identical to Major Mark II, with with magnetic sound head suitable for es, ls and fs, and magnetic pre-amplifier unit. Price £320.



**Rank Precision Industries Ltd.** *Address on page 177.*

**Bell & Howell Model 631 P.** Similar to Model 631 but with plug-in magnetic sound head identical with type used on Model 640. Re-designed amplifier incorporates selector switch and permits instant changeover from optical to magnetic reproduction. Head supplied suitable for es, ls and fs. Hs head available separately. Price £280. Single case

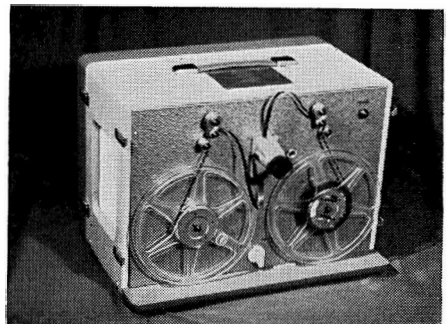

*Dominus Projector/Recorder Mk. I*

## PROJECTORS

Model 631CP also available as above but with detachable built-in 6-in. speaker. Price £243.



**RCA (Great Britain) Ltd.** *Address on page 179.*

**RCA Hollywood Star.** Modified version of the RCA Hollywood but with magnetic head suitable for reproduction of es, ls and fs. Selector switch permits instant change-over from optical to magnetic sound. Price £278. Transformer, £19 10s. Conversion of "Hollywood" to "Star", £27 5s.



**Neville Brown & Co. Ltd.** *Address on page 175.*

### Projector/Coupler Outfits

**Bauer T.10 S Projector.** sps 110v to 240v AC. Lamp: 12v 100 watts A1/186. Capacity: 400 ft. Fixed speed 16 fps. Lens: Kiptagon 16 mm fl.4. Socket for connecting sound coupler. Power Rewind. Weight 11 lb. 4 oz. Price £45.

**Bauer K Coupler.** For use with any tape recorder running at  $3\frac{3}{4}$  i/s. Single capstan. Electrical connection only with projector. Price £8 10s.



**Johnsons of Hendon.** *Address on page 176.*

**Eumig P8 Projector.** sps 110v to 240v AC. Lamp: 12v 100 watts A1/186. Capacity: 400 ft. Variable speeds. Lens: 20 mm fl.4. Hand Rewind. Weight 12 lb. Price £32.

**Phonomat.** Tape coupler attachment for Eumig P8. Synchronises with any tape recorder running at  $3\frac{3}{4}$  i/s. Converts projector to power rewind. Price £18 15s.

**Cinex Limited,** Bolex House, Burleigh Gardens, Southgate, N.14. Tel.: Foxlane 1041. Cables: Cinex London.

**Paillard Bolex Model M8R.** sps 110v to 250v AC. Lamp: 110v 500 watts A1/8. Capacity: 400 ft. Variable speeds. Power rewind. Lens: fl.4 15, 20 or 25 mm. Weight 11½lb. Price £59 17s. 6d.

**Paillard Bolex Synchronat.** Tape coupler for use with Paillard Bolex M8R projector. Projector requires modification to accept flexible drive between projector and coupler. Suitable for tape recorder running at  $3\frac{3}{4}$  i/s, or with tape recorder at  $7\frac{1}{2}$  i/s by means of an additional capstan. Outfit includes special projection table for positioning projector, recorder and coupler. Price £25.



**Peeling & Komlosy,** 181 Victoria Street, Dunstable, Beds. Tel.: Dunstable 1357.

**Movilux 8A.** sps 240v AC. Lamp: 8v 50 watts A1/185. Lens: Zeiss Sonnar fl.3 20mm. Permanent lubrication system. Induction motor gives uniform speed of 16 fps. Power rewind. May be used in synchronisation with any tape recorder by

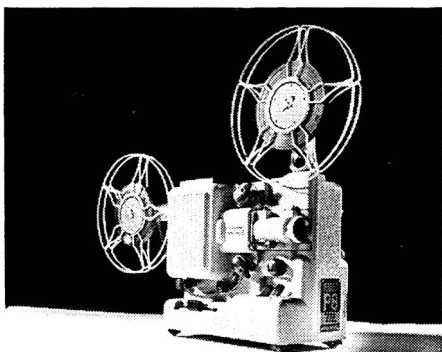

*Eumig P8M Imperial Projector*

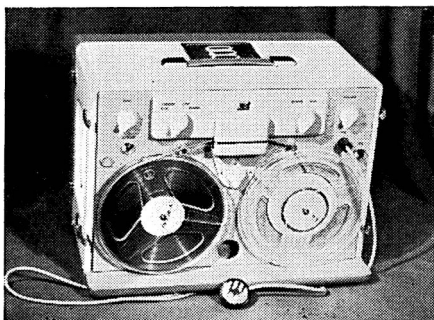

*Dominus Projector/Recorder Mk. II*

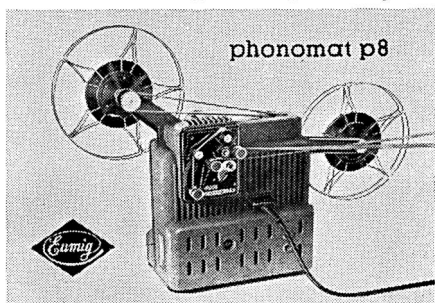

*Eumig P8 Projector showing phonomat tape attachment*



## SOUND PROJECTORS — 8 MM

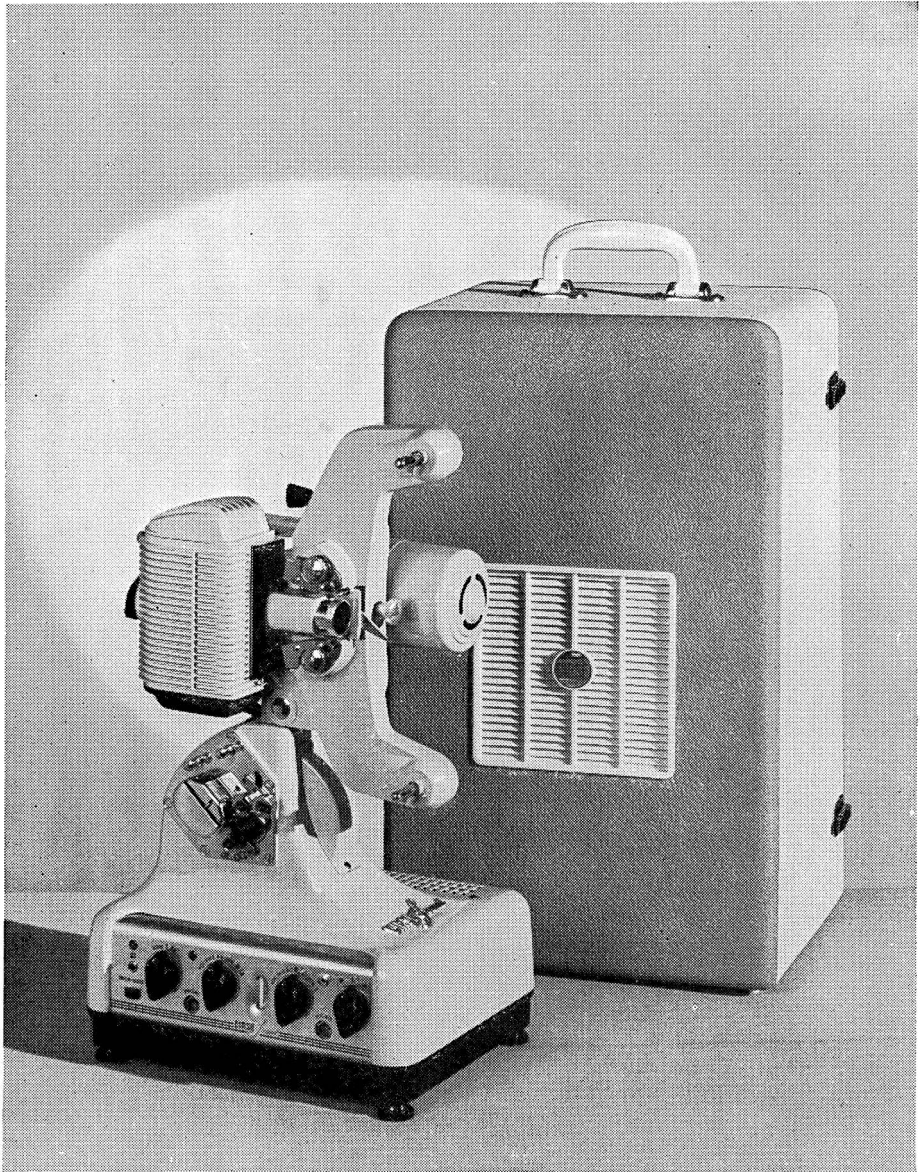

● Even more limited than for 16 mm equipment is the choice of sound projection equipment for 8 mm film; and, of course, for this film gauge the sound facilities are magnetic only. Many cine enthusiasts with tape recorders synchronise their apparatus with "couplers", but very good quality sound projectors are available for handling striped 8 mm film, and the "Cirse Sound" model illustrated above is deservedly popular. It is a combined Record/Playback instrument. Full details will be found in the directory section, and further details of the "Zonastripe" service for 8 mm users are given towards the end of the directory

means of the Zeiss sound coupler designed for this model. Available in five attractive colours. Price £52 19s. 6d. Case, £6 12s. 6d.

**Sound Coupler for Movilux 8A.** Plugs into the top of the Movilux 8A projector. Film and tape run over a common drive. No flexible shaft required between coupler and recorder. Price £9 12s. 6d. Case which also takes projector and accessories, £6 12s. 6d.

**Movilux 8B Projector.** sps 110, 125, 150, 220 and 240v. Lamp: 8v 50 watts A1/185. Lens: Zeiss P Sonnar fl.3 20 mm. Induction motor, providing three fixed speeds, 16, 18 and 24 fps. Power rewind. Price £62 12s. 6d.

**Moviphon B Sound Recorder.** Tape Recorder designed to work with Movilux 8B projector. Driven by flexible shaft from projector. Power supply by electrical connection with projector enables twin track recordings to be made. Supplied complete with speaker having built-in amplifier. Amplifier output: 3 watts. Price £123 5s. with speaker and microphone.

**Synchro Switch.** Attachment for Movilux 8B Projector, enables any tape recorder to be started automatically. Price £4 2s. 6d.

★

**Specto Limited, Vale Road, Windsor, Berks.**  
Tel.: Windsor 1241/2. Cables: Specto Windsor.

**Projectors available in 8 mm, 9.5 mm, and 16 mm.** sps 200 to 250v AC or DC or at slightly extra cost multi-voltage models from 110v to 250v AC or DC. Lamp: 110v 500 watts A1/8. Lens: 20 mm fl.6. Capacity: 800 ft. Variable speeds. Power rewind. Weight 13½ lb. Prices: 8 mm £43 15s.; 9.5 mm £48 10s.; 16 mm. £52.

**Speed Controller for Specto 500 models.** Attachment for fitting to 500 models to control projector speed exactly at 16 fps. Twin pressure button control for slightly increasing or decreasing projector speed. The speed controller can easily be fitted following maker's instructions. Price £9 15s.

★

**Dominus (England) Limited, 29 Cromwell Road, South Kensington, London, S.W.7.**  
Tel.: Kensington 8263. Cables: Domineng, Wesphone, London.

**Dominus Mark II Projector/Recorder.** Single unit projector and tape recorder. sps 200/240v AC. Lamp: 8v 50 watts A1/185. Amplifier output: 3.5 watts. Speaker: 7 in Elliptical. Capacity: Film 400 ft. Tape 1,200

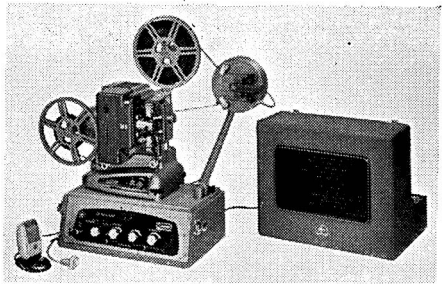

*Paillard Bolex Sonoriser*

ft. Speeds: Film 16 fps. Tape 3¾ or 7½ i/s. Lens: fl.5 25 mm Boyer. Weight 33 lb. Power rewind. fr on tape only. Pickup and microphone sockets with mixing facilities. Price £120.

★

## SERVICES & ACCESSORIES

### Magnetic Stripe Attachments

**Paillard Bolex Sonorizer.** 8 mm Magnetic Stripe attachment designed especially for use with Paillard Bolex M8R projector, but suitable for any 8 mm projector of similar design. Sound head to picture gate spacing 136 frames. sps 110, 125, 160, 220 or 240v AC 50 or 60 cycles. Amplifier output: 4 watts. Two input sockets mic. 0.1 mV/200 ohms. For tape recorder and record player: 100mV/500k ohms. Monitoring by neon indicator. Sound head supported by single column from the amplifier plinth. Projector stands on amplifier so that striped film passes through the sound film before passing through the projector. Unit packs away into speaker case. Weight 28½ lb. Superimpositions possible or complete erasure. Supplied complete with microphone, cables. Price £90.

★

### Stroboscopes

**Arrowtabs Limited, 93 Church Road, Hendon, N.W.4.** Tel.: Sunnyhill 3311/2.

**Strobe-o-Disc.** Synchronises any tape recorder running at 3¾ or 7½ i/s with any cine projector running at either 16 fps with three bladed shutter, or with a projector running at 24 fps with a two bladed shutter. Depends upon variable speed being fitted to projector. Disc is mounted on the edge of the recorder, at correct projector speeds the Strobe is stabilised. If the strobe moves the projector speed is adjusted. Price 35s. 6d.

**H.S. Engineering Company**, Malvern Close, Kenton, Harrow, Middx.

**Drumsyne Unit.** Stroboscope Disc supplied on small mounting bracket suitable for attaching directly to the deck of any tape recorder. Tape detours round the disc and is illuminated by attaching a small mirror on the projector lens. Two strobe tracks on the disc indicate 16 and 24 fps. Price 32s. 6d.



#### Magnetic Striping Service

**Zonal Film Facilities Limited**, Tower House, Hammersmith Broadway, London, W.6. Tel.: Riverside 8741. Cables: Zonograms, Hammer, London.

**Striping service** offered for all sizes of film; 16 mm films can be striped with es, hs and fs. Balancing stripe applied with 16 mm es. Fully coated film available in 8 or 16 mm, minimum length 400 ft.



#### Sound Laboratory Services

**United Motion Pictures**, 24 Denmark Street, London, W.C.1. Tel.: Temple Bar 2025.

**Duplicating** of all types of 16 mm undertaken. Colour and black-and-white films with magnetic stripe printed to optical track. Recording studio facilities available. Tapes and films synchronised on optical sound track. Details on application.



**Rank Precision Industries Ltd.**, G.B. Film Division, Aintree Road, Perivale, Middx. Tel.: Perivale 7481. Cables: Gesescope, Perivale.

**16 mm Duplicating** undertaken. 16 mm films with magnetic track printed on to optical sound track. Details on application.

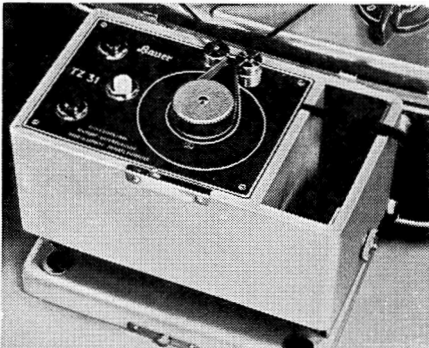

*Bauer Tape/projector Coupler N*

#### Sound Film Negative and Positive Raw Stock

**E.M.I. Sales & Service Ltd.**, Recording Materials Division, Blythe Road, Hayes, Middx. Tel.: Southall 2468. Cables: Emiservice London.

**Emifilm.** Fully coated perforated stock for sound film tracks. Made in three gauges—35, 17.5 and 16 mm. This sprocketed magnetic recording film is designed for cine, telecine and industrial use, for work where absolute synchronism is essential.

**Type 351** (35 mm) in 1,000 ft. reels. Prices: (1 to 19 reels) £8. (20 and over) £7 17s. 6d. per reel.

**Type 171** (17.5 mm) in 1,000 ft. reels. Prices: (2 to 18 reels) £4 5s. (20 and over) £4 2s. 6d. per reel.

**Type 161** (16 mm) in 1,000 ft. reels. Prices: (2 to 18 reels) £3 17s. 6d. (20 and over) £3 15s. per reel. In 1,200 ft. reels (1 to 19) £4 12s. 6d. (20 and over) £4 10s. per reel. In 2,400 ft. reels: (1 to 9) £9 5s. (10 and over) £9 per reel. Prices for shorter lengths, also illustrated leaflet giving specifications, dimensions, etc. on application. **Note:** Add the following suffixes to type numbers (e.g. 161B/D) for these different windings. A=Wound Oxide "in"; B=Oxide "out"; A/S=Oxide "in", single perforated; B/S=Oxide "out" single perforated; A/D=Oxide "in", double perforated; B/D=Oxide "out", double perforated.

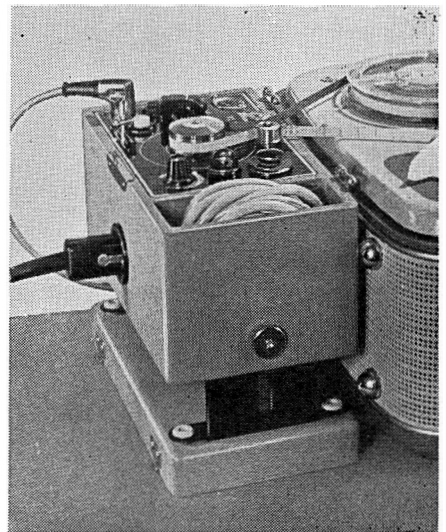

*Bauer Tape Coupler Model S*

# UNCLASSIFIED EQUIPMENT

★ *Details of the following equipment arrived too late for inclusion in the relevant directory. For full address where not mentioned, see directory referred to.*

**Argosy Radiovision Ltd.**, Eastern Avenue, West, Romford, Essex. Tel.: Romford 45991.

**28 TR.** G.P. portable tape recorder BSR deck. Price with tape and mic., £29 8s.

★

**Challen Instrument Co.** (see Battery portable tape recorders).

**Minivox Model C** Battery portable tape recorder  $3\frac{3}{4}$  and  $1\frac{7}{8}$  i/s. F.R.: up to 10,000 c/s at  $3\frac{3}{4}$  i/s. Output 600 milliwatts, 5-in. speaker unit. Spec. otherwise as model "B". Price £43 1s.

★

**Chitnis Electronics Ltd.** (see Domestic tape recorders).

**Model 9/54K.** G.P. portable recorder 4-track stereo.  $3\frac{3}{4}$  i/s,  $5\frac{3}{4}$  in. spools. F.R.: 30-16,000 c/s  $\pm$  3dB; S-N 55dB. Output 3 watts per channel. Superimposing, monitoring, stereo balance control. M.E. level ind.  $13 \times 10\frac{1}{2} \times 6$  in. Price £65 2s.

★

**Daystrom Ltd.** (see Constructional Kits).

**Heathkit USC-1.** Luxury stereo control unit. Inputs: Gram 1, 3-4mV; Gram 2, 150mV; Tape 1, 2.5 mV; Tape 2, 150 mV; Radio 150 mV; Mic. 3 mV; Aux. 4 mV 150 mV. Output, 1.3 volts. Push button selector, treble, bass, balance, volume. Variable low pass filter 4-12 Kc/s, switched rumble filter at 60 c/s. Size  $13 \times 4\frac{1}{2} \times 11\frac{1}{2}$  in. To operate with Heathkit MA-12 power amplifier. Price £17 19s. 6d.

**Heathkit OS-1** Service Oscilloscope. A compact portable unit for servicing and general laboratory work. Size  $5 \times 8 \times 14\frac{1}{2}$  in. Weight  $10\frac{1}{2}$  lb. Price £18 19s. 6d.

★

**Electrochord**, 5-6 Lorrimer Buildings, Olney Road, Walworth, London, S.E.17. Tel.: Rodney 3730.

**Electrochord Consolette** portable tape recorder, Collaro Studio deck. Price £44 2s., or £46 3s. 6d. with legs.

**Electrochord G.P.** portable. B.S.R. deck. Price £27 6s.

★

**Fisher Radio Corp. Inc.** - Distributed in the U.K. by Wilmx Ltd., 70 St. Stephen's House, Bridge Street, Westminster, London, S.W.1. Tel.: Whitehall 3213.

A range of Fisher products will be released in the U.K. during the Autumn of 1960,

these will include an 18 watts per channel integrated stereo amplifier; and a 50 watts per channel integrated stereo amplifier, with provision for a 3rd channel. Two radio tuners, an FM tuner and an FM/AM tuner.

**Kinemati SB1** visual stereo balance indicator. Price approx. £8.

★

**Gainsborough Tape Recorders**, 189 Northcote Road, London, S.W.11 Tel: Bat. 4718.

**Gainsborough G.P.** portable tape recorder. Collaro Studio deck. Price £41 19s.

★

**Garrard Engineering & Mfg. Co. Ltd.** (see Pickup accessories directory).

**SPG3** Stylus pressure gauge. 0-12 grammes with  $\frac{1}{2}$  gram. indication. Price 14s. 8d. (U.K. purchase tax 4s. 10d.).

★

**Goldring Mfg. Co. (Great Britain) Ltd.** (see Pickup directory).

**Stylus microscope** designed especially for the examination of pickup styli; it has variable magnification from  $\times 50$  to  $\times 150$  providing illumination both under and behind the stylus tip. A clip is fitted to hold any type of stylus in position under the lens. Price on application.

★

**Gramophone Co. Ltd.**, Blythe Road, Hayes, Middx. Tel.: Southall 2468 (see Amplifier directory).

**EMI Stereo pickup**, variable reluctance type. Range stereo substantially flat, 40-15,000 c/s, monaural 30-20,000 c/s. D.P. 2.5 grams, provided with its own lowering and raising device. Price including U.K. purchase tax, £19 19s.

**Model 558 AM/FM tuner.** Variable tuning. 88-108 Mc/s. 545-1,600 Kc/s. Magic eye tuning ind. Multiplex output. Cathode follower output stage. Self-powered. Price including U.K. purchase tax, £39 18s.

**Model 519.** Book case speaker system.  $13 \times 8$  ins. elliptical bass unit and two 3-in. tweeters, crossover at 4,500 c/s. Price £28 7s.

★

**K.G.M. Electronics Ltd.**, Bardolph Road, Richmond, Surrey. Tel.: Richmond 7171.

**Cinecorder**, intended primarily for use with Eumig Imperial 8 mm cine projectors. By the

use of perforated tape 100% synchronisation accuracy between tape and film is possible. Size  $16\frac{1}{2} \times 13\frac{1}{2} \times 8\frac{1}{2}$  in. Weight 28 lb. Price approx. £50.

★

**John Lewis & Co. Ltd.**, Oxford Street, London, W.1 and branches throughout Britain.

**Jonell Playdeck.** G.P. portable tape recorder. B.S.R. deck. M.E. level ind.  $2\frac{1}{2}$  watts output. Monitoring. Extension speaker socket. Size  $14\frac{1}{2} \times 14 \times 8$  in. Weight 19 lb. Price with tape, mic. and connecting lead, £24 3s.

★

**M.S.S. Recording Co. Ltd.** (see Tape recorder directory).

**Record/Replay and Erase tape heads.** High output which is sufficient to give a signal/noise ratio of over 60 dB relative to the noise of the first stage. Prices on application.

★

**Rogers Development (Electronics) Ltd.** (see Amplifier directory).

**Master Stereo control unit.** Inputs: Stereo pickup 3 mV; Monaural pickup 3 mV; Aux. 8 or 30 mV; Dual tape replay 1.5 mV; Dual tape replay 250 mV; Dual Mic. 3 mV; Dual tape record output sockets 250 mV. Selection by 6 push button; 6-position equalisation switch 3 disc and 3 tape. Treble, bass, balance, volume; ganged controls, 3-position low pass filter plus variable slope control. 3-position-high pass filter. 3-position function selector. Size  $14 \times 6\frac{1}{2} \times 5$  in. Weight 10 lb. Suitable for use with almost all power amplifiers. Price £35.

★

**Stereosound Productions Ltd.**, 12-14 Wakefield Road, Brighouse, Yorkshire. Tel.: Brighouse 2084.

**Carousel Radiotape.** G.P. Consolette tape recorder with provision for built-in FM tuner. Veneered walnut cabinet with legs. Price with spool of tape, £40 19s.

★

**A. R. Sugden & Co. (Engineering) Ltd.** (see Pickup directory).

**Omni-directional speaker enclosure** in distinctive Formica walnut finish designed to take an 8 in. speaker unit and a 3 in. H.F. unit. Size  $40 \times 16 \times 12$  in. Provisional price £22 10s.

Matching console to take Connoisseur turntable pickup and stereo amplifier. Size  $32 \times 18 \times 17$  in. Provisional price £27 10s.

**Tannoy Products Ltd.** (see Speaker directory).

**Type III LZ Dual-Concentric 10 in.** Moulded fibre cone. Gap flux (L.F.) 10,000 gauss (H.F.) 15,000 gauss H.C. 10 watts r.c.f. 1,800 c/s. Adjustable imp. 4, 8 or 15 ohms. Price approx. £22 10s.

★

**Teppaz S.A.**, Lyon ler, France - Sole U.K. distributors, **Selecta Gramophones Ltd.**, 50 Southwark Bridge Road, London, S.E.1. Tel.: Waterloo 2311.

**450 Integrated stereo amplifier.** Input sensitivity 100 mV at 1,000 c/s for Pickup, 7 mV at 1,000 c/s for special microphone model. Treble and bass control with visual indicator; slide controls for volume and balance. Output 6 watts per channel. Dist. 0.9% at 1 watt, 1.9% at 6 watts. Response 20-20,000 c/s. H and N - 60 dB. Out. imp. 2, 4, 8 and 15 ohms. Size  $14 \times 7 \times 5$  in. Weight  $10\frac{1}{2}$  lb. Price not yet available.

**C336 Integrated amplifier.** 8 watts output, slide controls for bass and treble with visual indicator. Size  $11 \times 7 \times 4\frac{1}{2}$  in. Weight  $10\frac{1}{2}$  lb. Price not yet available.

**Duo Dynamic speaker enclosure.** One 3D 2-in. drive unit and 3 tweeters. H.C. 10 watts. Impedance 8 ohms. Size  $28 \times 18 \times 12$  in. Weight 18 lb. Price not yet available.

★

**Technical Suppliers Ltd.** (see Speaker drive unit directory).

**MX3.** Crystal microphone. Response 50-13,000 c/s. Rec. load imp. 0.5 to 5 megohm. Price with desk stand, £2 5s.

★

**Walter Instruments Ltd.** (see Domestic tape recorder directory).

**404 G.P. portable recorder**  $7\frac{1}{2}$  and  $3\frac{3}{4}$  i/s. One motor. 7-in. spools. F.R.: 50-12,000 c/s at  $7\frac{1}{2}$  i/s. S-N  $< -35$  dB. M.E. level ind., straight-through amp.; provision for cine strobe; print circuit amp.; outlet from pre-amp stage; extension speaker socket. Size  $16\frac{1}{4} \times 12\frac{1}{4} \times 8\frac{1}{2}$  in. Weight 24 lb. Price with tape and mic., £44 2s.

**Mark IV mains/battery portable recorder.**  $3\frac{3}{4}$  i/s.  $5\frac{1}{2}$ -in. spools. F.R.: 50-9,000 c/s  $\pm 3$  dB. S-N  $< -40$  dB. M.E. level ind. Outlet from pre-amp stage. 7 transistors are used. 2.5 watts output. Price £49 7s.

★

**Wellington Acoustic Laboratories** (see Tape accessory directory).

**Waltrak.** A pocket Oscillator audio source providing 1,000 c/s signal from 0.01v to 2.5v. Battery operated. Size  $6\frac{3}{4} \times 2 \times 2$  in. Weight  $1\frac{1}{4}$  lb. Price £6 10s.

# AKG

AKUSTISCHE - u - KINOGERAETE GMBH

## *in the service of sound*

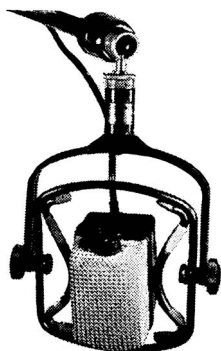

D.25

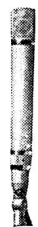

C.12

### D.25—STUDIO DYNAMIC

30-15,000 c/s,  $\pm 2.5$  dB. Front to back ratio — 20-25 dB. Sensitivity at 1,000 c/s — 0.22mV/microbar. Imp. — 60 or 200 ohms.

### D.24/B—STUDIO DYNAMIC

30-16,000 c/s  $\pm 2.5$  dB. Front-to-back ratio — 20 dB. With bass-compensating switch.

### C.12

A professional condenser microphone having electronically controlled variable cardioid pattern. As used by the world's

AKG microphones are sought after and used all over the world. The range available includes studio condenser and dynamic types with cardioid patterns which can be varied as required in use (these are used by broadcast, T.V. and film organisations throughout the world) and others particularly suitable for mono and stereo recorders at all levels of requirements. Many other types are available and details will gladly be sent on request.

most important radio, T.V. film and recording organisations.

### D.88—STEREO DYNAMIC

A very fine twin dynamic microphone with broad cardioid pattern and wide, smooth response. Ideal for modern stereo and mono recorders.

### D.11/N

Newly designed dynamic cardioid microphone with smooth response from 70 to 15,000 c/s. Produced specially for domestic tape recorders.

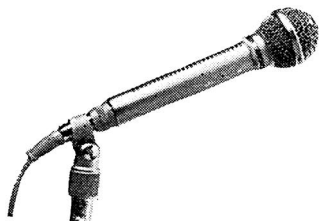

D.24/B

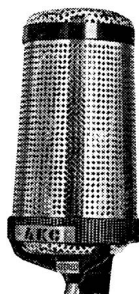

D.88

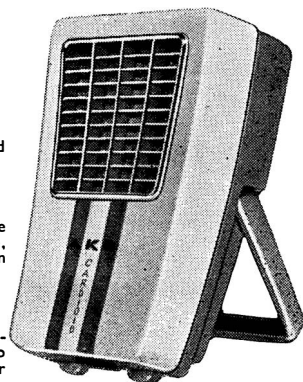

D.11/N

For further details write to the Sole Agents for U.K. and British Commonwealth.

# POLITECHNA

(LONDON)  
LTD.

3 PERCY STREET  
LONDON, W.1

Phone: LANgham 6236/7/8



# Presenting- outstanding Hi-Fi Equipment by COLLARO



**The RP594**  
4-Speed STEREO and MONAURAL  
Record Playing Unit

A fine new four-speed gramophone unit with a dynamically balanced, transcription quality motor.

Normally fitted with the latest counterbalanced type of pick-up arm which will house any of the "Studio" range of cartridges, including the ceramic stereophonic. The pick-up will track perfectly with a stylus pressure of 5-7 grammes.



**The "STUDIO" Tape Transcriber**  
Incorporated in many new Tape  
Recorders by leading Manufacturers

A three-speed machine giving speeds of  $1\frac{1}{2}$ ,  $3\frac{3}{4}$  and  $7\frac{1}{2}$  I.P.S., employing three motors. Heavy balanced flywheel with small diameter spindle as capstan gives a "wow" figure of less than .15% at  $7\frac{1}{2}$  I.P.S. Space is provided for the inclusion of a monitor or stereo playback head. Twin track single direction, using two magnetic heads, light piano key type controls. Rewind and fast wind on 1,200 ft. in 65 seconds.

Years of manufacturing experience have gone into the design of these two superb instruments.

# COLLARO LIMITED

**RIPPLE WORKS, BY-PASS ROAD, BARKING, ESSEX**

Telephone: Rippleway 5533 Telex: 28748 Telegrams: Korllaro, Telex, Barking

Makers of Record Changers, Tape Transcribers, Gramophone Units, Pick-ups, Electric Motors, etc.

# DIRECTORY OF HI-FI DEALERS

**IMPORTANT NOTE:** The following list is of shops where stocks of equipment are kept, and where facilities for demonstration exist. It is not necessarily a complete list, and we invite new dealers to submit details for future publications.

## LONDON AREA

AUDIO SERVICES, 189 East Barnet Road, New Barnet, Herts.

BERRYS (SHORT WAVES) LTD., 25 High Holborn, W.C.1

B.K. PARTNERS LTD., 229 Regent Street, W.1

THE CHELSEA RECORD CENTRE, 203 Kings Road, S.W.3

CITY SALES & EXCHANGE LTD., 93 Fleet Street, E.C.4

CLYNE RADIO (COMPONENTS) LTD., 18 Tottenham Court Road, W.1

CUSTOM HIGH FIDELITY, 371 Green Lanes, Palmers Green, N.13

ELECTRONICS (FLEET STREET) LTD., 152/3 Fleet Street, E.C.4

C. G. GODWIN LTD., 7 The Broadway, Wood Green, N.22

GRAMOPHONE EXCHANGE LTD., 80-82 Wardour Street, W.1

H. C. HARRIDGE, 8 Moor Street, Cambridge Circus, W.1

HARRODS LTD., Knightsbridge, S.W.1

H.M.V., 363 Oxford Street, W.1

HOLLEY'S, 315 Camberwell Road, S.E.5

ALFRED IMHOF, 112 New Oxford Street, W.1

LARG & SONS LTD., Hanover House, 76/77 High Holborn, W.C.1

LASKY'S RADIO, 207 Edgware Road, and 42 Tottenham Court Road

LEE ELECTRONICS, 400 Edgware Road, W.2

LEKTRA PRODUCTS, 118 Gordon Road, W.13

LEWIS RADIO, 120 Green Lanes, Palmers Green, N.13

MODERN ELECTRICS LTD., 164 Charing Cross Road, W.C.2

MUSIC IN THE HOME, 100 Queensway, W.2

MUSICRAFT, 80-82 Uxbridge Road, Ealing, W.13

NEWBURY RADIO, 305 Romford Road, Forest Gate, E.7

H. NORMAN DAVIS LTD., 665 Watford Way, Mill Hill, N.W.7

RADIO CENTRE, 33 Tottenham Court Road, W.1

RIMINGTON VAN WYCK LTD., 42/43 Cranbourn Street, W.C.2

H. L. SMITH & CO. LTD., 287-9 Edgware Road, W.2.

A. L. STAMFORD, 98 Weymouth Terrace, E.2

STANWOOD RADIO LTD., 715 High Road, Leyton, E.10

STERN RADIO LTD., 109 Fleet Street, E.C.4

STUDIO 99, 57 Fairfax Road, Swiss Cottage, N.W.6

TELE-RADIO (1943) LTD., 189 Edgware Road, W.2

JOHN TRAPP LTD., 371 Green Lanes, Palmers Green, N.13; 15 Crouch End Broadway, N.8

TELESONIC LTD., 153 Tottenham Court Road, W.1

TROUGHTON & YOUNG LTD., 143 Knightsbridge, S.W.1

WEBBS RADIO, 14 Soho Street, W.1

## BANGOR (N. WALES)

JOHN SHINN & SONS LTD., "Melody House", High Street

## BATH (SOMERSET)

C. MILSOM & SON, North Gate

## BEXLEYHEATH (KENT)

Broadway Radio, 228 Broadway

## BIRMINGHAM

GRIFFIN RADIO LTD., 122 Bristol Street, Birmingham 5

HOLLICK & TAYLOR, 16 Grosvenor Road, Handsworth Wood, Birmingham 20

JEWKES & CO., 285 Broad Street

## BLACKPOOL

F. BENFELL LTD., 17 Cheapside

## BOGNOR REGIS

TANSLEY & COOKE LTD., 3/4 Odeon Buildings

## BOLTON

HARKER & HOWARTH, 7 The Arcade, Bradshawgate

STEREOLECTRICS, 150 Higher Bridge Street

## BOURNEMOUTH (HANTS.)

NATIONAL RADIO SUPPLIES, 66 Holdenhurst Road

## BRIGHTON (SUSSEX)

JOHN KING (FILMS) LTD., East Street

LANES, 11 Gardner Street

LYON & HALL LTD., 92 Western Road

## BRISTOL (SOMERSET)

BRISTOL & WEST RECORDING SERVICES LTD., 6 Park Row

RECORD CENTRES (BRISTOL) LTD., 5 Denmark Street, Centre 1

## BROADSTONE (DORSET)

BREACH OF BROADSTONE, 173 The Broadway

## CAMBRIDGE

ADAMS & DELLAR LTD., 66 Regent Street

H. GEE, 94a Mill Road

K.P. CAMERA SHOP, 12a King's Parade

G. P. REECE, 1 & 2 Peas Hill

UNIVERSITY RECORDINGS, 16 Burleigh Place

## CANTERBURY

GOULDENS, 36 High Street

## CARDIFF

J. GOUGH & CO. LTD., 148-154 North Road

## CARLISLE

MISONS, Citadel Row

## CHELTENHAM

CAVENDISH HOUSE (CHELTENHAM) LTD., Ray Electrical, 287 High Street

## CHICHESTER (SUSSEX)

STORRY'S, 83 North Street

# FRANCIS OF STREATHAM

*invite all  
Hi-Fi and Recorder  
enthusiasts to their  
South London Showrooms*

FOR LARGE AND UP-TO-DATE STOCKS  
OF EQUIPMENT BY LEADING  
MANUFACTURERS AS ADVERTISED  
IN HI-FI NEWS, TAPE RECORDER, ETC.

- |                 |                    |
|-----------------|--------------------|
| ★ FERROGRAPH    | ★ LEAK             |
| ★ BRENNELL      | ★ QUAD             |
| ★ GRUNDIG       | ★ JASON            |
| ★ PHILIPS       | ★ GARRARD          |
| ★ TELEFUNKEN    | ★ Lenco            |
| ★ REFLECTOGRAPH | ★ LUSTRAPHONE      |
| ★ VORTEXION     | ★ RESLO            |
| ★ SIMON         | ★ ARMSTRONG        |
| ★ FI-CORD       | ★ DULCI, etc. etc. |

**NO CHARGES FOR  
CREDIT FACILITIES**  
★  
**LARGEST SELECTION  
OF LATEST MODELS**

Personal attention  
to all enquiries  
without obligation.

**WRITE ★ CALL ★ 'PHONE**  
*Please mention Hi-Fi Year Book when writing*

## FRANCIS OF STREATHAM

**169-171 and 181, STREATHAM HIGH ROAD, LONDON, S.W.16**

Between Streatham Station and St. Leonard's Church ★ Phone: STReatham 0466 & 0192

**COVENTRY**

ELECTRONIC SERVICES, 110 Gosford Street  
RADIO EXPERIMENTAL PROD., 33 Much Park Street  
R.E.S. (COVENTRY) LTD., 128 Far Gosford Street

**CHRISTCHURCH (HANTS.)**

RONALDSONS, 10 Castle Street

**CULCHETH (LANCS.)**

JOHN SHINN & SONS LTD., "Melody House", 435  
Warrington Road

**DARLINGTON**

PALMERS, 3 East Street

**DERBY**

DALTON & SONS LTD., 11 London Road  
DIXONS (DERBY) LTD., Strand Arcade  
VICTOR BUCKLAND LTD., 37-39 London Road

**DORKING**

THE HIGH FIDELITY CENTRE, 61 West Street

**DUNDEE**

LARG & SONS (DUNDEE) LTD., 16-24 Whitehall  
Street

**DUDLEY (WORCS.)**

RADIO TELEVISION SERVICE, 214 High Street  
J. P. WHITTAKER & SON, 214 High Street

**EASTBOURNE**

MODERN TECHNICAL SERVICES, 71 Seaside Road

**EDINBURGH**

ACOUSTIC PRODUCTS, 54 Elm Row  
GEO. JEFFREY, 23 Earl Grey Street  
W. JEFFREY & SON LTD., Audio House, 23 Earl Grey  
Street  
J. NICHOLSON, 1 Haddington Place

**EXETER**

FILDEWS (ENGINEERS) LTD., 99 Fore Street

**FARNHAM (SURREY)**

THE RECORD SHOP, 26/27 Downing Street

**GLASGOW**

JAMES KERR & CO. LTD., 435 Sauchiehall Street

**GRIMSBY (LINCS.)**

JOHN ANGLIN, 385 Cleethorpe Road  
CHARLES PERRITT LTD., 242 Freeman Street  
LINCOLNSHIRE INSTRUMENT CO., 77 Cartergate

**GUILDFORD**

J. A. TOWNSEND LTD., 5 Tunsgate

**HALIFAX**

TREVOR FAWTHROP LTD., 17 Rawson Street

**HAMPTON HILL (MIDD.X)**

MELFORD RADIO, 58 Windmill Road, & 181 High Street

**HANLEY (STAFFS.)**

HI-FI SOUND EQUIPMENT, 116 Birches Head Road

**HARROGATE**

JOSEPH NICHOLSON, 13 Montpelier Parade

**HIGHCLIFFE-ON-SEA (HANTS.)**

J. H. WOOD .117 Ringwood Road

**HIGH WYCOMBE (BUCKS.)**

M. W. KEEN, The Chantry Studio, Paul's Row

**HOVE (SUSSEX)**

RECORD ROUNDUP, 154 Portland Road, Hove 3

**HUDDERSFIELD**

GORDON ROBERTS, Yorkshire Sound Centre, 5  
Outcote Bank  
J. WOOD & SONS LTD., 67 New Street

**HULL**

EAST HULL RADIO & RECORDS, 27 Holderness Road

**IPSWICH (SUFFOLK)**

R.C.S., 61 Fore Street

**KEIGHLEY (YORKS.)**

J. S. RAMSBOTHAM & CO. LTD.

**KIDDERMINSTER**

F. W. LONG, 14 Mill Street

**KINGSTON-ON-THAMES (SURREY)**

R. K. APPELBY, 30 London Road

**LEAMINGTON SPA**

TYSONS, 41 Russell Street

**LEATHERHEAD (SURREY)**

MAURICE RICHARDS LTD., Radio House, The Crescent

**LEEDS**

VALLANCE & DAVISON LTD., 144 Briggate  
P.W.B. AUDIO, 41 Call Lane

**LEICESTER**

G. W. COWLING LTD., 26 Belvoir Street  
DALTON & SONS LTD., 76 Granby Street  
LEICESTER CO-OPERATIVE SOCIETY LTD., High Street

**LEIGH (LANCS.)**

JOHN SHINN & SONS LTD., "Arcadia", Market Street

**LIVERPOOL**

BEAVER RADIO LTD., 60-62 Whitechapel  
LAMBOLA RECORDING COMPANY LTD., 95 Liverpool  
Road, Liverpool 23

**LOWESTOFT**

E.J.P. SOUND SYSTEMS LTD., 118 High Street

**LUTON (BEDS.)**

S. FARMER & CO., 2 Wellington Street, 83 George Street  
COVENTRY RADIO, 189 Dunstable Road

**MACCLESFIELD (CHESHIRE)**

HI-FI HOUSE, 123 Chestergate

**MAIDSTONE (KENT)**

HIGH FIDELITY (MAIDSTONE) LTD., 57 King Street

**MALVERN**

RANFORD RADIO LTD., Barnards Green

**MANCHESTER**

FORSYTH BROTHERS LTD., 126-128 Deansgate  
LANCASHIRE HI-FI, 8 Deansgate  
HIMES & ADDISON, 37 John Dalton Street, Albert  
Square 2  
NORTHERN ELECTRONIC COMPONENTS, 227b,  
Oxford Road  
RARE RECORDS, 4 Oxford Station Approach

**MIDDLESBROUGH**

AUSTIN KYME LTD., 67 Corporation Road  
PALMERS OF MIDDLESBROUGH, 106 Newport Road

**MITCHAM (SURREY)**

HOME RADIO (MITCHAM) Ltd., 187 London Road

**MONTROSE**

LARG & SONS, 135 High Street

# Stern's

## for VERY HIGH FIDELITY

### MODEL "C" TAPE PRE-AMPLIFIER

INCORPORATING THE NEW FERROX CUBE POT CORE PUSH-PULL OSCILLATOR and THREE-SPEED TREBLE EQUALISATION by means of the latest FERROX CUBE POT CORE INDUCTOR, Prices . . . INCLUDING SEPARATE SMALL POWER SUPPLY UNIT:

**Hire Purchase Terms**—Assembled Unit only. Deposit £3/8/- and 12 monthly payments of £1/4/11.

**COMPLETE KIT OF PARTS**      **£14.00**      **ASSEMBLED AND TESTED**      **£17.00**

Deposit £3/8/- and 12 months of £1/4/11. Assembled unit only. ALSO AVAILABLE EXCLUDING POWER SUPPLY UNIT FOR

A HIGH FIDELITY Tape Preamplifier based entirely on the latest design by MULLARD LABORATORIES. It is ideally suitable to form the "LINK" required to add tape facilities to "high Fidelity" and domestic sound installations now in use. PRICES EXCLUDING this Unit £11/15/- and £14/10/- respectively.

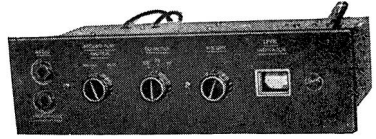

CAN BE SUPPLIED MATCHED FOR BRENELL · COLLARO WEARITE · MOTEK · TRUVOX TAPE DECKS

### THE MODEL HF/TR3 TAPE AMPLIFIER

Incorporating

**THREE-SPEED TREBLE EQUALISATION** by means of the latest FERROX CUBE POT CORE INDUCTOR

PRICE for

**COMPLETE KIT OF PARTS**      **£12.15.0**      **FULLY ASSEMBLED AND TESTED**      **£16.10.0**

**HIRE PURCHASE:** Deposit £3/6/6 and 12 months at £1/4/2. —

A very high-quality amplifier based on the very successful Type "A" design completed in the MULLARD LABORATORIES. ONLY NEW HIGH-GRADE COMPONENTS are incorporated including MULLARD VALVES and a GILSON OUTPUT TRANSFORMER . . . other features are: Magic Eye Recording Hand Indicator—Effective Tone Control—Monitoring and Extension Speaker Sockets—has own Power Supply and can be used as independent Amplifier for direct reproduction of Gram Records or from Radio Tuner. Overall size 11 x 6 x 6 in.—Truvox-Collaro—or Brenell—please specify which. Send S.A.E. for leaflet or 2/6 for Assembly Manual.

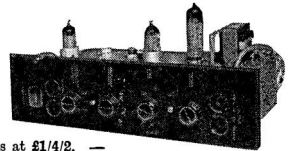

### THE MODEL HF/G2P TAPE PREAMPLIFIER THE MODEL HF/G2A TAPE AMPLIFIER

Designed to our usual High Technical Standard, being based on the very successful Mullard Tape Designs. They incorporate MULLARD VALVES and only HIGH-GRADE COMPONENTS . . . AS A RESULT WE PRESENT

**TWO UNITS METICULOUSLY MATCHED TO CORRECTLY OPERATE**

**THE NEW GARRARD "MAGAZINE" TAPE DECK**

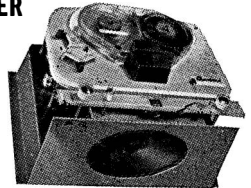
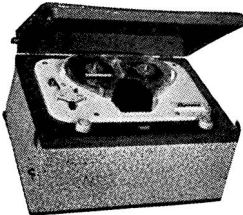

Both units form an entirely new "Easy to handle" presentation, each is completely self contained with power supply. Loudspeaker (Amplifier HF/G2A only), and all INPUT and OUTPUT sockets being incorporated on the chassis, which itself is constructed to allow for direct attachment to the tape deck (as shown in illustration). Thus the tape deck with the Amplifier (or Pre-Amplifier) fixed to it form ONE COMPLETELY SELF-CONTAINED WORKING UNIT which requires only screwing into a Cabinet and Connecting to the Mains supply.

#### MODEL HF/G2A AMPLIFIER

- Complete Tape Amplifier—Incorporating . . .
- Magic Eye Level Indicator
- Volume Control
- Superimpose Switch
- Effective Tone Control
- Monitoring Facilities
- Extension Loudspeaker Socket
- Inputs for recording from . . . Mike, Gram and Radio Tuner.
- Incorporates Loudspeaker and Power Supply on Chassis.

#### MODEL HF/G2P PRE-AMPLIFIER

Such as our MULLARD RANGE of Amplifiers, and also admirably suitable to operate through the Pick-Up Sockets of most Radio Receivers. It incorporates:

- Magic Eye Level Indicator and Control
- Superimpose Switch
- Inputs for recording from . . . Mike, Gram and Radio Tuner
- Power Supply on Chassis

#### WE OFFER AS FOLLOWS:

- (a) MODEL HF/G2R PORTABLE TAPE RECORDER  
Includes Spool of L.P. Tape and Crystal Microphone . . . . . **£33.0.0**  
H.P. Terms: Dep. £6/12/-, and 12 months of £2/8/6.
- (b) MODEL HF/G2A-D, comprising AMPLIFIER and TAPE DECK. Includes Spool of L.P. Tape and Loudspeaker . . . . . **£27.10.0**  
H.P. Terms: Dep. £5/10/-, and 12 months of £2/0/4
- (c) ASSEMBLED and TESTED AMPLIFIER, MODEL HF/G2A . . . . . **£15.0.0**  
H.P. Terms: Dep. £3, and 12 months of £1/2/-.
- (d) MODEL HF/G2PP PORTABLE PREAMPLIFIER, Complete in Portable Case (like HF/G2R) H.P. Terms: Dep. £6, and 12 months of £2/4/-.
- (e) MODEL HF/G2P-D Comprising PRE-AMPLIFIER and TAPE DECK. Includes Spool of L.P. Tape H.P. Terms: Dep. £5/4/-, and 12 months of £1/15/2.
- (f) ASSEMBLED and TESTED PRE-AMPLIFIER MODEL HF/G2P . . . . . **£14.0.0**  
H.P. Terms: Dep. £2/16/-, and 12 months of £1/0/6.

As is usual with GARRARD products this Tape Deck is a Precision Engineered Unit of Excellent Quality operating two tracks at 3 1/2 in./sec. speed. It is the "Easiest to Handle" Tape Deck, having only two controls and incorporates the new instantaneous Tape loading Magazine which makes tape loading as simple as putting on a Record.

# STERN RADIO LTD

109 and 115 FLEET STREET,  
LONDON, E.C.4      FLEet 5812/3/4

**NEWCASTLE-UPON-TYNE**

PAYNE &amp; HORNSBY LTD., 3 Andrews House, Gallowgate

HAYMARKET RADIO, 23 Leazes Park Road

**NEWTON ABBOT**

D. O. H. COLES LTD., 13 Courtenay Street

**NORTHAMPTON**

CRYER'S 222/224 Wellingborough Road

**NOTTINGHAM**

ALEX OWEN LTD., Station Road, Beeston

**OXFORD**

LOWE &amp; OLIVER, Ship Street

HORNS, 6 South Parade

L. WESTWOOD, 46 George Street

**PETERBOROUGH**

CAMPKIN'S RECORD SHOP, 12 Park Road

ROY SPACKMAN, Cowgate

**PLYMOUTH**

ALBERT E. FORD LTD., 84 Cornwall Street

HAROLD JONES, 63 Cornwall Street

**PORTSMOUTH (HANTS.)**

ERNEST WYATT, 10 Queens Road

**READING**

BARNES &amp; AVIS LTD., 138-141 Friar Street

HERBERT & LASCELLES LTD., 22-25 St. Mary's Butts,  
31 Friar St., 59 Oxford Rd.

HICKIES, 153 Friar Street

**RICHMOND (SURREY)**

MUSICRAFT, 13 King Street

**SALISBURY (WILTS.)**

J. F. SUTTON, 89 Crane Street

**SLOUGH**

HICKIES, 67/69 High Street

**SOLIHULL (WARCS.)**

H. C. HOLLOWAY, 2 High Street

**SOUTHALL (MIDDX.)**

MUSICRAFT, 20-22 High Street

**SHEFFIELD**

PHILIP CANN, 4 Dixon Lane

VULCAN ELECTRONICS, 339 Shoreham Street,  
Sheffield 2**SOUTHAMPTON**HAMILTON ELECTRONICS (SOUTHAMPTON) LTD.,  
35 London Road

MOXHAM'S LTD., 96 St. Mary's Road

J. F. SUTTON, 421 Shirley Road

UNIVERSITY CAMERAS, 12 Bargate Street

**STOCKPORT**

FAIRBOTHAM &amp; CO. LTD., 47 Lower Hillgate, Stockport

**SUNDERLAND**

ROSE BROS., Burdon House, Holmeside

**SUNNINGDALE**

PACK'S LTD., London Road

**THORNTON HEATH (SURREY)**NUSOUND RECORDING CO., 3-8 Brigstock Parade,  
London Road**TRURO**

EDMUND FORD, 9 Pydar Street

**TUNBRIDGE WELLS**GOULDEN & CURRY LTD., The Royal Library, High  
Street

PERCY POWELL RADIO LTD., 54 High Street

**WALMGATE (YORKS.)**

CUSSINS &amp; LIGHT LTD., Walmgate, York.

**WESTHOUGHTON (LANCS.)**

"MAXTONE", 247 Church Street

**WARRINGTON**

11 Wilson Patten Street

**WIGAN**JOHN SHINN & SONS LTD., "Melody House", 43  
Hallgate**WOLVERHAMPTON**

FENWICK'S, Fenwick Buildings, Great Brickkiln Street

PODMORE LTD., 19 Merridale Road

VOLTIC RADIO, Queen's Arcade

**WORCESTER**

JOHNSON SOUND SERVICES, 46 Friar Street

**WORTHING**

BARNES &amp; SPICER LTD., 4 Connaught Buildings

BOWERS & WILKINS LTD., 1 Becket Buildings, Little-  
hampton Road

J. W. MANSFIELD LTD., 8-10 Liverpool Road

## TAPE RECORDER SPECIALISTS

★The following is a short list of dealers specialising in the sale of tape recorders and associated equipment.

**LONDON**DICKINSONS OF PALL MALL LTD., 11 Royal Opera  
Arcade, Pall Mall, S.W.1ESSEX TAPE RECORDER CENTRE, 2 Maryland Station,  
Stratford, E.15, and at 205 High Street North, East  
Ham, E.6FRANCIS OF STREATHAM, 169-171 Streatham High  
Road, S.W.16

MAGNEGRAPH, 1 Hanway Place, W.1

QUEENSWAY RECORDING STUDIOS, 123 Queensway,  
W.2RAPP TAPE RECORDER SPECIALISTS, 181 Dalston  
Lane, E.8R.B. TAPES CO. LTD., 179 Stoke Newington High Street,  
N.16THE RECORDER CO., 188 West End Lane, West  
Hampstead, N.W.6

R. E. W. EARLSFIELD LTD., 545 Garratt Lane, S.W.18

THE TAPE RECORDER CENTRE LTD., 75 Grand Parade,  
Green Lanes, Harringay, N.4

TELETAPE, 59a Edgware Road, W.2

**BLACKPOOL**

TAPE RECORDER CENTRE, 226 Waterloo Road

**BROMLEY (KENT)**

HOWARD PHOTOGRAPHIC, 218 High Street, Bromley

**CREWE**

MILLER &amp; PALIN, 11 Delamere Street

**NOTTINGHAM**NOTTINGHAM TAPE RECORDERS LTD., Burton  
Street**HULL (E. YORKS.)**

A. BROWN &amp; SONS LTD., 24-28 George Street

**RIPON (YORKS.)**

MUSIC FOR ALL, Westgate



**NEWCASTLE-UPON-TYNE**

PAYNE & HORNSBY LTD., 3 Andrews House, Gallowgate  
 HAYMARKET RADIO, 23 Leazes Park Road

**NEWTON ABBOT**

D. O. H. COLES LTD., 13 Courtenay Street

**NORTHAMPTON**

CRYER'S 222/224 Wellingborough Road

**NOTTINGHAM**

ALEX OWEN LTD., Station Road, Beeston

**OXFORD**

LOWE & OLIVER, Ship Street  
 HORNS, 6 South Parade  
 L. WESTWOOD, 46 George Street

**PETERBOROUGH**

CAMPKIN'S RECORD SHOP, 12 Park Road  
 ROY SPACKMAN, Cowgate

**PLYMOUTH**

ALBERT E. FORD LTD., 84 Cornwall Street  
 HAROLD JONES, 63 Cornwall Street

**PORTSMOUTH (HANTS.)**

ERNEST WYATT, 10 Queens Road

**READING**

BARNES & AVIS LTD., 138-141 Friar Street  
 HERBERT & LASCELLES LTD., 22-25 St. Mary's Butts,  
 31 Friar St., 59 Oxford Rd.  
 HICKIES, 153 Friar Street

**RICHMOND (SURREY)**

MUSICRAFT, 13 King Street

**SALISBURY (WILTS.)**

J. F. SUTTON, 89 Crane Street

**SLOUGH**

HICKIES, 67/69 High Street

**SOLIHULL (WARCS.)**

H. C. HOLLOWAY, 2 High Street

**SOUTHALL (MIDDX.)**

MUSICRAFT, 20-22 High Street

**SHEFFIELD**

PHILIP CANN, 4 Dixon Lane  
 VULCAN ELECTRONICS, 339 Shoreham Street,  
 Sheffield 2

**SOUTHAMPTON**

HAMILTON ELECTRONICS (SOUTHAMPTON) LTD.,  
 35 London Road  
 MOXHAM'S LTD., 96 St. Mary's Road  
 J. F. SUTTON, 421 Shirley Road  
 UNIVERSITY CAMERAS, 12 Bargate Street

**STOCKPORT**

FAIRBOTHAM & CO. LTD., 47 Lower Hillgate, Stockport

**SUNDERLAND**

ROSE BROS., Burdon House, Holmeside

**SUNNINGDALE**

PACK'S LTD., London Road

**THORNTON HEATH (SURREY)**

NUSOUND RECORDING CO., 3-8 Brigstock Parade,  
 London Road

**TRURO**

EDMUND FORD, 9 Pydar Street

**TUNBRIDGE WELLS**

GOULDEN & CURRY LTD., The Royal Library, High Street  
 PERCY POWELL RADIO LTD., 54 High Street

**WALMGATE (YORKS.)**

CUSSINS & LIGHT LTD., Walmgate, York.

**WESTHOUGHTON (LANCS.)**

"MAXTONE", 247 Church Street

**WARRINGTON**

11 Wilson Patten Street

**WIGAN**

JOHN SHINN & SONS LTD., "Melody House", 43 Hallgate

**WOLVERHAMPTON**

FENWICK'S, Fenwick Buildings, Great Brickkiln Street  
 PODMORE LTD., 19 Merridale Road  
 VOLTIC RADIO, Queen's Arcade

**WORCESTER**

JOHNSON SOUND SERVICES, 46 Friar Street

**WORTHING**

BARNES & SPICER LTD., 4 Connaught Buildings  
 BOWERS & WILKINS LTD., 1 Becket Buildings, Littlehampton Road  
 J. W. MANSFIELD LTD., 8-10 Liverpool Road

## TAPE RECORDER SPECIALISTS

★ The following is a short list of dealers specialised in the sale of tape recorders and associated equipment.

**LONDON**

DICKINSONS OF PALL MALL LTD., 11 Royal Opera Arcade, Pall Mall, S.W.1  
 ESSEX TAPE RECORDER CENTRE, 2 Maryland Station, Stratford, E.15, and at 205 High Street North, East Ham, E.6  
 FRANCIS OF STREATHAM, 169-171 Streatham High Road, S.W.16  
 MAGNEGRAPH, 1 Hanway Place, W.1  
 QUEENSWAY RECORDING STUDIOS, 123 Queensway, W.2  
 RAPP TAPE RECORDER SPECIALISTS, 181 Dalston Lane, E.8  
 R.B. TAPES CO. LTD., 179 Stoke Newington High Street, N.16  
 THE RECORDER CO., 188 West End Lane, West Hampstead, N.W.6  
 R. E. W. EARLSFIELD LTD., 545 Garratt Lane, S.W.18  
 THE TAPE RECORDER CENTRE LTD., 75 Grand Parade, Green Lanes, Harringay, N.4  
 TELETAPE, 59a Edgware Road, W.2

**BLACKPOOL**

TAPE RECORDER CENTRE, 226 Waterloo Road

**BROMLEY (KENT)**

HOWARD PHOTOGRAPHIC, 218 High Street, Bromley

**CREWE**

MILLER & PALIN, 11 Delamere Street

**NOTTINGHAM**

NOTTINGHAM TAPE RECORDERS LTD., Burton Street

**HULL (E. YORKS.)**

A. BROWN & SONS LTD., 24-28 George Street

**RIPON (YORKS.)**

MUSIC FOR ALL, Westgate

# ADVERTISERS' INDEX

	Page		Page
ACOUSTICAL MANUFACTURING CO. LTD.	Front	MAGNAPHON ... ..	244
	Cover	METRO-SOUND MANUFACTURING CO. LTD.	240
ALLAN, RICHARD RADIO LTD. ... ..	225	MODERN ELECTRICS (RETAIL) LTD. ... ..	239
ALTOBASS LTD. ... ..	208	MULTIMUSIC LTD. ... ..	199
ARMSTRONG WIRELESS & TELEVISION CO. LTD.	210	MUSICRAFT ... ..	236
BEAM-ECHO LTD. ... ..	231	PHILIPS ELECTRICAL LTD. ... ..	213
BRENNELL ENGINEERING CO. LTD. ... ..	228	POLITECHNA (LONDON) LTD. ... ..	187
BURNE-JONES & CO. LTD. ... ..	232	PYE LTD. ... ..	201
BUTCHER, THOMPSON DIAMOND ... ..	218	R. B. TAPES LTD. ... ..	207
CAPE ELECTROPHONICS LTD. ... ..	222	RECORD HOUSING ... ..	212
CHAPMAN, C. T. (REPRODUCERS) LTD. ... ..	245	ROGERS DEVELOPMENTS (ELECTRONICS) LTD.	250
CHELSEA RECORD CENTRE ... ..	211	ROMAGNA SOUND EQUIPMENT LTD. ... ..	214
COLLARO LTD. ... ..	188	S.M.E. LTD. ... ..	229
CONNAUGHT (TAPE RECORDERS) LTD. ... ..	238	SIMON EQUIPMENT LTD. ... ..	197
COSMOCORD LTD. ... ..	241	SOUND SALES LTD. ... ..	256
DECCA RADIO & TELEVISION CO. LTD. ... ..	217	SPECTO LTD. ... ..	202
E.A.P. (TAPE RECORDERS) LTD. ... ..	251	STANDARD TELEPHONES & CABLES LTD. ... ..	253
E.M.I. SALES & SERVICE LTD. ... ..	204, 205	STERN RADIO LTD. ... ..	192
E.T.D. RADIOSTRUCTOR ... ..	227	SUGDEN, A. R. & CO. LTD. ... ..	224
FRANCIS OF STREATHAM ... ..	190	"THE TAPE RECORDER" ... ..	219
GARRARD ENGINEERING & MANUFACTURING CO. LTD., THE ... ..	247	TAPE RECORDER CENTRE, THE ... ..	233
GOLDRING MANUFACTURING CO. (GREAT BRITAIN) LTD. ... ..	223	TAPE RECORDERS (ELECTRONICS) LTD. ... ..	194
GOODMANS INDUSTRIES LTD. ... ..	209	TANNOY PRODUCTS LTD. ... ..	237
HARRIDGE, H. C. ... ..	203	TECHNICAL SUPPLIERS LTD. ... ..	235
HEATHKIT (DAYSTROM) LTD. ... ..	206	TRUVOX LTD. ... ..	220
IMHOF, ALFRED LTD. ... ..	248	TUTOR TAPE CO. ... ..	226
JASON MOTOR & ELECTRONIC CO. ... ..	243	VORTEXION LTD. ... ..	242
LARGS OF HOLBORN ... ..	215	WATTS, CECIL E. LTD. ... ..	198
LASKY'S (HARROW ROAD) LTD. ... ..	200	WEBB'S RADIO ... ..	234
LEAK, H. J. & CO. LTD. ... ..	221	WELMEC CORPORATION LTD. ... ..	255
LONG PLAYING RECORD LIBRARY LTD., THE	249	WELLINGTON ACOUSTIC LABORATORIES LTD.	216
LOWTHER MANUFACTURING CO. ... ..	254	WHARFEDALE WIRELESS WORKS LTD. ... ..	196
LUSTRAPHONE LTD. ... ..	230	WHITELEY ELECTRICAL RADIO CO. LTD. ... ..	246
		W. & N. ELECTRONICS LTD. ... ..	252

# A "SOUND" QUARTET

EACH ONE IS A "MUST" FOR THE SOUND  
REPRODUCTION ENTHUSIAST AND MUSIC LOVER

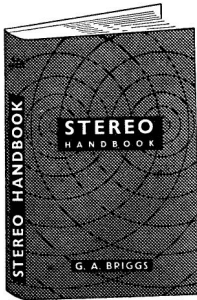

## STEREO HANDBOOK

by G. A. BRIGGS

Technical Editor R. E. COOKE, B.Sc. (Eng.)

A new book by G. A. BRIGGS presenting information on domestic stereo in a straightforward manner; relieved by humorous touches. 146 pages, 88 illustrations. 15 chapters including: Pickups - Loudspeakers - Amplifiers - Stereo Tapes - Recording Techniques - Record and Stylus Wear - Stereo Broadcasting - Room Acoustics - Concert Halls.

PRICE 10s. 6d. (11s. 6d. Post Free)

Other books by G. A. BRIGGS:

## LOUDSPEAKERS

5th edition. 336 pages. 230 illustrations. Standard reference work on loudspeakers. 31 chapters including: Reminiscences - Frequency Response - Directional and Phase Effects - Baffles, Cabinet and Horns - Electrostatic Speakers - Stereo - Audio Fairs and Concert Halls. Sales to date over 57,000.

PRICE 19s. 6d. (20s. 9d. Post Free)

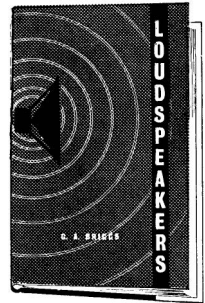

## SOUND REPRODUCTION

3rd edition, fourth impression, 368 pages, 315 illustrations. Chapters on Resonances - Cabinets - Room Acoustics - Response curves with Oscillograms - Crossover networks - Recording Systems - Records - Pickups, etc. Total sales exceed 47,000.

PRICE 17s. 6d. (18s. 6d. Post Free)

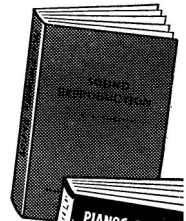

## PIANOS, PIANISTS AND SONICS

A book for sound enthusiasts and music lovers written in G. A. Briggs' entertaining style. Chapters on piano history and construction - Harmonic analysis - Touch - Tone - Tuning, etc. 192 pages, 102 illustrations.

PRICE 10s. 6d. (11s. 6d. Post Free)



**Wharfedale**  
WIRELESS WORKS LTD  
IDLE BRADFORD YORKS

Sold by radio dealers  
and bookshops  
Published by  
Wharfedale  
Wireless Works Ltd.  
Telephone: Idle 1235/6  
Grams: 'Wharfedel'  
Idle Bradford

For Styling,  
Performance and  
Workmanship

## The best of Both Worlds

*Cadenza Ribbon*

MICROPHONE ➡

A worthy link in the chain between live sound and perfect recording, the Cadenza ribbon microphone has been designed to give performance to studio standards whilst remaining in the medium price range. The unique arrangement of ribbon and magnets gives an output which is flat to within close limits over the wide range from 50 c.p.s. to 12,000 c.p.s. Patent No. 810064. Cadenza dual impedance microphone head only in presentation case, **8½ gns.** Cadenza dual impedance microphone, with tripod desk stand, connected 11 ft. of cable. Complete in presentation case, **10 gns.**



*Cadenza Crystal*

← MICROPHONE

Top crystal performance, robust and handy, these qualities and the low price make this an ideal second microphone or an excellent partner to any tape recorder. Complete with tripod desk stand, hinged to allow adjustment of microphone head angle, **3½ gns.**

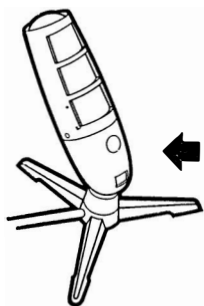

**Simon Equipment Limited**

46-50 George St., London W.1 Tel: WELbeck 2371

TA3482

## PROVED

The finest method for cleaning records.  
Already over 200,000 enthusiastic users.  
All Static and Dust completely  
removed from Your Records as  
they are played

THE

# “Dust Bug”

AUTOMATIC GRAMOPHONE  
RECORD CLEANER

PATENT APPLIED FOR

Instantly Fitted. Suitable for all  
Types of Record. Quality Im-  
proved. Surface Noise and Wear  
Reduced.

STANDARD MODEL FOR TRANSCRIPTION  
AND SINGLE RECORD PLAYERS.

PRICES  
REDUCED **17/6** (Plus 7/-  
purchase tax)

From Your Dealer, or

**CECIL E. WATTS LTD.**

(Sound Recording and Reproduction)

Darby House, Sunbury-on-Thames, Middx.

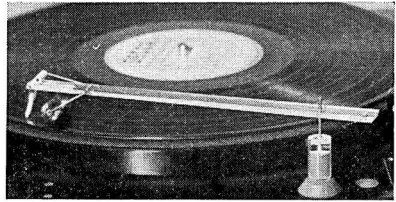

The Dust Bug may be placed in any convenient position around the turntable and the adjustable pin of the pillar raised if necessary so that the arm is approximately parallel to the surface of the record.

The use of the fluid dispenser should only provide a trace of dampness to the plush pad. It is not intended that any fluid should be transferred to the record. The slightly damp pad provides a leakage path for the discharge of any static in the record and assists in the collection of dust, etc.

The Dust Bug is the only record cleaner capable of thoroughly cleaning the groove without affecting the record surface in any way.

*The*

# PARASTAT

(Regd.)

TREATMENT FOR L.P. RECORDS (PATENTS APPLIED FOR)

Buy where there is a “Parastat” service — Used by dealers who have the customer’s interests at heart

This Machine serves three main purposes in the handling of all types of Gramophone Records.

1. It cleans simultaneously both sides of the entire surface of the record (including the label), and removes every particle of dust or foreign matter from the grooves in less than ten seconds.
2. Renders the record permanently inert to all Static charges induced by any means, leaving no trace on either groove or record surface.
3. Reduces the coefficient of friction between stylus and groove wall at all points of violent acceleration reducing tracing distortion wear and surface noise.



CECIL E. WATTS LTD. - DARBY HOUSE - SUNBURY-ON-THAMES - MIDDLESEX

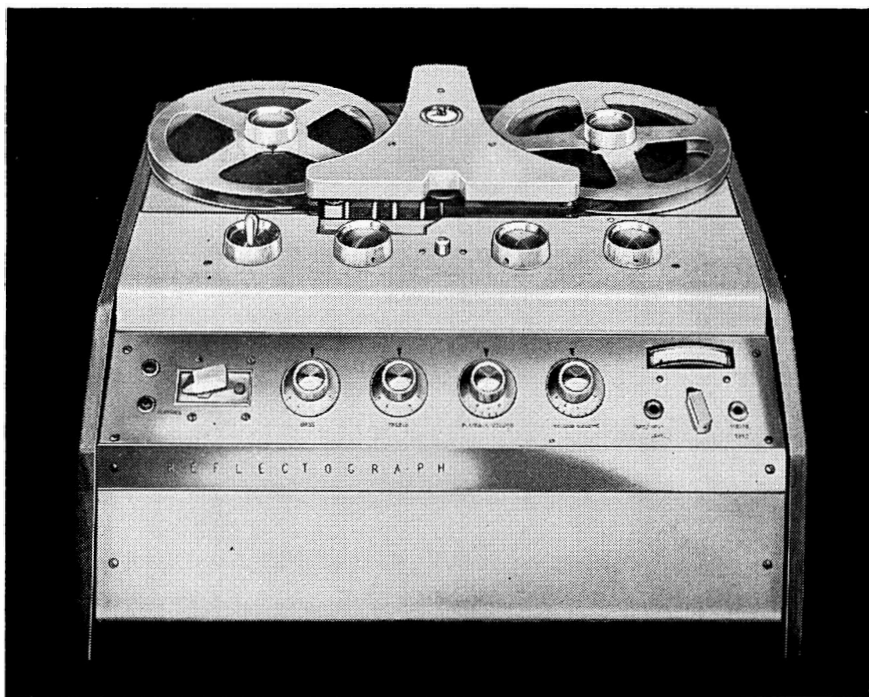

*New*

# REFLECTOGRAPH

## MODEL A Professional-Type Tape Recorder

The new Model A tape recorder is precision engineered for utmost reliability. Years of experience in the manufacture of tape recorders are behind this machine.

### TAPE DECK

- ★ Utmost reliability—no rubber pulleys to wear.
- ★ Instant stop and start. Single knob electrical variable speed wind—1,200 feet wound in 45 seconds. Capacity for up to 8½" reels.
- ★ Heavy duty, direct drive, synchronous motor, 2 special Garrard reel motors.
- ★ Auto stop, 2 speeds 7½ and 3½ i.p.s. Precision tape indicator.

Patent application No. 1109/60. Registered Design Application 895860. World patents pending.

### AMPLIFIER

- ★ Tape/input switch for direct comparison between input and recorded signals.
- ★ Frequency response (7½ i.p.s.): ±2 dB from 40-10,000 c/s (Equalised to CCIR standards).
- ★ Signal to noise ratio: —50 dB approx. (un-weighted including hum).
- ★ Inputs: microphone and radio.
- ★ Outputs: head pre-amplifier and external speaker (15 ohms).
- ★ Calibrated record level meter.

Price, with half track erase, record and play-back heads, one way operation and self-contained 3 watt amplifier **95 GNS.**

See and hear it at your Multimusic dealer

**Multimusic Limited**

Maylands Avenue, Hemel Hempstead, Herts. Tel: Boxmoor 3636

# LASKY'S RADIO

## ALL THAT'S NEW IN HI-FI EQUIPMENT

Choose  
from  
London's  
Largest  
Stocks  
of



- ★ AMPLIFIERS
- ★ CONTROL UNITS
- ★ PICKUPS
- ★ LOUDSPEAKERS
- ★ SPEAKER SYSTEMS
- ★ RECORD PLAYERS
- ★ AUTOCHANGERS
- ★ TRANSCRIPTION  
TURNTABLES
- ★ AM/FM TUNERS
- ★ TAPE DECKS
- ★ TAPE RECORDERS
- ★ MICROPHONES
- ★ CABINETS & SPEAKER  
ENCLOSURES

H.P. TERMS AVAILABLE

Both  
addresses  
open all day  
Saturday.  
Close 1 p.m.  
Thurs.

**207 EDGWARE ROAD, LONDON, W.2**  
Few yards from Praed Street. PADDington 3271/2

**42 TOTTENHAM COURT ROAD, W.1**  
Nearest station Goodge Street. MUSEum 2605

Our Demonstration Studios at both addresses enable you to judge all leading makes and types of equipment, assisted by specialist staff who have the necessary "know-how". If unable to call,

### SEND FOR OUR NEW 1960 HI-FI CATALOGUE

Approx. 100 large pages, size 11¼" x 5¼".

A comparator-catalogue to help you obtain economic quality and design. Deals with every aspect of monaural and stereo reproduction and brings you up-to-date on the very latest developments. By far the finest, most interesting, fully comprehensive catalogue ever offered to the hi-fi enthusiast.

Price 3s. 6d. Post 6d.

Fully refundable  
on making  
your first  
purchase.

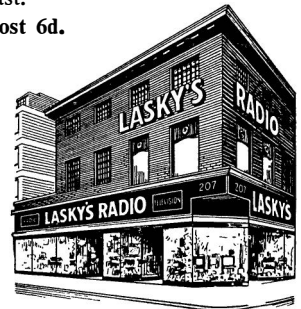

Please address Mail Orders and enquiries to Lasky's Radio, Dept. YB, 207 Edgware Road, London W2



# today's best-looking listening



The Pye Mozart Stereo Amplifier Model HFS20M provides an undistorted output of 10 watts per channel on magnetic or crystal pick-up. Chassis & mono models available.

The new Pye Mozart Cabinet — at once functional and beautiful — was designed for the connoisseur. Available in mahogany or walnut veneers.

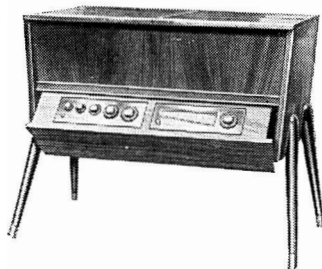

The Pye Mozart FM Tuner (Model HFT108M) for the very best in interference-free radio listening. Tuning 88 to 108 mc/s. Self-powered.



The Pye "Mozart" Loudspeaker (Model HF10/BS) has one high flux 8" unit and one 4" tweeter, giving an extended frequency range and excellent performance from a relatively small enclosure. In walnut or mahogany veneers. Legs optional.

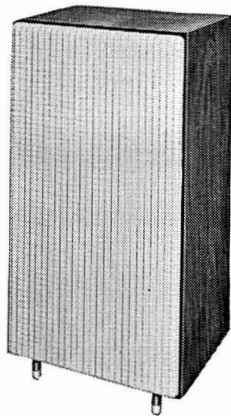

The Pye HF15SMT Speaker—comprising 12" Baker's bass unit and 4" Richard Allen tweeter—is the most outstanding instrument in its price range available today. Available in walnut or mahogany veneers.

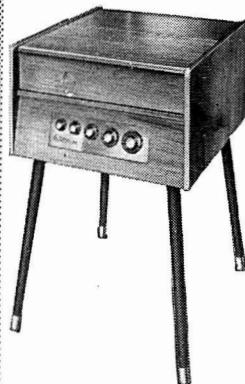

The Pye Mozart Lowboy (Model HFP1)—incorporating a Mozart Amplifier—combined with the Mozart Companion Speaker offers the enthusiast the basis of a craftsman-built high fidelity system at a very reasonable cost. Stereo may be added later. The units are beautifully finished in matching walnut veneers. A Stereo Model is available.



At Pye, high fidelity is a specialist business. Years of research at the famous Pye laboratories in Cambridge lie behind today's Pye High Fidelity Range. Created by the scientist, built by craftsmen and finished by the skilled cabinet-maker, the Pye High Fidelity Range is certainly today's best-looking listening.

**HIGH FIDELITY SYSTEMS**  
 Pye Ltd., High Fidelity Division, 65 Fairview Rd., London, S.W.16



# the FANTABULOUS NEW Specto 171

SORRY! we just had to coin a word to describe this amazing new tape recorder!

Modern, compact, neat and built to the highest possible specification of quality that is synonymous with all SPECTONE Audio Equipment.

# the Spectone

# 171

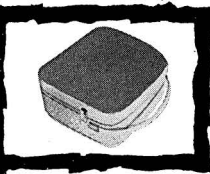

Here is the tape recorder that possesses all the features you have come to expect, such as built in superimposition and mixing facilities, provision for external amplifier and speakers, variable monitoring during recording etc., etc., but at a fraction of the usual size, weight and price.

## PLUS CASSETTED TAPES!

The latest and most sensible advance in recorder technique yet—the tape magazine. The reel of tape and take up spool are housed in a complete plastic container. All you have to do is take it, clip it, and away you go, no tape threading—one hand operation all the way.

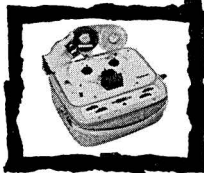

**Specto**  
LIMITED

*Write or 'phone now for new illustrated brochure, or see it at your local dealer.*

SPECTO LIMITED, VALE ROAD, WINDSOR, BERKS. Windsor 1241

# PART EXCHANGE

We are always willing to accept your unwanted Hi-Fi equipment, tape recorder or Classical LP records for cash or in exchange for other goods. Let us have full details and we will make an offer.

ALWAYS IN STOCK

Rogers, Quad, Leak and Jason equipment, Quad Electrostatic Speaker, Ferrograph Tape Recorder.



● *Quad 22 Control Unit. Price £25.*

Send for lists of recommended

**NEW AND USED ITEMS**

# H. C. HARRIDGE

**8 MOOR STREET, CAMBRIDGE CIRCUS, W.1**

*Hours of Business:—*

*Monday*  
*Tuesday*  
*Wednesday* } 10 a.m. to 5.30 p.m.

*Friday* 10 a.m. to 7 p.m.  
*Saturday* 9 a.m. to 5 p.m.  
*Thursday* CLOSED ALL DAY



# Emitape

**the world's finest  
magnetic recording tape  
with the highest technical standards**

EMI SALES & SERVICE LTD

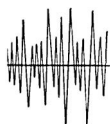

# Perfection in Recording

Behind those brilliant, flawless performances on your favourite records lies a major technical triumph—EMITAPE! For some years now the “masters” of most LP and STEREO records have been made on the same .0015 in. base Emitape that you can buy . . .

Proved technical superiority and durability of the PVC recorded tape—make Emitape the choice of world-famous companies like “H.M.V.”, Columbia, Parlophone—for recording all the greatest artists of our day . . . For the same reason, the B.B.C., Independent Television and broadcasting authorities all over the world use hundreds of millions of feet of Emitape every year; it is equally in demand in the fields of industry and science.

Backed by EMI's unique experience—going back over 60 years—and manufactured in the largest and most modern magnetic tape factory in Europe, Emitape is the basis for perfection in recording.

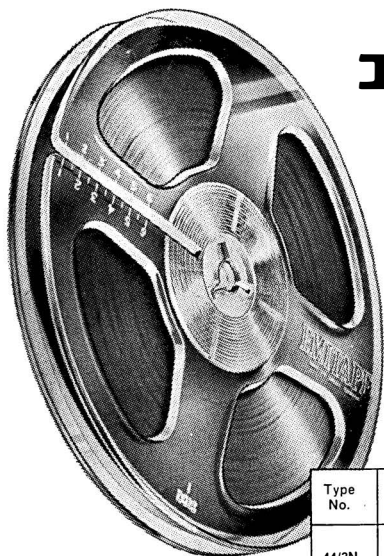

## Emitape

44"

Popular (Acetate)

88"

General Purpose

99"

Long Play

- \* High sensitivity
- \* Low Noise level
- \* Anti-static
- \* Low 'print through' factor
- \* Freedom from curl and stretch

Type No.	Title	Size	Length approx.	Price in EMICASE	Price without EMICASE
44/3N	"Message"	3½" dia.	175'	—	6. 9.
88/3		3" dia.	175'	—	7. 6.
99/3		3" dia.	250'	—	9. 6.
88/3N		3½" dia.	175'	—	7. 6.
99/3N		3½" dia.	250'	—	9. 6.
44/6	"Junior"	5" dia.	600'	—	18. 0.
88/6		5" dia.	600'	£1. 3. 6.	£1. 1. 0.
99/9		5" dia.	850'	£1. 10. 6.	£1. 8. 0.
44/9	"Continental"	5½" dia.	850'	—	£1. 4. 6.
88/9		5½" dia.	850'	£1. 10. 6.	£1. 8. 0.
99/12		5½" dia.	1200'	£1. 17. 6.	£1. 15. 0.
44/12	"Standard"	7" dia.	1200'	—	£1. 10. 0.
88/12		7" dia.	1200'	£1. 17. 6.	£1. 15. 0.
99/18		7" dia.	1800'	£2. 12. 6.	£2. 10. 0.
88/18		"Professional"	8½" dia.	1750'	—
99/24	8½" dia.		2400'	—	£3. 12. 6.

THE WORLD'S  
FINEST



ELECTRONIC  
KIT-SETS

Whether you require

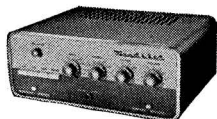

Tape Deck Record Player, Tuner, Amplifier,

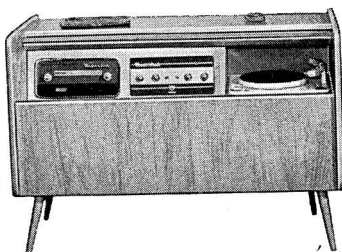

a cabinet to house them in,

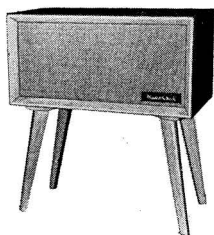

loudspeaker  
systems,

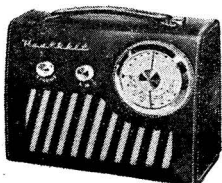
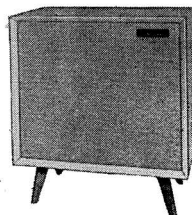

Radio

or



Test Equipment

You cannot do better than buy a *Heathkit* model from

**DAYSTROM LTD.**

DEPARTMENT H.Y.  
GLOUCESTER, ENGLAND

A MEMBER OF THE DAYSTROM GROUP

Manufacturers of

**THE LARGEST SELLING ELECTRONIC KIT-SETS IN THE WORLD**

what  
goes on  
in tape?

**R. B. TAPES** know! The best recorders of today are always in stock and our organisation is in the forefront of the latest developments in this exciting field.

All our machines may be bought on very convenient terms under our own 12-months guarantee and our famous free after-sales service.

We specialise in conversions.

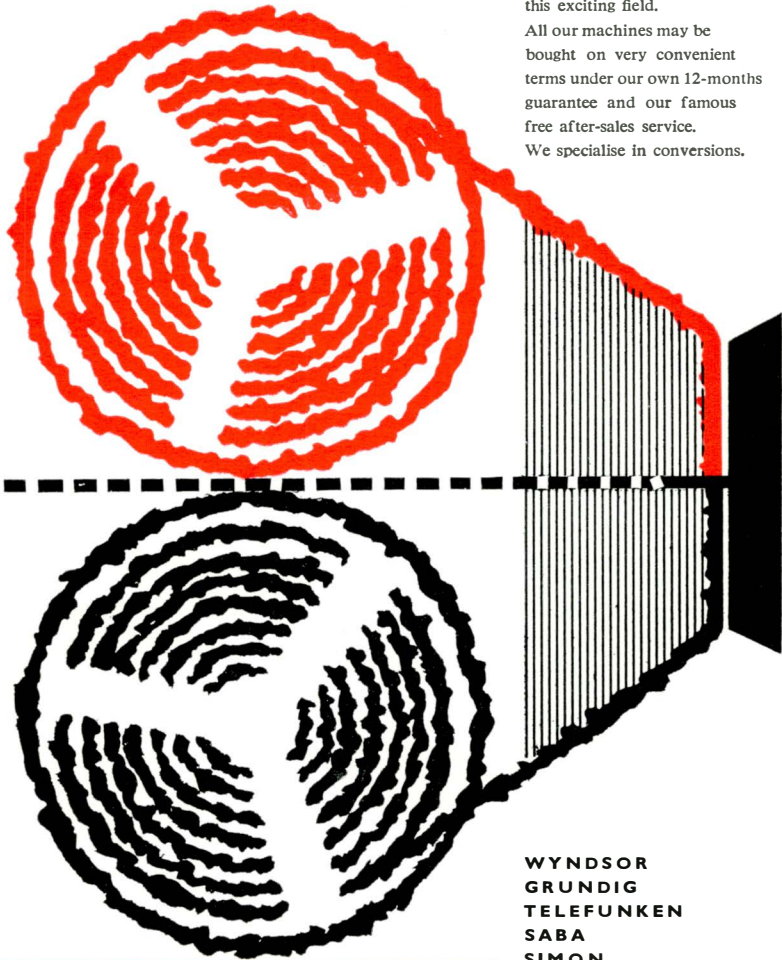

ERICH ROSENTHAL 60

WYNSOR  
GRUNDIG  
TELEFUNKEN  
SABA  
SIMON  
ABBEY  
ELIZABETHAN  
SPECTONE  
VERITONE  
ETC ETC



< AGENTS FOR >

**R.B.TAPES**

**NORTH LONDON'S LEADING TAPE-RECORDER AND RECORD SPECIALISTS**

**179 STOKE NEWINGTON HIGH ST  
LONDON N16 CLISSOLD 9477**



# ALTOBASS

## HIGH FIDELITY AMPLIFIERS

*just that much better — every time!*

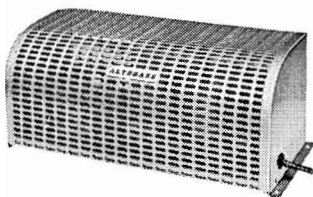

### 510 AMPLIFIER

An excellent stand-  
ard amplifier with a  
power output of 10  
watts at 0.1 per cent  
distortion. Separate  
pre-amplifier.  
23 gns. complete.

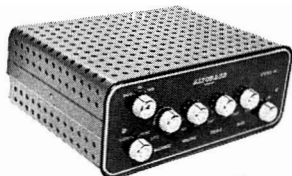

### STEREO 44

A complete, build-it-yourself kit for the  
enthusiast, with step-by-step instructions. Can  
be connected to crystal or ceramic pick-ups,  
radio tuner or equalised tape.

18 gns. complete.



### *Seventy* PRE-AMPLIFIER

A high gain unit for use with any type of pickup.  
May be fed direct from a tape head.

16 gns.

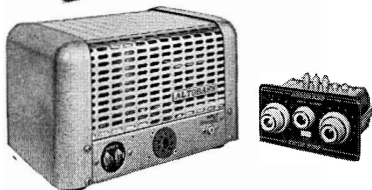

### TWIN-TWO STEREO AMPLIFIER

A simple, inexpensive system for stereophonic  
reproduction of very good quality.

16 gns. complete.



### STEREO 70 PRE-AMPLIFIER

A most comprehensive pre-amplifier for the  
reproduction of stereo discs and tapes. Suitable  
for use with any type of stereo pickup.

23 gns.



### TWIN-TWELVE POWER AMPLIFIER

Two 12 watt power amplifiers are incorporated  
in this unit on a common chassis. For use  
with the Stereo 70 pre-amplifier.

29 gns.

ALTOBASS LIMITED · PERCY ROAD · LEICESTER · ENGLAND

# New

## High Fidelity Loudspeaker Manual

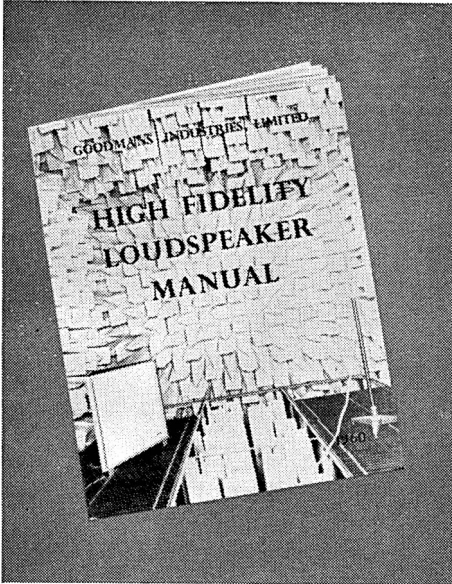

Goodmans High Fidelity Loudspeakers and loudspeaker systems have achieved world wide renown. A policy of continuous development maintains this position of leadership, and ensures that every model produced provides the best possible performance value in its price category.

# Free

The NEW EDITION of Goodmans High Fidelity Loudspeaker Manual contains details and specifications of all Goodmans High Fidelity products, together with detailed information on choosing a loudspeaker, the design and construction of enclosures, stereophonic systems, stage built multiple unit loudspeaker systems, etc., etc., fully illustrated.

# GOODMANS

**GOODMANS INDUSTRIES LIMITED** Axiom Works, Wembley, Middx.

*Tel.: WEMbley 1200 (8 lines) Grams: Goodaxiom, Wembley, England*

Europe's largest manufacturers and the World's largest exporters of High Fidelity Loudspeakers

# Armstrong

## PCU27 STEREO PRE-AMPLIFIER

£26 . 10 . 0

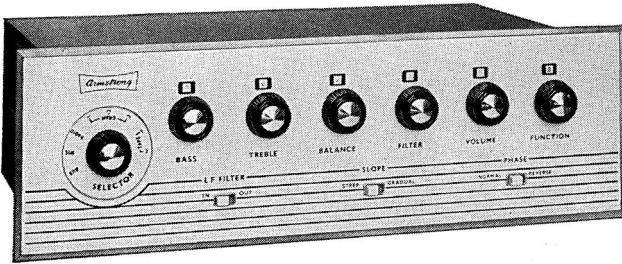

The PCU 27 has been designed for the enthusiast who wants the best. The best of stereo and the best of monaural. Every possible sound source is provided for, every desirable adjustment and control is included and virtually any high fidelity amplifier can be connected to it. Examine the specification, look at the facilities. It's not cheap but it is good. (*See Editorial Amplifier section.*)

## A10 Mk II POWER AMPLIFIER

£21 . 10 . 0



The A10 MkII, established in the top rank of high fidelity amplifiers, is ideal for use with the PCU 27. Use two for stereo or one for monaural with the facility of subsequent conversion to stereo by adding the second amplifier. If a monaural system is required both now and in the future, the well known Armstrong Control Unit MkII (£10.10.0) should be used. (*See Editorial Amplifier section.*)

## ARMSTRONG WIRELESS & TELEVISION CO. LTD.

Writers Road, Holloway, London, N.7. North 3213

*We also specialise in complete stereo and monaural tuner/amplifier chassis, AM/FM and FM tuners and Short-wave tuners. Send for full description and technical specifications.*



**CHELSEA RECORD CENTRE**



**203 KINGS ROAD SW3 · FLA 2596**



**STEREO AND MONO HI-FI EQUIPMENT  
TAPE RECORDERS (ALL LEADING MAKES)**



**RECORDS**

**OPEN till 8 pm  
Thursday 1 pm  
BUS STOP 11 19 22**

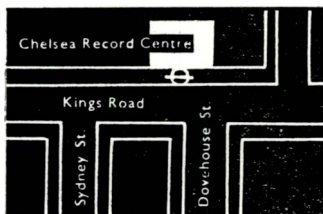

# Matching Hi Fi Furniture



We offer a range of seven cabinets, all matching in style and finish, for the Hi Fi enthusiast. All our cabinets are intelligently designed, well made and meticulously finished. Our illustration shows the **RAVEL Equipment/Record Storage Cabinet**.

The RAVEL will hold every kind of turntable (auto-change or transcription) *plus* tape deck, *plus* amplifier and pre-amp, *plus* a radio tuner, the controls being hidden behind a sliding door. The right hand section of this cabinet is divided to take either 200 seven inch, *or* 100 twelve inch records, or a mixture of both.

**DIMENSIONS:** 37" wide × 19" deep × 20" high plus 9" legs.  
Both Motor Boards measure: 17½" wide × 16" deep.

**FINISH:** Medium walnut or medium mahogany. **price 21 guineas**

*OTHER CABINETS IN THIS MATCHING-IN-STYLE-AND-FINISH RANGE ARE:*

The **POLONAISE Equipment Cabinet** (the largest in the range) with a motor board measuring 42" × 17"

**PRICE 20 guineas**

The **DELIUS Equipment/Record Storage cabinet**, a console-style cabinet with lift-up lid and opening doors.

(20" wide × 20" deep × 36" high)

**PRICE 22 guineas**

The **HAYDN Equipment Cabinet** (motor board measures 15¾" × 19¾")

**PRICE £10.19.0**

The **CAPRIOL Equipment Cabinet**—motor board measures 15¾" × 29½"

**PRICE £12.19.0**

The **CAPRIOL Speaker Enclosure** designed for us by Goodmans for their 12" Speakers and multiple systems.

**PRICE £13.19.0**

The **CAPRIOL Record Cabinet** will hold 300 records and costs **£10.19.0**

*Almost every name in the "Directory of Hi Fi Dealers" is a Record Housing stockist*

WRITE FOR NEW ILLUSTRATED CATALOGUE TO DEPT HF 60

**RECORD HOUSING**

BROOK ROAD LONDON N22 · BOWES PARK 7487/8

# PHILIPS

## MEANS

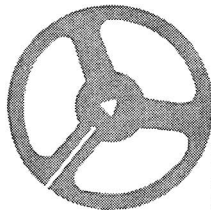
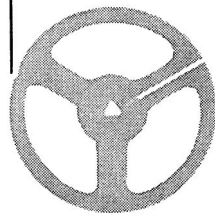

After many years of developing and manufacturing high-quality sound reproduction equipment, it is only natural that Philips should make Hi-Fi equipment that ranks with the finest available. It's precision-engineered to reproduce the recorded sound perfectly, adding nothing of its own, subtracting nothing from the original. Philips large and comprehensive Hi-Fi range includes: transcription arms, dual and single-cone loudspeakers, turntables and pick-up heads.

Philips also offer ultra-modern tape recorders that create entirely new standards of performance for instruments in their price range. And, of course, Philips magnetic tapes are already well known for their faultless reproduction and long-life reliability. Get the best from Hi-Fi with the best of Hi-Fi equipment — Philips. See the range at your dealer's or write for full details to:



by Stanley Kelly, design consultant to the Audio industry

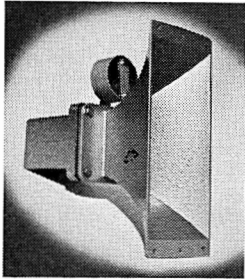

THE KELLY  
**RIBBON HF LOUDSPEAKER**  
Mk II

The ribbon Loudspeaker is acknowledged the most successful method of reproducing the higher audio frequencies. Who better than Stanley Kelly to provide the practical reality? Who else would think of providing a genuine Response Curve with each Unit taken from the actual speaker?

Brief specification.

Frequency Range: 2Kc/s to 20Kc/s  
within -1 and +2dB  
2 Micron Aluminium Ribbon  
(shock resistant, reducing distortion).

Built-in matching transformer.  
Power Capacity: Up to 10 watts maximum.  
Impedance: 15 ohms nominal.  
price 10 gns.

THE KELLY  
**WOOFER UNITS** Mk I & II

Designed to meet exacting requirements for reproducing the lower frequencies. Recommended for use with a first-class H.F. Unit (preferably the Kelly RIBBON Mk II).

Two externally similar models—Mk I & II—are available. Both models incorporate many unique design features and have been engineered to maintain consistent high quality performance.

price Mk I—2" voice coil unit 14 gns.  
price Mk II—4" voice coil unit 24 gns.

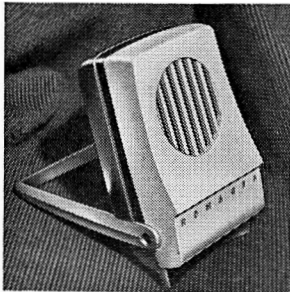

KELLY  
**ROMAGNA MICROPHONES**

An entirely new design concept for Microphones, providing high Quality Performance with Crystal, Magneto Dynamic, and Ribbon Models. Full details and response curves available. SK performance and quality at very low cost.

Crystal 25/-  
Magneto Dynamic 39/6  
Ribbon 59/6

**ROMAGNA**  **REPRODUCERS**

ENFIELD · MIDDX.

Factory Sales Representatives; K. H. Williman & Co. Ltd.,  
Blackford House, Sutton, Surrey. 'Phone: Vigilant 3700 / Melville 1491



for the finest **HI-FI** equipment available



In this luxurious showroom you can relax, listen and compare all that is best in Hi-Fi. We built this special comparator in our own workshops, to enable you to hear innumerable combinations of amplifiers, loudspeakers, tuners, gramophone pick-ups and tape recorders—all by a flick of a switch! Now you can *really* compare the

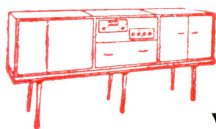

latest in both monaural and stereophonic equipment. Another equally spacious showroom displays a wide range of cabinets, from Period style to contemporary.

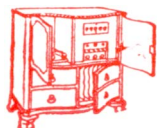

Whether you are an expert or making your first enquiry, our technical staff will find it a pleasure to help you.



# LARGS

*of Holborn* for High Fidelity

76-77 HIGH HOLBORN, LONDON, W.C.1

Telephone: CHAncery 2626 (Private Branch Exchange)

Near Holborn Tube Station

Buses 7, 8, 22, 23, 25 pass the door

# WELLINGTON ACOUSTIC LABORATORIES

The famous WAL GAIN PRE-AMPLIFIERS . . . .

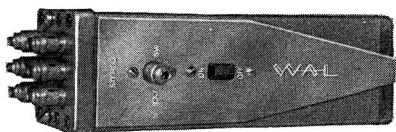

## STEREO £7.10.0

The amplifier (transistorised) that gives you the EXTRA GAIN you need, with without hum or distortion. Supplied complete with connection instructions, phono-plugs, screened lead, battery. Send for full details. Size 7" x 2" x 2 $\frac{1}{8}$ " high.



## MONO £5.0.0.

Transistorised pre-amplifier, high gain, low noise. Supplied complete with battery, screened lead phono-plugs, and connection instructions. Numerous applications. Size 3 $\frac{3}{8}$ " x 2" x 2 $\frac{1}{8}$ " high.

## NEW . . . . The WALTRAK . . . .

The pocket audio oscillator (with battery life of 3,000 hours), which supplies the missing signal to "dead" sets. Output 1,000 cps sine wave. Over 2v max. Calibrated. 1v, 0.1v and .01v tapings. Invaluable to SERVICE ENGINEERS, LABORATORIES, KEEN AMATEURS, for fault tracing, stereo matching, recording bias check, etc., etc. Supplied complete with special probe, clips, battery, connection instructions. Size 7" x 2" x 2 $\frac{1}{8}$ " high.

## WALTRAK £6.10.0

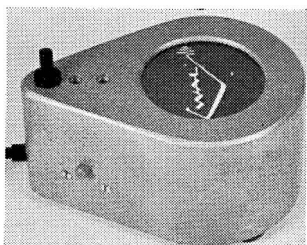
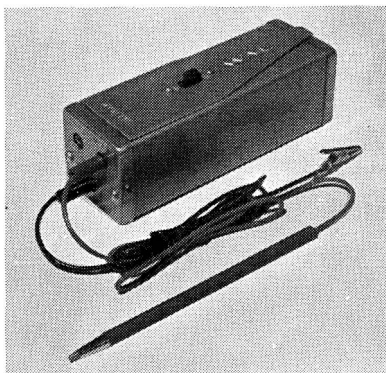

(photograph with acknowledgements to "Amateur Cine World")

## WAL ERASER £7.18.6

Known the world over by tape recording enthusiasts. Wipes both tracks off entire reel of magnetic tape in 30 secs. without running through recorder. "Cleans" message reels, office dictation, authors' MSS, home recordings, etc. 220-250v or 110-125v AC Mains. Size 6 $\frac{1}{2}$ " x 4 $\frac{3}{8}$ " x 3 $\frac{3}{8}$ ".

## THE DUO-REFLEX SPEAKER

Incorporates Laboratory-built high flux Alcomax unit, with special speech coil, etc. Crossover unit and H.F. pressure tweeter. Modern cabinet design in medium walnut.

£27.10.0

Send for full descriptive leaflets; the WAL GAINS, WALTRAK, and WAL TAPE ERASER are all supplied in specially designed cartons; we are pleased to advise customers on technical queries on any of our products. Trade display sales cards available for dealers. EXPORT INQUIRIES are particularly welcomed and we specialise in overseas orders.



—Ask your dealer for WAL products  
WELLINGTON ACOUSTIC LABORATORIES LTD. Farnham, Surrey, England

Telephone: Farnham 6461 and 4961

# THE WORLD'S FINEST PICK-UP



## made with watchmaker's precision



Decca ffss pick-up stereo head with 0.0005" radius diamond stylus.  
Complete with arm:  
20 gns (tax paid)



Decca mono head for microgroove discs, with 0.0009" radius diamond stylus.  
HEAD ONLY: £10.19s  
(tax paid)



Decca mono head for 78 rpm discs, with 0.0028" radius diamond stylus.  
HEAD ONLY: £10.19s  
(tax paid)

Now two supplementary heads are available for the world's finest pick-up: one for mono microgroove discs (the stereo head gives excellent results from modern LPs and EPs in good condition but a separate mono head may be found desirable for some others), and one for 78s. The new heads will be distinguished by a small red label for LPs and EPs and a green one for 78s. They have a frequency range of from 30 c.p.s. to more than 25 kc/s. Their output is 1 mV/cm/sec which means that the pick-up is suitable for use with amplifiers giving the maximum required volume with an input of 15mV or less. Their tip mass is 0.5 grams, and their compliance  $10 \times 10^{-6}$  cm/dyne. The termination should not be less than 20,000 ohms. The correct playing weights for these heads (i.e. 3 grams for microgroove and 5 grams for 78) is automatically obtained when the appropriate head is attached to the arm, this itself having been adjusted before leaving the factory to give a playing weight of 3.5 grams with the stereo head. The new heads, of course, have the stereo cartridge's well-known advantages of low amplitude and intermodulation distortion, accurate tracking even of inner groove high frequency transients and negligible record wear.

# DECCA ffss\* STEREO PICK-UP

*\*Full frequency stereophonic sound*

## NOW FOR EVERY KIND OF RECORD

Decca Radio and Television Ingate Place Queenstown Road London SW8

# THOMPSON, DIAMOND & BUTCHER LTD.

UNIVERSITY STREET, LONDON, W.C.1

Phone: EUSton 3494 (twenty lines)

*Manufacturers of Monaural and Stereophonic Record Reproducing Equipment*

LEADING DISTRIBUTORS TO THE TRADE OF HIGH FIDELITY  
EQUIPMENT AND RECORDS

Showroom Facilities for Dealers

## AMPLIFIERS and TUNERS

Leak  
Quad  
Rogers  
Lowther  
Avantic  
Chapman  
C.Q.  
Dulci

## SPEAKERS

Wharfedale  
Goodmans  
W.B.  
Rogers  
C.Q.  
B.J.  
G.E.C.  
Kelly  
Lowther  
Philips  
Quad

## RECORDERS

Brenell  
Cossor  
Elizabethan  
Grundig  
Telefunken  
Stella  
Stuzzi  
H.M.V.  
Trix  
Truvox  
Philips  
Walters  
Korting  
Clarion, etc.

## MOTORS

Connoisseur  
Collaro  
Garrard  
Lenco  
Philips

## PICKUPS and CARTRIDGES

Acos  
B.J.  
Decca  
Elac  
Garrard  
Goldring  
Leak  
Philips

## TAPES

Emitape  
Scotch Boy  
B.A.S.F.  
Mastertape  
Philips

## SUNDRIES

All Styli  
(Sapphires and  
Diamonds),  
Pressure Gauges,  
Record Cleaning  
devices, etc.

Write to have New Season's Trade Hi-Fi Catalogue sent to you on publication

**FOR THE MOST COMPREHENSIVE STOCKS and PROMPTEST SUPPLIES**

**YOU, THE DEALER, CAN RELY UPON**

# T.D.B. SERVICE

# *the* **TAPE RECORDER**

**THE FINEST "TAPE" PAPER**

● Overseas agencies are invited to write to our Distribution Dept. for supply details of this lively magazine.

● Readers in all parts of the world may join our subscription list. 12 monthly copies plus annual index, 24/- (U.S.A. and Canada \$3.25)

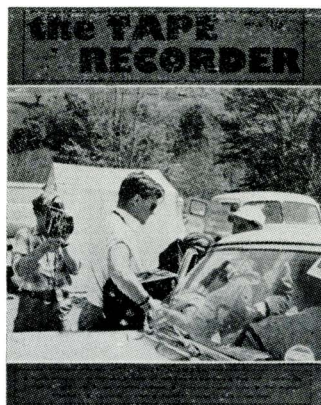

**PRICE 1/6 MONTHLY**



**THE TAPE RECORDER**  
99 MORTIMER STREET, LONDON, W.1



# TRUVOX

**ALL THAT THE NAME IMPLIES**

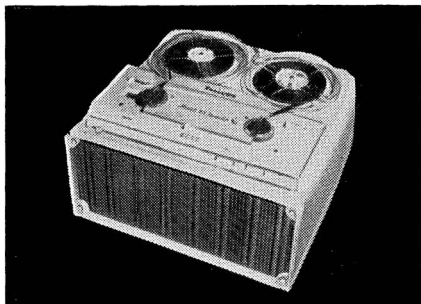

**Model R7  
Tape Recorder**



**Model R6  
Tape Recorder**



**Model MK6  
Tape Deck**

Also manufacturers of Tape Recording Amplifiers, Radio  
Jacks, Telephone Adapters and Stethoset Headphones.

*Fully descriptive literature available on request.*

**TRUVOX LTD., NEASDEN LANE, LONDON, N.W.10**  
Telephone: Gladstone 6455

# Britain's Best Hi-Fi Equipment . . .

*LEAK Amplifiers are the choice of professional engineers such as the B.B.C. (over 500 delivered), The South African Broadcasting Corporation (600), ITV and many other Commonwealth and Overseas broadcasting and TV systems, who use them for transmitting and/or monitoring the broadcasts to which you listen. Also, many of the gramophone records to which you listen are cut via LEAK Amplifiers.*

The "Point-One Stereo" pre-amplifier is designed so that it can be used with any Leak monaural power amplifier or a combination of any two Leak monaural power amplifiers additionally to its more normal use with the "Stereo 20" or "Stereo 50".

Extract from Test Report by J. C. G. Gilbert reprinted from the Music Trades Review. The full two-page Test Report and an illustrated brochure on the amplifiers will be sent you on request.

"The Point-One Stereo" pre-amplifier is probably the most comprehensive unit in existence covering every requirement for stereo tape, disc and radio plus monaural amplification for any form of input signal . . . it is difficult to think of any additional requirement that one would ever wish. The equipment performs with the high performance always associated with the tradition of Leak equipment. It is a fine example of design and construction, and the pre-amplifier can be used with any other Leak main amplifiers. How the pre-amplifier can be sold for as little as £21 can be answered only by Harold Leak . . . \*  
Summing up, therefore, one can highly recommend the Leak stereo system for use with any current monaural or stereo input whether it be from pickup, tape, radio or microphone.

*\*The prices are made possible by our world-wide sales*

*Monaural*

- VARISLOPE III PRE-AMPLIFIER
- TL/12 PLUS POWER AMPLIFIER
- SOUTHDOWN CABINET

**TOTAL £55 : 13s.**

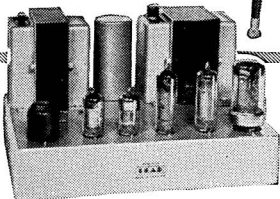

TL/12 Plus Amplifier 18 gns.

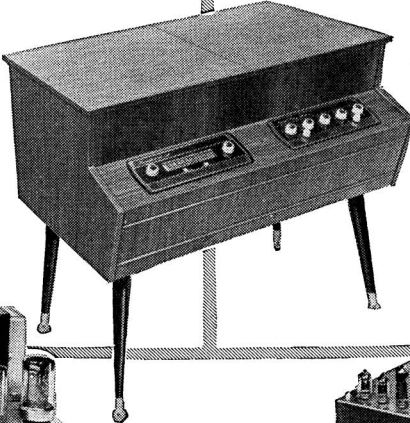

**Point-One Stereo Pre-Amplifier £21**



*Stereo*

- POINT-ONE STEREO PRE-AMPLIFIER
- STEREO 20 POWER AMPLIFIER
- SOUTHDOWN CABINET

**TOTAL £72 : 9s.**

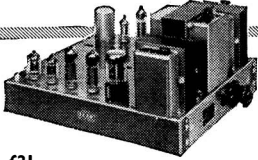

Stereo 20 Amplifier 29 gns.



*the first name  
in High Fidelity  
since 1934*

H. J. LEAK & CO. LTD.,  
BRUNEL RD., WESTWAY FACTORY ESTATE, LONDON, W.3

\*Phone: SHEpherds Bush 1173/4/5 \*Grams: Sinusoidal, Ealux, London

Ask your Dealer to  
show you Leak Equipment

Please send me Test Report

Brochures

NAME.....

ADDRESS.....

.....HFYB



# New Cape Amplifiers for Laboratory Professional and Home Use

The new range of Cape Audio Equipment includes an improved version of the original VLI, still unsurpassed in performance after five years, and a high fidelity amplifier, the VL2, bristling with new features essential to the highest quality monaural or stereo reproducing system.

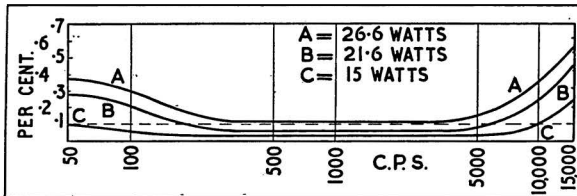

This diagram shows the total harmonic distortion content of the original VLI amplifier, over the whole audio range. It is not possible to compare this performance with that of other amplifiers as no other manufacturer has chosen to publish this information.

The range of audio units includes subamplifiers, originated by Cape, for use with pickup, tape deck and microphone and a new monaural/stereo preamplifier.

*Full details from the manufacturers*

**CAPE ELECTROPHONICS LTD**

43-45 SHIRLEY HIGH STREET  
SOUTHAMPTON

Telephone: 74251

"...of the highest class"

**GOLDRING Lenco  
TRANSCRIPTION MOTOR, GL60**

"The motor . . . is extremely quiet." "The turntable . . . took 3½ minutes to come to rest from a speed of 78 r.p.m. An excellent testimony to smoothness of running." "Rumble . . . non-existent at normal settings." "No sign of 'wow'." ". . . the arm is excellent and will appeal especially to those who wish to change cartridges frequently." "As a final test a stereo cartridge was fitted . . . again no evidence of rumble . . . and the overall performance of the GL60 is so good that it can be recommended to those who want a transcription motor and arm of the highest class"—(Technical Report, "The Gramophone," May 1959.)

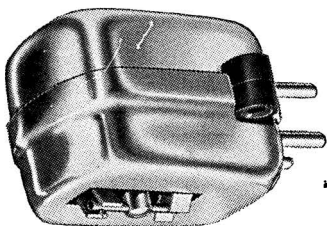

**GOLDRING "700"  
STEREO CARTRIDGE**

Variable Reluctance: with 0.5 mil diamond stylus. Fits modern transcription arms wired for Stereo (e.g. Goldring G60 transcription arm as fitted to GL60 transcription motor).

... and for Monaural Reproduction  
. . . the famous "600" Variable Reluctance Cartridge.

stereo equipment



by **GOLDRING**

**GOLDRING MANUFACTURING CO. (GT. BRITAIN) LTD.**

486-488 High Road · Leytonstone

London · E.11

Telephone: Leytonstone 8343

**Superb equipment by**



**for stereo or monaural**

**STEREO AMPLIFIER AND CONTROL UNIT TYPE S66**

Twin channel, delivering 7.5 watts per channel with ultra linear output stage. Inputs for P.U., Tape and Radio, sensitivity being 6m.V. Separate treble and bass controls.

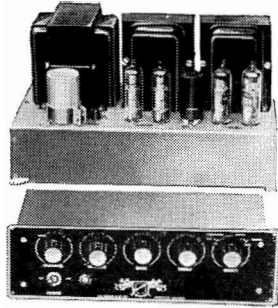

**2 SPEED TRANSCRIPTION MOTOR**

33½ r.p.m. and 45 r.p.m. Full 12" turntable is lathe turned. New nylon graphite bearings. Synchronous motor dynamically balanced. Neon indicator on/off warning light.



**STEREO PICKUP TYPE CSI**

Pickup arm fitted with integral lifting device. The pickup head employs miniature ceramic units, frequency range 20-16,000 c.p.s. output 20m.V with channel separation of 20-25db. Downward pressure 3½-4 grams. Diamond stylus. Will accept Mark II monaural heads.

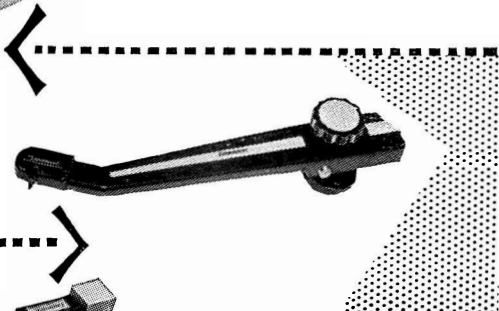

**STEREO PICKUP MARK III**

Designed to accept both monaural and stereo heads. Adjustable for heights of various turntables. Pickup head specification identical with the Type CSI.



**VARIABLE 3 SPEED MOTOR**

For 33½, 45 and 78 r.p.m. Stroboscope fitted with internal light source. Synchronous motor dynamically balanced resiliently mounted. Mechanical speed change giving 4% variation on all speeds.

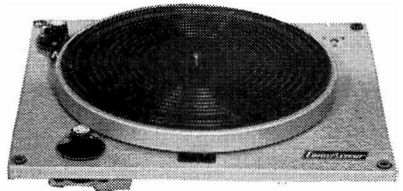

**A. R. SUGDEN & CO. (ENGINEERS) LTD.**  
**MARKET STREET, BRIGHOUSE, YORKSHIRE**

**HIGH FIDELITY  
SPEAKERS AND  
ENCLOSURES BY**

**Richard Allan**

**THE  
GOLDEN  
EIGHT**



Features:—  
8" diameter.  
1" centre pole.  
48,000 Maxwells.  
5 watts max. peak  
input.  
60 to 10,000 c.p.s.  
14 oz. Alcomax 11  
magnet.

Price £2 10s.  
Plus Tax

Features:—  
10" diameter.  
1½" centre pole.  
82,000 Maxwells.  
10 watts max. peak input.  
40 to 9,000 c.p.s.  
2 lb. Alcomax 11 magnet.

**THE  
GOLDEN  
TEN**

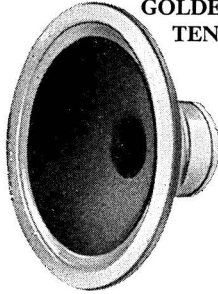

Price £5 12s. Plus Tax  
FOAM SURROUND

Price £5 5s. Plus Tax  
STANDARD  
SURROUND

Features:—  
12" diameter. 2" centre pole.  
182,000 Maxwells.  
15 watts max. peak input.  
25 to 5,000 c.p.s.  
4¼ lb. Alcomax 11 magnet.

Price £12 12s. Tax Free

**THE  
GOLDEN  
TWELVE**

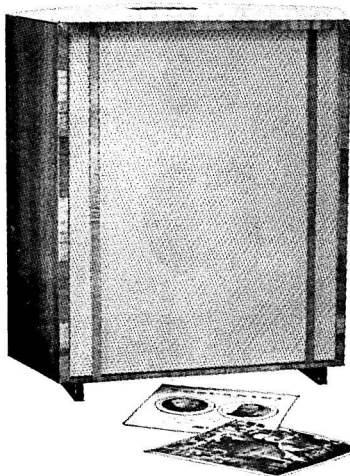
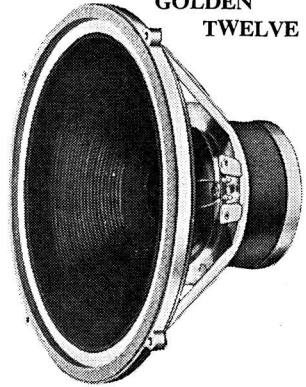

*The*  
**“EMPRESS”**  
*enclosure*

One of the range of Richard Allan High Fidelity enclosures, the “EMPRESS” is recommended for the most critical listener. It is a three unit system and has a frequency coverage from 25 to 17,000 c.p.s.

Price £37 16s. Complete  
Tax Free

For details of these and other High Fidelity products write to:  
Richard Allan Radio Ltd., Batley, Yorks.



# THE "TUTOR" DE LUXE

is a guaranteed  
High Fidelity  
instrument

RETAIL PRICE 59 Gns.

ALTERNATIVE SPEED RANGE  $1\frac{7}{8}$ " ,  $3\frac{3}{4}$ " and  $7\frac{1}{2}$ " p.s. SPEAKER 7" x 4"—  
5.7 watt output—Superimposing and mixing facility, Monitoring through  
its own speaker; very high frequency response with switch compensation.  
Large extension speaker in a separate deep lid **£5.50**

(One year free service guarantee)

**TUTOR AMPLIFIER AND POWER  
PACK** completely assembled and mounted  
on grey rexine covered wooden frame,  
specially designed for Collaro Mark IV deck,  
complete with diagrams and instructions.  
**£20.10.0** (One year free service guarantee)

**THE TUTOR-STUDIO** has 5.7 watt  
output of amazing quality.  
Retail Price **46 gns.**

**LANGUAGE COURSES ON TAPES**  
(based on the world-known Harraps publi-  
cations). Prices include handbooks.  
Full elementary courses **£3.3.0**.  
Full comprehensive courses **£6.6.0** ( $3\frac{3}{4}$ " p.s.)

Write to our new address:

Telephone: MACaulay 3999

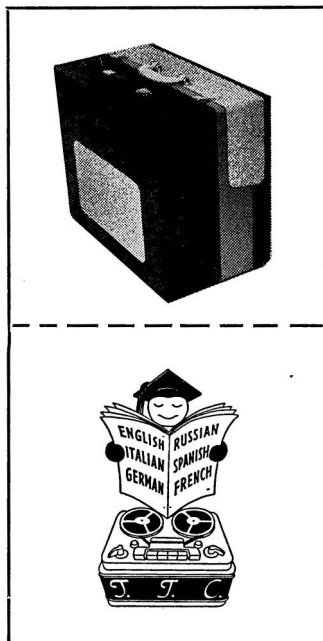

**TUTOR TAPE COMPANY, Orkney St., London, S.W.11**

**LEARN** Train at home in your spare time  
**RADIO & TV SERVICING**  
 this new, easy, practical way!



**YOUR OWN... BUSINESS...  
 CAREER... OR  
 FASCINATING HOBBY**

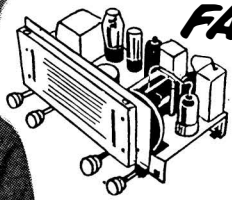

*Electronics is rapidly becoming a great new industry with far reaching applications into every field of modern activity. You can learn all the essentials of this new science at home in your spare time and turn your knowledge to good purpose! Now is your chance to set up your own business and be your own boss!*

**RADIOSTRUCTOR EQUIPMENT COURSES  
 MAKE LEARNING SO SIMPLE**

You learn by building actual equipment with the big kits of components and parts which we send you. You advance by simple steps using high quality equipment and performing a whole series of interesting and instructive experiments—there are no complicated mathematics! Instruction manuals and our teaching staff employ the latest techniques for showing clearly how radio works in a practical and interesting manner; in fact, you really have fun whilst learning! And you end by possessing a first-rate piece of home equipment with the full knowledge of how it operates, and how to maintain it afterwards. In fact, for those wanting help with their radio career training, to set up their own full or part-time servicing business, or the hobbyist, this new and instructional system is exactly what is needed and it can be provided at very moderate cost with payments available. Post the coupon now, for full details. There is no obligation of any kind.

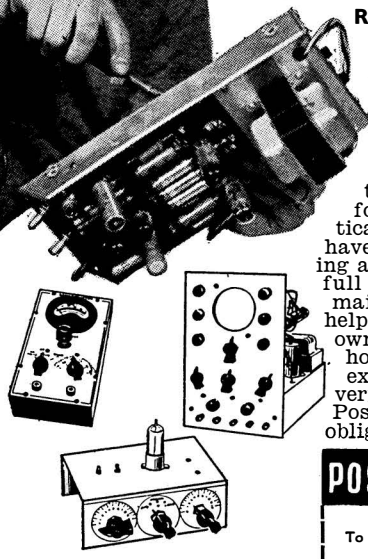

- NO MATHEMATICS
- EASY TERMS AVAILABLE
- ALL TEST EQUIPMENT SUPPLIED
- PERSONAL TUITION
- FINEST EQUIPMENT

**POST TODAY** for **FREE** brochure

To RADIOSTRUCTOR, (Dept. G86)  
 40 RUSSELL STREET, READING, BERKS.

Please send Brochure  
 without obligation to :

Name \_\_\_\_\_ } **BLOCK**

Address \_\_\_\_\_ } **CAPS**

\_\_\_\_\_ } **PLEASE**

(831) We do not employ representatives 1960ED



**RADIOSTRUCTOR**

BRITAIN'S LEADING RADIO TRAINING ORGANISATION

# The famous *Brenell* range

- each model with exceptional features

Versatility—realism—precision engineering at its best. Tape recording equipment made by Brenell is the outcome of nearly 10 years' research and manufacturing experience. Brenell products present outstanding possibilities to those who wish to purchase a complete tape recorder and those who prefer to purchase decks and amplifiers for building into their own design of furniture or with existing Hi-Fi equipment.

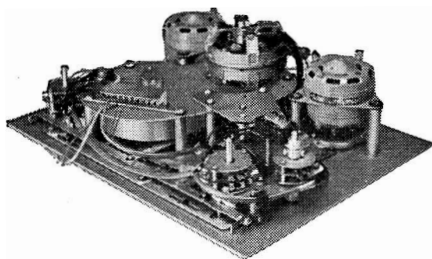

1

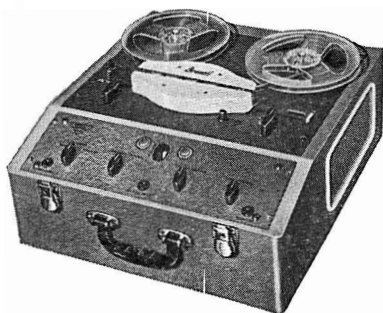

3

1. **Mk. 5 DECK.** 4 operating speeds, four heads can be fitted, 8½" spools accommodated. Only two switches (interlocked for safety). These control record, playback, wind and rewind and have extended shafts for fitting extra wafers if necessary. 28 gns.

3. **Mk. 5 RECORDER.** Four recording speeds 15, 7½, 3½ and 1½ i.p.s. Permits use of 8½" reels (2,400 ft. of tape for long play. 1½ i.p.s. over 8 hours). Three independent motors. Monitoring facilities. Fast rewind (1,200 ft. in 45 seconds). 64 gns. including 1,200 ft. of tape.



2



4

Full details of these models are available from Brenell Engineering Co. Ltd.—the sole manufacturers.

2. **3 STAR.** Three speeds (7½, 3½ and 1½ i.p.s.) with frequency correction at each speed. Push button control. Mechanical interlock. Pause key. Printed circuit amplifier. Separate bass and treble controls. High quality speaker (8" X 5"). Approved by Council of Industrial Design. 58 gns. including 1,200 ft. of tape, spool and microphone.

4. **STEREO REC/PLAYBACK.** Record and re-plays stereo also monaural (half track). Plays directly from gram pickups—stereo or monaural. Frequency compensation at 3 speeds (7½, 3½ and 1½ i.p.s.). Two modulation indicators—one for each track. Two speakers within cabinet. 89 gns., or with two microphones 95 gns.

**BRENELL ENGINEERING CO. LTD.,** 1a, Doughty Street, London, W.C.1 CHA 5809 and HOL 7358



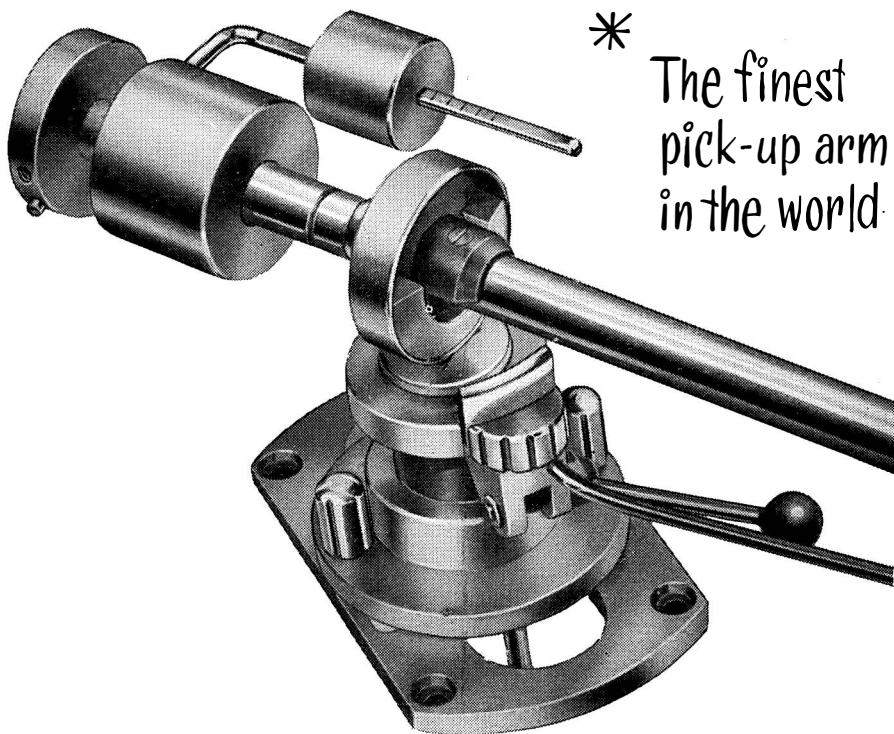

\*  
The finest  
pick-up arm  
in the world.

Only when your equipment includes one of these superb arms can the full possibilities of disc reproduction be realised.

Their many features include:—Mirror finished pillar bearings. Arm carried on virtually frictionless knife edges.

Automatic lowering and raising anywhere on the record by hydro-mechanical control. Sliding base for instant tracking correction. Vertical height adjustment. Unique system provides for lateral and longitudinal balance of arm. Stylus pressure range 0.5 grammes. No weighing device required. Suitable for all stereo and mono cartridges, Decca ffs, Expert special, Ortofon heads, etc.

permitting hitherto unattainable quality.

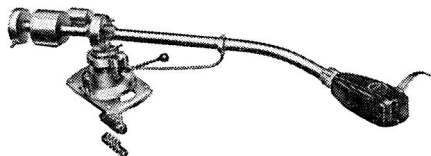

Prices:

Model: 3009 9" Arm £18 15s. 0d. +  
£6 5s. 0d. U.K. P. Tax  
Model 3012 12" Arm £20 12s. 6d. +  
£6 17s. 6d. U.K. P. Tax

# S M E

MODELS 3009 & 3012

## PRECISION PICK-UP ARMS

*Manufactured by*

**S.M.E. LTD · STEYNING · SUSSEX · ENGLAND**

Telephone: Steyning 2228



# BRITISH-MADE MICROPHONES

*consistently specified  
for quality and reliability*

THE LUSTRAPHONE RANGE includes a number of microphones designed for special applications as well as models eminently suitable for recording and studio use. Some of the latter are detailed below. Literature on request.

## **LD.66—DYNAMIC**

An entirely new modern style moving-coil microphone designed particularly for use with tape recorders. Response is substantially flat from 70 to 12,000 c/s. In Low, Line, High and Condenser impedances. Prices according to impedance and mounting from £4.2.6.

## **LFV.59—"FULL VISION" DYNAMIC**

Lustraphone's famous "Full Vision" microphone as used for TV, stage, film and other professional work. Face diam. only  $1\frac{3}{8}$ ". Available as a hand microphone or for stand mounting. In Low, Line or High impedances. £8.18.6.

## **VR.64—RIBBON VELOCITY**

A robustly designed instrument of somewhat miniature proportions which greatly increases the uses of this type of microphone. The specially suspended ribbon is triple-blast screen protected. Response is substantially flat from 50 to 13,000 c/s. Complete on base with cable. Low, Line or High Impedance. £7.17.6.

## **VR.53—STUDIO RIBBON**

Bi-directional, high fidelity model for broadcasting, recording and other professional requirements. Has a high level of sensitivity and extended frequency response. For stand mounting. Low, Line or High impedances. £9.19.6.

## **VR/65—TWIN RIBBON STEREO**

Two vertically stacked ribbon microphones for stereo use with switching arrangements for mono application. 30 gns.

**TRANSISTORISED 4 CHANNEL MICROPHONE MIXER  
STANDS and BASES • ACCESSORIES**

**LUSTRAPHONE LTD.,**  
**ST. GEORGES WORKS, REGENTS PARK RD., LONDON, N.W.1**  
Telephone: PRImrose 8844

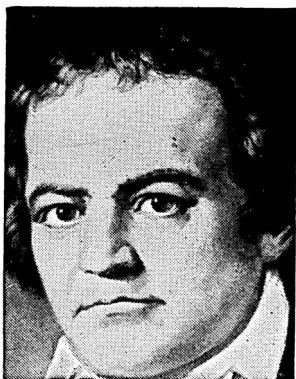

# Who is your favourite composer?

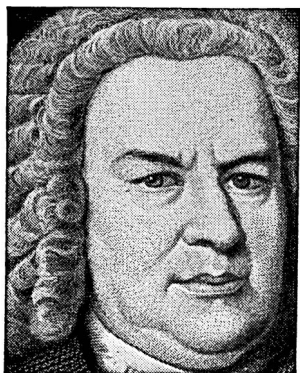

Bach or Berlioz? Moussorgsky or Mozart? Beethoven or Brahms? If you use an Avantic high fidelity sound system it doesn't matter which, for an Avantic amplifying system has no favourites. It reproduces every kind of music faithfully—adding nothing and subtracting nothing from the recording or broadcast.

All Avantic amplifiers have push-pull output stages for low distortion and smooth response, and this includes the remarkable SPA11 Stereophonic Amplifier at 28 guineas. The Avantic range includes monophonic and stereophonic amplifiers as well as power amplifiers, pre-amplifiers, loudspeaker systems in attractive cabinets and radio tuner units.

If you love music you will appreciate Avantic reproduction

## Avantic

BEAM-ECHO LIMITED, LONDON, W.1

Showrooms at : 8 Eccleston Street, S.W.1. Tel : SLOane 0695-7

# BJ THE PROFESSIONAL'S CHOICE



**B-J ELAC  
210 & 310  
STEREO CARTRIDGES**



**B-J  
STEREO CARTRIDGE  
(CRYSTAL)**



**B-J COUNTER  
WEIGHT  
UNIT**

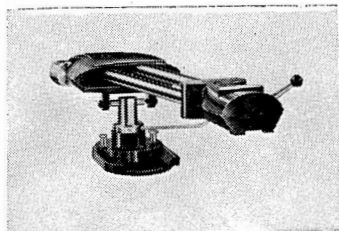

**SUPER 90 Mk II**

There is no magic which makes one pickup track the record more accurately than another or one reproducer design sound more life like.

These qualities are made through technical insight and practical know how. BJ arms have been **designed** to overcome tracking error.

BJ cartridges have been **designed** to do justice to this arm's performance and BJ re-producers are as technically sound as we can make them.

Acceptance by the Council of Industrial Design is a tribute to the technical and artistic excellence of BJ pickups and reproducers. *And they are designed for YOUR equipment.*

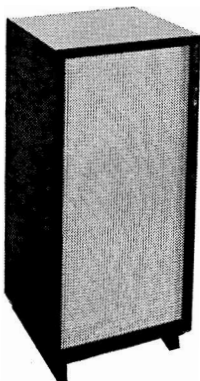

BJ Sonetta



**TOP 'C'  
TWEETER**

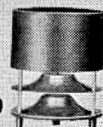

**TREBLE 20**

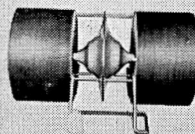

**TREBLE TWIN**

**BURNE-JONES & COMPANY LTD.**  
18 BRUNSWICK ROAD · SUTTON · SURREY

Telephone:  
VIGilant 5050

# 5 sound reasons for choosing from the TAPE RECORDER CENTRE

 **NO-INTEREST TERMS**  
on all orders over £30

 **FREE ILLUSTRATED 72-PAGE CATALOGUE**  
the most detailed publication of its kind

 **HUGE STOCKS OF ALL MAKES**  
ensuring quick delivery to all parts of the country

 **HONEST, INFORMED ADVICE**  
from enth usiastic tape-recording and Hi-Fi specialists

 **COMPREHENSIVE MAINTENANCE SERVICE**  
and inexpensive maintenance contract if desired



<b>Tape Recorders</b>	Kurland	Jason	Garrard	<b>Tape</b>
Grundig	Reps	Dulci	Connoisseur	Emitape
Elizabethan	Revox	Pamphonic	Golding	Scotch Boy
Ferroglyph	WyndSOR	Stentorian	T.S.L.	BASF
Vortexion	Regentone	Avantic	Stirling Tuners	Grundig
Walter	Perth-Saja	Pilot	Acos	Telefunken
Brenell	Elektron	Collaro	Lustraphone	Elpico
Reflectograph	Minivox	Elpico	Elpico-Geloso	Soundrite
Simon	Korting	Decca	Simon-Cadenza	Gevaert
Harting		Philips	Reslo	Philips
Telefunken	<b>Hi-Fi Equipment</b>	Wright &	Record Housing	Agfa
Philips	<b>Microphones</b>	Weaire	Linear	<i>All Accessories,</i>
Spectone	<b>Speakers, etc.</b>	G.E.C.	Tannoy	<i>Tapes, etc. by</i>
Verdik		Goodmans	Ortofon	<i>return of post.</i>
Veritone	Leak	C.Q.	R.C.A.	<i>All makes in</i>
Stuzzi-Magnette	Quad	Wharfedale	Lowther	<i>stock</i>
Fi-cord	Rogers	Elac	Film Industries	
TruvoX	Armstrong	B.J	Audiomaster	

You can choose with confidence from the leading Specialists:

## THE TAPE RECORDER CENTRE

The Tape Recorder Centre Ltd.

Dept. HFY, 75 Grand Parade, Green Lanes, Harringay, London, N.4.

STAmford Hill 1146

# Choose them in comfort . . . Hear them at leisure!

*How to get there. From Tottenham Court Road Tube Station go westward along Oxford Street. Soho Street is the first on the left.*

Make your way

to

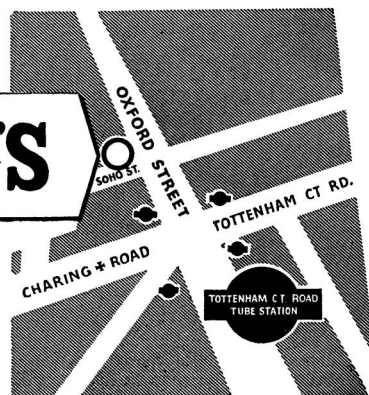

You'll find everybody at Webb's to be cheerful and helpful—without any high pressure sales talk. We have one of the largest selections of the best in hi-fi equipment in London. Come and compare the merits of any combination of Amplifier, Speaker, Pickup and Radio, in comfort and at your leisure.

● **AMPLIFIERS** by

ACOUSTICAL ROGERS B.T.H.	ARMSTRONG LEAK R.C.A.
--------------------------------	-----------------------------

● **SPEAKERS** by

GOODMANS VITAVOX TANNOY WHARFEDAILE	SOUND SALES ROLA CELESTION W.B.
--	--

● **F.M. & A.M. RADIO UNITS** by

ACOUSTICAL ARMSTRONG	CHAPMAN JASON
-------------------------	------------------

● **PICKUPS & MOTORS** by

COLLARO TANNOY GARRARD	CONNOISSEUR LEAK EXPERT
------------------------------	-------------------------------



Webb's unrivalled stocks cover everything from a replacement stylus to complete de luxe outfits. Attractive Hire Purchase terms available.

**14 SOHO STREET, OXFORD STREET, LONDON, W.1**

Telephone: GERrard 2089 and 7803

Shop hours: 9 a.m. to 5.30 p.m. (7 p.m. Thursday), 9 a.m. to 1 p.m. Saturdays.

# TSL

(FIRST WITH 4-TRACK STEREO RECORDERS)

## PRESENT THEIR FINEST PROGRAMME YET

Long recognised as the leading importers and distributors for the finest Continental recorders TSL lead again with a better-than-ever programme of 4-track stereo recorders (which TSL were first to introduce into Britain) and hi-fi equipment. In the latter section are the Thorens Transcription Unit (described by "Hi-Fi News" as "a Rolls-Royce among Transcription Motors") and Ortofon Pickups. The 4-Track Stereo Recorders (usable also as mono instruments) bear world-famous names for quality and craftsmanship, and need no add-on unit to make live stereo recordings. *Your dealer stocks TSL lines. Leaflets gladly sent on request.*

### 4-TRACK STEREO/ MONO RECORDERS

#### HARTING HM.8

2 speeds ( $7\frac{1}{2}$  and  $3\frac{3}{4}$ ), second speaker in lid. Fully equipped for all required facilities. No add-on unit needed.

#### KORTING KM.128

$3\frac{3}{4}$ " p.s. All modern facilities and exceptional standards of performance. Unsurpassed value. No add-on unit needed.

#### ELEKTRON 9S/4K

$3\frac{3}{4}$ " p.s. Finely engineered recorder of amazingly compact size. Needs no add-on unit.

### ORTOFON PICKUPS THORENS TRANSCRIPTION MOTOR

#### MONO RECORDERS—

TSL "Vedette"

#### PRE-RECORDED TAPES

Mono and Stereo

#### TSL MICROPHONES—

M.1 Moving Coil High Fidelity  
(Instant High/Low Matching)

S.2 Dynamic Stereo

MX.3 Hi-Fi Crystal

#### TSL-LORENZ SPEAKERS

TSL 3-CHANNEL MIC. MIXER

Görler Components

***Go for the lines that TSL distribute  
they are modern, dependable and obtainable through  
good stockists everywhere.***

Comprehensive catalogues with full technical specifications on request.  
In case of difficulty write to:

## **TECHNICAL SUPPLIERS LIMITED**

HUDSON HOUSE, 63 GOLDHAWK ROAD, LONDON, W.12

Telephone: SHEpherds Bush 2581/4794

Telegrams—Home: TEKNIKA LONDON, W.12. Overseas: TEKNIKA, LONDON



# LET'S TALK BUSINESS...



Is a reputation for selling quality goods worth having? This is not a frivolous question. You know as well as we do that there *are* dealers who are prepared to foist inferior equipment (yes, let's be blunt about it) onto their customers and to push cheapness rather than guide them towards good value. They think this is the way to get rich quick.

Where do they get these ideas from? From Rolls Royce? From I.C.I.? From Leica?

No. A reputation for quality and good value *is* worth while. A thoroughly satisfied customer breeds business, generates goodwill.

People who buy from MUSICRAFT are enthusiastic about it. They admire the company who made the product and the dealer who supplied it. Their friends are infected by their enthusiasm. Then more customers come to MUSICRAFT.

In this way we shall prosper. 'Easier to say than to do', you may be thinking. Why not find out? Why not make a visit this week to our newly extended showrooms at Richmond, where we have our Hi-Fi Schemes and Suggestions beautifully displayed in delightful room settings, both period and contemporary.

One of the pleasant surprises you will find is that we give a Free Twelve Months Maintenance Guarantee with all Tape Recorders, irrespective of make, price, cash or h.p. wherever you live.

## **Musicraft**

13, KING STREET,  
RICHMOND, SURREY

Tel.: RIC 6798 & 1410

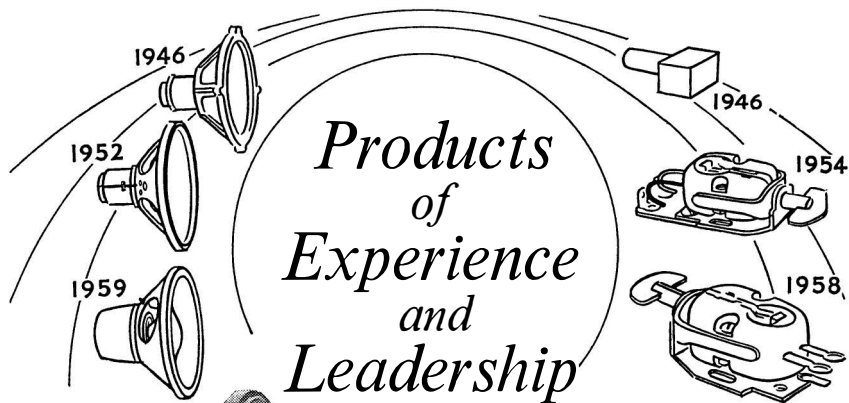

*Products  
of  
Experience  
and  
Leadership*

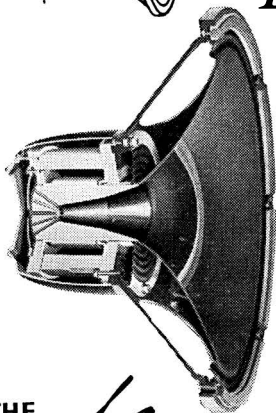

THE

*Monitor*

DUAL CONCENTRIC

The Monitor Units, latest in the long line of Tannoy Dual Concentric Loudspeakers mark another Tannoy achievement.

From the introduction of the first Dual Concentric Loudspeaker, Tannoy have won an established place as the quality standard for faithful reproduction.

The Monitor Units embody all the unique features of the earlier widely acclaimed 12" and 15" Units, but include the revolutionary Magnetic Shunt, and the H.F. Acoustic Balance Cavity, both important contributions to improved quality of reproduction.

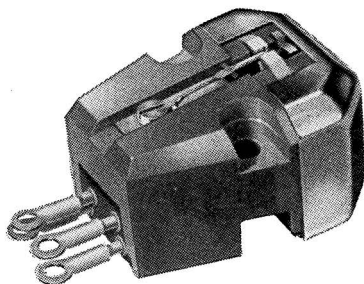

THE

**VARI-TWIN Mk II**

*Compatible Stereo Cartridge*

This triumph of Tannoy research provides a magnetic stereo cartridge completely hum-free. Mounting in close proximity to motors and power amplifiers is now a practical proposition. The Vari-Twin Mk II is designed for micro-groove stereophonic discs made to Westrex 45/45 system. It is however, fully compatible and, with appropriate stylus, monaural discs may be played. It can be mounted in any standard shell or arm suited to its low tracking pressure of 3-4 grms.



Founder Chairman: GUY R. FOUNTAIN

TANNOY PRODUCTS LIMITED WEST NORWOOD LONDON S E 27  
Tel.: GIPsy Hill 1131

*One of the Tannoy Group of Companies*

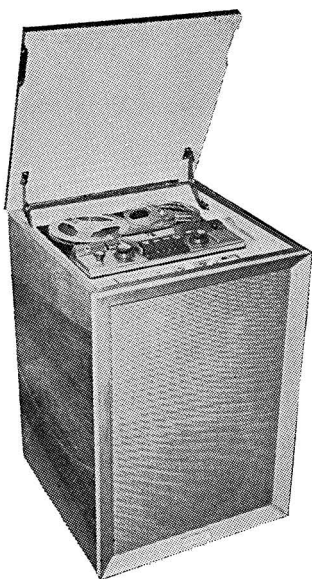

# CUSTOM BUILT

*by*

# CONNAUGHT



Connaught specialise in hand-built tape units for the connoisseur. A versatile basic design allows for a wide range of facilities to cater for all tastes and requirements.

## Console



● **Console Taperecorder.** The Harting deck is employed giving two-speed operation,  $7\frac{1}{2}$  and  $3\frac{3}{4}$  i.p.s. Separate record and playback amplifiers. 12 watts peak output. It is housed in an attractive cabinet containing a 3-speaker infinite baffle system. **Price, with Ribbon microphone, £125.**

● **Tape-O-Gram.** There are three variations, 1a and 1b are monaural models incorporating Dulci tape deck, AM/FM radio unit, 10 watt amplifier, record player to individual choice, four unit speaker system, and record storage space. **Price £210-£250** depending on equipment included. Model 1c is a stereo version using two separate speaker cabinets, a Garrard 301 and Decca stereo pickup. The tape deck has facilities for stereo tape replay. **Price £375.**

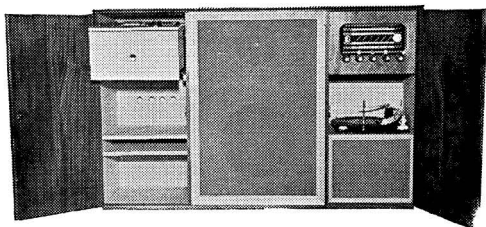

**Tape-O-Gram Model 1A**

*Send for illustrated booklet*

**CONNAUGHT (TAPE RECORDERS) LTD.,**  
1 King's House, 396 King's Road, Chelsea **Tel.: FLaxman 6575/6**

AVANTIC  
BINSON  
B.J.  
BRENNELL  
C.Q.  
CHAPMAN  
COLLARO  
CONNOISSEUR  
COSMOCORD

## EQUIPMENT FOR TAPE, DISC & RADIO

# MODERN ELECTRICS (RETAIL) LTD.

DECCA  
DULCI  
ELAC  
FERROGRAPH  
G.E.C.  
GARRARD  
GOLDRING  
GOODMANS  
GRAMPIAN  
GRUNDIG  
JASON  
KELLY  
LEAK  
LENCO  
LUSTRAPHONE  
ORTOFON  
PHILIPS  
QUAD  
REFLECTOGRAPH  
RESLO  
ROGERS  
RONETTE  
TANNOY  
THORENS  
TRUVOX  
VITAVOX  
W.B.  
WHARFEDALE

*We send the best of  
Britain's Hi-Fi and  
Tape Equipment  
everywhere*

Our service reaches to every part of the world, and extensive selections of our up-to-the-minute stocks appear regularly in our advertisements each month in "Hi-Fi News", "The Gramophone", "Wireless World", etc. If you cannot call, send us your enquiries without obligation. Whatever you order, no matter how small or how large, it is given prompt and personal attention at all times.

AS EXCLUSIVE DISTRIBUTORS FOR THE BINSON "ECHOREC" Electronic Echo Unit, we invite enquiries for full information which will gladly be sent on request. This unit, which enables controlled echo to be imposed on a signal costs 140 gns (\$420, U.S.A.) and is widely used by broadcasting, recording and other organisations. Professional and Trade Discounts.

## MODERN ELECTRICS (RETAIL) LTD.

164 CHARING CROSS ROAD, LONDON, W.C.2

(Three shops from Tottenham Court Road Stn. Und.)

Telephone: TEM 7587 and COV 1703 Cables: MODCHAREX, LONDON

# AUDIO ACCESSORIES by

# METRO-SOUND

## FOR YOUR RECORD PLAYER AND TRANSCRIPTION UNIT

*Metro Sound make for you Britain's finest range of  
Replacement Styli*

To their superb range of High Fidelity TRANSCRIPTION Diamonds Metro-Sound now add the POPULAR Diamond at a cost little higher than many Sapphires—Ask your Dealer for full details.

*Your listening pleasure is increased by also using the other  
METRO-SOUND Record Care Accessories which include:—*

The World-famous STYLOMETER enabling a positive check on Stylus Playings.  
Anti-Static Record Cleaning Fluid.  
Record Cleaning Pads.  
45 rpm NonSlip Adaptors.

## FOR YOUR TAPE RECORDER

Metro-Sound introduce their exciting and exclusive range of Accessories—approved and recommended by Leading Tape Recorder Manufacturers.



### KLENZATAPE

Faulty recording, distortion and noisy playback, incomplete erasure and numerous other faults are of ten due to oxide and dirt deposits from the tape on the Record and Erase Heads of Tape Recorders, METRO-SOUND proudly presents KLENZATAPE, a new and scientific device designed to clean these inaccessible surfaces as easily as playing 12 ft. of normal tape. Price 12/6d. per kit.

### METRO-TABS

For immediate identification of recorded passages. Colourful acetate tabs, under .002 in. thin—2 sets each of 10 pairs, different colour coding. 20 pairs in all. Dimension of tabs ensures that opposite track recordings may be made or played without interference. Tabs supplied in the most comprehensive Index devised. Clearly visible on a fully wound spool. Upper and Lower tracks indicated separately.

Price 3/11d. Complete set with Index.



## METRO-SOUND AUDIO ACCESSORIES

—ALL THE BETTER TO HEAR WITH

*For descriptive leaflets write to:—*

**The METRO-SOUND MFG. CO. LTD., 19a Buckingham Rd., London, N.1**

Telephone: GLIssold 8508/7

# Acos Progress, 1960

---

The remarkable new Acos HI-LIGHT pick-up arm is the outstanding contribution of the year to superb mono and stereo reproduction. The HI-LIGHT tracks at under 1 gramme on mono, and 2 grammes on stereo, virtually eliminating record wear. The frequency range is from 20-20,000 c/s  $\pm$  3dB.

Acos have long paid particular attention to the protection of records, and the Acos Changer Dust Bug, which clips easily over most well-known changer arms, prolongs stylus life up to 5 times.

Acos styli are individually tested at 500 times magnification to ensure the very minimum of record wear. There are Acos styli for all mono and stereo Acos, Garrard, Collaro, BSR and other well-known pick-ups and cartridges.

The famous Acos ranges of mono and stereo cartridges and microphones this year again include some brilliant new models, notably the MIC 44 ACOSTEREO microphone and MIC 45 hand microphone.

 **ARE DOING THINGS IN STYL!**

Cosmocord Ltd Waltham Cross Herts Tel.: Waltham Cross 25206

# Vortexion

The W.V.A. tape recorder now has provision for Stereo plug in heads to enable this recorder to replay Stereo. The regular models are retained with additions and improvements.

Our high standard which has made these recorders famous has been maintained, resulting in their being chosen for the foremost musical centre in this country.

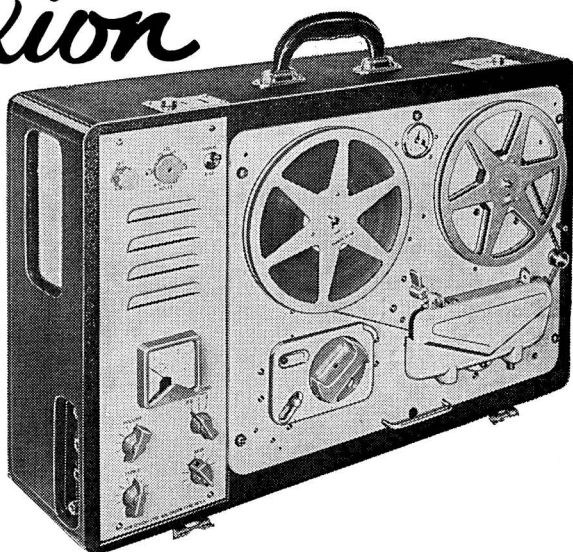

## **TWELVE-CHANNEL ELECTRONIC MIXER**

This is similar to the 4-channel, but is fitted with 12 hermetically sealed controls, 12 balanced line microphone transformers potted in mu-metal boxes, and a mains transformer also potted in mu-metal. All components which can affect noise are tested and selected before insertion. It is supplied in standard steel case or 7 inch rack panel.

## **30/50 WATT AMPLIFIER**

Gives 30 watts continuous signal and 50 watts peak Audio. With voice coil feedback distortion is under 0.1%, and when arranged for tertiary feedback and 100 volt line it is under 0.15%. The hum and noise is better than -85 dB referred to 30 watt.

It is available in our standard steel case with Baxendale tone controls and up to 4 mixed inputs, which may be balanced line 30 ohm microphones or equalised P.U.s to choice.

## **120/200 WATT AMPLIFIER**

Will deliver 120 watts continuous signal and over 200 watts peak Audio. It is completely stable with any type of load and may be used to drive motors or other devices to over 120 watts at frequencies from 20,000 down to 30 cps in standard form or other frequencies to order. The distortion is less than 0.2% and the noise level -95 dB. A floating series parallel output is provided for 100-120 v. or 200-240 v. and this cool running amplifier occupies 12½ inches of standard rack space by 11 inches deep. Weight 60 lb.

## **VORTEXION LIMITED**

**257/263, The Broadway, Wimbledon, London, S.W.19.**

Telephones: LIBerty 2814 and 6242-3

Telegrams: "Vortexion, Wimble, London"



# Jason



## LEADERSHIP IS MAINTAINED

Since the first Jason F.M. Tuner Kit came into being (countless thousands have been sold and are still selling) the company have extended into ever wider fields of hi-fi activity. Their name has come to stand for good design and quality above everything. The Stereo/Mono Amplifier J.2-10 mk.111 is unsurpassed, for wherever a good amplifier is needed, be it with tape-deck, modern small output stereo P.U., radio or any other source of signal. The Jason TV Sound/FM Switched Tuner is another high-light in the Jason Programme which includes tuners to match the J.2-10 mk.111 as well as kits for building stereo amps and various types of tuners. JASON TEST EQUIPMENT in kit form is yet one more success. Here keen amateur and professional alike, are offered such things as Audio Signal Generator, Oscilloscope, Crystal Controlled Calibrator, Wobbulator, Power Packs and Voltmeter built or in kit form. Unusually copious and interesting literature is available free on request from your stockist or direct. JASON LEADERSHIP IS TRULY MAINTAINED —YOU CANNOT BUY BETTER.

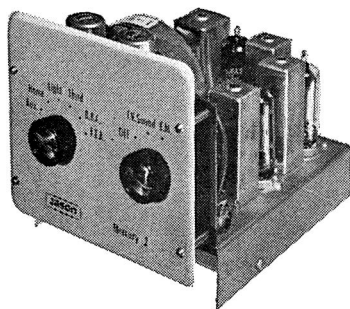

**AMPLIFIERS • TUNERS  
BUILT AND IN KIT FORM**

**TEST EQUIPMENT  
IN KIT FORM**

**THE JASON MOTOR & ELECTRONIC CO.**

3-4 (YB) Gt. Chapel St., Oxford St.,  
London, W.1. GER. 0273

# MAGNAFON TR60

## 1960's MOST OUTSTANDING RECORDER

### TECHNICAL SPECIFICATION

Power: For use on A.C. mains 200-230 volts, 50 cps. Also available for 100-130 volts, 60 cps. Consumption 90 watts. Speeds:  $1\frac{1}{2}$ ,  $3\frac{1}{2}$  and  $7\frac{1}{2}$  ips.

Loudspeaker: Elac high efficiency 8 x 5 in. unit on large baffle.

Output: 3.5 watts from amp at low distortion. 15 ohms extension speaker socket. Advanced push-pull bias and erase oscillator ensuring low tape background noise and distortion.

Hi-Fi Output taken from the amp, before the output stage.

Equalisation: to C.C.I.R. recommendation.

Microphone: Acos Mic. 40 supplied.

Monitor: through its own built-in loudspeaker or headphones. Separate monitor volume control.

Tone: Separate bass and treble controls, which provide cut and lift, are provided.

Tape deck: Motek K10 with pause control and digital type precision place indicator. Storage compartment for microphone and mains lead.

Dimensions:  $15\frac{1}{2}$  in. x  $16\frac{1}{2}$  in. x  $7\frac{1}{2}$  in. Weight 26 lb.

Amplifier: This can be used without running the tape deck motors.

Mixing: Separate volume controls for microphone and radiogram inputs.

Superimposing: A compensated erase on/off switch is fitted to allow new recording over old.

★ Press Button Controls ★ Straight through Amp ★ Mixing ★ Superimposing ★ 6 Hours' playing time ★ Three Speeds



12 MONTHS'

GUARANTEE

**Price 49 gns.**

Matching Legs optional, extra 2 gns.

*Sole Distributors:*

**MARKET DEVELOPMENTS, 221 BISHOPSGATE, LONDON, E.C.2**

*Telephone: BISHopsgate 9415*

# Chapman

## lead with quality and elegance

Our standard of excellence is reflected in the continual reliable performance of Chapman equipment throughout the world. For those prepared to spend a little more Chapman products will prove an outstanding long-term investment.

**The finest British Components**  
**Fully tropicalised throughout**  
**Use of Sound Design Techniques**  
**Stringent Quality Control and Testing**  
**Always up to Specifications**  
**Contemporary Styling**

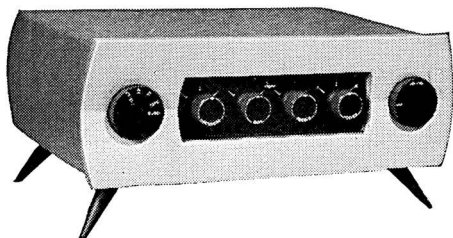

The 305 is a comprehensive stereo or single-channel control unit and affords every facility for high-quality stereo or single-channel radio, gram and direct or pre-recorded tape reproduction without a separate pre-amplifier.

**305 Stereo Control Unit 18 Gns**

Rated at 8 watts per channel this compact double push-pull amplifier is designed for use with a high-quality stereo system. It is especially suitable for direct connection to our 305 Stereo Control Unit.

**305 Stereo Main Amplifier 20 Gns**

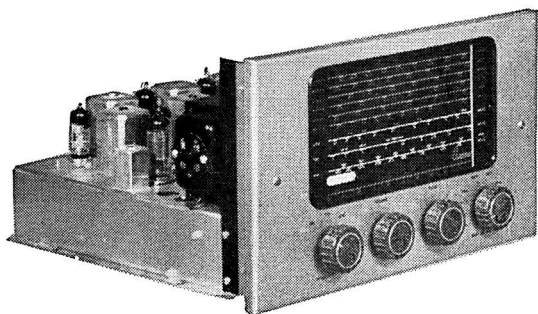
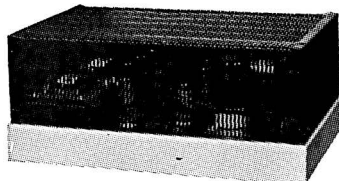

This is the finest AM/FM tuner in our range and combines the stability and sensitivity of a first-class communication-type receiver with the low distortion and wide frequency response required of the modern high-fidelity amplifier.

**S6BS/FM Tuner £67 10.0**

### **G. T. CHAPMAN (REPRODUCERS) LIMITED**

Chapel Lane High Wycombe Buckinghamshire  
HIGH WYCOMBE 2474

# Stentorian

## HIGH FIDELITY AT REALISTIC COST

The items illustrated are representative of the wide range of W.B. Hi-Fi equipment. A noteworthy recent addition is the "Stentero" Stereophonic Speaker System embodying many novel features. Our experience in sound reproduction covers 33 years: such a background is a guarantee of quality. Full details of all W.B. products will gladly be sent on request.

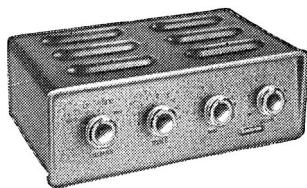

W.B.8 Amplifier £19.19.0.

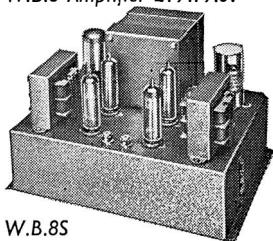

W.B.8S Stereo Amplifier £23.15.0.

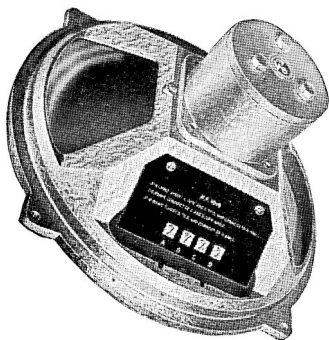

Stentorian Cambric Cone Hi-Fi Units.

The Famous H.F.1016 at £7.12.3  
Others from £1.2.6.

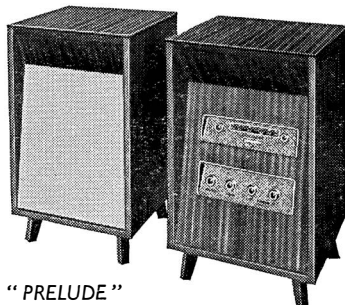

"PRELUDE"  
ready-to-assemble cabinets in striped sapsle from £9.19.6 to £13.13.0.

Ready-to-assemble cabinets in polished walnut from £5.10.0 to £16.16.0.

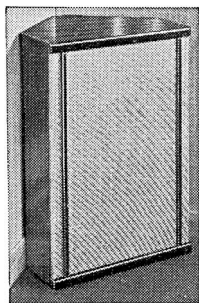

Prelude Horn-Loaded Cabinet £19.10.0.

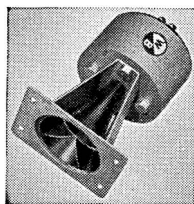

Tweeter Units from 33/3 to £12.12.0.

HF.817 Speaker £10.16.6.



Stentorian Extension Speakers from 60/-

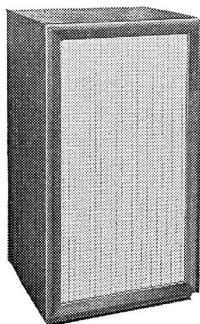

COLUMN LOUDSPEAKERS  
Cabinet for H.F.816. Unit £18.18.0.  
Cabinet for H.F.610 Unit £9.19.6.

WHITELEY ELECTRICAL RADIO CO. LTD • MANSFIELD • NOTTS

W.B.110

Telephone: MANSFIELD 1762-5

# fit Garrard for Good

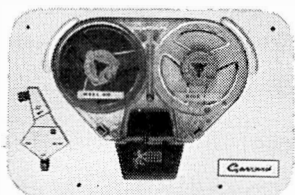

## TAPE DECK

Unique in design the magazine loading makes tape recording and play-back simple. No threading, anchoring or spilling of tape.



## MODEL TPA 12

Transcription Pickup Arm designed to reduce tracking error to a minimum; plays up to 16" records. Fitted with M.P.M. 4 Plug-in Moulding which accepts most cartridges.

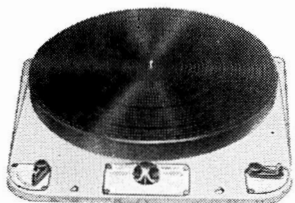

## MODEL 301

The transcription motor for the connoisseur and used by the B.B.C. and broadcasting stations throughout the world.

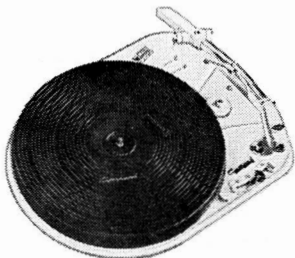

## MODEL 4HF

A high-quality, 12" diameter Single Record Player fitted with latest TPA 12 Pickup Arm using M.P.M. 4 Moulding which will take almost all present-day pick-up cartridges.



## MODEL TA Mk II

A single record player particularly suitable for the home constructor. It is mounted on a rectangular unit plate.



**THE GARRARD ENGINEERING & MANUFACTURING CO. LTD**

SWINDON • WILTSHIRE

Tel: SWINDON 5381 (5 lines) Telex 44-271

# EXCLUSIVE!



**IMHOFS**

## hi fi cabinets

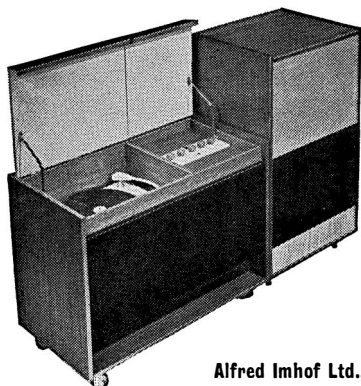

See the complete range of hi-fi cabinets at Imhofs—every design **exclusive!** As well as listening to the widest range of hi fi and stereophonic systems you can see cabinets of various sizes and designs to blend with virtually any decor. And don't forget, Imhofs can custom-build your equipment into walls, into ceilings—in fact conceal your hi-fi system completely. From instruments to cabinets—you can't do better than visit Imhofs. There's always something new!

If you live too far away to call in, please send for a leaflet on our cabinets or for the latest edition of our book 'This Year of Hi-Fi'

Alfred Imhof Ltd., Dept 100, 112-116 New Oxford Street, London, WC1 MUS 7878

AVAILABLE FROM ANY GOOD BOOKSELLER

(INCLUDING ALL BRANCHES OF MESSRS. W. H. SMITH)

THE **STEREO**  
RECORD GUIDE

*THE STEREO RECORD GUIDE* is a comprehensive review of all stereo records available in the field of classical music (with an additional section on light music), reviewed by three critics who have made a speciality of stereo from its inception. Edited by Ivan March, the co-authors are Edward Greenfield of *The Guardian* and Denis Stevens of *The Gramophone*. The foreword by Percy Wilson, technical editor of *The Gramophone*, traces the background and history of stereo.

Available in a handsomely bound first edition, with an attractively designed permanent dust jacket, the Stereo Record Guide is an essential purchase for any music lover or record collector.

**21/-**  
NET  
FULLY  
ANNOTATED

ORDER YOUR COPY NOW

from any bookseller, through any record dealer who sells books, or  
by sending 22/3 with order direct to publishers:

THE LONG PLAYING RECORD LIBRARY LTD. · Squires Gate Station Approach · Blackpool · Lancs.

# Reproduction

*as true as the Master Recording ...  
with the MACKIE "DELTA"*

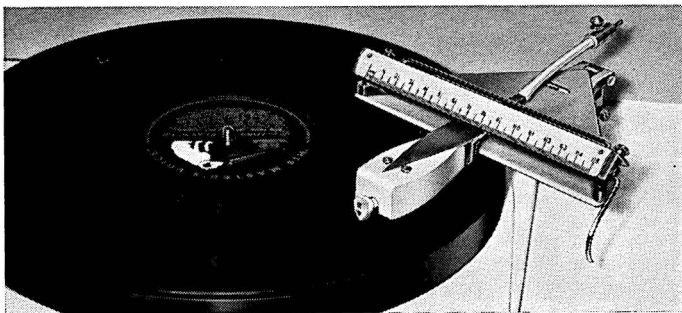

For enthusiasts who really want reproduction as true as the original, the Mackie Parallel Tracking Arm is a "must". By following exactly the grooves made by the original cutting stylus, everything in the record is reproduced without distortion or deterioration. Stylus and record wear is virtually eliminated, and tracking error is completely banished. An engraved scale, used in conjunction with a pickup lowering device, enables precise passages of music to be located without any damage to stylus or record.

For fully descriptive illustrated folder please send s.a.e. (3d.) to sole selling agents:

**THE LONG PLAYING RECORD LIBRARY LTD.**  
SQUIRES GATE STATION APPROACH · BLACKPOOL · LANCs.



# THE NEW RD JUNIOR STEREO AMPLIFIER

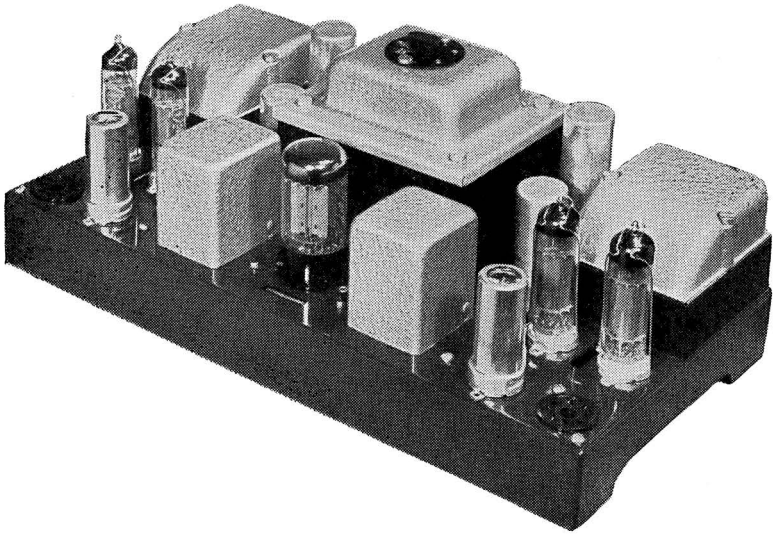

The one amplifier with every worthwhile feature—yet costing only £28 . 10 . 0!

**E**SSENTIALLY a stereo version of the extremely successful RD JUNIOR Monaural Amplifier, this new amplifier retains all the features of the original design, plus a number of valuable detail improvements.

Push-pull Mullard EL84 valves, used in the firmly established "Ultra-Linear" circuit, provide a nominal output of 12 watts per channel—peak figure 15 watts—a rating more than adequate for all normal home use. The total harmonic distortion at 12 watts output is .2%.

High-grade multi-section Output Transformers feature grain orientated laminations and simplified speaker matching—three alternative impedances being available.

Particularly generous smoothing includes a dual section filter ensuring extremely low hum level. Exceptional Power/Frequency Response characteristics have been achieved, power output being well maintained at both ends of the audio scale.

Additional features include, ample spare power for radio units etc., dual A.C. outlets, phase reversal slide-switch etc.

Top quality materials allied to an unusually high standard of workmanship ensure maximum long term reliability—a factor reflected in the TWO YEAR Guarantee covering every ROGERS unit made.

The RD JUNIOR Range includes:—

- |                               |                     |                             |                       |
|-------------------------------|---------------------|-----------------------------|-----------------------|
| ★ Monaural Amplifier          | £17.0.0             | ★ Stereo Amplifier          | £28.10.0              |
| ★ Mk II Monaural Control Unit | £11.0.0             | ★ Mk II Stereo Control Unit | £18.0.0               |
| ★ Variable FM Receiver        | £18.5.6 (+£6.4.9d.) | ★ Switched FM Receiver      | £11.5.0 (+£3.16.10d.) |

Illustrated Literature free on request:—

**ROGERS DEVELOPMENTS (ELECTRONICS) LTD**

RODEVCO WORKS • 4-14 BARMESTON ROAD • CATFORD • LONDON, S.E.6

# EVERYONE'S GOING ELIZABETHAN

## GOING FOR THE NEW MAJOR!

New model with performance standards not previously available in any portable tape recorder.

A standard of performance and a range of facilities only found previously in highest grade professional equipment. A specially fitted 3 micron gap recording head gives phenomenal frequency response and the 6 watts push-pull output ensures sound reproduction of a uniquely high order.

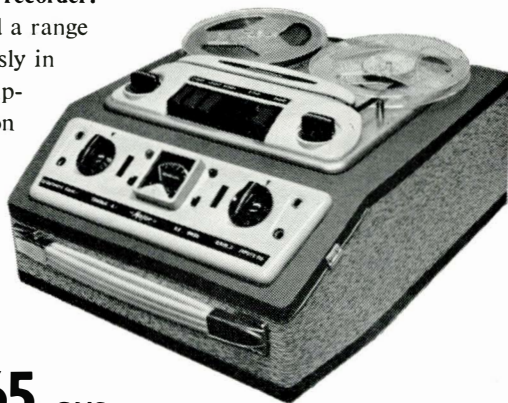

**MAJOR**

**65** GNS.

*Microphone optional extra.*

## GOING FOR BRITAIN'S MOST POPULAR TAPE RECORDERS

It's happening everywhere. Suddenly everyone is seeing the sense of buying a British tape recorder. Finding that British electronics, British engineering have no equals in this world. And finding that nowhere else do electronics and precision engineering combine so effectively as in the Elizabethan range.



### GOING FOR THE AVON!

Today's most astonishing tape recorder value. A first-class machine with excellent recording quality and sound reproduction. With facilities for sound mixing and superimposing. With simple controls, elegant styling—and all at a record low price.

**AVON 27** GNS.  
COMPLETE



### GOING FOR THE PRINCESS!

Going for tremendous performance . . . terrific value . . . and getting both. 3 speeds, 7" spools, four hours' playing time. Facilities for mixing and superimposing.

**PRINCESS 39** GNS.  
COMPLETE

**ELIZABETHAN  
TAPE RECORDERS**

# See and hear this **A**udiomaster Star Equipment!

---

## **Audiomaster Brecon Stereo Unit**

8 watts per channel. Distortion 0.5% at 6 watts, 1% at 8 watts, response 40 c/s—15,000 c/s  $\pm$  2 db. For Cabinet or panel mounting. **£33.15.0**

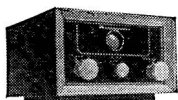
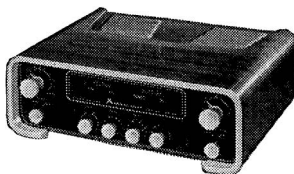

## **Audiomaster Mono Tape Amplifier**

A complete SELF-POWERED tape amplifier **£26.14.0**

---

## **Audiomaster Stereo Tape Amplifier**

For use with the Harting deck using Telefunken heads. Amplifier contains two record channels easily monitored by a 1-inch Cathode Ray Tube. **£33.15.0**



## **Audiomaster**

### **'Golwyn' Stereo Amplifier and Pre-Amplifier**

A new pre-amplifier with a very full specification at a modest price. Input sensitivity is high enough for any magnetic pickup but a handy switch enables crystal pickups to be used without further adjustment. **Approx. £20.0.0 each**



---

## **Audiomaster**

### **'Conway' Stereo Control**

Plays direct from tape heads with a sensitivity of 2 mV. **£28.10.0**

---

The Audiomaster range offers new products, carefully designed to offer maximum interchangeability, with new finishes, new high performance standards. Make sure your listening plans for 1960 include Audiomaster.

*Write for full specification and literature now.*

# **w. & n. electronics LTD.**

80-82, Uxbridge Road, Ealing, London, W.13 Telephone: EALing 4774 (3 lines)



# High Quality microphones

Often the least considered link in the electronic chain, the microphone is an important factor if the highest quality sound reproduction is to be achieved. Any initial loss of quality can never be regained in the amplifying equipment however good it may be.

STC microphones are precision made instruments utilising the finest materials and techniques and will satisfy the most fanatical Hi-fi enthusiast for high quality reproduction of speech and music.

*The microphones  
you see on television*

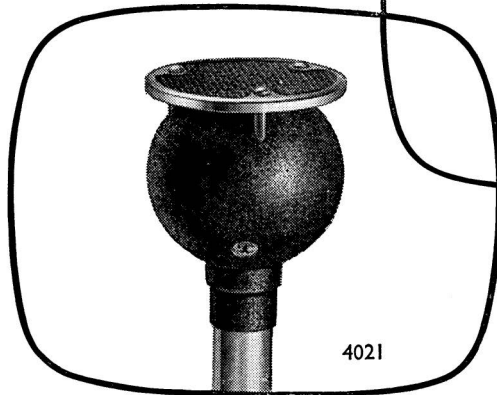

4021

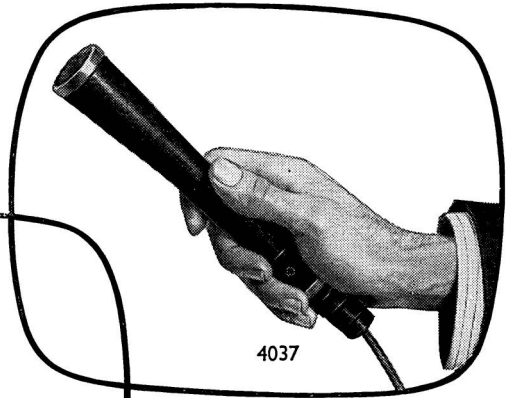

4037

#### OTHER MICROPHONES IN THE RANGE

- 4032 Hand Microphone
- 4035 General Purpose Microphone
- 4105 Cardioid Microphone
- 4033 Cardioid Microphone
- 4104 Commentator's Lip Microphone

Each STC microphone is individually tested to a very exacting specification over the whole range of its performance.

#### 4021

#### *Moving coil microphone*

Firmly established for high-quality studio work and acoustical measurement.

#### 4038

#### *Ribbon microphone*

One of the world's best, and specially suitable for the reproduction of music

#### 4037

#### *Moving coil microphone*

Light-weight. Unobtrusive appearance. High-fidelity, omni-directional polar response.



*Standard Telephones and Cables Limited*

PUBLIC ADDRESS DEPARTMENT

CONNAUGHT HOUSE - ALDWYCH - LONDON - W.C.2.

# Lowther *once again present advanced technique in each product offered for 1960*

*tuner units  
a.m. — f.m.*

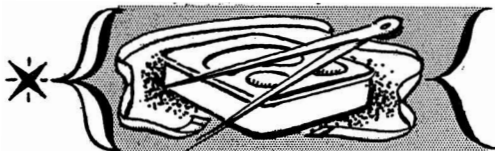

M E A S U R E M E N T

*transistor  
pre-amplifiers*



S P E C I F I C A T I O N

*pick-ups*

*equaliser and  
control units*



M U S I C I A N

*power amplifiers*

*loudspeaker  
drive units for  
horn loading*



L I S T E N E R

*loudspeakers for  
monitoring or  
laboratory*

*— from every point of view*

undoubtedly the greatest range of sound reproducing equipment including the Lowther Acousta Twin on offer for professional or amateur requirements.

**THE LOWTHER MANUFACTURING COMPANY**

LOWTHER HOUSE : ST. MARK'S ROAD : BROMLEY : KENT

Telephone: RAVensbourne 5225

The Man who knows what's inside says :

You get more out of

# TELEFUNKEN



## TELEFUNKEN 'Magnetophon 75K-15'



Tape speeds of  $3\frac{3}{4}$  ips and  $1\frac{7}{8}$  ips with frequency response of 60-16,000 cps and 60-9,000 cps. Playing time of 6 hrs. 20 mins. on  $5\frac{3}{4}$ " DP tape. Tone control. Extension speaker socket.

52 Gns\*

## TELEFUNKEN 'Magnetophon 76K'

Four-tracks allow playing time of over 12 hours! Two speeds and frequency response of 30-16,000cps at  $3\frac{3}{4}$  ips and 30-9,000 cps at  $1\frac{7}{8}$  ips. Transistorised pre-amplifier stage. DC heating of valves. Simultaneous playback of two tracks.

64 Gns\*

## TELEFUNKEN 'Magnetophon 85KL'

Two speeds of  $7\frac{1}{2}$  ips and  $3\frac{3}{4}$  ips with frequency response of 30-20,000 cps  $\pm$  3db and 30-15,000 cps, 6 watt push/pull power stage. Separate Bass and Treble controls. DC heated pre-amplifier valves.

78 Gns\*

**A full selection of Telefunken Accessories, Microphones and Tapes are available.**

*\*All prices excluding microphone*

*Send for illustrated literature*

WELMEC  
CORPORATION  
LIMITED

147/148 Strand  
London WC2

Telephone: Temple  
Bar 3357 and  
Covent Garden 2092

# TELEFUNKEN

*The originators of Tape Recording*



# STOP PRESS

*As manufacturers of the world's finest  
Sound Equipment for receiving,  
recording and reproducing  
since 1931, we have a world  
export division, plus a range  
of Tuners, Amplifiers and  
Loudspeakers for the  
perfectionist.*

*May we send you  
details of our  
latest products?*

R. N. WELLINGTON

*Managing Director*

SOUND SALES LIMITED

SOUND LABORATORIES

WEST STREET FARNHAM SURREY ENGLAND · FARNHAM 6461-2-3

---

USA — CANADA — PARIS — NEW ZEALAND — SINGAPORE, ETC.

---



# FOR THE SOUND ENTHUSIAST

★ 'Hi-Fi News' is the leading British monthly journal for all Hi-Fi enthusiasts. Finely produced, and profusely illustrated, it brings you all the latest news and reviews in the most interesting and comprehensive form. . . . . 2/- MONTHLY

PRICE: TWO SHILLINGS

# Hi-Fi News

NOVEMBER, 1959 Vol. 4 No. 6

**RECORD NEWS**



— IN THIS NUMBER —

- Do-it-Yourself section, with two constructional features
- Hi-Fi Shopping on £90
- Television Pictures on Tape
- Readers' Problems Solved
- Audio News
- Reviews of Classical, Jazz and Popular Discs
- Looking at Stereo
- Reviews of equipment
- For your Better Listening
- Details of New Products
- Readers' Postbag

★ 'Hi-Fi News' is on sale at all the leading bookshops, news stands and Hi-Fi dealers throughout the world. Overseas retailers are invited to write for agencies.

Published Monthly by

## CLASSICAL RECORD NEWS LIMITED

99 MORTIMER STREET, LONDON, W.1.