

www.hi-fiworld.co.uk

hi-fi

DIY
SUPPLEMENT
No. 63
INSIDE
THIS ISSUE!

FEBRUARY 2002

UK £2.75
Malaysia Rm18

WORLD

& computer audio

STRONG ALLAES

We test the new Naim Allae loudspeaker



plus : the new Videologic DRX-601ES DAB tuner competes with Creek's analogue T43

plus

- Budget bookshelf speaker group test
 - Bryston B-60 integrated amp
 - Plinius Jarrah phonostage
 - NAD T531 DVD/CD player
- Denon UD-M30 mini system
- Wharfedale Diamond 8.3 loudspeakers

Computer Audio World

- Soundblaster Audigy Platinum
- Apple's iPod
- Predator CD-RW

COMPETITION
Win an excellent
Creek CD 53 CD player
worth £1200!

FEBRUARY 2002



02 >

+ 100s of classified ads full of secondhand bargains!!!



THE KOMRI. PREVIOUSLY UNHEARD TECHNOLOGY.

This uncompromising full-range loudspeaker is designed to let you hear every pure note and every subtle nuance of the live musical performance captured by the recording.

The Komri five-way loudspeaker utilises newly developed loudspeaker technology for the sub-bass, bass, midrange, high-frequency and super high-frequency drivers. Two completely independent servo controlled bass drivers incorporating Linn's Class-V Active Servo Bass technology drive the lowest frequency range. The four upper range drivers have been mounted closely together in an optimised acoustic array.

To find your nearest Linn specialist where you can experience the Komri for yourself visit www.linn.co.uk or call the Linn Helpline on 0500 888 909.



LINN



Even though staunch Thatcherites will try to persuade you otherwise, I can now reveal that we share a lot more in common with our mainland European brethren than many had hitherto thought. What is it that bonds us so strongly together with our cross channel counterparts? A love of fine art, classical music and poetry? I think not. I can exclusively reveal that the one factor that gels us is the humble audio valve.

Visiting a friend in The Netherlands recently I found myself sitting in a bar pondering the meaning of life over the fortifying combination of an ice cold lager and a toasted cheese and ham sandwich on a Saturday lunchtime. A strong nudge almost shot both out of my hands as one of my companions eagerly attracted my attention and jabbed an excited finger up above the bar. Bolted vertically to the wall above the barman's head were two of the beefiest looking valve amps I'd ever seen, resplendent in stainless steel cases with blue LEDs, with VU meters pumping away - they were real jaw-droppers. These were no cast out Leak or Quad antiques but brand spanking new Art Deco style working models powering the bar's sound system! I managed to discern from the bar manager from whence these monsters came - and found myself trotting just five minutes down the road, tutting mate and wife in tow! When I reached my destination it was awash with quality hi-fi for sale (much of it tubular) and manned by the designer of the aforementioned amps - an enthusiastic, friendly and very trendy dude of perhaps no more than thirty years, who informed me that the Dutch were big fans of valve powered tunes.

This was no shock, as our World Audio Design kits are popular there and we get plenty of website 'hits' from The Netherlands, as well as Germany, Denmark and Italy. It seems that diehard European audiophiles can't get enough of high quality audio of this type. What was a shock (albeit a pleasant one) was to find that it was younger people interested in valves. For example, the bar in which the amps in

question were located was a city rock and dance tunes clientele (and what better was them?), of which I was one but true!

That isn't the case here in the UK, generally valves are associated with a certain type of listener, potentially qualified for a Saga holiday. There's room for improvement, though, as guitar amplification such as Marshall is favoured by many for its 'classic' sound which is powered by (in Marshall's case), you guessed it, valves. We in the UK have one of the strongest traditions of valve amplifier production, but the classic amps from the likes of Quad and Leak are associated with listeners of a certain generation, stereotyped as those who listen to fusty old chamber music and survive on a diet of well brewed tea and cup cakes.

In Europe, from what I can glean, tube amps are regarded as something distinctly more funky. Long may it continue and as we move headlong into a unified Europe it may even rub off on us Brits. You've got to hand it to the mainlanders - not only do they appreciate fine art, classical music and poetry, they also manage to make valve amps hip! ■▲



Simon Pope

how we test the products

- Hi-Fi World has its own advanced test laboratory and acoustically treated listening room.
- Hi-Fi World has a dedicated in-house team of experienced listeners. We review thoroughly by extensive auditioning, rather than by quick-fire group listening tests.
- Hi-Fi World's engineering team designs a wide range of products in-house. No other hi-fi magazine is so expert and dedicated.

£ ——— NICE PRICE - Represents excellent value for money.

★★★★ EXCELLENT - Superb sound, among the best available.

★★★★ VERY GOOD - Well worth a listen.

★★★ ADEQUATE - Room for improvement.

★★ POOR - Seriously flawed. Forget It!

Half globes are added for those products that we feel are between categories

FEBRUARY 2002

WORLD AUDIO DESIGN

www.worldaudio.co.uk

Computer Editor
David Price
email: editor@worldaudio.co.uk

Design & Layout Editor
Faiza Chunara
tel: +44 (020) 7625 3124
fax: +44 (020) 7328 1844
e-mail: adproduction@hi-fiworld.co.uk

Production/Photography Editor
David Noble
tel: +44 (020) 7625 3134
fax: +44 (020) 7328 1844
e-mail: classifieds@hi-fiworld.co.uk

Advertising
Ewan Hawkes
tel: +44 (020) 7624 9022
fax: +44 (020) 7328 1844
e-mail: adsales@hi-fiworld.co.uk
Amanda Sweeney
tel/fax: +44 (020) 8864 4760
e-mail: advertising@hi-fiworld.co.uk

Accounts
Michael Ogazi
tel: +44 (020) 7625 8032
fax: +44 (020) 7328 1844

Credit Control
Louise Palfrey
tel: +44 (0) 1923 270833
fax: +44 (0) 1923 260588
e-mail: subscriptions@hi-fiworld.co.uk

WORLD AUDIO DESIGN
Technical Manager - Nick Lucas
www.worldaudiodesign.co.uk
tel/fax: +44 (0) 1908 218 836
e-mail: nick@worldaudiodesign.co.uk

Publisher
Noel Keywood
e-mail: publisher@hi-fiworld.co.uk

Private & Trade Classified Ads
tel: +44 (020) 7625 3134
fax: +44 (020) 7328 1844
e-mail: classifieds@hi-fiworld.co.uk

Subscriptions & Back Issues
9:30am - 12:00 noon
tel: +44 (0) 1923 270833
fax: +44 (0) 1923 260 588
e-mail: subscriptions@hi-fiworld.co.uk

Distributed by
Comag Magazine Marketing,
Tavisstock Road, West Drayton,
Middlesex UB7 7QE
Tel: +44 (0) 1895 444 055

Printed by
Southern Print, Dorset
Tel: +44 (0) 1202 622 226

Our Agents in Malaysia
Millennium Hi-Fi & AV
Simon Chang
Showroom & office, 500-1-3 First Floor
Wisma Indah (Shen Court), Jalan Tun Razak
50400 Kuala Lumpur, Malaysia
Tel: 603 9283 8171 Fax: 603 9281 3762
e-mail: info@millennium-audio.com

All unsolicited submissions and goods are at the owner's risk. We accept no responsibility for such submissions, nor do we undertake to return them.

No material may be reproduced from this magazine without publisher's written permission.
© Audio Publishing Ltd



February Contents

News

Loudspeakers

BUDGET BOOKSHELF GROUP TEST 9



We listen to six of the brightest stars in the budget bookshelf sector. Find out which gets our vote.

NAIM ALLAE

We get the exclusive on the impressive new floorstander from Naim Audio. David Price listens with interest.



WHARFEDALE DIAMOND 8.3



Dominic Todd encounters the top of the Wharfedale Diamond range. Will this floorstander be a genuine gem?

amplifiers

BRYSTON B-60 50



Mani Sandher listens to the entry level integrated amplifier from the Canadian professional specialist.

digital source players

AUDIONOTE CDT-ZERO CD & DAC-ONE 41



This is the entry level CD and DAC from the valve specialists. Find out if this combination has the bottle to compete with the best.

NAD T531 52



Here is the new budget DVD player from NAD. Like the rest of the company's products it promises to concentrate on audio quality. Will David Price be suitably impressed?

VIDEOLOGIC DRX-601ES/CREEK T43 22



Noel Keywood tests out two competitive tuners from both sides of the broadcast fence. Will the digital Videologic impress or will it be analogue all the way with Creek's T43?

vinyl

PLINIUS JARRAH PHONO STAGE 37



The Jarrah is the £600 MM/MC phono amp from the land of the Kiwi. David Price dons his Maori outfit and gets down.

systems

DENON UD-M30 26



Simon Pope encounters this cute CD receiver with matching Mission-built speakers.

accessories

CABLES 59



Simon Pope listens to three interconnects priced £150 and over.

features

BUDGET UPGRADES 19

HFW gives you more advice and tweaks to get the best from your budget system.

THE NAIM GAME 62



David Price reports from the Salisbury HQ of the British stalwarts.

regulars

WORLD NEWS 6

NEXT ISSUE 7

READERS LETTERS 44

Hi-Fi World's team reply to your letters and e-mails.

SUBSCRIPTIONS 83



Hi-Fi World is second to none for news and reviews. Subscribe today!

HI-FI WORLD KITS 64

HI-FI WORLD LIBRARY 68

A comprehensive selection of titles covering audio, valve amplifiers, loudspeakers, solid state electronics and more.

CLASSIC CUTS 60

This month Andy Giles chooses Goats Head Soup by the Rolling Stones.

COMPETITION 61



Win a superb Creek CD53 CD player worth £1200 in our New Year competition.

OLDE WORLDE 77



This month David Price highlights Naim's classic CDS.

COLUMNS 71,73,75

The World team get to grips with issues facing both the industry and hi-fi alike.

SPECIALIST HI-FI DEALERS 76

Got a problem? - see a specialist.

DIAL-A-DEALER 78

Who sells what, and where to find them.

MEET YOUR MAKER 80

Who makes what, and how to get in touch.

WORLD FAVOURITES 87

Components which we know to be truly worthy of audition.

WORLD CLASSICS 92

Our list of products that have stood the test of time.

MARKETPLACE 107

READERS CLASSIFIED 125

The definitive place to find classic audio components.

ADVERTISERS INDEX 130

computer audio world

SOUNDBLASTER AUDIGY PLATINUM 81

The latest product from SoundBlaster.

APPLE'S IPOD 84

We preview the tastiest audio player of the year, the iPod.

PREDATOR CD-RW 86

lomega's Predator CD-RW takes CD burning to new heights.

DIY SUPPLEMENT NO.63 95

NEWS 97

300B SINGLE-ENDED POWER AMPLIFIER KIT 98

Clive Meakins builds a 300B single-ended power amplifier kit from Hong Kong.

DIY MULTI-METER 104

Nick Lucas came across a DIY bargain from Rapid Electronics.

LETTERS 105

world news

► DENON LAUNCH NEW LINE-UP

At a recent London launch Denon introduced its latest AV products to the UK press. Star of the show was the £1800 all-dancing AVC-A11SR, the world's first amplifier with dts 24/96 sound processing and the first to combine dts 6.1 ES Discrete and Dolby Pro-Logic 2 with THX post processing. In addition to this, two more receivers were launched as well as a new DVD-Audio player and a stylish new separates audio system. The DVD-1600 DVD-A player features audio-



presets. It also has timer and alarm functions. Other system options include a cassette deck, MiniDisc recorder and the SC-M201 'speakers designed in collaboration with Mission.

only mode, internal Dolby Digital and dts decoding and headphone Virtual Surround Sound for £600. The chic new system 201 offers the high quality audio performance of the company's entry level hi-fi products in a stylish separates system for under £1000. It features a 50W per channel integrated amplifier with a phono stage for vinyl option, a CD player with 24bit DACs and two optical outputs, and an RDS tuner with 40

Hayden Laboratories Ltd.
Hayden House
Chiltern Hill
Chalfont St. Peter
Bucks SL9 9UG
www.denon.co.uk

► BFA GO IT ALONE

The British Federation of Audio, a body made up of industry specialists to monitor and promote the audio industry, has now become fully independent and has been made a limited company. It was originally formed back in 1965 by thirty or so British manufacturers, with the intention of promoting the wide use of its products both here, but most importantly, abroad. It continues to do this, as well as sponsor British manufacturers (with the aid of British Trade International) for international shows and exhibitions such as the annual ICE in Las Vegas.

Further objectives of the BFA will be, among other things, to present a unified voice for the industry, improve the promotion of high quality consumer audio and monitor new industry trends. Membership of the Federation is open to any company, organisation, magazine or individual working in the UK, in the field of consumer audio-video.

British Federation of Audio
PO Box 365
Farnham
Surrey GU10 2BD
www.british-audio.org.uk



► ONKYO'S INTEGRAL VISION OF THE FUTURE

The high-end Integra Division of Onkyo (which features Apogee digital technology) is the latest big name to sign up to Imerge's XiVA software framework technology, the rapidly developing standard for hard disc and internet based electronic products. XiVA can receive, record, store, access and manage vast amounts of digital entertainment content using hard disks as the primary storage medium. Integra will apparently make a multi-zone hard-disc audio system powered with XiVA where the music will distributed around a house by Ethernet, employing so-called Integra 'thin clients' for a complete home entertainment system. Hayao

Kamiya responded to the agreement by stating "We are expanding from our core of AV home theatre oriented products to new challenges in the digital home network field. In this way we aim to remain a powerful, forward-looking company and Imerge are offering us advantages in terms of experience, knowledge and time to market."

Onkyo UK distribution:
Jamo UK Ltd.
Oakfield Park
Bilton Road
Rugby
Warwickshire CV22 7AL
Tel: 01788 556777
www.onkyo.net
www.xiva.com

►► LINN GO DISKO!

The venerable LP12 turntable could soon be the choice of big name DJs, if veteran vinyl spinster David Mancuso is anything to go by. The New York based DJ is a big Linn fan and now uses a pair of LP12 turntables in place of the more specialised but sonically inferior Technics decks, the industry standard, at his so-called 'loft parties'. Whilst the LP12 isn't exactly ideal for mixing, as it lacks a pitch control, Mancuso is driven by sound quality over practicality and now specifies LP12s with Linn's top specification Ekos arms and Archiv cartridges. Linn Products have partnered Mancuso events in London, Glasgow, New York, Tokyo, Antwerp and Milan where capacity crowds approach 2000. The system also features a Linn 5103 system

controller with the LIMBIK surround sound processing. As Mancuso says "Once the channel delays for the five individual Limbik channels were adjusted for the room size and to account for 2,000 people on the dance floor, the sound was quite simply awesome, seamless and above all else, so musical. I had not heard sound this good at a disco in almost thirty years of deejaying in New York." Mancuso is currently signed to London-based Nuphonic Records who have issued his Loft party Volumes 1 and 2 on both CD and vinyl.



Linn Products: 0141 307 7777

www.nuphonic.co.uk
www.theloftnyc.com
www.linn.co.uk

►► KEF'S NEW Qs



Following on from the last crop of new models from the Kent-based company, KEF have announced details of two new Q Series products. The Q3 and Q5 both incorporate the company's latest version Uni-Q technology and also feature technology used in the flagship Reference Series 'speakers. The models have the new ergonomic styling of the range, with the curved sections and the Uni-Q 'pod'. The Q3 is a magnetically shielded two-way floorstander featuring the new

metal dome neodymium tweeter and a 160mm Uni-Q driver. The Q5, described as a two and a half way design featuring a high frequency and midrange array, plus a 160mm bass unit with its own tuned enclosure and port. Both are available now priced £399.99 for the Q3 and £599.99 for the Q5.

KEF Audio Ltd.
 Tovil, Maidstone
 Kent ME15 6QP
 Tel: 01622 672261
www.kef.com

►► KOMRI, TOGETHER

November 23rd saw Linn taking to the road with its brand new Komri loudspeaker. Carlisle's Crown and Mitre Hotel was host to the crowded event, organised by Peter Tyson Hi-Fi, which saw an assorted selection of audio's good, bad and ugly including Linn Products' supremo Ivor Tiefenbrun. A fine time was had by all, with the Glasgow boys achieving a far better sound than you'll hear at any show - unsurprising considering the



£86,000 total cost of the system! A sneaky peek of Linn's DVD Classik was given - expect a £2,000 video player with built-in five-channel amplification, with neat styling resembling the company's own 5102 preamp, complete with centrally



mounted disc-loading tray. Certain Linn folk reckon it outperforms the two-channel Classik in stereo mode, too.

next issue

here's a little taster of what we hope to bring you next month

LINN KOMRI

This is the new flagship loudspeaker from Linn, in an exclusive review. With awesome weight and a matching price tag it promises to be a landmark product.

ROGUE AUDIO 99/M120 PRE & POWER AMPS

This pre/monoblock combination from the States is a stylish valve package. See what the tube experts make of it next month!

SEPARATES SYSTEMS

We test out a selection of one-make separates systems from specialist hi-fi manufacturers. Which will offer the best value, and why?

► MAGNAT VINTAGE 105

Although not a mainstream name on these shores, German manufacturer Magnat are well respected in their home country and on the continent - mainly for their involvement in car audio. The company specialise in big sounding 'speakers with plenty of drive and bass, but in the past have skipped somewhat on subtlety (their symbol is a refreshingly non hi-fi Bulldog, for example) except for the previous models in their top range Vintage series. Now the Vintage series has spread lower down the product range to incorporate entry level models starting with this, the £120 Vintage 105.

Build quality is good, with a small but pretty solid cabinet with gently rounded edges designed to prevent diffraction and reflections. A knock on the side of the cabinet results in a boxy but not too resonant sound. The front MDF baffle houses an aluminium coned mid/bass unit and a 25mm dome tweeter. The port is located to the rear and we have a pair of single wire connectors of decent quality.

The 105s have the forward sound of the company's traditional sonic stamp, but are less crude than previous models. It's a big and bold sound that gives a good out-of-the-box feel. Whilst far from being the most sophisticated 'speaker around, the 105 is nonetheless exciting and fast, which could appeal to many buyers at this price point. The Blue

Note Brazilian jazz compilation had plenty of groove and funk, emphasising what a good way with rhythm the 105s have. Being overtly critical, sometimes the instruments were a tad too coloured, but at this level that can sometimes be a bonus - few 'speakers around this price point are deliberately neutral in character. Drums were fast and clean, although the upper echelons of the cymbal work could be a bit splashy and hard.

Bass was impressive, as Bjork's 'Homogenic' CD demonstrated, having plenty of grunt and apparent depth. Vocals, though, could be a little too pushed forward at times - a common trait of metal cones.

With classical music the 105s gave a good performance as far as space and staging go but instrumental timbre erred toward sounding synthetic, perhaps due to the inherent forward nature of the 'speakers.

There was a good spread of sound with Beethoven's 'Eroica' symphony, with double basses rich and powerful, but further up the frequency scale a certain amount of information was lost in the midrange.

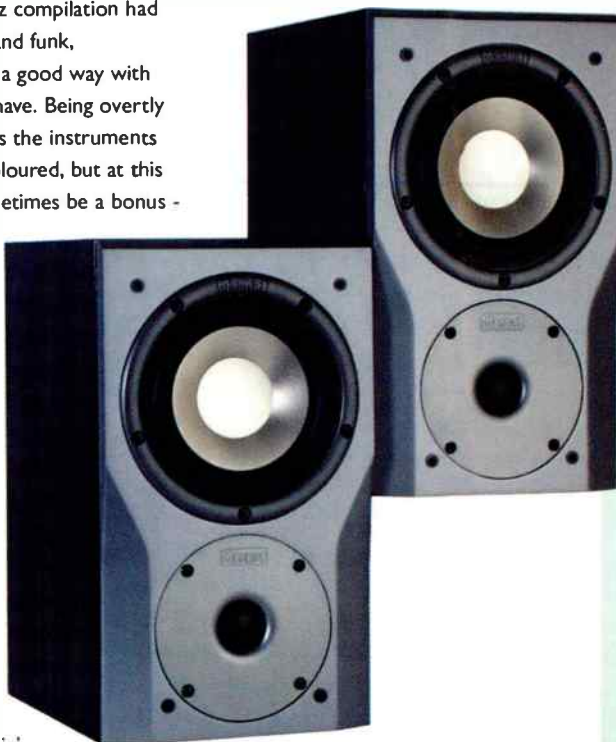

More than enough was present in the upper frequencies, however.

The Magnats offer pretty good value for money in both build and sound and are more than worth a listen for those who favour rock or dance music. ■ ▲

Magnat Vintage 105 £120

FSM Ltd.
Unit 4 The Nelson Centre
Portfield Rd
Portsmouth
PO3 5SF
Tel: 0239 269 0999

MEASURED PERFORMANCE

The Magnat Vintage 105 has a noticeable lift in high frequency output and will sound bright. It will need to be partnered with care, preferably with a fairly smooth sounding amplifier like a Creek. Otherwise, its frequency response is reasonably smooth so the 'speaker should be low on colouration and strong in its detailing. The tweeter has a high impedance and does not draw current so it will not stress an amplifier.

Bass rolls down slowly below 125Hz, reaching -6dB or so at 63Hz. This is quite good, even if it doesn't quite match the Diamond for example. A damped response like

this suggests the Magnat should be used close to a rear wall.

The loudspeaker's voltage sensitivity was a mediocre 83dB, equal to some like the Mission, but below the Wharfedale. The 105 has a fairly innocuous impedance curve that shows an absence of strong reactance - a good sign - plus a high impedance tweeter matched to a 4ohm woofer. This results in a 6 ohm loudspeaker.

The Vintage 105 is well engineered in every respect. It will sound clean and detailed, but also quite bright. **NK**

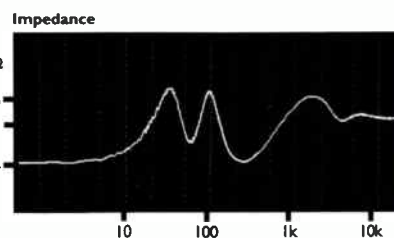
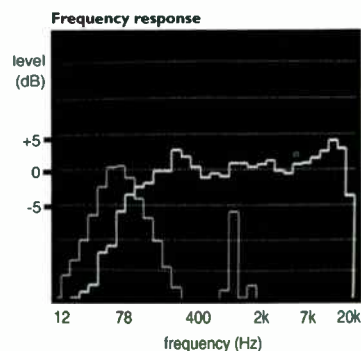

World Verdict



Not half bad for the money, the Vintage 105s are fast and exciting but also a tad too forward sounding.

▶ **WHARFEDALE DIAMOND 8.1**

The Diamond 8.1 is small in stature (296x198x181mm) and features a front port (so close placement to a rear wall isn't a problem). This shares the baffle with a 130mm Kevlar woven cone bass/mid unit and a 25mm fabric dome tweeter. The overall look may not be to all tastes but it's modern and, to a certain extent, funky. High quality bi-wire connections finish off the build quality in a positive way.

Sound quality is somewhat different from the budget bookshelf norm, sharing a sound more in the KEF Cresta mould as opposed to the open and out-of-the-box Mission sound. This gives the impression of a very sophisticated and smooth customer, more akin to a £600-plus product than something from the cheap end of the market. It's been voiced to deliver this taste of the high end at a low end price. And it works. The 8.1 has good detail and cohesion well beyond the traditional sound found in this bracket. A Blue Note compilation of Brazilian music saw the Diamonds really sing, delivering a detailed and fluid sound that was highly impressive. Treble was commendably smooth and bass, whilst not especially low, was nonetheless highly tuneful and

discernable - good at this price point. Most revealing of all though was the 'speaker's midrange detail which, at the £120 mark, is almost unheard of. This is what gives the 8.1 its high-end appeal - and it's very different to what you'd expect at the price.

This loudspeaker is also good with classical. Strings are lush and realistic and wood wind natural, light and airy.

One thing the 8.1 doesn't do is to create an overtly out of the box sound that spreads an orchestra throughout the room but what is there is of commendably high timbral quality.

The Diamonds won't immediately grab you by the throat and shake the living daylights out of you but neither will you be in the land of Nod after five minutes. They are a 'speaker that you can easily live with. ■ ▲



Wharfedale Diamond 8.1 £120.00

Wharfedale International Ltd.
IAG House
Sovereign Court
Ermine Business Park
Huntingdon,
Cambs.
PE29 6XU
Tel: 0845 458 0011

MEASURED PERFORMANCE

Under test the Diamond 8.1s had a fairly full sound with good body, the pink noise test signal showed. Analysis of this noise shows that in its frequency response the 'speaker has a gentle fall toward high frequencies, although treble is quite well extended. The Diamond could well sound smooth and quite large for a small 'speaker.

Also visible in our third-octave response analysis is a small dip at the crossover point, but it's not deep enough to detract from the projection of detail. The port has a resonance that is large enough to disturb the response curve so there will be some audible colouration from this source, especially as the port faces forward.

Bass output is well damped and rolls down below 80Hz. However,

there's still good forward output at 40Hz, which is quite low. The port doesn't do much to extend bass down below this frequency, but the Diamond has healthy bass output for a small loudspeaker. It has been designed to be used close to a rear wall, however, hence the forward firing port.

The Diamond was sensitive for a small loudspeaker, delivering 86dB Sound Pressure Level from one nominal watt of input. The Impedance trace has some steep slopes, caused by high reactance, and it bottoms out at 4ohms, so this is not an especially easy load to drive.

The Diamond 8.1 has a few minor blemishes, but it is basically well balanced

and has good bandwidth for its size. It should sound quite impressive. **NK**

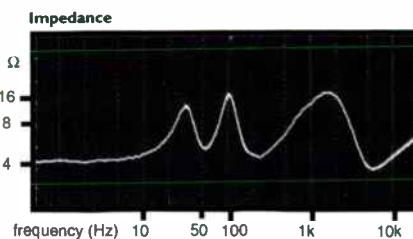
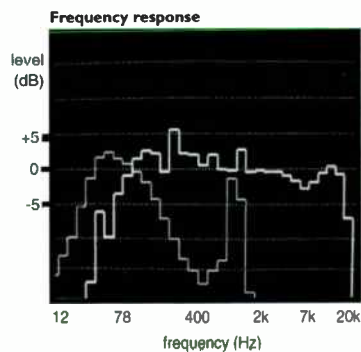

World Verdict



An audiophile bargain, the 8.1s have it all.

Walrus Systems

11 New Quebec St, London W1

air tight
allaerts
amazon
apollo furniture
argento
audible illusions
audio note
audio physic
audio synthesis
avantgarde
breuer dynamic
brinkmann
canary audio
cartridge man
cat
cawsey cables
clearaudio
coph nia
decca london
dnm
duevel
dynavector
ear yoshino
ergo
final lab
graham
incognito
lyra



No home cinema, multi-room, or computer audio.
No sir, just good old fashioned superb sound from
Walrus, the premier Valve and Vinyl specialist!

(clockwise) Michell Gyro SE / RB300 (£975)
Notts Analogue Spacedeck / Spacearm (£1380)
SME Model 10 (£2643 - arm extra)
EAR V20 amplifier (£2699)
Papworth SE amplifier (£1700)
EAR 834P MM phono stage (£380)
Musical Fidelity Nuvista CD (£2999)
(NB: Check availability - limited edition model)
Brinkmann amplifier (£2000, or £2500 inc DAC)
Spendor SP2/3 (£1295)
Avantgarde Uno (£6809, in midnight blue)

Don't delay. Give Les or Pete a call now!

michell engineering
morch
musical fidelity
nordost
nottingham analogue
ortofon
papworth
phy cables
pluto
pro-ject
reference 3a
rega turntables
ringmat
shun mook
sme
spendor
stax
sugden
sumiko
tci cables
tom evans
townshend audio
transfiguration
trilogy
tron
vaessen
van den hul
verdier
yamamura churchill



For info on these, and much more, including our numerous second-hand items,
please visit our popular website: www.walrus.co.uk

* interest free credit available on most items, subject to status *

tel: 020 7724 7224

fax: 020 7724 4347

email: mail@walrus.co.uk

web: www.walrus.co.uk

Enjoy music more

Forget all you know about valve amplifiers. Ask for a home trial of the RA-01 and prepare to be delighted.



RA-01 monoblock from £6995 per pair
Full-range, natural, detailed and expressive

*Renaissance
Amplification*

RA-01
22W triode amplifier

Available from:

Acoustic Arts – 01923 245250

audio solutions - 07787 543031

***Sounds of Music* - 01892 539245**

stoneaudio UK – stoneaudio.co.uk

Walrus Systems - 020 7724 7224

"These amplifiers really are a bit special." – Andy Grove, *hi-fi world* December 2001

"Here was a sound you could leave playing all day." – Martin Colloms, *Hi-Fi News* September 2001

"The measured performance of this 300B amplifier is as good as it gets." – Noel Keywood, *hi-fi world*

"The whole performance was reproduced with musicality and emotion ..." – Andy Grove, *hi-fi world*

Distributed by Integrated Engineering Solutions Ltd - 023 8090 5020

www.highendaudio.co.uk

MISSION m71

Mission have, for quite some time now, been the ones to beat when it comes to budget 'speaker design. They seem to get the right recipe of creating an impressive sound from fairly modest means and the same goes for their latest range of entry level product in the m7 range.

The m71 featured here is the latest entry level product from them and the smaller of the two standmount models (although a smaller m70 is soon to be launched). The dimensions are pretty miniscule. Otherwise, the m71s are virtually identical to the 72s and 73s.

Build quality is impressive for the money, with solid-ish cabinets and decent bi-wire terminals located at the rear, along with the port (the previous budget 701 had it front mounted). Drive units are also of good quality, the silk dome tweeter being accompanied by a bonded woven glass composite mid/bass unit.

Placing the 'speakers a good foot or so from the rear wall and firing straight down the room as Mission suggest (not 'toed in') the 71s deliver a sound in the true Mission mould; they have superb imaging and space, although sounding a tad thin at times. Bjork and the Blue Note Compilation both had oodles of life and vitality along with true hi-fi credentials such as the aforementioned pin point imaging and a deep sound stage. Treble was nicely smooth and sweet and the midband had plenty of detail.



Bass was nimble and tuneful, although not too deep, as the dimensions dictate. Bjork's vocals were excellent, with good forward projection, a strong tone and a pleasing lack of sibilance. When pushed at high volumes the 71s had a tendency to 'shout' a little but managed to maintain the coherence of recordings.

The Missions were also good with classical orchestral music (few are at this price point) which was a big bonus. There wasn't so much accuracy of instrumental tone but there was enough space and ambience in the sound to manage a pretty faithful reproduction of the airy Giuliani/LA Philharmonic

recording of Beethoven's 'Eroica' on DG.

The m71s are a good all rounder with plenty of ambience and superb staging and imaging. Vocals sound great and the treble is smooth but some may find the bass, whilst very low for the dimensions, somewhat lacking in tautness. ■ ▲

Mission m71 £130

Symphonix Ltd.
Stonehill
Huntingdon
Cambs
PE29 6EY
Tel: 01480 451777

MEASURED PERFORMANCE

The m71 is academically accurate in its frequency response. Our analysis clearly shows an almost straight line with little variation from 80Hz all the way up to 20kHz. This suggests many things, including low colouration, good presentation of detail, quite a forward sound balance and perhaps some dryness in the bass. The port extends output down to 40Hz, so the m71 can handle all frequencies down to the lowest bass notes. The port is tuned to 52Hz and keeps the bass unit under good control.

Sensitivity was mediocre at 83dB, even though Mission use a 4ohm bass unit. The impedance curve is smooth

enough, so is low on reactance and energy storage. It reaches 8ohms across high frequencies and is resistive here, so high frequency distortion from the amplifier will stay low. Overall impedance measured 6ohms.

The m71 measures very well and will have a well damped, dry, fast and detailed sound, with smooth and extended treble. This is an impressive budget design. **NK**

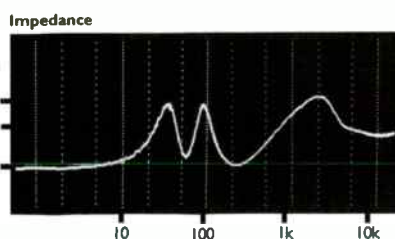
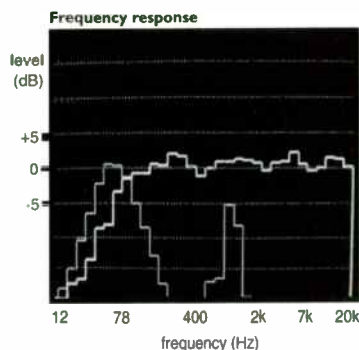

World Verdict



Good value, with many fine hi-fi traits. Great imaging and detail but sometimes thin in the bass.

fig.1. AV receiver that sounds great in Dolby Digital.



"A strong budget contender for forward thinking music fans" **Hi-Fi Choice September 2001**

"Great stereo performance, commendably solid build" **What Hi-fi? Sound and Vision September 2001**

"At this price point, nothing sounds better than NAD" **Essential Home Cinema October 2001**

fig.2. AV receiver that sounds great in stereo.



"A strong budget contender for forward thinking music fans" **Hi-Fi Choice September 2001**

"Great stereo performance, commendably solid build" **What Hi-fi? Sound and Vision September 2001**

"At this price point, nothing sounds better than NAD" **Essential Home Cinema October 2001**

Sounds obvious, doesn't it?

Unfortunately, AV products have always been a trade-off, usually sacrificing musical finesse in favour of brute strength and making too many compromises for them to ever find a place in an audiophile system. Now, NAD brings its wealth of experience in producing award-winning, no-nonsense stereo products to the world of home cinema, and the same principles of simplicity and value that make our amplifiers and CD players world-beaters, are now producing truly earth-shattering AV receivers, DVD players and multi-channel amplifiers.

Contact us for your nearest NAD Home Cinema dealer, and figure it out for yourself.

► BOSTON CR75

Mmm. . .OK with the grills on but the minute they're whipped off the CR75s aren't exactly the prettiest puppy in the litter. Despite this, the 'speakers are well built, as we've come to expect from the chaps at Boston.

Quite a few things mark these 'speakers out as different from the rest of the auditionees. A moulded back baffle and front panel form a kind of frame around which the cabinet sides are attached. At the back also there are mounting points for wall brackets, making wall mounting an option that is easier to exploit than normal.

The drive units are a little unusual for the market sector. The recessed tweeter uses a heatsink within the cabinet to prevent overdriving and the 135mm bass/mid driver is constructed from a co-polymer material. To the rear we have a wide-ish port accompanied by single wire terminals.

These 'speakers have a big, open sound typical of a high sensitivity bookshelf design. It's also one that is smooth and rounded, which makes marriage with most types of recordings and music an easy task. The Blue Note Brazilian compilation on vinyl sounded lush and warm, with fairly good upper band detail and a deep sound stage. Bass was powerful and fairly deep, but lacked enough speed attack to really impress.



Imaging wasn't the sharpest and the sonic picture tended to sound more massed than separated. Bjork's well produced 'Homogeneic' album proved that these 'speakers can really go loud if you so wish them to. They open out to produce a big, room filling sound and don't strain or shout when pushed, like so many at the price point.

Upper band detail wasn't the best around and there was a softness that veiled the overall picture to a certain extent.

With classical the 75s gave a fair performance with nice smoothness and refinement to Beethoven's 'Eroica' but overall there could have

been more involvement.

The 75s are by no means bad but they are a bit off the pace when it comes to the best at the price, lacking a needed touch of excitement. Detail and insight are lacking but they do play anything you throw at them with the same pleasantness. ■ ▲

Boston C75 £200

CS£
Unit 9 Centre Park Holdings
The Airfield
Tockwith
York
YO5 8QF
Tel: 01423 359054

MEASURED PERFORMANCE

Here's yet another budget loudspeaker with an impressively smooth response all the way up to 20kHz. The absence of serious peaks or dips suggests there will be little colouration or innate character to this 'speaker. It will likely sound quite dry, detailed and possibly a little on the bright side. Below 125Hz bass output rolls away smoothly, measuring -6dB at 80Hz, which is a fairly high figure. Below this frequency the port takes over, extending output down to 40Hz. I would expect the CR75 to have slightly lighter bass than the other 'speakers in this group and it should be used close to a rear wall.

The impedance curve of the

CR75 is smooth enough across the frequency range, by modern standards. There's little reactance, except around bass/port resonance as always. The bass unit is a 4ohm design, but the tweeter impedance is 8ohms, making a 6ohm loudspeaker overall. The CR75 has quite a high voltage sensitivity of 86.4dB, meaning it will go loud for any particular volume control position.

Boston's CR75 is a good, modern bookshelf design with every aspect of performance well handled by its designers. Again though, like the Mission and Magnat, it is a little on the 'academic' side and might sound just a bit dry and light. **NK**

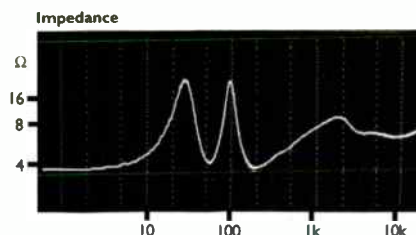
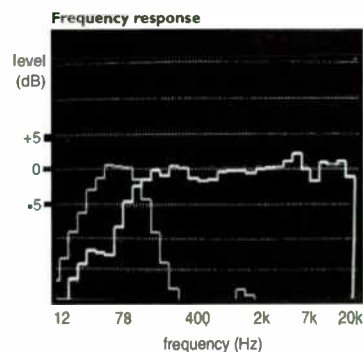

World Verdict



A big, full and smooth sound but one that ultimately doesn't involve. Not the most attractive design.

▶▶ JM LAB CHORUS 706

These 'speakers bear little resemblance to the typical budget box. The company use technology similar to that found in their higher level Electra and stratospheric Utopia ranges. Of French design but apparently manufactured in Hungary, their build quality is solid and impressive for the class.

Immediate attention grabbers are the postbox-like front port and the unusual design of the tweeter. Placing the port to the bottom of the front baffle, like that of the Diamond 8.1, means that close placement to a rear wall is an option. This style of port works no differently to any other laminar flow design and should create the same amount of low frequency information as most other 'speakers.

The tweeter uses an inverted 'titanium' dome, as found in the rest of the company's products. It is 'protected' by the vertical metal bar which also lessens high frequency resonance of the tweeter.

What remains is fairly standard to the breed. The cabinet is sensibly sized at 370x200x260mm and features a vinyl wrap finish available in three 'colours'. Loudspeaker connectors are of the good quality single wire type.

JM Labs traditionally have a fairly high sensitivity sound and the new models, as represented here, are no different in this respect. With the Brazilian jazz compilation on vinyl and Bjork's 'Homogenic' on CD the 706s gave a nice, full sounding performance. Bass was impressive for



the cabinet size and they have a good grip on dynamics and speed.

The overall sound errs on the dry side but partly because of this, it is also well detailed and lucid. Imaging was also pretty good. Also on the plus side they don't fall prey to the tendencies of most French designed 'speakers, that of forward treble. For a metal dome tweeter the Chorus unit is very smooth and sweet - a nice surprise.

With classical music in the shape of Beethoven's 'Eroica' symphony the music benefited from the big, dynamic sound. Instruments were clearly defined with a good sense of scale and depth. Instrumental timbres could

have been bettered slightly, as violins scratched a little, and woodwind and brass sounded a tad synthetic.

The 706s are a fine sounding 'speaker if you favour dynamics and drive and want a big and forceful sound, although they could strain under heavy driving. ■ ▲

JM Lab Chorus 706 £229

Focal-JM Lab UK Ltd.
Lonsdale House
52 Blucher Street
Birmingham
B1 1QU
Tel: 0121 616 5126
www.focal-jmlab.co.uk

MEASURED PERFORMANCE

Like Acoustic Energy and Wharfedale, in the Chorus 706 JM Lab offer an impressively smooth frequency response coupled with some low frequency lift to add a little body to the sound, and weight to the bass. With no crossover suckout and almost ruler flat treble the Chorus 706 should sound smooth and detailed. Forward bass output extends down to 40Hz and the port provides a little extension down to 25Hz or so. This is a wide bandwidth loudspeaker that should sound quite large relative to its cabinet size.

The slot shaped port is tuned low to 38Hz. It works in conjunction

with a 4ohm bass unit, exerting quite good damping. Above 200Hz impedance rises from 4ohm to above 8ohms, levelling out at high frequencies. Low rates of change indicate there's little reactance in the load and at 6.5ohms overall impedance the Chorus is reasonably easy to drive. Voltage sensitivity was very high at 87dB; under test it was obviously very loud for one watt of input.

The Chorus 706 is a neatly engineered loudspeaker in every area. It uses high quality drive units and integrates them well to give a fine result. **NK**

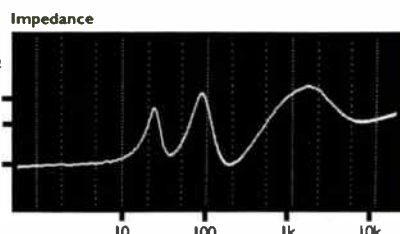
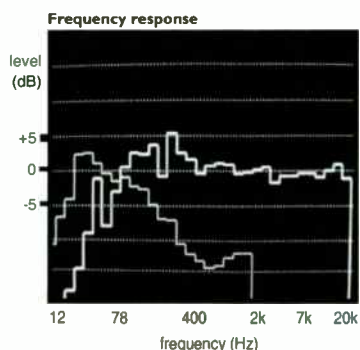

World Verdict



A big and dynamic sound with a smooth treble. Strain a bit when pushed but overall fine 'speakers.

▶▶ **ACOUSTIC ENERGY
AESPRIT 300c**

The new Aesprit 300c isn't exactly bargain basement priced, but it still has a fairly affordable price tag which many would consider entry level. These 'speakers are visually attractive and their build quality is, as you'd expect at this price, very good, with a sturdy, well braced 15mm MDF wrap cabinet supporting a thick 30mm front baffle. The bass/mid drive unit has a low mass 150mm flared and profiled aluminium cone, chosen for its speed and agility. It is bonded to a 32mm voice coil for good power handling and is a long throw design, mounted on a diecast chassis. The accompanying tweeter is a 25mm Neodymium design. Power handling is rated at 100W and impedance at 8ohms. The cabinet features two front ports which allow close placement to a rear wall and bi-wiring is catered for via good quality binding posts.

Like the previous models in the Aegis range, the Aesprit is brimming with life and attack. Bjork's 'Homogenic' had depth and plenty of power, mixed with control and grip. Bass was very tight and midrange well detailed.

Imaging also impressed, especially with the old style mix of the Brazilian compilation on a Blue Note vinyl LP which had oodles of upper frequency detail. Using a metal coned drive unit the sound is always going to be

slightly forward and not as smooth as some may wish for. This was highlighted in female vocals, which could 'scream' a bit at high levels. However the tweeter is smooth, which means a fairly sweet treble quality exists. There is some forwardness to the mid/bass frequencies. Despite these slight failings the sound with jazz and rock was very fine and cohesive.

With classical there was a good amount of detail in the upper ranges of the orchestra and a good spread of sound, although at times it could be quite 'dry' with a lack of ambience.

Instrumental timbre was good, although brass was slightly raspy and metallic. It's not the most natural performer with classical but the emphasis on rhythm is beneficial and gives the sound plenty of drive. Coloration was minimal, giving the 300cs a transparency worthy of the 'true hi-fi' stamp.

The Aesprits are a good loudspeaker that represent the upper



end of the budget bracket. They have speed and agility, coupled with good build quality. Whilst not the cheapest option here they are still a very good buy indeed. Highly recommended. ■ ▲

Acoustic Energy Aesprit 300c £275

Acoustic Energy Ltd.
16 Bridge Road
Cirencester
Glos
GL7 1NJ
Tel: 01285 654432

MEASURED PERFORMANCE

A smooth upper treble characterises this Acoustic Energy 'speaker, as others before it. The company use a very good tweeter and it shows in measurement and listening too. Our one-third octave response analysis clearly shows this as a flat line at right. Together with an absence of crossover suckout I would expect the AE 300c to have refined yet detailed treble, well integrated with the rest of the performance.

To give the sound some body there's a little low frequency lift, before bass tails off to -6dB at 40Hz. Curiously the ports overlap forward output, rather than taking over from it, and the AE shuts off fairly sharply

at 40Hz as a result. There's no port colouration, unlike the other 'speakers.

Acoustic Energy loudspeakers usually have an amenable impedance characteristic and this one was no exception. Shallow slopes indicate low reactance and the bass unit draws less current than usual, overall impedance measuring out at exactly 8ohms. Voltage sensitivity was quite healthy all the same at 85dB SPL.

The Aesprit 300c is a refined design that will likely give an excellent sound: balanced, smooth and accurate. It is very well engineered. **NK**

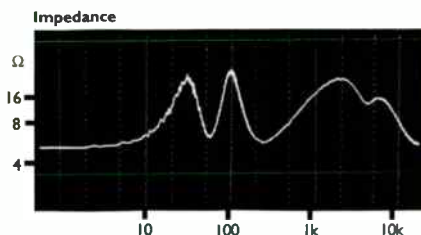
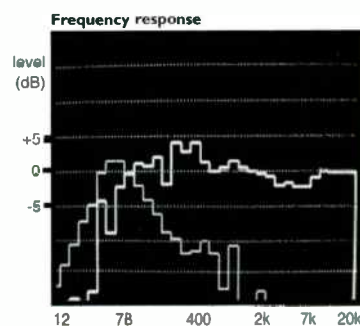

World Verdict



Plenty of life and verve, with a fast sound. A cracking little design.

UNISON RESEARCH

For a lifetime of musical enjoyment



S6

Single-ended pure Class-A integrated amplifier. This is how Hi-Fi World (April 2001) described it:”Strong, confident power delivery, wide tonal palette, with sweetness, warmth, rhythmic alacrity and a deliciously clean, open sound.....
“At the price, It’s easily the best tube amplifier I’ve heard...Superb value for money”.

S2K

Pure Class-A all-tube amplifier using the legendary KT-88 power valve in single-ended mode for maximum transparency and detail. The sound it gives is delightful, unforced and natural. S2K is truly a machine for making beautiful music.



SR1

Combines the virtues of valve and solid-state in a thoroughly modern, fuss-free design. With 80 watts per channel dynamic Class-A power, plus the grace and delicacy you would expect from triode valves. The SR1 really gives you the best of both worlds.



For more information on the range of Unison Research Products please contact:



23 Richings Way, Iver, Bucks, SL0 9DA, England
Tel: 01753 652 669 Tel: 07000 853 443 Fax: 01753 654 531
www.ukd.co.uk email: post@ukd.co.uk

*models illustrated: S6, £1600. S2K, £1295. SR1, £1250. All complete with radiowave remote control.

CHEAP THRILLS

In the second installment of our affordable upgrades feature we tackle support and isolation for your components and tell you how to clean up your dirty mains!

►► Isolation platforms and racks - are they necessary and do they work?

A specialist hi-fi rack is for the audiophile who wishes to glean as many subtle nuances from their system as possible. It's a well known fact that structural vibration can hold back the potential of any hi-fi equipment. Turntables, of course, require stable placement more than any other part of your system or they'll simply sound rotten and pitch inaccurate.

It's not the same with amps or even CD players, but there's no denying that a specialist designed equipment rack or isolation system, including support cones actually work and in certain instances can be an affordable, if subtle, upgrade. You can get hold of a half decent hi-fi rack for around £50.

Most racks have a hollow metal frame with either glass or specialist material shelves for less vibrational absorption. There's no doubt having everything equally matched on a surface will tighten things up sonically, but reaching up to the far echelons of rackdom (£1000-£4000) won't bring the sort of magic to many that the money suggests - if you want a change for this money get a new system!

Isolation platforms can also be effective, although are more expensive than many think, starting at around £80 or so. These add a tad more attack and speed to the music, although again for budget buyers the outlay may not always be worth it.

On the plus side for the budget conscious, there are some pretty good value buys around when it comes to alternative support systems such as the Clear Light Audio RDC isolation cones. For £25 for a set of four they are best placed under your

CD player and there should be slightly more focus to the sound, creating a seemingly faster response. Also check out Tenderfeet from the venerable Michell Engineering, at £8.95 or £11.95 (depending on size) these are also a great buy and an ideal Xmas present for your audiophile mate, should you feel generous!



Clear light's RDC cones are an effective and relatively cheap upgrade

Dirty mains - does cleaning up the electrical supply bring results?

It's a well known fact that the majority of peoples' homes have bad mains supply. Cleaning up the source by a number of easy and cheap means can be an effective way of making your system sing. Radio frequency interference (RFI) is everywhere and can sometimes hold back the potential of your hi-fi, no matter how budget it is. There are a number of designs that claim to filter out unwanted RFI that start at around £20 or so. Audioquest's RF stoppers at around £40 for four are a good start.

Another way of improving the sound when dealing with mains is to use specialist high grade mains sockets and power cords. Again the differences are subtle but mains sockets of this sort are cheap (around £5 upwards) and can be bought from electrical stores as well as specialist audio catalogues/retailers. Audio power cables and power blocks designed to clean up sound are often

far more expensive but there are good 'budget' versions available from the likes of Kimber in the shape of their YellO power cable.

Lastly there is a whole bunch of mains conditioners and filters on the market that get to the root of the problem. Mains filters attempt to stabilise and clean up the electrical current, creating a 'new' electrical source from which to run your system. These can be very pricey, such as the £3000 or so that the Accuphase version will set you back but there are more humble versions around such as the excellent and highly effective Clearway. At £200 this isn't exactly cheap but it will suit any system, so as you upgrade your components the Clearway can stay.

Slightly cheaper filters are available from FineFilter (£160) and the simple Hype 5 Pollution Eraser for £100. ■ ▲



The Clearway is a fine upgrade for your mains supply

CONTACTS

www.audiophilecandy.com (for Clear Light and FineFilter, plus lots more)
Russ Andrews, tel: 0800 373467 (for Kimber)
Chord Company, tel: 01722 331 674

KEF UNI-Q® LOUDSPEAKERS

The
Reference
for a
new
generation

MODELS SHOWN ARE THE (BACK ROW LEFT TO RIGHT): MODELS 201, 203, 205, 207. (FRONT ROW LEFT TO RIGHT): MODELS 202c and 204e. KEF AND UNI-Q IS PROTECTED UNDER GB PATENT 2 236929, US PATENT NO. 5,548,657. WORLDWIDE PATENTS PENDING. FOR DETAILS ON KEF'S NEW REFERENCE SERIES PLEASE CONTACT KEF AUDIO (UK), FREEPOST MA1332, ECCLESTON HUAD, TONIL, MAIDSTONE, KENT ME15 6BR. FREE PHONE 0800 7315620. www.kef.com

What you see here is an approach to pure sound using technologies found nowhere else.

At the heart of the new Reference Series are completely new Uni-Q® drivers - the ultimate refinement of KEF's most acclaimed innovation, providing the perfect point source to which all speakers aspire.

With superlight double neodymium magnet assemblies concentrating exceptional power, they comfortably outperform even their illustrious predecessors.

A metal dome Uni-Q tweeter? You bet - one whose elliptical profile has been perfected by Finite Element Analysis. Check out the filled polypropylene cone of the first ever Uni-Q driver dedicated solely to the midrange.

The limited movement required at these frequencies allows a perfectly flat new surround that virtually eliminates intermodulation effects, as well as any discontinuities that might impair the incredibly smooth HF response.

Notice the titanium dome hypertweeter™ in its own chrome-plated steel enclosure. With flat response to 50 kHz and useful energy up to 80kHz, it extends way beyond human hearing range. But just as a 200mph car outperforms anything else on the road at normal speeds, this massively extended performance envelope delivers every last sonic detail encoded in modern formats like SACD and DVD Audio.

Then there's the ultra-low distortion bass. No wonder, with balanced Faraday loops above and below each LF coil. And with each driver radiating directly from its own enclosure, the standing wave distortions that usually afflict tall cabinets are conspicuously absent. The result is the clearest, most open bass you've ever heard.

There's lots more to tell, of course. To get the full picture, please call the number below and we'll send you an information pack.

The Reference for a new generation. Created by KEF because only KEF can.



KEF UNI-Q TECHNOLOGY

19mm titanium dome Hypertweeter™



Aluminium Faraday loop in centre of bass unit



UNI-Q™ exploded view



KEF REFERENCE



RADIO BY



Noel Keywood compares the latest DAB tuner from Videologic with good old fashioned analogue. Is the time now right to go digital?

▶▶ VIDEOLOGIC DRX-601E/ES

I first tested Videologic's DRX-601E digital tuner back in our February 2001 issue. It got unlucky. We pitted it against one of the best VHF/FM tuners I have ever heard – a Denon TU-S10 – and the Denon came off best. Aware they could do something about this, Videologic decided to come back with the DRX-601ES, a tuned up version of the original '601E, designed to give a sound that could match the best FM tuner. It does too – at a price that makes sense. In this review I compared it to Creek's effective VHF/FM T43 to see if DAB is now a clear improvement over traditional radio.

Let's look at prices first. The DRX-601ES is available for around £350, whilst the T43 costs a fairly significant £399. For this you get VHF/FM, plus medium wave and long wave (Europe only), all in a neat package with twenty-nine station presets. With the Videologic you get DAB only.

In use, how many stations you can get on VHF depends upon your location and aerial, but most people will find it difficult to get many more than ten to fifteen. I use a large outdoor aerial pointing to Wrotham (BBC) and Crystal Palace (Commercial) from Central London and tuned in twenty seven VHF stations of reasonable quality with the T43, compared to thirty four DAB

stations all of high quality from the DRX-601ES.

A simple station count isn't enough though; DAB has a host of stations simply not available on VHF and if you could do without another little number from Steps or S Club Seven, then DAB is the place to go, with plenty of rock from XFM, WLN, Big London and Century, to name a few in the London area. Perhaps surprisingly there are only two stations devoted to classical music, Classic FM and Radio 3, just like Band II, but there's a swathe of easy listening from Heart through to Saga, plus sports, news and financial (Bloomberg) channels.

Although Digital Audio Broadcasting (DAB) is a complex technology the DRX-601ES is easy to set up. Conventionally sized, light in weight and low in height it slots into a

hi-fi system without difficulty. It took me just minutes to unpack, plug in, turn on and tune in. That's because Videologic supply a wire aerial and the 601ES tunes in automatically. DAB tuners are designed to do this; they lock onto transmission groups called 'ensembles' and each ensemble provides a host of stations. There's no conventional turn-the-knob tuning, because discrete DAB stations don't exist. In effect they're all scrambled together in fixed blocks that take up relatively little air space. The tuner finds these blocks when it auto-tunes and that's it; you have your stations.

The big tuning knob you can see on the Videologic is a station selector. It rolls smoothly with a light detent action, each click bringing up a station name on the blue fluorescent display screen. For the reason I explained above, DAB



NUMBERS



stations are identified by name, not by frequency. Finding stations was quick and easy. Pressing an Info button toggles the display over to show data rate or signal strength. Most programmes are transmitted at 128kbps, the same low data rate used by mp3 music files. This is where DAB starts to show what it really is, a clever transmission system that can cram a lot of stations into a small amount of waveband space. It uses 10:1 data reduction to achieve this, however, and at times it can be heard, even if the effect is subtle and transitory.

I was soon in trouble with the wire aerial Videologic supply, strong burbling sounds on commercial stations (an ensemble) telling me signal strength was dangerously low, even though I live only six miles or so from the Alexander Palace DAB transmitter in North London. DAB can be a bit unpredictable like this so although it can in theory work with a very weak signal, an aerial may well be needed even in primary reception areas. Connecting up to the TV aerial brought in a strong signal and so did a full sized indoor DAB aerial.

All VHF/FM tuners need a relatively strong signal (1mV or more) for minimum hiss, which in most areas means using a proper aerial. This adds to cost if you don't already have one, something to bear in mind with a tuner like the T43. It doesn't make much sense to pay a not inconsiderable £399 then use a piece of wire. You can get fantastic sound quality from modern VHF/FM tuners partnered with a good aerial - and this included the Creek I found.

CREEK T43

Physically, the T43 was almost curiously like the DRX-601SE, being compact in its dimensions, light and simple to install, with a fuss-free front panel. The tuning system is similar too: once stations have been tuned in and stored, they are selected by spinning the tuning knob, which sequences through the stored frequencies. Pressing a Mode button switches back to conventional tuning. Auto-tune is provided too.

The T43 has useful signal strength and tune accuracy indicators, as well as a Multipath indicator, something I have not come across before. If you want the best from VHF/FM, these indicators are essential. Signal strength shows whether the aerial is good enough to get the tuner into 'full quieting', meaning minimum hiss. It was interesting to see how VHF/FM and DAB compare in this respect. DAB does have a lower measured noise figure but VHF/FM is so quiet you cannot hear hiss in any case. Most noise comes from the broadcast programme itself; I heard humming and whirring sounds, tape hiss and strange graunching noises from what sounded like a damaged old LP when listening intently to classical on both Radio 3 and Classic FM. Neither tuner produced audible hiss in itself though.

These tuners sounded very alike. Both reached a high standard, the T43 offering what is basically a neutral, uncoloured and balanced presentation as VHF/FM goes. Anyone expecting digital to sound better will be disappointed with DAB, but

Videologic have been successful in re-balancing the sound of the DRX-601 to better match that of VHF/FM. The problem they face is the characteristic sound of the transmitter-end mpeg data reduction system, which tends to make DAB sound a little bass light and lacking in warmth. This made the original DRX-601E sound a trifle sterile. The DRX-601ES has been successfully re-balanced to counteract this, having an almost identical presentation to the T43. At times on Radio 2 I noticed that when really deep, rumbly bass was in the programme the T43 reproduced it but the DRX-601ES did not. However, you don't often get high quality programme material like this on radio. It's a feature of Radio 2 mainly, to which I always turn when judging tuners off-air.

Otherwise, with quality tuners like this you are listening as much to the studio equipment, including some fierce dynamic range compression systems used to make sure music sounds 'loud' to overcome background noise, especially in cars. This sort of compression

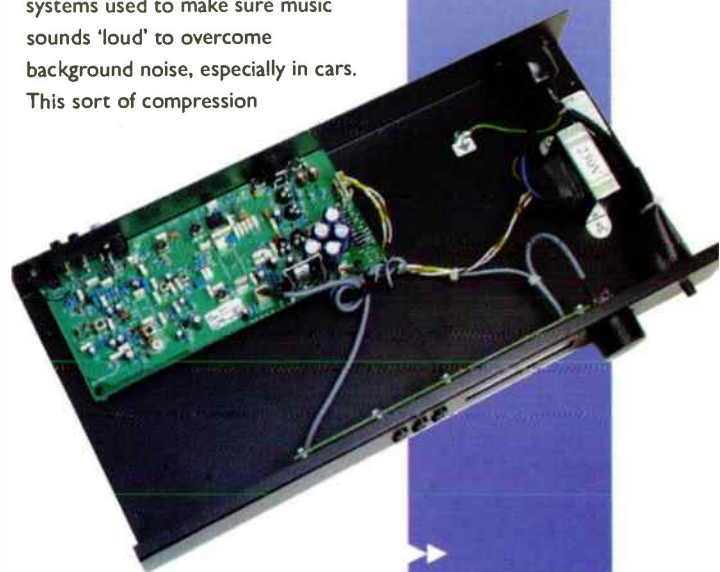

ROKSAN

The full picture.....

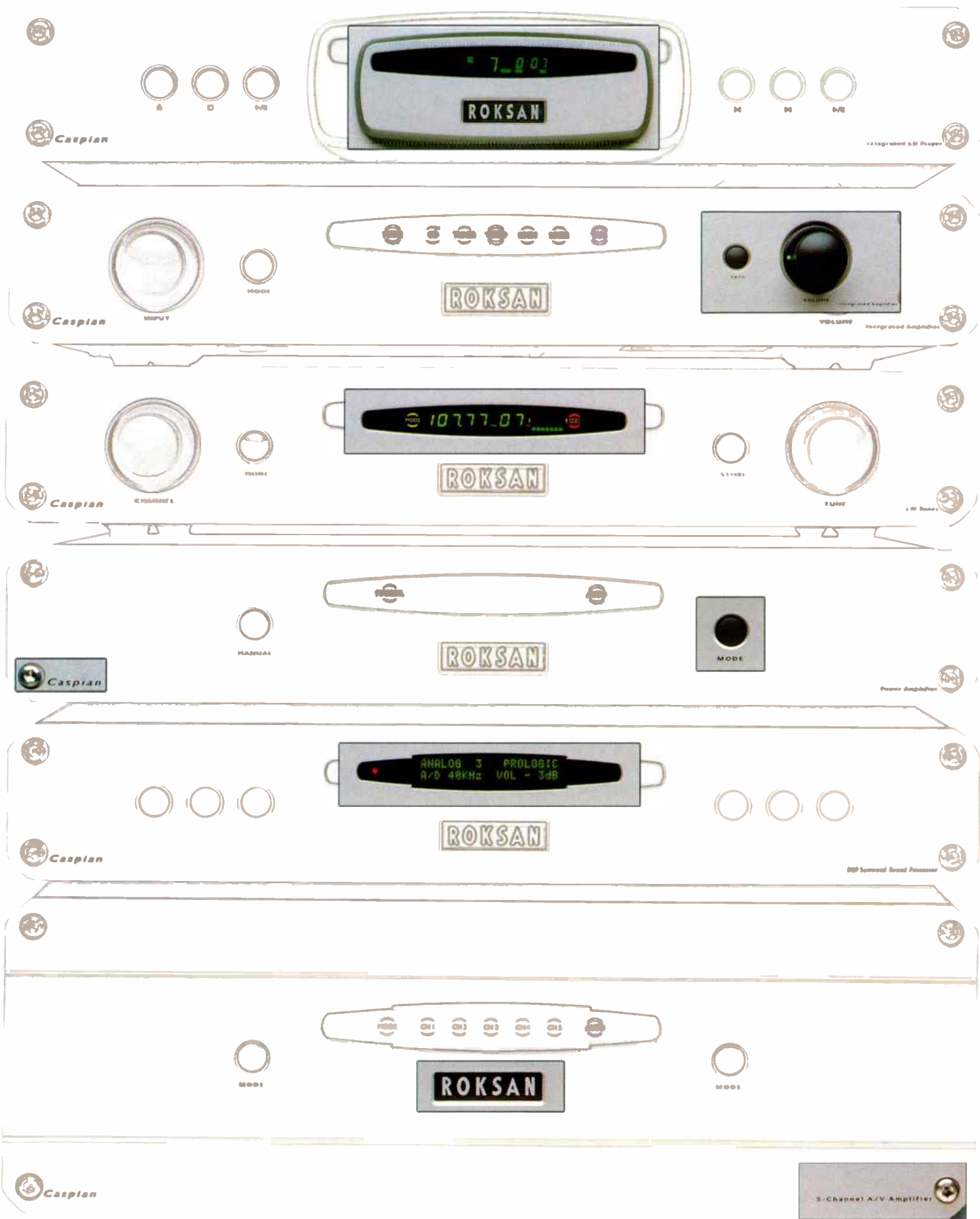

Distributors: Henley Designs Ltd
Unit 10 Moorbrook, Southmead Industrial Park, Didcot, Oxon, OX11 7HR.
Tel: 01235 511166, E-mail: henley.designs@virgin.net, WWW.henleydesigns.co.uk

◀ tends to overwhelm everything. Switching between programmes like Capital and XFM on VHF and DAB revealed almost no difference between the two tuners as a result.

Although I found it hard to tell the difference between VHF/FM and DAB when comparing the Creek to the Videologic, I did get a feeling of a sense of sterility from DAB generally. At times, on well recorded complex classical programme from Radio 3 and Classic FM, differences did become clear. Orchestral string sections sounded soft and a little blurred through DAB, almost certainly a result of data reduction, rather than tuner limitations. In the scheme of things though, such differences were reasonably small and fleeting in nature, against the variable and often mediocre sound quality available generally.

Had I hung both tuners off the

same piece of wire then the T43 would have been hissy of course, unlike the DRX-601ES. Being run from an outdoor aerial the T43 was always in full quieting under test, its signal strength meter showing maximum. So DAB can in practice match the best that VHF/FM can do from a simpler aerial set up. That's one benefit. Another is a greater range of stations. I found myself listening to Century and Big-London, for example, which both transmit classic Rock; there's little of this on VHF/FM nowadays. Conversely, you don't get pirates on DAB so there's no Reggae, Rap or Soul as yet.

Creek and Videologic are in some ways quite alike in their approach, combining thoughtful and effective engineering with a useful understanding of the fine details that make a product sound good. I liked both of these tuners. They were easy

to install, set up and use and they both gave excellent sound quality. Differences between the two were minor in this respect. Videologic's DRX-601ES now offers superb sound quality with minimum hassle, plus the wide variety of stations DAB offers. But if you don't live in an area covered by DAB, Creek's T43 will provide a subtly richer and more detailed sound, providing you use it with an appropriate aerial. ■ ▲

Videologic DRX-601ES £349

Videologic UK Ltd.
Tel: 01923 277488
www.videologic.com

Creek T43 £399

Creek Audio
Tel: 020 8361 4133
www.creekaudio.co.uk

MEASURED PERFORMANCE

VIDEOLOGIC DRX-601ES

An off-air DAB test transmission showed Videologic have applied fixed equalisation in the analogue output stages to give +1.5dB plateau boost of low frequencies and a similar amount of plateau cut at high frequencies in the DRX-601ES. Our third-octave analysis of a fixed tone sequence (below) clearly shows this, as well as confirming the fact that this tuner's frequency response runs from 20Hz to 20kHz. A 3dB variation in response is quite significant, but the DRX-601ES did sound smooth and very well balanced in use, almost identical now to a flat-response VHF/FM tuner. Note that if the DRX-601ES is paired with an external DAC the equalisation will not apply.

Frequency response apart, the DRX-601ES still measures as before, being hiss free, of negligible distortion and highly sensitive. It is an excellent DAB tuner with a fine measured performance. **NK**

Frequency response	20Hz-20kHz
Stereo separation	65dB
Distortion (50% mod.)	0.009%
Hiss (IEC A)	-103dB
Signal for minimum hiss	6µV
Output	2V

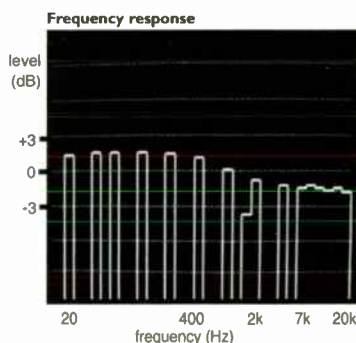

CREEK T43

The T43 differs from most VHF tuners in that it lacks a pilot tone (mpx) filter notch at 19kHz. This allows its audio response to extend smoothly out to 20kHz, our analysis clearly showing how it rolls down slowly and smoothly above 10kHz. Most tuners extend flat to 15kHz or thereabouts before a 'brick wall' notch filter takes effect. The Creek manages a similar measured -1dB bandwidth figure of 14kHz, but doubtless its phase characteristics are a lot less severe. I feel the smoothness of its sound owes something to this result.

Although the T43 lacks a pilot/sub-carrier filter pilot tone suppression was good at -53dB, suggesting the tuner uses phase cancellation instead. There were modulation products around the pilot and subcarrier frequencies all

the same, much like any VHF/FM tuner. Distortion was very low, measuring 0.12%, likely coming as much from the test generator as the tuner at this level. Audio output was high at 750mV.

The highest segment on the signal strength display lit above 1mV so this display does usefully show when the tuner is in full quieting.

There are some nice touches in the engineering of the T43, subtleties that lift it above the norm. It is very much in the Creek mould of things - elegant and very effective. **NK**

Frequency response	4Hz-14kHz
Stereo separation	28dB
Distortion (50% mod.)	0.12%
Hiss (CCIR)	-74dB
Pilot	-53dB
Sub-carrier	-70dB
Signal for minimum hiss	1mV
Output	750mV

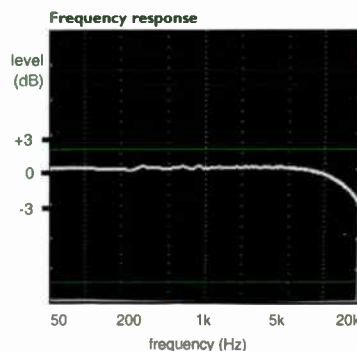

Two excellent tuners: both offer good value and a fine sound.

LITTLE WONDER

Simon Pope discovers bigger isn't necessarily better with Denon's UD-M30 one box wonder.



It's only over the past few years that the one box system has gained credibility with audio journalists. They've been popular with the public for ages, as everyone craves quality, usability and aesthetics in one affordable package. Only recently have all three have been amalgamated by the likes of TEAC and Kenwood, and the higher echelons of audio in the shape of Linn's Classik and the Cyrus Quattro.

We must not forget Denon, who have a tried and tested recipe for success in this area. It is repeated in the elegant form of the UD-M30 CD Receiver reviewed here. There are some options available to this package including a matching CD-R or cassette deck which can be attached via the two inputs, or the cute little SC-M50 'speakers, made for Denon by none other than Mission, and used in this review.

The UD-M30 is remarkably easy to set up and use and comes with a very comprehensive and stylish remote control. The unit comprises a CD player, RDS and EON tuner and an adequate output of 20W per channel. There's also a clock/timer section with a sleep function for those who like to nod off to the Shipping Forecast or Bells On Sunday.

Once connected to the 'speakers, one small gripe here being the cheap plastic clip connectors rather than banana plugs, the system looked compact, sleek and unobtrusive. As the 'speakers feature a small front firing port they can be placed against a back wall with little detriment to the performance.

Putting a favourite CD, in the form of Supergrass's eponymously titled album, into the smooth loading drawer, I was treated to a genuinely fine and surprisingly clean sound. This product won't pound out bass or grab you by the throat, but it has a sound that works extremely well in small rooms, delivering a detailed and open sound that pound-for-pound matches many budget separates for clarity.

The 'speakers have all the right Mission traits, such as a depth of stage and excellent imaging, which is refreshing to find in a package such as this. Although the SC-M50s are of minuscule proportion, they give a good open sound with a fair amount of bass and good treble. If you need a bit more bass, incidentally, the UD-M30 features a Super Dynamic Bass button which when switched will blossom out the low end a little more - but to sensible proportions. It actually works quite well for filling out the sound a tad more in larger rooms, for example.

Tuners have always been a speciality of Denon and so it was easy to rely on this section of the UD-M30. The radio is easy to use and gives a good account of itself. Radio 3 and 4 both had a nice 'dead' sound to voices that resembled the traits of a stand alone hi-fi tuner. With music on Radio 3 there was timbre to be found in orchestral instruments and a good sense of reality generally existed in

the broadcast.

With commercial radio stations the studio compression and effects didn't hurt so much as they would through a high-end dedicated tuner, which of course, is no bad thing as most stations have some kind of compression, albeit to a different level. Capital and Kiss sounded full and lively with plenty of bass but also not too much sibilance, which can be the major problem with these stations.

I was mightily impressed with this little package. Any hi-fi fanatic wishing to set up a system in the bedroom/kitchen/study etc. will be pleasantly surprised by the UD-M30 and SC-M50 'speakers. The combination gives a clean and detailed performance, to which the 'speakers contribute much. In this respect Denon's little system is the best option around £300 by far, showing that one-box CD receivers are not the also-rans they were in the past. ■ ▲

Denon UD-M30 £300
Denon SC-M50 £70

Hayden Labs
Chiltern Hill,
Chalfont St. Peter,
Bucks
SL9 9UG
Tel: 01753 888447

World Verdict



Great sounding and great value package. 'Speakers are impressive too.

sevenoaks sound & vision

sale starts

15th December

The Sevenoaks Sound & Vision sale incorporates a wide range of leading products.

With more than forty outlets nationwide, the experienced staff are able to give expert advice when choosing hi-fi components, home cinema systems, and the very latest technologies - like recordable DVD and widescreen plasma.

The following pages show a selection of the numerous sale offers that can be found in-store, and with the added peace of mind of Sevenoaks competitive pricing policy, and the ability to spread the cost of buying with 0% finance option, Sevenoaks Sound & Vision are the perfect choice.

Hi-Fi Components and Systems

Pages 2-5

Digital Tuners • CD Players • CD Recorders
Amplifiers • Loudspeakers • Systems

Outlets Nationwide

Pages 6-7

Who are Sevenoaks? • Sevenoaks Online • Outlet Details
Christmas and New Year Opening



more entertaining



Systems
Best Buy £1000 plus



LINN



Classik K CD Receiver

"Since the Scottish company added a tuner to the amp/CD player, mouths have gaped even wider in appreciation. The addition of colour options panders to the public's taste for kit to match their interior design, but it doesn't just look lovely in the lounge: the Classik sounds simply marvellous. Boasting fine impact and drive, it retains its grip even as it thumps out rock and dance tracks. Ask it to play quite acoustic music and its smooth, liquid presentation impresses still further. The Classik offers the performance you'd expect from hi-quality separates in one lovely package - this is a very superior product." ★★★★★ **WHAT HI-FI? | Awards 2001**

Sale £899.95

DENON

D-M30 CD Receiver

Sale £199.95

SC-M50 Speakers

Sale £59.95

"Denon's gorgeous D-M30 has a fine pedigree - and a record of success. Its forebear the D-M3 kept impressing us with its balance of good looks and great sound, winning two What Hi-Fi? Awards on the trot. Now the latest generation takes home a Product of the Year gong two years in a row. On its own merits, too, as this is much more than a rehash of the D-M3. Upgraded audio circuitry, improved power supply and the Mission-designed speakers all improve the package. The sound is superb, well-balanced and weighty... It's a big system in a very cute box." ★★★★★ **WHAT HI-FI? | Awards 2001**

Optional CD Recorder:

CDR-M30 CD-RW Recorder Sale £149.95



VideoLogic DRX-601ES Digital Tuner



"New name, new format, new winner: the VideoLogic story is as simple as that. The £299 DRX-601E digital tuner came out of nowhere to establish the firm as a major player in the digital tuner market. With this upgrade, VideoLogic goes one step further: it's still a DRX-601E at heart, but quite apart from the sleek silver styling and sexy blue LEDs it now has a

better, white-on-blue display, and what the company calls 'Psycho-acoustic Compensation' - a form of signal processing designed to make the tuner sound less digital.

And it works: the DRX-601ES has a presentation that's rich, clean and extremely informative. Bass is big and powerful, while the midband and treble are well controlled. The style alone would justify the slight price rise; the sound quality makes it a Product of the Year."

★★★★★ **WHAT HI-FI? | Awards 2001**

Sale £329.95

Also Available: Sony STD777ES Sale £429.95



more entertaining

World Radio History



ARCAM DiVA
CD92T CD Player
Sale £799.95
A85 Amplifier
Sale £699.95



Arcam's quest for higher performance, has led to the development of the DiVA series, the most complete range of high performance home entertainment equipment ever launched by a specialist audio manufacturer. Innovative design and production techniques have enabled Arcam to build on established values of excellent sound quality and value. All DiVA products are available in Silver or Black.



Stereo Amplifiers
 Best Buy £601-£1000

DIVA A85 "You'll have realised by now that we rather like this amp. It took us completely by surprise, and further strengthens Arcam's already impressive product range... The A85 is superb, and we can't wait to put it up against its peer in a group test." ★★★★★ **WHAT HI-FI? | March 2001**



TEAC
Reference 300 System



Systems
 Best Buy £501-£1000

"Teac's Reference 300 system is an absolute belter. The company's Reference series has won lots of awards and many admirers in the past, and the 300 range at £200 less than the bigger 500 series, is no disappointment. Your £600 buys you everything but speakers: an amplifier, tuner, CD player and cassette deck, CD-Synchro recording, optical digital output and built-in timer. This being a Teac, upgrading will not be a problem when you get that new job, with a DVD player and multichannel amp among the most recent options... As beautifully built as we've come to expect from Teac, this system delivers the goods with style." ★★★★★ **WHAT HI-FI? | Awards 2001**

Sale £499.95

MISSION
M71 Speakers

"With silky smooth treble, staggeringly refined detail and a bass that digs deep and punches hard, they're little short of miraculous when you consider the price... The Mission M71s are truly exceptional speakers for the money." ★★★★★ **WHAT HI-FI? | Awards 2000**

Sale £99.95



Please Note: Some products may not be available at all outlets. Advertisement valid until at least 16th January 2002. E&OE.



marantz

CD6000Ki Signature
CD **Sale £429.95**
PM6010Ki Signature
Amplifier **Sale £329.95**

CD6000 Ki Signature "The result is a player of real power and grace, and one that sounds dynamic, exciting and fresh. Rhythms are tight and clean while the live atmosphere of discs is conveyed with a real 'you are there' feeling. Even massive scale and weight isn't beyond the Marantz: it delivers all the bass your amp and speakers can handle without ever drowning out the high stuff. The audiophile bargain of the Nineties is back, and it's even better!." ★★★★★ **WHAT HI-FI? | Awards 2000**

PM6010 Ki Signature "Yes, this is the most expensive amplifier in this group, but provided you like its bright yet weighty, detailed yet wide-open sound, it's still something special." ★★★★★ **WHAT HI-FI? | September 2001**

marantz

DR6000 CD-RW Recorder **Sale £299.95**



"Most CD recorders make excellent copiers but are less than brilliant as plain CD players. Not so this Marantz: the DR6000 is a recorder you can also use as your main CD player, using your existing machine as a source for recording, for unless you have a very good machine in the £400+ league, chances are the Marantz is going to outperform it.

Whether playing its own recording or standard CDs, the DR6000 sounds big, confident and highly detailed, delivering a sound with real presence and few sonic foibles. Fast rhythms are delivered with terrific conviction, and the way the Marantz digs out detail of percussion and brass instruments knows no rival at the price. What's more, recordings made on this machine have bags of punch and impact, sounding virtually identical to the original discs.



The work that has gone into making the Marantz a good CD player has resulted in a fine recorder that also earns its keep as a system upgrade. No, it's not the least expensive recorder around, but it's one of the best, and worth every penny." ★★★★★ **WHAT HI-FI? | Awards 2000**



Cresta 2
Speakers (cherry Finish)



"It's been a few years since KEF made an assault on the entry-level speaker sector. Well it's back with a vengeance with the Cresta 2s and, as proved in October's affordable-standmounter *supertest*, they are the class of their field. These well-built and handsomely-finished 37cm-tall boxes employ a 25mm soft dome tweeter allied to a 13cm long-throw mid/bass driver, and they're biwireable, too, something not often found at this price point. When wired and placed on a pair of sturdy stands, the Cresta 2s sing in a way that belies the £150 price. As good with the atmosphere and excitement of a live recording as with the punchy basslines of dance music, the Cresta 2s have all the qualities of a truly classic loudspeaker." ★★★★★ **WHAT HI-FI? | Awards 1999**

Sale £99.95



Please Note: Some products may not be available at all outlets. Advertisement valid until at least 16th January 2002. E&OE.

more entertaining

World Radio History

page **four**



ROKSAN

Caspian MKII

CD **Sale £799.95**
Amp **Sale £729.95**

Founded in 1985, Roksan's objective has always been to bring high-end specialist hi-fi to every home. Today with the Caspian range, that goal has been fully achieved.



Caspian CD Player "If you can stretch to it, though, Roksan's Caspian is the player to go for. Yes, it's the most expensive here, but no rival can touch it when it comes to bringing music to life - regardless of genre. And that's what hi-fi is all about." ★★★★★ **WHAT HI-FI?** | May 2001

Caspian Amplifier "The Caspian has been around for a few years, but Roksan has developed it to a point where it now leads the class in all-round terms. In specific areas other amps equal it, but overall none can beat its combination of clarity, timing and dynamics. The Caspian is a worthy winner." ★★★★★ **WHAT HI-FI?** | February 2001



MONITOR AUDIO Silver 8i Speakers

"No other speaker in this test can match the Monitor Audios when it comes to delivering seismic basslines with sofa rattling power and weight. That this part of the spectrum also enjoys plenty of speed and control confirms the Silver 8is' position as bass kings... A great speaker needs more than simply great bass, however, and the Silver 8is do far more than merely thump. With the likes of Curtis Mayfield's 'Move On Up', they produce a sound of such verve that it becomes hard to sit still... They produce music with plenty of excitement - but don't forget the subtleties too. Add excellent build and an easy load and these Monitor Audios make a formidable case for themselves." ★★★★★ **WHAT HI-FI?** | April 2001

Sale £599.95

MUSICAL FIDELITY

X-A2 Amplifier

"Resolution is never in doubt, and yet this is music-making very definitely on the human scale, the X-A2 being as much about a natural balance as electrical ability. It's capable of driving even big, demanding speakers, is upgradeable with the addition of extra Musical Fidelity power amps - when things get even more special - and is an absolute steal for the money. The X-A2 is set to become even more of a What Hi-Fi? favourite than the X-A1 it replaces."

★★★★★ **WHAT HI-FI?** | September 2000

Sale £399.95

Also Available: X-Ray CD Player **Sale £699.95**





who are sevenoaks?

Founded as Sevenoaks Hi-Fi in the summer of 1972, the original shop, in the market town of Sevenoaks, Kent, quickly gained a reputation for offering a wide range of products at competitive prices, and providing excellent service.

Exciting new technologies like compact disc, meant that throughout the 1980's there was considerable interest in hi-fi and Sevenoaks were able to grow. By 1990, the company was established as one of the leading independent hi-fi specialists in the country.

More stores were opened and a number of the original shops were relocated. In 1995 the important decision was made to change the name to Sevenoaks Sound & Vision, reflecting the wide appeal of new audio visual products.

After twenty-nine years of trading, the company has more than forty outlets nationwide, and is for many of the UK's leading manufacturers of electronics and loudspeakers, their largest and most successful retailer.

The people at Sevenoaks appreciate that customers have a choice. This appreciation has meant that over the years Sevenoaks have had to adapt. As new products and technologies have arrived, the staff have been trained to ensure that they can explain the issues, simply and informatively. This orientation to customer service remains, and the implementation of a company charter is one example of this commitment.

By staying true to the original ideals of offering a wide range of the latest products, at competitive prices, and providing superb service in pleasant surroundings, Sevenoaks are able to listen, recommend, demonstrate and supply the products that best suit the needs of their many customers.

As the world becomes a more complex place and people search for entertainment and relaxation, Sevenoaks Sound & Vision believe that whatever the requirement, they have the solution.

sevenoaks online

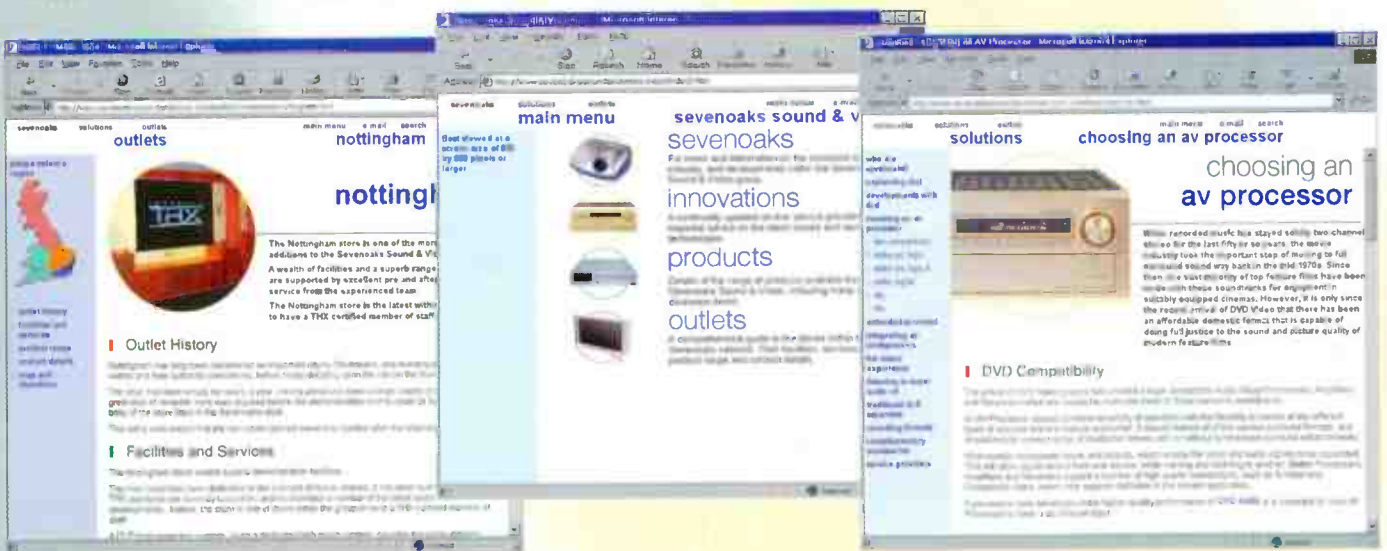

www.sevenoaks soundandvision.com

The Sevenoaks Sound & Vision website has news and information on the Sevenoaks group and its 44 outlets nationwide. The website is designed to provide you with answers to the questions you may have when buying new equipment.

The site has comprehensive guides to a range of products and technologies from vinyl and compact disc to all the latest formats, including DVD Audio, SACD and widescreen plasma monitors and front projection systems.

There are regularly updated stock clearance lists with hundreds of products on offer and detailed pages to help you locate your nearest store.

For impartial advice and information, just click on sevenoakssoundandvision.com.



more entertaining



scotland and north

Aberdeen 491 Union Street **01224 587070**
aberdeen@sevenoakssoundandvision.com

Edinburgh 5 The Grassmarket **0131 229 7267**
edinburgh@sevenoakssoundandvision.com

Glasgow 88 Great Western Road **0141 332 9655**
glasgow@sevenoakssoundandvision.com

Hull 1 Savile Row, Savile Street **01482 587171**
hull@sevenoakssoundandvision.com

Leeds 112 Vicar Lane **0113 245 2775**
leeds@sevenoakssoundandvision.com

Liverpool 16 Lord Street **0151 707 8417**
liverpool@sevenoakssoundandvision.com

Manchester 69 High Street, City Centre **0161 831 7969**
manchester@sevenoakssoundandvision.com

Newcastle 19 Newgate Street **0191 221 2320**
newcastle@sevenoakssoundandvision.com

Preston 40-41 Lune Street **01772 825777**
preston@sevenoakssoundandvision.com

Sheffield 635 Queens Road, Heeley **0114 255 5861**
sheffield@sevenoakssoundandvision.com

midlands and east

Bedford 29-31 St Peters Street **01234 272779**
bedford@sevenoakssoundandvision.com

Cambridge 17 Burrell Street **01223 304770**
cambridge@sevenoakssoundandvision.com

Ipswich 12-14 Dogs Head Street **01473 286977**
ipswich@sevenoakssoundandvision.com

Leicester 10 Loseby Lane **0116 253 6567**
leicester@sevenoakssoundandvision.com

Lincoln 20-22 Corporation Street **01522 527397**
lincoln@sevenoakssoundandvision.com

Norwich 29/29a St Giles Street **01603 767605**
norwich@sevenoakssoundandvision.com

Nottingham 597-599 Mansfield Road **0115 911 2121**
nottingham@sevenoakssoundandvision.com

Oxford 41 St Clements Street **01865 241773**
oxford@sevenoakssoundandvision.com

Peterborough 36-38 Park Road **01733 897697**
peterborough@sevenoakssoundandvision.com

midlands and west

Birmingham 12 Queensway Arches, Livery Street **0121 233 2977**
birmingham@sevenoakssoundandvision.com

Bristol 92b White Ladies Road, Clifton **0117 974 3727**
bristol@sevenoakssoundandvision.com

Cardiff 104-106 Albany Road **029 2047 2899**
cardiff@sevenoakssoundandvision.com

Cheltenham 14 Pitville Street **01242 241171**
cheltenham@sevenoakssoundandvision.com

Exeter 28 Cowick Street **01392 218895**
exeter@sevenoakssoundandvision.com

Plymouth 107 Cornwall Street **01752 226011**
plymouth@sevenoakssoundandvision.com

Swansea 24 Mansel Street **01792 465777**
swansea@sevenoakssoundandvision.com

london and south east

Brighton 57 Western Road, Hove **01273 733338**
brighton@sevenoakssoundandvision.com

Bromley 39a East Street **020 8290 1988**
bromley@sevenoakssoundandvision.com

Chelsea 403 Kings Road **020 7352 9466**
chelsea@sevenoakssoundandvision.com

Crawley 32 The Boulevard **01293 510777**
crawley@sevenoakssoundandvision.com

Croydon 369-373 London Road **020 8665 1203**
croydon@sevenoakssoundandvision.com

Epsom 12 Upper High Street **01372 720720**
epsom@sevenoakssoundandvision.com

Guildford 73b North Street **01483 536666**
guildford@sevenoakssoundandvision.com

Holborn 144-148 Grays Inn Road **020 7837 7540**
holborn@sevenoakssoundandvision.com

Kingston 43 Fife Road **020 8547 0717**
kingston@sevenoakssoundandvision.com

Maidstone 96 Week Street **01622 686366**
maidstone@sevenoakssoundandvision.com

Reading 3-4 Kings Walk Shopping Centre **0118 959 7768**
reading@sevenoakssoundandvision.com

Sevenoaks 109-113 London Road **01732 459555**
sevenoaks@sevenoakssoundandvision.com

Southampton 33 London Road **023 8033 7770**
southampton@sevenoakssoundandvision.com

Southgate 79-81 Chase Side **020 8886 2777**
southgate@sevenoakssoundandvision.com

Swiss Cottage 21 Northways Parade, Finchley Road **020 7722 9777**
swisscottage@sevenoakssoundandvision.com

Tunbridge Wells 28-30 St Johns Road **01892 531543**
tunbridgewells@sevenoakssoundandvision.com

Watford 478 St Albans Road **01923 213533**
watford@sevenoakssoundandvision.com

Witham (Essex) 1 The Grove Centre **01376 501733**
witham@sevenoakssoundandvision.com

christmas and new year opening hours

Sunday 16th December

Most Outlets Open - Please confirm before travelling.

Sunday 23rd December

Most Outlets Open - Please confirm before travelling.

Christmas Day

All Outlets Closed.

Boxing Day

All Outlets Closed.

Sunday 30th December

Most Outlets Open - Please confirm before travelling.

New Years Day

Most Outlets Closed - Please confirm before travelling.

Sundays in January

Most Outlets Open - Please confirm before travelling.

Check www.sevenoakssoundandvision.com for latest information.

ALLAE-D FORCES



Naim's enigmatically named new Allae loudspeakers assault David Price's preconceptions.

How can I put this politely? Naim loudspeakers have traditionally been the province of the devoted Naim fan, and an 'acquired taste' at that. The past few years have seen Naim's brand values shift subtly from hardcore, hairshirt hi-fi to a more egalitarian position, attempting to appeal to a broader range of listeners. For example, the company's amps now have remote controls, a sensible range of inputs and even - of late - very sleek and svelte looking styling.

Where then does this leave the company's loudspeakers? The Allae is the epitome of the 'new breed' - using bang-up-to-date design and engineering principles to bring that olde Salisbury magic to a new generation of music lovers.

The Allae is certainly a joy to behold. A combination of curved and non-parallel surfaces make it arresting to look at (and Naim would also point out this reduces internal standing waves). There's a range of modern, real wood veneers (American Cherry, Maple, Black Ash and Santos Rosewood) for the 940x240x280mm cabinets. Needless to say, the review samples were finished beautifully.

The big idea is resonance - or a lack thereof. To wit, the Allae drivers are separated into their own enclosures to reduce mechanical interference. Naim PIPs (precision interface pins) separate the individual cabinets: the lower cabinet acoustically loads the bass-mid driver, whilst the PIPs define the air gap between the two cabinets, providing a controlled distribution reflex port, free of the usual turbulence problems.

Another interesting touch is the cast aluminium stands, which combine a leaf spring and spikes to control the

critical interface between loudspeaker and floor. This springing is such that the bass appears solid (and unsprung) when the mid-bass section is removed, facilitating easy location on the floor.

Inside both cabinet walls and on the outside of the drive units, Naim has used thermally stable brass mass dampers to control and reduce resonance. The drivers themselves comprise a bespoke Naim 200mm mid-bass unit featuring a computer modelled aluminium chassis and split-mass aluminium phase plug to improve heat dissipation and power handling.

The 19mm wide-dispersion Scan tweeter is spring-mounted to provide extra isolation and mechanical filtration between the cabinet and drive unit.

All of this adds up to a loudspeaker with a claimed 100W power handling, healthy 89dB sensitivity and a frequency response of 30Hz-20kHz +/- 3dB.

My listening kicked off with the £1,125 CD5, £625 NAC115 and £750 NAP150, with both CD5 and NAC115 driven by a £475 FLATCAP2. Very briefly, with the 5 series there was the trademark Naim rhythmic grip, but a good deal of vagueness in image location and a slightly asthmatic bass. I wasn't altogether disappointed - they were still a lively listen - but I'd suggest that people only use these with 5 series front end is used.

My point is - rather circuitously - that these speakers are so damn good that they could be the last ones that most people would ever need to buy. Using the higher end Naim electronics brought a stunning transformation - one that made me

forget I was listening to speakers that cost 'just' £2,000. As usual, 4hero's brilliant second album ('Two Pages') was wheeled out to put the poor review candidates through their paces. Awesome! The Allaes kicked and punched their way through the sinewy rhythmic and dynamic twists and turns of 'Spirits In Transit' with incredible aplomb. Lightning fast, razor sharp, exhaustively detailed yet incredibly musical, it was a total 'live vibe' in the listening room. The snare sound was sublime, as was its incredibly tight interplay between cymbals and tablas - I've never heard it so good. The Fender Rhodes sounded beautifully alive - vibrant and spread widely across the recorded acoustic; you got the sense you were listening to it from a concert PA. And yet despite all these firecracker dynamics, the Allaes remained civilised - as evinced by the smooth, lilting ARP string sounds hanging at the back of the mix. It was at this point that I realised the Allae is a surprisingly neutral and couth speaker, if the electronics in the chain permit.

David Sylvian's 'Orpheus' brilliantly revealed the Allaes' essence - once again they were very hot on the showy stuff (leading edges and attack transients, etc.) but when the pace slows you realise how subtle they can be. Just as the gaps between the notes were very 'black' - there being virtually no overhang - intricate nuances in the mix were more audible with the Allaes than any of its price

◀ rivals I've heard. Likewise, the Byrds' 'You Ain't Goin' Nowhere' demonstrated how they could cut through the 'gloop' of a messy mix to bring the subtlest of fine detailing - the song became alive with the singer's gentlest vocal inflections and breathing. All this time, of course, the Allaes obliged with a wondrous 'walking' bass line.

The Go-Betweens' 'Streets of Your Town' showed off the Naim speakers' superb soundstaging at their best. They're not great on hanging instruments far back behind the plane of the speakers - instead, everything goes upward and forward, giving a vast, expansive recorded acoustic with bold and tight image projection. In fairness they don't match the pin-point precision of dual concentrics, or even some conventional floorstanders, but what they lack in millimetric accuracy is more than compensated for by their brassy, 'out

there' attitude. The strummed guitar part starting this song was incredibly confidently placed, and well ahead of the plane of the speakers.

Tonally, the Allaes are surprisingly good for Naim loudspeakers, confirming my idea that these aren't just 'voiced' to be forward and powerful, but actually let the character of the front end flood out. Everything from the rich, woody double bass and rasping French horns in 4hero's 'Escape That' to David Sylvian's uniquely resonant vocal strains showed the Allae's textural dexterity.

Tonally these 'speakers are quite dry - as you'd expect - and lean. Their bass could be characterised as light, but in fairness it lacks the woody, boxy coloration you get with most floorstanders (thanks to over-resonant cabinetry). The answer is to place them a little closer to the wall than usual and use the very best front end you can.

The Allaes have few weak points for such a purposeful design focused on getting to the music's heart and soul. I would have loved more air and space from those Scanspeak tweeters - treble is smooth but doesn't exactly indulge lovers of the high notes.

Likewise, the very lowest bass notes are just a little compressed and

sat upon when you've cranked the volume up - a decent sub would work wonders here.

Finally, these speakers have a 'brightly lit' mid-band, so are best not matched with forward front ends. They should also be set up with care and devotion.

Brilliant, then - awesomely musical and a riot to listen to. I adore the Allaes for their focused, no-nonsense approach to music making. Better still, I have an inkling that they'd partner a lot of softer, soggier, non-Naim high end systems superbly too - by drawing them out of their shells and getting into the music's groove. A top effort from the Salisbury boys, and one of the very best £2000 loudspeakers available.



Naim Allae £1,990

Naim Audio
Southampton Road
Salisbury
Wilts SP1 2LN
Tel: 01722 332266
www.naimaudio.co.uk

MEASURED PERFORMANCE

Like other Naim loudspeakers I have tested in the past, if less so, the Allae has a characteristic mid-band emphasis that will give it good projection. Low frequency output slopes downward in a peculiar fashion but reaches down to 40Hz in quite a smooth way. The distributed port arrangement seems to have good damping, because of the acoustic resistance of the carefully dimensioned port I suspect. The low frequency end of the impedance curve is well damped, so all in all Naim's bass loading system seems to be pretty effective. The 'speaker reaches downward smoothly to 40Hz and the port extends this down to 25Hz or so.

At the other end of the frequency spectrum the tweeter provides a very smooth and well integrated performance, right up to 16kHz. The Allae should have easy

going treble as a result.

Naim have engineered an interestingly flat impedance curve that measures out at 7.7ohms. So the Allae is an almost perfect 8 ohms and especially non-reactive. Producing 85dB SPL from one nominal (and true) watt of input the Allae was reasonably sensitive considering its high impedance. Ironically, although Naim amplifiers are designed to be very good at driving current into low loads the Allae is an easy and undemanding load. However, the nature of a 'speaker as a load says a lot about it's acoustic effectiveness and in this case the picture is a very good one - which is no accident.

The Allae is an interesting piece of loudspeaker engineering that will certainly have its own sound, which in

many areas could well be a notch above what is generally available. It is very well engineered. **NK**

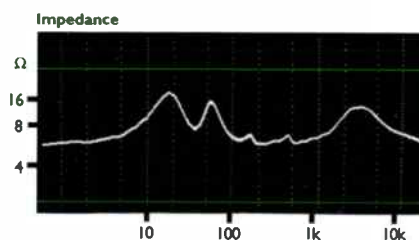
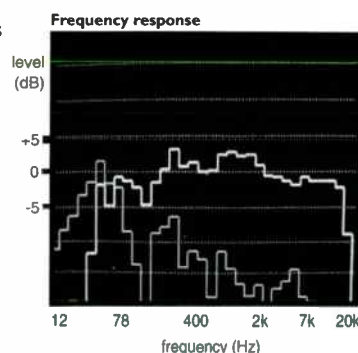

World Verdict



Match with care and you'll get an incredibly powerful and engaging sound, with surprising sophistication. Fine value.



SOUNDS PERFECTION



BAT VK 5i REMOTE PRE / VK60 POWER MINT BOXED £5495
 AUDIONOTE M3 PHONO EX CON MILITARY
 SPEC VALVES £2495
 SUGDEN MASTERCLASS POWER AMP BOXED MINT £1895
 AUDIONOTE QUEST MONOBLOCKS EX-DEM £1895
 PARASOUND DAC 2000 (JOHN CURL SPECIAL) ONLY £995
 VIENNA ACOUSTIC MOZART SPKS ROSENUT BOXED £1095
 AUDIONOTE OTO SE PHONO MINT BOXED £1095
 J.M.LABS ELECTRA 905 SPEAKERS BLACK SUPERB AT £795
 PARASOUND AVC 1800 BOXED HARDLY USED ONLY £695
 AUDIONOTE P1 SE POWER AMP BOXED £695
 CHORD SPM 600 POWER AMPLIFIER £1095
 TRIANGLE ZEPHYRS XS MINT BOXED £495
 VIENNA ACOUSTICS HADYNS BOXED MINT £475
 PRIMARE A 20 AMP BOXED MINT £449

PARASOUND CD-P 1000 CD PLAYER £295
 ARCAYDIS BABY 2 NEW BOXED £400 NOW ONLY £295
 PASS LABS ALPHI 3 POWER AMPLIFIER MINT £1395

SPECIAL OFFER ON DEMO UNITS

LEXICON MC 1 PROCESSOR MINT BOXED £2995
 PARASOUND AVC 2500 MINT BOXED ONLY £1495
 LEXICON DC 1 LEVEL 4 SOFTWARE BOXED £1495
 ELECTROCOMPANET DMB 120 POWR MINT £1395
 ELECTROCOMPANET 4.6 PRE-AMP BOXED £775
 BOSTON ACOUSTIC 10X SATS SET OF 4 MINT BOXED £795
 AUDIONOTE CD 3 PLAYER BOXED £775
 SONIC FRONTIERS ANTHUM II AMP BOXED £875
 AUDIONOTE ZERO PRE & MONOBLOCKS MINT BOX £795
 ALCHEMIST 2 24BIT CD PLAYER BOXED £695

SPECIALIST IN ANALOGUE AND DIGITAL WE STOCK

J.M.LABS * LEXICON * PARASOUND PRIMARE *
 PROJECT * TRIANGLE * REL SUBWOOFERS *
 VIENNA ACOUSTICS * AVID * PROJECT * SME *
 ROKSAN * STRAIGHT WIRE * MICHELL *
 ACOUSTIC DESIGN * AUDIONOTE
 MONITOR AUDIO * BOSTON * SUGDEN
 AUDIO ANALOGUE * GRAFF

NORDOST VALHALLA CABLES

FOR FRIENDLY SERVICE CALL NIGEL

01326 221372

MOBILE:- 07798 554357

Email :- nigel@soundsperection.co.uk

kathryn@soundsperection.co.uk

Web :- www.soundsperection.co.uk

THE NEW AFFORDABLE PHONO AMPLIFIER FROM TRICHORD RESEARCH

DINO



Moving Coil
 Moving Magnet
 Switchable Gain
 Switchable Loading
 Super Regulators
 Discrete Output Stage
 Upgradeable Power Supply

Tel: +44 (0)1684 573524
 Fax: +44 (0)1684 577380

www.trichordresearch.com

STAGE CRAFT



David Price reviews a Plinius phono stage finished in the wood of the same name - Jarrah.

There aren't many hi-fi folk who started work at the Australian Hydro Electricity Commission in Tasmania. Peter Thomson's ascent to the managing director of a highly respected audiophile manufacturer down under has been a long one, but Plinius is now a purveyor of some fine audiophile fare.

After moving to a new job in architectural aluminium design and fabrication, he went to New Zealand to establish a factory in Palmerston North, on behalf of a Christchurch-based family business. But Peter's love of music meant that it wasn't long before he began working on his own hi-fi products, and in 1980 Plinius Audio Systems Limited was formed.

After more than two decades of steady growth and merger with Craft Audio Ltd. in 1987, the company is one of the country's pre-eminent audio brands.

The Jarrah was introduced in 1996 as a 'low cost' phono option for users requiring a high quality, yet affordable way to handle vinyl sources. It works with pickup cartridges from low output moving coils to standard output moving magnets, selected by jumpers and cartridge load switches fitted near the centre of the very neat single printed circuit board. It's housed in an aluminium case with a solid Jarrah front panel - which is said to be a tribute Peter Thomson's native land. Juice comes courtesy of a separate external power supply, with the rectification and regulation circuitry at the front of the circuit board.

Listening was done with my Michell Orbe, packing a new Origin Live Silver 250 and Ortofon Kontrapunkt B moving coil. The Jarrah was compared to the Michell Dino, which also does the biz with both coils and magnets. The Jarrah has a wide, open and even

sound, as Scritti Politti's 'Perfect Way' showed. Not too dissimilar to the Michell in its clear, matter-of-fact character, there was none of the smooth, euphonic silkiness of, say, Densen's DP Drive or the 'in your face' get-up-and-go of Creek's OBH-8SE. Rather, the Jarrah treads a balanced line and doesn't try too hard to influence the proceedings. Bass was deep and extended, but didn't boom or exhibit any signs of overhang - it's just a touch dry compared to the Dino (which is itself no EAR 834P!) but still managed to sound convincing. Better still was the way it tied into the midband. Rather than sounding like two separate preamps each doing their own things, it managed to integrate the low frequencies with the midband very well. This all-important 'presence' region was very impressively voiced, the Jarrah giving an even-handed and comprehensive rendition of Moloko's 'Time is Now'. Vocals were smooth and yet earthy, with a touch more grain than the sensibly middle of the road Dino could muster. Don't confuse this with distortion though - the Plinius was simply doing its job by conveying the singer's voice in all its glory.



WELCOME TO LIVE MUSIC IN YOUR HOME

THE EXCITING NEW WORLD OF RINGMAT AND STATMAT

Imagine - your favourite artists performing in person in your own home! Imagine how this would sound if you listened on LP, CD or DVD. How would it differ?

Fix this difference in your mind, for it is now possible to obtain this extra dimension from hi-fi systems if they are enhanced using our new Ringmat and Statmat products. Results from even inexpensive systems are simply amazing.

Ringmat and Statmat are not replacement components for your hi-fi system but work with it to remove that "veil" which previously has always differentiated "live" from pre-recorded sound.

Ringmat products are de-coupling components that are used for supporting LPs and electronic hi-fi equipment and speakers in a way totally different from more traditional forms of support.

Statmat products derive from very thin film coated with special conductive inks to form very powerful, though passive, electronic devices. The use of this film, in conjunction with the Ringmat products, removes that "veil" from the reproduction of recorded music. The film is used in various ways, such as placing it on the label side of a CD, DVD, SACD, or CD-ROM disc, or placing it under an LP. It should also be placed under all equipment and speakers.

And now **Ringmat Audiophile Cables** will carry the signal from source to speakers without the losses that usually occur with hi-fi systems.

VINYL

For vinyl lovers, the basis for good sound has to be the support of the LP on the platter. **Ringmat** is the pre-eminent record mat for virtually all turntables, either the XLR at £50 or the new Anniversary at £70.

Further improvements on a massive scale can then be achieved by using;

- **LP Blue Statmat** and **Statcap** to remove static;
- **Ringmat Spacers** to remove resonance from your turntable and platter and to fine tune stylus rake angle/VTA, and;
- **Ringcap** to remove vibrations emanating from the centre of the record.

All of these can be purchased separately or in one fell swoop as the **Ringmat Support System**, the best value for money upgrade possible for any turntable.

CD, SACD, DVD, CD-ROM

For digital sources, the **CDi Blue Statmat** at £37.50 will totally transform playback, removing all that edginess and those other unwelcome features associated with using the silver disc. Close to top analogue performance without quite surpassing it, but wait until SACD has matured as a media source.....

UPGRADING

If you have earlier Ringmat or Statmat products, these can be exchanged for the latest versions at a special upgrade price.

PUTTING SOUND INTO FOCUS

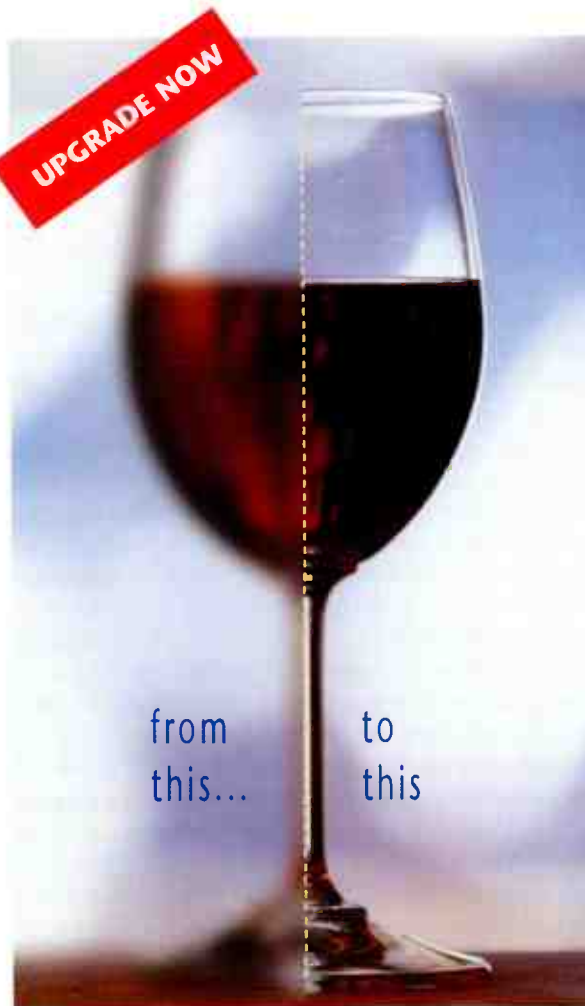

YOUR WHOLE SYSTEM

All your components and speakers should be protected from static and other unwanted electronic fields by using **Statfeet** underneath each of them. They should also be supported by **Ringmat Feet** and/or **Ringmat Domes**, as appropriate for each component's design and situation. We can advise you on this.

The icing on the cake is **Ringmat Audiophile Cables**. We researched these because no other cable provided the level of performance required to realise the potential of other Ringmat and Statmat products. The speaker cable is available now and the interconnects later in 2002.

MONEY-BACK GUARANTEE

All products purchased from us have a no-quibble money-back guarantee as well as help and advice in getting the best out of our products in your system.

DON'T MISS OUT!

dial 01277 200 210
visit www.ringmat.com
or e-mail us at
enqhifiw@ringmat.com

NOW

RINGMAT DEVELOPMENTS

PO Box 200 Brentwood
Essex CM15 9FB GB

 **RINGMAT**

Soundstaging was decently strong and confident, without being particularly bold or well articulated. Whereas the Dino was a little more able to communicate the spatial relationship between instruments at the front and back of the mix, the Jarrah pulled things in a little closer. In this respect it doesn't help the sense of detail - the Dino giving the impression of more clarity by letting those bell-like Roland digital synth parts chime out of the mix more conspicuously. In truth though, the Plinius is impressively detailed nonetheless - stereo imaging left to right is usefully clear and well defined, and there's a lot going on if you listen for it. You could say that in this sense, it's less 'hi-fi' than the Dino and more like real music.

Treble was another competency - the Plinius offering up a smooth and airy presentation without embellishing things. Hi-hats sounded clean, but weren't as silky as the Michell, and certainly not as rose tinted as any valve phono stage. Instead, you get a balanced, even-handed, workmanlike effort that neither adds or detracts. Herbie Hancock's 'The Prisoner' let the Jarrah conjure up a convincing

acoustic, with satisfying airiness, making for a convincingly atmospheric performance. There wasn't a whole lot of glistening, shimmering or chiming going on, just an accurate, no-nonsense acoustic with a good deal of room to breathe.

Rhythmically the Plinius is something of a snake in the grass - despite its relatively sober tonal character, it's no slouch. Indeed, you find yourself tapping your toes sooner than you'd expect - Oasis's 'Slide Away' can be quite dirge-like through some phonostages, but the Jarrah cut to the rhythmic chase and worked hard on bringing out the swing. It isn't a big bopper like Michell's Delphini, but neither is it a wet blanket like the Densen DP-Drive whose even-

handed, slightly dry tonality it shares.

Overall I liked this phono amp - it's definitely a well-sorted design and I would enthusiastically recommend an audition. The problem is that in both price and character it rather falls between two stalls. It suffers from offering a taste of transistor detail and valve liquidity, whilst excelling in neither.

Likewise, its price point puts it awkwardly between entry level, 'value for money' designs and cost-no-object product you've always promised yourself. If you can get a Creek for under £200 that isn't a million miles behind, or a £1000 Michell Delphini that's light years better, why go for the middle option? ■ ▲

Plinius Jarrah £600

Absolute Analogue
PO Box 30429
London
NW6 7GY
Tel: 020 8459 8113



MEASURED PERFORMANCE

There were some unusual and interesting features in this phono stage. It has a very high output capability of 23V, which in turn gives it a good input overload ceiling of 95mV on MM. The (low) gain available is quite high at x240, or on HIGH setting x600 for MC. Around x100 is usual for MM cartridges, but x1000 for MCs. The Plinius falls somewhere between, meaning it will cope with all MMs, including those with low output, as well as most MCs.

The frequency response of this stage was peculiar in possessing significant bass boost, which our analysis clearly shows. Gain starts to

rise (relative to the RIAA recommendation) below 100Hz, peaking by +3dB at 20Hz. This unfortunately means there is a lot of gain available right down at warp frequencies of 5Hz and lower. So although the Plinius will have strong bass it will also emphasise warps, something to be borne in mind. At the other end of the frequency spectrum the Plinius extends right out to 52kHz. Input noise was a low 2.16µV which means hiss will not be a problem.

This is an interesting phono stage, but it's departure from RIAA is quite strong and record warps will be emphasised. **NK**

Frequency response	5Hz-52kHz
Separation	84dB
Noise (e.i.n.)	2µV
Distortion	0.01%
Gain	x240/x600
Overload	23V out/95mV in

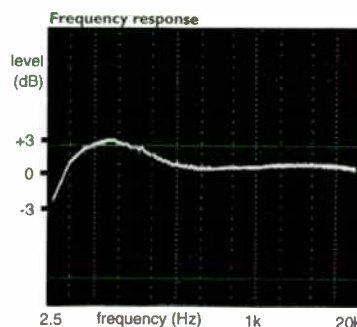

World Verdict



Musical, even handed and built well, this has much to offer - only the high price and stiff competition detract from the package.

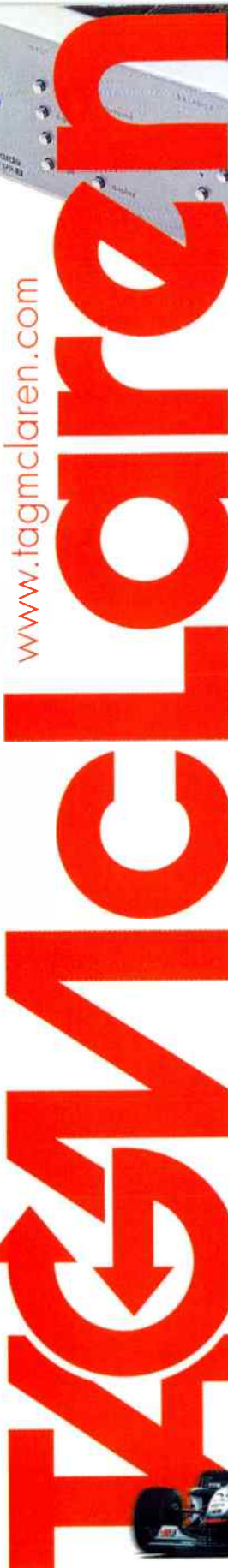

AV32R: maybe the most versatile av processor ever?



"Most home cinema processors can also double as component preamplifiers, but they are rarely transparent enough for serious use in quality systems. However, the AV32R is... This processor is a tour de force."
What Video & TV - 8/01

"Few processors can match the AV32R and none at the price comes close."
Hi-Fi Choice - 6/01

"I can endorse the AV32R whole heartedly... It would be very difficult to improve on its thoughtful design, basic performance, and craftsmanship, and its inherent simplicity appeals to me strongly."
Stereo Reviews Sound & Vision - 6/00

"Performance lives up to very high expectations, thanks to combination of finesse, clarity and control. Advanced software and full upgradeability protect substantial initial investment."
Audio Video - 4/01

"The AV32R can lay claim to being one of the very best audio products on the market. This machine will not only provide you with high-grade audio reproduction, it should also remain at the cutting edge for some time to come."
Essential Home Cinema - 7/01

"Flexibility is built into the AV32R at every level. Unlike others of this type, however, the processor is particularly well adapted to the task. Using stereo source material, it is particularly transparent and clean, easily matching many component two-channel audiophile preamplifiers... The AV32R is an equally excellent multi-channel processor too. Image steering is smooth, and imagery is generally seamless and homogeneous."
Home Entertainment - 9/00



Processing Formats

Mono, Direct, Pro Logic, Dolby Digital, DTS, TMS 7, DTS-ES Matrix, THX, THX Surround EX (Dolby EX)

Optional Formats

HDCD, Pro Logic II, DTS ES 6.1 Discrete, DTS Neo:6, MPEG-2

Upgrades via the Internet

PC owners can download software, incl. new sound formats, from the Internet

Latest DSP Technology

The field-leading 32-bit Analog Devices Sharc 21065L allows processing at all native sampling rates, incl. 96kHz/24bit

Minimal Jitter for superb sound

A twin phase-locked loop reduces jitter to a minimum, resulting in crisp sound

TAGtronic Sync Link

Allows the DVD32R to synchronise its clock to the AV32R, resulting in the lowest jitter technically possible

Enhanced TAGtronic Bus

This multi-device network allows information to be shared between products and can interface with multi-room systems

Best components

Multi-layer glass epoxy pcbs, soldered using a nitrogen filled reflow oven & wave soldering are combined with ultra stable Vishay resistors and ultra low noise Elna Cerafine and Wima capacitors

Proven Upgradeability - not just promises

Nine upgrades since launch, for all AV32R -old and new- including:

- Dolby Pro Logic II
- THX Surround EX (Dolby EX)
- HDCD
- TMS 7
- DTS-ES + Matrix
- Remote controller I/O
- Automation triggers

And more are coming:

- DTS-ES 6.1 Discrete
- DTS Neo:6
- DTS 96/24
- 5.1 analog bypass
- Second 21065L DSP
- Second stereo zone
- Balanced (XLR) outputs
- Comp. video switching
- Internal video scaler
- Digital Video Interface
- DVD-A digital interface
- Precision tuner module



TAG McLaren Audio Latham Road, Huntingdon PE29 6ZU
tel: 0800 783 8007 e-mail: helpdesk@tagmclaren.com

To book an audition contact one of these authorised AV32R stockists:

Beds: Sevanoaks Sound & Vision, Bedford	01234 272779	Herts: Audio T Ltd, Chesham	01242 583960	Merseyside: Sevanoaks Sound & Vision, Liverpool	0207 722 9777	Sevanoaks Sound & Vision, Glasgow	0141 332 9655
Berks: Audio T Ltd, Reading	0118 958 5463	Audio T Ltd, Basingstoke	01256 324311	Music Matters Ltd, Stourbridge	0208 076 3355	Stereo Stereo Ltd, Glasgow	0141 248 4079
Sevanoaks Sound & Vision, Reading	0118 959 7768	Audio T Ltd, Chandler's Ford	02380 252827	Middle: Audio T Ltd, Enfield	0151 707 8417	Shropshire: Shropshire Hi-Fi, Shrewsbury	01743 232065
Bristol: Audio Excellence Ltd, Clifton	0117 926 4975	Sevanoaks Sound & Vision, Watford	01279 213533	Midlands: Frank Harvey Hi-Fi Excellence, Coventry	02476 525200	Radfords, Bath	01223 446245
Sevanoaks Sound & Vision, Clifton	0117 974 3727	The Audio File, Bishops Stortford	01279 506576	Music Matters Ltd, Sutton Coldfield	01384 444184	Sevanoaks Sound & Vision, Ipswich	01473 286977
 Bucks: Audio T Ltd, High Wycombe	01494 681300	HiFi Corner, Aston Quay	00353 1671 4343	Music Matters Ltd, Solihull	0121 354 2311	Audio T Ltd, Cambarley	01276 685597
Martin Kleiser Ltd, Beaconsfield	01494 681300	Sharwoods, Waterford	00353 1671 2622	Sevanoaks Sound & Vision, Birmingham	0121 212 2977	PJ Hi-Fi, Guildford	01483 504801
 Cambs: The Audio File, Cambridge	01223 304770	The Hi-Fi Shop, Belfast	02890 381296	Sound Academy, Wallcall	01922 473499	Sevanoaks Sound & Vision, Epsom	01372 745883
Doug Brady Hi-Fi, Warrington	01223 368305	Sevanoaks Sound & Vision, Sevenoaks	01732 459555	Stratford HiFi, Lunnington Spa	01926 888644	Sevanoaks Sound & Vision, Kingston	0208 547 0717
 Cheshire: Peter Tyson HiFi, Carlisle	01925 828009	Sevanoaks Sound & Vision, Tunbridge Wells	01892 523548	Stratford HiFi, Stratford upon Avon	01789 414533	Unilet Sound & Vision, New Malden	0208 942 9567
 Cambridgeshire: Sevanoaks Sound & Vision, Plymouth	01228 546756	Sevanoaks Sound & Vision, Preston	01772 825777	Sevanoaks Sound & Vision, Worcester	01926 888644	Audio Designs, East Grinstead	01342 314569
 Devon: The Audio Concept, Ealing	01392 491194	Audio Concept, Ealing	0208 567 0703	Sevanoaks Sound & Vision, Cardiff	01926 888644	Capital Sound & Vision, Crawley	01293 459352
 Dorset: Settons Hi-Fi, Bournemouth	01752 226011	Audio T Ltd, West Hampstead	0207 794 7848	Sevanoaks Sound & Vision, Exeter	01926 888644	The Powerplant (Hi-Fi) Ltd, Brighton	01273 775978
 Essex: Rayleigh Hi-Fi, Rayleigh	01202 555512	Billy Vee, Letchworth	0208 318 5755	Sevanoaks Sound & Vision, Hereford	01926 888644	Gilson Audio, Middlesbrough	01642 248793
Rayleigh Hi-Fi, Lullfildside	01277 264730	Centralfake.co.uk, West End	0207 631 0472	Sevanoaks Sound & Vision, Hereford	01926 888644	Audio Excellence Ltd, Cardiff	0292 022 8565
Rayleigh Hi-Fi, Rayleigh	01245 265245	Harrow Audio, Harrow	0207 730 1234	Sevanoaks Sound & Vision, Hereford	01926 888644	Audio Excellence Ltd, Swansea	01793 474608
Rayleigh Hi-Fi, Rayleigh	01708 680551	Listening Rooms, Chelsea	0208 930 9933	Sevanoaks Sound & Vision, Hereford	01926 888644	Audio T Ltd, Swindon	01793 538222
Rayleigh Hi-Fi, Rayleigh	01268 779762	Martin Kleiser Ltd, Chiswick	0207 244 7750	Sevanoaks Sound & Vision, Hereford	01926 888644	Worcester HiFi, Worcester	01905 612929
Sevanoaks Sound & Vision, Witham	01702 432525	Prestige Audio Ltd, Harrow	0208 868 3300	Sevanoaks Sound & Vision, Hereford	01926 888644	Moorgate Acoustics, Sheffield	014 275 6048
 Glos: Sevanoaks Sound & Vision, Gloucester	01452 300046	Sevanoaks Sound & Vision, Southgate	0208 886 2777	Sevanoaks Sound & Vision, Hereford	01926 888644	Sevanoaks Sound & Vision, Hull	01482 587171
				Sevanoaks Sound & Vision, Edinburgh	0131 229 7267	The HiFi Studios, Doncaster	01302 727274

TWO'S COMPANY

David Price spends some time with AudioNote's budget CDT-Zero and DAC-One combination.

Think of AudioNote's Zero mini components as a kind of alternative TEAC Reference Series. Indeed, so alternative is it that it has valves inside, plus an extremely cool instruction manual which begins thus, "Although the DAC-One 1.x is a digital component (there is no avoiding this unfortunately!)." Right on, daddio!

As far as I was concerned, this certainly got the review off to a good start. Peter Quartrop is a controversial figure, but even his detractors can't deny the man's passion for vinyl. This digital duo comes from a company that knows all too well the problems with digital - always a good sign.

Indeed, this is no gruesome twosome - together, the £549 transport and £749 DAC look very smart. Both get the benefits of the midi sized (120x220x300mm) chunky aluminium casework used by the rest of the Zero series, plus the thick retro brushed alloy front panels, weighing in at 4kg apiece. The display on the transport looks a bit naff in my estimation, and I can't say I like the Japanese-style writing on the DAC. This goes into detail about what's inside, and frankly isn't terribly useful - pretty much like the 'Super Twin Power Servo Feedforward Plus'-type scrawl you used to see on Jap amps!

So what is inside? The CDT features a pretty nondescript Sony transport, nicely laid out but nothing to get carried away with. The fascia is bafflingly free of buttons - it looks neat but it would be better to have at least open/close and play/pause buttons here for emergencies. In fact, they're hidden round the back - just



where you can't see (or use) them! Presumably, they're there in case you lose the remote - which I inevitably did.

The DAC One is a more interesting design, boasting AudioNote's '1x oversampling direct from disc circuit topology', borrowed from the considerably more expensive DAC5 Signature. This is claimed to dispense with all the correction measures used in other converters. The AD1865N converter chip itself is an 18bit multibit design which works at 44.1, 48 and 96kHz, truncating any datastream it receives up to 24bit resolution.

Then there's AudioNote's trademark tube connection, in the diminutive form of a solitary 6111WA anode follower output stage - hardly in the Ongaku league, but then again the only thing that glows in the dark on most DACs is the power LED. A 100,000-hour life (over nine years of continuous use) is predicted, and the valve generates so little heat that

cooling isn't a worry. A single coaxial input and one set of analogue outputs completes the picture round the back.

The AudioNote combo sounded pretty strange at first, but just like the manual says, filled out and smoothed up with use. Listening 'in anger' kicked off with Mercury Rev's sublime 'Deserter's Songs'. This modern, cleanly produced album isn't a particular sonic treat - sounding a bit bland and nondescript (quite unlike the music, I might add) - but the AN combo really got the best from it. As you'd expect, it's a pretty even sounding duo, with a pleasingly fulsome and rounded character.

Most impressive about this combo is the way it gently smooths off the rough edges from the sound, and yet keeps much of the dynamic and rhythmic information intact. Make no mistake, it isn't as grippy as Cyrus's own CD7/PSX-R (which costs a similar amount), but it is no less beguiling. Whereas the latter

COUNTDOWN TO



22 - 24 February 2002

10am - 5pm every day
at the Marriott Hotel,
Lower Castle St., Bristol

GETTING TO THE SHOW

By train: Temple Meads Station is a short distance from the Marriott and is accessible by bus, foot or taxi.

By car: from the M4 take J19 (M32 - Bristol). Follow signs for City Centre and RAC signs to the Show.



Easy local parking in Broadmead and Bond Street NCPs.

SOUND & VISION

THE BRISTOL SHOW

SEE & HEAR ALL THE LATEST PRODUCTS UNDER ONE ROOF, INCLUDING...

ACOUSTIC ENERGY: The AEGO PS home cinema system and AEGIS EVO Series

ARCA FURNITURE: A stunning new furniture range

ARCAM: FMJ+ THX home cinema components make their UK debut along with the DiVA CD62 entry level CD player

AUDIONET: The UK launch of the this leading German electronics brand

B&W: The new VM1 range and the outstanding Nautilus™ 800 Signature

CELESTION: The revolutionary new AVF302 loudspeaker

CYRUS: Amazing new Icon X4 loudspeaker along and the latest DVD 7 & CD7Q high-end CD / DVD players

NAIM AUDIO: The UK launch of the amazing new NAC SS2 pre-amplifier and other surprises are promised

SPENDOR: New 'S' Series loudspeakers

WILSON BENESCH: The new Odyssey Series including the Chimera loudspeaker

WHAT HI-FI? SOUND & VISION: There in person to answer all your questions

GREAT DEALS AND SPECIAL OFFERS AVAILABLE ONLY AT THE SHOW - PLUS YOUR CHANCE TO WIN SOME SUPERB PRIZES IN THE SHOW COMPETITION

Admission

Adults £6.00; Students/OAPs/UB40s £3.00;

Accompanied children under 16 free

BRANDS ON SHOW INCLUDE:

A.R.T. Audio, Acoustic Energy, AR Phantom, Arca Furniture, Arcam, Atacama, Audionet, Audioplan, Audioprism, AVID, B&W, Bandridge, Beyer Dynamic, Boston, Bow Technologies, Bryston, Bullet Plugs, Cable Talk, Case Logic, Denon, Diverse Vinyl, DNM reson, Echo Busters, Eton Subwoofers, Dynaudio, Eclipse, Ecosse, Elac, Epos, Emotive Excellence, Exposure, Fujitsu, Harman Kardon, Hi-Fi +, Hi-Fi Choice, Hi-Fi World, HNE Systems, Home Entertainment, Imerge, Ixos, Ixotica, Jamo, JM Lab, KEF, Klegg Audio, Living Control, Living Voice, Loewe, Marantz, Mark Levinson, Meridian, Michell Engineering, Miller & Kreisel, Ministry of Sound, Mission, Moon Electronics, Monster Cable, Musical Technology, Musicworks, Myryad, NAD, Naim Audio, Nordost, Optimum International 2000, Ortofon, Parasound, Partington, Pioneer, PMC, Primare, Pro-ject, ProAc, Prowire, PSB, Puresonic, Quad, Quadraspire, Redstripe, Rega, Reference Audio, REL, Relaxa, Resolution Audio, Revel, Roksan, RPG, Ruark, Russound, S.A.P., Sennhesier, Sequence, Sim Audio, Sonic Link, Sonus Systems, Sony, Sound Organistion, Soundstyle, Spendor, Standesign, Stands Unique, Stax, Steinhart Audio, Straightwire, T3, TAG McLaren Audio, Talk Electronics, Tannoy, Target, Teac, The Chord Company, The Direct Disc, Totem Acoustics, True Colours Industries, Tube Technology, van den Hul, Veda Products, Venus Futuretech, Veritas, Videologic, Vibe Technology, Vienna Acoustics, Vivanco, Vivante Music, Voodoo Isolation, VPI Record cleaning machines, Wharfedale, What Hi-Fi? Sound & Vision, Wilson Benesch, XTC, Yamaha and many, many more...

For the very latest information on new product launches check

www.bristolshow.co.uk

ORGANISED BY

audio
EXCELLENCE

audioT

Great Value Sound & Vision

in association with

WHAT HI-FI?
SOUND AND VISION

seemingly moves heaven and earth to impart every detail of every note's attack, sustain and decay characteristics, the AudioNote combo rounds a little of the notes' leading edges off (just softens them a tad), yet still sings out the rhythmic nuances and dynamic inflections.

Spin up Nirvana's 'Come As You Are' and you'll hear a slightly less firecracker rendition of the song, yet this combo sounds just - if not more - musically coherent and satisfying. It isn't one for forensic detail retrieval but the AN adds a touch of bottom end bloom at the expense of some tightness, a little bit of silk at the top and a big, brassy, bold midband that's positively brimming with musical detail. Even if the event is less exhaustively described, you still get more of a sense of its emotional impact.

Move to jazz and the AN is even happier. Although it's less able to tell you about the recording techniques and studio particulars, there's oodles of atmosphere and 'vibe'. Herbie Hancock's 'The Prisoner' was a joy, this combo proving more adept and communicating the tonal character of the instruments used in this classic sixties BlueNote recording. Flutes sounded more breathy, trumpets more grainy, double bass more full

bodied. The Cyrus combo sounded a touch analytical and monotone by comparison, despite being tighter and ultimately more dynamic.

Whatever kind of music you play through the AudioNote CDT-Zero/DAC One, you'll enjoy yourself. It's one of those 'feel good' hi-fi products that makes the best out of poor recordings (i.e. most) but doesn't quite give you the last nth degree of detail on the good ones. As such, it fits into the AudioNote Zero system superbly, but many spending nearly £1500 on a silver disc spinner might be after more refinement, composure and accuracy. Meridian's 506.24 has all this, plus much of the AN's benign, smooth and musical nature.

Alternatively, you could save yourself a couple of hundred quid and go for the almost as accomplished Arcam FMJ CD23. If you enjoy holding onto your seat and strapping



yourself in, there's always the Naim CD5 and to a lesser extent, Cyrus's CD7/PSX-R. The problem is that, although a great player, this AudioNote combo faces a lot of stiff competition at the price, and rather falls between a number of different stalls. Recommended all the same. ■ ▲

AudioNote CDT-Zero £549
AudioNote DAC-One £749

AudioNote UK Ltd.
125-127 Davigdor Road
Hove, E.Sussex. BN3 1SG
Tel: 01273 220511

MEASURED PERFORMANCE

Frequency response of the Audio Note DAC-One convertor was rather out of line with what is usual from CD, or from any source if it comes to that. As our analysis shows output starts to fall away above 5kHz, measuring -1dB at 7kHz. By the time the upper 20kHz limit is reached output has dropped to -7dB. This is excessive and will give the DAC-One an obviously warm or dull sound.

The distortion behaviour was more normal. There was some second harmonic at higher signal levels. It measured 0.2%, a level that is not normally encountered from digital but, being second harmonic only, it will have little subjective effect. As signal level decreased the Audio Note became quite linear, until -60dB or so when things started to go out of line a bit, distortion rising to around double the usual figure.

Output was very high at 4.6V,

meaning the DAC will sound very much louder than any other, the level usually being 2V. Separation and noise figures were good, but dynamic range limited at 102dB.

The DAC-One is a bit extreme in its characteristics. Frequency response is so restricted it will sound unusually warm or dull. **NK**

Frequency response	10Hz-7kHz	
	left	right
Distortion		
-6dB	0.2	0.2
-30dB	0.02	0.021
-60dB	0.73	0.77
-90dB	44	42
Separation	left	right
1kHz	81	82
20kHz	78	79
Noise	-110dB	
with emphasis	-110dB	

Dynamic range 102dB
Output 4.6V

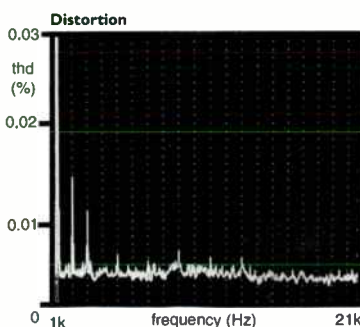
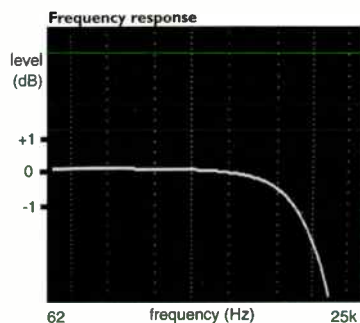

World Verdict



An enjoyably musical package, and beautifully presented too, but a touch too coloured to compete with the best of the rest.

letters & e-mails

Visit our website at www.hi-fiworld.co.uk or send your e-mails to letters@hi-fiworld.co.uk

Every letter we print wins a superb prize including Precious Metals interconnects and a **FREE** subscription to **Hi-Fi World** for the best letter of the month!!

LETTER OF THE MONTH

A SNIP AT WHAT PRICE?

Dear Hi-Fi World
All this recent talk
about SA-CD and

DVD-A seems to dodge the sort of issues that are much closer to the hearts of many of your readers. For example, a reviewer in another magazine once stated that on the system he was reviewing he could hear wire cutters on Peter Gabriel's 'Intruder' (PG3 album) as he sings the line "snipping the clippers". Many years have since passed and despite upgrades to my system, I still can't hear this effect on my vinyl copy of the album. I now suspect that the reviewer just made this up as a cunning ploy to bolster the hi-fi industry! Either that or, alas, my system still isn't good enough.

I use a Pink Triangle LPT turntable, OL RB300, Roksan Corus Black, X-LP and Copland CSA-8 amps feeding Celestion DL8 speakers. Before I contemplate a new pair of speakers, could you please 'spin the Orbe' and put me out of my misery. Did those clippers ever leave Peter's toolbox? If so, your

suggestions for a suitable upgrade please!
Yours, Alan

I can hopefully put you out of your misery, Alan. Ironically, it's SACD and DVD-A that are formats theoretically more likely to bring up such intricate high frequency detail such as this. I managed to get a copy (on CD) of the track in question from a buddy and couldn't detect any snipping of the clippers with a Meridian CD player. Sugden pre/power amps and a pair of Quad ESL-988 (just the tools for the job). Maybe it was a scratch on his record!

However, on the theoretical side, it all depends if you think Mr. Gabriel's wire clipping is an essential component of the sonic picture or not. I once encountered a chap who used to compile CDs of metal spades being dragged across concrete, with the intention of selling them to like minded individuals around the globe. I'd stick my neck out and say he hasn't retired to Mustique as yet, because people tend to buy CDs for music, not something they can recreate to near-

perfect accuracy on their barbecue patio. Likewise, few (hopefully) would relish the inclusion of a wire snip over a tuneful bass line or deft fingerwork on a fretboard. Little details such as this are purely of interest to the reviewer, who can 'compare and contrast'. If those that 'listen for pleasure' go down this route it could end in tears and personal bankruptcy!

My personal advice is to save your money, live without the snip (if it was ever there in the first place) and get into the communicative effect of the music. Rest assured that on paper at least your system is very fine and should have easily enough detail and lucidity for most applications. If you do favour the more clinical approach to audio detail you may get more high frequency intricacies from the likes of a pair of Jamo D80s (formerly the Concert 8s) but a more cohesive choice would be a pair of high sensitivity 'speakers such as Living Voice's awesome Avatars which would suit the Coplands a little better and deliver a wonderfully smooth and detailed sound that would better your Celestions. **SP** ■

ARCAM

Visit www.arcam.co.uk

for Arcam news, product information, technical support and advice on how to get the best from your system

Arcam, Pembroke Avenue, Waterbeach, Cambridge, CB5 9PB, England
Tel: +44 (0) 1223 203203 Fax: +44 (0) 1223 863384
support@arcam.co.uk www.arcam.co.uk



To snip or not to snip, that is the question. . .

MP3 - AND EASY?

I'm an audio equipment novice who simply wants to play my MP3 files through my stereo system for louder and better sound. I currently do that by connecting my laptop to my stereo amplifier using a cord that has a mini-jack on one end and two RCA jacks on the other. I am considering buying a new computer system though, and I am bewildered by all the equipment available for this. I don't know anything about soundcards or how I would connect a desktop system that has its own speakers to my stereo - can you help?

Ronan Lasso, Oceanside, California

The cheapest and easiest way to play your MP3s with hi-fi sound quality is to get a soundcard with a digital output and run it into your existing hi-fi DAC, MiniDisc or CD recorder. Any thus-equipped design would be fine, but as you're based in the US then a Turtle Beach Montego II Plus would be ideal - they're very popular in the States. Look out also for Yamaha's cheaper, ever-popular WF192 WaveForce. Even if you don't have an external DAC, the audio (LINE OUT) output of either of these soundcards would be quite listenable for MP3 or AAC purposes.

Another way is to buy a PC with a CD burner, and burn all your MP3s to CD-R. You can then buy one of the growing number of MP3-playback equipped CD or DVD players - everything from the Meridian 588 to NAD 531 has this facility now. This

would give excellent quality playback, using the player's internal DAC going straight into your amp.

Finally, consider an Edirol UA-3 USB audio adaptor, which plugs into the USB socket of any computer (made in the past 5 or so years) and offers both audio line outs or direct digital outputs, bypassing the computer's internal soundcard completely. This is available from www.edirol.co.uk, but as it is made by Roland (I believe) it may be available in the USA thus badged. It's an incredibly handy gadget and you can of course use it on any computer at home or work because it's hot-pluggable, and therefore easy to move between machines. **DP**



A soundcard with a digital output would do the trick

TRYING A CONVERSION

I am a subscriber to your excellent magazine, and particularly like your

computer audio section. Could you please advise me on this problem of how to get good integration of computer and analogue equipment? I am not a hi-fi nut, as the music is more important. My equipment comprises an MVL SS amplifier, Marantz 630 Pro CD Recorder, Technics DAB Radio, Pioneer MJ-D707 MD Recorder, Philips and Panasonic DCC Recorders and my trusty FonsCQ30/SME turntable. All are linked to a twin Pentium computer with Creative Live Drive. I can get direct digital output by coaxial or optical from my computer, so that could be fed to an external DAC.

I imagine I could improve the sound from some of the above equipment. Would I be able to get some gains from my MP3s, which I have recorded at 128, 192 and 256kbps, as conversion would be external and therefore separated from any computer noise and artefacts? If so, could you please suggest a solution which is not too esoteric? A dCS Elgar sounds nice but I am afraid it is out of my league! Seriously, I am looking for a converter which is up to date and ideally capable of upgrades. I am sure this will be of interest to your readers as conversion is only round the corner.

David Smith

Have you tried piping the optical digital out from your LiveDrive into one of your DCC or MiniDisc recorders? If you try each one in Monitor mode (usually achieved by pressing the 'Monitor' button or

selecting Record with no disc or tape in), you may find a considerable improvement. If either of your DCC decks are early, high end designs (as I suspect your Panasonic may be), you'll already have a very respectable DAC built in - that's the equal of any cheap



A3 RANGE.

MACHINED, MIL-SPEC ALUMINIUM
FRONT PANEL.

TWENTY-FOUR CARAT GOLD
PLATED FITTINGS.

REMOTE CONTROLLED.

PHONO STAGE.

POWERFUL, ROBUST, BUILT.

MUSICAL FIDELITY

external unit.

Which brings me onto this subject - external digital converters are very much the province of the high-end nowadays, so if you're on a budget you'd be best advised to buy second-hand.

In the context of your system, it certainly makes sense to upgrade the DAC, as you have so many sources that would benefit from this one upgrade. Decent DACs haven't got a whole lot better over the past 10 years - so unless you need HDCD or 24/192 capability, look no further than a used DPA Renaissance or Plink Triangle Da Capo, available for under £500. A cheaper but slightly less accomplished solution would be a Meridian 203 DAC7 - which would set you back less than £200 if you look hard enough. **DP** ■

Excuse me for butting in, but another DAC option is to check out the fine MSB 24/96 DAC. This is excellent value at £249 and a fine a DAC as you can get up to, say, £1000. Another cheapy option is the MidiMan Flying Cow for just over £100. Both also, incidentally, turn a bog standard DVD player into a CD playing star! **SP** ■



The Flying Cow is a fine new purchase for those after a quality DAC for little money.

|| NICKED IN THE BUD

Hello,
Until recently I was that apparently rare species in the hi-fi world: someone wholly happy with his hi-fi. However, after a visit from the local burglar, I now need to find suitable components to replace those stolen (incidentally, showing consummate poor taste, the miscreant didn't take my Rega Planar 3). My system was 7 or 8 years old, and consisted of a NAD CD player, an Arcam Alpha 5 amp and Mission 761 speakers. This gave me the full, relaxed sound I prefer. I've heard "better", more dynamic systems but

they're not for me.

I'd be very grateful if you could recommend a new CD, amp and speakers. Ideally, I'd like a minimalist amp (with phono stage). Is either Rega, Creek or, at a push, Audio Analogue likely to be to my taste? In terms of speakers, I would like some small floor-standers that can go close to a wall, though I suspect you'll recommend stand mounts, for reasons of sound quality.

The real virtue of my hi-fi was that I never thought about it, only the music it



was playing. I'd be very grateful if you could return me to this vanished paradise.
regards,
John Brosnan

You're not alone. A good friend of mine had a whole flat full of desirable hi-fi from the likes of Quad, Microseiki and Nakamichi and was broken into. However all that was

nicked was a rough old cheapy JVC tuner that he propped up a bookshelf with! So there's a lot to be said for bad taste.

Your trip back to Elysium starts here, John. If you liked what you had so much then stick as close to that as possible and you're on the right lines in your ideas. Starting at the source, NAD still make some of the finest budget CD players around. The C521 at £200 is a class leader, as is the more expensive and sophisticated sounding C541 at £330. Start with these and you have a good base for the rest. Next I'd plump for a Rega Brio (£298), a cute sounding and looking little integrated with a transparent yet smooth sound, it has

easily enough power and a fine phono stage - what else would you require?

The Brio matches Mission's 'speakers well. The £300 780 standmounts would be a fine choice but the cheaper m73s at £200 could fit the bill nicely. They are floorstanders with plenty of grunt and nice high sensitivity for a fine open sound. Any of the above choices would be a budget system worthy of inclusion in even the fussiest audiophile's abode! **SP** ■

The Brio is a sophisticated and sweet performer.

|| HARSH BUT TRUE

Thanks for an unbiased and informed mag, I have read many others but feel more 'connected' to your reviews. Maybe you could help me?

My current system seems to lack the tonal quality that seduces you into sitting down and 'drinking in' the music. I find that the sound is unconvincing and lacks separation and smooth, realistic definition. Could you give me some direction as to how I can improve things? My music taste is predominantly Rock/Pop, some Blues and Occasional Classical. I listen to both digital and analogue formats.

My system started its life in the early eighties (I can remember now the smug grin on my face, as I walked into the mystical surroundings of my hi-fi emporium). There I acquired a Thorens TD160 Mk2/Thorens arm and Ortofon VMS 30 mkII cartridge... along with Yamaha NS1000m speakers (mounted on stands which have castors - well cool!). In the last two years I have bought a Marantz CD-17 KIS, Musical Fidelity X-A1 amp and X-LP phono stage. QED Qudos 'speaker cable and Qnect 4 interconnects thread it all together. The units sit on veneered chipboard cabinets (no less!), in a 9' by 13' room.

I have often wondered about disclosing all this info, as I am sure the Hi-Fi World office is now in fits of tearful laughter, rolling around the pub floor wheezing... he matched his amp with WHAT !!!!!" Anyhow, as I concentrate to

remain unaffected by that vision I am happy to spend up to £650 in making any changes - O.K. 'corrections'. I would be happier buying more music, if I could get benefits for less.

Howard Barlow (not my real name.....obviously!!)

Don't be so harsh on yourself, Howard (or is it Ken?). Or us, for that matter! The thought of us being a bunch of patronising drunks couldn't be further from the . . er . truth!

Even in the lofty heights of hi-fi magazine editors' systems there's something that doesn't often feel right about the sound. It's the nature of the beast, I'm afraid - the audiophile as opposed to the hardware, that is.

What you regard as a change instead of a correction is indeed that. 'Upgrades' change the sound, not necessarily better it (unless say, 'speakers are out of phase, etc.) and they're only successful if the person who has to live with it likes it.

There's no denying that your system errs towards the bright end of the scale. The Yamahas are fine 'speakers, fast and dynamic, but aren't

the smoothest customers around. Likewise Musical Fidelity amplification and to a lesser extent, Marantz CD players. I'd say the Yamahas need calming down a little. With the financial resources you have to hand there are a couple of options available. The X-A1 isn't the cream of Musical Fidelity's crop any more and sounds a tad thin compared to the A3, for example. Although fine for many systems it's probably the weak link in your set up. Selling it secondhand could raise a few bob to add to your £650 and you could plump for something like the Sugden A21a, the latest generation of this timeless integrated. At £999 it delivers a

smooth and sophisticated high end sound. You'd have to crank it up a little as it's only 25W, but its 25W of Class A - equal to that of a valve power rating. Indeed, my esteemed colleague Mr. Price runs his "Yams" with a valve power amp.

Otherwise, try something from Audio Analogue such as their Puccini SE Remote at £750 or LFD's Mistral for £600, both musical and fluid performers. Or if you want to go in the more rhythmic and fast mode, give the £800 Naim Nait 5 a try - it could work well. Then when funds permit try out the Chord Company's cabling for that extra touch of cohesion and balance. **SP**



A bit of Puccini could calm down your system.

Why settle for anything else when you can OWN something this good!

Mail Order Direct on UK Freephone
0800 373467
quoting: AH22
and request a FREE catalogue or visit our website at
www.russandrews.com

The NEW Crystal Interconnect Range

Prices from £88 for 0.5m pair

These unique cables will give you a more relaxed and musical sound, improved soundstage and better bass. In the 'sound per pound' stakes they really are hard to beat!
The Crystal-Cu from £88,
The Crystal-H from £211 and
The Crystal-Ag from £322.



Crystal-Ag Interconnect

Sole UK Distributor for KIMBER KABLE



• 15TH ANNIVERSARY •

Russ Andrews Accessories

"for the best cables, CDs and accessories"

- Full Refund
- Cable Upgrades
- Lifetime Guarantee
- 30 Day Home Trial
- Expert Advice

Russ Andrews Accessories Ltd.,
FREEPOST NWW881A,
KENDAL, LA8 9ZA.

Tel: +44 (0)1539 825500
Fax: +44 (0)1539 825540
E-mail: AH22@russandrews.com
www.russandrews.com

► NEEDLE, DOCTOR

A friend, on getting a new cartridge, gave me an Ortofon MC 20 Super which he hoped I could sort out. It had hit the spindle on his Garrard 301 and thereafter only plays one channel. Don't laugh! His theory is that - with the stylus slightly to the left now - both channels in a recording are no longer located in tracking. Could he be right? I've been given to wonder, though, whether the cartridge has been damaged internally since the stylus doesn't appear woefully misaligned. I've suppressed the idea of taking a pair of tweezers to it for fear of making matters worse. In any case, are there any remedial services for cartridges as what comes from one channel is very nice indeed. And if so, what would the likely cost be? That is, would it be cost-effective?

Gilbert

If your friend thinks the analogue signal in LPs is no longer located in the groove, it sounds like he's been watching his platter revolve for slightly too long. You're right, of course, to suppose that the internals have been damaged, and sage and perspicacious in not getting your watchmaker's screwdriver out to have a look. Internal surgery is best left to an experienced specialist who's been wielding tweezers for years. This is why you should give Len Gregory (a.k.a. The Cartridge Man) a bell on 0208 688 6565 or have a look at www.thecartridgeman.com. He'll be able to advise you on the damage, and cost of a rebuild. At this point you'll have to take a view on whether you want to spend the sum on the Ortofon or on a new MC. Ortofon offer a like-for-like exchange, where you get a new MC20 Supreme for £355, through your nearest dealer. Phone Henley Design on 01235 511166. The MC20 Supreme was (is) a fine design, with Ortofon's characteristically sweet, smooth and open (albeit slightly mechanical) sound.

You could also think about about a Dynavector DV20X-L (£299) which would give it a run for its money - and also has a new stylus (obviously) which wouldn't need replacing for years. If cost is less of an issue, the one I'd aspire to in the £500 bracket is either Ortofon's own MC Kontrapunkt B or Lyra's Lydian B - both are dynamite, with the Lyra a little more detailed but less punchy. **DP**



The Kontrapunkt B is a cracking MC kartridge

► ELITE ASPIRATIONS

For many years my system was an Elite Rock/RB250/Decca Gold, Audio Innovations 300, Snell Type Jllls. A fun system that really played music, albeit not terribly subtly! CD arrived seven years ago with an Arcam Alpha 5+. This quickly became my main source, especially as my musical taste went more towards opera, classical and contemporary rather than more mainstream rock and pop. The problem with the turntable set-up is that it's going through a NAD phono stage that isn't too good. What should I do to make this work - I'm thinking of a new cartridge and phono stage - or would you recommend dumping it (it's half my life old!) and getting a GyroDec? I can't see vinyl being as major a source as CD for me given the lack of classical (or do you have some good sources?)

On the CD side, a recently-acquired LG DVD player somewhat outperforms the Arcam as a transport, which makes me think that technology has moved on, and that dedicated CD transports probably sound better than £150 DVD players! Is there an alternative to the rather expensive matching Meridian? Finally, I read recently about new Quad ESLs, and I'm mightily tempted. Would my 13w single-ended 859 drive them, or would this be a very expensive upgrade indeed? I adored the old ESL-63 but wanted some bottom-end - do the 989s do this? Also, are they able to work about two feet from a rear wall and be relatively cat-proof? I need a sense of direction here, as mistakes are starting to look pretty costly.

Adam Slim

First your vinyl. Yes, I know a number of good sources for classical - an internet search engine will glean plenty of results here. Better still, try record fairs and second-hand shops, and buy a decent record cleaner (such as a Moth) - or find a local hi-fi or record shop with a Keith Monks cleaning machine. A £1 classical LP with a 50p clean can often sound surprisingly good.

As to what turntable to buy - it

really depends on how much you're going to use your vinyl. If you get back into it - and many people are - then I'd go ahead and get a Michell GyroDec SE, complete with the latest DC motor, for £825. You could use your existing RB250 for a while, and then get it modded by Origin Live when funds permit.

Cartridge-wise, the closest thing to a modern day Decca is probably an Ortofon Kontrapunkt B - which is very punchy and energetic, but with a lot more finesse.

Your phono stage could be usefully upgraded with a Creek OBH-8SE (£130) or a Michell Dino (£299) if funds allow. If you don't want to commit to vinyl - I'd just go for the Creek phono stage and possibly a cheaper Dynavector DV10X4 and leave it at that.

CD transports are much of a muchness in my humble opinion. I'd go for a TEAC VRDS-T1 (ideally second-hand, for £300ish) and save my cash for getting it Clock 3 modded by Trichord, which really makes a difference in clarity and dynamics. The Quad would work with your EARs, but don't expect to get the Environmental Health round complaining about noise levels. A palliative would be to pair them to an active REL subwoofer (or even two), to really take the strain off your EARs. Carefully matched to your room and ancillaries, they'd sound superb - but I'd insist on a home dem from the supplying dealer before cash changes hands - and keep the cat in the other room! **DP**

Quad's ESL-989: the world's costliest cat scratching (di)pole!



GUARAN



Mani Sandher encounters the small but perfectly formed Bryston B-60, an entry level integrated from Canada.

▶ **W**hat sort of warranty would you expect on your newly purchased amplifier? One year? Three years, perhaps? How about a 20-year unconditional and fully transferable warranty? Well, that's what the Canadian manufacturer, Bryston, offer on every product they make. This is no hype or else everyone would be doing it. No, it's real confidence in design and manufacture, gained over a quarter of a century, serving both professional and consumer audio marketplaces.

Here, we take a look at the Bryston B-60, their base offering. This is an integrated amplifier, providing 60 watts per channel into 8 ohms and 100 watts per channel into 4 ohms, Bryston claim. There are provisions for four high level inputs, (CD, Tuner, Video and Aux) in addition to one tape loop. A headphone socket is provided on the front panel for those requiring monitoring and private listening provisions. At the rear of the case are gold plated, five-way speaker binding posts and gold plated RCA input and output connectors. Our sample came with an fairly chunky remote control that adjusts volume only.

Bryston have packed a lot into

the slim case of the B-60. All signal circuitry is fully discrete with no ICs in sight. Interestingly, the amplifier has one independent toroidal transformer and high current reserve for each of its two channels, eliminating channel-to-channel cross talk or interference. Other features include pre-out/main-in connectors, which allow for quick and easy multi-channel system integration.

Eager to hear what the B-60 had to offer, I connected it to my reference system: Sony SCD-1 (heavily modified), B&W Nautilus 803s, Analysis Plus Silver Oval interconnects & speaker cables, Townshend seismic sinks, Cardas Golden Cross mains leads and an Esopower mains conditioner. The speaker terminals on the B60, though easy to use, proved a tight squeeze for the 2.5mm-thick spades on my speaker cables. The B-60 was placed on a Townshend seismic sink to reduce the affect of any external vibrations and was left playing music for a couple of days before any serious evaluation.

Having now listened to the B-60 over an extended period of time, it seems to me that Bryston have focused heavily on getting a couple of

areas right, namely midrange purity and timing. To test the midrange, I first tried a bit of piano in the form of Manfredo Fest's 'Just Jobim' SACD. This sounds incredible (as do all DMP offerings), being a pure DSD live-to-2-track recording by Tom Jung - the music's not bad either! The B-60 shone in terms of midrange purity, smoothness and timing. Each note of the piano sounded nicely full and round, without any harshness or edginess. Percussion and drums lead the rhythm of the music nicely. Only on track S, 'Amparo', did the B-60 struggle with the lower octaves of the piano.

John Lennon's 'Double Fantasy' CD (MFSL 24K pressing) was replayed with high levels of resolution and depth. Separation and focus were also impressive, helping to reproduce Lennon and Ono's vocals in a rich yet insightful way, and creating the illusion of having them in the room - scary.

I next tried Claire Martin's 'Take My Heart' SACD on the Linn label. I find that Linn recordings require a system with real resolution and depth to get the most out of them. The B-60 didn't disappoint here, Claire's vocals being crystal clear and rich. The same was true playing Madonna's

TEED SUCCESS

'Ray of Light' CD. Track 11 on this CD starts with strange synthesised sounds that can verge on being painful to the ears. But through the B-60 they remained pure and smooth.

So, is the B60 perfect? No, but then what is? It's an accomplished performer in the midrange, and comes close to projecting the same naturalness as my Pass Labs X1/Aleph4 combo. But it does lack low and high-end extension. The delicately struck cymbals on 'Just Jobim' didn't sound quite as sweet as they should. It seems Bryston have compromised powerful transients and dynamics in favour of good timing, rhythm and pace.

Lenny Kravitz's '5' CD contains

some powerful low-end transients that the B-60 couldn't entirely manage, especially on track 14, 'American Woman'. My N803 speakers probably don't help here, being more difficult to drive than most.

Overall, I really like the B-60. Rather than trying to do too much, it focuses on getting a few important things right. For me, midrange purity is of paramount importance – it's where so much of the emotional content of the music sits. Good timing, rhythm and pace make music sound more. . .well, musical! The B-60 excels in both of these areas, to the slight detriment of low- and high-end

extension. If you're interested in buying a £1500 amplifier, do audition the B-60 with a top-flight front end and a pair of reasonably easy-to-drive speakers. You'll find that your favourite music sounds great. Should there happen to be a problem in the coming 20 years, don't worry, the B-60 will still be under warranty! ■ ▲

Bryston B-60
£1350 (remote £1550)

PMC Ltd.
43/54 Crawley Green Road
Luton
LU2 0AA
www.bryston.com



MEASURED PERFORMANCE

Under test the Bryston produced 66W into 8ohms and 90W into 4ohms. That's a useful amount for the average home and system, giving plenty of volume under most conditions. The distortion behaviour of this amplifier looked promising in some important areas. There was no increase into a low 4ohm load, as is so common. Since most loudspeakers now use 4ohm bass units this is becoming ever important. In the mid-band distortion was negligible, right up to full output. At higher frequencies there was a little second harmonic, but that is innocuous enough subjectively. Again the amplifier remained linear even into

low loads. The Bryston looked good in terms of distortion, producing little even under difficult conditions.

Bandwidth was quite wide, measuring 4Hz-62kHz, good enough for modern sources such as DVD-A and SACD. Noise was very low and channel separation high. Like many modern amps though the Bryston was a little insensitive, needing 440mV for full output. For older cassette decks and tuners this is a little low.

The Bryston is a neat looking amplifier that measures well. It should give a good account of itself.

NK

Power	66watts
CD/tuner/aux.	
Frequency response	4Hz-62kHz
Separation	80dB
Noise	-107dB
Distortion	0.006%
Sensitivity	440mV
dc offset	0.7/1.4mV

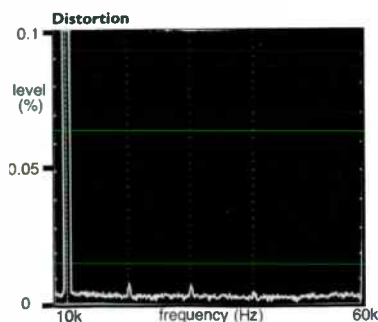

World Verdict



Clean and controlled, the B-60 has an impressive way with rhythm. Lacks a bit of low end slam, though.

WELCOME TO CHEAP SEA



NAD's new T531 CD/DVD player will not amaze you with its incredible looks or Herculean build, but it was never supposed to. David Price goes back to budget basics.

► This is an interesting product for two reasons. First, because it's a new NAD - lest we forget, this is a company that has done more than most in furthering the cause of impoverished audiophiles over the past two decades. Second, it's not a purpose-built CD player (à la NAD's C Series), but from the 'Theatre' series, which means it's ostensibly a DVD player that plays CDs.

The T531 is a versatile machine, just as you'd expect. As well as the claimed dynamite CD performance, it also has the ability to play CD-Rs, CD-RWs, and MP3 data discs recorded by your computer CD burner. Its spec includes a dts digital out (for use with an external decoder), which is useful even to us audio boys as there are a number of audio-only dts discs out there for our audiophile delectation. There's a component video output (on the 115V version only), a 10-bit Video DAC, the usual SCART with RGB and Composite Video outputs (230V version only), and PAL/NTSC compatibility with PAL 60 option (230V version only).

More up our avenue are the

coaxial and optical digital outputs and the usual RCA stereo analogue outputs.

Pulling this player out of its packaging was an eerily familiar experience - having owned more than a few NADs in my time, the straightforward construction quality and greeny-grey finish weren't new to me. It's hardly an auspicious bit of kit but the T531's light is well and truly hidden - until you feed its somewhat cheap feeling disc tray with something round and shiny.

The first silver frisbee to find itself spinning inside was Caravan's 'In The Land of Grey and Pink'. Feeding my World Audio K5881 and Yamaha NS1000Ms, the wee NAD made some surprisingly nice sounds. It's not the world's most detailed digital disc player, and there's a considerable lessening of air and space compared to the likes of my cheapo (£200, now no longer on sale) Cambridge CD4SE. Just as the high treble seems veiled and softened, the lower bass isn't the most powerful or extended you'll hear.

The NAD doesn't appear to be a mid-forward player, as its upper bass is pleasantly warm, and its lower

treble is sweet and smooth - both are characteristics, lest we forget, that NAD is famous for, as anyone who's ever owned a 3020 will tell you.

The T531 is an exceptionally musical performer at the price - it just gets into the music and enjoys itself. It's particularly strong on carrying melodies, as the Caravan disc proved. It isn't Naim-like in the sense that it doesn't grip, grip, grip - yet you still end up tapping your feet to the sumptuous and melodic sound emanating from betwixt your bass bins.

K-klass's 'Rhythm is a Mystery' showed the NAD's limited low bass ability - it doesn't like the bottom octave and prefers to forget they're there. Likewise, the Roland TR909 hi-hats sounded curtailed and lacking their characteristic 'glisten'.

The midband showed the T531 to be limited at placing stereo images within the mix - the synth glides seemed to hang about in the middle of the acoustic rather than being nailed to one spot. Likewise, there was a poor sense of the air around the vocalist - I couldn't clearly hear the booth in which she was singing, whereas my old budget reference the

TO THE TS

CD4SE made it plain as day. Despite this, the NAD gave an incredibly bouncy rendition of the song. Indeed, it sounds very 'organic' and ebbs and flows with the song without trying to deconstruct it or pronounce on its recording characteristics. Air's 'All I Need' merely confirmed this - the NAD turning in a wondrously warm, sweet, louche rendition that caught the mood brilliantly.

Tonally, the T531 is NAD through and through - which means warm and sugary, even if the original recording isn't. It's a great characteristic to have for a budget CD spinner, because the ancillaries are likely to be rough - but

through higher end kit it can often sound a bit samey and predictable. Nevertheless, Lonnie Smith's 'Think!' - a nicely judged late sixties Blue Note recording - sounded fantastic. Put through something like a Cyrus CD7/PSX-R you'll hear all the ragged edges, but the NAD doesn't bother with the unpleasant details and just gets into the groove. Once again, frequency extremes and image location could have been better, but the song's emotional force and delicate rhythms were carried surprisingly well. As a video player it's tops too, with a clear and lucid picture, as a DVD of New Order

revealed. Colours were natural and functions such as pause and fast forward operated well, with the picture still easily discernable.

It's a top little deck, the T531. NAD is right to claim its status as a legitimate piece of hi-fi - it sounds better than many budget CD-only Sonys, Pioneers and Marantz's at (almost) the same price - and of course plays DVD movies beautifully. ■ ▲



NAD T531 £330

Lenbrook UK Ltd.
Unit 2, Old Wolverton Road
Milton Keynes
Bucks MK12 5NP
Tel: 01908 319360
www.lenbrook.co.uk

MEASURED PERFORMANCE

The T-531 has a ruler flat audio frequency response that runs out to 20.25kHz. A response like this usually gives a slightly bright balance in practice, but the T531 is certainly accurate in this area.

There was a little more distortion than usual from CD, level measuring 0.03% at -30dB, normal music level. Our analysis shows this was due mainly to a slightly raised noise floor. At lower signal levels the rise was greater, distortion measuring 0.9% at -60dB instead of a more common 0.4% or so. This player isn't quite as linear as the best, but it puts up a reasonable performance.

Channel separation was high right across the audio band. Noise was low, but this was probably due to muting in view of the slightly raised noise floor in our distortion analysis.

Output was a normal 2V.

The T-531 offers a good enough set of results as a CD player, even if it doesn't quite match the best. **NK**

Frequency response 4Hz - 21.25kHz

	left	right
Distortion		
-6dB	0.008	0.009
-30dB	0.03	0.033
-60dB	0.886	0.9
-90	37	36
Separation	left	right
1kHz	100	101
20kHz	74	74
Noise		-114dB
with emphasis		-114dB
Dynamic range		107dB
Output		2.04V

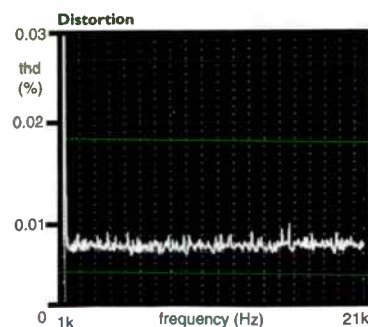
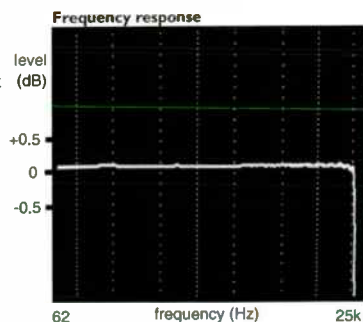

World Verdict



Brilliant value DVD/CD hybrid with loads of useful features and a warm, smooth and musical sound.



Probably the best CD Player money can buy.

Creek CD53 reference standard CD Player



You've heard the rest, now hear the best

With the advent of SACD and DVDA, you may be wondering why Creek have designed a new high-end CD player. Research has shown that while these new technologies allow for increased resolution, when plying discs recorded in the new formats, they are not so convincing at extracting the best from CD's. As CD has been around for 20 years, many people have built up large libraries of discs and want to get the best from them for years to come. Creek feel that a statement product is required to achieve this and have left no stone unturned in their attempt to achieve it. The CD53 is the ultimate reference standard, achieving the best performance money can buy. The CD53 uses a Philips transport, custom Creek software, ultra-low jitter master clock and waveform shaping, for maximum signal retrieval. In addition to its no compromise power supply circuitry, it uses professional standard balanced audio output filtering and buffer circuitry to provide the lowest noise and highest fidelity signal available.

Contact us for more details or visit our web site:-

Creek Audio Ltd, 2 Bellevue Road, Friern Barnet, London N11 3ER

Tel # +44 (0)20 8361 4133 Fax # +44 (0)20 8361 4136

email: info@creekaudio.co.uk internet: www.creekaudio.co.uk

ALL ROUND GEMS

The 8.3 is the big boy of the new Diamond series from the re-vamped Wharfedale brand. Dominic Todd discovers whether this floorstander is as class leading as its smaller siblings.

Wharfedale appear to be going through something of a renaissance of late. First we had the Pi-range, whose transparency of sound proved something of a revelation after years of not overly successful efforts from the former stalwart of the British 'speaker industry. Later in 2001 came the new Diamond 8 range. It's a range that, with the smaller 8.1 and 8.2, has already been well received within these pages. Now it's the turn of the biggest, so far, Diamond geezas of them all, the 8.3.

Lifting them out of the box, and almost breaking my back in the process, led me to believe that either these 'speakers had been seriously well built, or had cunningly been sand filled by Wharfedale. It turned out to be the later, yet brief tests without the sand showed just what a difference it can make.

As well as being sand fillable, the 8.3s are also bi-wirable, and feature a small plinth and MDF cabinets of marginal thickness with limited bracing. Pretty much text book stuff for a £200 floorstander. Rather more impressive are the good quality drive units. The silk dome tweeter and Kevlar woofer really wouldn't look out of place on a 'speaker costing twice as much. If only the same could be said for the rest of the finish. Still, for this price, something has to give and I'd rather have a dubious finish

and decent drive units rather than vice versa, any day.

In terms of price, the Wharfedales have plenty to contend with here. Favourite floorstanders of mine are the Mission M73s and Eltax Liberty 5+s, whilst one shouldn't rule out Tannoy's R1s either. All three cost exactly the same as the Wharfedales.

Using my usual system, Nelly Furtado's, 'Turn off the light', got proceedings underway. Just as I'd noticed with Wharfedale's previous Pi-range, the 8.3s immediately struck me with their excellent vocal reproduction. For a 'speaker of this price, the articulation and projection of vocals was extremely impressive. The resolution of guitar was equally fine, with real delicacy shown, again unusual from any speaker of this price.

Less good was a certain amount of congestion in the upper-bass response, which had the effect of spoiling the timing. It became clear at this point as to why Wharfedale had filled the 'speakers with sand, as without the ballast this aspect was emphasised. Ultimate bass response was also a little curtailed, in comparison with either the M73s or Liberty 5+s. Yet, by most £200 'speakers standards, the overall balance of sound was pleasingly full bodied.

'Les Jours Tristes', by Neil



Hannon and featuring in the film, *Amelie*, showed the Wharfedales in a very favourable light. It features an ensemble of acoustic instruments culminating in a rather busy mix. Crucially the 8.3s had little trouble in separating the instruments out, or in portraying their varying textures of sound. There was wonderful string definition from both banjo and mandolins, where I could almost trace the players' fingers along the strings.

Again the bass was a little 'shut in', which affected the 'speakers imaging somewhat. As the track became more complex, they did miss

EXPERIENCE THE CHORD EFFECT!

The first time you hear your sound system with Chord interconnecting cables will be the first time you've **really heard it**.

Be warned - the effect can be shattering.

Your eyes and ears will be opened. Your music will never sound the same again.

Specify Chord cables - Hear the light!



FOR SALES AND INFORMATION
CALL: 01722 331674 FAX: 01722 411388
E-MAIL: CHORD@CHORD.CO.UK
OR VISIT US AT WWW.CHORD.CO.UK

There are well-known amplifiers. There are highly regarded amplifiers. Then there is Spectral - recognised throughout the world as the leader.

Spectral -

the "Reference"

The keys to the Spectral sound - startling immediacy, fine detail, dancing rhythms and amazing clarity - stem from their **ULTRA-FAST RESPONSE** and **MEGAHERTZ BANDWIDTH**.

Spectral amplifiers rise and settle in 10 millionths of a second after the **FAST TRANSIENTS** and **COMPLEX HARMONICS** of a violin or trumpet, or the 1,000,000 to one ratio of loudest to quietest signals.

We hear this astonishing nimbleness as natural "**PRESENCE**", increased **DYNAMICS** and a wider palette of **TONE COLOURS**. We also hear more of the musicians' technique - bowing, plucking, breathing - and so much more of the emotion.

Spectral products evolve from the **LIVE EVENT**. Designer Prof Keith Johnson is the driving force behind **REFERENCE RECORDINGS**, and also the inventor of HDCD recording.

Spectral draw on techniques from high-tech fields such as microwave or instrumentation, where state-of-the-art is essential, then adapt them as **REVOLUTIONARY AUDIO** solutions.

You should hear the new Reference-level DMC-30S preamp and Series 2 DMA-150 power amp before you buy *any* other high-end amplification.

Visit www.spectralaudio.com

Customers say we make some of the **BEST SOUNDS** they have ever heard, so you know we can do the same in your home. Our advice will take account of your best components and guide you where change is needed, in stages you can afford.

You **AVOID EXPENSIVE MISTAKES**, enjoy music along the way and save money in the long run.

JUST LISTEN AND YOU'LL KNOW

CD: ACCUPHASE, ADVANTAGE, AUDIO SYNTHESIS, BAT, dCS (ELGAR, DELIUS PURCELL, GRIEG, VERDI) MERACUS, PASS, SAT, SUGDEN, WADIA. **VINYL:** BASIS, CLEARAUDIO, CROWN JEWEL, DNМ, GRAHAM, THE GROOVE, LEHMANN, MICHELL, SUMIKO BLUE POINT SPECIAL, TRANSGURATION. **AMPLIFIERS:** ACCUPHASE, ADVANTAGE, BALANCED AUDIO TECHNOLOGY, CAT, DNМ, GAMUT, HOVLAND, NAGRA, PASS, SAT, SONNETEER, SPECTRAL, SUGDEN. **LOUDSPEAKERS:** AUDIO PHYSIC, AUDIOSTATIC, BKS, ETHOS, LUMLEY, NEAT, IOTEM, VERITY AUDIO. **TUNERS:** ACCUPHASE, MAGNUM DYNALAB. **CABLES:** ARGENTO, CHORD Co., DNМ, HOVLAND, NORDOST, SILTECH, SPECTRAL, YAMAMURA CHURCHILL ETC. **SUPPORTS:** ARCICI, KINABALLI, STANDS UNIQUE

The Right Note

Music in the home

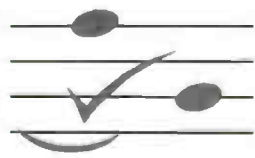

BATH

01225 874728

out on a few subtleties such as cymbal decay yet, overall, the 8.3s kept a good grip on the piece. My only real concern here was that with harsh ancillaries they could just overstep the mark from detailed to over bright.

This type of 'speaker is often bought to kick out bass lines from dusk 'til dawn. Hence, I loaded The Brand New Heavies, 'Shelter' into the CD player to see how they'd fair. In truth, whilst the dynamic range was more than fair, it did rather lack weight and authority. Attributes which the rivalling Mission and Eltax have by the bucket load. Yet the 8.3s have other attributes. Their transparent treble picked up nuances in the deliberately distorted vocals that most rivals would gloss over. The balance was also smooth and coherent, just not especially exciting.

Ian Shaw's 'Ruby' was more the Wharfedale's bag. Shaw's vocals positively leapt from the 'speakers possessing great definition and presence. Occasionally, such as the treble's fine transparency, it could sound just a little detached from the upper mid-band, yet overall the sound remained cohesive and very much together.

In summary, these 'speakers encapsulate the best features of both



emaciated with large scale and bass rich music. Their imaging is fine also.

Whilst the 8.3s are generally smooth and cohesive, they will occasionally surprise with a sense that the treble has become slightly detached from the rest of the mix. Perhaps of more concern is the lack of deep bass weight. Whilst I'm happy for this path to be taken with budget 'speakers, there will be some potential buyers who'll demand more bass.

Taking everything into account then, the Wharfedale 8.3s have some pretty impressive qualities, and are well worth adding to the auditioning list. What they lose to rivals in some areas they more than make up for in others.

budget stand mounts - speed, transparency and fine imaging - with those of budget floorstanders - bass weight and dynamic contrast.

In terms of vocal reproduction and delicate instrumental timbre, the 8.3s match or exceed the best at this price, regardless of size. They also have just enough grunt not to sound

Wharfedale Diamonds 8.3 £199.00

Wharfedale International Ltd.
IAG House, Sovereign Court
Ermine Business Park
Huntingdon
Cambs, PE29 6XU
Tel: 01480 431767
Web: www.wharfedale.co.uk

MEASURED PERFORMANCE

The floorstanding Diamond 8.3 is sand filled for stability and suppression of box resonance. This will give it stronger bass, with more attack. Bass will also be boosted by a lift in response from 80Hz - 125Hz, which raises output by no less than +5dB relative to the mid-band. It is quite a large bass boost and will give the Diamond 8.3 a noticeably bass-emphasised balance.

Forward output from the bass driver reaches down to 40Hz (-6dB), before the port takes over. The port has a fairly limited effect, the impedance curve suggests, but extends output down to 25Hz or so. It looks like Wharfedale have decided to ensure this 'speaker has a powerful bottom end.

Although further up the band the 8.3 is a bit bumpy in its frequency response, as our third-octave analysis shows, it basically maintains a

reasonably even balance right up to 16kHz, albeit a slow fall in overall output meaning the sound will have a warm balance.

A broad peak around 1.25kHz, where there is also a peak in port output, may indicate the presence of some colouration. It could possibly add a little brightness or similar, especially to violins.

As is common these days, Wharfedale use a 4ohm bass driver for maximum voltage sensitivity, allied to an 8ohm tweeter, giving a 6ohm overall impedance, which is exactly what we measured. There is some reactance in the load and it will draw current, so a hefty amplifier would help. However, the 8.3 goes loud enough from one nominal watt of input, delivering 87dB.

The Wharfedale 8.3 has been balanced to have big bass

and a generally smooth, warm sound. It should have good detail and innocuous treble. I suspect it will have strong appeal. **NK**

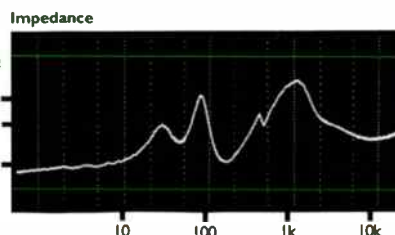
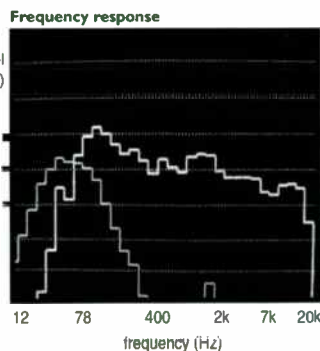

World Verdict

A touch more cohesive and sophisticated than rivals, with a very revealing treble. Some may wish for deeper bass but the 8.3s are up there with the best at the price.

campaign audio design

Hi-Fi Cables Manufacturer and Supplier

“Love Hertz”



Getting a better, more involving sound often means spending a lot of hard earned money. It's such a waste, because every system can benefit from our cables and accessories, at a fraction of the cost of some new “black box”. Here are some of the ways we can help.

We have Linear Crystal Oxygen Free Copper interconnects (£12.48) up to High Purity Silver balanced cables (£99.00) and high definition

loudspeaker cables in Silver Plated Copper or Pure Silver. Our mains cables add weight, power and scale, and with non-inductive RF filtering (£10.00) and over-voltage protection (£3.00) enhance performance still further. Gold plated AV cables, both RF (£19.95) and OFC Scart with PTFE insulation (£30.19), help bring picture quality in line with NICAM sound resolution.

We also have a cure for your noisy fridge or central heating motor (£3.50), enabling you to throw away your big mains noise suppressor, which has been giving you that “sat upon sound” for years. There's lots we can do to bring you closer to the emotion and energy of the performance. So confident are we, that

we offer a 21 day money back guarantee.

Ring or write for details:-

CAMPAIGN AUDIO DESIGN
Llandudno Road (HW)
Cardiff CF3 3PG
Tel:- 02920 779401

Website: <http://business.virgin.net/cad.cables/>



Trade and International Enquiries Welcome.



Our Beauty isn't only Skin Deep!



Quality amplifiers don't have to cost the earth!

icon Audio MC34-A

4x EL34, 2x 12AU7, 2x 12AX7. All hand wired. No printed circuit board. 2x 30 watts RMS. Audiophile components used throughout.

Even our price is beautiful ... only £599.95
Including delivery and 12 months guarantee including valves.

Try it for yourself for up to 30 days, full refund if not delighted. Visit our website for full description and detailed photo's (inc internal) www.iconaudio.co.uk or send now for our free info sheet, by phone or email.

SPECIAL OFFER order in January and get a Project phono pre-amp worth £40.00 FREE

icon Audio 351 Aylestone Road Leicester LE2 8TA
Phone 0116 25158791. email sales@iconaudio.co.uk



We accept Visa and MasterCard.
CE certified



definitive audio

Living Voice • Lowther • Vitavox • Electrofluidics • Art Audio • Border Patrol
Canary • DNM • Sugden • Wavac • Lyra • Monarchy • Western Electric • EMT
Wadia • Michell • Stax • Tom Evans • Nott'm Analogue • SME • Van den Hul

Part exchanged and ex-dem clearance.

Digital

	Sale	New
Sugden Masterclass CD - new - boxed	£1990	£2500
Helios Model CD2i - new	£890	£1200
Helios Model CD3i - ex-dem	£690	£900
Wadia 860x Ex Dem - boxed	£4950	£8000

Analogue

Nottingham Analogue 'Foot' - 12" carbon fibre tonearm - new	£700	£1100
Nottingham Analogue Space Deck - with SME arm mount	£650	£850
Helios Cyalene - tonearm	£590	£1350
Hadcock GH228 Super - 9" tonearm - nearly new	£440	£640

Loudspeakers

Living Voice Auditorium - Hi-Fi Choice 'Best Buy'		
2 pairs - Walnut - ex-dem	£1150	£1500
Cadence DS	£750	£1750
Kilpash LaScala Black	£1750	£3500
Quad ELS63 - fully reconditioned by Quad	£1100	£3000
Quad ELS63 - fully reconditioned by Quad	£900	£3000

Amplifiers

Border Patrol 300B SE - with new Western Electric valves.		
Light Oak - the best SE available - ex-dem	£3750	£4500
Canary Audio 301 - 24 watts stereo power amp with 2 matched pair Western Electric 300B - fabulous	£3900	£5200
Art Audio Concerto - integrated 40 Watts Class A. V.good	£1500	£2650
Joule Electra 2 box phono pre-amp	£800	£2000
Art Audio VPS - valve line pre-amp	£600	£1400
Sugden A21 - integrated (line only) ex-dem - mint condition	£750	£900
Musical Fidelity A1000 - 'super pre main' class A	£850	£1800
Cary '2A3' 7 watt power amp. 1992	£850	
Cary 5500 Line pre-amp. 1992	£550	
Unison Mystery One PR+	£950	£1750
Tube Technology MAC phono pre-amp. Fully refurbished by manufacturer. Including Hovland film and foil capacitors.	£900	£1400
Tube Technology line pre-amp with separate power supply. Fully refurbished by manufacturer.	£850	£1450

Tel 0115 973 3222 Fax 0115 973 3666

Internet: www.definitiveaudio.co.uk email: shout@definitiveaudio.co.uk

five star
performance
in audio equipment support
utilising vibration control technology

Hi Fi Choice

An earth-shattering upgrade
for your Hi Fi system
Best Buy September 1999

Customer Selection

The BASE platform
must rank as
one of the great
bargains in
Hi Fi



WHAT HI-FI?

extract from June 1999
This nicely finished platform
works superbly and for sheer
value for money, the Audiophile
BASE 01 takes top honours.
★★★★★

Top Accolades for BASE Audio Supports

Stereo (Germany) Feb 97 Maximum ★★★
Hi Fi World Feb 98 Outstanding ●●●●
What Hi Fi July 98 ★★★★★
Home Entertainment Oct 98 ★★★★★
Stereoplay (Germany) Feb 99 Outstanding
What Hi Fi June 99 ★★★★★
Hi Fi Choice Sept 99 Best Buy

Audiophile Furniture Ltd

The Square, Forest Row, East Sussex RH18 5ES

Tel: 01892 619319 e-mail: sales@audiophilebase.com
www.audiophilebase.com

THREE OF A KIND

Paying £150-plus for cable means it should deliver the goods. Simon Pope listens to three interconnects at the top end of the scale - will they deliver?



Origin Live Laminar Flow Reference £149/metre



John Dory Hi-Fi Silver Foil £200/metre



Neotech NA-12165 £425/metre

This is top dog in the Origin Live pack of three! It features a two core braided sheath, like the £85 Ultra, but has a different configuration of stranded conductors. The high quality phono plugs claim to have twice the conductivity of gold plated brass. The plugs are of good build quality but don't resemble Volvo spark plugs and the outer sheath is made from black PVC. Direction is discerned by the plugs on the source end being double banded.

Victoria's Spanish renaissance choral polyphony sounded open and intricate through the Reference, with voices well blended yet detailed. A good sense of acoustic ambience was also present, creating a fine resonant soundstage. With the hypnotic of Miles Davis's 'Kind Of Blue' the upper frequencies were nicely open and smooth and detail in the piano of Bill Evans was superb.

A good buy at the price, the Ultra may not have the Boa like dimensions of the Neotech but your money is spent here on sound quality only - it's a fuss free sound that will suit most set-ups, from midprice to high-end. It doesn't quite have the organic coherence of, say, Chord Company's Chorus at £200 but it picks up oodles of detail and creates space in recordings.

Origin Live
Tel: 02380 442183
www.originlive.co.uk

As anglers and gourmets will know this company is curiously named after a rather tasty fish, as opposed to the founder of the company (one hopes for his sake!). Both products available (analogue and digital interconnects) are designed by Allen Wright, the author of the Super Cables Cook Book. The analogue pair reviewed here now come with the acclaimed Neutrik Profi RCA plugs as standard. Construction is 99.99% pure silver foils incorporating a Teflon insulator, plus the addition of Kynar. The silver foils measure 3mm x 0.05mm which makes the cable quite fragile, so they should be handled with care.

However, the gentle handling pays off, as these are a real surprise. They deliver a true high-end neutral sound which is often the trait of much more expensive designs. Choral music was wonderfully natural and open, with perhaps a tad of emphasis on the upper frequencies, in the Nordost mould. The rest of the sound was beautifully open and balanced, with great insight and clarity. Miles Davis's Kind Of Blue benefited from this openness and sounded intimate and natural, with good speed and rhythm. These newcomers are very competent and they offer much - you could do a lot worse than to catch this particular fish.

John Dory Hi-Fi
Tel: 01282 867819
www.jdhifi.co.uk

These Neotech interconnects resemble a chunky design in the Monster/top-end Kimber mould, complete with locking plugs and plenty of girth. However, they actually originate from the Electric Wire & Cable company in Taiwan. The 12165 is a symmetrical type interconnect which employs a single crystal, pure silver solid conductor, between which are found hollow tubes. These are wrapped by PTFE tape, Mylar, nylon braid, a double shield of aluminium foil and a PVC jacket - a list that resembles a breakfast order for an alien in a US diner!

Sound-wise the Neotechs are full and beefy. This tended to suit Miles Davis better than choral music, which favours the more neutral sound. That's not to say the Neotechs are a disappointment, they are rich and powerful sounding, with good bass response and a smooth treble which never grates. The choir's voices had an impressive cohesion that sounded like a genuine body of sound which gave a good organic approach to reproduction. 'Kind Of Blue' sounded warm and fluid, with good presence and timing. These are very good, well constructed cables but are also on the hefty side when it comes to price - similar sounds can be gleaned for less. ■ ▲

Audiocom
Tel: 01646 685601
www.audiocom-uk.com

CLASSIC CUTS

They'd come a long way since Andy Giles encountered them in Walthamstow – but **GOATS HEAD SOUP?** Just what were the Rolling Stones on in 1973?

At the Assembly Halls, Walthamstow, in September 1963, I shared an alarmingly large joint with Keith Richard, who, subsequent to a few puffs, announced that after one album The Rolling Stones would retire. That first album emerged under a year later and – the rest is history. The fact that Keith got it slightly wrong is of little interest here – and just how many albums the Stones have made is anyone's guess.

Whatever, there were some good ones, some weird ones (did any of you catch 'Between the Buttons' in 1967?), some downright bad ones – and some gems. The 1973 offering - 'Goats Head Soup' was one such gem.

The album was recorded amid an absolute flurry of publicity at Byron Lee's Dynamic Sound Studios in Kingston, Jamaica and was always surrounded in controversy. At one end of the raging hullabaloo that surrounded its delayed release, was the perceptible incongruity of the schmaltzy 'Angie', with Keith Richard later granting that the worldwide success of the song as a single backfired and almost overshadowed the album from whence it came.

Meanwhile at 75 Rockefeller Plaza, New York, Ahmet Ertegun reached for the smelling salts and the phone number of the company lawyer when he heard the test pressing of 'Star***er'. Immediately, both Ertegun and Atlantic Records, who distributed the Stones products, were adamant - they didn't want that song on the album at any price.

Even though Mick Jagger insisted that 'It's our label', Atlantic argued that they might be arrested for trading pornography! They suggested that, three things were decidedly dodgy. First, not surprisingly, the title; secondly, a rather explicit reference in

the second verse to, er, feminine freshness and in the third and final verse, the line concerning a nameless groupie 'giving head to Steve McQueen', adding that they were frightened in case the actor called in his lawyers. Jagger refused to budge and eventually a compromise was reached. The title was changed to 'Star Star', a sloppy over-dub (US copies only) amusingly failed to remove the word 'pussy' and an undertaking was secured from a somewhat bemused Steve McQueen that he wouldn't sue. It was well worth the battle because Richard jams his guitar firmly between his knees and pulls out a brash boogie while Mick drools out the definitive groupie paeon. Pure Stones outrage.

But, amid all the confusion, at the centre of the controversy there was still an album; one that serves as a relaxed exercise in the fundamental deployment of rhythm and sound - those two basic ingredients that initially attract the listener to any record before the lyrics slip into focus.

The first four tracks are classic examples of the Stones moving carefully into slightly new territory. 'Dancing With Mr D' and 'Doo Doo Doo Doo Doo (Heartbreaker)' stand out in their continuing search for rich eclectic rhythms. The former trips the light fantastic with the Grim Reaper while the latter is an angry street- corner indictment of the American way of death with trigger-happy cops and doomed sub-teen junkies - which rises with intensity with the introduction of a sweeping Jim Price horn arrangement. Aside from the swirling strings that adorn the Jaggeresque impression of California dreaming on 'Winter' and the oddly neo-psychedelic 'Can You



Hear The Music', an austere aura of controlled lethargy prevails throughout most of the album. Take Richard's country concussed song of experience 'Comin' Down Again', Jagger's knockabout piano pumping on the 'Hide Your Love' studio jam and the revealing '100 Years Ago' with the line 'Don't you think it's sometimes wise -not to grow up!'

'Goats Head Soup is the only adequate representation of what we are because it's our latest effort,' admitted Mick Taylor. 'My favourite Stones album is Beggars Banquet and I didn't even play on it.' While Charlie Gillett pointed out that, according to the Theory of Relativity, 'a record is as good as other contemporary records allow it to be. And the only comparable rock in' groove records being made today, produced by Willie Mitchell in Memphis (Al Green, Otis Clay, Ann Peebles), do not match the relaxed power of all the tracks on Side One of Goats Head Soup.'

When Keith Richard saw how photographer David Bailey had transmogrified him into a death-mask on the sleeve, he remarked: 'Pretty grotesque innit! I think most people use the word 'charred' to describe it'. Not surprising. This record is ablaze from start to finish. ■ ▲

Rolling Stones, Goats Head Soup. Original recording on Rolling Stones COC 59101.

HI-FI WORLD'S

GREAT COMPETITION GIVEAWAY

WIN A SUPERB CREEK CD 53 CD PLAYER IN OUR NEW YEAR COMPETITION

Another Christmas is over and you have yet another dozen ill fitting socks of dubious hue to add to the pile of unwanted gifts in the attic. However, Christmas isn't necessarily over if you're reading this, as you can enter our February competition and get delivery of a £1200 CD player, courtesy of Creek Audio, which can take pride of place in your home.

Creek Audio Limited was started back in 1982 by Michael Creek with the view to fulfil the requirements of audiophiles on a budget by offering a range of well designed, quality components at a sensible price. Over the past nineteen years the company have forged themselves a successful business supplying hi-fi to people from all walks of life seeking and achieving the common goal of value for money.

In many ways Creek are unsung heroes of the British hi-fi scene. Without lavish advertising the company have gained a worldwide reputation for quality, with strong sales in the USA, for example. Recently the company acquired Epos, the respected loudspeaker name, and continues to develop and produce new Epos products along with Creek electronics.

Products both past and present range from accessory-like components such as the brilliant value OBH-12 passive preamp and OBH 8/9 moving magnet and moving coil phono stages, through the '43' midprice range of amps and source players, and up to the new high end '53' range of products.

Each range offers fine musical performance at a competitive price. Over the years we've reviewed most of Creek's products and always found them impressive in all aspects of their design at the price point - they often give a performance that exceeds rivals, and the latest top of the range CD player is no exception.



The 53 range is part of a concerted effort by Creek Audio to produce a range of products with high end sound quality, at an affordable price point.

With the development of SACD and DVD-A Creek decided to produce a statement product that will produce the best sound quality from existing CD collections, the result of which is the CD53. It took well over a year of development and research before this player was released. It features a Philips transport along with customised Creek software, an ultra-low jitter master clock and waveform shaping for maximum signal retrieval. There's also the added bonus of a professional standard balanced audio output as an alternative to the normal unbalanced phono outputs.

When we reviewed the CD53 back in our November issue it impressed us with every aspect of its performance. David Price wrote of its "beautifully natural, organic sound and exquisite sense of timing". He summarised his review thus: "A tremendously evocative silver disc spinner with an impressive ability to transcend the technical facets of a recording and just get on with the

music... a truly fine, musical performer". You can't argue with that can you?

The winner of this month's competition will find a CD53 on the way to them. Entering couldn't be easier. Simply answer the questions below on a postcard (**small postcards only please**) and send it to the address below by January 31st. The first correct answer picked out of our very large hat will be the lucky winner. ■ ▲

Hi-Fi & Computer Audio World Competition rules and conditions of entry

1. Only one entry per house hold.
2. Multiple entries will be automatically disqualified.
3. Purchase of the magazine is not a pre-condition of entry.
4. No correspondence will be entered into.
5. The Editor's decision is final.
6. No employees of Audio Publishing Limited, or of any companies associated with the production or distribution of the prizes may enter.

Competition Questions

[1] Who was the founder of Creek Audio

- [a] Michael Creek
- [b] David Creek
- [c] John Dawson
- [d] Dawson's Creek

[2] In which year was the company founded?

- [a] 1981
- [b] 1882
- [c] 1980
- [d] 1982

[3] Which loud-speaker company did Creek acquire?

- [a] Spendor
- [b] Wharfedale
- [c] Tannoy
- [d] Epos

[4] What transport does the CD53 use?

- [a] Sony
- [b] Philips
- [c] Toshiba
- [d] The Tube

February Competition
Hi-Fi World Magazine
Unit G4 IMEX House
The Park Business
Centre
Kilburn Park Rd.
London NW6 5LF

CONGRATULATIONS!

...to Mr. A Cann of Oakham, Rutland, the winner of our December competition. A Philips SACD/DVD-V/CD player is on its way to you!

THE NAIM GAME

Hi-Fi World visited Naim's Salisbury HQ to get the latest news and views from the audio stalwarts. David Price reports. . .

Visiting Naim Audio's Salisbury factory was an experience not to forget. Any British hi-fi nut who's followed the scene for over a decade will have the company's design ethos indelibly stamped deep into their psyche. So famous is it, that it's very hard not to know at least something about Naim's products, philosophy and history.

As a gauge to the company's significance, think of another successful manufacturer, of roughly similar age, size and/or niche - can you say the same about Meridian or Musical Fidelity, for example? No disrespect to Messrs Boothroyd, Stuart or Michaelson, but they have got on with the business of designing, manufacturing and selling hi-fi whereas Naim has done all this - and more. Like Linn, to which the Salisbury-based company was once famously allied, it has been spreading a philosophy too.

The cynics will say that Naim is just like any other brand, and that all its eccentricities (okay - here we go - unipivot tonearms, DIN plugs, weird speaker cables, exhaustive power supply options, no digital outputs on CD players, SNAIC shakers, non-biwireable speakers) are just clever marketing touches. Indeed even yours truly has to admit to having thought that treacherous thought too, at one time or another! But visiting the company and seeing what goes on dispelled any conspiracy theories I may have had in an instant. The frightening thing is - they really mean it, man!

The result is a range of charismatic (and rather eccentric) products which - more than almost any other brand - do what it says on



Paul Stephenson of Naim Audio at the Salisbury HQ

the label. It is unlikely that people who've spent the last forty years listening to Leak valve amplifiers will be hankering after a brace of Naim NAP250s - but for those wanting kick-ass dynamics and dizzying levels of grip, punch and control from their sources and amplification, Naim simply has no rivals.

Still, all the hocus-pocus stuff can be a bit annoying - why oh why can't a CDX be specified with a digital out for me to record CDs for the car? And does the ARO really have to have a non-adjustable headshell, with holes pre-drilled for just one cartridge? And couldn't we have at least one AUX input on the preamp using RCA phonos? Frankly, installing and using Naim gear can be a right pain in the posterior - but then again

it's worth it. Like a petulant classic car with a useless heater, twitchy handling on the limited and no boot space to speak of, you kind of grow to love its quirkiness.

Paul Stephenson is an unlikely but brilliant new supremo for the company - he's the yin to Julian Vereker's yang (or is it the other way round). Whereas Naim's founder was often an outspoken character, Paul is a bridge over troubled water. You get quietly spoken, reasoned and persuasive arguments. He knows Naim has had a bit of a hard time from the UK press, but he's happy to let the products speak for themselves, simple as that.

The most impressive part of editor Pope and my visit to Naim Audio was being whisked back to

Paul's pad for a quick listening session. No time for speech-making or grandiose presentations - he just hit the volume control and we were off (Naim devotees will know the equipment was already turned on, of course.!) The sound through those DBLs was awesome - power and punch without any of the Naim nasties you get if the system's mismatched or poorly set up (i.e. hardness and shrillness).

As PS ran through a range of CDs, including some very impressive recordings on Naim's own label, you couldn't help thinking, 'well, this is what all the fuss is about'. This towering, magnificent sound is why some people spend half their lifetimes working their way up the Naim upgrade ladder, why people buy all



Around 100 employees work at the Salisbury manufacturing plant



A mammoth stack of Naims past and present models adorn the listening rooms



Every ARO tonearm is built by hand

the special speaker cables, bespoke equipment supports and wretched stupid bloody DIN interconnects. If this is the result, I found myself thinking, I'd probably go through at all too.

Right now, Naim is moving into multichannel. They're not pious about stereo hi-fi - the philosophy is to get a good a sound as possible from all formats - which is why they still make the ARO! That's why you can expect to see some distinctly 'epoch-making' products from the Salisbury veterans in the not too distant future. Yes, I can exclusively reveal that Naim fans are set for the biggest surprise they've had in their lives since the company introduced its first remote control pre-amp. Watch this space unbelievers, because even you too could be - sooner or later - Naiming that tune! 🎧

PROBABLY THE BEST

NEW DEMONSTRATION ROOM NOW OPEN AT 12A SPRING GARDENS, NEWPORT PAGNELL,

KIT6550 VALVE INTEGRATED AMPLIFIER KIT & KAT6550 VALVE POWER AMPLIFIER KIT

£595



Ki6550
upgrade kit now
available £130

NEW KITS

£580



KaT6550
upgrade kit now
available £120

These are our new 6550 series amplifiers. A pure class A design providing 40 watts into a 8 ohm load, (available in a 4 ohm version if required) A truly high end design by Andy Grove, using Svetlana 6550Cs in push-pull (any 6550 or KT88 tube can be used with this amp). It features valve rectification (5U4) a choke pi filter power supply and is hard wired. Weighs 19kg with dimensions 390mm(w) x 330mm(d) x 190mm(h)

with valves or 220mm(h) with cage. Simon Pope says - "If you favour attack and rhythmic grip, together with a smoothness of sound that's incredibly easy to live with, the KiT6550 could well be the kit amp for you. The 6550 is one for those who like a valve sound married to the attack and clout of a good quality solid state design".

Kel84 VALVE INTEGRATED AMPLIFIER KIT

This is our brand new, low cost, beginner level amplifier kit. It features a pair of EL84 valves per channel in push-pull configuration. They give 15 watts into an 8 ohm load - plenty for medium sensitivity loudspeakers. The output transformers are Ultra Linear, keeping distortion down to a minimum. Up front the ECF80 input/phase splitter valve has an extremely smooth sound.

The Kel84 has very low hum, to solid-state standards. For simplicity the kit is built on a printed circuit board. A strong steel chassis is fronted by a 3mm anodised front panel and attractive chromed custom made knobs. There are five line level inputs, plus one monitor input, with a tape output included, all controlled from the front panel. The phono input sockets and 4mm banana socket speaker terminals are gold plated.

At rear is a mains switch, an IEC power input and an earth post. This kit is aimed at beginners. The instructions include pictures as well as diagrams, making them very easy to follow. At a UK price of £278.00 all inclusive you cannot ignore Kel84. Simon Pope says, "The quality that can be gleaned from this amp is a fine introduction to the joys of the valve sound. The Kel84 will highlight all the intricacies and depth of detail in your favourite recordings whilst retaining a warmth and fullness that is almost exclusive to pure valve amps and is rare at this price point."

Kel84 weighs 10kg. External dimensions with valves are 300mm(w) x 270mm(d) x 150mm(h).

£278



KAT88 VALVE POWER AMPLIFIER KIT

Here is the amazing KaT88. The circuit is similar to that of our popular KEL34 with a few changes to incorporate the Tesla, JJ branded KT88 power tetrode. This is a pure Class A push-pull design providing 36 watts into an 8ohm load. Andy Grove has come up with a gem of an output transformer (E/I). With the KT88 it offers a virtually unmatched result for a valve amplifier. Frequency response measures 11Hz to 75kHz, separation 71dB, noise 98dB, sensitivity 400mV and distortion 0.03%. "As valve amplifiers go, the KaT88 is one of the best measured performances I have ever come across", said Noel Keywood. Jon Marks said, "The KaT88 pulled a series of surprisingly fast, meaty basslines out of its trickbag when dealing with Suzanne Vega's Nine Objects Of Desire album. As if this wasn't enough, the mid and treble were nice too - cymbals had a deliciously natural, golden shimmer without sounding soft, and vocals were extremely transparent and crisply defined. KaT88 didn't hang around when it came to exploiting the virtues of its four output valves on numbers such as 'Leaves' and 'Suspect Sustain' from Cirrus' Land's End Jazz CD. Saxophone had a wonderfully smooth, realistic character, and acoustic guitar mixed speed with harmonic richness to very impressive effect. Asian Dub Foundation and Moloko showed no sign at all of the sluggish, woolly bottom-end and poorly-delineated bass beats that most valve amps are to blame for. Which makes the KaT88 an all-round, high-end bargain." Weight 16kg, external dimensions with valves are 330mm(w) x 300mm(d) x 190mm (h).

£468



KiT88
upgrade kit now
available £150

KaT88
upgrade kit now
available £140

DIY KITS IN THE WORLD

MILTON KEYNES, BUCKS MK16 0EE - CALL FOR DETAILS ON 01908 218836

ALL NEW SERIES II MODULAR PRE-AMP KIT

The PRE-II is a valve pre-amplifier with six inputs, tape monitor and two sets of output sockets. It utilises a high quality line driver transformer and x5 gain. The PHONO-II is a dedicated valve phono stage that incorporates a step-up transformer for MC users. Finally, PSU-II is a power supply unit that feeds both the PRE-II and PHONO-II.

Power Supply Unit (PSU-II)	£195.00
Pre-amplifier (PRE-II)	£195.00
Phono Stage (PHONO-II)	£110.00
Moving coil step-up transformer	£77.00
Passive pre-amplifier (PAS-II)	£215.00

NEW!



KAT34 VALVE POWER AMPLIFIER KIT & KIT34 VALVE INTEGRATED AMPLIFIER KIT

£480



**KAT34
upgrade kit now
available £120**

KIT34 is a 32 watt stereo valve integrated amplifier, featuring a pair of EL34s, in push-pull mode, per channel, plus an ECF80 pentode/triode as input/phase splitter. The power supply is valve rectified (2 x 5U4), using a heavy duty choke to achieve exceptional smoothing. The output transformers are 14% Ultra Linear tapped to keep distortion down to its lowest level and the kit is totally hard wired utilising three tag boards. It has five line level inputs, plus a tape-in and tape out, all controllable from the front.

NEW KITS

£495



**KIT34
upgrade kit now
available £130**

Simon Pope says, "This integrated bring together the best sonic virtues of our KIT88, kel34 and top of the range 300B PSE in an affordable package. The highlights of the sound are a deep and taut bass response, together with an open and highly detailed mid and high frequency response that only the best valve designs can achieve... a true valve classic!"
Weight 22kg, External dimensions with valves fitted - 390mm(w) x 360mm(d) x 210mm(h)

300B PSE MONOBLOC KIT

Our Parallel Single Ended amplifiers offer ultimate sound quality Each monobloc has two of the beautifully linear 300B directly heated triode in its output stage, producing 20 watts into an 8 ohm load. At the front we have a 6AU6 pentode and an ECC82 as the driver valve. This design utilises a 5U4 rectifier valve in the power supply, in combination with a 10H choke, giving an extremely quiet supply. Both mains and output transformers we E/I pattern.

For purists, feedback is switchable and the kit is totally hard-wired. For those that require valves we provide the superb Tesla 300Bs, Russian 5U4s and European 6AU6s & ECC82. Simon Pope says, "Not to put too fine a point on it, the sound these monoblocs create is among the finest that can be encountered in hi-fi." Our 300B PSE kit bears an affordable price of £875.00 (UK price) excluding valves. Each monobloc weighs 23kgs., external dimensions with valves: 25cm(w) x 38cm(h) x 22cm(d) per monobloc.

**300B PSU
upgrade kit now
available £150**

**£875
A pair**



KEL80 MONOBLOC AMPLIFIER KIT

Following the success of our budget KEL34 40watt kit amplifier, we have come up with a 'big brother' design. The output stage uses two pairs of TESLA EL34 pentodes in parallel-push-pull mode, allowing KEL80 to turn out 80 watts into an 8ohm load. Heading up the input stage we have the wonderfully linear Russian 6AU6 working into an American 5687 phase-splitter. KEL80's output transformers are 4ohm and 8ohm tapped. With an input sensitivity at around 380mV for full output, it will happily partner both passive and active pre-amplifiers. It is easy to assemble. Simon Pope says, "The proof of the pudding is in the eating and the KEL80 is a feast for the ears, with solid bass attack, lightning fast reactions, that emphasises musicality as well as power. At £649.00 a pair, a definite valve winner. Each monobloc weighs 12kgs., external dimensions with valves: 14cm(w) x 8cm(h) x 43.5cm(d).

**£649
A pair**



HD83 VALVE HEADPHONE AMPLIFIER KIT

The HD83 headphone amplifier is a beautifully simple design using Mullard ECL83 valves, a triode and power pentode housed in the same envelope. It works directly from any source, be it CD, tape, tuner etc., or from an amplifier's tape out or pre-amp out sockets. The circuit uses high specification E/I output transformers that will drive any headphone load from 16 ohms to over 300 ohms depending on how the secondaries are wired up. The HD82 is a single-ended design with the power pentode wired up in triode configuration for added sonic purity, and it is as quiet as a mouse. For sound quality Jon Marks says, "The bass is punchy and controlled without becoming artificial, while treble has the crispness of the best

solid-state, with the tonal purity, delicacy and speed associated with valves." External dimensions 18cm(w) x 30cm(l) x 8cm(h) weight 4kg.

£195



World Audio design

PROBABLY THE BEST DIY KITS IN THE WORLD

NEW DEMONSTRATION ROOM NOW OPEN AT 12A SPRING GARDENS, NEWPORT PAGNELL, MILTON KEYNES, BUCKS MK16 0EE. CALL FOR DETAILS ON 01908 218836

KLS10 HIGH TECHNOLOGY COMPACT MONITOR

Our mini-marvel uses an Audax carbon fibre bass/midrange unit, married to the world's most advanced tweeter, the piezo-electric gold dome HD3P from Audax. KLS10 offers high performance from a small package. The main speakers are designed to work alone, or with a dedicated subwoofer to extend their bass. Alone, they are suited to near-wall mounting and can be tuned by port adjustment to suit personal taste and location. They are easy to drive and need just 30-60watts. KLS10 is unique. Technically advanced, yet compact and relatively inexpensive, there is little to match it. Sensitivity 89dB 1W/1m, 15mm MDF, internal volume 9Ltrs, external dimensions 19cm(w) x 31cm(h) x 23cm(d).

Drive Unit & Crossover kit **£433.00**
Drive Unit only **£394.00**



£433

KLS10 GOLD SUBWOOFER

Designed to complement KLS10 Gold stand mounters by providing deep and open bass. The subwoofer is inexpensive, easy to build, comprising a simple crossover network with a high quality 8 inch Aerogel dual voice coil unit. A must for all KLS10 Gold customers. Sens. 89dB, volume 25 litres, external dimensions 28cm(w) x 43cm(h) x 34cm(d).

Drive Unit & Crossover kit **£164.00**
Drive Unit only **£78.00**



£164

KLS3 GOLD MK II ADVANCED TECHNOLOGY 3 WAY LOUDSPEAKER

KLS3 Gold uses the latest version of Audax's innovative oval gold dome piezo electric tweeter, giving it the sweetest and most extended treble. Married to a 4in. carbon fibre cone midrange driver for neutral and clear reproduction, and a powerful 8in. bass driver for superb depth, this is our top-of-the-line reference speaker. Sensitivity 90dB at 1W/1m, 25mm MDF, internal volume 60ltrs, external dimensions 26cm(w) x 100cm(h) x 35cm(d).

Drive Unit & Crossover kit **£633.00**
Drive Unit Pack **£495.00**



£633

Upgrade your KLS3s to Gold status. Includes latest oval gold dome piezo tweeter and all components.

for

£363

Mains transformers & Chokes

KIT6550/KAT6550 mains transformers
2 inch stack, 130mm(h)x120mm(w)x135mm(d) drop through fitting with zinc cap. Secondaries: 0V-240V 300mA, 3.15V-0V, 6A, 3.15V-0V-3.15V, 9A. Suitable for 120V & 240Vac operation

KEL84 mains transformer
1.5 inch stack, 90mm(h)x 80mm(w)x 95mm(d) drop through fitting with zinc cap. Secondaries: 0V-240V 300mA, 3.15V-0V-3.15V, 5.5A, suitable for 120/240V operation

KIT88/KAT88 mains toroidal transformer
120mm dia. x 60mm(h). Secondaries: 195V-0V-95V, 450mA/0V-27V, 100mA/3.15V-0V-3.15V, 9A, suitable for 120/240V operation

KIT34/KAT34/KIT6550/KAT6550 choke
1.25 inch stack, 65mm(h)x105mm(w) with fitting holes x 60mm(d), clamp fitting, 2.5 H, 350mA

300B PSE mains E/I transformer
130mm(h) x 95mm(w) x 115mm(d). drop through fitting with zinc cap. Secondaries: 380V-0V-380V, 180mA/150-0V-150V, 25mA/0V-5V, 1.2A/0V-5V, 1.2A/0V-5V, 3A/3.15V-0V-3.15V, 0.4A suitable for 120/240V operation

KEL80 mains toroidal transformer (encapsulated)
130mm dia. x 65mm(h). Secondaries: 195V-0V-195V, 390mA/0V-27V, 100mA/3.15V-0V-3.15V, 7.5A, suitable for 120/240V operation

HD83 mains toroidal transformer
80mm dia. x 35mm(h). Secondaries: 0V-165V, 75mA/3.15V-0V-3.15V, 1A, suitable for 120/240V operation

PSU-II mains toroidal transformer
80mm dia. x 35mm(h). Secondaries: 0V-270V, 60mA/0V-10V, 2A, suitable for 120/240V operation

TRANS1 mains toroidal transformer
95mm dia. x 50mm(h). Secondaries: 0V-370V, 150mA/0V-6.3V, 3.5A 300B E/I choke 65mm(h) x 70mm(d) x 80mm(w) open frame fitting, 10H, 180mA.

KEL84 E/I choke
0.5 inch stack, 40mm(h)x 35mm(d)x 70mm(w) clamp fitting, 1H, 250mA

PSU-II E/I
40mm(h) x 35mm(d) x 70mm (w) clamp fitting, 15H, 20mA

KIT34/KAT34 mains transformer
2.5 inch stack, 120mm(h)x115mm(w)x95mm(d), drop through fitting with zinc cap. Secondaries 365V - 0V - 365V, 300mA/0V - 5V, 6A/3.15V - 0V - 3.15V, 7.5A. Suitable for 120/240V operation.

Output transformers

KIT6550/KAT6550 E/I 16% TAPPED UL push-pull output transformer 2 inch stack, 80mm (w) x 95mm(l) x 100mm(h), drop through fitting with zinc cap. Primary-secondary 4.5K, 16% UL tapped. Secondary 4 Ohm, pls specify on order. max output 45 watts, max current 180mA, valves, KT88, 6550 etc

KEL84 E/I Ultra Linear push-pull output transformer
1.25 inch stack, 76mm(h)x 65mm(w)x 76mm(d) Primary - secondary, 8K with 12.5% UL cap - 8ohms, max o/p-15watts, max current 150mA valves EL84 etc

KIT88/KAT88 E/I push-pull output transformer
80mm(w)x95mm(l)x100mm(h). Primary-secondary 10K - 8ohms, max o/p-40watts, max current-160mA valves-KT88, 6550, EL34

KIT34/KAT34 E/I 14% tapped Ultra Linear push-pull output transformer
2 inch stack, 80mm(w)x95mm(l)x100mm(h), drop through fitting with zinc cap. Primary-secondary 6.4K, 14% UL taps. Secondary 8ohm, max output 34watts, max current 150mA, valves EL34, 6L6, 6CA7

KEL80 E/I parallel-push-pull output transformer
95mm(w)x115mm(l)x133mm(h). Primary-secondary 4.6K - 8 & 4ohms, max o/p-80watts, max current-250mA valves-EL34, 5881, 6L6

HD83 E/I single ended output transformer
40mm(w)x50mm(l)x55mm(h). Primary-secondary 4K - 4 x 64ohms windings, max o/p-1watts, max current-25mA valves-ECL83 etc

Pre-II E/I driver transformer
80mm(w)x60mm(l)x65mm(h). 6:1 step down transformer, max current-10mA valves-6922 etc pre-amp stage

300B PSE E/I parallel single ended output transformer
130mm(h) x 95mm(w) x 115mm(d), drop through fitting with zinc cap. Primary 1K5 Secondary 8R, output .

Printed circuit boards

- KEL84 Printed Circuit Board 280mm(w) x 135mm(l) x 1.6mm(d).
- KIT88 KaT88 Printed Circuit Board 140mm(w) x 310mm(l) x 2.4mm(d).
- KEL34 Printed Circuit Board 140mm(w) x 310mm(l) x 2.4mm(d).
- KAT88 Printed Circuit Board (a pair) 120mm(w) x 215mm(l) x 2.4mm(d).
- HD83 Printed Circuit Board 140mm(w) x 160mm(l) x 1.6mm(d).
- PSU-II Printed Circuit Board 105mm(w) x 130mm(l) x 1.6mm(d).
- PRE-II Printed Circuit Board 105mm(w) x 130mm(l) x 1.6mm(d).
- PHONO-II Printed Circuit Board 105mm(w) x 130mm(l) x 1.6mm(d).



Hi-Fi World in Malaysia at Millennium Hi-Fi & Av. Kuala Lumpur, Malaysia

Hi-Fi World is now distributed through good bookshops and newstands in Malaysia. For back issues, general enquiries and advertising, contact Simon Chang at Millennium Hi-Fi & Av.

Also available are products by World Audio Design, Michell, Trichord, Lowther and ReThm loudspeakers.

Millennium Hi-Fi & Av
500-1-3 First Floor, Wisma Indah (Shen Court),
Jalan Tun Razak 50400 K.L.

tel: 603 9283 8171 fax: 603 9281 3762

137 Jalan Pendekar 2, Taman Skudai Baru, 81300 Skudai, Johor DT
tel: 607 554 5171 fax: 607 554 7645

e-mail: info@millennium-audio.com



order on our website @

www.worldaudiodesign.co.uk

amplifier kits description

KaT6550 valve power amplifier kit (with valves)
 KaT6550 valve power amplifier kit (without valves)
 KaT 6550 upgrade kit
 KiT6550 valve integrated amplifier kit (with valves)
 KiT6550 valve integrated amplifier kit (without valves)
 KiT 6550 upgrade kit
 KaT34 valve power amplifier kit (with valves)
 KaT34 valve power amplifier kit (without valves)
 KaT34 upgrade kit
 KiT34 valve integrated amplifier kit (with valves)
 KiT34 valve integrated amplifier kit (without valves)
 KiT 34 upgrade kit
 Kel84 valve integrated amplifier kit (with valves)
 Kel84 valve integrated amplifier kit (without valves)
 Kel84 upgrade kit
 PSU II power supply unit module
 PRE II pre-amplifier module
 PHONO - II phono stage module (with valves)
 PAS II passive pre-amplifier module with 10K or 50K attenuator (pls specify)
 Moving Coil step up transformers
 KiT88 upgrade kit
 KaT88 Valve integrated amplifier kit (with valves)
 KaT88 Valve integrated amplifier kit (without valves)
 KaT88 upgrade kit
 HD83 Valve Headphone amplifier kit (with valves)
 Kel80 Valve Monobloc amplifier kit (with valves) - a pair
 Kel80 Valve Monobloc amplifier kit (without valves) - a pair
 300B PSE Valve Monobloc amplifier kit (with valves) - a pair
 300B PSE Valve Monobloc amplifier kit (without valves) - a pair
 300B PSE Upgrade Kit - a pair

order No.

KaT6550 (with valves)
 KaT6550 (without valves)
 KaT 6550 upgrade
 KiT6550 (with valves)
 KiT6550 (without valves)
 KiT 6550 upgrade
 KaT34 (with valves)
 KaT34 (without valves)
 KaT 34 upgrade
 KiT34 (with valves)
 KiT34 (without valves)
 KiT 34 upgrade
 Kel84 (with valves)
 Kel84 (without valves)
 Kel84 upgrade
 PSU - II
 PRE - II
 PHONO II
 PAS II
 MC - step up (pair)
 KiT88 upgrade
 KaT88 (with valves)
 KaT88 (without valves)
 KaT88 upgrade
 KaT88 upgrade
 HD83 (with valves)
 Kel80 (with valves)
 Kel80 (without valves)
 300B PSE (with valves)
 300B PSE (no valves)
 300B PSE upgrade kit

qty

Vertical column of checkboxes for quantity selection.

uk

(inc vat & carriage)
 £580.00
 £450.00
 £120.00
 £595.00
 £465.00
 £130.00
 £480.00
 £415.00
 £120.00
 £495.00
 £430.00
 £130.00
 £278.00
 £248.00
 £100.00
 £195.00
 £195.00
 £110.00
 £215.00
 £77.00
 £150.00
 £468.00
 £341.00
 £140.00
 £195.00
 £149.00
 £372.00
 £1177.00
 £875.00
 £150.00

overseas

(exc. vat & carriage)
 £495.00
 £380.00
 £105.00
 £510.00
 £395.00
 £110.00
 £410.00
 £354.00
 £105.00
 £420.00
 £365.00
 £110.00
 £237.00
 £212.00
 £85.00
 £167.00
 £167.00
 £95.00
 £185.00
 £66.00
 £130.00
 £399.00
 £291.00
 £120.00
 £167.00
 £353.00
 £487.00
 £1002.00
 £745.00
 £130.00

loudspeaker kits

KLS3 Gold mkII Drive Units
 KLS3 Gold mk II Drive Units + Crossover Kit etc
 KLS10 Drive Units
 KLS10 Drive Units + Crossover Kit etc
 KLS10-Subwoofer Drive Units
 KLS10 Drive Units + Crossover Kit etc

order No.

KLS3G-D
 KLS3G-C
 KLS10D
 KLS10C
 KLS10-subD
 KLS10-subC

qty

Vertical column of checkboxes for quantity selection.

uk

(inc vat & carriage)
 £495.00
 £633.00
 £394.00
 £433.00
 £78.00
 £164.00

overseas

(exc. vat & carriage)
 £422.00
 £539.00
 £336.00
 £369.00
 £67.00
 £140.00

parts description

KiT/KaT6550 mains transformer
 KiT34 mains transformer
 Kel84 E/I mains transformer
 KiT88/KaT88 mains toroidal transformer
 Kel80 mains toroidal transformer(encapsulated)
 HD83 mains toroidal transformer
 PSU-II mains toroidal transformer
 300B PSE E/I mains transformer
 KiT34 E/I choke
 Kel84 E/I choke
 KiT6550 choke
 300B PSE choke
 PSU-II E/I choke
 KiT34 E/I UL push pull output transformer
 KiT/KaT6550 E/I UL output transformer
 Kel84 E/I push-pull output transformer
 KiT88/KaT88 E/I push-pull output transformer
 Kel80 E/I parallel-push-pull output transformer
 HD83 E/I single ended output transformer
 Pre-II E/I driver transformer
 300B PSE E/I output transformer
 Kel84 Printed Circuit board
 KiT88/KaT88 Printed Circuit Board
 Kel34 Printed Circuit Board
 Kel80 Printed Circuit Board
 HD83 Printed Circuit Board
 PSU-II Printed Circuit Board
 PRE-II Printed Circuit Board
 PHONO-II Printed Circuit Board
 Tag board 2 x 16 connections (hard wiring)
 Alps blue audio grade 50K dual log potentiometer
 Alps blue audio grade 100K dual log potentiometer
 Stepped attenuator with resistor pack 10K of 50K (pls specify)
 LCR 22.5uF 440Vdc polypropylene capacitors
 Ansar 22.5uF 630Vdc polypropylene capacitors
 Jensen 0.47uF 630Vdc paper in oil capacitor
 Jensen 0.22uF 630Vdc paper in oil capacitor
 Jensen 0.22uF, 400V paper in oil capacitor
 Black Gate 220uF 50Vdc electrolytic
 Black Gate 4700uF 16Vdc electrolytic
 Black Gate 100uF 100Vdc electrolytic
 Black Gate 470uF 16Vdc electrolytic
 Black Gate 1000uF, 16V electrolytic
 Black Gate 100uF, 50V electrolytic
 KiT88/KaT88 chassis
 650V safety gloves (a pair)
 6550/34 cage

order No.

6550 mains T
 KiT34 - mains T
 Kel84 - mains T
 88 - mains T
 Kel80 - mains T
 HD83 - mains T
 PSU-II - mains T
 300B - mains T (each)
 KiT34 - choke
 Kel84 - choke
 KiT6550 choke
 300B - choke
 PSU-choke
 34 - O/P T (pair)
 6550 O/P T 4ohm?/8ohm?(pair)
 Kel84 - O/P T (pair)
 88 - O/P T (pair)
 Kel80 - O/P T (pair)
 HD83 - O/P T (pair)
 PRE-II - driver T (pair)
 300B - O/P T (each)
 Kel84 - PCB
 88 - PCB
 Kel34 - PCB
 Kel80 - PCB(pair)
 HD83 - PCB
 PSU-II - PCB
 PRE-II - PCB
 PHONO-II - PCB
 TAG
 ALPS - 50K
 ALPS - 100K
 Attenuator + resistor pack
 LCR - 22.5U
 ANSAR - 22.5U
 JEN - 0.47U
 JEN - 0.22U
 JEN - 0.22U, 400V
 BG - 220U
 BG - 4700U
 BG - 100U
 BG - 470U
 BG - 1000U16V
 BG - 100U50V
 88-CHAS
 SAFETY GLOVES
 34/6550 cage

qty

Vertical column of checkboxes for quantity selection.

uk

(inc vat & carriage)
 £110.00
 £100.00
 £55.00
 £83.00
 £83.00
 £39.00
 £39.00
 £130.00
 £45.00
 £20.00
 £45.00
 £50.00
 £20.00
 £130.00
 £130.00
 £88.00
 £143.00
 £187.00
 £94.00
 £77.00
 £140.00
 £24.00
 £41.00
 £12.00
 £52.00
 £20.00
 £20.00
 £20.00
 £20.00
 £3.50
 £14.00
 £14.00
 £75.00
 £10.00
 £18.00
 £20.00
 £16.00
 £12.00
 £12.00
 £10.00
 £8.00
 £10.00
 £8.00
 £6.00
 £100.00
 £14.00
 £65.00

overseas

(exc. vat & carriage)
 £95.00
 £85.00
 £47.00
 £71.00
 £71.00
 £34.00
 £34.00
 £111.00
 £39.00
 £17.00
 £38.00
 £43.00
 £17.00
 £110.00
 £110.00
 £75.00
 £122.00
 £160.00
 £80.00
 £66.50
 £119.00
 £20.90
 £35.15
 £11.40
 £44.65
 £17.00
 £17.00
 £17.00
 £17.00
 £3.00
 £12.00
 £12.00
 £65.00
 £8.50
 £15.20
 £17.00
 £14.00
 £10.20
 £10.20
 £13.60
 £8.50
 £7.00
 £6.80
 £5.20
 £85.00
 £12.00
 £55.00



World Audio Design Amplifiers fully built from Malaysia

Title	Description	Price (exc. VAT + Carriage)	Title	Description	Price (exc. VAT + Carriage)
1A40	40W EL34 integrated	£590.00	MB80	80W EL34 monobloc	£1190.00
1A36	36W KT88 integrated	£895.00	PA11	Valve pre-amplifier	£599.00
P20A	20W 5881 power amp	£795.00	PH11	Valve phono stage for PA11	£199.00

Order from our Far East Distributor: Millenium Hi-Fi & AV
 137 Jalan Pendekar 2, Taman Skudai Baru, 81300 Skudai, Johor DT, Malaysia
 Tel: 07 554 5171 - Fax: 07 554 7645 - email:mha8@pd.jaring.my

order information

NAME: _____
 ADDRESS: _____

 POST CODE: _____
 COUNTRY: _____
 TEL. (DAY): _____

Tel/Fax: 01908 218 836

I enclose cheque/postal order for £_____ made payable to World Audio Publishing Ltd. I wish to pay by Mastercard / Visa /Switch/ Solo. Please debit my account no: _____

Expiry Date: _____ Signature: _____
 (Switch/Solo only) Valid Date: _____ Issue No. _____

Prices were correct at time of print, 01/01/02 they are subject to change.
 If you wish for a built item, please phone for a quote / Valves included except where otherwise stated. If you would like a data sheet on any of the kits, please write a 'D' in the qty box

WARNING - World Audio Publishing Ltd. accept no responsibility for kits, parts or modifications made or supplied by third parties. Order on our website www.worldaudiodesign.co.uk
 Please send your completed order form to: WORLD AUDIO PUBLISHING LTD, 12a Spring Gardens, Newport Pagnell, Milton Keynes, Bucks MK16 0EE
 Tel: 01908 218836 email: order@worldaudiodesign.co.uk



WE HAVE OVER 30

ORDER 4 BOOKS & OVER & PAY ONLY £7.00 FOR P&P (UK ONLY)

AUDIO ELECTRONIC THEORY BOOKS



Electronics made Simple
by Ian Sinclair
This book covers the basic theory and principles of electronics. A good read for the beginner.
Code No 1420
£12.99 + £2.00 P&P (UK)



Build your own High-End Audio Equipment
by Elektor
Build your own High-End Audio equipment contains construction projects for solid state preamplifiers and power amplifiers, active cross-over filters, an active subwoofer, a mono/stereo compressor and a headphone amplifier.
Code No. 1390
£14.95 + £2.25 P&P (UK)

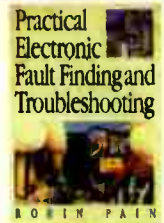

Practical Electronic Fault-Finding and Troubleshooting
by Robin Pain
This book explains the basic techniques needed to be a troubleshooter, using only basic equipment: a digital multimeter and an oscilloscope. Simple circuit examples are used to illustrate principles and concepts fundamental to the process of fault finding.
240pp 235mm x 156mm Paperback
Code No. 1430
£20.99 + £2.25 P&P (UK)



Build your own Electronic Test Instruments
by Elektor
This book contains designs for 17 measuring instruments, seven generators and analysers, ten miscellaneous instruments and a number of test ancillaries and auxiliaries. The designs range from a simple multicore cable designs contain a special printed circuit, drawing of which are given in an appendix.
Code No. 1400
£15.95 + £3.25 P&P (UK)



The LP is back
by Audio Amateurs
Your complete guide to LP care and maintenance designed to offer you everything useful for those who love and enjoy this older music medium. This covers the theory and care of LPs and the electronics and mechanics of its players.
154pp Paperback
Code No.1620
£8.00 + £1.50 P&P (UK)



The Joy of Audio Electronics
by Charles Hansen
This is a fail-safe guide to the pleasures of hands-on electronic construction. This book covers test and measurement projects, how to build simple kits, safety issues, the workplace, theory and resources. A must for the beginner who plans to build more advanced electronic projects in the future.
124pp Paperback
Code No.1650
£10.50 + £2.25 P&P (UK)

VALVE BOOKS



The Beginner's Guide to Tube Design
by Bruce Rozenblitz
This book takes a comprehensive look at tube audio design. It explains how vacuum tubes work and how to design with them. Rozenblitz covers stabilisation and testing, a description of 13 famous and classic amps and preamps and how to work effectively as a designer. A hands-on guide to construction techniques, tools and choosing components and tubes is provided. 1997, 132pp., 8 1/2" x 11"
Paper back
Code No. 1340
£15.50 + £2.25 P&P (UK)



Vacuum Tube Amplifiers
by Valley & Walman
This book is a well known reference valve text book and is assembled from pieces by ten knowledgeable authors. An absolute bible when it comes to valve electronics.
734pp 140mm x 210mm
Paperback
Code 1770
£29.95 + £ 4.00 P&P (UK)



Mullard Tube Circuits for Audio Amplifiers
Includes full designs for eleven power and control amps, including 5-20, using valves. Begins with a four chapter tutorial on getting the best sound from valve amplifiers.
142pp 8" x 10" Paperback Code 1030
£13.95 + £1.50 P&P (UK)



Audio Reality
by Bruce Rozenblitz
A fine read that investigates conductors, skin effect, impedance, interconnects, speaker cables, balanced lines, transmission lines, power cords, isolation transformers, damping systems, tubes, acoustics and much more. Also, includes 6 excellent detailed valve design projects, 80watt OTL, 25watt OTL, grounded grid pre-amp, 150watt amp., 6550 SE amp. and a grounded grid cascode phono preamp.
Paperback 128pp
Code No 1640
Price 21.50 + 2.25 P&P (UK)



An Approach to Audio Electronic Valves in Audio Frequency Amplifiers
by E. Rodenhuis
Originally published in 1954 by Philips, this book encourages amp. builders to experiment with design elements. Discussing the use of valve data, the function of different amplifier stages and includes detailed descriptions of eight designs. A wealth of practical data, measurements and interesting features will be found. A very good read.
Paperback 147pp
Code No. 1520
Price £12.95 + £2.00 P&P (UK)



Build your own Audio Valve Amplifiers
by Rainer Zur Linde
This book covers construction projects for preamplifiers, power amplifiers and two amplifiers for musical instruments aimed at the practical audio/hi-fi enthusiast. It offers much information on the operation of electron tubes, while the first chapter gives a short history of the thermionic valve.
paperback, 251pp, 235mm x 133mm
Code No.1320 £14.95 + 2.25 P&P (UK)



Radio Designer's Handbook 4th Edition
by Fritz Langford-Smith
This is a classic reference handbook for all who are interested in the design and application of audio amplifiers and radio receivers, and deals with basic principles and the practical design of all types of classic audio amplifiers, radio receivers and record-producing equipment up to the invention of the transistor, covering valves, valve testing, general theory and components; audio and radio frequencies; power supplies; design of complete AM and FM receivers, and reference information.
1498pp 216mm x 138mm Hard back
Code No. 1600
£39.99 + £6.00 P&P (UK)



Valve & Transistor Audio Amplifiers
by J L Hood
This is J L Hood's greatest work yet, describing the milestones that have marked the development of audio amplifiers, from the earliest valve amps to the latest solid state design. It is the complete world guide to audio amp design. Other contents: active & passive components, amplifiers, pre-amplifiers and power supplies.
250pp., 156mm x 232mm Paperback
Code No. 1530
£20.99 + £3.50 P&P (UK)

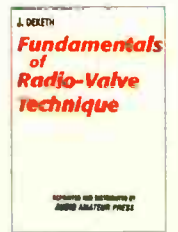

Fundamentals of Radio-Valve Technique
J. Deketh
This is part of the Philips technical series written in 1947 it was one of the most authoritative and comprehensive treatments of the nature and function of the vacuum tube.
334pp 6' x 9" Paper back
Code No. 1630
£21.50 + £2.50 P&P (UK)



The Williamson Amplifier
by D.T.N. Williamson.
Offers practical advice on how to build and set up the amplifier for best results.
40pp 8 1/2" x 11" Paper back
Code No. 1040
£9.95 + £1.50 P&P (UK)

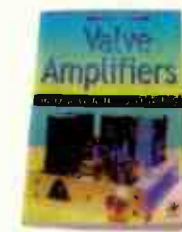

Valve Amplifiers (second edition)
by Morgan Jones, Audio Engineer
This book allows those with a limited knowledge of the field to understand both the theory and the practice of valve audio amplifier design, such that they can analyse and modify circuits, and rebuild an amplifier. Constructional techniques are also provided so readers can build from scratch designs that actually work.
488pp 6" x 9 1/4" Paper back
Code No. 1330
£25.99 + 3.50 P&P (UK)



The Best of Audio editorial projects
by Luciano Marci
This book contains six excellent audio projects - a high sensitivity speaker, a superb tube pre-amp, a 2A3 amplifier design, a project using the Russian 6C33CB and two projects using 300Bs as output valves. Overall the book is a fabulous read.
62pp paper back
book code 1750
£12.00 + £2.00 UK p+p

TITLES ON OFFER!!!

Manuale HI-FI a valvole Schemario 2°

An Italian publication with all circuit diagrams in standard conformation, therefore, all circuits are easy to follow. This book is dedicated to self makers and to Hi-Fi tube engineers. With a wealth of circuit diagrams from some of the best valve amplifiers, pre-amplifiers and phono equipment producers in the world. Including, Audio Research, Altec, Conrad Johnson, Art Audio, Luxman, Carver, Dynaco, Electrovoice, Leak, MacIntosh, Marantz, Quad, Radford, Quick Silver, numerous OTL designs, Verdier, VTL and Western Electric. Well worth the money.
208pp. 210mm x 300mm Paperback
Code No. 1720
£44.00 + £4.00 P&P (UK)



Getting the most out of Vacuum Tubes

From the cover, "Types and causes of tube failures, what to expect from tubes, testing methods and all about tube maintenance programs." This book is intended to offer explanations of why tubes fail and what to do about it. Discussions of catastrophic and degenerative failures; selecting tubes and tube types and testing and predicting tube performance.
160pp 140mm x 216mm
Paperback,
Code No. 1710
£13.95 + £2.00 P&P (UK)



Modern High-End Valve Amplifiers Based on Toroidal Output Transformers

Explains the whys and wherefores of toroidal output transformers at various technical levels. Discussed extensively within this book are designs for amplifiers from 10 to 100 watts. Finally, the author gives some attention to a number of special valve amplifiers, and to the theory and practice of negative feedback.
250pp 170mm x 240mm
Hard back
Code No. 1670
£24.95 + £2.50 P+P (UK)

First in High Fidelity The Products and History of H. J. Leak & Co. Ltd.

This book is the unique and comprehensive story about one of the world's best high-fidelity audio companies. Contained are 300 pictures, 30 circuit diagrams for classic designs of the day. There are also numerous anecdotes and contributions from ex-employees. A wonderful historical read.
270pp 195mm x 264mm Paperback
Code no. 1740
£19.95 + £3.25 P+P (UK)



Basic Theory and Application of Electron Tubes

This book is an excellent introduction into valves. It does just about everything its title suggests. Written in 1957 it was used by the US military as a text book in their electronics department. Superbly written it contains all you need to know.
215pp
200mm x 260mm Paperback
book code 1740
£17.95 + £3.25 P&P (UK)



Sylvania Technical Manual

This 13th edition contains data on more than 3300 electron tubes and semiconductor devices. Reprinted here without the TV picture tube section, this manual contains detailed information on Sylvania's devices including charts and diagrams. A master index is found in the front of the book for reference.
516pp 140mm x 216mm Paperback
Code No. 1700
£16.95 + £3.50 UK p+p

LOUDSPEAKER BOOKS

Testing Loudspeakers+

Joe D'Appolito, loudspeaker designer and consultant, has written the definitive text on testing loudspeakers. Dr. D'Appolito brings his expertise to the subject and provides you with a hands-on discussion of testing drivers and systems. He brings you the theory and physics behind loudspeaker testing in this volume.
Paperback
Code No. 1580
£24.95 + £2.50 P&P (UK)



Electrostatic Loudspeaker Design and Construction

Step by step guide to the design and construction of a full range electrostatic loudspeaker, including basic operating principles. Strongly recommended for those wanting to either build, repair and/or restore, or who are just interested in electrostatics.
243pp 7" x 9 5/8" Paperback
Code No. 1080
£16.95 + £3.25 P&P (UK)



The Loudspeaker Design Cookbook, 6th edition (new)

This best seller offers up-to-date design information for the home constructor. It uses modern Thiele-Small theory and parameters.
288pp 8 1/2" x 11 1/2" Paperback
Code No. 1090
£29.50 + £4.00 P&P (UK)

Bullock On Boxes

Using Thiele-Small parameters clearly, it offers lots of helpful tables and graphs to get to grips with the sizing of the box and port of a reflex loudspeaker.
72pp 8 1/2" x 11" Paperback
Code No. 1100
£12.95 + £2.00 P&P (UK)



Theory and Design of Loudspeaker Enclosures

Covers infinite baffle, reflex, passive radiator etc. in great detail with a highly mathematical approach, making it unsuitable for beginners but highly authoritative for experienced designers.
244pp 6" x 9" Paperback
Code: 1140
£23.95 + £2.50 P&P (UK)



Horn Loudspeaker Design

A collection of papers by Mr J. Dinsdale, that discuss the design and theory of this wonderful breed of loudspeaker. The book contains detailed drawings of numerous designs, including some Lowther classics. Also, included with the book is a 3.5inch floppy disc with straight forward software to assist in the design process. A serious reference for those with an interest in horn speakers.
112pp paper back & 3.5 floppy disc
210mm x 300mm
Code: 1730
£29.50 + £2.50 P&P (UK)

Audio Amateur Loudspeaker Projects

A collection of the 25 best speaker articles published in the Audio Amateur throughout the 1970s, this popular book is proof that great designs are never out of date. This volume is a rich source of theory, practice and design.
135pp 8 1/2" x 11" Paperback
Code No. 1550
£16.95 + £2.50 P&P (UK)



Loudspeakers: The Why and How of Good Reproduction

An easy to understand book on building loudspeakers, using empirical techniques that pre-date computer analysis. Strongly recommended for beginners.
88pp 5 1/2" x 8 1/2" Paperback
Code: 1070
£10.95 + £1.50 P&P (UK)



Acoustics & Psychoacoustics 2nd Edition

An introduction to acoustics, covering human perception of sound, notes and harmony, musical dynamics, timbre of musical instruments, acoustic model for musical instruments, hearing music different environments, deceiving the ear and processing sound electronically.
224pp 244 x 189mm
paperback
Code: 1370
£29.99 + £3.50 P&P (UK)

ORDER FORM

Please send (Code No.) _____ (enter codes clearly)

Pay: World Audio Publishing Ltd. £ _____ or debit my Mastercard/Visa/Switch/Solo (Card No) _____

Expiry date: _____ (Switch/Solo only) Valid Date: _____ Issue No. _____ Name: _____ Signed: _____

Delivery Address: _____

Tel: (Day) _____ Please return to: W.A.P. Ltd. 12A Spring Gardens, Newport Pagnell, Milton Keynes, MK16

0EE, ENGLAND TEL/FAX: 01908 218836 **ORDER ON LINE** Website: www.worldaudiodesign.co.uk E-Mail: nick@worldaudiodesign.co.uk

Please contact us for overseas P&P charges. Allow 28 days for delivery. All orders subject to availability. If further space is required please attach separate sheet. TICK BOX IF YOU HAVE ORDERED BEFORE



EAR B34P Signature - MM/MC boxed
£390

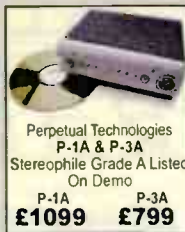

Perpetual Technologies P-1A & P-3A Stereophile Grade A Listed On Demo
P-1A **£1099** P-3A **£799**



£3999



CHORD DAC 64
On Demo - probably the most significant new product available for CD playback
£1900



EAR V 20 - Great reviews and a visual masterpiece - on demo
£2799



PS Audio PS600 with multiwave on demo - see what can be achieved with mains regeneration
£2700

NEW & EX DEMO EQUIPMENT

CHORD NEW £
DAC 64 (£1900) and CPM 3300 (£5595) on demo - full range available
Visit our web site for full details, prices, specifications and reviews

PS Audio
PS600 with multiwave on demo - Amazing review, see what can be achieved with mains regeneration - £2700
Visit our web site for full details, prices, specifications and reviews

Audio Note
Full range available, many items on demonstration - Visit our web site for full details, prices, specifications and reviews

STAX Headphones
Full range available - Visit our web site for full details, prices, specifications and reviews

Perpetual Technologies
If you read the HiFi News review on the amazing P-1A Digital to Digital processor and the P-3A Upsampling DAC 24/192, you will realise just how good they actually are at £1099 & £799 respectively, they will transform your CD playback in a way you could never have imagined. Visit our web site for full details, prices, specifications and reviews

CEC
Full range of these amazing Belt drive CD players transports and DACs available including the incredible TLS1Z Belt drive CD player with 24/356 upsampling for only £1625 - on demo. Visit our web site for full details, prices, specifications and reviews

Conrad Johnson
Full range available, visit our web site for specifications, prices & reviews.

Dynalab Tuners
Full range available, visit our web site for specifications, prices & reviews.

EAR
EAR V20 integrated, great reviews & a visual masterpiece - on demo 2799
EAR B61 power amp. Great reviews - on demo 3799
EAR B64 pre. Balanced inputs/outputs - on demo 1529
EAR B34P deluxe. MM/MC phono stage - on demo 889

EAR NEW £
MC3 MC step up transformer. Probably the best available - on demo 659
Full range available, visit our web site for specifications, prices & reviews.

Veritas
P400 Digital power amp 240w - on demo 2995

Manley Labs
Singingray Integrated Valve amplifier - on demo 2195
Purist pre amp on demo 1650
50w Monoblocks on demo 2250

Unison Research
NEW MODEL: DM Dual mono power amplifier 150w per channel, can be bridged to form a 500w mono block !!! ON DEMO - 850
S2K Pure Class A using the legendary KT-88 power valve. Single ended heaven. ON DEMO 1300
S2 single ended ultralinear Class A - on demo 975
SR1 valve & solid state ex demo 1250
S6 single ended pure Class A ex demo 1600
S8 single ended Class A 24w - on demo 2950
Simply Phono, stunning all valve NEW - on demo 510
PSU for simply phono NEW 400
Smart B45 mono blocks on demo - 3450

Kuzma
Stabi S with Stagi S tone arm on demo 1245

HEART
CD 6000 valve CD player. If you can find a better sounding CD player for up to £1,000 we would like to know what it is!! - on demo 590

Plinius
B100 100w on demo 1450
Jorah Phon stage on demo 599
B200 Integrated 175w with phono stage 2250

Pathos
Classic One - on demo 995
Twin Towers RR - Hybrid valve & solid state the best of both worlds. HiFi News loved it, so will you - on demo 3250

Audio Analogue NEW £

Belini remote pre-amplifier, superb on demo 560
Donizetti 100w monoblocks - on demo - pair 920
Maestro CD player - 24 bit 96 Khz upsampling - on demo 1500
Puccini SE Integrated amp - on Demo 635 540
Paganini 24 bit CD player
latest model on demo 795 695
Maestro 150w integrated amp on demo 2500

Audio Physic Speakers
On demo Virgo III, new model on demo £3999,
Avanti III £7599, Virgo II £3000 and Spark III £1695
Visit our web site for specifications, prices & reviews.

Craft
Vitale pre amp NEW on demo 379
Dakshini S, new model 50w - on demo 3300
Epoch Elite pre amp, reference quality, valve regulated psu. In new aluminum chassis - on demo 1000
Apparition Elite 15w per channel OTL power amp - on demo 1600

Opera speakers, Triangle Loudspeakers, Monitor Audio, Benz Micro, Lyra, Sumika, Dynovector
Visit our web site for specifications, prices & reviews.

Final Electrostatics
0.3 ex demo 1495 995
0.4 NEW - on demo 2500 2195

Loth-X
Othello precision turntable on demo 1145
Ion BS-1 speakers, 94db 400
Great HiFi news review 750
The all new Amaze on demo 98db efficient 1600
All new Aura floorstander on demo 98db efficient 1600

Lavardin
Full range available, visit our web site for specifications, prices & reviews.

improve your listening pleasure
visit our web site for reviews, up-to-date stock lists and much much more

CARED FOR USED EQUIPMENT

Turntables/Cartridges/Phono stages	NEW	EX
EAR B34P Signature MM/MC all valve phono stage	390	
Brand new Mitchell Gyrodec SE with acrylic cover and rear damp RB300	1175	795
Ortofon Jubilee boxed unused	1250	699
SME 309 Boxed New		629
SME 1V - Boxed NEW		890
Audio Note R-Zero phono stage. Boxed new. Unused	450	350
Linn LP12, Valhalla, Itok, boxed		690
Ortofon Rohmann boxed new	1200	649
Mitchell Gyrodec, clear plyth/cover. RB300 & QC PSU, Boxed as new	1695	995
Mitchell Gyro SE with RB300. Boxed as new		995

Amplifiers (Pre, Power, Integrated)	NEW	EX
Audion Black Shadow 845 Mono's, Stunning, 2 months old, Boxed		
Balance of Audion warranty	5000	3800
Audion Premier 2.0. 2 box with MM/MC phono stage. 2 mths old	2000	1100
Lavardin IT, boxed as new. Very rare		3250
Moon i5 Boxed NEW - black facia	2600	1999
Graaf GM20 OTL - boxed as new	3200	1895
Pathos Twin Towers RR - boxed as new	2400	1995
Primarc A30.1, new model with pre-out. Boxed new	1500	1250
Rokson ROK L2.5 pre S1.5 power and DS1.5 PSU, bxd as new	3500	1695
Quad 34 - Boxed unused. Very rare		275
EAR B34L, all valve line stage, as new	550	350

Speakers	NEW	EX
Audio Physic Virgo II - ex demo	3000	1999
Meridian DSP 5000 active speakers boxed	4125	2595
Quad ESL 63's, boxed	3300	1595
Gershman Avantgarde RX-20. Boxed	4900	2990
Verity Fidelio in Makore finish. One owner. Boxed	7300	5900
Wilson Watt/puppies 5.1	18000	6900
JM Labs Mezzo Utopia - boxed new	7400	5600
JM Labs Mini Utopia with matching stands - boxed	4900	2900
Monitor Audio GR20 (new model) boxed as new	1595	1095
A.R.T. Art 2 speakers, boxed as new in Piano Laquer, latest spec	6000	2695
Martin Logan Acruis 1 boxed as new	2700	1995

CD Players/Transports/DAC's	NEW	EX
Marantz SA-1 super audio CD player. boxed new still under warranty	5000	3995
Marantz CD-7 Boxed, ex demo, 2 year warranty	3600	2900
Sony SCD-1 New, Boxed unused	4000	3400
Sony SCD-1 Boxed as new, 12 months old	4000	2600
Audio Note CDT Zero. Boxed new unused	500	390
Electrocompaniet EMC-1, Boxed as new	2500	1450
Primarc D30.2 24/96 new model. Boxed new	1500	1195
Sonographe (Conrad Johnson) SD22 Boxed new, 4 mths old	850	390
Linn Kartik II with Numeric DAC both fitted with brilliant PSU, Boxed as new	3000	1395

Manley Labs	NEW	EX
Craft		
Kuzma		
Conrad Johnson		
Benz Micro		
Cardas		
Loth-X		
Unison Research		
Opera		
Audio Analogue		
Final		
Pathos		
Graaf		
LAT		
Monitor		
Diapason		
Esopower		
Ecosse		
Veritas		
Plinius		
Triangle		
Mitchell		
Audio Physic		
Lavardin		
EAR		
CHORD		
PS Audio		
CEC		
Perpetual Technologies		
Monitor Audio		
STAX		

Open Mon - Sat 9.30 - 5.30
E mail : info@connoisseuraudio.co.uk

www.connoisseuraudio.co.uk

01592 630652

Connoisseur Audio

There's gloom and doom in the music business at present, another loss from EMI making the headlines. As always the spectre of copying has been revived to explain everything. This time it's domestic CD recorders that are responsible for it all, according to one worried record business executive. Are people now copying CDs rather than buying them? Are CD sales in decline as a result?

I went to the British Phonographic Institute for their view on all this, which although partial – representing the music business – is nevertheless usually interesting for one reason or another. They report that in the third quarter (Q3) of 2001, meaning the months of July to September inclusively, overall sales revenue was down -4.2% on the previous year's Q3 figures – hence the doom and gloom. However, this single figure doesn't identify some strong trends that have had a serious impact on the figures. They're interesting to anyone who takes an interest in hi-fi and what the great British buying public are up to in aggregate.

Nothing is more final than the death of a format it seems. It is brutal too, if like me you have developed a small affection for some of our passing 'steam age' analogue technologies. And although not steam driven, the cassette is still from the 'steam age'. It was Philips solution to the problem of an easy-to-use tape recording system, launched in 1963, just as steam engines were being phased out of active service in Britain. Not everyone in the hi-fi business wanted to know when the humble pre-recorded cassette took over from the LP as Britain's number one music carrier, sales peaking at 98million in 1987, but it happened, believe it or not.

Modernity overtook the poor old cassette. Once people were exposed to the wonders of digital in the form of the CD, launched in 1983, they started to desert the cassette. Now, its sales are down to just below 1million, having dropped a massive 53% from last year. I was told long ago that market research had shown people just turn off from a technology, even when there's no

available alternative. They take up knitting instead I suppose. Once Britons decided the cassette was uncool, the digital cassette (DCC) was equally fated, by the way. Which brings me to the next surprise.

The MiniDisc was always marketed as being very cool by Sony. They pitched it as a fashion item for the young, not mentioning that really it was a high technology replacement for the cassette. Their advertising for it today is aimed at much the same audience as it was in 1991, when launched, and if a young audience is buying MD, then



dead.

I have to smile when I see the way the LP has bounced back from the

they're certainly not buying pre-recorded software. Sales are plummeting even faster than the pre-recorded cassette, now being listed as a paltry 100,000, no less than a 64% decline from last year.

MiniDisc is an eminently sensible medium in my view. It is small, durable, easy to use and has excellent sound quality. Japan apparently took to it, but America never did, and there ends the tale. In practice to accept MiniDisc into your life means changing all those CD players you own, in car, kitchen, bedroom and wherever to MiniDisc players. Looked at like this MiniDisc is just too expensive and this is one reason it never caught on.

I have to smile when I see the way the LP has bounced back from the dead, but is this an example of 'dead cat bounce'? OK, with pictures of turntables appearing on television regularly it's obvious that the LP has developed a new cool that no marketing man in his wildest dreams could ever have foreseen. But is it really going to last? Well, brace yourself. Year on year sales of 12in singles and LPs are UP, by 4.3% and 6% respectively. Annual sales of LPs now total 3million, quite a respectable figure. Even though Dance is behind this revival and the Ministry of Sound hasn't closed yet, I still find it hard to believe the cat

won't fall back to earth with a thud sometime soon.

Now onto the CD. In spite of the gloom about overall music sales, the Q3 figure for 2001 is still up on last year, albeit by a small +1.4%. So sales are not falling yet. Britons bought a massive 212 million CDs in the most recent twelve monthly period, rather contradicting any supposition that home copying is killing sales. It is the steep drop in singles and cassette sales that have affected the overall figures adversely.

Home taping never did kill music. Quite the reverse. At its peak in 1975 the LP sold 91.6 million units, followed by the pre-recorded cassette which peaked in 1989 at 83 million units. CD sales have exceeded both of them by a healthy margin. The BPI figures strongly suggest hi-fi is reducing down to the CD as our music carrier of the future, with LP given an honorary place in the Pantheon of formats we have known.

Music sales have increased steadily over the decades, in spite of all the feared threats. It isn't music sales that are changing so much as equipment sales, these figures suggest. ●



Noel Keywood

Why pay more and get less?

Plinius Amplifiers and phono stages

The incredible high end amplifiers from New Zealand. Including the extraordinary CD-LAD preamplifier, that redefines high end value for money.



Reference 3A Loudspeakers

The MM Du Capo loudspeaker. Described in *The Absolute Sound*® as "the finest small 2-way monitors I have heard in any home listening room".



Antique Sound Lab Amplifiers and phono stages

Coming Soon!

Due to arrive in the UK shortly

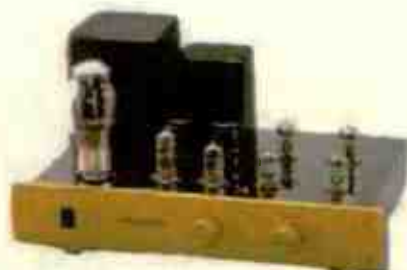

High end performance at a sensible price

Distributed in the UK exclusively by **Absolute Analogue™**

Address: PO Box 30429, London, NW6 7GY Tel/Fax: 020 8459 8113 Email: Absolute_Analogue@emil.mon.com

It's sale time, again. This is one of the busiest times for hi-fi retailers across the nation. At the time of writing the lead up to Christmas has already proved busy, and traditionally brisk trade should continue throughout January.

It comes as little surprise to find DVD leading the way again. Last year saw prices fall to just over £100, yet this Christmas has seen the main retailers advertising players from less than £80. Perhaps more significant has been the fall in price of branded machines. Whereas last year you'd have needed close to £300 to lay your hands on a reputable branded machine, this year it's closer to £200. Expect the discounters to be offering Panasonic, Pioneer and Toshiba for less than £150 as the sale period commences. Rather like MiniDisc, I expect this to be the point where prices bottom out, although demand should remain strong for some time yet, especially with the advent of 'affordable' recordable DVD still some way off.

With all the attention and some might say hype, which DVD has been attracting over the season, it's easy to overlook other formats. One such format that finally appears to be making inroads is Digital Audio Broadcasting (DAB). It's been some time now since Arcam launched the first DAB tuner and until recently take up has been sluggish, to say the least. Yet from the autumn of 2001, the format seems to have finally begun to gather momentum. The reason is simple: price. From the beginning of the year VideoLogic launched a sub £300 receiver. This was under cut in the summer with the arrival of the £250 Lektropack. Now DAB tuners are finally reaching the crucial £200 mark. Tellingly, the second best selling tuner in the run up to Christmas turned out to be the VideoLogic, just being pipped to the number one spot by Denon's stalwart TU-260. There are now several respected manufacturers on the brink of launching receivers between £150-£200. Hence, in terms of price, DAB has finally met the mark.

Yet there's more than simply price

that DAB needs on its side if it is to succeed. Reception is a key factor. Until recently, the BBC reported national coverage to be at 60%. Although they admitted these to be rather conservative figures, it still left much of the nation left out. Furthermore, no new transmitters were being built.

However, at the close of 2001, building had restarted and the coverage figure now stands at 65%. The plans are to have 80% of the population covered by 2003, rising to 85% by early 2004. If this still sounds rather some way away, cast your mind back to the introduction

” The majority of DVD players end up sitting beneath the TV, with the hi-fi being a separate entity altogether.

of Nicam stereo which took the best part of eight years to be rolled out.

More promotion of Digital comes from the promise of five new national services to be offered by the BBC over the course of the year. Local radio station licenses are also finally starting to be rolled out. So, with the combination of affordable prices, improving coverage and new services, I wouldn't be surprised to see DAB becoming the big hit of the year. Putting things into perspective, however, it's still unlikely to challenge DVD, or even CD in terms of boxes out the door.

Speaking of CD, sales have fallen slightly over the past year. There's no doubt that some sales have been lost to DVD, yet not as great an amount as some may have predicted. For the most part, those serious about their music are still buying separate CD players. The majority of DVD players end up sitting beneath the TV, with the hi-fi being a separate entity altogether. Sony have made a great push towards SACD over the season but, as yet, this has still really yet to capture the public's imagination. Just as DAB still needs better coverage, so SACD needs a healthier catalogue of discs before it can really take off.

The status quo regarding recordable formats remains much as before. Cassette tape continues its decline, with many manufacturers now

ignoring the format altogether, or relegating it to the back pages of the catalogue more usually occupied by a plastic turntable or two.

MiniDisc got a shot in the arm last year, thanks to Sony's Long Play system, but it is difficult to see how it will do anything but decline throughout this year. MiniDisc's trump card is portability, making it popular with students, musicians and commuters countrywide.

CDR hasn't been as popular as we thought. Even though players are now available for £150, sales have remained fairly steady. This is likely due to the fact that people record using their PCs, rather than any failing with the format itself. I also sense that those in the know are waiting to see what happens in terms of hard drive recording before selecting a particular recording format.

In summary - and with the crystal ball as help - I expect DVD sales to remain strong through the year, whilst CD player and MiniDisc sales decline slightly. CD recorders and vinyl will probably remain static, but analogue radio will really start feeling the pressure towards the end of the year. Yet, in the words of Murray Walker, anything can happen and anything does happen. Happy New Year. ●



Dominic Todd



just compare OUR prices for the BEST deals.



A selection of our ever changing offers for sale
 (all fully guaranteed)

Equivalent Sale
 New Price Price

A selection of our ever changing offers for sale
 (all fully guaranteed)

Equivalent Sale
 New Price Price

AMPLIFIERS

Thermionic OuTLaw Transformerless Int. Valve - Amp. (2 x 18 Watts / Push-Pull) MINT / As New	1200.00	795.00
Classe CAP-80 Remote Int. (2 x 80 Watts / Balanced-Inputs Etc.) MINT / Manual	1300.00	729.95
A.V.I. S-2000P Pre-Amp. / S2000M Mono-Blocs (2 x 150 Watts / Remote Control) MINT / Manuals	2350.00	1150.00
John Shearpe Phase 3 (2 x 50 Watts Power-Amp.) MINT / Boxed / Manuals	620.00	620.00
John Shearpe Phase 3 (2 x 50 Watts Power-Amp.) (Another One) MINT / Boxed / Manuals	620.00	620.00
Revox B-250 (2 x 150 Watts Int. Amp. With Full Remote-Control) (See Star Product) MINT / Boxed / Manuals	1200.00	595.00
Micromega Tempo I Int. (2 x 50 Watts) MINT / Manuals	700.00	369.95
Micromega Tempo I Int. (2 x 50 Watts) (Another One) MINT / Manuals	700.00	369.95
(Buy The Two And Bi-Amp. For £700.00 Saving £39.90)		
Exposure XII Pre. / XII Power Supply MINT / Boxed	1300.00	575.00
Arcam Alpha 5 Int. Amp. / Phono-Stage MINT / Boxed	230.00	139.95
Rotel RA-840BX4 (2 x 50 Watts / M.M. / M.C. Phono-Stage) VGC / Boxed / Manual		270.00
Creek 4140 S2 Int. (With M.M. Phono-Stage) MINT / Boxed / Manuals		250.00
Crimson Elektrik Series 500 Pre-Amp. (Battery-Powered / M.M. Phono-Stage) MINT		250.00
Quad 606 / I Power-Amp. (2 x 125 Watts) MINT / Manuals	700.00	389.95
Quad 34 Pre. (Buff) / DIN / (Discreet C.D. Input / M.M. / M.C. Phono-Boards) MINT / Boxed / Manuals	400.00	209.95
Quad 405 I Power Amp. Fair C.	500.00	169.95
Quad 77 Pre / Remote-Station / 77 Power-Amp. (Carbon Finish) MINT / Manuals	1600.00	849.95

TUNERS

Revox B-160 F.M. Tuner MINT / Boxed / Manuals	700.00	349.95
Meridian 204 Tuner / Timer VGC / Manuals	550.00	219.95
A&R (Arcam) T-21 F.M. Tuner With Pre-Sets VGC	N/A	89.95
Sony ST-SE 500 R.D.S. F.M. Tuner MINT / Boxed	140.00	79.95
Rotel RT-820L 3-Band Tuner VGC	N/A	59.95

TURNTABLES

Voyd (The Voyd) c/w Helios Orion Silver - Wired Tonearm / Koetsu Black M.C. (Standard PS.U.) VGC / Manuals	2800.00	1095.00
Notes: Analogue Spacedek / Spacearm / Stanton 681EEE M.M. Cartridge MINT / As New	1200.00 +	795.00
Linn Axis / Basik Plus / K-9 MINT	600.00 +	279.95
Dunlop Systemdek / Synrix PU-2 / Nagaoka MP-11 Boron (Original And The Best Systemdek) VGC	1000.00 +	219.95
Dunlop Systemdek IX 900 / Rega RB-300 / Ortofon 510 Cartridge VGC / Scratched Lid	500.00 +	219.95
Nottingham Analogue Mentor Tonearm (Linn Fix Option) MINT		800.00
Audio Technica AT 32E Moving-Coil Cartridge		200.00
Audio Technica AT OC-5 Moving-Coil Cartridge	MINT / Boxed / Manuals	150.00
Michell Iso Phono-Stage (Set For Low-Output M.C.) MINT	400.00 +	209.95
Monacor SPR (M.M. Phono-Stage) NEW / Excellent Value	N/A	29.95

(Lots of Vinyl in Stock and always WANTED)

(Record-Cleaning Service Available)
 Your Records Cleaned to Perfection on Moth Machine
 For £1.00 Each Including New Inner-Sleeve.
 (Maximum 10 at a time please)

...Turntables / Tonearms / Cartridges (M.M. / M.C.) "Urgently" Required...
 ...Also any "interesting" Vinyl Accessories: Clamps, Protractors, Stylus Scalers, Cleaning Devices etc.

LOUDSPEAKERS

Celestion "Art" 5000 Ribbon Hybrids / K-Stands (American Walnut) MINT / Boxed / Manuals	1500.00	495.00
Celestion Dittori 15 Fair C.	N/A	39.95
Meridian M-2 / Stands (Active) G / C Some Marks	1000.00 +	POA
Audionote ANJ/D 94db / Bi-Wire Etc. (Black-Ash) MINT / Boxed / Manuals	930.00	599.95
Audionote ANJ Stands (For The Above) MINT	300.00	149.95
B&W 80S Matrix VGC / Boxed / Manuals	1000.00	595.00
Pro-Ac Tablette 2000 Signature (Target R-1 Stands Available) MINT / Boxed / Manuals	900.00	499.95
Naim SBL Double-De-Coupled LS. VGC / Boxed	1800.00	795.00
Mission 752 Freedom (Hi-Fi Choice "Best-Buy") MINT / As New Boxed / Manuals	600.00	399.95
Mission 701 (2-Way Reflex / 100 Watts) MINT / Boxed	160.00	89.95
Chario Syntar 100 / Stands MINT / Boxed	500.00	229.95
Harbeth HL-5 2-Way Monitors VGC / Boxed	1200.00 +	369.95
Rega Elia Floorstanders VGC	410.00	189.95
Spendor 2020 MINT / Boxed	400.00	169.95
Kef 105 / II Monitors VGC / Manuals	2000.00 +	409.95
Kef Reference 101 / II Uni-Q Etc. MINT / Boxed / Manuals		600.00
Kef Coda Minis MINT / Boxed	130.00	79.95
Kef Cobalt HB-2R / Stands (Black-Ash) VGC / Manual		300.00 +
Etax Liberty 3 Plus (Bi-Wire Etc.) MINT	160.00	79.95
Mondaurt Short MS-3.10 Minis / Stands GC / No Grille Cloths	180.00	59.95

Lots of Loudspeaker Cables in Stock, both New & Used.

MISCELLANEOUS

Yamaha DVD-S700 Remote DVD Player (Region Two) (DVD's In Stock And Always Wanted) MINT / Boxed / Manual	600.00	199.95
Castle Keep Shielded Centre Speaker (Medium) MINT / Boxed / Manuals	250.00	129.95
Musical Fidelity X-Cans (Headphone Amplifier) MINT / Manuals	140.00	89.95
Apollo 3-Shelf Stand (Smoked-Glass) MINT	200.00 +	109.95
Target R-1 Super-Heavies (Lead-Shot Filled) (For Tablettets Etc.) MINT / Boxed	300.00	179.95
Atacama SE-24 Spiked-Stands MINT	70.00	45.00
Target HJ-18 "Heavy" Spiked LS. Stands VGC	100.00	49.95
Target 18" Column Stands VGC	60.00	34.95
Monacor SPS-35 Spike Kit (Gold or Anodised Black Finish) Loudspeaker Spikes NEW 9.95 (Per 4)		
Monacor SPS-45 Spike Kit (Small) Loudspeaker Spikes NEW 7.95 (Per 4)		
Monacor SPS-65 Spike Kit (Large) Loudspeaker Spikes NEW 9.95 (Per 4)		
Vivanco PHC (Optical to Co-Axial Converter) MINT / As New	30.00	15.00
Roni 4 m.m Banana Plugs (Screw-Type, No Soldering) NEW 6.95 Per Four		
Scart to Scart 21-Pin / Gold-Plated High-Grade Scart Cables Screened OFC / 1.5 Metres NEW Only	10.95	
Linn Incon MINT	30.00	18.00
Monacor 75 Ohm. Digital Incon. NEW	N/A	8.95
Nexera Gold 5-Pin DIN To 4 Phono NEW	N/A	9.95
Monacor SPS-20 Anodised Adjustable Polished Cone Equipment Supports NEW (Superb Spike System at a very good price) 19.95 Set of 4 (Black Anodised Or Gold Finish)		
discwasher CD Radial Cleaner VGC / Boxed	N/A	8.00
Monacor Power Concept Incons (0.8M. / 1.5M / 5.0M) Excellent Value Interconnects NEW Only	7.95	0.8M.
10.95 1.5M. or 14.95 5.0M. (Blue And Black)		
affordable-audio Bi-Wire LS. Cable (In Brown or White) NEW	Only	3.50 Metre
79-Strand LS. Cable (Black-Round-Section or White-Flat-Section) NEW	Only	1.25 Metre
Alisop Carbonoptic Record Brush VGC	N/A	5.00
Monacor DC-100 Carbon-Fibre Brush (Essential)	NEW	6.95
Various Plugs (RCA / DIN / Cannon Etc.) Various	NEW / SH	POA.

PRODUCT OF THE MONTH

Revox B-250 Remote Integrated Amplifier
 (2 x 150 Watts Solid-State Amplifier
 With Phono-Stage) In MINT Condition With Boxes And Manuals.
 (Matching B-160 F.M. Tuner Also Available)

Last RRP £1,200.00 Affordable Audio price @ £595.00

RECORDING EQUIPMENT

Revox B-77 Mk. II High-Speed 1/2 Track Reel to Reel (7 1/2 / 15 i.p.s. / Vari-Speed) VGC / NABs / Tape (Recent Service)	2500.00	529.95
Nakamichi DR-3 (2-Heads) MINT	450.00	209.95
Nakamichi BX-1 (2-Heads) VGC / Manual	N/A	149.95
Nakamichi BX-150E (2-Heads / Dolby B / C) VGC	N/A	149.95
Nakamichi BX-125E (2-Heads / Dolby B / C) VGC / Manuals	N/A	139.95
Rotel RD-865 (2-Motor / HX-Pro) MINT / Boxed	230.00	99.95
Yamaha KX-300 (Remote / HX-Pro Etc.) VGC / Boxed / Manual	200.00	79.95
Aiwa AD-WX909K Twin (3-Heads / Auto Reverse / Hx-Pro Etc.) G/C	N/A	69.95

DIGITAL

Primare D302 Remote Player With Balanced-Out Etc. MINT / As New / Boxed / Manuals	1500.00 +	895.00
Meridian 207 C.D. Player / Pre-Amp. c/w 209 Remote Control Station VGC / Manuals	1500.00	449.95
Classe CDP-3 HD/CD / Remote / Balanced-Out MINT / Boxed / Manuals	1400.00	715.00
Sugden Stemmform PDA-10 DAC (Arcam Chips) VGC	1500.00	495.00
Arcam Alpha 9 (HD/CD / Remote Etc.) MINT / As New	900.00	529.95
Arcam Alpha 5 "Plus" Remote Player MINT / Boxed	470.00	219.95
Arcam Alpha 5 Remote Player VGC / Boxed / Manuals	450.00	189.95
Arcam Black Box 50 D.A.C. (Sync-Lock) MINT / Boxed	500.00	219.95
Arcam Alpha Plus Player MINT / Manuals	400.00	129.95
Marantz CD-17 Remote MINT / Boxed	800.00	475.00
Marantz CD-4000 Remote Etc. MINT / Boxed / Manuals (Purchased New 11/2/01)	130.00	99.95
Marantz CD-67 SE Remote / Digital-Out Etc. MINT / As New / Boxed / Manual	350.00	179.95
Marantz CD-52 II Remote VGC / Manual	400.00	400.00
Marantz CD-52 SE Remote VGC	450.00	119.95
Marantz CD-55 II SE Remote VGC	250.00	89.95
Mission DAD-5 / DAC-5 (Two-Box Player) MINT	600.00	219.95
Mission PCM-7000 Remote Etc. VGC	600.00	119.95
Sony CDP-C245 (5-Disc Multi-Player) MINT	230.00	129.95
Denon DVD-620 Remote 18-Bit C.D. Player VGC	200.00	69.95

Hundreds Of Compact Discs In Stock And Always WANTED...
 ... (Complete Collections Purchased, JAZZ in particular)

SYSTEMS

Bang & Olufsen Beomaster 5000. Comprising: C.D. Player / Amplifier / Tuner / Loudspeakers / Remote Control Station. VGC / Manuals 1200.00 + Cash Price £350.00

affordable-audio will happily "build" Systems to your individual requirements, and if you purchase three or more components, i.e. (C.D. Player, Amplifier, & Loudspeakers), we will give you a *15% Discount on the total price! Please enquire for further details.
 *(Does Not Apply To Commission-Based Sales)

PLEASE VISIT OUR WEB-SITE (UPDATED DAILY)
E-MAIL: Sales@affordable-audio.CO.UK
WWW.affordable-audio.CO.UK

***** GOOD HI-FI SEPARATES WANTED *****

Phone anytime with your wants, stock changing daily. All equipment is sold with warranties.

Don't forget we can offer mail order. All major credit cards accepted.

We welcome part-exchange on any of the above. Affordable Audio is always keen to buy, (or part-exchange) Good quality Hi-Fi separates in good condition. Especially top British manufacturers products!



World Radio History

We can also sell your equipment for you on a commission basis. (Lowest rates/best return) (Please phone Paul for details!)

Never let it be forgotten - hi-fi is about music and the enjoyment thereof. But wouldn't we be kidding ourselves if we didn't rather like 'the whole smash' - all the extra bits that get bolted onto the deal?

Think, for example, of cars. These days, there are probably few better ways - for sporting drivers at least - of getting from A to B in something like, say, a Subaru Impreza Turbo. Any pocket rocket like this, with oodles of horsepower, 4WD, traction control and ABS will catapult you to the mother in law in less time than you could bear to think.

But what of the driving experience? Awesomely fast and grippy - yes - but is it really as much fun as your first Mini?

When we look to buy products - be it hi-fi, cars, motorbikes, or whatever - its strict ability to do the job simply isn't the whole story. To wit, there's something profoundly unsatisfying about a modern CD player that you switch on and just play. The sound certainly isn't bad - you can bet your bottom dollar that the likes of a Marantz CD6000OSE (or similar) would outperform the vast majority of turntables you had in your formative years in almost (and I stress 'almost') every respect. But somehow there's something curiously unfulfilling about owning and using it.

Back in the old days, your system's sound depended very much on your level of expertise in setting it up. If you blithely stuck your Dual CS505 deck on the floor it would sound appalling. You had to get into the hows and whys of the deck for it to give of its best - everything from cartridge selection, tracking weight and choice of mat (was that a Spectra, GA or Rega felt mat) informed how tight your bass would be, or how sparkling your highs.

Now though, we live in a 'plug and play' society. Bill Gates can be thanked for this phrase, as it describes - in a nutshell - where the whole of modern life is heading. It implies a hermetically sealed, idiot-proof world which requires absolutely no insight or understanding of the things (scientific, physical processes) going on around

you. It's nice and easy. The tragic thing is, you get out of life what you put in - or not much in this case.

Nowadays, if you buy three boxes and plug them in, you'll get a competent sound; one that many take to be 'hi-fi' and therefore good enough to tick off from the list of things they aspire to. Twenty years ago, not only did you have to buy these components, but understand them and laboriously (and lovingly) set them up too.

In 1983, my Rega 3 tracked its R100 cartridge at 1.75g with 1.5g of bias dialled in, on a light coffee table

“ Hi-fi, cars and bikes - consumer goods en masse - have now had the glitches designed out. They've evolved so much that now they miss the point.

that was meticulously levelled. It sounded best at over 20 degrees centigrade and when the stylus had played a full side. Now, the modern equivalent - the brilliant Rega Planet 2000 just sounds great, erm, all the time, anywhere.

My point is that the plug and play society has robbed us. It's made life easier, more casual. It's reduced and rubbished the noble idea of specialisation (something still alive and well in Japan, complete with its own 'otaku' subculture, thankfully). It's an easy come, easy go, undemanding approach to life that somehow dulls the mind and anaesthetises everyone it encroaches upon. It also encourages waste: to improve a system throw it away and buy a new one, rather than upgrade or modify.

Want to make a perfect music compilation? Once, only a Nakamichi would do - plus about half an hour of head cleaning, demagnetising, level setting and bias calibration. Now, just stick it into your PC and click on 'Easy CD Creator'.

Hi-fi, cars and bikes - consumer goods en masse - have had their

glitches designed out. They've evolved so much that now they miss the point. As well as a product's ability to fulfil its primary function (i.e. travelling, playing music etc.), there are a welter of other things we shouldn't forget. Ergonomics, the way the 'user' connects with the machine and the media, styling, the historical importance of the brand, etc.

All these things add to the overall experience - not just of performing the primary function, but of being alive. That's why some old blokes still blat around on equally old BSAs, when there's a Honda that's a thousand times better in every respect 'on paper', they could just as easily be riding.

Likewise, that's why a lot of us are still seduced by the weird and the wonderful in hi-fi's historical canon - from the severely compromised but utterly irresistible sound of old valve amps to the madcap designs of Lecson, Gale and Transcriptors et al. What a shame that we can never go back. ●

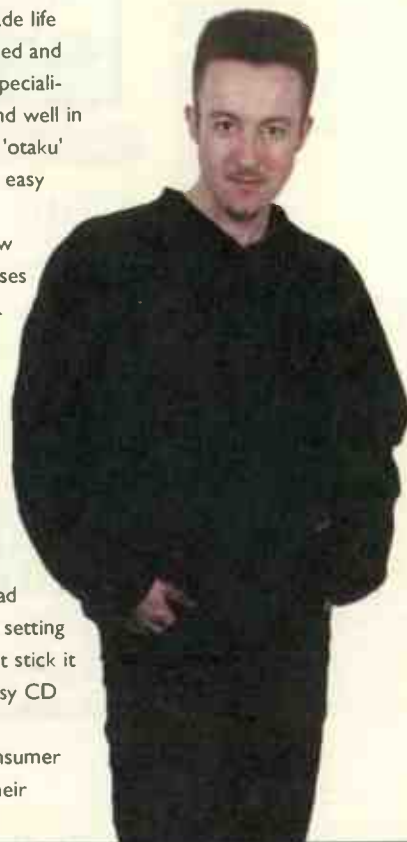

David Price

LONDON

ORANGES & LEMONS

INSTANT 0% FINANCE AVAILABLE SERVING LONDON FROM BATTERSEA

Juicy fruit from London's newest, freshest hi-fi/home cinema retailer. Telephone demonstrations or just pop in. All the usual, i.e. friendly and efficient service, free home installation + credit cards.

THE INNOVATIVE AUDIO/VISUAL HI-FI RETAILER. ARCAM, CABLETALK, CHORD CO, DENON, EPOS, MARANTZ, NAD, NAIM, REGA, ROKSAN, ROTEL, ROYD, RUARK, SOUNDSTYLE, STANDS UNIQUE, YAMAHA.

NOW IN OUR SEVENTH SPARKLING YEAR.

020-7924 2040

61/63 WEBBS ROAD, SW11
Visit www.orangesandlemonshifi.com

O'Brien Hi-Fi

AUDIO ANALOGUE

MARTIN LOGAN COPLAND

ARCAM • ANTHEM • AUDIOGRAM • AUDIO RESEARCH • AUDIO TECHNICA • BEYER • CABLETALK • CHORD • CREEK • DENON • DENSEN • JADIS • JECKLIN • MICHELL • MUSICAL FIDELITY • NAD • NAIM • OPERA • PRECIOUS METALS • QED • REGA • ROGERS • ROK • SENNHEISER • SILTECH CABLES • SME • SONNMEYER • SONUS FABER • TEAC • THORENS • TRANSPARENT CABLES • UNISON RESEARCH • WILSON

Clearance / Second Hand / Ex Dem Equipment - Details on request

0% Instant Finance Available

New Demonstration Room • Free car parking • Major Credit Cards
Personal Export • Mail Order • Installation Service • Repair Facilities
5 mins walk Raynes Park BR • 20 mins Waterloo
5 mins from A3 (Raynes Park B282exit) • 25 mins N125, June 10

60 Durham Rd, West Wimbledon, London SW20 0TW
Est. 1966
Tel: 020 8946 1528 Fax: 020 8946 0331

We aim to provide a well chosen selection of quality hi-fi and accessories including

FHJ, ARCAM, B&W, NAUTILUS, DYNAVECTOR, LINN, LOEWE, MERIDIAN, M&K, NAIM, PIONEER, PROCEED, NEAT, REGA, ROTEL, SHAHINIAN, YAMAHA + more

www.infidelity.co.uk

f

Open Times - Fri 10.30am - 7pm, Saturday 10am - 6pm

Infidelity

INDECENTLY GOOD HI-FI

9 High Street, Hampton Wick, Kingston upon Thames, Surrey KT1 4DA
Tel: 020 8943 3530

27 BOND STREET, EALING LONDON W5 5AS TEL. 081 - 567 8703

Audio Analogue, Art Glass, Ash Designs, Avik, B&O, B&W, Cabletalk, Chord Company, Creek, Denon, Epos, Harman Kardon, Infinity, KEF, Lat, Marantz, Musical Fidelity, NAD, Nakamichi, Nordost, Orelle, Onkyo, Primare, Quad, Roksan, Rotel, Ruark, Sennheiser, SonicLink, Sound Style, Stands Unique, Straightwire, Supra, Tag McLaren, Target, Teac, Thorens, van den Hul.

10 - 6 pm Mon., Tues., Friday, & Sat. Late night Thur., closed Wed.

Two demonstration rooms. Free local delivery and installation. Repairs and Services

SOUTH

WORTHING AUDIO

28 Trimple Gate W. Sussex RH11 1UA
(01323) 212100

The friendly shop with the best sound system in the South.
Talk Electronics - Friendly Advice - 3 Year Guarantees
Easy Parking - Open Mon-Sat 11am-6pm
Late Night Wed 7.30pm

Address includes: Dynaudio, Ruark, Graham, Naim, Rega, Creek, Sonneteer, Kora, Cymba, Talk Electronics, and many more.....

SOUTH WEST

SOUTH WEST ANALOGUE

SME - MICHELL - NOTTINGHAM ANALOGUE - LORICRAFT GARRARD - PROJECT - ORTOFON - TUBE TECHNOLOGY 64bit Valve CD Player, Remote Control Hybrid Integrated Valve Amplifier CROFT VOODOO Isolation platforms/Loudspeakers, Equipment Stands and Turntable lift off Perspex Covers. Record cleaning service - Secondhand equipment

01643 851 351

graham@southwestanalogue.fsnet.co.uk

NORTH

Basically Sound

NORWICH • NORFOLK

Audio Analogue, Bryston, Creek, Living Voice, Naim Audio, PMC, Project, Rega, Sonneteer, Talk Electronics, Teac, Tube Technology, Unison Research, Wilson Audio Note and many others

The Old School
School Road, Brackley, Norfolk NR11 8HG
Tel (01508) 510827

EAST

STOWSOUNDS

These And More Available From:

Creek	JM Labs
Epos	Living Voice
Exposure	Neat Acoustics

For A Demonstration & Expert Advice Call
Stowmarket (01449) 675060

Stow Farm, Barrow Lane, Gt. Finborough, Stowmarket

VINYL

THE DIRECT DISC

VINYL VINYL VINYL

Thousands of records always in stock.
+ a full range of sought after compact discs.
Extensive search service for wanted albums.

Comprehensive 96 page full catalogue available at £1.50

Telephone / Fax 01992 447764
Or visit our web site on www.directdisc.demon.co.uk

CHERISHED RECORD CO

UK SUPPLIERS OF VPI TURNTABLES, RECORD CLEANING MACHINES AND ACCs. HUGE SELECTION OF NEW & USED LPS & CDS

www.cherished-record-company.co.uk

01579 363 603

World Radio History

MAIL ORDER

Russ Andrews Accessories
Mail Order Direct

Q. How do I get the best sound from my system?
A. Order our free booklet!
It's essential reading for anyone who wants to hear the best music their system can deliver, and it's full of free tips and advice on how to upgrade your system. Call and request your free copy quoting ref. AH22 or visit our website where you can download it now.

UK FREEPHONE
0800 373467

Russ Andrews Accessories Ltd., FREEPOST NW99BRTA, Keston LA8 9ZA
Tel: +44 (0)1539 825500 Fax: +44 (0)1539 825540
E-mail: AH22@russandrews.com
www.russandrews.com

VALVES & TUBES

CVC Chelmer Valve Company

Buy CVC. PREMIUM HI - FI valves direct from us. All valves processed for improved performance. We also have stock of MAJOR BRAND types inc. MULLARD, GEC, BRIMAR, RCA, GE, PHILIPS, etc.

The Stables, Baddow Park, Ct. at Baddow, Chelmsford, Essex. CM2 7SY
Tel: 01245 241301 Fax: 01245 241309
E-mail: sales@chelmervalue.com

£600

Mr. Andrew Everard in Gramophone Magazine "delivers a sound that's both smooth and refined ... allied to a good degree of clarity and finesse"

Hi-Fi Choice "It's a 'classic valve sound'... warm and cuddly...vocals are generally lifelike and involving"

FREE colour literature. **£600 with free delivery**

Phone 01634 373410 anytime. **1 month home trial**

www.affordablevalvecompany.com

SERVICES & CONSULTANTS

Front End Problem?

contact
The Cartridge Man

It doesn't have to cost an arm and a leg to get the best - listen to my Koetsu - and Decca - eater.

Also agents for Croft, Hadcock, E.A.R. Michell & Moth.

plus cartridge re-tipping service
020 8688 6565

Website: www.thecartridgeman.com

SWEET 16

Naim's CDS was one of the company's seminal early adventures in digital audio. David Price listens to this sixteen-bit special.

Funny isn't it? This time ten years ago, CD player manufacturers were scrambling to get their first 'Bitstream' digital disc spinners out into the shops. Philips had pipped everyone to the post with its famous CD850/II, and the rest, as they say, is history. All of a sudden, multi-bit CD players and DACs were about as fashionable as your little sister's old Bros singles.

All was not what it seemed though. While Marantz fast began to clean up in the budget market with its Bitstream CD52SE, the upper echelons of audio proved less eager to jump onto the good ship 'One Bit'. There were two reasons for this - the first was simply why spoil a winning formula? If you'd spent two years honing your multibit based masterpiece, why go back to the drawing board and do it all again simply in order to write that magic word 'Bitstream' on your player's front panel? The second reason was that some tortured souls actually believed multibit sounded better - or should we say 'more musical' - anyway.

Naim's CDS was born from this idea. It was not a trendy piece of cutting edge high tech but it sure as hell sounded good. Launched in 1991, the CDS wasn't a conventional two box player like its rival Linn Karik/Numerik, but was split into CDS CD player and XPS power supply sections. This was because the company considered (and still does) that the separation of transport and DAC caused more problems than it solves. The biggest was jitter, which Naim characterised as causing increases in non-correlated distortion, lower resolution and inferior signal-to-noise ratios. True to form, the CDS also lacked a digital

output - heresy to a world full of ever-so-trendy high-end two-box players!

The CDS duly comprised a proprietary full width Naim box housing an XPS power supply, on top of which another box sat containing the CD player itself. Inside this were selected versions of the Philips TDA1541 Silver Crown multibit DAC chip, and another important part of the equation, a CDM-44 transport. Many designers still believe this to be the best and most suitable for high quality CD players. Naim did too, which is why they bought as many as they could get their hands on, in anticipation of the CDS's long and happy production run. The transport was augmented by a quality, top loading CD door arrangement and the famous Naim 'puck' which functioned much like an old record stabiliser weight of yore.

Needless to say, the player sounded superb, fast propelling itself into the realms of 'classic' CD players. Best characterised as a 'vinyl lover's delight', it offers incredible musicality and firecracker dynamics if properly set up. This isn't as easy as some, requiring careful levelling (just like a turntable), and clean discs and laser (Naim recommend the use of Bluetack for this purpose, interestingly).

Many believe the CDS to be the most natural 'music making' CD player around, describing it as akin to a good turntable. You get a rich, vivid, tactile sound that simply gushes forth from your loudspeakers, without giving so much as an inkling that it's a digital disc being spun. Listen hard and you'll hear that trademark 'brightly lit' upper mid band and a very slight fizzy



quality to the treble, but you'll be churlish in the extreme if you let this interfere with this CD spinner's deliciously musical sound.

Downsides? The CDS is a bit finicky sometimes. Like the vinyl turntables it emulates so well, it has more than a passing interest in the quality of the disc surface it's playing. This means meticulous care on your part if you aren't going to get all your silver frisbees sounding like remixes from MC Scratchy.

The CDSII arrived in 1997, loosing the multibit DACs and early transport. Heavily redesigned, it sounded quite different to the original - in some ways better, in others a little more polite. In many ways, the newer version is by far the more sensible option, but many love the original CDS for its character and vintage appeal. It's a deliciously musical little box (or two) of tricks, and many will want it for this reason alone. The good news is that there are more around second-hand than you'd think, the bad news is that they're expensive - and sellers can more or less name their own price, circa £700. ■ ▲

DIAL-A-DEALER

This is a comprehensive directory of Hi-Fi Dealers throughout the UK and Ireland.

BEDFORDSHIRE

RICHARD'S AUDIO VISUAL 4 Greyfriars Bedford. Tel: 01234 365165. Stockists of: Arcam, Audioquest, Beyer, B&W, Bose, Cable Talk, Cyrus Denon, Marantz, Mission, Moth, Ortofon, Pioneer, Pro-Ject, Quad, REL, Rotel, Ruark, Sennheiser, Sound Style, Stands Unique, Teac, van den Hul & more! Expert friendly service - Listening room. Pioneer Reference Point, Visa / Access.

BRISTOL & BATH

THE RIGHT NOTE Tel: (01225) 874728. Just think: most audiophiles listen for most of the time to systems that are 'not quite right'. Are you happy with yours? Forget the reviews and trying to put together a system like a patchwork quilt with the 'best' bits around. It's our job to do the assessing, you judge our results. We'll help you to plan a system for the future, even if you spread the purchases. Leave the 'up-grade-itis' behind, save money and enjoy music all the time. Just listen, and you'll know. CD: Acuras, Audio Synthesis, Classe, DCS, Enlightened Audio Design, Mercus, Orelle, Wadia, XTC. Vinyl: Basis, Crown, Jewel, Graham, Michell, Sumiko, Transfiguration. Amps: Acuras, Audio Sculpture & more. Speakers: Audio Arstry, Audio Physics & more. Tuners: Fanfare, Magnum Dynalab & many more. Cables: Chord, DNM, Silver Sounds & more. (Credit Cards Accepted).

V'AUDIO HiFi Consultants: 36 Druid Hill, Stoke Bishop, Bristol, BS9 1EJ. Tel: 0117 968 6005. ATC, AVI, Alon, Audio Analogue, Audiomeca, Cadence Valve, Chord Amps, Electrocompaniet, Harman Kardon, Heybrook, Jamo, LFD, Lyra, Opera, Ortofon, Pink Triangle, Ruark, Mark Levinson, Michell, REL, SME, Shearne, Sonic Link, Sugden, Townshend, Triangle, Unison Research Valve Amps. Home Cinema demonstrated including, A/V Amps, DVD Players, Video Projectors and Screens. Demos by appointment only. Home trial facilities. Free installations. We are not a shop.

BUCKINGHAMSHIRE

NORTHWOOD AUDIO 98 Cambridge St, Aylesbury, Tel: 01296 428790. Established since 1992. Independent specialist retailer. Extensive Hi-Fi, A/V and Multiroom experience catering to your needs. From Vinyl to SACD, Valve to Solid State, from LCD to Plasma, Audiomeca, Audio Note, Cable Talk, Castle, Chord, The Chord Company, Cura, Denon, Elac, Epos, Exposure, Heart, JM Labs, KEF, Linn, Marantz, Michell, Micromega, Monitor Audio, NAD, Nakamichi, PMC, ProAc, Quadraspire, Rega, REL, Revox, Roksan, Rose, Rotel, Ruark, Sony, Sennheiser, Sonus, Talk Electronics, Tannoy, Teac, Tube Technology, Videologic, Vienna Acoustic. Export orders welcome. 2 demo rooms. Credit facilities available.

Website: www.northwoodaudio.co.uk
Email: info@northwoodaudio.co.uk

TECHNSOUND 8 Granville Square, Willen, Milton Keynes, MK15 9JL. Tel: (01908) 604949. Fax: (01908) 202166. Audiophile Hi-Fi and Home Cinema specialists. All major brands stocked from Arcam to Yamaha. Meridian Digital Home Theatre dealer. Video projection, Plasma screens. Custom installation. 2 demo rooms and expert advice.
Email: hifi@technosound.co.uk
www.technosound.co.uk

CAMBRIDGESHIRE

THE AUDIO FILE 41 Victoria Road, Cambridge. Tel: 01223 368305. 'For the best in British Hi-Fi and Home cinema entertainment'. Visit or call to arrange a dem with products from: Arcam, Linn, Naim, Rega, Cyrus, Absolute Sounds, Kef, Sony, Yamaha, Rel, Ruark, Denon.

CHESHIRE

ACOUSTICA 17 Hoole Rd, Chester CH2 3NH. www.acoustica.co.uk. Tel: 01244 344227. All that's best in HiFi & Home Cinema from quality manufacturers including Naim, Rega, Arcam, Musical Fidelity, Rotel, Seleco Projectors, Kef, Ruark, Densen, Primare, Teac, JM Lab, Nakamichi, Quadraspire, Celestion & Crimson. We offer friendly, helpful advice, interest free credit & trade-in facilities, and deliver & install systems throughout Cheshire, Merseyside & North Wales. Opening hours are Tuesday to Saturday 10.00 until 5.30, evenings by arrangement

ACTON GATE AUDIO 4 Ruabon Road, Wrexham, North Wales, Tel: 01978 364500. Audio Visual Specialists. Arcam, Audio Analogue, Bose, B&W, Celestion, Castle, Denon, Harmon Kardon, Jamo, Marantz, Michell, Mission, Onkyo, Pro-Ject.

Musical Fidelity, NAD, Micromega, Myrad, QUAD, Radford, Rotel, Ruark, Tannoy, TDL, Teac, Thorens, UKD, Unison Research, Yamaha, DSP Club Member, Demo Room, installation service, Easy Parking and Motorway access. All major credit cards accepted. 9.30 - 5.30 daily. Closed Sunday & Monday.

DOUG BRADY HI-FI Kingsway Studios, Kingsway North, Warrington, WA1 3NU Tel 01925 828009 Fax 01925 825773. Visa, Mastercard, Lombard Tricity. 2 dem rooms, home trial. Agencies include: Arcam, Tag McLaren, AVI, B&W, Castle, Caspian, Chord Electronics, Exposure, Harbeth, Heybrook, Krell, LFD, Michell, Meridian, Musical Fidelity, Monitor Audio, Naim, Nautilus 800 series, Pink Triangle, ProAc, Roksan, SME, Wilson Benesch, XTC and many more.

CORNWALL

SOUNDS PERFECTION 'Cornwall's most exclusive Audio retailer'. Agencies include: Audio Analogue, Audio Design, Audio Note, AudioQuest, Audio Spectrum, AR, Avid, Border Patrol, Boston, Dynavector, Electrocompaniet, Graaf, Henley, JM Labs, Lexicon, Michell, Monitor Audio, Musical Fidelity, Ortofon, Parasound, Primare, Project, NAD, Nakamichi, Nordost, Philoshopy, REL, Roksan, Ruark, Rotel, Totem, Tom Evans, Tsunami, S.M.E., Sugden, Stands Unique, Unison Research, Teac, Vienna Acoustics, Triangle, Trichords, WBT, Sonic Link. Home Demonstrations by Appointment. Tel/Fax: 01326 221372 Mobile 07798 554357 email nigel@soundsperfection.co.uk website www.soundsperfection.co.uk

DORSET

MOVEMENT AUDIO 588 Ashley Road, Poole, Parkstone, Dorset BH14 0AQ. Tel: (01202) 730865/380018. Arcam, B&W, Castle, Chord Electronics, Cyrus, Denon, Marantz, Michell, Mission, Pioneer, Tannoy Dimension, Yamaha. 2 Dem rooms. Listen to the available choice and decide at your leisure - no pressure, no obligation. Our staff enjoy music, with our choice of products, you can too! Service Department. Free installation. Home trial facilities. Access, Visa, Amex, Diners Card. Credit facilities available, Open Tuesday-Saturday 10-5.30. www.movement-audio.co.uk

MOVEMENT AUDIO 926 Wimborne Road, Winton, Bournemouth, Dorset, BH9 4DH. Tel: (01202) 529988/520066 Arcam, B&W, Denon, KEF, Marantz, Mission, Musical Fidelity, Opera, Pioneer, Quad, Roksan, Ruark, Yamaha. Full dem facilities available, also home dem. Friendly expert advice. Service Department. Free installation. Home trial facilities. Access, Visa, Amex. Open Tuesday-Saturday 9.30-5.30

DAWSONS OF WESTBOURNE Home Cinema Specialists. Main agents for Bang & Olufsen, Harman Kardon, JBL, REL, Mordaunt Short, Sony, Technics and TDL. Demonstration facilities include our unique Dolby pro-logic system comparator for the ultimate way to choose the perfect system. Also on demonstration large screen televisions from Thomson, Sony and Ferguson with video projectors from Sharp and Seleco. Dawson's, 23 Seamoore Road, Westbourne, Bournemouth 01202 764965

WEYMOUTH HI-FI 33-35 Maiden Street, Weymouth, Dorset DT4 8BA. Tel: (01305) 785729/766345. Arcam, B&W, Denon, KEF, Marantz, Mission, Musical Fidelity, Panasonic, Pioneer, Quad, Sony, Tannoy, Yamaha. Dem room. Friendly professional advice. Only quality hi-fi dealer in Weymouth area. Service Department. Free installation. Home trial facilities. Access, Visa, Amex, Switch, Delta Mastercard. Interest free credit. Instant credit. Open Mon-Sat 9.30-5.30

ESSEX

GRAYSTON SOUND & VISION 33 Sir Isaac's Walk, Colchester. (01206) 577682. Alchemist, Arcam, B&W, Boston Acoustics, Castle, Denon, Harman Kardon, KEF, Linn, Loewe Opta, Meridian, Michell, Musical Fidelity, Philips, Pioneer, Project, Rotel, Sennheiser. Superb demo rooms, free regional delivery and installation. Regular music and surround evenings, home demonstrations. Excellent credit facilities.

GLOUCESTERSHIRE

THE RIGHT NOTE - Bath. For specialist advice and home demonstrations. See BRISTOL & BATH.

HEREFORDSHIRE

ENGLISH AUDIO 37 Whitecross Road, Hereford, HR4 0DE. (01432) 355081. Arcam, A.T.C., B&W, Castle, Cura, Cyrus Centre, Elac, Denon, JM Lab.

KEF, Loewe, Marantz, Mission, Musical Fidelity, NAD, Naim, Pink Triangle, Pioneer, Project, QED Systemline, REL, Rotel, Ruark, John Shearne, Stax, System Audio, Teac, Vienna Acoustics, Wadia, and Yamaha. Single speaker dem room, home trial facilities, free installation, service dept, Access/Visa. Credit arranged. Open Mon-Sat. 9.30-5.30pm. BADA members.

HERTFORDSHIRE

AUDIO FILE (THE) 27 Hockerill Street, Bishops Cleeve, Herts. Tel: (01279) 506576.

DARBY'S OF ST. ALBANS, 6 Market Place, St Albans, Herts. Tel: (01727) 851596. Fax: (01727) 812217. Email: sales@darbystvhifi.co.uk Hertfordshire's premier Hi-Fi/Audio Visual specialists established 1946. Full Home Cinema demonstration suite. Whether your needs are large or small, we stock it all: Arcam, Cyrus, JVC, Yamaha, Quad, Denon, Sony, Bang & Olufsen, Pioneer, REL, KEF, Mission, Ruark, Celestion and many more. Free planning service. Free Delivery and basic installation. Full workshop facilities. Open 9-6 Mon-Sat.

LANCASHIRE

ADVENTURES IN HI-FI 5, Bishopgate, off Haligate, Wigan, WN1 1NL. Tel: 01942 234202. For the best hi-fi and home cinema products from quality manufacturers including Naim, Rega, Cyrus, NAD, KEF, Denon, Dynavector, Rotel, Shahinian, JM Lab, PMC, Project, Quadraspire, Seleco and Sanyo projectors. We offer friendly advice, excellent demonstration facilities, 0% finance, free delivery and installation throughout the North West. Opening hours 10.00 - 5.30pm Tuesday to Saturday evenings by appointment.

LEICESTERSHIRE

LEICESTER HI-FI 6 Silver Walk, St Martins Square, Leicester LE1 5EW. Tel: (0116) 2539753. Email: info@leicesterhifi.co.uk www.leicesterhifi.co.uk Arcam, B&W, Chord Electronics, Copland, Cyrus, Denon, Greig Loudspeakers, KEF, Marantz, Michell, Miller & Kreisel, Musical Fidelity, NAD, Nakamichi, Nautilus, Mission, Project, Rotel, Sanyo Projection, Talk Electronics, Teac, Technics, Yamaha, and many more. 4 Listening areas over 3 floors. We can demonstrate, deliver and install. Including A.V. and Multiroom. Credit Facilities. All cards taken, open 6 days 9.30-5.30.

LONDON

BABBER ELECTRONICS SERVICE CENTRE 158 Uxbridge Road, West Ealing, London, W13 8SB. Tel: 020 8579 6315. Akai, Aiwa, A&R, Celestion, Dual, Goodmans, Harman Kardon, JBL, JVC, Kenwood, Marantz, Panasonic, Sennheiser, Sony, ES range, Tannoy, Technics, Wharfedale, Yamaha and many more. Auth. Service Dept. Credit Facilities, Open 10.30 - 5.30 Mon-Sat.

INFIDELITY 9 High Street, Hampton Wick, Kingston-upon-Thames. Tel: (020) 8943 3530. for full details see entry under SURREY

HIFI EXPERIENCE 227 Tottenham Court Road, London W1. 020 7580 3535. Arcam, Cyrus, Denon Gold, Quad, Kef, Meridian, Yamaha, Marantz, McCormack, Mirage, Nakamichi, Musical Fidelity, PAFF and many more. Open 10.00-7.00 Mon-Fri. 9-6 on Sat. Service dept. Credit facilities, delivery and free installation.

THE LISTENING ROOMS 161 Old Brompton Road, London SW5 0LJ. (020) 7244 7750/59. Fax (020) 7370 0192. Linn, Quad, Meridian, Nakamichi, Arcam, Audiolab, Acoustic Energy, SME, Audio Research, Krell, Wadia, Theta, Apogee, Martin Logan, Pioneer, Tannoy, Systemdek, Stax, Pink Triangle, Michell, Monitor Audio, Yamaha, Marantz, KEF, Bose, Celestion, Epos, Mission, Denon, Neat Petite. Mon-Sat 10-6pm.

THOMAS HEINITZ LTD 35 Moscow Road, Bayswater, London, W2 4AH. Tel: 020 7229 2077. Fax: 020 7272 9348. Email: info@thomasheinitz.com.

Web site: www.thomasheinitz.com. Established in 1952, Thomas Heinitz has a long history of providing the best music and AV systems available. We continue to offer the highest standard of service in the most relaxed atmosphere. Whatever your needs, from multiroom and home cinema to a high quality stereo system, we offer consultation, design specification, architect liaison and installation. In order to ensure your system is tailored to your exact requirements, for quotes contact our manager Johnny Drum.

DIAL-A-DEALER

GREATER MANCHESTER

ADVENTURES IN HI-FI S. Bishopgate, off Hallgate, Wigan, WN1 1NL. Tel 01942 234202. See our main entry under LANCASHIRE

MANCHESTER

REPLAY AUDIO 64 Flixton Road, Urmston, Manchester. M41 5AB Tel 0161 202 9922. Audio Analogue, Bryston, Creek, DNM, Exposure, LFD, Michell, Myriad, NAD, Onkyo, Ortofon, Pink Triangle, Project, Soneteer, Sugden, Trichord, Unison Research, Teac, Loudspeakers from Acoustic Energy, A.R.T., Audio Physic, AVI, Blueroom, Epos, Harbeth, Living Voice, Monitor Audio, Neat, PMC, Royd. Lots of cables and accessories available. We are just off Junction 10 of the Manchester Ring Road (M60), five minutes from The Trafford Centre. Our demonstrations are relaxed and informal and help and advice is free! Phone or visit our web site www.replay.dial.pipex.com or email replay@dial.pipex.com

MERSEYSIDE

ACOUSTICA 17 Hoole Rd, Chester CH2 3NH. Tel 01244 344227. See our main entry under "Cheshire".

MIDDLESEX

RIVERSIDE HI-FI 422 Richmond Road, East Twickenham, Middlesex. TW1 2EB. Tel: 020 8892 7613 Fax: 020 8892 7749. www.riversidehifi.co.uk Arcam, Bose, B&O, Castle, Copland, Denon, Krell, Marantz, Martin Logan, Michell, Monitor Audio, Musical Fidelity, NAD, Pioneer, Project, Rel, Sonus Faber, Sony, Tag McLaren Audio, Tannoy, Teac, Theta, Wilson. Finance available. Subject to status. Written details available on request. Export orders welcome. UK mail order available. 3 demonstration rooms. All major credit cards. Open 10am-5.30pm Mon-Sat.

NORFOLK

BASICALLY SOUND The Old School, School Road, Bracon Ash (Nr Norwich), Norfolk, NR14 9HG. Tel: (01508) 570 829. Stockists of the following leading Hi-Fi: Audio Analogue, Beyer, Bryston, Denon, Dynavector, Epos, Grado, Naim, PMC, ProAc, Rega, Royd, Sennheiser, Talk Electronics, Teac and more. Bada members, 2 comprehensive demo rooms.

NORTHAMPTON

CLASSIC HI-FI At Classic Hi-Fi we cover the best in quality sounds. Be it a question of taste, a question of balance or a question of price, we're the ones to help. We stock: Marantz, Nad, Pioneer, Roksan, Yamaha, Heybrook, LFD, Sugden, Rotel, Kenwood, B & W, Kef, Rogers, Monitor Audio, Musical Fidelity, Tannoy, Shearman Audio, Royd, Audio Alchemy, Teac and many more. For more details call: 01536 310855

LISTEN INN 32 Gold Street, Northampton, NN1 1RS. Tel: 01604 637 871. The World's Finest Hi-Fi from Arcam, Audio Analogue, Chord Company, Copland, Denon, FMJ, Fujitsu, Kef, Krell, Linn, Loewe, Martin Logan, Meridian, Miller & Kriesel, Mission, NAD, Naim, Proac, Rega, Rotel, Sennheiser, Sonus Faber, Wilson Benesch, Yamaha. Dedicated Viewing & Listening Rooms, Friendly Staff, Fresh Coffee, 2 Full Years Warranty, Part Exchange Welcome, Free Car Parking, Interest Free Credit, Members of BADA. Open 10am-5.30pm (Closed Thursday).

NOTTINGHAMSHIRE

NOTTINGHAM HI-FI CENTRE 120-122 Alfreton Road, Nottingham. Tel: 0115 9786919. Multi-room specialists. Hi-Fi, Home cinema. All leading brands stocked. Three superb demonstration areas. Two year parts and labour guarantee. Home trials. On site service facility. Full delivery and installation service. Easy free parking. BADA Dealer. Established 1968. Mon-Sat 9.00-5.30

OXFORDSHIRE

OVERTURE HI-FI 3 Church Lane, Banbury, Oxon OX16 8LR. Tel (01295) 272158. Email sales@overture.co.uk Website: www.overture.co.uk Arcam, Bose, Cura, Denon, Kef, Linn Products, Miller & Kriesel, Mission, NAD, Naim Audio, Yamaha. For sensible unbiased advice, call Oxfordshire's audio experts. Superb demo facilities. No appts. necessary. Home Cinema, Plasma TV, Projectors, Lutron Lighting, MultiRoom and Commercial installations. Access/Visa, instant credit. Mon-Fri 10-6, Sat 9.30-5.30

SHROPSHIRE

ADAMS & JARRETT Hi-Fi and Home Cinema Specialist. Phone or visit us at 6-18, Norman Road, St. Leonards-on-Sea, E.Sussex. (01424) 437165/432398. Stockist of quality equipment including: Audio Innovations, Meridian, Kef, Ruark, Marantz, NAD, JBL, Royd, Dai, Jamo, Onkyo, Rel, Traget, Cable Talk, Technics, TDC, Yamaha, Kenwood. Air conditioned listening rooms, on site service and repair facilities

STAFFORDSHIRE

ACOUSTICA 114 Wolverhampton Rd, Stafford ST17 4AH. www.acoustica.co.uk Tel 01785 258216. All that's best in HiFi & Home Cinema from quality manufacturers including Naim, B&W, Musical Fidelity, Rotel, Selec Projectors, Kef, Ruark, Teac, JM Lab, Rega, NAD, Yamaha, REL, Sanyo projectors, Fujitsu. We offer friendly, helpful advice, interest free credit & trade-in facilities, and deliver & install systems throughout Staffordshire & the Midlands. Opening hours are Tuesday to Friday 10.30 until 6.00, Saturday 10.30 until 5.00.

SUFFOLK

ANGLIA AUDIO The Street, Hesseset, Bury St Edmonds, Suffolk, IP30 9AZ. Tel. 01359 270212. "Hi-Fi and speaker centre dedicated to quality hi-fi since 1971. Open 10-6. Closed Weds and Sundays. Evening and Sunday Demos by appointment.

AUDIO IMAGES 128 London Road North, Lowestoft, Suffolk, NR32 1HB. Tel: 01502 582853. Arcam, Acurus, Castle, Rotel, Moth, Triangle, QTA, Sugden, Denon, Yamaha, Mirage, M & K, Definitive, Musical Fidelity, plus the incredible Rothwell range. Refreshingly different selection. Dem Room, Professional AV installer's from budget to high end. Full credit facilities. 9.30 to 5.30 Mon & Sat ~ 9.30 to 6.00 Tues to Fri.

EASTERN AUDIO 41 Bramford Road, Ipswich, Tel. 01473 217 217. Fax 01473, 215705. Quad, Arcam, Audiolab, Meridian, Mission, Denon, Rotel, Marantz, NAD, Sony, Rogers, Nakamichi, Systemdek, Technics, Celestion, B&W, Tannoy, Morel Thorens and Top Tape. Also stock a wide range of accessories. usual credit facilities. A BADA dealer.

SURREY

INFIDELITY 9 High Street, Hampton Wick, Kingston upon Thames, Surrey, KT1 4DA. Tel. 020 943 3530. Email: infidelity@compuserve.com - Web Address: infidelity.co.uk Stockists of: Linn, Naim, Arcam, Meridian, Rega, B&W Nautilus, Neat, Proceed, Royd, M&K, Rotel, Stax, Shanhian, Dynavector. Open 10.30 - 7.00 Tues - Fri, 10.00 - 6 Sat.

SUSSEX (EAST)

ADAMS & JARRETT For the best Audio Visual Specialist with friendly helpful staff phone or visit us at 6-18 Norman Road St. Leonards-On-Sea, East Sussex. Tel. 01424 437165/432398. Copland, Castle, Denon, Densen, Dynaudio, Jamo, Kef, Kenwood, Marantz, Meridian, Musical Fidelity, NAD, Onkyo, Primare, Rel, Rotel, Ruark, Tannoy, Technics, Yamaha, interest free credit available subject to status. Visa, Mastercard.

WEST MIDLANDS

ACOUSTICA 114 Wolverhampton Rd, Stafford ST17 4AH. See our main entry under "STAFFORDSHIRE".

MUSIC MATTERS

Birmingham - 363, Hagley Road, Edgbaston. B17 8DL. Tel: 0121 429 2811.

Solihull - 93-95, Hubs Mount Road, B92 0JL. Tel: 0121 342 0254.

Stourbridge - 9, Market Street D48 1AB. Tel: 01384 444184.

Sutton Coldfield - 10, Boldmere Road, B73 5TD. Tel: 0121 354 2311. Arcam, Alchemist, Apollo, Audioquest, Audio Research, B&W, Cable Talk, Castle, Celestion, Chord, Copland, Cyrus, Denon, DPA, JBL, Kef, Krell, Marantz, Martin Logan, Meridian, Musical Fidelity, Panasonic, Pioneer, REL, Rotel, Ruark, SME, Sennheiser, Sonus Faber, Tag McLaren, Teac, Theta, Yamaha etc. Classical CD's available at Birmingham only. Demonstration rooms, service and installation. BADA member. VISA / MASTERCARD / AMEX / SWITCH. Open: 10-5.30 Tuesday to Saturday. Late night Thursday till 7.00 (not Stourbridge).

SOUND ACADEMY For the Midlands. The Parade, Sutton Coldfield, Tel. 0121 321 2445 & High Street, Bloxwich, Nr Walsall, (sharing the ASDA shopping centre) Tel 01922 493499. Hosts 4 private studios plus a Home Theatre Cinema with Tube & LCD Projectors. The best in hi-fi from Naim, Arcam, Audiolab, Chord, Meridian, Monitor Audio and many more. So... if you've taken time to read this, please let us make you welcome. Phone 0121 321 2445 for Sutton or 01922 493499 for Walsall. Call in and to browse our exciting display of hi-fi and home cinema equipment. Mail order available. interest free credit S.T. Status. Open 6 days, 9am to 5.30pm. Please call for late night. Expert Advice, Cable Dressing and Installation.

WILTSHIRE

SALISBURY HI-FI LTD 15 Catherine Street, Salisbury, Wiltshire SP1 2DF. Tel (01722) 322169/330841. Arcam, B&W, Celestion, Denon, Kef, Marantz, Meridian, Mission, Musical Fidelity, NAD, Opera, Pioneer, Ruark, Tannoy, Yamaha, 2 Dem

rooms. Friendly, relaxed atmosphere. Professional advice. Home dem available. Service department. Free installation. Home trial facilities. Access, Visa, Amex. Interest free credit. Instant credit. Open Mon-Sat 9-5.30.

THE RIGHT NOTE - See under BATH & BRISTOL heading.

YORKSHIRE (NORTH)

SOUND ORGANISATION YORK, 2 Gillygate, York YO31 7EQ. Tel (01904) 627108. Carefully chosen Hi-Fi and AV equipment includes Arcam, B&W, Nautilus, Denon, Linn, Naim, Rega, Rotel, Stax etc 3 dem rooms incl. Home Cinema and Linn connect. Service Department. Home installations. Instant Credit and major credit cards. Closed Mondays. Phone for chat and more details. www.soundorg.co.uk

YORKSHIRE (EAST)

ZEN AUDIO 35 George Street, Hull Tel. 01482 587397. "Comfortable listening rooms; Home dems; Personal, friendly service; Free installations. Agencies include: Arcam, Audiolab, Atacama, Audio Innovations, Audio Note, Audion, Alchemist, B&W, Cable Talk, Chord CO, DPA, Densen, Denon, DNM, EAR, Exposure, Fi-Rax, Harbeth, Heybrook, Impulse, KAR, Kef, Michell, Micromega, Monitor Audio, Musical Technology, Myriad, NAD, NAIM, Pioneer, REL, Rehdeko, Rotel, Royd, Ruark, Shearman Audio, Stands Unique, Sugden, Spondor, Sonic Link, TEAC, TDL, Tube Technology, Vivanco and many others.

YORKSHIRE (SOUTH)

THE HI-FI STUDIOS

Hi-Fi - Home Cinema - Custom Installation
Tel: Doncaster 01302 727274 or 01302 725550.
E-Mail: info@thehifistudios.freeserve.co.uk
Web Site: www.thehifistudios.co.uk
Musical Fidelity, Electrocompaniet, ProAc, PMC, JM Lab, Ruark, Castle, TEAC, Unison Research, Monitor Audio, Impulse, Primare, Harbeth, NAD, Michell Turntables, Nottingham Analogue Studios, Audio Analogue, Living Voice, Densen, Celestion, Kef, Opera, Trichord Research, Nordost, Stands Unique, Ortofon, Project, Goldring, REL, Denon, TAG McLaren, Rotel, Yamaha, Proceed - plus many more. Viewing & Demonstration by appointment in a unique setting. Home trials and installation. Card facilities and 0% available. Please phone for more information. BADA. CEDIA.

YORKSHIRE (WEST)

Huddersfield Hi-Fi Centre

Hi-Fi • AV • Widescreen Plasma • Installation Service
4 Cross Church St. Huddersfield. 01484 544668. Brands inc. Arcam, B&W, Castle, Kef, Marantz, Mission, Musical Fidelity, NAD, Project, Sugden etc. 2 Dem Rooms, Mon-Sat 9-5.30, Thurs 9-8, Closed Wed.

Huddersfield Hi-Fi Centre Halifax
3-5 King Cross St. Halifax. 01422 366832. Brands inc. Arcam, B&W, Castle, Kef, Marantz, Mission, Musical Fidelity, NAD, PRO-AC, Project, Sugden etc. 2 Dem Rooms, Mon-Sat 9-5.30, Closed Thursday.

WALES

NORTH WALES

ACOUSTICA 17 Hoole Rd, Chester CH2 3NH. Tel 01244 344227. See our main entry under "Cheshire".

ACTON GATE AUDIO 4 Ruabon Road, Wrexham, North Wales. Tel. 01978 364500. See our main ad under Cheshire.

VINYL/RECORD MAIL ORDER

DIVERSE VINYL 10 Charles Street, Newport, NP20 1JU. Tel/Fax: 01633 259661/256261. Email: sales@diverse-music.co.uk Probably the most varied and impressive selection of brand new LPs you'll find anywhere: international new releases, reissues and audiophile products. Also UK distributor of the Disco Anti Stat LP Cleaning Device. Call for a free catalogue, or visit www.diverse-music.co.uk

PRE-OWNED MAIL ORDER

AFFORDABLE AUDIO. (NORTHAMPTON) Pre-Owned Hi-Fi Specialists. 168 Wellingborough Road, Northampton, NN1 4DU. Tel/Fax: 01604 231261 or Tel: 01933 273281 Mobile: (0370) 877893, Email: sales@affordable-audio.co.uk Website: www.affordable-audio.co.uk Urgently required: compact disc collections, hi-fi separates, especially Linn products, Naim Audio, Cyrus Electronics, Musical Fidelity, Quad Electronics, almost anything British/American. Cash waiting, part exchange welcome. We also stock lots of audio accessories, compact discs, vinyl, DAT players. All equipment is sold with warranties. All Credit Cards accepted. Please phone anytime for stock update.

DIAL-A-DEALER

MEET-YOUR-MAKER

A reference guide to Britain's manufacturers and distributors

AFFORDABLE VALVE COMPANY £600 Valve amplifier. Powerful 40 watts. Powerful bass. See colour photograph in 'Specialist Hi-Fi Dealers' section. Mr Andrew Everard in Gramophone Magazine "delivers a sound that's both smooth and refined...allied to a good degree of clarity and finesse" Free colour literature. Telephone 01634 373 410 anytime. Website: www.affordablevalvecompany.com

AUDIOPHILE FURNITURE LTD The Square, Forest Row, East Sussex RH18 5ES Tel: 01342 826262. Fax: 01342 824845. Manufacturers of the patented BASE Vibration Control Platforms and the Modular Audio Support System. These Products are endorsed by Hi-Fi World. Also newly introduced are the Resonance Controlled Hi-Fi Cabinets which are multi level modular design and available in various sizes and wood finishes. Please telephone for more details and a product portfolio.

AUDIO SYNTHESIS Manufacturers of the outstanding DAX digital to analogue converter, comes DAX-2, a new Hi-End reference converter able to dig deeper into the digital source than ever before! A new addition to the superb PASSION series of all Vishay controllers has just been introduced in the form of PASSION 8, a fully remote controlled uniquely transparent passive preamplifier, the perfect match for DESIRE. By word of mouth our DESIRE power amplifier is rapidly convincing listeners, whether passive or active! New for 1997 is TRANSCEND a state of art CD transport with AES, coaxial, AT&T glass and Toslink outputs. Audio Synthesis, PO BOX 50, Nottingham, NG9 1DZ. Tel: (+44) (0)115 922 4138. Fax: (+44) (0)115 922 9701.

BORDER PATROL 63 Berriedale Avenue Hove BN3 4JD Tel/Fax 01273 276716. Manufacturers of Power Supply Units for valve amplifiers, Single-Ended Power Amplifiers and high quality Transformers. The Border Patrol PSU: valve-rectified choke input filter power supply units which dramatically improves the sound of valve amplifiers: models available to suit Audionote, Audio Innovations, Audion, Art Audio, Cary, Unison Research, World Audio Designs. The Border Patrol 300B SE single-ended valve amplifier featuring interstage driver transformers and valve rectified choke input filter power supplies. Border Patrol transformers: high quality output (PP and SE), interstage and pre-amp output transformers and high value inductors.

CREEK AUDIO LTD 2 Bellevue Road, Friern Barnet, London N11 3ER Tel: 020 8361 4133, Fax: 020 8361 4136. E-mail: info@creekaudio.co.uk Internet: www.creekaudio.co.uk - Creek Audio build stylish Hi-Fi products in the UK, combining state of the art electronic design, with full bodied, accurate and musically rewarding sound. Our standard size products come in two award-winning ranges, the entry level 43 series and higher priced 53 series. These include: CD43 Mk2 - CD player with 24 bit resolution DAC, T43 AM/FM Tuner, Integrated Amps - 5350, 5350SE and 4330 MK2 (described by Stereophile Magazine as the best amp under \$1000). Our A43 Mk2 and A53 Power Amps range from 50 to 250 Watts and both P43 and P53 Pre-Amps offer passive and active operation with remote control. In addition we have an award winning OBH range of small products: OBH-8/8SE MM and OBH-9 MC Phono Pre-Amplifiers, OBH-11 and 11 SE Headphone Amplifiers, OBH-10 and 12 Remote Control Passive Pre-Amps and OBH-14 - 24 bit DAC. See our home page for further details or call us for leaflets.

DBS AUDIO. PO BOX 91, Bury St Edmunds, Suffolk. IP32 7JU. Phone: 01284 723933 Fax: 01284 723933. Suppliers of Electro-Acoustic measuring equipment and CAD software to the audio industry. NEW: Clio win and Clio win Lite, the latest Windows versions of the Globally-established Clio Electro-Acoustic measuring system, used for loudspeaker design. Quality Control and electronics testing by many major audio companies. Clio win is the full (lab) system and Clio win Lite a lower-cost version for smaller companies and serious hobbyists. Both use the same purpose-built Clio HR200 ISA card, with its in-built mic, pre-amp and phantom powering. The matching Mic 01 (or Mic Lite) plugs straight in to make a complete system. Both versions offer the same high accuracy and ease of use: Clio win Lite simply has fewer functions. Common features include MLS testing (to eliminate sound reflections), sine and third-octave analysis, impedance, Thiele Small Parameters, LC meter, software and manual on CD ROM -- plus much more. Measurements may be exported to our Netcalc soft-

ware for accurate and easy crossover design. Also available: Boxcalc and Boxdraw bass optimisation packages and Outline speaker measuring turntable. Write or E mail and we will send fuller information and prices. Also, visit Audiomatica's new Website at: www.audiomatica.com

EMINENT AUDIO Distributor of Croft Valve Amplification Tel 01902 656517. Fax 0121 681 8772. Mobile 0956 921740 U.K. Stockists are: Classique Sounds (Leicester) GT Audio (London NWV) Nottingham Analogue, Purist Audio, The Cartridge Man (Len Gregory - Croydon), call for overseas distributors.

EPOS ACOUSTICS 2 Bellevue Road, Friern Barnet, London N11 3ER. Tel: 020 8631 8864, Fax: 020 83614136.

Email: info@epos-acoustics.com Website: www.epos-acoustics.com. Innovative design and superior sound distinguish EPOS speakers from other brands in a similar price category. Adhering to the EPOS tradition of musicality and communication, the new M12 follows closely the style of the successful ES12, and was awarded five gold stars in the March 2001 edition of What Hi-Fi? For more information about the M12 or the new M15 please see our home page or call us for leaflets.

FALCON ACOUSTICS LTD Tabor House, Norwich Road, Mulbarton, Norwich, Norfolk, NR14 8JT. Tel. (01508) 578272. U.K. distributors of FOCAL drive units and SOLEN (Chateaux) polypropylene capacitors and the largest inductor manufacturer in the U.K. Comprehensive range of DIY Speaker Parts and Kits, Sub-Bass and Electronic Filters. "Everything but the wood" Enquiries should be accompanied by a 44p stamped addressed envelope.

IAN EDWARDS The Old Chapel, 282 Skipton Road, Harrogate, Yorks. Tel. 01423 500442. Somebody Somewhere must make better storage units for CDs, Music, LPs, HiFi, Books, etc. than Ian Edwards. BUT until he appears, why not send for the brochure showing a selection of HAND MADE units. To do this please send 3 x 2nd class stamps.

JEM DISTRIBUTION (FI RAX) Springfield Mills, Spa Street, Ossett, Wakefield, WF5 0HW. Tel: 01924 277626. Fax: 01924 270759. Fi-Rax offers a new dimension in audio visual racking. High quality aluminium construction. Finishes available to your choice. Fully adjustable 6mm glass shelving sound insulation on shell/feet. Custom created to suit your system. Free delivery throughout the UK. For further information or a free brochure contact JEM Distribution.

LANGREX SUPPLIES LTD 1 Mayo Road, Croydon, Surrey. CR0 2QP. Tel: 020 8684 1166. Fax: 020 8684 3056. One of the largest distributors of electronic valves, tubes and semi-conductors in the UK, and USA manufacturers. stock. We specialise in obsolete types including original UK and USA made audio valves. Telephone or fax for an immediate quotation.

NORTON TECHNOLOGIES LTD Manufacturers of the acclaimed AirPower LP12 Power Supply. 14 Rothesay Avenue, Chelmsford CM2 9BU. (01245) 283125

NOTTINGHAM ANALOGUE STUDIO Tel: 01773 762947. Design and manufacture of quality analogue audio. We're in the business because we realise how important music is. Our turntable arms and cartridges sell the world over. Our Main UK Dealers: Radlett Audio. Tel: 01727 85577. The Audio Consultants: Tel: 020 7380 0866. Walnut Systems: Tel: 020 7724 7224.

PLATFORM 7 High density marble ISOLATION PLATFORMS for all makes of equipment RACKS/STANDS. An elegant way to UPGRADE. Improves clarity better BASS control. 3 Abbots Drive, North Wembley, Middlesex HA0 3SB. Tel: 020 8904 2646. Also NEALGAR DISTRIBUTION Tel/Fax 01296 24756.

PMC/BRYSTON Emmy award winning manufacturers of the highest quality loudspeakers and amplification. Industry standard in Mastering, Film Scoring, Broadcast and Post Productions. (5.1 & Stereo) PMC Products: Compacts, Floorstanders, and Large passive & active monitors. Prices range from £500 to £32,000. Finished in a large selection of exquisite real wood veneers, all PMC loudspeakers are available in horizontal mirrored pairs, centre channels and complementary subs for 5.1 surround systems. Bryston's balanced range of products include R/C Preamps, Integrated Amp modules for all the PMC range, Mono, Stereo 150WV to 800W per ch, 3 Ch, 4 ch and 5 channel THX amplifiers, Surround processors,

all with distortion figures and build quality to die for. Every product is available in silver or black backed by a 20 year warranty. PMC Ltd 43-45 Crawley Green Road, Luton, LU2 0AA. Tel: 08704 441044 Fax: 08704 441045 Email: sales@promonitor.co.uk Web: www.pmc-speakers.com

REL ACOUSTICS North Road, Bridgend Ind Est. Bridgend, Mid Glamorgan, CF31 3TP. UK. Tel. 01656 768 777, international +44 656 768 777. Fax: 01656 766 093. international. +44 656 766 093. Email: contact@rel.net Web: http://rel.net The UK's only specialist sub-bass speaker manufacturer. "The only one that works". Get your dealer to give you a home demo and find out what the fuss is all about.

RDE TANDBERG HI-FI SERVICES Holly Tree House, The Green, Full Sutton, YORK YO4 1HW. Tel: 01759 372795. The service, overhaul and reconditioning of all Tandberg hi-fi products regardless of age.

SONIC LINK The Derwent Business Centre, Clarke Street, Derby. DE1 2BU Tel: 01332 361390. Fax: 01332 200698. "Makes the World's Finest Hi-Fi Cable From the Highest Quality Materials" SonicLink Black Rhodium interconnect uses Rhodium plated wire, Vermillion uses pure Titanium wire. S-Gold mains cable improves the picture quality in TVs, computer monitors and home cinema as well as sound in hi-fi systems. Best selling products include Red, Silver Pink and Violet interconnects, AST75x2 AST200x2 and S130x2 Biwire loudspeakers cables and Green digital 75 ohm interconnect.

SOUND BYTES 72 Novar Drive, Hyndland, Glasgow, G12 9TZ. Tel. 0141 339 7595 Fax. 0141 339 7592 e-mail bytes@colloquium.co.uk. We specialise only in mass loading material. After hours exhaustively testing SOUND BYTES with various types of speakers, we know it works and so do you - we have never had a single complaint. Call us for advice on how much to add to your equipment for the best performance and the location of your nearest dealer.

SOUND IMAGE UK LTD. 52 Milton Road, London SW14 8JR. Tel: 020 -8255-6868. Importers and distributors of the finest audio equipment, featuring the stunning Boulder 2.000 series and the complete range from Norwegian manufacturer Electrocompaniet.

JE SUGDEN & CO LTD Valley Works, Station Lane, Heckmondwike, West Yorkshire, WF16 0NF. Tel. 01924 404088. Email jesugden@compuserve.com. Superb amplifiers and compact disc players from the original class A Company. Our unique wide-bandwidth Masterclass series sets new standards in sound reproduction and can be upgraded to 180 Watt balanced monoblocks. Prices start from £549.00 for the incredible Audition-T and £649 for the legendary A21a. Contact us now for Brochures, reviews and purchase details. British owned - British built.

TALK ELECTRONICS Unit 12, Farnborough Business Centre, Eelmoor Road, Farnborough, Hampshire, GU14 7XA. Tel: 01252 378383. Please ring for details

TAG McLAREN AUDIO - The Summit, 11 Latham Road, Huntingdon, Cambs, PE18 6ZU. Tel +44 (0) 1480 415600 Fax +44 (0) 1480 52159. Combining science and technology with distinct style, TAG McLaren Audio's complete range of audio and audio-visula products are designed to bring maximum pleasure to the discerning listener. To find out more visit our website at www.tagmclarenaudio.com, email us on HelpDesk@tagmclarenaudio.com or contact our helpdesk on freephone 0800 783 8007.

TECH-LINK distributes some of the best performing hi-fi and a/v accessories currently available in the U.K. These include: Puresonic, best known for its range of high performance interconnects and connectors, and cable adapters for a wide variety of hi-fi and a/v applications in its range; Tech-Link's own brand Switch Boxes are the perfect solution to multiple applications - for example, its highly acclaimed TAS-1 is a very practical and inexpensive way of switching your speakers between hi-fi and home cinema systems; and Shark - a range of very exclusive high quality cables, interconnects and connectors. For more information, contact: Tech-Link at Units 1/2, 76a Farnley Road, London, SE25 6NX. Tel: 020 8771 8388, Fax: 020 8771 1840.

To advertise in Meet Your Maker please call Ewan Hawkes on 020 7624 9022

MEET-YOUR-MAKER

computer

advertising@computeraudio.co.uk

editorial@computeraudio.co.uk

news@computeraudio.co.uk

audio world

www.computeraudio.co.uk

BIG AUDIGY DYNAMITE

David Price tries out Creative Labs' latest and greatest computer audio tour de force, the SoundBlaster Audigy Platinum.

In the world of serious soundcards, Creative Labs is not a name to drop. The company made its name in bringing bleeps and buzzes from the latest PC CD-ROM games straight to your multimedia loudspeakers. Never in its original gameplan did it expect to usurp the likes of Digidesign or Yamaha in the grown up world of pro computer audio recording.

The SoundBlaster Live! was its first foray into the world of sonic respectability. It wasn't half bad, bringing an admirable blend of facilities (including those all-important digital audio ins and outs) along with reasonable sonics to countless cash-strapped computer audiophiles. But neither was it quite good enough - its EMU101K chip converted everything to 48kHz oversampling, preventing bit-for-bit copying of 44.1kHz sources (i.e. CD-quality digital audio). The onboard converters weren't particularly special either, although to be fair they weren't bad at the price.



Nevertheless, this was the card Brits, Yanks and Europeans turned to in droves when they wanted something just a bit better than the rubbish that came bundled with their PCs as standard - and quite right too.

That's all old hat now, because the new Audigy promises all this and more - "The Definitive Professional Audio Solution", as CLabs so modestly puts it! Without getting into ridiculous detail, it promises better sound (thanks to its 24/96 resolution digital converters), more powerful

digital signal processing and better connectivity.

The new converters give a claimed signal-to-noise ratio of 100dB, and a new EAX, Advanced HDT chip (processing up to 4 complex environments simultaneously, and offering new algorithms like Environment Panning and Morphing) will keep gamers and musicians happy.

Last but by no means least is SBI394T connectivity - which is Creative Labs-speak for FireWire.

FIREWIRE

The new Audigy offers 'SB1394T Connectivity' which is Creative Labs' Speak for FireWire. This is a high speed serial data connection in IEEE 1394 specification, giving data transfer rates of up to 400Mbps, plus hot-plug support for EASB of connecting or disconnecting external devices, intercomnection of up to 63 devices. There's one FIREWIRE socket on the LiveDrive, plus another round the back on the soundcard's rear panel.

◀ Yes, the Audigy offers two FireWire connections, which are a dream come true to anyone doing serious digital audio or video editing.

One of the Audigy Platinum's best features - carried over from the latter versions of the SBLive! - is the LiveDrive. It's a silly name for an incredibly useful thing. Essentially it's an interface panel that slots into one of the spare (five and a quarter inch) drive bays in your PC and offers front panel (hurrah!) access to all your digital inputs and outputs, plus that all-important FireWire. It's bristling with features - there are connectors for optical and coaxial digital ins and outs, a quarter inch headphone jack, complete with volume control, a quarter inch Line In 2 and Mic In 2 with gain control, MIDI In and Out (using mini DIN connectors), a stereo Aux In (using two RCA phonsos - perfect for hooking up to your hi-fi), a single FireWire port and an Infra-red Receiver.

GET CONNECTED

At a stroke, fumbling around the back of your PC is banished. Want to record direct from your DAT or MiniDisc? Fine, no problem - just plug its optical or coaxial cable into the LiveDrive, select it using the bundled software and Bob's your funny uncle! Want to hook up your portable CD writer? Easy - just plug it into the front panel. This feature alone makes computers take one step nearer the big wide world outside. You can tell the folks at Creative Labs have been thinking more about real people using computers for audio than anyone at the swanky soundcard manufacturers ever did!

LiveDrive aside, the Audigy is a standard PCI soundcard that fits into a slot on your motherboard, its rear panel facing out onto the outside world offering up 3.5mm line level stereo minijack sockets for front and rear speakers to take advantage of the unit's full Dolby Digital 5.1 multi-channel surround capabilities (yes, it's got that too). You also get 3.5mm jacks for Line in, Mic in, headphones

out and a second FireWire, while on the card itself are analogue CD in and digital audio in ribbon connectors.

Onboard is a 32-bit chip that does all the sound effects, synthesis and digital signal processing. It offers real-time digital effects like reverb, chorus, normaliser, pitch shifting, and distortion across any audio source, and also has a customisable Plug-In Effects architecture which allows new audio effects to be downloaded from the net. It can play back up to 64 different audio channels simultaneously, each with its own independent sample rate. The 24bit digital converters work at up to 48kHz sampling rates. When 16bit resolution is selected, they offer 8, 11.025, 16, 22.05, 24, 32, 44.1 and 48kHz sampling frequencies, with 96kHz achievable by upsampling or downsampling to 48kHz before processing.

BUNDLE OF JOY

As with the SBLive! Platinum, the software bundle is frankly dazzling. The Creative Labs software includes Audio HQ, Creative Recorder, Creative TaskBar, Creative Remote Center, Creative Surround Mixer, Creative MiniDisc Center, Creative PlayCenter 3, Creative WaveStudio, Creative Oozic Reactor, Creative Diagnostic, Creative Vienna SoundFont Studio. Essentially this is all the basic sound editing, recording and music making software you'll ever need, and then some. Then there's the 'third party' software, including Steinberg's Cubasis VST, WaveLab Lite and ReCycle Lite (Soundfont Edition), Ulead VideoStudio 4.0 SE Basic, Arturia's Storm - Platinum Edition, MixMeister Technology's MixMeister 3.03, Unibrain S.A.'s FireNet 2.x, iM Networks Inc.'s iM Tuner (Internet radio). This is quality - Steinberg's WaveLab Lite being a particularly capable audio recorder.

As with all soundcards these days, there's nothing terribly complex about getting it up and running. Basically, you remove one of the blanking plates from the back of your

PC case, slot the card into a vacant PCI slot on your computer motherboard, push out one of the front drive bay blanks on your PC's case and slot in the LiveDrive, screw everything into place and connect up the various ribbon cables in the way shown in the manual. Then it's a case of switching on and letting Windows detect the new hardware, pointing it in the direction of the drivers contained on (one of) the bundled CD-ROMs. This done, you can load up as much (or as little) of the bundled software at your leisure - the most useful being Creative Audio HQ which handles all the basic audio activities.

Sound quality is obviously better than the previous SoundBlaster Live!, but don't expect it to topple the likes of, say, Guillemot's MaxiSound ISIS. It has a smooth, rounded character with impressive levels of detail and a firm, tight - if somewhat lightweight - bass and crisp treble. The Audigy's new DAC is a real improvement over its vague and wishy-washy sounding processor - with its handling of dynamics and rhythms now reaching respectable budget hi-fi standards.

This card is not a specialist hi-fi 'audiocard', and if you expect it to be you'll end up disappointed. But if you want to dip a toe into the world of computer audio - including playing back WAV, MP3 and AAC files, recording or copying analogue or digital hi-fi sources or doing basic audio restoration - it's absolutely brilliant. The sound isn't bad, but the LiveDrive, complete with FireWire connectivity, turns your PC into a powerful, versatile multimedia tool that you can easily hook up to your hi-fi equipment. Considering the welter of bundled bits, it's a bargain at its (often discounted) £153 selling price. The best starter soundcard ever made. ■ ▲

SPECIFICATIONS

Creative Labs claim an A-Weighted signal to noise ratio of 100dB, a crosstalk figure of 100dB, Total Harmonic Distortion & Noise at 1KHz (A-Weighted) of 0.004% and a frequency response of 10 Hz to 22 kHz (-3dB). These are based on digital-to-analogue audio playback (e.g. CDDA, WAV, MP3, Dolby Digital).

World Verdict

Not the best soundcard ever made, but an awesomely well put together package with brilliant connectivity. A bargain for beginners!

SUBSCRIPTIONS



UK SUBSCRIPTION £27

VISIT OUR WEBSITE: www.hi-fiworld.co.uk

Get your issue of **hi-fi** straight to your door!

Get to our amazing classified ads first and grab a bargain!!

Run by dedicated hi-fi engineers and enthusiasts, HI-FI World has become famous for its informative reviews and radical kit designs.

MISSED AN ISSUE?

Back issues also available at a cost of £3.50 only (includes P&P), payment by cheque only - overseas please contact us for details.

Send cheque to: Hi-Fi World, Freepost LON3478, London, NW6 6YR.

OVERSEAS SUBS RATES

Airmail Middle East & South-East Asia	£60	Airmail Europe	£50
Airmail USA, Canada, Australia, Japan, Korea & China	£70	Surface Mail	£40

Credit Card Hotline Monday - Friday 9.30am - 12.00 noon: Tel: +44 01923 270 833 Fax +44 01923 260 588

By post: Make cheque or postal order payable to: Audio Publishing Ltd, sent in an envelope marked: Hi-Fi World, Freepost LON3478, London, NW6 6YR

HI-FI WORLD SUBSCRIPTION FORM

I would like to pay by cheque made payable to Audio Publishing Ltd. Credit Card Airmail Surface Mail

Please debit my VISA/MASTER/SWITCH Card No. (Switch card issue No _____)

Expiry Date: _____ Cardholder Signature: _____



Name _____
Address _____

Delivery Address (if different) _____

Post Code _____

Daytime Tel: _____

Start Issue _____

MAC AT

David Price previews at the tastiest digital audio player dish this year, Apple's iPod.

► **A**n event at Apple's headquarters in Cupertino, California in October saw Steve Jobs announcing, "the unveiling of a breakthrough digital device", with the catch being, "hint: it's not a Mac".

Apple's iPod is an important product for two reasons. First, it's a brilliant bit of kit in its own right that raises the digital walkie game still higher. Second - and more importantly - it's further confirmation, as if we needed it, of which way the wind is blowing for both the recording and IT industries. Here we see one of the computer business's most influential players (with a tremendous canon of innovative design behind it) going out on a limb to bring digital music to the masses. And when it's Apple, you just know it's gonna be tasty!

iPod is a digital music player 'the size of a deck of cards' which stores 1,000 songs on its hard drive. It costs £329 for the stainless steel cased version. Like Creative Labs' DAP Jukebox that came over a year before, it has a 5GB hard drive (offering around 1,000 'CD quality' songs), but iPod connects to Macs only using FireWire via Mac OS 9 and Mac OS X. It includes a 10-hour lithium polymer battery and offers 20 minutes of anti-skip protection. The software bundled is Apple's famous iTunes, which syncs with iPod automatically. A free download of this is now available from Apple's website at www.apple.com/ipod/itunes.html.

From the acknowledged masters of modern industrial design - if you

don't believe me then look at how many High Street electrical goods now have iMac-style translucent plastic bits - iPod is a slick bit of kit. It is not, however, innovative looking. It gets its beauty not from any particularly striking form, but its impeccable build quality, slim (102x62x19mm) dimensions and ergonomic

brilliance. Its crisp, fine pitch 160-by-128-pixel six line high-resolution display is backlit by white LEDs, which not only makes it supremely readable but also kind of different.

The Auto-Sync system automatically downloads all your iTunes songs and playlists into your iPod whenever you dock it, and keeps them up to date. This removes the most tiresome part of running a digital audio portable at a stroke. Steve Jobs again; "With iPod, Apple has invented a whole new category of digital music player that lets you put your entire

music collection in your pocket and listen to it wherever you go". Not completely true this - vis the aforementioned CLabs DAP Jukebox and Hango's PJBox - but iPod certainly integrates better with its host computer than most.

FireWire is the key to its slick operation. It lets you download an entire CD into iPod in under 10 seconds and 1,000 songs in less than 10 minutes. That's 30 times faster than USB-based players. The days of snail-like Rio 300 parallel port connections are gone forever! Better still, the FireWire cable also allows the unit to function as a portable hard drive for storing large computer files, graphic images and digital movies! Power management is no less impressive. When you're transferring music via FireWire, iPod automatically

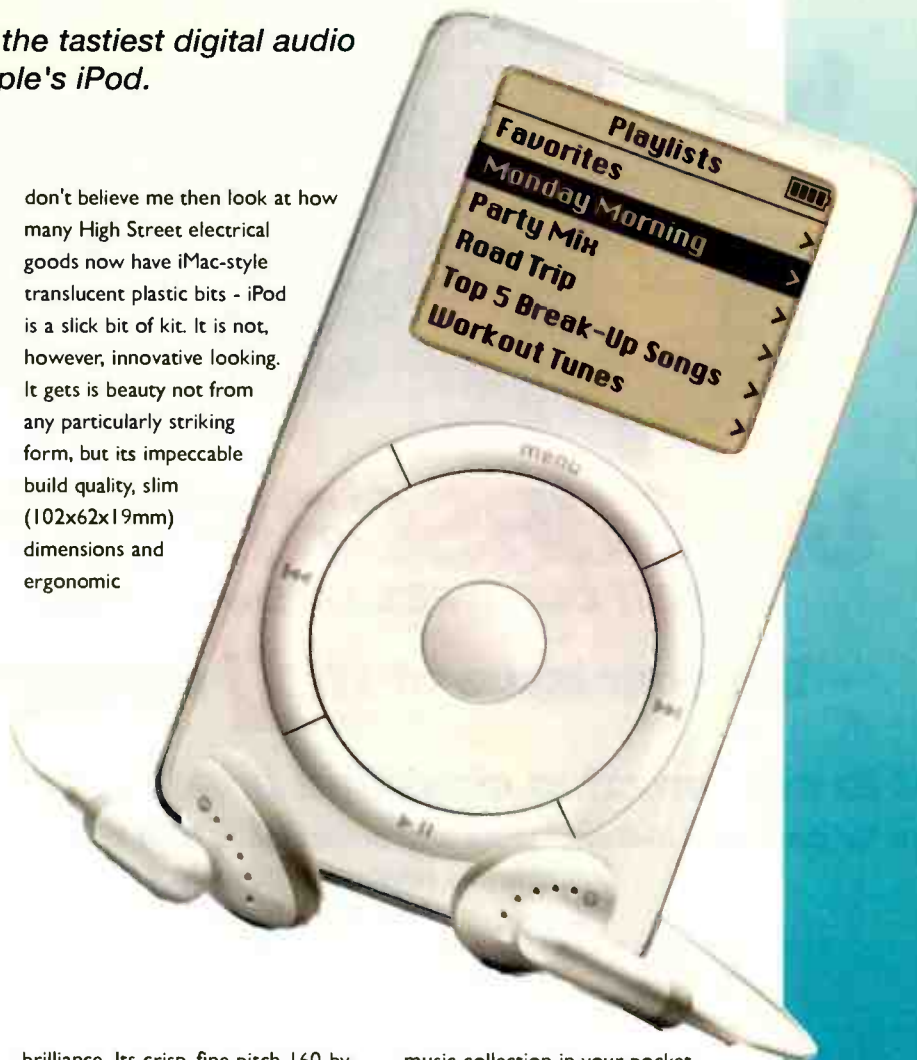

MAC- WHO?

Apple ignited the personal computer revolution in the 1970s with the Apple II and reinvented the personal computer in the 1980s with the Macintosh. Apple is committed to bringing the best personal computing experience to students, educators, creative professionals and consumers around the world through its innovative hardware, software and Internet offerings.

TACK!

charges its internal batteries, but you can also recharge using the supplied AC adapter when you're on the go. The 32MB memory lets the device achieve its impressive 10 hour battery life (between charges) by limiting the amount of time the hard drive is spinning.

Never one to follow others as far as ergonomics go, Apple's iPod uses a novel scroll-wheel, which you operate with your thumb to access your music collection. This lets you scroll through your various playlists with just one hand, and even automatically speeds up when going through long lists. It also has a vast range of

customisable settings, like shuffle, repeat, start-up volume, sleep timer and menus in multiple languages including English, French, German and Japanese. It even displays song data in any of these languages, letting you mix and match songs from all over the world.

iPod plays music in MP3 and MP3 VBR (variable bit rate) formats at up to 320kbps, as well as AIF and WAV formats. Shame there's no support for AAC though, although this should only be a matter of time. Certainly, there's upgradeable firmware for precisely this reason. Interestingly, Apple has paid attention to the non-

headline matters of the analogue output stage - iPod is equipped with a (relatively) beefy 60mW amplifier and even the bundled headphones have half-decent neodymium magnets for better sound. The package also includes the aforementioned iTunes 2 CD, FireWire cable and FireWire-based power adapter. ■ ▲

APPLE IPOD £329

Apple UK2 Furze Ground Way
Stockley Park East,
Uxbridge

Middlesex UB1 1BB

Apple Store 0800 039 1010.

www.apple.com/ukstore

COMMENT - WOT NO PC?

Why has Apple just launched a brand new digital audio portable now - when (a) it doesn't support PCs and thus excludes 90% of its target market, and (b) the profit mark up on a low priced (\$399) digital audio portable is far lower than a premium priced, added-value computer such as an iMac?

The answer is obvious - to bolster its own platform to the exclusion of its arch rival Microsoft. Music is a killer application for computers - the writing has been on the wall for a while now - and Apple isn't stupid. If it can make the best functioning, most sleekly designed digital walkie then people will want to buy the platform it requires - Mac computers. Well, this is the theory. Getting style-conscious, music loving consumers into Mac showrooms is an important way of selling Apple's somewhat overpriced and esoteric (by the low standards of a PC saturated market, at least) computers. Its launch date is also eerily similar to that of Microsoft's new XP operating system. Ho hum!

The iPod isn't the epoch-making product the Creative Labs DAP Jukebox was in the autumn of 2000.

It's essentially the same, but noticeably smaller, sleeker and more user friendly thanks to some clever ergonomics work and a FireWire port. Whether this will be enough to get people into Mac showrooms remains to be seen. It's an audacious move to try to sell into a tight consumer market, and one that the likes of Sony and Panasonic (in Japan at least) appear to have sewn up. The high-ish £329 price might just be a little too much to potential purchasers who also need to buy a computer to go with it. The iPod is brilliantly specified, but whether the product's target buyers want such a robust feature set at such a high price is a leading question.

Greg Joswiak, Apple's Senior Director of Hardware says there are about 7 million Macs with a FireWire port, and that, "we have very little doubt that every (iPod) we build, we can sell". He adds nonchalantly that the focus this year was on bringing the iPod out for Macs, but says the company will consider making it compatible with Windows-based PCs "when we get some free time. While we know the experience won't be as good (with

a PC), we will probably look at that down the road".

So can Apple prevent users from connecting an iPod to a Windows PC right now? Highly unlikely. Indeed, the company once tried to make its own wireless LAN (Local Area Network) a Mac-only product, but the AirPort was quickly modified to be accessed from PCs. In truth, the iPod is essentially just a glorified hard drive - what gives it its 'iPod-ness' is the iTunes software, which can likely be modified too.

The only real problem is the communications technology that transfers the music data uses FireWire (IEEE 1394 serial communications protocol), which all modern Macs - but only a few PCs - have. Windows PCs are designed by Intel, which until very recently decided to focus on the rival USB (Universal Serial Bus) technology. Now though, FireWire is arriving on PCs en masse, and the only iPod incompatibility being that it loses the charging facility whilst transferring music. Whether iPod massively boosts Mac sales, or just those of add-on PC FireWire cards, remains to be seen!



World Verdict



An elegant mp3 player for aspiring Mac owners with deep wallets. Esoteric.

CATCH THIS!

lomega's new Predator CD-RW is taking portable CD burning to new heights, says David Price



From the company that brought you the Zip, Jaz and Klik! drives - and latterly the HipZip - comes one of its most mainstream and conventional products. By lomega standards, that is - because as CD burners go, this is avant-garde stuff. Although a direct rival to Sony's brilliantly designed but poorly executed Digital Relay, and more recently Plextor's capable but dull S88TU, lomega's Predator CD-RW FireWire promises the best of both worlds. It's hip and funky like the former, and very nearly as well screwed together as the latter.

It's an incredibly versatile little product, and so it should be at its hefty £250 price tag. It reads, writes or rewrites most types of CD formats, making it an ideal storage solution for users who want to copy and distribute music (perish the thought!) or any other data, for that matter. You can save your own music compilations (or CD copies) on to standard CD-Recordable (CD-R) and CD-ReWritable (CD-RW) disks, which then play in most modern CD players. Unlike hi-fi CD recorders, which use the expensive, audio grade blank discs, being a computer burner, the Predator uses cheap data blanks costing under 50p per 74 minute disc. The results are exactly the same as the audio discs, the difference in price being down to an arcane copyright levy charged on the audio discs, plus the intense price competition that data grade CD-Rs are subject to.

The Predator comes in a number of guises, both PC and Mac compatible with a choice of FireWire or USB interfaces (although the latest USB 2.0 isn't available yet, at the time of writing). In its faster FireWire guise, it offers respectable 8x4x32 speeds (just a little slower than the Plextor reviewed last month, but far faster than the Sony). The package includes the drive itself, a FireWire data cable, audio cable, external power supply with European power cord and a single CD-R disc is supplied. The PC package tested here came bundled with MusicMatch Jukebox Plus, Adaptec's Easy CD Creator 4.0 and Direct CDTM 3.0, lomega QuikSync 2 (albeit a 30 day trial version) and Adobe Activeshare. Mac versions have Adaptec Toast 4.1.2, MusicMatch Jukebox Plus and MGI Photosuite.

lomega know a thing or two about making boring old computer peripherals both interesting to look at and easy to use. You can make your own minds up about its aesthetics, but the manual is undoubtedly one of the best of its type I've seen. There's a beginner's section with basic, step-by-step instructions which even computer duffers can follow. Clear, concise and colourful, it's typical of the company's ethos. Starting up was a breeze, with all the software installing easily from a single, common menu. The bundled Adaptec EzCD 4.0 software is pretty behind the times these days, but in truth it's little inferior to the latest Roxio EzCD 5 once you've got the hang of it. Computer audiophiles will doubtless appreciate its built-in, on-the-fly MP3 to WAV conversion facility.

(using EzCD, for example) are rapid and reliable. As always though, it's best to stick at 4x or under for audio use, lest you get flangey, phasey effects. The Predator makes fine sounding discs (as I always say, the media seems to have as much, if not more, effect than the burner), although they could be slightly inferior to the superb Plextor S88TU, which is admittedly far more expensive.

Generally then, a fine product. The lack of a BURN-Proof facility is a glaring omission, but then again this is a cheaper, more mass market device than so-equipped CD-R portables. If this doesn't worry you - and it won't unless you're doing other work on your PC while you're burning CDs - then the lomega Predator comes heartily recommended. ■ ▲

lomega Predator Firewire
External £250.21
www.lomega.com/europe

PREDATOR SPECS

Write 1.2MB/sec, Rewrite 0.6MB/sec, 650MB general capacity. Up to 80 minutes of audio. Random access time: up to 125ms. System requirements: Pentium 166 MHz or higher, IBM PC compatible with available 5.25" drive bay, Microsoft Windows 95/ 98/ 2000/ NT 4.0, 4x CD-ROM drive, 16MB of RAM to run software or 740 MB hard drive space (for original CD duplication)

WHAT'S FIREWIRE?

Also known as IEEE1394, it's a very fast and convenient system that connects computers to external peripherals. It's faster than the older USB system, but retains its superb 'hot swappable' facility which lets you plug and unplug things without having to switch off the computer first.

World Verdict

Fine value PC CD burner with superb ergonomics and useful software - only the lack of a BURN-Proof facility detracts from its obvious charm.

welcome to

world favourites

Here's a list of products that are a good buy. We've tried to cater for a range of tastes, identifying strong products in every area. We're agnostic so you'll find a wide range of products, from valve pre-amps through to MiniDisc players. Products marked * are recently out of production but make a good second-hand buy.

Prices shown are those at the time of the review



Roksan Caspian CD player
Solid as a ROK

COMPACT DISC

ARCAM FMJ CD23 £1100
This British-built player is extremely versatile. Controlled and detailed with a musical insight that few match. (Jul 2000)

CAMBRIDGE CD4SE* £200
A touch soft in the treble but outstanding in every other respect. (Feb 98)

KENWOOD DP-3080/III* £180
Has great clarity and presence for the price. Not as naturally expressive as the CD4SE though. (Feb 98)

LINN KARIK III* £1775
Under rated and overlooked, the final Karik was a gem. Superb transport gives a brilliantly tight, grippy dynamic sound, albeit tonally rather dry.

MARANTZ CD-17 KI-S £1100
The Marantz excels in all areas. Without doubt this is one of the most involving CD players on the planet. Build quality is also exemplary. (Sep 97)

MARANTZ CD-63 MKII KI-S* £400
Similar to the CD-63SE but more powerful bass and an all-round smoother sound. The famous KI tweaks pay off again. Whether or not it is still pre-eminent against the vastly improved competition is a matter of opinion.

MERIDIAN 506 20-BIT* £1100
Very detailed and revealing player. More cerebral than visceral sounding, however. (May 95)

MUSICAL FIDELITY X-RAY £800
Commonsense sturdy CD player of exceptional ability. Clear and detailed with high quality internal processing system. The X-Ray is inclined to show up poor recordings, but it's only doing its job! (Feb 99)

NAD S500 £1000
This dynamic top of the range Silverline spinner delights with any type of music. Exciting, sophisticated sounding and highly recommended. (Jun 2000)

ROKSAN CASPIAN £895
The Caspian has a smooth, slightly bright sound with some of the clearest treble in the business. Very engaging, dynamic character. (Aug 97)

ROTEL RCD 951 £300
HDCC capability at a midrange price. Plain Jane looks but solid construction. There is some higher than average measured distortion which may take the edge off this otherwise tempting product. (Aug 99)

COMPACT DISC TRANSPORTS

SONIC FRONTIERS TRANSPORT £6999
Cutting-edge design and technology combine to make this one very desirable product. The only problem is the fantasy hi-fi price. (Sep 98)

TEAC P-30 £2500
Cheap it isn't, but then it sounds like a million digital dollars. Nothing short of superb. (Jun 97)

TEAC VRDS-TI £600
Excellent mid-price silver disc spinner with a powerful, expansive and warm sound. Easily beats most sub-£1000 designs. A good choice for the budget conscious who want the best. (Feb 95)

DACs

CAMBRIDGE AUDIO DACMAGIC 3* £99
Superb value for money with extensive facilities and solid, detailed sonics. Upgrades any sub-£300 player.

DCS ELGAR £8500
Future-proof convertor which will handle 24/96 and 24/192. Extremely open and natural performer. (Nov 97)

DPA LITTLE BIT 3* £299
A taste of the high end on a budget. Rich, clean, punchy sound transforms budget CD players.

MIDIMAN FLYING COW £299
Excellent as a DAC and doubles as an ADC for archiving to CDR. (Jun 98) Great value, as is junior version Flying Calf at £109. (Feb 99)

MUSICAL FIDELITY X-DAC* £300
A bargain for normal CDs and even better with HDCDs. (Nov 97)

SONIC FRONTIERS PROCESSOR 3 £6999
Quality never comes cheap! This DAC oozes class and when matched with the Transport 3 is certainly up with the best. (Sep 98)

TURNTABLES

LINN SONDEK LP12 BASIK £1100
Off the pace these days in many respects but still an extremely sweet and engaging listen with a quintessentially analogue sound.

MICHELL GYRODEC SE £775
Exquisitely built, infinitely upgradeable deck that gives true high end sound at mid-fi prices.

MICHELL ORBE £2000
Fantastically capable all rounder with commanding, powerful, detailed sound that gets the best from almost any arm and cartridge. Supreme build, brilliant value. (Apr 95)

ORIGIN LIVE STANDARD (KIT) £145
Good in standard form with AC motor; frighteningly good with a DC motor and battery PSU.

PINK TRIANGLE TARANTELLA £680
Not only does the Tarantella have more style than a catwalk full of models, it also combines PT's usual clarity with real authority. (Oct 97)

PRO-JECT DEBUT £110
Straight out of the box and onto the shelf! Nothing short of a bargain. Vinyl's never had it so good, so cheaply!

REGA PLANAR 2 £214
Brilliant starter deck with extremely polished manner. Better built £274 Planar 3 is a great all-in-one package that eats mid-price CD players for breakfast.

ROKSAN XERXES X £1295
DSU or XPS 3.5 power supply £150/170 extra. Excellent pitch stability from a new Swiss motor and outboard power supply. Very tight bass, fine dynamics and revealing clarity. (Jan 97)

SYSTEMDEK IIX900*/RB250 £330
A fine all-rounder and easy to upgrade too. More depth and breadth than Rega Planar 3. (Sep 94)

VESTAX BDT-2000 £225
A stylish looking deck with infinitely variable speed 16-90 rpm, DC belt drive and built-in MM phono stage. Good value, with plenty of chassis room for alternative arms, if required. (Sep 99)

TONERMS

HADCOCK 242 SE £649
Latest of a long line of unipivot arms. Added mass makes the 242 suitable for both low compliance MCs and straw-in-the-wind high compliance types. Revised geometry and chromium plating completes a first-class job. (Jun 2000)

NAIM ARO* £975
Truly endearing and charismatic performer - wonderfully engaging mid-band makes up for softened frequency extremes

REGA RB300 £180
Some may prefer the simpler RB250 at £130. Detailed, tight, rhythmic sound but tonally rather grey and cold-sounding. Still excellent value, though.



Distributed by

Henley Designs Ltd

Unit 10 Moorbrook, Southmead Industrial Park, Didcot, Oxon, OX11 7HR.
Tel: 01235 511166 E-mail: henley.designs@virgin.net

WWW.henleydesigns.co.uk

MANTRA AUDIO

Specialist Suppliers of Audio Accessories
www.mantra-audio.co.uk

CARTRIDGE SELECTION - STYLUS				REPLACEMENT STYLUS	
Audio Technica				Swiss Quality Diamond Stylus	
1006	£74	£51 GEX	£51	ADC XLM NA III	£10.00
1012 EX	£93	£65 GEX	£65	AN 5 AN 60	£11.00
1022 EX	£122	£84 GEX	£84	AN 2 AN 70	£10.00
1042	£140	£98 GEX	£98	Dual DN 145 E DN 165 E	£10.00
Erhlich L X H	£123	£93 GEX		JVC GR00 Super F	£14.00
Erhlich	£232	£163 GEX		JVC DT 55 DT 60	£19.00
*EX - Exchange price for a fitting All manufacturers of cart-nose accepted				National EPS 24 CS, P 30 D, P 33 D	£11.00
				Ortofon FF 15 E II VMS 20 F II OM 20	£15.00
				Pioneer PN 210, PN 220, PN 240	£11.00
				Shure N 75 C, SC 35 C,	£11.00
				N 75 ED T2, N 75 EJ T2	£13.00
				N 95 ED, N 95 EJ, N 75 3 (78)	£15.00
				VN 35 E	£18.00
				N 95 HE, N 97 HE, VN 35 HE	£25
				Sony ND 142 G, ND 150 G, ND 155 G	£11.00
				CN234	£13.00
*** OVER 500 STYLUS TYPES STOCKED ***					
GRADO - LECTON					
GRADO					
Prestige Series		SR-60	£77		
		SR 80	£93		
		SR-125	£139		
		SR-225	£186		
		SR-325	£279		
Reference Series		RS-1	£609		
		RS-2 (new)	£439		
All items guaranteed authentic new originals see our website for full selection of accessories order direct from our secure online catalogue					
*EX - Exchange price against any Audio Technica, Denon, Ortofon or Shure moving coil high cartridge					
MAIL ORDER: 100% CASH PRICE, 100% PAYABLE TO US DELIVERY TO YOUR HOME DELIVERY & 100% MONEY-BACK GUARANTEE TO SATISFY OR REFUND YOUR ORDER					
<small>MANTRA AUDIO: 100% CASH PRICE, 100% PAYABLE TO US DELIVERY TO YOUR HOME DELIVERY & 100% MONEY-BACK GUARANTEE TO SATISFY OR REFUND YOUR ORDER</small>					

Lumley LAMPROS

*Designed for the purist,
the music lover and the rest
of the family*

Any colour
and any wood finish



Distributed by: Metropolis Music, 6 London Road, Tunbridge Wells, Kent, TN1 1DQ
Tel: 01892 539245 Fax: 01892 616383

Distributors for Boulder, Passlabs, B.A.T. Advantage, Hovland, Burmester, SAT, VTL, Sound Lab, Kharma, Meadowlark, Copulare, Acoustic Zen

Prices shown are those at the time of the review



Musical Fidelity X-Cans2
Warm, sumptuous, sweet sound

SME 3009SII £309
Once state of the art, but no longer. Weak at frequency extremes and detail, but its legendary serviceability makes it a cult in Japan. Can be picked up for peanuts second-hand. (Jan 93)

SME 309 £689
A down-market version of the IV and V with aluminium armtube and detachable headshell. Tight, neutral sound with good tonality, but lacks the IV's pace and precision. Like the older SME 3009 series, this arm is also available in 10" and 12" versions. (Jan 93)

CARTRIDGES

AUDIO TECHNICA AT-110E £30
Great starter cartridge that's refined, detailed and musical beyond its price. Best value MM under £50

GOLDRING 1012GX £74
An accomplished MM with a solid bass, slightly forward midband and clean transients. Very reasonable price for such an able performer. (Jul 93)

DNM MICA £185
Better Goldring's 1042 and costs only £135 on trade-in. An assured and transparent MM. (Feb 98)

DYNAVECTOR DV20X-H £299
The best modern budget MC combines deliciously sweet sound with fantastic get-up-and-go. High output version works a treat with valve phono stages too.

MUSIC MAKER £575
When mated with a good quality arm, this hand finished high-output pick-up gives an ear-boggling account of itself. Very high compliance ensures maximum information retrieval. An absolute (grain orientated) gem. (Feb 99)

ORTOFON MC 7500 £2000
Conclusive proof that there's hope for the world. It's a long time ago now but this high-priced favourite still earns its niche - CD lovers would die if they heard it. (May 94)

ORTOFON MC 15 SUPER II £140
Not quite as good as the dearer Supremes but the Super II is a splendid introduction to the joys of moving-coil cartridges.

GOLDRING 1042 £130
One of the best Moving Magnet cartridges going, with beautiful treble and muscular bass. New low price makes it a bargain.

ORTOFON ROHMANN £1000
In a way it's MC 2000 meets MC 7500 with great tonal strengths and a dynamo sound. (Apr 96)

INTEGRATED AMPLIFIERS

AUDIO ANALOGUE PUCCINI SE £595
This superbly-built Italian integrated has a lucidity and control which leaves others nowhere. Sound stage a wow. (Dec 97)

AUDIOLAB 8000a * £495
Well rounded integrated with smooth and detailed sound plus a huge feature count. Great build makes later versions a top used buy.

DENON PMA-250SE £160
It might not have bags of grunt but the Denon can sound exceedingly natural and open. (Feb 97)

McINTOSH MA6800* £3735
The MA6800 not so much plays music as takes control of it, with effortless bass drive. (Sep 95)

MISSION CYRUS 2 * £299
Classic eighties minimalism combines arresting styling with clean, open, lively sound. Further upgradable with PSX power supply.

MUSICAL FIDELITY X-CANS2 £160
Warm, sumptuous, sweet sound h/phone amp. gives startling results with a decent set of headphones.

NAIM NAIT 3 * £575
Superb rhythms and dynamics make for great music making, but tonally monochromatic. Super optional phono stage makes it ideal for vinyl junkies.

ROKSAN CASPIAN £695
Smooth, warm integrated with remote control that works happily into most 'speakers. (Dec 97)

SONNETEER ALABASTER £995
Builds on the strengths of the Campion with ample control, colour and drive. (Oct 97)

PHONO STAGES

CREEK OBH-8 SE £180
Punchy, rhythmic character with oodles of detail makes this a great budget audiophile product.

LFD MISTRAL PHONO STAGE * £300
The Mistral has a warmth and involvement that make many pricier stages sound overpriced.

MICHELL DELPHINI MONOBLOCS £1995
Analogue tour-de-force gives supremely clean, detailed and finely resolved sound with breathtaking dynamics. Great value, even at this price.

MUSICAL FIDELITY X-LP £125
One of the famous MF X series. Full marks throughout for clarity and detail. Switchable between MM and MC. Indestructible build! (May 99)

PRO-JECT PHONO BOX £39
Not the last word in many respects but a thoroughly honest piece of work. Inexpensive introduction to all that vinyl has to offer. MM and MC provision plus choice of two impedances.

ROKSAN ARTAXERXES X £950
With the Atessa PSU the Artaxerxes X MM/MC stage still shines. Great stage depth, neutrality and tonal colour. (Oct 97)

Billy Vee
SOUND • SYSTEMS

248 Lee High Rd. Londnn SE13 5PL (Mon - Sat 10am to 6.30pm Closed Thurs & Sun)

NOT ONLY A CLASSIK BUT MUCH MORE

Call 020 8318 5755 or 8852 1321 now!

Save over £300 on this Linn/Celestion System

This is just one of the fabulous systems available during our Autumn promotion. The offer may be limited in quantity but you can be sure that any product or system we stock is available for audition and backed by experienced staff who work to fulfill the Billy Vee pledge - to give the ultimate in musical satisfaction

- Free delivery (U.K. Mainland) & local installation included
- Five year parts and two year labour warranty on this system
- Deferred & Interest Free Credit available 0% APR - Call for details.
- Arcam, B&W, Linn, Naim, Rega, TAG & more available for audition

Complete with speaker leads - just plug & play only :-



Individually, Linn Classik - any colour £995. Celestion Compact A £599

world favourites

SONNETEER SEDLEY £399
Combines transparency and fine dynamics with excellent rhythmic ability. (May 98)

PRE-AMPLIFIERS

AMC 1100 £150
Suffers from un-defeatable tone controls but an extremely good value piece of kit. Partners the similarly budget level AMC 2200 power amplifier, also at £150. Comfortable beginners' choice. (Mar 99)

AUDIO ANALOGUE BELLINI £475
Showcases AA's characteristic mix of clarity and musicality and blasts the competition. (Apr 98)

CHORD CPA1800 £1800
Clarity, insight and control are second to none - an addictive mixture. (Mar 98)

CROFT VITALE £350
A modestly priced valve pre-amp with exceptionally transparent performance. MM phono stage plus three line stages are standard. Volume controls are separate for each channel, thus giving balance adjustment. A remarkable item in all respects. (Feb 2000)

XTC PRE-I * £1000
Almost valve-like in its smoothness, the line-level Pre-I is warm and seductively clear. (Nov 96)

POWER AMPLIFIERS

ARCAM 9 * £400
With 70W on tap, the 9P will drive most loudspeakers with a spacious and detailed sound. Good bass welly too. (Dec 96)

CHORD SPM400 £1400
There's a sense of effortless power to the Chord that gives music real scale and presence. (Mar 98)

MARANTZ MODEL 9 * £8000
Authentic reproduction monoblocs still more than cut the sonic mustard. Highly expensive and highly sought after. (Mar 97)

MICHELL ALECTO £1989
Crisp, clean and beautifully controlled with gorgeous styling. Partnered with the £1650 Orca this is a superb winning combo. (Oct 98)

MUSICAL FIDELITY X-A200£1000/pair
200W of high-end monobloc power in a grooved tube. (Aug 98)

NAIM NAP180 £1060
Partnered with a NAC82, this has classic Naim control, and a superbly rhythmic presentation.

TUNERS

CAMBRIDGE T500 £180
An extremely engaging tuner with a performance at odds with its low price. Not exactly a Troughline, but you may not notice... (Feb 99)

CREEK T43 £399
Excellent detail, separation and dynamics. A great little tuner and unbeatable at this price. (May 98)

MARANTZ ST17 £600
A positive dreadnought of a tuner. Sweet and refined but with a heavy punch when needed. A tuner of this quality demands a decent aerial. (Jul 99)

MISSION CYRUS FM7* £300
Clear and lucid sound puts it up with the best. Superb build too. (Apr 94)

NAIM NAT03 £595
The NAT03's warm, atmospheric sound is further proof of Naim's proficiency with tuners. (Sep 93)

SONY ST-SA3ES* £250
Beguiling RDS tuner for the sonically discerning. Good ergonomics and sensitive too. (Apr 97)

CASSETTE DECKS

AIWA AD-S750* £200
Sonically a very decent machine at the price. Comes fitted with Dolby B, C and the dead handy Dolby S. (Apr 96)

AIWA AD-S950* £300
A stable transport, superb head and Dolby S make the AD-S950 an excellent all-rounder. (Feb 95)

KENWOOD KX-3080* £160
A simple deck, but excellent-quality head and transport give top quality sound. (Oct 96)

PIONEER CT-S740S £430
A great piece of engineering from Pioneer, with first-rate sound. (Jun 96)

YAMAHA KX-580SE* £250
The 'SE' tag is more than a marketing gimmick. Sound is solid and clear with Dolby S. (Sep 97)

LOUDSPEAKERS

CASTLE EDEN £469
Impressively vice-free 'speakers that offer great transparency and involvement. One of a select band that simply makes music regardless. (Mar 97)

EPOS ES12 * £495
Strong, punchy bass is allied to finely detailed, articulate midrange and sparkling treble. (Oct 96)



Kef Cresta I loudspeakers
A very musical sound

KEF CRESTA I £100
Delightfully sophisticated presentation for the price. Won't blow the roof off, but will deliver a very musical sound. (April 2000)

KLIPSCH HERESY II £1100
An outstanding high sensitivity loudspeaker with midrange and treble horns coupled with infinite baffle 12" bass driver. Effortless, fast and accurate. (May 99)

MISSION 752 * £495
Cracking mid-price mini towers combined HDA drive units and metal dome tweeters with surprisingly warm results. Benign load characteristics makes them great for valves.

MISSION 771 £170
Characteristically fast, punchy Mission sound from the Aerogel mid/bass and silk-dome tweeter. (Jul 98)

Billy Vee
SOUND SYSTEMS

248 Lee High Rd, London SE13 5PL (Mon - Sat 10am to 6.30pm Closed Thurs & Sun)

You can't touch it but you sure can feel it
You can't see it but you really can hear it
Call 020 8318 5755 & join us for true -

HI-FI PERFORMANCE



What is true hi-fi performance?

Here's a simple truth. You can believe what you read but you will never really know how good something is until you listen. A demonstration is worth a thousand words and our hi-fi systems all have one thing in common, we guarantee you will get more from your music! When you hear what we mean, you will never look back. Honest!



Rega
The New Brio Amplifier

QUAD ESL 63 * £3450
A reference against which all other loudspeakers are judged, the '63s have superb imaging and genuine transparency.

TANNOY AMS8 * £2700
Bold sounding pro active monitor with solid bass, clear midrange and delicious treble. (Aug 96)

TANNOY MERCURY m2 * £140
A true audiophile bargain which embarrasses many more expensive boxes. Never mind the price, let your ears decide. (May 97)

MINIDISC PLAYERS

KENWOOD DM-9090 £500
One of the best MD players yet. ATRAC 4.5 gives clean and very musical recordings from this Kenwood. (Jan 98)

SONY MDS-JB930Q £250
Great mid-price machine that adds better build and facilities to the '530's already excellent sonics.

SONY MDS-JA50ES * £1300
This Sony can put the wind up Nakamichi cassette decks when used with better blank MDs. (Apr 98)

SONY MDS-JE555ES £520
MiniDisc recorder
The best sounding MD deck made so far, thanks to awesome build and heroic ATRAC-DSP Type R coding.



Alesis Masterdisk
A glimpse of the future

SONY MDS-JE510 £300
An impressive sound and unmatched convenience make this MiniDisc player an excellent buy.

DIGITAL RECORDERS

ALESIS MASTERDISK £1400
A groundbreaking hard disc recorder with a built-in CD drive. An amazing bit of kit, and a glimpse of the future. (July 2000)

KENWOOD DMF-9020 £500
An excellent tool for home recording, combines convenience, superb sound and a fair price. (Aug 99)

MARANTZ DR-17 £1100
Probably the best sounding CD recoder on the market. Built like a brick out house with a true audiophile sound. HDCD compatible. (July 2000)

PHILIPS CDR-765 £360
One of the first twin deck recorders/players that boasts high speed dub facility. Playback could be warmer, but still a bargain. (Oct 99)

PIONEER PDR-555RW £480
Excellent mid-priced CD recorder that both plays and records with equal panache. (Oct 99)

SONY TCD-8 DATMAN * £599
Super clean and detailed sound makes this an amazing portable. Not as robust as it should be though.

DVD PLAYERS

DENON DVD-5000 £1600
Monster build, as you'd expect at this price. Facilities and gadgets galore and drop-dead high end looks. A very smooth and sophisticated sound, although not as good as similarly-priced CD players. (Mar 99)

PIONEER DV-717 £700
Well built and a solid performer, with a 'true' 24/96 digital output. Facilities in abundance and a controlled, exciting way with CD replay. Shame it lacks a Dolby Digital decoder! (Sep 99)

SONY DVP-S725 £490
One of the best buys in the DVD market. Available in a dour white case, but the facilities and performance more than make up for this. Excellent with both music and visuals, and a whole host of up to the minute facilities to keep you occupied. (Mar 2000)

HEADPHONES

JECKLIN FLOAT MODEL TWO £99
Wonderful panel-like and open sound from these esoteric-looking headclamps. Do not wear in public unless you like being made a fool of!

SENNHEISER HD-490 £50
Good value cans with an exciting and bassy sound. Everything one should look for in headphones at a sensible price.



Nordost Blue Heaven
A simple and effective upgrade

INTERCONNECTS

CHORD COMPANY CHAMELEON 2 £90/m
One of our favourite favourites, the Chameleons are musical performers with a smooth yet open sound.

DNM RESON £40/m
Neutral and transparent, and a steal at forty quid!

NORDOST BLUE HEAVEN £150/m
Some of the fastest and most transparent cable around. A simple and effective upgrade.

VAN DEN HUL ULTIMATE THE FIRST £260/0.6m
Carbon interconnects that help you forget the electronics and concentrate on the music. Miraculous transparency.

LOUDSPEAKER CABLE

CHORD COMPANY RUMOUR £9.95/m
The Rumour is our reference at the price. Tight and tuneful bass mixed with air and space results in a cracking cable for the money.

DNM RESON £6.95/m
This cable has a transparency of sound that's rarely heard at the price. Excellent value for money.

NORDOST BLUE HEAVEN £375/3m pair
This isn't cheap, but it sounds absolutely fab. An open and spacious sound that simply carries music.

Billy Vee
SOUND SYSTEMS

NEW YEAR DISPLAY CLEARANCE BARGAINS

SOME AS NEW WITH 1 YR WARRANTY. 24HR DEL ONLY £5. CHECK AVAILABILITY BEFORE ORDERING.
CALL SALES: (020) 8318 5755 or 8852 1321 - 248 Lee High Road, London, SE13 5PL.
0% APR is available on purchases of more than £800. Please call for details. * Prices Correct at 12/06/01 £30E

Arcam A65 Amplifier NEW!	(379.00)	£269.00	Linn CD12 CD Player E/D (2Yr G/tee)	(12000.00)	£7995.00
Arcam A75 Amplifier NEW!	(450.00)	£299.00	Linn Keilidh Blk S/H (1Yr G/tee)	(775.00)	£395.00
Arcam AVR100 Receiver NEW!	(799.00)	£399.00	Marantz DV4100 DVD Player (1Yr G/tee)	(399.00)	£249.00
Arcam FMJ A22 Amplifier NEW!	(999.00)	£729.00	Marantz DV7000 DVD Player (1Yr G/tee)	(599.00)	£399.00
Arcam FMJ CD23 CD Player NEW!	(1099.00)	£849.00	Marantz SR5000 AV Receiver (1Yr G/tee)	(499.00)	£325.00
B&W 603/S2 Speakers	(550.00)	£249.00	Naim NAC72 Preamp (1Yr G/tee)	(760.00)	£449.00
KEF Q35.2 Speakers	(350.00)	£249.00	Naim NAT 02 Tuner (2Yr G/tee)	(1240.00)	£849.00
Linn Genki CD Player (2Yr G/tee)	(995.00)	£695.00	Naim AV1 Surround Procs E/D (2Yr G/tee)	(1835.00)	£659.00
Linn AV5130 Processor-No DTS (2Yr G/tee) (4200.00)		£999.00	Naim SBL Passive Speakers S/H (1Yr G/tee)(2500.00)		£1099.00
Linn AV5140 Speakers (Cherry)(2Yr G/tee) (2150.00)		£1395.00	Naim CD2 CD Player S/H (1Yr G/tee)	(1995.00)	£1099.00
Linn 5150 Subwoofer-Cherry (2Yr G/tee)	(2999.00)	£1995.00	Naim Intro Spkrs - Beech (1Yr/Gtee)	(790.00)	£590.00
Linn Kairn Line Preamp (1Yr G/tee)	(1400.00)	£799.00	Rega Jura Speakers (2Yr G/tee)	(498.00)	£329.00
Linn LP12/Lingo/Akito S/H (1Yr G/tee)	(2250.00)	£1250.00	Vision 42" Plasma Screen (1Yr G/tee)	(5300.00)	£2795.00

welcome to world classics

CASSETTE

NAKAMICHI DR-7

A great machine with Nakamichi's legendary heads. The lowest cost 'true' Nakamichi at the time, retailing for £600.

NAKAMICHI CR-7

The last of the great ones, and definitely the best Nakamichi ever (yes, better than a Dragon).

YAMAHA TC-800G

Early classic in serious cassette, its ski-slope looks got it a cult following once it had ceased to be simply ugly.

CD PLAYERS

MERIDIAN 207

Beautifully-built two-box with pre-amp stage. Very musical although not as refined as modern Bitstream gear. No digital output.

PIONEER PD-91

Beautifully-built player with easy upgrade routes for modifiers. Not knockout as it stands but get one cheap and have a go!

CAMBRIDGE CD1

The first two box player with weighted mechanics and even an optional Drop-out/errata indicator. Radical and effective at the time - a classic.

AMPLIFIERS

LEAK POINT ONE, TL12 & TL10

Ancestors of hi-fi, consequently expensive nowadays. As with all vintage valve stuff, overhauling is de rigueur before use, using original parts if possible.

LEAK PRE-AMPS

Line of 'good for their time' pre-amps. Use of 6FB6 pentode valve for high gain rules out ultra performance. Not the highest-fi.

LEAK STEREO 20

Excellent workaday classic valve amp. In good order the 20 will not disgrace itself. Various upgrades are available from specialist repairers.

LEAK TL12+

Plentiful monobloc equivalent of Stereo 20. Reasonably inexpensive and a creakers' dream. Genuine valve hi-fi on a budget.

NAD 3020

You can't argue with success! NAD's budget transistor integrated gave thousands their first taste of hi-fi and remains great value.

QUAD 33/303 PRE/POWER

Great style and construction, also bullet proof. Warm and woolly sound, but easy going. A good introduction to early transistor audio classics.



Garrard 401
A legendary turntable.

QUAD 22/II PRE/POWER

One of the all-time classic valve amplifiers. Unusual circuit but it works beautifully. 22 pre-amp not up to today's standards.

SUGDEN A21

Seventies transistor integrated has an eminently likeable smoothness and musicality. Limited inputs via DIN socket.

TECHNICS SE-A5 Mk2

Nice transformer and electronics, shame about the case-work. With tweaking, this 150watt can sound sweet.

LOUDSPEAKERS

KLIPSCHORN

Not exactly plentiful or cheap but a splendid beast. For efficiency they have seldom been equalled. Space hungry!

AUDIO ILLUSION

23 Langley Broom
Langley, Berkshire SL3 8NB
(2 mins June 5 off the M4)
TEL: (01753) 542761 FAX: (01753) 772532
www.audioillusion.co.uk
mailto:audioillusion@btinternet.com

Two completely different ways to achieve the ultimate goal -

PERFECT SOUND

Whether it be Home Cinema or Audio - there should be no compromise -



Each System winners of an



PIEGA

"these speakers blow that 'posh design equals poor sound' concept to pieces"
- Adam Rayner
HCC

AERIAL

"this is a Home Theatre experience of the highest order"
- Stuart Robinson
HCC



0% FINANCE (subject to status) with up to 3 years to pay.

For further information and your local dealer please contact AUDIO ILLUSION

LEAK SANDWICH

Rather warm sounding big infinite baffle but cheap with it. With a reasonably powerful amp can sound quite satisfying.

LOWTHER PM6A

High quality full-range driver; still manufactured. High sensitivity, as fitted to many classic horn designs.

MAGNEPLANAR SMGa

Touch dry in the bass but a technological loudspeaker with genuinely musical abilities.

MISSION 770

Father of the 77 range which continues to this day. Well mannered with a warm sound and a kind load to amplifiers.

QUAD ESL57

Unrivalled. Properly serviced there is nothing like them. Their natural presentation may make them caviar to the general.

YAMAHA NS1000M

Hi-tech favourites of the Japanese and Americans. Viewed more warily in the UK but can give excellent results.

TANNOY GRF & AUTOGRAPH

Folded horn monsters which certainly sound good if you have the space. For Tannoy vintage see HFW November 1998.

WHARFEDALE SUPER 8 RS DD

Ideal experimenters' driver. High sensitivity ~14,000 Gauss magnet and extended frequency range. Inexpensive too!

TANNOY YORK, LANCASTER

Many similar models of infinite baffle or reflex design. Not the last word in tautness but the drivers work well in modern cabinets.

VINYL

ACOS LUSTRE

Very honest piece of kit, well made and easily adjusted. Vinyl beginners could do very much worse.

ALPHASON HIR100S

First class arm, up to present-day standards. Buy carefully, though, as there's no service available now.

ARISTON RD11

A one-time king of turntables very similar to the Linn LP12. Now deposed but worth a look at the right price.

LINN AXIS

Uncomplicated, lower-price version of the famous Sondek. Less expensive than some of its stablemates.

GARRARD 301 & 401

Legendary turntables, once fairly plentiful. Excellent back-up available; many different custom plinths available. High quality.

GOLDRING LENCO 88 & 99

Great deck for the kitchen table enthusiast. Garrard fans won't look at 'em but cheap and capable. Servicing available.

HADCOCK 228

Recently out-classed by Hadcock's updated 228 Special Edition but a proper hi-fi arm for all that. Makers still service.

MICHELL FOCUS ONE

20 years and still going strong. Early runner in the 'modern' turntable cycle with a first class arm. Factory servicing available.

SHURE M75

Recent line-contact improvements have left the M75 behind but the wide range of needles make it a handy tool.

SME 3009 IIS

Everlasting classic tone-arm. Spares permanently available from SME. No longer the last word but peanuts second-hand.

THORENS TD124

Best classic deck ever! Judging by the prices they fetch it's possible - 78rpm too!

THORENS TD150

Mid-price deck with a keen following. No real difficulty with servicing - novices may find the suspension system unnerving.

TRIO L-07D

Knockout heavyweight from 1980 with stainless bearing and 11lb platter! Not a give-away and beware! - spares scarce.

TUNERS

LEAK TROUGHLINE (ORIGINAL)

Interesting ornament but no longer hi-fi. Limited coverage of 88MHz to 100MHz only.

LEAK TROUGHLINE II & III MONO

Arguably the best-sounding tuners ever. Adaptation for stereo easy via phono multiplex socket.

LEAK TROUGHLINE III STEREO

Excellent tuner with indifferent stereo decoding circuit. Best when adapted to use modern outboard decoder.

MARANTZ ST-8

Possibly the ultimate Tardis console, including an oscilloscope for checking the strength of signal. Expensive even now.



Leak Troughline II Mono
Arguably the best sounding tuner ever

Lumley
METROPOLIS

Your search is over

- Pure single ended
- Pure class 'A'
- 100 watts into 8 ohms
- Electronics ten years guarantee
- Valves three year guarantee



Distributed by: Metropolis Music, 6 London Road, Tunbridge Wells, Kent, TN1 1DQ
Tel: 01892 539245 Fax: 01892 616383

Distributors for Boulder, Passlabs, B.A.T. Advantage, Hovland, Burmester, SAT, VTL, Sound Lab, Kharma, Meadowlark, Copulare, Acoustic Zen

hi-fi World

FEBRUARY 2002 No63

diy supplement/contents No63

DIY NEWS

97

THE BILLIE 300B SINGLE-ENDED POWER AMP 98

Clive Meakins builds a 300B single-ended power amplifier kit from Hong Kong.

RAPID ELECTRONICS 318 DIGITAL MULTIMETER 102

Needing a new multimeter, Nick Lucas came across a DIY bargain from Rapid Electronics.

DIY LETTERS

105



www.maplin.co.uk

Your one-stop online source for hi-fi and AV cables, connectors and accessories

■ 15,000 products ■ Detailed product data ■ Live stock updates ■ Same day despatch



CHELMER VALVE COMPANY

Chelmer Valve Company, The Stables Baddow Park, Great Baddow, Chelmsford, Essex, CM2 7SU, England.

email: sales@chelmervalue.com ☎ 44 (0)1245 241301 Fax: 44 (0)1245 241309 www.chelmervalue.com

for High Quality Audio Tubes

Everybody in the audio tube business knows that the justly famous brand names of yesteryear like Brimar, GEC, Mullard, RCA, Telefunken etc. etc. are scarce and often quite expensive. Although we supply all major brands as available (and we have many in stock) our policy is to offer a range of tubes, all new and mostly of current manufacture, the best we can find from factories around the world, which we process to suit audio applications. The result - CVC PREMIUM Brand. Our special processing includes selection for low noise, hum & microphony on pre-amp tubes and controlled burn-in on power tubes to improve stability avoid tubes with weaknesses etc.

A selection of CVC PREMIUM Audio Tubes

PRE-AMP TUBES	POWER TUBES	POWER TUBES (continued)	DIODES ETC.
ECC81 5.90	EL34G 8.30	6L6/5881/WXT 8.90	5Y3GT 4.80
ECC82 5.90	EL34 (JJ) 8.50	6V6GT 5.50	5Z4GT 5.80
ECC83 5.90	EL34(Large Dia) 11.00	6X6 11.50	
ECC85 6.60	EL84 5.50	6146B 11.00	
ECC88 5.70	EL509/519 13.00	6336A 48.00	B5A (Ch or PCB) 1.60
ECF82 5.50	E84L/7189 7.50	6550WAWB 15.00	Ditto, Gold Pl 3.00
ECL82 6.00	KT66 11.00	7581A 12.00	Octal (Ch or PCB) 1.80
ECL86 6.30	KT66R 22.50	807 10.70	Ditto, Gold Pl 4.20
EF86 6.00	KT77 13.20	811A 11.80	UX4 (4-Pin) 3.60
EF80F Gold Pin 11.00	KT88 13.50	812A 31.00	Ditto, Gold Pl 5.50
E81CC Gold 8.00	KT88 (Special) 17.00	845 (New des)33.50	4 Pin Jumbo 10.00
E82CC Gold 9.00	KT88 (GL Type) 30.00		Ditto, Gold Pl 13.00
E83CC Gold 8.50	PL509/519 9.90	EZ80 5.10	5 Pin (For 807) 3.30
E88CC Gold 8.80	2A3 (4 pin) 15.50	EZ81 6.00	7 Pin (For 6C33C) 4.70
6EU7 7.00	2A3 (8 Pin) 17.50	GZ32 15.50	9 Pin (For EL509) 5.00
6SL7GT 8.90	211 23.00	GZ33 15.50	Screen can B5A 2.20
6SN7GT 5.30	300B 45.00	GZ34 7.20	Ditto, Gold Pl 4.30
6922 6.40	6C33C-B 25.00	GZ37 15.50	Top Con. (For 807) 1.70
7025 7.00	6L6GC 7.60	5U4G 6.30	Ditto, (For EL509) 2.00
		5Y4GT 7.60	Retainer (For 5881) 2.20

And a few "Other Brands" (inc. Scarce types).

5R4GY Film-GE 8.50	6SL7GT STC 13.00	12E1 STC 12.50	6580C Siemens 18.00
5R4WBY Chatham 10.50	6SN7GT Brimar 13.00	12HT4C GE 7.00	6146B GE 18.50
5Y3GT Sylv 6.50	12AT7WA Mullard 6.00	300B JJ 56.00	A2900 GEC 15.00
6AS7GT Sylv 12.00	12AU7 Mullard 12.00	300B Svetlana 80.00	E88CC Mullard 14.80
6AU6VC Sylv 5.10	12AY7 GE / RCA 8.40	300B WE 185.00	F2a Siemens 145.00
6B4G Sylv 27.00	12AZ7 Westh. 8.00	805 USA 52.00	KT66 GEC 69.00
6BX6 Brimar 5.40	12BH7A RCA 14.00	5942A GEC 15.00	KT88 JJ 17.40
6BX7GT GE / RCA 9.00	12BY7A GE 9.50	8080 Telefunken 13.30	KT88 Svetlana 35.00
6CG7EFO7 8.50	12E1 STC 12.50	6950A GE 31.50	PK25 KR 128.00

ALL PRICES IN U. K. POUNDS £
Please note extras: carriage charge (£3.00 in U.K.) & In EEC VAT (17.50%). When ordering please state if matching required (add £1.00 per tube). Payment by credit card (VISA, AMEX etc.) or TRANSFER or CHEQUE (UK only). FAX email or POST your ORDER for immediate attention - We will send PROFORMA INVOICE if required. MILLIONS OF OTHER TUBES & SEMICONDUCTORS IN STOCK

Valve Amplifiers sound better still with CVC PREMIUM Valves!

PRICE VALIDITY TO END APRIL 2002 - ASK ABOUT ANY TYPES NOT ON THIS LIST

TECHNICAL & GENERAL

SOME NECESSITIES - FROM THE ORIGINAL CLASSIC TURNTABLE SPECIALISTS

CONNOISSEUR

		£12.60	£1.90
BD1/2 Drive Belt			
BD1/2 Motor Suspension kit		£15.50	£2.50
SAU.2 Headshell		£18.50	£2.90
SAU.2 Connecting Lead		£16.50	£3.20

GARRARD Standard Models

Wired arm tubes	from	£14.50	£2.90
Cartidge carriers (sliders)		£12.50	£1.90

301/401 Transcription models

Original Thrust pad assembly		£13.50	£2.50
Original Idler tension spring		£3.65	£1.90
Original Brake pad		£3.40	£1.90
Xeroxcopy Owners Manual 301 incl. full size mounting template		£9.30	£1.90
		£7.20	£1.90

Replacement 301 control knobs On-Off/Speed select	pair	£21.50	£2.90
Replacement 301 suppressor unit		£7.20	£2.50
Replacement 301 motor pulley (-2%), (-1%), (Std), (+1%)	each	£16.50	£2.50
Replacement 301 Chrome mounting bolts nuts, washers.	set	£7.85	£2.50
Recommended Lubrication set - early 301 or 301/401	(specify)	£7.20	£1.90

GOLDRING/LENCO

Idler wheel (lock-nut or clip fixing)		£22.50	£2.90
Tension spring		£3.85	£1.90
Arm pivot bearings - with fitting instructions		£9.85	£1.90
Spindle/Main bearing assembly	GL 69/72	£21.00	£3.90
	GL 75/78	£26.50	£3.90
Chassis suspension springs (set of 4)	set	£21.25	£3.90
Headshells	from	£23.25	£2.80
Instruction books	from	£5.20	£1.90

THORENS

TD.124 series			
Idler wheel original		£29.50	£2.90
Idler wheel our redesigned replacement		£16.50	£2.90
Drive belt		£19.60	£1.90
Suspension rubbers ('mushrooms')		£17.50	£2.90
TD.150/160			
Drive Belt		£17.90	£1.90
Suspension springs (-1%), (Std), (+1%) (set of 3) set		£14.50	£2.90
Suspension - main bushes (set of 3) set		£14.50	£2.90
Armbands TD.150 blank		£12.50	£2.50
	TD.160	£10.20	£2.50

CECIL WATTS Dustbugs & spares - incl. Preemer wicks

Cartridges and styli for 78s and Mono LPs in addition to current Stereo LPs

TECHNICAL & GENERAL

PO BOX 53, CROWBOROUGH, EAST SUSSEX, TN6 2BY
TELEPHONE: 01892 654 534

Ansar Supersound Polypropylene Axial Capacitor

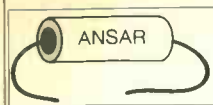

Audio quality. For Supersound & detailed sound with EXTREMELY low distortion. High purity high quality metallized polypropylene 100%.

Part no	Description	L x Ø mm	Price
CPW100	Ansar 1000PF 50V	32 x 6.5	2.00
CPW150	Ansar 1500PF 50V	32 x 7.5	2.00
CPW200	Ansar 2200PF 50V	32 x 9.0	2.00
CPW300	Ansar 3300PF 50V	32 x 10.0	2.00
CPW400	Ansar 4700PF 50V	32 x 11.0	2.00
CPW500	Ansar 6800PF 50V	32 x 11.5	2.00
CPW1000	Ansar 10K 50V	32 x 12.5	2.00
CPW1500	Ansar 15K 50V	32 x 14.7	2.00
CPW2000	Ansar 22K 50V	43 x 14.8	2.50
CPW3000	Ansar 33K 50V	43 x 17.8	3.00
CPW4000	Ansar 47K 50V	43 x 20.7	3.00
CPW5000	Ansar 68K 50V	43 x 22.8	3.50
CPW10000	Ansar 100K 50V	43 x 26.5	4.00
CPW15000	Ansar 150K 50V	55 x 34.1	4.00
CPW20000	Ansar 220K 50V	55 x 39.3	7.50
CPW30000	Ansar 330K 50V	55 x 42.8	7.50
CPW40000	Ansar 470K 50V	55 x 44.7	9.00
CPW50000	Ansar 680K 50V	83 x 46.0	12.00
CPW100000	Ansar 1000K 50V	83 x 51.7	13.00
CPW150000	Ansar 1500K 50V	83 x 55.1	16.00
CPW200000	Ansar 2200K 50V	83 x 56.8	18.00
CPW300000	Ansar 3300K 50V	115 x 55	20.00
CPW400000	Ansar 4700K 50V	115 x 61	20.00

Dual Polypropylene Smoothing Capacitors

Part no	Description	L x Ø mm	Price
CPW1000	Proppol 10K 50V	100 x 50	25.00
CPW1500	Proppol 15K 50V	115 x 51	30.00
CPW2000	Proppol 22K 50V	115 x 51	30.00

Philips Polypropylene Axial 1%

Part no	Description	Price	Part no	Description	Price
CPW100	Proppol 10K 50V	0.40	5881	BEAM TETRODE	19.00
CPW150	Proppol 15K 50V	0.40	5882	RECTIFIER	19.00
CPW200	Proppol 22K 50V	0.40	5883	BEAM PENTODE	26.00
CPW300	Proppol 33K 50V	0.40	5884	TETRODE	17.50
CPW400	Proppol 47K 50V	0.40	5885	TRIODE	14.50
CPW500	Proppol 68K 50V	0.40	5886	TETRODE	14.50
CPW1000	Proppol 100K 50V	0.40	5887	TRIODE	11.00
CPW1500	Proppol 150K 50V	0.50	5888	TRIODE	11.00
CPW2000	Proppol 220K 50V	0.50	5889	TRIODE	11.00

Audio Electrolytics Radial

Part no	Description	Price
CPW200	Proppol 2200PF 50V	0.50
CPW300	Proppol 3300PF 50V	0.50
CPW400	Proppol 4700PF 50V	0.50
CPW500	Proppol 6800PF 50V	0.50
CPW1000	Proppol 10K 50V	0.70
CPW1500	Proppol 15K 50V	1.00
CPW2000	Proppol 22K 50V	1.50

These superior electrolytics offer a low impedance with the superior resulting in a very open & detailed sound. The use of high temperature anodes ensure long life expectancy in a single & double row.

Alcap Bipolar Electrolytics

Part no	Description	Price
1150	Lo Imp Hi Temp 2200PF 50V	0.30
202750	Lo Imp Hi Temp 2.200F 50V	0.30
4027100	Lo Imp Hi Temp 4.000F 50V	0.30
10103	Lo Imp Hi Temp 1000PF 50V	0.30
22103	Lo Imp Hi Temp 2200PF 50V	0.30
47103	Lo Imp Hi Temp 4700PF 50V	0.40
100103	Lo Imp Hi Temp 10000PF 50V	0.60
220103	Lo Imp Hi Temp 22000PF 50V	0.80
470103	Lo Imp Hi Temp 47000PF 50V	1.50
1000103	Lo Imp Hi Temp 100000PF 50V	2.50
4700103	Lo Imp Hi Temp 470000PF 50V	2.50

Valve Holders - High Quality Valve Bases. Chassis Mounting With Screw Fittings.

Part no	Description	Price
CPW100	Ansar 1000PF 50V	0.40
CPW150	Ansar 1500PF 50V	0.40
CPW200	Ansar 2200PF 50V	0.40
CPW300	Ansar 3300PF 50V	0.40
CPW400	Ansar 4700PF 50V	0.40
CPW500	Ansar 6800PF 50V	0.40
CPW1000	Ansar 10K 50V	0.40
CPW1500	Ansar 15K 50V	0.40
CPW2000	Ansar 22K 50V	0.40
CPW3000	Ansar 33K 50V	0.40
CPW4000	Ansar 47K 50V	0.40
CPW5000	Ansar 68K 50V	0.40
CPW10000	Ansar 100K 50V	0.40
CPW15000	Ansar 150K 50V	0.40
CPW20000	Ansar 220K 50V	0.40
CPW30000	Ansar 330K 50V	0.40
CPW40000	Ansar 470K 50V	0.40
CPW50000	Ansar 680K 50V	0.40
CPW100000	Ansar 1000K 50V	0.40
CPW150000	Ansar 1500K 50V	0.40
CPW200000	Ansar 2200K 50V	0.40
CPW300000	Ansar 3300K 50V	0.40
CPW400000	Ansar 4700K 50V	0.40
CPW500000	Ansar 6800K 50V	0.40

High Quality Valves

Part no	Description	Price
5881	BEAM TETRODE	19.00
5882	RECTIFIER	19.00
5883	BEAM PENTODE	26.00
5884	TETRODE	17.50
5885	TRIODE	14.50
5886	TETRODE	14.50
5887	TRIODE	11.00
5888	TRIODE	11.00
5889	TRIODE	11.00

Valve Holders - High Quality Valve Bases. Chassis Mounting With Screw Fittings.

Part no	Description	Price
5881	BEAM TETRODE	19.00
5882	RECTIFIER	19.00
5883	BEAM PENTODE	26.00
5884	TETRODE	17.50
5885	TRIODE	14.50
5886	TETRODE	14.50
5887	TRIODE	11.00
5888	TRIODE	11.00
5889	TRIODE	11.00

Fully Gold Plated Phono (RCA) Plugs with spring coil cable grip.



Very High Quality Phono (RCA) Plugs



Very high quality with grey metal with heavy gold plated connections. No solderable (S) & PTFE finishes. Very sensitive.

Part no	Description	Price
PPG100	GOLD PTFE PLUGS 1/4" up	£3.50
PPG150	1/2" Silver CABLE	£4.00
PPG200	GOLD PTFE PLUGS 1/4" up	£3.50
PPG250	1/2" Silver CABLE	£4.00

High Quality Components at the right price. Please add £3.00 carriage + VAT to all orders. Credit Card phone orders accepted.

www.cricklewoodelectronics.co.uk
www1.sales@cricklewoodelectronics.com

Cricklewood Electronics Ltd, 40 & 42 Cricklewood Broadway, London NW2 3ET. Tel: 020 8452 0161 Fax: 020 8208 1441

SEASONS GREETINGS

from
The U.K.'s Premier Repair & Restoration Centre

IT DOESN'T MATTERwhether your equipment is Old, New, in Kit form, Valve, Solid-state, Audio or R.F.

We will....

Repair, Restore, Re-calibrate, Re-align:-
Tape recorders by *Revox, Tascam* (up to 1") and Teac
Valve amps., pre-amps., tuners, cinema amps.,
theatre-organ amps., industrial p.a. amps. from *Radford, Quad, Leak, Kalee, Clarke & Smith, Compton, Grant, Parmeko, RCA, Altobass* etc.

Valve Communications Receivers and Transmitters
(to 30MHz/2kW/6'3" tall) by *KW, Marconi, Labgear, Eddystone, Redifon, Ajax, RCA, Tiger...* and so on.

We will....

Build that Kit for you
Re-build it if you've had a go but it's gone pear-shaped.

We will....

Custom-build for you a published Classic design.
(Fancy a *Williamson??* Or a *912+?* A *3-3*, maybe? No problem)
Design something special and build the prototype.

All this,
as well as being an Authorised Service Centre for such respected names of the Digital Era as *Denon, Pioneer, Kenwood, Yamaha.*

Overall,
some pretty comprehensive facilities....and it will take only a few minutes of your life plus a few pence from your pocket to call/fax and discuss your requirements: **0113 244 0378.** Or write!

AUDIO LABORATORIES (LEEDS)

3 Kildare Terrace Industrial Estate,
Leeds LS12 1DB, England.

audioXpress... It Just Sounds Better

Your Favorite Audio - One New Magazine!

- PROJECTS
- REVIEWS
- THE NEWEST TECHNOLOGIES
- AUDIO CLASSROOM
- and Much More!

Only \$59.95 US
for 12 Issues!

Subscribe To This Great Monthly Publication Today!

audioXpress • PO Box 876 • Peterborough, NH 03458-0876 USA • Phone: 603-924-9464
Fax: 603-924-9467 • E-mail: custserv@audioXpress.com

ORDER ONLINE AT: www.audioXpress.com

WHITE NOISE

AUDIO KITS, MODULES, COMPONENTS

PRODUCTS INCLUDE:- Power Amplifiers 30-250W, Preamplifiers, Phono stages, Active Crossovers, Power Supplies, Buffer Amplifiers, Balanced line drivers / receivers, Stepped attenuators, Gold plated connectors, Cables, Capacitors, Resistors, Semiconductors, Transformers, Subwoofers, Loudspeaker drive units

<p>WHITE NOISE 11 STATION ROAD BEARSDEN GLASGOW G61-4AW</p>	<p>http://homepage.ntlworld.com/david.white38 Email:- david.white38@ntlworld.com Tel:- 0141-942-2460 (until 9pm) Fax:- 0141-587-7377</p>
---	---

e-mail us with news at - diynews@hi-fiworld.co.uk

KIT & COMPONENT NEWS

► YOU'VE GOT THE POWER

A new Canadian website sells valve and MOSFET amp kits as well as test equipment and real diehards have the opportunity to build their own laboratory power supply for the test bench. Invaluable for all dedicated DIYers, a lab power supply is essential for many amateurs as well as professionals. The kit costs \$449 (Canadian) and is provided with a digital volt meter and a digital ammeter. There is an integrated fan so the power supply can apparently operate at full load for an extended period. It is also supplied with housing, knobs and transformers as well as a digital display.



www.qkits.com

► NICEY IC!

Fancy designing your very own digital amplifier? Profusion are distributing the new Tripath TA2022 Class-T digital power amplifier IC that uses Digital Power Processing technology (DPP). This apparently offers the audio quality of class-AB and the power efficiency of Class-D. The 32pin SSIP package is fully integrated, with internal FETs and claims to have a high dynamic range compatible with CD, DVD and internet audio. This new distribution should ensure that digital amplifiers will be cropping up from many sources. Watch this space!



Profusion plc
Southend on Sea
Essex SS2 6UN
Tel: 01702 543500
www.profusionplc.com

► AUDIO-COM GO HI RES

Audio-Com are now featuring upgrades for both the Marantz SA-1 and Sony's SCD-1 high end SACD players. This involves replacement of the existing clocks with a Super Clock and extensive audio board modifications. Their comprehensive website also includes tips on completing the task and a guide through how to do it. The upgrades do not alter the circuits and are available in sections or as complete packages.



The Sony SCD-1 DA convertor section with Black gate de-coupling, super regulator and OPA 627 module

PRICES FOR SA-1

Audio board electrolytic capacitors = £339.36
Superclock/33.8688MHz = £175
Total parts costing = £514.36

PRICES FOR SCD-1

Audio board electrolytic capacitors = £201.14
Audio board resistors = £567.00
Audio board regulators = £199.75
Audio board op-amp modules = £130.00
Power board electrolytic capacitors = £287.26
Power board regulators = £119.85
Total parts costing = £1505.00

In addition to the player upgrades, Audio-com also now have a range of newly developed Elna ROS series capacitors, which use a newly developed separator paper. The main material of this separator is silk fibre mixed with Manila hemp



The new Elna ROS!



Superclock replaces the existing master clock circuit in the Marantz SA-1

fibre, which was inconceivable as a material of capacitors in the past. Price details are available from the Audiocom website.

Meanwhile, look out for a comprehensive step-by-step guide to the upgrade for the SCD-1 in our next supplement.

Audiocom UK
Unit 14 Pier Road
Pembroke Dock SA72 6TR
Tel: 01646 685601
www.audiocom-uk.com

BUILDING

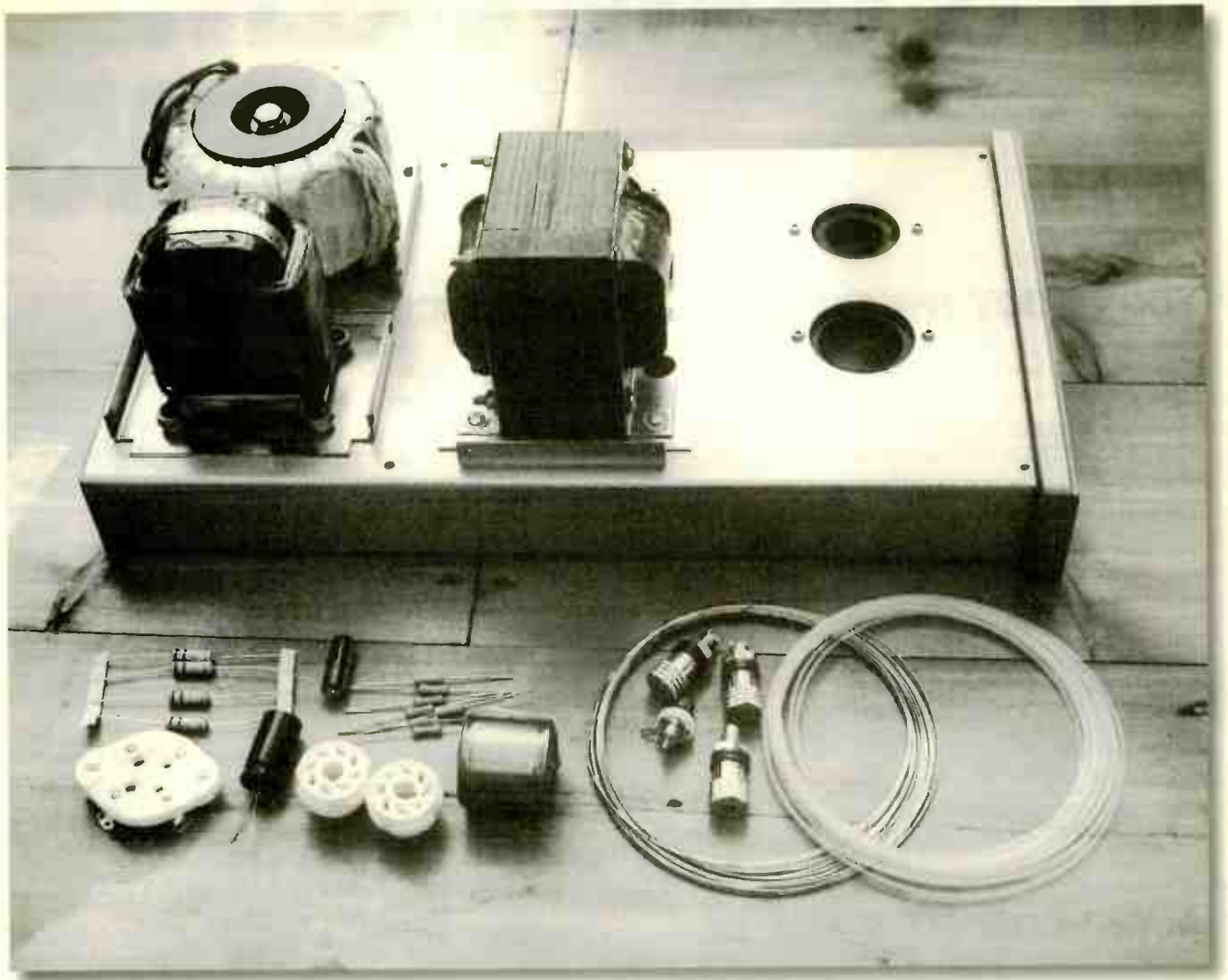

Clive Meakins builds a 300B single-ended power amplifier kit from Hong Kong.

Do you want to build an Single-Ended Triode (SET) "power" amplifier that will have a chance of driving typical speakers? Your best option is to use the 300B triode valve. The 2A3 isn't powerful enough. There are higher wattage triodes, but unfortunately they run at very high voltages. You need to live to hear your creation! Even though many of the hard-core SET brigade deride the 300B as overrated, it is well suited to normal domestic situations. Large horns are not required. For the tweaker, SET's have the great advantage of a very low component count, making small changes very noticeable.

Going the scratch-build route starts at around £850 just for the ironware for two monoblocks from a well-respected British manufacturer. There are a few 300B SET kits on the market - just scour the internet for the options. Most kits start at £800 to £1,000

with VAT and shipping. Using exotic components pushes prices higher.

The "Billie" kit, described here, comes from www.diyhifisupply.com. The basic 32kg kit comes into the UK at around £770 including shipping and import duty, based on US\$775 without shipping and tax. The Billies are a kit version of the Consonance M500 manufactured by Opera Audio in China. Diyhifisupply themselves operate out of Hong Kong. Its power output is 9 Watts, with 2V input sensitivity into 100k input impedance. The 300B heaters are fed DC and purists prefer AC, but audible hum levels frequently cause distress which is why many commercial amplifiers use DC.

The valves are Chinese, with the 300B from Valve Art, though you can specify the well-reviewed TJ Mesh Plate as a higher cost option. Traditional paper and wax are present

in the output transformer and the choke is reassuringly hefty. Wiring is point-to-point, save for the power supply capacitors which come pre-installed on a pcb. Open sided cages are supplied to protect the valves, children and pets.

The circuit is not unusual. The rectifier is a 5Z3, driver is 6N9P (6SL7) operating as shunt regulated push-pull (SRPP); its cathode bypass capacitor is a Black Gate. The 300B is self-biasing with plate voltage at around 400V with 78mA plate current. The output transformer has 4 and 8 ohm taps. The phono input socket is on the side but can be at the rear. Side positioning gives a very short signal path.

I was sent the version that most people order. This included Jensen PIO coupling capacitors, Kiwame carbon film resistors and CCC (continuous cast copper) high purity

BILLIES

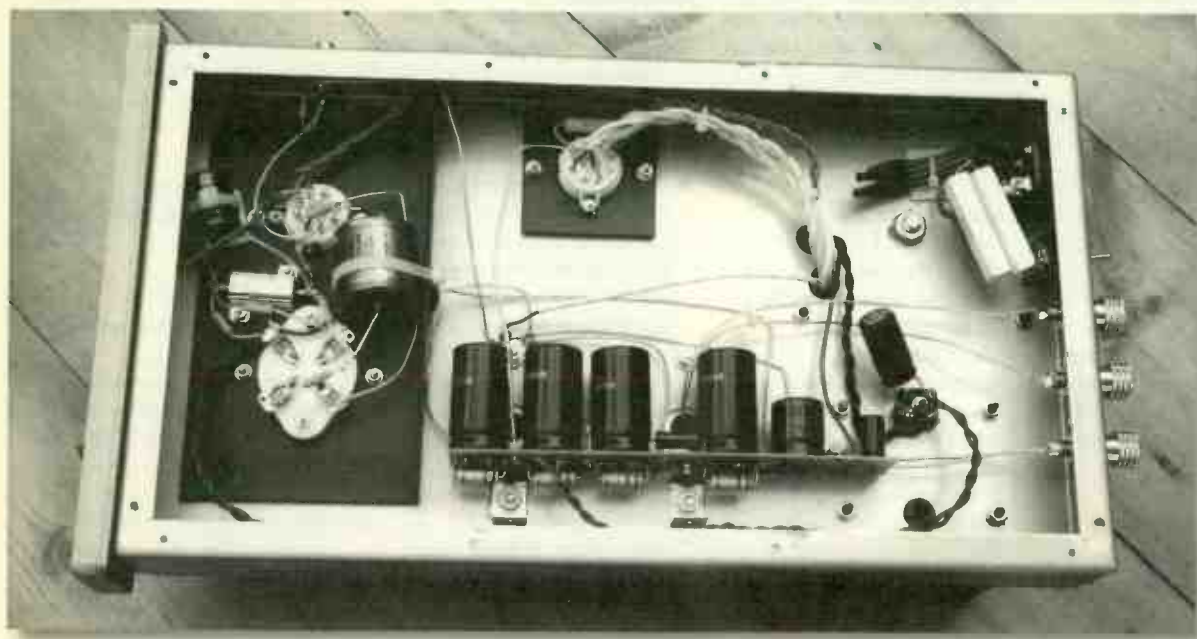

enamelled copper wire with clear sleeving. CCC is a good idea; using stranded wire could have nasty consequences if stray strands were to cause shorts. This amounts to a very attractive spec that gives a total UK imported price of around £830.

THE BUILD

The kit should have arrived with all hardware assembled. It seems this batch (and possibly others in future) didn't have the valve sockets installed. It took an hour or so to fit the sockets to each amp. Actually, I prefer the kit this way, since it allows me to check all bolts for correct tightness after their long journey. Just be careful, when tightening the hex bolts for the ceramic valve holders I held the nuts with my fingers and used my hex key the "wrong" way around to reduce leverage. I screwed up tight, but not so tight as to crack the ceramic. While you're at it, check the 25W resistor bolts. You'll find the chassis is spacious, with plenty of room for exotic capacitors.

I decided to scrape away some paint underneath the mounting bolts for the ironware, earth-to-chassis connection and the single earth point. I discussed this with Brian Cherry at diyhifisupply. He's not found any gain in performance by doing this. In humid regions, such as Hong Kong, you just end up with a rusty chassis. Anyway, I felt better about ensuring good metal-to-metal contact.

The instructions are good, with many pictures; they come pretty close to being idiot proof. Providing you can solder, draw children's dot-to-dot diagrams and can put

together a Meccano kit, there should not be any problems. The key is not to rush, double check everything and enjoy the assembly. To reduce the likelihood of my wife claiming on my life insurance, I used high voltage resistant gloves for testing. The need for safety cannot be overstressed.

There's quite a lot of wiring to do at first. The components come later and are quite quick to install. The enamelled CCC wire can have the enamel burnt off with a soldering iron though I preferred to scrape it off with a modelling knife.

When knitting in the components I used some of the CCC clear sleeving on the component leads, there is enough spare. This lessens the chance of shorts and reduces shock hazard when testing.

After I'd tested the amps I decided to upgrade the 300B cathode bypass capacitor to a Black Gate NH Series 160V type. This was my only change to the kit. It's simply begging for a good quality capacitor here. This is a big upgrade that provides greater scale, bass and simply much more of everything. It's well worth the high cost of the Black Gates.

Following initial testing I needed to install a resistor in series with the IEC socket and change the resistor following the rectifier. This is just fine tuning to get voltages absolutely spot on. Brian at diyhifisupply will advise on this.

THE SOUND

I initially tested voltages into a dummy load then fired up the monoblocks into my 17 year old "budget" Mordaunt Short MS15s. I was

amazed by what I heard just on the testbench. Musical coherence was so obvious. I could easily live with this unusual pairing.

I used CD feeding into a Michell (now "Trichord by Michell") Orca preamp. The Billies were now connected to my Mordaunt Short Performance 860 floorstanders and two REL Storm subwoofers. I was expecting I might need to use my solid-state amps to drive the 860's bass. The 860's are 6 ohm nominal with a 3.8 ohm minimum. Ease of drive could be a problem. At least the efficiency is 90db so reasonable levels were expected. On the 8 ohm tap the sound was a touch bass light. On the 4 ohm tap the bass and richness throughout the frequency range kicked in. The 860's needed no solid-state assistance or, should I say hindrance!

Hum levels were very low. With the 860's I could just hear some hum with my ear almost inside the bass cones. No problem here. I can't imagine there'd be a problem even with significantly more efficient speakers. 9W can't be enough, can it? Whilst I couldn't reach headbanging levels in my 18x15ft room, it was all but. These amps will work with many speakers on the market today.

The valves and particularly the Black Gates need at least 100 hours to burn-in properly so while this was happening I tried my Audio Synthesis Passion switched attenuator. The Billies have a 2V input sensitivity, not ideal for a passive pre. The result was anaemic. Use an active preamp to drive the Billies.

Everyone who heard these amplifiers talked about their big sound, instruments

Kit & Component Suppliers

CLASSIC TURNTABLES

Technical & General
P.O. Box 53, Crowborough,
East Sussex TN6 2BY.
Tel: 01892 65 45 34.

The original specialist source of spares, replacements and expertise for the classic turntables. Years of actual experience and comprehensive range of parts (originals and re-manufactures), manuals, ancillaries, No dubious 'improvements' - no harmful 'modifications'. Our specialities: Connoisseur; Garrard; Goldring; Lenco; S.M.E.; Thorens; Watts; Ortofon; Shure; Cartridges and styli for 78s, Mono LPs, Stereo LPs.

COMPONENT SUPPLIERS

AudioCom (UK),
Unit 14 Pier Road
Pembroke Dock
Pembrokeshire, SA72 6TR
Tel: 01646 685601
Fax: 01646 685602
Website: www.audiocom-uk.com
E-Mail: enquiries@audiocom-uk.com

Massive range of audio components and accessories available including Black Gate electrolytics, Elna SILMIC (Silk Fibre) electrolytics, Audyn-Cap film and foil capacitors, OFC air core and copper foil inductors, high power resistors, loudspeaker crossovers, high-end cable, Vishay & Holco resistors, 99.9999% pure Silver wire, DACT CT1 & CT2 attenuators, audio connectors, spikes & damping materials, plus over 50 loud-speaker kits. Active products include the SUPERCLOCK master clock plus super-low noise PSU, & Q-power super-low noise discrete regulators. A new, 365 page 2001 handbook is available for £3.50 (UK) and £5.00 (overseas).

White Noise
11, Station Road, Bearsden
Glasgow G61 4AW
Tel: 0141 942 2460
Fax: 0141 587 7377
Email: david.white38@ntworld.com
Supplier of the widest range of standard and audiophile kits for solid state pre-amplifiers, power amplifiers, headphone amplifiers, power supplies, MM/MC phono stages, active crossovers, balanced i/o modules, and stepped attenuators; more kits in the pipeline. All kits use the highest quality, glass fibre, solder masked, silkscreened, PCBs. We also supply a wide range of active (esp. Japanese transistors and Exicon mos-fets) and passive components, gold plat-

ed connectors, and silver plated wires. Write, phone or email for a free catalogue. Mail order only.

LOUDSPEAKER KIT SUPPLIERS

Audio Note (UK Ltd)
Unit C, Peacock Ind. Est.
125-127 Davigdor Road
Hove, East Sussex BN13 1SG
Tel: 01273 220511
Fax: 01273 731298

Suppliers of a large amount of components for the Audiophile Kit builder. Valve amplification data and vintage circuits also available. See the double page spread in the back section of the main issue for extra & more detailed information.

Falcon DIY Speakers
Falcon Acoustics Ltd.,
Tabor House,
Norwich Road, Mulbarton,
Norfolk NR14 8JT.
Tel: 01508 578272

UK distributors of FOCAL drive units & kits, and ETON loudspeakers, plus SOLEN (SCR-Chateauroux) polypropylene capacitors. We are the largest specialist Audio inductor manufacturer in the UK. We also stock Audio Amateur Publications and Audio Computer Software and a comprehensive range of D.I.Y. speaker kits, parts, accessories and books. Please send large SAE (44p) for free price list. "Everything but the wood".

IPL Acoustics, Chelsea Villa, Tors Park, Ilfracombe, North Devon, EX34 8AY
Tel/Fax: 01271 867 439

Website: www.iplacoustics.co.uk
IPL Acoustics supply a range of 7 transmission line, 3 conventional, speaker kits, and kits for centre speakers and active subwoofers. We also supply a full range of drive units from Audax, SEAS, Morel and Legend Acoustics (Ribbon Tweeters) as well as custom built metal coned drivers. Also included is a range of capacitors, inductors and quality cabinet accessories as well as Silver Plated PTFE insulated cables.

SPECIALIST UPGRADE SERVICES

AudioCom (UK),
Unit 14 Pier Road
Pembroke Dock
Pembrokeshire, SA72 6TR
Tel: 01646 685601
Fax: 01646 685602

Website: www.audiocom-uk.com
E-Mail: enquiries@audiocom-uk.com
Release the full potential of your digital source with CD/DVD upgrades from audiocom. Available is the highly acclaimed SUPERCLOCK master clock oscillator. (Dave Berriman fits the S-Clock to the Teac VRDS-10SE and comments...."there was not one area of music reproduction which didn't improve") SUPERCLOCK super low noise power supply, & Q-power ultra-low noise discrete regulators. Why not contact us to see how this service can be adapted to suit your requirements?

VALVE AND OUPUT TRANSFORMER SUPPLIERS

Wilson Valves, 28 Banks Avenue, Golcar, Huddersfield, West Yorks HD7 4LZ.
Tel: 01484 654650/844554
Fax: 01484 655699
E-mail: wilsonv@zoo.co.uk
We stock over 2,500 different types of valves, N.O.S. and New. Please send a S.A.E. for full list. No charge for matching. Most major credit cards accepted.

Watford Valves
3 Ryall Close, Bricket Wood,
St. Albans, Herts AL2 3TS
Tel: 01923 893270
Fax: 01923 679207
Specialist in new old stock and current production valves. Sole UK distributor of the Harma Diamond range selected for their superior performance. Huge range held, stockists of Mullard, GE, Philips, National, Brimar, Sylvania, Telefunken, RCA, MOV and many more. All valves are new boxed and guaranteed. For free price list and specialist advice call or fax Derek Rocco, Watford Valves.

Chelmer Valve Company Ltd
The Stables, Baddow Park
Great Baddow, Chelmsford, Essex CM2 7SY
Tel: 01245 241301
Fax: 01245 241309.
Email: sales@chelmervalue.com
Web Site: www.chelmervalue.com
Supplier of premium range of audio valves, other valves and components also available. (Please see our main advertisement in this supplement).

Langrex Supplies Ltd
1 Mayo Road, Croydon,
Surrey CRO 2QP
Tel: 020 86841166
Fax: 020 86843056
One of the largest distributors of elec-

tronic valves, tubes and semi-conductors in the UK by original UK and USA manufacturers. Obsolete types are a speciality. Telephone or fax for an immediate quotation.

Billington Export Ltd.
1E Gillmans Trading Estate,
Billingshurst,
West Sussex
RH14 9EZ
Visitors by appointment only please
Fax: 01403 783519
E-Mail: sales@bel-tubes.co.uk
Website: www.bel-tubes.co.uk
Minimum order - UK£100.00 + VAT + Carriage

Export £150.00 + Carriage
Specialists in guaranteed new/old stock, current production valves & tubes. Also CRT for audio, hi fi (as well as industrial uses). A vast archive of vintage and obsolete types including limited quantities of Mullard, GEC, Sylvania, Philips, Brimar, Telefunken, RCA and others. Large stocks of Chinese, Russian, El and Tesla etc. A 50-page valve catalogue is available on request. Major stockists of the excellent Billington Gold brand. Contact us for quotations - attractive price on larger orders.

Audio Specialist,
W. Marriott
73 Stonyford Road,
Sutton-In-Ashfield,
Notts,
NG17 2DL
Tel: 01623 461128
Email: wasmariott@talk21.com
Transformers. One of the world's widest range manufactured. Mains choke's, output transformers etc. From the standard I/E M6 to the awesome Hi-B nickle double C-Core's wound with the superb 6N cardas copper cable. All types of transformers manufactured. One off a speciality. A superb range of accessories and components supplied. Steel copper, brass etc cases available for that special project. All types of repairs, modification undertaken. Rebuilds, kits built to both thermionic solid state. Classic vintage equipment always sought, working or not. Catalogue £3.50 redeemed on first order over £30.00

TO ADVERTISE IN THE
KIT & COMPONENT
SUPPLIERS PAGE
PLEASE CALL
020 7624 9022

Email:
diyadvertising@hi-fiworld.co.uk



soundstaging beautifully with space around them and tremendously lifelike vocals. There's a natural decay to notes, a slightly rounded bass which is also bouncy and detailed. There was plenty of detail but not in a forced way; it was easy to listen to and exciting. Pace, rhythm and timing were excellent. I couldn't directly compare the amplifiers to other 300B SETs. I'm confident they are at least the equal of most I have heard and will outperform most of the (assembled) competition that would set you back between £2,000 and

£4,000.

You often read that a particular SET is mainly suited to certain types of music. This is not the case here. What they do like is well-recorded music. Heavily processed music tends to sound ordinary, much like any other amplifier. This is a problem with the software, not the amplification.

Now for some tube rollin'. Changing the 5Z3PA rectifiers for Sovtek 5AR4/GZ34 added more scale in the bass; they also pushed some internal voltages higher. This is

easily fixed. Mullard GZ32 rectifiers produced a big lush sound, with voltages not as high as the GZ34. They sound and look beautiful.

Swapping the 6N9P for a Philips 6SL7WGT JAN gave a slightly darker and more refined sound. Brimar 6SL7GT gave additional air with a richer sound, perhaps too rich with some combinations. Going to Sylvania 6SL7GT gave air but a less rich bass, probably the best balance. I should add my thanks to Jim Fish at Wilson Valves for finding me the NOS valves.

Sovtek's 300B EH added more body and was a little richer or less bright than the Valve Art. The way you hear it depends upon the rest of your system.

CONCLUSION

The Billies represent just about the lowest cost way of owning a 300B SET. Having built your own amps you'll be confident in tweaking and changing components. You will hear individual component changes easily.

With a sensible complement of valves provided as standard the Billies are fantastic value, producing a tremendous sound. You'll have great fun building them and even more fun making music. If you're in the market for a 300B SET kit, you can't go wrong with the diyhifisupply's Billies. ■ ▲



METER MADE

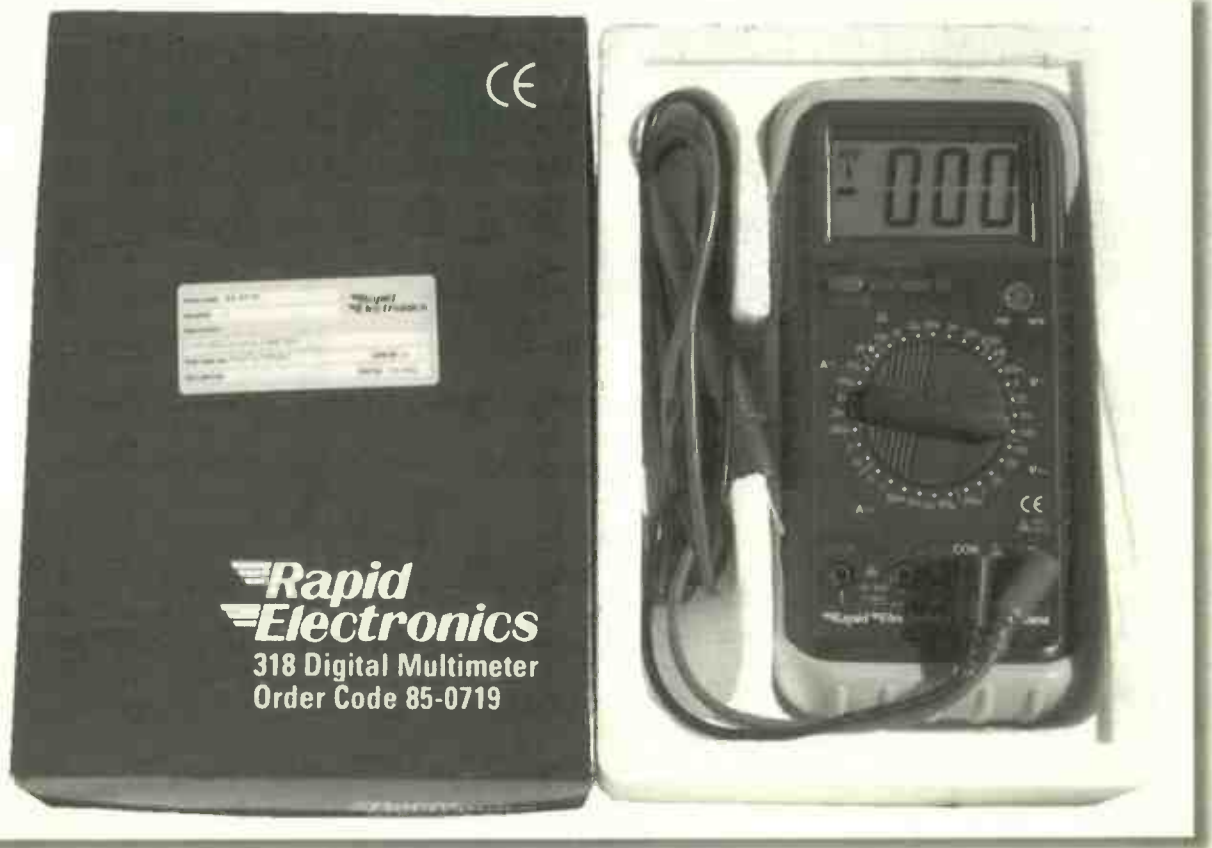

Needing a new multimeter, Nick Lucas came across a DIY bargain from Rapid Electronics.

► **A**fter 4 years of sterling service my Wavetek multimeter finally gave up the ghost. Its failure was probably due to numerous desktop bungy jumps, long spells sitting close to the soldering iron and a fair few incidents of electrical distress through mis-settings of control dials - plus a great many hours of use.

So my search began for its replacement. With cost being most important I grabbed a pile of catalogues, from Maplin, RS (Radio Spares) and Rapid Electronics.

The latter, you may not have heard of. Rapid Electronics is a mail order electronics catalogue company based in Colchester. They sell all the standard stuff and are very similar to Maplin in this. Where they differ is in their price, because they are generally cheaper, although on some items you have to order larger quantities (100 off), such as low wattage resistors, screws and nuts etc. Capacitors on the other hand are available in low quantities. Check out their excellent range of high voltage axial capacitors, ideal for the 'old style' tag board valve amp. construction. They are

not as well known as Maplins and do not appear on the shelves of W H Smith, but their single volume mail order catalogue of 800 pages can be purchased for just £3. They accept all major credit cards and cheques and will gladly do business with private individuals. Besides cost being an important consideration, when it comes to multimeters a digital meter is essential for me, purely through ease of reading. Time is important when you are trying to hold a probe; trying to decipher the scales of an analogue display is too much for me. I need to see a clear digital reading as I tend to only have a few seconds before I slip and have to re-probe. When there's 450V or so at the end of the tip I like to get measuring over and done with sharpish! Another important factor is the meter's specifications. As I regularly have my head inside a valve amplifier it is essential to be able to read high voltages of 1000V - and not less. You have to pay a lot of money for +1000V meters, be it a top spec. Fluke or an analogue Avometer, and besides, after some eight years of valve servicing I have only had my hands on

one +1000Vdc amplifier, one of Andy Grove's 211 parallel single-ended creation that had a huge 1500Vdc high tension line. I do actually have an Avo 8 under my desk, just in case such an occasion ever arises again! Having the nerve to use it is another matter.

Also, working a lot with valve amplifiers I find myself battling with that old demon, hum. I use the low ac volts range of a multimeter for this, placing the probes across the speaker output posts when connected to a dummy load. Not being able to hear it while on the test bench it is vital I can take a quick look at the hum level so the meter must be able to read to the nearest 0.1mV ac.

Some meters can measure capacitance and inductance. This feature was present on my old Wavetek but, I must admit, I only ever used the inductance meter on a couple of occasions to determine the value of unmarked speaker inductors, so it was hardly worth investing £30.00 or more for this feature.

Searching through RS I located a couple of candidates, but felt them a little over priced. Maplin had a few contenders but they lacked ►►

LANGREX SUPPLIES LTD

DISTRIBUTORS OF ELECTRONIC VALVES, TUBES AND SEMICONDUCTORS AND I.C.S.

1 MAYO ROAD • CROYDON • SURREY CR0 2QP

PHONE

020 8684 1166

24 HOURS EXPRESS MAIL ORDER SERVICE ON STOCK ITEMS

E-MAIL LANGREX@AOI.COM

FAX

020 8684 3056

A selection of our stocks of **New Original Valves/Tubes.**
Many other brands available

STANDARD TYPES			SPECIAL QUALITY TYPES			OTHER TYPES		
ECC83	E.I	3.00	A2900/CV6091	GEC	17.50	12BY7A	GE	7.00
ECC85	RFT	5.00	E82CC	SIEMENS	7.50	5687WB	ECG	6.00
ECC88	BRIMAR	6.00	E83CC	TESLA	7.50	5814A	GE	5.00
ECC88	MULLARD	10.00	E88CC/CV2492	BRIMAR	10.00	6072A	GE	6.00
ECH81	MULLARD	3.00	E88CC GOLD PIN	TESLA	8.50	6146B	GE	15.00
ECL82	MULLARD	5.00	ECC81/CV4024	MULLARD	6.00	6201	GE	6.00
ECL86	PHILIPS	7.50	ECC81/M8162	MULLARD	7.50	6336A	RCA	35.00
EL36	MULLARD	5.00	ECC81/6201	MULLARD	10.00	7027A	GE	25.00
EL37	MULLARD	30.00	ECC82/CV4003	MULLARD	10.00	7308	SYL	5.00
EZ81	MULLARD	7.50	ECC82/M8136	MULLARD	12.50	7581A	SYL	15.00
EZ80	MULLARD	5.00						
GZ33/37	MULLARD	20.00						
GZ32	MULLARD	25.00						
5Z4G	BRIMAR	6.00						
6V6GT	BRIMAR	7.50						
12BH7	BRIMAR	12.00						
12E1	STC	10.00						
13E1	STC	85.00						
807	HYTRON	7.50						
811A	RCA	25.00						
6080	MULLARD	10.00						

THESE ARE A SELECTION FROM OUR STOCK OF OVER 6000 TYPES. PLEASE CALL OR FAX FOR AN IMMEDIATE QUOTATION ON ANY TYPES NOT LISTED. WE ARE ONE OF THE LARGEST DISTRIBUTORS OF VALVES IN THE UK. SAME DAY DESPATCH VISA/ACCESS ACCEPTABLE. OBSOLETE TYPES A SPECIALITY.

CREDIT CARD MIN ORDER £10.00.

OPEN TO CALLERS MON. - FRI. 9AM - 4PM. CLOSED SATURDAY

U.K. P&P 1-3 VALVES £2.00, 4-6 VALVES £3.00 ADD 17.5% VAT TO TOTAL INC P+P O'SEAS P & P PLEASE ENQUIRE



Watford Valves

7 DAYS A WEEK 9AM - 9PM The Audiophiles Choice
All output valves multi-tested and digitally matched
Full no quibble guarantee. Expert advice on all valve amps

ECC81	Philips	7.00	KT66	Harma	25.00
ECC82	Philips.	6.00	KT66	G.E.C.	80.00
ECC83	GE	15.00	KT88	JJ Tesla	25.00
ECC83	Sylvania	12.00	KT88	Svetlana	34.00
ECC83	Philips	10.00	KT88	G.E.C.	125.00
ECC83	R.F.T	10.00	2A3	R.C.A.	50.00
ECC83S	JJ Tesla	7.00	2A3	Fivre	50.00
ECC84	Mullard	7.00	300B	JJ Tesla	68.00
ECC85	R.F.T.	8.00	5687WB	Philips	7.00
E88CC/6922	Harma	15.00	5751	G.E.	10.00
ECF80	Mullard	8.00	5842WA	Ratheon	10.00
ECL83	Amprex	7.00	5881WXT	Sovtek	7.00
ECL86	A.E.G	10.00	6550C	Svetlana	22.00
EF80	Mazda	6.00	6500EH	Sovtek	22.00
EF86	Svetlana	8.00	6550WE	Sovtek	18.00
EF804S	Telefunken	35.00	6AU6WC	Philips	4.00
EF806S	Tesla	20.00	6CG7	E.I.	8.00
EL34EH	Sovtek	8.50	6L6G	Brimar	20.00
EL34	Svetlana	10.64	6SL7GT	Brimar	6.00
EL34	Siemens	45.00	6SN7GT	Sovtek	5.00
E34L	JJ/Tesla	8.50	7199	Philips	20.00
E84L	Harma	6.00	7591A	Harma	10.00
EL519	E.I.	12.00	7868	G.E.	40.00
GZ32	Harma	9.00	12AX7	Svetlana	7.23
GZ34	Sovtek	8.00	12AX7LPS	Sovtek	8.00
			12AX7EH	Sovtek	8.00



WORLD AUDIO DESIGN UPGRADE

In many circles the JJ Tesla 300B and Svetlana KT88 are considered the best of their types. This month owners of the following W.A.D. amps can enjoy selected & tested valves at a fraction of the normal retail prices. These tubes provide improved detail, lower noise and less microphonics. This upgrade will be the best audiophile purchase you'll ever make!

300B PSE MONOBLOC Upgrade

4 x JJ Tesla 300B matched
2 x Philips 6AU6WC
2 x Philips ECC82
2 x Harma 5U4G
£284 the set
plus VAT & carriage



KAT 88 Upgrade

4 x Svetlana KT88
2 x Philips 6AU6WC
2 x Philips ECC82
£128 the set
plus VAT & carriage



Full range of capacitors now in stock

WATFORD VALVES 3 Ryall Close,
Bricket Wood, St Albans, Herts AL2 3TS

Fast mail order/next day delivery/World Wide shipping
1000's more valves stocked. Prices exclude VAT and carriage.



01923 893270

Fax: 01923 679207

www.watfordvalves.com



MOBILE 032893 24.74

◀ that all-important 1000Vdc spec I need. My final choice lay within the pages of the Rapid Electronics catalogue, page 635 to be exact. It was Rapids own 318 digital LCD multimeter offered at an excellent price of £18.50 excluding VAT. I ordered immediately and Business Post dropped it off the very next day. To lists its features -

- dc voltage 0.1mV - 1000V max
- ac voltage 0.1mV - 700V max
- dc current 0.01uA - 10A max
- ac current 10uA - 20A max
- Resistance 0.1ohm - 200Mohm
- Diode tester yes
- Transistor tester yes
- Continuity tester yes
- Auto switch-off if not used within 40 minutes
- physical size 31.5mm x 91mm x 189mm

The package comes with a protective rubberized holster that allows the meter to stand at an angle and even has holders to store the test probes that were provided. A PP3 battery is pre-installed and there's an instruction manual.

My view.

After a month in the field, I cannot fault the 318. It's a rugged unit, which is easy to use. It is also easy to see the display, which is larger than normal LCD display. The test probes are outstanding. Being pin sharp they reduce the chance of slippage and the actual sharpness penetrates the dirt and scum that can prevent a measurement from being taken successfully with blunt probes. The instruction booklet is very clear. Rapid Electronics also offer a calibration service for an additional £29.00

excluding VAT that pushes your meter into BAND A (very good range of accuracy). I did not go for this facility, as this type of accuracy is not essential when one works with valves. Besides, the standard meter has good accuracy through all its functions. Rapid Electronics also offer a 328 model that possesses the ability to measure capacitance, frequency and temperature and there's a 955 auto-ranging multimeter. It is very similar to the 328 except for autoranging and a slightly smaller display. One drawback to the 328 and 955 is that at the lower end of the scale ac voltage measurements are made in 1mV steps - not good enough for hum measurement in my opinion. I went for the 318, basically because I am a myopic tech who likes turning switches - and I am obsessed with hum levels! ■ ▲



All multimeters mentioned can be purchased from Rapid Electronics.

Rapid Electronics Ltd can be contacted at
 Severalls Lane,
 Colchester,
 Essex, CO4 5JS
 tel. 01206 751166
 e-mail, sales@rapidelec.co.uk
 website - under construction

Meter type	Order code No	price (ex. VAT)
318	85-0719	£18.50
328	85-0721	£29.50
955	85-0732	£29.50
calibration service	89-0010	£29.00
carriage charges also apply		

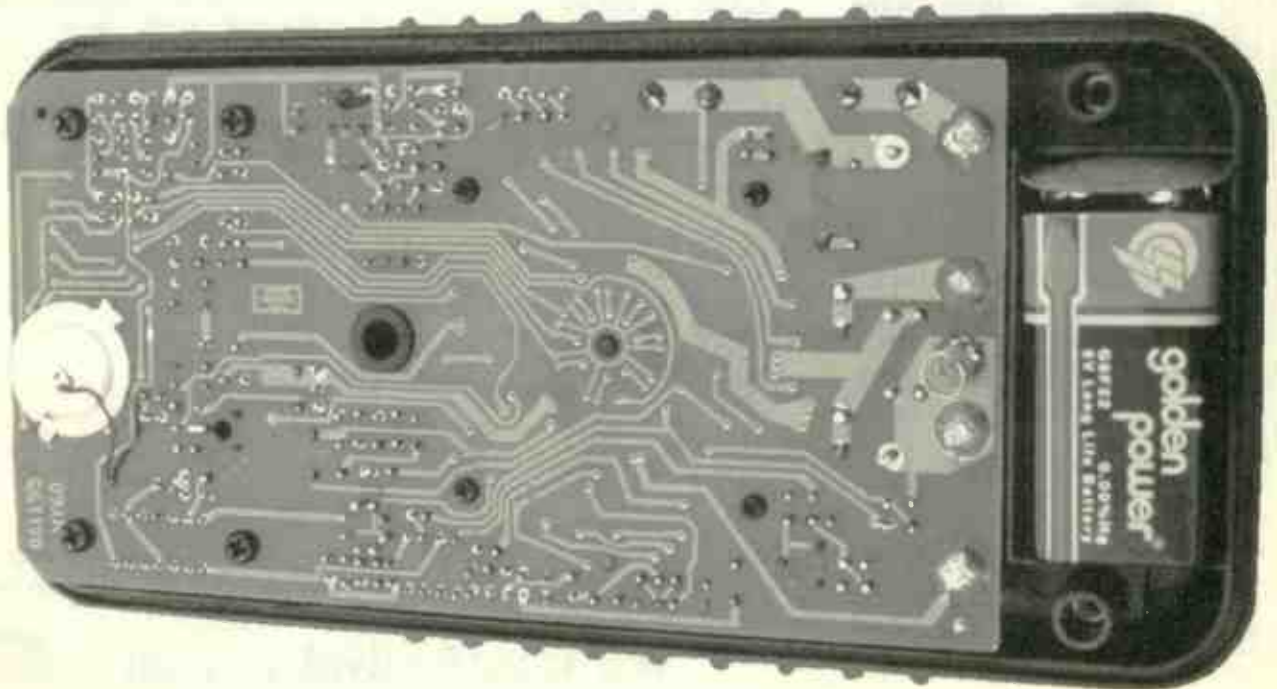

e-mail us with news at - diynews@hi-fiworld.co.uk

D.I.Y. LETTERS

Got a problem? Hi-Fi World's experts answer your DIY and kit queries

▶▶ BLAST FROM THE PAST

I recently took my Troughline 2 tuner to be overhauled and the engineer who accepted the work enthused to me about a stereo decoder he had matched to a Troughline for a customer. Apparently the design was by Tim De Paravicini but the case had the "World Audio" logo. Can you tell me any more and is it still available?

Simon Hilton,
Cumbria

This was a kit/built external stereo decoder for the Leak Troughline tuner designed and sold by Tim De Paravicini. We reviewed it in the July 1992 edition, and published a circuit. Tim called it a World Audio project because a kit like this did not fit in with his company's products.

It was an inspired idea where the mono channel, which carries most information, was valve based, as was the output stage, being built around two ECC83 double-triodes. The difference channel (stereo information) was processed by Motorola MC1310 solid-state decoder. It offered superb results, and sounded pretty amazing but is not now available. **NK ■**

▶▶ POT OF GOLD

I've been using an old valve amp made by Pioneer (SA-810) and recently, the volume control made some metallic noises when the I turned the knob and one of the channels went silent. On closer inspection I discovered that one half of the potentiometer had disintegrated. I also noticed that apart from the usual three terminals, each pot has an extra lug, which is attached at approximately 1 o'clock position to the carbon track (i.e. roughly half way through). I bought a new pot and, as I suspected, it has just "normal" terminals.

I have two questions:

- 1. What do I do with the cables that were attached to those additional lugs?*
- 2. the new pot is 100 k whereas the one that is being replaced is 500 k. Does it matter?*

I would be most grateful for your help. Many thanks -

Marek Podlucky,

It's likely that the terminal you talk about is for 'loudness' compensation at low levels, or for changing the 'law' of the control using an external resistor. Either way, you can leave it disconnected, without affecting basic performance. However, it is quite likely that the circuit will change behaviour for the worse if you substitute 100k for 500k. You should at least use a 500k pot. If possible trace out the circuit to see what values it uses and see if you can understand it. **NK ■**

▶▶ PHONO TUNES

I have some great sounding and easy to execute improvements for anyone with a World Audio Phono II stage and a spare £80.00 to spend. I changed C10/C11 (0.1uF) coupling capacitors for Audio Note copper-foil/paper-in-oils. The result was a fantastic improvement in bass leading edge transients (attack) and mid/treble detail and nuance. Timing also seemed to improve and "gel". My partner, who loves listening, was similarly impressed - to the extent she has let me spend again!

So, last week I changed C18/19 (2.2uF) for Hovland Musicaps. WOW!! Further audible improvement in timing and resolution particularly on 'difficult' tracks like the Talking Heads track 'Born Under Punches' from the Remain in the Light LP. It's interesting how timing and resolution seem to 'play' on each other and when both are in the zone, how the recording can move to a different plane.

I've now spent a total of £350.00 on my Phono II and I challenge anything in the market under £1500 to touch it for value for money or sound quality. The only small issue is the noise floor which could be a little lower, quieter, darker, call it what you will (I love how you reviewers can associate sound with colour!).

Who's complaining anyway, as it gives me something else to play with and improve on! So next maybe the power supply... a sprinkling of fast recovery diodes and maybe a Blackgate here or there - who knows. Now what we need from the guys at World Audio is a hardwired version (Silver wire, Vishays and/or Caddock's, ANI/Hovland Caps, etc).

My system comprises: Rega 25, RB600, Exact, WA Phono II (modified), Chord Chameleon Interconnects. Amplification is Spark/Cayin Audio AS8i EL34 based integrated and the speakers are Cadence Amaya Electrostatic Hybrids. I have a CD player too but it needs upgrading - a Marantz CD63K1. I'm looking at the new Chord DAC64 or the Perpetual Technology P-1A/P-3A with the CD63 relegated to a transport role.

Regards
Gary Young

SERIES II - PHONO II PHONO STAGE MODULE CIRCUIT DIAGRAM SIGNAL CIRCUIT (ONE CHANNEL)

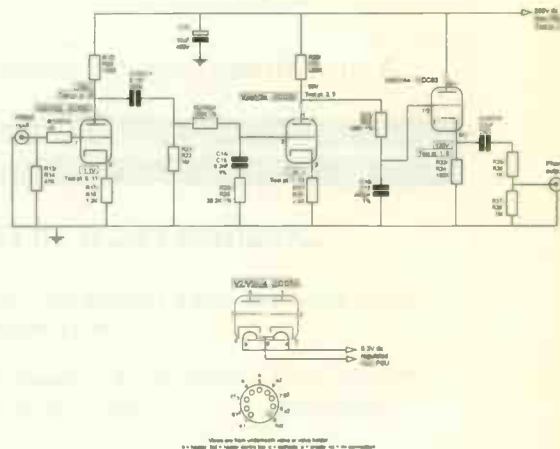

There will always be a little hiss from a valve phono stage. Although the ECC87 is a little quieter than the ECC83 we used, it is microphonic and often hard and brittle sounding. An alternative we have yet to try are cryogenically treated valves from Pearl of Canada (www.pearl-hifi.com). They are slowly cooled to -117C then brought back to room temperature after a few hours. This relaxes stresses in the metals, Pearl claim, reducing noise and improving sound quality. Pearl also put the valves through a rigorous testing procedure to eliminate duffers.

Good valve phono stages are a revelation. A valve regulated power supply will bring further improvements, you'll find. **NK ■**



Audio Note
Music's Finest Conductor
Test & Quality Control Engineer

The Audio Note Co. is a specialist hifi company making both analogue and digital products for the music enthusiast. we are world leaders in several areas of valve amplification and digital technology.

For our expanding plant soon to be set up in Newhaven, we are looking for one and possibly more qualified electronics engineers with hands on experience in both test and quality control procedures.

The applicant must have proven experience in test and fault finding to component level and general quality control procedures. be able to work independently. liaise with production and research & development on all matters concerning design changes, updates etc.

If you fit this bill, regardless of age, you should apply for this position, we operate a friendly no smoking environment and provide a good competitive salary structure with longterm prospects.

Apply to.

P. Qvortrup
Managing Director

Audio Note Co Ltd. Unit C, Peacock Industrial Estate, Lyon Close,
 125 - 127, Davigdor Road, Hove, BN3 1SG, East Sussex, England.
 Tel. +44 (0) 1273 220511 Fax 731498
Email: info@audionote.co.uk Company Reg. No. 3357356.
 Vat Reg. No. 699 3396 60

Advanced high speed, ultra-low noise discrete regulators.

Replaces standard voltage regulators in CD/DVD and SACD players providing improved low level information, sound stage and musicality.

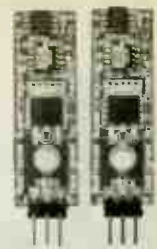

Super regulator



audiocom-uk.com
 01646 685601

AD825
 Op-Amp Module

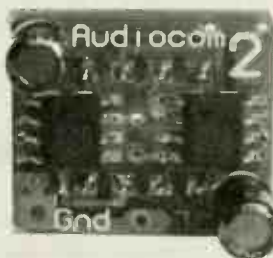

Op-amps used in CD players are generally of poor quality, corrupting the analogue signal. AD825 is a high performance drop-in replacement board providing a more natural and musical sound, with greater dynamics, detail and transparency.

A new breakthrough cable design



LAMINAR FLOW ULTRA

"A high end sound with a sensible look and price tag"
 HI-FI WORLD July 2001

"The Ultra's are a deeply satisfying musical product and supreme bargain"
 Stereo Times August 2001

Laminar flow cable is a groundbreaking new design of cable. The "Ultra" version is guaranteed to outperform all other interconnects up to 4 times it's price and the "Reference" is a cable that reviewers use to judge other cables due to it's incredible transparency and musicality.

With a money back guarantee if not satisfied you have nothing to lose. Why not order a pair or see your local Origin Live dealer.

Advanced interconnect: £45 per stereo pair
Laminar flow Ultra Interconnect: £85 per stereo pair
Laminar flow Reference Interconnect: £159 per stereo pair

For further information contact
Origin Live, 87 Chessel Crescent, Bitterne,
Southampton, SO19 4BT
Tel: 02380 442183 / 578877 - Fax: 02380 398905

WEBSITE: http://www.originlive.com
EMAIL: origin.live@virgin.net



CHELMER VALVE COMPANY

Chelmer Valve Company, The Stables Baddow Park, Great Daddow, Chelmsford, Essex, CM2 7SU, England.

email: sales@chelmervalve.com ☎ 44 (0)1245 241301 Fax: 44 (0)1245 241309 www.chelmervalve.com

for High Quality Audio Tubes

Everybody in the audio tube business knows that the justly famous brand names of yesteryear like Brimar, GEC, Mullard, RCA, Telefunken etc. etc. are scarce and often quite expensive. Although we supply all major brands as available (and we have many in stock) our policy is to offer a range of tubes, all new and mostly of current manufacture, the best we can find from factories around the world, which we process to suit audio applications. The result - CVC PREMIUM Brand. Our special processing includes selection for low noise, hum & microphony on pre-amp tubes and controlled burn-in on power tubes to improve stability avoid tubes with weaknesses etc.

A selection of CVC PREMIUM Audio Tubes			
PRE-AMP TUBES	POWER TUBES	POWER TUBES	RECTIFIER TUBES
ECC81 5.90	EL34G 8.30	(continued)	(continued)
ECC82 5.90	EL34 (JJ) 8.50	6L6WG/5881 8.90	5Y3GT 4.80
ECC83 5.90	EL34 (Large Dia) 11.00	6L6581 WXT 9.00	6Z4GT 5.80
ECC85 6.60	EL84 5.50	6V6GT 5.50	
ECC88 5.70	EL509/519 13.00	6080 11.50	SOCKETS ETC.
ECC82 5.50	EL509/519 13.00	6146B 11.00	B9A (Ch or PCB) 1.60
ECL82 6.00	EL84 5.50	6336A 48.00	Ditto, Gold Pl. 3.00
ECL86 6.30	KT66 11.00	6550WA/WB 15.00	Ortal (Ch or PCB) 1.80
EF86 6.00	KT66R 22.50	7581A 12.60	Ditto, Gold Pl. 3.80
EF86 6.00	KT77 13.20	807 10.70	Ditto, (4-Pin) 4.20
ES0F Gold Pin 11.00	KT88 13.50	811A 11.80	Ditto, Gold Pl. 4.50
E81CC Gold 8.00	KT88 (Special) 17.00	812A 31.00	4 Pin Jumbo 10.00
E82CC Gold 9.00	KT88 (GL Type) 30.00	845 (New des) 33.50	Ditto, Gold Pl. 13.00
E83CC Gold 8.50	PL509/519 9.90	RECTIFIER TUBES	5 Pin (For 807) 3.30
E88CC Gold 8.80	2A3 (4 pin) 15.50	EZ80 5.70	7 Pin (For 6C33C) 4.70
6EU7 7.00	2A3 (8 Pin) 17.50	EZ81 6.00	9 Pin (For EL509) 5.00
6SL7GT 8.90	211 23.00	GZ32 15.00	Screen cap B9A 2.20
6SN7GT 5.30	300B 45.00	GZ33 15.00	Ditto, Gold Pl. 4.30
6922 6.40	6C33C-B 25.00	GZ34 7.20	Flip Con. (For 807) 1.70
7025 7.00	6L6GC 7.60	GZ37 15.50	Ditto, (For EL509) 2.00
		5U4G 6.30	Retainer (For 5881) 2.20
		5V4GT 5.00	

***** And a few "Other Brands" (inc Scarce types) *****

5R4GY Firra/GE 8.50	6X7GT STC 13.00	13E1 STC 100.00	6X50C Svetlana 18.00
5R4WGY Chatham 10.50	6887GT Brimar 13.00	211T4C GE 120.00	6146B GE 18.50
5Y3WGT Sylv 6.50	12A77WA Mullard 6.00	300B JJ 56.00	A1900 GEC 15.00
6AS7GT Sylv 12.00	12AU7 Mullard 12.50	300B Svetlana 60.00	E88CC Mullard 14.60
6AU6WV Sylv 5.10	12AV7 GE - RCA 8.40	300B WE 150.00	File Svetlana 145.00
684G Sylv 27.00	12AZ7 Westh 8.80	800 USA 52.00	H17 GEC 69.00
68W6 Brimar 5.40	12BH7A RCA 14.00	800A GEC 15.00	H178 JJ 17.40
6BX7GT GE - RCA 9.00	12BY7A GE 9.50	800A Tels 10.00	H178 Svetlana 35.00
6CG76F07 8.50	11E1 STC 12.00	800A GE 31.00	H178 KR 128.00

ALL PRICES IN U. K. POUNDS £
 Please note extras: carriage charge (£3.00 in U.K.) & in EEC VAT (17.50%). When ordering please state if matching required (add £1.00 per tube). Payment by credit card (VISA, AMEX etc.) or TRANSFER or CHEQUE (UK only). FAX email or POST your ORDER for immediate attention - We will send PROFORMA INVOICE if required. MILLIONS OF OTHER TUBES & SEMICONDUCTORS IN STOCK

**** Valve Amplifiers sound better still with CVC PREMIUM Valves! ****

PRICE VALIDITY TO END APRIL 2002 - ASK ABOUT ANY TYPES NOT ON THIS LIST

WELCOME TO OUR MARKET PLACE

Here are a wide variety of specialist hi-fi products and services.

Keep an eye open for regular advertisers, who know the market and serve their customers in a friendly and reliable manner.

HICAM

CHERISHED PRE-OWNED HI-FI EQUIPMENT SOLD, PURCHASED, PIX. WE URGENTLY REQUIRE NAIM, MERIDIAN, AUDIOLAB, LINN EQUIPMENT MAIL ORDER ALWAYS A PLEASURE

	WAS	NOW		
ALCHEMIST NEXUS AFD32A 24 BIT CD PLAYER	1695	935	STAX UMESGA REFERENCE SR 007ASHM / 17 TUBE	2795
ALPACON AV105 2 SPEAKER STANDING BOXED	60	40	INVERGIER	50
ATAKAWA SE 24 SPEAKER STANDS NEW	75	10	FREEDUIS METALS GAMMA 1 METRE INTERCONNECT NEM	60
AUDIONOTE OTO INT AMP LINE LEVEL	499	595	PREFON 15 METAL SILVER SIGNAL 20X BALANCED INAV	500
LYRA HELKON SL MC CARTRIDGE NEW	1249	1695	PRECDUIS METALS SILVER SIGNAL 20X INTERCONNECT 1 METRE	425
EAR HEADPHONE AMP HP4 NEW	1695	1695	NAIM 32.5 PRE AMP EXCELLENT CONDITION	150
AVI S2000 MAX MONO BLOCKS NEW	1399	POA	PROJECT CLASSIC PROJECT 19510 PIANO BLACK NEM	460
AVI S2000M11 ANFM REFERENCE TUNER NEW	859	POA	NAIM NAIT 3 INT AMP BOXED/MINT	600
AVI PRO 999E SPK NEW	699	625	PSB ALPHA 6 ACTIVE SUBWOOFER AS NEW	1900
AVI S2000M2 REFERENCE 1490C CD PLAYER NEW	900	1900	ELAC CL 338 JET INIC STANDS NEW	2499
AUDIOLIBEST INDIGO 1X2 METRE PAIR	90	45	RJARK CL 10 CHERRY FINISH (NEW) SLIGHT MARK	900
AUDIOLISA EUPEN POWER CABLES FULL RANGE	POA	POA	RJARK DIAL CHERRY R ROSEWOOD (NEW) SLIGHT MARK	305
EARV 20 INTEGRATED CLASS A NEW	2798	1195	RJARK PROLOUGH CHERRY (NEW) SLIGHT MARK	995
EARV 100 VITA ACTIVE SUB BOXED AS NEW	550	460	RJARK VITA 100 1.5 SYSTEM BEECH (NEW)	1500
EAR 861 POWER AMP CLASS A 1 MONTH OLD	3599	2995	STAX SPS 4040 SYSTEM SIGNATURE 2 NEW	1195
DALI ROYAL MINULET MK2 CHERRY FINISH NEW	400	325	SONITEER BYRON CD PAYER AS NEW	795
EAR 805 INTEGRATED FREEMAN AMP NEW	2298	1995	SONITEER CAMPHOR INT AMP AS NEW	495
EAR 804P CHECKME CABLES MINIMO PHONO AS NFA1778	495	475	AUDIOTE AM15 CARTRIDGE TRANSFORMER	400
EAR 804P MINIMO PHONO STAGE	549	529	SME 300/512 ARM BOXED MINT	1000
EAR NCS MIC TRANSFORMER 1 MONTH OLD	658	529	TRICHOPTER T100 PSU NEW	225
EAR 834 INT AMP NEW	2198	1995	SONOLINK AS200 SHIRE SPK CABLE NEW	10
HEYBROCK QUARTZ ROSEWOOD FINISH	595	275	SONOLINK THE BASE 1 METRE PHR INTERCONNECT NEW	25
JBL CONTROL 1 SPEAKERS	40	40	SONOLINK THE REBEL SPK CABLE NEW	756
LAT S8000 SPEAKER CABLE 5MTR NEW	206	175	SONOLINK 8 WAY DISTRIBUTION BLOCK 2 METRE CABLE NEW	299
LAT 8 WAY DISTRIBUTION BLOCK 3 FT NEW	226	195	SONOLINK SIMPLICITY 1 METRE PHR INTERCONNECT NEW	35
LAT AC2 6 WAY DISTRIBUTION BLOCK 3 FT NEW	195	160	SONOLINK VIOLET 1 METRE PHR INTERCONNECT NEW	40
LAT AC2 POWER CABLE 3 FT NEW	195	65	STAX SPS 2020 NMC EAR SPEAKERS MINT	499
LAT IC100 MK2 1 METRE BOXED NEW	105	90	TAGMALAPH DOP J2 P/RO WOOD W/ROCH 2001	1100
SONOLINK 8 DISTRIBUTION BLOCK NEW	289	250	SUBIMO PEARL MK1 CARTRIDGE NEW	79
AUDIOTE ZERO TRANS OPT MIC NEW	595	595	SUBIMO BLUE POINT SPECIAL MIC NEW	279
MERIDIAN DSP 5500 2x100 SPEAKERS	1000	4500	TAL ELECTRONIC THUNDER 1 CD PLAYER	249
MERIDIAN 5500 CONVERTED TO HI FI ATIVE	2800	1315	JBL ELECTRONIC SPEAKER STRIPS PIANO BLACK	400
MERIDIAN 5500 AV PROCESSOR DTS 7.1 ETC	2800	1595	TRICHOPTER PS1 FOR DVD PHONO STAGE NEW	225
LYRA LYRINK BETA MIC CARTRIDGE NOT USED	1395	60	TOM EVANS MIC PROGRESSIVE MIC PHONO STAGE	499
MERIDIAN 515 CD PLAYER	1200	795	TRICHOPTER RESEARCH 500 POWER BLOCK	299
MICHELL DSP 5000 2x100 CENTRE SPEAKER	1995	1195	TRICHOPTER RESEARCH DINO MINIMO PHONO STAGE NEW	299
MICHELL LARGE PSU NEW	399	399	REC 42 INCH PLASMA TV NEW	6800
MICHELL ALECTO MONO BLOCKS AS NEW	1995	1995	VCH INTERGRATION 1 METRE PAIR BOXED	300
MICHELL GYRO SE/RE300 ARM	975	975	REC 51 INCH PLASMA TV NEW	9995
MICHELL ORGE SEALED BOX	7695	POA	100 MC 10 MC CARTRIDGE NEVER USED	709
MICHELL ORCA PRE AMP	1251	POA	NFA1778 100 800 CD PLAYER NEW	1299
MIRAVO INT 100 FM TUNER NEW	299	299	AUDIOTE AM15 CD 3 1X CD PLAYER NEW	1499
MICHELL GYROROCK 1.5D 100V 100W 4x 100W	1995	1995	AUDIOLAB 8000 G PRE AMP BOXED	1900
			VERI TRS 100 100W 100V 100W	220
			VERI TRS 100 100W 100V 100W	190
			VERI TRS 100 100W 100V 100W	675

OPEN MON-SUN 10AM-6PM
 FOR FURTHER DETAILS: TEL 01726 74474 / FAX 01726 70387
 MOBILE: 07973 233 380
 E-MAIL HICAM@FREEFIBRE.CO.UK
 OR VISIT OUR WEBPAGE HICAM.CO.UK



WANTED

HI-FI & accessories

any make, any age

BUY · SELL · TRADE

OPEN 7 DAYS 10am - 8pm
 Please bring official ID with address & signature when selling or exchanging

MUSIC & VIDEO EXCHANGE

56 Notting Hill Gate, London W11
 ☎ 020 7792 3474

480 Fulham Rd (Broadway), London SW6
 ☎ 020 7385 5350

95 Berwick St, Soho, London W1
 ☎ 020 7434 2939

www.buy-sell-trade.co.uk

LARGE SELECTION ON SALE

ALSO BUY, SELL, TRADE MUSICAL & PHOTOGRAPHIC EQUIPMENT

Oxford Audio Consultants Ltd.

OUR SUPERB SERVICE IS THE SAME REGARDLESS OF PRICE



Now Demonstrating



Ex-Demonstration & Previously Owned Equipment

SALE LIST - December 2001

NAIM 82 PREAMP	£1595	SH
NAIM 250 POWER AMP	£1195	SH
NAIM AUDIO 72/140	£ 795	SH
NAIM AUDIO FLATCAP	£ 150	SH
CHORD SPM1200C	£2795	SH
CHORD CPA3200 PREAMPLIFIER	£2695	SH
COPLAND 266 CD PLAYER	£795	SH
DYNAUDIO CONTOUR3.0 ROSEWOOD AS NEW	£1995	SH
WADIA 830 CD PLAYER	P O A	SH
KIMBER 8TC SPEAKER CABLE	P O A	SH
AUDIO ANALOGUE BELLINI PREAMP SILVER	£325	SH
LINN LP12/LVX	£350	SH
MUSICAL FIDELITY XP100 PREAMP	£495	SH
JADIS ORCHESTRA CD PLAYER EX DEM	£695	XD
KRELL 300i AMPLIFIER	£1795	SH
AUDIO RESEARCH LS9 PREAMPLIFIER	£1095	SH
THETA PROGENY	£595	SH
KRELL KAV300CD CD PLAYER	£1795	SH
COPLAND CDA288	£895	SH
LOEWE PLANUS 32" WITH CABINET ARCTIC EX DEM	£1350	XD
COPLAND CSA 8 AMPLIFIER	£799	XD
ARCAM 290 P POWER AMPLIFIER	£250	SH
ARCAM 290 INTEGRATED AMP	£250	SH
KRELL KAV300CD AS NEW	£2795	SH
KRELL 250P PREAMPLIFIER	£1795	XD
KRELL 300CD	£2295	SH
AUDIO RESEARCH VT50 POWER AMP AS NEW	£1995	SH
AUDIO RESEARCH D130 POWER AMPLIFIER EX DEM	£1295	XD
REGA PLANAR3	£150	SH
NAIM SBL BLACK EX DEM PASSIVE	£1295	XD
NAIM 90.3 POWER AMP	£ 350	SH
NAIM 72 PREAMP	£ 395	XD
PATHOS ACOUSTICS TWIN TOWERS AMPLIFIER	£2295	SH

0% INTEREST FREE CREDIT

Licensed Credit Broker

REFER TO OUR WEBSITE FOR THE LATEST UPDATED SALE LIST.

Agencies include: Acoustic Energy, Alphason, Alcatraz, Audio Analeg, Audio Research, Bayer, BOSE, Castle Chart Company, Copland, Omnitron, Orion, Disston, Dvin Electronics, EPOCH, Fujitsu, G&A Audio, Goldring, Graf, Integra Systems, IXOS, Jodie, Jamo, Kaf, Koetsu, Kral, Lexicon, Loewe TV/Video, Linn Classic, Lyrz, Marantz, Martin Logan, Michell, MRS Multiroom Systems, Musical Fidelity, NAD, Naim, NEC Gas Plasma Screens, Nakamichi, Nordost, Onkyo, Opera, Ortofon, Parasound, Pioneer, ProAC, Project Turntables, QED Multiroom, Quad, Quadraspe, REL Subwoofers, Rotel, Sennheiser, Sharp LCD TVs, SME, Sonus Faber, Sonus Systems, Synchrony, Synchrony, Sunda Unique, Svan, Swan, Sylvania, Tag McLaren, Tannoy, Teaco, Theta, Transparent Union Research, Van der Hul, Vibe Acoustics subwoofers, Vozoclogia, Vienna Acoustics, Wilson, Yamahe

TAX-FREE EXPORT SERVICE
MAIL-ORDER AVAILABLE ON MANY ITEMS

Contay House, Park End Street

Oxford OX1 1JD

Telephone: Oxford (01865) 790879

Facsimile: Oxford (01865) 791665

E-MAIL: Oxford.Audio@btinternet.com

WEBSITE: www.oxfordaudio.co.uk



V.A.T. No.
729580013



QUALITY USED
EQUIPMENT,
BOUGHT, SOLD,
PART EXCHANGE

TEL/FAX
0121 747 4246



URGENTLY REQUIRED
LINN, NAIM,
MERIDIAN, QUAD,
CASH WAITING

	RRP	NOW £
ACCUHASE DP70V DIGITAL VOLUME	5500	1995
ADVANTAGE P1 PRE	1600	895
ADVANTAGE A300 POWER	2600	1495
ART AUDIO DIAVLO 300B SE CHROME & GOLD POWER AMP	4500	1995
AUDIO LAB 8000C	N/A	150
ATC 50SL ACTIVE	7000	3995
AVI S2000 PRE	900	395
BASIS 1400 REGA RB300	1300	795
BOW TECHNOLOGIES WAZOO XL INTEGRATED AMP	2500	1495
CAL CL15 hddc digi vol bal NEW SEALED BOX	2195	895
CAL DX-2 CD EX DEM	650	295
CAL ICON MK 11 CD EX DEM	1100	495
CAL ALPHA 20 BIT DAC VALVE EX DEM	1495	695
CAL SIGMA DAC VALVE EX DEM	1100	495
CHARIO SYNTAR 100 TOWER BLACK	450	250
COPLAND CTA 505 POWER AMP	1900	895
COUNTERPOINT BIJOU-MYSTIC-ORPHEUM 5		
SPEAKER SYSTEM	1500	295
DENSEN DP DRIVE PHONO STAGE	350	250
JEFF ROWLAND MODEL 1 POWER AMP	3000	1195
KRELL KPS 20i/L CD/PRE	11000	3995
MAGNUM DYNALAB MD100R SILVER EX DEM	2050	1395
MAGNUM DYNALAB MD10 VIRTUAL DECODER EX DEM	N/A	295
MAGNUM DYNALAB SIGNAL SLEUTH EX DEM	350	195
MARANTZ SA-1 SACD PLAYER	5000	3695
MARANTZ CD7	3500	2795
MARANTZ CD 17 KI SIG BLACK	1100	695
MARK LEVINSON 380 PRE 6 MONTHS OLD	4450	2995
MERIDIAN DSP 6000	11000	4995
MERIDIAN DSP 6000 CENTRE	6000	2500
MERIDIAN 861 + EXTRA BOARDS	7000	4500
MIT 330 MK11 INTERCONNECT	300	150
MICHELL ARGO + HERA	N/A	395
MISSION 752 FREEDOM ROSEWOOD	800	295
NAIM NAC 72	850	395
NAIM 05 TUNER	800	495
NAIM CD2	2000	1095
NAIM NAP 140 OLD STYLE	N/A	350
NAIM 92	520	250
NAIM CD 3.5	1100	695
NAIM 90/3 X3	550	250
NHT 1.3A SPEAKERS PIANO BLACK EX DEM	500	295
NHT 1.1 SPEAKERS PIANO BLACK EX DEM	400	195
NEAT MYSTIQUE CHERRY	750	195
OPERA DUETTO CHERRY	430	250
ORANGE VALVE PRE M/M PHONO	1700	595
PROAC TABLETE 50 WALNUT	650	350
PRIMARE T20 TUNER	550	350
PROCEED AMP 2 (2 channel) THX	2000	995
PROCEED AMP 3 (3 channel) THX	3000	1495
QUAD 44 PRE BOXED SERVICED	N/A	195
REVEL ULTIMA GEM PIANO BLACK + stands	8000	3500
ROKSAN XERXES ARTEMIZ BLACK	N/A	395
RUARK EQUINOX WALNUT	2200	995
SHURE V15 MK111	N/A	50
SIM AUDIO CELESTE 4000 INTEGRATED	1000	295
SONIC FRONTIERS ANTHEM INTEGRATED AMP 2	2000	995
TANNOY ARDENS MK11 15 INCH DUAL CONCENTRIC	N/A	895
THETA PRO PRIME 11	1600	595
VAN DEN HUL THE SECOND DIGITAL XLR	150	75
VAN DEN HUL REVELATION HB 2X 1.5 PAIR	800	395
WILSON BENESCH ACT ONE CHERRY	7000	4750
XLO 4.1 SIGNATURE DIGITAL CABLE RCA	325	175

OPEN MON-SUN 10.00 TO 8.00
Website: www.centralaudio.co.uk
E-mail: tony@centralaudio.co.uk

BRAND NEW TONEARMS

Eminent Technology Air Bearing Tonearms
 Normal Price £2500 Our Price £1495
 Eminent Technology (magnesium wand) Air Bearing Tonearm
 Normal Price £2800 Our Price £1695

HEATHERDALE PRE-OWNED GUARANTEED EQUIPMENT EXPORT FACILITIES AVAILABLE

SPEAKERS

B&W DM 801 Speakers with Stands £125
 Celestion A1 Speakers £495
 Audio Note AN E/SP Walnut Finish Speakers £995
 Dynaudio Audience 10 Speakers £195
 John Bowers Active Speakers £695
 Meridian A500 Speakers £595
 KLH Speakers £195
 Kef 101/2 speakers £475
 Mission 782 Loud Speakers (Stand mount model) £250
 Selection of Thiel ex. Demo. Speakers. All with 10 year guarantee
 MAIN DEALER FOR ORCHID SPEAKERS

PRE AMPS

EAR 864 Pre Amp £1195
 NAD 114 Stereo Pre-Amp £99
 Perreaux SM6P Pre-amp 350P Power Amplifier £2750

Naim NAC 42.5 Pre-Amp £150
 Musical Fidelity MVT Pre Amplifier with PhonoStage + PSU £495
 Musical Fidelity "The Pre-amp" £175
 Exposure 21 Pre-amp NEW with remote £890
 Classe Audio DR5 Pre-Amp with PSU & Phono Stage (cost new £3900) £1995

AMPLIFIERS

Audio Note Neiro Power Amp £5495
 Perreaux SM6P Pre-Amp 350P Power Amplifier £2750
 Naim 120 Power Amplifier £175
 Rogers £400 Integrated Amplifier with phono-stage (NEW) £995
 Exposure 11/12 Super 8 £995
 Audionote P4 Monoblocks £3395
 Audio Research VT60 Power Amp £1295

CD PLAYERS & TRANSPORT

Mendian 602 CD Transport, 563 DAC Inc. balanced connecting cable £445
 Theta Jade CD Transport £1295
 Rotel BX 970 CD Player £130
 Teac VRDS 9 CD Player (mint) £650

DACS

MSB Link DAC 111 with PSU, Base, HOC and upsampler £850
 Mark Levinson ML30.6 Reference DAC (ex demo) £POA

MISCELLANEOUS
 Beyer 811 Headphones £110
 Teac A-33405 Tape recorder £595
 Quad 77 System Power Amp, Pre-Amp, CD Player and Tuner £2995
 Audio Note ANS7 MC Transformer with Phono-Phono Stage £8495
 Selections of MIT cables available at discounted prices

TURNABLES, CARTRIDGES & TONEARMS

Hadcock Tonearm (mint) £445
 Michelle Gyro Deck with out-board power supply £895
 Project Debut Gloss Black Turntable £99
 Koetsu Urishi Cartridge (unused) £1995
 Koetsu Itogawa Diamond Cartridge (unused) £4495
 Hellus Silver wired tonearm £995
 Thorens TD125 Turntable £286

BRAND NEW BOW WAZOO
 INTEGRATED AMPLIFIER NORMAL PRICE £2500 OUR PRICE £1995

NOW DEMONSTRATING THE MARK LEVINSON 383 INTEGRATED AMP

WE NOW OFFER 0% FINANCE (subject to status)
 PLEASE PHONE TO ARRANGE AN AUDITION
 MAIN DEALERS FOR MARK LEVINSON, THIEL, AND ABSOLUTE SOUNDS

ALL USED CARTRIDGES ARE CHECKED UNDER A MICROSCOPE BEFORE BEING OFFERED FOR SALE.

VISA - SWITCH - MASTER CARD - AMEX - DINERS CLUB WELCOME.
 WE TAKE PART EXCHANGE ON NEW & USED STOCK AND BUY IN FOR CASH

Soundcraft HiFi.com At 40 High Street, Ashford, Kent. TN24 8TE

February 2002

Hi-Fi Separates (! = Ex - demonstration)

Arcam A65 amp	£299	Linn Karik CD	£799
Arcam A-75 amp	£349	Linn Mimik CD	£499
Arcam A-85 amp	£599	Linn Axis Turntable	£250
Arcam CD-92	£649	Linn 5105 Power Amp	£899!
Arcam Alpha 10P3 pwr amp	£650!	Marantz PM6010K1 Amp	£299!
Audiolab 8000A	£249	Marantz DR4050 CD recorder	£249!
Castle Harlechs ant/oak	£850!	M/F A3 Amplifier	£599
Castle Harlech (cherry)	£700!	Naim NAC-62/ NAP 90/3	£499
Castle Richmond ant/oak	£199!	Naim CDS and CDPS	£2995
Castle Severn 2's (Birch)	£499	Naim AV-1 processor	£650
Jamo Concert Centre	£349	Pioneer VSX 859 THX receiver	£599!
Jamo Concert Diapole speakers	£199	Ruark Solus speakers rosewood	£899!
KEF Concerto 1	£399!	Ruark Dialogue Centre	£250!
Linn Numeric	£499	Yamaha MDX 596 mini Disk	£150!

Our exciting range includes: Arcam, DiVA & FMJ, Chord Electronics, Linn (CD12), Naim (NAP 500 & NBL), Rega, Musical Fidelity, Denon, Yamaha, Rotel, B&W Nautilus, PMC, Ruark, Castle, Kef, Loewe TV, Pioneer Plasma, Sim 2 DPL!
HOTLINE: 01233 624441 Fax: 01233 640333.

AV Separates (! = demonstration)

Arcam AVR 100 Receiver	£650	Pioneer NS-DV1DVD System	£999!
Denon DV-2500 DVD player	£399!	Pioneer XV-DV55 + S-59 spkrs	£649!
Denon DVD 5000	£799!	Sony DVPS 335	£199
Marantz DV-4100 zone free	£299!	Yamaha DVD-S510 zone free	£230!
Marantz DV-7000 DVD player	£499	Yamaha DSP E 800 processor	£279!
Marantz SR-7000 Av Receiver	£599	Yamaha AX-1 Amplifier	£1199
Pioneer 502 50" Plasma	£6995!		
Pioneer DV-535 DVD zone free	£199!		

Check our web site: soundcraft.hifi.com

Sound Investment

If you have invested expertise and money in building up a sound system to your own unique specifications, then why compromise with indifferent housing units?

Fi-Rax offers a new dimension in audio visual racking - from a range of standard designs to the flexibility to custom create a unit to suit your particular sound system and lifestyle.

- *High quality aluminium construction.
- *Finishes available to your choice
- *Fully adjustable 6mm glass shelving.
- *Sound isolation on shelving/feet.
- *Custom created to suit your system.
- *Free delivery throughout the UK.

Fi-Rax - a sound investment for those who want the best from their equipment.

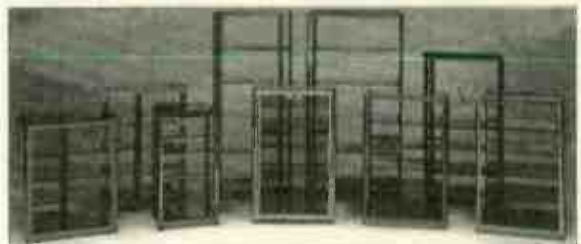

Audio Visual Furniture

For further information or a free brochure contact: JEM Distribution, Springfield Mills, Spa Street, Ossett Wakefield WF5 0HW.
Tel: 01924 277626 Fax: 01924 270759

Are you making the right connections?

Send for Britain's biggest catalogue of specialist cable and connections.

All available by mail order.
 Phone **020-8942 9124** or clip the coupon for your Free copy
www.custom-cable.co.uk

CUSTOM CABLE SERVICE

PO Box 4007, London SW17 8XG

Please send me your **FREE Custom Cable Catalogue**

Name _____

Address _____

Postcode _____

NO FURTHER INFORMATION REQUIRED

Send to: Custom Cable Service
 PO Box 4007
 London SW17 8XG

HFV 02/02



S/hand and ex-demo clearance items - February 2002

	Was	Now	
CD players DACs & Transports			
Audio Analogue Maestro CD Player Ex-Demo	1200	799	10% off
Audio Note CD1 S/H	695	299	10% off
Audio Note CD2/ Border Patrol PSU Fitted S/H	1699	999	10% off
Naim Audio CDI Integrated CD Player 96 S/H	1990	1099	10% off
Roksan DA2 DAC S/H	599	299	20% off
Roksan DS5 PSU S/H	579	325	20% off

Turntables Tonearms & Cartridges

Audio Note IO Kondo Built S/H	2500	749	10% off
Basis 1400/RB250 (New & Boxed)	1300	899	10% off
Benz Micro Gold MC Cartridge S/H	169	99	10% off
Conrad Johnson EV-1 Phono Stage Ex-Demo	1499	1349	10% off
Decca London Gold (J.Wright modded)	N/A	299	10% off
EAR MC3 Transformer (3 Months old)	625	499	10% off
Kuzma Stogi/Stabi S Turntable (New & Boxed)	1299	1099	10% off
Linn Axis Turntable S/H	N/A	249	10% off
Nottingham Analogue Tracer MM Cartridge	99	50	10% off
Rega 3 Turntable S/H	298	175	10% off
Roksan Shiraz Black 50 hrs Ex-Demo	995	599	20% off
Roksan DS1.5 PSU Ex-Demo	695	499	20% off
SME 20/2 Turntable S/H	3657	2499	10% off

Preamplifiers

Audio Note M1 Phono Preamplifier S/H	750	449	10% off
Audio Note M Zero S/H	449	275	10% off
Audio Note M Zero R Ex Demo	599	449	10% off
AVI 2000 Line Preamplifier S/H	850	449	10% off
Conrad Johnson Premier 17LS Ex-Demo	4500	3999	10% off
Conrad Johnson Premier 14 Ex-Demo	1999	1750	10% off
Electrocompaniet EC4R Preamplifier S/H	1250	599	10% off
Krell KAV-S Processor/Preamplifier DTS/AC3/Pro Logic S/H	14989	5999	10% off
Naim Audio NAC 92/N Preamplifier S/H	598	325	10% off
Roksan L1.5 Reference Line Preamplifier S/H	2250	1395	10% off
Roksan L2.5 Preamplifier S/H	1295	599	10% off
Spectral DMC10 Phono Preamplifier	N/A	995	10% off

Amplifiers

Audio Note Otto SE Phono S/H	1600	799	10% off
Conrad Johnson MV 55 Valve Power Amplifier S/H	1995	1099	10% off
Conrad Johnson Premier 11 Power Amplifier (New&Boxed)	3695	2799	10% off
Densen Beat 300 power Amplifier Ex-demo	795	599	10% off
DPA 200 s Power Amplifier S/H	499	299	10% off
Electrocompaniet AW60 (New&Boxed)	999	699	10% off
Golden Tube Audio SI-50 MKII Valve integrated (New&Boxed)	1100	699	10% off
Graaf Venticinque 25 Watt Integrated S/H	1795	995	10% off
Naim Audio NAP 90.3 Power Amplifier S/H	487	295	10% off
Roksan Rok S1.5 Power Amplifier S/H	1499	799	10% off
Unison Simply 4 Valve Integrated Ex-Demo	1600	999	10% off

Loudspeakers

Acoustic Energy AE1 MKII Black S/H	899	599	10% off
Boston Acoustics VR 10 Centre Channel (New&Boxed)	250	175	10% off
Infinity Outrigger jr Outdoor Speakers (New&Boxed)	249	129	10% off
Robertson Audio DX7 Cherry Ex-Demo	995	599	10% off

Loudspeakers (con't)

	Was	Now	
Totem Mani 2 Cherry S/H	3200	2250	10% off
Totem Tabu Mahogany Ex-Demo	2300	1599	10% off
Totem Arro MKII Cherry New& Boxed	1095	849	10% off
Totem Model One Signatures Cherry Ex-Demo	1695	1199	10% off
Velodyne TX810MK2 Subwoofer S/H	695	349	10% off

Cables & Accessories

Black Diamond Racing "The Pits" (New&Boxed)	180	99	10% off
Bow Technologies Wand Remote S/H	349	199	10% off
G- Flex isolators (New & Boxed)	199	75	10% off
Golden Sounds Ceramic Cones (New & Boxed)	85	49	10% off
Kimber Powercord 8TC wattgate 1m S/H	169	99	10% off
Kimber Powercord 4TC wattgate 1m S/H	89	49	10% off
Naim Audio 2x5m Speaker cables white S/H	N/A	45	10% off
Roksan HA01 1M Interconnect S/H	99	49	10% off
Sound Style 4 Tier in Green S/H	325	159	10% off
Transparent Music link Ultra Balanced 1m S/H	1499	995	10% off
XLO 2X7m Type 0.6 Speaker Cables Shotguned S/H	750	399	10% off
VanDen Hul Second 0.8m Balanced Interconnect S/H	230	149	10% off

Tuners & Tape Decks

Audiolab 8000T Tuner S/H	1200	599	10% off
Magnum Dynalab FT-R Remote Switcher for FT101A/Etude (New)	450	299	10% off

Clearance Items Under £100

Thorens TD125 Turntable S/H	N/A	99	10% off
-----------------------------	-----	----	---------

Midland Audio X-change are looking for Audio Research, Krell, Mark Levinson, Naim Audio, Theta, Wadia, cash paid call John Roberts on 01562 822236 now!

Suppliers and installers of High Quality Audio Systems

- 47 Laboratory
- Accuphase
- Audio Note
- Audio Research
- Avid
- Basis
- Cabasse
- Cardas
- Clearaudio
- Conrad Johnston
- Copland
- Dcs
- DNM / Reson
- Einstein
- Electrocompaniet
- Final
- Finite Elemente
- Graff
- Gryphon
- Lavardin
- Mark Levinson
- Martin Logan
- Michell
- Nagra
- Primare
- ProAc
- Rega
- Resolution Audio
- Sonus Faber
- Spectral
- SPM
- Sugden
- UKD

www.midlandaudiox-change.co.uk

call John Roberts Tel / Fax 01562 822236

181 Franche Rd • Kidderminster • Worcs • DY11 5AD

e-mail sales@midlandaudiox-change.co.uk

Mobile 07721 605966



TRUE COLOURS INDUSTRIES

email support@true-colours.com

Reviewers Favourite -- Hi-Fi News

TCI Cobra Interconnect

- 1.0m WBT phono to Phono £149.90
- 0.6m WBT phono to Phono £119.99
- 0.6m Neutrik XLR to XLR £139.99
- 1.0m Neutrik XLR to XLR £169.90



"...There was an overall feeling of neutrality and naturalness with this cable; it performed the vanishing trick that many aspire to but few achieve."

Tony Bolton Hi-Fi News

The Best Value Mains Powerleads

TCI Constrictor Powerleads

- 1.0m 13A to IEC £89.90
- 1.0m 13A to 4 Way £99.99
- 1.0m 13A to 6 Way £119.99
- 1.0m 13A to 8 Way £199.99
- extra 0.5m £25

COMPARED WITH KIMBER

"The main difference between these two leads was the extreme top end, where the True Colours had a slightly 'creamier' sound to it."

Tony Bolton Hi-Fi News



"Given their modest cost they really do represent the minimum you should be spending, even in the context of a budget system."

Roy Gregory Hi-Fi+ Magazine

SUPERB CABLES at SENSIBLE PRICES

TCI Adder Digital Interconnect

- 1.0m WBT Phono to WBT Phono £59.99
- 1.0m WBT Phono to BNC £59.99
- 1.0m BNC to BNC £59.99



**BEST BUY
WHAT HI-FI**

Overall Winner-Interconnects Supertest



**BEST BUY
Hi-Fi Choice**



TCI Viper Interconnect

- 0.6m TCI Locking Phono to Phono £49.99
- 1.0m TCI Locking Phono to Phono £54.99

Overall Winner Group Test WHAT HI FI

TCI Taipan S-Video Leads

- 1.0m 13A 4pin to 4pin S-Video £54.99
- 1.0m TCI Scart to Scart S-Video only connected £54.99
- Featuring TCI Taipan video cable and TCI Viper Hi-Fi interconnect
- 1.0m TCI Scart to Scart All Pins Connected (RGB) £84.99
- 1.0m TCI Scart to SVHS plug & 2 Phono £69.99



**BEST BUY
WHAT HI-FI**

Music Without Compromise Cables Without Equals

TCI Python Speaker Cable

- unterminated per metre £7.99
- 3.0m Stereo 4mm terminated £107.99
- 5.0m Stereo 4mm terminated £139.99
- 5.0m Biwire 4mm terminated £239.99

"It is balanced and well extended, especially in the bass, which plumbs almost to the full depth available" Hi-Fi Choice



Hi-Fi Choice

AVAILABLE MAIL ORDER

- Anglia Audio
Tel. 01359 270212
- Audiocraft
Tel. 018 9525 3340
- Doug Brady Hi-Fi
Tel. 01925 828009
- Eastern Audio
Tel. 014 7321 7217
- Kronos Hi-Fi
Tel. 028 8775 3606
- Hi-Fi Studios
Tel. 013 0272 5550
- Hi-Fi City
Tel. 019 2322 6169
- Lyric Hi-Fi
Tel. 028 9038 1296
- The Listening Rooms
Tel. 020 7244 7759
- Sevenoaks Hi-Fi (Preston)
Tel. 017 7282 5777
- Walrus Systems
Tel. 020 7724 7224
- Hi-Fi Corner (Dublin)
Tel. 00353 1671 4343
- Sherwoods (Waterford)
Tel. 00353 5187 2622
- For full dealer list contact
True Colours Industries on
077 1019 6949 or visit

Upgrade your Armlead

TCI Viper Armllead

- 1.2m SME 5pin Armplug to WBT Phono £124.99
- 1.2m WBT Phono to WBT Phono £89.99

Upgrade to a TCI cable now and hear and see what your system can really do.

TCI is continuing to build an excellent reputation for quality among dealers and end users alike. We have compared our cables openly at Hi-Fi shows against cables from Nordost, Van den Hul, CableTalk, Eccose Reference cables, QED and Ixos.

True Colours Industries

Unit 263
Lisburn Enterprise Centre
Ballinderry Road
Lisburn
BT28 2SA
Tel 077 1019 6949
Fax 087 0120 5923

<http://www.true-colours.com>

English Analogue

Supplier of quality second-hand classical records
Reasonable prices for truly collectable original vinyl from
the 1950s to the 1970s. Labels include:

- DECCA - SXL, SDD, SET, RCS, SPA, PFS
 - HMV - ALP, ASD, SAN, SLS
 - COLUMBIA - 33CX, SAX
 - RCA - SB - 2000/6000, VICS, SER
 - DEUTSCHE GRAMMOPHON, PHILIPS
- etc, also available

To increase your satisfaction, all the records sold are cleaned and audibly checked before being sold, free of charge, as well as a guarantee. The records are also supplied with a new innersleeve, as well as the old, to ensure a high standard. In addition, if you have any classical LPs you wish to sell or want a free catalogue, please contact:

3 Naseby Rise, Newbury, Berks, RG14 2SF, England
Tel: 44 (0) 1635 40242./ 44 (0) 7786 060994
Fax: 44 (0) 1635 524239

www.multiplex.co.uk/Records

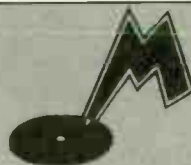

MUSONIC STYLI

**SPECIALIST MANUFACTURER &
SUPPLIER FOR MORE THAN 40 YEARS**

REPLACEMENTS & ORIGINALS

MANY OBSOLETE/78 VERSIONS

PICK-UP CARTRIDGES

RECORD/TAPE/CD ACCESSORIES

**WHY NOT TRY US AND HEAR THE
DIFFERENCE !!**

NAGAOKA CARTRIDGES NOW IN STOCK

For further information tel/fax/e-mail to:-

MUSONIC (UK) LIMITED
Unit 13 Wenta Business Centre Colne Way
Watford Hertfordshire WD24 7ND

Tel: 01923 213344 Fax: 01923 213355
E-mail:sales@musonic.co.uk

VISIT OUR NEW WEBSITE
www.musonic.co.uk

Trade and Export enquiries welcome



AUDIOJUMBLE

"2002"

Tenth Year Anniversary Special

Vintage valve amplifier display

ANNUAL SALE OF VINTAGE AND MODERN HI-FI EQUIPMENT AT:- THE ANGEL LEISURE CENTRE TONBRIDGE, KENT.

SUNDAY 17TH FEBRUARY 2002
10.30AM - 4.30PM

STALLS £25-00 ADMISSION £3-00

9:30am Early Entry £10-00

BOOKINGS/ENQUIRIES 01892-540022

LARGE CAFETERIA SERVING HOT AND COLD MEALS ALL DAY
MAIN LINE RAILWAY STATION WITHIN WALKING DISTANCE

* VALVE AMPS * TUNERS * RECORDS *
* SPEAKERS * COMPONENTS *
* BOOKS * CASSETTE DECKS * C.D. PLAYERS *

www.audiojumble.co.uk

WILLIAMS HART ELECTRONICS

HART ELECTRONIC KITS TRADED FOR OVER 30 YEARS



NEW LAYOUT

80Watt Mosfet Stereo Power Amp Kit
110Watt Mosfet Monoblock Power Amp Kits

ONE OF THE BEST AMPLIFIERS YOU WILL HEAR! Regardless of price
ON DEMO @ Wigan, Southend, Peterborough and Burnley



Single Ended Class A Valve Sound
15Watt Power Amp modules

FOR THOSE WHO WANT THAT VALVE
MIDBAND BUT BASS AND TREBLE TO MATCH



ACTIVE R/Control SUBWOOFER MODULE £177.30



Range of speaker Kits
Passive and Active

Advertise your Hi-Fi on my website (FREE)

Also: Award Winning Phono Stage Kit, Active Crossover Modules, Speaker Drive Units,
M Cap Capacitors, Cardcage Resistors, Remote Control Volume and much more

WEB SITE www.williamshart.com

e-mail: williamshart@classicfm.net

or Tel/Fax for catalogue 01942 253647, 121 Long Lane, Hindley Green, Wigan, WN2 4XD
PERSONAL VISITORS SHOULD PHONE FIRST TO AVOID DISAPPOINTMENT

Run by former Technical Director of Wilmslow Audio



MUSICAL IMAGES

PRODUCT		LIST	NOW
HOUNSLOW			
ACOUSTIC ENERGY AE 120SE Speakers	EX/DEMO	£600	£375
ACOUSTIC ENERGY AE 509 Speakers	EX/DEMO	£850	£425
DENON AVC-A1D Gold AV Amp	EX/DEMO	£2,000	£1,300
DENON DVD3300 Black or Gold DVD Player	NEW	£650	£550
MARANTZ PM6010OSE Amp	EX/DEMO	£230	£150
SONY MDSJB940 Black or Silver Mini-Disc Player	NEW	£330	£250
EDGWARE			
DENON DVD3300 Black or Gold DVD Player	NEW	£650	£550
JAMO CONCERT 11 American Cherry Speakers	EX/DEMO	£2,300	£1,200
JAMO CONCERT 8 Speakers	S/H	£1,350	£850
KEF TDM45 Subwoofer	S/H	£800	£550
MARANTZ CD17KI Gold CD Player	EX/DEMO	£1,200	£750
MARANTZ DR6000 CD Recorder	EX/DEMO	£400	£300
MARANTZ DV7000 DVD Player	EX/DEMO	£600	£325
MARANTZ PM17 Gold Amp	EX/DEMO	£1,000	£600
SONY MDSJB940 Black or Silver Mini-Disc Player	NEW	£330	£250
COVENT GARDEN			
CASTLE SEVERN2 Speakers	EX/DEMO	£700	£300
DENON AVR3300 AV Receiver	EX/DEMO	£800	£475
DENON DVD3300 Black or Gold DVD Player	NEW	£650	£550
NAD 533 Turntable	S/H	£220	£150
PRO-AC RESPONSE 3.8 Cherry Speakers	EX/DEMO	£3,990	£2,800
PRO-AC STUDIO 125 Yew Speakers	EX/DEMO	£1,100	£750
ROKSAN RADIUS Turntable + PSU	S/H		£200
THORENS TD166 MK6 Turntable, Arm & Cartridge	S/H	£500	£350
BECKENHAM			
CHORD DSC1100 Silver DAC inc Trigger	EX/DEMO	£2,815	£2,300
CYRUS AVMASTER+ Processor	EX/DEMO	£800	£400
DENON AVC-A1D Gold AV Amp	EX/DEMO	£2,000	£1,300
DENON DVD3300 Black or Gold DVD Player	NEW	£650	£550
MARANTZ CD 17 Black CD Player	EX/DEMO	£800	£500
MARANTZ CD17KI Gold CD Player	EX/DEMO	£1,200	£750
MERIDIAN M33 Speakers	EX/DEMO	£1,500	£1,100
MUSICAL FIDELITY XA-1 Amp	EX/DEMO	£480	£350

ALL BRANCHES KEF REFERENCE SPEAKERS SPECIAL OFFER

MODEL 1-2 Black/Cherry/Rosenut/Rosetta Burr	NEW	£1,350	£1,090
MODEL 2-2 Black/Rosenut	NEW	£1,750	£1,400
MODEL 3-2 Black/Albina Burr/Classic Rosewood	NEW	£2,750	£2,000
MODEL 4-2 Black/Cherry/Classic Rosewood	NEW	£3,650	£2,800

PLEASE VISIT OUR SHOWROOMS
OR CALL OUR HOTLINE
NUMBER FOR DETAILS. HURRY, MANY ARE
ONE-OFF ITEMS!!

SEE IT! HEAR IT! BUY IT!

Beckenham
126 High Street
Beckenham, Kent
BR3 1EB
Tel: 020 8663 3777
Fax: 020 8663 3555

Covent Garden
18 Monmouth Street
Covent Garden
London, WC2H 9HB
Tel: 020 7497 1346
Fax: 020 7497 9205

Edgware
173 Station Road
Edgware, Middlesex
HA8 7JX
Tel: 020 8952 5535
Fax: 020 8951 5864

Houslow
45 High Street
Houslow, Middlesex
TW3 1RH
Tel: 020 8569 5802
Fax: 020 8569 6353

E-Mail: sales@musical-images.co.uk

NOT VALID WITH ANY OTHER OFFERS OR PROMOTIONS E&OE

We are best known for our single-ended 300B power amplifiers and power supply upgrades for valve amplifiers, but did you know that we supply complete systems, new and used equipment, and components? We also provide support and servicing for Audio Innovations valve products. For full information visit www.borderpatrol.net or ring 01273 276716.

passion, grace & fire

www.borderpatrol.net

Selected products from:

BorderPatrol • Living Voice • SME • Audio Note • Cartridge Man • Goldring
Western Electric • Electrofluidics

BorderPatrol Brighton UK
Tel/Fax +44 (0)1273 276716
e-mail: bp@borderpatrol.net
www.borderpatrol.net



BorderPatrol

AUDIO MATTERS

NEW EX-DEM & PART EXCHANGE
EQUIPMENT FOR SALE
020 8255 0572/0973 436135

	LIST	SALE
Alchemist Kraken Anniversary MkII	£599	£POA
Alchemist Product 8 pre & pwr (on dem)	£2047	-
Alchemist Product 8 dac & drive (on dem)*	£1898	-
Alchemist The Statement pre amp ex/dem	£4999	£2295
Alchemist The Statement Stereo pwr ex/dem	£3999	£1995
Audion Black Shadows 845 valve monoblocks	£4000	£POA
Audion Silvernight 300B monoblocks	£2250	£POA
Audion Golden Nights	£4000	£2200
Bow Technology Wazoo (ex/d)	£2195	£1595
Bryston BP ST4 pwr	£2100	£1195
Chario Academy 1 solid walnut (ex/d)	£1299	£800
Classe DR 6L pre	£3400	£1295
DPA Renaissance CD player ex/d	£995	£595
Krell 250 CD Player	£2592	£1795
Krell Kav 300I	£2495	£POA
Linn Karin pre	£1400	£595
Mark Levinson 331 pwr	£4500	£2695
Mark Levinson 23.5 pwr	£7500	£3195
Meridian 551 int. amp	£845	£425
Meridian 555 pwr. amp	£750	£395
Naim 72 pre	£800	£395
Naim 90 pwr.	£487	£250
Perreux AC 3 pre ex.d	£1700	£1195
Perreux 6 ch. pwr amp	£2500	£1695
Roksan Caspian (AC3 DTS) pre & 5 ch. pwr amp (on/dem)	£2290	-
Ruark Prologue re 1 spks.	£999	£595
Monitor Audio 20SE	£2200	£950

A NEW RANGE OF VIENNA ACOUSTICS SPKS. NOW ON DEM

*New Product 8 from Alchemist Dac & Drive with 192 sampler in-built ON-DEM

Also On-Dem: Alchemist, Anthem, A.R.T. spks., Audiomeca, Audion Valve Amps, Cadence Spks., Chario, D.P.A., Goertz cables, Lavardin., Monarchy, Ortofon, Pink Triangle, Project T-T., Roksan., Sonic Frontiers, Triangle Spks., Van den Hul., Rogue Audio Valve Amps., Amphion Spks.

VISA/MASTERCARD ACCEPTED



PROGRESSIVE AUDIO



2 Maryland Court, Rainham, Kent, ME8 8QY
Telephone / Fax No. 01634 389004

WEBSITE: www.progressiveaudio.co.uk E-MAIL: dave@progressiveaudio.co.uk

We have the following ex demonstration and part exchange items for sale :

- ANTHEM (by Sonic Frontiers) amp 2 (silver) Mint £1200 S/H
- FINAL 0.3 Hybrid loudspeakers (cherry) mint £1150 S/H
- DNM series 3 pro amp with twin power supply £750 S/H
- PROJECT perspective turntable £650 Ex Dem
- ALON Lil Rascal loudspeakers £325 Ex Dem
- VAN DEN HUL the second i/c cable 1m £165 S/H
- PROAC Response 1 SC loudspeakers. Black. With Target R stands. Mint. Boxed. £1050. S/H.
- THETA D5 pro progeny DAC. Mint £850 S/H
- YBA CD2. As new. Silver. £2250. X/D.
- LFD LS1 Line stage. £525. S/H
- REGA Jupiter /to CD Transport and DAC with d'igital interconnect. £795. S/H.
- VERITAS H3 Horns. Piano black. As new. £4600. X/D.
- VERITAS 20'S. Piano Black. With stands. As new. £1250. X/D.
- BLACK Rhodium interconnect. 1.5m. Boxed as new. £795. S/H.
- ALON Petite loudspeakers. Walnut. As new. Boxed. £850. X/D.
- ALON 1 loudspeakers. Walnut. Excellent condition. Boxed. £795. X/D.
- ELEMENTAL Audio monolith. (£499) £300. X/D.
- ELEMENTAL Audio speaker stands (the best ever ?) £1500 new. £850. X/D.
- SONUS FABER concerto loudspeakers (walnut) with Partington stands £650 S/H
- MICHELL Argo HR Line pre amp. With Hera P/S. £650. X/D.
- MICHELL Iso HR. phono stage. With Hera P/S. Excellent condition. £495. S/H.
- ORIGIN LIVE Sovereign loudspeakers. Cherry. Good condition. £650. X/D.
- ACOUSTIC SOLUTIONS "Eight" loudspeakers. Oak. As new. With stands. £1200. X/D.
- LINN Kaber loudspeakers with stone stands. £825. S/H.
- JEFF ROWLAND Model 2 power amp with BPS 2 battery power supply plus SYNERGY 11 pre amp. £6000. S/H.
- AUDIONOTE AN-KSp speakers (Oak) with matching Audionote stands. £725. S/H.
- REGA EOS m/m +m/c phono stage. £250. S/H.
- CASTLE Harlech speakers (Natural Oak) Mint. Boxed. £525. S/H.
- AUDIONOTE AN-SPx reference speaker cables. 7 ft bi-wire set. £1650. S/H.
- TOWNSHEND Rock Mk11/Excalibur/OC7 turntable with plinth and cover and Merin power supply. £750. S/H.
- AUDIO MECA Mephisto CD drive Mint. Boxed £1250. S/H
- SUGDEN AU51 DAC Mint. Boxed. £750. S/H

NOW ON PERMANENT DEMONSTRATION THE SUGDEN MASTERCLASS INTEGRATED AMP AND CD PLAYER, RED ROSE ROSETTA AND ROSEBUDS, MOON ELECTRONICS, VELODYNE SUBWOOFERS, WADIA CD PLAYERS, AUDIO ANALOGUE MAESTRO CD PLAYER AND AMP MUSICAL FIDELITY 3D CD PLAYER, LIVING VOICE AND AUDIO PHYSICS LOUDSPEAKERS, AVID TURNTABLES AND CHAPTER AUDIO POWER AMP

UPGRADE YOUR TURNTABLE

"If you are thinking of upgrading your system..the Origin Live dc-motor kit should be high on your list for consideration" TNT AUDIO internet magazine April 2000.

"The single most important upgrade you can ever make to any record deck concerns the motor drivenothing can compare you for the shock of going DC, in a word Gobsmacking" COMMON GROUND MAGAZINE

"Its value is nothing short of tremendous" LISTENER MAGAZINE

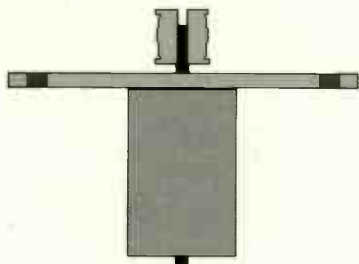

Whether you own a Linn Valhalla/Lingo, Rega or any other deck, the results of upgrading to the Origin Live dc motor and power supply are simply astounding. This high grade motor kit is designed as a drop in replacement for almost all turntable motors. Decks benefiting so far from this ultimate of upgrades include Linn, Roksan, Michell, Systemdeck, Rock, Rega etc. With a 12 Volt power supply it is safe and easy to fit. Guidance instructions are provided. At £262 with fully soldered and tested regulator board plus money back guarantee, this is a bargain out of all proportion to it's value in terms of performance. A larger purpose made transformer is also available as an optional extra at £175.

Why pay 4 times the price for less performance ?



LAMINAR FLOW ULTRA

"A high end sound with a sensible look and price tag"
HI-FI WORLD July 2001

"The Ultra's are a deeply satisfying musical product and supreme bargain"
Stereo Times August 2001

Laminar flow cable is a groundbreaking new design of cable. The "Ultra" version is guaranteed to outperform all other interconnects up to 4 times it's price and the "Reference" is a cable that reviewers use to judge other cables due to it's incredible transparency and musicality.

With a money back guarantee if not satisfied you have nothing to lose. Why not order a pair or see your local Origin Live dealer.

Advanced interconnect: £45 per stereo pair
Laminar flow Ultra Interconnect: £85 per stereo pair
Laminar flow Reference Interconnect: £159 per stereo pair

Make cheques payable to Origin Live and send to address shown
We can take credit card orders if you wish. Remember there is a no risk money back guarantee if not entirely satisfied.

EMAIL: origin.live@virgin.net

ORIGIN LIVE TURNTABLE KIT

Now you can save money and build your own high performance deck. The standard parts kit is offered at £282 and is complete apart from a plinth. The kit comes with a full set of drawings and guidance instructions. It allows for your creativity or there are optional parts that will enable you to assemble a tried and tested design within 1 - 4 hours. The optional parts include plinths for suspended and non-suspended designs along with sub-chassis etc. The optional parts upgrade the standard kit to high end performance levels and is probably the easiest kit you will ever make.

"this Vinyl front end had my jaw heading towards the floor with the solidity and transparency of the music it was making"...
" the standard came up with crystal clear images set in a broad sound stage"... "With all these goodies in place, the standard would give turntables at the £1200-£1400 mark a hard time."

HI-FI WORLD SUPPLEMENT

"is exceptionally easy to build and professional in both sound quality and appearance"

HI-FI NEWS SUPPLEMENT

In group comparison test of 8 turntables, WHAT HI-FI MAGAZINE stated "the origin live turntable is the best sounding deck here... if sonic ability is your top priority just go ahead and buy it... the origin live ultra sounds fantastic"(FIVE STAR RATING)

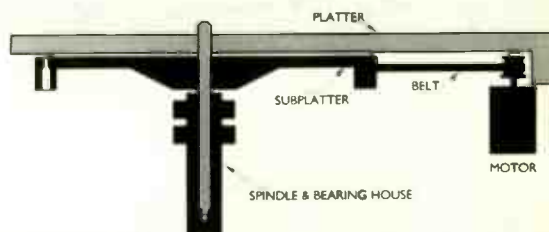

TURBOCHARGING YOUR REGA ARM

"Nothing less than total dynamite" HI-FI WORLD

If you are the proud owner of any Rega arm, why not utterly transform it into the league of super arms with the Origin live structural modification - £75. This modification will enable your Rega to perform at a level exceeding that of arms costing over £1200.

Rewiring with high grade litz cable is also offered at an additional £70, and external rewiring is £70.

"I have to say the Rega modifications turn this humble arm into a real Giant killer. Gone is the rather grey, sterile sound of the cooking Rega. Instead, tonal colour is fresh, dynamics have great speed and impact, and the sound stage is huge." HI-FI WORLD SUPPLEMENT NOV 97 (structural modification to a RB250) WHAT HI-FI gave this modification a 5 star rating.

For arm modifications we normally return your arm in 2 - 3 days

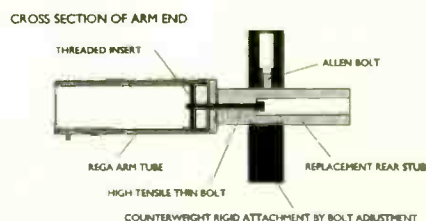

For further information contact
Origin Live, 87 Chessel Crescent, Bitterne,
Southampton, SO19 4BT

Tel: 02380 442183 / 578877 - Fax: 02380 398905

WEBSITE: <http://www.originlive.com>

HEATHCOTE AUDIO

TEL: 01992 653999 MOBILE: 07860 511111 E-MAIL ADDRESS: HeathcoteAudio@aol.com

VALVE AMPS

JADIS J480 CLASS A MONOBLOCKS (WERE £10,000) RE-VALVED SUPERB
RAYMOND LUMLEY M-150 MONOBLOCKS (MONSTERS)
COUNTERPOINT SA-20 X 2 (STEREO OR BRIDGED MONOBLOCKS)
AUDIOVALVE PPP-45 MONOBLOCKS
MICHAELSON AUDIO CHRONOS 4 BOX FAB ART DECO STYLE (WAS £10,130.00)
AUDIO INNOVATIONS SECOND AUDIO TRIDDE MONO'S 2X2 (ORDER PATROL MONO)
CONRAD JOHNSON PV10-AL PRE AMP
AUDIO INNOVATIONS 300 INTEGRATED MM/MC PHONO
AUDIO INNOVATIONS 300 INTEGRATED
AUDIONOTE OTO SE INC. PHONO STAGE
AUDIONOTE M-1 PRE AMP (WITH PHONO STAGE) EX DEM
AUDIONOTE P-2 POWER AMP EX DEM
COPLAND CT-401 INTEGRATED INC. PHONO STAGE
LUMLEY REFERENCE 120 MONOBLOCKS (NEW VALVES) TRIODE SWITCHABLE
MONRIO ASTY VALVE PRE (VERY PRETTY) NEW
CARY AE-ONE P LINE PRE AMP (EXPOSED VALVES)
ROTEL MICH RHCI0 PASSIVE PRE
AUDIO SYNTHESIS PASSION PRE (BLACK MARBLE CASE)
MICHAELSON & AUSTINMENT MORE TVA-1 KT88 POWER AMP CHROME CHASSIS

SOLID STATE

ELECTROCOMPANET FC-1 REMOTE INTEGRATED (WITH PRE-OUT) EX. DIS/DEM
ELECTROCOMPANET AW-60 POWER AMP (80 WATTS CLASS A) EX.DIS/DEM
SUGDEN AU-51 CLASS A POWER AMPS EX DIS/DEM
DENSON DM-30 PRE AMP (WAS £1600.00 NEW)
AUDIOLAB 8000 Q PRE-AMP
AUDIOLAB 8000 MONOBLOCKS
AUDIOLAB 8000 S
AUDIOLAB 8000 A LATE MODEL
DPA DSP-200 PRE AMP
DPA DPA-200S POWER AMP (BRIDGEABLE)
DPA 200 PHONO STAGE
ECA VISTA PRE AMP(SUPERB)
TAG MACLAREN 60-1 INTEGRATED FEW HOURS USE ONLY
EZO ARIA REMOTE INTEGRATED (VERY PRETTY) AS NEW- FEW HOURS USE
EXPOSURE 1V POWER AMP
MVL A2+ VERY HEAVY 100 WATT X 2 INTEGRATED VERY LITTLE USE
MUSICAL FIDELITY XA2 INTEGRATED AS NEW
ALCHEMIST FREYA PRE AMP & 2 GENESIS MONOBLOCKS EXTREMELY RARE/BEAUTIFUL
ROTEL MICH RHCI0 PASSIVE PRE
QED VECTOR REFERENCE REMOTE ACTIVE/PASSIVE PRE-AMP
MUSICAL FIDELITY P180
MUSICAL FIDELITY 3A PRE AMP
MUSICAL FIDELITY 3A PRE AMP
MUSICAL FIDELITY MA50 CLASS A MONOBLOCKS
DENON 2500 DIGITAL PRE AMP (MATCHES POA-4400 MONO'S)
LINX STRATOS PRE AMP & 2X 120 WATT MONOBLOCKS MM/MC ETC (VERY RARE/GOOD)
DPA ENLIGHTENMENT REMOTE PRE AMP (LIGHT DEM USE ONLY SUPERB)
TECHNICS SUC 2000 REMOTE PRE AMP/SEA-2000 POWER AMP VERY HIGH QUALITY
MAGNUM REFERENCE MP 125 PRE & 2 X MF125 MONOBLOCKS(140WATTS)
MUSICAL FIDELITY THE PRE-AMP & 2 TYPHOON BRIDGEABLE POWER AMPS(BALANCED)
MERIDIAN MCA
LINN PRETEK PRE AMP
LINN LK14K2 PRE-POWER + REMOTE
ION SP1 PRE-AMP & X-PACK-2 SEPARATE POWER SUPPLY
MISSION 776777 BATTERY PRE & MATCHING POWER (VERY RARE INC. MANUALS)
SUGDEN C51/P51/T51 PRE/POWER/TUNER RECENT £200 SERVICE
AMC AV81HTC PRE-AMP/PROCESSOR STEREO/PRO LOGIC/PBX REMOTE
SONY SDP-EPS95 DOLBY DIGITAL PROCESSOR AC-3 ETC
REVOX A-78 AMP COLLECTORS ITEM

CD

MERIDIAN 506-20 BIT & MSR REMOTE
MERIDIAN 200 TRANSPORT (SERVICED RECENTLY)
TRICHORD DIGITAL TURNTABLE AES/EBU & BNC
DPA PDM 2 LEGENDARY 2 BOX DAC (WAS £2500)
AUDIONOTE DAC-1 EX DIS AS NEW/BOXED
DPA ENLIGHTENMENT DAC MINT/BOXED
THETA CHROMA 396 DAC HCCD MINT/BOXED
TEAC D-TI DAC BRAND NEW BOXED
MICROMEGA T-DRIVE TRANSPORT & T-DAC (WAS £2080) PHONO & BALANCED
ROK SAN DFI 1.5 TOT LOADING TRANSPORT
ARCAM 8 CD PLAYER
MERIDIAN 203 DAC
ORELLE D-188 DAC
WOODSIDE DAC 1
PINK TRIANGLE ORDINAL DAC 7 (1307 FILTER)
MYRIAD T-10 CD PLAYER
ROTEL RDP/980 TRANSPORT
ROTEL RDP/980 DIGITAL PROCESSOR
TECHNICS SLPS 900 REMOTE VOLUME ETC
ARCAM DELTA 70 2 CD PLAYER DIGITAL/VOLUME OUT
ARCAM DELTA 170 TRANSPORT
ARCAM BLACK BOX 3 DAC
AMC CDBA BALANCED PHONO OUTPUTS
PIONEER PD 9700

VINYL

TOWNSEND ROCK WITH FLUID DAMPEH
PINK TRIANGLE PT T00 & PSU
HELIOS ORION 10 INCH TONEARM
HELIOS ORION TONEARM
STD 305M TURNTABLE & MAYWAVE ARM
TECHNICS SL-110 CLASSIC TURNTABLE
DAIS TURNTABLE (GOLD STUNNING LOOKS VERY RARE)MINT/BOXED
PROJECT 6 TURNTABLE & ARM NEW GOLDRING 1022 CARTRIDGE V.G.C.
LINN BASIK PLUS ARM
TOM EVANS MICROGROOVE/LTHOS PHONO STAGE
MICHELL DELPHENI PHONO STAGE
DPA 200 PHONO STAGE
COUNTERPOINT SA2 VALVE STEP UP SEPARATE PSU(WAS £1700 NEW)
SHURE REALISTIC RXT6 (EQUIVALENT V15-47) BRAND NEW
SHURE N75ED-T2 BRAND NEW
MISSION 773 LC. MC VERY LITTLE USE
GOLDRING 1020/1022/1042 ALL NEW STYLUS

AUDIO TECHINICA-AT705LTD EDITION GOLD (NEW ETYLUE)
AUDIO TECHINICA-AT-F300CC MC (APPROX 5 HOURS USE)

LOUDSPEAKER

B K S 107 MK 2 RIBBON HYBRID FLOORSTANDERS (HIGHLY REVIEWED)
AUDIONOTE ANE-SP AMERICAN OAK FINISH EX DISPLAY (NEW £3000)
MAGNAPLANFR SMD C SE HARDLY USED)
PROAC STUDIO-3 MONITORS
SNELL TYPE E MK3 VERY RARE
SD ACOUSTICS SD-06S (SMALLER BROTHER TO SD-1)
CASTLE EDENS
SPEENDOR SP-1 WALNUT ONE
INFINITY REFERENCE STANDARD KAPPA 5 EMIT RIBBON TWEETER SANTOS ROSEWOOD
TANNOY ARDENS 15'
TANNOY ARUNDEL 15' DRIVERS 95/98 DB SENSITIVE VERY RARE
CELESTION 7000 4FT. HIGH RIBBON TWEETER VERY RARE
WHARFPALE OPTION 1 HUGE ACTIVE ONLY 4 PAIRS MADE (WERE £8000NEW)
SONY TCD-08 PORTABLE DAT MACHINE AS NEW COND.
WILMSLOW AUDIO VORTEX VOLT DRIVERS PIANO BLACK EXT. X OVER
KEF CONCERTO.S
ROYD EDENS
PROAC SUPER TABLETS
CELESTION SL 600 SI (AEROLAM ENCLOSURES)
MONITOR AUDIO MA-703 FLOORSTANDERS (CHERRY WOOD FINISH)

TUNERS /TAPE

LINX AUDIO THETA TUNER FULL WIDTH (WAS EXPENSIVE) VERY HIGH QUALITY
SONY ST-SE 300 TUNER AS NEW
SONY TCK 700ES CASSETTE LITTLE USED 3 HEAD SUPERB ES BUILD
NAKAMICHI DR-9
AIWA HD-S100 PORTABLE DAT MACHINE AS NEW COND.
AIWA HD-S100 PORTABLE DAT MACHINE (REMOTE ETC)

RACKS/STANDS

SOUNDSTYLE XS 105 NEW STYLE (CURVED GLASS) 5 SHELF BLACK OR SILVER EX DIS.
SOUNDSTYLE X110 4 SHELF STAND SILVER (SLIGHT MARK ON REAR) EX DIS
SOUNDSTYLE AV TABLE SILVER
TARGET 5 SHELFSTAND BLACK GLOSS/SMOKED GLASS
SOUND ORG. 2530 AUDIO VISUAL STAND SILVER NEW
SOUND ORG. 2540 MIDI STAND
SOUND ORG. 2560
KUDOS S507 18 INCH SPEAKER STANDS SAND FILLED
SOUNDSTYLE SELECT 4 PILLAR 22 INCH SPEAKER STANDS SATIN SILVER/BLACK
ACOUSTIC ENERGY AE-1 DEDICATED LOUDSPEAKER STANDS
ACOUSTIC ENERGY AE-1 DEDICATED LOUDSPEAKER STANDS BRAND NEW BOXED
TARGET R4 LOUDSPEAKER STANDS VERY HEAVY WERE £300
SPECIAL OFFER
SOUNDSTYLE SPEAKER STANDS SOLID PILLAR ATECAMA STYLE BUT HIGH GLOSS BLACK, SILVER
OR SATIN BLACK FINISH SAND FILLABLE 18" OR 24" LOOK SUPERB LIMITED NUMBER
NEW/BOXED WHILE STOCKS LAST ONLY £75

CABLES

QED SILVER ANNIVERSARY AWARD WINNING BI-WIRE CABLE (LTD.STOCK) £650. METRE

LOUDSPEAKER CABLE
CARDAS HEXLINK 2 METRE PAIR £325
GOERTZ M1-3 DIVINITY 2.5 METRE PAIR AS NEW/BOXED £395
LINN LK-400 2.5 METRE PAIR £75
SONICLINK AST-150 X2 BI-WIRE 5 METRE PAIR (NEW) £55
DPA IS19 4.5 METRE PAIR £195
NORDOST FLATLINE GOLD BI-WIRE 3.7 METRE PAIR £125
ROKSAN HDC 815 2.9 METRE PAIR X 2 NEW £35
ROKSAN HDC 815 2 METRE PAIR NEW £25
SILVER SONIC (AMERICAN) 2.4 METRE LENGTH £50
OEHLBACKEABEL (SWISS) 11 METRE LENGTH BRAND NEW (WAS £15.M)
AUDIOQUEST INDIGO BLUE 3 METRE PAIR (BI-WIRE) £95
CABLE TALK 3 BI-WIRE 6 METRE PAIR £35
LOUDSPEAKER CABLE
VAN DEN HUL MCD 352 1.5 METRE PAIR (TERMINATED) £45
DPA IS19 4.5 METRE PAIR £195
NORDOST FLATLINE GOLD BI-WIRE 3.7 METRE PAIR £125
ROKSAN HDC 815 2.9 METRE PAIR X 2 NEW £35
SILVER SONIC (AMERICAN) 2.4 METRE LENGTH £50
OEHLBACKEABEL (SWISS) 11 METRE LENGTH BRAND NEW UNUSED (WAS £15.M)
AUDIOQUEST INDIGO BLUE 3 METRE PAIR (BI-WIRE) £95
CABLE TALK 3 BI-WIRE 6 METRE PAIR £35
INTERCONNECT
DPA BLACK SLINK 6 METRE PAIR (BALANCED XLR) £650
DPA BLACK SLINK 1/2 METRE £80/95
LINDSAY AUDIOPHILE SATIN GRAY (AMERICAN NEW/PACKED WAS £480)
ROKSAN HDC 01A ANALOGUE INTERCONNECT 1 METRE PAIR £50
ROKSAN HDC 02A ANALOGUE INTERCONNECT 1 METRE £35
ROKSAN 001 ISODA 1 METRE £75
ROKSAN ISODA 1/2 METRE £50
IKOS 104 2 X 1 METRE PAIRS £25
YFERA 1.5 METRE PAIR £60
SHARKWIRE BRAND NEW 1 X 3FT 1 X 2FT 2 X 1/2 METRE ALL NEUTRIK XLR BALANCED
TERMINATIONS £200 THE LOT
BEYER MICROPHONE CABLE 2 X 1 METRE PHONO PLUGS £30 EACH

DIGITAL

VAN DEN HUL AES/EBU £40
AUDIOQUEST AES/EBU PRO £80
AUDIOQUEST OPTILINK X TOSLINK £40
AUDIOQUEST AES/EBU PRO BALANCED 14 INCHS £75
BELDEN-M DATATWISTER AES/EBU 1 METRE £65
HIGH QUALITY OPTICAL CABLE AS USED BY DPA & MICROMEGA 1 METRE £15

SPECIAL OFFER

MOST EQUIPMENT STOCKED IS ONE OWNER MINT/BOXED, SIMILAR QUALITY VINTAGE AND MODERN EQUIP-
MENT REQUIRED FOR IMMEDIATE CASH PURCHASE. PLEASE PHONE GEORGE



RESERVE YOUR COPY TODAY!

Complete this form and hand to your local newsagent

Please reserve/deliver*(delete as appropriate)
Hi-Fi & Computer Audio World on a regular basis, commencing with the next issue, until further notice.

Name _____

Address _____

Signed _____

Date _____

Distributed to the news trade by

COMAG
MAGAZINE MARKETING

IAN HARRISON HI-FI

HI-FI AT DISCOUNT PRICES. FREE NATIONWIDE DELIVERY

9am - 9pm
INCLUDING SUNDAYS

TEL: 01283 702875

SALE NOW ON!

TRADE IN YOUR OLD MOVING COIL CARTRIDGE & SAVE UP TO 60% OFF THE RRP

CARTRIDGES & STYL	HIFI FURNITURE	HEADPHONES	DVD
DENON	APOLLO	SENNHEISER	SONY
SHURE	SOUND STYLE	SONY	DENON
AUDIO TECHNICA	SOUND	AKG	PHONO STAGES
GOLDRING	ORGANISATION	GRADO	
SUMIKO	ALPHASON	AUDIO-TECHNICA	MICHELL
TRANS-FIGURATION		DAT	CREEK
LONDON (DECCA)	CABLES	TASCAM	NAD
GRADO	SONIC LINK	SONY	AUDIO NOTE
ROKSAN	AUDIOQUEST	PANASONIC	EAR
VAN DEN HUL	VAN DEN HUL	CASSETTE DECKS	ROKSAN
ORTOFON	QED		TOM EVANS
AUDIO NOTE	ORTOFON	PIONEER	LOUDSPEAKERS
RESON	NORDOST	TEAC	HARBETH
CLEAR AUDIO	ARGENTO	SONY	CABASSE
KOETSU	AUDIO	DENON	SHUN MOOK
			EPOS
TONEARMS	TURNTABLES	MINI DISCS	AMPLIFIERS
ROKSAN	ROKSAN	SONY	DENON
SOUTHER	MICHELL	DENON	AUDIO NOTE
GRAHAM	CLEAR AUDIO	TUNERS	C.A.T.
MOTH	AUDIO NOTE	SONY	GAMUT
CLEAR AUDIO		DENON	ALOIA
			EAR
ACCESSORIES			
HiFi News Cartridge Alignment Gauge £5	Milty Zerostat 3		£30
HiFi News Test Record & Alignment Gauge	Audio Technica Stylus Cleaning Fluid £5		
Shure SFR2 Tracking Force Gauge £25	Clearaudio Carbon Fibre Record Cleaning Brush		£14

PLEASE PHONE TO CONFIRM PRICE & AVAILABILITY PRIOR TO ORDERING.
ALL GOODS ARE BRAND NEW & BOXED WITH FULL U.K. GUARANTEES.
NO EX. DEM OR EX DISPLAY GOODS. NO GREY IMPORTS. GOODS ARE NOT SUPPLIED ON APPROVAL. SORRY, NO GENERAL CATALOGUES. PLEASE PHONE OR WRITE FOR SPECIFIC REVIEWS, BROCHURES OR PRICES.
MAIL ORDER ONLY FROM: IAN HARRISON, 7 MILL HILL, REPTON, DERBY, DE65 6GQ. TEL: 01283 702875. 9am - 9pm INCLUDING SUNDAYS.

Sound Music

- Arcam A65 Integrated Amplifier(XD) - £250
- Arcam CD92 CD Player(XD) - £700
- Arcam AT51 Diva Tuner(Silver)(New) - £200
- Arcam AVR100 Surround Sound Amp(New)-£500
- Beard P500&P50 Pre&Power(Valve)(SH) - £875
- Castle Richmond (Rosewood)(XD) - £200
- Castle Severn Speakers(Maple)(XD) - £500
- Cyrus Discmaster/Dacmaster(SH) - £750
- Cyrus Pre-Amplifier (SH) - £400
- Energy Encore AV Sub & Sats (XD) - £850
- Jamo Home Cinema Speaker System(XD) - £300
- John Shearne Phase 2 Amplifier(SH) - £350
- Linn Majik I Amp & Sneaky Line Driver(XD)-£600
- Linn LK140 Power Amps (3 Available)(SH)-£550
- Meridian 508 CD Player(XD) - £850
- Meridian DSP 5000 Active Speakers(XD) - £3000
- Musical Fidelity A3 Integrated Amplifier(XD)-£700
- Musical Fidelity A300CR Power Amp(XD) - £1750
- Myryad MT100 Tuner (XD) - £300
- Myryad MC100 CD Player (XD) - £350
- NAD 216 THX Power Amplifier(XD) - £200
- NAD 319 Integrated Amplifier(XD) - £250
- Nakamichi Soundspace 5 System(XD) - £375
- Nakamichi Soundspace 8 System(XD) - £700
- Opera Super Pavarotti Speakers(XD) - £700
- Proac Studio 150 Speakers(Mahogany/XD)-£650
- Quad 44 Pre & 405 Power Amplifiers(SH) - £400
- Roksan Kandy Tuner(XD) - £200
- Rotel RCD 965BX CD Player(SH) - £200

Sound Of Music, 93-95 Nantwich Rd.
Crewe, Cheshire. CW2 6AW

Tel: 01270 214143

For : Linn, Arcam, Musical Fidelity, Castle, Roksan, Onkyo, Monitor Audio, Quad, NAD, Wharfedale, Loewe, Project, Meridian, S.M.E., & Many Others.



Hi-Fi & Audio Consultants
Sales and Service

Model	WAS	NOW
ARCAM DIVA 65 AMPLIFIER -	£379.95	£300.00
ALPHA 1 AMPLIFIER -	£230	£190.00
ALPHA 10 DAB TUNER -	£800	£675.00
BOSE 501 LOUDSPEAKERS -	£600	£350.00
CASTLE INVERSION 15 LOUDSPEAKERS -	£425	£275.00
CASTLE SEVERN II LOUDSPEAKERS -	£700	£495.00
CASTLE SEVERN II LOUDSPEAKERS -	£700	£495.00
CELESTION A 2 LOUDSPEAKERS -	£1500	£750.00
DENON AVP-1, POA-T3 & POA-T2 -	£4,950	£1,000.00
JAMO CONCERT 8 LOUDSPEAKERS -	£1,400,	£900.00
JAMO CONCERT 11 LOUDSPEAKERS	£2,300	£1,500.00
MUSICAL FIDELITY A 1 AMPLIFIER	-	£175
SONY TAN 55 ES POWERAMPLIFIER	-	£195.00
YAMAHA DSPE 492 PROCESSOR	£400	£125.00

12 Regent Street, Rugby, Warwickshire, CV22 5LP

Tel: 01788 540772

www.soundexpensive.com

Supradirect

The ONE STOP website for Supra cables to improve your Hi-Fi and/or Home Cinema system.

Home Cinema Users - Choose from Supra's range of composite, s-video, or RGB/Component video cables to improve your picture quality. Or use Supra co-ax digital or fibre optic cables from DVD to AV amp/receiver.
DIY'ers - Fit Supra Boxcon 4mm terminals to your amp or speakers.
Hi-Fi Nuts - Upgrade your existing cheap cables and enjoy better sound quality with Award-winning Supra speaker and interlink cables!

1 - VISIT

www.supradirect.co.uk

2 - VIEW the range online (or download the PDF catalogue)

3 - SELECT from a wide range

4 - SAVE money when you make your purchase

5 - ENJOY

EFF-JSL - Hi-Fi Choice "Best Buy"
Classic 4 - What Video "Best Buy"
Ply 3.4 - Hi-Fi Choice "Recommended"
Ply 3.4/S - Hi-Fi Choice "Recommended"

We belong to the Which? Webtrader Code of Practice

Bocchino Audio Connectors

Australia's finest range of high-end phono connectors
Upgrade your phono cables from the cheap, gold-plate on brass types (as normally fitted) to these luxurious gold & silver-plated, pure copper, one-piece phono plugs.

Brenda™ B7 - £109/pair

Brenda™ B9 - £149/pair



Common features: Each plug machined from a solid billet of 99.94% pure High Conductivity Oxygen Free Copper then plated with 15+ micron silver and 1.0+ micron hard gold. Signal tips plated with 3.0+ micron hard gold.

Now available from specialist accessory dealers.

Or visit our website at: www.bocchino-audio.co.uk

Also available for OEM customers - please contact sole UK distributor:
Bocchino Audio UK, PO Box 364, Maidstone, ME15 9FE

MATRIX HI-FI

VALVE AMP
REPAIRS

JANUARY SALE - 20% OFF ALL STOCK

VALVE CD PLAYERS FROM £330.00 ON DEMO - PLEASE PHONE FOR DETAILS.

AUDIO NOTE OTO SE - MINT	699.00
AUDIO NOTE ANJ/SPE INCLUDING STANDS BLK	750.00
BEARD P35 CHROME - MINT	450.00
CELESTION A1 SPEAKERS BLACK - NEW	499.00
CROFT SERIES 4S - ABSOLUTELY MINT	795.00
GOLDRING Lenco '88' RECORD DECK WITH SME 3009	
ARM ADC CARTRIDGE	150.00
HI-FI WORLD KAT-88 VASLTY UPGRADED	550.00
HEART/MARANTZ VALVE OUTPUT CD PLAYER	590.00
LEAK TL25 PLUS PR.	800.00
LINN CLASSIC VARIOUS COLOURS	995.00
LINN KEOSA FLOOR STANDERS - BLACK/MAPLE/CHERRY	399.00
MARANTZ CD-63	90.00
MARANTZ PM-6010 AMPLIFIER KI- SIGNATURE - BLK	240.00
PIONEER ER-420 VALVE RECEIVER	225.00
PRECIOUS METALS COPPERTECH DELTA	59.00

PRECIOUS METALS SILVER SS200 SIGNAL	187.00
PRECIOUS METALS SILVERCOPPERTECH 102 SIGNAL	110.00
PRECIOUS METALS SILVERTECH 52 SIGNAL	81.00
PROJECT 2.9 RECORD DECK WITH ORTOFON CART. CHERRY	399.00
PS AUDIO 5.6 PRE-AMP WITH MM/MC PHONO	550.00
QED PASSIVE CD PRE AMP ALPS POT.	65.00
QUAD II PAIR. Nr. MINT	700.00
RADFORD MA50 MONOBLOCS - MINT	1,699.00
ROGERS JUNIOR + PRE AMP - RARE	350.00
ROTHWELL INDUS PASSIVE PRE AMP STEPPED CONT.	399.00
ROTHWELL RUBICON POWER VALVE AMP	799.00
SONY MDS-JE320 MINI DISK PLAYER-NO REMOTE	120.00
SOUND ORGANISATION RACK - SILVER 4 SHELVES 40% OFF	120.00
SOUND STYLE XS RACK - ICE BLUE GLASS - 5 SHELVES	299.00
THORENS TD126 MKIV ELECTRONIC WITH SME 3009/PLINTH	260.00
TRIPPLETONE STEREO INTEGRATED	95.00
VAL 20WATT INTERGRADED VALVE STEREO EL34	399.00
VERDIN QUALITY 10 VALVE MONOBLOCS	350.00



● NEW HI-END HI-FI ● VINTAGE HI-FI FOR SALE & WANTED

MICHELL - ALCHEMIST, CELESTION, QED, AUDIOQUEST, MARANTZ - ETC...
NEW AND VINTAGE VALVES - INTERCONNECTS & SPEAKER - OFC & SILVER
WEALTH OF KNOWLEDGE SPANNING OVER 30 YEARS, FOR ENQUIRIES OR
A CONTROVERSIAL CHAT, ASK FOR DAVE OR LEE.

PHONE : (01322) 292391

FAX : (01322) 229908

E-MAIL: INFO@MATRIXHI-FI.CO.UK

WEB: WWW.MATRIXHI-FI.CO.UK

SHOWROOM

65 DARENTH ROAD

DARTFORD

KENT DA1 1LU

FREE EASY PARKING



01376 521132

07802 483698

CHELMSFORD, ESSEX

E-MAIL: soundstage@netlineuk.net

BY APPOINTMENT ONLY

PRE-OWNED EQUIPMENT

AUDIO INNOVATIONS SERIES 1000 MKII MONO'S WITH L1 VALVE PRE AMP	£1195
AUDIO INNOVATIONS ALTO CD PLAYER BLACK	£159
AUDION SILVER KNIGHTS 300B MONOBLOCS NEW VALVES 3 YRS OLD	£995
BEARD CA35/P35 II VALVE PRE-POWER (£2500 APPROX NEW)	£1295
DENON AVC-A1 GOLD BOXED AND IMMACULATE (£2000 NEW)	£795
DENON AVP-A1 GOLD BOXED AND IMMACULATE (£3000 NEW)	£995
DENON DVD-5000 GOLD WITH MULTI REGION CHIP FITTED SUPERB MACHINE	£995
DENON AVR 3300 DOLBY DIGITAL, DTS BLACK BOXED IMMACULATE	£449
EPOS HS12 DARK CHERRY BOXED WITH INSTRUCTIONS	£349
EPOS HS14 WALNUT SUPERB CONDITION	£349
EPOS HS11 LOUDSPEAKERS BLACK ASH WITH HARD COVERS	£199
IMPULSE TAUS CHERRY LOUDSPEAKERS-SUPERB (NEW £3300)	£1995
KEF REFERENCE MODEL 100 CENTRE LOUDSPEAKER BLACK	£199
LINN AV5103 AC3 RF LASER DISC INPUT DD PRE AMP IMMAC (£4750 NEW)	£1995
LINN ISOBARIKS DMS WALNUT LOVELY CONDITION BUYER COLLECTS	£695
LOEWE PLANUS 32" WIDESCREEN ARCTIS BOXED AND IMMACULATE	£895
MERIDIAN 500/566-20 BIT TRANSPORT/DAC BOXED AND IMMACULATE	£1495
MERIDIAN 602/606 TRANS/DAC BRAND NEW LASER BOXED/IMMACULATE	£1495
MICROMEGA STAGE 6 IMMACULATE AND BOXED	£529
MICROMEGA DRIVE 3/DAC BOXED AND IMMACULATE	£995
MONITOR AUDIO MA1800RHF GOLD TEAK	£595
MUSE MODEL 3 PRE-AMP REMOTE BLACK BOXED AND IMMACULATE	£1295
MUSICAL FIDELITY TFM ONLY TUNER BOXED AND IMMACULATE	£199
NAIM NAC32/SNAPS/NAP250 OLD STYLE SUPERB CONDITION	£995
NAIM NAC 72 PRE AMP BOXED AND IMMACULATE (£790 NEW)	£449
NAIM NAC 92 PRE AMP BOXED AND IMMACULATE	£279
NAIM NAIT3 PRE OUT MODIFICATION BOXED AND IMMACULATE (1999 MODEL)	£399
NAIM IXO 2-WAY ACTIVE X-OVER WITH VARIABLE FREQUENCY	£399
NAIM NAP140 OLD STYLE SUPERB CONDITION	£399
NAIM NAP903 BOXED AND IMMACULATE	£329
NAKAMICHI CR2 CASSETTE DECK	£175
NAKAMICHI CASSETTE DECK 2	£199
NORTON AIR POWER LP12 POWER SUPPLY EX DEMO	£595
PIONEER CLD95 ELITE LASER DISC PLAYER (£2000 NEW)	£495
PRO-AC TABLITTE 50 MAHOOGANY OR CHERRY-IMMACULATE	£395
PROCEED PCD SERIES 3 CD PLAYER (£3500 NEW)	£1695
QUAD ESL63-LATE MODEL APPROX 1992/93 BLACK WITH STANDS SUPERB	£1395
REGA PLANET CD PLAYER BOXED AND IMMACULATE	£299
ROKSAN CASPIAN CD PLAYER-SILVER OR BLACK AVAILABLE	£495
RUARK CL30 CHERRY WOOD (NEW £2500) WITH SILTECH AND XLO INTERNAL	
HARD WIRE UPGRADES AND WBT BINDING POSTS-SAVE OVER £500	£1995

PROFESSIONAL RECORD CLEANING SERVICE - KEITH MONKS MACHINE -
PLEASE RING FOR FURTHER DETAILS AND PRICES.

THREE MONTH WARRANTY ON ALL ITEMS

www.sound-stage.co.uk

STOWSOUNDS

Stonefarm Borough Lane, Great Finborough, Stowmarket, Suffolk, IP14 3AS

We have the following equipment to clear:

ENGINES

Creek Cd 53	1049
Micell Gyrodek	poa
Nakamichi BX 2	175
DPA Renaissance CD	550
Trichord Revelation CD	450
YBA CD 3	1500
Marantz 6 disc changer	150

GEARBOX

Creek 5350SE	725
Cyrus 2	150
Exposure 25 integrated	850
Micell Alecto monoblocks	650
Naim 32.5S	125
Naim 42.5K	95
Naim HiCap	160
Sonneteer Campion integrated	425
YBA 3 Pre Power	1725

EXHAUST

Epos M12	385
JM Lab Tantal 515	325
JM Lab Cobalt 810	525
JM Lab Electra 905	795
Living Voice range	Great
Rogers LS4a	140

FURRY DICE

Quad FM 4	175
Tripod Rack	100
Sound Organisation Z565	100
Soundstyle X105	175
Linn Classic	825
Rotel RT 950BX	125
Beyerdynamic DT911	140
Beyerdynamic DT531	80
Grado SR60	65
Kimber 8 way power block	140

Various interconnects, supports, cables at reduced prices.

Phone for details

Sale of CDs. Phone for latest list.

TEL: 01449 675060



84 FLIXTON ROAD
URMSTON
MANCHESTER
M41 5AB
0161 202 9922

SECOND HAND AND EX DEM ITEMS FOR SALE

CD PLAYERS

	RRP	SALE PRICE
Myryad T10 silver, as new	£400	£350
NAD S500 Silver Series	£1000	£850

AMPLIFIERS

Audio Analogue Bellini/Donizetti (silver)	£1100	£700
Crimson 610 preamp with MM/MC phono stage	£450	£200
Exposure 2010 integrated	£599	£499
LFD Mistral pre amp	£450	£300
LFD PAO power amp	£650	£300
Myryad T50/T70 pre/power with prologic	£949	£600
NAD S300 silver series	£1500	£1099
Unison Research S2K valve integrated	£1295	£1095

LOUDSPEAKERS

Acoustic Energy Aego 2 (NEW)	£300	£250
Acoustic Energy AE100	£229	£99
Audio Physic Step inc stand	£1299	£499
Epos M12 cherry	£499	£375
Monitor Audio Gold Reference 20	£1499	£1250
Monitor Audio Silver 3i	£279	£225
Naim SBL walnut	n/a	£599 ono
Neat Mystique II (natural ash) as new	£795	£650
Neat Petite III (rose)	£845	£499
Opera Platea (mahogany)	£795	£499
Totem Model One	£1249	£599

MISCELLANEOUS

Onkyo TX DS595 dolby digital/pro logic II	£495	£395
Onkyo TX DS777 THX receiver	£799	£499
Project RPM Four	£300	£249
Sonus Systems 5 shelf "Excel" rack	£269	£200
Teac Reference 100 system	£420	£349
Teac Reference 300 system	£599	£450
Teac DV3000 DVD player	£229	£189
Teac RW800 CD recorder	£349	£275

check out our website for up-to-date list : www.replay.dial.pipex.com

AWARD WINNING SUPPORT RANGE

You've read about it for years.
You've seen it on TV.

Now experience The Mana Effect™
at your local retailer...

BRISTOL AUDIO EXCELLENCE 0117 926 4975
CARDIFF AUDIO EXCELLENCE 029 2022 8565
CHELTENHAM AUDIO T 01242 583960
CHESTER AUDIO EXCELLENCE 01244 345576
EDINBURGH LOUD AND CLEAR 0131 226 6500
EXETER AUDIO EXCELLENCE 01392 491194
GLASGOW LOUD AND CLEAR 0141 221 0221
GLOUCESTER AUDIO EXCELLENCE 01452 300046
HARROW HARROW AUDIO 020 8930 9933
HIGH WYCOMBE AUDIO T 01494 558585
HULL ZEN AUDIO 01482 587397
LEEDS IMAGE AUDIO 0113 278 9374
LONDON THE CORNFLAKE SHOP 020 7631 0472
SWANSEA AUDIO EXCELLENCE 01792 474608
WIGAN ADVENTURES IN HI-FI 01942 234202

Mana Audio LTD

Unit E, Amlwch Industrial Estate, Anglesey LL68 9BX
Tel: 01248 450472 or 01407 830 530 Fax: 01407 830 535
E-mail: post@mana.co.uk www.mana.co.uk
Visit the Mana forum: www.manaforum.atinfopop.com

CLASSIQUE SOUNDS (LEICESTER) INC ONE THING,
VINTAGE HIFI & VALVE SPECIALIST

FOR SALE PR / POW R AMPLIFIERS

Linn LK1 pre-amp and remote. Good condition.	£ 249	Linn LK2 power amplifier. Good condition.	£ 279
Naim 180 power amplifier. Ex condition. Boxed.	£ 699	Naim 72 pre-amplifier. Boxed. MM Boards.	£ 349
Naim Flutcap power supply. Ex condition. Boxed.	£ 199	Musical Fidelity A1000 integrated amplifier.	£ 849
Kenwood KA660D integrated amplifier. Black.	£ 40	Myryad M120 int. amplifier. Mint/boxed/remote.	£ 349
Musical Fidelity A300 int. amplifier. Dual mono.	£ 749	Musical Fidelity B1. Nice condition.	£ 130
Quad 77 pre-amplifier with large LCD remote.	£ 495	Quad 77FM tuner with RDS. Good condition.	£ 395
Grant G69S integrated valve amplifier. 60 watts.	£ 599	Harmon Karlon integrated valve amp. 110V. V rare	£ 299
Audiolab 8000Q pre-amp. Mint/boxed/inst. Cost £1240	£ 649	Nad 1130 pre-amplifier. Excellent condition.	£ 79
Obelisk 2 integrated amplifier. Good condition.	£ 150	Audiolab 8000C pre-amplifier. Boxed/instructions.	£ 299
DPA Renaissance integrated amplifier. Mint. Boxed	£ 299	Mission Cyrus 2 amplifier. Mk1. Ex condition.	£ 169
Quad 303 power amplifiers from	£ 125	Arcam 290 integrated amp & remote. Small dem	£ 175
Nad 2140 power amplifier. Good condition.	£ 99	Alchemist Forsyth pre-amp. Mint. Boxed	£ 599
Nakamichi CA5 pre-amplifier. Ex cond. Cost £750	£ 375	Nakamichi PA5 100W/CH1 power amp. Cost £1300	£ 650
Proton AP1000 pre-amplifier. Cost £299.00. Glend	£ 110	Proton DP1200 Power amp. Cost £499. Good cond	£ 200
Linn Wakanda pre-amp + remote. Mottle finish.	£ 399	PS Audio Model two power amplifier. 230V model	£ 230
NVA A80 mono power amplifiers X 2. Good cond.	£ 799	NVA A60 stereo power amplifier. Good condition.	£ 295
AVI S2000 MI int amp & remote. Cost £999. Mint	£ 549	Linn LK100 power amplifier. Excellent condition.	£ 395
Musical Fidelity Pre-8 pre-amplifier. Mint. Boxed	£ 175	Arcam Alpha 3 amplifier. Mint. Boxed/Instructions	£ 100
Naim Nac 4.2.5 pre-amplifier with MC boards.	£ 150	Creek 4040 integrated amplifier. 5 pin din version.	£ 79
Parr Heahkat MA12 mono valve amplifiers.	£ 249	Quad 34 pre-amplifier. 5 pin din. Ex cond	£ 225
Musical Fidelity The Pre-amplifier. with MM/MC	£ 199	Technics SHG70 Graphic Equaliser. 12 presets	£ 80
Scott 410A integrated transistor amplifier.	£ 99	Mission Cyrus 1 amplifier. Good condition.	£ 120
Arcam Zeta 1 Pro logic Cinema amp. Cost £999.00	£ 450	Quad 33 pre amplifiers. From	£ 75
Leak Stereo 20 valve power amplifiers from	£ POA	Audio Innovations L2 Valve pre-amplifier. Line.	£ 399
Arcam Alpha 2 amplifier. Mint. Boxed/instr	£ 95	Connoisseur Sugden stereo valve pre/power amp. mint	£ 249

TURNTABLES

Revolver turntable and Linn LVX basic arm. 33/45	£ 150	Garnard 301 & 401 motor units all serviced from	£ 125
Thorns TD125/Audio technica 1100 amp/linth	£ 250	NVA phono 2 MC pre-amp + 2 X PSU. Awesome	£ 499
Revolver Rebel o/w Revolver arm & A/Technica.	£ 125	Thorns TD125 Chassis only	£ 59
Dual 505/4 record deck. Good condition/instr	£ 100	Trio KD550. Direct drive turntable.	£ 89
Thorns TD166BC Deck only Cut-out for SME. Bxd	£ 150	Thorns TD166 MK2 with thorns arm.	£ 89
Anson RD50 turntable. Boxed. Good condition	£ 99	Dual CS05-2 turntable. Mint condition. Boxed	£ 89

SPEAKERS

Mirage OM6 loudspeakers. Built in active subwoofer. Goes down to 18Hz. Cost new £2800. Bargain for only	£ 1299	Quad ESL57 speakers. All fully serviced with full 3 months warranty. Hear what ESL57s should sound like. From	£ 750 pr
Pair Quad ESL57 spks. Fully rebuilt. 1e 4 Recon bass & 2 recon treble units. All new electronics. 12m warranty	£ 1199	Ker C 20 Bookshelf monitor speakers in black	£ 499
Heybrook Heylos. Black. Boxed. Ex condition	£ 199	Pair Quad ELS63 speakers. Ex Cond. Bk. Serviced.	£ 1395
Kel concertos in super condition. Teak cabinets	£ 225	Richard alan monitor spks. 3 way. High efficiency.	£ 125
Pair Linn Keldifh in black with Kustone stands. Absolutely mint. 6 months old 4 yrs warranty left. (4900) Bxd	£ 595	Naim Intro speakers in black ash. Mint. Boxed	£ 90
Naim Intro speakers in black ash. Mint. Boxed	£ 450	Castle Penrube. Good condition. Super sound.	£ 70
Dynamab 2.8 ref speakers. Cost £1200 were £450	£ 249	Celestron D10n 15 complete with stands. Gfound	£ 80
B&W DM1200 -slight cabinet marks. Boxed	£ 79	Celestron D10n 44.	£ 80
Mordant Short MS20k Pearl. Black finish. New.	£ 169	Tannoy Chaisworths C/W. 12 inch monitor golds	£ POA
Roksan Ojan/3 speakers. Good condition.	£ 449	Tannoy Lancasters cabv/15 inch/monitor golds	£ POA

OTHER ITEMS

Audio note CDT Zero CD Transport. Ex Condition	£ 350	Audio note DAC 1 Valve CD DAC. Good condition	£ 400
Murantz SD275 twin cassette deck. Dolby B/C	£ 49	Technics SL-PG400A Mash CD player/remote.	£ 75
Goldring Electro 11 MC cartridge. In case.	£ 60	Cogan Hall loudspeaker cable. 1.5 metre pair.	£ 150
Nad 4020 tuner. Scratch on top hence	£ 35	Nakamichi CTP 2E CD player. Ex condition.	£ 250
Murantz CD50 Cd player. Ex condition.	£ 79	Chord Chameleon interconnect. For naim eqpt. Bxd	£ 49
Audio Alchemy Dac in the box with separate psu	£ 99	2 X 6M lengths of Linn K400 Biwire spkr cable	£ 79
Linn Basic plus tone-arm. Good condition.	£ 75	Rotel 950 CD player. Ex cond. Boxed.	£ 100
Micheli Iso Phono pre amp and PSU. Ex condition.	£ 249	Sugden SDD1 & SDA1 Transport & Dac/remote.	£ 849
Rotel RQ970 MM/MC phono pre-amplifier.	£ 89	Technics SL-PS620A CD player/remote.	£ 75
Rotel 965 BX CD player. Excellent condition	£ 150	Spare armature for SME series 3. New. Unused. Boxed	£ 55
Leak Troughline 3 stereo valve tuner. Fully serviced	£ 195	Teac TR450 tuner. AM/FM synthesized/RDS. Boxed	£ 69
Linn Tuner. Mint. Boxed. Very unusual. Cost £549	£ 249	Quad FM3 tuner in excellent condition.	£ 99
Arcam Alpha 5 cd player. Mint. Boxed/remote	£ 195	Murantz CD63 top loader cd player. Collectable.	£ 125
Arwa AD-S750 Dolby B-C-S/Hx pro Cassette. Mint.	£ 75	ADC ALT-1 tone-arm. Mint. Boxed. Unused.	£ 100
Avantic Beam Echo valve tuner. BM611. AM/FM	£ 149	Trio KT800L synthesiser tuner. AM/FM. Black.	£ 75
Quad 34 moving coil module. Mint. Boxed	£ 40	SME 300 tonearm film.	£ 120

QUAD ESL57 & ELS63 PANELS/SERVICING ETC

Reconditioned Quad ESL57 speakers from only £750.00. pr. Why spend £4000+?
Have your ESL57s refurbished for only £349.00/Pair. Ring for full details.
Exchange/recon ESL57 bass panel £120. Treble £100. ESL63 panels £100 Refurbished.
New socks for ELS63s £38 pr. Many other spare parts available. Please ring.
"Classique Sounds servicing restores the Quads to a position where they can hold their head high". Jon Marks. HIFI WORLD. April 1999. Full servicing facilities available.

Troughline tuner service & realignment £95.00. (excludes valves. Rarely needed).
Subject to tuner being in a serviceable condition, with no major faults or modifications. One thing stereo decoder (back in stock) £175.00 Ex review Hifi world.

TRANSLUCENT (somewhat of a bargain) Hifi World, Jan 1999
PURE SILVER INTERCONNECT CABLE
99.99% pure silver conductors. Quality gold plated RCA phono plugs.
Half Metre terminated £60.00 One metre terminated £80.00
7 day money back guarantee if not better than existing cable. Regardless of price or quality.

NEW Translucent pure silver mains cable. 3 amp. Intro offer. £99.00
One Thing Mains cables. Class 1 RFI suppressed. Silver plated conductors. Voltage spike protection. only...£55.00. 6 way mains block & lead only £99.00

NEW EAR/YOSHINO EQUIPMENT
Ear 834P MM/MC phono stage with/without volume . Brand new. Boxed at only £529
Ear 834P MM phono stage. No volume control. Brand new. Boxed at only £379
Ear 834L. Line only valve pre-amplifier. Amazing. Brand new. Boxed at only £479

NEW... Classique sounds 6 way heavy duty 13A mains blocks. Only £99.00
WANTED Vintage and modern hifi eqpt. Part exchange welcome.
Tel 0116 235821 or 07802 21 740 (Mobile). Callers by appt only.
Opening times 10.00am-6.00pm Mon-Friday 10.00am-2.00pm Saturday.
61 Aylestone drive, Aylestone, Leicester, LE2 8QE. Email classique_sounds@yahoo.co.uk



Salon

SCOTLAND'S FIRST AND FORMOST DEALER

"The List"

All Hi-Fi equipment guaranteed six months from date of purchase, "Supplied and Supported by The Audio Salon Ltd."

Phone for details and digital photo. Review sets, manufacturer websites, and brochures available on most US products.

All items available next day (UK) by UPS for £9 per box. US and Worldwide Export at cost - details on request.

List Sale

ANALOGUE

Audio Note IO2v-Gold s/n 2454	£2,450	£1,250
<i>Brand new, boxed, unused. Analog unsurpassed.</i>		
Audio Note AN-1S/ANVx Tonearm	£2,450	£1,250
<i>Brand new, boxed, unused. QC reviewer grade!</i>		
Audio Note Japan (Kondo) IO2	n/a	£ 500
<i>Rare and highly desirable; retipped</i>		
Valdi with ARM-Two	£1,410	£ 450
<i>Black Ash; AN silver-wired arm; AN IQ1 cartridge</i>		
Voyd With Zeta arm	£3,225	£ 1,099
<i>Black Ash; ANV silver-wired arm, mint</i>		
Fanfare FT-1 Tuner	£1195	£ 500
<i>Boxed, new, unused, acclaimed</i>		
Nakamichi CR1-E	£ 295	£ 100
Roksan Zerxes, Artemiz arm	£1,195	£ 500
<i>Black Ash</i>		

DIGITAL

Audio Note CD-2	£ 995	£ 499
<i>Latest model, as new</i>		
Arcam 250 CD Transport, Black Box 50 dac	£1,200	£ 400
CEC TL-1 Belt-drive CD Player	£ 5,000	£2,550
<i>Legendary machine, unique opportunity</i>		
David Manley The RefDac	£5,995	£1,995
<i>A Reference valve DAC, the reviews said it all</i>		
Mark Levinson 31.5 CD Transport	£9,995	£6,500
<i>12 months old, supplied by us, mint, 4-yr warranty</i>		
Meridian 508.24 CD Player	£2,195	£995
<i>Classic, acclaimed product, mint</i>		
Sugden SDT-1	£1,195	£ 495
<i>Amazing</i>		
Sugden MasterClass CD	£2,500	£1,995
<i>Ex Dem, Full Warranty</i>		



TIMBREDAC TT-1
ex-Wadia Heritage
£2,995 £1,000

VAC DAC-2 MkII + Power Supply (230vAC)*
Legend in the USA, this tube DAC is magnificent anywhere
£4,395 £1,995
WADIA 7 & 9 CD Transport and DAC £25,000 £9,995



WADIA 20 CD Transport £4,000 £1,995

WADIA 10 Optical Interface £2,900 £1,400 Use
with Wadia 9

AMPLIFIERS

Audiolab 8000A Mk II	?	£ 250 ?
<i>Late, black, phono stage</i>		
Audio Research Line Stage 3	£2,250	£1,350
<i>Balanced ip/op, mint, superbe</i>		
BAT VK500 with upgraded PSU 250wpc	£5,500	£2,499

David Manley SE/PP 300B Monoblocks
Switchable Push-pull, highly acclaimed US classic
£4,500 £1,495

David Manley Ref440 £11,995 £ 3,995
Reference valve monoblocks; review available

Exposure 14 pre-amp MM/MC £2,500 £ 895
Model 9 PSU for separate line and phono; both boxed, mint

MICREX Triode Pre-amp and 90 watt triode
Monoblocks; Jarrah wood/ gold; exotic, exquisite
£7,000 £1,999

NAIM 102 with MC phono card £1,200 £ 699

NAIM HiCAP £ 800 £ 499

NAIM NAP180 amp 60 wpc £1,150 £ 699
Above Naim items about 30 months old; mint

Nakamichi PA-7E £2,500 £1,250
Sony TAE-901 Esprit pre-amp ? £ 500
No box, no phono-stage

CINEMA AND 5.1 MUSIC

AMPRO HD1200 7" CRT Projector £9,995 £3,000
Both ex-dem, little used; first to see will buy

Faroudja VP400U Line Quadrupler £27,000 £7,995
PAL/NTSC, prize-winning product, brochure on request

Faroudja LD100 Line Doubler £19,500 £3,995
PAL/NTSC; broadcast quality, first to see will buy
Perraux 6100 six-channel x 150 wpc £4,990 £1,200

Pioneer Elite DV-09 DVD Player \$2,495 £ 695
*The ultimate luxury US DVD player; Region 1
DTS/THX, rare 96kHz upsampled audio digital o/p*

Proceed PMDT the ultimate DVD player
Modular, versatile, flexible, upgradable, incomparable



Proceed AVP the ultimate AV processor £ 4,995 £2,995
Software upgradable, 7.1, DTS, THX, etc. etc.

Proceed AMP2 Stereo amp 150wpc £2,995 £1,200

Snell & Wilcox G2 Interpolator/shoobox £30k £15,995
As new, photo quality from DVD!

Stewart 5-ft rear projection screen £4,995 £1,500
Includes mirror and frame

LOUDSPEAKERS

Dunlavy SC-IV (Oak) £8,000 £3,995

Dunlavy SC-V (Rosewood) £16,900 £7,495

ESP Harp (Cherrywood) £7,995 £2,495

ESP Concert Grand* £14,900 £3,995
Amazing reviews on both ESP products
KEF 103/4 + Kube (4 years) £1,300 £ 450



Genesis Model II.5 £22,000 £9,995

Genesis Model 5 (Rosewood) £15,000 £5,995

Genesis Model 6 (Rosewood) £8,500 £3,995

ProAc Response 2.5 (Yew) £2,970 £1,650

Revel M20 (Cherry) with pedestals £1,950 £1,199
6-months old, owner upgrading, new from us!
Revel Salons (black gloss/al) £14,995 POA

Von Schweikert VR4/silver (Rosewood) £4,500 £1,750

Von Schweikert VR4.5/silver (Walnut) £5,900 £2,495

Von Schweikert VR3 (Cherry) £1,995 £ 750
Ideal for 5.1 format; centre speakers also available
Yamaha NS-1000 (black) ? £ 500

Clearance List

LINN PRODUCTS

LP12 (Black) 6 months new, Lingo, Ittok, K9 (£2,375)
£1,200; Karik III CD player (£1,850) for £850; Numerik
DAC (£1,500) for £700; Kaim Pro pre-amp (£1,700) for
£650; 3 x LK-100 amps for £325 each; Keildh speakers
and stands £450; Keildh active cards (£500) for £200;
Kaber speakers £595; Kaber active cards x 3 for £200;
Kudos Tuner (£550) for £250; AV5101 Remote £100.

MERIDIAN

500 Transport £625; 505.24 CD Player £995; 563 DAC
££450; 501 pre-amp with phono stage £450; 605 mono
blocks x 2 £1,200; System remote controller £60

MARANTZ CD6000-OSE (£299) for £175; CD67-SE
unused (£299) for £125; ACOUSTIC ENERGY AE-120
£200; ROTEL RQ-970BX phono stage £75

Tel. 0141- 357 5700
Fax 0141- 339 9762
E-mail: info@audiosalon.co.uk
www.audiosalon.co.uk

TEL: 01428-651554 **P.G. Hi-Fi** FAX: 01428-654592

**Buying & Selling Vintage HiFi, Valves,
Classical LP Records & Spare Parts.**

Quad		Valve Alert	
All spares available for Quad and Quad 22		Mullart ECC61 Genuine N.O.S. Blue Box, Made In England	each £8
		Valves N.O.S.	
Quad 44 pre-amp	£150	ECC84 Mullard	£6
Quad AM2 Tuner	£40	ECC84 Brimar	£6
Quad QC II Pre-amp	£40	EF80 Mullard	£5
Quad FM1 Tuner	£40	ECC81/CV455 Mullard	£8
Quad II Mains Transformer	£120	ECC81/CV4024 Haltron	£5
Quad II Output Transformer	£120	ECC81/CV4024 White Box?	£5
Quad II Output Transformer (100v Line)	£50	Photocopies Of Circuit Diagrams + Vintage Hi-Fi Literature	
Quad II Choke	£30		
Quad II Fuse Holder	£10	Spare Parts For Quad + Leak - Transformers Etc.	
Quad II Chassis + Winding Loom	£35		
Quad FM1 + Decoder	£75	Garrard 301 Control Levers	
Quad 33/303/FM3	£280		
Quad 33/303 (33 needs service)	£170		
Quad ESL57 Electrostatic speakers bronze, superb condition serial no's 35882 + 35906	£600		
Please Phone For Details Of Other Quad/Leak/Garrard Spares			
Leak		Cartridges & Arms	
Leak TL12.1 (Pair)	£1500	Ortofon SL15E	£80
Leak Stereo 20	£250	Ortofon MC10 II	£50
Leak Stereo 60	£550	Ortofon MC15 super	£60
Models Of Leak Mono + Stereo Pre-Amps In Stock.		Decca professional arm	£100
		Shure V15 II cartridge	£20
Nakamichi 610 Pre-Amp/ 620 Power-Amp/ 630 FM Tuner	£500	Goldring 10-10 cartridge	£40
Tannoy HPD15" gold crossover (Single)	£50	Ortofon SPU-TE (built-in transformer) needs re-tipping	£80
HMV 555 Stereoscope Amp with cathode ray tube	£450	Decca FFSS stereo MKIII	£100
Garrard RC88 Autochanger Turntable	£20	Decca FFSS stereo MKI	£75
Sound Sales D.X. plus one tuner SW/MW/LW (approx. 1946) very rare	£200	Decca FFSS mono LP	£75
		Decca FFSS mono 78	£75
Valves (G E C. Mullard etc.)		Speakers	
KT66, ECC81/84, EF80		Spendor BC1A with built-in amps	£250
Many Others. Please Phone For Details.		Wharfedale Super 3 drive unit, needs new surround (single)	£20
		KEF K1 Slimline Monitors (pair)	£25
		Leak Sandwich Bohm (pair)	£100
		Please phone for details of Tannoy speakers, stock often changes before the next advert	
		Hammond Everell organ mod. S. 10 valve two keyboards with Vibrato + Reverb + Bass pedals. Overall size 35" h x 39" w x 22" d	

WANTED : LARGE COLLECTIONS OF CLASSICAL LP'S

ANNOUNCING THE APEX ACOUSTICS WEBSITE
www.apexacoustics.co.uk
 Check it out now for superb equipment at amazing prices plus interesting features.

Web Site Launch Special Offer System
 Arguably The Most Musical The Most Satisfying System You Can Buy? You Bet!!
 Sugden CD 21 - Sugden A21A Amplifier - Totem Arro's (Maple) Tuning Beaks And Townshend Isolda Deep Cryogenic Interconnects And Speaker Cable (Single Wire 3m per Side)
 Normally £3577 Offer Price £3250
 All Mint As New Including Carriage.

Web Site Bargains
 Musical Fidelity A3 CD Player Silver Trim £575 As New
 Musical Fidelity A3 Integrated Amp Silver Trim £699 As New
 Naim CDI DC Player 1994 Mint £825
 Manley Stingray Integrated 50w Valve Amp Ex Dem £1595
 Quad ESL 63's Serviced Re-clothed In Black Excellent £1195
 Vertitas 7's And Stands Satin Oak £750.00 Ex Dem
 Vertitas 25's Floorstanders Cherry £1030 Ex Dem
 P M C TB2 Cherry Ex Dem £550
 Townshend Isolda Deep Cryogenic Interconnects & Speaker Cables Now On Dem

VISA/ SWITCH /MASTERCARD/VISA DELTA NOW WELCOME

PHONE STEVE ON 01527 450500 / MOBILE : 07773198336 E-MAIL Apexnm@aol.com

diverse vinyl

10 charles st newport south wales np20 1ju
 01633 259661/256261 sales@diversevinyl.com

Forthcoming Releases

Chemical Brothers	Come With Us	£TBC
Eva Cassidy	Songbird	£TBC
Mott The Hoople	All The Young Dudes	£TBC
Tom Waits	Alice/Red Drum	£TBC

LOVE REISSUES ON SUNDAZED RECORDS - £15.90 each
LOVE/FOREVER CHANGES/DA CAPO/REVISITED

New Stock And Recent Releases

Basie/Bennet	Basie Swings Tony Sings	£26.90
Beatles	At The BBC (Reissue)	£18.90
Beautiful South	Solid Bronze Greatest Hits	£19.90
Fun Lovin Criminals	Loco (Belated LP Pressing)	£15.90
Eugene McDaniels	Headless Heroes Of Apocalypse	£11.90
Fred Neil	Bleeker & MacDougal	£15.90
Captain Beefheart	Grow Fins Volume 3 (in stock!!)	£19.90
Madonna	GHV2 - Greatest Hits 2	£TBC
Pete Townsend	Scoop - 3LP (Classic Records)	£49.90
Pink Floyd	Echoes The Best Of - 4LP set	£33.00
Paul McCartney	Driving Rain	£18.90
Robbie Williams	Swing When You're Winning	£15.90
Sarah Vaughan	You're Mine You (Roulette)	£16.50
Stephen Stills	Manassas (Classic Records)	£41.90
The Fall	Are U Are Missing Winner	£15.90
Gram Parsons	Safe At Home	£15.90
Dr John	Gris Gris (US reissue)	£10.90
Byrds	Preflyte Sessions/Sanctuary 3	£17.90

DIVERSE VINYL BEST SELLERS OF 2001

Beta Band	Hot Shots Part 2	£17.90
Bob Dylan	Love And Theft	£14.90
Cosmic Rough Riders	Enjoy The Melodic Sunshine	£10.90
George Harrison	All Things Must Pass 3LP set	£25.90
Richard Thompson	Action Packed	£17.90
McCartney & Wings	Wingspan 4LP set	£15.00
Mercury Rev	All Is Dream	£11.90
New Order	Get Ready	£12.90
Paul Weller	Days Of Speed	£14.90
Radiohead	Amnesiac	£18.90
REM	Reveal (US Import)	£21.90
Travis	The Invisible Band	£12.90
Turin Breaks	The Optimist	£12.90
White Stripes	White Blood Cells	£9.90

And not forgetting The Strokes, Nick Cave, Stereophonics, Eels Eric Clapton. Air, Elbow, Ash, Gorillaz, XTC, Manics, SFA

DISCO ANTI STAT LP CLEANER

Probably the most economical LP cleaning device on the market
Only £41.95



Call for details
 Call for a catalogue of over 3500 brand new LPs, or visit

www.diversevinyl.com

RETRO Reproduction

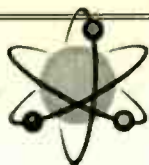

PS

When Tim de Paravicini does a job, he does it properly, whether it is a custom studio installation of an affordable phono pre-amplifier like the EAR 834P. With years of experience in design and manufacturing, nobody can come close to the unique point of view and life experience he puts into all of his designs.

When first launched, the 834P was the only valve phono stage you could buy with facilities for both good quality moving coil (MC) and moving magnet (MM) cartridges. In addition, the unit could be purchased with a volume control, allowing direct connection to a power amplifier. Now in its seventh year of production it still set the standard with fantastic soundstaging that all transistor phono stages can just dream off, coupled to low background noise and enviable reliability.

There are now four models in the EAR lineup:

The classic 834P uses the same circuit architecture as its more expensive brothers, and shares the same high quality sound through MM type cartridges, it is enclosed in a tough, rigid metal case and is fully "CE" type approved. price £380.00

The signature builds on the Classic 834P specification by adding a superb moving coil (MC) input stage, as well as the no-extra-price option of a high quality volume control. price £530.00

Top of the range, the Deluxe 834P comes in stunning chrome and gold cabinet, and has extra attraction and quality control. With different moving coil input options, this unit will fit the most demanding of audiophile systems. For the true vinyl enthusiast. price £800.00

MC3 - The ultimate stage for MC matching with 3 fixed transformer taps to cover all types of moving coil cartridges, and separate left/right grounding. MC3 in used in the new £10,000 312 pre. price £630.00

HARMONIC TECHNOLOGY SINGLE CRYSTAL CABLE
NOW IN STOCK *AT LAST I HAVE A CABLE TO DO ALL THE THINGS THE MANUFACTURE CLAIMS AND AT A RIDICULOUS LOW PRICE* PHONE FOR MORE DETAILS

New Showroom & Dem rooms now open
28a Haddington Place Edinburgh EH7 4AF Phone/Fax 0131 558 9989
Open 11.00am - 5.30pm - closed Monday & Sunday



PS

Ear Yoshino New Models

Ear 869 single ended triode integrated amplifier
Improved version of the classic 859 with revised output transformers modified input stage with the addition of a extra signal valve which has allowed an increase to 15watt of single ended power. also the 869 can be used as a power amp. Don't be fooled by its modest power output this amp drives real world speakers. price £2100.99

Ear 8L6 Integrated/Pre-main amplifier
Using 8 EL34 power valves to produce 50watt per channel in push pull class A with in-house designed output transformers. The 8L6 has been designed to meet a wide variety of needs from the most demanding of audio files to the professional seeking high quality monitoring equipment in the studio field. Valve life is long and replacement cost are modest. There is also a balanced power amp version with monoblocking capabilities to produce 100watt per channel. Price £2199.00

LIMITED PERIOD

Part Exchange your existing equipment against any Ear product and it will be valued at private prices not usual dealer rates.

NOW DEMONSTRATING
ATC CLASS A ACTIVE 10 SPEAKERS WITH SA2 REMOTE PRE AMP AT A VERY ATTRACTIVE PRICE

Used Equipment For Sale

- Revox A76 Tuner & A78 Int amp £295
- Haybrook Sextet £450
- Musical Fidelity XLP £90
- Musical Fidelity XTDD £80
- Magneplaner 3.3R outboard crossovers awesome new £3500
- Quad FM4 Tuner mint with box brown finish £195
- Quad 77 Int amp grey/blue finish £275
- Marantz heart valve modified CD player new £600 sale £390
- Sony 337 ES0 10kg monster a very fine player new £800
- JBL T1 2k boxed un-opened new £1600
- Marantz CD85 "Martin Colloms rave review" rosewood end stops 15 bit superb sounding player £295
- Naim SBL speakers black finish £695
- Lumley 120 mono block 120 watt per channel £1600
- Kenwood heavy weighted transport £195
- Primare A20 MKII integrated amp new £700
- System Deck IX turntable UPGRADE YOUR REGA from Art Audio valve headphones amp & line stage without board PSU new £750
- Arcam BR integrated amp as new £195
- MAD 312 integrated amp boxed mint £95
- Epos M15 floorstanding speakers cherry new model £595
- B&W 60352 floorstanding speakers cherry £295
- Musical Fidelity E10 integrated amp £175
- Sugden A21 new model integrated amp silver finish £595
- Lusman valve D105 CD player £195
- Rogers LS7 bookshelf speakers £95
- Rogers LS33 with AB33 £295
- Quad ESL63 black mini with stands £995
- Solisica Advanced Acoustic Design open battle design speakers outboard crossover with stands new £1000's?
- SME V tonearm boxed £995
- Proac response 25 loudspeakers bury oak finish new £2300 with Target R stands £1195

- Crimson battery 610 £95
- Rogers LS5 speakers £175
- QLM signature speakers with crossover and stands £995
- Musical Fidelity F25 remote pre £795
- Radford Tri Star 3 way speakers £195
- Pink Triangle Ordinal DAC £250
- Quad 33 wooden sleeve boxed as new £50
- Tube Technology Genesis 100watts monoblocs re-valved £1350
- Musical Fidelity P270 MKII power amp with MX pre £750
- Kel Reference 1.2 roseout finish new mint £995
- Cyrus III integrated amp £295
- Sugden T48 stereo tuner £1200
- Pioneer PD3703 CD player £165
- Sonus Faber Signum boxed new £995
- Audion golden knights 300b mono blocs new valves £1250
- Revox G36 open reel mint £395
- Conrad Johnson P110 pre amplifier as new £495
- Audio Research SP14 valve pre amp £295
- Audio Research CD11 cd player £2250
- Audionote K speakers with matching stands £750
- Kel Concerto speakers £125
- SME 309 tonearm £450
- EAR V20 integrated amp bargain price £1795
- EAR 834P £235
- Quad 77 integrated amp with Remote carbon finish £295
- Trilogy valve MC head amp £195
- Michelle CD power supply £250
- EAR 834 L valve line stage £275
- Revox A77 Open Reel £295
- Amcron DC-300A Power Amp £350
- Linn Wakanda MM & MC phono stage £295
- Counterpoint SA 5000 Pre - the ultimate Valve Pre Amp (very rare) £1495
- Audio Research LS2 one of the world's finest line preamps £1250
- Pioneer PD93 CD player battleship build quality with rosewood end stops new £1500 £495

- Pioneer CT-93 tape deck daly's cost new £600:00 £195
 - QED T-37 tuner £75
 - Dynalab Etude tuner "the best" new £1400 £795
 - Sennheiser HD580 headphones boxed as new £95
 - Chord Clearway mains conditioner new £225 £95
 - Croft DTL power amp 10 months old £595
 - Philips CD304 heavy weight build £75
 - Audiolab 8000A Int amp various from £195
 - Linsley Hood 75 de-lux Int amp £75
 - Linsley Hood power tran tuner £75.00
 - Celestion Dilton 10 bookshelf spk's £95.00
 - KEF R2 bookshelf spk's £95.00
 - Leak Sandwich 250 spk's £95.00
 - Marantz 105 tuner £65
 - Nytech power amp £125
 - Meridian 206 CD player £350
 - Audio Innovations L2 valve line stage £495
 - Audio Innovations S200 pre-amp with valve phono stage £375
 - Croft original micro valve pre-amp superb phono stage £175
 - Pioneer 33 reference tuner rosewood side panels £225
- Due In**
- Audio Research remote integrated amp £1795
 - Linn LM100 £295
 - Quad 606 £295
 - Quad II monoblocs consecutive serial numbers £195
 - various centre speakers £375
 - Sonos omni directional speakers £275
 - Gale 401 chrome ended speakers with matching stands £295
 - Garrard 301 £350
 - Linn LK100 power amp £1495
- Selected products from: ATC, Audio physic speakers, Ear Yoshino, Nottingham Analogue, Creek, Triangle, Sugden, Dynavector

ERGO ago-go

Mail order service for quality Swiss headphones
Free next day delivery hotline 01924 406016

ERGO MODEL ONE	£109.00	=====
ERGO MODEL TWO	£149.00	=====
ERGO MODEL AMT	£599.00	=====

ERGOPHONES are designed for fatigue free listening and can be used for many pleasure filled hours without discomfort. Acting as a true earspeaker, they have a wide bandwidth capability coupled with low distortion figures of less than 0.30%. All music types are replayed beautifully, offering a remarkable near-field listening experience. We guarantee superb sound quality at sensible price points.

More info available at www.precide.ch and info@audiosynergy.co.uk
Distributed in the UK by Audio Synergy Limited

SUGDEN HEIL AMT PRECIDE MDM ACE ERGO JECKLIN FLOAT

SUBSCRIPTIONS



UK SUBSCRIPTION £27

VISIT OUR WEBSITE: www.hi-fiworld.co.uk

Get your issue of **hi-fi world** straight to your door!

Get to our amazing classified ads first and grab a bargain!!

Run by dedicated hi-fi engineers and enthusiasts, Hi-Fi World has become famous for its informative reviews and radical kit designs.

OVERSEAS SUBS RATES

Surface Mail	£40
Airmail Europe	£50
Airmail Middle East & South-East Asia	£60
Airmail USA, Canada, Australia, Japan, Korea & China	£70

MISSED AN ISSUE?

Back issues also available at a cost of £3.50 only (includes P&P), payment by cheque only - overseas please contact us for details. Send cheque to: Hi-Fi World, Freepost LON3478, London, NW6 6YR.

Credit Card Hotline Monday - Friday 9.30am - 12.00 noon: Tel: +44 01923 270 833 Fax +44 01923 260 588

By post: Make cheque or postal order payable to: **Audio Publishing Ltd**, sent in an envelope marked: **Hi-Fi World, Freepost LON3478, London, NW6 6YR**

HI-FI WORLD SUBSCRIPTION FORM

I would like to pay by cheque made payable to Audio Publishing Ltd. Credit Card Airmail Surface Mail

Please debit my VISA/MASTER/SWITCH Card No. (Switch card issue No _____)

Expiry Date: _____ Cardholder Signature: _____

Grid of boxes for card number entry:



Name _____

Address _____ Delivery Address (if Different) _____

Post Code _____

Daytime Tel: _____

Start Issue _____

AUDUSA EUPEN CSA 2.5 MAINS CABLE - HI FI CHOICE SEPT 2001 BEST BUY AWARD



AUDUSA-Eupen CSA 2.5



AUDUSA EUPEN GNLM 5.0 mains cable

CSA and GNLM Cable with FERRITE TECHNOLOGY - A polymer material mixed with a considerable quantity of homogeneously fine high quality ferrite powder. This compound is called EMC/COM and it can be extruded around copper conductors. The ferrite itself is a non-conducting material, but it has a very interesting magnetic behaviour. As a ferromagnetic material, it will go through hysteresis loops whenever it is under influence of an alternating magnetic field. Consecutively magnetizing and demagnetizing the material will cause considerable losses of high frequency energy. This energy is absorbed in the ferrite grains and converted into heat. This effect is more or less proportional to the field frequency. By coating conductors with a thin layer of ferrite compound, high frequencies will be strongly attenuated, because their energy will be absorbed by the ferrite powder. This applies to high frequency disturbances that are propagating on the conductor and which we don't want to disturb the environment, as well as to surrounding interferences, which we want to prevent from disturbing the signals on our cable. The CSA cable which in addition to the above described ferrite technology is further protected with a foil shield and a drain wire and specifically manufactured for High End audio use.

£48 for 1.0m

£58 for 1.5m

£68 for 2.0m

off the reel £30
for 1st meter, £20
per m thereafter.

Fitted with IEC (Martin Kaiser) and MK Tough Plug. Figure of eight, 16 amp IEC, Bulgin, Neutrik etc also available. Plugs - USA, various European, Schuko, and other types. Cable can be supplied fitted to our all steel 4, 6 and 8 way distribution blocks. We can rewire the distribution blocks with Eupen cable as an extra cost option. Refer to our web site for details.

L A T INTERNATIONAL NJ USA - all cables now with SILVERFUSE conductors

LAT AC-2 HI-FI CHOICE - SEPT 2001 - RECOMENDED MAINS CABLE

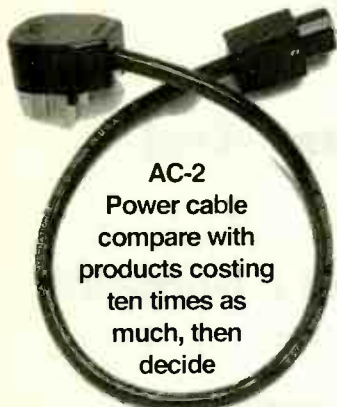

LAT AC-2 Power cable. We have developed a cabling (weaving) pattern along with an unusual shielding/filtering system that gets rid of the garbage that contaminates your components. The difference you hear with our cord is astounding. Our power cord takes advantage of silver in its design through use of our proprietary Silverfuse conductors. The conductors are 10 gauge and insulated with Teflon; the best insulation available. Fitted as standard with an IEC and MK Toughplug. Other connectors are available incl Schuko, 16 amp IEC, Figure of eight etc. 60cm £56, 90cm £68, 1.2m £78, 1.8m £99. other lengths available and off the reel at £39 per meter. SE version available with GP Tough plug and IEC, outer black braid all for an extra £12 irrespective of length 4,6 and 8 way all steel mains distribution blocks fitted with UK, Schuko or USA type sockets. CE tested and approved mains distribution units manufactured out of heavy gauge steel, finished in black and fitted with high quality Wadsworth 13amp sockets. It has no filters, circuit breakers, surge protection, transformers, resistors, capacitors, LED's, on/off switches, chokes, regulators, just fitted with 1m of LAT AC-2 mains cable. From £161 for 4 way, £194 for 6 way, £226 for 8 way.

NEW GOLD MK Tough plug with gold plated pins (£14), Otto Heil IEC with gold plated contacts (£10).

SILVERFUSE is a near alloy of silver and copper. IT IS NOT SILVER PLATED OR SILVER CLAD. Plating (or clad, which is the same thing as plating) causes a dioding effect when signal is passed through resulting in brightness and distortion. The Silverfuse process starts with seven nines OFHC copper wire with a diameter that is slightly larger than the required size. It is then pulled through a trough of molten silver. The wire with a silver deposit, is then forced through a compacting die where it is subject to tremendous pressure. The silver and the high purity copper are fused together into a near alloy. The compacting fusion also reduces the wire diameter to the desired size. No dioding subsequently occurs with this process. The result provides for the benefits of silver; which are excellent definition and clarity, with the high purity copper benefits of warmth and mellowness.

LAT AC-2 mains cable available with 16 amp IEC (MF, KRELL etc), Fig of eight, Bulgin, Neutrik etc sockets. UK, USA, Australia, Swiss, Denmark, France, Italy, Schuko and other plugs. Check our website for available variants.

LAT INTERNATIONAL - Analogue, Digital and Video interconnects and Speaker cable. Refer to www.audusa.com for further details or ask for reviews etc



SIEA 3D-LAB CDP, DAC, TRANSPORT AND DVD's

with SRC sampling rate and bit converter translates 16,18 and 20 bit inputs to 24 bits format. All 32, 44.1 and 48kHz frequency is re-sampled to 192 kHz. This is known as upsampling. The SRC is comparable with that used by DCS in the Purcell unit. Four CDP's with SRC from £1210 to £3999. All CDP's can be upgraded to the specification of the the better models.



DVD's with SRC, CV2, Sub-woofer output and optional Faroudja line doubler. CV2 provides CVBS, Y/C, YUV, RVB, RVB/S, RVB-SH-SV etc . DVD's with SRC and CV2 start from £1630. DVD with CV2 £1245. Coming soon five Digital amps



SUNFIRE CORPORATION

New Sunfire True Sub Woofer MKIV 11 inch cube 220v

Signature True Sub Woofer 13 inch cube 220v. Junior Sub Woofer 9 inch cube, Classic Tube Pre-amp, solid state power amps 2 channel and 5 channel and processor pre-amp - now MKII versions and optional 17 inch chassis.



www.hi-fiworld.co.uk

hi-fi

WORLD

& computer audio

Private Ads

Dealers must not advertise in the Private Classified section. Monthly consecutive insertions will be considered Trade advertising. The Publisher reserves the right to judge submissions.

RUARK EXCALIBERS (Black Piano Lacquer) £4,995.00 Musical Fidelity 3D-CD Player £2,450.00. Musical Fidelity A300-CR Power-Amp £1,495.00. Can deliver - all are as new with their boxes / manuals etc. Tel: 01622 721011 or 07973 899651 (Mar/I)

ROKSAN ROKI Original slate CD transport, DAI DAC, excellent condition, original boxes £450 ono. Nordost Silver Shadow digital interconnect, phono to BNC, best there is, £150 ono. Tel: 0794 136 8479 (Plymouth) (Feb/I)

PINK TRIANGLE DaCapo Dac, 22 bit filter and DC power supply with recent batteries. Rare combination, £1100 ono. 24 bit filter also available (£650 new) £300 ono. Tel: 0794 136 8479 (Plymouth) (Feb/I)

RUARK EQUINOX Loudspeakers (walnut), mint condition with new stands from factory. Stereophile recommended component. Deep bass from a small loudspeaker, £750 ono. Just upgraded to Dunley's. Tel: 0794 136 8479 (Plymouth) (Feb/I)

WANTED: REL STADIUM II sub bass. Any condition but must be sound electrically and mechanically. Garrard 401 Quartz locked power supply. Can collect. Can pay cash. Tel: 01909 470 192 evenings. (Feb/I)

ONE PAIR KLS 10 high tech mini monitor, gold dome, mahogany veneer plus KLS10 sub woofer plus Target stands £460. Tel: 0115 975 4070 (Nottingham) (Feb/I)

WANTED BY CASH: Naim passive-crossovers for DBL, Naim AVII, NAC52. Offers to: tekumse@hotmail.com (Feb/I)

TURNABLES: TECHNICS SL120 Mk2 arm SME Mk3 £180. Pioneer PL120 £40. Tuners: Hitachi 5500 £70, Delta 30 FM £40. Cassettes: JVC KD V II £40, KD A 66 £40. Power amp: Creek A42 £70. Tel: 01606 784 767 after 3.30. (Feb/I)

SPEAKERS WANTED: 2 x 14" 200 watt subwoofers, 2 x 10" 200 watt mid range. Must be excellent condition. Tel: D. Willis 02920 890 770 (Feb/I)

NAIM HI-FI SYSTEM SALE, CD2 CD player, NAC 82 pre-amp, HI-CAP power supply, NAP 250 power amp, SBL loudspeakers (cherry), QLN PROJEKT equipment rack (cherry). Complete system purchased from and installed by Grahams Hi-Fi in December 1997. Mint condition, very low usage, with all boxes and manuals. Sell complete for £6500. Tel: Mark 01708 224319 (Essex) (Feb/I)

NAIM NAIT3, good condition, £300. Tel: 0116 270 0989 (Feb/I)

LINN KAN speakers, 50 watts, £180. Nakamichi BX300E, 3 head cassette deck, £200. Creek Stereo FM tuner £80. Nakamichi 480, 2 head cassette deck £100. Naim Nap 140 power amp, Naim Hi Cap, Naim pre amp 32 5N, £700. Total system £1000. Tel: 023 9225 5481 (Feb/I)

MINT GARRARD 301 turntable £150. Leak Point One preamp £25. Quad mono tuner £25. Leak Stereofetic tuner £20. Quad ELS57 speakers for spares £120. Thorens TD150/II turntable £30. Tel: 01745 331 681 (Rhyl) (Feb/I)

A GREAT NAIM! NAC52 preamp with Supercap (2000), (remote, cables, manual). Mint £3500 (£5700 new). Call Vangelis 020 7727 4855. (Feb/I)

PINK TRIANGLE Export Helius Aureus Audio-Technica AT-OC5, little used £400. Tel: 01623 825 794 (Notts) (Feb/I)

TEAC VRDS TI DT1 DAC, mint condition, boxed, £450 ono. Acoustic Energy AE505 cherry finish, immaculate £450 ono (£850). Leak Troughline 2 c/w Galaxy 17, serviced by One Thing £150 ono. Philips RH544 Motion Feedback speakers, impressive £300. Tel: 0161 355 2905 or 07788 441 524 (Feb/I)

CALIFORNIA AUDIO Labs Tempest II. Classic valve output stage Cd player. Very rare, highly sought after two box player. Phenomenal sound, excellent condition. An all time great. (See Hi-Fi News November 1999) £1750 ono. May p/lex Audio Research power amp D76, D79 or D70 or VT50. Tel: 01509 215 230 (Feb/I)

WANTED: SONY Elcaset model EL7 must be mint and fully functional also Elcaset tapes wanted. Tel: 01279 724804 ask for Bob or 01582 793999 daytime (Feb/I)

NAIM NAP250 poweramp, recent Naim service, boxed £875 (new price £1850). Pioneer PDR-04, rare, top of range CDR recorder/player/remote, brand new, unused £595 (new price £1200) Tel: 01279 300 947 (Feb/I)

MICHELL ORBE-SE, RB300 £1500. Trichord Dino £275. Grace 707 MkII £300. ProAc Tablette 2000 £475. Due to health problems cancelled order. All brand new. Thorens TD166 MkVI, RB250, Supex SDX1000 £525. Teac VRDS-9 £375. Tel: 0117 955 6555 (Feb/I)

CELESTION SL600si on Master stands £350. Electrostatic Hybrid speakers from the USA. Black and stunning with matching subwoofers £950 (new cost £4000). Ittok LVII Asak, excellent £250. Tel: 0118 981 5681 or 07909 697 060 (Feb/I)

GRAMAPHONE, REGAL tabletop model, brass horn £100. 400+ hi-fi magazines: Hi-Fi News 1966-7, 1985-97, Hi-Fi For Pleasure 1974-84, Hi-Fi Answers/Audiophile 1977-94. £400 the lot. Tel: Richard 020 8991 0762 (London) (Feb/I)

DENON DVD 5000 £800 Toshiba 50900E as new £800. Audioplan Kontrast II speakers £500. Sony X77ES CD £450. Sony 703ES DAC £500. All mostly boxed and in mint condition. Tel: 0781 294 5704 (Mar/I)

MISSION 775 SM turntable, Mission arm, legendary top of range model £365, Sony Espirit TA-E900 preamp with superb phonostage (£2600) £475. Cartridge Man Musicman 2, virtually unused £295. Atacama Europa 5 tier stand £145 (£299) Tel: 020 8952 2044 (Feb/I)

AUDIO RESEARCH SPI0 MkII preamplifier, exceptionally fine condition. All original boxes and owners manual £1750. Tel: 0191 281 0260 (Feb/I)

BOSE LIFESTYLES System, includes 13 pairs Accustimax speakers, 1x AM9P bass unit, 1x AM3P bass units, includes 4 remotes. Hardly used, £2000. Tel: 0777 445 7619 (Feb/I)

CARTRIDGE MAN cartridge. Latest Mark Two version kept as spare, barely run in £295 (£575), Quad 303 serviced £90. Tel: 01424 755375 (East Sussex) (Feb/I)

MERIDIAN 504 tuner, unwanted gift, new, boxed £395. Sony Professional Walkman WMD6C, boxed, as new £215. Sony TAF500ES amplifier, excellent £95. Wanted: Thorens TD126 Mk4 or 5 turntable. Tel: 01275 835 334 (Bristol) (Feb/I)

GARRARD 401 in Aphellion plinth, recently serviced £360. Cartridge Man Musicmaker 2, virtually unused £295. Sony Espirit Tan TA-E900, classic pre-amp, superb MC/MM phonostage, handbook, boxed, £390. Mission 775 SM turntable, superb, £360. Tel: 020 8952 2044 (Feb/I)

NOTTINGHAM ANALOGUE Spacedeck spacearm and Tracer One cartridge. As new condition £700 ono. Castle Harlech SI speakers. Black ash. Excellent condition £350 ono. Tel: Shaun on Grimsby 01472 883 722 (Feb/I)

MUSICAL FIDELITY A300 integrated amplifier, remote, phono, pristine condition. One female owner £825. Mandrake (Siltech) silver interconnect 3 feet, cost £550 sell for £200. Tel: 01730 815171 (Feb/I)

EPOS ES30's, black ash. Three years old, perfect, unmarked with original packaging. Cost £2300, bargain £1400. Custom Design Aspect 500AV equipment rack, black with smoked glass shelves £225. Tel: 020 7742 3215 Email: chrisfruen@cs.com (Feb/I)

DELTEC DPA 50S pair bi-amped all cables offers or exchange. Michell Argo Hera £150. Yamaha DSPE 492 DDPI Dolby Digital processors offers. Panasonic Region I DVD offers. All good condition 01452 721271 or 07968 010939 (Feb/I)

MYRYAD MCD600 CD player £879 (£1300), MT100 tuner £349 (£600) M1240 integrated amp £999 (£1500). Ruark Solus loudspeakers (cherry) £829 (£1250) all less than 6 months old and boxed Tel: 023 808 726 20 (Feb/I)

ROKSAN DP-1 CD transport, vgc, boxed £575. Teac P-700 CD transport, unmarked £475. Pioneer F208 tuner, RDS, text, etc, as new, boxed £65. Tel: 07941 923881 (01273 698793 after 6pm) (Feb/I)

Classified Ads

PHONE FOR LATEST LIST

NEW, ED-DEM AND CLEARANCE ITEMS

	RRP	SALE	
Arcam Alpha 10	£799.00	£549.00	D
Arcam Alpha 8R Amp.	£350.00	£259.00	N+D
Arcam Alpha 7R Amp.	£280.00	£229.00	N+D
Arcam Alpha 9P Pre. Amp.	£400.00	£300.00	N+D
Acoustic Energy AE1 MKII	£995.00	£695.00	D
Copeland CDA266	£1,399.00	£1,195.00	D
Copeland CDA289	£1,985.00	£1,295.00	D
Krell KAV 500i Int. Amp.	£5,498.00	£3,895.00	D
Mission 701 speakers	£160.00	£119.00	N
Linn Kaber	£1,995.00	£695.00	D
Linn Keosa	£499.00	£369.00	D
Mission X space speakers	£199.00	£95.00	N+D
ProAc 3.8	£3,990.00	£2,990.00	D
Neate Mystique	£735.00	£499.00	D
Cyrus SL Amp	£400.00	£250.00	D
Cyrus AV Master Processor		£200.00	D
Audio Research VT50	£3,499.00	£2,279.00	D
Rotel RX965RDS A/V receiver	£950.00	£695.00	D
Tannoy Revolution R3 speakers	—	£249.00	S/H
Meridian 500 Transport (mint)	£1,350.00	£849.00	D
Meridian 502 Pre. Amp	£1,385.00	£995.00	D
Meridian M33 Active speakers	£1495.00	£995.00	N+D
Quad 77 Integrated Amp.	£700	£350	D

D = EX DEMONSTRATION, N = NEW, S/H = SECOND HAND

Hi-Fi Multiroom and home cinema

ACOUSTIC ENERGY ARCAM ASH DESIGN AUDIO
RESEARCH CELESTION COPELAND CYRUS
DENON KEF KRELL LINN TAG MCLAREN MARTIN
LOGAN MERIDIAN MICHELL MISSION MONITOR
AUDIO MUSICAL FIDELITY NEAT ACOUSTICS
PIONEER PROAC QED QUADRASPIRE REL SONUS
FABER SME STANDS UNIQUE STAX THETA
WILSON AUDIO ETC...

THE LISTENING ROOMS LTD

161 OLD BROMPTON ROAD LONDON SW5 0LJ
TEL: 020- 7244 7750/59 FAX: 020 - 7370 0192
www.listeningrooms.com E-mail: tlr@dial.pipex.com
Mon-Sat 10-6pm

SALAGO

High end Hi-Fi
from Etalon of Hungary

Leather handbags by Arrogance, Bosboom
and Tula **Hand Blocked Soft Furnishings**
Miniature Swords by Wilkinson
a very large selection of Brio Railway
over 150 different Beanie Babies
Mamod and Wileco Working
Steam Engines Meccano
Collector's Playing Cards
Chess Mah Jong and
Backgammon Juggling gear



For something a little different

Salago

The Old Butterwalk, Totnes, Devon. TQ9 5NP
Telephone (24hr) 01803 866981

Or buy from our web site
www.salago.co.uk

Acton Gate Audio Ltd.

The HiFi Centre

4 Ruabon Road, Wrexham, LL13 7PB
Tel: 01978 364500

email: sales@acton-gate.com
website: www.acton-gate.com

Winter sale

Alchemist Forsetti Amp	£650
Michell Syncro	£225
TDL RTL 3 Speakers	£200
Garrard 301	£220
Marantz Pm6010 ki+Cd6000 ki	£600
Arcam CD92	£690
Rotel RC980/RB980/RB980	£650
Audio Analogue Donizetti Power	£475
Audio Analogue Bellini Pre-amp	£395
Rega ELA Speakers	£150
Rotel 951 CD Ex.Disp.	£275
Quad 50e (pair)	£350
Linn Classik (silver,ex-dem)	£800
Michell Alecto Stereo	£999
Tannoy 613 Speakers	£150
Quad 988 speakers	£3000
Michell Gyro SE with RB 300	£850
Unison Research S2 valve amp	£830
Quad Forty pre/power (ex.dem)	£3400

used Quad bought and sold

MERLIN MUSIC V.S.M. - Millennium Edition with battery B.A.M. rated Class 'A' by Stereophile magazine who said, 'This is one music lover's speaker you need to hear, however much you're prepared to spend.' Go to www.merlinmusic.com to see the outstanding reviews. U.S.A. price \$7150 asking £4700. Tel: 01296 437314 (Aylesbury, Bucks.) P.S. They love valves (Feb/1)

MANA ACOUSTICS 3 shelf Hi-Fi stand. Custom made to fit M.F. Nu-Vista amp and CD player i.e. accepts 500mm in width. Buyer must collect, asking £350. Tel: 01296 437314, (Aylesbury, Bucks) (Feb/1)

FALCON DESIGN LS3/5A's ash veneer excellent sound/condition with stands £295. Rega 3 black mint condition includes cartridges/spare belt £175 Tel: 01981 550606 (Mar)

MISSION CYRUS amp and tuner plus 770F speakers Genexxa CD-1660 Technics RS-B755 tape deck all leads and connectors cost about £1200, will accept £330. Tel: Paul 01789 778658 (Feb/1)

NAKAMICHI CASSETTE deck model CR7E sounds superb casing immaculate, little used, hence sale £700. Tel: 01454 418 997 (South Gloucs.) (Feb/1)

MISSION 754 Freedom 5 floor-standing speakers oak, bi-wire, boxed, mint (£1400) £649. Harbeth HLK-6 standmount speakers, walnut bi-wire, mint (£1000) £599. Chord Chorus interconnect 1 mtr as new £130. Tel: 0115 960 3934 or 07779 045059 (Nottm) (Feb/1)

HOME BUILT floor standing speakers like KEF CS5 £175. Pair KEF B200A bass drivers £45. Beomaster 1200 tuner amplifier Wharfedale Linton speakers (new bass speakers) Dual CS505-2 turntable £165. Tel: 01322 220912 evenings (Feb/1)

MISSION CYRUS-2 plus PSX power supply £325 ono. Mission D.A.C. 5 DAC £85 ono. Linn Sara loudspeakers complete with Linn stands and Linn speaker cable v.g.c. £275 ono. Tel: 01835 862152 Email: john.swan@virgin.net (Feb/1)

AVANTIC VALVE amps £110. NAD 3020A £70. JBL SVA 1600 horn speakers £220. Copland CSA14 £500. Decca arm new £50. Leak ST20 grey refurbished £295. Tel: 01827 261082 (Tamworth) (Feb/1)

AUDIO INNOVATIONS 300 integrated valve amp v.g.c. £150. Heybrook TT2 basic plus Ortofon 510 £100. Leak Sandwich speakers 15ohm perfect working order £70 Tel: 01564 826794 (South Birmingham) (Feb)

BURMESTER 785 pre-amp (still one of the best) £450. DNM PAI poweramp £450. B & W CDM 9NT (red cherry) unused £1100. Alchemist Forsetti APD 20 Mk2 power amp (unused) £550. Tel: 01952 502097 (Telford) (Feb/1)

SONUS FABER Concertos walnut biwirable £595. Denon 304MC cartridge boxed as new £100. Tannoy Revolution R2 floor-standers £190. Stansesing five shelf rack £100. Apollo 60cm stands £45 Tel: 01243 863371 (Bognor Regis) (Feb/1)

LOWTHER TPI original model Type A corner horn finished in dark oak with PM3A drive unit. VGC. £750. Also pair standard Lowther Acoustas with PM7 units Tel: 01886 853385 (Worcs.) (Feb/1)

SONUS FABER Concerto grand piano speakers. Beautiful gloss black and leather finish, mint condition, original packaging £1100. Copland CSA28 amplifier, black fascia and remote, mint condition - £1000. Tel: 01904 628804 or 622323 (Feb/1)

LINN ISOBARIK speakers DMS model teak? finish with stands £500. Tel: 01932 820825 or Email: rts@newroad67.freemove.co.uk (Feb/1)

NAIM 32.5 K/N boards £195. Hicap £395. NAP 250 £695. NAT101 tuner £495. All mint boxed. Linn LP12 Valhalla Ittok LVII K9 Trampolin base, excellent condition boxed £550. Tel: 0121 422 4371 after 7pm (Feb/1)

AUDIOLAB 8000C & 8000P pair £395 Spondor SP2/2 C/W stands £195. Pioneer A-300 amp £45. Wharfedale Black Diamonds £45. Target 5 shelf stand £45. Yamaha tuner T-09 black £30. Tel: 01634 268 071 (Feb/1)

AUDIO SALON STRATOS II interconnect 0.5m £45. Soniclink AST 200 x2 2m bi-wire terminated pair £12. Russ Andrews 4PR jumper leads pair £25. Tel: 01293 786453 Email: richard.newman4@ertinternet.com (Feb/1)

CONRAD-JOHNSON PF-R. Remote control FET preamp. Amazing sound. Naim style musicality, incredible midband £1500. Naim Naxo-DBL, new style £375. Naim HiCap, upgraded to new style £375. Tel: 020 7774 6641 or 01245 283125 Essex (Mar/1)

P+M COMPONENTS MP211 monoblocs superb condition spectacular looks £1195. Audio Innovations Series 700 integrated amplifier 25wpc £595 superb. Quad 34 two tone metallic grey phono inputs excellent £175. Tel: 0796 0615375 (Feb/1)

BTH AIA stereo valve amp and control unit. Very rare. Similar circuit Leak Stereo 20 but with printed circuit. Original. Mullard valves. In daily use. £150. Tel: 01524 701051 (Lancaster area) (Feb/1)

CASTLE KENDAL speakers (mahogany), as new, boxed £150. Tel: 01702 556116 (S.E. Essex) (Feb/1)

EAR 834P MM/MC boxed £325. Audio Synthesis Passion £350. TDS Passive Harmoniser £75. Harmonic Technology Pro-Silway I/C 1m RCA £200. Leider Chanson silver phono I/C convertible to stereo £150. Harmonix 101 speaker cable 3m £150. All vgc. Tel: 01844 347729 (Bucks) (Feb/1)

FOR SALE pair Naim 135s (7/00) £2250. Supercap (6/01) £1600. NAC 82 (4/94) £1000. SBLs (92) £500. Tripod stands, any offers. Tel: 01984 629086 (Mar/1)

AUDIO NOTE P4 monoblock power amps, excellent condition £2100 ono. Audio Innovations 800 Mk3 power amp excellent condition £500 ono. All with original boxes and instruction. Tel: Andy 01642 482393 (Mar/1)

AUDIOLAB 8000A integrated amp - looks and sounds great - £175. Marantz CD63SE - perfect condition - £175, or £300 for both. Tel: 01494 580640 - leave message (Feb/1)

CASTLE ACOUSTICS Quarterwave Inversion 50 loudspeakers in yew. As new 5 yr guarantee £750. Castle Seven 2SE loudspeakers in black ash, as new guarantee £525 sounds looks superb Tel: 01756 701318 (Feb/1)

HARBETH HL Compact 7ES loudspeakers in eucalyptus mint boxed (£1300) £700. Acoustic Solutions speaker stands (£199) £100. Jamo Concert 8 loudspeakers maple boxed (£1329) £625 Tel: 01704 821146 (Preston area) (Feb/1)

NAIM NAP 250 NAC 62 exceptional condition £650. Kimber high current power cord 3ft £60. Standard power cord £40. Lat international AC2 power cord 13 ft £80. Tel: 01484 841482 (Feb/1)

CASTLE HOWARDS 'Series Two' in yew, mint condition cost £1300 - accept £650 with boxes. Pioneer open reel model 909 logic control NAB reels permaloy heads. Instructions. Beautiful machine. £260. Tel: 01782 265087 (Feb/1)

EXTRON RGB 119. Dedicated VGA and XGA computer to projector video interface with simultaneous local monitor viewing. RGBS or RGBHV outputs. 100-240Vac 50/60Hz £250. Tel: 01945 463077 (Feb/1)

YAMAHA NS100 speakers cherry six months old as new £100. No offers. Tel: 01772 687748 (Feb/1)

NAIM NAC52 Pre-amp w/ SuperCap (2000). All cables, remote, manuals, packaging, mint £3500. (was £5700) Tel: Vangelis 020 7727 4855 (Feb/1)

PIONEER ELITE DV-09 DVD/CD. (cost £1250) absolutely as new, boxed, c/w instructions plus 240Vac transformer, £650. Companion MJ-17D minidisc recorder also available. Tel: 01945 463 077 (Feb/1)

KEF Q35 Speakers (black). Very little use £120. QED Silver Spiral interconnects, 0.5 metre £45. Kimber CD Powercord £35. Signals Powercord £30. Tel: 01634 718 943 (Feb/1)

TAG MCLAREN System: CDT20R, DAC20. PA20R, 100P. Selling £3350, cost £5350 as new, boxes, manuals. Ruark Crusader II, oak, as new, boxes. Selling £1050, cost £1690. Tel: Chris 01428 641 768 (work) (Feb/1)

MICROMEGA TEMPO 'P' (pre-amp) + Tempo 'Amp' (power-amp), 120 WPC (1998). Top of range, inc. 2 pairs van den Hukl 'Source' interconnects, full remote, as new, boxed, (£2500) new, £795 ovno. Yamaha KXW482 twin tapes cassette deck, hi-fi separate, full logic remote, boxed as new £125 ovno. Tel: 0121 358 0459, mobile 07960 945 994 (Feb/1)

COMPLETE NAIM System, awesome sound, excellent condition, sold as boxed with all leads. Buyer collects. CDS, CDPS, NAC82 (incl. Naim moving coil phono input board, NAP250, Hi-Cap SBLs passive (black ash), Soundstyle equipment stand. Package price £5800. Tel: 07710 390 648 after 6pm, 0775 950 1906 after 6pm, 01294 311 037 answerphone or email: kenmcw@bigfoot.com (Mar/1)

QUAD ESL63 Speakers with stands, black grills £1200. See Revolver turntable with Ortofon MC15 Super 2, boxed £150. Musical Fidelity preamp 3A power-amp P140, boxed £350 pair. Tel: 0191 251 2087 (Feb/1)

CARY SLP-50 valve, pre, £1400 new, £700 ono. Art Audio Quintet valve stereo power, £1800 new, £800 ono. Both vgc, boxed, with manuals. Tel: Alan 01661 834 557, may reduce prices! (Feb/1)

CASTLE AVON loudspeakers (cherry) excellent condition, have seen very little use, £450 ono. Wanted: AKG K60 headphones circa 1969. Tel: 01373 822 040 (Feb/1)

NAIM NAIT3, good condition, £300. Tel: 0116 270 0989 (Feb/1)

Q.S. KITS.

DESIGNS ENGINEERED FOR EXCELLENCE WITH:-

- POLYPROP CAPS
- AIR CORED COILS
- HI-TEC DRIVERS
- TOP GRADE COMPONENTS

- CABINETS INCLUDED WITH OPTIONS ON FINISH
- NOTES AND SPECIFICATIONS
- COMPREHENSIVE INSTRUCTIONS
- AVAILABLE AS COMPLETED UNITS WITH STANDARD OR EXOTIC VENEERS
- DISCRETE COMPONENTS
- CUSTOM MACHINING SMALL PANELS, JOINTS & CUT-OUTS

FOR FURTHER DETAILS:-

Q.T.A. Systems
2 Wheatsheaf Way
Linton - Cambs CB1 6XB
Tel: 01223 891091

www.qtasystems.co.uk

AUDIO MATTERS

NEW EX-DEM & PART EXCHANGE

EQUIPMENT FOR SALE

020 8255 0572/0973 436135

	LIST	SALE
Alchemist Kraken Anniversary MkII	£599	£POA
Alchemist Product 8 pre & pwr (on dem)	£2047	-
Alchemist Product 8 dac & drive (on dem)*	£1898	-
Alchemist The Statement pre amp ex/dem	£4999	£2295
Alchemist The Statement Stereo pwr ex/dem	£3999	£1995
Audion Black Shadows 845 valve monoblocks	£4000	£POA
Audion Silvernight 300B monoblocks	£2250	£POA
Audion Golden Nights	£4000	£2200
Bow Technology Wazoo (ex/d)	£2195	£1595
Bryston BP ST4 pwr	£2100	£1195
Chario Academy 1 solid walnut (ex/d)	£1299	£800
Classe DR 6L pre	£3400	£1295
DPA Renaissance CD player ex/d	£995	£595
Krell 250 CD Player	£2592	£1795
Krell Kav 300I	£2495	£POA
Linn Karin pre	£1400	£595
Mark Levinson 331 pwr	£4500	£2695
Mark Levinson 23.5 pwr	£7500	£3195
Meridian 551 int. amp	£845	£425
Meridian 555 pwr. amp	£750	£395
Naim 72 pre	£800	£395
Naim 90 pwr.	£487	£250
Perreux AC 3 pre ex.d	£1700	£1195
Perreux 6 ch. pwr amp	£2500	£1695
Roksan Caspian (AC3 DTS) pre & 5 ch. pwr amp (on/dem)	£2290	-
Ruarq Prologue re 1 spks.	£999	£595
Monitor Audio 20SE	£2200	£950

A NEW RANGE OF VIENNA ACOUSTICS SPKS. NOW ON DEM

*New Product 8 from Alchemist Dac & Drive w/192 sampler in-built ON-DEM

Also On-Dem: Alchemist, Anthem, A.R.T. spks., Audiomeca, Audion Valve Amps, Cadence Spks., Chario, D.P.A., Goertz cables, Lavardin., Monarchy, Ortofon, Pink Triangle, Project T-T., Roksan., Sonic Frontiers, Triangle Spks., Van den Hul., Rogue Audio Valve Amps., Amphion Spks.

VISA/MASTERCARD ACCEPTED

We are best known for our single-ended 300B power amplifiers and power supply upgrades for valve amplifiers, but did you know that we supply complete systems, new and used equipment, and components? We also provide support and servicing for Audio Innovations valve products. For full information visit www.borderpatrol.net or ring 01273 276716

passion, grace & fire

www.borderpatrol.net

Selected products from:

BorderPatrol • Living Voice • SME • Audio Note • Cartridge Man • Goldring
Western Electric • Electrofluidics

BorderPatrol Brighton UK
Tel/Fax +44 (0)1273 276716
e-mail: bp@borderpatrol.net
www.borderpatrol.net



BorderPatrol

hi-fi

WORLD
& computer audio

Trade Ads

Dealers must not advertise in the Private Classified section. Monthly consecutive insertions will be considered Trade advertising. The Publisher reserves the right to judge submissions.

VINTAGE WIRELESS
COMPANY LONDON
Website: www.vintagewirelesslondon.co.uk
Buy-Sell-Exchange. Vintage wireless and classical audio. Repairs, spares, restoration, modification to all valve equipment. Quad II, Leaks etc, shipped worldwide, best prices, call us at 17 Bell Street, London, NW1 5BY. Tel: 020 7258 3448
Fax 020 7258 3449 Email: vwirelesslondon@aol.com (Oct02(I))

NEW WEBSITE launch
www.apexacoustics.co.uk check out bargains and features including Cyrus Disc/Dac master £825, Cyrus Power £275, Cyrus XPA £225, Rega Planet CD £415, Rega Mira amp £415, Dynaudio Audience 40's £250, see main ad. for more equipment. Phone Steve 01527 450 500, E-mail Apexnm@aol.com. (Feb(I))

THE DEMO ROOM - For new, ex-demo & used ex trade quality audio amplifiers, CD's, loudspeakers etc. Visits by appointment only. Tel: 0131 430 7817 (South Birmingham) (Feb(I))

AUDIOATMOSPHERE.COM exclusives: Gutwire, Pierre Gabriel, Power Snakes. Select range of components, accessories, spares. Also mods including fabled Black Gates. New Year offers list out now. Please Email: stuart@audioatmosphere.com or telephone 01785 711 232 (Feb(I))

WANTED - EARLY HI-FI LOUDSPEAKERS
Tannoy, Lowther, Parmeko, Voigt, Vitavox, RCA WE etc
TURNTABLES
Garrard, BBC301, EMT SME, Ortofon, Decca, etc.
VALVE AMPLIFIERS
AEI, EMI, Leak, Rogers, PYE-Quad, WE etc
AUDIO VALVES
DA30, KT66, KT88, PX4, PX25, PP3/350, VE300
CLEAR CRYSTAL SYSTEMS
John Petrie-Baker
Tel: 020 7328 9275

HIGH EFFICIENCY monitor loudspeaker, for valves or Class "A" transistor. Full range of Croft & EAR valve amplifier. 01942 257525 www.audioclassics.co.uk (dealer enquires welcomed on Model 'C') (Feb(I))

AMAZING INTERCONNECTS!
Hand built pure silver cables with world class connectors. Fantastic performance, money back guarantee. £105 per metre pair, £5 p&p. Other lengths available. Details: 0115 982 5772 after 7pm, Email: Bob@skydivers.co.uk (Apr(I))

FOR SALE Naim Nap 500 £6950. Naim NBL speakers/beece £4500. Customer retiring abroad. Also Naim SBL speakers/black £850. Contact Griffin Audio Ltd, Birmingham. Tel: 0121 622 2230 Email: griffinaudio@fsbdial.co.uk (Feb(I))

SONY CDP R1 Reference. Transport Das R1 Dac as new. (£6000) £2650. Audio Analogue Bellini preamp, Donizetti power-amp, Boxed with manual, £550. Revox B215 Reference cassette deck, excellent condition, (£1200) £450. Please telephone Jules on 01792 280061, E-mail: sales@sounddrjuleshifi.co.uk Web: www.sounddrjuleshifi.com (Feb(I))

LINN SONDEK, early 1980's £300. Myriad T20 CD player, as new £250. Transparent Music Link Super 25ft, interconnect RCA £600. Transparent Music Wave Plus Bi Wire Speaker cable 8ft £300. Nordost Flatline Gold bi-wire 3.5m £95. Please telephone Jules on 01792 280061, E-mail: sales@sounddrjuleshifi.co.uk Web: www.sounddrjuleshifi.com (Feb(I))

KRELL KRC-2 pre-amp as new £1990. Michell ISO / Hera £330 ono. Krell CD 10 Signature Transport. Approx 5 yrs old. mint, (£10,000) £4000. Groove phono stage brand new £1500. Please telephone Jules on 01792 280061, E-mail: sales@sounddrjuleshifi.co.uk Web: www.sounddrjuleshifi.com (Feb(I))

DX4/EX4 LOWTHERS Half Price, ex-demo. Less than 100 hours. 1 pair of each. Surplus to our requirements. Tel: 01483 268 814 or email: info@hornutopialoudspeakers.co.uk (Apr(I))

AUDIO TECHNICA OC9 cartridge brand new exchange £240. Crimson 610 / 620 pre / power £300. Deltac Black Slink 0.75 interconnect £90. Deltac Black Slink 1.0 mtr WBT's, £100. Denon POA660 mono blocks £650. telephone Jules on 01792 280061, E-mail: sales@sounddrjuleshifi.co.uk Web: www.sounddrjuleshifi.com (Feb(I))

CARY CAD SE 300B signature monoblocks, £2,595. Cary CAD 572 SE monoblocks £1395. Convergent JLI Signature cost £30K £POA. Restek Tensor amplifier (chrome/black) £1495. Vincent SV 233, remote, integrated £999. Brinkmann Pre £1200. Sutherland C200 Pre £4500. Krell KSP-7B/PSU £999. P.S. Audio 2 Power £395. Cello Reference DAC £3995. Rake Oyster CD £5500. Melos Valve CD/PSU £695. Audio Alchemy, 4 boxes CD/DAC 2 x PSU £1200. Nakamichi Dragon x 3 £1200 each. Nakamichi RX-505 £595. Nakamichi RX202 £395. Nakamichi 1000ZXL £1500. Vadia 2000 Digital £3995. Martin Logan CLII's £1995. Watts 5.1 £6995. Tel: 020 7349 9675, mobile: 07958 607613 (Feb(I))

TECHNICS SLP 1200 CD £280, SP10 MkII £250, Revox PR99 MkIII £750, Nagra T-Audio £1500, IVS £1200, EMT 950 £895, 948 £600, Sony CDS 3000, twin CD £1400, Studer A710 £250, A810 £450, A80RCII VU £650. Tel: 01246 275479 (Feb(I))



RESERVE YOUR COPY TODAY!

Complete this form and hand to your local newsagent

Please reserve/deliver* (delete as appropriate)
Hi-Fi & Computer Audio World on a regular basis, commencing with the next issue, until further notice.

Name _____

Address _____

Signed _____ Date _____

Distributed to the news trade by

COMAG
MAGAZINE MARKETING



classified ads order form

Dealers must not advertise in the Private Classified section. Monthly consecutive insertions will be considered Trade advertising. The Publisher reserves the right to judge submissions

**In a rush to get your advert published?
Why not use our Instant Internet Advert to
get on our website immediately.
Only £15 per week (7 days)**

SPECIAL OFFER
Book a private or trade classified advert, and get one months *FREE internet advert
**FREE internet adverts are published three weeks AFTER the magazine has been published*

RATES - ALL ADVERTS MUST BE PRE-PAID

Maximum length per advert is 30 words, each additional word is 50p extra. Telephone numbers and E-mail addresses are treated as one word. Model numbers are treated as one word i.e. Quad 303 = two words. Please tick the box for the advert required

- Instant Internet Only Advert Private or Trade published immediately £15 per week
 - Private magazine advert plus *FREE internet advert £10 per month
 - Private magazine advert display black box plus *FREE internet advert £15 per month
 - Trade magazine advert plus *FREE internet advert £10 per month
 - Trade magazine advert display black box plus *FREE internet advert £15 per month
- Please tick here if you **DO NOT WANT** your FREE internet advert

Please write or type your advertisement copy in block capitals with one word per box.

Please continue on a separate sheet if necessary.

WE WILL ACCEPT PHOTOCOPIES OF THIS FORM

1	2
3	4
5	6
7	8
9	10
11	12
13	14
15	16
17	18
19	20
21	22
23	24
25	26
27	28
29	30

Name _____
Address _____
Post Code _____
Daytime Tel: _____

Please debit my VISA/MASTER/SWITCH Card No.(Switch card issue No _____)

Expiry Date: _____ Cardholder Signature: _____

I enclose a cheque/postal order for £ _____ Made payable to: Audio Publishing Ltd.

Send in your private classified ads with our NEW Freepost service. No need for a stamp!

Send this form together with your payment in an envelope marked:
Hi-Fi World, FREEPOST LON3478, LONDON NW6 6YR

ADVERTISERS INDEX

- Absolute Analogue 72
- Acton Gate Audio 126
- Affordable Audio 74
- Apex Acoustics 121
- Arcam 44
- Audio T 42
- Audio Connoisseurs 70
- Audio Jumble 112
- Audio Illusion 92
- Audio Matter 113
- Audio Synergy 122
- Audiocom 106
- Audiolab Leeds 96
- AudioNote 106
- Audiophile Furniture 58
- AudioSalon 120
- AudioXpress 96
- Audusa 124
- Billy Vee 89, 90, 91
- Campaign Audio Design 58
- Central Audio 108
- Chelmer Valve 95
- Choice HI-FI 94
- Chord Company 56
- Classique Sounds 119
- Creek Audio 54
- Cricklewood Electronics 96
- Custom Cable 109
- Definitive (Brighton) 113
- Definitive (Notts) 58
- Diverse Vinyl 121
- Emporium (The) 116
- English Analogue 111
- Heathcote Audio 115
- Heatherdale 109
- Henley Designs 24, 88
- Hicam 107
- Ian Harrison 117
- Icon Audio 58
- Jem Distribution 109
- Kef 20,21
- Langrex 103
- Linn IFC
- Listening Rooms 126
- Lucid 49
- Mana 119
- Mantra Audio 88
- Maplins 95
- Matrix 118
- Midland Audio Exchange 110
- Mission BC
- Music & Video Exchange 107
- Musical Fidelity 46
- Musical Images 112
- Musonic 111
- NAD 14
- Naim IBC
- Origin Live 106, 114
- Oxford Audio Consultants 108
- PG Hi-Fi 121
- Progressive Audio 113
- QTA 128
- Replay 119
- Retro Reproductions 122
- Ringmat 38
- Russ Andrews 48
- Salago 126
- Sevenoaks 27, 28, 29, 30, 31, 32, 33
- Sony 8
- Sound of Music (Crewe) 117
- Soundcraft 109
- Sounds Perfection 36
- Sounds Of Music (Kent) 88, 93
- Sounds Expensive 117
- Soundstage 118
- Stowsounds 118
- Technical & General 95
- The RightNote 56
- Trichord Research 36
- True Colours 111
- UKD 18
- Watford Valves 103
- Wavelength 117
- White Noise 96
- Williams Hart 112

PRIVATE & TRADE CLASSIFIED ADVERTS COPY DEADLINES
MARCH 2002 ISSUE - THURSDAY 10TH JANUARY 2002
APRIL 2002 ISSUE - THURSDAY 7TH FEBRUARY 2002



Faithful to your music



Music as it was meant to be heard • Systems start from £3000

For your nearest stockist call +44 (0)1722 332266. Or visit www.naim-audio.com

World Radio History



MISSION



m70

series

Mission, Symphonix Ltd, Huntingdon PE29 6EY
Tel: +44 (0) 1480 423700, Fax: 01480 423701, Web: www.mission.co.uk