

THE
**WIRELESS
ENGINEER**

VOL. XIV.

MARCH, 1937.

No. 162

Editorial

Broad-band Television Cables

THE reason why high definition television cannot be broadcast on a medium wave-length is that the modulation frequency is so high that the band of wave-lengths covered would monopolise the whole of the medium band. A modulation frequency up to 10^6 on a carrier of 10^6 would cover the range from 0 to 2×10^6 whereas on a carrier of 50×10^6 the range covered is from 49 to 51×10^6 , *i.e.*, only 2 per cent. on either side of the carrier.

This high modulation frequency of 1 or 2 million has to be transmitted from the studio to the television transmitter, and the design of a cable capable of transmitting this current without undue attenuation and without distortion is by no means a simple matter and necessitates some radical departures from the usual construction. At these high frequencies loading is out of the question and other means must be found. In Germany the insulating material employed by Siemens and Halske and Felten and Guillaume is known as Styroflex, a flexible variety of Polystyrol or Trolitul which has a loss angle of about 1 per cent. of that of paper at these very high frequencies.* This Styroflex is wound into a spiral and this spiral is then wound in an open spiral around the central conductor in the style

of the coiled-coil lamp filament, so that the major portion of the insulation is air. The cable can be made either concentric or twin, but the former is preferred.

The losses in this dielectric material are so small that they may be neglected in calculating the attenuation, which is therefore due entirely to the copper loss. At these high frequencies the current is confined to a very thin surface layer of the conductor, the depth of penetration for copper at a frequency of 10^6 being equivalent to a uniform current density in a layer 0.066 mm. thick. The magnetic field is therefore confined almost entirely to the dielectric space and the inductance, capacitance, and characteristic impedance $Z_0 = \sqrt{L/C}$ of the concentric cable are easily calculated. Knowing the equivalent depth of penetration†

$t = \frac{1}{2\pi} \sqrt{\frac{10^9 \rho}{f\mu}}$ it is an easy matter to calculate the resistance for given radii of inner and outer conductors and thus to calculate the attenuation or damping constant $\beta = \frac{R}{2} \sqrt{\frac{C}{L}} = \frac{R}{2Z_0}$, the other term in the usual formula being negligible. For a given diameter of the external conductor there

* Kaden, *Arch. für Elek.*, 21 Nov. 1936, p. 691.

† Howe, *Journal Inst. Elect. Eng.*, Vol. 54, p. 475, 1916.

is an optimum size of central conductor to give minimum attenuation; for a larger central conductor the decrease of resistance is more than counterbalanced by the increase of capacitance. For a central conductor of copper the optimum ratio of diameter is 3.6 for an external conductor of copper and 3.8 for one of aluminium. From the above formulae it is obvious that the attenuation constant is inversely proportional to the overall diameter, assuming the optimum ratio, and directly proportional to the root of the frequency, both due to the variation of the effective copper cross-section. It is also proportional to the root of the effective dielectric constant κ of the space between the conductors. With the optimum design the characteristic impedance $Z_0 = 77/\sqrt{\kappa}$ ohms.

In the actual cable the outer conductor is not a solid cylinder but a spirally wound strip, and the result is that the current in it has a circumferential component, the magnitude of which depends on the pitch. To give flexibility to the cable it is essential that the pitch be not too great. The cable is thus a long solenoid, and the resultant axial magnetic field is forced to return in the narrow space between the outer conductor and the lead sheath. This causes circumferential currents in the outer layer of the conductor and in the inner layer of the lead sheathing, these currents limiting the penetration of the magnetic field but also causing losses and increasing the attenuation constant. These losses lend themselves to simple calculation. The less the space between the outer conductor and the lead sheathing the higher the density of the returning magnetic flux and the greater the currents and losses. The specific resistance of lead is about 12 times that of copper, and the loss in the lead is therefore an important factor. The spiral character of the outer conductor may thus cause the attenuation constant to be increased by between 50 and 100 per cent.

If the modulated high frequency current is to be transmitted without undue distortion it is necessary that the various frequencies not only suffer approximately the same attenuation, but also travel at the same velocity along the cable. As the frequency is increased the skin effect becomes more

pronounced, and the magnetic flux penetrates less into the conductor, thus reducing the inductance and increasing the velocity. For frequencies between 500,000 and 1,000,000 the depth of penetration is small, being 0.095 mm. for the former and 0.066 mm. for the latter, so that the effect on the inductance is not very pronounced. For a length of 1,000 km. the difference in the times of transmission of a group of waves at these two frequencies is 4.6 microseconds. This is by no means negligible but may be sufficient to make operation over this length impossible. When a modulated wave is analysed and represented by three vectors, one of which represents the carrier and the other two the side bands, one of the latter, having a higher frequency than the carrier, will travel faster, whereas the other having a lower frequency will travel more slowly. Initially these two vectors coalesce at the moment when they are either in phase or 180° out of phase with the carrier, thus giving the variation of amplitude of the resultant vector, but owing to the waves travelling at different speeds the resultant of the two side-band vectors becomes displaced and is no longer in line with the carrier vector. If the distance is so great that the upper side-band gains a quarter wave-length on the carrier whilst the lower side-band loses a like amount, the vector resultant of the side-bands will be at right angles to the carrier vector and will have little effect on the resultant amplitude. At what length of cable this obliteration of the modulation occurs will depend on the frequency of modulation, that is on the width of the frequency band, and on the carrier frequency, the permissible length increasing as the carrier frequency is increased and the bandwidth decreased. The length can be increased by increasing the size of the cable, so that the flux within the conductor forms a smaller fraction of the total flux, since the whole effect is caused by the variation with frequency of the former flux.

The research work on which these notes are based has been carried out in the laboratories of Siemens and Halske of Berlin; it forms a very interesting contribution to the subject of the design of television cables. G. W. O. H.

Arrangement for Simultaneously Registrating the Field-Intensities of Three Transmitters*

By J. J. Vormer

(Communication from the Radio-Laboratory of the Dutch State Telegraphs, The Hague, Holland)

SUMMARY.—A description is given of an arrangement, permitting the simultaneous recording of the field-intensities of three short-wave stations, working at about the same frequencies.

The apparatus has been so arranged that a normal triple recording-oscillograph can be used, notwithstanding the great field intensity-variations, which occur on these wavelengths. For that purpose the scale of the oscillograph is approximately logarithmic.

As the recordings may meet or even cut each other continually, a method has been devised which enables one to distinguish between the different curves.

IN connection with special receiving tests, the Radio-Laboratory of the Dutch State Telegraphs has developed a device which permits the simultaneous registration of the field-intensities of three short-wave transmissions, the frequencies of which are within a band of 100 kc/s.

The three frequencies, being received on a dipole-antenna of special dimensions, are applied together to a common high-frequency amplifier (Fig. 1—H.F.). This amplifier has a frequency-range from $5 \div 20$ Mc/s and

followed by an intermediate-frequency filter MF_0 , which lets the three intermediate-frequencies pass together. The output of this filter is connected to the grids of three valves in parallel, forming the inputs of three separate intermediate-frequency amplifiers MF_1 , MF_2 and MF_3 .

Every intermediate-frequency amplifier contains four amplifier-valves, coupled by means of tuned circuits. The band-width of each intermediate-frequency amplifier is about 8 kc/s. The condensers of the tuned

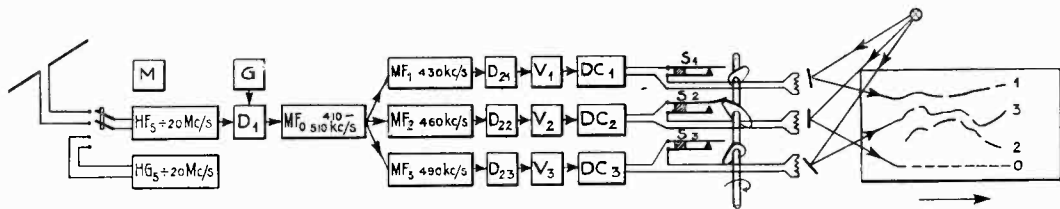

Fig. 1.

contains three high-frequency stages, the first being constructed in push-pull. After the high-frequency amplifier follows the high-frequency detector D_1 . Via a coupling-valve, a frequency generated by a local oscillator G is supplied to this detector at the same time. The frequency of this generator is chosen in such a way that the intermediate-frequencies after detection are between 410 kc/s and 510 kc/s. The detector is

circuits are variable, so the frequency of each amplifier can be varied over a limited range.

Each intermediate-frequency amplifier is followed by a second detector D_2 . The D.C.-voltage, which proceeds from the incoming signals after each second detector, is a measure of the field-strength of the corresponding station. Via a retardation-element V this D.C.-potential is applied to a D.C.-amplifier (DC Fig. 1), containing a valve with approximately logarithmic characteristic. The anode-current of each of

* MS accepted by the Editor, June, 1936.

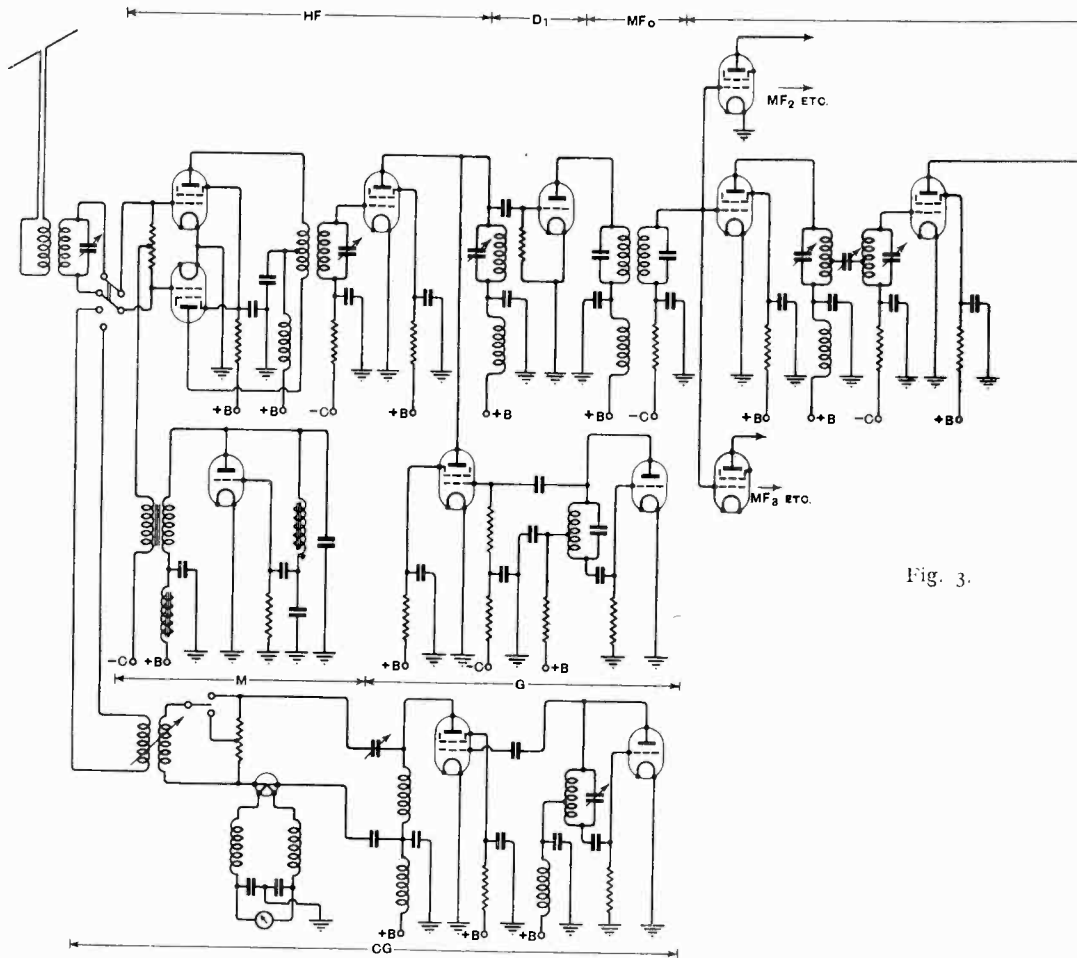

Fig. 3.

these valves is compensated. The variations of the anode-current pass the automatic interruptors S_1 , S_2 and S_3 , and are then applied to the triple recording-instrument. The object of the automatic interruptors is to interrupt the current flowing through the system of every oscillograph-mirror periodically in a special way. This facilitates the separation of the three curves. At the same time the interruptions produce a zero-line on the photographic paper.

The second detectors D_2 are diode-detectors (Fig. 3); the first detector is an anode-bend detector, but the signal applied to this first detector by the local generator G is strong in relation to the incoming signal. The conditions are therefore such that the D.C.-voltage after each second detector is,

over a wide range, proportional to the corresponding high-frequency A.C.-voltage at the input of the receiver, that is, proportional to the field-strength of the transmitter in question.

Such a linear relation is, however, not very well suited for recording purposes, if large ratios in the field-strength are expected.

Special difficulties arise if the available breadth of the photographic paper is limited. In the case under discussion, this dimension was only 50 mm. With a linear scale a field-strength of 1 per cent. of the maximum amplitude would only result in a deflection of 0.5 mm. We have, therefore, tried to obtain an approximately logarithmic scale-division.

If the static characteristic of a so-called

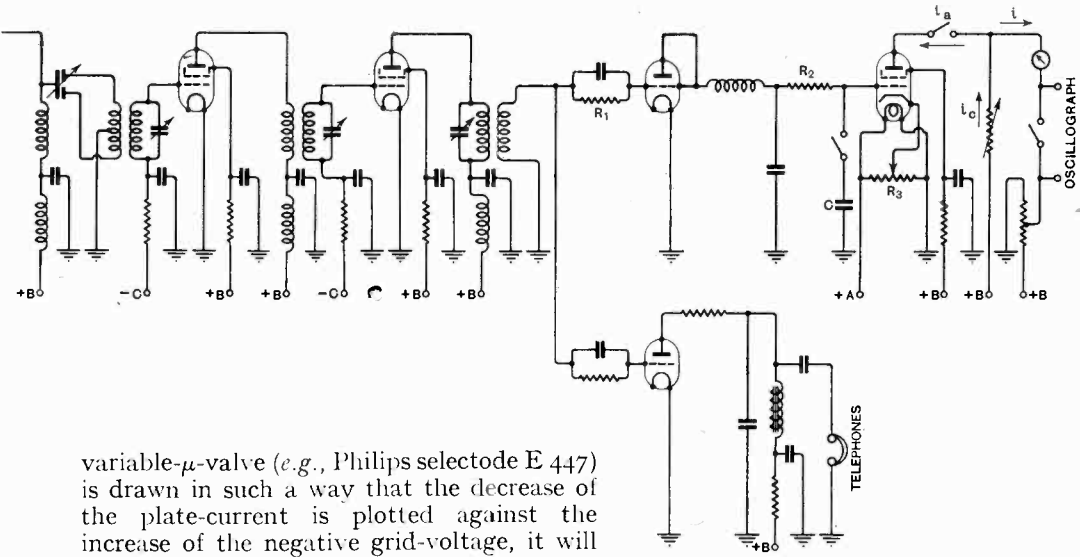

variable- μ -valve (e.g., Philips selectode E 447) is drawn in such a way that the decrease of the plate-current is plotted against the increase of the negative grid-voltage, it will be observed that this characteristic is more or less logarithmic over a wide range, if the constant grid-bias and the plate-voltage have a certain value.

Fig. 2 shows, that such a tube gives an easily measurable plate-current between 0.1 V. and 20 V. negative grid-voltage. This type of valve is used as a D.C.-amplifier after the second detector.

Fig. 3 gives a diagram of the arrangement. The D.C. voltage e_g , between the ends of the resistance R_1 , is applied to the valve E 447 as negative grid-voltage, through a retardation-circuit, consisting of a resistance R_2 and a condenser C . The constant negative grid-bias can be adjusted by means of the potentiometer R_3 . Fig. 3 shows that the negative grid-voltage at the E 447 increases with the potential at the resistance R_1 . Thus the anode-current i_a of the E 447 has its maximum value, when the voltage at R_1 is zero.

Fig. 3 shows at the same time the compensation-device. The variable resistance in series with the compensation-voltage is large in relation to the resistance of the branch in which the oscillograph-system and the mA-meter are placed. As the anode-current is compensated, the current flowing through the recording instrument has the value $i = i_c - i_a$.

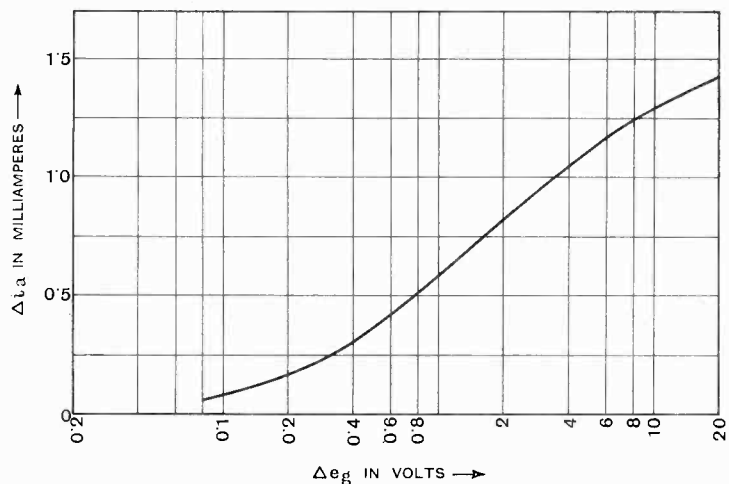

Fig. 2.

If the compensation-current i_c and the negative grid-bias are adjusted in such a

To facilitate the identification of the stations, a separate detector with telephone

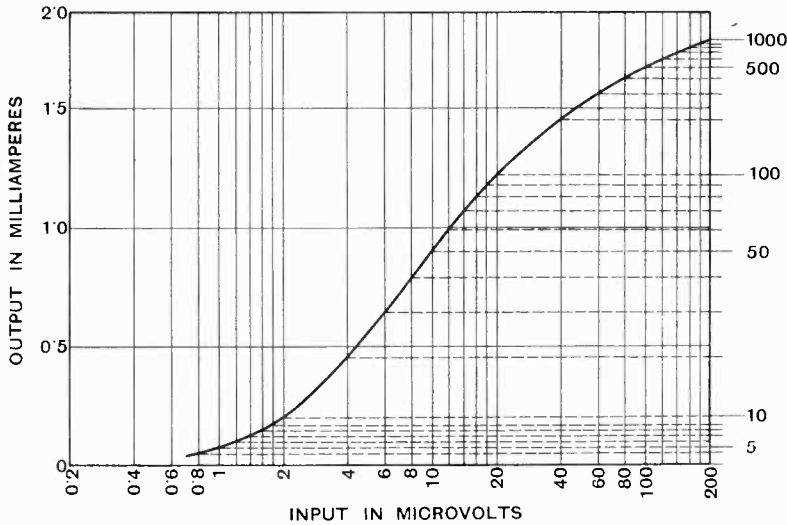

Fig. 4.

is placed in parallel with every second detector, while the incoming signals are modulated with a tone of about 1,000 c/s by means of a modulator, working on one of the high-frequency valves.

The apparatus is checked by means of a calibration-generator CG (Fig. 3). By means of this generator a voltage of exactly known amplitude and frequency can be applied to the input stage of the receiver.

manner that $i = 0$ if $e_g = 0$, then the current i through the recording-system varies between the limits 0 if $e_g = 0$, and i_c if $e_g = \infty$.

Hence the arrangement just described has the supplementary advantage that the

Fig. 4 shows the amplitude-characteristic of the whole receiver for one of the received frequencies. A relative calibration of the oscillograph-scale can be derived directly from this curve, and is indicated on the right of Fig. 4.

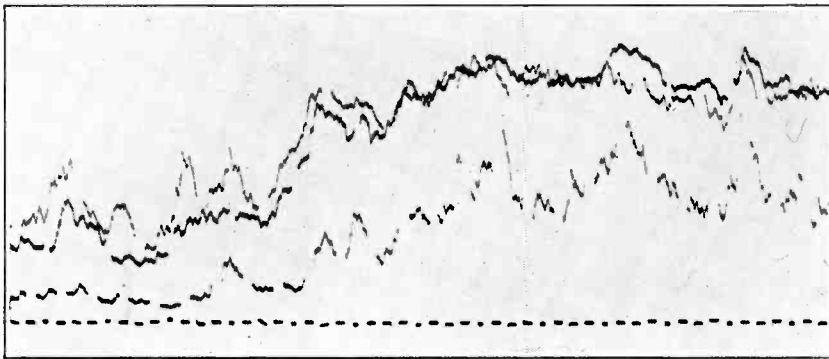

Fig. 5.

maximum amplitude of the recording-apparatus can never exceed a certain, previously determined, limit, notwithstanding the increase of the incoming signal.

A part of a record, taken with the apparatus, is shown in Fig. 5.

The whole apparatus runs on batteries, thus ensuring a high constancy.

Frequency Standardising Equipment*

By *H. J. Finden, A.M.I.E.E.*

SUMMARY.—In this paper a number of new principles as applied to the harmonic type of measuring apparatus are given, more particularly those affecting interpolation between adjacent harmonics.

It is shown that the usual method of interpolation is cumbersome to use, especially at the higher frequencies. The method is, moreover, liable to errors as it depends on the permanence of the law of the variable condenser in the oscillator and its short period stability.

A new method of measuring frequencies intermediate of harmonics from a multivibrator is given, whereby the accuracy of measurement depends only on that of the fundamental controlling frequency. The apparatus developed combines the advantages of the harmonic type of apparatus without being subject to the limitations of the latter. Some of the problems arising during the design are described, and the methods adopted in overcoming them are outlined.

(A) Survey of Existing Methods

(1) Harmonic Systems.

UNTIL recently most precision frequency measurements were based on the Abraham-Bloch multivibrator, developed in a practical form by the late Dr. D. W. Dye. Two valves form the nucleus of this system, and they are symmetrically coupled as shown in Fig. 5. It has been shown that this system forms a relaxation oscillator, having an output very rich in harmonics. The values of the grid capacitances C_3 and C_4 , and the grid resistances R_3 and R_4 , are so chosen that the relaxation period is approximately 0.001 second. The output from a 1,000 c/s fork is applied to this multivibrator, and providing there is sufficient power the frequency of the multivibrator will be pulled into synchronism with that of the tuning fork. When made of a material such as elinvar, with a low temperature coefficient, the tuning fork can readily be adjusted to have a frequency change of less than one part in 10^5 per degree C. Later developments on fork equipment employing temperature and barometric control have made a frequency accuracy and stability of a few parts in 10^7 possible.

Accuracy of the same order may be attained by the use of piezo-electric crystal controlled systems. The recently developed small temperature-coefficient crystals have been utilised for controlling the frequency of multivibrators, usually by employing a

crystal of some frequency such as 1,000 kc/s, which controls directly a multivibrator of 1,000 kc/s, and others at 100, 10, and 1 kc/s by subdivision.

While there is no difficulty in producing from a low frequency multivibrator harmonics strong enough to use even up to the thousandth, their separation and identification is not practicable. Adjacent harmonics of a high order are too close to one another for separation by one or two ordinary tuned circuits, and this limits the range of useful frequencies from any multivibrator. Dye in his well-known equipment arranges to use the 19th, 20th, or 21st harmonic of the 1,000 c/s multivibrator to control a second multivibrator whose natural frequency can be adjusted to be within the range of locking of either of the above harmonics. This variation of the natural frequency of the multivibrator is carried out by filament temperature adjustment which renders the use of supply mains with their short period fluctuations impossible. Dye extended the range of frequencies measurable to 2,000 kc/s by using the 100th harmonic of the 20 kc/s multivibrator. Even this was only possible with bulky inductances of low decrement and capacitances with fused silica insulation, these being necessary in the harmonic selector circuit to obtain tolerable discrimination between adjacent high order harmonics. A separate amplifier employing a stage of H.F., detector and L.F. was incorporated to assist in reinforcing the desired harmonics. The H.F. stage consisted of a tuned anode circuit, and some degree of circuit magnification was obtained

* MS. accepted by the Editor, March, 1936.

by adjustable inductive reaction. In the Dye method, since the controlling frequency for the 20 kc/s multivibrator is obtained from the 20th harmonic of the 1,000 c/s multivibrator all the harmonics of the former are modulated with 1,000 c/s. As no attempt was made to eliminate residual 1,000 c/s, the whole system required a certain amount of careful interpretation in practice. For example, when adjusting an unknown source to 1,000 kc/s, i.e., to the fiftieth harmonic of the 20 kc/s multivibrator, the harmonic selector will give an appreciable response for several channels 1 kc/s apart on either side of 1,000 kc/s. This leads to confusion in rapid operation, although a skilled operator can generally obtain usable discrimination by adjusting the amount of unknown signal. When control by subdivision from a high frequency is used, the lower frequency multivibrators are not required when measuring high frequencies, and the undesirable modulation of each multivibrator by the lower frequency multivibrators is eliminated, thus inspiring confidence in the operator. This is a definite advantage over the Dye system, except when adjusting a source to the exact frequency of a harmonic of one of the multivibrators, for example, 1,000 kc/s. In the absence of any 1,000 c/s modulation, there will be a band of some 100 c/s either side of resonance in which the heterodyne note between the source and the multivibrator harmonic is not easily apprehended, the width of a silence band depending on the low frequency response characteristics of the detector and amplifier. As the source is varied to approach 1,000 kc/s, the beat note will fall to, say, 1 c/s, which will be inaudible. If there happens to be 1,000 c/s modulation on the 1,000 kc/s harmonic, there will also be produced a 999 ~ beat note. This frequency is easily audible, and reaching the ear together with residual 1,000 c/s will give an audible effect of 1 c/s. By this means an apparent disadvantage is turned to good use, and a limited number of frequencies may be measured with great accuracy.

The method is not applicable to non-harmonic frequencies, and the usual interpolation oscillator is required, which to be of any use must have a very open frequency scale and good short period stability. Some fine adjustment to the oscillating circuit

constants permits this oscillator to be synchronised at the harmonic frequencies nearest above and below the unknown frequency, and this frequency is then determined by simple interpolation. The objections to this method are obvious. The law of the variable condenser in the oscillating circuit is liable to change through ageing and wear, while the time required to check frequencies on either side of the unknown is often a serious factor when taking tests on a source that is drifting, apart from the drift of the oscillator itself.

2. *Continuously variable types.*

We now come to the continuously variable valve oscillator, which has recently rivalled the harmonic form as a frequency sub-standard. In this the negative resistance characteristic of a tetrode is employed in such a way that the frequency is not modified by valve changes, except for differences in interelectrode capacitances. Provided that the decrement of the tuned circuit is kept low, it is possible to produce frequency meters whose calibration is not modified by more than 2 parts in 10^5 for 5 per cent. changes in valve potentials, but other difficulties arise. It may be shown that the frequency of oscillation of such a circuit is given by

$$f \approx \frac{1}{2\pi} \sqrt{\frac{1}{LC} - \left(\frac{R}{2L} + \frac{1}{2Cr}\right)^2}$$

where "r" represents negative resistance.

From this equation we see that the permanence of calibration depends chiefly on the inductance and capacitances. In the case of the inductance the temperature coefficient of inductance must be reduced to a minimum unless the coil is to be maintained at a constant temperature. Thermal compensated coils of reasonably low decrement and temperature coefficients approaching 10 parts in 10^6 per °C. have been described in this Journal, and represent some of the few attempts to overcome the difficulty. It is not an easy matter to compensate for temperature changes, more particularly as the most serious changes are those due to non-cyclic variation, which is always present to some degree when the conductors constituting the inductance are formed by bending. In order to secure an open frequency scale for the oscillator a

large number of inductances will be required to cover the range of frequencies in general use, and since the decrement of the circuit modifies the frequency it is not possible to effect coil changes by switching owing to contact resistance variation. Consequently,

one has a large number of coils, and damage due to careless handling has proved a serious objection from the point of view of the commercial user.

The capacitance which is the continuously variable portion of the circuit shares the

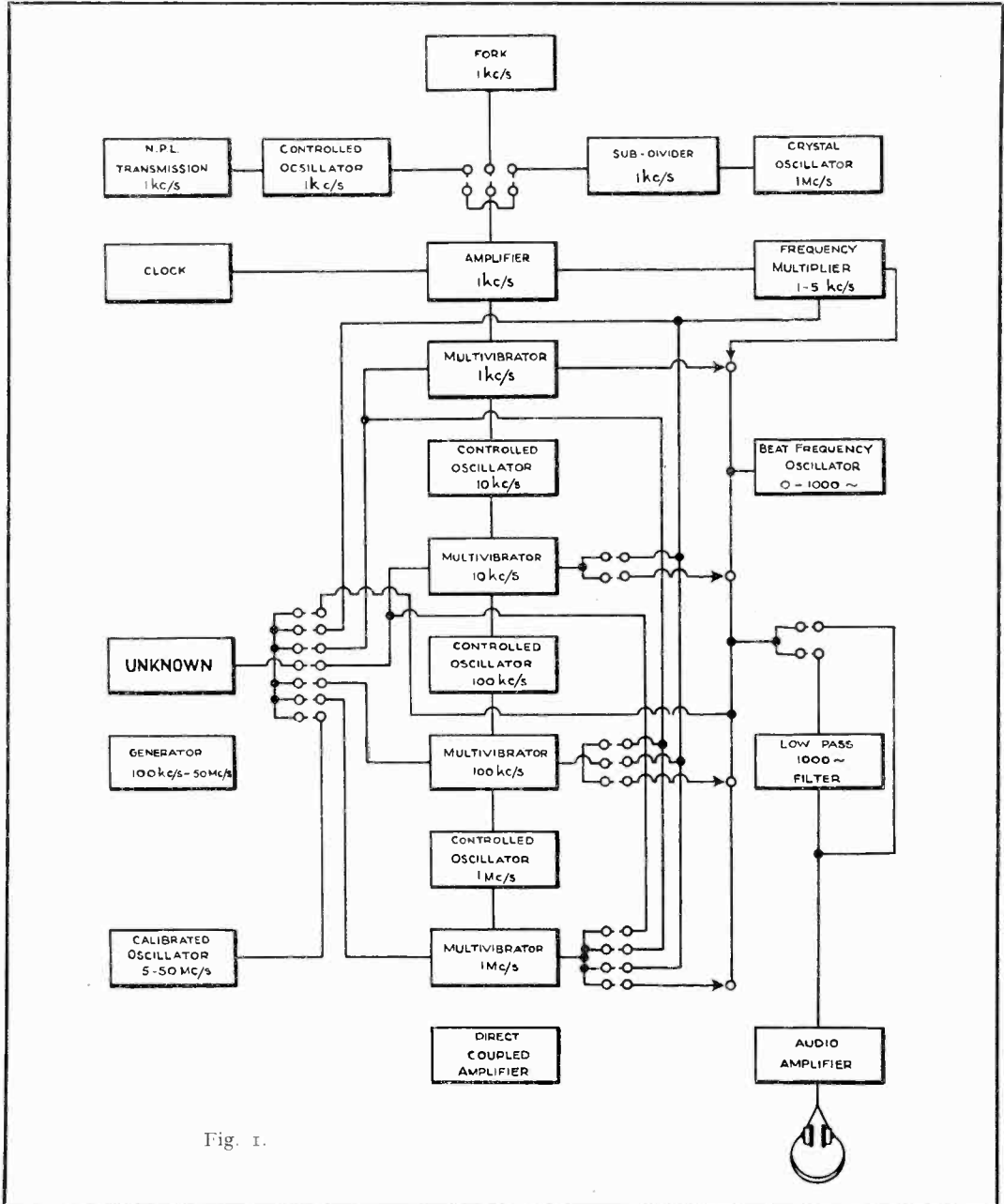

Fig. 1.

same troubles as the inductance, and in addition mechanical wear is another limiting factor. In this connection the series gap type of condenser represents the best solution to maintenance of calibration, and although it does not lend itself to a large ratio, other factors, such as scale reading accuracy and the desirability of high residual circuit capacity, outweigh this objection. A further limitation at present lies in the difficulty of obtaining a sufficiently low negative resistance to maintain oscillation much above 15 Mc/s. Without doubt, however, the simplicity of operation of a continuously variable oscillator makes a strong appeal, although in spite of the progress made it will probably remain in the sub-standard category.

(B) Ideal System

Having now considered the two principal methods of frequency measurement, we shall outline what are considered the requirements of the ideal system.

(1) The apparatus must be capable of being used as a harmonic frequency meter, controlled either by multiplication from tuning fork source or by subdivision from high frequency crystal controlled oscillator.

(2) Means must be provided for checking both the short period and the long period stability of the fundamental controlling frequency.

(3) It must be capable of standardising a source at any harmonic frequency to the accuracy of the controlling frequency.

(4) Interpolation between harmonics must be possible to the same accuracy.

(5) To be equally suitable for standardising precision type oscillators, powerful transmitters, and absorption wavemeters.

(6) A self-contained continuously variable oscillator must be provided of accuracy better than 0.25 per cent. for searching and experimental work. This may be used to heterodyne the unknown source, and will always determine the nearest harmonic available from any multivibrator prior to taking precise measurements.

(7) Visual and aural indications to be provided.

(8) The apparatus to be rack mounted and A.C. mains operated, with coils and con-

densers to be self-contained, and all ranges to be covered by multiway switches and ganged condensers.

(C) The Design of Equipment Adopted

(1) General.

In the design adopted the multivibrator control is obtained from a 1,000 c/s tuning fork, and means are provided for controlling at the same frequency by preliminary subdivision from a 1,000 kc/s crystal. Tuning forks usually have a temperature coefficient of frequency of a few parts in 10^6 , and in order to obtain the desired frequency accuracy of one part in 10^6 thermostatic control to 0.1°C . is provided. The fork chamber is not yet barometrically controlled, although it is hoped to do this at a later date in view of a possible pressure coefficient of a few parts in 10^7 per mm. Since it has been found easier to control multivibrators on their fundamental, a tuning fork was chosen in preference to a crystal control by subdivision. The equipment consists essentially of four multivibrators of fundamental frequencies 1, 10, 100, and 1,000 kc/s, and the harmonics of each are utilised only from the 5th to the 50th, special provision being made for measuring frequency from 5 kc/s down to 1 c/s. Associated with each of the first three multivibrators is an amplifier with tuned anode circuit to select and reinforce any chosen harmonic, the whole range being covered by internal coils and variable condensers. These selector circuits are electrically linked with a second series of circuits and identical with them, the controls for both being ganged. The primary function of the second series of circuits is to generate oscillations, for which purpose they are situated in the anode circuit of a tetrode which can be made to act as a dynatron by varying the grid potential. Each pair of circuits has a coupling coil which may be fed to a leaky grid detector, provision being made for injecting a voltage from the source under test in series in the earthy end of the coil. In this way the detector is fed with the unknown frequency and either a selected harmonic from the multivibrator or some output from a dynatron oscillator, according to the adjustment of the grid potential of the above-mentioned tetrode. After rectification the heterodyne frequency may be

above audible limits, easily audible, or possibly of zero frequency. The method of operation is best described by taking two examples, one at a harmonic frequency and one non-harmonic.

(2) Operation.

As an example of the former consider the measurement of 4,321 kc/s obtained from an oscillator of sufficient stability to require accuracy of measurement of high order. To effect this, some output from the said oscillator is fed to the detector on the 100 kc/s multivibrator, the multivibrator itself switched off, and the dynatron circuit made to self-oscillate. Searching will rapidly show that the 43rd is the nearest harmonic, and that the unknown lies between the 43rd and 44th. The multivibrator is now switched on, while the dynatron grid potential is increased until self-oscillation ceases, the dynatron circuit capacitance and its associated tuned amplifier capacitance being readjusted to tune to the 43rd harmonic. The difference frequency of 21 kc/s is neither audible nor visible as a beat frequency on a meter, and the process is therefore repeated using the 1 kc/s multivibrator, the operations being identical with those on the 100 kc/s multivibrator, except that the multivibrators are not turned off when searching for the 21 kc/s which is now the "unknown." It will, of course, be found exactly at the 21st harmonic of the 1 kc/s multivibrator and the difference frequency will now be zero, or for the purposes of the illustration, say, 1 c/s. A moving coil meter may now be plugged into the detector anode circuit in place of phones, and the 1 c/s seen and counted. Alternatively, the amount of 1,000 c/s modulation on the 21st harmonic may be increased, and beat notes obtained by the double beat method described in a previous note on the Dye method. The unknown is thus standardised to the same order of accuracy as that of the fundamental controlling frequency. As an example of a non-harmonic frequency let us add, say, 234 c/s, giving an unknown frequency of 4,321,234 c/s. By the process described above this is reduced by two steps to an audio note of 234 c/s, which frequency is mixed with the output from a special low-range beat frequency oscillator, and once again is made visible on a meter.

Brief consideration will show that any frequency up to 5,000 kc/s can be handled in this manner, but it will be seen that from this figure upwards the 100 kc/s multivibrator will not be required, although the 10 or 1 kc/s multivibrator will be used. Thus, 6,166,666 c/s will be measured as the 6th harmonic of the 1,000 kc/s multivibrator, plus the 17th of the 10 kc/s multivibrator, minus 3,333 c/s. The range of the beat frequency oscillator mentioned above is 0-1,000 c/s, and consequently the frequency of 3,333 c/s is not directly obtainable. Use is made here of an over-fed 1 kc/s amplifier, from whose distorted output the 2nd, 3rd, 4th and 5th harmonic may be selected at will and mixed with the 3,333 c/s, or any other frequency falling between 1,000 and 5,000 c/s, before passing it to the beat frequency oscillator. Further consideration will show that the beat frequency oscillator need only cover the range 0-500, or 500-1,000 c/s, as any resulting output from the final multivibrator can be made to fall in these ranges by correct choice of harmonic. In practice it has proved useful to be able to reach 1,000 c/s, and this unit, which is described elsewhere, has been allowed to retain its range.

(3) Simplicity of mechanical design.

It is profitable at this stage to review the position in the light of the requirements laid down for the ideal system. We have demonstrated that the system may be used to standardise an unknown frequency to the same order of accuracy as that of the fundamental standard, that the element of uncertainty inseparable from interpolation oscillators is removed, and that the need for a continuously variable heterodyne wave-meter has been met. Moreover, the apparatus is built almost entirely from commercial type coils and condensers, and does not demand the accuracy of workmanship or the skilled operation necessitated by other apparatus. As the method of operation changes slightly at 5 Mc/s it would be useful to consider the particular feature which is of such assistance up to this frequency, namely, the use of intensified harmonic selection.

(4) Harmonic Intensifier.

The function of the tuned harmonic

selector is to amplify and obtain sharp discrimination between adjacent harmonics of the multivibrator feeding it. In the interests of permanence of calibration of the tuned circuits, the residual capacitances are

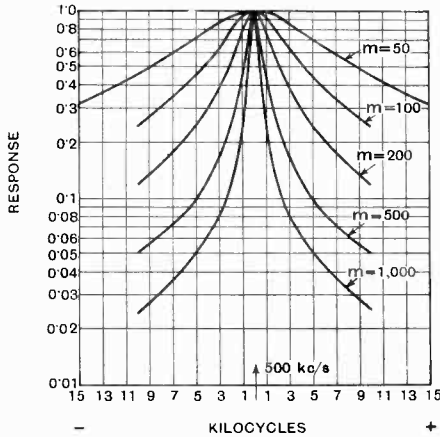

Fig. 2.

kept as high as possible, which limits the magnification of the screened inductances to 50 to 70. This figure may appear low, but no serious attempt was made to improve on this value, the chief concern being to arrange the harmonics so as to appear at equal angular intervals round the various ranges for ease of operation when used as a heterodyne wavemeter. Referring to Fig. 2 we see that at 500 kc/s for a circuit of magnification of 50, the adjacent harmonic of frequency 490 kc/s is only some 7 decibels down. Two tuned stages will give us something like 14 decibels, but this is not the most profitable way of improving the discrimination. It has already been mentioned that the anode circuit of the H.F. pentode amplifier valve is linked to another set of circuits in the anode of a dynatron. It is found that by judicious use of the grid potentiometer for this valve the magnification of the tuned circuit can be increased to 500 or even 1,000 before the circuit breaks into self-oscillation, for which latter value we find that the 490 kc/s harmonic is now over 32 decibels down when the circuit is tuned to 500 kc/s. With this figure there is no doubt at all regarding the order of the harmonic selected, and the feature is best appreciated when testing powerful transmitters, as it is then that difficulty is found in obtaining sufficiently weak coupling to

operate satisfactorily a selector circuit without intensifier, whereas with the intensifier the amount of unknown is unimportant within wide limits. Fig. 3 shows that with the improved magnification a greatly enhanced gain is obtained, which increase is very acceptable in the case of the 100 kc/s multivibrator, where the harmonics seem to suffer rapid attenuation as the order rises.

The above described method is used on the 1, 10, and 100 kc/s multivibrators, the upper limits on each being the 50th harmonic. We now come to a point where the method of operation changes, namely, in the use of the 1 Mc/s multivibrator whose harmonics are required from 5 to 50 Mc/s. Here we have difficulty in obtaining circuits good enough to permit self-oscillation with a tetrode whose negative resistance may only approach 8,000 ohms. Two valves of similar characteristics connected in shunt increased the range to 18 Mc/s, but this is a long way short of 50 Mc/s, and an alternative method was adopted. The dynatron circuit is replaced as a searching oscillator by a separate

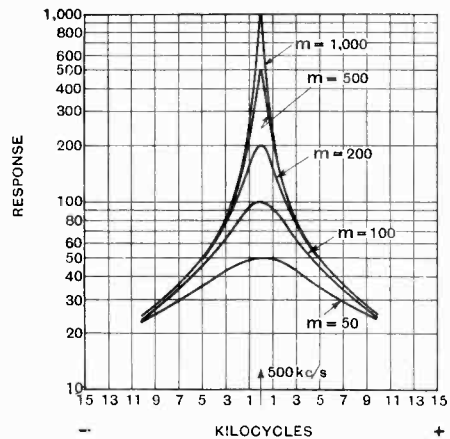

Fig. 3.

calibrated Hartley oscillator of range 5 to 50 Mc/s, while two tuned anode stages are used for harmonic selection. In this case the H.F. pentode arrangement is replaced by a two-stage electron-coupled amplifier. In this amplifier the anode of each tetrode is at a potential of -2 volts with respect to its cathode and it can therefore be directly connected to the next grid. In this way a stage gain of about 7 is possible at 40 Mc/s. The arrangements differ from

those of the lower frequency multivibrators owing to the fact that the difference frequency between the unknown and the nearest harmonic of the 1 Mc/s multivibrator may be anything from zero to 500 kc/s. Three positions of a switch provide a choice of a small choke, a large choke, or a resistance in both anode and grid circuits. This may be said to divide the difference frequency into 3 ranges, i.e., from 500 to 200 kc/s, from 200 to 50 kc/s, and less than 50 kc/s. The arrangement is entirely satisfactory both for sensitivity and noise level, the latter point being of some importance in view of the subsequent stages of gain and mixing in the case of non-harmonic frequencies (which will occur so long as persons continue to work in wavelength instead of frequency). It may not be out of place to mention here that it is the author's experience that frequency checks to the order of parts in 100,000 are often asked for when the frequency is in fact parts in 1,000 in error. The ability to make the selector circuits a calibrated search oscillator has therefore proved of considerable benefit, and little difficulty has been met in obtaining the self-oscillating frequency within 0.1 per cent. of that indicated when used as an amplifier. The accuracy may be immediately checked on any range and at any setting by causing the oscillating circuit to beat with a convenient harmonic of the multivibrator. As the scales are marked in harmonics of the multivibrator, zero beat should occur as the oscillator tunes through each scale marking, and in this way the magnitude of any error is at once apparent.

(5) Control of residual 1,000 c/s.

It will be remembered that when discussing the Dye type of multivibrator it was noted that, since the control for the 20 kc/s multivibrator was obtained from the 20th harmonic of the 1 kc/s multivibrator, all the harmonics are modulated with 1,000 c/s. In the equipment under discussion the same 1,000 c/s modulation will appear on the harmonics of the 10 kc/s multivibrator and 100 kc/s multivibrator unless means are adopted for preventing this. The required effect is achieved, without sacrificing the ability to impose such modulation when required, by the use of a controlled oscillator interposed between suc-

cessive multivibrators. The 10th harmonic is first amplified by an H.F. pentode stage with fixed tuning and variable gain, and the output from this amplifier is used to control a 10 kc/s self-oscillating circuit as shown in Fig. 4. This oscillator is actually a lightly driven dynatron of short-period stability of the order of 1 part in 50,000, and a small percentage of its tuning capacity is adjust-

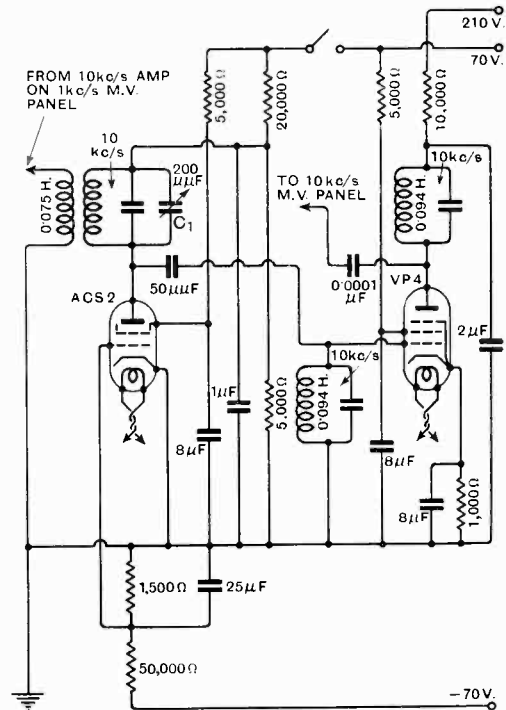

Fig. 4.

able as an external control, shown as trimmer C_1 , Fig. 4. This dynatron is followed by a further stage with fixed tuning and gain, and the output of this stage is sufficient to control the next multivibrator. It is found that with the gain control R_1 Fig. 5, at maximum the dynatron is held whatever the adjustment of the trimmer C_1 . As the gain is reduced the dynatron is no longer held, and adjustment of C_1 is required to bring the natural frequency nearer to the controlling frequency. Successive reduction of gain and adjustment of C_1 result in an uncontrolled frequency so close to the controlling frequency that the minimum control is sufficient to lock the dynatron. The criterion of control of this oscillator is the

beat note between any harmonic of the next multivibrator and its selector circuit used in the self-oscillating condition. Although the above procedure appears somewhat lengthy, in practice all that is necessary is to ensure that the multivibrators are actually controlled, to do which they are deliberately put out of control by reduction of gain on R_1 , or tuning on C_1 or the equivalent controls on the higher order units. Gradual increase of gain will result in the beat note above mentioned changing from the familiar slow slip tone to a steady note which no further increase of gain will alter. The whole arrangement is virtually a filter, and the more efficient it becomes as a filter the less the effect of the modulation on the next higher multivibrator. It will be noticed that the operator has not in any way sacrificed the ability to use the apparatus for

real use, every attempt is made to eliminate residual 1,000 c/s caused by stray coupling, to which end elaborate decoupling is provided on the 1 kc/s multivibrator, a $\frac{3}{16}$ -inch thick iron screen is provided for its 10 kc/s amplifier, while the grid of the selector amplifier valve is fed through a high-pass filter, starting at 5 kc/s. The capacitance C_2 and resistance R_2 give a rising frequency characteristic to compensate partially for the attenuation in harmonics from the multivibrator. As a final step it was found desirable to locate the tuning fork many yards away from the apparatus racks owing to its field and to run all connections in lead-covered cable.

(6) Visual Detection.

It has been mentioned elsewhere that when unknown frequencies have been deter-

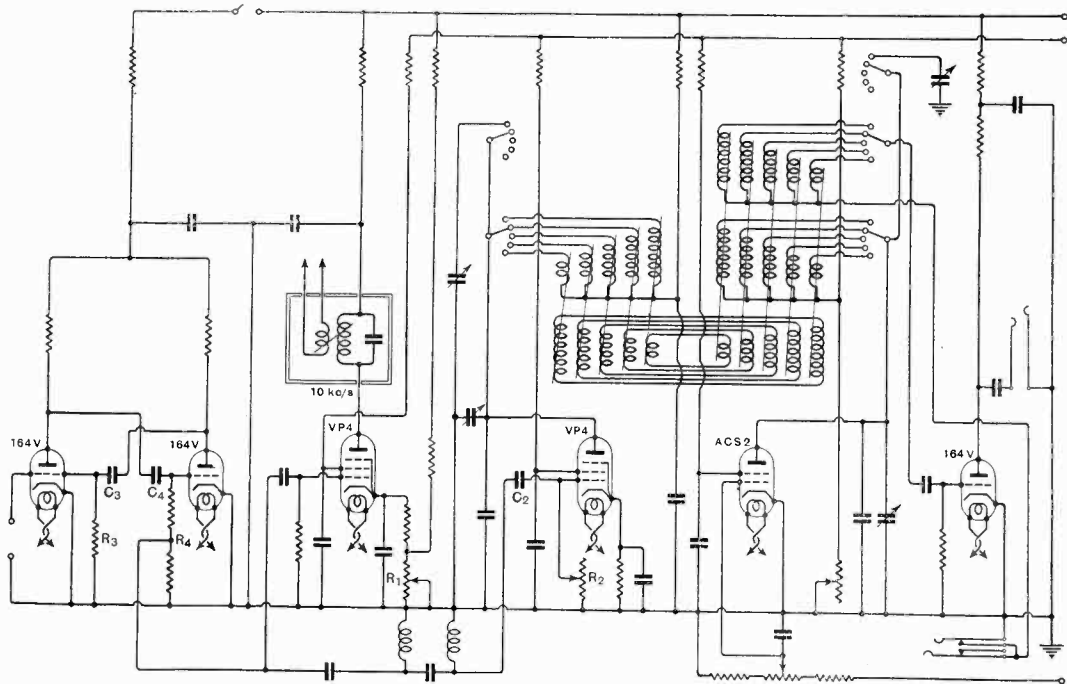

Fig. 5.

standardising harmonic frequencies by the double beat method, for all that is required in such cases is that the gain control R_1 be increased to its full extent, when the 1,000 c/s will reappear in the customary way on every harmonic.

In order to make the above control of

mined to within a few cycles per second, a moving coil d.c. meter may be inserted in an appropriate circuit and the said few cycles per sec. observed. The detectors associated with each multivibrator are of the leaky grid type and have a steady current of about 5 mA. When standardising

weak sources and using the necessary looseness of coupling to prevent any pulling effect it is found that anode current changes of the order of 0.1 mA are obtained. In order to amplify this effect, the author made use of a direct coupled amplifier giving a gain of fifty or more. The input to this amplifier is connected across the detector anode resistance and suitable arrangements made to back-off the steady drop. The arrangement worked well and gave adequate indications, but the backing-off voltage was naturally different for each detector on the four multivibrator units. When measuring non-harmonic frequencies the beat frequency oscillator may also be arranged to give visual indication of the final few cycles per sec., although the final valve in this case was an amplifier rather than a detector, and the meter was a rectifier instrument in place of a d.c. milli-ammeter.

(7) *The Beat Frequency Oscillator.*

This unit follows conventional practice, the two high frequency oscillators operating at 30 kc/s for zero beat. Each oscillator is provided with a buffer amplifier, and the oscillators are isolated to such an extent that pulling does not occur until a beat frequency of one cycle in ten or fifteen seconds is reached. Thermally compensated inductances are used, while the variable capacitance is provided by a condenser with exceptionally short and stiff rotor running in a large inverted cone bearing. An anode bend detector is used, followed by two stages of low frequency amplification, the final output being originally shown on a rectifier type meter. The stability of the beat frequency is better than one cycle per sec. for long periods from some minutes after switching on, in connection with which it should be noted that heater type valves are used throughout.

(8) *Checking the 1,000 c/s controlling frequency.*

The short period stability of the 1,000 c/s tuning fork is checked by means of the monthly N.P.L. standard frequency transmissions. The receiver used incorporates two stages of H.F. with A.V.C. and two low frequency stages which are tuned to a 1,000 c/s. The audio output is applied to a dynatron circuit whose uncontrolled fre-

quency is adjusted to 1,000 c/s in a similar manner to that described in the case of the inter-multivibrator oscillators. The N.P.L. 1,000 c/s is then applied through this controlled oscillator to drive the 1,000 c/s multivibrator. A 1,000 kc/s crystal with a cut to give a very small temperature coefficient is now used as a reference oscillator, its frequency adjusted to within one cycle per sec. given by the multivibrator when locked with the N.P.L. 1,000 c/s. The N.P.L. 1,000 c/s is now replaced by the tuning fork and the difference frequency observed by readjusting the tuning capacity of the crystal oscillator to give zero beat, the condenser dial being calibrated ± 5 c/s. It is thus possible to check 1,000 c/s to an accuracy of one part in 10^6 within a few seconds. This feature is very useful when the short period stability of temperature controlled standards is required. A very high signal-to-noise ratio is necessary to prevent mush superimposed on the N.P.L. 1,000 c/s momentarily allowing the multivibrator to fall out of synchronism.

The long-period check is obtained in the usual manner by running a 50 c/s wheel held by the multivibrator and comparing against standard time signals.

(9) *Final details.*

Other features of interest in the design include a powerful oscillator for calibrating absorption type wavemeters. A tuned amplifier stage is incorporated up to 20 Mc/s to prevent the load on the oscillator (as the wavemeter is brought into resonance) varying the frequency. The short-period stability of this oscillator is of the order of 1 part in 100,000 and a 0.5 per cent. calibration is provided to reduce time of setting to a desired frequency by means of the multivibrator.

The power unit for the whole equipment makes use of a four-gap voltage neon stabiliser for the H.T. This was necessary in order to maintain the anode potentials of the various dynatrons at a steady value. The stabiliser gives voltage taps of 70 volts and the first tap was earthed giving up to 210 volts available for the anodes and a 70 volt negative supply for grid bias.

The audio amplifier is quite straightforward, but a 1,000 c/s low pass filter can be switched into use when measuring fre-

quencies less than 15 kc/s or when frequencies of this order are obtained intermediate of multivibrator harmonics.

In conclusion, the author wishes to express his thanks to the Directors of the Plessey Co., Ltd., for permission to publish this paper and to Mr. D. Moody, under whose guidance a considerable amount of the work was conceived and carried out.

Correspondence

Mutual Inductance

To the Editor, *The Wireless Engineer*

SIR,—I was very interested in the article on "Mutual Inductance" by Mr. Grieg in your issue of July, 1936, and in the subsequent letter from M. Selz on the same subject in the November number. As the convention established by Mr. Grieg is different from that generally adopted in this country (see, for example, Butterworth, *Proc. Phys. Soc.*, Vol. 33, p. 312, 1921, and Hartshorn, *J. Sci. Instrs.*, Vol. 2, p. 145, 1925) it might be useful to give the more usual point of view.

In the first instance, it seems that the problem of the "sign" of a mutual inductance is allowed to become unnecessarily complicated. The practical issue, surely, is a very simple one—in a.c. work we are concerned with the *relative* phases of the primary current and secondary voltage and, in d.c. work, with the *relative* directions of these quantities. In order to discover what this relationship is in any given case we must have some basis for reference, and we can establish this very easily by joining one end of the primary winding to one end of the secondary winding, thus creating what is generally referred to as a "common point." There is nothing artificial about this, for in almost every practical case in which the sign of a mutual inductance is significant, we shall find that such a point exists. It is confusing to talk of "direction of windings" when so often in practice we are confronted with a box carrying four terminals and labelled "mutual inductance," of the internal arrangements of which we know nothing.

We can now consider the conventions as to sign. There is nothing fundamental about any convention—in this case we have two possibilities and to distinguish them we call them "positive" and "negative." At the National Physical Laboratory the convention is that a mutual inductance is *positive* when the secondary voltage *leads* the primary current in phase by 90° , and *negative* when the secondary voltage lags behind the primary current. This is equivalent to the statement that the mutual inductance is positive if, when the two windings have a common point, the establishment of a current in the primary winding flowing towards the common point creates a secondary voltage in such a direction that the common point possesses a negative polarity with regard to the other secondary terminal. (If the secondary circuit is closed, the induced current in the secondary *winding*

therefore flows away from the common point.) The application of this idea to the solution of a.c. networks by the familiar method of assuming the existence of "instantaneous currents" will be clear. This sign convention leads to the result that if two coils are connected in series to give *minimum* total inductance, then the mutual inductance between them is *positive*. This is the opposite of Mr. Grieg's convention. From the present point of view, then, the sign of a mutual inductance depends only on the method of connection (i.e., which points are made common). It can never be determined by the direction or phase of current or voltage—in fact, the dependence is in the opposite sense, for the sign of a mutual inductance determines the relationship between the phases of primary current and secondary voltage.

The significance of sign of a mutual inductance is brought out rather well by a consideration of the case of a simple valve oscillator, in which the grid and anode coils form a mutual inductance having a common point at one end of the filament. Oscillations in such a circuit will be maintained if the mutual inductance is *negative* according to the N.P.L. convention. It is interesting to note the remarks on this point made in one or two textbooks, for the way in which the circuit equations are written down usually follows simple algebraic lines, and the desire to obtain a negative coefficient for the dissipative term in the final differential equation often leads to the bald statement "M must be negative" without any realisation of the physical implications. The question is, however, well-discussed in other texts (e.g., L. B. Turner *Wireless*, p. 265, R. S. Glasgow "Principles of Radio Engineering," p. 266) where it is shown that the condition for maintenance of oscillations is that the e.m.f. developed in the grid coil should *lag* 90° *behind* the current in the anode coil, i.e., the mutual inductance between these coils is *negative* according to the N.P.L. convention.

N. F. ASTBURY.

The National Physical Laboratory,
Teddington, Middlesex.

11th January, 1937.

[In May, 1929, we devoted the editorial to a consideration of this subject and came to the conclusion that the convention adopted at that time by some of the staff of the N.P.L. was a very unfortunate one. We are still of the same opinion and learn with surprise and regret that it is still in use. We would refer readers interested in the subject to the above quoted editorial, but need only mention here that according to the N.P.L. convention the self-inductance of a coil with a mid-point tapping is equal to the sum of the inductances of the two halves *minus* the mutual inductance between them. An English scientific author recently complained to us of the trouble caused by this convention whenever he wished to refer to N.P.L. work on a certain subject. We suggest that someone at Teddington in a position to do so should veto the continuation of such a topsy-turvy convention, or if topsy-turvydom is preferred, should make it consistent by regarding the self-inductance of a coil as *negative*. How nice it would be to write $e = L di/dt$ without having to bother about a minus sign!—G. W. O. H.]

Quartz and Tourmaline*

By Peter Modrak, M.Sc., B.E., A.M.I.E.E.

(State Telecommunication Institute, Warsaw, Poland)

QUARTZ (SiO_2) very frequently occurs in nature in amorphous and crystalline form. Quartz crystals suitable for piezo-electric purposes are found in Brazil, Madagascar and Japan. Crystals of quartz

of the other class form one crystal as shown in Fig. 3b.

Quartz crystals resemble glass and are generally transparent.

The colour of the crystal depends upon the quantity of salts contained in it and varies from colourless to deep bluish.

Experiments show that for piezo-electric purposes only transparent quartz crystals are to be used.

The density of quartz is 2.65 at 0°C ., hardness 7.

Quartz belongs to uniaxial crystals having

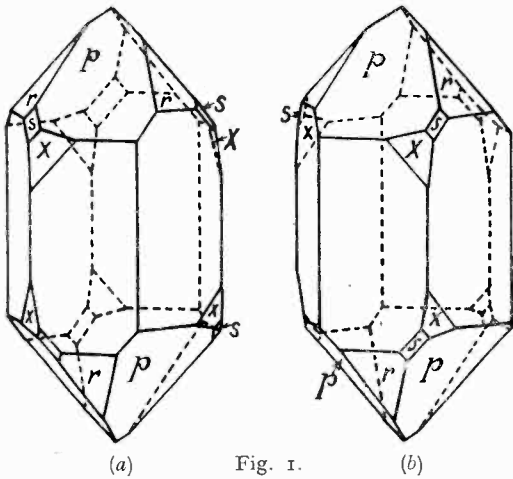

Fig. 1.

or hexagonal prisms terminate at one or both ends by hexagonal pyramids.

According to their structure, crystals are right- or left-handed. Fig. 1a represents a left-handed and Fig. 1b represents a right-handed crystal.

Both types of crystal are represented in the simplest and the most characteristic shapes.

But quartz very seldom appears in the simplest form. The most common occurrence of quartz crystals are twins formed in accordance with certain laws.

Sometimes two left-handed or two right-handed crystals form one crystal as shown in Figs. 2a and 2b. It occurs also that a right-handed and a left-handed crystal form a twin as shown in Fig. 3a.

Sometimes twins of one class and twins

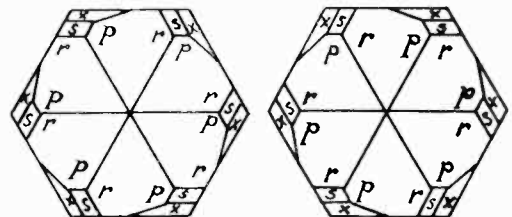
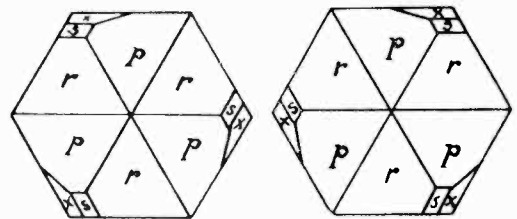
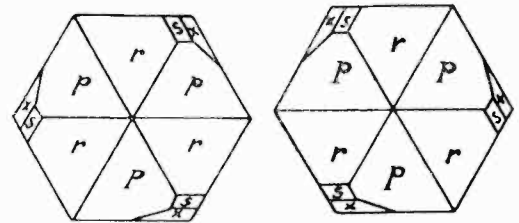

Fig. 2.

* MS. accepted by the Editor, March, 1936.

two indices of refraction. The index of refraction for the ordinary ray is 1.544 and for the extraordinary ray 1.553.

Another important property of quartz crystal is rotation of the plane of polarisation of light.

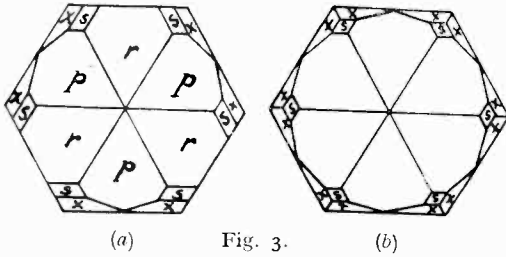

Fig. 3.

When a plate of quartz cut perpendicular to the optic axis is placed between two Nicol prisms set for extinction of light, it is found that light passes freely.

To attain extinction of light it is necessary to turn the analyser through a certain angle, depending upon the thickness of plate.

This angle is known as the angle of rotation of the plane of polarisation. This angle is different for different colours of light, as shown below.

The angle of polarisation per millimeter thickness is:

- for Red light (line A) 13°;
- for Yellow light (line D) 21.7°;
- for Violet light (line H) 51.2°.

Right-handed crystals rotate the plane of polarisation to the right, or in a clockwise direction, and left-handed crystals rotate it to the left or in a counterclockwise direction.

When quartz crystals are heated or cooled down electric charges appear at certain regions. This property is known as the pyro-electric property.

In 1880, J. and P. Curie showed that crystals exhibiting pyro-electric properties exhibit also piezo-electric properties.

When a crystal is deformed under the action of force electric charges appear on its surface. This property is known as the piezo-electric property and is exhibited also by tourmaline crystal and Rochelle salt.

Elastic properties of quartz vary in different directions.

To determine the elastic properties of quartz it is necessary to know the value of six coefficients.

These coefficients were determined by Voight and are as follows:

$$\begin{aligned}
 S_{11} &= 0.1298 \times 10^{-11} \\
 S_{33} &= 0.0990 \times 10^{-11} \\
 S_{44} &= 0.2005 \times 10^{-11} \\
 S_{12} &= 0.0166 \times 10^{-11} \\
 S_{13} &= 0.0152 \times 10^{-11} \\
 S_{14} &= 0.0431 \times 10^{-11}
 \end{aligned}$$

If it is desired to determine Young's modulus in a certain direction making angles θ , ψ , and ϕ with the X, Y and Z axes of the crystal as shown in Fig. 4, it is necessary to apply the formula:

$$\begin{aligned}
 \frac{1}{E} &= S_{11}(1 - \cos^2\phi)^2 + S_{33} \cos^4\phi \\
 &+ (S_{44} + 2S_{13}) \cos^2\phi (1 - \cos^2\phi) \\
 &+ 2S_{14} \cos\phi \cos\psi (3 \cos^2\theta - \cos^2\psi).
 \end{aligned}$$

This formula may be reduced to

$$\begin{aligned}
 \frac{1}{E} &= S_{11} \sin^4\phi + S_{33} \cos^4\phi + (S_{44} \\
 &+ 2S_{13}) \cos^2\phi \sin^2\phi + 2S_{14} \cos\phi \cos\psi \\
 &(3 \cos^2\theta - \cos^2\psi).
 \end{aligned}$$

From the above formula it is possible to

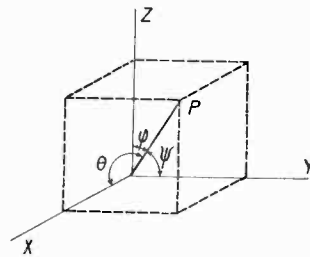

Fig. 4.

determine Young's modulus in the direction of either the X, Y or Z axis.

Thus in the direction of the Z axis, ($\phi = 0$, $\psi = 90^\circ$, $\theta = 90^\circ$), $\frac{1}{E_z} = S_{33} \cos^4\phi$

$\phi = S_{33}$ or Young's modulus $E_z = \frac{1}{S_{33}}$, because $\cos\phi = \cos^4\phi = 1$, the other terms disappearing, because $\theta = 90^\circ$ and $\psi = 90^\circ$

$E_x = \frac{I}{S_{11}}$ because $\phi = 90^\circ$, $\theta = 0^\circ$ and $\psi = 90^\circ$ and $\sin \phi = \sin^2 \phi = 1$, the other terms disappearing.

Similarly $E_y = \frac{I}{S_{11}}$ because $\phi = 90^\circ$, $\psi = 0^\circ$ and $\theta = 90^\circ$.

Substituting the numerical values of Voight's coefficients in these equations, the values of Young's moduli are :

$E_z = 10.1 \times 10^{11}$ and $E_x = E_y = 7.85 \times 10^{11}$.

Varieties of Quartz

Quartz exists in two varieties: Quartz α and quartz β .

Quartz α exists below 575° C. and exhibits piezo-electric properties; when temperature attains 575° C. the β variety is formed which does not exhibit piezo-electric properties.

With variation of temperature the dimensions of quartz α change uniformly in all directions and this change is proportional to the change of temperature. As soon as β variety is formed temperature coefficient of expansion of quartz changes considerably, being the smallest in the direction of Z axis which is called the optic axis and the largest in direction at right angles to this axis.

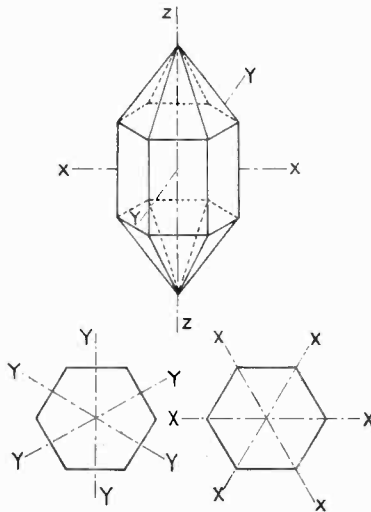

Fig. 5.

Due to this rapid and non-uniform change of temperature coefficient in the direction of the optic axis and at right angles to it,

crystals very often burst when passing from one variety to the other.

The angle of rotation of the plane of polarisation, Young's modulus, and the piezo-electric effect all change with variation of temperature.

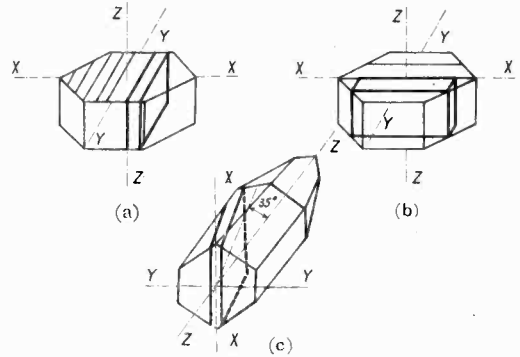

Fig. 6.

Piezo-electric effect at normal temperatures is practically independent of change of temperature.

At about 200° C. it decreases considerably and disappears above 575° C.

For further considerations quartz crystal will be represented in the simplest possible form as shown in Fig. 5.

Axis Z is defined as the optic axis of crystal.

Three axes perpendicular to Z-axis and to opposite sides of hexagon are known as mechanical or Y-axes.

Three other axes perpendicular to Z-axis and to Y-axis are known as electrical or X-axes.

Quartz plates for piezo-electric purposes are cut in the following manner :

(1) X or Curie cut. In this case the plate is cut along the optic axis and parallel to the Y-axis as shown in Fig. 6a.

(2) Y or 30° cut. In this case the plate is cut parallel to the optic axis and parallel to the X axis as shown in Fig. 6b.

(3) R or AT-cut. In this case the plate is cut parallel to the X axis and inclined at an angle of 35° to the Z axis as shown in Fig. 6c.

Every line parallel to the optic axis is regarded as an optic axis of the crystal. In the same way every line parallel to the X or Y axis is regarded as an X or Y axis.

For this reason quite a number of plates of particular orientation may be cut from one block of quartz. For piezo-electric purposes square, rectangular, circular, ring-shaped and elliptical plates are used.

Both right-handed and left-handed crystals are suitable for piezo-electric purposes. The only difference in their behaviour is the appearance of an electric charge of different sign upon the surface of plate when placed under pressure.

If, however, twins occur in the same block of quartz charges of different sign may partially or totally neutralise each other and the operation of the quartz plate may be uncertain.

For that reason it is very important to select proper raw material for piezo-electric purposes.

It is advisable to select quartz crystals free from cracks and other mechanical injuries that can be easily detected by eye. Twin crystals as described above should be rejected. It is necessary to test quartz for twins occurring on the edges of the same block of quartz. For this purpose the top pyramid and the bottom portion of quartz should be cut off at right angles to the optic axis and these boundary surfaces ground and partially polished.

Crystals prepared in this fashion should be placed in a beam of plane polarised light produced by reflection from a piece of glass and examined by a Nicol prism (see Fig. 7).

If there are no twins in the plate, slight adjustment of quartz and Nicol prism will produce uniform rainbow coloration. If there are twins or flaws in the portion of crystal the rotation of plane of polarisation

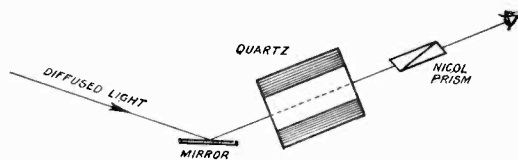

Fig. 7.

will be different for different rays. Thus characteristic interferences and beautiful coloration is produced.

These beautifully coloured portions of crystal should be rejected.

After examination for twins it is necessary

to determine the direction of the optic axis of the crystal. In most cases parallel fringes are observed on the hexagonal faces of crystals. The optic axis is perpendicular to the plane passing through any of those fringes. These fringes may be used as a guide for cutting plates of suitable orientation.

For a more accurate determination of the optic axis of a crystal, it is necessary to cut the quartz plate with its ends perpendicular to the optic axis, place it between two Nicols and view in the direction of this axis.

For the same thickness of plate the rotation of the plane of polarisation is a maximum if the optic axis of the plate is parallel to the viewing axis of the Nicols.

The accuracy of determination of the optic axis by this method is within 0.5° .

The method already described may be used for the determination of the optic axis in comparatively thin plates. When it is necessary to determine the optic axis in a block of quartz the apparatus represented schematically in Fig. 8a may be used.*

In this apparatus:

S is a source of light.

Q — quartz.

L and *L*₁ — lenses.

P — polariser.

A — analyser.

The polariser in this case is of special design (see Fig. 8b) in order to produce either rectilinear, elliptical or circular vibrations of light.

In this polariser *G* is a Glazebrook prism. *Q* is a quarter-wave plate for mercury green light.

Depending upon the relative position of prism *G* and plate *Q* various types of vibration may be produced.

The relative position of the prism *G* and plate *Q* may be changed from 0 to 45° in both directions.

It is provided that *G* and *Q* may be fixed and moved together as one unit. Due to this rotation the orientation of emerging vibrations may be changed without their deformation. The Glazebrook prism *G* is fixed in the cylindrical tube *C*; on the flange

* See *Revue D'optique*, No. 11, November, 1931.

of this tube are engraved divisions in degrees for determination of its positive relative to the cylindrical tube *B*.

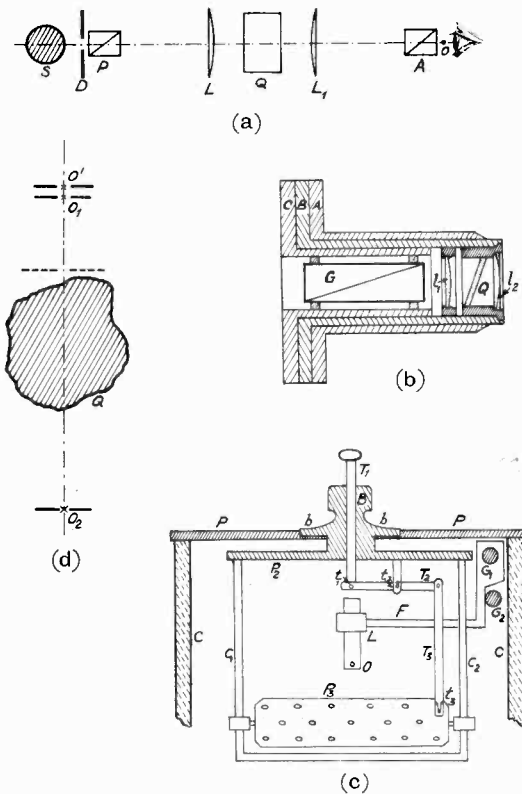

Fig. 8.

In the cylindrical tube *B* two lenses l_1 and l_2 and a quarter wave plate *Q* are fixed. Lenses l_1 and l_2 make the beam of light emerging from *Q* parallel, *B* is free to rotate in the cylindrical tube *A*. On the flange of this tube are engraved divisions in degrees. On the flange *B* there are two reference points for divisions on *C* and *A*.

Divisions on *C* indicate the ellipticity of the light, and divisions on *A* the position of the major axis of the ellipse with regard to the vertical line determined by the vertical axis of rotation of the crystal in the immersion vessel described below.

The focus of lens l_1 coincides with the image of the hole produced by lenses l_1 and l_2 . The construction of the analyser is analogous.

The quartz holder consists of a vessel for

immersion of quartz and a fan for the exhaustion of fumes produced by the liquid used for immersion. This latter is an ordinary exhaust fan and is not shown here.

The vessel for immersion is made of glass plates free from double index of refraction. Overall dimensions of the vessel are $30 \times 30 \times 30$ cm.

The walls are cemented together by means of zinc oxide cement and suitably protected against dampness. Sulphur and carbon tetrachloride are mixed in suitable proportion to make the refractive index of the mixture equal to that of quartz.

The quartz holder (see Fig. 8c) provides for complete rotary movement about a vertical axis and also for movement of 45° in both directions about a horizontal axis.

In this apparatus *P* represents the plate supported on the walls *C* of the vessel.

B is provided with flange *b* resting on plate *P* and may be rotated about a vertical axis.

Two rods C_1 and C_2 are fixed to the plate P_2 . To these rods an aluminium plate P_3 is suitably fixed.

A block of quartz is fixed to this plate by means of bolts passing through the holes in it. This plate may be rotated about a horizontal axis by means of a system of levers T_1, T_2 and T_3 .

G_1 and G_2 are two parallel guiding rods fixed to plate *P*. On these guiding rods slide two rods *F* carrying holders *L* to which two metal cylinders are fixed, each being provided with a hold *O*.

It is necessary to adjust the apparatus so as to make the line joining holes *O* parallel to the guiding rods.

For this purpose it is necessary to observe a distant luminous point through holes *O* and adjust cylinder *L* so that the luminous point is seen in every position of *F* upon guiding rods. In this case the line joining the holes *O* is parallel to the guiding rods G_1 and G_2 .

The optic axis of the quartz is determined in the following way. The block of quartz is fixed on plate P_3 and immersed in a suitable liquid. It is necessary to fix the quartz in such a position that a point at infinite distance may be seen through O_1, O_2 and the quartz. In this case line O_1, O_2 is parallel to a beam of light passing through the liquid.

Then a polariser and analyser are adjusted for circular vibrations. After this adjustment it is necessary to change the position of the crystal until light passing through the crystal is dimmed.

This position of the quartz is fixed and the quartz holder is removed from the vessel and placed upon a table.

In order to mark one point of the axis, it is necessary to remove the bar with hole O_1 as far as possible and bring it into coincidence with the plate having hole O' and centre these holes (Fig. 8d).

Then the bar with hole O' is moved along the guiding rods and is brought as near as possible to the crystal Q . Looking at the crystal through O_1 and O' we mark with India ink a suitable part of the surface of the quartz.

When the India ink is dry, it is necessary to rub off parts of the ink until the mark is round and in a straight line with holes O_1 and O' . The same method is used for marking a point on the opposite side of the crystal. The error of determination of the optic axis by this method is less than 20' for a crystal 10 cm. long and is near enough for all practical purposes.

For more accurate determination of the optic axis, a Roentgen spectroscope is used.

When X-rays are directed upon a quartz plate, they are partially reflected from the surface of quartz and partially penetrate into the quartz and then undergo reflection.

When rays reflected in the above manner fall upon a photographic plate, a spectral image is formed. From the relative position of bright and dark lines it is possible to determine the optic axis of the crystal.

With small sizes of crystals it is possible to form images upon a fluorescent plate.

With larger crystals it is necessary to take photographs of the image.

The time of exposure for suitable photographs depends upon the intensity of the X-rays, and varies from a few minutes to one hour or more.

The accuracy of determination of the optic axis is 1 in 1,000. This method is the most accurate one for detection of twin crystals.

When a quartz plate is placed in an electric field it vibrates mechanically. Depending upon the position of the electrodes, the

following mechanical vibrations may be produced:

- (1) Longitudinal and transverse vibrations,
- (2) Bending vibrations, and
- (3) Torsional vibrations.

Each of these vibrations has its fundamental frequency and harmonics.

According to the theory of elasticity the velocity of propagation of mechanical deformation in an elastic medium is given by the formula:

$$V = f\lambda \dots \dots \dots (1)$$

where V = velocity of propagation of deformation

f = frequency of vibration

λ = length of wave.

From (1) $f = \frac{V}{\lambda} \dots \dots \dots (2)$

If a rod fixed at the centre vibrates

$$\lambda = 2l \dots \dots \dots (3)$$

where l = length of rod in the direction of propagation of wave.

By substitution of λ from (3) in (2)

$$f = \frac{V}{2l} \dots \dots \dots (4)$$

But velocity of propagation of wave in an elastic medium is given by the relation

$$V = \sqrt{\frac{E}{D}} \dots \dots \dots (5)$$

where

E = Young's modulus

D = density of medium.

Substituting the value of V from equation (5) in equation (4) the following equation is obtained

$$f = \frac{1}{2l} \sqrt{\frac{E}{D}} \dots \dots \dots (6)$$

where l is expressed in cm

E in dynes per cm^2

D in grams per cm^3

f frequency in cycles per second.

Equation (6) is used for determination of dimensions of quartz plates for piezo-electric purposes.

The values of Young's modulus varies between 5.785×10^{11} and 10.3×10^{11} dyne/cm².

For calculation the mean value is generally used, viz., $E = 7.85 \times 10^{11}$ dyne/cm², and the value of $D = 2.654$ gram/cm³. The equation (6) may be simplified. For this purpose the value of $\frac{1}{2} \sqrt{\frac{E}{D}}$ is calculated and denoted by K .

$$\text{Thus } f = \frac{K}{l} \dots \dots \dots (7)$$

where f and l are expressed in the same units as in (6).

The value of K is known as the coefficient of frequency. In accordance with the theory of elasticity the elastic properties of quartz plates are the same in the plane perpendicular to the optic axis.

Due to this property the value of the coefficient of frequency is the same in the directions of axes X and Y .

For transverse vibrations and torsional vibrations corresponding values of modulus of elasticity should be used for determination of the coefficient of frequency.

The values of coefficients for plates of different orientation are given below.

X -cut plates are very frequently used for piezo-electric purposes.

For thickness vibrations of X -cut plates, the following design formula is used: $f_1 = 2870/a$, where

- f is the frequency of the X -wave in kc/s
- a is the crystal dimension in mm. in the direction of X -axis in mm.
- 2870 is the X -wave frequency constant in kc/mm.

X -cut crystals vibrate also along the Y -axis.

For longitudinal vibration along the Y -axis $f_2 = \frac{2700}{b}$ kc/s, where b is the crystal dimension in the direction of Y -axis.

A coupling frequency f_3 may also occur, which for square plates is $f_3 = \frac{3300}{b}$ kc/s where b is in mm. Sometimes X -cut plates are prepared in the shape of circular discs.

In this case fundamental frequencies may be calculated from the following

formulae :

$$f_1 = \frac{2870}{a} \text{ kc/s,}$$

$$f_2 = \frac{2715}{d} \text{ kc/s, and}$$

$$f_3 = \frac{3830}{d} \text{ kc/s, where}$$

a = thickness of disc in mm.

d = diameter of disc in mm.

The temperature coefficient of frequency for the thickness and Y vibration in X -cut plates is negative, depending mainly upon the temperature coefficient of Young's modulus in the XY plane.

The temperature coefficient for thickness vibration varies from 20 to 35 per 10^{-6} per 1° C. and for vibration along the Y -axis from 50 to 70×10^{-6} per 1° C., and from 40 to 70 for coupling frequency.

X -cut plates are very frequently employed in the drive circuits of transmitters.

The main advantages of X -cut plates is the ease with which the desired oscillation is secured, free from parasitic frequencies, and the comparatively small temperature coefficient.

For thickness vibration of Y -cut plates of large area, the following design formula is used

$$f_1 = \frac{1960}{b} \text{ kc/s where } b \text{ is in mm.}$$

For longitudinal vibration along the X -axis, the following formula is used

$$f_2 = \frac{2860}{a} \text{ kc/s}$$

where a is the crystal dimension in mm. along the X -axis.

The temperature coefficient for thickness vibration of Y -cut plates is positive and varies with the dimension along the X -axis of the plate and depends upon the temperature; it varies between $+100$ to -20×10^{-6} per 1° C. and may reach 0 under suitable conditions. The temperature coefficient for longitudinal vibrations along the X -axis of Y -cut plate is negative and varies from -20 to -35×10^{-6} per 1° C.

The main advantage of this type of plate is the ease with which it vibrates under pressure. For that reason the Y -cut plates are used in the drive circuits of transmitters

for marine and aviation purposes where the contact electrode of the crystal holder should be kept under pressure.

The disadvantage of *Y*-cut plate is frequent appearance of undesirable frequencies, generally a kilocycle or so apart from the fundamental frequency. Generally, it is very difficult to get rid of these parasitic frequencies.

For thickness vibration of *R*-cut or *AT*-cut plate, the following design formula is used

$$f_1 = \frac{1650}{a} \text{ kc/s}$$

where a = thickness of plate.

The main advantage of these plates is small temperature-coefficient of frequency, freedom from spurious vibrations and the ability to vibrate under pressure.

Due to these advantages *R*-cut or *AT*-cut plates are generally employed for stabilising frequency of transmitters when it is desired to avoid thermostats or when requirements of frequency stabilisations are very strict. By suitable choice of dimensions it is possible with *X*-cut plates to secure a crystal having one frequency only for a considerable variation in the tuning capacity of the valve generator.

If the dimensions are not suitable, so-called parasitic frequencies appear in the neighbourhood of the desired frequencies. These frequencies may be made to appear in the circuit by slight changes in the setting of tuning condenser.

These frequencies are due to mechanical coupling between possible standing wave systems in the plates.

By proper choice of dimensions these standing waves are brought into proper phase relations. Thus by grinding one of the sides of a plate it is possible to get rid of the parasitic frequencies.

In the case of *Y* cut plates it is not so easy to get rid of the spurious waves on account of the more complicated nature of the vibrations.

If these frequencies are eliminated at one temperature, they may reappear at some other temperature.

The main advantages of each cut have been enumerated.

The choice of suitable cut is determined by the requirements of particular circuit.

The author's experience shows that for certain samples of quartz it is impossible to excite *X*-cut plates for thickness vibrations. In such a case it is necessary to use *Y*-cut plates.

Direct stabilisation with quartz crystals is practicable down to about 40 meter waves. With waves below 40 meters the quartz plate is too thin and may be easily damaged during the operation of the transmitter.

When it is necessary to stabilise generators below 40 m wave an expensive system of frequency doublers and power amplifiers has to be employed.

For direct stabilisation at waves below 40 meters tourmaline is generally used.

(To be concluded.)

The Industry

LENSES and mirror drums for use in television work can now be produced by a moulding process making use of transparent synthetic resin plastics of the type of ICI "Perspex." It is stated that the material takes silvering well and lenses for photographic work are already in production. The firm concerned is Combined Optical Industries, Ltd., 21, Denmark Street, London, W.C.2.

"Measuring Instruments for all Communication Frequencies" is the self-explanatory title of a leaflet recently issued by Marconi-Ekco Instruments, Ltd., Electra House, Victoria Embankment, London, W.C.2. Instruments recently added to the series, and described in separate leaflets, include a Precision Variable Air Condenser, a Circuit Magnification Meter, a Radio-frequency Attenuator and a Valve Test Set.

Duddell Medal

THE Council of the Physical Society has awarded the fourteenth Duddell Medal to Professor W. G. Cady of the Wesleyan University, Middletown, Connecticut, U.S.A.

Amplitude Distortion

IN Fig. 4 in the article on Amplitude Distortion by J. H. Owen Harries in last month's issue, the resistance between the 75 ~ oscillator and the centre tap on the transformer secondary should be 5,000 Ω and not 50,000 Ω as shown.

Abstracts and References

Compiled by the Radio Research Board and reproduced by arrangement with the Department of Scientific and Industrial Research

For the information of new readers it is pointed out that the length of an abstract is generally no indication of the importance of the work concerned. An important paper in English, in a journal likely to be readily accessible, may be dealt with by a square-bracketed addition to the title, while a paper of similar importance in German or Russian may be given a long abstract. In addition to these factors of difficulty of language and accessibility, the nature of the work has, of course, a great influence on the useful length of its abstract.

	PAGE
Propagation of Waves	135
Atmospherics and Atmospheric Electricity	138
Properties of Circuits	139
Transmission	140
Reception	143
Aerials and Aerial Systems	144
Valves and Thermionics	145

	PAGE
Directional Wireless	147
Acoustics and Audio-Frequencies	147
Phototelegraphy and Television	149
Measurements and Standards	151
Subsidiary Apparatus and Materials	154
Stations, Design and Operation	161
General Physical Articles	162
Miscellaneous	162

PROPAGATION OF WAVES

840. INTERACTION BY RESONANCE OF RADIO WAVES.—V. A. Bailey. (*Nature*, 9th Jan. 1937, Vol. 139, pp. 68-69.)

For previous work see 1934 Abstracts, pp. 199 and 606. The writer has revised the theory there given and now finds "that, in regard to the amount of modulation which a wave W can impress on another W' , there may occur a notable degree of resonance when the angular frequency of the wave W " passes through the value He/m , "the 'gyro-frequency' corresponding to the total terrestrial magnetic force H in the part of the ionosphere concerned." "A radio station the wave of which has an angular frequency within about 5% of the local gyro-frequency can produce observable interference with suitable medium and long waves when this station radiates power at the rate of about one or two kilowatts." Conditions favourable to the occurrence of such resonance-interaction are indicated; observations previously reported (e.g. Stranger, 2252 of 1935) fulfil the theoretical requirements. The writer suggests that the values, in the E region, of the electron collision frequency and of the earth's magnetic force could be determined by making observations "with a station the frequency of which may be varied about the gyro-frequency."

841. REFLECTION FROM THE IONOSPHERE [Three Conditions for Reflection of Extraordinary Wave found by equating Group Velocity to Zero: the Third, hitherto unreported, corresponds to Small Difference between Penetration Frequencies for Ordinary and Extraordinary Waves observed in India].—R. N. Rai. (*Nature*, 16th Jan. 1937, Vol. 139, p. 115.)

842. THE DIFFRACTIVE PROPAGATION OF RADIO WAVES. II—ELEVATED TRANSMITTER AND RECEIVER.—Wwedensky. (*Tech. Phys. of USSR*, No. 11, Vol. 3, 1936, pp. 915-925: in English.)

Extension of the work dealt with in 1703 of 1936.

"In formula 7.3, which is applicable to the case $4\pi\sigma_2 \gg \epsilon_2\omega$, it is assumed that both sender and receiver are situated on the actual surface of the earth. In the present article we free ourselves from this latter limitation; i.e. it is supposed that both points . . . are situated at some point above the earth . . . Comparison with experimental results show satisfactory agreement. The limits within which the new formula may be applied are given." A curve is given which considerably simplifies calculations with the earlier formula: it can also be used with the new one. "The relation between values of q [see p. 924] with arbitrary magnitude of the parameter $\sigma^{1/2}\lambda^5/6$, and the value of q for $\sigma = \infty$, gives approximately the number by which the numbers found from Eckersley's formula must be divided in order to determine the absolute values of field intensity. It is seen that for very short waves the numbers calculated from Eckersley's formula exceed the true values by several tens of times." The Russian version of this paper is in *Journ. of Tech. Phys.* [in Russian], No. 11, Vol. 6, 1936, pp. 1837-1847.

843. SOLAR ERUPTIONS AND RADIO FADE-OUTS [occurred simultaneously on 30.12.1936].—(*Nature*, 9th Jan. 1937, Vol. 139, pp. 61-62: short note giving data and times.)

844. DIRECT EFFECT OF PARTICULAR SOLAR ERUPTIONS ON TERRESTRIAL PHENOMENA [Radio Fade-Outs: Sudden Ionisation in E Region: Special Magnetic Fluctuations: Connection with Sudden Outbursts of Highly-Penetrating Ultra-Violet Solar Radiation: Recent Results].—J. H. Dellinger. (*Phys. Review*, 15th Dec. 1936, Series 2, Vol. 50, No. 12, p. 1189.) See also 2904/5 of 1936.

845. ABNORMALITIES OF THE IONOSPHERE AND BRIGHT SOLAR ERUPTIONS [Coincidence in Time with Increase in Number of Atmospherics].—R. Bureau. (*Nature*, 16th Jan. 1937, Vol. 139, pp. 110-111.) See also 449 & 458 of February.

846. THE PROBABLE CAUSES OF THE SUDDEN DISAPPEARANCES OF SHORT RADIO WAVES AND THEIR RELATION TO MAGNETIC PHENOMENA.—R. Jouaust, R. Bureau & L. Eblé. (*Comptes Rendus*, 28th Dec. 1936, Vol. 203, No. 26, pp. 1534-1536.)

See also 458 of February. The sudden fade-outs are here attributed to the action of intense ionising agencies emitted by the sun in producing ionisation in E region or below it. "There seems to be no relation between the fade-outs and magnetic storms," but in 30 out of 46 cases examined there was a small bend in the curve of horizontal magnetic force at the time when the disappearance began. "It cannot be affirmed with certainty that there is a relation between the two phenomena."

847. OBSERVATIONS ON THE VARIATIONS OF THE EARTH'S MAGNETIC FIELD AT THE LEVEL OF THE IONOSPHERE.—I. Ranzi. (*Nuovo Cimento*, May, 1936, Vol. 13, No. 5, pp. 197-204.)

The writer's observations on the correlation (predicted by theory) between variations of phase of the echoes produced by magnetic double refraction, and the fluctuations of the magnetic field measured at ground level, suggest that the magnetic field at the level of the F₂ layer undergoes variations considerably greater than those observed at ground level.

848. RADIO AND MAGNETIC OBSERVATIONS AT NORTH-EAST LAND DURING THE TOTAL SOLAR ECLIPSE OF JUNE 19, 1936 [Data of Ionospheric Heights, etc.: Increase of Height of F₂ Region at Time of Maximum Eclipse].—A. B. Whatman & R. A. Hamilton. (*Nature*, 9th Jan. 1937, Vol. 139, pp. 69-70.)

849. IONOSPHERIC OBSERVATIONS DURING THE SOLAR ECLIPSE OF 19TH JUNE, 1936.—I. Ranzi. (*Nuovo Cimento*, July, 1936, Vol. 13, No. 7, pp. 297-303.) See also 4 of January.

850. [Australian] RADIO RESEARCH BOARD—8TH ANNUAL REPORT: WORK ON FADING AND THE IONOSPHERE.—(*Journ. of Council for Sci. & Indust. Res.*, Australia, Nov. 1936, Vol. 9, No. 4, pp. 277-280 and 281, 282.) See particularly 2073 of 1936 (where the page reference is given correctly: it is wrong in the present article). The receiver used is described as combining most of the merits of the frequency-change and pulse methods: the ellipse on the c-r screen indicates intensity and state of polarisation, including sense of rotation.

851. THE RADIOTECHNICAL EXPEDITION TO TROMSØ OF THE SOCIETY FOR THE ADVANCEMENT OF FUNDAMENTAL RADIO INVESTIGATIONS, AND ITS RESULTS.—K. Fränz. (*Zeitschr. f. Physik*, No. 11/12, Vol. 103, 1936, pp. 671-708.)

For a preliminary account of this expedition see Wagner, 1934 Abstracts, p. 259. The present paper gives details of the apparatus and results of investigations of directional errors and field strengths of broadcasting stations. The directional errors are regarded as due to changes in the polarisation of the waves; their diurnal and annual

variations are described, with their relation to magnetic variations. "No directional errors were observed at the times when signals appeared or, in general, during strong auroras and magnetic disturbances." Ionospheric observations on E and F regions with frequencies of 2 and 4 Mc/s are also described; more irregular ionisation of E region was found than at lower latitudes. No effect of corpuscular solar radiation on F region was detected. The diurnal and annual variations of ionisation with the position of the sun are discussed. "When the sun is 7.5° below the horizon, there is sufficient ionisation in F region to make 2 Mc/s the limiting frequency." The observations are given in tabular form for comparison with other geophysical phenomena.

852. "ANNÉE POLAIRE INTERNATIONALE 1932-1933: PARTICIPATION FRANÇAISE. TOME I" [Book Review].—(*Rev. Gén. de l'Elec.*, 31st Oct. 1936, Vol. 40, pp. 555-556.)

853. MEASUREMENTS OF THE INCIDENT ANGLE OF DOWNCOMING RADIO WAVES (FROM JANUARY TO JUNE, 1936).—Kusunose & Namba. (*Rep. of Rad. Res. in Japan*, Oct. 1936, Vol. 6, No. 2, pp. A-1 to A-8.) Continued from 2516 of 1936: charts only.

854. IONOSPHERIC AND MAGNETIC RECORDS IN JAPAN—VI: FROM OCT. 1935 TO APRIL 1936.—Minohara, Ito & others. (*Rep. of Rad. Res. in Japan*, Oct. 1936, Vol. 6, No. 2, pp. L-1 to L-21.) Continued from 427 & 2898 of 1936: charts only.

855. ON THE PROPAGATION OF THE 200 KC BAND WAVE IN JAPAN.—S. Inanami. (*Rep. of Rad. Res. in Japan*, May, 1936, Vol. 6, No. 1, Abstracts p. 1.)

856. THE PROPAGATION OF COMMERCIAL SHORT WAVES THROUGH HIGH LATITUDES [Measure of Difficulty of Transmission in terms of Aurora Frequency: etc.].—K. Ohno & K. Endo. (*Rep. of Rad. Res. in Japan*, Oct. 1936, Vol. 6, No. 2, Abstracts p. 14.)

The quantity $\int_0^s N ds$, obtained graphically, is the measure referred to.

857. ON COMPARATIVE MEASUREMENTS OF SKY-WAVE INTENSITIES OF SHORT WAVES [Effects of Irregularity, Slope, and Electrical Properties of Earth's Surface, and Other Conditions at Receiving Site: Effect of Incident Angle: etc.].—M. Nakagami & K. Miya. (*Rep. of Rad. Res. in Japan*, May, 1936, Vol. 6, No. 1, Abstracts pp. 7-8.)

When the maximum intensity over a period of one or two minutes is taken by means of a d.c. instrument, an accuracy of about 1 db is attainable for a fixed site (*cf.* Maeda, 644 of February).

858. NOTES ON THE FIELD-INTENSITY MEASUREMENT OF HIGH-FREQUENCY [Short] RADIO WAVES.—Maeda. (*See* 644 of February.)

859. THE PROPAGATION OF ULTRA-SHORT ELECTRO-MAGNETIC WAVES.—P. Labat. (*L'Onde Elec.*, Dec. 1936, Vol. 15, No. 180, pp. 768-784.)
Conclusion of the survey dealt with in 16 of January. The new sections deal with diffraction, propagation along the ground, and some results. The abnormally good communication in France in Dec. 1935 coincided with Appleton's report of exceptionally high ionisation (critical frequencies for upper layer around 12 Mc/s instead of usual 5 Mc/s) and the reception of American 8 m police transmissions in London at loudspeaker strength (Baird Television Company).
860. THE MEASUREMENT OF THE SIZE OF THE WATER PARTICLES IN MISTS.—N. Fuchs. (*Physik. Zeitschr. der Sowjetunion*, No. 3, Vol. 10, 1936, pp. 421-423: in German.)
861. SOUNDING THE ATMOSPHERE BY LUMINOUS RAY [slightly inclined to Horizontal, and photographed simultaneously at Different Points along Path].—J. P. E. Duclaux. (*Journ. de Phys. et le Radium*, Sept. 1936, Vol. 7, No. 9, pp. 361-364.) Giving enough height values to allow the complete trajectory to be drawn. Information regarding temperature, density, disturbances, etc., can thus be obtained, and (since the passage of the ray creates a luminous source at every altitude) the ozone layer height can be investigated.
862. ON THE ABSORPTION OF HERTZIAN WAVES PRODUCED BY AN ELECTRONIC GAS IN A MAGNETIC FIELD.—Majorana: Todesco: De Pace. (*Alta Frequenza*, Nov. 1936, Vol. 5, No. 11, pp. 734-735.) Majorana affirms the reliability of Todesco's work (see 12 of January) and suggests that difference of experimental conditions may account for De Pace's contradictory results.
863. SPARKING POTENTIALS AT ULTRA-HIGH FREQUENCIES [Variation with Gas Pressure, Electrode Distance, and Frequency: Experimental Results discussed theoretically].—J. Thomson. (*Phil. Mag.*, Jan. 1937, Series 7, Vol. 23, No. 152, pp. 1-24.) Extension of work (with application to the electrostatic theory of ionisation) referred to in 13 of 1935; an error in this paper is here corrected.
864. A DEVICE OF HIGH PRECISION FOR THE CONTROL OF SHORT-TIME SQUARE-TOPPED PULSES [using a Polarised Relay with Special Mercury Contacts].—W. Liebknecht. (*Zeitschr. f. Fernmeldetech.*, Nos. 9, 10 & 11, Vol. 17, 1936, pp. 137-141, 148-151, and 161-166.) Minimum pulse length, for a departure from rectangular form not exceeding 6%, is 1×10^{-4} sec.
865. THE DESIGN OF AN AUTOMATIC VARIABLE-FREQUENCY RADIO [Pulse] TRANSMITTER WITH AUTOMATICALLY TUNED RECEIVER, FOR USE IN THE INVESTIGATION OF RADIO PROPAGATION IN THE IONOSPHERE.—H. B. Wood. (*Journ. of Inst. of Eng., Australia*, Nov. 1936, Vol. 8, No. 11, pp. 403-414.)
The frequency is automatically and recurrently varied from 1.6 to 10 Mc/s, at a constant rate of 28 kc/s per second; the pattern is recorded by an automatically controlled camera. "A new method of calibration of the records, involving the use of de-focusing of the oscillograph, is described" [pp. 410-411: the image is de-focused for a brief interval each 1/1500th part of a second, so that the interval between successive marks corresponds to an effective height of 100 km].
866. VERTICAL DISTRIBUTION OF OZONE IN THE UPPER ATMOSPHERE [Sharp Concentration centering at 22 km].—B. O'Brien, F. L. Mohler & H. S. Stewart. (*Phys. Review*, 1st Dec. 1936, Series 2, Vol. 50, No. 11, p. 1099: abstract only.)
867. VARIATION OF THE ABSORPTION COEFFICIENTS OF OZONE AND THE TEMPERATURE OF THE UPPER ATMOSPHERE [Probable Values deduced from Experimental Law of Variation of Absorption Minima].—E. Vassy. (*Comptes Rendus*, 14th Dec. 1936, Vol. 203, No. 24, pp. 1363-1365.)
868. THE INFLUENCE OF TEMPERATURE ON THE ABSORPTION SPECTRUM OF OZONE (ACCORDING TO RECENT RESEARCHES): TEMPERATURE OF THE ATMOSPHERIC OZONE.—G. Déjardin. (*Journ. de Phys. et le Radium*, Dec. 1936, Vol. 7, No. 12, pp. 159-160 S.)
869. ULTRA-VIOLET CONTENT OF SUNLIGHT AT BOMBAY [about 2.43%].—Tawde, Trivedi & Patel. (*Indian Journ. of Phys.*, July, 1936, Vol. 10, Part 4, pp. 277-279.)
870. DIRECTIONS OF HOMOGENEOUS AURORAL ARCS [Average Value for North-East Land].—R. A. Hamilton. (*Nature*, 19th Dec. 1936, Vol. 138, p. 1059.)
871. RELATIVE INTENSITIES OF THE SYSTEMS OF NITROGEN BANDS EXCITED BY ELECTRON BOMBARDMENT: COMPARISON WITH THE SPECTRUM OF THE AURORA BOREALIS.—R. Bernard. (*Journ. de Phys. et le Radium*, Dec. 1936, Vol. 7, No. 12, pp. 158-159 S.)
872. ON THE ENERGY OF METASTABLE NITROGEN MOLECULES [Experimental Results: Afterglow Spectrum and Nature of Active Nitrogen].—H. Hamada. (*Phil. Mag.*, Jan. 1937, Series 7, Vol. 23, No. 152, pp. 25-33.)
873. ACTIVE NITROGEN [Bands in Afterglow not observed by Cario & Stille because of Impurities in Nitrogen].—J. Kaplan. (*Nature*, 16th Jan. 1937, Vol. 139, p. 115.) See 21 of January.
874. POLARISATION OF THE LIGHT OF THE NIGHT SKY.—I. A. Khvostikov & K. B. Panschin. (*Journ. de Phys. et le Radium*, April, 1936, Vol. 7, No. 4, pp. 187-188.)
875. METHOD OF CALCULATION OF THE PROPAGATION OF SIGNALS ALONG LINES.—G. Giorgi. (*L'Elettrotec.*, No. 19, Vol. 23, 1936, pp. 598-599: long summary only.)

876. PROPAGATION OF POTENTIAL IN DISCHARGE TUBES [Velocity of Propagation as Function of Pressure: Similarity to Lightning Flash].—Snoddy, Beams & Dietrich. (*Phys. Review*, 1st Dec. 1936, Series 2, Vol. 50, No. 11, p. 1094: abstract only.) Continuation of work referred to in 25 of January.
877. EXPERIMENTAL STUDY OF THE PROPAGATION OF A TRAIN OF PERIODIC WAVES ON THE SURFACE OF WATER.—J. Baurand. (*Journ. de Phys. et le Radium*, May, 1936, Vol. 7, No. 5, pp. 215-222.)
878. THE ELECTROMAGNETIC THEORY OF THE DIFFRACTION BY THE EDGE OF A SCREEN: EFFECT OF OPTICAL PROPERTIES OF THE SCREEN MATERIAL: ETC.—J. Savornin. (*Journ. de Phys. et le Radium*, Oct. 1936, Vol. 7, No. 10, pp. 434-440.)
879. PROPAGATION OF THE ELECTROMAGNETIC WAVE IN AN ANISOTROPIC BI-COMPLEX, and ON THE REFRACTION OF AN ELECTROMAGNETIC WAVE WITH PARTICULAR REGARD TO THE CASE OF TOTAL REFLECTION.—B. Ferretti; G. Usiglio. (*Nuovo Cimento*, April, 1936, Vol. 13, No. 4, pp. 104-179: pp. 180-193.)
- ATMOSPHERICS AND ATMOSPHERIC ELECTRICITY**
880. WAVE-FORMS OF ATMOSPHERICS AT MADRAS [drawn by Eye-and-Hand Method].—C. V. Rajam. (*Nature*, 19th Dec. 1936, Vol. 138, p. 1064.)
The observed types are illustrated and divided into (1) normal, (2) far-off lightning, (3) local lightning types. The noises they produce in a wireless receiver are discussed; data of the frequency of their occurrence, durations, intensities, high-frequency ripples, etc., are given, with a description of the diurnal variation in atmospheric activity on a normal day.
881. COMPARATIVE VARIATION OF ANOMALIES OF BAROMETRIC PRESSURE AND SOLAR ACTIVITY [Movements of Polar and Tropical Air compared with Rate of Variation of Sunspot Number].—L. Petitjean. (*Comptes Rendus*, 11th Jan. 1937, Vol. 204, No. 2, pp. 141-143.)
882. ABNORMALITIES OF THE IONOSPHERE AND BRIGHT SOLAR ERUPTIONS Coincidence in Time with Increase in Number of Atmospherics.—Bureau. (See 845.)
883. [AUSTRALIAN] RADIO RESEARCH BOARD: WORK ON ATMOSPHERICS.—(See pp. 280-281 of paper dealt with in 850, above.)
884. STORM SURGES ON MIXED [Overhead and Lead-Covered Cable] LINES.—P. Yersin. (*Bull. Assoc. suisse des Elec.*, No. 18, Vol. 27, 1936, pp. 521-524: in French.)
885. LIGHTNING INVESTIGATION ON A 220-kV SYSTEM: II [Max. Stroke Current 110 000 A: only 11% exceeded 30 000 A: All except a Very Few were of Negative Polarity: etc.].—E. Bell. (*Elec. Engineering*, Dec. 1936, Vol. 55, pp. 1306-1313.)
886. LIGHTNING SURGES ON TRANSMISSION LINES—NATURAL LIGHTNING.—Lewis & Foust. (*Gen. Elec. Review*, Nov. 1936, Vol. 39, No. 11, pp. 543-555.)
887. LIGHTNING INVESTIGATION ON TRANSMISSION LINES—VI.—Lewis & Foust. (*Elec. Engineering*, Jan. 1937, Vol. 56, pp. 101-106 and 189.)
888. PROTECTION AGAINST LIGHTNING INTERFERENCE [Use of "Drainage Coils" to reduce Surges due to Asymmetry of Protectors].—C. C. Cash. (*Bell Lab. Record*, Dec. 1936, Vol. 15, No. 4, pp. 125-128.)
889. THE PROTECTION OF ALPINE REFUGES AGAINST LIGHTNING.—Rebora. (*L'Electrotec.*, No. 16, Vol. 23, 1936, pp. 506-507.)
890. RULES FOR LIGHTNING CONDUCTORS [approved by the ASE and UCS].—(*Bull. Assoc. suisse des Elec.*, No. 21, Vol. 27, 1936, pp. 611-616: in French.)
891. INVESTIGATIONS OF KLYDONOGRAPH BRUSH-DISCHARGE FIGURES BY CURRENT AND POTENTIAL MEASUREMENTS WITH THE CATHODE-RAY OSCILLOGRAPH.—G. Dragu. (*Charlottenburg Thesis*, 1936: in German, 60 pp.: at Patent Office Library, London: Cat. No. 76 902.)
892. PROPAGATION OF POTENTIAL IN DISCHARGE TUBES [Similarity to Lightning Flash].—Snoddy & others. (See 876.)
893. THE PROBLEM OF THE MECHANISM OF STATIC SPARK DISCHARGE [Survey].—Loeb. (*Reviews of Mod. Phys.*, July, 1936, Vol. 8, No. 3, pp. 267-293.)
894. THE POTENTIAL DIFFERENCE AT AN AIR-WATER INTERFACE [measured with Water Drops inside Hollow Tube].—J. A. Chalmers & F. Pasquill. (*Phil. Mag.*, Jan. 1937, Series 7, Vol. 23, No. 152, pp. 88-96.)
895. PRESSURE AND TEMPERATURE VARIATION OF THE RECOMBINATION COEFFICIENT AND THE IONISATION BY GAMMA RAYS IN AIR AND CARBON DIOXIDE [with Current/Voltage Characteristics and Variation, with Field-Strength and Pressure, of Temperature Coefficient of Ionic Current: Pressures between 5 and 25 Atm.].—W. Mächler. (*Zeitschr. f. Physik*, No. 1/2, Vol. 104, 1936, pp. 1-33.)
896. ELECTRICAL CONDUCTIVITY OF THE AIR IN A POTASSIUM MINE IN CATALONIA [Measurements indicate that Presence of Potassium does not increase Ionisation near Granite Rocks].—C. Dauzère. (*Comptes Rendus*, 4th Jan. 1937, Vol. 204, No. 1, pp. 38-39.)
897. LONGITUDE EFFECT OF COSMIC RADIATION AND THE POSITION OF THE EARTH'S MAGNETIC CENTRE [Discrepancy between Positions determined from Magnetic and from Cosmic Radiation Measurements].—M. S. Vallarta. (*Nature*, 2nd Jan. 1937, Vol. 139, pp. 24-25.)

898. A DIRECT-READING COUNTING-RATE METER FOR RANDOM PULSES, and STATISTICAL ANALYSIS OF THE COUNTING-RATE METER.—Gingrich, Evans & Edgerton: Schiff & Evans. (*Review Scient. Instr.*, Dec. 1936, Vol. 7, No. 12, pp. 450-456; pp. 456-462.)
899. A RECEIVER FOR RADIOMETEORGRAPHS.—A. V. Astin & L. L. Stockmann. (*Review Scient. Instr.*, Dec. 1936, Vol. 7, No. 12, pp. 462-463.) A superheterodyne with broad i.f. tuning (about 50-100 kc/s), designed for pulse-type signals and having a low response to random noises.

PROPERTIES OF CIRCUITS

900. ANALYSIS OF THE VIBRATIONS ARISING IN MAGNETOSTRICTION FILTERS.—N. A. Lifshitz. (*Automatics & Telemechanics* [in Russian], No. 3, 1936, pp. 95-135.) See also 3317 of 1936.
901. SOME CHARACTERISTICS OF THE SIMPLE AND COMPOSITE MAGNETOSTRICTION BAR.—K. Aoyagi. (*Rep. of Rad. Res. in Japan*, Oct. 1936, Vol. 6, No. 2, pp. 51-67.)
 "The constants of an equivalent circuit of a 10 kc/s magnetostriction bar are determined, and its properties as an electro-mechanical electro-transformer are experimentally studied. A single-frequency valve oscillator with magnetostriction coupler is made and its characteristics investigated. These experiments have made it clear why the polarity of the grid coil of a magnetostriction oscillator of Pierce type must be reversed. The vibration characteristics of a magnetostriction bar with another rod at one of its ends, i.e. of a composite bar, are theoretically investigated."
902. TCHEBICHEFF'S METHOD OF APPROXIMATION AND ITS APPLICATION TO FREQUENCY FILTERS.—Le Corbeiller: Cauet. (*Rev. Gén. de l'Élec.*, 21st Nov. 1936, Vol. 40, pp. 651-657.)
903. THE THEORY OF MATRICES AND THE PROPAGATION OF WAVES [in Filters, etc.]—L. Brillouin. (*Journ. de Phys. et le Radium*, Oct. 1936, Vol. 7, No. 10, pp. 401-410.)
904. ON A RECIPROCALITY RELATION BETWEEN TWO KIRCHHOFF NETWORKS [Sufficient and Necessary Condition for associating a Network reciprocal to Any Given Network is that the Latter should be Plane].—R. Harmégnies. (*Ann. des Postes, T. et T.*, Dec. 1936, Vol. 25, No. 12, pp. 1122-1141.) By "plane" is meant that the branches intersect only at the corners, so that the network can be represented on a plane surface.
905. CONSTANT IMPEDANCE NETWORKS FOR LINE EQUALISATION [primarily for Multi-Channel Carrier Systems].—D. G. Tucker. (*P.O. Elec. Eng. Journ.*, Jan. 1937, Vol. 29, Part 4, pp. 302-308.)
 "The practical method of design outlined in this article gives results which are sufficiently accurate for line equalisation, and avoids the tedious calculations associated with Zobel's original methods."
906. CONTRIBUTION TO THE CALCULATION OF SHORT FILTER CHAINS [Formulae obtained from Difference Equations].—J. F. Böttcher. (*Telefunken Zeit.*, 1st Nov. 1936, Vol. 17, No. 74, pp. 47-54.)
 The currents and voltages throughout the filter chain are deduced from the recurrence formulae connecting the separate members, in the case of both T - and Π -filters. The connection between these formulae and those for cables with continuously distributed inductance, capacity, etc., is demonstrated. The results are applied to condenser and choke chains including ohmic resistances.
907. EXPANSION THEOREMS FOR LADDER NETWORKS [similar to Heaviside's Expansion Theorem and Its Extensions, but referring to Difference Equations instead of Differential Equations].—M. G. Malti & S. E. Warschawski. (*Elec. Engineering*, Jan. 1937, Vol. 56, pp. 153-158.)
908. AN EXTENDED TRANSFORMER EQUIVALENT CIRCUIT AND ITS APPLICATION TO THE CALCULATION OF EMITTER CIRCUITS.—W. Kautter. (*Telefunken Zeit.*, 1st Nov. 1936, Vol. 17, No. 74, pp. 42-46.)
 This equivalent circuit contains an ideal transformer with a ratio which is not purely real but includes a small imaginary part, in order to take account of the small phase rotation of the secondary voltage caused by the ohmic resistance of the primary winding. The quadripole equations are worked out; the equivalent conductance of the retroaction is found to contain a real and an imaginary part (Fig. 50b). The results are applied to the calculation of the resonance frequency of an emitter circuit; a slight detuning results and, when grid current is negligible, the oscillatory frequency is found to be the *series* resonance frequency.
909. ASYMMETRICAL BRANCHING FILTERS [Influence of Asymmetry on Characteristic Impedance and Transmission Equivalent].—O. Henkler. (*T.F.T.*, Nov. 1936, Vol. 25, No. 11, pp. 291-297.) In some cases a carefully chosen asymmetry can be used to give a frequency-independent transformation ratio differing from unity, so that a transformer, with its additional loss, can be dispensed with.
910. ANALYTICAL CONSIDERATIONS ON BAND-PASS FILTERS OF SUPERHETERODYNE RECEIVERS.—Fukata. (See 956.)
911. TENSOR ANALYSIS OF MULTI-ELECTRODE-TUBE CIRCUITS [as Amplifiers, Modulators, Detectors, and Oscillators].—G. Kron. (*Elec. Engineering*, Nov. 1936, Vol. 55, pp. 1220-1242.)
912. AMPLIFICATION LOCI OF RESISTANCE-CAPACITANCE COUPLED AMPLIFIERS [Method of Circular Loci applied to Determination of Vector Amplification as Function of Frequency or (at Fixed Frequency) of Any One of Circuit Constants].—A. C. Seletzky. (*Elec. Engineering*, Dec. 1936, Vol. 55, pp. 1364-1371.) For the method see 4004 of 1936.

913. THE THERMIONIC AMPLIFICATION OF DIRECT CURRENTS [Principles: Specific Circuits for Various Current Ranges].—P. A. Macdonald. (*Physics*, Aug. 1936, Vol. 7, No. 8, pp. 205-294.)

The basic physical phenomena underlying the use of thermionic valves for the amplification of direct currents, and the characteristics of thermionic amplifying circuits, are discussed. A summary of valve characteristics as functions of operating potentials includes descriptions of a floating-grid d.c. amplifier (see also 1168 of 1936), space-charge-grid valves, battery neutralising circuits, bridge circuits, a precision single-valve space-charge-grid balanced circuit, the valve electrometer, the negative-impedance circuit, two-valve circuits, integrating circuits and ballistic measurements, with practical considerations on the use of the circuits and tabulated data "for the construction of one particular circuit for each of the ranges of current" commonly arising.

914. FLUCTUATIONS IN A DYNATRON CIRCUIT.—Berstein. (See 989.)

915. PARTICULARLY LOW VALUES OF NEGATIVE RESISTANCE [obtained with Valves with 5 or more Electrodes: Values from 2000 Ohms (Pentode) down to 400 Ohms (Octode with 36 Volts on Anode)].—E. Viti. (*Alla Frequenza*, Nov. 1936, Vol. 5, No. 11, pp. 736-737.)

916. ON THE EFFECT OF A SECONDARY CIRCUIT ON QUENCHED OSCILLATORS.—Uda & Takeya. (*Rep. of Rad. Res. in Japan*, Oct. 1936, Vol. 6, No. 2, Abstracts pp. 14-15.) Short summary of the Japanese paper referred to in 462 of February.

917. THE INFLUENCE OF THE DISPLACEMENT CURRENT ON THE A.C. IMPEDANCE OF SIMPLE OSCILLATING CIRCUITS [Calculations based on Integral Equation for Current Density].—W. Wessel. (*Ann. der Phys.*, Series 5, No. 1, Vol. 28, 1937, pp. 59-70.) See also 521 of February.

918. SOME NEW EXPERIMENTS ON FREQUENCY DIVISION IN AN OSCILLATING CIRCUIT WITH AN IRON-CORED INDUCTANCE.—Rouelle. (*Rev. Gén. de l'Élec.*, 26th Dec. 1936, Vol. 40, pp. 811-819.) For a *Comptes Rendus* Note see 55 of January.

919. SWITCH-ON TRANSIENTS ON CABLE-LIKE COILS [Cathode-Ray Oscillograms confirm Theory of Formation of Pure Travelling Waves on Coils: Determination of Characteristics from Oscillograms: Agreement with Lecher-System Measurements].—H. Kroemer & A. Wallraff. (*Arch. f. Elektrot.*, 21st Dec. 1936, Vol. 30, No. 12, pp. 780-790.)

920. NON-LINEAR BUILDING-UP PROCESSES.—H. Tischner. (*T.F.T.*, Dec. 1936, Vol. 25, No. 12, pp. 319-322.) Further development of the work dealt with in 2217 of 1935.

TRANSMISSION

921. ON THE QUESTION OF THE OCCURRENCE OF OSCILLATIONS IN THE MAGNETRON [for Very Low Electrical Field Strengths: Rôle of Initial Electron Velocity].—S. A. Ssuslov. (*Physik. Zeitschr. der Sowjetunion*, No. 2, Vol. 10, 1936, pp. 262-263; in German.)

The writer has obtained oscillations with anode voltages as low as 5 volts, with the magnetic field much above the critical value; moreover, the shape of the curves of maxima suggests that oscillations would still persist at even lower voltages. The magnetron actually giving the curve of Fig. 1 had an un-split molybdenum anode of 3 mm diameter. "The existence of oscillations at very small electric field strengths appears very important as throwing light on the electron mechanism of magnetron oscillations. It is clear that the initial velocities of the electrons, which in ordinary working conditions can be neglected, must play an important rôle in our case of small electric field strengths. We might remark that the generation of oscillations completely without electric fields is possible in principle. The radial components of the statistically distributed initial velocities of the electrons must play the chief part in such generation. The theoretical and experimental investigation of oscillations of this kind is being continued."

922. THE VELOCITY DISTRIBUTION OF ELECTRONS UNDER THE INFLUENCE OF A MAGNETIC FIELD IN A HIGH VACUUM.—I. M. Wigdorshik [Vigdortschik]. (*Physik. Zeitschr. der Sowjetunion*, No. 2, Vol. 10, 1936, pp. 245-250.) German version of the Russian paper dealt with in 531 of February.

923. AN INVESTIGATION OF THE ADDITIONAL HEATING OF THE FILAMENT IN A MAGNETRON.—I. M. Wigdorshik. (*Journ. of Tech. Phys.* [in Russian], No. 11, Vol. 6, 1936, pp. 1864-1872.)

For previous work see 922, above. It has been observed by a number of investigators that when the magnetic field of a magnetron, having a complete cylindrical anode, is raised above the critical value, and the anode voltage is sufficiently high, the anode current may actually rise instead of falling off. With a further increase in the magnetic field the current diminishes steadily until the field strength is approximately double the critical value, after which a second rise in the current occurs. To each peak of the current corresponds a rise in the filament temperature. In this paper an investigation is presented of the causes to which the additional filament heating is due.

A critical survey of the existing theories on the subject is given, together with an account of experiments carried out by the author. The main conclusion reached is that both temperature rises are due to ionisation effects, the second rise being caused mainly by ionisation of the tungsten vapour emitted by the filament. A special magnetron constructed with a grid to screen the filament showed a great reduction in the additional filament heating.

924. INTERMITTENT OSCILLATIONS IN THE SPLIT-ANODE MAGNETRON [dependent on Presence of Gas (or Tungsten Vapours from Overheated Filament, in case of Well Out-Gassed Magnetron) : "Jumpy" Plate-Current Variation at Audio-Frequencies : a Cause of Feed-Choke Breakdown and of Differing Efficiencies of Tubes working under Almost Identical Conditions].—Lelyakov, Usikov & Vyshinski. (*Physik. Zeitschr. der Sowjetunion*, No. 2, Vol. 10, 1936, pp. 266-268 : in English.)
925. A NEW ELECTRON OSCILLATOR ["Osaka-Tubes" : Useful Output at 80 cm nearly 1 Watt for Anode Input of 5 Watts : also "Dwarf" and "Long" Waves].—K. Okabe. (*Rep. of Rad. Res. in Japan*, Oct. 1936, Vol. 6, No. 2, pp. 69-74.) See also 61 of January and 480 of February.

926. THE OSCILLATIONS OF ELECTRONIC SPACE CHARGES IN THE MAGNETRON.—J. J. Müller. (*Helvet. Phys. Acta*, Fasc. 8, Vol. 9, 1936, pp. 652-654 : in French.) For a long paper in German see 476 of February.

927. THE SHORTEST CONTINUOUS RADIO WAVES [6.4 mm Micro-Waves produced by Vacuum Tubes].—C. E. Cleeton & N. H. Williams. (*Phys. Review*, 1st Dec. 1936, Series 2, Vol. 50, No. 11, p. 1091.)

In an investigation "to determine the practical short-wave limit for electromagnetic waves produced by vacuum tubes," a split-anode magnetron operating in the electronic mode of oscillation gave "stable continuous waves of 0.64 cm wavelength." Data of construction and operation of micro-ray tubes giving wavelengths below 2 cm are tabulated. "The lower limit is determined by the strength of the magnetic field which it is practicable to obtain." Sufficient stability and output is obtained for the tubes "to serve as sources of electromagnetic radiation for many researches in this wavelength region."

928. ON THE THEORY OF MOTION OF ELECTRONS IN CROSSED ELECTRIC AND MAGNETIC FIELDS WITH SPACE CHARGE.—S. V. Bellustin. (*Physik. Zeitschr. der Sowjetunion*, No. 2, Vol. 10, 1936, pp. 251-256 : in English.)

"The solution of this problem for a plane condenser given by S. J. Braude [3437 of 1935] was criticised by Lewi Tonks [1389 of 1936], who has correctly observed that Braude's conclusion as to the absence of the magnetic cut-off is unacceptable from the physical point of view. . . . Neither Braude's reply nor his second paper where he treats the case of a cylindrical condenser [1390 & 1444 of 1936] elucidates the point at issue. It can be shown that the conclusions reached by Braude in examining the plane case result from an assumption implied in his initial equations, and can be claimed to have physical meaning only in so far as the equations in question remain valid." The assumption that the electrons move from the cathode to the anode, reach it, and do not return back to the cathode, "predeterminates all Braude's conclusions . . . the case when the magnetic field exceeds the critical value (*i.e.* the electrons do not

reach the anode) remains, thus, unstudied and must be treated separately."

This is done, and the resulting revision of Braude's work "removes the objections raised by Tonks and makes the conclusions reached by Braude acceptable both mathematically and physically." Finally, Braude's treatment of the case of the cylindrical condenser is similarly dealt with. For Braude's reply see *ibid.*, No. 3, Vol. 10, pp. 429-430.

929. TRANSMITTERS FOR MICRO-WAVES [Useful Output about 8-10 Watts between 70 and 100 Centimetres, using Magnetrons].—(*Alla Frequenza*, Nov. 1936, Vol. 5, No. 11, pp. 747-750.)

930. A VOLTAGE REGULATOR [for D.C. Supply of Magnetron Generators : 10% Change in Primary Voltage produces less than 0.2% Variation in Regulated Voltage of 1500 Volts].—C. G. A. von Lindern. (*Philips Transmuting News*, No. 3, Vol. 3, 1936, pp. 11-13 : in German and English.) For reference to the use of this regulator see Staal, 972, below.

931. "ELECTRONIC" OSCILLATIONS IN POSITIVE-GRID TRIODES, AND "RESONANCE" OSCILLATIONS IN MAGNETRON GENERATORS [at Fields greater than the Critical Field : Essentially of Same Type : Max. Amplitude with Both obtained in Neighbourhood of Max. Valve Capacitance : Similar Poor Wave-Form : etc.].—J. S. McPetrie. (*Journ. I.E.E.*, Jan. 1937, Vol. 80, No. 481, pp. 84-97.) See also 1735 of 1936.

932. ELECTRON OSCILLATION OF CONSTANT WAVELENGTH [using B-K Connection but with Plate slightly Positive] AND SUPER-REGENERATIVE ELECTRONIC AMPLIFYING-DETECTOR WITHOUT QUENCHING VALVE [using Electronic Valve generating Micro-Wave and 400-700 m Wave simultaneously].—S. Nakamura, R. Shino & H. Komaki. (*Rep. of Rad. Res. in Japan*, May, 1936, Vol. 6, No. 1, Abstracts p. 5.)

933. ON A SYSTEM OF ULTRA-SHORT-WAVE SIMULTANEOUS TELEPHONY [using Single U.S.W. Carrier doubly modulated with Long-Wave and Audio Frequencies].—Ohtaka & Hasegawa. (*Rep. of Rad. Res. in Japan*, Oct. 1936, Vol. 6, No. 2, Abstracts p. 19.)

Including an oscillographic investigation of the mechanism. The coincidence of the wave forms of the long waves is necessary to secure perfect and stable synchronisation of the communicating sets. "Transmission is accomplished by the ultra-short wave deeply modulated or interrupted by the long wave and modulated directly with audio-frequencies, or indirectly with audio-modulated long wave ; reception by super-regenerative detection." For earlier work see 504 of 1936.

934. NOTE ON A TRANSMITTER AND A RECEIVER FOR MICRO-WAVES OF 9-25 CENTIMETRES.—G. Nobile. (*Helvet. Phys. Acta*, Fasc. 8, Vol. 9, 1936, pp. 651-652 : in Italian.)

The transmitter employs combinations of retard-ing-field valves whose spiral grids are connected at

each end to a parallel-wire line. Dipoles with reflectors are used. Good amplitude modulation free from unwanted frequency modulation ("always present if the feed voltage is modulated") can be obtained by acting on the anode voltages of a group of two valves, connected in opposition, "in an opposed sense for each valve." In practice the micro-wave is not modulated directly but by the use of an auxiliary wave of 300-3000 metres modulated by the voice frequencies: a retarding-field detector is used, with a second valve providing regeneration to reduce the damping; "a surprisingly high sensitivity is thus obtained." With the auxiliary-wave system of modulation at the transmitter, the detector valve is followed by a receiver for ordinary wavelengths; this gives high amplification. A single micro-wave can thus be used simultaneously for two or more communications.

935. EXPERIMENTAL STUDIES ON DWARF WAVES WITH SPECIAL REFERENCE TO THE GRID-TUNED TYPE [Spiral Tuned Grid: 17 cm Sharply Directional Communication].—S. Nakamura, M. Abe & O. Nakano. (*Rep. of Rad. Res. in Japan*, May, 1936, Vol. 6, No. 1, Abstracts pp. 8-9.)

936. GENERATION OF ULTRA-HIGH-FREQUENCY OSCILLATIONS BY CATHODE RAY [scanning a Circle of Holes in a Disc: Independent Charges thus produced are Magnetically directed on to Two Electrodes joined to Lecher-Wire System].—Zeitline. (*Rev. Gén. de l'Élec.*, 26th Dec. 1936, Vol. 40, p. 208 D: French Pat. 804 718, pub. 31.10.1936.)

937. MICRO-WAVES: ELECTRONIC THEORY OF VALVES FOR THE HIGHEST FREQUENCIES: MICRO-WAVE GENERATORS [Comprehensive Survey].—N. Carrara. (*Alta Frequenza*, Nov. & Dec. 1936, Vol. 5, No. 11, pp. 691-733 and 773-814.)

The November instalment covers the introduction, the classical theory, the energy theory, and the calculation of transit times; also micro-wave generators of the retarding-field type and the various hypotheses regarding these (Barkhausen-Kurz, Möller, Rostagni, Knipping, etc.). Magnetron generators are dealt with at great length in the second (and final) instalment, which also includes a short section on "acorn" valves and valves deriving from the cathode-ray tube.

938. OSCILLATORS STABILISED BY RESONANT LINES [Critical Survey].—D. A. Bell. (*Marconi Review*, Sept./Oct. 1936, No. 62, pp. 14-24.)

"The frequency-stabilising action of resonant lines is due solely to their high value of Q . . . and any other circuit of similar Q would be equally effective. . . . The stabilising effect of high- Q circuits is primarily concerned with the effects of non-linearity of valve characteristic, grid current, variation of external loading resistance, and variation of valve amplification factor. It has a secondary effect in respect of change of external reactance connected to the oscillatory system and change of inter-electrode capacity of the valve. The temperature coefficient of the tuned circuit has, of course,

its usual effect; for a resonant line, the temperature coefficient of frequency should be equal to the linear coefficient of expansion of the material of which it is made (usually copper, 16.7 parts in 10^6 per °C)." A resonant line for frequencies below about 5 Mc/s would be excessively bulky.

939. "THE [Frequency] STABILISATION OF VALVE OSCILLATORS BY SYSTEMS WITH DISTRIBUTED CONSTANTS": CRITICISM.—Bell: Wwedensky, Michailow & Skibarko.

(In paper dealt with in 938, above). For the Russian paper in question see 98 of 1935. The parts of the work criticised by Bell concern the theory of valve oscillators in general. "Since the calculations of stability in the original paper were based on change of S [anode slope conductance of valve], which does not enter into the true frequency equation, it is not surprising that the experimental results found by [the Russians] were several times better than their predicted values."

940. ON THE FREQUENCY VARIATION OF QUARTZ-CONTROLLED SHORT-WAVE RADIO TRANSMITTERS [with Koga's Low-Temperature-Coefficient Plates].—S. Amari: Koga. (*Rep. of Rad. Res. in Japan*, May, 1936, Vol. 6, No. 1, Abstracts p. 9.)

Variations due to residual temperature coefficient and the shifting of the plate in its holder are found to be very small compared with those due to the shift in the anode tuning condition, especially when the oscillator output is adjusted almost to its maximum. Design of the crystal oscillator to eliminate, as much as possible, grid/filament capacity is actually disadvantageous as regards frequency stability: the smaller the capacity the wider the frequency variation caused by a definite capacity change.

941. AN EXTENDED TRANSFORMER EQUIVALENT CIRCUIT AND ITS APPLICATION TO THE CALCULATION OF EMITTER CIRCUITS.—Kautter. (See 908.)

942. SOME CONSIDERATIONS ON MODULATION AND ITS RELATED PROBLEMS [including the Meaningless Use of "Klirr" Factor in connection with Modulators].—S. Uda & K. Numazawa. (*Rep. of Rad. Res. in Japan*, May, 1936, Vol. 6, No. 1, Abstracts pp. 6-7.)

943. THE EFFECT OF VOLUME COMPRESSION ON THE TOLERABLE NOISE LEVEL IN ELECTRICAL COMMUNICATION SYSTEMS.—Pawley. (See 1009.)

944. NOISE DUE TO FILAMENT SOURCE [in Broadcasting Transmitters: Difficulty in Use of Choke Coils because of High Currents: Theoretical Causes of Ripple: Amount of Noise produced: Methods of Elimination].—M. Kono. (*Rep. of Rad. Res. in Japan*, Oct. 1936, Vol. 6, No. 2, Abstracts p. 17.)

945. FLUCTUATIONS IN A DYNATRON CIRCUIT, and PARTICULARLY LOW VALUES OF NEGATIVE RESISTANCE.—Berstein: Viti. (See 989, 915.)

946. RELAXATION OSCILLATIONS OF STABLE PERIOD, OBTAINED WITH A GAS-FILLED TRIODE [Amplitudes increase Linearly with Applied Voltage: Application to Measurement of High Resistances].—J. L. Fek. (*Journ. de Phys. et le Radium*, May, 1936, Vol. 7, No. 5, pp. 227-232.)

RECEPTION

947. NOISE IN SUPER-REGENERATIVE DETECTION [when Signals are Weak or Absent: Oscillographic Investigation of Its Cause, leading to a Suggested Method of Reduction].—Y. Ito. (*Rep. of Rad. Res. in Japan*, Oct. 1936, Vol. 6, No. 2, pp. 81-90.)

The writer regards the work of Barkhausen & Hässler (1933 Abstracts, p. 619) as a clue to the problem. Of the four causes of the self-oscillations which go to produce the background noise, the intermittent quenching voltage can be improved: "by employing a multivibrator or some other suitable apparatus for the local oscillator, and by causing the harmonics contained in the plate current, produced by the wave shape of the voltage, to be equal to the self-oscillatory frequency, the super-regeneration noise can be eliminated to a certain extent."

948. ON THE ACTION OF A SECONDARY CIRCUIT IN SUPPRESSING NOISE IN SUPER-REGENERATIVE RECEIVERS OF ULTRA-SHORT WAVES [Remarkable Suppressing Action of Secondary Circuit coupled with Primary Quenching Oscillator: Mechanism of the Action].—S. Uda. (*Rep. of Rad. Res. in Japan*, Oct. 1936, Vol. 6, No. 2, Abstracts p. 19.)

949. A SUPER-REGENERATIVE ELECTRONIC AMPLIFYING-DETECTOR WITHOUT QUENCHING VALVE.—Nakamura & others. (See 932.)

950. NOTE ON A TRANSMITTER AND A RECEIVER FOR MICRO-WAVES OF 9-25 CENTIMETRES.—Nobile. (See 934.)

951. AN ULTRA-SHORT-WAVE RECEIVER FOR RADIO-METEOROGRAPHS.—Astin & Stockmann. (See 899.)

952. FINDING THE ULTRA-SHORT BANDS [Simple Single-Wire Device for checking Receiver, more Convenient than Lecher Wires].—B. W. F. Mainprize. (*Wireless World*, 8th Jan. 1937, Vol. 40, pp. 42-43.)

953. NEW DETECTOR CIRCUIT [Anode-Bend Rectifier with Negative Feed-Back ("Infinite Impedance" Detector): Low Distortion for Deep Modulation: More Efficient than Diode].—W. N. Weeden: Hygrade Sylvania Corporation. (*Wireless World*, 1st Jan. 1937, Vol. 40, pp. 6-7.)

954. DISTORTION PRODUCED BY DELAYED DIODE A.V.C. [Theoretical and Experimental Investigation].—K. R. Sturley. (*Wireless Engineer*, Jan. 1937, Vol. 14, No. 160, pp. 15-27.)

In a superheterodyne receiver fitted with this type of a.v.c. it was found that the total harmonic distortion reached a maximum at a particular r.f. input voltage. This distortion was traced to the

delayed diode supplying the a.v.c. bias, and the effect of this valve was determined for various operating conditions, including the use of a h.f. filter. The distortion can be reduced to small values by a suitable choice of circuit constants: guiding lines for such a choice are indicated.

955. IMPROVING THE SIMPLIFIED VOLUME EXPANDER.—Weeden. (*Wireless World*, 15th Jan. 1937, Vol. 40, pp. 68-69.) See 2585 of 1936.

956. ANALYTICAL CONSIDERATIONS ON BAND-PASS FILTERS OF SUPERHETERODYNE RECEIVERS [with Accurate Formulae for Amplification of Capacitively and Magnetically Coupled Types].—M. Fukata. (*Rep. of Rad. Res. in Japan*, May, 1936, Vol. 6, No. 1, Abstracts p. 6.)

957. A.C. MAINS-DRIVEN AMPLIFIER OF HIGH CONSTANCY IN TIME.—J. F. Tonnie. (*Göttingen Thesis*, 1936: in German, 62 pp.: at Patent Office Library, London: Cat. No. 76 893.)

958. TEST-BENCH EQUIPMENT FOR THE ALIGNMENT, ETC., OF MASS-PRODUCED BROADCAST RECEIVERS [using a Central Signal Generator].—S. Janzen. (*E.T.Z.*, 10th Dec. 1936, Vol. 57, No. 50, pp. 1451-1452.)

959. THE QUANTITATIVE INVESTIGATION OF BROADCAST RECEIVERS [German P.O. Methods].—R. Moebes. (*T.F.T.*, Nov. 1936, Vol. 25, No. 11, pp. 297-301.)

960. PROGRESS REALISED IN RADIOELECTRIC RECEIVERS AND APPARATUS [in 1936].—M. Adam. (*Rev. Gén. de l'Elec.*, 19th Dec. 1936, Vol. 40, pp. 791-800.)

961. THE "KAMMERMUSIK" [Chamber Music] RECEIVERS I AND II.—Troeltsch & Schaaf. (*E.T.Z.*, 10th Dec. 1936, Vol. 57, No. 50, pp. 1456-1457.) For specially high quality. "Straight" circuits (to avoid the background noise and distortion arising from the mixing processes) and triple loudspeakers.

962. ELECTRICAL CHARACTERISTICS OF SUSPENSION-INSULATOR UNITS [Effects of Humidity, Corona, and Mechanical Stress].—C. L. Dawes & R. Reiter. (*Elec. Engineering*, Jan. 1937, Vol. 56, pp. 59-66.) "The authors feel that the results of this research may assist in the obtaining of a better understanding of insulator performance and design, as well as of radio interference resulting from surface discharge."

963. HIGH-VOLTAGE INSULATORS WHICH DO NOT PRODUCE BROADCAST INTERFERENCE.—Etab. Merlin et Gerin. (*Rev. Gén. de l'Elec.*, 28th Nov. 1936, Vol. 40, pp. 174-175 D: French Pat. 801 409, pub. 4.8.1936.)

964. BROADCAST INTERFERENCE BY H.T. INSULATORS AND ITS PREVENTION [by Treatment of Existing Insulators and by Better Design of New: a Testing Equipment].—F. Conrad. (*T.F.T.*, Dec. 1936, Vol. 25, No. 12, pp. 326-332.) From the German P.O.

965. INTERFERENCE-VOLTAGE MEASUREMENTS MADE ON SMALL MOTORS AND ELECTRICAL APPARATUS OF THE VILLAGE OF CARTIGNY, GENEVA [after Large-Scale Campaign of Interference Suppression].—Gerber & Roesgen. (*Bull. Assoc. suisse des Elec.*, No. 24, Vol. 27, 1936, p. 708.)
966. RADIO INTERFERENCE FROM SMALL CONTACT CURRENTS AT MUCH-GROOVED OVERHEAD LINES OF ELECTRIC TRAMWAYS.—W. Gerber. (*Bull. Assoc. suisse des Elec.*, No. 19, Vol. 27, 1936, pp. 545-546: in German.) Oscillographic investigation. For small currents (0.5 A, lighting supply) each separate groove may cause a complete extinction of the current, producing a quenched-spark-generator effect which causes serious interference.
967. BROADCAST INTERFERENCE FROM SODIUM-VAPOUR LAMPS [and Its Elimination].—L. Block. (*E.T.Z.*, 10th Dec. 1936, Vol. 57, No. 50, p. 1456: summary only.) See 3738 of 1936.
968. SCREENING A CATHODE-RAY OSCILLOGRAPH TO PREVENT BROADCAST INTERFERENCE ARISING FROM THE VARIABLE CHARGES ON THE FLUORESCENT SCREEN.—Zeitline. (*Rev. Gén. de l'Elec.*, 31st Oct. 1936, Vol. 40, p. 144 D: French Pat. 801 211, pub. 30.7.1936.)
969. THE MEASUREMENT OF THE STRENGTH OF BROADCAST INTERFERENCE [with the Siemens & Halske Interference Meter].—K. Müller & U. Steudel. (*Bull. Assoc. suisse des Elec.*, No. 21, Vol. 27, 1936, pp. 605 & 608: summary only, in German.) See also 1029 and 1032/3 of 1935.
970. ALTERATIONS TO THE VDE REGULATIONS FOR PREVENTION OF BROADCAST INTERFERENCE.—(*E.T.Z.*, 17th Dec. 1936, Vol. 57, No. 51, p. 1495.)
971. REPORT ON THE MEETING OF THE GROUP OF EXPERTS OF THE SPECIAL INTERNATIONAL COMMITTEE ON BROADCAST INTERFERENCE (CISPR) IN LONDON.—M. Dick. (*Bull. Assoc. suisse des Elec.*, No. 18, Vol. 27, 1936, pp. 524-525: in German.)

AERIALS AND AERIAL SYSTEMS

972. FULL-PARABOLIC REFLECTORS FOR MICRO-WAVES [Gain and Radiation Pattern: Theory and Experimental Confirmation].—C. J. H. A. Staal. (*Philips Transmitting News*, No. 3, Vol. 3, 1936, pp. 14-25: in German and English.)

The theoretical sections are based on the work of Darbord and of Brendel (see 1776 of 1936). The experimental work was carried out with 25 cm magnetron-generated waves, whose frequency and amplitude were kept specially constant by the use of a permanent magnet and of the supply-voltage regulator dealt with in 930, above. The parabolic reflector was made of wood, with a reflecting surface of copper filings applied with an adhesive. "A properly blended mixture . . .

ensures a minimum resistance, so that perfect reflection is bound to occur. Comparative experiments with plane full-metal mirrors and those of the construction described have not failed to confirm this assumption." The hemisphere in front of the valve was of copper.

It was found that the field strength was inversely proportional to the distance for ranges greater than 40λ . "Moreover it is remarkable that the apparent source of energy is not located in the focus, but some 5 metres beyond this point." The experimental radiation patterns showed good agreement with the calculated. The gain obtained from the measured curves was 19.5; calculation gave 20.5.

973. HIGH-FREQUENCY CURRENT MEASUREMENT [in Investigation of Current Distribution in an Ultra-Short-Wave Aerial].—H. Bühler. (*Helvet. Phys. Acta*, Fasc. 8, Vol. 9, 1936, p. 649: short summary only, in German.)

To avoid distorting the field, a rectangular exploring loop is used, small compared with the wavelength and containing a thermojunction. The calculated calibration of this device gives $I = I_0 \cdot \psi \cdot (1 + \phi)$, where ϕ represents the flux linkage of the loop with the aerial, ψ depends on the skin effect in the thermojunction, I_0 is the current indicated by the thermojunction, and I the aerial current.

974. ON THE RADIATION FIELD OF THE DIPOLE [Applications of Abraham's Elliptical-Coordinate Treatment].—H. Bühler. (*Helvet. Phys. Acta*, Fasc. 8, Vol. 9, 1936, pp. 649-650: in German.)

975. HORIZONTAL AERIALS AND DIRECT-COUPLED [Single-Wire] FEEDERS.—G. Latmirel. (*L'Electrotec.*, No. 19, Vol. 23, 1936, pp. 597-598: summary only.)

Experiments show that the efficiency of one-wire feeders is considerable and that the losses due to the imperfect conductivity of ground and to the earth connection can be kept low; troubles occurring with two-wire feeders, such as the variation of spacing produced by wind, are avoided. Moreover the single-wire feeder affords a simple way of employing horizontal aerials available for a number of wavelengths, e.g. over the range 15-40 metres.

976. STANDING AND PROGRESSIVE WAVES ON AERIALS [with Bottom or Mid-Point Feed: Theoretical Treatment].—E. Metzler. (*Bull. Assoc. Suisse des Elec.*, No. 21, Vol. 27, 1936, pp. 595-601: in German.)

"In the following paper the writer sets out to give a physically clear representation of the course of the current along an aerial, by analogy with an open line. Although for the sake of simplicity certain limitations are necessary, it is believed that on the whole a good picture of the fundamental relations can be obtained. . . . The treatment of an aerial as a homogeneous line is not strictly permissible, since its parameters, and therefore also its characteristic impedance, are continually varying. For the present investigation, however, a mean characteristic impedance is assumed and the lengths are measured in units corresponding to the smaller (fictitious) propagation velocity." From the conditions created by the progressive

wave for the current at the feeding point, the current in the aerial is determined in magnitude and phase. From the current distributions in aerials with base and mid-point feed, the vertical field-intensity diagrams are deduced; of the base-fed aerial the writer remarks (p. 600): "as consideration of formula 9a shows, the real and imaginary parts of the integral in 9 cannot simultaneously pass through zero, from which the important conclusion emerges that the field strength only vanishes for $\phi = \pi/2$. This fact however has hitherto remained unrecognised in the planning of aerials": he refers here to his paper dealt with in 3376 of 1936.

A numerical example is worked out for each of the two types of feed. The larger nodal current (for equal maximum currents) of the base-fed aerial (Fig. 9) makes itself obvious: the corresponding vertical diagram is Fig. 11, while Fig. 12 is a vertical diagram calculated on the usual assumption of a sinusoidal current distribution. The absence of a zero-radiation angle other than 90° is clearly seen in both Figs. 10 (mid-point feed) and 11, whereas Fig. 12 shows such a zero angle: similar results by Berndt & Gothe (1777 of 1936: "in this work the phase signs are erroneously interchanged . . .") are mentioned. The integral equations for the base-fed and mid-point-fed aerials (eqn. 9a and the corresponding un-numbered equation also on p. 600, referred to as 10a), become identical in the limiting case where $l = 2l' = \lambda/2$ (quarter-wave aerial), and the vertical diagrams also become the same. For a French version of this paper see *Bull. Tech. de l'Administr. des T. et des T. Suisses*, No. 5, 1936.

977. RADIATION IMPEDANCE BETWEEN TWO ORTHOGONAL HALF-WAVE RADIATORS, AND ITS APPLICATIONS.—Y. Kato. (*Rep. of Rad. Res. in Japan*, May, 1936, Vol. 6, No. 1, Abstracts p. 2.)

"As examples, theories concerning two types of broadcasting antenna are developed, one being a half-wave vertical antenna having four horizontal auxiliary half-wave radiators arranged radially at the top, and the other being four radiators arranged to form a horizontal square, known as a short-wave broadcasting antenna of Telefunken type."

978. DIRECTIONAL CHARACTERISTICS OF ANY ANTENNA OVER A PLANE EARTH [Theory: Expressions for Field as Function of Direction at Distances of Many Wavelengths: Numerical Work used to find Total Radiation from Antenna also determines Its Directional Characteristics].—W. W. Hansen. (*Physics*, Dec. 1936, Vol. 7, No. 12, pp. 460-465.) Extension of work dealt with in 3382 of 1936.

979. THE EFFECT OF THE DOWN-LEAD FROM THE ANTENNA SUPPORTING TOWER [Theoretical and Experimental Investigation of the Elimination of Field Disturbance by means of Down-Lead with Lower End Insulated or Earthed through Reactance].—H. Mitui & K. Suzuki. (*Rep. of Rad. Res. in Japan*, May, 1936, Vol. 6, No. 1, Abstracts pp. 2-3.)

980. THE EXTERNAL MODERNISATION OF VALENTIA RADIO STATION [Replacement of Old Tubular Masts by Lattice Type].—L. L. Hall. (*P.O. Elec. Eng. Journ.*, Jan. 1937, Vol. 29, Part 4, pp. 285-289.)

981. "BEITRAG ZUR BERECHNUNG VON MAST-FUNDAMENTEN" [Book Review].—H. Fröhlich. (*Electrician*, 4th Dec. 1936, p. 699.)

982. CALCULATION OF RESISTANCES TO GROUND [with Formulae for Various Forms of Grounding Conductor].—H. B. Dwight. (*Elec. Engineering*, Dec. 1936, Vol. 55, pp. 1319-1328.)

VALVES AND THERMIONICS

983. DISCUSSION ON "TRANSIT-TIME EFFECTS IN DIODES, IN PICTORIAL FORM."—Sloane & James: Moullin. (*Journ. I.E.E.*, Jan. 1937, Vol. 80, No. 481, pp. 103-106.) See 4058 of 1936. Moullin stresses the importance of the inter-electrode capacity changes in connection with frequency stability, and gives a simplification of the classic analysis, which he has carried out in the hope of throwing light on this effect.

984. A SPECTROSCOPIC STUDY OF THE MAGNETRON DISCHARGE [in Various Gases: Efficiency of Production of Higher States of Ionisation: Effect of varying Voltage, Current, and Gas Pressures].—O. Luhr & F. J. Studer. (*Phys. Review*, 1st Dec., 1936, Series 2, Vol. 50, No. 11, p. 1095: abstract only.)

985. PAPERS ON MAGNETRON GENERATORS.—(See 921/931 and 937.)

986. A HOT-CATHODE RECTIFIER VALVE WITH MAGNETIC FIELD AND LOW GAS PRESSURE.—Jurriaanse. (*Physica*, Jan. 1937, Vol. 4, No. 1, pp. 23-27: in German.)

A gas-filled hot-cathode rectifier is the more reliable (more free from back-discharge) the lower its gas pressure. But at a conveniently low gas pressure such as 10^{-3} tor (1 tor = 1 mm mercury) the working voltage may have risen from 11-12 volts to 60 or more volts, which means not only a waste of energy but also an undesirable amount of cathode disintegration and a consequent shortening of life. A magnetic field has the effect, as regards working voltage, of an apparent increase of gas pressure (see, for example, 125 of January), and the writer describes experiments with mercury-vapour tubes in which this fact is utilised. Tubes of 1.5×10^{-3} tor with a magnetic field were found to have the same working voltage (11 volts) and the same life as ordinary tubes of 8×10^{-3} tor, whereas the life of a low-pressure tube without a magnetic field (voltage about 40 volts) was about one-eighth of the normal.

987. "RÖHRENBUCH FÜR RUNDFUNK- UND VERSTÄRKERTECHNIK" [Book Review].—F. Bergtold. (*E.T.Z.*, 24th Dec. 1936, Vol. 57, No. 52/53, pp. 1523-1524.)

988. MODERN RECEIVING VALVES: DESIGN AND MANUFACTURE.—M. Benjamin, C. W. Cosgrove & G. W. Warren. (*Nature*, 2nd Jan. 1937, Vol. 139, p. 34: short note only of recent I.E.E. paper.)

989. FLUCTUATIONS IN A DYNATRON CIRCUIT.—I. Berstein. (*Physik. Zeitschr. der Sowjetunion*, No. 4, Vol. 10, 1936, pp. 510-517: in English.)

"The shot effect of secondary electron emission has been recently discussed by Ziegler and by Hayner [2190 (and 2618) of 1936: 143 of 1936]. The present paper treats in greater detail, with the aid of the Einstein-Fokker equation, the problem of the influence of the shot effect on fluctuations in an oscillatory circuit connected in series to an electron tube producing the dynatron effect." A conclusion reached by Ziegler is refuted.

990. SECONDARY EMISSION OF PURE METALS, and CRITICAL POTENTIALS OF SECONDARY EMISSION [and Their Agreement with Values corresponding to the Energy Levels of the External Orbits].—R. Warnecke. (*Journ. de Phys. et le Radium*, June, 1936, Vol. 7, No. 6, pp. 270-280: July, No. 7, pp. 318-320.)

991. THE SECONDARY ELECTRON EMISSION FROM OXIDISED SILVER AND MOLYBDENUM SURFACES.—A. V. Afanas'eva & P. V. Timofeev. (*Journ. of Tech. Phys.* [in Russian], No. 11, Vol. 6, 1936, pp. 1848-1854.)

Experiments were carried out to investigate the secondary electron emission from silver and molybdenum surfaces covered with a thin film of oxide. The apparatus used is described and the results obtained are shown in a number of curves. It appears that a sharp fall occurs in the secondary emission when a film of about 50 molecular layers of oxide is deposited on a silver surface, and that a further increase in the thickness of the film produces only a comparatively small effect. Similar results were observed with molybdenum surfaces: a tentative explanation of the phenomenon is offered.

992. LIBERATION OF SECONDARY ELECTRONS FROM METALLIC SURFACES BY ELECTRON IMPACT [and the Measurement of the Coefficient of Liberation].—P. Colombino. (*Nuovo Cimento*, May, 1936, Vol. 13, No. 5, pp. 205-213.)

993. PAPERS ON SECONDARY EMISSION, ELECTRON-MULTIPLIERS, IMAGE-TRANSFORMERS, ETC. (See 1045/1052.)

994. THE PROCESSES IN THE ACTIVATION OF OXIDE-COATED CATHODES: I—THE ALTERATION OF THE EMITTING SURFACE.—W. Heinze & S. Wagener. (*Zeitschr. f. tech. Phys.*, No. 12, Vol. 17, 1936, pp. 645-653.)

Authors' summary:—"The change of the surface of oxide-coated cathodes, with nickel or platinum base, during activation has been investigated by electron-optical image formation and simultaneous emission measurements. It is found that after only a very short heating the cathode is completely covered with emission centres. This coating changes comparatively little on further heat treatment, but the emission, on the other hand, alters very much. It is also found that the emission state reached by the thermal activation of cathodes with nickel tubes is stable and cannot be improved by further 'forming' by [electron] current flow [electrolytic 'forming']".

"The surface alteration occurring in the latter type of forming process (with emission) is also investigated, and it is found that the surface changes are slight compared with the emission changes. With cathodes 'poisoned' by oxygen the same emission picture is obtained as with 'non-poisoned' cathodes. The discussion of the results obtained leads to the conclusion that there is a very high probability that the greater part of the emission increase resulting from activation is due to the decrease of the internal 'loosening work' [Ablösearbeit: = ΔW , where W is Sommerfeld's "internal work function"—see van Geel, 1931 Abstracts, p. 513] of the electrons in the oxide layer, whilst the external work function is changed comparatively little." Thus neither de Boer's picture of the mechanism (activation greatly increases the constant A_i but leaves the work function practically unchanged), nor the dipole theory with its "islands of invariable work function," truly represents the process of activation.

995. FILMS FORMED ON ELECTRODES DURING ACTIVATION OF OXIDE-COATED CATHODES [attributed to Formation of Polymerised Carbon/Oxygen Compounds by Surface Reaction].—L. B. Headrick & E. A. Lederer. (*Phys. Review*, 1st Dec. 1936, Series 2, Vol. 50, No. 11, p. 1094: abstract only.)

996. INFLUENCE OF OXYGEN ON THERMIONIC EMISSION [of Thoriated Tungsten and Molybdenum] ACCORDING TO INVESTIGATIONS WITH THE ELECTRON MICROSCOPE.—H. Mahl. (*Zeitschr. f. tech. Phys.*, No. 12, Vol. 17, 1936, pp. 653-656.)

Author's summary:—(1) Oxygen most readily affixes itself to those thorium-coated crystallites of tungsten or molybdenum which are most strongly emissive in high vacuum. (2) The probability of adsorption of oxygen is specially high at the edges of spots on the cathode already coated with oxygen. (3) The evaporation of oxygen occurs progressively from the edge regions of the oxygen-free cathode spots. (4) The thorium coating appears not to be appreciably changed after the application and subsequent evaporation of the oxygen. (5) The intensity distribution, in the emission picture of the oxygen-coated cathode, appears different from that of the oxygen-free cathode with thorium coating. (6) For very low oxygen pressures the oxygen fixation, for a given thorium coating, takes place only below a definite temperature. (7) The adsorbed electro-negative oxygen appears to compensate the electro-positive dipole coating of thorium. (8) The influence of oxygen on the emissivity of hot cathodes throws light on some hitherto unexplained observations ("picture reversal") of other workers.

997. ELECTRON-OPTICAL OBSERVATION OF METAL SURFACES. I—IRON: FORMATION OF THE "CRYSTAL PATTERN" ON ACTIVATION [with Strontium: Features in Common with Activation of Thoriated Tungsten].—W. G. Burgers & Ploos van Amstel. (*Physica*, Jan. 1937, Vol. 4, No. 1, pp. 5-14: in English.) For Part II (on the transition of α into γ iron) see *ibid.*, pp. 15-22, and also 761 of 1936.

998. THE PROCESS OF THE SETTING FREE OF ELECTRONS FROM INCANDESCENT SOLID BODIES, ACCORDING TO ELECTRON-OPTICAL INVESTIGATIONS [on Thoriated Cathodes: Confirmation of Lenard's "Indirect" Hypothesis (Local Action due to Thermal Motion of Atoms) rather than the Richardson-Langmuir "Electron Gas" Hypothesis].—A. Gehrts. (*Zeitschr. f. tech. Phys.*, No. 12, Vol. 17, 1936, pp. 656-660.)
999. ELECTRON EXCHANGE IN THE THEORY OF METALS [Principles underlying Application of Fock Equations to Problems of Conductivity, Thermionic Emission, etc.].—J. Bardeen. (*Phys. Review*, 1st Dec. 1936, Series 2, Vol. 50, No. 11, pp. 1098-1099: abstract only.)
1000. THE THERMIONIC EMISSION OF PLATINUM [Measured Values of Work Function and Thermionic Constants: No Special Theoretical Explanations required for Platinum].—L. V. Whitney. (*Phys. Review*, 15th Dec. 1936, Series 2, Vol. 50, No. 12, pp. 1154-1157.)
1001. EMISSION OF NEGATIVE ELECTRICITY BY INCANDESCENT PLATINUM IN CHLORINE [Data of Increase of Emission at Various Pressures].—S. Kalandyk. (*Zeitschr. f. Physik*, No. 9/10, Vol. 103, 1936, pp. 583-597.)

DIRECTIONAL WIRELESS

1002. A STUDY OF THE DIRECT-READING ABSOLUTE ALTIMETER FOR AERONAUTICS BY THE RADIO WAVE REFLECTION METHOD ["Frequency Modulation" Principle].—S. Matsuo. (*Rep. of Rad. Res. in Japan*, May, 1936, Vol. 6, No. 1, Abstracts p. 10.)

The original paper was referred to in 3048 of 1936. Very small altitudes (less than 4 metres) are easily indicated: heights of over 160 metres are measured for a power consumption of 3.9 watts. For the author's paper on the frequency-modulation method applied to supersonic waves for shallow-water sounding see 1116 of 1935.

1003. BAD-WEATHER LANDING APPARATUS [for Aircraft: Telefunken Designs].—W. Moser. (*Telefunken Zeit.*, 1st Nov. 1936, Vol. 17, No. 74, pp. 5-18.)

General principles of the use of radio waves in directing the flight of aircraft, and American methods for facilitating landing in bad weather (when visibility on the ground is 30 to 50 m) are first described. The main part of the paper gives a detailed description of the apparatus designed by Telefunken for this purpose. The beacon emitter (circuit Fig. 1) works on a fixed wavelength of 9 m; the emitter of signals for arriving aircraft (Fig. 12) uses a wavelength of 7.9 m. Apparatus used on the aircraft includes a receiver designed for either of these wavelengths (Fig. 17). The aerodromes and machines which have been fitted with the apparatus are enumerated, with a diagram showing the arrangement inside a passenger air liner.

ACOUSTICS AND AUDIO-FREQUENCIES

1004. THE SOUND INSULATION OF SINGLE AND COMPLEX PARTITIONS [Experimental Results, with Curves showing Correlation between Sound Insulation and Weight of Single Homogeneous Partitions: Principles of Design of Sound-Insulating Constructions].—J. E. R. Constable & G. H. Aston. (*Phil. Mag.*, Jan. 1937, Series 7, Vol. 23, No. 152, pp. 161-181.) For previous work see 574/5 of February.
1005. SOME DATA ON A ROOM DESIGNED FOR "FREE FIELD" MEASUREMENTS.—E. H. Bedell. (*Journ. Acoust. Soc. Am.*, Oct. 1936, Vol. 8, No. 2, pp. 118-125.)
1006. THE EFFECT OF AIR COUPLING IN ACOUSTIC INSULATION BY MEANS OF ELASTIC SUPPORTS [Coupling due to Interspace Air can limit Advantage obtainable].—A. H. Davis & A. E. Knowler. (*Phil. Mag.*, Jan. 1937, Series 7, Vol. 23, No. 152, pp. 154-157.)
1007. NBC STUDIO DESIGN.—R. M. Morris & G. M. Nixon. (*Journ. Acoust. Soc. Am.*, Oct. 1936, Vol. 8, No. 2, pp. 81-90.)
1008. THE ELECTROACOUSTIC ARRANGEMENT IN THE STATE THEATRE IN THE "GENDARMEN-MARKT" IN BERLIN [Production of Stage Effects: Amplification: Circuits, Loudspeakers, etc.].—J. Kirstaedter. (*Telefunken Zeit.*, 1st Nov. 1936, Vol. 17, No. 74, pp. 28-35.)
1009. THE EFFECT OF VOLUME COMPRESSION ON THE TOLERABLE NOISE LEVEL IN ELECTRICAL COMMUNICATION SYSTEMS.—E. L. E. Pawley: Divoire. (*Wireless Engineer*, Jan. 1937, Vol. 14, No. 160, pp. 12-14.) Application of Divoire's methods (1899 of 1936) to the problem of volume compression.
1010. A MILLION-CYCLE TELEPHONE SYSTEM [Features and Technical Performance of the New-York/Philadelphia Coaxial Cable].—M. E. Strieby. (*Elec. Engineering*, Jan. 1937, Vol. 56, pp. 4-7.)
1011. ADJUSTABLE RESONATORS AND [Future Application to] ORCHESTRATION.—W. A. Osborne. (*Nature*, 19th Dec. 1936, Vol. 138, p. 1059.)
1012. MICROPHONES: PRESSURE AND VELOCITY TYPES [Electrodynamic, Piezoelectric and Capacity Construction in Each Type: Directional Characteristics, etc.].—F. N. G. Leever. (*Wireless World*, 1st Jan. 1937, Vol. 40, pp. 2-5.)
1013. ARRANGEMENT FOR ELIMINATING ACOUSTIC REACTION [with Microphone and Loudspeaker in Same Place: Microphone Winding on Inelastic Body which carries Loudspeaker Coil].—F. Gladenbeck. (*Hochf. tech. u. Elek. akus.*, Nov. 1936, Vol. 48, No. 5, p. 180: German Patent 628 216 of 6.3.34.)
1014. MICROPHONIC FLAMES.—Z. Carrière. (*Journ. de Phys. et le Radium*, Dec. 1936, Vol. 7, No. 12, pp. 145-146 S: summary only.)

1015. ON THE THEORY OF THE ELECTRO-DYNAMIC MICROPHONE.—L. Ya. Gutin. (*Journ. of Tech. Phys.* [in Russian], No. 11, Vol. 6, 1936, pp. 1885-1904.)

An equivalent electrical circuit of the microphone is derived, and a detailed theoretical investigation is presented of its operation, using network theory. Conditions are determined for obtaining a uniform input impedance (of the lowest possible value) for a given frequency range, and formulae are also derived determining, for a given load, the maximum efficiency of the microphone and the optimum mass of the moving coil. The theoretical discussion is illustrated by a number of numerical examples, and in an appendix a study is made of the operation of the Wenté & Thuras microphone using a tube for reinforcing the low-frequency response. In another appendix conversion formulae are derived for obtaining the various constants of the equivalent electrical circuits.

1016. ROCHELLE-SALT CRYSTAL MICROPHONE AND UNDER-WATER ACOUSTIC RECEIVER [including Method of Mounting Composite Crystal without Cementing Material: Very Wide Frequency Range—Audio and Supersonic Frequencies].—T. Sugimoto. (*Rep. of Rad. Res. in Japan*, May, 1936, Vol. 6, No. 1, Abstracts pp. 9-10.)

1017. EXPERIMENTS ON ACOUSTICAL WAVES OF LARGE AMPLITUDE [and Their Anomalies].—Ghiron. (*Alta Frequenza*, Nov. 1936, Vol. 5, No. 11, pp. 735-736.)

Referring to his theoretical work (1035 of 1936), Ghiron discusses some experimental results, recently obtained by Schmidt with large-amplitude oscillations in gas columns in pipes, which would seem to reveal the existence of effects very similar to his own theoretically predicted phenomena.

1018. CORRECTIONS TO "THE CALCULATION OF THE VIBRATION FORMS OF A CIRCULAR PLATE WHICH IS SUPPORTED AT THE EDGE WITH FRICTION . . ."—Ostroumov. (*Tech. Phys. of USSR*, No. 11, Vol. 3, 1936, p. 1005.) See 3801 of 1936.

1019. A METHOD OF ELIMINATING CAVITY RESONANCE, EXTENDING LOW-FREQUENCY RESPONSE, AND INCREASING ACOUSTIC DAMPING IN CABINET-TYPE LOUDSPEAKERS [Back of Cone coupled tightly to "Acoustical Labyrinth"].—B. Olney. (*Journ. Acoust. Soc. Am.*, Oct. 1936, Vol. 8, No. 2, pp. 104-111.) Including a description of Flanders's apparatus (1932 Abstracts, p. 589) for measuring acoustic impedance, modified so as to be suitable for large diameters.

1020. LOUDSPEAKERS FOR HIGH-FIDELITY LARGE-SCALE REPRODUCTION OF SOUND.—F. Massa. (*Journ. Acoust. Soc. Am.*, Oct. 1936, Vol. 8, No. 2, pp. 126-132.)

1021. PICK-UPS AND LOUDSPEAKERS ACCORDING TO VDE REGULATIONS [for Safety].—Harnisch & Gebhardt. (*E.T.Z.*, 3rd Dec. 1936, Vol. 57, No. 49, pp. 1421-1423.)

1022. MEASURING METHODS FOR LOUDSPEAKERS.—Steudel & Schaaf. (*Bull. Assoc. suisse des Elec.*, No. 22, Vol. 27, 1936, p. 642: summary only.)

1023. THE SUITABILITY OF THE VARIOUS KINDS OF PHOTOELECTRIC CELLS FOR SOUND-FILM TECHNIQUE.—Kotowski. (See 1055.)

1024. SOUND REPRODUCTION: FILM GRAVING METHODS USED IN FRANCE [for Broadcasting].—Philips. (*Electrician*, 11th Dec. 1936, p. 733.)

1025. SIMPLIFYING THE BEAT-FREQUENCY OSCILLATOR [for testing Receivers: Three Valves only, by use of Triode-Hexode as Mixer].—C. P. Edwards. (*Wireless World*, 22nd Jan. 1937, Vol. 40, pp. 82-84.) The advantage of the triode-hexode is the avoidance, without complications, of "pulling" and wave-form distortion at low frequencies; also its power of giving a large output voltage at the difference frequency without distortion, eliminating intermediate a.f. stages.

1026. TELEPHONOMETRY: ITS INTERNATIONAL BASES AND ITS APPLICATIONS TO THE STUDY OF THE ELECTROACOUSTIC PROPERTIES OF SUBSCRIBERS' MICROPHONES AND RECEIVERS.—P. Chavasse. (*Ann. des Postes, T. et T.*, Dec. 1936, Vol. 25, No. 12, pp. 1082-1121.)

1027. LOGARITHMIC AND LINEAR SCALE OF ACOUSTIC INTENSITY [Uses and Relations to Scale of Sensations].—Bürck, Kotowski & Lichte. (*Ann. der Phys.*, Series 7, No. 7, Vol. 27, 1936, pp. 664-668.)

1028. DEVIATIONS IN THE LOUDNESS JUDGMENTS OF 100 PEOPLE.—Steinberg & Munson. (*Journ. Acoust. Soc. Am.*, Oct. 1936, Vol. 8, No. 2, pp. 71-80.)

1029. AMERICAN TENTATIVE STANDARDS FOR NOISE MEASUREMENT Z24.2-1936: FOR SOUND LEVEL METERS Z24.3-1936.—(*Journ. Acoust. Soc. Am.*, Oct. 1936, Vol. 8, No. 2, pp. 143-146: pp. 147-152.)

1030. THE RÔLE OF ACOUSTICAL MEASUREMENTS IN MACHINERY QUIETING.—E. J. Abbott. (*Journ. Acoust. Soc. Am.*, Oct. 1936, Vol. 8, No. 2, pp. 133-142.)

1031. THE NATIONAL PHYSICAL LABORATORY [Work on Acoustics].—(*Engineering*, 20th Nov. 1936, pp. 547-549.) Based on the N.P.L. Report.

1032. ACOUSTICS AT THE PHYSICAL CONGRESS IN BAD SALZBRUNN [Notes on Papers on Recent Work on Supersonic Waves, Physiology of Hearing, Space Acoustics, Electrical Transmission of Speech and Music, Transient Phenomena in Organ Pipes, Resonant Properties of Stringed Instruments, &c.].—F. Trendelenburg. (*Naturwiss.*, 18th Dec. 1936, Vol. 24, No. 51, pp. 809-813.)

1033. THE STUDY OF THE DURATION OF CONTACT OF A PIANOFORTE STRING WITH A HARD HAMMER STRIKING NEAR THE END.—S. C. Dhar. (*Indian Journ. of Phys.*, July, 1936, Vol. 10, Part 4, pp. 305-311.)

1034. AN ELECTRODYNAMIC BRIDGE FOR STRINGED INSTRUMENTS [e.g. Violins] AND ITS POSSIBLE APPLICATIONS TO ELECTRO-ACOUSTICS AND BROADCASTING.—G. Giulietti. (*L'Electrotec.*, No. 18, Vol. 23, 1936, p. 567.)
1035. PHYSICAL NATURE OF CERTAIN OF THE VIBRATING ELEMENTS OF THE INTERNAL EAR [Experimental Support for Helmholtz's Resonator Theory from Effects of Reversal of Phase of Continuous Musical Tone].—Hallpike, Hartridge & Rawdon-Smith. (*Nature*, 14th Nov. 1936, Vol. 138, pp. 839-940.)
1036. VOCAL RESONANCE [Procedure for Investigation of Resonance Properties of Vocal Cavities, and Data obtained].—D. Lewis. (*Journ. Acoust. Soc. Am.*, Oct. 1936, Vol. 8, No. 2, pp. 91-99.)
1037. NEW VANTAGE GROUNDS IN THE PSYCHOLOGY OF MUSIC [Baconian Lecture].—C. E. Seashore. (*Science*, 11th Dec. 1936, Vol. 84, pp. 517-522.)
1038. SYNTHESISING SPEECH [Harvard Demonstration].—H. Dudley. (*Bell Lab. Record*, Dec. 1936, Vol. 15, No. 4, pp. 98-102.) See also 180 of January.
1039. STROBOSCOPIC PHENOMENA IN THE PASSAGE OF LIGHT THROUGH TWO SUPERSONIC WAVES.—R. Bär. (*Helvet. Phys. Acta*, Fasc. 8, Vol. 9, 1936, pp. 678-688 : in German.)
1040. THE BIOLOGICAL ACTION OF SUPERSONIC WAVES [on the Heart of Cold-Blooded Animals and on Yeast Cells].—F. Förster & A. Holste. (*Naturwiss.*, 1st Jan. 1937, Vol. 25, No. 1, pp. 11-12.)
1041. SOME NEW PHENOMENA PRODUCED BY SOUND VIBRATIONS [Acoustic Jets and Liquid Diaphragms: Sonic Amplifier and Pendulum maintained by Sound Vibrations.].—F. L. Hopwood. (*Nature*, 19th Dec. 1936, Vol. 138, p. 1059.)
1042. THE INFLUENCE OF THE VELOCITY OF DETONATION OF AN EXPLOSIVE ON THE VELOCITY OF THE SHOCK WAVE [Velocities of Detonation and of Shock Wave increase with Density of Explosive Charge and reach Maximum].—P. Laffitte & A. Parisot. (*Comptes Rendus*, 18th Jan. 1937, Vol. 204, No. 3, pp. 179-181.)

PHOTOTELEGRAPHY AND TELEVISION

1043. INTERLACED SCANNING IN TELEVISION [Different Methods and Their Suitability in Various Cases].—R. Urtel. (*Telefunken Zeit.*, 1st Nov. 1936, Vol. 17, No. 74, pp. 36-42.)

The general advantages and disadvantages of the method of interlaced scanning are first analysed. The methods available are then discussed; the general principle is shown in Fig. 39 and the properties of various special combinations of the interlacing are described. The combinations recommended as particularly suitable for various practical

requirements are given. The total combinations are classified (Fig. 42) into three main types *A*, *B*, and *C*, according to whether *z* (the number of lines in a raster) is equal to $2n$, $2n + 1$, or $2n \pm \frac{1}{2}$. These main types each have three subdivisions 1, 2 and 3, according to the position of the second raster; these are further subdivided into three groups *a*, *b*, and *c*, according to the moment of the first raster fly-back (fly-backs *b* and *c* occur $\frac{1}{2}t_z$ and $1t_z$, respectively, earlier than fly-back *a*; t_z being the duration of one line). Of the various combinations discussed, "only cases *A2a*, *A2c*, and *B1a* have been dealt with in the literature," but the special characteristics of all are shown in Fig. 42 as regards line phase (at the change from one raster to the other), "Sprunghöhe" (amplitudes of the two fly-backs—whether equal or unequal), etc.

1044. A CONTROLLABLE COLD-CATHODE-RAY OSCILLOGRAPH WORKED WITH AN AUXILIARY DISCHARGE.—F. A. Becker. (*Arch. f. Elektrot.*, 21st Dec. 1936, Vol. 30, No. 12, pp. 791-799.)

For previous work see 1501 of 1936. Here the construction and working of the new tube (Fig. 5) are described in more detail; the effectiveness of the auxiliary discharge is increased by lowering the pressure by opposite cathodes (Fig. 3) and by the presence of a magnetic field (Fig. 4). External photographs with a recording velocity of 250 km/s were obtained, using a voltage of about 10 kv. The brightness of the spot can be increased without distortion by using a stop before the cathode (Fig. 14); the tube may then be used for television reception. Oscillograms and experimental results are given to illustrate the good quality of the tube.

1045. AN APPARATUS FOR THE TRANSFORMATION OF LIGHT OF LONG WAVELENGTH INTO LIGHT OF SHORT WAVELENGTH. III—AMPLIFICATION BY SECONDARY EMISSION [and the Use of Curvilinear Electron Paths produced by Suitable Magnetic Fields.].—Coeterier & Teves. (*Physica*, Jan. 1937, Vol. 4, No. 1, pp. 33-40 : in English.)

For previous work see 240 of January. By the use of curvilinear magnetic fields it is possible to use a non-transparent photocathode, with its advantages. In Fig. 6, the "immersion system" of the photocathode gives a beam of 5000 volts. A similar ring-and-plate system along the curvilinear path has its caesium-treated plate at -4500 volts, so that the beam falls on the plate with a velocity of 500 volts and frees secondary electrons which in turn are accelerated in the opposite direction with a velocity of 4500 volts. Because of the spiral motion of the primary and secondary beams, the picture thus amplified and focused falls above the original photocathode, at a point where a fluorescent screen is introduced; or additional amplifying stages can be mounted, one above the other. An example of results is given.

1046. AMPLIFIERS FOR LIGHT [Image thrown on Photocathode reproduced on Fluorescent Plate very close to this but separated by Thin Opaque Semiconductor to prevent Optical Retroaction].—Barthélémy & Zeitline. (*Rev. Gén. de l'Élec.*, 28th Nov. 1936, Vol. 40, p. 175 D; French Pat. 802 244, pub. 31.8.1936.)

1047. ELECTRON OPTICS OF AN IMAGE TUBE [Experimental and Theoretical Study of Focusing Properties and Image Defects: Natural Limits imposed by Focusing Characteristics and Aberrations: Suggestions for Future Improvements].—G. A. Morton & E. G. Ramberg. (*Physics*, Dec. 1936, Vol. 7, No. 12, pp. 451-459.)

From the authors' summary:—(1) Description of fixed-focus and variable-focus electrostatic image tubes. (2) *Focusing properties*: measurement of the variation of image distances and magnification with object distance and ratio of applied voltages, for both types of tubes; calculation of potential distributions and electron paths; comparison of experimental and theoretical results. (3) *Aberrations*: Classification; measurement of tangential and sagittal image surfaces for fixed-focus tube; calculation of axial (chromatic and spherical) aberrations; calculation of field aberrations; comparison between measurements and calculation; reduction of field aberrations by curving the cathode.

1048. ABSORPTION OF SOME METALLIC HALIDES IN THE SCHUMANN REGION [Measurements of Absorption Bands].—H. M. O'Bryan & E. G. Schneider. (*Phys. Review*, 1st Dec. 1936, Series 2, Vol. 50, No. 11, p. 1096: abstract only.)

1049. EXPERIMENTS WITH MAGNETIC ELECTRON-MULTIPLIERS OF A.C. TYPE.—K. Okabe. (*Rep. of Rad. Res. in Japan*, Oct. 1936, Vol. 6, No. 2, pp. 75-79.)

"In a previous communication [4123 of 1936] the writer proposed, theoretically, the use of magnetic electron-multipliers of a.c. type, which he classified into three types, 1, 2, and 3. This paper gives the results of experiments made with types 1 and 2. . . . They show that there was no difference between experiment and theory. They also show that abnormal phenomena occur in some cases."

1050. ON THE CORRELATION OF THE SECONDARY EMISSION OF ELECTRODES POSSESSING PHOTO-SENSITIVITY AND THE THERMO-EFFECT OF IONS.—A. Dobrolyubski. (*Physik. Zeitschr. der Sowjetunion*, No. 2, Vol. 10, 1936, pp. 242-244.)

English version of the paper referred to in 245 of January. "On the basis of experiments on secondary emission of electrodes consisting of layers of Cs-Cs₂O-Ag, Cs-Cs₂O-Cu and Cs-Cs₂O-Ni, it was established that the coefficient of secondary emission—when these layers are bombarded by electrons—is in principle determined by their integral sensitivity in the ultra-violet region. . . . The secondary emission of electrons takes place in the surface of the lining, *i.e.* Cu, Ag, or Ni, underneath, and in the layer of Cs₂O. Therefore it is possible to obtain layers, and Kubetski tubes [243 of January] with such layers, without photo-sensitivity in the visible and infra-red regions, but having a normal emission of electrons." Tests here described, on Cs-Cs₂O-Ag layers, show that the saturation of secondary emission "does not take place at the cost of the destruction of the spatial charge, but by sucking out the electrons, with the electric field, from the lining [Ag] through the layer of Cs₂O.

At the same time the electrons are transferred, at the cost of the energy of the bombarding electrons, to a higher level of energy. The thermo-emission of ions also has a more profound origin than the photo-sensitivity in the infra-red region. . . ."

- 1050 bis. ON THE SECONDARY EMISSION OF ELECTRONS FROM A CAESIUM-OXYGEN ELECTRODE.—Timofeev & Pyatnitski. (*Physik. Zeitschr. der Sowjetunion*, No. 4, Vol. 10, 1936, pp. 518-530.) German version of the Russian paper dealt with in 604 of February.

1051. SIMULTANEITY OF THE ABSORPTION OF THE PRIMARY QUANTUM AND THE EMISSION OF SECONDARY RADIATION IN THE COMPTON EFFECT AND IN THE PHOTOELECTRIC EFFECT [Experimental Proof].—Piccard & Stahel. (*Journ. de Phys. et le Radium*, Aug. 1936, Vol. 7, No. 8, pp. 326-328.) Prompted by a paper by Shankland denying the coincidence.

1052. NEW PHOTOELECTRIC CELLS WITH TRANSPARENT CATHODES [with Caesium-Alloy (particularly Antimony/Caesium) Films deposited directly on Glass Wall: Sensitized with Oxygen].—Görlich & Sauer. (*E.T.Z.*, 17th Dec. 1936, Vol. 57, No. 51, p. 1474: summary only.)

1053. TIME LAG OF THE VACUUM PHOTOCCELL [Law of Proportionality between Quantity of Light and Photoelectric Current breaks down for Certain Cells and Very Short Illumination Periods: Duration of Induction Period].—R. A. Houston. (*Nature*, 2nd Jan. 1937, Vol. 139, pp. 29-30.)

1054. A NEW TYPE OF PHOTOEMISSIVE CELL.—G. A. Boutry. (*Comptes Rendus*, 11th Jan. 1937, Vol. 204, No. 2, pp. 120-122.)

The cell has a silver cathode with a guard-ring, both carrying photoemissive material. The anode is formed by a network of fine tungsten wires, which can be heated to incandescence, in a plane parallel to the cathode. The vessel containing the electrodes is large. Saturation is obtained for accelerating voltages of the order of three or four volts; there is practically no ionisation by collision. The cell was designed for precision photometry but the writer suggests that it may be used for television emitters, since the low voltage used would reduce background noise; it is pointed out, however, that the capacity is considerably larger than that of cells now used.

1055. THE SUITABILITY OF THE VARIOUS KINDS OF PHOTOELECTRIC CELLS FOR SOUND-FILM TECHNIQUE.—P. Kotowski. (*Telefunken Zeit.*, 1st Nov. 1936, Vol. 17, No. 74, pp. 18-27.)

The properties of alkali high-vacuum, gas-filled, barrier-layer and resistance photocells are described as regards the voltage they can deliver to a photo-cell amplifier, the "klirr" factor, noise, frequency curve, and length of life. It is found that the gas-filled alkali cells are at present the most suitable for use in sound-film technique, particularly in

respect of their frequency curves and the small degree of non-linearity in their characteristics.

1056. ON THE STABILITY OF SELENIUM PHOTOCELLS.—S. I. Freiwert. (*Journ. of Tech. Phys.* [in Russian], No. 11, Vol. 6, 1936, pp. 1855-1863.)

For previous work see 2741 of 1936. The present paper gives a theoretical as well as experimental investigation of the process of ageing of selenium barrier-layer photocells. On the basis of the results obtained it is suggested that the decrease with time of the photo-e.m.f. (i.e. of the potential difference at the terminals of the cell when this is open-circuited), and to a lesser degree of the photo-current, is probably caused by a fall in the resistance of the barrier layer. The deterioration of this layer is probably due to absorption of water vapour from the atmosphere, and (in the case of a gaseous barrier layer) also to the diffusion of the gas through the semi-transparent outer (gold) layer. Some improvement is obtained by covering the surface of the cell with a varnish. Of great importance for the stability of the cell is the atmosphere in which gold is deposited on the electrode, and experiments carried out with oxygen, hydrogen, and air have shown air to give the best results. The photocells prepared as above have shown when aged a very good stability, both with regard to photo-e.m.f. and photo-current, even under continuous illumination of the order of 15 000 lux lasting for 2 months.

1057. THE EXPLANATION OF THE PHOTOELECTRIC EFFECT WITH CUPROUS OXIDE.—W. Behrendt. (*Physik. Zeitschr.*, 15th Dec. 1936, Vol. 37, No. 24, pp. 886-901.)

The theories of the photoelectric effect at semiconductors are discussed; the conclusion is reached that Schottky's theory (see, for example, 1932 Abstracts, p. 419) is least in contradiction to the experimental results at present available. Measurements at various wavelengths of the variation of the photo-current yield in the "anterior-wall" effect for varying thickness of the superimposed metallic electrode are given (Figs. 1, 2) which make it probable that electron absorption is taking place in the metal. The photo-current with zero external resistance is found to be independent of the presence of a barrier layer. Measurements of thermoforces are given which show that there is no analogy between photo- and thermo-voltage for cuprous oxide. In a theoretical discussion, alterations in Schottky's theory are suggested; "the directional conductivity of the barrier layer is replaced by considerations of the long diffusion path of the electrons in the semiconductor and the marked absorption of electrons in the metal. The diffusion of the electrons set free by photoelectric action in the semiconductor is discussed. Formulae are found for the 'anterior-wall,' 'posterior-wall,' and crystal photoeffects, using Wolff's hypothesis (1932 Abstracts, p. 650), which agrees qualitatively with experimental results. From these formulae, conclusions are reached as to the temperature variation of photoelectric effects at semiconductors; they are confirmed by experiment."

1058. THE COOLING OF A SURFACE BY PHOTOELECTRIC EMISSION [Measurement of Energy lost by Surface agrees with Theoretical Expectation].—H. M. Zenor. (*Phys. Review*, 1st Dec. 1936, Series 2, Vol. 50, No. 11, pp. 1050-1053.)
1059. PHOTOCONDUCTIVITY IN [Insulating] CRYSTALS [Survey].—A. L. Hughes. (*Reviews of Mod. Phys.*, July, 1936, Vol. 8, No. 3, pp. 294-315.)
1060. SOME LUMINESCENT PHENOMENA IN CONNECTION WITH THE PRODUCTION OF SENSIBLY WHITE LIGHT [with Discharge Tube coated with Calcium Tungstate or Molybdate containing Rare Earth Elements].—M. Servigne. (*Comptes Rendus*, 7th Dec. 1936, Vol. 203, No. 23, pp. 1247-1249.) See also 259 of January.
1061. PRODUCTION OF WHITE LIGHT BY ELECTRICAL LUMINESCENCE IN GASES [Intense Gas Discharges produced for Very Short Periods at Rapid Intervals by Condenser in Series with Discharge Tube and Thyatron].—M. Laporte. (*Comptes Rendus*, 14th Dec. 1936, Vol. 203, No. 24, pp. 1341-1342.)
1062. WAVELENGTH STANDARDS IN THE EXTREME ULTRA-VIOLET [Suggested Wavelengths derived from Measurements].—K. R. More & C. A. Rieke. (*Phys. Review*, 1st Dec. 1936, Series 2, Vol. 50, No. 11, pp. 1054-1046: abstract p. 1096.)
1063. A METHOD FOR THE MEASUREMENT OF WIDEBAND CABLES [Natural Frequency excited in Open- and Short-Circuited Condition: Input Resistances are then Real and the Calculations are easily made].—H. Kaden. (*T.F.T.*, Dec. 1936, Vol. 25, No. 12, pp. 322-326.)
1064. A GERMAN EXPERT AT ALEXANDRA PALACE: INTERVIEW WITH THE DEPUTY-DIRECTOR OF TRANSMISSIONS, BERLIN.—Boese. (*World-Radio*, 25th Dec. 1936, p. 7.)
1065. TELEVISION AT THE 13TH GREAT GERMAN RADIO EXHIBITION, 1936.—G. Kette. (*T.F.T.*, Dec. 1936, Vol. 25, No. 12, pp. 332-339.)
1066. A NEW TELEVISION MONITORING SYSTEM [Cathode-Ray Oscillograph Equipment for checking Correct Ratio of Sight and Sound Output Powers].—W. S. L. Tringham. (*Marconi Review*, Sept./Oct. 1936, No. 62, pp. 28-29.)

MEASUREMENTS AND STANDARDS

1067. MEASURING THE NATURAL WAVELENGTHS OF WIRE CIRCUITS [with and without Air Gap] BY MEANS OF AN ULTRA-SHORT WAVE.—Ataka & Urano. (*Rep. of Rad. Res. in Japan*, Oct. 1936, Vol. 6, No. 2, Abstracts p. 16.) Summary of the Japanese paper referred to in 628 of February. See also 1068.

1068. ON A WAVEMETER FOR DECIMETRE WAVES ["Wire Wavemeter"].—Ataka & Mori. (*Rep. of Rad. Res. in Japan*, Oct. 1936, Vol. 6, No. 2, Abstracts pp. 18-19.)
From the paper dealt with above (1067), any simple single-turn wire circuit shows very sharp resonance, its fundamental natural wavelength being $\lambda = 2l$ for a circuit with a gap and $\lambda = l$ for a closed wire circuit. The "wire wavemeter," based on this, consists of parallel tubes, 8 cm long and 4 cm apart, each with a solid wire telescoping into it, the ends of these wires being closed by a thermojunction. The open ends of the tubes are connected through (a) a $3\ \mu\text{F}$ condenser; this gives a wave-range 102-66 cm; (b) a negligible capacity formed by a gap in the connecting wire, giving 62-50 cm; while (c) "with a short-circuited wire, wavelengths of from 50 cm to 36 cm can be measured."
1069. AN INDICATOR FOR ULTRA-SHORT WAVELENGTHS [Wavemeter with Two Major Ranges 200-30 and 32-3 Metres, selected by Plug & Socket: No Interchangeable Coils or External Batteries].—L. Bounds. (*Marconi Review*, Sept./Oct. 1936, No. 62 pp. 25-27.) Primarily for checking a commercial transmitter having its master-oscillator frequency of 2.5 Mc/s multiplied up in three stages to 45 Mc/s.
1070. PAPERS ON MAGNETOSTRICTION OSCILLATORS AND FILTERS.—Litshitz: Aoyagi. (*See 900/I.*)
1071. AN ANOMALY IN THE MAGNETOSTRICTION OF IRON [Phase Inversions between Bar Movement and Driving Current occur Not at Critical Points where Induction reverses (as with Nickel) but at Points of High Magnetisation].—G. Beauvais. (*L'Onde Elec.*, Dec. 1936, Vol. 15, No. 180, pp. 755-767.)
The behaviour of nickel has been studied by other workers, but "very little information on this subject is available regarding iron": the writer describes his tests to fill this gap, beginning with the construction of an interferometer in which water-cooling was provided to prevent the heat produced by the magnetising current from changing the temperature of the bar. The anomaly found was confirmed by another experiment (Fig. 8), but no explanation is offered.
1072. A SIMPLE FREQUENCY MONITOR FOR BROADCASTING TRANSMITTERS [Tuned Circuit with Quartz Plate and Thermoammeter: measuring Changes of 100 c/s in 735 kc/s].—H. Yokoyama. (*Rep. of Rad. Res. in Japan*, Oct. 1936, Vol. 6, No. 2, Abstracts pp. 15-16.)
1073. A WIDE-RANGE OSCILLATOR FOR THE HIGHER FREQUENCIES [50-5000 kc/s].—L. Arinige. (*Bell Lab. Record*, Dec. 1936, Vol. 15, No. 4, pp. 121-124.) Frequency variation about 5 cycles in 1 Mc/s when load impedance is changed from open to short circuit.
1074. DISCUSSION ON "A THYRATRON STROBOSCOPE" [for Frequency Measurement].—Spilsbury. (*Journ. I.E.E.*, Jan. 1937, Vol. 80, No. 481, p. 98.) *See 309 of January.*
1075. SOME METHODS OF LOCATING THE OPTIC AXIS IN QUARTZ [with Proof of Formulae employed and a Treatment of the Error due to Taper in the Specimen].—(*Marconi Review*, Sept./Oct. 1936, No. 62, pp. 1-7.)
1076. THE KINETIC BASIS OF CRYSTAL POLYMORPHISM, and THE GENERAL RÔLE OF COMPOSITION IN POLYMORPHISM.—M. J. Buerger. (*Proc. Nat. Acad. Sci.*, Dec. 1936, Vol. 22, No. 12, pp. 682-685; pp. 685-689.)
1077. HIGH-FREQUENCY CURRENT MEASUREMENT [along Ultra-Short-Wave Aerials].—Bühler. (*See 973.*)
1078. THE NATIONAL PHYSICAL LABORATORY: ELECTRICITY DEPARTMENT [including International Units, etc., and Measurement at Ultra-High Frequencies].—(*Engineering*, 20th & 27th Nov. 1936, pp. 549-550 & 576-578.) Based on the N.P.L. Report.
1079. APPARATUS FOR MEASURING FIELD STRENGTHS AT ULTRA-HIGH FREQUENCIES.—M. A. Divil'kovski & M. I. Filippov. (*Journ. of Tech. Phys.* [in Russian], No. 11, Vol. 6, 1936, pp. 1873-1884.)
It is suggested that by placing a mercury thermometer at a point in an ultra-high-frequency magnetic field and observing the temperature rise of the mercury for a definite time interval, the field strength at this point could be determined from previously prepared calibration curves. Similarly, thermometers with liquids having high dielectric losses, such as propyl alcohol, can be used for measuring the strength of an electrostatic field (*cf.* 1080, below). The method proposed is discussed in detail in its practical application to a Lecher system operating at a wavelength of 4.12 m. The experimental curves so obtained show a close approximation to the theoretical curves. In conclusion, methods are indicated for obtaining the calibration curves. *See also 264 of 1936.*
1080. THE MEASUREMENT OF ELECTRIC FIELD STRENGTHS AT [Ultra-] HIGH FREQUENCIES [by Heat generated in a Polar Dielectric].—N. N. Malov. (*Journ. of Tech. Phys.* [in Russian], No. 11, Vol. 6, 1936, pp. 2030-2031.)
In an article under the above title (267 of January) Braude has stated that the relaxation time he measured is double that measured by Malsch. It is suggested in the present note that in addition to the causes of this discrepancy enumerated in Braude's article, another factor may be of importance, namely the heating of the glass bulb of the indicator owing to the dielectric losses in the glass. To support this view it is shown that if an additional term (6'), which takes account of the heating of the bulb, is introduced into equation (6), a higher value of the relaxation time would be derived from equation (8). In conclusion, the possibility is indicated of utilising

this heating of the bulb for the direct measurement of electric field strengths. See also 1079.

1081. CALORIMETRIC MEASUREMENT OF DIELECTRIC LOSSES IN SOLIDS [at High Frequencies (1 Mc/s or over) and High Voltages (10 kV or over) in a Few Minutes by Transient Method].—H. H. Race & S. C. Leonard. (*Elec. Engineering*, Dec. 1936, Vol. 55, pp. 1347-1356.) The technique "can be more easily extended to ultra-high frequencies than can the conventional bridge or substitution methods."
1082. ABSOLUTE MEASUREMENT OF DIELECTRIC LOSSES AT HIGH FREQUENCIES WITH THE CONDENSER THERMOMETER [Detailed Discussion of Method: Measurements on Water and Organic Liquids: Voltage Dissociation Effect: Increase of Conductivity at High Frequencies due to Dipole Loss of Ion Pairs].—C. Schmelzer. (*Ann. der Phys.*, Series 5, No. 1, Vol. 28, 1937, pp. 35-53.)
1083. HIGH-VOLTAGE TESTING BY THE RECORDING OF DIELECTRIC LOSSES [to avoid Damage by Too Much Strain].—Keinath. (*Bull. Assoc. suisse des Elec.*, No. 25, Vol. 27, 1936, pp. 737-738: summary only.) See also 3521 of 1936.
1084. ON THE TECHNIQUE OF THE MEASUREMENT OF DIELECTRIC CONSTANTS [of Liquids] AT ULTRA-HIGH FREQUENCIES.—W. I. Kalinin. (*Physik. Zeitschr. der Sowjetunion*, No. 2, Vol. 10, 1936, pp. 257-259: in German.)
Modification of Drude's second method by the adaptation of a Darbord concentric-line wavemeter (1932 Abstracts, p. 346, last paragraph) which gives sharp resonance for a tight coupling to the oscillator and thus allows an ordinary microammeter to be used. Other advantages are also claimed, such as the elimination of disturbances from outside by the screening action of the outer conductor, which is earthed. Only a small sample of the liquid is needed (unlike Drude's first method): the container surrounds a small length of the inner conductor and is bounded by the outer, which has a small aperture for filling purposes.
1085. THE RESISTANCE AND CAPACITY BEHAVIOUR OF STRONG ELECTROLYTES IN DILUTE AQUEOUS SOLUTION. I—METHOD FOR THE SIMULTANEOUS OBSERVATION OF CONDUCTANCE AND DIELECTRIC CONSTANT AT HIGH RADIO FREQUENCIES [Wavelengths 10-180 Metres]: II—THE DISPERSION OF ELECTRICAL CONDUCTANCE.—Arnold & Williams. (*Journ. Am. Chem. Soc.*, Dec. 1936, Vol. 58, No. 12, pp. 2613-2616: pp. 2616-2624.)
1086. REMARKS ON THE PAPER BY VON ARDENNE, GROOS & OTTERBEIN ON "DISPERSION MEASUREMENTS IN THE REGION OF DECIMETRE WAVES."—M. Wien. (*Physik. Zeitschr.*, 1st Dec. 1936, Vol. 37, No. 22/23, pp. 869-871.)
For the paper in question see 4178 of 1936. A theoretical method is here given of determining the discontinuity wavelength λ_s of polar liquids from the dispersion of the dielectric constant. Its values are deduced from the measurements given in the paper and compared with those found by absorption measurements (e.g. 3124 of 1936). Discrepancies between the two values for various liquids may lead to further information concerning liquid structure.
1087. THE RANGES OF VALIDITY AND THE VALUES OF THE CONSTANTS OF LICHTENECKER'S VARIOUS FORMULAE FOR PROPERTIES OF MIXTURES [including Their Dielectric Constant and Conductivity].—D. A. G. Bruggeman. (*Physik. Zeitschr.*, 15th Dec. 1936, Vol. 37, No. 24, pp. 906-912.)
1088. MEASUREMENT OF THE DIELECTRIC CONSTANT OF SOME DILUTE SALT SOLUTIONS [Confirmation of Debye/Falkenhagen Theory for Quasi-Stationary State].—W. M. Mazee. (*Physik. Zeitschr.*, 15th Dec. 1936, Vol. 37, No. 24, pp. 914-916.) For method see 2021 of 1935.
1089. HIGH-FREQUENCY LOSSES AND QUASI-CRYSTALLINE STRUCTURE OF LIQUIDS [Theory of Effect of Quasi-Crystalline Liquid Structure on Frequency Variation of Dielectric Constant].—P. Debye & W. Ramm. (*Ann. der Physik*, Series 5, No. 1, Vol. 28, 1937, pp. 28-34.)
1090. CAPACITY AND LOSS MEASUREMENTS ON SMALL CONDENSERS [using the Geyger "C-tan δ Recorder"].—Keinath: Geyger. (*E.T.Z.*, 10th Dec. 1936, Vol. 57, No. 50, p. 1454: summary only.) See also Geyger, 1538 of 1936.
1091. A NOTE ON DIFFERENTIAL CONDENSERS AND RESISTORS [Method of Altering Their Range: Their Use for Measurement of Capacitance and Resistance Unbalances in Telephone Cables].—A. Rosen. (*P.O. Elec. Eng. Journ.*, Jan. 1937, Vol. 29, Part 4, pp. 319-321.)
1092. RELAXATION OSCILLATIONS OF STABLE PERIOD, OBTAINED WITH A GAS-FILLED TRIODE [and Their Application to Measurement of High Resistances].—Eck. (*See* 946.)
1093. METER WITH T-COIL MOVING SYSTEM [D.C. Quotient Meter, for Telemetering and Other Purposes].—Eggers. (*E.T.Z.*, 17th Dec. 1936, Vol. 57, No. 51, pp. 1484-1485.)
1094. AN IMPROVED VACUUM-TUBE MICRO-AMMETER [using D.C. Amplifier with Effect of Valve Characteristics on Calibration or Gain, and Tendency towards Drift, reduced to Second Order Effects by Negative Feedback].—A. W. Vance. (*Review Scient. Instr.*, Dec. 1936, Vol. 7, No. 12, pp. 489-493.)
1095. THE MEASUREMENT OF VELOCITY AND ENERGY DISTRIBUTIONS [Fundamental Considerations applicable to Various Branches of the Physics of Corpuscular Beams].—R. Kollath. (*Ann. der Phys.*, Series 5, No. 8, Vol. 27, 1936, pp. 721-741.)
Many branches of physics involve the experi-

mental determination of the velocity- or energy-distribution of a beam of charged particles. Here the relations are described between the values obtained by various methods of measurement and the coordinates of the desired distribution curves. Several published experiments in photoelectricity, secondary-electron emission, etc., are considered; the corrections required are evaluated numerically, in order to show that considerable errors may arise if the results are not correctly treated.

1096. THE EXACT EXPRESSION OF ROSA'S FORMULA FOR THE CALCULATION OF THE INDUCTANCE OF CYLINDRICAL AIR-COIL REACTORS.—F. Correggiari: Rosa. (*L'Elettrotec.*, No. 19, Vol. 23, 1936, pp. 602-603.)
1097. THE INDUCTANCE OF IRON-CORED COILS CARRYING DIRECT CURRENT [Calculations of Variation of Inductance with Length of Air-Gap in Iron Circuit: Effective Gap: Alignment Chart for determining Required Length of Gap].—G. F. Partridge. (*Phil. Mag.*, Jan. 1937, Series 7, Vol. 23, No. 152, pp. 99-106.) See also 310 of January.
1098. ELECTRICAL AND MAGNETIC DIMENSIONS.—G.W.O.H.: Lanchester. (*Wireless Engineer*, Jan. 1937, Vol. 14, No. 160, pp. 1-4.) Editorial in the form of a review of Lanchester's "The Theory of Dimensions & Its Application for Engineers."
1099. A PRACTICAL ABSOLUTE SYSTEM WHICH ALLOWS ABSOLUTE UNITS TO BE SUBSTITUTED FOR THE PRESENT INTERNATIONAL UNITS WITHOUT DIFFICULTY [Suggested Modification of Giorgi System].—H. König. (*Bull. Assoc. suisse des Elec.*, No. 22, Vol. 27, 1936, pp. 621-628: in French.) For correspondence see *ibid.*, No. 25, pp. 743-744.

SUBSIDIARY APPARATUS AND MATERIALS

1100. THE THERMIONIC AMPLIFICATION OF DIRECT CURRENTS.—Macdonald. (See 913.)
1101. THE INDUCTANCE OF IRON-CORED COILS CARRYING DIRECT CURRENT.—Partridge. (See 1097.)
1102. AN ARRANGEMENT FOR OBTAINING CATHODE-RAY OSCILLOGRAMS WITH ABSCISSAE PROPORTIONAL TO TIME [New Two-Triode Circuit allowing Photographic Recording of Any Wave Form, with Imperfectly Constant Frequency, over Range 50 c/s-200 kc/s].—Centineo. (*L'Elettrotec.*, No. 18, Vol. 23, 1936, pp. 561-564.)

After a preliminary discussion of various previous time-base circuits, the writer describes his new circuit (Fig. 6) which is simple both in construction and in adjustment over the wide frequency range named, and provides a very satisfactory saw-tooth potential (Fig. 8c). Assuming the connection *AB* (Fig. 6) to be made, a variable anode current flows through triode T_1 which creates, across the resistance R_1 (on right of diagram), a potential drop I_1R_1 which is applied across grid and filament of triode T_2 and which (if I_1R_1 is large enough) renders this grid so negative that the current I_1 cannot pass through T_2

and therefore charges the condenser *C*. Near the end of the charge, I_1 becomes so small that I_1R_1 can no longer block T_2 ; *C* discharges through this triode and through R_2 , producing a potential drop I_2R_2 which, as long as it remains large enough, blocks the triode T_1 . If the triodes are exactly similar and the charge and discharge circuits are of equal resistance, the potential across *C* is represented quite closely by an isosceles triangle: the required saw-tooth shape can be obtained by making either the charge current large compared with the discharge current, or *vice versa*. Fig 9f is the photographed oscillogram of a small heterodyne oscillating at 150 kc/s.

1103. A NEW POLAR COORDINATE CATHODE-RAY OSCILLOGRAPH WITH EXTREMELY LINEAR TIME SCALE [including a Modification with Spiral Time Base giving Total Length of over 4 Metres].—von Ardenne. (*Wireless Engineer*, Jan. 1937, Vol. 14, No. 160, pp. 5-12: *Zeitschr. f. tech. Phys.*, No. 12, Vol. 17, 1936, pp. 660-666.)

The special point about the mixed electrostatic and electromagnetic method of obtaining the rotary deflection is that the deflecting coil also forms the inductance of the oscillatory circuit whose voltage is applied to the deflecting plates: the magnetic field is thus automatically 90° out of phase with the electric field.

1104. A CONTROLLABLE COLD-CATHODE-RAY OSCILLOGRAPH WORKED WITH AN AUXILIARY DISCHARGE.—Becker. (See 1044.)
1105. CATHODE-RAY OSCILLOGRAPH ELLIPSES [Simple Statement of Rules for Interpreting the Ellipses obtained in Investigations of Phase and Amplitude Relations between Sinusoidal Voltages].—Millington. (*Marconi Review*, Sept./Oct. 1936, No. 62, pp. 8-13.)
1106. SCREENING A CATHODE-RAY OSCILLOGRAPH TO PREVENT BROADCAST INTERFERENCE.—Zeitline. (See 968.)
1107. ELECTRONIC TRANSIENT VISUALISERS [Circuits for Cathode-Ray Oscillographs].—Reich. (*Elec. Engineering*, Dec. 1936, Vol. 55, pp. 1314-1318.)
1108. THE RECORDING OF SEVERAL PROCESSES WITH A SINGLE OSCILLOGRAPH BY MEANS OF HIGH-SPEED SWITCHING [Survey].—Pfannenmüller. (*E.T.Z.*, 24th Dec. 1936, Vol. 57, No. 52/53, p. 1516: summary only.)
1109. ELECTRON MICROSCOPE FOR THE OBSERVATION OF THE EMISSION PATTERN OF METAL SURFACES.—Burgers & van Amstel. (See 997.)
1110. THE CONVERGENCE AND ACHROMATISATION OF CENTRED ELECTRON-OPTICAL SYSTEMS [Conditions derived from Signs of Coefficients and Their Derivatives in Simplified Differential Equation of Field].—Cotte. (*Comptes Rendus*, 18th Jan. 1937, Vol. 204, No. 3, pp. 170-172.)

1111. ON THE THEORY OF THE ELECTRON MIRROR.—Recknagel. (*Zeitschr. f. tech. Phys.*, No. 12, Vol. 17, 1936, pp. 643-645.)
 "The relation between electron lenses and electron mirrors was treated, with respect to the single electric lens [Fig. 1], by Henneberg & Recknagel [1568 of 1936]. . . . The term 'mirror' is not quite a happy one, since a more exact optical analogy is not an ordinary mirror but a lens series producing a turning-back of the ray by total reflection." The previous treatment was incomplete in two points—it left untouched the behaviour of the mirror in the neighbourhood of the "critical voltage," at which the system turns from a lens to a mirror, and it dealt only with the behaviour of rays close to the axis. The present work fills these gaps, and it is found that in the region of critical voltage the refracting power, plotted as a function of the lens voltage, takes on an oscillatory course and only reaches the critical voltage after an infinite number of swings (Fig. 3). In practice, as the voltage of the middle stop moves through the critical value, the mirror or lens produces, on a fixed screen, an infinite series of images which are upright or upside down according to the sign of the refracting power. The reversals pile themselves up in the neighbourhood of the critical voltage and are difficult to observe, particularly on grounds of intensity. The rest of the paper deals with the refracting power variations for various distances from the axis.
1112. ELECTRON MIRRORS [Apparatus using Reflecting Electric Potential Field as Mirror of Satisfactory Quality].—Hottenroth. (*Zeitschr. f. Phys.*, No. 7/8, Vol. 103, 1936, pp. 460-462.)
1113. THE ELECTRON OPTICS OF THE LONG MAGNETIC COIL [Improved Method for Theoretical Calculation of Correction Factor allowing for Inhomogeneity of Longitudinal Magnetic Field].—Busch. (*Ann. der Physik*, Series 5, No. 1, Vol. 28, 1937, pp. 11-20.) The results here derived were originally given by Busch in *Ann. der Physik*, Series 4, Vol. 81, 1926, pp. 974-993.
1114. ERRATUM: A DOUBLE-FOCUSING MASS-SPECTROGRAPH AND THE MASSES OF N^{15} AND O^{18} [Corrections to Dispersion Calculations].—Mattauch. (*Phys. Review*, 1st Dec. 1936, Series 2, Vol. 50, No. 11, p. 1089.) For the paper corrected see *ibid.*, 1st Oct. 1936, p. 617: cf. also Mattauch & Herzog, 1934 Abstracts, p. 570.
1115. FLUORESCENT SCREEN FOR CATHODE-RAY OSCILLOGRAPHS [Repulsive Force between Electrons, limiting Employable Ray Intensity by increasing Spot Diameter, diminished by Auxiliary Ring Cathode near Screen, creating Space Charge round Ray].—Zeitline. (*Rev. Gén. de l'Élec.*, 31st Oct. 1936, Vol. 40, p. 142 D: French Pat. 799 985, pub. 24.6.1936.)
1116. THE ABSORPTION AND FLUORESCENCE SPECTRUM OF INDIUM VAPOUR.—Wajnkranec. (*Zeitschr. f. Physik*, No. 1/2, Vol. 104, 1936, pp. 122-131.)
1117. EFFECT OF TEMPERATURE OF A URANINE SOLUTION ON THE DECAY TIME OF THE FLUORESCENCE.—Cram. (*Zeitschr. f. Physik*, No. 9/10, Vol. 103, 1936, pp. 551-559.)
1118. LAWS OF DECAY OF POLARISED FLUORESCENCES. II [Theory including Various Depolarising Phenomena].—Jabloński. (*Zeitschr. f. Physik*, No. 7/8, Vol. 103, 1936, pp. 526-535.)
1119. A NEW FLUOROMETER [using Piezoelectric Quartz instead of Kerr Cell].—Brüninghaus. (*Comptes Rendus*, 11th Jan. 1937, Vol. 204, No. 2, pp. 118-120.) For a preliminary reference see 2761 of 1935.
1120. REMARKS ON THE THEORY OF PHOSPHORESCENCE.—Blochinzew. (*Physik. Zeitschr. der Sowjetunion*, No. 3, Vol. 10, 1936, pp. 424-426: in German.)
1121. THE PHENOMENON OF ANODE-SPUTTERING AND THE DEPOSITION OF METALLIC FILM ON THE CATHODE OF A HADDING'S X-RAY TUBE.—Sharan. (*Indian Journ. of Phys.*, Sept. 1936, Vol. 10, Part 5, pp. 325-340.)
1122. THE FOCUSING OF X-RAYS, ANALOGOUS TO FOCUSING WITH A CONVEX LENS [New Method, applicable to Investigation of Structure of Very Thin Surface Films, etc.].—Arkharov. (*Tech. Phys. of USSR*, No. 10, Vol. 3, 1936, pp. 905-912: in German.)
1123. THE ELECTRICAL CONDUCTIVITY OF THIN METALLIC FILMS. I—RUBIDIUM ON PYREX GLASS SURFACES [with Anomalous Results due to Minute Amounts of Impurity on Substrate].—Lovell. (*Proc. Roy. Soc.*, Series A, 2nd Nov. 1936, Vol. 157, No. 891, pp. 311-330.)
1124. TEMPORAL RESISTANCE VARIATIONS OF THIN METALLIC FILMS, SPUTTERED IN A HIGH VACUUM [Resistance Decrease follows Hyperbolic Curve: Explanation by Breakdown of Crystal Lattice Disturbances in Film].—Vand. (*Zeitschr. f. Physik*, No. 1/2, Vol. 104, 1936, pp. 48-67.)
1125. THE VARIATION OF ELECTRICAL RESISTANCE AND REFLECTING POWER OF METALLIC MIRRORS CONDENSED AT LOW TEMPERATURES [Change from Haphazard to Crystalline Arrangement of Atoms in Metallic Film as Temperature increases].—Suhrmann & Barth. (*Zeitschr. f. Physik*, No. 3/4, Vol. 103, pp. 133-169.)
1126. REFLECTIVITY OF EVAPORATED SILVER FILMS [is Higher than That of Films deposited by Other Methods].—Edwards & Petersen. (*Phys. Review*, 1st Nov. 1936, Series 2, Vol. 50, No. 9, p. 871.)
1127. LABORATORY CEMENTS AND WAXES.—Walden. (*Journ. Scient. Instr.*, Nov. 1936, Vol. 13, No. 11, pp. 345-352.)
1128. MODERN HIGH-VACUUM PUMPS [Survey].—Klumb. (*E.T.Z.*, 10th Dec. 1936, Vol. 57, No. 50, pp. 1445-1448.)

1129. A MODIFIED MERCURY TRAP [ensuring Several Contacts with Cold Surface].—Crackston. (*Journ. Scient. Instr.*, Nov. 1936, Vol. 13, No. 11, p. 371.)
1130. A THYRATRON-CONTROLLED IONISATION GAUGE [for High Vacua].—Hoag & Smith. (*Review Scient. Instr.*, Dec. 1936, Vol. 7, No. 12, pp. 497-499.)
1131. THYRATRON WITH CONSTANT CONTROL-GRID CHARACTERISTIC [with Pilot Auxiliary Spiral Cathode, fed from Special Winding on Heating Transformer, between Main Cathode and Grid].—Thomson-Houston Company. (*Rev. Gén. de l'Élec.*, 31st Oct. 1936, Vol. 40, pp. 142-143 D; French Pat. 800 413, pub. 4.7.1936.)
1132. THE ABSORPTION ["Clean-Up"] OF THE INERT GASES IN THE ELECTRIC DISCHARGE [Rejection of Previous Explanations: Gas Atoms, in form of Ions, "shot" into Cathode Metal].—Alterthum, Lompe & Seeliger. (*Zeitschr. f. tech. Phys.*, No. 11, Vol. 17, 1936, pp. 407-412.)
1133. THE INFLUENCE OF THE EXCITED GAS ON THE PROCESSES IN THE CATHODE REGION OF THE GLOW DISCHARGE.—Reichrudel & Spiwak. (*Physik. Zeitschr. der Sowjetunion*, No. 2, Vol. 10, 1936, pp. 121-141; in German.)
1134. CONTRIBUTION TO THE DYNAMICS OF GLOW DISCHARGES.—Druey. (*Helvet. Phys. Acta*, Fasc. 9, Vol. 9, 1936, pp. 707-744; to be continued.)
1135. THE EQUILIBRIUM $2H_2 + O_2 = 2H_2O$ IN THE GLOW DISCHARGE.—Güntherschulze & Schnitger. (*Zeitschr. f. Physik*, No. 9/10, Vol. 103, 1936, pp. 627-632.)
1136. INVESTIGATIONS OF THE IGNITION VOLTAGES OF PRE-IONISED GLOW DISCHARGES [Influence of Second Discharge behind Network Cathode on Characteristics of Glow Discharges in Ne, He, A, H].—Deimel. (*Physik. Zeitschr.*, 1st Sept. 1936, Vol. 37, No. 17, pp. 610-623.)
1137. INVESTIGATIONS ON THE CONDENSED DISCHARGE [Electrical and Spectral Properties: High-Momentary Current Intensities deduced theoretically: Transition from Glow to Arc Discharge].—Bay. (*Zeitschr. f. Physik*, No. 7/8, Vol. 102, 1936, pp. 507-526.)
1138. THE TRANSITION FROM A GLOW DISCHARGE TO AN ARC DISCHARGE [Probability depending on a Number of Variables: Experimental Investigation].—Jurriaanse & Druyvesteyn. (*Physica*, Aug. 1936, Vol. 3, No. 8, pp. 825-840; in English.)
1139. A HOT-CATHODE RECTIFIER VALVE WITH MAGNETIC FIELD AND LOW GAS PRESSURE.—Jurriaanse. (See 986.)
1140. ON THE BUILDING-UP TIME OF A GLOW DISCHARGE [and the Existence of Non-Statistically Distributed Delays of Order of 10^{-5} to 1 Second], and THE CATHODE DROP OF THE GLOW DISCHARGE.—Schade: Gehrts. (*Zeitschr. f. tech. Phys.*, No. 11, Vol. 17, 1936, pp. 391-393; pp. 393-396.)
1141. SECONDARY EMISSION FROM COPPER DUE TO SLOW POSITIVE IONS OF ARGON [Measurements with Bearing on Mechanism of Glow Discharge].—Jones & Willott. (*Proc. Phys. Soc.*, 1st Nov. 1936, Vol. 48, Part 6, No. 269, pp. 830-837.)
1142. THE CHARACTERISTIC OF THE LOW-VOLTAGE [Hot-Cathode] ARC IN ARGON.—Kniepkamp. (*Zeitschr. f. tech. Phys.*, No. 11, Vol. 17, 1936, pp. 398-404.)
1143. THE 313A VACUUM TUBE [Low-Voltage Gas-Filled Relay, Voltage Regulator, or Rectifier: with Barium-Coated Electrodes].—Ingram. (*Bell Lab. Record*, Dec. 1936, Vol. 15, No. 4, pp. 114-116.) The sustaining voltage between one barium-coated control electrode and the anode is about 75 volts (breakdown voltage about 175): the corresponding values for the control gap between the two control electrodes are about 60 and 70.
1144. THE ELECTRON EMISSION OF AN OXIDE-COATED CATHODE IN AN ARC DISCHARGE [Results suggesting Hypothesis that Electron-Accelerating Field does not appear at Same Arc Current for All Parts of Oxide Surface, owing to Great Roughness], and A NEW DARK SPACE NEAR A HOT CATHODE IN AN ARC DISCHARGE.—Druyvesteyn & Warmoltz. (*Physica*, Jan. 1937, Vol. 4, No. 1, pp. 41-50; pp. 51-68; in German.) See also 3568 of 1936.
1145. ON THE QUESTION OF THE VALIDITY OF THE MINIMUM PRINCIPLE IN THE THEORY OF THE ARC DISCHARGE.—Elenbaas: Kesselring & Koppelman. (*E.T.Z.*, 17th Dec. 1936, Vol. 57, No. 51, pp. 1497-1500.)
1146. A METHOD FOR STUDYING PHENOMENA AT THE CATHODE IN ARC DISCHARGES [Photocell Method: Arc run on A.C., Photocurrent due to Radiation from Cathode observed during Half-Cycle when Arc is out].—Koller. (*Physics*, Aug. 1936, Vol. 7, No. 8, pp. 295-296.)
1147. MASS-SPECTROGRAPH INVESTIGATIONS OF NEGATIVE IONS IN GAS DISCHARGES AT HIGH PRESSURES [Nature of Carriers of Negative Charge in Air, Hydrogen, Inert Gases, etc.].—Tüxen. (*Zeitschr. f. Phys.* No. 7/8, Vol. 103, 1936, pp. 463-484.)
1148. BREAKDOWN STRENGTH OF AIR: INFLUENCE OF ELECTRODE SURFACE EFFECTS AT CONTINUOUS SINUSOIDAL RADIO FREQUENCIES [Experimental Investigation].—Seward. (*Electrician*, 25th Dec. 1936, Vol. 117, pp. 783-785.)

1149. SPARKING POTENTIALS [in Gases] AT ULTRA-HIGH FREQUENCIES.—Thomson. (See 863.)
1150. CATHODE PHENOMENA IN ARC DISCHARGES [with Tungsten and Carbon Electrodes: Two Different Arc Formations—Field Arc connected with Adsorbed Gas and Thermal Arc].—Becken & Sommermeyer. (*Zeitschr. f. Physik*, No. 9/10, Vol. 102, 1936, pp. 551–561.) See also 1190 of 1936.
1151. THE CARBON ARC IN VACUUM [Spectra and Starting Mechanism of Cold-Cathode Arc between Graphite Electrodes].—Newman. (*Phil. Mag.*, Jan. 1937, Series 7, Vol. 23, No. 152, pp. 181–186.)
1152. THE AIR-CARBON ARC IN HIGH VACUUM [started and maintained by Intense Electric Field near Cathode, rather than by Thermionic Emission].—Newman. (*Phil. Mag.*, Sept. 1936, Series 7, Vol. 22, No. 147, pp. 463–465.)
1153. THE TRANSITION FROM CORONA DISCHARGE TO SPARK IN NON-UNIFORM FIELD (COAXIAL CYLINDERS).—Suzuki. (*Journ. I.E.E. Japan*, June, 1936, pp. 755–761: English summary p. 42.)
1154. THE TOWNSEND COEFFICIENTS AND SPARK DISCHARGE [Quantitative Study of Pre-Spark Current between Plane Parallel Electrodes in Purified N_2 : Photoelectric Effect at Cathode provides Effective Secondary Mechanism].—Posin. (*Phys. Review*, 1st Oct. 1936, Series 2, Vol. 50, No. 7, pp. 650–658.)
1155. THE SPARK GAP SUPPLIED WITH A LARGE AMOUNT OF INITIAL ELECTRONS [Decreased Static Sparking Potentials].—Suzuki. (*Journ. I.E.E. Japan*, June, 1936, pp. 761–769: English summary p. 42.) Contrary to the results of other investigators with (presumably) small amounts of electrons; namely that the time lag was decreased but not the potentials. For theory see *ibid.*, July, pp. 807–816: English summary p. 47.
1156. STUDIES IN THE SPECTRA OF H.F. DISCHARGES IN MERCURY VAPOUR. II—COMPARISON OF ELECTRODELESS WITH EXTERNAL ELECTRODE EXCITATION: III—MODIFICATION DUE TO WAVELENGTH.—Robertson & Hay. (*Canadian Journ. of Res.*, Nov. 1936, Vol. 14, No. 11, Sec. A, pp. 201–208 & Plates.)
- Among other things, "evidence is given that the discharge obtained at 60 Mc/s differs from that obtained at the lower frequencies. At a low vapour pressure a discharge, characterised by great brilliance and the absence of spark lines, is obtained with the highest frequency. There is little to choose between the two types of excitation."
1157. THEORY OF "QUENCHING-GRID" CONTROL IN GASEOUS DISCHARGES [Kobel's Special Grid in Mercury-Vapour D.C. Arc Tubes].—Lüdi: Kobel. (*Helvet. Phys. Acta*, Fasc. 8, Vol. 9, 1936, pp. 655–677: in German.) See also Kobel, 1933 Abstracts, p. 636.
1158. PROGRESS AND NEW DEVELOPMENTS IN THE DESIGN AND USE OF MUTATORS [Symposium at Zurich].—(*Bull. Assoc. suisse des Elec.*, No. 24, Vol. 27, 1936, pp. 685–707: mostly in German.) Including a paper by Loosli on the new ignition method—"resonance ignition."
1159. "MERCURY ARCS."—Teago & Gill. (At Patent Office Library, London: Cat. No. 76 939.)
1160. THE METHOD OF PROBE MEASUREMENTS IN THE LOW-PRESSURE MERCURY DISCHARGE [Experiments showing Effect of Probe Support and Wall of Vessel on Current flowing to Probe].—Denecke. (*Ann. der Phys.*, Series 5, No. 7, Vol. 27, 1936, pp. 597–621.)
1161. SOME FACTORS INFLUENCING THE SPARKING POTENTIAL IN MERCURY VAPOUR [Effects of Bombardment of Electrode with Positive Ions and of passing Electron Current].—Lawton & Kingdon. (*Phys. Review*, 1st Dec. 1936, Series 2, Vol. 50, No. 11, p. 1095: abstract only.)
1162. EXPERIMENTAL INFORMATION ON THE ION LAYERS AT THE ELECTRODES OF [Mercury-Vapour] CURRENT DIRECTORS DURING THE DE-IONISING PROCESS.—Koch. (*Zeitschr. f. tech. Phys.*, No. 11, Vol. 17, 1936, pp. 446–452.)
1163. SELF-REGULATED COMPOUNDED RECTIFIERS [with Wide Variety of Characteristics].—Goodhue & Power. (*Elec. Engineering*, Nov. 1936, Vol. 55, pp. 1200–1205.)
1164. A NEW TYPE OF MERCURY-POOL RECTIFIER [Special Design to avoid Flash-Back Danger].—Libby. (*Proc. Inst. Rad. Eng.*, August, 1936, Vol. 24, No. 8, p. 1039: summary only.)
1165. ON THE EXTINCTION OF THE ARC FOCAL SPOT AT A MERCURY CATHODE [Current must be reduced to Zero for around 10^{-9} Sec. to prevent Re-Ignition].—Mierdel. (*Zeitschr. f. tech. Phys.*, No. 11, Vol. 17, 1936, pp. 452–455.)
1166. A NEW METHOD OF IMPROVING THE VOLTAGE REGULATION OF MERCURY-ARC RECTIFIERS.—Kusakari & Takahashi. (*Journ. I.E.E. Japan*, June, 1936, pp. 739–742: English summary pp. 39–40.)
1167. A NEW SYSTEM FOR THE PROTECTION OF MERCURY RECTIFIERS FROM ARC-BACKS AND OVERLOADS.—Speetsin. (*Izvestiya Elektroprom. Slab. Toha*, No. 7, 1936, pp. 61–66.)
- "A purely electrical circuit allowing the grid of the rectifier to attain a negative potential in the shortest possible time, owing to which the full time of breaking the current through the rectifier does not exceed 3 msecs.

1168. AN ULTRA-RAPID-ACTION SAFETY DEVICE FOR RECTIFIER EQUIPMENTS [for Radio Transmitters: Ignition Current reaches Rectifier Grids, through Triodes, from Coupling to Auxiliary Oscillator Circuit which is Stopped by Excessive Load Current: Trigger Action].—Posthumus. (*Philips Transmitter News*, No. 3, Vol. 3, 1936, pp. 1-10: in German and English). In a second method the auxiliary oscillator only functions in the event of excessive current, with the drawback that a defect in the protecting device is not obvious.
1169. THE ELECTRO-RESISTIVE EFFECT AND A RECTIFYING PROPERTY OF CARBORUNDUM CRYSTALS [Theory with Power Series for Current/Voltage Equilibrium].—Osterberg. (*Phys. Review*, 15th Dec. 1936, Series 2, Vol. 50, No. 12, p. 1187.)
1170. ORIGIN OF UNIPOLAR ELECTRICAL CONDUCTIVITY OF CARBORUNDUM [Values of Minimum E.M.F. required to liberate Photoelectrons differ for the Two Opposite Directions of Current Flow].—Khashtgir. (*Nature*, 2nd Jan. 1937, Vol. 139, pp. 28-29.)
1171. CHANGE OF STRIKING POTENTIAL THROUGH IRRADIATION.—Fucks & Seitz. (*Zeitschr. f. tech. Phys.*, No. 11, Vol. 17, 1936, pp. 387-391.) Discussion of the new experimental results dealt with in 347 of January and the theoretical conclusions therefrom. See also 1172/3, below, and 2360 of 1936.
1172. SPARKING [of Gas Discharge] WITH ALTERNATING VOLTAGE. SPARKING WITH PULSATING IRRADIATION [Theoretical Deduction of Formula for Sparking Condition with Alternating Voltage: Increase of Sparking Voltage with Frequency: Same Theoretical Value for Sparking Voltage with Pulsating Irradiation as for Direct Voltage and Constant Irradiation: Comparison with Experimental Results].—Fucks. (*Zeitschr. f. Physik*, No. 11/12, Vol. 103, 1936, pp. 709-727.) See also 1171, above.
1173. THE QUESTION OF THE INCREASE OF SPARKING VOLTAGE BY IRRADIATION [Increase of Sparking Voltage observed by Seitz & Fucks is probably due to Grease Vapour Impurities on Electrode Surfaces].—Schade. (*Naturwiss.*, 18th Dec. 1936, Vol. 24, No. 51, p. 813.) See 1171/2, above.
1174. VERY SHORT TIME LAG OF SPARKING [measured as Function of Overvoltage and Illumination, using Electro-Optical Shutter with Constant Illumination Method: Statistical and Formative Part of Time Lag: Theory of Sparking at High Overvoltages].—Wilson. (*Phys. Review*, 1st Dec. 1936, Series 2, Vol. 50, No. 11, pp. 1082-1088.)
1175. THE DISTRIBUTION OF RELAXATION TIMES IN TYPICAL DIELECTRICS [Theoretical and Experimental Confirmation of Wagner's Theory of Statistical Distribution: Frequency Variation of Dielectric Constant and Dielectric Loss Factor of Typical Dielectrics].—Yager. (*Physics*, Dec. 1936, Vol. 7, No. 12, pp. 434-450.)
1176. THE INFLUENCE OF A CONCENTRATED SPACE CHARGE IN CALCITE ON THE DIELECTRIC STRENGTH [Reference to Fowler's Theory of Breakdown of Solid Dielectrics].—Wenderowitsch & Worobjow. (*Physik. Zeitschr. der Sowjetunion*, No. 3, Vol. 10, 1936, pp. 413-420: in German.)
1177. RECENT PROGRESS IN DIELECTRIC RESEARCH.—Whitehead. (*Elec. Engineering*, Nov. 1936, Vol. 55, pp. 1180-1185.)
1178. A.C. CHARACTERISTICS OF DIELECTRICS FROM D.C. MEASUREMENTS [Method of 3 Exponentials: Charts].—Baños. (*Elec. Engineering*, Dec. 1936, Vol. 55, pp. 1329-1337.)
1179. ANOMALOUS EFFECTS IN THE MEASUREMENT OF THE VOLUME RESISTIVITY OF DIELECTRICS [depending on Polarity of Earthed Electrode: Effect of Nature of Electrodes and Humidity].—Tognana. (*L'Elettrotec.*, No. 16, Vol. 23, 1936, pp. 494-498.)
1180. CORRECTIONS TO "THE BREAKDOWN AND FLASH-OVER OF SOLID DIELECTRICS IN COMPRESSED NITROGEN."—Goldmann & Wul. (*Tech. Phys. of USSR*, No. 11, Vol. 3, 1936, p. 1005.) See 3580 of 1936.
1181. ELECTROLYTIC CONDENSERS AND THEIR BEHAVIOUR IN SERVICE.—Nauk. (*Zeitschr. f. Fernmeldeleech.*, No. 9, Vol. 17, 1936, pp. 129-134.)
1182. ON THE BREAKDOWN PHENOMENA OF INSULATORS BY THE APPLICATION OF ALTERNATING-CURRENT VOLTAGE.—Nakanisi. (*Journ. I.E.E. Japan*, Aug. 1936, pp. 909-914: English summary pp. 64-66.)
1183. CEMENT CONCRETE AND PINS FOR PORCELAIN INSULATORS [and the Advantages of Fused Quartz Concrete].—Stobie. (*Journ. Inst. Engineers Australia*, June, 1936, Vol. 8, No. 6, pp. 221-227.)
1184. TYPE NUMBERS AND MAKERS OF GERMAN ARTIFICIAL RESIN INSULATING MATERIALS.—(*E.T.Z.*, 3rd Dec. 1936, Vol. 57, No. 49, pp. 1442-1443.)
1185. LAMINATED PHENOLIC INSULATING MATERIALS.—Martin. (*Bell Lab. Record*, Dec. 1936, Vol. 15, No. 4, pp. 129-132.)
1186. THE SYSTEM LIME-BORIC-OXIDE-SILICA [Fundamental in Ceramics].—Flint & Wells. (*Journ. of Res. of Nat. Bur. of Stds.*, Nov. 1936, Vol. 17, No. 5, pp. 727-752.)
1187. ACETYLATED PAPER.—Standard Telephones & Cables. (*Electrician*, 27th Nov. 1936, pp. 657-658.)

1188. INSULATING MATERIALS: DETERMINATION OF DIELECTRIC STRENGTH OF SOLIDS [and the Avoidance of Errors due to Small Cracks].—Nederbragt. (*Electrician*, 27th Nov. 1936, p. 662.)
1189. THE RÔLE OF THE GAS CONTENT IN THE BREAKDOWN OF INSULATING LIQUIDS, and DETERMINATION OF THE INTENSITY OF ELECTRIC FIELD WHICH INITIATES DISCHARGE IN THIN LAYERS OF LIQUID DIELECTRICS.—Walther & Tscheljustkina; Tsikin. (*Tech. Phys. of USSR*, No. 11, Vol. 3, 1936, pp. 940-946; in German: pp. 947-955; in English.)
1190. METHODS OF INVESTIGATING THE PHYSICAL FIELDS [Magnetic, Electrostatic, and Thermal] OF ELECTRICAL MACHINES.—Roth. (*Bull. Soc. franç. des Élec.*, Jan. 1937, Vol. 7, No. 73, pp. 13-130.)
1191. ON THE APPARATUS FOR THE MULTIPLE ACCELERATION OF LIGHT IONS TO HIGH SPEEDS [Cyclotron: Detailed Description: Recent Advances in Design].—Lawrence & Cooksey. (*Phys. Review*, 15th Dec. 1936, Series 2, Vol. 50, No. 12, pp. 1131-1140.)
1192. A NEW COMPLEX A.C. COMPENSATOR.—Geyger. (*Arch. f. Elektrot.*, 21st Dec. 1936, Vol. 30, No. 12, pp. 806-811.)
For previous designs see 1930 Abstracts, pp. 118, 171 & 525. The present instrument (circuit Fig. 1) contains "two continuously variable mutual inductances, whose primary windings are in series and to each of whose secondary windings a potentiometer circuit is connected, from which voltages differing by 0° and 90° respectively from the primary current can be obtained. The compensator is particularly suitable for measurements in which the two partial voltages must have a definite phase relation to the currents circulating through the object under measurement."
1193. ON THE CALCULATION OF GRID CURRENTS IN ELECTRON RELAYS.—Sotskov. (See 1268.)
1194. A METHOD OF COMPENSATION FOR SUPPLY VOLTAGE VARIATIONS IN THERMIONIC VALVE CIRCUITS [Barretter used as Non-Linear Resistance to provide Grid Bias].—Hadfield. (*P.O. Elec. Eng. Journ.*, Oct. 1936, Vol. 29, Part 3, pp. 235-236.)
The constant-current part of the barretter curve is not approached, the barretter current being much below its normal rating: the resistance/current characteristics will not, therefore, deteriorate with life.
1195. ELECTRONIC VOLTAGE STABILISERS [Classification suggesting New Circuits and Performance Predictions].—Hunt & Hickman. (*Phys. Review*, 1st Dec. 1936, Series 2, Vol. 50, No. 11, pp. 1094-1095; abstract only.)
1196. AUTOMATIC VOLTAGE CONTROL IN ELECTRICAL MACHINES BY MEANS OF ELECTRONIC DEVICES.—Glebovich. (*Automatics & Telemechanics* [in Russian], No. 2, 1936, pp. 31-42.)
1197. A QUICK-RESPONSE AUTOMATIC VOLTAGE REGULATOR USING THERMIONIC VACUUM TUBES.—Tomota. (*Journ. I.E.E. Japan*, Sept. 1936, p. 1025; Japanese only.)
1198. A VOLTAGE REGULATOR [for Magnetrons].—von Lindern. (See 930.)
1199. CARBON-COMPRESSION VOLTAGE REGULATORS.—Grob. (*Zeitschr. f. Fernmeldetechn.*, No. 8, Vol. 17, 1936, pp. 117-122.)
1200. INKS FOR RECORDING INSTRUMENTS.—Waters. (*Journ. of Res. of Nat. Bur. of Stds.*, Nov. 1936, Vol. 17, No. 5, pp. 651-655.)
1201. A THERMIONIC RELAY CIRCUIT FOR A.C. OR D.C. SUPPLY FOR USE WITH A THERMIONIC REGULATOR [or other Switches passing Very Small Currents: using Ostar-Ganz Pentode].—Temple. (*Journ. Scient. Instr.*, Dec. 1936, Vol. 13, No. 12, pp. 414-415.)
1202. HOT-WIRE VACUUM SWITCHES [Control Input below 2 Watts: Chatter eliminated (2 Sec. Time Lag): Burning of Contacts avoided by Non-Inductive Nature of Hot-Wire Circuit].—(*Journ. Scient. Instr.*, Dec. 1936, Vol. 13, No. 12, pp. 419-420.)
1203. A THEORETICAL ANALYSIS OF HELMHOLTZ'S EQUATION [in Connection with Action-Time of Relays: Discrepancies between Theory and Practice: Analysis of Relay Equations].—Nazarov. (*Izvestiya Elektroprom. Slab. Toka*, No. 8/9, 1936, pp. 39-51.) For Bähler's work, here referred to, see 1929 Abstracts, p. 282.
1204. A SIMPLE RELAY FOR RECORDING COUNTER COINCIDENCES [with Circuit Diagrams].—Ehmer. (*Naturwiss.*, 18th Dec. 1936, Vol. 24, No. 51, pp. 814-815.)
1205. THE "SPARK COUNTER" AS A MAINS-DRIVEN DEVICE FOR COUNTING CORPUSCLES AND PHOTONS.—Greinacher. (*Helvet. Phys. Acta*, Fasc. 7, Vol. 9, 1936, pp. 590-595; in German.) For previous work see 2863 of 1935.
1206. GEIGER-MÜLLER COUNTERS FOR SPECIAL PURPOSES [including Photoelectric Counters for measuring Weak Light].—Locher. (*Phys. Review*, 1st Dec. 1936, Series 2, Vol. 50, No. 11, p. 1099; abstract only.)
1207. THE USE OF HIGH-FREQUENCY DISCHARGE TUBES AS ELECTRICAL COUNTERS.—Curran. (*Phil. Mag.*, Oct. 1936, Series 7, Vol. 22, No. 148, pp. 599-616.)
1208. A MECHANICAL COUNTER OF IMPROVED RESOLVING POWER FOR ELECTRICAL IMPULSES [Loudspeaker Movement actuating Stop-Watch Mechanism].—Tuck. (*Journ. Scient. Instr.*, Nov. 1936, Vol. 13, No. 11, pp. 366-367.)
1209. INVESTIGATIONS ON THE CORONA MOTOR.—Teichmann; Güntherschulze & Hesse. (*Zeitschr. f. Physik*, No. 11/12, Vol. 103, 1936, pp. 738-746.)
The corona motor is a development of the movement of a wire in a corona discharge reported by

- Güntherschulze, Hesse & Betz (3143 of 1936). Wires showed discontinuous changes in rotation frequency as the high voltage was varied continuously; with a rigid framework (Figs. 3, 4) the variation of frequency was continuous. Measurements of rotation velocities with and without heating and with different polarities are described. Pre-ionisation was found to affect the velocity only when the polarity was negative.
1210. CALCULATIONS OF ELECTRICAL SURGE-GENERATOR CIRCUITS [treated as Periodically Loaded Lines].—Lewis. (*Journ. of Res. of Nat. Bur. of Stds.*, Oct. 1936, Vol. 17, No. 4, pp. 585-603.)
1211. REVERSIBLE AND IRREVERSIBLE MAGNETISATION PHENOMENA OCCURRING WITH CHANGE OF TEMPERATURE.—Embrikos & Bittel. (*Physik. Zeitschr.*, 15th Dec. 1936, Vol. 37, No. 24, pp. 901-906.)
- An apparatus (Fig. 5) is described with which the hysteresis curves of various samples of nickel were determined; the sample under test was shaken before every measurement until a stable condition was reached. The hysteresis curves were found to be narrower than those obtained without shaking. The changes of magnetisation due to changes of temperature under constant magnetic field were found to consist of a reversible and an irreversible part, which could be measured separately. The reversible part is explained by the temperature variation of the spontaneous magnetisation. The change of electrical conductivity of the samples is found to be chiefly determined by the reversible processes. The distribution of the direction of the elementary magnetic vectors is discussed.
1212. THE TEMPERATURE VARIATION OF THE INTENSITY OF MAGNETISATION OF FERROMAGNETIC SUBSTANCES IN A WEAK MAGNETIC FIELD [Measurements: Sudden Increase of Intensity at a Certain Temperature: Explanation by Crystallographic Anisotropy].—Honda & Nishina. (*Zeitschr. f. Physik*, No. 11/12, Vol. 103, 1936, pp. 728-737.)
1213. TEMPERATURE VARIATION OF MAGNETOSTRICTION IN NICKEL [Measurements: Comparison between Saturation of Magnetisation and of Magnetostriction].—Döring. (*Zeitschr. f. Physik*, No. 9/10, Vol. 103, 1936, pp. 560-582.)
1214. MAGNETIC CONDUCTIVITY AS A SPECIFIC AND RELATIVE QUANTITY [Discussion of Discrepancy of Dimensions in Magnetic Equation $B = \mu H$: Removal by Introduction of "Specific Conductivity"].—Krug. (*Arch. f. Elektrot.*, 21st Nov. 1936, Vol. 30, No. 11, pp. 752-753.)
1215. OBSERVATIONS ON INITIAL SUSCEPTIBILITY IN THE PRESENCE OF TRANSVERSE MAGNETISATION.—Perrier & Favez. (*Helvet. Phys. Acta*, Fasc. 7, Vol. 9, 1936, pp. 563-573: in French.)
1216. FERROMAGNETISM OF THE ALLOYS OF IRON [and the Conditions of Validity of the $T^{3/2}$ Law: etc.].—Fallot. (*Ann. de Physique*, Sept. 1936, 11th Series, Vol. 6, pp. 305-387.)
1217. ALGEBRAIC REPRESENTATION OF MAGNETIC CHARACTERISTICS [Simple Approximate Formula $M = \phi + \phi^{2n+1}$].—Rougé. (*Bull. Soc. franç. des Élec.*, Sept. 1936, Vol. 6, pp. 881-892.)
1218. THE MAGNETIC SKIN EFFECT IN FERROMAGNETIC CIRCULAR CYLINDERS WITH WEAK AND STRONG ALTERNATING FIELDS [Calculations and Curves for Thermal Effect and Magnetic Field Energy].—Kyewski. (*Ann. der Phys.*, Series 5, No. 7, Vol. 27, 1936, pp. 625-642.)
1219. PRELIMINARY COMMUNICATION ON MAGNETIC AFTER-EFFECT.—Wittke. (*Ann. der Phys.*, Series 5, No. 7, Vol. 27, 1936, pp. 622-624.) Extension of work referred to in 4049 of 1935, giving more exact formulae deduced from measurements.
1220. THE VARIATION OF THE INTERNAL FRICTION AND ELASTIC CONSTANTS WITH MAGNETISATION IN IRON [with Method of Measurement using Composite Piezoelectric Oscillator]. PART I [Experimental Method: Results]: PART II [Formulae for Effect of Eddy Currents: Magnetostriction and Wiedemann Effect Coefficients: Final Data discussed in Light of Recent Ferromagnetic Theory].—Cooke: Brown. (*Phys. Review*, 15th Dec. 1936, Series 2, Vol. 50, No. 12, pp. 1158-1164: pp. 1165-1172.)
1221. DETERMINATION OF FERROMAGNETIC ANISOTROPY IN SINGLE CRYSTALS AND IN POLYCRYSTALLINE SHEETS [Calculations including Additional Term in Expression for Energy of Magnetisation].—Bozorth. (*Phys. Review*, 1st Dec. 1936, Series 2, Vol. 50, No. 11, pp. 1076-1081.)
1222. PAPERS ON THE FERROMAGNETIC ANISOTROPY IN IRON, NICKEL-IRON AND NICKEL-COBALT-IRON AT VARIOUS TEMPERATURES.—McKeehan, Pietz, Kleis. (*Phys. Review*, 1st Dec. 1936, Series 2, Vol. 50, No. 11, p. 1093: abstract only: 15th Dec., No. 12, pp. 1173-1181.)
1223. THE MAGNETIC ANISOTROPY OF SINGLE CRYSTALS OF IRON AND NICKEL [Theory: Magnetisation Curve: Moment acting on Crystal Disc in Magnetic Field: Comparison with Experiments].—Schlechtweg. (*Ann. der Phys.*, Series 5, No. 7, Vol. 27, 1936, pp. 573-596.)
1224. DISCUSSIONS ON "SILICON STEEL IN COMMUNICATION EQUIPMENT," "PRESENT STATUS OF FERROMAGNETIC THEORY," "PERMANENT MAGNET MATERIALS," AND "MAGNETIC ALLOYS OF IRON, NICKEL AND COBALT."—(*Elec. Engineering*, Aug. 1936, Vol. 55, No. 8, pp. 883-889.) See 745, 1989, 1608 and 743 of 1936.
1225. MAGNETIC PROPERTIES OF THE NICKEL-IRON ALLOYS [Summarising Account].—(*Nature*, 28th Nov. 1936, Vol. 138, p. 940: abstract of pamphlet from Mond Nickel Company.)

1226. THE ELECTRICAL PROPERTIES OF HIGH PERMEABILITY WIRES CARRYING ALTERNATING CURRENT [Changes in Electrical Resistance under External Longitudinal Magnetic Fields: Effect of Heat Treatment: Extension of Classical Theory of A.C. Conduction to take account of Hysteresis Property of Ferromagnetics].—Harrison, Turney, Rowe & Gollop. (*Proc. Roy. Soc., Series A*, 2nd Nov. 1936, Vol. 157, No. 891, pp. 451-479.) For preliminary letter see 2783 of 1935.
1227. PERMANENT MAGNETISATION OF STEEL BY A RAPID APERIODIC DISCHARGE [around 3×10^{-5} Second].—Chevallier & Laporte. (*Journ. de Phys. et le Radium*, Nov. 1936, Vol. 7, No. 11, pp. 453-460.)
1228. A COERCIMETER FOR MAGNETICALLY WEAK MATERIALS.—Potter & Coleman. (*Review Scient. Instr.*, Dec. 1936, Vol. 7, No. 12, pp. 499-501.)
1229. NOTE ON THE USE OF THE LLOYD-FISHER SQUARE FOR PERMEABILITY MEASUREMENTS.—Webb & Ford. (*Journ. Scient. Instr.*, Dec. 1936, Vol. 13, No. 12, pp. 386-392.)
1230. THE EFFECT OF AN EXTERNAL MAGNETIC FIELD ON THE TEMPERATURE OF CHANGE OF PHASE [of a Substance with Different Magnetic Susceptibilities in Different Phases: Calculations].—Justi. (*Physik. Zeitschr.*, 1st Nov. 1936, Vol. 37, No. 21, pp. 766-768.)
1231. TRANSFORMERS WITH MAGNETIC SHUNTS: CORRECTIONS.—Witz. (*Bull. Assoc. suisse des Elec.*, No. 26, Vol. 27, 1936, p. 777.) See 2820 of 1936.
1232. DAMPING BY PERMANENT MAGNETS [Theoretical and Experimental Treatment].—Babkin. (*Automatics & Telemechanics* [in Russian], No. 1, 1936, pp. 45-54.)
1233. DETERMINATION WITH THE MAGNETIC VOLTMETER OF THE BALLISTIC DEMAGNETISING FACTOR OF RODS OF SQUARE CROSS-SECTION.—Warmuth. (*Arch. f. Elektrot.*, 21st Dec. 1936, Vol. 30, No. 12, pp. 761-779.)
1234. THE DESIGN OF POWERFUL ELECTRO-MAGNETS: PART I—THE USE OF IRON.—Bitter. (*Review Scient. Instr.*, Dec. 1936, Vol. 7, No. 12, pp. 479-488.)
1235. AGEING OF PERMANENT ALUMINIUM-NICKEL-STEEL MAGNETS.—Kanter. (*Elektritchestvo*, No. 18, 1936, pp. 24-27: in Russian.)
1236. MAGNETIC ANALYSIS OF EVAPORATED BISMUTH FILMS [Experimental Determination of Susceptibility: Fibre Structure].—Lane. (*Phys. Review*, 1st Dec. 1936, Series 2, Vol. 50, No. 11, p. 1094: abstract only.)
1237. THE CIRCLE DIAGRAM OF THE "ELECTRIC AXLE" [Motor Synchronising System using Coupling Motors on Common Polyphase Network].—Schmitz. (*E.T.Z.*, 6th Aug. 1936, Vol. 57, No. 32, pp. 911-915.)
1238. THE RECORDING OF SCALES, ETC., ON CURVED SURFACES BY A PHOTOGRAPHIC METHOD.—Burmistrov. (*Journ. of Tech. Phys.* [in Russian], No. 4, Vol. 6, 1936, pp. 715-721.) For previous work see 1601 of 1936, and for a French version of the present paper see 2856 of 1936, which is erroneously stated to refer to the previous paper.
1239. ON WELDING SIMPLE AND COMPOSITE THERMOELEMENTS.—N. P. Kurin. (*Journ. of Tech. Phys.* [in Russian], No. 8, Vol. 6, 1936, pp. 1349-1351.) A method is proposed for welding thermoelements by passing an electric spark in water between the joint and an auxiliary electrode; the advantage of the method is that corrosion of the joint is avoided.
1240. CAPACITOR VOLTAGE TRANSFORMERS [Capacitive Voltage-Divider combined with Compensating Reactor: Theory, Construction, Applications].—Wellings, Mortlock & Mathews. (*Journ. I.E.E.*, Nov. 1936, Vol. 79, No. 479, pp. 577-584: Discussion pp. 587-594.)

STATIONS, DESIGN AND OPERATION

1241. ON AN ESTIMATION OF THE SERVICE AREA OF THE CALCUTTA STATION [with Calculated and Observed Results and Data on Aerial Efficiency, etc., and Effective Soil Conductivity].—Roy. (*Indian Journ. of Phys.*, July, 1936, Vol. 10, Part 4, pp. 295-303.)
1242. SOUTH AFRICAN BROADCASTING: IMMEDIATE DEVELOPMENTS.—(*World-Radio*, 11th Dec. 1936, p. 4.)
1243. TRADE WITH INDIA: PARTICULARS OF WIRELESS DEVELOPMENTS AND DETAILS OF IMPORTS.—(*Electrician*, 25th Dec. 1936, Vol. 117, p. 801.) From the Report issued by H.M. Stationery Office for the Department of Overseas Trade.
1244. WORK OF THE [French] NATIONAL BROADCASTING SERVICE.—Adam. (*Génie Civil*, 19th Dec. 1936, Vol. 109, No. 25, pp. 549-552.)
1245. AIRCRAFT TRANSMITTING AND RECEIVING EQUIPMENT TYPE VR 8 [Wave-Range 200-2000 Metres].—(*Philips Transmitting News*, No. 3, Vol. 3, 1936, pp. 26-27: in German and English.)
1246. NOTE ON THE SUBJECT OF RADIO-COMMUNICATION ON MOUNTAINS [Transmitting and Receiving Equipment weighing 3.9 kg and giving Telegraphic Communication over 34-91 km at Altitudes of 3000-4000 m: Wavelength around 83 m].—Roesgen. (*Bull. Assoc. suisse des Elec.*, No. 16, Vol. 27, 1936, pp. 437-439: in French.)
1247. [Alpine] TELEPHONIC NETWORK OF ORTLES-CEVEDALE [Land-Line with Ultra-Short-Wave Links].—(*Alta Frequenza*, Nov. 1936, Vol. 5, No. 11, pp. 751-758: *L'Elettrotec.*, No. 19, Vol. 23, 1936, pp. 582-590.)

1248. "AUTOMATIC PISTOL" TYPE OF MICRO-WAVE PORTABLE TRANSCIVER [Reflector and Valve at End of Barrel: Telescope mounted Above, locating Mouth opposite to Microphone: Morse Code by Trigger, Send/Receive by Second Trigger].—J. Pintsch Company. (*Rev. Gén. de l'Elec.* 31st Oct. 1936, Vol. 40, p. 143 D: French Pat. 800 427, pub. 4.7.1936.)
1249. TWO-WAY SPEECH BY WIRELESS: METHOD OF UTILISING THE PERSISTENCE OF HEARING [and Successful Tests on Ultra-Short Waves].—Marro. (*Electrician*, 1st Jan. 1937, Vol. 118, p. 5.) See also 181 of January.
- GENERAL PHYSICAL ARTICLES**
1250. THE SCATTERING OF LIGHT BY LIGHT ACCORDING TO THE BORN-INFELD THEORY.—Thomas. (*Phys. Review*, 1st Dec. 1936, Series 2, Vol. 50, No. 11, pp. 1046-1049.)
1251. THE RÔLE OF THE VELOCITY OF LIGHT IN THE ELECTROMAGNETIC EQUATIONS AND THE EQUIVALENCE OF ENERGY AND MASS.—Urbanek. (*Journ. de Phys. et le Radium*, April, 1936, Vol. 7, No. 4, pp. 158-162.) See also 3253 of 1935.
1252. THE TRANSMUTATION OF MATTER BY HIGH ENERGY PARTICLES AND RADIATION [Kelvin Lecture].—Cockcroft. (*Journ. I.E.E.*, Nov. 1936, Vol. 79, No. 479, pp. 532-540.)
1253. ON THE SATURATION OF EXCHANGE FORCES [Majorana and Heisenberg Forces].—Wigner. (*Proc. Nat. Acad. Sci.*, Nov. 1936, Vol. 22, No. 11, pp. 662-666.)
1254. THE KINETIC EQUATION FOR THE CASE OF COULOMB INTERACTION [of Charged Particles: Disagreement with Gabor's Work on Langmuir Plasma: Estimation of Free Wavelength and Rate of Temperature Equilibration of Ions and Electrons].—Landau. (*Physik. Zeitschr. der Sowjetunion*, No. 2, Vol. 10, 1936, pp. 154-164: in German.) For Gabor's paper see 1933 Abstracts, p. 230.
1255. ON THE RECOMBINATION OF DIATOMIC MOLECULES WITH EMISSION OF RADIATION [and Experiments with Tellurium Discharge].—Rompe. (*Zeitschr. f. tech. Phys.*, No. 11, Vol. 17, 1936, pp. 381-382.)
1256. THE BROWNIAN MOTION OF THE GENERALISED HARMONIC OSCILLATOR.—van Wijk. (*Physica*, Dec. 1936, Vol. 3, No. 10, pp. 1111-1119: in English.)
- MISCELLANEOUS**
1257. SOME ASPECTS OF THE RATIONALISATION OF THE EQUATIONS OF ELECTRICITY [and the Use of Tensors].—Bouthillon. (*Bull. Soc. franç. des. Elec.*, Dec. 1936, Vol. 6, No. 72, pp. 1175-1194.)
1258. TENSOR ANALYSIS OF MULTI-ELECTRODE-TUBE CIRCUITS [as Amplifiers, Modulators, Detectors, and Oscillators].—Kron. (*Elec. Engineering*, Nov. 1936, Vol. 55, pp. 1220-1242.)
1259. "HEAVISIDE'S OPERATIONAL CALCULUS AS APPLIED TO ENGINEERING AND PHYSICS: 2ND ED." [Book Review].—Berg. (*Electrician*, 4th Dec. 1936, p. 700: *P.O. Elec. Eng. Journ.*, Jan. 1937, Vol. 29, Part 4, p. 346.)
1260. NEW BASIC CRITICAL EQUATIONS AND METHODS IN THE CALCULUS OF VARIATIONS.—Kimball. (*Phil. Mag.*, Jan. 1937, Series 7, Vol. 23, No. 152, pp. 114-153.)
1261. SOME DIFFICULTIES IN THE PRACTICAL APPLICATION OF THE THEORY OF ERRORS.—Brelot. (*Journ. de Phys. et le Radium*, Dec. 1936, Vol. 7, No. 12, pp. 161-163 S.)
1262. ADDITION THEOREMS OF THE LEGENDRE FUNCTIONS.—Lagrange. (*Comptes Rendus*, 7th Dec. 1936, Vol. 203, No. 23, pp. 1225-1227.)
1263. THE MECHANICAL SOLUTION OF [Linear] SIMULTANEOUS EQUATIONS [with Real Coefficients: Theory and Construction of Machine].—Wilbur. (*Journ. Franklin Inst.*, Dec. 1936, Vol. 222, No. 6, pp. 715-724.)
1264. SOME MECHANICAL AIDS TO CALCULATION [Coradi Rolling Integrator and the Bush and Hartree Differential Analysers], and THE SIMULTANEOUS CALCULATOR [for Simultaneous Linear Equations].—Myers: Wilbur. (*Journ. of Inst. of Eng., Australia*, Nov. 1936, Vol. 8, No. 11, pp. 423-428: *Science*, 11th Dec. 1936, Vol. 84, Supp. p. 6.)
1265. NOTES ON THE DESIGN OF COMMUNICATION EQUIPMENT [particularly for Tropical and Sub-Tropical Countries].—Frome. (*P.O. Elec. Eng. Journ.*, Jan. 1937, Vol. 29, Part 4, pp. 275-279.)
1266. 12TH PHYSIKER- UND MATHEMATIKERTAG, BAD SALZBRUNN, 13TH-19TH SEPT. 1936 [with Numerous Short Summaries].—Lübcke. (*E.T.Z.*, 17th Dec. 1936, Vol. 57, No. 51, pp. 1479-1482.) Many of these papers are dealt with separately in these or previous Abstracts & References.
1267. A NEW CAPACITIVE METHOD FOR THE CONVERSION OF MECHANICAL INTO ELECTRICAL OSCILLATIONS AND *vice versa* [using Solid Dielectric instead of Air, giving increased Sensitivity and Other Advantages].—Sell. (See Lübcke, 1266, above.)
1268. ON THE CALCULATION OF GRID CURRENTS IN ELECTRON RELAYS [Valves and Thyatrons: with Particular Reference to Photo-Relays].—Sotskov. (*Automatics & Telemechanics* [in Russian], No. 4, 1936, pp. 71-75.)
1269. "RADIO AMATEUR'S HANDBOOK, 14TH EDITION" [Book Review].—American Radio Relay League. (*Wireless Engineer*, Jan. 1937, Vol. 14, No. 160, p. 27.)

Some Recent Patents

The following abstracts are prepared, with the permission of the Controller of H.M. Stationery Office, from Specifications obtainable at the Patent Office, 25, Southampton Buildings, London, W.C.2, price 1/- each. A selection of abstracts from patents issued in the U.S.A. is also included, and these bear a seven-figure serial number.

AERIALS AND AERIAL SYSTEMS

453 736.—Motor-car aerial consisting of a U-shaped rod or tube broadly tuned to the frequency at which the most serious "ignition" interference occurs.

Marconi's W.T. Co. (assignees of R. M. Smith). Convention dates (U.S.A.) 29th December, 1934, and 31st May, 1935.

455 164.—Retractable frame aerial for taking D.F. observations from an aeroplane in flight.

Short Bros. (Rochester and Bedford) and A. G. Parks. Application date 1st August, 1935.

TRANSMISSION CIRCUITS AND APPARATUS

453 733.—Signalling system utilising ultra-short wave valves of the closed hollow-resonator type.

N. V. "Meaf." Convention date (Germany) 27th October, 1934.

453 852.—High-powered oscillator controlled by an input of relatively low power and constant or pre-determined frequency.

Marconi's W.T. Co. and D. F. George. Application date 18th March, 1935.

454 059.—Stabilising the operation of a valve oscillator by utilising the harmonic frequencies for automatic regulation.

Cie Generale de T.S.F. Convention date (France) 24th November, 1934.

454 077.—Coaxial transmission line which also serves for tuning a valve generating ultra-short waves.

Standard Telephones & Cables (assignees of A. B. Crawford). Convention date (U.S.A.) 17th May, 1935.

454 208.—Oscillatory tuning circuit or resonator for ultra-short waves, and means for coupling it to an aerial.

N. V. Philips Co. Convention date (Germany) 18th March, 1935.

454 259.—Class B modulator giving a rectilinear response of constant amplitude over a wide frequency range.

Marconi's W.T. Co. and W. T. Ditcham. Application date 27th March, 1935.

2 034 787.—Oscillation generators in which the frequency is stabilised by a back-coupled tuning-fork.

A. J. Williams, Jr. (assignor to Leeds and Northrup Co.).

2 034 826.—Modulating and demodulating systems in which third-order components are utilised, i.e., currents proportional to the cube of the impressed voltage.

H. Nyquist (assignor to American Telephone and Telegraph Co.).

2 048 723.—Constant-frequency valve-generator with shunt circuits tuned to one or more harmonics of the fundamental.

W. A. Appleton (assignor to Radio Corporation of America).

RECEPTION CIRCUITS AND APPARATUS

453 261.—Electric or mechanical switching device for cutting out local disturbances from a wireless receiver.

N. V. Philips Co. Convention date (Germany) 13th April, 1935.

453 484.—Combined receiver for ultra-short wave television signals and medium or long wave sound signals.

A. C. Cossor, L. H. Bedford and O. S. Puckle. Application date 7th March, 1935.

453 538.—Artificial line used as a high impedance load for the anode of a beat-frequency amplifier in a superhet circuit.

Marconi's W.T. Co., J. D. Brailsford and R. F. O'Neill. Application date 16th March, 1935.

453 620.—Portable receiver in which the tuning and other circuit components are arranged as a unitary structure.

The High Vacuum Valve Co. and D. W. Sayers. Application date 19th June, 1935.

453 842.—High-frequency filter circuit comprising a quarter-wave artificial line, particularly suitable for feed-back or reaction control in valve amplifiers.

Marconi's W.T. Co. and N. M. Rust. Application date 16th March, 1935.

453 858.—Receiver circuit in which automatic tuning control is combined with noise-suppressing means.

Murphy Radio and G. B. Baker. Application date 19th March, 1935.

454 188.—All-wave receiver in which the different tuning elements are successively brought into circuit by the rotation of a disk-shaped member on which they are mounted.

British Thomson-Houston Co. Convention date (U.S.A.) 31st October, 1934.

454 257.—Method of synchronising the local oscillations used in homodyne systems of reception.

Marconi's W.T. Co. and G. M. Wright. Application date 27th March, 1935.

456 519.—Noise-suppressor circuit particularly suitable for battery-operated wireless receivers.

E. K. Cole and G. Bradfield. Application date 8th April, 1935.

VALVES AND THERMIONICS

453 121.—Method for firmly and accurately positioning the electrodes inside the bulb of a thermionic valve.

Marconi's W.T. Co. (assignees of N. R. Smith). Convention date (U.S.A.) 1st February, 1934.

453 137.—Thermionic amplifiers of the type in which the electrons emitted from the filament are collected into a definite jet or "beam."

Marconi's W.T. Co., G. M. Wright, G. F. Brett and N. M. Rust. Application date 4th March, 1935.

453 286.—Electrode assembly and connections for a high-powered generator valve.

Ferranti, M. K. Taylor and R. W. Sutton. Application date 9th April, 1935.

454 133.—Amplifying electric currents by making use of the effects of secondary emission.

British Thomson-Houston Co. Convention date (Germany) 7th March, 1935.

454 258.—Electrode structure for use in cathode ray tubes and in valves of the "beam" type.

Marconi's W.T. Co., G. M. Wright and G. F. Brett. Application date 27th March, 1935.

456 991.—Cold-cathode amplifier of the kind in which an electron stream is multiplied over a series of stages by secondary emission.

Marconi's W.T. Co. and E. W. B. Gill. Application date 24th May, 1935.

ACOUSTICS AND AUDIO FREQUENCY CIRCUITS AND APPARATUS

456 062.—Low-frequency amplifier with cathode coupling designed to emphasise the lower notes.

F. G. Frost and Halcyon Radio. Application date 28th March, 1935.

457 452.—Tone-control device with several different settings and free from objectionable "clicks" when changing from one setting to another.

J. Y. Johnson (communicated by Philco Radio and Television Corporation). Application date 25th May, 1935.

TELEVISION AND PHOTOTELEGRAPHY

453 223.—Electron-optical focusing arrangements in cathode-ray tubes used for television.

Radio-Akt. D. S. Loewe. Convention date (Germany) 9th December, 1933.

453 462.—Method of supervising a number of television transmitters linked to a common telephone line.

Electrical Research Products Inc. (assignees of A. D. Dowd and A. Weaver). Convention date (U.S.A.) 7th July, 1934.

453 496.—Electrode arrangement to facilitate alignment in a cathode-ray tube.

General Electric Co. and G. W. Seager. Application date 11th March, 1935.

453 847.—Band-pass filter circuit particularly suitable for television amplifiers.

L. R. Merdler and Baird Television. Application date 18th March, 1935.

453 886.—Inter-valve couplings with reaction control for a wide-band amplifier suitable for handling television signals.

Radio Akt. D. S. Loewe. Convention date (Germany) 20th December, 1933.

454 319.—Superhet receiver for television signals in which the intermediate frequency is between twice and four times the maximum picture signal frequency.

Radio Akt. D. S. Loewe. Convention date (Germany) 25th January, 1934.

454 511.—Direct-current amplifier particularly for television, in which provision is made to prevent "drift" in the output current.

Marconi's W.T. Co. (communicated by A. W. Vance). Application date 1st April, 1935.

454 831.—Short-wave receiver of high stability capable of handling wide-band signals such as television.

Marconi's W.T. Co. (assignees of B. Trevor and R. W. George). Convention date (U.S.A.) 23rd February, 1935.

454 956.—"Shaping" circuits for use in transmitting television signals.

Marconi's W.T. Co. and W. S. L. Tringham. Application date 10th April, 1935.

455 356.—Television transmitter designed to keep step with the general illumination-level or "background-brilliance" of the transmitted scene.

Marconi's W.T. Co., H. M. Dowsett and L. E. Q. Walker. Application date 18th April, 1935.

455 598.—Method of correcting for Trapezium-distortion in scanning systems for television.

Telefunken Co. Convention date (Germany) 8th July, 1935.

455 736.—Cathode-ray tube in which for the sake of increased sensitivity, large dispersion is tolerated and compensated for.

N. V. Philips' Co. Convention date (Germany) 31st January, 1935.

455 785.—Television system in which the foreground of the picture is scanned separately from but synchronously with the background parts.

T. Vrabely. Convention date (Hungary) 27th April, 1934.

455 797.—Method of controlling the size of the scanning spot in a cathode-ray tube whilst keeping it always in focus.

The General Electric Co. and L. C. Jesty. Application date 16th May, 1935.

SUBSIDIARY APPARATUS AND MATERIALS

453 136.—Kerr cell of the multiple type in which the inter-electrode capacities of the various pairs of plates are in series with the signal voltage.

Marconi's W.T. Co., H. M. Dowsett and L. E. Q. Walker. Application date 4th March, 1935.

457 195.—Microphone in which the flow of current is transverse to the direction of impact of the sound waves.

N. S. Rose and M. E. Angel. Application date 17th April, 1936.