

THE
**WIRELESS
ENGINEER**

AND
EXPERIMENTAL WIRELESS

VOL. XI.

DECEMBER, 1934

No. 135

Editorial

The Operation of Several Transmitters on the Same Wavelength

WHEN it is stated that several transmitters share a common wavelength, it is generally understood that they are entirely independent, and geographically so far removed from one another that, with the power available, the field strength of each is negligible within the service area of the others. Were there no Heaviside layer a large number of such stations could be accommodated even in Europe, but unfortunately it is during the evening hours, when quality of transmission is most important, that the Heaviside layer becomes very effective, with the result that such stations must be separated by very great distances to avoid mutual interference. What ratio of field strength is permissible is a matter of opinion, but it is generally agreed that that of the disturbing station should not exceed one per cent. of that of the desired station. As Hahnemann pointed out at the Oslo Conference in June, it is not a matter of great importance that stations sharing a wavelength but transmitting different programmes should maintain exact equality of frequency, for, although their carriers will produce a beat

note, it will be of a low pitch to which the ear is relatively insensitive, whereas, even if the carriers are of identical frequency, the side-bands will cause mutual interference of much higher frequencies to which the ear is very sensitive, and if the modulation is deep these side-bands may approach half the amplitude of the carriers.

There is, however, an entirely different system, first proposed we believe by P. P. Eckersley in 1924, and discussed very fully in a Paper before the Institution of Electrical Engineers by Eckersley and A. B. Howe in 1929. In this system transmitters in the same country, and therefore relatively near together, transmit the same programme on the same wavelength. The B.B.C. worked four relay stations on the same wavelength in 1926-1929, the wavelength chosen being 288.5 metres. This system has also been developed in Germany by the Lorenz Co. and several groups of transmitters are employing it. In this system it is of the utmost importance to maintain exact equality of frequency, the ideal being to keep the transmitters locked together, as it were, in

synchronism. There are many different ways in which an approximation to this ideal may be attained. The stations may each be provided with an electrically maintained tuning fork working at a frequency of about 2,000, which can be multiplied by, say, 500 in several stages to obtain a frequency of 10^6 corresponding to a 300 metre wave. If the forks are enclosed in thermostatically controlled enclosures the frequency can be kept constant to within 1 part in 10^5 . If the forks are replaced by quartz oscillators with a frequency of 250,000, the necessary frequency multiplication is reduced to 4 and, moreover, the frequency can be maintained constant to within 1 part in 10^6 or 10^7 . By enclosing the quartz oscillator in a cavity in a solid copper block, the outside of which is thermostatically controlled, and by placing this inside an enclosure maintained at an approximately constant temperature, the quartz temperature can be kept within a range of $\pm 0.005^\circ\text{C}$. In 1930 the Lorenz Co. installed this system in the three stations Cologne, Münster and Aachen, which worked on a single wave.

At a wavelength of 300 metres, two stations each with a variation of 1 in 10^5 may produce a beat note of 20 cycles per second, but if the variation is reduced to 1 in 10^6 , this is reduced to 2 cycles per second, which, although not giving an audible note, would produce a rapid fading of a throbbing character. By increasing the constancy of frequency still further, the period of the fading cycle is increased and thus rendered less obnoxious.

Frequency Control from a Common Source

Much closer regulation of frequency is possible if the stations are controlled from a common source by means of overhead lines or underground cable. In the former case the control frequency may be as high as 50,000, necessitating a multiplication by about 20 at each transmitter, but in the latter case the frequency could not be above about 2,000 for effective transmission. The first German tests were made with a control frequency of 30,000 transmitted over existing overhead lines. This was replaced later by the Lorenz system employing a cable and a frequency of 2,000. Instead of multiplying up this received 2,000 cycle current, it is preferable to use it to control a 2,000 cycle fork which

acts as a filter to any disturbances coming in on the cable. The Lorenz Co. have installed this system in the group Frankfurt, Trier, Freiburg, Cassel, and also in the group Hannover, Flensburg, Bremen, Magdeburg, Stettin. In another system patented by the Lorenz Co. the basic control is a quartz oscillator of about 10^6 cycles per second; for transmission over the cable a fraction of this frequency, viz., about 2,000 cycles, is employed. The controlled transmitters have also 10^6 cycle quartz oscillators as the first stage of their amplifiers, each fitted with a similar device for giving $1/500$ of this frequency. Any tendency for the locally produced 2,000 cycles to get out of step with the 2,000 cycles received over the cable causes the operation of a regulating device which corrects the tendency. The variation with this system is stated to be between 1 in 10^7 and 1 in 10^8 .

Wireless Synchronising Signal

It may be asked how, if the transmitters are locked in synchronism, it is possible for any variation of frequency to exist. Although running in synchronism, the coupling between them is elastic, like that between two alternators running in parallel, and they may swing slowly to and fro about a mean frequency, one being high when the other is low and vice versa.

It would be possible to use wireless transmission in place of the cable or overhead line, in fact the first experiments in this country between Daventry and Birmingham were made with wireless control at twice the working wavelength, but the difficulties involved have prevented its practical development. When the B.B.C. applied the single-wave system to a group of stations in 1926, viz., Edinburgh, Hull, Bradford and Bournemouth, they installed independent tuning-fork oscillators at each station, adjusted to equality of frequency, but the variation of frequency was stated to be 100 to 200 parts in a million, which is of a different order of accuracy from that of modern systems.

Even with the best modern systems it is very important that the strength of the disturbing field should be small compared with that of the desired transmitter. The permissible ratio of the fields depends on the variation of frequency mentioned above. Were the transmitters rigidly locked and not

elastically, the permissible ratio could be greater. Another point of importance is the degree of modulation. As Harbich first pointed out this should preferably be kept down to 30 per cent. or less in such systems, as otherwise, at those times and places where the two carriers are in opposition and thus give a small resultant carrier at the receiver, the side-bands will be excessive and cause distortion. On the other hand the modulation must not sink to too small a value in pianissimo passages or the throbbing or tremolo due to beats between the carriers will become too noticeable.

With a variation of frequency of 1 in 10^9 , which is the constancy claimed for the latest system with cable control installed in Germany by the Lorenz Co., and a modulation not exceeding 30 per cent., good reception is obtained even if the distant station produces a field strength half that of the nearer station. This figure is not much altered even if the two transmitters have identical frequencies with no variation. Experiments made by the B.B.C. in 1925 indicated that with perfect synchronisation the field ratio should not exceed 0.2, but the modulation employed was not stated nor the degree of perfection of the synchronisation. In all this it is, of course, assumed that both stations are giving the same programme.

A Particular Case

If two transmitters of equal power are about 160 miles apart and working at a wavelength of 300 metres, it is a simple matter, assuming the values of day and night field strength distribution agreed upon at the Madrid Conference, to plot out the area around each transmitter in which the distant transmitter will cause no appreciable interference. This is fully discussed in the paper by Eckersley and Howe referred to above; one finds that in the day, interference is experienced only over a very narrow band midway between the stations, but in the night satisfactory reception is only possible within a radius of about 60 miles, irrespective of the power if both stations have the same power. This figure for the radius assumes high quality frequency control of the latest type. If, instead of two, there are, say, half a dozen stations distributed roughly 150 to 200 miles apart, this radius of satisfactory

night reception will be reduced to about 45 miles. It is obvious from these figures that a country cannot satisfactorily be served by a single network, but that several networks working at different wavelengths would be necessary, the transmitters of one network being situated in the interference zones of the others. As an example of this Trier, Frankfurt and Freiburg form a triangle within which is Kaiserslautern; this would be in the interference zone—or mush area, as the B.B.C. call it—of the three transmitters; it is therefore linked up with the Nürnberg-Augsburg group which works on a different frequency.

Long Period Variations Unimportant

We would emphasise that the amazing figure of 1 in 10^9 given for the frequency variation of the most recent Lorenz system employing cable-connected tuning-forks is not really so amazing as it looks for it only refers to the variation which occurs in 4 seconds. The constancy over long periods is of minor importance compared with the variation which can occur during the time taken for the variation to travel over the cable and bring the distant transmitter to the new frequency. A slow change of frequency is relatively unimportant so long as the stations have the same frequency at any moment. This explains the displacement of quartz by the tuning-fork in the modern cable-connected systems. The time taken for the whole system to respond to a change of frequency in the master oscillator is about 4 seconds and any difference which may exist between the frequencies of the members of the group is limited therefore to the variation occurring during this time. Where the stations are not interconnected by a synchronising line, the conditions are, of course, much more onerous; in this case the quartz oscillator is superior to the tuning-fork.

G. W. O. H.

The Annual Index

With this issue is included the annual index to *The Wireless Engineer* and the full index to all Abstracts and References published during the year. The Abstracts Index is detachable, if desired, by opening up two wire staples on the last page.

Heptode Frequency Changers*

By Raymond J. Wey

SUMMARY.—From the static characteristics of a heptode valve are derived expressions for the conversion conductance and effective stage gain of the valve when operating as a frequency changer.

The expression for the conversion conductance was verified experimentally, using fifty cycle alternating voltages for signal and oscillator input, by the method of phase reversal of one voltage with respect to the other. Close agreement between calculated and observed values was obtained over a range of operating conditions. An approximate formula for the optimum heterodyne gave values very nearly equal to the observed values.

The expression for the effective stage gain in terms of constants derived from the static characteristics was also tested experimentally, using a heptode valve working under normal operating conditions, *i.e.*, with oscillator section of the valve generating radio-frequency oscillations, and with a radio-frequency input to the control grid of different frequency. An intermediate-frequency transformer, tuned to the beat frequency, formed the anode load.

Good agreement was obtained between the calculated and measured values of effective stage gain over a wide range of operating conditions.

The effect of curvature of the characteristics in limiting the input and output voltages is discussed briefly in relation to the design of the frequency changer stage.

1. Introductory Remarks

AT the present time there appears to be very little available data on the operation and performance of heptode frequency changers for superheterodyne receivers. Owing to the increasing importance of this type of receiver, and to the fact that the heptode or pentagrid valve had obvious advantages over the well-known two-valve frequency changer, it was decided to investigate the mechanism of frequency changing in heptode valves.

It is becoming normal practice to express the efficiency of a frequency changer by the term "conversion conductance," which is analogous to mutual conductance, since it represents the value of the beat frequency current produced in the anode circuit of the valve per volt signal input to the control grid, the valve operating with zero anode load. Conversion conductance is by itself a very important criterion of efficiency, but before the behaviour of the valve when operating with an anode load can be determined, it is necessary to know the effective impedance of the valve when operating. This value of effective impedance will be referred to hereafter as the "conversion impedance."

At the time of this investigation, the only heptode valve available was the American "Pentagrid" as used originally in *The Wireless World* New Monodial Superhet¹,

and the work to be described was confined to the operation of a valve of this type, a Sylvania 2A7 being actually used. Up to the present time the writer has not had an opportunity to examine the properties of the more recent types of heptode now available, but it is reasonable to assume similar, if improved, characteristics.

2. List of Symbols

- I_a = mean anode current.
- I_0 = anode current at zero oscillator grid bias and given control grid bias.
- i_a = instantaneous anode current.
- i_1 = instantaneous anode current when e_g and e_0 are in phase.
- i_2 = instantaneous anode current when e_g and e_0 are in phase opposition.
- e_g = inst. control grid potential measured from N .
- e_0 = inst. oscillator grid potential measured from M .
- E_0 = maximum value of oscillator grid alternating voltage.
- E_g = maximum value of control grid alternating voltage.
- M = value of oscillator grid bias to cause cut-off of anode current.
- N = value of control grid bias at point of intersection of assumed ideal characteristics.
- P = oscillator grid bias measured from M .
- Q = control grid bias measured from N .

* MS. accepted by the Editor June, 1934.

α, β = constants derived from static characteristics.

$$a = \frac{a}{I_0}$$

$$b = \frac{\beta}{I_0}$$

q = $2\pi \times$ signal frequency.

p = $2\pi \times$ oscillator frequency.

I_B = maximum value of beat frequency component of anode current.

E = anode voltage measured from the point of intersection X of projected characteristics.

g = slope of anode current—control grid characteristics at zero oscillator bias, for a given control grid bias.

I.F. output current in anode circuit, zero anode load.

$$g_c = \frac{\text{I.F. output current in anode circuit, zero anode load.}}{\text{R.F. signal input voltage to control grid.}}$$

= conversion conductance.

3. Static Characteristics

The heptode valve is, in effect, a combined triode and tetrode, but with the important

of two wires parallel to the cathode, so that although sufficient mutual conductance between it and the oscillator grid is obtained to enable reaction to be obtained in an oscillatory circuit, its effect upon the electron stream is negligible in comparison with that of the oscillator grid.

The cathode, first and second grids thus form, in effect, a cathode, the emission of which is controlled by the potential of the first grid. Surrounding these electrodes is grid No. 3, which, together with grid No. 5, is maintained at a positive voltage, forming an electrostatic screen around the control grid No. 4. A tubular anode surrounds the whole electrode assembly.

In practice, the signal input is applied to the control grid, the oscillator grid and oscillator anode being connected in the local oscillator circuit in the usual manner. The electron stream is first modulated by the oscillator grid at the heterodyne frequency, a portion is then attracted by the oscillator anode, and the remainder passes on through screening grid, No. 3, to the control grid, No. 4, where it is further modulated by the signal input, giving rise to beat frequency components. After passing through screening grid No. 5 the electron stream arrives at the anode, to which is connected the intermediate frequency transformer. As with

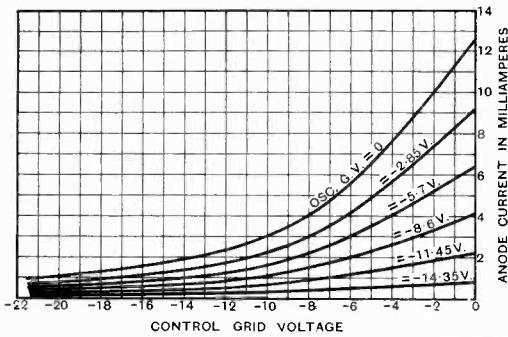

(Above) Fig 1.—Sylvania 2A7. Anode Voltage = 200, Osc. Anode Voltage = 150, Screen-grid Voltage = 100, Heater Voltage = 2.5.

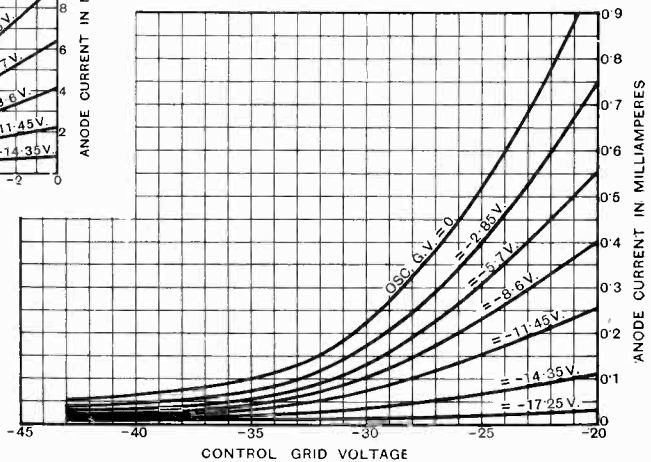

(Right) Fig 2.—Sylvania 2A7. Anode Voltage = 200, Osc. Anode Voltage = 150, Screen-grid Voltage = 100, Heater Voltage = 2.5.

feature of possessing one cathode and one electron stream. The grid nearest the cathode (No. 1 in Figs. 6 and 13), is the oscillator grid, while the grid No. 2 forms the oscillator anode. This grid consists actually

a screen-grid valve, a portion of the electron stream is attracted to the screening grids, giving rise to the s.g. current, which is usually supplied by a potential divider.

The dimensions and spacing of the

electrodes is such as to give variable-mu characteristics by variation of control grid bias, which is usually derived from the automatic volume control circuit.

The measured static characteristics of the pentagrid valve are shown in Figs. 1 and 2, which show the variation of anode current with variation of control grid bias, for various values of oscillator grid bias. It was found that effect of change of oscillator anode voltage on the working anode current (as distinct from the oscillator anode current) was negligible, and, since it appeared² that the normal oscillator anode voltage was of the order of 150 volts, this was the value adopted in measuring the static characteristics. It was considered advisable to limit the screening grid voltage to 100, in view of the rapid increase of anode current with screening-grid voltage. The mutual conductance also increases with s.g. voltage, and as it was desirable that the characteristics be measured under conditions of maximum efficiency, the screening-grid was maintained at 100 volts throughout the tests.

It is evident by inspection that over a small range of control grid potential, the anode current may be represented by a series of divergent straight lines, tangential to the actual characteristics at the mean control grid potential considered (Fig. 3).

By plotting the anode current—oscillator grid potential characteristics at various values of control grid potential, a series of curves, Fig. 4, of similar shapes but of differing slopes is obtained. These curves may be considered, to a sufficiently close approximation, to be of the form

$$i_a = \alpha e_0 + \beta e_0^2$$

Thus the anode current may be represented, for any given control and oscillator grid voltages, by the expression

$$i_a = \frac{e_0 g}{I_0} (\alpha e_0 + \beta e_0^2) = e_0 g (\alpha e_0 + \beta e_0^2) \dots \dots (1)$$

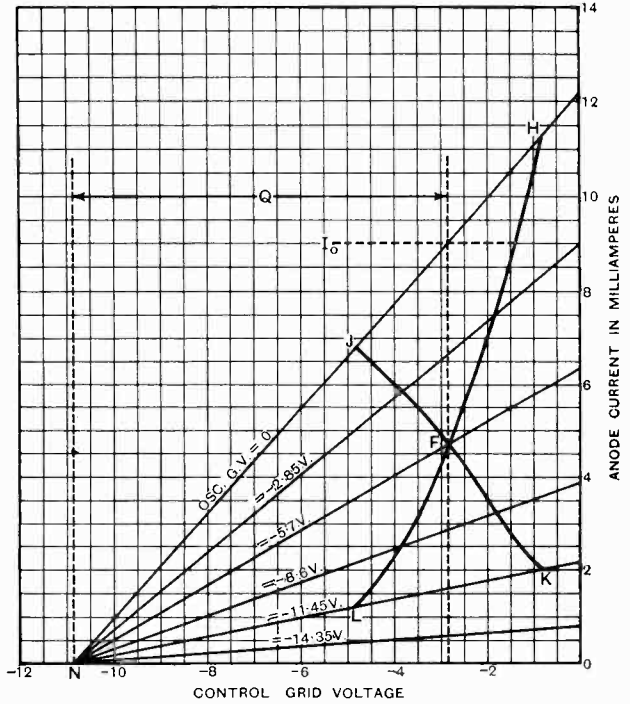

Fig. 3.—Ideal Characteristics of Sylvania 2A7. For control Grid Voltage = -2.85.

$$g = \frac{I_0}{Q} = 1.125 \text{ mA/volt.}$$

$$i_a = g \times e_0 (\alpha e_0 + \beta e_0^2) = 1.125 e_0 (.0011 e_0 + .00245 e_0^2)$$

4. Conversion Conductance

The control grid potential when operating may be expressed as

$$e_a = Q + E_a \sin qt$$

and the oscillator grid potential as

$$e_0 = P + E_0 \sin pt$$

Substituting in (1),

$$i_a = g(Q + E_a \sin qt) \{ a(P + E_0 \sin pt) + b(P + E_0 \sin pt)^2 \}$$

Expanding this, and neglecting all terms except those involving the mean anode current and the beat frequency components ($p + q$) and ($p - q$),

$$i_a = gQ \left(\frac{bE_0^2}{2} + aP + bP^2 \right) + g \frac{E_0 E_a}{2} (a + 2bP) \cos (p + q)t - g \frac{E_0 E_a}{2} (a + 2bP) \cos (p - q)t \dots (2)$$

From this it will be evident that the two beat frequency components are of equal magnitude, and the maximum value of either beat frequency component is

$$I_B = g \frac{E_0 E_g}{2} (a + 2bP)$$

and since the maximum value of the control grid input voltage is E_g , it follows that

$$g_c = \frac{I_B}{E_g} = \frac{gE_0}{2} (a + 2bP) \dots \dots (3)$$

The physical explanation of the action of the valve in producing beat frequency currents is evident from an examination of the characteristics. Referring to Fig. 3, let F represent the working point with no alternating input voltage applied to oscillator or control grids. The oscillator and control grid alternating potentials of pulsataces p and q respectively may be considered to be of one frequency and continuously varying phase displacement. Hence, when the two potentials are in phase, the anode current swings through HFL and when the potentials are in phase opposition the anode current swings through JFK . The waveforms of anode current during one complete cycle of input voltage are shown in Fig. 5, and it is evident that the mean anode current with signal and oscillator voltages in phase is greater than the mean anode current with signal and oscillator voltages in phase opposition, hence the production of a beat

frequency component. In this connection may be mentioned a paper by E. L. C. White³ dealing with the production of beat frequency currents in a screened-grid valve with oscillator voltage injected into the anode circuit.

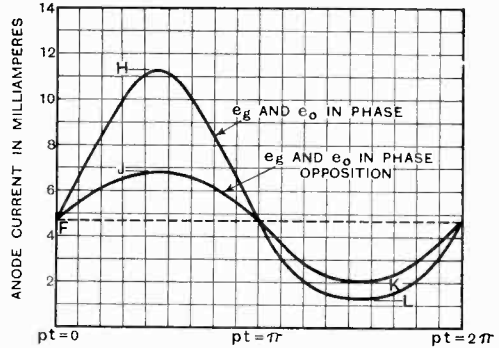

Fig. 5.—Waveform of Anode current for conditions shown in Fig. 3.

The foregoing explanation of the mechanism of frequency changing may also be made the basis of a second method of obtaining the expression for the conversion conductance. It will be apparent from Fig. 5 that the total swing of the beat frequency component is equal to the difference in mean values of the anode current for the two conditions considered, i.e., oscillator and control grid voltages either in phase or in phase opposition.

Thus

$$2I_B = \frac{I}{2\pi} \int_{pt=0}^{pt=2\pi} (i_1 - i_2) dt.$$

Also

$$i_1 = g e_{g1} (a e_0 + b e_0^2)$$

$$i_2 = g e_{g2} (a e_0 + b e_0^2)$$

and $i_1 - i_2 = g(a e_0 + b e_0^2) (e_{g1} - e_{g2})$

where

$$e_{g1} = Q + E_g \sin pt$$

$$e_{g2} = Q - E_g \sin pt$$

$$e_0 = P + E_0 \sin pt$$

$$\therefore i_1 - i_2 = g \{ a(P + E_0 \sin pt) + b(P + E_0 \sin pt)^2 \} \{ (Q + E_g \sin pt) - (Q - E_g \sin pt) \}$$

$$= g \{ a(P + E_0 \sin pt) + b(P + E_0 \sin pt)^2 \} (2E_g \sin pt) \dots (4)$$

Integrating between $t = \frac{2\pi}{p}$ and $t = 0$, i.e.,

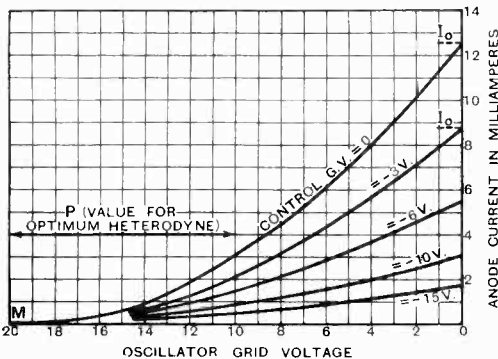

Fig. 4.—Sylvania 2A7. Anode Voltage = 200, Osc. Anode Voltage = 150. Screen Grid Voltage = 100, Heater Voltage = 2.5.

$$i_a = (a e_0 + b e_0^2)$$

$$= \{ .01(P + E_0 \sin pt) + .022(P + E_0 \sin pt)^2 \}$$

(For control Grid Voltage = - 2.85.)

over one complete cycle,

$$2 I_B = g E_g E_0 (a + 2bP) \text{ is obtained}$$

$$\text{or } g_c = \frac{I_B}{E_g} = \frac{g E_g}{2} (a + 2bP)$$

which result is identical with expression (3).

This expression only holds for values of oscillator grid voltage such that complete cut-off of anode current never occurs, since it has been assumed that $i_a = e_0 g (a e_0 + b e_0^2)$. To extend this equation to cover all values of oscillator grid voltage would result in a rather cumbersome expression, but this may be obviated by the following method.

Since it is usual to use a grid condenser and grid leak to ensure stability of the oscillator, it is evident that in this case the oscillator grid will be maintained at a negative potential with respect to the cathode, the mean value of this potential being approximately equal to the peak value of the alternating input. This is due, of course, to the flow of grid current which takes place during the positive peak of the grid voltage.

under these conditions the mean anode current during the negative half-cycle is small, and is nearly the same for either phase of the control grid potential. Its effect may therefore be neglected in comparison with the positive half-wave, at least for an approximate analysis. By integrating expression (4) over the positive half-cycle

only, i.e., from $t = \frac{\pi}{\rho}$ to $t = 0$ it is found that

$$2 I_B = 2g E_g \left\{ \left(\frac{a}{2} + bP \right) \frac{E_0}{2} + (a + bP) \frac{P}{\pi} + \frac{2bE_0^2}{3\pi} \right\}$$

Since, generally

$$a \ll bP \text{ and } \frac{P}{\pi} (a + bP) \ll \frac{2bE_0^2}{3\pi}$$

it may be said without serious error that

$$I_B = g E_g \left\{ \left(\frac{a}{2} + bP \right) \left(\frac{E_0}{2} + \frac{P}{\pi} \right) + \frac{2bE_0^2}{3\pi} \right\}$$

$$\text{or } g_c = g \left\{ \left(\frac{a}{2} + bP \right) \left(\frac{E_0}{2} + \frac{P}{\pi} \right) + \frac{2bE_0^2}{3\pi} \right\} \quad (5)$$

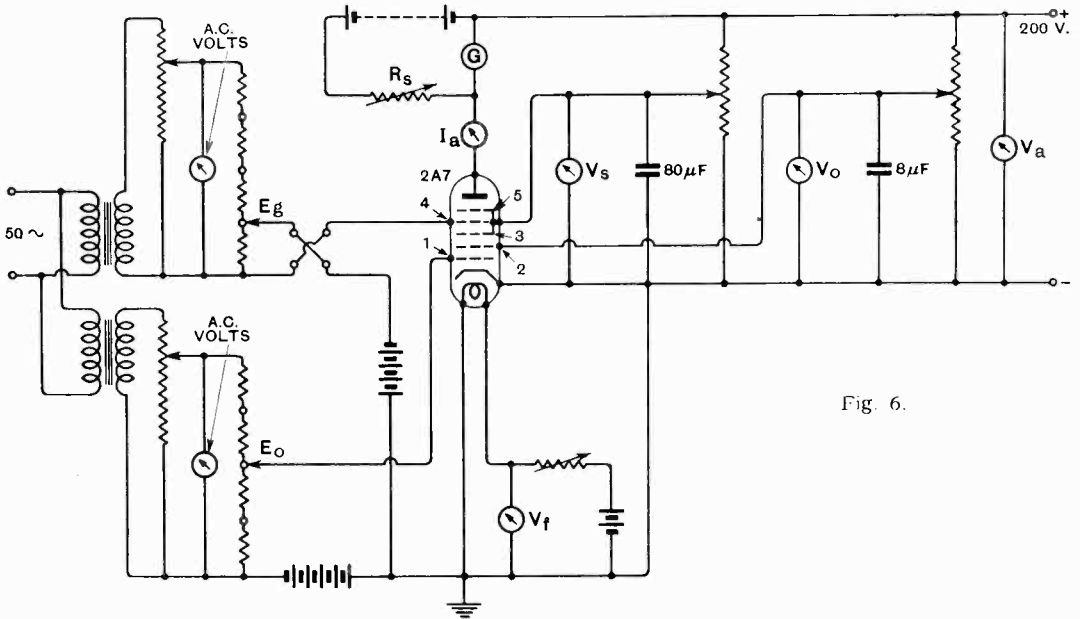

Fig. 6.

Thus, in order that the oscillator grid voltage may exceed the value M , it is necessary for the mean grid voltage to exceed $\frac{M}{2}$, assuming a symmetrical wave-form of oscillator input.

It will be seen from Figs. 4 and 5 that

It is unlikely in practice that the mean oscillator grid potential would exceed M , in which case (5) would be incorrect, since anode current would flow for a part of the positive half-cycle only. Thus the working range may be covered by equations (3) and (5).

5. Optimum Heterodyne

Since $E_0 + P = M$ very nearly, when working with an oscillator grid condenser and grid leak, it may be assumed that $P = M - E_0$, and, substituting in (3)

$$g_c = \frac{gE_0}{2} \{a + 2b(M - E_0)\}$$

Differentiating and equating to zero, the optimum heterodyne becomes

$$E_0 = \frac{a + 2bM}{4b} = \frac{a}{4b} + \frac{M}{2} \dots \dots (6)$$

Although this will always be slightly greater than $\frac{M}{2}$ and hence gives a value of E_0 falling outside the limits of expression (3), since $\frac{a}{4b}$ is very small compared with $\frac{M}{2}$, e.g., in the case considered, $\frac{M}{2} = 10$ and $\frac{a}{4b} = \frac{.0011}{.0098} = .113$, it may be stated without serious error that the *optimum heterodyne* is $\frac{M}{2}$ or one-half of the oscillator grid base.

6. Experimental Verification of Expressions for Conversion Conductance and Optimum Heterodyne

Probably the simplest method of experimentally checking these expressions is to supply the necessary control and oscillator

grid potentials from a 50 cycle source derived from the supply mains, and to note the change of anode current when the phase of one voltage is reversed with respect to the other voltage⁴. The actual connections of the apparatus used are shown in Fig. 6, from which it will be seen that the alternating grid potentials were derived from potential dividers fed from step-down transformers, the control grid being connected through a reversing switch. Steady grid potentials were provided by batteries, and the change of anode current was observed by means of a multi-range micro-ammeter, with the steady anode current "backed-off." Readings were corrected for the shunting effect of the "backing-off" series resistance R_s on the meter, and, as a precaution, the phase angles of the two transformers were measured and found to be the same to within about 25 minutes. The anode was maintained at 200 volts, the oscillator anode at 150 volts, and the screening grids at 100 volts. A series of tests, the conditions of which are tabulated in Table 1, were then made, as follows:—

Test 1.—The oscillator grid alternating voltage was adjusted so that the peak voltage was equal to the steady grid bias, thus approaching the conditions obtained in practice with a grid leak and condenser. The change of anode current on reversal of the phase of the control grid alternating

TABLE 1.
TEST CONDITIONS.

Test No.	CONTROL GRID.			OSCILLATOR GRID.			Results Shown in.
	Bias Voltage.	A.C. Input Voltage.	Freq.	Bias Voltage.	A.C. Input Voltage.	Freq.	
1	2.8 V.	Zero to 1.5 R.M.S.	50 ~	Zero to 17 V.	Peak Value = Bias Voltage	50 ~	Fig. 7 Fig. 8 (a and b)
2	2.8 V.	Zero to 1.5 R.M.S.	50 ~	Zero to 17 V.	Peak Value = $\frac{1}{2} \times$ Bias Voltage	50 ~	Fig. 8 (d and e)
3	2.8 V.	1 V. Peak	50 ~	10 V.	Zero to 10 V. Peak	50 ~	Fig. 9.
4	1.45 V. to 42.7 V.	Zero to 7 V. R.M.S.	50 ~	10 V.	10 V. Peak	50 ~	Figs. 10 and 11
5	2.85 V. to 33.1 V.	Constant (see Table 2)	1,000 k.c.	Approx. equal to Peak Input	Zero to 20 V. Peak	1,100 k.c.	Fig. 14, Table 2.
6	2.85 V. to 43.25 V.	Zero to 10 V. R.M.S.	1,000 k.c.	Approx. 10 V.	10 V. Peak	1,100 k.c.	Figs. 15 and 16

voltage was then found for a series of values of control grid alternating input, at each value of oscillator grid bias and oscillator alternating voltage. The control grid bias was kept constant at 2.8 volts, thus bringing the working point to the centre of a fairly straight portion of the charac-

for which range expression (3) is used. Over the remainder of the curve, between $\frac{M}{2}$ and M , the agreement is not so good, but this is to be expected, since expression (5), used for this range, involves further approximations.

It will be also observed that the measured optimum heterodyne occurs at about 10 volts, corresponding with the calculated value.

Test 2.—The previous test was repeated, but using oscillator alternating voltages of one half of the values used in Test 1, the steady oscillator bias values being the same. The measured values of conversion conductance are plotted in curve (d) Fig. 8, and the corresponding calculated values in curve (e) Fig. 8. It will be seen that the measured conversion conductance is very nearly equal to that predicted by the theory, i.e., one half the value obtained in Test 1.

Test 3.—With a control grid bias of 2.8 volts and an alternating input of one volt peak, the oscillator alternating input was varied between zero and 10 volts peak, with $P = 10$ volts. At each value of oscillator input, the change of anode current on reversing the phase of the control grid input was observed, and, since the control grid input was one volt peak, this was equal to twice the conversion conductance. Fig. 9

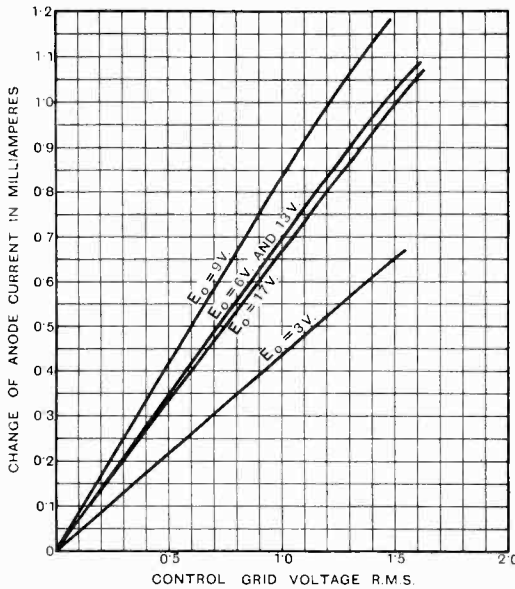

Fig. 7.

teristics (see Fig. 1). Since it was found that grid-current started at about -0.8 volts, the maximum permissible input was about 2 volts peak. Fig. 7 shows the results obtained and it will be seen that the characteristics are substantially linear.

One half the slope of the curve gives the conversion conductance, a curve connecting this with oscillator grid voltage being shown in Fig. 8(a). Using formulae (3) and (5) and values for the constants (a) and (b) as determined from the static characteristics, Fig. 2, at a control grid bias of 2.8 volts, values of conversion conductance were calculated for several oscillator voltages, the curve of Fig. 8(b) being obtained. The agreement between the observed and the calculated values is very good considering that ideal characteristics were assumed in deriving the expressions for conversion conductance. The errors are small for values of oscillator voltage up to 10 volts or $\frac{M}{2}$,

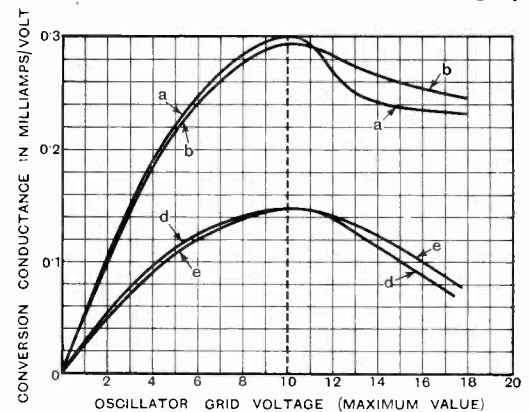

Fig. 8.

shows the values of conversion conductance so obtained plotted against oscillator input, and it will be seen that within the limits of experimental error, the points fall on a straight line passing through the origin, as predicted by expression (3).

Test 4.—With optimum oscillator input of 10 volts peak and $P = 10$ volts, the relation between change of anode current and control grid input was measured at a series of values of control grid bias. Fig. 10 shows the change of anode current obtained on reversing the phase of the input voltage, and it will be observed that the characteristics are linear for values of input likely to occur in practice, since the smaller values of grid bias are used with the smaller inputs. Fig. 10 also shows that no advantage will be gained by using less than 3 volts grid bias, in fact it will be advantageous to use a minimum bias of about 3 volts, thus avoiding an unnecessarily large anode current with consequent increased valve noise. This will also avoid unintentional delay in automatic volume control systems, since with the minimum bias of the order of one volt usually adopted, at least 2 volts of the A.V.C. voltage applied to the grid will be ineffective in reducing conversion conductance.

A curve connecting control grid bias and

points Fig. 11(b). Having calculated the maximum conversion conductance at one value of control grid bias (in this case for

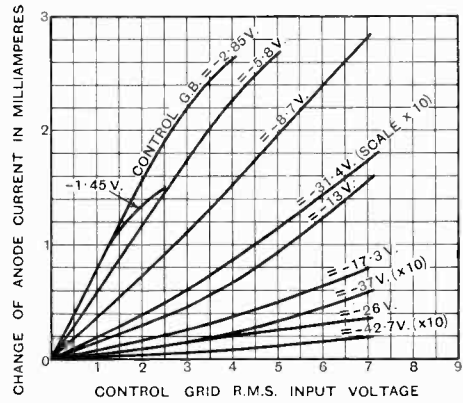
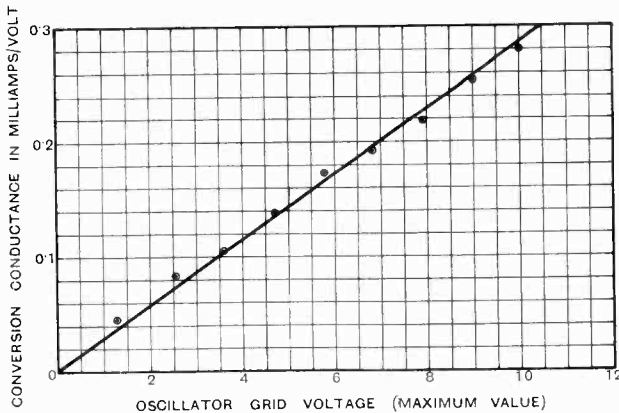

Fig. 10.

2.8 volts), to obtain the value at any other control grid bias it is merely necessary to multiply by the relative mutual conductances as measured from the static characteristics. It will be seen that the errors due to calculating the conversion conductance from the static characteristics are negligible for practical purposes.

7. Conversion Impedance and Conversion Amplifications

The effect of change of anode voltage on anode current was measured



(Above) Fig. 9.—Sylvania 2A7. Anode Voltage = 200, Osc. Anode Voltage = 150, Screen Grid Voltage = 100, Heater Voltage = 2.5, Control Grid Bias = -2.8 volts. Oscillator Grid Bias = -10 volts.

(Right) Fig. 11.—Conversion Conductance of Sylvania 2A7, with Optimum Heterodyne.

Oscillator grid bias = -10 v. Oscillator input = 10 v. peak.

(a) observed. (b) calculated.

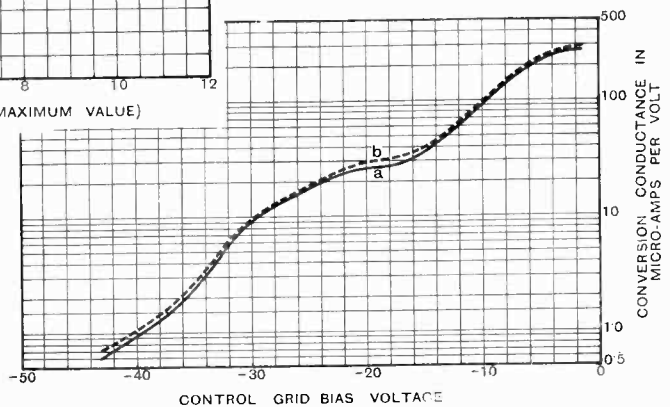

conversion conductance was then plotted, Fig. 11(a), from the slopes of the curves of Fig. 10, and also a curve from calculated

at various oscillator and control grid potentials. The range of anode voltage used was from about 250 to 130, at which value

linearity was departed from, owing to the proximity of the "dynatron" kink in the characteristic. Upon plotting the values obtained to a suitable scale, Fig. 12, it was at once evident that the anode current—
anode voltage characteristics over the range considered could be replaced by a series of divergent straight lines originating at a point *X* corresponding to zero anode current and —850 volts anode potential, irrespective of the oscillator and control grid potentials. Therefore, if *E* is the normal anode voltage measured from the origin *X* of the divergent straight lines, and δE is a change in anode voltage

$$\delta i = i \frac{\delta E}{E}$$

What is true for instantaneous values is equally true for mean values, hence

$$\delta I_a = I_a \frac{\delta E}{E}$$

That this is so will be seen from Fig. 12, which also shows the results obtained with various alternating voltages applied to oscillator and control grids.

Referring to expression (2), it will be seen that the mean anode current is given by

$$I_a = gQ \left(aP + bP^2 + \frac{bE_0^2}{2} \right)$$

$$\therefore \delta I_a = I_b = \frac{\delta E}{E} gQ \left(aP + bP^2 + \frac{bE_0^2}{2} \right)$$

Consider the valve to have a tuned anode circuit offering a dynamic resistance *R* to beat frequency currents, and negligible impedances at other frequencies, *e.g.*,

$$\frac{P}{2\pi}, \frac{q}{2\pi}, \frac{2q}{2\pi},$$

etc., appearing in the anode current. Let the variation of anode voltage caused by the beat frequency currents passing through the anode load be $\pm \delta E$ or $2\delta E$ total. The variation of anode current which would be produced by this change of anode voltage acting in absence of any beat frequency component is

$$\pm \frac{\delta E}{E} I_a$$

But the anode current must actually change by $\pm \frac{\delta E}{R}$ to produce a change of anode

voltage of $\pm \delta E$, hence the beat frequency component must change the mean anode current by

$$\begin{aligned} \pm I_b &= \pm \delta I_a \\ &= \pm \left(\frac{\delta E}{R} + \frac{\delta E}{E} I_a \right) \\ &= \pm \delta E \left(\frac{1}{R} + \frac{I_a}{E} \right) \end{aligned}$$

Since the instantaneous anode current is proportional to the anode voltage measured from point *X*, the conversion conductance

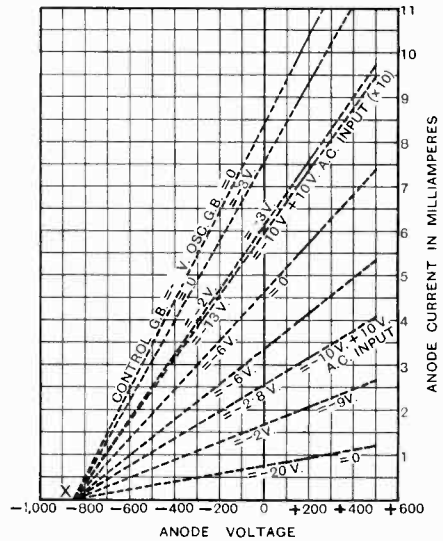

Fig. 12.

will also be proportional to the anode voltage. Thus the conversion conductance when δE is positive is

$$g_c \left(\frac{E + \delta E}{E} \right) = g_c (1 + \delta)$$

and when δE is negative the conversion conductance is

$$g_c \left(\frac{E - \delta E}{E} \right) = g_c (1 - \delta)$$

Hence

$$\delta I_o = E_o g_c (1 + \delta)$$

$$\text{and } -\delta I_a = -E_o g_c (1 - \delta)$$

$$\therefore 2\delta I_a = 2I_b = 2E_o g_c$$

$$\text{and } 2E_o g_c = 2\delta E \left(\frac{1}{R} + \frac{I_a}{E} \right)$$

or conversion amplification

$$= \frac{\delta E}{E_g} = \frac{g_c}{\left(\frac{1}{R} + \frac{I_a}{E}\right)} = \frac{Rg_c}{\left(1 + \frac{RI_a}{E}\right)} \quad (7)$$

This result is similar to the well-known expression for the amplification of a triode valve of mutual conductance g , internal resistance R_0 and anode load R , when amplification

$$= \frac{\mu R}{R + R_0} = \frac{gR_0R}{R_0 + R} = \frac{gR}{1 + \frac{R}{R_0}}$$

In (7) the effective impedance of the heptode valve is represented by the term

$$\frac{E}{I_a} = \frac{E}{gQ\left(aP + bP^2 + \frac{bE_0^2}{2}\right)}$$

For values of E_0 between $\frac{M}{2}$ and M , the mean anode current may be found approximately by integration of the anode current over the positive half cycle only. Putting

$$I_a = \frac{\dot{p}}{2\pi} \int_{t=0}^{t=\pi/\dot{p}} i dt = gQ \left\{ \left(a + bP\right) \left(\frac{E_0}{\pi} + \frac{P}{2}\right) + \frac{bE_0^2}{4} \right\} \quad (8)$$

The conversion conductance for this range has already been found (5), *i.e.*,

$$g_c = \dot{p} \left\{ \left(\frac{a}{2} + bP\right) \left(\frac{E_0}{2} + \frac{P}{\pi}\right) + \frac{2bE_0^2}{3\pi} \right\}$$

These values of g_c and I_a substituted in (7) give the conversion amplification for $E_0 = \frac{M}{2}$ to $E_0 = M$.

8. Experimental Verification of Expressions for Conversion Amplification

Since, when the valve is operating normally as a frequency changer in a superheterodyne receiver, the anode load is a tuned circuit possessing appreciable impedance only at frequencies near the beat frequency, and since this condition had been assumed in deriving the expressions for conversion conductance, it was obviously desirable to verify experimentally the expression under these conditions.

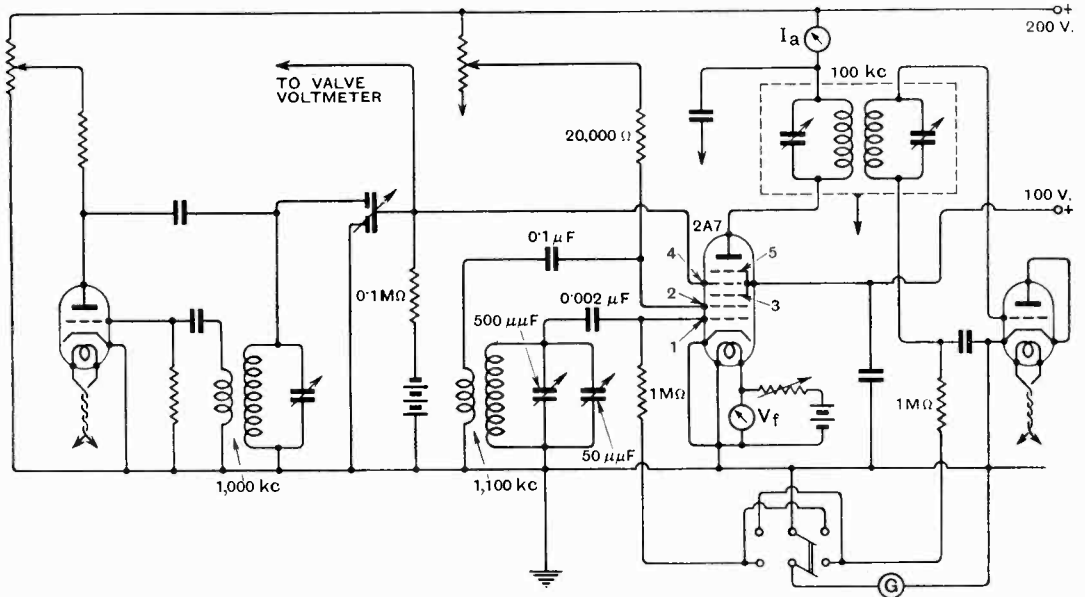

Fig. 13.

$e_g = Q$ and $e_0 = P + E_0 \sin pt$ in

$$I_a = \frac{\dot{p}}{2\pi} \int i dt = \frac{\dot{p}}{2\pi} \int g e_g (a e_0 + b e_0^2) dt,$$

and integrating between $t = 0$ and $t = \frac{\pi}{\dot{p}}$

The actual circuit used is shown in Fig. 13, and it will be seen that the input signal is derived from a parallel-fed tuned-anode triode oscillator, with grid leak and condenser for stability, arranged so that a

variable fraction of the output could be applied to the control grid of the heptode valve *via* a differential condenser, grid bias being provided through a 0.1 megohm leak.

The local or heterodyne oscillations were generated by the oscillator section of the heptode, using a parallel-fed tuned-grid arrangement, thus ensuring that the oscillator grid voltage was of reasonable purity of wave-form. A tuned intermediate frequency transformer was used in the anode circuit, the secondary winding being connected to a diode rectifier with an anode load of one megohm, in series with a sensitive galvanometer. The dynamic resistance of the complete I.F. transformer and diode combination was carefully determined at the resonant frequency of about 100 kilocycles, a mean value of 0.354 megohm being obtained. Also, the relation between I.F. primary voltage and rectified output was determined by feeding the primary from an oscillator operating at the resonant frequency of the transformer, a valve voltmeter being connected across the primary. The results, when plotted, showed a linear relationship between input voltage and rectified output, except for the small curved initial portion.

The grid leak and condenser combination of the oscillator section of the heptode was

also calibrated in order to determine the relation between radio frequency grid voltage and mean grid potential. The grid current passing through the grid leak was determined at various values of radio-frequency grid-voltage, as indicated by a valve voltmeter connected between grid and cathode. The resistance of the grid leak was measured, and thus the mean grid potential at any value of grid current could be found. The amplitude of oscillation was controlled by variation of oscillator anode voltage. A linear relation between R.F. input and mean grid potential was obtained at R.F. voltages greater than one volt peak. Also, it was found that over the range 4 to 20 volts peak input, the mean grid potential was approximately equal to the peak input, thus confirming the assumption previously made when calculating the optimum heterodyne.

Having completed these preliminary calibrations, a series of measurements of conversion amplification was made with various operating conditions, with the following results.

Test 5.—With anode voltage = 200 and screening grid voltage = 100, a series of readings was made of I.F. output with constant R.F. input, at various values of oscillator or heterodyne voltage. The fre-

TABLE 2.

ANODE VOLTAGE = 200. SCREENING-GRID VOLTAGE = 100.

Control Grid Bias Voltage.	Oscillator Grid Bias Voltage.	Oscillator Peak Voltage = E_0 .	R.F. Signal Input Voltage R.M.S.	I.F. Output Voltage R.M.S.	Conversion Amplification.
2.85	3.95	3.80	0.78	15.0	19.20
	6.68	6.68	0.78	26.5	33.95
	11.40	11.45	0.78	34.3	44.00
	19.60	20.00	0.78	34.4	44.10
13.0	5.10	5.0	1.11	9.5	8.55
	8.25	8.20	1.11	14.25	12.85
	11.20	11.25	1.11	15.43	13.95
	18.20	18.35	1.11	14.62	13.20
	25.55	26.00	1.11	13.10	11.80
24.5	4.60	4.50	1.11	3.80	3.42
	8.00	7.90	1.11	5.90	5.32
	11.30	11.35	1.11	6.35	5.72
	17.85	18.10	1.11	5.80	5.22
33.1	5.68	5.60	1.93	2.60	1.35
	8.30	8.25	1.93	3.45	1.79
	11.20	11.25	1.93	3.55	1.84
	18.90	19.20	1.93	3.25	1.68

quency of the control grid input throughout these tests was about 1,000 kilocycles, and the frequency of the oscillator input was about 1,100 kilocycles. From the value of oscillator grid current could be found the

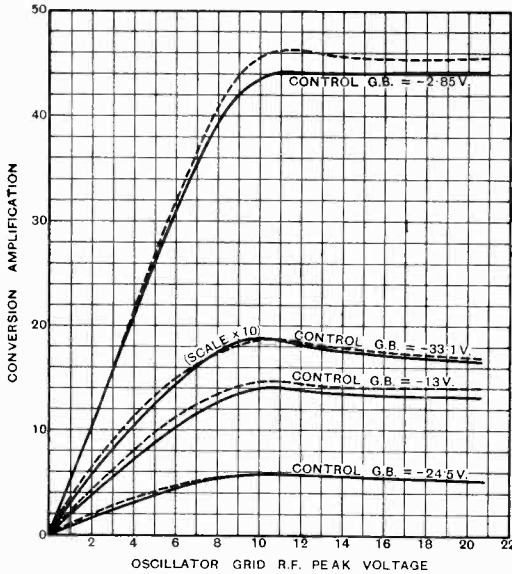

Fig. 14.—Conversion amplification of Sylvania 2A7.
 ————— measured.
 calculated.

mean grid potential and oscillator input, from the previous calibration. The amplitude of oscillation was adjusted by variation of oscillator anode voltage, since this had a negligible effect on the working anode current. The above procedure was repeated for a number of values of control grid bias, the results being shown in Table 2, and plotted in Fig. 14. It will be seen that the curves show an optimum heterodyne voltage of about 10 volts, as predicted by theory. The dotted line curves are calculated from expression (7), and show a satisfactory agreement with the measured curves, particularly, as would be expected, at values of E_0 below $\frac{M}{2}$, over which range the more accurate expressions for g_c and I_a are applicable in (7).

The slope of the curves at values of E_0 greater than $\frac{M}{2}$, i.e., above the optimum heterodyne, is very small, so that for practical purposes it may be assumed that the

conversion amplification reaches a constant value for oscillator voltages above the optimum. This is a fortunate circumstance, since it renders unnecessary in practice the critical adjustment of oscillator conditions. Furthermore, variations of oscillator voltage, resulting from variations of control bias in automatic volume control systems, are without serious effect on the conversion amplification providing the oscillator voltage never falls below the theoretical optimum of $\frac{M}{2}$. In this connection it is interesting to note that even if variation of oscillator conditions resulting from variation of control grid bias had effect on the conversion amplification, it would be of little moment in practice, and perhaps would be useful, since, with the oscillator correctly adjusted to optimum heterodyne at minimum control grid bias, any departure from optimum conditions due to increase of control grid bias would be assisting the action of the automatic volume control.

Test 6.—This series of tests was made to determine the maximum permissible input voltage which could be applied to the control grid without causing departure from a linear input-output relationship. The procedure was similar to that of the previous test, but the oscillator voltage in this case

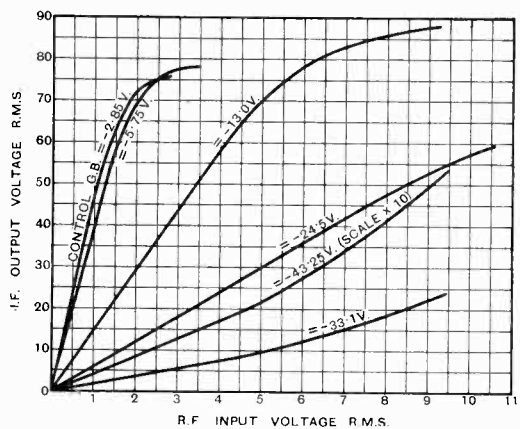

Fig. 15.

was kept constant at the optimum value of 10 volts, and the signal input voltage adjusted through a fairly wide range. This was repeated for various values of control grid bias. Fig. 15 shows the results obtained.

In a superheterodyne receiver the modulated I.F. output from the frequency changer is eventually rectified by the second detector, and the audio-frequency output from this has the same waveform as the envelope of the I.F. input, assuming linear detection. Hence any distortion of the envelope by the frequency changer (or any other predetector stage in the receiver) will be apparent as harmonic distortion in the audio-frequency detector output. The maximum permissible second harmonic distortion for good quality reproduction is usually estimated at 5 per cent., but since the output stage will contribute the major portion of this in a properly designed receiver, the distortion due to the frequency changer should certainly be less than 2 per cent.

Curves showing the maximum inputs and outputs for 2 per cent. second harmonic distortion are given in Fig. 16, the points being obtained from Fig. 15. It will be noticed that the maximum input falls to about 4 volts R.M.S. at large values of control grid bias, a point which should be remembered when designing the stages associated with the frequency changer. Where no signal frequency amplification is used, no trouble should be experienced from overloading, since the input derived from the aerial is seldom likely to rise above 4 volts R.M.S. even from the local station, when the higher values of grid bias are used to reduce amplification. At low values of grid bias, the permissible input falls to about 1.5 volts, but the actual input under these conditions will probably be only a small fraction of a volt, since the higher amplification obtained with low values of bias will be required only for weak transmissions.

With regard to the maximum output, it should be borne in mind that the curves relate

to the valve used with an anode load of 0.35 megohms. When, as is usually the case, a lower anode load is used, the maximum permissible output is reduced accordingly. The effect of the anode load in straightening the characteristics will be negligible at high

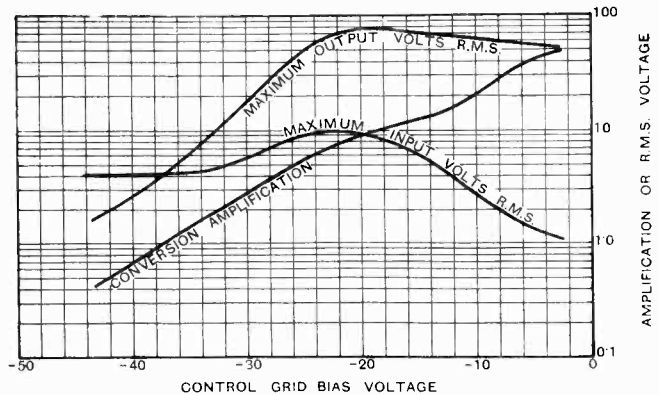

Fig. 16.

values of grid bias, since the anode load will then be very small compared with the conversion impedance of the valve. Hence the maximum input will remain constant for any normal anode load, and the maximum output will be proportional to the anode load.

At low values of bias, and correspondingly low conversion impedance, any straightening effect upon the characteristics which the anode load may have is of no account, the input being now very small. The valve will also damp the anode load to a larger extent at low values of bias, but this can easily be found from the conversion impedance $\frac{E}{I_a}$ as given in section 7.

REFERENCES

- 1 and 2. W. T. Cocking, *The Wireless World*, 21st and 28th July, 1933, pp. 34-37 and 52-56.
- 3 and 4. E. L. C. White, *W.E. and E.W.*, November, 1932, Vol. 9, pp. 618-621.
5. C. L. Lyons, *W.E. and E.W.*, July, 1933, Vol. 10, pp. 364-369.
6. C. L. Lyons, *The Wireless World*, 12th May, 1933, pp. 347-348.

Self-Bias and the Valve Load Diagram*

By W. T. Cocking

THE method of estimating the performance of a valve under working conditions by drawing load lines upon its static characteristics is well known and widely used, and when it is properly applied the optimum operating conditions for a valve, and its performance under those conditions, may be accurately determined. It might be thought, therefore, that nothing further would be required, but the writer has found that an extension of the method to cover the problems of automatic bias greatly increases its usefulness.

The usual system for automatic bias is shown in Fig. 1; the cathode is held at a potential positive with respect to the grid return lead by the voltage drop across the resistance R_1 due to the flow of anode current through it. At the frequency of operation of the valve the impedance between the valve cathode and negative

reactance to be negligibly small at the frequency under consideration.

So far as direct current is concerned, therefore, the load on the valve is $R_1 + R_2 + R_3$, but for the A.C. the load is only R_2 . The conditions may be accurately expressed in the usual way, which is indicated in Fig. 2.

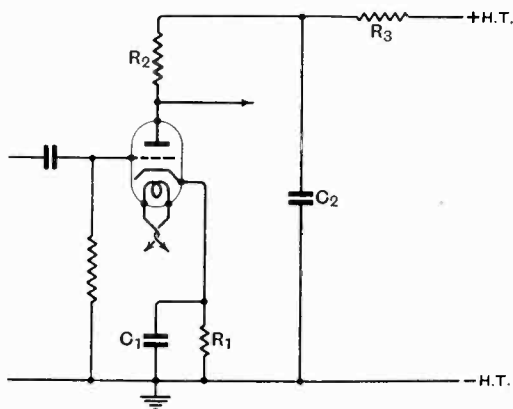

Fig. 1.—The usual resistance-coupled circuit.

H.T. is considered to be zero, since the bypass condenser C_1 should be sufficiently large for this to be approximately true. In the anode circuit, the usual coupling resistance R_2 and decoupling resistance R_3 are included, and the decoupling condenser C_2 is assumed to be sufficiently large for its

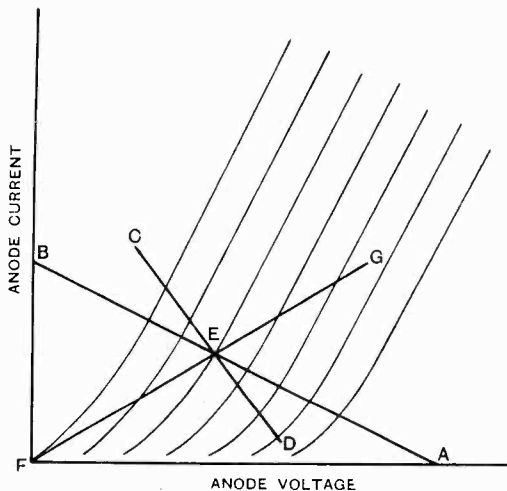

Fig. 2.—A family of valve curves showing the D.C. load line AB , the A.C. load line CD , and the bias resistance line FG .

A line AB of slope equal to $-1/(R_1 + R_2 + R_3)$ is drawn on the anode-volts— anode-current curves from the point on the anode voltage abscissae corresponding to zero anode current and the H.T. voltage available. The next step is to decide on the grid bias voltage, and a line CD of slope equal to $-1/R_2$ is drawn through the intersection of AB with the valve curve corresponding to this particular value of bias. This point E is the operating point of the valve. The operating conditions as regards D.C. are specified by the intersections of AB with the valve curves and as regards A.C. by the intersections of CD with the valve curves. The actual anode voltage and current of the valve are the values corresponding to the point E .

Now it will be seen that the bias resistance R_1 leads to some difficulty. Its value cannot be calculated until both the anode current

* MS. accepted by the Editor, June, 1934.

and the bias voltage are known, and neither of these is known until the valve load lines have been drawn. The load lines, however, include R_1 so that they cannot be drawn until R_1 is known.

It is, therefore, the common practice to ignore R_1 as far as the load lines are concerned, and it is true that it is usually small compared with $(R_2 + R_3)$; it is not always small, however. The D.C. load line can then be drawn, the optimum grid bias assessed, and the A.C. load line drawn, and R_1 calculated.

Although satisfactory results are secured in this way provided that proper care be exercised, the value of R_1 first chosen is usually of non-standard value, and fresh computations have to be made in order to find a suitable standard value. The writer has found it best, therefore, to choose a value for R_1 in the first place rather than for bias, and by drawing a suitable line on the valve curves it is readily possible to find the actual bias voltage applied to the valve. Moreover, since R_1 is known in the first place, it may be included in the anode load line and a more accurate result obtained.

Referring to Fig. 3, which shows a family of grid-volts—anode-current valve curves, the bias resistance can be represented by a line AB drawn with a slope equal to $1/R_1$ from the intersection of the zero anode current and zero grid voltage ordinates. The intersections of this line with the valve curves enable the anode voltage necessary for the production of the various values of anode current and grid bias for the particular valve to be read off.

It is rarely convenient to use grid-volts—anode-current curves, however, and it is usually better to draw the bias resistance line upon the anode-volts—anode-current curves. It will not, however, be a straight line, although it is often straight over a considerable region. This line is shown as FG on Fig. 2 and it obviously starts from the intersection of the zero grid volts curve with the zero anode current ordinate, for at zero current there is zero voltage across R_1 . The other points through which FG is drawn may be as readily obtained. For any value of negative grid voltage, divide the figure by the value of the resistance and so obtain the value of anode current necessary to produce that bias. The intersection

of the curve for that value of grid voltage with the current ordinate just calculated gives the required point. It should be noted that the scale of anode voltage does not enter into the question, for the line FG is plotted between the current scale and the valve curves themselves. Having drawn this line, the intersection with it of the D.C. anode load line immediately specifies the working point of the valve.

In design work, the usual procedure is to draw a number of bias resistance lines for different values of resistance, and upon drawing the anode circuit load lines the optimum value of bias resistance can readily be determined. Although they thus enable a considerable saving of time, an even greater point in favour of their use lies in the ease with which it is possible to estimate the effect upon operation of variations in components. Resistances are usually rated for value within certain specified limits, and it is not easy by ordinary methods to determine the effect upon the steady anode current of the different variations that may

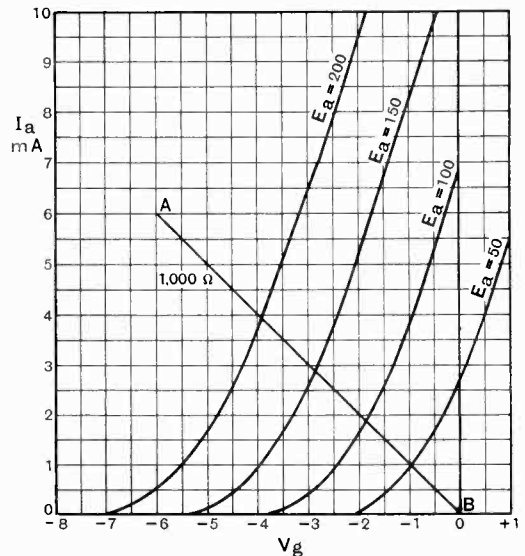

Fig. 3.—The bias resistance line AB is straight when drawn on the grid volts—anode current curves.

be met with. By drawing sets of load and bias resistance lines, however, the effect may be seen at a glance.

Suppose R_1 be given a nominal value of 1,000 ohms and R_2 and R_3 are 25,000 ohms

each. The diagram is shown in Fig 4, and *AB* represents the load for D.C. of 51,000 ohms for an H.T. supply of 300 volts, while

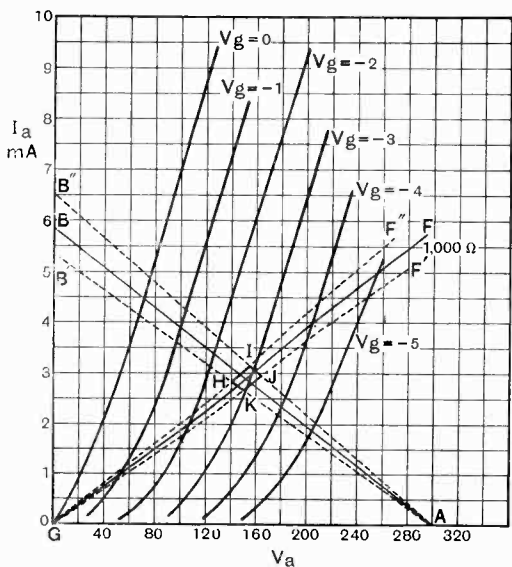

Fig. 4.—The bias resistance line may be used in estimating the effect of variations in components. The dotted lines represent changes of ± 10 per cent. in resistance values, and the operating area is *H I J K*.

FG is the bias resistance line. Now if the tolerance on resistance values is 10 per cent. R_1 may vary between 1,100 ohms and 900 ohms, as represented by $F'G$ and $F''G$ respectively, and $(R_1 + R_2 + R_3)$ may vary between 56,100 ohms and 45,900 ohms, represented by AB' and AB'' . Whatever the actual values of the resistances, therefore, the working point must be within the area *H I J K* bounded by the four lines representing the extremes of resistance values.

Strictly speaking, of course, this is not wholly accurate, for the point *H* represents a case where the bias resistance is 10 per cent. below its rated value and the total D.C. load 10 per cent. above its rated value, and the load cannot be as high as this. The point *H* is accurately specified for a D.C. load equal to $1.1(R_2 + R_3) + 0.9R_1$, but the error is usually negligible. The effect of variations in the A.C. load itself, of course, can be seen by drawing the appropriate load line through each of the four corners of the operating area.

The system is one which the writer has found to be particularly valuable when dealing with resistance-capacity coupled triodes, and it is also useful for assessing the operating conditions of triode output valves. It is obviously inapplicable to cases where bias is derived from a resistance in the common negative H.T. lead, or to tetrode or pentode valves, for in all these cases the bias is not dependent only on the anode current of a single valve.

Books Received

Electromagnetism.

By HECTOR MUNRO MACDONALD, M.A., F.R.S., Professor of Mathematics in the University of Aberdeen.

This book assumes an elementary knowledge of its subject with which it deals very exhaustively albeit its size is kept within reasonable compass. The text includes a discussion of the general equations of electrodynamics, applications to transparent material media and to conducting media, diffraction, radiation, resonances and moving electrical systems. Pp. 178 + xv. Published by Messrs. G. Bell and Sons, Ltd., York House, Portugal Street, W.C.2. Price 12s. 6d. net.

Making and Repairing Radio Sets.

By W. OLIVER.

A practical handbook for the amateur constructor which, as its name implies, deals thoroughly and in a practical manner with all aspects of the construction and maintenance of a wireless receiver. Pp. 123 with 30 diagrams. Published by Messrs. W. Foulsham and Co., Ltd., 10 and 11, Red Lion Court, Fleet Street, E.C.4. Price 1s. net.

The Wireless and Gramophone Trader Year Book, 1935. 256 pages. The Trader Publishing Co., Ltd., Dorset House, Stamford Street, London, S.E.1. Price 5s. 6d. (3s. 6d. to subscribers to *The Wireless Trader*).

This annual work of reference, now in its tenth year of issue, is available only to those connected with the radio and gramophone trades. It contains much useful information—technical, commercial, legal, and statistical—of interest to all branches of the industry, and, in addition, a diary section of practical size is included.

In the directory section are to be found some 1,800 addresses of manufacturers and wholesale agents, and there is also a Buyers' Guide giving sources of supply of more than 200 different classes of apparatus and other articles.

The technical section contains articles on the organisation and equipment of a dealers' service department, information on the suppression of interference, accumulator charging, etc., in addition to valve data tables.

The book has been completely revised, and many alterations and additions have been made to the 1935 edition.

The Development of the Receiving Valve

I.E.E. Wireless Section—Chairman's Address

THE opening meeting of the I.E.E. Wireless Section Winter Session was held on Wednesday, 7th November, when Mr. S. R. MULLARD, M.I.E.E., delivered his Chairman's address. At the opening of the meeting a vote of thanks to the retiring Chairman, Mr. G. Shearing, was moved by Mr. F. S. Barton and seconded by Dr. A. H. Rawlinson.

The new Chairman took as his subject the development of the receiving valve, particularly since the inauguration of broadcasting. Referring to the valve which occasionally attended accidental discoveries in the course of other investigations, he mentioned Edison's classical accidental effect which led, many years later, to the wireless valve. He then referred to pre-war valves and to the development of the hard valve during the war. The advent of broadcasting led to the great development of the hard valve, particularly to immediate means of improving filament performance. From this the speaker outlined the progress of the thoriated tungsten filament, discussing the processes of activation and the maintenance of emission. The next step in cathode-heating economy was the re-discovery of the oxide-coated cathode which had, indeed, been the original form used by Wehnelt. Manufacturing processes demanded a better method of formation than the original pasting, and had led to the vapour method of barium oxide deposition. This method, however, proving unsuitable for certain types of valve, had led also to the improvement of pasting formations, and both processes were now in use, with differences of behaviour which the speaker outlined. The same oxide coating had led in turn to the development of the indirectly heated cathode, and the construction of the cathode elements was illustrated. The speaker expressed the opinion that little further reduction of cathode temperature than that of present practice appeared likely. The really "cold" valve operating emissively at room temperature would involve other physical principles.

The lecturer then proceeded to the progress of the multi-electrode valve. Referring to the circuit needs which led to the development of the screened grid valve, he proceeded to the discussion of this type of tetrode and to the elimination of the negative resistance portion of the i_a/v_a characteristic attained by the introduction of the fifth electrode, as in the pentode (which, it will be remembered, the speaker's company first introduced to the British market). From this point he turned to the need of control of the effective amplification and to the development of the variable- μ valve and its application to h.f. amplification and to automatic volume control. This led, in turn, to a discussion of the different forms of multi-electrode valve, up to the latest tube of this type, the octode, and to the principle of "electron-coupling." The operation of the octode as oscillator and frequency converter (as in a super-heterodyne receiver) was

described and a typical circuit-diagram illustrated. Other "combined" valves were also discussed, and a series of slides was displayed showing the historical progress of the valve and details of construction of some of the newest types.

The Chairman then referred to the Catkin type of construction, and to the magnetron principle in short-wave oscillators. He concluded the address by a description of the latest type of ultra-short-wave valve, illustrating the details and dimensions of construction. Considerable amplification could now be got with waves of the order of 100 cms.

Book Review

Applied Acoustics

By H. F. OLSON, E.E., Ph.D., and FRANK MASSA, B.S., M.Sc., pp. 430 with 228 illustrations and diagrams. Published by Blakiston's Son and Co., Inc., 1012, Walnut Street, Philadelphia, U.S.A. Price \$4.50.

Under the stimulus of broadcasting and talking films the technique of sound reproduction and measurement has advanced in so many directions and at such a pace that only professional sound engineers who have grown up with the subject can hope to appreciate the strides which have been made. The difficulties of recruits to this branch of science have been further increased by the fact that the literature of the subject is distributed throughout the journals of the world.

This book will go far to remedy the situation. Every important development during the past decade is described in its essentials and while the subject matter is dealt with primarily in relation to the practical problems of the engineer, the extensions of classical theory where necessary have been included.

The first chapter gives a succinct summary of fundamental wave equations while the second is devoted to an analysis of dynamical systems. The middle section of the book gives a very full account of modern laboratory methods of acoustic measurement. The chapters dealing with the fundamental principles of design and practical construction of microphones and loud speakers provide all the essential information with which newcomers to the industry might be expected to be acquainted. The concluding chapters deal with architectural acoustics, the measurement of noise and the physiological aspects of hearing.

The authors, who are themselves actively engaged in commercial research and development work, are to be congratulated on the completeness of their survey, but more particularly on their sense of proportion in estimating the relative importance of recent developments. The book is quite up to date and contains references to papers published as recently as the beginning of this year.