

Shelved in Nunnally Medical Library  
Per 621.3

# EXPERIMENTAL WIRELESS

&

The WIRELESS ENGINEER

VOLUME VII.

JANUARY 1930.

NUMBER 76

2/6  
NET

A Journal of Radio Research  
& Progress

Published by

**ILIFFE & SONS, LIMITED**

DORSET HOUSE, TUDOR STREET, LONDON, E.C.4



# IGRANIC TRANSVERSE CURRENT MICROPHONE

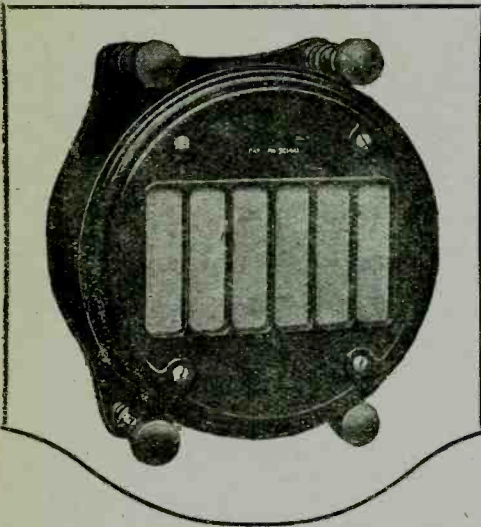

The current-path is parallel to the plane of the diaphragm, so that sound waves impinge at right-angles to the flow. The diaphragm is of non-conducting material, practically non-resonant and, therefore, responding evenly to all audible notes. Carbon granules of different sizes in groups ensure equal response over each band of frequencies. Will not pack. Gives perfect clarity and tonal balance. So stable and sensitive that it will operate at a distance from amplifier without loss of quality or output.

PRICE - - £17. 10. 0

IGRANIC MICROPHONE CONTROL UNIT. Price £6.0.0.

*Please write for details to Dept. J.986.*



149, Queen Victoria Street, E.C.  
Works: BEDFORD.

What the Pacific Engineering Laboratory Co.  
thinks of

## EXPERIMENTAL WIRELESS

& The WIRELESS ENGINEER

"This is one of the best technical wireless journals we have read, and we heartily recommend it to everyone."

"EXPERIMENTAL WIRELESS" is the Journal of Radio Research and Progress, and caters for advanced experimenters and radio research workers. Monthly, 2s. 6d. net, by post 2s. 8d. Subscription, 32s. per annum, post free. ILIFFE & SONS LTD., Dorset House, Tudor Street, London, E.C.4.

E.W. 10

Kindly mention "Experimental Wireless" when replying to advertisers.



# EXPERIMENTAL WIRELESS & The WIRELESS ENGINEER

VOL. VII.

JANUARY, 1930.

No. 76.

## Editorial.

### “Stenode Radiostat.”

A FEW weeks ago startling headlines in some of the daily papers announced a revolution in broadcast transmission and reception. The password of the revolutionaries was “Stenode Radiostat,” which is the name given to the apparatus and is derived no doubt from the Greek root “stenos” = “narrow,” although there is nothing narrow about the claims made for the apparatus. So little definite information concerning the apparatus has been published, however, that it is difficult to tell just how much of what has been published is due to journalistic imagination, and for the same reason one cannot discuss or criticise the apparatus. We understand that those who have attended demonstrations of the apparatus have not been allowed to examine the circuit of the apparatus, and that the demonstrations, while exhibiting certain interesting phenomena, were not of a character to enable one to form any opinion on most of the claims made. Although, therefore, we cannot criticise the threatened revolution we can discuss the constitution of the state which is to be revolutionised, and thus get a clear idea of what the inventor is up against.

#### The Problem.

Assuming a transmitter to have a wavelength of 300 metres, its carrier wave will have a frequency of  $10^6$ . When modulated by a pure sustained note of 1,000 cycles per

second its amplitude will rise and fall with this frequency. The wave received from this transmitter will be identical with that which would be received from three unmodulated transmitters with the carrier frequencies 999 kc., 1,000 kc., and 1,001 kc., all working simultaneously. Any receiver picking up one of these and not the others will not reproduce the 1,000-cycle note; to do this it is necessary to pick up the middle one and at least one of the two side waves. The ordinary receiver is tuned to the middle one, and picks up all three, but this is not essential since either side wave will give a beat note of 1,000 with the middle wave. In transatlantic telephony only one side wave is transmitted, the middle one being supplied by a local oscillator at the receiver. This only halves the width of the waveband required, a negligible saving compared with the claims made for the new apparatus. When the transmitter is modulated by an orchestra the side waves will have every possible frequency between 995 kc. and 1,005 kc., and apart from the single sideband method just mentioned, the receiver must respond to all these frequencies. The ideal would be an equal response over the whole range, and no response outside it—in other words, a band pass filter covering the above range, but failing this, a highly selective receiver, the response of which falls off on either side of the resonant frequency, and which gives, therefore, a weak reproduc-

tion of the higher notes, can be corrected by an audio-frequency amplifier designed to give greater amplification at the higher frequencies.

If the receiver be made so selective—it matters not how—that it does not respond to frequencies 1,000 or more above or below the carrier frequency, then it fails to pick up the component waves which constitute the 1,000-cycle note, and it cannot reproduce that note. If it does pick up these waves then it will pick them up equally well from whatever transmitter they may be radiated. Apart from directive aerials, no receiver can be trained to discriminate between a 999 kc. wave from one station and a 999 kc. wave from another station, and no transmitter can modulate a 1,000 kc. carrier wave at 1,000 cycles per second without producing a 999 kc. wave and a 1,001 kc. wave, nor can it produce a 1,000-cycle note at the receiving station without transmitting to that station at least one of these waves.

#### **Modulated or Unmodulated Interference?**

Let us assume, now, that our reception is being disturbed by an *unmodulated* transmitter with a frequency within the waveband 995-1,005 kc., say 999.5 kc. If we now introduce into our receiver a highly selective rejector circuit tuned to this frequency we may be able to cut out the disturbing wave, but we shall also cut out this frequency from the waves we wish to receive. This may not noticeably affect the quality, especially as we shall still receive the corresponding component, viz., 1000.5 kc., in the upper sideband, which will give the correct beat note with the carrier wave. It might be possible by using

several rejector circuits to eliminate several *unmodulated* interfering waves in this way without seriously interfering with the quality. In fact, it is conceivable that one might cut out one whole sideband and one or two frequencies on the other sideband and still get reasonably good results; it would be like a piano with one or two notes missing. We have emphasised the fact that we assume the interfering wave to be unmodulated; as soon as it is modulated it covers a frequency range and the steps taken to eliminate it are almost entirely defeated—not quite, because the carrier is still eliminated and only the weaker sidebands get through.

#### **More Information Needed.**

From published and unpublished accounts of the demonstrations given it would appear that the test interference was produced by a carefully adjusted unmodulated oscillator, and that its elimination required a careful adjustment of one element of the receiver—probably a slight adjustment of the crystal. If the non-modulation of the interfering oscillation is an essential condition for its elimination, the promised revolution has a long way to go. It would be interesting to know to what degree sensitivity has been sacrificed to obtain this result.

We await further details, especially as to actual results obtained in practice. We would suggest as a useful test the reception in London of Stuttgart (833 kc.) and Graz (851 kc.) while 2LO (842 kc.) is working. In view of the claims made for the system we feel, however, that we should apologise for suggesting anything so easy.

G. W. O. H.

# Frequency Variations of Valve Oscillators.

By D. F. Martyn, B.Sc., A.R.C.Sc., Ph.D.

EVERY experimenter using a valve oscillator must have been troubled at some time by the frequency changes which occur when the filament current or high-tension voltage of the valve is altered. These changes must have led him to suspect that the frequency of the oscillations generated could not be exactly  $\frac{I}{2\pi\sqrt{L_1C_1}}$ , and

hence that the generally accepted theories of the generation of valve oscillations were deficient so far as frequency was concerned. In Section I of the present article the various methods by which frequency changes can be produced are given, and the resulting types of frequency changes are described. Section II is concerned with the theory of the changes. In Section III an oscillator is described which is immune to these frequency variations. Such an oscillator will be of value as a master oscillator, for use as a heterodyne wavemeter, and for many refined physical measurements.

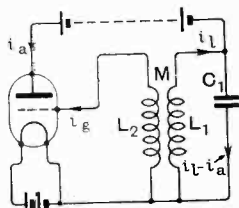

Fig. 1.—Simple plate-tuned oscillator.

frequency changes are described. Section II is concerned with the theory of the changes. In Section III an oscillator is described which is immune to these frequency variations. Such an oscillator will be of value as a master oscillator, for use as a heterodyne wavemeter, and for many refined physical measurements.

## Section I. Experimental.

We shall only consider the tuned plate untuned grid type of oscillator shown in Fig. 1.

The experimental results obtained with a tuned grid oscillator differ very little from those to be described. It is found that variations of frequency of the generated oscillations may be produced by change of any of the following quantities. (1) Filament current. (2) Plate voltage. (3) Grid voltage. (4) Coupling between the coils. (5) Resistance of any part of the oscillator. In addition to these variables the frequency depends directly, of course, upon the values of the inductance  $L_1$  and the capacity  $C_1$ , and to a much smaller extent upon the value of the inductance of  $L_2$ . The effect on the frequency

of these three quantities will be made clear later, in the theoretical analysis. Further, the frequency will depend on the type of valve used, to an extent which will appear in the sequel.

### 1. Effect of Filament Current on Frequency.

Typical curves illustrating the variation of frequency with filament current are given in Fig. 2 for different values of plate voltage. The general effect of increase of filament current is to produce a decrease of frequency. This decrease is slow to commence with, increases rapidly at a certain value of filament current, and then falls off again at high values of filament current. The total change of frequency is greater for high than for low plate voltages. In each case, when oscillations commence they have very nearly

the frequency  $\frac{I}{2\pi\sqrt{L_1C_1}}$ , but as the filament current is increased the frequency soon falls below this value. The extent of the fall may be as great as several octaves. In the

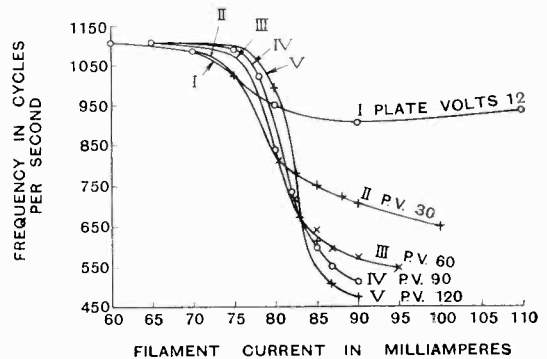

Fig. 2.—Variation of frequency with filament current.

actual case given in Fig. 2, the total variation is seen to be about one octave. The curves shown in Fig. 2 were obtained with no permanent grid bias. Similar curves are obtained with negative grid bias. If, however, a large positive grid bias is used, then the largest frequency variations are obtained with low values of plate voltage.

instead of with high values as in Fig. 2. It is found that the extent of the variation obtainable depends almost entirely upon the value of the ratio  $\frac{L_1}{C_1}$ . Where this ratio is large, then a variation of several octaves is possible, while if the ratio is small the

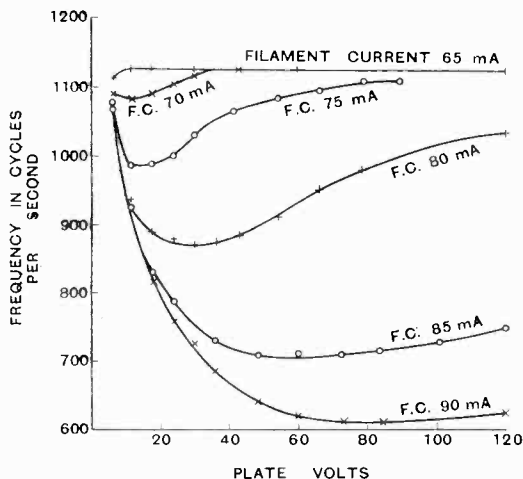

Fig. 3.—Variation of frequency with plate voltage.

variations are reduced to, say, 1 per cent.

In the case quoted  $\frac{L_1}{C_1}$  was 22 henrys per  $\mu\text{F}$ .

Other factors which lead to large variations of frequency are close coupling between the coils of the oscillator, the use of a grid coil with large inductance, and the use of a valve with a high mutual conductance and low impedance. All of these factors are of general application, and also lead to large variations of frequency in the cases described below.

## 2. Effect of Plate Voltage on Frequency.

Typical curves illustrating the variation of frequency with plate voltage are given in Fig. 3. As the plate voltage is increased from zero, oscillations commence with a frequency slightly below the value  $\frac{1}{2\pi\sqrt{L_1C_1}}$ .

Further increase of plate voltage produces a decrease in frequency. At a certain value of plate voltage a minimum frequency occurs, and further increase of plate voltage produces a rise in frequency. The total frequency change, which may amount to as

much as two octaves, is greater for higher values of the filament current. A further effect of using a higher value of the filament current is to move the position of minimum frequency to the right of the graph, so that the minimum occurs at a higher value of the plate voltage. For very low filament current values the curve shows an initial rise. In these cases it appears that the minimum has passed off the scale to the left. It is no longer obtainable because oscillations cannot be made to occur at a sufficiently low plate voltage. The effect of the coupling " $M$ " on the character of the frequency-plate voltage curves is as follows. Loosening the coupling reduces the rate at which the frequency changes with respect to plate voltage. Further, with looser coupling, in every case the position of minimum frequency on the curve is shifted to the right: *i.e.*, with looser coupling the minimum frequency occurs at a higher value of the plate voltage. Similar types of curves are obtained with very different types of valves. When positive grid bias is used the frequency becomes more nearly constant for large values of plate voltage.

## 3. Effect of Grid Bias on Frequency.

The general effect of changing a negative grid bias gradually to positive bias is to produce a decrease of frequency. At a certain value of positive grid bias, however, a minimum frequency occurs, and thereafter the frequency rises as the positive bias is increased. The greatest frequency changes are obtained when low plate voltage and high filament current is used.

## 4. Effect of Coupling on Frequency.

Fig. 4 shows the types of frequency variation found when the coupling is varied. The ordinate represents the reading of a condenser in the frequency-measuring circuit, and hence an increase in the condenser reading  $a^\circ$  corresponds to a decrease in frequency. Curves are given for different values of the plate voltage. Three distinct types of frequency variation exist, according to the value of the plate voltage. For low values of the plate voltage the frequency steadily decreases as  $M$  increases (type *a*). For medium values of plate voltage a minimum frequency occurs (type *b*). For high values of plate voltage a minimum

frequency occurs at a low value of  $M$  and a maximum frequency also occurs at a high value of  $M$  (type  $c$ ). In one instance only, a second minimum was observed at a high value of  $M$  (type  $c^1$ ). In all other respects this case conformed to type  $c$ . Similar types of curves are obtained with very different types of valve. In each case the filament current used was the normal value for the valve in question. Similar results are obtained at higher and lower values of filament current, provided that the values of the plate voltage are altered to correspond. Thus, when using lower values of filament current, the typical curves  $a, b, c$  are obtained for lower plate voltages than are necessary in the case considered.

**5. Effect of Resistance on Frequency.**

The effect of resistance is of greatest importance when it is in series with the coil  $L_1$  or the condenser  $C_1$ . These cases are considered separately below.

*(a) Resistance in Series with Coil.*

The variations of frequency produced are shown in Fig. 5, which shows curves obtained at various values of filament current and plate voltage. In each case, the initial

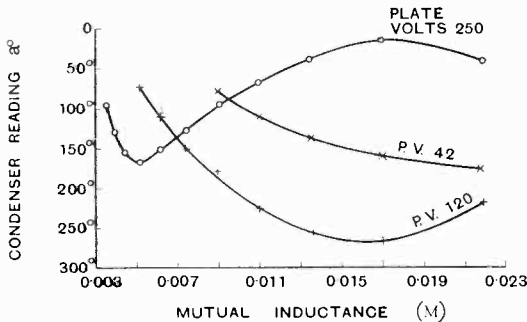

Fig. 4.—Variation of frequency with coupling.

increase of resistance produces a decrease of frequency. At a certain value of resistance, which is different for each curve, a minimum frequency occurs. Further increase of resistance produces a rise of frequency, which continues until extinction occurs. In each curve there is a "kink," or point of inflexion, at a value of  $R$  below that at which the minimum frequency occurs. In one or two instances it is observed that the frequency

actually rises in this "kink," so producing a subsidiary maximum frequency on the curve. This effect is difficult to obtain, however. Similar results are obtained with other valves and coils. In certain cases the

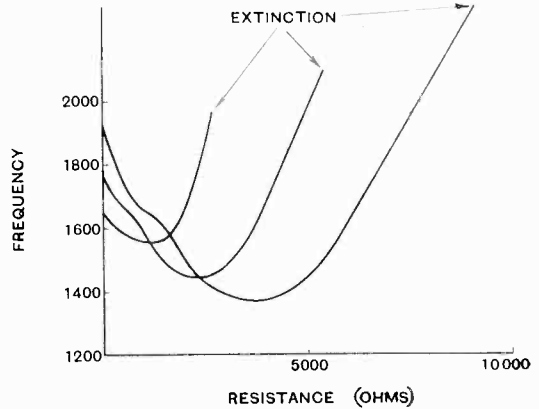

Fig. 5.—Variation of frequency with plate coil resistance.

latter part of the curve is not obtainable, extinction of oscillations occurring before the minimum frequency is reached. This occurs when a steady positive bias, of say ten volts, is imposed on the grid of the valve.

*(b) Resistance in Series with Condenser.*

In general, in this case it may be said that increase of resistance raises the frequency of the oscillations. It is possible, however, to obtain a minimum frequency in certain cases,<sup>(1)</sup> for a low value of resistance. The effect is sometimes obtainable when using close coupling, but is never so marked as that obtained when the resistance is in series with the inductive branch of the oscillator.

**Section II. Theory.**

The first theoretical study of the valve oscillator appears to have been made by Vallauri.<sup>(2)</sup> He found that theoretically the oscillations produced should have a frequency given by

$$\omega^2 = \frac{I}{L_1 C_1} \text{ where } \omega = 2\pi \times \text{frequency.}$$

On this theory, of course, the frequency should be quite independent of the filament current and plate voltage, etc. Later Eccles<sup>(3)</sup> developed a theory of the oscillator which took account of resistance in series

with the coil  $L_1$  and the condenser  $C_1$ . He found that

$$\omega^2 = \frac{1 + Rk_1}{L_1C_1 - SRC_1^2(R + S + k_1RS)}$$

where  $R$  is the resistance of  $L_1$ ,  $S$  is the resistance in series with  $C_1$ , and  $k_1$  is the reciprocal of the valve impedance.

In this case we see that a change of filament current or plate or grid voltage will alter the frequency, since the value of  $k_1$  will depend to some extent on these quantities. The extent of the frequency variation thus predicted is very small, however, for ordinary values of the resistances, and will rarely amount to as much as 0.1 per cent. It is of interest to observe that any factor which produces an increase in " $k_1$ " should produce a slight increase of frequency. For example, increase of filament current should produce an increase of frequency. Fig 2 shows that in practice the reverse of this effect is obtained. Moreover, experimental variations of several hundred per cent. can be obtained. Hence it is evident that there must be a cause of frequency variation of much greater importance than resistance. The question has also been attacked theoretically by Appleton and Greaves<sup>(4)</sup>. They took account of the curvature of the valve characteristics and deduced an expression for the frequency in the form of a series. Here again, however, the frequency variation accounted for is very much smaller than that observed practically. It is, in fact, considerably less than that accounted for by the resistance terms in Eccles' equation.

It has been proved<sup>(5)</sup> that by far the most important theoretical cause of frequency variation is the flow of grid current. A theory of frequency variation based on grid current is capable of explaining in detail all the experimental results described in Section I. An oscillator in which a large amount of grid current is flowing is subject to marked frequency changes, while if the grid current be reduced to a very small quantity, then the frequency remains remarkably steady even when the filament current and plate voltage, etc., are altered. When the resistances present are not large, and the frequency is not too high, then it is permissible to say that grid current is the sole cause of observed frequency variations. At very high frequencies two other causes of fre-

quency variation come into action. The first of these causes is the inter-electrode capacities in the valve, and the second is the finite time taken by the electrons from the filament to reach the electrodes.

### 1. Theory of Generation of Oscillations taking account of Grid Current.

In Fig. 1  $i_g$  represents the value of the grid current flowing at any instant, while  $i_l$  is the instantaneous value of the variable current in  $L_1$ , and  $i_a$  is the instantaneous value of the variable plate current. If we neglect for the moment the resistances present, then we may write down at once the following equations of the circuit:—

$$v_a = M \frac{di_g}{dt} - L_1 \frac{di_l}{dt} \quad \dots (1)$$

$$v_g = M \frac{di_l}{dt} - L_2 \frac{di_g}{dt} \quad \dots (2)$$

$$i_l - i_a = C_1 \frac{dv_a}{dt} \quad \dots (3)$$

As a first approximation we shall assume that  $i_a$  and  $i_g$  are each linear functions of the plate voltage  $v_a$  and the grid voltage  $v_g$ . Hence we obtain the two further equations necessary for the solution of the problem

$$i_a = k_1 v_a + k_2 v_g \quad \dots (4)$$

$$i_g = k_3 v_g + k_4 v_a \quad \dots (5)$$

By elimination between these five equations we obtain the following differential equation, giving  $i_l$ :—

$$k_3 C_1 (L_1 L_2 - M^2) \frac{d^3 i_l}{dt^3} + \{(L_1 L_2 - M^2)(k_1 k_3 - k_2 k_4) + L_1 C_1\} \frac{d^2 i_l}{dt^2} + \{L_1 k_1 + L_2 k_3 - M(k_2 + k_4)\} \frac{di_l}{dt} + i_l = 0 \quad (6)$$

The effect of plate voltage on grid current is usually small, so that we shall neglect  $k_4$  in comparison with  $k_3$ . Now experimentally we know that the oscillatory current in  $L_1$  has the form of a sine wave. Hence the solution of (6) must be of the form

$$i_l = I_l \sin \omega t$$

Substituting this solution for  $i_l$  in equation (6) and equating to zero the coefficients of



sin  $\omega t$  and cos  $\omega t$  we obtain two equations for  $\omega^2$ .

$$\omega^2 = \frac{I}{L_1 C_1 + k_1 k_3 (L_1 L_2 - M^2)} \dots (7)$$

$$= \frac{L_1 k_1 + L_2 k_3 - M k_2}{k_3 C_1 (L_1 L_2 - M^2)} \dots (8)$$

Equation (7) gives the frequency of the oscillations generated. Equation (8) gives the conditions necessary for undamped oscillations to be produced. Unless equation (8) is satisfied, either no oscillations will occur, or oscillations with a growing amplitude will be found. The oscillations will increase in magnitude until  $k_1$ ,  $k_2$ , and  $k_3$  attain values which satisfy equation (8). When this happens they will settle down into a steady state.

Since  $L_1 L_2$  is always greater than  $M$ , it is evident from equation (7) that the frequency of the oscillations generated is always less than the value  $\frac{I}{2\pi\sqrt{L_1 C_1}}$ . The amount

of this lowering is dependent upon the magnitude of the expression  $k_1 k_3 (L_1 L_2 - M^2)$ . If we take the numerical value of this expression for the case of the experimental variations shown in Fig. 2, we find that it has a value about four times that of  $L_1 C_1$ . By equation (7) this should represent a frequency variation of about an octave. This is just the extent of the variation observed by experiment. In the case of oscillators which experimentally give only a small variation, similar numerical calculation from the theory predicts a small variation. Hence it is evident that the grid current theory can explain frequency variations to the correct order of magnitude. That it also explains the shape of the experimental curves will appear later.

The quantity  $k_3$  may be eliminated from equation (7) by the aid of equation (8). Then

$$k_1 k_3 (L_1 L_2 - M^2) = \frac{I}{2L_2} \{ -C_1 M^2 + k_1^2 (L_1 L_2 - M^2) (\mu M - L_1) + \sqrt{C_1^2 M^4 + k_1^4 (L_1 L_2 - M^2)^2 (\mu M - L_1)^2} + 2C_1 k_1^2 (L_1 L_2 - M^2) (\mu M - L_1) \} \dots (9)$$

In this expression  $k_2$  has been replaced by  $\mu k_1$ , where  $\mu$  is the "amplification factor" of the valve, which is appreciably constant

over a wide range. We have now obtained an expression for the frequency in terms of  $L_1$ ,  $L_2$ ,  $M$ ,  $C_1$ , the constant of the valve  $\mu$ , and  $k_1$ . Hence in any particular case we may plot a curve showing the relation between frequency and  $k_1$ . Such a curve is shown in Fig. 6. Although we have eliminated  $k_3$  from the expression for the frequency

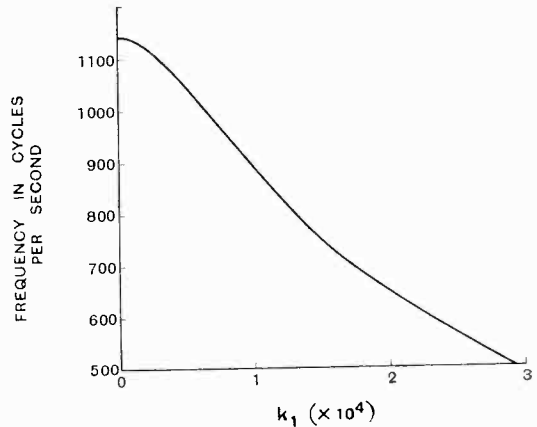

Fig. 6.—Effect of plate conductance on frequency.

it must not be thought that we have eliminated all question of grid current at the same time. From the condition of maintenance, equation (10) below, it is clear that  $k_3$  depends upon  $k_1$ . Hence to each value of  $k_1$  there corresponds a certain value of  $k_3$ , and a definite amount of grid current flows. Grid current, as represented by  $k_3$ , no longer appears directly in the expression for the frequency, but it is still acting, disguised as  $k_1$  with the aid of the condition of maintenance.

**2. Condition of Maintenance.**

Elimination of " $\omega$ " from equations (7) and (8) leads to the equation:—

$$-k_3 C_1 M^2 = L_1^2 k_1 C_1 - M L_1 C_1 \mu k_1 + k_1 k_3 (L_1 L_2 - M^2) \dots (10)$$

This is the "Condition of Maintenance" of the oscillations. For cases where the variations of frequency are small this equation reduces to

$$k_3 M^2 = k_1 L_1 (\mu M - L_1) \dots (11)$$

It is interesting to compare this condition

with that obtained on the assumption that grid current is zero, viz.,

$$k_1(\mu M - L_1) = 0.$$

It is difficult to see how this latter condition could ever be satisfied in ordinary circumstances. Thus, in any common case,  $M$  might have a value one-quarter that of  $L_1$ , and  $\mu$  might be, say, ten.  $\mu M$  is then considerably greater than  $L_1$ . We have to imagine that the oscillations keep on increasing until  $\mu$  has decreased greatly to a value which will satisfy the relationship  $\mu M = L_1$ . Experience indicates that  $\mu$  is sensibly constant, even over the bends of the characteristics, where  $k_1$  and  $k_2$  have changed greatly in value. On the other hand, if we consider equation (11) it is easy to see the course of events. When oscillations commence, the grid current increases until  $k_3$  has a value such that  $\frac{k_3 M^2}{k_1 L_1}$  is numerically equal to the difference between  $\mu M$  and  $L_1$ .

**3. Conditions for the Occurrence of Greatest Frequency Changes.**

From equation (7) it is clear that maximum frequency variations will be obtained when the ratio  $\frac{k_1 k_3 (L_1 L_2 - M^2)}{L_1 C_1}$  is as large as possible. From equation (9) we see at once that this requires that  $C_1$  shall be as small as possible. When  $C_1$  is small we have:—

$$\frac{k_1 k_3 (L_1 L_2 - M^2)}{L_1 C_1} = \frac{k_1^2}{C_1} \left( 1 - \frac{M^2}{L_1 L_2} \right) (\mu M - L_1) \quad (12)$$

The quantity  $\frac{M^2}{L_1 L_2}$  is always less than unity, and it may be kept small by making  $L_2$  large. Hence we deduce from equation (12) that the largest frequency changes will be found when

- (1) The capacity  $C_1$  is as small as possible.
- (2) The coupling  $M$  and the inductance of the grid coil  $L_2$  are as large as possible compared with  $L_1$ .
- (3) The "impedance" of the valve is as low as possible.
- (4) The "amplification factor" of the valve is as large as possible.

It will be seen that these conclusions are

in perfect agreement with the experimental results previously described. In practice, if we set out to design an oscillator which will give maximum frequency changes, then we are limited by the following considerations. Unlimited decrease of  $C_1$  is impossible by reason of the self-capacity of the coil  $L_1$ . Again, it is always possible to obtain a valve with a high value of  $k_1$ , but this is invariably accompanied by a low amplification factor. To obtain greatest frequency changes a valve must be used for which the ratio  $\frac{\text{mutual conductance}}{\text{impedance}}$  is as large as can be obtained. Unlimited increase of  $L_2$  is impossible by reason of the self-capacity of the latter coil. Thus the natural period of the grid coil must never be allowed to become an appreciable fraction of the periodicity of the oscillations or the theory considered above can no longer be expected to apply.

**4. Conditions for the Occurrence of Smallest Frequency Changes.**

For minimum frequency change, equation (12), which has been deduced on the assumption that  $C_1$  is very small, becomes invalid. Making use, however, of the condition of maintenance for small frequency changes, equation (11), we may write:—

$$\frac{k_1 k_3 (L_1 L_2 - M^2)}{L_1 C_1} = \frac{k_1^2}{C_1} \left( \frac{L_1 L_2}{M^2} - 1 \right) (\mu M - L_1) \quad \dots \dots (13)$$

$(\mu M - L_1)$ , which is always positive in sign, will be made very small by decreasing  $M$  and  $\mu$  and increasing  $L_1$ . In these circumstances,  $\left( \frac{L_1 L_2}{M^2} - 1 \right)$  will be kept small, provided  $L_2$  is made very small.  $k_1$  must be small and  $C_1$  large. The conditions which will give rise to the least frequency changes are therefore exactly the reverse of those described above for greatest frequency changes.

**5. Theory of Variation of Frequency with Filament Current.**

From considerations of equations (8) and (9) it is plain that, provided the values of  $L_1$ ,  $L_2$ ,  $M$  and  $C_1$  be kept constant, then the only way in which we can change the frequency of the oscillations is by alteration of the value of  $k_1$ . (It is assumed that  $\mu$  is

constant, which will be sufficiently correct provided the particular valve used is not changed). The problem of variation of frequency with filament current reduces therefore to the question of how  $k_1$  is affected by variation of filament current. In general, the effect of increase of filament current on the shape of the "lumped" valve characteristic<sup>(6)</sup> is to raise the upper or saturation bend, and hence to increase the length of the straight part of the curve. The slope of the straight part is also increased. A typical set of "lumped" characteristics at various values of filament current are shown in Fig. 7.

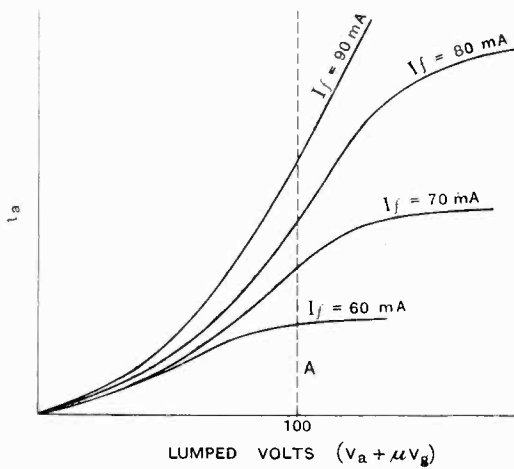

Fig. 7.—Lumped characteristics of triode valve.

We may now trace the effect of increase of filament current on the frequency of the oscillations. Imagine the plate potential to be set at 100 volts, and oscillations to commence when the filament current is 60 milliamperes. Then oscillations of small amplitude occur about the representative point A. At this point the slope of the curve (*i.e.*,  $k_1$ ) is small. Hence the oscillation

frequency is not far below the value  $\frac{I}{2\pi\sqrt{L_1C_1}}$ .

As the filament current increases, the representative point passes farther and farther on to the straight part of the curve. Hence  $k_1$  increases and the frequency decreases. At the same time the amplitude of the oscillations increases, and the oscillating point reaches along the volts axis towards the bottom bend. Eventually a stage is

reached at which the saturation bend becomes so high that it is not reached by the oscillating point.

If we commence with a higher plate voltage, then we need to make a correspondingly larger increase in filament current before getting on to the straight part of the characteristic. Hence with high plate voltages the initial rate of decrease of frequency is slow. At high plate voltages the negative excursion of the oscillating point towards the bottom bend is less. Hence the effective slope of the characteristic is greater, and the total frequency change greater at high plate voltages. When the filament current becomes so great that the oscillating point ceases to reach the upper bend of the characteristic, the rate of decrease of frequency again falls off.

When positive grid bias and a low value of plate voltage is used the case becomes somewhat different. Most of the emission current from the filament goes now to the grid. No longer can we say that the value of the plate voltage has little influence on the grid current. That is to say,  $k_4$  is no longer negligible. On the other hand  $k_2$  is now small, since the value of the grid voltage has little effect on the plate current. Hence if we go back to equations (7) and (8) and eliminate  $k_1$  this time we shall obtain an equation identical with equation (9) except

that  $k_1$  will be replaced by  $k_3$ , and  $\mu$  by  $\frac{I}{\nu}$  in the right-hand side of the equation.  $\nu$  is the "reflex factor" of the valve.<sup>(7)</sup> The frequency will depend now on  $k_3$  in the same way as it did formerly on  $k_1$ . But  $k_3$  is greatest when there is positive grid bias and low plate voltage. Hence when positive grid bias is used the largest variations of frequency will be obtained when the plate voltage is low, contrary to what is found when negative or zero grid bias is employed.

### 6. Theory of Variation of Frequency with Plate Voltage.

In this case also the variations of frequency may be traced to variation of  $k_1$ . Let us imagine (Fig. 7) that oscillations are started at a low plate voltage. Here  $k_1$  has a low value, and the oscillations have very nearly the frequency  $\frac{I}{2\pi\sqrt{L_1C_1}}$ . Increase of plate

voltage removes the representative point away from the bottom bend, so that  $k_1$  increases and the frequency falls. Eventually, as the plate voltage is increased, the representative point approaches the upper bend and the frequency commences to rise. If the amplitude of the oscillations is such that the oscillating point can reach both bends at once, then the minimum frequency occurs at a value of plate voltage about midway between the bends. Hence increase of filament current raises the position of this minimum frequency.

If the amplitude of the oscillations is small, then the oscillating point will not normally reach the upper bend of the characteristic. Hence increase of plate voltage will produce a continuous fall in frequency until a high voltage is reached sufficiently near to the upper bend. Hence the minimum frequency, for oscillations of small amplitude, will occur at a higher value of plate voltage than that for large oscillations. This explains why reduction of the coupling has the effect of shifting the position of the frequency minimum to a higher value of plate voltage. For higher values of filament current the length of the straight part of the characteristic is greater. Hence the effective slope  $k_1$  is greater and the total frequency lowering greater. When positive grid bias is used, and high plate voltage, it becomes easy to reach the saturation emission current of the filament and the frequency becomes sensibly constant with regard to variation of plate voltage.

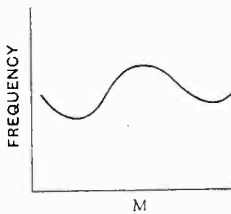

Fig. 8.—Variation of frequency with coupling.

**7. Theory of Variation of Frequency with Grid Bias.**

The explanation of the effect of grid bias follows precisely that given for the effect of plate voltage in Section (6) above. The experimental results are very similar in the two cases. From what has been said at the end of Section (5) it will be clear that the largest variations of frequency produced by change of grid bias will be obtained when the plate voltage is low and the filament current high. In these circumstances,  $k_3$

(the grid conductance) will be considerably larger than the normal values of  $k_1$  (the anode conductance).

**8. Theory of Variation of Frequency with Coupling.**

The theoretical effect of coupling on the frequency is given by equation (13). For small frequency variations, by differentiation we get

$$\frac{d\omega}{dM} = \frac{k_1^2 L_1 \omega^3}{2M^3} (\mu M^3 + \mu L_1 L_2 M - 2L_1^2 L_2) \quad \dots \dots \dots (14)$$

Taking the numerical values for  $L_1$ , etc., appropriate for the coils used in getting the experimental results, and plotting the function for different values of  $M$ , we find as follows. For low values of  $M$ ,  $\frac{d\omega}{dM}$  is negative.

It is zero for a value of  $M$  about the middle of the scale, and positive for high values of  $M$ . This corresponds to the experimental curve type (b) (Fig. 4). This type, therefore, that obtained at medium values of plate voltage, is the type of curve normally to be expected on theoretical grounds. In order to explain types (a) and (c), we require to consider the amplitude of the oscillations. It is well known that (8) if  $M$  be steadily increased, then the amplitude of the oscillations first increases from zero, reaches a maximum value, and thereafter decreases. If the representative point is near to one of the bends on the characteristic, then increase of amplitude sends the oscillating point round the bend, so reduces the value of the effective slope  $k_1$ , and increases the frequency. Hence if the plate voltage is such that the representative point is near to a bend in the characteristic, then the frequency will vary in the same way as the amplitude.

We see, therefore, that when we alter the value of the coupling  $M$  we have two influences operating to produce a change of frequency. One influence, that due to equation (14), tends to produce a minimum frequency at about the middle of the curve, while the other, that due to change of amplitude, tends to produce a maximum frequency at the same position. The resultant of these two effects produces a frequency variation of the type shown in Fig. 8.

This curve was obtained experimentally in only one case, while using a high plate voltage (type  $c^1$  in I (4) above). Adjustment of the plate voltage to a value approximately midway between the bends of the characteristic tends to eliminate the effect due to change of amplitude (type  $b$ ). Type ( $a$ ) is produced by proximity to the bottom bend of the characteristic. The amplitude at low values of  $M$  is in this case insufficient to produce an initial minimum. Type ( $c$ ) is that usually produced by proximity to the upper or saturation bend of the characteristic.

### 9. Variation of Frequency with Resistance.

In the development of the theory given in Section II, (I), all resistance terms were neglected. If the resistance  $R$  of the coil  $L_1$  be taken into account, then the expression for  $\omega^2$  becomes

$$\omega^2 = \frac{I + Rk_1}{L_1C_1 + k_1k_3(L_1L_2 - M^2) + C_1RL_2k_3}$$

and differentiating with respect to  $R$  :—

$$\frac{\partial(\omega^2)}{\partial R} = \frac{L_1C_1k_1 - L_2C_1k_3}{(L_1C_1)^2}$$

neglecting small quantities. From the latter equation we can find at once whether the frequency increases or decreases with variation of  $R$ . When the oscillations are of large amplitude ( $R$  small), then  $k_3$  is large, and  $\frac{\partial(\omega^2)}{\partial R}$  is negative. Hence when  $R$  is small, then the frequency decreases when  $R$  is increased. If, however, the oscillations are of small amplitude ( $R$  large), then  $k_3$  is very small and  $\frac{\partial(\omega^2)}{\partial R}$  is positive. Hence in this case the frequency rises when  $R$  is increased. For some intermediate value of  $R$  there must obviously be a minimum frequency. It was found by Vincent and Beak that this minimum frequency occurred when the peak value of the oscillating grid voltage was just sufficient to reach the upper bend of the grid volts/plate current characteristic. The explanation of this fact is now clear. It is precisely at this point (viz., when the excursion of the grid voltage is just beginning to reach to the upper bend) that  $k_3$  begins to increase very rapidly, and  $k_1$  to decrease. In other words, it is precisely at this point

that  $\frac{\partial(\omega^2)}{\partial R}$  changes sign, so producing a minimum frequency. If there is a steady positive bias on the grid, then  $k_3$  does not become small when the oscillations are infinitesimal. Hence  $\frac{\partial(\omega^2)}{\partial R}$  may be negative

just at the point of extinction, in which case the frequency always falls when  $R$  is increased, and consequently no minimum frequency is obtained. There remain to be considered the peculiar "kinks" which occur in the frequency/ $R$  curves. The explanation of these peculiarities can be obtained from measurements made on the values of the oscillating peak potentials for different values of  $R$ . It is found, as is to be expected, that the general effect of increase of  $R$  is to cause a reduction in the values of the oscillatory potentials. In the case of the plate circuit, however, it is found that the variation of the negative peak plate potential  $V_a$  is as follows. As the resistance is increased  $V_a$  first decreases, passes through a minimum value, and then commences to increase. On further increasing the resistance,  $V_a$  passes through a maximum value and thereafter steadily decreases until extinction. (It is probable that this latter effect is caused by the increase in the impedance of the plate circuit due to the increase in  $R$ . Thus, although the oscillatory current decreases when  $R$  increases, yet due to the increase in the impedance, the oscillatory voltage across the circuit may increase.) The value of  $R$  at which  $V_a$  passes through the minimum is found to be approximately the value of  $R$  at which the kink appears on the frequency/ $R$  curve. The explanation of the occurrence of the kink on the latter curve is now clear. As  $R$  increases from zero the frequency first falls until the stage is reached at which  $k_3$  begins to decrease rapidly, and  $k_1$  to increase. Normally, further increase of  $R$  would result in a rise in frequency. Just at this stage, however,  $V_a$  begins to increase again. This at once results in an increase in grid current (since the plate voltage  $V - V_a$  is now smaller, when the grid voltage is at its maximum positive value.) Hence  $k_3$  increases again, and the frequency commences to fall. The kink in the curve, then, occurs at the point at which the minimum frequency

would occur were it not for the anomalous behaviour of the oscillatory voltage  $V_a$ .

**10. Theory of Frequency Variation due to Inter-electrode Capacity.**

So far we have considered two causes of frequency variation, viz., grid current, and coil resistances. Of these two causes we have seen that grid current is by far the more important. The question now arises whether there are any other causes of frequency variation. One possible cause has not yet been considered—the effect of the inter-electrode capacities which are always present in the valve. Since these capacities are usually comparatively small, we do not anticipate that they will produce a serious variation unless the capacity present in the oscillatory circuit is also small. In these circumstances, and with no grid current or

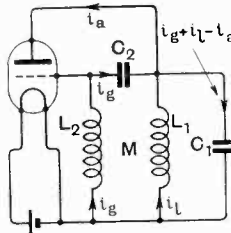

Fig. 9.—Oscillator with plate-grid capacity.

resistance present, we must find out whether variation of filament current or plate voltage (*i.e.*, of  $k_1$ ) will affect the frequency of the oscillations. It is obvious that the plate-filament capacity will be of no importance so far as variations of frequency are concerned, since it is in parallel with the oscillator condenser. Further, the grid-filament capacity is simply added to the self-capacity of the grid coil, and will not be of importance so far as variations of frequency are concerned. Hence we need only consider the plate-grid capacity  $C_2$  (Fig. 9).

Writing down the circuit equations:—

$$v_a = M \frac{di_g}{dt} - L_1 \frac{di_l}{dt} \quad \dots (15)$$

$$v_g = M \frac{di_l}{dt} - L_2 \frac{di_g}{dt} \quad \dots (16)$$

$$i_g + i_l - i_a = C_1 \frac{dv_a}{dt} \quad \dots (17)$$

$$i_g = C_2 \frac{dv_g}{dt} - C_2 \frac{dv_a}{dt} \quad \dots (18)$$

$$i_a = k_1 v_a + k_2 v_g \dots \dots (19)$$

Combining these equations we get:—

$$C_1 C_2 (L_1 L_2 - M^2) \frac{d^4 v_a}{dt^4} + \{C_2 (L_1 L_2 - M^2) (k_1 + k_2)\} \frac{d^3 v_a}{dt^3} + \{L_1 C_1 + C_2 (L_1 + L_2 + 2M)\} \frac{d^2 v_a}{dt^2} + \{L_1 k_1 - M k_2\} \frac{dv_a}{dt} + I = 0 \quad \dots (20)$$

Substituting the solution  $v_a = V \sin \omega t$  and equating to zero the coefficients of  $\sin \omega t$  and  $\cos \omega t$ , we get:—

$$C_1 C_2 (L_1 L_2 - M^2) \omega^4 - \{L_1 C_1 + C_2 (L_1 + L_2 + 2M)\} \omega^2 + I = 0 \quad \dots (21)$$

$$C_2 (L_1 L_2 - M^2) (k_1 + k_2) = L_1 k_1 - M k_2 \quad (22)$$

Equation (21) gives the frequency of the oscillations, while (22) gives the condition of maintenance. We see at once from (21) that the frequency does not depend on  $k_1$ . Hence we do not expect that change of filament current or plate voltage will affect the frequency directly.

There is, however, one possibility which must be kept in mind. When we increase the filament current we raise the temperature of the filament. This causes expansion of the electrodes, with consequent change of all the inter-electrode capacities. For this reason we may expect small changes of frequency when we alter the filament current or plate voltage, even although no grid current flows and the coil resistances are negligible. In general, the effect is very small, only becoming noticeable when the capacity  $C_1$  in the oscillating circuit is very small. We shall see later that this conclusion is verified experimentally, the frequency remaining remarkably constant with respect to change of filament current, etc., provided that grid current is negligible.

There is one other question which must be considered at this point. In the case of the inter-electrode capacities of a valve we are not dealing with perfect condensers. When the valve is working there is a cloud of electrons between the electrodes. Hence we are really dealing with condensers which have imperfect dielectrics. On theoretical and experimental grounds we find that the inter-electrode capacities will be greater when the filament of the valve is hot than when it is

cold. For example, Benham <sup>(9)</sup> has found empirically that  $C = C_0(1 + 6 \times 10^3 k_1)$  where  $C_0$  is the plate-filament capacity when the filament is cold, and  $C$  the observed value when the filament is hot. Without entering into the mathematical analysis we can see why such a result is to be expected. The effect of the conducting cloud of electrons round the electrodes is simply to increase the effective size of the plates of the inter-electrode condensers and also to decrease the distance between them. Both these causes tend to increase the inter-electrode capacities. Here, then, is another source of frequency variation. As we increase the filament current or plate voltage we change the density of the electron cloud and hence alter the inter-electrode capacities, thus producing a frequency change. Fortunately, the effect is small, and it decreases as the frequency increases. At high frequencies it is entirely negligible.

**11. Effect of Electron Motions.**

So far we have tacitly assumed, in connection with the internal action of the valve, that a change in voltage on one of the electrodes is accompanied by an instantaneous change in the current to that electrode. In other words, we have taken it for granted that the inertia of the electrons is negligible. Since, however, an electron takes a certain time to travel between the filament and the electrodes, it is conceivable, especially when very high frequency alternations of voltage occur, that an appreciable time lag will occur which may affect the frequency of the oscillations. The whole problem of the behaviour of thermionic systems at high frequencies has remained unattacked until recently, when Benham <sup>(10)</sup> examined the problem from the point of view of rectification by valves. The necessary mathematical analysis is complex, so we shall content ourselves with a brief outline, and apply the results to the problem of the generation of oscillations.

Let  $V$ ,  $P$ ,  $J$ , and  $U$  be the values of potential, space charge per unit volume, current density, and velocity at any point  $(x, \phi, \theta)$  and instant  $t$ . Then we may write at once

$$\nabla^2 V - \frac{1}{c^2} \frac{\partial^2 V}{\partial t^2} = -4\pi P$$

The term  $\frac{1}{c^2} \frac{\partial^2 V}{\partial t^2}$  refers to the propagation of the potential with velocity  $c$  through the space considered. If, however, as is usually the case in practice, the (time)<sup>2</sup> taken by electromagnetic waves to travel a given distance is negligible compared both with the (time)<sup>2</sup> taken by electrons to travel that distance, and also with the (time period of oscillation)<sup>2</sup> of  $V$ , then we may neglect this term. Hence we may write, since the lines of force are parallel with the  $x$  axis:—

$$\frac{\partial^2 V}{\partial x^2} = -4\pi P \dots \dots (a)$$

The current is composed of two parts, the electron current and the displacement current.

i.e.,  $J = PU - \frac{\partial^2 V}{\partial x \cdot \partial t} \dots \dots (b^1)$

The current  $I$  actually carried by the thermions is given by:—

$$I = PU \dots \dots (b)$$

The force acting on an electron is equal to the rate of change of momentum of the electron.

$$\therefore \frac{\partial U}{\partial t} + U \frac{\partial U}{\partial x} = -\frac{e \partial V}{m \partial x} \dots (c)$$

Further, since  $\frac{\partial J}{\partial x} = 0$  we get from (b<sup>1</sup>):—

$$\frac{\partial I}{\partial x} = -\frac{\partial P}{\partial t} \dots \dots (d)$$

We assume that

$$I_0 = I_0^1 + i_0 \sin \omega t + i_0^1 \sin^2 \omega t + \dots$$

where  $i_0$  and  $i_0^1$  are of the first and second order of small quantities respectively.  $I_0$  is the boundary value of the current and  $I_0^1$  is the steady boundary value of the current due to the high-tension plate battery. Thus we confine ourselves to small variations of potential about a large fixed potential due to the battery. In practice, in the case of an oscillator this condition is far from being satisfied. Without this assumption, however, the mathematics of the problem would become exceedingly complex.

We must remember then in considering the final results that they are necessarily only approximate, and must be regarded in

a qualitative rather than in a quantitative sense.

Combining equations *a*, *b*, *c*, and *d* we deduce (v. Benham, *loc. cit.*)

$$i_0 = \frac{3I_0^1}{2V^1} \left( 1 + \frac{13\omega^2 T^2}{600} + \dots \right) v$$

where  $V^1$  is the plate battery potential,  $v$  the amplitude of the small superimposed oscillatory potential, and  $T$  is the time taken by electrons to cross from filament to anode in the absence of an alternating field. It is assumed that  $0 < \omega T < 2$ .

Thus we may write

$$i = A \left( 1 + \frac{B\omega^2}{V_1} \right) v$$

where  $i$  is the instantaneous superimposed current flowing to an electrode due to the small variable voltage  $v$ .  $A$  and  $B$  are constants, and  $V_1$  is the steady voltage present at the electrode. When  $\omega$  is not large, we get the type of equation used in the analyses above, viz.,

$$i = A v$$

We see, therefore, that in writing down the characteristic equations of the valve we must replace  $k_1$ ,  $k_2$ , and  $k_3$  by the appropriate values of the expression  $A \left( 1 + \frac{B\omega^2}{V_1} \right)$ . All the results on frequency variation which we have worked out above will still hold, provided we replace  $k_1$  by  $k_1 \left( 1 + \frac{B\omega^2}{V_1} \right)$ , to a first approximation. The actual magnitude of  $\frac{B\omega^2}{V_1}$  is given by

$$\frac{B\omega^2}{V_1} = \frac{13\omega^2 T^2}{600} = \frac{13md^2\omega^2}{300eV_1}$$

where  $\frac{m}{e}$  is the ratio of mass to charge on an electron, and  $d$  is the distance between the electrodes of the valve. In practice this is a very small quantity, and would appear to be quite negligible even for very high frequencies (e.g.,  $10^7$  cycles per second). For reasons connected with finite emission velocities, however, there are grounds for believing that  $T$  is considerably larger than would appear from the above formula, thus making the term of appreciable magnitude. This is particularly the case when the filament current is high. It appears that in these circumstances, the electrons take some

time to disentangle themselves from the filament.

Further, it follows directly from the above formula that increase of plate voltage reduces the magnitude of the term in question. Summing up, then, we may say that the effect of electronic movements on the frequency is negligible, except at very high frequencies, with large filament current and low plate voltage. In these latter circumstances the effect is to slightly increase the value of the plate conductance. The conclusions worked out in the previous sections hold good, and in particular there will be no frequency variations in the case where no grid current flows and the resistances present are small.

### Section III. A Constant Frequency Oscillator.

In practice it is sometimes of the greatest importance to have an oscillator whose frequency will remain constant to one part in 100,000, or even more. From what has been said in previous sections, we see at once that grid current must be eliminated if possible. The resistance of the coils used must be low and the condenser used must have as large a capacity as is possible. The complete elimination of grid current is a matter of some difficulty. Two methods have been used. The first method, as used by Edgeworth<sup>(11)</sup> and Eller<sup>(12)</sup>, is to make use of a grid leak and condenser. This will not, in general, get rid of grid current completely, but nevertheless it will give a very constant frequency. Thus Eller used a UX 201 A valve, with  $L_1 = 257$  millihenrys,  $L_2 = 213.3$  millihenrys,  $M = 125.1$  millihenrys,  $R = 14.29$  ohms, a grid leak of 0.5 megohm, and a grid condenser of capacity 0.025  $\mu$ F. With this arrangement he found that the frequency remained constant to one part in ten thousand even when considerable alterations were made in the battery voltages. The second method aims at the complete elimination of grid current by means of the application of grid bias from a battery. For this purpose the conditions must be carefully adjusted, otherwise the oscillations will cease altogether before the grid current has been cut off. The necessary conditions may be summarised as follows:—

- (1) The high-tension voltage should be as large as the valve can take without damage.



(2) The coupling between the coils  $L_1$  and  $L_2$  must not be too loose.

(3) The negative bias on the grid should be large.

(4) The filament current should be as low as possible.

(5) The inductance  $L_2$  should be small.

The method of procedure is first to set (1), (2), and (5) to appropriate values. Next the filament current is gradually reduced until oscillations cease. The value of (3) is then readjusted until oscillations recommence. The filament current is again reduced, and the same procedure followed repeatedly until the filament current is so low that oscillations will only occur for a small range of grid bias variation. With the oscillator so adjusted, the filament current may be varied over an appreciable range without causing grid current to flow. This range decreases as the coupling is decreased. Using in this fashion an oscillator having coils constructed of low-resistance Litzendraht wire it was found that the frequency remained constant to one part in a million over a period of hours.

I am indebted to the Editors of the *Philosophical Magazine* for permission to reproduce several of the diagrams.

## References.

- (1) Vincent and Beak, *Proc. Roy. Soc.*, A 108, 1925, p. 225.
- (2) Vallauri, *L'Elettrotecnica*, 3 and 4, 1917.
- (3) Eccles, *Proc. Phys. Soc.*, 31, 1919, p. 137.
- (4) Appleton and Greaves, *Phil. Mag.*, 45, 1923, p. 401.
- (5) Martyn, *Phil. Mag.*, 6, 1928, p. 223.
- (6) Eccles, *Proc. Phys. Soc.*, 32, 1920, p. 92.
- (7) Llewellyn, *Bell Sys. Tech. Journ.*, 5, July, 1926.
- (8) Gutton, *La Lampe à Trois Electrodes*, p. 63.
- (9) Hartshorn, *Proc. Phys. Soc.*, Feb., 1929, and discussion.
- (10) Benham, *Phil. Mag.*, March, 1928.
- (11) Edgeworth, *J. Inst. Elec. Eng.*, March, 1926.
- (12) Eller, *Proc. Inst. Rad. Eng.*, 16, 1928, p. 1706.

And for general reference:—

- Eccles and Vincent, *Proc. Roy. Soc.*, A 96, 1920.
- Vincent, *Proc. Roy. Soc.*, A 97, 1920, p. 191.
- Martyn, *Phil. Mag.*, 4, 1927, p. 922.
- Obata, *Proc. Phys. Math. Soc.*, Japan, Jan., 1927.
- Martyn, Ph.D. thesis, London University.

## Books Received.

### B.B.C. YEAR-BOOK 1930.

Including special articles on matters of broadcasting interest; events of the past year; the history of the old B.B.C. from November 1922 to December 1926; General articles on musical, educational and dramatic broadcasting. Technical articles, tables and formulae. Pp. 463 with numerous illustrations. Published by the British Broadcasting Corporation, London, price 2/-.

GENERAL PHYSICS AND ITS APPLICATION TO INDUSTRY AND EVERYDAY LIFE. By Ervin S. Ferry, Prof. of Physics in Purdue University, U.S.A. (Third Edition.)

A textbook for technical students comprising the Elements of Dynamics, Sound, Heat, Electricity and Light, with 1,634 Problems or Examination Questions relating to these subjects. Pp. 839 + xix, with 603 diagrams and illustrations. Published by John Wiley & Sons, Inc., New York, and Chapman & Hall, Ltd., London. Price 20s. net.

MODERN GRAMOPHONES AND ELECTRICAL REPRODUCERS. By P. Wilson, M.A., and G. W. Webb, with a foreword by Compton Mackenzie.

A comprehensive text-book on the theory and practice of gramophone construction and the

various problems involved in the recording and reproduction of sound. Pp. 272 + xvi, with 116 illustrations and diagrams. Published by Cassell & Co., Ltd., London. Price, 10s. 6d. net.

RALPH STRANGER'S WIRELESS LIBRARY for the "Man in the Street."

- No. 1.—*Matter and Energy*. The Chemical Elements. Structure of the Atom, Heat, Cold, Energy, etc.
- No. 2.—*Electrified Matter*. Electrons, Distribution of Charges, Electric Fields, Discharges, etc.
- No. 3.—*Electronic Currents*, E.M.F., Ohm's Law, Alternating Currents, etc.
- No. 4.—*Magnetism and Electro-Magnetism*. Permanent Magnets, Electro-magnets, Induction, Dynamos, Motors, etc.
- No. 5.—*The Mathematics of Wireless*.
- No. 6.—*Batteries and Accumulators*. Charging, etc.

Written in simple language for the instruction of the ordinary non-technical man. Each part comprises 64 pages with numerous illustrations and diagrams. Published by George Newnes, Ltd., London. Price, 1s. each part. Further parts in preparation.

# The Refractive Index of Spaces with Free Electrons.

## A Mechanical Model.

By P. O. Pedersen (Copenhagen).

THE bending round the earth of the radio waves and the possible reflections of such waves from regions far away in space resulting in the echoes of long intervals—from 3 to 28 seconds—observed by Jørgen Hals and Carl Störmer,\* are both due to the diminution in the value of the refractive index caused mainly by the free electrons in the Kennelly-layer and in various parts of space within our solar system.

The existence of this diminution in the refractive index was proved by W. H. Eccles,† J. Larmor‡ and others.§ Several authors have calculated this influence of free electrons on the refractive index both for empty and for gas-filled spaces and both with and without a magnetic field, and the results of the various authors are generally in good agreement with each other.||

None the less, I think that the fact that the refractive index may be reduced in this way to values less than 1, which it has for free space, and even may go down to zero,

is somewhat unfamiliar to some amateurs though they may be seriously interested both in wireless theory and practice. The following elementary considerations may, therefore, possibly be of interest to some of the readers of this journal.

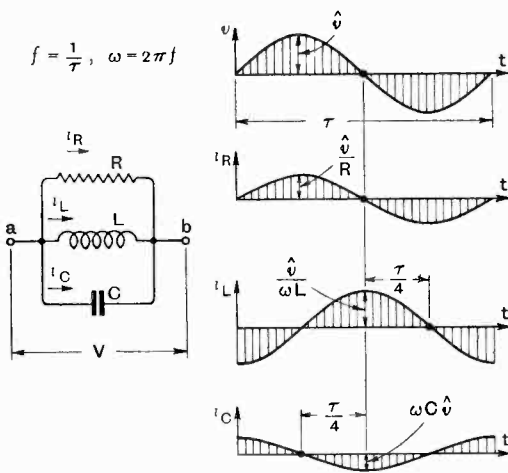

Fig. 1.

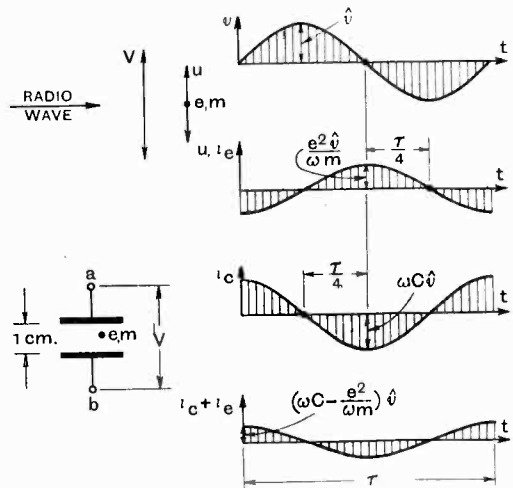

Fig. 2.

In Fig. 1 the resistance  $R$ , the self-inductance  $L$  and the capacity  $C$  are connected in parallel between the terminals  $a$  and  $b$ , subjected to the alternating voltage  $V$  of frequency  $f$ . The current  $i_R$  through the resistance will be in phase with the voltage and its amplitude will be  $\frac{\hat{v}}{R}$ . The current

\* *Nature*, November 3, 1928.

† W. H. Eccles: *Proc. Roy. Soc. (A)*, Vol. 87, p. 79, 1912.

‡ J. Larmor: *Phil. Mag. (6)*, Vol. 48, p. 1025, 1924.

§ P. O. Pedersen: "Propagation of Radio Waves" (*G.E.C. Gad.*, Copenhagen, 1927). Cited as "P.R.W."

|| P.R.W., p. 80-90, 95-116.

$i_L$  through the self-inductance will lag  $\frac{1}{4}\tau$  behind the voltage and its amplitude will be

$$i_L = \frac{\dot{v}}{\omega L} \dots \dots (1)$$

The current  $i_C$  through the condenser is  $\frac{1}{4}\tau$  in advance of the voltage and its amplitude is

$$i_C = \omega C \dot{v} \dots \dots (2)$$

The currents  $i_L$  and  $i_C$  will therefore always flow in opposite directions.

If

$$\frac{I}{\omega L} > \omega C \dots \dots (3)$$

the sum of the two currents  $i_L$  and  $i_C$  will be a current with the amplitude

$$\left(\frac{I}{\omega L} - \omega C\right)\dot{v} \dots \dots (4)$$

a quarter period behind the voltage. If

$$\frac{I}{\omega L} < \omega C \dots \dots (5)$$

( $i_L + i_C$ ) will have the amplitude

$$\left(\omega C - \frac{I}{\omega L}\right)\dot{v} \dots \dots (6)$$

and will be a quarter period in advance of the voltage.

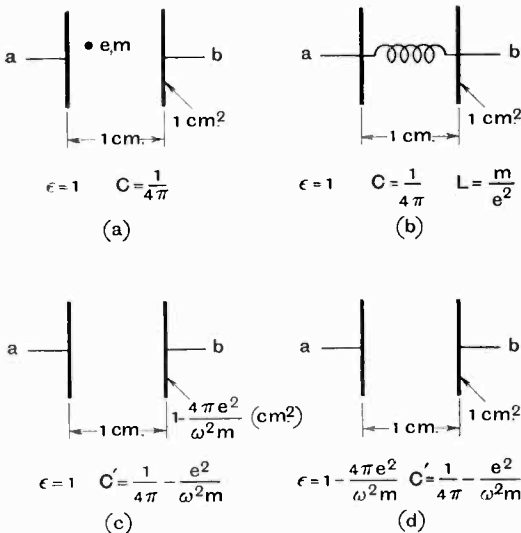

Fig. 3.

For

$$\frac{I}{\omega L} = \omega C \text{ or } \omega^2 LC = I \dots (7)$$

we have

$$i_L + i_C = 0 \dots \dots (8)$$

In this case of resonance the currents  $i_L$  and  $i_C$  will have exactly the same magnitude but opposite directions, and the current

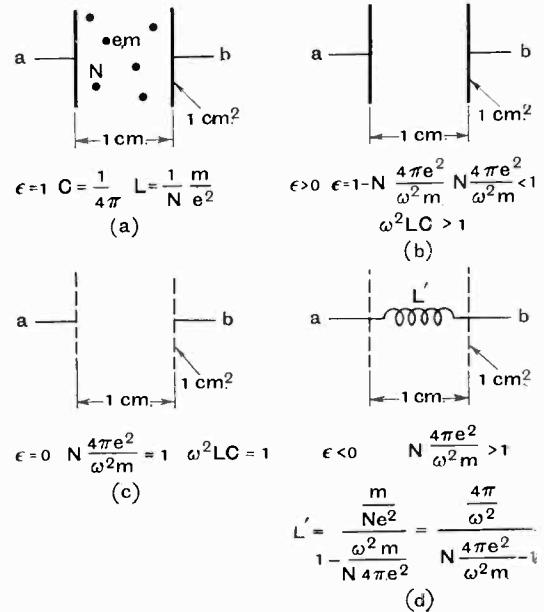

Fig. 4.

between the terminals  $ab$  will, therefore, in this case have exactly the same value as if both the condenser and the self-inductance were taken away.

This is all very familiar.

Next we will consider an electron with charge  $e$  and mass  $m$  in empty space subjected to the electric field  $V$  of a radio wave, see Fig. 2. The electron will be set in motion by the electric field in the wave, and its velocity  $u$  will be a quarter period behind the electric field and have a maximum value

$$\hat{u} = \frac{e}{\omega m} \dot{v} \dots \dots (9)$$

But a charge  $e$  moving with the velocity  $u$  is equivalent to a current element of  $I$  cm. length and with the strength  $i_e = e.u$ . The amplitude of the current in this current element is accordingly equal to

$$i_e = e\hat{u} = \frac{e^2}{\omega m} \dot{v} = \frac{\dot{v}}{\omega \cdot \left(\frac{m}{e^2}\right)} \dots (10)$$

The relation between the electric field in the wave and the electron-current  $i_e$  is therefore exactly the same as between the voltage and the current  $i_L$  in Fig. 1, provided the self-induction

$$L = \frac{m}{e^2} \dots \dots (11)$$

If such an electron is placed between the plates of a unit condenser, the plate distance being 1 cm and the plate area 1 cm<sup>2</sup>, and if this condenser is subjected to a voltage equal to the intensity of the electric field in the wave, then the current between the terminals *ab* of this condenser, see Fig. 3a, will be ( $i_e + i_o$ ), and these currents will always flow in opposite directions.

The current between the terminals *ab* will therefore be exactly the same if the electron is removed and the condenser shunted by a self-inductance equal to  $\frac{m}{e^2}$ , as shown in Fig. 3b.

The unit condenser in Fig. 3a containing 1 electron is therefore equivalent to a condenser with a capacity  $\frac{1}{4\pi}$  shunted by a self-inductance  $\frac{m}{e^2}$  but without any electron, as shown in Fig. 3b. But according to equation (6) this is again as far as the current between the terminals *ab* is concerned, equivalent to a condenser with the capacity  $C' = \frac{1}{4\pi} - \frac{e^2}{\omega^2 m}$  and, therefore, to the unit-condenser shown in Fig. 3d with the dielectric constant

$$\epsilon = 1 - \frac{4\pi e^2}{\omega^2 m} \dots \dots (12)$$

If the unit-condenser contains *N* electrons, Fig. 4a, we get instead of (10) the following equation

$$i_e = Ne\dot{u} = N \frac{e^2}{\omega m} \cdot \dot{v} = \frac{\dot{v}}{\omega \cdot \left(\frac{m}{Ne^2}\right)} \dots (10a)$$

The unit-condenser with *N* electrons is, therefore, equivalent to a condenser  $C = \frac{1}{4\pi}$  shunted by a self-inductance  $L = \frac{m}{Ne^2}$ . If

$$\omega^2 LC > 1 \text{ or } N \frac{4\pi e^2}{\omega^2 m} < 1 \dots (13)$$

this condenser is equivalent to the unit-condenser in Fig. 4b having a dielectric constant  $\epsilon$  determined by

$$\frac{\omega \cdot \epsilon}{4\pi} = \omega C - \frac{1}{\omega L} = \frac{\omega}{4\pi} - \frac{1}{\omega \cdot \left(\frac{m}{Ne^2}\right)}$$

$$\text{or } \epsilon = 1 - N \cdot \frac{4\pi e^2}{\omega^2 m} \dots (14)$$

If

$$\omega^2 LC = 1 \text{ or } N \cdot \frac{4\pi e^2}{\omega^2 m} = 1 \dots (15)$$

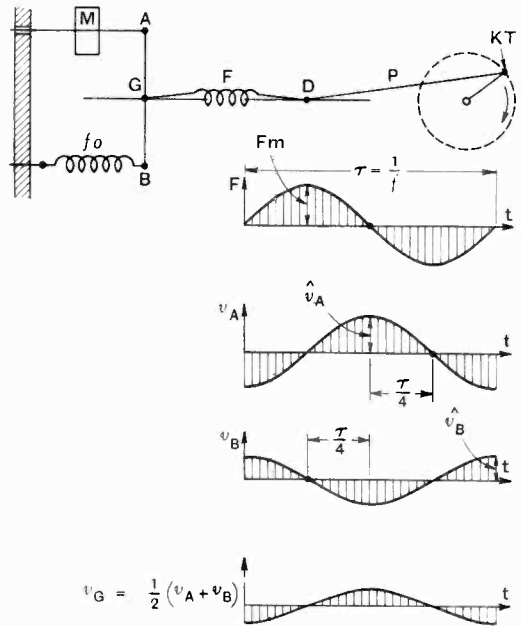

Fig. 5.

the equivalent dielectric constant is equal to zero, see Fig. 4c.

If

$$\omega^2 LC < 1 \text{ or } N \cdot \frac{4\pi e^2}{\omega^2 m} > 1 \dots (16)$$

the equivalent dielectric constant

$$\epsilon = 1 - N \cdot \frac{4\pi e^2}{\omega^2 m} \dots (17)$$

is negative.

In this case the unit-condenser with the  $N$  free electrons is equivalent to a self-inductance  $L'$  determined by

$$\omega L' = \frac{1}{\omega \cdot \left(\frac{m}{Ne^2}\right)} - \frac{\omega}{4\pi} \text{ or } L' = \frac{\frac{4\pi}{\omega^2}}{N \cdot \frac{4\pi e^2}{\omega^2 m} - 1} \dots (18)$$

and the above-mentioned metal plate the spring  $f_0$  is stretched.\*

All three points  $A$ ,  $G$  and  $B$  will move forward and backward with the frequency  $f$  of the crank-shaft, and it is easily proved that the maximum velocity  $\dot{v}_A$  of  $A$  is

$$\dot{v}_A = \frac{\frac{1}{2}\hat{F}}{2\pi f \cdot M} = \frac{\frac{1}{2}\hat{F}}{\omega M}, \quad (2\pi f = \omega) \dots (19)$$

$\hat{F}$  being the amplitude of the varying force exerted by the spring  $F$  upon the point  $G$ . The velocity of  $A$  will, however, be a quarter period behind the force  $F$ .

The maximum velocity  $\dot{v}_B$  of the point  $B$  will be

$$\dot{v}_B = \frac{\omega}{f_0} \cdot \frac{1}{2}\hat{F} \dots (20)$$

$f_0$  being the stiffness of the spring  $f_0$ .  $V_B$  will be a quarter period in advance of the force  $F$ .

The points  $A$  and  $B$  are, therefore, always moving in opposite directions, and the velocity  $V_G$  of the point  $G$  is evidently

$$V_G = \frac{1}{2}(V_A + V_B) \dots (21)$$

It thus appears that in the cases in which the equivalent dielectric constant is negative the unit-condenser with its free electrons is equivalent to a self-inductance.

Fig. 5 shows a schematical diagram of a mechanical model of a unit-condenser with free electrons, while Fig. 6 is a photograph of the actual model. By means of a crank  $KT$ , which is kept rotating with the frequency  $f$  by an electromotor, the tension  $F$  of the spring  $F$  is altered periodically with the period  $\tau = \frac{1}{f}$ . The other end  $G$  of the spring  $F$  is subjected to the same periodically varying force  $F$  and its movement is guided by the shown slit. A brass rod  $AGB$  is pivoted about  $G$ . At the end  $A$  of this cross rod is pivoted another rod carrying a mass  $M$  and having its other end guided by a well-oiled hole in a metal plate. Between the other end  $B$  of the cross-rod

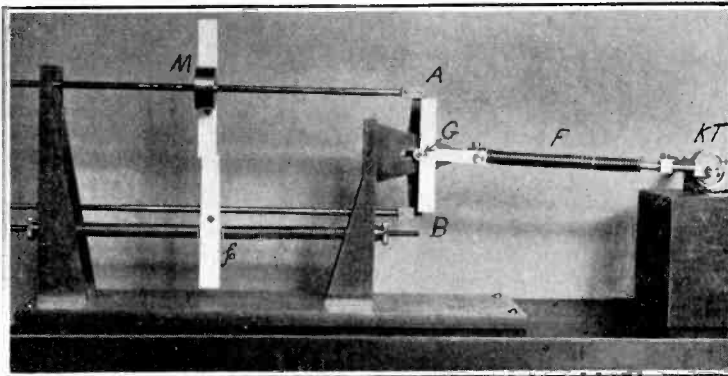

Fig. 6.

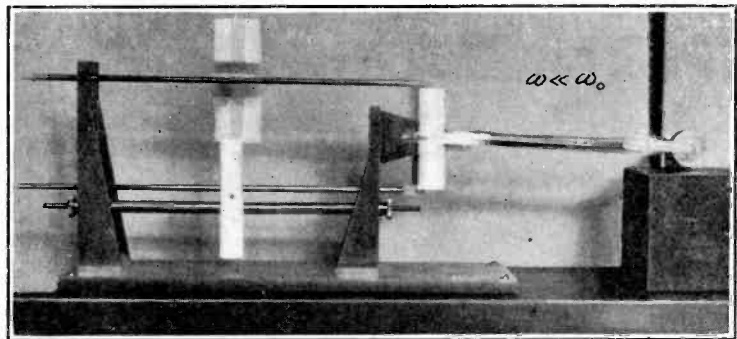

Fig. 7.—Low frequency, considerably less than the resonance frequency. This case corresponds to Fig. 4a, the dielectric constant being negative.

in which equation  $V_A$  and  $V_B$  always are of opposite sign.

\*In the actual model the point  $B$  is connected to the middle point of the spring  $f_0$ , both ends of this spring being fixed.

For  $V_A = V_B$

$$\frac{I}{\omega M} = \frac{\omega}{f_0} \quad \therefore \omega^2 = \frac{f_0}{M} = \omega_0^2 \dots (22)$$

and we have  $V_G = 0$ ,  $\omega_0$  being  $2\pi$  times the resonant frequency.

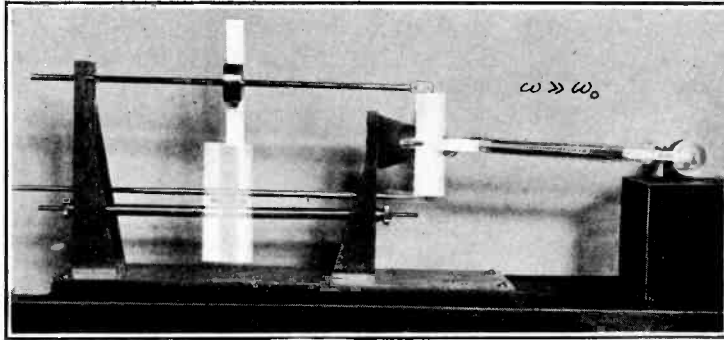

Fig. 8.—The frequency considerably higher than the resonance frequency. This case corresponds to Fig. 4b, the dielectric constant being positive.

For  $\omega < \omega_0$  the velocities of  $A$  and  $G$  are in phase, while for  $\omega > \omega_0$   $B$  and  $G$  are moving in phase.

Let  $\frac{1}{2}V_A$  represent the current due to the  $N$  electrons within the unit-condenser, and  $\frac{1}{2}V_B$  the current through the condenser, then  $V_G$  will represent the current between the terminals  $a$  and  $b$  of the condenser in Fig. 4a.

For  $\omega \ll \omega_0$  the "current"  $\frac{1}{2}V_B$  will be very small, while the "currents"  $\frac{1}{2}V_A$  and  $V_G$  will be very nearly equal and in phase, see Fig. 7. If  $\omega \gg \omega_0$  the "current"  $\frac{1}{2}V_A$  is very small,  $\frac{1}{2}V_B$  and  $V_G$  being very nearly equal and in phase, see Fig. 8.

If  $\omega = \omega_0$  the "currents"  $\frac{1}{2}V_A$  and  $\frac{1}{2}V_B$  will be equal but of opposite sign and the "current"  $V_G$  will be zero, see Fig. 9.

Having thus treated the behaviour of the unit-condenser with free electrons, we may consider the whole space as being built up of such unit-condenser, see

Fig. 10. The equivalent dielectric constant of the unit-condenser will, therefore, also be the dielectric constant of the space.

But how is the refractive index  $n$  dependent upon the dielectric constant  $\epsilon$ ? From elementary optics we know that

$$n = \sqrt{\epsilon} \dots (23)$$

and this formula is all right as long as  $\epsilon$  is positive, but for negative values of  $\epsilon$  it cannot be used. In reality (23) is only an approximate formula, valuable for positive values of  $\epsilon$  and for non-conducting media. If the conductivity of the medium is equal to  $\sigma$  formula (23) must be replaced by\*

$$n = \sqrt{\frac{\epsilon}{2} + \sqrt{\frac{\epsilon^2}{4} + (2\pi c^2 \frac{\sigma}{\omega})^2}} \dots (24)$$

For  $\sigma = 0$ , this formula reduces to

$$n = \sqrt{\frac{\epsilon}{2} + \sqrt{\frac{\epsilon^2}{4}}} \dots (25)$$

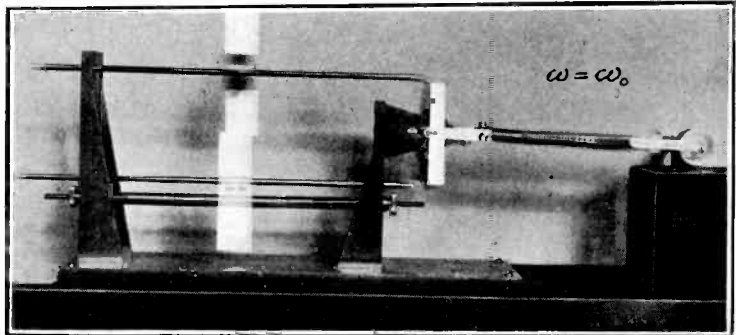

Fig. 9.—The frequency equal to the resonance frequency. This case corresponds to Fig. 4c, the dielectric constant being equal to zero.

For  $\epsilon > 0$  formulae (23) and (25) give the same value for  $n$ , but for  $\epsilon < 0$  it follows from (25) that  $n = 0$ .

It is well known from elementary optics

\* See f. inst. "P.R.W." formula (7), p. 117.

that a ray in a medium with the refractive index  $n_1$  can only be transmitted to another medium with index  $n_2$  if the angle of incidence  $\psi$  is less than the critical angle  $\psi_0$  determined by

$$\sin \psi_0 = \frac{n_2}{n_1} \dots \dots (26)$$

If  $n_2 = 0$  and  $n_1 > 0$ , all rays in medium (1) will be totally reflected at the transition layer between medium (1) and (2). No ray will, therefore, be able to enter the regions for which the dielectric constant is negative.

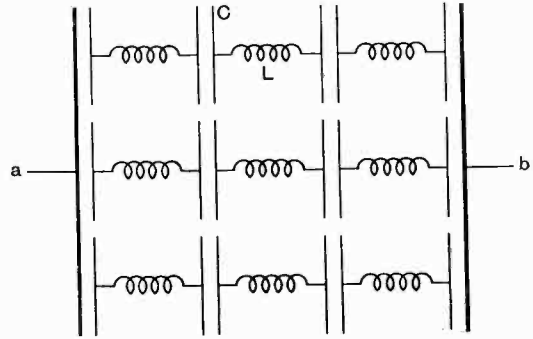

Fig. 10.—Space built up of unit-condensers with self-inductances  $L$  representing the free electrons.

## Correspondence.

*Letters of interest to experimenters are always welcome. In publishing such communications the Editors do not necessarily endorse any technical or general statements which they may contain.*

### P.D. and E.M.F.

To the Editor, E.W. & W.E.

SIR,—Mr. Wilmotte, replying to my criticisms of his article on the above subject, says that the difference between his views and mine is purely a difference of opinion and is not due, as I suggested, to an omission on his part of an important element of the problem. This may be true in so far as I based my arguments on the contention that electromagnetic forces were commonly associated with E.M.F. rather than with P.D., but it is by no means true of all my criticisms.

For example, Mr. Wilmotte repeats the statement that with reference to the equation

$$\mu \frac{\delta A}{\delta l} + \frac{\delta \phi}{\delta s} + Ri = 0$$

“the charges alone are responsible for the  $\frac{\delta \phi}{\delta s}$  term,” and says that it is evident that the fact that the potentials are retarded potentials does not affect the validity of his definition. It is quite true that it does not affect the validity of the definition, but it does invalidate the statement that the charges alone are responsible for the  $\frac{\delta \phi}{\delta s}$  term. This is not simply a personal opinion but, as I showed in my article, is an immediate consequence of the fact that the potentials are retarded ones. As I pointed out, it is precisely on account of this that the commonly accepted meaning of the E.M.F. induced in a distant antenna includes forces represented by the  $\frac{\delta \phi}{\delta s}$  term. It is not the electrostatic part of these forces which is included in the E.M.F., for, as Mr. Wilmotte recognises, this would be negligible, but the electromagnetic part arising from the fact that the  $\frac{\delta \phi}{\delta s}$  term depends partly on the current distribution in the transmitting antenna.

Thus although Mr. Wilmotte lays considerable stress on the variety of opinions which exist with regard to the meanings of P.D. and E.M.F., he clearly recognised the existence of a definite conception of what constitutes the E.M.F. in this particular instance and for that very reason modified his first definitions.

My further criticisms were directed against these modified definitions and the simple example which I took of their application to a circuit carrying a steady current showed that they were not in accordance with the generally accepted meaning of P.D. Mr. Wilmotte's comment is that I started by pointing out that his definitions were physically incorrect and then explained that they still remained consistent. This is far from being a correct statement of my argument, as I am sure Mr. Wilmotte will see on further consideration. I did not set out to prove by that simple example that his definitions were physically incorrect, or that they were inconsistent, but to show that they were not in accordance with generally accepted conceptions, because—to quote my article—“it is quite certain that the accepted meaning of the potential difference between  $A$  and  $C$  is that arising from the charge distribution on the *whole* circuit.” This statement is certainly not merely a personal opinion, but is simply a statement of P.D. as defined in the universally accepted theory of electrostatics, since the charges which produce potential differences in the case of a circuit carrying a steady current are essentially static charges. It answers very definitely Mr. Wilmotte's query as to whether it is not natural to consider the potential difference between  $A$  and  $C$  as due to the electrical conditions on the part  $ABC$  alone and add to it that due to the electrical conditions on the remainder of the circuit, calling the latter an E.M.F.

With regard to the last paragraph of Mr. Wilmotte's letter, I hardly think, in view of my article,

it can fairly be said that I have not considered the possibilities of his definitions and I trust the above remarks will make it clear that my criticisms by no means consisted entirely of expressions of my personal opinions.

E. A. BIEDERMANN.

Brighton.

Nov. 17th, 1929.

### Experimental Transmitting and Receiving Apparatus for Ultra-Short Waves.

To the Editor, *E.W. & W.E.*

SIR,—We have to thank Messrs. E. C. S. Megaw and C. Whitehead for their communications in the December issue of *E.W. & W.E.* referring to our paper on the above subject, which was published in the October and November issues. These letters show quite clearly that great interest is being taken in experimental research on ultra-short wavelengths; that is, below 10 metres.

Mr. Megaw makes some comments upon the symmetrical bridge network arrangement in which many of the circuits suitable for valve oscillators can be represented. He emphasises the desirability of complete symmetry and in this connection draws attention to the fact that we omitted to mention in our paper the circuit arrangement in which the d-c supplies to both grid and anode are made at the nodal point of the inductance. We are interested to learn his experience with a single valve oscillator circuit in which the nodal point tapping on the inductance is made variable in order to obtain the most satisfactory bridge balance position. As Mr. Megaw remarks, the existence of a nodal point in the inductance is not dependent on whether a connection is made to this point or not, and we would state that since writing the paper we have made a practice of omitting the tapping from the common connection of the tuning condensers in the loop receiver illustrated in Fig. 25, p. 616. All the receivers we have in use at present have only two connections to the receiving tuned loop, viz., from the ends to the anode and grid respectively.

Mr. Whitehead's remarks indicate that he has carried out sufficient experimental work himself to have become attracted to the subject, and to have appreciated some of the difficulties which accompany the carrying out of research on ultra-short wavelengths. Information upon many of the points he raises must, we are afraid, be left for communication in a later paper. We are very interested in his remarks upon the effect of coating the glass envelopes of small power valves with metal foil with a view to decreasing the lower limit of wavelength obtainable. We regret that we have had no experience on this phase of the subject, and we shall look forward with interest to the publication of his paper.

The reply to Mr. Whitehead's question as to why the "push-pull" type of oscillator has been

used to such a large extent will be found on p. 610 of the November issue of *E.W. & W.E.* The point is that two valves used in a push-pull connection can be made to give greater output when the high-tension supply voltage is limited. All the two-valve sets which we use will oscillate quite well with one of the valves disconnected, and this device is commonly used for testing single valves or for matching purposes.

We would suggest that the use of cab tyre twisted flex for feeders for short wave working must entail a certain loss of energy which is dissipated in the dielectric. In this connection we do not understand why Mr. Whitehead states that the decrease in aerial current, when such a type of feeder is connected between the oscillator and the antenna, cannot be accounted for by resistance losses occurring in the feeder. Incidentally, we note that Mr. Whitehead is able to measure his currents on a wavelength of 2.8 metres to four significant figures. We regret that the facilities in the way of current measurements at these frequencies which are at our disposal do not permit of such a high order of accuracy. We have found that reception of pure C.W. transmissions by the autodyne method is quite feasible, and that it is useful in the carrying out of relative signal strength measurements. With the type of receiver and oscillator which we use it is possible to hold two oscillation frequencies constant within about a thousand cycles for appreciable periods of time: this represents an accuracy of one part in 40,000 or more for uncontrolled oscillations. Where experiments involving audio-reception are being made, however, it is sometimes a great advantage to use a modulated C.W. source.

The purpose of our paper was intended to be a general clearing of some of the ground work involved in the technique of short wave transmission and reception prior to the use of the apparatus developed for the study of the propagation of such waves. We have not considered it desirable to spend too much time in exploring the possibilities of obtaining appreciable power outputs at the shortest wavelengths at which valves can be made to oscillate, as we have already appreciated that there is a large amount of work to be done in the study of the behaviour of waves within the wavelength band of approximately 4–10 metres.

Finally, we would suggest to our correspondents and to any other readers who are interested in experimental investigation on wavelengths of this order, that there is here a tremendous field for original research into an extremely fascinating subject. One of the advantages of work in this direction is possibly that the magnitude of the apparatus employed is necessarily limited, and that the components required, such as inductances and condensers, need not be expensive on account of their size.

R. L. SMITH ROSE.

J. STUART MCPETRIE.

Teddington, Middlesex.



# Naval Wireless Telegraph Communications.

Paper by Mr. G. Shearing, B.Sc., M.I.E.E., and Capt. J. W. S. Dorling, R.N., M.I.E.E., before the I.E.E. Wireless Section, on December 4th, 1929.

### ABSTRACT.

**T**HE paper gives a short account of wireless telegraph apparatus for naval purposes, and the chief technical features of some of the apparatus used under sea-going conditions.

The introduction is naturally historical and traces the growth of wireless telegraphy in the Navy from the first experiments commenced by the late Admiral of the Fleet Sir Henry Jackson (then Capt. H. B. Jackson, R.N.) on H.M.S. "Defiance" in 1896.

The second part of the paper deals with the requirements to be filled by a Naval W.T. system, and outlines the organisation of fleet and shore communications. The equipment of ships of the cruiser class and upwards has the following characteristics:—

- (1) Range (long-wave), 1,000 to 2,000 miles; 12 kW. H.T. input to transmitter.

- (2) Power (short-wave), 8 kW. H.T. input.
- (3) Receiving apparatus, long- and short-wave.
- (4) D.F. apparatus (Bellini-Tosi being fitted to most cruisers).
- (5) Fire-control sets are fitted for use when cruisers are concentrated in squadrons.

Apart from technical performance, the apparatus must be robust, simple to handle, reliable under all climatic conditions, proof against vibration and shock of gunfire.

The third part of the paper then discusses offices and apparatus generally. Typical office arrangements and dispositions of wireless gear are described and illustrated. Details are given of the power supplies for the Main W.T. Transmitter, operating controls and the assembly of frameworks, transmitter components, etc. The later transmitter designs employ master-oscillator types of generator circuits, the frequency in certain cases (for the

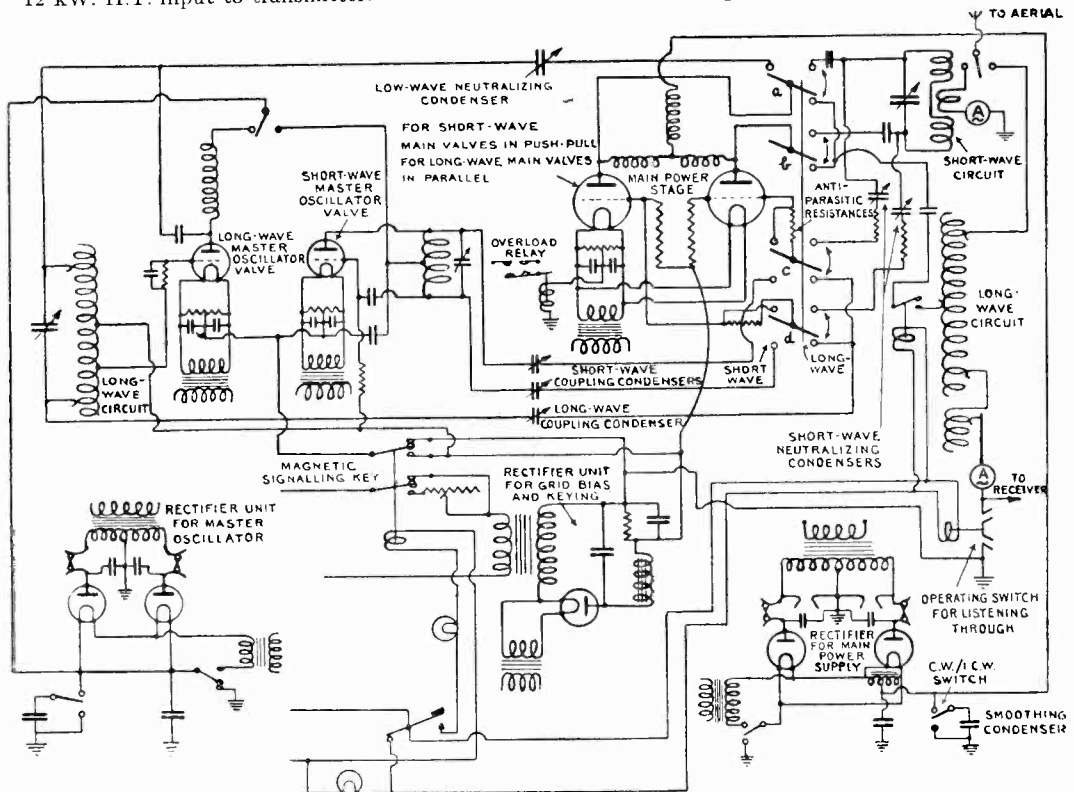

Fig. 19.—Naval type combined long-wave and short-wave master-controlled transmitter. Self-oscillating and low-power connections not shown. Switches a, b, c, and d, are gang-controlled two-way switches for long-wave or short-wave working.

shorter waves) being stabilised by quartz crystal control. The introduction of short waves has modified the requirements very considerably, and it has been necessary to arrange for the fitting of attachments to existing longer-wave sets for transmissions on 4,300 to 21,500 kc. per sec. (70 to 14 m.).

One of the more recent designs of circuit arrangements for a ship transmitter is shown in Fig. 19,\*

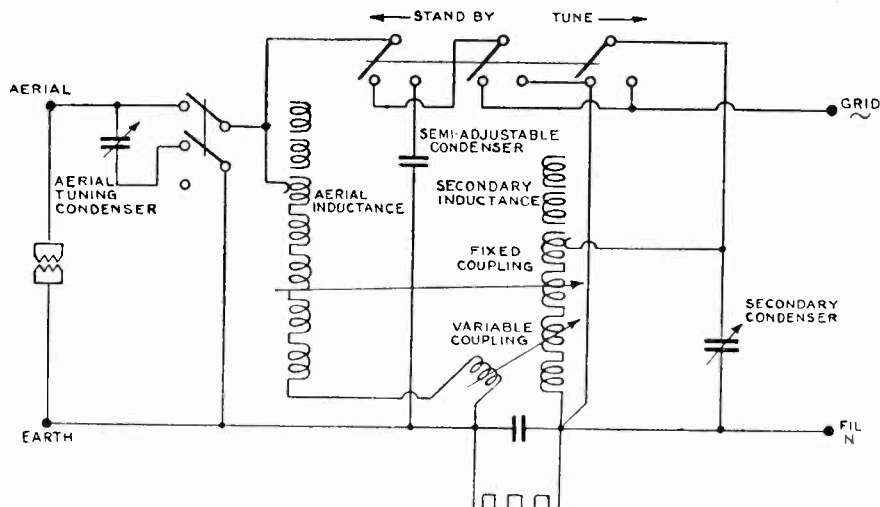

Fig. 25.—Schematic diagram of long-wave tuner.

where the control stages are designed for operation on either long or short waves. The main stage for short-wave operation comprises a high-frequency double-acting system of two valves, which are neutrodyned to avoid retro-action. For long-wave working the valves are used in parallel. Signalling is obtained by grid-potential control. Switching arrangements are provided whereby the change from long-wave to short-wave working can be effected.

For shore-station short-wave transmitters, used for point-to-point working, quartz crystal controls are employed for frequencies of the order of 7,500 to 10,000 kc. per sec. (40 to 30 m.). In certain cases frequency-doubler circuits are employed for transmissions on the corresponding band of 20 to 15 m., so that one crystal controls transmissions on the two waves. Automatic signalling is provided for by grid potential control of one of the power stages, using a Creed relay.

In the case of all naval ship transmitters, the circuit design is such that no spacing wave is sent out, and all ship transmitters have arrangements for "listening-through" while operating.

The coils for long-wave transmitters are wound on ebonite, paxolin, porcelain and pyrex glass. American whitewood is not so satisfactory when subjected to the humid atmosphere in ships. The coils for short-wave transmission are wound with copper tube, which carries a clip for wavelength adjustment. The coils are almost self-supporting,

but the end and middle turns are usually clamped to porcelain insulators. In all designs the maximum rigidity is necessary to secure constancy of frequency.

Two main types of aerial are employed, viz. :—

(i) Sausage aerials having two or more legs, each comprising 10 wires on circular spreaders of about 1ft. diameter.

(ii) Flat-roof aerials of about 6 or 8 single wires in parallel, arranged along yards of 30 to 40ft. in length.

The main receiving apparatus for heavy ships is installed in a silent room which forms a portion of the main wireless office. All receiving instruments are worked independently of the ship's mains, and the power supplies for H.T. and L.T. have, for this reason, been taken from accumulators, two complete sets being supplied for each office. Experimental investigations are at present in hand with rectified a.c. and with d.c. generators (with or without floating batteries) as alternative forms of supply.

Interference problems on shipboard arise from :—

- (a) Mutual interaction from adjacent receivers.
- (b) Morse key clicks.
- (c) Adjacent transmitters.
- (d) Coupling between aerials.
- (e) Faults on lighting supply leads.
- (f) Valve noises due to vibration.
- (g) Running machinery.

Besides the short-wave gear, reception is provided for over the band of 24,000 to 50 m. in three stages, viz., 12.5 to 600, 460 to 2,000 and 1,500 to 6,000 kc. per sec. (24,000 to 500, 650 to 150 and 200 to 50 m.). Earlier policy was towards the unit form of assembly, but more recently the unit construction has been departed from to a considerable extent. The later designs include note magnification and separate heterodyne in one unit, and in the case of reception on longer waves—of the order of 600 m. and above—special provision is made for multiple reception on one aerial.

\*The authors' original figure numbers are adhered to throughout this abstract.

A long-wave tuner which has had considerable application is shown in Fig. 25. It comprises two tuned coupled circuits and is designed for

- (i) tuning aeriels with widely varying capacities, for the entire range of 24,000 to 500 m.
- (ii) Tuning as an "acceptor" circuit for the frequencies above 60 kc. per sec. (5,000 m.). Stand-by and tune positions are provided as shown.

For short-wave requirements, two special types of tuner-amplifiers have been developed—one a simple oscillating detector with two stages of note magnification and no high-frequency amplification, and the other an oscillatory detector, preceded by a stage of h.f. amplification to prevent oscillations from reaching the aerial. A typical design of the latter is shown in Fig. 27. Despite the screened-grid valve, coupling was still found between the tuned-grid and tuned-anode circuits. This was reduced by the use of a very small condenser between the tuned-grid circuit and the grid of the valve.

The type of d.f. gear fitted depends on the structure of the ship. As a general rule, Bellini-Tosi loops are used, but, where suitable loops cannot be rigged, a rotating frame aerial is fitted. The frame must be placed as high as possible and well clear of metal work, which sometimes seriously limits the positions possible for the coil. In the

device and an additional rotatable scale is also provided which is driven by and held in step with the master gyro-compass of the ship. Thus a bearing relative to the ship's head can be taken directly on a fixed scale and true bearings are indicated directly on the rotating scale.

**Discussion.**

The discussion was opened by COMDR. J. A. SLEE, C.B.E., who recalled very early experiences in naval wireless telegraphy. PROF. C. L. FORTESCUE referred to the difficulties of naval conditions and complimented the authors on the simplicity of the designs shown in the paper. COMDR. DANIELS R.N., spoke of the practical working of Fleet wireless, and referred to the importance of organisation and discipline in the working of communications. The apparatus had to be capable of quick change of frequency, and he asked for information as to how the constancy of frequency was maintained in the apparatus described on quick changes of this kind. MR. L. B. TURNER noted the absence of any reference to radio-telephony in the paper, and also asked for information as to the possibility of impregnating American whitewood to make it suitable for naval conditions. MR. LUNNON discussed the aerial coupling arrangements in the transmitter, and insulating materials for transmitter coil formers. MR. H. FALKINER referred to the arrangements of power supply and protective

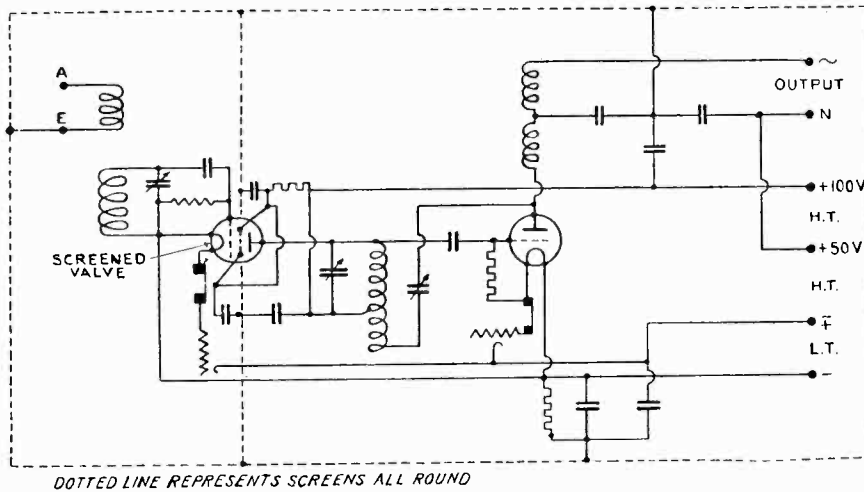

Fig. 27.—Short-wave tuner amplifier.

case of loops the aim is generally to place the loops so as to secure the greatest possible symmetry with respect to the whole metal-work of the ship. The fore-and-aft loop is invariably the more troublesome in this respect. The d.f. observation is made on ambiguous minimum, with sense addition. Scales are fitted with an automatic angle-dividing

devices, in particular to the need for individual valve overload devices. He also asked for information on details of the keying systems mentioned.

After the authors had briefly replied to the discussion, the meeting terminated on a vote of thanks moved by the Chairman, Capt. C. E. Kennedy-Purvis, R.N.

## Some Recent Patents.

The following abstracts are prepared with the permission of the Controller of H.M. Stationery Office, from Specifications obtainable at the Patent Office, 25, Southampton Buildings, London, W.C.2, price 1/- each.

### PREVENTING INTERFERENCE.

Application date, 8th June, 1928. No. 318672.

Three separate circuits are coupled to the receiving aerial. The main circuit is across the whole aerial inductance and feeds the detector *A*. The two side circuits are coupled to separate portions of the aerial inductance and feed detectors *B* and *C*. One side circuit has a natural frequency slightly above, and the other slightly below that of the main circuit. They are adjusted so that they are comparatively insensitive to the desired signal, but respond vigorously to any static or similar highly-damped oscillations present. The outputs from both circuits *B* and *C* are combined cumulatively in the transformers 1 and 2, but in opposition to the output in the transformer 3 from the main circuit detector

apart by an odd multiple of a quarter wave-length. Each pair is joined at the lower ends by a metallic conductor, which includes an impedance coupled to a receiver. The spacing of the coupling impedance relatively to the two antennæ limbs is such that the induced signal currents are cumulative for waves impinging on the system from one direction, but mutually cancel out for a signal wave approaching from the opposite direction.

Patent issued to Standard Telephones & Cables, Ltd.

### TELEVISION SYSTEMS.

Application date, 2nd August, 1928. No. 319454.

The image is converted into electrical impulses by means of an objective lens and an optical rotating

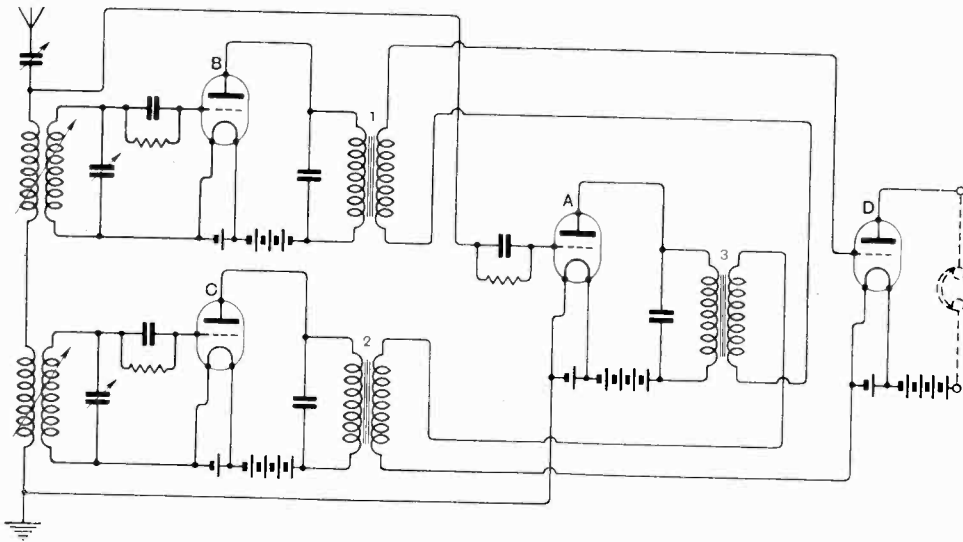

No. 318672.

*A*. In this way the audio frequency components of any highly-damped oscillations are cancelled out in the input to the final amplifier *D*, whilst the audible components of continuous-wave signals pass through unaffected to the final output. A similar balancing system may be interposed in the high-frequency circuits preceding the detectors.

Patent issued to E. C. R. Marks.

### DIRECTIONAL AERIALS.

Application date, 15th June, 1928. No. 319055.

A unidirectional aerial system comprises pairs of half-wave antennæ arranged parallel with the direction of propagation of the waves, and spaced

device. The arrangement produces an image which revolves about the optical axis, like a picture card with a pin inserted through the centre. A primary analysis is produced by means of a fixed slot, radial to the rotating image, whilst a secondary analysis is given by means of a disc having slots of suitable pitch traversing the fixed radial slot. The necessary masking effect is secured by a disc rotating at the same speed as the optical image. At the receiving end a similar arrangement is used in combination with a condenser lens and a lamp whose intensity is varied in accordance with the incoming energy. Natural-colour effects are secured by the use of suitable light-filters.

Patent issued to P. J. de Wet.

**THERMIONIC VALVES.**

*Convention date (U.S.A.), 22nd December, 1927.  
No. 302908.*

The grid is formed of two parts *A, B*, each containing punched-out portions or slats *P*, as shown in the separate detail drawing. The plate is similarly formed of two separate parts *C, D*, each of which is corrugated as shown. When assembled,

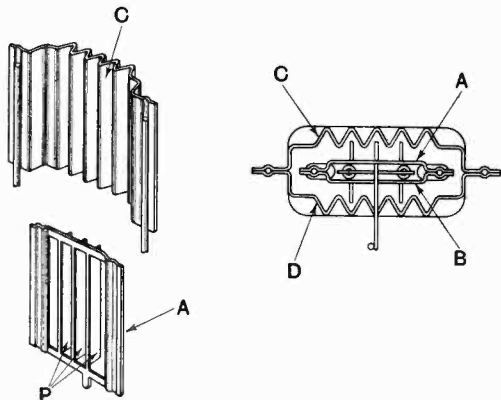

No. 302908.

the projections on the grid interlace with the corrugated plate so as to increase the effective control of the electron stream.

Patent issued to British Thomson-Houston Company, Ltd.

**MAINS-DRIVEN SETS.**

*Application date, 25th October, 1928. No. 318785.*

In order to reduce the peak voltages falling on the smoothing condensers used in mains units for supplying rectified A.C. for filament consumption, an artificial load is automatically connected in circuit when the filaments are switched off, and is retained in circuit until the switch to the main supply is broken. This permits the safe use of a more economical type of smoothing condenser than heretofore, and further renders the installation foolproof since it is immaterial which switch is broken first. The artificial load consists of a shunt resistance in series with a relay controlled by the magnetic field of one of the smoothing-chokes. So long as current is flowing through the choke, the relay is kept open; but when it ceases, the relay closes and brings the load resistance in shunt across the output leads from the rectifier.

Patent issued to Mullard Radio Valve Co., Ltd., and P. W. S. Valentine.

*Convention date (Germany), 27th January, 1928.  
No. 305049.*

The smoothing-chokes are inserted between a full-wave rectifier and the supply transformer, instead of between the rectifier and the receiving set as usual. The chokes are wound in the same sense on a common core. In this way the "choke"

action only occurs for even harmonics of the fundamental frequency. The odd harmonics, and the fundamental itself in full-wave rectification, being displaced by 180 degrees, mutually cancel out in the receiving-set.

Patent issued to Siemens and Halske A.G.

*Application date, 24th September, 1928. No. 319491.*

In order to prevent magnetic induction between the high-frequency coils and the iron core of the supply transformer in an all-mains set, a special screen is interposed between the two components in question. This removes a particular source of "hum" due to modulation of the incoming signal energy by the periodic frequency of the local supply mains.

Patent issued to S. G. S. Dicker.

**MAINS SUPPLY UNITS.**

*Application date, 28th March, 1928. No. 318159.*

In order to economise in the cost of the smoothing-inductance inserted in the filament-supply circuit of an all-mains receiver, a double-wound choke is used, one winding of which carries the rectified H.T. current, and the other winding the L.T. current. The windings are laid in opposite sense, so that the magnetic flux due to the D.C. component is neutralised, whilst the effective inductance for A.C. components is greatly increased as these are out of phase.

As shown in the Figure the winding *A* of the combined choke *K* is in the positive lead from the H.T. rectifier *R*, whilst the winding *B* is in the lead from the filament-supply rectifier *R*<sub>1</sub>. Variable resistances *X, Y* in the two outputs ensure equal

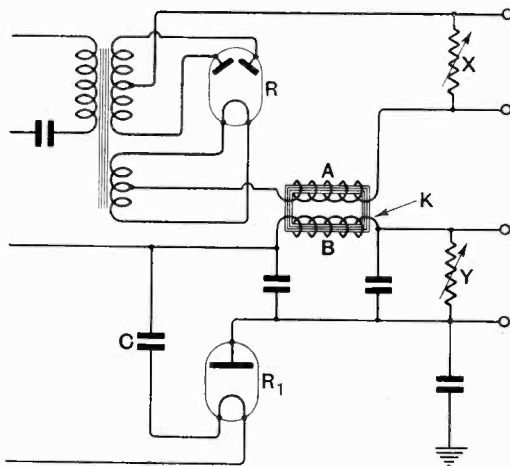

No. 318159.

ampere turns in the choke, whilst a condenser *C* in the input to the rectifier *R*<sub>1</sub> introduces the necessary phase-displacement in the ripple components.

Patent issued to H. Andrewes and Dubilier Condenser Co., Ltd.

**LOUD-SPEAKER HORNS.**

*Application date, 12th June, 1928. No. 319199.*

Fibrous material, such as cellulose pulpboard, impregnated with montan or carnauba wax, is used for making loud-speaker or gramophone horns. The material so prepared is stated to be proof against damp and temperature changes, and to have a desirable resonant quality.

Patent issued to H. Friedlander.

**PIEZO-CONTROLLED OSCILLATORS.**

*Convention date (Germany), 24th June, 1927. No. 292600.*

In order to protect the piezo crystal from excessive voltage, it is shunted across a portion only of the total impedance in the oscillatory circuit. As shown in the Figure, the main oscillatory circuit is fed from a power source *G*. One control crystal *K*<sub>1</sub> is shunted across a few turns on the inductance *L* whilst a second crystal *K*<sub>2</sub> is branched across the smaller of two condensers *C*<sub>1</sub>, *C*<sub>2</sub>. The arrangement stabilises the circuit against frequency-

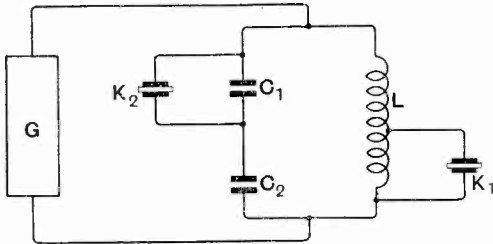

No. 292600.

changes due to variations in the operating conditions of the power-oscillator, as well as against capacity variations in the aerial caused by wind, rain, etc.

Patent issued to C. Lorenz, A.G.

**RECEIVERS FOR DIRECTION-FINDING.**

*Application date, 26th June, 1928. No. 319418.*

In a multi-valve set, suitable for D.F. work on aircraft, the field coils from the two loop aeri- als and the coupled input or search-coil are all arranged in a common casing with the valves and other circuit components of the receiver, but are screened therefrom by a special partition. The first two valve stages are screen-grid amplifiers choke-coupled, followed by a detector and two stages of L.F. amplification. Each valve is housed in a separate screened compartment.

Patent issued to Igranic Electric Co., Ltd., and D. Sinclair.

**GANGED TUNING CONDENSERS.**

*Application date, 26th June, 1928. No. 319421.*

Two or more condensers, ganged to a common control knob, are also arranged to allow of independent adjustment. As shown in the Figure,

the master control knob *K* drives a shaft *S* carrying one right-handed and one left-handed worm respectively engaging the spindles *A*, *B* of two tuning-condensers. For independent adjustment, a second knob *K*<sup>1</sup> is rotated in one direction or the other simultaneously with the master knob *K*. The screwed part *M* of the bearing-piece is fixed in the panel (not shown) of the set, whilst a second threaded part *N* engages a recess on the knob *K*<sup>1</sup>.

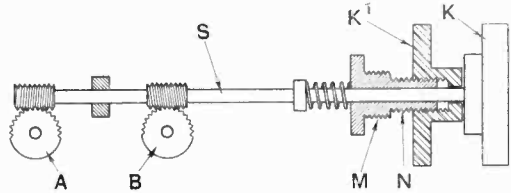

No. 319421.

As the knob *K*<sup>1</sup> is rotated, it moves bodily along the screw-thread *N* imparting a lateral motion to the whole shaft *S* in addition to the rotation due to the knob *K*. The result is that one of the spindles *A*, *B* is rotated at double speed, whilst the other is maintained stationary because the lateral movement of the shaft *S* neutralises its rotational drive on the worm gearing.

Patent issued to B. Hesketh.

**A DOUBLE-CONE SPEAKER.**

*Application date 3rd October, 1928. No. 318766.*

In order to produce a balanced response, two separate diaphragms are used, a large one to emphasise the lower notes, and a small one (nested inside the first) to favour the higher ranges. As shown in the Figure, the reed *R* drives the smaller cone *D* through a spindle *S*. A second reed *R*<sub>1</sub> driven by the same magnet, carries a hollow sleeve *S*<sub>1</sub>, on which a larger cone *D*<sub>1</sub> is mounted. The spindle *S* passes through the sleeve *S*<sub>1</sub> with sufficient clearance to avoid contact. The inside cone *D* has a slightly smaller apex angle than the outer cone *D*<sub>1</sub>, so as to minimise any interference

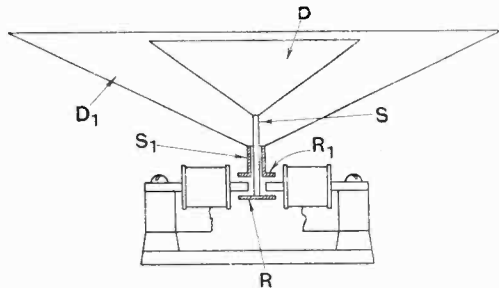

No. 318766.

effects in radiation, whilst the outer cone may be perforated or cut away in parts to increase the effective radiation from the inner cone.

Patent issued to C. French.

## Abstracts and References.

Compiled by the Radio Research Board and reproduced by arrangement with the Department of Scientific and Industrial Research.

### PROPAGATION OF WAVES.

A DETERMINATION OF THE DIELECTRIC CONSTANT OF THE GROUND.—J. A. Ratcliffe and W. F. B. Shaw. (*Nature*, 19th October, 1929, Vol. 124, p. 617.)

The attenuation curve ( $Hd$  plotted as a function of  $d$ ), from a series of tests up to a distance of 1,400 m. on a wavelength of 30 m., shows a maximum when  $d$  is about 600 m. The shape of this curve is found to be in agreement with Rolf's numerical calculations (see below) on Sommerfeld's theory, on the assumption of the values  $k = 20$  e.s.u. and  $\sigma = 2 \times 10^{-14}$  e.m.u. for the ground constants. "The value for  $\sigma$  is in agreement with the values previously found by using longer wavelengths." [Cf. Strutt, 1929 Abstracts, p. 623, who for shorter wavelengths—1.42 m.—obtained a value greater than  $10^{-12}$ ]. "The maximum on the curve is the characteristic feature which enables a reasonably accurate estimate of  $k$  to be made. No such characteristic feature is present when longer waves are used."

NUMERICAL DISCUSSION OF SOMMERFELD'S ATTENUATION FORMULA.—B. Rolf. (*Ingeniörs Vetensk. Akad.*, Stockholm, Handlingar Nr. 96, 1929.)

Much work has been done on the propagation of waves over great distances, involving the action of the Heaviside layer, but "astonishingly little has been done . . . to apply theoretical considerations to the study of their behaviour at short distances, as controlled chiefly by the nature of the soil and the construction of the radiating parts of the transmitter."

The present paper deals with one aspect of the problem—the working out of numerical examples from Sommerfeld's expression for the e.m. field at the surface of flat ground from a vertical Hertz dipole, and the comparison of these with actual field strength measurements. The writer introduces certain new variables  $q$  and  $b$  into Sommerfeld's expression, for the sake of simplified working: he writes  $2a^2 = qe^{ib}$  ( $a$  being the complex function of soil constants, wavelength and distance, occurring in Sommerfeld's expression). When  $\epsilon$ , the inductivity of the soil, is much greater than 1 (so that  $(1/\epsilon)^2$  can be neglected in comparison with unity) the following convenient approximations

are obtained, assuming  $\mu = 1$ :— $q = \frac{2\pi \sin b}{\epsilon + 1} \frac{r}{\lambda}$

and  $\tan b = \frac{(\epsilon + 1) \times 10^{-15}}{6 \cdot \sigma \lambda_{km}}$ . Here  $\epsilon$  and  $\sigma$  (conductivity) are in electrostatic and electromagnetic units respectively. Since  $\epsilon$  does not appear to be below 5 over any considerable area of natural ground (except for glaciers and perhaps for fresh polar ice), these values for  $q$  and  $b$  can be used for rapid calculations of  $\epsilon$  and  $\sigma$  from field strength

measurements. Tables are given allowing one to find the factor by which the distance  $r$  (in km.) must be multiplied to give  $q$  and  $b$  in some practical cases.

After defining the attenuation factor, the writer points out that even for very long waves over seawater a distance can be imagined so great that even for these the factor will decrease; while in all other cases than that of a perfect conductor the attenuation will ultimately decrease to zero as the first power of distance, so that the magnetic force will decrease as the inverse second power of distance. But for intermediate values of distance, the behaviour of the attenuation will in some cases be curiously complicated. A diagram showing successive shapes of attenuation curves, as the wavelength varies, indicates the many possible shapes of attenuation curves implicit in Sommerfeld's formula: a fact which is by no means obvious from a mere inspection of the various expansions derived from that formula. This leads the writer to consider the decrease to zero of the field strength at finite distances.

This can only happen if the attenuation factor falls to zero, which involves the simultaneous vanishing of the real and imaginary parts of this factor. The conditions for such a result are investigated, with the result that the writer is led to the statement that "for every constitution of the soil there exists a distance (or better, a narrow belt) such that the magnetic and electric fields of the transmitter vanish there when transmission is effected on one of an infinite series of wavelengths determined solely by the electrical constants of the soil." He gives a table showing cognate values of  $\epsilon$ ,  $\sigma$  and  $\lambda$ , and the appropriate distances in km. where the field vanishes, to reappear farther on. From this table it appears that this curious phenomenon, generally characteristic of short wavelengths, may (e.g., in wooded countries, or over lakes) reveal itself even in the lower broadcasting band.

The next portion of the paper deals with the construction of an Abacus, the use of which will be understood by the directions:—"To obtain field strength at distance  $r$  from transmitter, multiply  $377Ih/\lambda r$  by damping factor taken from the appropriate  $b$ -curve (see earlier in this Abstract) and read off on vertical scale." It applies only in so far as refracted waves and the earth's curvature are neglected; "but on medium wavelengths in daytime the two effects seem to cancel out for a considerable distance."

The paper ends with a table of Soil Constants in Sweden (Lemoine) and England (Barfield), and with a plea that only increased work on field strength measurements, published without any species of "smoothing," will lay a sound technical ground for the allocation of wavelengths for European broadcasting. "As to the usually alleged limitation of service area by refracted waves whose

sidebands have suffered from dispersion . . . adequate construction of antennæ is capable of abolishing this limitation in all practical cases—even at sun-spot maxima. Hence no regard ought to be taken of it."

EXPERIMENTELLE UNTERSUCHUNG ÜBER DIE LEITFÄHIGKEIT IONISierter LUFT BEI HOCHFREQUENZ (Experimental Investigation into the Conductivity of Ionised Air for High Frequencies).—A. Székely. (*Ann. der Physik*, 2nd Oct., 1929, Series 5, Vol. 3, No. 1, pp. 112-132.)

Research on the conductivity of the ionised air in the negative glow discharge, for currents of frequency 1 to  $5 \times 10^6$  cycles p.s. (actual wavelengths used were 2.2-58 m.). The resistance was found to increase with the square of the frequency, in agreement with theory. The carriers governing the resistance were electrons in approximate thermal equilibrium with the gas molecules. The conditions of the air during the measurements closely resembled in pressure and in nature and intensity of ionisation those which may be expected to exist in the Heaviside layer at 60-80 km.

MESURES DIURNES ET NOCTURNES DE LA QUANTITÉ D'OZONE CONTENUE DANS LA HAUTE ATMOSPHÈRE (Daily and Nightly Measurements of the Quantity of Ozone in the Upper Atmosphere).—D. Chalonge and P. Götz. (*Comptes Rendus*, 28th October, 1929, Vol. 189, pp. 704-706.)

Continuing the work referred to in 1928 Abstracts, pp. 285 and 517 (see also 1929 Abstracts, p. 625, Götz and Dobson) the writers have measured the thickness of the ozone layer above Arosa on several series of consecutive days and nights, using their special spectrograph for the lunar spectrum and this instrument and also a Dobson spectrograph for the solar. Their conclusion is that in our latitudes the sun causes no appreciable change in the thickness of the ozone layer.

IONIZATION IN THE ATMOSPHERE OF MARS.—E. O. Hulburt. (*Proc. Inst. Rad. Eng.*, Sept., 1929, Vol. 17, pp. 1522-1527.)

Calculations from the actions of gas diffusion and gravity. "Because of the skip distances for waves below 100 metres, it . . . may be conjectured that no wireless apparatus exists there for waves below 100 metres. Waves longer than about 100 metres will not pierce through the atmosphere of the earth. These calculations, apart from other considerations, support the conclusion that only a very optimistic experimenter would look for successful wireless communication between the Earth and Mars."

ÜBER DIE IONISIERUNG VON LUFT DURCH KATHODENSTRAHLEN VON 10-60 KV. (The Ionisation of Air by Cathode Rays of 10-60 kV.).—A. Eisl. (*Ann. der Phys.*, 30th Oct., 1929, Series 5, Vol. 3, No. 3, pp. 277-313.)

In the range tested, the mean energy for the formation of an ion pair was found to be constant and of the absolute value  $32.2 \pm 0.5$  volts.

ÜBER DAS AUFTRETEN VON IONEN BEIM ZERFALL VON OZON UND DIE IONISATION DER STRATOSPHERE (The Formation of Ions by the Disintegration of Ozone, and the Ionisation of the Stratosphere).—H. Hellmann. (*Ann. der Physik*, 26th Aug., 1929, Series 5, Vol. 2, No. 6, pp. 707-732.)

After discussing the various theories brought forward to explain the night-time ionisation of the upper atmosphere, the writer describes his laboratory tests to determine whether the disintegration of ozone gives rise to ionisation as has been stated by Gunckel and confirmed by Brewer. His methods were such that the arrival of one pair of ions from  $5 \times 10^{15}$  molecules of ozone would have been observed. Results were entirely negative.

THE UPPER ATMOSPHERE.—H. B. Maris. (*Terrest. Mag.*, No. 1, 1929, Vol. 34, pp. 45-53.)

Concluded from a previous number. Tables are given of partial pressures and densities, and lengths of free path for summer and winter, day and night.

ON THE INFLUENCE ON THE COMPOSITION OF THE AIR OF A POSSIBLE HIGH TEMPERATURE IN THE HIGHEST STRATA OF THE AIR.—H. Petersen. (*Pub. Danske Met. Inst., Communications Magnétiques*, No. 6, 1928, 15 pp.)

GRAVITATIONSWELLEN IN DER ATMOSPHÄRE (Gravitational Waves in the Atmosphere).—F. M. Exner. (*Wiener Anz.*, No. 11, 1929, p. 91.)

Pressure and temperature fluctuations with a daily period seem on the whole to agree with the theoretical conception of them as gravitational waves. On the other hand there occur, less often, similar fluctuations with horizontal pressure displacement. In the former case, pressure and temperature changes at the ground are of the same sign: in the latter case, of opposite sign (e.g. increase of pressure with setting-in of cold).

ORIGIN OF THE SEMI-DIURNAL PRESSURE WAVE IN THE EARTH'S ATMOSPHERE.—E. V. Newnham. (*Nature*, No. 3045, 1928, Vol. 121, pp. 353-354.)

REGISTRIERUNGEN DER FELDSTÄRKE VON RUND-FUNKWELLEN IN KÖNIGSBERG I. PR. (Records of the Field Strengths of Broadcasting Stations at Königsberg, Prussia).—W. Kauffmann: C. Wagner. (*E.N.T.*, Sept., 1929, Vol. 6, pp. 349-354.)

A description of an investigation (using the Anders apparatus) of signals from Langenberg and Oslo, in the nights of the winters of 1927 and 1928. A semi-automatic recording appliance is described, in which the observer, by turning a milled head, keeps the image of the electrometer thread always on zero, and by so doing produces a record of the deflections on a clockwork-driven paper strip (*cf.* "A Laboratory Curve Tracer," Abstracts, 1928, Vol. 5, p. 525). A few specimen records are given, typical of the various types of fading. The two stations have nearly equal wavelengths (468.8 and 461.5 m.) and very different powers (3,600 and



90 w.) The path of the one is 1,100 km. overland, direction SW; of the other, 800 km. NW, half over land and half over sea. A correlation between the records from the two transmitters for the same days is "undeniable. Quiet and disturbed days, days with lasting changes and days with temporary constancy usually occur for both stations simultaneously." Absolute measurements of the fields were made: their ratio was 6.5. Assuming the same absorption for the two paths, the ratio (from powers and distances) works out at 4.6, which agrees "sufficiently well." The various results are discussed in relation to modern ideas of the Heaviside layer. For these night-time signals no relation could be found with meteorological conditions.

AUSTRALIAN RADIO RESEARCH BOARD—ANNUAL REPORT.—(*Journ. Council for Sci. and Indus. Res., Australia*, August, 1929, Vol. 2, pp. 171-176.)

Among investigations on propagation, a good many of which were carried out for the Broadcasting Company of Australia, it was found that in Victoria and Tasmania the principal causes of absorption (for Broadcast wavelengths) were trees and mountains; these may produce a fall from 10 mv./m. to 1 mv./m. in a distance of 10 miles. It is found that there is a large increase in the field at the top of a hill compared with that on flat ground at the base ("hill effect"). Over sea, the daylight transmission of broadcast waves has been studied up to 85 m. "When the large loss of intensity arising from the curvature of the earth is corrected for by Macdonald's calculations, no other losses are observed . . . which agrees with Sommerfeld's theory of such transmission."

Regarding the design of field-less inductances for very high radio-frequencies, promising results have been obtained with a modified toroidal winding, embedded in a solidified dielectric and fitted with a closely fitting electrostatic shield; the latter, even at 7.5 megacycles frequency, only slightly increases the r.f. resistance.

THE USE OF SHORT WAVES FOR LONG DISTANCE COMMUNICATION.—(*Marconi Review*, Sept., 1929, pp. 18-21.)

A compressed recapitulation of some of the most salient features. According to the generally accepted ideas of ionic refraction in the Heaviside layer, the upper limit of wavelength for long distance communication is in the neighbourhood of 100 m., since the conditioning factor is that the electrons should be able to make many oscillations in the time between collisions with the molecules of the atmosphere, and this time—at heights above 80 km.—is taken to be about  $3 \times 10^{-7}$  sec. The lower limit of wavelength is given by T. L. Eckersley as about 8.6 m. for daytime.

Thus the available frequency band is from 3,000 to 34,880 kc. Regarding the choice of wavelength for least attenuation under given conditions of path, etc., a paper recently issued by the Marconi Company is mentioned, giving a series of empirical curves which can be used to obtain the signal strength of a station of known power at various

distances under different degrees of light, for various wavelengths. A table given in the present article shows the approximate distances in miles at which signals cease to be audible, from a transmitter of about 10 kw. power, for paths under intense daylight, assuming a "simple" receiver: these range from 900 miles for a 50-m. wave to 12,000 miles for a 15 m. wave. "For a route entirely in twilight, the attenuation on all wavelengths is greatly reduced. . . . Wavelengths of the order of 15-30 m. will generally be found to be the best for use on such a route. The attenuation of wavelengths above 40 m. is slight under conditions of complete darkness. On wavelengths below about 20 m., signals are reduced, probably owing to the fact that the ray is insufficiently bent." The frequency channel agreement at the 1929 Ottawa conference is quoted.

SUR LA COUCHE IONISÉE DE LA HAUTE ATMOSPHERE (The Ionised Layer of the Upper Atmosphere).—M. Ponte and Y. Rocard. (*L'Onde Elec.*, July, 1929, Vol. 8, pp. 306-314.)

Continuation of the paper dealt with in 1929 Abstracts, p. 500. After discussing the pros and cons as to the isothermal or adiabatic nature of the atmosphere, the writers adopt Gold's ideas of the lower, approximately adiabatic layer up to about 10.5 km., and the upper, isothermic layer outside this up to heights of more than 800 km. (as shown by the existence of aurora borealis at such heights). In order to obtain an estimate of the composition of this outer layer (which by the density/height exponential formula must consist almost entirely of hydrogen and helium), the writers quote Jeans's figures assuming a uniform temperature of the isothermal layer of 219° absolute: at 90 km. these give the number of molecules of hydrogen per cm.<sup>3</sup> as  $43 \times 10^{12}$ . Taking this value, *but changing Jeans's 219° to 300°* as a result of propagation of sound tests, the writers then apply the formulæ for the free paths of the hydrogen molecule obtained in their First Part.

This leads to the conclusion that if there is a Heaviside layer at 90 km., and if the density of hydrogen in this layer conforms with Jeans's calculations, *all waves longer than 64 cms. would suffer metallic reflection*. If, therefore, it is desired to retain the ideas of metallic reflection and "mirage," with a critical wavelength of about 60 m. as the dividing line, the writers suggest that the height of the layer must be between 170 and 330 km. or more, instead of Appleton's 80-100 km.; but that even then the figures for hydrogen content must be far lower than Jeans's and lower even than those (seven times smaller) given by the propagation of sound tests.

The other alternative is to abandon the explanation of short wave propagation by pure "mirage" effect. Finally, however, the writers appear to favour the idea (supported by "recent experiments which do not confirm Appleton's values" and which suggest the presence of Heaviside layers between 300 and 400 km.) that the sound propagation values are about correct, that there is a critical wavelength smaller than 50 m., and that the (or "a") Heaviside layer lies between 300 and 400 km. above the ground.

A further paper will "examine the resources furnished, for the study of propagation, by the use of the phenomena of diffraction and diffusion by the electrons of the upper atmosphere."

GROUP-VELOCITY AND LONG RETARDATIONS OF RADIO ECHOES.—G. Breit. (*Proc. Inst. Rad. Eng.*, Sept., 1929, Vol. 17, pp. 1508-1512.)

Author's summary:—"Van der Pol's hypothesis (1929 Abstracts, p. 97) that group-velocity may account for the retardation of echoes observed by Stoermer is analysed. It is shown that only under very special circumstances can the electron-distribution be proper. A favourable condition is obtained if the refractive index decreases exponentially with the height. It is shown that by slightly varying the electron-distribution anomalous results for skip-distance should follow. It is suggested that the echoes observed by Stoermer [at Oslo] and van der Pol [at Eindhoven] were splashes of the same echo focussed accidentally on a favourable patch of ground."

The above conclusion, that the group-velocity explanation is a possible one and corresponds to an electron-distribution for which  $\mu = e^{-v/a}$ , disregards the effect of absorption. But Appleton (1929 Abstracts, p. 98) and Thomas (p. 202) have pointed out the serious difficulty presented by absorption. The writer suggests that the possibility of relatively low absorption in the high regions should be allowed to "remain open."

Finally, he points out that assuming the correctness of van der Pol's explanation, we should expect changes in skip-distance to occur before or after the long echoes, and in particular we should expect that at such times oblique incidence on the layer would give shorter range than normal.

WIRELESS ECHOES OF LONG DELAY.—P. O. Pedersen. (*Proc. Inst. Rad. Eng.*, Oct., 1929, Vol. 17, pp. 1750-1785.)

A summary of this paper was dealt with in 1929 Abstracts, p. 565. See also Störmer, p. 623. Some additions have been made; for example, the writer refers to L. H. Thomas's letter (1929 Abstracts, p. 202)—"he does not, however, mention the fundamental difference, with regard to the attenuation of radio waves, between collisions taking place between charged particles of equal charges and equal masses and collisions in which the two particles have unequal masses or charges (or both)." He also refers to Gunn's "diamagnetic" theory of the solar diurnal variation, and Chapman's refusal to accept it: he adds that Bohr (1911) has proved that such a diamagnetic effect does not exist, and that Gunn's remarks do not meet the main point of Bohr's arguments.

STUDIES OF ECHO SIGNALS.—A. Hoyt Taylor and L. C. Young. (*Proc. Inst. Rad. Eng.*, Sept., 1929, Vol. 17, pp. 1491-1507.)

A continuation of the work dealt with in 1928 Abstracts, pp. 460-461. As prophesied, round-the-world signals have now been noticed on S. American Stations during the equinoctial periods, Buenos Aires (21,500 kc.) giving them repeatedly during

these periods and at no other time. Records showing these are given.

Another record from Buenos Aires shows how the 8,500 kc. transmission was rendered practically unreadable at hand speed, owing to prolongations due to short-time echoes; whereas on a simultaneous record on the harmonic 17,000 kc., perfectly clear-cut signals were obtained. Similar simultaneous records on Bogota, on 13,700 and 27,400 kc., show on the other hand a type of time lag which can be explained without reference to echoes, by the idea that the higher frequency arrives by low-angle paths with less reflections than the lower frequency: except under conditions involving rather unusual electron distribution in the layer.

Directional tests on short-time echoes surprised the writers by giving the most numerous and strongest echoes from the direction *not* of rough and hilly country (as was suggested as probable in the first paper) but of the sea. Further thought convinces them, however, that the surface of the sea is an excellent medium for throwing back the echoes—possibly owing to its high refractive index.

Recent tests show that echo signals exist during the daylight hours at least up to 30,000 kc. and possibly beyond. The exact timing of these signals is not yet known.

"We see nothing in our latest observations to cause us to change our opinion that short-time echo signals are returned not from a point in space away from the earth, but are thrown back from the surface of the land or sea by way, of course, of an intermediate reflection from the layer."

As regards the relatively long-time echoes, the writers see at present no way of deciding experimentally between the idea of return from zones of reception beyond the first and the idea of return from the first zone by abnormally retarding paths in the layer. The paper ends with a discussion of the observed drop in effective height near the sunset hours: "the first and immediate effect of approaching sunset will be to cool the atmosphere, causing a general drop in the layer height. A little later, all ultra-violet radiation will be cut off from the high layers and recombination will set in, causing the layer, which is normally lower after sunset, to show a greater effective height because of the reduced number of electrons (*cf.* Hulburt, 1929 Abstracts, p. 627, last par., also Breit, these Abstracts) although the actual height may still remain low. This seems a reasonable explanation of the effects we have observed and their variation with the time of the year. Later on in the evening, where we have to do with fairly high effective layer height, perturbations due to high atmospheric winds of unusual magnitude may cause turbulences and fluctuations such as are shown in some of our observations."

FURTHER STUDIES OF THE KENNELLY-HEAVISIDE LAYER BY THE ECHO-METHOD.—L. R. Hafstad and M. A. Tuve. (*Proc. Inst. Rad. Eng.*, Sept., 1929, Vol. 17, pp. 1513-1522.)

Authors' summary:—"Recent observations of the Kennelly-Heaviside layer by the echo-method are described. Multivibrator-modulation was used, giving extremely sharp 'peaks' on 4,435 and 8,870 kc. Practically all of the observations were

made on the former frequency, as 8,870 kc. skipped over the receiver, which was very near the transmitter. Two 24-hour series of observations showed a marked diurnal-variation in the effective height of the layer and in the echo-pattern received for each transmitted 'peak.' The echo-pattern shows multiplicities during the day and evening, but becomes very complex at night. A few observations made during the magnetic disturbance of October 17-19, 1928, showed an unusually great effective height and a change in the echo-pattern. Daytime heights for a number of days during the autumn of 1928 are given."

The writers prefer to postpone any extensive discussion of the significance or interpretation of these results in terms of electron-distribution, etc., until further data are available, particularly on frequencies differing considerably from 4,435 kc. and (if possible) at various distances from the transmitter. A few remarks may be quoted, however: "the approximate multiplicity of the echo-time for the first, second, and higher-order reflections leads naturally to the picture of wave-groups travelling up and down a number of times between the layer and the earth's surface, although as yet we do not commit ourselves definitely to this view." "The 8,870 kc. wave has been received strongly on two occasions [see summary], both times just preceding times of considerable magnetic activity (September 18th and October 18th, 1928), but the only pictures obtained showed single 'peaks,' the absence of a ground-wave preventing any measurement of height."

NOTE ON KENNELLY-HEAVISIDE LAYER OBSERVATIONS DURING A MAGNETIC STORM.—L. R. Hafstad and M. A. Tuve. (*Ferrest. Mag.*, No. 1, 1929, Vol. 34, pp. 39-44.)

During the magnetic storm of 17th October, 1928, the height of the layer, by the echo method, was 370-420 km.—some 100 km. higher than on normal evenings. The echoes presented a different form from the ordinary. On the day before the storm the conditions for reception were abnormally good.

AN ECHO INTERFERENCE METHOD FOR THE STUDY OF RADIO WAVE PATHS.—L. R. Hafstad and M. A. Tuve. (*Proc. Inst. Rad. Eng.*, Oct., 1929, Vol. 17, pp. 1786-1792.)

Authors' summary:—An experimental determination of the rate of change of radio-frequency phase of the separate downcoming echoes has been carried out. The small power crystal-controlled oscillator circuit of the 4,435-kc. transmitter operates continuously, the high-power pulse transmission being produced by modulating the power-amplifier circuits. A receiver was operated very near the transmitter, having rapid recovery from the paralyzing effect of the pulse ground wave and sufficient sensitivity to receive the echoes with good amplitude, and having a very slight coupling to the crystal-oscillator circuit such that the crystal "pick-up" was comparable to the echoes received. The echoes showed their changing radio-frequency phase by alternately adding to and subtracting from the constant crystal oscillator pick-up. This "interferometer" is naturally

sensitive to small changes in the optical path of the waves. The phase changes are regular, but the time of one 360 deg. phase change on 4,435 kc. varies from 1 sec. to 60 sec., or possibly longer during the day and evening, and at times changes between these limits in as short a time as 15 min. When multiple echoes are present, the second and third echoes phase in and out more rapidly than the first echo, but not by an even factor.

THE SIGNIFICANCE OF OBSERVATIONS OF THE PHASE OF RADIO ECHOES.—G. Breit. (*Proc. Inst. Rad. Eng.*, Oct., 1929, Vol. 17, pp. 1815-1821.)

Author's summary:—A method of observing the phase of radio echoes has been developed by Messrs. Tuve and Hafstad. The present note is intended to show to what extent the phase can be expected to be constant throughout the echo if the frequency-dispersion of the Kennelly-Heaviside layer is taken into account. It is shown that for reflections of 4000-kc. waves with a small retardation (effective height of 200 km.) the phase can be expected to be the same for the whole echo and that in this case the observed phase is a measure of the optical path. For echoes which spend a longer time in the layer (effective height of 1800 km.) the phase should not be constant and the average phase is not expected to be a measure of the optical path.

It is shown that by measurements on reflections with low retardation the ratio between the changes of (1) the equivalent height for interference and (2) the effective height for echo retardation is a measure of how much of the change is due to the layer moving as a whole and how much is due to a redistribution of electron-densities through the layer. A compression or expansion of a layer having an electron-density increasing in proportion to the height above the lower boundary should give a result by the interference-method of approximately one-third the value obtained by the echo-retardations.

It is shown that the broad echoes observed at night by Hafstad and Tuve are in all probability due to multiple echoes and not to frequency-distortion in the sidebands of the emitted pulses.

OBSERVATIONS SUR LA PROPAGATION DES ONDES ÉLECTRIQUES COURTES PENDANT L'ÉCLIPSE SOLAIRE DU 12 NOVEMBRE, 1928 (Observations on the Propagation of Short Waves during the Solar Eclipse of 12th November, 1928).—A. Stchoukin. (*L'Onde Elec.*, September, 1929, Vol. 8, pp. 411-419.)

Russian observations on waves of 26 and 35 metres. Records are reproduced, and the following deductions are made:—in spite of the partial nature of the phase, the eclipse had a definite effect; it produced large temporary increases of signal strength, normal values being restored in the intervals. The rapidity with which the ionised layer reacted to the eclipse showed that the ionisation of the layer (or at any rate of its lower part) follows almost instantly all variations of solar radiation; that is to say, that the coefficient of ionisation and recombination is distinctly large.

NOTES ON THE EFFECT OF SOLAR DISTURBANCES ON TRANSATLANTIC RADIO TRANSMISSION.—C. N. Anderson. (*Proc. Inst. Rad. Eng.*, Sept., 1929, Vol. 17, pp. 1528-1535.)

"The results are in general as follows:—(1) The higher daylight signal field strengths on 60 kc. obtaining during periods of increased solar disturbances are associated more with general magnetic activity than with individual storms. (2) Individual storms do tend to increase 60 kc. daylight signal fields, however. For the more severe storms during 1927 and 1928, the result was an increase of about 30 per cent on the day the storm began to about 75 per cent for the four or five days following. The effects of individual storms vary greatly, however. (3) The day-to-day signal fluctuations on 60 kc. are much greater during periods of greater magnetic activity and are greater during the winter months than during the summer months. (4) Magnetic disturbances are accompanied by a large decrease in short-wave signal field strength on the day of maximum activity. Even mild magnetic storms may be accompanied by a reduction of signal field to or below the measurement limit. The recovery is a matter of one to seven or eight days depending on the severity. (5) Within a narrow range, an approximate linear relation is found between daily short-wave radio field strengths expressed in decibels above or below 1  $\mu$ v. per metre and the daily average of the horizontal component of the earth's field."

THE PROPAGATION OF ENERGY BY WAVES.—W. W. Sleator. (Suppl. to *Journ. Opt. Soc. Am.*, Oct., 1929, Vol. 19, No. 4, Part 2, p. 8.)

Abstract only. If rope waves or plane sound waves travel along the  $x$  axis, and  $u$  is the displacement of a bit of the medium from its equilibrium position, then  $u$  is a function of  $x$  and  $t$ , and  $du = (du/dx) dx + (du/dt) dt$ . If  $du = 0$ , then  $dx/dt = S$ , the velocity of the waves, and  $S = (-du/dt)/(du/dx) =$  velocity of medium/condensation. In sound or rope waves, any small volume of the medium has *always* equal amounts of kinetic and potential energy ( $\frac{1}{2}dS^2 = \frac{1}{2}$  stress  $\times$  strain) and this equality gives  $S$  as  $\sqrt{F/m}$  for rope waves and  $\sqrt{n/d}$  for sound waves.

In plane waves of light the magnetic and electric fields, representing equal amounts of energy, are together in phase. May one write these two fields as time and space derivatives respectively so as to obtain the expression  $S = e/\sqrt{e}$  for the velocity of light? Having regard for the vector nature of  $E$  and  $H$  it is found possible to define a vector quantity  $u$  such that  $\text{curl } u = D$ , electric induction, and  $du/dt = H$ , magnetic field.  $u$  may be called the "light vector," and its maximum value  $U$  is properly the amplitude of the wave. Using this quantity, it appears that  $S = H/D$ , and the equality of energies gives at once  $S = e/\sqrt{e}$ . The use of  $U$  as amplitude gives energy transmitted as proportional to the square of frequency. The field of  $U$  about an isolated charge has axial symmetry.

ASYMPTOTIC DIPOLE RADIATION FORMULAS.—W. H. Wise. (See under "Aerials and Aerial Systems.")

PAPERS AND DISCUSSION ON PROPAGATION, ETC., OF ULTRA-SHORT WAVES.—Kohl, Fassbender, Hahnemann, Wagner, Meissner, Esau. (See under "Transmission.")

COMMERCIAL SHORT WAVE WIRELESS COMMUNICATION: SHORT WAVE PROPAGATION.—H. M. Dowsett. (See last section of Abstract under "Stations, Design and Operation.")

THE GENERATION AND RADIATION OF CIRCULARLY POLARISED WAVES.—Takagishi and Iso. (See under "Aerials and Aerial Systems.")

### ATMOSPHERICS AND ATMOSPHERIC ELECTRICITY.

REGISTRIERUNG VON ATMOSPHERISCHEN STÖRUNGEN (The Recording of Atmospheric).—R. Joscheck. (*E.N.T.*, Sept., 1929, Vol. 6, pp. 341-349.)

An account of the work at Halle, originated by Schmidt in 1906 and continued by the writer. The present paper deals with records taken (on a Siemens-Blondel loop oscillograph) in 1927 and early 1928. In agreement with Watson Watt and Appleton, the atmospheric were distinguished as aperiodic or periodic according to their time processes; as rounded or peaked according to the shape of their records; and as positive or negative according to the direction of the current—positive if the first impulse flowed from aerial to earth.

The tables indicate that the average duration of the aperiodic-positive atmospheric is equal to that of the periodic-negative; also, that the mean amplitude  $\Delta e$  of the aperiodic-positive disturbance is equal to that of the periodic-positive.  $\Delta e$  for the negative disturbances, aperiodic and periodic, is only about a third of the value for the positive disturbances.

Reception with a counter-balancing capacity instead of an earth seems to indicate that the superimposed interference waves of high periodicity (shown in some of the oscillograms) were introduced from the earth. Apart from this, the counter-balancing capacity produced no change in shape, duration, intensity or acoustic character.

Certain connections between oscillogram-form and the acoustic nature of the disturbances were shown, but "a difference between periodic and aperiodic disturbance in acoustic nature could not be found." Check observations at Clausthal (600 metres above sea-level) "gave no change in form, duration or acoustic character, but the percentage proportions of the four classes and the value of  $\Delta e$  were notably altered—probably owing to the influence of atmospheric conditions."

ON THE ULTRA-VIOLET LIGHT THEORY OF AURORA AND MAGNETIC STORMS.—E. O. Hulburt. (*Phys. Review*, 15th July, 1929, Vol. 34, No. 2, pp. 344-351.)

The ultra-violet light theory (see 1929 Abstracts, p. 101 and elsewhere) suggests (1) that because of

winds and unusual production of ions the ionised region of the high atmosphere may be in violent agitation during the day of a magnetic storm, that it grows calmer at night and becomes agitated the next day if the storm continues, and (2) that there may be auroral displays in polar regions with no magnetic storms in temperate latitudes, since one type of solar "flare" (containing mainly the atom-excitation wavelengths, and only a little of the shorter more ionising wavelengths) would give rise to many high-flying atoms or molecules which when ionised would fall to the polar regions and cause the aurora; whereas since such a flare does not produce many ions there would be no strong magnetic disturbance in temperate latitudes.

On the other hand, it also suggests (3) that auroral displays in *temperate* latitudes should as a rule be accompanied by magnetic storms, and (4) that polar aurora should follow several hours or a day after strong magnetic disturbances in temperate latitudes, and "since the ion migration to the poles is suppressed while the flare is at its greatest intensity one might expect the delay in the appearance of the aurora in high polar regions to be greater for a long-continued intense magnetic storm than for a shorter storm."

"These inferences are shown to be in agreement with the data from magnetic observatories and observations of aurora in temperate and polar latitudes."

DIE SENDE- UND EMPFANGSVERHÄLTNISSE IM HOCHGEBIRGE MIT BESONDERER BERÜCKSICHTIGUNG DER ATMOSPHERISCHEN STÖRUNGEN (Transmitting and Receiving Conditions on High Mountains, with Special Attention to Atmospherics).—J. Fuchs. (*Zeitschr. f. Hochf. Tech.*, Sept., 1929, Vol. 34, pp. 96-101.)

Investigations in Aug.-Sept., 1928, at the Sonnblick (Austria) Observatory, 3,106 metres above sea-level. As regards propagation from and reception at this height, observations show that they do not differ appreciably from results at ordinary levels. On the other hand, the writer concludes that such high situations are particularly suited to observations on atmospherics. All disturbances departing, either qualitatively or quantitatively, from the usual daily routine—minimum before noon, maximum at night—are connected with a definite phase of weather conditions at the observation point or its immediate neighbourhood. Thus regions and channels of low pressure, even if of slight intensity only, at a distance (by day) of less than 250 km. cause an important increase of atmospherics, especially "clicks." For conditions of high pressure, only slight "grinders" appear throughout the day, "clicks" appearing only in the evening and then only with slight intensity. The effect of low pressure zones more distant than 250 km. can be detected, by night only, by a general higher intensity of "clicks" and by direction-finding.

During any kind of precipitation, atmospherics of a special kind are noticed, designated "notes" (*tönen*), estimated at 25 to 3,000 p.p.s. and of such intensity that they may make all reception impossible. Observations show that "clicks" are caused by atmospheric electricity and originate in

the surfaces of discontinuity of masses of air of differing temperature: it is this type which gives rise to long-distance effects. "Notes," on the other hand, are note-frequency induction effects of purely local character, probably caused by invisible brush-discharges resulting from high electrical potential gradients: they often occur in groups during a precipitation, with several seconds' silence in between. Often two groups differing in note overlap: if they happen to be of the same note, the effect is merely to increase the intensity of the first-comer—a result quite distinct from the actual increase of intensity of a single group, which is regularly accompanied by a rise of pitch.

Towards the end of the precipitation the frequency of the "notes" often increases, "whistles" (estimated at 3,000 p.p.s.) very often occurring then. The strongest gusts of wind have no effect on the pitch or intensity of the "notes." Close lightning flashes produce new groups of these: distant flashes only produce "clicks." Even the heaviest clouds have no effect in producing "notes," whereas the slightest precipitation produces them during its whole duration. They are heard with about the same intensity on all wavelengths down to 20 metres; below this, down to 12 m., they decrease but are still strong enough to interfere seriously with field-strengths less than 15 microvolts per metre. On ultra-short wavelengths (6-2 m.) no amount of amplification will make them audible.

It is suggested that these "notes" may be allied in nature to what is known in England as "hissing" and has been described by Esau under the name of "whistles." But the writer is convinced that they have nothing to do with an aerial-charging effect: a completely insulated indoor aerial will receive them with the same relative intensity.

ON THE DIAMAGNETIC FIELD OF THE OUTER ATMOSPHERE.—S. Chapman. (*Terrestr. Mag.*, No. 1, 1929, Vol. 34, pp. 1-16)

Gunn's approximate calculations in support of his explanation of the solar diurnal variation  $S$ , when treated along lines of spherical harmonic analysis, still agree qualitatively with observed results. Quantitatively, however, the explanation demands a total number of ions per sq. cm. column amounting to  $5 \times 10^{16}$ , i.e., 1,000 times greater than Pedersen's estimate. If the latter is correct, the diamagnetic theory can only account for a part of the magnetic variation. It has the disadvantage, also, of failing to account for the asymmetry with regard to the noon meridian. Cf. same author, April Abstracts, p. 204, and elsewhere. See also Gunn, below.

THE DIAMAGNETIC THEORY OF UNDISTURBED TERRESTRIAL-MAGNETIC VARIATIONS.—ROSS GUNN. (*Terrestr. Mag.*, No. 1, 1929, Vol. 34, pp. 17-21.)

See Chapman, above. The writer mentions various circumstances likely to divide by ten the estimated maximum ion content of the atmosphere demanded by his theory. He explains the entry of the maximum magnetic variation before the arrival of the sun at its zenith by the large daily change of temperature and height of the diamagnetic layer.

A THEORY OF THE PERMANENT MAGNETIC FIELDS OF THE SUN AND EARTH.—Ross Gunn. (*Phys. Review*, 15th July, 1929, Vol. 34, No. 2, pp. 335-343.)

Author's abstract:—The motion of ions, executing short free paths under the influence of thermal agitation in an inhomogeneous magnetic field, in crossed magnetic and gravitational fields or in crossed magnetic and electric fields is shown to produce drift currents. The ion drifts are found to be opposite in direction to the drifts produced in the analogous cases of long free path. Under the condition of radial symmetry and a closed circuit the magnetic gradient gives rise to circular currents which flow in such a direction that magnetic regeneration takes place. Regeneration is limited by demagnetising currents arising from the thermal motions of the ions interacting with the resultant magnetic field and an internal electric or gravitational field. The magnetic moments of the sun and earth are calculated from data which are approximately known and the correct magnitudes obtained. The permanent fields arise from the thermal energy of the body and would be maintained if the bodies ceased their rotation. The asymmetry of the earth's magnetic field indicates that the hemisphere embraced by the Pacific Ocean is at a higher mean internal temperature than the rest of the earth.

THE AURORAL GREEN LINE AT 5206 Å.—V. M. Slipher and L. A. Sommer. (*Sci. News-Letter*, 14th Sept., 1929, Vol. 16, p. 158; also *Naturwiss.*, 11th Oct., 1929, Vol. 17, pp. 802-803.)

This line is now attributed to a transition in atoms of nitrogen: it has been obtained in the laboratory by electrical discharges in mixtures of nitrogen and inert gases. The high atmosphere must accordingly contain atomic nitrogen as well as nitrogen molecules and molecular ions and oxygen atoms (the last being responsible for the green line at 5577 Å., as shown by McLennan). In the German paper, recent auroral observations at the Lowell Observatory, interpreted by quantum mechanics, are shown to lead to this result.

L'ÉTÉ DE 1929 ET LES VARIATIONS SOLAIRES (The Summer of 1929 and Solar Variations).—H. Mémery. (*Comptes Rendus*, 23rd Sept., 1929, Vol. 189, pp. 469-471.)

A correlation between the marked recrudescence of sunspots during the summer of 1929 and the unusual heat in August and September. The same effect was observed in 1928.

DIE ERSTE MESSUNG DER SONNENSTRAHLUNG IM FLUGZEUG (The First Aircraft Measurement of Solar Radiation).—P. A. Galbas. (*Naturwiss.*, 4th October, 1929, Vol. 17, p. 782.)

The first aeroplane tests ever carried out, in June, 1929, were successfully made with Schulze's modified form of the Michelson-Marten actinometer. At 3,500 m., for a sun's angle of 37 deg., an intensity of 1.67 gm. cal./sq. cm. min. was measured. See also Büttner, same journal, 8th Nov., 1929, p. 877.

ZUR DEUTUNG DES ABSORPTIONSPEKTRUMS DER SONNENATMOSPÄRE (The Interpretation of the Absorption Spectrum of the Sun's Atmosphere).—L. A. Sommer. (*Zeitschr. f. Phys.*, 9th Nov., 1929, Vol. 58, No. 7/8, pp. 573-576.)

ELEMENTS IN THE SUN.—C. E. St. John. (*Proc. Nat. Acad. Sci.*, Oct., 1929, Vol. 15, pp. 789-793.)

THE LAG BETWEEN SOLAR ACTIVITY AND MAGNETIC ACTIVITY.—H. W. Fisk. (*Terr. Magnetism*, No. 2, 1929, Vol. 34, pp. 147-150.)

ON THE RECURRENCE OF MAGNETIC STORMS.—W. M. H. Greaves and H. W. Newton. (*Month. Not. R. Astr. Soc.*, No. 7, 1929, Vol. 89, pp. 641-646.)

A continuation of the work referred to in Abstracts, 1928, p. 579, and 1929, p. 387.

LIGHTNING.—G. C. Simpson. (*Nature*, 23rd November, 1929, Vol. 124, pp. 801-812.)

Slightly abridged form of the Twentieth Kelvin Lecture (full paper in *J.I.E.E.*, for November, pp. 1269-1282). On p. 814 a "News and Views" paragraph comments on the lecture: Simpson's "breaking-drop" theory of the generation of electrical energy can be readily accepted by the engineer; it is based on Simpson's discovery that when a drop of water is broken up in the air without striking anything, separation of positive and negative electricities takes place, as Lenard found it to do when pure water splashes against a solid obstacle. The reviewer considers that some definite statements in the lecture will almost certainly have to be modified later: e.g., that the resistivity of the lower atmosphere in clear weather is about  $4.5 \times 10^{15}$  ohms. He seems disinclined to accept the lecturer's theory that during a thunderstorm we have non-conducting clouds floating within a conducting atmosphere, "thus completely reversing our ordinary ideas. . . . It is difficult to believe that a cloud is a perfect non-conductor."

#### PROPERTIES OF CIRCUITS.

LES EFFETS SECONDAIRES DE LA RÉACTION (The Secondary Effects of Reaction).—E. Fromy. (*L'Onde Elec.*, July, 1929, Vol. 8, pp. 281-296.)

The ordinary way of regarding the result of reaction as represented by the equation  $r = R - R'$  leads to a number of conclusions which do not conform with actual results: thus the strength of signals should increase as the reaction is increased up to the oscillating point; the amplifying power should be the same for weak as for strong signals; different methods of reaction, provided they bring the circuit up to oscillating point, should give similar results; and the amplification obtainable should be independent of the value of  $R$ .

By a strict examination of the equations of the process, making no simplifying assumptions, the writer arrives at the result that the effect of the arrival of the incoming wave, reaching the receiver tuned to it and with reaction adjusted, is two-fold:

it produces an upsetting of tuning unless the e.m.f. of reaction is exactly in phase with the current, and an upsetting of reaction. The former effect, being small, is neglected for the moment (later, however, it is pointed out that it may be quite important if the reaction e.m.f. is greatly out of phase with the current). The latter effect, however, is by no means negligible: the effect of the incoming signal changes the apparent resistance of the circuit from  $R_0 (= R - f_o')$  to  $R' (= R - f_o' - \frac{1}{12} f_o''' I^2)$ , and since  $R_0$  was small by adjustment, the term  $-\frac{1}{12} f_o''' I^2$  may have a great effect. The change in reaction depends for its sign on the magnitude of  $f_o'''$ . If  $f_o''' < 0$ , as is usually the case—corresponding to smooth and reversible reaction—the incoming wave *increases* the apparent resistance of the circuit, and the amplification is reduced (it is this fact that makes the oscillation adjustment smooth and reversible). This "self-stiffing" is, *ceteris paribus*, greater the greater the value of  $I$ : hence the larger amplification of weak signals.

If  $f_o''' > 0$ , as occasionally happens—when the oscillation adjustment is sudden and irreversible—the incoming wave has the effect of decreasing the resistance, so that the modulation peaks carry past the limit and set up oscillation unless the reaction is voluntarily decreased—in which case the gain due to the reduced resistance is lost again.

In both cases, a large value for  $R$  is disadvantageous, since to make  $R_0$  small  $f_o'$  has to be larger as  $R$  is larger. This means that  $f_o'''$  must also be larger, with consequent greater upsetting of reaction by the incoming wave.

The intermediate case, when  $f_o''' = 0$ , is not realisable in practice. Theoretically, it means that none of the disturbing effects of the incoming wave, mentioned above, would occur; but no negative resistance exists with a characteristic curve which is either a straight line or a parabola, perfect and infinite. For very weak signals a point can be found on the actual curve where these conditions are very nearly reached.

The writer points out that the above results present a very close analogy to those obtained by him for interference with a reaction receiver by an outside station (*ibid.*, April–June, 1924). Thus the effect of the incoming wave on a reaction receiver is, in fact, to act as an interfering station on its own receiver.

In a subsequent paper the writer will examine the question in greater detail for two particular cases, the reaction autodyne valve and the resistance amplifier.

AMPLITUDENABHÄNGIGKEIT DER DYNAMISCHEN STEILHEIT BEIM RICHTVERSTÄRKER (Dependence of the Slope of the Dynamic Characteristic on the Amplitude, in Rectifier-Amplifiers).—M. v. Ardenne and K. Schlesinger. (*Zeitschr. f. Hochf. Tech.*, Sept., 1929, Vol. 34, pp. 91–95.)

The problem of the single valve circuit with reaction, using anode rectification, is considered theoretically and the results confirmed by experiment. In grid rectification, where the rectifying effect in the grid circuit and the amplification

carry on practically independently, the steepest part of the anode characteristic can be used, so that optimum rectification can be combined with gentle setting-in of oscillation; recent research has shown that this can also be attained with anode rectification, but only if the anode circuit is loaded with ohmic resistance. The present paper thrashes out this point. It is established that the introduction of ohmic resistance does produce the desired effect: that *only* ohmic resistance will serve: and that it must have a certain minimum value which can be calculated by formula. Under such conditions, results are good: in a receiver based on these results, with 8 megohms in the anode circuit and a valve with extremely high  $\mu$ -value and high anode voltage, smooth oscillation adjustment was obtained on short and broadcast waves, while rectification was so good that by adding one step of voltage amplification, short wave stations at great distances were received on the loud-speaker. Damped and modulated waves are well received; for heterodyne reception, on the other hand, the circuit is not good, since the amplitude of oscillation can only be pushed up with difficulty.

AN ANALYSIS OF TRIODE VALVE RECTIFICATION.—PART II.—S. E. A. Landale. (*Proc. Camb. Phil. Soc.*, October, 1929, Vol. 25, Part 4, pp. 482–490.)

Continuation of the paper referred to in 1929 Abstracts, p. 569. Author's summary: "Generally, when an alternating voltage is applied to a cumulative grid rectifier no grid current flows at mean grid potential. The behaviour of a rectifier working under these conditions is examined. An expression is derived for calculating rectified current for any applied voltage. As this equation is rather cumbersome to apply, a very simply empirical formula is given which is applicable for any value of applied potential whatever.

An expression is derived for the power absorbed by the rectifier. It is shown that as the applied voltage increases, the apparent resistance of the rectifier decreases and approaches half the value of the grid leak resistance.

Further, it is shown that rectified current depends on the peak value of the applied potential and that it is almost independent of ordinary wave-form variations, even when the applied voltage is small.

By slightly modifying the expression for rectified current we find that, in an amplifier, the grid current is a measure of  $V$  and, in an oscillator, the grid current is a measure of the output. The only condition is that  $V > 2b$  in both cases."

ERZWUNGENE KIPPSCHWINGUNGEN UND IHRE TECHNISCHE ANWENDUNGEN (Forced Relaxation Oscillations and their Technical Application).—E. Hudec. (*Arch. f. Elektrot.*, 1st Aug., 1929, Vol. 22, No. 4/5, pp. 459–506.)

The writer divides relaxation-oscillation generators into two classes—current type and potential type. Forced relaxation oscillations are produced when either type of generator has its natural oscillations controlled by an external a.c. Such control may be applied in three ways:—(1) direct, the control a.c. being applied in series; (2) by influencing the charging current to the condenser;

and (3) by influencing the oscillator characteristic. The last method is not applicable to the glow discharge oscillator, but can be applied to the alternative, triode-circuit relaxation oscillator which the writer uses in preference for investigations at high frequencies above about 6,000 p.p.s. (this being the limit at which the glow discharge tube can be used satisfactorily). This valve circuit consists of a small triode with a saturation current of about 1 mA. (condenser-charging valve) and a large triode whose anode current reaches about 50 mA. (discharge valve). The control voltage is produced by a Turner Kallirotron circuit.

Three types of forced relaxation oscillations are considered: synchronous, cyclical and "wild." The conditions governing the appearance of these three types are arrived at. The rest of the paper deals with the application of the controlled oscillations to the purpose which really lay at the root of these researches—the provision of a time base or cathode-ray oscillographs. If the control voltage and the forced oscillation voltages are applied to the two pairs of deflecting plates (at right angles), the property of the forced oscillations—of being proportional to time and also in perfect synchronism with the control voltage—gives the result that the control voltage appears on the screen as a stationary curve (*cf.* Vecchiacchi, 1929 Abstracts, p. 340).

Alternating voltages up to 400,000 p.p.s. can thus be recorded. Synchronism is so good that a photographic exposure of 15 minutes can be given without its resulting in blurring, though the curve is passed through 120 million times in that period. Applications to stroboscopic methods are also dealt with, briefly.

A NOTE ON THE STABILITY OF A VALVE AMPLIFIER.  
—E. B. Moullin. (*Proc. Camb. Phil. Soc.*, October, 1929, Vol. 25, Part 4, pp. 508-513.)

Author's summary:—This paper considers the stability of a valve amplifier which has an oscillatory circuit in the grid and in the anode circuit. An exact condition for stability is obtained for circuits which have no resistance, and it is shown that when both circuits have the same natural frequency instability is then impossible if the anode inductance exceeds  $\mu$  times the grid circuit inductance. This condition is believed to be new; in practice it is unnecessarily severe, but it is believed that stability should be sought by increasing the anode inductance and the grid circuit capacity. The stability of circuits which have resistance is too cumbersome to express generally, but it is discussed on broad principles; the stability and amplification of multistage amplifiers are also considered briefly.

NOTES ON THE DETECTION OF LARGE SIGNALS.—  
Sylvan Harris. (*Proc. Inst. Rad. Eng.*, October, 1929, Vol. 17, pp. 1834-1839.)

Author's summary:—The effect of large signals applied to the grid of a detector is discussed. It is shown that signals even as small as 50 mv. appreciably affect the tube parameters and influence the frequency distortion. The nature

of detector overloading is discussed and overload curves of the plate rectifier are presented.

DOUBLE-VALUED CHARACTERISTIC OF A DIRECT CURRENT FEED-BACK AMPLIFIER.—P. B. Carwile and F. A. Scott. (*Phil. Mag.*, November, 1929, Vol. 8, No. 52, pp. 680-684.)

A summary of this investigation was referred to in 1929 Abstracts, p. 570.

THE NUMERICAL ESTIMATION OF GRID RECTIFICATION FOR SMALL SIGNAL AMPLITUDES.—  
W. A. Barclay. (*E.W. and W.E.*, November, 1929, Vol. 6, pp. 596-601.)

In a former paper (*ibid.*, August and September, 1927) the writer showed that for all except very small signal amplitudes, the slope of the grid current characteristic when plotted logarithmically might be regarded as an index of detecting efficiency as far as the grid circuit of the valve is concerned. But one merit of the "cumulative grid" method of rectification is its sensitivity to weak signals, so the writer now gives a rapid means of utilising the grid characteristic to estimate detecting efficiency for such small signals. For such signals an exponential form can be assumed for the characteristic with sufficient accuracy, and by making use of the alignment principles developed by the writer (*ibid.*, 1927, pp. 261-270) he shows how  $\Delta$  ( $= v_0 - v_s$ , the change of mean grid voltage due to rectification of signal  $E$ ) may be accurately related for all values of circuit and valve constants by means of alignment charts. Having found  $\Delta$ , the actual values  $v_0$  and  $v_s$  of grid voltage prior to and during the passage of the signal can be obtained from the equations  $v_s = v_0 - \Delta$  and  $V = v - v_0$ ,  $v$  being the positive grid bias applied and  $V$  being the initial P.D. across the grid leak, obtained from a geometrical interpretation of one of the equations derived. Finally, from a knowledge of  $v_0$  and  $v_s$ , the variations in anode current may be ascertained.

DETERMINATION OF FREQUENCY AND DECUREMENT BY MEANS OF PLATE CURRENT VARIATIONS OF THERMIONIC OSCILLATOR TUBES.—J. T. Tykociner and R. W. Armstrong. (*Phys. Review*, No. 4, 1929, Vol. 33, p. 634.)

Abstract only. The intensity of the plate current feeding a valve oscillator varies with the frequency  $\omega$  of a coupled circuit. If the condenser setting of the latter is varied and  $\omega$  plotted against  $\Delta I_p$ , resonance curves are obtained representing  $\Delta I_p = f(\omega)$ . These curves were investigated within a range of 150 to 100,000 kc. The influence of filament current  $I_f$ , plate potential  $E_p$ , coupling  $k$  and decrement  $\delta$  was studied. The existence of critical values  $I_f'$  and  $E_p'$  was discovered, for which  $\Delta I_p = 0$ . Above these values  $I_p = f(\omega)$  is represented by peaked resonance curves, below these values the curves are inverted showing a depression.

The character and the maximum values of the  $\pm \Delta I_p$  curves depend also on the coupling and damping coefficients of the circuits. With the exception of a narrow zone near the critical points,



the  $\Delta I_p$  curves were found to correspond to Bjerkes resonance curves obtained with a thermogalvanometer in the coupled circuit. By compensating the steady part of  $I_p$ , a sensitive method was developed for measuring the frequency and logarithmic decrement of oscillating circuits, parallel wire systems and antennæ. No thermocouple or other device need be inserted in the measured circuit: the constants of the latter therefore remain unaffected. See also following abstract.

TUNING OF OSCILLATING CIRCUITS BY PLATE CURRENT VARIATIONS.—J. T. Tykociner and R. W. Armstrong. (*Univ. of Illinois Bulletin*, 16th July, 1929, Vol. 26, No. 46, 49 pp.)

A systematic study of the well-known phenomenon of plate current variation as a coupled circuit is brought near resonance: the primary object being to find a reliable way of using this effect for various practical purposes. Details of the method of investigation are first given: e.g., the d.c. component of the plate current was compensated for (in the measuring instrument) by a compensating valve.

Plate current tuning curves were obtained at all frequencies from 150 to 100,000 kc. (Later, audio-frequencies of 3 to 15 kc. were used also.) The influence of filament current and plate voltage upon the shape of these tuning curves was investigated. The existence of critical values for each of these variables was discovered. Above the critical values the current variations are positive, below the critical values they are negative. The effect of increasing the damping coefficient of the oscillator circuit is to shift the critical potentials towards higher values.

For the coupling coefficient there are two critical values: at the lower one the amplitude of the plate current tuning curves changes from positive to negative values, at the higher one the amplitude jumps (near resonance) to positions below or above that at resonance—this being what the Germans call the "ziehen" effect. Various properties of the tuning curves are described; e.g., in the region close to the critical values they usually show a variety of complex shapes, having one maximum situated symmetrically between two minima, or *vice versa*: at resonance the curves show either peaks or depressions, increasing with the coupling coefficient (the grid current tuning curves always show a depression at resonance). It was experimentally verified that the formation of plate current tuning curves is due to the oscillating valve varying its effective characteristic with frequency and load, influenced by the coupled circuit.

These plate current variations can be made good use of in frequency and decrement measurements, since the r.f. current indicator usually inserted (directly or inductively) in the wavemeter circuit is dispensed with, and the damping thereby reduced. For frequencies higher than 30 megacycles still further advantages are found, since any instrument in the wavemeter circuit affects and is affected by the distribution of current and potential: the plate current method is

particularly useful in Lecher wire systems; it is possible to remove the measuring instrument right away from the parallel wires, and to obtain accurate results with wires only  $\lambda/2$  in length.

An attempt was made to make use of these plate current variations to control automatically the frequency changes in an oscillating circuit so as to obtain constant frequency. Two relays, one working on increase and the other on decrease of plate current, were made to act on a vernier condenser in parallel with the main oscillating condenser; some success in stabilisation was obtained. The paper ends with an appendix describing a double-heterodyne method (*cf.* Aiken, 1928 Abstracts, p. 227) of measuring very small coupling coefficients (down to 0.001) which are generally difficult to measure.

INDUCTANCE AS EFFECTED BY THE INITIAL MAGNETIC STATE, AIR-GAP, AND SUPERPOSED CURRENTS.—H. M. Turner. (*Proc. Inst. Rad. Eng.*, Oct., 1929, Vol. 17, pp. 1822-1833.)

"Considering the importance of the subject it is surprising that there are so few data or curves in the literature showing the performance of inductance coils under widely varying conditions. It is hoped that the results here reported will be of interest and value to those who use or occasionally design choke coils or audio-frequency transformers. . . ."

THE NEUTRALISATION OF RESISTANCE.—W. E. Bruges. (*Elec. Review*, 24th Aug., 1928, Vol. 103, pp. 307-309.)

A method is proposed and examined for neutralising the effect of resistance in a circuit carrying oscillating currents, without causing distortion or instability, by injecting an e.m.f. which is proportional at every instant to the resistance-drop in the circuit. The application to a 3-valve receiver is described, and the application (see *Elec. Review*, 3rd Feb., 1928, p. 217) to neutralise the distorting effect of the iron in a step-down transformer: here no valve or amplifier is required.

DIE ANWENDUNG DES SIEMENSSCHEN CHRONOGRAPHEN ZUM STUDIUM ELEKTRISCHER SCHWINGUNGSKREISE (The Use of the Siemens Chronograph for the Study of Electrical Oscillating Circuits).—K. Smolinski. (*Gesell. d. Freunde der Wissen.*—Poland—1929, 2, pp. 9-40.)

The writer has successfully applied this apparatus, which was designed for measuring the velocity of bullets. A rather long summary will be found in *Physik. Berichte*, 1st Sept., 1929, pp. 1708-1709.

ZUR THEORIE DER AUSGLEICHSSCHWINGUNGEN (The Theory of Equilibrating [Transitional] Oscillations).—A. Kneschke. (*Ann. der Physik*, 15th Aug., 1929, Series 5, Vol. 2, pp. 555-575.)

The oscillations in question are those produced by a sudden change (e.g., of frequency or amplitude) in the forces producing the previous steady

oscillations: or in other words, they are the oscillations which bridge the gap between the two stable sets of oscillations, before and after such a change. Heaviside, followed by Wagner, has dealt with simple forms of the case (cutting in-and-out of d.c.); Deutsch has extended the treatment to pure periodic disturbances and Schmidt has considered the forced oscillations of a linear harmonic oscillator with irregular periodic excitation.

Starting out from the above knowledge, the present paper develops a General Theory of such equilibrating processes, dealing with systems first of one degree of freedom, then of  $n$  degrees and finally of an infinite number of degrees of freedom. For the special case of the equation of hyperbolic type (telegraphy equation, equation for damped oscillations) the equilibration theory is set up and the d'Alembert formula derived.

LES CYCLES LIMITES DE POINCARÉ ET LA THÉORIE DES OSCILLATIONS AUTO-ENTRETENUES (Poincaré's Limiting Cycles and the Theory of Self-sustained Oscillations).—A. Andronow. (*Comptes Rendus*, 14th October, 1929, Vol. 189, pp. 559-561.)

The writer takes the simplest case of self-sustained oscillations, namely, that which is represented by a system of one degree of freedom (in mechanics and physics), by a reaction between two substances (in chemistry), and by two co-existing species of animals (in biology). He shows that such oscillations correspond mathematically to the limiting cycles of Poincaré, and that the methods of the latter can be applied to the quantitative treatment of these oscillations. The series of phenomena accompanying them in the electrical case (e.g., the "drawing into tune" effect, called by the Germans "mitnehmen") must also be represented in the mechanical and chemical spheres. Cf. van der Pol, 1929 Abstracts, p. 42.

P.D. AND E.M.F.—R. M. Wilmotte. (*E.W. & W.E.*, Oct., 1929, Vol. 6, pp. 550-552.)

A reply to Biedermann's criticism (1929 Abstracts, pp. 630-631). The difference between the two writers is merely a difference of opinion and is not due (as Biedermann suggests) to the omission by Wilmotte of an important element of the problem: the fact that the potentials are in reality retarded potentials does not affect the validity of the definition. The advantages of Biedermann's suggested alternative definition lie in the simplification of the type of coupling existing in certain cases: the writer's definition possesses the important advantage of considerable mathematical convenience.

SCHIRMWIRKUNG UND WIRBELSTROMVERLUSTE EINES HOHLEN KREISZYLINDRISCHEN LEITERS IM MAGNETISCHEN WECHSELFELD (Screening Effect and Eddy Current Loss in a Hollow Cylindrical Conductor in a Magnetic Alternating Field).—H. Buchholz. (*Arch. f. Elektrot.*, 1st August, 1929, Vol. 22, No. 4/5, pp. 360-374.)

## TRANSMISSION.

VERSUCHE MIT ULTRAKURZEN WELLEN IM FLUGZEUGVERKEHR (Tests with Ultra-Short Waves in Aircraft Service).—H. Fassbender. (*E.N.T.*, September, 1929, Vol. 6, pp. 358-365.)

A paper on the Adlershof tests, carried out by the German Research Department for Aircraft, on communication by 3.7 m. waves. It covers much the same ground as the papers dealt with in Abstracts, 1928, p. 589, and 1929, p. 264. The very similar tests of the Lorenz Company are referred to (see Gerth and Schoppmann, 1929 Abstracts, p. 203). A long final section discusses very thoroughly the possible applications of these ultra-short waves for aircraft and the rival claims of the "short" waves (15-60 m.) and the band between 100 and 150 m. For ranges of hundreds of kilometres to over a thousand kilometres, the 15-60 m. waves seem pre-eminent, but for close communication (e.g., between aeroplanes of one squadron) they carry too far and cause interference. The ultra-short waves seem well adapted to this purpose, but have to compete with the 100-150 m. band. The decision between these two classes cannot yet be reached; much depends on future development of the respective receivers. One great advantage of the ultra-short over the longer waves is that they get away from earth-absorption at low heights, while the 100-150 m. waves require about 1,000 metres' height before this occurs.

The most important application, the writer thinks, is in close-quarter D.F. and in fog-landing. He envisages a rotating beam of 3 m. waves, similar to the Marconi short-wave rotating beacon for ships; though the difficulties are far greater for aircraft owing to their high landing speeds—20 metres per sec. for the Junkers F.13. Such a plan, moreover, does not provide for forced landings away from flying grounds.

In reply to K. W. Wagner, who referred to Duckert's results on the effect of atmospheric conditions in distorting the paths of waves, he points out that the tests were carried out in fine weather only.

Kohl suggests that Wagner's query as to deviation by atmospheric conditions could be answered in the laboratory by testing for change of wavelength in an artificial fog.

Meissner points out that the limitation of the 3 m. range to the "optical path" (which Fassbender considers definite) must not be considered an established law. According to Fassbender's curves, a mass height of 1,000 to 2,000 m. would be necessary to obtain a range of 200 km., whereas the speaker and Apel have obtained that range with masts only 10 m. high. He recalls, also, that after the successful Germany-South America 11 m. wave tests, 8 and 5 m. tests were made—with complete lack of success; but that in trying to receive these waves it was found that harmonics of a North American station, in this band of wavelengths, came in very well—indicating that 5-8 m. waves work well over great distances in the N-S direction but not in the E-W direction. Alexanderson, also, has found that a 3 m. wave will carry 3,000 miles in the N-S direction, whereas in the E-W direction its range is small.

Replying to Esau (who, on hearing for the first time that thousands of miles had been covered by a 3 m. wave, inquires whether fading was found) Meissner believes that it must have been, and that it must also have been present in Fassbender's tests, though here it would be masked by the use of super-regenerative receivers. Wagner, however, suggests that as periods of fading follow each other more and more closely the shorter the wave, perhaps with ultra-short waves they come so close together that they are not noticed.

Meissner continues that he was surprised at the small ranges obtained by Fassbender, and surmises that the fault lay in the waves making a bad "get-away" from the aeroplane.

Hahnemann, however (see below) considers that the "optical path" limit was definitely established by the Brocken Mountain range tests (see 1929 Abstracts, p. 203). The reason why Fassbender's ranges did not quite reach the sight limit was probably the noise-level in the aeroplane superimposing itself on the transmitted signals. He does not explain the large ranges referred to by Meissner; the only suggestion as to these comes from Fassbender, who suggests that they can be accounted for by analogy with the passage of a ray of visible light through a cloudy medium; the great power at the transmitter and the special aerial would help. In his paper (below) Hahnemann also recalls the fact that a beacon-fire can be seen a certain distance beyond the horizon.

**DIE BEDEUTUNG DER ULTRAKURZEN WELLEN FÜR DIE ELEKTRISCHE NACHRICHTENTECHNIK, INSBESONDERE DIE DER WELLENLÄNGEN VON 1 M. ABWÄRTS (The Importance of Ultra-Short Waves for Communication Purposes; especially Waves from 1 m. downwards).—W. Hahnemann. (E.N.T., Sept., 1929, Vol. 6, pp. 365-370.)**

A new nomenclature is used in this paper: waves between 1 and 10 m. are called "unit" waves, between 10 and 100 m. "ten" waves, and so on; while waves below a metre are divided into "deci" (between 1 m. and 10 cms.) and—presumably—"centi" (from 1 cm. to 10 cms.) and "milli" (from 1 cm. downwards). The paper—a brief survey—was followed by a demonstration of the easy control—concentration, reflection, polarisation, etc.—of 50 cm. waves.

**UNGEDÄMPFTE ELEKTRISCHE ULTRAKURZWELLEN (Undamped Ultra-short Electric Waves).—K. Kohl. (E.N.T., September, 1929, Vol. 6, pp. 354-358.)**

The opening paper at the recent special "Ultra-Short-Wave Meeting" of the E.V. and the Heinrich-Hertz Association. The first section, after referring to the Barkhausen-Kurz research, deals with the writer's experiments on the generation of waves of the order of 14-50 cms. (cf. Abstracts, 1928, pp. 464-465; 1929, pp. 269 (2), 327), and the effect of increased grid potential and emission current and decreased anode voltage in shortening the wavelength, by increasing the electron density of the dielectric in the grid-anode capacity and thus decreasing that capacity. Thus even the B-K

oscillations are governed by the usual circuit constants and are not "pure electron oscillations."

The second section deals with "optical" tests and experiments with 14 cm. waves (see September Abstracts, p. 508; also cf. Beauvais, p. 326). The rotation of the plane of polarisation can be illustrated by the use of a wire bent so that its three parts (each of length  $\lambda/2$ ) lie in the three planes: the part which lies perpendicular to the electric vector and which hitherto received no signals now receives them, because the third part sends out secondary radiation in a plane perpendicular to the electric vector.

Reflection of the emitted radiation back again to the valve shows an effect on the anode current varying with the position of the reflecting screen. This effect can also be shown by the introduction of a linear resonator in the field, which re-radiates back to the transmitter; maxima and minima are shown in the anode current indicator as the resonator moves over half wavelengths. The writer, by reducing the circuit constants, has succeeded in obtaining "monochromatic undamped waves down to 8 cm., and in propagating these in space. These represent the shortest obtainable up to the present" (but cf. Hollmann, June Abstracts, p. 326, and Okabe, August Abstracts, pp. 447-448). See also Smith-Rose, *E.W. & W.E.*, October, 1929.

**ULTRAKURZE WELLEN (Ultra-short Waves).—Kohl: Fassbender: Hahnemann. (E.T.Z., 26th Sept., 1929, Vol. 50, pp. 1389-1393.)**

Abridgments of the papers dealt with above.

**ÜBER DIE ERZEUGUNG SEHR KURZER ELEKTRISCHER WELLEN NACH DER SCHALTUNG VON BARKHAUSEN-KURZ (The Generation of Very Short Electric Waves by the B-K Circuit).—W. J. Kalinin. (Ann. der Phys., 15th August, 1929, Series 5, Vol. 2, No. 5, pp. 498-514.)**

The writer set out to improve on the results of Kohl, Hollmann and others, by obtaining more stable and more powerful waves and by simplifying the apparatus and technique. He used a Russian 10-watt transmitting valve and obtained particularly stable 14.4-14.6 cm. waves "whose intensity apparently exceeded that of all waves of the same order of wavelength ever generated." He even obtained 8 cm. waves of almost equal intensity, but this wave could not be kept going for more than 2 or 3 minutes on account of the great heating-up of the valve.

The 14.4 cm. waves, free from harmonics, were of such intensity that a linear oscillator ( $l = 7$  cm.) at 50-70 cm. distance gave a current of about 0.28 ma. in spite of the presence of the high-resistance detector.

In the course of the research, 4 zones were studied, corresponding to different grid voltages (90 v. for the 58 cm., 400 v. for the 14.4 cm. zone and 690 v. for the 8, 12 and 16 cm. zone). The wavelengths in no way conformed with the Barkhausen and Scheibe theory connecting them with the dimensions of the electrodes. The writer finds a definite relation connecting the wavelengths in the middle of the five zones: if  $V_n$  is the grid

voltage corresponding with the centre wave of the  $n$ th zone, then  $V_{n+1}/V_n = V_n/V_{n-1}$ , i.e., the grid voltages form a geometrical progression.

The writer ends by discussing the similarities and differences between his results and those of Potapenko and Grechova.

MODULATION BY MAGNETIC FIELD.—H. E. Hollmann. (See last paragraph of next abstract.)

DAS VERHALTEN DES ELEKTRONENOSZILLATORS IM MAGNETFELD (The Behaviour of the Electron Oscillator in a Magnetic Field).—H. E. Hollmann. (*E.N.T.*, Oct., 1929, Vol. 6, pp. 377-386.)

Author's abstract:—"The work deals with the effect of a homogeneous magnetic field on an electron oscillator, i.e., a triode in the Barkhausen-Kurz retarding potential arrangement with coupled oscillatory circuit. It is found that the magnetic field shortens the wavelength of the oscillations, behaving like a static anode retarding potential, so that even a positive anode potential can be compensated for. The result, apparently contradictory to theory, that the magnetic field causes frequency changes even in the zone of pure Gill-Morrell oscillations [in spite of the controlling oscillatory circuit] is due to the fact that the magnetic field displaces the whole Gill-Morrell zone towards the shorter wavelengths: [so that in the apparent G-M zone there is really the B-K or a transitional régime].

"The relations holding for the B-K oscillations remain good also for the 'higher frequency oscillations' [electron-pendulum-swings between grid and anode: occurring with fine-meshed grids, where the electrons proceeding from the cathode pass only *once* through the grid: cf. 1929 Abstracts, same author, p. 274, and Knipping, p. 571]. The magnetic field can cause a transformation of B-K oscillations into these 'higher frequency' oscillations. Still stronger fields produce yet another type of 'higher frequency,' regarded as magnetron oscillations within the grid": the electron paths are so bent even between cathode and grid that only part, if any, of the electrons reach the latter. In this case the grid can be replaced by a closed cylinder without appreciable effect. Cf. Hull, Zácák, Okabe, Yagi, and Slutzkin and Steinberg.

An attempt to produce the "higher frequency oscillations" by omitting the static anode retarding field and using a grid-like anode (thus obtaining a "grid-diode") and forcing the return of the electrons by the magnetic field only was unsuccessful; interesting results however were obtained (see following abstracts).

The writer then traces the shape of the emission current curve as a function of the magnetic field-strength, to the increase of space charge as a result of the pendulum-swings of the electrons, maximum space charge corresponding to minimum emission current. For close-meshed grids or for strong positive anode potentials the curves change to the well-known "magnetron" curves: thus the magnetic characteristic curves confirm the theory of the "higher frequency" oscillations.

"The dependence of the energy of oscillation on the external magnetisation forms a basis for a

simple method of modulation, which is independent of frequency in the G-M zone." The magnetising coil is traversed by a modulating current (e.g., from a microphone): a steady polarising current is used to get an optimum working point on the curve. Tests showed that this method gave as good transmission of music on these ultra-short waves as that obtained by other methods (1928 Abstracts, p. 580: 1929, p. 571).

EXPERIMENTAL TRANSMITTING AND RECEIVING APPARATUS FOR ULTRA-SHORT WAVES.—R. L. Smith-Rose and J. S. McPetrie. (*E. W. and W. E.*, October and November, 1929, Vol. 6, pp. 532-542 and 605-619.)

Part I gives a rapid but comprehensive survey of the progress in ultra-short wave generation, first for damped oscillations (by various spark methods) and then for undamped (ionic or electronic) oscillations; finishing with an account of some of their applications. Many references are made to the bibliography of more than 40 items given at the end of the October instalment. Part II is devoted to an analysis of circuits suitable for generating waves from 10 metres down to about 1.5 m. with the straightforward use of ordinary valves. A series of experiments indicated that with ordinary valves working under ordinary conditions this 1.5 m. was about the lower practical limit, though the theoretical minimum calculated from the electron path time was about half this. The evolution of the various single-valve short-wave circuits from the standard older longer wave circuits is clearly shown by diagrams and accompanying text; so also is the evolution of the symmetrical two-valve circuits originated by Eccles and Jordan.

The various circuits are then critically analysed from the point of view, chiefly, of small-power oscillators using ordinary receiving valves; and two such transmitters, used by the writers, are described and illustrated. Both these oscillators showed the phenomenon of fatigue, the output decreasing by some 25 per cent. in three hours' continuous working, and recovering completely after a short rest. Dielectric losses in the bases and glass wall are suggested. Part III deals with the design of larger transmitters, up to 1 kw., using transmitting valves. Two-valve circuits were adopted, the single-coil capacity-coupled push-pull circuit being the most convenient. Chokes in series with the grid leaks were used to prevent r.f. leakage into the filament leads. For modulating purposes the writers prefer anode potential modulation.

A section on Lecher wires and the measurement of wavelength leads to a discussion of methods of feeding the antenna, and of the radiation from the latter. A short section on the measurement of these very high frequencies, and its difficulties, ends Part III; Moullin's two-cylinder ammeter is here referred to (1929 Abstracts, p. 49) and the root idea of Wilmotte's "column of mercury" ammeter (acting as its own thermometer—see under "Measurements and Standards") is mentioned. Part IV deals with the development and use of simple receivers (detector with reaction, followed by a l.f. stage). A later paper is pro-

mised dealing with the use of supersonic heterodyne reception, which offers important advantages in this region of wavelengths.

**TRANSMITTING ON ULTRA-SHORT WAVES.**—R. L. Smith-Rose and J. S. McPetrie. (*Wireless World*, October 9th, 1929, Vol. 25, pp. 398-402.)

A description of current practice in transmission on wavelengths below 10 metres. A more comprehensive article on the subject by the same authors appears in *Experimental Wireless* (see above).

**LES ONDES ÉLECTRIQUES ULTRA-COURTES (Ultra-Short Electric Waves).**—E. Pierret. (*L'Onde Élec.*, Sept., 1929, Vol. 8, pp. 373-410.)

First part of a comprehensive survey of the production and application of waves below about 1½ metres. Numerous circuit diagrams are given, and the various theories involved are discussed. A bibliography of no fewer than 80 items is added.

**ÜBER FUNKENERREGUNG KURZER ELEKTRISCHER WELLEN UNTER 1 M. WELLENLÄNGE UND EINEN NEUARTIGEN STOSSFUNKSENDER (On Spark Methods of Generating Short Electric Waves below 1 Metre, and a New Quenched Spark Generator).**—W. Pupp. (*Ann. der Physik*, 4th September, 1929, Series 5, Vol. 2, No. 7, pp. 865-908.)

Starting from the Mie and Rukop design of quenched-gap oscillator, the writer has evolved an improved form fulfilling a number of desirable conditions: thus it is axially symmetrical; its parts are easily and accurately turned on a lathe and are quickly assembled, centred, etc.; it has good removal of heat—hence the possibility of hours of continuous working; it is fed from a d.c. battery instead of from an induction coil. The complex processes taking place in the gap are investigated by means of a glow-discharge tube, rotating mirror and oscillograph. Full details of these investigations are given.

The currents in the sparks amount to 650 and 480 amperes in two cases ( $\lambda = 57$  and 39 cm.). Examination of the very distinctive scar-markings on the surfaces of the gap gives an insight into the part played by mechanical-acoustical oscillations in the interior of the gap. The paper ends with a bibliography of 30 items.

**WAVE RESONANCE TUNING AND APPLICATION TO RADIO TRANSMISSION.**—W. R. Blair and L. Cohen. (*Proc. Inst. Rad. Eng.*, Oct., 1929, Vol. 17, pp. 1892-1896.)

For the use of the modernised form of the old "wave resonance tuning" as applied to reception, see Cohen, under "Reception." The present paper deals with the application to transmission: the important advantages are obtained of elimination of harmonics, extreme sharpness of tuning, and a convenient and relatively simple method for multiplex transmission. In the last application, each transmitter is separately associated with a wave conductor which is adjusted to the fundamental frequency of that transmitter, all the

(adjustable) metal plates of the various wave conductors being connected to the aerial. There is no interaction between the different transmitters: the current in the aerial is the sum of the currents due to the several transmitters when acting singly.

## RECEPTION.

**SUR UN NOUVEAU MODE DE RÉCEPTION DES ONDES ULTRA-COURTES (10-18 cm.) (A New Method of Reception for Ultra-short—10 to 18 cm.—Waves).**—E. Pierret. (*Comptes Rendus*, 4th Nov., 1929, Vol. 189, pp. 741-743.)

The method described is "completely different from the super-regenerative methods but has all the sensitivity of these without being more difficult to manage and without needing a second valve." A T.M.C. horned valve, similar to the one used for transmission (*Abstracts*, 1928, p. 465; 1929, p. 149), has its grid connected to a small antenna arranged on the focal line of a cylindro-parabolic mirror. A current antinode, a little less than  $\lambda/4$  from the end of the antenna, is connected by a wire to the + pole of a battery, which raises the grid to a potential (120-200 v.) much above that of the filament, which is connected to the negative pole.

The plate is maintained at a potential about equal to that of the filament; this potential is regulated by a potentiometer either across the filament battery or across a special battery. Between the grid and its battery is an oscillatory circuit with variable condenser, of wavelength 20-150 metres. A coil in the plate circuit, coupled to the oscillating circuit, produces oscillations in the latter when the coupling is suitably adjusted. The telephone receiver is either in the grid or in the plate circuit.

When the reaction coupling is increased so that oscillation sets in, the mean plate current changes by several milliamperes and that of the grid changes in the reverse direction by a similar amount. To receive the ultra-short signals, the coupling is adjusted to the threshold of oscillation. The arrival of the ultra-short waves modifies the mean grid potential and starts oscillations in the longer-wave circuit, thus producing variations in the telephone current. By suitable adjustment of heating current, circuit capacity, plate voltage and coupling, these oscillations can be made to extinguish themselves at the end of the signal. Telephony can be received. If the grid voltage is increased, it is necessary to increase the heating current and to decrease the plate voltage, the inductance and the capacity of the oscillatory circuit; the result is a more sudden setting-in of oscillation and a more sensitive but less easily adjusted receiver. The method has also been applied with success to 2-metre waves, and the writer is now trying to extend its use to still longer waves.

**FADING ELIMINATION.**—(German Patents 476917 and 477055, Telefunken Co., pub. 30th May and 3rd June, 1929.)

The first patent deals with fading due to rotation of the plane of polarisation. Two antennæ at right angles, each receiving one component,

cannot eliminate fading, since the components of similar phase add algebraically in the receiver. According to the invention, an artificial phase-difference of 90 degrees is established between the two components, so that no rotation of the plane of polarisation can cause extinction of signals.

In the second patent, the modulation is momentarily interrupted at intervals short compared with the fading period, and an "auxiliary note" transmitted which, by synchronous switching at the receiver, is led to an auxiliary apparatus regulating the bias of the receiver amplifier. The fading control is thus on the working wavelength, not merely on a neighbouring one (*cf.* Thierbach, 1929 Abstracts, p. 632).

DEVELOPMENT AND USE OF RECEIVERS AT VERY SHORT WAVELENGTHS.—Smith-Rose and McPetrie (*see under "Transmission"*).

CIRCUIT TUNING BY WAVE RESONANCE AND APPLICATIONS TO RADIO RECEPTION.—L. Cohen. (*Proc. Inst. Rad. Eng.*, Oct., 1929, Vol. 17, pp. 1868-1892.)

Author's summary:—Theoretical consideration of the wave resonance system of tuning with distributed values of inductance and capacity are given, together with circuit arrangements embodying this method of tuning. It is shown that a high degree of selectivity is obtainable and that it offers an effective method for the elimination of interference. Multiplexing both in the transmission and reception of radio signals can be readily realised.

BELOW 10 METRES.—R. L. Smith-Rose and J. S. McPetrie. (*Wireless World*, 23rd Oct., 1929, Vol. 25, pp. 470-473.)

Describing two receivers developed by the authors to meet the requirements of the simplest type of instrument which could be used in studying the propagation of very short waves. The first consists of a detector and single I.F. stage, using a centre-tapped input coil capacity-coupled to aerial and counterpoise. For wavelengths between 5 and 10 metres a condenser having a maximum capacity of 50 micro-microfarads is suitable for the main tuning condenser. To avoid unnecessary reactance in the leads at very high frequencies all wiring should be made in reasonably thick wire, say, No. 16 S.W.G. Such wire has the additional advantage of rigidity, an essential feature at these high frequencies. Suitable coils may be made from  $\frac{1}{4}$  in. or  $\frac{1}{2}$  in. aluminium or brass tubing. With  $\frac{1}{4}$  in. tubing and components complying with the above conditions it was found that with a centre-tapped 4-turn coil with internal diameter of 1 in. and 2 in. long, the wavelength range extended from 4.7 to 7 metres, while with another 4-turn coil of equal axial-length but having a diameter of  $1\frac{1}{2}$  in. the available range was from 5 to 12 metres.

The second is a small loop receiver designed to cut down the number of variables involved in transmission and reception by obviating the necessity for an aerial.

Using single-turn loops constructed of  $\frac{1}{4}$  in.

diameter copper tubing, the following wavelength ranges are covered with a tuning condenser, of which the minimum and maximum capacities are 2 and 25 micro-microfarads respectively (i.e., two condensers in series, each having minimum and maximum of 4 and 50 micro-microfarads).

Diameter of loop in inches.	Wavelength range in metres.
5	4.8-6.9
8	5.5-8.8
10	6.2-9.5
12	6.7-10.8

SELECTIVITY IN PLAIN TERMS.—R. T. Beatty. (*Wireless World*, 16th Oct., 1929, Vol. 25, pp. 432-435.)

Proposing the use of a new unit to express the selectivity of any receiver as a numerical quantity.

"Add the number of H.F. valves to the number of H.F. tuned circuits and multiply this sum by 0.2 times the geometric mean product of the coil magnifications. The result is the selectivity number."

"The number of kilocycles by which a single tuned circuit must be detuned to cause the ordinate of the resonance curve to fall to 0.1 of its value at resonance is obtained by dividing the frequency of the carrier wave in kilocycles by the selectivity number."

NOTE ON THE APPARENT DEMODULATION OF A WEAK STATION BY A STRONGER ONE.—S. Butterworth. (*E. W. & W. E.*, Nov., 1929, Vol. 6, pp. 619-621.)

Referring to Beatty's paper (*ibid.*, June, 1928) the writer points out that since this demodulation effect (which explains the fact that two stations are acoustically separable when mere inspection of the resonance characteristic of the receiver would lead one to expect very powerful interference) is of fundamental importance in the problem of selectivity, it is important that we should obtain quantitative notions as to its magnitude. He considers Beatty's conclusions as to the magnitude of the effect, in the case of perfect rectification, to be based on an error due to over-simplification of his mathematical treatment (*cf.* David, 1929 Abstracts, p. 390); he neglects the term  $Y \sin pt \sin \omega t$  in the equation:—voltage received by detector  $v = (X + Y \cos pt) \cos \omega t - Y \sin pt \sin \omega t$ , where  $X$  and  $Y$  are the strengths of the two signals to be rectified, of angular frequency  $\omega$  and  $(\omega + p)$  respectively. This leads to an erroneous form for the supersonic envelope; the mean current, recorded by a linear detecting instrument too sluggish to follow the supersonic ripple  $p$ , will in actual fact vary both with  $X$  and with  $Y$ , not (as Beatty found) with the stronger signal only.

Proceeding with his own treatment of the problem, the writer gives a table showing the relation between carrier wave ratio (depending on the resonance characteristic of the receiver) and the acoustic ratio, the latter being the important factor in estimating the selectivity. For a carrier wave ratio of 0.1, the acoustic ratio is 0.0052:

for 0.9 it is 0.63. This is for perfect rectification; curvature of the characteristic will increase the acoustic ratios. In fact, for weak signals where the rectification nearly follows the square law, the demodulating effect completely disappears and the acoustic ratio is the square of the carrier wave ratio. These squares are larger than the acoustic ratios for perfect rectification, being nearly twice as large for small ratios of carrier wave (e.g., 0.04 compared with 0.0202). Therefore, if the r.f. amplification is pushed up till there is a considerable voltage swing across the detector grid, a gain in selectivity of nearly 2 to 1 may be obtained—an additional argument in favour of adequate r.f. amplification.

**SELECTIVITY AND QUALITY.**—W. T. Cocking. (*Wireless World*, 30th Oct., 1929, Vol. 25, pp. 478-482.)

Advocating the use of the somewhat neglected method of tuning employing coupled tuned circuits, or band-pass filters, for obtaining square-top resonance curves and adequate selectivity in reception (in view of the opening of the B.B.C.'s high-power regional station at Brookman's Park) and as a means of limiting high note loss to only 10 or 20 per cent.

**H.F. TRANSFORMER DESIGN.**—A. L. M. Sowerby. (*Wireless World*, 23rd Oct., 1929, Vol. 25, pp. 446-448.)

A quantitative investigation of the means of adjusting h.f. transformer ratio to compromise between amplification and selectivity.

**IS APERIODIC R.F. AMPLIFICATION NECESSARY?**—R. Rechnittzer. (*Funkbastler*, April, 1929, Vol. 5, pp. 221-223.)

Von Ardenne considers that it is (see 1929 Abstracts, p. 510). The writer agrees that for frame reception where r.f. amplification of the order of 50,000 is necessary, aperiodic stages are almost indispensable; but he maintains that for an outside aerial or even an indoor aerial (r.f. amplifications 1,000 and 5-10 thousand respectively) two screen-grid stages give economy in valves together with the necessary selectivity.

**REGIONAL BROADCASTING: THE PROBLEM OF PROGRAMME SEPARATION.**—(*Electrician*, 18th Oct., 1929, Vol. 103, pp. 456-458.)

Simple methods of improving the selectivity of crystal and valve sets of early design are described and illustrated.

**NEW YORK RADIO SHOW.** (*Wireless World*, 30th Oct., 1929, Vol. 25, p. 485.)

A review of the apparatus on view at the Radio World's Fair, held at New York in September last. A marked tendency towards standardisation of design in American receivers is commented on. "The screen-grid tetrode is almost universally used for the radio frequency amplifier stages. There are usually four tuned circuits, including the input stage. All the sets have single tuning control with an additional knob for controlling volume and usually a third control for adjusting

the input circuit, which contains the antenna."

"One exhibit which deserves special mention was that of the Radio Frequency Laboratories, who showed a large number of sets divested of their cabinets so that visitors could easily examine their construction. This concern carries out research work for the benefit of its licensees, providing designs for set manufacture."

"It can be said that in the design of radio receiving sets the American manufacturers are, in some respects, ahead of the British. They have been working under different conditions. The enormous market open to the American manufacturer has been the chief reason of his rapid progress, and he has not found it worth while to economise on research. Moreover, the generally high level of wealth in the United States has permitted the manufacturer to neglect the very cheap set and concentrate all his energy on the reproduction of a higher quality product. Sets range from about £25 up."

**RADIO IN 1930.**—H. T. Cervantes. (*Scient. American*, Dec., 1929, pp. 498-500.)

Comments and illustrations of types of the latest U.S.A. broadcast receivers.

**H.F. AMPLIFICATION IN MODERN RECEIVERS.**—(*Wireless World*, 2nd Oct., 1929, Vol. 25, pp. 372-374.)

A review of the latest tendencies in British receiver design having regard to the imminence of the regional broadcasting scheme and the consequent need for greater selectivity. It is observed that the high possibilities of the screen-grid valve are not yet exploited to the utmost extent, a stage-gain of two or three hundred times not being attainable in factory-made instruments. Manufacturers prefer to offer two stages of moderate gain, rather than a single stage, thereby providing a greater degree of amplification, better selectivity, and a larger margin of safety with regard to stability.

## AERIALS AND AERIAL SYSTEMS.

**RICHTCHARAKTERISTIKEN VON ANTENNENKOMBINATIONEN, DEREN EINZELNE ELEMENTE IN OBERSCHWINGUNGEN ERREGT WERDEN** (Directional Characteristics of Aerial Combinations whose Elements are excited in Harmonics).—G. Gresky. (*Zeitschr. f. Hochf. Tech.*, October, 1929, Vol. 34, pp. 132-140.)

After referring to the work of Esau, Bouthillon, Mesny and Chireix on aerial systems excited on the fundamentals of their components, for directivity in a horizontal plane; and to the work of Abraham, van der Pol and others on systems excited to the higher harmonics, for directivity in a vertical plane, the writer defines the object of his own work as the investigation of combinations possessing directivity in both planes, and suitable both for transmission and for reception.

In this, the first of two parts, he deals with combinations of two aerials excited to the same harmonic (first or second), in series and in parallel

connection. If the spacing  $d$  is so arranged that 
$$d/\lambda = \frac{1}{2 \cos \beta_{\max}},$$
 (where  $\beta_{\max}$  is the angle of slope of the individual aerials giving maximum amplitude in the vertical plane), the sharpness of directivity for both types of connection is greater than, or at least as great as, that of one individual aerial; it is rather sharper for the series than for the parallel connection. The sharpness in the horizontal plane is a good deal greater for the parallel than for the series connection.

The second part will deal with the combination of two aerials excited to *different* harmonics, and with the combination of three aerials.

ASYMPTOTIC DIPOLE RADIATION FORMULAE.—  
W. H. Wise. (*Bell Tech. Journ.*, October, 1929, Vol. 8, pp. 662-671.)

The analysis of the radiation from dipoles as given by Sommerfeld and by von Hoerschelmann is deficient in one respect: it does not give the true asymptotic expressions for the radiation leaving at a considerable angle from the horizontal. The correct asymptotic formulæ have already been supplied by an appeal to the Reciprocal Theorem; lately Strutt has got them directly from the boundary conditions (1929 Abstracts, p. 329) and Weyl (1919) has derived the correct asymptotic formula for a vertical dipole at the surface of the earth by a method quite different from Sommerfeld's. In the present paper it is shown how they can be got merely by improving the rigour of Sommerfeld's analysis. Thus the author writes: "The goal of the paper being asymptotic formulæ for the sky waves of vertical and horizontal dipoles, the ground wave,  $P$ , will hereafter be ignored. This is possible because at the high frequencies for which dipoles are used, the ground wave is very highly damped.

"Sommerfeld gets an asymptotic expression for  $Q_1$  by noting that if we are at a great distance from the source, most of the value of the integral comes from that portion of the path of integration very close to  $h_1$ . . . . But he has replaced  $\sqrt{r^2 - h_2^2}$  by  $\sqrt{h_1^2 - h_2^2}$ . This is a needless approximation which ruins the symmetry, damages the utility, and tends to hide the physical meaning of the final result. To get the true asymptotic formula for  $Q_1$  it is necessary to confine the approximations to the purely operational variety, i.e., to make no approximations of substitution before integrating, but to let the approximation reside wholly in the manner of integrating. . . ."

THE FIELDS CLOSE TO A RADIATING AERIAL.—  
E. B. Moullin. (*Proc. Camb. Phil. Soc.*, Oct., 1929, Vol. 25, Part 4, pp. 491-507.)

"It is already known that the field at any point can be expressed formally when the distribution of current and charge in the source is postulated: it is shown in this paper that the field at all points very near to the source can be expressed by simple formulæ. Of course it is not an exact solution for the field due to a conductor of specified shape, because the postulated distribution of current and charge is incorrect. But so long as the conditions laid down are not departed from appreciably, the

solution will be substantially correct. Further, the field may be calculated for any distribution which is postulated, and therefore the degree of approximation can readily be assessed by the simple expedient of altering the postulated distribution in some simple manner reasonable to the specified problem."

The process of the solution is based on the following:—if  $\rho$  is the charge, moving with speed  $v$ , in a volume element  $d\tau$  which is distant  $r$  from the origin, then (since the currents and charge densities considered pulsate harmonically with frequency  $n = p/2\pi$ ) the retarded value of  $\rho$  (value obtaining at time  $t - r/c$ ) is of the form:— $\sin(pt - pr/c) = \cos(pr/c) \sin pt - \sin(pr/c) \cos pt$ . Since only points close to the origin are dealt with,  $pr/c$  is small: if, therefore, terms like  $\sin(pr/c)$  are replaced by their corresponding series, only the first few terms need be retained. The cases considered include (1) field of a specialised antenna (long thin wire terminated by conducting spheres of radii very great compared with the wire radius but very small compared with the length); (2) power radiated from a wire of any shape; (3) closed conducting circuit: circle of one turn; (4) rectangular circuit: plane circuit of any shape.

The methods are then applied to find the inductance of closed circuits: mutual inductance between two concentric circles: to calculate h.f. resistance losses in wires and coils (but the results do *not* account for the marked discrepancy between Butterworth's formulæ and measured results at frequencies above about  $10^6$  p.p.s.): skin effect losses, field within and without a tubular current.

ON STANDING ELECTRIC OSCILLATIONS ON A LINE EXCITED AT A POINT NEAR ITS CURRENT OR POTENTIAL LOOP, AND THE GENERATION OF ROTARY WAVES.—E. Takagishi and E. Iso. (*Res. Electrot. Lab. Tokyo*, July, 1929, No. 265, 35 pp.)

An account of experimental and theoretical investigations into the behaviour of a line conductor fed with r.f. current through a single feeder. The line currents on both sides of the feeding point, and the feeding current itself, can be varied considerably not only in their magnitudes but also in their phase relations by the displacement of the feeding point along the line or by the equivalent way of introducing variable reactances. The use of this fact is applied first to directive transmission and reception; the line is bent into a vertical U with the legs a quarter wavelength apart, and the exciting wavelength is made equal to one of the harmonic wavelengths of the whole conductor system. If then the phases in the two limbs are adjusted to differ by  $\pi/2$ , a heart-shaped transmitting characteristic is produced: a corresponding adjustment also applies to reception. A system of such aerials is illustrated, consisting of a row of 4 U's in line parallel to each other and spaced  $\lambda/2$  apart, connected to form two pairs. The line joining the two pairs receives the single feeder near its mid-point.

The conditions for the required phase-displacement are given by  $d = \pm 0.04 m\lambda^2$  where  $d$  is the displacement of feeder from mid-point,  $m$  is the number of quarter wavelengths on the whole length



of the aerial,  $\lambda$  is the exciting wavelength, and  $\alpha$  is the real term in  $\sqrt{YZ}$  ( $Y$  and  $Z$  being admittance and impedance of unit length of aerial). The

criterion of the adjustment is  $I_1 = I_2 = \frac{I_3}{\sqrt{2}}$

where  $I_1$ ,  $I_2$  and  $I_3$  are the currents in the two limbs and the feed current respectively.

The writers then deal with the generation of polyphase oscillations and the radiation of rotary (circularly polarised) waves. Just as the value of  $d$  given above resulted in balanced two-phase oscillations, so the value  $d = \pm 0.069 m\alpha\lambda^2$  gives balanced three-phase oscillations; while by a mere adjustment of the electrical lengths of  $n$  lines radiating from a common point, balanced  $n$ -phase oscillations may presumably be produced. To obtain experimental proof of the production of 3-phase oscillations, the writers used three wire conductors arranged in a symmetrical star about 1 metre above ground. The lengths were  $m_1 = m_2 = 1$ , and  $m_3 = 2$ ;  $m_3$  was used as the feeder. A wavelength of 40 m. was used. Owing to various disturbing causes, the observed and theoretical curves differed slightly, but the presence of a rotary field—due to the 3-phase oscillations—was shown.

By raising the aerial systems high in the air, the circularly polarised waves can be radiated. First attempts to test for special characteristics of propagation (as compared with that from a simple vertical aerial) gave negative results, but the writers are not yet satisfied. Reception of such waves can be accomplished with an ordinary aerial, but special results should be obtained by receiving on a special 3-phase aerial. According to the displacement of the point of connection (in direction as well as in magnitude) maximum or minimum signals should be received, thus giving special properties of selectivity.

The methods described above are the subject of numerous Japanese patents.

### VALVES AND THERMIONICS.

CALCULATION OF CHARACTERISTICS AND THE DESIGN OF TRIODES.—Y. Kusunose. (*Proc. Inst. Rad. Eng.*, Oct., 1929, Vol. 17, pp. 1706-1749.)

"The present paper, being an abridgment of a paper published in Japan (1929 Abstracts, pp. 330-331), is primarily intended for presenting a simple method of designing triodes."

VALVES OF TO-DAY.—(*The Wireless World*, October 2nd, 1929, Vol. 25, pp. 376-378.)

A survey of the latest receiving types on the British market with special reference to the methods employed to prevent grid emission in A.C. valves.

THE PENTODE AS AN ANODE RECTIFIER.—A. L. M. Sowerby. (*The Wireless World*, 2nd October, 1929, Vol. 25, pp. 391-394.)

The concluding part of an article referred to in last month's abstracts. Investigations into the damping effect produced by the pentode as a detector on the tuned circuit from which, in a normal receiver, it receives the voltage that it is called upon to rectify.

EINE NEUE METHODE ZUR BESTIMMUNG DER TEMPERATUR VON GLÜHFÄDEN (A New Method for Determining the Temperature of Filaments).—K. Schlesinger. (*Ann. der Physik*, 15th Sept., 1929, Series 5, Vol. 2, No. 8, pp. 933-975.)

After enumerating and criticising the various existing methods, based on optical processes (pyrometric and photographic methods), thermoelements, Maxwell's distribution of velocity law (by the variation of emission with retarding anode counter-potentials), etc., the writer describes his purely mechanical method, depending on the determination of the natural frequency of vibration of the filament as a stretched string. Twenty pages are devoted to the theoretical working out of the temperature/frequency relation. It is shown that this ratio can be determined from a knowledge of the frequency when cold and of a mechanical design constant which can be found by plotting the resistance characteristic in the region between cold and dull glow.

The rest of the paper describes the procedure employed. The most favoured way of causing the vibrations is by means of the output from a telephone or loud-speaker energised by an audio-frequency valve circuit (250-2,600 p.p.s.). Some filaments are sufficiently affected by being brought near to the source, but in all cases it is enough to connect the telephone diaphragm to the glass wall by a short stiff wire. The most favoured way of observing the filament oscillations is by allowing them to take place in a constant transverse magnetic field, and amplifying the resulting currents. In an appendix, the advantages of the method in commercial practice are discussed. An accuracy of 5 per cent. is easily reached.

### DIRECTIONAL WIRELESS.

NEUZEITLICHE VERFAHREN DER VERKEHRSSICHERUNG (Latest Safety Methods for Ships, Aircraft, etc.).—H. Fassbender. (*Zeitschr. des V.D.I.*, 2nd November, 1929, Vol. 73, pp. 1581-1584.)

A short, rather non-technical survey of modern methods, in Wireless D.F. (ships and aircraft); leader cables; infra-red reflection and the Behm "Echolot" (sound reflection) for close quarter warnings and height determination in aircraft; and shunting and train control by Wireless.

GUIDAGE MAGNÉTIQUE DES AÉRONEFS ET AÉRODROMES DE SÉCURITÉ (The Magnetic Guidance of Aircraft; Safety Aerodromes).—W. Loth. (*Comptes Rendus*, 14th October, 1929, Vol. 189, pp. 572-573.)

Variations of the leader-cable method for the guidance of aircraft are described. By using high frequencies (about 10,000 p.p.s.), reception can be either by aerial or frame. By using a combined aerial and frame for reception (as is done in receiving from radio-beacons, to avoid the 180 deg. error) it is possible to determine on which side of the line the aircraft is, if the frame is horizontal.

On the other hand, if the guiding cable oscillates as an aerial, there is no return current and its field will be circular. This allows an aviator, if he knows

his height, to determine his distance from the cable. In practice he will have to reverse his connections so as to find the aerial-frame combination giving weakest signals, in order to decide on which side he finds himself. But if the line, instead of oscillating as an aerial, takes the shape of two parallel lines forming a loop, the commutation can be made at the transmitter instead of at the receiver: in this case dots will be sent in the one sense and dashes in the opposite sense, so that the observer—keeping the receiver combination unchanged—will hear dots when on one side of the line and dashes when on the other.

If the aerodrome is surrounded by a circular line on posts, an observer in an aeroplane approaching from a distance of thirty kilometres or more can obtain, by aerial-frame reception, the following information:—(1) the direction of the centre of the aerodrome (receiving on a vertical frame along the long axis of the aeroplane, or—if in doubt as to the 180 deg. ambiguity—on this frame combined with an aerial); then (2) changing to his horizontal frame and aerial combination, his position with regard to the aerodrome (assuming the loop-shaped line and commutation at the transmitter, he will hear dashes as he approaches closely to the aerodrome: to avoid collisions in landing, it is proposed to divide this into eight sectors alternately for taking-off and landing, arranged according to the points of the compass, and he will be able to learn whether a suitable sector is available: telegraphic messages will inform him of details, wind, etc.); then (3) these dashes will turn into dots as he crosses the boundary and (4) will become a continuous dash as, in his descent, he passes through the horizontal plane of the frame formed by the lines. Finally, (5) the dashes will again appear as he descends below this level.

ÜBER EINEN NEUEN RICHTUNGSHÖRER (A New Sound Direction Finder—Maurer-Goerz).—Ch. v. Hofe. (*Zeitschr. f. Inst. Kunde*, No. 7, 1929, Vol. 49, pp. 331-341.)

Sound coming from the right is admitted only to the right ear; from the left, only to the left ear; thus the adjustment, for sound directly from the front, can be made with very great accuracy thanks to the binaural effect. Each of the two receiving organs is formed from a paraboloid of revolution cut along a plane passing through its focus. For conveying the sound to each ear an ellipsoid of revolution, similarly cut, is used—its focus coinciding with that of the paraboloid. Direction error is about  $\frac{1}{4}$  deg. For aeroplane noise, range is 20 km. for a paraboloid diameter of 1 metre.

### ACOUSTICS AND AUDIO-FREQUENCIES.

BEOBACHTUNGEN AM KOHLEMİKROPHON (Researches on the Carbon Microphone).—H. Salinger. (*E.N.T.*, October, 1929, Vol. 6, pp. 395-399.)

No clear idea exists as to why the resistance of a carbon microphone is so markedly greater under the influence of the voice than it is at rest. It may be assumed that the resistance/contact-pressure curve is very much bent; on

the other hand, possibly a noise causes a displacement of the mean working-point on this curve, so that the static and dynamic characteristics are not the same. The paper deals with an investigation into these processes, by the simultaneous oscillographic recording of the resistance changes and of the movements of the diaphragm. The latter were recorded by making the diaphragm form one plate of a condenser, the capacity-variations of which altered the frequency of a valve circuit.

Among the results, it was shown that at certain frequencies the microphone describes a hysteresis loop, so that the resistances at the go- and return-swings of the diaphragm are not equal. The diaphragm swings less far inwards towards the carbon than outwards; the least resistance is about equal to the resistance at rest; during the vibration the carbon is relatively looser than when at rest, even at the moment of greatest compression. The writer suggests that these results may also be of importance in connection with the threshold of sensation of the microphone. The existence of such thresholds has been deduced from tests with very weak sounds; it does not follow that they would produce distortion at greater levels of sound.

GRAMOPHONE PICK-UPS.—F. L. Devereux. (*Wireless World*, 30th Oct., 1929, Vol. 25, pp. 483-484.)

The three factors most essential to the successful design of an electromagnetic pick-up are summarised as follows:—

(1) A symmetrical arrangement of the magnet pole pieces to give differential vibrations of flux in the reed or armature. Provided the armature is accurately centred, amplitude distortion will be reduced to a level at which it can be turned to a useful purpose, while the restoring force required to hold the armature in a central position will be small.

(2) An armature of the smallest possible dimensions in which the best distribution of mass to give a small moment of inertia has been attained without appreciably affecting the efficiency of the magnetic circuit.

(3) The restoring force and damping must be adjusted to compromise between record wear, the frequency of the principal reed resonance, and the peak value of this resonance.

SUR L'APPAREILLAGE PERMETTANT L'ÉTUDE DU SPECTRE MUSICAL (Apparatus for the Study of the Musical Spectrum—Variable Note Generators).—I. Podliasky. (*L'Onde Élec.*, July, 1929, Vol. 8, pp. 297-305.)

The writer defines the four desirable properties of a note generator for the testing of acoustic apparatus:—large range of frequency, gradual progress in that range, sinusoidal nature of the wave, and constancy of amplitude on all the frequencies. After describing the English and American use of the heterodyne generator, and showing how the last quality is obtained by making the fixed heterodyne wave much weaker than the variable interfering wave, and the sin-

usoidal requirement by the use of a low-pass filter on the fixed wave output, he states that these two requirements are only approximately satisfied, owing to the fact that the rectifier never has a semi-linear (*sic*) characteristic and itself introduces harmonics; so that the generator (and the amplifier following it) has to be provided with filters needing careful design and adjustment.

He then describes and illustrates an apparatus consisting of a small audio-frequency homopolar alternator driven by a variable speed motor (or by hand for the very low frequencies) with a little tachometer dynamo on the same shaft, the voltage of this being indicated by a meter graduated directly in frequencies. With 60 teeth on the iron rotor, the frequency range is from 25 cycles or less to 8 kc. (speed, 8,000 r.p.m.); with 90 teeth, 12 kc. is reached. The excitation is from accumulators; the constancy of amplitude at the different frequencies is attained by making use of the fact that an alternator with low internal resistance and constant excitation gives an output practically independent of speed if the load is a pure inductance. In the apparatus used by the writer, the amplitude is constant within 3 per cent. at all frequencies above 50.

The rest of the paper deals with examples of the use of the apparatus—for the spectra of an amplifier (microphone to line) and of a sub-control amplifier.

#### PHOTOTELEGRAPHY AND TELEVISION.

DAS BILDÜBERTRAGUNGS-SYSTEM "FULTOGRAPH" (THE FULTOGRAPH PICTURE WIRELESS SYSTEM).—H. Bucek. (*Elektrot. u. Maschbau*, September 22, 1929, Vol. 47, pp. 830-834.)

An illustrated description. Among the points mentioned may be cited the following:—The original friction coupling for the synchronising action was found to be insufficiently precise, and has been replaced by a magnetic coupling; the important effect on reproduction of tuning the receiver time constant to the speed of the transmission is illustrated.

IMAGE TRANSMISSION BY RADIO WAVES.—A. N. Goldsmith. (*Proc. Inst. Rad. Eng.*, September, 1929, Vol. 17, pp. 1536-1539.)

An introduction to a series of papers by various authors on radio-transmission of stationary images or moving pictures (see next month's abstracts). The introduction deals briefly with the following aspects:—Comparison of Facsimile Transmission and Telegraph Transmission; The Relation of Facsimile to Television Transmission ("the speed of picture element transmission is . . . in the approximate ratio of 100 to 1 or more for television as compared to facsimile transmission"); The Relation of Television to Telephone Broadcasting; and Future Television Standardisation.

CHANNELS FOR PICTURE TELEGRAPHY AND TELEVISION.—(*Nature*, 12th October, 1929, V. 124, pp. 593-594.)

A paragraph welcoming J. Robinson's protest (in *Television*, Oct.) against the small band (max.

breadth 9,000 cycles) at present allocated to these branches of Radio, and calling upon workers and those interested in radio-optics to combine to improve the methods used and to increase the facilities afforded for its development.

THE KERR ELECTROSTATIC EFFECT.—E. F. Kingsbury. (Supplement to *Journ. Opt. Soc. Am.*, October, 1929, Vol. 19, No. 4, Part 2, p. 7.)

Abstract only. Curves are shown of the variation of the light transmission through the analyser as the voltage is applied, for the various polariser angles, and the result of replacing a monochromatic light by white light is discussed. Experimental data are compared with the calculated curves. As the system is ordinarily set, the transmission is proportional to the square of the sine of the product of a constant and the electric field squared. A better "fit" is obtained to the experimental data if the exponent to the sine is made greater than 2.0.

For use in telephotography, the light transmission characteristic has a restricted exposure range, and also considerable curvature at the lower values—necessitating an adjustment of the minimum exposure on a flat portion of the characteristic, and the inclusion of a non-linear section within the operating range. It is important to use nitrobenzol of low electrical conductivity. Nitrobenzol strongly absorbs ultraviolet and blue light up to about 4,400 A.U., which decreases its photographic efficiency.

ELECTRIC DOUBLE REFRACTION IN LIQUIDS (KERR EFFECT).—C. R. Larkin. (Supplement to *Journ. Opt. Soc. Am.*, October, 1929, Vol. 19, No. 4, Part 2, p. 7.)

Abstract only of a paper on a modified repetition of Pauthenier's 1920 work. "In each case so far studied . . . the light whose electric vector is parallel to the field is retarded, while the light whose electric vector is perpendicular to the field is advanced, their ratio being  $-2$  (within the limit of error of the observations) which agrees with theoretical considerations."

PHOTOELECTRIC EFFECT OF ALUMINIUM AND ITS AMALGAM.—A. Smits and H. Gerding. (*Physik. Zeitschr.*, 15th May, 1929, Vol. 30, pp. 322-325.)

The addition of small amounts of mercury to aluminium alters the photoelectric threshold and increases the photoelectric current four or five times.

KERR EFFECT IN THE VISCOUS HIGHER ALCOHOLS FOR A RADIO-FREQUENCY FIELD.—S. C. Sircar. (*Indian Journ. Phys.*, March, 1929, Vol. 3, pp. 409-424.)

A special kind of restoration of light between crossed Nicols quite different from the usual Kerr effect, is described. This is most conspicuous in the region of frequencies where there is a strong electric absorption: at such frequencies the liquid becomes translucent. The Kerr effect in undecyl alcohol is too small to be observed for a frequency

corresponding to 114 cm. wavelength: from this the writer deduces a time of relaxation in the Kerr effect, between  $10^{-8}$  to  $10^{-9}$  sec. for this particular liquid.

LICHTELEKTRISCHE UNTERSUCHUNGEN AN FESTEN DIELEKTRIKEN (Photoelectric Investigations on Solid Dielectrics).—P. Tartatowsky. (*Zeitschr. f. Phys.*, 1st Nov., 1929, Vol. 58, No. 5/6, pp. 394-401.)

Surface charges were produced, by electron bombardment, on crystals of rock-salt, mica and sulphur. The effect of light in dissipating these charges was studied, and the long wave limits found. A negative result for diamond confirmed the previous idea that with this crystal the electrons penetrate and do not form any appreciable surface charge. The tests lead to a determination, by the photoelectric effect, of that part of the total extraction-energy which deals with the removal of the electron away from the surface.

RÉCENTES APPLICATIONS DES CELLULES PHOTO-ÉLECTRIQUES ASSOCIÉES AUX AMPLIFICATEURS (Recent Applications of Photoelectric Cells Associated with Amplifiers).—P. Toulon. (*L'Onde Élec.*, July and Aug., 1929, Vol. 8, pp. 315-322 and 362-372.)

The first instalment deals with no definite applications but with considerations relating to various parts of the technique: I. The cutting-up of the light ray: the choice of frequency for this cutting-up: for feeble illumination, as in stellar photometry or in the use of a very dispersive and very absorbent spectroscope, a frequency of one per sec. may be very advantageous; resistance-capacity amplification is here desirable, with capacities of several microfarads: for most commercial applications musical frequencies are convenient, with transformer-coupled amplifiers ("since with this coupling the stage amplification is determined by the ratio of the powers furnished by the plates and passed on to the grids, whereas resistance-capacity coupling only gives an amplification in volts"): for very rapid phenomena—e.g., television—frequencies of  $10^5$  or  $10^6$  p.s. are needed; here the resistance-capacity coupling comes to the fore again, since with transformers it is difficult to avoid resonances which seriously slow up the speed of reaction by introducing parasitic effects.

II. The choice of accelerating potential for the cell. With low-pressure argon in the cell, the potential must be chosen to suit the quantity of light and the frequency used. For the low frequencies and weak illumination referred to in (I), the potential may be a few volts or tenths of a volt below the disruptive potential; the full benefits are thus obtained from the presence of ionisable gas—the advantage may amount to 100 times or more. For musical frequencies, on the other hand, it is desirable to keep 10 v. or more below the disruptive voltage to avoid irregularities or reduction of sensitivity. For high frequencies the accelerating potential must be small—say, 40 v.; the gain obtained from the presence of the gas is then only 3 or 4. "The use of vacuum cells seems to avoid these inconveniences and imposes itself for high frequencies. With feeble illumina-

tion it is prudent, even for [low?] frequencies, to reduce the accelerating potential considerably in order to avoid the *soufflement* which results from the flocculation of the electrified charges and which increases greatly with it."

III. Defects in insulation between cathode and anode play a serious part in cases of weak illumination and low frequencies (or in the extreme case of continuous current). Guard rings or the use of quartz containers are here very useful. For musical and still more for high frequencies, the cathode-anode capacity, and not the insulation, is the important factor, and must be reduced as much as possible—hence the use of a single wire for the anode.

IV. Precautions necessary in the design of the amplifiers. The matter is easy enough, when a 16 c.p. lamp is used, 50 cm. from the cell, but becomes very different with weak sources of light, etc. All kinds of parasitic and other troubles come in, and very complete screening, of the whole amplifier and of each stage, is more essential here than in any other wireless technique. If a loud-speaker is used, acoustic reaction must be guarded against very carefully.

The final part deals with various applications, such as for the judging of horse-races; the "Phonoluxmetre" (a photometric instrument working on a musical note) is treated with particular thoroughness.

THE PHOTO-IONISATION OF THE VAPORS OF CÆSIUM AND RUBIDIUM.—E. O. Lawrence and N. E. Edlesen. (*Phys. Review*, 15th July, 1929, Vol. 34, No. 2, pp. 233-242.)

THE CÆSIUM-MAGNESIUM PHOTOCELL.—V. Zworykin and E. D. Wilson. (*Journ. Opt. Soc. Am.*, Aug., 1929, Vol. 19, pp. 81-89.)

Authors' abstract:—"The values of the work functions of the alkali metals and their colour-sensitivity curves indicate definitely that caesium is the most favourable material for use in photocells.

"The practical difficulties of handling caesium metal have been overcome in the caesium magnesium cell, in which a freshly evaporated coating of magnesium not only binds an invisible layer of caesium to the walls of the cell, but also provides an electrical connection with the cathode terminal.

"Average colour-sensitivity curves are given for more than twenty cells. They show that the maximum sensitivity lies at about 4,850Å, as compared with 4,400Å for pure potassium, 5,390Å for pure caesium, and 5,560Å for the human eye.

"The photoelectric properties of the cell are detailed by means of response-voltage curves, response-illumination curves, and illumination limit curves. The maximum response for vacuum type cells is about 2 microamperes per lumen, and for gas-filled cells about 25 microamperes per lumen under normal operating conditions.

"Several commercial applications are described. Further development work is now in progress."

The writers mention that these cells have an indefinitely long life. Samples selected at random and operated at about 350 foot candles and at nearly saturation voltage have shown no appre-

ciable decrease in sensitivity over 10,000 hours. The dependence of current response upon temperature is practically zero.

**THE PHOTOELECTRIC THRESHOLD OF A DOUBLY-EVAPORATED FILM.**—R. B. Jones. (*Phys. Review*, 15th July, 1929, Vol. 34, No. 2, pp. 227-232.)

"The threshold of each double film is, therefore practically the threshold of the constituent which, when pure, has the longer wave-length threshold."

**ÜBER EINEN NEUEN LICHELEKTRISCHEN EFFEKT ON ALKALIZELLEN (A New Photoelectric Effect with Alkali Cells).**—E. Marx. (*Naturwiss.*, 11th October, 1929, Vol. 17, pp. 806-807.)

Under suitable conditions of light intensity and electrode-insulation, the charge-potential for illumination by light which is not monochromatic should (by Einstein's equation) depend simply on the shortest wavelength present in the beam. The writer, however, has allowed white light (from a carbon arc) to fall on a potassium cell in such a way that no light, either direct or reflected, can reach the anode; on introducing a filter passing the blue rays but absorbing the red, the charge-potential was increased. Thus the potential was diminished, by the presence of the longer waves, in comparison with the limiting potential corresponding to the shortest waves present. This diminishing effect was still more evident if the shortest waves were chosen in the region 370-470 $\mu$ . Other variations of the same effect are described.

### MEASUREMENTS AND STANDARDS.

**ÜBER DEN EINFLUSS DES INDUKTIV GEKOPPELTEN INDIKATORS AUF STEHENDE ELEKTRISCHE DRAHTWELLEN (The Effect of an Inductively-coupled Indicator on the Stationary Waves in Wires).**—W. Kessenich. (*Ann. der Phys.*, 26th July, 1929, Series 5, Vol. 2, No. 4, pp. 445-464.)

An investigation into the effect of the convenient inductively-coupled indicator-circuit (with thermoelement or crystal) used with a Lecher wire system. It is concluded that the asymmetry of the resonance curves, which remains even when the direct effect of the generating circuit is avoided, is due to a secondary field which propagates itself along the Lecher system and superposes itself on the standing waves. Further investigation as to the nature of this secondary field is required, but it can be got rid of by suitable coupling methods.

**EIN NEUARTIGE BRÜCKE FÜR DAS LECHER'SCHE PARALLELDRAHTSYSTEM (A New Form of Bridge for the Lecher Parallel Wire System).**—J. E. Scheel. (*Arch. f. Elektrot.*, 28th Sept., 1929, Vol. 22, No. 6, p. 632.)

At the end of the Lecher system nearest the transmitter the parallel wires are connected through a rectifier (crystal, thermopile, etc.). At the far end they are connected (through an impedance to prevent reflection, etc.) to the measuring instru-

ment. The special bridge is in the form of two thin highly conducting plates separated by a very thin layer of very good dielectric (*e.g.*, mica). Each plate is in contact with one only of the parallel wires. The bridge thus forms a practical short-circuit for the r.f. currents: for the rectified component it forms a barrier, so that the parallel wires act as leads for this component to the measuring instrument. The adjustment of the bridge is carried out from the far end of the system, where the observations are made.

**AN ABSOLUTE METHOD OF MEASURING HIGH-FREQUENCY CURRENTS.**—R. L. Smith-Rose; R. M. Wilmotte. (*Nature*, 26 Oct., 1929, Vol. 124, pp. 651-652.)

A description of Wilmotte's method of measuring high-frequency currents by the expansion of mercury through which the currents pass. The mercury, in a glass tube with thin walls, forms a straight conductor of circular section, and is surrounded by a concentric metal shield. The resistance of such a conductor can be accurately calculated at any frequency. The metal shield is in contact with ice to keep the cooling constants as steady as possible. The mercury column is in connection with a capillary tube, in which the rate of expansion of the mercury can be observed. Various precautionary details are mentioned. The first experimental model showed that it is possible to measure a d.c. of 10 amperes consistently to a few parts in a thousand. The variation in the calibration from day to day was found to be considerably less than 1 per cent., and it is probable that with a more suitably constructed instrument this variation could be reduced appreciably.

**SHORT WAVE SIGNAL STRENGTH MEASURING APPARATUS—II.**—T. L. Eckersley. (*Marconi Review*, September, 1929, pp. 9-17.)

In the May number of the *Review* the measuring set was described: the article concluded with an account of the methods used for calibrating such a set, and showed how the performance of the attenuator used can be checked against the mutual inductance by which the auxiliary calibrating signal is introduced into the aerial. The present paper describes the difficulties which arise when a "T" network is used as the attenuator, and how they may be overcome by very perfect shielding between input and output; it then deals with certain check tests and with the calculation of the voltage induced by the auxiliary oscillator.

**STATIC AND MOTIONAL IMPEDANCE OF A MAGNETO-RESTRICTION RESONATOR.**—E. H. Lange and J. A. Myers. (*Proc. Inst. Rad. Eng.*, Oct., 1929, Vol. 17, pp. 1687-1705.)

Authors' summary:—The equivalent series inductance and resistance of a long solenoid with nickel-steel bar has been investigated in relation to the excitation frequency for frequencies up to 14,000 cycles per second. Beyond 400 cycles per second, after which only a negligible flux penetrates to the centre of the bar, the inductance varies inversely with the square root of the fre-



quency, and the resistance directly with the square root of the frequency. The product of the resistance and inductance is substantially constant over the frequency range; also, the power factor angle of the bar is substantially constant. The field for the higher frequencies is shown to be confined largely to the circumference of the bar, at which zone the greater part of the magnetostrictive force is produced. The results are discussed in relation to the theory of flux distribution in the bar.

The effect of motion of the bar under the action of magnetostriction has been measured in terms of the motional impedance, and a circle diagram obtained. The ratio of motional resistance to reactance, in the vicinity of mechanical resonance of the bar, is of the order of magnitude of one to six thousand. The theory of total impedance, static and motional, is given, and the nature of the angular displacement of the resonant circle indicated.

Self-excitation by means of one 20A tube was found to be possible for the particular solenoid used in the measurements, by introducing in series with each half of the solenoid an air-core inductance to improve the low reactance-resistance ratio of the static impedance.

**PIEZOELECTRIC CRYSTALS FROM GRANULATED OR POWDERED MATERIAL.**—(German Patent 476506, Siemens and Halske, published 22nd May, 1929.)

Mixed with a fluid insulating material (shellac and artificial resin are named), the piezoelectric particles are oriented by an electric field in the presence of which the mass is allowed to solidify. Cf. Meissner, 1929 Abstracts, pp. 159-160 and 582.

**THERMIONIC RELAY FOR TEMPERATURE CONTROL.**—(*Electrician*, 1 Nov., 1929, Vol. 103, p. 541.)

A mains-driven, enclosed instrument for use with a mercury column or other form of thermostat. The reduction of the thermostat current to about 10 ma, allows a fine mercury column to be used, the surface remaining clear after prolonged use.

**EIN NEUES PENDEL MIT UNVERÄNDERLICHER SCHWINGUNGSZEIT (A New Pendulum with Constant Period).**—M. Schuler. (*Zeitschr. f. tech. Phys.*, October, 1929, Vol. 10, No. 9, pp. 392-395.)

The writer traces the inaccuracy of other pendulums (after the major disturbing causes have been removed, such as temperature and pressure variations) to change in length; for instance, if they are suspended by thin springs, these latter—after being bent millions of times—will stretch. He gives a curve showing the relation between period and distance between point of suspension and centre of gravity: as this distance decreases, the period decreases to a minimum but then increases: at the minimum of the curve lies the point where a given change of distance produces least effect on the period. Thus a pendulum built to conform

with this relation gives 0.02 sec. per day variation for a 1 mm. change of distance, as compared with 43 secs. given by an ordinary pendulum. In the new pendulum two weights, one above and one below the point of suspension, are so arranged that the radius of inertia is equal to half the length of the equivalent simple pendulum. The distance between the knife-edges on which it swings and the centre of gravity equals the radius of inertia. Clock-work errors are avoided by the absence of clock-work; the pendulum is driven electromagnetically, and synchronises a working-pendulum by photoelectric methods.

**EFFECT OF ATMOSPHERIC PRESSURE ON THE FREQUENCY OF A TUNING-FORK.**—Y. Namba. (*Nature*, 5th Oct., 1929, Vol. 124, p. 511.)

Results with a valve-maintained 1 kc./s. elinvar tuning-fork, over many months' use, suggested that the effect of atmospheric pressure could not be neglected for accurate purposes. A special test entirely confirms this: the fork does appreciable work in vibrating, and the air-loading varies the damping and hence the frequency. The test-curve is practically linear, the pressure-coefficient of frequency of the fork in air being

$$-(2.7 \pm 0.05) \times 10^{-7}$$

cycle per mm. of mercury increase of pressure.

**LA MESURE ABSOLUE DES FRÉQUENCES RADIO-ÉLECTRIQUES (The Absolute Measurement of Radioelectric Frequencies).**—B. Decaux. (*L'Onde Elec.*, Aug., 1929, Vol. 8, pp. 325-346.)

Author's summary:—The chief components of an installation for the absolute measurement of frequencies—the time-standard, standard oscillators for high and low frequencies—are linked together by multiplying and de-multiplying devices. The writer describes the principle of these instruments and the precautions necessary in their use. The second part gives brief descriptions of installations used in the U.S.A. and in Europe, particularly in France.

**PLATE CURRENT VARIATIONS AS A METHOD OF MEASURING FREQUENCIES AND DECREMENTS: OF STABILISING FREQUENCIES: A DOUBLE HETERODYNE METHOD OF MEASURING SMALL COUPLING COEFFICIENTS.**—J. T. Tykociner and R. W. Armstrong. (See under "Properties of Circuits.")

**NOTES ON STANDARD INDUCTANCES FOR WAVE-METERS AND OTHER RADIO FREQUENCY PURPOSES.**—W. H. F. Griffiths. (*E.W. & W.E.*, Oct., 1929, Vol. 6, pp. 543-549.)

Author's summary:—In this article are given methods of constructing inductances with a view to the elimination of sources of inconstancy of sub-standard wavemeter calibration which are attributable to these components of simple resonant circuits. Such sources of inconstancy have hitherto been unimportant but may now become appreciable owing to the reduction of other sources of inconstancy by recent improvements in variable condenser design.

In addition to inconsistency due to age, lack of robustness, and temperature-coefficient, that due to changes of self-capacity and effective resistance with variation of humidity is considered.

### SUBSIDIARY APPARATUS AND MATERIALS.

**HIGH VACUUM TECHNIQUE—EXPERIMENTAL STUDY OF EFFECT OF IONISATION ON PUMP SPEEDS.**—C. T. Knipp and P. C. Ludolph. (*Journ. Opt. Soc. Am.*, September, 1929, Vol. 19, pp. 152-157.)

The paper begins with illustrations and descriptions of umbrella and vertical nozzle types of mercury vacuum pumps developed by the writers; two of these are water-cooled externally, two (the most recent ones) internally. It then describes the surprisingly great effect on the speed of exhaustion produced by ionisation. For pressures of 0.1 mm. of mercury or more, the total change in speed produced by ionisation of the air being pumped was as much as 90 per cent. "The mechanism of the phenomenon is a little obscure." A possible suggestion is:—when the discharge is with the flow of air through the pump, i.e., when the electron flow is opposed to it, the pumping action is slowed down since the negative ions, under the action of the electric field and to some extent of bombardment, are flowing against the stream of air. The positive ions, being numerous only in the region in front of the cathode, have in comparison little effect, so that the net result is a slowing-down of the air stream. When the polarity is reversed a speeding-up of the air stream occurs.

**MINIATURE CONDENSATION PUMPS.**—K. C. D. Hickman. (*Suppl. to Journ. Opt. Soc. Am.* Oct., 1929, Vol. 19, No. 4, Part 2, p. 10.)

Abstract only. The utility of the Langmuir condensation pump has been limited by the necessity for water cooling and a liquid air trap. The miniature pump described, operating with n-dibutyl phthalate or butyl benzyl phthalate, will yield pressures as low as  $10^{-5}$  mm. without a trap, and pressures beyond measurement with the ionisation gauge when using a trap immersion in ice and salt. The pump is made so tiny that the heat losses are relatively great and water cooling is avoided.

**EINE HOCHVAKUUMPUMPE GROSSE LEISTUNG (A High Vacuum Pump of High Power).**—W. Gaede and W. H. Keesom. (*Zeitschr. f. Inst. Kunde*, No. 6, 1929, Vol. 49, pp. 298-300.)

With a pre-vacuum of 0.15 mm. mercury, exhausting-speeds of 130 and 422 litres per sec. are obtained for air and helium respectively.

**A NON-POROUS ALUMINIUM ALLOY FOR VACUUM CHAMBER CASTINGS.**—E. C. Nichols. (*Journ. Opt. Soc. Am.*, Sept., 1929, Vol. 19, pp. 164-165.)

Silicon aluminium (5 per cent silicon) is found to be remarkably non-porous, comparing favourably with glass. Particulars are given, and hints as to casting and machining.

**MOLECULAR AIR-PUMPS.**—E. N. da C. Andrade. (*Nature*, 26th Oct., 1929, Vol. 124, pp. 657-659.)

From a Royal Institution discourse.

**SELBSTTÄTIGE REGELUNG DES VAKUUMS VON KATHODENOSZILLOGRAPHEN (Automatic Vacuum Regulation in Cathode-ray Oscillographs).**—W. Rogowski, K. Beyerle and O. Wolff. (*Arch. f. Elektrot.*, 1st Aug., 1929, Vol. 22, No. 4/5, pp. 507-508.)

Changes from the optimum pressure are compensated for automatically by making the anode current (which is very sensitive to such changes) control the functioning of the air-pump. The oscillograph can be worked for hours on end without the pressure needing any attention.

**SYNCHRONOUS TIME-BASE FOR CATHODE-RAY OSCILLOGRAPHS, USING FORCED RELAXATION OSCILLATIONS.**—E. Hudc. (*See under "Properties of Circuits."*)

**THE MERCURY MENISCUS [AND THE USE OF LUBRICANTS TO PREVENT MERCURY—GLASS ADHESION].**—K. C. D. Hickman. (*Journ. Opt. Soc. Am.*, Oct., 1929, Vol. 19, No. 4, pp. 190-212.)

**GLASIERTE WIDERSTÄNDE (Glazed Wire-wound Resistances).**—(*E.T.Z.*, 17th Oct., 1929, Vol. 50, pp. 1528-1529.)

A new method of construction, which furnishes a "cushion" or a space between the wire and the glazing, allows these resistances to be loaded four times as heavily as an ordinary resistance of the same dimensions, while the life is increased.

**METAL ALLOY PATENTS.** (*Elektrot. u. Maschbau*, 15th and 22nd Sept., 1929, Vol. 47, pp. 820-821 and 838-839.)

Short summaries of various recent patents, in various countries, dealing with alloys of high electrical conductivity, special magnetic properties, high resistance, or powers of withstanding corrosion.

### STATIONS, DESIGN AND OPERATION.

**TRANSOCEANIC RADIO-TELEPHONY, SPAIN-S. AMERICA.**—(*Elec. Review*, 1st Nov., 1929, Vol. 105, pp. 752-753.)

Brief details of this recently inaugurated wireless link, which is the second largest area-to-area link in existence and by far the longest (6,400 miles as against 3,200 miles England-America).

"Special apparatus has been installed which alters the frequencies of the speech before transmission in such a way as to make the words entirely unintelligible when received by amateurs and other unauthorised listeners."

**COMMERCIAL SHORT WAVE WIRELESS COMMUNICATION.**—H. M. Dowsett. (*Electrician*, 11th Oct., 1929, Vol. 103, p. 429.)

Summary of a lecture at the annual convention of the Radio Society of Great Britain. The "Empiradio" services were dealt with first:

several types of projector aerial have been employed for commercial working in different parts of the world since the start of these services, but nowhere could be found "a concentration of beam radiation equal to that provided at an Empiradio station." Constancy of wavelength, too, is equal to that of the best of the crystal-controlled stations; this fact is attributed to the extreme care taken in the construction of the sets, and to the very complete monitoring system in use. This latter also ensures the reliability of the services, by keeping the central office advised as to the desirability of changing wavelength or route.

The long and short wave "Via Marconi" telegraph services were dealt with later. On 15 circuits these services transmit on seven long and ten short wavelengths, and the traffic from the corresponding 15 stations is received on about 39 long and 46 short wavelengths.

The speaker then dealt with the propagation of 15-100 m. waves. For all these wavelengths, signals fall off in strength up to 100 miles, but below 60 m. there is a recovery of strength with increase of distance, the extent of the recovery for daylight transmission being greater the shorter the wavelength; 15 m. waves, for instance, producing a strong signal at 9,000 to 10,000 miles. The angle of incidence at the ground of the down-going wave is given as about 15 deg.

In the *Marconi Review* for October, 1929, pp. 14-30, that part of the lecture dealing with the "Empiradio" services is reprinted in full. Among the diagrams are:—attenuation curves on various wavelengths and from various stations, for all daylight and all darkness transmission; and daily intensity curves of Capetown, Poona and Melbourne, for summer, winter and equinox.

**DAS FRANZÖSISCHE FUNKNETZ** (The French Wireless Network).—(*E.T.Z.*, 31st Oct., 1929, Vol. 50, pp. 1593-1594.)

**DEVELOPMENT OF BROADCASTING IN JAPAN.**—V. H. G. Parker. (*Elec. Communication*, October, 1929, Vol. 8, pp. 80-88.)

Mainly a description of the six new 10 kw. broadcasting stations distributed over the three chief islands of Japan. Additional small relay stations of 2-3 kw. are suggested in order to overcome the difficulties of distant reception owing to the mountainous nature of the country. Counterpoise systems were installed because of the high resistance of the soil, especially at Sapporo where the ground is frozen over for six months in the year; but tests at Sendai showed that under normal conditions the increased resistance of the earth system is more than counterbalanced by the loss in effective height due to the counterpoise.

**A SHORT WAVE PORTABLE MILITARY TRANSMITTER** (Type Z.S.A.3.).—(*Marconi Review*, Sept., 1929, pp. 22-25.)

Power is provided by a hand-driven generator giving 2 A. at 7 v. for filament-lighting and 65 mA. at 800 v. for anode supply. Working is on C.W. telegraphy on a spot wavelength of 30 m. No capacity other than that in the valve itself, is provided in the closed circuit: radiation is from a

half-wave aerial, the aerial circuit of the transmitter loading the whole aerial system to three-quarters of a wavelength. The D.E.T.I.S.W. oscillator valve has very small grid/anode capacity, these two electrodes being taken out at opposite ends of the valve.

**THE MARCONI ORGANISATION AT THE LONDON TERMINAL AIR PORT.**—J. M. Furnival. (*Marconi Review*, September, 1929, pp. 1-8.)

**BROADCASTING IN FRANCE: THE NEED FOR PROMPT ORGANISATION.**—(*L'Onde Élec.*, July, 1929, Vol. 8, pp. I, II, III and IV.)

An editorial on the needs of French broadcasting, and the action taken in other countries.

**ÜBER DIE KOHÄRENZLÄNGE DER ELEKTRONWELLEN** (The Coherence-Length of Electron Waves).—E. Rupp. (*Naturwiss.*, 8th Nov., 1929, Vol. 17, pp. 875-876.)

The writer applies the surface interference effects, obtained by Kikuchi by the passage of electrons through mica, to determine the coherence-length of the electron waves. A value of 50-60 is found—very small compared with that for light ( $10^7$ ).

**THE QUANTUM THEORY OF THE ABSORPTION OF LIGHT.**—J. Frenkel. (*Nature*, 16th Nov., 1929, Vol. 124, pp. 758-759.)

The writer applies Smekal's "double quantum switches" idea to the problem of absorption of light by conversion into heat. Results, though showing a small unexplained discrepancy, suggest that absorption of light is effected by atoms in intermediate states undergoing collisions of the second kind, with a temporary violation of the law of energy.

**PATHS OF CHARGED PARTICLES IN ELECTRIC AND MAGNETIC FIELDS.**—W. Bartky and A. J. Dempster. (*Phys. Review*, No. 6, 1929, Vol. 33, pp. 1019-1022.)

**THE MOTION OF A LORENTZ ELECTRON AS A WAVE PHENOMENON.**—A. M. Mosharrafa. (*Nature*, 9th Nov., 1929, Vol. 124, pp. 726-727.)

"I have been able to express the equation representing the uniform motion of the surface of a Lorentz electron in a form which strongly suggests that the 'parcel' or particle aspect of the phenomenon may be associated with the interference of two waves. . . ." The writer's investigation suggests that "our electrons would appear, from a ray of light, as rays of light; and a similar argument may show that our rays of light would appear as electrons."

**WIRKUNG EINES MAGNETFELDES AUF DIE DIELEKTRIZITÄTSKONSTANTE VON GASEN** (Effect of a Magnetic Field on the Dielectric Constant of Gases).—A. Pützer. (*Ann. der Phys.*, 30th October, 1929, Series 5, Vol. 3, No. 3, pp. 333-357.)

Gases tested were  $O_2$ ,  $H_2$ ,  $CO_2$  and  $N_2$ . A field of 8,000 gauss was used. No effect was found. Cf. Weigle: *Jejewski*, 1929 Abstracts, p. 401.



EFFECT OF GAMMA AND COSMIC RAYS ON THE CONDUCTANCE OF INSULATORS.—G. Guében. (*Ann. Soc. Sci. de Bruxelles*, April, 1929, Vol. 49, pp. 12-17.)

In an article on the technique of measuring penetrating radiations, the writer describes how the conductance of Ceresin increases to about 100 times its usual value after two or three hours' irradiation by gamma rays.

ÜBER EINE INTENSITÄTSBEEINFLUSSUNG DER BALMERSERIE IM KANALSTRAHL DURCH SCHWACHE MAGNETFELDER.—S. Levy and H. R. v. Traubenberg. (*Zeitschr. f. Phys.*, 29th July, 1929, Vol. 56, No. 7/8, pp. 435-440.)

AN ANALOGY FOR BEAMS OF PARTICLES OF A RECIPROCAL OPTICAL THEOREM DUE TO HELMHOLTZ.—R. H. Fowler. (*Proc. Cambridge Phil. Soc.*, April, 1929, Vol. 25, Part II, pp. 193-197.)

THE QUANTUM THEORY OF ELECTRONIC SCATTERING BY HELIUM.—N. F. Mott. (*Proc. Cambridge Phil. Soc.*, July, 1929, Vol. 25, pp. 304-309.)

POLARISATION VON MATERIEWELLEN (Polarisation of Material Waves).—A. Landé. (*Naturwiss.*, 9th August, 1929, Vol. 17, pp. 634-637.)

An investigation of the differences between optical and wave-mechanical polarisation, with the object of explaining the hitherto negative results of attempts to demonstrate the latter (*cf.* May Abstracts, p. 284, r-h column) and of pointing the way to positive results.

ENTWICKLUNG DER GRUNDLAGEN EINER STRENGEN THEORIE FÜR DIE DIFFUSION VON ELEKTROEN DURCH GASE (Development of the Basis of a Strict Theory for the Diffusion of Electrons through Gases).—H. Bartels. (*Zeitschr. f. Phys.*, 20th June, 1929, Vol. 55, No. 7/8, pp. 507-532.)

"A formal and exact treatment of the diffusion of slow electrons through the inert gases is given. The starting point is the far-reaching analogy developed in section I between electron diffusion and optical dispersion processes."

ÜBER DEN DURCHGANG VON KATHODENSTRAHLEN DURCH GITTERFÖRMIGE ELEKTRISCHE FELDER (The Passage of Cathode Rays through Grid-shaped Electrical Fields).—H. Bethe. (*Zeitschr. f. Phys.*, 11th May, 1929, Vol. 54, No. 9/10, pp. 703-710.)

A theory is developed which covers the experimental results of Hilsch and Pohl on the deflection of cathode rays of macroscopic electrical grid-fields (made by wires stretched at 0.40 mm. distance and alternately positively and negatively charged).

THE MOBILITY OF IONS IN GASES.—R. J. Van de Graaf. (*Nature*, 6th July, 1929, Vol. 124, pp. 10-11.)

Describes an improvement on the writer's method (*Abstracts*, 1928, Vol. 5, p. 525) and results

obtained. The improved apparatus has a high resolving power, and results show that—at least within narrow limits—"all the ions had the same mobility, which is 1.84 cm. per sec. as computed from the curve." The experiments were carried out in moist air at atmospheric pressure, the initial ionisation being obtained by the action of ultra-violet light on a zinc plate.

ZUR METHODE DER ABLENKUNG VON MOLEKULARSTRAHLEN (The Refraction of Molecular Beams).—I. I. Rabi. (*Zeitschr. f. Phys.*, 4th April, 1929, Vol. 54, No. 3/4, pp. 190-197.)

The full paper whose publication was foreshadowed in April Abstracts, p. 224.

EINE METHODE ZUR DIREKTEN MESSUNG DER INTENSITÄTSVERTEILUNG IN MOLEKULARSTRAHLEN (A Method of Direct Measurement of the Intensity Distribution in Molecular Beams).—J. B. Taylor. (*Zeitschr. f. Phys.*, 2nd Sept., 1929, Vol. 57, No. 3/4, pp. 242-248.)

A very accurate method based on Langmuir's statement that each alkali atom reaching a glowing tungsten filament gives up an electron and proceeds as a positive ion.

#### MISCELLANEOUS.

AUS DER GROSSEN DEUTSCHEN FUNKAUSSTELLUNG, 1929 (From the Great German Wireless Exhibition of 1929).—W. Burstyn. (*E.T.Z.*, 17th October, 1929, Vol. 50, pp. 1519-1522.)

RADIO INTERFERENCE FROM LINE INSULATORS.—Van Atta and White. (*Journ. Am.I.E.E.*, Sept. 1929. Summary in *Electrician*, 22nd Nov., 1929, p. 635.)

SOUND RECORDING ON STEEL TAPE AND WIRE.—Blattner Corporation. (*Electrician*, 18th Oct., 1929, Vol. 103, p. 472.)

A short article on Stille's system now being developed and brought up to date by the Blattner Picture Corporation at Elstree and the Telegraphie Patent Syndikat of Berlin. Records giving three hours' continuous reproduction have been made. Research in progress at the Stille Laboratories includes recording and reproduction of optical signs on steel tape, "as a substitute for television" (*cf.* *Thurm*, 1929 Abstracts, p. 335).

SOUND RECORDING ON STEEL WIRE AND TAPE.—Campbell Swinton, H. A. Hankey. (*Electrician*, 8th Nov. 1929, Vol. 103, p. 569.)

Both writers suggest that the method referred to above is only a revised version of Poulsen's "telegrafon."

METHOD OF ELECTRICAL PROSPECTING.—(French Patent 657367, Löwy, pub. 22nd May, 1929.)

The method depends on the measurement of two electrical quantities, one of which (natural frequency of an oscillator, angle of reflection, posi-

tion of an interference node or antinode) depends *only* on the distance of the conductive layer; whereas the other (*e.g.* decrement) depends on the nature of the material of the layer. The *depth* at which the layer lies is found by decreasing the power of the oscillator till the layer becomes out of range: the *nature* of the layer is deduced from the two quantities mentioned above, by means of an abac.

MEASUREMENT OF FILAMENT TEMPERATURE OF INCANDESCENT LAMPS (by Colour Matching by Photoelectric Methods).—C. H. Sharp. (*Suppl. to Journ. Opt. Soc. Am.*, Oct., 1929, Vol. 19, No. 4, Part 2, pp. 11-12.)

A PROPOSED METHOD OF LOCATING UNDERGROUND WATER AND SOME EXPERIMENTS THEREON.—B. F. J. Schonland. (Summary in *Nature*, 19th Oct., 1929, Vol. 124, p. 639.)

Experiments with a beam of 1.8 m. waves directed so as to strike the interface between dry earth or rock and underground water at an angle of 45 deg. Calculations for a 2 m. wave indicate that the reflected intensity should be about half the incident intensity. Interference between direct and reflected rays has been observed, suggesting a possible modification of the method.

FOG AND NIGHT LANDING OF AIRCRAFT.—W. Loth. (See under "Directional Wireless.")

L'ENREGISTREMENT DES OSCILLATIONS RAPIDES (The Recording of Rapid Oscillations)—H. Thoma. (*Génie Civil*, 12th October, 1929, Vol. 95, p. 369.)

Summary of an article in *Zeitschr. V.D.I.*, 11th May, 1929, on the Thoma modification of the ultramicroscope, dealt with in 1929 Abstracts, p. 590. A theoretical diagram is given.

RADIO-ECHO ALTIMETER.—E. F. W. Alexander-son. (*Automotive Industries*, 8th June, 1929, Vol. 60, p. 885.)

A short article on the altimeter referred to in 1929 Abstracts, pp. 168 and 286. The reporter states that it has been used successfully in actual flights. "When the ground is within 250 ft. a green light flashes on the cockpit panel; at 100 ft. a yellow light glows, and when the altitude is reduced to 50 ft. a red lamp lights." An oscillating receiver sends out waves which it receives again

alter reflection: every time the aeroplane changes altitude by half a wavelength the beat note goes through a complete cycle. "The echoes indicating height are periodic, becoming stronger as the plane approaches ground. The periodic character of the echo and the chance that the pilot would not see the instrument at the instant an echo was . . . recorded" is allowed for by a "memory-meter" which holds each altitude reading until a stronger echo, denoting a lower altitude, occurs.

SUBMARINE FINDER NOT YET "SURE FIRE."—(*Sci. News-Letter*, 2nd November, 1929, p. 271.)

"Rumours that the United States and other Powers are willing to abandon submarines because a sure means has been perfected for locating them under water, even when 'sleeping' on the bottom, seem to be without solid foundation. . . ."

OPTICAL TELEPHONY BY MEANS OF ULTRA-VIOLET OR INFRA-RED RAYS.—Q. Majorana. (Summary in *Nature*, 19th Oct., 1929, Vol. 124, p. 638.)

Reference to previous work was given in 1929 Abstracts, p. 115. By improved methods, using filtered infra-red light from a 500 Watt incandescent lamp, good telephony has now been obtained over ten kilometres. In the issue for 26th October, p. 674, another paper is briefly abstracted: laboratory tube experiments fail to reveal any sensible absorption of the radiant energy (ultra-violet or infra-red) when the tube is filled with either dry or wet air, provided that this is perfectly clear. Under certain cloudy conditions it appears that infra-red rays may be transmitted twice as far as ultra-violet rays.

COSMIC RAYS AND CANCER.—J. Joly. (*Nature*, 12th October, 1929, Vol. 124, p. 579.)

Referring to his suggestion (1929 Abstracts, p. 524) that change in the intensity of cosmic radiations might have influenced the incidence of malignant disease, the writer points out that since Millikan has found that at high altitudes the effective intensity of these rays is many times as great as at sea level, direct differential tests at high altitudes as to the progress of malignant disease, or as to its primary development, would throw light on a very obscure and important subject.