

**EVERYDAY**

**MARCH 1990**

# **ELECTRONICS**

**INCORPORATING ELECTRONICS MONTHLY**

**£1.40**

**FREE INSIDE!**

**MARCO**

**1990 SPRING  
CATALOGUE**

**BROADCAST  
RECEIVER**

**ELECTRONIC DICE**

**GETTING YOUR  
PROJECTS WORKING**

ISSN 0262-3617



9 770262 361003

**The Magazine for Electronic & Computer Projects**

A selection of products from our **BARGAIN LISTS**: Ring or write for a free copy of our latest list.



**COIN-OPERATED MECHANISM Z652**

Made by Coin Controls, this will accept various size coins by simple adjustment of 4 screws. Incorporates various security features - magnet, bent coin rejector, etc. Microswitch rated 5A 240V. Front panel 115 x 64, depth 130mm. Cost £10.85. Our price..... **£4.00**

**KEYBOARDS**



**Z8852 Keyboard:** Superb brand new keyboard 392 x 181 with LCD displaying 1 line of 10 characters and a further line with various symbols. 100 keys, inc. separate numeric keypad. Chips on board are 2 x 74HC05, 80C48. LCD + driver chips are easily removable from board. .... **£15.00**

**Z8857 High quality Alphanumeric keyboard** on aluminium frame 314 x 150mm. Contactless keys good for 20 million operations. Originally sold at over £100 each, they were used in a 'Printcom' portable terminal. Fully ASCII encoded output. Power supply +5V and -12V @ 35mA. Supplied with comprehensive data. .... **£14.95**

**Z8856 Cherry computer keyboard.** Very slim model 340 x 130 by only 14mm deep, including keys. Matrix output. 67 keys in pale/dark brown. .... **£4.00**

**Z8863 Keyboard.** High quality unit made by Micro Switch. 69 pale grey and blue keys. 6 red 5mm LED's, 15 various LS chips and socketed D8048 by Intel. Output via 7 way plug and there is a 4 way edge connector too. Keyboard frame is 317 x 128mm. PCB on which it's mounted is 285 x 170mm. Price..... Excellent value at **£12.00**

**TELEPHONE ANSWERING MACHINE**



**Z8874 Superb piece of German equipment.** This uncased model looks complete & is believed to be working. Size overall 305 x 163 x 57mm. On the PCB is a mains transformer (220V), relays & associated components. There are 2 mini-cassette decks, 6 position switch, Mic + amp circuit to record outgoing message. 2m mains lead with 2 pin plug, + a 6 core lead for connection to Telecom socket. Excellent quality & value. .... **£12.50**

**DISPLAYS**

**Z4243 Display panel** 152 x 112mm with NEC 8 digit display (Z1731); 8279-5, MC146818, 3 x uPA80C, & a couple of LS chips, crystal, etc. .... **£2.90**

**Z1731 NEC Vacuum Fluorescent Display FIP8BII.** 8 digit multiplexed output 10mm high. Heater voltage 2V, grid/anode voltage 24V. .... **£2.00**

**Z4115 8 digit 12.7mm high LCD and holder.** These are 14 segment devices allowing alphanumeric display. Normally costing over £15.00 we are offering these for just ..... **£4.50**

**Z4148 LCD as Z4115 but 6 digit, 50 pins.** Like RS 588-601. Their price 10.86. .... **£3.00**

**Z1732 Epson LCD 4 digit 8mm high.** .... **£2.00**

**Z1637 LCD Display - Direct drive 3 1/2 digit** similar to RS 588-572. 12.7mm high digits. Op voltage 4-12 RMS @ 32Hz typ. Supplied with data. .... **£2.00; 10+/£1.75; 25+ /£1.50; 100+ /£1.00**

**Z1560 7 seg display, 20mm high.** Common anode. .... Only 70p! 25+ /50p; 100+ /42p

**DL1416 Alphanumeric 4 character intelligent display 0.16"** ..... **£7.00**

**DL3416 4 digit intelligent alphanumeric display** with built-in drive and memory. ASCII ROM and multiplexing circuitry. TTL compatible inputs. +5V. Supplied with data. List price £41.50. .... **£8.00**

**1990 CATALOGUE**

128 PAGES OF ELECTRONIC COMPONENTS AND EQUIPMENT. HUGE RANGE! AMAZING VALUE! DON'T MISS OUT - GET YOUR COPY NOW - ONLY **£1.50 POST FREE!!!**

**HIGH QUALITY TEST EQUIPMENT**

**HITACHI OSCILLOSCOPES FOR QUALITY AND VALUE**



**VZ23 DC-20MHz, dual Channel, single time-base delayed sweep, DC offset, alternate magnifier, bin screen, 5mV/div vert. sensitivity 0.2µs/div-0.2s/div sweep time.** Complete with 2 probes, manual, mains lead. .... **£475**  
Other models from **£339** - full details in catalogue. Ask for colour brochure.

**METEX METERS**

8 different models in our catalogue I

- \* 4 1/2 digit 12mm LCD display
- \* 30 ranges incl 20A ac/dc
- \* Frequency counter
- \* Capacitance test with zero adjust
- \* Data hold switch
- \* Diode test
- \* Transistor test
- \* Continuity test
- \* Test leads with 4mm plugs
- \* Rugged yellow case
- \* Carrying case



M4650  
**£94.00**

Battery and instruction manual included.

AC volts 0-200m-2-20-200-750Vac ±0.5%  
DC volts 0-200m-2-20-200-1000Vdc ±0.5%  
AC current 0-2m-200m-20Aac ±1.0%  
DC current 0-200µ-2m-200m-20Adc ±0.5%  
Resist 0-200-2k-20k-200k-2M-20MΩ ±2.0%  
Capacitance 0-20p-200n-20µF ±2.0%  
Frequency 0-20k-200kHz ±2.0%  
Transistor hFE 0-1000 NPN/PNP  
Dims 176 x 90 x 36mm

**FREQUENCY COUNTER**



**FC5250 7 digit frequency counter** for frequencies between 10Hz and 150MHz. Power on/off, x1/x10 gate time and VHF/HF switches. Inputs via BNC sockets. Supplied complete with instruction manual and test lead. Requires an external 9Vdc nom 200mA power supply. Price..... **£65.00**

**DIGITAL CAPACITANCE METER**



**CM3300 High accuracy AUTORANGING 3 digit capacitance meter.** High resolution measurement in the range 0.1pF to 9990µF with 10 auto ranges. Range hold switch for batch testing capacitors. Range zero control. Inputs via spring terminals or test leads (supplied). Complete with leads and instruction manual. Price..... **£65.00**

**AF GENERATOR/COUNTER**



**AG2603AD A combined audio frequency signal generator and frequency counter.** A six character LED display allows direct reading of internally generated signal or signals from an external source. The frequency generator has a range of 10Hz to 1MHz with either square or sine waveforms and adjustable output level. The frequency counter has a range of 10Hz to 150MHz. Frequency range controlled by a 5-step selector and fine control. Adjustable output level with 0/20/40dB attenuator.

**AUDIO GENERATOR**

Frequency range..... 10Hz to 1MHz  
Output impedance..... 600Ω unbalanced  
Output control..... 0-20-40dB and fine adjuster  
Output control:  
Sine..... 8V rms max square  
..... 10V p-p max

**FREQUENCY COUNTER**

Frequency range..... 10Hz to 150MHz  
Input voltage..... Less than 50mV  
Max input voltage..... 3V  
Input impedance:  
High frequency..... 1MHz  
VHF..... 50Ω  
Power..... 240Vac 50Hz  
Dims..... 215 x 150 x 200mm  
Price..... **£175.00**

**RF GENERATOR/COUNTER**

Similar in appearance to above with same frequency counter. Spec:  
Frequency range..... 100kHz to 150MHz  
RF Output..... 100mV rms (up to 35MHz)  
Output control..... 0/20dB and fine adj.  
Modulation..... Internal 1kHz, external 50kHz-20kHz at less than 1V rms  
Price..... **£179.00**

**SIGNAL TRACER/INJECTOR**



**Y133 For fault finding on Audio & RF Equip, VU meter and speaker.** Level controls, 0-60dB atten. switch, I/P, O/P, ext spkr, and injector skts on Front panel. Size 200x140x96mm. Uses PP3. .... **£55.00**

**LCR BRIDGE**



**Y134C A fully transistorised AC bridge** which allows accurate measurement of resistances, capacitances, inductances and transformer turns ratios.  
Resistance range..... 0.1 to 11.1MΩ ±1%  
Inductance range..... 1µH to 111H ±2%  
Capacitance range..... 10pF to 1110µF ±1%  
Power..... 9Vdc (PP3 battery)  
Dims..... 200 x 138 x 90mm  
Price **£115.00**

**JUST ARRIVED**

Big parcel of FETS/MOSFETS inc. 2N7000 Series, IRF150/250, J Series, etc., etc., from 10p each! Ring or write for Price List.

**POWER SUPPLIES**

**(a) SWITCH MODE**



**ASTEC Model AA12531**  
I/P: 115/230V ac 50/60Hz. O/P: V1 + 5V 5A; V2 + 12V 0.15A. Size: 160 x 104 x 45mm. Partially enclosed panel with fixing holes in steel case on 120 x 125mm centres. Inputs and Outputs are on colour coded leads; there is also an EEC socket on a flying lead. .... **£6.95**



**Z660 Astec switched mode PSU**  
Type AA7271.  
This small PCB, Just 50 x 50mm will accept 8-24V input and give a stable 5V DC at up to 2A output. The 6 transistor circuit provides current overload protection, thermal cut-out and excellent filtering. Offered at the remarkably low price of just ..... **£5.00**

**(b) CONVENTIONAL**

**Z4215 Siliconix mains input, 4.5V DC 150mA** output to 3.5mm jack plug on 2m lead. Built-in continental 2-pin plug. Size 62 x 46 x 35mm ..... **£1.50**  
**Z4170 Plug In power supply.** Built in 13A plug. Output 6V DC 300mA on 2m long lead terminated in a 3mm power plug. British made to BS415 ..... **£1.50**  
**Z4208 Oric Power Supply.** Moulded plastic case with built in 13A plug. Output 9Vdc at 600mA delivered to 2m lead with 2.5mm power plug ..... **£3.50**

**FLASH GUN RETURNS**

(Lots more on latest Bargain List)

Hanimex electronic flash units that have been returned by the consumer to the place where purchased. These are offered complete & in good condition (many in original boxes) but have not been tested by us, so are offered without any guarantee. 4 models available, as listed:  
**Z4259 Type X140.** Hot shoe attachment. Size 75 x 60 x 25mm off/on switch & test button. Takes 2 x HP7. Originally sold at £7-£10. **£3.20**  
**Z4260 Type X215.** Similar to above. **£3.20**  
**Z4261 Type CX330.** Another with same features, + auto/manual switch, size 70 x 65 x 35mm. **£3.50**

**BREADBOARDS**

FREE, if requested, with every breadboard sold this month! K574 wire link pack with about 250 links for use with breadboard or PCB's!

**PROTOBLOC 1**  
**G708 Protobloc 1** has a total of 400 tie points consisting of two sets of 30 rows of 5 interconnected sockets plus 4 rows of interconnected sockets running alongside, suitable for use as power supply rails. All contact positions are clearly defined on an alphanumeric grid. ABS polymer board mounted on an adhesive foam base. Will accommodate up to three 16 pin devices. An ideal introduction to solderless circuit development systems. Size 80 x 60mm. .... **£2.50**

**PROTOBLOC 2**  
**G711 Protobloc 2** has a total of 840 tie points. Will accommodate up to seven 16 pin devices. Size 172 x 64mm. .... **£3.95**

**PROTOBLOC 2A**  
**G712 As above, but mounted onto a rigid base plate** complete with three 4mm terminals for power connections. A mounting bracket which clips into the base is also provided to accept a variety of components including switches and potentiometers, etc. Price..... **£6.95**

**PROJECT BOARD GL24**  
**G724 2 of type G711 mounted onto a rigid base plate** with 3 coloured terminals, for power connections. Overall size 225 x 150mm. Price..... **£13.95**

**PROJECT BOARD GL36**  
**G736 3 of type G711 and an additional strip** of 100 tie points mounted onto a rigid base plate with 4 coloured terminals. Overall size 242 x 195mm. Price..... **£19.95**



All prices include VAT; P&P £2.00 per order. Min Credit Card £5. No CWO min. Official Orders from Education welcome & min invoice charge £10.00. Our shop has enormous stocks of components and is open from 9-5.30 from Mon-Sat. Come and see us!  
**HOW TO CONTACT GREENWELD:** By Post: Use the address below: By Phone: (0703) 772501/783740 (ansaphone out of business hours); By Fax: (0703) 787555; By Email: MAG36026; By Telex: 94081101 GWELD  
Payment is accepted by cheque, postal order, cash inc. foreign currency bank notes/book tokens/Access/Visa/Connect.

443D MILLBROOK ROAD, SOUTHAMPTON, SO1 0HX.



# EVERYDAY ELECTRONICS

INCORPORATING ELECTRONICS MONTHLY



VOL 19 No 3 MARCH 1990

The Magazine for Electronic & Computer Projects

ISBN 0262-3617

PROJECTS ... THEORY ... NEWS ...  
COMMENT ... POPULAR FEATURES ...

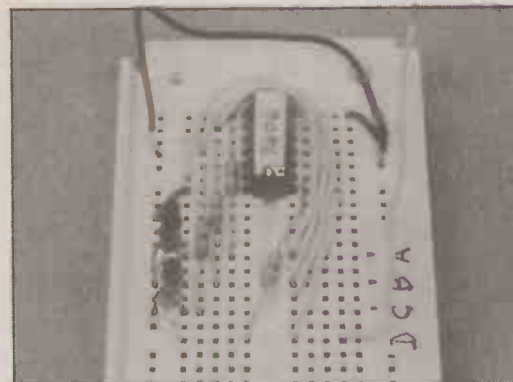
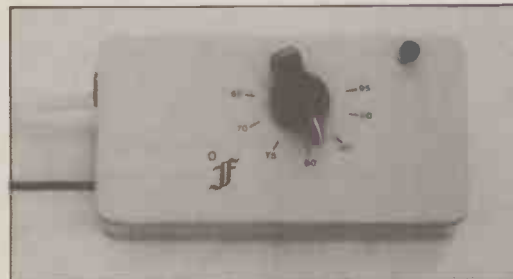
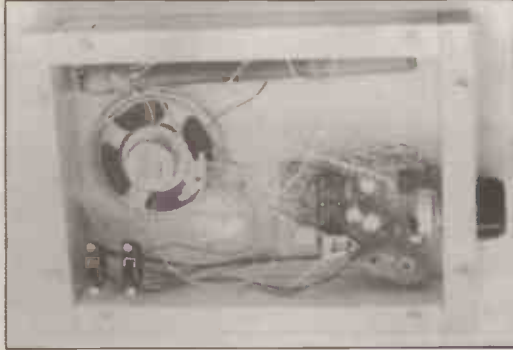

© Wimborne Publishing Ltd 1990. Copyright in all drawings, photographs and articles published in EVERYDAY ELECTRONICS is fully protected, and reproduced or imitations in whole or in part are expressly forbidden.

Our April '90 Issue will be published on Friday, 2 March 1990. See page 153 for details

Everyday Electronics, March 1990

## Projects

- SUPERHET BROADCAST RECEIVER** by Mark Stuart 160  
High tech i.c. design for m.w. and l.w. reception
- FERMOSTAT Mark 2** by Andy Flind 166  
An accurate thermometer with many applications
- ELECTRONIC DICE** by Chris Bowes 186  
A "pocket money" project which simulates the plastic cube!
- LINEAR SCALE OHMMETER** by T. R. de Vaux Balbirnie 192  
Easy to use piece of test gear
- EE WEATHER STATION** by Mike Feather 202  
Part 2: Temperature and Humidity sensing

## Series

- MICRO IN CONTROL — PART 4** by John Hughes 172  
Combinational logic
- AMATEUR RADIO** by Tony Smith G4FA1 184  
Communications Bibliography, Radio Shack, Dates
- ROBOT ROUNDUP** by Nigel Clark 196  
Investigating the world of robotics
- ACTUALLY DOING IT** by Robert Penfold 198  
Loudspeaker mounting, grilles and impedance
- BBC MICRO** by Robert Penfold 200  
Regular spot for Beeb Micro fanatics
- ON SPEC** by Mike Tooley 208  
The place for Spectrum and Sam micro owners

## Features

- EDITORIAL** 159
- MARKET PLACE** 169  
Free readers buy, sell and swop spot
- FOR YOUR ENTERTAINMENT** by Barry Fox 170  
ASA Loophole, CD Sales, Piracy, Head to Head, First Principles
- GETTING YOUR PROJECTS WORKING** Robert Penfold 178  
Don't be driven mad by projects that won't work!
- SHOP TALK** by David Barrington 209  
Product news and component buying for projects
- DOWN TO EARTH** by George Hylton 210  
Theory can be misleading!
- DIRECT BOOK SERVICE** 212  
Selected books by mail order
- PRINTED CIRCUIT BOARD SERVICE** 216
- ADVERTISERS INDEX** 220
- FREE** between pages 184 and 185  
**MARCO SPRING CATALOGUE**

Readers Service • Editorial and Advertisement Departments 159



### BAKERS DOZEN PACKS



All packs are £1 each. Note the figure on the extreme left of the pack ref number and the next figure is the quantity of items in the pack, finally a short description.

- BD2 5 13A spurs provide a fused outlet to a ring main where devices such as a clock must not be switched off.
  - BD9 2 6V 1A mains transformers upright mounting with fixing clamps.
  - BD11 1 6 1/2in speaker cabinet ideal for extensions, takes our speaker. Ref BD137.
  - BD13 12 30 watt reed switches, it's surprising what you can make with these—burglar alarms, secret switches, relay, etc., etc.
  - BD22 2 25 watt loudspeaker two unit crossovers.
  - BD30 2 Nicad constant current chargers adapt to charge almost any nicad battery.
  - BD32 2 Humidity switches, as the air becomes damper the membrane stretches and operates a microswitch.
  - BD42 5 13A rocker switch three tags so, on/off, or change over with centre off.
  - BD45 1 24hr time switch, ex-Electricity Board, automatically adjust for lengthening and shortening day, original cost £40 each.
  - BD49 5 Neon valves, with series resistor, these make good night lights.
  - BD56 1 Mini uniselector, one use is for an electric jigsaw puzzle, we give circuit diagram for this. One pulse into motor, moves switch through one pole.
  - BD67 1 Suck or blow operated pressure switch, or it can be operated by any low pressure variation such as water level in water tanks.
  - BD103A 1 6V 750mA power supply, nicely cased with mains input and 6V output leads.
  - BD120 2 Stripper boards, each contains a 400V 2A bridge rectifier and 14 other diodes and rectifiers as well as dozens of condensers, etc.
  - BD128 10 Very fine drills for pcb boards etc. Normal cost about 80p each.
  - BD132 2 Plastic boxes approx 3in cube with square hole through top so ideal for interrupted beam switch.
  - BD134 10 Motors for model aeroplanes, spin to start so needs no switch.
  - BD139 6 Microphone inserts—magnetic 400 ohm also act as speakers.
  - BD148 4 Reed relay kits, you get 16 reed switches and 4 coil sets with notes on making c/o relays and other gadgets.
  - BD149 6 Safety cover for 13A sockets—prevent those inquisitive little fingers getting nasty shocks.
  - BD180 6 Neon indicators in panel mounting holders with lens.
  - BD193 6 5 amp 3 pin flush mounting sockets make a low cost disco panel.
  - BD199 1 Mains solenoid, very powerful, has 1in pull or could push if modified.
  - BD201 8 Keyboard switches—made for computers but have many other applications.
  - BD211 1 Electric clock, mains operated, put this in a box and you need never be late.
  - BD221 5 12V alarms, make a noise about as loud as a car horn. Slightly soiled but OK.
  - BD242 2 Bin x 4in speakers, 4 ohm made from Radiomobile so very good quality.
  - BD252 1 Panostat, controls output of boiling ring from simmer up boil.
  - BD259 50 Leads with push-on 1/4in tags—a must for hook-ups—mains connections etc.
  - BD263 2 Oblong push switches for bell or chimes, these can mains up to 5 amps so could be foot switch if fitted into pattress.
  - BD268 1 Mini 1 watt amp for record player. Will also change speed of record player motor.
  - BD283 3 Mild steel boxes approx 3in x 3in x 1in deep—standard electrical.
  - BD305 1 Tubular dynamic mic with optional table rest.
  - BD400 4 Books, useful for beginners, describes amplifiers equipment and kit sets.
  - BD653 2 Miniature driver transformers. Ref. LT44. 20k to 1k centre tapped.
  - BD548 2 3.5V relays each with 2 pairs changeover contacts.
  - BD667 2 4.7 uF non-polarised block capacitors, pcb mounting.
- There are over 1,000 items in our Bakers Dozen List. If you want a complete copy please request this when ordering.
- TOASTERS** 2 slice toasters—may need slight attention. Only £3.00 each. Ref 3P84.
- PERSONAL STEREOS** Again customer returns but complete and with stereo head phones. A bargain at only £3.00 each. Our ref 3P83.
- MICROWAVE CONTROL PANEL** Mains operated, with touch switches. This unit has a 4 digit display with a built in clock and 2 relay outputs—one for power and one for pulsed power level. Could be used for all sorts of timer control applications. Only £6.00. Our ref 6P18.
- EQUIPMENT WALL MOUNT** It is a multi-adjustable metal bracket that could be used for mounting floor light, loudspeaker, TV camera, even a fan and on almost any sort of wall or ceiling even between wall and ceiling. The main fixing brackets rotate such that an inward or an outward corner can be accommodated. Front panel also tilts upward or downwards to a reasonable angle and can be easily removed separately for wiring. A very useful bracket. Regular price would be around £6 each. Our price only £3. Our ref 3P72. Or 2 for £5. Our ref 5P152.
- SUB-MIN TOGGLE SWITCH** Body size 8mm x 4mm x 7mm SBDT with chrome dolly fixing nuts. 3 for £1. Order ref BD649.
- COPPER CLAD PANEL** for making PCB. Size approx 12in long x 8 1/2in wide. Double-sided on fibreglass middle which is quite thick (about 1/16in) so this would support quite heavy components and could even form a chassis to hold a mains transformer, etc. Price £1 each. Our ref BD683.

### POWERFUL IONISER

Generates approx. 10 times more IONS than the ETI and similar circuits. Will refresh your home, office, workroom etc. Makes you feel better and work harder—a complete mains operated kit, case included. £12.50+£2 P&P. Our ref 12P51.

**REAL POWER AMPLIFIER** for your car, it has 150 watts output. Frequency response 20Hz to 20KHz and signal to noise ratio better than 60dB. Has built in short circuit protection and adjustable input level to suit your existing car stereo, so needs no pre-amp. Works into speakers ref. 30P7 described below. A real bargain at only £57.50. Order ref: 57P1.

**REAL POWER CAR SPEAKERS.** Stereo pair output 100W each. 4-Ohm impedance and consisting of 6 1/2" woofer, 2" mid range and 1" tweeter. Each set in a compact purpose built shelf mounting unit. Ideal to work with the amplifier described above. Price per pair £29.96. Order ref: 30P7.

**STEREO CAR SPEAKERS.** Not quite so powerful—70w per channel. 3" woofer, 2" mid range and 1" tweeter. Again, in a super purpose built shelf mounting unit. Price per pair: £27.95. Order ref: 28P1.

**VIDEO TAPES** These are three hour tapes of superior quality, made under licence from the famous JVC Company. Offered at only £3 each. Our ref 3P63. Or 5 for £11. Our ref 11P3. Or for the really big user 10 for £20. Our ref 20P20.



**ELECTRONIC SPACESHIP.** Sound and impact controlled, responds to claps and shouts and reverses when it hits anything. Kit with really detailed instructions. Ideal present for budding young electrician. A youngster should be able to assemble but you may have to help with the soldering of the components on the pcb. Complete kit £10. Our ref. 10P81

**12" HIGH RESOLUTION MONITOR** Amber screen, beautifully cased for free standing, needs only a 12V 1.5 amp supply. Technical data is on its way but we understand these are TTL input. Brand new in makers' cartons. Price: £22.00. Free delivery. Order ref: 25P10.

**14" COLOUR MONITOR** made by the American Display Tek Company. Uses high resolution tube made by the famous Japanese Toshiba company. Beautifully made unit intended for console mounting, but top and sides adequately covered by plated metal panels. Supplied with full technical spec. We have a limited number of these. All brand new still in makers' cartons. Price: £89 each plus £6 insured carriage. Order ref: 89P1.

**COMPOSITE VIDEO KITS** These convert composite video into separate H sync, V sync and video. Price £8.00. Our ref 8P39.

**BUSH RADIO MIDO SPEAKERS** Stereo pair. BASS reflex system, using a full range 4in driver of 40hms impedance. Mounted in very nicely made black fronted walnut finish cabinets. Cabinet size approx 8 1/2in wide, 14in high and 3 1/2in deep. Fitted with a good length of speaker flex and terminating with a normal audio plug. Price £5 the pair plus £1 post. Our ref 5P141.

**3 1/2in FLOPPY DRIVES** We still have two models in stock: Single sided, 80 track, by ChlNon. This is in the manufacturers metal case with leads and IDC connectors. Price £40, reference 40P1. Also a double sided, 80 track, by NEC. This is uncased. Price £59.50, reference 60P2. Both are brand new. Insured delivery £3 on each or both.

**10 MEMORY PUSHBUTTON TELEPHONES** These are customer returns and "sold as seen". They are complete and may need slight attention. Price £8.00. Ref. 6P16 or 2 for £10.00. Ref. 10P77. BT approved.

**REMOTE CONTROL FOR YOUR COMPUTER** With this outfit you can be as much as 20 feet away as you will have a joystick that can transmit and a receiver to plug into and operate your computer and TV. This is also just right if you want to use it with a big screen TV. The joystick has two fire buttons and is of a really superior quality, with four suction cups for additional control and one handed play. Price £15 for the radio controlled pair. Our ref 15P27.

**ASTEC PSU.** Mains operated switch mode, so very compact. Outputs +12v 2.5A, +5v 6A, ±5v 5A, ±12v 5A. Size: 7 1/2in long x 4 3/4 in wide x 2 1/4in high. Cased ready for use. Brand new. Normal price £30+, our price only £12.95. Order ref 13P2.

**VERY POWERFUL 12 VOLT MOTORS.** 1/2rd Horsepower. Made to drive the Sinclair C5 electric car but adaptable to power a go-kart, a mower, a rail car, model railway, etc. Brand new. Price £20 plus £2 postage. Our ref. 20P22.

**PHILIPS LASER**  
This is helium-neon and has a power rating of 2mW. Completely safe as long as you do not look directly into the beam when eye damage could result. Brand new, full spec. £30 plus £3 insured delivery. Our ref. 30P1.  
Mains operated power supply for this tube gives 8kv striking and 1.25kv at 5mA running. Complete kit with case £15. As above for 12V battery. Also £15. Our ref 15P22.

**GEIGER COUNTER KIT** Includes PCB, loudspeaker, and all components to build a 9v battery operated geiger counter. Only £39. Our ref 39P1

**12V TO 220V INVERTER KIT** This kit will convert 12V DC to 220V AC It will supply up to 130 watts by using a larger transformer. As supplied it will handle about 15 watts. Price is £12. Our ref 12P17.

**FULL RANGE OF COMPONENTS** at very keen prices are available from our associate company SCS COMPONENTS. You may already have their catalogue, if not request one and we will send it FOC with your goods.

**HIGH RESOLUTION MONITOR.** 9in black and white, used Philips tube M24306W. Made up in a lacquered frame and has open sides. Made for use with OPD computer but suitable for most others. Brand new. £16 plus £5 post. Our ref 16P1.

**12 VOLT BRUSHLESS FAN.** Japanese made. The popular square shape (4 1/2in x 4 1/2in x 1 3/4in). The electronically run fans not only consume very little current but also they do not cause interference as the brush type motors do. Ideal for cooling computers, etc., or for a caravan. £8 each. Our ref 8P26.

**MINI MONO AMP** on p.c.b. size 4" x 2" (app.)  
Fitted Volume control and a hole for a tone control should you require it. The amplifier has three transistors and we estimate the output to be 3W rms.  
More technical data will be included with the amp. Brand new, perfect condition, offered at the very low price of £1.15 each, or 13 for £12.00.



### J & N BULL ELECTRICAL

Dept. EE 250 PORTLAND ROAD, HOVE, BRIGHTON, SUSSEX BN3 5QT.  
MAIL ORDER TERMS: Cash, PO or cheque with order. Monthly account orders accepted from schools and public companies. Please add £2.50 postage to orders. Access and BCard orders accepted—minimum £5. Phone (0273) 734648 or 203500. Fax No. (0273) 23077.

### POPULAR ITEMS — MANY NEW THIS MONTH

**JOYSTICKS** for BBC Atari, Dragon Commodore, etc. All £5.00 each. All brand new, state which required.

**TELEPHONE TYPE KEYPAD.** Really first class rear mounting unit. White lettering on black buttons. Has conductive rubber contacts with soft click operation. Circuit arranged in telephone type array. Requires 70mm by 55mm cutout and has a 10 IDC connector. Price £2.00. Ref. 2P251.

**SUB-MIN PUSH SWITCHES** Not much bigger than a plastic transistor but double pole PCB mounting. 3 for £1.00. Our ref BD688.

**AA CELLS** Probably the most popular of the rechargeable NICAD types. 4 for £4.00. Our ref. 4P44.

**20 WATT 4 OHM SPEAKER** With built in tweeter. Really well made unit which has the power and the quality for hi-fi 6 1/2" dia. Price £5.00. Our ref. 5P155 or 10 for £40.00 ref. 40P7.

**MINI RADIO MODULE** Only 2in square with ferrite aerial and solid dia. tuner with own knob. It is superhet and operates from a PP3 battery and would drive a crystal headphone. Price £1.00. Our ref. BD716.

**BULGIN MAINS PLUG AND SOCKET** The old and faithful 3 pin with screw terminals. The plug is panel mounted and the socket is cable mounted. 2 pairs for £1.00 or 4 plugs or 4 sockets for £1.00. Our ref. BD715, BD715P, or BD715S.

**MICROPHONE** Low cost hand held dynamic microphone with on/off switch in handle. Lead terminates in 1.35mm and 1.25mm plug. Only £1.00. Our ref. BD711.

**MOSFETS FOR POWER AMPLIFIERS AND HIGH CURRENT DEVICES** 140v 100watt pair made by Hitachi. Ref. 2SK413 and its complement 2S118. Only £4.00 a pair. Our Ref. 4P42. Also available in H pack Ref. 2S199 and 2SK343 £4.00 a pair. Ref. 4P51.

**TIME AND TEMPERATURE LCD MODULE** A 12 hour clock a Celsius and Fahrenheit thermometer a too hot alarm and a too cold alarm. Approx 50x20mm with 12.7mm digits. Requires 1AA battery and a few switches. Comes with full data and diagram. Price £6.00. Our ref. 6P12.

**REMOTE TEMPERATURE PROBE FOR ABOVE.** £3.00. Our ref. 3P60.

**A REAL AIR MOVER** Circular axial fan moves 205 cubic foot per min which is about twice as much as our standard 4 1/2" fans. Low noise mains operated 6 1/2" dia. brand new. Regular price over £30.00. Our price only £10.00. Our ref 10P71.

**600 WATT AIR OR LIQUID MAINS HEATER** Small coil heater made for heating air or liquids. Will not corrode, lasts for years. Coil size 3" x 2" mounted on a metal plate for easy fixing. 4" dia. Price £3.00. Ref. 3P78 or 4 for £10.00. Our ref. 10P76.

**EX-EQUIPMENT SWITCHED MODE POWER SUPPLIES** Various makes and specs but generally +5, +12v ideal bench supply. Only £8.00. Our ref. 8P36.

**ACORN DATA RECORDER** Made for the Electron or BBC computer but suitable for others. Includes mains adaptor, leads and book. £12.00. Ref. 12P15.

**PTFE COATED SILVER PLATED CABLE** 19 strands of .45mm copper will carry up to 30A and is virtually indestructible. Available in red or black. Regular price is over £120 per reel. Our price only £20.00 for 100m reel. Ref. 20P21 or 1 of each for £35.00. Ref. 35P2. Makes absolutely superb speaker cable!

**NEW PIR SENSORS** Infra red movement sensors will switch up to 500w mains. UK made, 12 month manufacturers warranty, 15-20m range with a 0-10min timer, adjustable wall bracket. Only £20.00. Ref. 20P24.

**mitsubishi 3 1/2" DISC DRIVES** Brand new drives, 1/2 height double sided, double density warranted. Our price £60.00. Ref. 60P5

**NON-MEMORY PUSHBUTTON TELEPHONES.** Same condition as 10 Memory with redial £3.00. Our ref. 3P79. BT approved.

**DEHUMIDIFIERS** Domestic mains powered dehumidifiers these are customer returns and sold as seen. Price £30.00. Our ref 30P9. Callers only please. Also working dehumidifiers at £99.00 each.

**SPECTRUM PRINTER INTERFACE** Add a centronics interface to your Spectrum complete with printer cable for only £4.00. Our ref. 4P52.

**SPECTRUM SOUND BOX** Add sound to your Spectrum with this device. Just plug in. Complete with speaker, volume control and nicely boxed. A snip at only £4.00. Our ref. 4P53.

**BBC JOYSTICK INTERFACE** Converts a BBC joystick port to an Atari type port. Price £2.00. Our ref. 2P261.

**TELEPHONE EXTENSION LEAD** 5m phone extension lead with plug on one end, socket on the other. White. Price £3.00. Our ref. 3P70 or 10 leads for only £19.00! Ref. 19P2.

**LCD DISPLAY** 4 1/2" digits supplied with connection data £3.00. Ref. 3P77 or 5 for £10. Ref. 10P78.

**CROSS OVER NETWORK** 8 Ohm 3 way for tweeter midrange and woofer nicely cased with connections marked. Only £2.00. Our ref. 2P255 or 10 for £15.00. Ref. 15P32.

**REVERSING LIGHT ALARM** Fits to car reversing light and sounds when reversing. Only £2.00. Our ref. 2P248.

**BASE STATION MICROPHONE** Top quality uni-directional electret condenser mic 600 Impedance sensitivity 16-18kHz — 68db built in chime complete with mic stand bracket. £15.00. Ref. 15P28.

**MICROPHONE STAND** Very heavy chromed mic stand, magnetic base 4" high. £3.00 if ordered with above mic. Our ref. 3P60.

**SOLAR POWERED NICAD CHARGER** 4 Nicad AA battery charger. Charges 4 batteries in 8 hours. Price £6.00. Our ref. 6P3.

**MAINS SOLDERING IRON** Price £3.00. Our ref. 3P65.

**SOLDERING IRON STAND** Price £3.00. Our ref. 3P66.

**PIR SENSORS** Suitable for alarm systems etc. Nicely boxed. Priced at only £10.00. Our ref. 10P79.

**SHARP PLOTTER PRINTER** New 4 colour printer originally intended for Sharp computers but may be adaptable for other machines. Complete with pens, paper etc. Price £16.00. Our ref. 16P3.

**CAR IONIZER KIT** Improve the air in your car, clears smoke and helps prevent fatigue. Case req. Price £12.00. Our ref. 12P8.

**NEW FM BUG KIT** New design with PCB embedded coil 9v operation. Priced at £5.00. Our ref. 5P158.

**NEW PANEL METERS** 50uA movement with three different scales that are brought into view with a lever. Price only £3.00. Ref. 3P81.

**STROBE LIGHTS** Fit a standard edison screw light fitting 240V 40/60/75/100W. Flash rate available in yellow, blue, green and red. Complete with socket. Price £10 each. Ref. 10P80 (state colour required).

**ELECTRONIC SPEED CONTROL KIT** Suitable for controlling our powerful 12v motors. Price £17.00. Ref. 17P3 (heatsink required).

**EXTENSION CABLE WITH A DIFFERENCE** It is flat on one side making it easy to fix and look tidy. 4 core, suitable for alarms, phones etc. Our price only £5.00 for 50m reel. Ref. 5P153.

**METAL PROJECT BOX** Ideal for battery charger, power supply etc. Sprayed grey size 8" x 4" x 4". Louvred for ventilation. Price £3.00. Ref. 3P75.



**No. 3 LIST BAKERS DOZEN PACKS**  
All packs are £1 each, if you order 12 then you are entitled to another free. Please state which one you want. Note the figure on the extreme left is the pack ref number and the next figures are the quantity of items in the pack, finally a short description.

- BD152 1 Gas or liquid shut off valve, clockwork dial, setting can be on for up to 12 hours.
- BD153 1 Same as BD152 but thermostatically operated.
- BD154 1 12v operated drip proof relay, ideal for outdoor or in-car operation.
- BD158 4 12 way 5 amp screw down polythene bodied connector strips. Used to be called choc blocks when made of Bakelite.
- BD159 2 12 way 25 amp connector blocks.
- BD160 1pr Plug together 12 way connector bolts, ideal for quick joints in leads.
- BD168 2 Component mounting tag strips each with 50 stand-up tags.
- BD169 4 Short wave air spaced trimmers 3-30pf. Screwdriver operated.
- BD170 4 Assorted neon type numeric tubes made by HIVAC.
- BD175 1 2 watt mains motor driving gearbox, final speed 200rpm
- BD177 5 12v Lilliput bulbs.
- BD178 3 Panel mounting slim line indicator lights with amber lens. These take Lilliput bulbs
- BD179 3 Oblong mains neon indicator lights, approx 1in x 1/2in.
- BD181 100 PVC grommets for insulation through 3/4th hole.
- BD182 1 25pf air spaced tuning capacitor, small hole fixing with 1/4in spindle.
- BD189 1 20 amp double pole switch on flush plate which fits standard 3x3 electrical box, illuminated when on.
- BD190 1 20 amp dp switch but surface mounting, oblong shape.
- BD191 6 Lamp holder adaptors which takes two pin plug, also supplied.
- BD193 6 5 amp 3 pin flush sockets brown.
- BD196 1 In flex simmerstat for electric blanket soldering iron, etc.
- BD197 2 Thermostats, spindle setting — adjustable range for ovens etc.
- BD199 1 Mains operated solenoid with plunger 1in travel.
- BD201 8 Computer keyboard switches with knobs. pcb or vero mounting.
- BD205 1 Very small 12v operated relay with one pair change-over contacts.
- BD211 1 Electric clock, mains driven, always right time — not cased.
- BD212 1 Mains transformer 230v primary and two 8v 1/2amp secondaries.
- BD213 2 5 core curly leads, tinsel wire for phones, etc.
- BD214 2 Sub-min toggle switches double pole double throw.
- BD215 4 Mini dpdt slides switches with chrome dolly instead of the usual plastic toggle.
- BD216 1 Stereo pre-amp Mullard EP9001.
- BD217 100 Standard wire ending push-ons for standard 1/4in tags.
- BD218 100 Ditto, but tight angled.
- BD219 100 Soldercon tags. With these you can make your own sockets for ICs etc.
- BD224 1 Battery operated motor made for 9v cassette players but speed controllable by lowering voltage.
- BD227 4 50k quad pots. Standard 1/4in spindle single hole fixing.
- BD228 1 Ice stat thermostat. Ideal for controlling water pipe anti-freeze coils.
- BD229 1 Instrument buzzer, variable low, medium or soft.
- BD233 2 Eagle educational kits. One makes chemical balance with weights and the other has electricals for experiments.
- BD236 1 Mains transformer with 9v 750mA secondary.
- BD237 1 Computer grade electrolytic 3150µf at 40v.
- BD243 2 Bx4 16 ohm loudspeakers permanent magnet, 5 watts.
- BD245 4 Standard size pots: 1/2 meg with dp switch.
- BD246 4 Standard size 1/2meg with 1/4in spindle and dp switch.
- BD248 1 A noise suppressor/mains filter.
- BD249 1 13A socket on plate with spur, fits normal electrical box.
- BD253 1 Open thermometer — bimetal type, reads 200-500 deg F.
- BD266 1 Mains transformer 9v 1/2A secondary split primary so ok also for 115v.
- BD267 1 Mains transformer 15v 1A secondary p.c.b. mounting.
- BD291 1 Ten turns 3 watt pot 1/4in spindle 100ohm.
- BD298 1 15 amp round pin plug.
- BD300 1 Mains solenoid with plunger compact type.
- BD301 10 Ceramic magnets Mullard 1inx 1/2 x 3/4.
- BD303 1 12 pole 3 way ceramic wave charge switch.
- BD310 2 Oven thermostats
- BD313 5 Sub miniature micro switches.
- BD316 1 Round pin kettle plug with moulded on lead.
- BD453 2 2 1/4in. 60ohm loudspeakers.
- BD454 2 2 1/4in. 80ohm loudspeakers.
- BD465 3 5A round pin plugs will fit item BD193.
- BD466 4 7 segment I.e.d. displays.

## CAR STARTER/CHARGER KIT

Flat Battery! Don't worry you will start your car in a few minutes with this unit — 250 watts transformer. 40A bridge rectifier with data £3 plus £3 post.



Ex-Electricity Board. Guaranteed 12 months.

## SOUND TO LIGHT UNIT

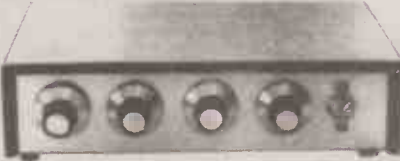

Complete kit of parts of a three channel sound to light unit controlling over 2000 watts of lighting use this at home if you wish but it is plenty rugged enough for disco work. The unit is housed in an attractive two tone metal case and has controls for each channel, and a master on/off. The audio input and outputs are by 1/4in sockets and three panel mounting fuse holders provide thyristor protection. A four pin plug and socket facilitate ease of connecting lamps. Special price is £16

## 12v MOTOR BY SMITHS

Made for use in cars, etc, these are very powerful and easily reversible. All 3in dia. They have a good length of spindle — 1/2"hp £4 1/4"hp £6

## 25A ELECTRICAL PROGRAMMER

Learn in your sleep. Have radio playing and kettle boiling as you wake — switch on lights to ward off intruders — have a warm house to come home to. You can do all these and more. By a famous maker with 25 amp on/off switch. A beautiful unit at £250

## PRINTER PLOTTER

prints on plain paper in four selectable colours, made by the famous Jap SHARP company for use with their PC MZ700/800, but with a simple interface details of which we expect to have shortly. This will in all probability work with your computer. We have to clear a store room so you can have this at only a fraction of its proper price, brand new with leads and makers instruction data, yours for only £16, but act quickly or you may miss the super bargain order ref is 16P3.

**DISC DRIVE** Double sided 2.8in cased and complete. Price £15. Our ref 15P35. extra discs available at £3.50 each. Our ref 3P50/2.

**DATA RECORDER** MZ800. Only £10.00 each. Our ref 10P84.

**RE-CHARGEABLE NICADS 'D' SIZE 4 AMP** These are tagged for easy joining together but tags being spot welded, are easy to remove. Virtually unused, tested and guaranteed £2.00 Our ref 2P141 or 6 wired together for £10.00 Our ref 10P47.

**RECORD PLAYER DEC BRS,** 12 volt operated, belt driven within 11in turntable, stereo cartridge. Will play 7in-10in or 12in individually at either 45rpm or 33rpm. Fitted speed selector and pick-up cueing lever. Price £12 plus £3 postage. Our ref 12P4.

**TORROIDAL MAINS TRANSFORMER** with twin outputs, 6.3v 2A and 12v 600mA, so ideal for FDD power supply. Price £5. Our ref 5P122.

**DOUBLE MICRO CASSETTE DECK** made by the Japanese ABS company. This takes two micro cassettes and is complete with motors solenoids to select the deck to use and record and playback heads. Price £10. Our ref 10P49.

**PAPST AXIAL FAN**—Manufacturers Ref No. TYP4580N. This is mains operated, 15 watt rating and in a metal frame with metal blades so OK in high temperatures. Body size approx 4 1/4in square x 1 1/2in thick. £6.00 each, plus £1.00 postage. Our ref 6P6.

**VERY POWERFUL MAGNETS.** Although only less than 1in long and not much thicker than a pencil, these are very difficult to pull apart. Could be used to operate embedded reed switches etc. Price 80p each, 2 for £1.00. Our ref BD642.



**MUSIC FROM YOUR SPECTRUM 128** We offer the Organ Master three octave keyboard, complete with leads and the interface which plugs into your 128. You can then compose, play, record, store, etc. your own music. Price £19 plus £3 special packing and postage. Our ref 19P1. Total price £22.

**20A DOUBLE POLE RELAY WITH 12V COIL** complete with mounting brackets, made by the Japanese Omron Company. Price £2 each. Our ref 2P173A.

**QUICK FIX MAINS CONNECTOR** A must for your workshop. Saves putting on plugs as you just push the wires under the spring clips. Automatically off when lid is up. Price £7.50. Our ref 7P5/1.

**BT HANDSET** with curly lead terminating with flat BT plug. Colour cream price £5. our ref 5P123.

**CAR SECURITY ALARM.** Protect your car against vandals and thieves. Our ultrasonic alarm on the back shelf of your car would sound off with a terrific noise if anyone opened the door, broke a quarter light or opened the boot. Complete equipment comprises the ultrasonic transmitter, receiver and siren housed in a very neat case, size 7in wide x 2 1/2in high x 4in deep, and its separate siren. The mains power supply which is included to operate the separate siren would not be required as the 12 volts could be obtained from the car battery. The price is £30. Our ref 30P5.

## POPULAR ITEMS

Some of the many items described in our current list which you will receive if you request it

**20V-0-20V** Mains transformers 2 1/2 amp (100 watt) loading, tapped primary, 200-245 upright mounting £4. Our ref 4P24.

**HIGH-VOLT CAPS.** Not ceramic, but the much more reliable foil type. Good range from 1nf to 35u at voltages 1kv to 2.5v. Keen prices, good quality discounts. Request list.

**BATTERY OPERATED TRAVEL MECHANISM** On a plastic panel measuring approx 9in x 3 1/2in, is driven by a reversible 12v battery motor, fitted with pulley and belt which rotates a threaded rod and causes a platform to travel backwards and forwards through a distance of approx 5in. Price £5. Our ref 5P140.

**MAINS OPERATED WATER VALVE** with hose connection for inlet and outlet suitable for low pressure. Auto plant watering, etc. Only £1 each. Our ref BD370.

**20 VOLT 4AMP MAINS TRANSFORMER** Upright mounting with fixing feet price £3. Our ref 3P59.

**12VOLT SOLENOID.** Has good 1/4in pull or could be made to push if fitted with a rod. Approx. 1 1/2in long by 1in square. Price £1. Our ref BD232A.

**160HM PM SPEAKERS.** Approx 7in x 4in. 5 watts. Offered at a very low price so you can use two in parallel to give you 10 watts at 8 ohms. £1. for the two. Our ref BD684.

**EHT TRANSFORMER** 4kv 2mA Ex-unused equipment £5. Our ref 5P139.

**VERY USEFUL MAGNETS.** Flat, about 1in long, 1/4in wide and 1/16in thick very powerful 6 for £1. Our ref BD247(a).

**CLEAR LAQUER.** Quick drying for the protection of transfers, markings, maps, etc. Also protects wood and metal. Exceptionally clear. Large can for £1. Our ref BD660.

**CASE WITH 13A PRONGS.** To go into 13A socket, nice size and suitable for plenty of projects such as battery trickle charger, speed controller, time switch, night light, noise suppressor, dimmers etc. Price 2 for £1. Our ref BD565.

**ALPHA-NUMERIC KEYBOARD.** This keyboard has 73 keys giving trouble free life and no contact bounce. The keys are arranged in two groups, the main area is a QWERTY array and on the right is a 15 key number pad, board size is approx. 13in x 4in. Brand new but offered at only a fraction of its cost. namely £3. plus £1 post. Our ref 3P27.

**4-CORE FLEX CABLE.** Cores separately insulated and grey PVC covered overall. Each copper core size 7/0 2mm. Ideal for long telephone runs or similar applications even at mains voltage. 20 metres £2. Our ref 2P196 or 100 metres coil £8. Our ref 8P19.

**METAL PROJECT BOX.** Ideal for battery charger, power supply etc. sprayed grey, size 8in x 4 1/2in x 4in high, ends are louvred for ventilation other sides are flat and unframed, price £3. Our ref 3P75.

**CAPACITOR BARGAIN.** Axial ended — 4700µf at 25V. Jap made, Normally 50p each, but you will get 4 for £1. Our ref 613

**SINGLE SCREENED FLEX.** 7.02 copper conductors, pvc insulated then with copper screen, finally outer insulation, in fact quite normal screened flex 10m for £1. Our ref BD668

**3 CORE FLEX BARGAIN No. 1.** Core size 5mm so ideal for long extension leads carrying up to 5 amps or short leads up to 10 amps. 15m £2. Our ref 2P189.

**3 CORE FLEX BARGAIN No. 2.** Core size 1.25mm so ideal for long extension leads carrying up to 13 amps or short leads up to 25 amps. 10m £2. Our ref 2P190.

**DISPLAY 16 CHARACTER 2 LINE** As used in telephone answering and similar machines. Screen size 85mm x 36mm x 9.3mm. Alpha-numeric, dot matrix module with integral CMOS micro processor, LCD display. Made by the EPSON Company, reference 16027AR. Price £10. Our ref 10P50.

**SUPER 8mm CINE PROJECTOR.** 600ft film capacity, reel to reel loading and governor controlled projection speeds of 18 and 24 fps. Sound output 3.5 watts, complete with zoom lens, recording microphone and handbook. Price £39.50. Our ref 39P2.

**THERE IS GOING TO BE A BURIAL!** For several years now we have been offering mains operated clocks at only £1 each. These are cooker clocks which in addition to telling you the time would also switch things on and off at pre-set times. However, despite this silly price these have been very slow sellers and as we have still almost 10,000 of them in a store which we have to clear we are making one even siller final offer before burying them. You can have 16 brand new clocks still in original packing for only, £5. Our ref 5P151. Add £3 post if not collecting.

## AC CAPACITORS

In addition to those listed on page 3 of our Comprehensive List we now have:

5uf 450v Tubular, quite small, 2 1/4in long x 1 1/4in diameter	Price £2.	Ref 2P46
4uf 440v 4 1/2in long and the discharge resistor fitted externally	Price £1.	Ref 3D703
6uf 660v That is nearly 2000v DC. In oblong can 4 1/2in x 2 1/4in x 1 1/4in	Price £2.	Ref 2P47
12uf 660v. A big capacitor 5 1/2in long oblong can x 3 1/2in x 1 1/4in	Price £2.	Ref 2P244
14uf 400v Tubular 3 1/2in long x 1 1/4in diameter	Price £2.	Ref 2P445
20uf 440V Tubular can 2 1/2in diameter can x 3in	Price £2.	Ref 2P200
25uf 370v Tubular can 1 3/4in diameter x 6in long	Price £3.	Ref 3P67
35uf 370v Tubular can 2in diameter x 5in high, ideal for power factor correction	Price £3.	Ref 3P21

**EVERLASTING BATTERIES.** 3 volt lithium. These have a shelf life in excess of 5 years so are ideal for emergency circuits, fire alarms and similar, which must always be ready to operate but which require little maintenance. Price 4 for £1. Our ref BD558.

## AIR IONISERS

By means of points raised to a very high voltage, ionisers re-structure the air you breathe, turning ordinary air molecules into potent negative ions. The effects of breathing in these ions can be quite startling. Almost everybody reports that it makes them feel good, and there is now strong evidence that it can also improve your concentration, make you more healthy and alert, make you sleep better, and even raise your IQ.

### THE MISTRAL AIR IONISER

The ultimate air ioniser. The Mistral has variable ion drive, built-in ion counter and enough power to drive five multi-point emitters with ease. Its nine main drive stages, five secondary drives and four booster stages give an immense 15 billion ions per minute output – enough to fill the largest room in a matter of seconds.

The parts set contains everything you need to build the Mistral: components, PCB, case, emitter and full instructions. If you're keen to increase the output still further, there's an optional eight-point internal emitter set to give extra ionising capability, and an almost silent piezo-electric ion fan to drive the ions away from the emitter and into the room.

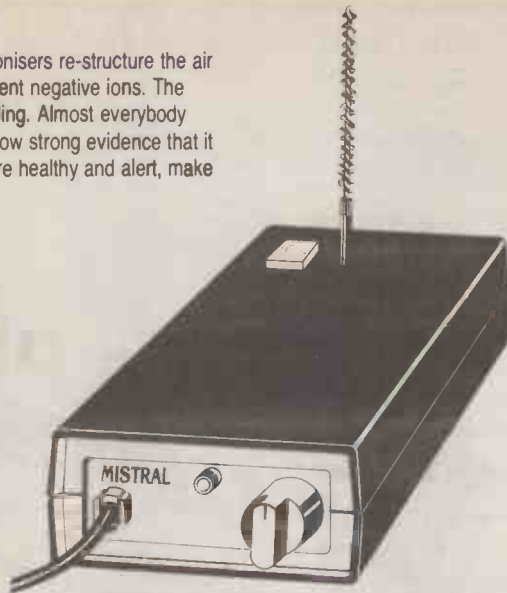

MISTRAL IONISER PARTS SET **£32.66**

INTERNAL EMITTER PARTS SET  
(optional) **£3.22**

ION FAN (optional) **£11.27**

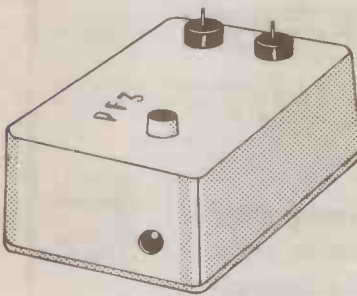

### PROPHET PF3

The Prophet performs its own special miracle on the dashboard of your car. First reports are most impressive: driving becomes a positive pleasure, easier to stay alert on long motorway journeys, a child cured of travel sickness. The ion effect is not to be underestimated. Don't forget the experiments either: there's the smoke trick, triffids, the living emitter, and more. The Prophet can be used anywhere with a supply of 9V to 12V DC, so don't restrict it to the car alone!

PROPHET PF3 PARTS SET **£21.39**

### THE Q-ION

Check out the ion levels around your house. The Q-Ion will measure the output of any ioniser, test the air to see where the ions are concentrating, help you set up fans and position your ioniser for best effect, and generally tell you anything you want to know about ion levels in the air. The readout is in the form of a bar graph which moves up and down as the Q-Ion sniffs the air in different parts of the room. Readings up to  $10^{10}$  ions per second, positive or negative.

Q-ION COMPLETE PARTS SET **£21.16**

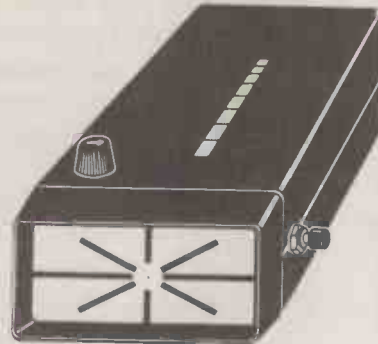

### KIRLIAN CAMERA

Bioplasmic fields, auras, or just plain corona discharge? No matter how you explain them, the effects are strange and spectacular. Can you really photograph the missing portion of a torn leaf? Can you really see energy radiating from your finger tips? Most researchers would answer 'yes' to both questions.

Our Kirlian photography set contains everything you need to turn the Mistral into a Kirlian camera, your bedroom or spare room into a darkroom, and to expose, develop and print Kirlian photographs (photographs made with high voltage electricity instead of light). The set includes exposure bed, safelight bulb, developing and fixing chemicals, trays, imaging paper and full instructions. A Mistral ioniser parts set is also required.

KIRLIAN-CAMERA SET **£19.78**

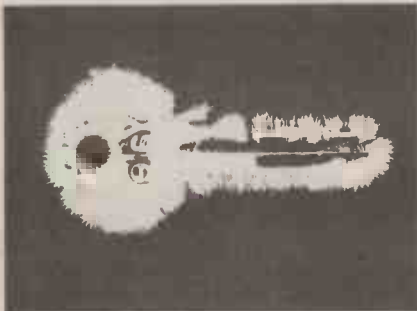

## IONISER EXPERIMENTS

### \* The Vanishing Smoke Trick

Light up a cigarette and gently puff smoke into a glass jar until the air inside is a thick, grey smog. Carefully invert the jar over the ioniser so that the emitter is inside. Within seconds the smoke will vanish! This is one of the best demonstrations of an ioniser's air cleaning action and with a large jar the effect is quite dramatic.

### \* Triffids

Connect a length of wire from the ioniser emitter to the soil in the pot of a houseplant. One with sharp, pointy leaves is best. Hold your hand close to the plant and the leaves will reach out to touch you! In the dark you may see a faint blue glow around the leaf tips – this works better with some plants than with others, so try several different types. The plants don't object to this treatment at all, by the way, and often seem to thrive on it.

### \* The Electric Handshake

Wear rubber soled shoes. Touch the ioniser emitter for a few seconds until your body is thoroughly charged up. When your hair stands on end, that's just about enough. Then give everyone you meet a jolly electric handshake. Just think, you could lose all your friends in a single evening! (A meaner trick still is to charge up a glass of water or a pint of beer. Even your family won't speak to you after that!)

Specialist  
SEMICONDUCTORS

Tel: (0600) 3715 LIMITED  
SALES DEPT., ROOM 111, FOUNDERS HOUSE, REDBROOK, MONMOUTH, GWENT.

#### ORDERING

All prices include VAT  
UK orders: please add £1.15 postage and packing.  
Eire and overseas: please deduct VAT and add  
£5.00 carriage and insurance.



#### ACCESS

Phone 0600 3715 for immediate  
attention to your Access order.

## ENLARGER TIMER/EXPOSURE METER

*A neat unit that avoids the need for test strips, controls the enlarger lamp and provides a 1Hz timing pulse for shading work.*



## FREE! GREENWELD 32 PAGE SPRING CATALOGUE SUPPLEMENT

*This catalogue supplement includes an offer of a free mains soldering iron with orders over £20. It contains extended ranges of Metex meters and disco equipment in addition to all the usual Greenweld goodies*

## DIGITAL EXPERIMENTERS UNIT

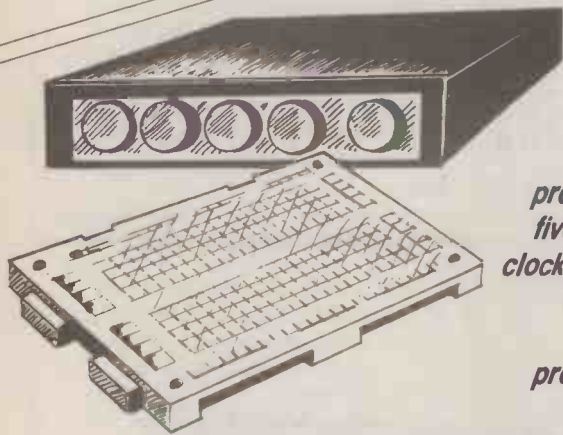

*The main requirements for building and testing most prototype digital circuits, apart from breadboards, are a five volt power supply and a pulse generator to provide clock signals. Ready made units which combine these two functions with a solderless breadboard assembly are available, but tend to be quite expensive. This unit provides a low cost home constructor alternative that is fairly basic, but offers a useful level of performance.*

## DIODE DATA

*A chapter from our new Everyday Electronics Data Book. It is an excellent reference for all types of diode, their characteristics, coding and specifications with hints and tips on using them and worked examples of relevant calculations. There are also sections on Zeners, Thyristors, Triacs and L.E.D.s. The only problem is that when you see how useful just one chapter is you will want the book.*

# EVERYDAY ELECTRONICS

APRIL ISSUE ON SALE FRIDAY MARCH 2 1990.

EVERYDAY  
ELECTRONICS

We deliver from stock - The fastest way to order is a fax !

### ULTRASONIC CAR ALARM



Complete Kit including case  
44.367BKL £ 30.40

This system is specially designed to protect your car and its contents against potential thieves. Low current consumption and high noise immunity are just two of its distinguishing features.

In addition the system has a voltage sensing device i.e. the alarm is also triggered if appliances are switched on by an unauthorised person (e.g. the interior lighting when the door is opened).

### SPM 130 Decibel Meter

(Elektor Electronics September 89)

Depending on their physical and mental state, human beings respond subjectively to ambient noise. Objective, absolute sound pressure level measurements therefore invariably require a specially designed test instrument, the decibel meter.

This portable instrument gives an accurate indication of the sound pressure level (SPL). The three SPL ranges (40 to 130 dB), three response modes,

and linear or A-weighted filtering provided by the meter enable many types of measurement to be carried out, from the tracing of ambient noise sources to establishing the sensitivity of a loudspeaker.

Complete kit 44.472BKL £ 99.50  
Ready assembled module 44.472F £ 160.50



### DIGITAL PROFESSIONAL ECHO 1000

(Elektor Electronics June 89)

This low cost echo unit is certain to impress music lovers - amateur and professional - everywhere. Excellent specification and top performance make the EU 1000 a winner and despite meeting professional requirements the unit will not make too big a hole in your pocket.

Working on the delta modulation principle on a digital base, delay times up to one second are possible at full bandwidth and large signal to noise ratio.

EU 1000, complete kit 44.255BKL £ 99.50  
EU 1000, ready assembled 44.255F £ 134.50



#### Specification

Input sensitivity:  
Input 1 : 2 mV  
Input 2 : 200 mV  
Delay Time:  
variable from 60 ms to 1 s  
Bandwidth :  
100 Hz to 12 kHz

#### Additional features:

- inputs mixable
- single and multiple echo
- adjustable delay level
- switchable vibrator
- switch-controlled noise suppression

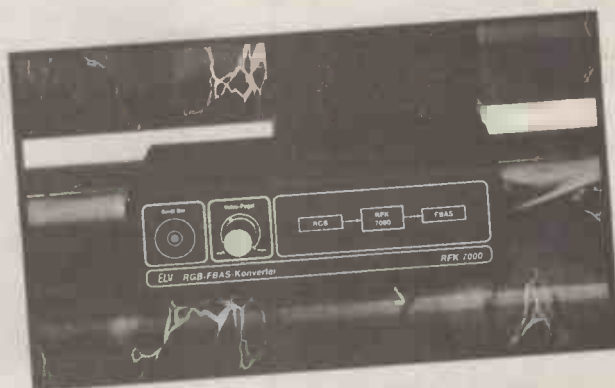

#### Ordering and payment:

- all prices excluding V.A.T. (French customers add 18.6%T.V.A.)
- send Euro-cheque, Bank Draft or Visa card number with order. Please add £ 3.00 for p & p (up to 2 kg total weight)
- postage charged at cost at heigher weight Air/Surface -
- we deliver worldwide except USA and Canada
- dealer inquiries welcome

### RFK 700 RGB-CVBS Converter

(Elektor Electronics October 89)

Nearly all computers supply as an output signal for colour monitors RGB signals. With the help of the RFK 7000 it is possible to record this signals with a videorecorder or to give them onto a

colour TV. The voltage supply is gained from a 12V/300mA-DC voltage mains adaptor.

Complete kit 44.525BKL £ 66.50

Ready assembled module 44.525F £ 119.50



We deliver from stock - The fastest way to order is a fax !

## S-VHS-RGB-CONVERTER SVR 7000

(Elektronik May 89)

Superb picture quality!

With the SVR 7000 video recorders and cameras of the new super VHS generation can be connected to colour TV sets which have a scart input socket, without adjusting the TV set itself. Connected between the S-VHS and TV, the SVR 7000 converts the separate luminance and chrominance signals of a super VHS into an equivalent, high-quality RGB signal.

Three controllers for contrast, colour and brightness optimise the picture quality even if input signals deviate from the norm.

A 4-pole mini-DIN input socket for the S-VHS picture signal, two BNC input sockets for left and right stereo-audio sound channels (only one BNC socket is required for mono) and a scart output socket are available to connect the unit. The voltage supply is gained from a 12V/300mA-DC voltage mains adaptor.



Complete Kit  
Ready Assembled Module

44.497BKL	£	76.25
44.497F	£	176.00

## VIDEO RECORDING AMPLIFIER

(Elektronik April 89)

Losses can easily occur when copying video tapes resulting in a distinct reduction in quality. By using this video recording amplifier, with no less than four (!) outputs, the modulation range is enlarged and the contrast range of the copy increases.

Two level controllers for edge definition (contour) and amplification (contrast range) allow individual and precise adaptation.



Complete Kit  
(including Box, PCB and all parts)  
44.324BKL £ 14.75

## MG 7000 MINI-FUNCTION GENERATOR



Complete Kit  
Ready Assembled Module

44.238BKL	£	62.15
44.238F	£	123.95

- Frequency Range: 0.2Hz to 200kHz
- Functions: Sine, Triangular, Saw-Tooth Square Wave
- Output Voltage: max. 10V - adjustable via attenuator
- Distortion Factor: approx. 0.5% (1kHz)
- Power Supply: via 2 x 9V block batteries

## GLP 7000 TRACKING TESTER

(Elektronik July/August 89)

Complete kit  
44.385BKL £ 49.80  
Ready assembled modul  
44.385F £ 119.50

Wow and Flutter Test Cassette  
Side A: 3150Hz - 10dB (DIN)  
Side B: white noise - 10dB for adjusting the sound head by ear  
44.385MK £ 11.00

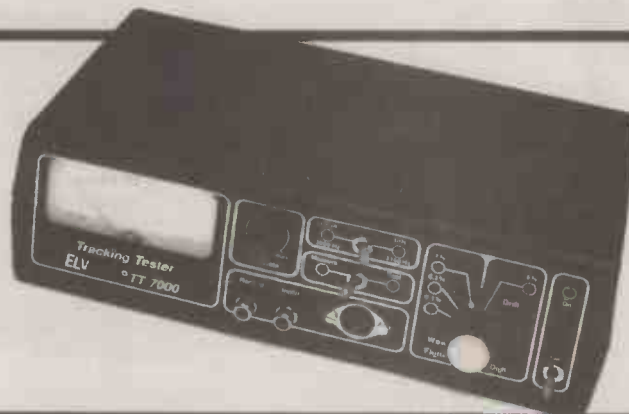

Good wow and flutter characteristics are a mark of quality in tape decks, reel-to-reel tape and VCRs. This tester not only allows you to take quick and exact measurements of wow and flutter, but also of drift.

- Here are the main features in brief:
- built-in, quartz-stabilised reference tone generator
  - switchable frequencies for wow and flutter measurements for DIN (3150Hz) and CCIR (3000Hz)
  - 1 additional range for drift measurements (+/-5%)

## IC TESTER FOR IBM-PC-XT/AT

With the ELV IC tester logic function tests can be carried out on nearly all CMOS and TTL standard components, accommodated in DIL packages up to 20 pin. The tester is designed as an insertion card for IBM-PC-XT/AT and compatibles. A small ZIF test socket PCB is connected via a flat band cable. Over 500 standard components can be tested using the accompanying comprehensive test software.

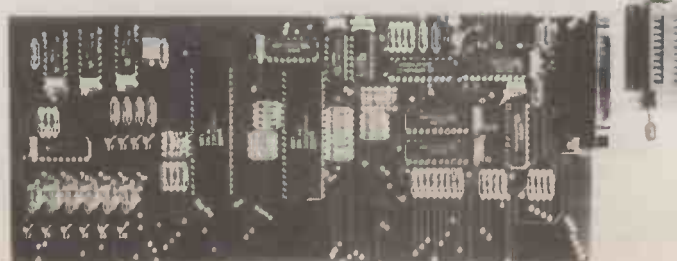

Complete Kit including Textool socket, connectors, sockets, Flat band cable, PCB, Software  
44.474BKL £ 60.85  
Ready Assembled Module  
GB474F £ 113.00  
Software, single  
44.474SW £ 17.85

# MAGENTA ELECTRONICS LTD

MAIL ORDER AND SHOP:  
EE86 135 Hunter Street,  
Burton-on-Trent,  
Staffs. DE14 2ST  
Tel: 0283 65435  
Fax: 0283 46932



All prices include VAT  
Shop open 9-5 Mon-Fri;  
9-2 Saturday  
Official orders welcome

Add £1  
p&p to  
all orders

## SUPERHET BROADCAST RECEIVER

EE MAR '90

At last, an easy to build SUPERHET A.M. radio kit. Covers Long and medium Wave bands. built in loudspeaker with 1 watt output. Excellent sensitivity and selectivity provided by ceramic I.F. filter. Simple alignment and tuning without special equipment. Kit available less case, or with pre-cut and drilled transparent plastic panels and dial for a striking see-through effect.

KIT REF 835

£15.99

## D.C. MOTOR GEARBOXES

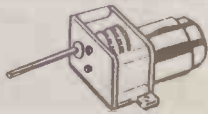

Ideal for Robots and Buggies. A miniature plastic reduction gearbox coupled with a 1.5-4.5 Volt mini motor. Variable gearbox reduction ratios are obtained by fitting from 1 to 6 gearwheels (supplied). Two types available:

**SMALL UNIT TYPE MGS £3.99**

Speed range 3-2200 rpm. Size 37x43x25mm

**LARGE UNIT TYPE MGL £4.55**

Speed range 2-1150 rpm. Size 57x43x29mm

Supplying Electronics  
for Education,  
Robotics, Music,  
Computing and much,  
much more!

Send NOW for our  
illustrated

**CATALOGUE**

Only £1.00!

## STEPPING MOTORS

A range of top quality stepping motors suitable for driving a wide range of mechanisms under computer control using simple interfacing techniques.

**ID35 PERMANENT MAGNET MOTOR — 48 steps per rev. £16.50**

**MD200 HYBRID MOTOR — 200 steps per rev. £16.80**

**MD35 ¼ PERMANENT MAGNET MOTOR — 48 steps per rev. £12.70**

**MD38 PERMANENT MAGNET MOTOR — 48 steps per rev. £8.95**

## MICRO IN CONTROL NEW SERIES STARTED EE DEC '89 STARTER KIT £21.95

ALL PARTS LISTED IN TABLE 1  
INCLUDING 5V 250mA SUPPLY  
AND K12 840 PIN BREADBOARD

## EDUCATIONAL BOOKS & BOOK PROJECTS

### ADVENTURES WITH ELECTRONICS

The classic Easy to Follow book suitable for all ages. Ideal for beginners. No soldering, uses an S-DEC breadboard. Gives clear instructions with lots of pictures. 16 projects — including three radios, siren, metronome, organ, intercom, timer, etc. Helps you learn about electronic components and how circuits work. Component pack includes an S-DEC breadboard and all the components for the series.

ADVENTURES WITH ELECTRONICS £4.75  
COMPONENT PACK (less book) £22.35

### FUN WITH ELECTRONICS

From the USBORNE Pocket Scientist series — An enjoyable introduction to electronics. Full of very clear full colour pictures accompanied by easy to follow text. Ideal for all beginners — children and adults. Only basic tools are needed. 64 full colour pages cover all aspects — soldering — fault finding — components (identification & how they work). Also full details of how to build 6 projects — burglar alarm, radio, game, etc. Requires soldering — 4 pages clearly show you how.

The components supplied in our pack allows all the projects to be built and kept. The book is available separately.  
FUN WITH ELECTRONICS Book £2.25  
COMPONENT PACK (less book) £17.55

### 30 SOLDERLESS BREADBOARD PROJECTS

A book of projects by R. A. Penfold covering a wide range of interests. All projects are built on a Verobloc breadboard. Full layout drawings and component identification diagrams enable the projects to be built by beginners. Each circuit can be dismantled and rebuilt several times using the same components. The component pack allows all projects in the book to be built one at a time.

Projects covered include amplifiers, light actuated switches, timers, metronome, touch switch, sound activated switch, moisture detector, M.W. Radio, Fuzz unit, etc.

**30 SOLDERLESS BREADBOARD PROJECTS Book 1 £2.95**  
**COMPONENT PACK £27.15**  
**VEROBLOC £7.49**

### ENJOYING ELECTRONICS

A more advanced book which introduces some arithmetic and calculations to electronic circuits. 48 chapters covering elements of electronics such as current, transistor switches, flip-flops, oscillators, charge, pulses, etc. An excellent follow-up to Teach-in or any other of our series. Extremely well explained by Owen Bishop who has written many excellent beginners' articles in numerous electronics magazines.

ENJOYING ELECTRONICS Book £3.60  
COMPONENT PACK £14.31  
VEROBLOC £7.49  
Note — A simple multimeter is needed to fully follow this book. The M102 BZ is ideal. £13.98

### A FIRST ELECTRONICS COURSE

A copiously illustrated book that explains the principles of electronics by relating them to everyday objects. At the end of each chapter a set of questions and word puzzles allow progress to be checked in an entertaining way. An S-DEC breadboard is used for this series — soldering is not required.

A FIRST ELECTRONICS COURSE BOOK £3.75  
PACK £22.35

## EVERYDAY ELECTRONICS KIT PROJECTS

ALL KITS HERE HAVE BEEN FEATURED IN EE. IF YOU DO NOT HAVE THE MAGAZINE WITH THE ORIGINAL ARTICLE, YOU WILL NEED TO ORDER THE REPRINT FOR 80p EXTRA. REPRINTS ALSO AVAILABLE SEPARATELY.  
KITS INCLUDE CASES, PCB'S, HARDWARE AND ALL COMPONENTS (UNLESS STATED OTHERWISE) CASES ARE NOT DRILLED, LABELS ARE NOT SUPPLIED.

Ref	Price	Ref	Price
835 SUPERHET BROADCAST RECEIVER Mar 90	£15.99	578 SPECTRUM I/O PORT less case Feb 87	£10.05
With drilled panels and dial	£12.99	569 CAR ALARM Dec 86	£13.24
Without above	£9.69	563 200MHz DIG. FREQUENCY METER Nov 86	£67.98
834 QUICK CAP TESTER Feb 90	£29.95	561 LIGHT RIDER LAPEL BADGE Oct 86	£10.86
833 EE 4 CHANNEL LIGHT CHASER Jan 90	£39.95	560 LIGHT RIDER DISCO VERSION	£20.89
815 EE TREASURE HUNTER Aug 89	£19.98	559 LIGHT RIDER 16 LED VERSION	£14.52
814 BAT DETECTOR Jun 89	£13.80	556 INFRA-RED BEAM ALARM Sept 86	£30.19
812 ULTRASONIC PET SCARER May 89	£22.71	544 TILT ALARM July 86	£8.33
807 MINI PSU Feb 89	£10.28	542 PERSONAL RADIO June 86	£12.28
806 CONTINUITY TESTER Feb 89	£31.93	528 PA AMPLIFIER May 86	£28.70
803 REACTION TIMER Dec 88	£28.72	523 STEREO REVERB Apr 86	£28.16
800 SPECTRUM EPROM PROGRAMMER Dec 88	£26.61	513 BBC MIDI INTERFACE Mar 86	£29.76
796 SEASHELL SYNTHESIZER Nov 88	£26.57	512 MAINS TESTER & FUSE FINDER Mar 86	£9.39
790 EPROM ERASER Oct 88	£7.44	497 MUSICAL DOOR BELL Jan 86	£19.95
786 UNIVERSAL NICAD CHARGER July 88	£16.35	493 DIGITAL CAPACITANCE METER Dec 85	£44.25
780 CABLE & PIPE LOCATOR April 88	£52.95	481 SOLDERING IRON CONTROLLER Oct 85	£5.83
769 VARIABLE 25V-2A BENCH POWER SUPPLY Feb 88	£14.53	464 STEPPER MOTOR INTERFACE FOR THE BBC	£8.95
763 AUDIO SIGNAL GENERATOR Dec 87	£22.31	COMPUTER less case Aug 85	£8.95
739 ACCENTED BEAT METRONOME Nov 87	£18.65	1D35 STEPPER MOTOR EXTRA	£5.47
740 ACOUSTIC PROBE Nov 87 (less bolt & probe)	£31.03	OPTIONAL POWER SUPPLY PARTS	£6.60
744 VIDEO CONTROLLER Oct 87	£18.29	461 CONTINUITY TESTER July 85	£8.05
734 AUTOMATIC PORCH LIGHT Oct 87	£15.24	455 ELECTRONIC DOORBELL June 85	£26.89
728 PERSONAL STEREO AMP Sept 87	£28.25	453 GRAPHIC EQUALISER June 85	£20.85
730 BURST-FIRE MAINS CONTROLLER Sept 87	£40.89	444 INSULATION TESTER Apr 85	£7.36
724 SUPER SOUND ADAPTOR Aug 87	£28.25	430 SPECTRUM AMPLIFIER Jan 85	£38.61
718 3 BAND 1.6-300MHz RADIO Aug 87	£28.17	392 BBC MICRO AUDIO STORAGE SCOPE INTERFACE	£5.89
719 BUCCANEER I.B. METAL DETECTOR inc. coils and case, less handle and hardware July 87	£71.43	Nov 84	£9.24
720 DIGITAL COUNTER/FREQ METER (10MHz) Inc. case July 87	£12.93	387 MAINS CABLE DETECTOR Oct 84	£14.00
722 FERMOSTAT July 87	£13.41	386 DRILL SPEED CONTROLLER Oct 84	£25.71
715 MINI DISCO LIGHT Jun 87	£16.54	362 VARICAP AM RADIO May 84	£6.05
707 EQUALIZER (IONISER) May 87	£37.97	337 BIOLOGICAL AMPLIFIER Jan 84	£6.06
700 ACTIVE I/R BURGLAR ALARM Mar 87	£8.94	263 BUZZ OFF Mar 83	£7.31
581 VIDEO GUARD Feb 87	£22.28	242 INTERCOM no case July 82	£18.78
584 SPECTRUM SPEECH SYNTH. (no case) Feb 87		240 EGG TIMER June 82	£10.03
		205 SUSTAIN UNIT Oct 81	£8.33
		108 IN SITU TRANSISTOR TESTER June 78	£6.67
		106 WEIRD SOUND EFFECTS GEN Mar 78	
		101 ELECTRONIC DICE Mar 77	

## INSULATION TESTER

EE APRIL 85



A reliable electronic tester which checks insulation resistance of wiring appliances etc., at 500 volts. The unit is battery powered simple and safe to operate. Leakage resistance of up to 100 Megohms can be read easily. One of our own designs and extremely popular.

KIT REF 444

£20.85

## PET SCARER

EE MAY 89

Produces high power ultrasound pulses. L.E.D. flashes to indicate power output and level. Battery powered (9V-12V or via Mains Adaptor).

KIT REF 812  
Mains Adaptor £1.98

£13.80

## DIGITAL FREQUENCY 200 MHz METER

EE NOV 86

An 8 digit meter reading from AF up to 200 MHz in two ranges. Large 0.5" Red LED display. Ideal for AF and RF measurements. Amateur and C.B. frequencies.

KIT REF 563

£62.98

## DIGITAL CAPACITANCE METER

EE DEC 85

Simple and accurate (1%) measurement of capacitors from a few pF up to 1,000  $\mu$ F. Clear 5-digit LED display indicates exact value. Three ranges - pF, nF, and  $\mu$ F. Just connect the capacitor, press the button and read the value.

KIT REF 493

£44.25

## 3 BAND SHORT WAVE RADIO

EE AUG 87

Covers 1.6-30 MHz in 3 bands using modern miniature coils. Audio output is via a built-in loudspeaker. Advanced design gives excellent stability, sensitivity and selectivity. Simple to build.

KIT REF 718

£28.25

## MOSFET VARIABLE BENCH 25V 2.5A POWER SUPPLY

EE FEB 88

A superb design giving 0.25V and 0-2.5A. Twin panel meters indicate Voltage and Current. Voltage is variable from zero to 25V. A Toroidal transformer MOSFET power output device, and Quad op-amp IC design give excellent performance.

KIT REF 769

£52.96

## MINI STROBE

EE MAY '86

A hand held stroboscope which uses 6 "ultra bright" LEDs as the light source. Designed to demonstrate the principles of stroboscope examination, the unit is also suitable for measuring the speed of moving shafts etc. The flash rate control covers 170-20,000 RPM in two ranges.

KIT REF 529

£14.76

## ACOUSTIC PROBE

EE NOV '87

A very popular project which picks up vibrations by means of a contact probe and passes them on to a pair of headphones or an amplifier. Sounds from engines, watches and speech travelling through walls can be amplified and heard clearly. Useful for mechanics, instrument engineers and nosey parkers!

KIT REF 740

£18.65

## 4 CHANNEL LIGHT CHASER

EE Jan '90

A 1000W per channel chaser with zero volt switching, hard drive, inductive load capability, mic sound sensor and sophisticated 'beat' detector. Chase steps to music or auto when quiet. Variable speed and mic. sens. LED mimic on front panel. Switchable for 3 or 4 channels. P552 output. Ideal for rope lights, pin spots, disco and display lighting.

KIT REF 833

£29.95

## EE EQUALISER

EE MAY '87

A mains powered Ioniser with an output of negative ions that give a refreshing feeling to the surrounding atmosphere. Negligible current consumption and all-insulated construction ensure that the unit is safe and economical in use. Easy to build on a simple PCB.

KIT REF 707

£16.54

## MUSICAL DOORBELL

EE JAN '86

This project uses a special I.C. pre-programmed with 25 tunes and 3 chimes. A Magenta design, the circuit is battery powered and only draws current whilst producing sounds. Two rotary switches select the tune required. Provision is made for three bell pushes, each of which sounds a different tune, so that three points of entry can be identified.

KIT REF 497

£19.95

## EPROM ERASER

EE OCT '88

Safe low-cost unit capable of erasing up to four EPROM's simultaneously in less than twenty minutes. Operates from a 12V supply. Safety interlock. Convenient and simple to build and use.

KIT REF 790

£26.57

## LIGHT RIDERS

EE OCT '86

Three projects under one title - all simulations of the Knight Rider lights from the TV series. The three are a lapel badge using six LEDs, a larger LED unit with 16 LEDs and a mains version capable of driving six main lamps totalling over 500 watts.

KIT REF 559 CHASER LIGHT

£14.52

KIT REF 560 DISCO LIGHTS

£20.89

KIT REF 561 LAPEL BADGE

£10.86

## EE TREASURE HUNTER

EE AUG '89

A sensitive pulse induction Metal Detector. Picks up coins and rings etc., up to 20cms deep. Low "ground effect". Can be used with search-head underwater. Easy to use and build, kit includes search-head, handle, case, PCB and all parts as shown.

KIT REF 815  
Headphones

£39.95  
£1.99

## STEPPING MOTOR INTERFACE

EE AUG '85

This interface enables 4 phase unipolar stepping motors to be driven from four output lines of any computer user port. The circuit is especially suitable for the ID35 motor and our MD200 which are commonly used in buggies and robot arms. Supplied complete with ribbon cable and connector for the BBC user port.

KIT REF 464

£8.95

# KITS & COMPONENTS

## ELECTRONIC GUARD DOG



One of the best burglar deterrents is a guard dog and this kit provides the barking. Can be connected to a doorbell, pressure mat or any other Intruder detector and produces random threatening barks. All you need is a mains supply, intruder detector and a little time.

XK125 ..... £24.00

## DISCO LIGHTING KITS



DL8000K 8-way sequencer kit with built-in opto-isolated sound to light input. Only requires a box and control knob to complete ..... £34.60

DL1000K 4-way chaser features bi-directional sequence and dimming 1kW per channel ..... £21.00

DL21000K Uni-directional version of the above. Zero switching to reduce interference ..... £11.80

DLA/1 (for DL & DLZ1000K) Optional opto input allowing audio 'beat'/light response ..... 80p

DL3000K 3-channel sound to light kit, zero voltage switching, automatic level control and built-in mic. 1kW per channel ..... £17.00

## POWER STROBE KIT

Produces an intense light pulse at a variable frequency of 1 to 15Hz. Includes high quality PCB, components, connectors, 5Ws strobe tube and assembly instructions. Supply: 240V ac. Size: 80x50x45. XK124 STROBOSCOPE KIT ..... £15.00



## VOICE RECORD/PLAYBACK KIT

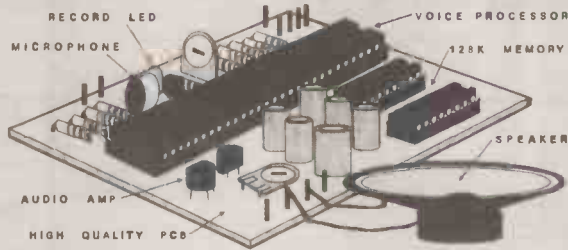

This simple to construct and even simpler to operate kit will record and playback short messages or tunes. It has many uses—seatbelt or lights reminder in the car, welcome messages to visitors at home or at work, warning messages in factories and public places, in fact anywhere where a spoken message is announced and which needs to be changed from time to time. Also suitable for toys—why not convert your daughter's £8 doll to an £80 talking doll!!

Size ..... 78x60x15 mm  
Message time ..... 1-5 secs normal speed, 2-10 secs slow speed

XK129 ..... £22.50

## TEN EXCITING PROJECTS FOR BEGINNERS

This kit contains a solderless breadboard, components and a booklet with instructions to enable the absolute novice to build ten fascinating projects including a light operated switch, intercom, burglar alarm and electronic lock. Each project includes a circuit diagram, description of operation and an easy to follow layout diagram. A section on component identification and function is included, enabling the beginner to build the circuits with confidence.

XK118 ..... £15.00

## MULTIMETER BARGAINS

A high accuracy Autoranging meter with Display Hold, Memory features.

AC volts ..... 0-2-200-750 1.2%

DC volts ..... 0-0.2-2-200-1000 0.8%

AC current 0-2m-200mA 1.2% 0-10A 2%

DC current ..... as for AC

Resistance 0-200-2K-20K-200K-2M 1%

Continuity ..... Buzzer sounds at /20 ohms

Size ..... 127x69x25mm

405 207 ..... £31.75

A 15 range Autoranging multimeter with 4AC, 5DC and 6 resistance ranges. Only 8x5x108mm. Complete with wallet. 405 206 ..... £19.50

Ask for a leaflet on our range of meters

## ELECTRONIC WEIGHING SCALES

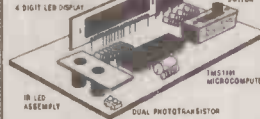

Kit contains a single chip micro-processor, PCB, displays and all electronics to produce a digital LED readout of weight in Kgs or Sts/lbs. A PCB link selects the scale—bathroom/ two types of kitchen scales. A low cost digital ruler could also be made. E51 ..... £7.20

## SUPER-SENSITIVE MICROBUG

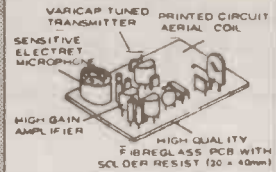

Only 45x25x15mm, including built-in mic. 88-100MHz (standard FM radio). Range approx. 300m depending on terrain. Powered by 9V PP3 (7mA). Ideal for surveillance, baby alarm etc. .... £5.50

## VERSATILE REMOTE CONTROL KIT



Includes all components (+transformer) for a sensitive IR receiver with 16 logic outputs (0-15V) which with suitable interface circuitry (relays, triacs, etc—details supplied) can switch up to 16 items of equipment on or off remotely. Outputs may be latched to the last received code or momentary (on during transmission) by specifying the decoder IC and a 15V stabilised supply is available to power external circuits. Supply: 240V AC or 15-24V DC at 10mA. Size (exc. transformer) 9x4x2 cms. Companion transmitter is the MK18 which operates from a 9V PP3 battery and gives a range of up to 60ft. Two keyboards are available—MK9 (4-way) and MK10 (16-way).

MK12 IR Receiver ..... £17.00

MK18 Transmitter ..... £7.80

MK9 4-way Keyboard ..... £2.40

MK10 16-way Keyboard ..... £7.00

601133 Box for Transmitter ..... £2.60

## SIMPLE KITS FOR BEGINNERS

Kits include all components (inc. speaker where used) and full instructions.

SK1 DOOR CHIME play a tune when activated by a pushbutton ..... £3.90

SK2 WHISTLE SWITCH switches a relay on and off in response to whistle command ..... £3.90

SK3 SOUND GENERATOR produces FOUR different sounds, including police/ambulance/fire-engine siren and machine gun ..... £3.90

SPECIAL OFFERS ON KITS FOR SCHOOLS AND TRAINING CENTRES—contact Sales Office for discounts and samples

## ELECTRONIC LOCK KIT



Don't lock yourself out! This high security lock kit will secure doors to sheds, garages or your front door and the built-in alarm will deter would be prowlers. Scores of uses including area access preventing unauthorised use of machinery or even disabling your car. One correct 4 digit code (out of 5000) will open the lock. Incorrect entries sound the alarm and disable the keyboard for up to 3 mins. Kit includes 12-way keypad, and operates from 9 to 15V (50uA) supply. Will drive relay or 701 150 lock mechanism.

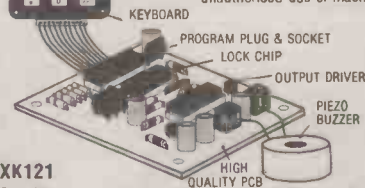

XK121  
£15.95

## MICROPROCESSOR TIMER

Kit controls 4 outputs independently switching on/off at 18 preset times over a 7-day cycle. LED display of time/day easily programmed. Includes box. CT6000K ..... £49.50

XK114 Relay kit for CT6000 includes PCB, connectors and one relay. Will accept up to 4 relays. 3A/240V c/o contacts ..... £4.75

701115 Additional relays ..... £1.80

TK ELECTRONICS  
13 Boston Road  
London W7 3SJ  
Tel: 01-567 8910  
Fax: 01-566 1916

ORDERING INFORMATION All prices exclude VAT. Free p&p on orders over £50 (UK only), otherwise add £1+VAT. Overseas p&p: Europe £3.50 elsewhere £10.00. Send cheque/PO/Barclaycard/Access No. with order. Giro No. 529314002. Local authority and export orders welcome. Goods by return subject to availability.



ORDERS: 01-5678910 24 HOURS

# EVERYDAY ELECTRONICS

INCORPORATING ELECTRONICS MONTHLY

The Magazine for Electronic & Computer Projects  
VOL.19 No. 3 March '90

## SPRING

Spring is upon us once again — well I know it's only February and you are probably watching the snow outside as you read this (Australian readers please lend us some sunshine), but this issue sees the first of the spring catalogues and our spring promotions — if we go any quicker we will disappear up the start of next year!

Anyway a free 32 page catalogue from Marco Trading is bound into this issue, there will be a different one in next month's issue and the following month we hope to carry a special extra supplement — more about that next month.

## SOR

This issue also marks a new era in EE sales, the magazine is now available to the trade (your local newsagent) on full SOR (sale or return). This should mean better availability from smaller newsagents who will not be taking any risk by carrying a few extra copies. We believe this will help us to further improve the sales of EE and eventually strengthen, and help us to improve, *your* magazine still more.

Please let us know if you have a problem getting hold of EE. A regular order with your newsagent should solve any problems — even if he does not deliver your copy he will hold it at the shop for your collection. Where there are supply problems we can usually sort them out — if we know about them — but with around 40,000 newsagents in the U.K. we cannot possibly check each one. As always your help and comments are appreciated.

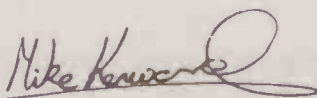

## SUBSCRIPTIONS

Annual subscriptions for delivery direct to any address in the UK: £16.00. Overseas: £19.50 (£37 airmail). Cheques or bank drafts (in £ sterling only) payable to Everyday Electronics and sent to EE Subscriptions Dept., 6 Church Street, Wimborne, Dorset

BH21 1JH. Subscriptions can only start with the next available issue. For back numbers see below.

## BACK ISSUES

Certain back issues of EVERYDAY ELECTRONICS are available price £1.50 (£2.00 overseas surface mail—£ sterling only please—inclusive of postage and packing per copy. Enquiries with remittance, made payable to Everyday Electronics, should be sent to Post Sales Department, Everyday Electronics, 6 Church Street, Wimborne, Dorset BH21 1JH. in the event of non-availability one article can be photostatted for the same price. *Normally sent within seven days but please allow 28 days for delivery.* We have sold out of Sept. Oct. & Dec. 85, April, May, Oct. & Dec. 86, Jan., April, May & Nov. 87, Jan., March, April, June & Oct. 88.

## BINDERS

Binders to hold one volume (12 issues) are available from the above address for £4.95 (£6.95 to European countries and £9.00 to other countries, surface mail) inclusive of post and packing. *Normally sent within seven days but please allow 28 days for delivery.* Payment in £ sterling only please.



**Editorial Offices**  
EVERYDAY ELECTRONICS EDITORIAL,  
6 CHURCH STREET, WIMBORNE,  
DORSET BH21 1JH  
Phone: Wimborne (0202) 881749  
FAX: (0202) 841692

See notes on **Readers' Enquiries** below—we regret that lengthy technical enquiries cannot be answered over the telephone

**Advertisement Offices**  
EVERYDAY ELECTRONICS ADVERTISEMENTS  
HOLLAND WOOD HOUSE, CHURCH LANE,  
GREAT HOLLAND, ESSEX CO13 0JS.  
Frinton (0255) 850596

**Editor** MIKE KENWARD

**Secretary** PAMELA BROWN

**Deputy Editor**  
DAVID BARRINGTON

**Business Manager**  
DAVID J. LEAVER

**Editorial:** WIMBORNE (0202) 881749

**Advertisement Manager**  
PETER J. MEW Frinton (0255) 850596.

**Classified Advertisements**  
Wimborne (0202) 881749

## READERS' ENQUIRIES

We are unable to offer any advice on the use, purchase, repair or modification of commercial equipment or the incorporation or modification of designs published in the magazine. We regret that we cannot provide data or answer queries on articles or projects that are more than five years old. Letters requiring a personal reply must be accompanied by a **stamped self-addressed envelope** or a **self-addressed envelope and international reply coupons**.

All reasonable precautions are taken to ensure that the advice and data given to readers is reliable. We cannot, however, guarantee it and we cannot accept legal responsibility for it.

## COMPONENT SUPPLIES

**We do not supply electronic components or kits** for building the projects featured, these can be supplied by advertisers.

We advise readers to check that all parts are still available before commencing any project in a back-dated issue.

We regret that **we cannot provide data or answer queries on projects that are more than five years old.**

## ADVERTISEMENTS

Although the proprietors and staff of EVERYDAY ELECTRONICS take reasonable precautions to protect the interests of readers by ensuring as far as practicable that advertisements are *bona fide*, the magazine and its Publishers cannot give any undertakings in respect of statements or claims made by advertisers, whether these advertisements are printed as part of the magazine, or are in the form of inserts.

The Publishers regret that under no circumstances will the magazine accept liability for non-receipt of goods ordered, or for late delivery, or for faults in manufacture. Legal remedies are available in respect of some of these circumstances, and readers who have complaints should address them to the advertiser or should consult a local trading standards office, or a Citizen's Advice Bureau, or a solicitor.

## TRANSMITTERS/BUGS/ TELEPHONE EQUIPMENT

We would like to advise readers that certain items of radio transmitting and telephone equipment which may be advertised in our pages cannot be legally used in the U.K. Readers should check the law before using any transmitting or telephone equipment as a fine, confiscation of equipment and/or imprisonment can result from illegal use. The laws vary from country to country; overseas readers should check local laws.

# SUPERHET BROADCAST RECEIVER

MARK STUART

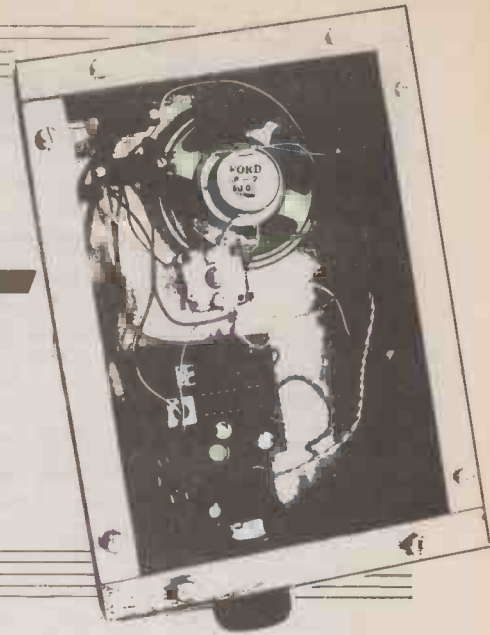

*An up to the minute, low cost design using a high-tech i.c. and ceramic filters for the i.f. stages. Tunes in the m.w. and l.w. broadcast bands and gives 1W loudspeaker output*

**A** RADIO must be one of the first projects attempted by most electronics enthusiasts.

In the distant past, building radios (or "wireless sets") was almost the only form of electronics construction, with a number of magazines carrying the word Wireless, or Radio in their title, and none with the word Electronics. Nowadays the tables are well and truly turned, and radio construction is a relatively small section of the electronics enthusiasts' activities.

As with all things electronic, new technology has made remarkable changes to both the components and to the circuits used in radio receivers. It is amusing to look at old books and magazines and see the size and weight of the "latest modern design" of the day.

Radio projects published more recently have been a lot smaller and lighter! They have also had the advantage of working from a single PP3 battery instead of a barrow load of accumulators!

Unfortunately, what published designs have gained in technology they have lost in variety. Dozens of TRF receivers have been published, almost all of them using the ZN414 i.c. This is a nice little i.c. and works well enough, but is completely lacking in interest and cannot match the performance of even a cheap commercial transistor radio.

To break the monotony, the design that follows uses two sophisticated i.c.s in a Superheterodyne circuit. It is easy to build, needs no special alignment of its tuned circuits, and has a performance that is up to modern standards.

## DESIGN

The design presented here should go a long way towards bringing new interest into radio construction. It uses two interesting i.c.s, one for the tuner and the other

as a power amplifier. The case in which the prototype was built is designed to allow all of the "workings" to be seen.

Two printed circuit boards were used so that the tuner and amplifier sections could be used separately in other applications. They were made as small as possible without using special components. The size of the whole radio is determined more by the ferrite rod and loudspeaker — indeed a larger loudspeaker could be used for even better quality output as more than one watt of audio power is available.

Alignment of the tuned circuits has always been one of the difficulties of su-

perheterodyne radio construction. In this circuit the use of a ceramic filter block guarantees excellent selectivity and allows the minimum amount of alignment necessary to be done simply by ear.

## SUPERHETERODYNE

The simplest form of radio receiver is the TRF or Tuned Radio Frequency circuit. In this the incoming Radio frequency signal is amplified and then fed straight to a detector stage to extract the audio modulation.

This technique has several disadvantages. The main one is its lack of selectivity or "tuning sharpness". A strong local signal will easily block out several weaker adjacent signals. Selectivity also varies across the tuning range so that the performance is not uniform.

These problems can be overcome to some extent by adding extra tuned stages but in the end the disadvantage of the added complexity exceeds the benefit of any improvements. In this situation the designer's best option is to return to

*The completed Superhet Broadcast Receiver mounted in a cabinet with clear plastic top and bottom panels showing positioning of the components.*

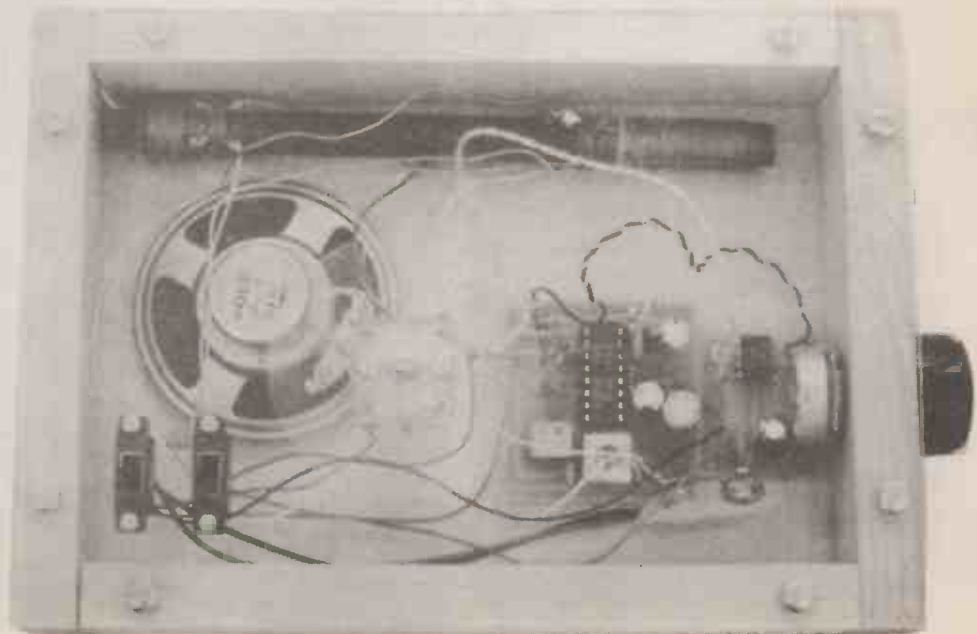

square one and attempt a totally different approach.

From such an approach the idea of the superheterodyne radio must have been born. The basis of the method is to convert the frequency of the desired signal to a fixed different frequency (known as the i.f. or *Intermediate Frequency*) at which all of the selectivity and amplification can be applied.

Applying the selectivity at a fixed frequency is easy because several fixed tuned circuits can be used. By making the i.f. fairly low it is possible to have high levels of amplification using simple circuitry, and to design filters to give practically ideal selectivity characteristics.

As all signals are amplified and filtered by the same stages the performance will be the same across the tuning range. A simple detector stage following the i.f. stages extracts the modulation in the normal way.

## HETERODYNING

The complicated part of this approach is converting the incoming frequency to the i.f. This is done by a process called "heterodyning", which is mixing the incoming signal with another signal from an oscillator (known as the *Local Oscillator*) in a special circuit that produces in its output the sum of the two frequencies and their difference.

By arranging the correct difference between the local oscillator frequency and the wanted signal frequency, the output of the mixer can be made to be at the i.f. This new frequency contains all the modulation of the incoming signal so that it can be amplified by the i.f. stages and detected to produce the wanted audio output.

To tune over a band of frequencies the "front end" of a superhet radio usually must have two tuned circuits. One for the local oscillator and the other (the aerial circuit) for the incoming signal.

As the tuning knob is turned the two circuits must be varied together so that their difference remains the same and equal to the i.f. This process is known as

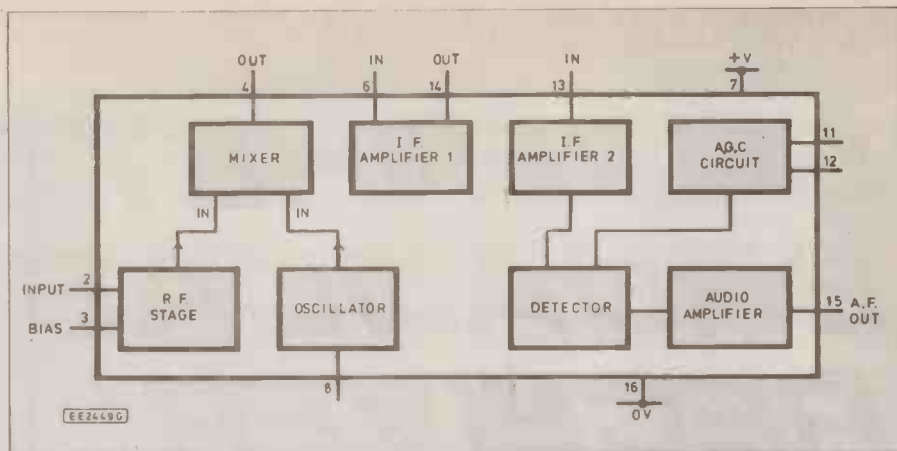

Fig.2. Simplified internal block diagram for the TEA 5570 radio i.c.

tracking, and is achieved nowadays by using a dual ganged tuning capacitor.

The two sections of the capacitor differ by the required amount to give the exact frequency difference across the band when used with the right oscillator coil and tuning coil. Minor differences are corrected using trimming capacitors and by tuning the coils - either by adjusting the oscillator coil core, or by sliding the aerial coil along its ferrite rod.

## CIRCUIT DESCRIPTION

The full circuit diagram of the Superhet Broadcast Receiver is shown on Fig. 1. As most of the circuit is taken up by IC1 it is also necessary to refer to Fig. 2. which gives a simplified internal view of the i.c.

The Local Oscillator frequency is set by coil L5 which is tuned by capacitor VC1a and its trimmer. L6 is the coupling coil to the oscillator circuit inside IC1 (pin 8). For long wave (L.W.) operation an additional capacitor C1 is connected in parallel with VC1a to produce the necessary lower frequency.

Incoming signals are picked up by the ferrite rod aerial which is wound with coils L1 to L4. On Medium Wave L1 is

tuned by VC1B and its trimmer, on Long Wave L2 is tuned. Each tuned winding has an associated coupling winding; L3 for MW and L4 for LW.

The switching around coils L3 and L4 is slightly out of the ordinary and works as follows. The values of capacitors C2 and C4 are so high that they can be considered short circuits at the frequencies concerned. On m.w. one end of L3 is shorted to ground via C2 and the other end connects to the i.c. input on pin 2.

The l.w. coil is short circuited by C2 and C4. On l.w. capacitor C2 is open circuit and L3 and L4 are connected in series to couple the lower frequency input to pin 2. The beauty of this arrangement is that it allows a simple s.p.d.t. slide switch to be used for band switching.

The output of the local oscillator is combined with the incoming signal in a special section of IC1 called a "Double Balanced Mixer". This combines the two inputs in a special (non-linear) way that generates sum and difference frequencies as previously mentioned.

The advantage of a double balanced mixer is that the two input signals are cancelled out and only the sum and difference frequencies are present in the out-

Fig. 1. Complete circuit diagram for the Superhet Broadcast Receiver. The dual-ganged tuning capacitor also contains the two trimmers.

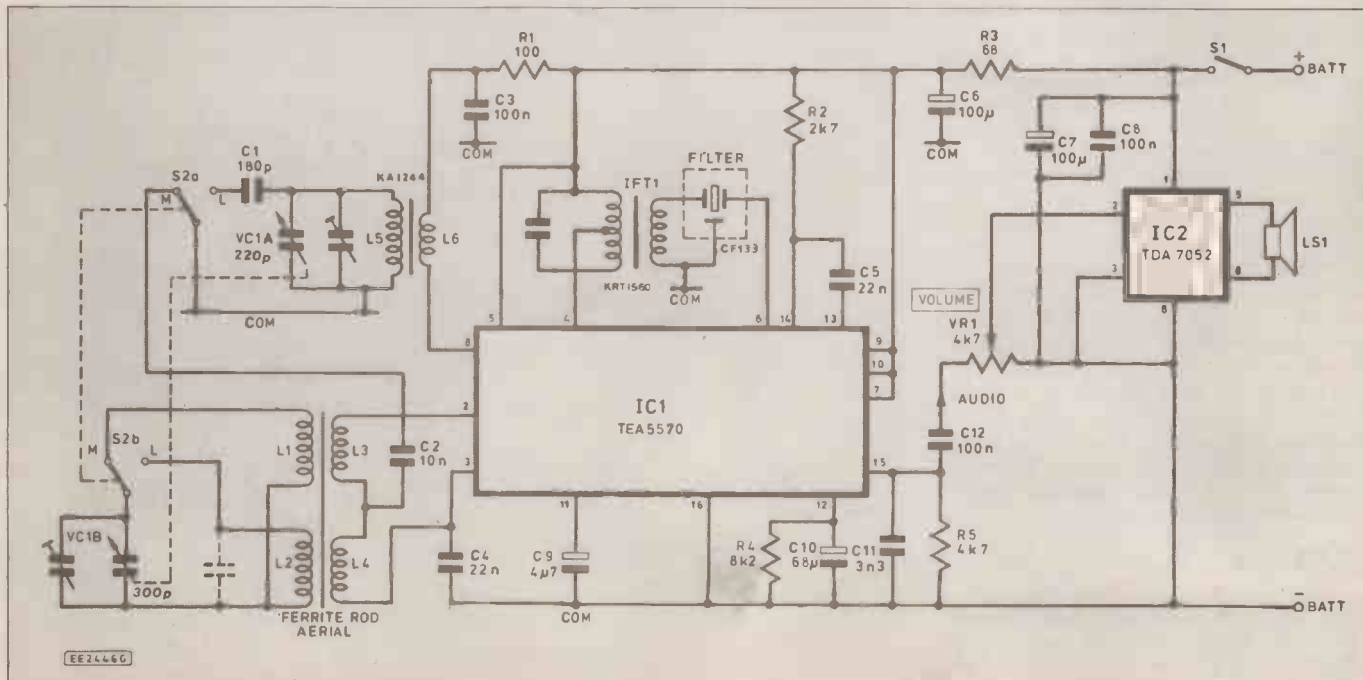

put. Other simpler mixers contain large amounts of the input frequencies, leading to inferior performance.

## INTERMEDIATE FREQUENCY

The output of the mixer, pin 4 of IC1 is fed into the tapping on IFT1. This is the beginning of the intermediate frequency filtering which gives the receiver its selectivity. IFT1 is tuned to 455kHz which is the standard intermediate frequency. The tapping on its input allows the primary

## COMPONENTS

### Resistors

R1	100
R2	2k7
R3	68
R4	8k2
R5	4k7

All 0.25W 5% carbon film

**Shop  
Talk**

See page 209

### Potentiometer

VR1	4k7 log. p.c.b. mounting
-----	--------------------------

### Capacitors

C1	180p ceramic plate 50V
C2	10n ceramic disc 50V
C3,C8,C12	100n ceramic disc 50V (3 off)
C4,C5	22n ceramic disc 50V (2 off)
C6,C7	100µ radial elect. 10V (2 off)
C9	4µ7 radial elect. 10V
C10	68µ radial elect. 10V
C11	3n3 ceramic plate 50V

### Tuning Capacitor

VC1a/VC1b	220p/300p miniature solid dielectric twin gang tuning capacitor, with built-in trimmers.
-----------	--

### Coils:

L1-L4	Ferrite rod aerial with LW and MW coils and coupling windings
L5-L6	MW oscillator coil with coupling winding, Type KA 1244
CF1	455kHz ceramic filter CF 133.
IFT1	Filter input coupling IF transformer, KRT 1560

### Integrated Circuits

IC1	TEA5570 AM/FM radio i.c.
IC2	TDA7052 BTL Audio Power i.c.

### Miscellaneous

S1, S2	D.P.D.T. min. slide switches
LS1	8 or 16 ohm loudspeaker, 55mm dia.
B1	9V battery, with clip (PP3)

Printed circuit boards available from the EE PCB service, codes EE679 and EE680; 8-pin d.i.l. socket; 16-pin d.i.l. socket; knob; mounting screws for VC1, S1 and S2; tuning disc and fixing screw; connecting wire, assorted colours thin stranded type (see text); single-ended solder pins; solder etc.

Approx. cost.  
Guidance Only

**£16**

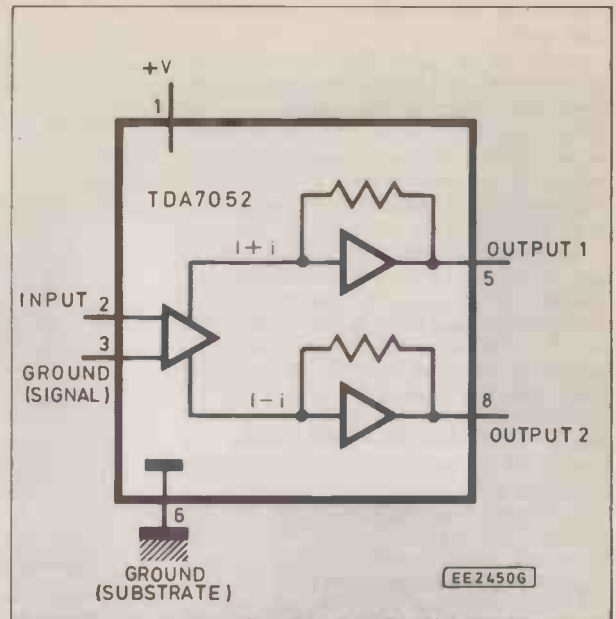

Fig. 3. Simplified internal diagram for the audio amplifier i.c. There are three amplifier blocks. The first provides gain and two outputs which are fed to the two speaker driver amps.

winding of IFT1 to be tuned quite sharply and so provide some of the selectivity.

The secondary winding of IFT1 provides a matched output for the ceramic filter which provides the rest of the selectivity. From the filter the output passes to the first i.f. amplifier then via C5 to the second i.f. amp, which is connected internally to the detector stage.

The output of the detector stage is amplified internally and passes to the output on pin 15. The audio output is filtered by capacitor C11 and passed on to the audio amplifier stage by C12. R5 is the detector load resistor.

## AUTOMATIC GAIN CONTROL

Additional components C9, C10 and R4 are associated with the a.g.c. (Automatic Gain Control) section of the circuit. This allows signals of widely differing levels to produce the same audio output from the detector. It works by measuring the average level of the detector output which

is used as a feedback signal after smoothing by capacitors C9 and C10, to control the gain of the mixer and first i.f. stages.

Other components resistors R1, R3, capacitors C3 and C6 are supply decoupling components that ensure stability of the high frequency circuits.

## AUDIO AMPLIFIER

There can be few circuits simpler than that using IC2 as the audio Amplifier to provide a voltage gain of 100 and drive 1W into 8 ohms from a 6V supply. Capacitors C7 and C8 provide the necessary good supply decoupling for stability, and VR1 the volume control.

The simplified internal circuit of IC2 is shown in Fig.3. there are three amplifier blocks. The first block provides the gain and produces two outputs which are in antiphase. These outputs feed independent power amplifiers which drive one end of the speaker each. This method of connection is known as BTL or Bridge Tied Load.

The two clear plastic panels laid out to reveal the positioning of the speaker, circuit boards, aerial, switches and tuning capacitor.

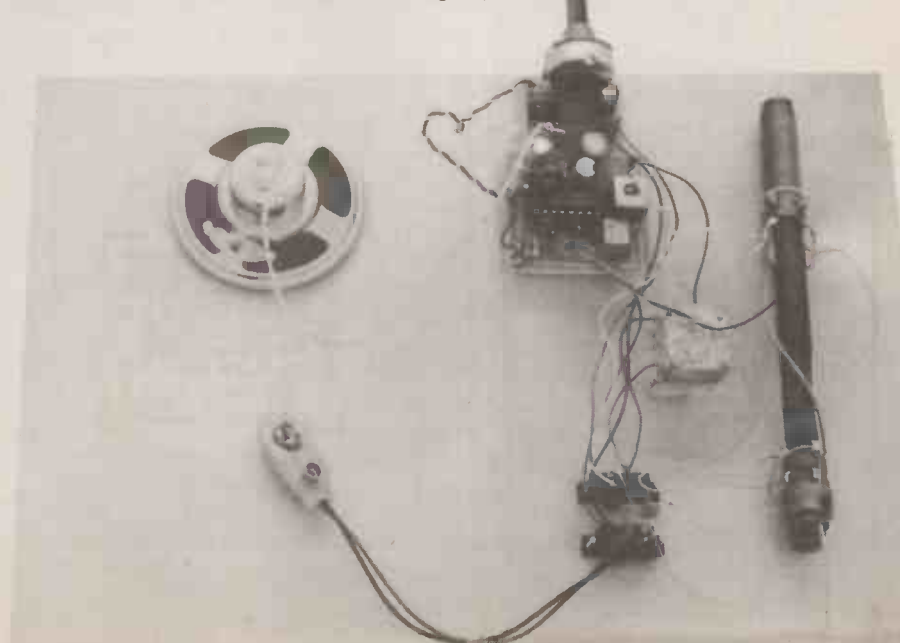



Two big advantages are obtained by this method. First, as both outputs are normally at the same d.c. voltage (close to half of the supply voltage – or “mid rail”) there is no need for a coupling capacitor in series with the speaker. Secondly, the available output voltage swing across the speaker is twice that available from a single-ended output.

This is clear if the two extreme cases are considered where pin 5 is at the positive supply and pin 8 is at 0V when the full supply voltage is applied one way across the speaker, and the opposite state with pin 5 at 0V and pin 8 at the positive supply voltage when the full supply is applied the other way across the speaker. The total voltage swing available is therefore  $2 \times V$  or twice the supply voltage.

This allows the circuit to deliver 1.2W into an 8ohm load with a supply voltage of just 6V. Overload protection is also incorporated so that the circuit can withstand any combination of output short circuits without damage – it is a very useful i.c. and deserves wider use in hobby circuits.

## CONSTRUCTION

Two printed circuit boards are used for the radio. The Tuner board component layout is shown in Fig. 4, and the Audio Amplifier board component layout in Fig.5. The boards are available for the *EE PCB Service*, codes EE679 and EE680.

Check both boards for blocked holes and solder whiskers, and then insert single-sided pins for the connection of the wiring. The single-sided pins normally used should be pushed right into the board from the track side so that the short spined section engages with the board material and locks the pins firmly in position with the heads flush against the p.c.b. tracks.

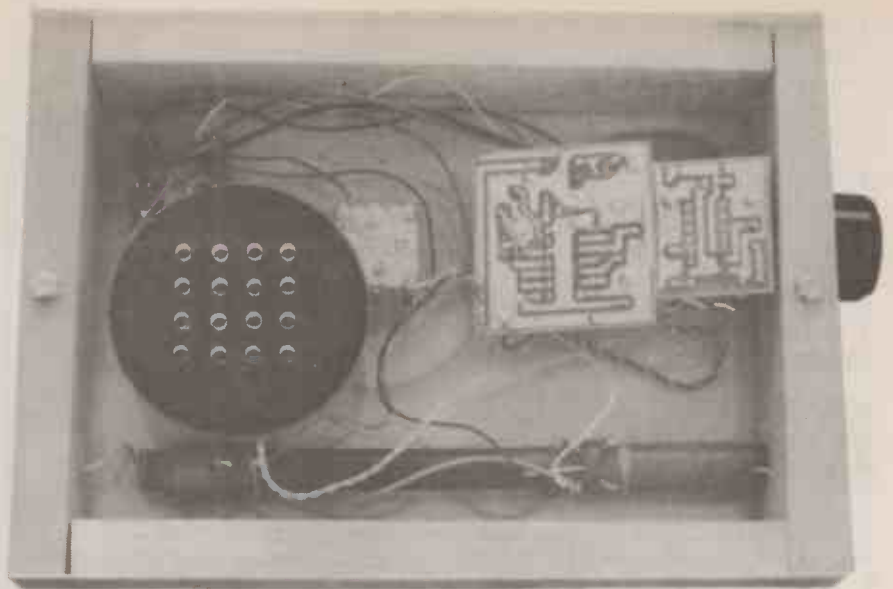

The two circuit boards are “Superglued” together and mounted on the volume control solder tags. The loudspeaker is mounted over a series of holes drilled in one of the clear panels.

Solder each pin into place and then fit the other components, starting with the smaller ones. Fitting i.c. sockets is always a good idea but can lead to instability in some high frequency circuits. This circuit was built using sockets and is perfectly stable.

Note the position of IC2 relative to the extra holes provided on the board. These holes allow an alternative audio chip to be fitted, and should be ignored.

The only components that must be fitted the right way round are IC1 and IC2 and the electrolytic capacitors C6, C7, C9 and C10. The filter and inductors L5/6 and IFT1 can only be fitted one way because of their pin arrangement.

The volume control VR1 may be fitted off the board if required and connected by wires. In the prototype the boards were glued together end to end using superglue (which gives an extremely strong bond) and mounted in the case using the potentiometer fixing bush.

## CASE

Many alternative layouts are possible and the constructor is encouraged to build the circuit into any other suitable housing which may be available. Note that metal cases cannot be used unless the ferrite rod aerial is fitted outside and away from the screening and de-tuning effect of conductive material.

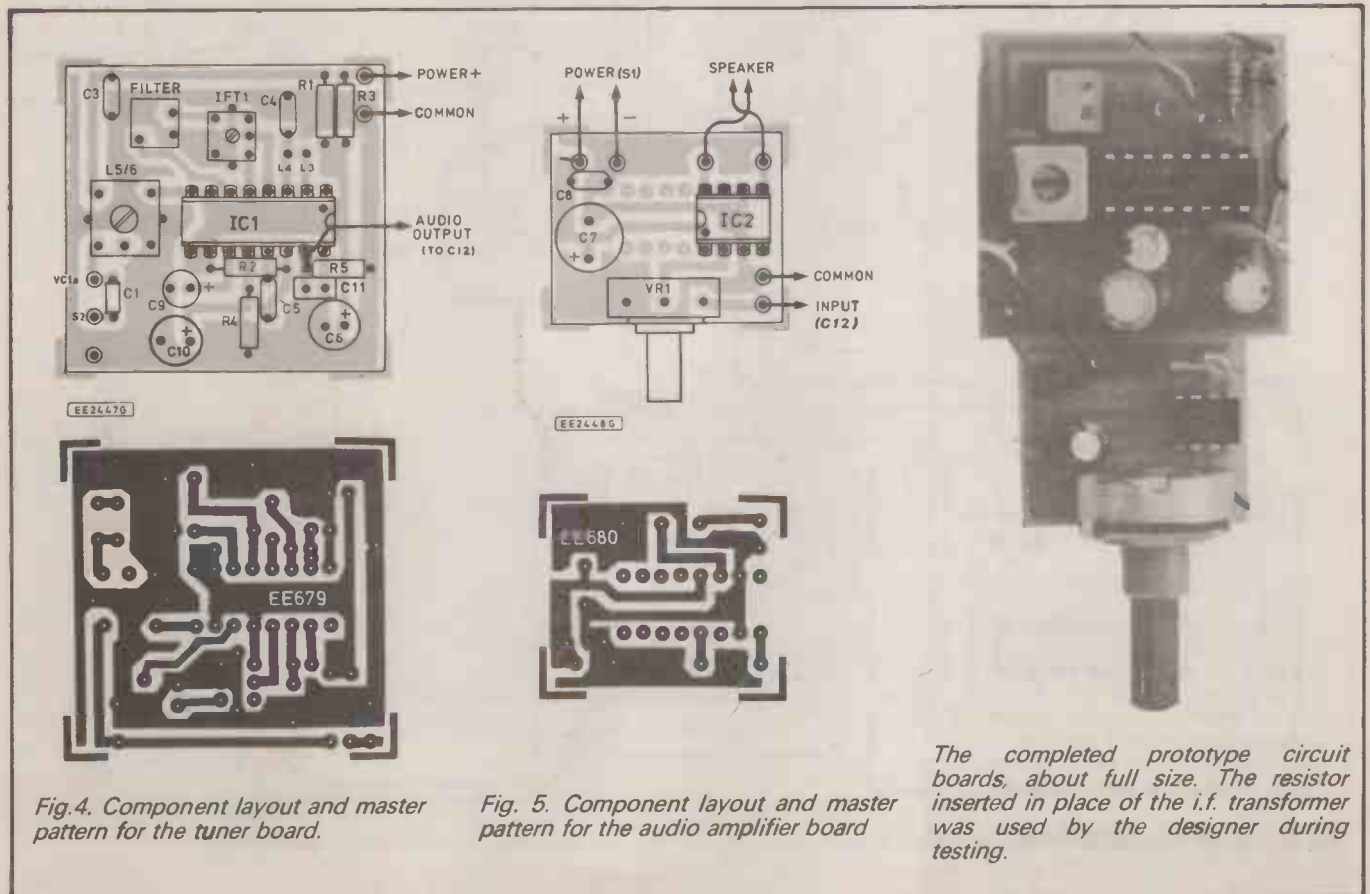

Fig.4. Component layout and master pattern for the tuner board.

Fig. 5. Component layout and master pattern for the audio amplifier board

The completed prototype circuit boards, about full size. The resistor inserted in place of the i.f. transformer was used by the designer during testing.

## WIRING

Interwiring is the section of construction requiring the most care but which should be fairly straightforward if the diagrams of Fig.6. and Fig.7. are followed. Before beginning it is recommended that the two switches and the tuning capacitor and ferrite rod are mounted in the case. This allows wires of the correct length to be fitted and ensures a neat stable result.

Begin by stripping off any wires already attached to the coils on the ferrite rod, and then identify the two coils by viewing them from the tag end. It is best to leave both coils in position on the rod whilst wiring.

The l.w. coil is a short fat wave winding with a red dot marking polarity as indicated in Fig.6. The m.w. coil is a long single layer coil and is identified by means of the long wire connecting to the far end of the pink winding. Use thin stranded wire obtained from stripping rainbow ribbon cable and stick to the colour codes shown in Fig.6. Note that capacitors C2 and C12 are fitted in the wiring.

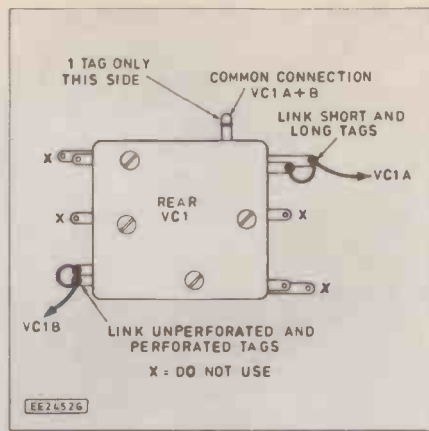

Fig.7. Connection details for the dual-gang tuning capacitor.

The connections to the tuning capacitor can be confusing, but if the specified type is used the three connections should be made easily. Fig.7. shows the required pins, all others should be ignored.

The wiring between the boards should be carried out as shown to avoid earth loops which can cause instability. Twisting the loudspeaker leads and the audio input leads is recommended to further aid stability.

Note that connecting to the p.c.b. wiring pins is easy if both pins and wires are heavily tinned first and then the connection made by applying the iron to both the pin and wire to melt together the solder on each. This method allows the job to be done with two hands instead of the usual three!

## TESTING

Check and double check the wiring and component types and polarity before applying power to the circuit. It is a good idea to have a 47 ohm resistor in series with the power supply or battery to reduce the potential fault current if there is a short circuit when first testing. If all is well and the circuit does not draw too much current it should be possible to hear some sort of noise from the speaker when moving the volume control. If a voltmeter is available check that the two outputs from IC2 are at mid rail and that power is present between pins 1 and 6.

With the wavechange switch set to m.w. it will probably be possible to hear some weak stations as the tuning dial is turned. Find one of these and then adjust the position of the m.w. coil on the rod for maximum output. If all is well it should be possible to obtain many stations at a good

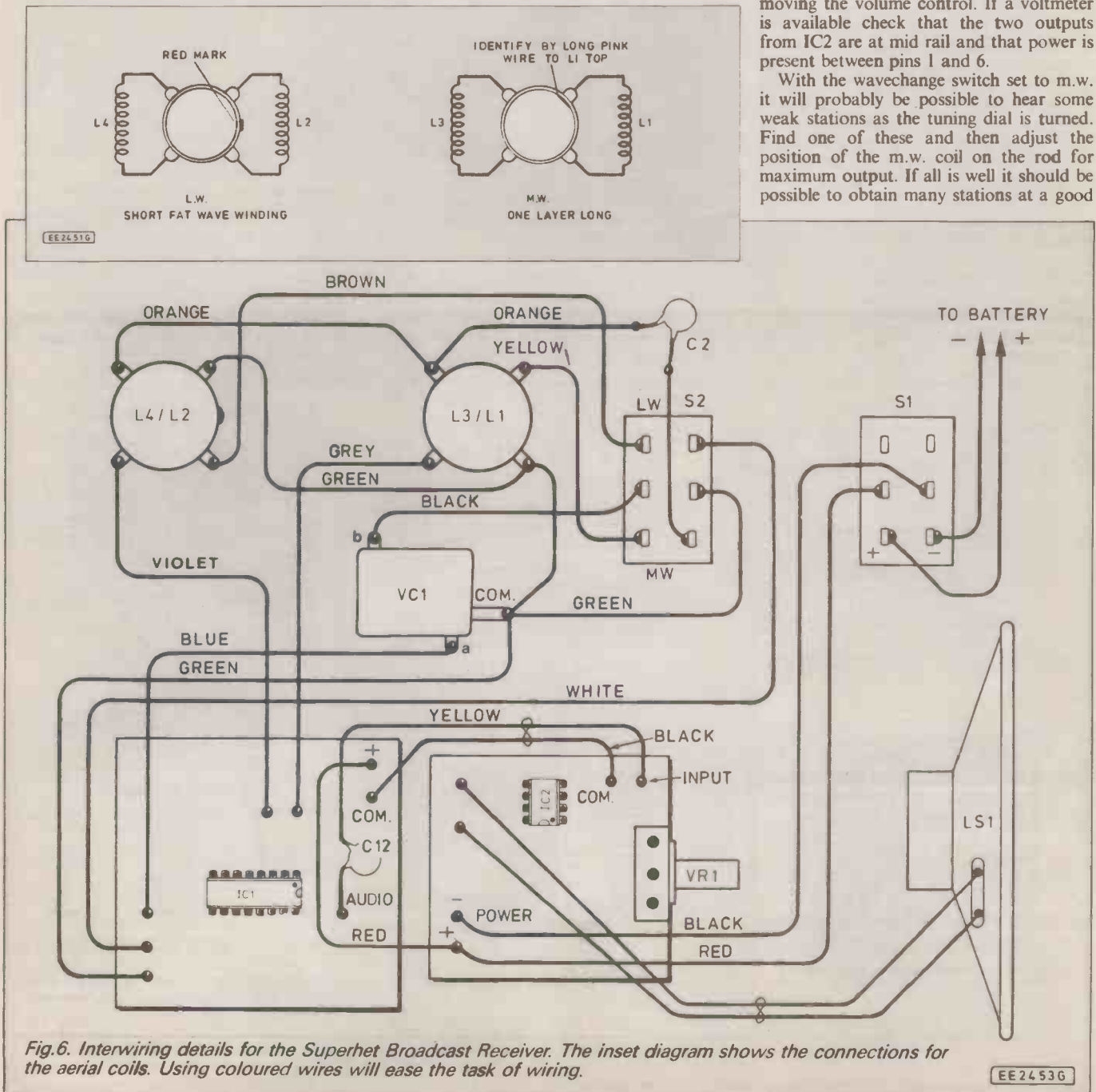

Fig.6. Interwiring details for the Superhet Broadcast Receiver. The inset diagram shows the connections for the aerial coils. Using coloured wires will ease the task of wiring.

level and to be able to "peak" each one by positioning the m.w. coil on the rod. The oscillator coil L5/L6 should not be touched yet and ideally will not require adjustment at all.

Find a medium strength station and rotate the ferrite rod until it is very weak. Now carefully adjust IFT1 for maximum output. Re-tune tuning capacitor VC1 for maximum output and repeat the adjustment of IFT1. Always make these adjustments with the aerial turned to give as weak a signal as can be heard sufficiently to be used. This ensures optimum tuning. IFT1 should not be touched again as it is now set perfectly to match the filter.

## LONGWAVE

Switch to l.w. and tune for BBC Radio 4. move the LW coil on the ferrite rod to obtain maximum output. If the coil needs to be too far off the end of the rod, adding a small amount of capacitance across L2 (shown dotted in the circuit) will allow correct tuning with the coil between 2mm to 20mm from the end of the rod.

Obtaining maximum output all across the scale is achieved largely by the correct choice of tuning components. To attempt to optimise this it is in order to make fine adjustments to L5 and the m.w. coil position and also to use the two trimmers on the end of the capacitor. Note that the two trimmers will have maximum effect at the high frequency end of the dial and should not be used in the mid-tuning range. Note also that they are single turn trimmers with no end stop so,



The completed radio showing the tuning disc, switches and volume control

don't ever try screwing them round and round in the hope of obtaining ever increasing capacitance.

The actual frequency coverage can be set by L5 and associated trimmer, but bear in mind that moving either of these will mean that the other setting will need to be re-adjusted. Take some time and good results will surely follow. Tuning problems or weak reception could indicate wiring errors so do double check this area.

## SUMMARY

Once built the Superhet Broadcast Receiver is ready for regular use. Its

performance will certainly stand up alongside commercial products. Battery drain will depend on frequency of use and volume levels, if required a clip of four or six AA cells could be used. A mains adaptor is also a possibility provided 9V is not exceeded, also expect an increase in interference as a lot of mains borne trouble can find its way into the circuit.

The plastic case used in the prototype is quite an appealing way of housing the project. Drilled clear front and rear panels and a clear tuning disc are available along with a full kit of parts for this project. □

**MINIATURE PASSIVE INFRA-RED SENSOR RP33**

Now supplied with switchable dual range 7 or 12 metres

Size: only 80x60x40mm. Wide 85° coverage. Switchable detection indicator.

The advanced intrusion detector operates by detecting the body heat of an intruder moving within the detection field whilst ignoring ambient changes. Easily installed in a room or hallway, the unit provides reliable detection of any intrusion. Operating from a 12V supply and requiring only 15mA, it is ideal for use with the CA 1382 or any equivalent high quality control unit. Supplied with full instructions its performance compares with detectors costing more than twice the price.

**ONLY £23.95 + VAT**  
Quantity discounts start at 3 units

**INFRA-RED SYSTEM IR 1470**

Consists of a separate transmitter & receiver, the system provides an invisible modulated beam which when broken operates the built-in relay. For use with security systems, but also ideal for photographic purposes and industrial applications. Size: 80x50x35mm.

**Only £25.61 + VAT**

**DIGITAL ULTRASONIC DETECTOR US 5063**

This advanced module uses crystal control transmitter & digital signal processing to detect movement at distance of up to 20ft or more. With built-in timing and 12V operation, it is ideal for a wide range of security applications.

**Only £14.93 + VAT**  
Suitable steel enclosure complete with necessary mounting pillars and blanks.  
**Only £3.95 + VAT**

**LIGHTING CONTROLLER DP 3570**

This versatile module provides timed switching of loads up to 3A, for pre-set times between 10 secs and 5 mins, the timed period being triggered by the opening or closing of an external loop or switch. The built-in 12V 250mA power supply is available for operating external sensors. Suitable plastic enclosure £2.85 + VAT

**Only £13.95 + VAT**

# SECURITY

SYSTEMS, MODULES, COMPONENTS

## SAVE £££

BY INSTALLING YOURSELF

**CPU 9000 SELF-CONTAINED ALARM SYSTEM**

Immediate Security Without Installation For Homes, Storerooms, Clubhouses, Caravans, etc.

■ Detects intruders up to 30ft. ■ Penetrating 103db Siren with auto reset ■ Compact size only 203x180x78mm ■ Easily extended for coverage of additional rooms or large areas.

This exciting new System which contains a Passive Infra-Red Sensor, Control Unit and Power Supply, together with a high output Siren all housed in the one compact steel case, provides immediate protection of a chosen area without the need for costly wiring and expensive installation costs. Operating from a standard 240V supply, provision has been made to incorporate a re-chargable 12V battery which is capable of operating the System for up to 10 days before re-charging becomes necessary, and which is carried out by the built-in charger. Where protection of more than one room is required, additional sensors may be wired to the main unit. An external siren unit may also be fitted to warn neighbours. Supplied with 2 keys and full operating instructions, the unit is fully guaranteed for 12 months. Immediate protection for only:

**Priced £67.72 + VAT**

**CA 1382 ADVANCED CONTROL UNIT that's simple to install and operate.**

- Fully automatic siren re-set.
- Audible entry/exit warning.
- Alarm sounded memory.
- 2 separate loop inputs + 24V circuits.
- Built-in electronic siren driver.
- Easily installed, full instructions supplied.

The latest control panel provides effective and reliable control for all types of security installations. Its advanced circuitry checks the loop circuits every time it is switched on, preventing incorrect operation. Using a simple 'on/off' key switch, it is easily operated by all members of the family. In addition it provides 24hr. personal attack protection. Housed in a steel case, it is supplied with full operating instructions.

**Only £44.95 + VAT** Available in kit form with fully-built electronics, £39.95 + VAT.

**CA 1250 LOW COST ALARM CONTROL MODULE**

This tried and tested control unit represents the finest value for money in control systems, providing the following features:

- Built-in electronic siren drives 2 loudspeakers
- Provides exit and entrance delays together with fixed alarm time
- Battery back-up with trickle charge facility
- Operates with magnetic switches, pressure pads, ultrasonic or I.R. units
- Anti-tamper and panic facility
- Stabilised output voltage
- 2 operating modes full alarm anti tamper and panic facility
- Screw connections for ease of installation
- Separate relay contacts for external loads
- Test loop facility.

**Price £21.35 + VAT**

**HW 1250 - ATTRACTIVE HOUSING plus HARDWARE FOR CA 1250**

An attractive steel case designed to house the Control Unit CA 1250 together with the appropriate LED indicators and key switch (available separately). Supplied with the necessary pillars, fixings, and punched front panel, the unit is given a professional appearance by the adhesive silk screened label. Size 200x180x700mm.

**Only £10.95 + VAT**

**POWER SUPPLY & MAINS SWITCHING UNIT PS 1265**

In addition to providing 12V stabilised output of 700mA, this module may be used to provide a switched 240V output for operating security lighting etc., when used in conjunction with the CA 1382, CA 1250, CPU 9000 etc.

Suitable plastic enclosure £2.85 + VAT.

**Priced at £12.95 + VAT.**

**RISCOMP LIMITED** Callers by Appointment Office hours Mon - Fri 9am - 5pm

Dept: EE3 51 Poppy Road Princes Risborough, Bucks HP17 9DB

## The Security Specialist

P&P U.K. Orders £1.50 per order Export add 10% Tel: (084 44) 6326 Fax: 08444 7102

ORDER BY MAIL OR TELEPHONE

MASTERCARD VISA

# FERMOSTAT Mk2

ANDY FLIND



*An accurate, interference free, solid-state thermostat originally developed for wine brewing but with a multitude of other uses.*

READERS who remember the original *Fermostat* project in the July '87 issue, will recall that it's purpose was to maintain an insulated cupboard at a steady eighty degrees Fahrenheit, to ensure rapid and reliable fermentation of the author's lethal home-brew. The recipe for the stuff was published with that project; hopefully not too many readers have poisoned themselves with it! (We can supply back numbers for £1.50 each for anyone who wants to try it! — Ed.)

Although the original 'stat has given faithful service, one minor snag has appeared. Last summer, the cricket commentaries on the workshop radio were occasionally interrupted by brief but annoy-

ing buzzing sounds, occurring each time the *Fermostat* turned on. The cause of this interference seemed to be the triac, turning on partway into each cycle until it had warmed up slightly.

## NEGATIVE DRIVE

Whilst this could probably have been cured simply by a change of triac, the author has since found that the particular device used is more reliable when operated with negative gate drive. This, coupled with the fact that the design of sensitive temperature controllers is a favourite occupation, led to a completely new design incorporating a number of improvements.

As well as negative gate drive, the new version has an LM335Z integrated temperature sensor instead of the original's thermistor. This costs more, but gives a more predictable and linear output, resulting in a linear control scale.

Another improvement is a zero-crossing detection circuit to control the point at which it turns on. This eliminates even the single "click" of interference when it turns on, meaning that it can operate as frequently as the user wishes without causing any problems.

Although some "hysteresis" has been built into the circuit, it can be omitted, giving very accurate control indeed. This may be useful, for example, to photographers, who often need to control the temperature of processing chemicals very closely.

## CIRCUIT DESCRIPTION

The full circuit diagram of the Electronic *Fermostat* Mk2 appears in Fig. 1. Low voltage for the electronics is derived from the mains supply by a capacitive voltage dropper, using C1 as the limiting device. *Note that this is a special capacitor intended to withstand continuous mains voltage, other types must NOT be used.*

Rectification is half-wave, by diodes D1 and D2, providing a supply that is negative of mains neutral. This is limited by Zener diode D3 to about 12V, and smoothed by capacitor C2. The mains transient suppressor VDRI protects the circuit especially the triac, from any high voltage spikes on the mains.

Resistor R2 disperses the stored charge in C1 when the unit is unplugged (to prevent the user receiving a shock from the plug!) and resistor R1 limits the maximum current flow until a fuse blows should C1 fail. Although this is a possibility that must be catered for, it seems to be a remote one. The author has never experienced a failure of one of these capacitors.

It is recommended that this project is used with a fused plug, fitted with a fuse of 3A or lower. Alternatively, a small cartridge fuseholder could be built into the unit itself for added safety.

Capacitive droppers, whilst not as safe as transformers, have several advantages. They are compact, cheap, don't hum, and don't run hot as most small transformers seem to do nowadays. They are efficient,

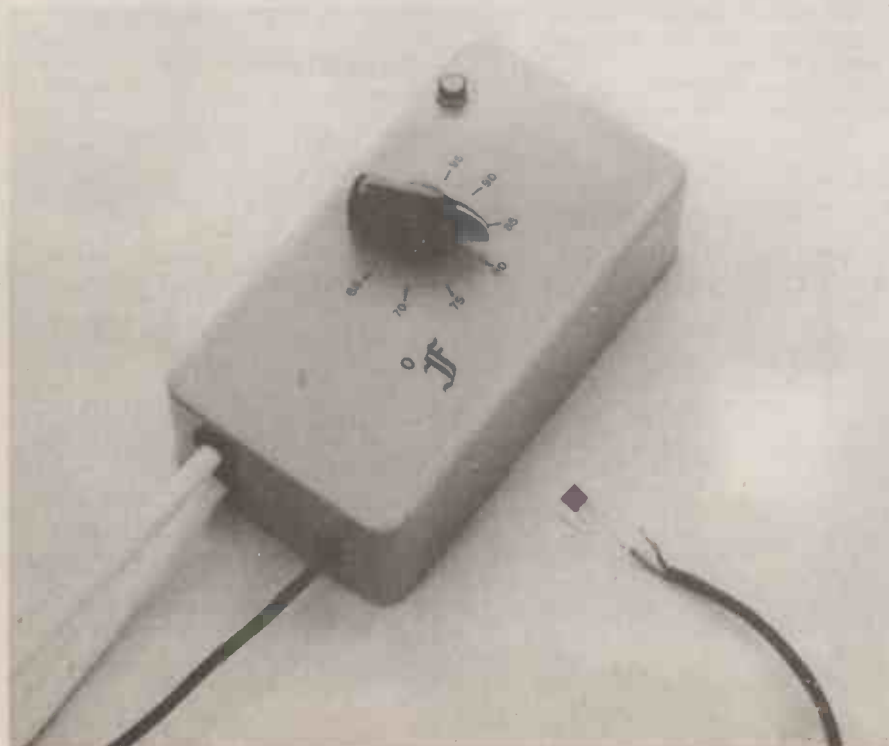

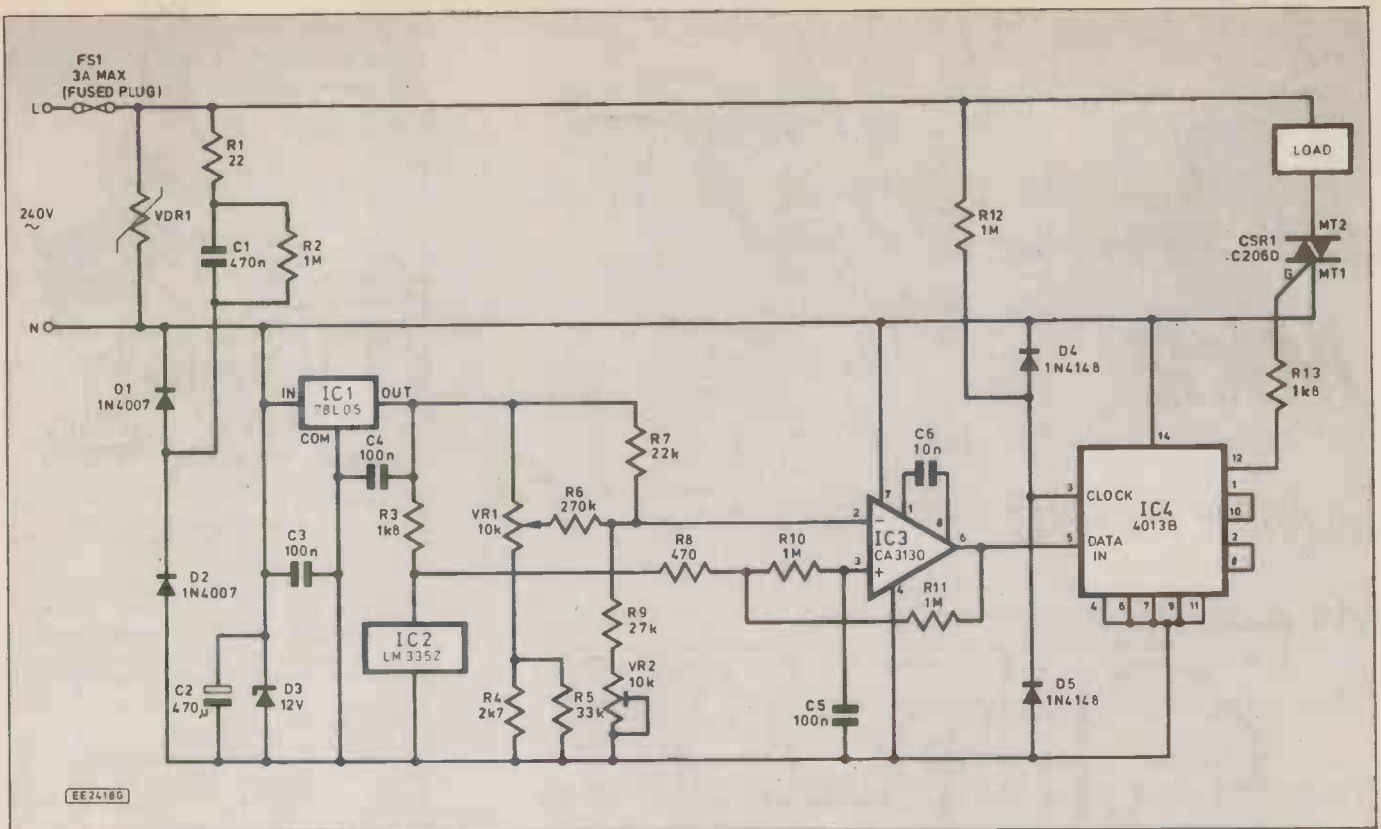

Fig. 1. Circuit of the Fermostat Mark 2

as the bulk of the unused current flowing through them is purely reactive; it will not increase the rotation of your electricity meter!

An accurately regulated voltage is required for the temperature measuring part of the circuit, this being obtained from a 5V 100mA regulator, IC1. Supplied with about a milliamp from resistor R3, the sensor, an LM335Z, develops 10mV for each degree Centigrade, starting from absolute zero. This, readers will recall from school physics, is 273 degrees below the usual zero Centigrade, so at zero it's output is about 2.73V. Adding on another 267mV for the Centigrade equivalent of the 80 degrees Fahrenheit operating point required, a figure of three volts total is reached.

Ignoring resistors R8 and R11 for the moment, any noise present on the input signal is filtered out by R10 and C5 before it goes to the non-inverting input (pin 3) of amplifier IC3. Resistor network R7, R9 and preset VR2 generates the equivalent three volts for the inverting input (pin 2), the small amount of adjustment available from VR2 catering for errors due to component tolerances etc.

The value of resistors R4 and R5 in parallel is such that at the centre of it's travel, VR1 should deliver three volts, with a variation of plus/minus two volts. Resistor R6 determines the effect this has on the reference voltage, thus setting the thermostat's range. The compensation capacitor C6 is necessary for stability with the 3130 amplifier (IC3).

Hysteresis, where the switch-off temperature is higher than the switch-on, is often required to prevent over-frequent operation of a thermostat. In this design it is introduced with positive feedback, through resistors R11 and R8. With the values shown the hysteresis is about one degree Fahrenheit.

When the input from IC2 is below the reference, the output of IC3 is low, and when above, it is high. This output goes to the "data" input, pin 5, of one of the two "D-type" flip-flops in IC4.

Pin 3 of IC4 is the "clock" input, driven from the mains through resistor R12 but clamped by diodes D4 and D5 so that it only just exceeds the supply rails. Thus the clock is driven "high" and "low" in synchronism with the mains. (Although the clock switching points don't exactly coincide with the zero-crossings in this design, they are close enough to eliminate interference).

Although the outputs of the 4013 (IC4) depend upon the data input, they only actually change on the rising edge of the clock. Thus, triac switch-on will always coincide with the mains zero-crossing.

Switch-off occurs only when the load current falls almost to zero, so with a resistive load such as a lamp or small heating element this will automatically coincide with zero crossing.

Two D-type flip-flops are contained within IC4. By connecting the outputs of the first to the "direct" inputs of the second, this is used as a buffer, mainly to give it useful employment! Each flip-flop has two outputs, one going high and the other low when it is "on". The low output is used, through resistor R13, so that when the input from IC3 is high, negative gate drive is supplied to the triac CSR1, to turn it on.

## CONSTRUCTION

Construction of this project should

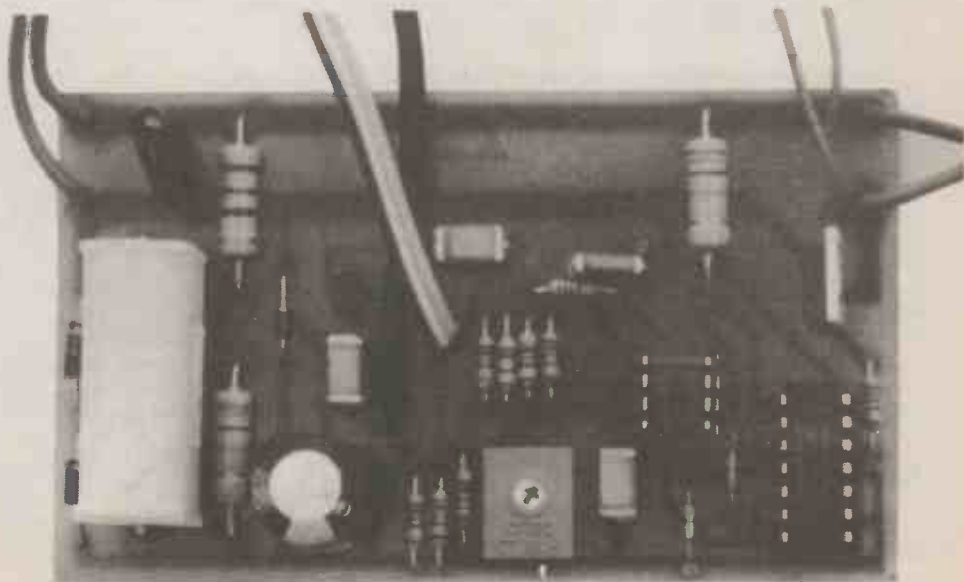

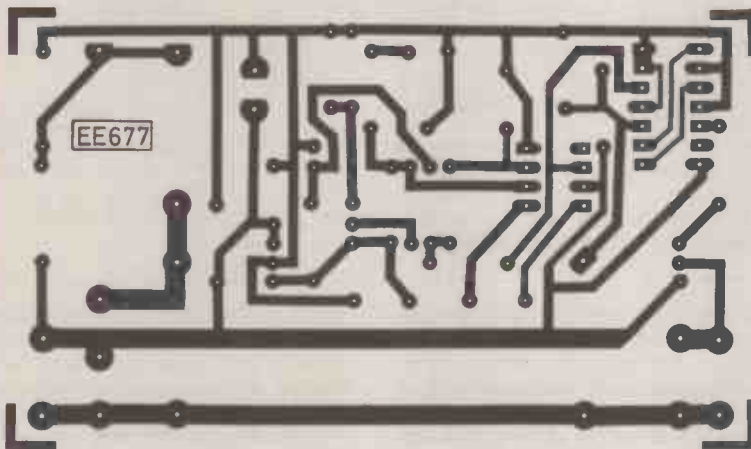
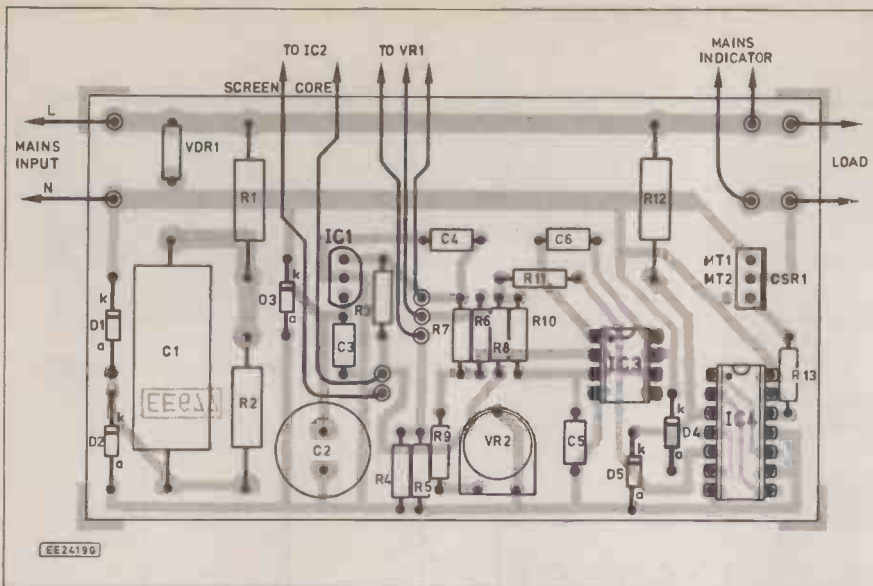

Fig. 2. P.C.B. Layout for the Fermostat

present few problems. Apart from the sensor (IC2), mains on indicator and set control VR1, all components are mounted on a single printed circuit board and the component layout is shown in Fig. 2. It is suggested that smaller components such as resistors and diodes are fitted first, simply because this is easier.

Do not fit IC4 or resistor R11 yet, though. R11 introduces hysteresis, but calibration is more easily carried out without this. If hysteresis is not required, R11 can be omitted and resistor R8 replaced by a wire link.

It is safe to use the project in this way as the zero-crossing detector will ensure clean switching, though in most control situations it will result in excessively rapid cycling of the heating device. Definitely not good for the gas boiler!

Take care to fit capacitor C2 and the five diodes the right way round. D.I.L. sockets are recommended for IC's 3 and 4.

The dangers of this circuit when energised from the mains should be obvious to readers of EE. *Under no circumstances should any part of the circuit or its wiring be touched when it is plugged into the 240V supply.* This includes the sensor and its lead, which should be insulated and installed so that no live part is uncovered. Bear in mind the hazards especially if it is intended to use the project with liquids, such as photographic chemicals. For this, complete potting of the sensor in resin is suggested.

Fortunately, much testing and all the calibration can be carried out with a safe, low voltage supply. Before testing, the project should be completed, with control, mains leads, and at least temporary connection to the sensor. Connections to the p.c.b. and controls are shown in Fig. 3.

The earth connection, if three-core flex is used, can be simply passed through from input to output. Although probably not strictly necessary, screened lead is suggested for sensor wiring.

The LM335Z has three leads, one of which is not required. It could be mounted in the box with the rest of the circuit, but this is not recommended as the three large resistors and the triac generate a small amount of heat. Although tiny, this could still affect accuracy. The project is intended for remote sensing anyway, mounted outside the author's home-brew fermentation cupboard with the sensor inside.

Although not shown on the circuit diagram, a small neon indicator can be fitted in parallel with the load, to show when it is "on". Connections for this are provided on the p.c.b. Leads to the board should be long enough to allow it to be placed clear of the box.

### TESTING

Before any testing, the five diodes should be checked in circuit, with a multimeter, as a faulty one may result in

## COMPONENTS

### Resistors

R1	22 1W
R2, R12	1M 1W (2 off)
R3, R13	1k8 (2 off)
R4	2k7
R5	33k
R6	270k
R7	22k
R8	470k
R9	27k
R10, R11	1M (2 off)

All 0.6W 1%, except where stated.

### Potentiometers

VR1	10k lin. carbon
VR2	10k sub.min preset.

### Capacitors

C1	470n mains suppression type. (250V RMS 50-60Hz).
C2	470µ elect. 25V radial lead.
C3, C4, C5	100n min. polyester layer (3 off)
C6	10n min. polyester layer.

### Semiconductors

D1, D2	IN4007 silicon diode (2 off)
D3	BZY78L012 12V 400mW Zener diode.
D4, D5	IN4148 silicon diode (2 off)
CSR1	C206D triac.
IC1	µA78L05 5V 100mA regulator.
IC2	LM335Z temperature sensor.
IC3	CA3130E CMOS op-amp
IC4	4013B CMOS dual D-type flip-flop.

### Miscellaneous

VDR1	Mains transient suppressor.
------	-----------------------------

Printed circuit board, available from *EE PCB Service* order code *EE 677*; case, ABS plastic 150mm x 80mm x 50mm; 8-pin d.i.l. socket; 14 pin d.i.l. socket; control knob; FS1 3A fuse (see text); 2-core screened lead; min. mains neon indicator lamp (optional); mains lead; connecting wire; solder etc.

Approx cost.  
Guidance only

**£15**

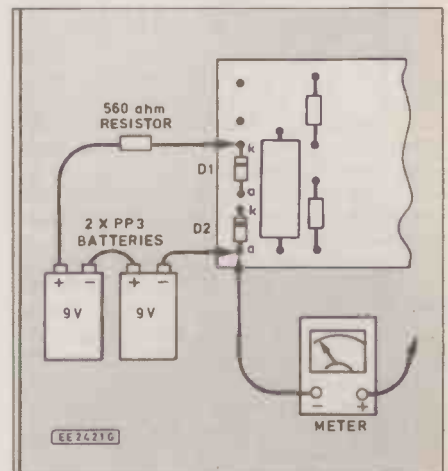
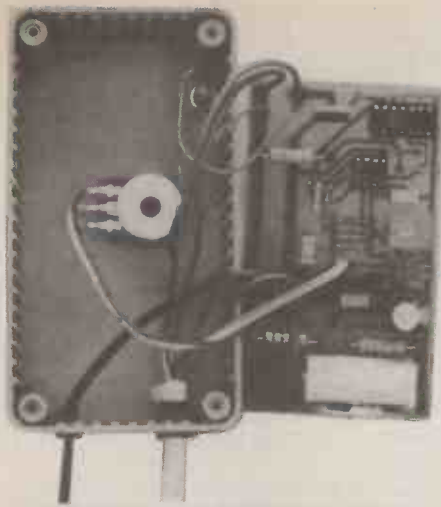

Fig. 4. Test supply set-up.

expensive damage on mains power. Next, with IC4 NOT fitted, the circuit should be "powered-up" as shown in Fig. 4, with 18V d.c. applied across diodes D1 and D2 through a 560-ohm series resistor. The



drain should be around 12mA, so a couple of PP3 batteries can be used. This should bring Zener D3 into operation, so presence of the 12V and 5V supplies can be checked.

Next the output of IC3 should be monitored with a meter, it's easiest to make the connection with a short wire soldered temporarily to the board, though it can be picked up from pin 5 on IC4's socket. Rotation of VR2 should cause the output of IC3 to switch from zero to 12V as the reference passes the input voltage from the sensor.

Incidentally, just to demonstrate the value of these checks, this one picked up a dud 3130 on the prototype. A brand-new one at that! Plugging in a replacement cured the problem.

### CALIBRATION

Assuming all is well, calibration is next. This consists of taking the sensor through the operating range and first setting the preset VR2 for the correct mid-point, then calibrating VR1.

If the sensor is waterproofed, it can be immersed in water at the desired temperature as measured by a mercury thermometer or some similar reference. If it isn't, the method used by the author may be helpful.

The water was placed in a plastic container, with the sensor pressed against its side with a drop of heatsink compound to ensure good thermal coupling, a

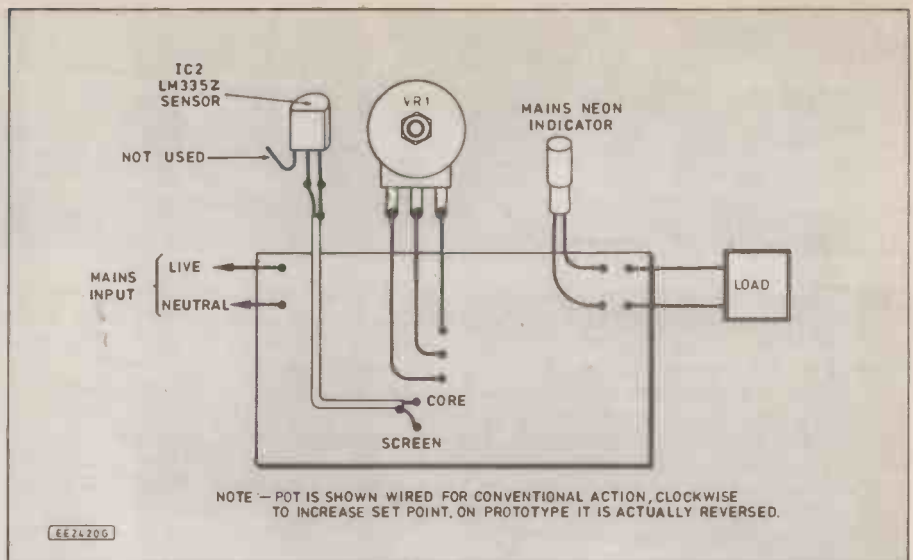

Fig.3. Interwiring to the p.c.b.

piece of polystyrene foam over it to prevent losses affecting it's output, and some adhesive tape holding it all in place. The only problem with this setup is that it takes slightly longer for the sensor to reach the set temperature than is the case if it is immersed.

To start with, VR1 is set to mid-travel, then the sensor is taken to the desired mid-range temperature and VR2 is adjusted for output switching at this point. Following this, the sensor is taken through the control range five degrees at a time, and the switching points are found and marked on VR1. That's all there is to it. Fiddly and time-consuming job, but fun!

Following calibration resistor R11 and IC4 can be fitted and the project assembled into the box for testing with mains power and a suitable load. If any further work is found necessary at this stage, **EXTREME** caution should be exercised. Hopefully all will be well.

Sensor mounting and load will depend on the intended use. Loads should be resistive, and of not more than a couple of hundred watts owing to the lack of a heatsink on the triac. If this is mounted on a small heatsink, perhaps off-board, then up to 750 watts can be supplied as it is a 3-amp device.

The prototype controls four 100W light bulbs, connected in two series pairs to act as a reliable heater. Used in this way they actually draw about 120W, as the filaments have less resistance at the lower temperature. The sensor is mounted in a plastic 35mm film container, drilled with plenty of holes to allow free passage of air.

### OTHER USES

Other uses for this project could include domestic heating control, so long as the load is not too high or inductive. Preset VR2 should permit adjustment to a more suitable range. Hysteresis can be adjusted by alteration of the value of resistor R11. Halving it, for example, would double hysteresis to about two degrees F. Some interposing device may be required if it is to operate pumps and solenoids.

Apart from home-brew fermentation and photographic chemical temperature control, one application to which it would be ideally suited is heating for tropical fish tanks. The sensor could probably be fitted to the outside of the tank, in a manner similar to that described in the calibration procedure. Further uses will no doubt suggest themselves to suit readers' own interests. □

# MARKET PLACE

**NEWBURY** 8840 printer. 240cps, 9-pin, wide. Buyer collects. Offers please. N'pton (0604) 644005 after 6 p.m.

**EVERYDAY** Electronics 1971-1984 bound. 1985-loose. Practical Wireless 1973-1978 bound. Sensible offers only. (0293) 22394.

**WANTED** user/man for Commodore 8032 — 5K computer or service man. Tel. (0896) 57909 after six or write to Edward Deerin, 73 Langley Drive, Galashiels, Selkirkshire TD1 2UB (Scotland).

**WANTED** high power a.m. transmitter. Send details to Craig D. Beck, 446 Coniscliffe Road, Darlington DL3 8AL.

**WANTED** circuit diagrams of valve power amplifiers 15 to 40 watts suitable for construction. Mr. R. Sheard, 76, Village Road, Garden Village, Hull HU8 8QT.

**CLEAROUT** components, panels, record decks, speakers, everything must sell! Tel. (0302) 333422.

**WANTED** Tektronix T547 scope manual or photocopy. G.R. Shaw. Tel. 01-954-9614 after 5.30 p.m.

**SURPLUS** boxes of components, hardware, boards, etc. Lots of bits. Many bargains. £5 per kilo + p&p. N. Johnson, 2, Chapel Field, Dixter Road, Northlam, E. Sussex TN31 6PQ.

**HAMEG** HM204-2 oscilloscope. Levell TG302 function generator, logic probes, microscope and more. All as new. Offers? Alan Scrimgeour, 01-340-6687 (Wood Green, London).

**TEKTRONIX** 545A valve 'scope. Excellent condition, 24MHz with manuals and brand new spare tube. £70. R. Meir, 78 Smithyfield Road, Norton, Stoke on Trent, ST6 8JT. Tel. (0782) 534361.

**WANTED** a disk drive socket and a plug suitable for an Atari ST. Must be cheap! Mr. J. Pearce, 18, Wallace Road, Ipswich, Suffolk IP1 5DB. Tel (0473) 45143

### FREE READERS ADS.

**RULES** Maximum of 16 words plus address and/or phone no. Private advertisers only (trade or business ads. can be placed in our classified columns). Pen pals or items related to electronics only. No computer software. EE cannot accept responsibility for the accuracy of ads, or for any transaction arising between readers as a result of a free ad. We reserve the right to refuse advertisements. Each ad. must be accompanied by a cut-out valid "date corner". Ads. will not appear (or be returned) if these rules are broken.

**WANTED** copies paid for manuals of Telequipment oscilloscope type S32AR and Advantec p.s.u. type PP32. George Turner, 'Oronsay', Hemp Lane, Wigginton, Tring, Herts. HP23 6HF. Tel. (044-282) 3344.

**TIL311** red hex displays, integral latch and decoder. RS price £9.32 each! Only £5.50 including data. Tel (0384) 634747.

**WANTED** antenna unit for Panasonic NV333 — part number ENP-E716 also remote for same. Cheap please. Mr. D. Wood, 57 Willis Pearson Ave., Bradley, Bilston, West Midlands WV14 8DA.

# FOR YOUR ENTERTAINMENT

BY BARRY FOX

## CD Sales

The statistics for CD sales point a rosy picture. In the UK they have for the first time overtaken sales of black vinyl LP's. The future is a clear split between CD and the music cassette, which continues to prosper too, thanks to near saturation of the population with personal stereos.

At a boxing match in Britain recently one of the fighters paraded from his dressing room to the ring with a pair of headphones clamped to his cauliflower ears. The referee had to prise them off him to start the bout. All the signs were that he would have happily fought with them on.

Philips, which takes a royalty from all CD players and all discs produced anywhere in the world by anyone, has every reason to be happy. The record companies are happy too. They have tapped the rich vein of re-releasing old music in the new CD format, as well as new all-digital material.

## Piracy

But there is one fly in the ointment. And that's South East Asia. I was in Malaysia recently, on the island of Penang which — thanks to generous no-tax incentives from the government to companies like Hitachi and National Semiconductor — is now the third largest manufacturer of semiconductors in the world, after Japan and the USA.

But even in the capital city, George Town, I could not find a single shop selling CDs. The only recorded music is on cassette.

Why? Because in that part of the

world piracy is the norm. The clothing is all fake Lacoste, Gucci and Boss. The perfume is fake Chanel 5. The watches are fake Rolex.

At less than £1 each, pre-recorded cassettes cannot possibly be genuine.

The grand plan of the record industry was to swing the world record market over from cassette to CD. Whereas pirates can make their cassette copies in a back room with just a couple of budget decks and a pile of cheap blank tapes, to press CDs you need a million pound factory, clean air and water supplies and a lot of know-how.

That's exactly why SE Asia hasn't yet shown any interest in CD. And exactly why the record industry is looking for any way to force the switch.

## Head to Head

Where *do* all those headphones go? The shops are full of them, but who needs more than one pair per personal stereo?

The answer is that headphones are delightfully fragile. People break them within a few months of buying a new personal stereo. So there is a thriving market for replacements.

On a radio phone-in recently a puzzled caller wanted to know whether he was being "snowed" by a dealer who said that he must use Sony "green ring" headphones with his Sony FM radio Walkman. The caller had tried using other headphones but could not get good f.m. reception. So was the dealer right? Is there some electronic magic in Sony's headphones?

I didn't know, so I asked Sony. The short answer is no, there is no magic. The green rings on the jack plug are just rings of green insulating material between the pins. They might just as well be yellow. In this respect, the dealer was talking through his hat. But there are a couple of useful, general principles.

Many people do not realise that portable personal radios rely on the headphone connecting cord as the f.m. aerial. If you buy headphones with a short cord, or wind it neatly into a tight roll, you may not get good f.m. reception.

If your personal stereo has a remote control switch on the headphone lead, for instance to start and stop the tape and alter playback volume, you must buy the same brand headphones. The remote usually works with d.c. voltages which operate on solid state logic. If the control signals do not match the logic, it will very likely "hang up". The whole player then refuses to work until a correct, matching pair of headphones is plugged in.

## Loophole

A decision by the Advertising Standards Authority recently identified an interesting loophole in the law.

A member of the public complained about an advertisement published by Tandy, for the Model 102 and 200 portable computers. These have an internal modem for electronic mail, and the advertisement claimed that they are "widely used by journalists because of their built-in software and modems, which facilitate the writing of reports and articles and the subsequent sending of files back to an office PC, via the telephone network."

True, but the advertisement also carried a red triangle warning which read: PROHIBITED FROM DIRECT OR INDIRECT CONNECTION TO ANY TELECOMMUNICATIONS SYSTEM RUN BY BRITISH TELECOMMUNICATIONS. ACTION MAY BE TAKEN AGAINST ANYONE CONNECTING THIS APPARATUS."

Not unreasonably, the complainant questioned the legality of promoting computers on the basis of apparent illegal use by journalists. But the ASA had to turn down the complaint.

Oftel, the Office of Telecommunications, confirmed to the ASA that the advertisement conformed to the Telecommunications Apparatus (Advertisements) Order 1985. It is not an offence in the UK to advertise unapproved telephone equipment, provided that the red triangle warning is included.

That's why you still see Tandy advertisements for both the 102 and 200 portables boasting that the "built-in modem can relay information from anywhere in the world" or "from wherever you are" — alongside a small print red triangle warning that doing this can land you in trouble in the UK.

## First Principles

Record companies are now busily re-issuing old recordings on compact disc, by blitzing them with high tech electronics. Often the music ends up sounding as if it has been filtered through a wet sock.

However, British company Nimbus went back to first principles, and the first quarter of the century when artists sang or played into a horn. The soundwaves vibrated a diaphragm which caused a stylus to cut a groove in a blank disc.

The recording was replayed by a stylus which vibrated a diaphragm in the neck of a horn to create soundwaves. Many people never heard the music as intended because the quality of the recording equipment far outstripped that of all but the most expensive domestic gramophones.

Nimbus obtained one of the very few remaining EMG Expert gramophones. These were "hand made by E. M. Ginn" for serious record collectors in the 1930s. Nimbus engineers replaced the original wind-up motor with a variable speed electrical motor, which drives the turntable by a belt. Soft thorn needles reproduce the sound through a papier mache horn (which Ginn often made from old London telephone directories).

They put a modern high quality microphone and digital tape recorder in front of the gramophone and played the records without any electronic processing whatsoever. The recording was made in the Ambisonics system.

This gives a lifelike surround of sound if loudspeakers are placed round the room, or stereo from a pair of speakers. Modern listeners thus get to hear what it was like to listen to Enrico Caruso, Richard Tauber and Claudia Munzio on an "Expert gramophone".

The recordings are released by Nimbus on the new Prima Voce label. Five Prima Voce CDs were available in late 1989, all of vocal music dating from 1906-1939. A sixth record was promised for January, 1990.

Nimbus engineers pledge that they have used absolutely no electronic signal processing tricks. All their effort goes into finding near-perfect original discs.

The only electronic aid is a speed control on the turntable motor. This adjusts replay speed to match the intended musical pitch. Many old recordings were labelled 78rpm, but had accidentally been recorded several rpm too fast or too slow.



MICRONTA  
 22-194  
 22-165  
 22-7001

# High Technology Test Equipment

## 30-Range Digital Multimeter

**£69<sup>95</sup>**

Features front-panel socket for transistor and capacitor tests. Low battery indicator, diode check function and continuity sounder. Measures to 1000 VDC, 750 VAC, 10 amps AC/DC current, 20 megohms resistance. 20  $\mu$ F capacitance and transistor gain. Requires 9v battery. 22-194



## Probe Style Autoranging Multimeter

**£29<sup>95</sup>**

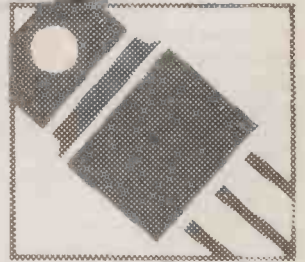

Data hold function enables you to freeze the display and to remove it from the circuit for more convenient reading. Measures to 400 volts AC/DC and resistance in K-ohms up to 2 megohms. Includes 2 button batteries. Overload protected. With carrying case ..... 22-165

## Regulated Power Supply

**£59<sup>95</sup>**



13.8 VDC Regulated Supply. Ideal for use with HAM transceivers. 5A continuous. 12A intermittent. 15A surge. 240 VAC, 50 Hz. Fused ..... 22-7001

## For The Best In High Quality Electronics

Over 400 Tandy Stores And Dealerships Nationwide. See Yellow Pages For Address Of Store Nearest You.

InterTAN U.K. Ltd., Tandy Centre, Leamore Lane, Walsall, West Midlands, WS2 7PS. Tel: 0922 710000

**Tandy**<sup>®</sup>

# MICRO IN CONTROL

JOHN HUGHES

Part Four



Starting from very basic principles this series quickly builds through logic to simple microprocessor control. It is based on the experiences gained through teaching courses on the subject.

**W**ITH the idea of basic gates under our belt we will now move on to look at how they can be used in circuits and Combinational Logic.

**S** Can we build up a logic circuit, a "gate"?

**I** We could build one from the circuit we have on our breadboard, but it isn't necessary, as they are made in the form of integrated circuits, or "chips". Here's one (shows a 14-pin integrated circuit, an i.c.).

An i.c. is built of transistors and diodes just like the ones we've been using, but several are made on a single chip of semiconductor, usually silicon, and are already wired up into a circuit by the manufacturer. Suitable input and output leads, and a power supply, are connected to its pins, and off we go.

**S** How can we test it when it's made?

**T** We need input and output test circuits. These we can choose to build, or we could use "ready-made" ones. They often form part of a "logic kit" designed to do just this; to help us to build and test various logic circuits.

We can use a "chip" to make ourselves an output testing unit. It's actually a member of the very large "family" of logic chips we'll be meeting as we proceed. The input unit can be very simple, just a switch, as we'll see. In fact, for our first "go" we can just plug the input leads into 0V ("FALSE") or into 5V ("TRUE").

Our unit is based upon the transistor circuit we have just been using, but we shall replace the torch bulb with a red l.e.d. We need not concern ourselves with the internal circuitry of the chip (unless we take up chip designing). We do, however, need to be aware of the kind of input and output signals the chip is intended to use or to generate.

In other words, we need to know what kind of circuits the chip "expects" to be connected to. We can find this information in the manufacturer's "Data Sheets". For many circuits, the details are similar, and we soon find it unnecessary to do more than remember a few easy "rules", such

as: **RULE 1** - Never use a power supply of (much) more than five volts.

**RULE 2** - Don't connect in a signal voltage greater than the supply voltage, or the wrong way round.

**RULE 3** - Don't demand too high a current from the output of the chip (don't connect too LOW a resistance "load").

Chips from the same "family" are designed so that, as a rule, the output signal of one circuit can be used as the

input signal of at least ONE following circuit (sometimes, it can be "fanned-out" to drive as many as ten). This makes it very easy to link up quite complex circuits quickly and to alter them as necessary during development.

The circuit of our checker is shown in Fig. 4.1, this also shows its layout on one end of the breadboard. You could build it on a small separate breadboard if you prefer.

Fig. 4.1. Output indicator. L.E.D.s must be the right way round. Slide switches can be used for inputs, or test by linking A, B, C, D in turn to 0V or 5V.

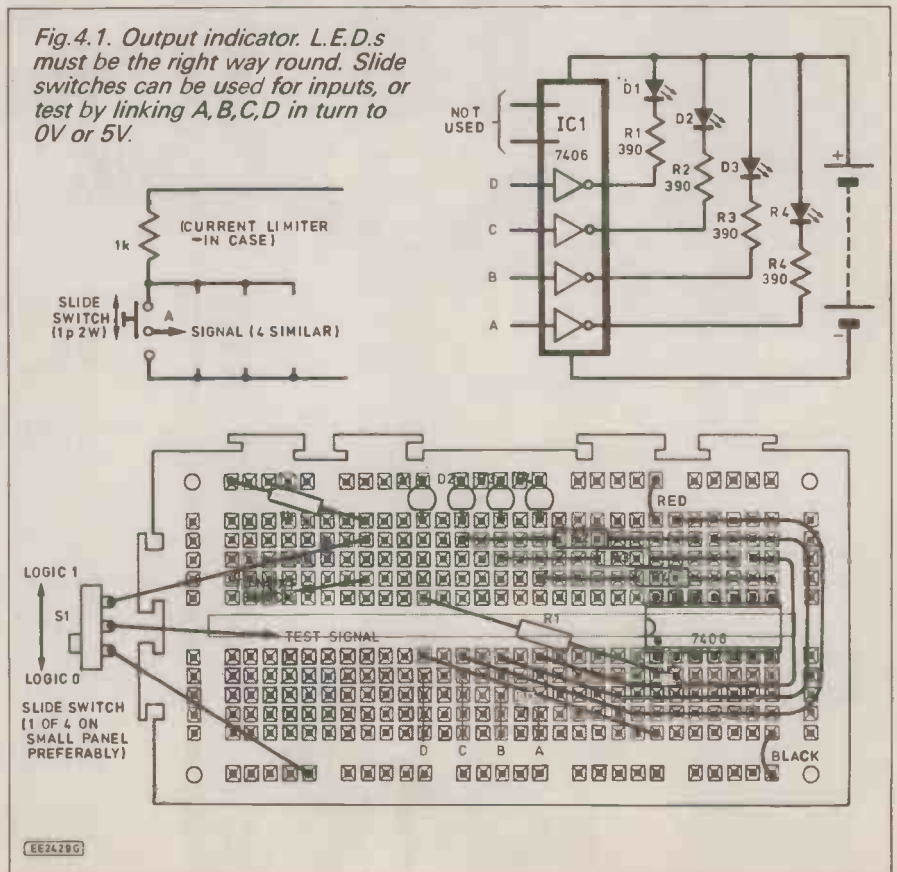

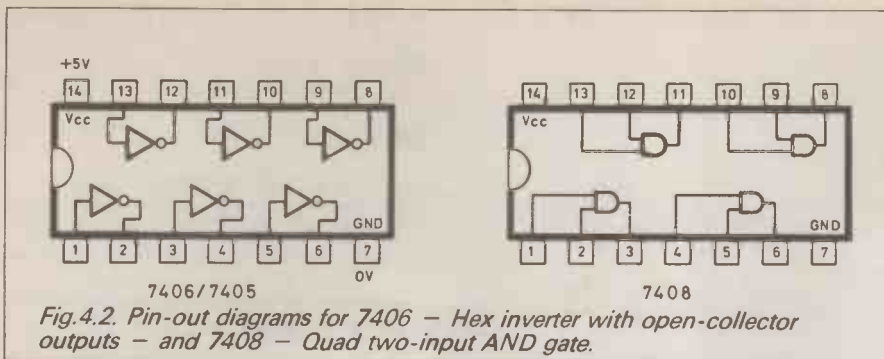

Fig. 4.2. Pin-out diagrams for 7406 – Hex inverter with open-collector outputs – and 7408 – Quad two-input AND gate.

A suitable switch arrangement to provide an “input unit” is also shown, in case we get fed up with plugging and unplugging the input leads. It’s very convenient to have FOUR separate circuits, as in the diagram, though we can make a start with only two or three.

Now for the chip. First, study its pin connection diagram (Fig. 4.2). Note that, whereas we read transistor base diagrams (and most others) as they appear from beneath the device, an i.c. diagram is always read from ABOVE the device, i.e. looking down on it. Pin 1 is the key one to find, near the notch or dimple as shown (Fig. 4.1). Then count anticlockwise to the rest of the pins.

Called “Hex inverters”, our chip, type 7406 (or 7405 will do), has “open-collector” outputs. We shall only use four of the six inverters, and use i.e.d.s, with resistor ballast, to link the collectors to the supply line. Most chips have internal collector links, but not this one.

Switch off the power, then insert the chip very carefully into the board, bridging the central channel, as in Fig. 4.1 taking special care not to allow the pins to bend. It’s a good idea to adopt the habit, for a start at least, of always positioning every chip with its notch (pin 1) at the left, to avoid wrong pin connections.

Next, add power links, red from pin 14 to the 5V line, and black from pin 7 to 0V. Check with the diagram.

**S** What does  $V_{cc}$  mean?

**T**  $V_{cc}$  on the manufacturer’s diagram means the “collectors’ voltage supply”, and GND is American “ground” for “earth”.

Keeping it tidy (you’ll be glad later), add the four resistors and the i.e.d.s, and finally the “signal” links, so as to end up with a neat arrangement of four sockets, each below its corresponding i.e.d. indicator. You may like to add a small sticky label as shown to complete the job.

Finally, re-apply power.

**S** My indicator is ON, though there’s no input connected yet.

**T** That’s normal with these circuits, as they have internal links which feed the transistor bases. If you link the input and set to 0V (not leave it “floating”) it should be OK. We can say that the input “floats up” to logic 1 if left unconnected. It can actually be useful later.

We’re ready now to use our unit to test another chip (the 7408). Look at its “pin-out” (in Fig. 4.2). Can you tell, from the diagram, what kind of circuits this chip contains?

**S** Gates / AND Gates / four of them

**T** That’s right. It’s got four “TWO-INPUT AND GATES”. It’s another member of the large family of chips called Transistor-Transistor-Logic (TTL) chips, the “74” series. We shall meet many more of them. (There’s another very popular family called CMOS

(“Complementary-symmetry Metal Oxide Semiconductor”) series. Each has its advantages and disadvantages, which we could discuss later.

Our chip is type number 7408 (or 74LS08 if more readily available). You can find out more about it and the rest in the manufacturer’s handbook, the TTL Data Book, but all we really need is the pin diagram above.

Now switch off the power for a moment, and carefully insert the chip in the board (Fig. 4.3), with pin 1 at the left. Now add links for the 5V supply (red) and the 0V line (black). Then take two input leads to the two input pins of one gate and an output lead from the output pin of the same gate (the diagram shows the top left gate being used).

Re-apply power, and operate the switches, noting the state of the output each time. We can now build up our Truth Table for the gate:

STEP 1: Across the top. Label two INPUT columns, A and B, and an OUTPUT column, X.

STEP 2: Now enter ALL POSSIBLE combinations of inputs under A and B. In this case there will be FOUR different possibilities. The best way to enter these is to write in the first four binary numbers including ZERO.

STEP 3: By plugging in links A and B to 0V or 5V in turn (or, if you’re posh, by operating your switches), note the output for each combination, and enter it under X.

Here is the TRUTH TABLE for an AND gate. Compare it with the results you obtained, to confirm that your chip is OK. You’d better check one or two of the other gates in the chip, too, by transferring the input and output leads to the appropriate pins.

Truth Table For the “AND” Gate

INPUTS		OUTPUT
A	B	X
0	0	0
0	1	0
1	0	0
1	1	1

The output of an AND gate, of course, is only TRUE (logic 1) when both A AND B are true, as in the bottom row.

**S** Can we try an OR gate?

**T** Sure. Would you care to look at the pinout sheets to see which chip we could try?

**S** The 7432 seems to have two-input OR gates (Fig. 4.4).

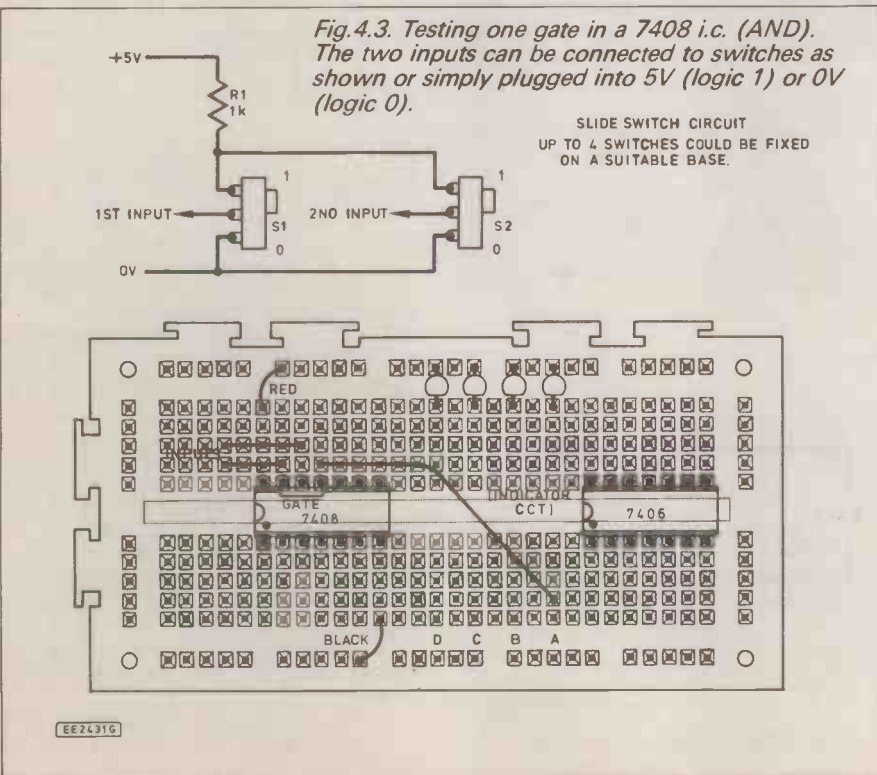

Fig. 4.3. Testing one gate in a 7408 i.c. (AND). The two inputs can be connected to switches as shown or simply plugged into 5V (logic 1) or 0V (logic 0).

SLIDE SWITCH CIRCUIT  
UP TO 4 SWITCHES COULD BE FIXED  
ON A SUITABLE BASE.

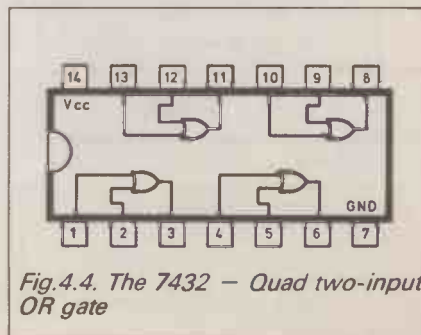

Fig. 4.4. The 7432 – Quad two-input OR gate

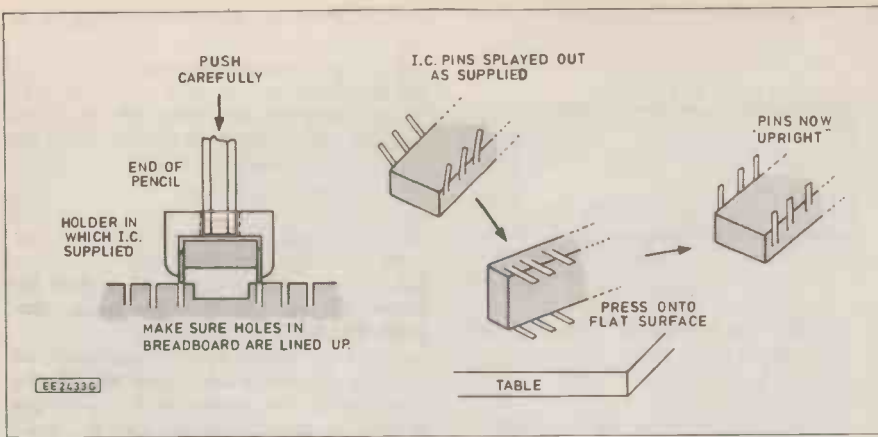

Fig.4.5. Handling integrated circuits

**S** (another) And we don't need to change the connections.

**T** A clever move. You can just, very carefully, prise out the AND chip (easy, one end at a time, with a tiny screwdriver, or even a ball-point pen, used as a lever), then insert as before, the new chip. Notch at LEFT, OK?

**S** Isn't there a special tool for handling chips?

**T** Yes, there are insertion and extractor tools which can help a lot if you have to handle many chips. You can use a pencil to push a chip into position from one of the plastic protectors in which they're sometimes supplied. You may also find it helpful, especially with large sized chips, to bend the row of pins along each side so as to get them more upright. Do this by pressing it gently, edgewise on a flat surface. The sketches may help (Fig.4.5).

Now let's get on with testing the OR gates. Don't forget to fill in a Truth Table again, then compare it with this one,

which, as you'll see if you think about it, describes the behaviour of an OR gate:

Truth Table for "OR" Gate		
INPUTS		OUTPUT
A	B	Y
0	0	0
0	1	1
1	0	1
1	1	1

Clearly different from an AND gate, isn't it?

**S** What would it be for the "exclusive-or" gate you mentioned earlier?

**T** Just the last row would differ. The output in this case would be 0 if BOTH inputs are 1. Such a gate, and many others, can be built up from the three basic ones. It is useful, along with the others, in circuits for performing arithmetic (binary, of course).

**S** There are also three and four-input gates, aren't there?

**T** And more, as no doubt we'll find uses for.

**S** I've heard, too, of NAND gates.

**S** (another) and NOR gates.

**T** That's our next move. We are looking at what is often called "Combinational Logic", for it's to do with combining a number of gates together, the output of one becoming the input of the next, and so on. A very important field of application of logic circuits.

If we stick an inverter (NOT) after an OR gate (Fig. 4.6) like this, we'll have a "NOT OR" or a NOR gate. Let's draw up its Truth Table. It's easy, because, if

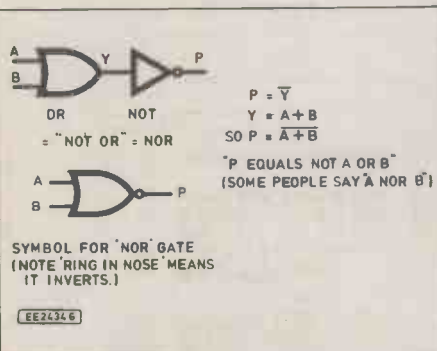

Fig.4.6. NOR gate

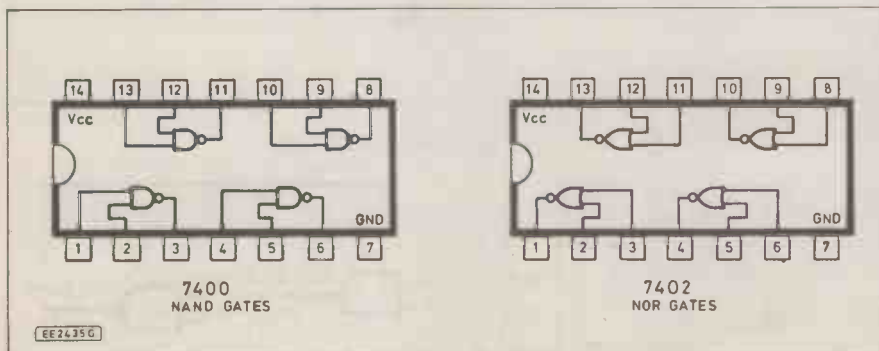

Fig.4.7. 7400 and 7402 pinouts. Notice the opposite "direction" of the gates in the 7402

we start with the OR gate table, what do we need to do to get the NOR table?

**S** Just reverse all the output values / invert the outputs / change 0 to 1 and 1 to 0.

**T** Easy, isn't it? Thus:

Truth Table for "NOR" Gate		
INPUTS		OUTPUT
A	B	P
0	0	1
0	1	0
1	0	0
1	1	0

Could we build one?

**S** There's one in the list. Type 7402?

**T** So there is. We COULD build one by linking the output of a 7432 gate to the input of a . . . which?

**S** 7404?

**T** Right, a 7404, which is a "Hex Inverter", but with the necessary internal links (not "open-collectors"). As you can imagine, it's a widely-used chip.

However, since you've spotted it, carry on and test the NOR gates in the 7402. Notice that it "points" the other way from the earlier chips, so you WILL have to alter some of the links this time (Fig.4.7).

**S** There's a NAND gate, too. Presumably "NOT AND"?

**T** Yes, and you can go on to test i.c type 7400, first in the family, and check its Truth Table, too:

(Try to work it out for yourself before looking at this)

Truth Table for "NAND" Gate		
INPUTS		OUTPUT
A	B	Q
0	0	1
0	1	1
1	0	1
1	1	0

**S** Why do we stick with only TWO inputs?

**S** (another) To keep the tables short

**T** Exactly. Every extra input will DOUBLE the number of rows in our truth table, won't it? At times, we may HAVE to deal with longer tables, but for now, it seems better to keep it simple. But do write out the truth table for a three or four input gate, just once, at least.

Here's a summary in table form, of the two-input gates we've looked at. Also the Boolean Algebra relations that apply: Fig. 4.8.

#### A Bucketful of NANDs

**T** An interesting feature of the "dual-function" NAND gate is that it can be made to perform literally ANY of the functions we've been talking about, at least, if we have a sufficient number of such gates. This makes it tempting for the designer of logic circuits to stick to one type of gate in order to economise on bulk purchase and the need for few different spares.

Here's an example. Suppose we have a "bucketful" of 7400 chips. Could we build, say an AND gate?

INPUTS		AND	OR	NOR	NAND
A	B	X = AB	Y = A+B	P = $\overline{A+B}$	Q = $\overline{AB}$
0	0	0	0	1	1
0	1	0	1	0	1
1	0	0	1	0	1
1	1	1	1	0	0

$P = \overline{Y} = \overline{A+B}$        $Q = \overline{X} = \overline{AB}$

EE2438G

Fig.4.8. Summary of truth table for four kinds of two-input gates

- S** We'd need an inverter, a NOT gate.  
**T** Exactly. Could we use one of our NANDs as a NOT?  
**S** (after some thought) Yes, if both inputs were tied together.  
**S** Or if one input were to be connected to the 5V line permanently.  
**T** Good. Yes, either of these would result in a NOT gate if you think about it. The Truth Table may help:

Truth Table for "NOT" gate

INPUTS		OUTPUT
A	B	P
0	0	1 A and B are equal in this row
0	1	1
1	0	1
1	1	0 and in this one.

Linking A and B would give us the result of just the top and bottom rows, which would be a NOT result. OK?

Connecting B (say) to 5V (logic 1) would restrict us to rows two and four, which shows the output opposite to input A each time. A NOT function again. (In fact, because, as we saw earlier, an UNCONNECTED INPUT will "float" up to logic 1, we will get the NOT effect if we simply ignore one of the inputs, though it might be better to make the connection to

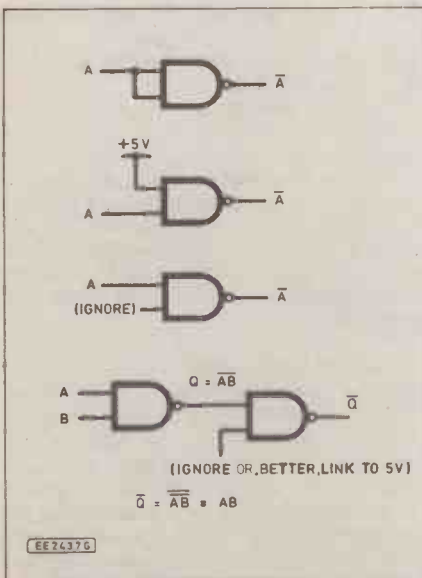

Fig.4.9. The top three arrangements act as inverters. A 7400 can also be used to make two AND gates — one is shown

5V to avoid the pickup of odd signals. For a quick test, this is the "easy" one.)

Here are the alternatives, (Fig.4.9) and the NAND equivalent of AND:

**S** How can we make an OR gate out of NANDs?

**T** It CAN be done, though it isn't obvious, is it?

This is a good moment to introduce a useful rule of logic. It's called "de Morgan's Rule". Actually, there are two of them. A sort of matched pair. They're easier to remember as they appear written, than as they sound in words. It might be a good exercise to try to think them out, but for now let's just write them down:

RULE 1  $\overline{A} + \overline{B} = \overline{AB}$

RULE 2  $\overline{A+B} = \overline{A} \cdot \overline{B}$

**S** They're all negatives!

**T** Yes, that's why they sound odd in words — all NOTs. However, they can be useful at times, such as now.

Here's the Boolean expression for OR (the one we want), also the expression for NAND (the ones we've got): A OR B is  $A+B$ , the NAND function means inverted AND. So, starting with  $A+B$ , let's invert it, to get  $\overline{A+B}$ . Right? Now, according to de Morgan, this is equal to  $\overline{A} \cdot \overline{B}$  (Rule 2).

Thus, if we take our signal A and invert it (using a NAND as an inverter, OK?), then do the same with signal B, we shall have NOT A and NOT B.

Send them through a two-input NAND gate (this is the clever bit), which will "AND" it into  $\overline{A} \cdot \overline{B}$  (which, by rule 2, equals  $\overline{A+B}$  remember), but will also INVERT it (because it's a NAND gate!) to

give us what we want,  $A+B$ , that is A OR B.

**S** Could we draw a diagram?

**T** By all means. We need one, don't we? Here it is (Fig.4.10). We'll add a wiring diagram for our chip, as before. What do you think we should do now?

**S** Try it out!

(They do so, and one of them adds:)

**S** If you add in the fourth gate, you can make a NOR.

**T** So you can. Using it as a final inverter. I'll just add it to the circuit diagram (Fig.4.11)

You can imagine that a "bucketful" of NORs could be made to imitate all the other gates, too, because it's also got a built-in inverter; it, too, is a "dual-function" gate.

**S** Can we try?

**T** Well, not just now, but if there's time later you may like to have a go. It's very similar to what we've just done. Probably uses the other Rule.

A "Combination Lock" circuit

**T** I'd like to proceed with another example of this "Combinational Logic", as it's called. We can try to work out our circuit first, then assemble and test it.

Let's suppose we have to build an electronic control for a lock, so that the user has first to set FOUR SWITCHES (since that's the number we have) (a real lock would be more elaborate), some on, some off, before operating a "Master Switch" to release the lock.

If we have set the switches to the wrong combination, an alarm is set off, and, of course, there's only ONE correct pattern for the switches. Right?

**S** We don't have an electronic lock.

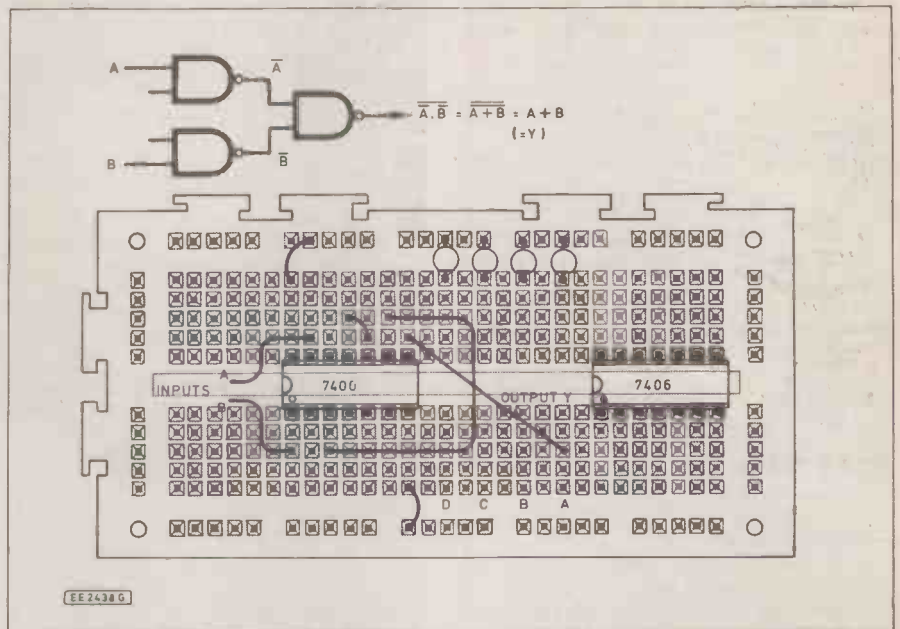

Fig.4.10. NAND equivalent of OR gate.

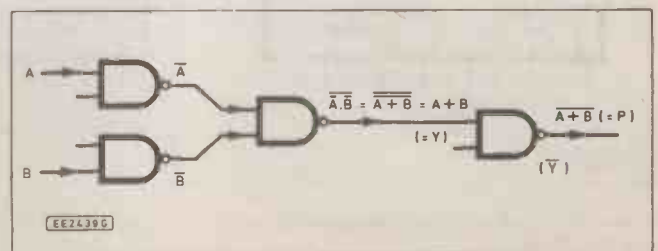

Fig.4.11. NAND equivalent of NOR gate.

**S** (others) We can use an indicator lamp.  
**T** Exactly. Although the real thing would be much more fun, we'll use our output indicator to test the circuit. Who knows, some of you may choose to build a "real" version as a project later on, with a loud bell or hooter!

**S** It could be done with a relay.

**T** Right. You could make the alarm even if you haven't got a real lock.

Well, how shall we set about the design? It often helps to draw up a Truth Table showing, as usual, all the possible input combinations, but this time putting in the outputs we want. THEN we seek to find circuits (gates) to do the trick. Here goes:

Lock Truth Table

INPUTS				OUTPUTS	
A	B	C	D	L	A
0	0	0	0	0	1
0	0	0	1	0	1
0	0	1	0	0	1
0	0	1	1	0	1
0	1	0	0	0	1
0	1	0	1	0	1
0	1	1	0	0	1
0	1	1	1	0	1
1	0	0	0	0	1
1	0	0	1	0	1
1	0	1	0	0	1
1	0	1	1	0	1
1	1	0	0	0	1
1	1	0	1	0	1
1	1	1	0	0	1
1	1	1	1	0	1

See what we meant about long Truth Tables with several inputs?

**S** It's two to the power of the number of inputs.

**T** Exactly. However, it's worth writing it all out this time. Anyone tell me the (decimal) value of the "secret" code? Just for the practice..

**S** Five

**T** Right again. Each column is worth TWICE the one on its right (in our familiar decimal or "denary" system, it's TEN TIMES), so the columns represent successive powers of two. We'll find this idea valuable when we're dealing with counting circuits and memory storage, later. Here we have one "FOUR" and one "UNIT", making five. No "EIGHTS" and no "TWOS".

Back to the Lock Design: Anyone notice the relationship between L and A?

**S** One is NOT the other | they're opposites.

**T** Good. So what do we need between them?

**S** A NOT Gate, an inverter.

**T** Well, that's easy. We can start drawing our diagram (Fig.4.12). It's just a box, with the necessary four inputs and two outputs. But we can now add the inverter between L and A.

**S** Or A and L?

**T** Could be. It's easy enough to alter it if we find it more convenient to do so. Now what do we need for the lock to open? For L to be logic 1?

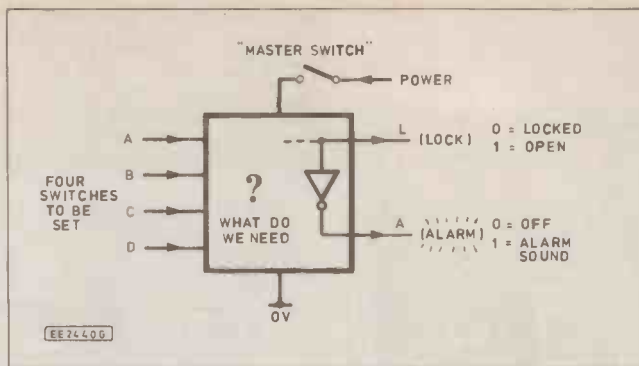

Fig.4.12 Electronic lock - first stage. We know that A (alarm) will always be the inverse of L.

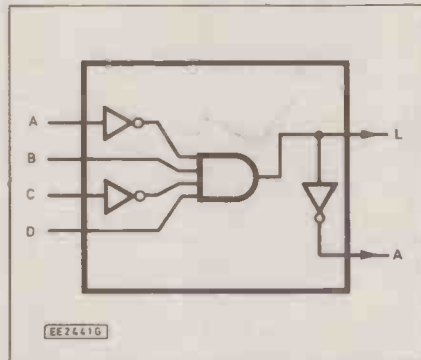

Fig.4.13. Electronic lock - final circuit arrangement. The 4-input AND gate will only give logic 1 to the lock L when B AND D AND (NOT A) AND (NOT C) are all at logic 1, which is the code we chose!

**S** A and C have to be 0, while B and D have to be 1.

**T** That's it. Now here's a useful way to provide for it. Let's INVERT A and C (the ones that are to be 0). Then these two inverted signals will have to be at logic 1, like the other two, so they'll ALL be "ones".

**S** We can send them to an AND gate!

**S** Or we could invert the others and use a NAND.

**T** Either is just the job. Let's draw it in (Fig. 4.13). Now we can try it. We'll use the four switches for inputs, setting them up BEFORE we switch on the power ("Master Switch"). We can use two Output indicators.

**S** It would be easy to arrange a different code. By putting the inverters somewhere else.

**T** Yes, or using more or fewer inverters. OK, you can each select your own code, then invite your neighbour to try to "crack" it. Get on with it now.

**T** (later) Most of you seem to have managed fine. You'll have realised that care must be taken to make exactly the right connections. Circuits, unfortunately, don't allow for plugging into "nearly" the correct socket! They've no sense of humour at all.

Another application of combinational logic is the so-called "ALU" (Arithmetic and Logic Unit) of a computer system. It's part of what is also called the CPU (Central Processing Unit), which in turn is the heart of the microprocessor.

Next Month: Sequential logic and pulse circuits.

Photograph of the output indicator (Fig.4.1) constructed on a breadboard.

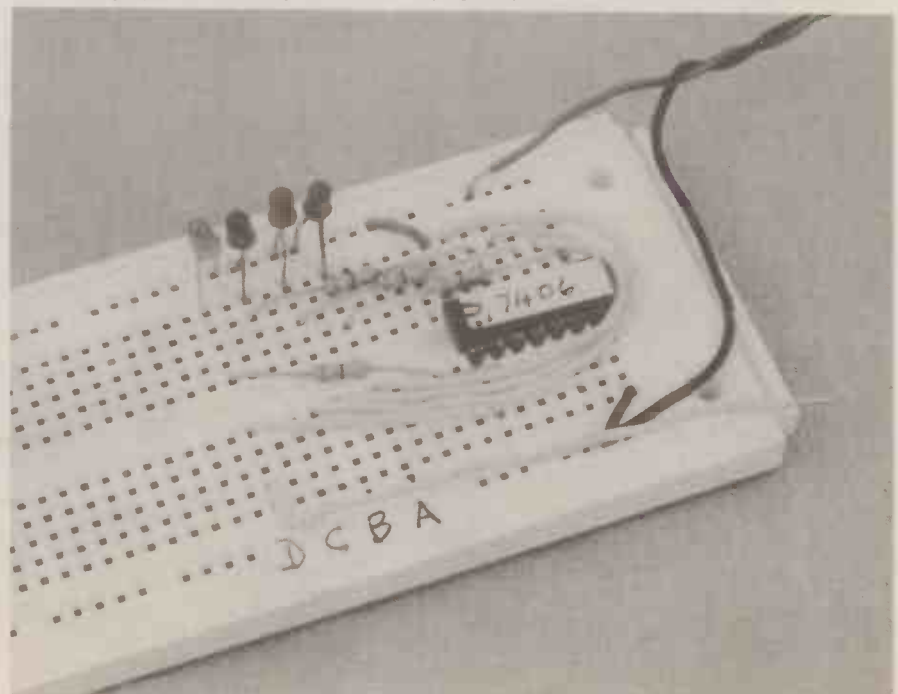

## THE RTC MONITOR II

100 WATT SPEAKER KIT £60.00 +£3.50 P&P (pair)

RESPONSE: 55Hz-20kHz

BASS POLYMER CONE D: 22cm

DOME TWEETER: 14mm

OVERALL SIZE (HWD): 382,252,204mm

RECOMMENDED AMP POWER: 10-100 watts per channel

The performance standard achieved in this compact design is distinctively superior to anything else available at the price. The drive units used are of sophisticated design and have been carefully integrated with a Complex Crossover.

Stereo performance is exceptionally good with a well focussed sound stage and sharp resolution of detail. Distortion throughout the frequency range is low even at quite high power input and this gives a great sense of dynamic range and openness especially when used in bi-wired mode.

Supplied with:— 2 READY CUT BAFFLES, ALL CROSSOVER COMPONENTS, 2 BASS MID-RANGE, 2 DOME TWEETERS, HOOK UP WIRE, GRILLE CLOTH, SCREW TERMINALS AND SCREWS.



## GOODMANS 60W CAR GRAPHIC



As new condition but have been returned by customers or shops, so they may need some attention. Hence the price of only £8.00 each. Order six of these units and you get the seventh one free. Postage £2.90

**LCD DIGITAL MULTI TEST METER** AC DC Voids resistance and DC Amps. Most of these units are new but have been returned or rejected by the store and sold with all faults at £11.00 each. Postage £1.00. (Made by Ross Electronics).

## ROSS PUSH BUTTON RADIO

Mains and battery operated. High quality VHF/FM, Medium and Long Wave reception. 6 pushbutton selected preset stations. Fully retractable telescopic aerial. Headphone/earphone jack socket.



Size 230H x 150W x 65D. Ref RE-5500. Brand new.

Price £14.95 + £2.80 P&P

**EXTRACTABLE HOUSING FOR YOUR CAR STEREO** ★ SIZE DIM E ★ HANDLE INCLUDED ★ SPACE FOR MEMORY BATTERY ★ 4 OR 2 SPEAKER SYSTEM.

ENABLES YOU TO REMOVE YOUR VALUED STEREO FROM YOUR CAR (WITHOUT THE AID OF A HAMMER AND CHISEL, CHAINSAW ETC). £9.95 postage £2.50

HILLS KITS IN STOCK ★ SEND FOR CATALOGUE

## MAIL ORDER £1 BARGAIN PACKS BUY 20 GET 1 FREE

Please state pack(s) required

No.	Qty. per pack
BP013	3 8"x5" Speaker 4Ω 6 watt made by E.M.I.
BP015B	1 30W dome tweeter. Size 90x68mit JAPAN made
BP016	6 2200µf can type Electrolytic 25V d.c. computer grade made in UK by PHILIPS
BP017	3 33000µf 16V d.c. electrolytic high quality computer grade UK made
BP018	3 2000µf 50V d.c. electrolytic high quality computer grade made in USA
BP019	20 20 ceramic trimmers
BP020	4 Tuning capacitors, 2 gang dielectric a.m. type
BP021	10 3 position, 8 tag slide switch 3 amp rated 125V a.c. made in USA
BP022	5 Push-button switches, push on push off, 2 pole change over. PC mount JAPAN made
BP023	6 2 pole 2 way rotary switch
BP024	2 Right angle, PCB mounting rotary switch, 4 pole, 3 way rotary switch UK made by LORLIN
BP025	4 3 pole, 3 way miniature rotary switch with one extra position off (open frame YAXLEY type)
BP026	4 4 pole, 2 way rotary switch UK made by LORLIN
BP027	30 Mixed control knobs
BP028	10 Slide potentiometers (popular values)
BP029	6 Stereo rotary potentiometers
BP030	2 100k wire wound double precision potentiometers UK made
BP031	6 Single 100k multitune pots, Ideal for varicap tuners UK made by PHILIPS
BP032	4 UHF varicap tuner heads, unboxed and untested UK made by PHILIPS
BP033	2 FM stereo decoder modules with diagram UK made by PHILIPS
BP033A	4 6"x½" High grade Ferrite rod. UK made
BP034	3 AM IF modules with diagram PHILIPS UK made
BP034A	2 AM-FM tuner head modules. UK made by Mullard
BP034B	1 Hi-Fi stereo pre-amp module inputs for CD, tuner tape, magnetic cartridge with diagram. UK made by MULLARD
BP035	6 All metal co-axial aerial plugs
BP036	6 Fuse holders, panel mounting 20mm type
BP037	6 In line fuse holders 20mm type UK made by BULGIN
BP038	20 5 pin din, 180° chassis socket
BP039	6 Double phono sockets, Paxolin mounted
BP041	3 2.8m lengths of 3 core 5 amp mains flex
BP042	2 Large VU meters JAPAN made
BP043	30 4V miniature bulbs, wire ended, new untested
BP044	2 Sonotone stereo crystal cartridge with 78 and LP styli JAPAN made
BP045A	2 Mono Cassette Record and play heads
BP046	4 6-0.6 4VA mains transformers, PC mount UK made
BP047	1 24V 0.3VA mains power supply. Brand new boxed UK made by MULLARD
BP049	10 OC44 transistors. Remove paint from top and it becomes a photo-electric cell (ORP 12) UK made by MULLARD
BP050	30 Low signal transistors n.p.n., p.n.p. types
BP051	6 14 watt output transistors. 3 complimentary pairs in T066 case (Ideal replacement for AD161 and 162s)
BP052A	1 Tape deck pre-amp IC with record/replay switching No LM1818 with diagram
BP053	5 5 watt audio ICs, No TBA800 (ATEZ)
BP054	10 Motor speed control ICs, as used with most cassette and record player motors
BP055	1 Digital DVM meter I.C. made by PLESSEY as used by THANDAR with diaoram
BP056	4 7 segment 0.3 LED display (red)
BP057	8 Bridge rectifiers, 1 amp, 24V
BP058	200 Assorted carbon resistors
BP059	1 Power supply PCB with 30V 4VA transformer. MC7818CT IC & bridge rectifier: Size 4"x2½"
BP061	5 6.35mm Mono jack plugs
BP063	5 6.35mm stereo switched jack sockets
BP064	12 Coax chassis mount sockets
BP065	1 3mtr Euro-mains lead with chassis socket

## 30+30 WATT AMPLIFIER KIT



An easy to build amplifier with a good specification. All the components are mounted on the single P.C.B. which is already punched and backprinted.

■ 30W x 2 (DIN 4 ohm)  
■ CD/Aux, tape I, tape II, tuner and phono inputs.

■ Separate treble and bass

■ Headphone jack

Size (H.W.D.) 75x400x195mm

Kit enclosed: case, P.C.B., all components, scale and knobs £36.80, post £3.50

(Featured project in *Everyday Electronics* April 1989 issue). Reprint Free with kit.

## TV SOUND TUNER



In the cut-throat world of consumer electronics, one of the questions designers apparently ponder over is "Will anyone notice if we save money by chopping this out?" In the domestic TV set, one of the first casualties seems to be the sound quality. Small speakers and no tone controls are quite common and that really is quite sad, as the TV companies do their best to transmit the highest quality sound. Given this background a compact independent TV tuner that connects direct to your Hi-Fi is a must for quality reproduction. The unit is mains operated. This TV SOUND TUNER offers full UHF coverage with 5 pre-selected tuning controls. It can also be used in conjunction with your video recorder.

£29.50 + £2.50 p&p

As above but with built-in stereo headphone amplifier for the hard of hearing

£35.90 + £2.50 p&p

**TV SOUND TUNER KIT £11.50 + £1.30 P&P**  
All parts including Varicap tuner, mains transformer, PCB with IC's capacitors and coils etc., to build the unit illustrated above; without case and scale.

**SHURE HIFI STEREO MAGNETIC CARTRIDGE** Fitted with an elliptical diamond stylus supplied with fitting kit and instructions. A good quality unit made to sell for well over twenty pounds due to scoop purchase, we are able to offer these at a fraction of the manufacturers price. All units are brand new and boxed. £7.20 each. If you order in multiples of five you get one free. Postage £1.30 (Made in U.S.A.)

**KOSS MINI SPEAKERS** Use instead of headphones on your personal stereo, just plug in instead of headphones. Koss sound cells can be mounted on top of your personal stereo with the holder supplied or simply detach for shelf mounting. This quality unit was made to sell for over seventeen pounds by the KOSS professional headphone company of the U.S.A. Due to a massive scoop purchase we can offer these units for £4.30 each or buy in multiples of ten and you get one free. Postage £1.50.

**KOSS STEREO HEADPHONES** High quality light weight stereo headphones fitted 3.5mm jack with adaptor to 6.4mm jack. Ideal use HiFi or personal stereos made to sell for nine pounds. Our price for this unit £4.25. Postage 60p.

**Hi-Fi stereo cassette deck transport mechanism, complete with 3 digit rev counter and tape heads, 12V d.c. operation. Unused manufacturers surplus JAPAN made**

£6.20 + £1.50 P&P 2 for £10 + £2.50 P&P

## MULTIBAND RADIO

VHF 54-176 MHz + AM CB BANDS 1-80

Listen to: AIR TRAFFIC CONTROL, AIRCRAFT, RADAR

PUBLIC UTILITIES

RADIO AMATEURS AND MANY MANY MORE

£17.95

POSTAGE £2.85

SQUELCH CONTROL "RUBBER DUCK AERIAL"

**RADIO AND TV COMPONENTS ACTON LTD**  
21 HIGH STREET, ACTON LONDON W3 6NG

MAIL ORDER TERMS, POSTAL ORDERS and/or CHEQUES with orders. Orders under £20 add £3.00 service charge. Nett monthly accounts to Schools, Colleges and P.L.C. only. ACCESS VISA. Phone orders between 9.30 & 12pm please. Overseas readers write for quote on delivery. Phone: 01-723 8432 or 01-992 8430. Callers 323 Edgware Road, London W2.

## SOLAR POWERED WOODEN MODELS

ATTRACTIVE AND EDUCATIONAL



Now you can experiment with solar energy - the energy source of the future!

Our solar powered static wooden model kits are designed to let you build your own models. Everything is supplied: A set of pre-cut and marked plywood; PVA cement; instruction sheet; solar cell module, a "music" IC for the gramophone model or a small d.c. motor (for the helicopter and aeroplane models); connecting leads and sandpaper

Helicopter with motor  
£8.40 plus £1 p&p

Aeroplane with motor  
£8.40 plus £1 p&p

Gramophone model with "music" i.c.  
£8.40 plus £1 p&p

SPECIAL OFFER — BUY ALL THREE and get the postage FREE

# GETTING YOUR PROJECTS WORKING

ROBERT PENFOLD



*Don't be driven mad by projects that won't work, we show you how to go about sorting them out. Fault finding and testing is all part of the skill and fun of successful project construction.*

**J**UST ABOUT every hobby must have one or two frustrating aspects. For the electronics hobbyist the two main potential causes of frustration are long waits for an elusive "out of stock" component, and the project that refuses to work.

The former might be outside your control, but the latter is not. Provided you set about things the right way it should be possible to get every project working properly.

Inevitably things will not always go perfectly first time, and a little effort will sometimes be required. This can be regarded as all part of the fun though. If electronics was totally without challenge it would not be the interesting and stimulating hobby that it is.

## Prevention Or Cure

The saying "prevention is better than cure" is just as applicable to the well being of your projects as it is to your own health. The occasional project that fails to work first time might be inevitable, but you should obviously strive to minimise the problem.

Make quite sure that you have the correct components. This is probably not a major cause of problems, and letters from readers who think that they might have obtained the wrong components mostly do not bring to light any errors.

Semiconductors are often available under several slightly different type numbers. This is a common cause of worries and confusion, but does not often lead to someone obtaining the wrong part.

On the other hand, there is a steady trickle of letters from readers who have obviously run into trouble by using an inappropriate component. The much given but still excellent advice is to obtain as many component catalogues as you can. There are so many different types of components available these days that even the biggest of component catalogues will not be able to satisfy all your component

requirements. Component catalogues contain a lot of useful information, and will help you to obtain the right parts.

Substitutes, "bargain" components, and components of almost the right value are fine for the experienced constructor. They are something the beginner should steer well clear of though. Without the ability to sort out the good from the bad (or unsuitable), for the raw beginner anything of this type is almost certain to be a false economy.

## Blobs and Splashes

By far the biggest cause of the problems with projects is bad soldering. With modern solders and components "dry" joints are more rare than they were in the past. Probably the main problems to watch out for these days are solder "blobs" and "splashes".

The blobs are small pieces of excess solder which bridge two adjacent pads of a printed circuit board. Mostly these become self evident when you are soldering the components to the board, but some of the smaller ones can be difficult to spot. Sometimes they are buried under some excess flux and are not visible at all.

Solder splashes are caused by excess solder falling from the iron and landing on the board. Again, these are mostly quite obvious, but sometimes they fall in the form of long thin trails which are very difficult to see.

Having completed a printed circuit board or stripboard it is a good idea to clean off any excess flux from the underside of the board so that a thorough visual inspection can be made. Special cleaners for this purpose are available, or methylated spirits can be used (remembering to treat this highly inflammable liquid with due caution).

The intricacy of modern circuit boards is such that a naked eye inspection might not reveal any short circuits that are present. A magnifying glass is a decided

asset when making visual checks for short circuits on all but the most simple of boards.

## First Steps

Of course, you can always wait to see if a project fails to operate, and only bother checking for solder splashes and blobs if problems should arise. This is a rather myopic attitude though. It is almost invariably much easier to check for short circuits before a board is fitted into its case and wired up to the rest of the project.

Clearing a short circuit before the project is switched on also guarantees that it will not damage any of the components. A short circuit will probably not have catastrophic consequences when the project is switched on, but it is clearly better to avoid this risk as far as possible.

When a project does fail to work on its initial testing, switch off at once and carry out a thorough recheck of the wiring. In most cases the problem will be due to something visual, and something which is therefore traceable without the need for any test equipment. Diodes, integrated circuits, or electrolytic capacitors connected around the wrong way are popular errors, as are crossed-over wires on transistors.

Connections to off-board components probably provide the greatest scope for making errors. Multi-tag components such as rotary switches can be a little confusing, so check all the hard-wiring against the wiring diagram and *circuit* very carefully. Using wires of different colours greatly reduces the risk of making mistakes in the first place, and renders any errors that are made very much easier to track down.

Look for signs of physical damage. Modern printed circuit boards often have very narrow tracks that are easily damaged. Check for broken or absent pieces of track. Although electronic components are, in the main, pretty tough, it



is still possible to damage them when fitting them to a board.

Printed circuit mounting polyester capacitors used to be the worst offenders. Recent components of this type seem to be much improved in this respect, but many of them are still susceptible to a leadout wire breaking off. The construction of some polyester capacitors is such that a leadout wire can become desoldered from the body of the component if you are not suitably quick at making the connections to the component.

Often the detached leadout wire will be perfectly apparent as you fit the component, but this might not always be the case. On several occasions I have checked faulty boards where the problem has proved to be due to a broken polyester capacitor which looks quite normal without some very close scrutiny.

A useful check is to gently pull on the body of each component on the board. This should reveal any detached leadout wires, and may bring to light other faults such as a "dry" joint or a lead which you have forgotten to solder at all (something more easily done than you might think).

## Dry Joints

Although relatively rare these days, if you should produce a "dry" joint it can be very difficult to track down. The tell-tale signs are an excessive amount of flux around the joint, a dull appearance instead of the normal shiny surface of the solder, and possibly a crazed surface. Also, the joint is likely to have a well rounded globular shape rather than the correct, slightly pointed mountain shape. However, there will not always be any obvious outward signs.

Most of the "dry" joints I have managed to produce in recent times were not of the classic type. Most "dry" joints are produced either by excessive flux which insulates the lead from the solder and (or) pad, or by solder which has insufficient flux and has seriously oxidised. Modern solders and components make it quite difficult to produce this kind of joint.

A more likely problem these days is component pins which are too short. In particular, a lot of current integrated circuit holders and preset resistors seem to have very short pins. What can happen with these if you are not careful is that on one or more of the connections there is just a cap of solder over the hole in the pad, with no contact being made to the pin.

With components that have short pins it is absolutely essential to ensure that they are fully pushed down onto the board before soldering them in place. The pin must always protrude at least a small amount on the copper side of the board.

Thankfully, "dry" joints which give no visual clues to their existence are something that only crop up quite rarely. The only way of tracking them down is to make continuity checks. If you have a multimeter, this will act as a continuity tester if it is used on a medium resistance (Ohms) range.

Low resistance ranges are best avoided as the test current can be quite high, and could damage delicate semiconductors in the circuit being checked. High resistance ranges are less than ideal as they often lack the ability to differentiate between zero resistance and a fairly low but significant resistance.

## Continuity Check

When doing a lot of continuity testing there is a lot to be said in favour of a checker that gives an audible indication of a short circuit. This removes the need to keep looking backwards and forwards between the tester and the test points.

There have been plenty of continuity tester designs of this type published in the past, and a few multimeters have a built-in "beeper" for this purpose. What is definitely NOT the right type of checker to use is something like a battery in series with a bell or a light bulb. The current flow through a setup of this type can be quite high, and would soon result in most of the semiconductors in an averaged circuit being "zapped."

Checking for "dry" joints is a matter of testing for continuity between the lead of each component, and the track it is supposed to connect to. This tends to be a bit awkward as the test points are on opposite sides of the board.

An alternative method is to check for continuity between two leads that connect to the same track. This is generally much easier, especially when checking a fibreglass circuit board where it is usually not too difficult to see the track pattern from the component side of the board. Of course, if a lack of continuity is detected, it is then necessary to check the two soldered joints to determine which one is faulty.

thyristor, integrated circuit, or practically any semiconductor component. Most circuits are riddled with these hidden semiconductor junctions.

For this type of testing a continuity checker which can ignore semiconductor junctions is a real asset. A multimeter should not give misleading results since any semiconductor junctions should result in a reading of substantially more than zero.

A useful feature of many digital multimeters is a "hi-lo" resistance switch. This does not have anything to do with high or low resistance readings — it refers to the voltage used for resistance measurements. In the "lo" setting the test voltage is about 0.2 volts or less. This is insufficient to forward bias a silicon junction, and when set to the "lo" mode a multimeter is effectively set to ignore semiconductor junctions in the test circuit.

## Voltages

If a thorough visual check for errors plus some continuity tests do not bring the fault to light, the next step is to try some simple voltage checks. This is conditional on the current consumption of the project being reasonably low.

With a high current consumption there is a real risk of components in the circuit being damaged if the supply is maintained more than briefly. Apart from a slight fire hazard, overheated components can

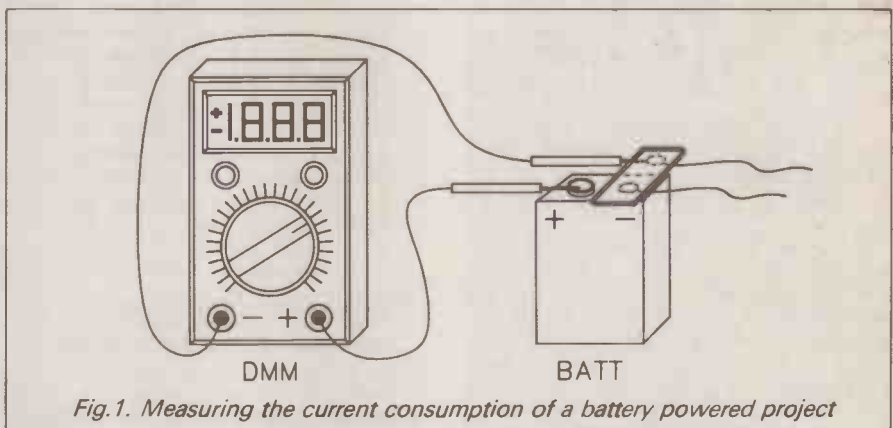

Fig.1. Measuring the current consumption of a battery powered project

If a dry joint is detected, clean off the old solder with the aid of a desoldering tool or desoldering wick. Clean up the pin or leadout wire and the pad by scraping them with the small blade of a penknife, and then resolder the joint. Check the new joint with the continuity tester to make sure that it is good.

A continuity tester is very good for locating accidental short circuits due to solder blobs and splashes. A visual check with the aid of a magnifier will often locate any short circuits. Use a continuity checker only after a visual inspection of the board has failed to bring results.

Start with the more likely places for short circuits, which means the areas of the board where the connections are most densely packed. This usually means at the pins of integrated circuits, multi-way connectors, and other multi-pin components.

Be warned that not all continuity testers are well suited to this type of testing. Some designs will indicate continuity between the test prods when they are actually connected via a forward biased semiconductor junction. This junction does not need to be in the form of a diode. It could be part of a transistor,

explode! The project's battery is also likely to be short lived if the current consumption is several times the correct figure. It is assumed here that the project is battery powered — *beginners would be well advised to avoid mains powered projects, and fault finding on mains powered units is certainly not something for those of limited experience.*

Just what constitutes an excessive current consumption depends on the particular project you are servicing. The article describing the project will probably give a rough indication of the expected current consumption. If this is quite low, say up to around five milliamps or so, a current consumption several times the expected figure is not likely to produce any damage. With a circuit that has a high current consumption of about 100 milliamps or more, even a current consumption at double the expected figure could be a bit risky.

In order to measure the current consumption of a project it is merely necessary to switch the multimeter to a suitable range and then connect it in the positive supply lead in the manner shown in Fig.1. With a digital multimeter it does not nor-

mally matter if the test prods are connected around the wrong way – the current reading will simply be a negative one. With analogue multimeters it is always essential to get the prods round the right way for current and voltage readings.

As the current may be much higher than the circuit's specified current consumption, always choose a range having a full scale value ten or more times the specified current consumption to minimise the risk of seriously overloading the meter.

If the current reading is grossly excessive, voltage checks will not be a practical proposition. There may then be little alternative but to remove and check the components one-by-one until a faulty one is found.

## First Voltage Checks

Assuming that the current consumption is within acceptable limits, the standard first voltage check is always to ensure that the supply is getting through to the circuit board correctly. For this test the supply can be checked at any points on the board where it is convenient to make connections to the two supply rails.

This check will often reveal an absence of the supply at the board. One reason for this is that battery connectors are notoriously unreliable. They can appear to be connected correctly when one set of press-studs are not fitted together reliably. Some careful squeezing of the outer press-stud using pliers will usually enable a reliable connection to be made.

The other main cause of problems with battery clips is a broken lead or connection inside the plastic cover. Pulling firmly on the two leads in turn should cause any broken or detached lead to come away from the connector.

Another common cause of problems is the on/off switch. Toggle switches, especially the very small types, do not generally seem to have the sort of reliability associated with other electronic components. If the positive supply is present on the input side of the switch but absent on the output side, then the switch would seem to be faulty.

Is the switch actually in the "on" position? Sooner or later practically everyone involved in electronics starts to fault find on a circuit only to discover that the unit simply was not switched on, plugged in, fitted with a battery, or something of this type!

Is the switch the right way up? It is very easy to inadvertently mount a switch upside-down, or to misinterpret which is the "on" setting and which is the "off" one.

If the supply voltage is present at the board, but is very low, this would suggest that the battery is flat. Bear in mind though, that the actual voltage supplied by a 9V battery can be anything from about 9.5 volts when new to around 7.5 volts when it is nearing exhaustion. A reading as much as 10 to 15 per cent below the battery's nominal voltage is therefore quite acceptable in most cases.

## Kirchhoff's Voltage Law

If the supply is present and correct the next step is to take some voltage measurements at various points in the circuit. It does not matter too much where you start in the circuit, but it is best to adopt a methodical approach. Otherwise you may end up checking some points twice and missing others out altogether.

If you are lucky you will have a set of typical test voltages to compare with your own measurements. In most instances no test voltage chart will be available. You will then have to look at the circuit and estimate the sort of voltage that should be present at each test point.

This is where Kirchhoff's voltage law can be used to good effect. If we take the example circuit of Fig. 2, it is fairly easy to guesstimate the voltages at the junctions of resistors R1-R2, and R2-R3. If you work out what percentage of the total resistance through this potential divider each resistor supplies, the voltage across each resistor will be that percentage of the voltage applied to the circuit.

You do not need to get out the calculator and do any precise calculations. Due to component tolerances and other factors the measured voltage could easily be 10 per cent or so away from the theoretical value. With most voltage checking you are just measuring to see if the measured voltage is reasonably close to the expected one, rather than checking for a precise test voltage.

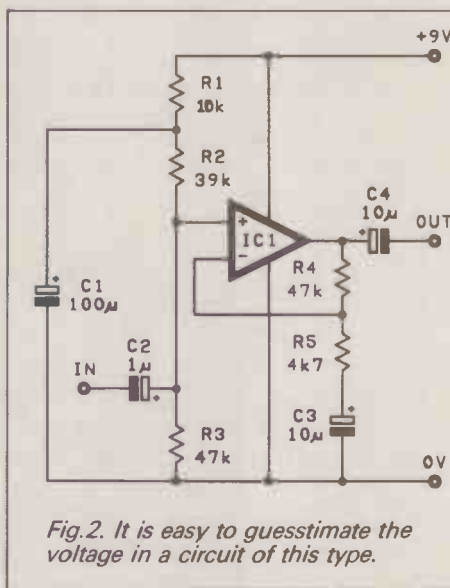

Fig. 2. It is easy to guesstimate the voltage in a circuit of this type.

In our example circuit, the combined resistance of R1 and R2 (49k) is almost equal to that of R3. The voltage at the junction of R2 and R3 should therefore be about half the supply potential, or around 4.5 volts in other words.

Voltage checks are usually made relative to the 0V "earth" supply rail, which in modern circuits is almost invariably the negative supply rail. The negative (-) test prod of the meter is therefore connected to the 0V rail, and the positive test (+) prod is applied to the test points.

The total resistance through the potential divider is about 100k (10k + 39k + 47k = 96k to be precise). Resistor R1 therefore represents about 10 per cent or so of the total resistance, and the voltage across this component is accordingly a little over 10 per cent of nine volts. This is obviously a little under one volt. The voltage at the junction of resistors R1 and R2 is therefore equal to the 9V supply less the voltage drop of 1V through R1, or roughly 8V.

The voltage gain through IC1 at d.c. is only unity, and the voltage at its output should therefore be about 4.5V (i.e. equal to the bias voltage fed to its non-inverting (+) input). It is standard practice for the output of an amplifier to be

biased to about half the supply voltage as this provides it with the greatest overload margin.

## Loading

Something that must always be borne in mind when making voltage checks is that the resistance of the test meter can affect the voltages in a circuit. This is not a major problem with digital multimeters which invariably seem to have an input resistance of 10 or 11 megohms. This does not mean that they will never produce significant loading of the test point, but any problems of this type are likely to be very rare indeed.

The situation is different with an analogue multimeter, where the sensitivity is usually 20k/volt. This means that the meter provides a resistance equal to 20k multiplied by the full scale voltage value (e.g. 200k on the 10 volt range). On the lower voltage ranges this gives a much lower input resistance than that of a digital instrument. Problems can be encountered when testing low current parts

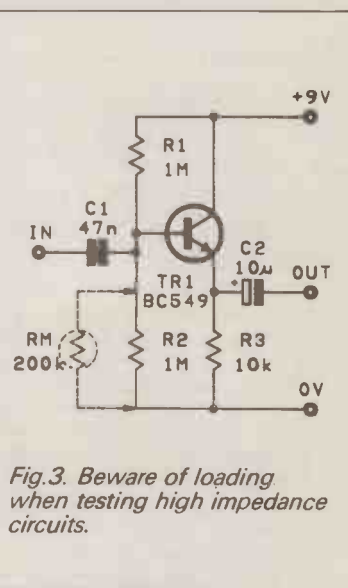

Fig. 3. Beware of loading when testing high impedance circuits.

of a circuit, such as at the input of the emitter follower stage of Fig. 3.

Resistors R1 and R2 bias the input of the circuit to half the supply voltage, or about 4.5 volts in other words. If this voltage is measured using a 20k/volt multimeter set to the 10 volt range, the 200k resistance of the meter is effectively shunted across resistor R2.

Working out the effective resistance of R2 will give an answer of about 166k, and the measured voltage would work out at roughly 1.3V. In this case a low reading would not indicate a fault, but one of around the 4.5V level would suggest that something was amiss (R1 having gone low in value for example).

It is worth noting that the circuit fed from a potential divider can also have a loading effect on the test voltages. In this case the input resistance of transistor TR1 would also tend to shunt resistor R2. However, most circuits are designed so that the effects of this type of shunting are minimal.

## Current Checks

Sometimes it can be useful to make checks on current rather than voltage. It can be very useful to know what current

each stage of a circuit is consuming, with any excess or lack of current indicating the stage which is at fault.

Unfortunately, current measurements are usually quite difficult to make. A break has to be made in the current path to provide a point at which the test meter can be connected. In some cases this would merely require that one lead of a component should be temporarily disconnected, but in many instances it would be necessary to make a break in a printed circuit track and then repair it again after the measurement had been made. This is something to be avoided if at all possible.

A technique that can often prove helpful is to measure the voltage across a resistor and then use Ohm's Law to work out the current flow. Take the example circuit of Fig. 4, which is for a simple common emitter amplifier. Some example test voltages are included on the diagram. It can be seen from these that there is one volt across R4, and four volts across R3 (9V - 5V = 4V).

Ohm's Law states that current equals voltage divided by resistance. In the case

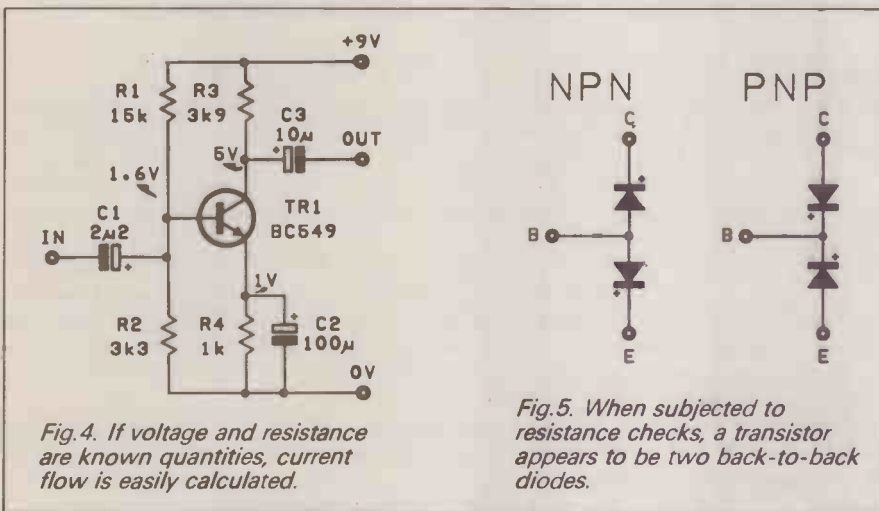

Fig. 4. If voltage and resistance are known quantities, current flow is easily calculated.

of resistor R4 this is 1V divided by 1000 ohms, which comes to 0.001 amps. It is often more convenient to have the resistance in kilohms (k) or megohms (M), which gives an answer in milliamps and microamps respectively. In this example 1V divided by one kilohm (1k) obviously gives an answer of one milliamp (1mA). Similarly, for resistor R3 dividing 4V by 3.9 kilohms gives an answer of (near enough) one milliamp (1mA).

Many audio circuits have series resistors in the positive supply rail which are part of a supply decoupling network. It can sometimes be helpful to measure the voltages across these resistors as a quick means of checking the current flow into each part of the circuit. It is a technique that can also be used with something like the load resistor for a Zener stabiliser, so that the current flow into the Zener diode can be checked.

Keep in mind that the validity of this method of checking is dependant on the resistor being serviceable. If the current flow seems inappropriate but the stage drawing the current does not seem to be faulty, remember to check the resistor on which the current test was based.

## Component Checks

Voltage checks will normally do no more than narrow down the location of

the fault to a particular stage. In order to determine the precise nature of the fault some component testing is usually required.

Resistors can be checked using any multimeter. In-circuit tests will lack reliability as there may be resistances in the circuit that are effectively in parallel with the component you are trying to measure. These can give a low reading. They can not give a high reading though, and (say) a 10k resistor that gives an in-circuit reading of about 40k must be a faulty component.

If you have a multimeter with a "hi-lo" resistance switch, set it to the "lo" mode when making in-circuit checks. This eliminates problems with semiconductor junctions shunting the test component, which is a frequent cause of low readings. In order to totally remove the effects of in-circuit shunting on the test component one of its leadout wires must be temporarily disconnected.

Some multimeters have capacitance measuring ranges, but this is a far from common feature. To measure the value of

Some multimeters have a built-in transistor checking facility. In the absence of such a feature the resistance range can be used to make a few basic checks on transistors. When checked in this way, a transistor appears to be two back-to-back diodes, as shown in Fig. 5. You should therefore obtain a diode action across the base - emitter and base - collector junctions, while there should be a very high resistance from the collector to the emitter with the prods connected either way round. This is admittedly a rather crude method of testing, but it should show up any serious defect in the test component.

Inductors and transformers are difficult to test properly, but they can easily be checked for a broken winding. An inductor is basically just a coil of wire, and as such it should have a fairly low resistance. Similarly, each winding of a transformer is a coil of wire, and should have a low resistance. There should be a very high resistance between the primary and secondary windings though.



This multimeter has built-in capacitance and transistor current gain ranges. Useful features which can be expensive if provided by separate units

## Final Tips

Logic circuits are difficult to test using just a multimeter. You can check to see if power is getting through to each integrated circuit in the unit, but it is not possible to do much more than this. You can check that static outputs are at an appropriate voltage (2V or less for logic 0; 3V or more for logic 1), but you can not detect pulse signals.

A logic probe will indicate the logic level at the test point including pulse indication. This is a much more suitable tool for logic testing. One of these can be bought or built at low cost, and should be regarded as an essential tool for anyone who is going to build more than the occasional logic circuit.

A crystal earphone makes an excellent signal tracer. It will produce an audible output from a signal of just a few millivolts, it has a reasonably high input impedance, and a very high input resistance.

A crystal earphone is useful for checking the signal at various points in an audio circuit, checking to see if there is any output from an audio oscillator, and this type of thing. It can even be useful when logic testing! Even very brief pulses seem to produce an audible "click" from the earpiece.

It has not been possible to give a complete course in project fault finding in the space available here, but this article should at least give you a good idea of how to go about locating faults. If you check the project connection by connection, and component by component, being careful and conscientious, you must eventually track down the fault. □

# FOUR SPECIAL PUBLICATIONS

FROM EVERYDAY ELECTRONICS



SEE DIRECT BOOK SERVICE pages—for full ordering details

## TEACH-IN 88/89 INTRODUCING MICROPROCESSORS

**£2.45** plus P & P

**A complete City and Guilds  
Certificate Course for 726/303  
Introductory Microprocessors**

Written by Mike Tooley BA this course can lead successful readers to a City and Guilds Certificate. Everything you need to know is included—even pre-test papers, etc.

From Terminology, Integrated Circuits and Logic Families in Part One, the course progresses in easy stages up to High- and Low-level Languages, Flow Charts and Assembly Language. Also featured is a range of eight Data Pages giving information on popular microprocessor chips. A comprehensive index is included, making this a valuable reference manual.

ORDER CODE: T1 88/89

## TEACH-IN No. 3 EXPLORING ELECTRONICS

**£2.45** plus P & P

By Owen Bishop

Designed to explain the workings of electronic components and circuits by involving the reader in experimenting with them. The book does not contain masses of theory or formulae but straightforward explanations and circuits to build and experiment with.

The text is split into 28 easily digestible sections, each with a separate project. The breadboard experiments assume no previous knowledge, start at semiconductor diodes and progress through bistables, timers, amplifiers, binary etc up to f.e.t.s and shift registers.

The projects include radio receivers, various timers and alarms, plus temperature sensors and water detectors etc.

An excellent source book for GCSE courses.

ORDER CODE T13

## ELECTRONIC PROJECTS Book 1

**£2.45** plus P & P

Contains twenty of our best projects from previous issues of EE, each backed with a kit of components. The projects are:

Seashell Sea Synthesiser, EE Treasure Hunter, Mini Strobe, Digital Capacitance Meter, Three Channel Sound to Light, BBC 16K Sideways Ram, Simple Short Wave Radio, Insulation Tester, Stepper Motor Interface, Eprom Eraser, 200MHz Digital Frequency Meter, Infra Red Alarm, EE Equaliser Ioniser, Bat Detector, Acoustic Probe, Mains Tester and Fuse Finder, Light Rider – (Lapel Badge, Disco Lights, Chaser Light), Musical Doorbell, Function Generator, Tilt Alarm, 10W Audio Amplifier, EE Buccaneer Induction Balance Metal Detector, BBC Midi Interface, Variable Bench Power Supply, Pet Scarer, Audio Signal Generator.

ORDER CODE EP1

## EVERYDAY ELECTRONICS DATA BOOK

**£8.95** plus P&P

By Mike Tooley BA

Published by EE in association with PC Publishing, this book is an invaluable source of information of everyday relevance in the world of electronics. It contains not only sections which deal with the essential theory of electronic circuits, but it also deals with a wide range of practical electronic applications.

It is ideal for the hobbyist, student, technician and engineer. The information is presented in the form of a basic electronic recipe book with numerous worked examples showing how theory can be put into practice using a range of commonly available components and devices.

A must for everyone involved in electronics!

Available from your local component supplier or direct from us.

ORDER CODE DATA

SEE DIRECT BOOK SERVICE pages—for full ordering details

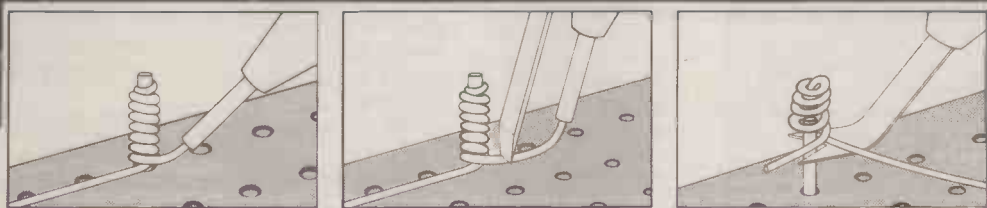
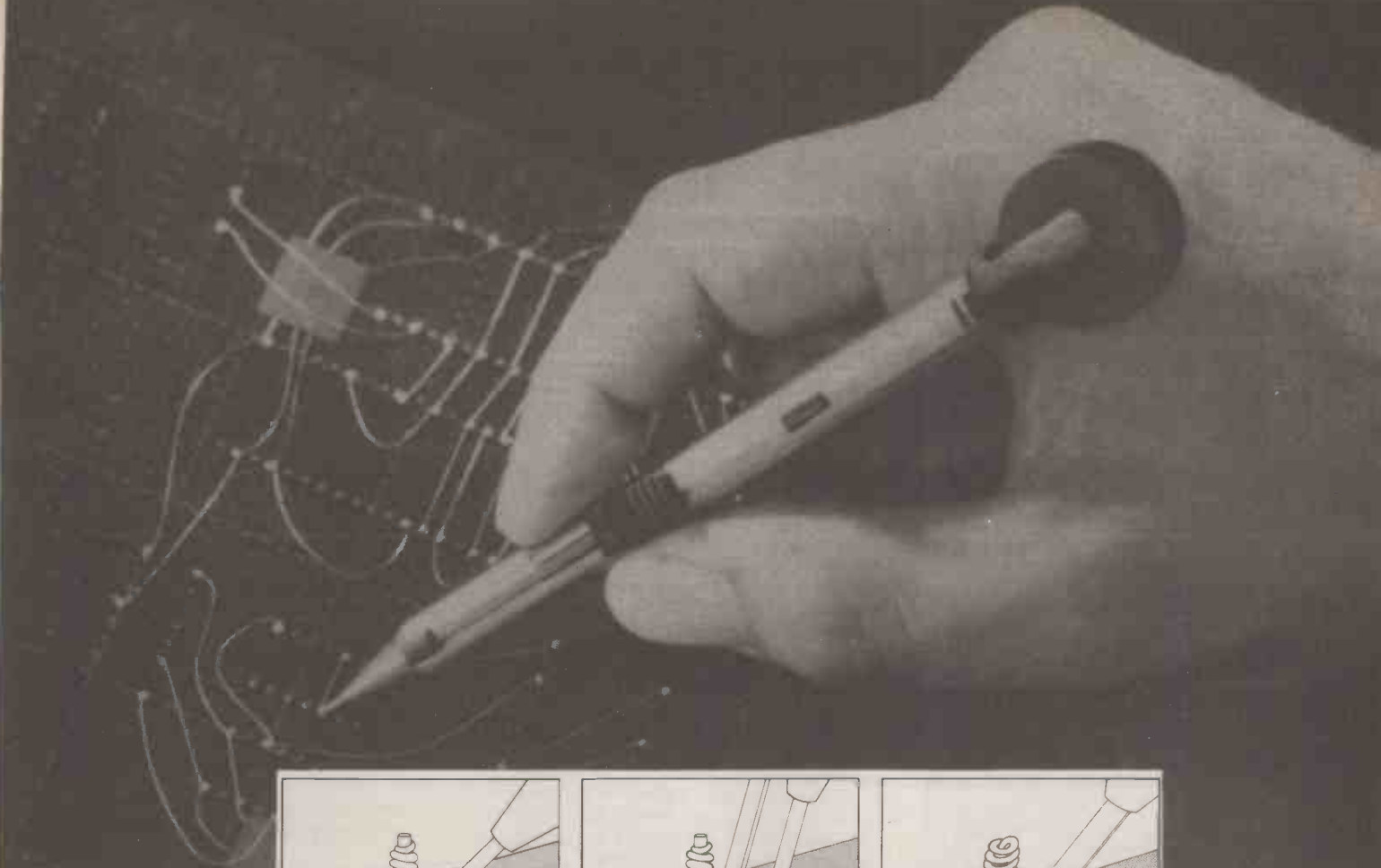

# EASIWIRES

## Circuit construction the easy way.

Solderless, quick and easy to learn. That's Circuigraph Easiwire from BICC-VERO. From now on you'll wonder why you ever used solder to construct your electronic circuits!

Consider the benefits Easiwire offers:

- You need no solder, no chemicals
- You simply wind the circuit wire around the pins
- You can re-use components
- It's easy to change
- The cost is low

What's more, Easiwire is ideal for circuit repairs.

In kit form, Easiwire comes complete with everything you need to construct circuits. That includes a wiring pen with integral cutter, two reels of wire, a component positioning and removal tool – and an instruction book. Of course kit items are available separately too.

Take advantage of the special offer price now. Complete the coupon below and send it to:

BICC-VERO Electronics Limited,  
Flanders Road,  
Hedge End,  
Southampton, SO3 3LG.

or phone 0489 788774 now with your credit card number  
(24-hour answering service)



Please rush me.....Easiwire kits.  
Special offer price £15. – (includes p & p and VAT).

I enclose cheque/postal order for .....  
made payable to BICC-VERO Electronics Limited.

Card number .....

Expiry date .....

Name .....

Address .....

.....Postcode .....

Signature.....Date .....

# ...REPORTING AMATEUR RADIO...

TONY SMITH G4FAI

## COMMUNICATIONS

### BIBLIOGRAPHY

An American company has recently published what it claims is the world's largest reference guide to amateur radio articles. Titled *"From Beverages thru Oscar"*, it claims to cover every article on every subject ever published in the main US amateur radio magazines since 1945, the last ten years of the RSGB's *Radio Communication* magazine, and references of significance from 289 other sources going back to 1908.

The author of this 52,880 reference volume is Rich Rosen, K2RR, a radio amateur for 31 years and a professional journalist. When he needed, and failed to locate, a reference volume which included amateur radio sources he decided to compile one himself.

He explains why in his preface. "Radio amateurs.... number almost a half million strong in the United States and are found in literally every other country in the world.... Many who have chosen to delve into the technical mysteries of radio have contributed immensely.

"Think of any major technological breakthrough in the field of communications and the probability is great that there were at least several radio amateurs present, advancing the state of the art. In many famous cases amateur radio discoveries were made prior to even commercial interest involvement.

"However, only a small percentage.... publish their findings in the professional and trade journals. Instead they employ consumer magazines as a conduit to express their ideas. This very fact has driven me to uncover this wealth of knowledge so that others might benefit.... Fifteen years of page by page scrutiny embodies this bibliography."

### READILY AVAILABLE

The US radio magazines are read by serious amateurs around the world. They contain much of interest to non-American readers, and many associated radio publications from that country are standard reference works in the UK despite slightly different nomenclature and circuit depiction.

Back issues can be obtained from specialist suppliers or by advertising in amateur magazines. Some libraries stock both current issues and previous numbers going back to their earliest days.

The bibliography is currently available on microfiche while a paperback version is being prepared. At US\$75.00 (limited time offer of \$49.95 for amateurs), I can't imagine a rush for it in this country by individuals, but it would be marvellous if public libraries could be persuaded to add it to their reference facilities. If you want to tell your librarian about it, the company's address is *Didah Publishing, PO Box 7368, Nashua, NH 03060, USA.*

## RADIO SHACK

Radio amateurs are notorious for the condition of their "shacks". While there are some who undoubtedly keep immaculate premises worthy of demonstration in the Science Museum, others more closely resemble the emporium of Messrs Steptoe and are essential in this form, their owners claim, for the true practice of their art.

Nothing is ever thrown away, shelves are bowed down with old equipment, books, magazines, half-completed projects, boxes of components, tools and instruments. Wires drape and intermingle and when the shelves are full everything spills over onto the floor and any available seating.

Somewhere in the midst of such a confusing, but undoubtedly interesting scene is to be found radio equipment with microphone, Morse key, teleprinter or other means of initiating meaningful signals to go out over the air. Naturally, any person in the house having an inclination to clean or tidy things up is totally banned from such an establishment.

Recently, *Radio Communication* (popularly known as RadCom) ran a competition to find the "Most Shambolic Shack in Britain". A total of 153 entries were received, painstakingly reduced to a shortlist of 10 by rigorous marking down of entries wherever there was evidence of attempts to bring order out of chaos or to provide material comforts for the operator.

Outright winner was Mr John Eley, G3LMR, of Leicestershire, who received 944 out of a possible 1000 marks. The judges took a poor view of some visible neatly stacked component drawers seen in his shack and some equally spaced 13A sockets.

The soft cover of a chair was frowned on but the poor feature was redeemed by the fact that this was occupied by Mr Eley's cat. Other features were specially commended making it an outstanding entry and Mr Eley received the first prize of a carved broom fitted with Albanian hedgehog bristles, the whole finished off with the RSGB motif.

Having been accused of being rather stodgy in recent years, RadCom seems much improved lately. Its international amateur news coverage is getting better all the time, it pays more attention to the beginner than it used to, and now it is even encouraging amateur radio to laugh at itself!

The magazine is available only to members and serves listeners as well as licensed amateurs. Full details of membership can be obtained by writing to RSGB, Lambda House, Cranborne Road, Potters Bar, Herts EN6 3JE.

## AMATEUR RADIO AND PITCAIRN

The journal of the Wireless Institute of

Australia, *Amateur Radio*, carried some interesting articles last year about Pitcairn Island, which has the greatest proportion of amateur radio operators to total population in the world. Six licensed operators out of fifty people – and all direct descendants from the original Bounty mutineers!

Octogenarian Andrew Clarence Young, VR6AY, has recorded how in 1921 he, his uncle, and cousin, learned the Morse code from a card left on the island by a ship's captain. They learned by flashing lights to each other between two mountains. The idea was to be able to stop ships passing at night to take their mail.

The first time they tried this from a boat it worked and hearing of the practice the Marconi Company sent the islanders a small crystal receiver with dry batteries. Continuing to practice sending with a buzzer, Andrew spent a long time trying to pick up ships' messages on this receiver.

One day he deciphered a message that the *"Corinthic"* was arriving the next day. The islanders took his word for it and began picking fruit in readiness for its arrival while Andrew spent an agonising night hoping he hadn't got it wrong. Fortunately, the ship appeared over the horizon at 7 a.m. in confirmation of the first radio message ever received on Pitcairn.

Andrew began receiving messages at 5 w.p.m. In 1928, he started transmitting with a spark transmitter, reaching 10 w.p.m. In 1938 a group of American amateurs donated some modern equipment which he operated as a licensed amateur station until 1939, resuming transmitting after the war.

The remoteness of the island, with supplies and mail reaching it by sea only two or three times a year, makes amateur radio a much more significant and valued facility than it is in some other parts of the world. I shall describe how it serves present day Pitcairn in a future column.

## DATES WORTH NOTING

The RSGB's next major international Convention and Exhibition will be held at the National Exhibition Centre, near Birmingham on 21-22 April 1990. Full details can be obtained from the RSGB as above.

The Southgate Amateur Radio Club is organising a new London Amateur Radio Show at the Picketts Lock Centre, Edmonton, London N18, on Friday and Saturday March 9 and 10 1990, admission £1. This looks like a big event with the opportunity to find out about the activities of many of the amateur radio organisations mentioned in this column from time to time, as well as seeing all the latest goodies on the stands of a variety of suppliers and makers

# MARCO Trading

ELECTRONIC COMPONENTS & EQUIPMENT

MAIL ORDER

WHOLESALE

RETAIL

ALL PRICES  
INCLUDE  
15% V.A.T.

SPRING  
1990

CATALOGUE  
SUPPLEMENT

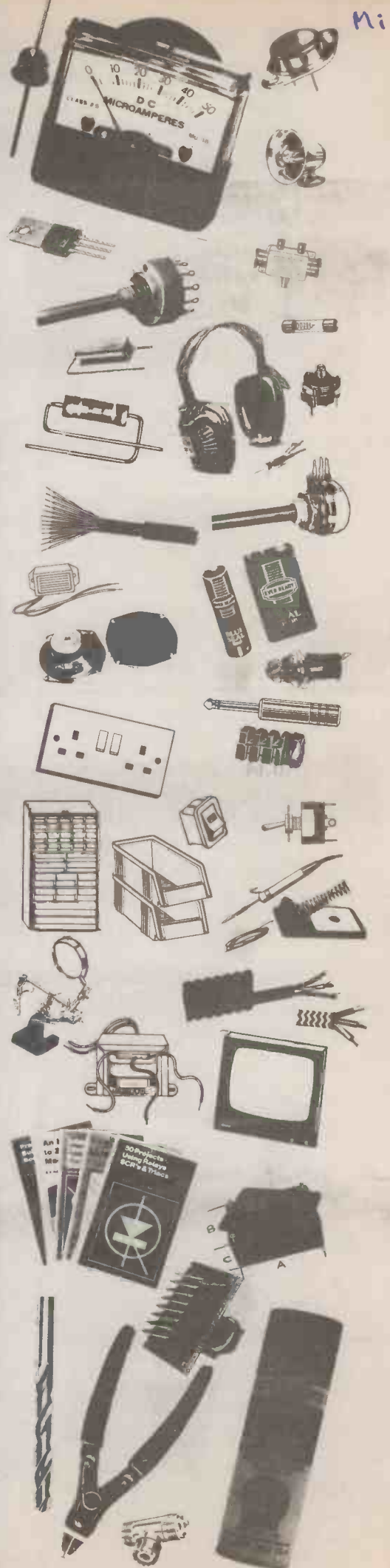

Mii



# MARCO TRADING



THIS BROCHURE CONTAINS ONLY A MINUTE SELECTION OF THE VAST RANGE OF PRODUCTS DETAILED IN OUR 1990 CATALOGUE - SEND £1 NOW FOR YOUR COPY.

Orders despatched by return of post, subject to availability.

POST & PACKING: U.K. £1.

**OVERSEAS:**

Europe	(all-up rate)	Rest of world surface	air
250g	£1.50	£1.50	£4.20
500g	£2.50	£2.50	£6.00
1kg	£4.00	£4.00	£8.00
2kg	£6.25	£6.25	£12.00
5kg	£8.50	£15.00	£23.00
10kg	£11.00	£25.00	£44.00

VISA/ACCESS orders accepted. 24 HOUR ANSAPHONE - 0939-32763. FAX - 0939 33800.

Account facilities available immediately for schools, colleges, universities, government departments, etc.

Companies requiring account facilities should telephone for details.

Full Terms & Conditions of Trade available on request.

FAX: 0939 33800

TELEPHONE: 0939 32763

TELEX: 35565

ALL PRICES NOW INCLUDE 15% V.A.T.

## HEAD OFFICE

MARCO TRADING,  
THE MALTINGS,  
HIGH STREET,  
WEM,  
SHREWSBURY. SY4 5EN

TEL 0939 32763 FAX 0939 33800 TELEX: 35565

## BRANCHES

WALTONS,  
55A WORCESTER STREET,  
WOLVERHAMPTON.  
WV2 4LL

TEL: 0902 22039

SUPERTRONICS,  
65 HURST STREET,  
BIRMINGHAM. B5 4TE

TEL: 021 666 6504



**SEND £1 NOW**  
FOR YOUR COPY OF  
OUR LATEST CATALOGUE  
CONTAINING OVER 200 PAGES,  
DETAILING THOUSANDS OF LINES.



INCLUDES DISCOUNT TICKETS  
PRE-PAID ENVELOPE, ORDER FORM  
& SPECIAL OFFERS SUPPLEMENT.



**AERIALS**

A RANGE OF BRITISH MADE, HIGH QUALITY AERIAL ACCESSORIES.

**T.V. AERIAL - INDOOR**



Made in U.K., B.E.A.B. approved aerial with log periodic design to give peak performance on all U.H.F. channels (21-68). Colour T.V. needs a particularly good aerial - this may be the solution where an outdoor aerial is not convenient.



ORDER CODE  
AER/CM7300

PRICE - £8.50

**T.V. INDOOR AMPLIFIER - 240V**



Made in U.K., 240V indoor amplifier that improves signal 3 times. Complete with aerial fly lead. Simply plug in.



ORDER CODE  
AER/CM7253

PRICE - £18.25



**SECOND SET AMPLIFIER - 240V**



Made in U.K., 240V amplifier that operates two U.H.F. T.V. sets from one aerial. Improves signal approx. 50% per outlet. Supplied complete with aerial fly lead.



ORDER CODE -  
AER/CM7243

PRICE - £16.95



**THIRD SET AMPLIFIER - 240V**



Made in U.K., 240V amplifier that operates three U.H.F. T.V. sets from one aerial. Improves signal approx. 75% per outlet.



ORDER CODE  
AER/CM7293

PRICE - £21.50



**C.B. INTERFERENCE SUPPRESSOR**



Made in U.K., simple to use, suppressor for minimising C.B. interference on U.H.F. T.V. reception.



ORDER CODE -  
AER/CM9700

PRICE - £5.99



**T.V./VIDEO/COMPUTER COMBINER**



Made in U.K., an effective device for simply connecting video/computer etc. to T.V. and selecting facility required at the flick of a switch.



ORDER CODE -  
AER/CM7042

PRICE - £4.95



**4-WAY**

Low-loss splitter giving 4 standard co-ax sockets from one standard co-ax plug. Low loss ferrite cored splitter circuits.

ORDER CODE  
AER/CAX/SP4

PRICE - £1.75



**AERIALS**

**EIGHT T.V.**

Ideal for small hotels, residential homes etc.

Runs 8 T.V. sets from one aerial.

The unit has 9 co-ax sockets, the aerial plugs into one and the T.V.s into the other eight.

**SPECIFICATION**

Band Width 40MHz-860MHz  
Gain 3dB per channel - total 21 dB  
Impedance 75 ohms  
Max. Output 80mV (38dBmV)  
Noise (signal/cross modulation - 46dB) 6dB  
Isolation between outputs 40dB min.  
Power 240V a.c. 50Hz  
Dimensions 250 x 100 x 60mm

ORDER CODE  
AER/AMP/BB

PRICE - £35.50

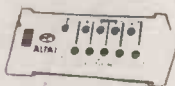

**ECONOMY T.V. AMPLIFIERS**

A range of good quality T.V. amplifiers.

**ONE T.V.**

Ideal where reception needs improving.

One in, one out antenna amplifier for both colour and black/white T.V.s.

White plastic case with ON/OFF switch and L.E.D. indicator and approx. 1 metre of mains cable.

**SPECIFICATION**

Band Width 300MHz-890MHz  
Gain 7dB - 1dB  
Impedance 75 ohms  
Power 240V a.c.  
Dimensions 125 x 79 x 50mm

ORDER CODE  
AER/AMP/E1

PRICE - £9.50



**TWO T.V.**

Operates two T.V. sets from one aerial.

One in, two out antenna amplifier for both colour and black/white T.V.s.

White plastic case with ON/OFF switch and L.E.D. indicator and approx. 1 metre of mains cable.

The unit has three co-ax sockets, the aerial plugs into one and the T.V. sets into the other two.

**SPECIFICATION**

Band Width 300MHz-890MHz  
Gain 7dB - 1dB  
Impedance 75 ohms  
Power 240V a.c.  
Dimensions 125 x 79 x 50mm

ORDER CODE  
AER/AMP/E2

PRICE - £11.50



**SINGLE FLUSH MOUNTING OUTLET**

Flush mounting co-ax socket with a white front plate. Fits to standard conduit and surface boxes. SEE ELECTRICAL SECTION. Screws supplied. No soldering required. For use with V.H.F. or U.H.F. signals.

Colour: White.

ORDER CODE  
AER/CAX/FMO

PRICE - 95p



**DOUBLE FLUSH MOUNTING OUTLET**

As above but with two completely separate co-ax sockets and screw terminals inside for two separate cables. Supplied complete with fixing screws.

Colour: White.

ORDER CODE  
AER/CAX/DFM2

PRICE - £1.20



**ATTENUATORS**

Three types available: 3dB, 6dB, 9dB.

TYPE	ORDER CODE	PRICE	1+	5+
3dB	AER/ATT3		£1.70	£1.60
6dB	AER/ATT6		£1.70	£1.60
9dB	AER/ATT9		£1.70	£1.60

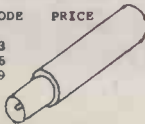

**MULTIWAY SPLITTERS**

**3-WAY**

Low-loss splitter giving 3 standard co-ax sockets from one standard co-ax plug. Low loss ferrite cored splitter circuits.

ORDER CODE  
AER/CAX/SP3

PRICE - £11.50



**CO-AXIAL LEADS**

**2 METRES - PLUG**

A T.V. aerial downlead, 2 metres in length with a co-ax plug on both ends.

Colours Available Black, White.

ORDER CODE  
AER/CAX/L/2P/COLOUR REQ'D

PRICE - 99p

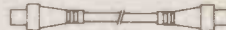

**2 METRES - PLUG/SOCKET**

A T.V. aerial downlead, 2 metres in length.

Right angle co-ax plug to co-ax socket.

Colours Available Black, White.

ORDER CODE  
AER/CAX/L/2PS/COLOUR REQ'D

PRICE - 98p



**CO-AXIAL CONNECTORS**

**SURFACE MOUNTING SOCKET**

Single surface mounting socket. Aerial lead enters through hole in rear and is screw fixed internally. T.V. aerial lead is then simply plugged into the outlet. Supplied with fixing screws.

Colour available: White.

ORDER CODE  
AER/CAX/SMS

PRICE - 65p



**SOCKET SPLITTER/COMBINER**

Surface mounting splitter allowing two connectors to one aerial lead. Supplied with fixing screws.

ORDER CODE  
AER/CAX/SSC

PRICE - 99p



**SOCKET SPLITTER/COMBINER/ - SWITCHED**

Same as the above combiner but this unit is switched. Supplied with fixing screws.

ORDER CODE  
AER/CAX/SSCS

PRICE - £1.25



**IN-LINE SPLITTER**

Aerial splitter giving two standing co-ax outlets from one input. Incorporating ferrite cores for low loss.

ORDER CODE  
AER/CAX/ILS

PRICE - 85p



**CO-AXIAL CONNECTORS**

PLUG - METAL - Standard co-axial plug with aluminium body and cap. COW/CAX/PM 20p

CHASSIS SOCKET - Panel mounting socket which protrudes above the chassis surface. Fixing centres 19mm x 68A Clear. COW/CAX/CS 12p

LINE SOCKET - Standard co-axial in-line socket with aluminium body and cap. COW/CAX/LS 25p

LINE CONNECTOR - For connecting two co-axial plugs together. COW/CAX/LINE 12p

## 2 AUDIO

### ULTRA-MINIATURE STEREO EARPHONES

Ultra-miniature stereo earphones (fit inside ears) packed in a cassette library case.

Spare earpads are included.

#### SPECIFICATION

Impedance 32 ohms  
Response 20-20000Hz  
Power 50mW  
Lead 1.2m straight screened  
Plug 3.5mm  
Weight 13 grams

ORDER CODE  
AUD/HP/H88

1+ 10+ 50+

PRICE - £1.50 £1.30 £1.00



### STEREO EARPHONES MH800S



£4.75

Ultra lightweight earphones with samarium cobalt magnets. 32mm black earpads. Packed in neat hinged plastic case.

Impedance 32Ω  
Response 20-20000Hz  
Power 20mW  
Lead 1.2m straight screened  
Plug 3.5mm stereo  
Weight 15g

### ULTRA-LIGHTWEIGHT STEREO HEADPHONE KIT

#### SPECIFICATION

Impedance 32 ohms  
Response 100-14000Hz  
Power 100mW  
Lead 1.2m straight screened  
Plug 3.5mm and 6.35mm stereo  
Extras 2 adaptors  
Weight 35 grams

ORDER CODE  
AUD/HP/MIN2A

1+ 10+

PRICE - £2.38 £2.00



### STEREO HEADPHONES

A set of headphones of standard construction. Double headband with padded ear cups. All black.

#### SPECIFICATION

Impedance 8 ohms  
Response 30-18000Hz  
Power 400mW  
Lead 1.75m straight screened  
Plug 6.35mm stereo  
Weight 300 grams

ORDER CODE  
AUD/HP/MS400

1+ 10+

PRICE - £4.99 £4.50



### HEADPHONE JUNCTION BOX - EDUCATIONAL

Educational listening station which permits simultaneous use of up to 8 pairs of mono headphones from a single input.

Coupling of 2 or more of these stations provides the facility for unlimited number of listeners.

Each headphone socket has individual volume control. Input lead has 2 plugs: one 1/2", one 3.5mm.

Dimensions 195 x 52 x 155mm  
Lead length 0.85m

ORDER CODE  
AUD/HP/J80X

PRICE - £17.85



### STEREO/MONO HEADPHONES

A basic model headphone with stereo/mono switch, black padded earcups and double headband.

#### SPECIFICATION

Impedance 8 ohms  
Response 30-18000Hz  
Power 300mW  
Lead 2m straight screened  
Plug 6.35mm stereo  
Extras Stereo/mono switch  
Weight 300 grams

ORDER CODE  
AUD/HP/110SM

1+ 10+

PRICE - £5.25 £4.90



### BUZZERS & sirens

#### MINIATURE BUZZER - 6V, 9V or 12V

A miniature solid state buzzer featuring long life high reliability, low current drain, no moving contacts, no arcing, no R.F. noise. Small but with a clear, penetrating sound.

#### SPECIFICATION

Frequency Approx. 800Hz  
Current Approx. 4mA

#### 6V Version

ORDER CODE - AUD/BUZ/6V

1+ 10+

PRICE - 90p 80p



#### 9V Version

ORDER CODE - AUD/BUZ/9V

1+ 10+

PRICE - 90p 80p



#### 12V Version

ORDER CODE - AUD/BUZ/12V

1+ 10+

PRICE - 90p 80p



The above buzzers are for d.c. operation only and approx. 100-150mm of lead is attached which is colour coded:

RED - POSITIVE; BLACK - NEGATIVE.

#### BUZZER - MUSICAL

A musical buzzer which plays seven popular American tunes including: Yellow Rose of Texas, Land of Dixie, Red, White and Blue, When the Saints Go Marching In, etc.

#### SPECIFICATION

Output 80dB @ 1m typ.  
Power 9V d.c. 50mA  
Dimensions 27 (diam.) x 22mm  
Fixing centres 34mm

ORDER CODE  
AUD/BUZ/MUS/LMB7

1+ 4+

PRICE - £2.65 £2.50



#### SIREN - PIEZO ELECTRIC

A high powered piezo electric siren which emits an earpiercing warbling sound. Ideal for alarms, annunciations, etc. White plastic body with mounting bracket. Internal circuitry. Leads: 300mm.

#### SPECIFICATION

Frequency 2.5kHz approx.  
Output 100dB (A) @ 1m typ.  
Power 12V d.c. 150mA  
Dimensions 57 x 42 x 37mm  
Fixing centres 22mm

ORDER CODE  
AUD/SIR/SP12

1+ 4+

PRICE - £6.50 £5.75



#### I.E.C. TYPE



I.E.C. Mains Distribution Unit - free-standing or wall mounting 4-way distribution unit. Maximum total load: 13A 250V A.C. each outlet rating: 6A 250V A.C. Supplied ready wired to 1 metre 13A cable complete with 4 plugs.

CON/IEC/DIST £8.90

### TELEPHONE PICK-UP COIL

A simple but effective device.

One end has a 3.5mm plug fitted which simply fits into 3.5mm socket of tape recorder, the other end attached by suction to almost any telephone enabling conversation to be recorded.

ORDER CODE

AUD/TCP  
PRICE - 85p



### 15 WATT AMPLIFIER - MONO

15 watt I.C. amplifier with protected output, especially useful in cars etc.

Incorporates built-in pre-amp inputs.

#### SPECIFICATION

Inputs 1: 1mV @ 30K  
2: 60mV @ 10K  
Frequency response 50Hz - 25kHz  
Power Source 10-18V d.c.  
Output power 12V - 6W  
14V - 9W  
16V - 12W  
18V - 16W  
Output impedance 4R  
Dimensions 80 x 50 x 22mm

ORDER CODE  
AUD/M/AMP

PRICE - £9.70



### PRE-AMP - MONO

High gain, multi-purpose mono pre-amp for magnetic cartridges, tape playback heads, low output microphones etc.

#### SPECIFICATION

Max. output level 2.5V (with 30mV input)  
Input impedance 50kohm  
Output impedance 5kohm  
Power source 9-12V d.c. 1mA  
Dimensions 60 x 35 x 20mm

ORDER CODE  
AUD/P/AMP

PRICE - £3.90



### PRE-AMP - STEREO

Input impedance 50kohm  
Output impedance 50kohm  
Amplitude gain 34dB  
Max. input 38mV  
Output level 1.8V r.m.s.  
Frequency response 30Hz - 20kHz  
Signal to noise ratio 50dB  
Crosstalk Better than 50dB  
Power source 9V d.c.  
Dimensions 85 x 27 x 58mm

ORDER CODE  
AUD/SPA

PRICE - £11.40



### COMPACT DISC CLEANER

Compact disc cleaning kit which cleans the disc with a radial action as recommended by the C.D. manufacturers.

Strong plastic case with hinged lid to retain C.D. chamolix pad for cleaning.

Kit is supplied complete with bottle of C.D. cleaning liquid and pad cleaning brush.

ORDER CODE  
AUD/CD/CLEAN

PRICE - £4.50



### ELECTRET MICROPHONE INSERTS

Sub-miniature omnidirectional electret condenser microphone insert ideal where space is limited and available in two sizes.

#### SPECIFICATION:

Diameter Type 1 - 10mm  
Type 2 - 6.3mm



ORDER CODE

TYPE 1 - AUD/MEC/1

TYPE 2 - AUD/MEC/2

PRICES 1+ 10+ 100+

TYPE 1 65p 60p 41p

TYPE 2 85p 80p 60p

ALL PRICES NOW INCLUDE 15% V.A.T.

**AUDIO**

**AUDIO MIXER & ECHO**

Professional 8-channel mixer with built-in echo. Each channel is switchable to mic, phono or line inputs and has its own bass, treble, echo, pan and slider level controls. Echo section has level, delay and repeat controls. Left and right outputs controlled by master sliders. Headphone monitoring of each channel or mixed output. Twin VU meters. Aux tape output. Phono and line inputs via phono sockets, mic inputs via 6.35mm sockets. Outputs via 6.35mm sockets.

Neat free-standing case with veneered wooden ends.

**SPECIFICATION**

Input impedance: Phono 47kohm/3mV  
 Mic 600ohm/0.3mV  
 Line 47kohm/100mV  
 Output impedance: Main 600ohm/1V  
 Headphone 8ohm/300mV  
 Frequency response: Phono 30-20kHz  
 Mic 30-16kHz  
 Line 20-30kHz  
 Hum & noise 2.5mV  
 Power 240V a.c. 50Hz  
 Dimensions 400 x 385 x 130mm

ORDER CODE  
**AUD/MIX/881**

PRICE - £199.00



**SOUND TO LIGHT UNIT - 100**

Rack mounting or free standing 3 channel sound to light unit with built-in microphone. Overall sensitivity control and 3 L.E.D. output mics on front panel. Fuse protection. Operating on Low, Medium and High frequencies.

**SPECIFICATION**

Output 3 x 1000W Max. total load 2800W  
 Power 240V a.c. 50Hz  
 Dimensions 240 x 120 x 50mm

ORDER CODE  
**AUD/SL/100**

PRICE - £32.95



**SOUND TO LIGHT UNIT - 400**

Rack mounting or free standing 3 channel sound to light unit using external connection from speaker lead to eliminate background noise pick-up. Bass, Middle, Treble and Master sensitivity controls. Fuse protection.

**SPECIFICATION**

Output 3 x 1000W Max. total load 2800W  
 Power 240V a.c. 50Hz  
 Dimensions 240 x 120 x 50mm

ORDER CODE  
**AUD/SL/400**

PRICE - £25.95



**DISCO TURNTABLE - PROFESSIONAL - BELT DRIVE**

High quality belt driven disc turntable. Fast start and stop from push-button switch. Electronically controlled 33/45 r.p.m. with pitch control and strobe. Well balanced tone arm with anti-skate control. Built-in record cue light. Complete with leads and 7" single adaptor.

ORDER CODE  
**AUD/TURN**

**£115.00**  
 +£3.50 CARR.

**SPECIFICATION**

FEATURES  
 • Flat start/stop  
 • Remote start/stop  
 • High quality tone arm  
 • Anti-skate  
 • Cue light  
 • Pitch control  
 • Turntable strobe  
 • Full manual operation  
 • Electronically controlled 33/45 r.p.m.

Wow and flutter Less than 0.1% wpm  
 Turntable platter 309mm diam. aluminium  
 Speed 33 1/3 r.p.m. and 45 r.p.m.  
 Tonearm Statically balanced  
 Power supply 240V a.c. 50/60Hz  
 Power consumption 5.0W  
 Dimensions 418 x 115H x 335mm  
 Net weight 10kilograms

**STEREO MIXER - 5 CHANNEL**

5-channel stereo sound mixer with mag/crystal pick-up select switches on phono channels. Talkover facility on mic channel. Selectable headphone monitoring. Outputs to amp and tape. Twin VU meters.

**SPECIFICATION**

Inputs: Mic 0.3mV 600ohm  
 Phono 3mV 50kohm (mag)  
 150mV 100k (cry)  
 Tape/tuner 150mV 100kohm  
 Outputs: Amp 1V  
 Tape 0.0V  
 Headphone 80mV @ 75ohm  
 Frequency response 20-20000Hz  
 S/N ratio 48dB  
 Power 240V a.c. 50Hz  
 Dimensions 334 x 100 x 192mm

ORDER CODE  
**AUD/HIX/5MM**

PRICE - £58.95



**STEREO MIXER - 5 CHANNEL**

5-channel stereo disco mixer in rack-mounting case capable of mixing a total of 10 phono line and mic inputs, switchable on the front panel. Twin 5-band graphic equalizer with insert/by-pass switch. DJ mic channel with low cut filter, pan pot and auto fade. Cross fader between channels 1 and 2. Separate L & R output levels and stereo/mono switch. Outputs to amp, tape and headphone.

**SPECIFICATION**

Inputs: Mic 0.3mV 600ohm  
 Phono 2.5mV 47kohm  
 Line/CD 150mV 47kohm  
 Outputs: Amp & tape 2V nom.  
 Headphone 150mV @ 8ohm  
 Frequency response 20-20000Hz  
 Hum and noise 6mV  
 Equalizer control frequencies 60, 250, 1k, 3.5k, 16kHz  
 Equalizer control range ±12dB boost or cut  
 Talkover Decrease 14dB program level  
 Power 240V a.c. 50Hz  
 Dimensions 360 x 265 x 88mm

ORDER CODE  
**AUD/HIX/MRT**

PRICE - £125.000



**STEREO MIXER - 4 CHANNEL**

4-channel stereo sound mixer. 5 inputs. Connections by DIN sockets.

**SPECIFICATION**

Input impedance: Mic 600ohm  
 Phono (magnetic) 50kohm  
 Aux 120kohm  
 Input voltages: Mic 1mV (10mV max.)  
 Phono (magnetic) 3mV (40V max.)  
 Aux 150mV (1.5V max.)  
 Output 0.2V for 50-500ohm  
 2V max.  
 Frequency response Flat ±3dB, 20-20000Hz  
 Power 2k 9V batteries (PP3 x 2)  
 or external 9V supply  
 Dimensions 230 x 180 x 55mm

ORDER CODE  
**AUD/MIX/SM1**

PRICE - £24.50



**STROBE UNIT - BOX**

Strobe light with circular reflector housed in veneered wooden cabinet. Variable speed control.

**SPECIFICATION**

Power 240V a.c. 50Hz  
 Dimensions 150 x 450 x 120mm

**ORDER CODE**

**AUD/STR/800**

PRICE - £19.95

**REPLACEMENT LAMP**

Replacement lamp for above Strobe Unit.

50V 10W Edison screw fitting.

ORDER CODE

**7D/STR800/RL**

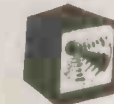

PRICE - £1.95

**LIGHT SEQUENCER - 700**

Rack mounting or free standing 5 channel light sequencer with additional constant channel. Speed and direction controls for sequencer, with 5 L.E.D. output mics on front panel. Attenuator control for constant channel. Fuse protection.

**SPECIFICATION**

Output 5 x 1000W Max. total load 2800W  
 Output 5 x 1000W Max. total load 2800W  
 Power 240V a.c. 50Hz  
 Dimensions 240 x 120 x 50mm

ORDER CODE  
**AUD/L3Q/700**

PRICE - £35.95



**LIGHT SEQUENCER - 800**

Rack mounting or free standing 10 channel light sequencer. Sound and direction controls and 10 L.E.D. output mics on front panel. Fuse protection.

**SPECIFICATION**

Output 10 x 1000W Max. total load 2800W  
 Power 240V a.c. 50Hz  
 Dimensions 240 x 120 x 50mm

ORDER CODE  
**AUD/L3Q/800**

PRICE - £42.95



**STROBE UNIT - RACK**

Top quality high output strobe light with parabolic-reflector. Housed in rack mounting case to match other special effect equipment: sound to light units (AUD/SL/100), (AUD/SL400); light sequencers (AUD/LSW/700), (AUD/LSQ/800).

Variable speed control. ON/OFF switch.

**SPECIFICATION**

Flash rate 5 - 25Hz  
 Power 240V a.c. 50Hz  
 Dimensions 240 x 120 x 50mm

ORDER CODE  
**AUD/STR/25**

PRICE - £29.50



**STEREO ANALOG ECHO UNIT**

Stereo analog delay with two input channels and two output channels with switchable output level. Left and right input level and output level controls. Balance, repeat level and delay time controls of electronic BBD echo. Footswitch ON/OFF and delay reverse facilities. Peak level indicators. Housed in compact satin black metal case.

**SPECIFICATION**

Inputs: Mic 3mV 10kohm  
 Inst. 10mV 300kohm  
 Frequency responses: Direct 10-20000Hz  
 Delay 60-3300Hz  
 Delay time 30-200mS  
 Controls Input level, Output level, Balance, Repeat level, Delay time, Output attenuators, Delay reverse.

Power 240V a.c. 50Hz  
 Dimensions 320 x 176 x 73mm

ORDER CODE  
**AUD/EU/8040**

PRICE - £125.50



**DIGITAL ECHO UNIT**

**SPECIFICATION**

Inputs: -20dB 70mV 500ohm  
 -50dB 2mV 15kohm  
 Frequency responses: Direct 16-19000Hz  
 Delay 16-66000Hz  
 6-520mS

Delay time Input level, Balance, Repeat level, Delay time.  
 Controls Repeat level, Delay time.  
 Power 240V a.c. 50Hz  
 Dimensions 320 x 175 x 74mm

ORDER CODE  
**AUD/EU/3100**

PRICE - £152.00



**ALL PRICES NOW INCLUDE 15% V.A.T.**

**BATTERIES**

**RECHARGEABLE**

AAA - This recent addition to our range, known as the "Triple A", replaces the dry cell version of the same size (HP16).

**SPECIFICATION**

Nominal capacity 180mAh  
 Nominal voltage 1.2V  
 Standard charging time 14 to 16 hours

ORDER CODE  
 BAT/NI/AAA (MP18, MN2400, UM4, AAA)

1+ 10+  
 PRICE £1.50 £1.30

AA - A direct replacement for the dry cell 'AA' battery (penlight).

**SPECIFICATION**

Nominal capacity 0.5Ah  
 Nominal voltage 1.2V

ORDER CODE  
 BAT/NI/AA (MP7, MN1500, UM3, AA)

1+ 10+  
 PRICE - £ 95p 85p

C - Commercial - A direct replacement for the dry cell 'C' battery (HP11).

**SPECIFICATION**

Nominal capacity 1.2Ah  
 Nominal voltage 1.2V  
 Max. charging current 120mA  
 Max. charging voltage 1.6V  
 Charging time 14 to 16 hours

ORDER CODE  
 BAT/NI/CC (eg. SP11, HP11, MN1400, UM2, C, C11)

1+ 10+  
 PRICE - £1.95 £1.80

C - Industrial - Identical to the Commercial battery but has a high rating i.e. 2Ah instead of 1.2Ah. This means that the Industrial battery will last that much longer than the Commercial cell. As these batteries are intended more for the manufacturer they may be supplied in a plain white sleeve.

**SPECIFICATION**

Nominal capacity 2Ah  
 Nominal voltage 1.2V  
 Max. charging current 200mA  
 Max. charging voltage 1.6V  
 Charging time 14 to 16 hours

ORDER CODE  
 BAT/NI/CI (eg. SP22, HP2, MN1300, UM1, D)

1+ 10+  
 PRICE - £3.40 £3.20

D - Commercial - A direct replacement for the dry cell 'D' battery (HP2).

**SPECIFICATION**

Nominal capacity 1.2Ah  
 Nominal Voltage 1.2V  
 Max. charging current 120mA  
 Max. charging voltage 1.6V  
 Charging time 14 to 16 hours

ORDER CODE  
 BAT/NI/DC (eg. SP2, HP2, MN1300, UM1, D)

1+ 10+  
 PRICE - £2.00 £1.85

D - Industrial - Identical to the Commercial battery but has a high rating i.e. 4Ah instead of 1.2Ah. This means that the Industrial battery will last that much longer than the Commercial cell. As these batteries are intended more for the manufacturer they may be supplied in a plain white sleeve.

**SPECIFICATION**

Nominal capacity 4Ah  
 Nominal voltage 1.2V  
 Max. charging current 400mA  
 Max. charging voltage 1.6V  
 Charging time 14 to 16 hours

ORDER CODE  
 BAT/NI/DI (eg. SP22, HP2, MN1300, UM1, D)

1+ 10+  
 PRICE - £4.75 £4.50

**ALL ORDERS RECEIVED BY 4p.m.**  
 BY POST, PHONE, TELEX OR FAX  
**DESPATCHED SAME DAY**  
 SUBJECT TO AVAILABILITY

**BATTERY CHARGER (Universal Nickel Cadmium)**

An attractive nickel cadmium battery charger ideal for charging to rechargeable batteries detailed above. The charger will charge all the sizes listed: AAA, AA, C, D and PP3 and up to four AAA, AA, C and D types and one PP3 can be charged at the same time. The charger has a hinged plastic dust cover for easy viewing. The five battery positions have L.E.D. 'CHARGE' indicators. The unit also has a switch allowing batteries to be checked for current state of charge.

**SPECIFICATION**

Power 240V a.c.  
 Dimensions 210 x 100 x 50mm

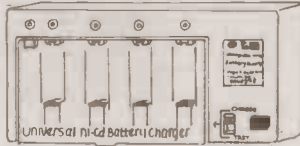

ORDER CODE  
 BAT/CHARGE/UNI

1+ 10+  
 PRICE - £4.99 £4.75



PP3 - A direct replacement for the PP3 dry cell battery.

**SPECIFICATION**

Nominal capacity 0.11Ah  
 Nominal voltage 9V  
 Max. charging current 11mA  
 Max. charging voltage 11V  
 Charging time 12 to 15 hours

ORDER CODE  
 BAT/NI/PP3 (MN1604, 006P, PP3)

1+ 10+  
 PRICE - £3.90 £3.75

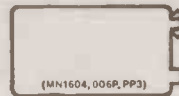

**AA (HP7) HOLDERS**



2xAAA	BAT/BOX/AAA1	30p	28p
4xAAA	BAT/BOX/AAA2	45p	42p
4xAAA	BAT/BOX/AAA3	44p	41p
1xAA	BAT/BOX/AA1.5V	17p	15p
2xAA	BAT/BOX/AA3V	18p	16p
4xAA	BAT/BOX/AA6VA	20p	18p
4xAA	BAT/BOX/6VB	20p	18p
4xAA	BAT/BOX/6VC	24p	22p
6xAA	BAT/BOX/AA9V	32p	30p
8xAA	BAT/BOX/AA12V	36p	34p
10xAA	BAT/BOX/AA15V	50p	48p
1xC	BAT/BOX/C1.5V	36p	34p
2xC	BAT/BOX/C3V	30p	28p
4xC	BAT/BOX/C6VA	32p	30p
4xC	BAT/BOX/C6VC	32p	30p
1xD	BAT/BOX/D1.5V	24p	22p
2xD	BAT/BOX/D3V	32p	30p
4xD	BAT/BOX/D6VA	32p	30p
4xD	BAT/BOX/D6VB	38p	36p

**C (HP11) HOLDERS**



**D (BP2) HOLDERS**

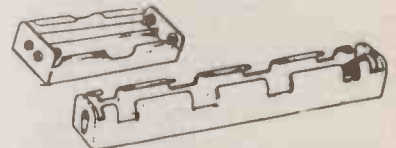

**SPECIAL OFFERS SPECIAL OFFERS SPECIAL OFFERS**

**RECHARGEABLE SPECIALS**

**12V RECHARGEABLE UNIT**

10 x 'D' size ni-cads (4 Ah) encapsulated in a black plastic case. Fuse holder. Gives 12V output when charged. Ex-equipment, fully guaranteed.

Dimensions: 245 x 75 x 75mm  
 \* THIS UNIT IS SUPPLIED, DEPENDING ON AVAILABILITY, EITHER IN 4-PIN VERSION OR 6-PIN VERSION. THE PRICE IS THE SAME FOR EITHER VERSION.

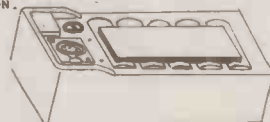

ORDER CODE  
 SO/132

PRICE - 1+ £9.20 (+£1.85 P&P)  
 10+ £8.05 (+£1.50 P&P PER 10 PACKS)

**CHARGER FOR ABOVE 12V UNIT**

These chargers are suitable for the above 12V Rechargeable Unit. The chargers are stated as 'fast charge units' but, to prolong the life of the units, we have modified them to a standard charger. Full charge of the unit being achieved after 10-12 hours (overnight) charging.

Supplied complete with mains lead and charging lead fitted with a 4-pin plug (6-pin plug version available upon request).

Although ex-equipment, these chargers are fully guaranteed by us.

Dimensions: 335 x 260 x 150mm

AVAILABLE IN EITHER 4-PIN OR 6-PIN VERSION - PLEASE STATE WHICH YOU REQUIRE WHEN ORDERING.



ORDER CODE  
 SO/135/VERSION REQ'D

PRICE - £11.50 (+£2.00 P&P)

**PLUGS FOR ABOVE UNIT**

4-PIN (BRAND NEW)

ORDER CODE  
 SO/133  
 PRICE - £2.00

6-PIN (EX-EQUIPMENT)

ORDER CODE  
 SO/134  
 PRICE - £1.50

**NI-CAD BATTERIES - 'C' TYPE TAG ENDED**

Good quality, ex-equipment, nickel-cadmium rechargeable batteries manufactured by Saft, Varta, General Electric etc.

Although ex-equipment, these batteries are fully guaranteed by us - any problems, simply return them to us and we will replace them.

Quantity available: 8,600

ORDER CODE  
 SO/068

1+ £1.00  
 PRICE - 10+ 75p (P&P £1.85 PER 10)  
 100+ 65p (P&P £3.50 PER 100)  
 500+ 57p (P&P FREE)

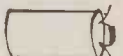

**NI-CAD BATTERIES - 'D' TYPE STANDARD**

Good quality, ex-equipment, nickel-cadmium rechargeable batteries.

**SPECIFICATION**

Nominal capacity ..... 4.0 Ah  
 Nominal voltage ..... 1.25V  
 Max. cont. charge rate ..... 500 mA

At these rates full charge is achieved after 12 hours.

Batteries are normally in banks of 10, so if quantity is less, the batteries may have small deposits of solder on the bottom and top after removal from the 12V rechargeable unit.



ORDER CODE  
 SO/069

1+ £1.10  
 10+ £1.00 (P&P £1.85 PER 10)  
 100+ 90p (P&P £3.50 PER 100)

**ALL GOODS  
 UP TO 750gms  
 SENT 1st CLASS**

**ALL PRICES NOW INCLUDE 15% V.A.T.**

## BOOKS

## POPULAR ELECTRONIC PROJECTS BP49

£2.50 R. A. Penfold  
Provides a collection of the most popular types of circuits and projects covering a very wide range of interests, including Radio, Audio, Household and Test Equipment projects.  
0 85934 053 8 1978 178 x 111 mm 144 pages

2.3 COMPONENT SPECIFIC  
See also book number I60

## MODERN OP-AMP PROJECTS BP106

£1.95 R. A. Penfold  
Includes a wide range of constructional projects which make use of the specialised operational amplifiers that are available today, including low noise, low distortion, ultra-high input impedance, low slew rate and high output current types. Circuits using transconductance types are also included.  
0 85934 081 3 1982 178 x 111 mm 112 pages

## HOW TO USE OP-AMPS BP88

£2.95 E. A. Farr

## How To Use Op Amps

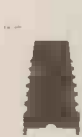

This book has been written as a designer's guide covering many operational amplifiers, serving both as a source book of circuits and a reference book for design calculations. The approach has been made as non-mathematical as possible and it is hoped, easily understandable by most readers, be they engineers or hobbyists.

0 85934 063 5 1982 178 x 111 mm 160 pages

## IC 555 PROJECTS BP44

£2.95 E. A. Farr  
Every so often a device appears that is so useful that one wonders how life went on before without it. The 555 timer is such a device. Included in this book are basic and general circuits, motorcar and model railway circuits, alarms and noise-makers as well as a section on the 556, 558 and 559 timers.  
0 85934 047 3 1982 178 x 111 mm 176 pages

## A PRACTICAL INTRODUCTION TO DIGITAL ICs 225

£2.50 D. W. Eastending  
Introduces the reader practically to digital ICs, this book is mainly concerned with the TTL types such as the 7400 series. Besides a number of simple projects, the author has included the full practical construction of a logic circuit test set which will enable the reader to identify and test his own digital ICs. Also included are the full constructional details and ways of using a more ambitious project — the digital counter timer.  
0 900162 66 X 1977 178 x 111 mm 80 pages

## 50 CIRCUITS USING 7400 SERIES ICs BP58

£2.50 R. N. Soar  
50 interesting and useful circuits and applications covering many different aspects of electronics using these freely obtainable, inexpensive and fantastically versatile series of devices.  
0 900162 77 5 1979 178 x 111 mm 80 pages

## DIGITAL IC PROJECTS BP84

£1.95 F. G. Rayer  
Contains both simple and more advanced projects and it is hoped that these will be found of help to the reader developing a knowledge of the workings of digital circuits.

To help the newcomer to the hobby, the author has included a number of board layouts and wiring diagrams. Also the more ambitious projects can be built and tested section by section and this should help avoid or correct faults that could otherwise be troublesome.  
0 85934 059 7 1981 178 x 111 mm 96 pages

## 50 CIRCUITS USING GERMANIUM SILICON AND ZENER DIODES BP36

£1.50 R. N. Soar  
Contains 50 interesting and useful circuits and applications, covering many different branches of electronics, using one of the most simple and inexpensive of components — the diode. Includes the use of germanium and silicon signal diodes, silicon rectifier diodes and zener diodes, etc.  
0 85934 039 2 1977 178 x 111 mm 64 pages

## 50 SIMPLE LED CIRCUITS BP42

£1.95 R. N. Soar  
Contains 50 interesting and useful circuits and applications, covering many different branches of electronics, using one of the most inexpensive and freely available components — the light-emitting diode (LED). Also includes circuits for the 707 common anode display.  
0 85934 043 4 1977 178 x 111 mm 64 pages

## 50 SIMPLE LED CIRCUITS—BOOK 2 BP87

£1.35 R. N. Soar  
A further range of uses for the simple LED which complements those shown in book number BP42.  
0 85934 062 7 1981 178 x 111 mm 64 pages

## 50 PROJECTS USING RELAYS, SCRs AND TRIACS BP37

£2.95 F. G. Rayer

Relays, silicon controlled rectifiers (SCRs) and bi-directional triodes (TRIACs) have a wide range of applications in electronics. These may extend over the whole field of motor control; dimming and heat control; delayed, timing and light sensitive circuits and include warning devices, various novelties, light modulators, priority indicators, excess voltage breakers etc. This book gives tried and practical working circuits which should present the minimum of difficulty for the enthusiast to construct. In most of the circuits there is a wide latitude in component values and types, allowing easy modification of circuits or ready adaptation of them to individual needs.  
0 85934 040 6 1977 178 x 111 mm 112 pages

## ELECTRONIC PROJECTS FOR CARS AND BOATS BP94

£1.95 R. A. Penfold  
Describes fifteen fairly simple projects for use with a car and/or boat. Each project has an explanation of how the circuit works as well as constructional details including a stripboard layout.  
0 85934 069 4 1981 178 x 111 mm 96 pages

## 50 (FET) FIELD EFFECT TRANSISTOR PROJECTS BP39

£2.95 F. G. Rayer  
Field-effect transistors (FETs) find applications in a wide variety of circuits. The projects described here include radio-frequency amplifiers and converters, test equipment and receiver aids, tuners, receivers, mixers and tone controls, as well as various miscellaneous devices which are useful in the home.

The actual FET to be used, in most cases, is not critical and many suitable types will perform satisfactorily. The FET is a low-noise, high gain device with a multitude of uses, the dual gate being of particular use in mixers and other applications.  
0 85934 042 2 1977 178 x 111 mm 112 pages

## MINI-MATRIX BOARD PROJECTS BP99

£2.50 R. A. Penfold  
Although there are obviously limitations to the amount of circuitry that can be accommodated on a small circuit board, the versatility of modern components is such that it is possible to design a wide range of projects that can be easily built using just a handful of components including the stripboard.

This book does just that, in providing a selection of 20 useful and interesting circuits, all that can be built on a mini-matrix board which is just 24 holes by 10 copper strips in size.  
0 85934 074 0 1982 178 x 111 mm 112 pages

## MULTI-CIRCUIT BOARD PROJECTS BP103

£1.95 R. A. Penfold

Contains information that allows the reader to build 21 fairly simple electronic projects, all of which may be constructed on the same specially designed printed circuit board. Furthermore, wherever possible, the same components have been used in each design to that with a relatively small number of components and hence low cost, it is possible to make any one of the projects or by re-using the components and PCB, all of the projects.  
0 85934 078 3 1982 178 x 111 mm 128 pages

## 2.4 SUBJECT SPECIFIC

See also book numbers 220, 222, 226, BP29, BP74, BP90, BP105, BP122, BP123, BP124, BP130, BP131, BP171, BP173, BP174, BP182, BP185, BP186, BP245, BP247, and BP253

## REMOTE CONTROL HANDBOOK BP240

£3.95 O. Bishop  
Replaces our original book BP73 and is aimed at the electronics enthusiast who wishes to experiment with remote control in its many aspects and forms.  
0 85934 185 2 1988 178 x 111 mm 240 pages

## ELECTRONIC CIRCUITS FOR THE COMPUTER CONTROL OF MODEL RAILWAYS BP180

£2.95 R. A. Penfold  
Shows the reader practical ways of using a number of the more popular micros for controlling, running and adding effects to model railways.  
0 85934 154 2 1987 178 x 111 mm 96 pages

## ELECTRONIC CIRCUITS FOR THE COMPUTER CONTROL OF ROBOTS BP179

£2.95 R. A. Penfold  
Provides information and circuits on computer control of electric motors (including stepper types), plus a range of useful sensors including visible light, infra-red, and ultrasonic types.  
0 85934 153 4 1986 178 x 111 mm 96 pages

## ELECTRONIC SCIENCE PROJECTS BP104

£2.95 O. Bishop  
These projects range in complexity from a simple colour temperature meter to an infra-red laser. There are novelties such as an electronic clock regulated by resonating springs, and an oscilloscope with solid-state display. There are scientific measuring instruments such as a pM meter and an electro-cardiometer. All projects have a strong scientific flavour. The way they work, and how to build and use them are fully explained.  
0 85934 079 1 1982 178 x 111 mm 144 pages

## MODEL RAILWAY PROJECTS BP95

£1.95 R. A. Penfold  
Provides a number of useful but reasonably simple projects for the model railway enthusiast to build, based on inexpensive and easily obtainable components.

The projects covered include such things as controllers, signal and sound effects units, and to help simplify construction, stripboard layouts are provided for each project.  
0 85934 070 8 1981 178 x 111 mm 112 pages

## ELECTRONICS SIMPLIFIED—CRYSTAL SET CONSTRUCTION BP92

£1.75 F. A. Wilson  
Especially written for those who wish to participate in the intricacies of electronics more through practical construction than by theoretical study. It is designed for all ages upwards from the day one can read intelligently and handle simple tools.  
0 85934 067 8 1982 178 x 111 mm 80 pages

## POWER SUPPLY PROJECTS BP76

£2.50 R. A. Penfold

Mains power supplies are an essential part of many electronic projects. This book gives a number of power supply designs, including simple unregulated types, fixed-voltage regulated types, and variable-voltage stabilised designs, the latter being primarily intended for use as bench supplies for the electronics workshop. The designs provided are all low-voltage types for semi-conductor circuits.

The book should also help the reader to design his own power supplies. There are other types of power supply apart from the mains to low voltage type and a number of these are dealt with in the final chapter, including a cassette power supply, ni-cad battery charger, voltage step-up circuit and a simple inverter.  
0 900162 96 1 1980 178 x 111 mm 96 pages

## ELECTRONIC TIMER PROJECTS BP93

£1.95 F. G. Rayer  
Covers many of the possible applications of timer circuits and should fulfill a wide range of interests. Some of the more complicated timer and clock circuits are made up from a number of simpler circuits which the author deals with individually. He then goes on to show how these may be combined together in various ways to make some quite sophisticated projects.

Also included are a number of specialist timer projects such as, car windshield wiper delay unit, darkroom timer, metronome, etc.  
0 85934 068 6 1981 178 x 111 mm 96 pages

## MORE ADVANCED POWER SUPPLY PROJECTS BP192

£2.95 R. A. Penfold  
Covers more advanced topics than those dealt with in the original book BP76 and also covers developments since the original book was written.  
Includes designs and circuitry for precision supplies, switch mode power supplies and computer controlled supplies as well as a number of miscellaneous circuits.  
0 85934 166 6 1988 178 x 111 mm 96 pages

## TEST EQUIPMENT CONSTRUCTION BP248

£2.95 R. A. Penfold  
Shows you how to build a wide range of simple test equipment that will be useful in the pursuance of your hobby after you have had the enjoyment of constructing it.  
0 85934 193 3 1988 178 x 111 mm 96 pages

## MORE ADVANCED TEST EQUIPMENT CONSTRUCTION BP249

£2.95 R. A. Penfold  
Follows on from book BP248 with constructional details of more advanced projects that will help you with your hobby.  
0 85934 194 1 1989 178 x 111 mm 96 pages

## ELECTRONIC GAMES BP69

£1.75 R. A. Penfold  
Contains a number of interesting electronic games projects using modern integrated circuits. The text is divided into two sections, the first dealing with simple games and the latter dealing with more complex circuits thus making the book ideal for both beginner and more advanced enthusiast alike.  
0 900162 90 2 1980 178 x 111 mm 96 pages

## ELECTRONIC SECURITY DEVICES BP56

£2.50 R. A. Penfold  
This book, besides including both simple and more sophisticated burglar alarm circuits using light, infra-red and ultrasonics, also includes many other types of circuit as well, such as gas and smoke detectors, flood alarms, doorphone and baby alarms, etc.  
0 900162 76 7 1979 178 x 111 mm 112 pages

## MORE ADVANCED ELECTRONIC SECURITY PROJECTS BP190

£2.95 R. A. Penfold  
Contains a number of more up-to-date and sophisticated projects, complete with PCB or stripboard layout, than our original book number BP56.

Covers: Opto alarms including pyro-sensor, infra-red and fibre-optic loop types. A computer based system showing how a home micro fitted with a user port can form the basis of a sophisticated alarm and monitoring system. Various alarms using mercury switches, magnetic dependent resistors, doppler shift and capacity effect on an RF oscillator etc.  
0 85934 164 X 1988 178 x 111 mm 112 pages

## PROJECTS IN OPTO-ELECTRONICS BP45

£1.95 R. A. Penfold  
Although many people tend to take opto-electronic devices and circuits for granted, it is hoped that this book will show even the most experienced reader that they can be used in a surprisingly wide range of applications.

The purpose of this book is to describe a number of projects which may be of interest to all electronics enthusiasts. Included are simple circuits using ordinary light emitting diodes (LEDs) as well as more sophisticated designs such as infra-red transmitters and detectors, modulated light transmission and also photographic projects, etc.  
0 85934 049 X 1978 178 x 111 mm 112 pages

## MODERN OPTO DEVICE PROJECTS BP194

£2.95 R. A. Penfold

Provides a number of circuits using more modern devices than book number BP45.

Includes designs for: simple fibre optic audio link; equivalent circuit for RS232C type data transmission and reception; light pen for BBC, Atari, Commodore and Amstrad computers; presence detector, broken beam detector; infra red reflected light sensor; LED stroboscope; etc. PCB layouts are included for more critical designs.  
0 85934 168 2 1987 178 x 111 mm 96 pages

## SOLID STATE NOVELTY PROJECTS 219

£0.85 M. El Babani  
The reader is shown how to build a number of different novelty projects using ICs and transistors. Included are the "Optomim", a musical instrument that is played by reflecting a light beam with your hand, water warbler for pot plants, musical tone generator, LEDs and ladders game, touch switch, electronic roulette wheel, etc.  
0 900162 60 0 1976 178 x 111 mm 96 pages

## PRACTICAL ELECTRONIC BUILDING BLOCKS—BOOK 1 BP117

£1.95

## PRACTICAL ELECTRONIC BUILDING BLOCKS—BOOK 2 BP118

£1.95 R. A. Penfold

Virtually any electronic circuit will need to consist of a number of distinct stages when analysed. Some circuits inevitably have unusual stages using specialised circuitry, but in most cases circuits are built up from electronic building blocks of standard types. These books are designed to aid electronic enthusiasts who like to experiment with circuits and produce their own projects, rather than simply following published project designs. The circuits for a number of building blocks are included in each book, and component values and type numbers are provided in each case. Where relevant, details of how to change the parameters of each circuit (voltage gain of amplifiers, cut-off frequencies of filters, etc.) are given so that they can be easily modified to suit individual requirements. No difficult mathematics is involved.



component values and types, allowing easy modification of circuits or ready adaptation of them to individual needs.  
0 85934 040 6 1977 178 x 111 mm 112 pages



BOOKS

DATA - VOLUME 1

Part One of transistor compendium covering A-BUY giving comprehensive technical data and drawings. Over 700 pages.

ORDER CODE - BK/DAT1 PRICE - £9.99

DATA - VOLUME 2

Part Two of transistor compendium covering C-Z giving comprehensive technical data and drawings. Over 1100 pages.

ORDER CODE - BK/DAT2 PRICE - £10.75

DATA - VOLUME 3

Volume Three of transistor compendium covering 2N21-2N6735 giving comprehensive technical data and drawings. Over 750 pages.

ORDER CODE - BK/DAT3 PRICE - £10.20

DATA - VOLUME 4

Part Four of transistor compendium covering 2Sa, 2SB, 25C, 2SD, 2SJ, 2SK, 3N, 3BJ, 3SK, 4000, giving comprehensive technical data and drawings. Over 1200 pages.

ORDER CODE - BK/DAT4 PRICE - £13.50

TO ORDER ALL FOUR ABOVE VOLUMES QUOTE - ORDER CODE - BK/DAT1-4 PRICE - £42.00

TRANSISTORS - A-Z

An equivalent book with short form technical data covering transistors A to Z.

Provides ratings, characteristics, case drawings, pin outs and selection tables. Over 300 pages.

ORDER CODE - BK/T/AZ PRICE - £6.90

TRANSISTORS - 2N-3N

An equivalent book with short form technical data covering transistors with prefixes 2N, 2SA, 2SB, 2SD, 2SK, 3N, etc.

Provides ratings, characteristics, case drawings, pin outs, etc. Over 400 pages.

ORDER CODE - BK/T/2N PRICE - £7.00

TO ORDER BOTH ABOVE VOLUMES QUOTE - ORDER CODE - BK/T/AZ+2N PRICE - £13.00

DIODES - VOLUME 1

This volume covers devices from A to ZZY.

Provides ratings, characteristics, case drawings, lead information and selection tables. 670 pages.

ORDER CODE - BK/D1 PRICE - £10.75

DIODES - VOLUME 2

This volume covers devices from 1N21 to 44983.

Provides ratings, characteristics, case drawings, etc. 526 pages.

ORDER CODE - BK/D2 PRICE - £10.65

TO ORDER BOTH ABOVE VOLUMES QUOTE - ORDER CODE - BK/D1+2 PRICE - £20.60

IC - LIN - VOLUME 1

Linear operational amplifiers, data and comparison tables for integrated op amps and comparators. Over 400 pages.

ORDER CODE - BK/LIN1 PRICE - £6.95

IC - LIN - VOLUME 2

Linear voltage stabilizers, data and comparison tables for integrated adjustable and non-adjustable voltage regulators. Over 350 pages.

ORDER CODE - BK/LIN2 PRICE - £6.99

TO ORDER BOTH ABOVE VOLUMES QUOTE - ORDER CODE - BK/LIN1+2 PRICE - £13.00

IC - C-MOS

C-MOS ICs data and comparisons. A5 format. 300 pages.

ORDER CODE - BK/CMOS PRICE - £8.95

IC - TTL

TTL digital data and equivalent book including 340 connection drawings, 21 case outline drawings. Over 500 pages.

ORDER CODE - BK/TTL PRICE - £19.50

THYRISTORS

Data dictionary and comparison table for Thyristors, Tetrodes, Trigger Diodes, Triacs, Unijunction Transistors and Programmable UJTs. Covers A to Z.

Provides ratings, characteristics, case drawings and selection tables. 496 pages.

ORDER CODE - BK/TH PRICE - £10.45

I. DATA & REFERENCE

I.1 SELECTOR GUIDES

TRANSISTOR SELECTOR GUIDE BP234 £4.95 J. C. J. van de Ven



Prepared using the latest computerized techniques, from a vast database of electronic component specifications, this unique guide offers a range of selection tables compiled so as to be of maximum use to all electronics engineers, designers and hobbyists. SECTION 1: Serves as a detailed introduction covering component markings, codings and standards, as well as explaining the symbols used and how the tables are arranged. SECTION 2: Tabulates in alphanumeric sequence the comprehensive

specifications of over 1400 JEDEC, JIS, PRO-ELECTRON and brand specific designated devices.

SECTION 3: Tabulates the devices in a similar fashion to the previous section but this time they are arranged by case type. SECTION 4: Considers particular limits to the electrical parameters when compiling the tables and it is sub-divided as follows:-

- (1) Darlington transistors
- (2) Devices that can handle voltages upwards of 300V
- (3) Devices that can handle currents upwards of 5A
- (4) Devices that can handle powers upwards of 5W
- (5) Radio frequency devices that operate upwards of 30MHz
- (6) FETs

SECTION 5: Illustrates package outlines and leadouts. SECTION 6: Consists of a SMD (surface mounting device) markings conversion list. 0 85934 179 8 1987 178 x 130 mm 192 pages

POWER SELECTOR GUIDE BP235 £4.95 J. C. J. van de Ven

Similar in style and presentation to BP234 but covers Power devices, including Diodes, Thyristors, Triacs, FET's and Power transistors etc. 0 85934 180 1 1987 178 x 130 mm 160 pages

DIGITAL IC SELECTOR GUIDE - PART 1 BP236 £4.95 J. C. J. van de Ven

Still in preparation but will be similar in style and presentation to BP234 and BP235. 0 85934 181 X 1987 178 x 130 mm 160 pages

DIGITAL IC SELECTOR GUIDE - PART 2 BP237 £4.95 J. C. J. van de Ven

Still in preparation but will be similar in style and presentation to BP234 and BP235. 0 85934 182 8 1987 178 x 130 mm 160 pages

LINEAR IC SELECTOR GUIDE BP238 £4.95 J. C. J. van de Ven

Still in preparation but will be similar in style and presentation to BP234 and BP235. 0 85934 183 6 1987 178 x 130 mm 160 pages

I.2 EQUIVALENTS

DIGITAL IC EQUIVALENTS AND PIN CONNECTIONS BP140 £5.95 A. Michaels

Shows equivalents and pin connections of a popular user-orientated selection of European, American and Japanese digital ICs. Also includes details of packaging, families, functions, manufacturers and country of origin. 0 85934 115 1 1985 264 x 195 mm 320 pages

LINEAR IC EQUIVALENTS AND PIN CONNECTIONS BP141 £5.95 A. Michaels

Shows equivalents and pin connections of a popular user-orientated selection of European, American and Japanese linear ICs. Also includes details of functions, manufacturers, and country of origin. 0 85934 116 X 1985 264 x 195 mm 256 pages

INTERNATIONAL TRANSISTOR EQUIVALENTS GUIDE BP85 £3.50 A. Michaels

Helps the reader to find possible substitutes for a popular user-orientated selection of European, American and Japanese transistors. Also shows material type, polarity, manufacturer and use. 0 85934 060 0 1981 178 x 111 mm 320 pages

INTERNATIONAL DIODE EQUIVALENTS GUIDE BP108 £2.25 A. Michaels

Helps the user in finding possible substitutes for a large user-orientated selection of the many different types of semiconductor diodes that are available. Besides simple rectifier diodes, also included are zener diodes, LEDs, diacs, triacs, thyristors, OCLs, photo and display diodes. Also wherever possible, material type, function or type of diode, and country of origin are shown. 0 85934 083 X 1982 178 x 111 mm 144 pages

I.3 GENERAL See also book numbers 160, BP251 and BP255

ELECTRONIC HOBBYISTS HANDBOOK BP233 £4.95 R. A. Penfold

Mr. R. A. Penfold has used his vast knowledge of hobby electronics to provide a useful collection of data for the amateur electronics enthusiast in a single source where it can be quickly and easily located. It includes a great deal of data on likely topics of interest, such as colour codes, integrated circuit pinouts, transistor leadout diagrams and data, basic circuit building blocks, etc. Some knowledge of electronics may be needed in order to make use of the information, but, in most cases, the reader is not simply provided with raw data, and where appropriate background information and explanatory notes are provided. 0 85934 178 X 1987 264 x 195 mm 96 pages

HOW TO IDENTIFY UNMARKED ICs BP101 £0.95 K. H. Reor

Shows the reader how, with just a test-meter, to go about recording the particular signature of an unmarked IC which should enable the IC to then be identified with reference to manufacturers' or other data. By now you are probably wondering what an IC signature is. It is a specially plotted chart produced by measuring the resistance between all terminal pairs of an IC. Originally published as an article in Radio-Electronics, one of the leading magazines in the U.S.A. 0 85934 076 7 1982 Chart

RADIO AND ELECTRONIC COLOUR CODES AND DATA CHART BP7 £0.95 B. B. Babani

Covers many colour codes in use throughout the world, for most radio and electronic components. Includes resistors, capacitors, transformers, field coils, fuses, battery leads, speakers, etc. 0 85934 006 6 1971 Chart

CHART OF RADIO, ELECTRONIC, SEMICONDUCTOR AND LOGIC SYMBOLS BP27 £0.95 M. H. Babani

Illustrates the common, and many of the not-so-common, radio, electronic, semiconductor and logic symbols that are used in books, magazines and instruction manuals, etc., in most countries throughout the world. 0 85934 029 5 1975 Chart

RESISTOR SELECTION HANDBOOK BP28 £0.60 B. B. Babani

Shows how to combine two preferred values of resistors to obtain virtually any required value of resistance. Also includes information about fixed resistors, standard ranges, colour codes and markings, power ratings and resistor calculations. 0 85934 031 7 1976 168 x 113 mm 48 pages

2. CIRCUITS & CONSTRUCTIONAL PROJECTS

2.1 ABSOLUTE BEGINNERS

See also book numbers BP92, BP99 and BP110

BEGINNERS GUIDE TO BUILDING ELECTRONIC PROJECTS 227

£1.95 R. A. Penfold Shows the complete beginner how to tackle the practical side of electronics, so that he or she can confidently build the electronic projects that are regularly featured in the popular magazines and books. Also includes examples in the form of simple projects that you can build. 0 900162 68 6 1977 178 x 111 mm 112 pages

ELECTRONIC PROJECTS FOR BEGINNERS BP48 £1.95 F. G. Rayer

Contains a wide range of easily made projects (including some that require no soldering) for the newcomer to electronics. Includes many actual component and wiring layouts to aid easy and successful construction. 0 85934 054 6 1978 178 x 111 mm 128 pages

IC PROJECTS FOR BEGINNERS BP97 £1.95 F. G. Rayer

Offers a range of simple projects based around a number of popular and inexpensive linear and digital integrated circuits. With most projects, complete layout and/or point-to-point wiring diagrams are included to help simplify construction. 0 85934 072 4 1982 178 x 111 mm 112 pages

30 SOLDERLESS BREADBOARD PROJECTS - BOOK 1 BP107 £2.25 R. A. Penfold

Each project, which is designed to be built on a "Verobloc" breadboard, is presented in a similar fashion with a brief circuit description, circuit diagram, component layout diagram, components list and notes on construction and use where necessary. Wherever possible, the components used are common to several projects, hence with only a modest number of reasonably inexpensive components, it is possible to build in turn, every project shown. Recommended by BICC-Vero. 0 85934 082 1 1982 178 x 111 mm 160 pages

30 SOLDERLESS BREADBOARD PROJECTS - BOOK 2 BP113 £2.25 R. A. Penfold

The companion volume to Book 1 (BP107) and presented in exactly the same style using "Verobloc". However, all the projects in this book are based on CMOS logic integrated circuits, whereas those in the first book were all designed using linear devices. The information contained in Book 1 about identifying components and using breadboards is not repeated here so that it is suggested that the absolute beginner start with the first book. Recommended by BICC-Vero. 0 85934 088 0 1983 178 x 111 mm 160 pages

2.2 GENERAL ASSORTED

See also book numbers BP117 and BP118

POPULAR ELECTRONIC CIRCUITS - BOOK 1 BP80 £2.95 R. A. Penfold

Contains a wide range of circuits which are accompanied by a short text giving a brief introduction, circuit description and any special notes on construction and setting-up that may be necessary. 0 85934 055 4 1980 178 x 111 mm 160 pages

POPULAR ELECTRONIC CIRCUITS - BOOK 2 BP98 £2.25 R. A. Penfold

Again, provides a wide range of designs for electronics enthusiasts who are capable of producing working projects from just a circuit diagram without the aid of detailed constructional information. However, where relevant, any special setting-up procedures are described. 0 85934 073 2 1982 178 x 111 mm 160 pages

# BOXES

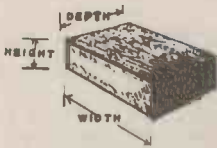

P.V.C. COVERED STEEL



ALL-ALUMINIUM

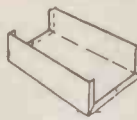

ALUMINIUM BOXES

BLACK LEATHER-GRAIN P.V.C. COVERED ALUMINIUM

WIDTH INCHES	DEPTH INCHES	HEIGHT INCHES	WIDTH MILLIMETRES	DEPTH MILLIMETRES	HEIGHT MILLIMETRES	ORDER CODE	PRICE
4.5	2.25	2.0	114	57	51	BOX/J2	£1.70
6.0	4.0	2.0	153	102	51	BOX/J6	£2.30
8.0	5.5	2.0	204	140	51	BOX/J9	£3.10
11.0	11.0	2.0	280	280	51	BOX/J26	£5.40
4.0	3.0	2.5	102	76	64	BOX/J3	£2.00
6.0	3.0	2.5	153	76	64	BOX/J5	£2.40
8.0	4.0	2.5	204	102	64	BOX/J8	£3.00
9.0	5.25	2.5	230	134	64	BOX/J12	£3.40
5.0	6.0	3.0	127	153	76	BOX/J11	£3.10
8.0	6.0	3.0	204	153	76	BOX/J14	£3.70
8.0	8.0	3.0	204	204	76	BOX/J19	£4.40
11.0	6.0	3.0	280	153	76	BOX/J20	£4.80
11.0	7.5	3.5	280	190	90	BOX/J29	£5.60
17.0	7.5	3.5	433	190	90	BOX/J46	£8.20
6.0	4.0	4.0	153	102	102	BOX/J10	£3.10
6.0	6.0	4.0	153	153	102	BOX/J15	£3.70
6.0	9.0	4.0	153	230	102	BOX/J22	£4.80
8.0	7.0	4.0	204	178	102	BOX/J23	£4.80
8.0	6.0	5.0	204	153	127	BOX/J24	£4.90
11.0	6.0	5.0	280	153	127	BOX/J33	£5.90
15.0	6.0	5.0	380	153	127	BOX/J45	£7.10
8.0	11.0	5.0	204	280	127	BOX/J44	£6.80
11.0	11.0	5.0	280	280	127	BOX/J60	£8.70
15.0	11.0	5.0	380	280	127	BOX/J83	£10.80
7.0	10.0	7.0	178	254	178	BOX/J49	£7.80
10.0	10.0	7.0	254	254	178	BOX/J70	£9.60
17.0	10.0	7.0	433	254	178	BOX/J119	£13.60

### 19" RACK CASES

Superb quality rack cases - already we have found a tremendous demand for these attractive units.

WE OFFER A GOOD RANGE OF SIZES AT VERY COMPETITIVE PRICES.

7-piece construction with 3mm aluminium front panel.

Top and bottom covers removable for easy access.

Supplied as separate parts for easy drilling, machining etc.

PANEL DIMENSIONS	CASE DIMENSIONS	ORDER CODE	PRICE
WIDTH INCHES	HEIGHT INCHES	WIDTH INCHES	DEPTH INCHES

19.0	1.75	16.75	6.0	1.375	BOX/U106	£14.15
19.0	1.75	16.75	9.0	1.375	BOX/U109	£15.75
19.0	1.75	16.75	12.0	1.375	BOX/U112	£17.50
19.0	3.5	16.75	6.0	3.125	BOX/U206	£17.15
19.0	3.5	16.75	9.0	3.125	BOX/U209	£19.20
19.0	3.5	16.75	12.0	3.125	BOX/U212	£21.30
19.0	5.25	16.75	6.0	4.875	BOX/U306	£22.45
19.0	5.25	16.75	9.0	4.875	BOX/U309	£24.85
19.0	5.25	16.75	12.0	4.875	BOX/U312	£27.15
19.0	7.0	16.75	6.0	6.625	BOX/U406	£27.00
19.0	7.0	16.75	9.0	6.625	BOX/U409	£29.80
19.0	7.0	16.75	12.0	6.625	BOX/U412	£32.55

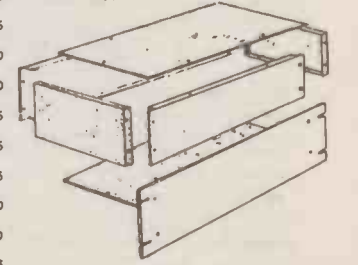

### ABS MULTIPURPOSE BOXES - STANDARD

A range of professional quality boxes, offering a high quality finish at a very realistic price.

Moulded in high impact ABS to give maximum strength, they are easily punched or drilled to produce a professional looking end-product.

Printed circuit board slots are provided on this range except for MB6.

All the lids are retained by 4 or 6BA countersunk posidrive screws into brass inserts.

Colour available: Black.



### ABS MULTIPURPOSE BOXES - MINIATURE

These miniature boxes are moulded in high impact ABS to give maximum strength. The lids are retained by four self-tapping screws.

They are easily punched or drilled making them ideal for use in the electrical and electronic industries as circuitry enclosures or junction boxes. Also ideal for the hobbyist looking for a professional finish to that project requiring a small box.

Colour available: Black



INTERNAL DIMENSIONS	WALL THICKNESS	ORDER CODE	PRICE 1+	PRICE 10+
mm	mm			

72	46	22	1.5	BOX/T3	72p	67p
107	53	18	2.0	BOX/T4	86p	82p

### ABS ECONOMY BOXES

An economy range of ABS boxes where low cost is a priority. Self-tapping screws are included.



INTERNAL DIMENSIONS	COLOUR	ORDER CODE	PRICE 1+	PRICE 10+		
L x W x D						
90	70	28	Black	BOX/IE2	72p	65p
116	78	33	Black	BOX/IE4B	98p	90p
116	78	33	White	BOX/IE4W	99p	91p
150	85	45	Black	BOX/IE3	£1.25	£1.05

### STICK-ON FEET

Grey moulded flexible feet with a strong pressure sensitive adhesive backing.

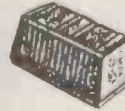

SIZE (mm)	HEIGHT	ORDER CODE	PRICE 1+	PRICE 10+
12.7 x 12.7	5.6	BOX/FEET/SO1	14p	12p
20.6 x 20.6	7.5	BOX/FEET/SO2	16p	14p

PLAIN ALUMINIUM

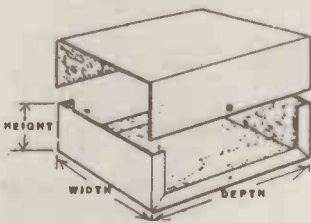

WIDTH INCHES	DEPTH INCHES	HEIGHT INCHES	WIDTH MILLIMETRES	DEPTH MILLIMETRES	HEIGHT MILLIMETRES	ORDER CODE	PRICE
2.0	3.0	1.0	51	76	26	BOX/A6	85p
2.0	4.0	1.0	51	102	26	BOX/A8	95p
2.0	5.0	1.0	51	127	26	BOX/A10	£1.10
3.0	4.0	1.0	76	102	26	BOX/A12	£1.15
2.0	3.0	1.5	51	76	38	BOX/A9	£1.05
3.0	4.5	1.5	76	114	38	BOX/A20	£1.25
3.0	5.5	1.5	76	140	38	BOX/A25	£1.50
2.0	4.0	2.0	51	102	51	BOX/A16	£1.20
4.0	4.0	2.0	102	102	51	BOX/A32	£1.55
4.0	6.0	2.0	102	153	51	BOX/A48	£1.80
3.0	5.0	3.0	76	127	76	BOX/A45	£1.85
4.0	6.0	3.0	102	153	76	BOX/A72	£2.25
5.0	7.0	3.0	127	178	76	BOX/A105	£2.70
4.0	10.0	3.0	102	254	76	BOX/A120	£3.20
5.0	6.75	4.0	127	171	102	BOX/A140	£3.25

INTERNAL DIMENSIONS	ORDER CODE	PRICE 1+	PRICE 10+		
mm					
76	58	35	BOX/MB1	£1.24	£1.18
95	71	35	BOX/MB2	£1.32	£1.26
115	95	37	BOX/MB3	£1.58	£1.50
145	95	55	BOX/MB5	£2.20	£2.05
165	119	75	BOX/MB7	£3.20	£3.05
207	122	77	BOX/MB4	£4.96	£4.80
213	142	57	BOX/MB6	£3.78	£3.63

### PSU-2

ABS box, two-part housing, ideal for mains to low voltage power supplies. Mains input cable will be securely clamped when fitted through the slot in the base, the latter being held in place by four self-tapping screws. An internal divider is provided for transformer/electronic isolation. The external appearance of the box is enhanced by ribbing.

Dimensions B.4.1/2"xH.2.3/8"xW.2.1/4"

Colour available: Black

ORDER CODE BOX/PSU-2

PRICE - £1.26 £1.16

ALL PRICES NOW INCLUDE 15% V.A.T.

**CABLES & WIRES**

**EQUIPMENT WIRE**

**SINGLE STRAND 1/0.6mm<sup>2</sup> (0.28mm<sup>2</sup>)**

Tinned 0.6mm conductor covered by 0.3mm wall thickness P.V.C.

Overall diameter 1.2mm  
Rating 1KV r.m.s. 1.8A @ 70°C

Colours available Black, Blue, Brown, Green, Grey, Orange, Pink, Red, White, Violet, Yellow.

ORDER CODE CBL/EM1/COLOUR REQ'D

PER MTR.	PER 100 MTR. REEL
5p	£2.65

**STRANDED 7/0.2mm<sup>2</sup> (0.22mm<sup>2</sup>)**

Tinned stranded conductor covered by 0.3mm wall thickness P.V.C.

Overall diameter 1.2mm  
Rating 1KV r.m.s. 1.4A @ 70°C

Colours available Black, Blue, Brown, Green, Grey, Orange, Pink, Red, Violet, White, Yellow.

ORDER CODE CBL/EM7/COLOUR REQ'D

PER MTR.	PER 100 MTR. REEL
6p	£3.00

**FLEXIBLE MAINS CABLE**

**2-CORE**

**0.5mm<sup>2</sup> (3A) ROUND**

Brown and Blue P.V.C. insulated 16/0.2mm plain copper stranded conductors moulded into a round P.V.C. outer sheath.

Diameter Approx. 5.4mm nominal  
Harmonised type H03W-P to BS6500

Colours available White, Black.

ORDER CODE CBL/MC1/COLOUR REQ'D

PER MTR.	PER 100 MTR. REEL
14p	£10.50

**0.75mm<sup>2</sup> (6A) ROUND**

Brown and Blue P.V.C. insulated 24/0.2mm plain copper stranded conductors moulded into substantial P.V.C. outer sheath.

Diameter Approx. 6.5mm nominal  
Harmonised type H05VV-F to BS6500 Ref. 3182Y

Colours available White, Black, Orange.

ORDER CODE CBL/MC3/COLOUR REQ'D

PER MTR.	PER 100 MTR. REEL
21p	£16.50

**3-CORE**

**0.5mm<sup>2</sup> (3A) ROUND**

Brown, Blue and Green/Yellow P.V.C. insulated 16/0.2mm plain copper stranded conductors moulded into a round P.V.C. outer sheath.

Overall diameter Approx. 5.8mm nominal  
Harmonised type H03VV-F to BS6500 Ref. 2183Y

Colours available White, Black, Orange.

ORDER CODE CBL/MC4/COLOUR REQ'D

PER MTR.	PER 100 MTR. REEL
20p	£17.00

**0.75mm<sup>2</sup> (6A) ROUND**

Brown, Blue and Green/Yellow P.V.C. insulated 24/0.2mm plain copper stranded conductors moulded into a substantial P.V.C. outer sheath.

Diameter Approx. 6.6mm nominal  
Harmonised type H05VV-F to BS6500 Ref. 3183Y

Colours available White, Black, Orange.

ORDER CODE CBL/MC5/COLOUR REQ'D

PER MTR.	PER 100 MTR. REEL
30p	£22.50

**1.5mm (15A) ROUND**

Brown, Blue and Green/Yellow P.V.C. insulated 30/0.25mm tinned copper stranded conductors moulded into a substantial P.V.C. outer sheath.

Diameter Approx. 9.8mm nominal  
Harmonised type H05VV-F to BS6500 Ref. 3183Y

Colours available Black, White.

ORDER CODE CBL/MC7/COLOUR REQ'D

PER MTR.	PER 100 MTR. REEL
46p	£35.00

**SURFACE WIRING CABLE (TWIN & EARTH)**

SIZE	ORDER CODE	PER MTR.	PER 50 MTR. REEL
1.0mm <sup>2</sup>	CBL/TE1	29p	£11.95
1.5mm <sup>2</sup>	CBL/TE2	39p	£15.20
2.5mm <sup>2</sup>	CBL/TE3	50p	£21.00
6.0mm <sup>2</sup>	CBL/TE6	£1.55	£33.00

**HI-FI LOUDSPEAKER CABLE - LIGHTWEIGHT**

A flexible twin cable with 'figure 8' shape.

Ideal for loudspeakers, bells, etc.

Stranded core twin 13/0.2mm P.V.C. covered with polarity line for identification.

Overall dimensions 4 x 2mm  
Max. current 10A

Colours available White, Grey, Black.

ORDER CODE CBL/TF8/COLOUR REQ'D

PER MTR.	PER 100 MTR.	PER 1000 MTR.
8p	£6.40	£58.50

**HI-FI LOUDSPEAKER CABLE - HIGH QUALITY**

A flexible twin cable with 'figure 8' shape.

This cable will handle upto 15A @ 60V r.m.s. (170V peak) making it suitable for amplifiers upto 500W output.

Stranded core twin 42/0.2mm copper P.V.C. covered with polarity line for identification.

Overall dimensions 6 x 3mm  
Max. current 15A

Colour available White.

ORDER CODE CBL/TF8/42

PER MTR.	PER 100 MTR. REEL
28p	£25.00

**CO-AXIAL CABLES**

**75ohm LOW LOSS UHF TV DOWNLEAD**

1/1.0mm solid copper conductor with heavily braided copper screening.

Air-spaced polythene insulation.

Overall diameter 6.5mm

Colours available White, Brown.

ORDER CODE CBL/CAX/75/COLOUR REQ'D

PER MTR.	PER 100 MTR. REEL
22p	£17.50

**50ohm RF CABLE - RG58 (CB)**

7/0.3mm slid copper conductor, heavily braided copper screening with solid polythene insulation.

Overall diameter 5mm

Colour available Black.

ORDER CODE CBL/CAX/50

PER MTR.	PER 100 MTR. REEL
20p	£15.00

**TELEPHONE CABLE**

**4-CORE**

Contains four solid tinned annealed copper conductors each 0.5mm diameter insulated with P.V.C.

Insulation colours Blue/White, White/Blue, Orange/White, White/Orange, White P.V.C.

Overall insulation 0.2mm<sup>2</sup>  
Nominal conductor area 0.80V  
Max. working voltage 0.25A  
Max. current per core 3.6mm  
Overall diameter

ORDER CODE CBL/TEL/4

PER MTR.	PER 100 MTR. REEL
15p	£12.00

**INDIVIDUALLY SCREENED CABLES**

**2-CORE**

Twin 'figure 8' 2 x 13/0.1mm  
Overall dimensions - 5.5mm x 2.5mm  
Colour available - Grey.

ORDER CODE CBL/ISC/2

PER MTR.	PER 100 MTR. REEL
15p	12p

**MICROPHONE CABLES**

**SINGLE**

Single 7/0.1mm. Overall diameter 3mm.  
Colour available - Grey.

ORDER CODE CBL/MIC/1

PER MTR.	PER 100 MTR. REEL
10p	£8.50

**EXTRA FLEXIBLE - HEAVY DUTY**

Heavy duty - noiseless cable.

Neoprene covered 'Oxygen Free Copper' core.

Stranded core 20/0.1mm  
Overall diameter 6.5mm.  
Colour available - Black.

ORDER CODE CBL/MIC/OP

PER MTR.	PER 100 MTR. REEL
95p	£75.50



**JUST ARRIVED**

**SATELLITE CABLE**



RG6 (CT100). Semi air-spaced 75Ω 1/1.0mm conductor. Copper braid and aluminium foil screens. 6.5mm OD. Black.

**PRICE - 50p PER METRE  
£28.50 PER 100 METRE REEL**

**SATELLITE CONNECTORS - F - TYPE**

**QUICK CONNECT TWIST-ON TYPE:**

**FOR RG58 CABLE - 25p EACH  
FOR RG6 CABLE - 35p EACH**

**SLDERLESS CRIMP STYLE:**

**FOR RG58 CABLE - 20p EACH**



## CAR ACCESSORIES

### IMMERSION HEATER

A very handy travelling immersion heater for boiling water, soup, etc. Plugs directly into car cigar lighter socket.

Power: 12V d.c. 120W.  
Lead length: 1m.

ORDER CODE  
CAR/IB  
PRICE - £2.50



### POWER SUPPLY

D.C. to D.C. adaptor. Plugs into car cigar lighter socket.

Outputs 3, 4.5, 6, 7.5, 9, 12V @ 800mA.

Has universal output spider plug, also 9V battery snap and polarity reversing facility.

ORDER CODE  
CAR/PSU/1  
PRICE - £2.75



### POWER EXTENSION LEAD

Adaptor lead to project cigar lighter-type socket to a distance of 2 metres.

Max. current: 5A.

A 5A fuse is built into the plug.

ORDER CODE  
CAR/PLE  
1+ 10+

PRICE - £2.20 £2.00



### CAR AERIAL CONNECTORS

ILLUSTRATION DESCRIPTION 1+



CON/CAR/ASP

**SKELETON PLUG** - Fits the aerial sockets of most car radios. 14p



CON/CAR/APP

**PLASTIC PLUG** - Similar to the Skeleton Plug but with plastic body and screw-on cap. 35p  
Solderless connections.  
Colour available - Black.



CON/CAR/ALS

**LINE SOCKET** - with plastic body and solderless screw terminals for easy connection. 38p  
Ideal for extending a car aerial lead.



CON/CAR/LC

**LINE COUPLER** - for simply joining two car aerial plugs. 66p



CON/CAR/ACS

**CHASSIS SOCKET** - to suit above car plugs. As fitted to many car radios. 24p  
Panel cut-out: 12.7mm.  
Fixing centres: 20mm x 6BA clear.



£19.50

### B007A STEREO CROSSOVER NETWORK YN1004

200W per channel stereo in-car crossover network for more sophisticated installations. Each channel is separated three ways into bass, mid and treble. Contained within an easy to mount black plastic housing. Connections to amp by flying lead. Connections to speakers by spring terminals.

Type 2 x 3 way  
Power 200W stereo  
Crossover frequencies 800 and 5kHz, 6dB/oct  
Impedance 4Ω  
Dims 200 x 135 x 55mm

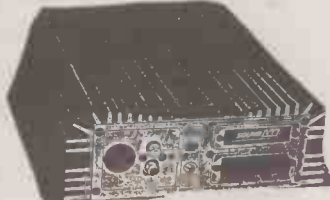

### B005K 2 x 150W POWER AMPLIFIER KB907

A high power stereo in-car amplifier, 2 x 150W stereo or 120W mono (switchable). Inputs accepted from low level sources or speaker outputs from a car radio cassette. Full short circuit and overheat protection. Low input gain control.

Output power 2 x 150W max  
120W mono  
Output Impedance 4-8Ω  
Distortion 0.05%  
Power 11-16Vdc  
Dims 196 x 65 x 250mm

### CAR EQUALIZER/BOOSTER - 60W

Slimline 10-band equalizer/booster with 60W total output power. Built-in 3.5mm stereo headphone socket. Twin 5 LED power level indicators. Front/rear fader control.

Mounting hardware included.

#### SPECIFICATION

Output power 30W per channel  
Frequency response 20-21000Hz  
Input impedance 230hm  
Control frequencies 30, 60, 120, 250, 500, 1k, 2k, 4k, 8k, 16kHz  
Control range 12dB boost or cut  
Output impedance 4-8ohm  
Power 12-14V d.c. negative earth  
Dimensions 149 x 120 x 28mm

ORDER CODE  
CAR/EB1  
PRICE - £29.99

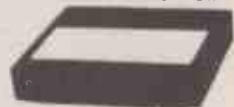

### CAR EQUALIZER/BOOSTER - 120W

High power stereo equalizer/booster. Twin 5-band graphic equalizer, fader control for front/rear speakers and twin 10-LED power indicators. Inputs for high or low level from car stereo.

Mounting hardware included.

#### SPECIFICATION

Output power 120W per channel  
Frequency response 30-20000Hz  
Input level 300mV (low) 2.5V (high)  
Input impedance 50ohm  
Output impedance 4-8ohm  
Power 12-14V d.c.  
Dimensions 150 x 45 x 135mm

ORDER CODE  
CAR/EB2  
PRICE - £33.50



### POWER AMPLIFIER

High power stereo in-car amplifier, 2 x 75W stereo or 150W mono (switchable). Input selector switch permits connections to normal and high power car stereo players. Power will ON/OFF automatically from remote connection to car stereo power lead. Input sensitivity selector.

Supplied complete with fitting instructions.

ORDER CODE  
CAR/PA  
PRICE - £39.99



## TWEETERS

### LOUDSPEAKERS

#### PIEZO CERAMIC TWEETERS - MOTOHOLA

##### 2" x 5" WIDE DISPERSION HORN

Size 2" x 5"  
Impedance 1000 ohms @ 1kHz  
Power nominal 15W  
Power maximum 35W  
Frequency response 3kHz-30kHz  
Output SPL 93dB  
Weight 60gms  
Dimensions 145 x 67 x 54mm

ORDER CODE  
LSP/ESH16A

PRICE - £6.95 EACH  
£12.50 PER PAIR

##### 2" x 6" WIDE DISPERSION HORN

Size 2" x 6"  
Impedance 450 ohms @ 1kHz  
Power nominal 20W  
Power maximum 35W  
Frequency response 2kHz-30kHz  
Output SPL 95dB  
Weight 100gms  
Dimensions 178 x 95 x 115mm

ORDER CODE  
LSP/ESH25A

PRICE - £9.95 EACH  
£18.00 PER PAIR

##### 3 1/2" HORN

Size 3 1/2"  
Impedance 1000 ohms @ 1kHz  
Power nominal 16W  
Power maximum 35W  
Frequency response 2kHz-30kHz  
Output SPL 100dB  
Weight 64gms  
Dimensions 95 (diam.) x 60mm

ORDER CODE  
LSP/ESH38A

PRICE - £5.90 EACH  
£10.00 PER PAIR



£39.99

### B009D 120W SHELF SPEAKERS RTS400

Hi-fi quality 3-way bass reflex rear shelf speakers. Unique design, gunmetal plastic cabinets with gold trim. 120W max. power handling per cabinet.

Maximum power 120W  
Frequency response 80-20000Hz  
Speaker sizes 4" woofer, 2" mid, 1" tweeter  
Impedance 4Ω  
Dims 295 x 120 x 160mm

## GRILLS



### LOUDSPEAKER GRILLS

A very attractive range of good quality loudspeaker grills.

Black finish, metal mesh grills with black rubber surround.

Very strong construction made from 1.1mm thick steel.

Available in six sizes: Grill pitch 11mm x 11mm.

DIAMETER	ORDER CODE	1+	4+
5"	LSP/GL5	£1.90	£1.75
8"	LSP/GL8	£2.75	£2.50
10"	LSP/GL10	£2.95	£2.65
12"	LSP/GL12	£3.85	£3.50
15"	LSP/GL15	£5.00	£4.50
18"	LSP/GL18	£8.50	£7.75



### B009B 50W DOOR SPEAKERS RTS510

High quality dual cone, door mounting speakers. Unique design gunmetal and black grill. 50W max. power handling per speaker.

Maximum power 50W  
Frequency response 80-18000Hz  
Speaker size 5" dual cone  
Impedance 4Ω  
Mounting depth 30mm

£11.99



### 1 1/4" ROUND - DOME TWEETER

Black metal and plastic bezel with domed mesh grill.

Size 1 1/4"  
Impedance 8 ohms  
Power nominal 50W  
Power maximum 65W  
Frequency response 2kHz-20kHz  
Output SPL 102dB @ 1W  
Magnet weight 5.3oz  
Overall weight 450gms  
Dimensions 98 (diam.) x 32mm

ORDER CODE  
LSP/DHT100

PRICE - £5.95 EACH  
£10.00 PER PAIR



# CONNECTORS

		PRICES	
		1*	10*
<b>1/4" (6.35mm)</b>			
CON/635/MJP/P	Mono jack plug, plastic.	24p	22p
CON/635/MJP/M	Mono jack plug, metal.	46p	42p
CON/635/SJP/P	Stereo jack plug, plastic.	34p	21p
CON/635/SJP/M	Stereo jack plug, metal.	62p	56p
CON/635/MCS/4	Mono chassis socket, Break/Break 4 tags.	28p	24p
CON/635/SCS/6	Stereo chassis socket, Break/Break 6 tags.	32p	30p
CON/635/GMCS/4	Mono gold-plated chassis socket, Break/Break 4 tags.	48p	45p
<b>2.5mm</b>			
CON/25/MP/P	Mono plug, plastic.	15p	12p
CON/25/MCS/M	Mono chassis socket, metal.	20p	18p
<b>3.5mm</b>			
CON/35/MP/P	Mono plug, plastic.	15p	12p
CON/35/SP/P	Stereo plug, plastic.	26p	24p
CON/35/RASP/P	Right-angle stereo plug, plastic.	30p	28p
CON/35/MCS/M	Mono chassis socket, metal.	20p	18p
<b>2-PIN DIN</b>			
CON/2P/P	Plug, non-reversible, plastic.	12p	10p
CON/2P/SP	Plug, non-reversible, plastic, solderless.	20p	18p
CON/2P/CS	Chassis socket, plastic.	12p	10p
CON/2P/LS	Line socket, non-reversible, plastic.	12p	10p
<b>3-PIN DIN</b>			
CON/3P/P	Plug, plastic, screened.	18p	16p
CON/3P/CS	Chassis socket, metal.	18p	16p
CON/3P/LS	Line socket, plastic, screened.	24p	22p
CON/3P/PBCS	PCB socket, right-angle, plastic.	25p	23p
<b>4-PIN DIN</b>			
CON/4P/P	Plug, plastic, screened.	20p	18p
CON/4P/CS	Chassis socket, metal.	18p	16p
CON/4P/LS	Line socket, plastic, screened.	24p	22p
<b>5-PIN 180° DIN</b>			
CON/5P180/P	Plug, plastic, screened.	20p	18p
CON/5P180/CS	Chassis socket, metal.	18p	16p
CON/5P180/LS	Line socket, plastic, screened.	24p	22p
<b>5-PIN 240° DIN</b>			
CON/5P240/P	Plug, plastic, screened.	20p	18p
CON/5P240/CS	Chassis socket, metal.	20p	18p
CON/5P240/LS	Line socket, plastic, screened.	24p	22p
<b>5-PIN 360° DIN</b>			
CON/5P360/P	Plug, plastic, screened.	22p	20p
CON/5P360/CS	Chassis socket, metal.	22p	20p
CON/5P360/LS	Line socket, plastic, screened.	26p	24p
<b>6-PIN DIN</b>			
CON/6P/P	Plug, plastic, screened.	22p	20p
CON/6P/CS	Chassis socket, metal.	22p	20p
CON/6P/LS	Line socket, plastic, screened.	24p	22p
<b>7-PIN DIN</b>			
CON/7P/P	Plug, plastic, screened.	24p	22p
CON/7P/CS	Chassis socket, metal.	24p	22p
CON/7P/LS	Line socket, plastic, screened.	28p	26p
<b>8-PIN DIN</b>			
CON/8P/P	Plug, plastic, screened.	38p	36p
CON/8P/CS	Chassis socket, metal.	38p	36p
CON/8P/LS	Line socket, plastic, screened.	45p	42p
<b>AUDIO</b>			
CON/AUD/4CP	4-pin chassis plug.	36p	61p
CON/AUD/4LS	4-pin line socket.	68p	63p
CON/AUD/7CP	7-pin chassis plug.	£1.20	£1.10
CON/AUD/7LS	7-pin line socket.	£1.28	£1.18
CON/AUD/8CP	8-pin chassis plug.	£1.28	£1.18
CON/AUD/8LS	8-pin line socket.	£1.38	£1.28
<b>BNC TYPE</b>			
CON/BNC/P	Standard BNC plug.	80p	70p
CON/BNC/1504	Chassis socket, round hole fixing.	80p	70p
<b>UHF TYPE</b>			
CON/UHF/PL259	Standard UHF plug.	52p	50p
CON/UHF/NC555	Reducer for PL259 plug - upto 5.2mm.	20p	18p
CON/UHF/SO239	Square chassis socket for PL259.	58p	53p
CON/UHF/PL258	In-line coupler - two PL259.	65p	60p
CON/UHF/NC563	In-line coupler - two PL259 sockets.	75p	70p
<b>BNC/UHF INTER-SERIES ADAPTORS</b>			
CON/BNC/1521/ADAP	BNC socket/PL259 UHF plug.	£1.25	£1.10
CON/BNC/1520/ADAP	BNC plug/SO239 UHF socket.	£1.50	£1.30
CON/BNC/RM97L	PL259 plug/phono socket.	85p	75p
CON/BNC/RM97M	BNC plug/phono socket.	88p	78p
<b>3-PIN XLR TYPE</b>			
CON/XLR/LP	'Canon' line plug.	£1.30	£1.20
CON/XLR/LS	'Canon' line socket.	£1.40	£1.30
CON/XLR/CP	Chassis plug.	£1.30	£1.20
CON/XLR/CS	Chassis socket.	£1.95	£1.80

		PRICES	
		1*	10*
<b>1mm</b>			
CON/1P/COLOUR REQ'D	Plug, silver plated, red or black.	18p	16p
CON/1S/COLOUR REQ'D	Socket, silver plated, red or black.	15p	13p
<b>2mm</b>			
CON/2P/COLOUR REQ'D	Plug, nylon isolated banana, red or black.	15p	13p
CON/2T/COLOUR REQ'D	Terminal Post, nickel brass, polypropylene insulation, red or black.	2p	35p
<b>4mm</b>			
CON/4PP/COLOUR REQ'D	Plug, plastic, red, black, green, blue, yellow.	15p	13p
<b>PBONO</b>			
CON/PH/PP/COLOUR REQ'D	Plug, plastic, red, black, white, blue, yellow, green, grey.	14p	12p
CON/PH/MP	Plug, metal.	21p	19p
CON/PH/MCS	Chassis socket, chrome.	18p	16p
<b>CO-AXIAL</b>			
CON/CAX/PM	Plug, metal.	20p	18p
CON/CAX/LS	Line socket, metal.	25p	22p
CON/CAX/LINE	Line connector - co-axial plug to co-axial plug.	12p	10p
<b>'D' TYPE SOLDER BUCKET TERMINALS (Gold Plated Contacts)</b>			
CON/D/9P	9-way plug.	35p	30p
CON/D/15P	15-way plug.	40p	35p
CON/D/25P	25-way plug.	45p	40p
CON/D/37P	37-way plug.	95p	90p
CON/D/9S	9-way socket.	35p	30p
CON/D/15S	15-way socket.	41p	36p
CON/D/25S	25-way socket.	48p	43p
CON/D/37S	37-way socket.	95p	90p
CON/D/COV/9	9-way cover.	35p	30p
CON/D/COV/15	15-way cover.	38p	33p
CON/D/COV/25	25-way cover.	40p	35p
CON/D/COV/37	37-way cover.	46p	41p
<b>AC POWER - IEC TYPE</b>			
CON/IEC/1	3-pin 240V AC chassis plug.	60p	55p
CON/IEC/2	In-line cable mounted socket.	48p	44p
CON/IEC/DIST	Mains distribution unit with 4 plugs.	£8.90	
<b>AC POWER - 8-PIN TYPE</b>			
CON/MP/P552	8-pin multi-pole mains outlet.	£1.05	95p
CON/MP/P551	8-pin multi-pole cable mounting plug.	£3.20	£3.00
<b>DC POWER - 2.1mm, 2.5mm &amp; 3.1mm</b>			
CON/DC/1.3	1.3 plug.	20p	18p
CON/DC/2.1S	2.1 plug - short.	12p	10p
CON/DC/2.1L	2.1 plug - long.	18p	16p
CON/DC/2.5S	2.5 plug - short.	12p	10p
CON/DC/2.5L	2.5 plug - long.	18p	16p
CON/DC/3.1	3.1 plug with moulded cable protector.	22p	20p
CON/DC/21S	2.1mm panel/chassis socket switched.	28p	26p
CON/DC/25S	2.5mm panel/chassis socket switched.	28p	26p
<b>CLIP TYPE</b>			
CON/CROC/MIN/COLOUR REQ'D	Miniature crocodile clip, insulated vinyl covers, 25mm, red or black.	10p	8p



**JUST ARRIVED**

Full Manuals Supplied

**TELEQUIPMENT D755 OSCILLOSCOPE**  
 DUAL TRACE  
 50MHz DELAY SWEEP  
 SECONDHAND — EXCELLENT VALUE —  
 SOLID STATE

**£300**  
 (P & P £15)

ALL PRICES NOW INCLUDE 15% V.A.T.

## 4-WAY - WITH LEAD & PLUG

A 4-way 13A socket, fused and with neon indicator. Fitted with 3 metres of cable terminating in a 13A fused plug.

Colour available: White.

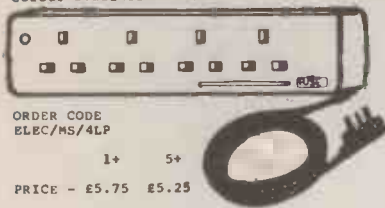

ORDER CODE  
ELEC/MS/4LP

1+ 5+  
PRICE - £5.75 £5.25

## MULTI-SOCKETS

### 4-WAY

A 4-way 13A socket, fused and with neon indicator. Colour available: White.



ORDER CODE  
ELEC/MS/4

1+ 5+  
PRICE - £3.99 £3.75

## 1\* DOMESTIC MAINS FUSES

Standard electrical plug fuses to BS1362.

RATINGS AVAILABLE: 2A, 3A, 5A, 13A.

ORDER CODE  
FUSE/M/RATING REQ'D

1+ 10+ 100+  
PRICE - 14p 12p 10p

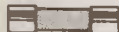

## SWITCHES

### ROTARY SWITCHES

Break-Before-Make Rotary Wafer Switches.

1-pole 12-way  
2-pole 6-way  
3-pole 4-way  
4-pole 3-way

1+ 10+  
PRICE - 75p 70p



### PUSH SWITCHES

PUSH-TO-MAKE - Red, Black, White, Blue, Green or Yellow.

ORDER CODE - SW/PTM/COLOUR REQ'D

1+ 10+  
PRICE - 22p 20p



### PUSH-TO-BREAK

ORDER CODE - SW/PTB  
1+ 28p 10+ 20p



### STANDARD TOGGLE SWITCHES

	SPST	ORDER CODE	1+	10+
	DPDT	SW/S/SPST	50p	45p
		SW/S/DPDT	60p	55p

### SUB-MINATURE TOGGLE SWITCHES

	1+	10+
SPST (2 tags)	85p	80p
SPDT (3 tags)	75p	70p
DPDT (6 tags)	65p	60p

### MINIATURE TOGGLE SWITCHES

	1+	10+
SPST (2 tags)	60p	55p
SPDT (3 tags)	64p	60p
DPDT (6 tags)	72p	66p
SPDT CENTRE OFF	75p	70p
DPDT CENTRE OFF	80p	75p

LATCHING PUSH SWITCH - SQUARE BUTTON - Red or Black.

ORDER CODE - SW/PL/COLOUR REQ'D  
1+ 10+  
PRICE - 46p 40p



### MINIATURE SLIDE SWITCH 6-TAG

Dimensions: 15 x 8 x 7mm.  
Rating: 250V 0.25A max.

ORDER CODE  
SW/SLD/MIN PRICE - 16p 14p



## MAINS PLUGS

### 13A 3-pin - FUSED

Standard (BS1363) supplied with 13A fuse fitted.

Colour available: White.

ORDER CODE  
ELEC/18F

1+ 10+ 100+  
PRICE - 50p 45p 40p

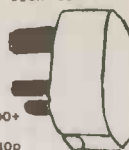

### 13A NIGHT LIGHT

For bedrooms, landings etc. This attractive plug emits a soft radiant glow providing reassuring and low cost lighting ideal for nursery, elderly person, disabled person etc. situations.

ORDER CODE  
ELEC/NL

1+ 5+  
PRICE - 99p 95p



### 3-WAY - FUSED

A 13A plug with three 13A outlets. Outlets on top, front and bottom. Fused.

Colour available: White.

ORDER CODE  
ELEC/MA/3F

1+ 5+  
PRICE - £1.95 £1.80



### 2-WAY

A 13A plug with two 13A outlets.

Colour available: White.

ORDER CODE  
ELEC/MA/2

1+ 5+  
PRICE - 85p 80p



## MICRO SWITCHES

### STANDARD - SPDT

A selection of V3 pattern microswitches. Plastic body.

Dimensions: 28 x 16 x 10mm.  
Rating: 6A 250V a.c.

STYLE	ORDER CODE	1+	10+
Button Type	SW/MIC/A	85p	80p
Roller Type	SW/MIC/B	95p	90p
Lever Type	SW/MIC/C	98p	93p



### KEYSWITCH

Standard keyswitch, frequently used as a security switch. Heavy chromed metal, Yale style key and screw terminals.

Type: SPST  
Rating: 1.5A  
Body dimensions: 30 x 19mm  
Fixing holes: 18.5mm  
Key removable: ON or OFF

ORDER CODE  
SW/KEY

1+ 10+  
PRICE - £2.20 £2.00



### GRADUATED DIALS

Scaled 1 - 10 with 180° graduations.

Fits to 0.25" spindle.

Available in 36mm diameter or 50mm diameter.

ORDER CODE  
KNOB/GRAD/36

1+ 10+  
PRICE - £3.90 £3.60



ORDER CODE  
KNOB/GRAD/50

1+ 10+  
PRICE - £4.75 £4.25



## TERMINAL BLOCKS

A range of 12-way clear polythene moulded strips, easily cut to required size.

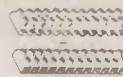

RATING Amps	ORDER CODE	1+	10+	100+
2.5	EKEC/TB/2	38p	34p	29p
5.0	ELEC/TB/5	39p	35p	30p
15.0	ELEC/TB/15	62p	58p	50p
30.0	ELEC/TB/30	£1.25	£1.20	£1.10
60.0	ELEC/TB/60	£3.40	£3.20	£3.00

## QUICK TEST

ONLY £9.99



## FUSEHOLDER

20mm PANEL MOUNTING

Colour available: Black.

ORDER CODE  
FUSE/PH/20

1+ 10+ 100+  
PRICE - 28p 25p 20p



## EXTENSION SOCKETS

### SINGLE - RUBBER

Single 13A 3-pin rubber extension lead socket.

Colours available: Black, White.

ORDER CODE  
ELEC/EXT/1/COLOUR REQ'D

1+ 5+  
PRICE - £1.20 £1.10



## MIXER KNOB

Grub screw fixing for 0.25" spindle.  
Diameter: 19mm.  
Depth: 15mm.

Colours available: Black, Red, Blue, Yellow, White.

Each knob supplied with the coloured cap of your choice. (Please state colours required when ordering.)

ORDER CODE  
KNOB/MIX/COLOUR REQ'D

1+ 10+  
PRICE - 25p 22p



SPARE CAPS - 5P EACH

## POINTER KNOB

Black plastic pointer knob with indicator line in white.

Grub screw fixing for 0.25" spindle.

ORDER CODE  
KNOB/POINTER

1+ 10+  
PRICE - 25p 20p



## MATCHING KNOB

Very attractive black control knobs with spun aluminium skirt and inlay. Available either calibrated 1 to 10 or with 'line indicator'.

Grub screw fixing for 0.25" spindle.



Available in three sizes: 23, 30 & 37mm.

ORDER CODE	1+	10+
KNOB/23/CALIB	42p	38p
KNOB/23/LINE	42p	38p
KNOB/30/CALIB	45p	41p
KNOB/30/LINE	45p	41p
KNOB/37/CALIB	50p	46p
KNOB/37/LINE	50p	46p

ALL PRICES NOW INCLUDE 15% V.A.T.



**RESISTOR KIT - 0.25W POPULAR**

A pack containing a total of 1,000 1/4W 5% carbon film resistors ranging in value from 10R to 10M.

In this pack we have included larger quantities of the more popular values.

Each value individually packed.

**CONTENTS:**

No. VALUE	No. VALUE	No. VALUE	No. VALUE	No. VALUE	No. VALUE	No. VALUE	No. VALUE	No. VALUE
10 x 10R	10 x 82R	10 x 390R	10 x 1K	10 x 8K2	10 x 39K	15 x 100K	5 x 820K	
10 x 17R	20 x 100R	30 x 470R	25 x 2K2	30 x 10K	30 x 47K	20 x 220K	20 x 1M	
10 x 15R	10 x 170R	20 x 560R	20 x 2K7	15 x 12K	20 x 56K	15 x 270K	10 x 2M2	
10 x 22R	10 x 150R	20 x 680R	20 x 3K3	15 x 15K	15 x 68K	15 x 330K	5 x 3M3	
10 x 33R	10 x 180R	10 x 820R	15 x 3K9	15 x 18K	10 x 82K	10 x 390K	10 x 4M7	
20 x 47R	20 x 220R	40 x 1K	25 x 4K7	20 x 22K	30 x 100K	20 x 470K	5 x 6H8	
10 x 56R	20 x 270R	15 x 1K2	20 x 5K6	15 x 27K	20 x 120K	10 x 560K	20 x 10M	
10 x 68R	20 x 330R	15 x 1K5	15 x 6K8	20 x 33K	15 x 150K	10 x 680K		

ORDER CODE 1+ 5+  
KIT/RES/25/POP £6.99 £5.99

**RESISTOR KIT - 0.25W (5 OFF EACH VALUE)**

A pack containing 305 resistors. Values as listed below. Each value individually packed and each bag marked with the value enclosed.

**CONTENTS: 5 OFF EACH VALUE:**

10R, 12R, 15R, 18R, 22R, 27R, 33R, 39R, 47R, 56R, 68R, 82R, 100R, 120R, 150R, 180R, 220R, 270R, 330R, 390R, 470R, 560R, 680R, 820R, 1K, 1K2, 1K5, 1K8, 2K2, 2K7, 3K3, 3K9, 4K7, 5K6, 6K8, 8K2, 10K, 12K, 15K, 18K, 22K, 27K, 33K, 39K, 47K, 56K, 68K, 82K, 100K, 120K, 150K, 180K, 220K, 270K, 330K, 390K, 470K, 560K, 680K, 820K, 1M.

ORDER CODE 1+ 5+  
KIT/RES/25/5 £3.75 £3.25



**RESISTOR KIT - 0.25W (10 OFF EACH VALUE)**

A pack containing 610 resistors. Values as listed below. Each value individually packed and each bag marked with the value enclosed.

**CONTENTS: 10 OFF EACH VALUE:**

10R, 12R, 15R, 18R, 22R, 27R, 33R, 39R, 47R, 56R, 68R, 82R, 100R, 120R, 150R, 180R, 220R, 270R, 330R, 390R, 470R, 560R, 680R, 820R, 1K, 1K2, 1K5, 1K8, 2K2, 2K7, 3K3, 3K9, 4K7, 5K6, 6K8, 8K2, 10K, 12K, 15K, 18K, 22K, 27K, 33K, 39K, 47K, 56K, 68K, 82K, 100K, 120K, 150K, 180K, 220K, 270K, 330K, 390K, 470K, 560K, 680K, 820K, 1M.

ORDER CODE 1+ 5+  
KIT/RES/25/10 £5.10 £4.60



**RESISTOR KIT - 0.5W POPULAR**

A pack containing a total of 1,000 1/4W 5% carbon film resistors ranging in value from 2R2 to 10M.

In this pack we have included larger quantities of the more popular values. Each value individually packed.

**CONTENTS:**

No. VALUE	No. VALUE	No. VALUE	No. VALUE	No. VALUE	No. VALUE	No. VALUE	No. VALUE	No. VALUE
5 x 2R2	10 x 12R	10 x 120R	20 x 600R	10 x 3K9	20 x 22K	20 x 120K	10 x 6H0K	
5 x 2R7	10 x 15R	10 x 150R	10 x 920R	25 x 4K7	10 x 27K	10 x 150K	5 x 820K	
5 x 3R3	10 x 22R	10 x 100R	40 x 1K	20 x 5K6	20 x 33K	10 x 180K	20 x 1M	
5 x 3R9	10 x 33R	20 x 220K	10 x 1K2	10 x 6R8	10 x 39K	20 x 220K	10 x 2M2	
10 x 4K7	20 x 47R	20 x 270R	10 x 1K5	10 x 8K2	30 x 47K	15 x 270K	5 x 3M3	
5 x 5R6	10 x 56R	20 x 330R	10 x 1K8	30 x 10K	20 x 56K	15 x 330K	10 x 4M7	
5 x 6R8	10 x 68R	10 x 390R	25 x 2K2	15 x 12K	10 x 60K	10 x 390K	5 x 6M8	
5 x 8K2	10 x 82R	30 x 470R	20 x 2K7	15 x 15K	10 x 82K	20 x 470K	20 x 10M	
10 x 10R	20 x 100R	2 x 560R	20 x 3K3	10 x 18K	30 x 100K	10 x 560K		

ORDER CODE 1+ 5+  
KIT/RES/5/POP £10.75 £9.75

**RESISTOR KIT - 0.5W (5 OFF EACH VALUE)**

A pack containing 365 resistors. Values as listed below. Each value individually packed and each bag marked with the value enclosed.

**CONTENTS: 5 OFF EACH VALUE:**

2R2, 2R7, 3R3, 3R9, 4R7, 5R6, 6R8, 8R2, 10R, 12R, 15R, 18R, 22R, 27R, 33R, 39R, 47R, 56R, 68R, 82R, 100R, 120R, 150R, 180R, 220R, 270R, 330R, 390R, 470R, 560R, 680R, 820R, 1K, 1K2, 1K5, 1K8, 2K2, 2K7, 3K3, 3K9, 4K7, 5K6, 6K8, 8K2, 10K, 12K, 15K, 18K, 22K, 27K, 33K, 39K, 47K, 56K, 68K, 82K, 100K, 120K, 150K, 180K, 220K, 270K, 330K, 390K, 470K, 560K, 680K, 820K, 1M, 1M2, 1M5, 1M8, 2M2.

ORDER CODE 1+ 5+  
KIT/RES/5/5 £5.40 £5.00



**RESISTOR KIT - 0.5W (10 OFF EACH VALUE)**

A pack containing 730 resistors. Values as listed below. Each value individually packed and each bag marked with the value enclosed.

**CONTENTS: 10 OFF EACH VALUE:**

2R2, 2R7, 3R3, 3R9, 4R7, 5R6, 6R8, 8R2, 10R, 12R, 15R, 18R, 22R, 27R, 33R, 39R, 47R, 56R, 68R, 82R, 100R, 120R, 150R, 180R, 220R, 270R, 330R, 390R, 470R, 560R, 680R, 820R, 1K, 1K2, 1K5, 1K8, 2K2, 2K7, 3K3, 3K9, 4K7, 5K6, 6K8, 8K2, 10K, 12K, 15K, 18K, 22K, 27K, 33K, 39K, 47K, 56K, 68K, 82K, 100K, 120K, 150K, 180K, 220K, 270K, 330K, 390K, 470K, 560K, 680K, 820K, 1M, 1M2, 1M5, 1M8, 2M2.

ORDER CODE 1+ 5+  
KIT/RES/5/10 £8.75 £7.75

**FUSE KIT - 20mm QUICK-BLOW**

A pack containing 80 Quick-Blow 20mm Fuses.

Each value individually packed and each bag marked with the value enclosed.

**Contents:**

No. VALUE	No. VALUE	No. VALUE
5 x 100mA	10 x 500mA	10 x 3.15A
5 x 250mA	20 x 1A	5 x 5A
5 x 315mA	5 x 1.6A	5 x 6.3A
	10 x 2A	

ORDER CODE 1+ 5+  
KIT/FUSE/QB2 £4.75 £4.25

**FUSE KIT - 20mm ANTI-SURGE**

A pack containing 80 Anti-Surge 20mm Fuses.

Each value individually packed and each bag marked with the value enclosed.

**Contents:**

No. VALUE	No. VALUE	No. VALUE
5 x 100mA	10 x 500mA	10 x 3.15A
5 x 250mA	20 x 1A	5 x 5A
5 x 315mA	5 x 1.6A	5 x 6.3A
	10 x 2A	

ORDER CODE 1+ 5+  
KIT/FUSE/AS2 £8.50 £7.50

**PRE-SET POTENTIOMETER KIT**

PRE-SET POTENTIOMETER KITS - HORIZONTAL OR VERTICAL - Over £12.00 worth at Catalogue Prices - Saving you over £4.00!!

A pack containing a total of 120 miniature Horizontal Pre-Set Potentiometers. A total of 13 different values. Each value individually packed.

**CONTENTS:**

No. VALUE	No. VALUE	No. VALUE	No. VALUE
5 x 100R	5 x 2K2	10 x 47K	5 x 1M
5 x 220R	15 x 4K7	20 x 100K	
5 x 470R	20 x 10K	5 x 220K	
15 x 1K	5 x 22K	5 x 470K	

ORDER CODE 1+ 5+  
KIT/POT/HORIZ £7.75 £7.25

A pack containing a total of 120 miniature Vertical Pre-Set Potentiometers. A total of 13 different values. Each value individually packed.

**CONTENTS:**

No. VALUE	No. VALUE	No. VALUE	No. VALUE
5 x 100R	5 x 2K2	10 x 47K	5 x 1M
5 x 220R	15 x 4K7	20 x 100K	
5 x 470R	20 x 10K	5 x 220K	
15 x 1K	5 x 22K	5 x 470K	

ORDER CODE 1+ 5+  
KIT/POT/VERT £7.75 £7.25

**ALL GOODS  
UP TO 750gms  
SENT 1st CLASS  
BLACK STAR**

**FREQUENCY COUNTERS**

- METEOR 100 - 100MHz £125
- METEOR 600 - 600MHz £155
- METEOR 1000 - 1GHz £204

**COUNTER-TIMERS**

- NOVA 200 - 200MHz £182
- NOVA 2400 - 2.4GHz £340

**COLOUR BAR GENERATOR**

- ORION £240

**P&P £3 ALL UNITS**

**ALL PRICES NOW INCLUDE 15% V.A.T.**



5 1/4" ROUND - BASS/MID RANGE

Compact bass/mid range speaker with cloth edged paper cone.

Frequency response ..... 50-8000Hz  
 Resonant frequency ..... 80Hz  
 Output SPL ..... 103dB @ 1W  
 Magnet weight ..... 10oz  
 Overall weight ..... 700gms  
 Dimensions ..... 150 (diam.) x 52mm

ORDER CODE  
 LSP/007

PRICE - £5.50 EACH  
 £9.50 PER PAIR

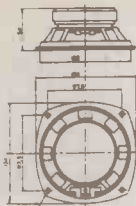

12" ROUND - 100W - EM12/100



PANE

Made in U.K.

Fane pressed steel chassis, professional, high power lead-guitar and bass-guitar speaker. Also suitable for PA work.

Ribbed paper cone with plastisised paper edge.

SPECIFICATION

Diameter ..... 12.1/8" (308mm)  
 Power rating ..... 100W r.m.s.  
 Resonant frequency ..... 75Hz  
 Frequency range ..... 60Hz-5KHz  
 Average sensitivity ..... 100dB - 1W @ 1M  
 Flux density ..... 13,500 gauss  
 Magnet weight ..... 38oz (1.08Kg)  
 Voice coil diameter ..... 2" (51mm)

ORDER CODE  
 LSP/EM12100

PRICE - £35.00 EACH  
 £65.00 PER PAIR

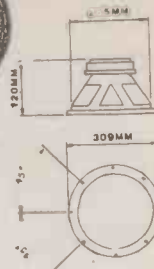
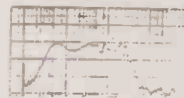

5 1/4" ROUND - FULL RANGE

Small size but high power full range unit. All black. Foam rubber edged paper cone. 1" aluminium voice coil.

Size ..... 5 1/4" round  
 Impedance ..... 8 ohm  
 Power nominal ..... 45W  
 Power maximum ..... 60W  
 Frequency response ..... 63-20000Hz  
 Resonant frequency ..... 63Hz  
 Output SPL ..... 92dB @ 1W  
 Magnet weight ..... 20oz  
 Overall weight ..... 1172gms  
 Dimensions ..... 131 (diam.) x 73mm

ORDER CODE  
 LSP/525LUX

PRICE - £9.95 EACH  
 £17.50 PER PAIR



12" ROUND - 200W - EM12/200



PANE

Made in U.K.

Fane pressed steel chassis, professional, high power lead-guitar and bass-guitar speaker. Also suitable for PA work.

Ribbed paper cone with plastisised paper edge.

SPECIFICATION

Diameter ..... 12.1/8" (308mm)  
 Power rating ..... 200W r.m.s.  
 Resonant frequency ..... 75Hz  
 Frequency range ..... 60Hz-5KHz  
 Average sensitivity ..... 102dB - 1W @ 1M  
 Flux density ..... 14,600 gauss  
 Magnet weight ..... 82oz (2.4Kg)  
 Voice coil diameter ..... 2 1/2" (63.7mm)

ORDER CODE  
 LSP/EM12200

PRICE - £55.00 EACH  
 £100.00 PER PAIR

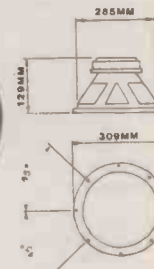

6 1/2" ROUND - FULL RANGE

Compact full range driver. Foam rubber edged paper cone. 1" aluminium voice coil.

Size ..... 6 1/2" round  
 Impedance ..... 8 ohm  
 Power nominal ..... 45W  
 Power maximum ..... 60W  
 Frequency response ..... 56-20000Hz  
 Resonant frequency ..... 38Hz  
 Output SPL ..... 98dB @ 1W  
 Magnet weight ..... 20oz  
 Overall weight ..... 1265gms  
 Dimensions ..... 165 (diam.) x 76.5mm

ORDER CODE  
 LSP/65LUX

PRICE - £10.95 EACH  
 £18.95 PER PAIR



12" ROUND - FULL RANGE



MCKENZIE

Made in U.K.

MCKENZIE professional series full range driver. 51.4mm voice coil. Cambric edged paper cone. Centre HF cone.

Size ..... 12" round  
 Impedance ..... 8 ohm  
 Power nominal ..... 85W  
 Power maximum ..... 170W  
 Frequency response ..... 40-15000Hz  
 Resonant frequency ..... 40Hz  
 Output SPL ..... 100dB @ 1W  
 Magnet weight ..... 139oz  
 Overall weight ..... 4500gms  
 Dimensions ..... 311 (diam.) x 136mm

ORDER CODE  
 LSP/1285TCB

PRICE - £47.00 EACH  
 £85.00 PER PAIR

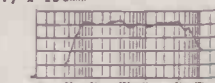

8" ROUND - FULL RANGE

Full range driver. All black. Foam rubber edged paper cone. 1" aluminium voice coil.

Size ..... 8" round  
 Impedance ..... 8 ohm  
 Power nominal ..... 40W  
 Power maximum ..... 60W  
 Frequency response ..... 38-18000Hz  
 Resonant frequency ..... 40Hz  
 Output SPL ..... 89dB @ 1W  
 Magnet weight ..... 18oz  
 Overall weight ..... 1310gms  
 Dimensions ..... 210 (diam.) x 94mm

ORDER CODE  
 LSP/8LUX

PRICE - £12.65 EACH  
 £22.00 PER PAIR



8" ROUND - 50W - EM8/50



PANE

Made in U.K.

Fane pressed steel chassis, professional, lead-guitar or multiple speaker bass system speaker.

Straight side paper cone with plastisised paper edge.

SPECIFICATION

Diameter ..... 8" (203mm)  
 Power rating ..... 50W r.m.s.  
 Resonant frequency ..... 90Hz  
 Frequency range ..... 70Hz-6KHz  
 Average sensitivity ..... 98dB - 1W @ 1M  
 Flux density ..... 9,000 gauss  
 Magnet weight ..... 18oz (0.58Kg)  
 Voice coil diameter ..... 1 1/4" (38mm)

ORDER CODE  
 LSP/EM850

PRICE - £19.95 EACH  
 £35.00 PER PAIR

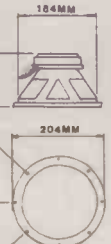

FANE LOUSPEAKER ENCLOSURE DESIGN AND CONSTRUCTION BOOK

The Fane Book contains a large selection of cabinet designs and enclosures for the loudspeaker units available in our catalogue. Guidelines are given for construction; pointing out the care needed to be given when selecting materials, sealing, making joints, mounting the driver units and wadding the cabinet. Twenty-three designs are detailed ranging from Small Bass Reflex Cabinets using 12" diameter Full Range Drivers through folded horns, to Massive Multi-Way High Power Systems.

Fully Illustrated.

ORDER CODE  
 LSP/BOOK1

PRICE - £3.00



18" ROUND



PANE

Made in U.K.

FANE die-cast alloy chassis professional multi-way fundamental bass support. 4" resin bonded hi-temp glass-fibre voice coil, curvilinear paper cone with plastisised cloth edge.

Size ..... 18" round  
 Power rating ..... 400W r.m.s.  
 Resonant frequency ..... 30Hz  
 Average sensitivity ..... 100dB  
 Flux density ..... 12,100 gauss  
 Magnet weight ..... 126 oz  
 Recommended enclosure size ..... 100-200 litres

ORDER CODE  
 LSP/EM18400

PRICE - £115.00 EACH  
 £210.00 PER PAIR



ALL PRICES NOW INCLUDE 15% V.A.T.

3 1/2" SUPER HORN - FLUSH MOUNTING

Flush flange. Exponential horn.

Size ..... 3 1/2" round  
 Impedance ..... 1000 ohms @ 1kHz  
 Power nominal ..... 16V  
 Power maximum ..... 35V  
 Frequency response ..... 3kHz-25kHz  
 Output SPL ..... 100dB  
 Weight ..... 62gms  
 Dimensions ..... 85 x 85 x 74mm

ORDER CODE  
 LSP/KSN5A

PRICE - £5.95 EACH  
 £10.00 PER PAIR

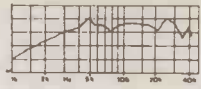

FANE BULLET TWEETER - BF200

The Fane Bullet Tweeter is suitable for reproducing high frequencies in two-way and multi-way P.A., disco, organ and sound amplification systems, with low distortion and superb reproduction and clarity characteristics. Machined from steel with a brushed diecast centre bullet on a large ceramic magnet assembly. A cross-over must be used with this unit to protect the drivers from low frequencies.

SPECIFICATION

Frequency range ..... 5 - 20 kHz  
 Power rating ..... 200W (System)  
 Average sensitivity 1W @ 1M ..... 103dB  
 Impedance ..... 8 ohm  
 Overall width ..... 4 1/2" (114.3mm)  
 Overall depth ..... 3 1/16" (78mm)  
 Total weight ..... 6 lbs. (2.7 kg)  
 Distortion ..... 3% T.H.D. @ 110dB  
   6% T.H.D. @ 25W  
   r.m.s. sine  
 Polar response @ 6dB ..... 5kHz 90°x65°V  
   10kHz 90°x36°V  
   15kHz 28°x24°V



ORDER CODE  
 LSP/BF200

PRICE - £48.95

3 1/2" SUPER HORN - REAR MOUNTING

Rear mounting. Exponential horn.

Size ..... 3 1/2" round  
 Impedance ..... 1000 ohms @ 1kHz  
 Power nominal ..... 16V  
 Power maximum ..... 35V  
 Frequency response ..... 3kHz-25kHz  
 Output SPL ..... 100dB  
 Weight ..... 68gms  
 Dimensions ..... 85 x 85 x 74mm

ORDER CODE  
 LSP/JSN1A

PRICE - £5.99 EACH  
 £9.99 PER PAIR

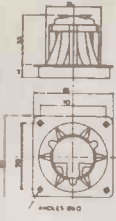
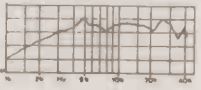

HIGH PASS FILTER SUITABLE FOR BF200

A 5kHz 300W high pass filter network suitable for use with Fane Bullet Tweeter BF200.

Impedance ..... 8 ohm  
 Input power ..... 300W  
 Attenuation ..... 16 dB/OCT  
 Cut-off ..... 5 kHz

ORDER CODE  
 LSP/BPF35X

PRICE - £5.75

CROSSOVERS

2-WAY - 100 WATT

2-way high power crossover with 3 selectable crossover frequencies.

Type ..... 2-way  
 Impedance ..... 8 ohms  
 Input power ..... 100W  
 Attenuation ..... 6dB/oct  
 Crossover ..... 2k, 2.5k or 4kHz

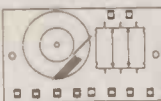

ORDER CODE  
 LSP/CYN2

PRICE - £4.95

3-WAY - 100 WATT

3-way high power crossover with 2 selectable crossover frequencies each for bass, mid and high range.

Type ..... 3-way  
 Impedance ..... 8 ohms  
 Input power ..... 100W  
 Attenuation ..... 6dB/oct  
 Crossover ..... 800 or 1.6kHz (B)  
   800-5k or 1.6k-7kHz (M)  
   5k or 7kHz (T)

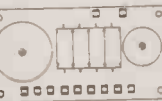

ORDER CODE  
 LSP/CYN3

PRICE - £8.00

ORDER CODE  
 LSP/BPF35X

PRICE - £5.75

CLAMP KIT

Speaker grill fixing kit

Comprising: 4 x nickel plated heavy duty steel clamping plates  
 4 x screws  
 4 x self-fixing nuts.

Suitable for speaker grills GL10, GL12, GL15 and GL18.

ORDER CODE  
 LSP/CKIT

PRICE - £1.75

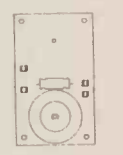

## FM Wireless Microphones

Wireless microphone systems available as a complete kit or in separate parts. All operate on the standard frequencies allocated to wireless microphones systems (173.8MHz, 174.1MHz, 174.5MHz, 174.8MHz and 175.0MHz). Please note that unless specific frequencies are requested, orders will be supplied with random frequencies from current stock.

NEW

SPECIAL PRICE £149.95

FM WIRELESS

**G200 PROFESSIONAL WIRELESS MIC SYSTEM WMS202**

A complete wireless microphone system comprising a G201 receiver with matching G202 microphone, windshield, 1.4m patch lead for connection of receiver to amp/mixer and one pair of racking brackets for the receiver. All packed in a tough vinyl case.

<p><b>Receiver</b></p> <p>Receiving frequencies ..... 173.8MHz, 174.1MHz, 174.5MHz, 174.8MHz or 175.0MHz                  Receiving system ..... Single super heterodyne conversion FM detector                  Intermediate frequency ..... 10.7MHz                  Antenna impedance ..... 75Ω                  RF sensitivity ..... 0.7μV                  S/N ratio ..... Better than 90dB                  Squelch threshold ..... Adjustable from 10dBμV to 40dBμV                  Image and spurious rejection ..... At least -80dB                  De-emphasis ..... 75μS                  Audio output level ..... 250mV at 600Ω                  Audio harmonic distortion ..... Less than 0.5%                  Power ..... 240Vac 50Hz/12Vdc                  Dims ..... 190 x 54 x 200mm</p>	<p><b>Transmitter</b></p> <p>Receiving frequencies ..... 173.8MHz, 174.1MHz, 174.5MHz, 174.8MHz or 175.0MHz                  Frequency stability ..... ±0.1%                  Modulation system ..... Frequency modulated FM                  Harmonic and spurious output power ..... Less than -45dB carrier level                  Pre-emphasis ..... 75μS                  Max frequency deviation ..... ±50kHz                  Frequency response ..... 70Hz - 12000Hz                  Distortion ..... Less than 0.5%                  S/N ratio ..... Better than 87dB                  Ambient temperature range ..... 0°C - 40°C                  Operating voltage range ..... 3.8V to 4.5Vdc</p>
---	---

NEW

£65.00

**G203 TIE CLIP MIC PT300**

Tie clip wireless mic. High quality electret insert connected to transmitter pack by 1.8m lightweight screened lead. Lightweight transmitter pack (125g with batteries) with belt clip and on/off switch. Power ..... 3 x AA batteries (not included). Transmitter specification same as G200 (WMS202)

NEW

£64.00

**G204 GUITAR TRANSMITTER GT300**

Professional wireless guitar transmitter pack via a 1.4m double screened noiseless lead with 6.35mm plug. Lightweight transmitter pack (125g with batteries) with on/off switch and belt clip. Power ..... 3 x AA batteries (not included). Transmitter specification same as G200 (WMS202)

**RIFLE MICROPHONE**

Super-directive sound collecting microphone. High sensitivity super cardioid electret condenser. Tubular element with foam windshield. Built-in amplifier and earphones.

Type...Uni-directional. Electret condenser  
 Impedance ..... 520 ohm (short distance)  
   2.3Kohm (long distance)  
 Response ..... 80-12000Hz  
 Sensitivity...-66dB @ 1kHz (short distance)  
   -56dB @ 1kHz (long distance)  
 Length ..... 280mm

ORDER CODE MIC/RIFLE      PRICE - £34.95      ORDER CODE MIC/VIDEO      PRICE - £35.95

NEW

£105.00

**G201 SIGNAL RECEIVER RC300**

Professional wireless microphone receiver for use with G202, G203 and G204 transmitters. Single super heterodyne system for dependable operation. 2-channel, 5-LED indicators for carrier and output signal levels. Output gain and signal squelch controls. Power ..... 240Vac 50Hz or 12Vdc via external adaptor (not supplied). Receiver specification same as G200 (WMS202)

PURCHASE TWO TOGETHER AT EXTRA LOW PRICES!

G201+G203  
£155

G201+G204  
£150



**OPTO**

**QUARTZ-HALOGEN SPOTLIGHT**



Hand held or hanging. Heat resistant poly-carbonate housing; highly polished reflector. Protective lens cover, doubles as base stand. With On/Off switch and 12ft curly cable terminating in cigar lighter plug. Produces 250000 candle power - 5 times the intensity of average car headlamps.

Power: ..... 12Vd.c. 4.5A. 55W  
 Dims: ..... 160 x 88 x 110mm

ORDER CODE  
 OPTO/QBS  
**PRICE - £5.99**



**PHOTOCONDUCTIVE CELL - ORP12**

A cadmium sulphide photoconductive cell which is sensitive to light.

ORDER CODE  
 OPTO/ORP12  
 1+ 10+  
**PRICE - 90p 85p**



**FLASHING LEDs**

5mm RED 60p  
 5mm GREEN 75p  
 5mm YELLOW 75p

**JUMBO LEDs**

10mm RED 75p

**LAMP HOLDERS**

**MES STANDARD**

An MES bulb-holder in a bakelite base with screw terminals.

Diameter of box: 31mm.  
 Fixing centres: 23mm.  
 Height: 18mm.  
 Colour: White.

ORDER CODE  
 OPTO/MES/BASE  
 1+ 10+  
**PRICE - 28p 25p**



**POTENTIOMETERS**

**ROTARY - SINGLE**

A range of carbon track potentiometers with plastic spindle and PCB mounting terminals.



Fixing hole required: 10.5mm (13/32")  
 Spindle diameter: 6.35mm (1/4")  
 Spindle length: Approx. 55mm  
 Power rating: 0.4W Linear 0.2W Log  
 Maximum voltage: 500V d.c.  
 Tolerance: ±20%

Supplied complete with fixing nut and washer. Available in Linear and Log, values as listed:

**Linear - 470R, 1K, 2K2, 4K7, 10K, 22K, 47K, 100K, 1M, 2M2, 4M7.**

ORDER CODE  
 POT/LIN/VALUE REQ'D  
 1+ 10+ 100+  
**PRICE - 50p 48p 40p**

**Log: 4K7, 10K, 22K, 47K, 100K, 220K, 470K, 1M, 2M2.**

ORDER CODE  
 POT/LOG/VALUE REQ'D  
 1+ 10+ 100+  
**PRICE - 50p 48p 40p**

**SPECIAL OFFER**

**12V TWIN FLUORESCENT LAMP  
 12" DOUBLE TUBES**

**ONLY  
 £5.99** GA  
 SPARE TUBES 99P



**ATTRACTIVE WHITE FITTING, RIBBED PERSPEX DIFFUSER, ON/OFF SW  
 3FT. CABLE, TRANSISTORISED CIRCUITRY, KEYHOLE FIXING  
 12V DC 8W TUBES. DIMENSIONS: 368 X 67 X 43 MM.  
 IDEAL FOR CARAVANS, BOATS, VANS ETC.**

**LED - STANDARD 5mm**

COLOUR	ORDER CODE	1+	10+	100+
Red	OPTO/LED/5R	12p	10p	6p
Green	OPTO/LED/5G	14p	12p	8p
Yellow	OPTO/LED/5Y	14p	12p	8p



**LED CLIP - STANDARD 5mm**

Panel mounting clip to suit standard 5mm LEDs detailed above.

ORDER CODE  
 OPTO/LED/5/CLIP  
 1+ 10+  
**PRICE - 5p 3p**



**LED - MINIATURE 3mm**

COLOUR	ORDER CODE	1+	10+	100+
Red	OPTO/LED/3R	12p	10p	6p
Green	OPTO/LED/3G	12p	10p	6p
Yellow	OPTO/LED/3Y	14p	12p	9p



**LED CLIP - MINIATURE 3mm**

Panel mounting clip to suit miniature 3mm LEDs detailed above.

ORDER CODE  
 OPTO/LED/3/CLIP  
 1+ 10+  
**PRICE - 5p 3p**



**NEON - SQUARE 240V**

Lens size: 15 x 12mm.  
 Overall length: 37mm.

Colours available: Red, Green, Amber.

ORDER CODE  
 OPTO/NEON/240/COLOUR REQ'D  
 1+ 10+  
**PRICE - 40p 35p**



**TORCH - TOOLBOX**

Plastic torch. Ideal for pocket or toolbox. Uses 2 x AA batteries (NOT included, available separately - See Batteries Section.)

ORDER CODE  
 OPTO/TORCH/A  
 1+ 10+  
**PRICE - 55p 50p**



**TORCH - PENLITE**

A very handy pocket torch, with clip for attaching to your top pocket. Uses 2 x AA batteries (NOT included, available separately - See Batteries Section.)

ORDER CODE  
 OPTO/TORCH/B  
 1+ 10+  
**PRICE - 75p 70p**



**TRANSFORMERS**



SECONDARY VOLTAGE	CURRENT	VA	DIMENSIONS (MM)			FIXING CENTRES (MM)	ORDER CODE	1+	25+
			W	X	B x D	(MM)			
6-0-6	100mA	1.2	36	31	30	45	TPX/1	£1.50	£1.40
9-0-9	100mA	1.8	36	31	30	45	TPX/2	£1.55	£1.45
12-0-12	100mA	2.4	36	31	33	45	TPX/3	£1.65	£1.55
0-12/0-12	500mA	12	56	47	43	69	TPX/3A	£3.75	£3.25
6-0-6	1.5A	18	50	42	443	62	TPX/9	£4.20	£3.90
7.5-0-7.5	1.0A	15	50	42	41	62	TPX/9A	£2.76	£2.46
9-0-9	1.0A	18	50	42	41	62	TPX/10	£2.90	£2.60
12-0-12	1.0A	24	56	47	54	69	TPX/11	£3.60	£3.30
15-0-15	1.0A	30	59	50	54	72	TPX/12	£4.10	£3.70
20-0-20	1.5A	60	68	57	66	79	TPX/13	£5.40	£4.20
0/12/15/20/24/30	1.0A	30	68	57	60	79	TPX/14	£6.36	£5.50
6-0-6	2.0A	24	59	50	54	72	TPX/15	£4.25	£3.85
9-0-9	2.0A	36	59	50	59	72	TPX/16	£4.65	£4.15
12-0-12	2.0A	48	68	57	55	79	TPX/17	£5.30	£4.85
0-12/0-12	2.0A	48	68	57	55	79	TPX/17A	£5.40	£4.95
0/12/15/20/24/30	2.0A	60	78	65	68	92	TPX/17B	£9.10	£8.15
20-0-20	2.0A	80	78	65	66	92	TPX/18	£7.40	£6.66
30-0-30	2.0A	120	78	65	66	92	TPX/18A	£9.05	£8.10
6-0-6	4.0A	48	68	57	54	79	TPX/18B	£5.50	£5.00
9-0-9	4.0A	72	68	57	66	79	TPX/18C	£6.98	£6.30
12-0-12	4.0A	96	78	65	70	92	TPX/18D	£8.50	£7.65
7.5-0-7.5	6.0A	90	78	65	70	92	TPX/18E	£8.60	£7.80
6-0-6	8.0A	96	78	65	72	92	TPX/18F	£9.98	£8.80
12-0-12	8.0A	192	96	83	82	78 x 74	TPX/18G	£16.50	£14.85

SECURITY EQUIPMENT - SURVEILLANCE

'CLOSED-CIRCUIT' TELEVISION SYSTEMS

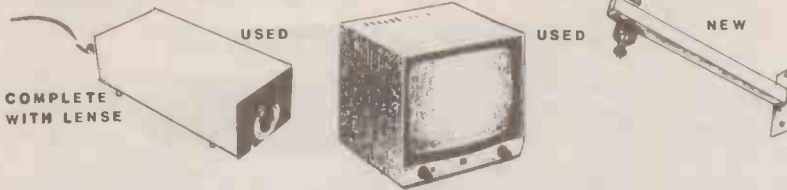

A SMALL RANGE OF 'USED' CLOSED-CIRCUIT TELEVISION EQUIPMENT, OFFERING EXCEPTIONAL VALUE-FOR-MONEY WITH A REAL SAVING OVER NEW, OFTEN UNAFFORDABLE, EQUIPMENT PRICES. ILLUSTRATIONS NOT TO SCALE & FOR GUIDANCE ONLY - ITEMS SUPPLIED MAY VARY.

COMPLETE SYSTEM - USED  
A REAL BARGAIN - BUY THE COMPLETE SYSTEM - AS DETAILED ABOVE & OVERLEAF (Bracket).  
COMPRISES: 1 x CAMERA (USED) 1 x MONITOR (USED) - 1 x BRACKET (NEW)

ORDER CODE  
SEC/SYSTEM/USED



PRICE - £160.00  
+£12.00 CARR.

AS OUT STOCKS ARE CHANGING ALL THE TIME, EXACT SPECIFICATIONS VARY - THEREFORE WE HAVE SUPPLIED ONLY THE BASIC INFORMATION.

PLEASE CONTACT OUR SALES DESK FOR UP-TO-DATE DETAILS OF EQUIPMENT AVAILABLE.

- \* HOME ALARM PACKAGE \*
- \* INCLUDES: \*
- \* 'OPTIMA ALARM CONTROL PANEL \*
- \* 'EXTERNAL RED BELL BOX \*
- \* '2 INTERNAL PASSIVE I.R. \*
- \* '2 DOOR CONTACTS \*
- \* 'SIREN FOR BELL BOX \*
- \* '100 MTRS. CABLE & CLIPS \*
- \* 'FULL FITTING INSTRUCTIONS \*
- \* ONLY £115 +£2.50 CARRIAGE \*
- \* (PHONE FOR FURTHER DETAILS) \*

SECURITY EQUIPMENT - SURVEILLANCE

SECURITY EQUIPMENT - ALARMS

EXTERNAL BELL BOX - STANDARD

FM TRANSMITTER - Made in U.K.



Very high quality 'Mini-Bug' - Ideal for baby alarm etc.!!  
A very good range is obtainable - we have obtained over 1/2 mile, but it does depend on conditions.

Simply remove cover - insert battery - and you're ready to go.  
Reception can be obtained on any FM radio.

Frequency ..... 105-109MHz FM  
Power ..... PP3 9V Battery (Not Included)  
Dimensions ..... 4.25" x 2.25" x 3/4"

ORDER CODE  
SEC/FMB1

PRICE - £9.99



FM TRANSMITTER KIT

For those of you who enjoy building kits - we now offer the above transmitter in kit form. Ideal for the beginner - supplied complete with full, easy to follow, instructions.

Box NOT INCLUDED - See our BOXES Section for suitable housing.

ORDER CODE  
SEC/FMKIT

PRICE - £7.50



Dimensions:

Height: 405mm  
Width: 270mm  
Depth: 140mm

COLOUR	ORDER CODE	PRICE
RED	SEC/AB/RED	£5.99
WHITE	SEC/AB/WH	£5.99
YELLOW	SEC/AB/YLL	£5.99
BLUE	SEC/AB/BL	£5.99



SURVEILLANCE SCOOP!!

LOWEST PRICES IN THE U.K.



CAMERA IMPACT & WEATHER RESISTANT

TWO TYPES AVAILABLE

VM100 - INCLUDES: Camera, Monitor, Camera Bracket, Power Supply and 40 metres of cable.

PRICE ONLY £149.99



VM200 WITH BUILT-IN INTERCOM - INCLUDES: Camera, Monitor, Camera Bracket, Power Supply and 40 metres of cable.

PRICE ONLY £199.99

IDEAL FOR HOME, OFFICE OR SHOP. THE MONITOR CAN EASILY BE MOVED FROM ROOM TO ROOM.

ACCESSORIES FOR VM100 SYSTEM:

ADDITIONAL CAMERA	£95.50
ADDITIONAL MONITOR	£95.50
SWITCH BOX	£65.00
WEATHER SHIELD	£15.00

ACCESSORIES FOR VM200 SYSTEM WILL BE AVAILABLE JANUARY 1990.

Simply Add £12 P&P to each order.  
Nothing More to add - V.A.T. Included in price.

OPTIMA PANEL



OPTIMA

Very sophisticated panel but simple to install.

Ideal for larger houses or commercial premises.

Micro-computer based - Four Zone plus P.A. and Tamper.

Security control unit, complying to the installation requirements BS 4737:1986.

Keypad controlled and programmed. Customer may omit any Zone. Bell set programmable from 1 to 99 mins. or Never.

Built-in internal sounder. High & Low volume. Permanent memory for last alarm with recall.

3mm Polycarbonate housing to BS 4737. Both R/C and software protection against false alarms and RFI.

ORDER CODE  
SEC/OPTIMA

PRICE - £49.50

OTHER PANELS LISTED

LOGIC 4

ORDER CODE  
SEC/LGC4 PRICE - £39.95

OPTIMA PLUS

ORDER CODE  
SEC/OPT/PLUS PRICE - £79.50

"EXTERIOR FLOOD LIGHT"  
WITH HALOGEN BULB 500W  
WEATHERPROOF, SAFEGUARD YOUR HOUSE



MADE OF BLACK ALUMINIUM  
RUBBER SEALED CONNECTION BOX,  
HINGED GLASS FRONTED BULB  
PROTECTION TO IP44, ADJUSTABLE  
MOUNTING BRACKET

ONLY £16.99

ALL PRICES NOW INCLUDE 15% V.A.T.

**MASTER SOCKET - 2/4A - SURFACE MOUNTING**  
 ORDER CODE BT/2/4A  
 PRICE - £3.25

**MASTER SOCKET - 3/4A - FLUSH MOUNTING**  
 ORDER CODE BT/3/4A  
 1+  
 PRICE - £3.30

**SECONDARY SOCKET - 2/6A - SURFACE MOUNTING**  
 ORDER CODE BT/2/6A  
 1+  
 PRICE - £2.50 £2.20

**SECONDARY SOCKET - 3/3A - FLUSH MOUNTING**  
 ORDER CODE BT/3/3A  
 1+  
 PRICE - £2.05 £1.95

**ADAPTOR - 10/3A**  
 ORDER CODE BT/10/3A  
 PRICE - £3.75

**PLUG-IN BELL TONE RINGER MTR**  
 ORDER CODE BT/MTR  
 PRICE - £6.95

**COMPONENTS**  
**4-WAY LINE PLUG - 431A**  
 ORDER CODE BT/431A  
 PRICE - 35p

**4-WAY LINE PLUG - 631A**  
 ORDER CODE BT/631A  
 PRICE - 50p

**EXTENSION LEAD**  
 Length: 5 metres  
 ORDER CODE BT/EXT/LEAD  
 PRICE - £4.30

**CABLES**

**\*LINE JACK CORD**  
 ORDER CODE BT/LJC  
 PRICE - 34p PER MTR.

**\*ONLY AVAILABLE WHILE STOCKS LAST.**

**LINE JACK CORD WITH PLUG**  
 ORDER CODE BT/LJC/PLUG  
 1+ 10+  
 PRICE - £2.20 £2.00

**TELECOM 4-CORE CABLE**  
 ORDER CODE CBL/TEL/4  
 PRE MTR. PER 100 MTR. REEL  
 PRICE - 15p £12.00

**TELECOM 6-CORE CABLE**  
 ORDER CODE CBL/TEL/6  
 PER MTR. PER 100 MTR. REEL  
 PRICE - 25p £20.00

**CABLE CLIPS**  
 ORDER CODE CBL/CLIP/BT  
 PKT. OF 10 PKT. OF 100  
 PRICE - 25p £1.50

**ECONOMY PHOTO ETCH PCB**

Good quality board, manufactured in FRG-50 laminate with positive working UV sensitive resist. Boards are protected by a black plastic film.

Available in both single and double sided.

**SINGLE SIDED**

SIZE (mm)	ORDER CODE	1+	10+
100 x 160	PCB/PB/SS1	£1.75	£1.60
100 x 220	PCB/PB/SS2	£2.05	£1.90
114 x 203	PCB/PB/SS3	£2.15	£2.00

**DOUBLE SIDED**

SIZE (mm)	ORDER CODE	1+	10+
110 x 160	PCB/PB/DS1	£2.05	£1.90
100 x 220	PCB/PB/DS2	£2.25	£2.10
114 x 203	PCB/PB/DS3	£2.35	£2.20

**STARTER PACK**

- Contents: 1 x Master Socket  
 1 x Secondary Socket  
 15 mtrs. x BT 4-core cable  
 50 x Cable Clips  
 1 x Line Jack Cord with Plug.  
 1 x Wiring Instructions.

£9.50

(Normal Catalogue Price of These Items When Sold Separately - £11.20.)

ORDER CODE BT/CONVERSION KIT

**SERVISOL SERVICE AIDS**

**SERVISOL AEROSOLS & OTHER PRODUCTS**

SWITCH CLEANING LUBRICANT	£1.60	£1.45
FOAM CLEANSER	£1.57	£1.43
PLASTIC SEAL	£1.86	£1.71
ANTI-STATIC SPRAY MIST	£1.60	£1.40
SILICONE GREASE - SPRAY	£1.97	£1.77
SUPA-FREEZE-IT	£2.00	£1.74
VIDEO & AUDIO TAPE HEAD CLEANER	£1.40	£1.21
AERO-KLENE	£1.46	£1.28
COLDKLENE 110 DEGREASING SOLVENT	£2.32	£2.03
EXCEL POLISH	£1.43	£1.25
SUPER 40	£2.35	£2.05
AERO-DUSTER	£2.11	£1.82

	1+	10+
SILICONE GREASE - TUBE	£2.35	£2.05
HEAT SINK COMPOUND	£1.53	£1.38
SOLDA-NOP - LIGHT GAUGE	£1.04	90p
SOLDA-NOP - STANDARD	£1.02	88p
SOLDA-NOP - INDUSTRIAL	£3.71	£3.21

**SECURITY EQUIPMENT - ALARMS**

**PASSIVE INFRA-RED DETECTOR - LYNX**

- More commonly shortened to PIR detectors.
- Very good quality, simple to install and very attractive and unobtrusive.
- SEE Page 44 for suitable cable (CBL/TEL/4) for connecting to alarm panel
- High quality lens design with the CDZ (Close Detector Zone).
  - High tech walk test with remote LED control.
  - High signal to noise ratio with fast response time
  - High immunity to RFI and line transients.

**SPECIFICATION**

Detection Coverage - 16 Zone wide angle 90° multi-beam on 3 detection levels.  
 Range - 12 metres max.  
 Adjustment - 0° (horizontal) 12° declination.  
 Mounting Height - Ground to 3 metres.  
 Target Speed - 0.2 m/sec. to 0.7 m/sec.  
 Voltage - 9 to 16V d.c.  
 Ripple - 5V peak/peak  
 Step Function Switch Tolerance - 7V.  
 Current Standing State - 10mA max.  
 Switching Output - NC clean contacts 0.5A/24V resistive 10 ohms \* in series.  
 Tamper Output - 0.5A/24V resistive.  
 Alarm Switch Time - 2 sec. minimum.  
 Detector - Dual element. Lithium Tantalate.  
 Signal/Noise Ratio - Typically 20.1 Min.).  
 LED - Three functions of operation:  
 1. Enable.  
 2. Disable.  
 3. Remote.

Operating Temperature - -10°C to + 50°C.  
 Dimensions - 60 x 91 x 34mm.  
 Weight - 95 gms.  
 Warranty - 2 years.

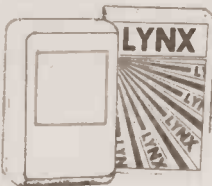

ORDER CODE SEC/PIR

PRICE - £29.50

ALL PRICES NOW INCLUDE 15% V.A.T.

**PCB EQUIPMENT**

**Hobbibloc -**  
 THE SOLDERLESS BREADBOARD  
 The prototyping method of building and testing circuits. Unique interlocking feature to achieve the size desired for every project.

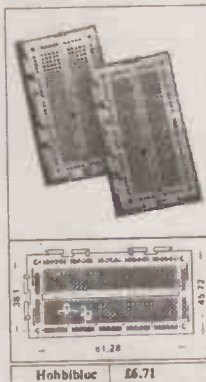

**LOGIC TEMPLATE**

Supplied in a protective wallet for safe-keeping.

ORDER CODE PCB/1139  
 PRICE - £7.99

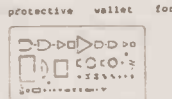

**Veroboard - FULLY PIERCED SINGLE SIDED**

The world famous Veroboard. Still considered the fastest and easiest permanent method of assembling electronic circuits.

- Material: SRBP
- Hole matrix: 2.54 x 2.54 mm
- Hole dia: 1.02 mm
- Parallel copper tracks

Board size(mm)	Holes/tracks	Order code
63x25	24/10	01-59543C
95x95	37/36	01-21073K
127x95	50/36	01-59542G
220x100	83/50	01-27652G
455x95	179/34	01-0040A

Order code (pkt 5)*	Price
01-59543C*	£1.81
01-21073K	£2.36
01-59542G	£1.99
01-27652G	£4.21
01-0040A	£6.78

**Veroboard - DOUBLE SIDED**

Board size(mm)	Holes/tracks	Order code
213x211	83/79	03-0109K

Order code	Price
03-0109K	£11.07

**Plain board - FULLY PIERCED**  
 Veropins are inserted into holes where required and components are then soldered directly to the pins. Circuit connections are made using insulated wire.

- Material: SRBP
- Hole matrix: 2.54 x 2.54 mm
- Hole dia: 1.02 mm

Board size(mm)	Order code	Price
95.25 x 454.7C	02-0134D	£4.42

**RADIUS AID/CIRCULAR PROTRACTOR - WITH BEVEL**

Contains 16 circles with radii from 1mm to 15mm.

Diameter: 115mm.

Material: Glass-clear Dunilon

ORDER CODE PCB/71P  
 PRICE - £1.60

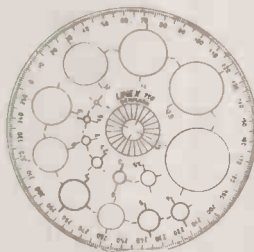

SEMI-CONDUCTORS

AC107	42p*	BC152	27p	BC516	40p	BD507	£1.10	BF355	42p	BU100A	£2.30
AC117K	36p*	BC153	20p	BC517	34p	BD518	95p	BF357K	60p	BU105	£1.40
AC125	70p	BC157	18p			BD519	95p	BF363	45p	BU108	£2.25
AC126	45p	BC158	18p	BC537	22p			BF366	40p	BU110	£2.44
AC127	35p	BC158A	22p			BD520	£1.30	BF367	30p	BU126	£1.60
AC128	34p	BC159	18p	BC546	14p	BD534	88p	BF371	32p	BU133	£1.90
AC128K	42p*	BC159B	20p	BC546A	16p	BD535	88p			BU204	£1.60
AC141	42p	BC159C	22p	BC546B	18p	BD537	90p	BF394	14p	BU205	£1.50
AC141K	58p*	BC160	38p	BC547	9p	BD538	98p	BF395	22p	BU206	£1.80
AC142	12p	BC160/16	42p	BC547A	10p					BU208	£1.80
AC142K	55p*	BC161	38p	BC547B	12p					BU208A	£1.50
AC151	56p	BC168B	25p	BC548	9p	BD562	85p	BF422	24p	BU225	£2.90
AC152	52p*			BC548A	12p			BF423	24p	BU226	£2.90
AC153	52p	BC170	10p	BC548B	12p	BD587	98p			BU312	28p
AC153K	54p*	BC171	10p	BC548C	12p	BD588	98p	BF450	30p	BU326S	£2.20
AC154	32p*	BC172	14p	BC549	10p			BF451	30p	BU407	£1.70
AC169	20p	BC173	14p	BC549B	10p	BD595	£1.80	BF457	30p	BU408	£1.80
AC176	35p	BC174	16p	BC549C	12p	BD596	£1.80	BF458	40p	BU426	£1.30
AC176K	52p*	BC176	25p			BD597	95p	BF459	40p	BU426E	£2.80
AC178	48p	BC177	25p	BC550	14p	BD600	75p			BU806	65p
AC179	48p*	BC179	18p	BC550B	14p	BD681	£1.00	BF479	40p	BUX80	£3.30
AC186	30p*			BC550C	16p	DD699	£1.80	BF594	32p	BUY69A	£3.40
AC187	36p	BC182	10p	BC556A	10p					BUY69B	£2.40
AC187K	44p*	BC182C	12p	BC557A	12p	DD700	£1.40	BF961	48p	BUY69C	£2.40
AC188	32p	BC182L	10p	BC558	12p	DD701	£1.60			C111E	82p
AC188K	40p*	BC183	10p	BC558A	14p	DD702	£1.20			C1129	24p
AC193K	46p	BC183C	12p	BC558B	14p	DD707	80p			CG61	75p
AC194K	48p*	BC183L	10p	BC558C	14p	DD711	65p	BF961	48p	CIL108B	15p
		BC184	10p	BC559B	14p	DD712	65p	BF961	48p	CIL108B	15p
ACY17	94p*	BC184C	12p	BC560C	14p	DD712	65p	BF961	48p	CRS1/40AP	£1.10
ACY18	94p	BC184L	12p			DD712	65p	BF961	48p	CRS3/40AP	£1.60
ACY19	94p	BC186	35p	BCY30A	£21.50	DD712	65p	BF961	48p		
ACY20	94p	BC187	26p	BCY31A	£21.75	DD712	65p	BF961	48p		
ACY21	94p	BC187	26p	BCY33A	£22.40	DD712	65p	BF961	48p		
ACY22	94p	BC192	39p	BCY34A	£0.75	DD712	65p	BF961	48p		
ACY28	98p			BCY40	£21.75	DD712	65p	BF961	48p		
ACY39	95p	BC206B	20p	BCY56	42p	DD712	65p	BF961	48p		
ACY40	98p	BC207A	16p	BCY70	20p	DD712	65p	BF961	48p		
AD140	92p	BC207B	18p	BCY71	22p	DD712	65p	BF961	48p		
AD142	98p	BC208C	25p	BCY72	22p	DD712	65p	BF961	48p		
AD143	98p	BC209C	28p	BCY88	£0.99	DD712	65p	BF961	48p		
AD149	£1.05	BC212	10p	BCY89	£0.65	DD712	65p	BF961	48p		
AD161	95p	BC212B	12p	BC210	£3.21	DD712	65p	BF961	48p		
AD162	80p	BC212L	12p	BC211	£2.60	DD712	65p	BF961	48p		
AD161/162MP	£1.70	BC213	10p	BD123	£2.80	DD712	65p	BF961	48p		
AF114	£1.20	BC213L	12p	BD129	90p	DD712	65p	BF961	48p		
AF115	£3.00	BC214	10p	BD130Y	75p	DD712	65p	BF961	48p		
AF118	£1.40	BC214L	12p	BD131	50p	DD712	65p	BF961	48p		
AF121	75p	BC214L	12p	BD132	50p	DD712	65p	BF961	48p		
AF124	85p	BC238	14p	BD133	52p	DD712	65p	BF961	48p		
AF125	60p	BC239C	14p	BD135	40p	DD712	65p	BF961	48p		
AF127	65p			BD136	40p	DD712	65p	BF961	48p		
AF139	70p	BC251	16p	BD137	40p	DD712	65p	BF961	48p		
AF147	70p	BC252	16p	BD138	40p	DD712	65p	BF961	48p		
AF149	70p	BC253B	16p	BD139	42p	DD712	65p	BF961	48p		
AF180	£2.50	BC257	24p	BD140	45p	DD712	65p	BF961	48p		
AF181	£2.75			BD142	£1.60	DD712	65p	BF961	48p		
AF186	85p	BC261A	22p	BD145	£1.82	DD712	65p	BF961	48p		
AF239	60p	BC261B	22p	BD150B	70p	DD712	65p	BF961	48p		
AF279S	£1.10	BC262	26p	BD157	95p	DD712	65p	BF961	48p		
		BC266	32p	BD160	£1.75	DD712	65p	BF961	48p		
AL102	£7.99	BC267	34p	BD165	50p	DD712	65p	BF961	48p		
AL113	£5.50	BC267	26p	BD166	50p	DD712	65p	BF961	48p		
ASV26	£2.30	BC268	36p	BD177	78p	DD712	65p	BF961	48p		
ASV27	£2.00			BD178	76p	DD712	65p	BF961	48p		
ASV28	£5.50	BC287	40p	BD179	80p	DD712	65p	BF961	48p		
ASV67	£4.30	BC294	42p	BD181	65p	DD712	65p	BF961	48p		
ASV74	£4.60	BC298	40p	BD183	78p	DD712	65p	BF961	48p		
ASV80	£5.70			BD187	72p	DD712	65p	BF961	48p		
ASZ17	£2.20	BC300	42p	BD188	90p	DD712	65p	BF961	48p		
AU106	£8.50	BC301	36p	BD201	70p	DD712	65p	BF961	48p		
AU110	£2.65	BC302	36p	BD202	72p	DD712	65p	BF961	48p		
		BC303	36p	BD203	74p	DD712	65p	BF961	48p		
		BC304	36p	BD204	72p	DD712	65p	BF961	48p		
		BC307A	15p	BD225	76p	DD712	65p	BF961	48p		
		BC308A	16p	BD232	60p	DD712	65p	BF961	48p		
		BC309A	15p	BD233	60p	DD712	65p	BF961	48p		
BC107	12p	BC317	14p	BD234	40p	DD712	65p	BF961	48p		
BC107A	15p	BC317B	14p	BD235	40p	DD712	65p	BF961	48p		
BC107B	16p	BC319	24p	BD236	45p	DD712	65p	BF961	48p		
BC108	12p			BD237	45p	DD712	65p	BF961	48p		
BC108A	14p	BC320	14p	BD238	56p	DD712	65p	BF961	48p		
BC108B	14p	BC321B	16p	BD239A	18p	DD712	65p	BF961	48p		
BC108C	14p	BC322	14p	BD243A	70p	DD712	65p	BF961	48p		
BC109	12p	BC323	90p	BD253	£1.20	DD712	65p	BF961	48p		
BC109A	14p	BC327	12p	BD376	38p	DD712	65p	BF961	48p		
BC109C	16p	BC328	12p	BD410	80p	DD712	65p	BF961	48p		
BC114	28p			BD433	52p	DD712	65p	BF961	48p		
BC115	28p	BC337	10p	BD434	60p	DD712	65p	BF961	48p		
BC116A	34p	BC338	12p	BD435	62p	DD712	65p	BF961	48p		
BC117	24p			BD438	60p	DD712	65p	BF961	48p		
BC118	35p	BC340	42p	BD441	90p	DD712	65p	BF961	48p		
BC119	38p	BC347	16p	BD442	£1.20	DD712	65p	BF961	48p		
BC125	22p	BC348	16p			DD712	65p	BF961	48p		
BC125B	28p	BC349	16p	BD433	52p	DD712	65p	BF961	48p		
BC126	24p	BC350A	20p	BD434	60p	DD712	65p	BF961	48p		
		BC351	18p	BD435	62p	DD712	65p	BF961	48p		
BC132	20p	BC352A	26p	BD438	60p	DD712	65p	BF961	48p		
BC135	21p			BD441	90p	DD712	65p	BF961	48p		
BC139	35p	BC360	38p	BD442	£1.20	DD712	65p	BF961	48p		
BC140	36p					DD712	65p	BF961	48p		
BC141	40p	BC377	36p			DD712	65p	BF961	48p		
BC142	36p					DD712	65p	BF961	48p		
BC143	36p	BC394	36p			DD712	65p	BF961	48p		
BC144	48p					DD712	65p	BF961	48p		
BC147	18p	BC413	18p			DD712	65p	BF961	48p		
BC147B	14p	BC413B	20p			DD712	65p	BF961	48p		
BC148	18p					DD712	65p	BF961	48p		
BC148B	12p	BC440	38p			DD712	65p	BF961	48p		
BC149	18p</										

MR502	45p			T1S43	62p	2N2894	50p	2N3906	20p	2S81560	66p
MR510	60p	TAG4444	£1.00	T1S73	38p	2N2904	48p	2N3964	48p		
MRB11	42p			T1S88	50p	2N2904A	36p				
MRB12	70p	TIP29	34p	T1S90	30p	2N2905	48p	2N4032	78p	2SC380	30p
MRB14	82p	TIP29H	38p	T1S91	25p	2N2905A	40p	2N4033	80p	2SC460	22p
MRB18	90p	TIP29C	40p	T1S92	34p	2N2906A	38p	2N4037	50p	2SC643A	£1.68
MRB50	99p					2N2907A	34p	2N4046	75p	2SC732R	40p
MRB54	99p	TIP30	36p	TY20	£2.45	2N2926C	12p	2N4058	14p	2SC9300	£2.80
MRP475	£3.30	TIP30A	38p			2N2926G	12p	2N4060	18p	2SC1030	£1.80
MRP479	£4.80	TIP30B	46p	XR3017	92p	2N2926Y	12p	2N4062	20p	2SC1098	94p
		TIP30C	42p			2N2955	£1.17	2N4124	26p	2SC1172T	£1.70
		TIP31	40p	ZTX107	18p			2N4236	£3.80	2SC1173	88p
MV5460	66p	TIP31A	40p	ZTX212	20p	2M3053	34p	2N4248	45p	2SC1279	50p
		TIP31B	42p	ZTX213	20p	2M3054	70p	2M4250	28p	2SC1306	£1.80
NAS246	£1.70	TIP31C	40p	ZTX239	20p	2M3055	48p	2N4286	20p	2SC1307	£2.00
		TIP32	40p	ZTX310	20p	2M3055A	54p	2N4288	20p	2SC1413A	£2.70
		TIP32A	44p	ZTX313	24p	2N3133	68p	2N4289	22p	2SC1444	£1.40
		TIP32B	46p	ZTX501	20p	2N3134	60p	2N4290	24p	2SC1449	90p
OC26	£2.80	TIP32C	48p	ZTX502	24p	2N3235	£2.65	2N4291	24p	2SC1507	60p
OC35	£4.75	TIP33	66p	ZTX504	28p	2N3250	58p	2N4292	24p	2SC1678	£1.60
OC36	£4.75	TIP33A	80p	ZTX531	24p	2N3254	68p	2N4292	£1.60	2SC1681	£1.00
OC42	80p	TIP33B	82p			2N3304	£4.20	2N4403	20p	2SC1758	68p
OC44	82p	TIP33C	85p	2N404	70p	2N3405	£1.88	2N4427	£1.65	2SC1908	£1.45
OC45	56p	TIP34	80p	2N525	£1.20	2N3440	90p	2N4442	£1.30	2SC1922	30p
OC70	50p	TIP34A	90p	2N696	52p	2N3441	90p	2N4459	£1.04	2SC1945	£2.88
OC71	50p	TIP34B	£1.00	2N697	40p	2N3442	£1.40	2N4661A	£1.51	2SC1953	£1.40
OC72	80p	TIP34C	£1.05	2N705	48p	2N3501	£8.30	2N4671	£2.10	2SC1957	£1.50
OC73	£1.40	TIP35	£1.48	2N706	24p	2N3502	£6.50	2N4902	£2.30	2SC1969	£1.99
OC75	70p	TIP35A	£1.80	2N708	24p	2N3505	40p	2N4906	£2.58		
OC76	70p	TIP35C	£1.55	2N744	42p	2N3583	£1.20	2N4918	70p	2SC2028	£2.10
OC77	95p	TIP36A	£2.60	2N760	42p	2N3633	70p	2N4921	80p	2SC2029	£2.70
OC81	78p	TIP36B	£2.70	2N914	32p	2N3643	26p			2SC2078	£2.40
OC81D	£1.10			2N916	46p	2N3646	40p	2N5042	£2.82	2SC2091	£1.40
OC139	£1.50	TIP41	42p	2N918	80p	2N3702	12p	2N5086	20p	2SC2098	£2.90
OC200	£4.60	TIP41A	44p	2N930	30p	2N3703	12p	2N5172	40p	2SC2122A	£3.20
OC203	£2.50	TIP41B	38p			2N3704	12p	2N5179	78p	2SC2166	£1.20
OC205	£3.40	TIP41C	40p	2M1131	70p	2N3705	12p	2N5208	40p	2SC2314	£1.10
OC271	£2.40	TIP42	44p	2M1132	30p	2N3706	12p	2N5245	60p	2SC2335	£1.50
		TIP42B	50p	2M1164	£3.10	2N3707	12p	2N5294	80p	2SC2371	£1.75
		TIP42C	60p	2M1302	£1.26	2N3708	12p	2N5298	12p		
OP156	16p	TIP47	60p	2M1304	£1.26	2N3709	12p	2N5321	98p	2S349	£5.00
				2M1305	84p	2N3710	12p	2N5449	28p	2S350	£5.95
ON236A	£1.94	TIP110	80p	2M1306	90p	2N3711	12p	2N5458	55p		
ORP12	90p	TIP116	75p	2M1307	90p	2N3715	£1.90	2N5459	48p	2SR30A	38p
R2008B	£1.75	TIP120	70p	2M1308	£1.29	2N3724	80p	2N5485	40p	2SR134	£5.50
R2010B	£1.00	TIP121	75p	2M1309	£1.20	2N3725	80p	2N5494	£1.10	2SR135	£5.95
R2322	75p	TIP122	70p	2M1711	60p	2N3740	£1.30				
R2323	80p	TIP125	72p			2N3741	£3.40	2N6027	40p	3M128	£2.46
R2540	£2.71	TIP126	80p	2N2194	50p	2N3766	£2.10	2N6107	69p	3M211	£3.52
		TIP127	75p	2N2177	55p	2N3771	£1.60	2N6122	£2.80		
S2M1	5p	TIP140	96p	2N2218	38p	2N3772	£2.65	2N6180	£2.80		
S6M1	5p	TIP141	95p	2N2219A	42p	2N3773	£1.99	2N6211	£3.88	3SR74	60p
SC45E	£2.50	TIP142	£1.60	2N2222	30p	2N3790	30p	2N6316	£3.88	3SR87	63p
ST2110	56p	TIP145	£1.50	2N2223A	32p	2N3794	20p	2N6318	£3.95	3SR88	70p
ST6120	55p	TIP146	£1.60	2N2243A	70p	2N3819	40p			3SR88L	60p
		TIP147	£1.70	2N2270	84p	2N3819	40p	2S321	£13.50		
				2N2369A	28p	2N3820	20p	2S746A	£4.50		
		TIP2955	80p	2N2401	80p	2N3827	20p				
				2N2570	£1.80	2N3866	£1.20	2S699A	90p		
		TIP3055	70p	2N2646	80p	2N3903	15p	2S841	80p		
				2N2784	£1.15	2N3904	18p	2S842	80p		
						2N3905	20p				

### VALVES

TYPE	PRICE	TYPE	PRICE	TYPE	PRICE	TYPE	PRICE	TYPE	PRICE	TYPE	PRICE
AZ31	£5.25	ECH35	£4.35	EY51	£1.10	PCL82	£1.35	UC92	£1.75	6J5GT	£4.15
AZ41	£2.35	ECH42	£1.75	EY06/B7	85p	PCL83	£2.95	UCC85	60p	6J6	£1.65
		ECH81	£1.15	EY88	85p	PCL84	95p	UCF80	£1.40		
CV850	£2.95	ECH83	£1.05	EY500A	£2.55	PCL86	£1.15	UCH42	£2.45	6K7C	£3.05
CV4015	£3.25	ECH84	£1.25	EZ40	£3.35	PCL88	£2.95	UCH81	90p	6K8G	£3.25
				EZ41	£3.45	PCL805	£1.20	UCL82	£1.00	6KD6	£7.50
				EZ80	£1.30			UCL83	£3.15		
DAF96	70p	ECL80	80p	EZ01	£1.30	PD500	£3.75	UDC81	£2.00	6Q7C	£2.95
DF96	72p	ECL82	£2.11							6Q7T	£2.95
DK96	£3.10	ECL83	£3.80	CY501	£1.65	PFL200	£1.15				
DL96	£1.65	ECL84	£1.25					UF41	£1.50	6SA7	£2.35
DM70	£2.35	ECL85	£1.20	CZ32	£2.45	PL33	£1.80	UF89	£2.95	6SG7	£3.20
DM71	£3.45	ECL86	£1.25	GZ34	£3.80	PL81	£1.45	UL84	£1.05	6SJ7	£2.95
DY51	55p			KT66	£13.55	PL82	55p			6U4GT	£2.35
DY86/87	80p			KT88		PL83	55p	UY41	£3.85	6V6GT	£2.00
DY802	98p					PL84	£1.20	UY85	95p		
		EF37A	£4.25	Gold Lion Select	£43.50	PL95	£1.75	2D21	£2.65	6X4	£1.75
		EF40	£4.05	GEC/Mullard	£40.00	PL504	£1.80	5Y4GT	£1.75	6X5GT	£1.15
EB8CC	£4.75	EF41	£1.60	Foreign	£18.80	PL508	£1.35	5Y3GT	£2.65	10P1	£1.75
EL10F	£5.95	EF80	50p			PL519	£5.55				
EA50	£1.45	EF83	£4.35	PC86	55p	PL802	£8.40	6A05	£2.45	12AU6	£3.20
EABC80	85p	EF85	50p	PC88	55p			6AU6	£1.60	12AV6	£1.35
EAP42	£1.78	EF86	£2.65	PC92	£10.90			6AV6	£1.75	12HG7	£7.25
EAF801	£1.75	EF89	£1.88	PC97	£1.50	PY32	see PY33				
EA90	£1.78	EF91	£2.35	PC900	£1.40	PY33	65p	6B05	£2.45	30C15	£1.05
EB91	65p	EF92	£2.65			PY81/800	£1.35	6B06	£2.20	30P5	£1.05
EBC41	£1.45	EP95	80p	PCC04	50p	PY88	85p	6BR6	£4.20	30P12	75p
EBC81	£1.10	EP183	52p	PCC85	95p	PY500A	£2.35	6BJ6	£1.75	30PL14	£1.75
FDF80	60p	EF184	64p	PCC88	85p	PY801	£1.35	6BW6	£2.95	30P19	£2.60
EF83	£1.35			PCC09	85p			6HZ6	£2.05	30PL1	£1.95
EF89	85p			PCC109	85p	U26	£1.60	6C4	£1.20	30PL13	£1.05
EC92	£2.10					U191	95p	6F2B	£1.75		
ECC81	£1.75	EL34	£3.95	PCF80	£1.35	U301	£1.15			VALVE BASES	
ECC82	£1.08	EL36	£1.60	PCF82	75p			6GR8A	£1.35	B9A 9-pin	£2.30
ECC83	£1.40	EL41	£4.05	PCF87	£1.35			6KR5	£2.05		
ECC84	£1.40	EL42	£2.95	PCF86	£1.35	UABC80	55p				
ECC85	65p	EL81	£8.05	PCF87	£1.35	UAP42	£1.85				
ECC86	£3.25	EL84	£1.30	PCF201	£2.75						
ECC88	£1.50	EL86	£1.45	PCF801	£2.75	URC41	£2.90				
ECC89	£1.75	EL95	65p	PCF800	£1.05	URC81	£2.05				
ECC91	£1.50	EL509	£7.25	PCF801	£1.50						
ECC189	£1.75	EL519	£7.25	PCF802	£1.10	URF89	60p				
ECC807	£3.05			PCF805	£1.65						
				PCF806	60p						
ECF80	£1.35	EM80	£1.50	PCF808	£1.15						
ECF82	£1.35	EM81	£1.50								
ECF83	£2.25	EM84	80p								
		EM87	£4.75	PCH200	£1.45						

### TV & VIDEO SPARES

**A COMPLETE RANGE COVERING ALL MAJOR BRANDS OF VIDEO HEADS, IDLERS, REMOTE HANDSETS, VIDEO BELTS, TRIPLERS, TURNTABLE BELTS, CASSETTE BELTS, ETC. ETC. ETC.**

**ALL INCLUDED IN OUR 1990 CATALOGUE**

**FULL 219 PAGES**

**DON'T MISS OUT**

**SEND £1 NOW FOR YOUR COPY.**

 **MANY ITEMS IN THIS CATALOGUE ARE MADE IN THE U.K. LOOK FOR THE FLAG !!**

ANTEX - MODEL C - 15W SOLDERING IRON

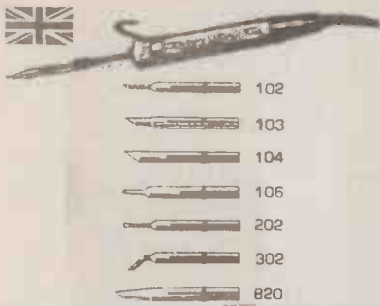

A Miniature Soldering Iron, bits fitted with opening clip to ensure easy change.  
220/240V 15W fitted with a 6ft. 3-core P.V.C. flex and a 2.3mm tip.

DESCRIPTION	ORDER CODE	1+	10+
C-15W Iron	SOLDER/IRON/C	£7.65	£6.75
Element to fit	SOLDER/ELEM/C	£3.75	£3.25
2.3mm 3/32" Tip	SOLDER/BIT/102)		
4.0mm 5/32" Tip	SOLDER/BIT/103)		
4.7mm 3/16" Tip	SOLDER/BIT/104)		
1.0mm 3/64" Tip	SOLDER/BIT/106)	£1.60	£1.50
2.3mm 3/32" Tip	SOLDER/BIT/202)		
2.3mm 3/32" Tip	SOLDER/BIT/302)		
2.3mm 3/32" Tip	SOLDER/BIT/820)		

ANTEX - MODEL CS - 17W SOLDERING IRON

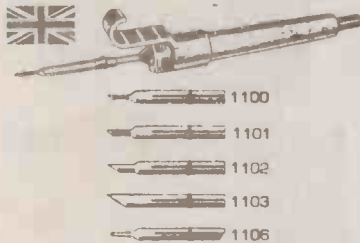

A 17W Precision Miniature Soldering Iron featuring a double shaft: an inner shaft of ceramic to provide near perfect insulation and virtually no leakage and an outer shaft of stainless steel for strength. Bits are secured on the element sheaths by a sliding ring which when removed towards the tip, allows the bit to slip on or off.

240V 17W fitted with a 6ft. 3-core P.V.C. flex and a 2.3mm tip.

DESCRIPTION	ORDER CODE	1+	10+
CS-17W Iron	SOLDER/IRON/CS	£7.75	£6.85
Element to fit	SOLDER/ELEM/CS	£3.95	£3.75
2.3mm 3/32" Tip	SOLDER/BIT/1100)		
3.0mm 1/8" Tip	SOLDER/BIT/1101)		
4.7mm 3/16" Tip	SOLDER/BIT/1102)	£1.60	£1.50
6.0mm 1/4" Tip	SOLDER/BIT/1103)		
1.0mm 3/64" Tip	SOLDER/BIT/1106)		

ANTEX - MODEL XS - 25W SOLDERING IRON

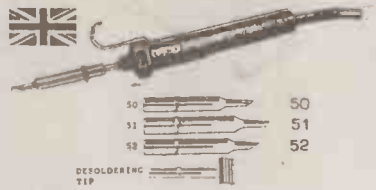

A 25W 240V Mains Soldering Iron ideal for soldering transistors and integrated circuits. Uses double shaft principle - as above. Bits are secured on the element sheaths by a sliding ring which when removed towards the tip, allows the bit to slide on or off.

240V 25W fitted with a 6ft. 3-core P.V.C. flex and a 3mm tip.

DESCRIPTION	ORDER CODE	1+	10+
XS-25W Iron	SOLDER/IRON/XS	£7.85	£6.95
Element to fit	SOLDER/ELEM/XS	£3.75	£3.25
2.3mm 3/32" Tip	SOLDER/BIT/50)		
3.0mm 1/8" Tip	SOLDER/BIT/51)	£1.60	£1.50
4.7mm 3/16" Tip	SOLDER/BIT/52)		
Desoldering Tip			
19.0mm 3/4" Tip	SOLDER/BIT/DS	£5.50	£5.30

SOLDERING IRON STAND

A soldering iron stand manufactured by Antex, for use with the previously mentioned irons, constructed from a high grade insulation material with a chromium plated steel spring. The sponge serves to keep the soldering iron bits clean - this must be kept damp. Spare bits can be accommodated on the stand. Spare sponges are available.

DESCRIPTION	ORDER CODE	1+	10+
Stand	SOLDER/ST4	£2.99	£2.75
Spare Sponge	SOLDER/ST4/SPONGE	40p	35p

SOLDERING IRON KITS

ANTEX - MODEL SK2 - 15W SOLDERING KIT

This kit contains a Model C 15W soldering iron, an ST4 stand and a length (1m) of cored solder.

DESCRIPTION	ORDER CODE	1+	10+
Kit - 15W	SOLDER/SK2	£10.75	£9.75

Full range of tips available - See C Iron.

ANTEX - MODEL SK6 - 25W SOLDERING KIT

This kit contains a Model XS 25W soldering iron and an ST4 stand, a length (1m) of cored solder and a booklet - "How To Solder".

DESCRIPTION	ORDER CODE	1+	10+
Kit - 25W	SOLDER/SK6	£10.85	£9.85

Full range of tips available - See XS Iron.

ANTEX - MODEL SK5 - 17W SOLDERING KIT

This kit contains a Model CS 17W soldering iron and an ST4 stand, a length (1m) of cored solder and a booklet - "How To Solder".

DESCRIPTION	ORDER CODE	1+	10+
Kit - 17W	SOLDER/SK5	£10.75	£9.75

Full range of tips available - See CS Iron.

ORIX PORTASOL GAS SOLDERING IRON

Overall size: 175 x 17mm. Supplied fitted with a 3.2mm tip.

NOT TO BE CONFUSED WITH A CHEAP IMPORTED VERSION.

DESCRIPTION	ORDER CODE	1+	5+
Orix Gas Iron	SOLDER/GAS	£18.75	£17.50
1.0mm Tip	SOLDER/TIP/G10)		
2.4mm Tip	SOLDER/TIP/G24)	£5.50	£5.00
3.2mm Tip	SOLDER/TIP/G32)		
4.8mm Tip	SOLDER/TIP/G48)		

REPLACEMENT NOZZLE

Replacement Teflon nozzle desoldering pump.

ORDER CODE  
TOOL/DESOLD/NOZ

PRICE	1+	10+
	69p	59p

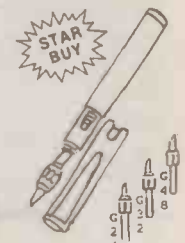

DESOLDERING PUMP

Very high quality - powerful suction desoldering tool with micro 1.5mm diameter nozzle, equipped with safety shield.

Manufactured in Western Europe.

Specification:

Overall dimensions	190mm length x 20mm diameter
Nozzle length	20mm
Nozzle tip	3.0mm O.D. diameter x 1.5mm I.D.
Weight	60gms

ORDER CODE  
TOOL/DESOL

£2.99



SOLDER SPECIAL OFFER

18SWG RESIN SOLDER.  
60% TIN 40% LEAD.  
MELTING POINT 185°C.

500gm. REEL	1+	10+	100+
	£4.95	£4.70	£3.95

22SWG RESIN SOLDER			
500gm REEL	1+	10+	100+
	£4.99	£4.75	£3.99

SMALL SOLDER PACKS	18SWG	22SWG		
2 YDS	1+	10+	1+	10+
2 yds.	40p	35p	50p	45p
3 yds.	55p	50p	65p	60p

ORDERS FOR 5 OR MORE REELS PLEASE ADD A FURTHER 75p TO OUR NORMAL £1 P&P.



ALL PRICES NOW INCLUDE 15% V.A.T.

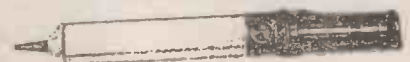



DIGITAL CAPACITANCE METER  
£54.00

★ 3½ digit 8mm LCD display  
★ Fully autoranging  
★ Display hold facility  
★ Diode and continuity test  
★ Probe styling  
★ Automatic polarity and zero  
★ Protective carrying case

Y123P 11mΩ YF120  
AC volts . . . . . 0-200-200-500Vdc ±2.3%  
DC volts . . . . . 0-200m-2-20-200-500Vdc ±1.3%  
Resistance . . . . . 0-200-2k-20k-200k-2M-20MΩ ±2%  
Dims . . . . . 133 x 29 x 17mm

RESISTANCE SUB-BOX  
Y125 RSB32



£27.50

Substitution box providing 32 different close tolerance resistors, 1W each, giving any value of R between 1Ω and 11MΩ. Resistors are connected in series. Quick connect spring-loaded terminals.

Dims . . . . . 139 x 88 x 33mm

RESISTANCE SUB-BOX  
Y129 DR510

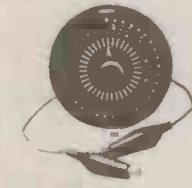

£6.20

A neat swivelling disc provides close tolerance substitution resistors of 36 preferred values from 5Ω to 1MΩ. Simple fix clips into circuit and swivel until optimum result is achieved.



LOGIC PROBE  
Y132 HYT07

£9.99

Logic probe suitable for displaying the logic state of each gate of TTL, CMOS, etc devices. Logic state displayed in light and sound. Pulse enlargement capability allows pulse detection down to 25nsec. Supplied with comprehensive instruction manual.

Working voltage . . . . . 4-16Vdc  
Thresholds: HI . . . . . 70% Vcc  
Lo . . . . . 30% Vcc  
Input impedance . . . . . 1MΩ  
Max. input frequency . . . . . 20MHz



LOGIC PROBE  
Y132A M625

£17.50

Logic probe/pulsar suitable for detecting the logic state of each gate of TTL, CMOS, etc devices. Pulsar function can be used to inject a pulse train into the circuit to aid fault finding.

Working voltage . . . . . 5-15Vdc  
Thresholds: HI . . . . . 70% Vcc  
Lo . . . . . 15% Vcc  
Input impedance . . . . . 120kΩ  
Max. input frequency . . . . . 50MHz  
Output pulse rate . . . . . 0.5 or 400Hz  
Pulse width . . . . . 10µs

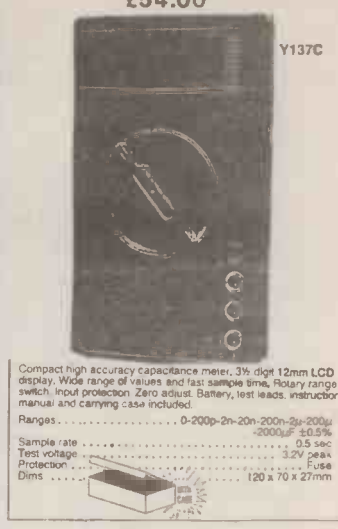

Y137C

Compact high accuracy capacitance meter, 3½ digit 12mm LCD display. Wide range of values and fast sample time. Rotary range switch. Input protection Zero adjust. Battery, test leads, instruction manual and carrying case included.

Ranges . . . . . 0-200p-2n-20n-200n-2µ-200µ-2000µF ±0.5%  
Sample rate . . . . . 0.5 sec  
Test voltage . . . . . 3.2V max  
Protection . . . . . Fuse  
Dims . . . . . 120 x 70 x 27mm



BATTERY TESTER  
Y126 HB207

£9.99

A compact dry cell battery tester capable of testing 15 voltage/battery types from 1.35V hearing aid batteries to 22.5V batteries. Test leads store in rear of case. Packed on attractive display card.

Dims: 105 x 64 x 32mm



3/4.5/6/7.5/9/12Vdc — 300mA  
Non-regulated output

P007 £4.99 88LUX

Plug-in power supply fits directly into 13A socket. Internal fuse overload protection. Polarity reversing socket. Voltage selector switch. Output via lead with 4-way "spider" plug.

Input voltage . . . . . 240Vac 50Hz  
Output voltage . . . . . 3/4.5/6/7.5/9/12Vdc  
Output current . . . . . 300mA  
Stability . . . . . 40%  
Ripple . . . . . 1V  
Dims . . . . . 74 x 52 x 46mm

WARNING: This unit is not stabilized. Its maximum rating is 300mA, and if less current is drawn there is a corresponding voltage rise. At less than 150mA this rise could be considerable.

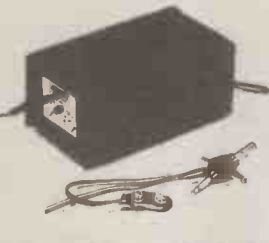

6, 7.5, 9, 12Vdc — 1 Amp  
Regulated output

P007N £6.25 REG1000

Regulated power supply with voltage selector and polarity reverse switches. LED "on" indicator. Input via 1.9m two-core mains lead. Output via 1.8m lead to 4-way spider plug and PP3 battery clip. Overall thermal fuse protection. Glass fuse output protection.

Input voltage . . . . . 240Vac 50Hz  
Output voltage . . . . . 6, 7.5, 9, 12Vdc  
Output current . . . . . 1000mA  
Stability . . . . . 2%  
Ripple . . . . . 10mV  
Dims . . . . . 122 x 67 x 55mm



8/9/12Vdc — 1A  
Regulated output AL12

P005A

Regulated power supply with voltage selector switch designed for use in fixed installations or fitted on flying leads. Input and output via screw terminals. Internal thermal fuse for overload protection. Suitable for use with P150, P150A, P151, P151A, P153 and P153B intercoms and P151BA electric door lock.

Input voltage . . . . . 240Vac 50Hz  
Output voltage . . . . . 8/9/12Vdc (selectable)  
Output current . . . . . 1A continuous  
Stability . . . . . 2%  
Ripple . . . . . 25mV  
Dims . . . . . 142 x 85 x 60mm

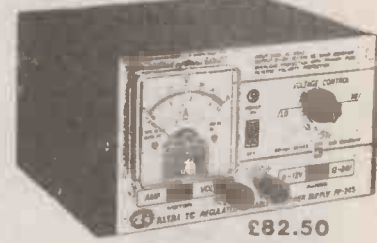

0-24Vdc — 5A  
Variable regulated output PP245

P004B

Variable regulated power supply with overload protection. Meter reads voltage or current (switched). Two voltage ranges 0-12V and 12-24Vdc. Ideal for laboratory use.

Input voltage . . . . . 240Vac 50Hz  
Output voltage . . . . . 0-24Vdc (2 ranges)  
Output current . . . . . 5A continuous  
Stability . . . . . 0.2%  
Ripple . . . . . 4mV  
Dims . . . . . 180 x 180 x 110mm



12Vdc — 650mA  
Regulated output

P007D £5.99 REG650

Plug-in 650mA regulated power supply with 12Vdc output. Plugs directly into standard 13A socket. Internal thermal fuse for overload protection. Polarity reversing socket. Output via lead with 4-way "spider" plug.

Input voltage . . . . . 240Vac 50Hz  
Output voltage . . . . . 12Vdc  
Output current . . . . . 650mA  
Stability . . . . . 2%  
Ripple . . . . . 10mV  
Dims . . . . . 82 x 61 x 60mm



3/4.5/6/7.5/9/12Vdc — 750mA  
Non-regulated output

P007B £4.50 PU750

Plug-in 750mA power supply (fits directly into 13A socket). Internal thermal fuse for safety. Polarity reversing switch. Voltage selector switch. Output via integral lead with 4-way "spider" plug and PP3 battery clip.

Input voltage . . . . . 240Vac 50Hz  
Output voltage . . . . . 3/4.5/6/7.5/9/12Vdc  
Output current . . . . . 750mA  
Stability . . . . . 40%  
Ripple . . . . . 1V  
Dims . . . . . 82 x 61 x 60mm

WARNING: This unit is not stabilized. Its maximum rating is 750mA, and if less current is drawn there is a corresponding voltage rise. At less than 400mA this rise could be considerable.



£35-00

VIDEO HEAD TESTER



A VHS video head tester for determining whether a video head is in good condition by detecting the wear state and displaying it on a meter. Complete with carrying case and leads.

ALL GOODS  
UP TO 750gms  
SENT 1st CLASS



Y142B AG2603AD

£170.00

A combined audio frequency signal generator and frequency counter. A six character LED display allows direct reading of internally generated signal or signals from an external source. The frequency generator has a range of 10Hz to 1MHz with either square or sine waveforms and adjustable output level. The frequency counter has a range of 10Hz to 150MHz. Frequency range controlled by a 5-step selector and fine control. Adjustable output level with 0/20/40dB attenuation.

AUDIO GENERATOR  
Frequency range . . . . . 10Hz to 1MHz  
Output impedance . . . . . 600Ω unbalanced  
Output control . . . . . 0, 20, 40dB and fine adjuster  
Output control: Sine . . . . . 8V rms max  
Square . . . . . 10V p-p max

FREQUENCY COUNTER  
Frequency range . . . . . 10Hz to 150MHz  
Input voltage . . . . . Less than 50mV  
Maximum input voltage . . . . . 3V  
Input impedance: High frequency . . . . . 1MHz  
MHz . . . . . 50Ω  
Power . . . . . 240Vac 50Hz  
Dims . . . . . 215 x 150 x 200mm



- ★ 14 ranges
- ★ Fuse and diode protection
- ★ Ohms zero
- ★ Mirrored scale
- ★ Leads with 2mm plugs. Battery and instruction manual included.
- ★ Miniature multimeter (including battery test)

AC volts	0-10-50-250-1000V ±5%
DC volts	0-2.5-50-250-1000V ±4%
DC current	0-10-250mA ±4%
Resistance	0-10k-100kΩ ±4%
Decibels	-20 to +62dB
Battery test	1.5V 'AA', 9V 'PP3'
Protection	Fuse and diodes
Dims	105 x 82 x 32mm

£8.75



- ★ 19 ranges (including 10A dc)
- ★ Fuse and diode protection
- ★ Battery test
- ★ Continuity buzzer
- ★ Audio output test
- ★ Ohms zero
- ★ Mirrored scale
- ★ Leads with 4mm plugs.
- ★ Battery and instruction manual included.

AC volts	0-10-50-250-1000V ±5%
DC volts	0-2.5-10-50-250-1000V ±4%
DC current	0-5m-50m-500m-10A ±5%
Resistance	0-10k-100k-10MΩ ±4%
Battery check	1.5V/75Ω 9V/450Ω
Decibels	-8 to +62dB
Audio power	-8 to +22dB
Protection	fuse and diodes
Dims	135 x 89 x 40mm

£13.75

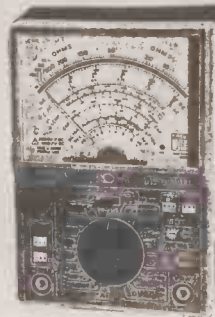

- ★ 27 ranges including 10A ac/dc
- ★ 2 capacitance ranges
- ★ 2 temperature ranges
- ★ Transistor hFE test
- ★ Continuity buzzer
- ★ Ohms zero
- ★ Fuse and diode protection
- ★ Test leads with 4mm shrouded plugs
- ★ Jewelled movement
- ★ Battery, thermocouple and instruction leaflet included

AC volts	0-2.5-25-250-1000Vac ±4%
DC volts	0-0.5-5-50-500-1000Vdc ±3%
AC current	0-250μ-25m-2.5A-10Aac ±5%
DC current	0-50μ-5m-500m-10Adc ±3%
Resistance	0-10k-100k-1M-10MΩ ±3%
Capacitance	0-100p-20μF ±5%
Temperature	0-300-2000°F ±5%
Transistor hFE	0-1000 NPN PNP
Decibels	-20dB to +62dB
Protection	Fuse and diode
Dims	160 x 110 x 50mm

£37.75



- ★ Super slim design (11mm thick)
- ★ Fully autoranging
- ★ 3½ digit 11mm LCD display
- ★ Data hold function
- ★ Diode test
- ★ Continuity test
- ★ Carrying wallet
- ★ Battery and instruction manual included

AC volts	0-2-20-200-500Vac ±2.3%
DC volts	0-200mV-2-20-200-500Vdc ±1.3%
Resistance	0-200-2k-20k-200k-2M-20MΩ ±2.0%
Dims	112 x 56 x 11mm (Excluding wallet)

£22.75



- ★ 14 ranges (including 10A dc)
- ★ 10mm 3½ digit LCD display
- ★ Automatic zero and polarity
- ★ Full overload protection
- ★ Over-range and low battery indication
- ★ Carrying case
- ★ Leads with 4mm plugs.
- ★ Battery and instruction manual included.

AC volts	0-200-750V ±1.2%
DC volts	0-2-20-200-1000V ±0.8%
DC current	0-2m-20m-200mA ±1.2%
Resistance	0-10A ±2%
Protection	Fuse and diodes
Dims	138 x 86 x 36mm

£29.95



- ★ 3½ digit 12mm LCD display
- ★ Autoranging voltage and resistance measurement
- ★ 10A ac/dc
- ★ Memory function
- ★ Display hold
- ★ Transistor test
- ★ Diode test
- ★ Continuity buzzer
- ★ Leads with 4mm plugs
- ★ Battery and instruction manual included.

AC volts	0-2-20-200-750Vac ±0.75%
DC volts	0-200m-2-20-200-1000Vdc ±0.5%
AC current	0-200m-10Aac ±0.75%
DC current	0-200m-10Adc ±1.0%
Resistance	0-2k-20k-200k-2M-20MΩ ±0.75%
Transistor hFe	0-1000 NPN/PNP
Dims	150 x 75 x 34mm

£42.95

PANEL METERS - MOVING COIL  
A VERY ECONOMICAL RANGE OF PANEL METERS.

PLASTIC CONSTRUCTION.

DIMENSIONS: 45mm HIGH x 51mm WIDE x 34mm DEEP

CUT OUT REQUIRED IS 38mm DIAMETER. FOUR BOLT FIXING.



F.S.D.	INTERNAL RESISTANCE	ORDER CODE	1+	10+
0.50uA	3500ohm	PANEL/164	£4.95	£4.50
0-100uA	3500ohm	PANEL/165	£4.95	£4.50
0-500uA	430ohm	PANEL/166	£4.95	£4.50
0-1mA	200ohm	PANEL/169	£4.95	£4.50
0-5mA	8ohm	PANEL/170	£4.95	£4.50
0-10mA	3ohm	PANEL/171	£4.95	£4.50
0-50mA	1.5ohm	PANEL/172	£4.95	£4.50
0-100mA	0.8ohm	PANEL/173	£4.95	£4.50
0-500mA	0.2ohm	PANEL/174	£4.95	£4.50
0-1A	0.1ohm	PANEL/175	£4.95	£4.50
0.2A	0.4ohm	PANEL/176	£4.95	£4.50
0-3A	0.3ohm	PANEL/176A	£4.95	£4.50
0-5A	0.02ohm	PANEL/177	£4.95	£4.50
0-10A	0.01ohm	PANEL/177A	£4.95	£4.50
0-25V d.c.	1000ohm/V	PANEL/178	£4.95	£4.50
0-30V d.c.	1000ohm/V	PANEL/179	£4.95	£4.50
0-50V d.c.	1000ohm/V	PANEL/179AB	£4.95	£4.50
0-300V d.c.	1000ohm/V	PANEL/179A	£4.95	£4.50
VU	1.228V a.c. (OVU)	PANEL/180	£4.95	£4.50

ALL ORDERS RECEIVED BY 4p.m.

BY POST, PHONE, TELEX OR FAX  
DESPATCHED SAME DAY

SUBJECT TO AVAILABILITY

**Y239**

Test leads with screw-on accessories: long prods, tip plugs, crocodile spade terminals, banana plugs, needle point tips. 1 pair each.

Max. current ..... 2A cont.

Length ..... 0.9m

Wire dia ..... 2.7mm

**UTL16K**

£2.75

**10 LEADS**

**Y237**      **£2.50**      **T801**

5 pairs differently coloured leads. Each end has sleeved crocodile clip same colour as lead.

Max. current ..... 0.5A cont.

Length ..... 430mm

Wire dia ..... 1.2mm

**Y229**

AVO test lead replacements. Highest grade materials. Red and black. Supplied with 2 crocodile clips and 2 insulated prods.

Max. current ..... 6A cont.

Length ..... 1m

Wire dia ..... 5.5mm

**PC1**

£4.75

ALL PRICES NOW INCLUDE 15% V.A.T.



METEX PROFESSIONAL MULTITESTERS AT COMPETITIVE PRICES!

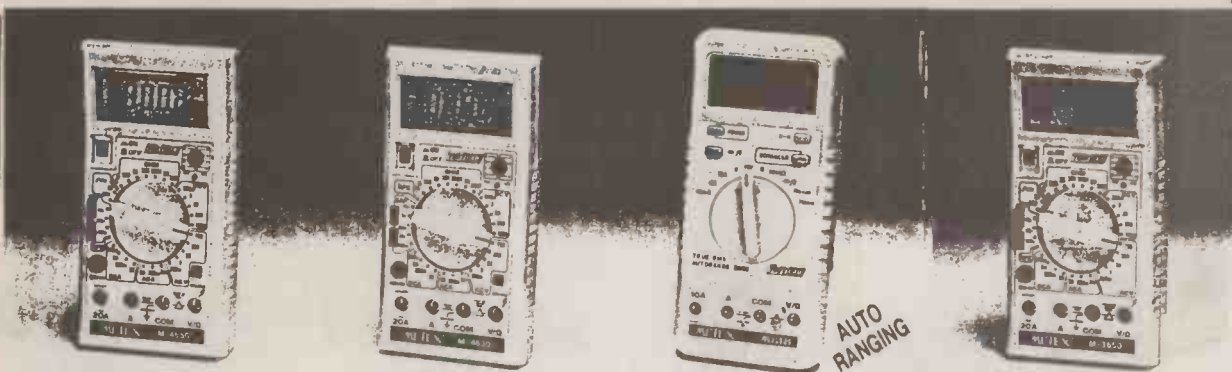

**Y123HD M4650**  
 ★ 4 1/2 digit 15mm LCD display  
 ★ 30 ranges including 20A ac/dc  
 ★ Frequency counter  
 ★ Capacitance ranges with zero adjust  
 ★ Transistor and diode test  
 ★ Continuity test with LED and buzzer  
 ★ Data hold switch  
 AC volts ..... 0-200m-2-20-200-750Vac ±0.5%  
 DC volts ..... 0-200m-2-20-200-1000Vdc ±0.5%  
 AC current ..... 0-200m-2m-20m-20Aac ±1.0%  
 DC current ..... 0-200m-2m-20m-20Adc ±0.5%  
 Resistance ..... 0-200-2k-20k-200k-2M-20MΩ ±0.15%  
 Capacitance ..... 0-2000pF-200n-20μF ±2.0%  
 Frequency ..... 0-20k-200kHz ±2.0%  
 Transistor hFE ..... 0-1000 NPN/PNP  
 Dims ..... 178 x 90 x 36mm

**Y123HB M4630**  
 ★ 4 1/2 digit 15mm LCD display  
 ★ 30 ranges including 20A ac/dc  
 ★ Capacitance ranges with zero adjust  
 ★ Transistor and diode test  
 ★ Continuity test with LED and buzzer  
 ★ Data hold switch  
 AC volts ..... 0-200m-2-20-200-750Vac ±0.5%  
 DC volts ..... 0-200m-2-20-200-1000Vdc ±0.5%  
 AC current ..... 0-200m-2m-20m-20Aac ±1.0%  
 DC current ..... 0-200m-2m-20m-20Adc ±0.5%  
 Resistance ..... 0-200-2k-20k-200k-2M-20MΩ ±0.15%  
 Capacitance ..... 0-2m-20m-200n-20μF ±2.0%  
 Transistor hFE ..... 0-1000 NPN/PNP  
 Dims ..... 178 x 90 x 36mm

**Y122HN M818**  
 ★ 3 1/2 digit 17mm LCD display  
 ★ Autoranging voltage and resistance  
 ★ High and low frequency ranges  
 ★ True RMS AC voltage and current  
 ★ Diode and continuity test  
 ★ Data hold switch  
 AC volts ..... 0-400m-4-40-400-1000Vac ±1.5%  
 DC volts ..... 0-400m-4-40-400-1000Vdc ±0.5%  
 AC current ..... 0-4m-40m-400m-2-10Aac ±1.5%  
 DC current ..... 0-4m-40m-400m-2-10Adc ±1.2%  
 Resistance ..... 0-4k-40k-400k-4M-20MΩ ±0.8%  
 Frequency ..... 0-4k-40k-400Hz ±2.2%  
 Dims ..... 187 x 87 x 34mm

**Y123HC M3650**  
 ★ 3 1/2 digit 17mm LCD display  
 ★ 30 ranges including 20A ac/dc  
 ★ Frequency counter  
 ★ Capacitance test with zero adjust  
 ★ Continuity test with LED and buzzer  
 ★ Transistor and diode test  
 AC volts ..... 0-200m-2-20-200-750Vac ±0.8%  
 DC volts ..... 0-200m-2-20-200-1000Vdc ±0.3%  
 AC current ..... 0-200m-2m-20m-20Aac ±1.8%  
 DC current ..... 0-200m-2m-20m-20Adc ±0.5%  
 Resistance ..... 0-200-2k-20k-200k-2M-20MΩ ±0.5%  
 Capacitance ..... 0-2000m-200n-20μF ±2.0%  
 Frequency ..... 0-20k-200kHz ±2.0%  
 Transistor hFE ..... 0-1000 NPN/PNP  
 Dims ..... 178 x 90 x 36mm

**Y122HM M4650B**  
 As above but with 40 point analog bargraph display

**Y122HK M4630B**  
 As above but with 40 point analog bargraph display

**Y122HB M818B**  
 As above but with 40 point analog bargraph display

**Y123HE M3650B**  
 As above but with 40 point analog bargraph display

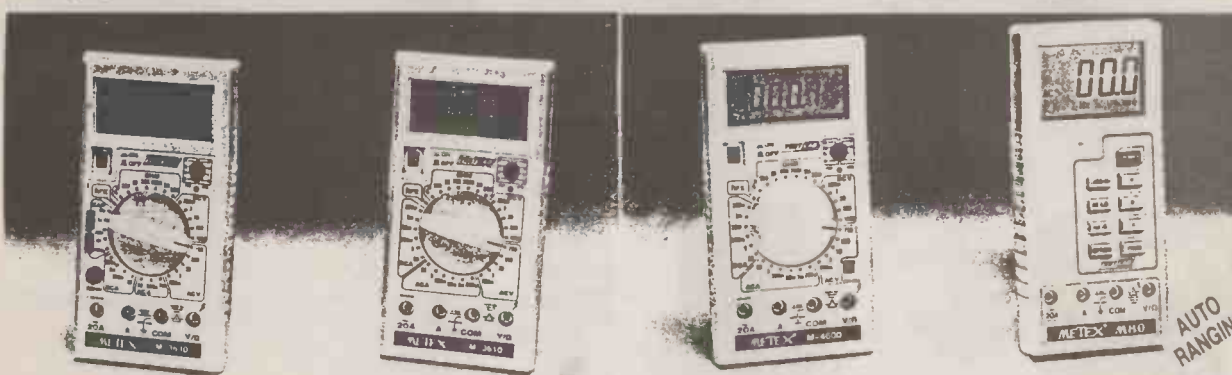

**Y123HA M3630**  
 ★ 3 1/2 digit 17mm LCD display  
 ★ 30 ranges including 20A ac/dc  
 ★ Capacitance ranges with zero adjust  
 ★ Transistor and diode test  
 ★ Continuity test with LED and buzzer  
 AC volts ..... 0-200m-2-20-200-750Vac ±0.6%  
 DC volts ..... 0-200m-2-20-200-1000Vdc ±0.3%  
 AC current ..... 0-200m-2m-20m-20Aac ±1.0%  
 DC current ..... 0-200m-2m-20m-20Adc ±1.2%  
 Resistance ..... 0-200-2k-20k-200k-2M-20MΩ ±0.5%  
 Capacitance ..... 0-2m-20m-200n-20μF ±2.0%  
 Transistor hFE ..... 0-1000 NPN/PNP  
 Dims ..... 178 x 90 x 36mm

**Y122G M3610**  
 ★ 3 1/2 digit 17mm LCD display  
 ★ 30 ranges including 20A ac/dc  
 ★ Transistor and diode test  
 ★ Continuity test with LED and buzzer  
 AC volts ..... 0-200m-2-20-200-750Vac ±0.8%  
 DC volts ..... 0-200m-2-20-200-1000Vdc ±0.3%  
 AC current ..... 0-200m-2m-20m-20Aac ±1.0%  
 DC current ..... 0-200m-2m-20m-20Adc ±0.5%  
 Resistance ..... 0-200-2k-20k-200k-2M-20MΩ ±0.5%  
 Transistor hFE ..... 0-1000 NPN/PNP  
 Dims ..... 178 x 90 x 36mm

**Y122HL M4600**  
 ★ 4 1/2 digit 15mm LCD display  
 ★ 30 ranges including 20A ac/dc  
 ★ Transistor and diode test  
 ★ Continuity test with LED and buzzer  
 ★ Data hold switch  
 AC volts ..... 0-200m-2-20-200-750Vac ±0.5%  
 DC volts ..... 0-200m-2-20-200-1000Vdc ±0.5%  
 AC current ..... 0-200m-2m-20m-20Aac ±0.8%  
 DC current ..... 0-200m-2m-20m-20Adc ±0.5%  
 Resistance ..... 0-200-2k-20k-200k-2M-20MΩ ±0.5%  
 Transistor hFE ..... 0-1000 NPN/PNP  
 Dims ..... 178 x 90 x 36mm

**Y123HF M80**  
 ★ Large 3 1/2 digit 21mm LCD display  
 ★ Autoranging volts, ohms, amps and frequency count  
 ★ 20 Amp ac/dc ranges  
 ★ LED and buzzer  
 ★ Data hold function  
 ★ Ruggedised, weatherproof case  
 ★ Diode and continuity test  
 ★ Auto polarity and zero  
 AC volts ..... 0-400m-4-40-400Vdc ±1.8%  
 DC volts ..... 0-400m-4-40-400Vdc ±0.5%  
 AC current ..... 0-4m-40m-400m-2-20Aac ±1.8%  
 DC current ..... 0-4m-40m-400m-2-20Adc ±1.2%  
 Resistance ..... 0-4k-40k-400k-4MΩ ±1.2%  
 Frequency ..... 0-4k-20kHz ±2.0%  
 Dims ..... 182 x 85 x 36mm

**Y122HJ M3630B**  
 As above but with 40 point analog bargraph display

**Y122HG M3610B**  
 As above but with 40 point analog bargraph display

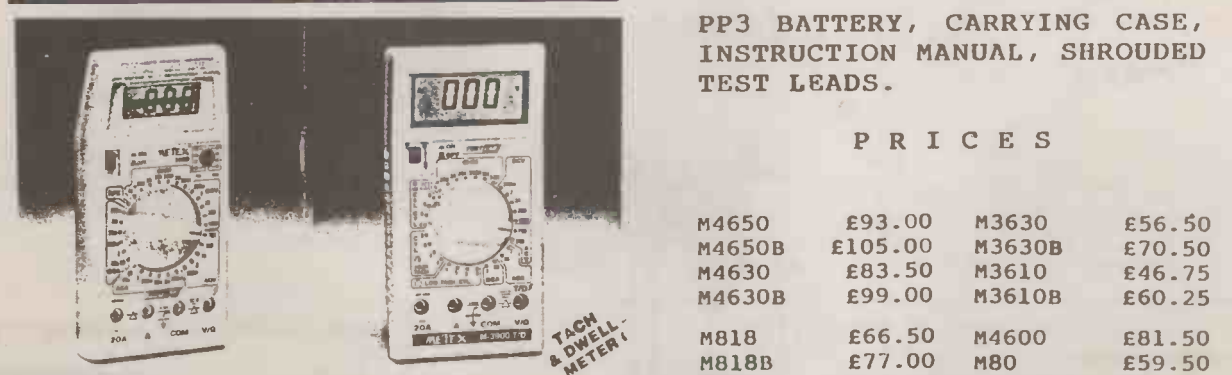

**Y122F M3800**  
 ★ 3 1/2 digit 12mm LCD display  
 ★ 32 ranges including 20A ac/dc  
 ★ Transistor test  
 ★ Diode test  
 ★ Rugged yellow case  
 ★ Fuse protection  
 ★ Automatic polarity and zero  
 AC volts ..... 0-200m-2-20-200-700Vac ±0.8%  
 DC volts ..... 0-200m-2-20-200-1000Vdc ±0.5%  
 AC current ..... 0-200m-2m-20m-20Aac ±1.8%  
 DC current ..... 0-200m-2m-20m-20Adc ±0.5%  
 Resistance ..... 0-200-2k-20k-200k-2M-20MΩ ±0.5%  
 Transistor hFE ..... 0-1000 NPN/PNP  
 Dims ..... 172 x 88 x 36mm

**Y131 M3900TD**  
 ★ 3 1/2 digit 17mm LCD display  
 ★ 20A ac/dc ranges  
 ★ Dwell angle display  
 ★ Low and high RPM ranges  
 ★ Diode and continuity test  
 ★ Rugged yellow case  
 AC volts ..... 0-200-750Vac ±1.2%  
 DC volts ..... 0-200m-2-20-200-1000Vdc ±0.3%  
 AC current ..... 0-2-20-200Aac ±1.8%  
 DC current ..... 0-2-20-20Adc ±1.2%  
 Resistance ..... 0-200-2k-20k-200k-2M-20MΩ ±0.5%  
 Low tach ..... 4, 5, 6, 8 cylinders - reading RPM ±2%  
 High tach ..... 4, 5, 6, 8 cylinders - reading RPM ±2%  
 Dwell ..... 4, 5, 6, 8 cylinders - dwell angle ±2%  
 Dims ..... 178 x 90 x 36mm

ALL METEX METERS ARE SUPPLIED COMPLETE WITH: PP3 BATTERY, CARRYING CASE, INSTRUCTION MANUAL, SHROUDED TEST LEADS.

PRICES

M4650	£93.00	M3630	£56.50
M4650B	£105.00	M3630B	£70.50
M4630	£83.50	M3610	£46.75
M4630B	£99.00	M3610B	£60.25
M818	£66.50	M4600	£81.50
M818B	£77.00	M80	£59.50
M3650	£61.00	M3800	£35.50
M3650B	£74.95	M3900TD	£61.50

ALL METEX METERS ARE BUILT & TESTED TO IEC348.

These products are carefully designed and manufactured in the spirit of old world craftsmanship. To ensure the highest quality and durability possible, all parts are individually checked and inspected before the meters are manufactured.

MINI DRILL

Precision geared plastic mini drill. Brass chuck will hold bits upto 1.2mm. Drill bit storage in handle.

Length: 115mm

ORDER CODE  
TOOL/M/DRILL

PRICE - £1.50



MINI VICE

ORDER CODE  
TOOL/VICR/1

PRICE - £1.50



ORDER CODE  
TOOL/CRIMP/MT

PRICE - £4.99

WIRE STRIPPER - SELF-ADJUSTING

ORDER CODE  
TOOL/MS/SA

PRICE - £4.99



HELPING HANDS - PLASTIC LENS

ORDER CODE  
TOOL/HELP/P

PRICE - £4.50



GLASS LENS

ORDER CODE  
TOOL/HELP/G

PRICE - £6.50

CIRCLIP PLIERS - INTERNAL/EXTERNAL

Professional quality.

This unique plier can remove and attach both internal and external circlips from 10-40mm.

Made of quality heat treated alloy steel with a black parkerized finish and laminated wood handles.

Capacity internal/external circlip 10-40mm  
Weight ..... 100gms  
Overall length ..... 135mm

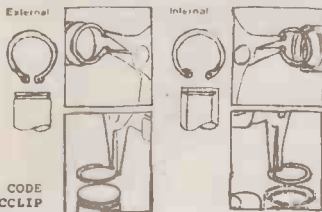

ORDER CODE  
TOOL/CCLIP

PRICE - £5.95

DRILL PRESS

5-speed, single phase, bench-top drill press for general purpose workshop use. 1/6 HP motor drives the 13mm chuck via a Vee belt and pulley wheels. Table adjustable for height and angle. Fitted with depth gauge and depth stop. Complete with instruction manual and chuck key.

Chuck capacity ..... 0-13mm  
Spindle speeds...600,900,1250,1750,2600rpm  
Spindle travel ..... 50mm  
Chuck to table clearance ..... 150mm  
Chuck to base clearance ..... 250mm  
Dimensions ..... 575 x 420 x 200mm  
Power ..... 240V a.c. 130W @ 1420rpm

ORDER CODE  
TOOL/DRILL/PRESS

£85.00 (+£3 CARR.)

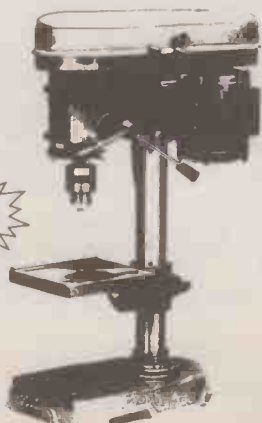

ELECTRIC DRILLS

RELIANT - 12V

A sub-miniature 12V electric drill suitable for drilling PCBs etc., and similarly light duties.

Features the latest automatic three jaw pin chuck with upto 1/8" capacity.

Rated voltage ..... 12V d.c.  
No-Load current ..... 175mA  
Full-Load current ..... 1.5A  
Torque ..... 100 GM CM  
Speed ..... 9000 rpm  $\pm 7\%$   
Body dimensions...76mm long x 33mm diameter  
Weight ..... 160gms

ORDER CODE  
DRILL/REL/12V

PRICE - £8.75



CUT & CLENCH

Cut and clench end cutter.

30° angled jaws.

Special cushion-grip handles render them soft and comfortable to handle when cutting and crimping leads, permitting an infinity of effortless operations.

Maximum capacity copper and soft wires upto 1.0mm diameter.

Weight: 70gms  
Length: 128mm

ORDER CODE  
TOOL/SC/TS30

PRICE - £2-50

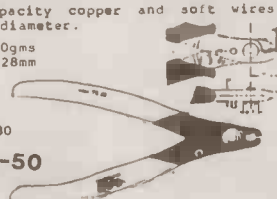

CUT & BEND

Cut and bend end cutter. Effortless in use - cuts and bends in one operation.

Special cushion-grip handles.

Maximum capacity copper and soft wires upto 1.0mm diameter.

Weight: 70gms  
Length: 128mm

ORDER CODE  
TOOL/SC/TP30

PRICE - £2-50

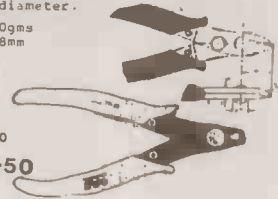

SCREWDRIVER SET

Y015A MC600

6-piece precision screwdriver set in hinged plastic case. Bright plated hardened and tempered blades with tough plastic handles.

Sizes:  
1.4, 1.8, 2.0, 2.4, 3.0 and 3.8mm



99P

5 pce set. 19-99



SATURN - MAINS

A miniature electric drill operating directly on 240V mains, suitable for drilling PCBs, thin metal sheet etc. Mains cable is about 2 metres long and moulded plug supplied must be cut off and a Standard 13A plug fitted.

Has three jaw pin chuck, as Reliant and Titan drills.

Rated voltage ..... 220-240V a.c.  
No-Load current ..... 160mA  
Full-Load current ..... 410mA  
Off-Load speed ..... 23,500 rpm  
Full-Load speed ..... 7,700 rpm  
Max. torque ..... 450 GM CM  
Body dimensions...127mm long x 57mm diameter  
Weight ..... 400gms

ORDER CODE  
DRILL/SAT/MAINS

PRICE - £15.85



19-PIECE SCREWDRIVER/SPANNER SET - BOXED

A superb set of precision tools in a hinged plastic case.

Contents

5pc Wrench spanners: 4.0, 4.5, 5.0, 5.5 and 6.0mm

5pc Hexagon nut drivers: 3.0, 3.5, 4.0, 4.5 and 5.0mm

3pc Small screwdrivers.

2pc Cross-headed screwdrivers: No.0 & No.1

1pc Awl.

3pc Allen keys: 1.5, 2.0 and 2.5mm

All the above fit into master swivelling handle (Tommy Bar facility).

ORDER CODE  
TOOL/SD/SP/BOX/19

PRICE - £4.75 TRIMMING TOOLS

HEXAGON TYPE

Length: 125mm

ORDER CODE  
TOOL/TRIM/HEX

PRICE - 25p

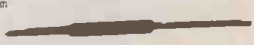

PRESET TYPE

Length: 130mm

ORDER CODE  
TOOL/TRIM/PT

PRICE - 85p

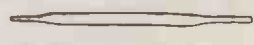

POT CORE TYPE

Length: 46mm

ORDER CODE  
TOOL/TRIM/PC

PRICE - 80p



SIDE CUTTERS

Top quality 5" side cutters, capable of cutting wires as fine as hair. Pressed steel construction, hardened and tempered with sprung jaws. Red plastic handles.

Length: 5"

ORDER CODE  
TOOL/ECON/ST109

PRICE - £1.99



# Weller Desoldering Stations

## DS700 SOLDERING & DESOLDERING STATION - 50 WATT - USED

ONLY APPROXIMATELY 30 OF THESE UNITS AVAILABLE - ALTHOUGH SECOND-HAND, THEY ARE REMARKABLE VALUE FOR MONEY. CURRENT LIST PRICE IS OVER £1,000!! HURRY! HURRY! HURRY! FIRST COME FIRST SERVED!!

It is suitable for production (rework) and laboratory application through its simple, positive operation and high performance. Working temperature of the soldering and desoldering instruments can be infinitely adjusted between 40°C and 450°C, being controlled by means of the Weller "Temtronic" system. Extensive choice of additional soldering tips available.

The target temperature and actual operational temperature is displayed on a three digit LED readout.

Vacuum for the desoldering instrument can be produced by the built-in pump or by using compressed air supply.

The latest precautions for avoiding interference voltages have been incorporated in this instrument, making it suitable for use with highly sensitive components without risk.

Complete with control unit, on/off light switch, desoldering iron, 2 safety stands. **Foot Switch.**

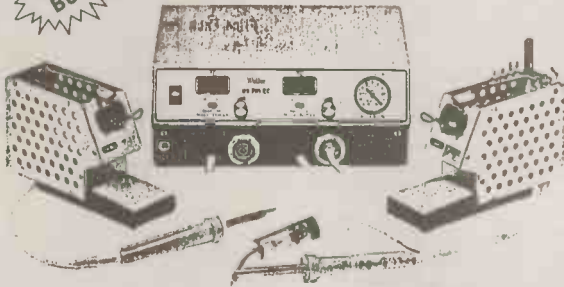

**Features:**

- Digital read-out for easy reading of temperature of soldering and desoldering iron.
  - Temperature range 40°C to 450°C, continuously adjustable ("Temtronic" system).
  - Sel/read-out switch for temperature indication.
  - Switch to select pump or compressed air supply.
  - Silencer.
  - Vacuum control.
  - Socket for potential balance.
  - Thermal overload switch.
  - Additional 24V power output for individual use.
  - Design complies with UK and European safety regulations.
- \* **Foot Operated Switch.**

LIST PRICE - £1,150 + ORDER CODE - SO/DS700  
V.A.T.

OUR PRICE - £250.00 INCL. V.A.T. (+£4 CARR.)

## SPECIAL OFFERS

### STEREO HEADPHONES A071B MSH87

Ultra-lightweight stereo headphones. All black construction with bright steel headband and orange earpieces. Complete with 6.35mm stereo adaptor.

Impedance ..... 32Ω  
Response ..... 100 - 16000Hz  
Power ..... 100mW  
Lead ..... 1.1m straight screened  
Plug ..... 3.5 + 6.35mm stereo  
Extras ..... Adaptor  
Weight ..... 44g



1+ 10+

PRICE - £1.50 £1.20

### TOROIDAL TRANSFORMER - 50VA U.K. MADE - SUPER QUALITY

Input: 120V/240V  
Output: 0-9V 0-15V  
Max. Load: 25VA per winding.  
Dimensions: Diameter 92mm  
Height 40mm

ORDER CODE  
SO/TORO  
PRICE - £9.50

### 12V 500 MA

POWER SUPPLY SPECIAL  
240V supply housed  
in black box with  
integral 13A plug.  
Output: 12V 500m/a

via lead with: 2.5mm  
DC plug

1+ £1.50 10+ £1.30

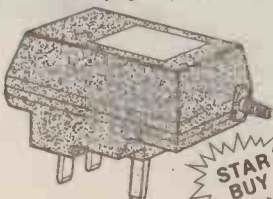

ORDER CODE  
SO/006A  
PRICE - £1.15

### PANEL SIGNS - SET NO. 3

Six sheets containing more than 1,000 words, letters and symbols: Receivers, Amplifiers, Transformers, Test Equipment, Safety Notices etc. (2 Safety Notices have white wording on a Red background).

### TRANSFORMERS

These British Made transformers manufactured by Repanco are the remaining stock of a television project.

Primary: 0.240V  
Secondary: 250-0-240 @ 600 m/A  
0-24 @ 300 m/A  
0-35 @ 500 m/A

Dimensions: 4" x 3.5" x 3"  
Quantity available: 396

ORDER CODE  
SO/105



PRICE - £2.99 (P&P £1.75)

### MODEL SPDC

FUJIYA Motor, complete with speed control board. Simply adjust speed by turning pre-set on the board. Very good quality.

Working voltage ..... 12V 0.5V  
Approx. body dimensions ..... 32 x 38mm  
Approx. shaft diameter ..... 2mm  
PCB size ..... 65 x 30mm  
Quantity available: 600

ORDER CODE  
SO/148

1+ 10+  
PRICE - £2.90 £2.50

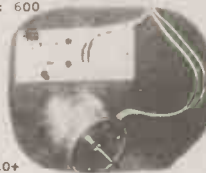

### ALUMINIUM SHEETS

DIMENSIONS: -----  
180MM 190MM 200MM 220MM

QUANTITY AVAILABLE: APPROX. 250.  
ORDER CODE - SO/014

1+ 10+ 100+  
PRICE - 50p 45p 30p

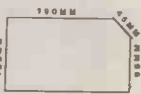

### 13A TEST PLUG

THIS DEVICE IS EXTREMELY USEFUL FOR TESTING YOUR 13A SOCKETS AND TELLING YOU WHAT, IF ANYTHING IS THE FAULT.

Simply plug the test plug into the socket and observe the amber lights.

ORDER CODE - SO/138

NORMAL PRICE £3.50!!  
SPECIAL PRICE ONLY 99p!!



### INSPECTION MIRROR

PVC insulated inspection mirror with 20mm diameter mirror.

Two types available:

TYPE 1 - with 140mm handle.

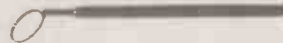

ORDER CODE SO/187/1 TYPE 2 - with 190mm handle.

ORDER CODE SO/187/1 PRICE - £2.25 £3.99

### TERMINAL BOX

TERMINAL JUNCTION BOX FOR POWERING D.C. ACCESSORIES, GIVES THREE PAIRS OF PILLAR SCREW TERMINALS COLOUR CODED RED AND BLACK. 90 CH LEAD FED FROM CIGAR LIGHTER PLUG.  
CURRENT: 3A MAX.  
DIMENSIONS: 84 X 55 X 32mm.

ORDER CODE - SO/158

1+ 10+  
PRICE - £1.50 £1.25



### IEC MAINS LEADS - 6A 250V

Good quality moulded leads, all the approved marks i.e. VDE, D. S. FI, N, etc. Moulded IEC socket on one end with 2-pin European style plug on other end. To use in U.K. simply cut off European plug and fit standard 13A mains plug.

Colour: Black  
Length: 2 metres  
We can offer substantial discounts on larger quantities.

ORDER CODE  
SO/IEC

1+ 10+ 100+  
PRICE - 85p 80p 65p



ALL PRICES NOW INCLUDE 15% V.A.T.

## AUDIO SPECIALS

WE HAVE, YET AGAIN, BOUGHT A BULK-PURCHASE OF REFURBISHED ELECTRICAL GOODS. ALL RADIOS AND CASSETTE PLAYERS ARE FULLY TESTED AND WE ARE GIVING A FULL 'NO-QUIBBLE' GUARANTEE FOR 3 MONTHS FROM DATE OF PURCHASE.

### ALBA - SCR-802 - TWIN-CASSETTE

FEATURES: FM STEREO/AM RADIO, TWIN CASSETTE, BUILT-IN MICROPHONE - BATTERIES OR MAINS.  
QUANTITY AVAILABLE: 36

OUR PRICE  
**£19.99**

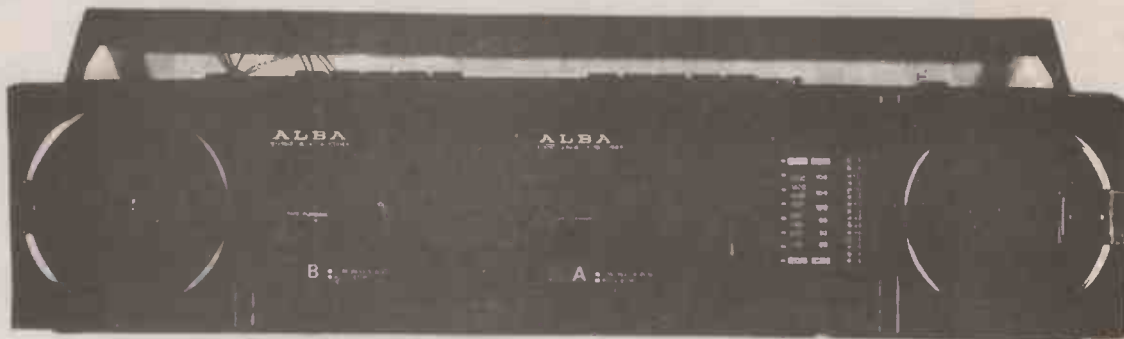

### SHARP - QT-242E - 2-WAY 4-SPEAKER

FEATURES: FM STEREO/AM RADIO, SINGLE CASSETTE, BUILT-IN MICROPHONE, SEPARATE HEADPHONE SOCKET, 2-WAY 4 SPEAKER, TONE CONTROL.  
QUANTITY AVAILABLE: 40

OUR PRICE  
**£25.99**



### AIWA - HS-P12

FEATURES: AUTO-STOP, CrO<sub>2</sub>/METAL SELECTOR.  
QUANTITY AVAILABLE: 133

OUR PRICE  
**£8.99**



### SANYO - MGR84

FEATURES: FM STEREO/AM RADIO, AUTO-REVERSE, 3-BAND GRAPHIC EQUALIZER.  
QUANTITY AVAILABLE: 31

OUR PRICE  
**£22.50**



### SANYO - MGR64

FEATURES: FM STEREO/AM RADIO, AUTO-STOP.  
QUANTITY AVAILABLE: 24

OUR PRICE  
**£18.50**



### AIWA - HS-G35 MK II

FEATURES: AUTO-REVERSE, 3-BAND GRAPHIC EQUALIZER, CrO<sub>2</sub>/METAL SELECTOR.  
QUANTITY AVAILABLE: 246

**STAR BUY**

OUR PRICE **£16.99**  
OR 2 FOR **£30.00**



### SONY - WM-F31

FEATURES: FM STEREO/AM RADIO, AUTO STOP, NORMAL/CrO<sub>2</sub>/METAL SELECTOR.  
QUANTITY AVAILABLE: 27

OUR PRICE  
**£19.95**



### SHARP - JC-102

FEATURES: AUTO-STOP, 3-BAND GRAPHIC EQUALIZER.  
QUANTITY AVAILABLE: 30

OUR PRICE  
**£9.99**



### SANYO - MGP35

FEATURES: AUTO-REVERSE, 3-BAND GRAPHIC EQUALIZER, MINI-HEADPHONE, REMOTE CONTROL.  
QUANTITY AVAILABLE: 33

OUR PRICE  
**£19.99**



### SONY - WM-BF22

FEATURES: FM STEREO/AM RADIO, AUTO-STOP, NORMAL/CrO<sub>2</sub>/METAL SELECTOR.  
QUANTITY AVAILABLE: 30

OUR PRICE  
**£19.99**



ALL PRICES NOW INCLUDE 15% V.A.T.

ALL PRICES NOW INCLUDE 15% V.A.T.



Miv

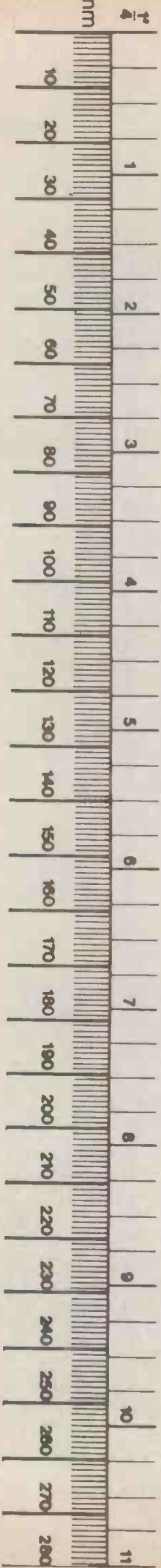

# HEAD OFFICE

**MARCO TRADING,  
THE MALTINGS,  
HIGH STREET,  
WEM,  
SHREWSBURY. SY4 5EN**

TEL:0939 32763 FAX:0939 33800 TELEX:35565

# BRANCHES

**SUPERTRONICS,  
65 HURST STREET,  
BIRMINGHAM. B5 4TE**

TEL: 021 666 6504

**WALTONS,  
55A WORCESTER STREET,  
WOLVERHAMPTON.  
WV2 4LL**

TEL: 0902 22039

# NEW!

## EVERYDAY **ELECTRONICS** **DATA BOOK**

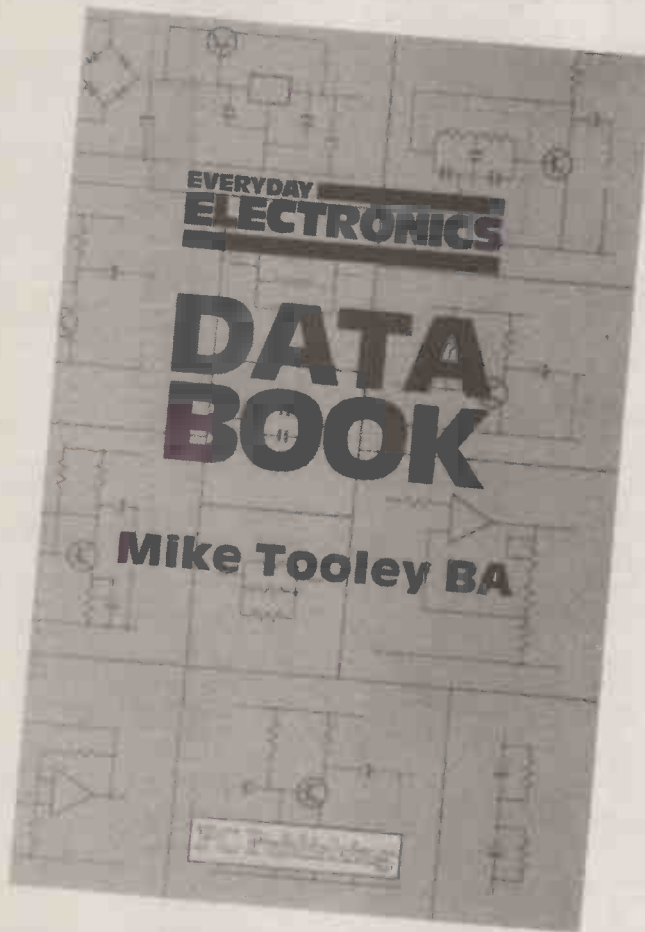

Written by Mike Tooley for EE and published in association with PC Publishing, this book is an invaluable source of information of everyday relevance in the world of electronics. It contains not only sections which deal with the essential theory of electronic circuits, but it also deals with a wide range of practical electronic applications.

It is ideal for the hobbyist, student, technician and engineer. The information is presented in the form of a basic electronic recipe book with numerous examples showing how theory can be put into practice using a range of commonly available 'industry standard' components and devices.

A must for everyone involved in electronics!

**Available from your local component supplier or direct from us.**

**See the Direct Book Service pages for ordering details.**

# ELECTRONIC DICE

CHRIS BOWES



*Electronic simulation of the plastic cube! Press the button and your luck will be displayed by l.e.d.s in the usual dice pattern.*

**T**HIS is basically a digital project which displays the values from one to six in the standard dice pattern indicating the values in the form of illuminated l.e.d.s.

## HOW IT WORKS

The Dice makes use of digital integrated circuits which, although complex circuits in their own right, are slightly easier to understand than analogue circuits because they are either on, (when they are said to be at the logic 1 state) or off in which case they are said to be in the logic 0 state. There are no intermediate values of voltage present, such as you would find in non-digital circuits.

This circuit basically consists of three separate sections. The first is a clock generator which is the standard 555 timer circuit that we have used before in this series. This is used to drive the second stage which is a counter circuit which is

based around a 4518 dual BCD (binary code decimal) counter. This counts through the binary sequence in the manner shown in Table 1.

The remainder of the circuit is used to decode the outputs from the BCD counter so as to either re-set the counter or to switch off and on the correct l.e.d.'s to indicate the output value.

## CIRCUIT DESCRIPTION

The circuit for the Electronic Dice is shown in Fig. 1. The clock generator is made up of IC1, R1, R2 and C1. These form a standard astable circuit which operates to give a square wave "clock" pulse at the output (pin 3) of IC1. The voltage at this point oscillates rapidly between the logic 1 and logic 0 states, at a frequency determined by the values of R1 and R2 and C1. The precise values of these components do not matter so long as they are roughly of the order quoted,

since the output frequency from the clock generator has no major effect on the operation of the rest of the circuit.

The clock output pulse from pin 3 of IC1 is fed to the CP<sub>1</sub> input of IC2. This acts as a clock input for the 4518 BCD counter which produces the binary sequence, given in Table 1 below, moving forward one step every time the output from pin 3 of IC1 goes from logic 1 to logic 0. This occurs for as long as the other (CP<sub>0</sub>) input is held in the logic 0 state. This is achieved by the operation of

Table 1. BCD Counter Sequence

Count Value	Outputs			
	D	C	B	A
0	0	0	0	0
1	0	0	0	1
2	0	0	1	0
3	0	0	1	1
4	0	1	0	0
5	0	1	0	1
6	0	1	1	0
7	0	1	1	1
8	1	0	0	0
9	1	0	0	1

Fig.1. Complete circuit diagram for the Electronic Dice.

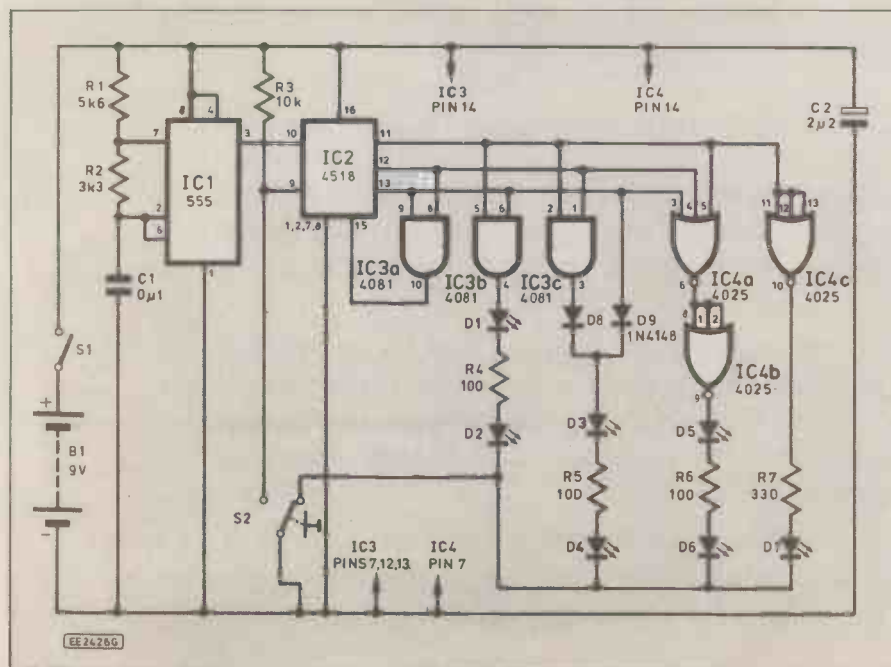

S2. When S2 is operated it causes the CP<sub>0</sub> input of IC2 to remain in the logic 0 state.

The l.e.d.'s of the display are so connected that when the switch is in this position they are not illuminated. The actual state of outputs of IC2 is thus not visible whilst IC2 is counting. When S2 is released the CP<sub>0</sub> pin is no longer connected to 0 volts and the logic state at this point is made to rise to logic 1 because of the connection through the "pull up resistor" (R3) to the positive power supply rail.

## OUTPUT

A dice only shows the values from one to six so we only actually require six displayed states. The counter circuit is then automatically reset to zero by a logic 1 state being applied to the reset input of IC2 every time it's count reaches six. This is achieved by IC3a which is a two input AND gate. The output of this gate remains in the logic 0 state until both of the inputs are in the logic 1 state. As soon



as this occurs the output from the gate switches from the logic 0 state to the logic 1 state.

The two inputs to the gate are connected to the B and C outputs from IC2. The only time that these two outputs are both in the logic 1 state is when the counter reaches the value of six. At all other counter values at least one of the inputs to IC3a is the logic 0 state. The output from IC3a is connected to the MR (Master Reset) input of IC2. As soon as the output from IC3a goes to the logic 1 state, the MR input of IC2 also goes to the logic 1 state, causing all of the outputs (O<sub>0</sub> to O<sub>3</sub>) of IC2 to go to the logic 0 state. The counter is thus reset to 0 and starts to count through the sequence again from 0. Because of the way in which the display is arranged this is actually indicated by the value of one on the display.

The remaining logic gates within the circuit are used to de-code the outputs from the counter to turn on the correct i.e.d.'s for the display. In order to be able to understand how this de-coding system works it is necessary to understand that in digital terms the value of zero is actually taken to be a value in its own right. In order to avoid wasting this value the figure shown on the display is in fact always one more than the value counted by the counter. Thus a counter value of zero is displayed as one, a counter value of one is displayed as two and so on until the counter value of five is used to display the six. The counter value of six is used to rapidly re-set the circuit to zero (as described above).

## DISPLAY

IC3b is used to drive i.e.d.'s D1 and D2 which are only used when the dice displays six. These are therefore required to be on only when the counter is at the value of five. In order to achieve this the inputs are connected to the A and C outputs of IC2. Thus when IC2 reaches the value of five the logic states of the two inputs of IC3b are both at the logic 1 state causing the output of IC3b to go to the logic 1 state. For all other logic states IC3b is in the logic 0 state.

Thus, when the output of IC3a is at the logic 1 state a current flows through the i.e.d.s and R4 to 0 volts via S2, when it is in the unoperated position. Resistor R4 is included in the circuit in order to reduce the current flowing through the i.e.d.'s to a safe level. If this resistor were not included in the circuit then the current drawn by the two i.e.d.'s would rise to a level which could cause their destruction and that of the integrated circuit driving them.

The circuit used to drive D3 and D4 is slightly more complicated, since they are required to be illuminated when the dice shows the values 4, 5, or 6. This corresponds to the occasions when the counter is at the values of 3, 4, or 5. Table 1 shows that there are actually two conditions which can occur when D3 and D4 should be illuminated. These are either when output C of the counter is in the logic 1 state (corresponding to a value of 4 or 5) or when outputs A and B of the counter are in the logic 1 state (corresponding to the value of 3).

The occasions when output C of IC2 is in the logic 1 state, can be easily detected by a simple connection to that output and the occasion when outputs A and B are

both in the logic 1 state together can be detected by means of a simple AND gate, as described previously. This is achieved by IC3c being connected to the A and B outputs. In order to prevent the connection of two outputs together, which would cause problems with the rest of the circuitry, two blocking diodes, D8 and D9, are incorporated into the circuit.

The function of these diodes is to allow a current to pass in one direction only, from the outputs through led's D3 and D4 to ground via R5 and S2, but to prevent the output current being fed back to the other output. This is achieved because diodes allow a current to flow in one direction only. The effect of these two diodes is to form a very simple OR gate which allows the output to be in the logic 1 state when either of the inputs are in the logic 1 state.

The remaining i.c. (IC4) is a three input NOR gate. An OR gate operates in the same way as the gate formed by D1 and D2, whilst a NOR gate operates in the opposite manner in so far that the output of the gate is in the logic 0 state if any of its inputs are in the logic 1 state. The output changes to the logic 1 state only if all of the inputs are in the logic 0 state. IC4a and IC4b are used in combination to drive i.e.d.'s D5 and D6 via their series resistor R6. These two i.e.d.'s are required to be on at all times except for the one occasion when the counter is displaying a value of zero. This is achieved firstly by detecting when output A, B, or C are in the logic 1 state by IC4a.

When any of these three outputs is in the logic 1 state IC4a produces an output which is in the logic 0 state. This is in fact the reverse of what we want and therefore IC4b is configured with all three of its inputs connected to the output of IC4a. The effect of this is to produce a NOT gate where the output from IC4a is the opposite of the input, thus when the output from IC4a is in the logic 0 state then the output from IC4b is in the logic 1 state and vice versa.

*Completed Dice showing the seven display i.e.d.s and "throw" switch.*



## COMPONENTS

### Resistors

R1	5k6
R2	3k3
R3	10k
R4-R6	100 (3 off)
R7	330

**Shop  
Talk**

See page 209

All 1/4 watt 5% tolerance

### Capacitors

C1	0μ1 MDC
C2	2μ2 tantalum 10V

### Semiconductors

D1 to D7	standard i.e.d. (7 off)
D8, D9	1N4148 (2 off)
IC1	555 timer
IC2	4518 dual BCD counter
IC3	4081 quad, two input AND gate
IC4	4025 triple, three input NOR gate

### Miscellaneous

S1	s.p.s.t. toggle switch
S2	s.p.d.t. push to change over switch
B1	9V PP3 battery and battery clip

Stripboards, 38 holes x 11 strips and 14 holes x 18 strips; plastic case approx. 100 x 75 x 40mm; connecting wire; fixings etc.

Approx cost.  
Guidance only

**£8**

## SPARE PARTS

It would have been possible to obtain the same outputs to drive i.e.d.'s D5 and D6 by simply using a three input NOR gate but the arrangement shown have been used in order to make use of the unused capacity of the integrated circuit, which

contains three gates. An inverting gate (usually referred to as a NOT gate) is required to drive I.e.d. D7. If we had not been able to make use of the spare capacity contained in IC4 it would have been necessary for us to have purchased a separate inverter integrated circuit which would have meant an additional i.c. to fit onto the stripboard, which is already crowded, and the additional expense of the extra chip. By using this slightly unusual method of making an inverter from a NOR gate to drive D5 and D6 we are in fact saving ourselves some expense and some complexity.

The final indicator D7 is required to be on whenever the count obtained from IC2 is either 0, 2 or 4. The easiest method of obtaining this function is to invert the logic state of IC2's output A. This is simply achieved by wiring the three inputs of IC4c together and so converting the three input NOR gate into a NOT gate. The output from IC4c is fed via R7, which is the safety dropping resistor, to D7. Because only one I.e.d. is included in this circuit R7 is of a different value to those used for R4, R5 and R6.

There is in fact one spare counter in IC2 and a spare gate in IC3 not used for this project. In order to prevent complications arising with the inputs of these gates being allowed to float to any random voltage the spare inputs are tied to a logic 0 state by being connected to the 0V power supply rail. Although the connections to the spare gate and the inputs to the spare

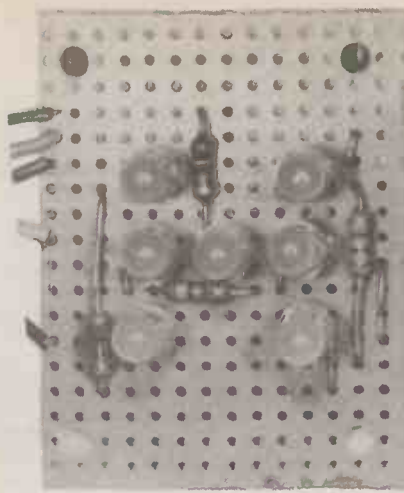

Display board ready for installation on the case lid.

counter are not shown in the circuit diagram you will find that the stripboard layout has been designed to take them into account.

### CONSTRUCTION

This project has been designed to be built on two pieces of stripboard. One of the pieces, which is 38 holes by 11 strips, is used to carry the main circuit board and

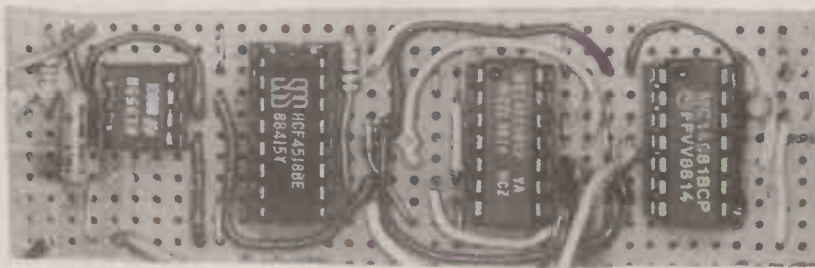

Fig. 2. The main clock, counter and decoder board component layout and details of breaks required in the underside copper tracks.

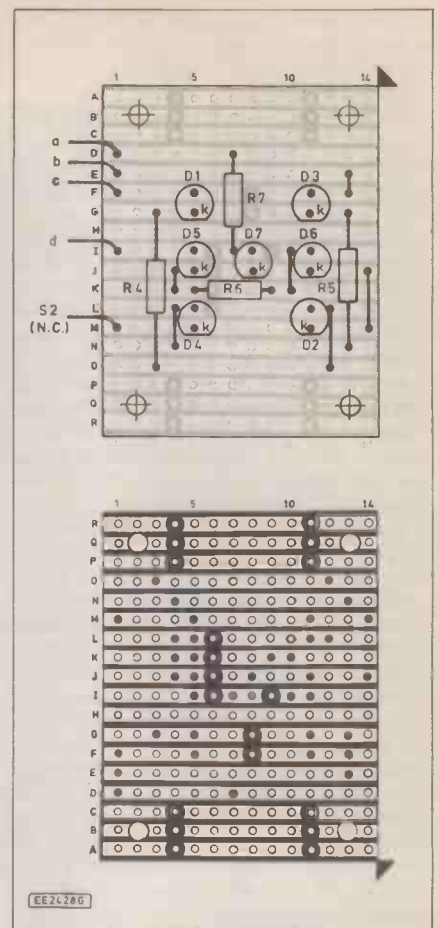
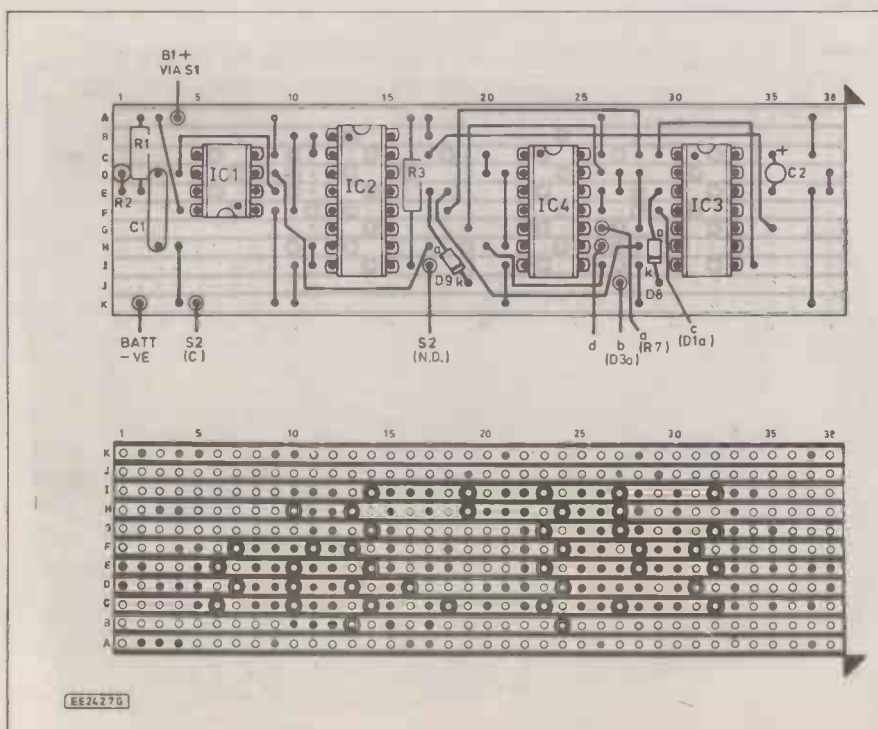

Fig. 3. Display board component layout and details of breaks required in the underside copper strips.

the other which is 14 holes by 18, strips is used to carry the display. The size of the main component board was chosen so as to fit into the slots in the case in to which the project was designed to fit. There is of course no reason why a larger piece of stripboard should not be used to construct this project if this is desired but it is not advisable for the circuit to be constructed on a board significantly smaller than recommended, since the component density is fairly high.

The component layouts for both boards are shown in Figs. 2 and 3. In both cases, once a suitable size piece of board has been cut, it will be necessary to make breaks in the track as shown using either a stripboard cutter or a suitable sized drill bit. It is very important that these track breaks are made at the correct points as shown in these diagrams and in order to make this easier the holes have been given numbers and the strips letters in the diagrams.

Once the tracks have been broken, care being taken to ensure that the break is complete, the boards can then be turned over and the components inserted. It is important to ensure that when the board is turned over the orientation is maintained as shown in the diagrams.

### COMPONENT INSERTION

The next stage of construction is to insert the components into the spaces shown in Fig. 2 (for the main board) and Fig. 3 (for the display). Although the order in which the components are inserted will not cause any alteration in how the circuit works you will probably find that it is much easier to construct this project if the

components are inserted in ascending order of size, starting with the wire links, then the smallest components, which are the resistors and the diodes.

Note that R2 is inserted into the board in a different way to the other resistors. In order to save space this resistor is installed into the board so that it is pointing away from the board whereas the other resistors are horizontal to the board. It is important to ensure that the diodes, D8 and D9, as well as the integrated circuits and C2, are inserted into the main board with the correct polarity. If the integrated circuits and C2 are not inserted into the board correctly there is a likelihood that permanent damage may be caused to these components if the battery is connected.

A very large number of wire links need to be made on the stripboard for this project. These should be made using insulated solid core wire. The integrated circuits should preferably be mounted in i.c. holders which should be soldered to the board along with the other components. The last stage in the construction process is to insert the i.c.'s into the correct holders, taking care to ensure that the notch on the integrated circuit corresponds with the notch in Fig. 2.

Some integrated circuits are not manufactured with the notch illustrated in the diagram but have a small circular indentation near to pin 1. In this case the integrated circuit should be installed with the indentation nearest to the notch in the end of the i.c. as illustrated in Fig. 2.

## DISPLAY BOARD

The display stripboard is relatively simple to construct but in addition to making the track breaks shown in Fig. 3 it will be necessary to drill the four mounting holes with a 3.5mm drill bit in the positions shown. Construction of this board should commence with the installation of the wire links and resistors, with the i.e.d.'s being installed as the last stage of the construction processes. It is important that the i.e.d.'s are installed with their polarity correct, since reversed polarity will prevent the circuit from working.

## INTERCONNECTION

The wire connections shown in Fig. 3 between the display board and the circuit board should be made with flexible, coloured, insulated wires and these should be of sufficient length so that when the case lid is removed the main circuit board can remain in its installed position.

Before connecting the display board to the main board it is recommended that the circuits should be checked by connection of the common negative wire to the negative terminal of a nine volt battery and connecting each of the four other wires in turn to the positive end of the battery. In each case the appropriate i.e.d.(s) should be illuminated when the wire is touched to the battery. If any circuit fails to operate then it will be necessary to check through the circuit using the resistance setting of a multimeter to see where the fault lies.

It should be remembered that with the exception of D7 all the other i.e.d.'s are wired as series pairs and in order for both of them to operate there must be a complete circuit through the first i.e.d., the dropping resistor and the final i.e.d. The most likely cause of problems on the display board is the incorrect polarity of the

i.e.d.'s since the action of the diode is to allow current to flow in one direction only. If either of the i.e.d.'s in the chain are incorrectly polarised this will prevent current flowing through the circuit and neither of the i.e.d.'s will illuminate.

Once the display board has been tested and is working correctly then the connections between it and the rest of the circuit can be made. In addition it will be necessary to make the connections to S2 before the circuit can be tested.

## TESTING

**BEFORE THE BATTERY IS CONNECTED** to the battery clips it is important that the boards should be checked visually to ensure that the wiring is correct, that there are no solder blobs bridging adjacent tracks and that no components are installed with reversed polarity. Once the visual check has been carefully completed then the battery can be installed into its clips and the circuit turned on.

With S2 not operated the display should have at least one and not more than six i.e.d.'s illuminated. Operating S2 causes the illuminated i.e.d.(s) to be turned off and releasing S2 should cause the i.e.d.'s to be illuminated but with the value actually shown being selected at random. The randomness of the circuit should be tested several times, by operating S2 several times. If this does not occur it will be necessary to fault find.

## FAULT FINDING

Fault finding on this circuit is most easily done if a logic probe is available but if this is not the case then an ordinary voltmeter can be used as long as it is remembered that the logic 1 state is indicated by the battery voltage being measurable between 0 volts and the point where the voltmeter lead is connected.

Similarly the logic 0 state is indicated by the presence of the battery voltage when the positive voltmeter lead is connected to the positive supply rail and the negative voltmeter lead is connected to the point at which the logic state is to be checked. It

is important that the tests are carried out this way rather than by assuming a logic 0 state to be present if 0 volts is measurable between the negative power supply rail and the point in question, since a zero voltage reading would also be obtained if there was an open circuit.

The first stage in fault finding is to check if any of the sub-systems within the project (clock, counter or display) are working correctly or whether the fault lies in all three. To a certain extent an initial diagnosis can be obtained by observing what happens to the display. If one or more of the i.e.d.'s is illuminated then the likelihood is that the power supply from the battery is being correctly fed to the power supply rails on the stripboard. If no i.e.d.'s are illuminated but all of the wiring to the display appears to be correct then a check should be made of the power supply.

## POWER SUPPLY TESTS

The first test is to ensure that the battery is in good condition by testing it whilst removed from the battery connector with the voltmeter. Approximately nine volts should be available, this should not alter significantly when the battery is connected to the battery connector and S1 is turned to the on position.

If the battery voltage does suddenly fall to a low value or 0 volts when S1 is turned to the on position then this would indicate that there is a major problem on the stripboard, which is likely to be caused by a short circuit or by an incorrectly inserted polarity sensitive component. In order to check this a visual inspection should be made of the board looking for incorrect linking wires, solder bridges, incomplete track breaks or integrated circuits or other polarity sensitive components wired into the circuit the wrong way around.

Should either IC1 or C2 be discovered to be inserted the wrong way round then it is likely that they will have been sufficiently damaged by this to require replacement. As a general rule IC2, IC3 and IC4, are unlikely to have suffered greatly from being incorrectly inserted. If no obvious

*Main circuit board slotted into the case and connected to the display board.*

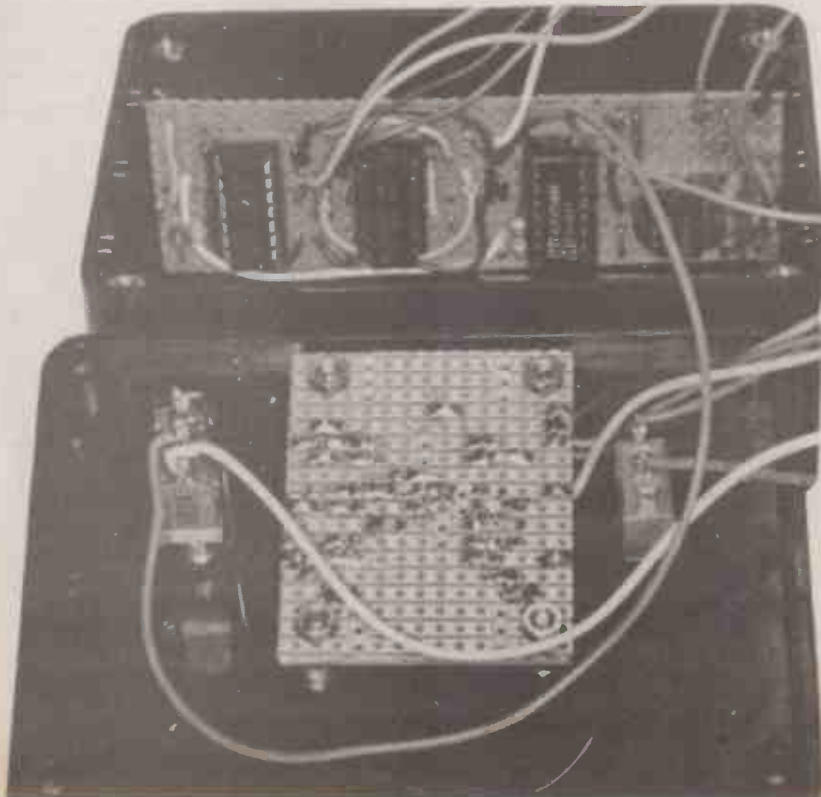

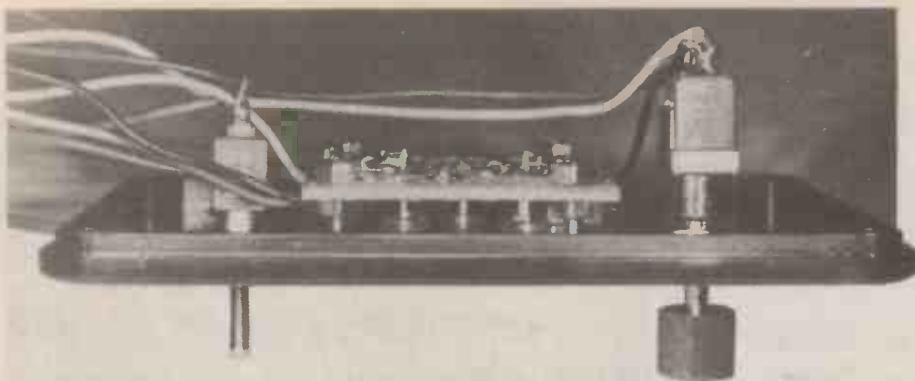

Side view of the case lid showing the display board attached to the lid by means of nuts and bolts.

fault can be detected by a visual inspection then it will be necessary to check through the circuit more carefully, removing components which might be suspect, one at a time until the fault disappears. This will be found particularly easy in the cases of the integrated circuits since they are installed in sockets.

### CLOCK, COUNTER AND DECODER TESTING

If the same l.e.d.'s are turned on every time S2 is released then it can be suspected that the clock circuit, counter circuit or decoder circuit may not be working properly. The clock circuit runs at an extremely fast rate and as a result it is very difficult to check the circuit through without access to an oscilloscope. It is therefore easier to slow the operation of IC1 down by temporarily increasing the value of C1. This is most easily done by connecting a capacitor with a value of between  $100\mu$  and  $2000\mu$  across the connections to C1.

If the common connection to the display is moved from the normally closed connection of S1 to the common connection of S2 then the operation of the circuit can be observed on the l.e.d.'s. With this modification when S2 is operated then the dice display should be seen to sequence through the values from 1 to 6 with the appropriate l.e.d.'s being illuminated. When S2 is released then the display should remain alight but should not change.

If this test reveals that the display is not altering but remains fixed with a valid

combination of l.e.d.'s being illuminated then this indicates that either the clock circuit is not providing an output pulse or the clock enabling input of IC2 is remaining at the wrong value. The easiest check to perform is that the logic state of pin 9 of IC2 is at logic 1 when S2 is unoperated but falls to the logic 0 state when S2 is operated. This is easily checked with a voltmeter or logic probe.

If the pin remains in the logic 1 state then the wire between S2 (normally open connection) and pin 9 should be checked. If the logic state of pin 9 remains in the logic 0 state then the track break between pins 8 and 9 of IC2 should be checked to ensure there is no short circuit across this point. If this reveals no obvious faults then the connection from the positive power supply rail, through R3 to pin 9 should be checked. It is also worth while to check that there is no solder bridge linking pins 9 and 10 of IC2.

The clock generator comprising of IC1, R1, R2 and C1 should be checked as for the 555 timer circuits described earlier in this series. The major points to check are firstly whether a clock pulse is present at the output (pin 3) of IC1. If a clock pulse is present at this point then it will not be necessary to check the clock circuit further. If the clock pulse is not present then the next stage is to check pins 8 and 4 of IC1 are connected to the positive power supply rail and that pin 1 is connected to the negative power supply rail.

The next stage is to check that pins 6 and 2 are effectively connected together and that the connections through the resistor chain of R1, R2 and C1 are correctly connected to the integrated circuit. When

the circuit is operating properly then a fluctuating voltage should be measurable at pin 7 and a slightly lower, but still fluctuating, voltage is measurable between 0 volts and pins 6 and 2.

If the voltage checks on pins 2, 6 and 7 reveal the absence of voltage then the connections through the resistor and capacitor timing chain should be suspected. If a visual, and if necessary a resistance check, of these connections reveals everything to be correct then the connections between pin 3 (the output) of IC1 and pin 10 (the clock input) of IC2 should be checked for the track breaks and solder bridges in the vicinity of these connections to ensure that there is no accidental open or short circuit.

If the display changes but provides invalid outputs then the circuitry associated with the l.e.d.'s which are not coming on at the correct point in the sequence, or are remaining on when they should be off, should be checked. Each invalid l.e.d. circuit should be carefully checked using the logic probe or voltmeter. The most likely causes of problems with the decoding and display circuit are incomplete breaking of the tracks near the logic gates and the outputs of IC2, incorrect wiring of the wire links, or l.e.d.'s being inserted into the circuit the wrong way around. If the display has been checked and tested prior to being connected to the main stripboard then the l.e.d.'s will be inserted in the correct way round and the last fault mentioned will not be present.

### CASE MOUNTING

This project has been designed to be mounted into a case. The first stage of preparation of the case is to carefully measure and mark the position of the holes which the l.e.d.'s will pass through when the display board is fitted to the underside of the case lid. It is important when determining the positioning of these holes to make sure that the display stripboard will not foul the main circuit stripboard when the case lid is fixed onto the case.

Once the position of the holes has been measured and marked then they should be drilled with a suitable sized drill bit. The display stripboard should then be offered into position and the holes used to hold the board in place should be marked and drilled out with a suitably sized drill bit. The position of the two switches (S1 and S2) should also be marked and appropriate size holes drilled.

Once the holes have been drilled the case lid can be lettered using rub down lettering which should be protected using several layers of clear spray-on varnish. Once the varnish has thoroughly dried then the case mounted components can be installed and if necessary the wiring trimmed to a suitable length. The main stripboard should be inserted into the appropriate slots in the body of the case and the circuit should be tested for correct operation before the case lid is screwed down.

### IN USE

The dice is fairly simple to use. All that it is necessary to do is to turn S1 to the on position and operate S2. The display should give a random value in the usual dice format, displaying the values of 1 to 6 in a random order. □

The main circuit board slotted into guides in the sides of the case.

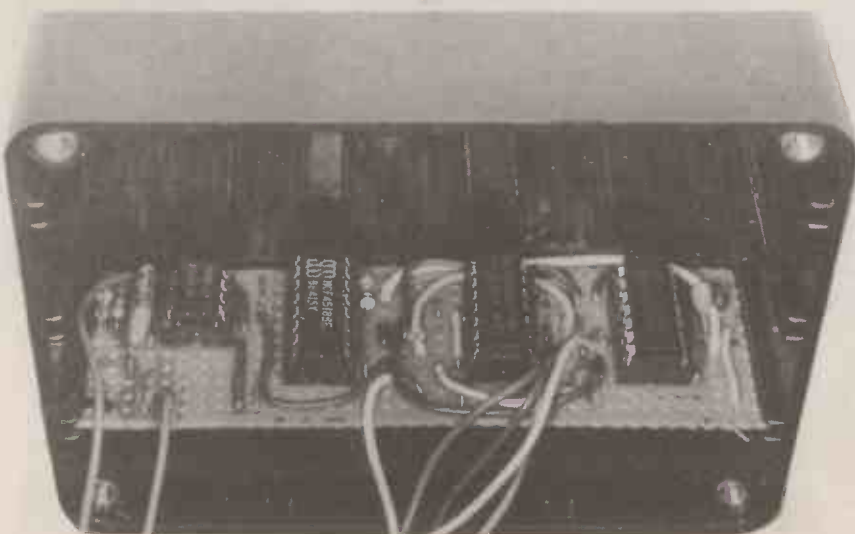

# D-MM GOOD VALUE!

*Cirkit's new range of Digital Multimeters offer a quite unbeatable combination of features and value:*



- Ranges include: frequency, capacitance and temperature
- Housed in strong ABS cases
- Overload protection on all ranges
- Full one year warranty
- 3½ digit, auto zero, auto polarity LCD, plus low batt indication
- 200 hour battery life
- All meters supplied with test leads, battery and manual

## TM5315B

- Remarkable value
- 18 ranges
- 10A dc current

dc volts: 200mV-1kV  
ac volts: 200V, 750V  
dc current: 200uA-10A  
resistance: 200Ω-20MΩ

Continuity and diode test  
Basic dc accuracy: ±0.8%  
Size: 128 × 72 × 33mm

Price **£19.99**

## TM5375

- Frequency measurement to 20MHz
- ac/dc current to 10A
- 24 ranges

dc volts: 200mV-1kV  
ac volts: 200mV-750V  
dc current: 200uA-10A  
ac current: 200uA-10A

Resistance: 200Ω-20MΩ  
Frequency: 2kHz-20MHz  
Continuity, diode & HFE test  
Basic dc accuracy ±0.5%

Price **£36.75**

## TM5365

- 30 ranges
- Frequency & capacitance measurement
- Compact size

dc volts: 200mV-1kV  
ac volts: 200mV-750V  
dc current: 200uA-10A  
ac current: 200uA-10A

Resistance: 200Ω-2000MΩ  
Frequency: 2kHz-200kHz  
Capacitance: 2nF-20uF  
Logic, continuity, diode and HFE test

Price **£37.90**

## TM175

- Freq. measurement to 10MHz
- Capacitance measurement 1pF to 20uF
- 39 ranges

dc volts: 200mV-1kV  
ac volts: 200mV-750V  
dc current: 200uA-10A  
ac current: 200uA-10A  
Resistance: 200Ω-2000MΩ

Capacitance: 2nF-20uF  
Frequency: 2kHz-10MHz  
Continuity, diode, HFE, logic & LED test.

Price **£57.49**

## TM135

- Temp. measurement
- Capacitance measurement
- 40 ranges

dc volts: 200mV-1kV  
ac volts: 200mV-750V  
dc current: 200uA-10A  
ac current: 200uA-10A

Resistance: 200Ω-2000MΩ  
Temperature: 200°-750°C  
Capacitance: 2nF-20uF  
Diode, HFE & continuity test

Price **£45.95**

## TM115

- 0.5% accuracy
- Transistor HFE test
- 26 ranges

dc volts: 200mV-1kV  
ac volts: 200mV-750V  
dc current: 200uA-10A  
ac current: 200uA-10A

Resistance: 200Ω-2000MΩ  
Continuity, diode & HFE test  
Basic dc accuracy ±0.5

Price **£33.67**

Prices Inc VAT.

Please add 90p for p&p.

# Cirkit



**Cirkit Distribution Ltd.**

Park Lane, Broxbourne, Herts EN10 7NQ.

Telephone (0992) 444111.

# Our very simple offer to hobbyists

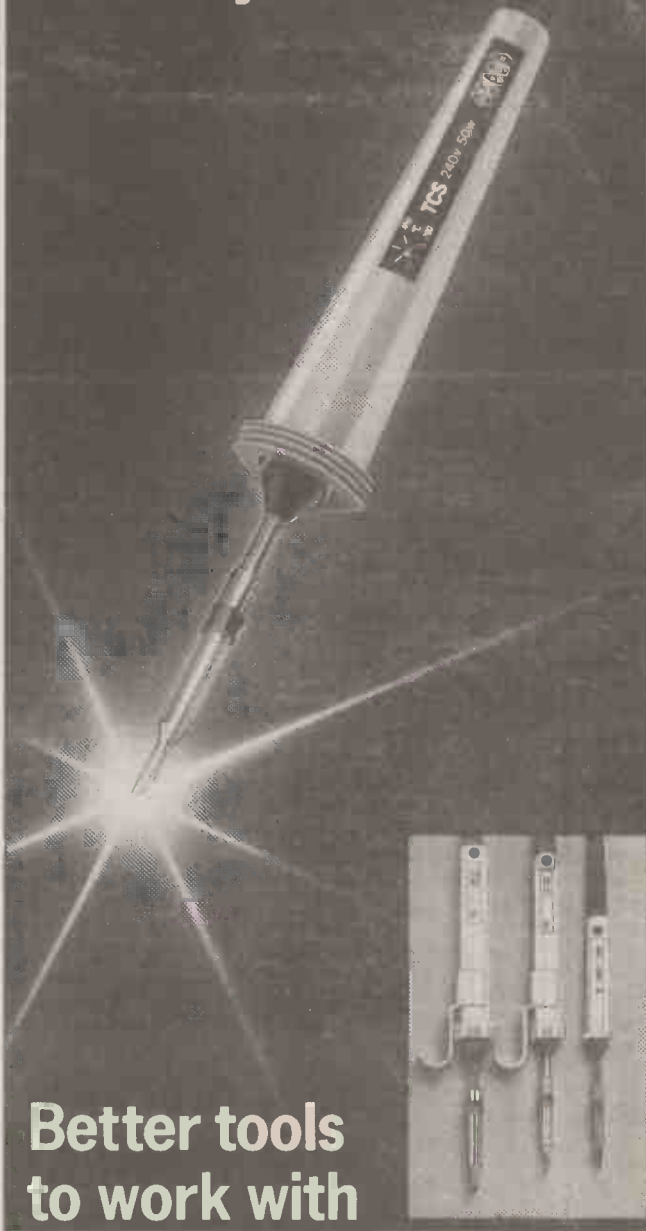

## Better tools to work with

- Antex TCS 240V 50W and TCS 24V 50W.

● Temperature Controlled Soldering Irons for electronic and electrical applications – an essential item in the hobbyist's tool kit.

- Temperature range 200° to 450° C. Analogue proportional control ± 1%. Max. temperature achieved within 60 seconds.

PLUS

- Antex M-12W; CS-17W; and XS-25W. Available in 240 or 24 volt.

- Tools specially designed for fine precision soldering.

**Ideal for all electronics craftsmen and hobbyists.**

**For full information on the comprehensive Antex range of soldering irons, power supply units and accessories, please clip the coupon.**

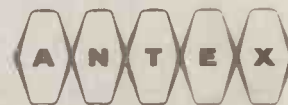

Electronics

Antex (Electronics) Limited, 2 Westbridge Industrial Estate, Tavistock, Devon PL19 8DE. Tel: 0822 613565. Fax: 0822 617598. Telex: 9312110595 AE G. Please send me full details of the full range of Antex soldering products.

Name \_\_\_\_\_

Address \_\_\_\_\_

Postcode \_\_\_\_\_ (EE 2)

# LINEAR SCALE OHMMETER

T. R. de VAUX-BALBIRNIE

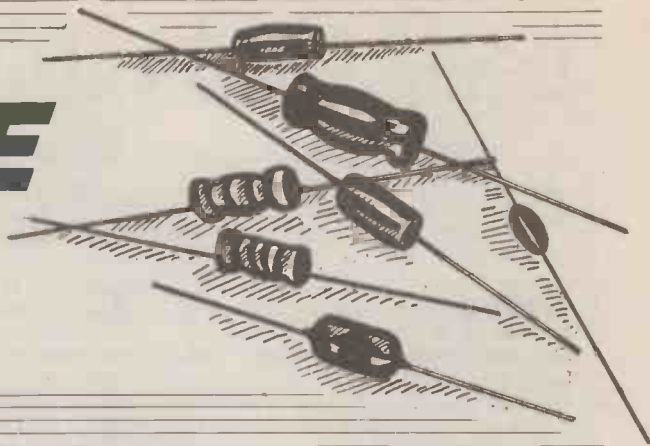

Check out resistors with this easy-to-use instrument

RESISTORS are the most common electronic components and appear in practically all circuits. The trend is to use very small ones (low power rating) where possible and the colour code on these can be hard to read.

This may be made more difficult if the resistor carries a four-band code (three significant figures plus multiplier) rather than the more usual three-band code (two significant figures plus multiplier). Tolerance and temperature coefficient bands add to the confusion and it is easy to select a wrong value which can ruin semiconductor components or prevent a circuit from working.

It is useful to have an instrument available to measure resistor values and this is the subject of this article. Such a meter will be found particularly useful for bulk testing resistor "bargain packs".

Many readers will already possess a multimeter. However, on the resistance setting, the traditional analogue meter is difficult to read since its pointer moves from a right-hand zero. Also, the scale is non-linear - that is, equal steps of resistance are not represented by equal divisions. Inexpensive instruments cover a

limited range only, with the high values being cramped together. This is a problem because high value resistors - those in excess of 1M - are frequently encountered in modern circuits. Digital meters do provide convenience and accuracy but are often too expensive for the occasional constructor.

## RANGES

The instrument described is accurate enough for amateur purposes - all resistors used with the prototype unit were measured to within ten percent of their true values. It is also reliable, inexpensive to construct and easy to read due to its left-to-right scale. The instrument covers the range 0 to 2M5 in five switched steps. These are 0 to 250 ohms (approximately), 0 to 2k5, 0 to 25k, 0 to 250k and 0 to 2M5. These full-scale readings are convenient since many resistors used in general electronics work have decade values - that is, 1k, 10k and so on and it is helpful if these lie near the centre of the scale.

The upper four ranges share a common linear scale. The lowest range has its own scale and here some non-linearity

does exist. Since this scale is calibrated separately, the full-scale reading will vary from unit to unit - in the prototype this was 500 ohms approximately but became very cramped between 250 and 500 ohms. The higher values will be more easily read from the next higher scale i.e. 2k5. The low scale will therefore be referred to as the 250 ohm scale in the text. The ohmmeter is battery-operated with a check facility to signal when battery replacement is due. Standby current consumption is 50mA maximum so, in occasional use, the battery will last for a long time.

In designing the circuit, the author first considered using a traditional pointer-on-scale meter to provide the readout. However, for ease of use a long scale is needed and this would require an expensive instrument. It became clear that the job could be done with a potentiometer and, on further thought, a slider pot was seen to have the advantage of clearer and more easily-marked scales. Some readers may wish to use a rotary potentiometer and this should present no problems.

## CIRCUIT DESCRIPTION

The circuit for the Linear Scale Ohmmeter is shown in Fig. 1. The design is centred around IC1, a programmable constant current source. This device provides

Fig. 1. Complete circuit diagram for the Linear Scale Ohmmeter

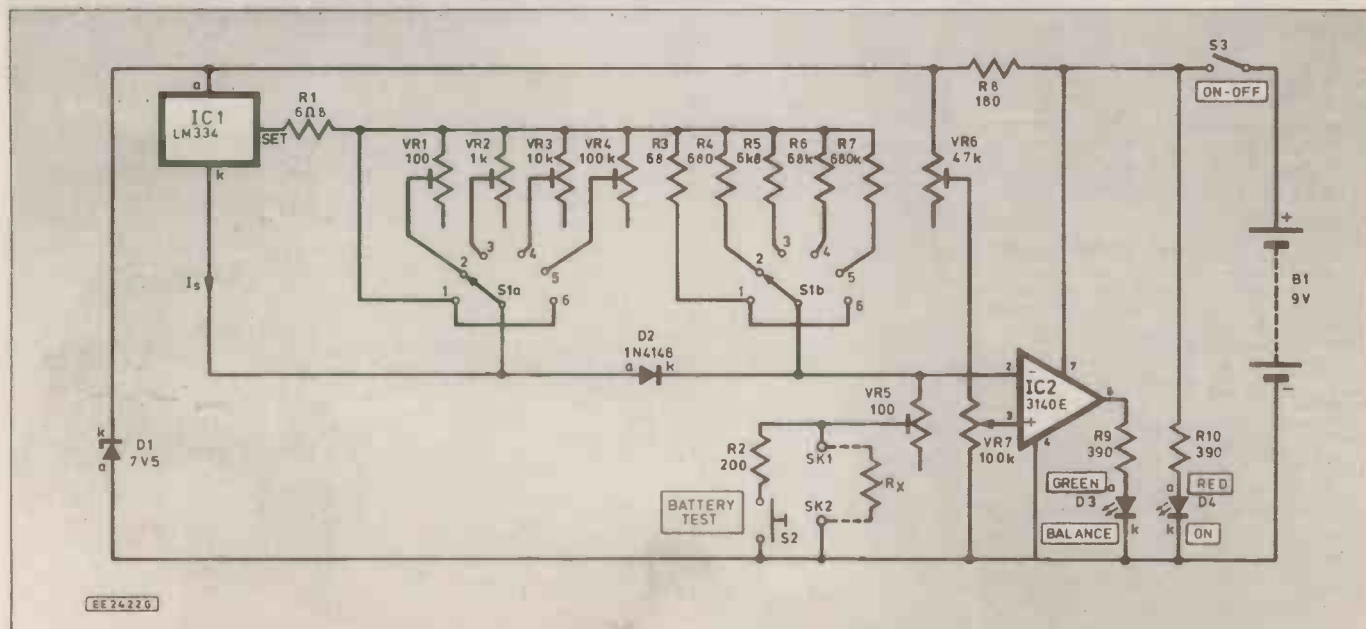

a certain current,  $I_s$ , flowing from anode to cathode whose value is determined by a resistor connected between the SET pin and cathode. In this circuit, IC1 is arranged to provide five values of  $I_s$ , by selecting fixed resistor, R1 only or R1 in combination with one of presets VR1 to VR4 using one pole (S1a) of a two pole six-position rotary switch, S1. The other pole, S1b, selects a set of fixed resistors, R3 to R7 each approximately ten times greater in value than the corresponding resistances set by S1a.

Resistors R3 to R7, together with diode D2, make  $I_s$  less temperature dependent than would otherwise be the case. Note that S1 position 6 is connected to position 1 so either position may be used to select the 250 ohm range. With the resistors specified, the values of  $I_s$  are approximately 20mA, 2mA, 200 $\mu$ A, 20 $\mu$ A and 2 $\mu$ A for S1 positions 1 to 5 respectively.  $I_s$  flows through VR5 and  $R_x$  (the resistor under test connected between sockets SK1 and SK2).

Neglecting VR5, Ohm's law predicts that a voltage will be developed across  $R_x$  equal to  $I_s \times R_x$  (the current flowing through it multiplied by its value). Since the current is constant, the voltage across  $R_x$  provides a measure of its resistance. By monitoring this voltage and displaying it on a calibrated scale, the resistance of  $R_x$  may be determined. The purpose of VR5 will be explained later.

Due to some lack of linearity in the operation of the circuit, the values of  $I_s$  cannot be predicted with accuracy, some means of adjustment is needed so that the upper four ranges fall onto a common scale. This adjustment is provided by VR1 to VR4 and will be made at the end of construction. The 250 ohms scale has no such adjustment since it is calibrated separately as mentioned earlier.

## VOLTAGE MEASUREMENT

The voltage across  $R_x$  could be measured with a pointer-on-scale voltmeter. However, even a good quality instrument has significant resistance and, with the small values of  $I_s$  associated with high resistance measurements would lead to serious error. This is because some of the current,  $I_s$ , would flow through the meter instead of through  $R_x$ . To solve this problem and at the same time to reduce constructional costs, IC2 and associated components are used as a voltage comparator — if the voltage at IC2 non-inverting input (pin 3) exceeds that at the inverting one (pin 2) the output (pin 6) is high (positive supply voltage). In other cases it is low. When the output is high, the green l.e.d, D3 (Balance), operates through current-limiting resistor, R9.

With S3 on, current flows to the system and red l.e.d on-off indicator, D4, lights through current-limiting resistor, R10. IC2 receives a direct battery positive connection to pin 7 but the inputs and IC1 have a regulated supply provided by Zener diode, D1, in conjunction with series resistor, R8. The importance of voltage stability will be explained later.

The voltage across  $R_x$  and VR5, is applied direct to IC1 inverting input. Meanwhile, a voltage dependent on the potential divider action of VR6 and VR7 is applied to its non-inverting input. VR6 is a preset control which is adjusted at the end of construction while VR7 is a slider

potentiometer whose control knob and scale appear on the front panel of the instrument.

With S1 set to the appropriate resistance range, VR7 is adjusted to the position where the voltage at the non-inverting input just exceeds that at the inverting one. At this point D3 (Balance) lights and a reading is made taking account of the range. Thus, a reading of 1.5 on the 250k range means a value of 150k. IC2 is a f.e.t. input op-amp — its input resistance is exceptionally high (one million megohms approximately) so negligible current flows into it. This means that this section behaves as an almost perfect voltmeter.

## MAXIMUM RESISTANCE

In operation, IC1 requires a certain minimum voltage — about 1V — between anode and cathode and, with a given supply voltage and minimum value of  $I_s$  (20 $\mu$ A), there will be a limit to the highest resistance which can be measured. This is approximately 3M. With VR6 omitted this maximum value would appear some distance from the right-hand end of VR7 travel and cause loss of effective scale length. To correct this, VR6 is adjusted so that the same voltage appears across it as across IC1 and the maximum measurable resistance then appears at full travel of VR7 control knob.

A high limit of 2M5 has been imposed to allow for small differences between individual components. However, some readers may wish to determine the true maximum value and calibrate the scale accordingly.

With VR7 slider moved fully to the left, a small residual resistance may remain due to its construction and this will mean that it does not read true zero. To counteract this, VR5 is adjusted at the end of construction to provide the same voltage across its ends as appears across the residual resistance. In this way, full left-hand travel corresponds to true zero. This will be correctly set on the lowest resistance range (250 ohms) where it is most important. On the other ranges it has negligible effect.

# COMPONENTS

**Shop  
Talk**

see page 209

## Resistors

R1	6 $\Omega$ 8
R2	200
R3	68
R4	680
R5	6k8
R6	68k
R7	680k
R8	180
R9, R10	390 (2 off)

Calibration resistors: 10, 20 (2 off) 50, 100 (2 off), 200, 2k, 20k, 200k, 2M. All 0.25 or 0.6W +/- 1% carbon

## Potentiometers

VR1, VR5	100 sub-min. horizontal preset (2 off)
VR2	1k sub-min. vertical preset
VR3	10k sub-min. vertical preset
VR4	100k sub-min. vertical preset
VR6	47k sub-min. vertical preset
VR7	100k linear slider potentiometer with control knob.

## Semiconductors

IC1	LM334Z programmable constant current source.
IC2	CA3140E MOSFET op-amp
D1	BZY88C 7.5V Zener diode.
D2	1N4148
D3	5mm green l.e.d
D4	5mm red l.e.d

## Miscellaneous

S1	2-pole 6-way rotary switch with control knob
S2	miniature push-to-make switch.
S3	miniature SPST toggle switch.
B1	PP3 battery and battery connector.
SK1, SK2	1mm sockets (2 off).

0.1 in matrix stripboard size 12 strips x 18 holes; 8-pin d.i.l i.c socket; plastic case approx 115 x 95 x 44mm.

Approx cost guidance only

**£12**



## VOLTAGE STABILISATION

Since the voltage applied to IC2 pin 3 is derived from the battery and since this voltage falls as the battery ages, stabilisation is necessary for accuracy. This is provided by Zener diode, D1, in conjunction with R8 which maintains a supply of 7.5V. Accurate results will then be obtained until the nominal 9V battery can no longer supply this voltage.

Push-button Battery Test switch, S2, connects a 200 ohm test resistor in place of R<sub>x</sub>. S1 is set to the lowest range (250 ohms) which draws the maximum I<sub>s</sub> of 20mA. If the battery can maintain this, the reading on VR7 scale will be "20" corresponding to the position of a red calibration spot.

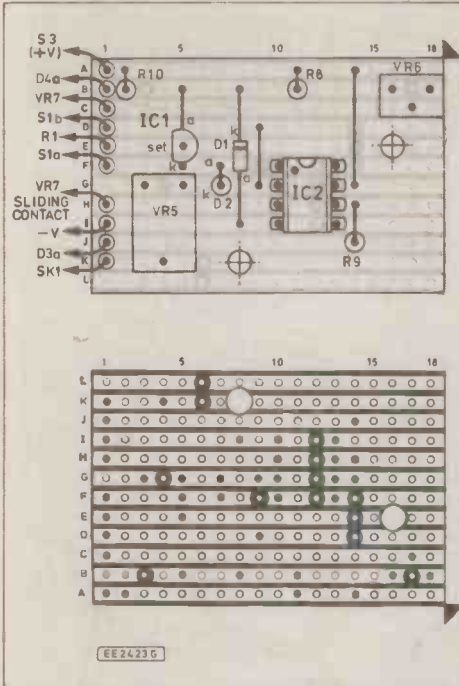

Fig. 2. Component layout and details of breaks in the underside copper tracks

## CONSTRUCTION

The better the linearity of VR7, the more accurate will be the results. However, the prototype unit was constructed using a standard quality component and performance turned out to be very good. Note however that VR7 must be a linear track component — a logarithmic (log) potentiometer is unsuitable as it would lead to a non-linear scale.

The circuit panel layout for the Linear Scale Ohmmeter is shown in Fig. 2. This uses a piece of 0.1 in. matrix stripboard size 12 strips x 18 holes. Cut this to size, drill the two mounting holes and make all the track breaks as indicated. Follow with the inter-strip link wires then solder all on-board components into position including the i.c. holder — do not insert IC2 yet, however. Take care over the polarity of D1 and D2. When soldering IC1, take care to do it quickly and use the full length of the wire ends to prevent heat damage.

Note that the set of calibration resistors specified in the components list are not mounted on the panel — they are used for testing and adjustment purposes at the end

of construction. R1 is also mounted off-board. Solder 15cm pieces of light-duty stranded connecting wire to strips A, B, C, D, E, F, H, I, J and K along the left-hand edge of the panel as shown. Use of "rainbow" ribbon cable here will greatly reduce the risk of wiring errors.

## INTERWIRING

Refer to Fig. 3 and solder R1, VR1 to VR4 and R3 to R7 around S1 contacts as indicated. Note particularly the way in which the presets are arranged. Drill holes in the lid of the box for VR7 fixings and a narrow slot for its sliding control. Drill holes for the 1mm sockets, the three switches and for the circuit panel. Mount all components and attach the circuit panel using short stand-off insulators on the fixings. Refer to Fig. 3 and complete the interwiring.

With S3 off, connect the battery and secure it to the base of the box using an adhesive fixing pad. It may be necessary to extend the wires of the battery connector. Adjust VR5 and VR6 sliding contacts fully anti-clockwise and adjust VR1 to VR4 to approximately mid-track position. Remove IC2 from its special packing and insert it into its socket with correct orientation. IC2 is a CMOS device and, as such, vulnerable to damage by static charge which might exist on the body. For this reason, do not touch the pins while handling it. Fit plastic feet to the bottom of the case to prevent scratching the work surface.

## TESTING AND CALIBRATION

Make two scales for VR7. The upper one is common to the four higher ranges. This is marked from zero at the left to 2.5 at full right-hand travel. Inter-

mediate values are marked in by careful measurement with a ruler and labelled with Letraset. The lower scale is marked out carefully while in position so it should be attached lightly to begin with.

Fit VR7 control knob and slide it fully to the right. With no resistor connected to the sockets and S1 set to any range, switch on S3. D4 (On-Off indicator) will glow. D3 (Balance) should remain off. Adjust VR6 clockwise to the position where D3 comes on then anti-clockwise until it is just off.

Set S1 to the 250 ohm range and link SK1 and SK2 using a short piece of copper wire, slide VR7 control knob fully to the left and adjust VR5 until D3 is just on. Full left-hand travel now gives a true zero reading. It may be that correct adjustment is provided with VR1 left fully anti-clockwise.

Calibration of the 250 ohm range should now be made by connecting combinations of the calibration resistors (10, 20, 20, 50, 100, 100 ohms) between SK1 and SK2. By connecting these singly or in series combinations all values between 0 and 300 ohms may be made up in 10 ohm increments. For example, 180 ohms may be made up by connecting 1 each 100, 50, 20 and 10 ohm resistors in series. Begin with 10 ohms and, with each value, move VR7 control knob until D3 just lights. Make a pencil mark on the scale at this position. The scale is then removed and the values labelled using Letraset (see photograph). Make a small red dot at the "20" position.

Attention may now be given to the four upper ranges. Connect the 2k calibration resistor to SK1 and SK2. Switch S1 to the 2k5 range and adjust VR7 control knob to the "2" position. Rotate VR1 sliding contact to the position where D3 is just on. Now set S1 to 25k and connect

Fig. 3. Interwiring from the circuit board to case mounted components

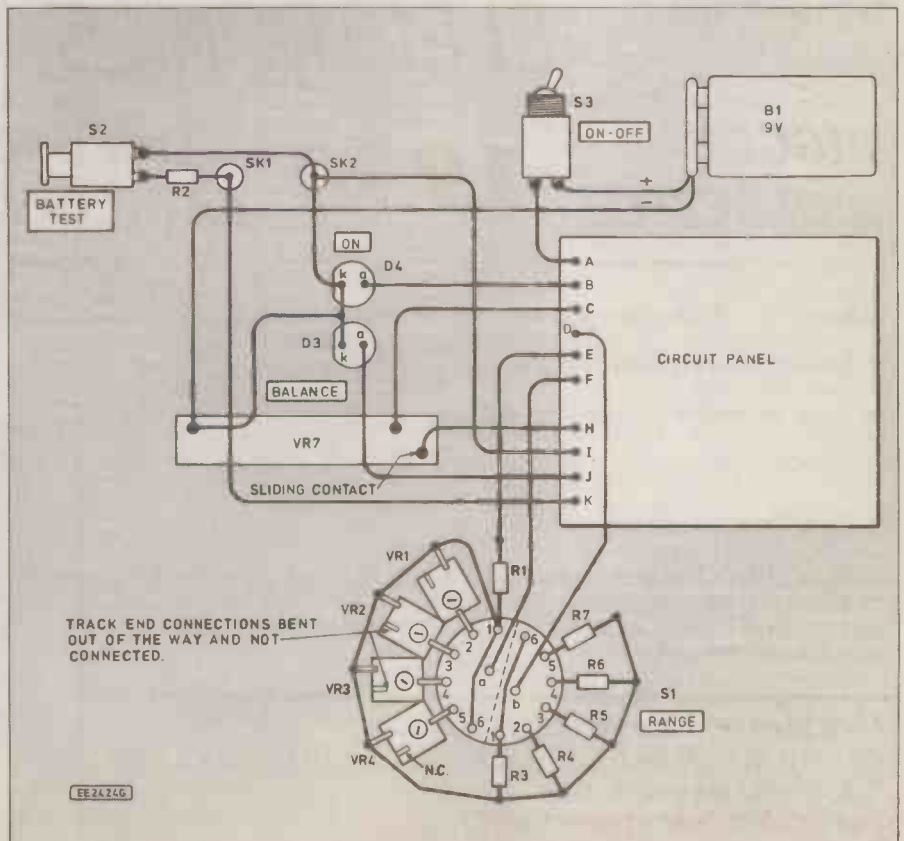



the 20k calibration resistor to SK1 and SK2. Without disturbing VR7 adjustment, rotate VR2 sliding contact to the position where D3 is just on again. The procedure should be repeated on the 250k and 2M5 ranges using the 200k and 2M calibration resistors respectively in conjunction with VR3 and VR4.

Readers wishing to extend the upper scales – in particular, to find the maximum measurable resistance on the highest scale – can do this by adjustment to VR1 to VR4. A scale will need to be marked off to show this value at maximum VR7 travel.

It only remains to attach the lid, label the switches and l.e.ds and put the instrument into service. Every so often the battery should be checked. To do this, set S1 to 250 ohms, slide VR7 control knob slightly to the left of the red spot and press S1 (Battery Test). If D3 is on, the battery must be replaced. Note that this test must be made without an external resistor connected to SK1 and SK2. Where resistors with thick or non-standard end leads are to be tested, they may not fit the sockets. It will then be necessary to make a pair of test leads with 1mm plugs on one end and crocodile clips on the other. □

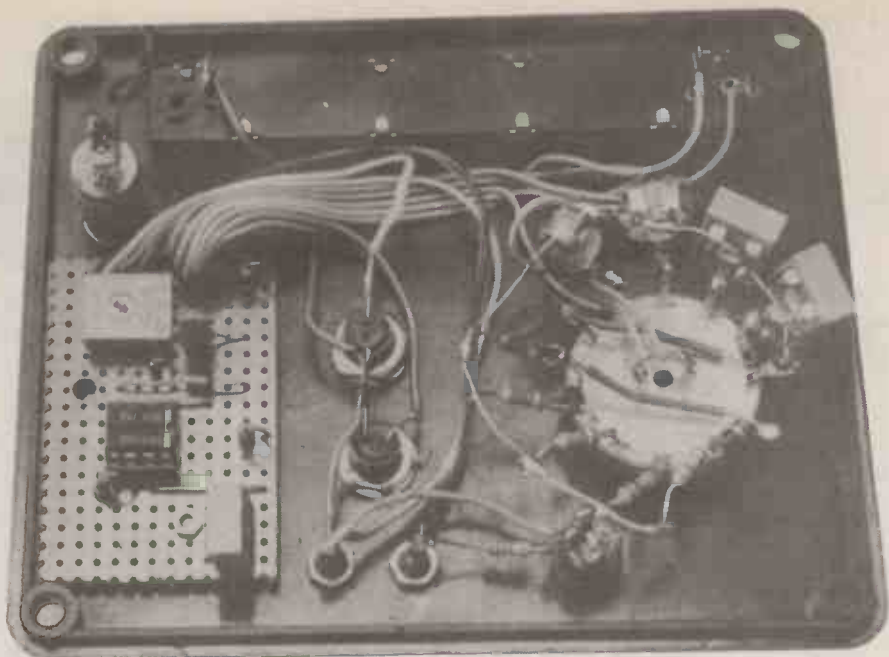

The completed "ohmmeter" showing the components mounted on the lid of the case, the ribbon cable wiring from the circuit board and the presets wired directly to the range switch tags.

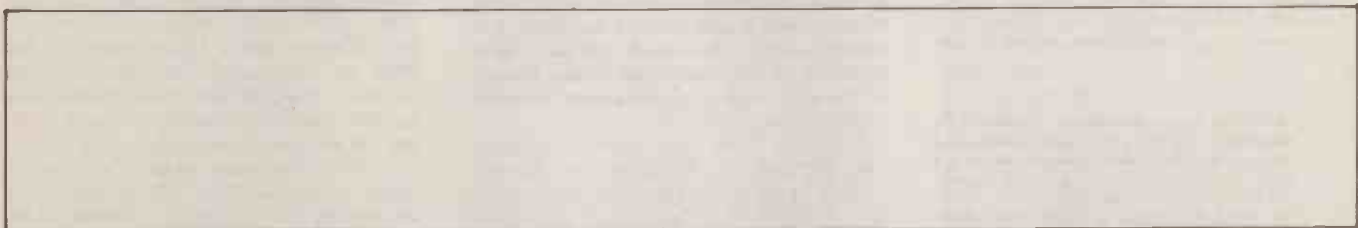

Remember the new  
Component Catalogue  
available from  
early 1990

# CRICKLEWOOD ELECTRONICS



**BIGGER  
AND BETTER**

**1990**

**COMPONENTS  
CATALOGUE**

- ONE OF THE LARGEST RANGES OF COMPONENTS IN THE UK
- FAST AND EFFICIENT SAME DAY PERSONAL SERVICE
- VERY COMPETITIVE PRICES; QUANTITY DISCOUNTS AVAILABLE
- DISCOUNT VOUCHERS INCLUDED
- NO MINIMUM ORDER

FILL IN THE COUPON AND POST IT WITH YOUR CHEQUE, PO ETC FOR £1.50 TO RECEIVE YOUR 1990 CRICKLEWOOD ELECTRONICS CATALOGUE AND VOUCHERS WHICH YOU CAN USE AGAINST YOUR NEXT PURCHASE

**Cricklewood Electronics Ltd**  
40 CRICKLEWOOD BROADWAY, LONDON, NW2 3ET  
Tel: 01-450 0995/452 0161  
Fax: 01-208 1441 Telex: 914977

## CRICKLEWOOD ELECTRONICS 1990 COMPONENTS CATALOGUE

PLEASE SEND ..... COPIES OF THE 1990  
CRICKLEWOOD ELECTRONICS CATALOGUE AT  
£1.50 TO:

NAME .....

ADDRESS .....

.....

.....

.....

Remittance enclosed £..... **E**

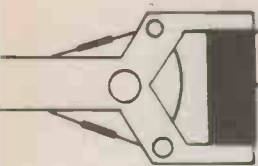

# Robot Roundup

## NIGEL CLARK



### SMART SHEEPDOG

Take one Smartie-shaped stand-alone mobile, add a few extras and with a bit of imagination you can have a pet dog for taking on walks or a working sheep-dog rounding up the sheep. That is the claim of Valiant Technology for its Roamer mobile now that all the extras promised at the time of launch a year ago are available. Or if you would prefer a car complete with headlamps and flashing indicators, that is also possible.

The main reason for the expansion in Roamer's already extensive capabilities has been the addition of a control box. It provides for four switched outputs, a stepper motor drive and one serial input. A pack of lamps and a sensor pack are also now available.

Combine the hand-held switch, connected to the control box on Roamer by long wires, from the sensor pack and the dog jacket from the jacket pack, also supplied by Valiant, and the mobile can be taken for a walk. Replace the switch with a sound sensor, program Roamer to recognise groups of noises, such as whistles, for example one whistle to turn left, two to turn right and so on, and you have a sheep dog. Attach a stepper motor, make a tail and your dog can wag its tail. Remove the dog jacket and make something to make Roamer look like a vehicle, replace the sensor and stepper motor by lights from the lamp pack, including a flasher unit, and you have a car complete with lights.

The examples could go on, depending on the imagination of the model builder. The sensor pack also includes two touch sensors and a light sensor and the lamps include l.e.d.s. The new additions join the previously available sets of jackets, including a classroom pack of 12, and the pen pack which enabled it to be used like a turtle. They all come with a large amount of documentation including programming and modelling suggestions.

Plans for the future include stepper motor packs and d.c. motor packs, once the necessary documentation has been prepared. Roamer, which has also been described as an upturned wok as well as a Smartie, follows in the Big Trak tradition of battery-powered mobiles which accept repeatable instructions entered by a keypad on its top. Roamer can hold up to 60 instructions but the number of movements can be expanded by the use of the REPEAT and PROCEDURE functions. It accepts instructions in a Logo-like language including the usual FORWARD, BACKWARD, LEFT and RIGHT. It can also be linked to computers and at present interfaces are available for the BBC series, Nimbus and IBM PC.

As a spin-off Valiant has developed a control console which can control models without the need to be attached to a computer. It was originally hoped that it would be available at about £150

plus VAT in September. However the support material was not completed in time and it is now expected in March.

The specification is still the same with eight switched outputs, eight inputs, two stepper motor drives and two counter units. While being a stand-alone device, either battery or mains powered, it can be linked to a computer for saving and downloading programs. Like Roamer it uses a language similar to Logo.

### PERCI

At the 1988 CDT exhibition at the NEC in Birmingham Proops Distributors was showing a group of items developed by the Department of Cybernetics at Reading University. It included a simple arm with a magnet on the end which picked up a ball bearing and placed it at the top of chute down which it rolled to its initial position to be picked up again. This simple activity was repeated endlessly.

However there was more to it than met the eye for there was an ulterior motive in building the arm. The university department intended it to show what could be achieved using simple technology and inexpensive materials. No electronics were involved as it worked purely by motors controlled by microswitches and relays. In the ball bearing example the two-axis arm moved until it hit a switch which caused the motor to reverse, the arm moving in the other direction until it hit another switch.

A kit for the arm, now known as PERCI, is available from Proops for a little less than £60. It includes all the parts and a supply of spares with instructions on how to make the arm and information on electromagnets, relays and relay logic circuits. While not being as complex or versatile as electronically-controlled arms PERCI (shown below) still gives an interesting insight into what can be done with fairly simple technology.



### FRIENDLY CONTROL

The latest equipment designed to assist in the teaching of computer control in primary schools has been created by the Birmingham Educational Computing Centre. The results of their endeavours are being sold by Economatics Education.

BECC had been asked to develop an economical and user friendly control system which would encourage the use of computer control work as a natural and integral part of the primary school curriculum. The result is the AB series of hardware and its associated Beacons software.

The hardware items include a controller, an interface with eight inputs and eight outputs, motor board, and sensor boards which include push switches and light sensors. Software is available for the BBC series, Nimbus and IBM PC. Software can be developed on the computer and then downloaded to the controller, freeing the computer for other uses. Each item has a discrete function in an attempt to make it easier to understand what each piece of electronic equipment is used for. It is said that the system builds on the pupils' basic knowledge of the working of a simple battery-switch-lamp circuit. It is intended for models built from the usual kits or "junk" material.

### BORN AGAIN DROID

Hasfield Systems is moving even further down the road to taking up where Colne Robotics left off. Having already started making the Armdroid again, in an upgraded form, now known as the Armdroid HS 1B, it has also reintroduced the Colvis vision system.

Colvis is being offered as a stand-alone system as well as an add on for the Armdroid. The arm, to which the Colvis's camera can be attached at the wrist, then uses the system to "see", reacting in various ways to a variety of shapes. The Colvis system on its own costs about £1,000.

As part of the general upgrading of the Armdroid Hasfield has now brought out a version for the Nimbus. The software provides the same facilities as for the other machines with which it can work, IBM PC, BBCs, Apple and Commodores.

Hasfield is also considering marketing some of the large amount of software which has been written for the Armdroid by people who have bought it. Being one of the pioneers in the educational robot market Armdroid has been around long enough in colleges and universities for an extensive range of software to have been built up. The details have yet to be settled but John Allright of Hasfield was confident that some of the software would be made available to a larger audience.

# HIGH GRADE COMPONENT PARCELS

**EVERYTHING  
MUST  
GO!**

## SEMI CONDUCTORS

What a selection! Every single parcel will contain: ICs, signal diodes, rectifiers, zeners, semiconductor VDRs, transistors, FETs, high voltage transistors, power transistors, triacs, voltage regulators, and a good deal more. Did I mention the varicap tuning diodes? The VHF transistors? The Schottky rectifiers? All the semiconductors you've ever wanted, but could never afford. This has to be one of the finest parcels we have ever offered. Don't miss it!

**PARCEL 9A:**  
200 SEMICONDUCTORS  
for £10! + VAT

**PARCEL 9B:**  
1000 SEMICONDUCTORS  
for £40! + VAT

## PRESETS

An attractive and very functional pack of preset pots. The parcels contain a high proportion of top quality cermet, both single and multi-turn. In fact they outnumber the carbon types! All styles and types are represented: open, enclosed, vertical, horizontal, square, round, 3/4" and 1 1/4" multi-turns, and so on. All values from a few ohms to several megs.

**PARCEL 11A:**  
200 PRESETS for £6 + VAT

**PARCEL 11B:**  
1000 PRESETS for £25 + VAT



## SWITCHES

Take a rocker switch in one hand, a roller microswitch in the other, and have yourself a rock 'n' roll party! OK, the the jokes aren't up to much, but the switches are superb. Lots of rocker switches - ideal as spares for household gadgets. Some, so I'm told, fit the dashboard cut-outs on Ford cars, so just think of the extra lights and stuff you could fit! Then there are the toggles, the push switches, the rotaries and the sliders. All tucked up snugly, bless their cotton socks, in our switch parcels. And all for 10p each or less - it's enough to make you explode with joy. Well, nearly enough.

**PARCEL 14A:** 100 ASSORTED  
SWITCHES for £10! + VAT

**PARCEL 14B:** 300  
ASSORTED  
SWITCHES  
for £25! +  
VAT



## H.V. POLYESTERS

Above 100n or so the price of non-electrolytic caps starts to rise steeply. To get one above 1µF will cost the earth, or at least a major planet. And not even an asteroid for change. These parcels contain caps to at least 4µ7. Replace those nasty non-polar electrolytics in your speaker crossovers, connect them across electrolytic smoothing and coupling caps in your hi-fi, stop using back-to-back tants in your projects. The larger caps will easily cost several ££s each from normal suppliers. We've got too many, so...

**PARCEL 15A:**  
200 HV POLYESTERS  
for £10 + VAT

**PARCEL 15B:**  
600 HV POLYESTERS  
for £25 + VAT



Unless otherwise stated, all the clearance parcels we offer contain brand new, top grade components. If some of the offers look too good to be true, all I can say is that the optimists will get some stunning bargains, the cynics will never know what they've missed, so everybody will be happy! All offers apply only while current stocks last - watch out for next month's parcels or, better still, be the first to hear about any new offers by putting your name on our mailing list.

**Access Orders:**  
Tel: 0600 3715

## CONNECTORS

If you ever again need to connect anything to anything else, the chances are you'll find the plugs and sockets for it in this parcel. Computers? There are D connectors, printer connectors, RS232 connectors, and so on. PCBs? There are edge connectors and pin connectors. RF connectors? No problem. Audio? There are speaker plugs and sockets, DIN connectors and much more. And all for 10p or less apiece! How can you resist it?

**PARCEL 10A:**  
100 ASSORTED CONNECTORS for £10! + VAT

**PARCEL 10B:**  
300 ASSORTED CONNECTORS  
for £25! + VAT



## MONSTER OPTO PARCELS

If it has anything to do with light, it's in here. There are LEDs of all shapes, sizes and colours, seven segment displays, infra-red senders and receivers, bar graph assemblies, opto switches, and who knows what else. The larger parcels have LCDs too. An excellent selection of top quality devices.

**PARCEL 12A:**  
100 OPTO DEVICES for £10 + VAT

**PARCEL 12B:**  
300 OPTO DEVICES  
for £25 + VAT



## RESISTORS

Supplied to you as they arrive with us: some bagged, some banded, some reeled, some loose. The mixture has 1/4W resistors in every single E12 value, with some E24 and an assortment of E96 precision types. Then there are 1/2W resistors and a nice selection of power types to 5W and above. The proportions vary from parcel to parcel, but you'll certainly have an excellent range of types and values.

I have absolutely no intention of counting out tens of thousands of resistors, so these are sold by weight. As a rough guide 1000 1/4W resistors weigh about 240g, so there are over 4000 of these to the Kg.

**PARCEL 13A:**  
10Kg RESISTOR  
PARCEL £30  
+ VAT

## JUNK!

Bits of equipment, PCBs, components, hardware, mags, books, data, everything electronic turns up at some time or other in our legendary JUNK parcels. There's so much unsorted stuff around the place we hardly know what goes in there ourselves! The components won't be neatly packed - once we've combed their hair and dressed them in their Sunday best, they go onto one of lists. In the JUNK parcel you see them in the raw state.

The first 10Kg is yours for £18 + VAT. After that, the price is £1 per Kg, so 11Kg will be £19 + VAT, 12Kg will be £20 + VAT, and so on. Have as much as you like!

**JUNK SPECIAL:**  
1 cwt for £50!  
+ VAT

**UK Orders:**  
Please add £2.50  
towards postage and  
packing and 15% VAT  
to the total  
**Europe and Eire:**  
Please add £6.00 carriage  
and insurance. No VAT  
**Outside Europe:**  
Please add £12.00 carriage  
and insurance. No VAT

# HIGHGRADE COMPONENTS LTD

Unit 111, 8 Woburn Road, Eastville, Bristol BS5 6TT  
Tel: 0600 3715 Fax: 0600 72262

H3

# ACTUALLY DOING IT!

by Robert Penfold

**E**LECTRONIC project building is not all high-tech, VLSI integrated circuits, and theory. It is as much mechanical as electronic in nature, and it is often the mechanics of project construction that result in the most head scratching. This is probably true for both beginners and those with a few years of project building experience behind them.

In this month's *Actually Doing It* we will consider an aspect of project construction that can sometimes provide a few difficulties to solve. The subject of our attention will be the humble miniature loudspeaker.

## SPEAKERS

Medium to large loudspeakers, by which we mean units of about 100 millimetres or more in diameter, invariably seem to incorporate a mounting bracket which will take four mounting screws. Mysteriously, miniature loudspeakers seem to be devoid of any obvious means of mounting. These components are mostly built for use in commercial pocket radios, intercoms, cassette recorders, etc.

With equipment of this type it is quite common for the loudspeaker to be fitted in place over its grille, with the main printed circuit board then being fitted in place on top of the speaker. In most cases there is a large round cut-out in the circuit board to accommodate the magnet at the rear of the loudspeaker. The idea is that when the circuit board is bolted in place, it puts a certain amount of pressure on the speaker so as to hold it firmly in position.

It would be possible to use the same technique with home constructed projects, but it is more difficult since the home constructor does not have the luxury of custom made cases (unless your forte happens to be case building). Also, on the face of it, the curvature and strain that this method of mounting places on the circuit board is asking for problems with broken tracks etc.

The standard home constructor approach to mounting small loudspeakers is to simply glue them in place. This needs to be done with due care, since smearing adhesive all over the diaphragm is not likely to do a great deal for the audio quality of a component which is probably not going to be too brilliant in this department to start with.

Virtually any good quality general purpose adhesive will do the job, including the popular "clear" adhesives and "quick-setting" epoxy types. A thin layer of adhesive placed around the front outer rim of the component should be sufficient to hold it firmly in place.

One problem you might encounter, and it is one that can crop up when gluing anything in place on a case, is that of many adhesives being ineffective when used with soft plastics. Some plastics are categorised as soft even though they may not seem to be particularly soft when in even moderately thick sheet form. Consequently, a case that may seem to be made of a hard plastic might actually be made of what has to be considered a soft plastic.

Polystyrene cases will work well with most adhesives. The only point to watch is that you do not smear any adhesive onto the outside of the case. Some types of glue attack this material, and it could be time consuming to polish out the marks left by the adhesive. Metal polish is good for removing this type of thing, or other marks and minor abrasions on plastic cases.

A fairly popular material for plastic boxes these days is ABS, and this, or any p.v.c.-like plastic, is likely to be problematic. The case may not be the only problem. I recently glued a loudspeaker in place on the lid of a plastic case. It fell off before too long, and the ring of glue on the loudspeaker could easily be pulled away in one piece! Where loudspeakers used to have metal frames with a paper-like material

on the front rim, they now seem to be largely constructed from semi-soft plastic.

Epoxy adhesives seem to be of little use with any softish plastic. General purpose adhesives of the clear variety (or the "non-solvent" types that are now largely replacing them) seem to be a better choice. The instructions supplied with most adhesives list the general types of material with which they can and cannot be used successfully.

## MOUNTING BRACKET

The alternative to gluing is to use some form of mounting bracket. In its most simple form this just consists of a strap of metal bolted in place over the loudspeaker, as in Fig. 1. This has the advantage that it is easy to remove the loudspeaker if the need should arise, and it also removes the danger of damaging the diaphragm by smearing it with adhesive.

Its drawbacks are that it is more difficult to implement successfully than you might imagine, and it will give a couple of unsightly screw-heads on the front panel. Ideally a fairly springy piece of metal (such as a strip of steel) is needed for this method of mounting. Aluminium would tend to stretch and deform too easily, requiring frequent tightening of the mounting bolts.

Some items of ready-made equipment use three or four small mounting lugs, and it should be possible for the home constructor to successfully use a similar approach. This simple scheme of things is illustrated in Fig. 2.

Again, it is better to use a springy material such as steel, rather than a soft material such as aluminium which will probably leave the loudspeaker slightly loose and rattling around before too long. In fact small pieces of plastic removed from an old project case perhaps, are liable to be the easiest to use and to give the best results.

## GRILLING

Obviously loudspeakers need to be mounted behind some form of grille if their sound output is to pass through the case and into the outside world properly. You can simply use a cutout that is slightly less than the diameter of the speaker. This should give good results as far as audio quality is

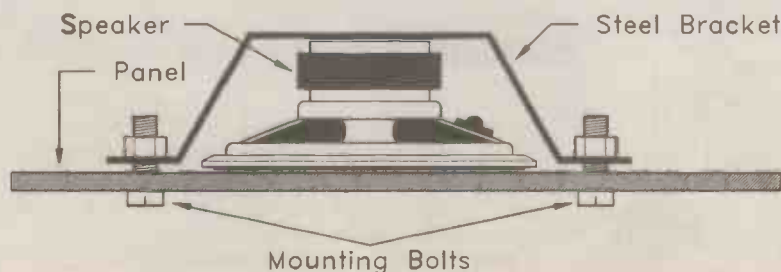

Fig.1. A simple method of clamping a miniature loudspeaker in position

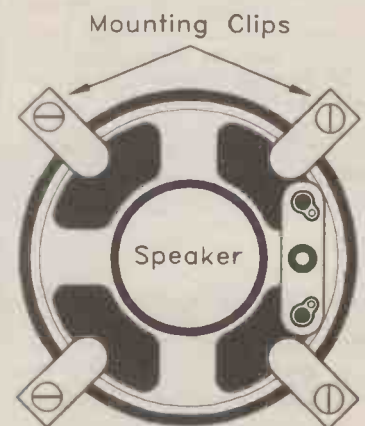

Fig.2. An easy but effective method of clamping a loudspeaker



## ... Noise Gate ... Noise Abatement ... Noise Gate ...

**A** USEFUL facility available on the Master 128 computer, but not present on the model B, is an audio output socket so that the sound generator's output can be coupled to an external amplifier and loudspeaker in order to obtain greater volume. If you look in the "User Guide" for the model B you will in fact find that it shows an audio output connector in the circuit diagram on page 503 ("AUDIO OUPUT PL16"). As I have pointed out before, this is in fact just a couple of pads on the printed circuit board, towards the front left hand corner of the board, near the loudspeaker and audio amplifier chip.

If you require an audio output on a BBC model B a certain amount of d.i.y. work will be needed. Provided you can find a suitable place on the case for the audio connector, this should obviously be pretty straightforward.

### NOISE

Having used more home computers than I care to remember during the course of the last few years, I have noticed a problem that is common to most of them. An audio output socket is a common feature, and so is the intrusively high noise level on the audio output signal! Some of the more recent computers are a bit better in this respect, but I have yet to encounter one that has a really 'clean' audio output.

The problem is not usually in the form of the standard white noise "hissing" sound. No doubt the usual "hiss" is present, but it is generally drowned out by much louder "buzzing" and "clicking" sounds. These are presumably signals generated by the digital circuits in the computer, and they can get into the audio signal via three basic routes. One is simply by stray pick up due to capacitive or inductive coupling. As the audio circuits of a computer normally only deal with medium impedance signals at quite high levels, this route is unlikely to give significant coupling.

The second route is via the earth rail, and is rather like the BBC computer's analogue port noise problem, but in reverse. Voltage drops through the earth tracks plus variations in the supply current combine to give earth terminals on the ports that are not at static voltages. While this is unimportant when interfacing digital circuits to the computer, it obviously compromises results when dealing with any form of analogue interfacing, including audio circuits.

Route number three is via the supply rails due to inadequate smoothing and decoupling. I have noticed that with most computers, but especially with the BBC model B, the quantity of noise from the built-in loudspeaker seems to noticeably increase when certain add-ons are fitted to the computer. This would suggest that the problem is mainly due to these last two causes, with noise on the supply lines probably being the main culprit.

### NOISE ABATEMENT

In a way it is not surprising that there is digital noise on the audio output signal. Computers generate large amounts of noise over a broad range of frequencies, making it likely that any audio circuits on the same board will pick up a certain amount of the audio frequency noise.

The problem is not insurmountable, since there are musical instruments and hi-fi equipment which successfully combine audio and digital circuits to provide virtually "silent" backgrounds. Presumably the audio noise level is not high in computer designers' lists of priorities.

There are possible ways of decreasing the noise problem. You could try adding more smoothing capacitors, a decoupling capacitor across the supply pins of the audio amplifier chip, etc. In practice, the chances of effecting a major improvement in this way are probably not very great.

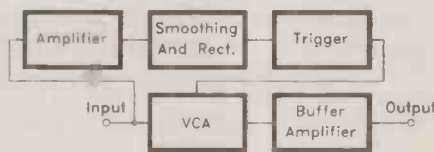

Fig. 1. Block diagram for the noise gate

### NOISE GATE

In my experience the only really effective solution to the problem is to add a noise gate between the audio output socket of the computer and the input of the hi-fi amplifier (or whatever). For processing normal audio signals a noise gate needs to be quite sophisticated in order to produce good results. However, the output from a simple sound generator unit such as that used in the BBC computer is much less demanding, and a relatively simple unit will provide satisfactory results. Note that although the design described here was built with the Master 128 computer in mind, it should work with virtually any computer that has a noisy audio output signal.

The function of a noise gate is quite simple, and it either enables the input signal to pass normally, or it severely attenuates it. The signal is allowed to pass if it exceeds a certain threshold level, or blocked if it does not. The idea is to have the threshold level set so that an ordinary signal is allowed to pass, but the background noise alone is at too low a level, and is blocked. When a proper signal is present it tends to mask the background noise. When there is no main signal the noise would normally be obtrusive, but is blocked by the noise gate.

In practice it can be difficult to get this system to work well. Many noise gates are actually quite sophisticated circuits using delay lines, or what are really audio expansion techniques rather than a true gating (on/off) action. The relatively

simple signals produced by most computer sound generators enable a basic noise gate such as the one described here to be used successfully, but it is only fair to point out that it is unlikely to be very effective with other audio signals.

### BASIC OPERATION

The block diagram of Fig. 1 helps to explain the way in which this simple noise gate functions. The main signal path is via a voltage controlled attenuator (v.c.a.) and a buffer amplifier. The latter merely ensures that the v.c.a. is loaded by a high impedance, and that it consequently has negligible losses when set for minimum attenuation.

A side chain produces the control signal for the v.c.a., and this has an amplifier as the first stage. The output from this stage is rectified and smoothed, and the resultant positive d.c. signal is roughly proportional to the amplitude of the input signal. It is fed to a trigger circuit that normally provides a low output voltage, giving minimum attenuation through the v.c.a. When the input voltage exceeds a certain level the output of the trigger circuit goes to the high state, causing the attenuation through the v.c.a. to switch to a very high level.

### THE CIRCUIT

The full circuit diagram for the Noise Gate is shown in Fig. 2. The v.c.a. is formed by TR1 plus R1, and this is a very crude type. With no bias applied to the base of TR1 it is cut off, and the signal can pass through R1 with only very slight losses caused by the loading of the buffer amplifier. With TR1 switched on, it provides a very low shunt resistance and produces massive losses through R1.

A very crude v.c.a. of this type is acceptable due to the simple nature of the signals being processed, and due to the fact that it is really only acting as a simple signal gate. The level of distortion at intermediate levels of attenuation is irrelevant, since it is only at these intermediate levels for an insignificant period of time. IC1 acts as the output buffer amplifier, and this is a simple operational amplifier non-inverting type.

The amplifier in the side chain is formed by IC2. The value of R8 controls the threshold level of the unit, and the specified value should be suitable for use with a Master 128. However, if necessary the value of R8 can be raised in order to lower the threshold level, or decreased in order to raise it.

Rectification and smoothing of IC2's output is provided by D1, D2, and C9. IC3 acts as the basis of the trigger circuit, and this is a conventional inverting type. Hysteresis (to combat instability with the input signal close to the threshold level) is introduced by R13.

The unit requires a supply voltage of about 9 to 12 volts, and a small 9 volt

battery is suitable as the power source. The supply does not need to be particularly well smoothed since the circuit includes "hum" filtering. The +12 volt output of the Master 128 may well be suitable, but I have not tried this.

## IN USE

In use the unit simply connects between the audio output of the computer and the input of the amplifier. The noise gate provides very slightly less than unity voltage gain, and it should not introduce any matching problems. If the computer and an amplifier work well together without

the noise gate, they should work just as well together with the noise gate added into the signal path.

The input and output cables must be of the usual screened audio type. Phono sockets are probably the best type to use for SK1 and SK2. These match the audio output socket of the Master 128, and phono sockets are probably the most common type on hi-fi amplifiers. Ready made phono leads are widely available, and are not difficult to make up yourself.

The quality of the sound generators in the BBC computers probably does not merit a powerful super-fi amplifier running at high volume. Using a good quality

audio system at moderate volume can certainly give much better results than the computer's integral amplifier/speaker combination though. This is especially so when running music software that utilizes the built-in sound generator.

When using an audio system that has high quality loudspeakers which utilize tweeters, remember that the power handling capabilities of the tweeters may be far less than the other driver units. Feeding strong high frequency signals into the system with the volume well advanced could easily burn out the coils in the tweeters, and is obviously something that must be carefully avoided.

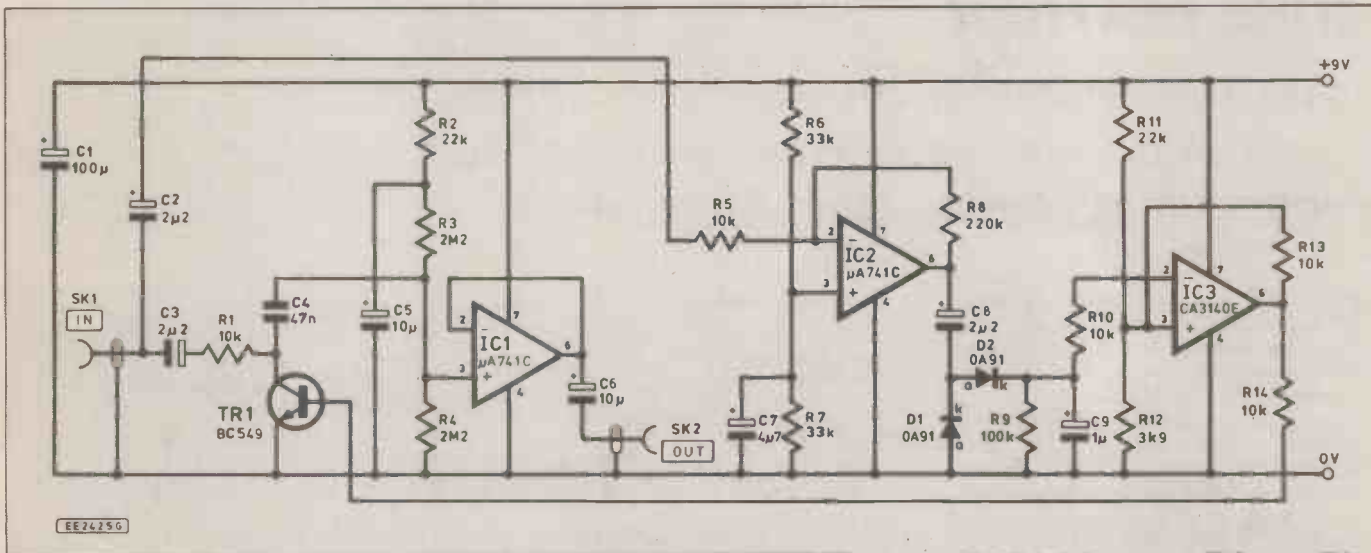

Fig.2. Circuit diagram of the Noise Gate



**HILLS COMPONENTS**  
established since 1973

can offer the trade a selection of nearly 4,000 product lines covering the following ranges

- Aerials & Accessories
- Batteries & Accessories
- Cables & Accessories
- Computer Accessories
- Connectors (all types)
- Electronic kits/Modules
- Filters/Fuses
- Hardware/Fixings
- Headphones/Intercoms
- Connecting leads (all types)
- Microphones
- Multimeters
- Passive Components
- P.C. Boards
- Relays
- Speakers
- Switches
- Service Aids
- Soldering Equipment
- Telephones & Accessories
- Transformers

**TRADE ENQUIRIES ONLY**

Please phone or write quoting your company name & address for a copy of our 1990 catalogue

**TRADE ONLY**



## ELECTRONIC KITS & MODULES

FOR HOBBYISTS ELECTRONICS ENTHUSIASTS  
EDUCATIONAL ESTABLISHMENTS ETC.

Build your own:  
Geiger-Mueller Indicator, Metal Detector,  
Stereo Amplifier, Digital Combination Lock, or  
any of the many other kits available for numerous applications

Each kit comes in component form with easy to follow instructions for assembly

**OVER 100 KITS TO CHOOSE FROM**

Some of the popular kits include

- \* Antenna Amplifiers
- \* Lie Detectors
- \* Alarm Systems & Monitors
- \* Infra-Red Light Barriers
- \* Sirens - Kojak-Warship-FBI-Ships-Space
- \* Electronic Barking Dog
- \* Micro-Wave Indicators
- \* Radios & Receivers
- \* Amplifiers (up to 200w)
- \* Car Aerial Amplifiers
- \* Lighting Consoles

**PLUS MANY MANY MORE**

Call us now for details of your local Stockist

**HILLS COMPONENTS LTD**  
Units 5 & 6  
Melinite Industrial Estate  
Brixton Road, Watford  
Herts WD2 5SL  
0923 52000

# EE WEATHER STATION PART TWO

## MIKE FEATHER

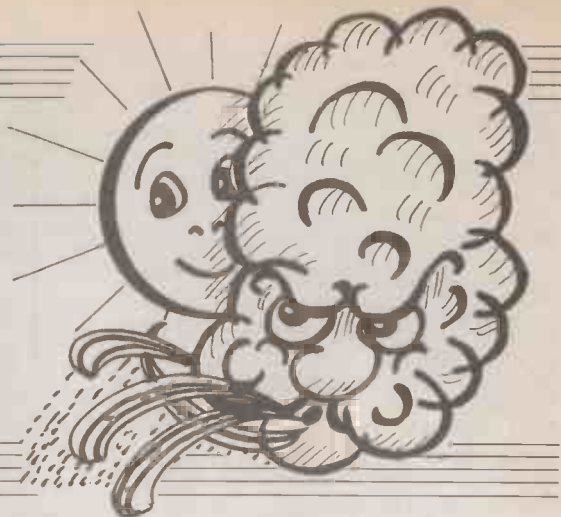

With the effects of the environment becoming more important each year, why not add some high-tech to your weather forecasting.

**F**OLLOWING on from the Wind Speed and Direction Indicator, described last month, we shall now proceed with details for a Temperature/Humidity unit for the EE Weather Station.

There are several different forms of temperature sensors available and we have chosen the relatively new LM35 semiconductor temperature sensors. These devices can be made to develop 10mV/degC over a wide range of temperatures and an important advantage is the fact that at 0°C the sensor output is zero.

A second LM35 is employed for humidity measurements and the system resembles a conventional wet and dry bulb hygrometer. The humidity is derived from the depression of the "wet bulb" sensor — see block diagram Fig.3, last month.

### TEMPERATURE/HUMIDITY

The complete circuit diagram for the Temperature/Humidity section of the Weather Station is shown in Fig. 17. Once again, this circuit is divided into two separate stages; sensing head and digital display.

*The completed Anemometer, Wind Direction and Temperature/Humidity sensor heads.*

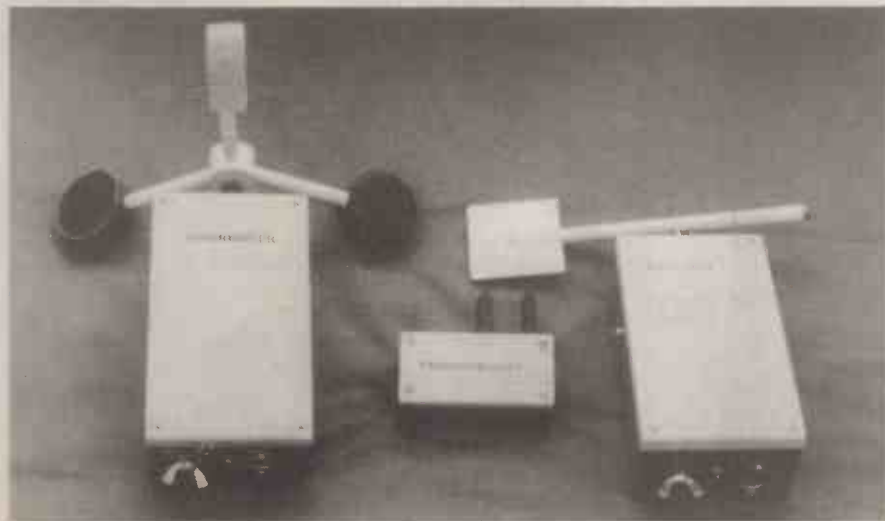

The sensor head uses two LM35 semiconductor centigrade temperature sensors IC1 and IC2. Diodes D1 and D2 are included in order to permit negative temperatures to be monitored, the arrangement shown providing an overall range of -50°C to +100°C.

Preset potentiometers VR1 and VR2 are 20-turn types and are included in order to provide equal output voltages from the two sensors i.c.s at the same temperature. The +5V supply for the sensor head is taken from the power supply board via the DIN socket SK6.

### DISPLAY

The temperature display unit employs a 7107 A/D converter display driver, IC3, which drives a three digit 7-segment i.e.d. display together with an extra digit for indicating negative temperatures. A s.p.d.t. switch S1 is used to select which of the two sensors — wet or dry "bulb" — is connected to the digital panel meter (7107) i.c.

The LM35 temperature sensors develop an output of 10mV/deg C so the overall voltage range to be measured is from -0.5V to +1.0V. The DPM chip (IC3) is thus set to its 2V range. Preset VR3

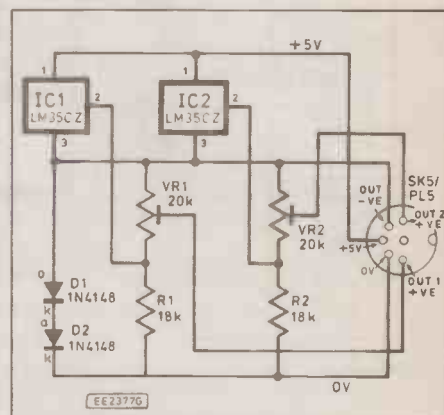

## COMPONENTS

### TEMPERATURE/HUMIDITY SENSOR HEAD

#### Resistors

R1, R2 18k  
0.25W 5% carbon film

#### Potentiometers

VR1, VR2 20k 20-turn min.  
preset, lin. (2 off)

#### Semiconductors

D1, D2 1N4148 signal diode  
(2 off)  
IC1, IC2 LM35CZ Centigrade  
temp. sensor (2 off)

#### Miscellaneous

SK5/PL5 6-pin 270° DIN socket  
and plug

ABS case; printed circuit board available from the EE PCB Service, order code EE678; tubing or ball-point pen case for housing sensors; connecting wire; solder etc.

Approx. cost  
Guidance only

# £14



provides a calibration facility whilst VR4 allows adjustment of the internal clock frequency and hence the rate of conversion.

The display driver IC3 requires a +5V supply and this is derived from the main positive unregulated supply via a 7805 voltage regulator IC4. A negative supply is also required and a 7905 negative regulator IC5 provides this.

Constructors might like to note that the current required for this negative supply is very small and that, instead of using a dual rail power supply (as in the prototype) it is possible to derive this negative supply from the DPM clock output using the circuit shown in Fig. 18. This would, of course, entail some modification to the display printed circuit board.

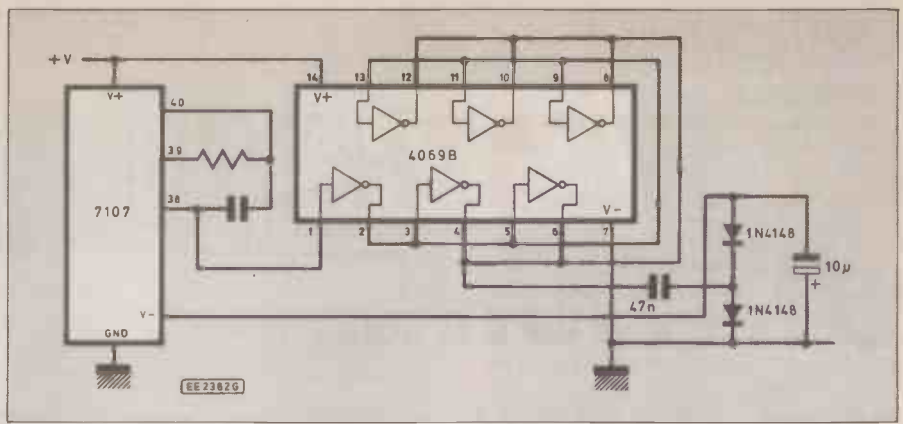

Fig.18. Alternative negative supply for the 7107 display driver i.c.

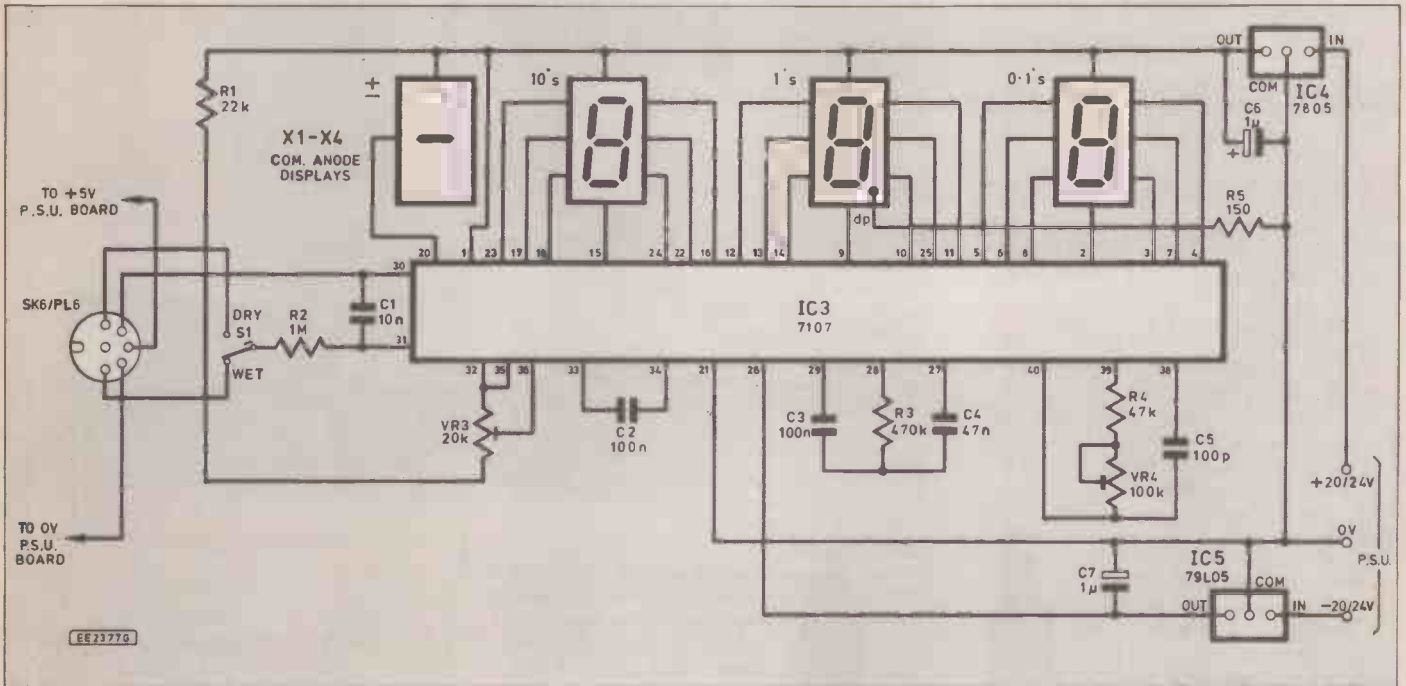

Fig.17. Complete circuit diagram for the Temperature/Humidity unit. The sensor head section is shown opposite.

Front panel layout for the EE Weather Station



## COMPONENTS

Guidance only

£20

### TEMPERATURE/HUMIDITY DISPLAY

#### Resistors

R1 22k R3 470k R5 150  
R2 1M R4 47k

All 0.25W 5% carbon film

#### Potentiometers

VR3 20k multi turn preset, lin.  
VR4 100k skeleton horiz. preset, lin.

#### Capacitors

C1 10n polyester  
C2, C3 100n polyester (2 off)  
C4 47n polyester  
C5 100p silver mica  
C6, C7 1µ elec. 16V (2 off)

#### Semiconductors

IC3 7107 A/D Con. I.e.d. display driver  
IC4 7805 +5V 100mA voltage regulator  
IC5 79L05 -5V 100mA voltage regulator  
X1-X4 7-segment, common anode I.e.d. display (4 off)

#### Miscellaneous

SK6/PL6 6-pin 270° DIN socket and plug  
S1 s.p.d.t. toggle switch  
Printed circuit boards, available from the EE PCB Service, codes EE671 and EE672; 40-pin d.i.l. socket (2 off); connecting wire; solder etc.

**Shop  
Talk**

see page 209

## CONSTRUCTION — TEMPERATURE/ HUMIDITY

The component layout and full size printed circuit board copper foil master patterns for the Sensor, Display and Drivers boards are shown in Figs. 19 and 21. These boards are available from the *EE PCB Service*, codes EE 671 and 672.

Care must be taken to ensure that the voltage regulators and electrolytic capacitors are inserted on the display board the correct way round. Also, to avoid any confusion, it is probably best to use multi-coloured ribbon cable when wiring from the board to the 7-segment displays.

The prototype unit employed four 0.5in common anode 7-segment i.e.d. displays, but other sizes could be used. Fig. 23 shows the connections between the display and display driver DPM i.c.

The complete Digital Display assembly is fixed to the front panel of the Weather Station display unit so that the i.e.d. displays are flush with the edges of the rectangular slots in the panel. The sensor select switch S1 is fixed to the rear panel of the unit alongside the 6-pin DIN input socket SK6.

The temperature/humidity sensors and the two diodes and presets are mounted in a small ABS plastics box as shown in Fig. 22. The sensor i.c.s should both project from the box as one of them needs to be kept wet. This can be accomplished by using some plastic tubing or an old disused ball-point pen barrel.

The presets and diodes are mounted on the small circuit board and slotted into the box as indicated. Connection to the remote display assembly is through 6-pin DIN sockets and plugs (SK5/PL5 and PL6/SK6) and four-core screened cable.

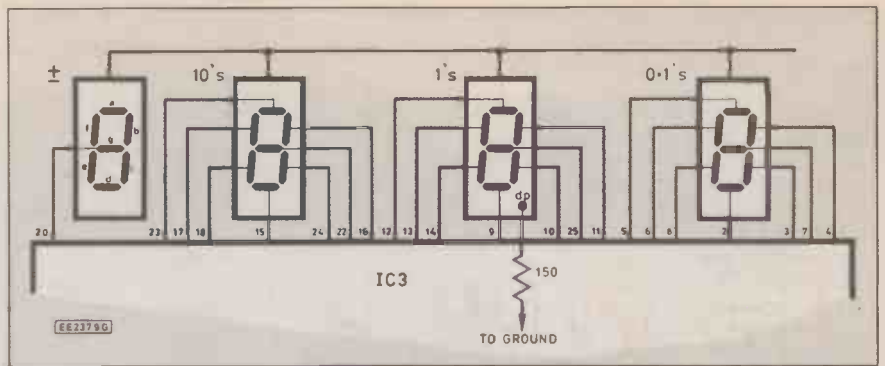
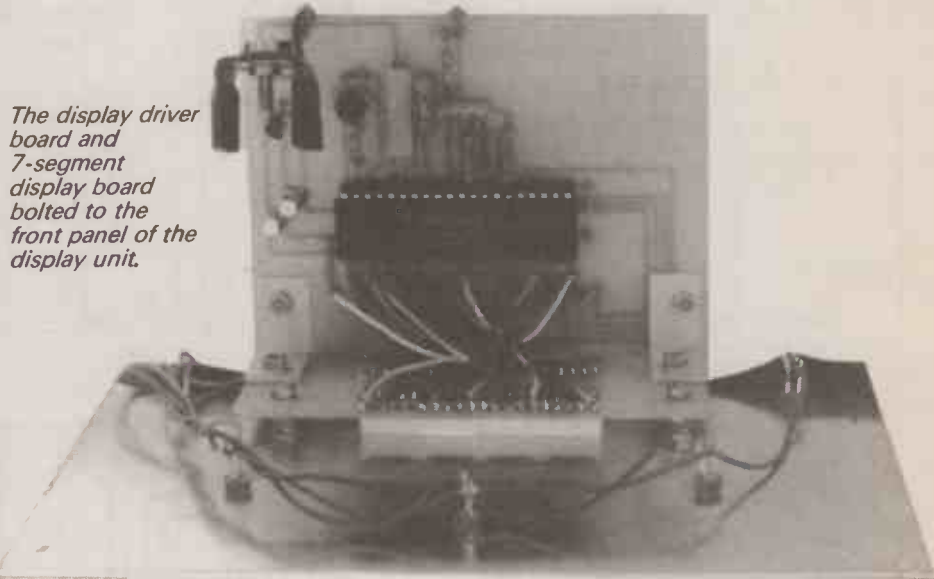

Fig.23. Connections between the 7-segment displays (X1 – X4) and the driver i.c.



The display driver board and 7-segment display board bolted to the front panel of the display unit.

The completed Temperature/Humidity sensor head showing the two detector i.c.s mounted on the end of two tubes and fixed with a resin glue.

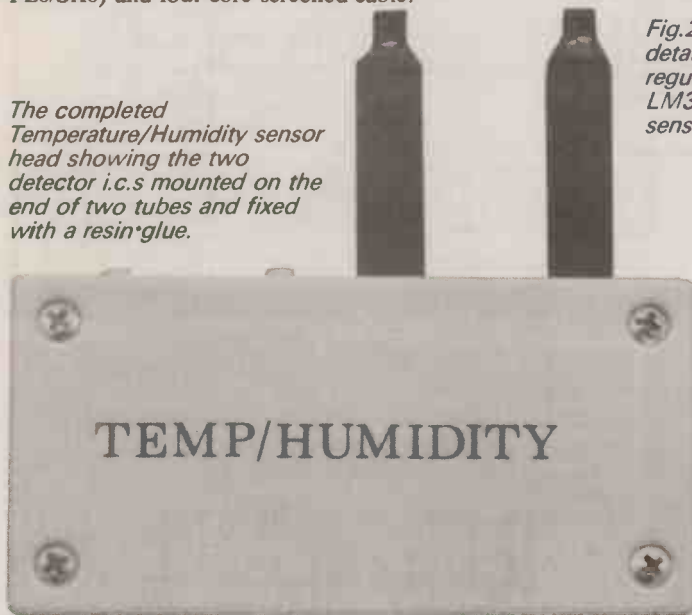
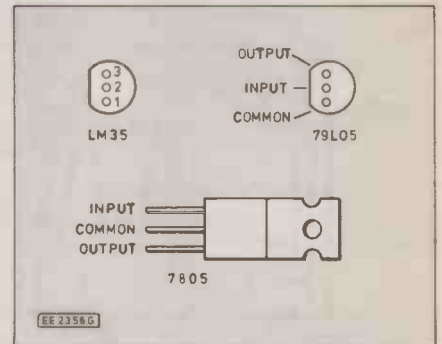

Fig.24 (right). Connection details for the two voltage regulators and the LM35CZ temperature sensor i.c.



Layout of components inside the sensor head. Refer to Fig.17 for wiring up the DIN socket.



(left) The finished sensor head board. Two holes are drilled in the board to take leads to the sensor i.c.s.

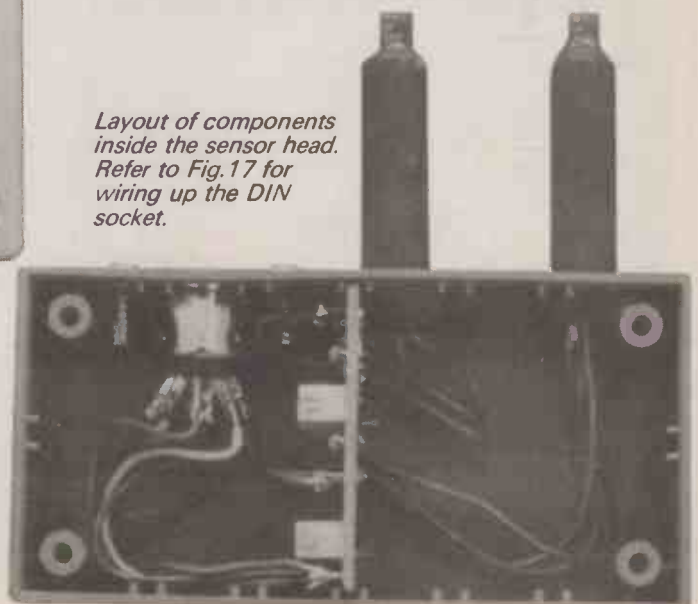

# TEMPERATURE/HUMIDITY DETECTOR

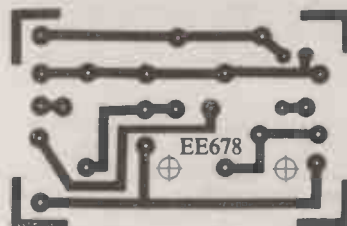
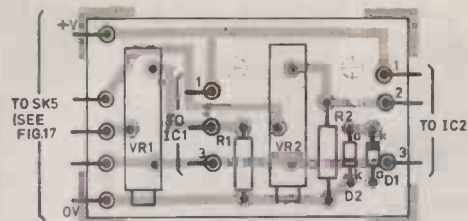
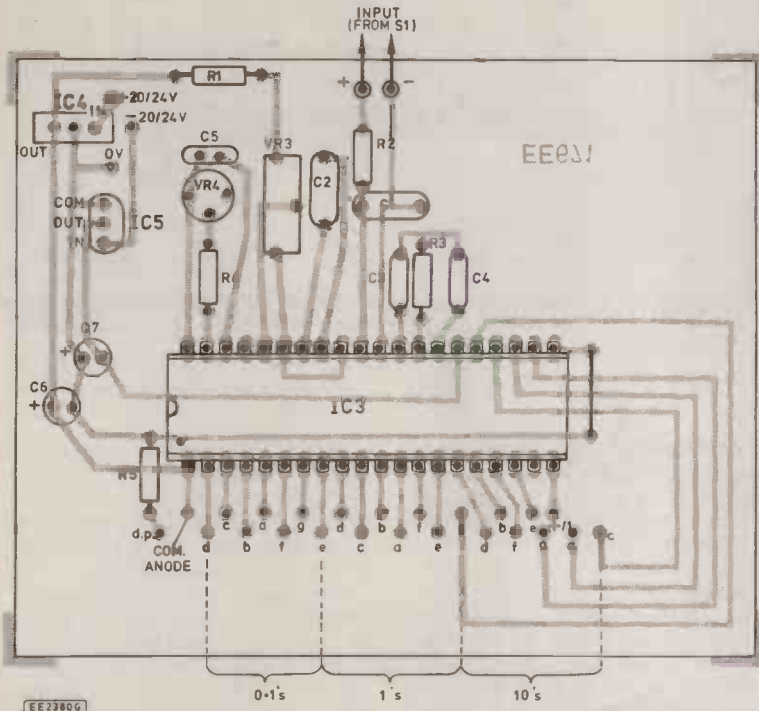

Fig.20. Component layout and printed circuit master for the sensor head.

Fig.19 (left). Component layout and printed circuit master for the display driver.

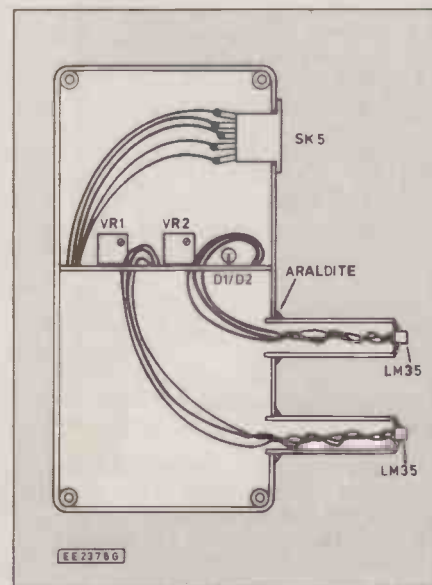
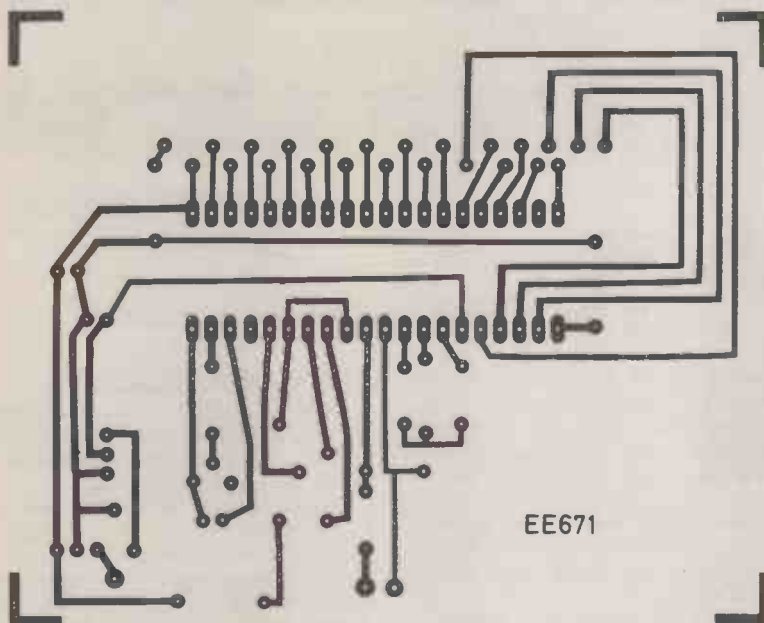

Fig.22. Layout of components inside the "sensor head" box.

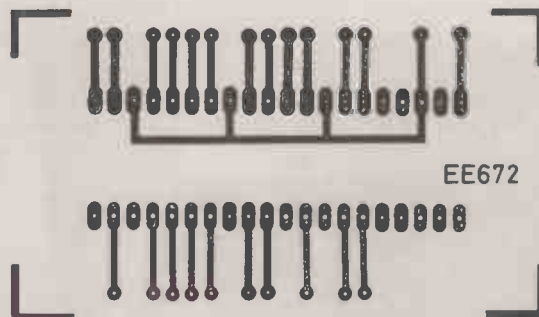
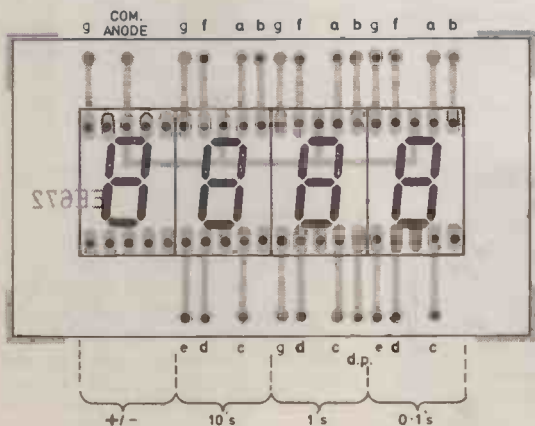
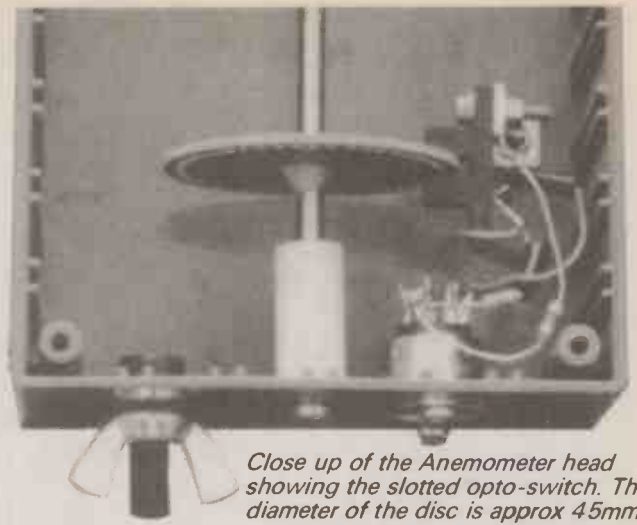

Fig.21. Component layout and full size printed circuit board master for the display board. Refer to Fig.19 and Fig.23 for connecting up information.



The three sensor heads plugged into the rear of the display cabinet.



Close up of the Anemometer head showing the slotted opto-switch. The diameter of the disc is approx 45mm.

## WEATHER STATION TESTING AND CALIBRATION

It is preferable to test each of the separate units before final installation in the display unit enclosure.

### Anemometer

The Anemometer head can be tested by applying a 6V power supply and connecting a voltmeter (10V range) between the signal output and 0V lines. Rotating the arms slowly should cause the output signal voltage to switch alternately between 0V and approximately 6V. Some adjustment of the position of the slotted opto switch may be required in order to achieve this.

The Anemometer head unit should now be connected to the wind speed display circuitry and power applied to this. Set VR1 to mid-track and rotate the arms: this should cause the i.e.d. bar display to give an indication which increases as the speed of rotation is increased.

Calibration can present problems but one method sometimes used is to take the unit for a trip in the car and compare the display readings with the car speed (choose a windless day!). VR1 can be adjusted to give a suitable range of measurable wind speeds.

The power supply can be derived from the car's own 12V system (via the cigar lighter?) in which case the voltage regulator IC5 should be bypassed. As an alternative, batteries can be used for the procedure.

Another method of approximate calibration is simply to site the Anemometer in its intended position and consult the Beaufort scale indications of the movement of trees etc.

### Wind Vane

The wind vane head unit should be tested in a manner similar to that employed for the Anemometer. A 5V supply is needed and this may be derived from a 6V battery with a 1N4001 diode wired between it and the wind vane head unit.

voltmeter indicates an output of 10mV/deg C for the sensor. So for example, at 20°C, the voltmeter should read  $20 \times 10 = 200\text{mV}$ . Repeat this procedure so that the other sensor gives exactly the same output at the chosen temperature.

The sensor unit should now be connected to the temperature display section of the circuitry and preset VR3 adjusted until the correct temperature is displayed. Control VR4 (converter clock rate) sets the rate of conversion and is best set at approximately half track.

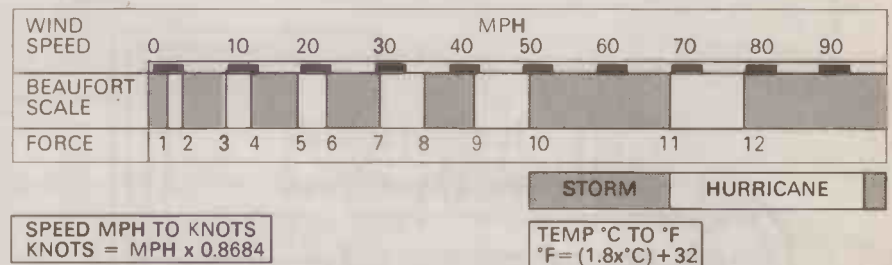

Fig.25. Wind speed conversion and information chart.

Using the voltmeter, check that each of the four outputs changes between the TTL low and high levels as the vane is rotated slowly. Again, some adjustment of the position of the sensor array may be necessary.

Now connect the unit to the display circuitry and rotate the vane. The direction indicator i.e.d.'s should light up in sequence if all is well.

"Calibration" involves installing the head unit in its intended location and rotating the box until the eight vane positions cause the appropriate i.e.d. to light up.

### Temperature/Humidity

A digital voltmeter was found to be most useful for testing and calibrating the Temperature/Humidity module. Wire up a 5V supply to the sensing head and connect the voltmeter to one of the sensors. At some known temperature, measure this voltage.

Adjust either VR1 or VR2 so that the

## FINAL ASSEMBLY

Each of the display units should now be installed in the Weather Station enclosure and the interwiring between sockets and the power supply completed.

The signal leads should be made up to the required length. In the prototype, these were several metres in length and no problems with signal degradation were apparent. As a final check, connect all the sensors to the display unit and ascertain that the whole system functions correctly.

The Anemometer and Wind Vane units were mounted together on a wooden spar which was then attached to a pole so as to locate the units some 10 metres above the ground. The temperature/humidity unit was situated outside a convenient window. The "wet bulb" of this unit has a short piece of cotton gauze attached to it, the lower end of which rests in a small container of water.

In order to determine the value of the humidity, it is necessary to consult a table of wet and dry bulb thermometer readings. These may be found in a number of publications, the commonest of which is perhaps "Physical and Chemical Constants" by Kaye and Labey, which should be available in a reference library

**Next Month: details of a Rainfall Gauge and Sunlight Indicator; both with digital readout.**

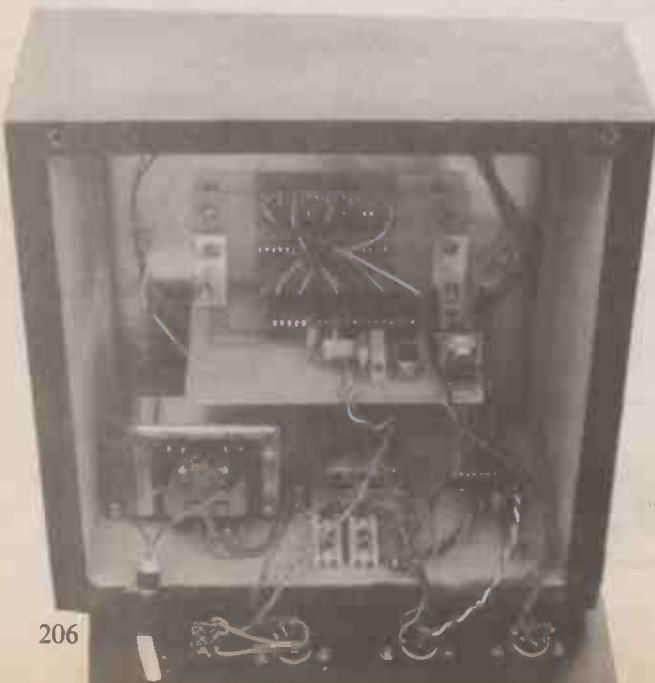

# THERE IS SOMETHING IN THIS FOR EVERYBODY

*no matter how far you are into electronics*

*With 134 new style pages and absolutely*

## FREE!

● **PHONE**  
0784 433 603  
Fax: 0784 435 216  
Telex: 264475  
Manchester  
061 432 4945  
Fax: 061 432 4127

● **WRITE**  
Electrovalve Ltd.  
FREEPOST  
28(e) St. Jude's Road,  
Englefield Green,  
Egham,  
Surrey TW20 8BR



● **ORDERS SENT POST FREE IN U.K.**  
● **ACCESS/VISA FACILITIES** (min. Order £5)  
**Head Office/Shop**  
28 St. Jude's Road, Englefield Green, Egham, Surrey TW20 0MB  
**Manchester**  
680 Burnage Lane, Manchester M19 1NA

Please mention this mag when answering

### NEW PRODUCTS

74HC series ICs		
74HC00 19p	74HC02 19p	74HC03 19p
74HC04 19p	74HC08 19p	74HC10 19p
74HC11 26p	74HC14 39p	74HC20 19p
74HC27 31p	74HC30 35p	74HC74 38p
74HC86 29p	74HC107 36p	74HC138 41p
74HC161 48p	74HC175 52p	74HC393 69p
74LS series ICs		
74LS00 20p	74LS02 20p	74LS05 20p
74LS30 20p	74LS32 20p	74LS51 20p
74LS90 30p	74LS93 30p	74LS107 23p
74LS112 23p	74LS138 35p	74LS139 35p
74LS151 38p	74LS164 38p	74LS193 55p
74LS245 58p	74LS374 52p	74LS375 64p
CMOS 4000 series ICs		
4001 19p	4002 19p	4011 19p
4012 25p	4013 26p	4014 45p
4015 56p	4016 91p	4017 40p
4018 63p	4019 29p	4020 45p
4023 19p	4027 36p	4040 45p
4046 51p	4049 29p	4066 29p
4070 21p	4071 19p	4075 19p
4076 74p	4081 19p	4082 19p
4510 47p	4511 47p	4514 £1.06

We can supply a wide range of components and TTL, CMOS and ECL ICs. We also supply PC, XT and AT spares at **LOW PRICES**. Write or phone for our FREE catalogue.

Serial I/O card for XT or AT only £16.00

Resistors at bulk prices **Your Mix**  
Carbon film, 0.25W, 5% 1p each or 45p for 50  
Metal film, 0.25W, 1% 3p each or £1.35 for 50  
Bargain pack, 100 mixed common value 0.25W 90p  
VC sockets, solder type (pin-price)  
14:10p, 16:11p, 20:14p, 24(0.6 or 0.3):16p.

Prototyping boards (Vero) IBM XT £45.00, IBM AT £52.00

ACCESS or AMERICAN EXPRESS welcome by post or phone. Callers by appointment please. VAT INCLUDED. Please add £1 for post and packing. Catalogue free. No minimum order charge.

### BLACKMORE ELECTRONICS LTD.

FREEPOST, Blandford Forum  
Dorset DT11 7BR

Office address: 4 The Plocks, Blandford

0258 451347 (24hr answerphone)

**IF YOU WANT A PC BUT CAN'T AFFORD ONE, or perhaps you want to upgrade yours but don't know how, send for our NEW book 'PC-DIY' which explains all about how to build, upgrade and fault-find PC XT and AT computers at LOW COST. 'PC-DIY' suits beginners and is a valuable reference for experts too!**

It lists all the parts you need, suggest sources of supply and give detailed descriptions of how to assemble a PC XT or AT to your specification. With 'PC-DIY' it's easier than you might think!

For your copy of 'PC-DIY' send a cheque for £7.95 (postage included) to Blackmore Electronics or phone our 24 hour hotline with your Access Card details. Available only from UK. Order code: 311

### SPECIAL OFFER!

#### COMPUTER BITS

Special offer! Floppy drive cleaning kits only 2.70 postage included. (State 5 1/4 or 3 1/2). We also sell mailers, pens, labels, binders, spares etc. etc.



## HART AUDIO KITS — YOUR VALUE FOR MONEY ROUTE TO ULTIMATE HI-FI

HIGH QUALITY REPLACEMENT CASSETTE HEADS



HART KITS give you the opportunity to build the very best engineered hi-fi equipment there is, designed by the leaders in their field, using the best components that are available.

With a HART KIT you have direct access to the friendly HART service, you are not dealing through, or paying for, any middlemen. Every HART KIT is not just a new equipment acquisition but a valuable investment in knowledge, giving you guided hands-on experience of modern electronic techniques. Telephone or write for our FREE LISTS giving full details of all our Kits, components and special offers. Here are a few selected items.

### AUDIO DESIGN 80 WATT POWER AMPLIFIER

This fantastic amplifier is the flagship of our range, and the ideal powerhouse for your ultimate hi-fi system. Featured on the front cover of the May issue of 'Electronics Today International' this complete stereo power amplifier offers World Class performance with the option of a stereo LED power meter and a versatile passive front end giving switched inputs, volume and balance controls. Tape, CD players, or indeed any 'flat' input may therefore be directly connected to bypass tone controls or give a 'stand alone' facility. The amplifier can also be supplied in 'slave' and 'monobloc' versions without the passive input stage and power meter.

All versions fit within the standard 400x260x75mm case to match our 400 Series Tuner range. ALL power supplies are stabilised, the heavy current supplies using the same mostet devices as the amplifier. The power supply, using a toroidal transformer, is in fact a complete module contained within a heavy gauge aluminium chassis/heat-sink and fitted with IEC mains input and output sockets. All the circuitry is on a proper printed circuit with low-resistance blade connectors for the six stabilised DC outputs. HART KITS don't leave you to fasten a few capacitors to the floor of the main chassis and wire the power supply the hard way! Remember with a HART KIT you get the performance you want at the price quoted through proper engineering design and the right components. We do not insult your intelligence by offering a kit at what seems a fair price and then tell you that you have to spend three times as much to get an upgraded model!

**K1100 Complete Stereo Amplifier Kit with LED Power Meter and 3-input Passive Stage. Total cost of all parts is £418.88**

**Our Discount Price for the Complete Kit ..... £365.98**

**K1100S Stereo Slave Version, with plain Front Plate ..... £308.43**

**K1100M 'Monobloc' mono version, with plain Front Plate ..... £224.15**

**RLH10 Reprints of latest 'Audio Design Amplifier' articles ..... £2.70**

**K1100CM HART Construction Manual with full parts lists ..... £4.50**

Reprints and construction manual can be purchased separately and their cost credited against subsequent kit purchase

All versions are supplied with dual primary mains transformers for use on 220/240v or 110/115v mains. Monobloc price does not include the construction manual.

SPECIAL OFFER until the end of February the K1100 kit will be supplied with the new ALPS low noise precision pots at NO EXTRA CHARGE

### LINSLEY-HOOD 400 SERIES SUPER HIGH QUALITY AM/FM TUNER SYSTEM

This is the ideal companion tuner to the 80W Audio Design Amplifier in any ultimate hi fi system with case size, front plate layout and even control pitches unified for stacking. Like the 80W Audio Design Amplifier this is your route to EK+ performance for a few tenths of the cost! Two designs by John Linsley Hood make up this combination of his ultra high quality FM tuner and stereo decoder described in 'Electronics Today International' and the Synchrodyne AM receiver described in 'Wireless World'. Novel circuit features in the FM section include ready built pre-aligned front end, phase locked loop demodulator with a response down to DC and advanced sample and hold stereo decoder together making a tuner which sounds better than the best of the high-priced exotica but, thanks to HART engineering, remains very easy to build and set up. The Synchrodyne section with its selectable band width provides the best possible results from Long and Medium wave channels, so necessary in these days of split programming. If you want the very best in real HF listening then this is the tuner for you. Since all components are selected by the designer to give the very best sound this tuner is not cheap, but in terms of its sheer sound quality, it is incredible value for money. To cater for all needs AM only and FM only versions are available as well as the full AWMF model, with any unit being upgradable at any time. For further details see our fully illustrated lists.

**K400 FM Only version, total cost of all parts is £211.90.**

**Our special discount price for complete kit only ..... £169.52**

**K400 AM/FM version, Discount Price for complete kit ..... £249.08**

### STUART TAPE RECORDER CIRCUITS

Complete stereo record, replay and bias circuit system for reel-to-reel recorders. These circuits will give studio quality with a good tape deck. Separate sections for record and replay give optimum performance and allow a third head monitoring system to be used where the deck has this fitted. Standard 250mV input and output levels. These circuits are ideal for fitting that old valve tape recorder back to life. Suitable stereo heads are available at very reasonable prices.

**K900W Stereo Kit with Wound Coils and Twin Meter Drive ..... £90.68**

**RJ51 Reprints of Original Descriptive Articles ..... £2.60**

### LINSLEY-HOOD CASSETTE RECORDER CIRCUITS

Complete record and replay circuits for very high quality low noise stereo cassette recorder. Circuits are suitable for use with any high quality cassette deck. Switched bias and equalisation to cater for chrome and ferric tapes. Very versatile and easy to assemble on plug-in PCBs. Complete with full instructions.

**Complete Stereo Record/Play Kit ..... £57.60**

**VU Meters to suit ..... £3.99 each**

**RLH1 & 2 Reprints of Original Articles ..... £2.70**

Our latest lists also give details of our ranges of specialist high quality AUDIO CONNECTORS and LEADS, cassette decks and seasonal special offers. Write or telephone for your FREE copy. (Overseas 2 IRCs Please, or 5 for Airmail).

Do your tapes lack treble? A worn head could be the problem. Fitting one of our replacement heads could restore performance to better than new! Standard inductances and mountings make fitting easy on nearly all machines and our TC1 Test Cassette helps you set the azimuth spot on. As we are the actual importers you get prime parts at lower prices, compare our prices with other suppliers and see! All our heads are suitable for use with any Dolby system and are normally available ex stock. We also stock a wide range of special heads for home construction and industrial users.

- HS16 Sennod Alloy Stereo Head. High quality head with excellent frequency response and hyperbolic face for good tape contact. £17.86  
HC40 NEW RANGE High Beta Permalloy Stereo head. Modern space saver design gives excellent high-frequency response with easy fitting and lower cost. Suitable for chrome, metal and ferric tapes, truly a universal replacement head, with ample quality for Hi Fi decks and cheap enough for car players! £6.65  
HX100 Special Offer Stereo Permalloy Head ..... £2.86  
HRP373 Downstream Monitor Stereo Combination Head ..... £44.39  
HQ551 4-Track Record & Play Permalloy Head for auto-reverse car players or quadraphonic recording ..... £16.79  
H524 Standard Erase Head ..... £2.59  
SM166 2/2 AC Erase Head, Standard Mount ..... £12.60  
HS9510 2/4 Stereo DC Erase Head ..... £8.70  
HQ751E 4/4 AC Erase Head, tracks compatible with HQ551 ..... £57.06
- We can supply card reader heads for OEMs at very keen prices.

### REEL TO REEL HEADS

- 999R 2/4 Record/Play 110mH. Suits Stuart tape Circuits ..... £13.34  
998E 2/4 Erase Head 1mH. Universal Mount. Suits Stuart ..... £11.96

### TAPE RECORDER CARE PRODUCTS

- HART TC1 TEST CASSETTE Our famous triple purpose test cassette. Sets tape azimuth, VU level and tape speed ..... £5.36  
DEM1 Mains Powered Tape Head Demagnetizer, prevents noise on playback due to residual head magnetisation ..... £4.08  
DEM115 Electronic, Cassette Type, demagnetizer ..... £8.61

Our new Winter '89 price list is FREE. Send for your copy now. Overseas customers welcome, please send 2 IRCs to cover surface post, or 5 for Airmail.

We now accept inland and overseas orders by post or telephone on all Access, Master and Visa Credit Cards.

Please add part cost of carriage and Insurance as follows:

INLAND: Orders up to £20 — £1; Orders over £20 — £2.50; Next day — £9. OVERSEAS: Please see the ordering information with our lists.

## QUALITY AUDIO KITS

24hr SALES LINE  
(0691) 652894

ALL PRICES INCLUDE VAT



HART ELECTRONIC KITS LTD.  
6 PENYLAN MILL  
OSWESTRY, SHROPSHIRE  
SY10 9AF



*a regular feature for the Spectrum Owner...*

by Mike Tooley BA

**T**HIS month, *On Spec* will be of particular interest to those of you who are proud new owners of an MGT Sam Coupé or those who may be thinking about purchasing one of these excellent machines in the future. The Coupé is the first of a promised line of microcomputers from Miles Gordon Technology which aim to provide the Spectrum owner with logical upgrade path to a range of machines which continue where Sinclair and Amstrad have feared to tread.

### System Variables

I have mentioned the Spectrum's System Variables on a number of occasions. System Variables are simply a set of data values stored in a set of reserved memory locations. Since these locations are in RAM, we can easily modify them and thus configure the machine to our own particular set of requirements. However, as with the humble "Speccy", it is important to note that not all of the system variables are suitable for modification. Furthermore, others (which are constantly updated by the system) can only be changed on a purely temporary basis.

Changes to a system variable can be made very easily by simply POKing new data into the location in question. Alternatively, if we just wish to *examine* the state of the system variable at a particular point in time we need only PEEK into the respective location.

The Coupé system variables are stored from address 23040 (5A00 hexadecimal) onwards. The SAM Coupé has many more system variables than its predecessor but this should come as no particular surprise since the machine is very much more powerful. Be aware that there are over a hundred system variables and MGT's documentation does not yet provide a *complete* list!

For those who would like to take a look at the Coupé's system variables (or, at least the first seventy of them) the following short program should suffice:

```
10 PRINT "List of System Variables"
20 PRINT
30 PRINT "Number"; TAB(8);"Address"; TAB(18);"Contents"
40 FOR x=0 TO 69
50 PRINT x; TAB(8); SVAR x;TAB(18);PEEK.SVAR x; TAB(26);
60 IF PEEK SVAR>31
```

```
70 PRINT CHR$(PEEK SVAR x)
80 ELSE PRINT "... "
90 END IF
100 NEXT x
```

Note that the foregoing listing has been printed using LIST FORMAT 2. Furthermore, for the sake of clarity, all of our *On Spec* SAM BASIC listings will appear in this format.

The program produces a display along the following lines:

#### List of System Variables

Number	Address	Contents
0	23040	62 >
1	23041	128
2	23042	129 =
3	23043	49 1
4	23044	48 0
5	23045	35 #
6	23046	84 T
7	23047	112 P
etc		

Where a system variable is non-printable it will appear as *two* full stops, "...".

The first few system variables displayed earlier are quite useful and have the following functions:

No	Name	Function
0	LNCUR	Cursor character used to denote the "current line" (default ">")
1	LCCUR	Cursor character used for input when CAPS lock is off (default CHR\$(129))
2	UCCUR	Cursor character used for input when CAPS lock is on (default CHR\$(128))
3	BIN1DIG	Character used by BINS to indicate "1" (default "1")
4	BIN0DIG	Character used by BINS to indicate "0" (default "0")
5	INSTHASH	Character used by the INSTR function as a wildcard (default "#")
6	SLDEV	Current device letter ("T" on a tape system)
7	SLNUM	Current tape SAVE speed, or default drive if the system is fitted with disk drives.

(Note that all three of the cursor characters contained in variable numbers 0, 1, and 2 appear on the screen in *inverse* video.)

As an example of modifying the System Variables, LCCUR may be changed to "?" by a command (or program statement) of the form:

**POKE SVAR 1, "?"**

Alternatively, UCCUR can be changed to a "!" by a command (or program statement) to the form:

**POKE SVAR 2, "!"**

As an exercise, Coupé owners may like to try the two foregoing POKes and ex-

amine the effect on the cursor characters, before running the program to list the System Variables a second time. The new cursor characters should appear in their respective locations within the table of System variables!

### Video output

For those of you lucky enough to possess a monochrome monitor, the Coupé will provide excellent 80 + column text in text mode. This mode is ideal for software development and also for serious applications such as word processing. This mode is even better when the Coupé is used with a high-resolution monochrome monitor (such as a Philips green screen monitor). In this case, the video and audio signals can be taken from the Coupé's SCART connector and fed via a SCART-to-phono cable (available from under £10 from most video shops) to the monitor.

### Watch that SCART!

Whilst on the subject of video, one of the pitfalls for the unwary is associated with the unconventional use of the SCART connector. Apparently, MGT are working on a version of the machine which they hope will find favour in the highly cost-conscious education market. This machine will derive its power from a matching colour monitor (rather than from a separate mains power supply/modulator box).

To keep things as simple as possible (and to avoid a plethora of cables at the rear of the machine), MGT have decided to provide +5V and +12V power supply inputs via the SCART connector. This connector (often referred to by Far Eastern manufacturer's as a "Euroconnector") is not normally expected to carry power rails and its specification only relates to video and audio signals!

If, like me, you decide to "tinker" with the Coupé's SCART connector, it is absolutely imperative that you avoid short-circuiting the positive supply rails to any of the signal lines. The consequence of not observing this precaution is that you are quite likely to destroy the ASIC (Application Specific Integrated Circuit) which is the "heart" of the Coupé and whose output pins are directly connected to the SCART connector. In fairness, the pin connections for the Coupé SCART connector are clearly shown in the excellent "SAM Coupé User's Manual". There must be a moral here somewhere!

### Graphics modes

Regular readers should not need reminding that the SAM Coupé boasts no less than four different graphics modes. Mode 1 is the standard "Spectrum Mode" which employs 32 character cells arranged in 24 lines. Mode 2 offers 32 character cells by 192 lines whilst Mode 3 employs 512 pixels by 192 lines and offers an 85 column screen when using characters having a pixel width of 6. Finally, Mode 4 is designed for the display of graphics and generates a screen image of 256 × 192 addressable points.

Each of the graphics modes has its own particular characteristics and peculiarities and several of SAM BASIC's graphics commands relate only to particular modes. Furthermore, the speed at which certain commands execute is determined by the graphics mode in use, as witnessed by the following demonstration program:

```

10 FOR m=1 TO 4
20  MODE m
30  FOR x=50 TO 150 STEP 50
40    FOR y=5 TO 50 STEP 5
50      LET xos=x
60      LET yos=y
70      CIRCLE 20,100,20
80      NEXT y
90    NEXT x
100   PRINT AT 12,12;"CIRCLES"
110   PRINT AT 13,12;"Mode = ";m
120   INPUT "Press <RETURN> for
        next mode";r$
130 IF r$="q" THEN STOP
140 NEXT m
150 GO TO 10

```

If you have any interest in programming Coupé graphics it may be worth checking this little piece of code out — you should find that Mode 4 is noticeably faster than any of the others!

### Advanced User Guide

Finally, it is perhaps worth mentioning that MGT's "Advanced User Guide" can be highly recommended. This document will be invaluable to anyone wishing to make use of the advanced features offered by the machine. Sections are included on the various hardware interfaces.

Coupé memory, screen modes, the keyboard, system variables, interrupts, SAM BASIC, ROM routines, the sound generator, and more. The manual is reasonably priced and provides endless bedtime reading for insomniacs like me!

**Next Month:** We shall be delving into memory-related topics on the SAM Coupé. We shall also be including some programming details for the Philips SAA1099 stereo sound generator.

Mike Tooley, Faculty of Technology, Brooklands College, Heath Road, Weybridge, Surrey KT13 8TT.

# SHOP TALK



BY DAVID BARRINGTON

## Superhet Broadcast Receiver

Quite a few of the components called up for the *Superhet Broadcast Receiver* are special items and will most probably be difficult to locate locally.

The audio amplifier i.c. TDA7052 seems to be fairly widely available, but the only source we have found for the radio i.c. type TEA5570 is from Magenta Electronics. The oscillator coil is a Toko device and was purchased from the same company. A large range of Toko coils are also carried by Cirkit, who are main distributors.

Ferrite rod m.w./l.w. aerials and solid dielectric tuning capacitors are stocked by most good component suppliers. However, you will have to choose carefully and check that the tuning capacitor is of the correct value and will fit on the p.c.b. before you purchase. Also, make sure the aerial has coupling windings.

A complete kit of parts, including p.c.b.s, fully drilled clear plastic panels and dial, is available for the sum of £15.99. A kit without dial and panels cost £12.99. Both kits may be purchased from Magenta Electronics, Dept EE, 135 Hunter Street, Burton on Trent, Staffs, DE14 2ST. Add £1 for p&p per order.

The two small single-sided printed circuit boards are obtainable through the *EE PCB Service*, codes EE679 and EE680 (see page 216).

## EE Weather Station

Before we tackle the problems of buying components for this month's installment of the *EE Weather Station* we should like to recap on some of last month's items.

We have been informed by Hobbykit (Fax 01 205 0603) that the OP160 infra red i.e.d. and the OP500 phototransistor called up for the Wind Direction Vane are American type numbers and devices. They say that provided there is enough interest they will be happy to try and obtain stocks, at a reasonable price. The same

company also have access to stocks of the special 3-bit Gray-to-decimal decoder i.c. type 7444 used in the Wind Direction Display unit.

Due to a slip up by the designer and ourselves we failed to give the diameter of the "interrupt" disc used in the Anemometer head. This should be 45mm diameter.

Of special interest to constructors of the Weather Station is a hardware kit from Maplin for a wind speed and direction indicator housing which looks as though they will be ideal for housing the circuits published in part one, last month. The hardware kit (£34.95) is designated: LM90X Wind Hardware Kit.

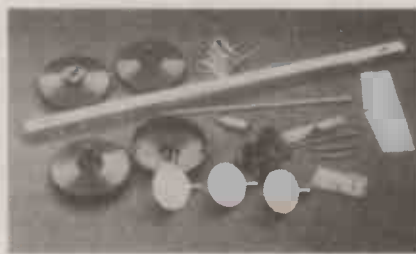

The 7-segment, common anode i.e.d.s used for the display in the *Temperature/Humidity* section of the Weather Station are stocked by most component suppliers, but be warned they do come in differing pinout arrangements. When ordering try to check the device against the circuit and p.c.b.

The 18-turn trimmer potentiometer seems to be in more common supply than a 20-turn type. The use of a 18-turn device should not affect the performance of the unit.

When ordering the temperature sensor i.c. it is important to ask for the Centigrade version, designated with the letters CZ. The rest of the semiconductors appear to be listed in most component suppliers catalogues.

The three printed circuit boards required for the Temperature/Humidity section of the Weather Station are available from the *EE PCB Service*, see page 216 for prices.

## Fermostat Mark 2

We make no apology for repeating the warning to readers about handling any mains driven equipment with extreme care. This applies equally to the *Fermostat Mark 2* and any other published mains design.

Under no circumstances should any part of the circuit or its wiring be touched when it is plugged in to the mains supply. This includes the temperature sensor i.c., which should be fully encapsulated.

It is most important to use the specified mains transient suppressor and mains rated capacitor. These should be available from most advertisers, but in case of difficulty they are currently stocked by Maplin — codes HW13P (Mains Trans Supp) and JR33L (IS Cap 0.047µF).

The rest of the components for this project should be readily available as "off-the-shelf" items. Note the use of one watt resistors for R1, R2 and R12.

The printed circuit board for the *Fermostat Mark 2* is available from the *EE PCB Service*, code EE677 (see page 216).

## Linear Scale Ohmmeter

The LM334Z programmable constant current source i.c. called for in the *Linear Scale Ohmmeter* is listed by many of our advertisers and should not cause any local sourcing problems.

The enclosed presets and slider potentiometer are now widely available. Remember to specify *linear* types when ordering. It is quite in order to use skeleton presets and a rotary potentiometer in this circuit. It will, of course, mean a different form of readout scale.

For good accuracy it might be beneficial to use one per cent carbon film resistors for the fixed resistors.

## Electronic Dice

We cannot foresee any component buying problems for the *Electronic Dice*, this month's "pocket money" project. The CMOSS 555 timer should also work quite well in this circuit.

## The Fax

Last month we gave details of the move of *Bi Pak* from Hertfordshire to Southampton and the publication of their free 1990 "bargain" catalogue.

We regret that we gave an incomplete Fax number and apologies to readers for any inconvenience caused. The correct fax for *Bi Pak* is as follows: **FAX 0703 787555**.

# DOWN TO EARTH

BY GEORGE HYLTON

## SIDEBANDS

In the 1930's, a stir was caused in radio engineering circles by the appearance, at an exhibition, of a "revolutionary" kind of AM radio receiver. The Stenode, as it was called, purported to have infinite selectivity.

It was claimed that problems of interference from broadcasts on neighbouring channels, which were beginning to be a nuisance, could now be eliminated. As many stations as desired could now be put on air, and as long as their "carrier frequencies" were different they could be separated by the Stenode's razor-sharp selectivity.

## THEORY AND PRACTICE

This caused some consternation among theoreticians. Mathematical analysis showed that the performance claimed for

the Stenode was impossible. In an amplitude-modulation (a.m.) radio system (Fig. 1a), a steady high frequency carrier wave ( $f_1$ ) is applied to a modulator. Also applied is an audio frequency signal ( $f_2$ ), shown here as a steady sine wave. The effect of the modulation process is to make the carrier vary in amplitude in the same way as the modulation frequency  $f_2$ , giving the output wave shown, where the "envelope" of the wave follows  $f_2$ .

Mathematical analysis shows this waveform to be a mixture of three steady high-frequency sine waves. One is the carrier  $f_1$ . The other two are sum and difference frequencies. One is  $f_1 + f_2$ , the other  $f_1 - f_2$ , see Fig. 1b. Since these new frequencies lie on either side of the carrier  $f_1$  they are called side frequencies.

Actual radio sound programme material (voice and music) consists, not of single steady audio sine waves but a complex mixture. Each audio frequency in the programme generates its own pair of side frequencies, so the single side frequencies are spread out into bands of frequency, called the upper sideband (sums) and the lower sideband (differences).

## SELECTIVITY

Now, it was obvious to the theorists that  $f_1$  in the modulated signal was just a steady, unchanging carrier. It could therefore convey no information about the modulation. All this must be contained in the sidebands.

A receiver tuned so sharply that it removed everything but the carrier  $f_1$  couldn't possibly deliver the modulation. It would have infinite selectivity for carriers but wouldn't give the listener any programmes.

Clearly, to allow the programmes to get through, the receiver's tuning must be broad enough to allow the sidebands to pass as well as the carrier. In terms of

a simple receiving scheme (Fig. 2) the bandpass filter must allow both carrier and sidebands to pass to the detector.

The detector, by rectifying the complex envelope signals then delivers the original audio, plus some high-frequency rubbish which is removed by the low-pass filter.

## REAL OR FICTIONAL

That, at any rate, was the classical, mathematics-based picture of a.m. radio. Yet here were these Stenode people saying it was all nonsense and that selecting the carrier alone was sufficient to give the programme.

Now, in the Thirties, laboratories were not equipped with digital frequency meters, precision synthesised signal generators, spectrum analysers and suchlike luxuries. Everything was analogue and relatively crude.

Engineers had taken the mathematical analysis on trust. Nobody had actually measured the spectrum of an a.m. signal. Could it be, after all, that sidebands were an illusion, a mathematical fiction?

The only convincing answer was to measure them. It was done, at the National Physical Laboratory, by making an extremely sharply tuned receiver and tuning it to frequencies around a carrier modulated with a steady audio sine wave.

If the audio is at, say, 3kHz and the receiver bandwidth is, say, 100Hz then it should be possible to tune in separately to the carrier and the two side frequencies. Taking measurements at intervals of say 100Hz should give an output spectrum like Fig. 3.

Well, it did. The mathematical analysis was vindicated. But why, in this case, did the Stenode work?

The answer lay in the true nature of its selectivity. No filter, however good, can reject all side frequencies completely. Something gets through: attenuated, certainly, but still there.

Given plenty of audio amplification and a bit of top lift (the more distant side frequencies, corresponding to the higher audio frequencies in the programme, are attenuated most) the programme can still be recovered. The Stenode used, for sharpness, a crystal filter (an innovation in those days) but it still let enough of the sidebands get through.

## PITFALLS OF THEORY

A triumph for theory? Well, yes, but a dangerous one. There were features of the Stenode which would have been worth exploring, but they weren't. And as time went by another case cropped up in

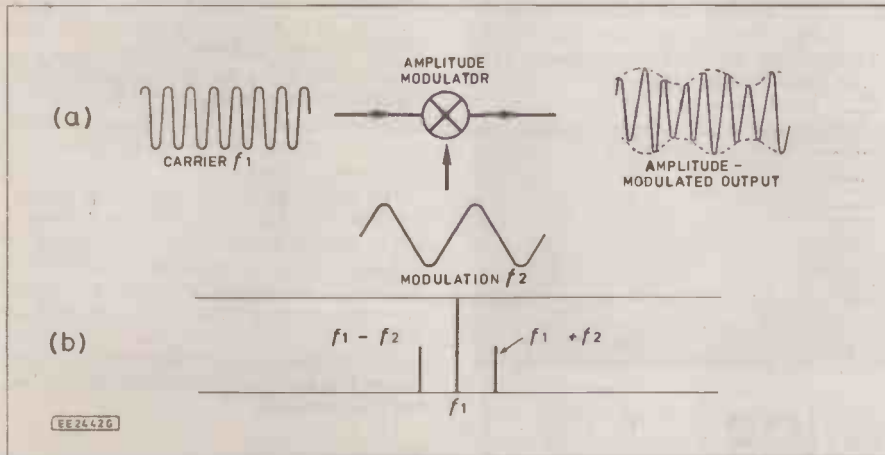

Fig. 1. (a) Amplitude modulation (a.m.) systems. (b) Spectrum of h.f. carrier ( $f_1$ ) amplitude modulated by a single audio frequency  $f_2$ .

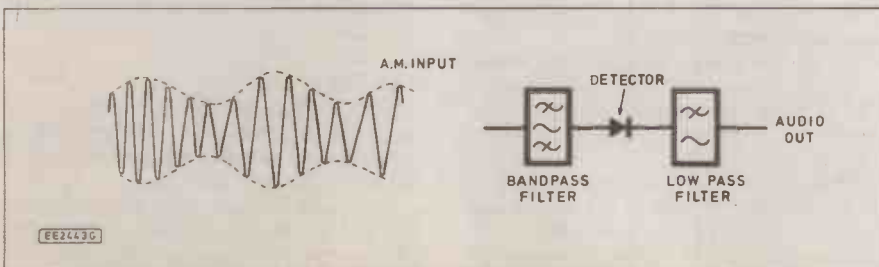

Fig. 2. Essentials of a.m. receiver.

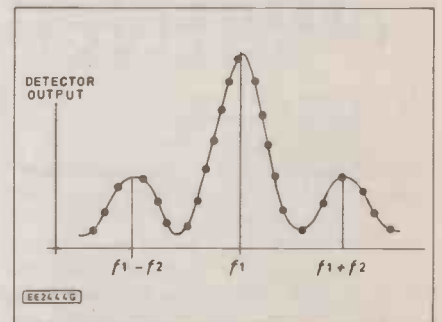

Fig. 3. D.C. output from detector when a very sharp bandpass filter is used in Fig. 2 and tuned across the signal spectrum.



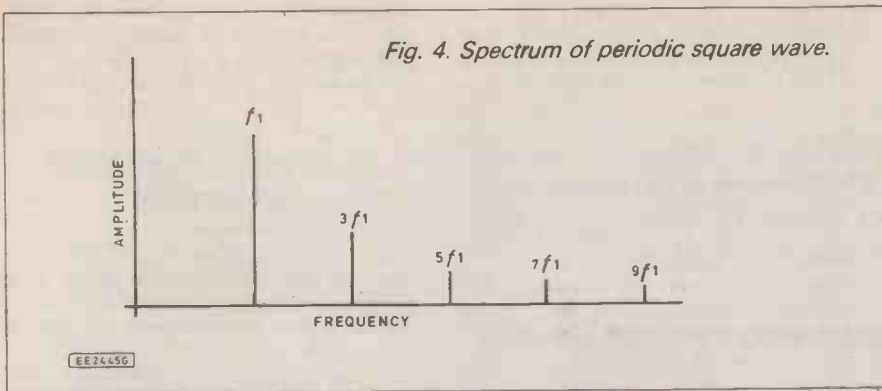

Fig. 4. Spectrum of periodic square wave.

which theory was shown to be positively counter-productive.

Engineers had come to realise that all communications systems have very limited bandwidth. To carry one medium quality a.m. radio channel requires a bandwidth of about 18kHz. This means that the sidebands of adjacent channels overlap. Carriers in the MW and LW bands cannot be spaced closer than 9kHz or 10kHz.

Then someone said: Suppose we take a carrier frequency of say 1000kHz and frequency-modulate it. By reducing the strength of the modulation we can reduce the amount of frequency deviation as much as we like.

Suppose the modulation pushes our 1000kHz up and down by 1kHz. Then the spectrum we need is only 999kHz to 1001kHz. By using another carrier, at say 1003kHz, we can fit in a second channel, occupying 1002-1004kHz, then another with a bit higher carrier frequency and so on. In this way we can pack lots of speech channels into our limited bandwidth.

This cannot be, said the mathematicians. They proved that there was a fundamental error. When a 1000kHz carrier is frequency-modulated so that it swings from 999kHz to 1001kHz, they showed, side frequencies are generated which lie beyond these limits.

In fact, mathematical analysis showed that the sidebands of a frequency-

modulated signal are much more extensive than those of an a.m. system. In the FM case, the sidebands extend to *infinity*. For this reason f.m. is useless as a means of transmitting several channels over the same medium. Each channel must interfere with every other one.

### PRACTICALITY

You know, of course, that f.m. is quite practical. True, it isn't used for medium and long wave transmissions, but it's a great success for VHF. Every f.m radio channel does not interfere with every other. So what went wrong with the theory?

A more careful analysis showed that, while f.m. sidebands do indeed extend to infinity, you can remove the side frequencies remote from the carrier without doing much damage to the modulation. You create a little distortion, that's all.

If this is tolerable, FM can be made to work. Your FM radio shows that in practice an excellent compromise between distortion and interference can easily be reached. The theoreticians had revealed something which was true (infinite sidebands) but irrelevant.

Not all theoreticians are as enslaved by their calculations. You still see, occasionally, disparaging references to the scientist who is said to have announced in years gone by that his calculations showed that a bumble-bee couldn't possibly fly.

The poor man knew perfectly well that it could. What he was really saying, with his tongue in his cheek, was that current knowledge of aerodynamics was inadequate to explain the bumble bee's flight. With wings that size, and that amount of body weight, available theory predicted that the amount of lift generated by flapping the wings is inadequate!

Many years later, another scientist, equipped with a high-speed cine camera, solved the problem. He showed that the bumble-bee swings its wings through such a wide arc that they meet and press together above its body. When subsequently they are pulled apart, a partial vacuum is created which pulls the insect upwards. This supplies the missing lift.

### RESPECT BUT SCRUTINIZE

The moral of these stories is: Respect theory, but scrutinize it carefully. The maths may be right, but the conclusions drawn may not.

Take, for example, the repeating square wave of Fig. 4. Theory shows that its spectrum consists of a fundamental frequency plus all the odd harmonics to infinity.

This reveals that in transmitting square waves there may be bandwidth problems. But in many practical cases all that is required is to transmit the information that a signal is present. For this, it may be enough to send only the fundamental, or only any one harmonic. The rest are irrelevant.

This kind of consideration led, in World War I, to the use of an ingenious device called the Fullerphone. D.C. Morse signals (which leave the Morse key as rectangular waves, rich in harmonics) were passed along telephone cables, together with speech. But first, the harmonics were attenuated by a low-pass filter with a cutoff below the speech range. The Morse no longer interfered with the speech. Also, it no longer contained high-frequency impulses which might be picked up at a distance by the enemy.

## OMNI ELECTRONICS

174 Dalkeith Road, Edinburgh EH16 5DX · 031 667 2611

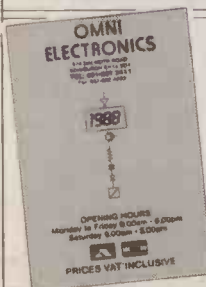

Have you sent for your copy of our catalogue yet?

If not, simply send 2X 1st class stamps for a copy by return.

A COMPREHENSIVE RANGE WITH SERVICE SECOND TO NONE

Open: Monday-Friday 9.00-6.00  
Saturday 9.00-5.00



### CAMBRIDGE COMPUTER SCIENCE LIMITED

- ☆ 10MByte Winchester, used, 3 months Wty ..... £42.00 each
  - ☆ 5.25" Disk Drives, 80 Tk, DSD ..... £34.00 each
  - ☆ 5.25" drive cases, room for drive, PSU & fan ..... £10.00 each
  - ☆ Buy a case, winchester & PSU together for ..... £64.00 each
  - ☆ Small cases, to fit 2 Half Ht 5.25" drives ..... £10.00 each
  - ☆ 5.25" Drives, Used-untested-no warranty ..... £15.00 each
  - (untested drives are sold on a strictly "as is" basis)
  - ☆ 5.25" Disks, DSD, 48 tpi boxes of 10 ..... £3.00 box
  - ☆ 50W PSU 5V 6A, 12V 2.5A, -5V 0.5A, -12V 0.5A ..... £16.00 each
  - ☆ Gould PSU 0-30V @5A Limited quantity only at ..... £45.00 each
  - ☆ Dual Data lead (BBC Micro to 2 Disk Drives) ..... £4.00 each
  - ☆ Power lead (BBC Micro to Disk Drive) ..... £2.00 each
  - ☆ Dual power lead (BBC Micro to 2 Disk Drives) ..... £4.00 each
  - ☆ 68000 CPUs (The first orders get 10MHz chips) ..... £3.50 each
  - ☆ 280A CPU, CTC, PIO £1.20 each; DMA £2.00 ..... £4.50 all 4
  - ☆ 74LS TTL, pick and mix, buy 10 or more for ..... £0.12 each
  - Types available: '00 '02 '04 '08 '11 '13 '20 '21 '26 '27 '30 '32 '38 '42 '74 '83 '96 '107
  - '109 '122 '132 '136 '139 '145 '151 '153 '167 '168 '163 '164 '191 '193 '298 '365 '670
  - ☆ EPROMS 27128 ..... used £1.50 each; new 27128-25 £2.50 each
  - ☆ 6264 8K Byte SRAM ..... 15 £3.00 each -12 £3.80 each
  - ☆ 65256 32K Byte rams (selling out soon) ..... £7.00 each
  - ☆ 8K Byte NV ram chips ..... £3.00 each £10.00 four
  - ☆ 20 pin dll low profile IC sockets ..... £0.50/10 £4.00/100
  - ☆ 40 pin dll low profile IC sockets ..... £0.60/10 £5.00/100
  - ☆ Keyboard, 100 keys on board LCD & micro if ..... £8.00 each
  - ☆ Toroidal mains transformer, 12V 4A & 0.4A, 12-0-12 1A & 2A, 9-0-9 2A ..... £8.00 each
  - ..... £4.00/1 £6.00/2 £8.00/3
- All items new unless stated. Add 15% VAT to all prices. Prices include postage.  
Add 50p to orders below £5.00 (Please Note mail order only, no facilities for callers)
- Send an SAE for our latest list or for more info.  
Dept EE, 374 Milton Road, Cambridge, CB4 1SU  
Tel: 0223 424602/0831 430496/0831 430552

# DIRECT BOOK SERVICE

The books listed have been selected as being of special interest to everyone involved in electronics and computing. They are supplied by mail order direct to your door. Full ordering details are given on the last book page.

## MORE BOOKS NEXT MONTH—MORE BOOKS NEXT MONTH

### AUDIO & MUSIC

#### SYNTHESIZERS FOR MUSICIANS

R. A. Penfold

Modern synthesizers are extremely complex, but they mostly work on principles that are not too difficult to understand. If you want to go beyond using the factory presets or the random poking of buttons, this is the book for you.

It covers the principles of modern synthesis—linear arithmetic as used by Roland, phase distortion (Casio), Yamaha's frequency modulation, and sampling—and then describes how the instruments are adjusted to produce various types of sound—strings, brass, percussion, etc. The theoretical side of synthesis is treated in an easy to understand way—the technical information being restricted to what you need to know to use your instrument effectively.

168 pages Order code PC105 £6.95

#### AUDIO

F. A. Wilson, C.G.I.A., C.Eng., F.I.E.E., F.I.E.R.E., F.B.I.M.

Analysis of the sound wave and an explanation of acoustical quantities prepare the way. These are followed by a study of the mechanism of hearing and examination of the various sounds we hear. A look at room acoustics with a subsequent chapter on microphones and loudspeakers then sets the scene for the main chapter on audio systems—amplifiers, oscillators, disc and magnetic recording and electronic music.

320 pages Temporarily out of print

#### INTRODUCTION TO DIGITAL AUDIO

Ian Sinclair

Digital recording methods have existed for many years and have become familiar to the professional recording engineer, but the compact disc (CD) was the first device to bring digital audio methods into the home. The next step is the appearance of digital audio tape (DAT) equipment.

All this development has involved methods and circuits that are totally alien to the technician or keen amateur who has previously worked with audio circuits. The principles and practices of digital audio owe little or nothing to the traditional linear circuits of the past, and are much more comprehensible to today's computer engineer than the older generation of audio engineers.

This book is intended to bridge the gap of understanding for the technician and enthusiast. The principles and methods are explained, but the mathematical background and theory is avoided, other than to state the end product.

128 pages Order code PC102 £5.95

#### MAKE MONEY FROM HOME RECORDING

Clive Brooks

Now that you've spent a fortune on all that recording gear, MIDI and all, wouldn't it be nice to get some of it back? Well here's the book to show you how.

It's packed with money making ideas, any one of which will recoup the price of the book many times over. Whether you have a fully fledged recording studio at home, or just a couple of stereo cassette recorders and a microphone, you'll be able to put the ideas in this book into practice and make money.

105 pages Order code PC104 £5.95

### TESTING & TEST GEAR

#### HOW TO TEST ALMOST EVERYTHING ELECTRONIC—2nd EDITION

Jack Darr and Defton T. Horn

Describes electronic tests and measurements—how to make them with all kinds of test equipment, and how to interpret the results. New sections in this edition include logic probes, frequency counters, capacitance meters, and more. (An American book.)

190 pages Order code T2925 £9.05

#### GETTING THE MOST FROM YOUR MULTIMETER

R.A. Penfold

This book is primarily aimed at beginners and those of limited experience of electronics. Chapter 1 covers the basics of analogue and digital multimeters, discussing the relative merits and the limitations of the two types. In Chapter 2 various methods of component checking are described, including tests for transistors, thyristors, resistors, capacitors and diodes. Circuit testing is covered in Chapter 3, with subjects such as voltage, current and continuity checks being discussed.

In the main little or no previous knowledge or experience is assumed. Using these simple component and circuit testing techniques the reader should be able to confidently tackle servicing of most electronic projects.

96 pages Order code BP239 £2.95

#### MORE ADVANCED USES OF THE MULTIMETER

R.A. Penfold

This book is primarily intended as a follow-up to BP239, (see above), and should also be of value to anyone who already understands the basics of voltage testing and simple component testing. By using the techniques described in chapter 1 you can test and analyse the performance of a range of components with just a multimeter (plus a very few inexpensive components in some cases). Some useful quick check methods are also covered.

While a multimeter is supremely versatile, it does have its limitations. The simple add-ons described in chapter 2 extend the capabilities of a multimeter to make it even more useful. The add-ons described include an active r.f. probe, a high resistance probe, an a.c. sensitivity booster, and a current tracer unit.

84 pages Order code BP265 £2.95

### TEACH-IN THEORY & REFERENCE

NEW



#### EVERYDAY ELECTRONICS DATA BOOK

Mike Tooley BA

(published by EE in association with PC Publishing)

This book is an invaluable source of information of everyday relevance in the world of electronics. It contains not only sections which deal with the essential theory of electronic circuits, but it also deals with a wide range of practical electronic applications.

It is ideal for the hobbyist, student, technician and engineer. The information is presented in the form of a basic electronic recipe book with numerous examples showing how theory can be put into practice using a range of commonly available "industry standard" components and devices.

A must for everyone involved in electronics! 256 pages Order code DATA £8.95

#### ELECTRONICS TEACH-IN 88/89—

##### INTRODUCING MICROPROCESSORS

Mike Tooley BA (published by Everyday Electronics)

A complete course that can lead successful readers to the award of a City and Guilds Certificate in Introductory Microprocessors (726/303). The book contains everything you need to know including full details on registering for assessment, etc.

Sections cover Microcomputer Systems, Microprocessors, Memories, Input/Output, Interfacing and Programming. There are various practical assignments and eight Data Pages covering the most popular microprocessor chips.

An excellent introduction to the subject even for those who do not wish to take the City and Guilds assessment.

80 pages (A4 size) Order code TI-88/89 £2.45

#### THE ILLUSTRATED DICTIONARY OF ELECTRONICS—4th EDITION

Rufus P. Turner and Stan Gibilisco

With more than 27,000 terms used in electronics today, this collection is THE most comprehensive dictionary available. Including all practical electronics and computer terms, it is as up-to-date as the latest advances in the field itself! Tables and data on subjects most often consulted for projects and experiments are included. Other conversion tables include English/metric and metric/English conversions for units of measurement of energy, power and volume, and Fahrenheit/Celsius temperature conversion charts.

Setting this edition apart from other electronic dictionaries is its emphasis on illustration. Featuring more than complete definitions, this fourth edition includes over 450 detailed drawings and diagrams.

All entries are listed in alphabetical order. Abbreviations and Initials are listed in sequence with whole words. All terms of more than one word are treated as one word. (An American book.)

648 pages Order code T2900 £23.65

#### MICROPROCESSING SYSTEMS AND CIRCUITS

F. A. Wilson, C.G.I.A., C.Eng., F.I.E.E., F.I.E.R.E., F.B.I.M.

A truly comprehensive guide to the elements of micro-processing systems which really starts at the beginning. Teaches the reader the essential fundamentals that are so important for a sound understanding of the subject.

256 pages Temporarily out of print

#### ELECTRONICS TEACH-IN No. 3 — EXPLORING

ELECTRONICS (published by Everyday Electronics)

Owen Bishop

Another EE value for money publication aimed at students of electronics. The course is designed to explain the workings of electronic components and circuits by involving the reader in experimenting with them. The book does not contain masses of theory or formulae but straightforward explanations and circuits to build and experiment with.

Exploring Electronics contains more than 25 useful projects, assumes no previous knowledge of electronics and is split into 28 easily digestible sections.

88 pages (A4 size) Order code TI3 £2.45

#### ELECTRONICS—A "MADE SIMPLE" BOOK

G. H. Olsen

This book provides excellent background reading for our *Introducing Digital Electronics* series and will be of interest to everyone studying electronics. The subject is simply explained and well illustrated and the book assumes only a very basic knowledge of electricity.

330 pages Order code NE10 £4.95

#### PRACTICAL ELECTRONICS

##### CALCULATIONS AND FORMULAE

F. A. Wilson, C.G.I.A., C.Eng., F.I.E.E., F.I.E.R.E., F.B.I.M.

Bridges the gap between complicated technical theory, and "cut-and-try" methods which may bring success in design but leave the experimenter unfulfilled. A strong practical bias—tedious and higher mathematics have been avoided where possible and many tables have been included.

The book is divided into six basic sections: Units and Constants, Direct-current Circuits, Passive Components, Alternating-current Circuits, Networks and Theorems, Measurements.

256 pages Order code BP53 £3.95

#### MICROELECTRONIC SYSTEMS N2 CHECKBOOK

R. Vears

The aim of this book is to provide a foundation in microcomputer hardware, software and interfacing techniques. Each topic is presented in a way that assumes only an elementary knowledge of microelectronic systems and logic functions. The book concentrates on 6502, Z80 and 6800 microprocessors and contains 80 tested programs, 160 worked problems and 250 further problems.

Order code NE04N £6.95

**ELECTRONICS-BUILD AND LEARN**

**R. A. Penfold**  
The first chapter gives full constructional details of a circuit demonstrator unit that is used in subsequent chapters to introduce common electronic components—resistors, capacitors, transformers, diodes, transistors, thyristors, fets and op amps. Later chapters go on to describe how these components are built up into useful circuits, oscillators, multivibrators, bistables and logic circuits.

At every stage in the book there are practical tests and experiments that you can carry out on the demonstrator unit to investigate the points described and to help you understand the principles involved. You will soon be able to go on to more complex circuits and tackle fault finding logically in other circuits you build.

120 pages Order Code PC103 £5.95

**PRACTICAL ELECTRONICS HANDBOOK**

**Ian Sinclair**  
Ian Sinclair has now revised this useful and carefully selected collection of standard circuits, rules-of-thumb, and design data for professional engineers, students and enthusiasts involved in radio and electronics. Covering passive and active components, discrete component circuits (such as amplifiers, filters and oscillators) and linear and digital i.c.s., the book includes many items which are not elsewhere available in a single handy volume. The operation and functions of typical circuits are described, while mathematics is limited to that necessary for deciding component values for any application.

This revised edition contains more details on computers and microprocessors and has been brought up to date throughout.

199 pages Order Code NE06 £7.95

**DATA & COMPONENT IDENTIFICATION**

**TRANSISTOR SELECTOR GUIDE**

This unique guide offers a range of selection tables compiled so as to be of maximum use to all electronics engineers, designers and hobbyists.

Section 1: Covers component markings, codings and standards, as well as explaining the symbols used.  
Section 2: Tabulates in alpha-numeric sequence the comprehensive specifications of over 1400 devices.  
Section 3: Tabulates the devices by case type.  
Section 4: Considers particular limits to the electrical parameters when compiling the tables.  
Section 5: Illustrates package outlines and leadouts.  
Section 6: Consists of a surface mounting device markings conversion list.

192 pages Temporarily out of print

**CIRCUITS & DESIGN**

**ELECTRONIC CIRCUITS FOR THE COMPUTER CONTROL OF MODEL RAILWAYS**

**R. A. Penfold**  
Home computers may easily be applied to the control of model railways and really quite sophisticated control, which needs only simple programming, is not too difficult to achieve. The main problem lies in interfacing the computer to the layout, but fortunately it is not too difficult or expensive to build suitable interfaces, and this book shows you how.

The projects consist of various types of controller, including a high quality pulse type, as well as circuits for train position sensing, signal and electric points control etc. The use of computers does not have to be restricted to massive layouts. Something as simple as an oval of track with a single siding can be given a new dimension by adding computer control and much fun can be had from these relatively simple set-ups.

88 pages Order code BP180 £2.95

**Electronic Circuits for the Computer Control of Model Railways**

R.A. PENFOLD



**Remote Control Handbook**

**REMOTE CONTROL HANDBOOK**

**Owen Bishop**  
Remote control systems lend themselves to a modular approach. This makes it possible for a wide range of systems, from the simplest to the most complex, to be built up from a number of relatively simple modules. The author has tried to ensure that, as far as possible, the circuit modules in this book are compatible with one another. They can be linked together in many different configurations to produce remote control systems tailored to individual requirements. Whether you wish simply to switch a table lamp on and off, or to operate an industrial robot, this book should provide the circuit you require.

226 pages Order code BP240 £3.95

**COIL DESIGN AND CONSTRUCTION MANUAL**

**B. B. Babani**  
A complete book for the home constructor on "how to make" RF, IF, audio and power coils, chokes and transformers. Practically every possible type is discussed and calculations necessary are given and explained in detail. Although this book is now rather old, with the exception of torroids and pulse transformers little has changed in coil design since it was written.

96 pages Order Code 160 £2.50

**ELECTRONIC CIRCUITS HANDBOOK**

**Michael Tooley BA**  
This book aims to explode two popular misconceptions concerning the design of electronic circuits: that only those with many years of experience should undertake circuit design and that the process relies on an understanding of advanced mathematics. Provided one is not too ambitious, neither of these popularly held beliefs is true.

Specifically, this book aims to provide the reader with a unique collection of practical working circuits together with supporting information so that circuits can be produced in the shortest possible time and without recourse to theoretical texts.

Furthermore, information has been included so that the circuits can readily be modified and extended by readers to meet their own individual needs. Related circuits have been grouped together and cross-referenced within the text (and also in the index) so that readers are aware of which circuits can be readily connected together to form more complex systems. As far as possible, a common range of supply voltages; signal levels and impedances has been adopted.

As a bonus, ten test gear projects have been included. These not only serve to illustrate the techniques described but also provide a range of test equipment which is useful in its own right.

277 pages Order code NE05 £14.95

**AUDIO IC CIRCUITS MANUAL**

**R. M. Marston**  
A vast range of audio and audio-associated i.c.s are readily available for use by amateur and professional design engineers and technicians. This manual is a guide to the most popular and useful of these devices, with over 240 diagrams. It deals with i.c.s such as low frequency linear amplifiers, dual pre-amplifiers, audio power amplifiers, charge coupled device delay lines, bar-graph display drivers, and power supply regulators, and shows how to use these devices in circuits ranging from simple signal conditioners and filters to complex graphic equalizers, stereo amplifier systems, and echo/reverb delay line systems etc.

168 pages Order code NE13 £11.95

**HOW TO DESIGN ELECTRONIC PROJECTS**

**R. A. Penfold**  
The aim of this book is to help the reader to put together projects from standard circuit blocks with a minimum of trial and error, but without resorting to any advanced mathematics. Hints on designing circuit blocks to meet your special requirements are also provided.

128 pages Order code BP127 £2.25

**50 CIRCUITS USING GERMANIUM SILICON AND ZENER DIODES**

**R. N. Soar**  
Contains 50 interesting and useful circuits and applications, covering many different branches of electronics, using one of the most simple and inexpensive of components—the diode. Includes the use of germanium and silicon signal diodes, silicon rectifier diodes and Zener diodes, etc.

64 pages Order Code BP36 £1.50

**KEY TECHNIQUES FOR CIRCUIT DESIGN**

**C. G. Loveday C.Eng MIERE**  
Deals with designing electronic circuits from scratch covering concepts such as target specifications, component selection (passive, discreted and i.c.s), the design cycle, derating and so on. Numerous design examples are given and several reader exercises all with fully worked solutions. The approach is essentially non-mathematical.

128 pages Order code BM1 £6.95

**DESIGNING WITH LINEAR ICs**

**G.C. Loveday**  
A book that deals with the design of the vital area of analog circuitry covering design with modern linear integrated circuit devices. The first chapter introduces the reader to important design techniques, test strategies, layout, and protection and also includes a section on the use of a typical CAD tool. There are separate chapters that cover in depth the use of op-amps, comparators and timers each with detailed design examples and reader exercises. A final chapter brings all the previous work together in a number of complete design problems with fully worked solutions. The text is essentially non-mathematical and is supported by many diagrams.

180 pages Order code BM3 £8.75

**DIGITAL IC EQUIVALENTS AND PIN CONNECTIONS**

**A. Michaels**  
Shows equivalents and pin connections of a popular selection of European, American and Japanese digital i.c.s. Also includes details of packaging, families, functions, manufacturer and country of origin.

256 pages Order code BP140 £5.95

**INTERNATIONAL TRANSISTOR EQUIVALENTS GUIDE**

**A. Michaels**  
Helps the reader to find possible substitutes for a popular selection of European, American and Japanese transistors. Also shows material type, polarity, manufacturer and use.

320 pages Order code BP85 £3.50

**CHART OF RADIO, ELECTRONIC, SEMICONDUCTOR AND LOGIC SYMBOLS**

**M. H. Banani, B.Sc.(Eng.)**  
Illustrates the common, and many of the not-so-common, radio, electronic, semiconductor and logic symbols that are used in books, magazines and instruction manuals, etc., in most countries throughout the world.

Chart Order Code BP27 £0.95

**OPTOELECTRONICS CIRCUITS MANUAL**

**R. M. Marston**  
A useful single-volume guide to the optoelectronic device user, specifically aimed at the practical design engineer, technician, and the experimenter, as well as the electronics student and amateur. It deals with the subject in an easy-to-read, down-to-earth, and non-mathematical yet comprehensive manner, explaining the basic principles and characteristics of the best known devices, and presenting the reader with many practical applications and over 200 circuits. Most of the i.c.s and other devices used are inexpensive and readily available types, with universally recognised type numbers.

182 pages Order code NE14 £10.95

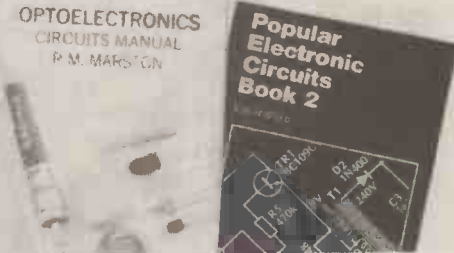

**A MICROPROCESSOR PRIMER**

**E. A. Parr, B.Sc., C.Eng., M.I.E.E.**  
Starts by designing a small computer which, because of its simplicity and logical structure, enables the language to be easily learnt and understood. The shortcomings are then discussed and the reader is shown how these can be overcome by changes and additions to the instruction set. In this way, such ideas as relative addressing, index registers, etc., are developed.

96 pages Order code BP72 £1.75

**POPULAR ELECTRONIC CIRCUITS -BOOK 1**

**POPULAR ELECTRONIC CIRCUITS -BOOK 2**

**R. A. Penfold**  
Each book provides a wide range of designs for electronic enthusiasts who are capable of producing working projects from just a circuit diagram without the aid of detailed construction information. Any special setting-up procedures are described.

BOOK 1 160 pages Order code BP80 £2.95

BOOK 2 160 pages Order code BP98 £2.95

**CMOS CIRCUITS MANUAL**

**R. M. Marston**  
Written for the professional engineer, student or enthusiast. It describes the basic principles and characteristics of these devices and includes over 200 circuits. All the circuits have been designed, built and fully evaluated by the author; all use inexpensive and internationally available devices.

pages Order code NE12 £9.95

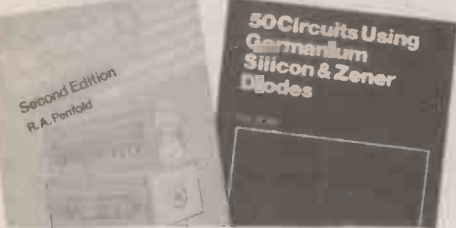

**30 SOLDERLESS BREADBOARD PROJECTS - BOOK 1**

**R. A. Penfold**  
Each project, which is designed to be built on a "Verobloc" breadboard, is presented in a similar fashion with a brief circuit description, circuit diagram, component layout diagram, components list and notes on construction and use where necessary. Wherever possible, the components used are common to several projects, hence with only a modest number of reasonably inexpensive components, it is possible to build in turn, every project shown. Recommended by BICC-Verobloc.

160 pages Order Code BP107 £2.25

**BOOK 2—All projects use CMOS i.c.s but the items on component identification etc., are not repeated from**

160 pages Order code BP113 £2.25

**ELECTRONIC PROJECTS — BOOK 1**

Published by *Everyday Electronics* in association with Magenta Electronics.

Contains twenty of the best projects from previous issues of *EE* each backed with a kit of components. The projects are: Seashell Sea Synthesiser, *EE* Treasure Hunter, Mini Strobe, Digital Capacitance Meter, Three Channel Sound to Light, BBC 16k Sideways Ram, Simple Short Wave Radio, Insulation Tester, Visual Guitar/Instrument Tuner, Stepper Motor Interface, Eprom Eraser, 200MHz Digital Frequency Meter, Infra Red Alarm, *EE* Equaliser Ioniser, Bat Detector, Acoustic Probe, Mainsteater and Fuse Finder, Light Rider — (Lapel Badge, Disco Lights, Chaser Light), Musical Doorbell, Function Generator, Tilt Alarm, 10W Audio Amplifier, *EE* Buccaneer Induction Balance Metal Detector, BBC Midi Interface, Variable Bench Power Supply, Pet Scarer, Audio Signal Generator.

128 pages(A4 size) Order Code EP1 £2.45

**HOW TO DESIGN AND MAKE YOUR OWN P.C.B.s**

R. A. Penfold

Deals with the simple methods of copying printed circuit

board designs from magazines and books and covers all aspects of simple p.c.b. construction including photographic methods and designing your own p.c.b.s.  
80 pages Order code BP121 £2.50

**HOW TO GET YOUR ELECTRONIC PROJECTS WORKING**  
R. A. Penfold

We have all built projects only to find that they did not work correctly, or at all, when first switched on. The aim of this book is to help the reader overcome just these problems by indicating how and where to start looking for many of the common faults that can occur when building up projects.

96 pages Order code BP110 £2.50

**ELECTRONIC SCIENCE PROJECTS**

O. Bishop

These projects range in complexity from a simple colour temperature meter to an infra-red laser. There are novelties such as an electronic clock regulated by a resonating spring, and an oscilloscope with solid-state display. There are scientific measuring instruments such as a pH meter and an electro-cardiometer. All projects have a strong scientific flavour. The way they work, and how to build and use them are fully explained.

144 pages Order code BP104 £2.95

**BEGINNER'S GUIDE TO BUILDING ELECTRONIC PROJECTS**

R. A. Penfold

Shows the complete beginner how to tackle the practical side of electronics, so that he or she can confidently build the electronic projects that are regularly featured in magazines and books. Also includes examples in the form of simple projects.

112 pages Order code No. 227 £2.25

**TEST EQUIPMENT CONSTRUCTION**

R. A. Penfold

This book describes in detail how to construct some simple and inexpensive but extremely useful, pieces of test equipment. Stripboard layouts are provided for all designs, together with wiring diagrams where appropriate, plus notes on construction and use.

The following designs are included: AF Generator, Capacitance Meter, Test Bench Amplifier, AF Frequency Meter, Audio Millivoltmeter, Analogue Probe, High Resistance Voltmeter, CMOS Probe, Transistor Tester, TTL Probe. The designs are suitable for both newcomers and more experienced hobbyists.

104 pages Order code BP248 £2.95

**RADIO, TV, SATELLITE**

**BEGINNER'S GUIDE TO RADIO—9th EDITION**

Gordon J. King

Radio signals, transmitters, receivers, antennas, components, valves and semiconductors, CB and amateur radio.

266 pages Order code NE08 £6.95

**AN INTRODUCTION TO RADIO DXING**

R. A. Penfold

Anyone can switch on a short wave receiver and play with the controls until they pick up something, but to find a particular station, country or type of broadcast and to receive it as clearly as possible requires a little more skill and knowledge. The object of this book is to help the reader to do just that, which in essence is the fascinating hobby of radio DXing.

112 pages Order code BP91 £1.95

**A TV-DXERS HANDBOOK**

R. Bunney

Roger Bunney is probably one of the leading authorities in this country on the subject. Includes many units and devices which have been designed and used by active enthusiasts, and often, considerable ingenuity and thought have gone into the development of such units to overcome individual problems. A practical and authoritative reference to this unusual aspect of electronics.

128 pages Order code BP176 £5.95

**SATELLITE TELEVISION INSTALLATION GUIDE—2nd EDITION**

John Breeds

This book is now firmly established as a leading study manual for satellite TV installers, technical colleges who run City & Guilds courses, and training schools in major companies. It will be invaluable to anyone who wants to set up a dish receiver.

It covers all aspects of satellite dish installation: Installation of indoor unit, Geostationary satellites, Site survey, Dish assembly, Signal polarisation, Setting up the dish, Polar mount dish, TV download and relay cable and F-connectors, EIRP footprint contours, Trouble-shooting guide, Glossary of terms and Useful addresses.

56 pages (large format) Order code JB1 £11.95

**NEWNES SHORTWAVE LISTENING HANDBOOK**

Joe Pritchard G1UQW

Part One covers the "science" side of the subject, going from a few simple electrical "first principles", through a brief treatment of radio transmission methods to simple receivers. The emphasis is on practical receiver designs and how to build and modify them, with several circuits in the book.

Part Two covers the use of sets, what can be heard, the various bands, propagation, identification of stations, sources of information, QSLing of stations and listening to amateurs. Some computer techniques, such as computer morse decoding and radio teletype decoding are also covered.

224 pages Order code NE16 £12.95

**DIRECT BOOK SERVICE**

(A Division of Wimborne Publishing Ltd.)

**TO ORDER**

Please state the title and order code clearly, print your name and address and add the required postage to the total order.

Add 75p to your total order for postage and packing (overseas readers add £1.50 for countries in Europe, or add £2.00 for all countries outside Europe, surface mail postage) and send a PO, cheque or international money order (£ sterling only) made payable to *Direct Book Service* quoting your name and address, the order code and quantities required to *DIRECT BOOK SERVICE, 33 GRAVEL HILL, MERLEY, WIMBORNE, DORSET, BH21 1RW* (mail order only).

See next month's issue for another three page selection of books.

Although books are normally sent within seven days of receipt of your order, please allow a maximum of 28 days for delivery. Overseas readers allow extra time for surface mail post.

Please check price and availability (see latest issue of *Everyday Electronics*) before ordering from old lists.

Note — our postage charge is the same for one book or one hundred books!

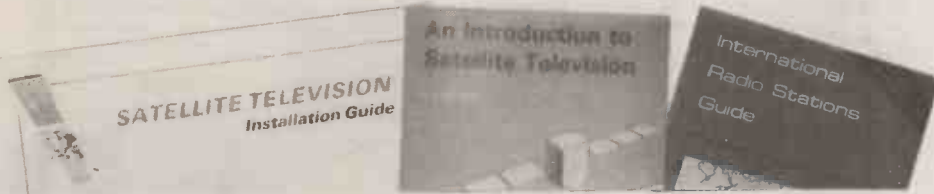

**COMPUTING**

**SERVICING PERSONAL COMPUTERS—2nd EDITION**

Mike Tooley BA

The revised and enlarged second edition contains a new chapter on the IBM PC, AT, TX and compatibles. It is essential for anyone concerned with the maintenance of personal computer equipment or peripherals, whether professional service technician, student or enthusiast.

240 pages (hard cover) Order code NE15 £20

**AN INTRODUCTION TO PROGRAMMING THE BBC MODEL B MICRO**

R. A. & J. W. Penfold

Written for readers wanting to learn more about programming and how to make best use of the incredibly powerful model B's versatile features. Most aspects of the BBC micro are covered, the omissions being where little could usefully be added to the information provided by the manufacturer's own manual.

144 pages Order code BP139 £1.95

**AN INTRODUCTION TO COMPUTER COMMUNICATIONS**

R. A. Penfold

Provides details of the various types of modem and their suitability for specific applications, plus details of connecting various computers to modems, and modems to the telephone system. Also information on common networking systems and RTTY.

96 pages Order code BP177 £2.95

**AN INTRODUCTION TO COMPUTER PERIPHERALS**

J. W. Penfold

Covers such items as monitors, printers, disc drives, cassette recorders, modems, etc., explaining what they are, how to use them and the various types and standards. Helps you to make sure that the peripherals you buy will work with your computer.

80 pages Order code BP170 £2.50

**HOW TO GET YOUR COMPUTER PROGRAMS RUNNING**

J. W. Penfold

Have you ever written your own programs only to find that they did not work? Help is now at hand with this book which shows you how to go about looking for your errors, and helps you to avoid the common bugs and pitfalls of program writing. Applicable to all dialects of the BASIC language.

144 pages Order code BP169 £2.50

**AN INTRODUCTION TO 6502 MACHINE CODE**

R. A. & J. W. Penfold

No previous knowledge of microprocessors or machine code is assumed. Topics covered are: assembly language and assemblers, the register set and memory, binary and hexadecimal numbering systems, addressing modes and the instruction set, and also mixing machine code with BASIC. Some simple programming examples are given for 6502-based home computers like the VIC-20, ORIC-1/Amos, Electron, BBC and also the Commodore 64.

112 pages Order code BP147 £2.95

**THE PRE-BASIC BOOK**

F. A. Wilson, C.G.I.A., C.ENG., F.I.E.E., F.I.E.R.E., F.B.I.M.

Another book on BASIC but with a difference. This one does not skip through the whole of the subject and thereby leave many would-be programmers floundering but instead concentrates on introducing the technique by looking in depth at the most frequently used and more easily understood computer instructions. For all new and potential micro users.

192 pages Order code BP146 £2.95

**JUST A SMALL SELECTION OF KITS FROM OUR EVER INCREASING RANGE**

Kit No.	Description	Price (each) £ (incl. VAT)
1001	0.2 WATT FM TRANSMITTER	4.16
1004	LIGHT SWITCH	5.83
1006	800 WATT MUSIC TO LIGHT	4.99
1009	1 WATT FM TRANSMITTER	5.42
1013	AM-FM-VHF RECEIVER	13.33
1018	GUITAR TREMELO	7.08
1020	0-5 MINUTE TIMER	5.42
1022	METAL DETECTOR	4.16
1026	RUNNING LIGHTS	8.33
1027	NI CAD BATTERY CHARGER	7.08
1029	4 SOUNDS ELECTRIC SIREN	4.99
1034	CAR BATTERY CHECKER	2.92
1036	TRANSISTOR TESTER	3.75
1038	AM-FM AERIAL AMPLIFIER	2.92
1044	GRAPHIC EQUALIZER	12.91
1045	SOUND EFFECT GENERATOR	6.66
1047	SOUND SWITCH	9.58
1055	RM RECEIVER USING TDA 7000	12.49
1059	TELEPHONE AMPLIFIER	8.33
1065	INVERTER 12V DC TO 220V AC	20.82
1069	12V DC FLUORESCENT TUBE UNIT	5.42
1073	VOICE ACTIVATED SWITCH	6.24
1075	ELECTRONIC DICE WITH LED's	6.66
1091	GUITAR PRE-AMPLIFIER	7.50
1098	DIGITAL THERMOMETER WITH LCD DISPLAY	20.82
1114	ELECTRONIC LOCK	7.50
1117	TV PATTERN GENERATOR	9.17
1119	TELEPHONE LINE RECORDING	4.16
1122	TELEPHONE CALL RELAY	6.66
1124	ELECTRONIC BELL	4.99
1125	TELEPHONE LOCK	6.66
1129	NEGATIVE ION GENERATOR	14.16
1131	ROBOT VOICE	6.66
1133	STEREO SOUND TO LIGHT	9.52
1203	MINI FM TRANSMITTER WITH MICROPHONE	4.16

*All kits are supplied complete including Silk Screened pcb, Components, Solder, Wire and full instruction sheet.*

*Purpose built boxes with silk-screened front panels are available for some of the above. Please consult our catalogue.*



**CREDIT CARD HOTLINE**  
**01-205 7485**

**LARGE STOCKS OF INTEGRATED CIRCUITS, SEMI'S, OTPO ELECTRONICS, CAPACITORS, RESISTORS, SWITCHES AND OTHER MISCELLANEOUS PRODUCTS ARE ALSO AVAILABLE FROM**  
**Hobbykit**

*For latest kit catalogue and price list send a large 45p S.A.E. to:*

**Hobbykit Ltd.**

**UNIT 19, CAPITOL INDUSTRIAL PARK  
CAPITOL WAY,  
LONDON NW9 0EQ  
FAX NO: 01-205 0603**



**The UK Distributor for the complete ILP Audio Range**



**BIPOLAR AND MOSFET MODULES**

The unique range of encapsulated amplifier modules with integral heatsink.

HY30	15W Bipolar amp.	£11.50	HY248	120W Bipolar amp (8ohm)	£25.20
HY60	30W Bipolar amp	£11.50	HY364	180W Bipolar amp (4ohm)	£39.25
HY6060	30W Stereo Bipolar amp	£24.45	HY368	180W Bipolar amp (8ohm)	£39.25
HY124	60W Bipolar amp (4ohm)	£19.00	MOS128	60W Mosfet amp	£40.70
HY128	60W Bipolar amp (8ohm)	£19.00	MOS248	120W Mosfet amp	£46.35
HY244	120W Bipolar amp (4ohm)	£25.20	MOS364	180W Mosfet amp	£75.75

**PLATE AMPLIFIERS**

Bipolar and Mosfet modules with the same electronics as above amplifiers housed in a different extrusion without heatsink.

HY6060P	30W Stereo Bipolar amp.	£20.10	HY364P	180W Bipolar amp (4 ohm)	£25.99
HY124P	60W Bipolar amp (4 ohm)	£14.85	HY368P	180W Bipolar amp (8 ohm)	£25.99
HY128P	60W Bipolar amp (8 ohm)	£14.85	MOS128P	60W Mosfet amp.	£36.60
HY244P	120W Bipolar amp (4 ohm)	£20.10	MOS248P	120W Mosfet amp.	£39.95
HY248P	120W Bipolar amp (8 ohm)	£20.10	MOS364P	180W Mosfet amp.	£66.85

Note: These modules require additional heatsinks

**POWER SUPPLIES**

Comprising toroidal transformer and DC board to power the ILP amplifier modules.

PSU30	Pre-amplifier	£10.80	PSU542	HY248	£27.40
PSU212	1 or 2 HY30	£19.25	PSU552	MOS248	£29.60
PSU412	HY6060, HY124, 1or2 HY60	£21.45	PSU712	HY244 (2)	£31.75
PSU422	HY128	£23.70	PSU722	HY248 (2)	£32.80
PSU432	MOS128	£24.75	PSU732	HY364	£32.80
PSU512	HY244, HY128 (2)	£26.35	PSU742	HY368	£34.95
PSU522	HY124 (2)	£26.35	PSU752	MOS364, MOS248 (2)	£34.95
PSU532	MOS128 (2)	£27.40			

**PRE-AMP and MIXER MODULES**

These encapsulated modules are supplied with in-line connectors but require potentiometers, switches etc.

HY6	Mono pre-amp with bass and treble	£9.30
HY66	Stereo pre-amp with bass and treble	£15.50
HY83	Guitar pre-amp with special effects	£18.95
B6	Mounting board for HY6	£1.15
B66	Mounting board for HY66 or HY83	£1.75

**POWER SLAVES**

These cased amplifiers are supplied assembled and tested in 60 and 120 watt Bipolar or Mosfet versions.

US12	60 watt Bipolar (4ohm)	£77.50	US32	60 watt Mosfet	£105.95
US22	120 watt Bipolar (4ohm)	£85.95	US42	120 watt Mosfet	£115.95

Prices include VAT and carriage

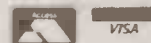

Quantity prices available on request  
Write or phone for free Data Pack

**Jaytee Electronic Services**

143 Reculver Road, Beltinge, Herne Bay, Kent CT6 6PL  
Telephone: (0227) 375254 Fax: 0227 365104

# PCB SERVICE

Printed circuit boards for certain constructional projects are available from the PCB Service, see list. These are fabricated in glass fibre, and are fully drilled and roller tinned. All prices include VAT and postage and packing. Add £1 per board for overseas airmail. Remittances should be sent to **The PCB Service Everyday Electronics, 6 Church Street, Wimborne, Dorset BH21 1JH.** Cheques should be crossed and made payable to **Everday Electronics (Payment in £ sterling only).**

Boards for some older projects – not listed here – can often be obtained from **Magenta Electronics, 135 Hunter St., Burton-on-Trent, Staffs DE14 2ST.** Tel: 0283 65435 or **Lake Electronics, 7 Middleton Close, Nuthall, Nottingham NG16 1BX.** Tel: 0602 382509.

**NOTE: While 90% of our boards are now held in stock and are dispatched within seven days of receipt of order, please allow a maximum of 28 days for delivery – overseas readers allow extra if ordered by surface mail. Please check price and availability in the latest issue before ordering. We can only supply boards listed in the latest issue. Boards can only be supplied on a payment with order basis.**

PROJECT TITLE	Order Code	Cost
Video Guard	FEB '87	556 £3.80
Spectrum I/O		557 £5.35
Computer Buffer/Interface	MAR '87	560 £3.32
Bulb Life Extender	APR '87	564 £3.00
Fridge Alarm	MAY '87	565 £3.00
EE Equaliser-Ioniser		566 £4.10
Mini Disco Light	JUNE '87	567 £3.00
Fermostat	JULY '87	569 £3.34
EE Buccaneer Metal Detector		570 £4.10
Monomix		571 £4.75
Super Sound Adaptor Main Board	AUG '87	572 £4.21
PSU Board		573 £3.32
Simple Shortwave Radio, Tuner & Amplifier		575/576 £4.90
Noise Gate	SEPT '87	577 £4.41
Burst Fire Mains Controller		578 £3.31
Electronic Analogue/Digital Multimeter		579 £6.40
Transtest	OCT '87	580 £3.32
Accented Metronome	NOV '87	582 £3.77
Acoustic Probe		584 £3.00
BBC Sideways RAM/ROM		585 £4.10
Twinkling Star	DEC '87	588 £3.00
Audio Sine Wave Generator		589 £3.03
Capacitance Meter	JAN '88	590 £4.10
Bench Amplifier		591 £5.51
Transistor Curve Tracer		592 £3.00
Bench Power Supply Unit	FEB '88	593 £4.01
Game Timer		583 £3.55
Semiconductor Tester	MAR '88	594 £3.19
SOS Alert		595 £3.00
Guitar/Keyboard Envelope Shaper		596 £4.23
Stereo Noise Gate	APR '88	597 £6.65
Pipe & Cable Locator		598 £3.00
Inductive Proximity Detector		574 £3.00
Multi-Chan Remote Light Dim	MAY '88	599 £3.00
Transmitter		600 £3.07
Receiver		605 £3.00
Door Sentinel		606 £5.91
Function Generator – Main Board		607 £4.19
Function Generator – Power Supply		
Multi-Chan Remote Light Dim	JUNE '88	601 £4.86
Relay/Decoder		602 £3.07
Dimmer Board		603 £3.00
Power Supply		604 £7.76
Mother Board		611 £3.00
Headlight Reminder		
Video Wiper	JULY '88	612 £6.75
Isolink		613 £4.21
Tea Tune	AUG '88	609 £3.00
Time Switch		614 £4.84
Suntan Timer		610 £3.07
Car Alarm		615 £3.12
Breaking Glass Alarm	SEPT '88	617 £4.27
Amstrad PIO		618 £6.77
Eprom Eraser	OCT '88	620 £4.07

Doorbell Delay	NOV '88	616 £3.56
Micro Alarm		621 £3.12
Infra-Red Object Counter Trans	} £9.28 as a set	622 £4.61
Receiver		623 £3.23
Display		624 £3.05
Seashell Sea Synthesiser		625 £4.84
Reaction Timer Main Board	DEC '88	626 £3.46
Display Board		627 £3.00
Downbeat Metronome		629 £4.84
EPROM Programmer (On Spec)		630 £8.29
Phasor		631 £5.64
Monkey/Hunter Game	JAN '89	634 £3.36
Continuity Tester	FEB '89	619 £2.67
4-Channel Light Dimmer		635 £7.67
Mini PSU		636 £3.23
Sound-to-Light Interface	MAR '89	637 £6.24
Midi Pedal		639 £7.00
Midi Merge		640 £3.00
Audio Lead Tester		641 £5.77
Light Sentinel	APR '89	
Main Control Board		632 £9.20
Remote Interface (4 boards)		633 £4.59
Electron User Port		638 £6.64
4-Channel Auto-Fader Interface		642 £6.80
Pet Scarer	MAY '89	644 £3.00
Electron A/D Interface		645 £4.84
Spectrum EPROM Programmer	JUNE '89	628 £7.87
Bat Detector		647 £4.95
Programmable Pocket Timer	JULY '89	648 £3.82
Electronic Spirit Level	AUG '89	649 £3.85
Distance Recorder		651 £5.23
Treasure Hunter		652 £3.73
Xenon Beacon	SEPT '89	650 £4.13
Probe Pocket Treasure Finder		653 £4.12
Power Supplies { – Fixed Voltage		654 £4.08
{ – Variable Voltage		655 £4.48
Music on Hold	OCT '89	646 £3.85
Power Supplies – 25V 700mA		656 £4.35
– 30V 1A		657 £4.55
EE Seismograph – Control		658 £4.08
– Detector		659 £4.22
Logo/Logo & Spectrum		660 £6.49
Wash Pro	NOV '89	643 £3.83
Biofeedback Monitor – Front End		661 £4.52
– Processor		662 £4.56
Power Supplies – 1.5V–25V 2A		663 £4.78
Logo/Logo & Spectrum Interface		664 £5.60
EEG Electrode Impedance Meter	DEC '89	665 £3.98
Biofeedback Signal Generator	JAN '90	666 £4.08
Four-Channel Light Chaser		667 £6.70
Quick Cap Tester	FEB '90	668 £3.92
Weather Station		
Anemometer – Freq/Volt Board		670 £3.94
– Optional Display		669 £3.73
Wind Direction		673/674 £4.22
System Power Supply		675 £3.59
Prophet In-Car Ioniser		676 £3.18
EE Weather Station	MAR '90	
Display Driver		671 £4.47
Display & Sensor Boards		672 & 678 £4.22
Fermostat Mk2		677 £4.28
Superhet Broadcast Receiver		
Tuner/Audio Amp		679/680 £4.22

Please note it is important to give project title as well as order code.

## EE PRINTED CIRCUIT BOARD SERVICE

Please send me the following p.c.b.s.

Order Code Project Quantity Price

.....

I enclose cheque/PO for £.....

Name.....

Address.....

Please allow 28 days for delivery (see note above)

BLOCK CAPITALS PLEASE

# JOIN UP WITH LITESOLD

Professional Soldering Equipment at Special Mail-Order Prices.

## SK18 Soldering Kit. £19.75

Build or repair any electronic project. LC18 240v 18w iron with 3.2, 2.4, and 1.6mm bits. Pack of 18 swg flux-cored 60/40 solder. Tweezers. 3 soldering aids. Reel of De-Solder braid. In PVC presentation wallet.



## ADAMIN Miniature Iron £8.60

Possibly smallest mains iron in the world. Ideal for fine work. Slim

nylon handle with finger grip. Interchangeable bits available 1.2, 1.6, 2.4, 3.4 and 4.7mm. Fitted with 2.4mm. 240v 12w (12v available). Presentation wallet.

## 'L' Series Lightweight Irons. 12w £9.20

High efficiency irons for all electronic hobby work. Non-roll handles with finger guards. Stainless steel element shafts. Screw-connected elements. Slip-on bits available from 1.6 to 4.7mm. LA12

model, 12w, 2.4mm bit. LC 18 Model, 18w, 3.2mm bit. 240v Std - 12v available. Presentation wallet.

## Soldering Iron Stands 3&4 £7.33

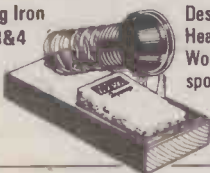

Designed specially for LITESOLD irons. Heavy, solid-plastic base with non-slip pads. Won't tip over, holds iron safely. With wiping sponge and location for spare (hot) bits. No 5 stand for EC50 iron No 4 stand for ADAMIN miniature Iron No 3 stand for LA12 and LC18 irons.

## De-Solder Pumps £8.65

High Quality version of increasingly popular type of tool. Precision made anodised aluminium body, plunger guard and high-seal piston. Easy

thumb operation. Automatic solder ejection. Conductive PTFE nozzle - no static problems.

Prices include p&p and VAT. Send order with Cheque/PO. Ring for Access/Visa sales

LIGHT SOLDERING DEVELOPMENTS LTD. DEPT. EE  
97-99 GLOUCESTER ROAD, CROYDON CR0 2DN. 01 689 0574

## SHERWOOD ELECTRONIC COMPONENTS 45 Rutland Street, Mansfield, Notts NG18 4AP SPECIAL PACKS - All at £1.00 each

SP1	12x5mm Red LEDs	SP32	4xCmos 4077
SP2	12x5mm Green LEDs	SP33	4xCmos 4081
SP3	12x5mm Yellow LEDs	SP34	2xCmos 4510
SP4	10x5mm Amber LEDs	SP35	2xCmos 4511
SP5	36x5mm 1 part LED clips	SP36	20x10µF/25V Rad.Elect.Caps.
SP6	12x3mm Red LEDs	SP37	15x100µF/35V Rad.Elect.Caps.
SP7	12x3mm Green LEDs	SP38	20x47µF/25V Rad.Elect.Caps.
SP8	10x3mm Yellow LEDs	SP39	12x470µF/16V Rad.Elect.Caps.
SP9	40x3mm 1 part LED clips	SP40	15xBC237 Transistors
SP10	50x1N4148 signal diodes	SP41	25xmixed Transistors
SP11	25x1N4001 rectifier diodes	SP42	2xLM1458
SP12	25x1N4002 rectifier diodes	SP44	12x5mm Leds-4 each, Red, Green Yellow
SP13	25xRad.Elect.Caps. (1-1000µF)	SP45	25x1N4000 series rect. diodes
SP18	15xBC182 Transistors	SP46	15x400mW zeners - assorted values
SP19	15xBC183 Transistors	SP47	5xminiature push button switches
SP20	15xBC184 Transistors	SP101	15 metres of 22SWG 60-40 solder
SP21	15xBC212 Transistors	SP102	15x8 pin DIL sockets
SP22	15xBC214 Transistors	SP103	12x14 pin DIL sockets
SP23	15xBC549 Transistors	SP104	12x16 pin DIL sockets
SP24	5xCmos 4001	SP105	5x74LS00 I.C.s
SP25	5x555 Timer	SP106	5x74LS02 I.C.s
SP26	5x741 Op-Amp	SP107	20xmixed presets - Hor. +Vertical
SP27	5xCmos 4002	SP108	15xBC382 Transistors
SP28	5xCmos 4011	SP109	15xBC557 Transistors
SP29	3xCmos 4013	SP110	4x74LS13 I.C.s
SP30	5xCmos 4025		
SP31	4xCmos 4071		

1 pack of your choice FREE when you buy any 10 of the above £1.00 packs.

### ADDITIONAL PACKS

SP50	25x5mm Red LEDs	£2.00
SP51	25x5mm Green LEDs	£2.00
SP52	50xRad. Elec. Caps.	£1.95
SP53	30xDIL sockets 8, 14, 16	£2.00
SP54	1xTIL38+1xTIL100	£1.80
SP57	100x1N4148 diodes	£1.75
SP65	60x3mm+5mm Leds	£4.80

### RESISTOR PACKS

0.25W Carbon Film resistors 10R-10M	£2.75
5 each value - total 365	£4.50
10 each value - total 730	£6.00
1000 popular values	2p ea.
Individual resistors	1p ea.
10+ one value	75p
100 one value	

CMOS		I.C.s		V. REGS.	
4000	25p	4070	27p	100mA	25p
4001	25p	4071	27p	78L05	25p
4002	25p	4072	27p	78L12	26p
4011	25p	4073	27p	78L15	26p
4012	27p	4075	27p	79L05	30p
4013	38p	4077	32p	79L12	30p
4017	55p	4081	27p	79L15	30p
4023	30p	4093	27p	1A	
4025	25p	4510	65p	LM339	55p
4027	50p	4511	65p	LM380-14	£1.25
4040	70p	4514	£1.25	LM723	80p
4047	65p	4515	£1.30	LM1458	55p
4049	40p	4516	65p	TL071	60p
4066	40p	4528	70p	TL072	80p
				TL081	40p
				TL082	65p

Cheques or P.O. to:  
**SHERWOOD ELECTRONIC COMPONENTS**  
Please add £1 P&P to orders under £20.00

This only a small sample of components stocked, send 75p for new 1990 catalogue, contains vouchers redeemable against orders over £5.00. NO VAT

## PUBLIC ADDRESS AND DISCO EQUIPMENT

# YOU PAY TRADE PRICES!



### MIXERS

Choose from 25 models ■ Mixers for home use, disco's, public address and studio use ■ From 4 to 16 channels ■ Also 6 and 8 ch midi systems ■ Equalizer mixers MRT60 and many more.



### DECKS

3 models heavy duty top quality with plinth/cover. ■ DLP1 belt drive quick start. ■ DLP2 direct drive system. ■ DLP3 quartz controlled quickstart direct drive.

### ECHO'S

■ VC1 analogue ■ 6040 stereo amplifier ■ 8040 digital echo ■ Also mini echo's.



### POWER AMPLIFIERS

■ Power boosters single channel: 100W, 175W and 2kW. 2-ch/stereo: 135 + 135W, 160 + 160 Watt and 1500 + 1500 Watt.

### DIGITAL DELAY/REVERB

■ 19" rack systems ■ Digital reverb with 63 user programs ■ Digital delay up to infinite repeat ■ Also multi-effects programmable unit.

### GRAPHICS

■ 19" rack systems ■ 31 band single channel ■ 2 x 15 band two channel, and 2 x 31 band two channel.

### CHASSIS SPEAKERS/ CABINETS

■ PA speakers 5 1/4" to 12" ■ Twin cone from 40 to 100 Watts ■ Various models disco/group speakers 10" to 18" various types ■ Bass speakers ■ Bass mids and mids ■ Also Rexine cabinets 10", 12" & 15" ■ Plus range of cabinet fittings and portable speaker stands and brackets.

### PIEZO TWEETERS

■ 10 models stocked from £2.95 to £7.95 ■ Square piezo £4.95.

### PUBLIC ADDRESS SPEAKERS

■ For PA and background music system with and without 100 volt line ■ OUTDOOR. Range of weatherproof systems at various power ratings ■ INDOOR. Columns for speech, columns for music ceiling speakers, suspension speakers, corridor speakers, wall speakers, music speakers - various sizes and types.

### AMPLIFIERS

■ With preamps ■ 240V AC models and 12V DC/240V AC or 24V DC/240V AC ■ From 15 Watts up to 175 Watts ■ Also background music tape amplifiers and paging amplifiers. ■ Plus range of mixer-amplifiers. ■ Choose from 25 models.

### MOBILE AMPLIFIERS

■ Range of 12 volt amplifiers up to 100 Watts ■ Also portable megaphones stocked and 12 volt power boosters.

### MICROPHONES/ STANDS

■ XLR/Jack etc ■ Mics for disco, public address and Hi-Fi ■ Good quality at low cost ■ Also stands, booms etc. and wireless microphone system

### OUTDOOR HORNS

■ Various models up to 12" with or without 100 volt line with drivers ■ Also range of horns with choice of drive units. ■ Accessories: Leads ■ Plugs ■ Adaptors ■ Transformers etc, for all PA requirements.

### HORN/ CROSSOVERS

■ 100 Watt midrange and tweeter horns ■ Also matching crossovers and filters up to 300 Watts.

CALL IN OR PHONE FOR BEST PRICES  
OPEN 6 DAYS A WEEK

## AUDIO ELECTRONICS

301 Edgware Road, London, W2 1BN  
Tel: 01-724 3564 Fax: 01-724 0322  
SALES OFFICE 01-258 1831  
Also at HENRY'S 404 Edgware Road, W2  
TRADE/EDUCATION ORDERS ACCEPTED

PA - DISCO CATALOGUE WITH DISCOUNT VOUCHERS Ref PAI  
Send A4 SAE (£1.00 UK) or £2 UK full products catalogue

The prepaid rate for semi-display space is £8.00 (plus VAT) per single column centimetre (minimum 2.5cm). The prepaid rate for classified advertisements is 30 pence (plus VAT) per word (minimum 12 words).

All cheques, postal orders, etc., to be made payable to Everyday Electronics. VAT must be added. Advertisements, together with remittance, should be sent to the Classified Advertisement Dept., Everyday Electronics, 6 Church Street, Wimborne, Dorset BH21 1JH. Tel: (0202) 881749.

### Kits

**FM MICRO TRANSMITTER KITS** 20mm x 28mm. £2.99 inc p&p. Cheques/PO to Minral, 39 Parkside, Orrell, Wigan, WN5 8LU.

**KITS.** Microtransmitter, VHF/FM, 14x25mm, including free microphone, £4.50. VHF/FM bleeper tracking transmitter, £7.99. Voice operated switch, £8.99. Telephone transmitter, VHF/FM, £4.99. Automatic telephone recording switch, £7.99. SAE list. ACE(EE). 99 Greenheath, Hednesford, Staffs. Access orders 05438 71902 (24 hrs).

**G.C.S.E. ELECTRONICS KITS.** Ten different £10.50 (+70p, p+p) or SAE for details. SIR-KIT ELECTRONICS, 70 Oxford Road, Clacton, CO15 3TE.

### Electronic Components

**ELECTRONIC COMPONENTS & TEST EQUIPMENT** For bargain list send SAE. Dept EE, 76 Wensleydale Road, Great Barr, Birmingham. B42 1PL.

### Miscellaneous

**PROTOTYPE PRINTED CIRCUIT BOARDS,** one offs and quantities, for details send s.a.e. to Mr B. M. Ansbro, 38 Poyning's Drive, Sussex. BN3 8GR, or phone Brighton 720203.

**KIA PICK A FREEBIE A.** Slider variable PSU; B.100 components T.C.R.'s plus projects; C. Slider 25W poweramp. Delete and return ad plus £3 (P&P). 8 Cunliffe Road, Ilkley LS29 9DZ

**WANTED** experienced Manager for busy electronics shop, West Midlands branch. Experience in electronics essential. Reply to Box 100, c/o Everyday Electronics.

### For Sale

**GENUINE PERSONAL REASONS** force the offer for sale of the multi-jig business which has been advertising in this magazine for some time. Sale to include Copyright, all relevant data, parts specs etc, sales data all parts and materials at date of sale and transfer of all orders current at and from date of sale. First offer of £2,500 secures. Genuine enquiries only please to: Everett Workshop Accessories, 5 Railway Terrace, Henllan, Llandysul, Dyfed SA44 5TH. Tel: 0559 371226.

### PRINTED CIRCUIT BOARDS SINGLE SIDED OR DOUBLE SIDED

1 BOARDS MADE FROM YOUR CIRCUIT DIAGRAMS  
2 BOARDS MADE FROM YOUR LAYOUT DIAGRAMS  
3 LAYOUTS DESIGNED FROM YOUR CIRCUIT DIAGRAMS AND PLACED ONTO CLEAR FILM (NEGATIVES AND POSITIVES SUPPLIED)  
ALL BOARDS ARE TINNED AND SUPPLIED WITH NEGATIVES AND POSITIVES FREE. ONE OFFS OR QUANTITIES CAN BE PRODUCED.  
ALL AT COSTS THAT YOU CAN AFFORD!  
**PRICES START AT £20**  
PHONE NOW FOR MORE INFORMATION ON  
**0705 325928**

**AGE A & G ELECTRONICS LTD.**  
ELECTRONIC COMPONENTS MAIL ORDER COMPANY.  
Electronic components, I.C.'s, diodes, LED's, capacitors, potentiometers, solar chargers, computer disks, video tapes, aerosols, etc.  
Brand new quality components at unbeatable prices.  
1990 catalogue is out now  
**ACCESS** (SEND £1 FOR YOUR COPY) **VISA**  
refundable with first order

100 Park Avenue, London E6 2SR. Tel: 01-552 2386

**WALTONS OF WOLVERHAMPTON**  
Established since 1947 - offering a complete range - I.C.'s, transformers, switches, pots, capacitors, resistors, kits, speakers, test equipment, books and lots, lots more!  
**COME AND SEE US AT: MON-SAT 9-6.00 pm**  
55A WORCESTER STREET, WOLVERHAMPTON  
TEL: 0902 22039

**ELECTRONIC COMPONENTS**  
EVERYTHING FOR YOUR NEXT PROJECT  
THE BIGGEST DISPLAY IN THE SOUTH IS AT  
**FRASER ELECTRONICS**  
42 ELM GROVE ★ SOUTHSEA ★ HANTS  
Telephone 0705-815584

**NEW VHF MICROTRANSMITTER KIT**  
Tunable 80-115 MHz, 500 metre range, sensitive electret microphone, high quality PCB, SPECIAL OFFER complete kit ONLY £5, assembled and ready to use £8.95 post free. Access/Visa orders telephone 021 411 1821 (24hrs).  
Cheques/P.O.s payable to:  
**QUANTEK ELECTRONICS LTD**  
(Dept. EE), 45a Station Road Northfield, Birmingham B31 3TE

**SERVICE MANUALS**  
Available for Colour Televisions, Mono Televisions, Video Recorders, Audio equipment, Music Systems, Car Radio's, Cameras, Test equipment etc. etc.  
Over 100,000 stocked, originals and photostats. LSAE Enquiries with Make/Model wanted.  
FREE catalogue Unique Repair and Data Guides for LSAE.  
**MAURITRON (EE)**  
8 Cherry Tree Road, Chinnor, Oxfordshire, OX9 4QY.  
Telephone: (0844) 51694. Office Hours  
Fax: (0844) 52554 anytime.

**PLEASE MENTION EVERYDAY ELECTRONICS WHEN REPLYING TO ADVERTISEMENTS**

*IF YOU WISH TO RESERVE A SPACE IN OUR CLASSIFIED SECTION, RING DAVID LEAVER ON (0202) 881749 AND HE WILL BE PLEASED TO ADVISE YOU ON YOUR REQUIREMENTS*

**DCS VARIABLE VOLTAGE D.C. BENCH POWER SUPPLY**  
1 to 24 volts up to 1/2 amp. 1 to 20 volts up to 1 amp. 1 to 16 volts up to 1 1/2 amps A.C. Fully stabilised. Twin panel meters for instant voltage and current readings. Overload protection.  
Fully variable. Operates from 240V AC. Compact Unit. size 9 x 5 1/2 x 3 in.  
**£42 inc. VAT + Post £2**

**RADIO COMPONENT SPECIALISTS**  
337 WHITEHORSE ROAD, CROYDON SURREY, U.K. Tel: 01-684 1665  
List, Large SAE. Delivery 7 days. Callers welcome. Closed Wednesday

**BLACK FOX AUDIO SYSTEMS**  
18 RUGELEY ROAD, CHASE TERRACE, WALSALL, WEST MIDLANDS WS7 8AQ  
**MOSFET POWER AMPLIFIERS**  
STEREO PFA25 25W + 25W in to 8ohms ..... £60.00  
STEREO PFA30 30W + 30W in to 8 ohms ..... £65.00  
Modules include two regulated power supplies one for each amplifier plus AC output 15-0-15 1A variable gain heatsinks.  
PFA50 50 watts in to 8 ohms PFA140 140 watts in to 8 ohms modules include heatsinks variable gain, voltage regulators on driver stage.  
**POWER SUPPLIES AVAILABLE BUILT TO ORDER NOT MASS PRODUCED ALL HAVE 5 YEAR GUARANTEE**

**TECHNICAL INFO SERVICES (EE)**  
76 Church St., Larkhall, Lanarkshire ML9 1HE  
Phone 0698 884585 Mon-Fri, 9-5,  
any other time 0698 883334. FOR FAST QUOTES  
WORLD'S LARGEST COLLECTION SERVICE MANUALS - Most unobtainable elsewhere. Prices range from only £4.50 - large s.a.e. any quotation, no obligation to buy.  
WORLD'S SOLE Suppliers of TV & Video Repair manuals, etc. from TV TECHNICAL, also such publishers as Heinemann, Newnes, TV Technic, Thorn etc. Every published service sheet in stock, supplied full size, not bits & pieces. CIV's or any combination £3.50 plus LSAE; any other single item £2.50 plus LSAE. Complete Circuit Sets for most Videorecorders only £7 set (no serv this made).  
LSAE for QUOTATIONS plus GIANT CATALOGUE - NEWSLETTERS - BARGAINS - FREE SIGHT as available.  
Comprehensive TV Repair Manual £9.50. Complete Radio Service and Repair Course £9.50. Complete Repair & Service Manuals - Mono TV £12.50. CTV £17.00. Video £19.50. Complete Repair Data with circuit - Mono TV £9.50. CTV £12.50. Video £10.50.  
£3.00 plus LSAE BRINGS THE ONLY COMPREHENSIVE SERVICE SHEETS & MANUALS, CATALOGUES plus FREE CHASSIS GUIDE and £4.00 OF VOUCHERS

**WEATHER STATION FOR THE BBC MICRO**  
Simply plug interface unit into analogue socket for Data logging and/or live 4 channels of information i.e. wind speed and direction, temperature and pressure. Complete package hardware, software and installation ideas. As sold to Schools and Colleges. Price £234 incl. VAT and P&P. FREE compass with each order to assist setting up wind vane. Also available Electronic Handheld Anemometer £75 and Electronic Rainfall measure £40 order direct from:  
**EIFFEL SYSTEMS, PO BOX 59, ASHFORD, KENT TN23 3EB. Tel 0233 637515**



## electronize Car Electronics

### MICRO-PRESSURE CAR ALARM

This new type of alarm is triggered by a unique pressure sensing system. As any vehicle door is opened, air is drawn out, causing a minute drop in air pressure. A sensor detects this sudden pressure change and sets off the alarm.

A sophisticated arrangement of electronic filters and timers provide features to match ultra-sonic systems but at a fraction of the cost.

- ★ 1 Micro-Pressure intruder detection.
- ★ 2 Operates on all doors and tailgate.
- ★ 3 No door switches needed.
- ★ 4 Automatically armed 1 minute after leaving vehicle.
- ★ 5 10 second entry delay with audible warning.
- ★ 6 Sounds horn intermittently for 1 minute.
- ★ 7 Easy fitting - only 3 wires to connect - no holes to drill.
- ★ 8 Compact design can be hidden below dashboard.
- ★ 9 All solid state Power MOSFET output - on relays.

MICRO-PRESSURE ALARM KIT £12.95  
ASSEMBLED READY TO FIT £18.95

### VOLT DROP CAR ALARM

Our latest alarm using the popular voltage drop method of triggering. Based on the timers of the micro-pressure alarm it offers features 4 to 9 above but relies on the existing door switch operation for triggering.

VOLT DROP ALARM KIT £11.75  
ASSEMBLED READY TO FIT £17.75

### TOTAL ENERGY DISCHARGE IGNITION

Our long established Extended CDI system retains the contacts to allow easy fitting whilst the electronics removes the adverse effects. The unique spark generating system still out performs the latest all electronic systems.

TOTAL ENERGY DISCHARGE IGNITION £18.95  
ASSEMBLED READY TO FIT £24.90

All Electronize kits include clear, easy to follow instructions, quality components and everything needed, right down to solder and heatsink compound.

Order direct (Please quote Ref. C04 and add  
or send for more details from: £1 post and packing per item.)

ELECTRONIZE DESIGN tel. 021 308 5877

2 Hillside Road, Four Oaks, Sutton Coldfield, B74 4DQ

Carbon Film resistors 1/4W 5% E24 series 0.51R to 10MΩ	1p
100 off per value—75p, even hundreds per value totalling 1000	£6.00p
Metal Film resistors 1/4W 10R to 1MΩ 5% E12 series—2p, 1% E24 series	3p
Mixed metal/carbon film resistors 1/2W E24 series 1R0 to 10MΩ	1 1/2p
1 watt mixed metal/Carbon Film 5% E12 series 4R7 to 10 Megohms	5p
Linear Carbon pre-sets 100mW and 1/4W 100R to 4M7 E6 series	7p
<b>Miniature polyester capacitors 250V working for vertical mounting</b>	
.015, .022, .033, .047, .068-4p, 0.1-5p, 0.12, 0.15, 0.22-6p, 0.47-8p, 0.68-8p, 1.0-12p	
<b>Mylar (polyester) capacitors 100V working E12 series vertical mounting</b>	
1000p to 8200p - 3p, .01 to .068 - 4p, 0.1 - 5p, 0.12, 0.15, 0.22-6p, 0.47/50V-8p	
<b>Submin ceramic plate capacitors 100V wkg vertical mountings. E12 series</b>	
2% 1.8pf to 47pf - 3p, 2% 56 pf to 330pf - 4p, 10% 390p - 4700p	4p
Disc/plate ceramics 50V E12 series 1P0 to 1000P, E6 Series 1500P to 47000P	2p
<b>Polystyrene capacitors 63V working E12 series long axial wires</b>	
10pf to 820pf - 3p, 1000 pf to 10,000pf - 4p, 12,000 pf	5p
741 Op Amp - 20p, 555 Timer	22p
cmos 4001 - 20p, 4011 - 22p, 4017	40p
<b>ALUMINIUM ELECTROLYTICS (Mfds/Volts)</b>	
1/50, 2.2/50, 4.7/50, 10/25, 10/50	5p
22/16, 22/25, 22/50, 47/16, 47/25, 47/50	6p
100/16, 100/25 7p; 100/50 12p; 100/100	11p
220/16 8p; 220/25, 220/50 10p; 470/16, 470/25	14p
1000/25 25p; 1000/35, 2200/25 35p; 4700/25	70p
<b>Submin, tantalum bead electrolytics (Mfds/Volts)</b>	
0.1/35, 0.22/35, 0.47/35, 1.0/35, 3.3/16, 4.7/16	14p
2.2/35, 4.7/25, 4.7/35, 6.8/16 15p; 10/16, 22/6	20p
33/10, 47/6, 22/16 30p; 47/10 35p; 47/16 60p; 47/35	80p
<b>VOLTAGE REGULATORS</b>	
1A + or - 5V, 8V, 12V, 15V, 18V & 24V	55p
<b>DIODES (piv/amps)</b>	
75/25mA 1N4148 2p, 800/1A 1N4006 6p, 400/3A 1N5404 14p, 115/15mA OA9†	6p
100/1A 1N4002 4p, 1000/1A 1N4007 7p, 60/1.5A S1M1 5p, 100/1A bridge	25p
400/1A 1N 4004 5p, 1250/1A BY127 10p, 30/15A OA47	8p
Zener diodes E24 series 3V3 to 33V 400 mW - 8p, 1 watt	12p
Battery snaps for PP3 - 6p for PP9	12p
L.E.D.'s 3mm, & 5mm, Red, Green, Yellow - 10p, Grommets 3mm - 2p, 5mm	2p
Red flashing L.E.D.'s require 5V supply only	50p
Mains indicator neons with 220k resistor	10p
20mm fuses 100mA to 5A Q/blow 5p, A/surge 8p, Holders pc or chassis	5p
High speed pc drill 0.8, 1.0, 1.3, 1.5, 2.0mm - 30p, Machines 12V dc	£7.00
HELPING HANDS 6 ball joints and 2 croc clips to hold awkward jobs	£3.50p
AA/HP/ Nicad rechargeable cells 80p each, Universal charger unit	£6.50p
Glass reed switches with single pole make contacts - 8p, Magnets	12p
0.1" Veroboard 2" x 1" 9 rows 25 holes - 20p, 3" x 1" x 2" - 24 rows 37 holes	60p
<b>TRANSISTORS</b>	
BC107/8/9-12p, BC547/8/9-8p, BC557/8/9-8p, BC182, 182L, BC183, 183L, BC184, 184L, BC212, 212L-10p, BC327, 337, 337L-12p, BC727, 737-12p, BD135/67/8/9-25p, BCY70-15p, BFY50/51/52-20p, BFX85-15p, 2N3055-50p, TIP31, 32-30p, TIP41, 42-40p, BU208A-£1.20, BF195, 197-12p	
All prices are inclusive of VAT. Postage 25p (free over £5). Lists Free.	

## THE CR SUPPLY CO

127 Chesterfield Rd., Sheffield S8 0RN

Tel: 0742 557771

Return posting

# THIS MONTH SPECIAL

A COMPLETE 12 volt AND 9 volt POWER SUPPLY,  
QUALITY BUILT AND COMPRISING A 50VA  
TRANSFORMER INPUT FILTERS AND 2 OUTPUT  
REGULATORS

OUTPUT 12v 2 AMP (MAY BE INCREASED WITH  
EXTERNAL TRANSISTOR, 9v 1AMP AND 24v UNREG  
SUPPLIED COMPLETE WITH CIRCUIT

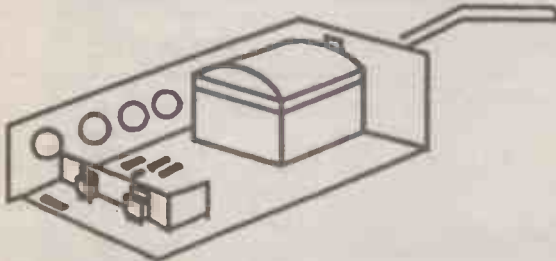

DUE TO BULK PURCHASE WE OFFER THE  
POWER PACK AT JUST £6.00 INC VAT AND CARR.

MANY VIDEO & TV MANUALS IN STOCK PLUS  
SPARES. SAE FOR LIST

## BELL RADIO

322 HUNGERFORD ROAD, CREWE CW1 1HG

TEL: 0270 582849

# SURVEILLANCE PROFESSIONAL QUALITY KITS

A range of high quality kits as supplied to leading UK security companies, all in-house designed and produced, not to be confused with cheap imports. All kits come fully documented with concise assembly and setting-up details, fibreglass PCB and all components. All transmitters are fully tuneable and can be monitored on a normal VHF radio or tuned higher for greater security. Build up service available if required.

MTX. Micro-miniature audio transmitter. 17mm x 17mm, 9V operation. 1000m range	£12.95
VT500. Hi-power audio transmitter. 250mW output. 20mm x 40mm 9-12V operation. 2-3000m range	£15.95
VOX75. Voice activated transmitter. Variable sensitivity. 30mm x 40mm, 9V operation. 1000m range	£18.95
CTX900. Sub-carrier scrambled audio transmitter. Cannot be monitored without decoder fitted to radio. 30mm x 40mm. 9V operation. 1000m range	£21.95
DSX900. Sub-carrier decoder unit for monitoring CTX900. Connects to radio earphone socket. Provides output for headphones. 35mm x 50mm. 9-12V operation	£21.95
HVX400. Mains powered audio transmitter. Connects directly to 240V AC supply. 30mm x 35mm. 500m range	£18.95
XT89. Crystal controlled audio transmitter. High performance, 100mW output. Supplied with xtal for 108MHz. Others available to 116MHz. 85mm x 28mm. 9V operation. 2-3000m range	£36.95
TKX900. Tracker/Beeper transmitter. Transmits continuous stream of audio pulses. Variable tone and rate. Powerful 200mW output. 63mm x 25mm. 9V operation. 2-3000m range	£21.95
ATR2. Micro size telephone recording interface. Connects between telephone line (anywhere) and cassette recorder. Tape switches automatically with use of phone. All conversations recorded. Powered from line 10mm x 35mm	£12.95
TLX700. Micro miniature telephone transmitter. Connects to line (anywhere) switches on and off with phone use. All conversations transmitted. 20mm x 20mm. Powered from line 1000m range	£12.95
XML900. RF bug detector. Variable sensitivity. Triggers LED and beeper when in presence of RF field. Detects MTX 15-20 feet. 55mm x 55mm. 9V operation	£26.95
XL7000. Professional bug detector/locator. Variable sensitivity. Twin mode ten segment LED readout of signal strength with variable rate beeper. Second mode AUDIO CONFIRM distinguishes between localised bug transmission and normal legitimate signal such as pagers, cellular etc. 70mm x 100mm. 9V operation	£54.95

UK customers please send cheques, PO's or registered cash. Please add £1.50 per order for P&P. Goods despatched ASAP allowing for cheque clearance. Overseas customers send sterling bank draft or Eurocheque and add £5.00 per order for shipment. Credit card orders accepted on 0827 714476. Trade enquiries welcome.

Send 28p stamp for New 1990 Full Catalogue



The Workshops, 95 Main Rd  
Baxterley, Nr. Atherstone  
Warks CV9 2LE



0827 714476

## MAIL ORDER AND RETAIL SHOP

Stockist of

Large range of Semiconductors: Transistors, Diodes, Zeners, Thyristors Triacs, regulators, opto isolators LED. Integrated circuits: TTL, Cmos, CPU, support device, Roms-proms, controllers and generators etc.  
Resistors: Pots, presets, Capacitors including computer grade, trimmers, tuners etc.  
Chokes, transformers, Relays, Buzzers, Speakers etc.  
Switches: standard, miniature, slide, rockers, pushbuttons etc. Connectors: large range including ready made leads, IDC, URQ, Din, plugs and sockets etc. Dill sockets: low profile and wire wrap etc.  
Panel meters, soldering irons, solder suckers, solder etc. Aerosol switch cleaners, lubricants, protectors and freezers etc. Motors, modulators, trimmers, oscillator modules, rechargeable batteries, solar panels etc.  
Power supplies Linear and switch mode by Astec, Femell, Siemens, Advance, Gould, Gresham etc.  
Disc Drive Units: 5.25, 3.5 inches, hard disc, and cables etc.  
Test Instruments: Analogue, Digital, Oscilloscopes, Generators etc. Large range of instrument cases.

### WE BUY COMPONENTS AND INSTRUMENTS

Callers Welcome, Shop Hours: Mon., Tu., Thu.,  
Fri. 9am to 5.30pm Wed. & Sat. 9am to 2pm

#### COMPACT SWITCH MODE

Supplies — 51 watts to 1 kilowatt. Various Voltages. Please Ring for further Details.



**Fuselodge Ltd.**



267 Acton Lane, Chiswick, London W4 5DD Telephone: 01-994 6275

## ADVERTISERS INDEX

ANTEX ELECTRONICS .....	191
AUDIO ELECTRONICS .....	217
BELL RADIO .....	219
BICC-VERO ELECTRONICS .....	183
BK ELECTRONICS .....	Cover (iii)
BLACKMORE ELECTRONICS .....	207
BULL J & N .....	150/151
CAMBRIDGE COMP. SCIENCE .....	211
CIRKIT DISTRIBUTION .....	191
CIRKLEWOOD ELECTRONICS .....	195
CR SUPPLY COMPANY .....	219
ELECTRONIZE DESIGN .....	219
ELECTROVALVE .....	207
ELY FRANCE .....	154/155
FUSELODGE .....	220
GREENWELD ELECTRONICS .....	Cover (ii)
HART ELECTRONIC KITS .....	207
HIGHGRADE COMPONENTS .....	197
HILLS COMPONENTS .....	201
HOBBYKIT .....	215
ICS .....	220
JAYTEE ELECTRONIC SERVICES .....	215
LITESOLD .....	217
LONDON ELECTRONICS COLLEGE .....	220
MAGENTA ELECTRONICS .....	156/157
MAPLIN ELECTRONICS .....	Cover (iv)
NUMBER ONE SYSTEMS .....	220
OMNI ELECTRONICS .....	211
RADIO & TV COMPONENTS .....	177
RISCOMP .....	165
SHERWOOD ELEC. COMP. .....	217
SPECIALIST SEMICONDUCTORS .....	152
SUMA DESIGNS .....	219
TANDY .....	171
TK ELECTRONICS .....	158

## BTEC ELECTRONICS TECHNICIAN FULL-TIME TRAINING

**2 YEAR**  
**BTEC National Diploma (OND)**  
**ELECTRONIC & COMMUNICATIONS ENGINEERING**  
(Electronics, Computing, Television, Video, Testing & Fault Diagnosis)

**1 YEAR**  
**BTEC National Certificate (ONC)**  
**ELECTRONIC ENGINEERING**  
**1—INFORMATION TECHNOLOGY**  
(Electronics, Satellite TV, Networks, Telecomms)

**2—ELECTRONIC EQUIPMENT SERVICING**  
(Electronics, Television, Video Cassette Recorders, CCTV, Testing and Fault Diagnosis)

**3—SOFTWARE ENGINEERING**  
(Electronics, Assembler, BASIC, Pascal, CAD/CAM)

**4—COMPUTING TECHNOLOGY**  
(Electronics, Computing Software/Hardware, Microelectronics)

**10 MONTHS**  
**BTEC Higher National Certificate (HNC)**  
**COMPUTING TECHNOLOGY & ROBOTICS**  
(Microprocessor Based Systems, Control, Robotics)

*These courses include a high percentage of college based practical work to enhance future employment prospects*  
*No additional fees for overseas students*

*Shortened courses of from 3 to 6 months can be arranged for applicants with previous electronics knowledge*

**THOSE ELIGIBLE CAN APPLY FOR E.T. GRANT SUPPORT AN EQUAL OPPORTUNITIES PROGRAMME**

**O.N.C. and O.N.D.**  
**Next Course Commences**  
**Monday 23rd April 1990**  
**FULL PROSPECTUS FROM**

**LONDON ELECTRONICS COLLEGE**  
(Dept. EE), 20 PENYWERN ROAD  
EARLS COURT, LONDON SW5 9SU  
Tel: 01-373 8721

## MAKE YOUR INTERESTS PAY!

More than 8 million students throughout the world have found it worth their while! An ICS home-study course can help you get a better job, make more money and have more fun out of life! ICS has over 90 years experience in home-study courses and is the largest correspondence school in the world. You learn at your own pace. When and where you want, under the guidance of expert 'personal' tutors. Find out how we can help YOU. Post or phone today for your **FREE INFORMATION PACK** on the course of your choice.

<b>GCSE / GCE / SCE</b> <b>ELECTRONICS</b> BASIC ELECTRONIC ENGINEERING (City & Guilds) ELECTRICAL ENGINEERING ELECTRICAL CONTRACTING/ INSTALLATION	<b>CAR MECHANICS</b> <b>COMPUTER</b> PROGRAMMING TV, VIDEO & HI-FI SERVICING RADIO AMATEUR LICENCE EXAM (City & Guilds)	SEE ORACLE PAGE 871
Course of Interest .....		
Name: .....		
Address: ..... P.Code .....		
International Correspondence School, Dept. ECS30, 312/314 High Street, Sutton, Surrey SM1 1PR. Tel: 01-643 9568 or 041-221 2926 (24 hrs)		

# MAKING ELECTRONICS C.A.D. AFFORDABLE

- ★ HAVE YOU BEEN PUTTING OFF BUYING PCB CAD SOFTWARE?
- ★ ARE YOU STILL USING TAPES AND A LIGHT BOX?
- ★ HAVE YOU ACCESS TO AN IBM PC/XT/AT OR CLONE INCL. AMSTRAD 1640 & 1512?
- ★ WOULD YOU LIKE TO BE ABLE TO PRODUCE PCB LAYOUTS UP TO 17" SQUARE?
- ★ WITH UP TO 8 TRACK LAYERS AND 2 SILK SCREEN LAYERS?
- ★ PLUS DRILL TEMPLATE AND SOLDER RESIST?
- ★ WITH UP TO 8 DIFFERENT TRACK WIDTHS ANYWHERE IN THE RANGE .002 to .531"?
- ★ WITH UP TO 16 DIFFERENT PAD SIZES FROM THE SAME RANGE?
- ★ WITH PAD SHAPES INCLUDING ROUND, OVAL, SQUARE, WITH OR WITHOUT HOLE, AND EDGE CONNECTOR FINGERS?
- ★ WITH UP TO 1500 IC's PER BOARD, FROM UP TO 100 DIFFERENT OUTLINES?
- ★ WITH AUTO REPEAT ON TRACKS OR OTHER FEATURES—IDEAL FOR MEMORY PLANES?
- ★ THAT CAN BE USED FOR SURFACE MOUNT COMPONENTS?
- ★ WITH THE ABILITY TO LOCATE COMPONENTS AND PADS OR GRID OR TO .002" RESOLUTION?
- ★ WITH AN OPTIONAL AUTO-VIA FACILITY FOR MULTILAYER BOARDS?
- ★ WITH THE ABILITY TO CREATE AND SAVE YOUR OWN SYMBOLS?
- ★ THAT IS AS GOOD AT CIRCUIT DIAGRAMS AS IT IS AT PCB's?
- ★ THAT CAN BE USED WITH EITHER CURSOR KEYS OR MOUSE?
- ★ WHERE YOU CAN LEARN HOW TO USE IT IN AROUND HALF AN HOUR?
- ★ WHICH WITH EASY PLOT AND EASY-GERB CAN OUTPUT TO PEN-PLOTTER OR PHOTO-PLOTTER (VIA BUREAUX)

WRITE OR TELEPHONE FOR FULL INFORMATION

**BRITISH DESIGN AWARD 1989**

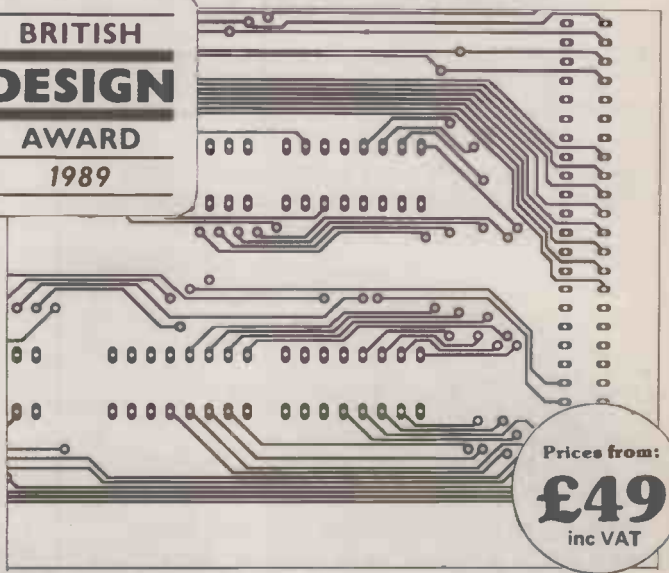

Prices from:  
**£49**  
inc VAT

## EASY-PC, TINY-PC, EASY-PC, TINY-PC, EASY-PC, TINY-PC, EASY-PC

**Number One Systems Ltd**  
Ref. EVD. HARDING WAY, SOMERSHAM ROAD  
ST IVES, HUNTINGDON, CAMBS PE17 4WR

AMEX, VISA, ACCESS, WELCOME  
Telephone: 0480 61778 (5 lines)

Published on approximately the first Friday of each month by Wimborne Publishing Ltd., 6 Church Street, Wimborne, Dorset BH21 1JH. Printed in England by Benham & Co. Limited, Colchester, Essex. Distributed by Seymour, 334 Brixton Road, London SW9 7AG. Sole Agents for Australia and New Zealand — Gordon & Gotch (Asia) Ltd., South Africa — Central News Agency Ltd. Subscriptions INLAND £16.00 and OVERSEAS £19.50 (£37 airmail) payable to "Everyday Electronics" Subscription Department, 6 Church Street, Wimborne, Dorset BH21 1JH. EVERYDAY ELECTRONICS is sold subject to the following conditions, namely that it shall not, without the written consent of the Publishers first having been given, be lent, resold, hired out or otherwise disposed of by way of Trade at more than the recommended selling price shown on the cover, and that it shall not be lent, resold, hired out or otherwise disposed of in a mutilated condition or in any unauthorised cover by way of Trade or affixed to or as part of any publication or advertising, literary or pictorial matter whatsoever.

**OMP POWER AMPLIFIER MODULES-TURNABLES-DIMMERS-LOUDSPEAKERS-19 INCH STEREO RACK AMPLIFIERS**

**OMP POWER AMPLIFIER MODULES**

Supplied ready built and tested.  
Now enjoy a world-wide reputation for quality, reliability and performance at a realistic price. Four models available to suit the needs of the professional and hobby market, i.e., Industry, Leisure, Instrumental and Hi-Fi etc. When comparing prices, NOTE all models include Toroidal power supply, Integral heat sink, Glass fibre P.C.B., and Drive circuits to power compatible Vu meter. Open and short circuit proof.

THOUSANDS OF MODULES PURCHASED BY PROFESSIONAL USERS



OMP100 Mk 11 Bi-Polar Output power 110 watts R.M.S. into 4 ohms, Frequency Response 15Hz - 30KHz - 3dB, T.H.D. 0.01%, S.N.R. - 118dB, Sens. for Max. output 500mV at 10K, Size 355 x 115x65mm. PRICE £33.99 + £3.00 P&P.

**NEW SERIES II MOS-FET MODULES**



OMP/MF 100 Mos-Fet Output power 110 watts R.M.S. into 4 ohms, Frequency Response 1Hz - 100KHz - 3dB, Damping Factor >300, Slew Rate 45V/uS, T.H.D. Typical 0.002%, Input Sensitivity 500mV, S.N.R. - 125dB, Size 300 x 123 x 60mm. PRICE £39.99 + £3.00 P&P.



OMP/MF200 Mos-Fet Output power 200 watts R.M.S. into 4 ohms, Frequency Response 1Hz - 100KHz - 3dB, Damping Factor >300, Slew Rate 50V/uS, T.H.D. Typical 0.001%, Input Sensitivity 500mV, S.N.R. - 130dB, Size 300 x 155 x 100mm. PRICE £62.99 + £3.50 P&P.



OMP/MF300 Mos-Fet Output power 300 watts R.M.S. into 4 ohms, Frequency Response 1Hz - 100KHz - 3dB, Damping Factor >300, Slew Rate 60V/uS, T.H.D. Typical 0.0008%, Input Sensitivity 500mV, S.N.R. - 130dB, Size 330 x 175 x 100mm. PRICE £79.99 + £4.50 P&P.

NOTE.— MOS-FET MODULES ARE AVAILABLE IN TWO VERSIONS, STANDARD — INPUT SENS. 500mV BAND WIDTH 100KHz, PEC (PROFESSIONAL EQUIPMENT COMPATIBLE) — INPUT SENS. 775mV, BAND WIDTH 50KHz, ORDER STANDARD OR PEC



Vu METER Compatible with our four amplifiers detailed above. A very accurate visual display employing 11 L.E.D. diodes (7 green, 4 red) plus an additional on/off indicator. Sophisticated logic control circuits for very fast rise and decay times. Tough moulded plastic case, with tinted acrylic front. Size 84 x 27 x 45mm. PRICE £8.50 + 50p P&P.

**LOUDSPEAKERS**



LARGE SELECTION OF SPECIALIST LOUDSPEAKERS AVAILABLE, INCLUDING CABINET FITTINGS, SPEAKER GRILLES, CROSS-OVERS AND HIGH POWER, HIGH FREQUENCY BULLETS AND HORNS, LARGE S.A.E. (30p STAMPED) FOR COMPLETE LIST.

**McKENZIE:— INSTRUMENTS, P.A., DISCO, ETC.**

**ALL MCKENZIE UNITS 8 OHMS IMPEDENCE**

- 8" 100 WATT C8100GPM GEN. PURPOSE, LEAD GUITAR, EXCELLENT MID. DISCO. RES, FREQ. 80Hz FREQ. RESP. TO 14KHz SENS. 99dB. PRICE £29.30 + £2.00 P&P
- 10" 100 WATT C10100GP GUITAR, VOICE, ORGAN, KEYBOARD, DISCO, EXCELLENT MID. RES, FREQ. 70Hz FREQ. RESP. TO 6KHz SENS. 100dB. PRICE £35.58 + £2.50 P&P
- 10" 200 WATT C10200GP GUITAR, KEYBOARD, DISCO, EXCELLENT HIGH POWER MID. RES, FREQ. 45Hz FREQ. RESP. TO 7KHz SENS. 103dB. PRICE £48.67 + £2.50 P&P
- 12" 100 WATT C12100GP HIGH POWER GEN. PURPOSE, LEAD GUITAR, DISCO. RES, FREQ. 45Hz FREQ. RESP. TO 7KHz SENS. 98dB. PRICE £37.59 + £3.50 P&P
- 12" 100 WATT C12100T TWIN CONE) HIGH POWER WIDE RESPONSE, P.A., VOICE, DISCO. RES, FREQ. 45Hz FREQ. RESP. TO 14KHz SENS. 100dB. PRICE £38.58 + £3.50 P&P
- 12" 200 WATT C12200B HIGH POWER BASS, KEYBOARDS, DISCO, P.A. RES, FREQ. 40Hz FREQ. RESP. TO 7KHz SENS. 100dB. PRICE £65.79 + £3.50 P&P
- 12" 300 WATT C12300GP HIGH POWER BASS LEAD GUITAR, KEYBOARDS, DISCO, ETC. RES, FREQ. 45Hz FREQ. RESP. TO 5KHz SENS. 100dB. PRICE £87.51 + £3.50 P&P
- 15" 100 WATT C15100BS BASS GUITAR, LOW FREQUENCY, P.A., DISCO RES, FREQ. 40Hz FREQ. RESP. TO 5KHz SENS. 99dB. PRICE £55.05 + £4.00 P&P
- 15" 200 WATT C15200BS VERY HIGH POWER BASS. RES, FREQ. 40Hz FREQ. RESP. TO 4KHz SENS. 99dB. PRICE £75.10 + £4.00 P&P
- 15" 250 WATT C15250BS VERY HIGH POWER BASS. RES, FREQ. 40Hz FREQ. RESP. TO 4KHz SENS. 99dB. PRICE £82.54 + £4.50 P&P
- 15" 400 WATT C15400BS VERY HIGH POWER, LOW FREQUENCY BASS. RES, FREQ. 40Hz FREQ. RESP. TO 4KHz SENS. 102dB. PRICE £96.47 + £4.50 P&P
- 18" 400 WATT C18400BS EXTREMELY HIGH POWER, LOW FREQUENCY BASS. RES, FREQ. 27Hz FREQ. RESP. TO 3KHz SENS. 99dB. PRICE £172.06 + £5.00 P&P

**EARBENDERS:— HI-FI, STUDIO, IN-CAR, ETC.**

ALL EARBENDER UNITS 8 OHMS (Except EB8-50 & EB10-50 which are dual impedance tapped (4 4 & 8 ohms).

- BASS, SINGLE CONE, HIGH COMPLIANCE, ROLLED FOAM SURROUND
- 8" 50 WATT EB8-50 DUAL IMPEDENCE, TAPPED 4 8 OHM BASS, HI-FI, IN-CAR. RES, FREQ. 40Hz FREQ. RESP. TO 7KHz SENS. 97dB. PRICE £8.90 + £2.00 P&P
- 10" 50 WATT EB10-50 DUAL IMPEDENCE, TAPPED 4 8 OHM BASS, HI-FI, IN-CAR. RES, FREQ. 40Hz FREQ. RESP. TO 5KHz SENS. 99dB. PRICE £12.00 + £2.50 P&P
- 10" 100 WATT EB10-100 BASS, HI-FI, STUDIO. RES, FREQ. 35Hz FREQ. RESP. TO 3KHz SENS. 96dB. PRICE £27.76 + £3.50 P&P
- 12" 60 WATT EB12-60 BASS, HI-FI, STUDIO. RES, FREQ. 28Hz FREQ. RESP. TO 3KHz SENS. 92dB. PRICE £21.00 + £3.00 P&P
- 12" 100 WATT EB12-100 BASS, STUDIO, HI-FI, EXCELLENT DISCO. RES, FREQ. 26Hz FREQ. RESP. TO 3KHz SENS. 93dB. PRICE £38.75 + £3.50 P&P
- FULL RANGE TWIN CONE, HIGH COMPLIANCE, ROLLED SURROUND
- 5 1/2" 60 WATT EB5-60TC (TWIN CONE) HI-FI, MULTI-ARRAY DISCO ETC. RES, FREQ. 63Hz FREQ. RESP. TO 20KHz SENS. 92dB. PRICE £9.99 + £1.50 P&P
- 6 1/2" 60 WATT EB6-60TC (TWIN CONE) HI-FI, MULTI-ARRAY DISCO ETC. RES, FREQ. 38Hz FREQ. RESP. TO 20KHz SENS. 94dB. PRICE £10.99 + £1.50 P&P
- 8" 60 WATT EB8-60TC (TWIN CONE) HI-FI, MULTI-ARRAY DISCO ETC. RES, FREQ. 40Hz FREQ. RESP. TO 18KHz SENS. 89dB. PRICE £12.99 + £1.50 P&P
- 10" 60 WATT EB10-60TC (TWIN CONE) HI-FI, MULTI-ARRAY DISCO ETC. RES, FREQ. 35Hz FREQ. RESP. TO 12KHz SENS. 86dB. PRICE £16.49 + £2.00 P&P

**TRANSMITTER HOBBY KITS**

PROVEN TRANSMITTER DESIGNS INCLUDING GLASS FIBRE PRINTED CIRCUIT BOARD AND HIGH QUALITY COMPONENTS COMPLETE WITH CIRCUIT AND INSTRUCTIONS

3W FM TRANSMITTER 80-108MHz, VARICAP CONTROLLED PROFESSIONAL PERFORMANCE, RANGE UP TO 3 MILES, SIZE 38 x 123mm, SUPPLY 12V @ 0.5AMP, PRICE £14.49 + £1.00 P&P

FM MICRO TRANSMITTER (BUG) 100-108MHz VARICAP TUNED COMPLETE WITH VERY SENS FET MIC, RANGE 100-300m, SIZE 56 x 46mm, SUPPLY 9V BATT, PRICE £8.82 + £1.00 P&P



3 watt FM Transmitter



POSTAL CHARGES PER ORDER £1.00 MINIMUM. OFFICIAL ORDERS WELCOME FROM SCHOOLS, COLLEGES, GOVT. BODIES, ETC. PRICES INCLUSIVE OF V.A.T. SALES COUNTER, VISA ACCESS ACCEPTED BY POST, PHONE OR FAX

\* PRICES INCLUDE V.A.T. \* PROMPT DELIVERIES \* FRIENDLY SERVICE \* LARGE S.A.E., 30p STAMPED FOR CURRENT LIST.

**OMP VARISPEED TURNTABLE CHASSIS.**



OPTIONAL MAGNETIC CARTRIDGES

STANTON AL500  
PRICE £16.99 + 50p P&P

GOLDRING G850  
PRICE £6.99 + 50p P&P

★ MANUAL ARM ★ STEEL CHASSIS ★ ELECTRONIC SPEED CONTROL 33 & 45 ★ VARI PITCH CONTROL ★ HIGH TORQUE SERVO DRIVEN DC MOTOR ★ TRANSIT SCREWS ★ 12 DIE CAST PLATTER ★ NEON STROBE ★ CALIBRATED BAL. WEIGHT ★ REMOVABLE HEAD SHELL ★ 1/2" CARTRIDGE FIXINGS ★ CUE LEVER ★ POWER 220/240V 50/60Hz ★ 390x305mm ★ SUPPLIED WITH MOUNTING CUT-OUT TEMPLATE.  
PRICE £59.99 + £3.50 P&P.

**OMP MOS-FET POWER AMPLIFIERS, HIGH POWER, TWO CHANNEL 19 INCH RACK**

THOUSANDS PURCHASED BY PROFESSIONAL USERS



**NEW MXF SERIES OF POWER AMPLIFIERS**

THREE MODELS:— MXF200 (100w + 100w) MXF400 (200w + 200w) MXF600 (300w + 300w)

All power ratings R.M.S. into 4 ohms.

FEATURES: ★ Independent power supplies with two Toroidal Transformers ★ Twin L.E.D. Vu meters ★ Rotary interlocked level controls ★ illuminated on/off switch ★ XLR connectors ★ Standard 775mV inputs ★ Open and short circuit proof ★ Latest Mos-Fets for stress free power delivery into virtually any load ★ High slew rate ★ Very low distortion ★ Aluminium cases ★ MXF600 Fan Cooled with D.C. Loudspeaker and Thermal Protection.

USED THE WORLD OVER IN CLUBS, PUBS, CINEMAS, DISCOS ETC.

SIZES:— MXF 200 W19" x H3 1/2" (2U) x D11" MXF 400 W19" x H5 1/4" (3U) x D12" MXF 600 W19" x H5 1/4" (3U) x D13"

MXF200 £171.35  
MXF400 £228.85  
MXF600 £322.00

SECURICOR DELIVERY £12.00 EACH

**OMP LINNET LOUDSPEAKERS**

THE VERY BEST IN QUALITY AND VALUE



MADE ESPECIALLY TO SUIT TODAY'S NEED FOR COMPACTNESS WITH HIGH OUTPUT SOUND LEVELS FINISHED IN HARDWEARING BLACK VYNIDE WITH PROTECTIVE CORNERS GRILLE AND CARRYING HANDLE, INCORPORATES 12" DRIVER PLUS HIGH FREQ. HORN FOR FULL FREQ. RANGE. 45Hz-20KHz BOTH MODELS 8 OHM. SIZE H18" x W15" x D12"

CHOICE OF TWO MODELS

POWER RATINGS QUOTED IN WATTS RMS FOR EACH CABINET

OMP 12-100 (100W 100dB) PRICE £159.99 PER PAIR

OMP 12-200 (200W 102dB) PRICE £209.99 PER PAIR

SECURICOR DEL.— £12.00 PER PAIR

**IN CAR STEREO BOOSTER AMPLIFIER**



**TWO SUPER HIGH POWER CAR STEREO BOOSTER AMPLIFIERS**

150 WATTS (75+75) INTO 4 OHMS  
300 WATTS (150+150) INTO 4 OHMS  
FEATURES:—  
★ HIGH & LOW INPUT IMPEDANCES  
★ HIGH & LOW INPUT SENSITIVITIES  
★ VARIABLE INPUT GAIN CONTROL  
★ SHORT CIRCUIT OUTPUT PROTECTION  
★ POWER REQUIREMENT 12V. D.C.  
PRICES: 150 WATT £43.00  
300 WATT £95.00 + £3.00 P&P EACH

**PIEZO ELECTRIC TWEETERS—MOTOROLA**

**PIEZO ELECTRIC TWEETERS — MOTOROLA**

Join the Piezo revolution. The low dynamic mass (no voice coil) of a Piezo tweeter produces an improved transient response with a lower distortion level than ordinary dynamic tweeters. As a crossover is not required these units can be added to existing speaker systems of up to 100 watts (more if 2 put in series). FREE EXPLANATORY LEAFLETS SUPPLIED WITH EACH TWEETER.

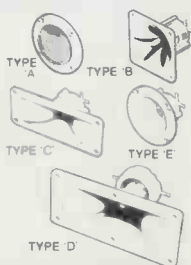

TYPE 'A' (KSN2036A) 3" round with protective wire mesh, ideal for bookshelf and medium sized Hi-fi speakers. Price £4.90 each + 50p P&P.  
TYPE 'B' (KSN1005A) 3 1/2" super horn. For general purpose speakers, disco and P.A. systems etc. Price £5.99 each + 50p P&P.  
TYPE 'C' (KSN6016A) 2" x 5" wide dispersion horn. For quality Hi-fi systems and quality discos etc. Price £6.99 each + 50p P&P.  
TYPE 'D' (KSN1025A) 2" x 6" wide dispersion horn. Upper frequency response retained extending down to mid range (2KHz). Suitable for high quality Hi-fi systems and quality discos. Price £9.99 each + 50p P&P.  
TYPE 'E' (KSN1038A) 3 3/4" horn tweeter with attractive silver finish trim. Suitable for Hi-fi monitor systems etc. Price £5.99 each + 50p P&P.  
LEVEL CONTROL Combines on a recessed mounting plate, level control and cabinet input jack socket. 85x85mm. Price £3.99 + 50p P&P.

**STEREO DISCO MIXER**

STEREO DISCO MIXER with 2 x 5 band L & R graphic equalisers and twin 10 segment L.E.D. Vu Meters. Many outstanding features 5 Inputs with individual faders providing a useful combination of the following:—

3 Turntables (Mag), 3 Mics, 4 Line including CD plus Mic with talk over switch Headphone Monitor, Pan Pot L & R, Master Output controls, Output 775mV. Size 360x280x90mm. Supply 220-240V.  
Price £134.99 — £4.00 P&P



**B. K. ELECTRONICS Dept EE**

UNIT 5, COMET WAY, SOUTHEND-ON-SEA, ESSEX. SS2 6TR  
TEL: 0702-527572 FAX: 0702-420243

# Double Tops

DUAL BAND VHF (45W)/UHF (35W)

FM MOBILE TRANSCEIVER

When only the best is good enough - and

you still want something better...

- ★ Cross Band Full Duplex
- ★ 4 Scanning Modes
- ★ 10 Function Memory Channels
- ★ Highly Visible Colour LCD Display
- ★ Illuminated Front Panel Controls
- ★ 5 Channel Spacing Steps
- ★ Built-in Duplexer
- ★ Function Keys have Unique Audible Tone
- ★ Bell Function
- ★ Compact & Lightweight

#### Accessories Included:

- ★ Hand-held microphone
- ★ Mobile mounting bracket
- ★ Mounting hardware
- ★ Power cable



**ALINCO**  
from MAPLIN  
the authorised  
distributor

This very high quality 2m/70cm FM dual band mobile transceiver has been specially designed to provide maximum performance and operating convenience in an ultra compact package. An impressive array of features gives maximum flexibility in mobile installations. The transceiver has an output power of 45W (VHF) 35W (UHF) and incorporates a high/low power switch. The unit is provided with 10 programmable memories. Channel spacing is in 5, 10, 12.5, 20 and 25kHz steps. There are four scanning modes:

1. VFO scanning of the entire band.
2. Memory scanning of selected memories.
3. Programmed band scanning of a selected segment of the band.
4. Priority scanning allows selection of a frequency, in VFO or memory, to serve as a priority frequency.

A duplexer is built-in so that when an antenna for both bands is in use, only one feeder cable for the transceiver is necessary.

The unit is supplied with a comprehensive instruction manual. It is illegal to transmit with this unit unless you hold a Radio Amateur's Class B (or A) licence.

Quote Reference DBT20 £499.95

## PLUS TOP VALUE AMATEUR RADIO VHF FM Handheld 2m Transceiver

- ★ Ultra compact, lightweight design
- ★ 6.5W Output Power (with optional 12V battery pack)
- ★ Simple Operation
- ★ Easy to See LCD Display
- ★ 10 Channel Memories
- ★ Battery Save
- ★ Function Lock
- ★ Tone Burst
- ★ Amazing Compact Size Only 3x6x17 cm approx.

A very high quality, lightweight, 2m handheld transceiver, incorporating many useful features. This transceiver is extremely simple to operate, most functions can be performed with one hand!

Quote Reference AHT20 £219.95

#### 12V Ni-Cad Battery Pack

For use with either above hand-held transceivers. A 12V 700mAh battery pack with integral DC-DC converter which allows the transceiver to be powered from a car cigarette lighter socket.

A charger is also available for use with this pack.

Battery Pack NBP20 £59.95 Charger NBC20 £14.95



## VHF/UHF FM Dual Band Handheld Transceiver

- ★ 6W VHF/5W UHF Output Power (with optional 12V battery pack)
- ★ Cross Band Full Duplex Operation
- ★ Frequency selection by Direct Keyboard Entry or Step Up/Step Down
- ★ Automatic Battery Save Function
- ★ 20 Memory Channels
- ★ Built-in DTMF Keypad and Encoder
- ★ Amazing Compact Size Only 3x6x19 cm approx.

This unit is very compact and is one of the smallest dual band transceivers currently available. With the battery pack supplied output power is 2.5W for VHF and 2W for UHF. Frequency selection is either by direct keypad entry of the required frequency or by using step up/step down buttons in increments/decrements of 5kHz, 100kHz and 1MHz. An automatic battery save (ABS) function will extend battery life considerably. There are 20 memories (10 VHF and 10 UHF) for storing operating, offset and tone frequencies. The scanning facility has a priority function which has the ability to scan between chosen VHF and UHF frequencies. A 10dB RF attenuator is switch selectable and can be used in areas of high RF saturation.

Quote Reference DHT20 £369.95



**Maplin** ELECTRONICS

P.O. Box 3, Rayleigh, Essex SS6 8LR.

**CREDIT CARD HOTLINE**

0702 554161



PHONE BEFORE 5PM FOR SAME DAY DESPATCH

or call in at a Maplin store in Birmingham, Bristol, Leeds, Hammersmith, Edgware, Manchester, Nottingham, Newcastle-upon-Tyne, Reading, Southampton and Southend-on-Sea.

Add 75p for carriage on all mail orders. If only ordering a catalogue, just add 50p carriage.

Subject to availability. Prices may change after May 1st 1990.

**SEE THE COMPLETE RANGE OF TRANSCEIVERS AND LOTS MORE IN OUR BUMPER 580-PAGE CATALOGUE ON SALE NOW AT ALL BRANCHES OF WHISMITH - PRICE £2.25!**