

EVERYDAY ELECTRONICS

JULY 1987

INCORPORATING ELECTRONICS MONTHLY

£1.20



**EE BUCCANEER
METAL DETECTOR**

**Digital Counter/
Frequency Meter**

**Mysteries of Midi
+ MIDI THRU BOX**

FERMOSTAT



PLUS... BBC MICRO · ON SPEC · ROBOT ROUNDUP

The Magazine for Electronic & Computer Projects

EVERYDAY ELECTRONICS

INCORPORATING ELECTRONICS MONTHLY

ABC

MEMBER OF THE I.A.C. 1987
SOCIETY OF CALCULATORS

VOL 16 No.7

JULY '87

The Magazine for Electronic & Computer Projects

ISSN 0262-3617

PROJECTS... THEORY... NEWS...
COMMENT... POPULAR FEATURES...

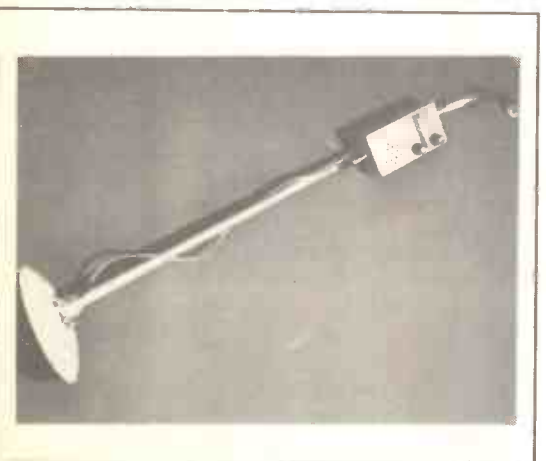
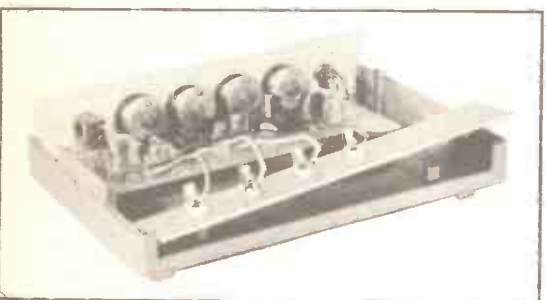
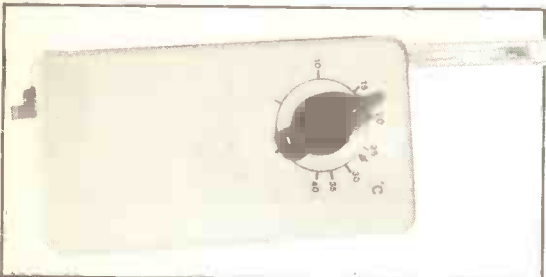
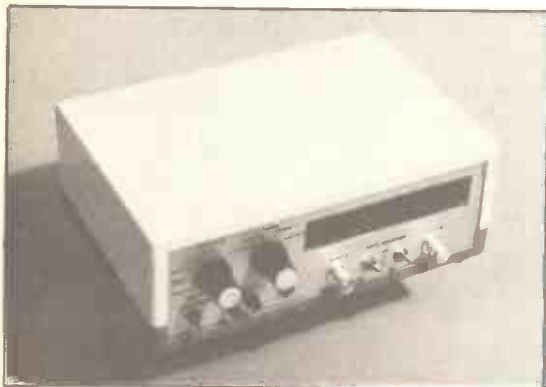

Projects

- EE BUCCANEER METAL DETECTOR** by Andy Flind 352
It won't cost a fortune to make, but it might make yours!
- DIGITAL COUNTER/FREQUENCY METER**
by Mike Tooley BA 367
High quality test instrument
- MONOMIX** by R. A. Penfold 376
Simple four channel monophonic mixer
- TELEPHONE ALARM** 380
Simple phone call alert—An "Exploring Electronics" project
- MODEL SPEED CONTROL** 380
Speed control for low voltage d.c. motors
- MIDI THRU-BOX** by Sam Withey 386
Low cost connector for master and three slave units
- FERMOSTAT** by Andy Flind 396
Economical temperature controller for home brewers and winemakers

Series

- ROBOT ROUNDUP** by Nigel Clark 358
Investigating the world of robotics
- DIGITAL TROUBLESHOOTING** by Mike Tooley 364
We end this series by investigating the popular STE bus and offer suggestions for further study
- EXPLORING ELECTRONICS** by Owen Bishop 380
Part Thirteen: Two more circuits to demonstrate the versatility of the Op-Amp
- ACTUALLY DOING IT** by R. A. Penfold 384
Basics of project building
- BBC MICRO** by R. A. & J. W. Penfold 392
Regular spot for Beeb fanatics
- AMATEUR RADIO** by Tony Smith G4FA 1 399
Emergency!; Re-Issue of Old Licences
- ON SPEC** by Mike Tooley BA 400
Readers Sinclair Spectrum page

Features

- EDITORIAL** 351
- REGENERATIVE RECEIVERS-2** by Joe Pritchard 360
Theory and practice of these low cost radio sets
- READERS DISCOUNT SCHEME** 362
- SHOPTALK** by David Barrington 363
Product news and component buying
- READERS LETTERS** Your news and views 372
- NEWS** What's happening in the world of electronics 374
- COUNTER INTELLIGENCE** by Paul Young 385
A retailer comments
- MYSTERIES OF MIDI** by Sam Withey 386
An explanation of the use of the Musical Instrument Digital Interface
- BOOK SERVICE** Our own service for readers of EE 394
- MARKET PLACE** Free readers buy and sell spot 401
- DOWN TO EARTH** by George Hylton 403
Automatic audio level control
- PRINTED CIRCUIT BOARD SERVICE** 404
- ADVERTISERS INDEX** 408
- SPECIAL OFFER** TK Electronic Guard Dog 375

© Wimborne Publishing Ltd 1987. Copyright in all drawings, photographs and articles published in EVERYDAY ELECTRONICS is fully protected, and reproduction or imitations in whole or in part are expressly forbidden.

Our August 1987 issue will be published on Friday, 17 July 1987. See page 383 for details.

Readers' Services • Editorial and Advertisement Departments

351

OMEGA ELECTRONICS

252A HIGH STREET, HARLESDEN, LONDON NW10 4TD
TEL: 01-965 5748 24HRS

NEW NAME IN ELECTRONIC COMPONENT DISTRIBUTION
WE CAN SOURCE ALMOST ANY ELECTRONIC COMPONENT—
IF IT EXISTS WE WILL TRY AND FIND IT.
IF WE DON'T STOCK WHAT YOU NEED WE WILL GET IT FOR YOU
WE SPECIALISE IN CREDIT CARD 24HRS TELEPHONE ORDERING
A QUICK CALL WILL CHECK STOCK & AVAILABILITY AND CURRENT PRICES

OUR STOCK RANGE INCLUDES:

DISCRETE DEVICES

TRANSISTORS (complete range)
DIODES (complete range)
FETS
POWER MOSFETS
OPTO-ELECTRONICS
LED'S ALL SHAPES AND SIZES
THYRISTORS, TRIACS
VOLTAGE REGULATORS

LOGIC DEVICES

(Very Competitive Pricing)
400 Series CMOS
74LS TTL
74S TTL
74HC/74HCT High Speed Cmos
COMPLETE RANGE

COMPUTER IC's

CPU & SUPPORT DEVICES
Comprehensive range
INTERFACE DEVICES
EPROM's
PROM's
MEMORY DEVICES

ASK FOR OUR FREE
SEMICONDUCTOR & PASSIVE
COMPONENTS CATALOGUE

WE ARE ALSO STOCKISTS FOR
AMSTRAD PC &
PCW COMPUTERS
IBM COMPATIBLE SOFTWARE
PLEASE PHONE OR WRITE
FOR FURTHER INFORMATION

CONTACT US FOR
SURFACE MOUNT
PASSIVE OR
SEMICONDUCTORS

PASSIVE COMPONENTS

RESISTORS
POTENTIOMETERS
CAPACITORS all types
IC SOCKETS

LINEAR DEVICES

We can source almost any Linear
Device
CONSUMER
DIGITAL/ANALOGUE
CONVERTERS

ORDERS FROM SCHOOLS, COLLEGES, GOVERNMENT DEPTS,
TRADE OEM'S ETC ACCEPTED
QUANTITY QUOTATIONS ON ALMOST ANY ELECTRONIC PASSIVE
& SEMICONDUCTOR DEVICE

OVERSEAS TRADE AND PRIVATE ENQUIRES WELCOME

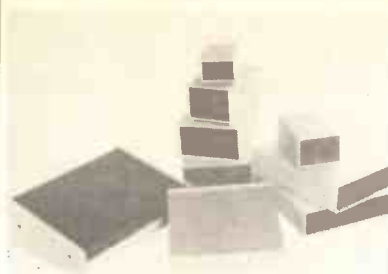

BOXING PROBLEMS???

LOOK NO FURTHER!!

Choose from our standard range below, or if you are looking for a specific size, then we can produce YOUR OWN CUSTOM BOX WITHOUT ANY TOOLING COSTS, with all holes, slots, PCB grooves, etc, already machined in, ready to assemble.

| H | W | D | |
|----------|-----|------|--|
| C1: 30 | 50 | 80* | |
| C2: 40 | 60 | 90* | |
| C3: 50 | 70 | 110* | |
| D10: 50 | 100 | 110* | |
| D20: 35 | 145 | 170* | |
| D30: 40 | 120 | 170* | |
| D40: 70 | 110 | 145* | |
| D50: 60 | 160 | 170 | |
| D60: 100 | 180 | 210 | |
| D70: 70 | 200 | 215 | |
| GA1: 93 | 280 | 160 | |
| GA2: 140 | 400 | 205 | |

CONSOLE BOXES

PRG1: 20/60 x 130 x 160*
PRG2: 35/70 x 230 x 160*
PRG3: 35/77 x 290 x 190

All sizes are in millimetres,
and are internal.

All made from high impact resistant plastic which is easily drilled or cut.

Boxes marked * are available through Kirkit Distribution Ltd., Park Lane, Broxbourne, Herts.

For other sizes and details of Custom Service contact us at the address below.

Distributor enquiries welcome.

BAFBOX LTD.

Unit A, Park End Works, Croughton,
BRACKLEY NN13 5LX
Telephone: 0869 810830

The Archer Z80 SBC

The SDS ARCHER – The Z80 based single board computer chosen by professionals and OEM users.

★ Top quality board with 4 parallel and 2 serial ports, counter-timers, power-fail interrupt, watchdog timer, EPROM & battery backed RAM.

★ **OPTIONS:** on board power supply, smart case, ROMable BASIC, Debug Monitor, wide range of I/O & memory extension cards.

from £185 + VAT.

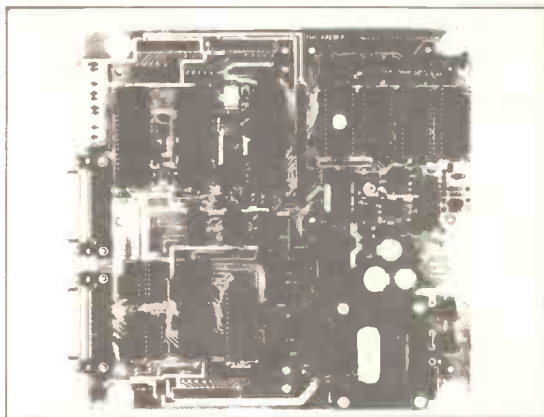

The Bowman 68000 SBC

The SDS BOWMAN – The 68000 based single board computer for advanced high speed applications.

★ Extended double Eurocard with 2 parallel & 2 serial ports, battery backed CMOS RAM, EPROM, 2 counter-timers, watchdog timer, powerfail interrupt, & an optional zero wait state half megabyte D-RAM.

★ Extended width versions with on board power supply and case.

from £295 + VAT.



Sherwood Data Systems Ltd

Sherwood House, The Avenue, Farnham Common, Slough SL2 3JX. Tel. 02814-5067

SECURITY

Systems, Modules, Accessories

COMPLETE SECURITY SYSTEMS START FROM

ONLY £39.95 + VAT



US 5063 £13.95 + VAT
DIGITAL ULTRASONIC MOVEMENT DETECTOR



CA 1250 £19.95 + VAT
CONTROL UNIT



CK 5063 £37.00 + VAT
SELF CONTAINED ULTRASONIC ALARM KIT



IR 1470
£25.61 + VAT
50 FOOT I.R. BEAM SYSTEM

Shown above is a small sample of our comprehensive range which includes:
Magnetic contacts ★ Vibration switches ★ Bell boxes
★ P.A. switches ★ Cable ★ Door & window locks etc. etc.

Send for full details or come to our Showroom and see the units on demonstration.

Monday to Friday 9am to 5pm

Saturday 9am to 1pm

FROM THE SECURITY SPECIALISTS **RISCOMP LTD**

Dept. EE77,
51 Poppy Road,
Princes Risborough,
Bucks HP17 9DB.
Tel: (084 44) 6326

Add 15% VAT to all prices
Add 75p post and packing to all orders
Order by telephone or post using your credit card

TWO GREAT HOBBIES

ONLY £119.99 INC VAT



...IN ONE GREAT KIT!

The K5000 Metal Detector Kit combines the challenge of DIY Electronics assembly with the reward and excitement of discovering Britain's buried past.

THE KIT — simplified assembly techniques require little technical knowledge and no complex electronic test equipment. All stages of assembly covered in a detailed 36 page manual.

THE DETECTOR — features Analytical Discrimination & Ground Exclusion, backed by the proven pedigree of C-Scope, Europe's leading detector manufacturer.

Ask at your local Hobby/Electronics shop or contact:—

CSCOPE C-Scope International Ltd., Dept. EE88,
Wotton Road, Ashford, Kent TN23 2LN.
Telephone: 0233 29181.

NEW! from Cirkit

SUMMER 1987 ELECTRONIC CONSTRUCTORS CATALOGUE



6 MULTIMETERS TO BE WON

PRICE ONLY £1.20

- Many new lines
- Extended range of test equipment

- £11 worth of discount vouchers
- 6 Multimeters to be won in easy to enter competition.
- Available at your local newsagent or direct from address below.

Cirkit

Access

VISA

(0992) 444111

Cirkit Distribution Ltd Park Lane, Broxbourne, Herts EN10 7NQ
Telephone: (0992) 444111 Telex: 22478

CROTECH — YOUR SINGLE CHOICE!

Specification Highlights

- DC — 20MHz Bandwidth
- 2mV/div Sensitivity
- 40ns — 0.2s/div Sweep
- Triggering, Auto and Level
- Active Component Tester
- Test voltage: 8.6V (28mA)



Crotech Instruments Limited

2 Stephenson Road, St. Ives, Huntingdon, Cambs. PE17 4WJ

Telephone: (0480) 301818



£220*

*Excluding Delivery and VAT
Correct at time of going to press

At a price and display size to suit your choice.

3036 — 130mm CRT

3031 — 95mm CRT



£199*

Also available from Audio Electronics & Henry's

super alpha electronics

Dept. EE, P.O. Box 21,
Selsey, Chichester,
West Sussex PO20 0TH



0243
607108

— ALL ORDERS DESPATCHED SAME DAY BY FIRST CLASS POST —

TRANSISTORS

| | |
|---------|------|
| BC107 | 0.15 |
| BC107A | 0.15 |
| BC107B | 0.15 |
| BC108 | 0.15 |
| BC108A | 0.18 |
| BC108B | 0.15 |
| BC108C | 0.15 |
| BC109 | 0.18 |
| BC109B | 0.18 |
| BC109C | 0.18 |
| BC182 | 0.12 |
| BC182B | 0.12 |
| BC183 | 0.12 |
| BC183B | 0.12 |
| BC184 | 0.12 |
| BC212 | 0.12 |
| BC212B | 0.12 |
| BC213 | 0.12 |
| BC213B | 0.12 |
| BC214 | 0.12 |
| BC327 | 0.16 |
| BC337 | 0.16 |
| BC548 | 0.12 |
| BCY70 | 0.22 |
| BCY71 | 0.22 |
| BD131 | 0.60 |
| BD132 | 0.60 |
| BD135 | 0.34 |
| BD136 | 0.35 |
| BD239A | 0.50 |
| BF258 | 0.60 |
| BFX85 | 0.40 |
| BFX88 | 0.40 |
| BFY50 | 0.37 |
| BFY51 | 0.37 |
| BFY52 | 0.39 |
| TIP31 | 0.42 |
| TIP31A | 0.48 |
| TIP31B | 0.56 |
| TIP31C | 0.54 |
| TIP32A | 0.42 |
| TIP32C | 0.42 |
| TIP33A | 1.00 |
| TIP41A | 0.63 |
| TIP42A | 0.55 |
| TIP3055 | 0.76 |
| TIP2955 | 0.76 |
| ZTX300 | 0.17 |
| ZTX500 | 0.17 |
| 2N3053 | 0.60 |
| 2N3054 | 1.60 |
| 2N3707 | 0.12 |
| 2N3703 | 0.12 |
| 2N3705 | 0.12 |
| 2N3771 | 1.40 |
| 2N3904 | 0.15 |
| 2N3906 | 0.15 |

OPTO ISOLATORS

TIL111 transistor o/p 1.10
TIL113 Darlington o/p 1.20
3021 Triac driver 1.50

LEDs

T1 3/4 5mm
Red 0.18
Yellow 0.18
Green 0.18
Super bright
T1 3/4 5mm
Red 0.35

TRIACS

TIC206D 3 Amp 400V 0.75
TIC225D 8 Amp 400V 0.90

ZENER DIODES

BZY88C 500m W
4V7 0.10
10V 0.10
12V 0.10
BZX55C 500m W
24V 0.10
BZX85C 1.3 Watt
4V7 0.20
10V 0.20
12V 0.20
24V 0.20

VOLTAGE REGULATORS

LM317T
+1.2V to 37V 1.50
LM341P
+5V 0.60
LM7905
-5V 0.70

BRIDGE RECTIFIERS

W004 1.5A 0.50
6005 6A 0.90

VERO BOARD

0.1" matrix
Unclad breadboard 0.1"
104x65mm 0.65
Copper clad 37 strips wide
4p per hole
Copper clad 41 strips by 40 holes
plus four mounting holes £2.20
Spot face cutters £1.99

CAPACITORS

Electrolytic axial or radial

| | | |
|--------|-----|------|
| 10uF | 25V | 0.08 |
| 47uF | 25V | 0.10 |
| 100uF | 25V | 0.12 |
| 470uF | 25V | 0.28 |
| 1000uF | 25V | 0.36 |
| 220uF | 25V | 0.15 |

Tantalum

| | | |
|--------|-----|------|
| 0.1uF | 35V | 0.10 |
| 0.22uF | 35V | 0.10 |
| 0.47uF | 35V | 0.10 |
| 1uF | 35V | 0.10 |
| 2.2uF | 35V | 0.15 |
| 4.7uF | 35V | 0.20 |

Ceramic

| | | |
|--------|------|------|
| 220pF | 500V | 0.06 |
| 470pF | 500V | 0.06 |
| 1000pF | 100V | 0.06 |
| 2200pF | 100V | 0.06 |
| 4700pF | 100V | 0.06 |

RESISTORS

Metal Film 5% 1/3 Watt
2p each
100R 680R 1K 1K2 2K2
15K 22K 27K 33K 39K
47K 56K 68K 82K 100K
120K 150K 180K 220K
270K 330K 390K 470K
560K 680K 820K 1M

SKELETON PRESETS

Miniature horizontal or
vertical Values: 100R
220R 470R 1KΩ 2K2 4K7
10KΩ 22KΩ 47KΩ
100KΩ 220KΩ 470KΩ
1MΩ 0.19

LINEAR ICs

| | | | |
|--------|------|--------|------|
| 741C | 0.18 | NE5534 | 0.80 |
| NE555 | 0.30 | ZN414 | 0.90 |
| NE556 | 0.65 | ZN416 | 1.60 |
| LM301 | 0.28 | LM308 | 0.70 |
| NE5532 | 1.20 | TL081 | 0.50 |

enquire for more devices

B.T. APPROVED TELEPHONES

B.T. Statesman with last number redial

| | |
|--------|-------|
| Stone | 31.26 |
| Brown | 31.26 |
| Maroon | 31.26 |
| Grey | 31.26 |

B.T. Viscount with last number redial

| | |
|----------|-------|
| Beige | 26.04 |
| Ice Grey | 26.04 |
| Red | 26.04 |
| White | 26.04 |

B.T. Freeway cordless 700ft range Security coded, last number redial with base paging

| | |
|-------|-------|
| Ivory | 85.00 |
|-------|-------|

Sockets, extension leads, cable, enquire for prices

Carriage on telephones and telephone accessories £1.50
Add 15% VAT to total allow ten days for delivery.

ACCESSORIES

DPDT centre off slide switches, 80HM earpieces, 450Hz Buzzers,
ABS Boxes, Ribbon cable, Potentiometers, Soldering Irons, Desolder
Pumps, Solder, Soldering Iron Bits and Elements. P.O.A.
Kits for 1987 EE features, Price lists

DIODES

| | |
|--------|------|
| IN4001 | 0.05 |
| IN4002 | 0.05 |
| IN4003 | 0.06 |
| IN4004 | 0.06 |
| IN4007 | 0.08 |
| IN4148 | 0.06 |
| IN4448 | 0.06 |

IC SOCKETS

| | |
|-------------|------|
| low profile | |
| 8 pin DIL | 0.07 |
| 14 pin DIL | 0.12 |
| 16 pin DIL | 0.13 |
| 24 pin DIL | 0.20 |
| 40 pin DIL | 0.30 |

SUPER ALPHA GUARANTEE

All components brand new and by top manufacturers to full specification.

ORDERING: Cash, Postal-Order, Visa, orders despatched same day by first class post. Add 50p p&p to order then add 15% VAT. Telephone orders welcome with Visa, orders accepted by answer service outside office hours. Overseas orders add £2.00 no VAT. Prices subject to alteration.

*This is just a small selection of our stock.
Please phone for further details.*

EVERYDAY ELECTRONICS

INCORPORATING ELECTRONICS MONTHLY

The Magazine for Electronic & Computer Projects

VOL 16 N°7

July '87

EDUCATION AND ALL THAT!

MY EDITORIAL in the May issue has resulted in some correspondence from interested parties, much of which is published in this issue—see page 372. It is very pleasing to see the remarks of one apprentice on the value of his schooling in electronics. No doubt his school and teachers will be slightly embarrassed by his remarks but we are only too pleased to show others just what is being achieved by dedicated people on limited resources in some areas.

I will leave you to draw your own conclusions on the subject. However, if anyone would like to make further comments, we would be very pleased to publish more letters. No doubt those we have received represent just the tip of the iceberg.

FURTHER EDUCATION

Perhaps it is now time to reveal a few of our plans for the future. As many of you will be aware we are gradually selling out of the back numbers containing our *Teach-In '86* series (published in the October '85 to June '86 issues). The series has been highly acclaimed by readers and is of course therefore very popular. In order to continue to make the information available we are in the process of reassembling all the parts of *Teach-In '86*, plus the eight test gear projects that were published with it, into a book. We expect this to be available for around £2 during the autumn—more details in a couple of months.

Readers of long-standing may wonder why we are republishing this series when we would normally be starting "Teach-In '88" this autumn. The reason for this is a rather special one—there will be no "Teach-In '88"! No we have not gone mad, *Teach-In* is being replaced this year by a revolutionary series on microprocessors.

Our new series will be based on the City and Guilds certificate—Introductory Microprocessors (726/303)—we believe this is the first time a consumer electronics magazine has published a series which can lead to a recognised formal qualification. The course and City and Guilds assessment can be taken by any UK reader. It will be necessary to register as an external candidate at an approved centre (a small fee will be payable to the centre).

In this way we hope to encourage readers to gain a recognised qualification and hopefully follow this up with the more advanced stages. Again, full details will be given in a couple of months.

Our contributor Mike Tooley is working on the series for us with the approval and collaboration of City and Guilds. The Introductory Microprocessors examination syllabus will be published by City and Guilds at around the time our course will start (October issue published September 18th)—in fact Mike Tooley has been involved with the preparation of this syllabus for City and Guilds.

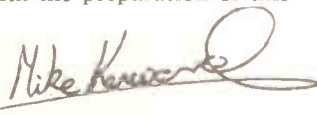

BACK ISSUES & BINDERS

Certain back issues of EVERYDAY ELECTRONICS and ELECTRONICS MONTHLY are available price £1.50 (£2.00 overseas surface mail) inclusive of postage and packing per copy. Enquiries with remittance, made payable to Everyday Electronics, should be sent to Post Sales Department, Everyday Electronics, 6 Church Street, Wimborne, Dorset BH21 1JH. In the event of non-availability remittances will be returned. **Please allow 28 days for delivery. (We have sold out of Oct. & Nov. 85, April, May & Dec 86.)**

Binders to hold one volume (12 issues) are available from the above address for £4.95 (£9.00 overseas surface mail) inclusive of p&p. **Please allow 28 days for delivery.**

Payment in £ sterling only please.

Editorial Offices

EVERYDAY ELECTRONICS EDITORIAL,
6 CHURCH STREET, WIMBORNE,
DORSET BH21 1JH
Phone: Wimborne (0202) 881749

See notes on **Readers' Enquiries** below—we regret that lengthy technical enquiries cannot be answered over the telephone

Advertisement Offices

EVERYDAY ELECTRONICS ADVERTISEMENTS
4 NEASDEN AVE., CLACTON-ON-SEA, ESSEX
CO16 7HG. Clacton (0255) 436471

Editor MIKE KENWARD

Personal Assistant

PAULINE MITCHELL

Assistant Editor/Production

DAVID BARRINGTON

Assistant Editor/Projects

DAVID BRUNSKILL

Editorial: WIMBORNE (0202) 881749

Advertisement Manager

PETER J. MEW Clacton (0255) 436471

Classified Advertisements

Wimborne (0202) 881749

READERS' ENQUIRIES

We are unable to offer any advice on the use, purchase, repair or modification of commercial equipment or the incorporation or modification of designs published in the magazine. We regret that we cannot provide data or answer queries on articles or projects that are more than five years old. Letters requiring a personal reply **must** be accompanied by a **stamped self-addressed envelope** or a **self-addressed envelope and international reply coupons**.

All reasonable precautions are taken to ensure that the advice and data given to readers is reliable. We cannot, however, guarantee it and we cannot accept legal responsibility for it.

COMPONENT SUPPLIES

We do not supply electronic components or kits for building the projects featured, these can be supplied by advertisers.

OLD PROJECTS

We advise readers to check that all parts are still available before commencing any project in a back-dated issue.

We regret that **we cannot provide data or answer queries on projects that are more than five years old.**

ADVERTISEMENTS

Although the proprietors and staff of EVERYDAY ELECTRONICS take reasonable precautions to protect the interests of readers by ensuring as far as practicable that advertisements are *bona fide*, the magazine and its Publishers cannot give any undertakings in respect of statements or claims made by advertisers, whether these advertisements are printed as part of the magazine, or are in the form of inserts.

The Publishers regret that under no circumstances will the magazine accept liability for non-receipt of goods ordered, or for late delivery, or for faults in manufacture. Legal remedies are available in respect of some of these circumstances, and readers who have complaints should address them to the advertiser or should consult a local trading standards office, or a Citizen's Advice Bureau, or a solicitor.

SUBSCRIPTIONS

Annual subscription for delivery direct to any address in the UK: £14.00. Overseas: £17.00 (£33 airmail). Cheques or bank drafts (**in £ sterling only**) payable to Everyday Electronics and sent to EE Subscription Dept., 6 Church Street, Wimborne, Dorset BH21 1JH. **Subscriptions can only start with the next available issue.** For back numbers see the note on the left.



E. E. BUCCANEER INDUCTION BALANCE METAL DETECTOR

ANDY FLIND

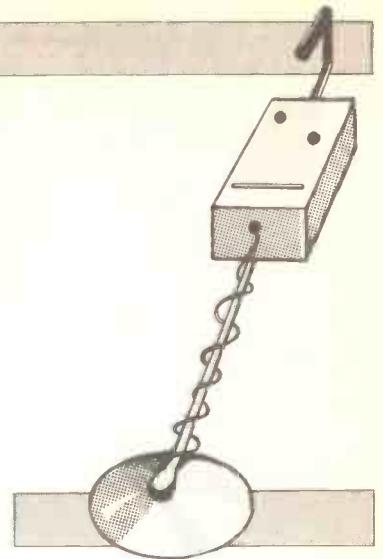

An induction balance metal detector. Providing good sensitivity with ease of use and construction

ALTHOUGH the "boom" passed a few years ago, metal detecting remains a popular hobby, with some tens of thousands of enthusiasts in Britain alone. At least two magazines are devoted to the pastime, and many areas have clubs which organise outings and rallies. For most users the enjoyment lies in the interest of their finds, though the odd spectacular discovery still occasionally makes headlines.

Recently a hoard of ancient Church treasures valued at £5million was unearthed. Good metal detectors are expensive however, even a simple one is far from cheap and may not be very satisfactory to use. Luckily, it's not too difficult to build a detector effective enough for serious use; both the interest of construction and the saving in cost can be considerable.

TYPE

Of the many types of metal detector, the best known are Beat Frequency Operation, Pulse Induction, and Induction Balance. The first, though simple, is rather insensitive and now practically obsolete. The second can be extremely powerful and has the advantage (for amateur constructors) of simple coil construction. However, it is very sensitive to the minute scraps of iron found on many sites, making it tedious to use. The third, I.B. for short, has many different

forms. Complicated (and expensive) models can reject iron, foil and false signals caused by the ground whilst some can almost distinguish what has been detected. Simpler versions cannot do all these things, but it is still possible to obtain good sensitivity whilst rejecting iron.

BLOCK DIAGRAM

The block diagram of such a detector is shown in Fig. 1. The "search head" contains two coils. One of these, the transmitter or "Tx" coil, is driven by an oscillator, setting up an alternating magnetic field. The receiving or "Rx" coil is positioned so that it partially overlaps the Tx. By adjusting the amount of overlap a point can be found where the voltages induced in the Rx coil "null", or cancel out so that little or no electrical output is produced. A metal object entering the field causes an imbalance, resulting in a signal.

In a simple I.B. circuit the rise in amplitude is used to signal the metal's presence, so the following stages consist of amplification, accurate conversion to "peak value" (a d.c. signal), further amplification, and a means of presenting the final output as an audible tone of increasing volume. An adjustable d.c. offset control is used to adjust the initial sound threshold, this being known as "tuning".

SENSITIVITY

In this type of circuit more sensitivity is obtained if the coils are, in fact, slightly offset from null. If this offset is in the direction of "too far apart", iron and other permeable objects cause an initial reduction in amplitude, whilst conductive ones produce an immediate rise. In this way some iron rejection can be built in.

Simple detectors are notorious for great sensitivity to foil, or silver paper, because they often use fairly high search frequencies, where large "skin effect" currents are induced in the foil. The low search frequency used by the Buccaneer, around 20kHz, helps to reduce this problem to some extent.

CIRCUIT DESCRIPTION

The full circuit diagram of the *EE* Buccaneer appears in Fig. 2. The oscillator, based on IC1 and transistors TR1 and TR2, may appear a little strange. It is required to produce a reasonable amount of transmitted power with moderate battery consumption, whilst being very stable with varying temperature. The transistors supply the power; being driven into saturation they provide a squarewave drive of almost rail-to-rail amplitude. R6 controls the power sent to the coil.

Impedance matching for the best possible efficiency from the resonant coil circuit is achieved by tapping the capacitance instead of the coil, as this simplifies coil construction. Feedback is sensed by IC1 which drives the transistors. Finally, again for efficiency, the coil is wound with thicker (28 s.w.g.) wire than usual to obtain a good "Q" factor.

Moving to the receiving section, this again begins with a tuned coil, set to the same frequency as the transmitter. At first sight it would seem that a high "Q" factor here would also improve the sensitivity but in practice, it was found difficult to tune the two circuits accurately enough and the resulting detector was badly affected by signals from the ground ("ground effect"). The Rx coil is therefore damped a little by R7 to increase the bandwidth, and the drop in amplitude is made good by gain from TR3.

The circuit must now detect the peak value of the amplified signal and convert

Fig. 1. Block diagram of the induction balance metal detector.

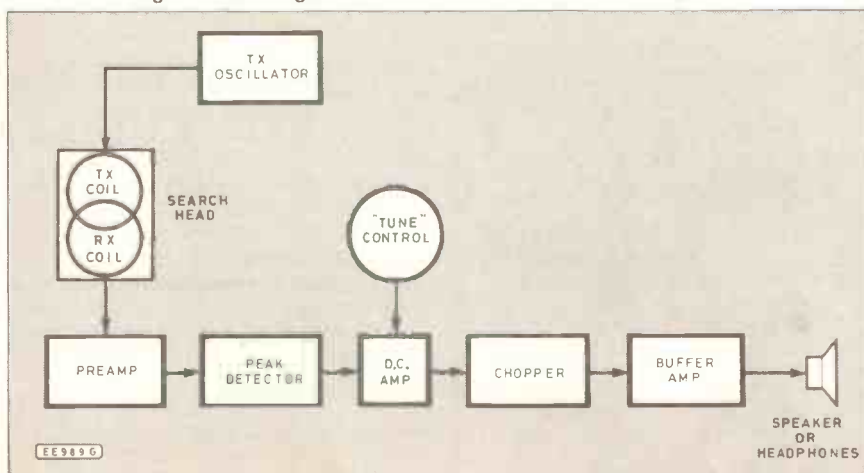

this to a d.c. level. This cannot be done with a simple diode as changes in temperature would cause constant, annoying drift; overcoming this leads, as can be seen, to some complexity. The circuit is best explained with the help of the simplified drawing Fig. 3.

The maximum positive voltage reaching TR1 base consists of the reference voltage plus the peak positive value of the signal from C1. If this exceeds the voltage at TR2 base (from C2), TR1 will conduct, in doing so it will turn on TR3 which will raise C2's voltage until it matches the input. So long as transistors TR1 and TR2 are similar in type and closely coupled thermally, the effects of temperature on their base-emitter junctions will cancel, having no effect on the output. Their emitters should be fed by a current source, shown here as a simple resistor.

TRANSISTOR ARRAY

In the complete circuit, all the *npn* transistors in this section are contained in a CA3046 integrated array. The numbers refer to the pins on the chip, which contains the emitter-coupled pair TR4 and TR5, ideal for this application, plus three extra transistors. Two, TR8 and TR9, are configured as a current source for the emitters, whilst the third is amplifier TR3. Because the operating conditions of TR4 and TR5 should be closely matched, and TR4 is "off" most of the time, TR6 has been added to take most of the current-carrying work away from TR5.

The input is applied through C11, the adjustable reference is supplied by VR1 and VR2, respectively "coarse" and "fine" tuning controls, and the output appears as a

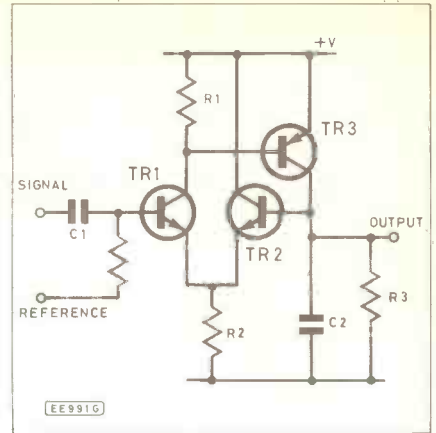

Fig. 3. The simplified peak detector circuit.

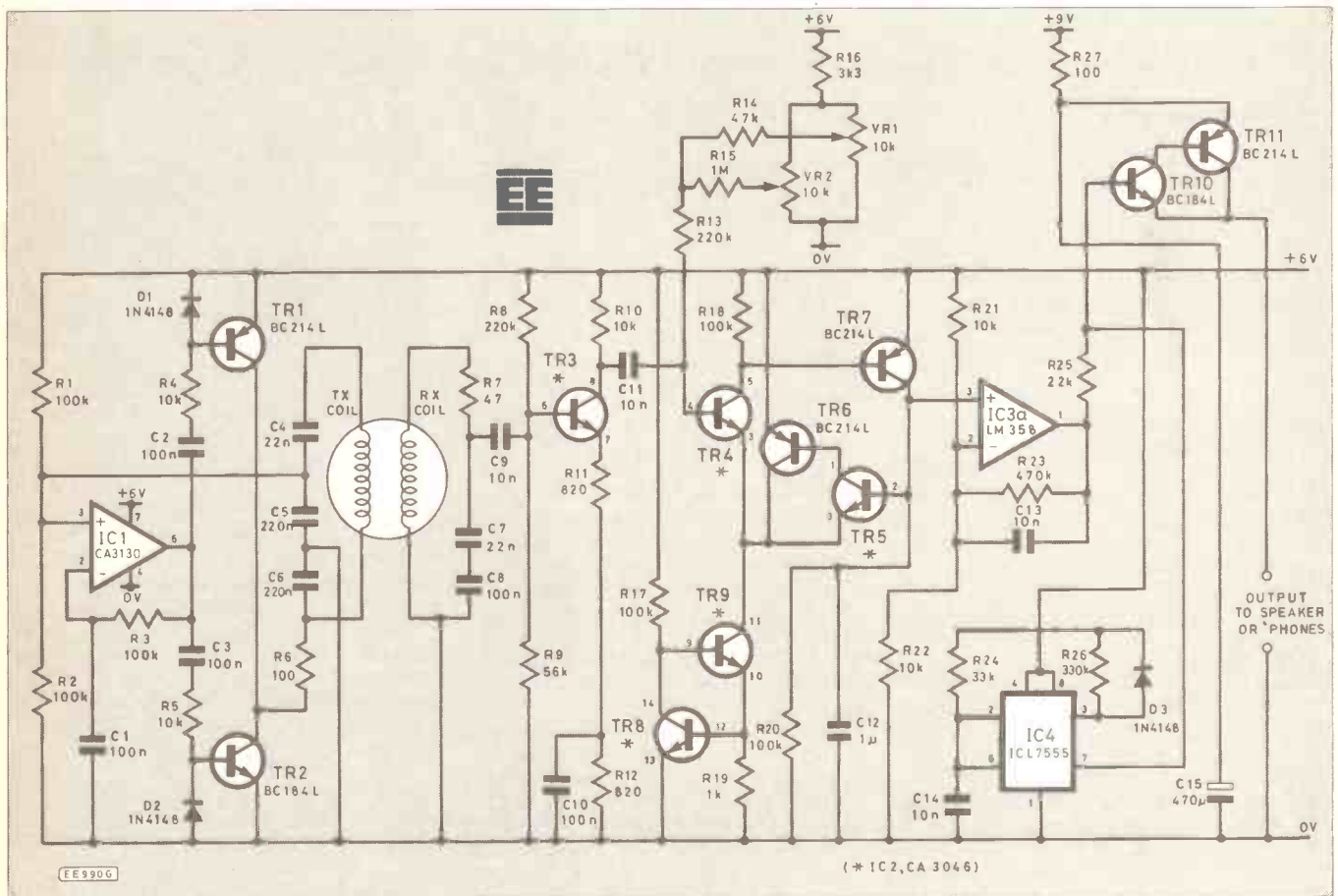
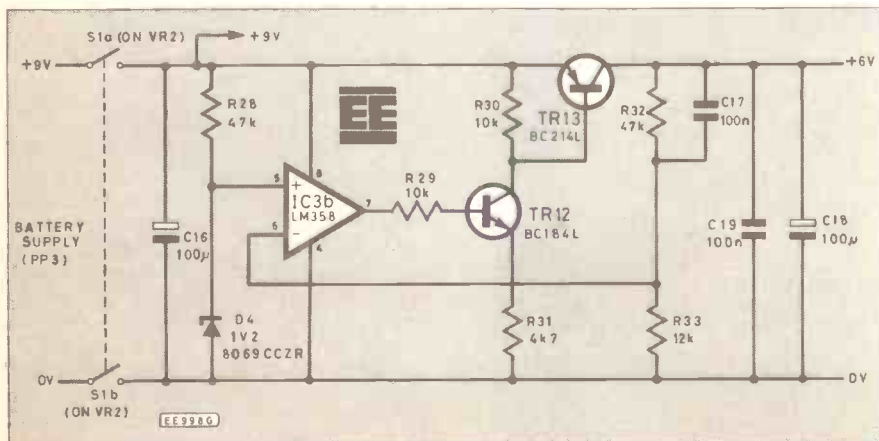
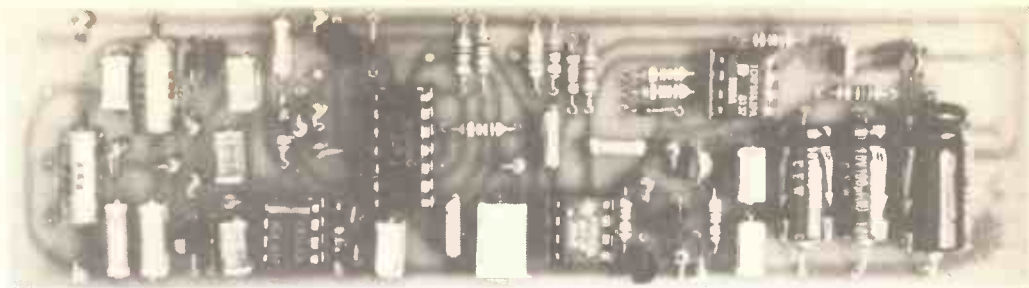

Fig. 2. Complete circuit diagram for the EE Buccaneer Metal Detector. The power supply section is shown below.



voltage on C12. The stability obtained with this admittedly rather complex arrangement has proved quite outstanding, enabling the detector to outperform almost any other design of its type.

The remaining circuitry is quite straightforward. IC3a provides d.c. gain, the output being initially set (by VR1 and VR2) just above zero, and rising to nearly six volts on a strong signal. It is necessary only to chop it up and buffer it to make it audible. Chopping is done by IC4, a 7555 low-power timer connected as an oscillator. Pin 7 of this chip is the output of the transistor intended for discharging the timing capacitor, this being switched on when the "output" (pin three) is low. Here it is used to pull the voltage from R25 low.



Component layout on the completed printed circuit board.

(Left) The completed metal detector showing the control box and the search coil arrangement.

The printed circuit board is available from the *EE PCB Service*, order code EE570.

ing. It also provides protection for IC4, a rather static-sensitive device in the author's experience. The printed circuit board component layout is shown in Fig. 4 and the p.c.b. track pattern in Fig. 5. The board construction should be completed, but at this stage none of the i.c.'s should be plugged in as this will be done during testing.

CONTROL BOX

Before testing the board, the control box should be assembled as it will be found useful for much of the test procedure. As clearances in the box are small, precise drilling details are given in Fig. 6 to ensure it all fits. The speaker "grille" is a pattern of holes, there being scope for some personal artistry here! Assembly consists of fitting sockets, pots VR1 and VR2, and gluing the speaker into place. An impact adhesive such as "Evostick" is suitable for this purpose. Wiring is shown in Fig. 7.

The headphone socket connections face outwards, with the volume reducing resistor soldered to them so that it can be easily selected to suit the 'phones to be used. Its value will have to be found by experiment, a suggested starting point is around 200 to 300 ohms. A switched socket is required to turn off the speaker when 'phones are in use. It doesn't matter if they're connected in series or parallel, but there should be no possibility of short-circuiting the output as the plug is inserted and removed, as this can cause output transistor destruction. Socket wiring details shown in Fig. 8 are for the most common types. Connect the controls and the switch to the board, but leave the other connections for the time being.

TESTING

About the worst misfortune that can befall a constructor testing a new project is that some drastic fault causes heavy current drain and damages expensive components. A current limiter of some kind can prevent this. It may be that a limited bench supply is available but, if not, a few pence invested in the simple device shown in Fig. 9 is well worth while. This is placed in series with the positive supply and will normally have very little effect, but if a fault is present, it will limit the current to about 25 milliamps.

Most of the circuit can be checked out as follows. With just controls and switch wired to the board, apply power through the limiter. Monitor the current taken with a meter. After an initial surge as electrolytics charge, the drain should drop to a very low value, about 0.2mA. Switch off, plug in IC3, and try again. This time the current should settle to about 1.8mA. Check the voltage across C18, which should be close to six volts as the regulator is now working.

Small speakers produce the most efficient loud noises when fed with short pulses, so the mark-space ratio of IC4 is arranged to convert the output into this form. Transistors TR10 and TR11 do the buffering, after which the output will drive speaker or headphones.

SUPPLY

For good stability a well regulated supply is essential. With only nine volts to start with, dropping below seven as the battery ages, the two volts differential required by most integrated regulators is unacceptable so the supply circuit shown was developed. This uses a 1.2V bandgap reference. IC3b compares this with a divided portion of the output from TR13, intended to be six volts, and drives the transistors as necessary. This circuit works with a differential, or "drop-out" down to 0.1V

CONSTRUCTION

Board construction for this project is straightforward providing some simple precautions are observed. Firstly, since the layout is fairly compact, a fine-tipped iron and reasonable soldering skill are required. The polycarbonate capacitors are the compact layer type supplied as "poly layer". C4 and C7 are both one per cent tolerance, this being important for matching the tuned circuits. Transistors TR2 and TR6 emitter leads are bent to clear underlying tracks on the board, do this carefully before fitting them.

The bandgap device D4 may be supplied in a three-lead package identical to the transistors, or a slightly smaller two-lead version. The latter can be fitted using the lower two holes in the p.c.b., with the flat on the same side as before. Use sockets for all four integrated circuits as this simplifies testing and, where necessary, trouble shoot-

Positioning of components inside the control box.

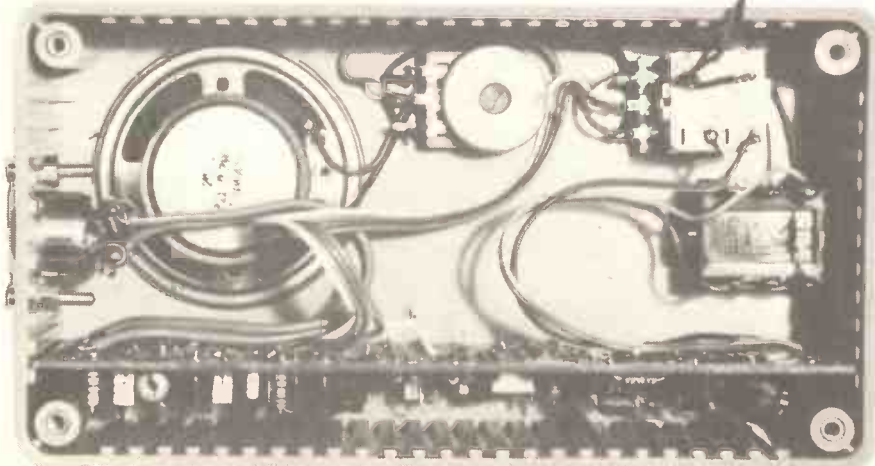

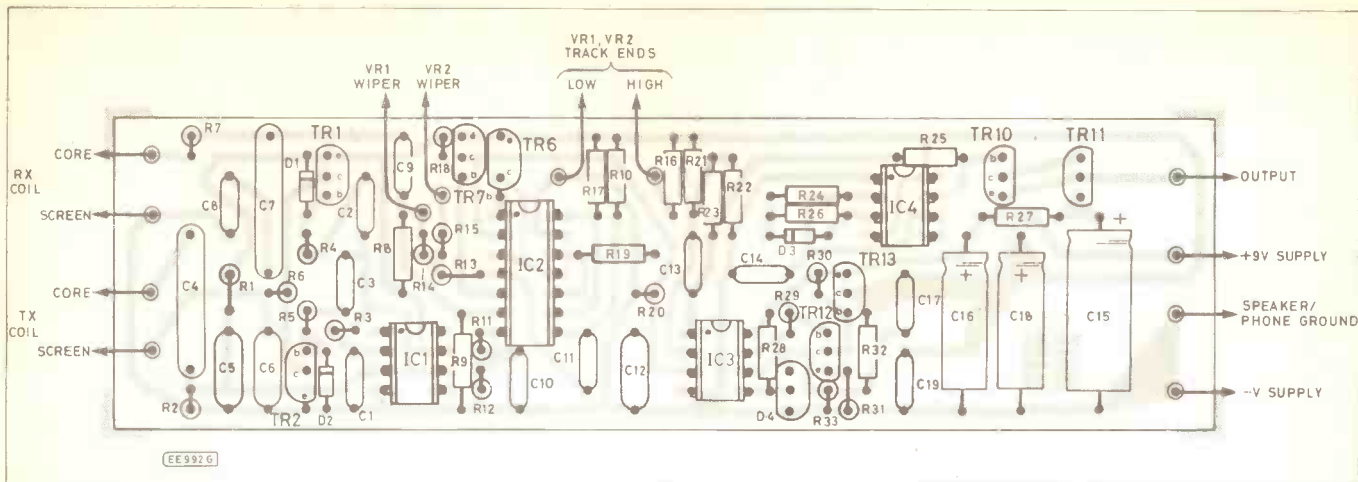

Fig. 4. Component layout on the printed circuit board.

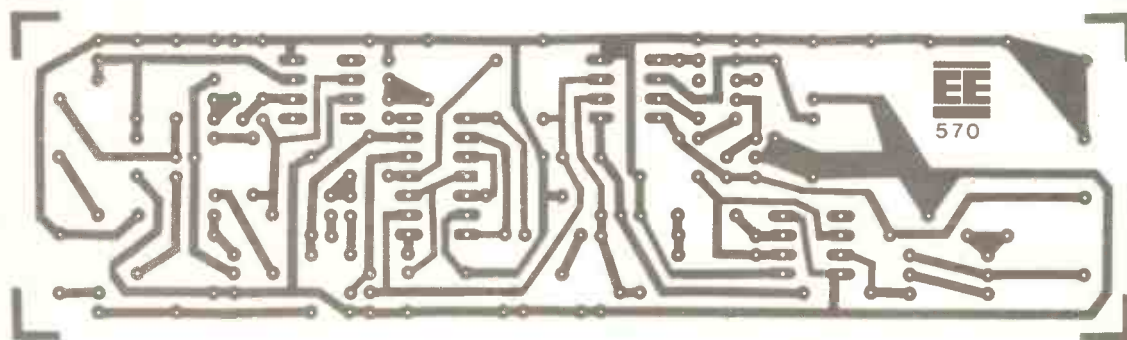

Fig. 5. Full size printed circuit board foil master pattern.

COMPONENTS



Resistors

| | | | |
|--------------------|--------------|-----|------|
| R1,R2,R3,R17,R18. | 100k (6 off) | R15 | 1M |
| R20 | | R16 | 3k3 |
| R4,R5,R10,R21,R22, | 10k (7 off) | R19 | 1k |
| R29,R30 | | R23 | 470k |
| R6,R27 | 100 (2 off) | R24 | 33k |
| R7 | 47 | R25 | 22k |
| R8,R13 | 220k (2 off) | R26 | 330k |
| R9 | 56k | R31 | 4k7 |
| R11,R12 | 820 (2 off) | R33 | 12k |
| R14,R28,R32 | 47k (2 off) | | |

All 0.6 watt 1% type

Potentiometers

| | |
|-----|-----------------------------|
| VR1 | 10k lin. carbon |
| VR2 | 10k lin. carbon with switch |

Capacitors

| | |
|------------------|-------------------------------|
| C1,C2,C3,C8,C10, | 100n polyester layer (7 off) |
| C17,C19 | |
| C4,C7 | 22n 1% polystyrene (2 off) |
| C5,C6 | 220n polyester layer (2 off) |
| C9,C11,C13,C14 | 10n polyester layer (4 off) |
| C12 | 1µ polyester layer |
| C15 | 470µ axial elect. 10V |
| C16,C18 | 100µ axial elect. 10V (2 off) |

Semiconductors

| | |
|-------------------|-------------------------------------|
| IC1 | CA3130 C-MOS op-amp |
| IC2 | CA3046 transistor array |
| IC3 | LM358 dual op-amp |
| IC4 | ICM7555 C-MOS 555 timer |
| TR1,TR6,TR7,TR11, | BC214L silicon <i>pnp</i> (5 off) |
| TR13 | |
| TR2,TR10,TR12 | BC184L silicon <i>nnp</i> (3 off) |
| D1,D2,D3 | IN4148 silicon diode (3 off) |
| D4 | 8069CCZR 1.2 volt Voltage Reference |

Miscellaneous

Printed circuit board, available from *EE* PCB Service—Code *EE570*; d.i.l. sockets 8-pin (3 off); d.i.l. socket 14-pin; case, ABS box 150 × 80 × 50mm; control knobs (2 off); PP3 battery container with clip; DIN plug and chassis socket, 5-pin 240 degree; switched stereo jack socket; 8 ohm loudspeaker, 50mm diameter; 28 s.w.g. (0.375mm) enamelled copper wire; 2 metres twin individually screened cable; hardware; plastic plate, plastic bracket, PTFE tape, cooking foil, fibreglass repair kit, tubing for handle etc., see text.

See
**Shop
Talk**
page 363

COMPONENTS
approximate
cost **£22**
plus hardware



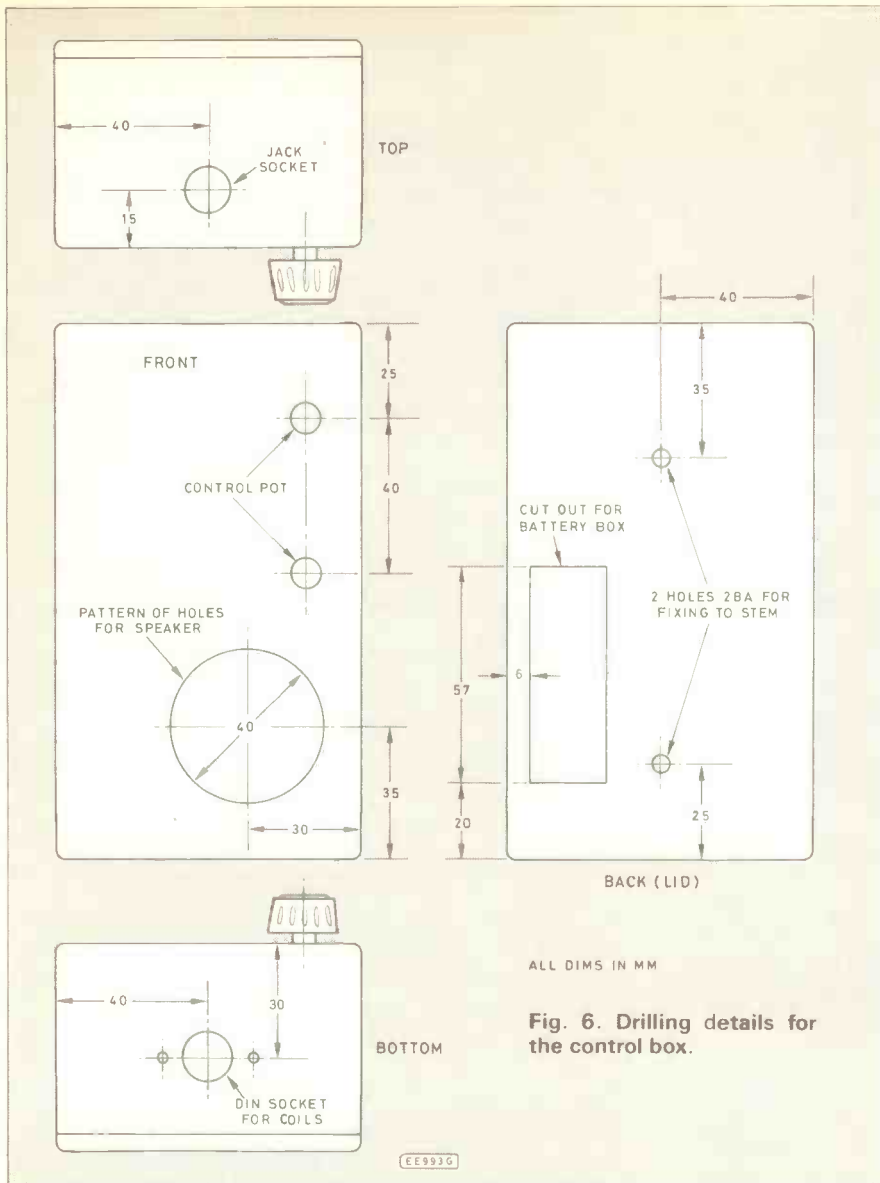

Fig. 6. Drilling details for the control box.

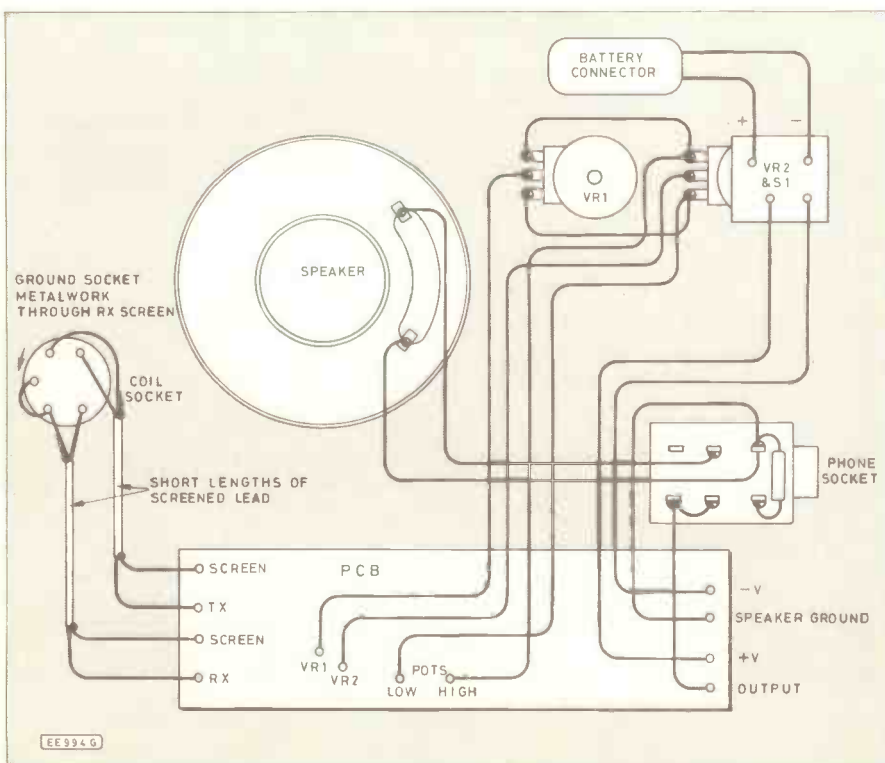

Fig. 7. Interwiring details for the off-board components mounted inside the control box.

Plug in IC2 (with power off; always switch off when working on the board) and check that drain rises to two or three milliamps. Check the voltage across C12, the 1 μ polyester. This should be variable from zero to about four volts with the setting of coarse control VR1. If so, check the voltage on pin seven of IC4's socket which should rise sharply from zero to within a volt or so of main supply at some point on VR1's range. If all seems well, connect the speaker, fit IC4 and switch on again, this time without the current limiter.

Adjustment of VR1 should turn a loud tone on and off. Try making it just audible, using both controls. At this point, place a finger on the Rx coil input connection; this should increase the volume, due to injection of stray a.c. pickup from mains wiring etc. Everything bar the oscillator, which needs the Tx coil, has now been tested so fit IC1 and complete connections to the box. When the coils are connected the complete circuit will draw around 12 to 14 milliamps, plus whatever is required to generate the sound when an object is detected.

SEARCH HEAD

Search head construction is next. Although this can be built in many ways, the method to be described has served well for several designs, producing a neat, pivoting waterproof head. The one slight disadvantage is weight, due to the resin used. The hardware consists of a rigid melamine plastic plate (flexible types are not suitable) 190mm in diameter. The prototype used a brand called "Style", the best place to find these plates being caravan equipment stockists.

The inside of the plate should be roughened with emery paper so that resin will stick firmly to it. To the plate is screwed a pair of L-shaped plastic brackets, cut from a fixing intended for square section rainwater "downspouting". This can be obtained from builders' merchants; whilst there buy a reel of PTFE plumbers' jointing tape. The stem fits between the brackets and is held by a threaded rod with a wingnut at each end, allowing the head to be tilted to the required angle and tightened by the user. A hole is drilled to allow entry of the "figure of eight" screened twin cable to the coils.



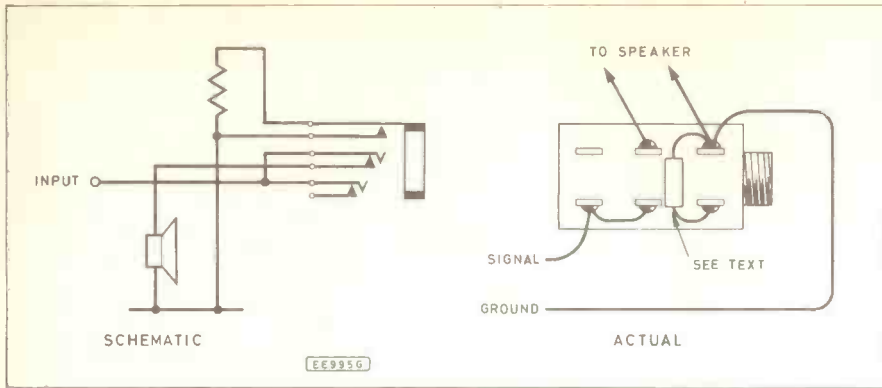

Fig. 8. Headphone socket circuit and wiring arrangement.

Coil winding starts with a sheet of paper taped to a soft board. A 110mm diameter circle is marked out and pins stuck around it at five to ten millimetre intervals, sloping outwards slightly. 100 turns of 28s.w.g. enamelled copper wire are wound around the circle (don't use a different gauge as performance may be affected). Winding is easier if the wire is first passed through the tube from a ballpoint pen, it can then be "written" into place. The wound coil is secured with temporary twists of wire and removed from the board. A binding of PTFE tape is applied, the wire ties being removed in the process. Bunching of the wire may prove a slight problem as "full circle" is approached, an initial looser binding of PTFE will help here. PTFE is used as it's impervious to the resin used later for potting. The coil can now be bent into something approaching its final shape, a sort of lopsided oval as shown in Fig. 10.

With the coil tightly bound and insulated, a "Faraday" electrostatic shield is added. Thin, stranded hookup wire is stripped to a length of about three inches, the strands are then divided into two and wound around the coil in each direction starting near the connections. This provides a sound connection to the cooking foil which is now cut into 10mm wide strips and wrapped around the coil. A gap of about 10mm is left at some point to prevent the shield forming a closed turn around the circumference of the coil. Finally, the coil is again bound and insulated with more PTFE. The two coils are identical, the second being made in exactly the same way.

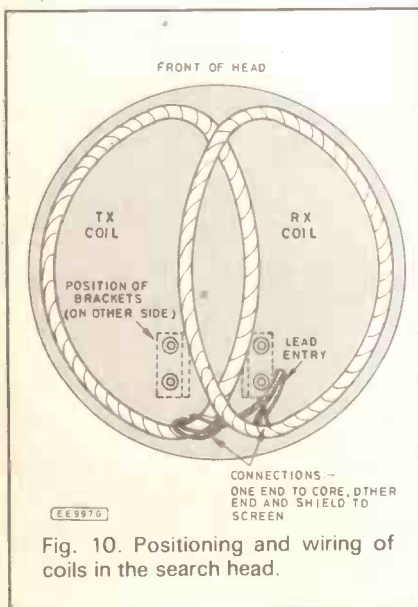

Fig. 10. Positioning and wiring of coils in the search head.

SETTING UP THE HEAD

"Fastglas" resin is used to pot the coils into the head. Motoring accessory shops can supply a small kit containing resin, hardener, a measuring beaker and glass matting. A brush and cellulose thinners to clean it with are also needed. The approximate coil

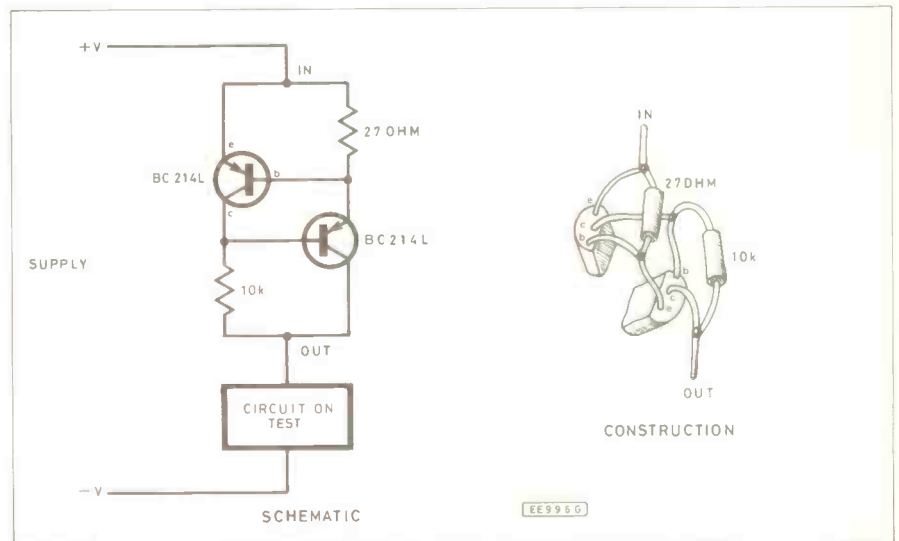

Fig. 9. Test circuit for current limiter.

positions can be seen from Fig. 10. They should be connected by their lead to the circuit, with a meter arranged to read the voltage across C12. The sound can be silenced either by disconnecting the speaker or by inserting a spare plug into the headphone socket. VR1 should be turned right down. If the overlap of the coils is adjusted very carefully, a point will be found where the meter dips very sharply. This is the "null", or balance point, close to the final coil position. The coils should be clamped here, clothes pegs are useful for this, whilst their outer edges are fixed in place with some resin.

When the resin has set the pegs can be removed, and the central parts of the coils carefully adjusted to find the position giving lowest output. If the meter falls to zero, an adjustment of VR1 will cause it to read again. This should all be done well away from any metal of course, save for the screws in the assembly itself. When the lowest output has been found, move the coils in the direction of "too far apart" until the voltage on C12 has risen by about half a volt; this will give the detector greater sensitivity and enable it to reject most iron. Having set the coils to the correct point they can be fixed with more resin. In practice the

process should proceed in several stages, fixing a little more of the coils at each step, mixing about 30cc of resin at a time.

If the coil is potted in solid resin it will be very heavy, so the larger gaps should be filled with something light and bulky. Expanded polystyrene cannot be used as alas, resin attacks it. In the past the author has used soft Balsa wood, but corrugated cardboard was tried for this design and appears just as effective. A covering of the glass matting is applied with the final coat of resin for a neat, tough finish.

The stem may be wood, plastic pipe, or metal. Aluminium tubing is best, and can be bent to shape with a pipe-bending tool or possibly a bending spring. Copper tubing would probably be as good, though heavier. If a metal stem is used, the last 150mm or so should be made from wood dowel glued to the tubing with Araldite, to prevent the metal being placed hard against the most sensitive area of the head. As a finishing touch, a bicycle handlebar grip makes a neat handle.

IN USE

Detectors of this type are capable of surprising results. Simple, rapid operation means that on many sites users may find as much as those with powerful discriminators, since most buried objects are not, in fact at very great depths. As a guide to sensitivity, "in air" the prototype will just detect a 2p coin at about 200mm, by 150mm the signal is clear, and at 100mm it's really singing out. These figures will not apply "in the ground", where depth will depend largely upon the mineralisation present. On many sites false signals will be caused by "ground effect".

Most inland areas, especially those where man's presence has been concentrated, contain ferrous particles which cause a negative response with this detector. Salt-wet beaches are conductive and will usually produce a positive output. Good detecting consists of keeping the tuning adjusted as near the threshold as possible, holding the head at a constant height close to the ground, and searching slowly and methodically. Finally, most really successful treasure hunters engage in a lot of research before they venture out, studying old newspaper reports, ancient tithe maps and the like at their local libraries.

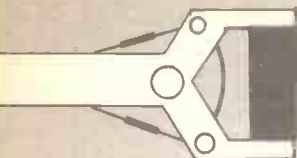

Robot Roundup



NIGEL CLARK

SCHOOLS

The arrival of robotics and control technology on school curricula is recent enough not to have become bogged down by traditional teaching methods. The subjects are also general enough to allow for a range of imaginative approaches which give children the opportunity to develop at their own pace.

The interest developed at a North Wales school in the building of a saleable buggy was developed into a GCE/CSE course where continuous assessment rather than formal examinations were used to gain the qualification.

BARNET

Now primary children, from age four upwards, are being given the opportunity to take advantage of the possibilities in the London Borough of Barnet. Ron Allen, head of the primary science and technology support unit in the borough said the idea of introducing younger children to the subjects is a good way of helping in the teaching of science and technology.

There is much equipment available to help in teaching the subjects, for example simple kits to illustrate the uses and capabilities of electricity. But most of these involve learning by following a set of instructions with little possibility of further development by the children using their own ingenuity. Control technology is seen as a way of extending the children's abilities by encouraging them to think for themselves.

Allen gave a simple example of a group which had made an electrically-operated drawbridge. They built it and had it working quite quickly. But when it was connected to the computer they found a problem which had not been considered before. Once the computer switched on the drawbridge it did not stop.

The children realised they had been stopping the movement as soon as the drawbridge reached the top because they could see when to stop it. The computer did not have the same information and so did not know when to stop. A sensor was added and the drawbridge became fully computer controlled.

Using the same skills of defining a problem and working their way through it other children are looking at the more complex workings of human movement and how they can be replicated by machine.

Allen added that the subjects had also been introduced as ends in themselves. New technology is rapidly becoming very sophisticated and the rate of progress is increasing. It is vital that children be able to come to terms with the latest changes. Much of the difficulty in understanding new technology is in its unfamiliarity, he said. It is sensible to introduce robotics and control technology to children as soon as possible, hence the move into the primary schools.

He thought many other authorities throughout the country were adopting the same policy but Barnet had carried it further than most. Having set the objectives however Allen and his staff quickly discovered that their ability to meet them was limited by the equipment which was available. They decided to develop their own and the Barnet Control-It box was born.

CONTROL-IT

In its present state it has 13 output ports providing simultaneous outputs and eight inputs. Outputs can be provided at any number of voltages with six and 12 volts as standard using the internal transformer. The unit can thus drive car accessories as well as the more usual Lego and Fischer-technic parts.

There are four motor outputs, eight other outputs and a separate port to allow the box to be used simply as a transformer. Allen said it was thought worthwhile to have the added facility because few schools said they had a transformer.

Supplied with the package are a number of sensors including a push button switch, mercury tilt switch, light sensor and a magnetic reed switch. Others are being considered, particularly sound and temperature sensors.

Unusually the connections are not made by jackplugs but into pairs of negative and positive sockets. Allen said that they wanted the system to complement existing subjects. Children knew that electricity had a positive and a negative and might be confused by both apparently in the same wire.

"Some of the connections can look like spaghetti junction but it does not appear to cause problems," he said.

The software is designed to be very user friendly. Allen said that they wanted to teach science and technology without having to teach computer studies first. The

writing was given to a local 15-year-old who produced a system in which prompts and instructions are given in clear English rather than code or the truncated English of BASIC.

Error trapping is similarly clear and precise. When something goes wrong, rather than merely giving an error message, it shows the area in which a mistake has been made. The software also encourages children to break down complex problems into more easily understandable chunks by only accepting 20 steps at a time. The manual includes a full description of the system and some example routines.

Work began on the package about two years ago and has been on trial in a number of schools for the past year. Now it is being used in 46 primary schools with children using it to control simple devices like the lights in a dolls house or more complex machines like Lego robots.

The subject is being extended to cover the whole of the borough. Courses are being run by the unit for teachers and the system is being made available to schools which are interested.

"We prefer to do it this way rather than provide material to all the schools and find some of it gathering dust in a cupboard," said Allen. It has also been put on general sale through Commotion. The Control-It complete with manual and sensors cost £160.

The unit is looking at ways of extending the systems uses within Barnet. A pilot scheme has been started in the first, second and third years of the borough's secondary schools; initial feedback has been very positive.

A resource pack for teachers based on the experiences of present users is being assembled. This will include a number of the projects that use the box, including the control of lights and a rain detector. The latter project involves the use of a peg, two nails and sugar cube!



Pupils Jessica Toms, Elizabeth Stevens, Marina Alexander and Elizabeth Eaves from Tudor School, Barnet using the Control-It box for time experiments.

443D Millbrook Road, Southampton
SO1 0HX. Tel. (0703) 772501/783740

All prices include VAT; just add 60p P&P
(£2 sale items)

Min Access order £5. Official
orders from schools etc. wel-
come — min invoice charge £10.

Our shop has enormous stock of components and is open
9-5.30 Mon-Sat. Come and see us!!!



SUMMER SALE

SEND FOR YOUR FREE SALE LIST NOW!!

Yes, folks, it's time for our Super Summer Sale again, with hundreds of Bargains!
Up to 66% off our already low, low prices!!

Dozens of **half price** items!!

But stocks are limited, so it's first come, first served!

ORDER NOW to be sure of your share!!

Our **SALE** list and Bargain Lists are **FREE!!**

Our 80 page Catalogue costs just £1, with vouchers worth £1.50.

1/2 PRICE PANELS

| | |
|------------------------------|-------|
| Z914 1W Mono Amp..... | 75p |
| Z915 1W Stereo Amp..... | £1.75 |
| Z916 Am Tuner..... | 75p |
| Z925 Relays..... | 95p |
| Z926 Relay/Triac..... | 92p |
| Z927 Reeds..... | 30p |
| Z918 Inverter..... | £1.25 |
| Z919 Inverter..... | £1.10 |
| Z912 RF Panel..... | 75p |
| Z910 RF Panel..... | 75p |
| Z911 RF Panel..... | 35p |
| Z913 RF Panel..... | 35p |
| Z942 Joystick Interface..... | £1.00 |
| Z974 Mixer Amp..... | £1.25 |
| Z469 10W Amp Panel..... | £1.25 |
| Z955 'Simon' Panel..... | 50p |
| Z497 AM/FM Tuner..... | £6.45 |

7 SEG DISPLAYS—
MAN6740 40p; 10/£3.00
Others on P.78 of Cat. 30p; 10/£2.00;
100/£15.

FIBRE OPTICS—66% OFF!!

20m coils 1mm core—
single £4.00 £2.00
twin £6.00 £2.00

**COMPUTER BOOKS—up to 90%
off!!** £9.95, £6.95, £5.95
Now 10 for £6!

UHF Modulator 50% off
Aztec UM1286 £6.00 £3.00

1/2 PRICE PACKS

| | | |
|------------------------------|-------|-------|
| K547 Zener diodes..... | £4.50 | £2.25 |
| K544 Mullard polyesters..... | £4.75 | £2.35 |
| K556 Fuseholders..... | £2.00 | £1.00 |
| K557 Terminal strips..... | £2.40 | £1.20 |
| Z525 Vero offcuts..... | £3.80 | £1.90 |

25% OFF PACKS

| | | |
|-------------------------------|-------|-------|
| K548 Tantalum caps..... | £6.50 | £4.85 |
| K549 Variable caps..... | £5.75 | £4.30 |
| K546 Mica/ps/cer caps..... | £2.75 | £2.05 |
| K554 Thermistors..... | £8.00 | £6.00 |
| K555 Fuses..... | £3.95 | £2.95 |
| K538 Diodes..... | £2.50 | £1.85 |
| K541 PCB Panels..... | £7.00 | £5.25 |
| K542 Reed Relays..... | £4.30 | £3.20 |
| K530 Polyester..... | £3.95 | £2.95 |
| K518 Disc Ceramics..... | £1.00 | 75p |
| K503 Wirewound Resistors..... | £2.00 | £1.50 |
| K505 Pots..... | £1.70 | £1.25 |
| W4700 Push button banks..... | £2.95 | £2.20 |
| K526 Heatsinks..... | £5.50 | £4.10 |
| K527 Hardware..... | £4.00 | £3.00 |
| K534 Sleeve Pack..... | £1.00 | 75p |
| K536 74 Series Pack..... | £4.00 | £3.00 |
| K537 I.C. Pack..... | £6.75 | £5.05 |
| K538 Diode Pack..... | £2.50 | £1.85 |
| K539 L.e.d. Pack..... | £5.95 | £4.45 |
| K540 Resistor Pack..... | £2.50 | £1.85 |
| K535 Spring Pack..... | £1.70 | £1.25 |
| K524 Opto Pack..... | £3.95 | £2.95 |
| K525 Preset Pack..... | £6.75 | £5.05 |
| K528 Electrolytic Pack..... | £3.95 | £2.95 |
| K531 Precision resistors..... | £3.00 | £2.25 |

| | | |
|-----------------------|-------|-------|
| K532 Relays..... | £6.00 | £4.50 |
| K517 Transistors..... | £2.75 | £2.05 |
| K523 Resistors..... | £2.50 | £1.85 |
| K520 Switches..... | £2.00 | £1.50 |

'NEWBRAIN' PANELS

Z494 Motherboard microprocessor panel 265 x 155mm. Complete PCB for computer, Z80, char EPROM, etc. 68 chips altogether + other associated components, plugs, skts, etc. £4.00

Z495 RAM panel. PCB 230 x 78mm with 14 x MM5290-2 (4116) (2 missing) giving 28k of memory. Also 8 LS chips. These panels have not been soldered, so chips can easily be removed if required. £3.75

'NEWBRAIN' PSU

BRAND NEW Stabilized Supply in heavy duty ABS case with rubber feet. Input 220/240V ac to heavy duty transformer via suppressor filter. Regulated DC outputs: 6.5V @ 1.2A; 13.5V @ 0.3A; -12V @ 0.05A. All components readily accessible for mods etc. Chunky heatsink has 2 x TIP31A. Mains lead (fitted with 2 pin continental plug) is 2m long. 4 core output lead 1.5m long fitted with 6 pole skt on 0.1" pitch. Overall size 165 x 75 x 72 mm. £4.75 ea 10 for £32

**SCOPES!
5% OFF
ALL MODELS**

**10% OFF
all ANTEX
PRODUCTS!!**

**10% OFF
all VERO
PRODUCTS!!**

Full details of all sale items in
Catalogue/Bargain Lists

ALL ABOVE ARE SALE ITEMS: MIN ORDER VALUE £10 + £2 POST

SOLDER SPECIAL!!!



- ★ 15W 240Vac soldering iron
- ★ High power desolder pump
- ★ Large tube solder

ALL FOR £7.95

NEW PANELS

Z620 68000 Panel. PCB 190 x 45 believed to be from ICL's 'One per Desk' computer containing MC68008PB (8MHz 16/8 bit microprocessor, + 4 ROM's, all in skts; TMP5220CNL, 74HCT245, 138, LS08, 38 etc..... £5.00

Z625 32k Memory Board. PCB 170 x 170 with 16 2kx8 6116 static RAM's. Also 3.6V 100mA memopack nicad, 13 other HC/LS devices, 96W edge plug, 8 way DIL switch, R's, C's etc..... £4.80

Details of other similar PCB's in latest list.
Z621 Teletext Unit. Keyfax T100 manufactured for the US market, hence 120V ac supply (but Tx can easily be changed for 240V model). Smart wooden case 430 x 257 x 68mm, housing chassis with Rx/decoder circuitry, Mullard VM6700 module, channel display, i/p & o/p skts. Believed to be new & working, but no data..... £20.00
Z622 As above but no wooden case £15.00

sinclair

QL BOARD
PCB 370 x 117, partially assembled with 16 x 4164's giving 128k of RAM; 2 x LS257, LS245, 1488, 1489, HAL16L8. Also 2 x Ferranti ULA's for microdrives. None of the chips have been soldered so can easily be removed. £12.00

SPEAKERS
Z578 Sub-min speaker 30 x 30 x 3mm thick by Fuji. 16R 0.4W. 60p ea; 10 £3.70; 25 £7; 100 £22; 1000 £180.
Z575 70 x 45mm 45R 0.5W 55p ea; 10 £3.30; 25 £6; 100 £20

SOLDER
500g reels resin cored. 18g..... £5.95
500g reels resin cored 22g..... £7.95

sinclair

MICROVISION

We have a quantity of these units in varying states. From labels attached to some of the PCB's it seems after assembly on the production line they did not function correctly. No attempt has been made to repair them, though — Instead the following parts were removed:

- RF Tuner
- Vol control & switch
- ZN401E chip

Because of the varying needs of constructors and the differing states of the microvisions, we are offering the following alternatives:

| | |
|---|-------|
| Z555 Grade A: PCB in good condition with CRT fitted. Supplied as seen with circuit diagram and notes..... | £6.95 |
| Z556 PCB in good condition with CRT that has been removed, but maybe repairable. Conductive paint (15ml bottle £3.45) will probably be needed to remake contacts..... | £3.95 |
| Z558 CRT in 'as seen' condition — possibly repairable..... | £2.00 |
| Z559 PCB in good condition without CRT..... | £2.50 |
| Z560 Circuit diagram and notes: 7 pages detailing tech. spec., description, cct operation, fault diagnosis & repair, aid to fault-finding chart, picture set up procedure, PCB layout, info on the various possibilities..... | £2.00 |
| RF Tuner £6.95; ZN401 chip £9.95; Vol control + switch with knob £1.00 | |

1987 CATALOGUE

Out now!! Bigger and better than ever — 80 pages packed with components and equipment, from humble resistors to high tech scopes! Bargain List, Order Forms and £1.50 Discount Vouchers all included for just £1.00 inc. post.

+ FREE! KIT-CAT

24 page illustrated catalogue with over 100 kits from simple amplifiers to complex EPROM programmers — also computer interface kits enabling many popular computers to be linked with the outside world. PLUS kits utilizing breadboards for beginners.

ENTERPRISE SIXTYFOUR

Z601 Complete PCB from above — Z80A, 64k of RAM, UHF modulator. Just needs keyboard, TV & PSU. Supplied with lots of data: Full circuit diagram, connections for expansion port, ROM bay, joysticks ports, printer port, video output, serial port. Also demo cassette + 2 booklets that were supplied with complete machine..... £20.00
Data only..... £2.00

LOGIC PROBE

For TTL, CMOS etc. LED and sound indication Pulse enlargement capability allows pulse direction down to 25nsec. Max f = 20 MHz 4-16V. I/P Z:1M £9.99

REGENERATIVE RADIOS Part 2

JOE PRITCHARD (GIUQW)

LAST MONTH, we examined the principles behind the regenerative receiver and saw how the circuit works. We also looked at some simple "building blocks" that we might use to design and build our own regenerative receivers. This month, it's time to get the soldering irons out as we see a couple of practical experimental designs for you to try out.

A very simple set is shown in Fig. 1, based around the Hartley oscillator. L1a is the aerial coil; currents flowing in this coil from the aerial induce a voltage in L1b. VC1 and L1b form a tuned circuit, and the rest of the components to the left of R2 and C2 form the oscillator. VR1 and C1 control the regeneration, C1 by limiting the amount of signal from the tuned circuit to the amplifier formed by TR1 and VR1 by limiting the positive feedback into the tuned circuit via the L1b tap. R1 biases the transistor.

Components R2 and C2 form an r.f. filter, and IC1 takes care of the audio amplification.

Coil L1 was home wound on a former supplied by Electrovalue (part number 228-090) as shown in Fig. 2. A ferrite core is available for this type of former (Electrovalue part 228-107) and this can be used to tune the coil. Using this former made it possible to form "plug in" coils, for this and a number of other simple radio sets. For a start, try winding a coil as follows:

L1a is 50 turns of close wound 36 s.w.g. wire, stuck with a dab or two of Evo-stik. L1b is 10 turns of 36 s.w.g. wire, tapped at 5 turns. With

the ferrite core in the centre of L1b, a tuning range of 5.5 to 8.5MHz was achieved.

You might like to try other coils in the circuit as well.

CONSTRUCTION

The prototype set was built on normal Veroboard, and a second version was built on tag strip. Both sets gave similar results. The following rules should be adhered to when building any regenerative set, if you haven't got a layout diagram.

1. Build the circuit as rigidly as possible. This is particularly important for the elements of the circuit that form the r.f. oscillator/amplifier part of the circuit. The coils should be tightly wound.
2. Wherever possible, isolate output circuits from input circuits. For example, with Veroboard, cut strips that run from the r.f. section of the receiver to the audio section even if there's no direct connection to the strip. Capacitive coupling can wreak havoc here!
3. As well as the usual 100 μ capacitor across the supply, it's occasionally useful to try a 0.01 μ capacitor across the supply as well.
4. When mounting transformers, r.f. chokes and coils, try and put them as far apart as possible unless you intend some sort of coupling to exist between them. If possible, mount

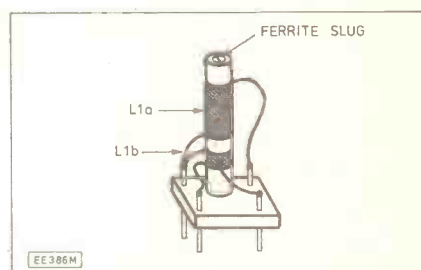

Fig. 2. Coil details for circuit of Fig. 1.

chokes and aerial coils, etc. at 90 degrees to each other.

5. If you use a metal case, then use the chassis as a circuit earth. This will entail you connecting the moving vanes of the tuning capacitors to earth. If a tuning capacitor hasn't got one end connected to earth, then insulate it from the front panel.
6. Any controls that are panel mounted should be held as rigidly as possible. Again, watch for unintentional connections between different controls if the panel is metal.
7. For tuning controls, a slow motion drive is a good idea. I use a 6:1 drive which is generally available for a few pounds. This makes tuning much easier.

OPERATION

Connect up a battery and a pair of eight ohm headphones. Connect a short 600mm aerial to the aerial connection of the set. In addition, connect up a few feet of wire to the earth terminal of the set. Now, turn the regeneration pot. until it's close to minimum resistance. Turning the tuning control, you should hear a few squeals and whistles. If so, then tune in a whistle, and gently turn the pot. back towards maximum resistance. You should hear the squeal replaced by a station. The setting of this control is a little fiddly to get used to, but once mastered is quite easy. For Morse code (c.w.) and single sideband (s.s.b.) signals, advance the regeneration control so that the set is "oscillating"—that is, a loud rushing noise and a whistle when stations are tuned in. This set is not really suitable for c.w. and s.s.b., however. You shouldn't let the set oscillate too much; apart from the awful noise, you are generating radio waves at the frequency to which you're tuned!

Fig. 1. Simple regenerative set for constructors.

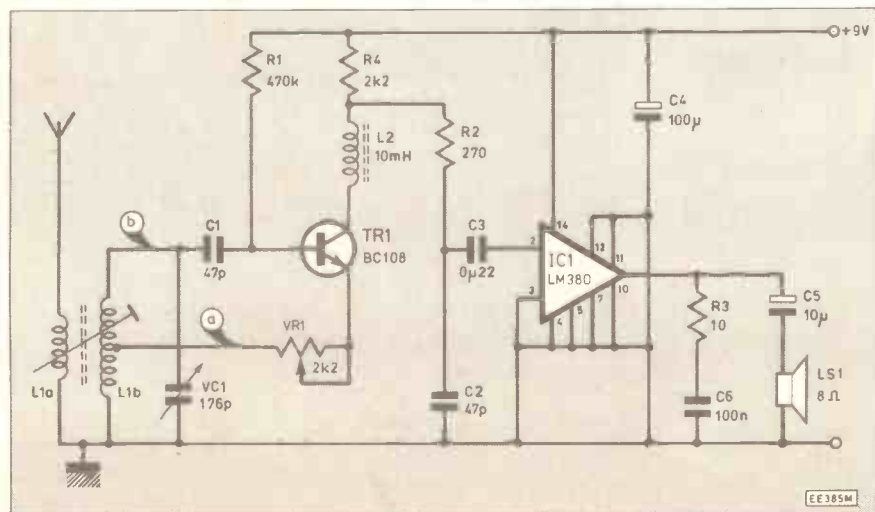

HAND CAPACITY

With simple sets there is occasionally a strange effect whereby the operator tunes a signal, removes his or her hand from the tuning control, and . . . the signal disappears! This is due to the capacitance of the human hand causing a change in the tuned circuit frequency. Due to the good selectivity of regenerative sets, we only need to have the tuned circuit frequency changed by a matter of a few kilohertz and the signal is gone.

The wire connected to the earth of the set will solve this problem if a metal chassis is used and the tuning control is connected to the chassis as indicated in point "5" of the constructional notes above. An alternative way of solving this is to mount the controls some distance behind the front panel and extend the shaft of the tuning control with a non-conducting shaft. Plastic rod can be obtained, from a model shop, of the correct diameter and can be connected to the shaft of the tuning control with a "coupler", available from most suppliers. The control knob or slow motion drive is thus isolated electrically from any part of the control. The problem here, though, is the increased size of the case for the set.

AERIALS

To misquote a Yorkshire saying, "There's nowt so queer as regenerative receivers" as far as aerials are concerned. Although an aerial is usually necessary to get signals into the tuned circuit, long aerials can actually prevent a regenerative radio set from working properly. This is because a long aerial "loads" the tuned circuit, reducing its efficiency and effectively cutting down the gain of the amplifier. Obviously, this will make it difficult or impossible to get the set into oscillation.

A few solutions are shown in Fig. 3 for those of you lucky enough to have long aerials. In Fig. 3(a), the twist of wire forms a small value (a few pF) capacitor between the aerial and the receiver. This cuts down the loading on the set. The use of L1a in Fig. 1 also cuts down loading. The arrangement in Fig. 3(c) is best used with an aerial input coil like L1a, and it works by reducing the strength of the signal reaching the receiver. Regenerative sets can easily be upset by "over-loading", where a strong signal which

Fig. 3. Overcoming the problems sometimes caused by long aerials.

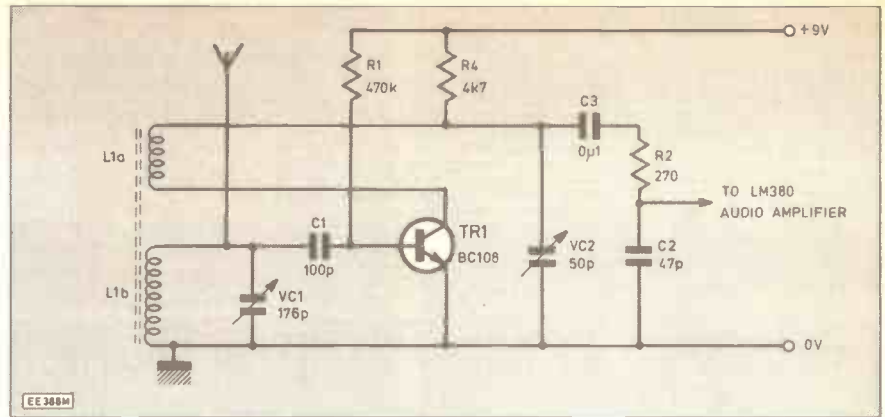
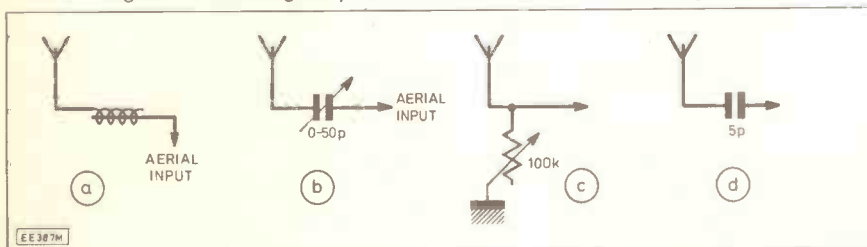

Fig. 4. A slightly more expensive but better performance circuit.

can be heard at any setting of the tuning control. Fig. 3(c) will help prevent this.

PROBLEMS

Regenerative receivers have a reputation for being sets that are a little "awkward". Many problems are due to the user being unused to the type of receiver, and these can only be overcome with practice. However, here are a few pointers to solving problems with the set in Fig. 1.

If the set is unstable, and regeneration cannot be controlled:

1. Decrease the value of C1.
2. Increase the value of R1.
3. Increase the value of R4.
4. Increase the loading due to the aerial.
5. Move tap on L1b closer to the "earthy" end of the coil.

All these have the effect of reducing the gain of the set. You might also try varying the position of the tap on L1b, moving it towards the earthy end of the coil. Finer control can sometimes be obtained by putting a smaller resistor in for VR1, say 500 ohms. In this case, the point at which regeneration starts will be more easily found. You may need a trimmer in series with the variable, so that the trimmer can be set to bring the total resistance of VR1 and trimmer into a range that will allow control of regeneration.

If regeneration cannot be obtained at all:

1. Increase the value of C1.
2. Decrease the value of R1, though not below about 100k.
3. Decrease the value of R4, though not below about 1k.

4. Decrease the loading due to the aerial.
5. Is the battery flat?

These will all increase the gain of the set, either by altering the amount of signal fed back or increasing the gain of the amplifier.

If you have difficulty tuning the set:

1. Check that you're not over-loading.
2. Check that both ends of the tuning capacitor are connected up.
3. If headphone leads appear to alter the tuning as they move, try improving the r.f. filter between the r.f. stage and the audio stage. (see last month).
4. If you have hand capacity effects, see above.

If you try a short aerial, you may get better results by connecting it directly to points (a) or (b) on Fig. 1. I built the circuit with a variety of transistors. The BC108, ZTX300 and 2N222 all worked quite well.

A SECOND SET

To finish off this introduction to regenerative sets, Fig. 4 shows a design which is slightly more expensive than Fig. 1, because of the use of two tuning capacitors. However, it is a better performer than the earlier set in that the regeneration is easier to control. The circuit is a little odd; those of you in the know about such things may be surprised that I applied the output from the tuned circuit directly to the base of a bipolar transistor. This is normally seen with f.e.t.s. However, the circuit appears to work quite well.

The components have been numbered as in Fig. 1, and the problem solving guide above can, with a few amendments, be applied for this circuit as well.

The big difference is in the way in which the feedback is applied and controlled. In Fig. 4, feedback is by L1a to the tuned circuit formed by VC1 and L1b. The degree of feedback is controlled by the setting of VC2, which diverts much of the r.f. back to earth, rather than allowing it to be fed

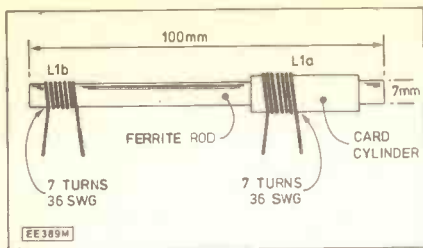

Fig. 5. Coil details for the circuit of Fig. 4.

back to the tuned circuit. The two coils must be "in phase" for positive feedback to occur (see last month). Fig. 5 shows how the coils were arranged in the prototype.

OPERATION

Once built, a short aerial can be PERMANENTLY connected to the aerial connection. The aerial in this set, as it is directly connected to the tuned circuit, has a direct effect on

regeneration and tuning. Connect up a battery and headphones. You should hear a gentle hissing noise. Adjust VC1 and VC2 so that their vanes are fully meshed. Now, slowly move L1a along the ferrite rod until you hear an increase in the hissing noise. The set is now oscillating.

If you can't get this to happen, reverse the connections to L1a; you most probably had the phase wrong. Turn VC2 until the oscillation stops. If you can't get it to stop, then shift L1b backwards until you can. Now open VC1 up totally. At some point of VC2 you should be able to stop the oscillation again. The set is now set up and you can now stick L1a in position. The aim of this procedure is to get the set so that you can bring it into oscillation with VC2 at any position of VC1.

As with all regenerative receivers, the set is at its most sensitive just below the point of oscillation. The set is used by simply adjusting the regeneration control to just below the point at

which oscillation starts, as indicated by the rushing noise when no stations are being received, or a whistling when a station is being received. Then use VC1 to tune stations in. This is much easier to do than to describe! With the coil shown in Fig. 5 I was able to receive frequencies in the range 3.5 to 7.5MHz. With a slow motion drive on VC1, s.s.b. and c.w. transmissions in the 80 and 40 metre amateur band were received quite easily. You might like to experiment with the coil, to get higher or lower frequencies. You could even try coils without a ferrite rod, though I haven't tried this.

Well, I hope that you've enjoyed this quick foray into the world of regenerative receivers. It's a fascinating field and one which provides the short wave listener with the added thrill of hearing the world on a home made set. Try out some of your own ideas; it's surprising how often simple receivers give excellent results!

EE READERS DISCOUNT SCHEME



Readers—you can obtain a 5% discount on goods from the advertisers listed using coupons cut from EE, provided you follow the rules below:

CROTECH's complete range of single and dual trace oscilloscopes along with accessories is eligible for the discount scheme. For orders below £250.00 then one voucher is required, on orders above £250.00 only two vouchers are required. This could mean a saving of over £14.00 on our 3132 Dual Trace 20MHz scope.

CPL ELECTRONICS

Kits for *Everyday Electronics* and *Electronics Monthly* and *Practical Wireless* projects including kits for the "Teach In" series. Plus a wide range of competitively priced components, hardware, test equipment and tools. We can also supply, in many cases, "one off" kits for specific projects. Free price lists on request.

GREENWELD ELECTRONICS LTD.

A full range of components at our shop in Southampton; open 9-5.30 Mon-Sat, as well as many surplus lines, all available by mail order. Bargain List free with our Catalogue. Send for your copy today, only £1 inc. post. Now even better value with EE Discount Vouchers!

OMNI ELECTRONICS are willing to give a 5% discount on all orders over £10.00, excluding VAT, if a valid voucher is enclosed. We stock a wide range of components—ideal for the hobbyist. Goods listed in our catalogue are generally in stock, orders will be sent by return post. Why wait?

EE BOOK SERVICE, a 5% discount will be given on the total cost—including postage—of all orders that are sent with a valid voucher. Our complete list of books appears in each issue together with ordering details.

E.S.R. ELECTRONIC COMPONENTS supplies the full range of Velleman kits which include amplifiers, light controllers, power supplies, timers and computer interfaces. To complement these kits E.S.R. can offer connectors, switches, control knobs and project cases. A range of small handtools, soldering irons, test equipment and service aids is also available.

BECKER-PHONOSONICS, established 1972. Designers and suppliers of a wide range of kits for projects published in *Everyday Electronics* and other leading periodicals. Range includes musical and audio effects, computer controlled circuits and Geiger counters. EE discount scheme applies to all full kits over £30 goods value, excluding Geiger counters.

RADIO COMPONENT SPECIALISTS

Amplifiers—(PA, disco, music), audio leads all types, components, capacitors, potentiometers, resistors, disco lighting, sound to light units, disco decks, disco consoles, disco mixers, echo chambers, fuzz lights. Multimeters, mains transformers, microphones, stands, leads, goose necks, speakers with or without cabinets, tweeters, mid range units, 100V line matching audio transformers, etc.

TK ELECTRONICS stock a wide range of components including triacs, ICs & opto together with other accessories (switches, tools, multimeters, buzzers, crystals, Antex, Velleman and Vero products, etc.). We specialise in kits for timers, disco and home lighting, remote control kits for beginners. Send s.a.e. and 50p (refundable on first order) for catalogue.

RULES

- Discounts are available from advertisers listed on this page.
- Unless otherwise stated by the advertiser, discounts are only available on orders over £20 in value.
- Unless otherwise stated by the advertiser, one voucher is required for each £50 value of the order placed (i.e. for orders between £20 and £50 send one voucher, between £50 and £100 send two vouchers, etc.)
- Cut out vouchers (not photostats) must be sent when claiming the discount.
- Each voucher sent must be valid on the day of posting (i.e. it cannot be used after its expiry date).
- Discount is not available on "sale" or "special offer" items.
- You must indicate on your order that the 5% EE Readers Discount has been deducted from the payment sent.
- All advertisers reserve the right to refuse this discount on any item supplied.



SHOP TALK



BY DAVID BARRINGTON

Catalogue Received

We are always reading stories of how Scotland is booming with hi-tech and electronic start-ups (Scottish Development Board), but we hear very little of component suppliers for the lucrative hobby market.

With such a "boom" it is very surprising how many of our readers bemoan the lack of local stockists. If any of our readers in Scotland would like to inform us of their local suppliers we would be happy to pass the information on to other readers.

However, from the little feedback we have had, the service provided by **Omni Electronics** seems to make up for this shortcoming. Their latest 24-page catalogue contains quite a variety of components which should meet the needs of most constructors. Items ranging from motorised sirens to computer hardware are listed.



We understand that, being a family run business, they are able to give a personal service and are quite happy, within reason, to try and locate those "obscure" or hard to purchase components that unavoidably do appear in some published projects.

All prices listed include VAT and there is a flat rate charge of 60p for postage and packing. Orders are computer processed and are generally sent out the same day as received.

Copies of the catalogue are obtainable by sending 20p plus a 13p or 18p stamp for postage to: **Omni Electronics, Dept EE, 174 Dalkeith Road, Edinburgh, Scotland EH16 5DX.**

If you are on the lookout for reasonably priced cases to enhance the appearance of your project, without having to design the board layout and wiring to fit the case, **Bafbox** have installed new machinery for producing small quantity plastic enclosures.

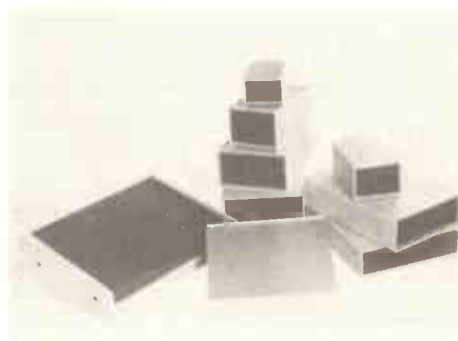

Apart from the high costs of mould tooling used in injection moulding techniques, the standard approach is to machine up plastic sheet in the flat and then fold it to form a box. Although, for small quantities, it is cheaper than injection moulding, the drawback with this method, claim **Bafbox**, is that it is confined to rectangular section boxes.

With the new machining facilities, they claim they are able to produce a plastic case in virtually any combination or size. Apart from a choice of colours, printed circuit board slots or guides can be machined in to the sides and mounting holes, such as D-connectors and switches, can be included.

For the small manufacturer, screen printing can be added to the case and a company can have its own case, ready for assembly, in low hundred quantities. It is claimed that a prototype case can be produced for companies within 10 days.

For the home constructor, there is a comprehensive standard range available off-the-shelf to choose from and already **Circuit** are carrying a good selection of cases. For further details of their "custom designed" service interested parties should write to: **Bafbox Ltd., Dept EE, Unit A, Park End Works, Croughton, Brackley, NN13 5LX.**

CONSTRUCTIONAL PROJECTS

EE Buccaneer Metal Detector

Most of the components for the **EE Buccaneer Metal Detector** appear to be standard items and should not cause buying problems. The transistor array i.c.,

type CA3046, should be stocked by most component suppliers.

One word of warning, when ordering the transistor type BC184L it is important to purchase the type with the L suffix as the pin connections for the device vary and can cause confusion.

The 1.2V Voltage Reference device, type 8069CCZR, may prove difficult to locate and the only source we have been able to find is from **Maplin**, order code YH39N.

Fermostat

Only a couple of items need special attention when purchasing components for the **Fermostat** project.

Some readers may have trouble sourcing the thermistor type VA1055S, this is currently listed by **Marco, Maplin**, and **Omni Electronics**. The printed circuit board is available through the **EE PCB Service**, see page 404.

The mains transient suppressor appears to be only available from **Maplin**, code HW13P. The mains suppressor type capacitors should be available from most advertisers, but in case of difficulty they are also stocked by **Maplin**.

Digital Counter/Frequency Meter

Our Digital Test Gear project this month features a versatile **Digital Counter/Frequency Meter** and some constructors may be confronted with purchasing problems when trying to locate several of the components used.

The 4-digit common anode multiplexed displays and the counter i.c. used in the prototype are RS Components types. These devices were purchased through their **Electromail** mail order service. The order code for the counter i.c. is 307-941, and the code for the displays is 587-024. They will also supply the red polarised display filter, order code 586-548.

Several advertisers now stock crystals for model control and microprocessor applications and the 10MHz crystal used here should not prove too difficult to locate. The one used in our model is an RS type, but **Circuit** and **Maplin** are also able to supply 10MHz crystals. The case dimensions may vary slightly but the characteristics appear to be identical.

Most component suppliers stock rotary switches with adjustable end-stops and the choice of case is left to the constructor, the one used in our model is a Verobox type 202-21035F.

For prices of the displays and counter i.c., readers should ring **Electromail** on 0536 204555. Whilst ringing ask about their latest "bumper" components catalogue—we are still awaiting ours!

Monomix

Most component suppliers should carry stocks of the "ultra low noise op-amp" type NE5534 called for in the **Monomix** project. They are currently listed by **Omni, Omega** and **Maplin**.

The rest of the items for this project are all standard off-the-shelf components and should not present any buying problems.

We cannot foresee any component buying problems for the **Midi ThruBox** or the two Exploring Electronics projects—**Telephone Alarm** and **Motor Speed Control**. Suitable low voltage d.c. motors are stocked by **Magenta** and **Stewart of Reading**.

DIGITAL Trouble Shooting Part Nine

MIKE TOOLEY BA

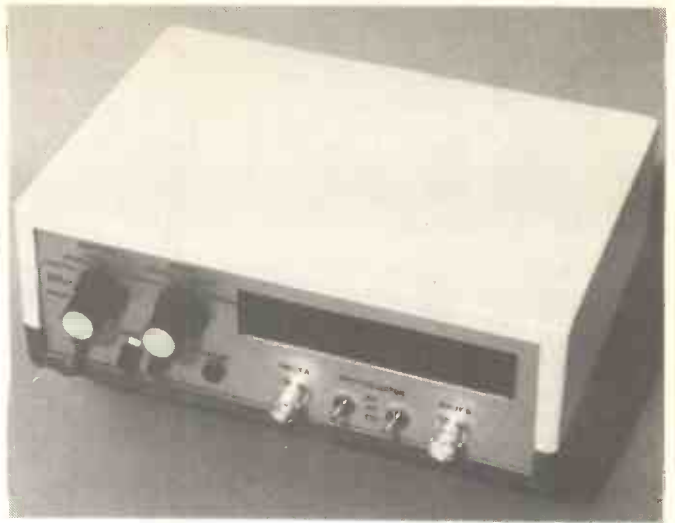

We draw this nine part series on Digital Troubleshooting to a close by taking a look at the widely used and increasingly popular STE bus. We also conclude by offering suggestions for further study and reading, plus, of course, a practical "test gear" project.

IN LAST month's instalment of *Digital Troubleshooting* we dealt with two methods of interconnecting microprocessor based systems and peripheral devices in the form of the popular RS-232C and IEEE-488 standards. This month we draw the series to a close by taking a look at a complete microcomputer based digital system based on the increasingly popular STE bus. We conclude by offering some suggestions for further study together with a recommended reading list.

THE STE BUS

The STE bus is a relatively new standard for microcomputer systems which is becoming widely used in industry. The standard uses Eurocard modules interconnected by means of a 64-way bus and follows the proposed IEEE standard known as "P1000". The bus caters for three types of board for processing, I/O, and signal conditioning. Since processors control the flow of data on the bus, they are often referred to as "bus masters". I/O cards, on the other hand, are referred to as "bus slaves".

Depending upon the application, STE bus I/O boards are available for digital input and output, analogue input, or analogue input and output. Digital I/O boards employ programmable parallel I/O devices (see Part Seven) whilst analogue I/O boards make use of appropriate analogue to digital converters (ADC) or digital to analogue converters (DAC).

The STE bus processors are available with a serial RS-232C interface (see Part Eight, last month) for connection to a terminal or external host microcomputer system. An STE bus card is also available in order to facilitate interconnecting with the IEEE-488 general purpose instrument bus (see last month). All of this makes the STE bus extremely flexible and versatile!

STE bus processors invariably comprise a single board computer containing CPU, ROM, RAM and bus interfacing hardware. Since all of this is contained on a standard Eurocard (measuring 100mm x 160mm) the packing density is quite high. Indeed, one of the most popular STE bus processors uses over 30 chips and no less than four of these are 40-pin DIL types!

A typical STE bus processor is shown in outline block schematic form in Fig. 9.1. Readers may like to compare this with the arrangement discussed in Part Five (Mar '87)!

The processor is a Z80-CPU operating at clock frequency of 4MHz. The basic system clock generator operates at 16MHz and is controlled by a 16MHz quartz crystal (see Part Five). The 16MHz clock is divided to provide the following clock signals:

- (a) 8MHz for the dynamic RAM controller
- (b) 4MHz for the CPU and serial interface (RS-232C)
- (c) 2MHz for the disc controller

The system 16MHz clock is also fed to the STE bus for use by slave cards. Since only one 16MHz clock should be present at any

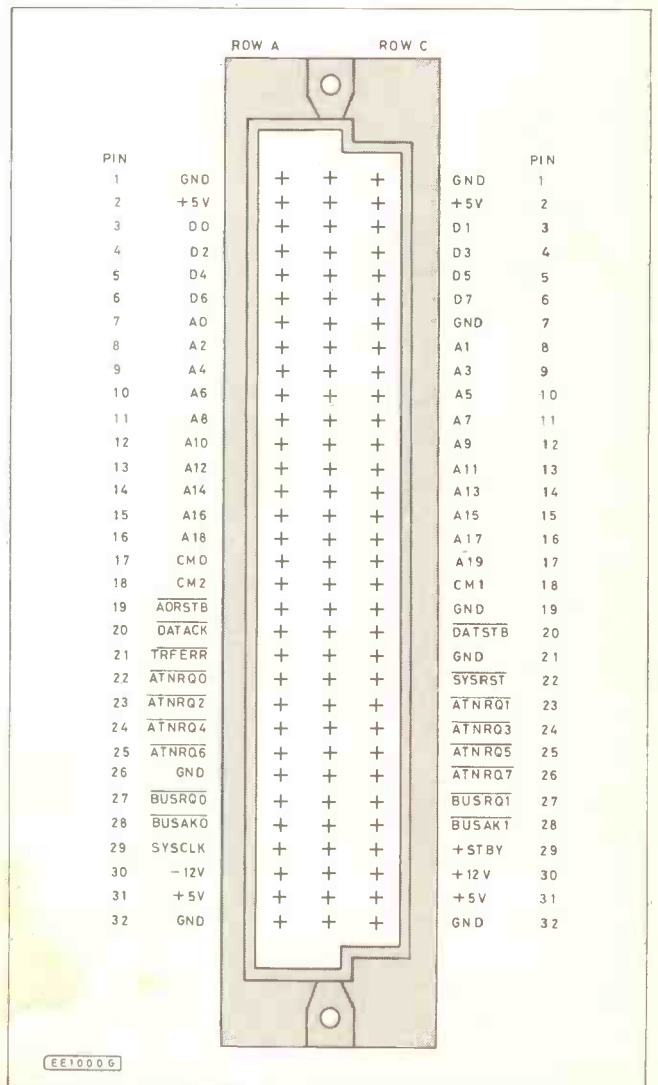

Fig. 9.2. The STE bus connector pin-out details, viewed from the board side.

one time on the bus and more than one processor card may be fitted, a facility for disabling this output is incorporated in the form of a link on the printed circuit board.

The dynamic RAM controller provides the multiplexed data and active low row address and column address select (RAS and CAS) signals for the eight 64K x 1 bit dynamic RAM chips (see Part Six—April '87). The disc controller is a dedicated LSI device and the serial interface is a programmable serial interface controller (see Part Seven). The serial interface incorporates the necessary level shifting to implement a full-specification RS-232C interface (see Part Eight).

The data and address buses are buffered from the STE bus by means of two octal drivers (in the case of the address bus) and one octal transceiver (in the case of the data bus). All three of these devices have tri-state outputs (see Part Two) and can thus be isolated from the external bus when required.

BUS CONNECTOR

The STE bus connector pin-out is shown in Fig. 9.2. The function of the signals present are as follows:

- D0 to D7 Eight data lines
- A0 to A19 Twenty address lines
- ADRSTB Address strobe. This line is taken low to indicate that a valid address has been placed on the bus.
- DATSTRB Data strobe. This line is taken low to indicate that valid data has been placed on the bus.
- CM0 to CM2 Command modifiers which indicate the type of bus cycle (see note below).
- BUSRQ0-1 Bus request lines. These lines are taken low when a potential bus master wishes to gain access to the bus.
- BUSAK0-1 Bus acknowledge lines. These lines are taken low to indicate that the bus request has been granted. A potential bus master may only drive the bus when it has received an acknowledge signal on the bus request line.

- DATAACK This handshake line is asserted by a bus slave on a write cycle in order to indicate that it has accepted data or, on a read cycle, to indicate that its data is valid.
- TRFERR A bus slave asserts this signal instead of DATAACK if an error is detected.
- ATNRQ0-1 Attention request/interrupt lines. (ATNRQ0 has the highest priority).
- SYSCLK 16MHz system clock.
- SYSRST System reset.

Note: The command modifier lines signal I/O and memory read and writes operations according to the following truth table:

| CM2 | CM1 | CM0 | Bus Cycle |
|-----|-----|-----|--------------|
| 0 | 0 | 0 | Reserved |
| 0 | 0 | 1 | Reserved |
| 0 | 1 | 0 | Reserved |
| 0 | 1 | 1 | Acknowledge |
| 1 | 0 | 0 | I/O write |
| 1 | 0 | 1 | I/O read |
| 1 | 1 | 0 | Memory write |
| 1 | 1 | 1 | Memory read |

A typical STE bus configuration is shown in Fig. 9.3. A single processor card is used in conjunction with two slave boards; an analogue input board and a digital I/O board. Program and data storage is provided by means of a disc drive and the system accepts commands via a serial RS-232C link from a terminal or host microcomputer operating in "terminal emulation mode".

All of the bus cards used in Fig. 9.3 are linked together using a "backplane". This consists of a printed circuit fitted with 64-way DIN 41612 sockets on a 0.8in. pitch. The backplane links together similarly numbered pins on each connector and has on-board

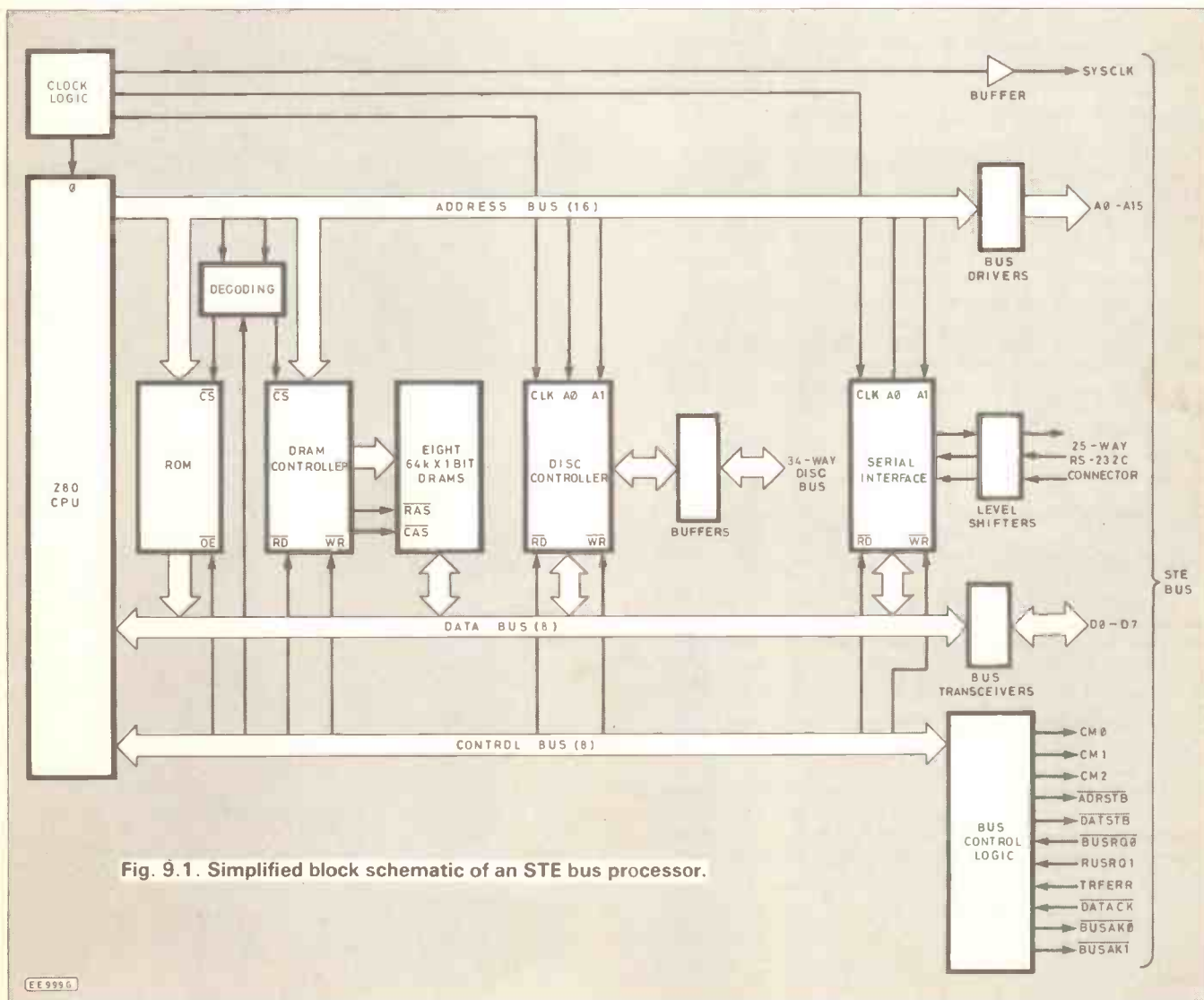

Fig. 9.1. Simplified block schematic of an STE bus processor.

SUGGESTED READING

For those readers who would like to pursue specific aspects of the Digital Troubleshooting series in more detail without taking a formal course of instruction, the following is a list of recommended reading:

TTL COOKBOOK

The TTL Cookbook by Don Lancaster (published by Howard Sams, ISBN 0-672-21035-5) is a superb collection of hints, tips, facts and figures covering all facets of TTL. A selection of the most popular TTL devices is discussed in some detail (together with pinouts for each device). The book also has a useful section on timers.

CMOS COOKBOOK

The CMOS Cookbook by Don Lancaster (published by Howard Sams, ISBN 0-672-21398-2) is similar to its TTL counterpart and makes equally good reading.

THE TTL DATA BOOK FOR DESIGN ENGINEERS

The TTL Data Book for Design Engineers (published by Texas Instruments Europe, ISBN 3-88078-034-X) is the definitive text covering all types of TTL devices. The book is a valuable source of reference information and includes electrical characteristics and pin connecting data for just about every conceivable TTL device.

TOWERS' DIGITAL IC SELECTOR

The Towers' International Digital IC Selector by T. D. Towers (published by Foulsham, ISBN 0-572-01179) provides abridged data and pin connecting information for over 13,000 digital integrated circuits. Appendices provide some useful reference information on i.c. logic types and codings, package outlines, pinouts, manufacturer's codings, manufacturers' proprietary "house" codings, abbreviations and a glossary.

COMPUTER ENGINEER'S POCKET BOOK

The Computer Engineer's Pocket Book by Michael Tooley (published by Heinemann Newnes, ISBN 0-434-91967) is a compendium of facts, figures, circuits and data and includes TTL and CMOS pinouts, logic gate characteristics, microprocessor data, and information on a variety of common support devices.—Available through *EE Book Service* £8.95: code NE01.

SERVICING PERSONAL COMPUTERS

Servicing Personal Computers by Michael Tooley (published by Newnes Technical Books, ISBN 0-408-01502-0) sets out the principles and practice of personal computer servicing. A large number of representative circuits are discussed and simple diagnostic routines are provided.

RS-232 MADE EASY

RS-232 Made Easy, by Martin Seyer (published by Prentice Hall) attempts to explain, in a very straightforward manner, the operation of the RS-232C interface. Step-by-step instructions are given on connecting a variety of common (and some not-so-common!) peripherals to microcomputers. The EIA electrical specifications for RS-232C and RS-449 are discussed in some detail.

MICROPROCESSORS AND DIGITAL SYSTEMS

Microprocessors and Digital Systems by Douglas Hall (published by McGraw-Hill, ISBN 0-07-025552-0) provides an excellent introduction to microprocessor based systems and includes chapters on the use of test equipment, digital logic gate characteristics and interfacing, flip-flops counters and shift registers, D/A and A/D converters, microprocessor structure and programming, and prototyping and troubleshooting microprocessor based systems.

The International Student Edition of this publication is especially good value!

terminator networks which help to minimise transmission mismatch and signal ringing. The backplane assembly is usually mounted in some form of rack into which the cards slide using clip-in guides.

FAULT FINDING ON BUS SYSTEMS

Readers should not be deterred by the apparent complexity of the microcomputer based system shown in Fig. 9.3. The system can be considered as a number of interlinked sub-systems and each sub-system can similarly be divided into its constituent elements. Furthermore, the use of a bus makes fault finding very straightforward; it being possible to isolate various parts of the system just be

removing the card in question and substituting a card which is known to be functional!

Additional complications do arise when several potential masters (processors) share a bus. If one, or other, processor is unable to gain access to the bus it may "hang" because some other master already has control of the bus and has not released it. In such an event it will be necessary to check the \overline{BUSRQ} and \overline{BUSAK} lines using a logic probe or an oscilloscope. If the lines are enabled, check the control modifier lines to ensure that the bus cycle is not an acknowledge cycle and that the unsuccessful processor is asserting the data strobe line.

If \overline{DATSTB} has been asserted, a $\overline{DATAACK}$ or \overline{TRFERR} signal should have been received from the slave card. If these signals have not appeared, check that the slave card responds to the address that the processor is generating. Note that many slave cards require the \overline{SYSCLK} signal to be present on the bus for timing and problems can arise if several processors are both generating this signal simultaneously!

It is also important to note that bus I/O cards are usually fitted with links which provide selection of addresses and attention request lines. These links should be adjusted so that no conflicts occur between bus cards. When new or replacement cards are to be fitted to a system, care should be taken to ensure that the links are correctly set before fitting. The penalty for not observing this simple rule can be many hours of frustration!

Finally, when diagnosing faults on complex systems do not forget to overlook the obvious! In any event, it is important to make some assessment of the system before starting out. The following ten point checklist should help in this task:

1. Has the equipment operated correctly previously or has the fault only recently occurred?
2. If there is no record of correct performance, can the fault be attributed to incorrect design or a faulty component during manufacture?
3. If the fault has only recently occurred, in what circumstances did the equipment fail?
4. Is the fault present all the time or is it intermittent?
5. If the fault is intermittent, in what circumstances does it arise? (Is the fault dependent upon temperature?)
6. Is it possible to predict when the fault will occur?
7. If so, can these conditions be reproduced so that the fault manifests itself permanently?
8. What parts of the equipment are operating correctly?
9. Can the fault be isolated to a particular part?
10. Is the fault a known "stock fault" that has been documented elsewhere?

Fig. 9.3. A typical STE bus configuration.

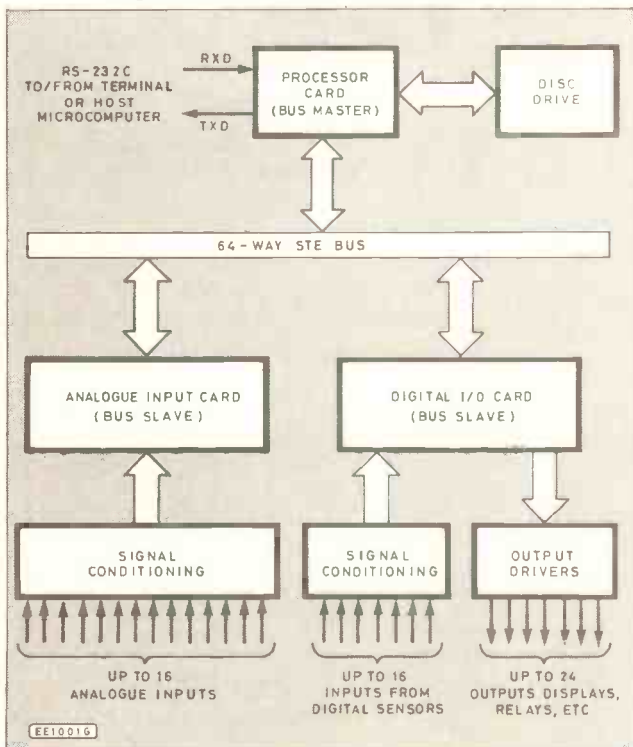

All of these questions should be answered BEFORE attempting to make any measurements or remove any suspected parts. The practised digital troubleshooter will make this sort of assessment as a matter of course however the beginner can be well advised to get into the habit of using them as his initial "checklist"!

FURTHER STUDY

Readers who have followed the series this far may wonder what they can do to further enhance their potential for digital troubleshooting. Whilst there is absolutely no substitute for hard won "hands-on" experience, several courses are widely available which can certainly help aid one's understanding of the subject and also provide some structured practical exercises related to fault finding.

CITY AND GUILDS ELECTRONIC SERVICING (224)

The City and Guilds Electronic Servicing (224) popular course is offered by a large number of further education colleges and other approved centres throughout the United Kingdom. The scheme is also available outside the UK for colleges which have received City and Guilds approval.

The course is available in three parts and entry is at the discretion of the centre and its controlling authority in consultation with industry. The scheme is primarily designed for students who are gaining practical experience at work, however mature candidates are usually made welcome at most centres. Courses generally commence in September for examinations in June.

The *Part I* syllabus provides an elementary introduction to electronics servicing and includes such topics as electronic systems, electronic units, transmission, waveforms, and electrical supplies. At *Part II*, the syllabus is divided between "Core Studies" and either "Television and Radio Reception" or "Industrial Equipment". This latter option includes such topics as logic circuits, number systems, and microprocessor applications.

The *Part III* scheme presents the students with a choice of options appropriate to his or her own specialism. Options which are particularly relevant (and which follow on logically from this series) are "Digital Techniques" and "Microprocessor Computer Systems".

These options can be studied concurrently at a large number of centres and your local college of further education should be able to provide you with further information.

CITY AND GUILDS MICROCOMPUTER TECHNOLOGY (223)

The City and Guilds 223 scheme is a relatively new programme which, like the 224 scheme, is also available in three parts. *Part I* deals with introductory topics but, unlike the *Part I* 224 scheme, is entirely biased towards digital equipment and microprocessors or microcomputers. The course involves three main areas of study; hardware, software, and interfacing and is ideal for those wishing to specialise in the field of microprocessors or microcomputers.

Part I topics include fundamental concepts, microprocessor architecture, characteristics of logic elements, system interconnection, and storage devices. *Part II* topics include peripheral devices and interfaces, prototyping and troubleshooting microcomputer systems, and principles of programming.

Like the 224 programme, admission to a course of study is at the discretion of the college or other approved centre and prospective students should enquire of the availability of the programme locally. Examinations are provided three times a year but most courses are designed to run from September to June.

CITY AND GUILDS INFORMATION TECHNOLOGY (726)

The City and Guilds 726 scheme is, unlike the 224 and 223 schemes, a modular programme for which assessment is available "on demand".

Approximately twenty-five individual modules are currently available and those that are likely to be of most interest to readers include "Introductory Digital Electronics", "Elementary Digital Electronics", and "Intermediate Digital Electronics". The basic philosophy of the programme is that the student progresses at his or her own pace with assessment (including multiple choice or written tests and practical assignments) provided at regular stages throughout the course.

In order to follow one or more 726 modules it is necessary for prospective students to register with an approved centre (these include colleges, ITECs, and some schools). Readers who feel that this type of study is appropriate to them may like to know that in conjunction with City and Guilds and local centres, Everyday Electronics will shortly be offering a programme of study for the 726 module entitled *Introductory Microprocessors*.—This course is due to start in the autumn so make sure that you stay with us until then! □

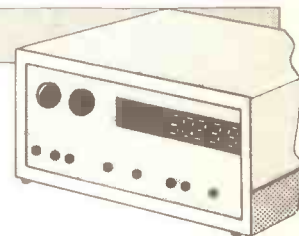

DIGITAL COUNTER/ FREQUENCY METER

MIKE TOOLEY B.A.

OUR final Digital Test Gear Project deals with the construction of a versatile Digital Counter/Frequency Meter. This handy unit is completely self-contained and can perform a variety of time and frequency related measurements on digital as well as analogue signals.

Potential constructors should be aware that since this is the most ambitious of our Digital Test Gear Projects it should not be attempted by the rank newcomer to electronic construction. However, those who have successfully built one or more of our previous projects should have very few problems!

CIRCUIT DESCRIPTION

The Digital Counter/Frequency Meter is based upon the popular 7216A Universal Counter chip. This device comprises a high frequency oscillator, decade timebase

Specifications . . .

| | |
|---------------------|--|
| Functions | 1. Frequency (Input A) 2. Period (Input A) 3. Frequency Ratio (Input A/Input B) 4. Time Interval (Input A—Input B) 5. Unit Counter (Input A) 6. Internal Oscillator Frequency |
| Ranges | 1. 0.01s/1Hz 2. 0.1s/10Hz 3. 1s/100Hz 4. 10s/1kHz |
| Display | Eight digits |
| Inputs | a.c./d.c./TTL |
| Sensitivity | 100mV r.m.s. sine wave 30mV pk-pk square wave |
| Supply | Four C-type dry cells or four C-type Nickel Cadmium cells |
| Battery Life | Approximately ten hours operation |



counter, eight decade data counter and latches, a seven segment decoder, digit multiplexers and eight digit drivers which can directly drive large i.e.d. displays. The counter inputs are rated for operation at a maximum frequency of 10MHz in frequency and unit counter modes and 2.5MHz in other modes.

The 7216A can function as a frequency meter, period counter, frequency ratio meter, time interval counter, or as a totalising counter. Minimal external circuitry is necessary in order to implement a full-

function instrument as witnessed by the complete circuit of the Digital Counter/Frequency Meter shown in Fig. 1.

Since both of the 7216A (IC1) signal inputs (input A at pin 28 and input B at pin 2) are digital (with a typical switching threshold of 2V with a 5V d.c. supply), external input signal conditioning is essential. This is provided by means of two wideband amplifiers formed by transistors TR1, TR2 and associated components for Input A, and TR3, TR4 and associated components for Input B.

The input circuits are identical and aim to provide a reasonable square wave output of 5V pk-pk (peak-to-peak) for sinusoidal input levels of as little as 100mV r.m.s., when the Input Selectors (switches S1 and S2) are switched to the a.c. position. The input selector also caters for d.c. coupled signals (important for low frequency applications and event counting) while a TTL position ensures optimum response for large amplitude input signals.

Display Hold and Reset facilities are provided by switches S3 and S4 respectively while Range and Function switching are provided by S5 and S6 respectively.

DISPLAY

In order to economise on wiring, the Digital Counter/Frequency Meter uses two four-digit common anode multiplexed seven-segment displays (IC2 and IC3), the pin connections for which are shown in Fig. 2. Supply decoupling is provided by means of capacitors C6 to C9 while diode D3 is used to reduce the supply voltage when working from dry rather than rechargeable batteries. When rechargeable cells are used, D3 is simply bypassed by means of a link on the stripboard.

When the unit is operated from rechargeable (Nickel Cadmium) cells, the batteries may be recharged when the unit is not in use (i.e. when switched "off") by connecting sockets SK3 and SK4 to a 12V d.c. supply (e.g. Bench Power Unit or 12V Car Battery). Diode D2 protects against inadvertent reverse connection of the charging supply

Fig. 1. Complete circuit diagram for the Digital Counter/Frequency Meter.

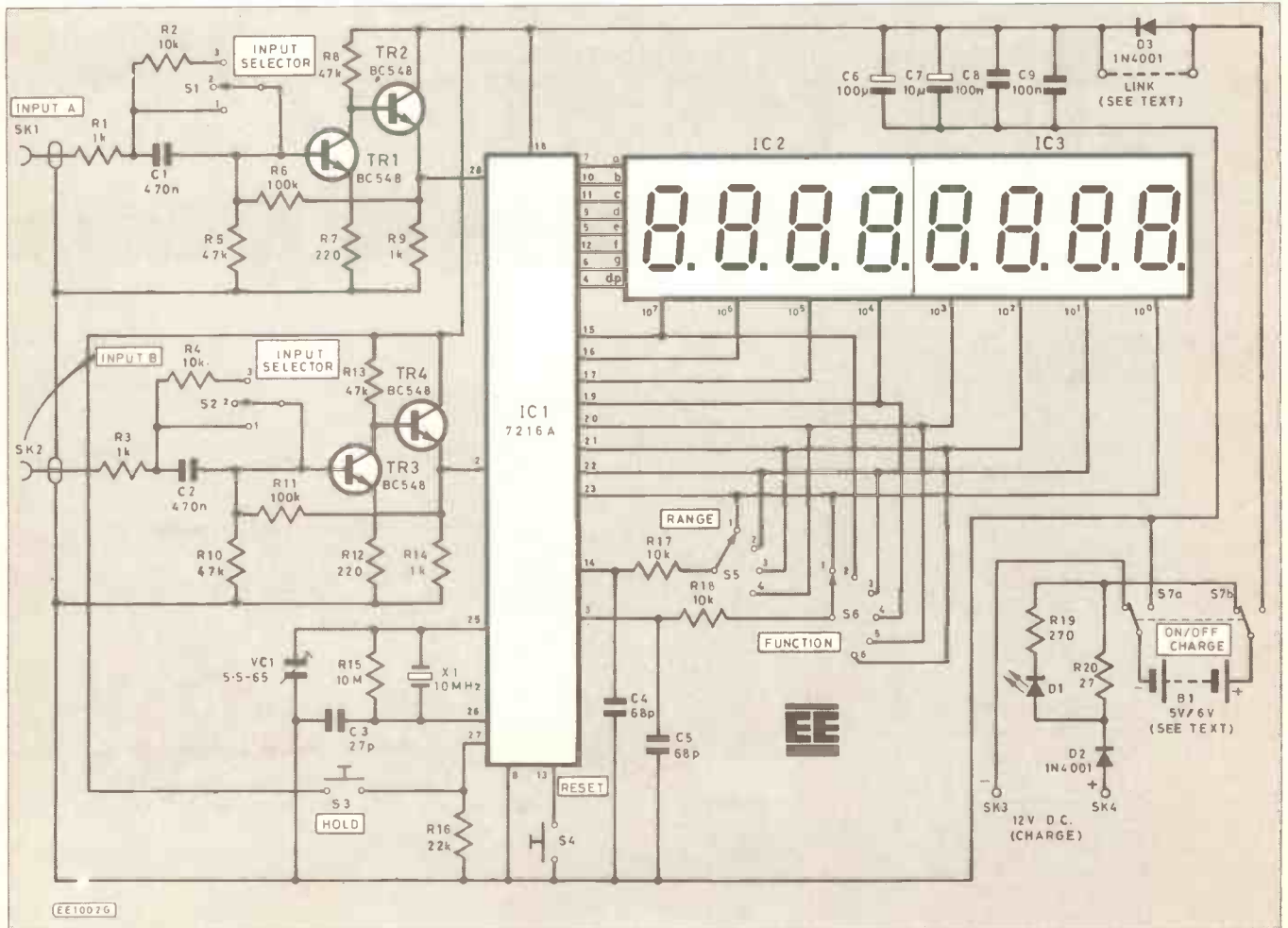

(which would otherwise damage the batteries!), while D1 indicates that the battery is being charged.

The charging current is limited to approximately 230mA by resistor R20 (which **MUST** be rated at 2.5W or more). The time taken to obtain a full charge (assuming that the batteries are fully discharged in the first place!) is approximately 12 hours.

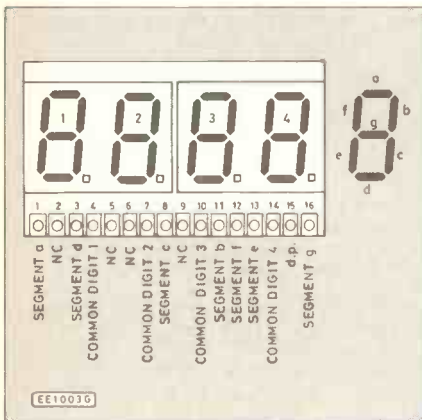

Fig. 2. Pinning details for the display modules.

CONSTRUCTION

With the exception of the front panel mounted components and battery holder, all of the Digital Counter/Frequency Meter components are mounted on a 0.1in. matrix stripboard measuring approximately 110mm x 110mm and having 40 tracks each with 40 holes. This may be cut from a standard size stripboard.

The stripboard component layout of the Digital Counter/Frequency Meter is shown in Fig. 3. Readers should note that a total of 45 track breaks are required and these should be made using a spot face cutter. If such a tool is unavailable, a sharp drill bit of appropriate size may be substituted.

The following sequence of component assembly is recommended: i.c. sockets, terminal pins, displays, links, resistors, diodes, and capacitors. Before inserting the integrated circuit into its holder and mounting the board in its final position, constructors should very carefully check the components, links, and track breaks. Furthermore, it is also worth checking that all of the polarised components (including l.e.d.s, diode and electrolytic capacitors) have been correctly orientated.

Careful examination of the underside of the board for dry joints, solder splashes, and bridges between adjacent tracks should also be undertaken at this stage. When the board has been thoroughly checked, the integrated circuit should be inserted into its holder (taking care to ensure correct orientation).

FRONT PANEL

The interwiring of the front panel mounted components is shown in Fig. 4. The display aperture (100mm x 20mm) should be carefully marked out and then cut using a circular section tension file. The inner surface of the aperture can then be filed smooth using an engineer's hand file. Any residual roughness of the inner surface can be removed with abrasive (silicon carbide) cloth.

The red polarised display filter should then be fitted to the rear of the front panel,

COMPONENTS

Resistors

| | |
|---------------|-------------|
| R1,R3,R9,R14 | 1k (4 off) |
| R2,R4,R17,R18 | 10k (4 off) |
| R5,R8,R10,R13 | 47k (4 off) |
| R6,R11 | 100 (2 off) |
| R7,R12 | 220 (2 off) |
| R16 | 22k |
| R15 | 10M 0.5W |
| R19 | 270 |
| R20 | 27 2.5W |

All 0.25W 5% carbon except where stated

See
**Shop
Talk**
page 363

Capacitors

| | |
|-------|----------------------------------|
| C1,C2 | 470n min. polyester 100V (2 off) |
| C3 | 27p polystyrene |
| C4,C5 | 68p min. ceramic (2 off) |
| C6 | 100µ p.c. elec. 16V |
| C7 | 10µ elec. 25V |
| C8,C9 | 100n polyester (2 off) |
| VC1 | 5.5-65p min. trimmer |

Semiconductors

| | |
|---------|---|
| D1 | Red l.e.d. (fitted with bezel) |
| D2,D3 | 1N4001 (2 off) |
| TR1-TR4 | BC548 npn transistor (4 off) |
| IC1 | 7216A counter |
| IC2,IC3 | 4-digit common anode multiplexed displays (2 off) |

Miscellaneous

| | |
|-------|---|
| X1 | 10MHz HC18/U crystal. |
| S1,S2 | Min. s.p.d.t. toggle switch, with centre-off. |
| S3,S4 | Min. normally-open momentary pushbutton switch. |
| S5 | 1-pole 4-way rotary switch (1P 12W type with rotation stop adjusted). |
| S6 | 1-pole 6-way rotary switch (1P 12W type with rotation stop adjusted). |
| S7 | Min. d.p.d.t. toggle switch. |

28-pin low profile i.c. socket; Verobox measuring 205 x 140 x 75mm approx., Vero part number 202-21035F; optional tilt-leg assembly; single-sided 1mm terminal pins (23 required); stripboard 0.1in. matrix measuring 110mm x 110mm approx. (see text); nuts, bolts, and mounting pillars (4 sets required); BNC chassis mounting sockets (2 required); 2mm chassis mounting sockets (1 black and 1 red); knobs (2 required); battery holder for four C-size cells; red polarised display filter (measuring 110mm x 35mm x 0.76mm).

Approx. cost
Guidance only

£58 plus case

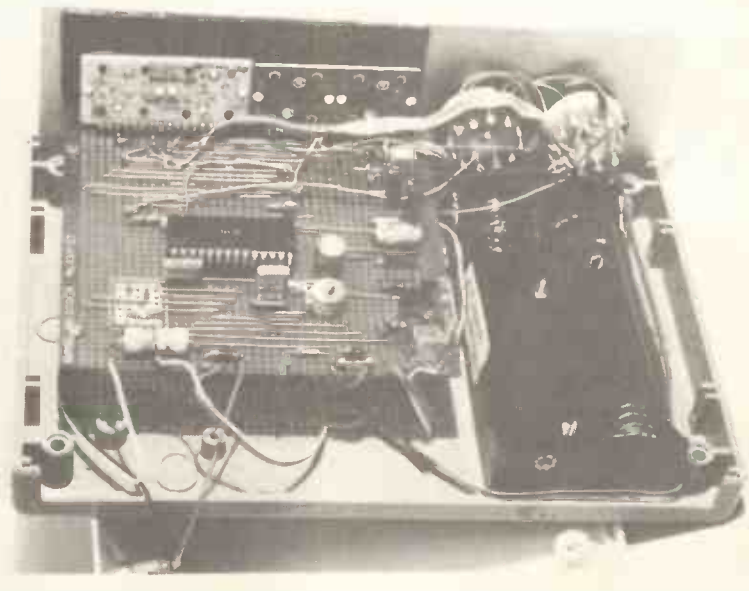

taking care to ensure that the correct surface is facing outwards. The display filter should be carefully glued into place using an epoxy resin based adhesive applied to the extreme edges of the filter.

The minimum amount of adhesive sufficient to retain the filter in place should be used and great care should be taken to avoid transferring adhesive to the exposed parts of the filter. With care, the finished result should be comparable with a professionally finished front panel.

Once wiring of the front panel has been completed, the stripboard should be mounted in the base of the case using four tapped pillars approximately 28mm in length. The wiring between the front and stripboard can then be completed as shown in Figs. 3 and 4.

This can be achieved with lengths of ribbon cable. Note, however, that it is important to keep the wiring as *short* and *direct* as possible. Failure to observe this precaution may result in "glitches" which will cause spurious readings at low battery voltages.

Finally, the battery holder should be secured to the base of the case using M3 nuts and bolts and the charging sockets (SK3 and SK4) fitted to the rear panel.

TESTING

If using dry batteries, ensure that the "dotted" link wire (see Figs. 1 and 3) is NOT in place before inserting four 1.5V C-type dry cells into the battery holder. If using rechargeable cells, check that the "dotted" link wire HAS been soldered in place, then insert four freshly charged C-type Nickel Cadmium cells into the battery holder.

Switch S5 to the "on" position and measure the d.c. supply voltage appearing across capacitor C7. This should be in the range 4.5V to 5.5V. If this is not the case, check the wiring of switch S7.

The Function switch S6 should then be set to the "Check" position and the Range switch S5 set to "0.01s/1Hz". If all is well, the display should read "10000.0" (indicating an internal clock frequency of 10000kHz).

If this reading is not obtained check the wiring to IC1, IC2, IC3, S5 and S6. If the display is blank (i.e. none of the l.e.d. segments is illuminated, check first that the supply is present at IC1 pin 18 and then check crystal X1, R15, VC1, C3 and associated wiring.

Having obtained a display of 10000.0 with the Function and Range settings as before, press Reset switch S4. The display should change to "0" for as long as the button is held down. (Note that leading zeroes (i.e. those before the decimal point) are not displayed.)

Release S4 and depress the Hold switch S3. The display should not change (i.e. it should remain at 10000.0) for as long as the button is held down. Release S3, and select each range in turn and check that the following indications result:

| Range | Indication |
|-----------|------------|
| 0.01s/1Hz | 10000.0 |
| 0.1s/10Hz | 10000.00 |
| 1s/100Hz | 10000.000 |
| 10s/1kHz | 0.000.0000 |

Note that, in the latter case, the leading digit ("1") overflows at the left hand side of the display and that 10s elapses before the count is completed and the display is updated. If the indications given are not obtained, check carefully the wiring of switches S5 and S6.

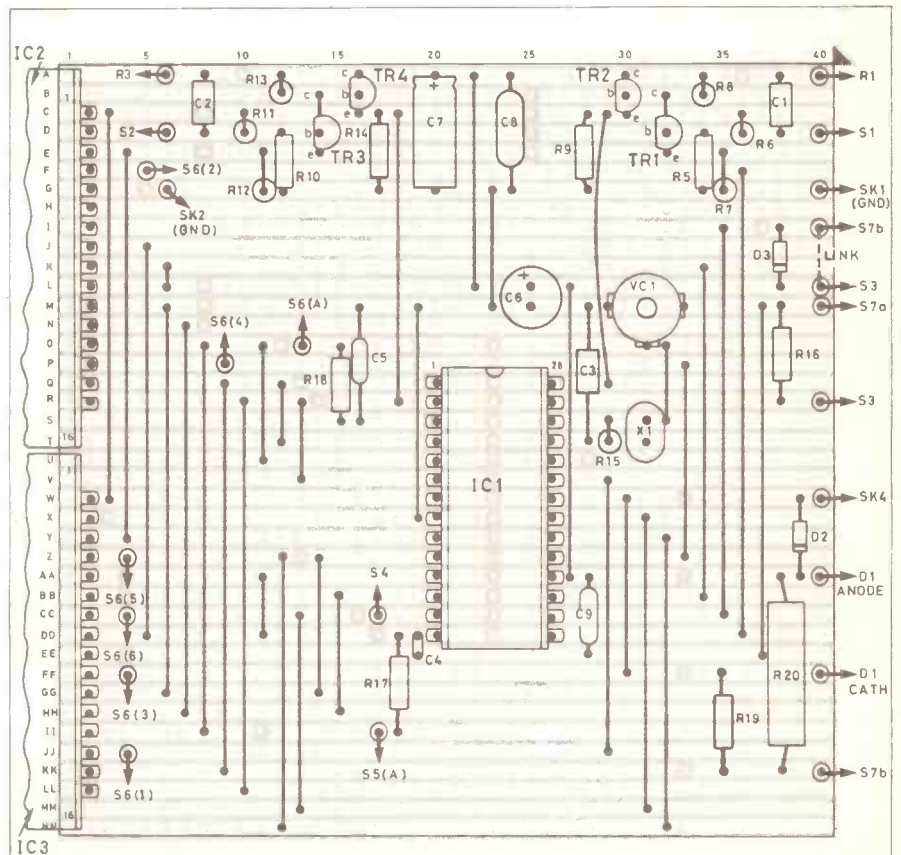
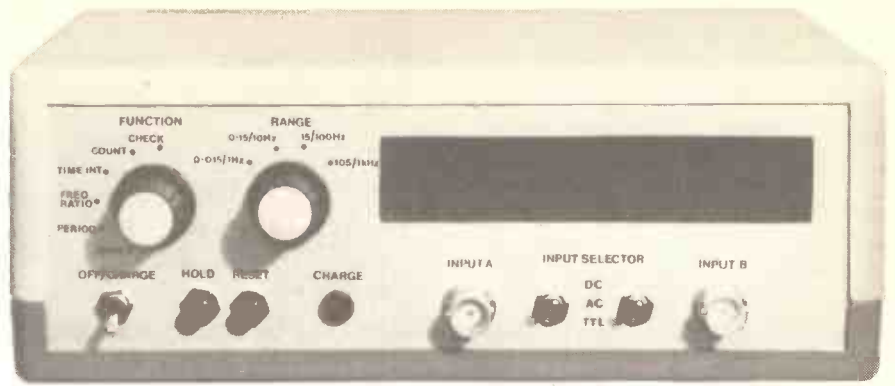
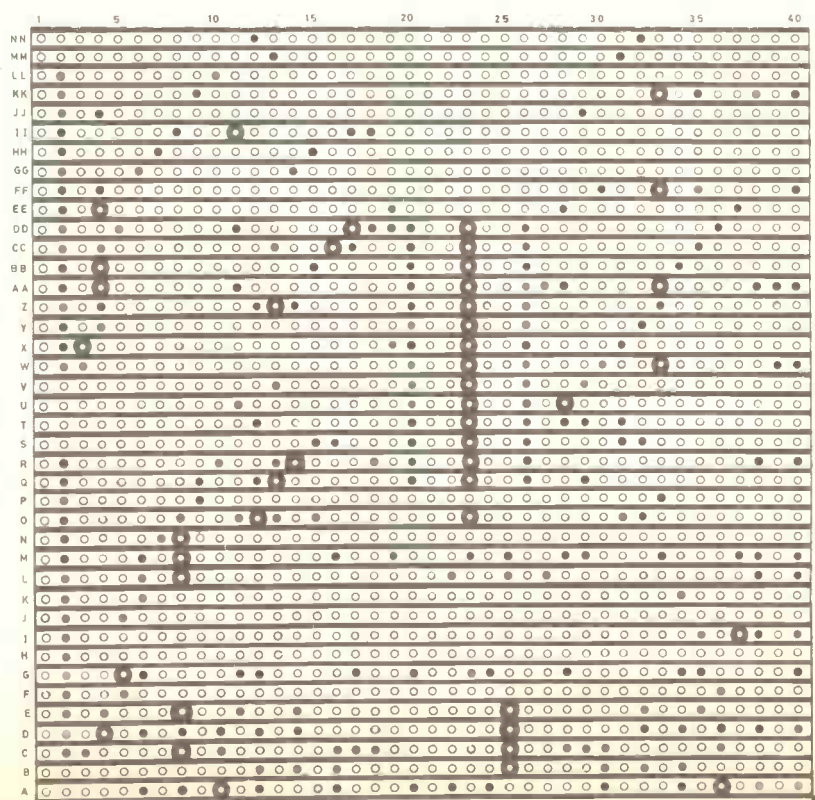

Fig. 3. Circuit board component layout and details of breaks to be made in the underside copper tracks (45 off).



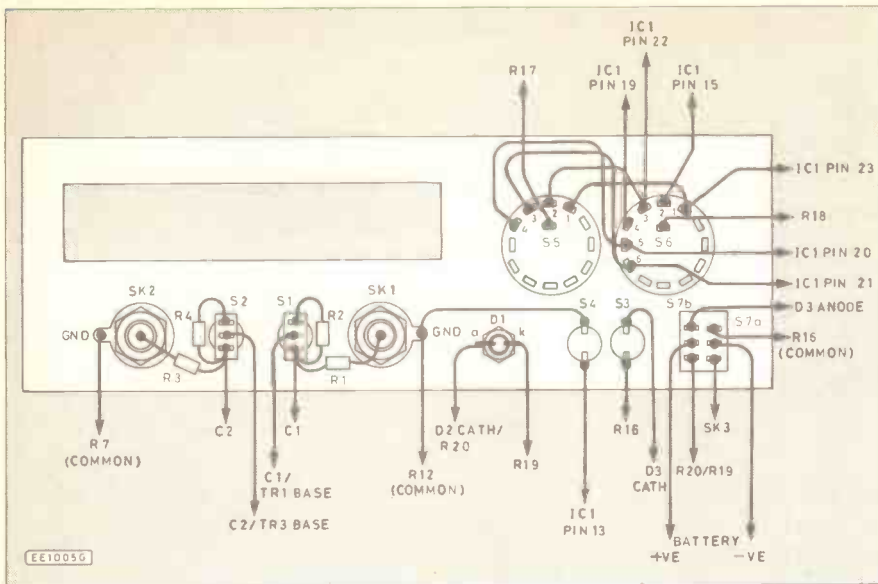

Fig. 4. Interwiring to the front panel mounted components.

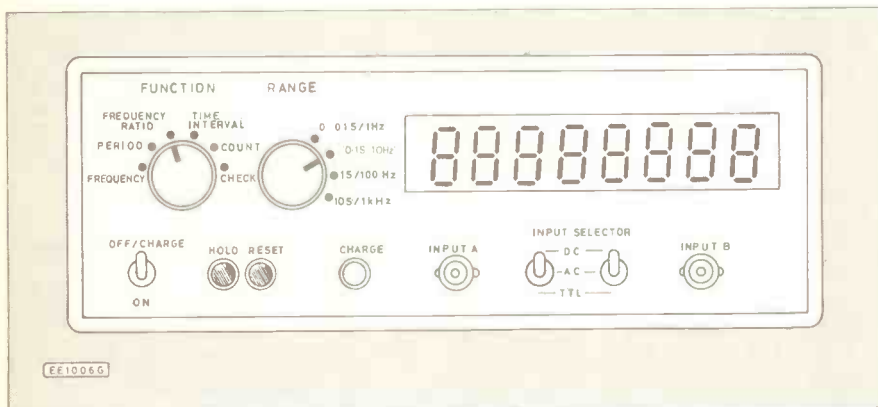
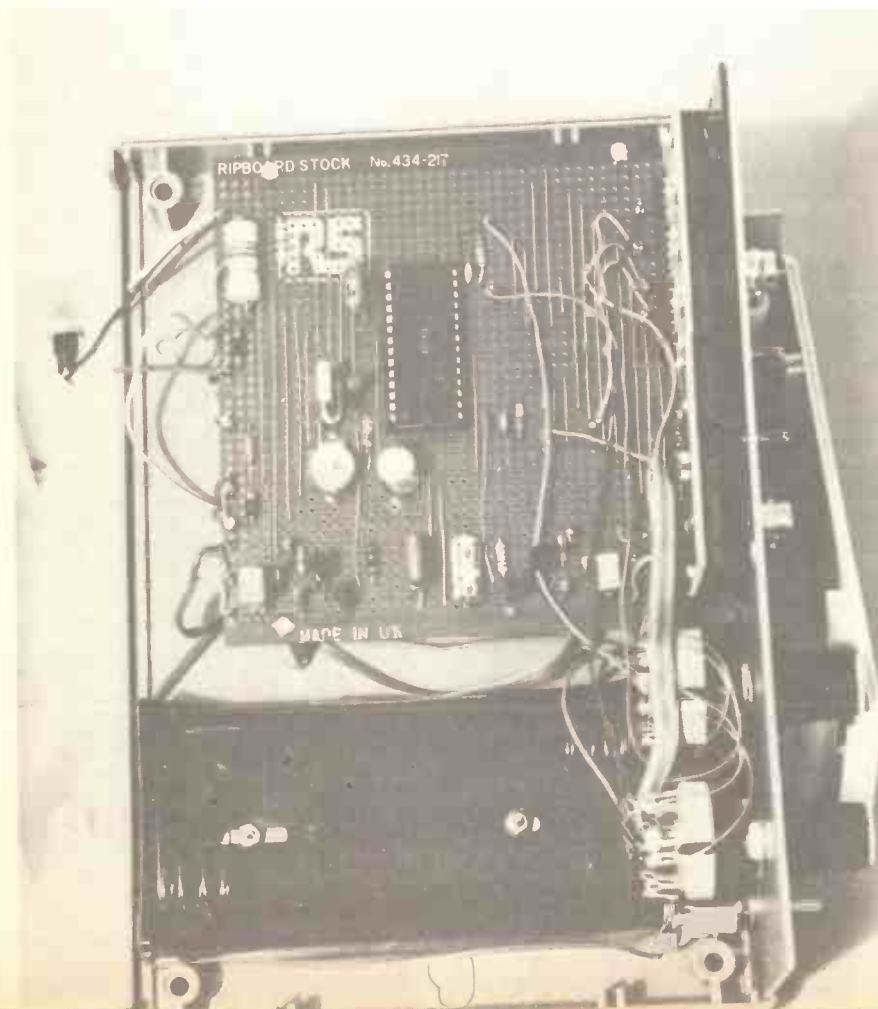

Fig. 5. Layout of controls and labelling on the front panel.



DIGITAL TEST GEAR PROJECTS

- Regulated Bench PSU*.....NOV 1986
- Logic Probe*.....DEC 1986
- Logic Pulser*.....JAN 1987
- Pulse Generator*.....FEB 1987
- Digital IC Tester*.....MAR 1987
- Current Tracer*.....APR 1987
- Audio Logic Tracer*.....MAY 1987
- RS232C Breakout Box*.....JUN 1987
- Digital Counter/
Frequency Meter*.....JUL 1987

Now return to the 0.01s/1Hz range and select each of the functions in turn. Check that the following indications are produced:

| Function | Indication |
|-----------------|------------|
| Frequency | .0 |
| Period | .0 |
| Frequency Ratio | |
| Time Interval | .0 |
| Count | |
| Check | 10000.0 |

If the indications shown above are not obtained, carefully check the wiring associated with switches S5 and S6.

Finally, the Digital Counter/Frequency Meter should be tested using a TTL signal source (e.g. the Pulse Generator described in Part 4—Feb '87). Apply a 500Hz square wave (or pulse waveform having approximately 50 per cent duty cycle) to the input of the Digital Counter/Frequency Meter.

Select Frequency on the function switch S6 and 1s/100Hz on the range switch S5. Check that the display reads approximately ".500" on each setting of Input Selector switch S1, then return S1 to the TTL position. Check that the following indications are produced as the function switch is rotated:

| Function | Indication |
|-----------------|------------|
| Frequency | .500 |
| Period | 2000.000 |
| Frequency Ratio | n/a |
| Time Interval | n/a |
| Count | (see note) |
| Check | 10000.000 |

Note: In this position the display will count (starting from zero on the least significant digit). Check the operation of the Hold and Reset switches (S3 and S4) with the function switch in this position.

This completes the testing of the instrument which is now ready for use. The typical life of a battery is between eight and twelve hours operation and thus the additional expense of Nickel Cadmium cells will soon be recovered! The Digital Counter/Frequency Meter will operate with supply voltages as low as approximately 4.5V. Below this, the display will become noticeably dim and the instrument may produce spurious readings. □

LETTERS

Lets the beginner down very badly

Sir—It was with considerable interest that I read your editorial comment in the May edition of EE on electronics teaching in schools. It comes as no surprise that school subscriptions have dropped over the last few years. The fall in interest is probably due to some of the following factors:

1. The conflict between teachers and their employers.
2. The rapid reduction in the amount of club activity outside school hours—hence the discontinuation of electronics clubs.
3. Shortage of physics teachers—hence those in school are vastly overworked preparing pupils for exams.
4. An increase in the social problems in school.
5. The need for teachers to spend more and more time addressing themselves to dealing with children's social needs rather than extend their intellectual awareness.
6. Children, quite naturally, spend more time than ever before worrying about their social situation and are less willing to indulge in things like electronics. Ten years ago the situation was very different.
7. There has been a steady increase in the number of pupils reading the photo strip magazines that highlight social problems. Technical magazines, including computer magazines, have almost disappeared from school children's private reading.

This may make depressing reading but there are other factors. I have been teaching biology in an Oxfordshire comprehensive school for nearly 20 years and in other schools in the UK and USA before that. I have felt for some time that I should learn some electronics in order to broaden the work we do in school and make it more relevant to the modern world. I have looked in vain for a suitable Teach In.

I started with EE *Teach In* '78. I bought a kit of electronic components and placed a regular order for EE. I followed the course with great interest and success until the January '78 edition. The February edition and subsequent editions were quite beyond me. You can imagine my frustration.

I have continued to buy EE but it certainly lets the beginner down and down very badly but it is the best magazine available. If a cookery or needlework magazine for beginners was as casual about its explanatory notes as the electronic press then there would be a lot of cookery and needlework publishers out of business. I have made a very extensive search of the literature and there is almost nothing for the absolute beginner. The essential features for a beginners series are:

1. The material must be embarrassingly simple (as the first four editions of *Teach In* '78 were).
2. A course must remain very straightforward to the end.
3. The course should build on what has been learned. There should be no great leaps without adequate explanation.
4. The possible applications should be

emphasised far more. This needs a vast expansion.

5. Theory and jargon should be kept to a minimum.
6. Some articles for beginners need to be very long indeed, in order to cover all eventualities.
7. To relieve the strain of following instructions, little stories and fascinating facts should be included as a good teacher would when he/she sees the class dropping off to sleep or walking out of the door.
8. Far more effort needs to be put into finding out the needs of the reader and the problems encountered while learning.
9. What is needed is a "Learn In Series".

I have found teaching myself electronics so difficult that I have written several articles for magazines and submitted some material for a book. A series on electronics for beekeepers is coming out this winter in their national magazine and the physics periodical *VELA News* has printed three articles for beginners. The emphasis in these articles is simplicity and application.

Now for the good news. The demand for EE could increase because:

1. The new GCSE courses emphasise practical work and application.
2. GCSE courses are to be extended from 16+ to 17+ this September.
3. GCSE approach will be extended to "A" level the following year.
4. Schools in Scotland are already following GCSE type courses.

If EE is to appeal to school children then the new style exams should provide a catalyst. Sales in Scotland should have increased recently if it is serving the needs of pupils following a new style electronics course.

If you would like any help in reaching the education market I would be only too willing to discuss the problems and make suggestions. I look forward to hearing from you.

George Bowron
Yarnton, Oxford

I am sure you will find that our later Teach In series have improved on those of nine years ago. Teach In '86 has been highly acclaimed and we intend to reprint it as a book in the near future.

EE is a consumer magazine which must run on a commercial basis. EE is not a school text book, it is designed to appeal to a wide range of readership and we cannot therefore cover the very basic end in great depth. We simply do not have the space for "vast expansion" and articles which are "very long indeed".

We cannot do the teachers' job—we can only assist with the learning process.

Lack of Interest

Sir—I do not wish to renew the subscription to your magazine. This in no way reflects on the quality of your magazine, but is due to lack of interest by pupils.

L. Badger
Hartridge Comprehensive School,
Gwent.

Good basic electronics

Sir—Referring to your Editorial in *Everyday Electronics* May 1987, about the level of electronics teaching in schools, I would like to say that the school I attended and quite a few others in this area teach a fairly good basic electronics course with very limited time and cash resources.

I left school last year (June '86) at the age of 16 and went on to gain a place on the technical apprenticeship scheme as a Trainee Technician Apprentice (TT(A)), at British Telecommunications' Research Laboratories at Martlesham Heath, near Ipswich.

My friends and colleagues at work who saw the Editorial in question, all agree with the fact that their schools did very well with the limited resources.

For example, at my particular school, Copleston High School, Ipswich, the 5th Year Technology class had 20 pupils in it last year and of the 20 projects that were built, seven were electronic and approximately 50 per cent of the remaining projects were electromechanically based. The seven electronic projects included an electronic switch for switching eight computers to one printer, a computer controlled buggy, a complete set of disco lighting equipment for stage or disco use, an intercom from a circuit in an old *Everyday Electronics* and a photographic timer with a light for processing—again part of the circuitry came from EE (the timer was based on the *Games Timer*, January '85). This is just a sample of the projects built in 1986.

Another thing is that everyone who was entered for an examination in Technology passed ("O" level or CSE). At design competitions run by various companies, there were always a lot of electronic projects from schools in the area.

My school won a design competition run by Ransomes, with my project of disco lighting equipment. Another school, in Bury St. Edmunds—King Edwards Upper School—won a regional final in the B.P. Buildarobot competition.

I am not saying that we were taught everything about electronics at my school, but we were taught the basics, which then gave us a good base to work from. If when we were building our projects we needed more information, a large range of data sheets and catalogues with i.c. pinouts were available for use.

So if your project was computer based it was left up to you to read the books and data sheets you needed. This system worked extremely well because everyone got a good understanding of what they were doing and this helped them in their write-up which everyone had to do for the exam. The teachers were also available as a data source.

The school also has a very large collection of *Everyday Electronics* which helped everyone a great deal. The school still gets EE every month from the local newsagent and the new copy is displayed in the school library for a month, then it is placed in the collection for reference purposes. On top of all this, the school has a past pupil who has been coming back to the school on a Wednesday evening for the past 16 years? He now works for the Eastern Electricity Board in the communications department and he is always willing to help pupils by giving them extra data and different approaches to their project.

The two teachers involved, Mr. Chenery and Mr. Parr run a club type of organisation on Wednesday evenings when pupils can go in and use school equipment. Mr. Parr also makes his room available to 5th year pupils every lunchtime and Mr. Chenery will come in for a couple of days a week during school holidays to help so a pupil can spend a whole day doing his project.

The Technology course at Copleston

must work because of 40 taken on as (TT(A)s at British Telecom's Research Labs. At Martlesham in September 1986, six were from Copleston and four of these had followed the Technology course.

If it was not being recommended to buy *Everyday Electronics* by Mr. Chenery in the 3rd Year, I probably would not be writing this letter. I have been devouring (!) every copy of EE since February '84.

As a totally unrelated comment to your Editorial, I would like to say that EE is great as it is very well presented and has a wide variety of projects.

Anthony Willmott
Ipswich

Further education

Sir—I am writing in response to your Editorial featured in the May issue of *Everyday Electronics*. I agree that the study of electronics in schools and further education colleges should be more widely available. At 16 I will always remember the first small amplifier I built—this initiated my interest in electronics. I did not take up electronics again for several years until I attended evening classes last year. Since then, I continue to keep up my interest and it is now more important, I feel, as I am a student teacher, involved in further education.

Unfortunately in further education, electronics is only a small part of the CPVE. (Certificate in Pre-Vocational Education) course offered to 16-year-olds. Also, it is a component of BITEC and other courses. In further education one needs to be flexible, as colleges are undergoing constant change. In doing so, students on CPVE for example are given a few hours of teaching on electronics and that is all. Therefore they are not able to undertake specific detailed study of the subject. Thus, they do not learn enough to build their knowledge upon.

The course is non-examinational and students are given numerous "taster" assignments to complete, one of which is a basic aspect of electronics. I shall be seeking a teaching appointment in the future and hope I may teach electronics in further education. I would also very much like to see 16-year-olds study for a one-year GCSE course in electronics. This qualification is specific and would provide a very real opportunity for training, or employment in the electronics field. However, with the real presence of CPVE, many students are steered away from learning real skills. However, these are only my views and I agree with your Editorial.

P. C. Joseph B.A. (Hons.)
London

Those who "give up"

Sir—I noted with interest your earlier editorial regarding the importance of further encouraging the interests and activities of children in electronics. I too see the value of this subject both in the educational development of children and to the larger society and therefore I was determined to advance my own understanding of the subject with a view to helping youngsters in my own school.

However, it soon became clear that there are some obstacles to the growth of interest in electronics. In the March editorial you make the point that "it is sad but

true that some readers give up electronics because their first project fails to operate." I am sure this is true but from the range of possible reasons for this sad rejection of the subject I would single out one obstacle which I believe looms large to many potential hobbyists or students. This obstacle is the difficulty of the subject as perceived by the reader who tries to assimilate the contents of certain electronics books and magazine articles.

Many technical writers do not appear to have identified the important skills involved in good communication and teaching. Thus they do not first ensure that the reader has a proper grasp of those concepts which are fundamental to the developmental part of the article. Any builder will first make sure of the foundations upon which he proposes to lay bricks. Some writers handle the subject-content in an inappropriate way. Additionally the style of language they choose may also be inappropriate. Some writers use unnecessarily long and complex sentences. They use negative sentences instead of positive ones. They use the passive tense when they could use the active tense and they use too many qualifications and conjunctions. In short the technical author needs to ensure that he or she possesses some expertise in basic teaching and communication skills.

The problem of poor communication is not confined to electronics publications. One has only to look at the jargon-ridden field of computing to appreciate the point. Clearly a proportion of magazine articles will cater for the more advanced student or constructor. The author of such an article will rightly assume a knowledge of certain concepts and terminology on the part of his readers. However, the author still needs to take care in the exercise of good communication skills, irrespective of the academic level of his article. This care is necessary as a courtesy to the reader so to facilitate his understanding. It also serves to encourage and help a wider range of readers some of whom might otherwise have "given up."

M. H. Winfield
Winsor
Southampton

Excellently written

Sir—I am writing to ask you whether or not you have any plans to publish separately the series of articles currently being published in *Everyday Electronics* entitled *Digital Trouble Shooting*.

Having missed the first six articles, I fear I may have missed what appears to be a very informative series of articles that would prove very useful to students studying the new GCSE exam C.D.T. Technology and in particular the modules of Digital Microelectronics.

Electronics is an integral part of the C.D.T. Foundation course which all pupils, boys and girls, must study during their first three years at school and continue to study in either C.D.T. Technology GCSE courses or else in GCSE courses in Science.

It is only recently that I have come across your magazine on the bookshelves, but I would like to take this opportunity of saying that I think it is excellently written and most informative. I wonder if there is any possibility of having out of date copies of your magazine donated to the school library on a regular basis, in order to build

up a Resource Centre for students studying Technology and Electronics Courses.

S. Turner
Technology Coordinator
Litcham High School
King's Lynn

We hope that the Digital Trouble Shooting series will be published as a book this winter. Sorry we cannot donate issues but back numbers are available—see the Editorial page for details.

Free components

Sir—Over the summer and autumn period we are placing free component offers with a number of magazines (see below—Ed.). We hope this will help readers, enthusiasts and project constructors.

Having recently toured this country visiting and talking with electronic and hobby enthusiasts from Speke, Durham, Lincoln, Birmingham etc.. I have not found the promised land of milk and honey. In fact quite the reverse, with less children interested in an electronics career and talent scouts with cheque books from the States awaiting the graduates from our colleges and universities.

FREE READERS OFFER
50 FREE ASSORTED CAPACITORS . . . individually packed Polystyrenes, Ceramics, Polyesters and data . . .
SIMPLY POST THIS ADVERT + 50p coin (p&p)
To KIA-8 Cunliffe Road, Ilkley, LS29 9EA.
No photocopies accepted—one per household.

Keith Lawrence
K.I.A.

Club News

The national Amateur Radio and Computer club, AMRAC, has just revised its membership subscriptions. The club produces its own 40-page newsletter entitled "AMRAC User".

The AMRAC is keen to encourage the formation of local groups, which hold regular meetings and promote digital communications at a "grassroots" level. Such groups have already been established in Hampshire, the Thames Valley and Essex.

The new subscriptions will be £8 UK; £10 Europe, and the rest of the World £12. Further details on the club may be obtained by sending a self addressed envelope to the Secretary: Mr. P. Bridges G6DLJ, AMARAC, PO Box 39, Hythe, Hants. SO4 6WY, or on Prestel mailbox 703847754.

Phil Bridges, G6DLJ
Hythe, Hants.

Commodores?

Sir—I have been buying the magazine since the beginning of 1983 and am well pleased at the range of projects that you have published. My only (!) grumble: Why do BBC and Spectrum owners get their own pages? I own a Commodore 128 and wish that there would be an "Open Dore" page(s). Are there any specific reasons why this is not done? Commodore machines are surely just as well sold as (if not more than) other machines. I know Commodore circuits are "vaguely" supplemented in such circuits as *Power Lighting Interface*—January '85.

I don't think I'd be alone in this view. Great mag.

S. Hudman
Swindon
Any other Commodore owners out there?



CABLE & SATELLITE '87

We take a brief look at a new exhibition highlighting all the latest trends and developments in cable and satellite TV held in London recently.

OVER 29 million households in Europe, about 7 per cent of the total population, are already linked to either cable or TV master antenna systems, creating a market worth a projected \$3 billion by 1990. In the US, more than 1,000 hotels already have a satellite dish installation providing residents with a choice of service.

There is often confusion as to what precisely "satellite television" means. The press has been filled with stories concerning cable TV, DBS and a variety of variations.

Essentially, satellite TV covers all these areas, with a satellite functioning as a transmitter mast occupying the "high ground" of a geostationary earth orbit. By orbiting at the same speed as the Earth's rotational velocity, the satellite appears to hover over the same spot on the Earth's surface and this enables the antenna to be firmly locked in position. All those areas within the "footprint" or reception area should then be able to receive good quality sound and vision.

Exhibition

Exhibitors ranged from satellite consortiums to programme providers, and many equipment manufacturers launched new products at the show. With a complete receiving system for under £1,000 now a reality, but not yet a fact, it was possible to compare the different types on show.

On view for the first time, outside the current trials in Clyde, Scotland, was the interactive Consumer Channel, which allows viewers to dial up and request videos or "infomercials" (longer, informative advertisement).

A special feature at the show included a simulated "cable home" of the future, demonstrating how cable and satellite will revolutionise information technology (IT), home entertainments, services and advertising.

Representatives from WH Smith's Satellite Programmers Clearing House were on hand to explain licensing and encryption (coded signals to stop unlicensed viewing) to the public. Also, they gave details of their Screen Sport, Lifestyle and The Arts channels.

For world news, visitors to the CNN stand were able to see their 24-hour news channel relayed live from Atlanta, Georgia, via *Intelsat 5*, CNN broadcasts weather, sport, business and financial news, interspersed with stop press world events, to over 50 countries around the world and over 36 million cable households in the USA alone.

Canadian owned, BEL-tronics UK were showing prototypes of several new products, including a "little Bel" system (which use a 90cm dish) expected to retail for about £600, making a complete customer satellite receive only system, TVRO for short, cost only £800, according to a BEL representative.

British Telecom International announced

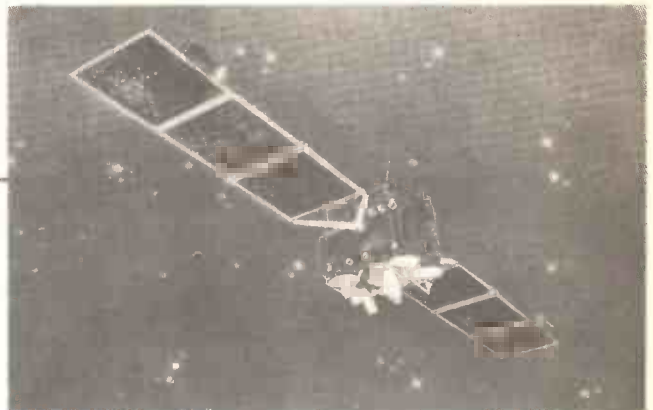

EUTELSAT I-F2 satellite

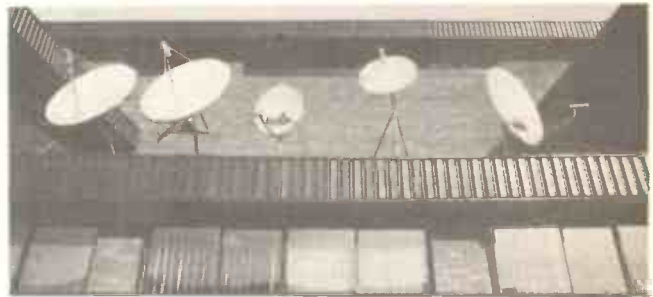

The range of Handic (High Wycombe) dishes right includes a "DIY" version.

that it will be leasing 11 transponders on the first private enterprise European commercial satellite, *ASTRA*, as well as eight on the *Eutelsat* series 2 satellite. That could mean eight English language channels available to viewers of satellite TV via *ASTRA* alone, by the end of 1988.

BTI's investment in the industry's future could be of major significance. Marcus Bicknell, commercial director, and Pierre Meyrat managing director of *ASTRA*, the Luxembourg consortium, discussed the implications with conference delegates.

What's On

INTELSAT V

- **Premiere**—9 hours of recent box office movies every day.
- **The Children's Channel**—exclusively for young children and teenagers, 8 hours every day.
- **Screen Sport**—sports and leisure programming, 6 hours.
- **Cable News Network**—24 hour US and international news coverage.
- **Lifestyle**—4 hours daytime viewing aimed at female market.

EUTELSAT F1

- **Music Box**—from the UK, 18 hours a day of rock videos, chat shows and concerts.
- **Sky Channel**—General entertainment (coded), 18 hours.
- **Teleclub**—German movie channel, 8 hours.
- **Filmnet**—Dutch movie channel—English spoken, 24 hours.
- **Worldnet**—Daily news and current affairs from the USA, 2 hours.

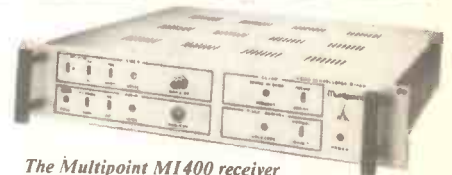

The Multipoint MI400 receiver is claimed to be the world's most powerful.

The flat antenna developed by Matsushita and the COM-SAT Corporation, USA.



Conference

At the conference sessions, topics ranging from satellite launch schedules to the supply and cost of Europe's new TV programmes were discussed. Delegates were able to hear of the plans for Germany's TV Sat and France's TDF, the first European DBS services, as well as that of newly-licensed BSB (British Satellite Broadcasting), Britains' privately funded DBS service.

On the technical side, speakers were able to discuss and formulate decisions on satellite transmission standards and encryption, and the realities of the UK's home satellite system. Also the availability and launch schedule for Europe's satellites were outlined by leading executives from *Intelsat*, *Eutelsat*, *Telecom* in France and *Arianespace*, whose launch programme is critical to the growth of satellite TV in Europe.

SPECIAL OFFER...



ELECTRONIC GUARD DOG KIT

£22.95

including VAT and postage

If the best deterrents to a would be burglar are good locks on windows and doors, the next best is without doubt a dog running around the premises. Dogs, however, have to be fed, walked and generally looked after and many people do not own a dog for these reasons.

With the holiday season in mind, when many homes are vacant, TK Electronics have produced an Electronic Dog Kit whose bark is definitely worse than its bite! It may be connected to a doorbell, pressure mat or any other intruder detector and will produce a random series of threatening barks making the would be intruder think again and try his luck elsewhere.

The kit is supplied with a high quality printed circuit board, all components, including a mains transformer and full instructions. A horn speaker is also supplied which is essential to produce the loud sound required. The "dog" can be adjusted to provide barks ranging from a "Terrier" to an "Alsatian", and contains special circuitry to produce a random series of barks giving a more realistic effect. While it will not bring you your paper and slippers in the evening, our "dog" will give you peace of mind. It is guaranteed not to require "walkies" and will not chew the carpet.

This wonderful kit creature is available to all *EE* readers at a special *EE* offer price.

All orders, together with the special offer coupon, should be sent to: *EE* Dog Offer, TK Electronics, 13 Boston Road, London W7 3SJ. Tel: 01-567 8910. Overseas readers (outside Europe) please add £3.50 postage

| Please supply | | Value |
|---|-----------------------------------|---------|
| Quantity | Electronic Guard Dog Kit @ £22.95 | |
| Overseas readers add £3.50 postage | | Total £ |
| Visa/Access or Cheque No..... | | |
| Signature..... | | |
| Name..... | | |
| Address..... | | |
| | | |
| | | |
| OFFER CLOSSES Friday, August 21, 1987 | | |
| Name..... | | |
| Address..... | | |
| | | |
| | | |
| Post to: <i>EE</i> Dog Offer TK Electronics, 13 Boston Road, London W7 3SJ | | |

MONOMIX

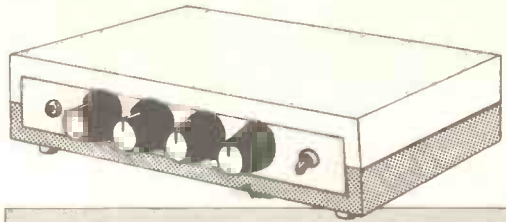

R. A. PENFOLD

A straightforward mono mixer designed primarily with the video enthusiast in mind

MIXER designs for the home constructor are not exactly a rarity, but they are no less useful because of this. In fact, they rank amongst the most utilitarian of projects, and are understandably popular. Many designs are for complex stereo units with a wide range of features, but for many applications these have considerable overkill, and are unnecessarily complicated and expensive.

This mixer design is a simple four channel monophonic type which was designed primarily with the video enthusiast in mind. One input is for a microphone and the other three are line level inputs for sources such as cassette decks, tuners, etc. The unit is intended for use when editing home videos, where a straightforward copy of the video signal is being made, but the audio is being dubbed with a commentary and (or) background music.

The general idea is to have a microphone feeding into the appropriate input so that the commentary can be added, the audio output from the video recorder feeding into one of the line inputs, and the output from (say) a cassette deck feeding into another line input and providing the mood music. This leaves a spare line input which can be used with a second music source, if desired, or rather than adding the commentary live via the microphone, it can be recorded and mixed in via the third line input.

It has to be emphasised that although the unit was designed specifically for use in a video set up, it is a useful general purpose mixer which must have a multitude of possible applications.

MIXER BASICS

The most simple type of mixer is a

Fig. 1. A passive two input mixer.

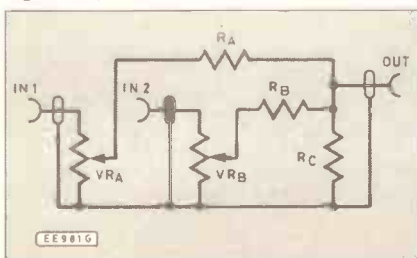

passive circuit, and Fig. 1 shows the circuit diagram for a basic two input mixer of this type. The true mixing part of the circuit is formed by the three fixed resistors, R_A , R_B , and R_C . A voltage applied to the left hand end of R_A causes a current to flow through both R_A and R_C , resulting in a certain portion of the input voltage appearing across R_C . A straightforward potential divider action in other words. The same thing occurs when a voltage is applied to R_B . With signals applied to both resistors, the current through R_C is the sum of the two currents through R_A and R_B , giving the required mixing action.

Only two input resistors are shown in Fig. 1, but more can be added if extra inputs are needed. VR_A and VR_B are volume control style variable attenuators (or "faders" as they are more often called in this application) added at the inputs.

This type of circuit is adequate in some cases, but it has its shortcomings. One of these is simply the loss of signal through the circuit due to the potential divider action across R_C and the input resistors. The losses can be minimised by making the value of R_C high in relation to that of R_A and R_B .

However, this exacerbates a second problem, which is the lack of isolation between the inputs. Any input signal fed into R_A will not just cause a signal to be developed across R_C and fed to the output, but will also produce the same signal across R_B and VR_B . From VR_B it is fed to Input 2.

An allied problem that stems from this is that of adjustment of one fader control affecting the signal level on the other channel. This occurs because VR_A and R_A effectively form a variable resistance in parallel with R_C , as do VR_B and R_B . Adjusting one of the potentiometers, therefore, effectively alters the value of R_C , and the gain from the other input to the output.

For a passive mixer to work well it is important for R_C to have a very low value in relation to R_A and R_B . Ideally, R_C should be

a short circuit so that the two inputs are totally isolated, but this would give no output signal, and in practice R_C is given the lowest practicable value. A low value means high losses through the circuit even with the faders at maximum gain, and normally a circuit of this type has to be followed by an amplifier to compensate for the losses.

SUMMING MIXER

If an active circuit is to be used there is a better way of doing things than simply having a passive mixer followed by an amplifier, and this alternative is to use an operational amplifier in the summing mode mixer configuration. Although this often seems to be regarded as a totally different concept to the passive mixer configuration, it is really very similar in principle. It is based on a standard inverting amplifier circuit (Fig. 2).

Operational amplifiers were originally intended for use in d.c. amplifying applications where they operated from dual balanced supplies, and in the inverting mode the non-inverting (+) input would be biased to the central 0V earth rail. In audio applications it is more usual for operational amplifiers to be powered from a single supply with a potential divider (R_C and R_D) providing a bias voltage of half the supply voltage for the non-inverting input. D.C. blocking capacitors are not included in Fig. 2, but would normally be included at both the input and the output of the circuit.

Operational amplifiers can be a little confusing at first as they have two inputs. What is actually being amplified is the voltage difference between the two inputs, and the output goes positive if the non-inverting (+) input is at the higher voltage, or negative if the inverting (-) input is at the higher potential. The voltage gain is extremely high at typically 100,000 times or more, and only a fraction of a millivolt is needed across the inputs in order to send the output fully positive or negative.

Fig. 2. Basic operational amplifier, inverting mode circuit.

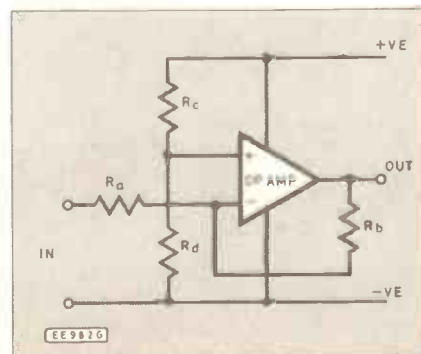
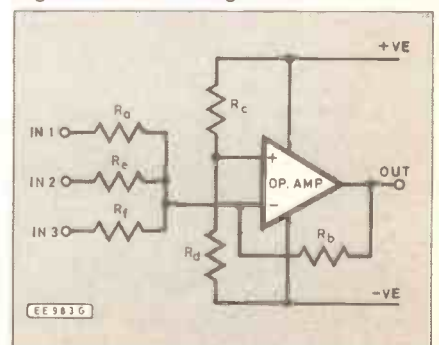

Fig. 3. Basic summing mode mixer circuit.



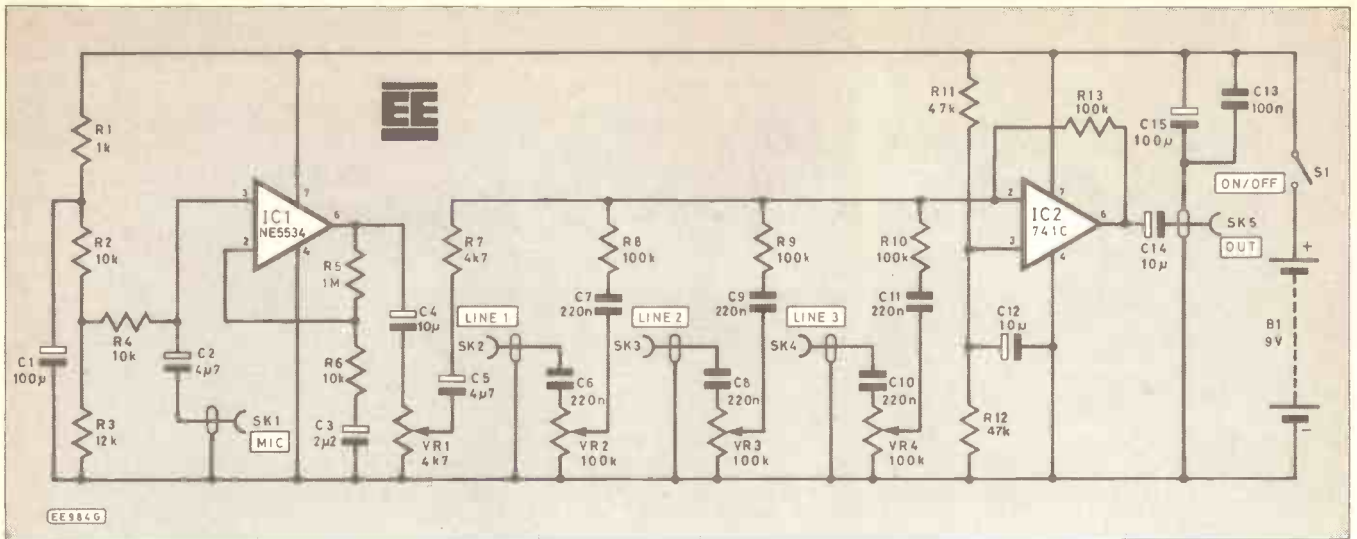

Fig. 4. Circuit diagram of the four channel Monomix.

In this circuit the output assumes the half supply voltage bias level under quiescent conditions due to the negative feedback via R_b . In other words, if the output should go more positive than this for some reason, even very slightly, the coupling through R_b results in the inverting input also going more positive.

Bearing in mind that the non-inverting input is biased to half the supply voltage, this results in a voltage difference across the inputs which sends the output negative to re-establish the balance. If the output should drift negative of the bias level for some reason, this would again produce a voltage difference at the inputs, but of the opposite polarity so that the output is sent positive and the voltage difference is again eliminated.

If an input signal is applied to the amplifier, this upsets the balance of the circuit by altering the voltage at the inverting input. The output voltage will change in an attempt to correct this and rebalance the input potentials.

If we take a simple example, with the input taken one volt positive of the bias level, the output will go one volt negative. A potential divider action across R_a and R_b then sets the inverting input at the half supply voltage bias level, but this assumes that R_a and R_b are equal in value. If R_b is higher in value, then a higher output voltage swing is required in order to balance a given change in input voltage. The voltage gain of the circuit is equal to R_b/R_a , and this is termed the "closed loop" voltage gain, which should not be confused with the very high "open loop" gain of the operational amplifier itself.

The basic summing mode mixer circuit is shown in Fig. 3, and it only differs from the

inverting amplifier mode in that there are additional input resistors (R_e and R_f) which provide the circuit with its extra inputs. In operation it is essentially the same as the inverting amplifier, but the output takes up potentials that balance the sum of the input voltages. Taking a simple example, with input of +1, +3, and -2 volts with reference to the bias level, this would give a total input potential of +2 volts, and the output would be 2 volts negative of the bias level. This again assumes that all the resistors in the feedback circuit are of the same value, which they need not be. By making some input resistors lower in value than others, some inputs can be made more sensitive than others. The fact that the signal is inverted through the circuit is of no consequence as it makes no audible difference to the reproduced audio.

What is called a "virtual earth" is formed at the inverting input. In a d.c. amplifier circuit the inverting input is stabilised at the 0V earth potential by the negative feedback action, and although it is not genuinely connected to earth, the effect is much the same as if it was. In an a.c. circuit the inverting input is stabilised at a fixed potential above the (negative) earth rail, and still forms a virtual earth. In many cases this is all of purely academic importance, but in a mixer circuit it is of crucial importance as the virtual earth provides total isolation between the inputs. It seemingly provides the impossible by feeding the input resistors to a short circuit to earth but still providing an output signal, and an output signal which can be a greatly amplified version of the input signal at that. With the input resistors effectively feeding into a short circuit, the input impedance is equal to the value of the input resistor.

CIRCUIT DESCRIPTION

The full circuit diagram of the Monomix mixer appears in Fig. 4, and this breaks down into two main sections; the microphone preamplifier (IC1) and the mixer (IC2).

Starting with the microphone preamplifier, this has operational amplifier IC1 in a simple non-inverting mode amplifier. R_5 and R_6 form a negative feedback network which sets the voltage gain at about 40dB (100 times) and R_4 sets the input impedance at about 10k. The circuit is primarily intended for use with medium impedance dynamic microphones, or types which have comparable output characteristics (such as electret types with a built-in step-up transformer). The circuit has sufficient gain to operate with low impedance dynamic microphones as well, but it is not suitable for operation with crystal microphones.

Note that IC1 is a high quality low noise device which consequently gives the circuit an excellent signal to noise ratio. Inexpensive alternatives such as the 741C will work in the circuit, but will give something approaching ten times the noise level obtained with the NE5534.

The mixer circuit closely follows the basic circuit described previously, but the number of inputs has been increased to four, d.c. blocking capacitors have been added at the inputs and output, and a fader control has been included at each input. The input resistor for the channel which is fed from the microphone preamplifier is much lower in value than the other input resistors and feedback resistor R_{13} . Whereas there is unity voltage gain from each of the other inputs to the output (with

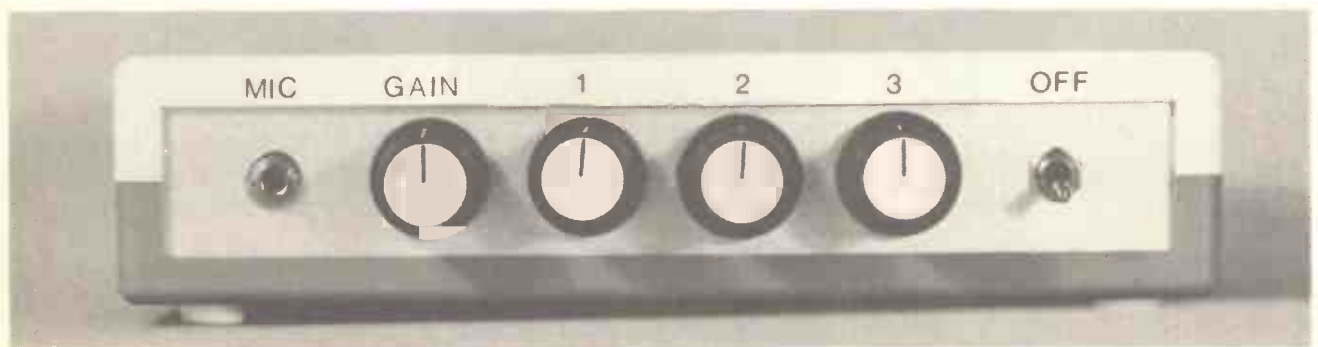

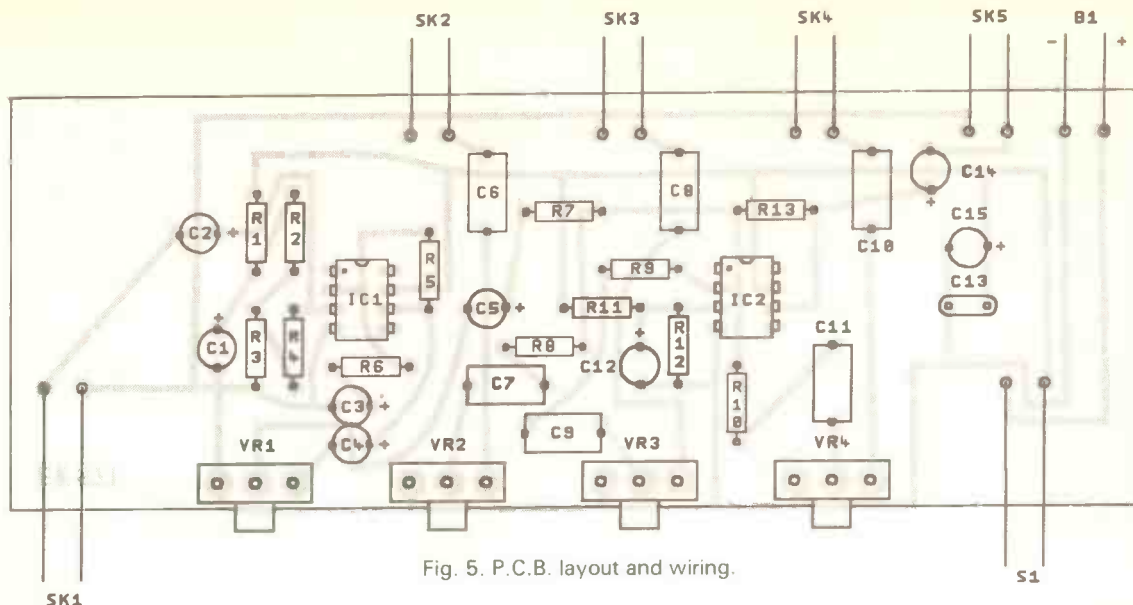
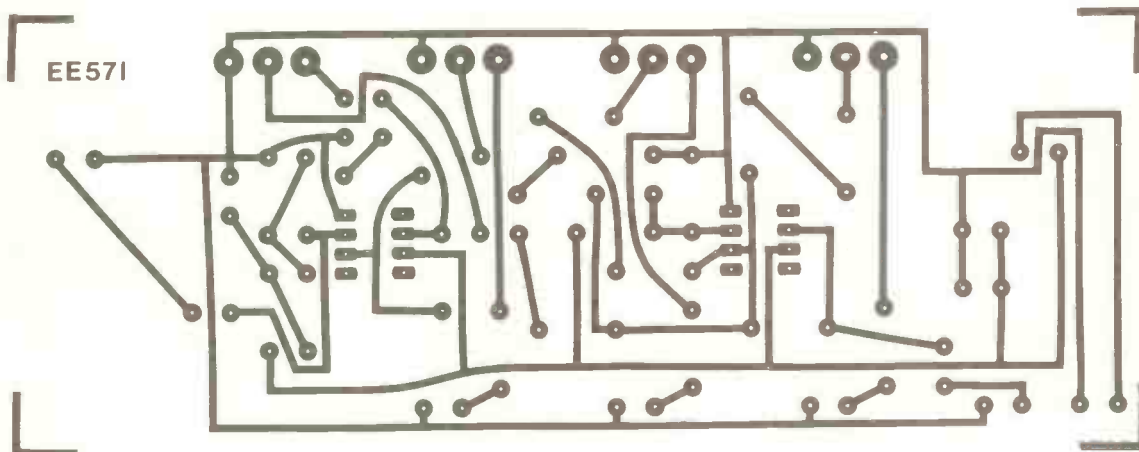

Fig. 5. P.C.B. layout and wiring.



COMPONENTS

See
**Shop
Talk**
page 306

Resistors

- R1 1k
- R2,R4,R6 10k (3 off)
- R3 12k
- R5 1M
- R7 4k7
- R8,R9,R10, 100k (4 off)
- R13
- R11,R12 47k (2 off)

Capacitors

- C1,C15 100µ radial elect. 10V (2 off)
- C2,C5 4µ7 radial elect. 63V (2 off)
- C3 2µ2 radial elect. 63V
- C4,C12, 10µ radial elect. 25V (3 off)
- C14
- C6,C7,C8, 220n miniature
- C9,C10,C11 polyester layer (6 off)
- C13 100n ceramic

Potentiometers

- VR1 4k7 carbon
- VR2-VR4 100k carbon (3 off)

Semiconductors

- IC1 NE5534 ultra low noise op. amp.
- IC2 741C op. amp.

Miscellaneous

- SK1,SK2, 3-5mm jack sockets
- SK3,SK4,SK5 (5 off)
- S1 Miniature s.p.s.t. toggle switch
- B1 9 volt battery (PP3 size)

Printed circuit board, available from the EE PCB Service order code EE571; case, about 180 x 120 x 39mm; battery connector; small control knobs (4 off); 8 pin d.i.l. socket (2 off); wire, solder, etc.

Approx. cost
Guidance only

£14.50

faders at maximum gain), there is over 26dB of gain from this input to the output. This gain is needed to augment that of the preamplifier which on its own would be too low for satisfactory operation with most microphones, especially low impedance types.

The circuit is powered from a small nine volt battery, and as the current consumption is only about 4.5 milliamps this is an economic way of powering the unit.

CONSTRUCTION

Construction is greatly simplified by having practically all the components, including the four potentiometers, mounted on-board. Details of the printed circuit board are shown in Fig. 5.

Neither of the integrated circuits are static-sensitive types, but the NE5534 is not a particularly cheap device and it would definitely be advisable to use a socket for this one. The capacitors must be miniature printed circuit mounting types if they are to fit into the available space, and obviously the potentiometers must also be of the printed circuit variety if they are to be mounted direct on the board. Make sure that they are fully pushed down onto the board before connecting them, and use plenty of solder. The four potentiometers provide the only form of mounting for the board which they effectively bolt to the front panel via their mounting bushes. The mounting holes in the front panel must be accurately drilled at the correct pitch.

Exploring electronics

OWEN BISHOP

This series is designed to explain the workings of electronic components and circuits by involving the reader in experimenting with them. There will not be masses of theory or formulae but straightforward explanations and circuits to build and experiment with.

Part 13 Two operational amplifier projects

FOLLOWING on from last month's project, we continue this month with two simple projects that help to demonstrate the versatility of the operational amplifier. The op-amp, as it is often called for short, has many transistors and resistors inside, connected as an amplifier that has very high gain.

TELEPHONE ALARM

Our first project is a simple Telephone Alarm and the complete circuit diagram is shown in Fig. 13.1. This alarm "listens" for the telephone bell and sounds an alarm in another room or in the garden when it rings. It also has applications as a baby alarm.

The action is very similar to that of the Touch Switch described last month except that the source of current is a crystal microphone MIC 1.

CONSTRUCTION

The demonstration breadboard component layout for the Telephone Alarm is shown in Fig. 13.2. Commence construction by positioning the i.c. and carefully inserting all the link wires. This should be followed by the rest of the components and the lead-off wires to the microphone, buzzer and switch S1.

The power supply to the 741 i.c. requires a voltage greater than zero at pin 7, and a voltage less than zero at pin 4. By splitting the battery supply into two sections as shown in Fig. 13.3, we can arrange for +3V and -3V supplies. This is the minimum voltage at which the i.c. will work.

The recommended voltage is 5V to 8V and the i.c. will give its best performance within that range. However, 3V is easier to obtain as only a standard battery-holder and four 1.5V cells are required.

There is no need for an expensive microphone. The cheapest possible

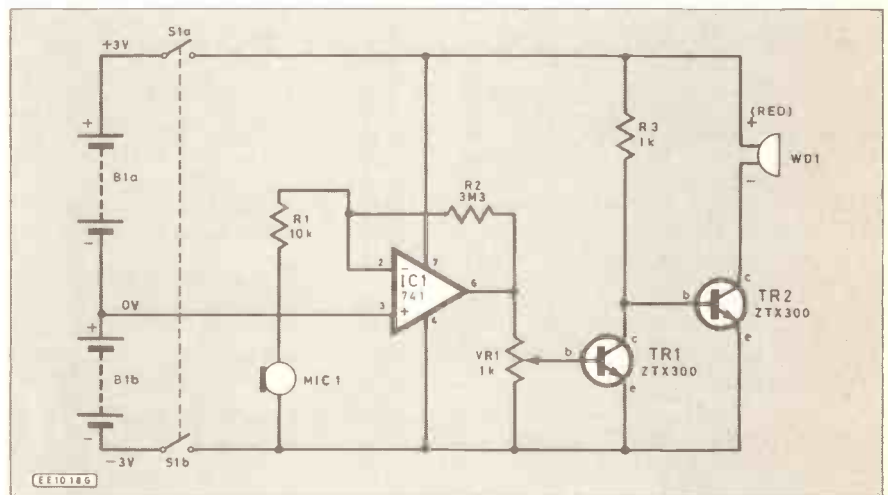

Fig. 13.1. The complete circuit diagram for the simple Telephone Alarm.

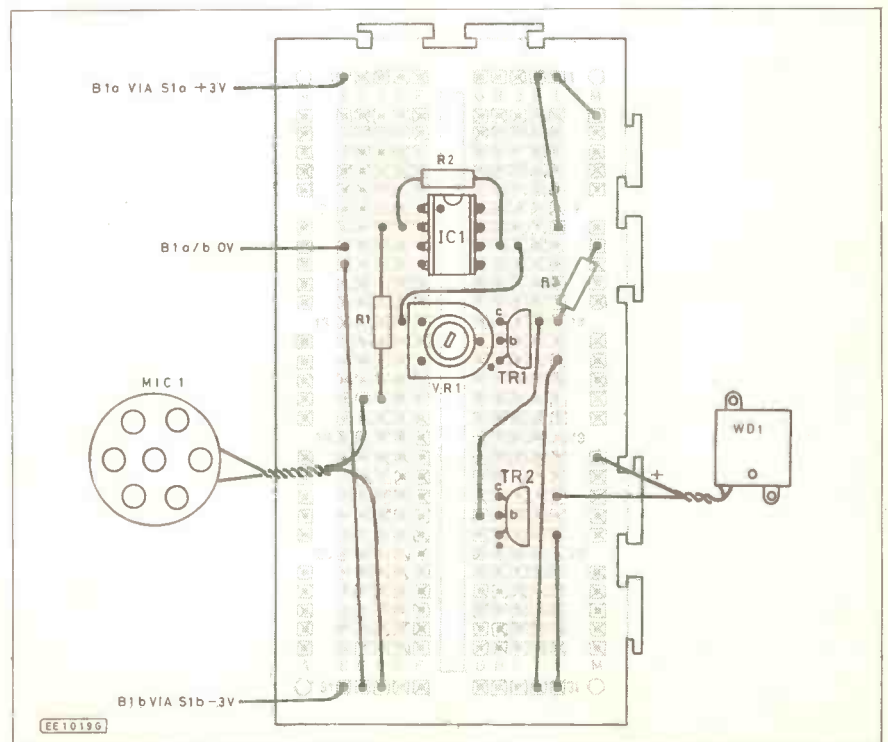
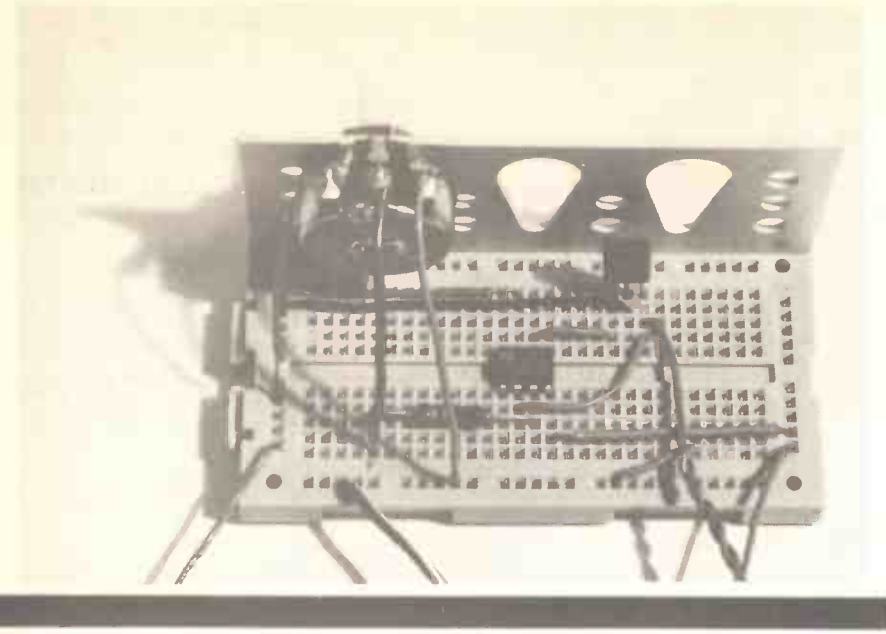

Fig. 13.2. Demonstration breadboard component layout for Telephone Alarm.



"microphone insert" will do. Place it close to the telephone.

The variable preset potentiometer VR1 is adjusted so that the alarm sounds when the telephone rings, but not when other noises are made in the room. The buzzer is connected to a long pair of wires leading to the room where the telephone bell cannot be heard.

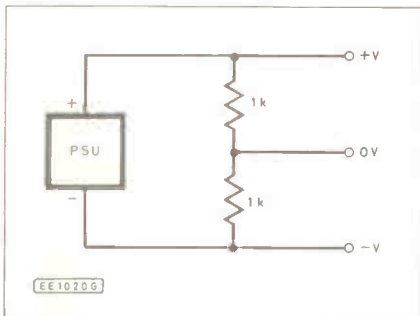
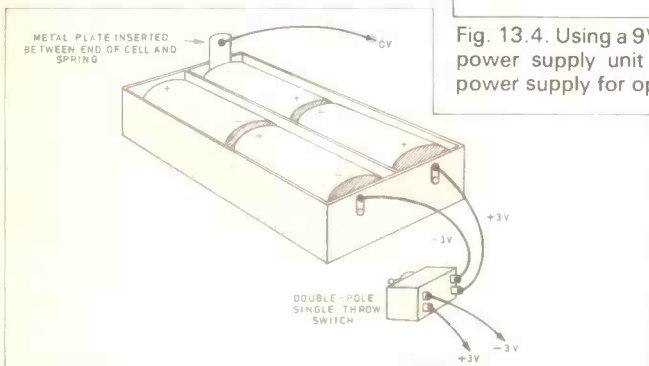

Fig. 13.4. Using a 9V or 12V d.c. mains power supply unit to provide a split power supply for op-amp circuits.

Fig. 13.3. Suggested method of producing a split power supply using a battery holder.

MODEL SPEED CONTROL

Last month's Touch Switch project described how you could control a low-voltage d.c. motor, but this was limited to simply turning the motor on or off. With this project you can control the speed of the motor.

The circuit diagram for the Model Speed Control is shown in Fig. 13.5.

This circuit gives very realistic effects when used with models, for it holds the motor at constant speed, even though the load on it varies, and even when the motor is set to turn slowly.

HOW IT WORKS

When a motor is running, it generates a voltage (called a *back e.m.f.*) that

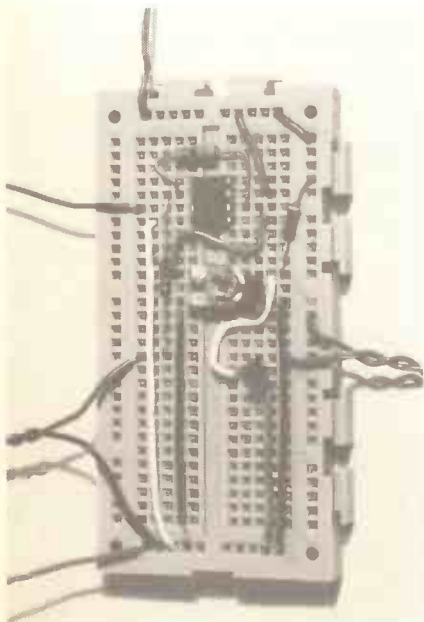

TELEPHONE ALARM

Resistors

- R1 10k
- R2 3M3
- R3 1k
- All 0.25W
- 5% carbon

See
**Shop
Talk**

page 363

Potentiometer

- VR1 1k miniature horizontal preset

Semiconductor

- TR1, TR2 ZTX 300 *npn* transistor
- IC1 741 operational amplifier

Miscellaneous

- S1 DPST toggle switch
 - MIC1 Crystal microphone insert
 - WD1 Solid state audible warning device
- Split power supply, four 1.5V cells and battery holder (see Fig. 13.3); breadboard; 8-pin d.i.l. socket; connecting wire.

MOTOR SPEED CONTROL

Resistors

- R1 10k 0.25W, 5% carbon

Potentiometer

- VR1 1k horizontal miniature preset or rotary spindle type

Semiconductors

- TR1 BD131 medium power *npn* transistor
- IC1 741 operational amplifier

Miscellaneous

- S1 DPST toggle switch
 - B 1a,b Four 1.5V cells and battery holder or mains PSU unit (see Fig. 13.4)
- Breadboard; 8-pin d.i.l. socket; connecting wire.

is opposite in direction to the voltage (*driving e.m.f.*) applied from the battery. The back e.m.f. is proportional to the speed. It is greater if the motor is going at maximum speed, and is zero when the motor is still.

When the motor is running, the back e.m.f. partly cancels out the driving e.m.f., so that the current that flows to the motor is just enough to keep it turning at that speed. If we suddenly apply a mechanical load to the motor, the motor turns more slowly. This means that the back e.m.f. is reduced, so that more current flows through the

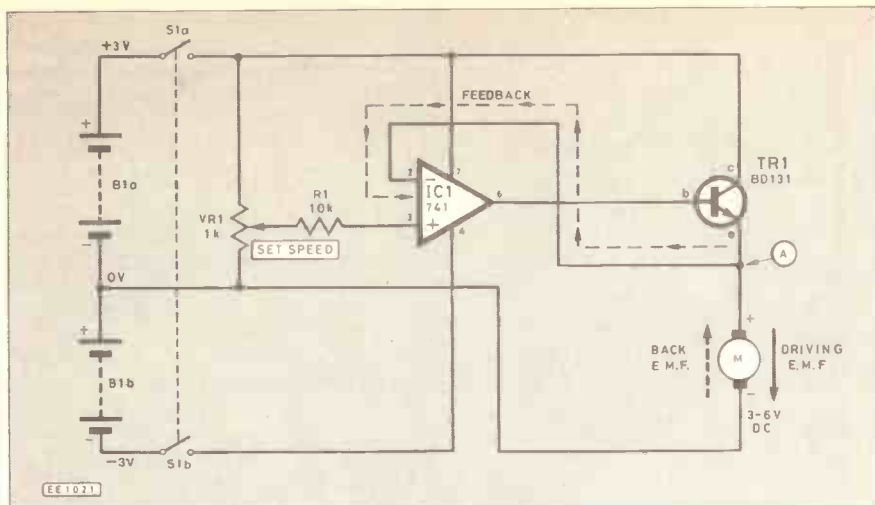

Fig. 13.5. Complete circuit diagram for a d.c. Motor Speed Control.

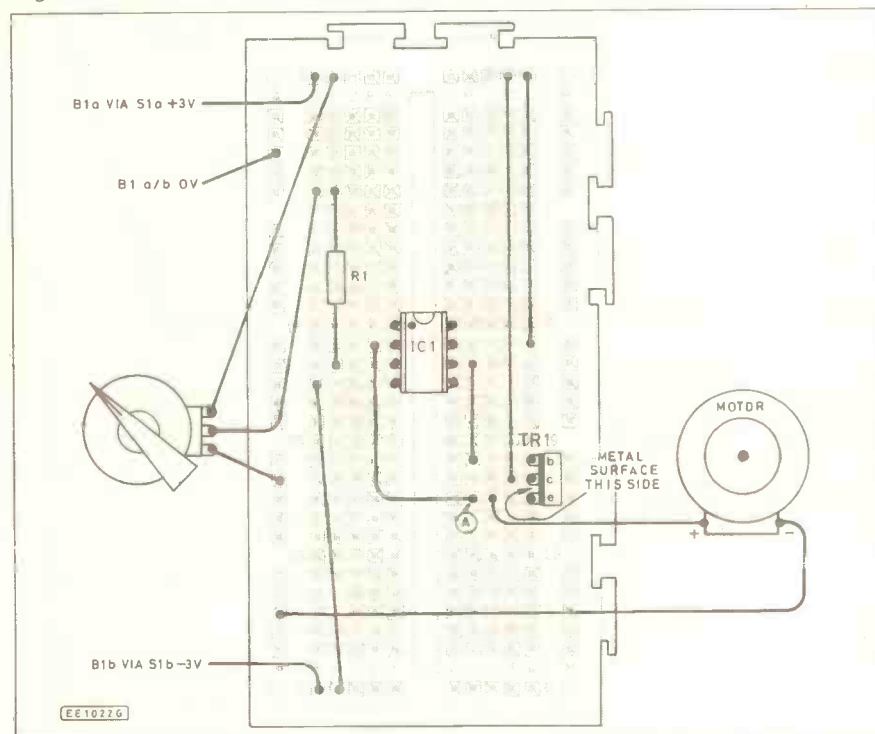

Fig. 13.6. Demonstration "test bed" for the D.C. Motor Speed Control.

motor. If the load is enough to stop the motor turning, there is no back e.m.f. and the full driving e.m.f. causes a large current to flow through the motor.

Motors are generally designed to take the small currents that flow when they are running, but *not* the large currents that can flow when they are jammed. The coils of the motor may burn out if it is prevented from turning. To obtain steady speed and to avoid the danger of burning out, we need to be able to sense the e.m.f. that is actually supplied to the motor terminals (driving e.m.f. *minus* back e.m.f.) at any given speed and how it changes under changing load. We also need to be able to increase or decrease the driving e.m.f. so as to keep a steady current flowing to the motor. This is where an op amp can be of great help.

The speed of the motor is set by the voltage we apply to the non-inverting input pin 3 ("+") of the amplifier. By altering VR1 we can apply any voltage between 0V and +3V.

When a voltage of 1V, for example, is applied, the amplifier output goes high, sending base current to transistor TR1. This turns TR1 on and current flows through the motor. As this happens the voltage at A rises. As it rises, the voltage at the inverting output of the op-amp pin 2 ("-") rises too, for this is also connected to point A. The voltage *difference* between the two op-amp inputs is thus reducing the current to the motor slightly.

Now suppose an extra load is applied to the motor. The motor turns more slowly, this reduces the back e.m.f. and makes the voltage at A rise suddenly. But at the instant that this happens, the op-amp senses the change. As explained above the difference between the voltage at its inputs becomes less than before, so its output current falls.

The transistor TR1 is turned off just enough to keep the voltage at A from rising above the original value. If the load is removed from the motor, it is

able to turn more quickly. Back e.m.f. increases.

The fall in voltage at A increases the difference between the input voltages, output current increases and TR1 is turned on a little. Once again, the op-amp acts to keep the voltage at A constant. In short, a rise in voltage at A reduces the current, making the voltage at A fall again. Conversely, a fall in voltage at A increases the current, making the voltage at A rise again. Thus, the action of the circuit is to maintain a constant voltage at A, its level depending on the setting of VR1. The motor turns at constant speed. If we vary the setting of VR1, the circuit always comes to a stable state with the motor running at a steady speed.

CONSTRUCTION

The demonstration breadboard component layout for the Motor Speed Control is shown in Fig. 13.6. Commence construction by inserting the i.c., resistor and transistor on the "test bed". This should be followed by the link wires and lead-off wires to the motor, speed control potentiometer and the power supply via switch S1.

This circuit is designed for small motors that run on 3 to 6 volts supply. If you want to use it with motors that need higher voltage, you may increase the voltage of the supply to the op-amp. Remember to increase *both* halves of the supply by equal amounts. The maximum voltage allowed is +18V and -18V.

The transistor can take a current up to 3A, which is just enough for most small motors. If you find the transistor gets hot, bolt a heatsink to it. You can buy a heatsink, but it is easy to make one from a small piece of aluminium sheet.

If you need to run a motor that takes heavy current use a 2N3055 transistor, which can take up to 15A.

Note that only direct-current motors can be controlled by this circuit.

FEEDBACK

The subject of feedback has been mentioned earlier in this series. The motor control circuit provides another good example of this technique.

The *output* of the circuit can be considered to be the current arriving at point A. Most of this proceeds to the motor, but a minute proportion of it is fed back to the inverting input (pin 2) of the op amp. As explained earlier, the effect of feedback in this circuit is to counteract any changes in output such as are caused by variations of back e.m.f.

Since the feedback acts to *counteract* changes in output we call it *negative feedback*. In general, negative feedback is used to produce stability in the operating condition of a circuit.

Next month: Audio Amplifier using an Op-Amp.

AUGUST FEATURES...

DIGITAL CHIP TESTER

Many digital integrated circuits are essentially gates of some sort, and as such are suitable for computer analysis in conjunction with a simple interface unit. Once the basic pin function data has been entered a computer can then be used as a chip tester, and as an educational logic analyser.

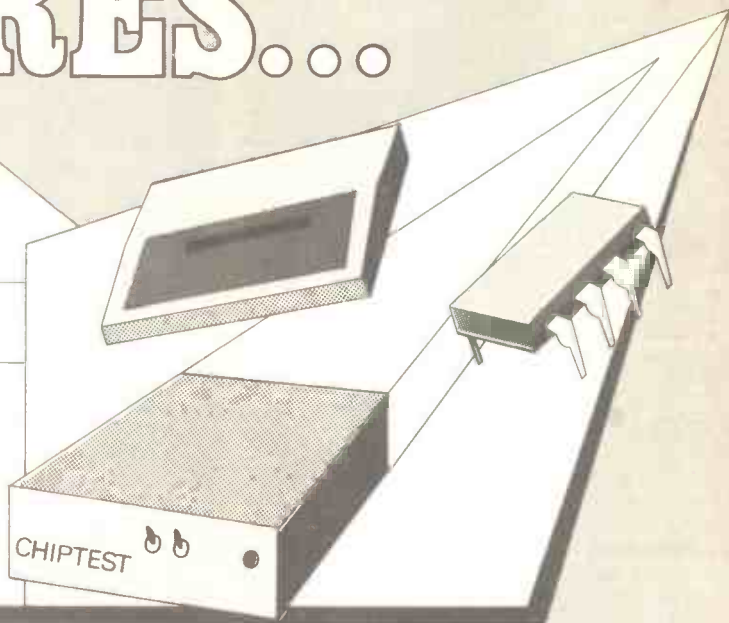

POWER GENERATION

We all tend to use electricity without thinking of just how it is generated or how it gets to our homes etc. This article looks at the sources of our power and how it is distributed throughout the UK. The next time you flick a switch you might reflect on the multi-million pound industry that makes the light light! If you have never seen the inside of a power station the photographs in this article will impress you.

IMMERSION HEATER TIMER

Any way of saving household energy is welcome. One item for consideration is the immersion water heater—if used indiscriminately the cost can be excessive. This project is an electronic timer designed to control the immersion heater.

Super Sound Adaptor

A considerable improvement in television sound quality can often be achieved simply by tapping off the audio signal from a "Tape" or "Earphone" output and feeding it through an audio system. Even quite a modest audio system can provide a surprising improvement in quality. This unit provides a good pseudo-stereo effect through bookshelf speakers or an existing audio system.



EVERYDAY ELECTRONICS

AUGUST ISSUE ON SALE FRIDAY, JULY 17

Actually Doing it!!

THE USE of ready-made printed circuit boards undoubtedly makes electronic project construction far easier than it used to be, which is probably just as well since the average complexity of projects is probably far higher now than say twenty years ago. With the aid of a ready-made printed circuit board it is possible for beginners at electronics to build quite complex projects with a reasonable chance of success, although I would strongly recommend building at least a couple of simple projects before trying anything more adventurous. Even using a printed circuit board it is still necessary to achieve a reasonable standard of construction if the finished unit is to work properly, and to continue doing so well into the future.

In this month's *Actually Doing It* we will consider the basics of project building using printed circuit boards, including the potentially disastrous business of mounting power semiconductors.

INITIAL STAGES

It does not usually matter too much which order the components are fitted onto the printed circuit board, but logically the hardier components should be fitted first, working through to the more delicate ones which are fitted last. This reduces the risk of damaging a component already fitted to the board while adding a new component. It is also a good idea to leave any large or heavy components until the end, as these can make the board rather unwieldy and seriously slow down the assembly process. In practice this generally means fitting the link wires and pins first, then passive components such as resistors, capacitors, and inductors, then the semiconductors such as integrated circuits and transistors, and finally adding any large components such as transformers. These days most constructors use sockets for integrated circuits, and in this case the sockets should be mounted quite early in the proceedings with the devices themselves not being fitted into place until all the other components have been soldered to the board.

Some boards are of double-sided or pseudo double-sided construction. With a single-sided board the copper tracks are on one side of the board with the components fitted on the other. This is very restrictive in that it is not possible for copper tracks to cross over one another without connecting to each other. A double-sided board overcomes this problem by having copper tracks on the component side of the board as well, and taking connections through the board from one side to the other. This enables tracks to be taken from one side of the board to the other, crossing many other tracks on the way, but being woven through the board and around these tracks so as to avoid any short circuits to them.

From the constructional point of view a through-plated double-sided board is the easiest to deal with, as this is supplied with the connections through the board already

produced as part of the manufactured process. It simply requires the components to be soldered in place, and is really no different to building a single-sided board. Through-plated boards are relatively expensive, and virtually impossible for the amateur constructor to produce. They are used in few home constructor projects.

PSEUDO DOUBLE-SIDED

Many projects use what is really a sort of pseudo double-sided arrangement, where the board only actually has copper tracks on one side, but link wires are used to carry connections through and across the board. This may not give the neatest looking results, but it is inexpensive and quite easy as far as building the board is concerned. The link wires are made from about 22 to 24 s.w.g. tinned copper wire, and pieces trimmed from resistor leadout wires are quite suitable for this purpose. The easiest way of adding the links is to solder one end in place first, then thread the other end through the board, pull the wire tight with pliers, trim off the excess wire, and then solder the second end of the wire in place. Although this method is quick and simple it does not give very reliable results. Pulling the wire taut tends to severely weaken it, and the links can then be easily broken. Failing to pull the wire taut tends to leave it looping well above the board which does not look very neat, and is mechanically not very strong or reliable.

It is much better to take the time to form each link so that it fits nicely into place on the board, place the board track side uppermost on the workbench, trim the ends of the link to size using wire clippers, and then solder it in place. Do not try to hold links in place with your fingers when soldering them in place—they get extremely hot. If the work-top is likely to be damaged by the heated link wires, protect it with an old piece of plywood, chipboard, or something of this type.

Board designers normally arrange things so that any link wires are quite short, and this usually renders it unnecessary to insulate them. However, if any link wire is longer than about 15 millimetres it is not a bad idea to fit it with a piece of p.v.c. sleeving. This avoids the possibility of it becoming bowed and coming into electrical contact with another lead.

A third type of board is the sort which has copper tracks on both sides, but with no through-plating. Pins must be soldered in place at the points where connections must be taken through the board. In fact reliable connections and quite neat results can be obtained using about 20 to 22 s.w.g. tinned copper wire. The end of the wire is threaded just through the board and soldered in place. Then the wire is trimmed off on the other side of the board and soldered in place here. In reality this is not quite as easy as it sounds, as it is very easy to desolder the wire on one side of the

board while it is being connected to the other side. This does not necessarily matter as the solder on both sides of the board may solidify once the soldering iron bit has been removed, leaving two good joints. The main danger is that of the short piece of wire sticking to the bit and being removed on the bit when it is withdrawn from the joint.

THROUGH-PINS

It is much better to use the proper printed circuit through-pins. These should not be confused with the pins of the type that are used for off-board connections. Through-pins are much shorter, and when fitted in place they only protrude slightly on the opposite side of the board. They are normally too wide to be pushed right into the holes in the board, and must be pushed in place using the hot bit of a soldering iron, as in Fig. 1. Little pressure on the pin should then be needed. The pin is then soldered to the pads on both sides of the board.

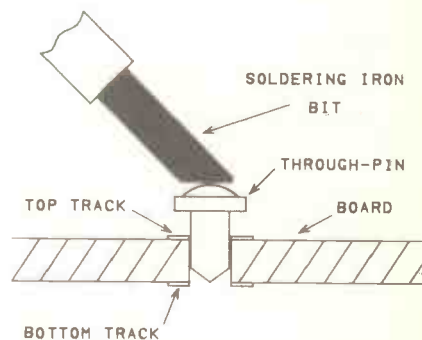

Fig. 1. Fitting a through-pin with the aid of a soldering iron.

Ordinary printed circuit pins for off-board connections come in two varieties—the single and double-sided type. Normally off-board connections will only need to be made on one side of the board, and the single sided type will suffice. The constructional notes for the project should make it clear when double-sided pins are required. It is not a good idea to use these pins for through-board connections as they are really too large, and might get in the way when other components are fitted to the board later on. It is not uncommon for through-board connections to be positioned under integrated circuits or other components. Where this is the case it is absolutely essential to fit the pins in place before the components are fitted to the board.

Printed circuit pins are often a very tight fit in the holes in the board, even assuming that pins of the correct size are used (normally one millimetre diameter pins are required). Pin insertion tools are available, but these may not always be sufficient. Where the pins are a tight fit it is not a good idea to force them in place as this risks cracking the board. It is much better to push them firmly in place, and if they will not push fully home use a soldering iron to complete the job. Both double and single-sided pins are always inserted from the track side of the board.

COMPONENT MOUNTING

The main point to watch when mounting components is that they are fully pushed down onto the board. It does not matter whether the device is a simple resistor or a complex multi-pin component, for mechanical strength construction relies on

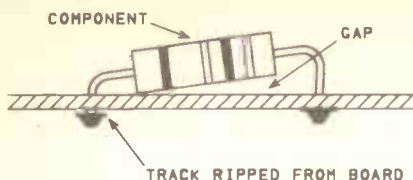

Fig. 2. A gap between component and p.c.b. risks tearing track from the board.

there being no significant gap between the component and the board. If you leave such a gap there is a real risk of any pressure on the components breaking the copper tracks away from the board (Fig. 2). This is not the place for a discussion on soldering, but until you have had some practice at soldering and have become reasonably competent at it you should avoid the temptation to jump in and start building a project. Either that or be prepared to write-off the first project to experience.

Power semiconductors are sometimes simply bolted to the board, or more usually the device is bolted to the board with a heatsink between the device itself and the board. A heatsink, incidentally, is just a piece of metal which helps to conduct heat away from the component and into the surrounding air. If the heatsink is inadequate, or the power device is in poor thermal contact with it, the component is almost certain to overheat and be destroyed. Where the device is bolted direct onto the heatsink there should not really be any problems with inadequate thermal contact, but a smear of grease or a silicon substitute on the underside of the compo-

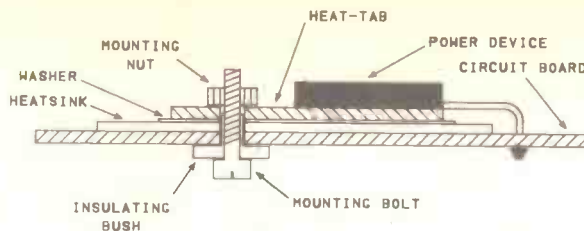

Fig. 3. Using an insulating washer and bush when mounting a power semiconductor.

nent will ensure good thermal transfer into the heatsink.

Problems can arise when insulation is needed between the component and the heatsink. The heat-tab usually connects internally to one terminal of the component, and construction is often such that the heatsink connects to earth. Some power semiconductors are designed to have the heat-tab at what would normally be earth potential, or to have an electrically isolated tab, but there are still plenty that do not fall into either of these categories. Use of the appropriate insulating kit is then essential.

This kit consists of a thin plastic washer which fits between the semiconductor device and the heatsink, and a plastic bush which fits over the mounting bolt (two bushes and bolts are required for devices with the TO3 style case or a similar type). The insulating kit is used in the manner shown in the cross section of Fig. 3, with the washer insulating the device from the heatsink, and the bushes insulating the mounting bolt from the heatsink. The

mounting bolt is still in connection with the power device, and this is sometimes essential as it can be necessary to make a connection to the device via a soldertag fitted on the mounting bolt.

When mounting power devices in this way it is advisable to use a thin layer of silicon grease on the underside of the device to aid good thermal contact with the heatsink. The main problem when using insulation kits is that of the insulating washer failing to be effective, and it is not unusual to have to slacken off the mounting nut slightly, reposition the washer, and tighten up the nut again in an attempt to get everything just right. Always check that the insulation is effectively by using a continuity tester to ensure that the heat-tab and heatsink are not in electrical contact. Failure of the insulation will at best blow a fuse, and at worst could result in a great deal of expensive damage to the unit.

Robert Penfold

COUNTER INTELLIGENCE

BY PAUL YOUNG

Speechless

A FRIEND of mine recently purchased a well known make of word processor which he assured me would answer all his problems especially replying to his mail. Two weeks later he was speechless with rage and still struggling to produce his first letter.

When he had simmered down sufficiently to talk coherently, he pointed to the two instruction manuals, each one nearly the size of a telephone directory and shouted, "Completely useless, most of the essential information is missing", and I had to agree with his criticism. Manufacturers spend hundreds of thousands of pounds designing a wonderful example of electronic wizardry and not worrying about the instruction manuals. Without a good manual, the purchaser has a useless chunk of machinery.

I was discussing this with a well-known lady journalist, and she told me that a friend of hers had been offered £60,000 a year to produce a computer manual. She added that now she is the only person who can explain it. It comes down to this, you need the expert to explain it but they are the worst people to produce the manual, for the simple reason that they take too much for granted.

The answer I am sure is a team, three experts who would explain it and three

writers who would convert their explanations into simple language. The finished result would be given to three ordinary people who had never seen a computer at close quarters, together with three computers still in their packing. They would then be asked to produce a letter.

Every time they hit a snag they could refer it to the experts, who would re-word it or fill in the gaps, pass it back to the writers to re-write and finally back to the guinea pigs. I would then give it to three outsiders to try out and see what happened.

A rather expensive way of producing a manual, you may argue, but I think it would certainly pay off. The system on which the US Navy was designed is, "A system designed by geniuses to be run by idiots". The problem is, that geniuses are notoriously bad at assessing the needs and perceptions of idiots.

Everyday Optics

One of the most startling pieces of news I have come across lately, is that the Heriot Watts University in Edinburgh have announced the first optical digital circuit. Although at present it is only at the stage transistors were in the fifties, many experts believe this is the greatest break through since the valve was made obsolete, and by the turn of the century all computers will be optical.

Operation is by laser beams and instead of transistors you have transphasors. The transphasors can be built up to form an integrated circuit and no connecting wires are necessary. Transphasors are cascadable, and because of the properties of laser light, hundreds of operations can be carried out in unison.

The "Connections" can be altered while the apparatus is running, add to that, the speed of operation is 200 times faster than the conventional chip, and you can see we have a formidable rival to our current computers (no pun intended). I only hope that they produce instruction manuals to go with them which are just as advanced.

Oh! Mr. Porter

Customers shopping at the supermarket in Tsukuba, Japan, are spared the hassle of trundling their goods round the store. They can hire an electronic porter who pushes the trolley and follows them around, and all the customer has to do is clip an ultrasonic transmitter on to his or her belt or handbag.

It does look like something out of "Star Wars" and whether it is programmed to come out with the right expressions when another "porter" accidentally bumps into it, I don't know.

As for me, I detest shopping and would much rather have a system that lets you sit at home with a computer display of the groceries on the screen. I then just select my requirements from the picture and tap out the correct code numbers. The goods would be wrapped up given to the porter who would deliver them to my door, and I wouldn't even have to tip him—there is bliss for you.

MYSTERIES OF MIDI & MIDI THRU BOX

SAM WITHEY



An explanation of the use of the Musical Instrument Digital Interface and a simple project

ADVANCES in modern technology enable a single musician to play several instruments simultaneously, or a group of musicians to perform together with precision timing, an essential element in the enjoyment of playing or listening to music. These functions became possible because of the development of the sequencer and the MIDI interface. The sequencer is a microprocessor controlled module which is similar in use to the multi-track recorder, but which stores information regarding pitch, timbre, amplitude, timing and control signals in digital form. This data, when transferred to a digital, polyphonic synthesizer, causes the synthesizer to play automatically, together with any other digital keyboards and drum machines linked by MIDI interface.

All modern digital electronic instruments are microprocessor controlled and the MIDI interface ensures that the processor clocks are synchronised in order that they will all perform functions at the precise times. The term MIDI is derived from the initials of Musical Instrument Digital Interface and is an internationally agreed standard of communication between microprocessor systems used in music applications. It enables the chaining of two or more instruments, equipped with the interface, by means of a single cable between each. The interface was designed and developed through the co-operation of major musical instrument manufacturers to overcome the problem of linking together instruments produced by different companies.

MIDI laid down rules by which digitised musical information could be transmitted and received in a standard form. Both the software and hardware specifications are formally documented and have been accepted by most leading electronic musical instrument manufacturers since its development in 1982. While MIDI Implementation Charts and transmit/receive data bit patterns are supplied with instruments, unfortunately, instruction manuals supplied with the instruments offer very little

useful information about the operation of MIDI and some instructions deviate from the standard. It is hoped here to put some clear meaning into the standard instruction set, to help non-technical reader/instrumentalists get a little more out of their instruments.

MIDI is a bi-directional asynchronous serial interface similar to the familiar RS232 serial interface, but with a much higher baud rate of 31.250, which is arrived at by subdividing 1MHz. Unlike the RS232, which has signal voltage levels of +3V to +12V and -3V to -12V, the MIDI interface only requires 0V to 5V logic signal levels. The inputs are opto-isolated to ensure the absence of earth loops which prove so troublesome with many items of audio equipment. Connections are via standard five pin, 180 deg. DIN sockets and provision is made for MIDI-IN, MIDI-OUT and with some instruments, MIDI-THRU, this being a buffered direct copy of the MIDI IN signal; Fig. 1.

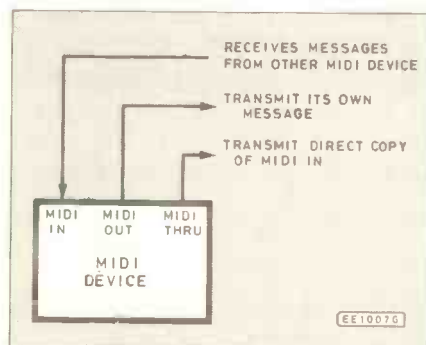

Fig. 1. MIDI THRU is a copy of MIDI IN.

FORMAT

The format of the MIDI interface was chosen as a compromise between speed and low cost. The transmission speed is high enough for all but the most sophisticated applications and is cheap enough to be included in even the least expensive units. Although information is in serial form, the microprocessor speed is sufficient to give the impression that sound is instantaneous. The microprocessor in each machine is able, through a specialised software language, to translate the digital coding received from the Master source, digital data being identical whether transmitted, or received.

The Master unit can be any unit in a group that can include keyboards, synthesizers, drum machines, sequencers and

computers. Normally the choice depends on whether pre-programmed music is being played, or whether one or more keyboards are being played in real time, with backing from other instruments or sequencers. Ultimately the choice will always fall on the instrument which offers the simplest instruction set, or the most suitable unit for a specific application. As an example, the author uses a sequencer as Master when tracks have been programmed into it. The eight-track sequencer then controls the start and stop of a programmable keyboard, and programmable drum machine, together with the timbre, pitch, time values and effects on eight independent tracks of a synthesizer. In addition to this, the keyboard and synthesizer can be split and played in real time if required. As an alternative, the author, when playing in real time, uses the keyboard as Master, with MIDI controlled, pre-programmed rhythms stored in the drum machine and MIDI selected tones from the synthesizer that play simultaneously with the Master keyboard. As the author's machines have no MIDI THRU facilities a MIDI THRU box has been designed and is described later in this article.

EXAMPLES

To illustrate the examples above, in the first instance the MIDI OUT of the sequencer is plugged into the Master or IN socket of the MIDI THRU box. The outputs from the box are then connected to the MIDI IN sockets of the synthesizer, keyboard and drum machine with standard five pin DIN leads and in any order, Fig. 2.

In the second example the MIDI OUT of the keyboard is plugged into the Master socket of the MIDI THRU box and two of the outputs connected to the synthesizer and drum machine, Fig. 3.

In the situation shown in Fig. 4 synthesizers A and C have MIDI THRU sockets which make the following functions possible. If A is played, the performance data of A will be sent through its MIDI OUT to B, which will sound. C will not sound as it is connected to the MIDI OUT of B. This is because the data fed into the MIDI IN of B is not outputted through the MIDI OUT. Therefore when A is played only A and B will sound.

If B is played, B's data will be sent from its MIDI OUT to the MIDI IN of C, making C sound. At the same time, a direct copy of the signal will be sent from C's MIDI THRU socket to the MIDI IN of A causing A to sound. Therefore playing B causes A, B and C to sound. In theory many MIDI

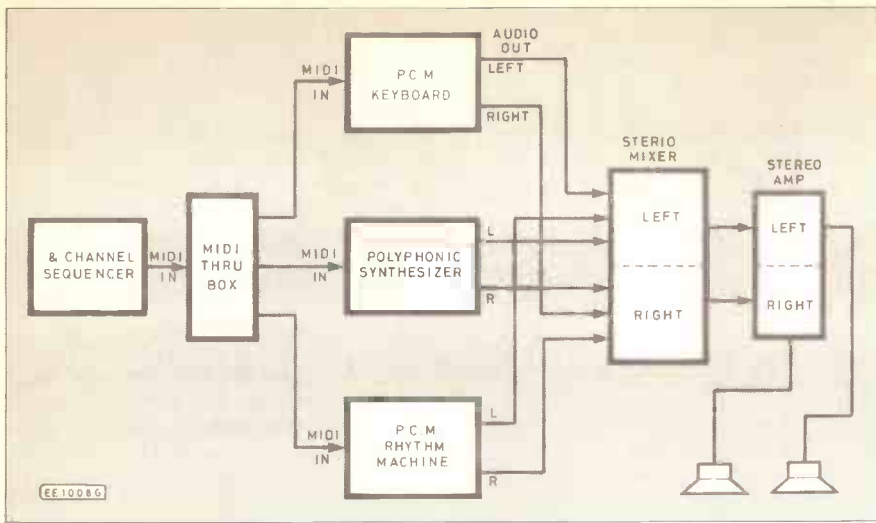

Fig. 2. Example of connections using MIDI THRU.

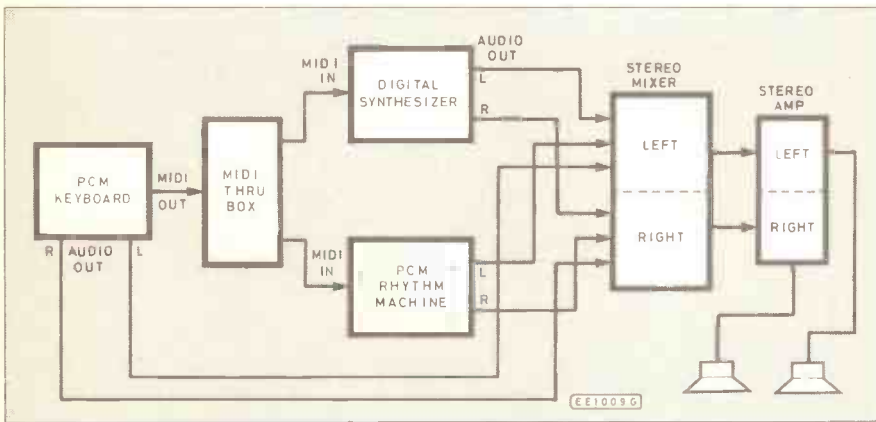

Fig. 3. Keyboard driving synthesizer and rhythm machine.

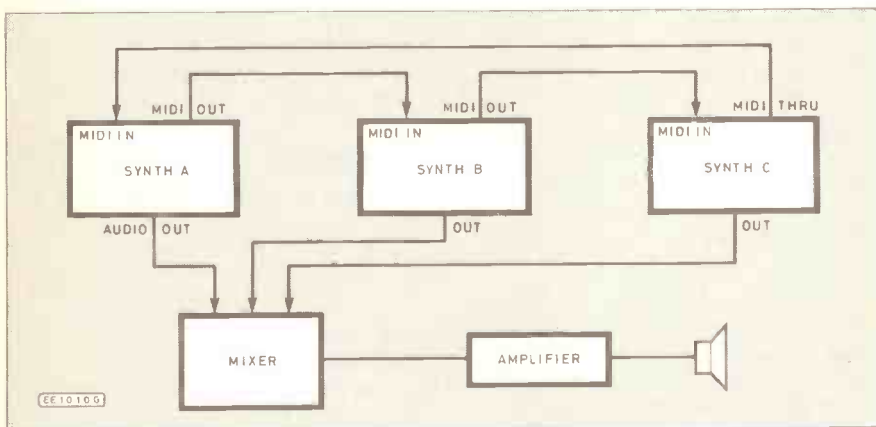

Fig. 4. Synth A, B and C will sound if B is played.

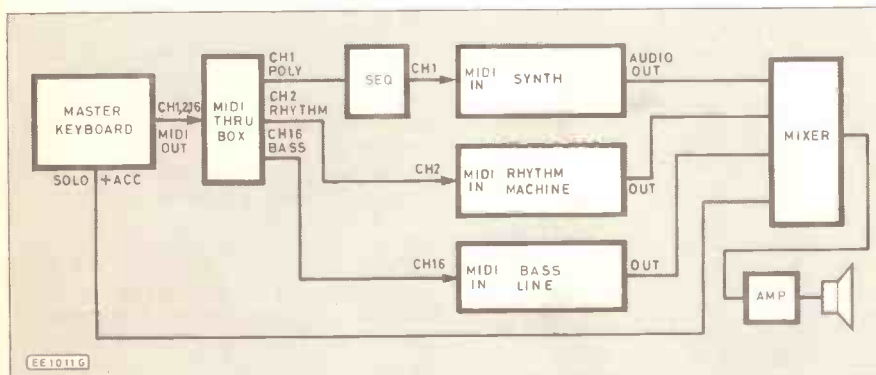

Fig. 5. An example of channelising.

devices can be connected by using MIDI THRU's, but as these are buffered outputs there will be a time when delays are noticeable. This makes the MIDI THRU box the more efficient method of distribution, or channelising as this is known.

Some machines that do not have MIDI THRU sockets send the data fed to it at its MIDI IN direct to its MIDI OUT socket, while others have a single socket with selectable MIDI OUT, MIDI THRU. Yet again some have only a single MIDI IN socket because the others are considered unnecessary.

As modern instruments produce a stereo output these effects should be maintained by using a mixer with left and right input channels.

CHANNELISING

A single MIDI cable can be used to transmit several messages to different instruments at the same time through one of the sixteen channels, Fig. 5. Each message, carrying information of pitch, tone, modulation etc. is sent on a different channel and the receiving instruments are tuned in to the channels carrying the information you wish them to respond to. Although every instrument has 16 channels at its disposal, the number of channels that can be used at any time depends on the number of functions the instrument and its associated modules are each capable of. For instance, an instrument that is limited to rhythm, bass, accompaniment, poly and solo can utilise five different channels to transmit data to modules assigned to receive the messages.

The set-up illustrated below left shows a typical method of distribution. Any channel number can be chosen for each function, providing the receiving module is capable of "tuning in" to a particular channel. Some modules are only equipped with a single channel and have to be allocated that channel exclusively. In the example it is assumed that the Bass Line is only capable of receiving on Channel 16.

The concept of channelising is similar to that when television stations broadcast by transmitting wireless signals (each comprised of sound, vision, teletext, synchronisation signals etc.) through different channels respectively. A TV set receives all the information from one antenna, but can select any desired broadcast by switching the channel selector.

The chart lists the codes of Channel and System messages. The first byte of Channel messages have a note triggering code and channel number.

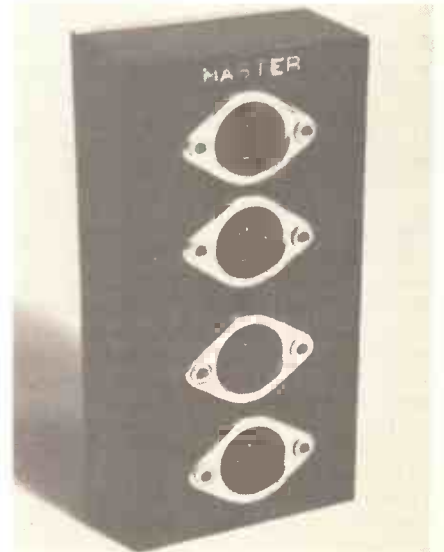

TRANSMITTED and RECOGNISED DATA

| STATUS 1st Byte | DATA | | Description |
|--------------------|----------|----------|---|
| | 2nd Byte | 3rd Byte | |
| 1000nnnn | Okkkkkkk | Ovvvvvvv | Note Off Receive only function n = channel number 0-15 (Channels 1-16) k = key value 0-127 (limited by keyboard) v = note velocity 0-127 (key off velocity) ignored |
| 1001nnnn | Okkkkkkk | Ovvvvvvv | Note On/Off n = channel number 0-15 k = key 0-127 v = note velocity 0-127 (0 = Note Off 64 = Note On) |
| 1011nnnn | Occccccc | Ovvvvvvv | Control Change and Mode Messages n = channel number 0-15 c = control number 0-127 c = 1 modulation wheel c = 5 Portamento time c = 6 master time c = 64 sustain c = 65 portamento off c = 92 tremolo c = 93 chorus c = 94 celeste c = 123 all notes Off v=0 c = 124 OMNI Mode Off v=0 c = 125 Omni Mode On v=0 c = 126 Mono Mode On v=0 c = 127 Poly Mode On v=0 (123-127 All Notes Off) v = note volume 0-127 (0 = Note Off 127 = Note On) |
| 1100nnnn | Oppppppp | | Program Change n = channel number 0-15 p = program 0-127 (tone or rhythm pattern storage—typically 32 ROM, 32 RAM) |
| 11110011 | Osssssss | | Song Select s = song 0-127 (song or rhythm sequence typically 8 ROM 8 RAM) |
| 11111000 | | | Clock Transmitted when internal clock is selected |
| 11111010 | | | Start |
| 11111100 | | | Stop |

Note Numbers: The range 0-127 are semi-tone intervals covering 10 octaves of 12 semi-tones plus 7 semi-tones. No commercial keyboard covers this range. A typical five octave keyboard would cover the range 36-96 C to C, 60 being Middle C. Octaves 0-11, 12-23, 24-35 would sound at 36-47. Octaves 97-108, 109-120 and notes 121-127 would sound at 85-96.

MODES

The 16 channels can be used in four different modes compiled from OMNI ON/OFF, POLY and MONO and these cause the most confusion. In OMNI ON mode a receiver will recognise the messages on all channels without discrimination, which could sound quite chaotic. In OMNI OFF mode a receiver will accept information exclusively on a selected channel. POLY means that more than one note can sound at the same time. The number of notes is dependent on the number of DCOs, or Digitally Controlled Oscillators, the instrument, or synthesizer has and how they are employed.

Eight note chords are playable for one oscillator, and double this for two oscillators, but a tone produced by using both oscillators can only make eight notes sound. MONO means only one note will sound on each channel. Other notes, in a different voice, can sound from other channels. Typi-

cally one channel could play bass line, another could play the solo line, a third could play first harmony, etc. One point to note here is that MIDI cannot turn a monophonic synthesizer into a polyphonic instrument.

MODE 1—OMNI ON, POLY

Voice messages are recognised in all voice channels and assigned to voices polyphonically.

MODE 2—OMNI ON, MONO

Voice messages are recognised in all channels and control only one voice monophonically. Only one sound is emitted.

MODE 3—OMNI OFF, POLY

Voice messages are recognised in the channel selected by the receiver and are assigned to sound polyphonically.

MODE 4—OMNI OFF, MONO

Voice messages are recognised in the channel selected by the receiver and are assigned to sound monophonically, and with a sequencer enables the assignment of different voices to individual channels, according to the capacity of the sequencer. This mode is useful if a polyphonic synthesizer is used to control monophonic synthesizers.

Normally, when power is first applied to a MIDI device it defaults to Mode 3. Most

keyboards transmit and receive, or recognise only in Mode 3, while synthesizers are also able to utilise Mode 4. The latter are normally capable of altering messages received in Mode 1 to Mode 3 and those received in Mode 2 to Mode 4. Rhythm machines normally default to Mode 3 to transmit, but also recognise Mode 1.

There are two kinds of MIDI messages; Channel messages and System messages. Channel messages contain channel numbers, Voice messages and Mode messages. The most basic of these are Note On and Note Off. The Note On message includes what key and how hard it is pressed. The Note Off indicates what key is released. Key numbers can be assigned to the drum voices of a rhythm machine. Control keys such as vibrato and sustain are communicated as Control Change messages.

A MIDI Master device can deliver Mode messages to slave devices. Program Change messages are associated with tone colours or rhythm patterns stored in memory and vary with each instrument. Only by comparison can tones be matched. System messages can be set without setting a MIDI channel. These include Song Select, which are arrangements utilising the tones, or patterns stored in Program Change; Clock, which is set for Internal on the Master and MIDI on slave devices and the Start/Stop functions. Exclusive messages are used in the tone colour data of synthesizers or for communication of sequencer data. It is original for each manufacturer with its own ID number.

Shown right is a typical MIDI Implementation Chart supplied as a standard form with all MIDI instruments. This should be studied in conjunction with the channel message table.

MIDI THRU BOX

As previously stated MIDI THRU is a buffered duplication of the MIDI IN signal. Unfortunately, many manufacturers, such as Technics, Casio and Roland, do not include this socket. However, at its best it cannot match a MIDI THRU box, which allows any of the devices to be used as the Master and provides several MIDI THRU outputs. The simple unit to be described overcomes the lack of THRU outputs.

For reasons of safety and to ensure the absence of earth loops, the MIDI IN signal is opto-isolated. The interface uses five pin, 180deg. A-Type DIN sockets. MIDI IN uses pins four and five of the socket, where pin four is connected to the cathode of the isolator i.e.d. via a current limiting 220ohm resistor and pin five goes direct to the anode of the i.e.d. There is a protection diode across the isolator i.e.d. There is no earth connection. MIDI OUT has an earth connection at pin two and +5V at pin four via a 220ohm current limiting resistor. The c.p.u. signal comes to pin five via a buffer, which is comprised of two inverters, followed by a 220ohm current limiting resistor. MIDI THRU is a duplication of this circuit, but connected to the MIDI IN at the c.p.u., see Fig. 6.

MIDI THRU boxes are simple devices, which are expensive to purchase from a dealer, yet simple and inexpensive to make for oneself. The box described here can cost as little as £1.30 for the Master/Two slave version, or around £3.50 for the Master/Five slave version, where 50 per cent of the cost is in the case.

MIDI IMPLEMENTATION CHART

| Function | | Transmitted | Recognised | Remarks |
|--------------------|--|----------------------|--------------------------------------|--|
| Basic Channel | Default Changed | 1-16 1-16 | 1-16 1-16 | Memorised |
| Mode | Default Messages Altered | Mode 3 X ***** | Mode 3 POLY/MONO Mode 1-3, 2-4 | OMNI ON/OFF ignored |
| Note Number | Range | 36-96 ***** | 0-127 36-96 | 0-11, 12-23, 24-35=36-47 97-108, 109-120, 121-127=85-96 ● |
| Velocity | Note On Note Off | X X 9n v=0 | X X 9n v=XX | XX=ignored |
| After Touch | Keys Channel | X X | X X | |
| Pitch | Bender | O | O | 8 bits effective 0-12 half tones |
| Control | 1 | O | O | Vibrato Master Tune Sustain Pedal Chorus |
| | 6 | X | O | |
| | 64 | O | O | |
| | 93 | *OX | O | |
| Program Change | Range | O 0-63 ***** | O 0-63 0-31, 32-63 | 0-31 preset 32-63 memory |
| Exclusive | | O | O | Timbre, sequencer data and others |
| Common | Song Pos | X | X | |
| | Song Sel | *OX 0-16 | X | |
| | Tune | X | X | |
| Real Time | :Clock | O | O (Midi mode) | |
| | :Commands | O | O | |
| Aux: Local ON/OFF | | X | O | |
| Mes: All Notes OFF | | O | O | |
| sag: Active Sense | | X | X | |
| es: Reset | | X | X | |
| Notes | *OX Whether or not the data for these items can be transmitted can be set. ● Numbers change when transpose switch used. | | | |

Mode 1: OMNI ON, POLY
Mode 3: OMNI OFF, POLY

Mode 2: OMNI ON, MONO
Mode 4: OMNI OFF, MONO

O: YES
X: No

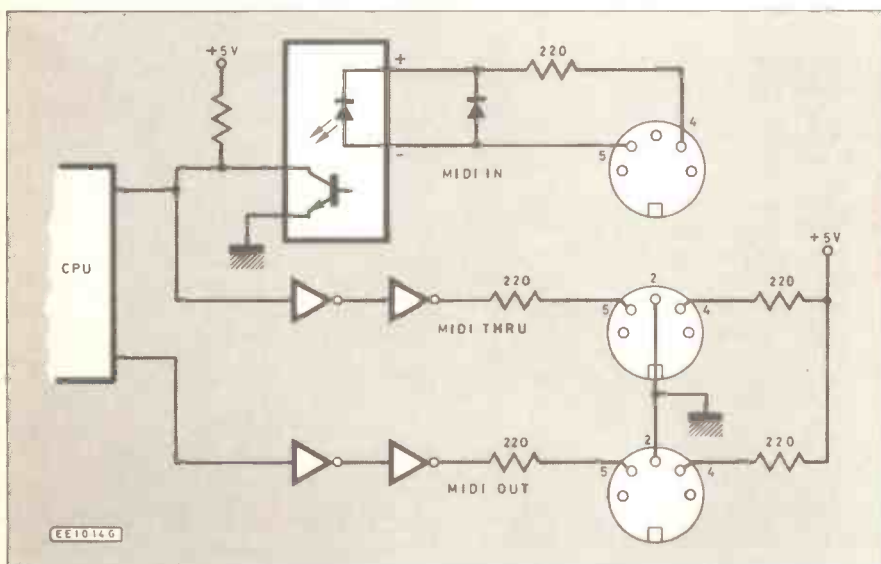

Fig. 6. Connection of MIDI THRU at the c.p.u.

CIRCUIT AND CONSTRUCTION

Whilst guidelines are provided later on for constructing boxes of several forms of outputs, the description here is for a Master and three slaves, which can serve a keyboard, synthesizer/sequencer, rhythm composer and computer, or similar set-up. The

unit is constructed in a potting box measuring approximately 100 x 50 x 25mm. Because of the simplicity of the unit, the circuit description and construction will be described together.

Four sockets are mounted on the potting box to provide access for the MIDI OUT signal from the Master source and three for distribution. The ground rail is run through

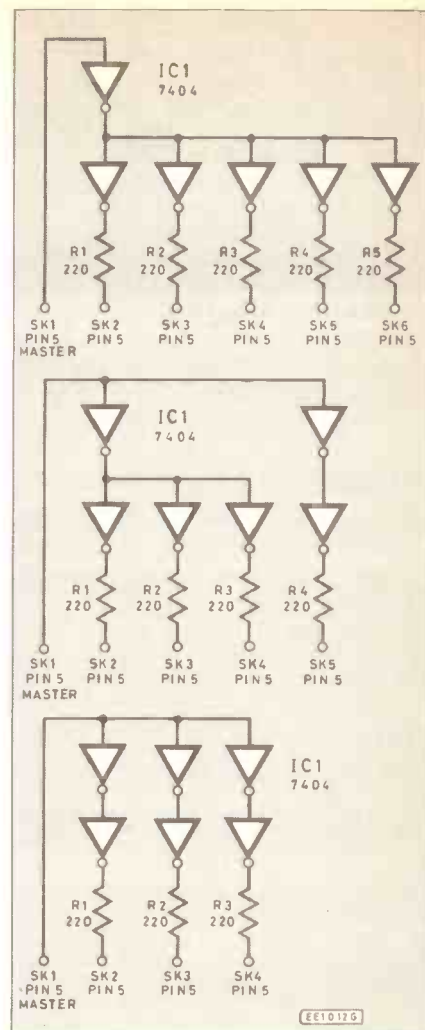
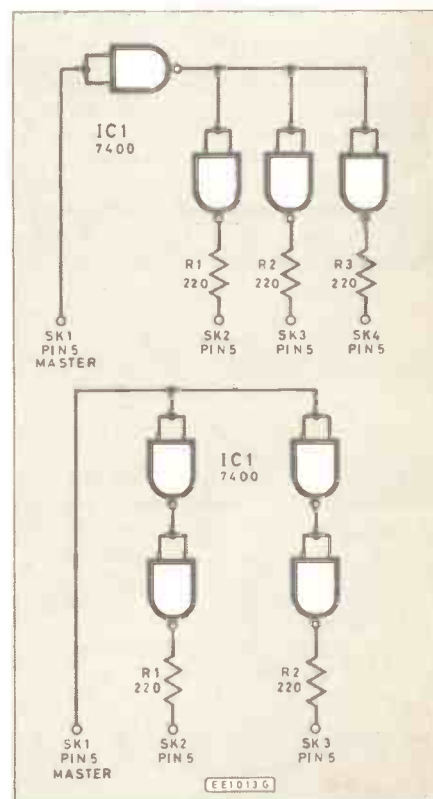
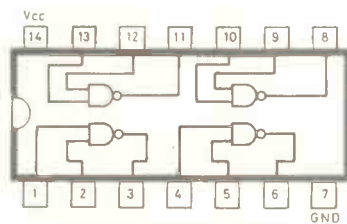
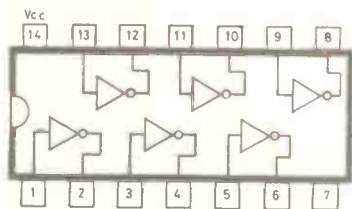
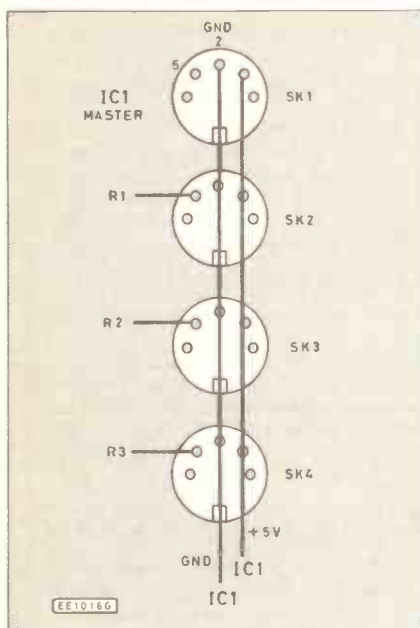
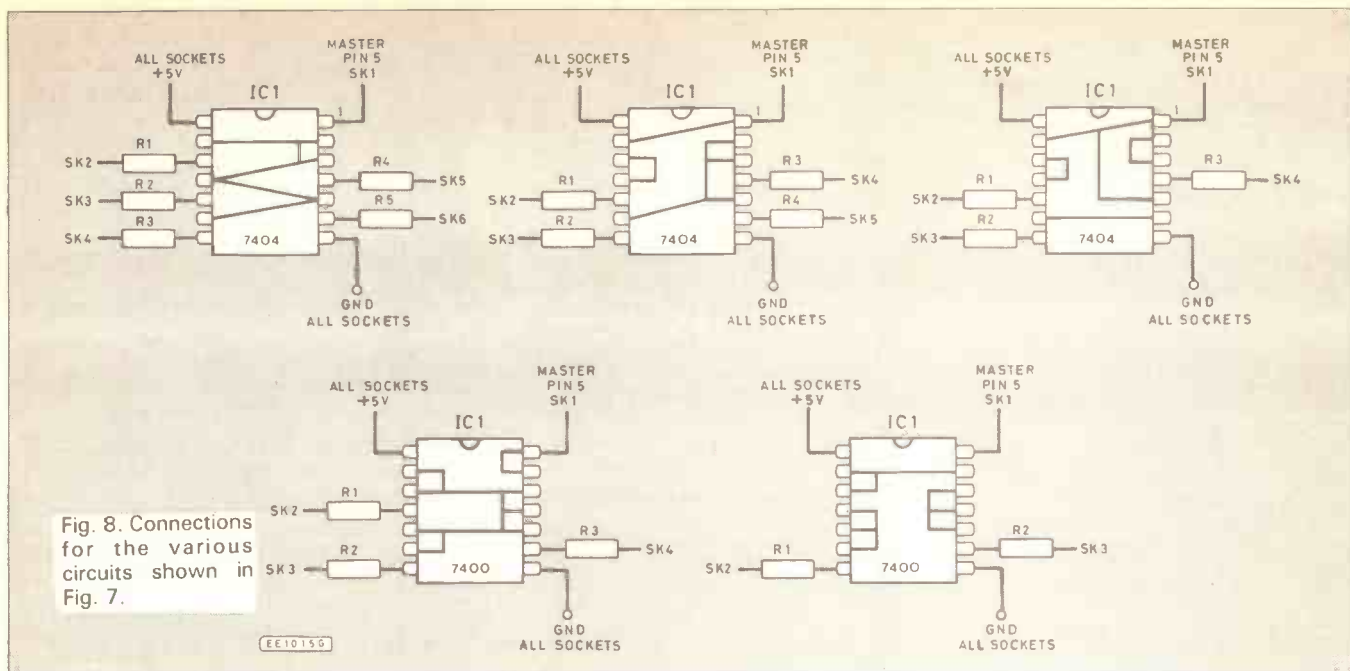

Fig. 7 (above). The 7404 Hex inverter connections for master and five, master and four, master and three THRU boxes. (Below) The 7400 quad two input NAND connections for master and three or master and two THRU boxes.





pin two and the ground pin on all four sockets. As the +5V at pin four already has a current limiting resistor at the Master source there is no need for any in the box, therefore pin four of all sockets can be connected with a single rail. Pin five of the Master socket must be connected to all buffer inputs and pin five of the MIDI THRU sockets will each require a 220ohm current limiting resistor. They will be used as connecting leads between buffer outputs and sockets and should be soldered to the i.c. before insertion in the box.

It is up to the individual whether to use a 7400 quad two input NAND gate with its inputs connected together and treated as inverters, or to use the 7404 Hex inverter (Fig. 7). If the 7400 is used, the i.c. is turned on its back and the output from one inverter connected to the inputs of the other three inverters. An insulated single strand wire is soldered to the first inverter input for later connection to pin five of the Master socket, 220ohm resistors are soldered to the outputs of the other inverters, to be connected to pin five of individual THRU sockets.

If the 7404 is used, the inverters are connected in three inverter pairs and treated similarly. Single strand red and black wires are soldered to pins 14 and seven respectively for connection to the +5V and ground rails of the sockets. Having linked inverters and soldered connecting leads and

resistors, the i.c. is laid on its back in the box, in a convenient place and the leads trimmed to a suitable length before soldering to the sockets (Fig. 8). The leads should hold the i.c. firmly, but it can be stuck down if required. After testing, a thick piece of card, or board can be cut to be stuck neatly into the bottom of the potting box. The Master socket should be clearly marked.

The diagrams (Figs. 8 and 9.) show the pin side of the sockets and the bottom view of the i.c.s. The ground and +5V rails can each be a short length of tinned wire which passes through the holes in the socket pins. □

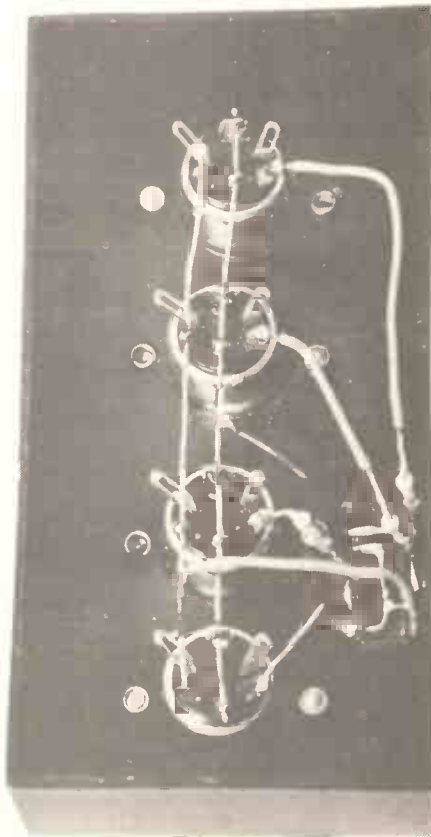

COMPONENTS

For Master/Three slave version—see text

Resistors

R1 to R3 220 $\frac{1}{4}$ W carbon (3 off)

Semiconductors

IC1 7400 or 7404 (see text)

Miscellaneous

SK1 to SK4 (4 off) five pin 180 degree A-type DIN sockets; Connecting wire; potting box approx 100 x 50 x 25mm.

Approx. cost
Guidance only

£3 (see text)

For KITS & COMPONENTS -
Choose the easy way - with *refundable with first order*

Send
50p* & SAE
for CATALOGUE

ORDERS: RING (01) 567 8910 - 24 HRS.

NEW POWER STROBE KIT



Designed to produce a high intensity light pulse at a variable frequency of 1 to 15Hz this kit also includes circuitry to trigger the light from an external voltage source (eg. a loudspeaker) via an opto isolator. Instructions are also supplied on modifying the unit for manual triggering, as a slave flash in photographic applications or as a warning beacon in security applications. The kit includes a high quality pcb, components, connectors, 5W's strobe tube and full assembly instructions. Supply: 240V ac. Size: 80 x 50 x 45.
XK124 STROBOSCOPE KIT £12.50

NEW HIGH SECURITY LOCK KIT



Designed for use with our lock mechanism (701 150) this kit will operate from a 9V to 15V supply drawing a standby current of only 50µA. There are over 5000 possible 4-digit combinations and the sequence can be easily changed. To make things even more difficult for an unauthorised user an alarm can be sounded after 3 to 9 incorrect entries—selectable by means of a link. The alarm can sound for a few seconds to over 3 minutes during which time the keyboard is disabled preventing further entries. A latched or momentary output is available making the unit ideal for door locks, burglar alarms, car immobilisers, etc. A membrane keyboard or pushbutton switches may be used and a beep sounds when a key is depressed. Kit includes high quality PCB, all components, connectors, high power piezo buzzer and full assembly and user instructions.
XK121 LOCK KIT £15.95
350 118 Set of Keyboard Switches £4.00
701 150 Electric Lock Mechanism £16.50

REMOTE CONTROL SWITCH KIT



Comprises a compact 9V (PP3) powered single channel unencoded infra-red transmitter and a mains powered receiver; this kit is ideal for switching table lamps, radios, etc. on and off remotely. Range 20ft. Max. load 500W (240V ac. only). Size—Transmitter: 7 x 5 x 3cm (including box). Receiver: 7 x 3.5 x 3cm.
MK6 TRANSMITTER £4.95
MK7 RECEIVER £11.50

NEW ELECTRONIC GUARD DOG KIT

One of the best deterrents to a burglar is a guard dog and this new kit provides the barking without the bite! The kit when assembled can be connected to a doorbell, pressure mat or any other intruder detector and will produce a random series of threatening barks making the would be intruder think again and try his luck elsewhere. The kit is supplied complete with high quality PCB, transformer, all components and instructions. All you need is a mains supply, intruder detector and a little time. The kit even includes a horn speaker which is essential to produce the loud sound required. The "dog" can be adjusted to produce barks ranging from a Terrier to an Alsatian and contains circuitry to produce a random series of barks giving a more realistic effect.
XK125 Complete kit of parts £21.95

ELECTRONIC SIREN KIT

Produces an extremely loud piercing swept frequency tone from a 9-15V supply. Enable input for easy connection to alarm circuits. Includes 5in. Horn Speaker.
XK116 £8.65

Mini Siren
 As above, but with a small speaker (instead of horn speaker) for internal use. Complete with box.
XK117 £4.70

PROPORTIONAL TEMPERATURE CONTROLLER KIT

Uses "burst fire" technique to maintain temperature to within 0.5°C. Ideal for photography, incubators wine-making, etc. Max. load 3kW (240V ac.). Temp. range up to 90°C. Size: 7 x 4 x 2.5cms.
MK4 £7.10

TEN EXCITING PROJECTS FOR BEGINNERS

This Kit has been specially designed for the beginner and contains a **SOLDERLESS BREADBOARD, COMPONENTS**, and a **BOOKLET** with instructions to enable the absolute novice to build TEN fascinating projects including a light operated switch, intercom, burglar alarm, and electronic lock. Each project includes a circuit diagram, description of operation and an easy to follow layout diagram. A section on component identification and function is included, enabling the beginner to build the circuits with confidence.
ORDER NO XK118 £13.75

XK102-3-NOTE DOOR CHIME

Based on the SAB0600 IC the kit is supplied with all components, including loudspeaker, printed circuit board, a pre-drilled box (95 x 71 x 35mm) and full instructions. Requires only a PP3 9V battery and push-switch to complete.
AN IDEAL PROJECT FOR BEGINNERS £6.00

HOME LIGHTING KITS

These kits contain all necessary components and full instructions & are designed to replace a standard wall switch and control up to 300W of lighting.

| | |
|--|--------|
| TDR300K Remote Control Dimmer | £16.45 |
| MK6 Transmitter for above | £4.95 |
| TD300K Touchdimmer | £8.50 |
| TS300K Touchswitch | £8.50 |
| TDE/K Extension kit for 2-way switching for TD300K | £2.70 |
| LD 300K Light Dimmer | £4.35 |



TR ELECTRONICS
13 BOSTON RD
LONDON W7 3SJ
Tel: 01-567 8910

SEND 9"x6" S.A.E. & 50p FOR CATALOGUE OR CALL AT SHOP MON-FRI 9-5pm SATURDAY 10-4pm

ORDERING INFORMATION: ALL PRICES EXCLUDE VAT

FREE P&P on orders over £20 (UK only), otherwise add 75p + VAT. Overseas P&P: Europe £2.75. Elsewhere £6.50. Send cheque/PO/Barclaycard/Access No. with order. Giro No. 529314002.

LOCAL AUTHORITY AND EXPORT ORDERS WELCOME GOODS BY RETURN SUBJECT TO AVAILABILITY



JOIN UP WITH LITESOLD

Professional Soldering Equipment at Special Mail-Order Prices.

EC50 Mains Electronic Iron. £33.16



proportional electronic temperature control inside the handle. Adjustable 280° to 400°C. Burn-proof 3-wire mains lead. Fitted 3.2mm Long-Life bit. 1.6, 2.4 and 4.7mm available. 240v a.c.

Features spike-free, solid state

SK18 Soldering Kit. £16.70

Build or repair any electronic project. LC18 240v 18w iron with 3.2, 2.4, and 1.6mm bits. Pack of 18 swg flux-cored 60/40 solder. Tweezers. 3 soldering aids. Reel of De-Solder braid. In PVC presentation wallet.

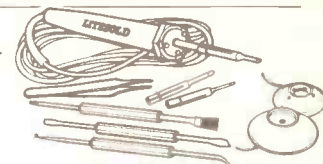

ADAMIN Miniature Iron £7.67

Possibly smallest mains iron in the world. Ideal for fine work. Slim nylon handle with finger grip. Interchangeable bits available 1.2, 1.6, 2.4, 3.4 and 4.7mm. Fitted with 2.4mm. 240v 12w (12v available). Presentation wallet.

'L' Series Lightweight Irons. 12w £7.68

High efficiency irons for all electronic hobby work. Non-roll handles with finger guards. Stainless steel element shafts. Screw-connected elements. Slip-on bits available from 1.6 to 4.7mm. LA12 model, 12w, 2.4mm bit. LC 18 Model, 18w, 3.2mm bit. 240v Std - 12v available. Presentation wallet.



Soldering Iron Stands 3&4

No.5 £5.99
No.7 £6.22

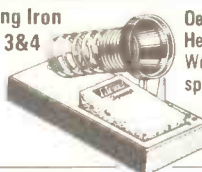

Designed specially for LITESOLD irons. Heavy, solid-plastic base with non-slip pads. Won't tip over, holds iron safely. With wiping sponge and location for spare (hot) bits. No 5 stand for EC50 iron No 4 stand for ADAMIN miniature iron No 3 stand for LA12 and LC18 irons.

Replacement Bits

For all above irons. Non-stick designs, machined from special copper alloy, with Inconel retaining rings. Two types - Chromium plated with copper face (for economy and ease of use) and Iron plated with

Pre-tinned face (Long Life). State tip size, iron and type.

| | Copper | L/L |
|---------------|--------|-------|
| EC50 | - | £1.74 |
| Adamin 12 and | | |
| LA12 | £1.00 | £1.71 |
| LC18 | £1.12 | £1.90 |

Yellow £1.33 Green £1.39

For simple, safe and effective de-soldering of all types of joint, using a standard soldering iron. Handy colour-coded packs of 1.5 metres in 3 widths: Yellow - 1.5mm, Green - 2mm, Blue - 3mm.
Blue £1.44 per Reel

De-Solder Pumps £7.28

High Quality version of increasingly popular type of tool. Precision made anodised aluminium body, plunger guard and high-seal piston. Easy thumb operation. Automatic solder ejection. Conductive PTFE nozzle - no static problems.



Tool Sets

Top quality Japanese metric hardened and tempered tools. Swivel-top chrome plated brass handles. Fitted plastic cases. 113 set - 6 miniature screwdrivers 0.9 to 3.5mm £3.92
 227 set 5 socket spanners 3 to 5mm £2.98
 305 set 2 crosspoint and 3 hex wrenches 1.5 to 2.5mm £2.86
 228 set 20 piece combination: 5 open, 5 skt spanners, 2 crosspoint, 3 hex and 3 plain drivers, scribe, handle/holder £6.42

Microcutters. £5.39 Light weight hardened and precision ground. Flush cutting. Screw joint, return spring, cushion-grip handles. Safety wire-retaining clip.

Soldering Aids.



Set of 3 £4.45
 Scraper/Knife, Hook/Probe, Brush/Fork. 3 useful double-ended aids to soldering/desoldering/assembly. In plastic wallet.



ADAMIN Electric Stylus. £16.71
 Writes like a ballpoint in Gold, Silver, Copper or 6 colours, on card, plastics, leather etc. Personalise wallets, bags, albums, books, models... Operates at 4.5v from its own plug/transformer - totally safe. Supplied with coloured foils.

SEND FOR OUR ORDER FORM TODAY AND JOIN UP WITH THE PROFESSIONALS

Prices include P&P and VAT. Send order with Cheque/PO. Ring for Access/Visa sales, or ask for order forms.
LIGHT SOLDERING DEVELOPMENTS LTD. DEPT. E M
97-99 GLOUCESTER ROAD, CROYDON CR0 2DN. 01 689 0574

Beeb...Beeb...Beeb...Beeb...Beeb...

...RPM and Frequency Meter...

IN THIS month's article we will consider two comparatively little used aspects of the BBC micro, one hardware orientated and one which is part of the firmware. Starting with the hardware, a little known feature of the 6522 VIA used to provide the user port is its shift register. Possibly it is not a well-known feature as it is not one of the most useful ones, but it is certainly worth knowing the basics of using this register. You may never need to use it, but it could just be perfectly suited to some future application you may have for the machine.

Shifty Characters

There are numerous integrated circuit shift registers available, but these rarely seem to be used in home-constructor projects. The basic function of a shift register is to take in parallel data and send it out in serial form, or to take in serial data and convert it to a parallel output. In fact the shift register in the 6522 VIA has a number of operating modes, and it can be used to both transmit and receive serial data. The shift register is at address &FE6A, and this is the address for both read and write operations. Its operating mode is controlled by bits 2 to 4 of the auxiliary control register at address &FE6B, and details of the eight modes available are provided in the table given below.

| Bit 2 | Bit 3 | Bit 4 | MODE |
|-------|-------|-------|---|
| 0 | 0 | 0 | Disabled |
| 1 | 0 | 0 | Shift in at timer 2 controlled rate |
| 0 | 1 | 0 | Shift in at system clock rate |
| 1 | 1 | 0 | Shift in at external clock rate |
| 0 | 0 | 1 | Shift out at timer 2 controlled rate (free running) |
| 1 | 0 | 1 | Shift out at timer 2 controlled rate (single shot) |
| 0 | 1 | 1 | Shift out at system clock rate |
| 1 | 1 | 1 | Shift out at external clock rate |

In all modes line CB2 is used as the serial input or output. Although on the face of it the signal provided by the unit is much the same as a standard RS232C serial type in nature, this is not really the case. The shift register can certainly be used for serial communication, but of a different type to RS232C serial links. RS232C and similar serial links (including the compatible RS423 type of the BBC micro) are asynchronous types. This means that the data is transmitted together with additional bits which the receiving terminal uses to permit proper decoding of the received data. Simply clocking out the data from the shift register in serial form is not good enough, as

the receiving equipment has no means of determining the beginning of each byte.

The shift register in the 6522 does not have any built-in facilities for adding start, stop, and parity bits, but it can be used for synchronous communications links. In other words, a second data line is used between the transmitting and receiving terminals, and this sends some form of timing information along with any transmitted data on the first line (an earth line is also needed of course). The standard synchronous arrangement, and the one supported by the 6522, is where a clock signal is transmitted along with the data, and this clock signal is used at the receiving circuit to shift in the data at the correct rate.

A half duplex (one way) link of this type would therefore be something along the lines of Fig. 1. Note that line CB1 is used as the clock input/output line. Also note that the same basic set up can be used with the receiving terminal providing the clock signal. The main requirement for synchronous communications is that the same clock signal is used by both the transmitting and receiving circuits. The system can be made to operate properly with either terminal providing the timing signal.

Modes

Looking at the modes offered by the 6522, the first one simply disables the shift register so that CB1 and CB2 are freed for their normal handshaking role. In the second mode the shift register clocks in data at a rate controlled by timer 2. In fact it is only the low byte of timer 2 at &FE68 that is used, and the signal is clocked in at a rate of one bit every $2 \times (N+2)$ clock cycles. As only one byte of timer 2 is used, 'N' can be any integer from 0 to 255. In the third mode the data is clocked in at the system clock rate, but two clock cycles are needed per bit. In terms of baud, this gives a baud rate of 500k.

Although synchronous operation may not seem possible in these modes, CB1 acts as an output which can be used to clock out data from the transmitting shift register.

The fourth mode is perhaps the most useful receiving one, and this uses CB1 as an input. Data is shifted in at a rate controlled by the signal applied to CB1.

The other four modes are all output modes. In the first of these timer 2 controls the transmission rate, and the value in the shift register is transmitted repeatedly. Although this may seem to be completely useless, as we shall see next month, it does have practical applications. These are nothing to do with serial communications though.

The next mode is the same as the one described above, but data is only outputted once. The next two modes are much the same, but the transmission rate is at half the system clock frequency or a rate determined by a clock signal fed to CB1.

In next month's Beeb Micro article we will look at some possible applications of the shift register.

USING EVAL

EVAL is one of the most powerful features of BBC BASIC. It is a rare function, found in few other versions of the language and this explains why it is less used, and perhaps less understood, than it might be.

To begin, it might be a good idea to compare EVAL with its much more common relative, VAL. The VAL function takes a string argument, and "turns it into a numeric value". There are more formal and pedantic ways of putting it, but that description will be readily understood. For the BBC version of VAL to work, the string must begin with a valid numeric character, which can be a numeral 0 to 9, the decimal point, or a plus or minus sign. Anything other than these and the function will return zero (in the BBC version—other versions of BASIC treat this as an error).

The BBC version of VAL cannot convert strings representing hexadecimal quantities into numeric values (i.e. strings beginning with "&"). This could be considered a shortcoming nowadays, as several other versions of BASIC, including the Amstrad Locomotive BASIC can convert hex strings with VAL.

Fig. 1. The basic set up for a synchronous communications link.

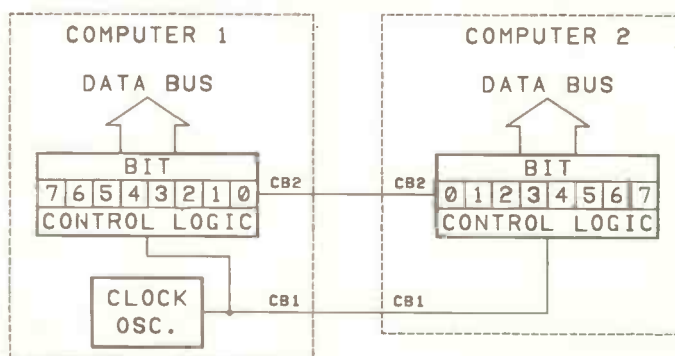

When you think about it, all numeric values entered from the keyboard must first be entered as strings of characters, and the VAL function must be used by the interpreter to convert them to internal numeric format. This explains why even the most primitive BASICs have VAL, and also STR\$, necessary to perform the reverse function when numeric values have to be printed.

EVAL also takes a string argument, but instead of simply converting valid numeric characters to numeric form, it passes the string to the interpreter's expression evaluator to be worked out fully. This means the string may contain arithmetic calculations, references to variables, and also BASIC functions like COS, SIN, LOG. EVAL can also perform string manipulations on string arguments, using the functions LEFT\$, RIGHT\$ and MID\$.

EVAL can be used to convert hexadecimal strings to numeric form. The following program demonstrates this.

```
10 REPEAT
20 INPUT HEX$
30 PRINT EVAL(HEX$)
40 UNTIL FALSE
```

This requires the strings to be preceded with the '&' character. If you want to just be able to type in the hex digits, this is quite simple.

```
10 REPEAT
20 INPUT HEX$
30 PRINT EVAL("&" + HEX$)
40 UNTIL FALSE
```

In line 30, the string concatenation is performed, adding the ampersand to the hex digits, and then the string is converted to a numeric value.

So for what is EVAL useful? The usual examples, as given in the manual, are a simple program to use the computer as a calculator—pointless as you can use PRINT from command mode—and entering expressions in order to plot their graphs. On this page we are more concerned with control and measurement applications. EVAL can be useful when you want to alter the value stored in a variable on, say, a percentage basis. Here is a simple timer program.

```
10 REPEAT
20 INPUT "Please enter time: "
newtime
30 T=TIME
40 REPEAT
50 UNTIL TIME >
T+newtime*100
60 VDU7
70 UNTIL FALSE
```

In this program, when you want to alter the time you have to enter the new time required in seconds. What if you just want to increase the time by a fifth, or 20%. It is easy enough to write a line to enable you to enter the multiplication factor and calculate the new time, but that makes it difficult to enter a new time with no relationship to the old time. You would need two separate inputs for the two purposes.

By using EVAL, one input can be used for both purposes, provided you know the name of the variable used to store the time. I suggest "oldtime".

```
10 REPEAT
20 INPUT "Please enter time: "
newtime$
25 oldtime=EVAL(newtime$)
30 T=TIME
40 REPEAT
50 UNTIL TIME > T+oldtime * 100
60 VDU7
80 UNTIL FALSE
```

Note that the input at line 20 is now a string, and that the name of the variable in line 50 has been altered. Line 25 is the new one, performing the evaluation.

With this version, if you want to enter a time directly in seconds, you can do so just as before. If you want to increase the old time by a multiplication factor, you would enter, for example "oldtime *120/100" for an increase of 20%. You could also enter, for example, "oldtime +10", or "oldtime * 5 - 2" or even "oldtime * (5-2)". You can even use BASIC functions in the expression, so you could enter "oldtime +10*LOG(oldtime)" if you needed to!

There are many control applications where this can be useful, not just concerned with timing.

EVAL cannot be used to execute BASIC statements like PRINT or DRAW, just BASIC functions used within expressions. It also cannot be used to execute proce-

dures. It can, however, be used to execute user-defined functions. This can be the basis of some interesting techniques to implement command interpreters.

Normally to interpret typed-in commands in a BASIC program you have to follow the input of the command by a series of IF... THEN lines to call the appropriate procedures for the command. However, BBC BASIC allows you to do anything in a function that you can do in a procedure, so by rewriting the procedures as functions you can execute them using EVAL. The following listing is the basis of this technique.

```
10 REPEAT
20 INPUT COMMAND$
30 A=EVAL
("FN"+COMMAND$)
40 UNTIL FALSE
50 END
100 DEF FNCLS
110 CLS
120 RET=TRUE
130 =RET
200 DEF FNHELLO
210 PRINT "HELLO"
220 RET=TRUE
230 =RET
```

This example implements two commands. Typing in CLS will clear the screen, and typing in HELLO will cause that word to be printed. Adding further commands is simply a case of adding functions with appropriate names. There is also no difficulty at all in passing parameters to the functions. These can just be typed in after the name, in brackets, in the usual way.

Of course, a function returns a value, and you have to do something with it. In this case a numeric value is returned and it is simply assigned to a dummy variable. A more interesting way is to make each function return a string. You can then make line 30 PRINT EVAL("FN" + COMMAND\$). The string returned can be something like "OK" if all goes well, or a message if the operation fails for some reason, or of course you can return a null string.

The main problem with EVAL is that it is very difficult to trap errors when using it, as any error which can occur in evaluating an expression can be generated. It should, therefore, be used with discretion in programs which may be used by others.

PROTEUS

The Weaver of Nightmares

—No12 OUT NOW



FREE FULL COLOUR FANTASY POSTER IN EVERY ISSUE

PROTEUS—THE BEST SOLO ROLE PLAYING GAME MAGAZINE AVAILABLE ON SALE AT YOUR NEWSAGENTS NOW—85p

BOOK SERVICE

The books listed below have been selected as being of special interest to our readers, they are supplied from our editorial address direct to your door.

DATA AND REFERENCE

PRACTICAL ELECTRONICS CALCULATIONS AND FORMULAE

F. A. Wilson, C.G.I.A., C.Eng., F.I.E.E., F.I.E.R.E., F.B.I.M.
Bridges the gap between complicated technical theory, and "cut-and-try" methods which may bring success in design but leave the experimenter unfulfilled. A strong practical bias—tedious and higher mathematics have been avoided where possible and many tables have been included.
The book is divided into six basic sections: Units and Constants, Direct-current Circuits, Passive Components, Alternating-current Circuits, Networks and Theorems, Measurements.
256 pages **Order Code BP53 £2.95**

ESSENTIAL THEORY FOR THE ELECTRONICS HOBBYIST

G. T. Rubaroe, T.Eng (C.E.I.), Assoc.I.E.R.E.
The object of this book is to supply the hobbyist with a background knowledge tailored to meet his or her specific requirements and the author has brought together the relevant material and presented it in a readable manner with minimum recourse to mathematics.
128 pages **Order Code 228 £2.50**

MICROPROCESSING SYSTEMS AND CIRCUITS

F. A. Wilson, C.G.I.A., C.Eng., F.I.E.E., F.I.E.R.E., F.B.I.M.
A truly comprehensive guide to the elements of micro-processing systems which really starts at the beginning. Teaches the reader the essential fundamentals that are so important for a sound understanding of the subject.
256 pages **Order Code BP77 £2.95**

COMMUNICATION

F. A. Wilson, C.G.I.A., C.Eng., F.I.E.E., F.I.E.R.E., F.B.I.M.
A look at the electronic fundamentals over the whole of the communication scene. This book aims to teach the important elements of each branch of the subject in a style as interesting and practical as possible. While not getting involved in the more complicated theory and mathematics, most of the modern transmission system techniques are examined including line, microwave, submarine, satellite and digital multiplex systems, radio and telegraphy. To assist in understanding these more thoroughly, chapters on signal processing, the electromagnetic wave, networks and transmissions assessment are included, finally a short chapter on optical transmission.
256 pages **Order Code BP89 £2.95**

AUDIO

F. A. Wilson, C.G.I.A., C.Eng., F.I.E.E., F.I.E.R.E., F.B.I.M.
Analysis of the sound wave and an explanation of acoustical quantities prepare the way. These are followed by a study of the mechanism of hearing and examination of the various sounds we hear. A look at room acoustics with a subsequent chapter on microphones and loudspeakers then sets the scene for the main chapter on audio systems—amplifiers, oscillators, disc and magnetic recording and electronic music.
320 pages **Order Code BP111 £3.50**

HOW TO IDENTIFY UNMARKED ICs

K. H. Recorr
Shows the reader how, with just a test-meter, to go about recording the particular signature of an unmarked i.c. which should enable the i.c. to then be identified with reference to manufacturers' or other data. An i.c. signature is a specially plotted chart produced by measuring the resistances between all terminal pairs of an i.c.
Chart **Order Code BP101 £0.95**

RADIO AND ELECTRONIC COLOUR CODES AND DATA CHART

B. B. Babani
Although this chart was first published in 1971 it provides basic information on many colour codes in use throughout the world, for most radio and electronic components. Includes resistors, capacitors, transformers, field coils, fuses, battery leads, speakers, etc. It is particularly useful for finding the values of old components.
Chart **Order Code BP7 £0.95**

CHART OF RADIO, ELECTRONIC, SEMICONDUCTOR AND LOGIC SYMBOLS

M. H. Banani, B.Sc.(Eng.)
Illustrates the common, and many of the not-so-common, radio, electronic, semiconductor and logic symbols that are used in books, magazines and instruction manuals, etc., in most countries throughout the world.
Chart **Order Code BP27 £0.95**

INTERNATIONAL TRANSISTOR EQUIVALENTS GUIDE

A. Michaels
Helps the reader to find possible substitutes for a popular selection of European, American and Japanese transistors. Also shows material type, polarity, manufacturer and use.
320 pages **Order Code BP85 £2.95**

TRANSISTOR RADIO FAULT-FINDING CHART

C. E. Miller
Used properly, should enable the reader to trace most common faults reasonably quickly. Across the top of the chart will be found four rectangles containing brief description of these faults, viz—sound weak but undistorted, set dead, sound low or distorted and background noises. One then selects the most appropriate of these and following the arrows, carries out the suggested checks in sequence until the fault is cleared.
Chart **Order code BP70 £0.95**

DIGITAL IC EQUIVALENTS AND PIN CONNECTIONS

A. Michaels
Shows equivalents and pin connections of a popular selection of European, American and Japanese digital i.c.s. Also includes details of packaging, families, functions, manufacturer and country of origin.
256 pages **Order code BP140 £4.95**

LINEAR IC EQUIVALENTS AND PIN CONNECTIONS

A. Michaels
Shows equivalents and pin connections of a popular selection of European, American and Japanese linear i.c.s. Also includes details of functions, manufacturer and country of origin.
320 pages **Order code BP141 £4.95**

INTERNATIONAL DIODE EQUIVALENTS GUIDE

A. Michaels
Designed to help the user in finding possible substitutes for a large selection of the many different types of diodes that are available. Besides simple rectifier diodes, also included are Zener diodes, i.e.d.s, diacs, triacs, thyristors, OCIs, photo and display diodes.
144 pages **Order code BP108 £2.25**

NEWNES ELECTRONICS POCKET BOOK

E. A. Parr
Newnes Electronics Pocket Book has been in print for over twenty years and has covered the development of electronics from valve to semiconductor technology and from transistors to LSI integrated circuits and micro-processors. To keep up to date with the rapidly changing world of electronics, continuous revision has been necessary. This new Fifth Edition takes account of recent changes and includes material suggested by readers of previous editions. New descriptions of op. amp. applications and the design of digital circuits have been added, along with a totally new chapter on computing, plus other revisions throughout.
315 pages (hard cover) **Order Code NE02 £8.95**

CIRCUITS AND DESIGN

ELECTRONICS SIMPLIFIED —CRYSTAL SET CONSTRUCTION

F. A. Wilson, C.G.I.A., C.Eng., F.I.E.E., F.I.E.R.E., F.B.I.M.
Especially written for those who wish to participate in the intricacies of electronics more through practical construction than by theoretical study. It is designed for all ages upwards from the day one can read intelligently and handle simple tools.
80 pages **Order Code BP92 £1.75**

50 CIRCUITS USING GERMANIUM SILICON AND ZENER DIODES

R. N. Soar
Contains 50 interesting and useful circuits and applications, covering many different branches of electronics, using one of the most simple and inexpensive of components—the diode. Includes the use of germanium and silicon signal diodes, silicon rectifier diodes and Zener diodes, etc.
64 pages **Order Code BP36 £1.50**

50 SIMPLE LED CIRCUITS

R. N. Soar
Contains 50 interesting and useful circuits and applications, covering many different branches of electronics, using one of the most inexpensive and freely available components—the light-emitting diode (LED). Also includes circuits for the 707 common anode display.
64 pages **Order Code BP42 £1.95**

COIL DESIGN AND CONSTRUCTION MANUAL

B. B. Babani
A complete book for the home constructor on "how to make" RF, IF, audio and power coils, chokes and transformers. Practically every possible type is discussed and calculations necessary are given and explained in detail. Although this book is now rather old, with the exception of torroids and pulse transformers little has changed in coil design since it was written.
96 pages **Order Code 160 £2.50**

MICRO INTERFACING CIRCUITS—BOOK 1

MICRO INTERFACING CIRCUITS—BOOK 2

R. A. Penfold
Both books include practical circuits together with details of the circuit operation and useful background information. Any special constructional points are covered but p.c.b. layouts and other detailed constructional information are not included.

Book 1 is mainly concerned with getting signals in and out of the computer; Book 2 deals primarily with circuits for practical applications.

Book 1 112 pages Order code BP130 £2.25

Book 2 112 pages Order code BP131 £2.25

A MICROPROCESSOR PRIMER

E. A. Parr, B.Sc., C.Eng., M.I.E.E.
Starts by designing a small computer which, because of its simplicity and logical structure, enables the language to be easily learnt and understood. The shortcomings are then discussed and the reader is shown how these can be overcome by changes and additions to the instruction set. In this way, such ideas as relative addressing, index registers, etc., are developed.
96 pages **Order code BP72 £1.75**

A PRACTICAL INTRODUCTION TO MICROPROCESSORS

R. A. Penfold
Provides an introduction which includes a very simple microprocessor circuit which can be constructed so that the reader can experiment and gain practical experience.
96 pages **Order code BP123 £1.95**

HOW TO USE OP-AMPS

E. A. Parr
This book has been written as a designer's guide covering many operational amplifiers, serving both as a source book of circuits and a reference book for design calculations. The approach has been made as non-mathematical as possible.
160 pages **Order code BP88 £2.95**

PRACTICAL ELECTRONIC BUILDING BLOCKS—BOOK 1

PRACTICAL ELECTRONIC BUILDING BLOCKS—BOOK 2

R. A. Penfold
These books are designed to aid electronic enthusiasts who like to experiment with circuits and produce their own projects, rather than simply following published project designs.

BOOK 1 contains: Oscillators—sinewave, triangular, squarewave, sawtooth, and pulse waveform generators operating at audio frequencies. Timers—simple monostable circuits using i.c.s, the 555 and 7555 devices, etc. Miscellaneous—noise generators, comparators, mixers and triggers, etc.

BOOK 2 contains: Amplifiers—low level discrete and op-amp circuits, voltage and buffer amplifiers including d.c. types. Also low-noise audio and voltage controlled amplifiers. Filters—high-pass, low-pass, 6, 12, and 24dB per octave types. Miscellaneous—i.c. power amplifiers, mixers, voltage and current regulators, etc.
BOOK 1 128 pages Order code BP117 £1.95
BOOK 2 122 pages Order code BP118 £1.95

HOW TO DESIGN ELECTRONIC PROJECTS

R. A. Penfold
The aim of this book is to help the reader to put together projects from standard circuit blocks with a minimum of trial and error, but without resorting to any advanced mathematics. Hints on designing circuit blocks to meet your special requirements are also provided.
128 pages **Order code BP127 £2.25**

POPULAR ELECTRONIC CIRCUITS —BOOK 1

POPULAR ELECTRONIC CIRCUITS —BOOK 2

R. A. Penfold
Each book provides a wide range of designs for electronic enthusiasts who are capable of producing working projects from just a circuit diagram without the aid of detailed construction information. Any special setting-up procedures are described.

BOOK 1 Temporarily out of print
BOOK 2 160 pages Order code BP98 £2.25

COMPUTING

GETTING THE MOST FROM YOUR PRINTER

J. W. Penfold
Details how to use all the features provided on most dot-matrix printers from programs and popular word processor packages like Wordwise, Visawrite and Quill, etc. Shows exactly what must be typed in to achieve a given effect.
96 pages **Order Code BP181** **£2.95**

A Z80 WORKSHOP MANUAL

E. A. Parr, B.Sc., C.Eng., M.I.E.E.
This book is intended for people who wish to progress beyond the stage of BASIC programming to topics such as machine code and assembly language programming, or need hardware details of a Z80 based computer.
192 pages **Order Code BP112** **£3.50**

AN INTRODUCTION TO 68000 ASSEMBLY LANGUAGE

R. A. & J. W. Penfold
Obtain a vast increase in running speed by writing programs for 68000 based micros such as the Commodore Amiga, Atari ST range or Apple Macintosh range etc., in assembly language. It is not as difficult as one might think and this book covers the fundamentals.
112 pages **Order Code BP184** **£2.95**

THE ART OF PROGRAMMING THE ZX SPECTRUM

M. James, B.Sc., M.B.C.S.
It is one thing to have learnt how to use all the Spectrum's commands and functions, but a very different one to be able to combine them into programs that do exactly what you want them to. This is just what this book is all about—teaching you the art of effective programming with your Spectrum.
144 pages **Order Code BP119** **£2.50**

AN INTRODUCTION TO PROGRAMMING THE COMMODORE 16 & PLUS 4

R. A. Penfold
Helps you to learn to use and program these two Commodore machines with the minimum of difficulty by expanding and complementing the information supplied in the manufacturer's own manuals.
128 pages **Order Code BP158** **£2.50**

AN INTRODUCTION TO PROGRAMMING THE BBC MODEL B MICRO

R. A. & J. W. Penfold
Written for readers wanting to learn more about programming and how to make best use of the incredibly powerful model B's versatile features. Most aspects of the BBC micro are covered, the omissions being where little could usefully be added to the information provided by the manufacturer's own manual.
144 pages **Order Code BP139** **£1.95**

AN INTRODUCTION TO PROGRAMMING THE ACORN ELECTRON

R. A. & J. W. Penfold
Designed to help the reader learn more about programming and to make best use of the Electron's many features. Adds considerably to the information already supplied in the manufacturer's own instruction manual.
144 pages **Order Code BP142** **£1.95**

AN INTRODUCTION TO PROGRAMMING THE ATARI 600/800 XL

R. A. & J. W. Penfold
Especially written to supplement the manufacturer's own handbook. The information supplied will help the reader to master BASIC programming and to make best use of the Atari's many powerful features.
128 pages **Order Code BP143** **£1.95**

AN INTRODUCTION TO PROGRAMMING THE AMSTRAD CPC 464 AND 664

R. A. & J. W. Penfold
The Amstrad CPC 464 or 664 running with Locomotive BASIC makes an extremely potent and versatile machine and this book is designed to help the reader get the most from this powerful combination. Written to complement rather than duplicate the information already given in the manufacturer's own manual. Also applicable to the CPC 6128.
144 pages **Order Code BP153** **£2.50**

AN INTRODUCTION TO PROGRAMMING THE SINCLAIR QL

R. A. & J. W. Penfold
Helps the reader to make best use of the fantastic Sinclair QL's almost unlimited range of features. Designed to complement the manufacturer's handbook.
112 pages **Order Code BP150** **£1.95**

AN INTRODUCTION TO Z80 MACHINE CODE

R. A. & J. W. Penfold
Takes the reader through the basics of microprocessors and machine code programming with no previous knowledge of these being assumed. The Z80 is used in many popular home computers and simple programming examples are given for Z80-based machines including the Sinclair ZX-81 and Spectrum, Memotech and the Amstrad CPC 464. Also applicable to the Amstrad CPC 664 and 6128.
144 pages **Order Code BP152** **£2.75**

AN INTRODUCTION TO 6502 MACHINE CODE

R. A. & J. W. Penfold
No previous knowledge of microprocessors or machine code is assumed. Topics covered are: assembly language and assemblers, the register set and memory, binary and hexadecimal numbering systems, addressing modes and the instruction set, and also mixing machine code with BASIC. Some simple programming examples are given for 6502-based home computers like the VIC-20, ORIC-1/Atmos, Electron, BCC and also the Commodore 64.
112 pages **Order Code BP147** **£2.50**

THE PRE-BASIC BOOK

F. A. Wilson, C.G.I.A., C.ENG., F.I.E.E., F.I.E.R.E., F.B.I.M.
Another book on BASIC but with a difference. This one does not skip through the whole of the subject and thereby leave many would-be programmers floundering but instead concentrates on introducing the technique by looking in depth at the most frequently used and more easily understood computer instructions. For all new and potential micro users.
192 pages **Order Code BP146** **£2.95**

HOW TO GET YOUR COMPUTER PROGRAMS RUNNING

J. W. Penfold
Have you ever written your own programs only to find that they did not work! Help is now at hand with this book which shows you how to go about looking for your errors, and helps you to avoid the common bugs and pitfalls of program writing. Applicable to all dialects of the BASIC language.
144 pages **Order Code BP169** **£2.50**

AN INTRODUCTION TO COMPUTER COMMUNICATIONS

R. A. Penfold
Provides details of the various types of modem and their suitability for specific applications, plus details of connecting various computers to modems, and modems to the telephone system. Also information on common networking systems and RTTY.
96 pages **Order Code BP177** **£2.95**

AN INTRODUCTION TO COMPUTER PERIPHERALS

J. W. Penfold
Covers such items as monitors, printers, disc drives, cassette recorders, modems, etc., explaining what they are, how to use them and the various types and standards. Helps you to make sure that the peripherals you buy will work with your computer.
80 pages **Order Code BP170** **£2.50**

COMPUTER TERMINOLOGY EXPLAINED

I. D. Poole
Explains a wide range of terms that form the computer jargon used by enthusiasts. Includes a reference guide to the more commonly used BASIC commands.
96 pages **Order Code BP148** **£1.95**

THE PRE-COMPUTER BOOK

F. A. Wilson
Aimed at the absolute beginner with no knowledge of computing. An entirely non-technical discussion of computer bits and pieces and programming.
96 pages **Order Code BP115** **£1.95**
preprehensive specifications of over 1400 devices.

NEWNES COMPUTER ENGINEER'S

POCKETBOOK

Michael Tooley
An invaluable compendium of facts, figures, circuits and data, indispensable to the designer, student, service engineer and all those interested in computer and microcomputer systems. It will appeal equally to the hardware or software specialist and to the new band of "software engineers". This first edition covers a vast range of subjects at a practical level, with the necessary explanatory text. The data is presented in a succinct and rapidly accessible form so that the book can become part of an everyday toolkit.
205 pages (hard cover) **Order Code NE01** **£8.95**

PROJECT CONSTRUCTION

HOW TO GET YOUR ELECTRONIC PROJECTS WORKING

R. A. Penfold
We have all built projects only to find that they did not work correctly, or at all, when first switched on. The aim of this book is to help the reader overcome just these problems by indicating how and where to start looking for many of the common faults that can occur when building up projects.
96 pages **Order Code BP110** **£1.95**

HOW TO DESIGN AND MAKE YOUR OWN P.C.B.s

R. A. Penfold
Deals with the simple methods of copying printed circuit

board designs from magazines and books and covers all aspects of simple p.c.b. construction including photographic methods and designing your own p.c.b.s.
80 pages **Order Code BP121** **£1.95**

BEGINNER'S GUIDE TO BUILDING ELECTRONIC PROJECTS

R. A. Penfold
Shows the complete beginner how to tackle the practical side of electronics, so that he or she can confidently build the electronic projects that are regularly featured in magazines and books. Also includes examples in the form of simple projects.
112 pages **Order Code No. 227** **£1.95**

RADIO

AN INTRODUCTION TO RADIO DXING

R. A. Penfold
Anyone can switch on a short wave receiver and play with the controls until they pick up something, but to find a particular station, country or type of broadcast and to receive it as clearly as possible requires a little more skill and knowledge. The object of this book is to help the reader to do just that, which in essence is the fascinating hobby of radio DXing.
112 pages **Order Code BP91** **£1.95**

INTERNATIONAL RADIO STATIONS GUIDE

Completely revised and updated, this book is an invaluable aid in helping all those who have a radio receiver to obtain the maximum entertainment value and enjoyment from their sets.
Clearly shown are the station site, country, frequency and/or wavelength, as well as the effective radiation power of the transmitter.
128 pages **Order Code BP155** **£2.95**

NEW RELEASE

TRANSISTOR SELECTOR GUIDE

Prepared using the latest computerised techniques, from a vast database of electronic component specifications, this unique guide offers a range of selection tables compiled so as to be of maximum use to all electronics engineers, designers and hobbyists.
Section 1: Covers component markings, codings and standards, as well as explaining the symbols used and how the tables are arranged.
Section 2: Tabulates in alpha-numeric sequence the comprehensive specifications of over 1400 devices.
Section 3: Tabulates the devices in a similar fashion to the previous section but this time they are arranged by case type.
Section 4: Considers particular limits to the electrical parameters when compiling the tables and it is subdivided as follows: Darlingtons transistors; devices that can handle voltages upwards of 300V; devices that can handle currents upwards of 5A; devices that can handle powers upwards of 5W; radio frequency devices that operate upwards of 30MHz; FETs.
Section 5: Illustrates package outlines and leadouts.
Section 6: Consists of a surface mounting device markings conversion list.
192 pages **Order Code BP234** **£4.95**

EE BOOK SERVICE

TO ORDER

Please check the latest issue for price and availability.

Add 50p per order postage (overseas readers add £1, surface mail postage) and send a PO, cheque or international money order (£ sterling only) made payable to **Everyday Electronics** (quoting the order code and quantities required) to **EE BOOK SERVICE, 6 CHURCH STREET, WIMBORNE, DORSET. BH21 1JH.**

Although books are normally sent within seven days of receipt of your order please allow a maximum of 28 days for delivery. Overseas readers allow extra time for surface mail post.



FERMOSTAT

ANDY FLIND



Cheap temperature control for home brewers . . . and for lots of other uses

ONCE upon a time, the author lived in a house possessing a large cupboard behind a gas boiler. The temperature in this cupboard averaged at least eighty degrees so it was soon filled with buckets of potent fermenting home-brew, all of which matured rapidly and very well indeed. Sadly, a removal ended all this. The new house had no such cupboard; even the airing cupboard was ineffective, the cylinder being much too well lagged. The quality of the booze fell dramatically, while production time more than doubled. Without some form of prompt and drastic action, a sober life loomed.

Clearly, means of warming the brew was required. Commercial gadgets are available for this purpose, both immersion heaters like those used in aquariums and warming tapes for wrapping around the buckets. However, with four large buckets to heat, the estimated cost of either method came to more than £50—an unacceptable outlay. Something more economical was needed.

The solution adopted was a compact, specially heated brewing cupboard. Con-

structed in a workshop corner from scrap chip and blockboard, it was lined throughout with inch-thick polystyrene foam, the white stuff often used for packaging. Sheets of this can be bought from insulation specialists. It's important to line the floor since most home-brew yeasts are "bottom working", i.e. they form on the bottom of the bucket so this, too, must be warm. The flooring insulation was topped with hardboard. Tests suggested that a maximum of around forty watts would be needed to maintain the temperature, so a heat source of about a hundred watts was provided. At first this was an old hair-drier (the type with a quiet, brushless motor); later this was replaced with four hundred-watt light bulbs connected as two series pairs, giving a total of about 120 watts. The series connection improves reliability and keeps them from getting too hot, important as the insulation is inflammable.

CIRCUIT

Simple, reliable and accurate temperature control was required, and experiments eventually resulted in the circuit of Fig. 1. This operates as follows: Capacitor C1, with diodes D1 to D3 and C2, provide a rectified and smoothed low voltage supply for the electronics. Capacitive mains droppers can be a useful alternative to transformers; they're efficient, and the capacitor is smaller and cheaper than the equivalent transformers.

The output in this circuit is about 12 volts, set by Zener D3. This is further reduced and regulated to 5 volts by IC1.

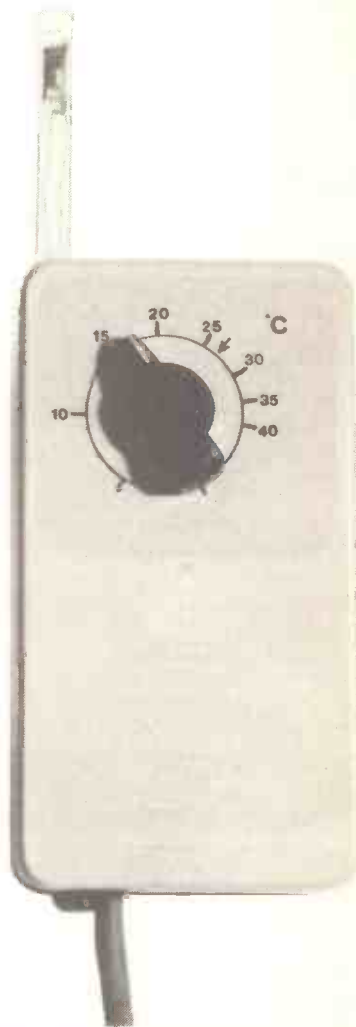
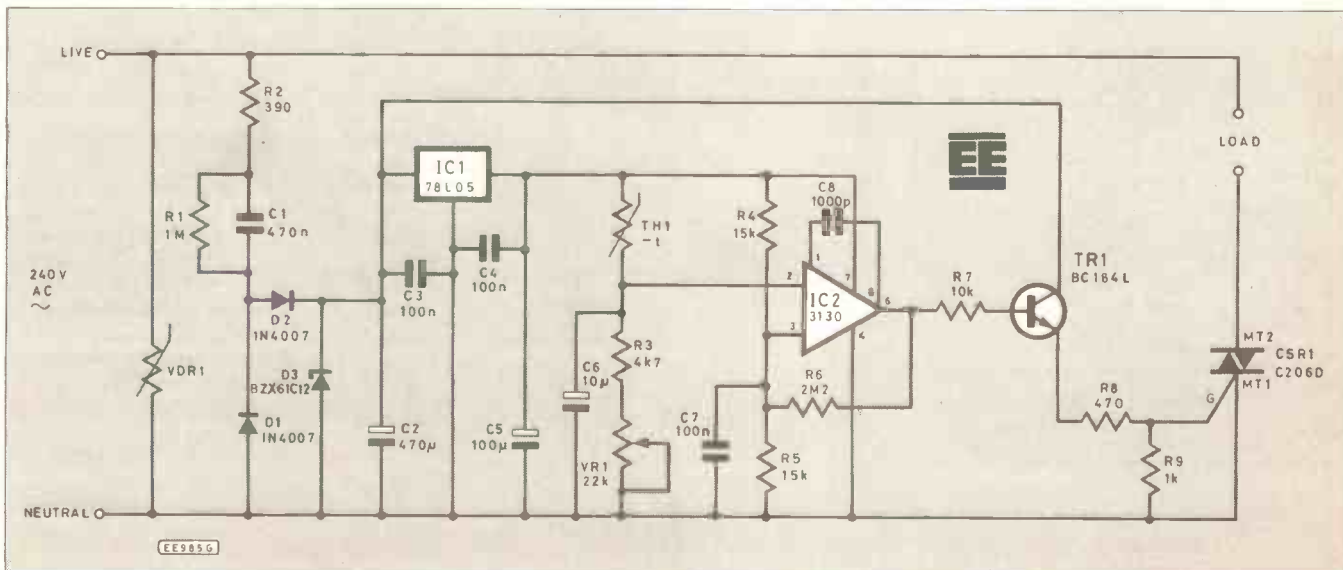

Fig. 1. Complete circuit diagram of the Fermostat.



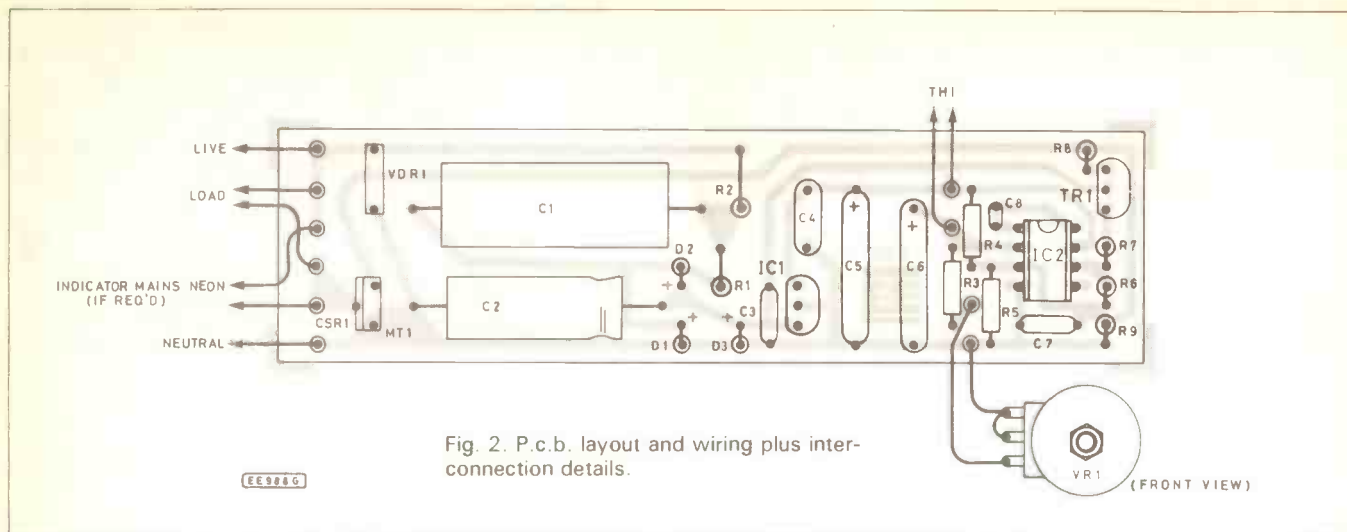
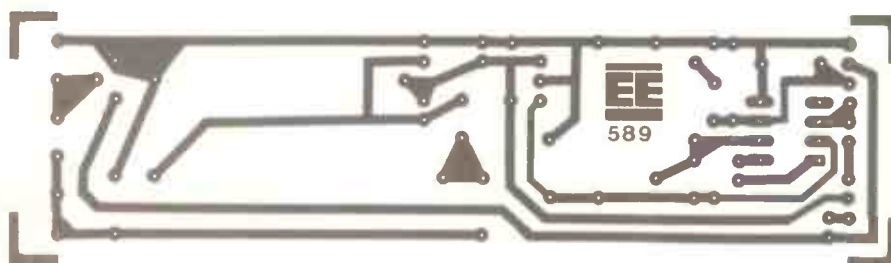

Fig. 2. P.c.b. layout and wiring plus inter-connection details.



VDR1 is a "mains transient suppressor" for removing any high voltage spikes on the mains, a useful protection for C1 and the triac. R1 removes any charge remaining on C1 when the unit is disconnected, without it a nasty shock can be received from the pins of the plug!

The heart of the controller is op. amp. IC2. R4 and R5 set the non-inverting input to half supply, 2.5 volts, while the inverting

input is connected to a divider formed by thermistor TH1, and the control VR1 with R3. The thermistor's resistance increases with falling temperature. If it is higher than VR1 and R3 (too cold), the inverting input voltage is the lower of the two, so the output goes high (on). When the thermistor has the lower resistance (too hot), the inverting input voltage is the higher so the output goes low (off).

To prevent over-sensitivity to minute variations in temperature, C6 slows the response to small input changes and R6, by applying positive feedback, gives the circuit a small amount of hysteresis. C7 decouples any noise, etc., at the non-inverting input, this being mainly, in the author's case, r.f. Next door lives a CB enthusiast with a thirty-foot aerial mast. They're not quite extinct—yet! The output from IC2 is buffered by TR1 to drive the triac. Note the type, C206D, selected for its low gate drive requirements. Other types may not function in this circuit.

COMPONENTS

See
**Shop
Talk**
page 363

Resistors

| | |
|--|-------------|
| R1 | 1M 1 watt |
| R2 | 390 1 watt |
| R3 | 4k7 |
| R4,R5 | 15k (2 off) |
| R6 | 2M2 |
| R7 | 10k |
| R8 | 470 |
| R9 | 1k |
| All 0.5 watt 1% types except R1 and R2 | |

Potentiometer

| | |
|-----|----------------------|
| VR1 | 22k lin. carbon pot. |
|-----|----------------------|

Capacitors

| | |
|----------|----------------------------------|
| C1 | 470n 250V mains suppression type |
| C2 | 470µ axial lead elect. 25V |
| C3,C4,C7 | 100n polyester layer (3 off) |

| | |
|----|----------------------------|
| C5 | 100µ axial lead elect. 10V |
| C6 | 10µ axial lead elect. 25V |
| C8 | 1000p ceramic |

Semiconductors

| | |
|-------|--------------------------------|
| IC1 | µA78L05AWC +5V 100mA regulator |
| IC2 | CA3130E CMOS op-amp |
| TR1 | BC184L transistor |
| CSR1 | C206D triac 400V 3A |
| D1,D2 | 1N4007 diode (2) |
| D3 | BZX61C12 Zener diode, 12V 1.3W |

Miscellaneous

VDR1 mains transient suppressor; TH1 VA1055S thermistor; ABS box, 120 x 65 40mm; pointer knob; 8-pin d.i.l. socket; tube from cheap ball-point pen; silicone rubber sealant; printed circuit board, available from the EE PCB Service: order code EE569.

Approx. cost
Guidance only

£12 (including case)

CONSTRUCTION

Construction of this project is quite straightforward although, as always, it's best to proceed in steps, testing where appropriate. Note that *all parts of this circuit must be treated as "live", no part should be touched while the unit is connected to the mains*. Begin by fitting the 12 volt supply components, R1, R2, C1, C2, D1 to D3 and VDR1. If you can, test D3 before insertion. If it is open-circuit a high voltage will develop across C2 and could cause much damage.

Fortunately, Zeners are fairly reliable and in the author's experience generally fail short-circuit. When complete, this section can be tested. Arrange for temporary connection to the mains but, for safety, connect the voltmeter across C2 before plugging in, and set it to a range of a couple of hundred volts or more. Then plug in. If the voltmeter hardly moves, reduce the range until it can be read; the output should be about 12 volts. If it is, disconnect from the supply and fit the five volt components, C3 to C5 and IC1. Connect the meter across C5 and energise again, the output should be five volts.

When the five volt supply operates correctly, disconnect the supply and complete the entire project. Connect a temporary lead to each end of C2—they can be tacked

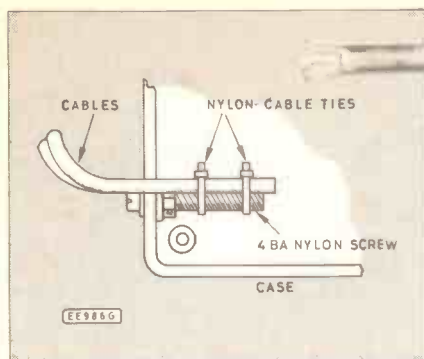

Fig. 3. Cable fixing details.

onto the p.c.b. tracks—these will be used for testing and calibration. Fig. 2 shows the physical layout of the unit. The cord-grip is simply a nylon 4BA screw in the side of the box to which the two leads are secured with nylon cable ties, as shown by Fig. 3.

The thermistor, a VA1055S rod type is rather delicate. It is advisable to keep it outside the box to obtain a quick and true response, so it is potted into the clear plastic tube from a ballpoint pen. The potting agent is Dow Corning silicone rubber aquarium sealant, which comes in a container with nozzle and plunger like a large syringe, enabling the compound to be forced right along the tube. The probe must be sealed in this way to ensure full electrical insulation of the thermistor. Fig. 4 shows the arrangement in detail. The finished "probe" is glued into the box with ABS cement, leaving about two inches protruding. Probe positioning is up to the individual constructor, of course, but if it is to be fitted to the box like the prototype, it might be better to leave this until calibration is complete.

CALIBRATION

The use of the leads attached to C2 will now become apparent. A nine volt battery (e.g. PP3) is used to power the electronics

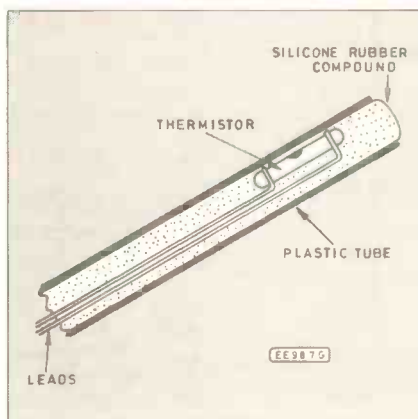

Fig. 4. Insulation of the probe is essential.

through these, in series with a 0–10mA meter. This avoids the danger of trying to calibrate a mains powered unit. When the unit is "off", i.e. the control at a low setting, it will draw about three milliamps. When it is "on", this should rise to about 10mA, the difference being the gate current applied to the triac. This allows operation of everything except the triac itself to be tested safely and, since the switching point can be clearly seen as the control is turned, calibra-

tion can be carried out with battery power only.

Calibration can now be carried out with water, and EE readers will need no reminding of the dangers of mixing water and live mains. Calibration is the usual tedious task with warm water and thermometer. The water temperature is adjusted in, say, five degree Centigrade steps, the probe is immersed for two or three minutes to ensure it settles to the water temperature, then the control position where switching occurs is marked. The spacing will be non-linear due to the characteristics of the thermistor, being closer towards the higher end of the scale.

Linearity correction is possible, but it was felt inappropriate for this simple and robust little circuit. When calibration is complete the probe can be glued into place and, when the glue fumes have died away, the box cover fitted.

Finally, a suitable load such as a hundred-watt light bulb should be used to check triac operation. The triac is a three-amp device but, since it is not provided with a heatsink, the maximum load driven should not exceed about two hundred watts. The unit must be fed from a suitably fused mains plug and no metal screws should pass through the plastic case. □

SAKÉ

Given an efficiently insulated and heated cupboard, with accurate and reliable temperature control, only one thing is now missing... the hooch itself! At the risk of offending wine-making purists (and those who thought this was an electronics magazine!) here's a perfect recipe for beginners: Rice and Raisin, also known as "Saké". It's cheap, easily made from readily available ingredients, ready in just four weeks and horribly strong! The taste isn't bad either...

The ingredients are:

| | One gallon | Three gallons |
|---------------------------|------------|---------------|
| Natural brown rice | 1.75 lb | 5 lbs |
| Raisins | 1 lb | 3 lbs |
| Sugar | 3 lbs | 9 lbs |
| Water | 1 gal | 3 gals |
| Juice from 1 orange | | 2 oranges |
| 1 lemon | | 2 lemons. |
| Yeast and yeast nutrient. | | |

The equipment needed is:

Fermentation bucket, two or five gallon, with sealing lid. Pierce the lid and insert a short length of plastic tube, plug the end of this with tissue to form a vent. Gallon "demijohn" glass jars and airlocks. Large straining funnel and fine strainer bag. Finings, e.g. "Boots liquid wine finings". Filter, e.g. "Boots wine filter".

The yeast, nutrient and equipment is available from Boots or homebrew specialists. Any general-purpose yeast and nutrient will do, but for best results it's worth finding "Leigh-Williams" dried live yeast, which seems to withstand the high alcohol content better than most. Boots no longer stock this brand, so a search of the specialist shops will be necessary.

To brew:

Boil sugar in about a quarter of the water. Place all remaining ingredients except yeast and nutrient in the fermentation bucket, the water should be cold. Don't mince or grind anything, use it all whole. Add the

hot sugar solution. When cool enough, add yeast and nutrient to instructions, stir, and place in fermentation cupboard. 80 degs F (27 degs C) seems about right for this brew. Leave for three weeks (it will smell lovely for the first week or so!). Then strain into the demijohn(s), add finings to instructions, and leave to clear for a week. Finally, pass through the filter, which will also have instructions. Then drink, but preferably not all at once!

After straining the first lot, don't discard the pulp. Boil up another lot of sugar, pour onto the pulp, swill it around and make up to the full quantity again with cold water. Add a fresh lot of orange and lemon juice, yeast and nutrient, and treat as before. This will provide a second lot of wine, usually drier and lighter than the first, at very low cost. After straining this second lot, discard the pulp and start afresh.

When the cold wind doth blow, and your project won't go—a drop of the above won't half help to raise the spirits!

...REPORTING AMATEUR RADIO...

TONY SMITH G4FAI

EMERGENCY!

One has only to follow the daily news to know that disasters or emergencies are always occurring. Often on such occasions there is a need for effective communications by the emergency services, but by their very nature, emergencies are not situations which can be fully anticipated and provided for in the finest detail.

There are always unexpected problems and it is not unusual for the authorities to call on voluntary organisations for help when official resources are under pressure. One such organisation is RAYNET, the Radio Amateurs Emergency Network, which has members and groups throughout the UK, and which answers many calls for help each year.

For example, in 1978 Birmingham, Britain's second largest city, was completely without an ambulance service due to industrial action. The St John Ambulance Brigade stepped in to provide round-the-clock emergency cover and there was an immediate need for radio communication between their ambulances and headquarters. Local RAYNET groups were alerted and within two hours 17 mobile stations had converged on SJAB headquarters, the necessary aerials had been erected and a base station was operational.

1000 CASES

Every ambulance was accompanied by a "radiotail" in the form of an amateur radio mobile station, enabling the St John's duty officer to deploy his vehicles and staff to best advantage. The base station was in continuous operation for 18 days. Over 7000 messages were handled, 170 RAYNET members were involved and over 1000 emergency ambulance cases were dealt with.

None of this happened by chance. RAYNET groups are constantly preparing for the unexpected. They hold regular training sessions to test and confirm their areas of radio coverage. Exercises are held with the "user" services to practice message handling under simulated emergency conditions. Then, when the call comes, there is total commitment, as the Birmingham experience demonstrates.

RAYNET's origins go back to 1953 when disastrous storms struck the east coast of Britain. Floods brought death and destruction and all communications, including telephones, government wireless stations and utility services, were closed down for days.

Radio amateurs, ignoring the (then) terms of their licences, put their stations, skills and communications experience at the disposal of the authorities throughout the crisis. When Humber Radio went out of action, for instance, amateurs maintained a continuous watch on the shipping frequencies and four times in the space of a few hours intercepted distress signals at sea.

LEGALISED

It had long been felt that there was a need for some formal organisation to enable amateur radio to be properly used on such occasions, and out of the 1953 experience RAYNET was formed. The use of amateur stations to pass messages for others was illegal then, even in emergency situations, so to put RAYNET on a legal basis the terms of the amateur licence were amended.

Today, amateurs can legally pass messages under emergency or exercise conditions at the request of the police, the Red Cross, the SJAB, and county or borough emergency planning officers. This includes communications at county shows and similar functions, sponsored walks, public events, and civil defence operations.

RAYNET is a completely voluntary organisation. The radio equipment is usually the property of individual members, but some groups do have base stations located, and ready for emergency use, in police stations, county or borough emergency headquarters, Red Cross, and St John, premises, etc.

The emergency communications offered can be adapted with great skill and ingenuity to meet virtually any situation. Mobile or handheld equipment can be provided as well as base stations linked, as necessary, to emergency headquarters. There has been increasing use of RTTY (radio teleprinter) in recent years, and packet radio is now attracting interest with its potential for error-free reception.

WINTER CONDITIONS

During last winter's heavy snow conditions RAYNET was as busy as ever. In Leicester it operated a "snowdesk" service in collaboration with the CEPO providing travel information for mobile amateurs and the community at large. The area covered, with the help of repeater GB3CF, extended from Birmingham to Newark and from Sheffield to Luton. The service operated for 40 hours over 4 days, and over 3000 messages were passed.

In Norfolk, RAYNET assisted the police, CEPO, the ambulance service, health authority, social services, and highway department. They were involved in getting patients and doctors to hospital, conveyance of urgent drugs, baby's milk, fuel and provisions, to various parts of the county, a search for a missing person, and road condition surveys. The total activity exceeded 6000 RAYNET hours.

In Strathclyde, RAYNET together with the army helped provide the social services with communication controlled transport from Garelochhead to Harthill and from Kirkintilloch to Kilmarnock. RAYNET also helped with its own four-wheel drive vehicles, delivering food parcels, 50p pieces for meters, and carrying DHSS officials making payments. They delivered coal and calor gas, checked on

pensioners and others at risk; collected and delivered donations of blankets to those in need; collected absconders from police stations and returned them to children's homes; took persons from flooded homes into care, and a baby home from hospital.

These are just examples of RAYNET activity last winter, and a good number of groups were engaged in similar work in other parts of the UK. It all goes to show that there can be a lot more to amateur radio than just sitting down in a warm shack and talking into a microphone!

This is the public service facet of amateur radio, often unreported, which gives amateurs the opportunity to make a contribution to the community in which they live, using the skills and expertise they have acquired through their hobby. All amateurs, potential or licensed, can find a place to match their abilities in RAYNET.

RE-ISSUE OF OLD LICENCES

The DTI has announced a change of policy regarding the re-issue of lapsed amateur radio licences. Prior to 1958 licences were issued on the basis of different qualifications to the present Radio Amateur's Examination. Such licences, with their associated original call-sign, could not be re-issued after lapsing unless the current RAE qualification was obtained. This has led to a situation in which some amateurs who were licensed before 1958 have been able to retain their licences by keeping them current (although no longer active in the hobby), while others who lapsed their licences have had to take the RAE if they wished to operate again.

Now, the original holder of a lapsed pre-1958 licence can apply for his or her old licence to be re-issued without examination. The onus is on the applicant to provide firm evidence of previously having held the licence, plus proof of identity. This announcement follows on from the concession announced last June which extended for life the validity of the amateur Morse test, thus bringing its validity into line with that of the Radio Amateurs Examination. The only anomaly left was the question of pre-1958 lapsed licences and, after representations from the RSGB and consideration of several individual cases, the DTI decided to bring this into line as well.

Licensees with call-signs structured G5 plus three letters will not, however, be able to obtain their old calls as this series was recently withdrawn from use and current holders were issued with new call-signs. Anyone who held an amateur licence before 1958, and who would like to get back into the hobby under this new arrangement, should apply with appropriate documentary evidence to the DTI, Radiocommunications Division, Amateur Radio Section, Room 613, Waterloo Bridge House, Waterloo Road, London SE1 8UA.

ON SPEC

*a regular
feature for
the Spectrum
Owner...*

by Mike Tooley BA

THIS month, as promised, we shall be taking a look at Ocean's brand new development system for the Spectrum, "Laser Genius". We begin, however, with some problems raised by owners of the new Plus Two machine.

Plus Two Problems

Several regular readers of this column have written to ask whether our projects are compatible with the Plus Two machine should they decide to "upgrade". Other, newcomers to the column, already have the new Spectrum Plus Two and have asked for some clarification on the bus connections at the rear of the machine.

Readers will undoubtedly be aware that the Plus Two can operate in one of two basic modes, "48K" and "128K". In the former case, the "standard" Spectrum memory map (i.e. that of the 48K Spectrum and Spectrum Plus) has been preserved.

As far as I am aware, and with the notable exception of the Video Output Interfaces described in November 1985 EE, all the projects published in *On Spec* will work with the Plus Two machine when running in "48K mode". In addition, many others will work with the Plus Two operating in full "128K mode". Whilst on the subject, although the Sound Synthesiser (May and June EE) will work quite happily in the Plus Two operating in "48K mode", there is little point in using this particular interface with the latest machine as it already has its own built-in sound synthesiser!

Sensibly, Amstrad have maintained virtually the same pin assignment of the edge connector on the Plus Two as that used with the expansion connector on all previous machines (16K, 48K and Spectrum Plus). It is annoying, however, to note that the error concerning pin-22 on the upper side of the connector still persists.

This line (pin-22) is still shown as "-12V" but, in reality, it is a 20V high frequency a.c. signal having a mean value of approximately 10.5V. This line should not be loaded (it is driven directly from the collector of the oscillator used in the d.c.—to—d.c. inverter) and any require-

ment for an external -12V rail should be satisfied some other way. *You have been warned!*

Other differences involve pins 14 to 17 on the lower side of the connector (marked "not used"). These lines are, in fact, active and were used for video signals in previous models of the machine. They are redundant on the Plus Two machine since the video signals are available as R, G, B and composite PAL on the eight pin DIN connector at the rear of the machine. This is a much more sensible scheme than that of providing the colour difference signals (U, V, and Y) at the edge connector!

A perennial problem of the Plus Two relates to the connections used for the 9-way D-connector fitted to the joystick interface. Just why Amstrad decided upon a different pin convention is open to speculation.

In any event, compatibility problems can be overcome by either modifying the wiring of a conventional "Atari standard" joystick or by manufacturing an adaptor (using a 9-way D-type plug and socket). To assist Plus Two owners in this task, Fig. 1 shows the pin connections required.

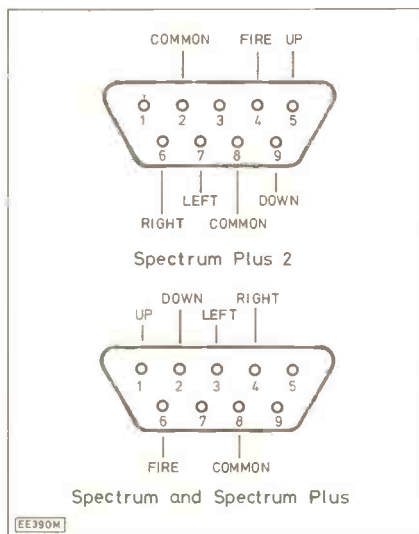

Fig. 1. Joystick connector (pin view).

Laser Genius

Some months ago, whilst looking at three of the most popular enhanced BASIC packages for the Spectrum, I reviewed Ocean's "Laser BASIC". The general finding was that, whilst this was a very neatly produced package which offered a great deal to the user wishing to develop programs using sprites, it offered little in the way of the more general enhanced facilities available with Mega BASIC and Beta BASIC.

It was interesting, therefore, to learn that Ocean have introduced another in their series of "Interactive Software" for program developers. This time they have produced Laser Genius, a complete program development environment for those programming in assembly language. My own favourite in this area has long been Hisoft's excellent "Devpac" and it was with some initial doubts that I began to examine Ocean's claims for their rival development package.

The four basic components of the Laser Genius are an editor, assembler, monitor, and analyser. The assembler is co-resident

with the editor whilst the analyser forms an optional extension to the monitor.

The editor is a joy to use. It offers full screen editing using the cursor controls, a forty column display, and beautifully smooth scrolling. The editor produces tokenised source files (thus saving memory space) which can be loaded and saved from/to tape or microdrive from within the editor.

The editor uses block/paragraph numbering rather than line numbering and listings are automatically formatted. The two-pass assembler is then invoked by the command 'ASSEM'. Assembly is fast with the usual error and warning messages appearing on the screen at the end of each pass.

The command 'TABLE' generates a symbol table whilst 'EXECUTE' can be used to run the code generated by the assembler. Warnings are also given when entering text into the editor. This nice feature saves a lot of wasted time, particularly for the newcomer!

The editor has two outstanding features which greatly simplify program development. The first is an ability to repeat a previous command simply by steering the cursor to the appropriate line and pressing 'ENTER'.

The second is that, by virtue of the screen buffering employed, one has a complete record of what went on in a programming session. One simply scrolls the screen backwards to see what went on previously. Anyone who has done any measure of program development will understand just how valuable this feature can be!

I put the editor/assembler through its paces with some simple code routines and then, after testing the code from within the editor, saved it to tape for later analysis with the monitor/analyser.

Monitor/Analyser

The monitor and analyser has to be loaded separately (after performing a reset) and the user has a choice of using either high or low memory. The monitor also employs a 40 column display which shows register contents, flags, memory contents, stack contents, and has separate areas for disassembly as well as a command edit line. The debugger has all the usual facilities expected of a Z80 debugger as well as a number of special features including slow running (in eight different modes), an excellent trace facility, and up to eight breakpoints.

With graphics applications in mind, the monitor has a handy "virtual screen" facility. The user's own screen is restored once program execution has terminated.

There is, however, one slight snag; the user has to find 6912 free bytes of memory in which to store the virtual screen whilst the monitor "front panel" is being displayed. Provided one has this amount of memory to spare, the facility can be extremely useful!

The functions of the monitor are further extended with the analyser. This unusual extension allows "intelligent" breakpoints (i.e. breakpoints which will stop a slow run when a user-definable condition occurs).

The analyser uses a subset of the FORTH language. Doubtless the reason for the choice of FORTH is the compactness of the language coupled with fast speed of execution. Newcomers to FORTH need not worry overmuch as the rudiments of the

language can soon be acquired sufficient to make full use of the analyser without recourse to other texts.

The monitor and analyser was checked using the code previously saved to tape; the program being "slow run" and "traced" with the various modes available. The monitor performed impeccably at all times and would undoubtedly cope admirably with the most flawed of programs.

Laser Genius is provided with a comprehensive 150-page manual. The manual is logically arranged and contains a number of useful appendices.

Beginners to assembly language programming would, however, do well to

acquire one or more introductory level texts in order to make full use of the package. Lance Leventhal's *Z80 Assembly Language Programming* must be considered the outstanding reference source in this respect though a number of cheaper texts have appeared in recent years with the Spectrum specifically in mind.

All in all, Laser Genius can be highly recommended. It does provide a complete environment for Spectrum program development and, by any standard, represents exceptionally good value for money.

Any reader intending to develop assembly language programs would do well to purchase this package as a first step—it will undoubtedly repay the investment

many times over in terms of time saved and ease of use. Well done Ocean, this one really is a winner!

If you would like a copy of our *On Spec Update*, please drop me a line enclosing a large (A4 size) stamped addressed envelope.

Mike Tooley,
Department of Technology,
Brooklands Technical College,
Heath Road, Weybridge,
Surrey, KT13 8TT.

Next month: We shall be dealing with the construction of a simple five-channel optically isolated input port.

MARKET PLACE

ELECTRONICS course, cost £130 plus everything for beginner. Multimeter, drill, iron, etc., plus some books. Offers. C. Miskimmin, 27 President House, King Square, London EC1V 8DB.

WEIR P.S.U. 0-17V d.c., 0-13V a.c. £20. Tel: 0934 31931.

CIRCUIT diagram for 'Trecoscope' range electronics. Circuit diagram Beamec tube tester made by Grünther. W. T. Moorby, 83 Kellet Rd., Carnforth, Lancs. LA5 9LR.

DISABLED person requires books on radio repair or where to obtain same. Your help appreciated. Mr. E. Berry, Tidal House, Commercial Road, Penryn, Cornwall.

ENTHUSIAST retiring. 3 large 10kg parcels. 500+ new components. Other goodies. £15 each, post free. Mr. K. G. Bailey, 40 Seymour Close, Selly Park, Birmingham B29 7JD. Tel: 021-472 3688.

REQUIRE microwave oven leakage detector circuit or where I can obtain one ready made. B. Marshall, 32 Fairfield App, Wraybury, Nr. Staines, Middx. TW19 5DS. Tel: 078 481 2289.

NEEDED October 85, June 86 *Everyday Electronics*. F. Chappell, 129 Bourne Ave., Hayes, Middx. UB3 1QR. Tel: 01-561 4801.

WANTED *Radio and Electronics Constructor*, January 1973 issue. Also possible source for oscilloscope type C.R.T. Paul Fellingham, 26 Fitch Drive, Brighton, E. Sussex BN2 4HX.

PRINTER dot-mat parallel Centronic horizon N.L.Q. V.G.C. £155 ono. Tel: Brighton 410715.

NORTHERN IRELAND Commodore user group. Members from anywhere in UK welcome. Send sae to address below: Mr. P. Gilchrist, 3 Toberhewny Lane, Lurgan, Co. Armagh, N. Ireland BT66 7EE.

CBM 8024 printer. 132 column. Needs new print head. Otherwise OK. No offer refused. W. A. L. Smith, Woodlands, Vicarage Lane, Nonington, Kent CT15 4JT. Tel: 0304 840404.

WANTED circuit for Fisher amp-tuner type 400 TTM. S. Bennett, 'Ashley', Lambs Lane, Lawshall, W. Suffolk. Tel: 0284 830411.

ANY information wanted on how to operate Mael 4000 computer with Logabax printer. J. S. House, Church View, Atherton, Umberleigh, N. Devon EX37 9HY.

COMMODORE 64, Vic 20 Disc Drive 2 printers cassette player, approx. 600 software items, colour monitor £500 o.n.o. David Rees, The Old Rectory, Thurlbear, Taunton, Somerset TA3 5BW.

TWO 8 megabyte hard disc drives, PSU, cables, manuals £100 o.n.o. Mark, 082-98 241 evenings. Mark Butler, Isle Farm, Tilston, Nr. Malpas, Cheshire SY14 7HN.

ACORN Electron with elite. £65. Also two ½ inch nine digit fluorescent displays 9-LT-03 £5 each (multiplexed). S. Timmons, 6 Comley Avenue, Poulton-le-Fylde, Lancashire.

FREE READERS ADS.

RULES Maximum of 16 words plus address and/or phone no. Private advertisers only (trade or business ads. can be placed in our classified columns). Items related to electronics only. No computer software. EE cannot accept responsibility for the accuracy of ads. or for any transaction arising between readers as a result of a free ad. We reserve the right to refuse advertisements. Each ad. must be accompanied by a **cut-out valid** "date corner". Ads. will not appear (or be returned) if these rules are broken.

REGULATED POWER SUPPLIES, 5V/10A 5V/5A 24V/1.5A £15 each. 18 AVT vertical antenna £35 or exchange bench DMM. Mike Zagorski, 7 Reid Road, Invergordon, Ross-shire IV18 0QF.

WANTED plug-in Tele Text Orit and back numbers of *Everyday Electronics*. J. Fulton, Derrynaseer, Dromore, Co. Tyrone BT78 3BE.

TIL311 7-seg. LEDs with decoders £1 each. 2716 Eproms 50p. Tel: 0491 681237 after 6pm.

TWO EM102 solid state oscilloscopes 30MHz dual-beam needing attention £100. Tel: Tim on Hastings 438022.

PIONEER SA5300 stereo amplifier also belt drive turntable. Swap Spectrum 48K with extras, printer, interface etc. Ivan Comiskey, 33D North Great Clarence Street, Summerhill, Dublin, Ireland.

LEARAKIT Oscilloscope by BNRES plus electronic lessons and manuals. Offers please Mr. L. Pounder, 110 Baring Street, South Shields, Tyne & Wear NE33 2BA.

VALVE Oscilloscope Solartron unfunctioning. Contains many transformers. Tube OK. Must collect. £10. Also superb C64 system. Mr. Keith Parker, Westbourne Farm, Fulbourn, Cambridge CB1 5ED. Tel: Cambridge (0223) 247980.

Please read the **RULES** then write your advertisement here—one word to each box. Add your name, address and/or phone no. Please publish the following small ad. **FREE** in the next available issue. I am not a dealer in electronics or associated equipment. I have read the rules. I enclose a **cut-out valid** date corner.

Signature..... Date.....
COUPON VALID FOR POSTING BEFORE 17 JULY, 1987
(One month later for overseas readers.)

SEND TO: EE MARKET PLACE, EVERYDAY ELECTRONICS, 6 CHURCH STREET, WIMBORNE, DORSET BH21 1JH.

BLOCK CAPITALS PLEASE

| | | | |
|-----------------|--|--|--|
| | | | |
| | | | |
| | | | |
| | | | |
| | | | |
| Name & Address: | | | |
| | | | |
| | | | |
| | | | |

For readers who don't want to damage the issue send a photostat or a copy of the coupon (filled in of course) with a **cut-out valid** "date corner"

FOR YOUR ENTERTAINMENT

BY BARRY FOX

New Technology

The daily newspaper *Today* recently celebrated its first year in print. Colourful proprietor Eddie Shah has gone back to publishing free-sheets in the provinces because *Today* is struggling. Sales have not yet reached the 0.5 million break-even point and the paper is said to be losing £2.5 million a week. (Is there really that much money in the world?)

Whether *Today* succeeds or fails, the newspaper publishers have good reason to be grateful to Eddie Shah. By introducing new technology to the newspaper industry he opened the floodgates and made it possible for all the publishers to junk 100 year old machinery and work practices. "New technology" is of course the buzz phrase used to describe a computer system which lets journalists type words into a terminal, display them on screen for editing and then feed them direct to the presses. It cuts out the laborious intermediate step of casting printing plates out of molten metal. The other publishers in Fleet Street watched what Shah was doing and learned from his mistakes and teething problems. I encountered some of those problems first hand. It was quite an eye-opener.

Last summer I was asked to write some articles for *Today* and was encouraged to send them by telephone line from my home computer, direct into the *Today* computer. Making the connection, with a 300 baud modem, was relatively easy because I was already set up to use the Telecom Gold electronic mail system. For anyone new to baud rate, parity, data, stop and start bit settings it would have been even less fun.

The *Today* computer, a PDP 11, obediently swallowed my article and displayed it on the editor's screen. He wasn't too pleased, however. Every word and sentence had been run into one enormous paragraph, with the spaces between words removed at the end of every line. The result was a wodge of gibberish.

I asked the *Today* computer room for advice. They knew only that the system had been set up to receive data from Tandy portables and did odd things with input from anything else. The *Today* computer room told me try Hastech, the new technology firm in Reading, which had installed their system.

I asked Hastech. And asked. And asked. Promised advice never materialised. Calls weren't returned. When I did get to speak with the Hastech "experts", who supposedly knew all about the *Today* system, they told me I should seek advice from the firm which had made my computer; I just couldn't get it through to them that the problem was a matter of compatibility between the Hastech system software and the wide range of wordprocessing software used by desk top PCs. The make of computer hardware was out of the equation.

A succession of Hastech people did everything but answer my question. Eventually they started saying that *Today* would have to pay them for a new software "module" to cope with my special prob-

lem. Suspecting that Eddie Shah might not take kindly to this I gave up asking for advice and switched to the simple question—how does the Hastech new technology system handle incoming end-of-line and end-of-paragraph markers? With an answer to that I could jiggle my software to suit it.

Letters detailing the problem and asking the question went unanswered. I sent a string of telexes to the Hastech head office in America. This went on for over two months and no-one ever did give me an answer. Finally Hastech came up with the classic cop-out. I should talk to *Today*, they said, because it was up to them to decide whether they wanted me to have access to their system. We had gone full circle!

At the end of all this I could well understand why the newspaper industry has been so reluctant to modernise. It's easier to stay in the 19th century.

I did finally find out how to crack the problem. No thanks to Hastech, though. London software company Psion worked it out. I'll pass on the information for the benefit of anyone who is still, or is in the future, faced with similar communication problems between a mini and a PC. If my experience is anything to go by, there is a yawning communications gap between the professional computer industry, which works with minis, and the small business world of desktop PCs—even though there is often a need for PCs and minis to communicate by hard wire network or telephone line.

The Hastech system at *Today* seems to have been set up to strip out all carriage returns and paragraphs. So it generates one long stream of text which it then reformats on the screen of the *Today* editor's wordprocessor. The Tandy portable sends text as a stream of words with spaces between each one. The Hastech system then reformats this stream into a readable paragraph. So all is well with input from a Tandy portable.

But many desktop wordprocessors put a carriage return at the end of each line, so there is no space between the word at the end of one line and the word at the beginning of the next. When the Hastech system strips out these carriage returns, the words at the end of each line run into the words at the beginning of the next line. This happens because there is now nothing—neither space nor line break—in between.

The solution is to put a space in at the end or beginning of each line. It is a laborious process to do this manually. The trick is to set the PC software to replace each carriage return with a space or add a space at each carriage return and line feed. This can be done with some communications programs which will substitute one character for another. Or it can be done by a word processing program which has the option of printing to a file (i.e. onto disc) instead of to a printer and on to paper.

The story has a twist in the tail. When, with the help of Psion, I had finally cracked the system, I sent through a story to *Today* about new Walkmen personal stereos. With bated breath I phoned the editor to

check whether it had arrived safely. "Oh yes," he said, and read it back to me.

The title was correct, but the text was a report on cricket in the West Indies. At that point I gave up and posted a print-out of the correct text.

The Cornflake Fix

We have all read about—and mostly been bored stiff by—the Big Bang. That's the deregulation of share and money trading in the City, with heavy reliance on computers that go wrong.

The City money men are like junkies deprived of their fix if they can't keep a watch on the share prices and money markets. That's why at least one City restaurant, "Coates" in London Wall, now has a TV screen over the bar which is linked by telephone line to Telerate; the viewdata system which tells the stockmarket how much people are winning and losing.

Coates also has a satellite dish on the roof and a VHS video machine so that it can screen endless pop videos on another set alongside the Telerate statistics. The system was rigged by a London hi fi dealer, quaintly named "The Cornflake Shop".

They needed a set with several video inputs. But not many British sets have one video input, let alone several. Cornflake ended up buying a foreign Nordmende set which has two Scart or Peritel sockets, as well as an aerial socket.

Continental manufacturers are now building Scart sockets onto all their video and TV equipment (it's compulsory in France) because one 21-pin socket gives the widest possible range of input and output options. The Continentals are doing this for a very good reason. When direct broadcasts from satellite start in France and Europe, probably some time this year, they will use the MAC system in FM on Super High Frequencies. Although MAC is a 625 line, 50Hz format, SHF-FM-MAC signals are incompatible with all existing TV sets and video recorders which work with a.m. signals at v.h.f. or u.h.f. and PAL or SECAM.

A MAC DBS decoder on top of the set will process the MAC f.m. signal coming down from space and put out a Component or RGB video signal. This will feed from a Scart socket on the decoder direct into the Scart socket of a TV set or video recorder.

Sets with normal PAL or SECAM composite inputs won't be any use unless the satellite decoder additionally converts the signal to composite PAL or SECAM—which is a clumsy process. Now that most shops are stocking conversion leads that let you connect Scart sockets to conventional audio or video sockets, it makes sense—when buying new equipment—to look for Scart sockets.

Incidentally, the French also like Scart because it helps make a TV set the centre of a home automation system, with high quality signals coming in from a computer or video recorder. This is one reason why the French and German governments are prepared to subsidise DBS while people slowly buy MAC receivers and decoders.

Poor Robert Maxwell and his Mirror Group still don't seem to have woken up to all this and are still talking about broadcasting soon from a continental satellite into Britain—blissfully unaware that no-one will have the necessary MAC decoders.

DOWN TO EARTH

BY GEORGE HYLTON

AUTOMATIC AUDIO LEVEL CONTROL

If you listen to short-wave broadcasts you may have noticed that some of the presenters in them do a lot of heavy breathing. When they pause to draw breath you hear a gasp. The same thing, to a lesser extent, is heard on some domestic programmes on medium and long waves. These presenters are not chronic bronchitics. If you were with them in the studio you'd hear nothing unusual. The breathiness heard at the receiver is the accidental result of the treatment given to the audio signal at the transmitter.

MODULATION DEPTH

Radio transmitters do not have unlimited power. In the law-abiding parts of the

world the power is limited by international agreement. For a short-wave transmitter this could be 50-100kW. Even in less law-abiding countries economics and technical feasibility combine to impose their own limit, say 1MW.

To make the best use of the available power, engineers want to impress the programme on the carrier wave as strongly as possible. In an amplitude-modulated (a.m.) transmission (as used in long, medium and short-wave broadcasts) this means that the carrier should be modulated as deeply as practicable. It's the audio signal from the studio that modulates the carrier. So this audio signal should be of adequate strength to produce a good depth of modulation.

On the face of it this is no problem. All that needs to be done is to turn up the gain of the microphone amplifier or playback desk to deliver enough output to produce the required depth of modulation, isn't it?

The trouble is that the strength of speech and music varies from moment to moment. A gain setting which enables the softer parts to modulate deeply makes the louder parts overmodulate and distort. Since the loudest parts of speech may give microphone output voltages a thousand times greater than the softest parts the engineer has a real problem. With orchestral music the range is much greater and the problem much worse.

COMPRESSION

The way out is to devise some system which automatically boosts the low-level parts of the audio, or weakens the high-level passages. This compresses the volume range, enabling the modulation to be reasonably deep even during the softer sounds. Compressors usually work by detecting the strongest sounds and turning the volume down. If there is a quiet passage, the gain rises again.

Experience shows that the best arrangement is to make the gain-control system respond rapidly (in milliseconds) to a rise in volume but recover more slowly (in hundreds of milliseconds) during an ensuing quiet passage. In this way, when a loud voice is speaking, the compressor has a long enough memory to keep the gain low during the normal intervals between words or syllables, but recovers rapidly enough at the end of a question to cope with a reply from a softer voice.

When the timing is optimised in this way, however, the gain rises rapidly enough at the end of a sentence to boost the sound of an intake of breath. Hence the apparent gasping of the announcer who comes to the end of a sentence, pauses for an instant, then takes a deep breath just when the compressor is turning up the gain.

gain. The effect on music can be much worse. A concert grand may be turned into a honky-tonk piano.

METHODS

Despite these shortcomings audio compression and its close relative, automatic level control (ALC) as used in tape recorders, work well enough to be really useful.

A very simple method is to pass the audio signals through a limiter which prevents the peak voltages from exceeding a certain fixed value. One possible limiter (Fig. 1) is a pair of silicon diodes, connected back-to-back in parallel and fed with audio via a high resistance. The diodes short the audio path if the peak level exceeds about 600mV, removing the shaded portions.

This crude system has been used, in some parts of the world, but it's a poor one. The signals, being peak-clipped, are badly distorted. Some of the distortion can be removed by passing the clipped audio through a low-pass filter, but the quality is still unpleasant.

A better system (Fig. 2) is to adopt the principle of automatic gain control (a.g.c.) used in radio receivers. The audio at the output of an amplifier is rectified, smoothed to give a d.c. control voltage or current, and applied as a bias to reduce gain. The time constant RC of the smoothing circuit is made long enough to hold the gain reasonably steady during natural pauses in speech.

This system has disadvantages. Unless the output impedance of the amplifier is very low, the detector clips the peaks off the audio when the diode conducts to charge C. This can be dealt with by good design, but there is another difficulty. Any amplifier suitable for a.g.c. distorts the waveforms of the signals it is handling. In a radio, this isn't serious, because it's the r.f. or i.f. carrier wave which is distorted.

The extra, unwanted frequencies which make up most of the distortion products are removed by the i.f. filters. But with audio a.g.c., filtering doesn't help much, because most of the distortion products lie within the wanted audio band. It would improve matters to turn the audio into a high-frequency signal, apply a.g.c., filter out the nasties and then reconvert to audio. That greatly reduces distortion; so much so that even a peak-clipping limiter (Fig. 1) becomes fairly tolerable.

One reason why a.g.c. (Fig. 2) gives bad distortion is that the full audio signal is applied to the amplifier. Distortion is usually worst when the signal is large. It is much better to arrange for the signals to be reduced by the system before they are applied to the circuit that produces a.g.c. This leads to the arrangement of Fig. 3. Like Fig. 1, this uses diodes across the signal path, but now they are controlled, not by the incoming signal directly but by an a.g.c. current derived from the output.

This d.c. control current is much greater than the low level signal currents in the diodes, and the diodes behave, to the signal, rather like resistances. The greater the control current, the lower the resistance and the higher the attenuation. The audio levels in brackets illustrate the point. Only about 1mV of audio is applied to the diodes so even though these are non-linear devices distortion is relatively low. In a refined version the diodes are replaced by f.e.t.s and attenuate with very little distortion.

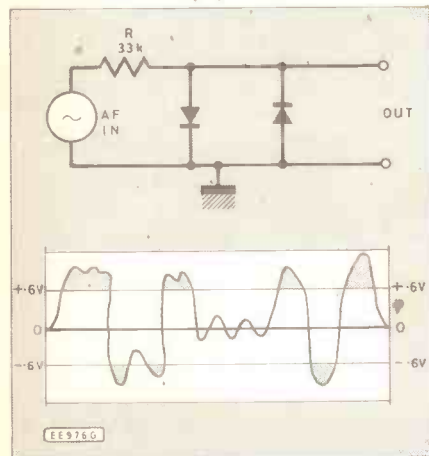
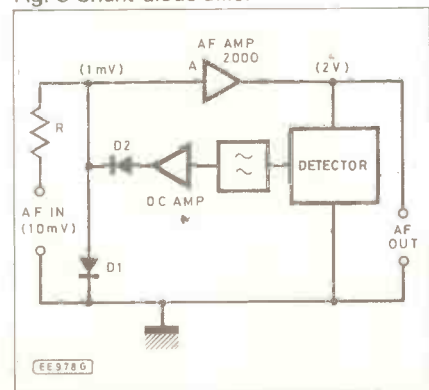
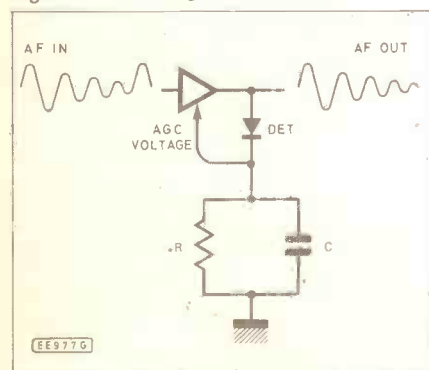

Fig. 1 Clipped audio

Fig. 2 Automatic gain control



PCB SERVICE

Printed circuit boards for certain constructional projects are now available from the PCB Service, see list. These are fabricated in glass-fibre, and are fully drilled and roller tinned. All prices include VAT and postage and packing. Add £1 per board for overseas airmail. Remittances should be sent to: The PCB Service, Everyday Electronics Editorial Offices, 6 Church Street, Wimborne, Dorset BH21 1JH. Cheques should be crossed and made payable to Everyday Electronics. (Payment in £ sterling only.)

Please note that when ordering it is important to give project title as well as order code. Please print name and address in Block Caps. Do not send any other correspondence with your order.

Readers are advised to check with prices appearing in the current issue before ordering.

NOTE: Please allow 28 days for delivery. We can only supply boards listed in the latest issue. Boards can only be supplied by mail order and on a payment with order basis.

| PROJECT TITLE | Order Code | Cost |
|--|------------|-------|
| — JULY '83 — | | |
| User Port Input/Output <i>M.I.T. Part 1</i> | 8307-01 | £4.82 |
| User Port Control <i>M.I.T. Part 1</i> | 8307-02 | £5.17 |
| — AUGUST '83 — | | |
| Storage Scope Interface, BBC Micro | 8308-01 | £3.20 |
| Car Intruder Alarm | 8308-02 | £5.15 |
| High Power Interface <i>M.I.T. Part 2</i> | 8308-03 | £5.08 |
| Pedestrian Crossing Simulation <i>M.I.T. Pt 2</i> | 8308-04 | £3.56 |
| — SEPTEMBER '83 — | | |
| High Speed A-to-D Converter <i>M.I.T. Pt 3</i> | 8309-01 | £4.53 |
| Signal Conditioning Amplifier <i>M.I.T. Pt 3</i> | 8309-02 | £4.48 |
| Stylus Organ | 8309-03 | £6.84 |
| — OCTOBER '83 — | | |
| D-to-A Converter <i>M.I.T. Part 4</i> | 8310-01 | £5.77 |
| High Power DAC Driver <i>M.I.T. Part 4</i> | 8310-02 | £5.13 |
| — NOVEMBER '83 — | | |
| TTL/Power Interface for Stepper Motor <i>M.I.T. Part 5</i> | 8311-01 | £5.46 |
| Stepper Motor Manual Controller <i>M.I.T. Part 5</i> | 8311-02 | £5.70 |
| Speech Synthesiser for BBC Micro | 8311-04 | £3.93 |
| — DECEMBER '83 — | | |
| 4-Channel High Speed ADC (Analogue) <i>M.I.T. Part 6</i> | 8312-01 | £5.72 |
| 4-Channel High Speed ADC (Digital) <i>M.I.T. Part 6</i> | 8312-02 | £5.29 |
| Environmental Data Recorder | 8312-04 | £7.24 |
| Continuity Tester | 8312-08 | £3.41 |
| — JANUARY '84 — | | |
| Biological Amplifier <i>M.I.T. Part 7</i> | 8401-02 | £6.27 |
| Temp. Measure & Control for ZX Comprs Analogue Thermometer Unit | 8401-03 | £2.40 |
| Analogue-to-Digital Unit | 8401-04 | £2.56 |
| Games Scoreboard | 8401-06/07 | £9.60 |
| — FEBRUARY '84 — | | |
| Oric Port Board <i>M.I.T. Part 8</i> | 8402-02 | £9.56 |
| Negative Ion Generator | 8402-03* | £8.95 |
| Temp. Measure & Control for ZX Comprs Relay Driver | 8402-04 | £3.52 |
| — MARCH '84 — | | |
| Latched Output Port <i>M.I.T. Part 9</i> | 8403-01 | £5.30 |
| Buffered Input Port <i>M.I.T. Part 9</i> | 8403-02 | £4.80 |
| VIC-20 Extension Port Con. <i>M.I.T. Part 9</i> | 8403-03 | £4.42 |
| CBM 64 Extension Port Con. <i>M.I.T. Part 9</i> | 8403-04 | £4.71 |
| Digital Multimeter Add-On for BBC Micro | 8403-05 | £4.63 |
| — APRIL '84 — | | |
| Multipurpose Interface for Computers | 8404-01 | £5.72 |
| Data Acquisition "Input" <i>M.I.T. Part 10</i> | 8404-02 | £5.20 |
| Data Acquisition "Output" <i>M.I.T. Part 10</i> | 8404-03 | £5.20 |
| Data Acquisition "PSU" <i>M.I.T. Part 10</i> | 8404-04 | £3.09 |
| A.F. Sweep Generator | 8404-06 | £3.55 |
| Quasi Stereo Adaptor | 8404-07 | £3.56 |

| | | |
|---|-------------|-------|
| Simple Loop Burglar Alarm | 8405-01 | £3.07 |
| Computer Controlled Buggy <i>M.I.T. Part 11</i> | | |
| Interface/Motor Drive | 8405-02 | £5.17 |
| Collision Sensing — MAY '84 — | 8405-03 | £3.20 |
| Power Supply | 8405-04 | £4.93 |
| Infra-Red Alarm System | 8406-01 | £2.55 |
| Spectrum Bench PSU — JUNE '84 — | 8406-02 | £3.99 |
| Speech Synthesiser <i>M.I.T. Part 12</i> | 8406-03 | £4.85 |
| Train Wait | 8406-04 | £3.42 |
| Ultrasonic Alarm System | 8407-01 | £4.72 |
| Electronic Code Lock — JULY '84 — | | |
| Main Board | 8407-03 | £2.70 |
| Keyboard | 8407-04 | £3.24 |
| — AUGUST '84 — | | |
| Microwave Alarm System | 8408-01 | £4.36 |
| Temperature Interface—BBC Micro | 8408-02 | £2.40 |
| — SEPTEMBER '84 — | | |
| Op-Amp Power Supply | 8409-01 | £3.45 |
| Micro Memory Synthesiser — OCT '84 — | 8410-01* | £8.20 |
| Drill Speed Controller | 8410-04 | £2.40 |
| — NOVEMBER '84 — | | |
| BBC Audio Storage Scope Interface | 8411-01 | £2.90 |
| Proximity Alarm | 8411-02 | £2.65 |
| TV Aerial Pre-Amp | 8412-01* | £2.40 |
| Digital Multimeter — DEC '84 — | 8412-02/03* | £5.20 |
| Mini Workshop Power Supply | 8412-04 | £2.78 |
| Power Lighting Interface | 8501-01 | £8.23 |
| Games Timer — JAN '85 — | 8501-02 | £2.40 |
| Spectrum Amplifier | 8501-03 | £2.40 |
| Solid State Reverb | 8502-01 | £3.68 |
| Computerised Train Controller — FEB '85 — | 8502-02 | £3.38 |
| — MARCH '85 — | | |
| Model Railway Points Controller | 8503-01 | £2.78 |
| Insulation Tester | 8504-02 | £2.53 |
| Fibrealarm — APRIL '85 — | 8504-03 | £3.89 |
| Auto Phase | 8505-01 | £3.02 |
| Amstrad CPC464 Amplifier | | |
| Mains Unit — MAY '85 — | 8505-02 | £2.56 |
| Micro Unit | 8505-03 | £2.56 |
| Voltage Probe | 8505-04 | £2.67 |
| Graphic Equaliser — JUNE '85 — | 8506-01 | £3.21 |
| Computerised Shutter Timer | 8506-02 | £2.40 |
| Mono-Bi-Astables (Experimenters Test Bed) | 8506-03 | £2.45 |
| Across The River | 8506-04 | £2.63 |
| Amstrad User Port — JULY '85 — | 8507-01 | £3.17 |
| Nascom Printer Handshake | 8507-02 | £2.40 |
| Electronic Building Blocks—1 to 4† | 8508-01 | £2.98 |
| Tremolo/Vibrato | 8508-02 | £4.03 |
| Stepper Motor Interface— AUGUST '85 — | 8508-03 | £2.40 |
| Drill Control Unit | 8508-04 | £2.90 |
| — SEPTEMBER '85 — | | |
| RIAA Preamp Input Selector | 8509-01 | £2.40 |
| Transducers Resistance Thermometer | 8509-03 | £2.64 |
| Transducers Semiconductor Temp. Sensor | 8509-04 | £2.72 |
| Transducers Strain Gauge — OCT '85 — | 501 | £2.87 |
| Soldering Iron Power Controller | 504 | £2.40 |
| Transducers— — NOV '85 — | | |
| Magnetic Flux Density Amplifier | 505 | £3.93 |
| Hallowe'en Projects (single board price) | 506 | £2.68 |
| Electronic Building Blocks — 5 to 8† | 508 | £3.07 |
| Opto Intensity Transducer — DEC '85 — | 509 | £2.70 |
| Digital Capacitance Meter | 512 | £5.22 |
| Mains Delay | 503 | £2.40 |
| Musical Doorbell — JAN '86 — | 507 | £2.91 |
| Tachometer—Transducers | 513 | £2.52 |
| Touch Controller | 510 | £2.65 |
| Function Generator — FEB '86 — | 514 | £3.10 |
| Function Generator PSU Board | 515 | £2.40 |
| pH Transducer | 516 | £2.75 |

*Complete set of boards.

M.I.T.—Microcomputer Interfacing Techniques, 12-Part Series.

†Four separate circuits.

| PROJECT TITLE | Order Code | Cost |
|---------------------------------|------------|-------|
| Mains Tester & Fuse Finder | 517 | £2.40 |
| BBC Midi Interface | 518 | £3.26 |
| Stereo Hi Fi Preamp | 519 | £5.70 |
| Interval Timer | 520 | £2.40 |
| Stereo Reverb | 521 | £2.89 |
| PA Amplifier | 511 | £2.67 |
| Mini Strobe | 522 | £2.40 |
| Auto Firing Joystick Adaptor | 523 | £2.73 |
| Watchdog | 524 | £2.81 |
| Percussion Synthesiser | 525 | £5.65 |
| Personal Radio | 526 | £2.40 |
| Tilt Alarm | 527 | £2.40 |
| Electronic Scarecrow | 528 | £2.40 |
| VOX Box Amplifier | 529 | £2.40 |
| Headphone Mixer | 530 | £4.56 |
| Solar Heating Controller | 533 | £3.32 |
| Car Timer | 538 | £2.40 |
| Freezer Failure Alarm | 534 | £2.40 |
| Infra Red Beam Alarm (Trans) | 536 | £3.32 |
| Infra Red Beam Alarm (Rec) | 537 | £3.32 |
| Scratch Blanker | 539 | £5.43 |
| 10W Audio Amp (Power Amp) | 543 | £2.58 |
| (Pre-Amp) £4.78 Pair | 544 | £3.18 |
| Light Rider—Lapel Badge | 540 & 541 | £2.70 |
| —Disco Lights | 542 | £4.55 |
| —Chaser Light | 546 | £3.23 |
| Modem Tone Decoder | 547 | £2.76 |
| 200MHz Digital Frequency Meter | 548 | £4.12 |
| Dual Reading Thermometer | 549 | £5.87 |
| Automatic Car Alarm | 550 | £2.40 |
| BBC 16K Sideways RAM | 551 | £2.40 |
| (Software Cassette) | 551S | £4.95 |
| Random Light Unit | 552 | £4.70 |
| Car Voltage Monitor | 553 | £2.40 |
| Mini Amp. | 554 & 555 | £4.55 |
| Video Guard | 556 | £3.05 |
| Spectrum I/O | 557 | £3.78 |
| Spectrum Speech Synthesiser | 558 | £3.88 |
| Computer Buffer/Interface | 560 | £2.66 |
| Infra Red Alarm: Sensor head | 561 | £3.35 |
| PSU/Relay Driver | 562 | £3.60 |
| Alarm Thermometer | 559 | £2.40 |
| Experimental Speech Recognition | 563 | £3.80 |
| Bulb Life Extender | 564 | £2.40 |
| Fridge Alarm | 565 | £2.40 |
| EE Equaliser—Ioniser | 566 | £3.28 |
| Mini Disco Light | 567 | £2.40 |
| Visual Guitar/Instrument Tuner | 568 | £3.18 |
| Fermostat | 569 | £2.67 |
| EE Buccaneer | | |
| Metal Detector | 570 | £3.28 |
| Monomix | 571 | £3.80 |

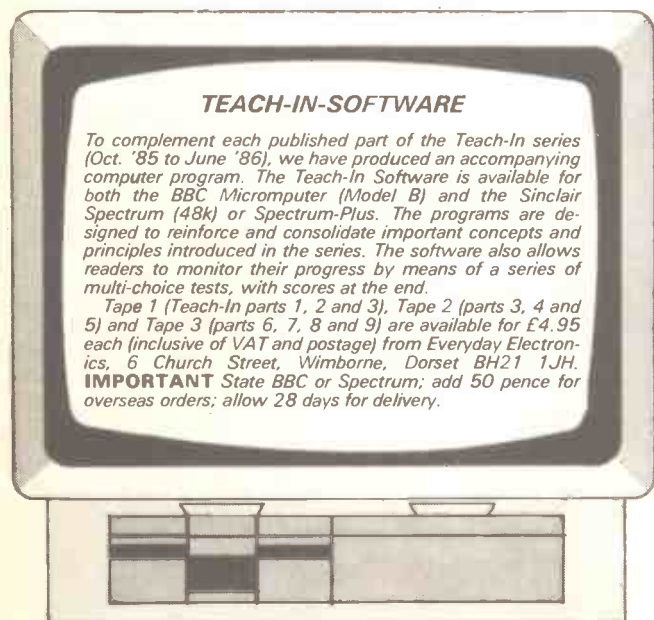

TEACH-IN-SOFTWARE

To complement each published part of the Teach-In series (Oct. '85 to June '86), we have produced an accompanying computer program. The Teach-In Software is available for both the BBC Microcomputer (Model B) and the Sinclair Spectrum (48k) or Spectrum-Plus. The programs are designed to reinforce and consolidate important concepts and principles introduced in the series. The software also allows readers to monitor their progress by means of a series of multi-choice tests, with scores at the end.

Tape 1 (Teach-In parts 1, 2 and 3), Tape 2 (parts 3, 4 and 5) and Tape 3 (parts 6, 7, 8 and 9) are available for £4.95 each (inclusive of VAT and postage) from Everyday Electronics, 6 Church Street, Wimborne, Dorset BH21 1JH. **IMPORTANT State BBC or Spectrum; add 50 pence for overseas orders; allow 28 days for delivery.**

EE PRINTED CIRCUIT BOARD SERVICE

Please send me the following p.c.b.s.

Make cheques/PO payable to: **Everyday Electronics**
(Payment in £ sterling only)

| Order Code | Quantity | Price |
|------------|----------|-------|
| | | |
| | | |
| | | |
| | | |

I enclose cheque/PO for £.....

Name.....

Address.....

Make cheques/PO payable to: **Everyday Electronics**

Please allow 28 days for delivery

BLOCK CAPITALS PLEASE

SUBSCRIPTIONS

Sell-out disappointment can upset any reader! So why not take out a year's subscription and make sure of every issue, by post, straight from the Publisher? Complete the order form below and post to: EVERYDAY ELECTRONICS, Subscription Dept., 6 Church Street, Wimborne, Dorset BH21 1JH. Tel. 0202 881749.

Annual subscription rates:
UK £14. Overseas £17 (£ sterling only)
Overseas air mail £33 (£ sterling only)

EVERYDAY ELECTRONICS SUBSCRIPTION ORDER FORM

Annual subscription rates:
UK £14. Overseas £17 (surface mail) £33 (air mail)

To: Everyday Electronics,
Subscription Dept., 6 Church Street, Wimborne, Dorset
BH21 1JH.

Name.....

Address.....

I enclose payment of £..... (cheque/PO in £ sterling only payable to Everyday Electronics)

Subscriptions can only start with the next available issue. For back numbers see the Editorial page

EVERYDAY ELECTRONICS

Reach effectively and economically today's enthusiasts anxious to know of your products and services through our semi-display and classified pages. The prepaid rate for semi-display spaces is £8.00 per single column centimetre (minimum 2.5cm). The prepaid rate for classified advertisements is 30 pence per word (minimum 12 words), box number 60p extra. All cheques, postal orders, etc., to be made payable to Everyday Electronics VAT must be added. Treasury notes should always be sent registered post. Advertisements, together with remittance, should be sent to the Classified Advertisement Dept., Everyday Electronics, 6 Church Street, Wimborne, Dorset BH21 1JH. Tel: 0202 881749.

Electronic Components

DELUXE WALKIE TALKIES LONG RANGE 49MHZ. £24.99/pair (normally £31.49). Satisfaction or refund. Send £3 now, pay balance upon receipt. 48hrs delivery. Xenon (Dept EE9), 24 Wharnclyffe Street, Barnsley, Yorkshire.

Service Manuals

SERVICE SHEETS from £2.50/1sae civ/music/combis £3.50/1sae. Sae Newnes & TV Technic Books in stock. Thousands Service & Repair Manuals. SAE Free Review/pricelists. TIS (EE), 76 Church St, Larkhall (0698 883334), Lanarkshire.

WORKSHOP SERVICE MANUALS

Thousands stocked, most makes, models, types, audio, TV, video, test, amateur etc. LSAE enquiries/quotation and FREE Review/price lists with details of our Unique Repair and Data Guides, from Valves to Videos.

MAURITRON (EE), 8 CHERRY TREE ROAD, CHINNOR, OXON OX9 4QY.

Printed Circuit Boards

PRINTED CIRCUIT BOARDS produced to own personal requirements. Please send SAE for details to: Mr. B. M. Ansbro, 38 Poynings Drive, Hove, Sussex.

Special Offers

FREE MEMBERSHIP to a new national electronics club. For details and a free pack of components worth over £10 send only £1 p&p to Dept. EE, Woodside, Dowsett Lane, Ramden Heath, Billericay, Essex CM11 1JL.

CASSETTE MOTORS large and small. 2 for £1.00. Mono and stereo cassette tape heads. 2 for £1.00. Microphone small for cass, tel. etc. 2 for £1.00. Please add 75p p&p, no VAT. Access card accepted. Golden Orange Supplies, Brockhollands Road, Woodside, Bream, Lydney, Glos. Tel: 0594 563009.

TURN YOUR SURPLUS

ICS transistors etc into cash, immediate settlement. We also welcome the opportunity to quote for complete factory clearance. Contact **COLES-HARDING & CO**, 103 South Brink, Wisbech, Cambs. *ESTABLISHED OVER 10 YEARS* Tel: 0945 584188

2000 TV TUNERS

UHF TV TUNERS WITH 7-BUTTON CHANNEL SELECTOR. HOUSED IN SLIMLINE CASE, COMPOSITE VIDEO OUTPUT. BRAND NEW. CHEAP TO CLEAR.

£26.95 + VAT EACH

SCREENS MICROCOMPUTERS & ELECTRONICS
MAIN AVENUE, MOOR PARK,
NORTHWOOD, MIDDX.
TEL: 09274 20664 TLX: 929224 SCREEN G

★ BAKER ★ GROUP P.A. DISCO AMPLIFIERS post £4

150 watt Output, 4 Input Mixer pre-amp. Illustrated £99
150 watt Output, Slave 500 mv. Input 3 Speaker Outputs £80
150 + 150 watts Stereo, 300 watt Mono Slave 500 mv. Inputs £145
150 watt P.A. Vocal, 8 Inputs, High/Low Mixer Echo Socket £149
80 watt Mobile 240v AC and 12v DC, 4-8-15 ohm + 100v Imp. £89
Compact P.A. amp 20 + 20 Stereo or 40 watts Mono £65
30 watt Guitar/P.A. Amplifier, 2 inputs £59
30 watt COMBI, 12in Speaker, Treble, Base etc. £95
500 watt Heavy Duty Mono Slave Amplifier £275

| FAMOUS LOUDSPEAKERS | | FULLY GUARANTEED | | | |
|---------------------|-------------|------------------|-------|--------|-------|
| Make | Model | Size | Watts | Ohms | Price |
| GOODMANS | HFAAX | 7 1/2 x 4 in. | 100 | 8 | £38 |
| GOODMANS | HB WOOFER | 8in. | 60 | 8 | £16 |
| BAKER | DISCO/GROUP | 10in. | 50 | 8/16 | £22 |
| BAKER | MID-RANGE | 10in. | 100 | 8 | £30 |
| BAKER | DISCO/GROUP | 12in. | 120 | 8/16 | £35 |
| WEM | WOOFER | 12in. | 300 | 8 | £65 |
| GOODMANS | DISCO/GROUP | 12in. | 120 | 8/15 | £39 |
| BAKER | DISCO/GROUP | 15in. | 100 | 8/16 | £44 |
| H + H | DISCO/GROUP | 15in. | 100 | 4/8/16 | £54 |
| H + H | DISCO/GROUP | 15in. | 200 | 8/16 | £89 |
| GOODMANS | HP/BASS | 15in. | 250 | 8 | £82 |
| GOODMANS | HPD/BASS | 18in. | 230 | 8 | £92 |

COMPACT FULL RANGE SPEAKER SYSTEMS size 24 x 17 x 12in.
120 watts £100, 200 watts £130, 400 watts £180 each. Carr. £10.
MID-N-TOP 300 watts add on system complete £140 each. Carr. £10.

DISCO CONSOLE Twin Decks, mixer pre amp £149. Carr. £10.
Ditto Powered 120 watt £199; or Complete Disco £299. Carr. £30.

| MAINS TRANSFORMERS VALVE TYPE 240V PRIMARY | | Price Post |
|---|---------------------|------------|
| 250 0-250V 80mA, 6V 3A, 0-5, 6V 1A | | £10 £2 |
| 350 0-350V 250mA, 6.3V 6A CT | | £16 £2 |
| 220V 25mA, 6V 1 Amp £3.00 | 220V 45mA, 6V 2 Amp | £4 £1 |
| STEP-UP STEP-DOWN 240V-120V 150W £9, 250W £12, 500W | | £15 £2 |

LOW VOLTAGE MAINS TRANSFORMERS £5.50 each post paid
9V, 3A; 12V, 3A; 16V, 2A; 20V, 1A; 30V, 1A; 30V, 5A + 17-0-17V, 2A; 35V, 2A; 20-40-60V, 1A; 12-0-12V, 2A; 20-0-20V, 1A; 0-12-27V, 2A.

| RECORD DECKS. P&P £2. Many others in stock. Phone for details. | | | |
|--|-------|--------|-----------|
| Make | Drive | Supply | Cartridge |
| JAP Single | Belt | 12V DC | Magnetic |
| BSR Single | Belt | 240V | Magnetic |
| BSR Single | Rim | 240V | Ceramic |
| BSR Auto | Rim | 240V | Ceramic |
| Garrard Auto | Rim | 240V | Ceramic |

PROJECT CASES. Black Vinyl Covered Steel Top. All Base
4 x 2 1/2 x 2 1/2 in. £3.00; 5 x 4 x 1 1/2 in. £4.00; 8 x 5 x 2 in. £4.50 p.p. £1;
11 x 6 x 3 in. £5.00; 11 1/2 x 6 x 5 in. £10.00; 15 x 8 x 4 in. £13.50 p.p. £2.
ALUMINIUM PANELS 18 w.g. 12 x 12in. £2.50; 14 x 9in. £2.40; 6 x 4in.
65p; 12 x 8in. £1.80; 10 x 7in. £1.50; 8 x 6in. £1.00; 14 x 3in. £1.
12 x 5in. £1.15; 16 x 10in. £2.70; 16 x 6in. £1.80 p.p. 65p each
ALUMINIUM BOXES. MANY OTHER SIZES IN STOCK
4 x 2 1/2 x 2 in. £1.35; 3 x 2 x 1 in. £1.15; 6 x 4 x 2 in. £2.00; 8 x 6 x 3 in. £3.40;
12 x 5 x 3 in. £4.00; 6 x 4 x 3 in. £2.50; 10 x 7 x 3 in. £4.00 p.p. £1.

| HIGH VOLTAGE ELECTROLYTICS Many others in stock | | | |
|---|-----|------------|-----|
| 20/500V | £1 | 220/400V | £2 |
| 32/350V | 50p | 8+8/450V | £1 |
| 47/350V | £1 | 20+20/350V | 75p |

AIR SPACED TWIN GANGS 365 + 365 + 25 + 25p £2.00.
REVERSE VERNIER cord drive 90p. Spindle Extender £1.50.
VERNIER DIALS. 0-100, 36mm. £3.00, 50mm £3.50.

RADIO COMPONENT SPECIALISTS

337 WHITEHORSE ROAD, CROYDON
SURREY, U.K. Tel: 01-584 1665
Post 85p Minimum. Callers Welcome
List, Large S.A.E. Delivery 7 days Closed Wednesday

ORDER FORM PLEASE WRITE IN BLOCK CAPITALS

Please insert the advertisement below in the next available issue of **Everyday Electronics** for Insertions. I enclose Cheque/P.O. for £ (Cheques and Postal Orders should be made payable to Everyday Electronics)

| | | | | | | | | | |
|--|--|--|--|--|--|--|--|--|--|
| | | | | | | | | | |
| | | | | | | | | | |
| | | | | | | | | | |

HEADING REQUIRED:

NAME

ADDRESS

EVERYDAY ELECTRONICS
and ELECTRONICS MONTHLY
Classified Advertisement Dept.,
6 Church Street,
Wimborne,
Dorset BH21 1JH.
Telephone 0202 881749

RATE: 30p per word, minimum 12 words. Box No. 60p extra. VAT must be added.

7/87

OMNI ELECTRONICS

We stock a wide range of components: transformers, switches, pots, ICs, capacitors, resistors, diodes, boxes, triacs, LEDs, cable, connectors, PCBs—in fact, all you need for your projects.

SEND FOR CATALOGUE NOW

— send 20p + 13p or 18p stamp or call at our shop Mon–Fri 9am–6pm, Sat 9am–5pm.

174 Dalkeith Road
EDINBURGH EH16 5DX
031-667 2611

MAKE YOUR INTERESTS PAY!

More than 8 million students throughout the world have found it worth their while! An ICS home-study course can help you get a better job, make more money and have more fun out of life! ICS has over 90 years experience in home-study courses and is the largest correspondence school in the world. You learn at your own pace, when and where you want under the guidance of expert 'personal' tutors. Find out how we can help YOU. Post or phone today for your FREE INFORMATION PACK on the course of your choice. (Tick one box only!)

| | | | |
|--|--------------------------|--|--------------------------|
| Electronics | <input type="checkbox"/> | Radio, Audio and TV Servicing | <input type="checkbox"/> |
| Basic Electronic Engineering (City & Guilds) | <input type="checkbox"/> | Radio Amateur Licence Exam (City & Guilds) | <input type="checkbox"/> |
| Electrical Engineering | <input type="checkbox"/> | Car Mechanics | <input type="checkbox"/> |
| Electrical Contracting/Installation | <input type="checkbox"/> | Computer Programming | <input type="checkbox"/> |
| GCE over 40 'O' and 'A' level subjects | | | <input type="checkbox"/> |



Name _____ P. Code _____
Address _____
International Correspondence Schools, Dept ECS77, 312/314 High St.,
Sutton, Surrey SM1 1PR. Tel: 01-643 9568 or 041-221 2926 (24 hrs).

OSCILLOSCOPES

TELEQUIPMENT D75 Dual Trace 50MHz Delay Sweep £325
S.E. LABS SM111. Dual Trace 18MHz Solid State Portable AC or External DC operation 8 x 10cm display with manual £185
TELEQUIPMENT D61. Dual Trace 10MHz. With manual £150
TELEQUIPMENT D43. Dual Trace 15MHz. With manual £100
TELEQUIPMENT S54A. Single Trace 10MHz Solid State. With manual £110

MULTIMETERS

AVO 9 Mk4 (Identical to AVO 8 Mk4 but scaled differently). Complete with Batteries & Leads £55
AVO 8 Mk2 Complete with Batteries & Leads £45
Above Items in GOOD WORKING ORDER—appearance not A1 hence the price.
AVO TEST SET No 1 (Military version of AVO 8) Complete with batteries, leads & carrying case £65
AVO Model 7x. Complete with batteries, leads & carrying case £40
AVO type TEST LEADS. Red & Black with 2 Croc-Clips & 2 Prods (p&p £2) £5
Analogue Pocket Multimeters Philips/Taylor/Avo etc. Complete with Batteries & Leads ... from £10

FARNELL SINE/SQUARE SIGNAL GENERATOR type LFM2. 1Hz–1MHz. Compact. £80 ea (p&p £5)

STEPPING MOTORS

Type 1: 200 Steps per rev. 4 Phase (5 wire) 12/24V. Torque 25oz inch (will run on 5V with reduced torque) £15 ea
Type 2: 6/12 Steps per rev. 3 Phase. 12/24 (will work on 5V) £2 ea. 5 off £7.50
Type 3: NORTH AMERICAN PHILIPS 24 Steps per rev. 4 wire 5V 3-3Amps 0-250 rpm. 200PPs £6 ea
Type 4: 200 Steps per rev. 120V (3 wire) Torque 25oz inch £4 ea
Type 7: WARNER 24 Steps per rev. 3 Phase (6 wire). 28V. Holding Torque 45oz inch £5 ea

AVO TRANSISTOR TESTER TT169
Handheld GO NODD for in situ testing. Complete with batteries, lead & instructions. p&p £3. Now only £12

COMMUNICATION RECEIVERS

RACAL RA17L 500kHz–30MHz. only £150 each with manual
EDDYSTONE 730/4. 480kHz–30MHz. only £110 each with manual

SPECIAL OFFERS

COSSOR OSCILLOSCOPE CDU150. Dual Trace 35MHz. Delay Sweep. Solid State. Portable 8x10cm Display. With Manual NOW ONLY £180 each
Optional Front Protection Cover containing 2 Probes & Viewing Hood £10
SOLARTRON OSCILLOSCOPE CD1400. Dual Beam 15MHz. With Manual ONLY £65 each
AVO VALVE TESTER CT160. Suitcase style. 22 Bases. (P&P £7) ONLY £25 each

DISK DRIVE PSU. 240V in 5V 1-6A & 12V 1-5A Out. Size W125mm. H75mm. D180mm. Cased. Unused ONLY £10 ea (p&p £2)
DOWTY KEYBOARD (as in LYNX MICRO). Push to make. Cased ONLY £5 ea (p&p £2)
SWITCHED MODE PSU ± 12V 0-25A; 5V 15A; 24V 1-4A £30 ea (p&p £3)
DATRON 3000 PROM COPIER (copies up to 10) £150 ea (p&p £7)

ISOLATING TRANSFORMERS

240V IN—240V OUT
500VA £15 ea P&P £5. 100VA £8 P&P £2
240V IN—24V OUT
500VA £6 P&P £5. 200VA £4 P&P £4

B+K PRECISION CRT restorer/analyser Model 467. Supplied with 2 bases and manuals (p&p £7) ONLY £125 each
LABGEAR COLOUR BAR GENERATOR KG1 8 Test Patterns (p&p £4) ONLY £40 each

NEW EQUIPMENT

HAMEG OSCILLOSCOPE 605. Dual Trace 60MHz. Delay Sweep. Component Tester £583
HAMEG OSCILLOSCOPE 203 8. Dual Trace 20MHz. Component Tester + 2 Probes £314
All other models available.

BLACK STAR FREQUENCY COUNTERS P&P £4
Meter 100–100MHz £99
Meter 600–600MHz £126
Meter 1000–1GHz £175
BLACK STAR JUPITOR 500 FUNCTION GENERATOR. Sine/Square/Triangle. 0-1Hz—500kHz. P&P £4 £110
BLACK STAR ORION Pal/TV/Video Colour Pattern Generator £199

HUNG CHANG DMM 7030. 3½ digit. Handheld 28 ranges including 10 Amp AC/DC 0-1%. Complete with batteries & leads. p&p £4 £39.50
As above DMM 6010 0-25% £33.50
OSCILLOSCOPES PROBES. Switched x1; x10. p&p £2 £11

USED EQUIPMENT—WITH 30 DAYS GUARANTEE. MANUALS SUPPLIED IF POSSIBLE. This is a VERY SMALL SAMPLE OF STOCK. SAE or Telephone for Lists. Please check availability before ordering. CARRIAGE all units £16. VAT to be added to Total Goods & Carriage.

STEWART OF READING

Telephone: 0734 68041

110 WYKEHAM ROAD, READING, BERKS RG6 1PL
Callers welcome 9 a.m. to 5.30 p.m. Mon-Fri (until 8pm Thurs)

TELEVISION/COMPUTER FULL-TIME TRAINING

(FULL TIME COURSES APPROVED BY THE BUSINESS & TECHNICIAN EDUCATION COUNCIL)

2 YEAR
BTEC National Diploma (OND)
ELECTRONIC &
COMMUNICATIONS ENGINEERING
(Electronics, Computing, Television, Video, Testing & Fault Diagnosis)

15 MONTHS
BTEC National Certificate (ONC)
ELECTRONIC EQUIPMENT SERVICING
(Electronics, Television, Video Cassette Recorders, CCTV, Testing & Fault Diagnosis)

15 MONTHS
BTEC National Certificate (ONC)
COMPUTING TECHNOLOGY
(Electronics, Computing Software/Hardware, Microelectronic Testing Methods)

9 MONTHS
BTEC Higher National Certificate (HNC)
COMPUTING TECHNOLOGY & ROBOTICS
(Microprocessor Based Systems, Fault Diagnosis, ATE, Robotics)

THESE COURSES INCLUDE A HIGH PERCENTAGE OF COLLEGE BASED PRACTICAL WORK TO ENHANCE FUTURE EMPLOYMENT PROSPECTS

NO ADDITIONAL FEES FOR OVERSEAS STUDENTS

SHORTENED COURSES OF FROM 3 TO 6 MONTHS CAN BE ARRANGED FOR APPLICANTS WITH PREVIOUS ELECTRONICS KNOWLEDGE

O.N.C. 21st September 1987
FULL PROSPECTUS FROM

LONDON ELECTRONICS COLLEGE (Dept EE)
20 PENYWERN ROAD, EARLS COURT,
LONDON SW5 9SU. Tel: 01-373 8721.

Zenith Electronics

Kits — Modules — Hardware

YOU KNOW US FOR OUR TRANSMITTER KITS NOW
TAKE A LOOK AT OUR GROWING RANGE OF
QUALITY KITS AND READY-BUILT PROJECTS
MODULES AND ELECTRONIC HARDWARE

The following are examples of our proven product designs in kit form:

- ★ Miniature FM Transmitter; 60–145MHz. Kit £6.95; R/Built £8.95.
- ★ 3 Watt FM Transmitter, 80–108MHz. Kit £13.99; R/Built £18.99.
- ★ 10 Channel Variable Speed Running Light; Drives LEDs or mains lamps. Kit £14.97.
- ★ 3 Note Electronic Door Chime unit; 9 volt operation, 3 melodious tones; variable frequency. Kit £9.83.
- ★ 300 Watt Light Dimmer unit for 240 volt mains lights. Kit £6.95.
- ★ 5 Code Digital Code unit plus Key Pad—select own code; 9 volt. Kit £14.21.
- ★ 5–100 Watt Electronic Loudspeaker Overload Protector, adjustable. Kit £11.11.
- ★ VU Meter 10 LED indicator; –5 to +12dB range. Kit £12.59.
- ★ Automatic light controller; automatically turns on and off lights at pre-set times and triggered by darkness. Kit £25.08.
- ★ Mains Wiring and Metal Detector; complete with case. £11.00
- ★ Digital Clock module; 12–24 hour timing; LED type—£17.49, or LCD type—£22.80.
- ★ Amplifier Power Meter; 10 LED indicator from 0-25–100 Watt Input—9 volt operation. Kit £9.52.
- ★ Light sensitive relay unit; variable sensitivity trigger control; senses light or dark—selectable. Kit £8.45.

ALL KITS CONTAIN FULL INSTRUCTIONS: P.C.B.s AND COMPONENTS.

ALL PRICES INCLUDE VAT AND POSTAGE & PACKING.

OVERSEAS ORDERS—ADD 10% TO ABOVE PRICES.

PLEASE SEND CHEQUE OR POSTAL ORDERS WITH ORDER.



Zenith Electronics, 14 Cortlandt Business Centre,
Hailsham, E. Sussex, U.K. BN27 1AE.
Tel: 0323 847973

£1 BARGAIN PACKS

Buy 10 packs ... get one free (your choice)

PK 1. 350 Assorted resistors. Full length leads.
 PK 2. 400 Assorted resistors. Pre-formed leads.
 PK 3. 60 Assorted resistors. Wire wound.
 PK 4. 200 Assorted mixed capacitors.
 PK 5. 200 Assorted ceramic capacitors.
 PK 6. 50 Electrolytic capacitors.
 PK 7. 2 2200µf 100 volt capacitors.
 PK 8. 2 4700µf 30 volt capacitors.
 PK 9. 12 Assorted rotary potentiometers. Single gang.
 PK 10. 6 Assorted rotary potentiometers. Dual gang.
 PK 11. 12 Assorted slider potentiometers.
 PK 12. 40 Assorted pre-set potentiometers.
 PK 13. 5 100k lin multiturn potentiometers.
 PK 14. 5 1 meg lin multiturn potentiometers.
 PK 15. 12 Assorted switches.
 PK 16. 1 bank 4-way push button switches c/w knobs.
 PK 17. 1 4 pole 5-way wiper switch.
 PK 18. 15 Assorted control knobs.
 PK 19. 20 Assorted plugs and sockets.
 PK 20. 2 Pairs D.C. plugs & sockets c/w leads & PP3 clip.
 PK 21. 25 Assorted transistors. All new & coded.

PK 22. 15 Assorted I.C.'s. All new & coded.
 PK 23. 50 Assorted unmarked & untested I.C.'s.
 PK 24. 100 Assorted diodes.
 PK 25. 20 E.H.T. diodes.
 PK 26. 3 Large power-fin heatsinks. T03.
 PK 27. 1 4 section 7 segment l.e.d. clock display.
 PK 28. 20 Assorted neons. Panel mounting & wire ended.
 PK 29. 1 Microphone c/w lead, switch, plugs & stand.
 PK 31. 3 Dynamic earpieces c/w lead & 3.5mm plug.
 PK 32. 2 Telescopic aerials.
 PK 35. 1 Large cassette motor.
 PK 36. 1 Wire pack. Mains cable.
 PK 38. 1 Wire pack. Connecting wire. Assorted colours.
 PK 39. 300 Assorted resistors. 1/2W or less F.T. leads.
 PK 40. 200 Assorted Polyester capacitors.
 PK 41. 12 Push to make switches. pcb mounting.
 PK 42. 12 Push on - Push off switches.
 PK 43. 4 Assorted toaster elements.
 PK 44. 3 Assorted record player styli.
 PK 45. 50 Assorted L.F. and tuning coils.
 PK 46. 35 Assorted resistors 1% tolerance.

Postal order or cheque with order. Please add £1 postage & packing per order.
 Access and Barclaycard orders welcome, minimum £10. Please phone orders before 4pm.
 Electronics magazines, we have an extensive range of back issues. 50p for current lists.

**MJR WHOLESALE, Unit 3, 238 Waterside,
 Chesham, Bucks HP5 1PG. ☎ 0494 771033**

INDEX TO ADVERTISERS

| | | | |
|------------------------------|-----------|-----------------------------|----------|
| AUDIOKITS | 408 | MAPLIN ELECTRONICS | Cover IV |
| BAFBOX LTD | 347 | MARCO TRADING | 346 |
| BI-PAK | 346 | M.J.R. WHOLESALE | 408 |
| B.K. ELECTRONICS | Cover III | OMEGA ELECTRONICS | 347 |
| BULL, J. & N. | Cover II | OMNI ELECTRONICS | 407 |
| CIRKIT HOLDING | 348 | PHONOSONICS | 408 |
| CROTECH INSTRUMENTS | 348 | RADIO COMPONENT SPECIALISTS | 406 |
| C-SCOPE | 348 | RISCOMP LTD | 348 |
| ELECTRONIZE DESIGN | 346 | SHERWOOD DATA SYSTEMS | 347 |
| GREENWELD ELECTRONICS | 359 | STEWART OF READING | 407 |
| I.C.S. | 407 | SUPER ALPHA ELECTRONICS | 349 |
| LIGHT SOLDERING DEVELOPMENTS | 391 | T.K. ELECTRONICS | 391 |
| LONDON ELECTRONICS COLLEGE | 407 | XEN-ELECTRONICS | 379 |
| MAGENTA ELECTRONICS | 350 | ZENITH ELECTRONICS | 407 |

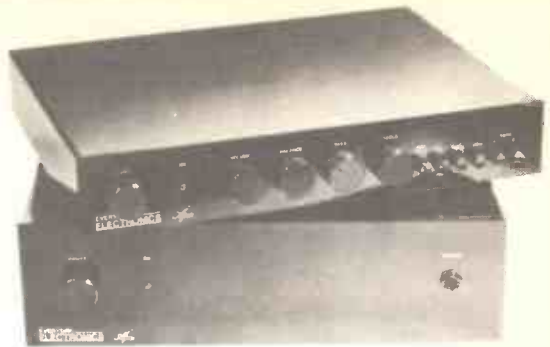

The EE APEX PREAMP AND POWER AMP KITS

Build this superb preamp and power amp kit and enjoy high fidelity sound at a fraction of the cost of comparable ready built amplifiers.

Complete kits as described in March-June issues of Everyday Electronics including high current transformers and attractively styled cases with high quality components.

Preamp £192.50
 Power amp-stereo £192.50

Or build it with the very best components available including IAR Wonder caps, Extended foil polystyrene capacitors, bulk foil resistors, Holco precision resistors, silver plated switches, gold plated phono sockets and Kimber cable for internal wiring.

Preamp £410
 Stereo Power amp £310
 Mono Power amp £232

All components including PCBs available separately

For full parts price list of the EE Apex preamp and details of **AUDIOKITS** audiophile components and kits,

please send 9" x 4" SAE to:

AUDIOKITS Precision Components
 6 MILL CLOSE, BORROWASH, DERBY DE7 3GU. Tel: 0332 674929

CONSTRUCTIONAL

KIT CATALOGUE

PHONOSONICS

FASCINATING ELECTRONIC PROJECTS

- ★ BE KIT CREATIVE
- ★ RAISE YOUR SKILLS
- ★ LEARN BY BUILDING
- ★ ENJOY BY USING



THROUGH ELECTRONICS UNDERSTAND ESSENTIAL TECHNOLOGY

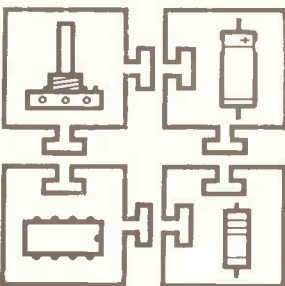

- ★ MUSIC MODULES
- ★ GEIGER COUNTERS

- ★ DIGITAL INTERFACES
- ★ MANY MORE FINE DESIGNS

POPULAR PROJECTS FROM A LEADING AUTHOR

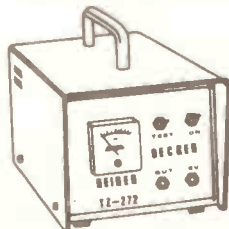

KITS THAT FIT

MUSIC AND EFFECTS

| | | |
|-------------------------------|-----------|--------|
| A-D-A Interface* | Set 251 | 61.00 |
| Chip Test 16-Pin* | Set 258S | 32.50 |
| Chip Test 24-Pin* | Set 258F | 39.30 |
| Chorus Flanger Dual Compander | Set 235 | 59.99 |
| Cybervox Voice FX | Set 238 | 22.99 |
| Digital Delay & MCS | Set 228 | 44.76 |
| Disco Light Control | Set 234RK | 198.50 |
| Echo-Reverb Stereo | Set 245F | 62.50 |
| Equaliser 3-Chan | Set 218 | 57.66 |
| Event Counter | Set 217 | 25.33 |
| Flanger (Mono) | Set 278 | 39.50 |
| Guitar Modulo | Set 153 | 28.45 |
| Micro-Scope* | Set 196 | 23.56 |
| Micro-Trace* | Set 247 | 44.50 |
| Mini-Sampler | Set 261 | 19.50 |
| Mixer 4-Ch Stereo | Set 246 | 75.00 |
| Mixer Simple 4 Chan | Set 229S | 89.95 |
| Mock Stereo | Set 256 | 19.99 |
| Morse Decoder* | Set 213 | 24.37 |
| Noise Gate | Set 269 | 22.16 |
| Phaser-Enhanced | Set 227 | 26.61 |
| Polywhatsit! FX | Set 226 | 42.36 |
| Rhythm Gen* | Set 252 | 122.69 |
| Ring Modulator | Set 185 | 34.64 |
| Storm Wind & Rain | Set 231 | 45.58 |
| Thunder & Lightning | Set 250W | 29.50 |
| Tuner-Micro* | Set 250T | 29.50 |
| Tuner-Simple* | Set 257 | 55.32 |
| Vodalek Voice FX | Set 259 | 22.50 |
| | Set 155 | 18.31 |

* Computer controlled (BBC, C64, PET)
 Most PCBs available separately

LOW COST GEIGER COUNTERS



NUCLEAR FREE ZONES?
 CHECK THEM OUT -
 GET A GEIGER

THE PE GEIGER WAS
 SHOWN ON BBC TV
 "TAKE NOBODY'S WORD
 FOR IT" PROGRAM

Detectors for environmental and geological monitoring - know your background! You'd be amazed at the quantities sold since Chernobyl.

METERED GEIGER (PE MK2)
 Built-in probe, speaker, meter, digital output. Detector tube options - ZP1310 for normal sensitivity, ZP1320 for extrasensitivity.
 Kit-form - SET 264 - (ZP1310) £59.50, (ZP1320) £78.50

Ready-built = TZ272 - (ZP1310) £75.50, (ZP1320) £94.50

AUDIO GEIGER (EE MK2)
 Built-in probe (ZP1310), speaker, digital output.
 Kit-form SET 265 MK2 £49.50. Ready-built TZ274 £65.00

GEIGER-MITE SET 271 £39.50
 Miniature geiger with ZP 1310 tube. LED displays radiation impacts. Socket for headphones or digital monitoring. Kit-form only.

Send A4 SAE for detailed catalogue, and with all enquiries (overseas send £1.00 or 5 I.R.C.'s). Add 15% VAT. Add P&P - Sets over £50 add £2.50. Others add £1.50. Overseas P&P in catalogue. Text photocopies - Geiger & DDL Texts £1.50 each, others 50p, plus 50p post or large SAE. Insurance 50p per £50. Mail order, CWO, CHO, PO, Access, Visa.

**PHONOSONICS, DEPT EE77, 8 FINUCANE DRIVE,
 ORPINGTON, KENT BR5 4ED. Tel: 0689 37821**

OMP POWER AMPLIFIER MODULES

OMP POWER AMPLIFIER MODULES Now enjoy a world-wide reputation for quality, reliability and performance at a realistic price. Four models available to suit the needs of the professional and hobby market, i.e. Industry, Leisure, Instrumental and Hi-Fi, etc. When comparing prices, NOTE all models include Toroidal power supply, Integral heat sink, Glass fibre P.C.B. and Drive circuits to power compatible Vu meter. Open and short circuit proof. **Supplied ready built and tested.**

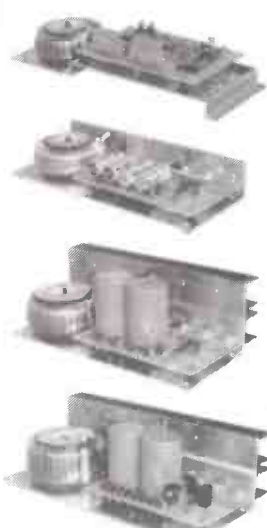

OMP/100 Mk II Bi-Polar Output power 110 watts R.M.S. into 4 ohms. Frequency Response 1Hz - 30KHz -3dB. T.H.D. 0.01%. S.N.R. -118dB. Sens. for Max. output 500mV at 10K. Size 355 X 115 X 65mm. **PRICE £33.99 + £3.00 P&P.**

OMP/MF100 Mos-Fet Output power 110 watts R.M.S. into 4 ohms. Frequency Response 1Hz - 100KHz -3dB. Damping Factor 80. Slew Rate 45V/uS. T.H.D. Typical 0.002%. Input Sensitivity 500mV. S.N.R. -125dB. Size 300 X 123 X 60mm. **PRICE £39.99 + £3.00 P&P.**

OMP/MF200 Mos-Fet Output power 200 watts R.M.S. into 4 ohms. Frequency Response 1Hz - 100KHz -3dB. Damping Factor 250. Slew Rate 50V/uS. T.H.D. Typical 0.001%. Input Sensitivity 500mV. S.N.R. -130dB. Size 300 X 150 X 100mm. **PRICE £62.99 + £3.50 P&P.**

OMP/MF300 Mos-Fet Output power 300 watts R.M.S. into 4 ohms. Frequency Response 1Hz - 100KHz -3dB. Damping Factor 350. Slew Rate 60V/uS. T.H.D. Typical 0.0008%. Input Sensitivity 500mV. S.N.R. -130dB. Size 330 X 147 X 102mm. **PRICE £79.99 + £4.50 P&P.**

NOTE: Mos-Fets are supplied as standard (100KHz bandwidth & Input Sensitivity 500mV). If required, P.A. version (50KHz bandwidth & Input Sensitivity 775mV). Order - Standard or P.A.

Vu METER Compatible with our four amplifiers detailed above. A very accurate visual display employing 11 L.F.D. diodes (7 green, 4 red) plus an additional on/off indicator. Sophisticated logic control circuits for very fast rise and decay times. Tough moulded plastic case, with tinted acrylic front. Size 84 X 27 X 45mm. **PRICE £8.50 + 50p P&P.**

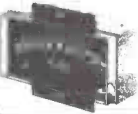

LOUDSPEAKERS 5" to 15" up to 400 WATTS R.M.S. Cabinet Fixing in stock. Huge selection of McKenzie Loudspeakers available including Cabinet Plans. Large S.A.E. (28p) for free details.

POWER RANGE
8" 50 WATT R.M.S. Hi-Fi/Disco.
20 oz. magnet 1 1/2" ally voice coil. Ground ally fixing escutcheon. Res. Freq. 40Hz. Freq. Resp. to 6KHz. Sens. 92dB. PRICE £10.99 Available with black grille £11.99 P&P £1.50 ea.
12" 100 WATT R.M.S. Hi-Fi/Disco
50 oz. magnet. 2" ally voice coil. Ground ally fixing escutcheon. Die-cast chassis. White cone. Res. Freq. 25Hz. Freq. Resp. to 4KHz. Sens. 95dB. PRICE £28.60 + £3.00 P&P ea.

McKENZIE
12" 85 WATT R.M.S. C1285GP Lead Guitar/Keyboard/Disco.
2" ally voice coil. Ally centre dome. Res. Freq. 45Hz. Freq. Resp. to 6.5KHz. Sens. 98dB. PRICE £29.99 + £3.00 P&P ea.
12" 85 WATT R.M.S. C1285TC P.A./Disco 2" ally voice coil. Twin cone.
Res. Freq. 45Hz. Freq. Resp. to 14KHz. PRICE £31.49 + £3.00 P&P ea.
15" 150 WATT R.M.S. C15 Bass Guitar/Disco.
3" ally voice coil. Die-cast chassis. Res. Freq. 40Hz. Freq. Resp. to 4KHz. PRICE £57.87 + £4.00 P&P ea.
10" 60 WATT R.M.S. 1060GP Gen. Purpose/Lead Guitar/Keyboard/Mid. P.A.
2" voice coil. Res. Freq. 75Hz. Freq. Resp. to 7.5KHz. Sens. 99dB. PRICE £19.99 + £2.00 P&P.
10" 200 WATT R.M.S. C10200G Guitar/Keyboard/Disco.
2" voice coil. Res. Freq. 45Hz. Freq. Resp. to 7KHz. Sens. 101dB. PRICE £44.76 + £3.00 P&P.
15" 200 WATT R.M.S. C15200 High Power Bass.
Res. Freq. 40Hz. Freq. Resp. to 5KHz. Sens. 101dB. PRICE £62.41 + £4.00 P&P.
15" 400 WATT R.M.S. C15400 High Power Bass.
Res. Freq. 40Hz. Freq. Resp. to 4KHz. Sens. 102dB. PRICE £89.52 + £4.00 P&P.

WEM
5" 70 WATT R.M.S. Multiple Array Disco etc.
1" voice coil. Res. Freq. 52Hz. Freq. Resp. to 5KHz. Sens. 89dB. PRICE £22.00 + £1.50 P&P ea.
8" 150 WATT R.M.S. Multiple Array Disco etc.
1" voice coil. Res. Freq. 48Hz. Freq. Resp. to 5KHz. Sens. 92dB. PRICE £32.00 + £1.50 P&P ea.
10" 300 WATT R.M.S. Disco/Sound re-enforcement etc.
1 1/2" voice coil. Res. Freq. 35Hz. Freq. Resp. to 4KHz. Sens. 92dB. PRICE £36.00 + £2.00 P&P ea.
12" 300 WATT R.M.S. Disco/Sound re-enforcement etc.
1 1/2" voice coil. Res. Freq. 35Hz. Freq. Resp. to 4KHz. Sens. 94dB. PRICE £47.00 + £3.00 P&P ea.

SOUNDLAB (Full Range Twin Cone)
5" 60 WATT R.M.S. Hi-Fi/Multiple Array Disco etc.
1" voice coil. Res. Freq. 63Hz. Freq. Resp. to 20KHz. Sens. 86dB. PRICE £9.99 + £1.00 P&P ea.
6 1/2" 60 WATT R.M.S. Hi-Fi/Multiple Array Disco etc.
1" voice coil. Res. Freq. 56Hz. Freq. Resp. to 20KHz. Sens. 89dB. PRICE £10.99 + £1.50 P&P ea.
8" 60 WATT R.M.S. Hi-Fi/Multiple Array Disco etc.
1 1/2" voice coil. Res. Freq. 38Hz. Freq. Resp. to 20KHz. Sens. 89dB. PRICE £12.99 + £1.50 P&P ea.
10" 60 WATT R.M.S. Hi-Fi/Disco etc.
1 1/4" voice coil. Res. Freq. 35Hz. Freq. Resp. to 15KHz. Sens. 89dB. PRICE £16.49 + £2.00 P&P

PANTEC HOBBY KITS. Proven designs including glass fibre printed circuit board and high quality components complete with instructions.

FM MICROTRANSMITTER (BUG) 90/105MHz with very sensitive microphone. Range 100/300 metres. 57 x 46 x 14mm (9 volt) Price: £8.62 + 75p P&P.
3 WATT FM TRANSMITTER 3 WATT 85/115MHz varicap controlled professional performance. Range up to 3 miles 35 x 84 x 12mm (12 volt) Price: £14.49 + 75p P&P.
SINGLE CHANNEL RADIO CONTROLLED TRANSMITTER/RECEIVER 27MHz. Range up to 500 metres. Double coded modulation. Receiver output operates relay with 2amp/240 volt contacts. Ideal for many applications. Receiver 90 x 70 x 22mm (9/12 volt). Price: £17.82 Transmitter 80 x 50 x 15mm (9/12 volt). Price: £11.29 P&P + 75p each. S.A.E. for complete list.



3 watt FM Transmitter

POSTAL CHARGES PER ORDER £1.00 minimum. OFFICIAL ORDERS WELCOME, SCHOOLS, COLLEGES, GOVERNMENT BODIES, ETC. PRICES INCLUSIVE OF V.A.T. SALES COUNTER VISA/ACCESS/C.O.D. ACCEPTED



* PRICES INCLUDE V.A.T. * PROMPT DELIVERIES * FRIENDLY SERVICE * LARGE S.A.E. 28p STAMP FOR CURRENT LIST

BURGLAR ALARM

Better to be 'Alarmed' then terrified. Thandar's famous 'Minder' Burglar Alarm System. Superior microwave principle. Supplied as three units, complete with interconnection cable. **FULLY GUARANTEED.**

Control Unit - Houses microwave radar unit, range up to 15 metres adjustable by sensitivity control. Three position, key operated fascia switch - off - test - armed. 30 second exit and entry delay.

Indoor alarm - Electronic swept freq. siren. 104dB output.

Outdoor Alarm - Electronic swept freq. siren. 98dB output. Housed in a tamper-proof heavy duty metal case.

Both the control unit and outdoor alarm contain rechargeable batteries which provide full protection during mains failure. Power requirement 200/260 Volt AC 50/60Hz. Expandable with door sensors, panic buttons etc. Complete with instructions.
SAVE £138.00 Usual Price £228.85
BKE's PRICE £89.99 + £4.00 P&P
? Why buy a collection of self-assembly boards!

IDEAL for Workshops, Factories, Offices, Home, etc. Supplied ready built.



OMP LINNET LOUDSPEAKERS

The very best in quality and value. Made specially to suit today's need for compactness with high sound output levels. Finished in hard wearing black vinylite with protective corners, grille and carry handle. All models 8 ohms. Full range 45Hz - 20KHz. Size 20" X 15" X 12" Watts R.M.S. per cabinet Sensitivity 1W. 1mtr. dB.

OMP 12-100 Watts 100dB. Price £149.99 per pair.
OMP 12-200 Watts 102dB. Price £199.99 per pair. Delivery: Securcom £8.00 per pair



OMP 19" STEREO RACK AMPS



Professional 19" cased Mos-Fet stereo amps. Used the World over in clubs, pubs, discos etc. With twin Vu meters, twin toroidal power supplies, XLR connections. MF600 Fan cooled. Three models (Ratings R.M.S. into 4ohms), Input Sensitivity 775mV

MF200 (100 + 100)W. £171.35 Securcom
MF400 (200 + 200)W. £228.85 Delivery
MF600 (300 + 300)W. £322.00 £10.00

1 K-WATT SLIDE DIMMER

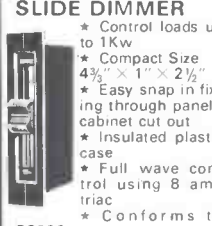

* Control loads up to 1Kw
* Compact Size 4 1/2" X 1" X 2 1/2"
* Easy snap in fixing through panel/cabinet cut out
* Insulated plastic case
* Full wave control using 8 amp triac
* Conforms to BS800

* Suitable for both resistance and inductive loads. Innumerable applications in industry, the home, and disco's, theatres etc.
PRICE £13.99 + 75p P&P

BSR P295 ELECTRONIC TURNTABLE

* Electronic speed control 45 & 33 1/3 r.p.m. * Plus/Minus variable pitch control * Belt driven * Aluminium platter with strobed rim * Cue lever * Anti-skate (bias device) * Adjustable counter balance * Manual arm * Standard 1/2" cartridge fixings * Supplied complete with cut out template * D.C. Operation 9-14v D.C. 65mA
Price £36.99 - £3.00 P&P.



ADC Q4 mag. cartridge for above. Price £4.99 ea. P&P 50p

PIEZO ELECTRIC TWEETERS MOTOROLA

Join the Piezo revolution. The low dynamic mass (no voice coil) of a Piezo tweeter produces an improved transient response with a lower distortion level than ordinary dynamic tweeters. As a crossover is not required these units can be added to existing speaker systems of up to 100 watts (more if 2 put in series). **FREE EXPLANATORY LEAFLETS SUPPLIED WITH EACH TWEETER.**

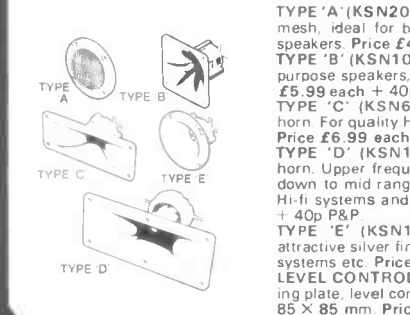

TYPE 'A' (KSN2036A) 3" round with protective wire mesh, ideal for bookshelf and medium sized hi-fi speakers. Price £4.90 each + 40p P&P
TYPE 'B' (KSN1005A) 3 1/2" super horn. For general purpose speakers, disco and P.A. systems etc. Price £5.99 each + 40p P&P
TYPE 'C' (KSN6016A) 2" X 5" wide dispersion horn. For quality hi-fi systems and quality discos etc. Price £6.99 each + 40p P&P
TYPE 'D' (KSN1025A) 2" X 6" wide dispersion horn. Upper frequency response retained extending down to mid range (2KHz). Suitable for high quality hi-fi systems and quality discos. Price £9.99 each + 40p P&P
TYPE 'E' (KSN1038A) 3 3/4" horn tweeter with attractive silver finish trim. Suitable for hi-fi monitor systems etc. Price £5.99 each + 40p P&P
LEVEL CONTROL Combines on a recessed mounting plate, level control and cabinet input jack socket. 85 X 85 mm. Price £3.99 + 40p P&P

STEREO DISCO MIXER

STEREO DISCO MIXER with 2 X 5 band L & R graphic equalisers and twin 10 segment L.E.D. Vu Meters. Many outstanding features 5 Inputs with individual faders providing a useful combination of the following - 3 Turntables (Mag), 3 Mics, 4 Line plus Mic with talk over switch, Headphone Monitor, Pan Pot, L & R Master Output controls. Output 775mV. Size 360 X 280 X 90mm.
Price £134.99 - £3.00 P&P



B. K. ELECTRONICS

UNIT 5, COMET WAY, SOUTHEND-ON-SEA, ESSEX. SS2 6TR TEL: 0702-527572

Go Racing this Summer with the Super Apache Scale Model Car!



The Apache

A superb ready-built scale-model off-road racer complete with a 2-CHANNEL DIGITAL PROPORTIONAL RADIO CONTROL SYSTEM – for the price of the RC system alone!

All this is included in the price:

Ready-built 1/4 scale model car (overall size 325 x 186 x 130mm, 12.8 x 7.3 x 5.1 in.).

Front and rear low-profile semi-pneumatic rubber tyres.

Front wheel independent suspension.

High or low gear selection.

Sealed box with differential gearing.

Powerful motor gives scale speeds up to 140 mph.

Front and rear coil-spring shock absorbers.

2-channel digital proportional radio control transmitter (and receiver).

(Standard 27MHz AM – no licence required in UK).

Servo-controlled proportional steering.

Proportional motor speed control in forward and reverse.

EVEN MORE SUPER SUMMER SAVERS!!

If you are already a Maplin customer, soon you will be receiving (if you haven't already) a bumper bundle of smashing Summertime specials, plus the chance to win a beautiful, sleek, Ford XR3i (if you register in the prize draw before 1st July 1987).

If you are not a Maplin customer, but would love to know more about the special offers and have a chance to win the car, fill in the coupon below with your personal details, tick the appropriate box, and post it now.

*Batteries and ni-cad charger not included. Car requires 8 AA cells (ni-cad recommended YG00A £1.35 each). Transmitter requires 6 AA cells, (alkaline SX69A 55p each or ni-cad as above). NB – and if you have a collision at 100mph or more, you'll be pleased to hear that spare parts are available.

I'LL BE RACING THIS SUMMER WITH MY SUPERB APACHE CAR!

Please rush me my Apache model racer, with 2 channel digital proportional radio control system. I wish to receive:

| | Code | Qty | Price |
|---------------------|-------|--------------|-------|
| Apache model racer | SX08J | | |
| AA ni-cad battery | YG00A | | |
| AA alkaline battery | SX69A | | |
| | | Total | |

All prices include VAT. Please add 50p towards postage. If order below £5.00, please add 50p handling.

I enclose cheque/postal order made payable to Maplin Electronic Supplies Ltd., or see credit card details.

Here are my personal details:

Customer Number

Name

Address

.....

Post Code

I have never been a Maplin Customer, but I would be pleased to receive details of the super Summertime special offers.

Tick box.

If you have already received the Summertime special offers, please use the Order Coupon supplied with that

Tick box.

Please register me in the prize draw.

I authorise you to debit my Credit Card account for the cost of goods despatched.

Credit Card Number

Access: American Express/Mapcard/Visa

Delete as required

Note: Goods will be despatched only if the address given is the cardholder's address

If ordering by Credit Card please sign:

Signature: Expiry Date

Maplin

Send to:
Maplin Electronic Supplies Ltd.
P.O. Box 3, Rayleigh, Essex, SS6 8LR. Telephone, Credit Card Sales (0702) 554161 Enquiries (0702) 552911

EE 7/87