

# TOP PROJECTS



*Special*

LINSLEY HOOD 80W MOSFET AMPLIFIER

MICRO MONITOR SPEAKERS

DIGITAL DOORBELL

HOW TO MIDI A PIANO

AERIAL AMPLIFIER

GUITAR TUNER

TWIN-LOOP PULSED METAL LOCATOR

TREMBLER MOTION DETECTOR

CAMERA TRIGGER

FOOTPEDAL POWER

REV RIDER

PRIORITY QUIZ SWITCH

£1.50

or free with ETI February 1990

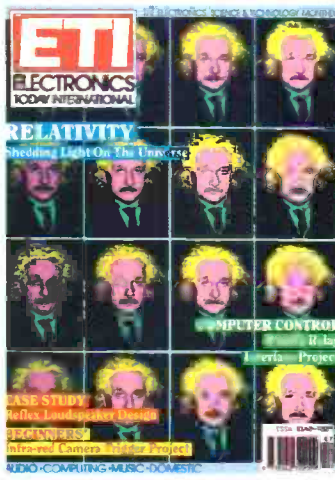



**NOTHING ELSE COMES CLOSE**

The leading mag for the electronics enthusiast – out on the first Friday every month

# Top Projects

## 1989

Edited by Paul Freeman & Jez Ford

### CONTENTS

**Digital Doorbell**  
Shock the salesmen and annoy the neighbours with this ingenious sampling doorbell

4

**Rev Rider**  
The noisiest simulator your bike ever heard

20

**Guitar Tuner**  
Keep in time with perfect pitch-adjustments for bass including

37

**Present for Granny**  
A headset to pump up the volume — Linsley Hood design

51

**Aerial Amplifier**  
A high quality design to dig a clear picture from the deepest snow

24

**Twin Loop Treasure Seeker**  
A powerful pulsed twin loop design

42

**How to Midi a Piano**  
Turn any synth, piano or Fender Rhodes into a MIDI master

54

**Micro Monitor Loudspeakers**  
A reflex cabinet design

8

**Trembler Detector**  
Protect equipment and irritate friends with this motion detector

28

**Pedal Power**  
Guitar quality input stage and footpedal supply

63

**JLH 80W Audio Design Amplifier**  
Simply the best — Linsley Hood's MOSFET amplifier

11

**Priority Quiz Switch**  
For games and contests

30

**Camera Trigger**  
For remote work and full of expansion possibilities

48

**PCB Foils** 32  
**PCB Service** 66  
**Ad Index** 66

ETI Top Projects 1989 is reprinted from projects published in Electronics Today International — the leading UK magazine for electronics enthusiasts. If you have any comments on this magazine or wish to contribute projects or articles to ETI please write to the Editor at: ETI, Argus House, Boundary Way, Hemel Hempstead, Herts HP2 7ST.

The contents of this publication including all articles, designs, plans, drawings and programs and all copyright and other intellectual property rights therein belongs to Argus Specialist Publications. All rights conferred by the Law of Copyright and other intellectual property rights and by virtue of international copyright conventions are specifically reserved to Argus Specialist Publications Limited and any reproduction requires the prior written consent of the company. ©1989 Argus Specialist Publication Limited. All reasonable care has been taken in the preparation of the magazine contents but neither the authors nor publishers can be held legally responsible for errors.



**CONTRIBUTORS:** Rashid Adat, Laurie Barron, Ken Blackwell, Kieth Brindley, John Brockhurst, Paul Chappell, Robert and David Crone, John Linsley Hood, John Jameson, Jeff Macauley, Stuart Richards, Gordon Tomlinson

Published by Argus Specialist Publications Ltd, Argus House, Boundary Way, Hemel Hempstead, Herts HP2 7ST. Typesetting and origination by Project 3, Whitstable. Printed and bound by Acorn Web Offset Ltd Bradford, W. Yorks



# DIGITAL DOORBELL

*John Jameson's front door greets visitors with a blood curdling scream, a fanfare and the chimes of Big Ben thanks to his ingenious sampler doorbell*

This project provides you with the means to have a totally unique doorbell. Almost any sound effect lasting up to three seconds can be emitted at considerable power whenever a visitor calls. If you have several doors, you could build several units and have them announce *Front Door*, *Back Door* or you could sample the neighbours' bloodhound and frighten the wits out of your postman.

The possibilities for such a project are limited only by your imagination. Slightly modified, the unit could even find uses in electronic music, as a simple but versatile drum effect.

To make things easy for you, the author has arranged to provide a range of sound effect ROMs, and a tape to EPROM service (see *Buylines*) so you won't need a sampler and an EPROM programmer to build the project.

## Construction

The project is constructed on a 4x4in double sided PCB with only the loudspeaker and the power and bell push sockets mounted off the board. This design is simple enough to build up completely before testing, provided you have the proper PCB.

Start by making the through-hole connections or 'vias' first. Don't forget the ones under the EPROM. Next insert then solder in the six pins used to make the external connections and add the passive components. The ICs should go in last.

Only the EPROM need be mounted in a socket. IC3,4 and 5 will have to be soldered in as their legs make further through-hole connections. These are CMOS devices so take the usual anti-static precautions of earthing yourself and everything else in sight when doing this.

If you house the unit in the recommended box, the PCB will be glued in, so it is highly advisable to test it thoroughly and get it working on the bench. A 15V DC power supply will do just as well as AC for testing so you can use your bench supply. Initially, power the unit up without an EPROM inserted. Several simple tests can now be made.

First and foremost, check the 5V supply is present. The output from the DAC, IC6, should be at around 2.5V (it is seeing &OFF on its inputs) and the output of the LM380, pin 9, should be at about 7-8V. Switch off, insert a programmed EPROM, set the DIP switches as detailed in Table 1, set RV1 at mid range and switch on.

If all is well, the unit should emit the sample and go quiet. Triggering the unit by shorting the bell push terminals should cause it to emit the sample once and stop.

If you get nothing, use a crystal earpiece or a scope to trace the fault back down the analogue path. If nothing is coming out of the DAC, see if data is coming out of the EPROM. Failing that, check around the address counter and the clock. Highly distorted sound might simply be due to shorted address or data connections around the ROM.

Once you have a working doorbell and assuming you are using the recommended case, drill a grid of holes in the top of the case for the loudspeaker and bolt it to the top (or glue it using Araldite or something similar). Drill two more holes at one end of the box for the two jack sockets. The prototype has the 2.5mm connector for power and the 3.5mm one for the bell push, though this is not at all crucial.

If you plan to mount the unit on a wall, drill a couple of holes in the bottom of the case, and file them into keyhole shapes so you will be able to hang the unit on a couple of screws in the wall.

Put the PCB in the bottom of the box at the other end from the mounting holes (so as to avoid the screws shorting things on the underside of the board) and measure up connecting wires to go from the PCB pins to the sockets and the loudspeaker. Wire up these connections, check everything and then glue the PCB onto the bottom of the box using Araldite. Finally screw the lid onto the box and wire up cables to your bell transformer and bell push.

You will need a bell transformer with a 12V tap. Also, bear in mind that sticking a jack plug into a socket causes a momentary short, so turn the power off to the transformer while setting everything up.

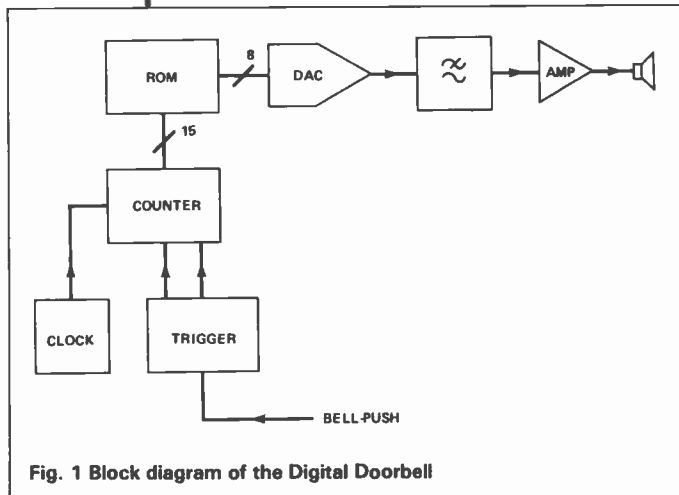
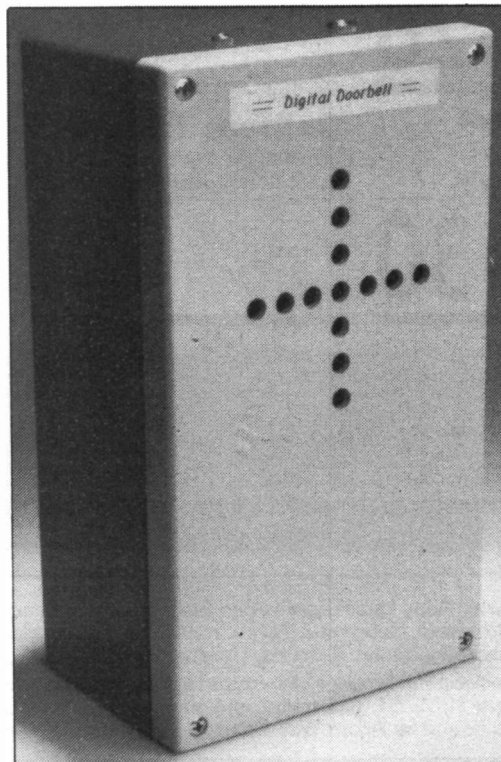

Fig. 1 Block diagram of the Digital Doorbell



TOP PROJECT

## Samples

For the benefit of those readers who want to program their own EPROMs, here is the procedure you will

need to follow for the doorbell of your dreams.

Firstly, follow the normal procedure for sampling a sound on your sampler. If you want it to play back

## HOW IT WORKS

The unit is in effect a self-contained, play-only sampler. The sample data is stored on a standard EPROM and the rest of the design consists of a clock, a trigger circuit, an address counter, a DAC, a 4-pole filter and a power amp. The arrangement is shown in the block diagram (Fig. 1).

The clock is (almost inevitably) a 555 timer — in this case the CMOS version. The component values have been chosen to make it oscillate at around 10kHz giving up to 3.2s sample length with a 32K EPROM (27C256).

As with all sampling systems the bandwidth is restricted to half the clock frequency and is therefore about 5kHz. This may seem low to hi-fi purists but it is equivalent to that of AM radio and quite adequate, given that the sound will emanate from a cheap 4in loudspeaker.

Pressing the bell push (SW6) triggers the monostable IC5 which resets the address counter made from IC3,4. The monostable is configured to be edge triggered and non-retriggerable which means that however long the bell push is pressed, the pulse from the monostable will only last about 20ms, after which its Q output will return low.

Once the reset pulse has ended, the address counter will start counting and data will be fed to DAC IC6 and the analogue stages causing the doorbell to burp, scream, bark or what you will.

If an 8K EPROM is in use, SW1 will be closed and SW2,3 open. This means that A13 will be connected to the clock enable of the address counter. It should be clear that when a count of 8192 is reached, A13 will go high disabling the counter and stopping the system until the counter is reset.

SW5 selects retriggerable or non-retriggerable operation. If it is open, then re-pressing the bell push will re-start the sample from the beginning. If SW5 is closed, then the monostable will be held reset until the sample has finished, thus preventing the sample being retriggered while it is playing.

The chosen filter is a fixed cut-off 4-pole Chebyshev low pass filter and is a good example of economic design. The output from the DAC ranges from 0 to 2.5V, and the overall gain of the two filter stages is just over five. It follows that if the output of the DAC were fed directly into the filter, an output swing of over 12.5V would be required. Normally you would achieve this using  $\pm 12V$  or 15V rails but by choosing op-amps capable of single rail, low voltage operation and by doing a few simple calculations, it is possible to power the filter from the regulated 5V rail required for the EPROM.

R11 and R12 attenuate the signal from IC6 so it will not drive the second op-amp, IC8, into overload. C4 removes the DC content from the output of the DAC and R21 in combination with R12 sets a new DC bias level for both op-amps. Bearing in mind that the DAC has an output impedance of 10k, application of simple resistors in series/parallel theory to the network shows the impedance at the node (without the filter connected) would be 8k. R13 then makes this up to near enough 39k as required for the filter.

C9 couples the filter to the output stage, RV1 sets the volume and the LM380 provides power amplification sufficient for the purpose.

A standard 78L05 regulator circuit provides the supply for the logic and the filter while the LM380 is run off the unregulated supply, which should be about 15V from a 12V AC input.

# TOP PROJECT

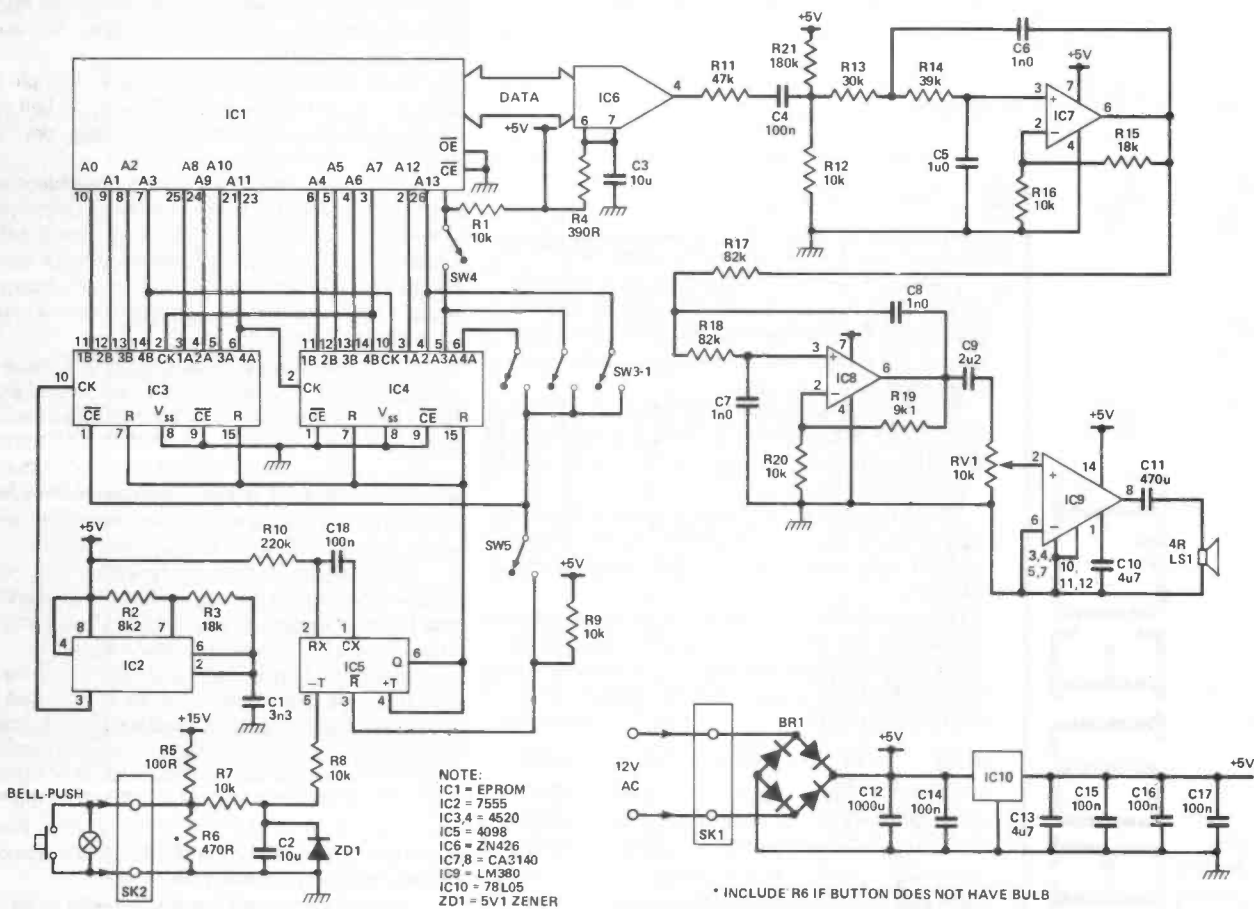

Fig. 2 The full circuit diagram of the doorbell

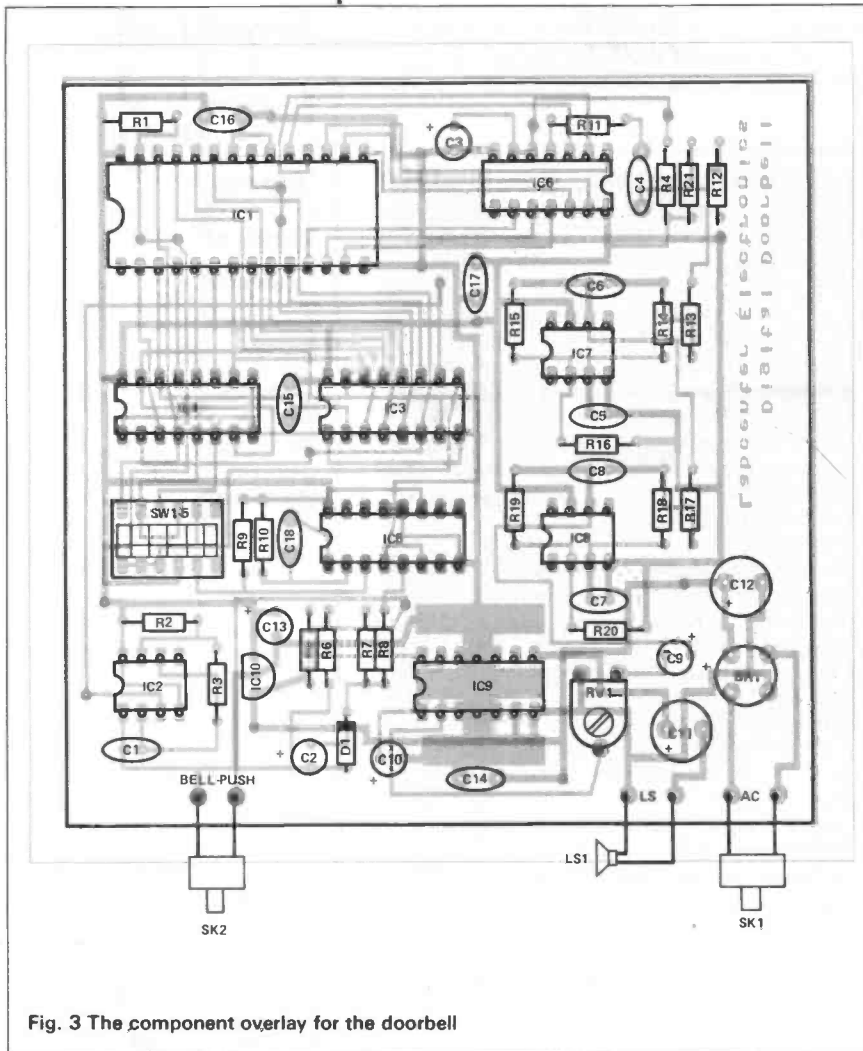

Fig. 3 The component overlay for the doorbell

at its natural pitch, try to sample it at a rate of 10kHz, or at least a multiple of that. You will then need to extract a binary dump of the sample. This is easiest if your sampler is home made and based on a home computer.

Those of you who have built my Amstrad Sampler (ETI, September 1987) and have the full software, will find that the SMP file is a direct binary dump of the sample and is in the same 8-bit linear format used by the doorbell.

The Spectrum Sampler (ETI, November 1985 to July 1986) uses logarithmic ADC and DACs, so you will need to write a program to convert the data to linear form.

MIDI sampler owners with a home computer based MIDI interface should be able to extract samples from their machines using the MIDI sample dump protocol.

Having got a linear sample dump, the next job is to adjust it for the 10kHz playback. If you sampled at 10kHz, you can omit this step. If you sampled at 20kHz, then you need a program to average succes-

ROM	SW1	SW2	SW3	SW4
27C64	ON	OFF	OFF	OFF
27C128	OFF	ON	OFF	OFF
27C256	OFF	OFF	ON	ON

SW5 OFF — retriggerable mode  
SW5 ON — non-retriggerable mode

Table 1 The DIP switch settings

## PARTS LIST

### RESISTORS (all 1/4 W 5% unless specified)

R1,7,8,9,12,16,20	10k
R2	8k2
R3,15	18k
R4	390R
R5	100R
R6	470R
R10	220k
R11	47k
R13	30k 1%
R14	39k
R17,18	82k
R19	9k1 1%
R21	180k
RV1	10k horiz preset

### CAPACITORS

C1	3n3 ceramic disc
C2,3	10µ 25V radial electrolytic
C4	100n polyester
C5,6,7,8	1n0 ceramic disc
C9	2µ2 63V radial electrolytic
C10,13	4µ7 63V radial electrolytic
C11	470µ 16V radial electrolytic
C12	1000µ 16V radial electrolytic
C14,15,16,17,18	100n dipped multilayer

### SEMICONDUCTORS

IC1	2764 or 27128 (see text)
IC2	7555
IC3,4	4520
IC5	4098
IC6	ZN426
IC7,8	CA3140
IC9	LM380
IC10	78L05
ZD1	5V1 zener
BR1	W005

### MISCELLANEOUS

LS1	4in 4R 2W speaker
PL1	2.5mm jack plug
PL2	3.5mm jack plug
SKT1	2.5mm jack socket
SKT2	3.5mm jack socket
SW1-5	6-way DIP switch
SW6	single pole push switch

PCB. Case 190x110x74mm. IC sockets. Wire. Glue. Nuts and bolts.

## BUYLINES

All the electronic components should be readily available. The recommended case is sold by Rapid Electronics (Tel. (0206) 272730) as order code 30-0420. Alternatively, a kit including the PCB, all components, one standard sound effects ROM (8K or 16K) and the case, but not including a bell transformer is available from Labcenter Electronics, 14 Marnier's Drive, Bradford BD9 4JT. The cost is £29.95 plus 50p postage inc VAT. The PCB is available for £7.20 plus 30p postage.

Write to Labcenter for details of the Tape-to-Sample service and for a list of standard sound effect EPROMS.

sive pairs of bytes, and for 30kHz, your program should average groups of three bytes.

Once this is achieved, you now need to ensure the data is represented such that &000 represents the most negative value, &080 represents quiescent conditions, and &OFF represents the most positive

# TOP PROJECT

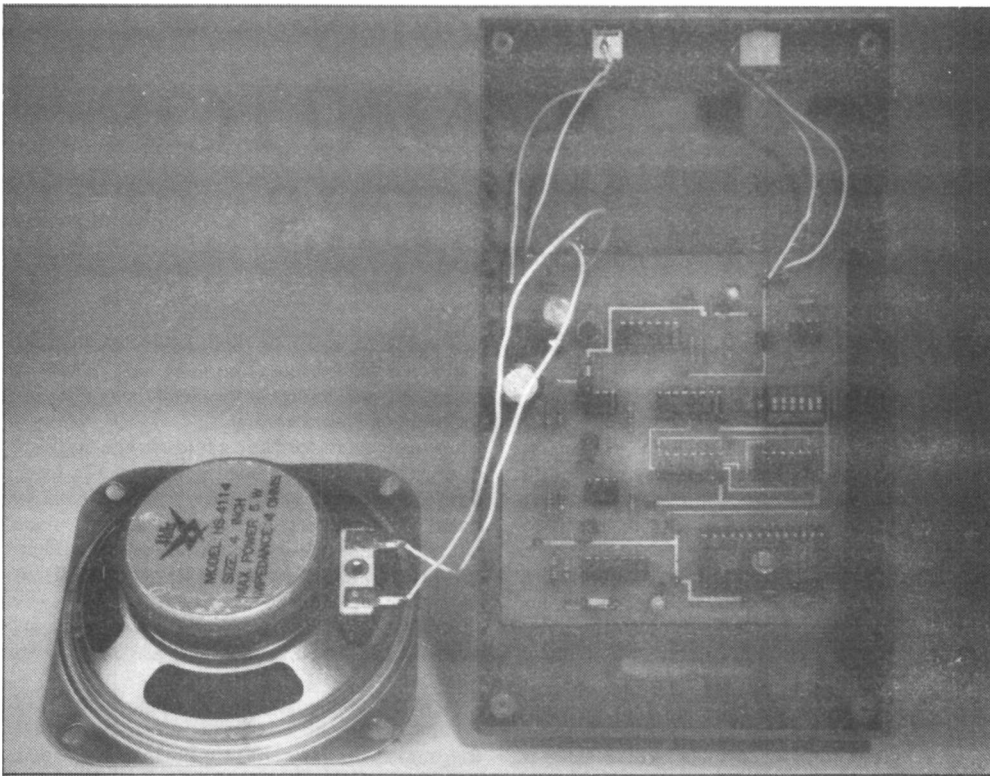

value. Again, Amstrad Sampler owners need do nothing here.

Choose an EPROM type large enough to hold the data (8K, 16K or 32K) and then pad out the sample dump with &080 so as to fill the ROM. The

first byte of the ROM should be &080 as well, so as to prevent a sharp click occurring at the end of the sound.

Finally, transfer the data to your EPROM programmer to blow the device.



Remember the new  
Component Catalogue  
available from  
early 1990

## CRICKLEWOOD ELECTRONICS

**BIGGER  
AND BETTER**

**1990 COMPONENT  
CATALOGUE**



- ONE OF THE LARGEST RANGES OF COMPONENTS IN THE UK
- FAST AND EFFICIENT SAME DAY PERSONAL SERVICE
- VERY COMPETITIVE PRICES; QUANTITY DISCOUNTS AVAILABLE
- DISCOUNT VOUCHERS INCLUDED
- NO MINIMUM ORDER

FILL IN THE COUPON AND POST IT WITH YOUR CHEQUE, PO ETC FOR £1.50 TO RECEIVE YOUR 1990 CRICKLEWOOD ELECTRONICS CATALOGUE AND VOUCHERS WHICH YOU CAN USE AGAINST YOUR NEXT PURCHASE

**Cricklewood Electronics Ltd**  
40 CRICKLEWOOD BROADWAY, LONDON, NW2 3ET  
Tel: 01-450 0995/452 0161  
Fax: 01-208 1441 Telex: 914977

### CRICKLEWOOD ELECTRONICS 1990 COMPONENTS CATALOGUE

PLEASE SEND ..... COPIES OF THE 1990  
CRICKLEWOOD ELECTRONICS CATALOGUE AT  
£1.50 TO:

NAME .....

ADDRESS .....

.....

.....

.....

Remittance enclosed £.....

# REFLEX ACTION MICRO MONITOR SPEAKERS

Jeff Macauley gets out the glue and reports on the ports of his bass reflex loudspeaker design

Last month I described in some detail the basic principles behind the design of reflex speakers. This month I've taken the opportunity to get my hands dirty and actually build one. There's nothing to beat the practical application of theory and so I present the following design which I hope will prove both instructive and a spur to like-minded readers to have a go!

Despite the fact that the theory behind speaker design is now fairly well explored, building a speaker will always throw up interesting challenges. For example this project started with running the characteristics of some woofers through the *Optibox* computer program I detailed last month.

Although I live in a flat where space for audio equipment is somewhat limited I like my fair share of bass so I'm always on the lookout for small systems with good low end extension. I came across the woofer used in this project in the Tandy catalogue. Although it's only four inches in diameter and is primarily intended for in-car use its characteristics make it ideal for a micro monitor application. The unit, Tandy catalogue number 40-1022A,

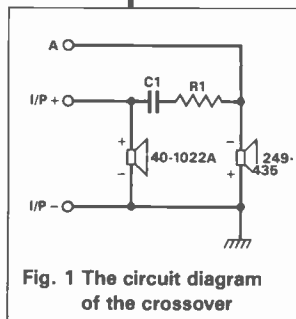

Fig. 1 The circuit diagram of the crossover

has the following specifications.

Resonant frequency	$f_0$	= 55Hz
Total Q	$Q_{ts}$	= 0.35
Equivalent volume	$V_{as}$	= 0.23 cu ft

If we plug these values into the equations given last month we come up with the following information. Optimum volume  $V_0 = 0.169$  cubic feet, cutoff frequency 62Hz!! I've seen enclosures of over a cubic foot which cannot reach that low.

This obviously merited further investigation so I went down to my local Tandy store and bought a pair. I then embarked on the process of testing them to make sure the parameters were as stated. I was not disappointed. Both units measured up very closely to the published spec and in addition the enclosed data sheet promised a very smooth midrange response and a top end rolloff of about 5kHz.

There were only two flies in the ointment. Firstly the quoted sensitivity of 84dB/W is on the low side as is the published power rating of 10W rms. However I have been driving mine at neighbour-disturbing levels from my 35W/ch amp for over a month with no signs of distress to the drivers. My initial reservations as to the spl obtainable and the woofer's durability have proved unfounded.

I finally chose, after some deliberation, a cabinet volume of 0.166 cu ft. The reason for the slight change in volume was rounding the dimensions to whole numbers: 3dB cut off at 64Hz, ripple 0.1dB. The final external dimensions of the enclosure are 9.5in by 5.75in by 9in (h x w x d). A cabinet this small has the advantage that the panels are more rigid and hence

less liable to resonate and colour the sound. I eschewed the normal .75in thick high density chip board for the more cosmetically pleasing white melamine covered variety.

Any constructor that cares to can choose the high density stuff in preference as long as the internal dimensions are retained. An 8ft length of 9in wide board will amply provide two cabinets for less than £7. Unless one actually enjoys woodwork or has masochistic tendencies it is worth getting your local timber yard to cut the board for you. It is absolutely essential to have the cuts made accurately (this will prevent the possibility of the air turning blue as you fit the case together).

To complement the woofer a high quality tweeter is required. As with woofers there is a large variety on the market. I finally chose a Philips polycarbonate dome type which is available from Electromail, catalogue number 249-435. The main reason for this choice is that I have had wide experience of this unit and know its strengths. It has a good flat response from 3-20kHz, amplitude variations being kept to within a couple of dB. It is also very sensitive and capable of wide dispersion.

## Considering Crossovers

Having decided on our drivers and the cabinet size, the next task is to decide on a crossover. To understand how well or dismally a crossover works it is first necessary to consider the tasks it is required to perform.

The obvious function is to divide the incoming signal into the high and low components. Unfortunately this is complicated by the fact that the speaker units don't present pure resistive loads. Another complication is that back emf is generated by the units as they operate and this behaviour is both amplitude and frequency dependent. Add to this a compensation for response deviations in the driver and you end up with a very complex network that evades straightforward analysis.

The other alternative is to accept that some variations are inevitable and minimise these by choosing drivers that are inherently flat in their operating range. A simple network can then be designed which gives good results. Luckily both the units chosen here are fairly flat (to within a couple of dB of their operating range) and therefore the simple approach can pay dividends.

Getting back to the immediate problem of designing a crossover for the speaker in hand I made the following observations. Firstly the frequency response of the woofer is flat within  $\pm 2$ dB and has a well damped hf rolloff, 3dB down at 5.5kHz. Secondly the tweeter is far more efficient than the woofer and has a well controlled 'bass' resonance at 2kHz. It is also sensibly flat between 5 and 20kHz.

It followed from these observations that the easiest solution was to leave the woofer response as it is and precede the tweeter with a first order network. It means an asymmetric crossover and implies a careful choice of turnover frequency to avoid response

TOP PROJECT



anomalities. This was the design path chosen and the resulting circuit is shown in Fig. 1. The tweeter is several dB 'hotter' than the woofer which means its signal must be attenuated. This is the function of R1. C1 is chosen to produce a  $-3\text{dB}$  point at  $5.5\text{kHz}$  in conjunction with the series resistance of R1 and the tweeter's impedance. Note that the tweeter is phase inverted with respect to the woofer due to the drive signal phase differences between them.

Despite its simplicity this network does the job it was intended to do and has a couple of advantages compared to more conventional designs. It's extremely easy to drive, the impedance doesn't fall below  $7R$ . It uses no coils and because of the high value of R1 a normal value polyester cap can be used for coupling.

Even so, I always find the advantages of an active crossover boost performance further, and a suitable design for the Micro Monitors will follow next month.

## Construction

The required wood cuts are shown in Fig. 2. While dimensions here are in millimetres, the *Parts List* quotes in inches since many timber yards have yet to find their way in to the '80s!

Mark out the panels for the drivers and port. The tuning duct is a length of plastic piping with an internal diameter of  $1.25\text{in}$  ( $31\text{mm}$ ) which has an overall external diameter of  $1.5\text{in}$  ( $37.5\text{mm}$ ). The internal area is thus  $3.14r^2 = 1.22\text{in}^2$ . Plugging this value into the port equation gives a length of  $4.1\text{in}$ ,  $104\text{mm}$ . The piping used is available at plumbers supply merchants and a metre length cost me all of  $84\text{p}$ .

Note that the port is mounted on the rear baffle. This is mainly because a small frontal area is required to give good stereo imaging. It has no adverse effects on the sound because at the low frequencies at which the port operates the speaker's radiation pattern is omnidirectional anyway. Cutting the pipe accurately is more difficult. A mitre box is almost essential. If you don't have one the easiest way is to wrap a piece of card tightly around the tube to obtain a straight edge which can be slid up and down. Mark off the length you need by drawing around the card. Using a hacksaw carefully make a cut around the circumference of the tube before cutting it through.

Having got to this stage, final assembly of the enclosures can commence. Everyone is entitled to their own foibles when it comes to adhesives. Mine is to use a contact adhesive *Thixofix* which is widely

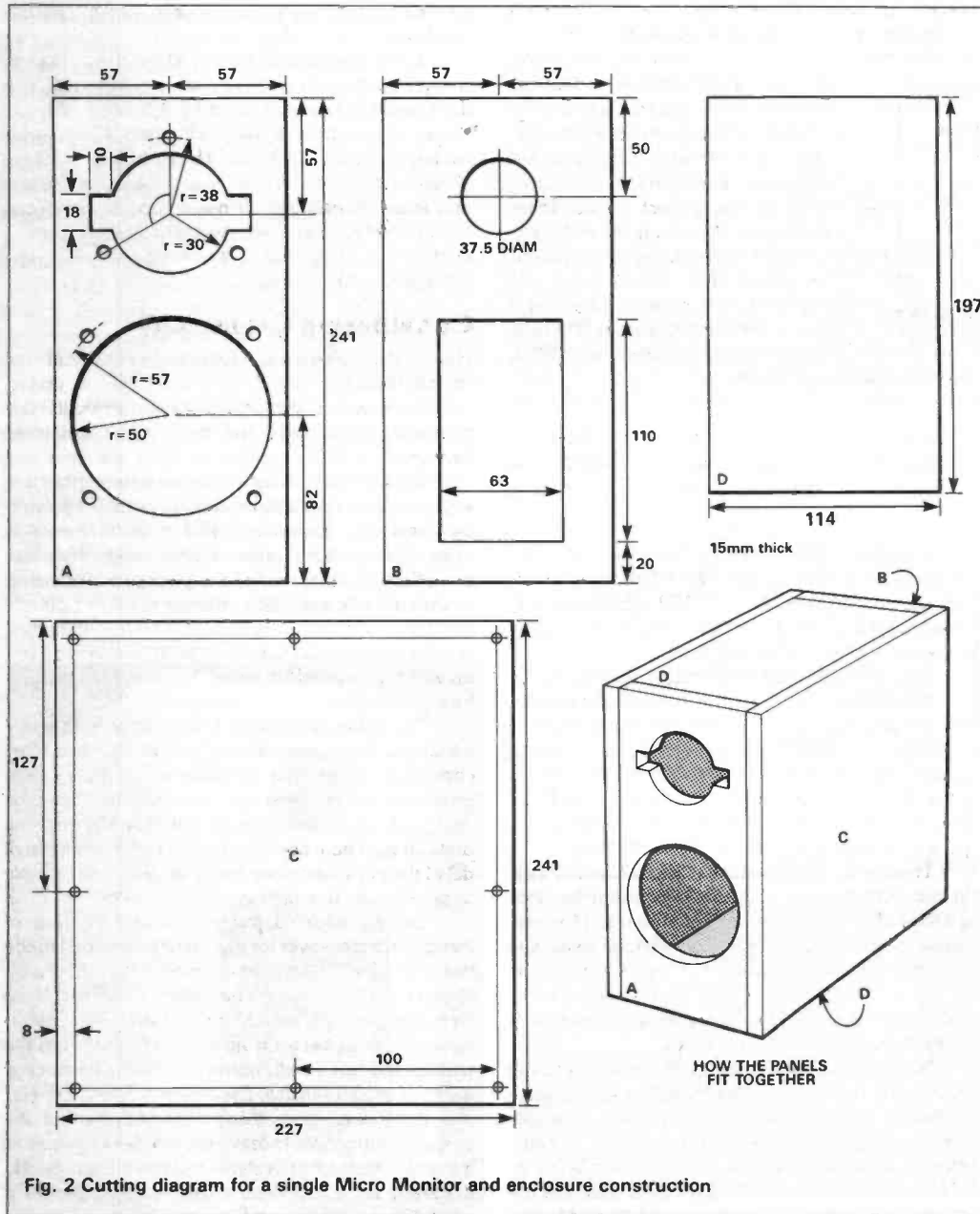

Fig. 2 Cutting diagram for a single Micro Monitor and enclosure construction

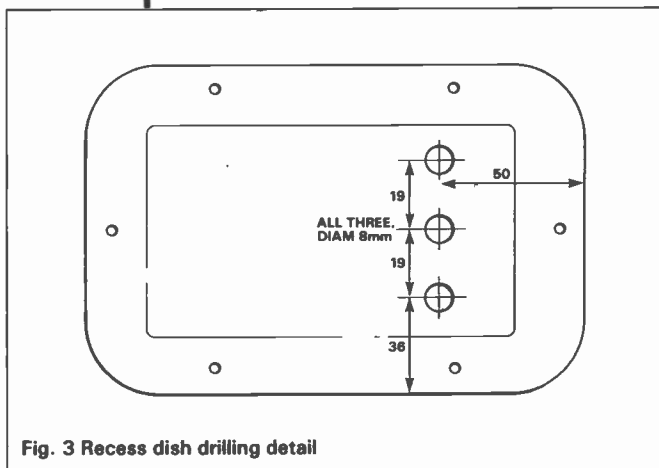

Fig. 3 Recess dish drilling detail

available. One smears the surfaces to be joined with glue, then leaves them for ten minutes or so for the glue to cure. The panels can then be slid together and positioned precisely. Firm pressure then completes the bond.

Whatever adhesive is used it is as well to use it liberally as this will stop air leaks.

Once the case has been glued it needs to be screwed together. I used 1in no8 self tappers for this job. Drill pilot holes 1/8in (3mm) diameter to take the screws and countersink these. I have detailed the screw positions on Fig. 2. These should be adhered to.

Having built the case, attention can be turned to sealing it to prevent air leaks. This is most easily done with 'polyfiller'. Mix it up into a stiff paste and work it along the panel seams with your finger. Wipe the excess away with a damp cloth. The hole for the port is best cut with a hole cutter. A nest of these, suitable for cutting various diameter holes between one and two inches, can be obtained from your local tool shop for a few pounds. These are a useful addition to anyone's tool box. To fit the port into position I used araldite rapid. The other apertures are larger and are

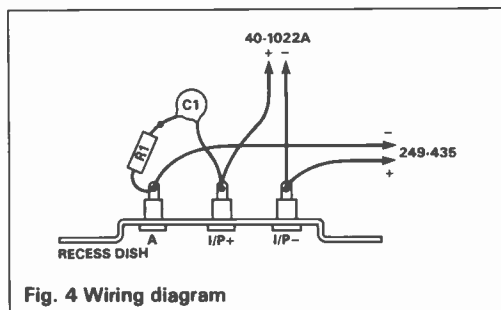

Fig. 4 Wiring diagram

## PARTS LIST

### ONE CHANNEL ONLY

R1	47R 1W wirewound
C1	470n 100V polyester wkg
Woofer	Tandy 40-1022A
Tweeter	Electromail 249-435
Recess Dish	Maplin FS34M
Wood	15mm thick Melamine covered chipboard
	2-off 9 1/2 x 4 1/2 in
	2-off 9 1/2 x 9 in
	2-off 4 1/2 x 7 3/4 in
	104mm length of 1 1/4 in id plastic tubing. 3-off 4mm panel mounting sockets.

best tackled with a jigsaw or jigsaw attachment. If this is not available then a coping saw can be used.

Reflex enclosures cannot be stuffed with sound absorbants like other forms of enclosure. To do so will wreck the carefully calculated relationship between driver and enclosure resonance. For this reason the interior is left unstuffed.

One nuisance with the woofer is that the mounting holes are slightly recessed from the frame. This means that in order to seal the driver against air leaks, further action must be taken. The best idea is probably to stick some self adhesive draught excluder tape around the hole before mounting the driver. A less strenuous alternative used on the prototypes was to seal around both units with polyfiller after mounting them. The tweeter hole should be similarly treated.

Before fitting the drivers into position it is as well to solder the leads to the terminals. Because of the simplicity of the crossover unit this is simply wired across two of the terminals as shown in Fig. 4 drawing. Nothing elaborate is required here — I used 12in lengths of 5A twin speaker cable from Halfords. This has the advantage that one of the conductors is identified with a white strip along the insulation thus allowing easy phasing of the units.

For connections to the drivers I used three 4mm banana sockets/channel. If these are connected as shown in the schematic then upgrading the speaker to active operation becomes easy. The drilling for the rear access dish is shown in Fig. 3.

Final assembly consists of mounting and wiring the crossover and terminals then screwing the rear panel into position. Remember to seal around the back plate with more polyfiller to ensure airtightness.

At this stage all that remains is to test the unit out and finish the cabinet as desired. If you've never used melamine faced board before you will find that edging strip is available to cover the bare chipboard. This is first trimmed to the correct width and applied to the edge by ironing over it. The backing adhesive bonds with the heat.

In conclusion this pair of speakers can be built for a total expenditure of less than £40 the pair. They have a better bass response for their size than any others I have heard. What's more important is that this response is nicely damped with no audible ripple in the response. They also offer a good transient response and a 3-dimensional stereo image. They can also be simply and fairly cheaply upgraded to active use as detailed in a forthcoming article.

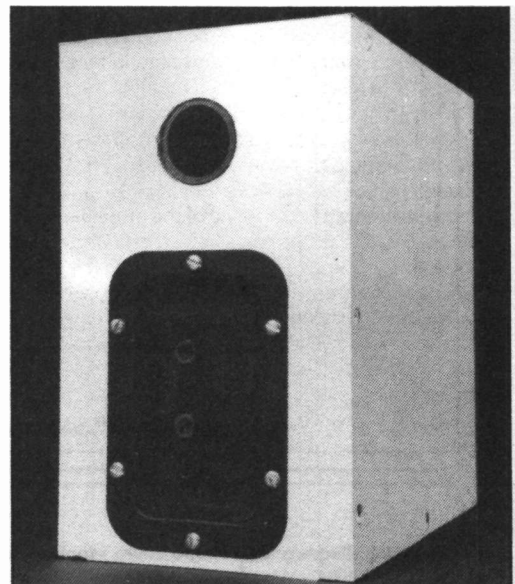

# John Linsley Hood's AUDIO DESIGN

## 80W MOSFET AUDIO AMPLIFIER

# TOP PROJECT

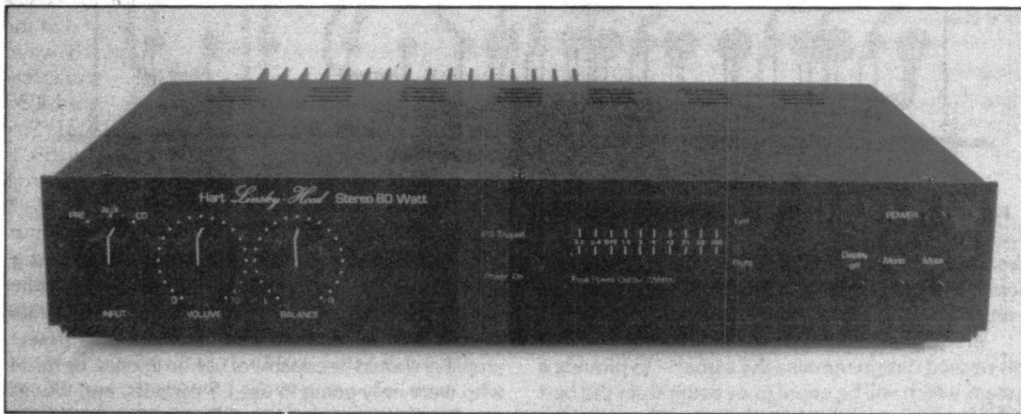

*John Linsley Hood improves on the best amplifier you can build*

**T**here is an old adage which says that it's nice to be clever but it's a lot more clever to be nice. Translated into audio amplifier terms this could read that it is nice if equipment has an excellent technical specification, but it is even better if it sounds nice.

Of course it is gratifying if gear scores top marks on both counts but the former, sadly, does not guarantee the latter. It is salutary, from time to time, to visit one of the more run-of-the-mill High Street 'hi-fi' shops to be reminded that some quite horrible noises can emerge from combinations of reasonably prestigious seeming kit.

This lack of agreement between conventional measurements and perceived sound quality poses a problem for any designer in the audio field. Account must be taken, however reluctantly, of the claims of those who base their judgement of equipment performance on listening trials, and checks made to see whether these claims have foundation in fact.

I admit to reservations about many of the effects attributed to the characteristics of minor amplifier components in amplifier circuitry, particularly where these are clearly peripheral to its function. However in places such as the negative feedback loop (which defines the whole performance of the amplifier) and in the supply line decoupling (which establishes the relationship of the system to the 0V line) there are good technical reasons why component type may affect sound quality and there are small but measurable (and reproducible) effects which can be demonstrated. Having looked at a wide range of these marginal aspects of audio quality, I incorporated those I thought to be sensible into the design of my 80W amplifier featured in ETI from June to September 1984.

In general, I am very well pleased with the performance of this amplifier which is, I think, the best design I have done so far. In the view of some experienced 'audiophiles' whose opinions I respect,

it is significantly better than other amplifiers of their acquaintance. It has also attracted some very flattering comment from constructors in the correspondence columns of the 'hi-fi' press.

I share the general regret that a kit of parts for this design did not become available at the time of the original publication. Now that a kit specialist, Hart Electronic Kits, has produced the necessary components, PCBs and metalwork for the power amplifier, I have taken this opportunity to do a little tidying up in areas generally related to convenience rather than performance.

The pre-amplifier has also been given a few amendments, notably the addition of a moving coil head amplifier stage and new tone controls. Hart is

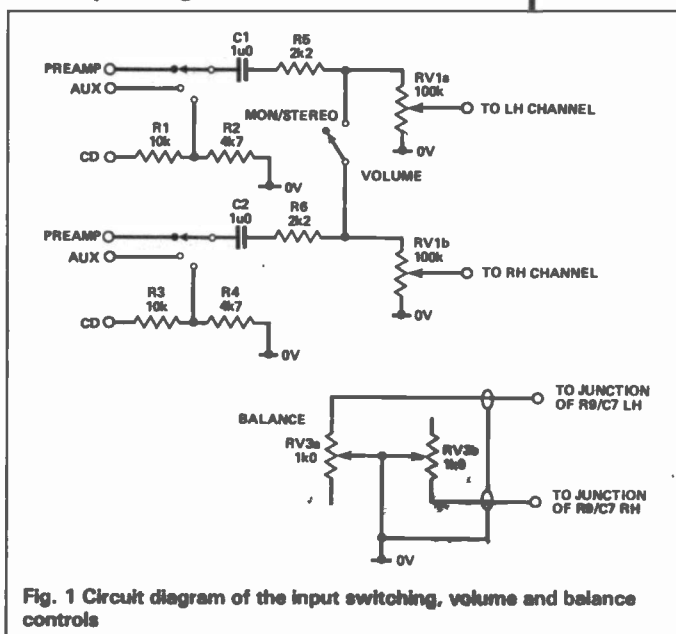

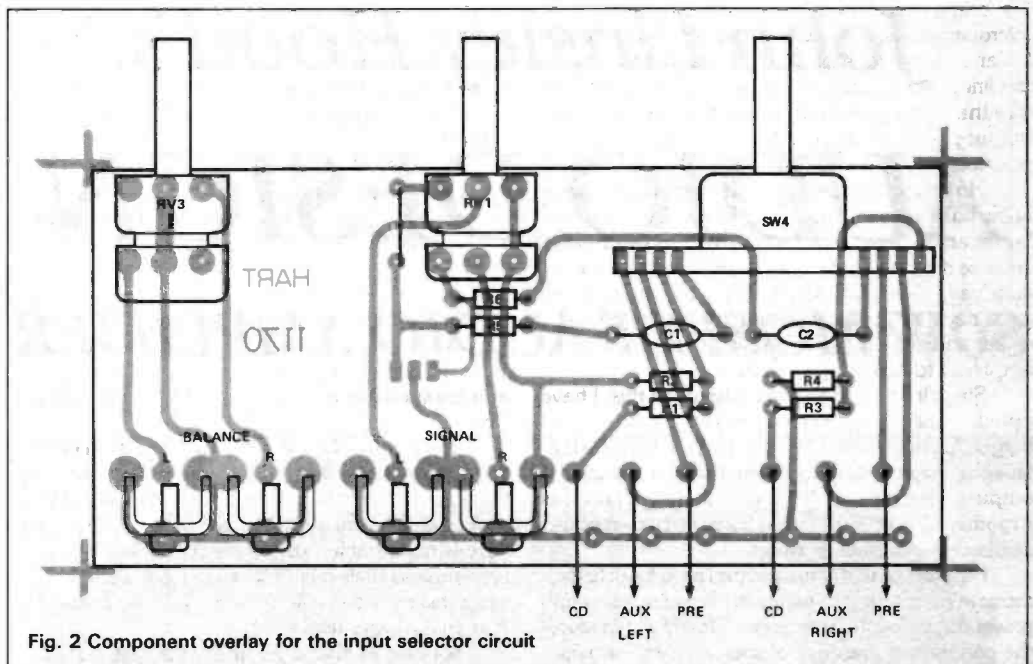

Fig. 2 Component overlay for the input selector circuit

already working on the kit for the pre-amplifier and hopes to have it available later this year. It will be featured in ETI at that time.

In both the power and pre-amplifiers my aim with this revised design remains the same — to provide a system which will be equal to or better than the best of the contemporary market offerings, without making the whole system too expensive for the average potential constructor.

### Input Switching

It was an oversight on the original design not to provide an input selector switch to accompany the

'gain' and 'balance' controls on the input of the power amplifier which would have increased the versatility of the power amp. I should have thought of this earlier since I had specifically intended that the power amplifier should be capable of use on its own, by those who were only going to use LS outputs, and whose sources (for example tape, CD or radio) would not need frequency response adjustment.

The small circuit modifications involved are shown in Fig. 1 and the component overlay in Fig. 2.

### Output Power Indication

The power output display which I had provided for

## COMPONENT CHARACTERISTICS

I have read much, and have been given much advice by some of my experimentally minded friends, on the way in which the nature of a component (as distinct from its actual electrical value) can influence the quality of the sound of an amplifier. I have made a lot of tests to see if I agree with these findings. Mainly the differences are too small for me to be able to say definitely whether there is a change and if so whether it is better or worse.

I do not say that these differences do not exist or that when a lot of very small changes are added together the cumulative effect will not be greater. What I think is that, in most cases, the changes are very small in comparison with those alterations in sound quality which arise from different circuit approaches. I feel that I am better employed in trying to optimise these.

There is one exception to my reluctance here and this concerns capacitors, particularly those in the feedback loop of a feedback amplifier and to a lesser extent those in the signal line.

This is a complex business but there appear to be a few general rules. The extent to which a capacitor will influence the sound depends on the signal voltage which could appear across it, upon its impedance in relation to the other circuit parameters, and upon its dielectric hysteresis and dielectric loss. In a feedback loop, a low leakage aluminium electrolytic is greatly preferable to a tantalum type but must operate with a polarising voltage present across it. Electrolytics will usually benefit from the presence of a parallel connected non-polar type.

Ceramic capacitors can cause some curious effects due to the voltage dependence of their capacitance and should be left to RF circuitry. Silvered mica types seem quite harmless but there is nothing which they can do which polystyrene ones will not do better.

In level low level audio circuitry, such as moving coil head amps,

aluminium electrolytics appear to work quite well (which is a good thing since the alternative ways of amassing the necessarily large values of capacitance would be extremely bulky — not to mention the cost).

At higher signal voltage levels, polypropylene, polystyrene, polycarbonate and polyester types, in that order of preference, are better than electrolytics — if one has to use a capacitor at all. If one can rearrange the circuit to avoid or lessen the number of capacitors in the signal line, this is worthwhile.

There is not, I think, much difference between polystyrene and polypropylene types and the latter tend to be more variable in quality — perhaps due to some manufacturers saving pennies by using a packaging grade polypropylene film instead of the more expensive electrical quality material, or perhaps by an inadvertent substitution of film types.

I have tried, therefore, particularly in the revised version of the preamplifier, to recast the circuitry in a form where the capacitors used are the optimum choice for their circuit function in terms of sound quality, practicability and cost. The same considerations apply to the other components used — none of which has escaped scrutiny.

The other major areas in the choice of components are, in order of importance, the switches and connectors (which should have a contact area appropriate to their likely current flow and should be gold plated in low level circuitry) and the integrated circuits such as op amps and voltage regulators. These are now very widely available from a range of sources, but the performance of notionally identical devices from some of the minor manufacturers can sometimes be very poor due to lack of adequate quality control. It pays, therefore, to spend a little extra for a component from a major producer.

the original system used a pair of moving coil microammeters, connected to provide peak-reading linear scale power meters. I thought that the choice of a linear power scale would be useful since it would give the user a good idea of how close he was to the output power overload region — which would, in practice, probably be a bit above 100W per channel.

However, the meter pointers were nearly always at the bottom end of the scale. I know that in my own home, and with my own 'BBC monitor' type LS units, I very seldom use more than about 3W peak, but I had assumed, incorrectly, that there were out there in the great beyond more stalwart audiophiles whose eardrums and neighbours would allow them to push their amplifiers to much higher power levels.

Since it seems that I had misjudged this, I have opted instead for a fairly conventional twin LED bargraph circuit (Fig. 3). This gives a near instantaneous peak-reading, log-scale display, covering the output power range 0.2-100W. This design provides a module which would be usable as an output power display for other audio amps.

I appreciate that some people like to listen to their music in near darkness, where the flickering bar-graph power display might be tiresome. Others would resent the continuous presence of such a visual intrusion, even in full lighting. I have therefore arranged that the display can be switched off when not needed.

The same LED display panels also carry the power 'on' and power supply overload 'trip' warning LEDs. The overlay is shown in Fig. 4. In order to power this bargraph display circuit, a pair of  $\pm 15V$  lines is also derived from the power supply unit by way of a small additional piece of circuitry, shown later.

## Power Supplies

Experience has indicated that a few changes would be useful here. The circuit is shown in Fig. 5. In particular, fault reports from constructors suggest that Q17, an MJ2501 pnp 'Darlington' transistor (in the main  $\pm 55V$  power supply line), is more vulnerable to damage on PSU output short-circuits than I had hoped. In some cases, when this caused the transistor

to go open circuit. Q7 and R31 would try to pass the output current instead and this wasn't good for them. I have included two diodes, D23 and D31 (together with D24 and D30 in the -ve channel) to prevent this undesired current flow through the over-current protection circuit.

However, the main improvement in the PSU — principally to ensure that the output lines were truly s/c proof (but which also seems to have given a slight sonic bonus by way of a small lift to the already high level of audio 'transparency') — is that the series 'pass' transistors in both lines are replaced by power MOSFETs, since these are both faster in action and also much more rugged devices. The circuit changes required to allow this substitution are relatively slight, and are shown in the amended PSU circuit diagram (Fig. 5).

The use of MOSFETs here would also allow the HF stabilisation capacitors (C7 and C8) in the loop feedback circuit to be omitted, since with MOSFETs, which have a very good HF response, the feedback loop is quite stable without them. I would however recommend their retention at about the 3n0 value, since this has no ill effect and an increase in stability margin is always useful.

A point I'd like to make here is that there is a current vogue for using greatly oversized mains transformers because it is thought by their users that this modification somehow improves the 'solidity' of the sound. So it might, in a simple transformer-rectifier-reservoir capacitor PSU, provided that the reservoir capacitors were adequately large and the conducting impedance of both the rectifiers and the wiring joining them to the transformer and to the reservoir capacitors was adequately low.

However, a competently designed electronically stabilised PSU can have an output impedance of a small fraction of an ohm, even down to subsonic frequencies and to match this impedance characteristic with conventional capacitors would require values in excess of 1Farad.

I do not recall ever seeing a 1F 80V working capacitor but were such components available they would be both dear and bulky — an inelegant and

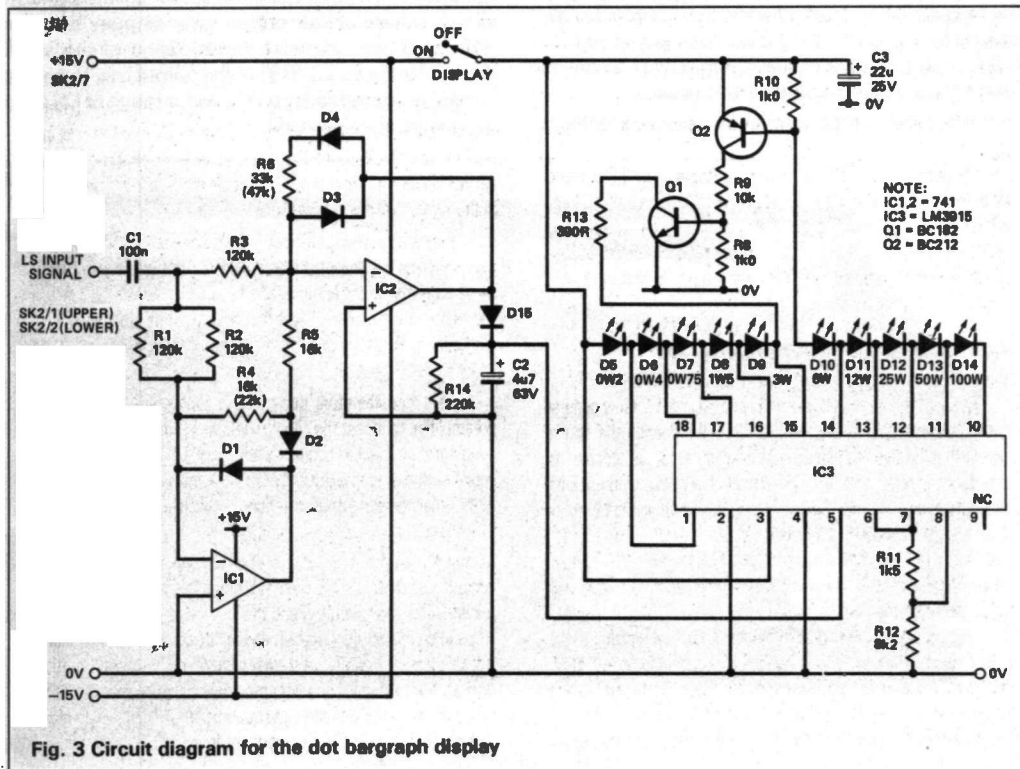

Fig. 3 Circuit diagram for the dot bargraph display

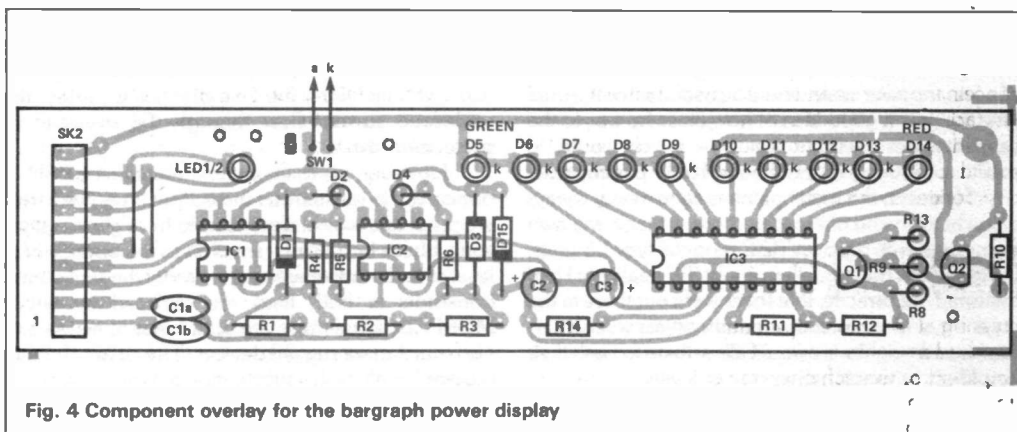

Fig. 4 Component overlay for the bargraph power display

wasteful way of approaching the problem of PSU design. An additional advantage of an electronically stabilised PSU is that it also effectively isolates the power amplifier from the mains transformer, whose characteristics will then be relatively unimportant so long as it is adequately rated to deliver the required input voltage without overheating. Also it doesn't contribute any annoying mechanical 'hum' or unwanted stray magnetic fields.

The power supply for the LED bar-graph display needs only to be stable enough to give a constant LED brightness and to avoid exceeding the voltage or dissipation ratings of the bar-graph IC. The circuit used employs a single transistor emitter follower (Q23 or Q24) whose base is supplied with a  $\pm 16V$  potential from a simple zener diode voltage regulator.

The power supply unit has an output voltage which is capable of adjustment and could stand as a quite versatile independent module, to upgrade other amplifiers designed with rather cruder PSU arrangements. It has therefore been designed as a monoblock unit on a heavy gauge aluminium sub-chassis, with the PCB shaped to fit around the toroidal mains transformer.

In the 80W design, this sub-chassis also carries the LS output connections (via 4mm binding posts), the mains inlet and output sockets and provides heat sinking for the PSU MOSFETs which are mounted in holders and fitted with insulating covers to obviate inadvertent case-to-chassis short circuits.

The new component layout is shown in Fig. 6.

## DC Offset Protection

In order to avoid the need for relay contacts in the LS output lines (in the event of a DC offset arising) I had included a protection circuit in the PSU system (Q9, Q11, Q13, Q14 in the +ve line, and Q10, Q12, Q15, Q16 in the -ve line), which would shut down the PSU in the event of an offset.

I had, however, erred on the side of excessive caution, and this could cause the PSU to shut down on quite legal low frequency excursions — especially from compact discs, which have a very good sub-sonic response. I propose therefore that two 470k resistors, R42 and R43, should be added between the bases of Q9 and Q11 to the 0V line, to reduce the 'trip' sensitivity of the circuit.

Please note that there was a misprint on the original diagram which showed D11/D18 joined to the 0V line. Most constructors spotted this but if it was left uncorrected, it rendered inoperative the second shut-down mechanism in the PSU, which is designed to be triggered if an excessive difference occurs between the PSU  $\pm$  output voltage levels.

## The Power Amplifier

The circuit (Fig. 7) of this is unchanged from that shown in ETI in July 1984, except for an amendment to the values of the output gate stopper resistors R18, 19, 21 and 22, and the inclusion of the small damped inductor L1/R31 in the output line, to ensure complete compatibility with a wider range of LS units or strange speaker cables.

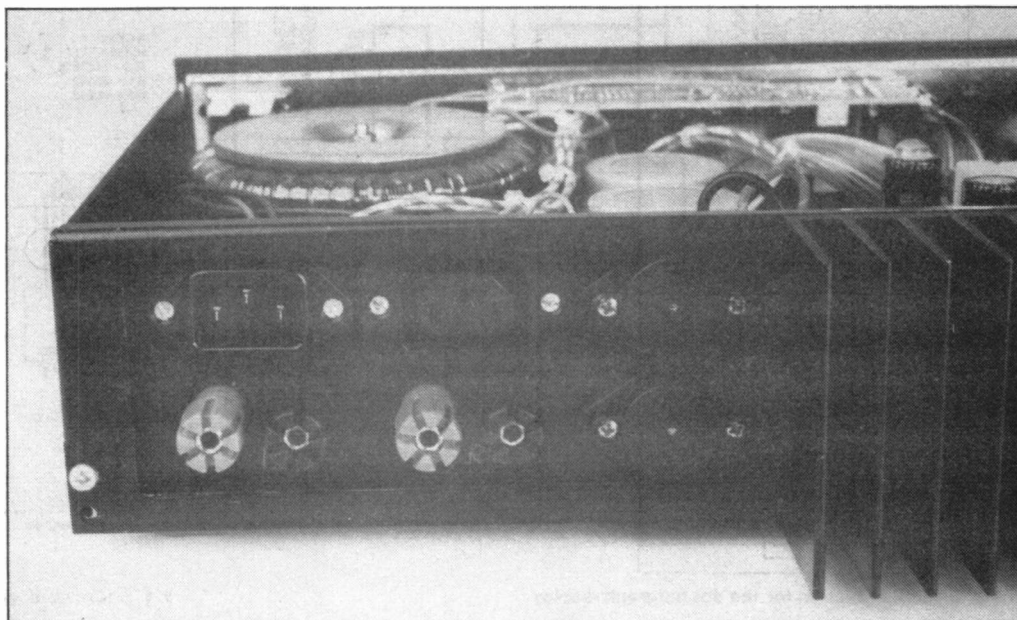

# TOP PROJECT

The added input switching arrangements have already been noted but there are also some changes added in the evolution of the 'kit' design which concern the balance and stereo/mono switching. This last facility was included to save difficulty if the amp was driven from a mono input source, such as a TV sound pick-off socket. The recommended PSU component overlay is shown in Fig. 6.

## Physical Layout And Kit Evolution

Looking at the efforts of friends and acquaintances who had made their own PCBs and assembled this amplifier from scratch made me aware, not for the first time, just how many things it was possible to do wrong. Even the unwise connection of earth points may destroy the purity of the output signal, let alone

the effect of allowing a pair of unscreened input wires to trail across the chassis underneath the power amp and PSU boards.

I was, therefore, very happy to find that Hart was prepared to invest the quite considerable amount of effort needed to work out a neat and fully debugged kit for this design, and I am grateful that they were prepared to make and submit prototypes for me to test and to make layout amendments with very good grace when I felt that some aspect might be improved.

Unfortunately, because their works is some hundreds of miles away from my own lab., the task of evolving a fully 'designer approved' collection of hardware has taken rather longer than either of us had hoped.

I had initially underestimated the amount of space which would be taken up by the PA and PSU boards and the toroidal mains transformer. There is

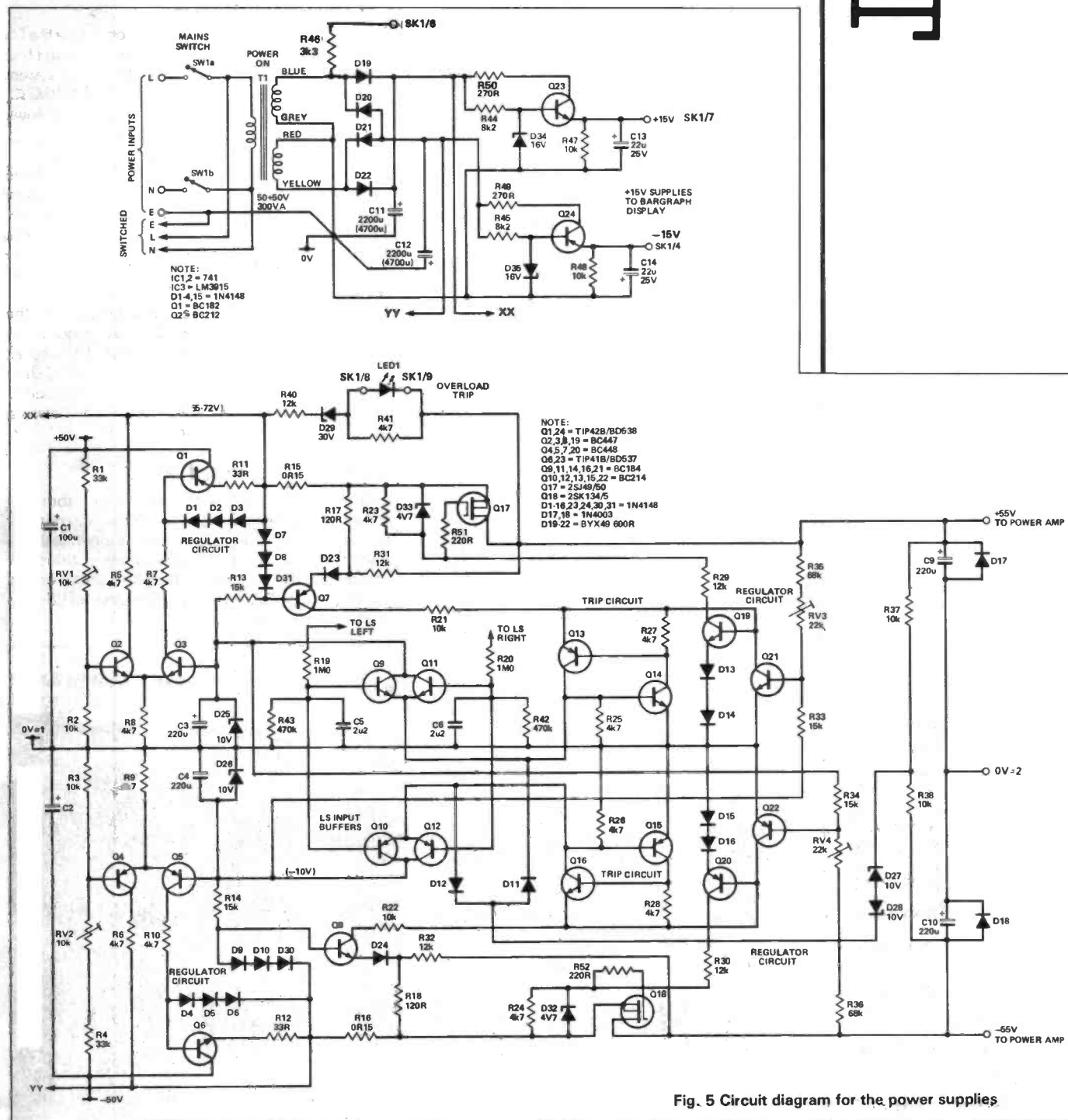
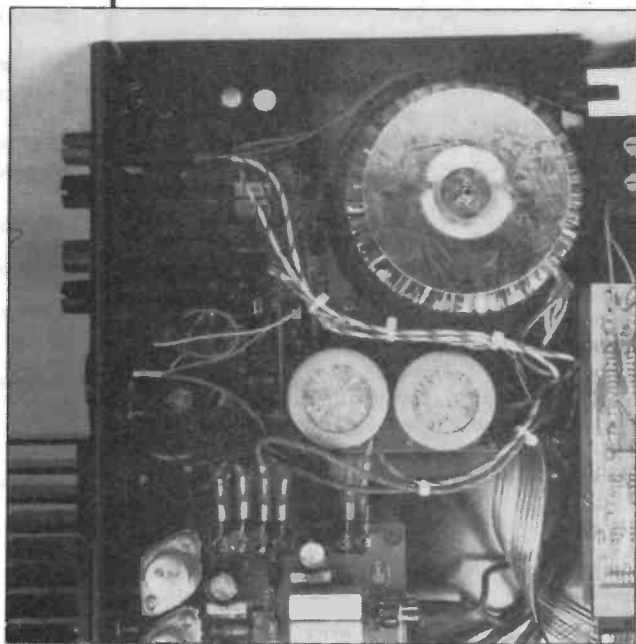

Fig. 5 Circuit diagram for the power supplies



## PARTS LIST

### Bargraph Power Meter

Parts for one channel only

RESISTORS (all .3W or better. Bracketed values for 4R speakers)

R1-3	120k
R4,5	16k (22k)
R6	33k
R8,10	1k0
R9	10k
R11	1k5
R12	8k2
R13	390R
R14	choice of 220k (slow decay) or 82k (medium decay)

### CAPACITORS

C1	100n polyester radial, pitch 7.5mm
C2	4u7 63V electrolytic radial, pitch 2mm
C3	22u 25V electrolytic radial, pitch 2mm

### SEMICONDUCTORS

IC1,2	741 or LF351
IC3	LM3915

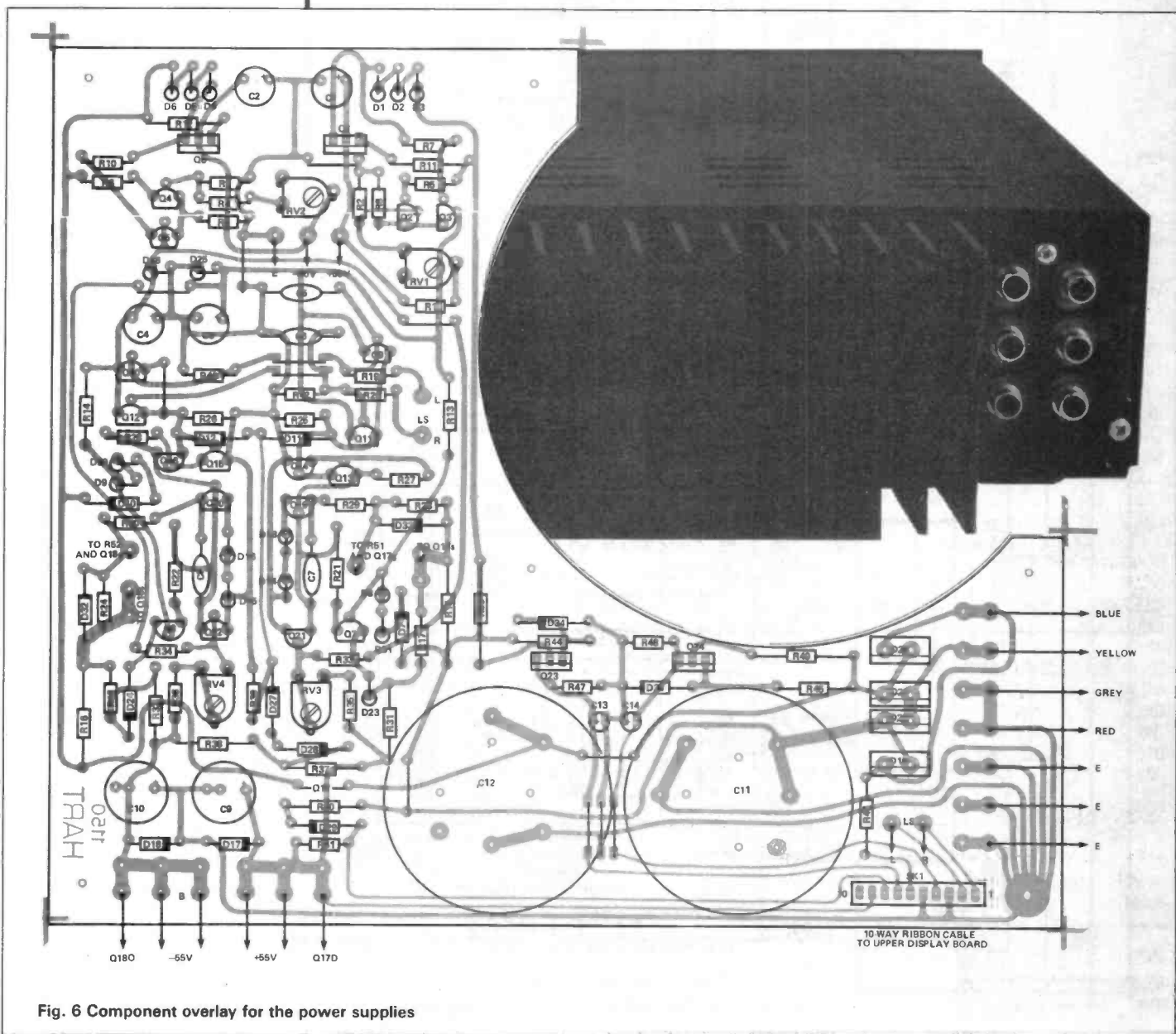

Fig. 6 Component overlay for the power supplies



Q1	BC182 (D pad)
Q2	BC212 (D pad)
D1-4,15	1N4148
D5-14	LED bargraph display assembly
LED1	red LED, upper PCB only
LED2	green LED, lower PCB only

#### MISCELLANEOUS

SK2	10-way 2.5mm pitch socket (upper PCB only)
-----	--

PCB. IC sockets. 90° LED mounting. PCB 2-pin header, 2.4mm. Jumper socket. 3-way header and prewired socket for SW1.

#### Power Amplifier

RESISTORS (all .3W metal film 1% unless specified)

R1,14	150k
R2	4k7
R3	1k2
R4-6	1k0
R7	47k
R8	820R
R10	470k
R11	470R
R12	56R
R13	39R
R15	22k
R18,19	330R
R20	8R2 2.5W w/w
R21,22	270R
R23-27	OR22 2.5W w/w
R28	10R
R29	10k
R30	39k
R31	8R2 ½W (matrix for L1)
RV2	1k0 lin cermet preset
RV4	2k2 balance preset
R9	2k 2

#### CAPACITORS

C1,6,10,12,14,16	470n polycarbonate film radial 15mm
C2	330p polystyrene film axial
C3	100p polystyrene film axial
C4,15	100n polycarbonate 10mm
C5	1n0 polystyrene film axial
C7	2x4u7 polycarbonate film radial 27.5mm
C8	2x10p polystyrene film axial in series
C9,11,17,18	220u 63V electrolytic radial 7.5mm
C13	220n polycarbonate film radial 10mm
C20	100u 25V radial electrolytic 7.5mm
C21	10n polycarbonate film radial 5mm

#### SEMICONDUCTORS

Q1,2,6	BC448
Q3,5,7,8	BC184
Q4,11	BC214
Q9	BF870
Q10	VN1210M
Q12,14	2SK135
Q13,15	2SJ50
Q18	2N5459
D1,2	8V2 zener 400mW
D3,4	1N4148

#### MISCELLANEOUS

L1 6 turns 24swg ECW on R31  
PCB. Transistor pads (12). Gold phono sockets (2). Heatsink TO3 angle (4). PCB male tabs .250 horizontal (8). Diode cradles (4). Insulating discs (5).

#### Power Supply

RESISTORS (all .3W 5% or better)

R1,4	33k
------	-----

R2,3,47,48	10k
R5-10,23-28,41	4k7
R11,12	33R .5W
R13,14	15k .5W
R15,16	OR22 2.5W w/w
R17,18	120R
R19,20	1M0
R21,22,37,38	10k 0.5W w/w
R29,30	12k
R31,32,40	12k 0.5W
R33,34	15k
R35,36	68k
R39	100k
R42,43	470k
R44,45	8k2 0.5W
R46	3k3 0.5W
R49	2k2 0.5W
R50	270R 2.5W w/w
R51,52	220R
RV1,2	10k preset horiz
RV3,4	22k preset horiz

#### CAPACITORS

C1,2	100u 63V elec radial 5mm
C3,4	220u 40V elec radial 5mm
C5,6	2u2 63V polyester radial 15mm
C7,8	3n0 polystyrene axial
C9,10	220u 63V elec radial 5/7.5mm
C11,12	4700u 80V PCB mount can type
C13,14	22u 25V elec radial 12mm

#### SEMICONDUCTORS

Q1,24	TP42B/BD538 (TO220 heatsink)
Q2,3,8,19	BC447
Q4,6,7,20	BC448
Q6,23	TP41B/BD537 (TO220 heatsink)
Q9,11,14,16,21	BC184
Q10,12,13,15,22	BC214
Q17	2SJ49/50 fitted with insulated covers and
Q18	2SK134/5 holders on power supply chassis
D1-16,23,24,30,31	1N4148
D17,18	1N4003
D19-22	BYX49 600R
D25-28	10V zener 400mW
D29	24/30V zener 400mW
D32,33	4V7 zener 400mW

#### MISCELLANEOUS

SK1 10-way 2.5mm pitch vertical  
T1 50-0-50 300VA toroidal  
PCB. Chassis. PCB tabs. Diode cradles. Heatsinks. Speaker terminals. Mains switch. Mains inlet and outlet sockets + cover boots.

#### Input selector section

RESISTORS (all .3W 5%)

R1,3	10k
R2,4	3k3 RV1 100k log, 2-gang
R5,6	2k2 RV3 1k0 lin 2-gang

#### CAPACITORS

C1,2	1u0 polycarbonate rad 15mm
------	----------------------------

#### MISCELLANEOUS

SW1,2 SP push switch  
SW3 2P push switch  
SW4 4P push switch 3W  
PCB. Phono plugs and sockets (4). Gold phono sockets (6).

Main chassis. Heatsink 190x75x50mm. 1 chassis cover. Backplate. Frontplate. Dial plate for display. Knobs.

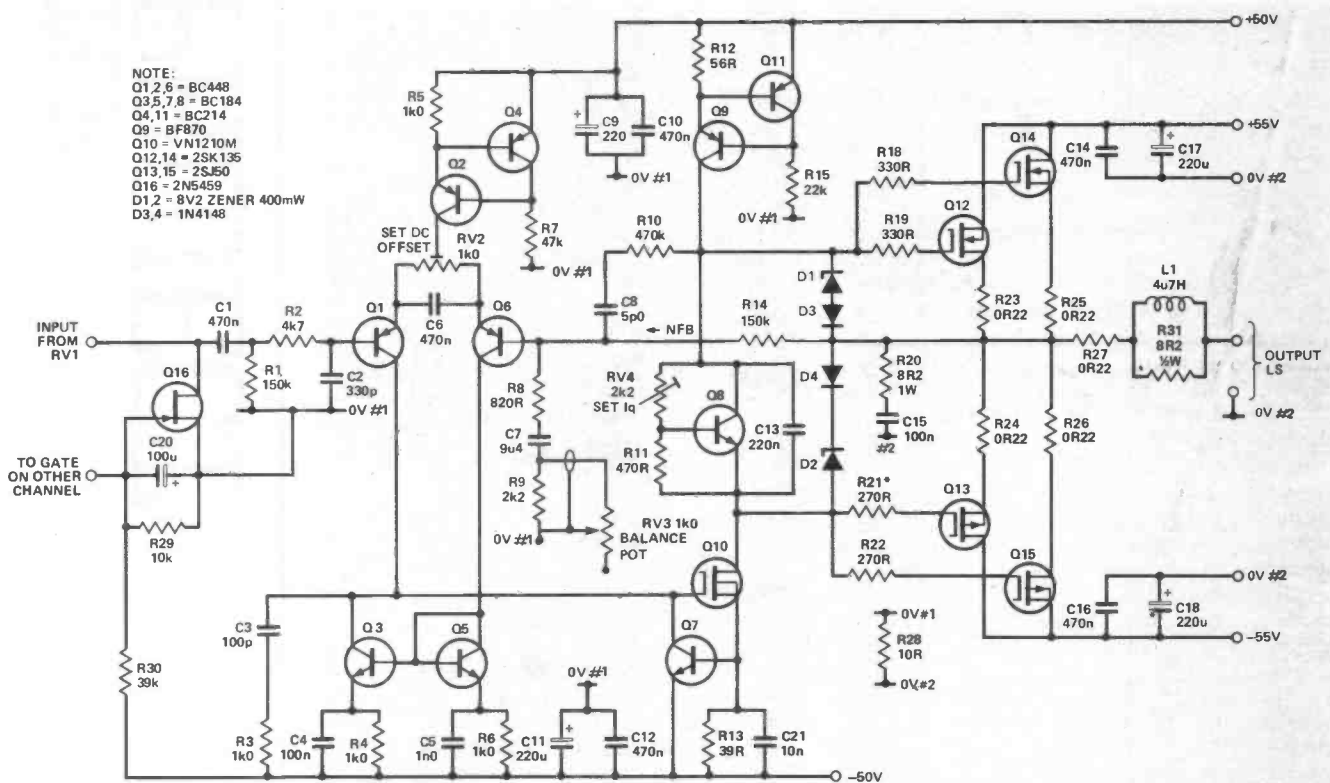

Fig. 7 Circuit diagram of the complete power amplifier

also the electrically desirable, but physically impossible, condition that the two power amp PCBs should occupy the same space, so that there would be no unwanted 'loops' in the wiring between them and the inputs, outputs and power transistors, and so that all the input and output wiring should be of the same length.

A further desirable aspect of the layout is that the connecting leads to the power MOSFETs should be

carefully arranged since, with these devices, if one doesn't watch one's step it is very easy to find that one has unwittingly constructed a VHF oscillator.

Hart solved the problem of the MOSFET connections very neatly by attaching an angle bracket (see photo) in thermal contact with the main heat sink to the PCBs and then directly mounting the MOSFETs through this bracket on to the tracks of the PCB. This also solves the problem of accidental mis-connection to the pins.

Their solution to the requirement of identical position of both boards was to mount the two power amp boards flat, one above the other, separated by spacers between the boards. Preset adjustments are made either from above or through access holes in the metal chassis.

In order to make it easy to remove the power amp boards, the input and 'balance' control connections are made via gold plated phono connectors and the heavy current power supply and output connections by means of 63/0.2mm stranded wire and flat tab push-on connectors.

The critical requirements of the earth return connections are satisfied by care in the layout of the PCBs and by joining the two amplifier output 0V lines, 'E2', by identical length, heavy duty cables to a common earth point on the PSU board, together with the lower current 'E1' points. The earthy side of the LS output is then taken directly to the PA PCBs from their respective LS output binding posts.

In order to avoid input earth loops, the six gold-plated phono input sockets (CD, aux. and preamp.) are mounted on a small separate PCB, which commons the earth returns so that this can be taken by one only of the six screened wires to the input selector board. This input socket panel also isolates the input earths from the chassis.

The input selector board has its four outputs via further gold plated phono sockets which take the

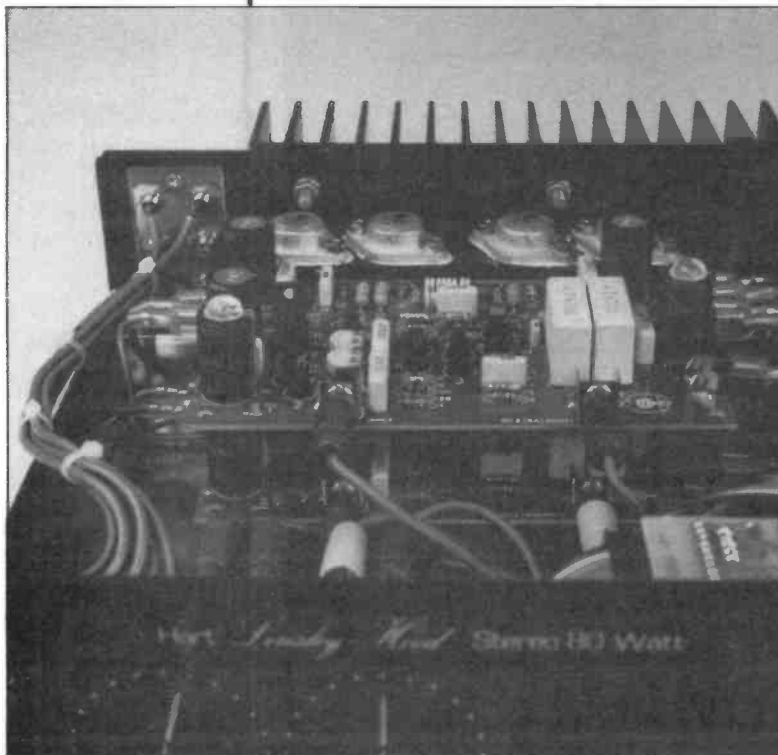

stereo pairs of signal and balance control connections through screened cables to the two power amp boards via the mono/stereo and mute switches.

## Performance

My intention in evolving this design was to offer a circuit which would outperform by a significant margin all but the very best audio amplifiers available today. I do not think that this aim is quite as vain as it might seem, because it is my belief that many apparently near-perfect designs are spoiled by their pursuit of an 'over kill' in aspects where further improvements bring little benefit, while neglecting such things as 'settling time' or loop stability margins, which are very important in terms of sound quality though never specified.

The technical specification for this design, in terms of output power, power bandwidth, harmonic and intermodulation distortion, is fully in line with modern expectations and the transient response is, I believe, a good bit better than average since this is one of the areas which tend to be neglected in commercial hardware.

However, there are aspects of design which affect sound quality but which are not easily related to technical measurements. This is not, I am sure, because they cannot be measured but because we (and I think I speak for most of the designers working in this field) cannot be sure what it is we need to measure. Where I know that one approach in terms

of circuit architecture or component choice gives a better sound quality, or even seems better, than another which is electrically apparently identical, I have deliberately opted for that which gives the best sound.

Since the success of the project depends to a large extent on layout and wiring detail, I have been surprised and pleased by the occasional very enthusiastic letters which have appeared in the 'hi-fi' press, from constructors who have overcome the fairly major problems involved in the construction of this circuit.

I am, therefore, very grateful both to Hart Electronic Kits who have put so much effort into making this design a practicable reality rather than just a beguiling chimera, and to ETI for allowing me a second bite at this cherry. It is now my hope that this amplifier may provide the constructor with a unit which will not be outclassed in any company.

## BUYLINES

Everything in this amplifier design is available from Hart Electronic Kits Ltd, 4 Penylan Mill, Oswestry, Shropshire SY10 9AF. Tel: (0691) 652894.

A complete price list for each section can be obtained from Hart. The special price for a complete kit is £318.25+VAT, Hart code K1100. A slave version without input selector and bargraph costs £269.07+VAT, code K1100s.

Add £2.00 p+p or £9 for next day delivery.

# TOP PROJECT

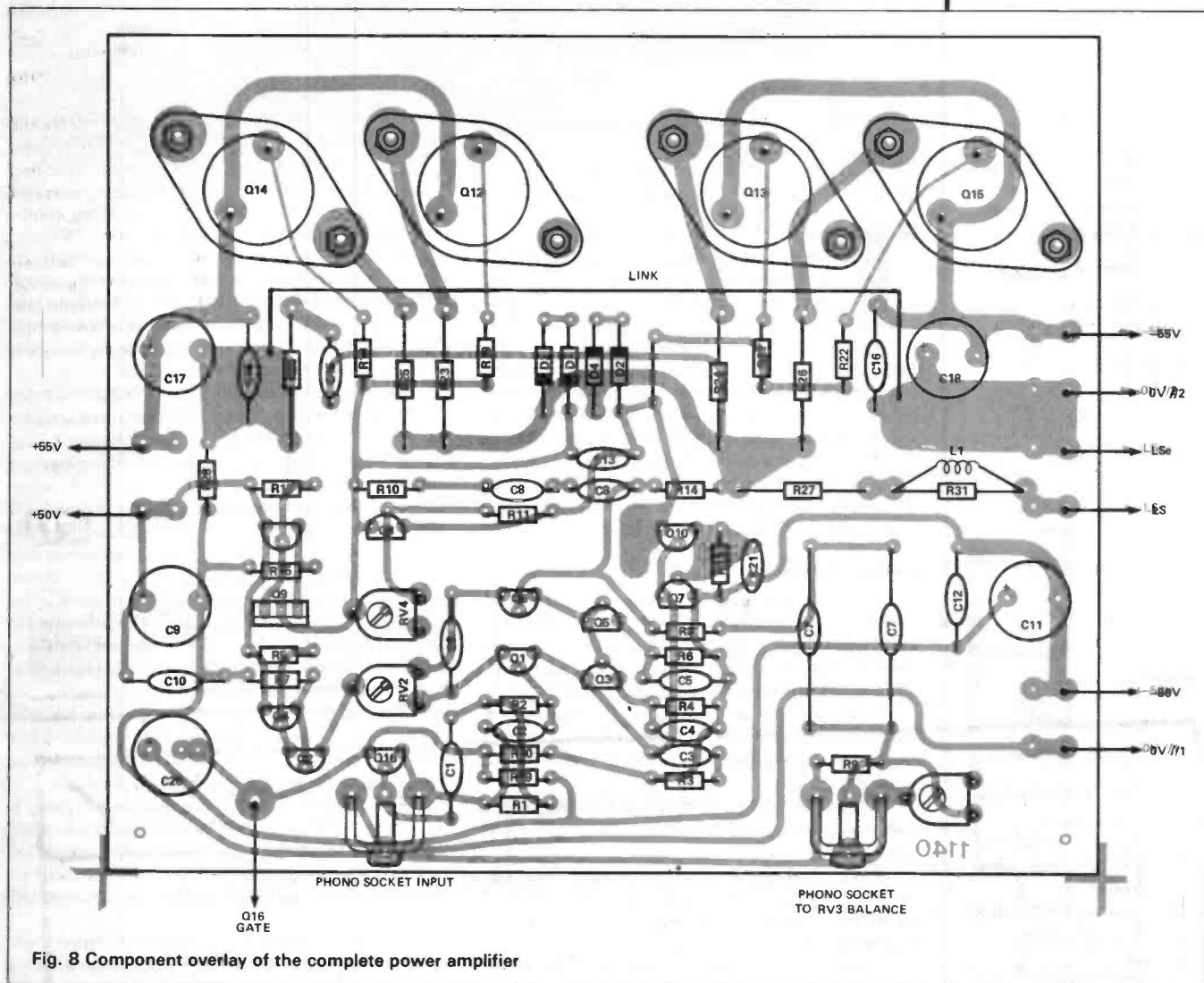
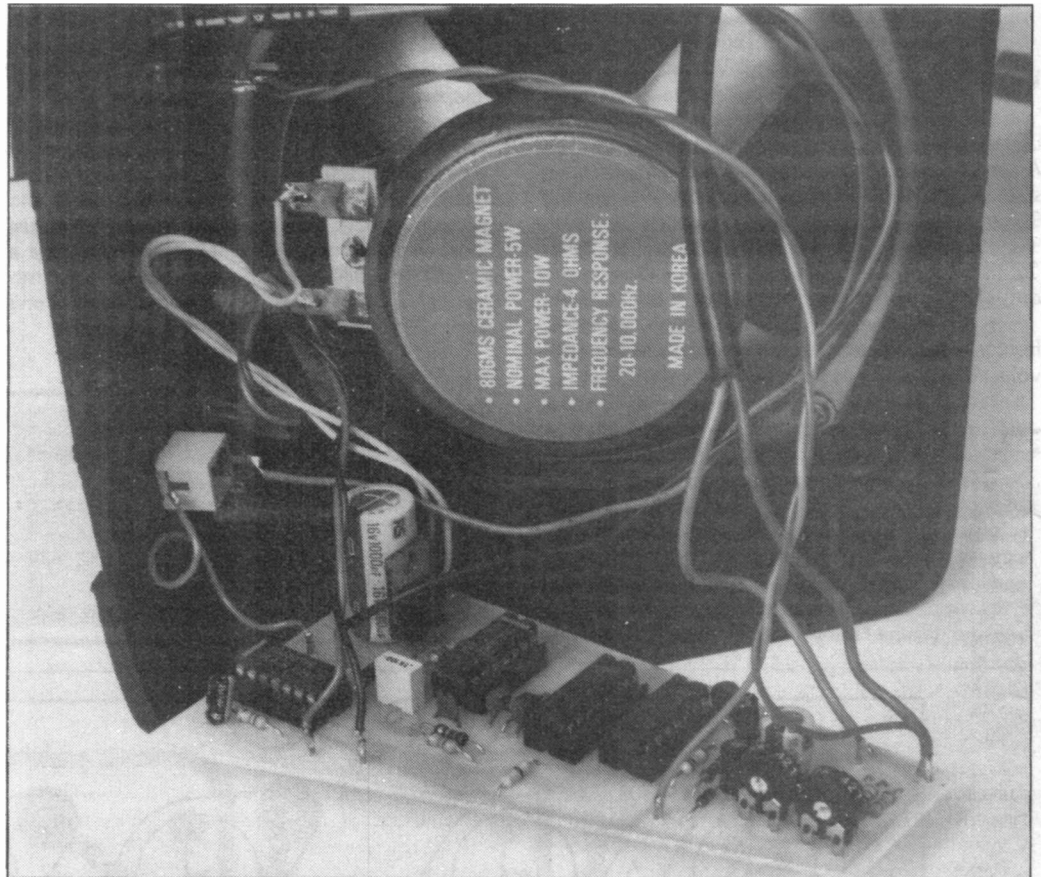

Fig. 8 Component overlay of the complete power amplifier

# REV-RIDER



*Stuart Richards  
converts his Raleigh  
into a Kawasaki 1300  
with the help of this  
motorcycle simulator*

## TOP PROJECT

**T**his project was inspired by my childhood memories of making my bicycle sound like a motor bike by fixing a piece of cardboard near the rear wheel so that it flapped against the rotating spokes. The customary items to use were a piece of cigarette packet from the gutter and a wooden clothes peg stolen from Mum.

The Rev-Rider described here is a solid state version complete with ignition key, adjustable tickover, push-button revving control, flashing LED and last but not least a siren to annoy the neighbours.

The project is simple to construct, will give hours of pleasure from a small 9V battery and can be fitted to any vehicle (even an exercise bike!)

### Construction

The prototype was built in a surface mounting car speaker case with a piece of paxolin as the back baffle to the case (Fig. 2). The speaker was left in situ and the PCB designed to fit to one side of the case (which explains the lop sided shape of the board!).

Cheap car speaker units are easily obtainable for little more than the cost of a drive unit alone. A high quality drive unit is not required as the Rev-Rider is hardly hi-fi.

Before assembling the board, familiarise yourself with Fig. 3, checking orientation of all polarised components.

Start with smallest components first — resistors, diodes and links — then progress through to ICs and capacitors finishing with presets and the power Darlingon, Q1.

I recommend fitting IC sockets. They prove invaluable if you need to change an IC.

Insert single sided pins at the off-board connections. This will allow wires to be connected and disconnected from the component side of the board. To fit these, push them through from the copper side as far as you are able then carefully push them the rest of the way with a hot iron, then solder to the track. This completes assembly of the board.

For convenience, the 'Ignition Switch' is simply a 3.5mm jack socket, with a short-circuited plug for the key. Drill a 2mm hole through the plastic plug cover to accept a key-ring and fob. This key will prove easy to replace if lost!

Drill holes in the case to accept jack socket, LED (5mm diameter) and push buttons if fitted. The LED will be a tight fit but should be secured with epoxy adhesive. Install the jack socket and push buttons, connect these together following the diagram leaving sufficient length of wire to enable the board to be released if necessary. Mount a 9V alkaline battery to the side of the case using a double sided adhesive pad. You shouldn't need to change this very often!

The two push buttons SW1,2 can either be fitted in the speaker case or mounted near the handlebar grip and connected to the board using thin 3-core mains cable taken through a hole on the case.

A simple way to mount the switches this way is by using a metal bicycle bell, first removing the striker and other internal bits. One or two holes are drilled in the side to accept SW1 and/or SW2 and the bell clamped to the handlebars so they can be operated by the thumb.

A back panel for the case can be cut from a sheet of plastic or hardboard using the speaker case as a template. Drill the two holes in the rear panel and

# TOP PROJECT

mount to the speaker case using M3 nuts and bolts.

Parts from two bells were again used to clamp the case to the handlebars of the bicycle but suitable clips can be obtained from any hardware/cycle shop.

Check again all wiring, battery polarity and correct insertion of all ICs. Insert ear plugs and switch on!

## Kick Start

You should hear an engine type noise somewhere between a slow tickover and a high-pitched scream. Adjust the tickover control RV2 to the desired tickover speed. If you get no sound at this stage, check first that 9V is getting to the board. The VCO input of IC3, Pin 9 should be at 1.9-2.6V according to the charge on C2. If this seems in order, look for a square wave output on Pin 4 of IC3.

If you have no scope, a multimeter connected from 0V to Pin 4 should read an average of half supply volts (4.5V). The voltage on the reservoir capacitor

C9 will be almost 9V at tickover and will decrease as the revs increase, as more energy is used by the speaker.

Press SW1, revs should increase slowly up to a maximum which can be set by adjusting RV1. Release SW1, revs should decrease again to the set tickover

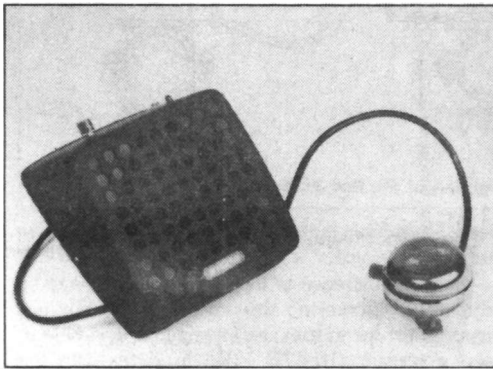

## HOW IT WORKS

The heart of this project is a voltage to frequency converter. This gives out a square wave pulse train, the frequency of which is proportional to a DC voltage that we apply to its input. For convenience, we use a 4046B phase lock loop IC which includes the voltage to frequency converter.

By applying an increasing voltage input to IC3, the 'revs' will increase and vice-versa. Capacitor C2 gives the circuit inertia, acting like a flywheel in an engine. Pressing the Rev button SW1, charges C2 via R1, R3 and D2, the maximum revs being set by RV1. Releasing SW1 allows C2 to discharge via RV1, R1, R2 and D1.

To achieve a steady tickover speed, independent of battery condition, the VCO input requires a positive offset of about 1.9V. To do this, a constant current of 0.56mA from regulator diode D3, passes through R4 and 'jacks up' the bottom end of C2. RV2 allows this voltage to be adjusted by shunting R4 and R5. D4 prevents C2 from being reversed biased. C3 ensures the circuit starts up slowly at switch on.

To give a high volume output with low battery consumption, the loudspeaker is fed with short duration pulses at 4-6V in amplitude. Q1 drives the speaker in emitter follower mode, drawing peak currents of over 1A from the reservoir capacitor C9. Resistor R15 limits the current drawn from the battery.

IC4 is used as two monostables triggering on alternate positive and negative edges of the VCO square wave output. To achieve a more realistic sound, these monostables are given different time constants, (typically 50 and 150 microseconds) resulting in alternate short and long pulses to the speaker.

Capacitor C8 slows the edges of the pulses making the noise more 'user-friendly'.

The resulting output provides ample volume while the drain on the battery is less than 5mA at tickover, rising to about 20mA at high revs.

The siren effect is obtained by utilising a 4066B quad analogue switch IC to change over the input of the VCO IC3, from the revving circuit previously described to triangular waveform generator IC2b.

The triangular signal from IC2 pins 1 and 2 passes through the switch IC1a and is AC coupled via R6 and C1 to the cathode of current regulator diode D3, modulating the VCO input signal to IC3 via R7 and closed switch IC1b.

Pressing the siren button SW2, brings this into action and also effectively shorts R15 allowing greater volume in the Siren mode.

Two paralleled spare gates, IC2c, drive the flashing LED directly from the square wave output of IC2b.

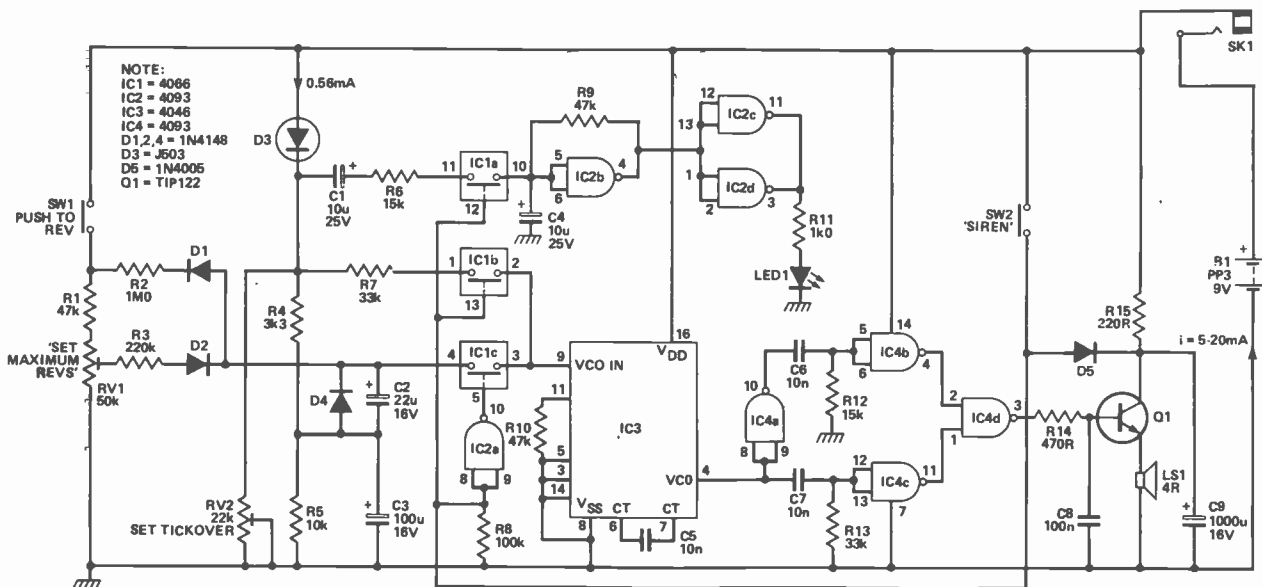

Fig. 1 The circuit diagram of the Rev-Rider

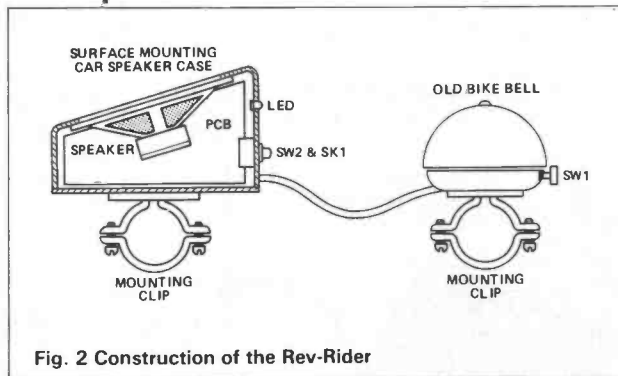

Fig. 2 Construction of the Rev-Rider

speed. Press Siren button SW2, the circuit should give loud wailing noise.

You can increase or decrease wailing speed by reducing or increasing the value of R9. For test purposes (or for indoor use) it may be desirable to insert a resistor (10-47R 1/4W) in series with the loudspeaker to reduce the volume to a tolerable level.

### Further Thoughts

The project outlined here suggests only one means of varying the speed of the output. Readers with mechanical flair might like to fit a proper throttle using a potentiometer connected either to a twist-grip or lever operated throttle.

'Gear changes' can be effectively achieved by switching in different values of charge resistor instead of R3 to give differing rates of charge/discharge of C2.

A slightly unstable tickover speed, as in many two-strokes can add further realism by slowly changing the voltage at the junction of R4/R5.

Types of speakers and enclosures will change the sound dramatically — a speaker mounted inside a cardboard tube for example will add resonance and give a nice popping sound like many 50-100cc machines.

With small changes the circuit could be adapted to other toys such as lawn mowers, pedal cars and so on. I wish you hours of fun.

## PARTS LIST

### RESISTORS (all 1/4W 5%)

R1,9,10	47k
R2	1M0
R3	220k
R4	3k3
R5	10k
R6,12	15k
R7,13	33k
R8	100k
R11	1k0
R14	470R
R15	220R
RV1	47k preset
RV2	22k preset

### CAPACITORS

C1,4	10µ 25V radial electrolytic
C2	22µ 16V radial electrolytic
C3	100µ 16V radial electrolytic
C5,6,7	10n ceramic
C8	100n polyester
C9	1000µ 16V radial electrolytic

### SEMICONDUCTORS

IC1	4066B
IC2,4	4093B
IC3	4046B
Q1	TIP122
D1,2,4	1N4148
D3	J503
D5	1N4004
LED1	5mm Red LED

### MISCELLANEOUS

B1	9V battery
LS1	4R 10W loudspeaker
SK1	3.5mm jack socket
PL1	3.5mm jack plug
SW1,2	SPST push switch
PCB, Case, Battery clips, Connecting wire, Mounting clips, Nuts and bolts.	

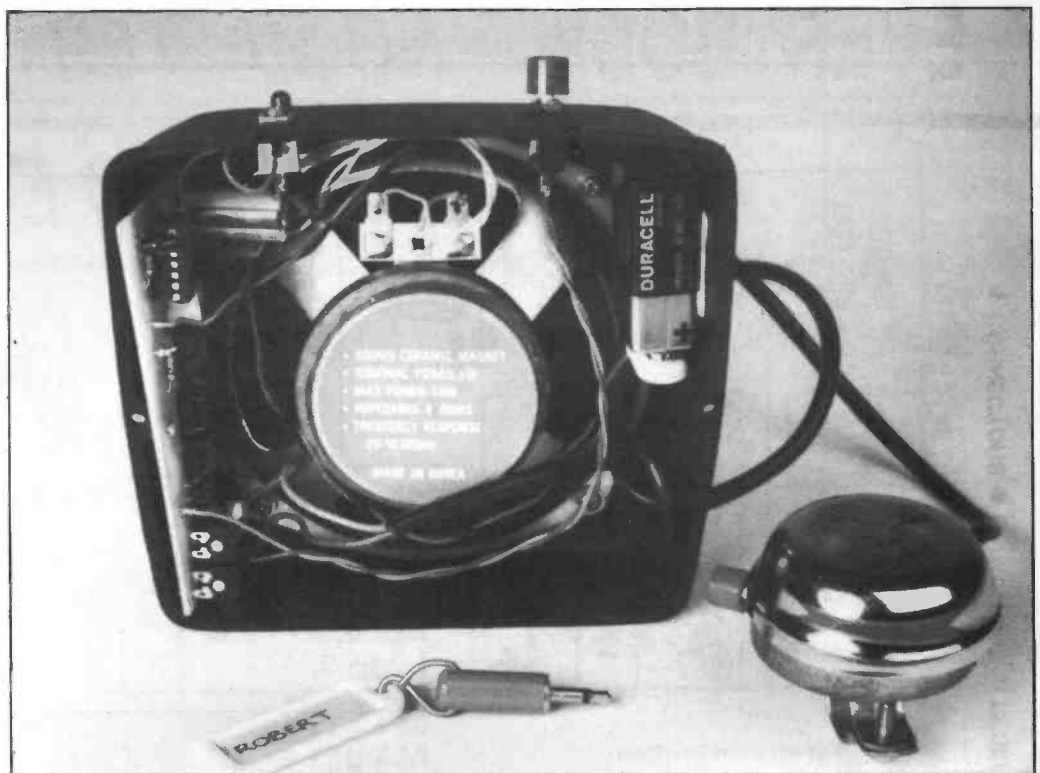

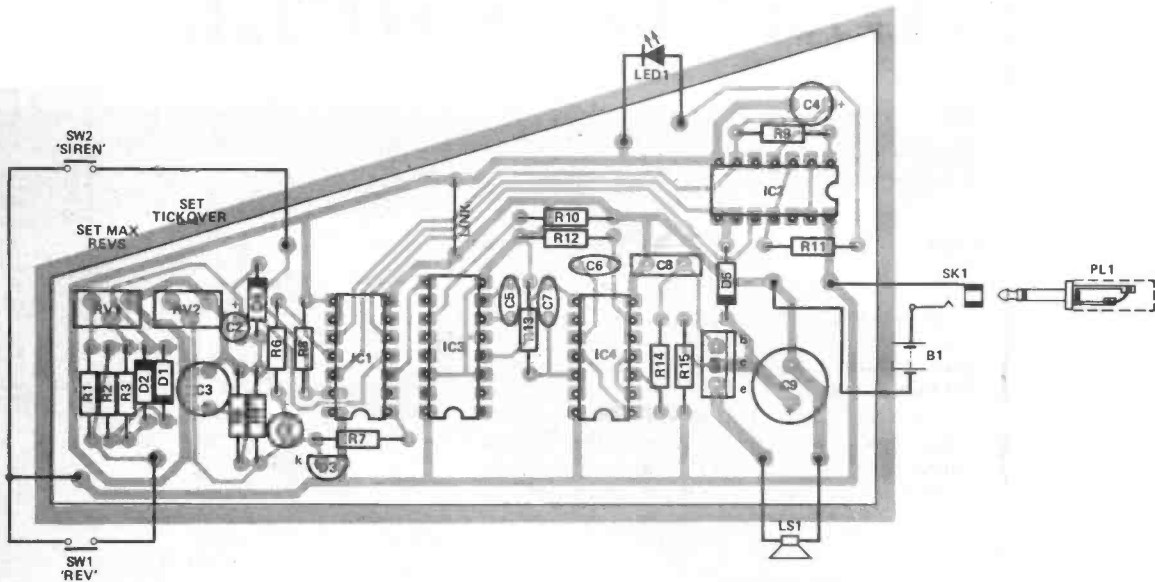

Fig. 3 The component overlay

## BUYLINES

Most of the parts for the Rev-Rider should pose no particular problems. A complete kit of parts for the Rev-Rider excluding a battery and the case back baffle is available from Technova Developments, Grange Walk, Wroxham, NR18 8RX (Tel: (06053) 2215) for £16.50 plus VAT plus £1.75 postage.

A suitable speaker and case can be purchased at a variety of

shops including Tandy, motorist accessory shops and your local component stockists. The case and speaker used in the prototype is available from Technova for £3.95+VAT+£1.75 postage. The J503 constant current diode (D3) is available from Electromail as part number 283-463 or from Technova for £1.20+VAT+75p postage. The PCB is available from Technova for £2.25+VAT+75p postage.



# THERE IS SOMETHING IN THIS FOR EVERYBODY – NO MATTER HOW FAR YOU ARE INTO ELECTRONICS

# FREE!

134 newly styled pages and it's absolutely

Getting your copy couldn't be easier

● CONNECTORS ● CAPACITORS ● RESISTORS

PLEASE MENTION THIS MAG WHEN REPLYING

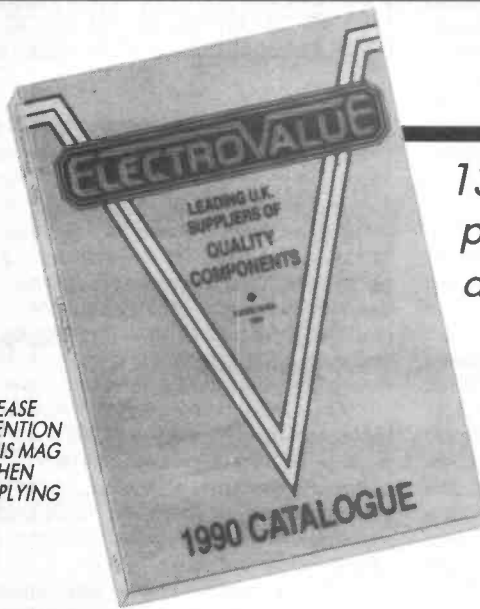

**PHONE**  
0784 433 603  
**FAX** 0784 435216  
**TELEX** 264475  
(For Manchester)  
061 432 4945  
**FAX** 061 432 4127

**WRITE**  
Electrovalue Ltd  
**FREEPOST**  
28A St Judes Road,  
Englefield Green,  
Egham,  
Surrey TW20 8BR  
(No stamp needed)

**CALL**  
at either shop  
**Mon-Fri 9.00-17.30**  
**Sat 9.00-13.00**  
Access Visa facilities  
(minimum value £5.00)  
Orders send post free  
in UK

**ELECTROVALUE LTD.,**  
28G St Jude's Rd., Englefield Green, Egham, Surrey TW20 0HB

● SWITCHES ● OPTO-ELECTRONICS ● DISTRIBUTORS OF SIEMENS FINE QUALITY PRODUCTS ● METERS ● TOOLS

# AERIAL AMPLIFIER

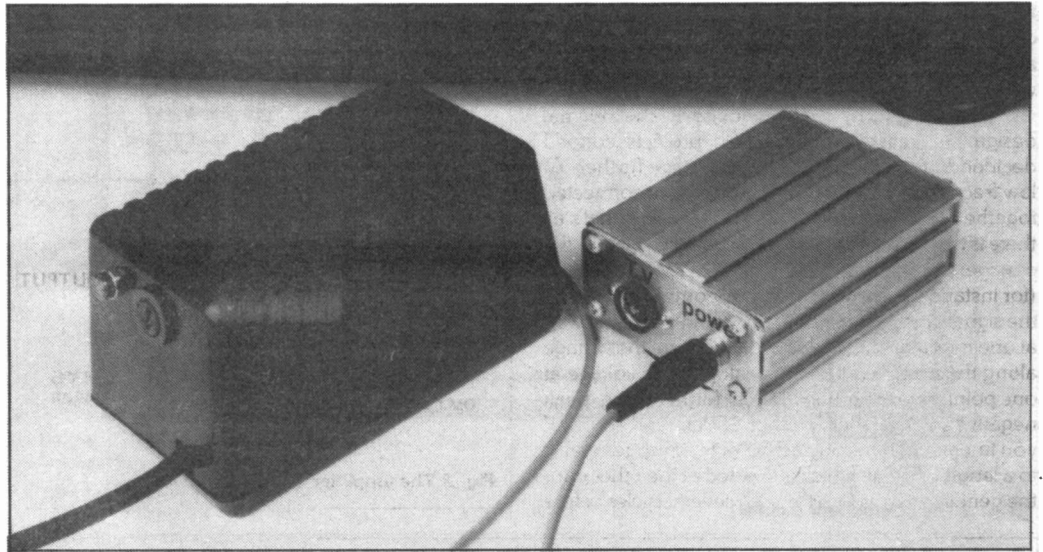

*Paul Chappell, ETI's illustrious Projects Editor, adds even more class to a former First Class project*

**W**hat do project editors do in their spare time? Build other peoples' projects, of course! The last one I had a go at was Keith Brindley's *Traveller's Aerial Amp* from the September 1988 issue of ETI. Although Keith designed it for mobile TV addicts — caravanners and the like — my reason for building it was to get decent pictures from the portable TV and indoor aerial in my London flat. I felt that a smarter looking box was called for, and a mains power supply of course, but first I took a good look at the PCB layout.

Laying out PCBs for UHF circuits can be a very tricky business. A few millimetres of component lead or PCB track can look like a whopping great inductor at TV frequencies (not great in value, which will be the same at any old frequency, but great in its effects!). Two conductors side by side will make a pretty good capacitor.

When you think that 10pF at 500MHz (the kind of frequency we're dealing with) has the same effect as 1 $\mu$ F at 5kHz or 100 $\mu$ F at 50Hz (and bearing in mind that you'll be hard pressed to lay out a PCB without introducing capacitances of this kind of size), it's amazing that any UHF circuit ever works. Imagine trying to make an op-amp circuit work with 1 $\mu$ F capacitors connected here and there between adjacent pins and 10mH inductors in series with all the leads. Rather you than me!

For audio frequency circuits, we're used to thinking in terms of lumped components. Two pieces of wire running side by side will have a certain capacitance, bring them closer together and the capacitance will increase, put certain materials between them and the capacitance will be increased still further. But a home-made two-wire capacitor will never have anything like the capacitance needed for an audio coupling capacitor, let alone a power supply smoothing cap. So we buy specially made parts where the two wires have been spread out into a huge area placed very close together and interleaved with a suitable dielectric material to intensify the effects. Since the capacitance effect that goes on inside the capacitor is perhaps a million times larger than the effect that occurs between two adjacent tracks on the PCB, we think of the capacitance as being concentrated in the

component and for the most part ignore any that goes on elsewhere.

For UHF circuits, the capacitance and inductance effects that turn up whether you want them or not are comparable in size to the components you're using and certainly can't be ignored. Every single PCB track, piece of wire and component lead has to be regarded as an extra component in the circuit. The capacitance and inductance of these new components is not concentrated at a certain point but is distributed along their length, so two adjacent PCB tracks will look to the circuit like the combined inductor and capacitor of Fig. 1.

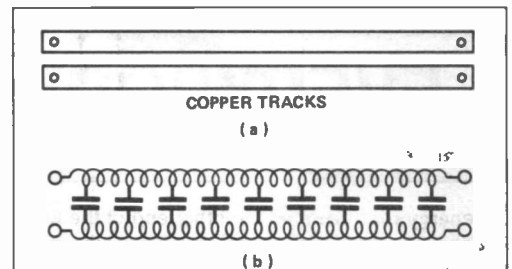

**Fig. 1** The electrical appearance of PCB tracks at (a) low frequencies and (b) UHF frequencies

A first guess at what this circuit does would probably be that it acts as a low-pass filter. However it has one very interesting characteristic: if you balance up the ratio of inductance to capacitance just so and terminate the circuit with a certain resistance, you can fool the drive circuit into thinking it's driving a resistance and the receiving circuit into thinking that the signal comes from a resistive source.

On a PCB, you trim the inductance to capacitance ratio by adjusting the width of the track. This leads to the track dimensions chosen by Keith in his design. An extension of the idea can lead to all kinds of reactive components being made just by the size and shape of the PCB tracks: inductors, capacitors, tuned circuits and so on.

This sorts out the main signal connections. The next consideration is to prevent signals being fed back from output to input, which could very easily cause

TOP  
PROJECT



the circuit to oscillate. The first line of defence here is to use a ground plane (a large area of copper connected to ground) on the component side of the PCB and even better to have the same on the track side too. You can think of this as making the capacitance to ground at any point of the circuit large in comparison with any other stray capacitances, taking away energy which might otherwise end up in the wrong place.

Ground planes were included in the original design but being a cautious old projects editor I decided to take the technique one stage further. At low frequencies, if two areas of copper are connected together, they'll be at the same voltage and that's all there is to say about the matter. With UHF signals, the changes are going on so fast that on a TV downlead (for instance) there will be several complete cycles of the signal along its length. If you could freeze the wire at one moment in time and then measure the voltage along the wire, you'd find a peak positive voltage at one point, zero at perhaps 150cm further along, peak negative voltage after another 150cm and so on. If you imagine connecting a 500MHz signal generator to a length of cable which is shorted at the other end, the generator would go through several cycles before

bottom edge of the screening piece is soldered all the way along to the top ground foil of the main PCB.

## Construction

The circuit hasn't been changed at all — it's shown in Fig. 2. If it is to be permanently connected to its power supply, you can miss out D1 altogether — just connect

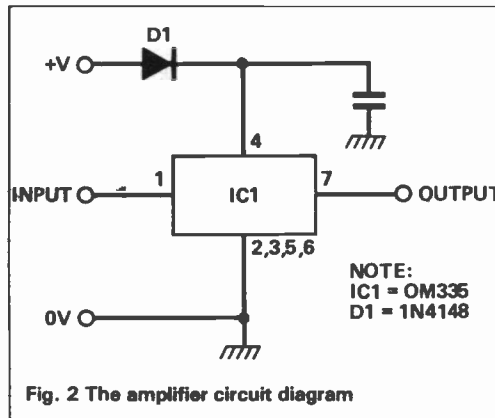

Fig. 2 The amplifier circuit diagram

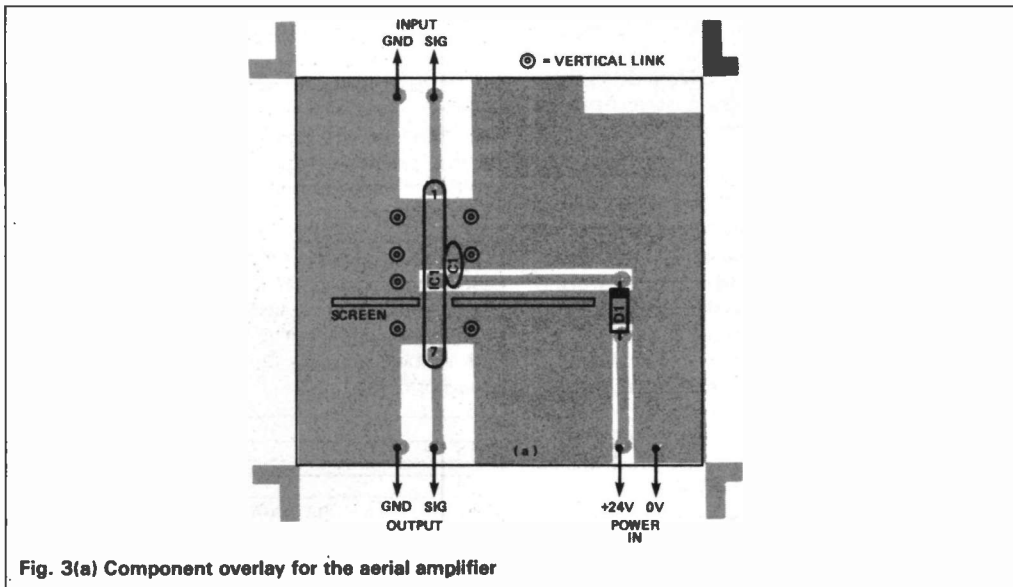

Fig. 3(a) Component overlay for the aerial amplifier

the energy even reached the other end of the wire, so a short circuit at UHF doesn't mean quite the same thing as it does at low frequencies. Eventually you'd get standing waves set up along the length of the cable — not at all what you'd expect if you fed the output of your audio amp into the same shorted length of cable. You might find the idea hard to swallow but if you're having any truck with UHF circuits, you better believe it!

The very same thing applies to the PCB — if you have a ground plane, you can't just think of it as an area of copper at 0V. The voltage will actually vary at different parts of it and a voltage difference can exist between the top and bottom ground foils of the board. One thing that helps to keep the circuit in order is to connect the top and bottom foils of the PCB together in several places, particularly around the IC where the signals originate. If you've already built Keith's circuit, it's an easy enough matter to drill a few extra holes in the PCB and put in through links, just to be on the safe side!

One more thing I did was to include a screening piece made from an offcut of PCB material to further isolate the input of the circuit from the output. This straddles the IC like a cowboy on his horse. The

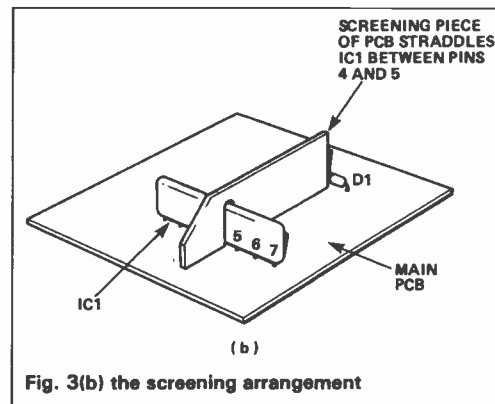

Fig. 3(b) the screening arrangement

a piece of wire across its position on the PCB.

The component overlay is shown in Fig. 3. In mounting the OM335 there are two conflicting requirements: one is that the IC should be as close as possible to the PCB, the other that pins 2,3,5 and 6 should be soldered to the top foil of the PCB. The trick is to leave a gap just wide enough for the solder to be applied, without having the IC standing on long

stalks (each one of which will become an unwelcome inductor). If the IC stands with 1mm of the leads showing above the board, this will be about right.

The capacitor should be mounted with the lead which connects to pin 4 of the IC as short as possible, and the other lead soldered on both sides of the board. The diode you just put in as usual. All the other holes, apart from the ones at the edges of the board (which will later connect to the sockets) should be used for through-links: use offcuts from the diode and capacitor leads, post them through the holes and solder to the top and bottom foils of the PCB.

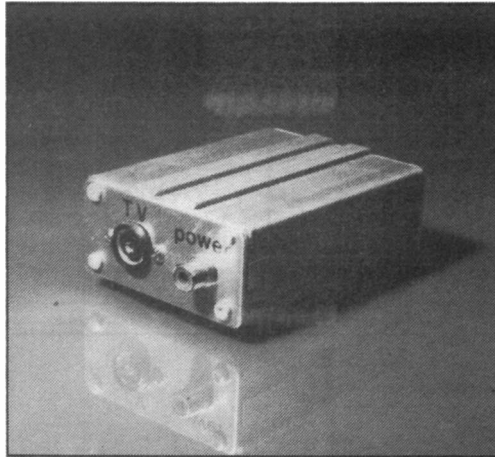

The dimensions of the screening piece are shown in Fig. 4. If you intend to use the specified case, it would be just as well to follow them exactly. If not, just cut a rectangle of PCB material and make a slot in one edge to fit the IC. The screen slips over the body of the IC between pins 4 and 5 and is soldered to the top foil of the PCB all along the edge. The best method is to solder at one or two points to hold the screen in place, then to run solder all the way along the join.

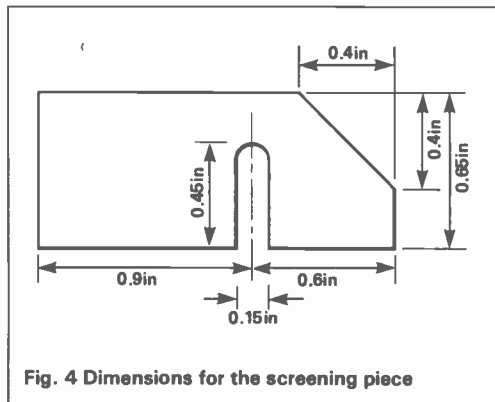

Fig. 4 Dimensions for the screening piece

The drilling positions for the front and rear panels of the case are shown in Fig. 5. The TV sockets are mounted just above the top surface of the top side of the PCB using the shortest possible lengths of wire. To see how much you need, screw one of the sockets to a panel, slide the PCB into the lowest slot in the box, fix the panel to the box, then sight along the top of the board to gauge the distance from board to socket terminals.

Attach both TV sockets and the phono (power inlet) socket to the PCB, soldering all earth wires to both foils of the board. Then fix the output and power sockets to the front panel, with the TV socket mounted behind the panel. To the rear of the input socket, glue a 4BA nut behind each flange.

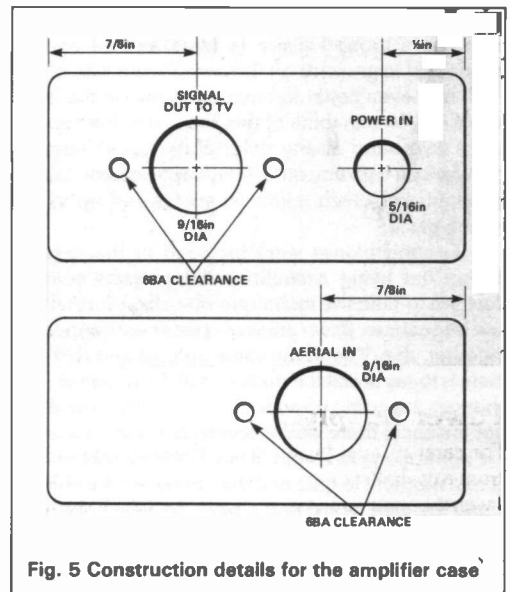
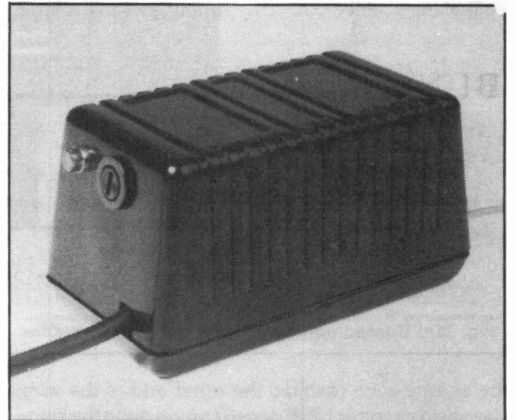

Fig. 5 Construction details for the amplifier case

Slide the PCB into the lowest slot in the case until the front panel meets the body of the case, then screw the panel in place. Screw the rear panel to the input socket, then screw that to the box too. The aerial amp is now complete!

If you're using the rubber feet, they come in the form of a strip which should be cut into two lengths, each the length of the body of the case. Before putting on the rear panel, you simply slide them into the grooves on the underside of the case. The panel holds them in place.



## PARTS LIST

### CAPACITORS

C1	100n ceramic
C2	1000 $\mu$ F 35V electrolytic
C3	10 $\mu$ F 35V tant

### SEMICONDUCTORS

IC1	OM335
IC2	7824
D1	1N4148
D2-5	1N4001

### MISCELLANEOUS

FS1	500mA anti-surge fuse
T1	PCB mounting mains transformer, 0-12, 0-12 secondary

For power supply - Neon lamp. Fuse holder. PCB supports. Case. PCB. Phono plug. Length of mains wire. Bell wire or screened wire (for a neater appearance). For amplifier - TV sockets. Phono socket. Case. PCB.

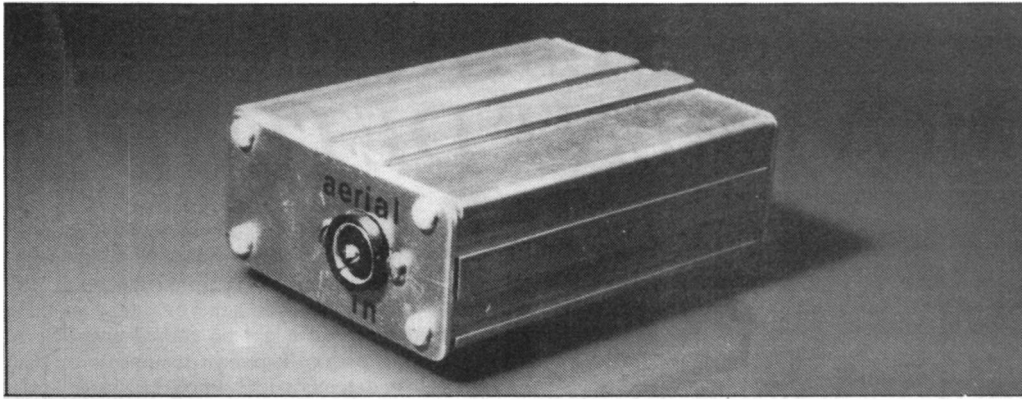

## Power Supply

For caravan and camping use the amp can be run from a car battery or dry batteries but for my purposes I wanted a mains power supply. The circuit is shown in Fig. 6 and the component overlay in Fig. 7. There's nothing complicated about the construction.

I used a 24V regulator, since this is the voltage at which the IC gives its maximum gain but if you can't get hold of one a 12V or 15V regulator will do. I used the 1A version since the 'L' version doesn't seem to be available at 24V. There's no need for a heat sink — the amp takes very little current.

The PCB is attached to the bottom of the case by means of self-adhesive supports, avoiding any drilling. The fuseholder and 'on' indicator go right at the very top of the case — be careful to put them high enough so they don't foul the transformer. To take the power to the amp, a length of bell wire with a phono plug at the end is fine. Make sure to connect the plug so that the positive side of the supply goes to the inner

pin (perhaps that diode is a good idea after all!). The wire should be knotted just behind the exit hole in the case to prevent any strain on the PCB connections, as should the mains wire for the same reason.

After checking with a multi-meter to make sure that the power supply is indeed giving 24V, it's time to plug everything together. The aerial plugs into the input socket of the amp and a length of TV co-ax connects the output to your receiver. The power supply plugs into the power inlet on the amp and that's about it.

Oh yes, you have to turn the TV on too! Happy viewing.

## BUYLINES

Various parts sets for this project are available from Specialist Semiconductors Ltd. See their ad. for details.

The OM335 on its own can be had from Electromail (tel: (0536) 204555) or from Highgrade Components, 8 Woburn Road, Eastville, Bristol BS5 6TT.

PCBs are available from our PCB service — details on the centre pages. For DIY PCB etchers, the patterns are printed on page 61.

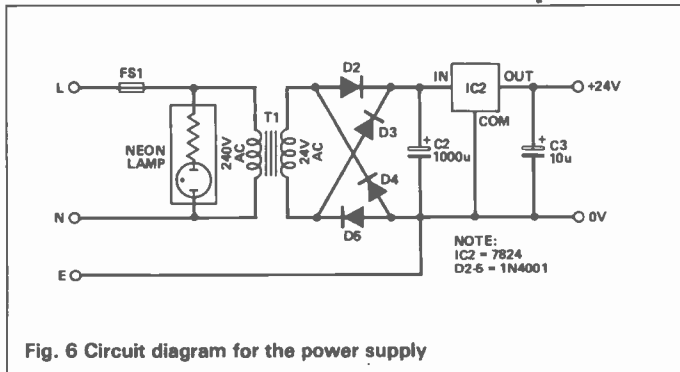

Fig. 6 Circuit diagram for the power supply

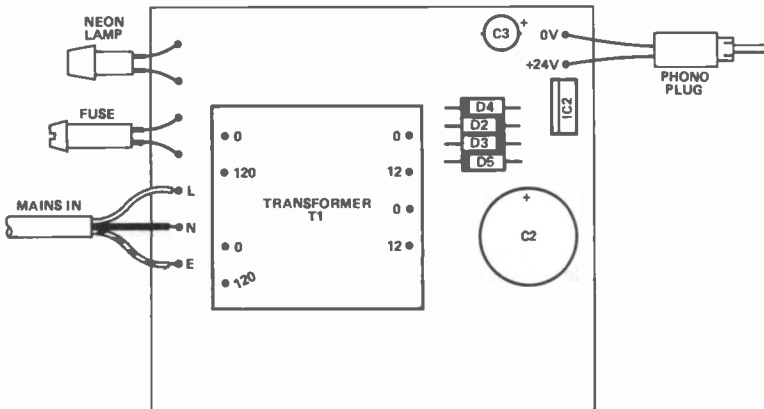

Fig. 7 Component overlay for the power supply

# TREMBLER MOVEMENT DETECTOR

Rashid Adat has a simple circuit to ward off thieves

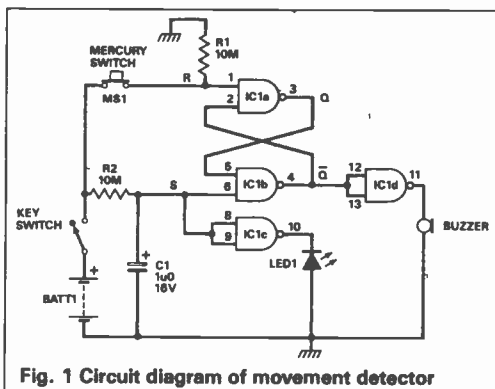

Fig. 1 Circuit diagram of movement detector

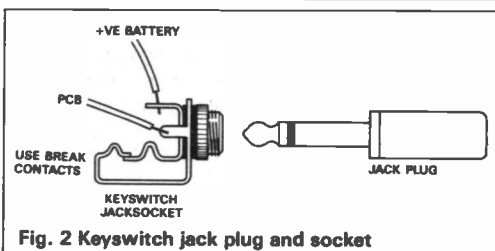

Fig. 2 Keyswitch jack plug and socket

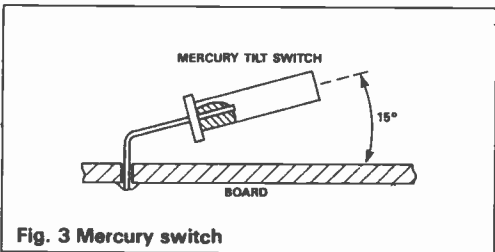

Fig. 3 Mercury switch

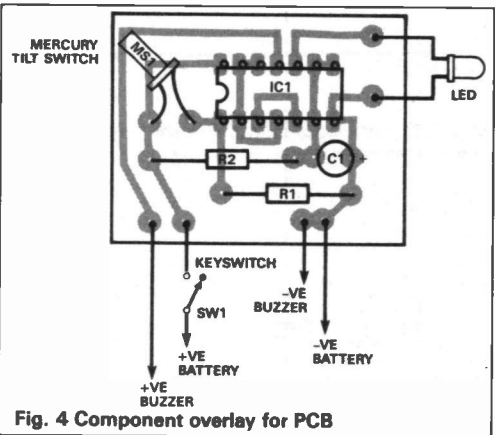

Fig. 4 Component overlay for PCB

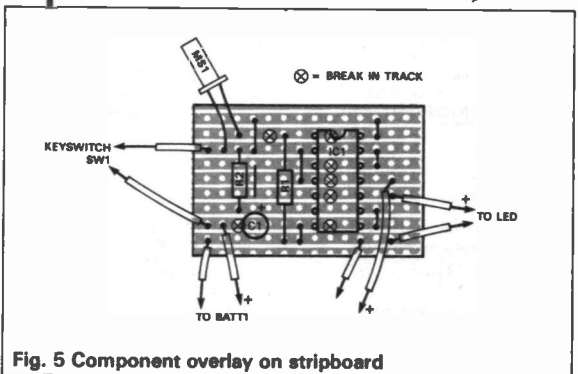

Fig. 5 Component overlay on stripboard

Here is a simple design for a movement detector with possibilities when used as a security device. It could protect expensive electronic apparatus, personal documents or indeed anything in a container that might be carried away by an unauthorised person. To protect documents in a filing cabinet, the detector could simply be placed in the drawer and when the drawer is opened, a high intensity sound results.

The main sections of the device are: motion detector (a mercury tilt switch), control logic and a high intensity audible buzzer. All parts are mounted in a small plastic box. The box has an LED to show the setting time and battery condition, a keyswitch socket to enable and disable the detector and several holes to allow the sound to leave.

So, to set our sentinel, here is what you do. Place or attach the box to the piece of apparatus you want to protect (preferably out of sight) and withdraw the jack plug. The jack plug functions as part of the switching device that enables the circuit when it is removed from the socket. When this happens, the LED turns on for approximately 10 seconds. After this time, the LED goes out and the circuit enters standby mode.

Thereafter, any motion imparted to the box is sensed by the mercury tilt switch. The angle of the switch to the circuit board was set at about 15 degrees (Fig. 1). This provides detection when the box is tilted slightly. The angle can be adjusted for maximum sensitivity. If movement in the horizontal plane is required, the angle should be made as small as possible. The mercury switch could also be pointed at a corner of the box thus providing a detection of tilt in two planes. Any tilt or movement results in the triggering of the buzzer. The circuit is designed to sound a 90dB tone continuously and can only be silenced by inserting the key (jack plug) into the socket. This cuts power to the circuit.

If you wanted extra security you could use a keyswitch. With the jackplug it is just possible to shove a paper clip into the socket, short it out and reset the circuit. However this takes a fair amount of time to work out (as the ETI cleaning staff have discovered much to their chagrin), particularly if you're an alarmed burglar. In the meantime, the high intensity buzzer really is very loud.

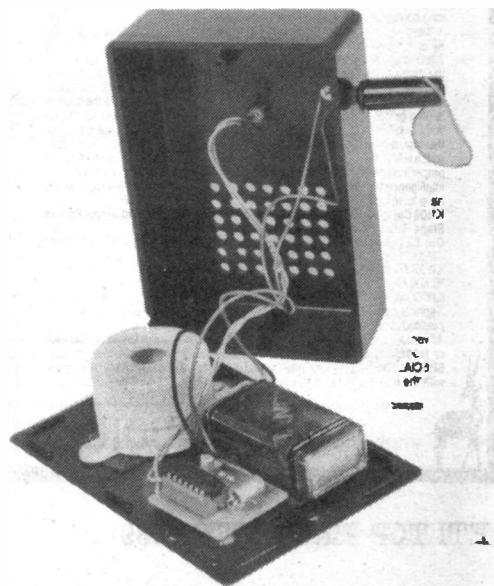

TOP  
PROJECT

## Construction

Construction is fairly simple for this project. When using the PCB, mount and solder a 14-pin dual-in-line socket first. Then solder the two resistors, capacitor and mercury switch as shown in Fig 4. Next solder the wires in for the connections to the battery, keyswitch, buzzer and LED. The wires to the LED and switch must be long so that the two halves of the box can be separated easily.

As the IC is a CMOS device, care must be taken when handling and inserting it into the socket. Make sure your body is earthed when carrying out this operation.

All the circuitry is then housed in a plastic box of suitable size. The one used in the prototype measured 114 x 76 x 30mm. The PCB, buzzer and

battery can be mounted by simply sticking them inside the box with double-sided foam tape.

When constructing the movement detector on stripboard (Fig. 5), cut the copper lines first using a sharp drill bit. Then mount and solder the socket. Place the wire links in next and solder the components in as before. Finally, a matrix of holes was drilled in the plastic box to let the sound out.

## BUYLINES

All components are easily available. The buzzer is available from Maplin, cat no. FK84F and the mercury tilt switch also available from Maplin, cat no. FE11M. The PCB is available at £2.50 or the complete kit at £11.99 from the author at 20 Highview St, Bolton BL3 4DQ.

## HOW IT WORKS

Once the key is removed, the LED is switched on for a period of about 10 seconds. This length is determined by the values of C1 and R2 (see Fig. 1). When the voltage on C1 reaches the threshold value of 3.6V, the input to NAND gate c (connected as an inverter) goes high resulting in a low output from pin 10. The LED switches off.

ICa and ICb are connected as an R/S flip flop and when the key switch is first removed, S sets to logic 0 (low) and R to logic 1 (high) because the mercury tilt switch is normally closed in its relaxed

position. The output from ICb (pin 4) adopts a logic 1 state. This output remains at logic 1 even when C1 has passed its threshold voltage making S go high. The circuit is now in its standby mode.

If the box is moved, MS1 will open. R will now go low (logic 0) and the bistable will flip making ICb output go low. ICd serves as an inverter and its output will change at this point supplying the voltage to trigger the buzzer. The circuit can then only be switched off by re-inserting the jack plug in the key switch.

## PARTS LIST

### RESISTORS (all 1/4 W 5%)

R1,2 10M

### CAPACITORS

C1 1µ 16V electrolytic

### SEMICONDUCTORS

IC1 4011BE quad 2 i/p NAND

MS1

mercury tilt switch

SW1

2.5mm jack plug and break contact socket

X1

buzzer piezo-electric type

LED 1

5mm LED and holder

BATT 1

9V PP3 type and clip

Plastic case and printed circuit board.



# TOP PROJECT



## HART AUDIO KITS — YOUR VALUE FOR MONEY ROUTE TO ULTIMATE HI-FI

### HIGH QUALITY REPLACEMENT CASSETTE HEADS

HART KITS give you the opportunity to build the very best engineered hi-fi equipment there is, designed by the leaders in their field, using the best components that are available. With a HART KIT you have direct access to the friendly HART service, you are not dealing through, or paying for, any middlemen. Every HART KIT is not just a new equipment acquisition but a valuable investment in knowledge, giving you guided hands-on experience of modern electronic techniques. Telephone or write for our FREE LISTS giving full details of all our Kits, components and special offers. Here are a few selected items.

### AUDIO DESIGN 80 WATT POWER AMPLIFIER



This fantastic amplifier is the flagship of our range, and the ideal powerhouse for your ultimate hi-fi system. Featured on the front cover of the May issue of 'Electronics Today International' this complete stereo power amplifier offers World Class performance with the option of a stereo LED power meter and a versatile passive front end giving switched inputs, volume and balance controls. Tape, CD players, or indeed any 'flat' input may therefore be directly connected to bypass tone controls or give a 'stand-alone' facility. The amplifier can also be supplied in 'slave' and 'monobloc' versions without the passive input stage and power meter. All versions fit within the standard 420x280x75mm case to match our 400 Series Tuner range. All power supplies are stabilised, the heavy current supplies using the same mosfet devices as the amplifier. The power supply, using a toroidal transformer, is in fact a complete module contained within a heavy gauge aluminium chassis/heatsink and fitted with IEC mains input and output sockets. All the circuitry is on a proper printed circuit with low-resistance blade connectors for the six stabilised DC outputs. HART KITS don't leave you to fasten a few capacitors to the floor of the main chassis and win the power supply the hard way! Remember with a HART KIT you get the performance you want at the price quoted through proper engineering design and the right components. We do not insult your intelligence by offering a kit at what seems a fair price and then tell you that you have to spend three times as much to get an upgraded model! K1100 Complete Stereo Amplifier Kit with LED Power Meter and 3-input Passive Stage. Total cost of all parts is £418.88. Our Discount Price for the Complete Kit ..... £365.98 K1100S Stereo Slave Version, with plain Front Plate ..... £309.43 K1100M 'Monobloc' mono version, with plain Front Plate ..... £224.15 RLH10 Reprints of latest 'Audio Design Amplifier' articles ..... £2.70 K1100C HART Construction Manual with full parts lists ..... £4.50 Reprints and construction manual can be purchased separately and their cost credited against subsequent kit purchase. All versions are supplied with dual primary mains transformers for use on 220/240V or 110/115V mains. Monobloc price does not include the construction manual. SPECIAL OFFER extended until the end of February the K1100 kit will be supplied with the new ALPS low noise precision pots at NO EXTRA CHARGE.

## HART AUDIO KITS —

### LINSLEY-HOOD 400 SERIES SUPER HIGH QUALITY AM/FM TUNER SYSTEM

This is the ideal companion tuner to the 80W Audio Design Amplifier in any ultimate hi-fi system with case size, front plate layout and even control pitches unified for stacking. Like the 80W Audio Design Amplifier this is your route to £K+ performance for a few tenths of the cost! Two designs by John Linsley Hood make up this combination of his ultra high quality FM tuner and stereo decoder described in 'Electronics Today International' and the Synchronome AM receiver described in 'Wireless World'. Novel circuit features in the FM section include ready built pre-aligned front end, phase locked loop demodulator with a response down to DC and advanced sample and hold stereo decoder together making a tuner which sounds better than the best of the high-priced exotica but, thanks to HART engineering, remains very easy to build and set up. The Synchronome section with its selectable bandwidth provides the best possible results from Long and Medium wave channels, so necessary in these days of split programming. If you want the very best in real Hi-Fi listening then this is the tuner for you. Since all components are selected by the designer to give the very best sound this tuner is not cheap, but in terms of its sheer sound quality it is incredible value for money. To cater for all needs AM only and FM only versions are available as well as the full AM/FM model, with any unit being upgradable at any time. For further details see our full illustrated lists.

K400FM FM Only Version, total cost of all parts is £211.90  
Our special Discount Price for complete Kit only ..... £169.52  
K400AM/FM Full AM/FM version, Discount Price for complete Kit ..... £249.08

### STUART TAPE RECORDER CIRCUITS

Complete stereo record, replay and bias circuit system for reel-to-reel recorders. These circuits will give studio quality with a good tape deck. Separate sections for record and replay give optimum performance and allow a third head monitoring system to be used where the deck has this fitted. Standard 250mV input and output levels. These circuits are ideal for bringing that old valve tape recorder back to life. Suitable stereo heads are available at very reasonable prices.

K900W Stereo Kit with Wound Coils and Twin Meter Drive ..... £90.68  
RJS1 Reprints of Original Descriptive Articles ..... £2.60

### LINSLEY-HOOD CASSETTE RECORDER CIRCUITS

Complete record and replay circuits for very high quality low noise stereo cassette recorder. Circuits are suitable for use with any high quality cassette deck. Switched bias and equalisation to cater for chrome and ferric tapes. Very versatile and easy to assemble on plug-in PCBs. Complete with full instructions.

Complete Stereo Record/Player Kit ..... £57.60  
VU Meters to suit ..... £3.99 each  
RLH1 & 2 Reprints of Original Articles ..... £2.70

Our latest lists also give details of our ranges of specialist high quality AUDIO CONNECTORS and LEADS, cassette decks and seasonal special offers. Write or telephone for our FREE copy. (Overseas 2 IRCs please, or 5 for Airmail.)



Do your tapes lack treble? A worn head could be the problem. Fitting one of our replacement heads could restore performance to better than new! Standard inductances and mounting make fitting easy on nearly all machines and our TC1 Test Cassette helps you set the azimuth spot on. As we are the actual importers you get prime parts at lower prices, compare our prices with other suppliers and see! All our heads are suitable for use with any Dolby system and are normally available ex stock. We also stock a wide range of special heads for home construction and industrial users.

HS18 Soudat Alloy Stereo Head. High quality head with excellent frequency response and hyperbolic face for good tape to head contact ..... £17.86

HC40 NEW RANGE High Beta Permalloy Stereo head. Modern space save design for easy fitting and low cost. Suitable for chrome metal and ferric tapes, truly a universal replacement head for hi-fi decks to car players and at an incredible price too! ..... £6.65

HX100 Special Offer Stereo Permalloy Head ..... £2.86

HRP373 Downstream Monitor Stereo Combination Head ..... £44.39

HQ551 4-Track Record & Play Permalloy Head for auto-reverse car players or quadruphonic recording ..... £16.79

HS24 Standard Erase Head ..... £2.59

SH166 2/2 AC Erase Head, Standard Mount ..... £12.60

HS9510 2/4 Stereo DC Erase Head ..... £8.70

HQ751E 4/4 AC Erase Head, tracks compatible with HQ551 ..... £57.06

We can supply card reader heads for OEMs at very keen prices.

### REEL TO REEL HEADS

999R 2/4 Record/Play 110mH. Suits Stuart Tape Circuits ..... £13.34

998E 2/4 Erase Head 1mH. Universal Mount. Suits Stuart ..... £11.96

### TAPE RECORDER CARE PRODUCTS

HART TC1 TEST CASSETTE Our famous triple purpose test cassette. Sets tape azimuth, VU level and tape speed ..... £5.36

DEM1 Mains Powered Tape Head Demagnetiser, prevents noise on playback due to residual head magnetisation ..... £4.08

DEM115 Electronic, Cassette Type, demagnetiser ..... £8.61

Our new WINTER '89 List is FREE. Send for your copy now. Overseas customers welcome, please send 2 IRCs to cover surface post, or 5 for Airmail.

We now accept inland and overseas orders by post or telephone on all Access/Mastercharge and Visa credit cards.

Please add part cost of carriage and insurance as follows:

INLAND: Orders up to £20 — £1; Orders over £20 — £2.50; Next day — £9.

OVERSEAS: Please see the ordering information with our lists.



## QUALITY AUDIO KITS

24hr SALES LINE  
(0691) 652894

ALL PRICES INCLUDE VAT

# PRIORITY QUIZ SWITCH

*Ken Blackwell presents his fair fare to adjudicate over the most cantankerous contestants*

**T**his simple priority switch was designed for use as a quiz controller, with four contestants answering questions on a first-press first-served basis.

Such a situation provides obvious design criteria for consideration. The push switches should be remotely positioned from the main unit and clear indication of the winning switch should be available for all to see. There should also be a simple and instantaneous reset facility and of course the circuit has to be scrupulously fair, otherwise you'll have a panel of contentious contestants before the game is out!

So this unit switches the first received signal from any number of inputs (four in this particular case but it is trivial to expand the unit), latching this signal and

illuminating the relevant LED. If it were desired the LED could be replaced by a relay or opto-isolator to trigger a much bigger light design — or even to light contestants' names in front of them. Bob Holness eat your heart out!

## Construction

The circuit with four switches has been designed to fit into small handheld case from the company listed in *Buylines*. To give the clearest indication of the 'winner', different colour LEDs are used for each contestant and the switches and the wires to them are of the same colour as these LEDs. The coloured wires in the prototype were removed from a multi-strand cable after stripping the screen and outer cover.

The PCB layout is very straightforward and is shown in Fig. 2. The switches SW1-4 are obviously outside the case. Stripboard could be used as an alternative to the PCB.

The LEDs are positioned so that they are already in alignment to poke through holes in the box lid. The leads of the LEDs should be left long enough for the board to sit in the bottom of the case with the tops of the LEDs just above the height of the case.

Note that LED4 is a tricoloured LED. The centre leg is the cathode (negative bias) and goes to the common rail. Join the two outside legs of LED4 together to the positive position.

The four LEDs will mount through the top of the

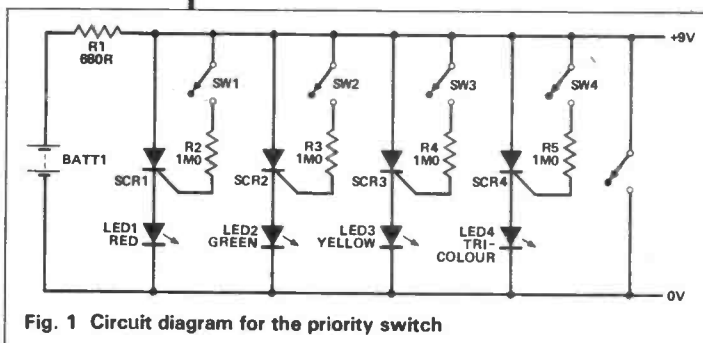
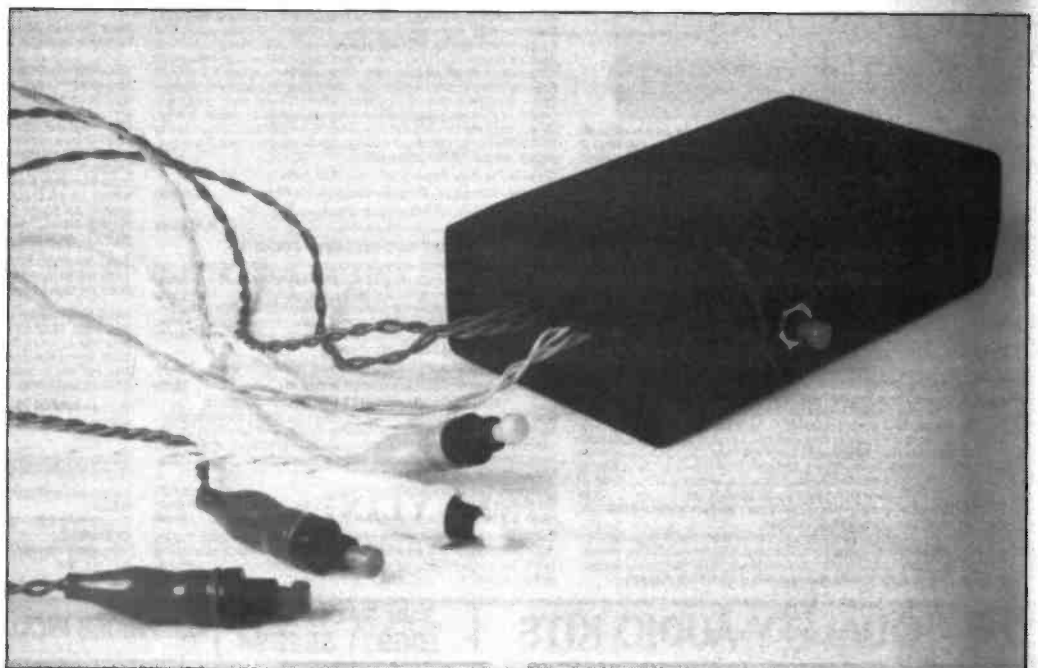
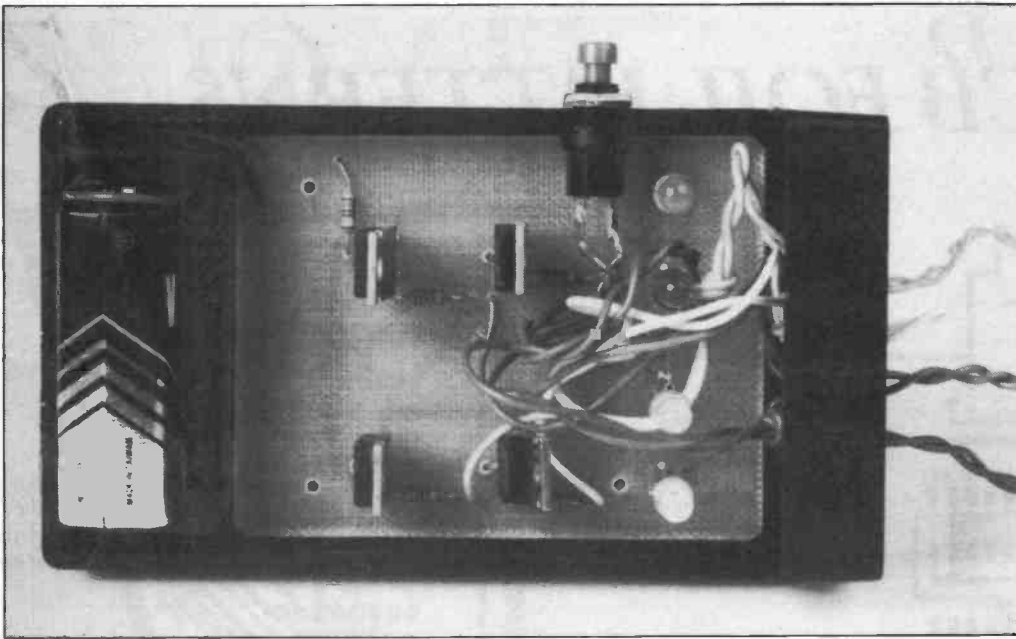

Fig. 1 Circuit diagram for the priority switch

TOP  
PROJECT



# TOP PROJECT



box, so use the PCB or stripboard as a template to mark the positions for four 6.35mm holes into which you can insert 5mm plastic clips and bezels for a tidy finish.

The wires to the trigger switches leave through the front template. Drill four evenly spaced 5mm exit holes across the centre width of the blank and fit 3mm plastic bezels. Through each hole pass one of the pairs of coloured wires. It might be a good idea to ensure that the wire lengths are the same for each switch — although this will make about as much difference to the fairness of the circuit's action as the different lengths of PCB track or the different actions of almost identical switches, it is the first thing a punter will identify as the cause of his slow reactions!

The reset switch can be mounted anywhere you like, remotely or on the case itself. A 7mm hole is required to mount the recommended switch on the case.

With all the switches and LEDs wired up it remains only to connect the battery and to practice your catchphrase as quiz show host!

## HOW IT WORKS

The circuit consists of thyristor switches each comprising a normally open push button switch, a thyristor with a high resistance gate resistor and an LED.

Any number of these can be placed parallel to each other — the circuit illustrated in Fig. 1 uses four.

The circuit is restricted to supply only enough current for one module to operate, about 13mA for an LED supply. To restrict power resistor R1 is placed in the positive supply and all connections are made below this.

When one switch is closed, power is passed through that gate resistor, activating that module. As soon as it is conducting the remaining modules experience a voltage drop down to about 3V. Although other switches are pressed there is insufficient power to switch a second module.

To reset the circuit, switch SW5 shorts the 13mA to ground, unlatching the thyristor.

Different values of R1 would allow more or all modules to be lit simultaneously. This could be used for, say, four different teams to hit their button on completion of a task, in the style of the Krypton Factor or It's a Knockout.

Note that if different thyristors are used, the values of the gate resistors R2-5 may need to be lowered (between 470k and 1M $\Omega$ ) to counter a higher base resistance in the thyristors.

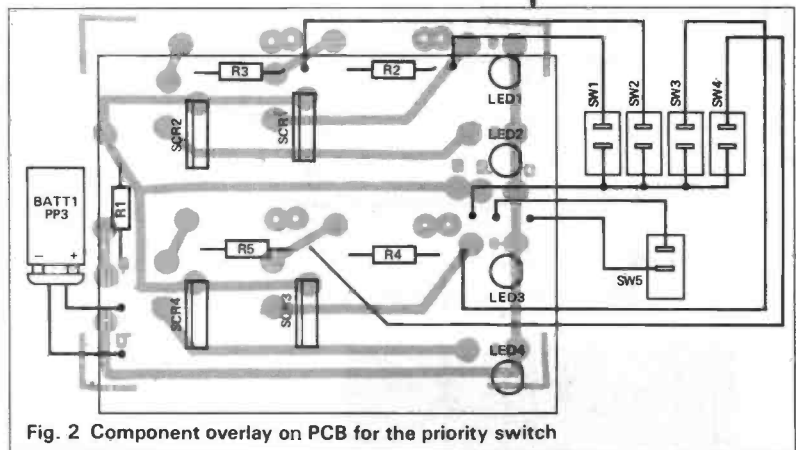

Fig. 2 Component overlay on PCB for the priority switch

## PARTS LIST

### RESISTORS (all 1/4W 5%)

R1	680R
R2-5	1M $\Omega$

### SEMICONDUCTORS

SCR1-4	TIC106D
LED1	5mm red LED
LED2	5mm green LED
LED3	5mm yellow LED
LED4	5mm tri-colour LED

### MISCELLANEOUS

BATT1	9V PP3 battery
SW1	push-to-make switch red
SW2	push-to-make switch green
SW3	push-to-make switch yellow
SW4	push-to-make switch white
SW5	push-to-make switch black
PCB or stripboard. LED bezels and clips. Wire and boots coloured to match SW1-4. Case.	

## BUYLINES

All the components in the prototype were obtained from Rapid Electronics, Hill Farm Industrial Estate, Boxted, Colchester, Essex CO4 5RD. Tel: (0206) 272730.

The PCB is available from the ETI PCB Service.



# PCB FOIL PATTERNS

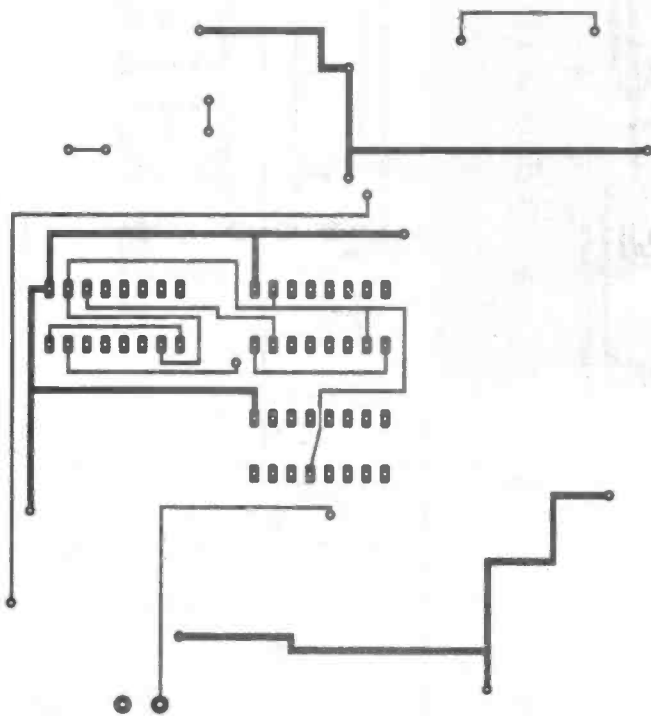

The Digital Doorbell topside foil

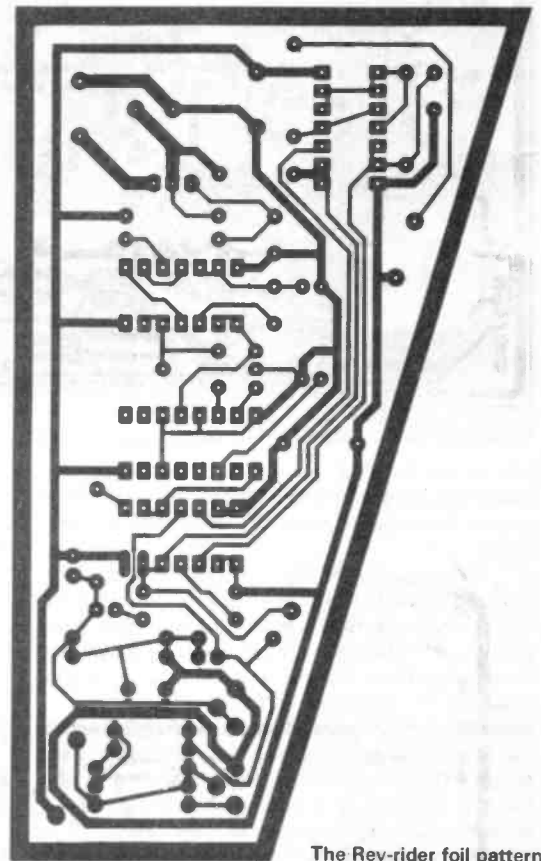

The Rev-rider foil pattern

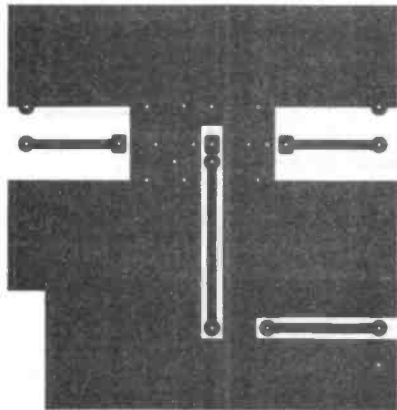

The Aerial amplifier board

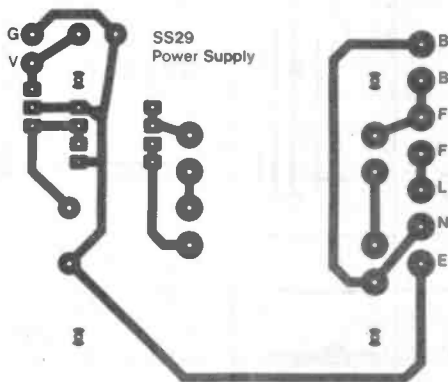

The Aerial amp power supply board

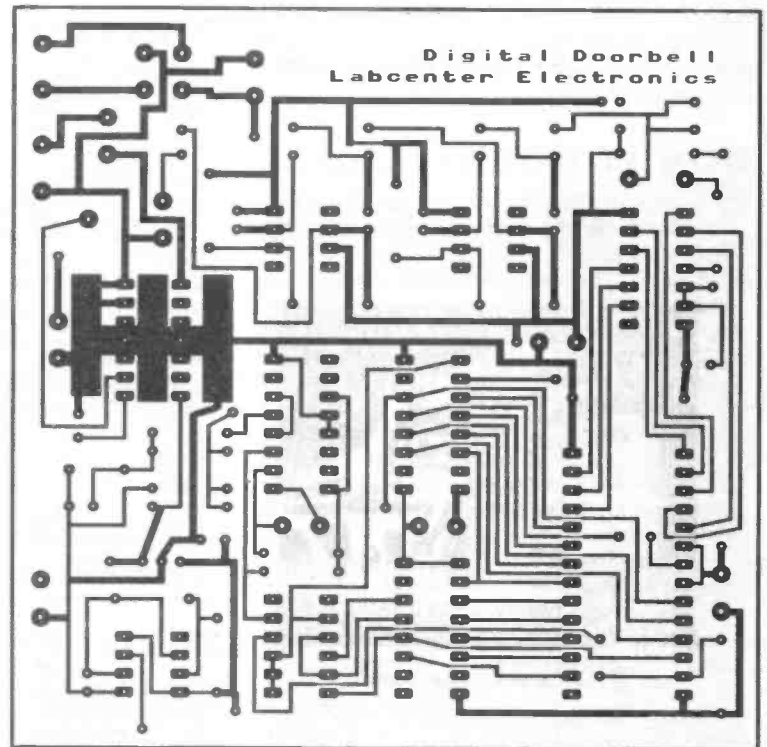

The Digital Doorbell solderside foil



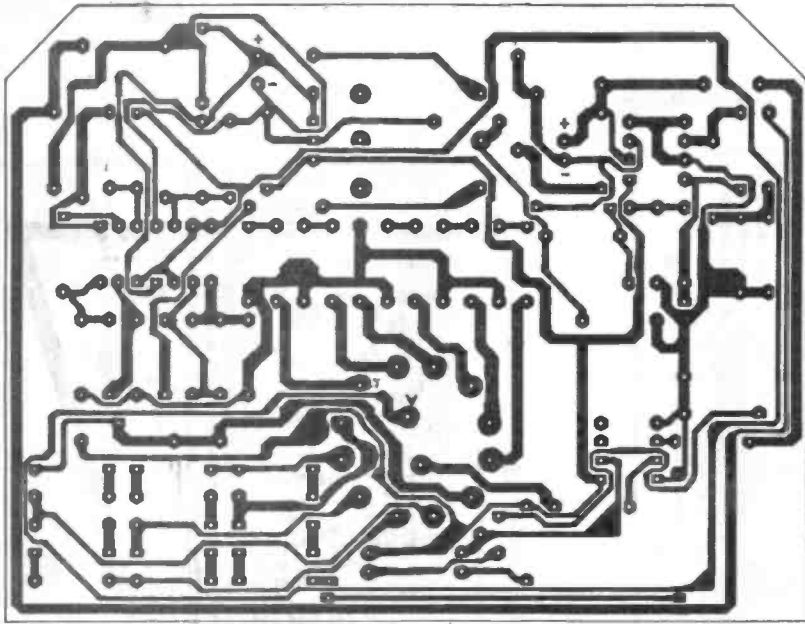

The guitar tuner foil

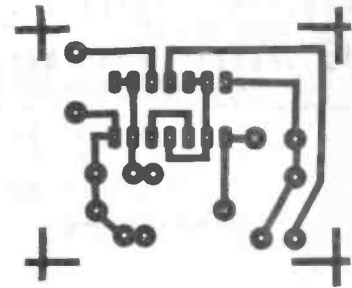
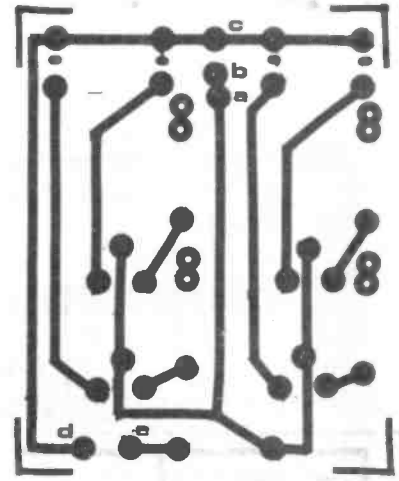

The Trembler board

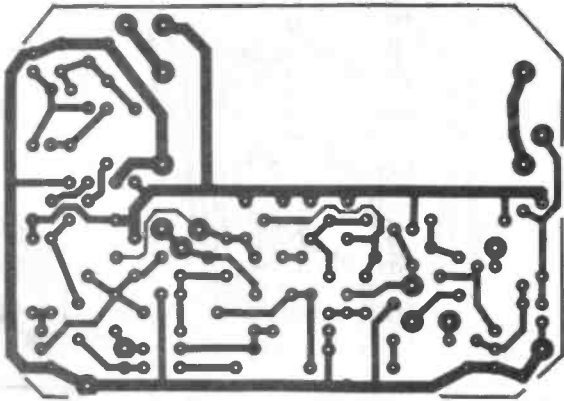

The hearing booster for Granny

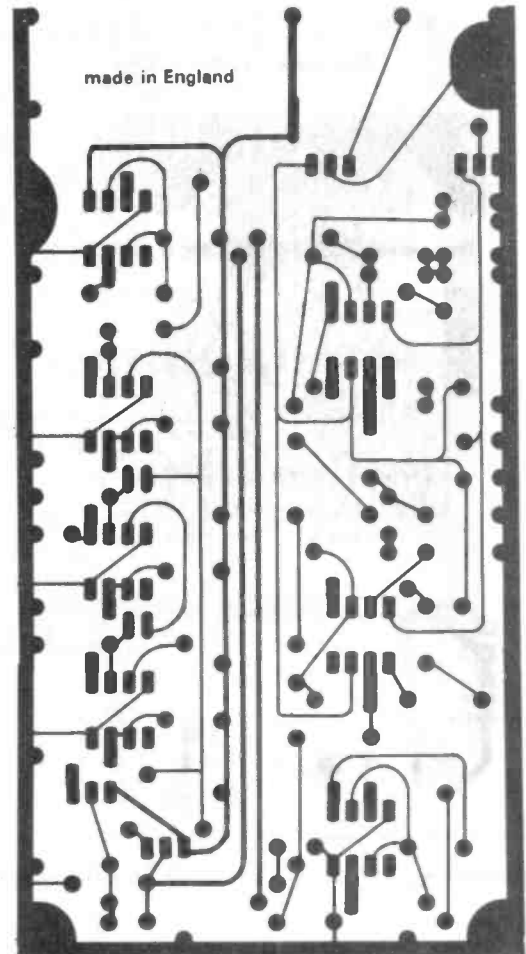

The Twin loop metal locator board

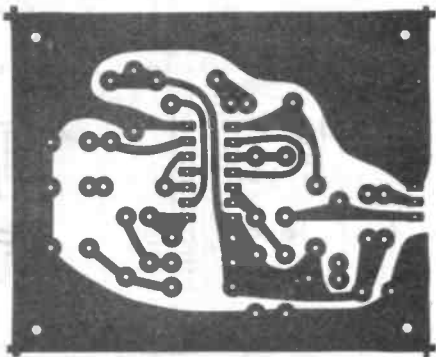

The Camera Trigger board

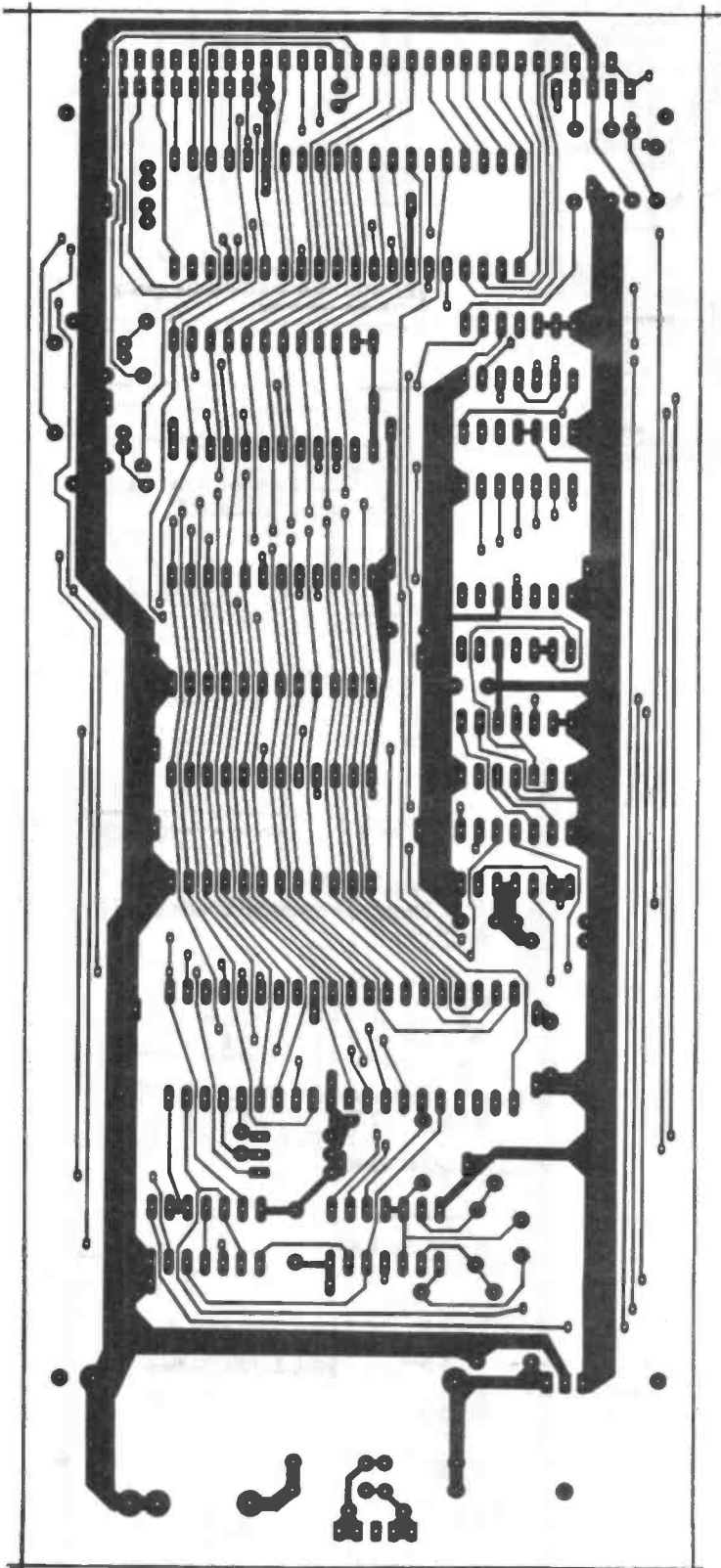

The MIDI keyboard processor and power supply foil pattern solderside

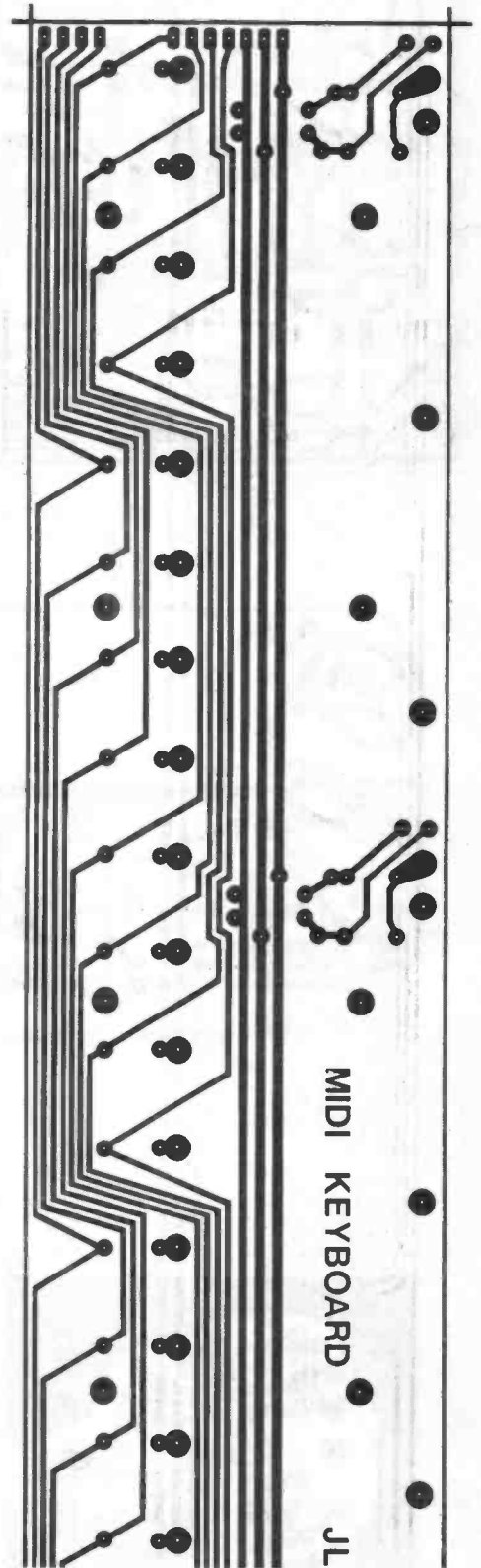

The MIDI keyboard contact foil pattern

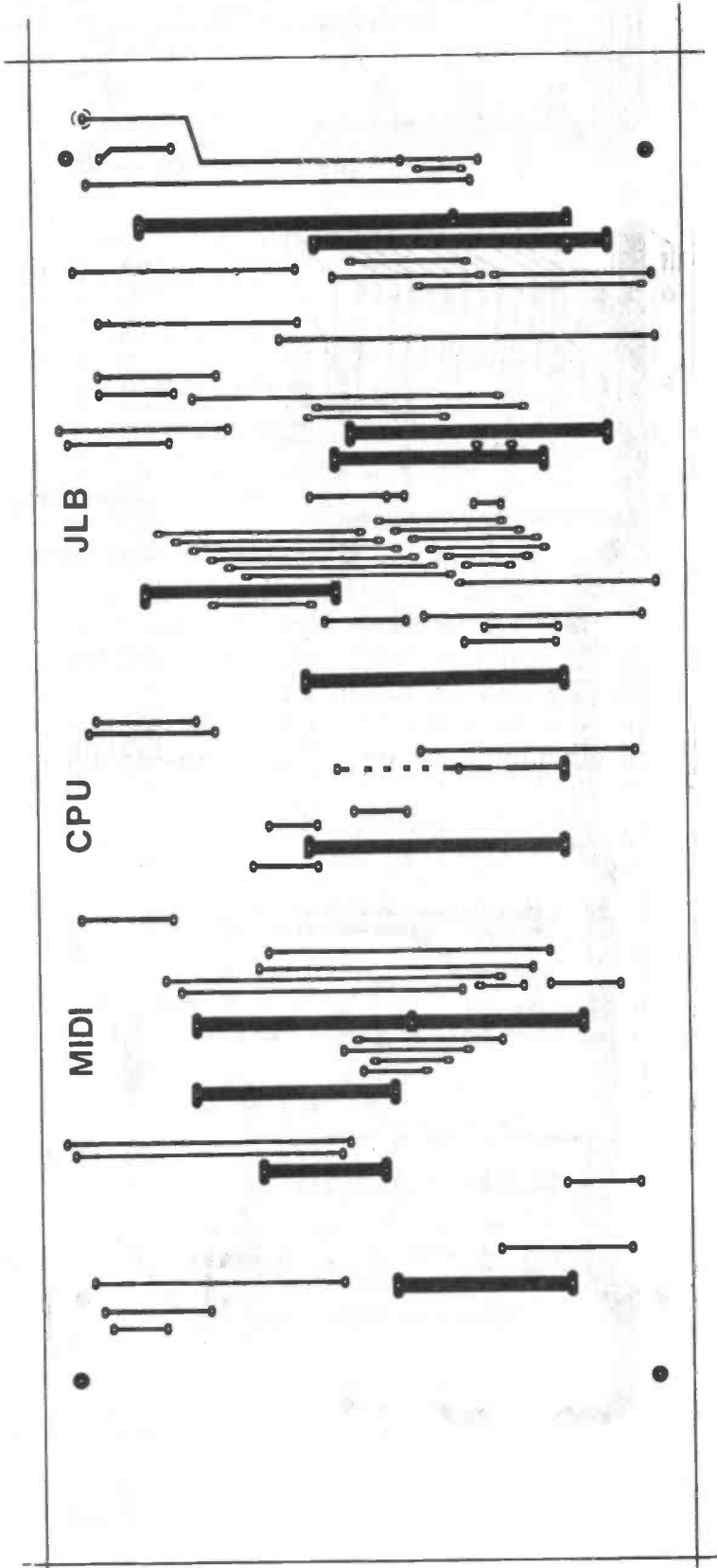
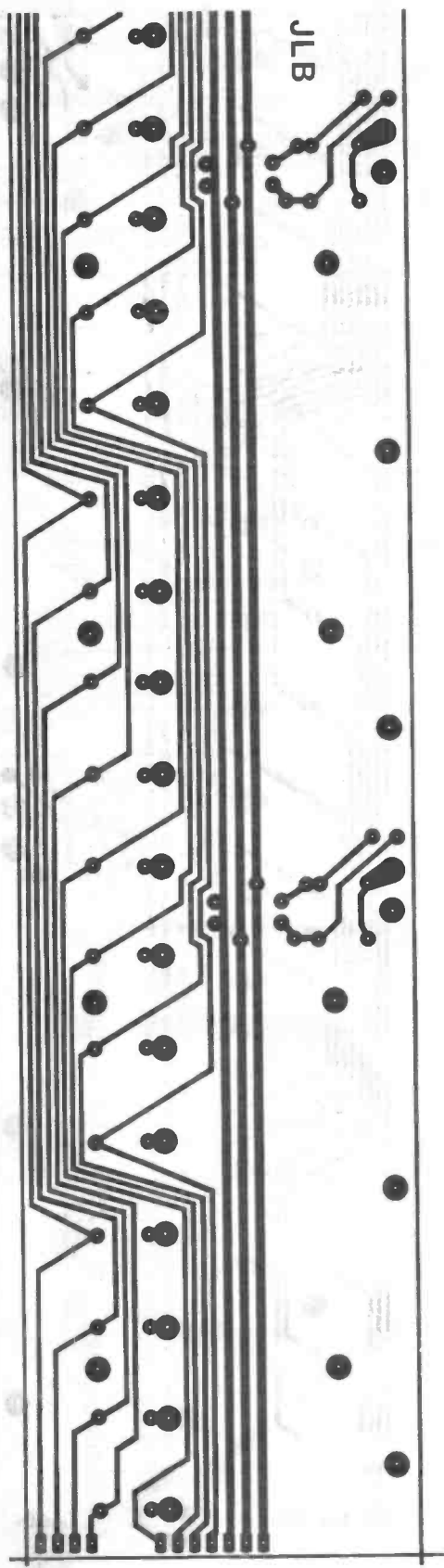

The MIDI keyboard processor and power supply foil pattern topside

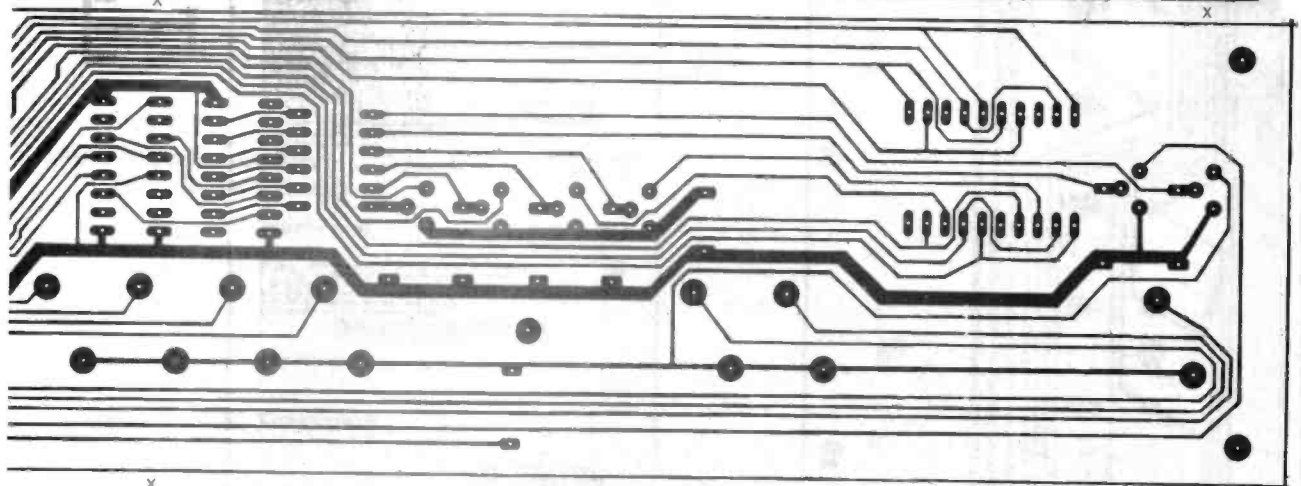
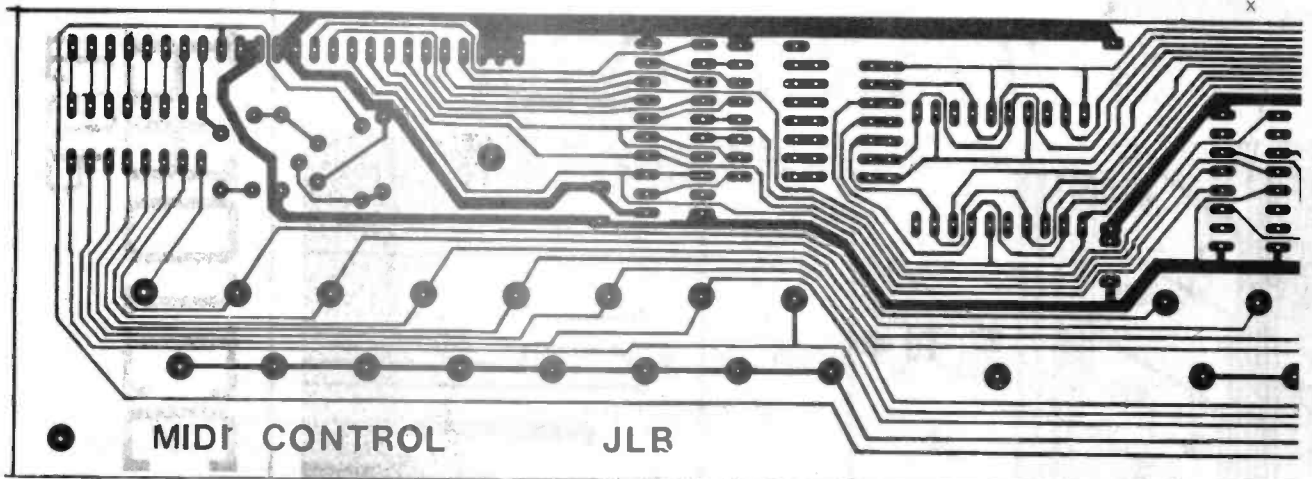

The MIDI keyboard control panel foil pattern

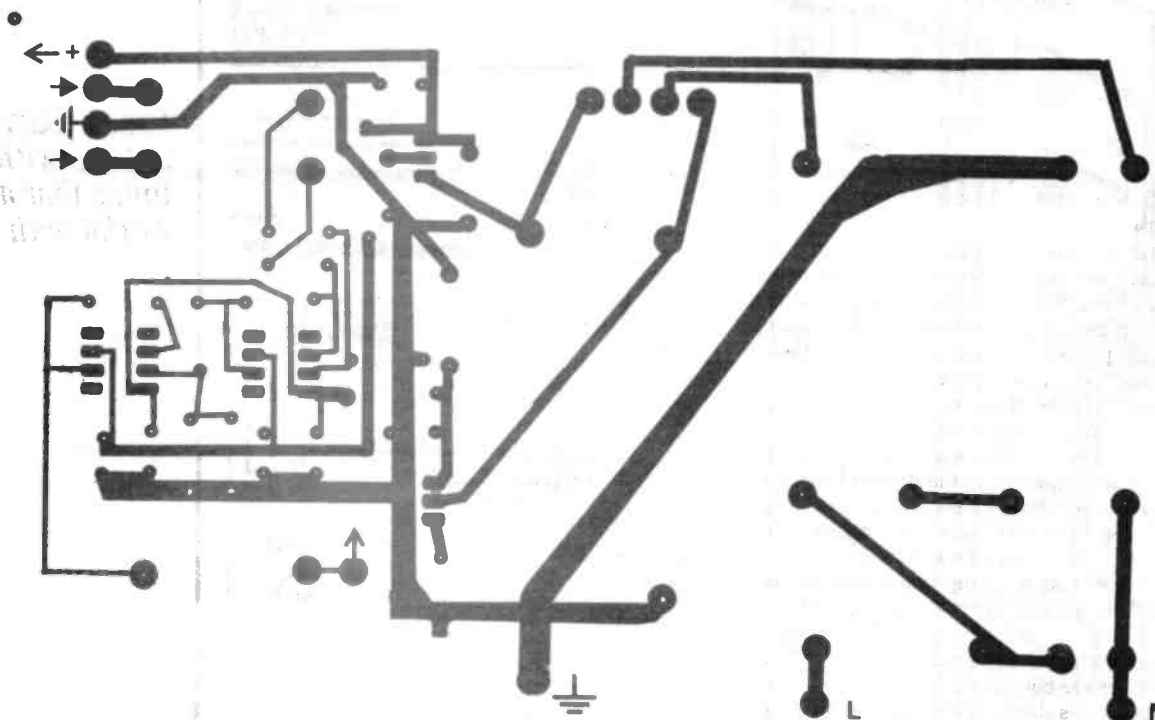

Pedal Power main board

# GUITAR TUNER

# TOP PROJECT

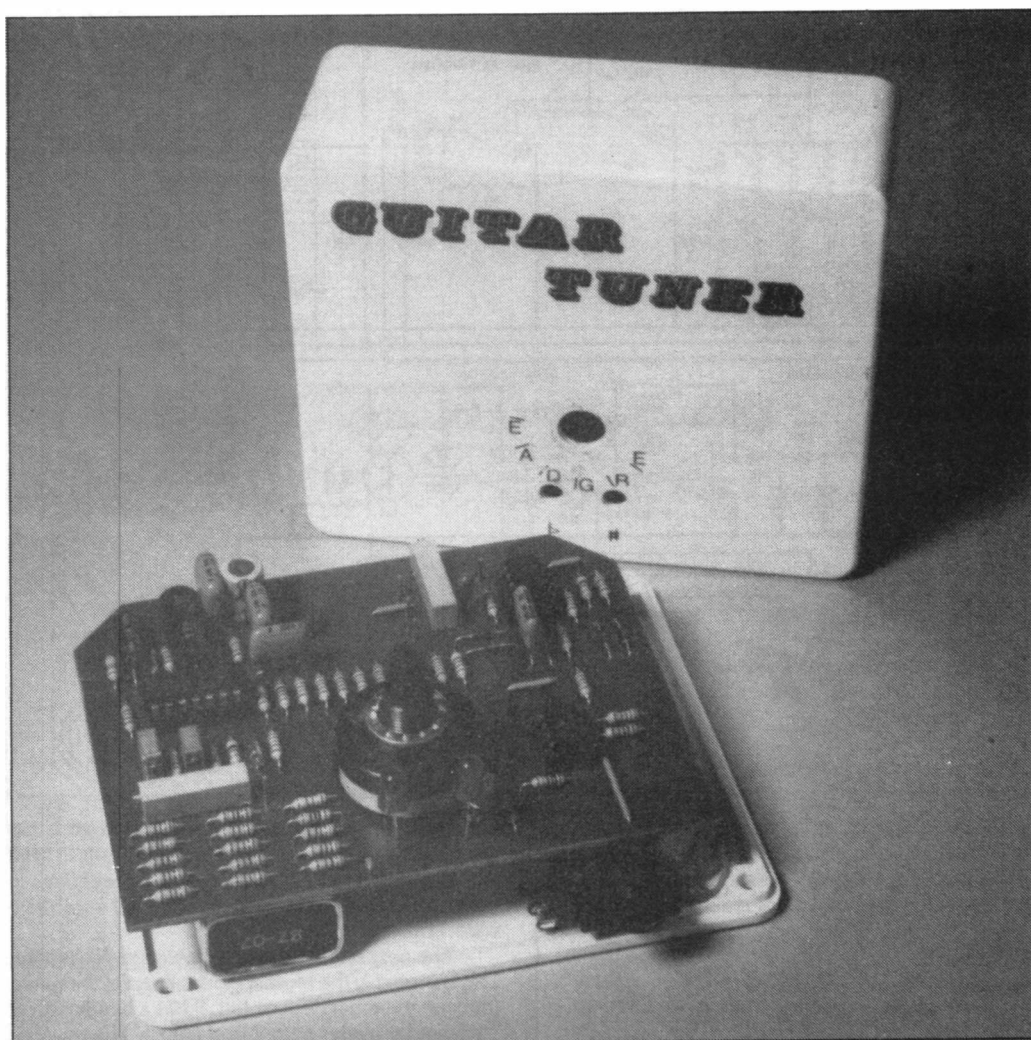

**A**s a guitarist and bass player I have always considered that silent electronic guitar tuners, giving a visual indication when a string is in tune are an asset to any player.

Apart from poor performances, the best way to get your audience really agitated is to make them suffer fifteen minutes or so of random twangs as the band 'tunes up' prior to the performance. Silent tuners eliminate completely this most unprofessional and annoying prelude to a performance.

In 1981 I was therefore keen to build my own tuner when a project for an inexpensive silent tuner appeared in one of the electronic hobbyists magazines. On completion of this project I tested it using a signal generator and frequency meter. The unit worked perfectly and I was impressed with its performance . . . for about three minutes.

When I tried to tune my guitar with it, the indicator LEDs jumped around so much that I assumed I had read the project title incorrectly and it was in fact a random lighting display.

To date I have built about half a dozen tuners published in various electronics hobbyists magazines — all bar one with the same result — they work fine with the almost pure sinusoids or square waves of a signal generator but are completely useless for tuning guitar strings.

The only one that did operate correctly used an

expensive 'top octave generator' IC, moving coil panel meter and two PP3 batteries. The cost of that project made a strong case for buying a commercially manufactured tuner.

My guess is that all of the designers of these projects suffered from the same handicap — they

*Laurie Barron keeps in tune with a guitar tuner that actually works with guitars*

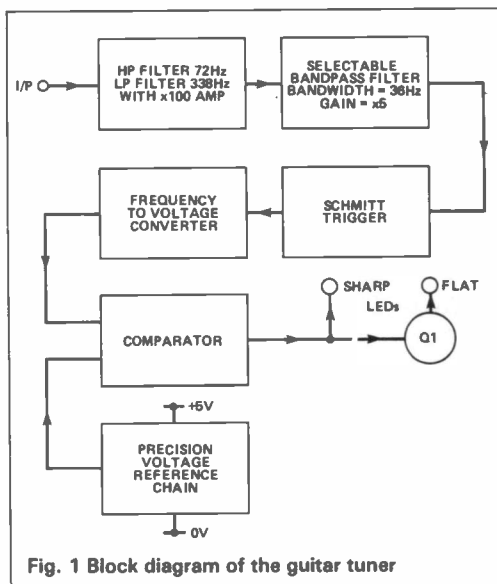

Fig. 1 Block diagram of the guitar tuner

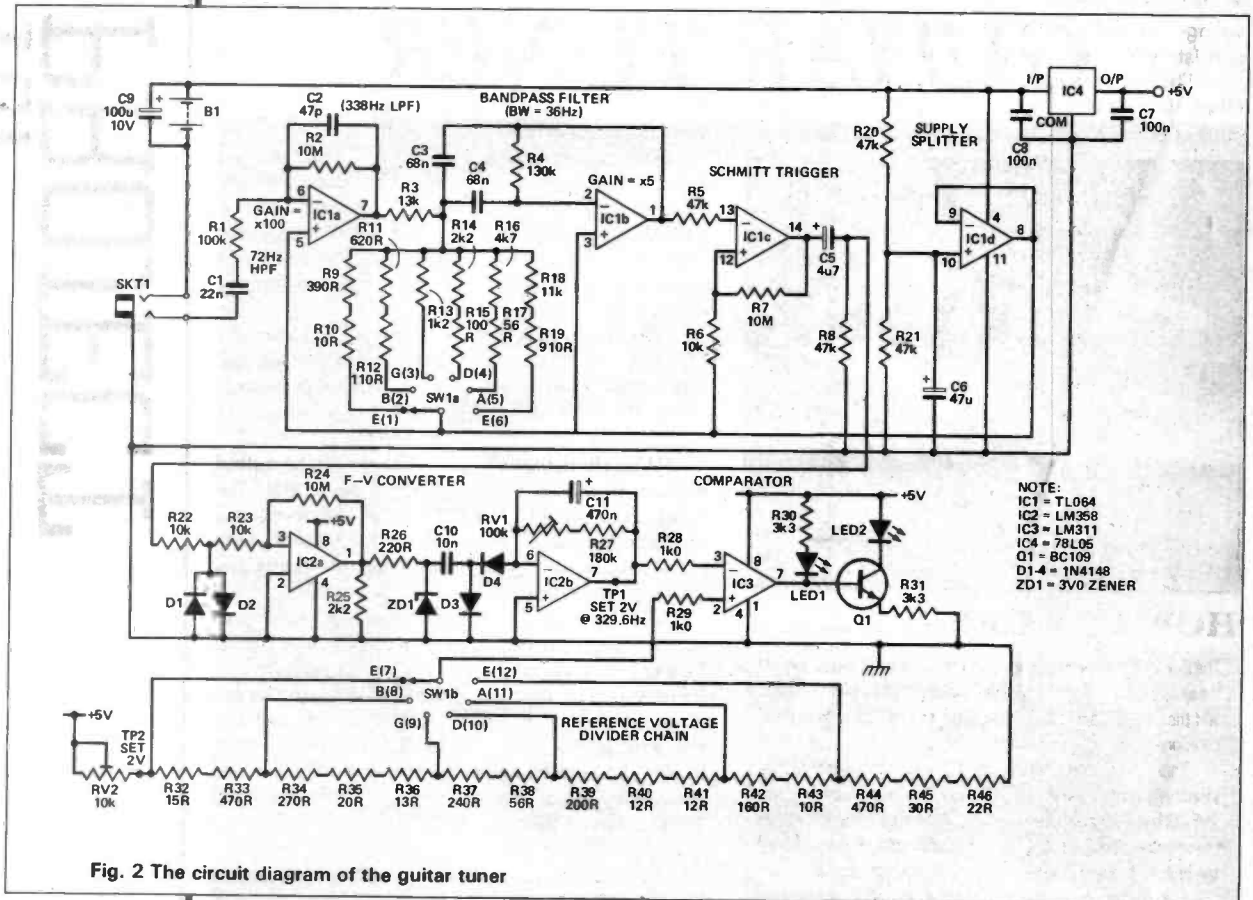

Fig. 2 The circuit diagram of the guitar tuner

were not guitarists and therefore did not possess guitars. In consequence of this, they all produced designs which responded correctly to waveforms that were almost pure but did not realise the output from

Guitar			Bass		
Tone	Frequency	Volts	Tone	Frequency	Volts
E	329.628	2.000	G	97.9989	2.000
B	246.942	1.515	D	73.4162	1.510
G	195.998	1.212	A	55.0000	1.137
D	146.832	0.916	E	41.2034	0.854
A	110.000	0.692			
E	82.4069	0.522			

Table 1 Tones, frequencies and outputs of F-V converter

a guitar is rich in harmonics and that these harmonics must be eliminated, leaving only the fundamental frequency before being compared with reference frequencies or voltages.

### Design Approach

The way I have approached this design is to look back over these failed designs, extracting the best ideas and adding efficient filtering to the input signal to effectively eliminate the unwanted harmonics.

The result is a tuner that uses a comparison of the output from a frequency to voltage converter with reference voltages derived from a precision voltage divider chain. The recent availability of cheap 1% resistors (3p each) from suppliers such as Maplin makes this an extremely economic approach which has produced a guitar tuner that costs less than £9,000 to build (excluding PCB and case).

Referring to the block diagram of Fig. 1, the guitar signal first passes through a high pass filter with a cut off frequency of 72.34Hz to remove mains hum.

Next follows a combined x100 amplifier and 338Hz low pass filter. From Table 1 it can be seen that the highest frequency required is about 330Hz so it

makes sense to first remove all frequencies above that value. Because of the very high gain, the output from this stage is clipped, but this causes no problems in this circuit as the final waveform required is a square wave anyway.

The next stage is the switchable bandpass filter. This is probably the most important part of the tuner, (the one the others leave out!). It has a bandwidth of 36Hz and provides a signal gain of x5. The purpose of this stage is to effectively eliminate all frequencies not within 18Hz either side of the frequency of the note to be tuned. The output from this stage is a crude square wave of the fundamental frequency only.

The fundamental frequency now passes to a Schmitt Trigger stage. This gives a clean square wave at the fundamental frequency. The components selected for this stage ensure that its output amplitude and frequency will remain constant for several seconds, almost until the string ceases to vibrate, the amplitude of the input signal can decay to about 10µV before correct operation ceases and the string must be struck again.

The next stage is the heart of the unit. It is actually an adaption of Paul Chappell's *Frequency Meter Module* design, (ETI April 1986). This configuration provides the frequency to voltage converter (F-V converter). Some component values are changed from the original design for use in this application but the principle remains the same.

The output does not exactly follow Mr Chappell's 'rule of thumb' formula, although if voltage/frequency is plotted from the values given in Fig. 2 it will be seen the relationship between voltage and frequency is still linear.

The purpose of this stage is to convert the filtered fundamental frequency of each string into a voltage level and then to pass this voltage level to one input of a standard LM311 comparator. The other comparator input is fed into a selected reference

voltage, derived from a voltage divider chain, consisting of a series of 1% tolerance resistors.

The divider chain is simply worked out using Ohm's law. The divider chain was calculated for a current of 1mA, this value helps to keep the power

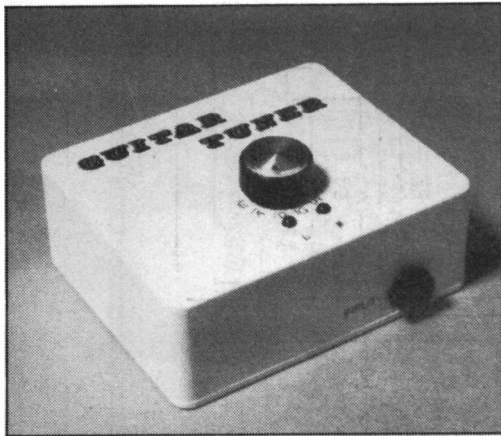

## HOW IT WORKS

The low level guitar signal, which is rich in harmonics passes through the simple high pass filter of R1 and C1 with cut off frequency 72.4Hz and then the low pass active filter network of IC1a and associated components (cut off frequency 338.63Hz).

This combination from the tuner's input to the output of IC1a effectively gives us a simple bandpass filter of centre frequency 205.49Hz and a bandwidth of 266.3Hz. The low pass filter attenuates the unwanted frequencies above the top open string of the guitar and the high pass filter helps eliminate any mains hum pick up.

Frequencies within these passbands are amplified by a factor of  $\times 100$  which boosts the input signal to a usable value, which can be measured well into the decay time.

The amplified signal then passes through IC1b and associated components which constitute a selectable, narrow, bandpass filter of bandwidth 36Hz. This configuration effectively removes all of the unwanted harmonics, leaving only the fundamental frequency.

From the bandpass filter the signal passes through IC1c which with its associated components is configured as a Schmitt trigger. This serves the purpose of squaring up the signal fed to the frequency to voltage part of the circuit. The components for the Schmitt trigger are selected for very low upper and lower trigger points to activate the trigger almost until the string ceases to vibrate altogether.

IC1d and associated components act to split the single 9V supply into a dual 4.5V supply required for use by IC1.

From the Schmitt trigger the signal passes to IC2a,b and associated components, configured as a frequency to voltage converter circuit. This circuit is really an adaption of the 'Frequency Meter Module' published in ETI April 1986 and the reader is referred to this text for a detailed explanation of its operation.

At the bottom of the circuit diagram is the reference voltage divider chain of RV2 and R32-46. The value of each block of 1% resistors has been chosen to give a voltage division equal to the intervals between the notes of the open guitar strings after frequency to voltage conversion. TP1 is initially set up to 2.000V with RV2. This sets up the reference voltages which will remain accurate until the battery voltage falls to below 7V.

The outputs of the frequency to voltage converter circuit and the reference voltage divider chain are fed to the two inputs of comparator IC3 via resistors R28 and R29. This IC performs a comparison between the output of the V-F converter circuit and the selected output of the reference voltage divider chain.

If the note is flat, then the output of the comparator will be high, allowing Q1 to conduct, switching on LED2 fully and extinguishing LED1. If the note is sharp, the output of the comparator will be low and LED1 will be switched on and LED2 extinguished. When the note produces a voltage equal to the reference voltage divider chains selected voltage, the comparators output will be half of its high level, thus allowing only partial conduction of Q1 and hence LED1 and LED2 will be equally illuminated.

consumption of the unit low and also makes for extremely easy calculation of the divider chain as the value of resistance between each reference point and 0V is simply the F-V output voltage  $\times 1000$  which gives the required resistance in ohms.

The comparator stage simply compares the voltage level from the F-V converter stage with the selected reference voltage from the divider chain. If the F-V output is higher than the reference voltage (the note is 'sharp') then the comparator output will swing towards its negative supply rail (0V). This will light the 'sharp' LED indicator.

On the other hand if the voltage level from the F-V converter is lower than the reference voltage (the note is 'flat') then the comparator will swing towards its positive rail (5V). This supplies base current to transistor Q1, lighting the 'flat' LED.

When both the reference voltage and the output voltage from the F-V converter are equal, the comparator output will be at half of its high level, thus only allowing partial conduction of Q1 and hence both LEDs will now be equally illuminated, indicating that the string is 'in tune'.

For those of you who like to analyse each part of a circuit, so that individual blocks can be extracted for use in future designs, the diagrams and formulae for each part of the circuit up to the F-V converter are given in Fig. 3. Further information on the F-V converter part of the circuit can be found by reference to Paul Chappell's *Capacitance Meter Module* and *Frequency Meter Module*, in the March and April 1986 issues of ETI.

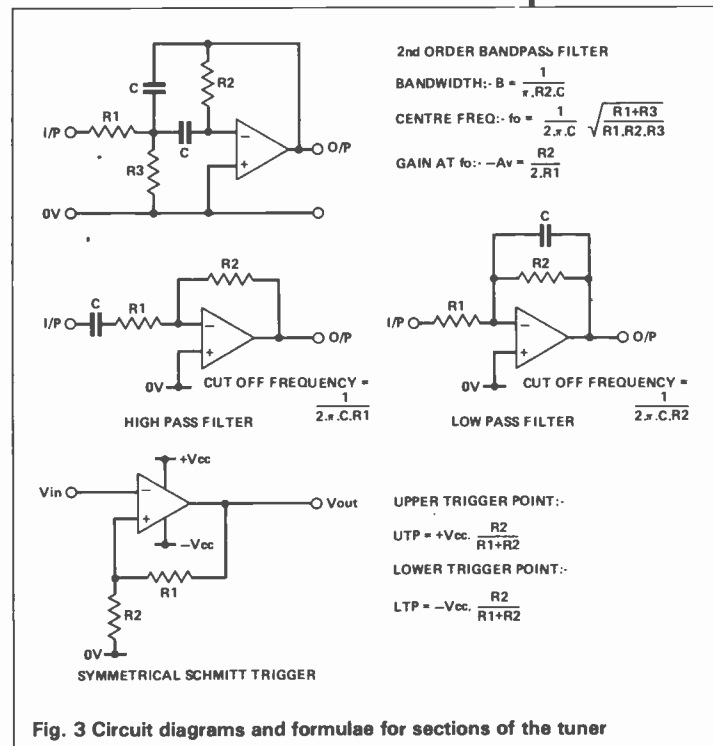

Fig. 3 Circuit diagrams and formulae for sections of the tuner

## Construction

Although 1% resistors are used in the critical positions (and ideally for the entire assembly) even this degree of accuracy can cause problems with some of the larger resistors in the divider chain. In the worst case, resistors R33 and R44 (470R) could vary from their marked value by as much as 4R7 each. This variation would affect the accuracy of the tuner and I would recommend that all of the resistors of 200R or over in the divider chain (R33,34,37,39,44) are selected

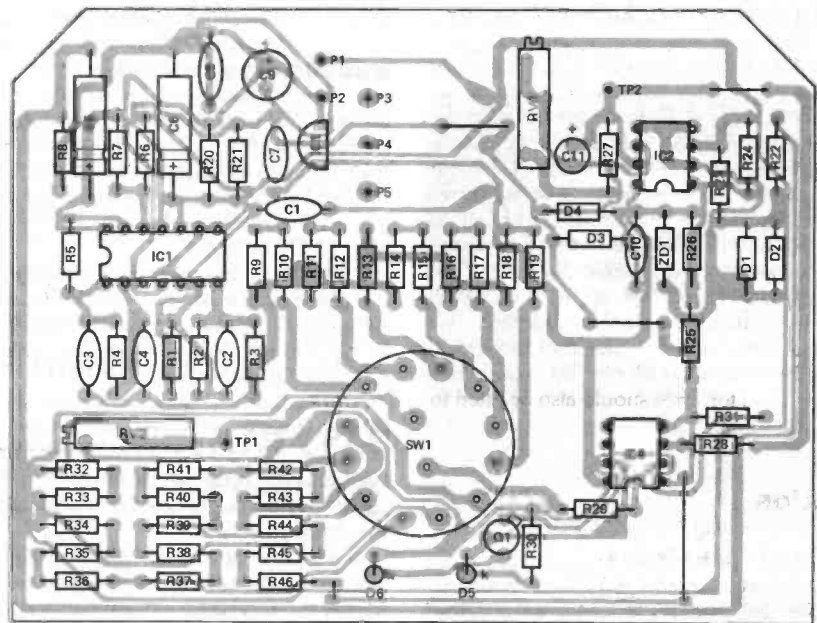

Fig. 4 The component overlay for the guitar tuner PCB

## PARTS LIST

### RESISTORS (¼ W 5% except where specified)

R1	100k
R2,7,24	10M
R3	13k 1%
R4	130k 1%
R9	390R 1%
R10,43	10R 1%
R11	620R 1%
R12	110R 1%
R13	1k2 1%
R14,25	2k2 1%
R15	100R 1%
R16	4k7 1%
R17	56R 1%
R18	11k 1%
R19	910R 1%
R23	10k
R26	220R
R27	180k
R28,29	1k0 1%
R30	3k3 1%
R31	3k3 1%
R32	15R 1%
R33	470R 1%
R34	270R 1%
R35	20R 1%
R36	13R 1%
R37	240R 1%
R38	56R 1%
R39	200R 1%
R40,41	12R 1%
R42	160R 1%

R44	470R 1%
R45	30R 1%
R46	22R 1%
RV1	100k 18-turn cermet preset
RV2	10k 18-turn cermet preset

### CAPACITORS

C1	22n polyester
C2	47p polystyrene
C3,4	68n 5% polycarbonate
C5	4µ7 10V axial electrolytic
C6	47µ 16V axial electrolytic
C7,8	100n polyester
C9	100µ 10V radial electrolytic
C10	10n 5% polyester
C11	470n tantalum

### SEMICONDUCTORS

IC1	TLO64
IC2	LM358
IC3	LM311
IC4	78L05
Q1	BC109
ZD1	3V 500mW zener
D1-4	1N4148
LED1,2	red LED

### MISCELLANEOUS

B1	9V PP3 battery
SK1	stereo ¼in jack socket
SW1	2 pole 6 way rotary switch
PCB, MB3 case. Battery clip. Connecting wire.	

with an accurate digital multimeter or some other accurate device for measuring resistance, to select the values closest to those specified. The easiest way of achieving this is to order a pack of ten of each value from Maplins and select the best from each pack for each value.

The component overlay is shown in Fig. 4. Fit the wire links first, followed by the resistors, off-board connector pins, IC sockets, capacitors, presets, the

rotary switch and last the semiconductors. Do not fit the LEDs at this stage.

The 14 PCB holes for the rotary switch must be drilled slightly larger (1.2mm) than those in the rest of the board. The pins of the rotary switch must have each eyelet cut off as close to the eyelet as possible, to allow the switch to be fitted to the board.

The next task is to drill the holes in the case for the rotary switch, LEDs and jack socket in accordance



with the positions shown in Fig. 5. If you are not using the MB3 type box, pay special attention to the relative positions of the holes for the LEDs and the rotary switch.

Fit (but don't solder) the two LEDs to the PCB, ensuring that the anodes and cathodes are in the positions shown in Fig. 4. Remove the nut from the rotary switch and holding the PCB with the rotary switch uppermost, fit the rotary switch and PCB to the case. Fit the switch nut and tighten to finger tightness. Square the PCB to the case. Now push the LEDs into their respective holes in the case so that their entire dome areas are just proud of the case. Now solder the leads of the LEDs to the PCB, ensuring that their position does not move during this operation.

Fit the jack socket to the case and connect it. Screened cable is not necessary for this application. The battery connector wires should also be fitted to the PCB at this stage.

## Calibration

This operation is carried out with the PCB assembly out of the case. To calibrate the tuner connect a 9V battery to the battery connector and insert a mono jack plug into the jack socket. Connect an accurate voltmeter between TP2 and 0V and adjust RV2 until a reading of exactly 2V is obtained.

Now connect a square or sine wave signal with a frequency of exactly 329.628Hz and an amplitude of between 20mV and 5V to the input of the unit. Turn the rotary switch fully anticlockwise. An accurate voltmeter is now connected between TP1 and 0V and RV1 is adjusted until a reading of exactly 2V is obtained. The tuner is now fully calibrated.

If you are not fortunate enough to possess a signal generator and frequency meter then simply connect an accurately tuned guitar or keyboard to the input of the tuner, strike the open top E string or play keyboard E of 329.628Hz, allow a half a second for the frequency of the string to stabilise and adjust RV1 until a reading of 2V is obtained with the voltmeter connected between TP1 and 0V.

The reading will remain constant for several seconds but the string may have to be struck several times with this method until the potentiometer adjustment reaches 2V.

The unit can now be replaced in its case and the respective switch positions of E, A, D, G, B, E, (eat all day great big eggs) in a clockwise direction marked around the switch.

## Using The Tuner

Power is applied to tuner by simply inserting the guitar jackplug into the socket.

Select the required note on the switch and strike the appropriate string, after a short period the LEDs will stop jumping and an indication of whether the string is sharp or flat will be given by the LED that remains illuminated. It is always best to tune from flat upwards, so if the string is sharp, loosen it, strike the string again and turn the appropriate machine head of the guitar until both LEDs are equally illuminated. The string is now 'in tune'.

After very little experience with this unit you will find the tuning of each string can be achieved with only striking the string once and then adjusting the machine head.

The current consumption of the tuner is less than 12mA, and power is only applied to the unit when the guitar jack plug is actually inserted into the tuners socket. As the tuner is only used for the few minutes required to tune a guitar, a standard 9V PP3 type

battery should last for many months. The tuner will remain accurate until the battery voltage falls below 7V.

## Bass Players

If you're not a budding Eric Clapton but you are a potential Jack Bruce, don't despair, you haven't been forgotten. The same PCB can also be used to make a bass guitar tuner.

Simply substitute the component values and links as shown below for those in the main component list and omit components as indicated.

In addition, use a frequency of 97.9989Hz when adjusting RV1 or the top G string (or a G of 97.9989Hz on the keyboard).

The switch positions should be labelled E, A, D, G.

## BASS PARTS

### RESISTORS (all 0.6W 1%)

R9	2k4
R10,36,42-44	link
R11	4k7
R12	300R
R13	13k
R14	91k
R15	6k8
R16-19	omit
R27	750k
R32	20R
R34	330R
R35	43k
R37	270R
R38	13R
R39	820R
R40	18R
R41	16R

### CAPACITORS

C1	47n polyester
C2	150p polystyrene
C3,4	100n 5% polycarbonate

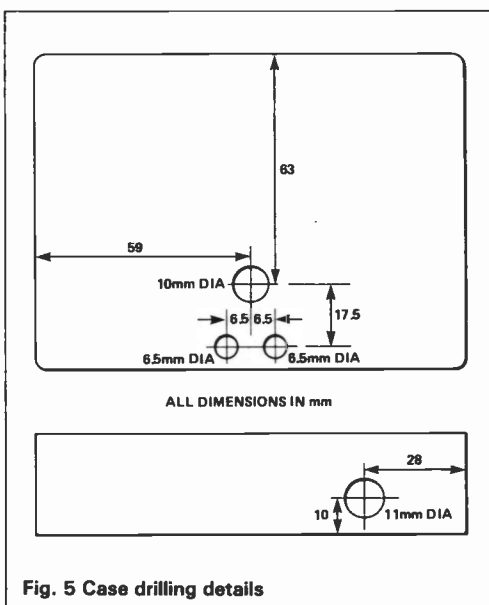

Fig. 5 Case drilling details

## BUYLINES

All components can be obtained from Maplin or indeed many other suppliers. The PCB is available from the ETI PCB Service.



# TWIN LOOP TREASURE SEEKER

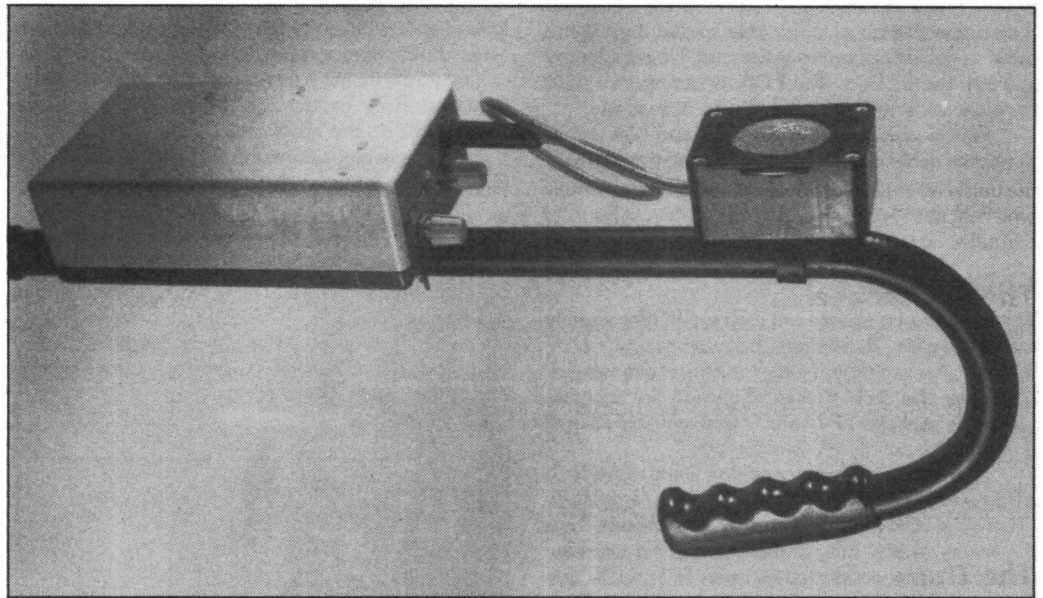

*Robert and David Crone present their snouted seeker that exposes the treasure other detectors cannot reach*

**P**ulse metal detectors are powerful and versatile machines but in their basic form they suffer from ground effect and radio interference. However a very simple modification can almost entirely eliminate these two problems.

The principle of the pulse metal detector is very easy to understand. A large pulse of current is transmitted through a coil of wire and the resulting magnetic field induces eddy currents in nearby coins or metal objects. The eddy currents continue to flow after the transmitted pulse has ended and they in turn induce small voltages back into the coil. These voltages are amplified and detected in a receiver which operates an audio indication, usually a click generator.

A problem with this is that the transmitted pulse induces eddy currents in mineralised ground causing a ground effect signal. Secondly the coil acts as a good

aerial for long and medium wave radio broadcasts, producing interference. So what can be done about these problems?

The ground effect comes from a large area and is almost constant over a flat surface like a wet sandy beach after the tide has gone out. If we were to position a second search coil about 100mm from the original then it would pick up the same amount of ground effect. Now if we were to subtract the outputs of the two coils the ground effect from each would cancel out. However the system would still pick up coins because the distance between the coils is large compared with a coin. By similar reasoning, medium and long wave radio broadcasts will cancel out as the field strength of these signals does not change significantly in 100mm and each coil will receive the same amount of interference.

So the second coil is a modification to the pulse

TOP  
PROJECT

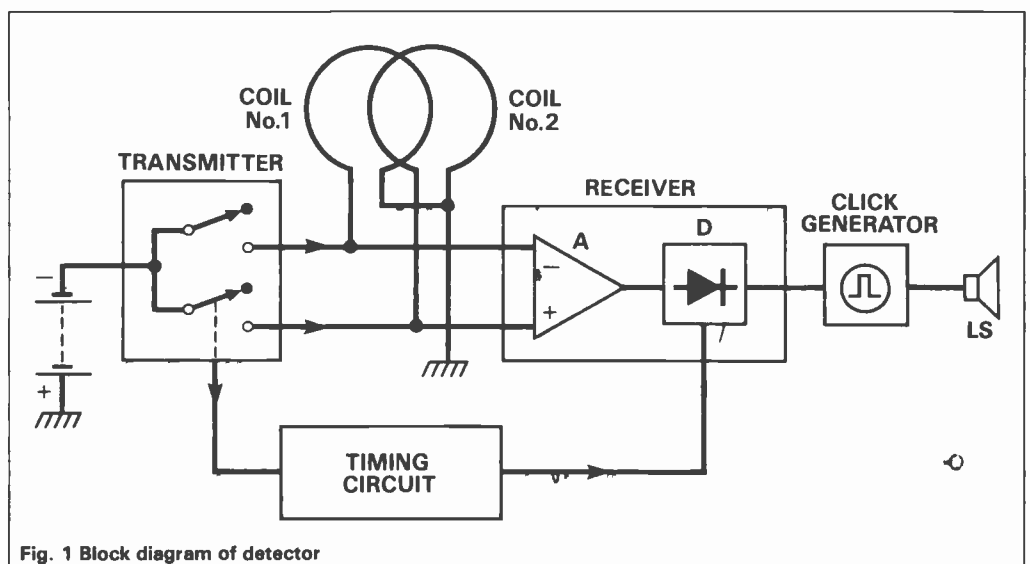

Fig. 1 Block diagram of detector

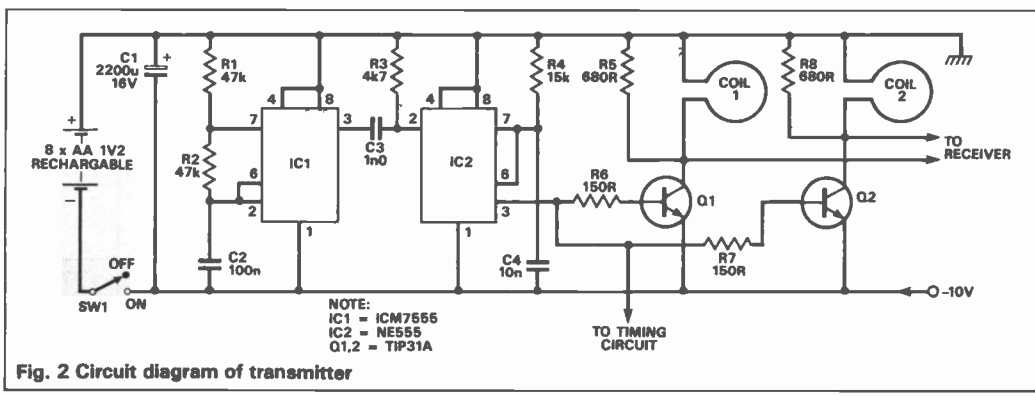

Fig. 2 Circuit diagram of transmitter

detection system. Figure 1 shows a block diagram of the unit. The central feature is the search coil assembly which in practice consists of two coils each of 200mm diameter and overlapping by 100mm.

### The Transmitter

Figure 2 shows the circuit diagram of the transmitter. IC1 is wired as an oscillator running at 100Hz. IC2 is triggered 100 times per second from IC1 via the differentiating network of R3 and C3. Each time IC2 is triggered its output goes high for 165µs and drives the two power transistors hard on into saturation. The full battery voltage is now applied across the coils and the current in each one builds up to about one amp.

### The Timing Circuit

Fig. 3 shows the circuit diagram of the timing circuit. IC3 is triggered from the transmitter at the end of the 165µs current pulse. Its output goes high for 36µs and then IC4 is triggered via C8 and R11. IC4 runs for 50µs and its output goes to the receiver where it switches on the detector for 50µs.

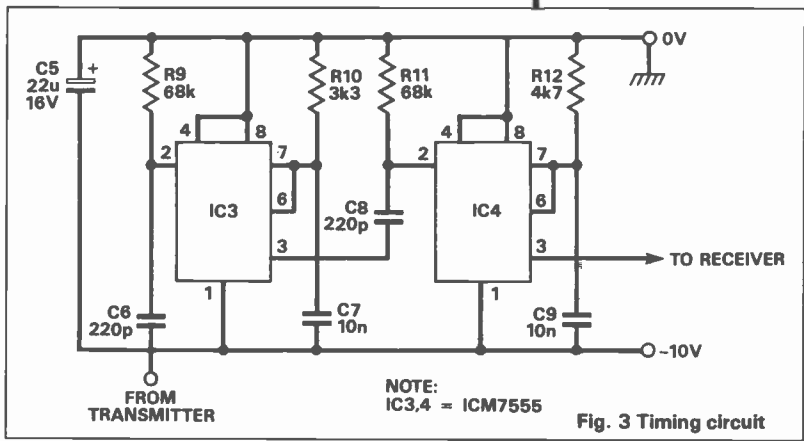

Fig. 3 Timing circuit

### The Receiver

Fig. 4 shows the circuit diagram of the receiver. The outputs from the coils are fed to the inputs of the

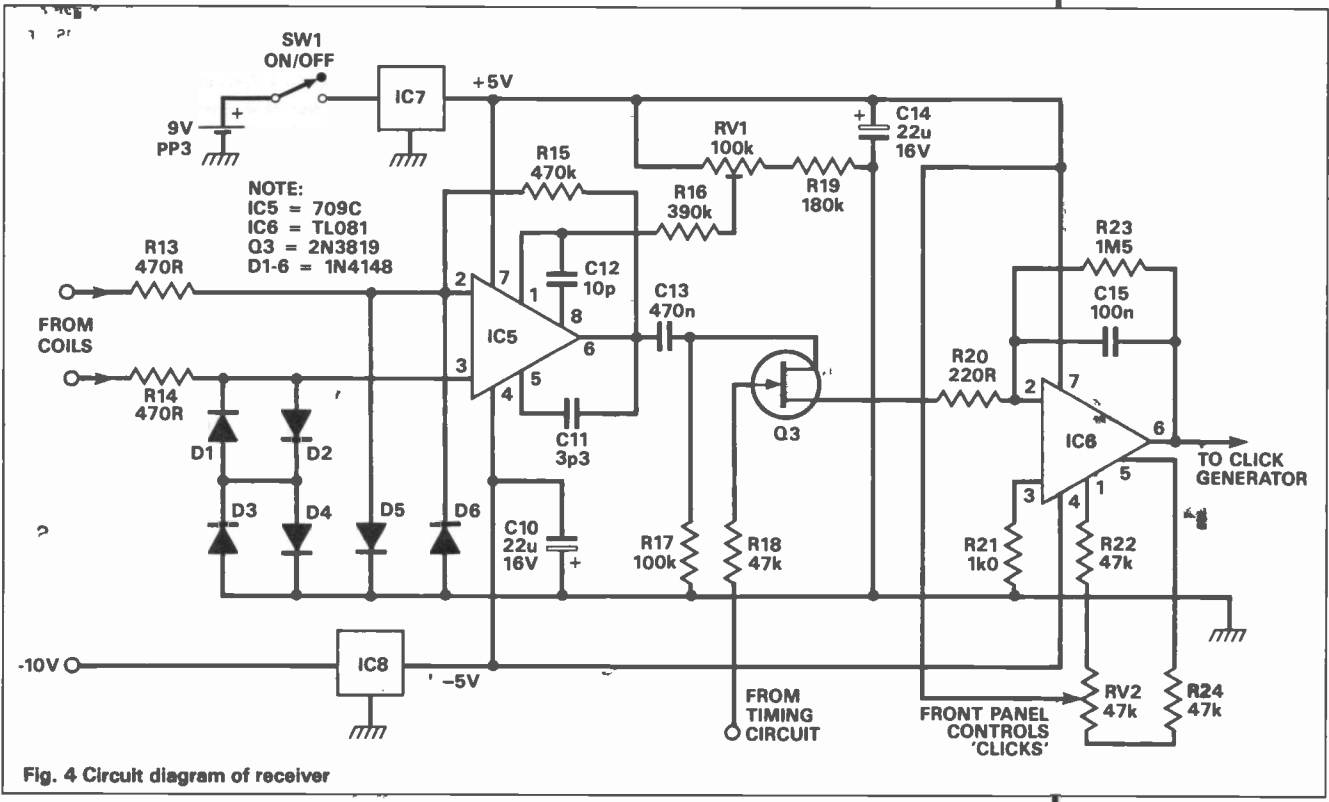
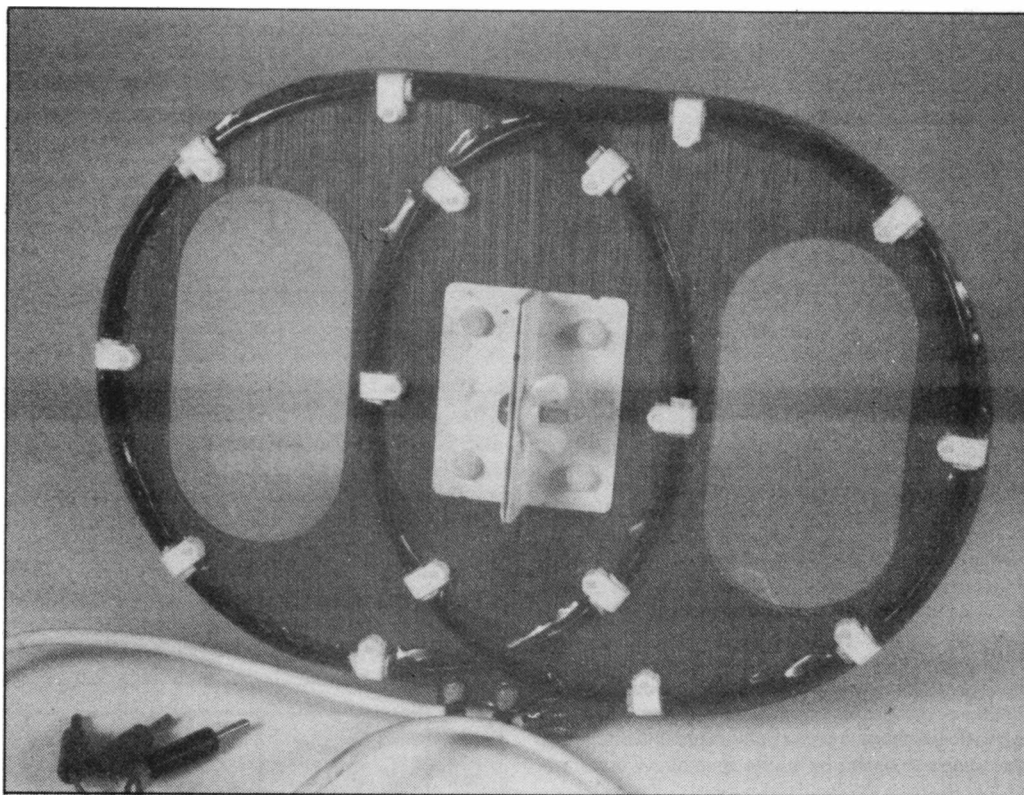

Fig. 4 Circuit diagram of receiver



to  $-1V$  by adjusting RV1 and set the receiver output to  $-0.3V$  by the front panel control RV2.

### The Click Generator

Fig. 5 shows the circuit of the click generator. With no input at all, Q4 is off and the circuit is inoperative. However with  $-0.3V$  coming in from the receiver, Q4 starts to conduct very slightly and the circuit starts to click slowly. The clicks rapidly turn into a high pitched whistle as the search coil approaches a coin.

### Construction

The circuit is built on a single PCB and the components should be mounted according to the component overlay in Fig. 6. The usual precautions should be taken with the ICM7555s as these are CMOS devices. You need to keep yourself earthed when handling these chips.

Once all the components have been mounted on the PCB, the board can be drilled in the four

corners. The board is held firm in a plastic control box by four nylon cuts and bolts. Terminal pins were used on the PCB for external connections to the switches, potentiometers, sockets and battery connections.

Drill the required holes in the plastic control box. You will probably have to do a little additional filing for the volume, click control pots and the audio socket.

To make the search coils, first obtain a piece of scrap 25mm chipboard and hammer into it a 200mm diameter circle of nails, wind 30 turns of no 26swg enamelled copper wire around the nails and secure the windings with string or cotton ties. Pull out a few nails, remove the coil and then wind a second coil. Then mount the coils, overlapping by 100mm as in Fig. 7 on a suitable piece of 6mm plywood and fasten them down with plastic cable clips and plastic screws. Connect the coils up to a few feet of 3-core cable terminated at the other end in 4mm plugs. Alternatively you could use 2-core screened audio cable and use the screen for the common connection.

At this stage you would be advised to bench test the machine to check that you have wound the coils

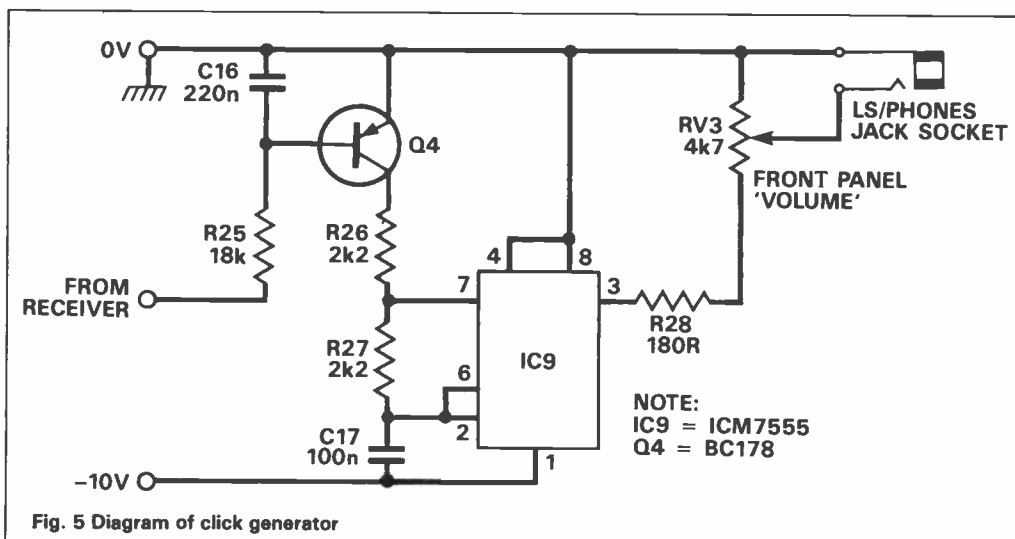

Fig. 5 Diagram of click generator

correctly so that the current in each coil flows in the same circular direction. A method of testing the phasing or current direction in each coil, apart from inspection, would be to pass a small direct current through each coil and then detect the magnetic field produced with a small compass. The coils would need to be placed in the vertical plane with the compass positioned at the centre of each ring. If the currents are in the same direction, the compass will indicate that this is so.

## The Printed Circuit Board

Fig. 6 shows the component overlay. Make sure the components are placed in the correct positions. Once the 165 $\mu$ s pulse has finished, the reservoir capacitor C1 starts to charge up with a large current. This causes a voltage drop in the wiring. If any voltage drop gets on to the earth rail, it will be amplified and interfere with the system operation. For this reason separate wiring for the two battery supplies must be used and nothing but the battery may be connected to the left of C1.

## The Coils

Fig. 7 gives the details of the coil assembly. Mount the coils on a plywood frame and cut away as much wood as possible to reduce the weight. A few feet of 3-core mains cable is suitable for connecting the coil assembly to the 4mm sockets on the plastic control box. Everything must be plastic or wood. Finally keep in mind that the current in each coil is flowing in the same direction ie they are driven in phase.

## Batteries

Eight 1.2V AA size rechargeable cells provide the -10V supply. The machine consumes around 80mA of current so the batteries will give about five hours of continuous running. When the batteries are discharged, the click generator will go out of control. A 9V PP3 or MNI604 battery provides the positive supply for the op-amps. A voltage converter is not used to obtain this supply as these devices require an oscillator, the output of which might get into the

receiver and cause interference. All the batteries are mounted inside the lid of the plastic control box and secured with strong rubber bands.

Then encapsulate the coils with Araldite and put the assembly into a warming compartment so that the Araldite melts and permeates into the windings before setting. Use plastic angle material to attach the assembly to a plastic or wooden stem. *No metal* should be used in the construction of the coil assembly. Any metal nuts, screws, washers or solder tags will upset the system.

An 80cm length of 20mm plastic tubing may be used to make the handle for the control box and can be bent into the traditional 'shepherd's crook' shape by means of a bending spring and hot water. A bicycle handlebar grip slipped on to the top end makes an ideal handle hold.

A 50cm straight length of 16mm plastic tubing can be used for the stem. One end was dipped in hot water and flattened with pliers and then attached to the coil assembly by means of a plastic nut and bolt. The stem is then slid up into the handle until the total length suits the operator and then bolted into position.

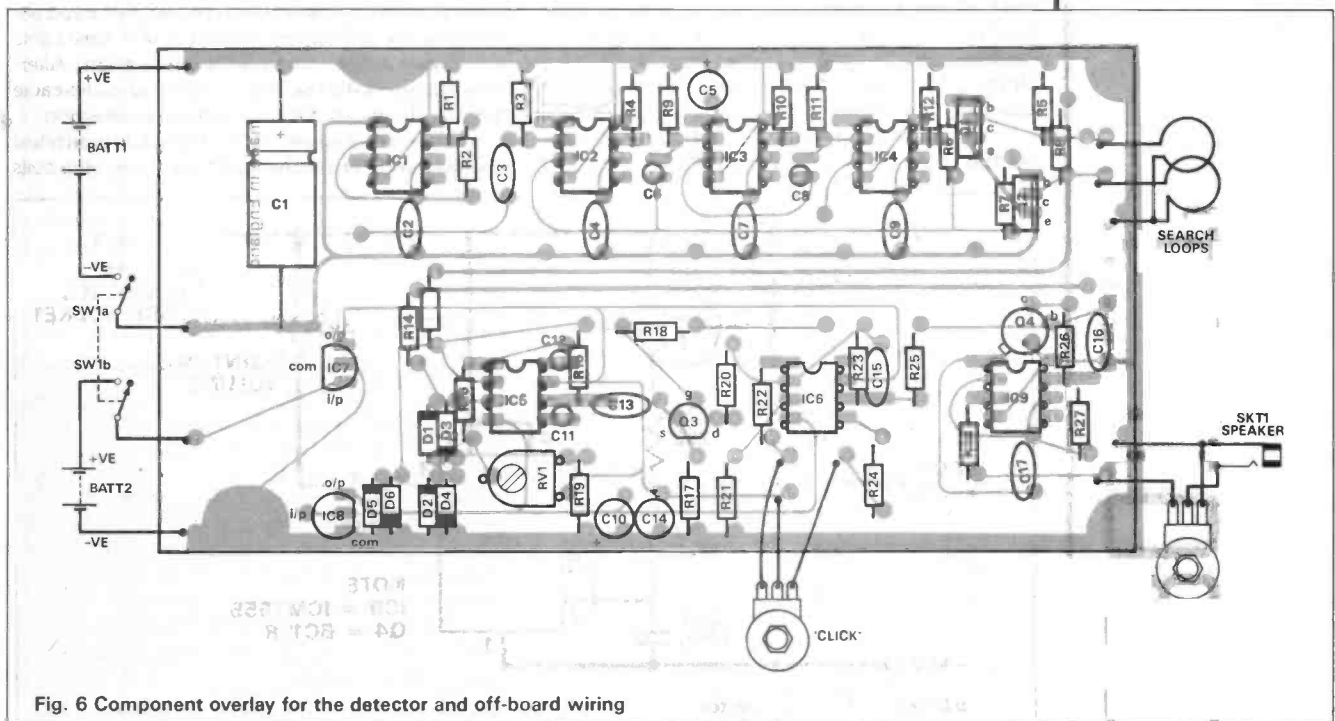
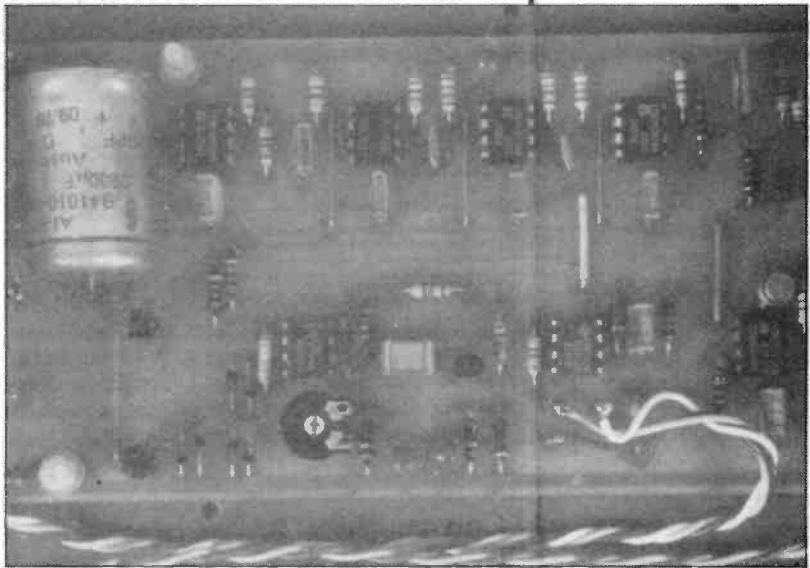
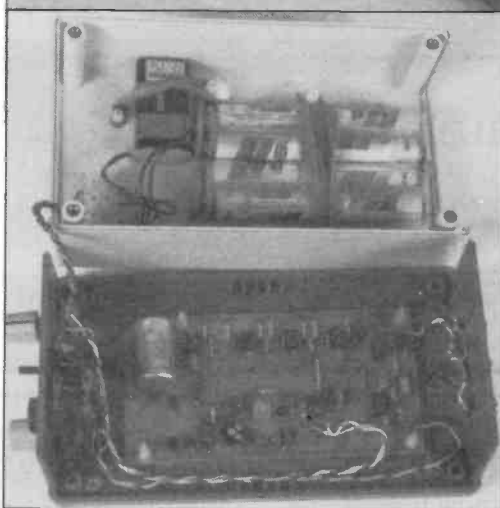
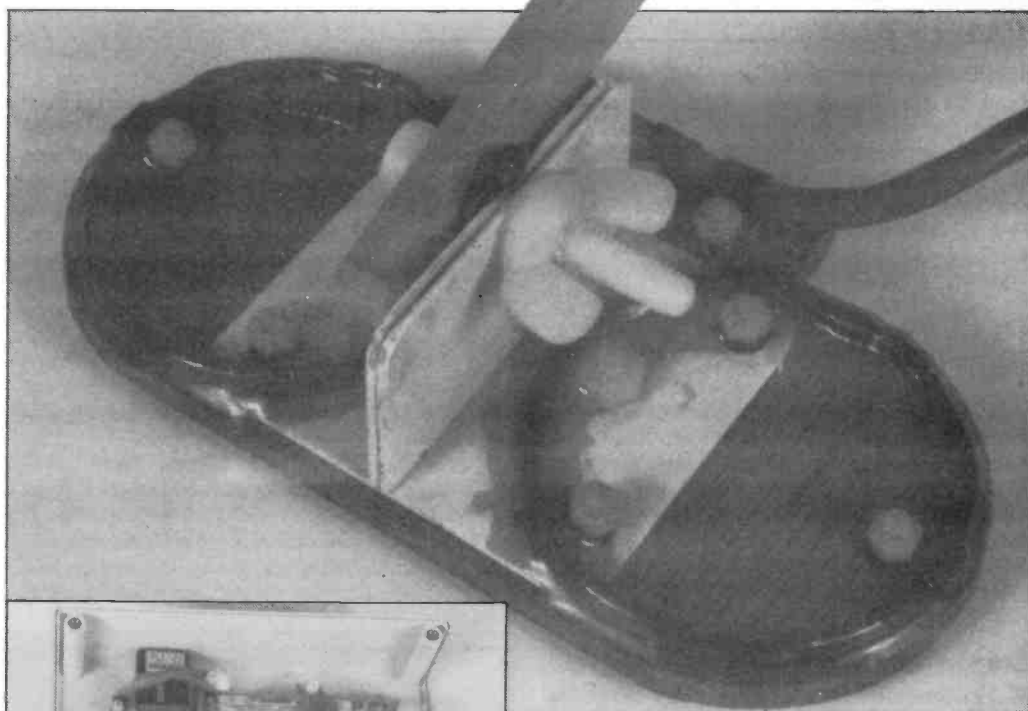

Fig. 6 Component overlay for the detector and off-board wiring



Alternatively one could use a wooden walking stick or adapt whatever non metallic material one has to hand. The only metal materials permitted are a few screws in the control box and the two screws securing the control box to the handle. Finally, insert a rubber washer between stem and coil assembly. This gives a non slip attachment to stop the search head angle being moved by rough grass.

## Testing

The initial testing should be done in a metal free environment. Most work benches and tables contain large numbers of nails, screws and brackets so the reader is advised to suspend the coil assembly from the ceiling on a length of string to ensure that it is well clear of metal. With the click generator set to one click per second the operator will notice a significant increase in the click rate if a two pence coin is taken to a distance of 180mm from the search coil.

Once small pieces of metal have been located with the general purpose search coil, the final pinpointing can be carried out with a snout probe shown in Fig 7b and in the above photograph. This probe was constructed in a similar manner to the general purpose coil expect that the coils do not overlap. Each coil is made from 48 turns of 30swg enamelled copper wire making the loops 50mm in diameter and 70mm between centres.

## HOW IT WORKS

The operation is as follows. The two switches in the transmitter close simultaneously for 165 $\mu$ s and allow a current of one amp to flow through each coil. This operation is repeated every 10ms (a frequency of 100Hz). The coin signals picked up by the coils along with the interference and ground effect are then routed to the op-amp A in the receiver (Fig. 1). Here the interference and ground effect cancel out and the amplified coin signals are passed on to the detector D. Detector D is switched on by the timing circuit 36 $\mu$ s after the end of the current pulse and for a duration of 50 $\mu$ s. The  $\mu$ s delay is to allow the coils to settle down because the sudden loss of the current causes a very large voltage spike to appear across each coil. The DC output of the detector now goes to the click generator which starts to click rapidly as the search coil approaches a coin.

24 TURNS OF No. 26 SWG ENAMELLED COPPER WIRE. 200mm (10in) DIAMETER. 100mm OVERLAP

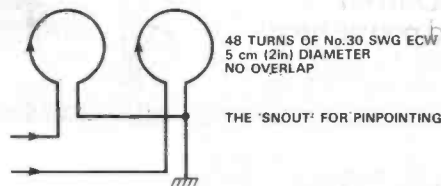
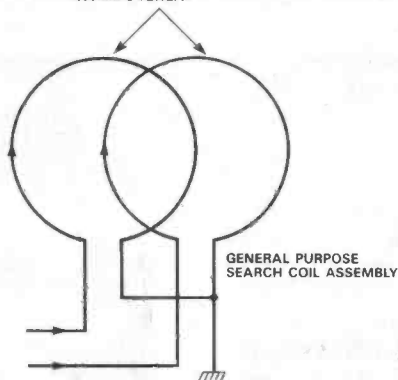

Fig. 7 (a) General purpose search coil assembly  
(b) The snout for pinpointing

## PARTS LIST

### RESISTORS (all 1/4W 5%)

R1,2,18,22,24	47k
R3,12	4k7
R4	15k
R5,8	680R
R6,7	150R
R9,11	68k
R10	3k3
R13,14	470R
R15	470k
R16	390k
R17	100k
R19	180k
R20	220R
R21	1k0
R23	1M5
R25	18k
R26,27	2k2
R28	180R
RV1	100k horiz preset
RV2	47k lin
RV3	4k7 lin

### CAPACITORS

C1	2200µ axial electrolytic
C2,15,17	100n polyester 7mm
C3	1n0 polyester 7mm
C4,7,9	10n polyester 7mm
C5,10,14	22µ 16V tant bead
C6,8	220p 63V ceramic
C11	3p3 63V ceramic
C12	10p 63V ceramic
C13	470n polyester 7mm
C16	220n polyester 7mm

### SEMICONDUCTORS

IC1,3,4,9	ICM7555/PA
IC2	NE555
IC5	µA709CP
IC6	TL081
IC7	78L05
IC8	79L05
Q1,2	TIP31A
Q3	2N3819
Q4	BC178
D1-5	1N4148

### MISCELLANEOUS

BATT1	8x1.2V AA rechargeable batteries
BATT2	1x9V PP3 battery
PL1-3	4mm plugs: 2 red, 1 black
PL4	2.5mm mono jack plug
Sk1-3	4mm sockets: 2 red, 1 black
SK4	mono 2.5mm chassis jack socket
SW1	double pole, double throw switch

Case. Enamelled copper wire, 28swg and 30swg. Plastic tubing, 16mm and 20mm. 6mm plywood. Plastic angle. Cable grips. Glue (Araldite).

## BUYLINES

You should have no problem in obtaining components as they are all readily available. The enamelled copper wire is available from Maplin who can also supply the 709 op-amp.

The plastic control box in the prototype was a Vero-box type 202-21031 but any box of equivalent size will do. A variety of plastic tubing is available in most DIY stores but must be rigid to make a good handle.



## The Archer Z80 SBC

The **SDS ARCHER** – The Z80 based single board computer chosen by professionals and OEM users.

- ★ Top quality board with 4 parallel and 2 serial ports, counter-timers, power-fail interrupt, watchdog timer, EPROM & battery backed RAM.
- ★ **OPTIONS:** on board power supply, smart case, ROMable BASIC, Debug Monitor, wide range of I/O & memory extension cards.

CIRCLE NO. 122 ON REPLY CARD

## The Bowman 68000 SBC

The **SDS BOWMAN** – The 68000 based single board computer for advanced high speed applications.

- ★ Extended double Eurocard with 2 parallel & 2 serial ports, battery backed CMOS RAM, EPROM, 2 counter-timers, watchdog timer, powerfail interrupt, & an optional zero wait state half megabyte D-RAM.
- ★ Extended width versions with on board power supply and case.

CIRCLE NO. 147 ON REPLY CARD

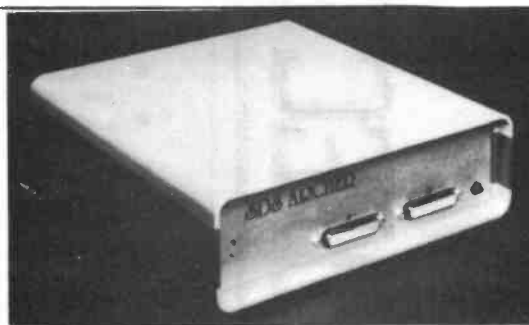
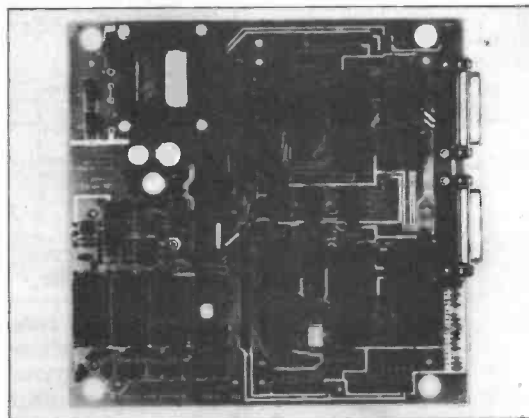

## Sherwood Data Systems Ltd

Unit 6, York Way, Cressex Industrial Estate, High Wycombe, Bucks HP12 3PY. Tel: (0494) 464264

# CAMERA CONTROLLER

Keith Brindley builds a snappy project for beginners to turn your camera into a sophisticated remote-triggered device

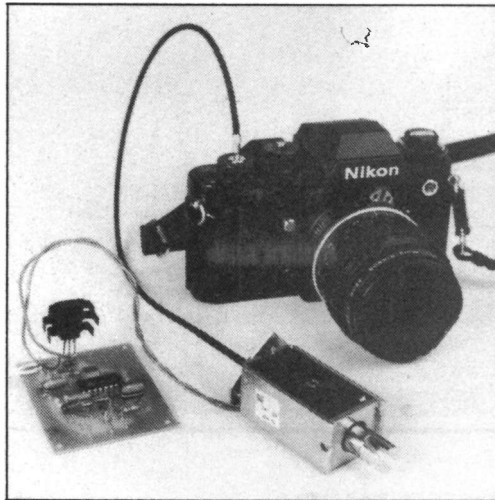

**T**o start we must make it clear that this project is not in itself a particularly useful addition to your camera gadget bag. It can be used to control the camera's shutter release but its *real* advantage will be found later. You see, the ETI Camera Controller acts as a multi-function, electronic shutter release interface which, in the future, can be used with other projects which allow the camera to be remotely operated in a wide variety of ways.

release of the camera to the electronics world. The camera then, effectively, has an electronically-operated shutter release. With the addition of one or more of the later projects listed here it becomes quite a sophisticated photographic tool.

The design is for battery-powered operation — if you're going to use such a device to trigger your camera outside it's hardly likely you'll have a mains power point at the camera's position. So the solenoid used is of low-voltage (12V) operation. However, the power required to operate a cable release and a camera's shutter is quite large so the solenoid is a beefy one, which requires a fair current (about 1A). Your common-or-garden dry cell isn't going to be able to provide the current needed. Instead, you should use two, PP3-sized NiCd batteries. These have two advantages. They are rechargeable and their operating voltage (8.4V, 16.8V in series) is within the maximum 18V limit for the integrated circuit used — a CMOS device. Alkaline batteries could provide a voltage of exactly 18V — too close for comfort.

Observant readers will note the use of a cheap Darlington pair transistor to ensure a low source current requirement from the CMOS chip, while providing adequate drive current for the solenoid.

## Construction

Circuit of the ETI Camera Controller is shown in Fig. 2. As usual in *1st Class* projects, a choice of

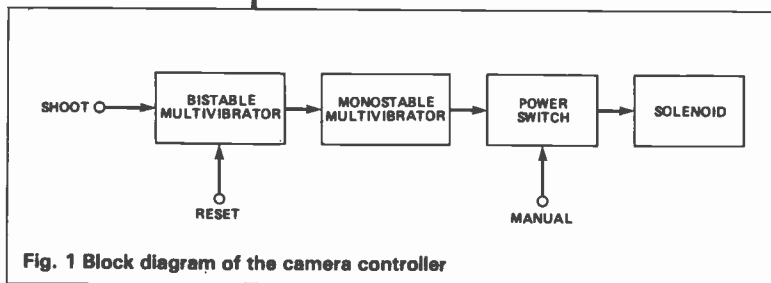

Fig. 1 Block diagram of the camera controller

## HOW IT WORKS

Figure 1 shows a block diagram of the ETI Camera Controller. A bistable multivibrator (that is, a flip-flop) is used as an interface to incoming electronic shoot pulses. These pulses set (or flip) the bistable into the triggered state. Once set, the bistable cannot be re-triggered until it has been reset (flopped!).

Once set, the bistable output triggers a monostable multivibrator, with an on period of about one second. The monostable output controls a power switch which in turn controls a low-voltage solenoid. In addition to this automatic mode, the power switch can be controlled manually.

The circuit is shown in Fig. 2. Gates IC1a,b form the bistable multivibrator which is set by incoming shoot pulses and reset by incoming reset pulses. A LED is used to show when the bistable is set and to warn the user it must be reset before it will trigger the solenoid.

Gates IC1c,d form the monostable multivibrator which is triggered by the output of the bistable. Its on state is determined by the values of capacitor C5 and resistor R8, following the approximate relationship:

$$\text{Time} = 0.8 \times C5 \times R8$$

which, for the given component values, is as near as dammit 0.8 seconds.

Output of the monostable drives the power switch, formed by power Darlington transistor Q1. This directly drives the solenoid. Diode D3 is incorporated in parallel with the solenoid, to prevent the back EMF generated when the solenoid is de-energised from damaging the transistor. This is effectively shorted to the positive power supply rail through the diode.

Manual override of the power switch is provided by resistor R10, which when connected to the positive supply rail, creates a secondary base current to transistor Q1 cancelling all effects of the preceding circuit.

The later projects (all *1st Class*) will include:

- a light-beam trigger — when someone or something interrupts an infra-red beam of light, the camera will be triggered. Ideal for candid shots of, say, birds entering or leaving a bird-house or surprise shots of intruders breaking into guarded premises
- a sound-operated trigger — to trigger the camera on the detection of a sound
- a remote trigger — to operate the camera from a distance for, say, self-portraits
- a fixed-interval timer trigger — allowing photographs to be taken at a number of fixed times, to show, say, a flower head opening up in stages through the day
- a variable-exposure time trigger — allowing the camera to be triggered for longer periods than are available on the camera's built-in exposure time mechanism

The Camera Controller links to your camera with a standard cable release, operating the cable release (with the help of a low-voltage solenoid) to trigger the camera on reception of an electronic pulse. So, quite simply, the project interfaces the mechanical shutter

TOP PROJECT



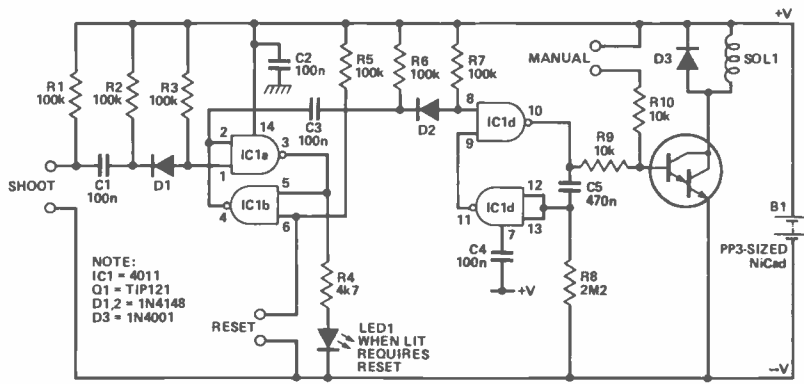

Fig. 2 Circuit diagram of the camera controller

construction techniques is offered: printed circuit board or stripboard. Both methods are straightforward and apart from a few points are more-or-less self-explanatory.

On PCB, construction doesn't need to follow any particular order, although it's probably best to leave the integrated circuit till last. PCB layout, component overlay and wiring details are shown in Fig. 3. If you aren't too sure, insert components following an imaginarily logical order of complexity. That is, insert and solder passive components first (resistors then capacitors), simple semiconductors second (diodes then the transistor) and the complex semiconductor (the integrated circuit) last.

Although a socket was used in the prototype to mount the IC, it's by no means essential, and 4011s aren't too pricey anyway, so it can be soldered directly into the PCB without worry. Nevertheless, if you're not using a socket, go easy on the heat. Solder one pin then leave the IC to cool before moving on to solder the next pin.

On stripboard, it's probably best to follow this order of inserting and soldering components pretty rigidly. The stripboard layout, component overlay and wiring details are shown in Fig. 4. Before you start, however, make all copper track cuts then insert and solder all wire links. It's far easier doing all these fiddly

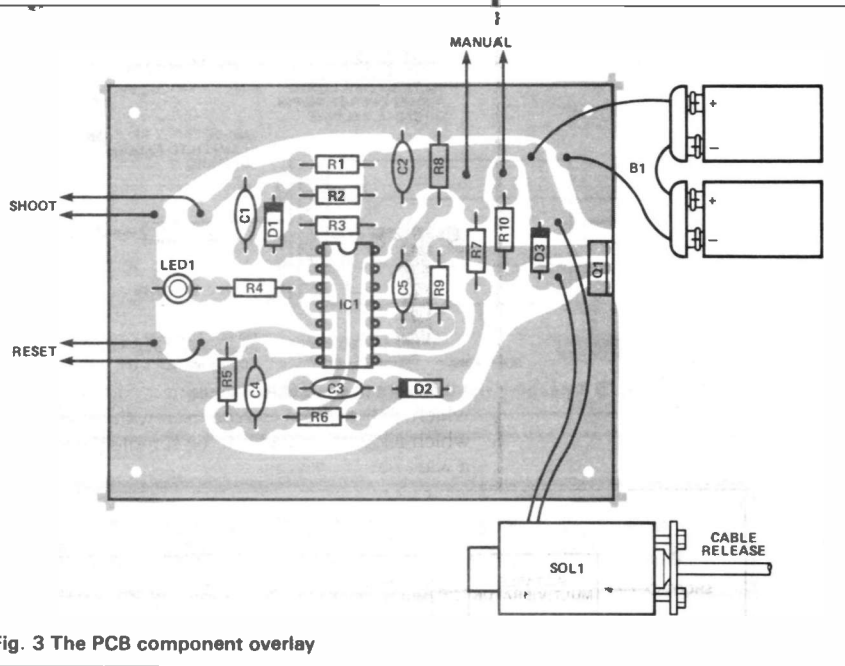

Fig. 3 The PCB component overlay

## PARTS LIST

### RESISTORS (all 1/4W 5%)

R1,2,3,5,6,7	100k
R4	4k7
R8	2M2
R9,10	10k

### CAPACITORS

C1,2,3,4	100n polyester
C5	470n foil

### SEMICONDUCTORS

IC1	4011
Q1	TIP121
LED1	red LED
D1,2	1N4148
D3	1N4001

### MISCELLANEOUS

B1	16.4V battery (2xPP3 NiCd)
SOL1	12V DC 10W solenoid
PCB or stripboard. Battery clips. Cable release. TO220 heatsink. IC socket. Wire. Case.	

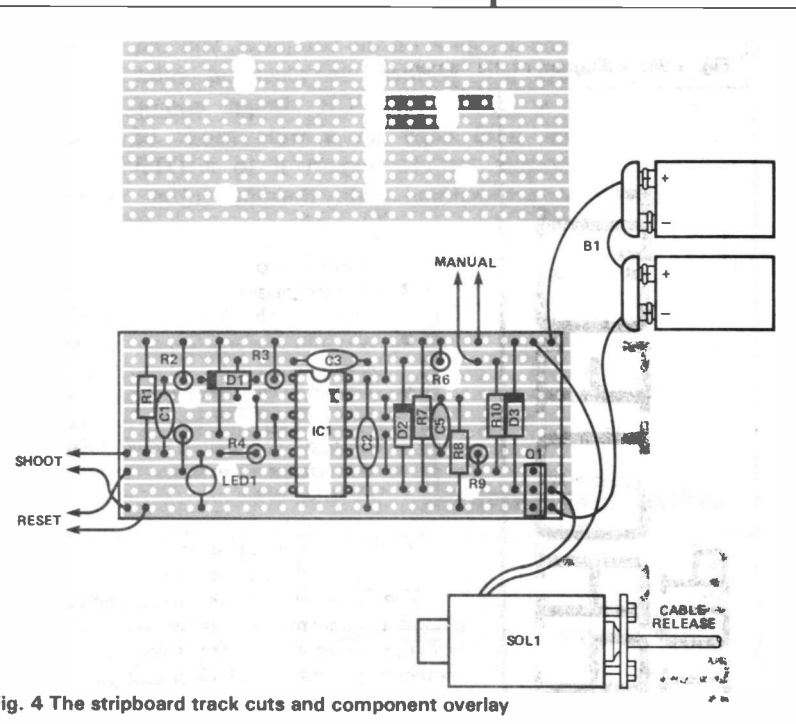

Fig. 4 The stripboard track cuts and component overlay

things before components are mounted.

On either PCB or stripboard, it's a good idea (though, again, by no means essential) to use circuit board pins where all off-board wire connections are to be made. Their use means it is simple to make a connection, particularly so after the board has been fastened down.

Whichever construction method you choose, check that no solder links or bridges are present between components or IC pins.

Although we've offered no suggestions for housing your completed project, any suitably-sized box can be used. It's here, however, that the interface between the project and the cable release takes place, using a solenoid. So this is where readers may have to use a little ingenuity to ensure the solenoid operates the release satisfactorily.

A possible method of linking the solenoid to the cable release is shown in Fig. 5. As the solenoid is energised, its plunger must push in the cable release's operating pin. The method shown couples the cable

release's operating pin directly to the solenoid's plunger giving a pretty 'solid' and robust interface.

## Setting Up

There's not a lot to do here. Test the project initially unconnected to the camera. When power is first applied, the LED may light. If so, connect between the two reset terminals (using, say, a screwdriver) and the LED will go out. Now, connect between the shoot terminals — the solenoid should energise for a short while (about one second) then stop. The LED should now be lit. Further attempts to connect the shoot terminals should *not* operate the solenoid. Resetting the project, however, by connecting the reset terminals will allow the shoot terminals' connection to energise the solenoid again.

It should be noted, here, that although we've been talking about connecting between terminals to provide shoot and reset triggers — by touching the terminals with a screwdriver — there's nothing to stop switches being used. Also, for future use, these triggers will be generated electronically by other circuits — negative-going pulses will trigger both shoot and reset.

The shoot-then-reset operation can be effectively over-ridden by connecting the manual terminals — the solenoid should energise for as long as the manual terminals are connected.

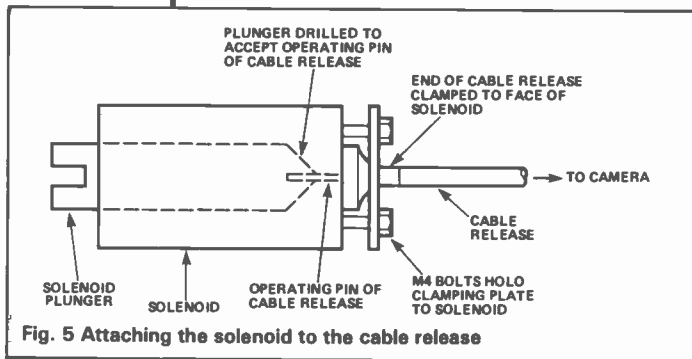

## BUYLINES

The solenoid is the only difficult bit and it's available from Electromail as part 349-709. For a suitable cable release for your camera, call in at your local camera shop!



# C.A.D. SOFTWARE MADE EASY

## ISIS SCHEMATIC CAPTURE

An exceptionally easy way to draw circuit diagrams on your PC. Once the design is on the computer, you can generate a parts list, perform an electrical rules check, extract a netlist for PCB design and/or simulation, print hard copy on a wide range of printers and plotters, or else export it to a DTP package to create professional quality documentation.

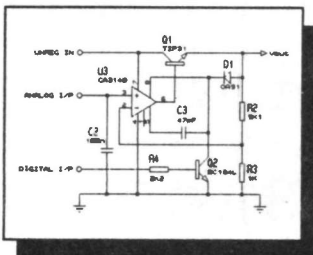

- Auto wire routing.
- Auto dot placement.
- Auto name generator.
- Powerful editing facilities.
- Object oriented 2D drawing with symbol library.
- Support for hierarchical and multi-sheet designs.
- Comprehensive device libraries.
- Output to dot matrix, pen plotters or lasers.

## PC-B PRO/AR PCB DESIGN

User friendly PCB layout software with optional auto-router. The layout editor (PC-B PRO) handles 2 copper layers plus overlays and solder resists whilst the auto-router (PC-B AR) will route single or double sided boards on a 25 or 50 thou grid. Together with ISIS, you have an integrated design system that really puts your computer to work.

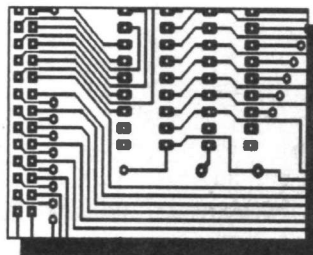

- Auto generation of silk screen/overlay as components are placed.
- Auto generation of solder resists.
- Configurable object sizes.
- On screen overview display.
- On screen pin numbering.
- Connectivity highlight.
- Back netlist verification against schematic.
- Dot matrix, laser, pen plot and Gerber drivers.

**labcenter**  
Electronics

### PRICES

ISIS .....	£399
PC-B (entry level PCB CAD) .....	£69
PC-B PRO .....	£229
PC-B PRO/AR .....	£399
ISIS+PC-B PRO .....	£599
ISIS+PC-B PRO/AR .....	£749



Call for **FREE** demo disks - 0274 542868.



14 Marriner's Drive, Bradford. BD9 4JT

# A PRESENT FOR GRANNY

# TOP PROJECT

One of the most common problems that elderly people have to put up with is a gradual loss of hearing sensitivity. Unfortunately, this problem is made more irritating by the way that the rest of us tend to assume that they are daft as well — when they simply didn't hear what we said.

The NHS does its best to help but they have only a limited range of appliances which they can dispense. These are mainly small units which sit on top of the ear, with a microphone which points backwards — fine for hearing what people are saying behind one's back but not as useful for hearing what the person standing in front of one is saying.

The NHS units, being small, are also liable to get trodden on, mislaid or dropped into unlikely places, and are dear (hundreds of pounds-ish) to replace when lost.

However, from the point of view of the DIY electronics fraternity, the task of making a gadget which will amplify the output from a small microphone and will operate an earphone is neither difficult nor costly, provided that one doesn't aim to make it too miniaturised. This, in a sense, can be an advantage since if it isn't too small, it won't be so easily lost.

A word of warning is necessary at this point. The manufacture and supply of 'hearing aids' is a very profitable business — especially for the private enterprise side of the market. It is therefore, quite predictably, hedged around with official restrictions to prevent others from homing in on this market. So, no-one other than an officially approved manufacturer can market such devices as 'hearing aids', and no-one but a registered 'hearing aid' dispenser can sell them.

This does not restrict what one can do oneself if one has a mind to but it must be called something other than a 'hearing aid'! The few firms which exist in this country outside the patronage of the NHS refer to their products as 'binaural amplifiers' or 'microphone amplifiers'. Again, I suppose one can call it what one likes so long as it isn't sold.

## Design Considerations

There is quite a range of small 'electret' condenser-type microphones available, nearly all of which contain an integral FET buffer amplifier, of the general form sketched in Fig. 1. These require a small DC voltage in the range 2-15V to make them work.

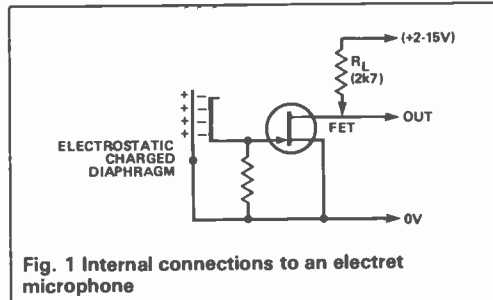

Fig. 1 Internal connections to an electret microphone

Some of these are '3-terminal' devices, with the FET load resistance inside the unit but most require the load resistor to be added externally, as shown in the diagram. Either of these types are usable.

There is also quite a range of small headphones on sale, for use with 'Walkman' type personal cassette players or personal radios. These are typically 30R impedance and require a few milliamps of drive. Check these before you buy, since some of the very cheap ones are too insensitive to be of much use.

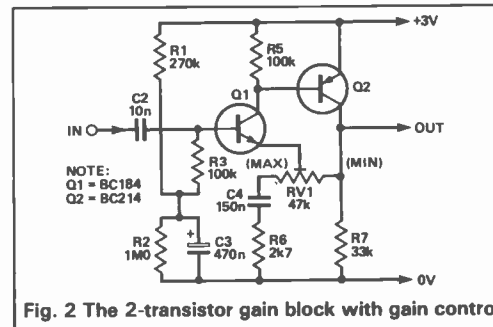
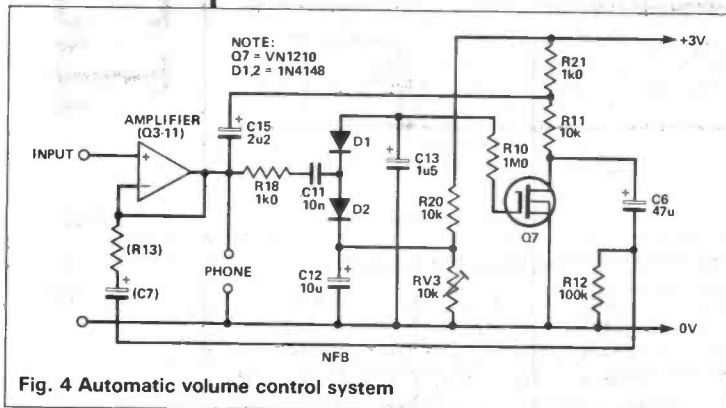
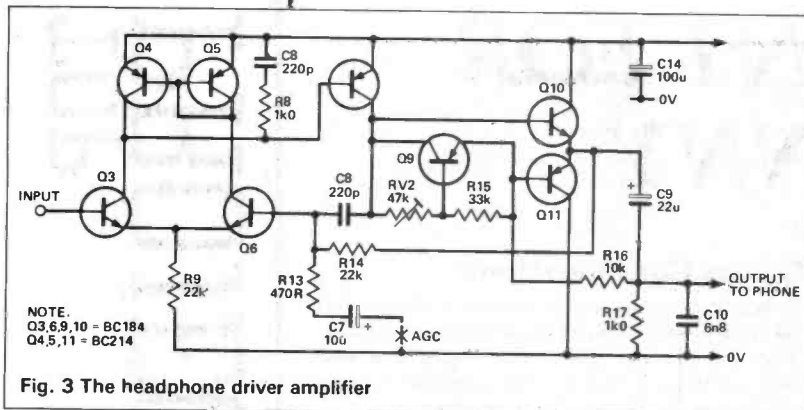

Fig. 2 The 2-transistor gain block with gain control





Between the microphone and the earpiece one must insert an amplifier giving an adjustable gain somewhere in the range 30-500 which will operate from 3V DC (the electret microphone requirements rule out 1.5V operation, as does the need to produce enough volume from a 30R earphone) and which won't take too much current.

Finally, it has to fit inside some fairly strong metal

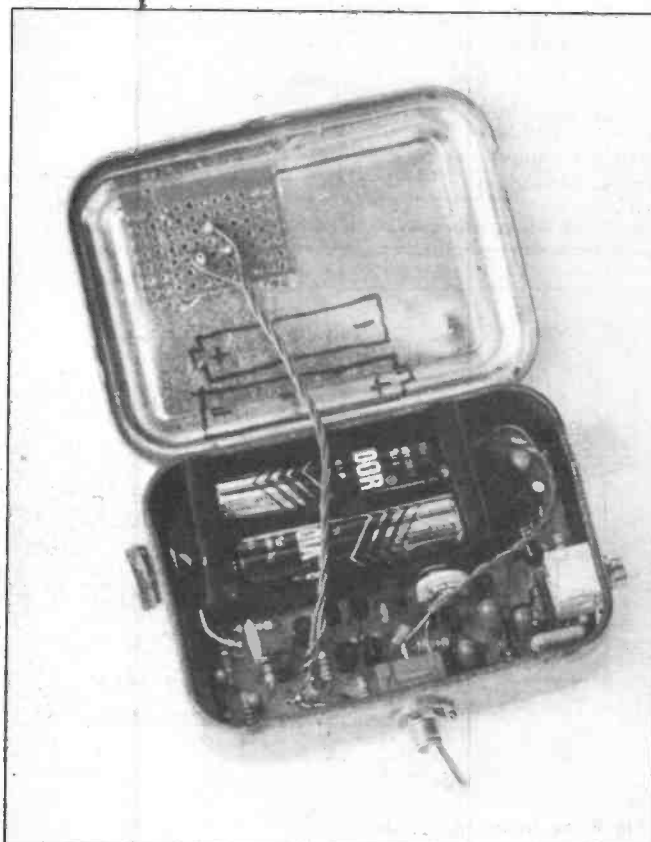

container to give electrostatic screening and protection, such as the little hinged lid tins in which, in more expensive days, tobacco and cough sweets were sold and which are now largely to be found in the workshop or mending box, full of screws or safety pins.

## Circuit Design

The basic 2-transistor gain block of Fig. 2 will operate quite happily down to about 1.5V and will provide a peak-to-peak output voltage swing which is close to the limits set by the supply lines. It also provides a convenient means of adjusting the gain, by varying the amount of negative feedback. R1 and R2 are chosen to set the DC output level at about half the supply line voltage.

The following stages Q3-Q11, shown in Fig. 3, comprise a miniaturised hi-fi amplifier with a push-pull output operating on a 1mA quiescent current setting, giving a total quiescent battery demand of 2mA.

The 'bootstrapped' driver load (C9/R16), though now not used much in true hi-fi designs where a constant current source load for the driver stage is preferred, makes the best use of the limited supply voltage. Prior to clipping, with a 30R load and 3V supply, the overall THD is of the order of 0.02%.

## Automatic Gain

This is a facility which lifts this circuit out of the ordinary 'run of the mill' microphone amplifiers and greatly adds to its usefulness. Unfortunately, with the very limited available supply voltages and output swings, most of the normal AGC systems are inapplicable.

The circuit of this is shown in Fig. 4, and it operates by using the dynamic impedance of a small signal MOSFET device as part of the feedback loop of the amplifier to Fig. 3. When the MOSFET device (in this case a VN1210 but any similar enhancement-mode MOSFET will work as well) is conducting, it has a dynamic drain-source impedance of only a few ohms and the gain of the amplifier of Fig. 3 is  $22k/470 = 47$ .

In the normal quiescent state, the MOSFET is biased into conduction by the voltage developed across RV3, at a forward gate-source potential of about 1-1.5V. The AGV action arises because the output signal voltage from the amplifier is then rectified by the diode-pump circuit of D1, D2, C11 and C13, to provide a negative-going output voltage which progressively biases off the MOSFET and causes its dynamic impedance to rise.

As the MOSFET becomes an open-circuit, the gain of the output amplifier drops towards unity since the load resistor for the MOSFET is also bootstrapped by C15 and R21.

Sadly, this kind of AGC wouldn't be useful in true hi-fi applications since, when it is operating with the MOSFET somewhere between fully on and cut-off, it worsens the THD from about 0.02% to about 0.5%, mostly second harmonic. At small signal levels or large ones, when the MOSFET is either fully on or cut-off, the THD reverts to the lower figure.

This circuit will hold the output constant over at least a 100:1 input signal range and will do a lot to compensate for the wide range of ambient sound levels which exist in practice.

## Construction

The complete circuit of the unit is shown in Fig. 5. A suitable PCB layout is shown in Fig. 6. The mic should be mounted at one end of the case in a small rubber grommet to give some measure of sound isolation

# PARTS LIST

<b>RESISTORS (all 1/4W 5%)</b>		C5,8	220p polystyrene
R1	270k	C6	47μ tantalum
R2,10	1MΩ	C7,12	10μ tantalum
R3,5,12	100k	C9	22μ tantalum
R4,6	2k7	C10	68n ceramic
R7,15	33k	C13	1μ5 tantalum
R8,17,18,21	1kΩ	C14	100μ tantalum
R9,14	22k	<b>SEMICONDUCTORS</b>	
R11,16,20	10k	Q1,3,6,9,10	BC184
R13	470R	Q2,4,5,8,11	BC214
R19	470k	Q7	VN1210
RV1,2	47k preset	D1	1N4148
RV3	10k preset	<b>MISCELLANEOUS</b>	
<b>CAPACITORS</b>		B1	2x AAA batteries
C1,3	4μ7 tantalum	SW1	SPST toggle switch
C2,11	10n ceramic	PCB, Electret microphone, Case, Battery holders, Connecting wire.	
C4	150n ceramic		

# TOP PROJECT

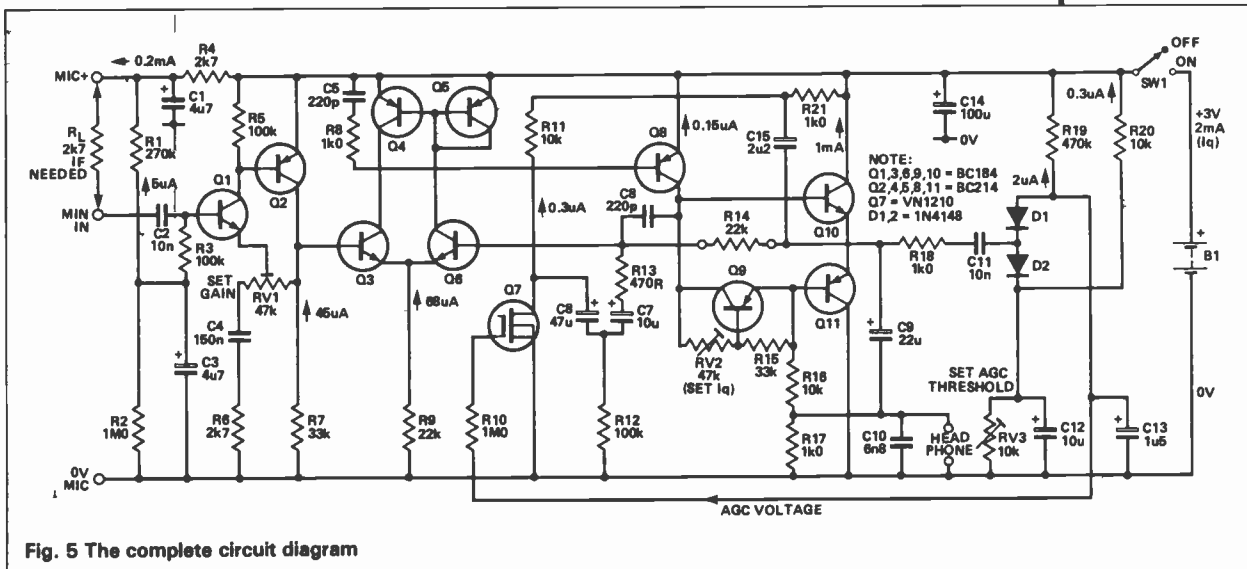

Fig. 5 The complete circuit diagram

from the case. The 3mm phono jack for the headphone is mounted at the other end. A small preset pot is mounted on the hinged lid of the tin to allow an easily accessible adjustment to the sensitivity of the unit.

Power is provided by a pair of AAA sized batteries in small battery holders and should give a life of some hundreds of hours before battery replacement is needed. Ideally, the works would have been held in place by screws and stand-off spacers but on the prototypes the relative shallowness of the tin did not give adequate height, so the PCB was held in place by a couple of small strips of double-sided adhesive foam, after the copper side of the PCB was liberally covered with insulating tape to prevent any short-circuits from the protruding solder blobs to the tin can.

Setting up is simple. Set RV1 and RV3 to maximum and RV2 to minimum resistances and then adjust RV2 to give a total supply current of 2mA. Set the gain (RV1) to a level at which there is an adequate level of loudness on some sound (such as a radio) and gradually reduce RV3 from its maximum resistance value until the output sound level just begins to fall.

With devices of this type, it is undesirable that the LF response should be too good since most LF sounds are just noise or room resonances and add nothing to the information content. The LF gain can be reduced further, if needed, by reducing the values of C4, C7 or C9. In the prototypes, I mainly used

tantalum bead types for all the larger values in the interest of compactness but this is at the constructor's choice, depending on how much space there is available.

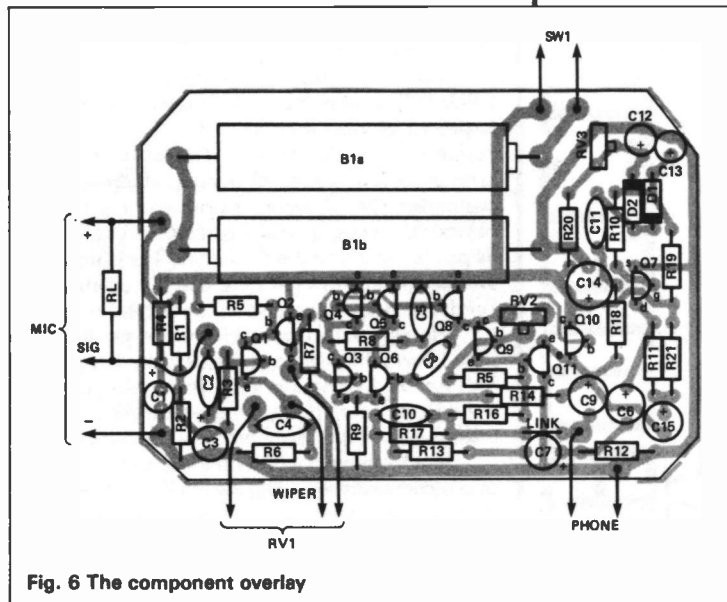
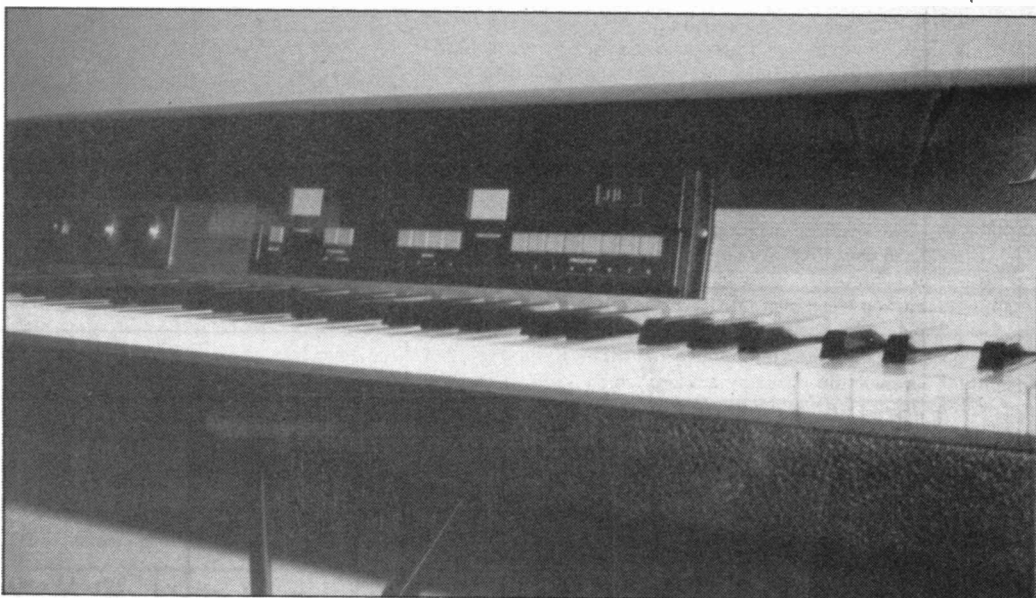

Fig. 6 The component overlay

# HOW TO MIDI A PIANO



*John Brockhurst  
explains the key to  
converted keyboards*

TOP  
PROJECT

**O**ver recent years there have been considerable advances in the level of technology available to the working musician. There are however still occasions when that favourite old keyboard or piano sound would still be best suited to the music but the absence of MIDI means either having no synthesiser part or working as a one handed pianist. Lack of adequate funds is a saddeningly common problem that precludes the purchase of one of the latest fully-equipped keyboards.

The project presented here is the solution to the problem. A stand-alone MIDI processor tailored to the needs of the pianist that is both inexpensive and relatively undemanding from a constructional point of view. It handles up to 88 notes — that's over seven octaves, certainly enough for any keyboards and about right for most pianos.

The unit consists of three modules: the CPU/PSU section, the control/display panel and the keyboard contact assembly. The first two will be common to all constructors. The keyboard contact arrangement however will need a certain amount of customising to whatever instrument it is fitting — obviously no single design could be presented to fit all pianos, synths and stylophones. The photographs and illustrations shown here use the example of a Fender Rhodes piano and will be helpful as a guide.

Please note that it is much easier to produce MIDI note information without the velocity information. This system does handle this velocity information but it should be noted that such a system does require a reasonable level of mechanical competence.

Much has been written in these and other pages over recent years regarding the MIDI specification and those who are unfamiliar with the techniques involved would probably benefit by reading through those ETI back issues (you do keep them don't you?). Also recommended in this respect is *The ETI Guide to*

*Making Music* from last autumn, which also looks at the subject in some detail.

## Processor Prelude

Okay so where do we start? Clearly we will need some means of recognising which keys are being played and how hard. We also need to know if the sustain pedal is being used. Realising that not all synthesisers are equipped with a sustain function, we must find a means of providing this. It would also be nice if we can select the sound that the synth produces, and provide visual indication of the selected patch and MIDI channel in use.

We then have to set up a serial link conforming to the MIDI protocol. Clearly this is a task well suited to a microprocessor and this design uses the Z80A.

Much has been said about choosing microprocessors and it is worth mentioning the reasons for choosing the Z80A for this application. Most of the time, our processor will be scanning the keyboard to see which keys are being used and how hard they are being played (how long the key depression takes). This is a repetitive task with speed being of prime concern. However, fast processors are relatively more expensive and demand the use of fast peripheral chips.

A look at the specification sheet for a typical microprocessor shows that operations completed within the chip are usually much faster than those requiring access to external devices. The Z80 has 14 internal general purpose registers available to the programmer, enabling much of the work to be completed within the CPU. It is also one of the cheapest processors currently available and would appear quite well suited to the job.

By opting for the Z80A which runs at the increased speed of 4MHz we are able to allow ourselves the luxury of adding wait states to memory cycles, relieving the speed constraints on these chips and further reducing cost.

The Z80 also automatically includes wait states in all input and output instructions, thus placing lower demands on our peripheral chips.

Having decided on our processor we will need some memory, an ACIA and some ports to communicate with the outside world. This design uses the 6850 ACIA and 8255 PPI in these positions.

Finally, we have to decide if we will use interrupt driven timing routines for the keyboard scanning or rely on software techniques. We need to know the time taken to depress a key to determine how loud a note is. To achieve this, we must examine the key at regular intervals keeping these intervals as short as possible. The interrupt technique would certainly keep the timing constant but if we are to avoid the interrupt service routine being called whilst it is still being executed, the period between interrupts must be somewhat longer than the time required by the routine and this results in a reduction in speed.

This design uses a different approach. Since the hardware will handle 88 keys, the time spent examining any key is just over one percent of the total time — if we include the other routines the processor has to cope with, this figure falls quite a lot further. By keeping the time spent processing a key which is in use as short as possible, the difference in time required to process an active key is very nearly the same as for a dormant one and makes no difference to the subjective response of the keyboard.

## Construction

The first decision to be taken is how the modules are going to be fitted to the keyboard, with particular reference to the keyboard contact assembly. The processor will handle keyboards with up to 88 notes and if the recipient keyboard is longer than this it will be necessary to decide which keys are to be excluded.

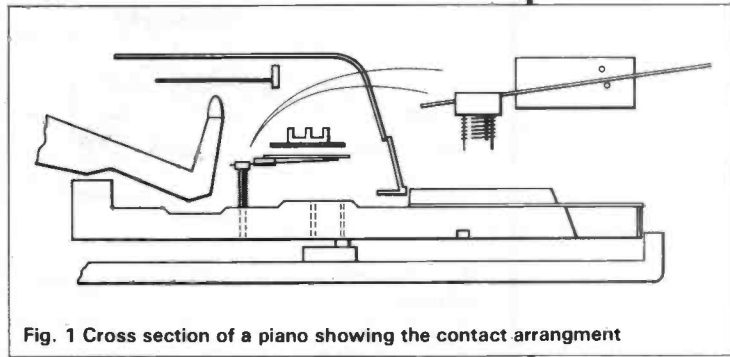

Fig. 1 Cross section of a piano showing the contact arrangement

Bear in mind that some synths or expanders only work within a limited range and either transpose or ignore notes outside these limits. A further point to consider here is that the software provided expects the lowest keyboard note to be E. Although facility is provided within the software to transpose the keyboard, if the power supply to the keyboard is interrupted the processor will default to the E setting. Any unused contacts need only be ignored, so provided there are sufficient spare positions available it would make sense for the unit to power up in tune!

Next a point must be found where there is sufficient clearance to accommodate the contact assembly. Ideally this would be either under the front of the keys, or above and behind the key pivot as in Fig. 1, at a point where the key travel is about 3 or 4mm. A layout for a keyboard PCB is provided in Fig. 2 but as the spacing between notes is not always the same from keyboard to keyboard and the errors are cumulative along the length of the instrument, it might be preferable to use stripboard. The PCB allows 164mm per octave.

The recommended contact construction (Fig. 3) uses bus-bars and contact wires since this is both

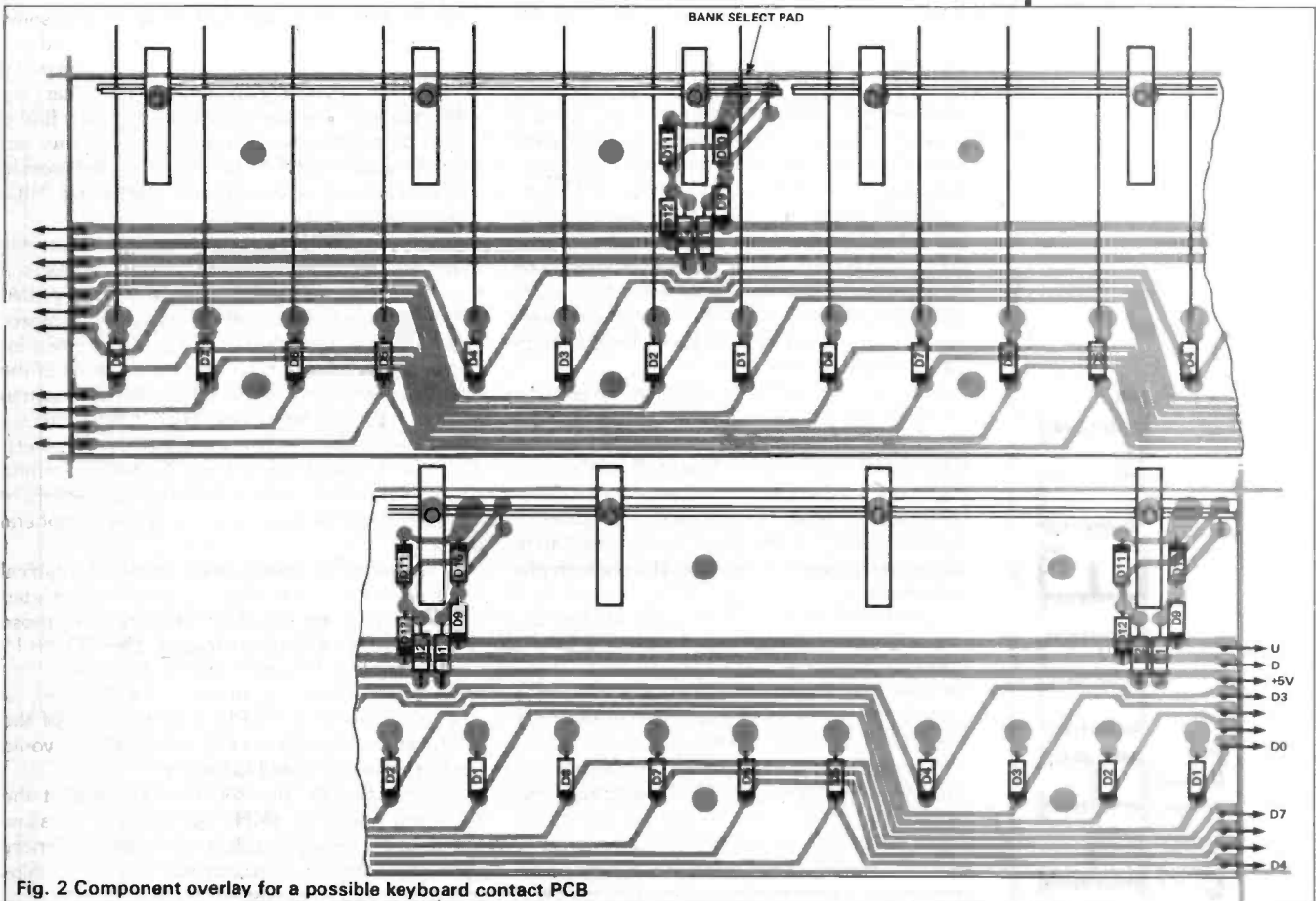
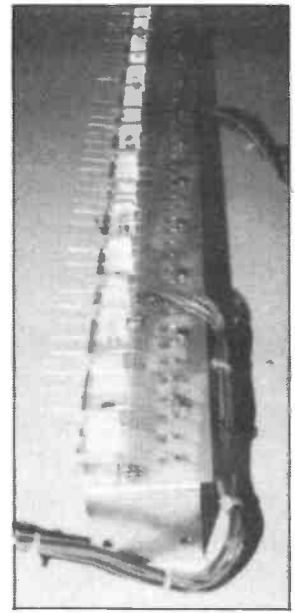

Fig. 2 Component overlay for a possible keyboard contact PCB

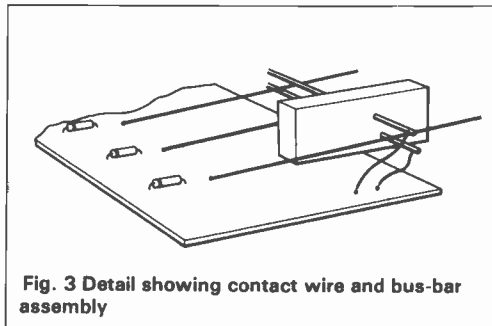

Fig. 3 Detail showing contact wire and bus-bar assembly

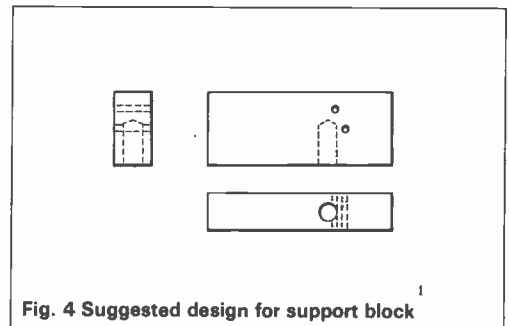

Fig. 4 Suggested design for support block

cheap and reliable and has the added advantage of being easily adjusted. However it might be possible to use single pole changeover switches provided these are not of the kind with tactile feedback (click action).

Whatever form of contact is chosen, it is important to realise that the completed contact assembly must be as rigid as possible. If the key travel is 4mm and the contact assembly moves by 2mm relative to the keys as a result of springing or vibration, then clearly most of the dynamics of the keyboard will be lost. A support brace made from extruded aluminium can be recommended here as quite substantial sections are easily obtained from the local hardware store and offer good support for minimum weight.

Assuming that you will be using bus-bars and contact wires, the bus-bars will need to be mounted in parallel with the PCB and cut to length to accommodate eight notes each. This requires that a large number of support blocks be made or purchased with a similar design to the one illustrated in Fig. 4 (three support blocks per key bank is suggested).

If these are to be made, it is strongly recommended that time is invested in designing a jig to ensure that the blocks are all exactly the same since this will be reflected in the performance of the

completed unit. Such a jig need only consist of a piece of metal arranged to enable accurately positioned holes to be drilled in the support block.

The keyboard circuitry can now be assembled with the contact wires being brought out between the bus bars as shown, care being taken to check that there is sufficient spring in the wires to ensure reliable contact with the upper bus-bar when the key is at rest. Then check carefully for shorts and track continuity. The diodes can also be checked with a test meter at this stage, as once assembled within the depths of the piano these can prove time consuming to replace. Finally, the wires can be connected to the bank select pads and the keyboard bus tracks and arranged neatly to form the wiring loom.

The next stage is to fit the contact adjustment screws to the keys. These screws will probably be about 25mm long and should have a slotted head. 6BA brass cheese-head screws are recommended.

The keys should be drilled with a hole which will allow the screw to be threaded in or out of the key as required. Again, care should be taken to keep mis-alignment to a minimum.

The screws should be rotated until their head slots are parallel to the contact assembly fitted to the keyboard with the contact wires being laid through the

## HOW IT WORKS

The Processor circuit diagram is shown in Fig. 5.

IC 1a and IC 1b form a crystal oscillator running at 4MHz and this is buffered by IC 1c for use as the system clock. This signal is also buffered by IC 1c and then divided by 8 in IC 4 to provide a 500kHz clock for the ACIA IC 11, where it is internally divided again by 16 to give the 31.125kHz MIDI clock.

IC 3 and IC 2c are used to insert *wait* states whilst the processor is accessing memory to ensure that slow devices will work without difficulty. IC 2a in conjunction with C4, R5 and D5 provides a positive going reset pulse at power-up to reset the output ports IC 12. This pulse is inverted by IC 2b to reset the processor.

With the exception of IC 6c which serves to buffer the output from IC 11, all the remaining gates perform the address decoding for the processor. At first glance it might seem that IC 7d does nothing but this gate is essential to meet the timing requirements for IC 12.

The port outputs of IC 12 are used to connect the keyboard and control panel to the processor, PA and PC being configured as outputs and PB as input. Output ports are only rated to source 1mA or sink 1.6mA and this means that the circuits connected here should have a high impedance.

Unfortunately, because of the necessarily long leads required to connect the keyboard contact assembly, this would mean both reduced noise immunity and slower rise times for the keyboard scanning signals, particularly true in the case of PC3 and PC4 which switch between the upper and lower bus-bars and see all 11 contact banks in parallel. This problem is removed by buffering these data lines and this is the purpose of Q1 and Q2. Resistors R9 and R10 in the MIDI output circuit serve to protect the unit from failure in the event of a short arising in the MIDI lead.

With reference to the circuit diagram for the control panel (Fig. 6), PC1 and PC2 are used as enable signals for latches IC 2 and IC 4. IC 1 is

a BCD to decimal decoder which is used to decode the address output by the microprocessor on PA0 to PA4 and held in IC 2.

Darlington driver array IC 3 provides the segment drive current sink for the displays LED1 to LED4. Q1 to Q6 provide the corresponding source currents for the display and the switch array. Diodes D1 to D8 prevent the data output bus PB being shorted in the event of more than one switch being pressed at any one time.

D6 and R16 (which are mounted on the CPU panel) and the circuit around Q7 serve to cancel the effect of capacitance in the lead connecting the sustain foot switch to the processor which, if mounted externally, will probably be several feet long. When the processor switches Q1 on via PA, the capacitance in this lead is seen in parallel with the switch and because of the high frequencies involved pulls PB7 high indicating that the switch is closed. However, Q1 also turns Q7 on via R20 taking PB7 low via R23 and D9 cancelling this effect. When the switch really is closed D6 allows Q1 to pull PB7 high and signal the processor accordingly.

In the circuit diagram of the keyboard contact assembly (Fig. 7), the key contacts are arranged in groups of eight and read into the processor via PB.

The circuit comprising D1 to D12 is repeated every eight notes as many times as necessary to cover the length of the keyboard. As we are examining up to 88 notes in groups of eight, we could have 22 bus-bars. To avoid the expense of another port these busses are diode AND gated onto PB. In order for a key to pull the data bus PB high we need simultaneous logic high signals on both on the bank select line PA1-7 or PC5-7 and on U or D which decide whether the key is being tested to be in the upper or lower rest state, allowing the bus to be pulled high by R1 or R2. Any key which does not pull the bus high is deemed to be in use, but as unused positions never reach a high level false MIDI triggering can not occur.



# TOP PROJECT

slots of the screw heads ensuring precise control of the contact both vertically and laterally. A piece of thin stiff wire with a small hook formed in the end can be invaluable here to lift the contact wires in or out of the slot in the screw head whilst the screw is being adjusted.

A correctly adjusted contact wire should leave the upper bus-bar when the key is about 15% depressed and should make contact with the lower bus-bar as the key nears the end of its travel. This final adjustment is most easily checked when the unit is fully assembled using a synth sound with a short attack and decay envelope as the contact points can then be accurately assessed.

The effect of any dimensional errors in the bus-bar support blocks will by now be apparent and any unacceptable errors can be rectified. When you are quite sure that the contacts are correctly adjusted, a small application of contact adhesive to the screw head will ensure that the wire does not come adrift.

The processor and power supply are assembled on a double sided PCB (Fig. 8). There are several links between the upper and lower PCB tracks and these will need to be fitted first. Some of these links are

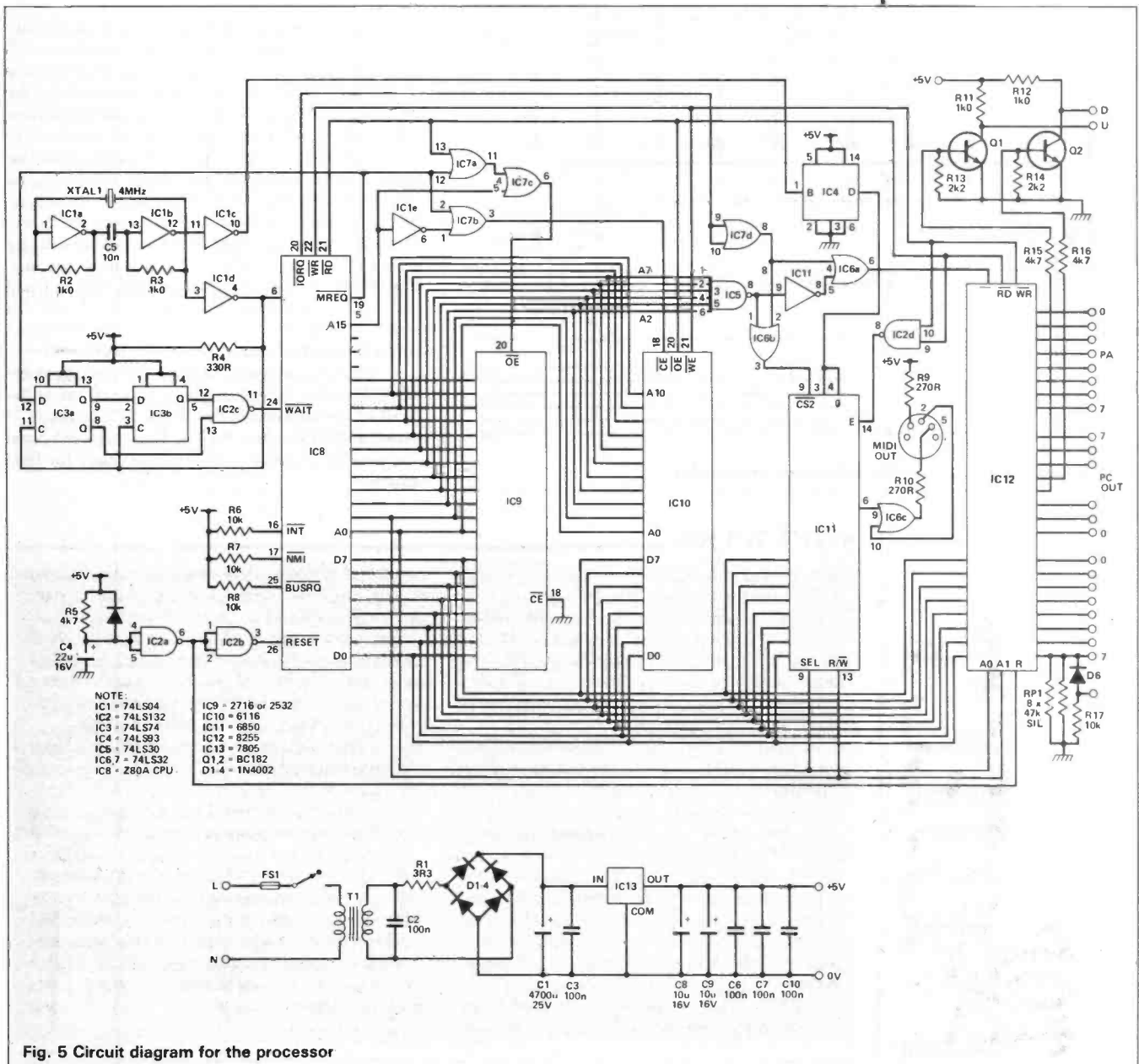

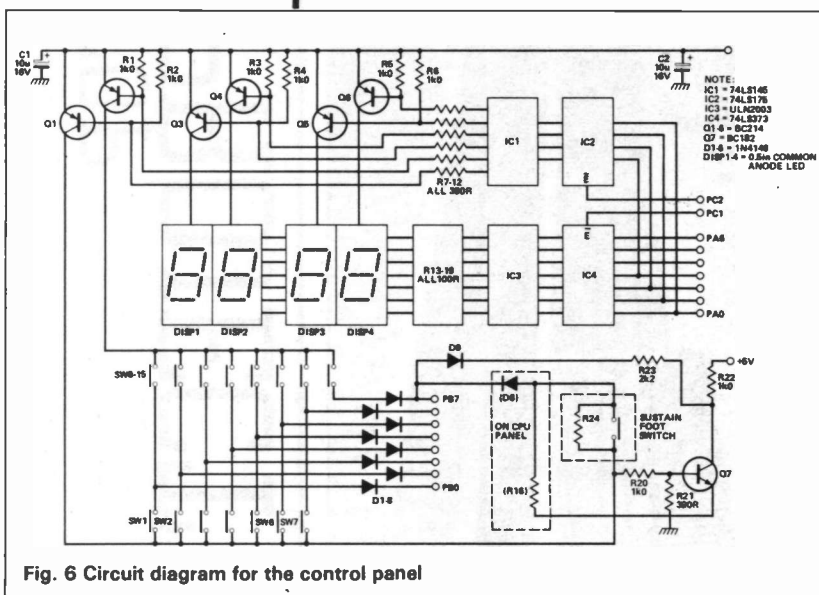

Fig. 6 Circuit diagram for the control panel

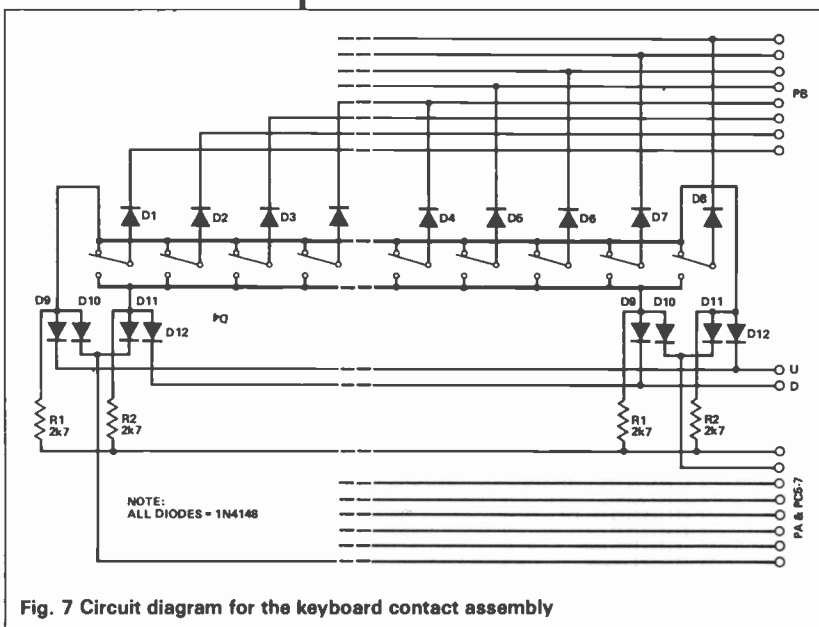

Fig. 7 Circuit diagram for the keyboard contact assembly

beneath IC sockets and it is well worth a second check to be quite sure that all of these links have been soldered correctly.

Next fit the diodes and capacitors (observing polarity), resistors, transistors, IC sockets, connectors and power supply components. The regulator should be mounted on a small heatsink but it does not lead a hard life and will not need heatsink compound.

The board can now be powered up after checking for shorts to ensure that the power supply is giving +5V and that this is present at the respective pins of the IC sockets. If all is well, disconnect and discharge the power supply using a suitable resistor and fit the crystal and the TTL ICs. Care should be taken when fitting the crystal as the wires can short to the case if they are bent too close to the body. (This would not be good practice in any case).

### Testing

Next if you have access to an oscilloscope, there is an easy way to check the operation of the micro-processor. Push short lengths of fine tinned copper wire into pins 9 to 17 of the EPROM socket and join them all together, temporarily shorting D0-D7 to ground.

Now fit the processor observing static precautions. When the unit is powered up the processor will sequentially count through its address range and this can be seen on the scope giving an indication that the processor is working. Address lines A0 to A6 will have refresh addresses present but A7 to A15 should have clean square wave signals of reducing frequency on them. This works because the Z80 op code &00 is the NOP instruction and tells the processor to do nothing. As the data bus has been shorted to ground by the wires, the processor reads NOPs from what it thinks is the EPROM and interprets these as program data. The processor thus scans its entire 64K memory map looking for something to do (poor thing) and this activity is easily seen on the scope. Any problems can be diagnosed far more easily at this stage.

Assuming all is well, remove the wires from the EPROM socket (observing static precautions as the EPROM socket is connected to the CPU by the PCB tracks) and fit the remaining ICs. The completed panel can now be mounted in the piano ready for final testing.

## SOFTWARE

A hexadecimal listing of the software for the unit is given in Listing 1. Operation of the keyboard supported by this code is as follows:

On power up, the unit defaults to operation on MIDI channel 1 with the selected synth patch as bank 1 program 1. This will be indicated on the display. At this time, the default tuning for the keyboard is that the lowest note will be E (middle C is the 33rd note on the keyboard).

Pressing SW2 or SW3 will advance or lower the MIDI channel and this will be displayed on LED1 and LED2.

Program selection on the active channel is provided by switches SW4 to SW15, giving access to the first 32 patch memories of the synthesiser being used. These are arranged as four banks of eight, the last selected sound being displayed on LED3 and LED4.

If the MIDI channel is changed whilst the keyboard is being played, any notes which are in use will be turned off to prevent these notes latching on. Notes are not turned off when the program is changed.

When the channel is changed, the program selection is stored and recalled when the channel is next selected. Pressing SW1 toggles between MIDI modes 1 and 3 (OMNI on POLY and OMNI off POLY) and corresponding MIDI messages are sent on all 16 channels. This enables all instruments to be played either individually or coupled together. In mode 1, selection of a program will be accepted by all active instruments capable of receiving program change data although the

keyboard will still be transmitting on the displayed channel. The unit does not update its memory for other channels as this greatly speeds access to sounds when returning to mode 3.

SW1 has a second function. When pressed simultaneously with SW4 the processor will scan the keyboard and assign the first key press it encounters to be middle C. Whilst it is primarily intended that this transpose function should enable the synth to be in the same key as the piano, thickening effects can be obtained when transposing by an octave or a fifth. Since the software suppresses 'illegal' notes, the range of tuning is limited only by the receiving synthesiser.

To enable maximum compatibility with other equipment, the software does not use 'running status', and sends genuine note off messages. Active sensing is not used.

Finally, a word about sustain. Many expanders do not have a sustain function, whilst some manufacturers use a dedicated MIDI code to access sustain routines provided within their equipment. To gain the best of both worlds, the software emulates the sustain function by not turning notes off until either the pedal is released or the key is re-struck. Sustain will therefore be provided up to the polyphonic limit of the synth being used, and thereafter will be dependant on the synth's own operating system.

Assembly of the control panel (Fig. 9) should present few problems. Care should be taken to avoid overheating the push switches when soldering them in as the plastic supporting the leads melts easily.

Otherwise, apart from observing correct orientation of components and careful checking for shorts, this should be a routine operation.

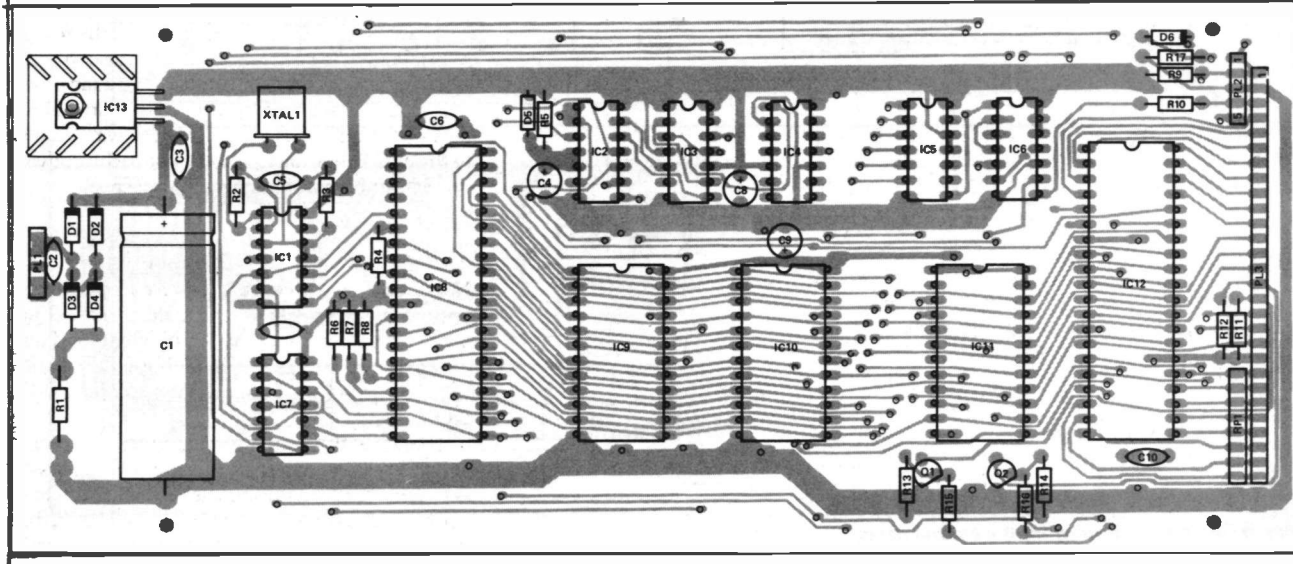

Fig. 8 Component overlay for the processor and power supply

0000	C3 A0 00 00 00 00 00 00 00 D9 68 26 81 77 14 04 D9	0220	02 DB 01 4F DB 01 B9 20 FA 32 77 80 C9 DD 21 7C
0010	C9 00 00 00 00 00 00 00 00 00 00 00 00 00 00 00	0230	80 3E 1A D3 02 AF D3 00 3E 18 D3 02 3A 74 80 32
0020	32 F6 80 CD F4 80 C9 00 00 00 00 00 00 00 00 00	0240	FA 80 C6 03 D3 00 D6 02 E6 03 32 74 80 3E 1C D3
0030	00 00 00 00 00 00 00 00 00 DB FE CB 4F 28 0F D9 7A	0250	02 AF D3 00 3E 1A D3 02 CD F8 80 D3 00 3E 18 D3
0040	FE 00 28 08 26 81 69 7E D3 FD 0C 15 D9 C9 01 08	0260	02 C9 C5 D5 E5 FD 21 70 00 21 7C 80 11 F0 80 1A
0050	10 02 08 10 04 08 10 08 08 10 10 08 10 20 08 10	0270	FE 09 30 08 36 00 23 3C E7 77 18 07 36 06 23 D6
0060	40 08 10 80 08 10 00 88 90 00 48 50 00 28 30 00	0280	09 E7 77 13 23 1A E6 18 0F 0F 0F 3C E7 77 23 1A
0070	3F 06 5B 4F 66 6D 7C 07 7F 67 00 00 00 00 00 00	0290	E6 07 3C E7 77 E1 D1 C1 C9 21 79 80 7E E6 7F 2B
0080	00 00 00 00 00 00 00 00 1C 00 00 00 00 00 00 00	02A0	46 77 B8 C5 D5 E5 C4 CA 02 E1 D1 C1 2B 7E 2B 46
0090	00 00 00 00 FD 7E 00 C9 DD 7E 00 C9 DD 77 00 C9	02B0	77 B8 C8 D8 06 FF 04 1F 30 FC 3A F1 80 E6 18 B0
00A0	3E 82 D3 03 3E 03 D3 FC 3E 15 D3 FC 31 FF 87 21	02C0	32 F1 80 CD 62 02 CD 82 03 C9 4F 90 30 0E 3A 7A
00B0	00 80 0E 07 06 FF 36 00 23 10 FB 0D 20 F8 06 58	02D0	80 FE 01 C0 CD CC 03 AF 32 7A 80 C9 3E 01 B9 20
00C0	21 00 80 36 1F 23 10 FB 01 18 00 11 E8 80 21 88	02E0	04 32 7A 80 C9 3C 32 7A 80 CB 41 20 3F CB 49 C4
00D0	00 ED B0 D9 06 00 48 50 D9 CD 62 02 00 00 00 00	02F0	30 03 CB 51 C4 59 03 CB 59 28 05 06 00 CD 1C 03
00E0	CD 00 01 FF FD 21 E0 07 CD 41 01 CD FE 01 FF CD	0300	CB 61 28 05 06 08 CD 1C 03 CB 69 28 05 06 10 CD
00F0	2D 02 CD 99 02 18 E9 00 00 00 00 00 00 00 00 00	0310	1C 03 CB 71 28 05 06 18 CD 1C 03 C9 3A F1 80 E6
0100	21 57 80 11 4E 00 06 0B 1A D3 00 1C 1A D3 02 13	0320	07 B0 32 F1 80 CD 62 02 CD 82 03 C9 CD 97 03 C9
0110	1A 2C 71 08 00 DB 01 4F DB 01 B9 20 FA FE FF 28	0330	DD 21 D8 80 3A F0 80 FE 0F C8 57 32 FE 80 3A F1
0120	16 08 D3 02 13 1A 2C 71 08 00 DB 01 4F DB 01 B9	0340	80 CD FC 80 CD EA 01 7A 3C 32 F0 80 32 FA 80 CD
0130	20 FA 08 10 D4 71 C9 2C 71 08 1C 1A 4A 10 CA 71	0350	F8 80 32 F1 80 CD 62 02 C9 DD 21 D8 80 3A F0 80
0140	C9 21 00 80 11 59 80 0E 01 06 58 1A A1 28 11 CB	0360	FE 00 C8 57 32 FE 80 3A F1 80 CD FC 80 CD EA 01
0150	76 20 29 36 1F 2C CB 01 30 03 FF 1C 1C 10 EC C9	0370	7A 3D 32 F0 80 32 FA 80 CD FC 80 32 F1 80 CD 62
0160	1C 1A 1D A1 28 28 CB 76 20 07 CD B1 01 CB F6 18	0380	02 C9 DD 21 D8 80 3A F0 80 32 FE 80 F6 C0 CF 3A
0170	E4 CB 7E 28 E0 CD D0 01 CB BE 18 EE 3A 79 80 E6	0390	F1 80 CD FC 80 CF C9 C5 CD EA 01 CD A9 03 47 3E
0180	80 28 07 CD D0 01 36 1F 18 CB 36 DF 18 C7 CB 7E	03A0	3C 3D 10 FD 32 E8 80 C1 C9 CD 00 01 21 5A 80 0E
0190	28 0E 3A 79 80 E6 80 28 07 CD D0 01 7E E6 1F 77	03B0	01 06 58 7E A1 20 0E CB 01 3D 02 2C 2C 10 F4 CD
01A0	7E D9 67 E6 C0 6F 7C E6 1F 28 01 3D B5 D9 77 18	03C0	2D 02 FF 18 E4 3E 58 90 6F 36 00 C9 3A 7B 80 FE
01B0	A4 C5 D5 3E 58 90 47 3A E8 80 80 CB 7F 20 0E 4F	03D0	00 20 0B 16 7C CD E8 03 3E FF 32 7B 80 C9 16 7D
01C0	3A F0 80 F6 90 CF 79 CF 7E E6 1F E7 CF D1 C1 C9	03E0	CD E8 03 AF 32 7B 80 C9 06 10 78 3D F6 80 CF 7A
01D0	C5 3E 58 90 47 3A E8 80 80 CB 7F 20 0B 4F 3A F0	03F0	CF AF CF 10 F5 C9 00 00 00 00 00 00 00 00 00
01E0	80 F6 80 CF 79 CF AF CF C1 C9 21 00 80 06 58 CB		
01F0	76 28 07 CD D0 01 7E E6 1F 77 2C 10 F1 C9 3E 01	0400-07D0	00 00 00 00 00 00 00 00 00 00 00 00 00 00 00
0200	D3 00 3E 1C D3 02 3E 18 D3 02 DB 01 4F DB 01 B9	07E0	01 02 03 04 05 06 07 08 09 0A 0B 0C 0E 10 12 14
0210	20 FA 32 79 80 3E 02 D3 00 3E 1C D3 02 3E 18 D3	07F0	16 18 1A 1D 20 24 28 2D 33 3B 46 53 60 6D 7F 7F

Listing 1 Hex dump for the CPU EPROM

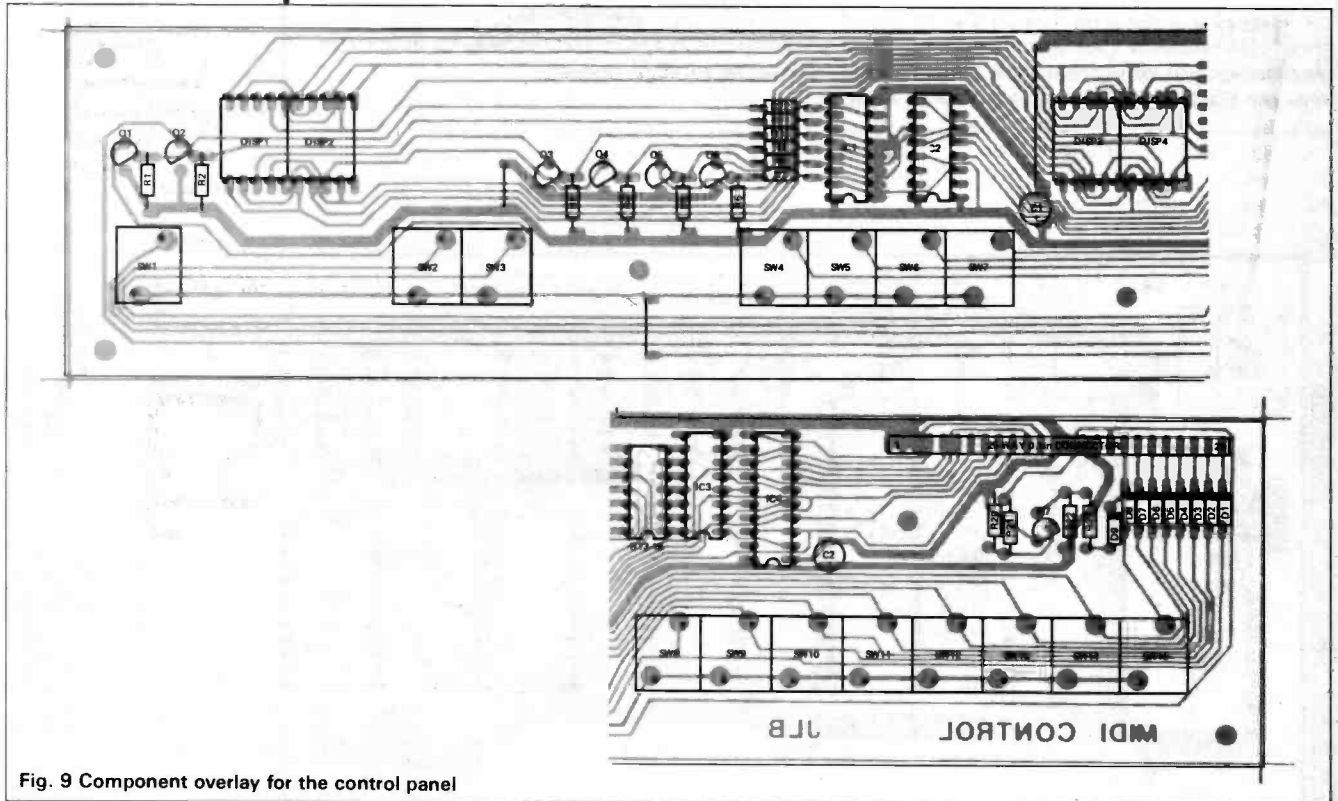

Fig. 9 Component overlay for the control panel

## PARTS LIST

**CPU**  
**RESISTORS** (all 1/4 W 5% unless specified)  
 R1 3R3 2.5W w/w  
 R2,3,11,12 1k0  
 R4 330R  
 R5,15,16 4k7  
 R6-8,17 10k  
 R9,10 270R  
 R13,14 2k2  
 RP1 8x47k SIL network

**CAPACITORS**  
 C1 4700μ 25V  
 C2,3,6,7,10,11 100n  
 C4 22μ 16V tantalum  
 C5 10n  
 C8,9 10μ 16V tantalum

**SEMICONDUCTORS**  
 IC1 74LS04  
 IC2 74LS132  
 IC3 74LS74  
 IC4 74LS93  
 IC5 74LS30  
 IC6,7 74LS32  
 IC8 Z80A CPU  
 IC9 2716 or 2532  
 IC10 6116  
 IC11 6850  
 IC12 8255  
 IC13 7805  
 Q1,2 BC182 or similar  
 D1-4 1N4002

**MISCELLANEOUS**  
 PL1,2 5-way 0.1in connector  
 PL3 30-way 0.1in connector  
 T1 9V 1A transformer

XTAL1 4MHz crystal  
 PCB. Heatsink (21°C/W). Wire. PCB pins.

**Control Panel**  
**RESISTORS** (All 1/4 W 5%)  
 R1-6,20,22 1k0  
 R7-12,21 390R  
 R13-19 100R  
 R23 2k2

**CAPACITORS**  
 C1,2 10μ 16V tantalum  
 C3 220μ 16V tantalum

**SEMICONDUCTORS**  
 IC1 74LS145  
 IC2 74LS175  
 IC3 ULN2003  
 IC4 74LS373  
 Q1-6 BC214  
 Q7 BC182  
 D1-9 1N4148  
 DISP1-4 0.5in common anode LED

**MISCELLANEOUS**  
 CONN1 optional 25-way 0.1in connector  
 WS1-15 SPST (see Buylines)  
 PCB. Wires. Mounting screws.

**Keyboard Assembly**  
**RESISTORS** (1/4 W 5%)  
 All 2k7

**SEMICONDUCTORS**  
 All diodes 1N4148  
 PCB or stripboard. Adjustment screws. Wires. Bus bars and support blocks (see text).

## INTERCONNECTIONS

Since the positioning of the modules for this project will largely be determined by the keyboard to which they are to be fitted, it is not possible to give concise details of the interconnecting loom. Instead, here are the wiring details in tabular form.

If the connecting wires between the CPU panel and the control panel are more than about six inches long, it is recommended that C3 (220µ 16V) is fitted to (or close to) the rear of the control panel with the case connected to pins 1-3 and the positive terminal connected to pins 15-16.

Note: This table shows the data and address wiring for the control

panel coming via the keyboard contact assembly. In some cases it may be preferable to re-route these wires directly to the CPU panel if this will give shorter or tidier wiring.

The connections to the 5-pin connector PL2 are as follows:

- 1 Footswitch screen
- 2 MIDI +ve to pin 4 or MIDI socket
- 3 MIDI ground to pin 2 of MIDI socket
- 4 MIDI output to pin 5 of MIDI socket
- 5 Footswitch inner.

CPU Connector Pin Number.	Control Panel Connector Pin Number.	Contact Assembly Connection Point.	
1 Wired to	17	Bank select pad 1	
2 Not used			
3 Not used			
4 Wired to			
5 Wired to			Bank select pad 2
6 Wired to			Bank select pad 3
7 Wired to			Bank select pad 4
8 Wired to			Bank select pad 5
9 Wired to			Bank select pad 6
10 Wired to			Bank select pad 7
11 Wired to			Bank select pad 8
12 Wired to			Bank select pad 9
13 Wired to			Bank select pad 10
14 Wired to			Bank select pad 11
15 Wired to			Keyboard U bus
16 Wired to			Keyboard D Bus
17 Wired to	11		
18 Wired to			
19 Not used	15	Keyboard D7 line	
20 Wired to			
21 Wired to			Keyboard D6 line
22 Wired to			Keyboard D5 line
23 Wired to			Keyboard D4 line
24 Wired to			Keyboard D3 line
25 Wired to			Keyboard D2 line
26 Wired to			

CPU Connector Pin Number.	Control Panel Connector Pin Number.	Contact Assembly Connection Point.
27 Wired to		Keyboard D1 line
28 Wired to		Keyboard D0 line
29 Wired to	1	(already connected)
30 Wired to	2	
	1,2	
	3 Not used	
	4 Wired to	Bank select pad 7
	5 Wired to	Bank select pad 6
	6 Wired to	Bank select pad 5
	7 Wired to	Bank select pad 4
	8 Wired to	Bank select pad 3
	9 Wired to	Bank select pad 2
	10 Wired to	Bank select pad 1
	11,12	(already connected)
	13,14	Not used
	15	(already connected)
	16 Wired to	Keyboard +5V line
	17	(already connected)
	18 Wired to	Keyboard D7 line
	19 Wired to	Keyboard D6 line
	20 Wired to	Keyboard D5 line
	21 Wired to	Keyboard D4 line
	22 Wired to	Keyboard D3 line
	23 Wired to	Keyboard D2 line
	24 Wired to	Keyboard D1 line
	25 Wired to	Keyboard D0 line

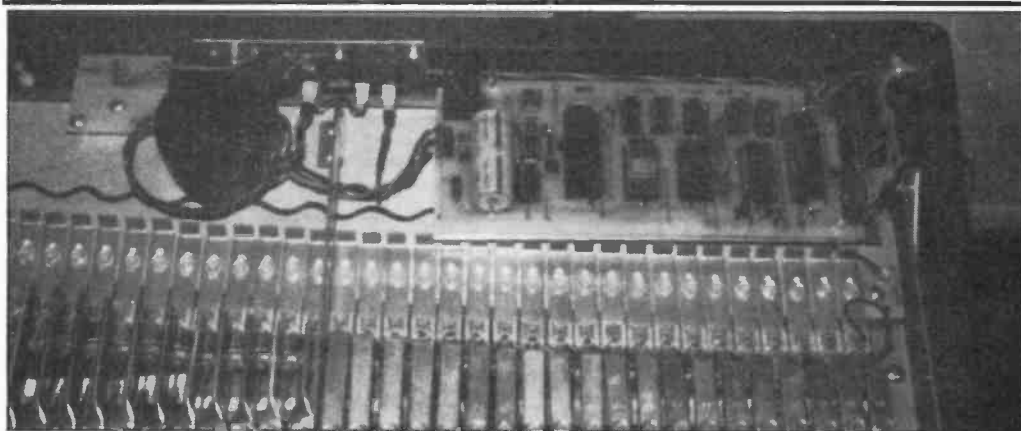

## BUYLINES

Most of the components are available from Maplin and other major suppliers. The ACIA 6850 is available from Farnell (tel: (0532) 636311) or Trilogic (tel: (0274) 684289). The control panel IC3 (ULN2003) is available from Electromail (tel: (0536) 204555).

The author can supply pre-programmed EPROMs at £15.00. Contact J. Brockhurst, 57 Berwick Road, Rainham, Essex RM13 3XQ.

Two alternative versions of the software are available. The first is a cut-down version allowing operation of the unit without the control panel, supplied with details of the small hardware modification

necessary. The second is an enhanced version allowing simultaneous operation on two MIDI channels with selectable cutoff points and keyboard response. This permits layered sounds and velocity crossfading, plus control via MIDI of volume and channel selective MIDI mode.

Both alternative versions cost £20 and include software routines and system variable lists.

The moulded plastic cover for the control panel (see photographs) is available from the author for £17.50 including the printed label.

# TOP PROJECT

**WE HAVE THE WIDEST CHOICE OF USED OSCILLOSCOPES IN THE COUNTRY**

H.P.1740A Dual Trace 100MHZ Delay Sweep. Trig	£500
TELEQUIPMENT D83 Dual Trace 50MHZ Delay Sweep	£300
GOULD OS3000A Dual Trace 40MHZ Delay Sweep TV Trig	£300
TELEQUIPMENT D755 Dual Trace 50MHZ Delay Sweep	£275
COSSOR CDU150 Dual Trace 35MHZ Delay Sweep	£180
GOULD OS1100 Dual Trace 30MHZ TV Trig	£210
S.E. LABS SM111 Dual Trace 18MHZ	£130
TRIO CS1566A Dual Trace 20MHZ	£250
H.P.1220A Dual Trace 15MHZ TV Trig	£200
GOULD OS255 Dual Trace 15MHZ TV Trig	£210
PHILIPS PM3233 Dual Beam 10MHZ TV Trig	£200
GOULD OS250A Dual Trace 10MHZ TV Trig	£140
THIS IS JUST A SAMPLE — MANY OTHERS AVAILABLE	
TEKTRONIK 2215 dual trace 60MHZ sweep delay with manual, probes front cover, pouch, only	£500
MARCONI TF2015 AM/FM 10-520MHZ Sig Gen with TF2171	£550
MARCONI TF2015 without Synchroniser TF2171	£425
MARCONI TF2016 AM/FM 10KHZ-120MHZ Sig Gen with TF2173	£400
MARCONI TF2016 without Synchroniser TF2173	£300
MARCONI MOD Meters TF2300; TF2300B; TF2303 from DYMAR 1525 AM/FM 0.1 — 184MHZ Sig Gen	£100
H.P. 520B Signal Generator 7 — 11GHZ	£400
H.P. 618C Signal Generator 3.8 — 7.6GHZ	£400
H.P. 618B Signal Generator 1.8 — 4.2GHZ	£400
FERROGRAPH RTS2 Recorder Test Set	£275
WOLKE Wow & Flutter Meter ME108	£100
LEADER LMV186A Two Channel Millivolmeter 5HZ-500KHZ. 100uV — 300V	£150
FEEDBACK FG601 Sig Gen 0.001HZ-1MHZ Sine/Sq/Tri	£100
MARCONI Automatic Distortion Meter TF2337A 400HZ or 1KHZ Measures down to 0.01%	£75
LEVELL OSCILLATORS TG152/TG200 Series, from	£150
MARCONI TF2700 UNIVERSAL LCR BRIDGE Battery, from	£150
<b>HAMEG MODULAR SYSTEM</b>	
HM8001 Main Frame with HM8032 Sine Wave Generator 20HZ-20MHZ; HM8030.2 Function Generator 0.1 — 1MHZ Sine/Sq/Triangle and HM8011.2 Digital Multimeter 4½ digit, only	£375
SADELTA MC321 COLOUR BAR GENERATOR RF Bands 1,3,4 & Video.8 Functions. Sound Carrier. Unused (p&p £7)	£125
SADELTA COLOUR BAR GENERATOR PAL MC101.8 Patterns. Pocket Size. Rechargeable Batteries. Complete with Battery Charger Adaptor. Unused (p&p £4)	£50
LABGEAR COLOUR BAR GENERATOR KGI 8 Test Patterns (p&p £4) each only	£40
LABGEAR CROSSHATCH GENERATOR Type CM6038.08 Crosshatch Grey Seale Blank Raster. Mains or battery. (p&p £3)	used £18 used £12
TRIO RF SIGNAL GENERATOR Type SG402 100KHz 30MHZ Unused (p&p £7)	£50
ADVANCE SG62B AM 150KHz-220MHZ (p&p £7)	£45
<b>TELEPHONES</b>	
Yes real dial type telephones that don't slide around the desk. Type no. 746 supplied with standard BT plug (used). Quantity discount (p&p £3) only	£5
TEKTRONIX OSCILLOSCOPE 2235 Dual Trace 100MHZ Delay Sweep	£750
PHILIPS OSCILLOSCOPE PM3217 Dual Trace 50MHZ Delay Sweep	£500
GOULD OS300 Oscilloscope Dual Trace 20MHZ	£250
GOULD 1421 Digital Storage Dual Trace 20MHZ	£750
THANDAR TA2080 Logic Analyser 20MHZ. 8 Channel	£375
THURLBY PL320QMD 0-30V 2A Twice. Quad Mode Digital Meters	£200
FEEDBACK FSG606 Sweep Function Generator 0.01HZ — 1MHZ (p&p £7)	£200
SOLARTRON 7045 Multimeter 4½ digit LED 30 ranges Auto/Manual (p&p £7)	£125
LOGIC PROBE type 3300A TTL/Cmos (p&p £3)	£18
FARNELL Oscillator LFM3 10HZ-10MHZ Sine/Square	£200
RACAL 9915 Freq Counter 10HZ-520MHZ (Crystal Oven)	£150
RACAL 9900 Series Universal Counter Timers from	£150
MARCONI ATTENUATORS TF2162 DC-1MHZ 600 ohm. 0-111dB. (p&p £7)	£35
HATFIELD ATTENUATORS 50 ohm DC-250MHZ 0-100dB/600 ohm DC-1MHZ (New Price £135) (p&p £4) only	£50
<b>AVO MULTIMETERS (p&amp;p £10 all Units)</b>	
AVO 8s: 9s and Ministry Versions. With Batteries & Leads, from	£50
TEST LEADS for Avos. Red & Black with 2 croc Clips & 2 prods (p&p £3)	£5
Black EVER READY Case for Avos. Un-used (p&p £4)	£15
BATTERIES 15Volts (p&p extra)	£3 each 10 for £25
AVO TRANSISTOR ANALYSER RMk2. CT446 suitcase style. With batteries & operating instructions (p&p £7) only	£25
MARCONI AF Power Meter TF893A 20HZ-35KHZ. 20mW-10W. With Manual (p&p £7) only	£25
MARCONI RF Power Meter TF1152A/1 DC-500MHZ 0.5 — 25W. 50 ohm With Manual (p&p £7) only	£30
<b>NEW EQUIPMENT</b>	
HAMEG OSCILLOSCOPE HM1005 Triple Trace 100MHZ. Delay Timebase	£726
HAMEG OSCILLOSCOPE HM 604 Dual Trace 60MHZ Delay Sweep	£575
HAMEG OSCILLOSCOPE HM203.6 Dual Trace 20MHZ. Component Tester	£314
HAMEG OSCILLOSCOPE HM205.2 Dual Trace 20MHZ Digital Storage	£527
All other models available — all oscilloscopes supplied with 2 probes	
BLACK STAR EQUIPMENT (p&p all units £5)	
APOLLO 10 — 100MHZ Counter Timer Ratio/Period/Time Interval etc	£222
APOLLO 100 — 100MHZ (As above with more functions)	£295
METEOR 100 FREQUENCY COUNTER 100MHZ	£99
METEOR 600 F FREQUENCY COUNTER 600MHZ	£126
METEOR 1000 FREQUENCY COUNTER 1GHZ	£178
JUPITOR 500 FUNCTION GENERATOR 0.1HZ-500KHZ. Sine/Sq/Tri	£110
ORION COLOUR BAR GENERATOR Pal/TV/Video	£209
All other Black Star Equipment available.	
HUNG CHANG DMM 7030 3½ digit. Hand held 28 ranges including 10AmpAC/DC 0.1% Acc (p&p £4)	£39.50
As above DMM 6010 0.25% Acc	£33.50
Carrying Case for above	£3
OSCILLOSCOPE PROBES Switchable x1; x10 (p&p £3)	£11
Used equipment — with 30 days guarantee. Manuals supplied if possible This is a VERY SMALL SAMPLE OF STOCK. SAE or Telephone for lists. Please check availability before ordering.	
CARRIAGE all units £16. VAT to be added to Total of Goods & Carriage	

**STEWARTS OF READING**

110 WYKEHAM ROAD, READING, BERKS RG6 1PL

Tel: 0734 68041 Fax: 0734 351696

Callers welcome 9am-5.30pm Mon-Fri (until 8pm Thurs)

# D-MM GOOD VALUE!

*Cirkit's new range of Digital Multimeters offer a quite unbeatable combination of features and value:*



- Ranges include: frequency, capacitance and temperature
- Housed in strong ABS cases
- Overload protection on all ranges
- Full one year warranty
- 3½ digit, auto zero, auto polarity LCD, plus low batt indication
- 200 hour battery life
- All meters supplied with test leads, battery and manual

## TM5315B

- Remarkable value
- 18 ranges
- 10A dc current

dc volts: 200mV-1kV  
ac volts: 200V, 750V  
dc current: 200uA-10A  
resistance: 200Ω-20MΩ

Continuity and diode test  
Basic dc accuracy: ±0.8%  
Size: 128 x 72 x 33mm

Price **£19.99**

## TM5375

- Frequency measurement to 20MHz
- ac/dc current to 10A
- 24 ranges

dc volts: 200mV-1kV  
ac volts: 200mV-750V  
dc current: 200uA-10A  
ac current: 200uA-10A

Resistance: 200Ω-20MΩ  
Frequency: 2kHz-20MHz  
Continuity, diode & HFE test  
Basic dc accuracy ±0.5%

Price **£36.75**

## TM5365

- 30 ranges
- Frequency & capacitance measurement
- Compact size

dc volts: 200mV-1kV  
ac volts: 200mV-750V  
dc current: 200uA-10A  
ac current: 200uA-10A

Resistance: 200Ω-2000MΩ  
Frequency: 2kHz-200kHz  
Capacitance: 2nF-20uF  
Logic, continuity, diode and HFE test

Price **£37.90**

## TM175

- Freq. measurement to 10MHz
- Capacitance measurement 1pF to 20uF
- 39 ranges

dc volts: 200mV-1kV  
ac volts: 200mV-750V  
dc current: 200uA-10A  
ac current: 200uA-10A  
Resistance: 200Ω-2000MΩ

Capacitance: 2nF-20uF  
Frequency: 2kHz-10MHz  
Continuity, diode, HFE, logic & LED test.

Price **£57.49**

## TM135

- Temp. measurement
- Capacitance measurement
- 40 ranges

dc volts: 200mV-1kV  
ac volts: 200mV-750V  
dc current: 200uA-10A  
ac current: 200uA-10A

Resistance: 200Ω-2000MΩ  
Temperature: 200°-750°C  
Capacitance: 2nF-20uF  
Diode, HFE & continuity test

Price **£45.95**

## TM115

- 0.5% accuracy
- Transistor HFE test
- 26 ranges

dc volts: 200mV-1kV  
ac volts: 200mV-750V  
dc current: 200uA-10A  
ac current: 200uA-10A

Resistance: 200Ω-2000MΩ  
Continuity, diode & HFE test  
Basic dc accuracy ±0.5

Price **£33.67**

Prices Inc VAT.  
Please add 90p for p&p.

# Cirkit



**Cirkit Distribution Ltd.**

Park Lane, Broxbourne, Herts EN10 7NQ.  
Telephone (0992) 444111.

# PEDAL POWER

The background to this project is quite simple. A friend plays guitar semi-pro and uses several effects pedals. He had a problem with battery eliminators and cables cluttering his stage area and so he asked for help. The solution was equally simple. A small box fitted to the rear of the amplifier providing a 9V feed for the effects pedals. This power feed and signal return became combined into a single multi-way cable and the power supply box evolved into the form presented here.

A basic design consideration is that it should fit unobtrusively into the rear of an amplifier. The unit must be compact, yet robust and so the enclosure chosen is a very sturdy aluminium extrusion that neatly houses a single 100x160mm Eurocard-size PCB. All the components mount onto the card and this simply slots into the housing.

To ensure simple operation there are only three connections to the unit. Firstly, mains power is tapped from the amplifier, preferably after the on/off switch. A second lead carries the output to the main amplifier signal input. This is soldered to the circuit board inside the main amplifier but could be provided on a flying lead/jack plug. Finally, a multiway DIN socket provides a connection to the effects pedals.

As this is an 'add-on' in a critical position, it is vital that no compromises are made in component selection. Consequently high quality components are used throughout to ensure that the unit never becomes the 'weak link' in the chain.

The input stage uses a basic differentiation amplifier to accept the incoming signal and a voltage follower to buffer the output to the main amplifier.

The power supply is configured to supply approximately 9V for the effects pedals. With reference to the circuit diagram in Figure 1, the power supply follows traditional linear supply practice of

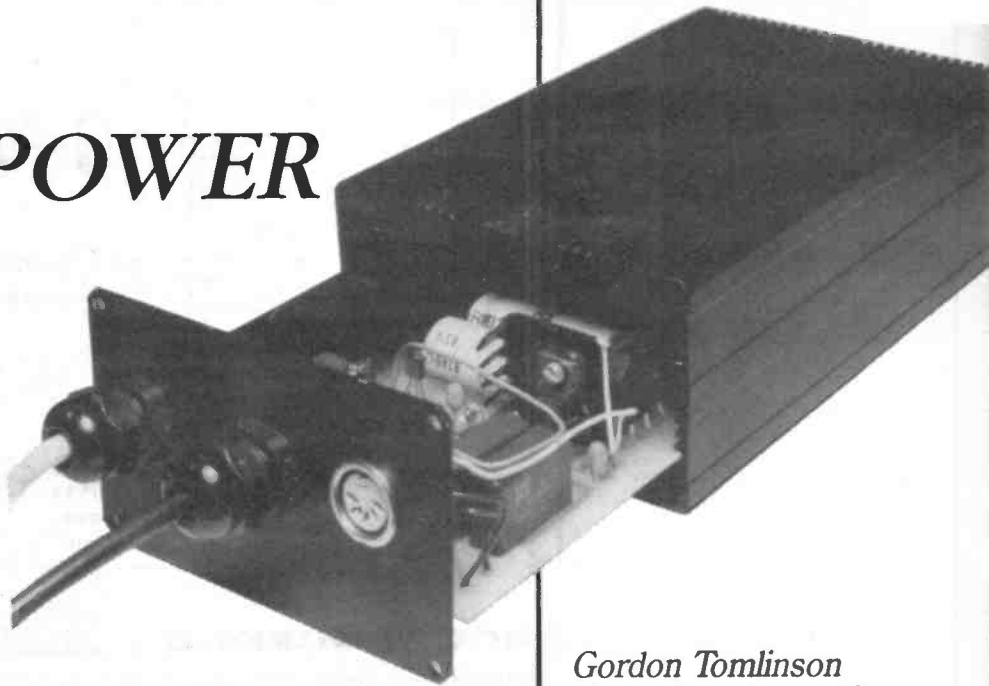

*Gordon Tomlinson shows how to cut the cabling on stage*

transformer/rectifier/capacitor/regulator. VDR1 is a voltage dependant resistor and zaps any large mains spikes. They are a good idea in any equipment.

The negative regulator supplies only two ICs and is a low-power type. Its output is 'shifted' from -5V to -8.9V by the application of a 3.9V zener diode to its earth terminal. This useful trick is also applied to the positive regulator. However this supplies the main power output and must be of the 7805 type.

If a good quality component with A1 amp rating is used and well heatsinked, it will happily supply 400/500mA, which is more than enough for five effects pedals. Note that regulators will only deliver their maximum rated current in cool conditions with a minimal input to output voltage drop (about 2V). The greater the voltage drop across the regulator, the lower its output current potential. Resistors R1 & R2 provide a constant load to ensure the regulators keep regulating. Capacitors C3 to C8 ensure that supplies are kept as clean as possible. It is very important to heatsink IC1 as it can become quite warm.

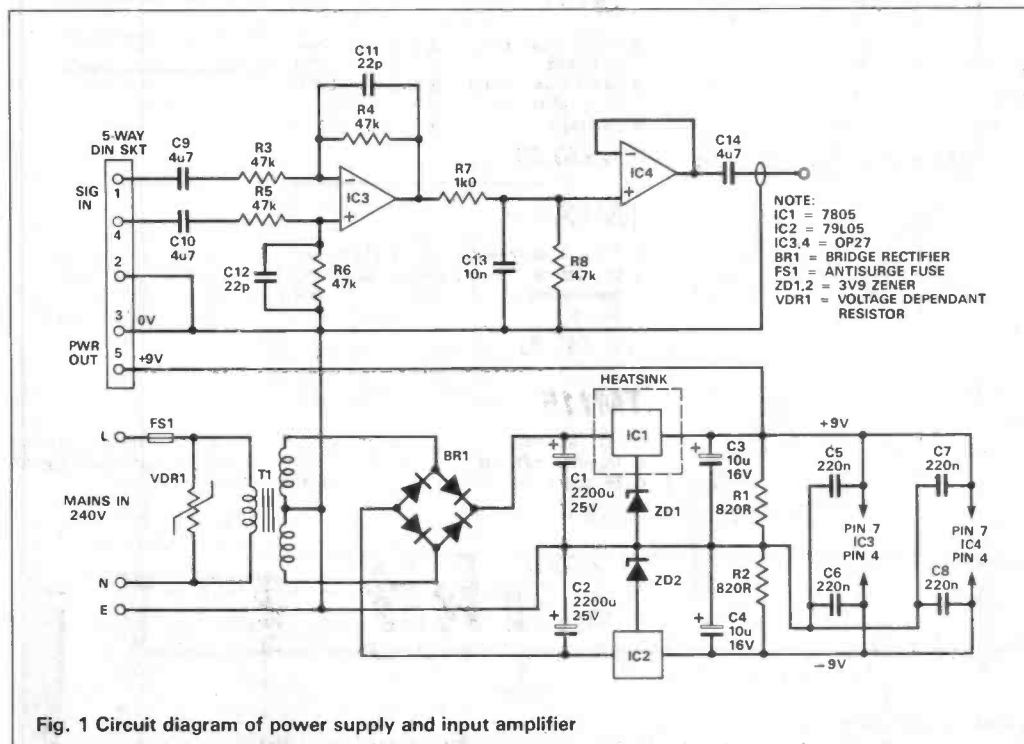

Fig. 1 Circuit diagram of power supply and input amplifier

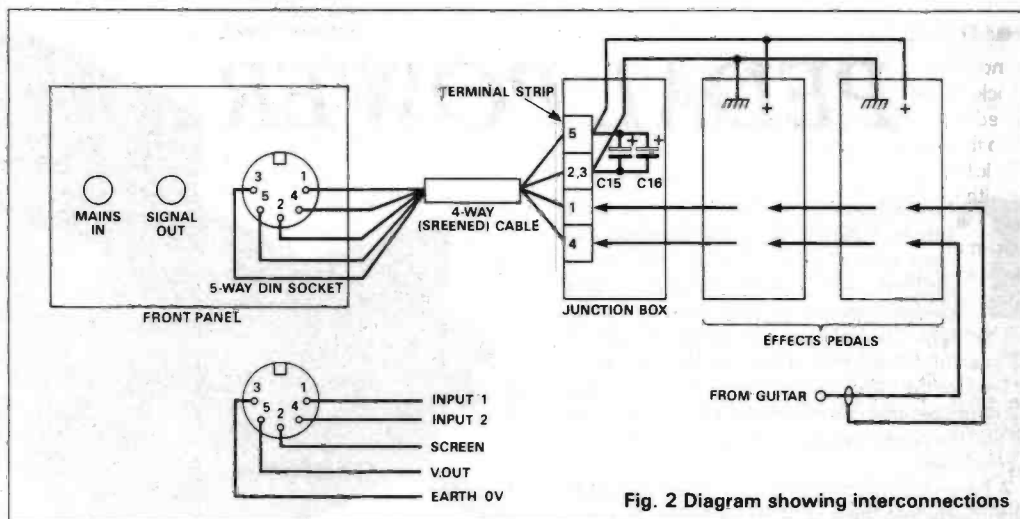

Fig. 2 Diagram showing interconnections

## HOW IT WORKS

The signal handling circuitry is built around two OP27 operational amplifiers. These are quite expensive but you only need the lowest grade version.

The first stage is a basic differential amplifier. Many different formats of differential amplifier exist, and the most simple single chip version was chosen. The differential amplifier works by effectively looking at the signals presented to its inputs, and it acts in one of two ways. If the signals are different it amplifies the difference by a factor determined by  $R4/R3$  (when  $R4=R6$  and  $R3=R5$ ). If the signals are the same then they are attenuated by the common mode rejection ratio (CMRR) of the circuit. The amount of CMRR is determined by the choice of op-amp, the auxiliary components used and circuit topology. If we had expected high levels of interference, we could have

exploited the 90+ dB CMRR capability of the OP27. But we would have been forced to use closely matched (0.01%) resistors and a trimmer for C12. However in our application we do not expect high levels of interference. We can happily use 1% standard resistors. With the values shown we have an overall gain of one.

A disadvantage of a single chip stage is that the inputs are presented with unequal impedances. However this is not important here.

The network  $R5, C13$  serves as a passive low pass filter, progressively attenuating unwanted high frequency signals. Finally the second OP27 forms a simple voltage follower (its output follows its input) and this provides a low output impedance to drive into the standard amplifier.

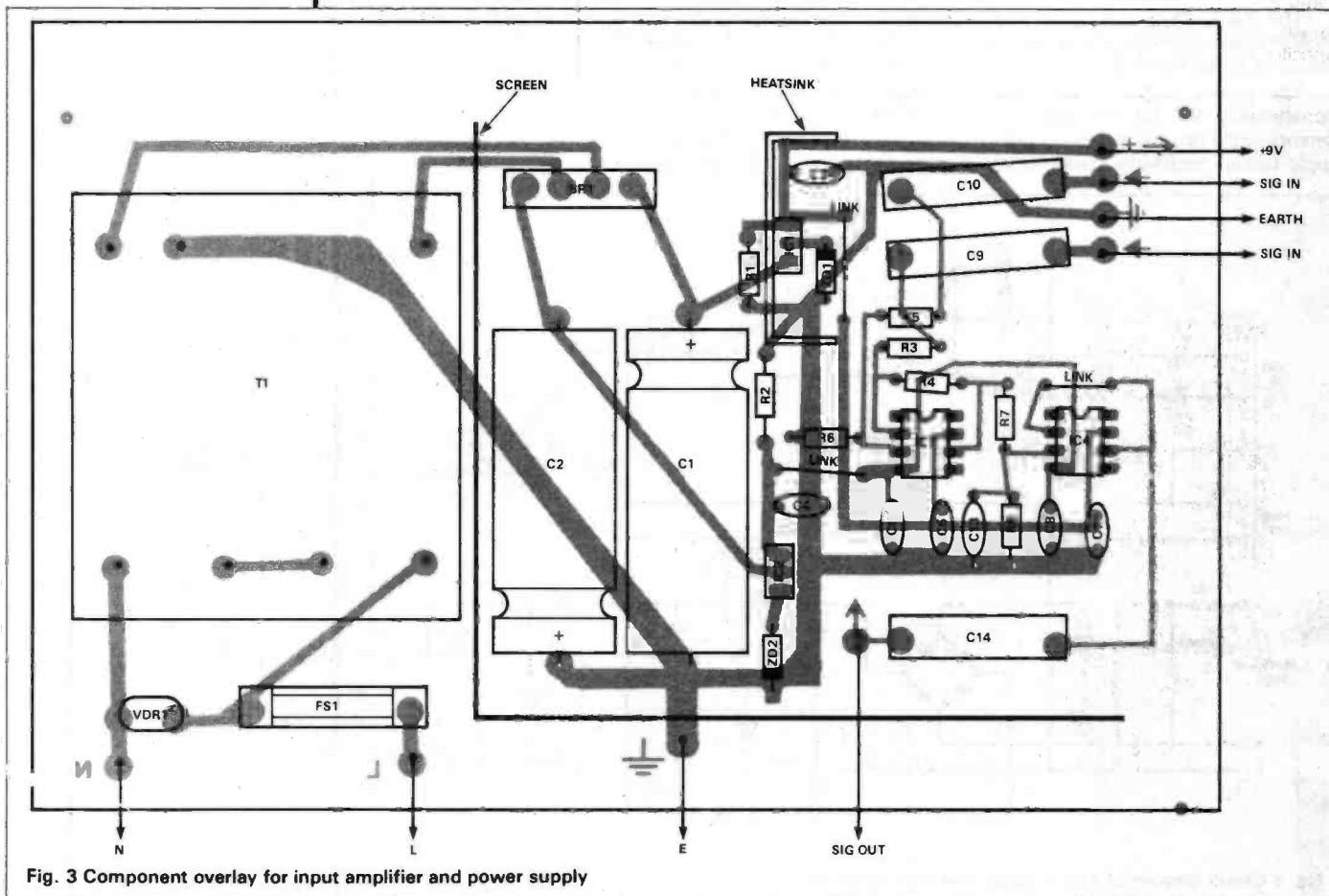

Fig. 3 Component overlay for input amplifier and power supply



## Construction

The end cover of the housing must be drilled to accept the sockets and glands. This is the only metalwork involved unless you decide to make a small divider to keep the mains cable away from the other circuitry.

Basic board construction follows standard practice. Start with the small components and work your way through to the larger items, finishing with the transformer. When finished have a break and then recheck everything, especially components that are polarity conscious.

Wiring the unit to the outside world is quite straight forward and is just common sense as shown in Figure 2. The 9V power supply and signal returns are taken by a single multiway cable to the five pin din connector. You may prefer something more beefy and expensive such as an XLR connector.

How you interface the signals at the pedal end is up to you. Remember to keep cable lengths to a bare minimum. Two important points to note: capacitors C11 and C12 are soldered piggy back to resistors R4 and R6 and capacitors C15 and C16 are used at the pedal end of the line.

## Getting Going

If you own a scope or signal generator then testing will probably be second nature. If you do not and run into a problem, the first thing to check is the power supply. Do you have mains? Are the regulators correctly oriented? Do you have voltage at the IC supply pins? If you are using IC sockets, have you plugged them in the wrong way? It is basically a simple circuit and should not be hard to fault find.

Where and how you fix it in the amplifier is up to you. Make sure that it is secure and not too close to the hot bits. Do not be tempted to compromise on component quality. If the main amplifier has a capacitor at its input it will be possible to remove capacitor C14. Over to you . . .

## PARTS LIST

### RESISTORS (all 1% metal film 1/4W)

R1,2	820R
R3-6,8	47k
R7	1k

### CAPACITORS

C1,2	2200 $\mu$ 25V electrolytic
C3,4,16	10 $\mu$ 16V tant
C5-8	220n plastic film
C9,10,14	4 $\mu$ 7 polycarbonate/film
C11,12	22p polystyrene, close tolerance
C13	10n plastic film
C15	100 $\mu$ 16V electrolytic

### SEMICONDUCTORS

IC1	7805
IC2	79L05
IC3,4	OP27
ZD1,2	zener diode 3.9V
VDR1	voltage dependant resistor

### MISCELLANEOUS

BR1	diode bridge 1.5A
FS1	250mA anti-surge
T1	9-0-9V 18VA
Cable & glands. 5 pin din skt and plug. Heatsink for IC1. Alloy screen. Fuse holder. Case.	

## BUYLINES

The parts are not cheap but they are easily available. The transformer is RS/Electromail catalogue number 208-333. Tel: (0536) 204555. The alloy case is available from West Hyde Developments Ltd. Tel: (0296) 20441.

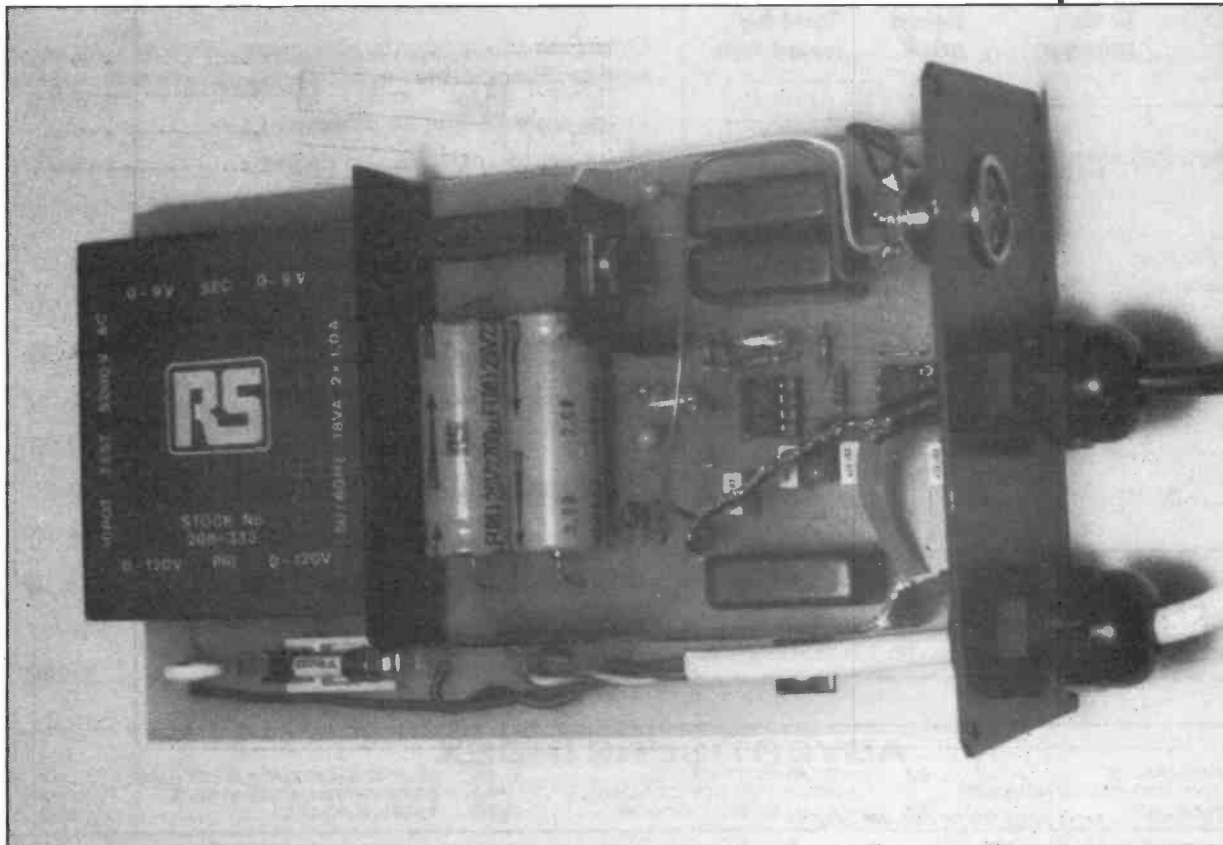



# Top Projects

## PCB SERVICE

1989

Don't waste those winter evenings spilling etching solution on the living room carpet. Let the ETI PCB Service take the strain. All ETI project PCBs (except those available elsewhere - see *Buylines* in the projects concerned) can be bought ready made from the PCB Service. The boards are made to a high standard and drilled and tinned all ready for assembling your project.

To avoid errors, please use the coupon below (or a photocopy) and send your order with a cheque or postal order made payable to ASP Ltd to:

**ETI PCB Service  
Readers' Services  
Argus House  
Boundary Way  
Hemel Hempstead  
Herts HP2 7ST**

Orders can also be taken by phone from Access or Visa card holders. Phone (0442) 41221 during office hours.

Please allow 28 days for delivery.

Aerial Amplifier Main Board E8907-4 .....	£3.25
Aerial Amplifier Power Supply E8907-5 .....	£3.25
Trembler Motion Detector E8909-2 .....	£2.50
Priority Quiz Switch E8907-2 .....	£3.25
Guitar Tuner E8905-1 .....	£5.50
Twin Loop Treasure Seeker E8909-1 .....	£5.50
Camera Trigger E8904-1 .....	£3.25
Granny's Hearing Booster E8901-5 .....	£3.25
MIDI Piano Converter CPU E8906-2 .....	£13.10
MIDI Piano Converter Keyboard E8906-3 .....	£13.10
MIDI Piano Converter Control E8906-4 .....	£10.60
Pedal Power E8912-4 .....	£8.80

**Please supply me the following PCBs:**

Number required	Code number	Board price	Total for board type
Total.....			£ .
Post & Packing.....			£0.75
Grand Total.....			£ .

**ORDER TO BE SENT TO: (block capitals please)**

Name .....

Address .....

.....

.....

.....

Post Code .....

**ADVERTISERS INDEX**

CIRKIT HOLDINGS .....	62	HART ELECTRONICS .....	29	SHERWOOD DATA SYSTEMS .....	47
CRICKLEWOOD ELECTRONICS .....	7	LABCENTER ELECTRONICS .....	50	STEWARTS OF READING .....	62
ELECTROVALUE .....	23	MAPLIN ELECTRONICS .....	OBC	TSIEN (UK) LTD .....	IBC



**A COMPLETELY NEW DIMENSION IN SOUND QUALITY!**

# NICAM

## 728 DECODER PROJECT KIT

The Maplin NICAM 728 Decoder converts the additional digital code present\* in the TV signal to a high quality stereo soundtrack with a quality similar to that of Compact Disc.

This fully working system is based upon the Toshiba NICAM chip set which has only just become available. For full project construction details, see the December 1989 edition of Electronics – The Maplin Magazine (XA35Q price £1.20). It's on sale from November 3rd, so get your copy TODAY!

\*Currently being transmitted from Crystal Palace and Emley Moor. See the Maplin Magazine Issue 34 for IBA launch schedule.

Upgrades almost any modern colour TV set – no need to purchase a new TV set or VCR!

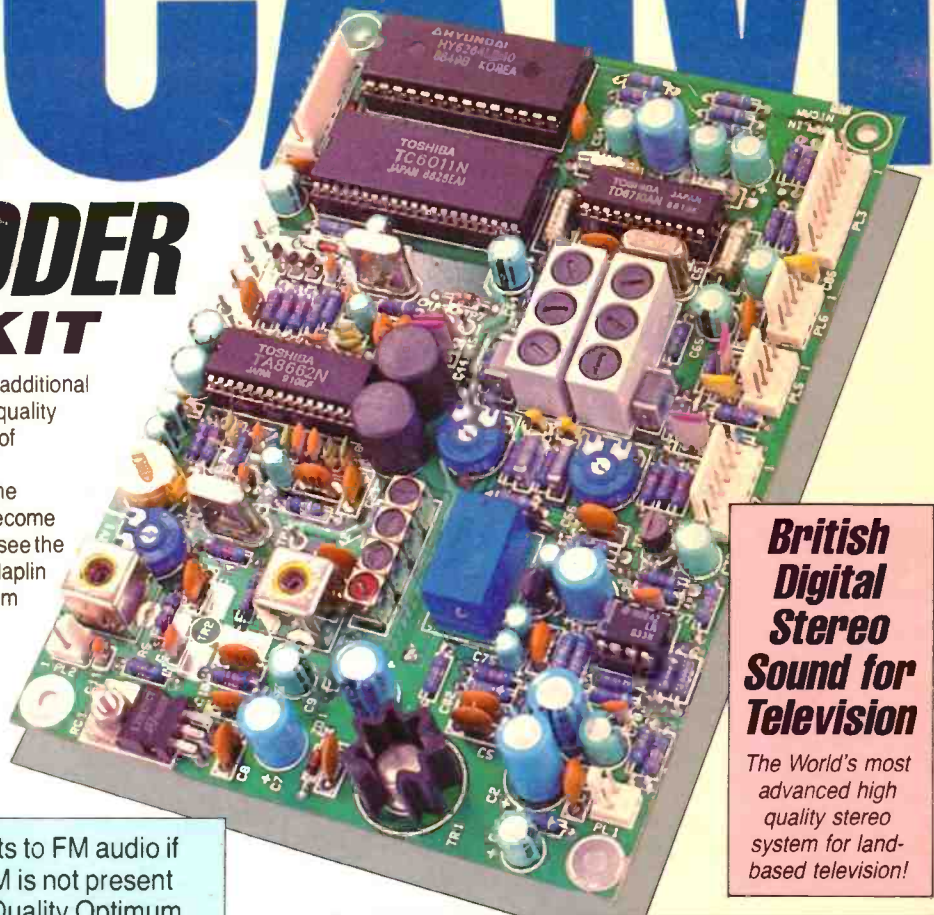

**British  
Digital  
Stereo  
Sound for  
Television**

The World's most advanced high quality stereo system for land-based television!

### Features

- ★ Single +12V power requirement
- ★ Automatic audio switching (Mono-Stereo-Bilingual)
- ★ British Design
- ★ Reverts to FM audio if NICAM is not present
- ★ High Quality Optimum Performance without any additional ICs
- ★ NICAM mode indicators

## ARE YOU SWITCHED ON TO NICAM 728?

Get the November 1989 copy of Electronics – The Maplin Magazine – for full details on the NICAM 728 project. Available from all good newsagents. Or take out a subscription – Order XA00A at £7.20.



- ★ Kit available from November 1989
- ★ Features 'how-to-build' project details

## TELEVISION ENGINEERS

Order  
5 NOW  
AND PAY ONLY  
**£65**  
PLUS VAT EACH

This price available to trade only, ring 0702 552961 and quote LP02C special 5 off deal reference: ETI.

Normal Price £99.95 (Inc. VAT) each  
(Order Code LP02C)

Initial availability limited – book your orders now!

**Maplin** ELECTRONICS

**CREDIT CARD HOTLINE**



**0702 554161**

PHONE BEFORE 5PM FOR SAME DAY DESPATCH

ALL PRICES INCLUDE VAT.

All items subject to availability, all items will be on sale in our shops in Birmingham, Bristol, Leeds, Hammersmith, Edgware, Manchester, Nottingham, Newcastle-upon-Tyne, Reading, Southampton and Southend-on-Sea.