

FOUNDED 1925
INCORPORATED BY
ROYAL CHARTER 1961

"To promote the advancement
of radio, electronics and kindred
subjects by the exchange of
information in these branches
of engineering."

THE RADIO AND ELECTRONIC ENGINEER

The Journal of the Institution of Electronic and Radio Engineers

VOLUME 37 No. 5

MAY 1969

Why Hold Conferences ?

THE calendars of most learned societies and professional engineering institutions over recent years have increasingly featured symposia, conferences and conventions lasting from one to three or four days. There has in fact been comment both in the publications of the institutions and in the Technical Press on this trend which is considered by some to be at the expense of the traditional evening meeting where a single paper is presented and discussed at length. The value of evening meetings has been stressed by this Institution in the past and while certainly they form a smaller *proportion* of the total activities, their *number* is being maintained by the I.E.R.E. if not by other bodies. In passing, it is interesting to note that the Engineering Industry Training Board recognizes attendance of engineers at a conference as being part of a company's training programme for purposes of grants—attending evening meetings is regarded as the individual's personal effort.

Consideration of the reasons for the growth in popularity of the more extensive type of meeting needs to take into account several factors which have become more important during the past decade. Foremost is perhaps the almost bewildering rate of innovation in all technologies—most marked in electronics and associated fields. Except in rather special instances, conferences usually will deal with fairly narrow specializations simply because this is the best way for the average engineer to keep up with developments in his field. Advances take place over a fairly narrow front and research effort may well be large and diverse so that several papers on the different approaches are necessary. Naturally in the early stages of a completely new technology, for example the transistor or the laser, a more widely ranging approach is necessary.

The one- to three-day meeting can more easily provide opportunities for engineers to meet informally than can an evening meeting—always provided that the number present is not so large as to defeat this object! Opportunity for free and informal discussion is of course achieved *par excellence* at the conference held outside London where the majority of the participants can be in residence, a factor which has been paramount in the planning of I.E.R.E. conferences over the past ten years: out of 16 conferences lasting two days or more in the period from 1961 to the end of 1969, 11 were or are to be residential. The three conferences arranged by the Institution this year, in which several other institutions and societies have collaborated, are in the universities at Southampton, Canterbury and Loughborough respectively, and they do, it is believed, provide a most effective way of avoiding the distractions and limitations of a London-based conference.

Not that the residential conference is entirely without its disadvantages. The limitations in size of lecture theatres at some universities and, more generally, the restricted number of rooms available in the halls of residence mean that latecomers may unfortunately have to be disappointed. The 'Lasers and Opto-electronics' Conference in Southampton in March was 'over-subscribed' in this respect and those intending to take part in the 'Digital Methods of Measurement' and 'Industrial Ultrasonics' conferences in July and September should apply as early as possible.

What of the plans for 1970? Already the Council has agreed to the initial planning for conferences on Automatic Test Systems and Electronic Engineering in Oceanography, and announcements will be made shortly of their scope, dates and venues. These and other conferences which are still under discussion are essential to provide the opportunities for keeping up-to-date that are so necessary in these days of increasing specialization.

F. W. S.

INSTITUTION NOTICES

Annual General Meeting

The Eighth Annual General Meeting of the Institution since incorporation by Royal Charter will be held on Wednesday, 22nd October 1969, at the London School of Hygiene and Tropical Medicine, Keppel Street, Gower Street, London, W.C.1, starting at 6 p.m. The Chair will be taken by the President, Sir Leonard Atkinson, K.B.E.

Nominations for election to the 1969-1970 Council will be printed in the May-June issue of the Institution's *Proceedings*; the Agenda will appear in the July-August issue; and the Annual Report to the Council will be published in the September-October *Proceedings*. Members overseas may obtain copies of these issues free of charge, on application to the Secretary.

Income Tax Relief on Subscriptions

Under Section 16 of the Finance Act 1958, the whole of the annual subscription paid by a member of the I.E.R.E. is a permissible deduction from the emoluments assessable for income tax purposes.

Applications for relief can only be accepted where the subscription is defrayed out of the emoluments of the office. A further condition is that membership should be relevant to the office or employment of the claimant.

Members who have not already made application to their H.M. Inspector of Taxes should apply for form P. 358.

Members resident in the Channel Islands may obtain similar relief, and should apply in writing to their appropriate States Income Tax Office.

Meeting Notices

Posters giving details of Institution meetings in London and in Local Sections are sent regularly to selected government and industrial research and development organizations throughout Great Britain according to the location and nature of the meeting described. The co-operation of members would, however, be welcomed in ensuring that these efforts are directed most efficiently and comment by members is invited in the following instances:

- (a) From members whose organizations do not at present post up details of I.E.R.E. meetings on their notice boards and would like to receive copies.
- (b) From members whose organizations post up I.E.R.E. meeting notices centrally but could make use of extra copies for other parts of the establishments.

Requests to be placed on the mailing list for meeting notices during the next session should be sent to the

Meetings Officer at the Institution. (Telephone: 01-636 1901, Extension 2.) It would be helpful if members were to suggest the geographical locations of the meetings of interest and, in the case of Institution meetings in London, which of the Specialized Groups' activities should be notified.

Courses in Electronics

The July issue of *The Radio and Electronic Engineer* will contain a separate advertising supplement devoted to courses in electronic engineering and associated subjects which are being arranged by universities, colleges of technology and technical colleges throughout the British Isles. Details will be given of full-time, part-time and short courses for all qualifications relevant to the professional, or intending professional, engineer.

Members in educational establishments are invited to write for details of rates, etc. to the Institution's Advertisement Manager, at 9 Bedford Square, London, W.C.1 (or telephone 01-636 1901, ext. 21). The circulation of the supplement will be confined to members and subscribers in the British Isles, representing an initial print order of 10,000. Members overseas may obtain a copy for reference purposes by writing to the above address.

A Note for Engineers Travelling Abroad

There are members of the Institution working in almost every country throughout the World. The many members who travel widely in the interests of their profession can always be assured of a welcome from their colleagues in the countries which they visit.

Arrangements for meetings, whether formal or informal, between visiting members and local sections or other groups will gladly be initiated by the headquarters of the Institution, or by secretaries of local sections or regional representatives. The presentation of a short informal paper is especially appreciated by members in countries where numbers are not yet large enough to support a Section.

Change of Address

Members are requested not to delay in advising the Institution at 9 Bedford Square, London, W.C.1, immediately they change their address. A form for this purpose is included in the back pages of the *Journal*. Because of delays in post, overseas members should advise their local secretary at the same time as they advise London.

Failure to notify the Secretary at 9 Bedford Square causes considerable delay in members receiving *Journals*, notices of meetings and other communications. In addition, postal charges fall on the Institution for *Journals* which have to be sent out a second time.

Global Communications: Current Techniques and Future Trends

By

R. W. CANNON,

C.Eng., F.I.E.E., F.I.E.R.E.†

Reprinted from the Proceedings of the I.E.R.E. Convention on 'Electronics in the 1970s', held in Cambridge from 2nd to 5th July 1968.

Summary: The current demand trends for telecommunications are surveyed. The principal technical parameters of systems and equipments are reviewed. The discussion covers bearer systems and the exploitation of systems. Some likely future trends are suggested.

1. The Demand Situation

At the beginning of 1967 there were 208.5 million telephones in the world, the total having doubled in 11 years. Nearly half of these (98.8 M) were in the U.S.A.; Japan held a distant second place with 16 M, followed by the United Kingdom, West Germany, U.S.S.R., Canada, France and Italy. A total of 31 countries had more than a half million telephones and at the other end of the scale Pitcairn Island, of H.M.S. *Bounty* fame, had 15 telephones for its 98 inhabitants.¹

Historically, international, and even more so intercontinental, telecommunications were predominantly telegraphic due to the unavailability of high-quality long-haul voice circuits, and total global revenues reflected this. Europe has, of course, been an outstanding exception to this situation for a long time.

Over the last few years there has been an accelerating change in the traditional pattern with the introduction of high-quality voice links over long-haul routes. In those areas able to take advantage of this the number of international telephone calls has been rising by about 20% per annum, with consequent effect on the contribution of this service to global revenues.

There is nevertheless a continued need and preference for the printed word, and the growth of high-quality systems has enabled this to be met by a rapidly expanding telex service. This growth too, where facilities allow, has generally been at the rate of some 20% per annum.

The natural development for a telecommunications user is to go from telex to a private leased circuit and this type of service also has been in the forefront of the expansion made possible by improved facilities. Large users such as airlines have made use of comprehensive systems of this type (see Fig. 1).

All these developments have tended to affect the growth of the public message service where the rate is

rarely more than some 2 to 5% per annum, and in many relations is static.

When considering the effect of the foregoing on global revenues it is as well to remember that this is still a period of transition. The stage of development reached in the European and North Atlantic area is considerably farther ahead than that reached in other parts of the world. Therefore, because the great bulk of global revenue arises in the European and North Atlantic area and the major proportion of that revenue is from telex and telephone, it can be said that the

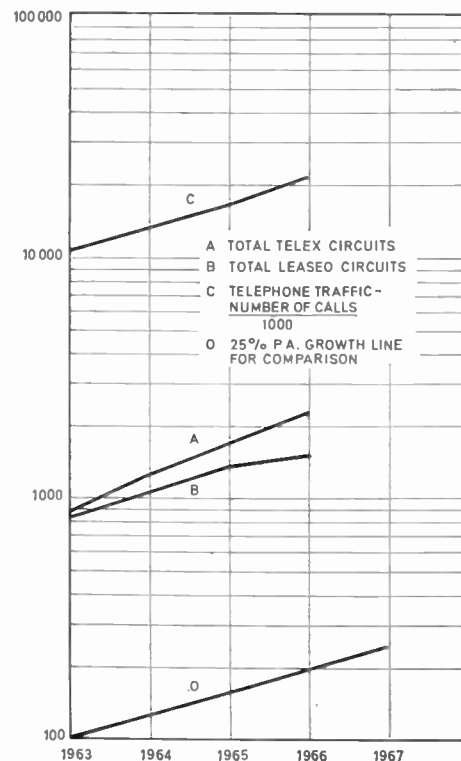

Fig. 1. Growth of international telecommunications. Based on statistics of the International Telecommunications Union.

† Cable and Wireless Ltd., Mercury House, Theobalds Road, London, W.C.1.

major proportion of global revenue arises from these services. However, it should be borne in mind that for the greater part of the world speaking geographically the bulk of the revenue at present still arises from the public message telegraph service.

Part 1. BEARER SYSTEMS

2. H.F. Radio Telephone

2.1. Radio Telephone Transmitters

For many years the main volume of intercontinental telephone traffic was carried by h.f. radio circuits operating between the main centres of population. These circuits still carry a very considerable volume of traffic in spite of the spread of high-grade systems such as coaxial submarine telephone cables and communications satellites.

The last 15 years of h.f. radio operation has seen a change over to independent sideband (i.s.b.) transmission which has resulted in better speech quality and a more efficient use of both the h.f. spectrum and the equipment. Improvement in equipment design has resulted in greater linearity and this has made it possible to carry two 3-kHz speech channels on each sideband where sufficient clear space is available on either side of the allocated frequency. By international agreement the use of i.s.b. has been adopted for fixed services using transmitter powers of over 100 watts since January 1967.²

The present day h.f. telephone transmitter normally consists of a low-power drive and modulator stage followed by a linear amplifier in which the signal at the radiated frequency, made up of two sidebands used independently and a low-level carrier, is brought up to the final radiated power. The drive stages generally consist of a modulator and a series of mixers to convert two audio frequency input signals to an i.s.b. signal at the radiated frequency. The mixer oscillators are controlled by crystals with a switched selection of crystals controlling the radiated frequency. The overall frequency stability of such an arrangement may well be about 5 parts in 10^6 which compares favourably with the internationally agreed tolerance of 15 parts in 10^6 .

Alternatively the transmitter may be driven from a synthesizer controlled by a high-stability master oscillator common to all the transmitters in the station. Modulation may be introduced in the synthesizer so that the output is an i.s.b. signal at the radiated frequency which is then fed into the linear power amplifier. The advantage of a synthesizer drive is that any frequency within the range of the transmitter can be selected as required and as all the synthesizers on the station are driven from a common source it is easy to obtain an overall improvement in stability by replacing the common master oscillator by one of a

As for the future, it is certain that one of the principal features of the growth pattern will be a very great increase in the international and intercontinental flow of high-speed data at speeds of up to 48 kilobits per second.

higher grade. An overall frequency stability of about 2 parts in 10^8 can be achieved in this way at a reasonable cost.

The linear power amplifiers, which are now virtually universal, are often self-tuning to the input frequency and to any variation in output circuit impedance. This permits quick frequency changing as it is only necessary to change the drive frequency and in some cases the aerial, and the automatic tuning system will complete the tuning and loading of the transmitter in about half a minute. Transmitter output is generally at 50 Ω impedance so that coaxial feeder cable may be used. The outputs from all the transmitters are brought to a commutation point within the transmitter building to permit easy interchange of transmitters and aerials. The aerial feeders from this point are taken underground until they are well clear of the building and each may then be changed to 600 Ω balanced-twin open-wire feeder by means of a wideband impedance matching transformer, for what may well be a long run to the aerial site.

Aerials are usually large rhombics on 45 m (150 ft) masts, two rhombics being mounted one above the other on one set of masts, one for the day frequency and one for the night frequency in use on the particular circuit.

2.2. Radio Telephone Receivers

Radio telephone receivers are also generally fed from rhombic aerials and in this case the wideband matching transformer is generally placed at the bottom of the twin-wire down-lead from the aerial. Coaxial feeder cable is taken from the transformer underground to the receiving room. Whilst coaxial cable is more expensive than twin-feeder it reduces the amount of noise picked up and the cross-talk between feeders. All the coaxial cables terminate on a commutation board in the receiving room, usually employing plug and socket-type r.f. connectors. Also mounted on the commutation board are wideband distribution amplifiers which enable four to six receivers to be connected to any one aerial. All internal distribution between the commutation board and the receivers is by means of small-size coaxial cables.

The receivers are generally of the double super-heterodyne type, tunable over a range of about 3–27 MHz with automatic frequency correction and automatic gain control derived from the low-level pilot

carrier radiated by the transmitter. Demodulation is achieved by means of a locally generated carrier at the second i.f. frequency which is usually 100 kHz. With the present standards of transmitter and receiver frequency stability automatic frequency correction is essential at the receiver in order to keep the received carrier at the second i.f. frequency within 20 Hz of the locally generated carrier. This is necessary for satisfactory telephone reception.

Diversity reception is not generally used for speech because distortion arising from the effects of selective fading makes it difficult to combine two diversity paths effectively. The receiver first oscillator is preferably crystal controlled with selection of spot frequencies by switching between six or so crystals. Alternatively the required fixed oscillator frequency may be obtained from a synthesizer controlled by a high stability master oscillator source, as in the case of transmitters.

Synthesizer outputs can generally be controlled in steps of 100 Hz or 10 Hz, depending on the cost of the unit. Finer control is not usually considered necessary.

The major trend in h.f. equipment is the changeover from the thermionic valve to solid-state devices. Transistors are already widely used in the drive stages of high power transmitters and completely solid-state transmitters are available for powers of well over 100 W. Solid-state receivers have been developed but those for high-grade fixed services are not yet up to the standard of valve receivers, the main problem being cross modulation in the early stages when there are strong interfering signals in close proximity to the wanted signal. Solid-state diodes have replaced power rectifiers, both in receivers and transmitters.

The increasing use of solid-state devices has already resulted in greater reliability, lower heat dissipation, smaller size, lower power consumption and lower weight. These improvements have in turn allowed savings to be made on building space and air-conditioning plant, and have helped greatly where floor loading has been a limiting factor on the placement of equipment. The growing use of synthesizers for both transmitters and receivers offers hope that a.f.c. will in due course cease to be required with consequent reduction in the cost of receivers.

3. H.F. Radio Telegraph Transmitters and Receivers

These are nowadays basically i.s.b. radio telephone transmitters and receivers which provide 3 kHz voice channels that can carry various types of frequency division multiplex telegraph systems along with telephone channels. A point of difference between telephone and telegraph reception is that dual diversity with spaced aerials is used for the latter. The audio frequency outputs from the two diversity paths are fed into voice frequency telegraph receiving equipment

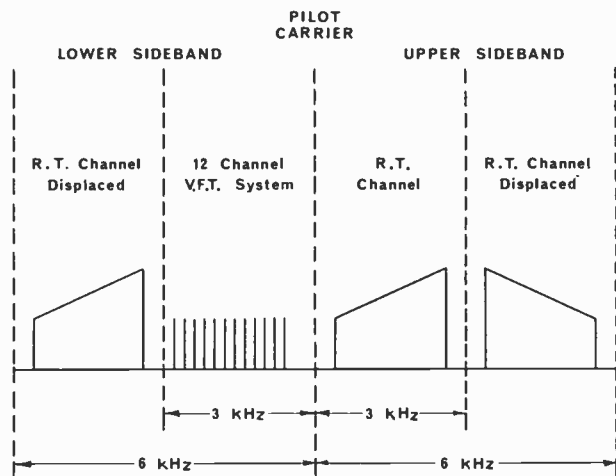

Fig. 2. Spectrum of i.s.b. transmission.

where the channels of each path are separated by filters and the corresponding channels then combined in diversity.

Whilst telegraph frequency multiplexing systems are discussed elsewhere in more detail, Fig. 2 shows the frequency spectrum of a composite i.s.b. transmission which is carrying one 12-tone frequency division multiplex telegraph system and three 3-kHz voice channels.

The remarks made above about the trend towards solid-state equipment naturally apply equally to all radio telegraph equipment.

Congestion in the h.f. spectrum has been troublesome for a number of years and in the absence of other types of international communications radical steps would be needed in the near future to prevent further deterioration of the situation. The rapid spread of high-capacity systems which do not use the h.f. spectrum has, however, given some relief in this respect and one might assume that at some point in the future, probably still many years away, the h.f. spectrum would be reserved primarily for mobile station use. Even in this field, however, there is a good prospect of satellite communications offering an excellent service.

To sum up, the future of radio telephone and telegraph services is in theory one of gradual phasing out. In practice there is little doubt that the h.f. spectrum will continue to be heavily used for many years during which time there will certainly be further interesting technical development.

4. Submarine Coaxial Cable Systems

4.1. History and Development

The construction of the present world-wide repeated submarine telephone cable network started with the first transatlantic link, TAT-1, which was

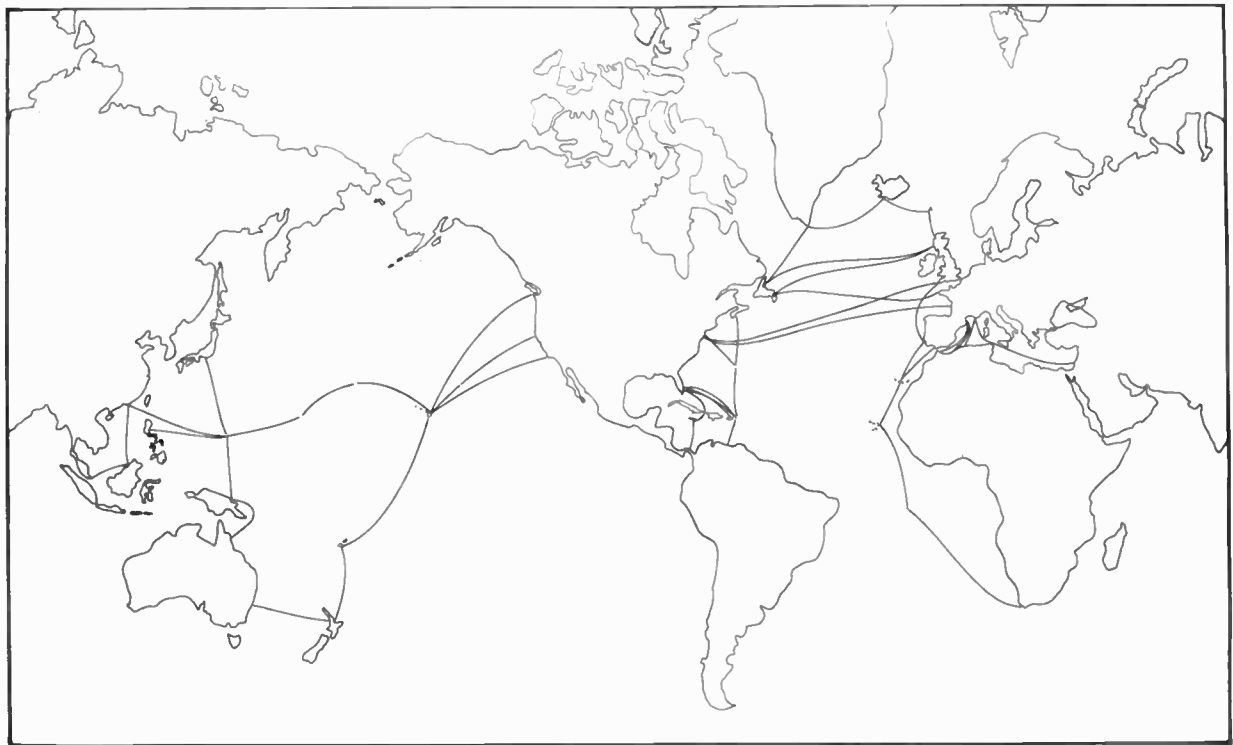

Fig. 3. Commercial submarine cable systems. (All systems illustrated are in service or in process of construction.)

laid and put into service in 1955–56. TAT-1 was engineered jointly by the American Telephone and Telegraph Company and the British Post Office, the latter being responsible for the higher-capacity section between Newfoundland and Nova Scotia. It is jointly owned by the AT & T, the B.P.O. and the Canadian Overseas Telecommunication Corporation.

This system, and the initial few which followed, employed armoured cable of conventional design with long thin flexible repeaters. Transmission permitted 36 4-kHz channels in one direction only, hence two cables were necessary per system.

The development of the B.P.O. lightweight cable which permitted the use of rigid, physically larger bi-directional repeaters led to the laying of the first single cable system, CANTAT, again transatlantic, in 1961. This system was engineered by the B.P.O., wholly manufactured in Britain and is jointly owned by Cable and Wireless Ltd. and the Canadian Overseas Telecommunication Corporation. It has a capacity of 80 3-kHz circuits.

In 1963 the first American single cable system was laid. This employed an unarmoured cable basically similar to the earlier British cable and joined Florida with Jamaica in the West Indies. It had a design capacity of 128 3-kHz circuits which has since been increased by at least 10 further 3-kHz circuits.

Since that date the cable systems laid and brought into service have increased rapidly in number and bandwidth. Systems are now in production on both sides of the Atlantic providing a design capability of 720 3-kHz circuits (American) and 640 3-kHz circuits (British). These are the first deep-water systems to employ transistor repeaters. Development of even wider band systems is well advanced and 12-MHz systems (1140 4-kHz circuits) are to be laid across the North Sea.

Figure 3 shows a map of the principal inter-continental coaxial systems now in service or under construction.

4.2. Submarine Cable System Design

4.2.1. Design principles

Submarine cable systems essentially comprise the terminal stations at each end of the system and the submarine cable and repeaters which provide the broadband transmission path.

Access to two of the system elements, the cable and the repeaters, is difficult and costly when compared with land systems, hence a fundamental submarine system design approach is to make these elements as reliable as possible in service, so as to ensure a trouble-free life of at least 20 years. Development of deep-water submarine systems only proceeded after many

years of research and experience with shallow water systems. The laying of the first trans-oceanic system proceeded only after it had been demonstrated that an economic standard of reliability could be expected.

4.2.2. Terminal equipment

Special transmission equipment is required at the terminal of a submarine system so that the basic groups or supergroups to be carried over the system can be assembled into the appropriate cable frequency bands with the desired pre-emphasis and impedance.

As has been mentioned, the recent systems have all been of the single-cable variety, i.e. the signals for both directions of transmission are carried over a single cable, the separation of the two directions being effected by the use of different frequency bands. A typical cable frequency spectrum is shown in simplified form in Fig. 4. It will be noted that the two terminals are designated 'A' and 'B'; by convention the 'A' terminal transmits the lower frequency band and receives the upper frequency band.

In the design and construction of terminal transmission equipment, considerable effort must be employed to ensure that the stringent performance criteria that are essential can be met.

Such criteria arise from the possibility that a circuit will traverse several sets of cable terminal equipment in an international connection. (To take an extreme example, a London-Kuala Lumpur terrestrial circuit traverses 12 submarine cable sections.) It is a further requirement of most submarine systems that because of their high capital cost, they should be suitable for carrying 3-kHz-spaced audio channels rather than the 4-kHz-spaced channels usual on inland systems, in order to make the most economical use of the available bandwidth. This requirement can be met satisfactorily only if the unwanted tones which commonly occur on carrier equipment as multiples of 4 kHz (due to the necessary use of carrier supply equipment generating carrier signals of comparatively high power at multiples of 4 kHz) are eliminated or suppressed. The discrimination required against such tones is commonly 70 dB down on test-tone levels, whereas for systems designed to carry only 4-kHz-spaced audio channels these tones fall between channels and the discrimination required is very much reduced. A further complication is that the submarine system terminal equipment must be capable of working satisfactorily when connected to a system in which the repeater nearest the terminal might be any distance, varying from a few yards to a full repeater section of several miles from the terminal, as dictated by system planning conditions. It is thus necessary for the relative levels at the interface between terminal equipment and cable system to be capable of variation over a range of 40 dB or more without degradation of

performance—no mean achievement for modern systems carrying upwards of 600 channels.

Due to the high-revenue-earning capacity of inter-continental circuits and the corresponding high loss of revenue (and customer-confidence) resulting from even quite short interruptions, the reliability of the equipment is of the utmost importance. A recent British development, the 5-MHz submarine cable system, for example, is capable of carrying up to 640 simultaneous telephone conversations and the failure of one amplifier, say, in the terminal equipment, could result in interruption to all of these circuits for several minutes. Transmission paths are usually duplicated, therefore, so that alternative equipment can be switched in quickly should any fault, or incipient fault, become apparent. The more recent systems employ automatic changeover schemes controlled by pilot signals and in these cases the break in transmission caused by transmission path failure is reduced to 10–15 ms. Intentional changeovers, initiated manually, to facilitate maintenance routines for instance, result in breaks of less than one millisecond.

Comprehensive pilot signal facilities are employed to monitor the performance of the terminal equipment

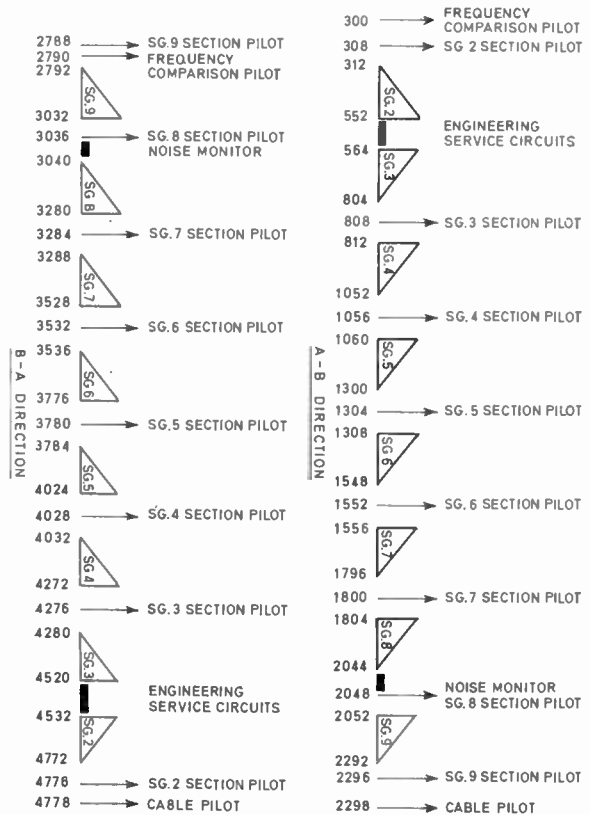

Fig. 4. 5-MHz deep sea submarine cable system frequency spectrum.

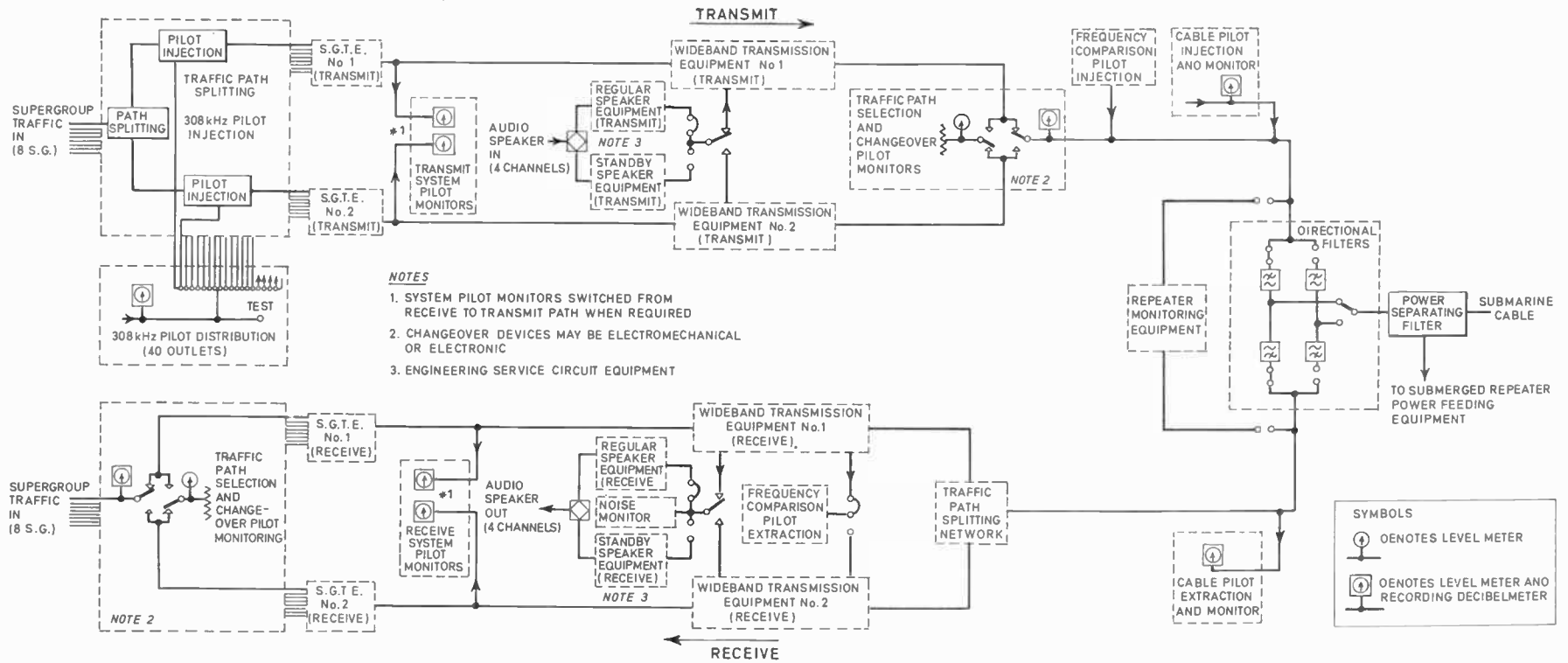

Fig. 5. 5-MHz submarine cable system. Block schematic of terminal equipment.

and the submerged system but it is not usual to use automatic gain regulation techniques since submarine systems are extremely stable.

A block diagram of a typical terminal equipment arrangement is given in Fig. 5 (a recent British 5-MHz system).

4.2.3. Submarine systems power-feeding equipment

The power-feeding equipment is located in the submarine cable terminal station. Its purpose is to feed along the cable central conductor the direct current necessary to energize the submerged repeaters. The return path for the current is provided by earth connections at both ends. Since the repeaters are connected in series as far as the power feeding equipment is concerned, the current to be supplied is a constant factor for a given design of system regardless of length. The voltage to be supplied depends on the following factors:

- (a) voltage drop per repeater;
- (b) number of repeaters in the system;
- (c) total resistance of the cable centre conductor;
- (d) difference of potential which may from time to time exist between the points on the Earth's surface near the terminal stations where the system earth electrodes are located;
- (e) whether the system is to be fed with power from one or both ends of the cable.

It is necessary to ensure that the line current is regulated within close limits of the design value, typically 0.5%, in order to obtain maximum life from repeater components, particularly valves, and to maintain constant gain. Particular attention must be paid to transient response so that when power is applied to an uncharged cable, or in the event of a cable fault or interruption, excessive current surges are avoided.

The total system voltage may be extremely high. A system has been in use for several years which has a total voltage of 11.8 kV, and still higher values will soon be in service. Such voltages exceed the permitted maximum potential to earth that the repeaters can safely withstand. It is therefore arranged that one

terminal station supplies a potential to the cable equal to about half the total system voltage. The distant terminal power feeding equipment is then connected in 'series-aiding' so as to provide the other half of the system voltage, and to take up any variations in earth potential, etc., so that the line current is kept sensibly constant. This arrangement is called 'double-end feeding'.

In order to reduce the likelihood of the cable system accidentally losing power, it is normal to use two supply units at each end of the system, each of which usually provides part of the system power and either of which is capable of taking over immediately the full load should the other fail (see Fig. 6).

For added security each supply unit draws its input power from a separate source (see Figs. 7 and 8). For these long systems it is often thought desirable to provide a duplicate suite of power feeding equipment at each terminal with facilities for load transfer without interrupting power.

For shorter systems where 'single-end feed' is permissible it may nevertheless be decided to provide facilities for 'double-end feed' for security of service. In such cases it is highly desirable that the design should permit instantaneous reversion to 'single-end feed' in the event of failure of the equipment at one end. Two power supply units would usually share the load at each end but it would not be necessary to provide standby suites of equipment and load-transfer facilities.

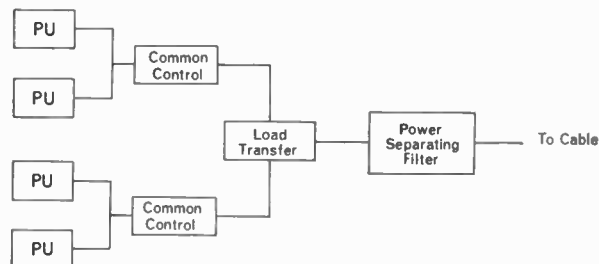

Fig. 6. This power-feeding set-up is duplicated at the far end of the cable when double-end feeding is necessary. Any one power unit (PU) can feed half system-volts. Where single-end feeding is permissible two PUs without load transfer facilities are used at each end. In this case any one PU can feed the total system volts.

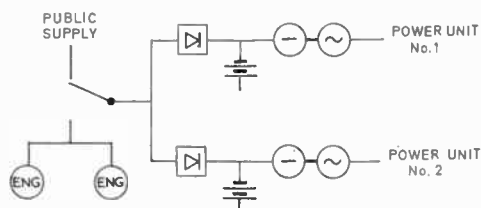

Fig. 7. A typical power chain using rotating machinery to give a no-break a.c. supply.

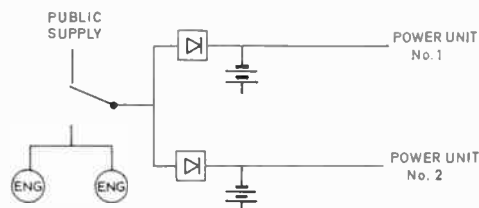

Fig. 8. A simplified power chain using inverters with the power-feeding equipment.

If for any reason it should be found desirable to provide power-feeding equipment at one end only of a short cable system, and in this context 1000 miles might be considered short, one would also consider providing a standby suite and load-transfer facilities.

In view of the high voltages used the equipment design incorporates safety interlocks, and since at the time of applying power to the cable adequate communications may not exist between the terminal stations (or between cable ship and shore during laying and repair operations), detailed safety procedures are laid down and rigorously followed.

The power-feeding equipment is provided with alarms which draw attention to deviations from normal current and voltage values. Deviations in excess of predetermined values are arranged to switch off the equipment if they are such that a dangerous situation could arise or the cable and repeater system could be damaged.

4.2.4. Submarine repeaters

A repeater is an assembly of filters, amplifiers, equalizers and other electronic components enclosed in a single watertight and pressure-resistant steel housing. Since the advent of torsion-balanced lightweight cable (described in Section 4.2.5) it has been possible to employ repeaters of dimensions capable of taking equipment for both-way transmission thus obviating the need for two unidirectional cables.

As stated above, great importance is attached to reliability and during repeater manufacture and assembly, meticulous attention is paid to every detail that might be a cause of failure. To increase reliability in service, valve-type repeaters are fitted with two amplifiers so that in the event of failure of one, service can still be maintained without interruption. Transistor repeaters are expected to be even more reliable.

Common duplicate high gain amplifiers are provided for the two directions of transmission and these are associated with directional filters and feedback networks. Each repeater contains built-in equalization of the repeater gain characteristic to match the characteristic submarine cable loss. Residual misalignments are corrected by the insertion of submerged equalizers approximately every 10 repeaters.

Supervisory circuits comprising filters and frequency-doublers or modulators are also incorporated in each repeater. These circuits enable the terminal station to verify the performance of each repeater as regards gain, noise and intermodulation.

The maximum power-feeding voltage which can be withstood by the end repeaters is the limiting factor as regards the length of valve-type repeated systems. The voltage drop across a valve repeater with 415 mA

d.c. is about 75 V; whereas transistor repeaters require a feed current of approximately 150 mA with a voltage drop of approximately 20 V across each repeater.

4.2.5 Submarine cable

The fundamental properties required of submarine cable are integrity against natural and man-made hazards during and after installation and predictability of electrical performance to facilitate the construction of high-performance systems. There are two basic types of coaxial submarine cable, lightweight—used in deep water (over 1000 m), and armoured—used in shallow depths where the cable is more vulnerable to damage.

The inner conductor of lightweight cable is of tubular construction and because of the skin conduction effect at high frequencies it is possible for the strength member of the cable to be at the centre. The strength member is constructed of high tensile steel wire arranged in layers of opposite lay thus avoiding the tendency to twist under tension and the subsequent kinking experienced with conventional cable which is armoured with helical single-lay exterior wires. An additional advantage is that the strength member is completely protected from corrosion.

The coaxial structure of both lightweight and armoured cable comprises an inner conductor of copper tape (solid copper centre in the case of some armoured cables) and an outer conductor over the polythene insulation of helical or longitudinal aluminium tape. Copper tape is used for the outer conductor of some American cable types. An outer sheath of polythene is extruded over the outer tapes. In intermediate and shallow depths armouring wire is used overall.

Specially designed ships are necessary for laying the cables on the ocean bed.

4.3. Submarine System Maintenance

Because of the importance and high revenue-earning capacity of long distance repeated cables, every effort is made to prevent the occurrence of interruptions and to ensure that the out-of-service time is kept to a minimum when these do occur. Some of the steps taken to this end in system design have already been described. Physical interruptions to the cable continuity can occur, however, and for the repair of such interruptions a small fleet of cable repair vessels exists. These highly specialized ships are stationed at various strategic positions all over the world, ready to undertake a repair at very short notice.

Associated with each ship base there is usually a depot where spare submarine plant, additional to that

carried on the ship, is stored. Sufficient spare plant (cable and repeaters) is usually carried to cover any catastrophic event as well as any normal interruptions which may occur during the life of each system.

The majority of cable faults are due to fishing activity and ships' anchors. Although heavier armouring of the shallow-water coaxial cables has been adopted to counter these hazards, the increase in the size of trawlers as well as their numbers, together with the tendency to fish at greater depth, is likely to increase the cable failure rate due to these causes. A ploughing-in technique for burying cables is now in process of development and it is hoped that this will result in a reduction of hazard from man-made causes.

Repeater failure to date has been very small. Of some 1000 submarine repeaters in service on Commonwealth systems, only one fault resulting in interruption to traffic has occurred. Due to natural wear-out of components the repeater failure rate may increase slightly, but the indications are that average repeater life will extend well beyond the previously estimated 20 years.

4.4. Future of Submarine Systems

A trans-oceanic system capable of transmitting 1140 4-kHz circuits will shortly become available. This represents a tremendous advance when one considers that 13 years ago the first trans-oceanic system was laid with only 36 voice circuits.

The world-wide demand for more sophisticated communications facilities continues to increase and even further development of submarine systems is within the realm of possibility. A significant reduction in the attenuation of coaxial cable, perhaps by the use of different materials and/or design would be a logical first step. In the future, transmission by submarine waveguide and powering of submarine repeaters by radioactive-isotopic generators are two further possibilities, but enormous problems will have to be overcome before a flexible low-loss waveguide, capable of withstanding submarine pressures, can be contemplated seriously.

Much has been written and said about the future of submarine systems in relation to satellite systems. Both methods of long distance communications are in the process of quite rapid development and it is now almost universally accepted that they will co-exist in the future. In fact a wholly satisfactory world network would not be possible without the complementary use of both systems. For example, the introduction of high-grade multiple access satellite communications between points which at present have quite small traffic streams, may be expected to stimulate demand, so that after some years one or two of the routes concerned will carry sufficient traffic to justify the provision of a cable.

5. Satellite Communications

The global network of submarine telephone cables has linked all continents and provided high usage routes between most of the major world centres of trade. Satellite communications, now developing very rapidly, can provide a similar service, whilst offering the additional facility of multi-point destinations individually comprising a small number of channels. The capital cost of an Earth station and the satellite capacity rentals are such that this method of communication becomes viable when carrying a total of 24 or more circuits.

The present practice in satellite communications is to use synchronous satellites, and planned systems also use this type of satellite. It was thought at first that the transmission delay of approximately 250 ms would prove unacceptable to telephone users, due to echo suppression difficulties, but several years' experience has shown that these circuits are acceptable. Only three such satellites are necessary for global coverage (Fig. 9).

INTELSAT, an international body which owns and controls (through the Interim Communications Satellite Committee (I.C.S.C.)), the spacecraft used in the global system, has four types of system in operation or in an advanced stage of planning, known as *Intelsat I, II, III* and *IV*. *Intelsat I* (formerly known as *Early Bird*) and *II* are already in operation providing 240 circuits through each satellite. *Intelsat III*, put into orbit early in 1969, has an individual satellite capacity of 1200 circuits, and *IV* is expected to top the 5000 mark. The satellites receive signals in the 6-GHz frequency band, and retransmit them in the 4-GHz band.

Due to present limitations in satellite radiated power, it is necessary for Earth stations to use highly directive antennae, and cooled parametric pre-amplifiers in order that the received signal be above an f.m. threshold already extended by feedback techniques. The most recent advances in Earth station technology are in the design of parametric amplifiers of exceptional bandwidths, now over 500 MHz at the 1 dB points, and in the 'shaping' of the antenna surfaces to achieve the maximum gain possible. The I.C.S.C. have laid down performance criteria which Earth stations must satisfy before they are allowed to operate with the INTELSAT system. The prime factor is the Earth station 'figure of merit', defined as the ratio of antenna gain at 4 GHz to the receiving system noise temperature. Modern receiving systems, employing parabolic antennae approximately 27 m in diameter, and parametric amplifiers cooled in closed-circuit helium cryogenic systems, are achieving figures of merit of about 41.5 dB referred to 1°K.

It seems certain that the future development of

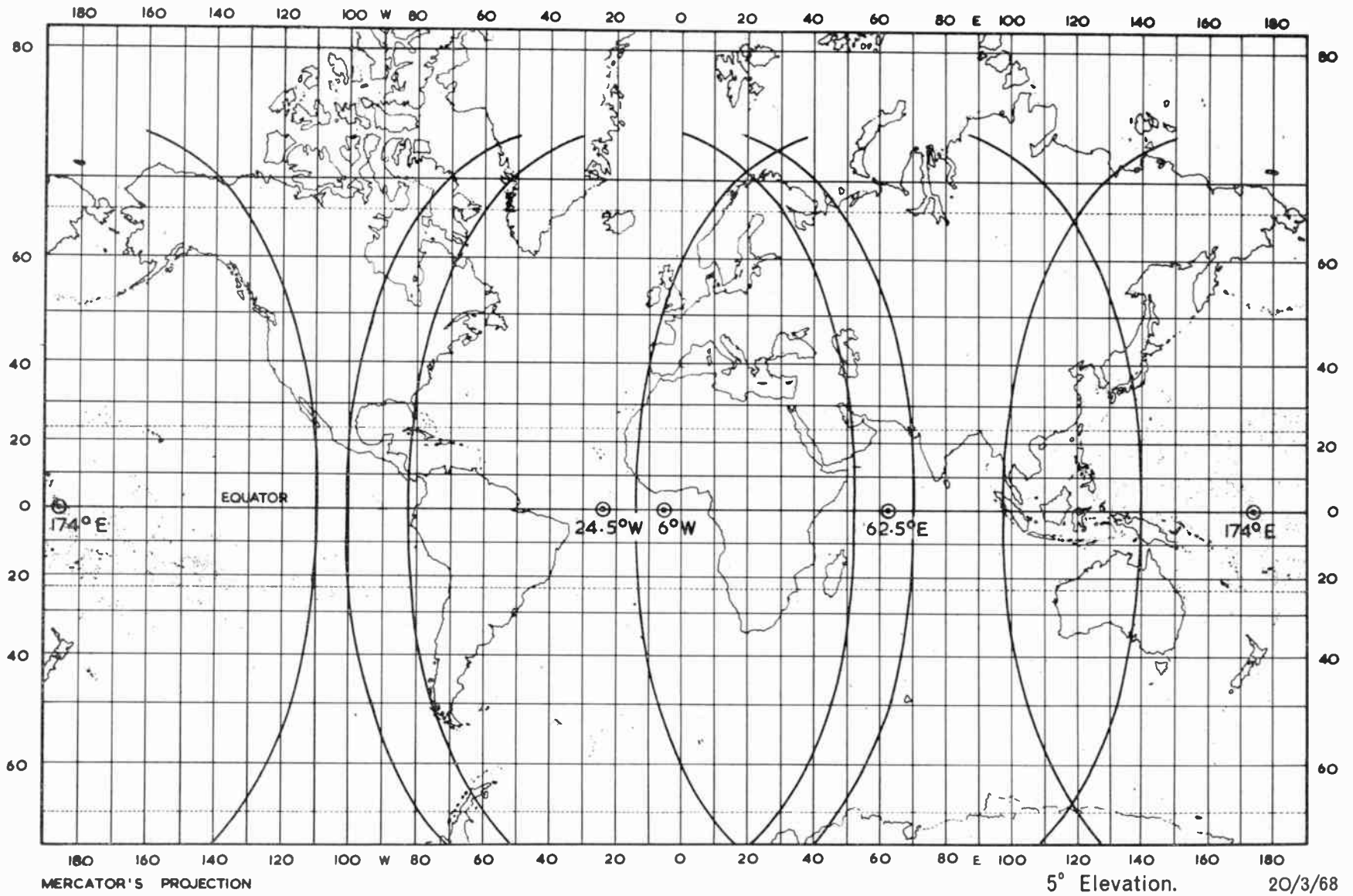

Fig. 9. Intelsat III coverage areas.

satellite communication systems will be based upon increasing satellite-radiated power. The use of directive aerials has been limited by the spinning of the whole satellite for stabilization purposes. The *Intelsat III* series satellites will have a mechanically-despun aerial system, and it is expected that electrically-despun aerials of improved reliability will follow.

The power amplifier capability of satellites is limited by the available power supply, and the need to avoid intermodulation between carriers transmitting through a common amplifier by working below the saturation power of the output tube. Power supplies have so far been based on solar cells and much improvement in efficiency of these devices has been obtained. Nuclear power sources are not featured in any plans at present, although satellite experiments have used them.

Increasing the available power from the satellites will enable savings to be made at the associated Earth stations. The *Intelsat IV* series satellites will be bandwidth limited, i.e. their capacity will be determined by the bandwidth of the satellite transponders (there would be several in each satellite) and not by the total power output available as at present. This could result in stations with smaller antennae becoming economic, and the prospect of dispensing with cooled parametric amplifiers with their attendant maintenance and servicing requirements would be welcome.

The use of higher frequency bands, particularly 10–15 GHz, and up to 30 GHz, is under study, although here the main emphasis is on regional and domestic use.

Satellite systems have proved their value as trunk telephony bearers; they have provided intercontinental television links for the first time; future uses under investigation include navigation, ship-shore and air-ground relay, improved meteorological surveying and, possibly, television broadcasting direct to domestic receiving apparatus. This last application would require narrow beam satellite transmitting antennae and extremely accurate station-keeping synchronous satellites, so that antenna steering at the receivers is not required.

It should be mentioned that military satellite communication systems have also been established, and their potential in this field is also very great.

6. Line-of-sight Radio Relay Systems

Radio relay systems comprising a large number of line-of-sight links operating at microwave frequencies (2–10 GHz) are widely used for both national and international bearer circuits. Because such systems are required to carry all types of traffic, the performance requirements for each individual link must be

stringent, if the overall performance of, say, 50–100 such links in tandem is to be acceptable. Radio relay systems of significance globally normally operate to the standards recommended by the International Radio Consultative Committee (C.C.I.R.).³

6.1. Characteristics of the Radio Path

The use of frequencies between 2 and 10 GHz means that optical distances only can be traversed in single hops, since path losses increase rapidly if the line-of-sight condition is not met. Narrow beam aerials are used, of parabolic or horn-reflector type giving beamwidths of the order of 1°. Thus ray optics can be used to trace the path of the signal, and reflection and possible obstruction points observed visually from proposed sites. Microwaves are subject to refraction by atmospheric inhomogeneities and reflection by buildings and the sea.

Route planning must take account of possible sub-refraction conditions, when the radio waves are bent towards the Earth, resulting in near obstructions becoming actual obstructions. This is particularly important on oversea paths where reflections can cause difficulties before actual obstruction takes place. At the higher frequencies, rain causes serious attenuation.

If line-of-sight conditions cannot be attained between terminals it may be possible to use single or double passive reflectors, consisting of large (up to 14×18 m) flat bill-board structures. These are normally employed only at the higher microwave frequencies.

6.2. Station Configuration

It is normal practice in microwave systems to arrange for an extra r.f. channel on each link so that poor conditions or equipment failure on one of the main channels does not cause loss of service. The spare channel may be common to several main channels, and occasionally it may be used independently of main traffic channels for television programme links.

On difficult links, two r.f. channels may be provided for each baseband, and either frequency or space diversity used with combiners or switch selection of the better channel at the receiving station.

Where the capacity required on a trunk route exceeds that of one r.f. carrier, several may be used in the same frequency band. On highly congested routes it may be necessary to use several frequency bands and in this case the horn reflector-type aerial is preferred since it can handle several r.f. bands whereas separate centrally-fed or Cassegrain-fed paraboloidal aerials would be required for each band (Fig. 10). This difference in performance results from the long flare which is possible in the case of the horn reflector

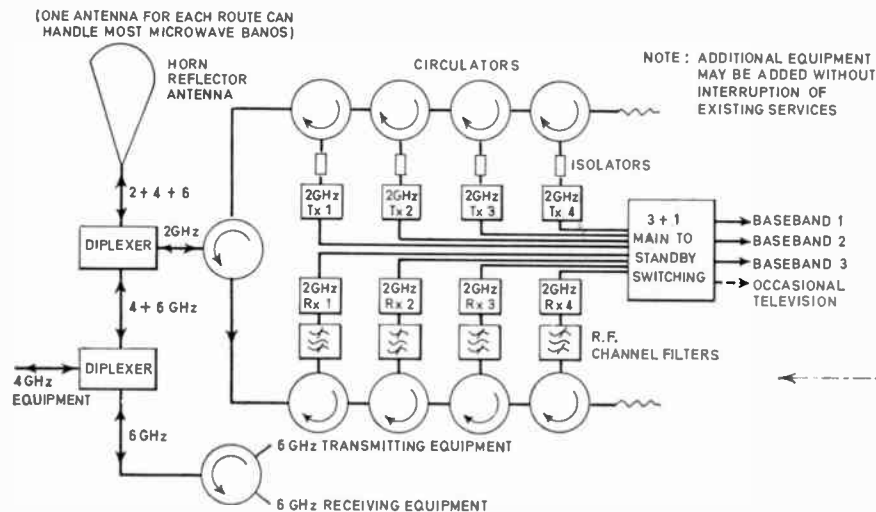

Fig. 10. (left) Microwave terminal configuration for 3 + 1 4-GHz and 2- and 6-GHz systems.

aerial which provides a good match over a wider bandwidth than is the case with the feed arrangements for the normal paraboloidal aerials.

To avoid feeder runs to the top of tall towers use is occasionally made of the arrangement shown in Fig. 11, but this can only be used where r.f. channels can be adequately spaced to avoid increased interference problems.

6.3. Equipment

Most modern microwave equipment is completely solid state; the only exceptions are output power amplifiers (often travelling-wave tubes) and receiver local oscillators (occasionally klystrons). This results in low power output (typically 2 W at 2 GHz falling to ¼ W at 7 GHz) but electrical power requirements are much reduced, enabling use of thermoelectric and other self-contained power sources for repeaters sited on remote mountain-tops.

6.4. Future Possibilities

As in the satellite communications field, one of the most obvious future developments is the increasing use of higher frequency bands. Increasing propagational difficulties are expected due to atmospheric absorption and multipath effects,⁴ and it may well be that alternative routing ('geographical diversity') will be necessary to avoid the effects of rainfall attenuation.

It is to be expected that the capacity of microwave systems will increase, but there may be less need for very high-capacity systems as alternative routing becomes more widespread. It is also possible that another form of transmission, e.g. domestic or regional satellite systems or guided microwave, will take over as the highest capacity bearer. Microwave radio relay equipment of 2700 voice circuit capacity has recently become available.

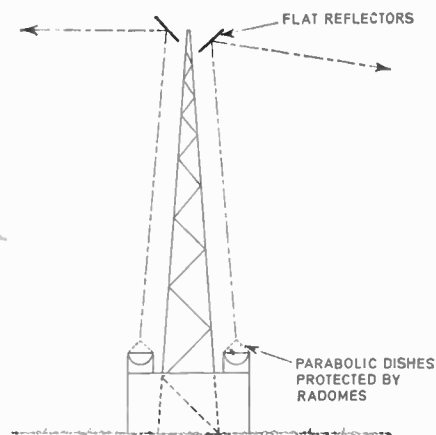

Fig. 11. Repeater station using reflectors.

It is likely that higher transmitter powers and improved receiver noise figures will be achieved in fully solid-state equipments as techniques and solid-state devices advance. It is probable that the use of higher frequency bands will depend upon suitable solid-state devices being available.

With improvements in equipment reliability, the number of standby channels required decreases and 7+1 2700-circuit systems are quite possible compared with the present 6+2 960-circuit systems.

7. Tropospheric Scatter Systems

Tropospheric scatter systems are widely used by military authorities where the lack of repeater stations is a security advantage and the somewhat poorer performance and restricted capacity, relative to microwave systems, is acceptable. Civil use is in general limited to those links, for example between islands,⁵ where repeaters are impossible and yet overall link lengths are sufficiently short that performance roughly comparable with that of a coaxial cable can be achieved, but at lower cost.

7.1. Restrictions

Due to the nature of the propagation mechanism, the deflection of u.h.f. radiation to the receiving station far beyond line-of-sight by elevated elemental

layers in the troposphere (Fig. 12), high and widely variable path losses are encountered. To achieve an acceptable performance, large antennae (up to 35 m) and high transmitter powers (normally 1 or 10 kW) are used, together with diversity receiving techniques, normally a combination of space and frequency separated (Fig. 13). It is often necessary to resort to low-noise preamplifiers (transistor, tunnel diode, or parametric, depending upon frequency band) but cryogenics are not worthwhile since the antenna noise figure (which is high since it points at the horizon) determines the receiving system noise figure. F.m. feedback techniques may be used on marginal circuits.

A major source of noise in high capacity, long distance scatter systems is path intermodulation caused by frequency selective fading in the propagation medium. Although high gain aerials to some extent offset this, it becomes the limiting factor when high capacity is required. Normal capacities are 48–120 telephone channels.⁶

7.2. Future Development

From what is said above, it is apparent that tropo-scatter systems are limited by the nature of the propagation mechanism, rather than by any shortcomings in equipment capabilities. It is expected, therefore, that any major improvements must come

from studies into the ways of combatting these adverse conditions, and the outcome of these is harder to predict than equipment developments. However, some promising lines of research at present are concerned with new forms of diversity, e.g. angle diversity, and new forms of modulation, specifically pulse code modulation.

There is room for considerable improvement in the design of combiners, either baseband or predetection, and the extension of low-noise transistor amplifiers to the 2- and 4-GHz bands can be expected.

It is unlikely that large advances in tropospheric scatter systems will take place, but increasing use of systems of the present type will be made as broadband communications are required in remoter areas. There are at present some 3 million equipped circuit miles of tropospheric scatter systems in the world, including those carrying military traffic only.

8. Long Distance Waveguide Transmission

There seems little doubt that the next two decades will see increasing use of guided microwaves for very high capacity trunk bearer circuits. This form of bearer is unexploited at present, and its potential is great.

Waveguides, usually of rectangular cross-sections, are commonly used as microwave feeder lines, but the

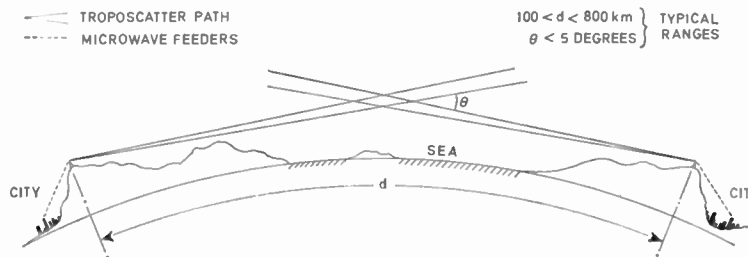

Fig. 12. Typical troposcatter path profile.

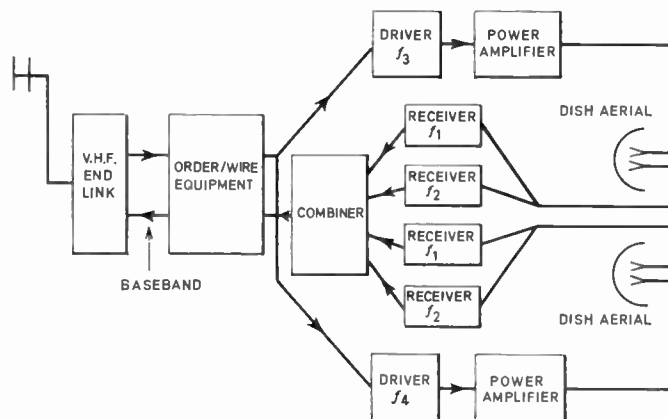

Fig. 13. Quadruple diversity terminal.

configuration most likely to be used for longer distance transmission employs a very low loss mode of propagation in circular cross-section guide. Problems to be overcome include mode conversions at irregularities and at bends, where power is lost due to formation of much more lossy modes, and the design of economical and practical repeaters, and launchers.

It has been estimated that as many as 100 000 telephone circuits could be carried by one such system, and it has been suggested that waveguides be laid into new motorways to alleviate wayleave problems and facilitate straight sections. Perhaps it should be questioned whether it is wise to gather so many channels into one bearer, and whether limitations in reliability would not force alternative routing.

At present conventional microwave radio relay systems are expanding rapidly, but it may be found necessary at some point to 'go underground' to avoid mutual interference problems on some routes.

9. The Laser

The laser is perhaps one of the most fascinating devices in the field of communications, in that its output of coherent light can be modulated in the same ways as can a radio-frequency carrier.⁷

It has been said that with suitable modulation techniques a single laser beam could carry all the conversations which are, at any moment, taking place all over the world. However, as indicated in Section 6.4, the need for, or even desirability of, bearers of such enormous capacity is in some doubt. Firstly, there is no single route which will require such capacity in the foreseeable future and, secondly, bearers carrying great numbers of circuits of all kinds entail correspondingly heavy investment in standby and auto-

changeover facilities. Route, or 'geographical' diversity would be essential.

The laser beam is affected by atmospheric turbulence, and for reliable communication it would seem essential to enclose the beam in a tube, within which stable refraction conditions can be maintained, with refocusing devices at intervals between repeaters.^{8, 9} These requirements rob the laser of some of its potential advantage over conventional microwave systems and suggest a closer comparison with guided microwaves. The very high potential traffic capacity of the latter type of system also means that it will be a long time before we have to use the laser for the sake of its enormous information carrying ability. It remains to be seen whether, in due course, economic considerations favour guided-microwave or laser systems.

If lasers do come into general communications use, national rather than intercontinental networks are likely to be the first to benefit, since the problems involved in building a transoceanic laser system are immense, though in these days one hesitates to say insoluble.

Laser repeaters in earth-orbiting satellites could also be used for intercontinental communications, but there are conflicting opinions about the relative efficiencies of lasers and microwaves for space communications.^{10, 11}

Summarizing, then, one can only say that communicators are watching the continuing development of the laser with the greatest interest, and are setting up experimental links using it. Its general entry into the communications field as a device with clear-cut advantages over established techniques remains difficult to envisage in detail.

Part 2. EXPLOITATION OF BEARER SYSTEMS

10. Lincompex

One of the major difficulties in operating point-to-point radio-telephone circuits over h.f. paths has been the transmission of the varying amplitude content of speech intelligence by means of amplitude modulation over a path whose attenuation is constantly varying. Conventional compander techniques, as used on stable circuits, rely upon the retention of some of the original amplitude variation in the transmitted speech, and this is used to set the receiving compander continuously to the right point on its operating characteristic. This is obviously unworkable when the path itself introduces amplitude variations.

A further shortcoming of conventional h.f. radio-telephone circuits is that the wide variations in path-attenuation often cause a circuit to be operating at an overall loop gain. Singing would therefore occur if

special steps were not taken to prevent it by introducing singing-suppressors in the shape of voice-operated transmit/receive switching. Unfortunately received noise can cause malfunctioning of the switching circuits, with the result that received speech is 'clipped', small fragments of speech being suppressed due to the failure of the transmit path to open readily. Even when this effect is not immediately evident, the smooth flow of conversation is to some extent impeded by the existence of transmit/receive switching.

With the linked compressor and expander ('Lincompex') system of operating a radio-telephone circuit, the subscriber's speech is compressed to a sensibly constant level (in fact, two compressors operate in tandem to provide an output that is constant within ± 1 dB for input speech variations over a 40 dB range), while an amplitude assessor

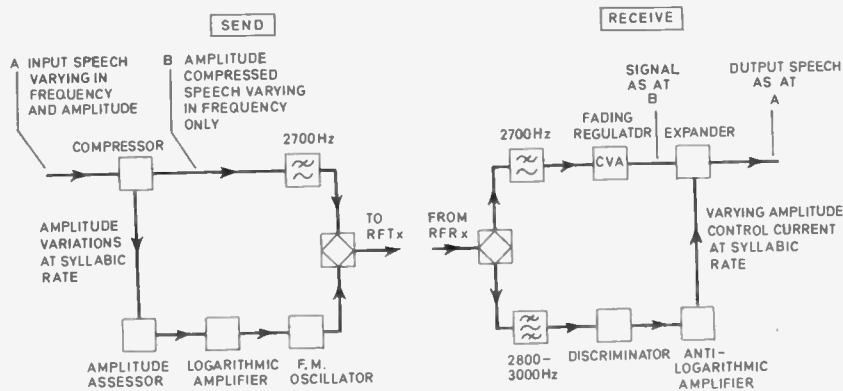

Fig. 14. Lincompex radiotelephone terminal simplified block schematic.

'extracts' the a.m. content of the speech intelligence in the form of a control current varying in magnitude at syllabic rate. This current modulates the frequency of an oscillator so that its output changes by 2 Hz for a change of 1 dB in level of speech input at the amplitude assessor. In order to achieve this relationship, however, the control current is passed through a logarithmic amplifier before being applied to the f.m. oscillator. The a.m. content of speech is thus transferred to a separate f.m. channel which is transmitted within the normal 3-kHz speech bandwidth to control the associated expander in the receive terminal. Although this channel is susceptible to interference, the narrow bandwidth of the filter in the associated receive terminal reduces the likelihood of such an occurrence and a reliable means of transmitting the amplitude intelligence is achieved.

A low-pass filter in the speech path restricts the upper limit of speech to 2700 Hz and the bandwidth of the f.m. oscillator is restricted to 2810–2990 Hz. The two paths are then combined to produce a composite signal within the normal 250–3000 Hz speech channel.

The steady level of the transmitted speech enables an improvement in transmitter utilization to be made, which in turn will produce a better average signal/noise ratio at the receiver.

At the receive terminal, the speech and control signals are separated and amplified to constant level in order to counteract any residual variations in amplitude caused by fading. The demodulated control signal develops a current which is used to adjust the expander gain, thus restoring the original variations of speech-signal amplitude (Fig. 14).

Since the expander output level depends solely on the frequency of the control tone, which is directly related to the input level at the distant terminal, the overall system can be maintained at a constant level, amounting to a small loss as on any stable telephone

transmission system. Singing suppressors, with their inherent disadvantages, become redundant, thus increasing the ease of conversation between subscribers. If, however, the route propagation delay is over 10 milliseconds it is necessary to follow normal telephone practice and use echo suppressors.¹²

The British Post Office, who developed the system, have carried out extensive field trials which have established a marked improvement in circuit usage efficiency over the performance of conventional terminal equipment.

A Lincompex r.t. circuit was set up between Barbados and Guyana early in 1968 and it is proposed to equip other circuits as quickly as possible. Over the years the Barbados–Guyana path has proved difficult to operate efficiently due to the high-density sporadic E layer often prevalent in that area which adversely affects ionospheric propagation. Reports on circuit performance with Lincompex are most encouraging.

The availability of Lincompex would have been a great asset during the era when the h.f. spectrum was the sole bearer of long-haul r.t. channels. However, even in the present day of rapid expansion in the wideband voice-multiplex field, h.f. has a continuing role to play in providing feeder circuits in many overseas areas and, less frequently, in long-haul situations where ready access into a wideband system is not convenient. It is in these applications that Lincompex will prove invaluable for three reasons.

(1) The widely varying levels which have to be tolerated when using conventional telephone terminals on h.f. circuits can cause overloading and distortion on individual channels of other multiplex systems where the two are linked. Lincompex ensures a normal range of speech levels.

(2) As subscribers become used to the high quality transmission standards provided on channels in stable voice-multiplex systems, they will be less patient with the poor quality and clipping often encountered on

conventional h.f. r.t. channels. Lincompex will make a considerable contribution towards reducing the possibility of a subscriber noticing any difference in the type of transmission medium being used.

(3) Initial tests to establish the feasibility of using pulse-tone dialling techniques over Lincompex have proved most encouraging.

In short Lincompex has an important role to play, not only on point-to-point h.f. services, but also as a means whereby h.f. and stable voice-multiplex systems can be satisfactorily linked together, to the benefit of communications as a whole.

11. Voice Multiplexing Equipment

Voice multiplexing equipment is employed at the transmit terminals of carrier telephone systems to assemble a number of audio frequency telephone channels into standard frequency bands which can then be presented to the carrier system terminal equipment. At the receive terminals, the multiplex equipment accepts a wideband signal from the carrier system and breaks this signal down into its component audio frequency channels.

The most commonly used method of assembling the individual audio channels into wide frequency bands is based on amplitude-modulated, frequency division multiplex principles, with single-sideband suppressed carrier transmission. Using these principles, each audio channel, after frequency translation, occupies a discrete part of the wideband frequency spectrum.

Another method of channel assembly is also available, notably time division multiplex (t.d.m.), which is now being used to improve the channel carrying capacity of junction circuits, and which may well extend into the international field in years to come.

11.1 Frequency Division Multiplex Systems

11.1.1. Channel assembly

The usual basic 'unit' for carrier telephone systems is the '4-kHz' audio channel, which has an effective bandwidth of 3.1 kHz, i.e. from 0.3 to 3.4 kHz. A 'group' is an assembly of a specified number of channels (normally 12 4-kHz channels) whose frequency bands occupy adjacent bands in a frequency spectrum. For an assembly of 12 4-kHz channels, therefore, the group bandwidth is 48 kHz.

Similarly, a 'supergroup' is an assembly of five groups, occupying a bandwidth of 240 kHz. Five supergroups are in turn assembled into a 'mastergroup' and three mastergroups into a 'supermaster group', although in these latter cases the bands are not continuous. For example, 8- or 12-kHz inter-supergroup spacing is usual in the assembly of mastergroups.

Audio channels of other bandwidths are sometimes

encountered. In particular, '3 kHz' channelling is in common use on submarine systems to make the most economical use of the available cable system bandwidth. Such 3-kHz channels have an effective bandwidth of 2.85 kHz and occupy the band 0.2–3.05 kHz. In this case, the 48-kHz group is assembled from 16 channels. The manner in which channels, groups and supergroups, etc., are assembled is governed by recommendations of the C.C.I.T.T. (International Telegraph and Telephone Consultative Committee) to ensure uniform standards and compatibility between administrations and operating agencies. Figures 15–19 illustrate the usual schemes by which channels are assembled, up to the supergroup stage. The numbering of channels, groups and supergroups is also illustrated.

11.1.2. Equipment

The basic equipment used for conventional voice multiplexing consists of:

Channel translating apparatus—for assembling channels into groups.

Group translating apparatus—for assembling groups into supergroups;

and so on.

The interface conditions, i.e. signal level and characteristic impedance between apparatuses, are largely standardized.

11.1.3. Ancillary equipment

Some flexibility in the interconnection of channel and group equipment, group and supergroup equipment and so on is usually desirable. For this purpose, distribution frames are interposed in the transmission path. These frames can be used in addition for the connection of ancillary equipment such as automatic gain control equipment, pilot injection and monitoring equipment, equalizing equipment, etc. At intermediate stations in a chain, where groups and supergroups are to be transmitted without demodulation to voice frequencies, 'through group' or 'through supergroup' filters can be connected as required using the distribution frames.

11.1.4 Development

Voice multiplexing equipment was first used in the early 1920s in conjunction with early, low capacity (e.g. three-channel) carrier systems. Since those days, the capacity of systems has increased tremendously. Inland coaxial cable systems carrying up to 2700 voice channels are currently in use. Multiplex equipment construction practices have developed accordingly and whereas with the early equipment the channel translating apparatus alone occupied one rack and had a capacity of only three channels, current practices employing fully transistored, modular construction techniques enable one 9-ft high rack, occupying a floor

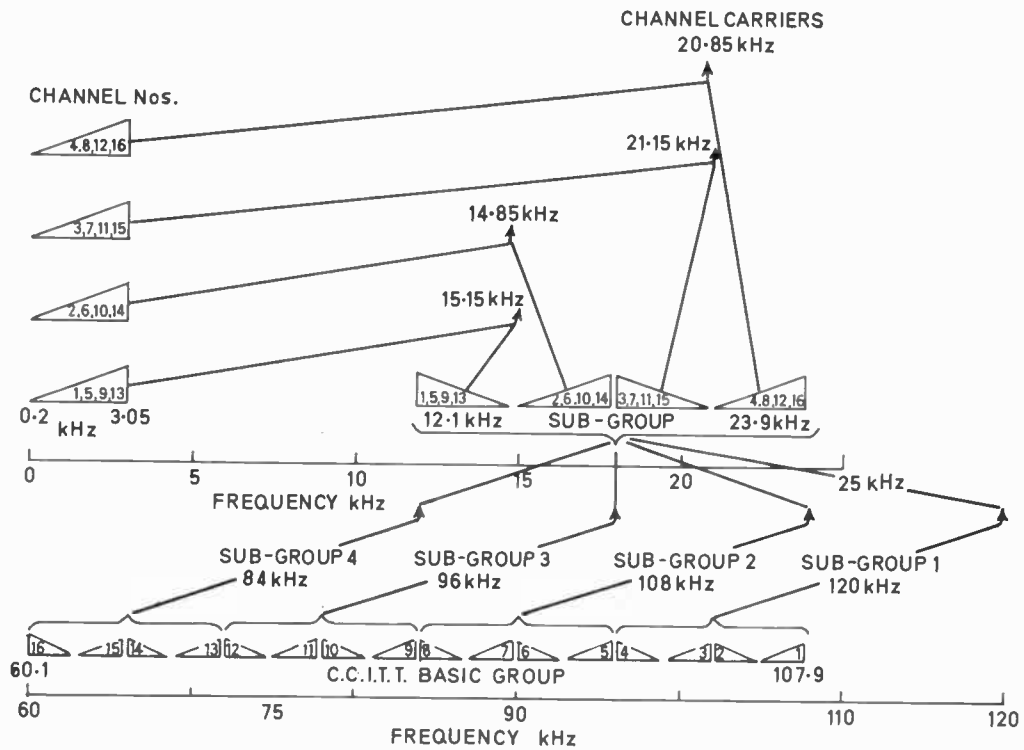

Fig. 15. 16 x 3 kHz translation (double mod/demodulation).

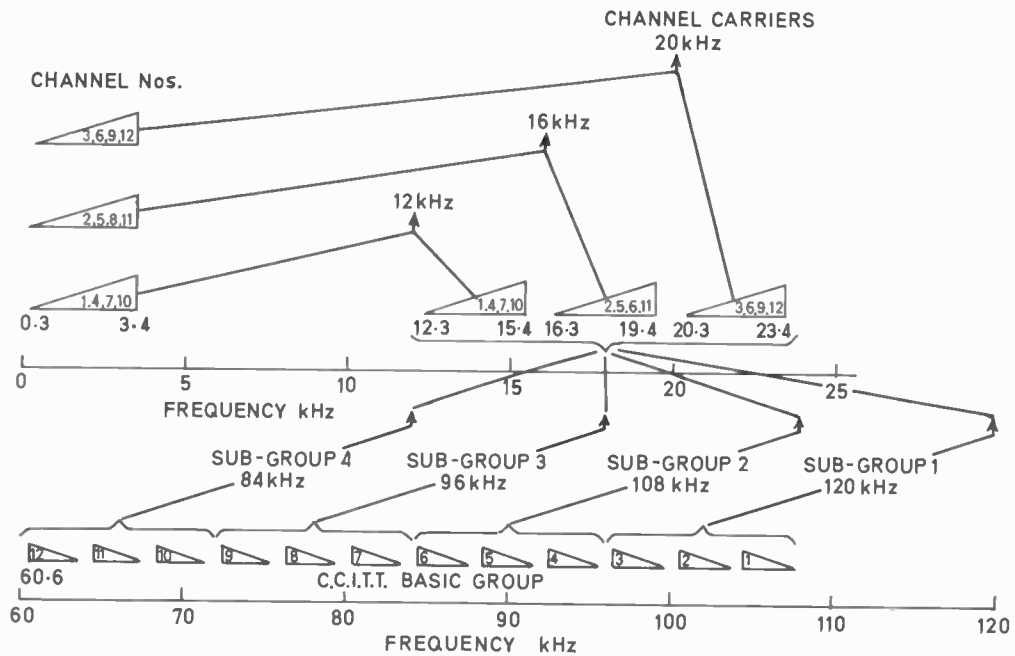

Fig. 16. 12 x 4 kHz translation (double mod/demodulation).

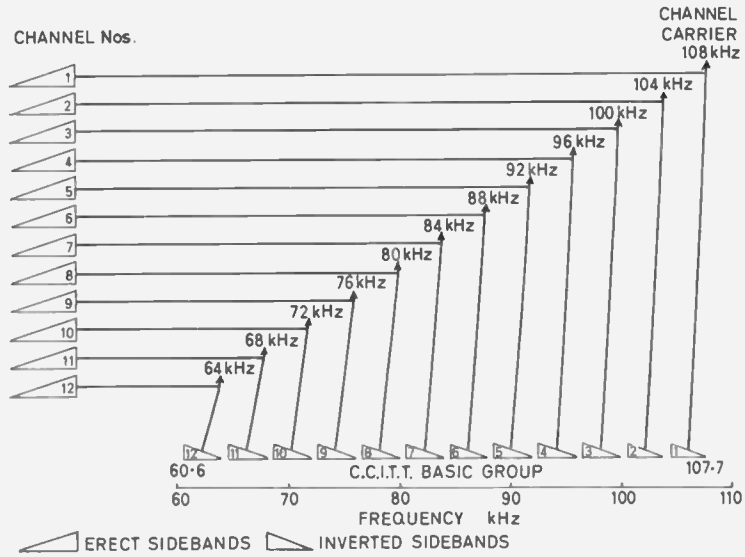

Fig. 17. 12 × 4 kHz translation (single mod/demodulation).

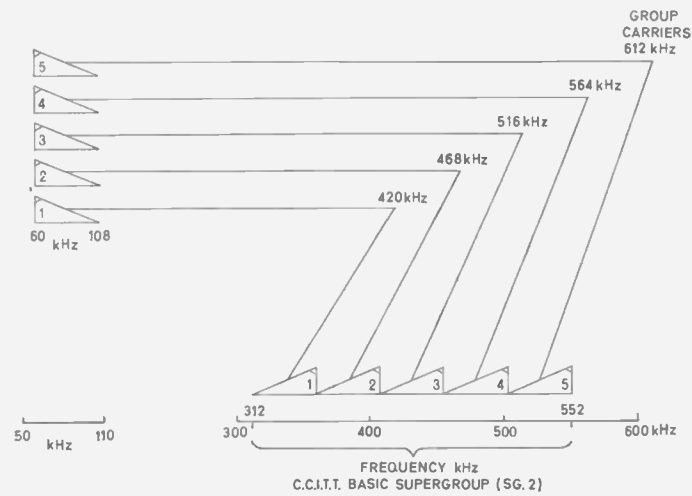

Fig. 18. Group translation.

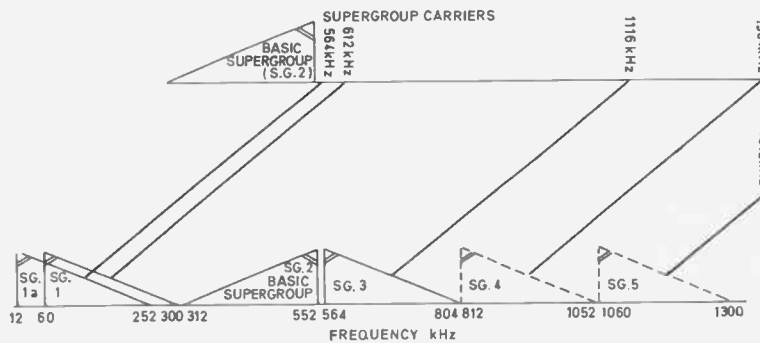

Fig. 19. Supergroup translation.

area of less than $2\frac{1}{2}$ ft², to accommodate up to 180 channels.

11.2 Time Division Multiplex

This method of channel assembly entails the sampling of the signal in each channel at intervals which are sufficiently small to allow the highest wanted channel frequency to be followed.

The samples are converted into digital form and this may be done in a number of ways, e.g. pulse position modulation, pulse width modulation and pulse code modulation. The latter is the system which is already in use on junction circuits, and it is widely preferred because of its good noise immunity and because it facilitates regeneration.

Encoded samples from the various channels to be transmitted are interleaved to form a high speed pulse train which becomes the equivalent of the f.d.m. baseband. Channel reception takes place by means of the synchronous examination of all samples representing the signal in that channel, and the conversion of the samples back to analogue form.

There is as yet no international agreement on a t.d.m. multiplexing hierarchy such as exists in the case of f.d.m.^{13, 14}

The wider use of t.d.m. would have implications in the national and international switching field which are touched upon later.

An interesting possibility, which has been shown to be feasible, is the use of t.d.m. instead of f.d.m. to provide multiple access to communications satellites.¹⁵

12. Telephone Switching

12.1. Growth of International Telephone Traffic: Transit Switching

The great improvement in transmission quality of submarine cable and wideband radio circuits compared with conventional h.f. radio has been a most potent influence on demand, and wherever these facilities have been introduced for the first time an immediate increase in international telephone traffic has been experienced, often of 100% or more. When accompanied by improvements in the national networks feeding the international routes, such as the introduction of fully automatic working (s.t.d.), even greater increases are experienced. As stated in Section 1 continuing growth rates averaging 20% per annum are being experienced in the field of international telephony, and this means that demand doubles in less than four years.

Faced with such increases it is apparent that it would be quite impossible to continue to operate international telephone services on a manual basis, requiring the services of operators in both the country

of origin and that of destination working point-to-point circuits on a ringdown basis, as had been the practice in the days of h.f. radio. The first step in rationalization is to introduce semi-automatic working whereby the operator in the originating country is able to dial direct to the distant subscriber without requiring the intervention of the distant operator. Such a method of working reduces the number of operators and operating positions required for the international service and can reduce unremunerative occupancy of the circuit.

It is, of course, neither technically practical nor economically justifiable to provide direct semi-automatic circuits between all countries whose inhabitants might at some time require to communicate together so that at an early stage in the development of an international network it is necessary to provide automatic transit switching centres to connect together international trunks, and thereby interconnect countries between which there are no direct circuits. These transit switching centres are similar to conventional telephone exchanges, but must be able to recognize the country to which the call is to be routed and switch it to that country or, if no direct circuits are available, to the next transit exchange in accordance with routing information which is stored in the control equipment of the exchange. This capacity to store routing information, which may occasionally have to be revised, is one of the major requirements of a transit exchange. Others are that the time to set up a connection shall be kept to a minimum and that the transmission performance shall be consistent with that of the systems being connected together. The type of exchange which meets these requirements most satisfactorily today is the electromechanical crossbar system, since this has a central processor (or common control) which is very suitable for controlling the routing of international traffic. However, there are many developments in exchange technology only a few of which we can consider here.

12.2. Techniques of Transit Switching

The principles of central processor control (or common control) were established many years ago in the crossbar type of exchange. Here the switching machine is built up of crossbar switches (or multi-selectors) each of which have typically 20 inlets and 50 outlets, any inlet being connected to any outlet by operation of appropriate relays. The central processor takes the form of electromechanical registers and markers which, on receiving the digital information relating to a call from the incoming junction or subscriber's line, determine by means of inbuilt logic how the call is to be established through the switching matrix and operate the appropriate crossbar switch relays.

This division of the exchange into the two areas of switching and control gives the development engineer an interesting opportunity when the rising cost of electromechanical components but the falling cost of electronics encourages him to investigate the possibility of an electronic exchange. In the field of control there is much to be said for the introduction of electronic techniques. The high speed of solid-state logic leads to a reduction in number of control elements required while the development of computer technology has paved the way for stored program control. This type of control relies for its decision-making function on a program written in a semi-permanent store, while the logic functions are performed under the control of this programme in a minimum of solid-state logic. Such a control system has great flexibility, enabling standard hardware to be used for a very wide range of control, network management, traffic observation and other functions.

On the switching network side, the prospects for the application of electronics are not so favourable. The speed of the operation of solid-state circuitry is not of any advantage in space division networks, where each connection is given an individual path through the network for the duration of the call. This capability is of value in time division networks, where a common path is shared by a number of different connections on a time sharing basis, but where the incoming and outgoing links are analogue in form the cost of per-line multiplex equipment is prohibitive. However, with the development of p.c.m. as a modulation system in its own right, and the resultant presentation of links to the network in a digital form, the cost of multiplexing is considerably reduced and in the future we may expect rapid developments in this field.

In the immediate future we may expect electro-mechanical switching networks, either in the form of crossbar switching or array of relays such as the reed-relay, under the control of a stored program control processor to provide the most economic solution for international transit exchanges. The introduction of electronic techniques in the field of control is likely to have far-reaching consequences. The first of these will undoubtedly be the introduction of common channel signalling. The current methods of transmitting digital information required to establish international calls is by means of voice-frequency tones within the speech band. With central processor control, there are considerable advantages to be gained in terms of speed of operation and facilities available in connecting together the central processors of exchanges working into each other by means of a medium-speed data channel, so that digital information can be passed directly between the processors. A specification for such a system, known as C.C.I.T.T. Signalling System No. 6, was presented to the Plenary

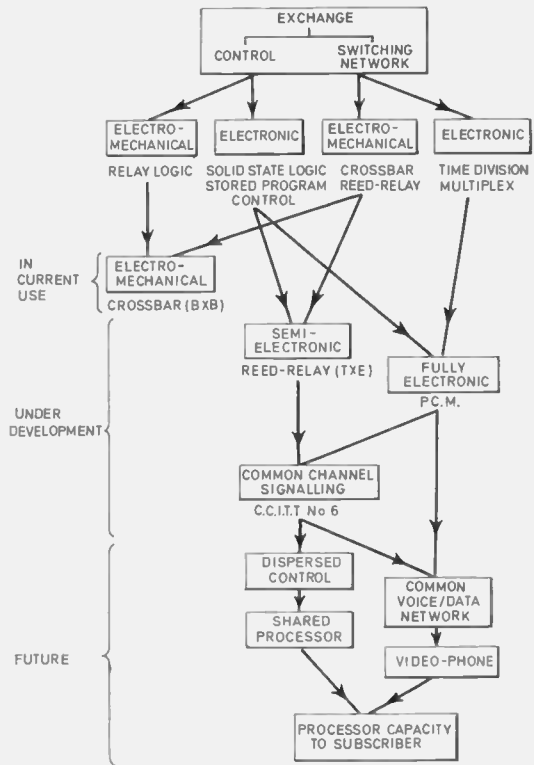

Fig. 20. Exchange techniques.

Assembly of the C.C.I.T.T. at Mar del Plata in October 1968, and field trials started shortly after.

A logical development of common channel signalling might well be to transmit between exchanges not only digital information relating to calls to be established, but the actual establishment instructions themselves. A central processor could thus be used to control not only its own switching network, but also that of neighbouring exchanges over high-speed data links.

In the next few years we may foresee the use of general-purpose computers to control switching networks, with additional capacity available for such applications as message switching, accountancy and traffic data processing.

In the more distant future, when computer techniques become sufficiently advanced it might be possible to share processor capacity with other utilities, industries or government agencies, although it is more likely that this would be on a national rather than international basis.

On the switching network side, the introduction of electronic switching techniques may well lead to common voice/data switched networks, with such services as videophone and access to computing capability available to the subscriber. In the more immediate future the introduction of automatic

transit switching of international telephone calls will permit the growth of the semi-automatic service and ultimately a fully automatic service with subscribers able to dial international calls on a global basis (Fig. 20).

13. Automatic Error Correction

The teleprinter using the 5-unit International Telegraph Alphabet No. 2 is used almost exclusively in national and international telecommunication networks. In the 5-unit code each character consists of five equal length elements and this simplifies the mechanical and electrical equipment involved in the process of conversion from keyboard operation to electrical signals and from electrical signals to printed copy. The code does have the disadvantage, however, that the maximum number of combinations available is limited to 2^5 , i.e. 32, and every one of the possible combinations is allocated to a specific character symbol or function. In fact many of the 32 combinations perform alternative functions depending upon whether they are preceded by the 'figure shift' or the 'letter shift' code character. This 5-unit code therefore has no redundancy which means that when errors are introduced into 5-unit signals due to noise on the transmission path it may be impossible to detect them even by eye and will certainly be impossible to detect them automatically. Furthermore, the 5-unit code uses an initial start signal and a final stop signal at the beginning and end of every character in order to ease synchronization problems and should the start or stop signal be affected by noise, synchronism can be lost to the extent that a number of consecutive characters may be incorrectly received.

Until a few years ago these weaknesses of the 5-unit code caused serious difficulties when signals had to be passed over high frequency radio circuits which have an inherent tendency to be noisy. However, some 18 years ago Dr. Van Duuren of the Netherlands Post & Telegraphs produced a system using a 7-unit code which has been standardized by C.C.I.R. and C.C.I.T.T. and universally used for about 15 years in international telegraph communications. In this code all characters have mark and space elements in the same ratio, namely 3/4. There are 35 possible combinations having this ratio. Thirty-two of these are used to provide the combinations normally available from the 5-unit code, two are used to convey supervisory signals for telex working, and the third for requesting a repetition of signals.

The advantage of the Van Duuren 7-unit system is that errors introduced by noise will in general alter the 3/4 mark/space ratio and this fact will be detected at the receiving end. The character in error will not be printed and the transmitting end will be automatically requested to repeat the signal which will then be correctly printed at the receiving end with no

indication of any error having been received. It is, of course, possible that noise may introduce element errors within a character without altering the 3/4 ratio, for example one mark element may be dropped and another spurious mark element inserted and this sort of error cannot be detected. Fortunately this does not happen very often and in practice this type of error correction system provides a major improvement in the accuracy of printing telegraph circuits operating on h.f. radio bearers.

The usual form of the error correcting equipment also provides time-division multiplex facilities which will accept two 5-unit start/stop inputs converting them to 7-unit code and combining them in character interleaved time division multiplex to form a single aggregate signal of 96 bauds. A further stage of multiplexing, this time by element interleaving, can be used to produce a 4-channel, 192-baud aggregate. Synchronization is obtained by driving equipments from very stable oscillators and the receiving equipment is arranged to synchronize with the incoming signals. In this way a receiving margin of at least $\pm 45\%$ is achieved. The sending terminal has the ability to store several characters (3, 4 or 7, depending on the propagation time of the circuit) and repeat these stored characters when requested by the receiving end. Provision is also made for the subdivision of any of the 50 baud channels into quarter-speed channels, and multiples thereof, and such sub-speed channels are very useful for providing private circuits for individual customers who may very well not have sufficient traffic to justify the cost of a full-speed 50-baud channel.

It will be seen that the above system requires a return path over which automatic requests for repetition may be made. It is possible to achieve some degree of error protection where no return path is available by the use of different types of code known as forward-acting error correcting codes. One such system converts a 5-unit 50-baud start-stop input into a 10-unit synchronous output, the first 5-units of which are the same as the 5-unit input, and the second 5-units of which are parity elements. This system compares the first five information elements with the second five parity elements and decides whether:

- (a) the character has been received correctly in which case it is passed on to the receiving teleprinter as a standard 5-unit start/stop signal;
- (b) a single element has been mutilated in which case the error is automatically corrected and the character passed to the teleprinter;
- (c) a multiple error has been received, in which case the equipment is unable to correct the error but passes a special error indication signal to the teleprinter.¹⁶

Finally, a further condition is possible in which the mutilations are such that an error cannot be detected and an incorrect character is printed. This system is probably not of great value for use on very bad circuits but can usefully improve a fairly good circuit to a very good circuit.

The standard Van Duuren system has been developed from electromechanical equipments through thermionic valve, cold cathode and transistor variations. Further development which might for example lead to the provision of a number of error-corrected circuits by means of one program-controlled computer will probably be inhibited by the accelerating trend towards the provision of bearer systems of higher grade than h.f., e.g. coaxial submarine telephone cables, satellite communication systems, etc. The existing type of equipment, i.e. fully transistorized, has been developed to a very high standard of reliability, however, and will probably continue to be used for many years.

14. Telegraph Multiplexing

Since the earliest days of telegraphy there has been pressure to squeeze the last ounce out of available bandwidths. From time to time it has seemed that the availability and/or cost of bandwidth have been reduced to the extent that interest in telegraph time division multiplexing would wane but this has never been the situation for very long, and we are currently still in the position where telegraph multiplexing techniques assume as much importance as they did over 80 years ago when the definition read 'multiplex telegraphy: a system of telegraphy in which more than four messages can be simultaneously transmitted over a single wire.'¹⁷

When h.f. radio telegraphy became available it offered the possibilities of much higher maximum baud speeds than the existing telegraph cables and initially this capability was exploited by means of high-speed morse. This was largely superseded by various types of telegraph time division multiplex usually providing two channels of printing telegraphy, until the advent of single sideband transmission when frequency division multiplex began to be used to provide 3, 6, 12 and even more telegraph channels per 3-kHz voice channel. These systems generally use frequency-modulated voice-frequency tones or two-tone systems. This is the current situation on h.f. radio and individual frequency division channels are still widely subdivided by time division methods.

The selective fading normally present on an h.f. radio circuit can cause differences of many decibels to occur between the received level of adjacent tones, and this places onerous requirements upon the receiving channel filters. These requirements have been eased by the general adoption of 170 Hz spacing between

channels—rather wider than is necessary when more stable bearer systems are used.

The system in most common use employs 12 tones spaced by 170 Hz in the band 425–2975 Hz. This can provide a 6-channel, two-tone system, using two tones per channel, or a 12-channel frequency-shift system with a shift of ± 42.5 Hz on each tone. Either arrangement gives a working speed of 100 bauds per channel, but the 12-channel arrangement requires the more stable circuit.

Another system evolved during the early days of i.s.b. working and still in regular use, employs three tones spaced by 1000 Hz, in the band 600–2600 Hz. A frequency shift of ± 150 Hz is usually used and a working speed of 200 bauds is obtained on each tone. This allows the use of an error-correcting multiplexer carrying four 50-baud teleprinter channels in time-division multiplex.

For use on modern high-quality telephone channels of 3- or 4-kHz bandwidth the C.C.I.T.T. has standardized a.m. and f.m. frequency division multiplexed systems employing 22 or 24 120-Hz spaced channels. International systems usually employ frequency modulation and are designed for a nominal modulation rate of 50 bauds (C.C.I.T.T. Recommendation, 1956). In 1964 further standards followed providing for 100-baud channels spaced by 240-Hz and 200-baud channels spaced by 360 and 480 Hz. However, this does not make for the most efficient use of trunk circuits and once again time division multiplexing has been adopted to extend the telegraph capacity of the basic 3- or 4-kHz bearer circuits. Draft recommendations have now been produced for a synchronous time division, element-interleaved system providing either two or three multiplexed 50-baud channels over one 120-Hz voice frequency telegraph channel. The resultant aggregate modulation rates are $82\frac{2}{3}$ bauds for two channels and $123\frac{2}{3}$ bauds for three-channel operation. Each time division channel can be subdivided into quarter or half of a full-speed channel. If the $123\frac{2}{3}$ baud aggregate is carried on 120-Hz v.f.t. channels special steps must be taken to compensate for the distortion which occurs due to the fact that single elements of alternately reversed polarity will be suppressed, the first keying sidebands falling outside the channel filters. The re-insertion of these signals at the receiving end is generally referred to as characteristic distortion compensation.

The future prospect is one of further increases in available bandwidth and reduction in its cost. Nevertheless new systems are appearing which not only increase further the number of 50-baud channels which may be derived from one voice channel (108 in one instance) but also make provision for data channels at varying modulation rates. So long as

multiplexing equipment costs appreciably less than the circuit bandwidth which it saves it will continue to be in demand. This situation is likely to persist longest on very long international connections of course.

Internationally standardization on any new system has become a difficult task because of the innumerable possible permutations and combinations of telegraph, data, facsimile and special multiplex channels which may be brought together in one voice channel; this study is proceeding in the C.C.I.T.T.

It is possible that a frequency division system, based on the present frequency-modulated voice frequency system may, at least initially, prove to be the simplest approach.

However, for full exploitation of a basic voice channel or indeed of a basic 48-kHz group or any other standard slice of bandwidth it is probable that the most efficient system will be found in direct time division multiplexing, using high-speed data modems. This approach is also under close study. Since flexibility is vital in any attempt to exploit such complex aggregate signals on an international scale it is possible that the computer will provide the most suitable answer to the multiplexing problem.

Eventually an all-digital p.c.m. network may satisfy the demand for greater efficiency in multiplexed systems.

15. Message Switching

With the circuit-switching services which are now spreading extensively around the world one may well ask whether there is still a requirement for message-switching. Economics provide the answer. On long haul (and therefore relatively high cost) inter-continental channels it is important to maintain the highest efficiency of utilization and this can only be done by maintaining a high channel loading through the use of store-and-forward techniques. There are two main methods of achieving the required time-shared, message-interleaved use of trunks: the store-and-forward message relay centre and the controlled-party line system although there are of course numerous variations of each and combinations of the two. International message-switching centres vary in size throughout the world from perhaps three channels in the smallest case to 100 channels in the largest, and different methods must be adopted according to the size category into which these centres fall. There are, for example, still many message relay centres which employ manual re-processing of messages although even in these centres it has been found convenient to automate at least the message numbering process and the simplest way of achieving this has been to convert all messages to perforated tape form which is then torn to separate individual messages so that automatic numbering may take place as each new tape is entered into its transmitter. Further develop-

ments of these principles are push-button routing and continuous tape semi-automatic operation which require only elementary format regulations. The push-button router enables an operator to scan an incoming message, determine its destination and by pressing the appropriate button to insert on the perforated tape at the head of the message the code necessary to direct the message to that destination.

Fully automatic operation has become practicable during the last few years as a result of international agreement through the C.C.I.T.T on the format for automatic message-switching and also because of the wider availability of reliable telegraph channels. On private networks where international agreement was unnecessary automation had already taken place. Fortunately the stored-program computer was available to meet the need for full automation because without it the complexity and inflexibility of conventional methods in the end become unmanageable.

Computer-based message switching systems are in operation or are going into operation in many parts of the world including the U.S.A., Canada, Australia and Hong Kong, and in the private sector computers are providing an invaluable, rapid and efficient service for airlines, railways, military and other authorities although some of these do not yet have global connections.

As mentioned in connection with telephone switching, we can foresee a continuation of the tendency towards total integration of services and it is also possible to envisage that store-and-forward systems will always have a part to play. The increasing volume of data and other records to be transmitted will undoubtedly still require the services of the storage system and indeed when a digital network encompasses the globe employing digital system techniques, one might even expect to find store-and-forward facilities available for speech should a demand arise for one-way verbal messages.

The immediate future will probably see the application of computer-based message switching systems to the transfer and retrieval of data linking up with data processing centres throughout the world, both for off-line and real-time operation. Once computer control is established it becomes appropriate to apply the computer capabilities to such functions as telegraph multiplexing, error correction and circuit control. A good example of computer-based circuit control is offered by the controlled party line system which was mentioned earlier as one of the two main methods of achieving high channel loading. The controlled party line system was evolved essentially to connect a number of message transmission and reception points into a network so that each may send to any of the others or receive from them without the

necessity of having separate lines from each to all others, an obviously wasteful system, and without the possibility of two terminals contending for the same channel simultaneously.

Whilst such systems have been in use on the North American continent for a number of years, mainly for private user networks, they have not as a rule been used for overseas relations. This has been largely because the real time nature of the control signals has prohibited their use on error-corrected h.f. radio circuits. With the advent of unprotected but highly reliable international telegraph circuits such systems are extending on to international links. Figures 21 and 22 show how a reduction in the number of circuits (which may be long-distance international links) may be effected.

The main features of a controlled party line system are as follows:

(a) *Control Station.* One station on the network, usually at the main traffic centre, is equipped with the units required to control the network.

(b) *Anti-contention.* In order to avoid two stations contending for the same circuit each station is invited to transmit ('polled') in turn, by means of its own unique 'start code' which is generated automatically and sent as part of a pre-programmed cycle of such codes by the control station. If on being 'polled' a station does not have a message loaded into its automatic tape transmitter its outstation unit will automatically send a 'No traffic' response code which causes the control station to send the next transmitter start-code in the polling cycle.

(c) *Selective Printing.* Each station is assigned its own unique 'receive/select' code on recognition of which its receiving equipment (teleprinter reperforator, etc.) is activated.

(d) *Assurance.* When a station is ready to send, its message tape will start to run upon receipt of its transmitter start code and the tape will carry the necessary receive/select code or codes to activate the required receiving station or stations. After the first receive/select code has been transmitted the auto-transmitter will halt to await an automatically generated answer

back from the called station. On receipt of the answer-back transmission will re-commence and either the message is sent or in the case of multi-destination messages the next receive/select code only is sent and a further answer-back awaited. If an answer-back is not received (due to any one of several reasons which might interfere with the proper reception of the message) then the control station which is continuing monitoring the line, sends its own answer-back and at the same time connects a special reception point into circuit known as the 'intercept position'. On receipt of this answer-back the calling station re-commences transmission and its message is received on the intercept position at the control station. Thus the responsibility for clearing the message to its correct destination is transferred to the control station and a system blockage due to the correct station being unable to receive is avoided. Message assurance of this type is generally confined to half duplex systems.

Various other safeguards are built into these systems, the main objective being to reduce operator attention to a minimum so that staff other than skilled operators can be used. Message format requirements are kept to a minimum and usually require only the prefacing of each message with the receive/select code appropriate to its intended destination and following this the carriage-return and line-feed signals which indicate the 'end of select' condition and finally, the terminating of each message with an 'end of message' code. The receive/select codes need not be perforated at the time the message tape is prepared as it can be inserted later by means of the push-button routing device which has already been mentioned.

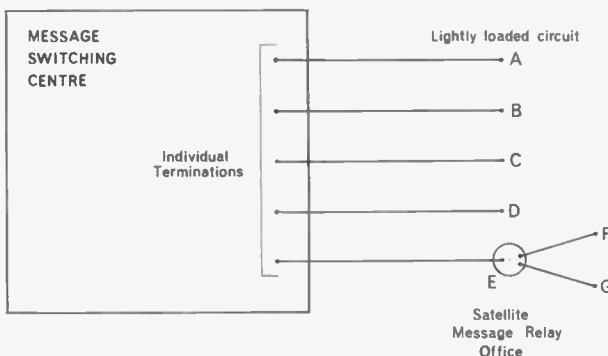
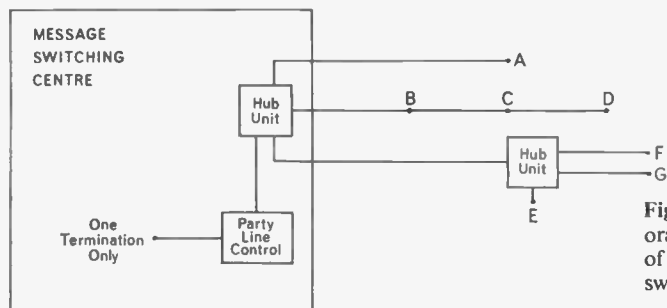

Fig. 21. Diagram showing individual terminations in message switching centre and satellite message relay office at E.

Fig. 22. Possible rearrangement of network in Fig. 21, incorporating controlled party line working, with reduction in number of circuits connected to and terminations in the message switching centre, together with elimination of message relay point at E.

Controlled party line systems may be worked on a half-duplex or full-duplex basis, the choice being mainly governed by the traffic flow on the network. A half-duplex network is so arranged that signals transmitted by any one station are received at all the others, although only 'printed out' at the selected stations, and thus direct interchange of traffic between stations on the network is possible. A full-duplex network is usually arranged such that each station can only receive from and transmit to the control station which is thus operated on a store-and-forward basis. Therefore where there is a large proportion of traffic to be exchanged between stations, half-duplex working has advantages and, on the other hand, when the main traffic flow is to/from one central point, full-duplex working has advantages. Full-duplex operation as a rule requires more equipment than half-duplex but in general gives better utilization of channel capacity, and therefore each requirement for controlled party-line systems has to be examined to determine the most suitable and economical method of working.

The main users to date on an international basis have been the airlines, who wish to be able to exchange traffic with a number of touch-down points on a flight path without a multiplicity of point-to-point circuits or telegraph exchange centres. These systems are now extending to more general commercial use, however, where they enable head offices to maintain continuous contact with several distant branch offices via perhaps only one main international trunk route. Figures 23 and 24 give examples of typical airline and commercial applications.

Message exchange within an office block or factory complex can also be facilitated by the use of a controlled party-line system. Whilst in the past these systems have been confined to conventional 5-level telegraph circuits at speeds up to 75 bauds, the techniques are equally applicable to the acquisition and dissemination of data on high-speed data networks. In the U.S.A. there is already more use of 8-level codes than 5-level and this tendency may be expected to continue, as these systems achieve general commercial application. For example, a central on-line data processor can be kept continuously up-dated by data picked up from the various subsidiary offices on the network in order to take the necessary action, e.g. in the case of a chain of wholesale outlets and warehouses, the whole process of stock control, invoicing, originating orders to suppliers, transport movements and all related functions can be entirely automatic and be directly controlled by up-to-the-minute information received from the outlets. The use of this type of private data network has been growing rapidly in North America and can be expected to expand on a world-wide basis wherever there is a concentration of business activities.

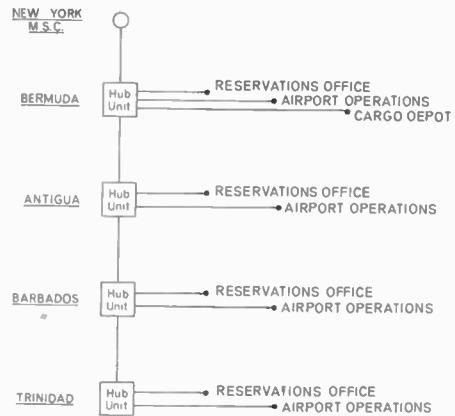

Fig. 23. Typical airline application.

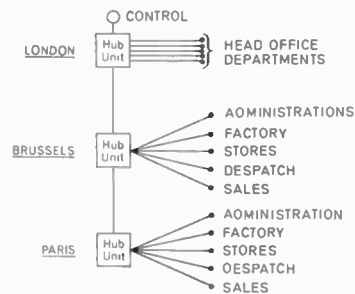

Fig. 24. Typical commercial application.

16. Telex and Leased Circuits

16.1. Telex

From the outset, it should perhaps be made clear that telex is a specific service and the word should only be applied to that particular service. It is sometimes incorrectly used to describe private or restricted teleprinter switching systems. Telex can be defined as:

'A subscriber's switched telegraph service enabling the users to communicate directly and temporarily with one another by means of 5-unit start-stop apparatus.'

The telex service is therefore a means whereby a subscriber in a country can call and communicate with any other subscriber in that country or any other country in the world (with certain limited exceptions). The charge made for a call is based on the distance separating the two parties and the time for which the connection is set up. Telex is analogous to the public telephone service, the difference being that communication is by teleprinter instead of voice.

In the United Kingdom an internal telex service first came into operation in 1932 as an adjunct of the public telephone service. It also started in other European countries about this time and an international service first became available from the United

Kingdom in 1936. However, it was not until post-war years, i.e. late 1940s, that the telex service really got into its stride and the present-day picture is that it is available in every industrialized country and many developing countries. At the end of 1965 there were over a quarter of a million telex stations in use throughout the world.

The advantage of telex over telephone is, of course, the fact that a printed copy is available. Telex calls can also be made to unattended offices and by means of the automatic answer-back device on the teleprinter, the calling party can be sure he is connected to the wanted party and that the receiving teleprinter is working. This is a big advantage for international working where large time-differences occur. Although the telephone service has a much longer history than telex it was the latter, in the United Kingdom, that first introduced automatic direct subscriber to subscriber selection on international calls, first to the Continent of Europe and subsequently to the U.S.A.

The C.C.I.T.T. recommendation covering international telex working specifies that the 5-unit international alphabet No. 2 code, should be used and operated at a speed of 50 bauds. This code and speed is also used by all countries for their internal telex system except the TWX network in the U.S.A. In the case of TWX subscribers, initially a 5-unit code was used operating at 45 bauds but machines have now been introduced using the ASCII 8-unit code operating at 110 bauds, and the American International Carriers have to carry out the necessary conversions when handling an international call to/from a TWX subscriber. Whether the rest of the world will follow and introduce a switched public network using an 8-unit code, either as a replacement for the existing telex service or in addition, is not yet clear. However, with so much capital involved in the basic teleprinters and telegraph channelling equipment it would seem that many years must elapse before a complete replacement of the present 50-baud 5-unit telex service could be accomplished even if this were generally desired. There is as yet, however, no indication of any decrease in the rate of telex expansion both in numbers of subscribers and amount of traffic handled. The C.C.I.T.T. have also only recently introduced another set of signalling criteria (type C) and other recommendations which will provide for a fully automatic intercontinental telex service including transit switching.

Some countries are already offering the means of transmitting data internally at speeds ranging up to at least 1200 bauds over the switched public telephone network and whether this will be expanded into the international field as opposed to a separate telegraph/data switched network is a matter that is under consideration and is the subject of study by the C.C.I.T.T.

16.2. *Leased Circuits*

As its name implies this heading simply covers circuits which are rented or leased to customers for their sole use. It may be for as little as a quarter-speed telegraph circuit (i.e. a quarter of a 50-baud 66 words per minute circuit) for eight hours a day, up to a bandwidth suitable for a television link for a short period of the day. In the telegraph field, leased circuits are a growing and very important activity. This is in no small part due to the wider use of computers which necessitate bringing data from various sources to a centralized point for processing, and to the increasing number of private message switching networks.

17. Data Transmission

We have started to talk about 'data transmission' only in recent years, since the advent of computers, in fact. 'Data' has of course been transmitted globally ever since the first coded signals were sent over the submarine telegraph cable but only in recent years has this been set in a form suitable for automatic processing.

Many of the requirements and associated problems which have arisen in the field of data may be found to have their parallels in past telephone and telegraph techniques. The present need for an immediate response from a computer to an enquiry by a remote out-station, for instance, may be likened to the requirements of telephonic and telex connections. There are difficulties, however; telephone and telex enquiries are made between one firm and another and the interchange of information between subscribers is quite unrestricted provided that the human brains involved have been 'programmed' to accept the language used. When it comes to data transmission between computers, however, these programming difficulties considerably restrict the interchange possibilities between different companies and different continents. It is therefore true to say that data transmission tends to take place almost exclusively between a computer centre or centres of an organization and its own out-stations or subscribers. We must consider what effect this has on global data communication. It means that international data transmission is generally limited to those organizations which are truly international in organization, i.e. those with offices in different countries. Because of this limitation, international data communication is still in its infancy compared with national systems. It also means that such communication is almost entirely point-to-point rather than in complex system configurations, and these point-to-point requirements are usually best met by leased international circuits.

It may be assumed that the development of international standards for data format will allow a very rapid increase in the amount of data exchange globally

and in the complexity of system configuration. During such an increase in demand, factors which will play an important part in determining the facilities which a subscriber might require are: transmission rate, response time, type of code, configuration of network required, etc. The telex system may be used for data transmission but because of its limited speed capability it cannot handle large volumes of data. Within its limitations, however, the telex network can and does provide service for data customers whose volume of data cannot justify a leased circuit and whose response time requirements are not too stringent.

With certain limitations codes other than 5-unit can be used over the telex network. It is however necessary to know whether any regeneration takes place on a given circuit before one can be sure whether a departure from standard telex signalling conditions may be made. Any special terminal equipment necessary for sending non-standard signals would have to be approved by the administration concerned.

For switched services above telex speeds we must turn to the telephone network which, though not designed as a carrier of data signals, does provide a ready, code-independent means of transmitting data up to 1200 bits per second between any two existing telephone subscribers. In this case the limitations of the telephone system as a data bearer are such that error control would usually be required.

It is however now in use for transatlantic and European data-transmission and will shortly be extended to other parts of the world. C.C.I.T.T. have standardized a modem for use over the switched telephone network at signalling rates of 600/1200 bits per second. This employs frequency shift keying for synchronous or asynchronous data transmission, and a low-speed return channel is available for error control. For data transmission at 200 bauds over the switched telephone network, the C.C.I.T.T. have issued recommendations for a frequency shift modem for full duplex operation.

17.1. *Private Networks*

For off-line data transmission the slow response time of the switched telephone network is relatively immaterial, but for a fast-response system the network is virtually useless. Only a private network will meet the demands of the real-time systems. Computations have to be performed during the time that the physical processes are transpiring and the results of these computations have to be fed back to guide the processes. In the case of administrations such as NASA the physical processes are taking place at great speed and this has necessitated the development of private high-speed point-to-point networks. Operators such as airlines expect response times to seat reservations enquiries to be measured in seconds and, with branch offices throughout the world, it has been

necessary to develop private multipoint networks combining the advantages of channel efficiency with the necessary response time. This will no doubt continue to satisfy the requirements of many of the larger users until a separate switched data network is available offering the same facilities.

The data signalling rate commonly in use over special quality private voice-data networks is 2400 bits per second although this is by no means universal and modems are available for signalling rates up to 9600 bits per second. The associated modulation rate and method differ widely between different manufacturers, although there is a strong body of opinion in favour of a quaternary phase-modulation system for use where a 2400-bits-per-second international standard is required. For wideband data transmission over international 48-kHz carrier groups, the system which is likely to be adopted universally is an a.m. vestigial sideband suppressed-carrier system operating at 48 kilobits per second.

17.2. *Future Networks*

It is expected that a demand will arise for fast-response switched-data services at various speeds. To cover immediate requirements it is possible that a 200-baud telegraph-type network will be developed for low-speed data transmission. In the more distant future it is envisaged that as mentioned earlier, p.c.m. techniques will provide the basis of an all-digital network meeting the demands of data, speech, facsimile and telegraph. On a global basis, however, this may still be several decades away.

18. **Television**

Television may be used for:

- Entertainment and/or instruction
- Surveillance of remote areas or documents
- Two-way conference links
- Two-way videophone links.

Internationally, only the first of these uses has achieved significance, and even so, much of the exchange of programme material is via film or tape.

Real-time transmission between countries takes place via line-of-sight microwave links or coaxial cables wherever possible, but existing submarine coaxial cables do not have the necessary bandwidth (approximately equivalent to 1000 telephone channels). Transoceanic television transmission has therefore become possible only since the advent of communications satellites. This type of television link is now used routinely, but the large bandwidth and satellite power requirements inevitably give rise to heavy rental charges.

The demand for point-to-point international television links spanning long distances seems likely to be

limited at least partially to common-language areas, and even these frequently have sufficient time difference to limit live programme-exchanges to a relatively small part of the 24 hours. Such links are therefore unlikely to be dedicated to television use; they are likely to be established basically for telephone purposes and made available for television on an occasional basis. Operationally, this is far from ideal, since the process of taking down something like 1000 telephone circuits, even for a short television transmission, can cause very great dislocation of telephone traffic over a period much longer than the programme itself. Where standby links are available, it may be possible to use the standby link for television whilst retaining the main link on telephone service.

Investigations are in train which may well lead to great reductions in the bandwidth required for television, by removing line-to-line and frame-to-frame redundancy. By quantizing the analogue signal into, for instance, 64 discrete levels and converting to p.c.m., an amelioration of the signal/noise ratio requirements may also be obtained. The indications are that these improvements will only be secured by means of high capital investment in terminal equipment, and the use of such equipment would therefore be confined, at least initially, to high-usage or high-rental links.

A further likely development in the field of international television is direct broadcasting from satellite to the home. Whether this arrangement is overtaken by the concept of a high-capacity physical information link into each home remains to be seen.

No doubt the recently demonstrated conference television link will eventually be available for international use, and should our standard of living rise sufficiently, we may all demand videophones. In this case the full potential capacity of the laser might well be needed.

19. Summing Up

Summarizing very briefly all that has been said about future trends it can be said with a high degree of certainty that an ever-greater degree of computer control will be used in the communications field, that the various types of service—telephone, television, data and facsimile—are likely to be integrated within a global digital system based on p.c.m.

The trend from thermionic to solid-state devices will continue, and discrete solid-state devices will no doubt steadily be replaced by integrated circuits. Large-scale integration and linear integrated circuits will come into widespread use.

With a fair degree of certainty we can suggest that present bandwidth limitations will tend to disappear—particularly if the laser can be integrated into a viable

communications system. Operating against this trend, however, will be an accelerating demand for bandwidth to carry a multiplicity of services—probably into the home as well as the office and factory.¹⁸

20. Acknowledgments

In conclusion, I wish to thank the Engineer-in-Chief of Cable and Wireless Ltd. for permission to publish this paper, and I gratefully acknowledge the help and encouragement which I have received from colleagues during its preparation.

21. References

1. Data taken from 'The Worlds Telephones' published by the American Telephone and Telegraph Company.
2. I.T.U. Panel of Experts, Final Report, 1963, Recommendation No. 1.
3. C.C.I.R. Recommendations 393-1 and 395-1, Documents of the XIth Plenary Assembly, Oslo, 1966, Vol. IV, Part 1, p. 62.
4. Bell, J., 'Propagation measurements at 3.6 and 11 GHz over a line-of-sight radio path', *Proc. Instn Elect. Engrs*, 114, No. 5, p. 545, May 1967.
5. Cannon, R. W., Wilkinson, D. and Rider, G. C., 'Operational experience with a tropospheric-scatter radio-relay link', *Proc. Instn Elect. Engrs*, 113, No. 9, p. 1460, September 1966.
6. Beach, C. D. and Trecker, J. M., 'A method for predicting interchannel modulation due to multipath propagation in FM and PM tropospheric radio systems', *Bell Syst. Tech. J.*, 42, No. 1, p. 1, January 1963.
7. Laudise, R. A., 'The search for non-linear optical materials for laser communications', *Bell Laboratories Record*, 46, No. 1, pp. 3-7, January 1968.
8. Subramanian, M. and Collinson, J. A., 'Modulation of laser beams by atmospheric turbulence', *Bell Syst. Tech. J.*, 46, No. 3, pp. 623-48, March 1967.
9. Cooper, B., 'Optical communications in the Earth's atmosphere', *I.E.E.E. Spectrum*, 3, No. 7, pp. 83-88, July 1966.
10. Brookner, E., Kolker, M. and Wilmotte, R. M., 'Deep-space optical communications', *I.E.E.E. Spectrum*, 4, No. 1, pp. 75-82, January 1967.
11. Dimeff, J., Gunter, W. D., Jr. and Hruby, R. J., 'Spectral dependence of deep-space communications capability', *I.E.E.E. Spectrum*, 4, No. 9, pp. 98-104, September 1967.
12. Watt-Carter, D. E. and Wheeler, L. K., 'The Lincompex system for the protection of h.f. radio-telephone circuits', *P.O. Elect. Engrs J.*, 59, p. 163, October 1966.
13. Frost, A. C., 'High order multiplexing of p.c.m. systems', I.E.E. Colloquium on Pulse Code Modulation, 1968.
14. Cattermole, K. W., 'Proposals for a digital telecommunication network', I.E.E. Colloquium on Pulse Code Modulation, 1968.
15. Pearson, K. W., 'Satellite multi-access operation with p.c.m.', I.E.E. Colloquium on Pulse Code Modulation, 1968.
16. *Point-to-Point Telecommunications*, 9, No. 1, October 1964.
17. Houston's Electrical Dictionary, 1889.
18. Granger, S. H., 'Post Office wideband distribution network in Washington New Town', *P.O. Elect. Engrs J.*, 61, Part 1, pp. 1-2, April 1968.

Manuscript first received by the Institution on 30th May 1968 and in final form on 19th February 1969. (Paper No. 1254/Com. 12).

© The Institution of Electronic and Radio Engineers, 1969

POINTS FROM THE DISCUSSION

The Chair was taken by Professor G. B. B. Chaplin

Major V. M. Ivey: Can Mr. Cannon give any indication, in quantitative terms, of any increase in m.t.b.f. that has been achieved in h.f. telecommunication equipment by changing over from valve to transistor equipments, taking into account any increases in complexity that have occurred?

Has the introduction of frequency synthesized equipment given rise to any increase in the routine maintenance load because of the need to maintain the frequency accuracy of the equipment by adjustments of the master oscillator etc., against an external frequency standard at regular intervals.

Mr. R. W. Cannon (*in reply*): There has been a fairly consistent doubling of m.t.b.f. as between valve and transistor equipment of similar function and complexity. The residual faults in the transistor equipment are seldom due to the transistors themselves.

As far as my Company is concerned routine maintenance has not been affected by the introduction of frequency-synthesized equipment. We still continue our long-established practice of regularly checking radiated frequencies, and this provides assurance of both the

synthesizer settings and the master oscillator accuracy. The requirement to reset the master oscillator is rare in practice.

Mr. K. M. McKee: One of the problems in computer controlled message switching systems is the difference between the telex transmission rate and the operating rate of the computer. Input and output buffer stores are required. Could the author comment on the approach to the buffering problem with reference to the new Hong Kong installation mentioned and illustrated in his paper.

Mr. Cannon (*in reply*): Compatibility between serial low-speed telegraph signals and parallel high-speed data handling in the processor is provided by a hardware device (communication line terminal) associated with each line. On input, characters are assembled bit by bit to form a complete parallel data character in an assembly register. Parallel data from this register is then transferred into the processor via a communication multiplexer handling up to 32 low-speed lines. Similarly on output, a 'disassembly register' is used.

Commonwealth Telecommunications Conference

The Commonwealth Telecommunications Council held its Fourth Meeting at Marlborough House in London from April 14th to 25th. The meeting was attended by representatives of 21 Commonwealth countries and the British overseas territories. Mr. C. J. Gill, Director of the External Telecommunications Executive, General Post Office, was Chairman.

The Assistant Postmaster-General, Mr. J. Slater, M.P., officially opened the meeting and, in welcoming the delegations, emphasized the importance of the Commonwealth deriving the maximum benefit from recent developments in telecommunications, particularly in connection with the *Intelsat III* satellite over the Atlantic, Indian and Pacific Oceans.

The Meeting was devoted to the better management of the Commonwealth telecommunications partnership and the affairs of the Commonwealth Telecommunications Organisation, of which the Council forms part. The principal items were the approval of the Council's budget for 1969-70, a review of the current study of collaborative financial arrangements,

discussion of the future pattern of Commonwealth and world tariffs, and the establishment of working procedures for the Council's secretariat in London, the Commonwealth Telecommunications Bureau.

Mr. Gill was elected as Chairman for a further term of office, and Mr. D. Bowie, the Canadian Representative, as Vice-Chairman.

Twenty-three Commonwealth countries are entitled to be represented on the Council; Pakistan is the only major country not to be a member of the Commonwealth Telecommunications Partnership. On this occasion nearly 40 representatives and advisers, from 20 Commonwealth countries and the British Overseas Territories, took part. Most representatives on the Council are senior telecommunications officials.

On the evening of April 21st, the President of the I.E.R.E., Sir Leonard Atkinson, welcomed the representatives to the Institution's headquarters where they were able to meet members of the Council and other senior members concerned professionally with telecommunications.

Forthcoming Conferences

Computer Science and Technology

The many factors influencing the performance of a computer system will be discussed at a conference on Computer Science and Technology, to be held at the University of Manchester Institute of Science and Technology from 30th June to 3rd July 1969.

The conference is being organized by the I.E.E. in association with the I.E.R.E., the Institute of Mathematics and its Applications and the Institute of Physics and The Physical Society.

There have been few opportunities for engineers and software writers to become acquainted with each other's work. One of the aims of the conference is to present papers on these related topics which will bridge the hardware-software gap.

The long-term solution to this problem lies in the education and training of computer engineers. At a session on this topic speakers from universities and colleges of technology will be concerned with the education of computer-system engineers and the specification of computer facilities for educational establishments.

Further details and registration forms are available from the Conference Department, I.E.E., Savoy Place, London, W.C.2.

Management and Economics

An International Symposium on Management and Economics in the Electronics Industry is to be held in Edinburgh from 17th to 20th March 1970. The conference is being organized by the Institution of Electrical Engineers' Scottish Centre and the I.E.R.E. Scottish Section, with the co-sponsorship of the local sections of the Institution of Mechanical Engineers, the Institution of Production Engineers, the British Computer Society, the I.E.E.E., the British Institute of Management, the Institute of Chartered Accountants of Scotland, the Institute of Cost and Works Accountants, the Institute of Marketing and the National Economic Development Council for the Electronics Industry.

While the conference is designed to discuss a wide range of subjects in the field of management and economics, special emphasis will be placed on practical problems and current achievements. Specific subjects will include:

Management of innovation; marketing; economics of production (cost control, etc.); management services (planning and information); personnel and training; the role of Governments.

In view of the rapid expansion of electronics in

Scotland, and the international character of many of the companies and organizations, world wide interest is expected in this meeting and it is intended to be of particular value to all those involved in a practical way with these aspects of the Industry.

Further details and registration forms may be obtained from the I.E.E. Conference Department, Savoy Place, London, W.C.2.

Problems of Safety and Failure

The need for reliability of any fabricated device is surely self-evident: whilst the failure of a wall mounted tin-opener is irritating, the failure of a motor car's brakes may have fatal consequences. But the failure of a complex defence system could change the course of history. However, the problem of ensuring reliability and minimum failure is an intricate one.

A three-day conference on Safety and Failure of Components is being organized by the Institution of Mechanical Engineers at the University of Sussex from 3rd to 5th September 1969. Details regarding registration and the scope of the conference may now be obtained from the Conference Department, I.Mech.E., 1 Birdcage Walk, London, S.W.1.

Digital Satellite Communication

A major impact on all aspects of satellite communication over the next five years is expected to result from the introduction of digital techniques, especially pulse code modulation. In recognition of the economic and technical implications of this, Intelsat, the international consortium of over 60 nations, is sponsoring a conference on Digital Satellite Communications, which is being co-sponsored by the I.E.E. and will be held at Savoy Place, London, from 25th to 27th November 1969. The programme will cover:

Systems, including performance targets and comparisons with analogue systems; coding and modulation; signalling and switching, including interface with terrestrial networks; demand assignment and multiple access techniques; error control; interference.

The technical programme committee invites contributions and intending authors should submit synopses of between 500 and 1000 words as soon as possible.

Further details and registration forms may be obtained from the Intelsat-I.E.E. Joint Conference Secretariat, Savoy Place, London, W.C.2.

Telecommunications Services in the United Kingdom

By

J. S. WHYTE,

M.Sc. (Eng.), C.Eng., F.I.E.E.†

Reprinted from the Proceedings of the Institution's Convention on 'Electronics in the 1970s', held in Cambridge on 2nd to 5th July, 1968.

Summary: The U.K. telecommunications system has been built up over many years and now forms a very extensive network. Broad-band links on coaxial cable and microwave radio systems interconnect more than 150 towns and cities and by 1971 the total wide-band capacity is planned to exceed 170 000 MHz-miles of both-way transmission plant linking some 270 towns and cities. In the junction network the application of digital techniques is permitting multi-channel transmission to be economically employed over distances much shorter than has been possible in the past using analogue transmission and within two years it is planned to have more than 400 000 channel-miles of p.c.m. plant in use. The introduction of digital transmission into the junction network opens the door to new possibilities in the switching field. A variety of new services is in preparation and work in the research laboratories gives some pointers to the communication systems of the future.

1. Introduction

The telecommunications system of the United Kingdom is based upon a network which is the result of steady growth over a period of more than 70 years. It is already a large network—the total capital assets of the Post Office in telecommunications plant exceed £1500M—and it is growing at the rate of £250M per annum. In common, however, with all the developed countries of the world, the rate of growth is increasing and all the indications suggest that this trend will continue for many years to come. Not only are there increasing demands for connexion to the system and increasing traffic on the system, but also the user, particularly in business and industry, is becoming increasingly aware of the benefits to his industrial and business efficiency which flow from a broad-based telecommunications capability in which the straightforward telephone connexion as now understood will come to play a minor role.

2. The Existing System

The existing systems and services provided by the Post Office have become highly integrated with the commercial and social structure of the country and those of us who are concerned with the development of these services recognize what an important contribution the existence of adequate and economical communications can make to the commercial and industrial prosperity of the country. Some of the developments which will lead to new types of service in the future can also be seen to be capable of making a significant contribution to the quality of domestic and social life.

† Post Office Telecommunications Headquarters, Long Range Studies Division, London, E.C.2.

Before describing some of the new techniques and technologies which are being introduced and are under study it may be as well to recapitulate the basic elements of the system. Firstly there is the equipment on the subscriber's premises—historically the telephone instrument. Individual subscribers are connected to a local switching point, the exchange, by pairs in a multi-pair cable, each of which is either exclusive or shared with a second subscriber. Subscribers on the same exchange may be connected together, on demand, via the switching plant and when the requirement is to establish communication with a subscriber on a distant exchange, the originating exchange is connected to the called exchange over a junction circuit or, for longer distances, over a trunk circuit. The connexion between the originating and terminating exchanges over junctions or trunks may or may not involve additional, intermediate, or tandem, switching points.

This pattern of elements making up the communication network was established from the very earliest days of public telephony service and has remained until the present but during the past few years the distinction between switching and transmission has been eroded and it is essential to treat the network as an entity.

Electrical communications started during the 19th century with the invention and development of telegraphy. In time the telegraph services, although they still exist today and continue to fulfil an important function, were eclipsed by the invention and development of the telephone. The first public telephones in the United Kingdom were installed during the 1870s and from this time they have grown in number until today they exceed 11 million.

The past 20 years have seen the growth of non-telephone services. The first of these to assume major significance was television and since the late 1940s the broad-band circuits provided by the Post Office for the broadcasting authorities have grown to more than 8000 channel-miles.

The past 15 years have seen a remarkable expansion in telex service, which is growing within the U.K. at a rate of more than 18% per annum and it is interesting to note that some 40% of originating traffic is routed to overseas destinations.

A third example of non-telephone service is that of data transmission and with the rapidly growing use of computers this is a requirement which is certain to grow at an even greater rate in the near future. Data transmission facilities were first offered over the switched telephone network by the Post Office in 1961 and by the end of this year Datel services will cover the speed range from 100 bits/s to 2400 bits/s; details of the services offered are given in the Appendix to this paper. The services are established over the telegraph network, the telephone network, or over private wires as appropriate to the requirements of the customer, and modems at the interface between the customer's plant and the Post Office plant convert the customer's signals to the internationally agreed forms for transmission and back again. In the case of Datel 600, for example, frequency modulation of a v.f. carrier signal is used. There are at present some 2000 modems in use in the U.K. and it is estimated that these will grow to over 40 000 within the next four years.

Another feature of the present telecommunications scene has been the growth, during the last decade, of international traffic. It is interesting to note that a big upsurge in the volume of North Atlantic traffic coincided with the introduction of the first long-distance submarine telephone cable systems in which the British Post Office carried out pioneering work in conjunction with the American Telephone and Telegraph Corporation. Our island position has made it no accident that we have played a leading role in the development of these systems, and that the only cable ship that existed in the world capable of readily laying the first transatlantic telephone cable belonged to the British Post Office. This international growth means that planning cannot be based on national needs alone. Development has to be undertaken against the background of world-wide needs for fast, accurate and economically acceptable communications. This implies an increasing interdependence of national plans; national numbering plans are one excellent example and international signalling and data interchange are other extremely important areas where international collaboration is vital to the continued expansion of global telecommunication facilities. Effective international collaboration in these

matters is achieved through the work of the specialized agencies of the International Telecommunications Union, the C.C.I.T.T. and the C.C.I.R. together with growing collaboration within Europe between the members of C.E.P.T. (European Conference of Post and Telecommunications Administrations).

3. The Near Future

Before looking towards the more distant future some of the new plant to be introduced in the next few years will be described.

3.1. *Subscriber's Apparatus*

A variety of new types of subscriber's apparatus is just beginning to enter service and other devices are in course of preparation. For example, the loud-speaking telephone permits the user to write and use his hands freely whilst speaking on the telephone and the design standardized by the Post Office is an example of advanced development in which voice switching is used, and many of the disadvantages of earlier similar instruments have been overcome. Repertory diallers will soon become available which permit the user to store frequently used numbers on a small instrument attached to his telephone. Any of the preselected numbers may be signalled by pressing a single start button. A tele-writer attachment will soon become available in which a stylus moved over a paper at the sending end causes a pen at the distant station to move in a corresponding manner so permitting drawings, sketches, manuscript etc. to be transmitted over the normal telephone circuit. Further away in time are devices such as the view-phone and the combination of these new devices will move the subscriber's installation nearer to the concept of a complete communications terminal rather than a simple telephone instrument.

3.2. *Data Transmission*

The expected growth of data transmission requirements is being catered for in a number of ways. It is a feature of data transmission that, unlike telephony, a wide range of different types of requirement exists and this divergence will increase rather than decrease. Thus for an individual conversing with a computer via a keyboard instrument telegraph speeds are appropriate; for a data collection service the requirement may be to pass a very small amount of data from a large number of widely separated points at low speed and infrequent intervals; for the withdrawal of information from a remote file store to present on a visual display higher speeds are necessary; and for direct computer-to-computer data interchange very much higher speeds are appropriate. The Datel 300 service, which is mentioned in the Appendix, is an example of a facility designed ex-

pressly to meet the needs of customers who wish to collect small quantities of data at one central point from a number of out-stations. By contrast, the design of modems to permit the introduction of a high-speed 48 kilobaud service is well advanced and this new service will be introduced between London, Birmingham, and Manchester next year.

All the switched data services referred to so far operate on circuit-switching principles. In the message-switching field the STRAD† system was introduced at Gatwick Airport for switching airline operational traffic in 1959 and has provided valuable experience with this type of facility, exposing some of the technical and operational difficulties. Recently message-switching equipment was brought into use for handling overseas telegraph traffic and a proposal for multi-destination telex (Multitelex) traffic by means of computer-based store-and-forward message-switched systems is under active study.

The use of the existing telephone switching network for data transmission offers the extremely important advantage of its wide penetration which enables data transmission service to be offered between virtually any two points in the country and to the majority of other countries throughout the world. This degree of penetration is unlikely ever to be exceeded by any special-purpose data transmission network. However, bandwidth considerations alone impose speed restrictions on the service that can be offered and a variety of alternative systems is under study which would enable new and even more comprehensive services to be offered. Particular attention is being given to the store-and-forward type of network and the Post Office is co-operating with the National Physical Laboratory in the study of networks of the type described by Mr. D. W. Davies in another paper presented to this Convention.‡ One of the attractions of this approach is the dissociation of the network transmission rate from the subscribers' transmission rate as well as the possibilities offered for error control and automatic alternative routing. Nevertheless, there is still a considerable amount of work to be completed before it can be confidently said that this solution is economically viable. This depends, *inter alia*, on the rate of growth of data traffic, the distribution of traffic with distance, the mix between different data rates, and the mix of message lengths. The Post Office has therefore initiated a full-scale market study in an endeavour to provide the basic information indispensable for a proper economic appraisal of these systems.

† Signal Transmission and Distribution.

‡ 'A communication network for real-time computer systems', *The Radio and Electronic Engineer*, 37, No. 1, pp. 47-57, January 1969.

3.3. Switching Plant.

The bulk of switching plant in the existing telephone exchanges is two-motion selector Strowger type. Co-operative development between the Post Office and the principal telecommunication manufacturers in the U.K. has led to designs of new types of electronic telephone exchange which in due time will replace the existing equipment which, although it has given cheap and reliable service for many decades, suffers from a number of disadvantages. The first of the new electronic exchanges to find full acceptance in the public network is the TXE2 exchange, which has now become standard provision for telephone exchanges up to 240 erlangs total traffic, which corresponds to about 2000 lines at average calling rates. It is a register-controlled exchange in which the speech paths are switched on a space division basis using reed relays; these consist of magnetic blades overlapping at one end, having a gold-plated contact area and enclosed within a miniature glass tube, the whole being inserted in a solenoid which provides the operating flux. The enclosure of the contacts within a controlled atmosphere ensures that they are free from the effects of dust and mechanical damage and therefore may be expected to provide an excellent low-resistance contact throughout a long working life without any need for adjustment. Freedom from contact noise coupled with high reliability and low maintenance costs are features which are especially attractive at a time when labour costs are steadily rising.

Each exchange has a pair of identical control units and these are exercised alternately every eight minutes. Every time a circuit is set up it is automatically checked before extension to the subscriber, and a second attempt made if the first check fails. Detected failures result in an automatic print-out of conditions at the time of failure. This feature should make a very substantial contribution to the effectiveness of maintenance.

To cater for the larger type of exchange a second type of register-controlled, reed relay exchange, known as the TXE4 has been designed. This is capable of handling up to 4500 erlangs total traffic or 40 000 lines whichever is reached first, and a full-scale field trial is about to commence in the Tudor exchange in London.

Together with the crossbar types of exchange which are already being installed for the trunk transit network and will shortly be installed for new trunk switching centres, the London sector switching centres and some local exchanges, these types are likely to form the mainstay of the next generation of switching plant to follow Strowger.

Typical of the new customers' services which would be possible with the new types of electronic exchange are:

(a) *Abbreviated Calling*. This enables a user to set up a call, ultimately to any point in the world, by using a code with only three or four digits. The exchange equipment is arranged to recognize the calling line, to accept the particular code signals and to make up from its memory the complete number wanted using the received code to distinguish which of several such numbers to use. The user can record any number at will against any of his allotted codes and the exchange will continue to make this translation until it is deliberately altered by the user.

(b) *Subscriber Controlled Transfer*. This permits the user to signal to the exchange another number to which he wants his incoming calls to be transferred. The facility permits transfers to long distance as well as local numbers. While the user's number is on transfer the telephone concerned may still be used to originate calls. A variation of the facility allows transfer to an operator or even the total barring of incoming calls when the subscriber does not wish to be disturbed.

(c) *Subscriber's Controlled Conference*. This permits the user to set up calls to several other numbers, both long-distance and local, and finally to connect all the numbers concerned into a conference group.

(d) *Call Waiting Signal*. This informs a user already engaged speaking that another caller wants to speak to him. The user can accept the second call if he so desires after releasing the first: privacy is inherent.

(e) *Call Stored*. This will permit a caller who receives a 'busy' signal to leave the demanded call in a store at the exchange for later automatic completion.

(f) *Freefone*. This permits a subscriber to invite callers, local or long distance, to telephone to the station concerned without charge, the cost of the call being borne by the receiving telephone station.

3.4. Transmission

The inter-city network in the United Kingdom is provided mainly by f.d.m. multi-channel cable and microwave radio links which inter-connect more than 150 towns and cities, and by 1971 will inter-connect more than 300 towns. The wideband links can be sub-divided into standard bandwidths of 4000, 240, and 48 kHz, to provide hypergroup, supergroup and group links respectively which can be inter-connected to provide long distance transmission paths of defined characteristics without passing through intermediate switching points. Development of improved transmission plant has been continuous and intense for many years and the application of these developments, particularly exploiting wider and wider bandwidths on given cable routes, has resulted in the cost per channel mile being progressively decreased by 10 to 1 since 1920. This process is continuing and despite the growing importance of digital systems

to be referred to later, there still remains scope for further cost reduction on analogue transmission systems.

As the bandwidth to be used on the cable is increased so the spacing of the repeaters has to be decreased and before the transistor was available this posed serious problems because the size of the repeaters, and the relative complexity of the power-feeding arrangements, necessitated these being installed in surface buildings. The repeater spacing on a 12 MHz system is 3 miles (5 km) and it is clear that any significant reduction in this spacing would pose serious problems in finding sites for the buildings, particularly in urban areas. The arrival of the transistor repeater permitted the change from surface buildings to buried installations and solved what might otherwise have become an extremely intractable problem.

The microwave radio relays in the network are suitable for 625-line colour television as well as for other telecommunication services and are used to interconnect the television network switching centres in the principal cities, both for entertainment and commercial or industrial closed-circuit television needs.

The cost of multiplexing equipment is independent of circuit length whereas the cost of transmission equipment is roughly proportional to circuit lengths, and it therefore follows that there is a minimum distance, in given circumstances, at which the terminal costs dominate the picture and multi-channel operation becomes uneconomic compared with the provision of separate physical circuits. Because 65% of all junction circuits are less than 5 miles there is a very great incentive to reduce the minimum economic length of multi-channel systems.

One of the most significant developments affecting this situation is the introduction of pulse-code modulation to permit multi-channel working over pair-type cables on the shorter junction routes. In these systems each audio channel is sampled 8000 times per second and the resulting signal samples are encoded into a group of binary digits which identifies the amplitude of the sample. In the U.K. system 24 such channels are then interleaved on a time-division basis and one bit per channel is added to the pulse code group to provide signalling and synchronizing information. The digital nature of the line transmission signals enables them to be regenerated at frequent intervals and thus gives a transmission system which is extremely robust in the face of interference.

The majority of the existing short-distance junction network is provided on loaded pair-type cables and the relatively high levels of crosstalk between pairs at high frequencies has hindered their economical use for

multi-channel signals on an analogue basis, but the robust characteristics of p.c.m. avoids this difficulty. The usual spacing of loading coils is 2000 yards (1800 m) and when these cables are converted to p.c.m. working the loading coils are removed and replaced by regenerative repeaters, power fed with direct current over the cable pair. Separate pairs must be used for each direction of transmission so that after allowing for some pairs in the cable which cannot be converted an improvement of some tenfold in pair utilization is obtained compared with two-wire audio. Adoption of this technique has permitted the economical provision of junction circuits on a multi-channel basis down to some 8 or 10 miles in length. As the volume of production grows, and as large-scale integration techniques are applied to the logic circuits, there are good prospects of making these systems economical at even shorter distances. By the middle of 1970 the Post Office plans to have more than 400 000 channel miles of p.c.m. systems in operation.†

4. The Future

Looking towards the future one can discern a number of trends:

- (a) The establishment of many new non-telephone services.
- (b) The very large scale growth of data transmission, both at very high speed to link together computer centres and at low speed to serve a large number of data collection points.
- (c) The ending of the Strowger switching era with the adoption of electronically controlled space division exchanges using reed relays or crossbar switches, followed by the growth of stored program controlled techniques.
- (d) A growing use of digital techniques within the network, with the p.c.m. already in use in junction networks spreading to the main line trunk network and, in suitable circumstances, with digital switching being integrated with transmission.
- (e) In the very long term a progressive movement towards an all-digital network.

The following sections describe a number of research and development activities that illustrate these trends.

4.1. *Integrated P.C.M. Switching and Transmission*

When there is a concentration of p.c.m. junction routes, such as will occur in the London directory exchange area, the application of p.c.m. switching appears attractive. If circuits in point-to-point p.c.m.

links are connected together in a space division tandem exchange four analogue-to-digital conversions are necessary. If, however, a digital exchange capable of directly switching p.c.m. signals can be devised the analogue-to-digital conversions on each side of the tandem are no longer required and the length of junction over which p.c.m. can be economically introduced correspondingly shortened. Transmission advantages also accrue from such an integrated system, because quantizing noise, which arises at each analogue-to-digital interface, will be reduced since in the integrated system the analogue-to-digital conversion occurs only at the terminal exchanges.

An experimental p.c.m. tandem exchange has been designed and constructed at the Post Office Research Station, Dollis Hill, and following successful laboratory tests has been installed at Empress Exchange in West London. It is now undergoing trials prior to switching live traffic between Acorn, Ealing, and Shepherds Bush exchanges.

For the purpose of the Empress experiment the junction network is operated as a star arrangement with p.c.m. translating equipment at the local exchanges. These terminals are provided with pulse generators which are locked to the incoming signals and provide timing information for both directions of transmission; thus the digit rate of information received at the tandem is the same as that transmitted from it. It is also necessary to accommodate variations in delay due to cable temperature changes and this is achieved by providing an aligner in each group of channels at the tandem. The aligner provides variable delay by reading incoming digits into a small store at the rate of the incoming signals and reading out the information at the tandem exchange clock rate.

However, although by this means the signals arriving at the tandem switch will all be aligned in time, problems may still arise if a signal arriving from exchange A in time-slot N finds that time-slot N on the route going towards the desired exchange is already occupied. To cater for this eventuality the exchange arrangements include not only zero delay connections between incoming and outgoing routes but also delayed connections so that different time-slots may be inter-connected.

The use of integrated p.c.m. transmission and switching is economically attractive only with relatively high traffic density and this precludes its use at the moment in terminal exchanges. A variety of possible solutions to this problem is under study, including both the use of hybrid space and time division exchanges and the use of remote concentrators in the local network which would operate under the control of a processor in a nearby exchange. In situations in

† A fuller discussion of p.c.m. was given in another Convention paper: Cattermole, K. W., 'The impact of pulse code modulation on the telecommunication network', *The Radio and Electronic Engineer*, 37, No. 1, pp. 33-45, January 1969.

which the use of t.d.m. exchanges is not yet economic an alternative approach which is under active study is the use of space division switching operating under the control of a processor with stored program. Such a processor could in fact control more than one exchange and some very far reaching possibilities are opened up by considering a number of exchanges in an area operating together under the control of a single central processor issuing its commands over high-speed data links.

4.2. Rationalized Local Distribution Networks

The local network connecting individual subscribers to their exchange poses particular problems because it represents a substantial amount of capital investment—over £400M in all at the moment—which has to be held at the exclusive disposal of subscribers whose calling rate may be very low and in economic terms the return on the capital is low. The Post Office is studying a variety of ways in which better utilization of plant and more services to the subscribers can be achieved. One interesting experiment aimed at providing a comprehensive communication system to all households and fully integrating the facilities in the local distribution network is being undertaken at Washington New Town. This town, on which construction has just started, has been selected for the experiment in which every house will be served by individual telephone pairs and a common coaxial cable installed underground at the time of construction. The wideband distribution network over the coaxial cable will employ frequency-division multiplex transmission in the frequency range 40–225 MHz. Householders will connect commercial television and v.h.f. sound receivers to this distribution cable and will be able to receive all the television programmes distributed by B.B.C. and I.T.A. on 405 lines and 625 lines, together with B.B.C. Radio 1, 2, 3 and 4, and the Durham local radio programme in Band 2. Spare capacity in the line frequency spectrum is available for future exploitation by other wideband services such as educational and closed-circuit television.

The main highway cable will be equipped with underground d.c. power-fed repeaters at approximately 400-yard (360 m) intervals, and spurs which will extend into individual houses. Some 300 dwellings will be equipped and ready for occupation early in 1969.

As a longer term objective studies are being pursued into the feasibility of providing a single highway distribution network linking all premises in an area and capable of providing a wide range of services including telephony to all users. Various possibilities are being studied, including a digital ring main operating on a coaxial cable, but other transmission media such as optical fibres are not ruled out.

4.3. Educational Television and Confravision

The provision of television services over the local distribution network into the home is paralleled by two other developments in the service. In London, a very extensive closed-circuit television system is at present being installed to serve more than 1000 schools and to provide eight or nine separate 625-line television channels to each school.† Another service, of very great potential interest to the business community, has recently been installed and demonstrated for experimental services between Post Office Headquarters in London and its Research Station at Dollis Hill. This service, known as Confravision, links a specially-equipped studio in each location over a high-quality television circuit. In each studio are two picture monitors, one showing up to five people seated at the distant conference table and the other showing the participants at the local end. A high-quality 4-wire sound system is installed and it has been found that these arrangements permit the conduct of business in a very speedy and relaxed manner. Special cameras are provided which enable diagrams on a 3 ft × 2 ft (90 × 60 cm) white-board to be transmitted and displayed at the distant end, as well as facsimile equipment for the direct transmission of documentary information between the two studios. If public demand is sufficient to justify the capital investment, studios could be established in major cities throughout the country which could be booked in advance for the conduct of business meetings, sales promotion campaigns, and similar activities. Not only has the experimental installation been visited by many potential United Kingdom users, but it has also attracted attention from overseas and has been the object of visits from other countries, including the United States and Canada.

4.4. New Transmission Media

Looking further ahead one can see the growth of large numbers of new services, including, for example, viewphone, surveillance services such as fire and burglar alarms, the remote reading of gas, electricity, and water meters, remote surveillance of the young and the elderly, the remote interrogation and operation of domestic equipment such as cooking appliances and heating appliances, visual displays in the home for information retrieval from data banks and for shopping, educational and other new services. The time scale in which services of this type will be introduced depends on many factors in which economics are likely to be more significant than technological feasibility.

Some of these services will be very extravagant in bandwidth; for example, if 1% of telephone calls were

† 'Television and education', *The Radio and Electronic Engineer*, 36, No. 4, p. 218, October 1968.

viewphone calls it would more than double the bandwidth requirement of our national transmission system and if only 5% of calls were viewphone they would completely dominate the requirements for bandwidth. For these reasons development work is under way at the Post Office Research Station and elsewhere of new transmission media with the aim of providing bandwidth at reasonable cost on a scale vastly greater than anything achieved so far. The two techniques attracting most attention are the use of circular waveguides and fibre optics. At the site for the new Post Office Research Station at Martlesham Heath a 1-mile (1.6 km) length of circular waveguide is being installed in co-operation with University College London, for experimental work. It now seems certain that practical solutions exist to all the technical problems that will be involved in installing such a waveguide as a commercial proposition; the early difficulties which demanded extremely high precision in laying of the guide can be overcome by a number of techniques, and if the traffic growth rate justified it an operational system could probably be installed within 10 years.

Further away, but even more attractive, is the use of filaments of glass fibre as waveguides for light. A filament 100 μm in diameter having an inner core a few μm in diameter could carry at least 1000 telephone channels so that a cable containing 100 fibres could be assembled within a 6 mm outer diameter polythene sheath and could provide an equivalent of about 50 000 two-way telephone channels, with repeaters every 2 km along the route. It is not yet possible to say whether all the technical and practical problems of such a system can be solved, but research work is actively under way and the prospects so far look very encouraging.

It will be appreciated that within the confines of a paper of this type an exhaustive review of developments is impracticable; a selection has therefore to be made and those described are ones which it is hoped will be of particular interest to participants in the Convention.

In conclusion, there has certainly never been a time in the history of telecommunications when the rate of growth of the network and the rate of advance of technology have been so great. The switching and distribution networks are being developed, extended, and modernized by all the techniques available that can contribute to business efficiency and productivity. It has to be recognized however that the possibilities that spring from advanced technologies have to be reconciled with the pre-existing capital investment in former technologies and this reconciliation has to be achieved on a sound business basis and in ways that best deploy scarce skills and resources, human and material, in the service of the community.

5. Acknowledgment

The author is indebted to the Senior Director of Development of the Post Office for permission to publish this paper.

6. Appendix: Post Office Datel Services

Datel services are a combination of a particular type of line and, where necessary, a modulator-demodulator (modem) unit to provide a customer with a data transmission facility for a stated speed range. The Datel services available now and planned for introduction in the near future are described briefly below.

Datel 100 Service

All data transmission facilities provided on telegraph circuits up to a maximum speed of 100 bits per second. The service includes provision of a circuit, either telex or a private circuit, and terminal equipment which may, besides normal teleprinters, include automatic tape transmitters, reperforators and error detection units for transmitting and receiving data in any 5-bit alphabet. Privately-owned equipment may be used and the service will include switching units to allow connexion of such equipment to the circuit.

Datel 200 Service

This service provides serial data transmission over telephone circuits at speeds up to 200 bits per second, enabling the exploitation of low cost terminal equipment, in association with the Post Office Datel Modem No. 2, for simultaneous incoming and outgoing transmissions.

Datel 300 Service

This service provides facilities for multi-frequency data collection systems operating unidirectionally at speeds up to twenty characters per second over telephone circuits. It is designed to meet the needs of customers who wish to collect small quantities of data at one central point from a number of outstations. Two systems will be provided—one, which will be for use where data at the outstation are recorded on punched cards and variable data can be transmitted manually from a simple numeric keyboard; the other, where data can be recorded on punched tape, or edge punched cards. All the outstation equipment, and the in-station modem, will be provided by the Post Office.

Datel 600 Service

This is a serial data transmission service over telephone circuits at speeds up to 1200 bits per second. The Post Office Datel Modem No. 1 provides two types of transmission, i.e. up to 600 or up to 1200 bits per second, with an optional 75 bits per second return channel.

Datel 2000 Service

This service offers telephone private circuits with improved transmission characteristics, for which a surcharge over the normal private circuit rental, dependent upon the type of improvement provided, will be made. Data transmission speeds up to 2000 bits per second—or even higher—should be possible, although this will depend to a considerable extent on the type of modem to be used. The Post Office does not supply the modems, and no guarantee can, therefore, be given regarding transmission rates that can be achieved.

Datel 2400 Service

This service—available late 1968—will enable transmission of serial binary data at a fixed rate of 2400 bits per second over 4-wire private circuits with improved transmission characteristics. Facilities

providing 75 bits per second return channel(s) and alternative working over the public telephone network at a fixed rate of 600/1200 bits per second will be available. The Post Office Datel Modem No. 7 has been specially designed for this service and has standard interface connexions to enable the connexion of suitable G.P.O. approved terminal equipment.

Additional Facilities

The facility of 'unattended answering' over telephone circuits, which allows a data transmission terminal to be automatically interrogated from a distant point, is being developed and will be available in those Datel Services where Post Office modems are provided.

Manuscript received by the Institution on 1st July 1968. (Paper No. 1255/Com. 13).

© The Institution of Electronic and Radio Engineers, 1969

POINTS FROM THE DISCUSSION

The Chair was taken by Professor G. B. B. Chaplin

Mr. R. P. Gabriel: In Section 4.2, 'Rationalized Local Distribution Networks', the experiment in Washington is described as a fully integrated system and the Postmaster-General in the House of Commons was recently permitted by his department to refer to 'a comprehensive cable' to be used there.† In fact it is nothing of the kind; it is perfectly clear both from Mr. Whyte's paper and from Mr. S. H. Granger's recent paper‡ that the system consists of an ordinary telephone network and an entirely separate fully conventional, common-or-garden, v.h.f. television relay system. V.h.f. relay systems are an unhappy compromise between the requirements of a rational design for wired broadcasting on the one hand and the requirements of television receivers designed to work from aerials on the other hand. A notable example of their troubles is that the Post Office themselves have been unable to allocate for these systems in a number of areas the five channels which will be required at the end of next year; that is to say, two 405-line and three 625-line programmes. As the Post Office know very well, if the network and the receivers are designed as parts of one single whole, it becomes possible first to do a decent engineering job and, secondly, to save about £20 per subscriber in the total capital cost of television reception or, in terms of annual cost, one can show the subscriber a saving of at least £5 per annum in his overall cost for sound and vision reception.

I must also take Mr. Whyte to task for the implication later on in the same Section of his paper that the commercial television receivers will reproduce the sound programmes which are to be distributed in Band II. Of course

they will not and, as most people do not have a v.h.f. radio receiver, they must spend an additional £15 or so to buy one.

Mr. J. S. Whyte (in reply): As Mr. Gabriel remarks, it is quite clear from my paper, and from Mr. Granger's recent paper, that the distribution cable arrangements at Washington comprise separate telephone pairs and a common wideband coaxial cable. This scheme is only a first step and the paper specifically refers to other studies in hand leading towards single cable distribution systems.

The Washington installation will provide the Post Office with useful information on the practical problems of providing, installing and maintaining a wideband network in the local distribution area environment. Even with this first step, economic benefits accrue from the sharing of common plant, such as trenches, ducts, jointing boxes and cabinets, and from the common planning for the simultaneous provision of the telephone and coaxial cable.

On the question of the allocation of channels it is true that in some areas, where there are strong local signal fields and where there may be a few receivers with minimal immunity against direct pick-up, there could be some difficulty in the allocation of channels. At Washington we intend to provide six channels, for two 405-line and four 625-line programmes.

Whilst agreeing with Mr. Gabriel that there is engineering attraction in a system designed as a single whole, the Washington scheme was designed to give the user freedom to choose any make of receiver for connexion to the system.

On the last point, it is, of course, quite true that customers requiring the sound programme must provide their own v.h.f. receivers just as they would for direct broadcast reception.

† *Hansard*, 20th January 1967.

‡ Granger, S. H., 'Post Office wideband distribution network at Washington New Town', *P.O. Elect. Engrs J.*, 61, Part 1, pp. 1-2, April 1968.

Dr. K. R. Sturley: What will be the annual charge per household in the Washington New Town for the broadcast programme facilities provided by the G.P.O.?

Mr. Whyte (in reply): We are providing a service to the Washington Development Corporation and the Post Office has no contractual relationship with the householders.

Mr. R. C. Hills: The Government have now given approval to the duplication of the existing 405-line television services of both B.B.C. and I.T.A. in the u.h.f. bands using the 625-line standard. It is planned that by this means all existing services, in colour, will be available to viewers in the main population centres during the early 1970s on the common line standard, thus paving the way for the ultimate phasing out of the present 405-line transmissions. In view of this it seems a rather backward step to introduce into the Washington experiment, aimed at rationalizing domestic telecommunications distribution in the future, a system which appears to be based on the distribution of existing v.h.f. services at their usual carrier frequencies, with a suitable translation of the u.h.f. services into unusual channels in the v.h.f. system. Such a system has monochrome limitations which are well known, and the introduction of colour will serve only to aggravate the choice of translation frequencies if objectionable beat patterns are to be avoided. If 'in-built' domestic television distribution installed with other services such as electricity and telephones is considered a desirable feature of the U.K. telecommunications network in the 1970s, would this not be better planned from the start on a rational basis using optimum distribution parameters, even if this means that a special receiver is rented and installed in a viewer's home in the same way that a telephone instrument is provided today.

Once again the question arises of the liberty of the individual to receive what broadcast transmissions he pleases. I am fully aware of the cogent arguments advanced for a wired relay system of television broadcasting in urban areas, and accept that such is often capable of providing a service superior to that which the average viewer can expect to receive 'off-air'. However, the suggestion that wired distribution, possibly under monopoly control, may become the standard for all new urban development during the 1970s and thereafter, appears to deal this particular liberty a particularly powerful

blow, and I should like to think that such a policy would always be considered complementary to the right to enjoy 'off-air' reception rather than as an obligatory alternative to it.

Mr. Whyte (in reply): As I mentioned in my reply to Mr. Gabriel, one of the objectives of the Washington scheme was that we should provide complete freedom of choice to the user in the selection and acquisition of his receiver. If this desideratum did not apply other options are open for the transmission system and we have taken advantage of this in the London Schools Television System where up to nine 625-line vision and sound channels are assembled in a line frequency spectrum of 40-140 MHz. But it is necessary to provide a suitable tuner at each of the receivers.

On the question of liberty of the individual there is no suggestion in my paper that wired distribution under monopoly control would become standard in the 1970s. Even so, I suggest that Mr. Hill's anxiety is largely academic because the laws of nature relating to v.h.f. propagation effectively limit the possibility of many alternative off-air programmes.

Mr. J. K. Skwirzinski: In connection with the London scheme of television educational network, are any plans being made to extend it into a conversational mode so that individual subscribers may interrogate the central station, thus ensuring a two-way communication.

We should be very careful of implementing 'piped-in' media in whole communities, thus depriving them of choice of information.

Mr. Whyte (in reply): To the first question the answer is 'No'. Our part in the London Schools Television Project is to provide a network to meet the requirement of the educational authorities. As I understand it, the intention is that the television system should be an aid to teaching and not supplant the teacher who would deal with any questions arising from the televised lesson.

The second question is covered in part by my reply to Mr. Hills, but it does not necessarily follow, as implied by the question, that piped transmission deprives communities of freedom of choice; indeed, it may increase it. This situation might be different if it were practicable for individuals to receive television broadcasts off-air direct from other countries.

Of Current Interest

Appleton Memorial Lecture for U.R.S.I.

The Royal Society's British National Committee for Radio Science has proposed that at the triennial General Assemblies of the International Union of Radio Science (U.R.S.I.) an Appleton Memorial Lecture be delivered by a leading scientist working in the field of ionospheric physics. The Lecture is to commemorate the work of the late Sir Edward Appleton, the distinguished British Nobel Prize man in physics, and particularly his long association with the International Union of which he was President from 1934 to 1952. The Royal Society is providing the honorarium awarded to the lecturer.

The first Lecturer, selected by a committee of U.R.S.I., is Professor W. I. Axford of the University of California. He is distinguished for his contributions to upper atmospheric physics including his wind-shear theory of the sporadic-E layer of the ionosphere. His Appleton Memorial Lecture will be delivered at the forthcoming General Assembly of the Union at Ottawa in August 1969.

British Companies at WESCON

A record number of fifteen British electronics firms are to take part in the WESCON exhibition in San Francisco from 19th to 22nd August 1969, under the sponsorship of the Electronic Engineering Association. This E.E.A. co-ordinated drive follows the Association's support of British firms at the 1969 I.E.E.E. Exhibition in New York earlier in the year, and is being arranged within the framework of the Board of Trade 'joint-venture' scheme. The E.E.A. is making considerable efforts to promote a greater awareness among British firms of the potentially large market for electronics equipment that exists in the U.S.A.

Scientific and Technological Manpower

The Electronics Economic Development Committee has recently formed a working group on scientific and technological manpower. Its task will be to evaluate the manpower requirements of the electronics industry taking account of studies already made of scientific and technological manpower. The group will also consider the requirements for education, training, re-training and deployment of qualified manpower. In the light of these requirements recommendations will be made to the EDC on the manner in which it should influence those bodies responsible for improving the stock and deployment of qualified manpower.

The chairman of the group is Professor G. D. Sims (Fellow), Head of the Department of Electronics and Dean of the Faculty of Engineering at the University of Southampton and an independent member of EDC.

Two other members of the Institution are serving on the group:

Rear Admiral J. Grant, C.B., D.S.O. (Companion) who is Director of the Conference of the Electronics Industry, and Mr. G. D. Clifford, C.M.G., the Director of the Institution.

Other members of the group are: Miss V. E. M. Bowell (Science Research Council); Mr. R. G. Fall (Assistant Secretary, Ministry of Technology); Mr. A. D. Priestland (Controller of Staff Development, Mullard Ltd.); Mrs. M. Venning (Engineering Industry Training Board); Mr. J. A. F. H. Pease-Watkin (The Marconi Co. Ltd.).

The secretary is Mr. E. R. Tudway of the National Economic Development Office.

The Evaluation of Industrial R & D Projects

An investigation has started at the University of Stirling into the allocation of industrial research and development funds between competing projects. Supported by a Science Research Council grant of £12,680 over three years to Professor F. R. Bradbury, the study will start work in the field of engineering and extend later to electronics and chemicals.

The principal investigator in the team of 'technological economists' has direct experience of operating, controlling and planning research budgets and resource allocation in a large industrial chemical concern. Other members of the group include a management economist, a physicist, an engineer and an operational research specialist. Together they make up a multi-disciplined team. The research, which will use existing techniques where appropriate, will be based on actual industrial projects selected from those going on at the Ministry of Technology's National Engineering Laboratory at East Kilbride in the first instance. The University's technological economics group works in close collaboration with the Ministry of Technology's Programmes Analysis Unit at Harwell and also undertakes contract research on evaluation of research projects with the National Engineering Laboratory. The group has recently extended its advisory work by the formation of an Industrial Projects Service to attack the problems of smaller firms wishing to make the best use of their resources.

Technological economics is potentially a most rewarding field. Project evaluation covers a range from justification of effort on highly speculative search for major inventions—for which the rewards to industry may be great and the chances of success correspondingly small—to the more easily accepted product and process improvement researches for which the payoff is smaller but more certain. The objective of Professor Bradbury's research is to develop a practical model of the R & D situation useful to the research and development manager in industry. It has to reconcile the mathematician's approach with the real life industrial situation.

Contrast and Brightness Control in Colour Television Picture Monitors

By

M. J. D. NURSE,

C. Eng., M.I.E.E.†

Based on a paper presented at the International Broadcasting Convention held in London on 9th to 13th September, 1968.

Summary: The three guns of the colour-picture tube are fed through d.c. controlled amplifiers. The potentials which control gain and d.c. level are themselves controlled by error signals derived from the video signal at black and white levels. Elaborate and expensive ganged controls are not needed.

1. Introduction

A colour picture monitor requires three identical video amplifiers to control the modulation of the three guns of the cathode-ray tube. The problem faced is to design these three video amplifiers so that their d.c. levels and gains can each be controlled together, thus as the brightness and contrast controls are varied the colour balance of the picture remains constant. Ideally the controlling should be done by d.c. means so that unnecessary routing of the video signals is avoided. This also offers the possibility of providing remote control of brightness and contrast as is common practice in current monochrome monitors.

The use of d.c. control signals eliminates the problem of having expensive ganged controls whose tracking accuracy and tolerance need to be good to provide adequate results. It also avoids the other alternative of a ganged step attenuator, which, whilst allowing the necessary tracking accuracy between amplifiers to be maintained, results in controls that are unfamiliar. Also, since step attenuators are not continuous, accurate matching between monitors with different c.r.t. sensitivities is not possible.

The solution described removes the necessity for accurate potentiometers by controlling both the gain and d.c. level of the amplifiers by d.c. control potentials. Each control potential is compared with a potential derived from the signal at the black and white levels, and the resultant error signals are used to provide corrections to the amplifiers concerned. By this method each amplifier is accurately referred to the two d.c. controls, enabling all three amplifiers to maintain adequate tracking of both d.c. level and gain throughout the range of the controls.

2. Design Considerations

The use of transistors makes the design feasible; it would have been extremely cumbersome using valves. For example, the three video output amplifiers, which

provide the majority of the voltage gain, are all mounted on a printed circuit which is mounted directly on the c.r.t. base. This method minimizes the stray capacitance of each output circuit and allows an adequate bandwidth to be maintained with a high collector load. In all, ten transistors, eleven diodes, six spark gaps and numerous resistors and capacitors are mounted on this printed circuit.

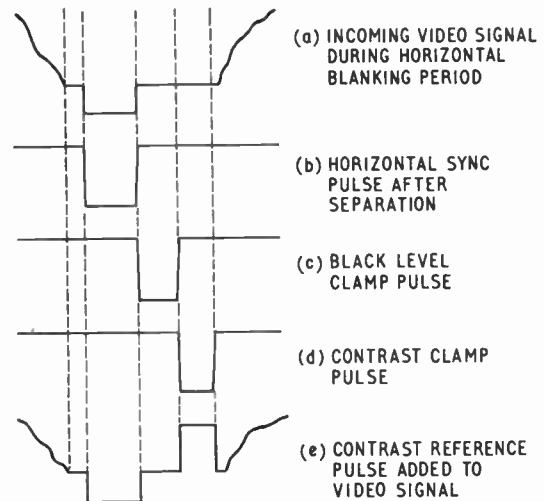

Fig. 1. Waveform timing.

To begin with, the video signal has to contain information that will provide a reference black and a reference 'white'. The reference black is provided by back porch and reference 'white' is obtained by inserting a pulse of controlled amplitude into the latter half of back porch (Fig. 1(e)). This is referred to as the contrast pulse.

The contrast pulse is obtained by the second of two pulse forming circuits in the sync separator. The first pulse generator, timed from the trailing edge of horizontal sync, provides clamp pulses of 2.0–2.5 μ s width to key the black level clamp (Fig. 1(c)). The second pulse generator, timed from the trailing edge

† Pye TVT Ltd., Studio Laboratory, Coldhams Lane, Cambridge.

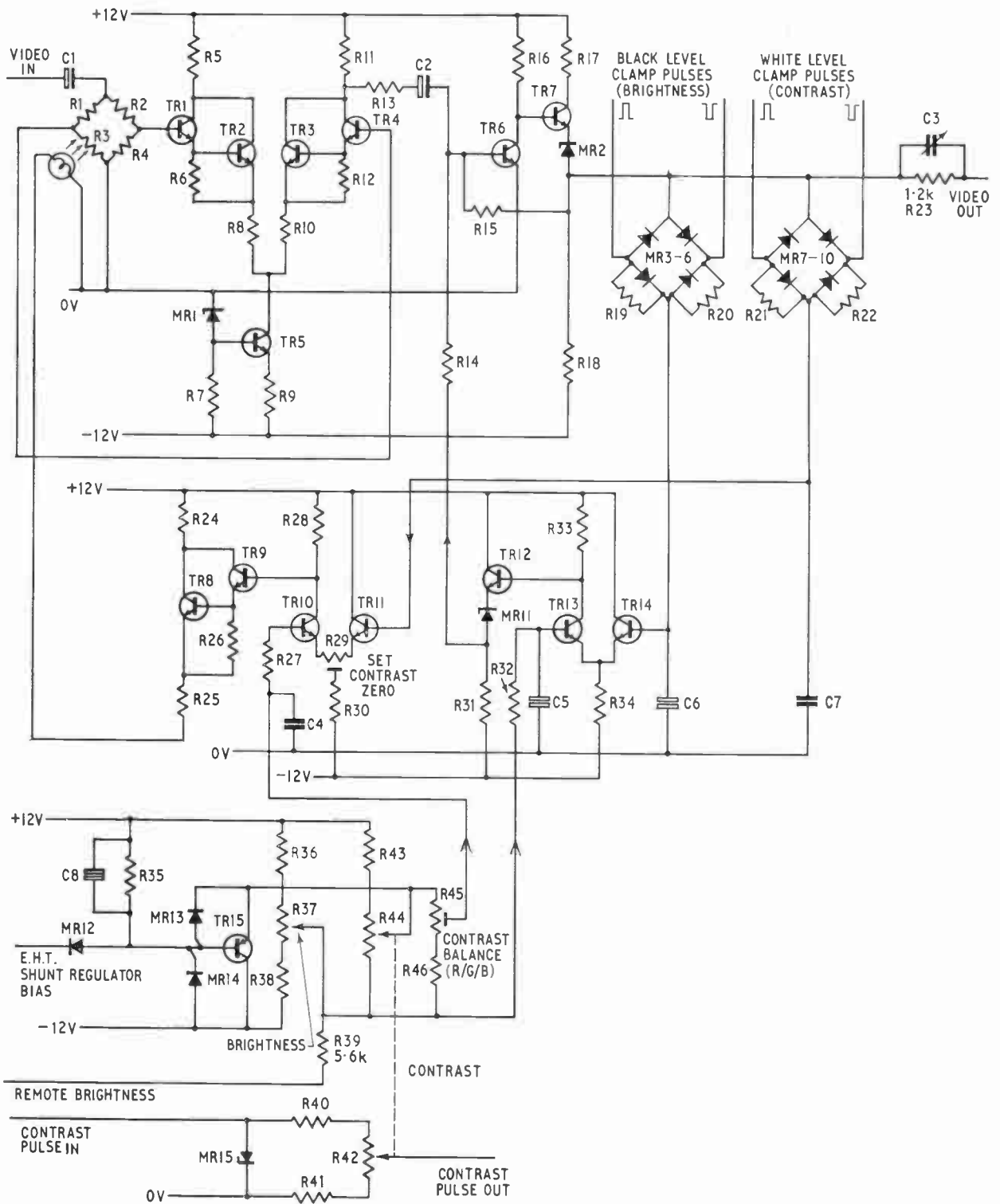

Fig. 3. The main amplifier.

of the first, provides clamp pulses of the same width to key the contrast clamp and provides the contrast pulse (Fig. 1(d)).

3. Circuit Description

The input amplifiers (Fig. 2, TR1-3) are unity gain, long-tailed pairs which have the dual function of providing high input impedances, and isolation of the contrast pulse from the incoming lines. Their gains are closely controlled by using high stability, close tolerance resistors and the contrast pulse is also added via a unity gain amplifier of high stability.

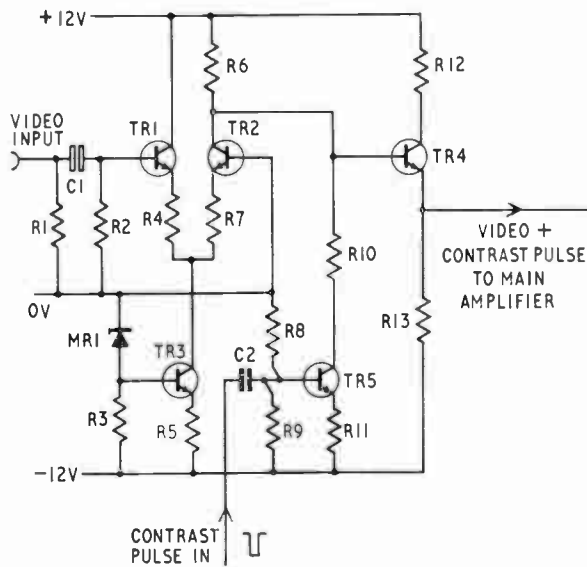

Fig. 2. The input amplifier.

The main amplifiers (Fig. 3) each consist of an input resistive bridge driving a paraphase amplifier, TR1-5, which then feeds a 'feedback pair' amplifier, TR6-7. The output of the second amplifier contains two shunt clamp diode bridges, the first bridge is keyed by the black level clamp pulses and provides a direct voltage on its storage capacitor equal to the signal output voltage during back porch. This black level d.c. is compared with the reference d.c. from the brightness control and any error is amplified and applied as a correction to the input of the feedback pair. Thus the black level of each amplifier is held at the same voltage as the d.c. on the brightness control.

Similarly the second diode bridge is keyed by the contrast clamp pulses and provides a direct voltage on its storage capacitor equal to the signal output voltage at the tip of the contrast pulse. This direct voltage is compared with the reference d.c. from the contrast

control and the error signal after amplification is applied to a lamp which controls the value of a light dependent resistance in one arm of the input resistive bridge. Thus the amplitude of the contrast pulse at the output of each amplifier is equal to the difference between the brightness and contrast d.c. references.

It follows that when zero contrast is required the two d.c. references are required to be equal so the zero end of the contrast control is returned to the slider of the brightness control. In practice, it is found that there is some residual signal left at the output of the video amplifiers due to small variations of V_{BE} in the comparison amplifiers: this is noticeable even when using matched pairs of transistors and matched quads of diodes. To remove this residual error a trimming potentiometer is inserted between the emitters of the contrast comparison amplifier.

Since both black and 'white' levels are continually monitored by the comparison amplifiers, any variation of gain or d.c. level in any of the amplifier circuits due to tolerance of transistor gains or temperature is eliminated. A tracking tolerance of 3.5% between amplifiers and a gain stability of less than 2% with a differential variation between amplifiers of $\pm 0.5\%$ is achieved.

If the colour monitors were only required to operate with a fixed input voltage of say 1V, then a contrast pulse of a fixed amplitude of 1V would be all that was necessary for insertion into the amplifier. However, it is required that the monitor shall be capable of handling an input signal range from 0.25 V to 1.4 V.

To cater for this input signal range the contrast pulse is initially clipped to a known amplitude with a Zener diode, MR15, its amplitude is then varied through a potentiometer network between the 0.25 and 1.4 V levels in such a manner that at zero contrast the 1.4 V pulse is inserted so that the largest anticipated signal can be turned to zero. At maximum

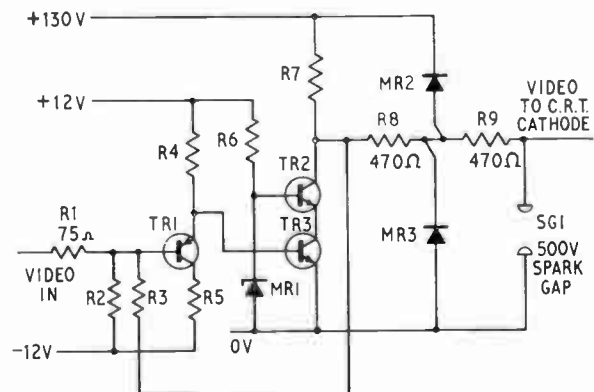

Fig. 4. The output amplifier.

contrast the 0.25 V pulse is inserted so that the smallest anticipated signal can be given sufficient gain. This does result in using a dual-ganged potentiometer for contrast, but the track linearities of this control are not critical as both the d.c. reference and the inserted pulse amplitude are common to each amplifier. Thus amplifier tracking is not affected.

Each output amplifier consists of three transistors (Fig. 4). The p-n-p emitter-follower, TR1, is inserted to provide temperature compensation for V_{BE} drifts of the lower half of the amplifier TR3. The upper half of the amplifier provides the voltage gain, but since it is coupled in a common base configuration it has a large emitter feedback keeping temperature variations to a minimum. Heavy negative feedback is applied from the collector of TR2 to the input base of the emitter-follower and is biased so that without any signal input lead connected the base is at earth potential.

The resistor coupling the main amplifier to the output stage is divided into two sections, R23 (1.2 k Ω) in the main amplifier and R1 (75 Ω) at the input of the output amplifier, since the junction at the base of the emitter-follower is a virtual earth, the 75 Ω also terminates the coaxial cable feeding the output amplifiers.

4. Other Points of Interest

The storage capacitor, C6, in the black level clamp is large and retains the charge from line to line, but the contrast storage capacitor, C7, is intentionally kept small as the lamp inertia of the control element provides the necessary storage.

To provide high internal loop gain in the output amplifier the current amplifier has no emitter resistor to provide safety from overdrive. This can quickly damage the output transistor. In order to prevent this the Zener diode, MR1, in the base of the voltage amplifier is biased so that it provides a low impedance during normal operation, but becomes a high impedance on overdrive. Thus the base current is limited, the base voltage falls and limits the collector current to a safe value.

Using transistors for video drive to the c.r.t. introduces the problem of protecting these devices from voltages flashing back from the e.h.t. on the final anode. It has been found necessary to use two

protection circuits connected in cascade; the two diodes connected in series across the output h.t. supply are normally non-conducting but during an e.h.t. flashover one or other conducts and prevents the output collector from swinging beyond the supply limits. However, since the diodes have to be low capacitance types, the energy in a flashover can be sufficient to damage them and they usually become short-circuit due to excessive current. This can be prevented by absorbing the majority of the flashover energy in a spark-gap which is designed to break down with voltages exceeding 500 V. The series resistances limit the currents through the transistor and diodes to a safe value; 500 Ω has been found sufficient for this purpose, and not sufficient to upset the h.f. response of the signal at the c.r.t. cathode. A compact and inexpensive source of spark-gaps has been the use of reed switches, most of which are designed to have break-down voltages of between 500 and 800 V. The energy in a flashover does not appear to be large enough to damage the reed switch for this application. The reed switch has the advantage over the more economical gap in a printed circuit in that the break-down voltage is not dependent upon the external ambient pressure and humidity.

To prevent excessive beam current being drawn by the c.r.t. the bias on the e.h.t. shunt regulator is coupled via a diode, MR12, to a transistor TR15 connected in parallel with the contrast control. Normally the diode is open circuit and the transistor is non-conducting, thus not affecting the contrast circuit, but when excessive current is attempted the bias of the shunt regulator falls rapidly negative, switching the transistor on and cutting back the gain of all amplifiers.†

Remote brightness is achieved by injecting a swing of ± 12 V via the 5.6 k Ω resistor R39, but so far the other requirement of remote contrast has not been successful as all circuits investigated have resulted in a variation of black level at the same time.

† Mothersole, P. L., 'Hybrid Colour Television Receiver for PAL System'. Mullard Ltd., November 1966.

Manuscript in final form received by the Institution on 5th March 1969. (Short Contribution No. 115/Com. 14.)

© The Institution of Electronic and Radio Engineers, 1969

The Bipolar Transistor as a Voltage-operated Device

By

E. A. FAULKNER,
Ph.D., C.Eng., F.I.E.R.E.†

Summary: It is often advisable to operate bipolar transistors under voltage-driven conditions in order to take advantage of the predictability of the transconductance at any specified operating current.

In a recent paper‡ I made the remark that a great deal of misunderstanding has arisen from the assertion made by nearly every author of texts on circuit design that the bipolar transistor is basically a current amplifier. This remark has led to so many inquiries that I now feel that it would be helpful to engineers to provide some further discussion on this point.

From a physical point of view, the forward current flow through a bipolar transistor is directly caused by the applied base-emitter voltage, which establishes a difference between the Fermi levels on the two sides of the junction. The basic equation which describes this action is the Shockley relation, which for reverse collector bias and $V_{BE} \gg kT/e$ can be written in the form

$$I_C = I_S \exp(eV_{BE}/kT)$$

This equation, on being differentiated, leads to the well-known result

$$g_{te} = dI_C/dV_{BE} = eI_C/kT \quad \dots(1)$$

In the case of a practical silicon planar device, the validity of this equation is limited at the lower end of the I_C range by the effect of leakage current, and at the upper end by the effect of base resistance. With modern high-gain small-signal devices and at frequencies below about 1 MHz, equation (1) is applicable for collector currents in the range from say 100 nA to a few milliamperes; over this enormous range it is substantially true to say that the transconductance of the transistor is independent of construction, type and size, being determined only by the collector current, the temperature and by fundamental physical parameters.

Although the transconductance is the basic property of a transistor, it is of course true that if we drive any device from a source impedance much greater than its input impedance the stage gain will be determined by the current gain of the device (i.e. the product of its transconductance and its input impedance) rather than by its transconductance alone. One of the most important properties of the bipolar transistor is that from a given source impedance we can choose to voltage-drive it or to current-drive it by suitably choosing the d.c. operating current.

Obviously, it is in the current-driven mode that the transistor will give its greatest possible stage gain. However, in evaluating this method of operation we should bear in mind three important facts:

(1) The low-frequency current gain h_{fe0} is, unlike the transconductance, a more or less unpredictable quantity.

(2) The bandwidth of the current-gain characteristic is very much less than that of the transconductance.

(3) In the common-emitter connection, a transistor cannot give a good noise figure if it is current-driven. This point is perhaps the best criterion for deciding from its terminal characteristics whether a device is 'inherently' current- or voltage-operated; for example, the traditional moving-coil galvanometer, which is undoubtedly current-operated, can give an excellent noise performance when current-driven.

It is true that a bipolar transistor in the common-base connection can give a noise figure close to unity when current-driven, and also has a well-defined current gain; but it is not logical to suppose that the basic operating principle of the device could depend on the configuration in which it is connected, and the common-base connection must be regarded simply as a case of parallel current feedback. An exactly analogous situation arises in the case of the vacuum triode in the grounded-grid connection. The validity of this approach is emphasized by the fact that the common-base stage cannot give a good noise figure when the source resistance is large compared with h_{ie} .

Although it has now become fairly well accepted by professional engineers that an input stage should normally be operated at a low enough current to ensure that h_{ie} is substantially greater than the source resistance, the advantages of voltage-driven conditions in later stages are often overlooked. For example, in direct-coupled a.f. complementary feed-back amplifiers some designers make a special point of ensuring that the collector resistor of the first stage is greatly in excess of h_{ie} of the second transistor; to achieve this a parallel RC combination or a Zener diode are sometimes included in the emitter lead of the second transistor, or the first-stage collector resistor may be returned to a higher potential rail. It is often possible to achieve an improvement in performance as well as a simplification in design by using a much lower value of collector resistor and thus substantially voltage-driving the second stage. The resulting reduction in open-loop gain is counteracted by a reduction in its variability with respect to variations in h_{fe} of the second transistor from one individual device to another, so that there is no need for the closed-loop gain repeatability to be affected. On the other hand, the resulting improvement in open-loop frequency response may remove the necessity for compensating capacitors, and the overall temperature coefficient may be considerably improved because the negative temperature coefficient of g_{te} tends to counteract the positive one of h_{fe} in the output stage.

† J. J. Thomson Laboratory, University of Reading, Whiteknights, Reading.

‡ Faulkner, E. A., 'The design of low-noise audio-frequency amplifiers', *The Radio and Electronic Engineer*, 36, No. 2, pp. 117-30, August 1968.

Finally, a word about the choice of transistor operating currents. There are still many designers who operate small-signal bipolar transistors at unsuitably high currents, simply because they adhere to the current at which the maker has specified the h_{fe} range. The usual logic behind this approach seems to be that the devices must be 'intended' for use at or near the test current. In reality, the test current may be chosen for some quite arbitrary reason—for instance, one of the best transistors on the market for low-current operation ($100 < h_{fe} < 500$ at $1 \mu A$) has its h_{fe} specified only at 2 mA, and it appears that this is entirely due to the difficulties experienced by

the automatic test equipment in measuring very low values of base current! For the equipment manufacturer, it is usually advisable to choose the best operating currents on the basis of circuit requirements and to set up jigs for the rapid pass-or-fail measurement of h_{fe} at these currents. It is encouraging to see that a major British instrument manufacturer is about to produce an instrument for the rapid measurement of h_{fe} at low currents.

Manuscript received by the Institute on 5th March 1969 (Short Contribution No. 116/CC45).

© The Institution of Electronic and Radio Engineers, 1969

Contributors to this Issue



Richard W. Cannon (F. 1968) is Deputy Chief Engineer of Cable & Wireless Ltd., a position he has held for three-and-a-half years. He has been with the Company for the whole of his professional life, and has held progressively more responsible engineering posts in many overseas cable and radio stations. He joined the Engineer-in-Chief's Department in London in 1960

and has since been closely involved in technical negotiations on international cable systems and more recently with the *Apollo* Project Earth Station on Ascension Island, and with Intelsat and the associated Earth Stations in various parts of the world. Mr. Cannon joined the Institution's Communications Group Committee in December of last year.



Dr. J. G. Gardiner (G. 1963) joined the staff of the Post-graduate School of Electrical and Electronic Engineering at the University of Bradford as a Lecturer last September. He is a graduate of the University of Birmingham, where he received his Doctorate in 1964 for a thesis on carrier storage phenomena in non-linear circuits. He was then granted a Rascal Research Fellowship

from 1964 to 1966 in the Department of Electronic and Electrical Engineering at Birmingham, working on modulators, mixers and step recovery harmonic generation. Between 1966 and 1968 Dr. Gardiner was a research engineer with Rascal Communications Ltd. at Tewkesbury.



John S. Whyte is Deputy Director of Engineering at the Post Office, having special responsibility for long range studies. He graduated with a London University degree from Northampton Polytechnic, London, and subsequently served at the Post Office Research Station, Dollis Hill and at the associated Radio Research Laboratory near Cardiff for over 20 years.

During this period he worked on a variety of research projects in the radio and line communication field, in the later years being particularly concerned with pulse code modulation techniques and high speed data transmission. In 1965 Mr. Whyte was seconded to H.M. Treasury to take charge of the Computer Division in which post he had overall responsibility for the introduction of computers into all Government Departments. He was appointed to his present post in 1968.



M. J. D. Nurse has been with Pye Ltd., Cambridge, for just over twenty years. His special responsibilities since 1958 have been in the development of high quality television studio monitors and associated equipment. He received his technical education at Cambridgeshire Technical College and during the war served in the Royal Navy.

A note on Mr. D. A. H. Johnson will appear in a subsequent issue of 'The Radio and Electronic Engineer.'

Single-balanced Modulators using Square-law Resistors (S.C.L. Diodes)

By

J. G. GARDINER,
B.Sc., Ph.D. (Graduate)†

Summary: The potentially low-noise properties and accurate square-law characteristic of the square-law resistor suggest applications in modulating circuits in which large dynamic range and signal-handling capabilities are required. In this paper, the conversion losses of a number of single-balanced modulators are evaluated, each circuit possessing source and load terminations which are either resistive or, at most, frequency-selective over only one band of frequencies. The performance of a practical diode is compared with that of an ideal square-law device, i.e. one possessing zero shunt conductance.

List of Principal Symbols

g	diode incremental conductance
$g(t)$	time-varying diode conductance
g_0, g_1, g_2, \dots , etc.	Fourier components of $g(t)$, mean value, fundamental, second harmonic respectively
G_L	signal-circuit load conductance
G_S	signal-circuit source conductance
i	diode current
$i_0, i_{1-}, i_{1+}, \dots$, etc.	components of i at signal frequency (ω_s), and products $\omega_c - \omega_s, \omega_c + \omega_s$ respectively
I_d	diode bias current
I_c	local oscillator drive current amplitude in diode
$k = R_L/R_S$	
P	coefficient of linear-term in diode characteristic
Q	coefficient of V^2 -term in diode characteristic
R_L	signal-circuit load resistance
R_S	signal-circuit source resistance
V_d	diode bias voltage
V_c	local-oscillator drive voltage amplitude at diode
ω_c	angular frequency of local oscillator
ω_s	angular frequency of small input signal

1. Introduction

Considerable interest has been shown recently in the properties of square-law two-terminal elements in modulator applications by reason of the high degree of discrimination against unwanted modulation products which can be obtained from such devices. Hitherto, work has concentrated on the square-law relationship between elastance and charge in the abrupt-junction varactor and a number of varactor, or 'parametric' converters have been reported.^{1,2} However, the varactor converter is inherently unsuitable for high-ratio down-conversion since the three-frequency upper-sideband device, which is the simplest and therefore most readily realizable, has a down-conversion loss proportional to the conversion ratio and a poor noise performance in comparison with the corresponding up-converter. In consequence, whilst varactor up-converters are satisfactory, an alternative is still sought for down-conversion applications.

A device recently developed by Wright³ possesses an extremely accurate square-law $I-V$ characteristic over a wide range of forward bias voltage. This characteristic derives from space-charge limited current flow in a high-resistivity semiconductor and this conduction mechanism has two further advantages:

- (i) It is not limited by minority carrier storage effects so that performance is maintained up to high frequencies.³
- (ii) It provides space-charge smoothing of noise components resulting in a potentially very low noise device.

It is therefore of interest to determine the conversion loss characteristics of the more widely used modulator configurations in which the non-linear (or time-varying) resistance is provided by the forward-biased square-law diode. In this paper the conversion losses and optimum terminating conditions are evaluated

† Formerly with Racal Communications Ltd., Tewkesbury, Gloucestershire; now at the Postgraduate School of Electrical and Electronic Engineering, University of Bradford.

for five modulator types employing not more than one tuned circuit in either source or load.

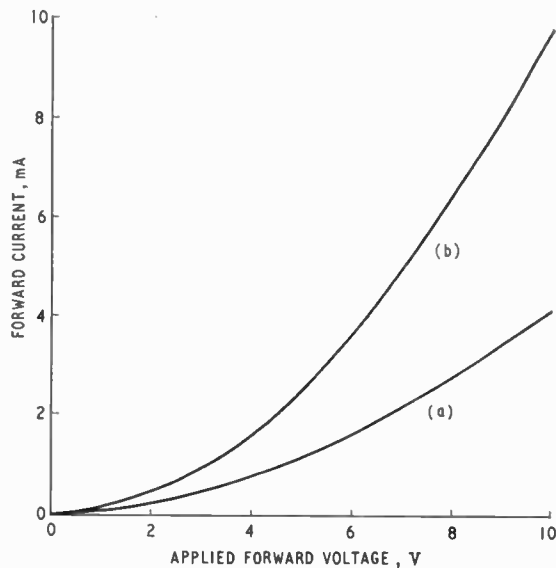

Fig. 1. Measured characteristics of two prototype diodes.
 (a) worst case diode $I = 0.064V + 0.035V^2$
 (b) $I = 0.033V + 0.096V^2$.

2. The Diode Characteristic

The diode characteristic may be represented to a high degree of accuracy⁴ by the expression.

$$I = PV + QV^2 \dots\dots(1)$$

The ratio P/Q takes a value of 0.1–0.5 in present devices and the square-law characteristic is maintained to current values of about 10 mA corresponding to applied voltages of up to 20 V depending upon the desired resistivity of the diode, which may be readily adjusted during manufacture to suit circuit requirements.

Figure 1 shows the forward characteristics of an early prototype diode and a more recent device having P/Q ratios of 1.8 and 0.34 respectively. The prototype device is used in subsequent calculations to represent a 'worst case', an ideal case being characterized by a P/Q ratio of zero.

It is assumed for the purposes of analysis that the signals to be modulated are sufficiently small for the incremental resistance of the square-law diode to be considered linear at any instant, the value of this resistance being determined solely by the local-oscillator signal.

This assumption permits further simplification; balance with respect to the local oscillator is normally achieved by using a bridge of diodes as shown in Fig. 2 but under 'small signal' conditions this may be replaced for the purposes of analysis by a single diode with a parameter variation determined by the local oscillator. This substitution is assumed throughout.

Sinusoidal local-oscillator supplies are assumed and both current and voltage pumping are possible but voltage pumping is preferable from the point of view of obtaining low intermodulation distortion.⁵ One current-pumped modulator is evaluated, however, but is seen to be more lossy than the corresponding voltage-pumped circuit.

Thus, if the diode is voltage-pumped, the incremental conductance, g , may be written

$$g = \frac{dI}{dV} = P + 2QV \dots\dots(2)$$

and if V comprises a number of frequency components (and d.c. bias) then the conductance may be written as a time-varying quantity

$$g(t) = g_0 + g_1 \cos \omega_c t + g_2 \cos 2\omega_c t + \dots \dots(3)$$

where ω_c is the frequency of the local oscillator.

The modulator equivalent circuits used in the following Sections were originally proposed by Howson⁶ in connection with the analysis of conventional modulators switched by variable mark/space local-oscillator supplies.

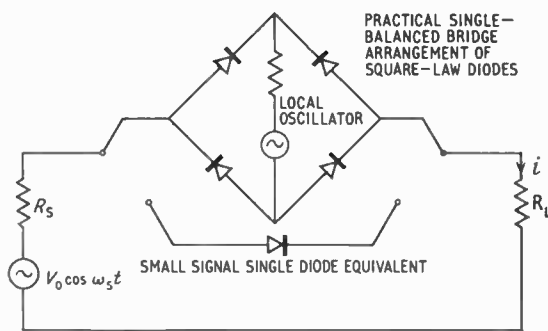

(a) Resistively terminated series modulator.

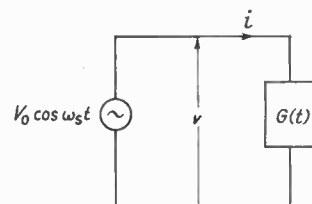

(b) Equivalent circuit of (a).

Fig. 2. Square-law diode modulator, resistive terminations.

3. Voltage-pumped Diodes between Equal Resistive Terminations

The circuit of this modulator is shown in Fig. 2(a) with its equivalent circuit in Fig. 2(b). It is seen that the source and load terminations are combined with the pumped-diode to give a time-varying conductance $G(t)$ where

$$G(t) = G_0 + G_1 \cos \omega_c t + G_2 \cos 2\omega_c t + \dots \dots (4)$$

A current, i , circulates containing all modulation products

$$i = i_0 + i_{1-} + i_{1+} + \dots \dots (5)$$

where i_0 is the component at signal frequency, i_{1-} that at lower-sideband frequency and so on.

Now

$$i = v \times G(t) \dots (6)$$

and since only one voltage, V_0 , exists across $G(t)$

$$i_{1-} = \frac{1}{2} V_0 G_1 \dots (7)$$

Putting $R_s = R_L = \frac{1}{2} R$ and defining conversion loss due to the lower sideband as

$$A = 10 \log \frac{\text{maximum available power from source}}{\text{power in load at sideband}} \dots (8)$$

then

$$A = 20 \log \frac{V_0}{R i_{1-}} \dots (9)$$

$G(t)$ is evaluated in the Appendix and gives

$$G_1 = \frac{1/R}{g_0 + 1/R} [g_1 - g_0 K_1] \times \left\{ 1 + \sum_{m=3,5,7}^{\infty} K_1^{m-1} \frac{m!}{2^{m-1} \left(\frac{m-1}{2}\right)! \left(\frac{m+1}{2}\right)!} \right\} \dots (10a)$$

$$K_1 = \frac{g_1}{g_0 + 1/R} \dots (10b)$$

$$R = R_s + R_L \dots (10c)$$

The series of eqn. (10) converges slowly but the summation is readily performed by computer and Fig. 3(a) shows the results obtained for the prototype and ideal diodes when a 10 V d.c. bias and a 20 V peak-to-peak local-oscillator drive are applied and the terminations varied. A minimum loss of 16.2 dB is obtained with the ideal diode the prototype device yielding an additional 1.1 dB of loss. Figure 3(b) shows a comparison between predicted and measured performance of the other diode of Fig. 1 used in this circuit.

Local-oscillator levels referred to in these and subsequent diagrams are calculated from eqn. (58) in the Appendix.

4. Voltage-pumped Diodes, Load Anti-resonant at Sideband Frequency

Figure 4(a) shows this configuration and its equivalent circuit.

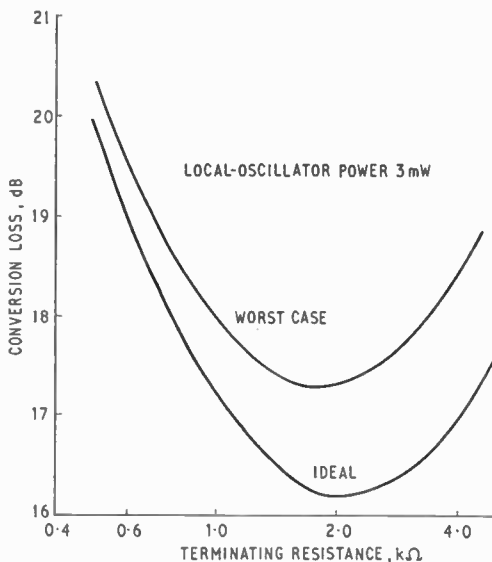

(a) Voltage driven modulator, equal resistive terminations.

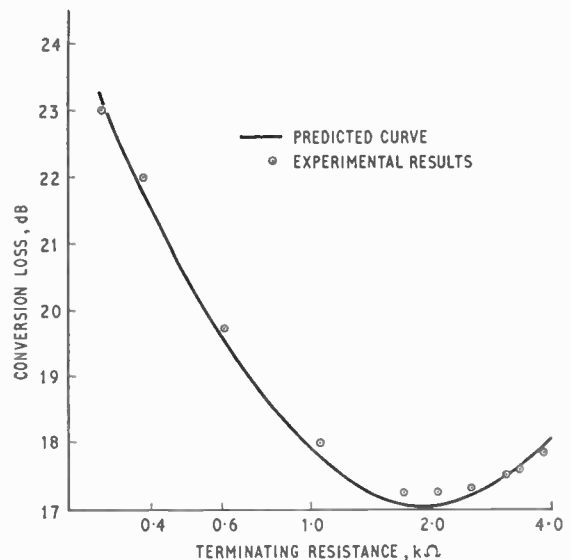

(b) Comparison between measured and predicted losses, equal resistive terminations.

Fig. 3.

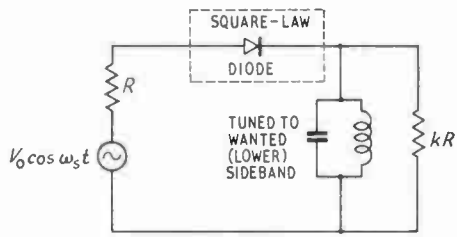

(a) Modulator with load anti-resonant at sideband.

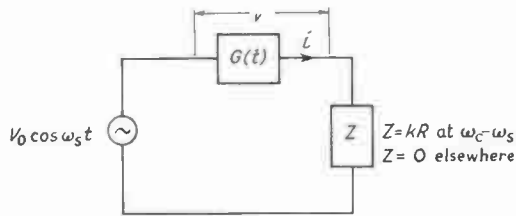

(b) Equivalent circuit of (a).

Fig. 4.

If a current i_{1-} flows in the load then the voltage appearing across this

$$v_1 = i_{1-} kR \quad \dots\dots(11)$$

and since

$$v = v_0 + v_{1-} + v_{1+} + \dots \quad \dots\dots(12)$$

the circuit equation for Fig. 4(b) may be written in terms of $G(t)$ as in the previous case. Taking components at the wanted-sideband frequency this gives:

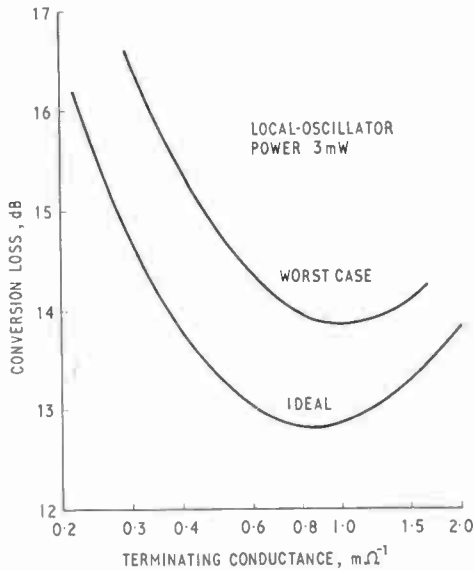

Fig. 6. Effect of terminating conductance: comparison between ideal and worst-case diodes.

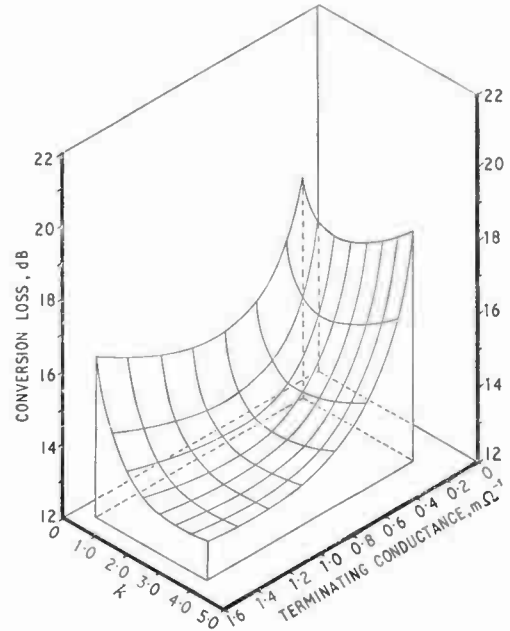

Fig. 5. Conversion loss variation with k and R for modulator shown in Fig. 4.

$$i_{1-} = (-kRi_{1-})G_0 + \frac{1}{2}v_0G_1 \quad \dots\dots(13)$$

$$i_{1-} = \frac{\frac{1}{2}v_0G_1}{1+kRG_0} \quad \dots\dots(14)$$

Taking G_1 from eqn. (9) and G_0 from eqn. (42) in the Appendix

$$G_0 = \frac{-(1/R)^2}{g_0 + 1/R} \left\{ \frac{g_0}{-1/R} + \sum_{n=2,4,6}^{\infty} \frac{K_1^n}{2} \frac{n!}{2^{n-1}[(n/2)!]^2} \right\} \quad \dots\dots(15)$$

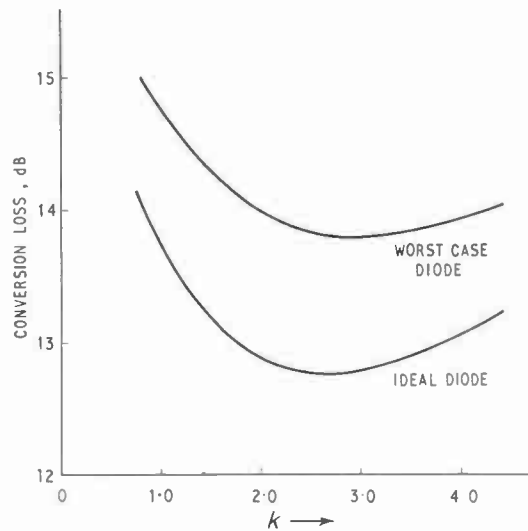

Fig. 7. Variation of conversion loss with k : comparison between ideal and worst-case diodes.

Now it is seen from Fig. 4(b) that since Z is a short-circuit at all frequencies other than the wanted sideband no voltage at frequency ω_s is developed across it. Thus the component of v at signal frequency, v_0 , must take the value of the source e.m.f., i.e. $v_0 = V_0$. Substituting this value in eqn. (14) and solving for A by the definition of eqn. (8) gives

$$A = 20 \log \frac{1+kRG_0}{G_1 R \sqrt{k}} \quad \dots\dots(16)$$

Optimization with respect to the two variables k and R is most readily achieved by numerical methods and the relationship between conversion loss and these parameters is plotted in the form of an isometric graph, Fig. 5, for the prototype diode. The ideal diode performance is compared with the prototype in Figs. 6 and 7 under optimum conditions of the other variable in each case.

A bias of 10 V and a 20 V swing were again employed and a minimum loss of 12.8 dB was obtained for the ideal diode, an improvement of 3.4 dB over the untuned case. The prototype diode was correspondingly worse by about 1 dB.

5. Voltage-pumped Diodes: Load as in Section 4. Source Anti-resonant at Signal Frequency

The circuit of this modulator is shown in Fig. 8(a). In this case the conductance variation of the diode alone is sufficient to permit solution as is shown in the equivalent circuit of Fig. 8(b). The circuit equation may be written for the frequencies in question:

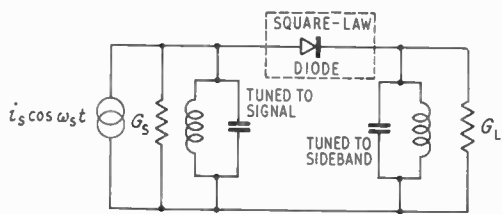

(a) Double-tuned series modulator.

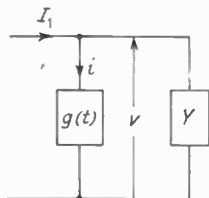

(b) Equivalent circuit of (a).

Fig. 8.

at ω_s ,

$$I_1 = v_0(G+g_0) + \frac{1}{2}v_{1-}g_1 \quad \dots\dots(17)$$

at $\omega_c - \omega_s$,

$$0 = v_{1-}(G+g_0) + \frac{1}{2}v_0g_1 \quad \dots\dots(18)$$

which gives

$$v_{1-} = \frac{\frac{1}{2}g_1 I_1}{(G+g_0)^2 - \frac{1}{4}g_1^2} \quad \dots\dots(19)$$

and

$$A = 20 \log \frac{(G+g_0)^2 - \frac{1}{4}g_1^2}{Gg_1} \quad \dots\dots(20)$$

The optimum value of G is found by differentiation to be

$$G_{opt} = \sqrt{g_0^2 - \frac{1}{4}g_1^2} \quad \dots\dots(21)$$

Since the optimum terminating conductance is calculable from g_0 and g_1 , it is convenient to examine the variation of conversion loss with increasing local-oscillator drive, in this case under optimum terminating conditions. This is carried out in Fig. 9.

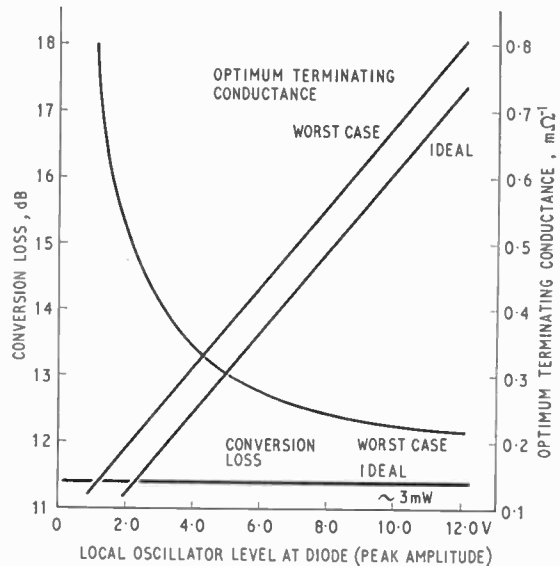

Fig. 9. Terminating conductance and conversion loss for a double-tuned series modulator.

It is of interest to note that in the ideal diode case the optimum conversion loss is independent of the amplitude of the local-oscillator output, this variable only affecting the value of the optimum terminations as shown. In a practical diode with a finite P/Q ratio the loss becomes a function of this quantity and increases rapidly for low values of V . However, in the case of the prototype diode it is seen that at a local-oscillator output level of 10 V the loss is only 0.6 dB above the ideal minimum obtainable. This minimum is seen to be 11.4 dB in the ideal case.

6. Voltage-pumped Diodes: Load as in Section 4. Source Resonant at Sideband Frequency

This circuit is shown in Fig. 10(a) with its equivalent, Fig. 10(b). In this case the resonant shunt is represented by an impedance Z which takes the value zero at all frequencies except $(\omega_c - \omega_s)$ at which it is $(-R)$. As in Section 4, the circuit equations may be written using the same expression for $G(t)$

$$i_{1-} = -v_L G_0 + \frac{1}{2} v_0 G_1 \quad \dots\dots(22)$$

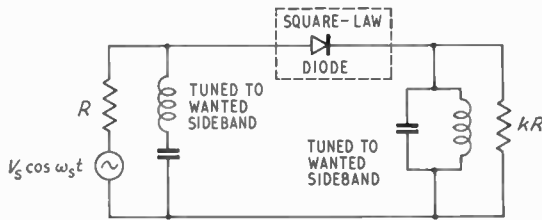

(a) Modulator with source termination short-circuited at wanted sideband frequency.

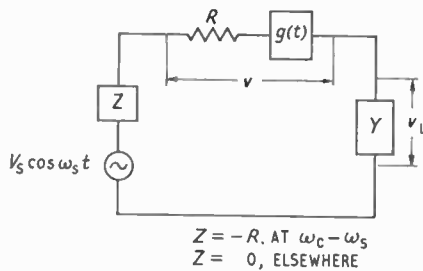

Fig. 10. (b) Equivalent circuit of (a).

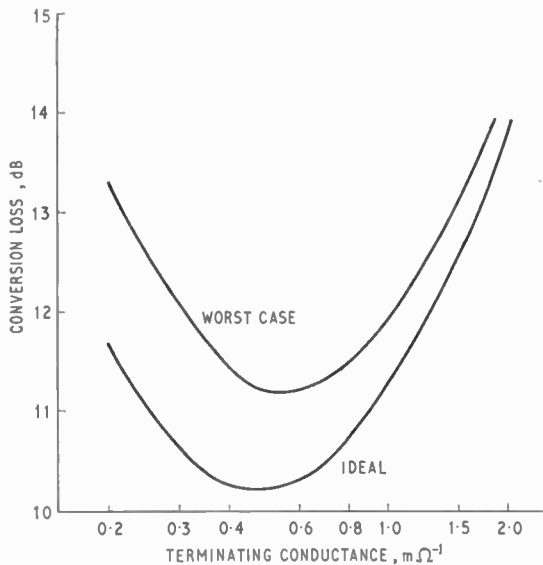

Fig. 12. Variation of conversion loss with terminating conductance in the case of the modulator shown in Fig. 10.

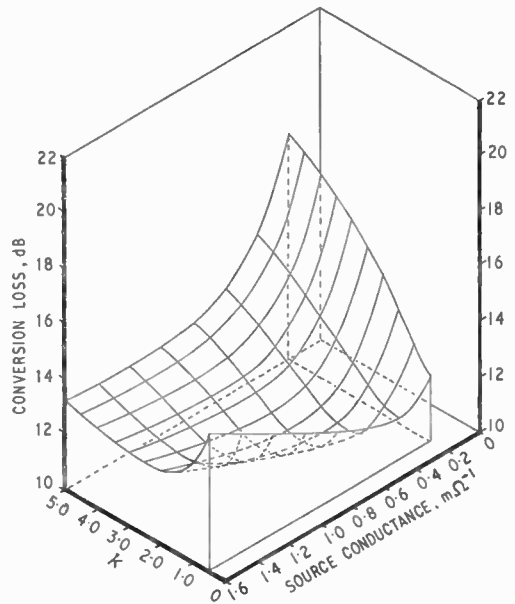

Fig. 11. Conversion loss variation with k and R for modulator shown in Fig. 10.

and since

$$v_L = (1 - k) R i_{1-} \quad \dots\dots(23)$$

$$i_{1-} = \frac{\frac{1}{2} v_0 G_1}{1 + (k - 1) R G_0} \quad \dots\dots(24)$$

which gives

$$A = 20 \log \frac{1 + (k - 1) R G_0}{G_1 \sqrt{k R}} \quad \dots\dots(25)$$

As in the case discussed in Section 4, there are two unknowns and an isometric curve (Fig. 11) indi-

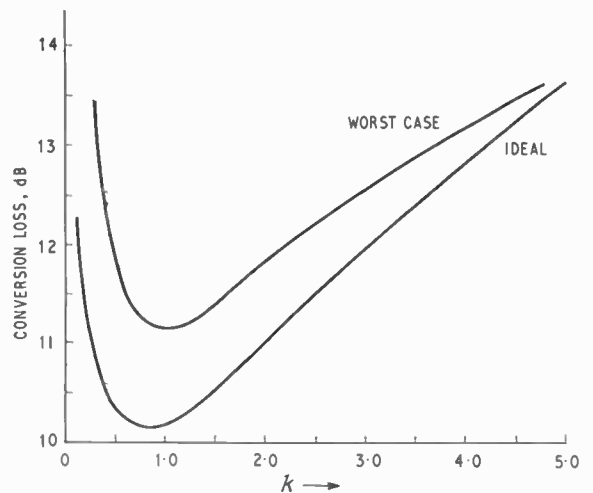

Fig. 13. Variation of conversion loss with k for the modulator shown in Fig. 10.

ates the loss dependence on these quantities for the prototype diode, again assuming 10 V d.c. bias and drive amplitude. The ideal diode is again shown in comparison with the optimum performance of the prototype diode in Figs. 12 and 13. It is seen that the minimum loss is now 10.2 dB.

7. Modulators with Source and Load Resonant at Signal and Sideband Frequencies Respectively

So far the circuits analysed have concentrated upon selective terminations chosen to restrict the number of voltages appearing across the diode, since this, by virtue of the diode characteristic relating current to the square of voltage, should produce the least intermodulation distortion. However, it is known that modulators exist in which low loss is achieved by arranging the diode to conduct for most of the local-oscillator cycle.⁶ It would appear that the square-law diode pumped by a sinusoidal local oscillator will exhibit this property since high resistance is obtained only for a small portion of the drive cycle as the sum of bias and pump voltages approaches zero.

Two possibilities exist as mentioned in Section 2. These are voltage pumping and current pumping.

7.1. Voltage-pumped Diodes

The analysis of this circuit, shown in Figs. 14(a) and (b), is closely related to that of the earlier case (Section 5) excepting that, as is clear from the equivalent circuit, the diode time-variation is required to be of the form:

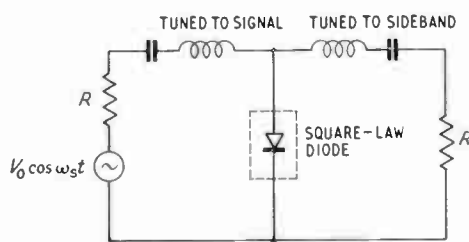

(a) Double-tuned shunt modulator, current fed.

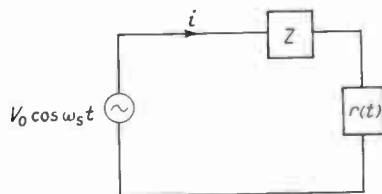

(b) Equivalent circuit of (a).

Fig. 14.

$$r(t) = r_0 + r_1 \cos \omega_c t + r_2 \cos 2\omega_c t + \dots \dots (26)$$

This leads to

$$i_{1-} = \frac{\frac{1}{2}r_1 r_0}{(R+r_0)^2 - \frac{1}{4}r_1^2} \dots (27)$$

which gives the gain as

$$A = 20 \log \frac{(R+r_0)^2 - \frac{1}{4}r_1^2}{Rr_1} \dots (28)$$

and the optimum terminating resistance as

$$R_{opt} = \sqrt{r_0^2 - \frac{1}{4}r_1^2} \dots (29)$$

Expressions for r_0 and r_1 are derived in the Appendix (Section 11.2), namely

$$r_0 = \frac{1}{P+2QV_d} \left\{ 1 + \sum_{n=2,4,6}^{\infty} \frac{K_2^n}{2} \frac{n!}{2^{n-1}[(n/2)!]^2} \right\} \dots (30)$$

$$r_1 = \frac{-1}{P+2QV_d} \times \left\{ K_2 + \sum_{m=3,5,7}^{\infty} K_2^{m-1} \frac{m!}{2^{m-1} \left(\frac{m-1}{2}\right)! \left(\frac{m+1}{2}\right)!} \right\} \dots (31)$$

where

$$K_2 = \frac{2QV_c}{P+2QV_d} \dots (32)$$

and V_d and V_c are d.c. bias voltage and drive amplitude respectively.

Thus the optimum terminating conditions and minimum loss obtainable for a given value of bias and carrier amplitude are readily calculated and are plotted in Figs. 15 and 16.

As in the case discussed in Section 5, the ideal diode yields a constant loss and the prototype device gives an additional 0.5 dB loss above this minimum at 10 V drive amplitude. However, this modulator is not significantly less lossy than that described in Section 5, an ideal minimum of 10.8 dB being the best obtainable.

7.2. Current-pumped Diodes

The analysis proceeds as above except that in this case the expression for $r(t)$ takes a different form. This is developed in the Appendix (Section 11.3) and results in the following:

$$r_0 = \frac{K_3}{4Q} [P^2 + 4QI_d]^{\frac{1}{2}} \times \left\{ 1 + \sum_{m=3,5,7}^{\infty} \frac{2m(2m)! (K_3 I_c)^{m-1}}{(2m-1)(2^m \cdot m!)^2 2^{m-1} (m-1) C_{(m-1)/2}} \right\} \dots (33)$$

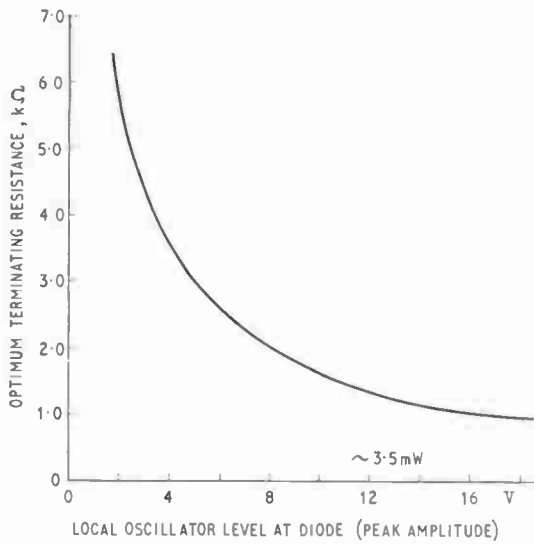

Fig. 15. Variation of optimum terminations with drive for a double-tuned shunt modulator.

$$r_1 = \frac{-K_3}{4Q} [P^2 + 4QI_d]^{1/2} \times \left\{ \frac{K_3 I_c}{2} + \sum_{n=4,6,8}^{\infty} \frac{2n(2n)! (K_3 I_c)^{n-1}}{(2n-1)(2^n \cdot n!)^2 2^{n-2} \binom{n-1}{n-1} C_{n/2}} \right\} \dots\dots(34)$$

where I_d is the bias current, I_c the drive current swing and K_3 is given by

$$K_3 = \frac{4Q}{P^2 + 4QI_d} \dots\dots(35)$$

and $\binom{m-1}{m-1} C_{(m-1)/2}$ and $\binom{n-1}{n-1} C_{n/2}$ are binomial coefficients.

It is immediately apparent that this modulator is significantly more lossy than the voltage-pumped equivalent, the minimum loss obtainable with the ideal device being 14.2 dB. The variation of loss with pump-current amplitude is shown in Fig. 17.

8. Conclusions

The performances of the more widely-used single-balanced circuits have been evaluated when square-law resistors are used as the non-linear elements. The results may be summarized as follows:

- (i) As might be expected, since only the forward characteristic of the device is employed, conversion losses considerably in excess of those achieved with modulators using conventional switching diodes are experienced.
- (ii) The double-tuned series modulator, which produced the least intermodulation distortion, also possesses low loss of only 1.2 dB in excess of the best obtainable from circuits containing a maximum of one filter in each termination.

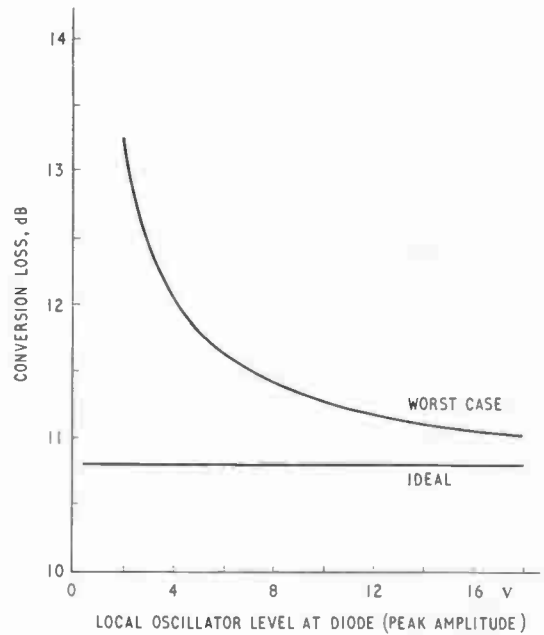

Fig. 16. Variation of conversion loss with drive level for a double-tuned shunt modulator.

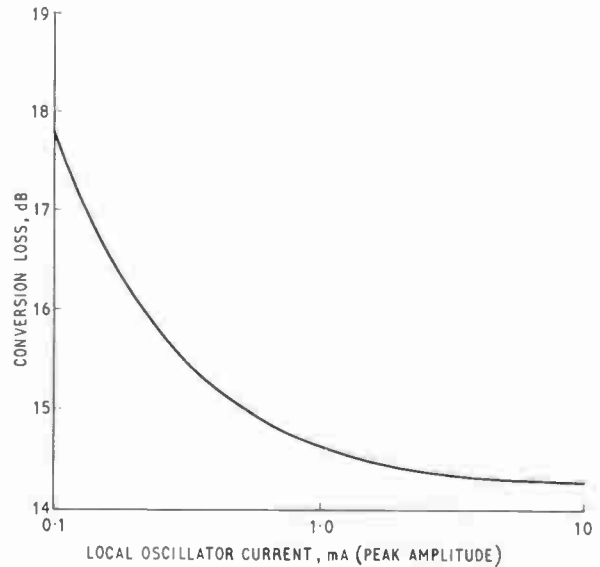

Fig. 17. Shunt modulator, current-driven diodes; variation of conversion loss with drive level.

- (iii) The presence of shunt linear conductance in the square-law device itself is not a serious limitation in practice since with present prototype devices losses within 1 dB of the ideal are achieved with modest local-oscillator powers and when used to provide a high degree of linearity a high-level drive will be supplied in any case.

9. Acknowledgments

The author is indebted to Dr. G. T. Wright of the Department of Electronic and Electrical Engineering, Birmingham University, for making available prototype diodes for experimental work, to Professor D. P. Howson for valuable comments and criticism, and to The Board of Directors, Racal Communications Ltd., for permission to publish this paper.

10. References

1. Perlman, B. S., 'Current-pumped abrupt-junction varactor power-frequency converters', *Trans. Inst. Elect. Electronic Engrs on Microwave Theory and Techniques*, MTT-13, pp. 150-61, March 1965.
2. Gikow, E., 'Wide dynamic range preselectors', *Trans. I.E.E.E. on Aerospace and Electronic Systems*, AES 2, pp. 94-101, January 1966.
3. Wright, G. T., 'Transit time effects in the space-charge-limited silicon diode', *Solid State Electronics*, 9, pp. 1-6, January 1966.
4. Wright, G. T., 'Square-law silicon resistor', Provisional Specification, Department of Electronic and Electrical Engineering, Birmingham University, July 1966.
5. Lepoff, J. H. and Cowley, A. M., 'Improved intermodulation rejection in mixers', *Trans. I.E.E.E.*, MTT-14, pp. 618-23, December 1966.
6. Howson, D. P., 'Single-balanced rectifier modulators', *Proc. Instn Elect. Engrs*, 109, Part C, pp. 357-64, January 1962. (I.E.E. Monograph No. 500E.)

11. Appendix

11.1 Combined Conductance Variations of Diode and Load

$$\frac{1}{G(t)} = \frac{1}{1/R} + \frac{1}{g(t)} \quad \dots\dots(36)$$

$$G(t) = \frac{1}{R} (g_0 + g_1 \cos \omega_c t) \left(\frac{1}{R} + g_0 + g_1 \cos \omega_c t \right)^{-1}$$

$$G(t) = \frac{g_0 \frac{1}{R}}{g_0 + \frac{1}{R}} (1 + K_1 \cos \omega_c t)^{-1} + \dots\dots(37)$$

$$+ \frac{g_1 \frac{1}{R}}{g_0 + \frac{1}{R}} (1 + K_1 \cos \omega_c t)^{-1} \cos \omega_c t \dots(38)$$

since

$$\cos^n \theta = \frac{1}{2} \frac{n!}{2^{n-1} [(n/2)!]^2} + \text{terms in } \cos 2\theta, 4\theta, \text{ etc., for } n \text{ even} \quad \dots\dots(39a)$$

$$= \frac{n! \cos \theta}{2^{n-1} \left(\frac{n-1}{2}\right)! \left(\frac{n+1}{2}\right)!} + \text{terms in } 3\theta, 5\theta, \text{ etc., for } n \text{ odd} \dots\dots(39b)$$

$$G(t) = \frac{g_0 \frac{1}{R}}{g_0 + \frac{1}{R}} \left\{ 1 + \sum_{n=2,4,6}^{\infty} \frac{K_1^n}{2} \frac{n!}{2^{n-1} [(n/2)!]^2} - \sum_{m=1,3,5}^{\infty} \frac{K_1^m}{2^{m-1} \left(\frac{m-1}{2}\right)! \left(\frac{m+1}{2}\right)!} \cos \omega_c t \right\} + \frac{g_1 \frac{1}{R}}{g_0 + \frac{1}{R}} \left\{ - \sum_{n=2,4,6}^{\infty} \frac{K_1^{n-1}}{2} \frac{n!}{2^{n-1} [(n/2)!]^2} + \left[1 + \sum_{m=3,5,7}^{\infty} \frac{K_1^{m-1}}{2^{m-1} \left(\frac{m-1}{2}\right)! \left(\frac{m+1}{2}\right)!} \right] \cos \omega_c t \right\} \dots\dots(40)$$

Thus, if

$$G(t) = G_0 + G_1 \cos \omega_c t + \dots \dots\dots(41)$$

$$G_0 = \frac{g_0 \frac{1}{R}}{g_0 + \frac{1}{R}} + \left\{ \frac{g_0 \frac{1}{R}}{g_0 + \frac{1}{R}} - \frac{g_1 \frac{1}{R}}{K_1 \left(g_0 + \frac{1}{R}\right)} \right\} \times \sum_{n=2,4,6}^{\infty} \frac{K_1^n}{2} \frac{n!}{2^{n-1} [(n/2)!]^2} \dots\dots(42)$$

$$G_1 = \frac{g_1 \frac{1}{R}}{g_0 + \frac{1}{R}} \left\{ 1 + \sum_{m=3,5,7}^{\infty} \frac{K_1^{m-1}}{2^{m-1} \left(\frac{m-1}{2}\right)! \left(\frac{m+1}{2}\right)!} \right\} - \frac{g_0 \frac{1}{R}}{g_0 + \frac{1}{R}} \times \frac{m!}{2^{m-1} \left(\frac{m-1}{2}\right)! \left(\frac{m+1}{2}\right)!} \left\{ (K_1 + 1) \sum_{m=3,5,7}^{\infty} \frac{K_1^m}{2^{m-1} \left(\frac{m-1}{2}\right)! \left(\frac{m+1}{2}\right)!} \right\} \dots\dots(43)$$

which, since

$$K_1 = \frac{g_1}{g_0 + \frac{1}{R}}$$

reduces to eqns. (10) and (15).

11.2 Time-varying Resistance of Voltage-pumped Diode

$$r(t) = \frac{1}{g(t)} \quad \dots\dots(44)$$

and

$$g(t) = \frac{dI}{dV} = P + 2QV \quad \dots\dots(45a)$$

if

$$V = V_d + V_c \cos \omega_c t \quad \dots\dots(45b)$$

$$g(t) = P + 2QV_d + 2QV_c \cos \omega_c t \quad \dots\dots(46)$$

$$r(t) = \frac{1}{(P + 2QV_d)(1 + K_2 \cos \omega_c t)} \quad \dots\dots(47)$$

where

$$K_2 = \frac{2QV_c}{P + 2QV_d} \quad \dots\dots(48)$$

$$r(t) = \frac{1}{P + 2QV_d} \{1 - K_2 \cos \omega_c t + K_2^2 \cos^2 \omega_c t - \dots\} \quad \dots\dots(49)$$

which from eqns. (39) gives

$$r(t) = \frac{1}{P + 2QV_d} \left\{ 1 + \sum_{n=2,4,6}^{\infty} \frac{K_2^n}{2} \times \right. \\ \times \frac{n!}{2^{n-1} [(n/2)!]^2} - \left[K_2 - \sum_{m=3,5,7}^{\infty} K_2^{m-1} \times \right. \\ \left. \times \frac{m!}{2^{m-1} \left(\frac{m-1}{2}\right)! \left(\frac{m+1}{2}\right)!} \right] \cos \omega_c t + \\ \left. + \text{terms in } 2\omega_c t, 3\omega_c t, \text{ etc.} \right\} \dots\dots(50)$$

11.3 Time-varying Resistance of Current-pumped Diode

From eqn. (1)

$$V = \frac{-P \pm \sqrt{P^2 + 4Q(I_d + I_c \cos \omega_c t)}}{2Q} \quad \dots\dots(51)$$

where I_d and I_c are respectively d.c. bias and drive current amplitudes. Taking only the positive result from eqn. (51)

$$V = \frac{1}{2Q} \left\{ (P^2 + 4QI_d)^{\frac{1}{2}} \times \right. \\ \left. \times \left[1 + \frac{4Q}{P^2 + 4QI_d} \cdot I_c \cos \omega_c t \right]^{\frac{1}{2}} - P \right\} \dots\dots(52)$$

Defining incremental resistance $r(t)$ as

$$r(t) = \frac{dV}{d(I_c \cos \omega_c t)}$$

and putting

$$K_3 = \frac{4Q}{P^2 + 4QI_d}$$

$$r(t) = \frac{1}{2Q} \left\{ (P^2 + 4QI_d)^{\frac{1}{2}} \times \right. \\ \left. \times \left[\frac{K_3}{2} + \dots \frac{n(-1)^{n-1}(2n)!}{(2n-1)(2^n n!)^2} K_3^n I_c^{n-1} \cos^{n-1} \omega_c t \right] \right\} \quad \dots\dots(53)$$

Extracting $K_3/2$ gives

$$r(t) = \frac{1}{(P^2 + 4QI_d)^{\frac{1}{2}}} \times \\ \times \left\{ 1 + \dots \frac{2n(-1)^{n-1}(2n)!}{(2n-1)(2^n n!)^2} (K_3 I_c)^{n-1} \cos^{n-1} \omega_c t \right\} \quad \dots\dots(54)$$

As before, even powers of $\cos \omega_c t$ yield d.c. components and odd powers yield components at $\omega_c t$. Again using eqns. (39)

$$r(t) = \frac{1}{(P^2 + 4QI_d)^{\frac{1}{2}}} \left\{ 1 + \sum_{n=3,5,7}^{\infty} \frac{2n(2n)!}{(2n-1)(2^n n!)^2} \times \right. \\ \times \frac{(n-1)C_{(n-1)/2}}{2^{n-1}} (K_3 I_c)^{n-1} - \\ - \left[\frac{K_3 I_c}{2} + \sum_{n=4,6,8}^{\infty} \frac{2n(2n)!}{(2n-1)(2^n n!)^2 2^{n-2}} \times \right. \\ \left. \times (n-1)C_{(n/2)} (K_3 I_c)^{n-1} \right] \cos \omega_c t - \\ \left. + \text{terms at } 2\omega_c t, 3\omega_c t, \text{ etc.} \right\} \dots\dots(55)$$

11.4 Calculation of Pump Powers

Returning to eqn. (1) and putting

$$V = V_d + V_c \cos \omega_c t$$

$$I = \left[V_d(P + QV_d) + \frac{V_c^2}{2} \right] + \\ + V_c(P + 2QV_d) \cos \omega_c t + \frac{V_c^2}{2} \cos 2\omega_c t \quad (56)$$

Since for minimum distortion only the fundamental component of the local oscillator voltage can exist across the diode and the component of current at ω_c is given in eqn. (56), the effective resistance to the local oscillator is

$$R_c = \frac{1}{P + 2QV_d} \quad \dots\dots(57)$$

and the power dissipated in this resistance is

$$P_c = \frac{V_c^2}{2} (P + 2QV_d) \quad \dots\dots(58)$$

Manuscript first received by the Institution on 19th May 1968 and in final form on 10th January 1969. (Paper No. 1256/CC44.)

Cross-Correlation Techniques and their Application to Communication Channel Evaluation

By

D. A. H. JOHNSON, M.Sc.,
M.N.Z.I.E., C.Eng., M.I.E.E.†

Presented at the Second New Zealand Electronics Convention (NELCON II) organized by the New Zealand Section of the Institution and the New Zealand Electronics Institute and held in Auckland in August 1968.

Summary: Cross-correlation methods for determining the time domain response of systems are finding increasing use in the communications field. This paper discusses the adapting of these techniques to communication channel testing. Present-day solid-state devices enable compact and economical test equipment to be constructed. The immunity of the method to noise and interference suggest that 'on-line' testing in the presence of normal traffic might be possible. Results of a computer simulation seem to confirm that 'on-line' testing is indeed feasible, and that low-level test sequences may be used to obtain channel response information with sufficient accuracy to operate automatic time domain channel model synthesizers or equalizers.

1. Cross-Correlation Method

The technique of cross-correlation is widely used in the field of automatic control¹ for obtaining system weighting functions, but is still somewhat neglected by communication engineers. It involves applying random test signals to the channel under test and performing input/output cross-correlations (see Fig. 1). The result of the process, for each value of τ , represents the channel impulse response, $h(\tau)$.

The impulse response completely defines the channel performance in the time domain and is a convenient characteristic for assessing the performance of a channel for data transmission. This is because the channel time dispersion is proportional to the radius of gyration of the squared impulse response about its centre of gravity.² It is this time dispersion which determines the degree of intersymbol interference, and which hence sets the lower bound on the channel error rate. Thus a 'good' channel will have an impulse response with a small 'side-lobe' content.

The channel transfer function, and hence the amplitude and phase response in the frequency domain, can be deduced from the impulse response by transformation, or they can be measured directly. However, in this form, the channel information is not convenient for assessing the data performance. The time dispersion can be expressed in terms of the quadratic sum of the amplitude distortion, and the amplitude weighted phase distortion, averaged over the channel bandwidth.² The identification of a 'good'

channel, which would have a slow amplitude roll-off, a 'flat' pass-band, and a linear phase characteristic away from the band edges, is obviously more difficult.

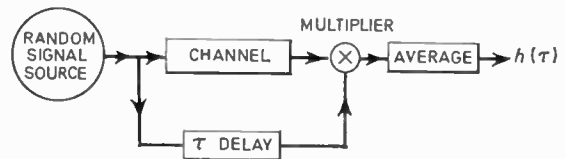

Fig. 1. Cross-correlation method for evaluating the impulse response.

By rewriting the convolution integral relating channel input $x(t)$, the channel impulse response, and the channel output $y(t)$, in terms of the auto-correlation and cross-correlation of the input and output signals, it can be shown that

$$\Psi_{x,y}(\tau) = \int_{-\infty}^{\infty} h(t) \cdot \Psi_{x,x}(\tau-t) \cdot dt \quad \dots\dots(1)$$

$\Psi_{x,y}(\tau)$ and $\Psi_{x,x}(\tau)$ are the cross-correlation function (c.c.f.) and auto-correlation function (a.c.f.) of the test signal. For a random test signal $\Psi_{x,x}(\tau-t)$ is zero except at time $t = \tau$, and the expression simplifies to:

$$\Psi_{x,y}(\tau) = h(\tau) \quad \dots\dots(2)$$

where $h(\tau)$ is the required impulse response.

The c.c.f. is described by the following process:

$$\Psi_{x,y}(\tau) = \lim_{T \rightarrow \infty} (1/2T) \int_{-T}^T y(t) \cdot x(t-\tau) \cdot dt \quad \dots\dots(3)$$

† Formerly at the Department of Electrical Engineering, University of Canterbury, Christchurch, New Zealand; now at the University of Melbourne.

A method of obtaining the c.c.f. is shown in Fig. 1. For each value of delay τ , the c.c.f. is the averaged value of the product of $y(t)$, and a delayed replica of the input, $x(t)$. This averaging may be carried out with a simple low-pass filter.

A further simplification arises from eqn. (1). The randomness property required is only that the a.c.f. be zero over the period for which $h(\tau)$ is significant. This permits a very convenient class of binary pseudo-random test signals, namely, 'M-sequences' to be used.³ The a.c.f. of these sequences is very nearly zero except at a succession of equally-spaced intervals, $N \cdot \Delta t$. N is the number of '1's and '0's of the generating feedback shift register, before the sequence repeats, and Δt is the shortest element length. Figure 3 shows a recording of part of such a sequence. Thus it is only necessary for $N \cdot \Delta t$ to be much greater than the response time of the channel.

An advantage to the communication engineer accrues from the use of the pseudo-random sequences. They permit copies of the input signal to be generated at the output end of the channel where the correlator is usually situated. (See Fig. 2.) This avoids the need for a return path to provide a sample of the input, a factor which is unattractive to engineers. A new problem is of course substituted, that of synchronizing

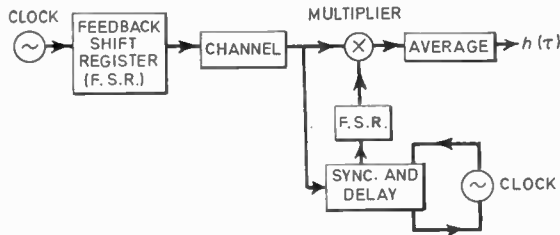

Fig. 2. Two-generator system for communication channels. Correlator reference signal generated locally.

and phasing the locally-generated replica, but well established techniques may be adapted for the purpose. Particular patterns in the M -sequences, namely the all '1's state may be recognized, and exploited for phasing. Alternatively, the local clock frequency may be slightly offset so that the local sequence 'sweeps' across the received sequence until correlation begins.

2. On-line Evaluation

The cross-correlation method is inherently insensitive to noise and other random disturbances. It is the extent to which the 'extraneous' signals correlate with the test signal, rather than their relative level, which determines the error in the estimate of $h(\tau)$.

If $z(t)$, the normal traffic signal, is present as well as

the test sequence, then

$$\begin{aligned} \text{c.c.f.} &= (1/2T) \int_{-T}^T x(t) \cdot [z(t-\tau) + y(t-\tau)] dt \\ &= h(\tau) + (1/2T) \int_{-T}^T x(t) \cdot z(t-\tau) dt \end{aligned} \quad \dots\dots(4)$$

The integral term of eqn. (4), representing the correlation of the test signal and the 'interfering' signal, will in general be small, simply because the test signal is random. The term does however represent an error in the estimate of $h(t)$, and needs to be minimized by optimum choice of test signal and integration period. In specific cases, optimum phasing of the test sequence in relation to the start of the integration period can minimize the error.^{4, 5}

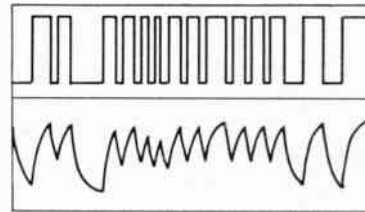

Fig. 3. Chart record of part of a 2047-bit pseudo-random binary sequence at the input and the output of a first-order system.

One of the aims of this study is to assess the potential of the method for evaluating the channel characteristic while normal traffic is present on the channel, and to develop simple equipment suitable for every-day testing. Longer-term aims are the evolution of methods of using the information about the channel response, obtained on line, to improve the data performance. These methods would involve synthesizing local replicas of expected symbol patterns to assist the detector decision process, or alternatively direct synthesis, on line, of the optimum time domain equalizing filter.

3. Results

3.1. Experimental

Two feedback shift registers were constructed with transistor-resistor integrated circuit logic elements. The sequence length was 2047. While delayed versions of the sequence can be generated by modulo-2 addition of the outputs of various stages of the generating shift register,⁶ the two-generator method,⁷ was chosen as being more flexible. Control logic was developed to inhibit clock pulses from one of the generators at a controlled rate, thus permitting a continuous scan of the input sequence with the reference sequence.

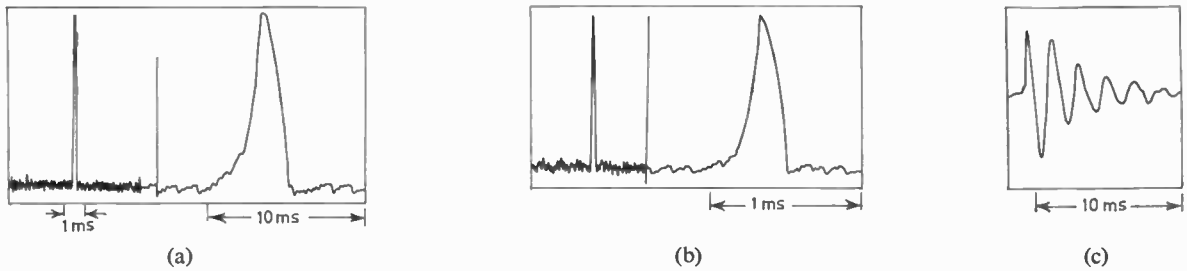

(a) Impulse function from auto-correlation of a 2047-bit pseudo-random sequence.
 (b) As (a), but taken in the presence of a strong interfering carrier 6 dB above the test sequence level.
 (c) Impulse response of second-order system taken under same conditions as (b).
 System natural frequency: 500 Hz, test sequence clock frequency: 6 kHz.

Fig. 4.

Figure 4 shows chart recordings of the averaged correlator output for an ideal (i.e. purely resistive) channel with and without an interfering signal present. The insensitivity of the output to the presence of other signals can be readily seen.

3.2. Computer Simulation

The accuracy of the correlation estimates of the channel time response were determined by performing computer simulations on the 360/44 digital computer. In the program the channel was simulated by simple first- and second-order networks, while the data signal was simulated by another pseudo-random sequence of length 2047. In selecting test sequence and clock

frequencies for both test and interfering sequences, obviously unsatisfactory combinations were avoided (such as harmonically-related clock frequencies).

The other parameters of the simulation, test signal level, integration time etc., were varied to determine trends. Some of these are displayed in Fig. 6.

Accuracy checks were based on computer graph plots of the c.c.f. values superimposed on calculated response curves. In addition, r.m.s. error was computed over the region where $h(\tau)$ was significant, and expressed as a percentage of the principal response peak (Fig. 6). For a given test signal level the accuracy improved as the integration time increased. For example, when a test signal 10 dB below the traffic signal at the channel input, and having a clock frequency five times the channel cut-off, was used, integration times equal to 1 sequence length resulted in an error of 37%, and integration times equal to

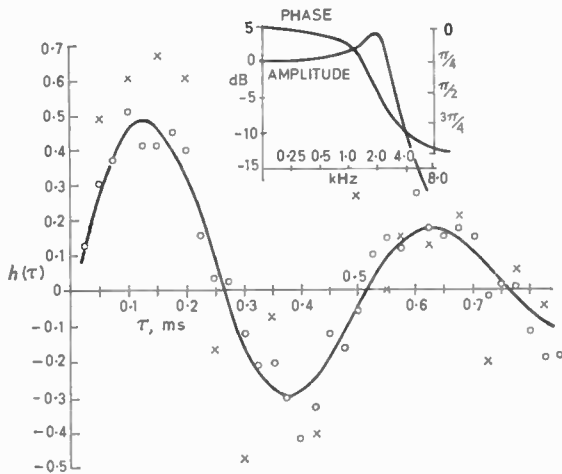

Fig. 5.

Correlation estimates of $h(\tau)$ for a second-order system (see inset for amplitude and phase characteristics), taken in the presence of a simulated data signal. Data signal: 2047-bit sequence; clock rate 1.7 kHz. Test signal: 511-bit sequence; clock rate 20 kHz; level 10 dB below data signal at input.

- Correlator output for integration time of 200 ms.
- × Correlator output for integration time of 25 ms.
- Correlator output in absence of data signal.

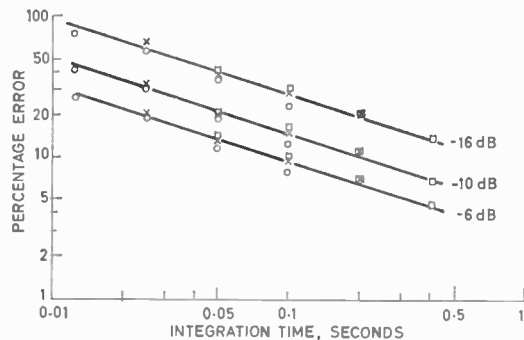

Fig. 6. R.m.s. error in impulse response for the second-order system (Fig. 5), due to the presence of a simulated data signal. Test signal level relative to the data signal level at the channel output indicated on the error graphs. Test sequence clock frequencies are:

- 40 kHz
- × 20 kHz
- 10 kHz

8 sequence lengths resulted in an error of 13%. Truncation and computing time limitations made longer integration periods impracticable.

Figure 5 shows the typical scatter of correlation estimates of the channel response, around the true channel impulse response, when integration time is insufficient. In spite of the scatter, nearly all the points have the correct sign which is an important point considering that sign information alone is sufficient for tap gain setting.⁸

4. Applications

4.1. Channel Evaluation

The correlation method evaluates the complete time response of communication channels, in contrast to the peak-to-average ratio method,^{9, 10} which yields only a single figure rating of channel distortion. Both methods, however, are very much more relevant to data channel evaluation than the traditional frequency domain methods. Again, while both methods require special test signals to be injected, only the correlation method has the necessary immunity from other interfering signals to make it potentially capable of an 'on-line' use. The results of the computer simulation support the view that 'on-line' operation is feasible.

Although the method appears rather complicated for every-day quality checking, the equipment can in fact be easily and relatively cheaply constructed with present-day solid-state devices.

The injection of low-level test signals is of course only one method of achieving on-line evaluation. Other approaches involve modification of the data stream by modulo-2 addition with the test sequence,¹¹ or phase modulation of a carrier by the test sequence in quadrature to the data modulation.¹² These techniques are appropriate to more advanced adaptive systems, where the complexity is justified. The low-level injection method does, however, permit general-purpose testings of any data circuit without modification of the data set.

4.2. Model Synthesis

The ability to synthesize, from information about the channel response, either a local model of the channel, or the equalizing filter, is necessary for optimizing the communication system as a whole.

Synthesis of the channel model enables replicas of echoes on the two-way telephone channel to be generated and used to cancel the delayed echoes received from the far end. Automatic synthesis based on correlation measurements of low-level random signals is feasible and the 'on-line' feature should facilitate adjustment of time varying channels. Synthesis based on actual speech signals has been shown to be theoretically possible;¹³ however a

practicable system must also be able to adapt to the widely-varying speech levels, each of which requires a unique setting of the control loop, a seemingly intractable problem.

For data systems, response information derived from correlation measurements can in theory be used to synthesize the optimum time domain equalizing filter. One example of present-generation time domain equalizers⁸ requires test pulses to be transmitted at least initially, and the tap gain adjustment process proceeds iteratively based only on the sign information of the channel response function. Another approach, the 'adapicom' system,² specifically developed for h.f. radio links, uses a rather more rapid, although 'sub-optimum' tap-setting strategy, and permits short bursts of data to be transmitted between adjustment phases. An 'on-line' approach using low-level test sequences appears to be feasible, and could be effective with slowly time varying channels. Another approach under study uses the channel response information to assist the detector symbol identification, rather than equalize the channel response.

Apart from their use on high-speed data systems and long-distance telephone systems, the automatic synthesizers may well provide the solution to the problem of transmitting data and video signals over low-quality links and telephone cable pairs.

4.3. General Measurements

Other applications include most areas where channel properties need to be measured, such as cross-talk and intermodulation in multi-channel systems, and fading and multi-path in radio channels.

5. Conclusion

Cross correlation techniques using 'M-sequences' are attracting growing interest in the communication field wherever the properties of channels and devices are to be measured. The investigation described herein, a feasibility study for a useful general-purpose on-line channel tester, is only one of a number of fruitful avenues of study. Another objective is to find optimum ways of utilizing channel response information to improve transmission performance.

6. References

1. Godfrey, K. R., 'Theory and application of pseudo-random sequences', *Control*, **10**, p. 305, June 1966.
2. Di Toro, M. J., Manulec, J. and Goldberg, B., 'Design and performance of a new adaptive serial data modem in a simulated time variable multipath h.f. link', *Conference Record of I.E.E.E. Annual Communication Convention*, p. 769, June 1965. (Paper No. GC-6A3.)
3. Golomb, S. W. (ed.), 'Digital Communications With Space Application' (Prentice Hall, Englewood Cliffs, N.J., 1964).

CROSS-CORRELATION TECHNIQUES AND COMMUNICATION CHANNEL EVALUATION

4. Douce, J. L., Ng, K. C. and Walker, A. E. G., 'System identification in the presence of a ramp disturbance', *Electronics Letters*, **2**, No. 7 p. 243, July 1966.
5. Barker, H. A., 'Choice of pseudo-random binary signals for system identification', *Electronics Letters*, **3**, No. 11, p. 524, November 1967.
6. Tsao, S. H., 'Generation of delayed replicas of maximal-length binary sequences', *Proc. Instn Elect. Engrs*, **111**, p. 1803-06, November 1964. (I.E.E. Paper No. 4561E, 1964.)
7. Korn, G. A., 'Random Process Simulation and Measurements', p. 173 (McGraw-Hill, New York, 1966).
8. Lucky, R. W. and Rudin, H. R., 'An automatic equalizer for general-purpose communication channels', *Bell Syst. Tech. J.*, **46**, p. 2179, November 1967.
9. Schwartz, G. R. and Anderson, T. C., 'A Simplified Method of Determining Error Performance'. C.C.I.T.T. Contribution No. 87 to Special Study Group A, 1961-1964.
10. Wilkinson, R. B., 'Development of a peak to average ratio measuring unit', *New Zealand Engineering*, **21**, p. 528, December 1966.
11. McAuliffe, G. K. and Motley, D. M., 'Equalization for data transmission', I.E.E.E. Wescon Convention Paper No. 12/4, 1968.
12. Zimmerman, M. S. and Kirsch, A. L., 'The AN/GSC-10 ("Kathryn") variable rate data modem for h.f. radio', *Trans Inst. Elect. Electronics Engrs on Communication*, **COM-15**, p. 197, April 1967.
13. Sondhi, M. M., 'An adaptive echo canceller', *Bell Syst. Tech. J.*, **46**, p. 497, March 1967.

Manuscript first received by the Institution on 23rd October 1968 and in final form on 29th January 1969. (Paper No. 1257/Com 15.)

© The Institution of Electronic and Radio Engineers, 1969

STANDARD FREQUENCY TRANSMISSIONS—April 1969

(Communication from the National Physical Laboratory)

April 1969	Deviation from nominal frequency in parts in 10 ¹⁰ (24-hour mean centred on 0300 UT)			Relative phase readings in microseconds N.P.L.—Station (Readings at 1500 UT)		April 1969	Deviation from nominal frequency in parts in 10 ¹⁰ (24-hour mean centred on 0300 UT)			Relative phase readings in microseconds N.P.L.—Station (Readings at 1500 UT)	
	GBR 16 kHz	MSF 60 kHz	Droitwich 200 kHz	*GBR 16 kHz	†MSF 60 kHz		GBR 16 kHz	MSF 60 kHz	Droitwich 200 kHz	*GBR 16 kHz	†MSF 60 kHz
	1	- 300.1	- 0.1	0	534		448.9	17	- 300.1	- 0.1	+ 0.2
2	- 300.0	0	+ 0.1	534	449.0	18	- 299.8	0	+ 0.2	541	458.7
3	- 300.0	0	+ 0.2	534	449.8	19	- 299.9	0	+ 0.2	540	458.3
4	- 300.0	0	+ 0.2	534	450.5	20	- 300.0	- 0.1	+ 0.2	540	458.8
5	- 300.0	0	+ 0.2	534	450.8	21	- 300.0	- 0.2	+ 0.1	540	460.7
6	- 300.0	- 0.1	+ 0.2	534	451.4	22	- 300.0	- 0.2	0	540	462.2
7	- 299.9	- 0.1	+ 0.1	533	450.1	23	- 300.3	- 0.2	- 0.1	543	463.8
8	- 300.1	- 0.1	+ 0.1	534	452.1	24	- 300.1	- 0.1	- 0.1	544	464.7
9	- 300.1	- 0.1	+ 0.1	535	452.1	25	- 300.1	- 0.1	- 0.1	545	465.5
10	- 300.3	- 0.1	+ 0.2	538	452.7	26	- 300.1	- 0.2	0	546	467.3
11	- 299.9	- 0.1	+ 0.2	537	453.9	27	- 300.1	0	0	547	467.7
12	- 300.2	- 0.1	+ 0.1	539	454.3	28	- 300.1	- 0.1	0	548	468.4
13	- 300.1	- 0.1	+ 0.1	540	455.0	29	- 300.0	- 0.1	0	548	468.9
14	- 300.0	- 0.1	+ 0.2	540	455.7	30	- 300.0	0	0	548	469.2
15	- 300.1	- 0.2	+ 0.1	541	457.2						
16	- 300.1	- 0.1	+ 0.2	542	457.9						

All measurements in terms of H.P. Caesium Standard No. 334, which agrees with the N.P.L. Caesium Standard to 1 part in 10¹¹.

* Relative to UTC Scale; (UTC_{NPL} - Station) = + 500 at 1500 UT 31st December 1968.

† Relative to AT Scale; (AT_{NPL} - Station) = + 468.6 at 1500 UT 31st December 1968.

Radio Engineering Overseas . . .

The following abstracts are taken from Commonwealth, European and Asian journals received by the Institution's Library. Abstracts of papers published in American journals are not included because they are available in many other publications. Members who wish to consult any of the papers quoted should apply to the Librarian giving full bibliographical details, i.e. title, author, journal and date, of the paper required. All papers are in the language of the country of origin of the journal unless otherwise stated. Translations cannot be supplied.

STABILIZING EMITTER FOLLOWERS

New stabilization methods for emitter followers, taking maximum overshoot, the rise time, and the delay time into consideration, are proposed and analysed in a paper from the Department of Electronics of Kyushu University. This method can reduce the large rise and delay times encountered in the usual stabilization methods.

The four methods, 'base R', 'base CR', 'collector CR', and 'emitter LR', are proposed as new stabilization methods and their merits are compared with one another from the point of view of delay time. Furthermore, experiments performed on the stabilization characteristics using alloy transistors and epitaxial planar transistors are compared with theoretical calculations. Good agreement between them was obtained, and it is thought that these stabilization methods can be considered useful for suppressing excessive ringing in transistor emitter followers.

'Suppression of ringing in emitter followers', M. Yoneyama and F. Ueno, *Electronics and Communications in Japan* (English language edition of *Denshi Tsushin Gakkai Ronbunshi*), 51, No. 1, pp. 95-103, January 1968.

MONOPULSE ANTENNA

To obtain a relative good side-lobe level, a new configuration for a monopulse antenna has been developed for the German satellite Earth Station by Rohde & Schwarz. The 48 single radiators are mounted on a plane reflector at distances to each other of 0.55λ to 0.9λ . For improving the difference diagrams, the four quadrants of the antenna intermesh. This follows by alternating assignment of the radiators arranged on the symmetry axes of the antenna. The monopulse antenna is used for receiving satellite signals at frequencies of 136 to 138 MHz. The calculated values, the measuring methods and the results are given in the paper.

'Monopulse antenna at DVL Earth station for satellite radiocommunication', H. Öttl and L. Thomanek, *Nachrichten-technische Zeitschrift*, 21, No. 12, pp. 799-802, December 1968. (In English.)

OPTICAL COMMUNICATIONS

Called the 'Quantum Counter', a binary channel using light of very low intensity as a carrier is described in a paper from the Institute for Communications Engineering at Munich. Besides disturbances caused by background light, interference occurs due to fluctuations of the signal intensity because of light quantization. By counting the arriving photons the receiver tries to recover the information sent. Two transmission methods proved to be particularly suitable for this channel: digital pulse position modulation (p.p.m.) with correlation detection, and 'two-step modulation' (d.s.m.). With both methods low error rates can be obtained in spite of heavy disturbances, in

the case of p.p.m. with very low energy per bit, and in that of d.s.m. with free choice of coding, permitting, for example, the application of error-correcting codes.

'The quantum counter: a communications receiver with minimum energy requirements', S. Geckler, *Archiv der Elektrischen Übertragung*, 23, No. 3, pp. 137-46, March 1969.

ACCURACY OF LEVEL METERS

Modern telecommunication systems require high-precision level measuring instruments. Means are described in a paper from the laboratory of the German firm of Wandel and Goltermann by which the level measuring accuracy can be increased and, at the same time, the ease of operation can be simplified.

The sub-assemblies of a level meter which are responsible for its measuring accuracy, can only be improved at a considerable increase in cost. It is possible, by means of a special calibration facility, to place the demands for accurate measurements in these sub-assemblies, where they can more easily be fulfilled. The error of the measuring range selector is reduced to the error of a voltage divider, which operates at a low fixed i.f. The frequency response of the complete instrument is reduced to the frequency response of an additional calibration mixer, which operates under the most favourable frequency response conditions. A built-in linearity control circuit indicates errors caused by overloading. Automatic sequential calibration simplifies the operation of the instrument.

'Possibilities for increasing measuring accuracy for simplifying operation of selective level meters', H. Bayer, *Nachrichten-technische Zeitschrift*, 22, No. 4, pp. 235-239, April 1969.

HORN FEED FOR PARABOLOID ANTENNAS

When the conventional horn feeds are used, the total efficiency of paraboloid antennas is limited by the inadequate adaptation of the horn-aperture illumination to the field distribution existing in the focal plane of the reflector.

It is shown in a paper from the Werthhoven Research Institute for High Frequency Physics that certain improvements can be attained if, besides the fundamental mode, a second mode in the feeding waveguide is used for horn excitation. As shown by mathematical analysis, the theoretical improvement of the efficiency of such an optimally dimensioned feed amounts to 8% for a Cassegrain antenna with $F : D = 1.27$. The proper excitation of the two modes is relatively simple with the investigated conical waveguide transition. Measurements on a model feed constructed on the basis of the results of this paper showed good agreement with the theory.

'An improved horn feed with two wave modes for shallow paraboloid antennae', E. Ludwig, G. Ries and E. Zocher, *Archiv der Elektrischen Übertragung*, 23, No. 4, pp. 209-215, April 1969.