

# The Journal of the BRITISH INSTITUTION OF RADIO ENGINEERS

FOUNDED 1925

INCORPORATED BY ROYAL CHARTER 1961

*"To promote the advancement of radio, electronics and kindred subjects  
by the exchange of information in these branches of engineering."*

---

VOLUME 23

FEBRUARY 1962

NUMBER 2

---

## THE COMMON MARKET AND PRODUCTIVITY

PUBLIC attention and Parliamentary time in Great Britain is much concerned with the possibility of Britain joining the European Economic Community. Opinion is based on the value of free trade in Europe with a population exceeding 250 million coupled with a desire to maintain preferential trading agreements within the British Commonwealth.

When the European Common Market was first mooted, the editorial in the Institution's *Journal* for April 1957 commented on the importance of securing wider agreement on engineering standards as a necessary factor in international trading.

Present considerations also include the need to improve the rate of production in Great Britain; first, because increasing international or European competition demands cheaper, but still reliable, manufactured goods; secondly, this has to be achieved without impairing Britain's social, Commonwealth and international commitments; and thirdly, to maintain and even improve standards of living in Great Britain which are among the highest in the world.

The challenge of keener competition incontrovertibly demands more efficient production of manufactured goods. The lead of the British Productivity Council in launching "National Productivity Year" is, therefore, to be strongly commended.

The "Year"—from November 1962 to November 1963—is being supported by employers' organizations, trade unions and professional engineering institutions. The "Year" is under the Patronage of H.R.H. The Duke of Edinburgh. In a foreword to the booklet setting out the proposals, His Royal Highness has stated:

"Efficiency can only be maintained by a continuous process of improvement and innovation. Therefore, the great value of the National Productivity Year will lie in the atmosphere which it generates, the contacts which it helps to make and the need for a continuing effort which it manages to stimulate."

The Institution therefore welcomes the opportunities which will be provided in National Productivity Year for showing the most effective ways in which radio and electronics can be used toward improving productivity and increasing efficiency.

The Institution's policy in encouraging the application of electronics to industry is already well known, as indeed are the meetings and Conventions which it has promoted on automation, equipment reliability, and new production techniques—all of which may well be reviewed again during the "Year".

The President of the Institution, who is Vice-Patron of the "Year", has suggested that the 1963 Convention be devoted to such a theme as Electronic Aids to Productivity. This proposal has been enthusiastically adopted by the Council.

## INSTITUTION NOTICES

### New Year Honours

The Council of the Institution has congratulated the following members whose names appeared in the New Year Honours List. Their appointments are to the Military Division of the Most Excellent Order of the British Empire.

Captain Frederick Leslie Millns, D.S.C., R.N. (Member), as Ordinary Commander of the Order. Captain Millns has been Commanding Officer of the Naval Electrical School, H.M.S. *Collingwood*, since 1959. He previously held various appointments as fleet electrical officer, latterly with the Home Fleet.

Commander Kenneth Arthur William Pilgrim, R.N. (Member), as Ordinary Officer of the Order. Commander Pilgrim was until recently on the Naval Staff of the British Joint Service Commission in Washington; he has now returned to the Admiralty at Bath. While serving as a member of the Institution's Technical Committee, Commander Pilgrim was responsible for the preparation of the Committee's report, "Recommended Methods of Expressing Measuring Instrument Characteristics, I. A.M. and F.M. Signal Generators."

### "Selected Abstracts from *J.Brit.I.R.E.*"

A new edition is in preparation, and will shortly be available, of the publication "Selected Abstracts from the *Journal* of the Brit.I.R.E.". The period to be covered is from January 1952 to December 1961; also included will be details of papers to be published in the first part of the present year.

The "Selected Abstracts" is in effect a cumulative ten-year index to the Institution's *Journal*. It has however an added advantage over the usual type of such publications in giving informative details on the content of each paper published in a period during which the size of the *Journal* has doubled. The papers are arranged according to the Universal Decimal Classification for ease of reference and an author index is included. A full list of Institution reports is also given.

Orders may now be placed for the "Selected Abstracts" which costs 5s. post free.

### Index to Volume 22

The index to Volume 22 of the *Journal* (the second half of 1961. July to December) has now been prepared and copies are being sent with this issue to all members and subscribers.

Members are reminded that they may send their *Journals* (six issues plus index) to the Institution for binding. The charge for this service is 16s. 6d., postage extra (Great Britain 3s.; other countries 4s.).

### "Symposium on Practical Electronic Aids for the Handicapped"

The Programme and Papers Committee, in collaboration with the Medical and Biological Electronics Group Committee, has arranged a Symposium on "Practical Electronic Aids for the Handicapped", which will be held on Wednesday, 28th March, at the School of Pharmacy, Brunswick Square, London, W.C.1. The following papers will be presented:

"Print Recognition Apparatus for Blind Readers"—  
J. H. Davis, Ph.D.

"An Ultrasonic Blind Guidance Aid using Frequency Modulation Echo-Location Principles"—L. Kay, B.Sc.(Eng.).

"Modern Aids to Hearing"—M. C. Martin.

"Artificial Voice Apparatus"—R. V. Tait, B.Sc., L.D.S., R.C.S.(Eng.).

"Myo-electric Control of Artificial Muscles"—  
A. Bottomley, M.B., and A. Nightingale, Ph.D.

"Cardiac Pacemakers"—J. G. Davies.

The meeting will start at 11 a.m. and the first two papers listed will be presented before lunch. The afternoon papers will be presented between 2 p.m. and 6 p.m.

Members of the Institution will not require tickets; non-members however are asked to apply to the Institution for invitations.

### "Recent Developments in Industrial Electronics"

The Symposium on "Recent Developments in Industrial Electronics" announced in the Programme Booklet has been extended in scope to last *three* whole days—Monday 2nd April to Wednesday 4th April inclusive. Further details of the programme and registration charges will be ready at the beginning of March and members wishing to receive early advice of the arrangements are asked to send a stamped addressed envelope. The programme will also be published in the March *Journal*.

### Symposium on Electron Beam Machining Techniques

A one day symposium has been arranged in London on Tuesday, 10th April on the above subject at which five papers will be presented by workers in the field from Great Britain, Germany and the United States. Admission will be by invitation only, and a number of tickets have been reserved for members of the Brit.I.R.E. Those wishing to attend should write directly to: Mr. M. A. Cruikshank, Degenhardt and Co. Ltd., 6 Cavendish Square, London, W.1. The Symposium is being sponsored by the German optical company of Carl Zeiss.

# Hinkley Point Temperature Scanning Equipment

By

R. I. OSTLER, B.Sc.(Eng.) †

AND

J. M. TYRRILL, B.Sc. †

*Presented at the Symposium on "Electronic Instrumentation for Nuclear Power Stations" in London on 29th March 1961.*

**Summary:** The equipment described is a data handling system with magnetic drum storage. Approximately 600 graphite, fuel element and gas exit thermocouples are scanned and the remainder of the 720 input positions are used for self-checking purposes. It is a high speed system, taking 144 seconds for a complete scan; there is a store of 20 scans, representing 48 minutes. Long life and extreme reliability of input switching is achieved using reed relays driven by transistors in a matrix arrangement. Analogue to digital conversion is performed directly on the outputs of the thermocouples which are linearized so that the output is in degrees C rather than thermocouple e.m.f. Readout is on strip printers, a typewriter and a tape punch. The operating range of the equipment is from 0–799° C, the long term overall accuracy (excluding thermocouple variations) being  $\pm 3^\circ$  C.

## 1. Introduction

Considerable temperature variation may exist inside a nuclear reactor and so the early method of monitoring temperature, using a number of chart recorders, gave no guarantee that the temperature at all points was kept to a safe limit. Thus the need for rapidly available and detailed information, at any time, of the temperature associated with the nuclear reactor led to the use of a high-speed scanning system employing magnetic drum storage. Two identical systems are employed at the Hinkley Point nuclear power station, one for each reactor. Each equipment is required to scan a maximum of 720 thermocouples (about 600 are used in practice) and to store the readings for approximately 48 minutes so that trends may be detected. In view of the requirement of 20 years' life with a minimum of servicing and faults, great care has been taken in the choice of components and the circuit technique employed. A further requirement of the system, arising from the length of thermocouple cable between the reactor and the equipment, is that it shall operate with a few volts at 50 c/s between thermocouple earth and the local equipment earth. The equipment is designed to ensure that the error caused by 5 V a.c., maximum under normal conditions, is less than 1 deg C. It is expected, however, that under surge or fault conditions several hundred volts will appear between thermocouple ground and equipment earth. At such times the equipment will not be damaged, but it is not expected that the system will give correct readings.

## 2. General Description of System

The reactor is divided into twelve zones, each containing three sub-zones. The thermocouple leads associated with six of the zones are brought out of the reactor on the East side and the remaining thermocouples are brought out on the West side. The two groups of cables, having changed in junction boxes from chromel-alumel to copper-constantan compensating cable in the normal way, are terminated near the reactor, in "cold junction cubicle east" and "cold junction cubicle west". ‡ Cold junction compensation is performed in these cubicles and the thermocouple voltages, on twisted copper pairs of wires, pass to the equipment room, a distance of several hundred feet. In the first of the three equipment cubicles the selection of the thermocouples for data handling, and also for the single point recorder, is carried out.

The output from the switching unit is fed directly into the analogue-to-digital converter. The digitized output obtained, in binary decimal form, is written on to the drum in an appropriate position. Three separate circuits are used to read the values from the drum. These operate the two line printers, and the typewriter or the tape-punch (Fig. 1). An arithmetic unit compares the three readings taken from the drum with a common low level alarm and the appropriate individual high temperature alarm levels. Because of the complexity of the equipment internal testing facilities are included in the design. When either an equipment or a temperature alarm occurs, a print command

† Marconi Instruments Ltd., St. Albans, Hertfordshire.

‡ Ezer Griffiths, "Methods of Measuring Temperature", (Charles Griffin, London, 1947).

is given to the first line printer, the sole purpose of which is to provide a record of all alarms. The second line printer is normally performing the same function and cross checks are made between the two printer drive circuits. The second printer may, however, be used to present a record of all the stored values of any

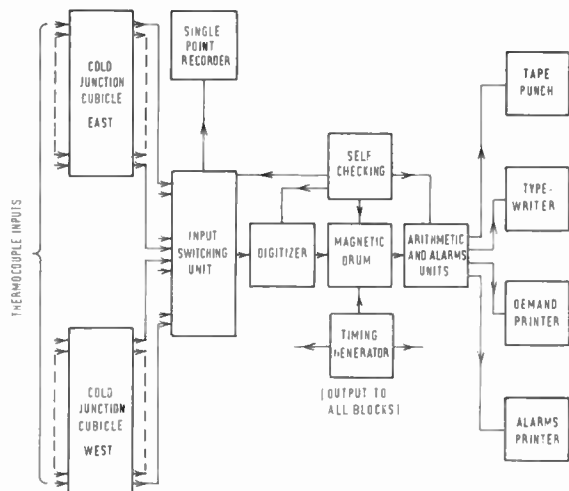

Fig. 1. Block diagram of temperature scanning equipment.

one thermocouple, or a log of current values, or the value of any selected point as it is measured during each scan whether in alarm condition or not. The typewriter can print out a log of one scan of all thermocouples or a log of the high level alarm values which are stored on the drum. If a reactor trip occurs the tape punch is used to record all the values stored on the magnetic drum at the time of the trip, and for as long as required subsequently.

### 3. Cold Junction Compensation

The chromel-alumel thermocouple leads are terminated for convenience near the reactor in junction boxes, and the outgoing cables, which are copper constantan, divide to go to the east and west cold junction cubicles. The two junction boxes are similar and each contain input terminal boards, a cold junction plate and a thermostat. The input boards provide terminations for the incoming cables and also patching to the cold junction plate. The cold junction plate is only required to maintain a uniform temperature; the actual cold junction compensation is effected using a small thermostat in which are fitted auxiliary thermocouples, linked into the cold junction boxes. A thermocouple being measured is connected in series with the appropriate thermostatically controlled auxiliary thermocouple, so that the effective cold junction temperature is that of the thermostat (Fig. 2). The thermostat is actually at 45° C and the correction

necessary to measure temperatures with respect to 0° C is performed in the analogue to digital converter. Using this system the problems associated with the thermostatic control of a large number of cold junctions is avoided. The cold junction plate is a sheet of aluminium 1/2 in. thick and approximately 3 ft 6 in. square. Stud terminals are mounted through the sheet, whose surfaces are anodized and coated with epoxy varnish to obtain electrical insulation with good thermal conductivity between the plate and the terminals. The whole plate is thermally insulated with expanded polystyrene to avoid thermal gradients across the plate, and leads going to the cold junctions are fed through a thermally insulated "tunnel". The cold junction plate provides terminals for the data processing equipment and other equipment using thermocouples. A considerable advantage of this system over the use of thermistor or resistance bridge compensators is that a fault in the system can be readily detected. The control system, employing solid-state components throughout, maintains the thermostat temperature constant to better than 0.2 deg C. A bimetallic switch is provided to give a warning if the temperature rises or falls by more than 2 deg C.

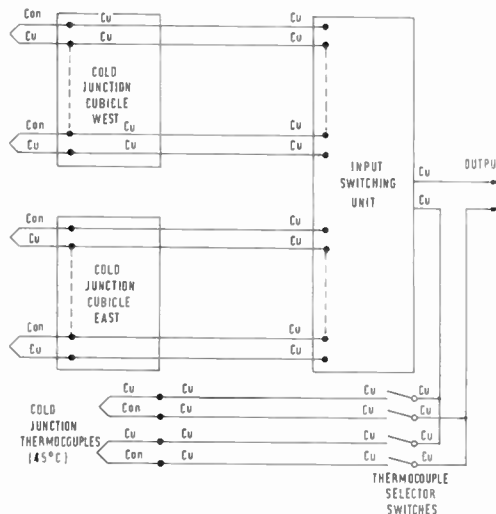

Fig. 2. Cold junction compensation.

A reference voltage supply feeding a potentiometer chain is included in each cubicle to provide voltages suitable for testing the operation of the analogue-to-digital converter.

### 4. Input Switches

The first equipment cubicle contains the input switches which select the thermocouple for the data handling and also the thermocouple for the single point recorder. Several factors governed the choice

of switch to be used for these low level signals. The switch must be reasonably fast to fit into the design of the system. The device must operate for a long time, without attention, and must not introduce spurious voltages. Many switches are not acceptable because of their limited life or the noise generated by dirty or moving contacts. A certain type of rotary switch which has gold plated contacts and is semi-dust proof, has been found satisfactory and is used for the selection of the thermocouple for the single point recorder. For the input switching a larger number of operations is required and for this the reed relay has been chosen. The reed relay, being a sealed unit, is extremely reliable. Tests have shown that in this application, where about  $5 \times 10^6$  operations are required, the switch will give  $10^9$  operations without any measurable change in contact resistance. Two reeds are placed in one coil to switch both thermocouple leads. The power required for operation makes it convenient to drive the relays from transistors. A further advantage of the reed relay in this application is that the scanning sequence could be modified if desired by changing the coil connections rather than the thermocouple leads.

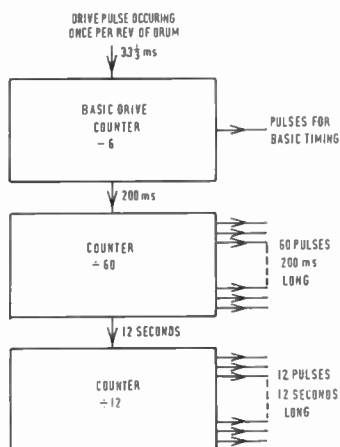

Fig. 3. Input switching drives counters.

The drive for the reed relay scanner is shown in Fig. 3. Timing is derived from the magnetic drum which rotates at 1800 rev/min. A pulse occurring once per revolution (every  $33\frac{1}{3}$  ms) drives a six-position counter to produce a pulse of 200 milliseconds repetition rate. This pulse is the drive for the reed relay counters which control the operation of the 720 reed relays. A  $12 \times 60$  matrix is used to feed the 720 drive transistors associated with the reed relays. The scanner moves on one position every 200 ms. The appropriate cold junction thermocouple is also selected by these counters. The output of the switching unit

appears on one pair of copper wires, the voltage across which represents the temperature difference of the reactor with respect to  $45^\circ \text{C}$ .

The thermocouples are scanned zone by zone. Thus if any one zone overheats, a barrage of consecutive alarms will appear on the alarm printer so that the operator's attention is quickly drawn to the fault. Each zone is allocated a maximum of 59 thermocouple addresses, not all of which are used. Of the 59, 27 addresses are allocated to thermocouples measuring graphite temperatures, 15 addresses to thermocouples measuring gas exit temperatures, and 17 to thermocouples measuring fuel element temperatures. An addressing system has been devised to enable the operator to recognize quickly the location of any thermocouple.

### 5. Analogue-to-Digital Conversion

An important feature of the system design is the low level digitizer which operates directly on the thermocouple signals.<sup>†</sup> No moving parts are employed because of the long life required and also because of

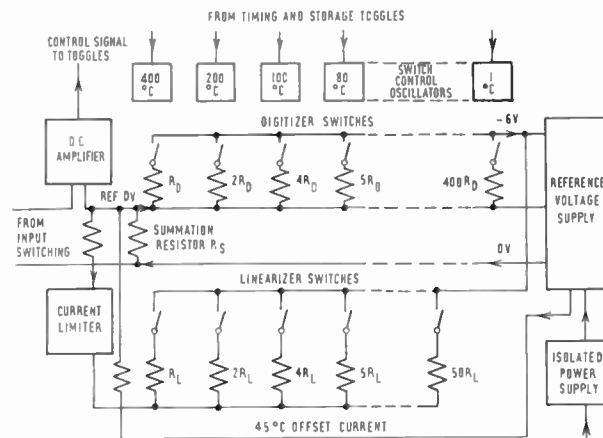

Fig. 4. Analogue to digital converter.

the speed at which the equipment must operate. A self-balancing feedback system is employed and the circuit comprises solid state components throughout. The time taken to digitize, which is independent of the input level, is about 120 ms. The digitizer consists of a timing unit, a subtractor, and a d.c. amplifier (Fig. 4). The timing unit is part of the drum system and its associated ring counters; its purpose is to determine when the switches in the subtractor unit should close and for what length of time. The switching in the subtractor unit is performed by transistors. Each transistor switch connects an analogue resistor

<sup>†</sup> R. L. G. Gilbert, "An analogue to digital converter with long life", *J. Brit. I.R.E.*, 20, pp. 529-35, July 1960.

$R_D$  across a reference supply which maintains a stabilized voltage between the  $-6\text{ V}$  and reference  $0\text{ V}$  lines. The current flowing through these resistors, which are arranged in a binary decimal sequence, to  $-6\text{ V}$  supply, passes through the summation resistor,  $R_S$  from the  $0\text{ V}$  line. The input to the d.c. amplifier is the difference between the input voltage and the voltage across the summation resistor. The action of the digitizer is as follows.

After the signal has been switched and any transients have died away, the first section of the digitizer is switched so as to produce a voltage corresponding to  $400\text{ deg C}$  across the resistor  $R_S$ ; if the thermocouple voltage is less than this, then the d.c. amplifier will operate to switch off the first section of the digitizer, otherwise it will remain set until the measurement is completed. After a fixed time interval of approximately  $10\text{ milliseconds}$ , the second section of the digitizer is switched on (corresponding to  $200\text{ deg C}$ ) and the sequence is repeated. Eventually the last section of the digitizer, corresponding to  $1\text{ deg C}$  is switched and checked, and the temperature is then stored in the digitizer in binary-decimal form. The zero stability required is better than  $3\text{ deg C}$  over any period (on account of the absolute accuracy required); this limit corresponds to about  $120\text{ }\mu\text{V}$  total drift, and a transistor chopper amplifier is used with a drift lower than the above figure by a factor of at least 4. The errors due to leakage currents and voltage drops in the transistor switches are less than  $0.1\%$ .

Since at the completion of the digitization process a voltage is produced to balance the output of the thermocouple, very little current is taken from the source and the input impedance of the digitizer is very high. During the process of digitization, sometimes a current is fed into the source and sometimes it is taken from the source, but the net effect is negligible upon the single point recorder when the latter is connected to the same thermocouple as the data handling equipment.

A circuit is included in the digitizer to compensate for the non-linearity between temperature and thermocouple e.m.f. The maximum error in measurement when the circuit is used is  $1\text{ deg C}$  at  $130^\circ\text{ C}$ , but the error generally is less than  $\frac{1}{2}\text{ deg C}$ . The circuit approximates the non-linear characteristic of the thermocouple to two straight lines, as shown in Fig. 5. It comprises a set of switches and resistors similar to those in the digitizer, the summated current passes through a limiter and into the feedback circuit. Above a certain temperature extra current is fed into the resistor  $R_S$ , giving a change of slope to the characteristic.

A current is also fed into the summation resistor to compensate for the  $45\text{ deg C}$  offset on the thermocouple signal.

The whole of the input circuit which connects to the thermocouple floats with respect to earth and stray capacitance is kept to a minimum. The storage toggles control oscillators, the outputs of which are fed through low capacitance transformers and rectified to control the transistor switches. The d.c. amplifier input chopper likewise floats, the waveforms being passed through transformers. The voltage reference supply, which is also isolated from earth, has a mercury battery as its primary standard; it is expected that the battery will need replacement about every two years.

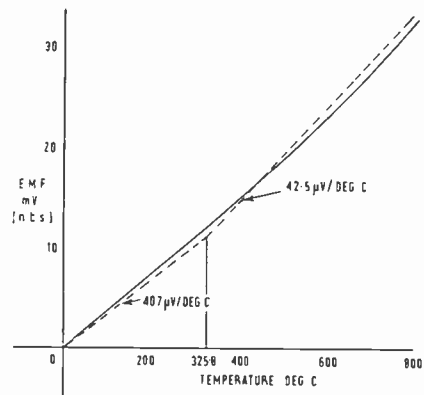

Fig. 5. Linearizer characteristic.

### 6. Magnetic Drum Storage

The whole digitizing operation takes  $100\text{ ms}$ , which leaves  $100\text{ ms}$  available for switching the thermocouples and feeding the digitized voltage into the storage system. A  $9\text{ in.}$  magnetic drum is used to store the digitized readings during the previous  $48\text{ minutes}$  and also to store the high level alarm values. Each track of the drum is divided into  $2880\text{ sectors}$ , i.e.  $240\text{ groups of }12$ ; the first sector of each group of  $12$  is not used, the remaining  $11\text{ sectors}$  are used to store the  $11\text{ digits}$  which represent a temperature, so that  $240\text{ readings}$  may be stored on each track. Sixty tracks are used to store all the measured values during the past  $48\text{ minutes}$ . Three tracks on the drum are used to store the  $720\text{ high alarm levels}$  for each input, and a further three to store information on the type of input which is applied to each position. In this way points which are not connected to active thermocouples may be distinguished or used as test points; in addition the normal high and low alarms may be suppressed for any selected inputs, so that any number of thermocouples may be used in the alarms scan. The drum also has a pair of "marker" tracks which are used to indicate the position into which the information from the thermocouple presently being measured should be fed. A mark is written on one of these

tracks at the last digit of the previous word, and is moved forward one word every 200 ms; its position is regularly checked during each scan. Counters, similar to those used for the input reed relay switching, count down from the clock track, which has 2880 complete cycles, to produce pulses corresponding to each thermocouple address.

The track on the drum currently in use is selected by rotary switches with gold plated contacts. Interchangeable plug-in printed boards are used for the circuits associated with the drum, the boards and mating sockets having their contact areas gold plated.

### 7. Arithmetic and Read-out

Three separate circuits are used to read the values from the drum; these operate the two line printers, and the typewriter or the tape-punch.

For the alarms printer each word is read from the drum shortly after it is written on, and is compared with the common low alarm and individual high alarm. Either type of alarm produces a print command and so operates the printer. In addition a print command may arise as the result of an equipment alarm. Two separate types of alarms may be given by the system; first the continuously monitored alarms (e.g. supply voltages, etc.) and second, alarms arising from specific tests performed at fixed times during the scan period. Both types may be identified by an arrangement of asterisks in the print out. Time is printed on the line following the alarm or series of consecutive alarms and the following line is blank. A single alarm or barrage of alarms is thus easily distinguishable.

Normally the demand printer is performing the same function as the alarms printer and comparison is made between the two line printer drives. This second

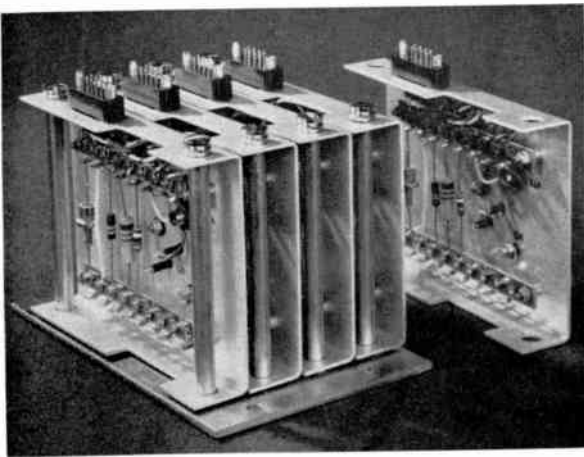

(a) Rotary switch drive units, showing mounting details.

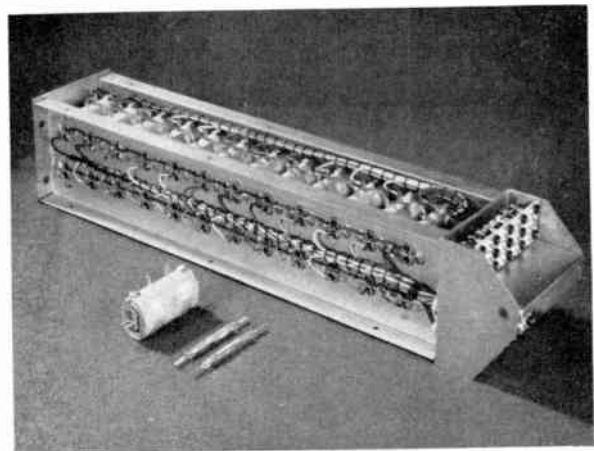

(b) Reed relay mounting unit, showing details of reeds and coils.

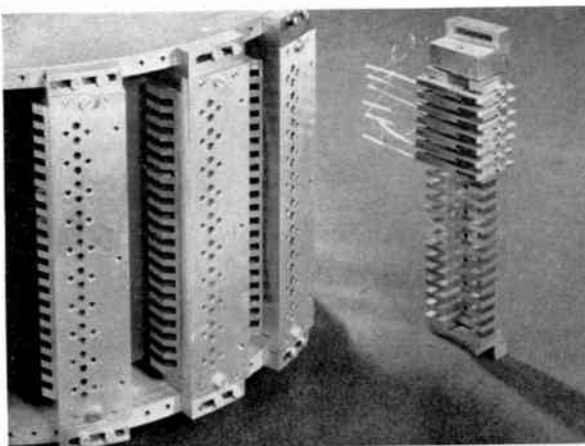

(c) Magnetic drum with head mounting blocks.

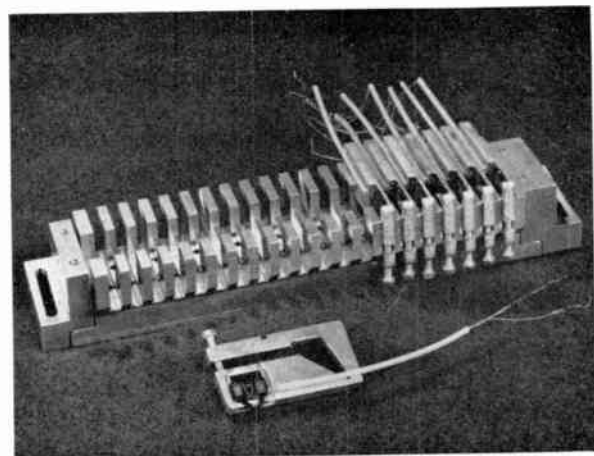

(d) Details of head mounting block and heads.

Fig. 6. Constructional details of the temperature scanning equipment.

printer may, however, be used to extract from the memory all the recorded values for any given thermocouple; the selection of this thermocouple is by means of knobs mounted by the printer on the control desk. The demand printer can also be made to log the current values by means of a switch on the control desk. Each printer will operate once every hour to print out the time, to ensure that the printers are performing correctly.

The typewriter is arranged to print out, when required, a log of one scan of all thermocouples. The high level alarm values stored on the magnetic drum may also be printed out on the typewriter if desired. A time clock is provided to initiate a typewriter log automatically at pre-determined intervals.

If a trip signal is received from the station as much information as possible is required for subsequent investigation. The magnetic drum stores such a quantity of information that the use of a computer is warranted. A tape punch has therefore been chosen to record all the values stored on the drum at the time of the trip, and for as long as required subsequently. New information is being fed into the drum as fast as the punch can present the old information, and so the readings presented are always those made 48 minutes previously. Accordingly, 48 minutes after a trip signal has occurred, the values being recorded are those made at the time of the trip, and further recordings give readings made after the trip occurred.

### 8. Self-checking Facilities

A number of tests are incorporated in the equipment, and a fault panel is included in the main cubicle with a number of warning lamps and reset buttons. Arising from these tests two separate types of equipment alarm may be given by the system. One of these is the continuously monitored alarms comprising checks on power supply voltages, drum speed and the reed relay input switches. The second type of equipment alarm arises from specific tests performed at fixed times during the scan period. In this classification are the checks made between the computer timing system and the drum reference marker, the relay drive counter and the computer timing system, etc. The operation of the high and low alarm detection circuits are tested with fixed digital inputs. The digitizer is checked for correct operation of hundreds, tens and units; these tests are performed by feeding in appropriate voltages from reference voltage units in the cold junction cubicles to some of the input positions which are not required for active thermocouples. Also in this second category of equipment alarms is the comparison between the line printer drive circuits.

If an equipment alarm occurs, then in order to assist in tracing the fault one of a group of lamps mounted in the equipment cubicle is illuminated, and remains so until an associated "re-set" press-button is pushed. A further group of "fleeting" lamps indicating when a fault is present assist in tracing intermittent faults.

In order to assist in general maintenance, a "marginal" switch is provided so that digital circuits can be operated under conditions less favourable than usual; any weak circuit elements can thus be detected and replaced. This facility is, of course, most useful in tracing incipient faults which may be due to the gradual ageing of components.

### 9. Conclusion

The design of the equipment has been controlled by two factors. First there is the need for detailed readily obtainable information concerning the state of the reactor. Second there is the requirement of long trouble-free life. Magnetic drum storage has been chosen because of the relatively low cost per bit of information stored and its reliability. Solid-state circuits are employed and special switches are used for low level signals. High accuracy of measurement is achieved by digitizing the thermocouple signals directly. Self-checking facilities are incorporated to bring to the operator's notice an equipment fault as quickly as possible and to assist in fault finding. There is facility for suppressing alarms on any input position so that the alarms printer may operate on any number of the total of about 600 thermocouples. The store is utilized by the demand printer which may print a log of current values or a historical log of all the stored values for any selected thermocouple. A typewriter may be used to present a log of one scan of the stored values on the drum or a log of high alarm levels. In the event of a trip occurring in the station a tape punch records all the values stored on the drum before the trip and for as long as required subsequent to the event. The tape can then be fed into a computer for detailed investigation.

### 10. Acknowledgments

The authors would like to thank the Management of Marconi Instruments Limited for permission to publish this paper, and also those working at Marconi Instruments who have been responsible for the design and construction of the prototype system.

*Manuscript first received by the Institution on 21st April 1961 and in final form on 10th July 1961. (Paper No. 700.)*

© The British Institution of Radio Engineers, 1962



# Hinkley Point Neutron Flux System

By

P. J. KEELEY, B.Sc.†

*Presented at the Symposium on "Electronic Instrumentation for Nuclear Power Stations" in London on 29th March 1961.*

**Summary:** Conventional ion chamber and logarithmic amplifier techniques are employed without involving elaborate and sophisticated instrumentation. A minimum of different instrument types has been aimed at. A comprehensive built-in system of operational testing has been designed which obviates the need for portable test gear, and reduces the number of personnel required to carry out such testing.

## 1. Introduction

The power of a nuclear reactor is assumed to be proportional to the total neutron population within the reactor. In operation, the neutron population is determined by measuring the neutron flux at certain selected points around the outside of the reactor.

The flux within the reactor from the shut-down condition to full power covers a range of about 8 decades. It was not considered practicable to try to design one instrument to cover this large span and so the neutron flux is measured in two overlapping logarithmic ranges. The measurement of the top three decades is duplicated by linear measurement. The instrumentation, consisting of a total 17 logarithmic and linear channels, operates safety trips if the power is raised too quickly or beyond a pre-set value. The channels which operate these safety circuits are triplicated and feed signals respectively to three reactor safety lines arranged so that if a trip signal occurs in any two safety lines the reactor will be shut down. This reduces the possibility of shutting down the reactor by spurious trips caused by failure of instruments, which are of the "fail safe" type.

## 2. Ion Chambers

At Hinkley Point the neutron flux in all cases is measured by ion chambers. The neutrons escaping from the reactor are first slowed down or "thermalized" by graphite thermal columns and then detected by ion chambers located within the thermal columns. The ion chambers give output currents directly proportional to the neutron flux.

The ion chambers are sensitive to gamma radiation as well as to neutrons. When the reactor is running at or near full power, the current from an ion chamber due to gamma radiation from the reactor is insignificant compared with that due to neutrons. For measurement of the neutron flux in the medium power range the ion chambers are covered by thimble-

shaped shields made of lead, which, although having a high attenuation factor for gamma radiation, are almost transparent to neutrons. By this method the currents from the ion chambers due to incident gamma rays are reduced to negligible proportions compared to those due to the neutron flux at all but the lowest reactor power levels. Gamma rays incident on the ion chambers come from two sources. The reactor itself emits gamma rays and the equipment in the vicinity of the reactor, after having been activated by the neutron flux, also emits gamma rays. If the reactor is shut down after a period of high power operation the gamma intensity due to the activated components will remain high for a short while so that, unless special precautions are taken, the currents from the ion chambers due to gamma rays will completely swamp those due to the neutron flux at very low power levels immediately after shutting down. The chambers for use at low powers are shielded with extra thick lead thimbles designed to give a reduction factor of  $10^4$  in gamma intensity. Type RC6 gamma compensated ion chambers, having a gamma sensitivity lower by a factor of 30 than the normal uncompensated RC7 type, are used for this range. Immediately after shut-down it has been estimated that the gamma radiation incident on the chamber will be approximately 0.8 roentgen/hour which will result in a current of  $1.6 \times 10^{-13}$  amps flowing. It is also estimated that the neutron flux into the chamber with the reactor shut down will be about 750 neutrons/cm<sup>2</sup>/s which will give rise to a chamber current of  $1.1 \times 10^{-11}$  amps. It can be seen that, with the figures quoted, the current due to gamma rays is well under 10% of that due to neutrons, this figure being the quoted overall measurement accuracy of the system.

As has been stated, the estimated neutron flux into the low level chambers with the reactor shut down is 750 neutrons/cm<sup>2</sup>/s, giving rise to a current of  $1.1 \times 10^{-11}$  amps. This high flux is achieved by the use of several large installed neutron sources within the reactor to facilitate a quick start-up, and the

† Marconi Instruments Ltd., St. Albans, Hertfordshire.

resulting ion chamber current falls conveniently within the lower end of the measurement range of a conventional period meter. A pulse counting system for measuring the neutron flux at very low reactor powers can therefore be dispensed with, resulting in a lower initial cost of instrumentation, a substantial reduction in the number of instruments to be held as spares, and less time spent in routine testing and maintenance.

### 3. The Low-power Logarithmic Channels

The anticipated range of neutron flux to be measured is from 750 neutrons/cm<sup>2</sup>/s at shut-down to  $3 \times 10^{10}$  neutrons/cm<sup>2</sup>/s at full power equivalent to 1000 MW. The range from shut-down to approximately 100 MW is measured by three similar channels known as low-power logarithmic channels. This title is usually abbreviated to "low log channels". Each channel is associated with one of the three safety lines and consists of an RC6 ion chamber feeding a head amplifier and d.c. amplifier with an overall logarithmic transfer characteristic and which, in turn, feed a differentiating amplifier. The combination of logarithmic d.c. amplifier and differentiating amplifier is normally referred to simply as a period meter. The logarithmic amplifier section measures currents on a logarithmic scale over a range of seven decades upwards from  $5 \times 10^{-12}$  amps. The differentiating amplifier section measures the rate of change of these currents in terms of time in seconds taken for a given current to double itself. This is known as the doubling time.

These instruments feed external indicators and recorders located in the control room and also operate certain trigger circuits contained within the instrument. One of these trigger circuits operates to give an alarm when the doubling time falls to a value which is nominally set at 46 seconds. A second trigger circuit opens a pair of contacts in the appropriate safety line should the doubling time fall below 15 seconds. A third trigger circuit, also connected to the appropriate safety line, operates when the neutron flux rises above a predetermined low value. This circuit is primarily to safeguard against an accidental slow rise in neutron flux at very low power levels and is rendered inoperative when it is desired to increase power to a higher level.

### 4. The High-power Logarithmic Channels

There are again three channels, normally called high log channels, each being associated with one of the safety lines. They measure neutron flux from a power level of something less than 1 kW to full power of 1000 MW using ion chambers and period meters in a similar way to the low log channels but in this case type RC7 ion chambers are used and the logarithmic d.c. amplifiers measure ion chamber currents over

seven decades from  $5 \times 10^{-11}$  amps upwards. The only difference however between the low log and high log period meters lies in the current meter calibration so that they may be interchanged by simply changing meters. The bottom three decades of the high log measurement range will not normally be used in practice as this range is adequately covered by the low log channels.

Trigger circuits are again incorporated to give an alarm when the doubling time falls to 46 seconds and to open-circuit the appropriate safety line at a doubling time of less than 15 seconds. The third trigger circuit in this case operates at a power level of approximately 10 MW to give an indication that the low log channels are nearing the upper limit of their range. The low log ion chambers are then partially withdrawn from the thermal column to a region of flux 1/1000th of that prevailing in the thermal column in order to avoid excessive activation by neutron bombardment and to avoid depletion of the electrode coatings. This operation is carried out by push-button control from the control desk. This third trigger circuit can also be used when power is being reduced to give a warning that the low log ion chambers should be re-inserted.

### 5. Log Power Testing

Each pair of log power channels (one low log and one high log) associated with a given safety line has, built into its main equipment cubicle, a set of test facilities with which all the necessary routine tests to ensure correct functioning and calibration may be performed. (See Fig. 1.)

In routine testing of these log power channels it is first necessary to check the ion chamber h.t. voltage, which is derived from a transistor d.c. converter powered by a 12 V battery. The same type of converter is used to provide h.t. for both RC6 and RC7 chambers. The battery is kept on floating charge by a voltage stabilized charging unit. With this system of h.t. supply for the ion chambers it is found that no trouble is experienced with spurious doubling-time trips due to voltage surges on the mains, a factor which could prove to be very troublesome with certain other systems. The actual voltage on the ion chambers is monitored by a meter on the transistor converter unit and by depressing a switch the output voltage of the unit is measured on the same meter. This will indicate immediately whether any loss of h.t. on the chamber is due to supply failure or to a break in the supply cable. The converter also contains a circuit which gives an alarm when the voltage on the ion chamber falls by more than 40% of its nominal value. This alarm circuit can be tested by operation of a second switch on the converter which lowers the voltage of the h.t. output by approximately 45%.

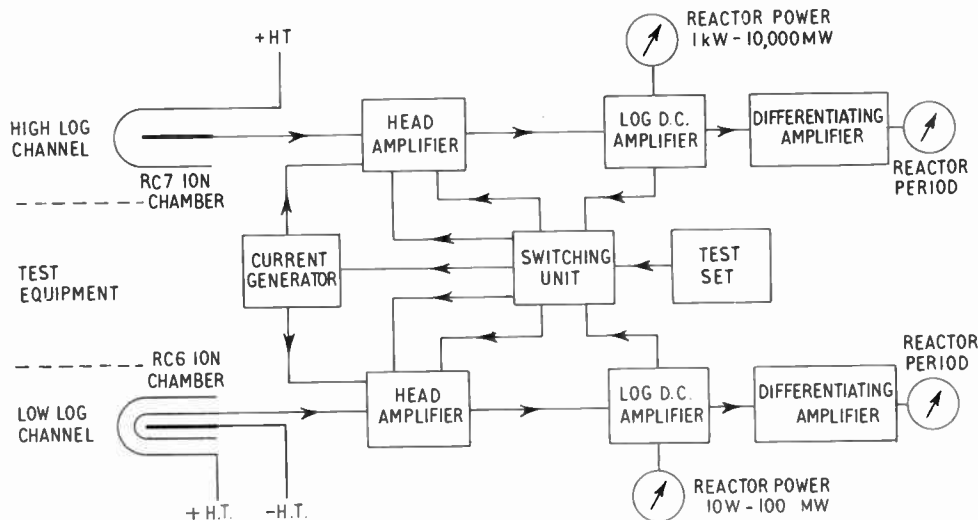

Fig. 1. Schematic for one pair of log power channels.

The second stage in the testing procedure is to check the functioning and calibration of the logarithmic d.c. amplifiers, which includes the head amplifiers. A switch selects either the high log or the low log channel for testing, leaving the other functioning normally. When the channel to be checked is switched into the test condition, two distinct operations are effected. Firstly, the input circuit of the head amplifier is transferred from its associated ion chamber to a generator which provides a series of known currents. This changeover is accomplished by a specially-designed solenoid-operated change-over switch of very high insulation; the switch also earths the signal cable from the ion chamber which would otherwise charge up to the voltage of the chamber h.t. Contact potentials, which sometimes cause misleading results at low levels, are not important in this case as we are dealing with a constant current source. The second operation consists of connecting a ramp function generator, usually known as a period meter test set, in series with the feedback loop from the logarithmic amplifier output to the head amplifier. The ramp function generator is concerned with the testing of the differentiating amplifier and so, as it is not required yet, its output is short circuited.

The current generator has outputs of  $10^{-11}$  amps to  $10^{-5}$  amps in seven decade steps. The required output value is selected by a very high insulation stepping relay which is controlled from the main cubicle. The current generator has to be located near to the head amplifier because the time-constant due to the capacitance of a long cable would render the system impracticable on the lower current ranges. The calibration of the log d.c. amplifier is checked by injecting known currents from the current genera-

tor to the head amplifier and checking the reading of the front panel ion chamber current meter. At the same time, with a knowledge of the factor relating ion chamber current to reactor power, the various associated external power indicators in the control room can be checked.

After checking the log d.c. amplifier a required fixed current is injected from the current generator into the head amplifier and the ramp function generator is brought into use. With this arrangement an input current to the head amplifier can be simulated, the logarithm of which varies linearly with time; that is, the period meter can be made to read a constant doubling time, the magnitude of which depends on the slope of the ramp function. This method of simulating a doubling time is used because of the difficulty in practice of producing very small currents with the required exponential functions over a range of several decades. Using different ramp function slopes, the calibration of the front panel doubling-time meter, and also that of the external indicators in the control room, can be checked at various selected points.

A further facility for environmental testing is also provided for the low log channels in the withdrawn position. With the reactor at high power, the low log ion chambers are withdrawn, as has already been described, into a region of flux three decades lower than that in the thermal column. Prior to a controlled shut-down of the reactor it is necessary to ascertain that the low log channels are functioning correctly before re-insertion of the ion chambers into the thermal columns.

Controls are provided in the main equipment cubicles to insert partially the withdrawn low log

## REPORT OF THE 36th ANNUAL GENERAL MEETING

*The Institution's Annual General Meeting, the twenty-eighth since Incorporation under the Companies' Acts, was held at the London School of Hygiene and Tropical Medicine on Wednesday, 24th January 1962.*

*The Chair was taken by Mr. L. H. Bedford, C.B.E., M.A., B.Sc., F.C.G.I. (an Executive Vice-President), and when the meeting opened at 5.35 p.m., 54 corporate members had signed the Minute Book.*

The Chairman called upon the Secretary, Mr. Graham D. Clifford, to read the notice convening the meeting, which had been circulated to members and published in the December 1961 *Journal*. The meeting then proceeded to the Agenda as follows.

### **1. To confirm the Minutes of the 35th Annual General Meeting held on the 11th January 1961.**

The Secretary stated that the Minutes of the last Annual General Meeting were published on pages 190–192 of the February 1961 *Journal* and that no adverse comment had been received. The Chairman's proposal that those Minutes be signed as a correct record of the proceedings was approved unanimously.

### **2. To receive the Annual Report of the Council for the year ended 31st March 1961.**

Before formally presenting the Annual Report, Mr. Bedford said that the main object of this Annual Meeting had been described in the Report which had accompanied the publication of the Institution's Accounts in the December *Journal*. It was, he said, the last Annual General Meeting of the Institution as a body incorporated under the Companies' Acts. Henceforth, the Institution would operate under the terms of its Charter of Incorporation. A Special General Meeting of corporate members would be convened in the near future to consider the draft Bye-Laws which had to be submitted for the approval of the Privy Council.

Referring to the final Annual Report of the Council, published in the January 1962 *Journal*, Mr. Bedford said:

“Achievement of our Charter has to a large extent been possible because of the splendid work of our various Standing Committees during the past thirty-five years. It has been our custom to give an account of their work in every Annual Report.

“First of all, we have our usual accurate account of the way in which our Membership Committee has examined applications for membership. It is sufficient, I think, for me to point out that not only did the Institution achieve its highest figure of membership during the year, but also had a record number of proposals and a record increase in membership.

“The report of the Technical Committee is always of particular interest to members. The Committee has been responsible for a number of very interesting recommendations and may also be regarded as the Committee which sponsored the development of Specialized Groups. Normally we do not single out any individual member of a Committee, but I think the Institution as a whole would want me to record that, because of Mr. F. G. Diver's ability, the Technical Committee has for six successive years strongly recommended his re-appointment as its Chairman. We are very grateful to Mr. Diver and to all members of his Committee for the work they do for the Institution.

“The Examinations and Education and Training Committees jointly maintain the Institution's professional standards of membership and examination and make a great contribution to the development of technical training facilities in our particular field. Together with the Membership Committee, they set the professional standards of our Institution which, over the years, have done so much to ensure that we became a fit and proper Institution to receive a Royal Charter. I do commend these sections of the Report for careful study.

“Handicapped as we are by the limitations of our present accommodation, we may nevertheless feel pleased—if not satisfied—with the facilities that are provided through the Institution's Library. Our services in this direction very much emphasize the importance of our providing more extensive Institution accommodation in order that we may give members an even better service in library information.

“I come finally to the work of the Programme and Papers and Specialized Group Committees. Their section of the report gives practical instance of the very wide range of activity now covered by the professional radio and electronic engineer. These Committees, together with the Technical Committee, form what we might call the learned society activities of the Institution.

“We are extremely well served by nearly 100 members who serve on these various Committees. Their work is subject to inspection not only at Annual General Meetings, but at every meeting which the Institution holds. In London one meeting per week

has been averaged during the session and at least one a month by most of our various sections in Great Britain and overseas. These meetings, our Conventions, Symposiums, and the regular publication of our monthly *Journal* and other reports, played a tremendously important part in assessing our fitness to become a Chartered body.

"It is, therefore, with a sense of indebtedness to all our Standing Committees that we express our thanks to all the members who have served us in this way; I take particular pleasure, as a Past President of the incorporated Institution, in asking you to join me in those thanks by approving the Annual Report for the year ended 31st March 1961."

In seconding the adoption of the Annual Report of the Council, Mr. J. A. Sargrove (Member) said for many years he had been concerned with Institution affairs and served on the Council and Standing Committees. During that time he had opportunity of noting the considerable help given to the Institution by the Secretary, Mr. Graham D. Clifford. He knew that he was speaking on behalf of all members in asking that the adoption of the Annual Report should be coupled with thanks to Mr. Clifford who, for nearly twenty-five years had given unceasing effort to implementing the Institution's objects, culminating in the achievement of a Royal Charter.

The proposal was received with acclamation, and the 35th Annual Report was approved unanimously.

### **3. To receive the Auditor's Report, Accounts and Balance Sheet for the year ended 31st March 1961.**

The Chairman called upon the Honorary Treasurer, Mr. G. A. Taylor (Member), to deal with this item.

Mr. Taylor first referred to the statement in the December *Journal*, which quoted Article 22 of the Royal Charter of Incorporation, namely:

"The property and moneys of the existing Association shall from the date of these Presents become and be deemed to be the property and moneys of the Institution, and shall, as soon as may be, be formally transferred to the Institution or such person or persons on its behalf as the Bye-Laws may prescribe."

This statement was accompanied by the Institution's Income and Expenditure Account and Balance Sheet for the year ended 31st March 1961.

He continued:

"It would be idle to pretend, Mr. Chairman, that the Finance Committee and myself are wholly satisfied with the assets we are handing over to the Chartered Institution. I will not elaborate on the tremen-

dous changes which have taken place in the fiscal structure of our country in the thirty-six years' life of the Institution. We all know that until recent years we have had a tremendous struggle in balancing our accounts. We have overcome our difficulties in two ways. First, as the Balance Sheet shows, we are able to hand over to the Chartered Institution fixed assets and investments, including the moneys apportioned to our Building Appeal, of some £37,500.

"Some explanation of these Accounts was given in the December 1961 *Journal*. Your Finance Committee has not found it easy to balance the budget with the constantly increasing costs of administration and services to members. We believe that with a new era in front of the Institution, as a Chartered body, we may also be entering a new year of some financial stability which will enable us more easily to meet the increases in expenditure which we anticipate in consequence of yet further development and activity.

"Even before the Charter was granted, members of the Institution agreed on 7th June last year to certain increases in subscriptions which will enable us to meet rising costs and will, we believe, enable us to produce an even better Income and Expenditure Account than the one which is before you tonight.

"In the eight years that I have been the Honorary Treasurer of the Institution, my task at Annual General Meetings has always been relatively easy insofar as our Accounts have constantly improved. The year ended 31st March 1961 was no exception, and I have no hesitation in formally moving the adoption of the Accounts for the year, and proposing that the Assets and Liabilities of the incorporated Institution be transferred to the chartered Institution."

The proposal was seconded by Mr. J. L. Thompson (a Vice-President) and approved unanimously.

### **4. To express thanks to the Institution's Solicitors, Braund and Hill, 6 Gray's Inn Square, London, W.C.1.**

and

### **5. To express thanks to the Institution's Auditors, Gladstone, Jenkins & Co., 42 Bedford Avenue, London, W.C.1.**

Mr. Bedford said that with the approval of the meeting he proposed to deal with Items 4 and 5 together, and stated:

"Since 1937 the Institution has been advised on legal matters by Mr. Charles Hill, and more recently by Mr. Gray Hill, of Braund and Hill. I would like to see recorded in the Minutes of this meeting appreciation of the services of Mr. Charles Hill who, for so

many years, was responsible for advising the Institution on alterations to our Memorandum and Articles of Association to meet the changing conditions which developed since our original incorporation in 1932. He was also responsible for many negotiations we had with the Inland Revenue, the leases of our existing building, and many other legal matters on which the Council of the Institution required advice from time to time.

“More recently, Mr. Gray Hill has been our legal adviser, particularly in the matter of preparation of our Petition for the grant of a Royal Charter. Messrs. Braund and Hill will be recommended as Solicitors and legal advisers to the Chartered Institution. I am sure you will wish to take this opportunity of thanking Mr. Charles and Mr. Gray Hill for all their work for the Institution during the past years.

“For the past twenty years we have also been greatly helped by the Institution’s auditors, who have also assisted as advisers on accountancy problems. Again I would like to mention the individual rather than the name of the practice by saying that we have had invaluable advice and help from Mr. Hugh Jenkins, F.C.A. Since 1946 Mr. Jenkins has personally been responsible for the annual audit of the Institution’s finances as well as accountancy advice. I am sure you would also wish our thanks to be recorded in the minutes of this final meeting of the incorporated body.”

The meeting gave its assent to both these recommendations with acclamation.

#### 6. Award of Premiums and Prizes.

The Chairman said that having completed the formal business of the Annual General Meeting the next stage of the proceedings was a very welcome one, namely, to present awards to those authors who had made outstanding contributions to the Institution’s *Journal*.

Mr. Bedford then presented Premiums and Awards† to:

Dr. G. T. Wright (Clerk Maxwell Premium).

Mr. R. A. Waldron (Heinrich Hertz Premium).

Mr. E. Davies (Arthur Gay Premium).

Mr. C. H. Dix and Mr. W. E. Willshaw (Leslie McMichael Premium).

Mr. E. C. Fellows (Lord Rutherford Award).

Mr. E. M. Bradley (Charles Babbage Award).

The recipient of the A. F. Bulgin Premium, Dr. A. Kraus of Munich, was unable to be present, but Mr. Bedford stated that the Award had been despatched with the Council’s congratulations.

The Secretary reported the regret of Council that several of the Premiums were not awarded this year. It was hoped that papers of sufficient merit, under the various terms of award, would be published during the next year to justify the award of all Institution Premiums.

The Chairman was sorry that the winners of the Examination Prizes† could not be present at this meeting, but congratulations would be recorded and the prizes had been sent to:

Oded Smikt (*Graduate*), President’s Prize.

Sushil Kumar Takkar (*Student*), S. R. Walker Prize.

Wilfred Bennett (*Graduate*), Associated Television Prize.

#### 7. Any other business

The Secretary stated that notice of any other business had not been received and the Chairman then declared the 36th Annual General Meeting of the Institution and the last to be held by the body incorporated under the Companies’ Acts to be at an end.

† A full list of the winners of Premiums and Awards was published in the *Journal* for September 1961 (page 178) and the Examination Prize winners were listed in the Annual Report (*Journal* for January 1961, page 11).

# REPORT OF THE ANNUAL GENERAL MEETING OF SUBSCRIBERS TO THE Brit.I.R.E. BENEVOLENT FUND

*The meeting was held at the London School of Hygiene and Tropical Medicine on Wednesday, 24th January 1962, and commenced immediately after the termination of the proceedings of the 36th Annual General Meeting of the Institution.*

Mr. L. H. Bedford, C.B.E., M.A., B.Sc., M.Brit.I.R.E., F.C.G.I., asked Mr. Graham D. Clifford, Honorary Secretary of the Fund, to preside over the meeting.

## **1. To confirm the Minutes of the Annual General Meeting of Subscribers held on 11th January 1961.**

Mr. Clifford read the notice convening the meeting which had been published in the December 1961 *Journal*. The Minutes of the last Annual General Meeting, which had been published in the March 1961 *Journal*, were approved and signed as a correct record of the proceedings.

## **2. To receive the Annual Report of the Trustees for the year ended 31st March 1961.**

Before presenting the Annual Report of the Trustees, Mr. Clifford stated that he wished to inform subscribers to the Fund that conditions under which the Fund operated had been published on pages 170-171 of the 1961 edition of the List of Members of the Institution. For some time it had been thought that those Rules should be revised and there had been some consultation with the Honorary Solicitor to the Fund on the proposed revisions. It was hoped that during the next twelve months a special meeting of subscribers to the Fund would be called in order to discuss and, if thought fit, approve some alteration in the legal constitution of the Fund. Mr. Clifford continued:

“The Institution’s Benevolent Fund was inaugurated in 1941 and up to 31st March 1961 we have distributed in grants alone over £6,000. In addition, we have purchased four bursaries at Reed’s School, where six children nominated by the Trustees have been educated. Obviously it gives the Trustees considerable satisfaction to be able to assist in this way. We are a little sorry that more members have not contributed to the Benevolent Fund, and we would like again to commend to you the idea of completing a Deed of Covenant. Completion of a covenant does not cost the subscriber any extra to make his contribution worth while, but the Trustees are able to augment it by recovery of the tax paid by the subscriber.”

Mr. Clifford stated that the Trustees particularly appreciated the work done by many members,

especially in local Section areas, in drawing attention to cases of financial difficulty, and in many instances visiting a member or widow to see what assistance the Trustees could best give. Obviously the Annual Report could not adequately reflect all this background work but the Trustees were grateful for this additional support.

The Annual Report of the Trustees was approved unanimously.

## **3. To receive the Income and Expenditure Account for the year ended 31st March 1961.**

Mr. Clifford referred to the total of over £10,000 in investments, the interest from which provided an additional annual income for the Fund. This could be very useful if heavy demands had to be met which might exceed the income from donations. A conservative investment policy was thus very necessary. As a comparatively young body, he thought that the demands on the Benevolent Fund would inevitably be greater in the years to come. For this reason, the Trustees hoped to see a great improvement in the total income from donations and investments which, for the year under review, was just over £1,500. Mr. Clifford continued:

“The amounts made in grants and donations are much the same as in the previous year. We have, however, made a considerable increase in the purchase of Bursaries. The Trustees have continued to support the three Schools referred to in their Report, even though, in the year under review, we have not had cause, fortunately, to nominate a child for admission to one of those Schools. The Trustees felt that in a year when there were no excessive demands upon the Fund, we should continue to purchase bursaries.

“I would like to make special reference to our local Sections, most of whom now make a considerable contribution to the Fund.”

The Trustees also gratefully acknowledge the continued support given by the Radio Industry Clubs of London and Manchester.

Mr. Clifford felt that subscribers would agree that the Accounts and Balance Sheet of the Benevolent Fund showed a very satisfactory state of affairs and he had pleasure in moving their adoption. The motion was seconded by Mr. J. L. Thompson and passed unanimously.

**4. To elect Trustees for the year 1962.**

Mr. Clifford stated "We have been very indebted for several years to Professor E. E. Zepler and Mr. G. A. Marriott who, by virtue of their office as Presidents, have also acted as Trustees of the Benevolent Fund. They have, however, recommended that as in any other organization, it is undesirable to continue constant re-election and in order to permit the election of other subscribers as Trustees, they have tendered their resignation. It is proposed, if the subscribers agree, that Rear Admiral Sir Philip Clarke, Air Vice-Marshal C. P. Brown and Mr. A. A. Dyson be re-elected as Trustees, and that we should elect for the first time to the Board of Trustees, Mr. Ieuan Maddock, who is a member of the Council, and Mr. E. A. W. Spreadbury, who has for many years served on various Committees of the Institution. Both gentlemen are, of course, subscribers to the Benevolent Fund."

This proposal was approved unanimously and the meeting was then invited to consider the appointments of Honorary Secretary and Honorary Treasurer. Mr.

Graham D. Clifford and Mr. G. A. Taylor respectively were re-elected to these two offices.

**5. To appoint the Honorary Solicitor.**

and

**6. To appoint the Honorary Auditor.**

Mr. Clifford asked that these two items be taken together inasmuch as Mr. Hill and Mr. Jenkins worked very closely together in giving their voluntary assistance to the Trustees.

The meeting approved unanimously the re-appointment of Mr. C. Gray Hill as Honorary Solicitor and Mr. R. Hugh Jenkins as Honorary Auditor.

**7. Any other business.**

Notice of other business had not been received and after thanking all subscribers for their support during the year the Chairman declared the Annual General Meeting of subscribers to the Benevolent Fund at an end.

Following the business of the Annual General Meetings, members adjourned for a short while and then re-assembled to hear a paper sponsored by the Electro-Acoustics Group Committee. The paper, "The Development of a Very High Quality Loudspeaker" by Mr. H. J. Leak (Member) and Mr. D. A. Barlow, M.Sc. (Associate), will be published in a forthcoming issue of the *Journal*.



# Trochotron High-Speed Beam Switching Tubes

By

D. REANEY

(Associate Member)†

Presented at a Symposium on "Electronic Counting Techniques" in London on 26th April 1961.

**Summary:** The trochotron high-speed beam switching tube is described and the characteristics discussed. Expressions for the maximum discrimination and maximum continuous counting rates are derived. Binary, single pulse and sine wave drive circuits are discussed. Methods of extending the number of output channels and of generating staircase or analogue waveforms are illustrated. Details are given of remote digitron read-out, and mention made of a method of modulation.

## 1. Introduction

The Trochotron is a hot-cathode multi-electrode tube containing a number of open box electrodes and operating in a constant magnetic field. It was first described by Professor H. Alfvén in 1947-48, although the actual tube described then<sup>1, 2</sup> was not quite the same design as the ones under discussion in this paper.

The tube takes its name from the motion of electrons in crossed electric and magnetic fields. These

guided by varying the position, within the tube, of the equipotential line along which it is travelling.

Current can be extracted from the beam in two ways: firstly the beam can impinge upon an electrode at the same potential as itself, or secondly, the beam can be guided into a narrow slit where the electric field is very much more effective than the magnetic field in the same region. This latter is the more useful, as with suitable design the beam can be com-

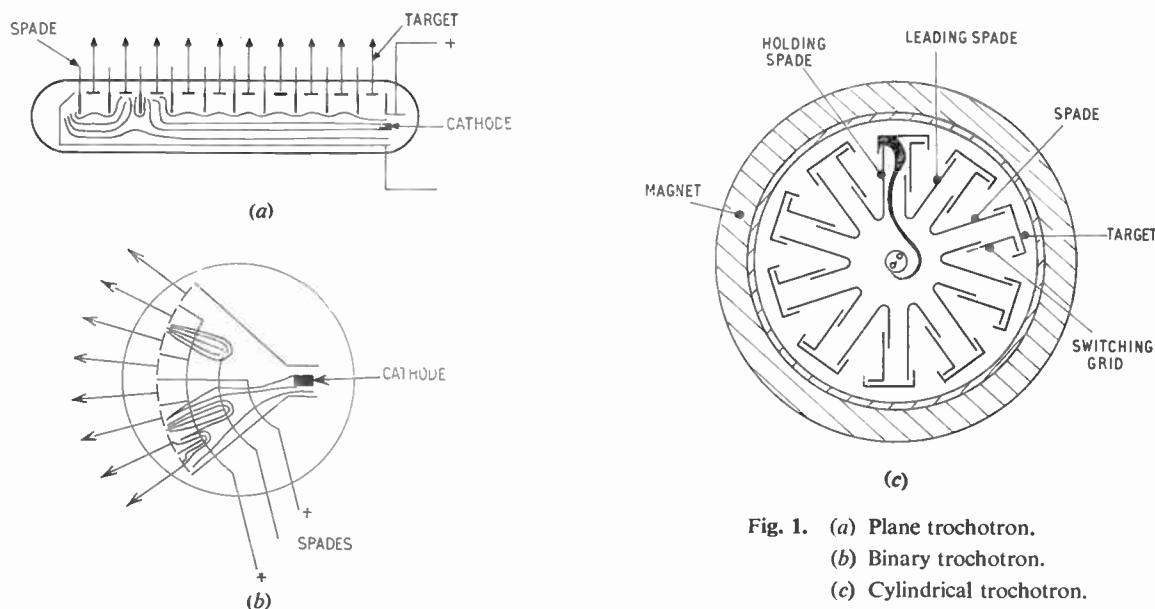

Fig. 1. (a) Plane trochotron.  
(b) Binary trochotron.  
(c) Cylindrical trochotron.

are trochoidal in nature and the motion is described in many text books. The important feature is that, with a space charge present, a beam consisting of electrons each following a trochoidal path can be formed, and that the beam, as a whole, will follow an equipotential line.<sup>3</sup> The beam can be directed or

pletely collected. The magnitude of the current is discussed in Appendix 1. Three different basic designs of trochotron are possible and these are illustrated in Fig. 1. They are (a) the plane trochotron, (b) the binary trochotron, and (c) the cylindrical trochotron. Of these only the cylindrical type is at present available commercially and this paper will deal exclusively with this type.

† Ericsson Telephones Ltd., Beeston, Nottingham.

Further reference to Fig. 1(c) will illustrate the general disposition of the electrodes and the nomenclature which will be used to describe the operation.

**2. Operation of the Tube**

After applying suitable voltages to the electrodes it will be found that no appreciable current flows, as the tube is normally operated above cut-off, i.e. the magnetic field strength is sufficiently large to prevent electrons reaching any of the electrodes.

If the potential of one of the spades is now reduced to that of the cathode, a complex trochoidal beam is formed and follows an equipotential from the cathode across to the gap between the spade which is at zero, and the adjacent spade which is at the spade supply voltage. Once within this gap, the beam (now degenerating) is controlled completely by the electric field in the gap.

After entering the gap the beam travels approximately down the centre, bends slightly towards the switching grid and then swings sharply across to the gap between the zero voltage spade and the associated target. Part of the beam is collected by the tip of the spade and the balance by the target.

There is, as yet, no automatic locking of the beam, and this is accomplished by using the spade characteristic. This is shown as Fig. 2 and is obtained by holding all the targets, switching grids and nine of the spades at a fixed potential and plotting the characteristic of the remaining spade (holding spade).

It will be seen that it has a sharp peak in the vicinity of the cathode potential and that in conjunction with a resistive load a stable operating point exists at "a". The intersection at "b" is on a negative slope and that at "c" represents cut off.

When suitable resistors are inserted in the spade connections, the beam is formed and locked. The targets are remote from the cathode and are only

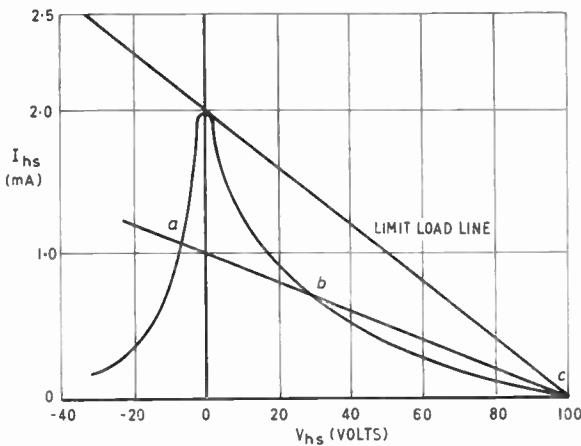

Fig. 2. Holding spade characteristic.

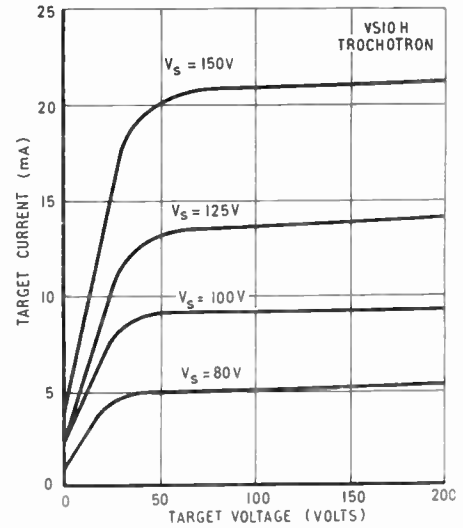

Fig. 3. Target characteristic.

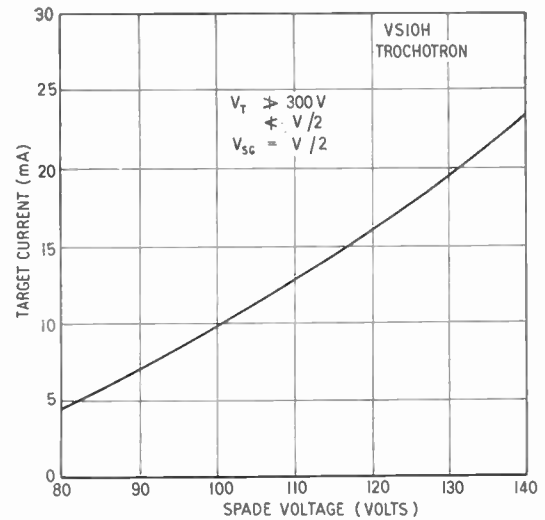

Fig. 4. Relationship between target current and spade voltage.

effective in the final collection of the beam, which results in the targets having a characteristic similar to that of a pentode. This is illustrated in Fig. 3, and above the knee of the curve the target voltage has little effect on the target current.

The magnitude of the target current is controlled by the voltage of the spades for a given tube geometry and a typical relationship is shown as Fig. 4. Design is generally aimed at achieving as high a current as possible for a given spade voltage.

The switching action of the tube is achieved by means of electrodes called switching grids, which are held normally at a positive potential equal to about half the spade voltage. As the switching grid voltage

is reduced, the equipotential that the beam is following moves nearer to the switching grid and the next spade (leading spade). This results in the leading spade starting to collect part of the beam. The potential of the leading spade begins to fall and the beam therefore moves further over. This cumulative action leads to the spade collecting the whole of the beam current. Due to the influence of the magnetic field the beam will rotate until the current is being collected by the side of the spade adjacent to the target about to draw current. As the spade potential falls, the beam current to the spade decreases and that to the associated target increases. In the normal locked condition the holding spade current is about 10% of the target current. The switching action of the tube is very fast and after switching the now lagging spade recovers to the spade supply potential.

In order to prevent the tube from switching more than once if the input drive pulse is very long, the switching grids are connected alternately in groups of five and are referred to as "odd" and "even" respectively.

### 3. Characteristics of the Tube

The most important characteristics of the tube are:

- (a) Cut-off characteristic.
- (b) Holding spade current/voltage relationship.
- (c) Leading spade current/voltage relationship.
- (d) Switching grid current/voltage relationship.
- (e) Maximum discrimination.
- (f) Maximum continuous speed.

These will be discussed in greater detail particularly in respect of limits.

#### 3.1. Cut-off Characteristic

As previously stated, the tube operates above cut-off, and the effective radial electrostatic field is contributed by the spades. This results in a relatively unrestricted range of target voltages. The important parameter is the magnitude of leakage current permissible to the spades. These leakage currents arise from slight variations in the magnetic field and also from the fact that in the rotating space charge some exchange of energy takes place between electrons, resulting in some of them gaining sufficient energy to reach the spades. The number of such electrons is related to the magnetic field strength and the magnitude of voltage between the spades and cathode. The leakage current must not be sufficient to cause appreciable reduction of a spade potential when flowing through the associated spade resistor. It is thus necessary in manufacture to ensure two things, first, that the total leakage current is less than a

specified value and second, that it is substantially uniformly distributed between the ten spade electrodes.

With a typical trochotron such as the Ericsson type VS10H a limit of  $7.5 \mu\text{A}$  per spade is set and in production values of  $3-5 \mu\text{A}$  are realized. This cut-off current is very dependent upon the uniformity of the magnetic field and any disturbance of this field due, for example, to accidental contact of the magnet with other magnetic materials will result in a greatly increased leakage current and consequent degrading of the tube performance.

#### 3.2. Spade Characteristic

The function of the spades is to form and lock the beam. They are also responsible for the magnitude of the target current.

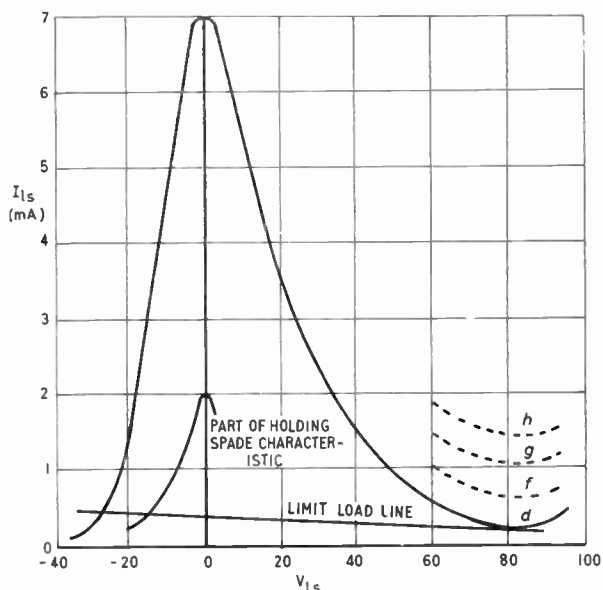

Fig. 5. Leading spade characteristic.

It will be seen from Fig. 2 that the minimum resistor is the one whose load line is a tangent to the peak of the spade characteristic. A maximum also exists, associated with the leading spade, and this is shown as Fig. 5. This shows the current/voltage relationship of the spade next to switch while the holding spade is maintained at the appropriate holding spade voltage. The limit load line is tangential to the curve at "d" and must also intersect the holding spade characteristic at the appropriate holding spade voltage "e". The partial curves "f", "g" and "h" show the effect of lowering the switching grid voltage. The "tail" of the curve is quickly raised well above the load line and the tube switches, the characteristic decaying rapidly to that of the holding spade. The degree of

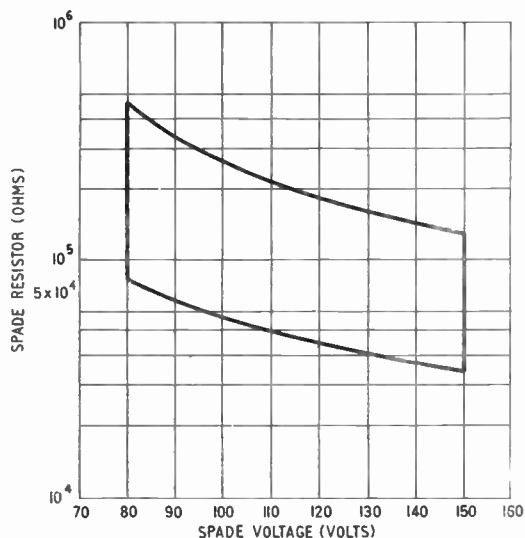

Fig. 6. Operational area diagram.

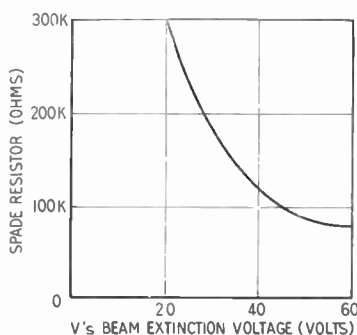

Fig. 7. Relationship between spade resistor and beam extinguish voltage.

lift of the tail of the loading spade characteristic is a measure of the reliability of the tube to switch, and is determined very largely by the geometry of the switching electrodes. As the minimum and maximum spade resistors are functions of the spade voltages, these are very conveniently combined in a single operational area diagram, a typical example of which is given in Fig. 6.

If the spade voltage is steadily reduced, a point is reached where the tube reverts to the cut-off condition, i.e. the beam extinguishes. This is known as the beam extinguishing voltage ( $V_s$ ) and is a function of the value of the spade resistors.

A typical curve is shown as Fig. 7 and this curve is used in the design of the clearing and beam forming circuits described in Fig. 13 and also in the determination of the theoretical maximum continuous counting speed.

A further important characteristic in connection with the spades is the existence of "N" current. This

is current flowing to an electrode which is normally negative with respect to the cathode. As a result the spade which is locking the beam takes up a potential of several volts negative with respect to the cathode. The "N" current arises from oscillations within the complex trochoidal beam which allow interchange of energy by the electrons. Those electrons which gain energy are thus able to reach spades even against small retarding fields, and in flowing through the holding spade resistor take the spade potential negative. The magnitude of the "N" current increases with increasing spade voltage and consequently the actual holding spade voltage is a function of the spade supply voltage and the spade resistors for a given magnetic field and tube geometry. Typical values of holding spade voltage are  $-10$  volts for the type VS10H and  $-2$  volts for the VS10K low voltage tube. Although the lower limit spade resistor for normal operation of the tube is defined in the way described, a further limit resistor can be defined by drawing a load line which is tangential to the leading spade current peak. The area between this line and the limit of the holding spade represents a region where the tube will switch and then beam extinguish. This mode of operation is used to extend the number of output channels to greater than ten (Fig. 14) using two or more tubes.

### 3.3. Switching Grid Characteristic

The action of the switching grids is to move the equipotential, along which the beam is travelling, in such a way as to allow part of the beam to be collected by the leading spade. The resulting cumulative action causing the rapid switching of the beam to the next position.

Two characteristic types of switching electrode are possible, one using a small diameter circular rod and the other using a flat plate of much greater area. Each gives rise to a slightly different electric field distribution within the tube, and differing input impedances.

The flat plate type of electrode, such as is used in the Ericsson type VS10H draws a current of some  $400 \mu\text{A}$  during part of the switching operation and has an input capacitance of about  $25 \text{ pF}$ . The circular rod type on the other hand is designed to be an essentially zero current switching grid and has a smaller input capacitance. The main advantage of the flat plate lies in the much greater lift in the tail of the leading spade characteristic resulting in a much improved switching action. The switching grids normally have a positive potential, the magnitude of which is dependent upon the voltage at which the tube switching action is initiated. It must lie outside the region of self switching and yet not be so high as to

make excessive demands on the drive circuits. The voltage is also related to the spade supply voltage and should form a fixed percentage of this. Typical values are 50% for the plate type and 25% for the rod type.

### 3.4. Maximum Discrimination

This is defined as the ability of the tube to distinguish between two pulses occurring very close together in time. It is essentially the minimum switching time of the tube.

Reference to Fig. 8 shows a typical spade characteristic and load line for a VS10H trochotron. The time to switch is determined by the time to discharge the spade capacitance, and this may be considered as occurring in two stages. First, the whole of the beam

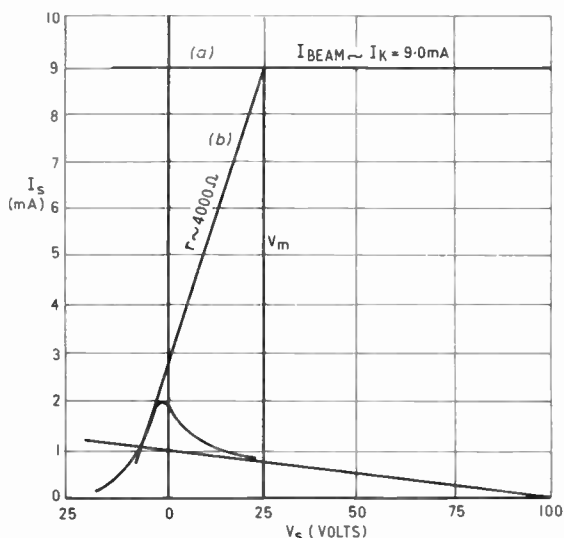

Fig. 8. Diagram to illustrate method of determining minimum switching time.

current flows into the spade and discharges the capacitance from the spade supply voltage to a value designed  $V_m$ . This is the point at which the associated target starts to draw current and the spade capacitance then discharges to the holding voltage exponentially. This characteristic can be approximated by two straight lines, which also enable a value to be found for  $V_m$ . The two straight lines are given by (a) a line representing the beam current, and (b) a line coincident with and having the same slope as the positive side of the spade characteristic, in the vicinity of the operating point. This has a slope of  $I/r$  and both are drawn in Fig. 8. The intersection of these two lines occurs at  $V_m$ . As the initial spade voltage ( $V_s$ ) and spade capacitance ( $C_s$ ) are known, the time to reach  $V_m$  is

$$t_1 = \frac{C_s(V_s - V_m)}{I_b} \quad \dots\dots(1)$$

For all practical purposes  $I_b = I_k$  and can be used without introducing any appreciable error. From this point the spade voltage falls exponentially with a time constant given by

$$C_s \left( \frac{R_s r}{R_s + r} \right)$$

As  $R_s$  is very much greater than  $r$  the time constant can be simplified to  $C_s r$  and the voltage is in the locking region in twice the time constant.

Therefore

$$t_2 = 2C_s r \quad \dots\dots(2)$$

and the total time is given by

$$T = t_1 + t_2 = \frac{(V_s - V_m)C_s}{I_k} + 2C_s r \quad \dots\dots(3)$$

Inserting typical values from Fig. 8 gives

$$\begin{aligned} t_1 &= 0.1 \mu s \\ t_2 &= 0.06 \mu s \\ T &= 0.16 \mu s \end{aligned}$$

Practical measurements of the switching time have shown that values between 0.15 and 0.17 microseconds are typical, and that the straight-line approximations made are reasonably justified. The significance of these results is further discussed in the section devoted to discrete pulse operation.

### 3.5. Maximum Continuous Speed

The maximum continuous speed is determined principally by the recovery time of the spades. Unlike the conditions when switching, there is no beam current to assist the spade to recover and the recovery time is governed by the time constant  $R_s C_s$ .

A complication exists in that when switching at high speed with the beam formed on a given spade and target, the other spades are all at different voltages. These range in value from near the holding spade voltage, which is negative, to substantially the spade supply voltage on the leading spade. It has been observed experimentally that it is necessary for about a half of the spades to have risen to at least the minimum spade voltage ( $V'_s$ ) for satisfactory operation of the tube. The spade voltage after switching, is given by

$$V = (V_s - V_{hs})[1 - \exp(-t/C_s R_s)] \quad \dots\dots(4)$$

Referring again to Fig. 7, for a given spade resistor a minimum voltage to maintain the beam exists ( $V'_s$ ), and in the limit this must be equal to  $V$ .

Therefore

$$T = C_s R_s \log [(V_s - V_{hs}) / (V_s - V_{hs} - V'_s)] \text{ seconds} \quad \dots\dots(5)$$

Inserting typical values of  $R_s = 100 \text{ k}\Omega$ ,  $C_s = 10 \text{ pF}$ , and  $V'_s = 45 \text{ V}$  from Fig. 7,

$$T = 0.54 \times 10^{-6} \text{ seconds}$$

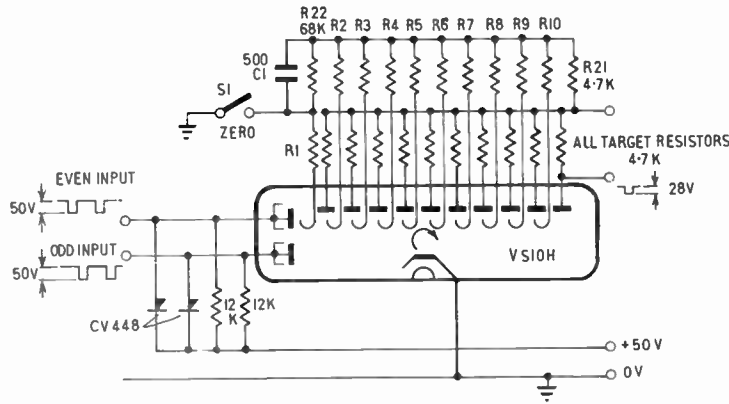

Fig. 9. Basic trochotron circuit.

and this represents the time in which the spade has recovered to  $V'_s$ . However, as previously stated, about half of the spades should have reached at least  $V'_s$ . This leads to the maximum speed of

$$F_{max} = 2/T = 3.7 \times 10^6 \text{ pulses/second} \dots\dots(6)$$

In practice, of course, the actual maximum would have to be less than this to avoid the risk of beam extinction. If the switching grids are connected to cathode the tube will free run and measurements show this speed to be  $3.3 \times 10^6$  pulses/second typically, which gives reasonable agreement with eqn. (6).

**4. Basic Circuits**

A basic circuit is shown in Fig. 9 which is capable of operation up to  $10^6$  pulses/second and will produce an output pulse of some 28–30 volts. The spade voltage is the most critical as the target current is a function of this. The target voltages are relatively unrestricted.

Clearing the tube and forming the beam is accomplished using the network R21, R22 and C1. The tube is driven by negative pulses of some 55 volts amplitude and duration greater than 0.5  $\mu$ s.

**5. Drive Circuits**

Three different methods of driving the tube are available:

- (a) Pulses applied alternately to each set of switching grids.
- (b) Pulses applied to the switching grids in parallel.
- (c) Use of a sine wave.

The most usual method is (a), the outputs being obtained from the anodes of a binary stage. The design of such binary counters is discussed in many text books and a typical example is given in Fig. 10(a). The minimum input impedance of the trochotron consists of say, 30 pF in parallel with 12 k $\Omega$  and it is desirable that the coupling capacitors from the binary stage should be at least 250 pF and 330 pF is

generally recommended. Diodes are used to clamp the switching grids at the bias level.

Operation is also possible if the switching grids are connected in parallel, and the drive pulse is sufficiently short to prevent the beam from switching more than once. This is described as discrete or single pulse operation and a typical circuit is shown in Fig. 10(b). The pulse is derived from a blocking oscillator and it may be necessary to increase the switching time of the tube by the addition of small capacitors across the spade resistors.

The third method of driving the tube is by means of a sine wave. A centre-tapped transformer is used, the switching grid bias being supplied via the centre tap. The circuit of Fig. 10(c) is extremely simple, but counts both half cycles so that the switching rate is equal to  $2f$ .

**6. Target Output**

The maximum target output is limited by:

- (a) The maximum permissible voltage across the tube ( $V_{Tmax}$ ).
- (b) The restriction that the target voltage must not fall below the knee of the target characteristic.

This occurs at approximately half the spade voltage and we may write

$$V_{o \text{ max}} = (V_{T \text{ max}} - V_s/2) \dots\dots(7)$$

Care must also be taken that the maximum dissipation of the tube is not exceeded.

If the target output voltage exceeds about 75 volts, it is necessary to consider the effect of internal feedback via the tube inter-electrode capacitances. Undue feedback results in erratic operation and may even cause beam extinction. The effects of this feedback may be reduced by the connection of small capacitors (10 pF) across the spade resistors, although this will reduce the maximum speed of the tube.

It should also be noted that the output voltage is a function of the switching rate above about

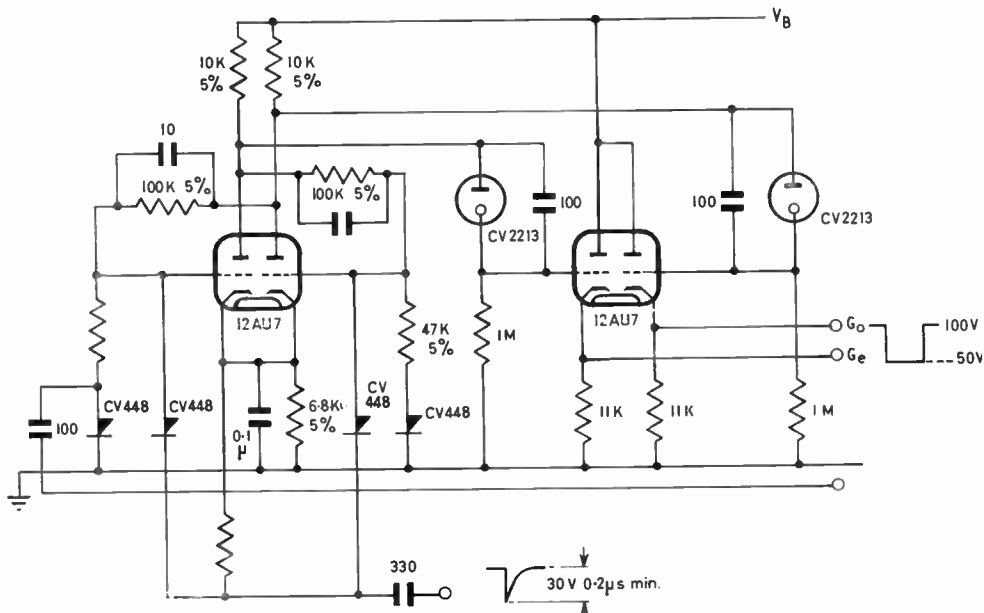

(a) Binary drive.

Fig. 10. Typical drive circuits.

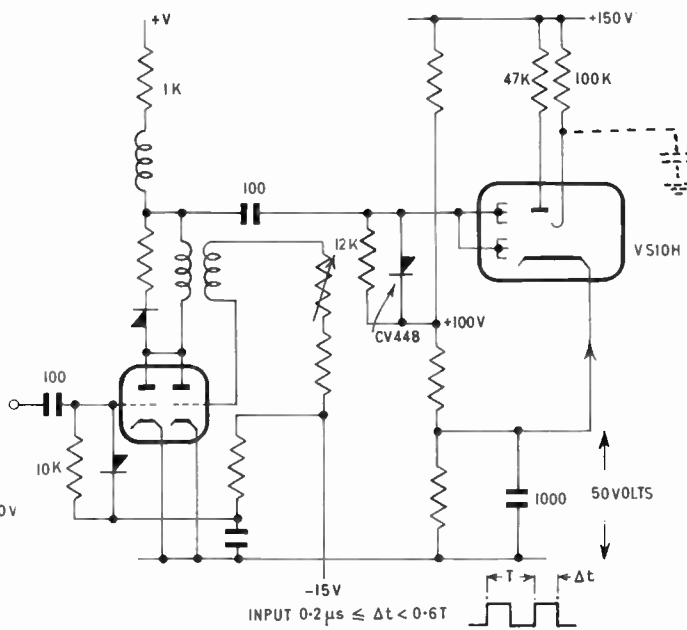

(b) Discrete pulse drive.

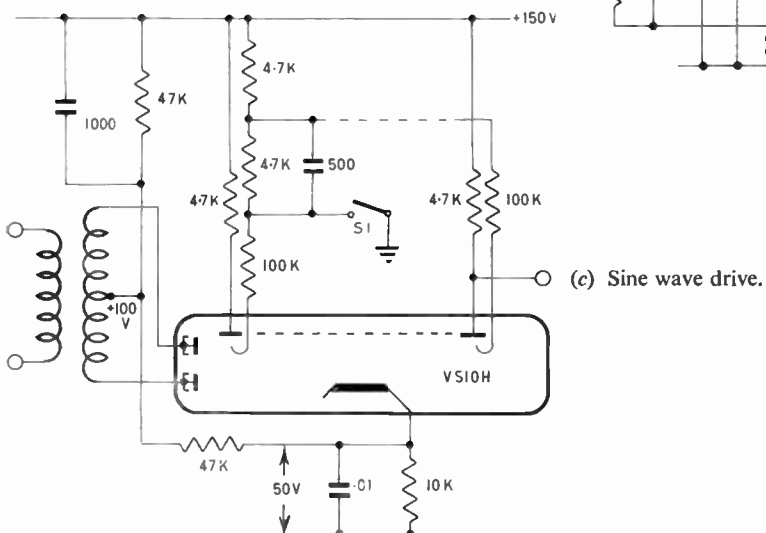

(c) Sine wave drive.

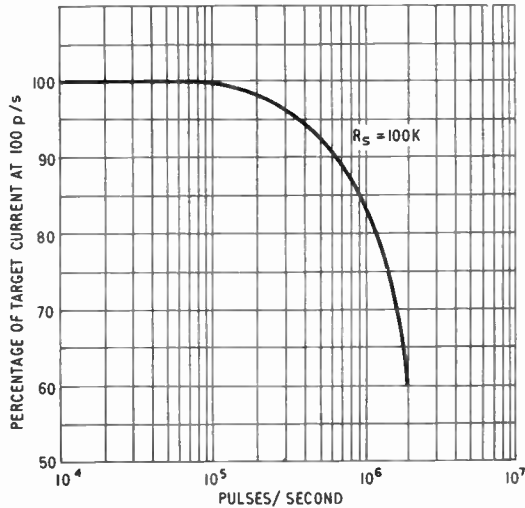

Fig. 11. Variation of target current with counting rate.

$250 \times 10^3$  pulses/second. This arises from the inability of the spades to recover to the full spade supply voltage in the time available. A reduction in target current of about 50% occurs when switching at  $2 \times 10^6$  pulses/second and Fig. 11 shows a typical variation of current with switching rate.

Some variation of current (typically 5%-6%) exists between targets due to small physical differences and from slight non-uniformity in the magnetic field. The effects of these variations can be reduced by the introduction of negative feedback from a cathode resistor. The resistor should be by-passed with about 1000 pF and this facilitates d.c. coupling from the drive circuit to the switching grids. A typical cathode

resistor should raise the cathode potential to between 50 V and 75 V to earth, and will reduce the typical target current variation mentioned by 30% to 50%.

### 7. Read-Out

Some convenient means of sensing the position of the beam is desirable. This may take the form of a visual read-out, and various methods are available. It is possible to use relays to operate lamps at low speeds, transistors performing a similar function, or one of the gas-filled register tubes,<sup>5,6</sup> (e.g. the "Digitron") giving a direct numerical read-out. The trochotron is well suited to this latter method as there is no speed limitation, and the constant current output is the ideal condition for the Digitron. A circuit is shown as Fig. 12, it will be noted that a permanent voltage of about 120 V is maintained across the Digitron tube. The target current in flowing through the target resistor produces the additional voltage necessary to strike the appropriate digit.

### 8. Resetting the Tube

This can be done either manually or electronically. The manual resetting circuit is shown in Fig. 9, and operates by first clearing the tube and then forming the beam on the selected spade and target.

The tube is cleared by momentarily reducing all the spade potentials to zero, via the switch and capacitor C1. The potential of spades other than the zero spade must then rise to a value greater than  $V_c$ , the beam extinction voltage.

Fig. 12. Digitron read-out from a trochotron.

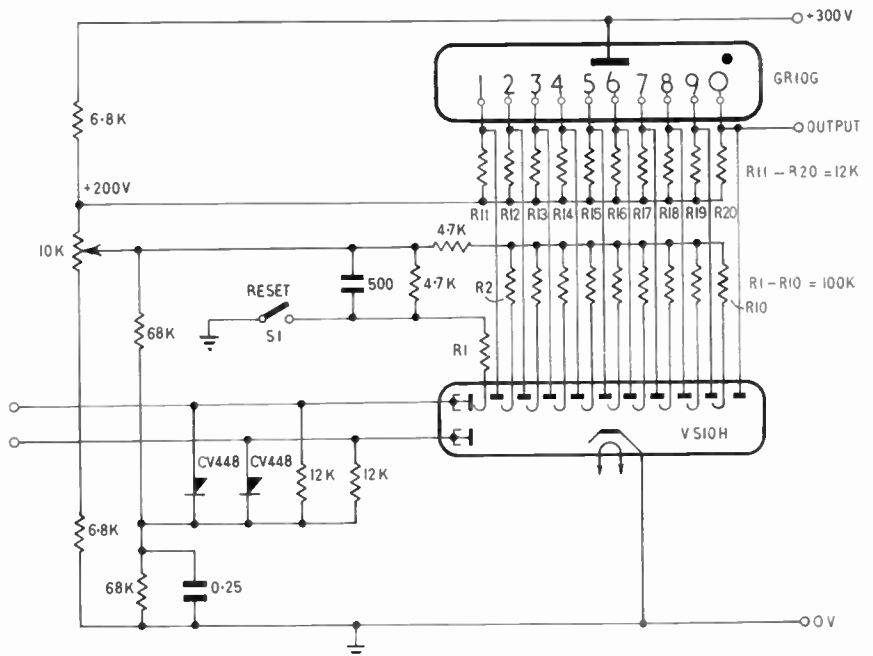



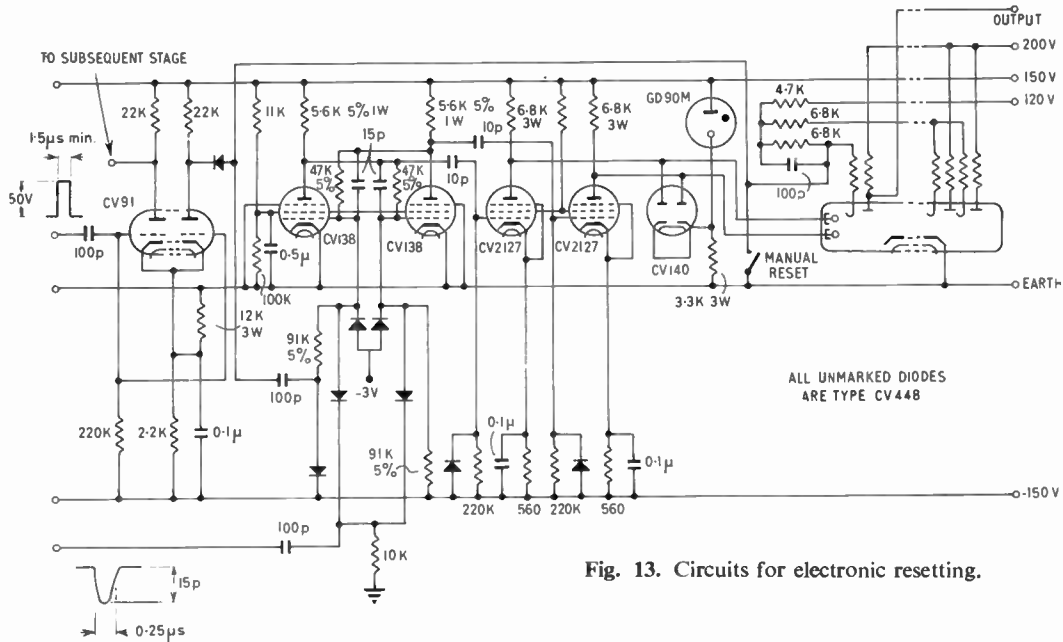

Fig. 13. Circuits for electronic resetting.

The rise of the zero spade potential is delayed by the charging of C1 and therefore the beam forms on the zero spade.

The design equations are as follows:

$$R_1 + R_{22} \approx 1.1 R_s$$

$$R_1 / R_{22} > 10$$

$$R_{22} / R_{21} \approx 1.5$$

$$R_{22} C_1 > R_s C_s \quad (C_s = \text{spade capacitance})$$

Electronic resetting is possible by means of a pulse applied either to the zero spade or to the cathode.

Figure 13 illustrates one method, a negative pulse being applied to the spades having a minimum duration of 1.5 μs.

In the circuit shown in Fig. 13 the reset pulse is also used to reset the switching grid bistable drive circuit.

**9. Miscellaneous Circuits**

Many circuits are possible using the trochotron, but space allows only two circuits to be discussed.

The first is the extension of the outputs to numbers greater than ten. This can be achieved using two or more tubes and making use of the "switch and beam extinguish" facility. This latter has been mentioned previously and is obtained by operating one of the spades with a resistor having a value between the limits set by the peak currents of the holding spade and the leading spade. When the beam is switched to this spade it automatically extinguishes the beam, providing a short pulse at the target. This pulse is used to reduce the potential of one of the spades on

the next tube and forms the beam. This action is very fast and no loss of counting ensues. A maximum of nine outputs are available from each tube. A suitable circuit is given in Fig. 14. The second circuit produces a staircase waveform or analogue voltage. This is easily achieved by the use of the circuit in Fig. 15, variation in the values of resistors enables an analogue voltage to be produced. The number of channels can be extended by the use of the circuit of Fig. 14.

**10. Modulation**

The target current can be modulated by means of a voltage superimposed on the spade supply voltage. Care must be taken to ensure that the spade voltage remains within the operating limits specified, and it is desirable that the ratio of switching frequency to modulating frequency is as high as possible. Satisfactory results have been obtained using a switching frequency of 500 000 pulses/second and modulating frequencies up to 10 000 c/s.

**11. Tube Life**

Life tests have shown that the life of these tubes is likely to be of the order of 10 000 hours or better. Tests over 5000 hours have shown about 5% variation in target current due, almost certainly, to ageing of the magnet.

**12. Specialized Trochotrons**

The tubes described so far have been general purpose tubes operating up to 2 × 10<sup>6</sup> pulses/second and with target currents between 5 mA and 20 mA.

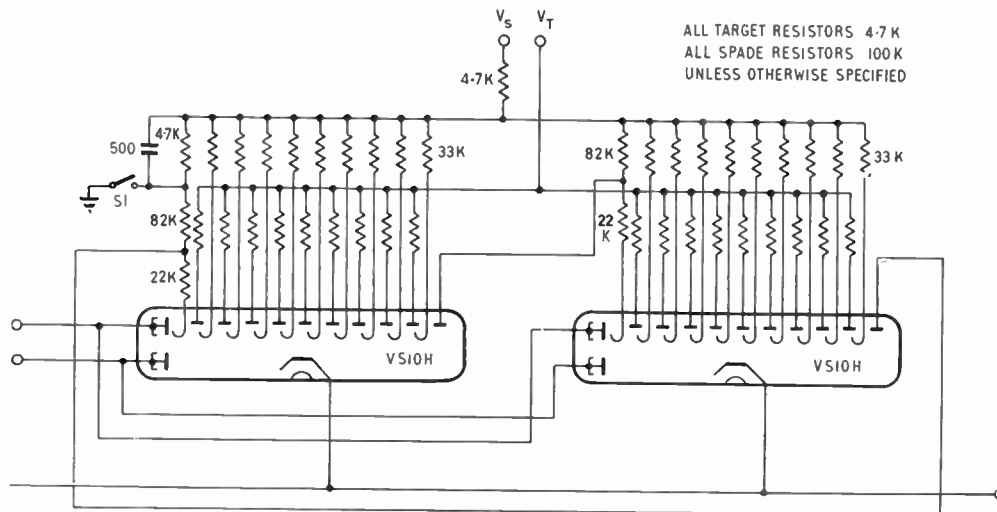

Fig. 14. Circuit to extend the number of output channels.

Disturbances of the magnetic field are of the greatest importance and may cause malfunctioning of the tube. A range of tubes has therefore been developed which are shielded magnetically, and are particularly suited to operation in large stray fields, near a synchrotron magnet for example. This shielding is achieved using a mu-metal shield and a tapered magnet.

It is possible to produce trochotrons which will operate up to  $10 \times 10^6$  pulses/second by including the spade resistors inside the bulb and reducing the stray capacitances to a minimum. The resulting target currents are of the order of a few milliamperes.

Finally mention must be made of the Burroughs' Beam X tube. This tube has the magnetic field supplied by ten rod magnets which also perform the function of target electrodes. This results in a physically smaller tube, which is less affected by external fields.

13. Conclusions

The trochotron is a tube capable of fast operation and good discrimination. It is fundamentally a very reliable tube requiring only that the switching grid voltage be reduced to the switching level for longer than the minimum switching time.

These tubes can perform a wide range of operations in the field of computing, particle counting, frequency and time measurement, pulse distribution, time interval generation etc., with a high degree of reliability.

14. Acknowledgments

The author wishes to thank Dr. J. H. Mitchell, Director of Research, and the directors of Ericsson Telephones Limited, for permission to publish this paper.

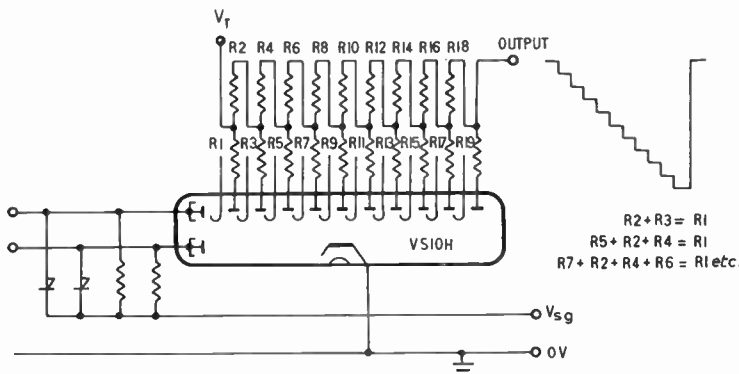

Fig. 15. Generation of a staircase or analogue waveform.

15. References

1. H. Alfven, et al., "Theory and applications of trochotrons", *Trans. Royal Inst. Technology, Stockholm*, No. 22, 1948.
2. J. Bjorkman and L. Lindber, "Development of trochotrons", *Ericsson Technics*, No. 1/1954, p. 6.
3. S. P. Fan, "The magnetron beam switching tube", *J. Brit. I.R.E.*, 15, p. 335, July 1955.
4. J. Millman and H. Taub, "Pulse and Digital Circuits", p. 140. (McGraw-Hill, New York, 1956.)
5. N. McLoughlin, D. Reaney and A. W. Turner, "The digitron: a cold-cathode character display tube", *Electronic Engineering*, 32, p. 140, March 1960.
6. G. Higgins, "A gas-filled glow discharge character display tube", *J. Brit. I.R.E.*, 22, p. 133, August 1961.
7. "Cold Cathode and Beam Switching Tube Technical Handbook." Ericsson Telephones Limited, Beeston, Notts.

16. Appendix 1: An Approximate Determination of the Beam Current

The cylindrical trochotron may conveniently be regarded as consisting of two regions, one from the cathode to the limit of the circulating current (the beam cut-off radius) and the second from the beam

cut-off radius to the target. The interest in the region lying between the cathode and the beam cut-off radius lies in the fact that this supplies the beam current to the second region. Within these limits the circulating current is not affected by the fact that one of the spades may be at cathode potential and the tangential current at the beam cut-off radius is the beam current.

The differential equations for the static magnetron are

$$\ddot{r} - r\dot{\theta}^2 = -\frac{e}{m} r\dot{\theta}Bz - \frac{e}{m} E_r \quad \dots\dots(8)$$

$$\frac{1}{r} \cdot \frac{d}{dt}(r^2\dot{\theta}) = \frac{e}{m} \dot{r}Bz \quad \dots\dots(9)$$

where  $r_c$  = cathode radius,  $r_s$  = spade radius and the space charge exists up to  $r_h$ .

Assuming  $\dot{\theta} = 0$  at the cathode and neglecting  $z$  components, eqn. (8) can be integrated to give

$$\dot{\theta} = \frac{1}{2} \frac{e}{m} B \left(1 - \frac{r_c^2}{r^2}\right) \quad \dots\dots(10)$$

Inserting (10) into (8) and assuming  $\ddot{r} = 0$  gives the field strength

$$E_r = \frac{1}{4} \frac{e}{m} B^2 r \left(\frac{r_c^4}{r^4} - 1\right) \quad \dots\dots(11)$$

From this can be obtained

$$\text{space charge density} = q = -\frac{1}{2}\epsilon_0 \frac{e}{m} B^2 \left(1 + \frac{r_c^4}{r^4}\right) \quad \dots\dots(12)$$

$$\text{potential} = V = \frac{1}{8} \frac{e}{m} \cdot B^2 r_c^2 \left(\frac{r}{r_c} - \frac{r_c}{r}\right)^2 \quad \dots\dots(13)$$

The beam current is the tangential current between cathode and space charge boundary ( $r_h$ ) and is given by

$$I_{\text{beam}} = \int_{r_h}^{r_c} q \cdot l \cdot \dot{\theta} r dr \quad \dots\dots(14)$$

from which is obtained a solution

$$I_B \frac{r_c}{l} = \frac{1}{8}\epsilon_0 \left(\frac{e}{m}\right)^2 B^3 r_c^3 \times \left[ \frac{r_h^2}{r_c^2} - \frac{r_c^2}{r_h^2} - 2 \ln \frac{r_h}{r_c} - \frac{1}{2} \left(1 - \frac{r_c^4}{r_h^4}\right) \right]$$

This equation is rather cumbersome and graphical solutions are given for it in Fig. 17 and for eqn. (13) in Fig. 16.

Dealing first with Fig. 16 the point corresponding to  $V_s$  and  $r_s/r_c$  is determined and a tangent is drawn from this point to the appropriate  $Br_c$  curve.

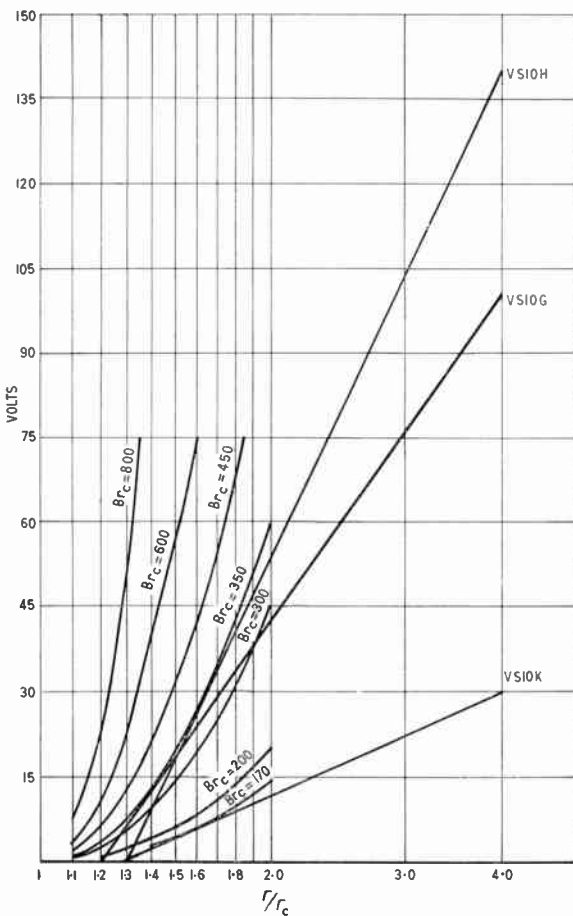

Fig. 16. Graph to determine the beam cut-off radius.

Table 1

Type	$r_s$ (mm)	$r_c$ (mm)	$r_s/r_c$	$B$ (gauss)	$B_{rc}$	$V_s$	$k(r_h/r_c)$	$\frac{I_B r_c}{l}$	$I_B$ calc. (mA)	$I_B$ obs. (mA)
VS10G	3.44	0.85	4.0	420	350	100	1.32	0.4	12.0	10.0
VS10H	3.44	0.85	4.0	420	350	140	1.43	0.7	22.0	20.0
VS10K	3.44	0.85	4.0	200	170	30	1.43	0.075	2.3	2.0

( $l = 26$  mm)

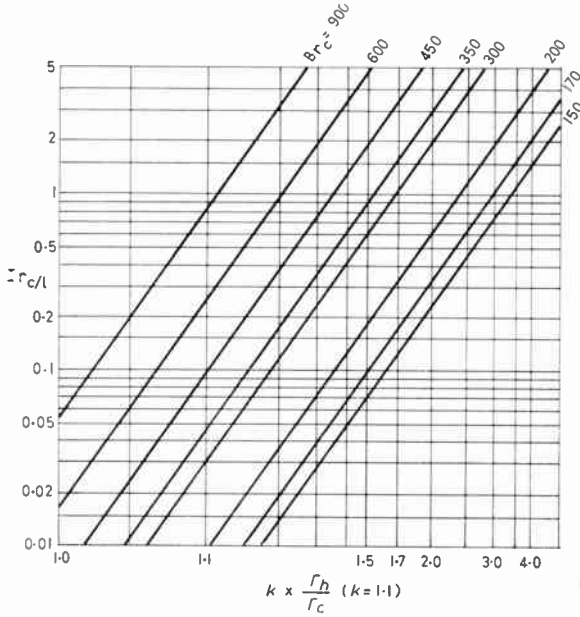

Fig. 17. Graph to determine the approximate beam current.

The tangential point gives the values of  $V$  for the edge of the space charge and the value of  $r_h/r_c$ —which yields the beam height.

The value of  $r_h/r_c$  multiplied by an empirically determined constant ( $k = 1.1$ ) is now entered in Fig. 17 together with the value of  $B_{rc}$  and  $I_B(r_c/l)$  is read off. The value of  $I_B$  can then be determined.

The process is illustrated for three tubes of similar geometry, but differing fields and spade voltages in Table 1. From the results it will be seen that tolerably good agreement exists, bearing in mind that the effects of beam degeneration etc., have been disregarded.

*Manuscript first received by the Institution on 29th August 1960 and in revised form on 13th March 1961 (Paper No. 702).*

© The British Institution of Radio Engineers, 1962

# The Dielectric Triode : A Low-Noise Solid-State Amplifier

By

P. W. WEBB, M.Sc.†

AND

G. T. WRIGHT, D.Sc.†

**Summary:** Current fluctuations in the space-charge-limited dielectric triode are discussed. It is shown that the noise power level in this device is considerably less than in the space-charge-limited vacuum triode or in the diffusion limited transistor.

The maximum sensitivity of any amplifying device is determined by the random fluctuations which are present in its operation and which are inherent in its mechanisms. Evidently, if very weak signals are to be amplified and are not to be lost in the device fluctuations, or noise, it is necessary that the device should possess as low a noise figure as possible. The space-charge-limited dielectric triode<sup>1,2</sup> is very promising in this respect and it is the purpose of this note to examine quantitatively the origin and magnitude of intrinsic electrical noise in this device.

At frequencies such that displacement current can be neglected and the arrival of each charge carrier at the collector electrode be regarded as an impulse the current density is given by

$$J = \rho v \quad \dots\dots(1)$$

and current fluctuations may be represented by

$$dJ = \rho dv + v d\rho \quad \dots\dots(2)$$

The direct interpretation of this equation in terms of the physical mechanisms occurring is that current fluctuations are caused by fluctuations in velocity of the carriers moving across the device and by fluctuations in the density of charge carriers in the conduction levels of the device.

Under space-charge-limited conditions the traversal of each carrier cannot be regarded as an independent and random event and it is not possible to calculate current fluctuations by application of probability theory as in the discussion of pure shot noise. It is possible to avoid this difficulty, however, by applying thermodynamic arguments; these are appropriate because the space-charge-cloud of mobile carriers moving across the device retains thermal equilibrium with the crystal lattice and may thus be regarded as having a definite temperature. Direct application of Nyquist's derivation of thermal noise is thus permissible with the result that the mean-square current fluctuation is given by

$$\overline{\Delta i^2} = 4kT_l G \Delta f \quad \dots\dots(3)$$

†Electrical Engineering Department, University of Birmingham.

where  $i$  is the mean current through the device,  $T_l$  is the temperature of the crystal lattice, and  $G$  is the incremental conductance. The accurate calculation of the conductance to obtain an accurate estimate of the current fluctuation is difficult,<sup>3</sup> but a close approximation is obtained from Child's equation for solids to give

$$G = \frac{9\epsilon\mu AV_g}{4w^3} \quad \dots\dots(4)$$

where  $V_g$  is the inner potential difference and  $w$  is the spacing between virtual cathode and control electrode.

The thermal noise given by eqn. (3) may be regarded as a space-charge-reduced shot noise. Expressed in this way we have

$$\overline{\Delta i^2} = 2ei\Gamma_d^2 \Delta f \quad \dots\dots(5)$$

where  $\Gamma_d^2$  is the space-charge reducing factor for the dielectric triode; by comparing eqns. (3) and (5) it is found to be given by

$$\Gamma_d^2 = 4\left(\frac{kT_l}{eV_g}\right) \quad \dots\dots(6)$$

Similar arguments have been applied to the space-charge-limited vacuum triode although the difficulty in this case is to decide exactly what is the temperature of the electron space-charge; for this reason the use of thermodynamic arguments is a dubious procedure. The case of the vacuum triode is generally discussed by super-position of the thermal and drift velocities of the carriers although this approach is known to provide results which conflict with experiment. However, the discrepancy has been explained by Bell<sup>4</sup> who has made a detailed examination of the problem based on considerations of the conservation of energy and momentum. The space-charge reducing factor for the vacuum triode is found to be

$$\Gamma_v^2 = 4\left(\frac{kT_c}{eV_e}\right) \quad \dots\dots(7)$$

where  $T_c$  is the cathode temperature and  $V_e$  is the effective grid-plane potential measured from the virtual cathode. This expression agrees well with

experimental observations and estimates the effective temperature of the electron space-charge to be  $T_e = 1.31 T_c$  rather than the generally used value of  $T_e = 0.644 T_c$ .

The equivalence of eqn. (6) for the solid-state device and eqn. (7) for the vacuum device is to be expected for the noise mechanism is the same in each case. However, noise is smaller in the former case because the temperature of the space-charge is lower. Using representative values of temperature and applied voltage the thermal noise power in the cooled dielectric triode should be of the order of one-tenth that in the vacuum triode. This is a significant improvement particularly as the dielectric triode is a solid state device. In this connection it is of interest to note that experimental measurements on cadmium sulphide dielectric diodes<sup>5</sup> have confirmed that noise power levels are considerably less than would be expected on the basis of pure shot noise. Space-charge reducing factors considerably less than unity have been measured although not so small as are indicated by eqn. (6). However, the experimental devices available at present certainly contain some additional noise mechanisms such as electron trapping; the significant feature of the observations is that the total noise level is considerably less than pure shot noise showing that space-charge reduction of noise is present.

Although these discussions have been based on a consideration of basic mechanisms only, it is apparent that the dielectric triode is a solid-state amplifier having potentially a very low noise level. In this respect it offers very considerable improvement over the transistor.

#### Acknowledgments

One of us (P.W.W.) would like to acknowledge the receipt of a maintenance grant from the Central Electricity Generating Board.

#### References

1. G. T. Wright, "A proposed space-charge-limited dielectric triode", *J. Brit. I.R.E.*, 20, pp. 337-55, May 1960.
2. G. T. Wright, "The space-charge-limited dielectric triode", *Solid State Electronics* (To be published).
3. G. T. Wright, "Mechanism of space-charge-limited current in solids", *Solid State Electronics*, 2, pp. 165-87, 1961.
4. D. A. Bell, "Electrical Noise", Chap. 7, (van Nostrand, New York, 1960).
5. N. J. Anderson and B. Meltzer, "Noise smoothing factors in insulator diodes", *J. Electronics & Control*, 11, pp. 111-3, 1961.

*Manuscript first received by the Institution on 18th October 1961 and in final form on 23rd November 1961.*

(Contribution No. 41)

© The British Institution of Radio Engineers, 1962

# Theory and Experimental Characteristics of a Tunnel Triode

By  
W. FULOP, Ph.D.†  
AND  
S. AMER, Ph.D.‡

Presented at a joint meeting with the Institute of Physics on "Tunnel Diodes" held in London on 7th February 1961.

**Summary:** The tunnel triode, which could perhaps be more correctly described as a double based tunnel diode, has the negative resistance characteristics of its tunnel junction influenced by an ohmic, lateral current flow in one of the degenerate regions which for this purpose has two ohmic contacts. Since the tunnel characteristics cannot readily be represented by analytic functions, the performance of the device was evaluated with the aid of a computer. For this purpose a fixed tunnel characteristic for an elemental junction area was assumed and this was then integrated across the junction face for various bias currents. A number of geometries were investigated and the results are shown. The characteristics thus obtained show good agreement with those measured of fabricated devices. Multi-valued current-voltage operation is considered for two configurations.

## 1. Introduction

The characteristics of degenerately doped abrupt  $p-n$  junctions were first investigated by Esaki§ who showed such doping distribution to have negative resistance in the nominally forward-biased direction.

Due to the very high electric fields present in these narrow junctions appreciable quantum tunnelling occurs already at zero bias, though obviously there is no net current flow. On increasing forward bias the electric field in the junction is reduced; this decreases the tunnel component of the increasing net current until it switches, via a negative resistance region, into the "normal" forward conduction mode of a  $p-n$  junction. The inherent relaxation time of this switching effect is extremely small, and circuit engineers have not been slow in exploiting this as a two-terminal amplifying or switching device, though the preference has always been for three-terminal devices.

One way of influencing the two-terminal tunnel characteristics is to place two ohmic contacts in one of the degenerately doped regions, and pass a current between them parallel to the junction face. We have investigated such a structure, both theoretically and experimentally, obtained good agreement, and shown that the negative resistance characteristics between two terminals can be profoundly affected by a lateral base current flow introduced by a third terminal. The point of this paper, then, is merely to report the theory and experimental results of some of our initial

attempts to influence the tunnel junction characteristics; these attempts can at this stage be only considered as purely exploratory.

## 2. Analysis

Though with the help of a digital computer the path of numerical calculations was finally adopted, the analytical equations describing the operation of the device are readily established. These equations are derived here as they help in understanding the operation of this device; they are not evaluated analytically since some of the assumptions are too simplifying for the results to have more than a purely qualitative significance.

Reference is made to Fig. 1, which shows schematically the tunnel triode in question. The  $p^+$  side of the junction is assumed to be equipotential (this could be assured by placing the ohmic contact to the  $p^+$

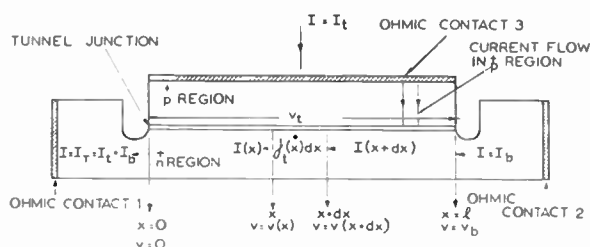

**Fig. 1.** Structure of a tunnel triode. Positive biasing shown: i.e. bias on contact 2 with respect to contact 1 (common terminal) in such direction so as to reduce forward bias  $v_a$  at  $x = l$ . With  $n^+$  region double contacted as shown contact 2 would for this case be positively biased with  $I_b$  (negative) flowing from right to left; when  $p^+$  region is double contacted, contact 2 would, for "positive" biasing, be negatively biased with respect to contact 1 with  $I_b$  (positive) flowing from left to right.

† Standard Telecommunication Laboratories Ltd., Harlow, Essex.

‡ Standard Telephones and Cables Ltd., Footscray, Kent.

§ L. Esaki, "New phenomenon in narrow germanium  $pn$  junctions", *Phys. Rev.*, **109**, No. 2, p. 603, 15th January 1958.

3.1. Calculations for  $t = 1 \text{ mil}$

Figures 5 and 6 show this for positive and negative biasing respectively for the geometry and resistivity as shown in Fig. 3, the value of  $t$ , the thickness of the double contacted  $n^+$  region, being 1 mil. For positive biasing the current peaks decrease and move to higher values of  $v_t$  with the negative resistance disappearing for a fixed value of  $I_b$  ( $\sim 120 \text{ mA}$ ). On the other hand, for negative biasing current peaks increase at first to a maximum, and then decrease, moving to lower values of  $v_t$ . This should be compared with the oscillograms obtained from fabricated devices particularly those of Diode No. 2 (Figs. 13 and 14).

Another arrangement which illustrates the multi-valued current voltage operation is the  $I_b$ - $v_b$  characteristic at constant  $I_t$  value. This requires the value of  $v_b$  to be known, which could be readily plotted from available computer data. Figure 7 shows this for positive biasing; from the curves it can be seen that for given values of  $I_t$ , multi-valued operation in  $I_b$  and  $v_b$  can be obtained. This follows readily from, for instance, Fig. 5, where a fixed value  $I_t$  is seen in general to intersect a given  $I_b$  curve three times, giving three values of  $v_t$  for which, from computer data, the three values of  $v_b$  can be obtained. Practical devices confirm this multi-valued operation, and this is discussed below.

In Fig. 7 the curves for the first, second or third intersect of a given  $I_t$  value with a fixed  $I_b$  curve of Fig. 5 are in order of increasing  $v_t$  values. Thus, for example, if we concentrate on the curves for  $I_t = 20 \text{ mA}$  we have for positive biasing at  $I_b = -20 \text{ mA}$  the following  $v_b$  and  $v_t$  values

$$I_t = 20 \text{ mA} \quad I_b = -20 \text{ mA} \text{ (positive biasing)}$$

	$v_t$ mV	$v_b$ mV
1st intersect	51	67
2nd intersect	193	98
3rd intersect	458	70

To be noted is that although the value of  $v_t$  increases

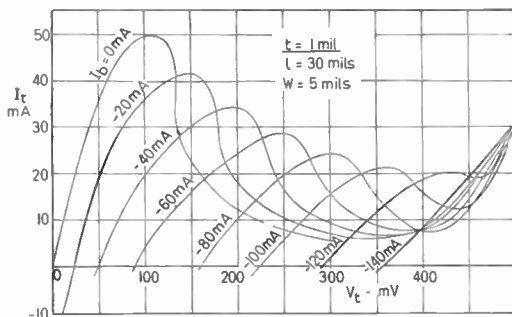

Fig. 5. Positive biasing, i.e. forward bias  $v_b$  at  $x = l$  lowered by applied bias.  $n^+$  region ( $\rho = 0.002 \text{ ohm cm}$ ) double contacted,  $I_b$  negative.

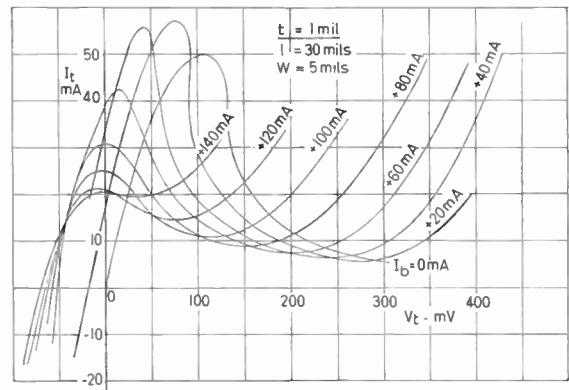

Fig. 6. Negative biasing, i.e. forward bias  $v_b$  at  $x = l$  increased by applied bias.  $n^+$  region ( $\rho = 0.002 \text{ ohm cm}$ ) double contacted,  $I_b$  positive.

rapidly with increasing order of intersection,  $v_b$  seems to peak at the second intersect.

If now switching between the various states given by these intersections can be induced, the large jumps in  $v_t$  at constant  $I_b$  and  $I_t$  values with only small expenditure in  $v_b$  obviously hold promise of power gain.

However, the problem of conditions of stability for traversal of given curves requires further elucidation; and on that no doubt hinges the question of whether in theory the possibility of gain, however small, for any of the configurations exists.

The  $I_b$ - $v_b$  curves ( $I_t = \text{const.}$ ) have also been plotted for the negative biasing region where much the same arguments hold as for the positive region.

3.2. Calculations for  $t = 0.3 \text{ mil}$

The calculations were repeated for a value of  $t = 0.3 \text{ mil}$  and the  $I_t$ - $v_t$  ( $I_b = \text{const.}$ ) characteristics both for positive and negative biasing are shown in Figs. 8 and 9 respectively. They are beginning to look somewhat more unusual, the bending over of the current peaks being due to the increased biasing effect of a given  $I_b$  current. Even the self-biasing ( $I_b = 0$ ) is quite significant. Also on all curves part of the region, which under more normal conditions is all negative resistance, has now become positive.

An improvement on the previous curves for  $t = 1 \text{ mil}$  is the reduction of the ratio  $I_{br}/I_{t0}$  where  $I_{br}$  is the bias current required to just remove negative resistance and  $I_{t0}$  the peak current for  $I_b = 0$ .

In Figs. 10 and 11 multi-valued voltage current operation is once more apparent, but unlike the case for  $t = 1 \text{ mil}$ , this now not only involves large changes in  $v_t$ , but those in  $v_b$  are now also quite appreciable, as can be seen from Table 1.

Furthermore the plotting of Figs. 10 and 11 has now been complicated by the fact that over a certain



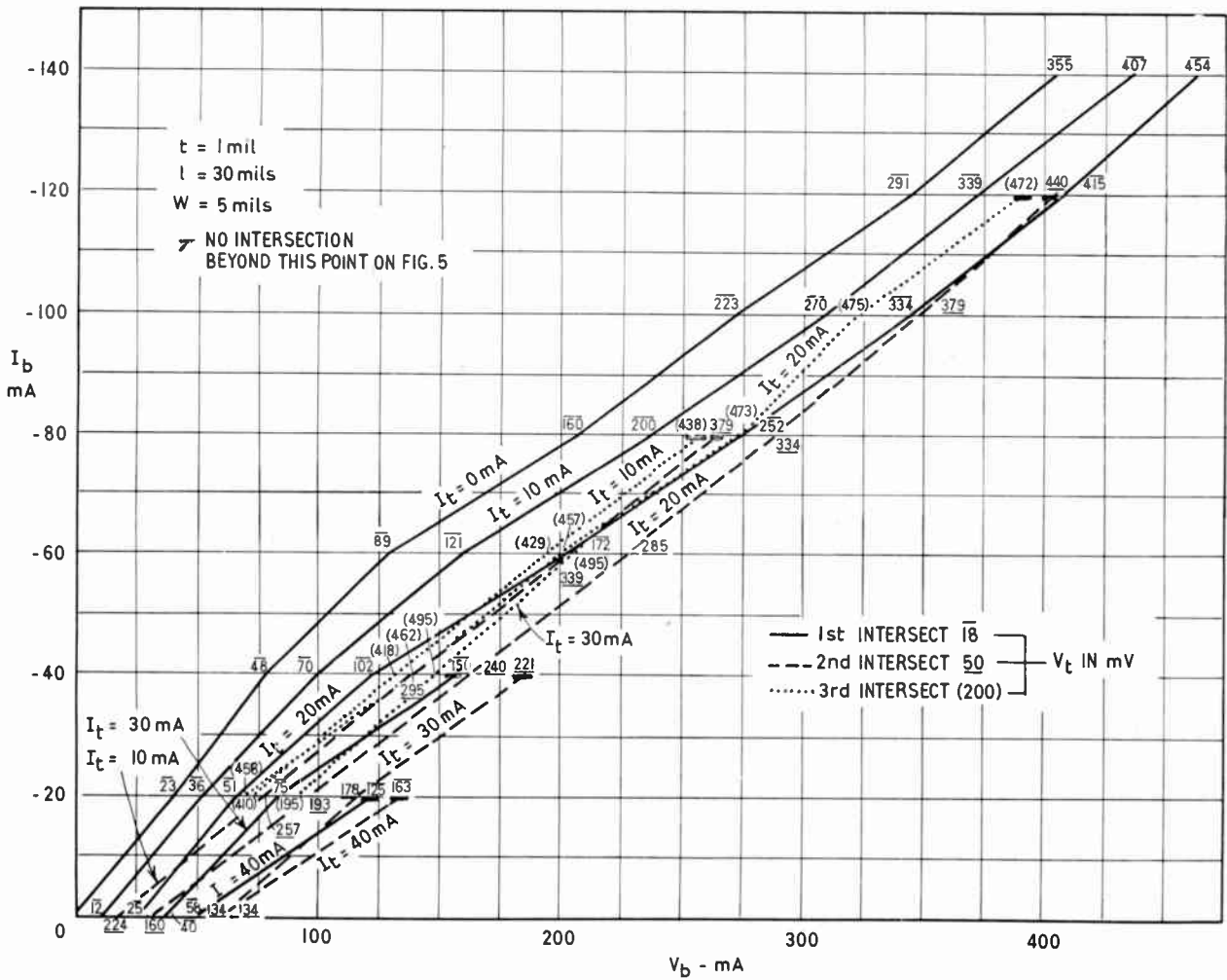

Fig. 7. "Positive" biasing,  $I_b$  negative.

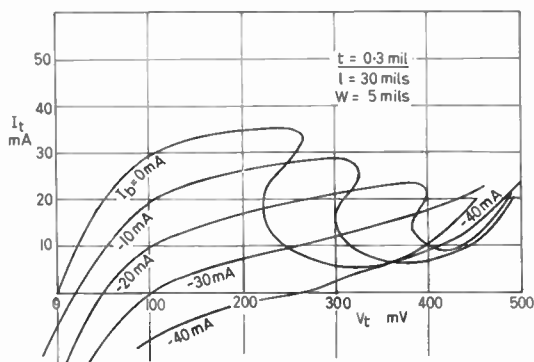

Fig. 8. Positive biasing, i.e. forward bias  $v_o$  at  $x = l$  lowered by applied bias.  $n^+$  region ( $\rho = 0.002 \text{ ohm cm}$ ) double contacted,  $I_b$  negative.

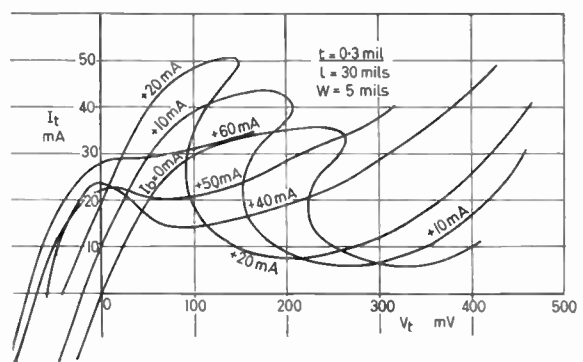

Fig. 9. Negative biasing, i.e. forward bias  $v_o$  at  $x = l$  increased by applied bias.  $n^+$  region ( $\rho = 0.002 \text{ ohm cm}$ ) double contacted,  $I_b$  positive.

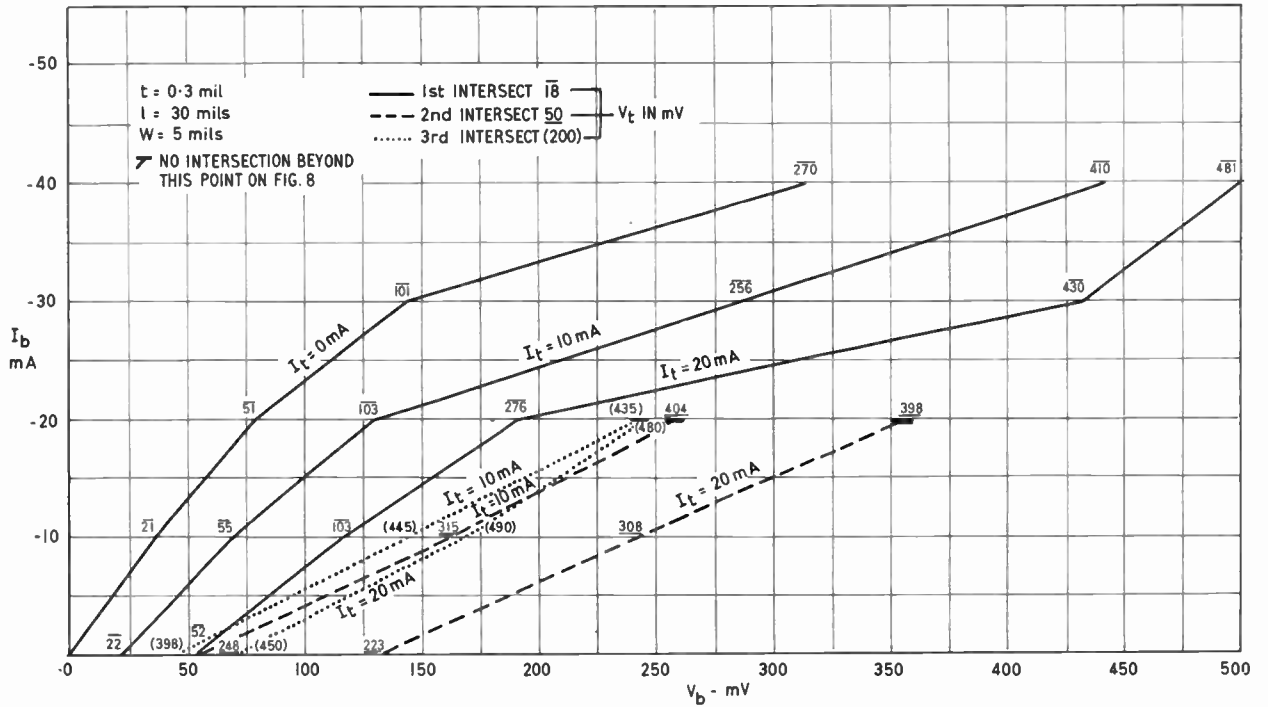

Fig. 10. "Positive" biasing,  $I_b$  negative.

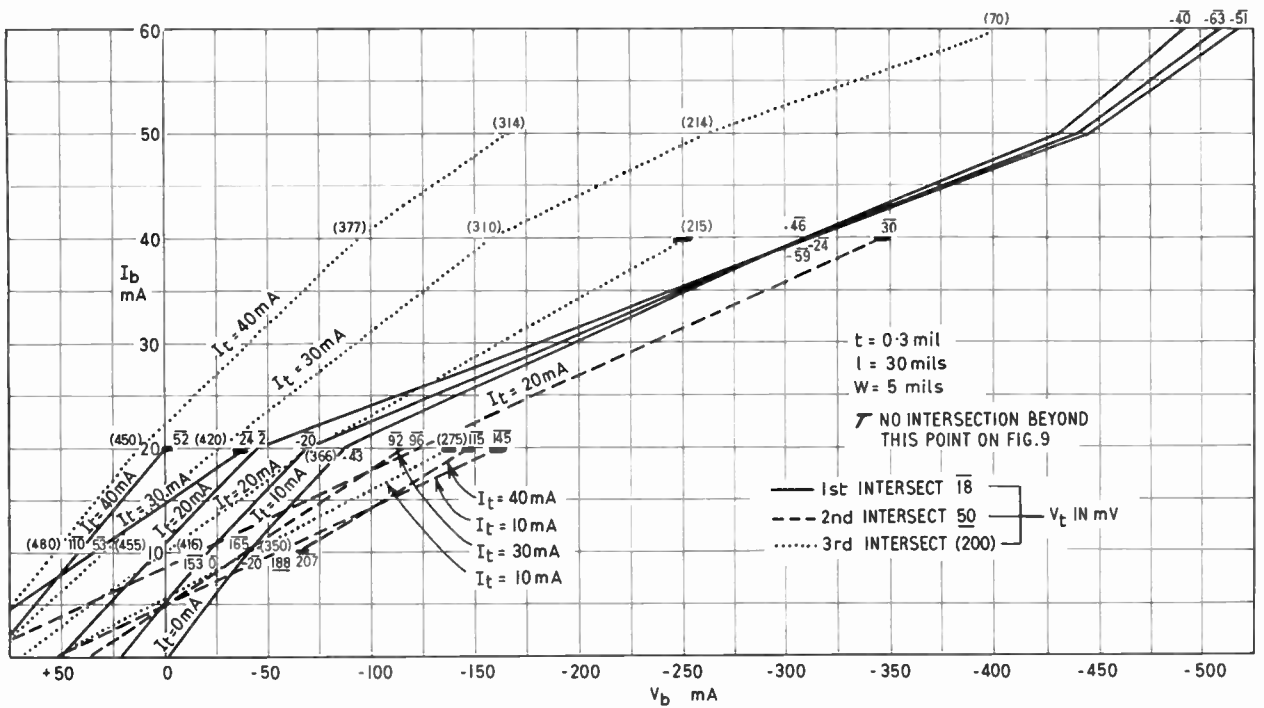

Fig. 11. "Negative" biasing,  $I_b$  positive.

range of values of  $v_t$ , corresponding to the second intersect of Figs. 8 and 9, there are now three values of  $v_b$  for a given value of  $v_t$ . By inspection it could readily be determined which of the group of values of  $v_b$  gave a "reasonable" second intersect curve on Figs. 10 and 11, though here also a further proliferation in multi-valued operation giving two or three "second intersect" curves cannot be ruled out.

In Table 1 a typical range of values of  $I_b$  and  $v_b$  (positive biasing) is quoted for a fixed value of  $I_t = 10$  mA.

Table 1

$I_b$ mA "positive" bias	$v_t$ mV	$v_b$ mV	
0	22	22	1st intersect
	248	(55, 190, 224)	2nd "
	398	44	3rd "
-10	55	70	1st intersect
	315	(163, 260, 297)	2nd "
	445	145	3rd "
-20	103	131	1st intersect
	404	(260, 370)	2nd "
	435	246	3rd "

$I_t = 10$  mA

The italicized values of  $v_b$  were chosen for the plot of Fig. 10 though some of the other combinations could give further "second intersect" curves.

Calculations for lower values of  $t$  (0.1 mil) gave such distorted characteristics (strong self biasing) that further work was discontinued.

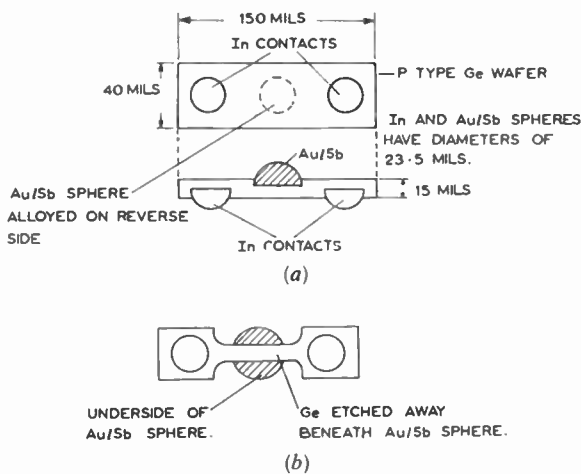

Fig. 12. (a) p-type germanium wafer showing dimensions and arrangements of base contacts. (b) The wafer after selective etching to form bridge across Au/Sb dot.

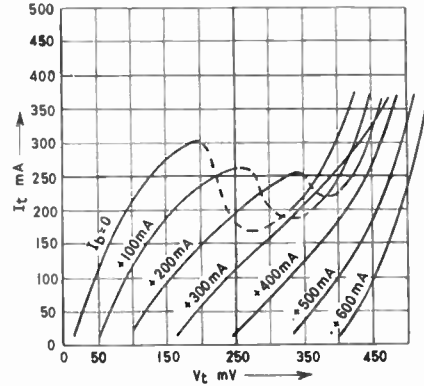

Fig. 13. Diode No. 2, positive bias characteristics.

4. Fabricated Devices

The method of fabrication is not claimed to be optimum but merely made use of the facilities available at the time, which consisted of germanium alloying techniques.

Figure 12(a) shows the dimensions of the p-type Ge wafer and the arrangements of the two In ohmic base contacts. Figure 12(b) shows how the Ge was selectively etched away to form a bridge across the Au/Sb dot. This is necessary to avoid current paths connecting the two In dots which do not pass across the junction face and which would thus tend to short out the desired biasing effect looked for. This Ge bridge across the Au/Sb dot acts as the active base region across which the bias current passes. Its thickness  $t$  was etched down to the limits of mechanical strength of the structure when mounted on a header. No ready methods were available at the time to measure this thickness, but it is believed to be in the region of 1-5 mils. For added mechanical strength the mounted devices were dipped in a resin after the etching had been completed, and then finally encapsulated.

4.1. Measured Characteristics of Fabricated Devices

The measured characteristics seem to agree well with the above outlined theory. Figure 13, which shows the positive bias characteristics of one of the triodes made, does not look unlike Fig. 5. It can be seen that for  $I_b = 300$  mA the negative resistance region has been completely eliminated.

Figure 14 shows the negative bias characteristics of the same diode, which rather resembles Fig. 6. The peak currents at first increase with increasing  $I_b$  and move into the negative  $v_t$  quadrant. Negative resistance is practically completely eliminated for  $I_b = 500$  mA.

The multi-valued, non-linear current voltage relationship for the  $I_b-v_b$  configuration ( $I_t = \text{const.}$ ), which was discussed in some detail for the theoretical

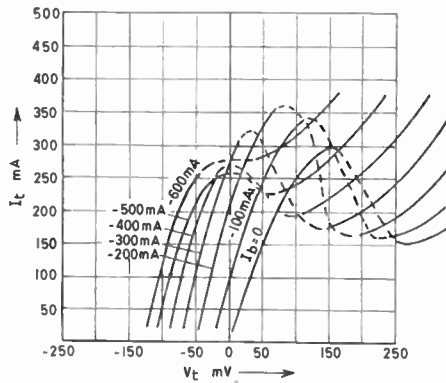

Fig. 14. Diode No. 2, negative bias characteristics.

structures, was borne out in practice. Figure 15 illustrates this for Diode No. 2 for "positive" biasing ( $v_e$  reduced at  $x = l$ ), and  $v_t$  forward-biased.

5. Other Structures

Further elaborations on the simple structure outlined in this paper have been considered which convert the device from three- to four-terminal operation. Figure 16 illustrates these.

In (a) the fourth terminal is capacitively coupled to the double contacted region, the output between terminals 3 and 4 constituting a negative resistance in series with a capacitance, and no doubt possessing more isolation from bias terminals 1 and 2 than the three-terminal device.

In (b) both degenerate regions are double contacted and the arrangement bears some similarity to double contacted  $p-n$  junctions doped at normal semi-

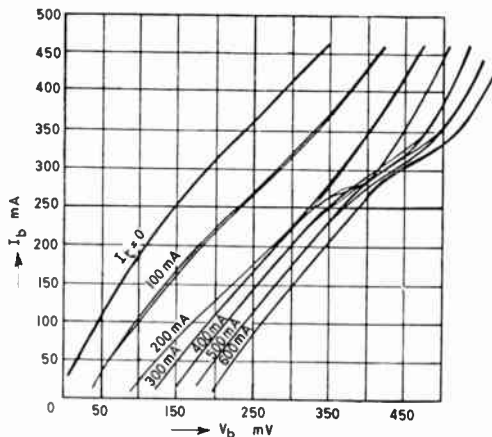

Fig. 15. Diode No. 2,  $I_b, v_b$  characteristics.  $I_b$  in direction of "positive" bias.  $I_t$  in forward biasing steps of 100 mA.

conductor levels. The latter have been reported to have circulator properties.

Both four-terminal device structures are being considered further but results are not yet available.

6. Conclusions

The theoretical and experimental characteristics of a tunnel triode whose structure could really be considered as a double-based tunnel diode are discussed. Its negative resistance between two terminals can be profoundly affected by a bias current flowing between the two terminals of the double-contacted base. Multi-valued current voltage operation is demonstrated for two configurations both theoretically and for experimental devices. Some other possible structures are also discussed.

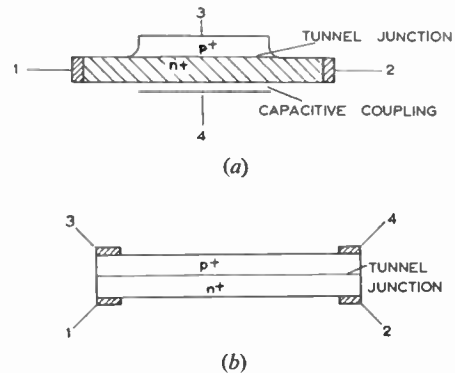

Fig. 16. (a) Terminal 4 capacitively coupled to double contacted base region. Base terminals 1 and 2; output terminals 3 and 4.

(b) Both degenerate regions are double contacted.

7. Acknowledgments

We acknowledge the ready help given by Dr. G. N. Roberts and Dr. J. Przybylski of Standard Telephones and Cables in having these devices made, and Mr. D. G. N. Hunter of Standard Telecommunication Laboratories in making his Stantec Zebra computer facilities available and performing the necessary computations. Finally we acknowledge the permission to publish this paper given by Standard Telecommunication Laboratories Ltd. and Standard Telephones & Cables Ltd.

Manuscript received by the Institution on 14th April, 1961 and in final form on 13th June 1961 (Paper No. 703).

© The British Institution of Radio Engineers, 1962.

# Some Radio Astronomy Techniques

By

R. C. JENNISON, Ph.D.†

*Presented at the Convention on "Radio Techniques and Space Research" in Oxford on 5th-8th July 1961.*

**Summary:** The field of modern radio astronomy is reviewed and particular mention is made of those techniques which have led to advances in other fields of science. Radio telescopes and interferometry are described. Cosmic radio sources are discussed and some suggestions made regarding their nature. Radar echoes from the Moon and planets are mentioned and the paper concludes by discussing radio astronomical techniques in space vehicles.

## 1. Introduction

Radio Astronomy techniques have a triple qualification for consideration at this Convention. Radio Astronomy itself was a fully fledged technique for the investigation of outer space before the first satellites were placed in orbit, and the subject has contributed considerably to our knowledge of the earth's ionosphere, the solar system and interplanetary space. Secondly, radio astronomy instruments, and in particular the big radio telescopes, though envisaged for purer pursuits, found an immediate application in the tracking of satellites and space probes. Finally the radio astronomers themselves have proposed a number of important experiments in space vehicles in order to further their knowledge of their own subject and probably glean advantageous information about the topside of the ionosphere and the conditions in interplanetary space.

## 2. Radio Telescopes and Interferometers

From the earliest days of Radio Astronomy there has been a need for aerials of high gain and high resolving power. The attack on the problem has been twofold. If the requirement is for high sensitivity then a large collecting area is required and this may be achieved with an extended array or with a paraboloid antenna. If the system is required to be fully steerable, then the paraboloid is the simplest solution and has the advantage in versatility of conversion to other frequencies. The Jodrell Bank radio telescope is still the largest instrument in this class, though others are now appearing in various corners of the earth. In particular, the Radio Physics Section of the Australian Commonwealth Scientific and Industrial Research Organization has a 210-ft steerable paraboloid in an advanced state of construction. We look forward to hearing a progress report on this instrument during the Convention.<sup>1</sup>

In many cases the radio astronomer is interested in such a high resolving power that it would be

extremely costly, and often impossible, to achieve this by the construction of a single large aperture. This has led to the development of various large interferometer systems and synthetic methods of constructing fine beamwidths. In this general sphere lie some of the most noteworthy contributions of radio astronomy to radio and physical technology.

The earliest radio interferometers used in radio astronomy were the Cliff interferometer in Sydney and the solar interferometer at Cambridge. These were direct radio analogues of the optical systems known as Lloyd's mirror and the Michelson stellar interferometer (see Fig. 1). Soon a further optical

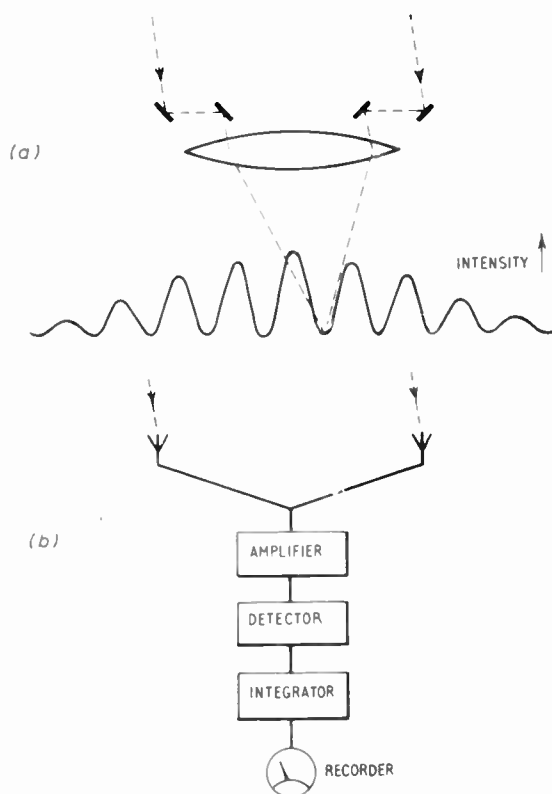

Fig. 1. The optical and radio analogues of the Michelson stellar interferometer.

† Nuffield Radio Astronomy Laboratories, Jodrell Bank.

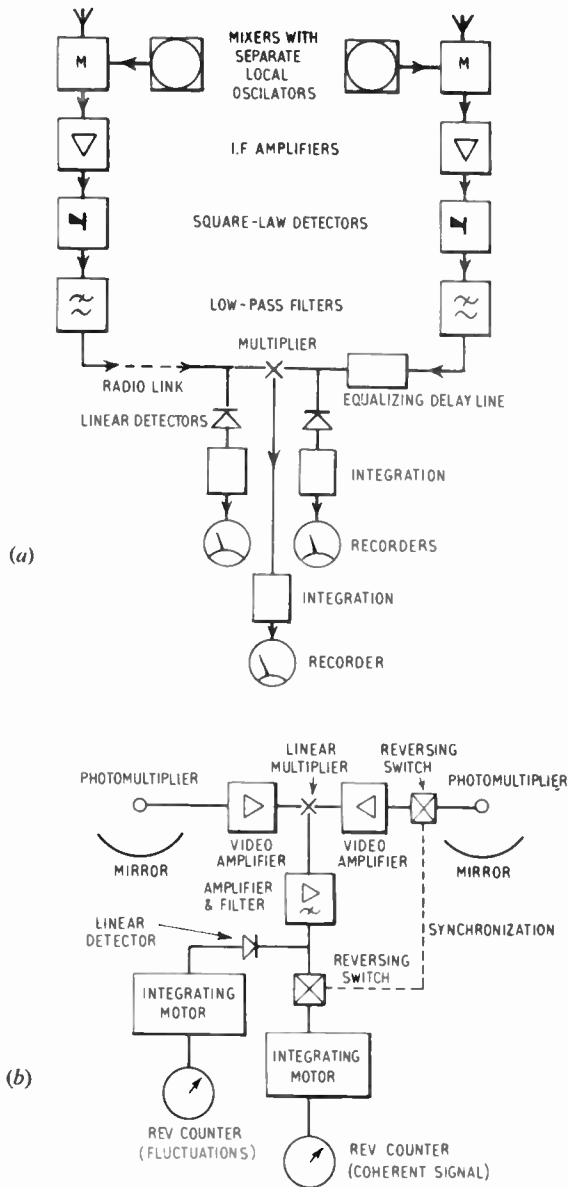

Fig. 6. The intensity interferometer: (a) radio version, (b) optical version. (See, for example, Jennison.<sup>22</sup>)

60 000 wavelengths. At this spacing four radio stars, from a selection of ten under observation, appear to be still unresolved. It would appear that these objects, which probably lie near the limit of the observable universe, have equivalent temperatures exceeding  $10^9$  °K and are considerably more efficient radiators than the colliding galaxies in Cygnus.

In all interferometers the time delays must be equalized and, with the exception of the intensity interferometer, all local oscillators must either be common to both limbs or re-introduced to preserve coherence (Fig. 7).

### 3. Cosmic Radio Transmitters

The study of the mechanisms for the production of radio frequency energy in the cosmic radio sources is itself a vast field which may one day produce important applications in earthbound analogies. Both plasma and synchrotron processes of radiation have been studied and it is likely that mechanisms of the former type may operate in certain solar phenomena whilst in others, and in the distant radio "stars" the latter is a more likely process. Recent results have shown that a large number of the distant radio sources appear to be double. This is not an effect that could be produced by refraction as it is relatively insensitive to frequency, on the other hand the two halves of these double sources appear to be very evenly matched. It is not yet established if these distant radio stars are the spectacle of galaxies in explosion or pairs of galaxies in collision. If the latter is the correct interpretation it may be that two vast systems containing magnetic fields locked into their

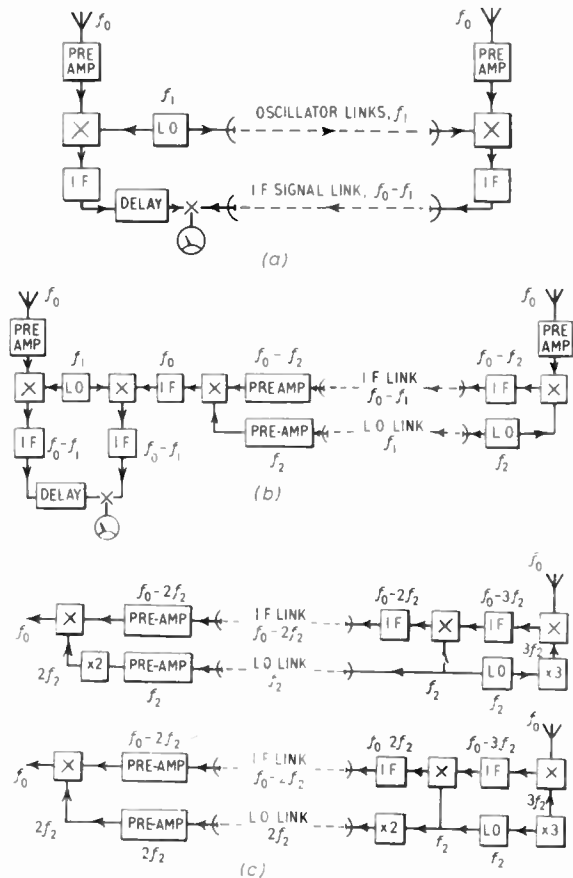

Fig. 7. Typical techniques for preserving coherence in radio link interferometers.

- (a) Simple coherent radio link interferometers.
- (b) Homodyne link interferometer.
- (c) Alternative homodyne links.

gaseous structures, collide with like poles facing. This would result in a compression of the gas between the magnetic lines of force in a very short time scale, and the escape route for the accelerated electrons would be around a ring at the interface where the magnetic field is radial. Electrons escaping in this field would radiate by a synchrotron process to produce two separate bright regions when the toroidal interface is viewed edge on, and a ring distribution from the facial aspect. Figure 8 illustrates the stages in these processes.

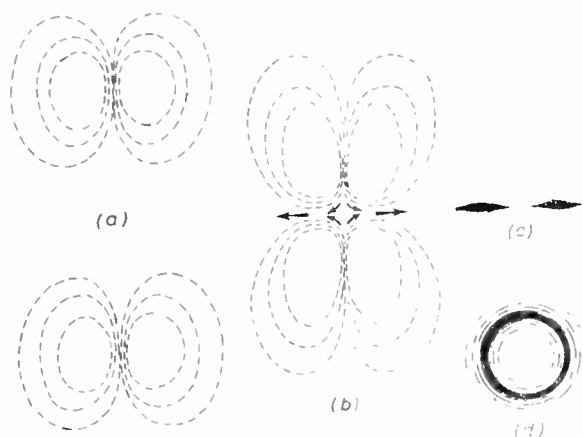

Fig. 8. A possible method for the production of doublets in cosmic radio sources by the collision of two gaseous systems containing magnetic fields.

- (a) The two field systems before collision.
- (b) The intersection of the fields causing acceleration of the electrons in the pinch between the systems.
- (c) The brightness distribution in the plane of the pinch resulting from synchrotron emission of the accelerated particles.
- (d) The brightness distribution normal to the plane of the pinch.

The planet Jupiter has been found to emit intense bursts of radio noise on a narrow band of frequencies around 20 Mc/s. The character of the noise bursts is similar to earth-bound thunderstorms but it is unlikely that Jovian thunderstorms are the true explanation and the origin of this radiation remains an enigma. In addition to this burst-like activity Jupiter also radiates over the range from a few hundred to a few thousand megacycles with a greatly enhanced

noise temperature, much in excess of the true temperature of the planet. It has been suggested that this radiation may come from a system of Van Allen belts around the planet, and it may be that space vehicles will find the answer before the radio astronomers resolve the problem.

The planet Venus also radiates at a somewhat higher temperature than that observed by optical astronomers. The discrepancy is not so marked as in the case of Jupiter and the observed temperature of 600 °K in the millimetre waveband could be a true measurement of the temperature beneath the cloud layer which obscures the planet. In this connection it is worth noting that the presence of oxygen and water vapour in the atmosphere of Venus may be detectable with millimetre spectrometer equipment mounted in a space probe in the vicinity of the planet.

A very useful by-product of radio astronomy which is finding increasing use in the field of radio engineering, is the technique of calibrating the directivity pattern of large aerial systems by using the radiation from one of the small intense radio stars, in particular Cassiopeia A and Cygnus A. Secondly, these radio stars may be used to calibrate the absolute sensitivity or noise factor of a complete equipment including the aerial system, and they provide a rapid check on the operation of large satellite or space probe tracking systems without the need to use auxiliary equipment. These calibrations have been made possible by the accurate measurement of the positions, diameters and intensities of these sources. The relevant details are given in Table 1.

#### 4. Radar Echoes from the Moon and Planets

Early work on radar astronomy paved the way for current communication links via the Moon and passive satellites such as Project *Echo*. It is now relatively simple to communicate from England with the U.S.A. or Australia using the Moon as a passive reflector and a bandwidth of the order of a kilocycle. In the early days the problem of fading of the Moon echoes was troublesome, but it was soon ascertained that the pronounced slow period fading was a result of Faraday rotation in the Earth's ionosphere; the remaining fading is due to lunar

Table 1

Source	Position <sup>4</sup>		Flux Density at 178 Mc/s <sup>3</sup>	Diameter and Structure <sup>5</sup>
	Right Ascension	Declination		
Cassiopeia A	23 h 21 min 10.7 ± 2 s	58° 32.1 ± 1.0'	$1.1 \times 10^{-22}$ W/m <sup>2</sup> /cs <sup>-1</sup>	4 min dia. disc with spur
Cygnus A	19 h 57 min 44.4 ± 1 s	40° 35.0 ± 1.0'	$8.1 \times 10^{-23}$ W/m <sup>2</sup> /cs <sup>-1</sup>	double source approx. 2 min × 20 s

libration producing an apparent "wobble" of the target. The reflection on the Moon is confined to a central bright region more like the reflection from a ball-bearing than that from a matt surface. A large number of low data rate channels could simultaneously use the Moon as a reflector but the periodic disappearance of the object, the fast fading and the propagation delay do not render it ideal as a communication element.<sup>6</sup>

A fascinating new extension of the aperture synthesis technique applied to a radar system was suggested by Ryle and applied to the Jodrell Bank telescope. In this technique, the oscillator must have very high stability so that the phase of the transmitted signal is conserved over a long train of pulses. In the time taken to transmit these pulses the relative positions of the Earth and Moon will have changed and as the flywheel action enables a Fourier synthesis to be performed, we obtain the equivalent aperture of a very large aerial with a correspondingly small beam-width scanning the Moon. Preliminary results with this system have been most successful and it is hoped to combine the technique with accurate ranging in order to map the Moon's surface in detail.

A recent accurate measurement which has marked relevance to the subject of this Convention is the very precise determination of the solar parallax by the accurate ranging of radar echoes from Venus. These measurements, which fix the absolute scale of the solar system, were made concurrently at Jodrell Bank and in Russia and the U.S.A. The Jodrell Bank observations give a figure for the parallax of  $8.7943 \pm 0.0003$  seconds of arc and were reported in *Nature* of May 6th this year.<sup>7</sup> We are fortunate to have reports from our Russian and American colleagues during this Convention.<sup>8, 9</sup>

### 5. Electronic Techniques in Radio Astronomy

This subject of electronic techniques used in radio astronomy is so large and varied that justice could not be done to it within the scope of this paper. Let it suffice to say that the demands that radio astronomers have placed on very low noise factor and high stability systems, have done much to further the development of many present techniques. In particular masers and parametric amplifiers were incorporated in radio telescopes almost from the moment of their conception and radio astronomers have contributed considerably to methods of improving the stability of these systems.

At the opposite end of the power spectrum, the development of planetary techniques has called for the solution of a number of problems in high power long pulse transmission, though the current philosophy in this field is to use c.w. transmission in order to improve the signal-to-noise ratio. The criterion in

this type of radar is the mean power rather than the peak pulse power, as the signals are integrated at the output of the receiver.

### 6. Radio Astronomical Techniques in Space Vehicles

Two parts of the radio frequency spectrum are limited by the earth's ionosphere. The millimetre spectrum, where many interesting spectral bands are situated, is severely restricted by local molecular absorption and it would be rewarding to fly spectrometers in satellites to search for these spectral bands in more distant objects. For the present, the technological difficulties of performing these measurements appear to be prohibitive.

Radio astronomical measurements in the frequency spectrum from 15 Mc/s to 500 kc/s have been difficult to perform from the earth because of the intervention of the ionosphere, which limits the required signals and at the same time introduces considerable terrestrial interference. Artificial earth satellites have now made possible the extension of useful measurements into this part of the spectrum and we shall be hearing a paper by Dr. F. G. Smith on this subject.<sup>10</sup>

Despite the ability of rockets and satellites to surmount the F layer, a number of problems still remain, notably that of obtaining a narrow beam aerial system to enable surveys of high resolution to be performed.

Various interesting interferometer and long wire aerial systems may be conceived in which pairs of satellites, or a single satellite in two sections connected by long cables, may carry the aerial elements, but, as the wavelengths concerned are typically a few hundred metres, it is evident that an aerial system a few kilometres across may be required. This aerial system must either be capable of controlled orientation, or else it must slowly rotate in space whilst its attitude is continuously recorded.

The difficulties of constructing aerial systems of the type described would not warrant their use in space until measurements have been made with more elementary and compact systems. It is therefore of interest to see if use can be made of the environment of the satellite to achieve a high resolution, even if the vehicle is equipped with only a simple dipole. The results of an analysis of this topic will be given by the author in a paper in Session V.<sup>11</sup>

### 7. References

1. E. G. Bowen and H. C. Minnett, "The Australian 210 ft radio telescope", *J.Brit.I.R.E.*, 23, pp. 49-54, January 1962.
2. R. Hanbury Brown and R. Q. Twiss, "A test of a new type of stellar interferometer on Sirius", *Nature*, 178, pp. 1046-8, 10th November 1956.



3. R. Q. Twiss and R. Hanbury Brown, "The question of correlation between photons in coherent beams of light", *Nature*, **179**, pp. 1128-9, 1st June 1957.
4. B. Elsmore, M. Ryle and P. R. R. Leslie, "The positions, flux densities and angular diameter of 64 radio stars observed at a frequency of 178 Mc/s", *Mem. Roy. Astron. Soc.*, **68**, Part II, pp. 61-7, 1959.
5. R. C. Jennison and V. Latham, "The brightness distribution within the radio sources Cygnus A (19N4A) and Cassiopeia A (23N5A)", *Monthly Not. Roy. Astron. Soc.*, **119**, No. 2, pp. 174-83, February 1959.
6. P. A. Webster, "Long distance communication via the Moon", *J. Brit. I.R.E.*, **22**, No. 3, pp. 257-64, September 1961.
7. J. H. Thomson, J. E. B. Ponsonby, G. N. Taylor and R. S. Roger, "A new determination of the solar parallax by means of radar echoes from Venus", *Nature*, **190**, pp. 519-20, 6th May 1961.
8. V. A. Kotelnikov, "Radar contact with Venus", *J. Brit. I.R.E.*, **22**, No. 4, pp. 293-5, October 1961.
9. L. Malling and S. W. Golomb, "Radar measurements of Venus", *J. Brit. I.R.E.*, **22**, No. 4, pp. 297-9, October 1961.
10. F. G. Smith, "Radio astronomy from rockets and satellites", *Brit. I.R.E.* 1961 Convention paper. To be published.
11. R. C. Jennison, "Proposed satellite techniques for performing a high resolution survey of the radio sky at medium wavelengths", *J. Brit. I.R.E.*, **22**, No. 3, pp. 205-8, September 1961.
12. R. C. Jennison, "A phase-sensitive interferometer technique for the measurement of the Fourier transforms of spatial brightness distributions of small angular extent", *Monthly Not. Roy. Astron. Soc.*, **118**, No. 3, pp. 276-84, September 1958.
13. Jodrell Bank Staff "Radio Astronomy". Occasional Notes of Royal Astronomical Society. (R.A.S. London 1954.)
14. A. C. B. Lovell, "Meteor Astronomy". (Clarendon Press, Oxford, 1954.)
15. J. L. Pawsey and R. N. Bracewell, "Radio Astronomy". (Clarendon Press, Oxford, 1955.)
16. R. C. Jennison, "Radio astronomy and the radio amateur", *R.S.G.B. Bulletin*, **31**, pp. 24-6, 63-4, July and August 1955.
17. R. Hanbury Brown and A. C. B. Lovell, "The Exploration of Space by Radio". (Chapman & Hall, London, 1957.)
18. H. C. Van de Hulst (Editor), "Radio Astronomy". I.A.U. Symposium No. 4 (Cambridge University Press, London, 1957.)
19. Radio Astronomy Issue, *Proc. Inst. Radio Engrs*, **46**, p. 1, January 1958.
20. R. D. Davies and H. P. Palmer, "Radio Studies of the Universe". (Routledge and Kegan Paul, London, 1959.)
21. F. Graham Smith, "Radio Astronomy". (Penguin Books, London, 1960.)
22. R. C. Jennison, "Fourier Transforms and Convolutions for the Experimentalist". (Pergamon, London, 1961.)

*Manuscript received by the Institution on 5th July 1961. (Paper No. 704.)*

© The British Institution of Radio Engineers, 1962.

## D.S.I.R. Grants to Universities for Radio Astronomy and Nuclear Research

Grants will be offered towards the cost of building and maintaining two new radio telescopes at Cambridge University and at the Jodrell Bank Station of Manchester University, and a nuclear reactor for research and teaching to be set up in Scotland. This was announced in Parliament just before Christmas recess, as written answers to questions by Lord Hailsham, the Minister for Science, and by Mr. Denzil Freeth, the Parliamentary Secretary. They were replying to questions asking whether a decision had yet been taken in respect of the five major research grants approved in principle by the D.S.I.R. Research Council. Final approval of these projects had to be postponed last summer because the scientific expansion in all fields seemed likely to exceed planned financial resources.

The D.S.I.R. hopes to make an announcement later about the remaining two projects. These would provide two further nuclear reactors, one for London University and the other for Manchester and Liverpool Universities jointly.

The grants now being offered, which represent a total expenditure of £1.2 million, are as follows:

£466,000 to Professor Martin Ryle, F.R.S., Cambridge University, for a triple paraboloidal radio telescope;  
 £236,000 to Professor Sir Bernard Lovell, F.R.S., Manchester University for a fully steerable radio telescope; and  
 £450,000 to the Scottish Universities for a low-energy nuclear reactor.

The Cambridge telescope will consist of two fixed and one rail-mounted paraboloidal aerials each of 52 ft diameter. It will be used to examine the intensity distribution of radio sources in a limited part of the sky with greater sensitivity than is possible with the existing aerial array.

Professor Lovell's new instrument—known as Mark II—will be fully steerable and elliptical in shape with a major axis of 125 ft. It will be used in conjunction with the existing 250 ft telescope at Jodrell Bank, to which it is similar in principle, as an interferometer system to determine the position of astronomical radio sources with greater accuracy. It will also be used for a programme of observations on its own.

## News from the Sections . . .

### East Midland Section

The growth of the electronics industry in the East Midlands over recent years has been accompanied by a corresponding increase in the number of Institution members in the area. Proposals for the establishment of a local section have been put forward by a group of members for the holding of a series of four exploratory meetings in Leicester. The first of these took place on 25th October when Mr. N. B. Griffin, Ph.D. (Associate Member), of Royal Radar Establishment, Malvern, spoke on "Achieving High Reliability in Electronic Equipment". He began by examining the problems facing the equipment designer in choosing components to give the required reliability under arduous conditions. Attention has to be given to ambient temperatures of operation, shock and vibration and components must be selected to meet the requirements set by those conditions. Methods of building, wiring, encapsulation and printed circuitry to increase reliability were discussed. Dr. Griffin concluded by discussing the use of procurement specifications for components.

The second meeting was held on 6th December when Mr. P. James gave a paper on "Transistors in Computers and Control Equipment". By way of introduction he offered a justification for the replacement of the valve by the semiconductor as a circuit element in computer design. Three points were dealt with, namely, the relative reliabilities of the two components, physical size of the final machine and power dissipation in the form of heat.

Mr. James then introduced the basic logical operations of AND, OR and NOT and continued to the practical realization of these operations in specific circuits. Two methods of employing transistors were shown: the transistor was allowed to bottom in the slower speed circuits, but for high-speed working more complicated circuits were used to define the transistor currents more precisely. The future demand for higher speeds of operation implied a need for new techniques in the production of high-speed transistors.

P. G. C.

### North-Western Section

On 2nd November at the College of Science and Technology, Manchester, Mr. A. J. Rees read a paper entitled "V.H.F. Communications Receivers and Transmitters Using Transistors". He first spent some time on describing the development of alloy diffused types, the introduction of which has already proved of considerable significance in the fields of h.f. and v.h.f. communications. Some signal transistors with useful power amplification at frequencies greater than 200 Mc/s and h.f. power transistors are now in quantity production.

Completely transistorized transmitter-receivers, developed primarily for marine distress equipment, show power efficiencies on "transmit" greater than 30% and on "receive" the efficiency is almost that of the audio output stage. A circuit has been developed for frequencies between 1 and 10 Mc/s, which gives 4 watts of r.f. power at 8 Mc/s, and a similar performance is obtained on the marine distress frequency of 2.182 Mc/s. A conventional Class B push-pull output circuit comprises germanium transistors operated in the grounded emitter configuration but attached without insulation to the chassis (thereby earthing the collector) for optimum heat transfer. A similar circuit using large silicon transistors has delivered 100 watts at 5 Mc/s and a further circuit using experimental germanium transistors delivers one watt at 100 Mc/s.

Small signal alloy diffused transistors are used in the receiver section of 160 Mc/s mobile communications equipment and the design is based on a single superhet system using 10.7 Mc/s crystal filter to obtain the required 25 kc/s bandwidth. The choice of circuit and operating point of the mixers and r.f. amplifier stages is made to obtain optimum compromise between gain, noise, blocking cross-modulation and inter-modulation.

F. J. G. P.

### Montreal Section

A meeting was held by the Section on 20th November, at the McConnell Engineering Building, McGill University, at which Mr. W. Barlow spoke on "Some Aspects of Paralleling High Power Broadcast Transmitters". He pointed out that the technique of paralleling complex electronic equipment for greater reliability is becoming increasingly common. It was, however, important that the increased number of components involved should not increase the number of faults occurring since, in the case of commercial broadcast and television stations, off-air time represented a severe loss of revenue.

The television transmitter complex on Mount Royal, Montreal, consists of two sets of parallel transmitters (eight in all) feeding split antenna systems. Maximum reliability is obtained with this system, together with a useful improvement in performance. Mr. Barlow then showed how attention had been paid to the problems of identifying a fault in one-half of a parallel pair at the same time ensuring uninterrupted service with the remaining half. Details of input, phasing, monitoring and fault alarm circuits were given. Because of the paralleled operation, more time was available for servicing, giving economy in test equipment, spares and personnel and it had been found that only six operators were required to man all shifts on the eight transmitters.

K. N. C.

# A Pulse Time Multiplex System for Stereophonic Broadcasting

By

G. D. BROWNE †

*Presented at an Electro-Acoustics Group meeting in London on 23rd November 1960 and subsequently before the South Midlands Section (26th January 1961), the West Midlands Section (22nd March 1961) and the North Eastern Section (8th November 1961).*

**Summary:** A system for v.h.f. broadcasting of stereophonic sound by means of time division multiplex is described. The possibility of adding a third channel is briefly discussed. Encoding, decoding and synchronizing arrangements are shown and results of preliminary measurements are presented.

## 1. Introduction

It has long been an aim to improve the normal monophonic image of broadcast and recorded sound by the development of stereophonic techniques.‡

Initially, true binaural systems were considered but were unacceptable because the listeners needed to wear earphones (corresponding to the two microphones in the studio). However, a major breakthrough occurred when it was appreciated that a very satisfactory stereophonic effect could be established by the use of two or more spaced loud-speakers—placing no more restriction on the comfort and movement of the listener than the television viewer already accepts. Systems of recording and sound reproduction were rapidly developed on this basis and it was found that acceptable results could be achieved using only two horizontally spaced reproducers each with its own microphone and amplifier channel. The B.B.C. already use such a system for experimental broadcasts.

When the question of regular stereophonic broadcasting is considered, the need for duplication of facilities (for the two channels) becomes a major disadvantage on the grounds of receiver complexity and bandwidth conservation. It is also very desirable not to have to broadcast the stereo programme on a separate broadcast channel from that used for the same programme for monophonic listeners. Thus, requirements for compatibility and reverse compatibility must be met, together, for economic reasons, with as small a penalty as possible in complexity in the stereophonic receiver. The performance of a system must also be such that an acceptable fidelity and

signal-to-noise ratio are achieved both monophonically and stereophonically over a service area which is little different from that provided by a normal monophonic system under similar conditions.

Accepting twin-channel facilities, stereophonic transmission comprises two parts, that corresponding to the output of the left-hand microphone, which will be referred to as the A signal, and that from the right-hand microphone which will be called the B signal. Neither of these signals alone will convey all the information, so that in the interests of compatibility a suitable compromise must be established. It is generally agreed that the sum of the two signals, that is, (A+B) is an acceptable monophonic equivalent of a stereophonic source. Thus in any system the (A+B) information (which is sometimes called the M component) must be made available for the monophonic receiver, preferably without the need of switching or modification to the receiver. In the case of stereophonic reception, it is necessary at the receiving end to provide means of separating the A from the B information so that the relevant signals may be routed to their respective loudspeakers. To meet the requirements of reverse compatibility, a stereophonic receiver should be able to accept a monophonic transmission and reproduce it (monophonically, of course), again preferably without switching or other complication at the receiver.

In v.h.f. transmission systems where bandwidth is generally adequate, the (A+B) signal can be used to modulate the principal carrier in the normal manner. If, for stereo purposes, a subtractive combination, i.e. (A-B) can also be independently transmitted a fairly obvious possibility arises. The stereophonic receiver can then separately recover the (A+B) and (A-B) information and by a further process of addition and subtraction finally yield the original signals in the following manner:

$$(A+B) + (A-B) = 2A$$

$$(A+B) - (A-B) = 2B$$

† Mullard Research Laboratories, Redhill, Surrey.

‡ A *stereophonic* system is defined in B.S. 661:1955 "Glossary of Acoustical Terms" as "a sound transmission system in which two or more channels are arranged to give to the listener an impression of the spatial distribution of the sounds". *Monophonic* is not a strictly accurate term for the present system of sound broadcasting but as the often used alternatives—monaural or single channel—are either definitely incorrect or ambiguous, it will be used here.

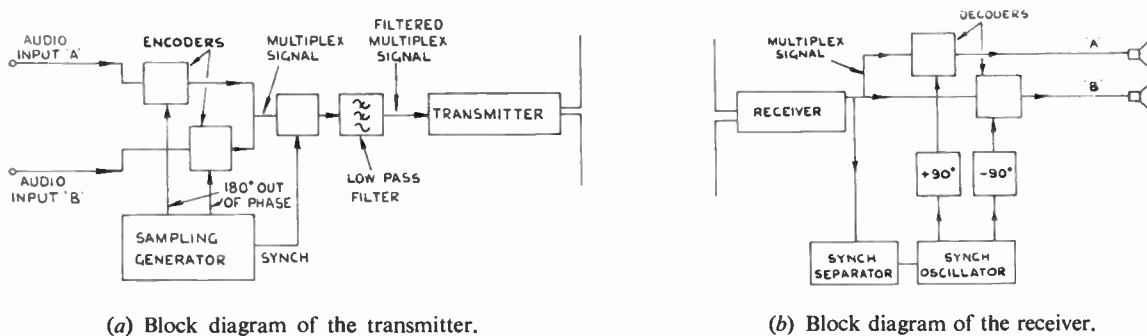

Fig. 1. The Mullard Stereophonic System.

A convenient method of sending the (A – B) information (sometimes called the stereo or S component) is to cause it to modulate a sub-carrier of the order of 50 kc/s and to impress the result on the main carrier. The monophonic receiver will, of course, disregard the sub-carrier information as being outside the audio range, and detect only the sum signal. The stereo receiver, on the other hand, would be provided with circuits for demodulating the sub-carrier to recover (A – B) and for reconstituting A and B.

A number of proposals on these lines have been made, principally in the U.S.A. and Germany, the main points of difference being the manner in which the sub-carrier is modulated.

## 2. The Mullard System

### 2.1. Basic Requirements

The assumed requirements are broadly those discussed in Section 1, i.e. to provide a broadcast service for normal two-signal stereophony comprising the A and B components the sum of which represents the compatible signal. Reverse compatibility must also be realized.

Accepted standards of audio fidelity and bandwidth must be met and any deterioration of signal-to-noise ratio should be kept to a minimum. Possibilities for economic receiver design are important and must be kept constantly in mind. Clearly, also, transmitter modifications, although a prime cost, should be inexpensive and, if possible, simple.

Finally, the radio frequency bandwidth should be no greater than that allocated to normal monophonic transmissions.

### 2.2. Description of the System

The multiplex signal to be radiated comprises a train of unipolar pulses in which, for example, the *even* numbered pulses are amplitude modulated with one of the audio signals. The *odd* numbered pulses are modulated with the other audio signal. A suitable receiver separates the *odd* pulses from the *even*

pulses and routes the information to the respective loudspeakers. Owing to the relatively rapid sampling rate no information is lost and the fact that the information is pulsed is not apparent.

The concept, then, is time division multiplex although it will be seen later that the multiplex bandwidth has been reduced to a logical minimum. It will also be seen that the spectral content of the multiplex signal has much in common with the sub-carrier systems.

## 3. Encoding

For purposes of stereophonic transmission, the audio signals A and B are sampled in turn (Fig. 1), producing two time-interlaced amplitude modulated pulse trains as shown in Figs. 2(a) and 2(b). A simple circuit which illustrates the principle involved is seen in Fig. 3. The sampling generator operating at 32.5 kc/s, provides two anti-phase outputs which are fed to V1 and V2 respectively. The choice of sampling rate is determined by two main factors which are: (i) it must exceed twice the highest audio modulation frequency involved (say 15 kc/s) in order to avoid "difference" tones, and (ii) it should otherwise be as low as possible to conserve bandwidth.

A and B represent suitably pre-emphasized audio information which is applied under class A conditions to the control grids of the two valves, the suppressor grids of which control the anode current in pulse form. Although for pictorial clarity pulses with an angle of flow of about 90 deg. are shown, pulses having longer duration are preferred.

The outputs from V1 and V2 are added (in the common anode load) to provide a waveform as illustrated in Fig. 2(c). Since this signal alone does not contain any information to resolve the A or B ambiguity in a subsequent receiver, it is necessary to provide a suitable reference. Accordingly, a small synchronizing signal at the fundamental sampling frequency, but in phase quadrature with the sampling phase, is introduced. This is seen in Fig. 2(d), which

also shows the effects of bandwidth limitation provided by a suitable low pass filter.

3.1. Practical Encoder

Consideration of the circuit shown in Fig. 3 will make it clear that 100% pulse amplitude modulation is represented by a control grid excursion from cut-off to the onset of grid current. Even with feedback the harmonic distortion is likely to be considerable. A better and preferably more flexible circuit is necessary for practical applications.

Figure 4 shows an experimental encoder which gives very satisfactory results, is sufficiently flexible and has a very low value of distortion. Two anti-phase sampling pulse sources are provided but the circuitry for only one channel is illustrated. The half ECC83 (which is grid current biased) produces pulses whose duration or angle of flow is determined largely by the extent of grid excitation. A "slice" of such pulses is selected by means of the catching diodes EB91. The positive-going limit is determined by the voltage dividing network associated with the lower diode while the mean level of the negative-going limit is set by the other diode and the potential of the cathode of the cathode follower, the grid of which is fed with pre-emphasized audio signals so that negative-

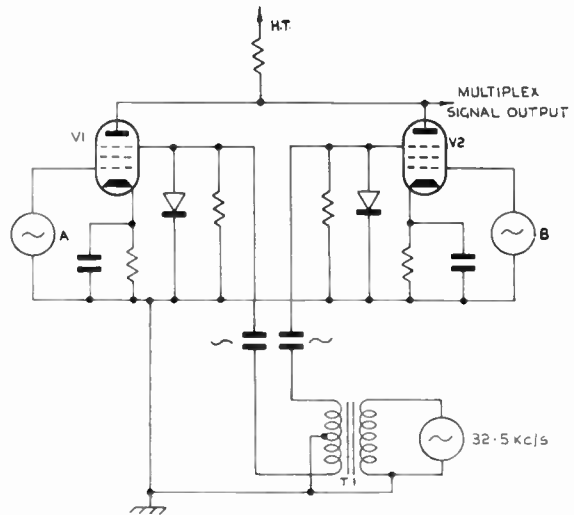

Fig. 3. Simplified circuit of the encoder.

going amplitude modulated pulses are produced at the junction of the two diodes. An exactly similar process occurs on the other channel and the two pulse trains are combined in a double cathode follower shown in the lower part of the diagram. A low-pass filter and means of introducing the synchronizing signal (not shown) are added and the output is then available for direct modulation of the radio transmitter.

4. Radio Transmitter

A normal frequency modulation transmitter capable of giving a deviation of  $\pm 75$  kc/s may be used. Certain modifications would probably have to be made to the modulator to enable it to handle frequencies up to about 80 kc/s. This should be neither expensive nor difficult.

5. Radio Receiver

A normal receiver is used up to and including the output circuit of the frequency discriminator, which is maintained at adequate bandwidth to recover the multiplex signal shown in Fig. 2(d). The negative-going synchronizing pulses are separated (on an amplitude basis) in a suitable circuit and are used to phase lock a local oscillator operating at the multiplexing frequency. The output of the oscillator is re-phased by  $\pm 90$  deg. to obtain the correct in-phase, anti-phase relationship for operating the decoding or gating valves. These are thereby synchronized with the encoders at the transmitter and then reproduce the signals A and B respectively. After de-emphasis these signals are then routed to the two output amplifiers.

In the case where the stereo receiver is receiving a monophonic transmission, no synchronizing pulses are available and the monophonic signal appears in

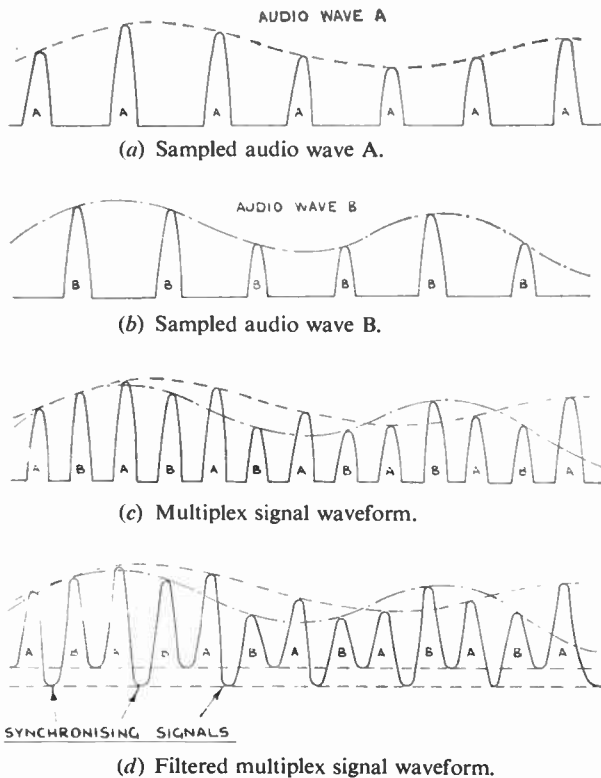

Fig. 2. Waveforms in the stereophonic system.

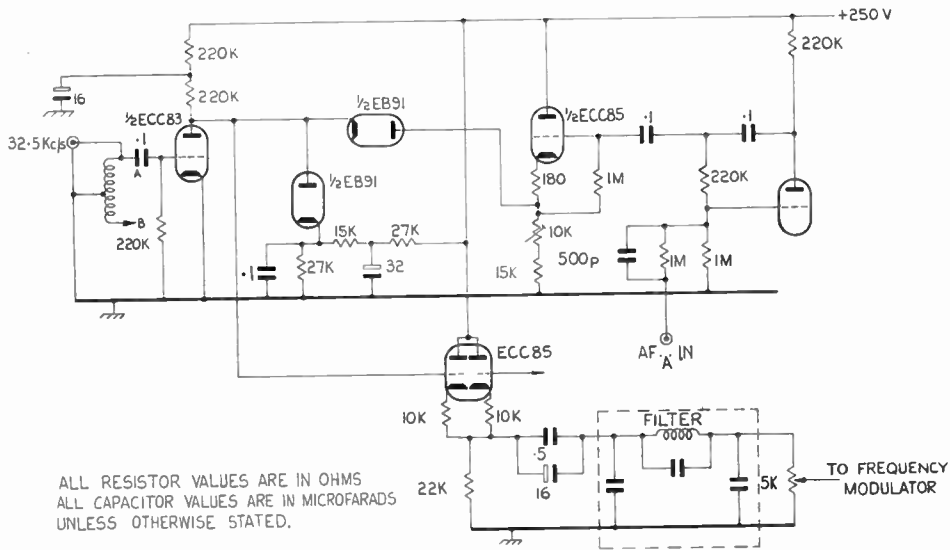

Fig. 4. Circuit diagram of an experimental encoder.

both audio output circuits, irrespective of whether the (decoding) local oscillator free runs or stops under these conditions. If the latter course is adopted an advantage in signal-to-noise ratio is obtained.

5.1. Practical Decoder

A circuit diagram of a decoding arrangement is shown in Fig. 5. The multiplex signal is recovered from the discriminator such that the synchronizing pulses are positive-going. The pentode section of the ECF80 using grid current bias operates as an amplitude discriminating synchronizing separator which excites its tuned anode circuit at the fundamental multiplexing frequency. This output then synchronizes the triode section of the ECF80 working as an oscillator whose in-phase and anti-phase outputs are applied to the suppressor grids of the gating valves EH90. The necessary  $\pm 90$  deg. phase shift occurs in the

synchronizing process. Negative-going amplitude modulated signal pulses are phase inverted in the pentode EF80 and are thus applied positive-going to the control grids of the EH 90s. De-emphasis networks in the anode circuits of these valves not only serve their prime purpose but also attenuate any components at the multiplexing frequency thereby reducing the possibility of overloading subsequent audio amplifiers.

5.2. An Inexpensive Decoder

In order to exploit the economic possibilities of the stereo system, it was thought necessary to give some consideration to the kind of decoder or "adaptor" which might be used in medium or cheaply priced domestic receivers. The circuit diagram of such an arrangement is seen in Fig. 6. Here again the multiplex waveform is recovered with synchronizing pulses

Fig. 5. Circuit diagram of a practical decoder.

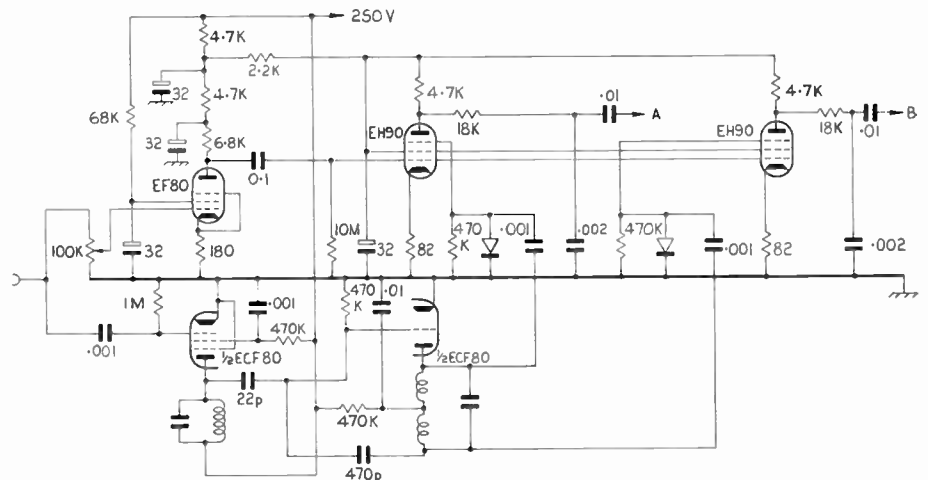

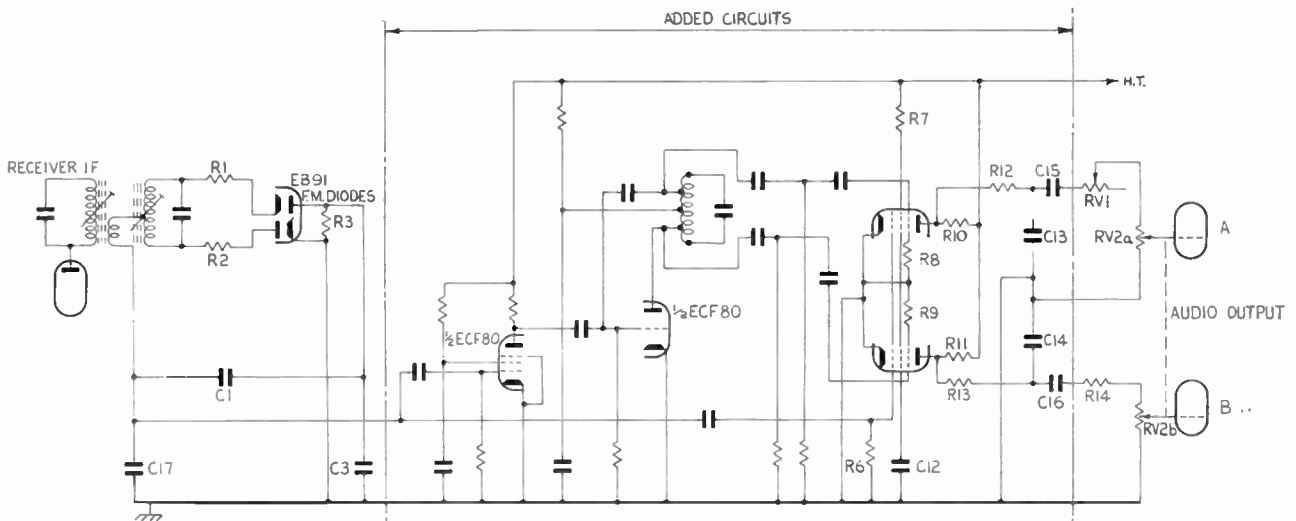

Fig. 6. Circuit diagram of an inexpensive decoder.

in the positive-going direction. These are separated by the pentode section of an ECF80 running to grid current on a short grid base. Amplified synchronizing pulses appear at the anode and are made to synchronize the local oscillator associated with the triode of the ECF80. The necessary phase change of 90 deg. is accomplished by two-stage resistance-capacitance networks. This method was adopted because one stage was, of necessity, already present. The two gating valves are pentodes in a common envelope. It will be noticed that the amplitude modulated signal pulses are fed in a negative-going direction to the control grids of the pentodes but this is not a disadvantage. The total power consumption of such a unit is quite small and should represent only a minor additional drain on the resources, for example, of a stereo radiogram with f.m. tuner. A practical embodiment in the form of an "adaptor" is illustrated in Fig. 7.

### 6. Frequency Spectrum

In view of bandwidth limitations due to radio frequency channel allocations and the currently adopted techniques in typical monophonic receivers, it is necessary to confirm that the system can be operated within these restrictions.

The filtered multiplex waveform (Fig. 8) fed to the frequency modulator of the transmitter has a frequency spectrum consisting of (A+B) at audio frequency, (A-B) double side-band a.m. on a controlled sub-carrier at the sampling frequency, and (A+B) double side-band a.m. on a sub-carrier at the second harmonic of the sampling frequency. There is, in addition, a small steady component at the sampling frequency which represents the synchroniz-

ing information (see Fig. 1). Since audio bandwidth is usually 15 kc/s and the sampling frequency is 32.5 kc/s, the bandwidth required by the multiplex waveform is 80 kc/s.

Those who prefer the analysis of a spectral response to the simple concept of time multiplexing will observe that (A+B) is radiated on the principal carrier thus providing compatibility. For stereo reception the two sub-carriers are demodulated by a re-introduction of a frequency—and phase—locked local oscillator. There are no difficulties in complete synchronization since separation is achieved on an amplitude basis. Furthermore, there is no need

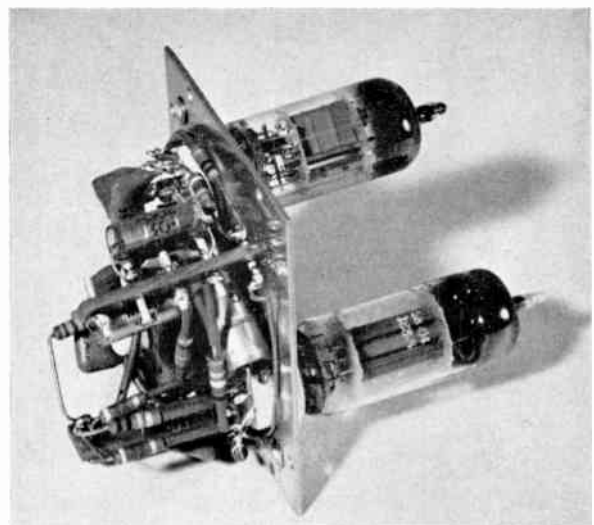

Fig. 7. A practical version of an adaptor for a typical receiver.

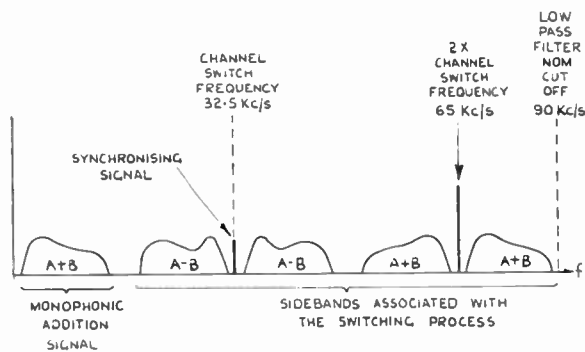

Fig. 8. Frequency spectrum fed to the modulator of the transmitter.

separately to recover  $(A+B)$  and  $(A-B)$ , nor the necessity for any matrixing arrangement. In this system correct recombination is achieved automatically in the simple valve circuits.

Such a modulation spectrum is acceptable in broadcast f.m. transmitters without exceeding the radio frequency bandwidth normally employed, for example, in band II. By retaining a multiplexing signal bandwidth of 80 kc/s, ease of receiver synchronization is achieved without either radiating a special synchronization signal from the transmitter or complicating the receiver by the inclusion of high quality filters.

## 7. Performance

The Mullard System basically provides two, equal, linear, symmetrical and independent paths and therefore is capable of transmitting two-signal stereophony, or bilingual or other two-signal broadcasts, with a performance whose symmetry is limited only by any imperfections in the instrumentation employed. In this connection obviously it would therefore be right to provide the best possible engineering at the transmitter so that the radiated signal would be impeccable. Thus those who have the inclination and resources could avail themselves of the full potentialities of the system. For more usual domestic entertainment it would be possible to achieve a quality of reproduction equal to current standards at a relatively low cost. It is not impossible that many existing stereo radiograms already incorporating an f.m. tuner could be furnished with simple adaptors as for example the unit described in Section 5.2.

To avoid complications in series heater chains it seems likely that a suitable "transistorized" adaptor could be devised.

Most present band II receiver designs would provide adequate i.f. bandwidth for all the necessary components of the transmitted signal to be collected and recovered for decoding without distortion.

## 7.1. Audio Fidelity

### 7.1.1. Frequency response

Audio frequencies in the normal range of 30 c/s to 15 kc/s will be transmitted by the system with a fidelity limited only by instrumental imperfections. An experimental embodiment of the system was set up for general test purposes. Using an aerial input of  $-54$  dB (referred to 1 mW) measurements showed that the audio frequency response was within  $\pm 1$  dB between 30 c/s and 15 kc/s.

### 7.1.2. Non-linear distortion

Measurements were made of second harmonic and third harmonic distortion at various frequencies in the audio band. At 100% pulse amplitude modulation the total harmonic distortion was about 1% but for lower values of modulation depth the figure became proportionally lower.

## 7.2. Cross-talk

Some preliminary calculations and measurements indicate that the cross-talk of the A input into the B output and vice-versa is well below the maximum permissible for stereophonic broadcasting and will also be acceptable for many bilingual and other twin-signal transmissions. More recent work, however, suggests that it may well be possible still further to improve performance in this respect and thus allow the simultaneous radiation of two distinct music programmes. The experimental apparatus used was designed primarily for stereophonic transmission rather than for two-programme purposes. No special precautions were taken, therefore, to reduce cross-talk between channels to an absolute minimum. (For example, "double" valves were used, one half for each channel.) However, a figure of about  $-30$  dB was achieved for the whole audio frequency range for various values of pulse amplitude modulation.

## 7.3. Signal-to-noise Ratio

All communication systems which provide two channels of information where one previously existed must pay some penalty for the added advantage. The price is usually a deterioration of signal-to-noise ratio. The performance of the Mullard system in this respect is of the same order as other systems offering the same facilities. It should be borne in mind that normal v.h.f. f.m. reception conditions are such that in general an excellent signal-to-noise ratio is achieved and its reduction by quite an amount should not be serious. The reduction in service area when using the system in comparable conditions to normal monophonic broadcasting is also expected to be small owing to the character of the improvement threshold in f.m. reception.



7.3.1. Compatible loss

Under conditions of compatibility, that is in circumstances where a monophonic listener is receiving a stereophonic broadcast, there will be a deterioration in signal-to-noise ratio. Clearly, this is because he is not receiving the whole of the transmitted information; in fact, he only accepts the (A + B) audio component. In order to have a suitable reference and to establish the general performance of the transmitter and receiver, measurements were made on a purely monophonic basis. Theoretically the deterioration should amount to about 6 dB and practical measurements confirm this forecast by yielding a result of about this value.

7.3.2. Stereo loss

The deterioration of signal-to-noise ratio on stereophonic transmission and reception will, to an extent, depend on the aerial input level since the overall noise distribution is not, in practice, truly triangular. Measurements were made at three input levels namely, -55 dB, -70 dB and -80 dB with reference to 1 mW and the corresponding deteriorations were 17 dB, 20 dB and 23 dB relative to standard monophony. The theoretical value appears to be approximately 23 dB. Although such deterioration may seem large it must be remembered that in the case of standard monophony the absolute signal-to-noise ratios lie between better than 60 dB and 80 dB for the aerial inputs quoted so that in the all-stereo case the figures will fall between 40 dB and 66 dB. Such signals should be quite acceptable.

7.3.3. Reverse compatibility

The stereophonic receiver will accept, of course, a monophonic transmission and may be operated in either of two conditions. First, it may be left in the stereo condition with the decoding local oscillator running (free) in which case there will be a small deterioration of signal-to-noise ratio due to high frequency noise components being heterodyned into the audio band. Secondly, the oscillator may be switched off thus giving two normal monophonic channels and the resulting signal-to-noise deterioration will be zero.

8. Future Possibilities

8.1. "Storecasting"

In certain parts of the world, notably in the U.S.A., it is a desirable feature of v.h.f. broadcasting systems that there should be the possibility of transmitting a further programme, in addition to the "public" broadcast, on the same radio frequency carrier. The extra programme, which in general need only be of medium quality, is hired on a subscriber basis as background music for shops, restaurants and so on.

This technique, apparently evoking little or no interest in Europe, is popularly known as "storecasting".

To carry this requirement into effect, it is usual to modulate the additional programme on a sub-carrier which, if properly chosen, will not interfere with normal domestic reception. Special receivers can demodulate this sub-carrier and provide the required result. A major difficulty, however, is to place this sub-carrier in the available spectrum. Either it must encroach on, and therefore restrict, the bandwidth allocated for normal purposes, or it must be placed outside the usual band thereby increasing the total bandwidth required.

In the twin-channel stereo system described above and with reference to Fig. 2, it will be seen that the negative-going pulses spaced between the synchronizing signals are "idle". By suitably restricting the amplitude modulation on the normal A and B stereo channels, a small degree of amplitude modulation can be impressed on these otherwise "idle" pulses.

Figures 9 (a) and 9 (b) show positive-going modulated pulses corresponding to the normal A and B signals. Immediately following the B information, negative-going pulses modulated by C information are inserted (Fig. 9 (c)). The three-channel multiplex waveform is seen in Fig. 9 (d). Finally, the complete

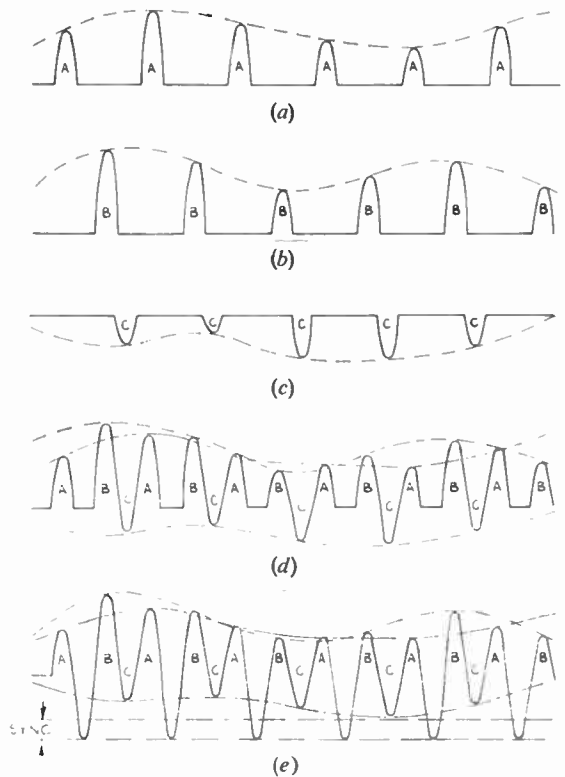

Fig. 9. Illustrating the use of negative-going "idle" pulses to carry a third channel.

multiplex waveform after addition of the synchronising pulses and suitable filtering is shown in Fig. 9 (e). It is this signal that is passed to the modulator of the radio transmitter.

The spectral content of the complete information is seen in Fig. 10. Recovery of this additional modulation could be effected on an amplitude discrimination basis in special "storecast" receivers. Domestic receivers, also operating on an amplitude discrimination basis, would disregard this extra information and function as normal stereo apparatus.

As far as can be seen, little or no additional bandwidth would be required for this new facility. No practical work on this aspect has yet been undertaken.

### 8.2. "Single-channel Techniques"

It is not impossible that decoding (gating) in the stereophonic receiver could be achieved as late as at the speech coils of the two loudspeakers. Although wideband power amplifiers would be required, this technique could lead to attractive developments in "single-channel" stereophonic apparatus for radio, gramophone and tape reproduction.

## 9. Conclusions

- (i) The Mullard stereophonic system operates with fidelity, is fully compatible and reversely compatible.
- (ii) The system provides adequate cross-talk performance for the achievement of excellent stereophonic transmission and of bilingual and most other twin-signal operations.
- (iii) The system has near optimum requirements in regard to transmitter and receiver simplicity and of radio frequency channel occupancy.
- (iv) The deterioration of signal-to-noise ratio is relatively small under conditions of compatible reception, moderate and probably quite acceptable for fully stereophonic conditions. Due to the nature of the improvement threshold in f.m. reception the effective stereophonic to monophonic service area should be nearly the same and the full stereophonic service area only slightly less than for a corresponding standard monophonic broadcasting system.
- (v) If desired, a third channel suitable for "storecasting" may be added.

## 10. Acknowledgments

The author wishes to acknowledge the considerable encouragement received from Messrs. R. M. Godfrey and P. R. Joanes in the development of the system and also the assistance of Mr. R. A. Powell who has carried out much of the experimental work. Thanks are also due to the Director of the Mullard Research Laboratories and the Directors of Mullard Ltd., for permission to publish this paper.

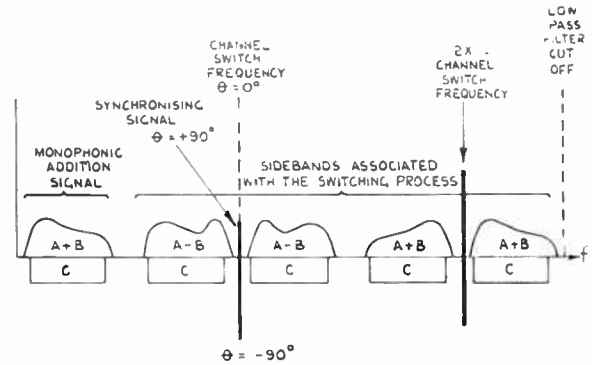

Fig. 10. Frequency spectrum of a "three channel system"

## 11. Appendix: Signal-to-Noise Ratio

The rigorous treatment of the signal-to-noise performance for the Mullard Stereophonic Broadcasting System has been reported by P. R. Joanes.† This appendix gives a simplified explanation.

In any communications system it is necessary to determine—even approximately—its performance with regard to signal-to-noise ratio.

Unless all operating conditions are rigorously specified, detailed calculations tend to be misleading and tedious. With the Mullard Stereo System, as indeed with most others, performance criteria are inter-related. For example, change of encoder conditions affect both "compatible" loss and stereophonic signal-to-noise ratio; the improvement of one may cause deterioration of the other. It is an open question at the moment as to which condition should be optimized.

Bearing this in mind, a very general and simplified attempt is made in the following paragraphs to predict signal-to-noise performance. Transmitter deviation due to synchronizing information has been ignored, and all deteriorations are assessed relative to standard monophonic conditions, i.e., ± 75 kc/s deviation.

### 11.1. Signal-to-noise Ratio with Standard Monophony

It has been shown‡ that the modulation depth of any noise component is given by:

$$(m_n)_x = \left[ \frac{E_n}{E_c} \cdot \frac{f_x}{F_d} \right]$$

where  $(m_n)_x$  = noise modulation depth at output noise frequency  $f_x$

$E_n$  = noise voltage

† P. R. Joanes, "Theoretical Signal-to-Noise Reduction in the Mullard Stereophonic Broadcast System", M.R.L. Tech. Note No. 435, 1960.

‡ K. O. Ainslie, "F.M. versus A.M. Broadcast Reception", M.R.L. Report No. 41, 1949.

- $E_c$  = carrier voltage
- $f_x$  = frequency separation between noise component and the carrier
- $F_d$  = maximum deviation frequency of the system

and its power is:

$$n_x = p \left[ \frac{E_n}{E_c} \cdot \frac{f_x}{F_d} \right]^2$$

where  $p$  is the noise power per unit bandwidth. Taking into account a pre- (and de-) emphasis time constant  $T$  we have

$$n_x = p \left[ \frac{E_n}{E_c} \cdot \frac{f_x}{F_d} \right]^2 \frac{1}{(1 + \alpha^2 f_x^2)}$$

where  $\alpha = 2\pi T$  ( $= 2\pi CR$ )

Hence the noise with a normal receiver, over an audio frequency pass-band up to a frequency  $F_p$  is

$$N_{STD} = 2 \int_0^{F_p} p \left[ \frac{E_n}{E_c} \cdot \frac{f_x}{F_d} \right]^2 \frac{1}{(1 + \alpha^2 f_x^2)} df_x$$

Putting  $T = 50 \times 10^{-6}$ ,  $F_p = 15 \times 10^3$  and

$$F_d = 75 \times 10^3$$

this gives

$$N_{STD} = 19.2q$$

where

$$q = 2p \left( \frac{E_n}{E_c} \right)^2$$

### 11.2. Stereophonic Transmission—Monophonic Reception

In this case it is assumed that the transmitter is operating at 100% p.a.m. on both channels, and is deviated to  $\pm 75$  kc/s. Examination of Fig. 2 (d) will make it clear that, although the pulses are of sine form, the "mark-to-space" ratio is effectively unity. This represents an audio loss of 6 dB, and since the noise remains unchanged, the signal-to-noise deterioration or "compatible" loss is also 6 dB. Measurements confirm this figure.

### 11.3. Stereophonic Transmission—Stereophonic Reception

Considering full stereophonic operation, it is clear that in either channel the audio information pulse is present for one quarter of the total available time. This means a drop of 12 dB in audio level relative to standard monophony.

It is now convenient to consider the increase in noise in one channel. Consider a gating pulse of

square waveform. Such a waveform is equivalent to

$$\frac{1}{2} + \frac{2}{\pi} \left[ \cos \omega_s t - \frac{1}{3} \cos 3\omega_s t + \dots \right]$$

where  $\omega_s$  refers to sampling frequency (32.5 kc/s). Higher order multiples of  $\omega_s t$  need not be considered since they fall outside the i.f. pass band, and it is doubtful if the  $3\omega_s t$  term is of much significance.

The noise spectrum thus becomes

$$(m_n)_x = \frac{1}{2} \left[ \frac{E_n}{E_c} \cdot \frac{f_x}{F_d} \right] + \left[ \frac{E_n}{E_c} \cdot \frac{1}{F_d} \right] \left[ \frac{1}{\pi} (f_x - F_s) \right]$$

Considering noise power in the spectrum up to  $F_p$  we have

$$N = \left[ \frac{E_n}{E_c F_d} \right]^2 \left[ 2 \int_0^{F_p} \left( \frac{1}{2} \right)^2 \cdot \frac{f_x^2}{1 + \alpha^2 f_x^2} \cdot df_x + 2 \int_{-F_p}^{+F_p} \left( \frac{1}{\pi} \right)^2 \left\{ \frac{(F_s + f_x)^2}{1 + \alpha^2 f_x^2} \right\} df_x \right]$$

Evaluating, this gives

$$N = 173q$$

Therefore  $\frac{N}{N_{STD}} = 9$  approximately or 9.5 dB

Since the audio signal will be 12 dB down the deterioration of signal-to-noise ratio for stereo-stereo operation is about 22 dB.

This approximation is closely confirmed in practice.

### 11.4. Monophonic Transmission—Stereophonic Receiver

*Gating oscillator not running.* With the gating oscillator switched off the receiver (as regards either channel) is a normal monophonic receiver so that the signal-to-noise deterioration under these conditions is zero.

*Gating oscillator operating.* The gates will be open for half the available time. This accounts for a loss of audio level of 6 dB. The noise present will be as for stereo operation, i.e. an increase of 10 dB. Thus the deterioration of signal-to-noise ratio in this case is 16 dB. Experimental results gave slightly better figures. However, it is apparent that a marked advantage may be gained by disabling the gating oscillator during monophonic reception.

*Manuscript first received by the Institution on 24th November 1960 and in final form on 16th May 1961 (Paper No. 705).*

© The British Institution of Radio Engineers, 1962.

## APPLICANTS FOR ELECTION AND TRANSFER

As a result of its meeting on 16th January the Membership Committee recommended to the Council the following elections and transfers.

In accordance with a resolution of Council, and in the absence of any objections, the election and transfer of the candidates to the class indicated will be confirmed fourteen days after the date of circulation of this list. Any objections or communications concerning these elections should be addressed to the General Secretary for submission to the Council.

### Transfer from Associate Member to Member

DARBY, Arthur Douglas. *London, W.C.2.*

### Direct Election to Associate Member

ANSARI, Imtiaz Ahmad, M.Sc. *Karachi, Pakistan.*  
 BASU, Lalit Mohan, M.Sc. *Calcutta, India.*  
 BRYANT, Alan Roy. *Feltham, Middlesex.*  
 COWLES, Leonard Edward James. *Hayes, Middlesex.*  
 FOOTT, Douglas Edward. *Woking, Surrey.*  
 GRANT, Brian Eric. B.Sc. *Camberley, Surrey.*  
 HALL, Ronald George. *Liverpool.*  
 HOLTHAM, Peter Victor. *London, E.18.*  
 LAIT, John, M.A.(Cantab). *Faringdon, Berkshire.*  
 MAYNARD, Eric John. *High Wycombe, Buckinghamshire.*  
 VELEY, Lieutenant Commander Victor Frederick Charles, B.A.(Oxon), R.N. *Horndean, Hampshire.*  
 YOUNG, Major Gerald Ian, R.E.M.E. *Malvern Link, Worcestershire.*

### Transfer from Graduate to Associate Member

BEALE, Stanley George. *Stevenage, Hertfordshire.*  
 BURT, Dennis William. *Grays, Essex.*  
 EAGLESTONE, Reginald Fredrick. *Croydon, Surrey.*  
 HALL, Michael William George. *Hemel Hempstead, Hertfordshire.*  
 HUBBLE, Raemond Arthur. *Bromley, Kent.*

### Direct Election to Associate

ACRES, Alan Birt. *Westcliff-on-Sea, Essex.*  
 LEADBITTER, Anthony Charles Frederick. *Hatfield, Hertfordshire.*  
 PROUT, Richard Owen. *Cheltenham, Gloucestershire.*  
 REID, Wing Commander William Dunn, M.B.E., R.A.F. *Maidenhead.*  
 TEMPEST, Kenneth. *Carshalton, Surrey.*  
 WARD, Peter Keith Newman. *Beaconsfield, Buckinghamshire.*

### Transfer from Student to Associate

LOTT, Captain Roger Stuart, R. Sigs. *Singapore.*

### Direct Election to Graduate

ADAMS, William Gordon. *Tadsworth, Surrey.*  
 ANDERSON, Gordon Raymond. *Brighton, Sussex.*  
 BLIGHT, Barry Malcolm. *London, N.W.9.*  
 BRUCE, Stewart Malcolm. *Harrow, Middlesex.*  
 CHANDRA, Suresh, B.Sc., M.Sc. *Allahabad, India.*  
 CONIBEAR, Peter Terence. *Cowplain, Hampshire.*  
 COOPER, Peter David. *Chippenham, Wiltshire.*  
 DODD, Michael Ian. *Ilford, Essex.*  
 DRYSDALE, John Douglas. *Buenos Aires, Argentina.*  
 DYSON, Arthur Frank, Dip.El. *Great Yarmouth, Norfolk.*  
 GINN, Robert Alan. *Manchester.*  
 \*HARKNETT, Maurice Richard. *Southsea, Hampshire.*  
 HORNE, Arthur Philip. *Huddersfield, Yorkshire.*  
 LUDLOW, John Herbert. *Malvern, Worcestershire.*  
 MALTBY, Dennis Hugh. *Crewkerne, Somerset.*  
 PARR, Alan Arthur. *Liverpool.*  
 PITT, David John. *Ronford, Essex.*  
 RAKSHIT, Dilip Kumar, M.Sc. *Calcutta, India.*  
 RUNDLE, William Charles. *London, S.W.15.*  
 RUSSELL, Thomas William. *London, S.W.19.*  
 SMITH, Frank Campiche Jaquard. *London, S.E.9.*  
 SUMANATILAKE, Piyadigamage, S. Dip.El. *Teddington, Middlesex.*  
 TRACEY, Michael Alan. *Staines, Middlesex.*  
 TUCKER, Roger Lewis Raymond. *Rickmansworth, Hertfordshire.*  
 WEISSELBERG, Moshe. *Haifa, Israel.*  
 WHEELER, Peter Frederick. *Chelmsford, Essex.*

### Transfer from Student to Graduate

BARNACLE, John William. *Shenfield, Essex.*  
 FORSEY, Michael. *London, S.W.17.*  
 HARLING, Norman. *Cheltenham, Gloucestershire.*  
 KHANNA, Kanwal Kumar. *New Delhi, India.*  
 LEWIS, Frederick. *Ashford Common, Middlesex.*  
 MOSLEY, John Malcolm. *Feltham, Middlesex.*  
 NEWINGTON, Donald George Alfred. *Southampton, Hampshire.*  
 POULETT, Anthony. *Bognor Regis, Sussex.*  
 WALKER, Mervyn Eric. *Aylesbury, Buckinghamshire.*

## STUDENTSHIP REGISTRATIONS

The following students were registered at the 21st November and 14th December meetings of the Committee. The names of a further 36 students registered at the January meeting will be published later.

GOYAL, Badrinarain, K., B.Sc. (Hons.). *Bombay.*  
 HORWOOD, Peter John. *London, E.12.*  
 JACOB, Easo Mulamootil, B.Sc. *Kerala, India.*  
 JAMES, Vallyaparambil, B.A. *Emakulam, India.*  
 JEEVARATNAM, S. *Brunei Town, Borneo.*  
 JOHNSON, John Edward. *Plymouth, Devon.*  
 KAKERI, Madhukar Mangesh, B.Sc. *Bombay.*  
 KALPAGAM, Venkataraman, Ph.D., M.Sc. *Andhra Pradesh, India.*  
 KAMALESH-KUMAR, T. V. *Bangalore.*  
 KAPOOR, Capt. Bandri N., M.Sc. *Avadh, India.*  
 \*KEYMER, Clifford. *Tilehurst, Berkshire.*  
 KHAN, Hamidur Rahman. *Southampton.*  
 KIRK, David R. *Gorad Valley, Anglesey.*  
 KOTASTHANE, Sham Dinkar. *Bombay.*  
 KRISHNAMOORTHY, K. R. *Bangalore.*  
 KRISHNAN, K. A., B.Sc. *Bangalore.*  
 LAWRENCE, Brian Richard. *Ilford, Essex.*  
 LEVY, Selwyn. *Springs, South Africa.*  
 LIM PECK HOCK. *Singapore.*  
 MAYAR, Manoharan, B.Sc. *Chengannur, India.*  
 MCCONNELL, Bryan. *Reading, Berkshire.*  
 MCGROGAN, Gerard J. *Antrim, Ireland.*  
 MADAN GOPAL, Kansal, B.Sc. *Karnal, India.*  
 MATTA, Sushil, B.Sc. *New Delhi.*  
 MERCER, Royston Arthur. *Southall, Middlesex.*  
 MULTANI, Shamoo G., B.Sc. *Bombay.*  
 NADKARNI, Anant S., M.Sc. *Bihar, India.*  
 NAGABHUSHANA, Hebbale S. *Bangalore.*  
 NAGAPPA, Nanjangud G., B.Sc. *Bangalore.*  
 NAGARAJAN, R. *Bombay.*  
 NARAYANA, Duda, B.Sc. *Visakhapatnam, India.*  
 NAYEEM, M. A., B.Sc. *Hyderabad, India.*  
 NEDUMKUNNEL, Joseph J., B.Sc. *Kottayam Dt., India.*  
 NWAGALAKU, Sidney Onwumere. *Lagos.*  
 OLADOKUN, Dominic Lalekan. *Lagos.*  
 OLIVER, Roger John. *Bedford.*  
 PADMANABHAN, Grodaloor R., B.Sc. *Madras.*  
 PAGE, Mohan Gopalrao, B.Sc. *Bombay.*

PATEL, Damador D., B.E. *London, N.4.*  
 PILLAI, K. P. Vasudevan, B.Sc. *Alwaye, India.*  
 PINCHES, Arthur Roger. *Chelmsford, Essex.*  
 POULETT, Anthony. *Bognor Regis, Sussex.*  
 POWELL, David John. *Bootle, Cumberland.*  
 RAJAMANI, Gopala N., B.E. *Madras.*  
 RAMAMURTHY-IYER, A. *Madras State.*  
 RAMESAN, P. M., B.Sc. *Tripunithura, India.*  
 RANGA RAO, V. K., B.Sc. *Krishna Dist., India.*  
 SETHI, Waryam Singh, B.Sc. *New Delhi.*  
 SHADAKSHARAPPA, G., M.Sc., B.Sc. *Sekondi, Ghana.*  
 SHAKESPEARE, Geoffrey. *Kirkuk, Iraq.*  
 SHARMA, Suraj Prakash. *Meerut City, India.*  
 SHINDE, Vinayakrao B. *Cochin, India.*  
 SIMPSON, George A. *Bracknell, Berkshire.*  
 SMITH, Robert Derrick. *Walton-on-Thames.*  
 SRICHANDRAN, C. K., B.Sc. *Neyveli, India.*  
 SRINIVASAN, K., M.Sc. *Orissa, India.*  
 SRINIVASAN, V., M.A., B.Sc. *Madurai, S. India.*  
 SRIVASTAVA, Harish C., B.Sc. *Bahrach, India.*  
 STANISLAUS, Joseph, B.Sc. *Bangalore.*  
 SUBRAHMANYAM, Patlu S., B.Sc. *Bangalore.*  
 SUBRAMANIAM, R. *Vijayawada, India.*  
 TAMBAY, Aloysius Leo. *Bangalore.*  
 TAN WAH THONG, Dip.El. *Singapore.*  
 THURLOW, Henry Charles C. *Londonderry.*  
 VANAJAKSHI, K., M.Sc., B.Sc. *Bangalore.*  
 VASDEV, Baldev Singh, B.A. *Nairobi.*  
 WARBURTON, Peter Douglas. *Manchester.*  
 WARD, Sgt. Nicholas Peter, B.F.P.O. No. 151.  
 WILSON, David. *Millom, Cumberland.*  
 ZAFARUL, Haq, B.Sc. *Lahore.*  
 ZAMBRANO-PÉREZ, Jose A. *London, S.E. 27.*  
 BEECHAM, Paul Malcolm. *Enfield, Middx.*  
 BENJAMIN, Hermann. *Transvaal, S. Africa.*  
 BOWYER, Benjamin Edward. *Chesterfield.*  
 BRIGGS, Allan. *B.F.P.O. 69.*  
 BROOKE-STEWART, Jeffrey Edward. *Torquay.*

BROWN, Peter James. *Bedford.*  
 BULLOCK, Dennis. *Hull, Yorkshire.*  
 CARPENTER, Brian. *East Croydon.*  
 CHACKAL, Rizk Fathi. *London, N.7.*  
 DARE, Roderick Michael. *Bristol.*  
 DAVIES, David. *Abercynon, Glamorgan.*  
 EZERENDU, Ikwuakolam Silvanus. *Lagos.*  
 GERRARD, Lieut. P. W., REME. *B.F.P.O. 29.*  
 HASAN, Maqsoodul. *Karachi, Pakistan.*  
 HOLMES, John. *Woodford, Cheshire.*  
 HONEY, George William. *Huntingdon.*  
 JOLLY, Keshav Rattan. *Bombay.*  
 KNIGHT, Flying Officer David Richard, R.A.F. *King's Lynn.*  
 LAWRENCE, John Leonard. *London, N.13.*  
 LOURDES, Robert S. B.Sc. *Tanjore, India.*  
 MEADOWCROFT, Alan John. *Reading, Berks.*  
 MELHUISS, Kenneth R. *Thurso, Caithness.*  
 NARAYANA SWAMY, B., B.Sc. *Bangalore.*  
 NILSEN, Kai J. *Vancouver, Canada.*  
 PADMANABHAN, K., B.E., M.Sc. *Madras.*  
 PADIYA, Jugalkishore, B.Sc. *Maharashtra, India.*  
 PRICE, Colin Stewart. *Bexley, Kent.*  
 PUNCH, Richard James. *Norwich, Norfolk.*  
 ROWBOTHAM, Philip Alan. *Reading, Berks.*  
 SAPRA, Lieutenant Ram Kishore, B.A., E.M.E. *Kirkee, India.*  
 SARDUL SINGH, S. *Perak, Malaya.*  
 SIMS, Mervyn D. *Weston-super-Mare.*  
 SUNDARARAJAN, M., B.Sc. *Madras.*  
 SRINIVASACHARY, K., M.Sc., B.Sc. *Bombay.*  
 SRINIVASAN, S., B.Sc. *Madras.*  
 STOTT, Alan Ernest. *Darlington.*  
 \*SWAMY, Kavasseri. *Babina, India.*  
 TAN JOK KEE. *Petaling Jaya, Malaya.*  
 THIRUMALAI, Norton. *London, N.16.*  
 WHEATON, John Edward G. *London, S.W.15.*  
 WHITE, Gordon. *Birmingham.*  
 WEATHERSTONE, Andrew T., B.Sc. *The Hague.*  
 WICHELOW, James Arthur. *Walton-on-Thames.*

\* Reinstatements.

# Rocket Measurements of the Upper Ionosphere by a Radio Propagation Technique

By

S. J. BAUER, Ph.D.†

AND

J. E. JACKSON, B.S., M.S.†

*Presented at the Convention on "Radio Techniques and Space Research" in Oxford on 5th-8th July 1961.*

**Summary:** High altitude measurements of the electron density distribution have been performed well above the F2 peak of the ionosphere by using the two-frequency rocket-borne propagation experiment of Seddon. An example of a measurement of the electron-density profile up to 620 km by means of the c.w. propagation technique is presented, including the inferred scale height and temperature of the upper ionosphere. For the anticipated measurements up to an altitude of one earth radius using the c.w. propagation experiment, the variation of the ionosphere below a vehicle must always be considered in order to arrive at reliable local electron density data. A correction for this time variation can be made by using recorded information on the ordinary and extraordinary propagation modes at two harmonically related frequencies. This correction procedure is briefly outlined.

## 1. Introduction

The rocket-borne c.w. propagation technique for measuring ionospheric electron density introduced by Seddon<sup>1</sup> is based upon the measurement of the dispersive Doppler effect at two harmonically-related frequencies  $f$  and  $6f$ . This Doppler effect is the result of the motion of a rocket-borne transmitter within the ionosphere and can be expressed as a change in the phase path  $P$  of the transmitted radio wave

$$\dot{P} = \frac{2\pi f}{c} \left[ n_R \dot{r} + \int_0^R \frac{dn}{dt} dr \right] \quad \dots\dots(1)$$

where  $f$  is the transmitted frequency,  $c$  is the velocity of light *in vacuo*,  $n_R$  is the refractive index at the rocket which is related to the electron density  $N$  through the Appleton-Hartree formula, and  $\dot{r}$  is the velocity component of the rocket in the ray-direction. The integral term represents the time variation of the refractive index (or electron density) along the ray path. For low altitude flights and nearly vertical rocket firings as was the case in earlier experiments, the latter term is, in general, negligibly small. However, with the extension of the c.w. propagation experiment to higher altitudes and more oblique propagation paths, the integral term must be considered as a correction term to permit arriving at accurate local electron densities.

† Goddard Space Flight Center, National Aeronautics and Space Administration, Greenbelt, Md., U.S.A.



Fig. 1. Payload of the *Argo D-4* sounding rocket with antennas extended. The *Scout* payload will be similar.

order  $H' = 200$  km is obtained. Assuming local thermodynamic equilibrium and the major ionic constituent to be atomic oxygen as measured by satellites, this scale height corresponds to a temperature  $T = 1640^\circ$  K for the altitude region from 350 to 620 km. This is compatible with daytime temperatures derived from satellite density data.<sup>2</sup>

**4. C.W. Propagation Technique for High Altitude Rockets**

For a quiet ionosphere and relatively low altitude flights, the simplified correction procedure described above is adequate. This is not the case for instances when the ionospheric electron density distribution varies rapidly with time, e.g. at sunrise or during ionospheric disturbances. Furthermore, for altitudes well above 1000 km, the integral term in eqn. (2) can assume major importance even for almost vertical firing since the contribution of the time-varying integral term may become comparable in magnitude to the first term representing the local electron density.

In principle, the integral term can be eliminated if simultaneous Doppler and Faraday-rotation measurements are being made, as first suggested by Kelso.<sup>3</sup> For frequencies above 100 Mc/s this procedure is relatively straightforward. For frequencies as low as 12.267 Mc/s which provide a more sensitive measure of the ionospheric electron density, a simple approximation to the Appleton-Hartree formula is not sufficient for an accurate determination of the local electron density. However, with all the quantities measured in the c.w. propagation experiment it is possible to arrive at a solution for the local electron density at the rocket, based on the complete Appleton-Hartree formula and taking into account the effect of a time-varying electron density distribution along the ray path.

The sum ( $\Sigma$ ) and difference ( $\Delta$ ) of the ordinary and extraordinary beat frequencies as defined by the eqn. (2) are given by:

$$\Sigma = \frac{mf}{c} \left[ \mathcal{N}_1 \dot{r} + \int_0^R \frac{d}{dt} \mathcal{N}_1 dr \right] \dots\dots(6)$$

$$\Delta = \frac{mf}{c} \left[ \mathcal{N}_2 \dot{r} + \int_0^R \frac{d}{dt} \mathcal{N}_2 dr \right] \dots\dots(7)$$

were  $\mathcal{N}_1 = (n_o^{(h)} + n_x^{(h)}) - (n_o^{(l)} + n_x^{(l)})$  and  $\mathcal{N}_2 = (n_o^{(l)} - n_x^{(l)}) - (n_o^{(h)} - n_x^{(h)})$

and the other quantities have their previously defined meanings.

The quantities  $\mathcal{N}_1$  and  $\mathcal{N}_2$  are expressed in terms of the refractive indices given by the complete Appleton-Hartree formula. Because of the rather

time consuming computations it is convenient to represent  $\mathcal{N}_1$  and  $\mathcal{N}_2$  graphically as a family of curves using the electron density as the variable and various magnetic field values as parameters.

Setting  $\mathcal{N}_1 = \lambda \mathcal{N}_2$ , where  $\lambda(N, \mathbf{H})$  is a parameter which depends upon the electron density  $N$  and the earth's magnetic field  $\mathbf{H}$ , we can now re-write eqns. (6) and (7) as

$$\lambda \mathcal{N}_2 \dot{r} + \bar{\lambda} \int_0^r \frac{d \mathcal{N}_2}{dt} dr = \frac{c}{mf} \Sigma \dots\dots(6a)$$

$$\mathcal{N}_2 \dot{r} + \int_0^r \frac{d \mathcal{N}_2}{dt} dr = \frac{c}{mf} \Delta \dots\dots(7a)$$

where

$$\bar{\lambda} = \frac{\int_0^r \mathcal{N}_1 dr}{\int_0^r \mathcal{N}_2 dr}$$

and  $\int_0^r \mathcal{N}_1 dr$  and  $\int_0^r \mathcal{N}_2 dr$  can be computed by numerical integration from the complete Appleton-Hartree formula on the basis of an approximate electron density profile, and the known variation of the earth's magnetic field with altitude.

The simultaneous solution of (6a) and (7a) yields

$$\mathcal{N}_2 = \frac{c}{mf} \left[ \frac{\Sigma - \bar{\lambda} \Delta}{(\lambda - \bar{\lambda}) \dot{r}} \right] \dots\dots(8)$$

The local electron density at the rocket can now be determined from  $\mathcal{N}_2$  by means of the complete Appleton-Hartree formula.

It should be noted that the general correction outlined above includes the time variation of the electron density distribution along the ray path due to the geometry of the trajectory, as well as the explicit time variation of the ionosphere. Although in principle the general correction could be applied to rocket flights below 1000 km, such as the one illustrated earlier, the procedure is more complicated because of the additional evaluation of the beat-frequency difference  $\Delta$ , as well as the roll correction. Furthermore, for a quiet ionosphere it does not improve the accuracy of the local electron density above that obtained by means of the relatively simple obliquity correction.

The previous discussion is based on rather idealized conditions. However, with research-rockets, near-vertical firings with zenith angles of 4 deg to 10 deg can be realized. Thus, problems like refraction or path-splitting of the ordinary and extraordinary propagation modes do not become as serious—at least not on the upward leg of the trajectory which is mainly

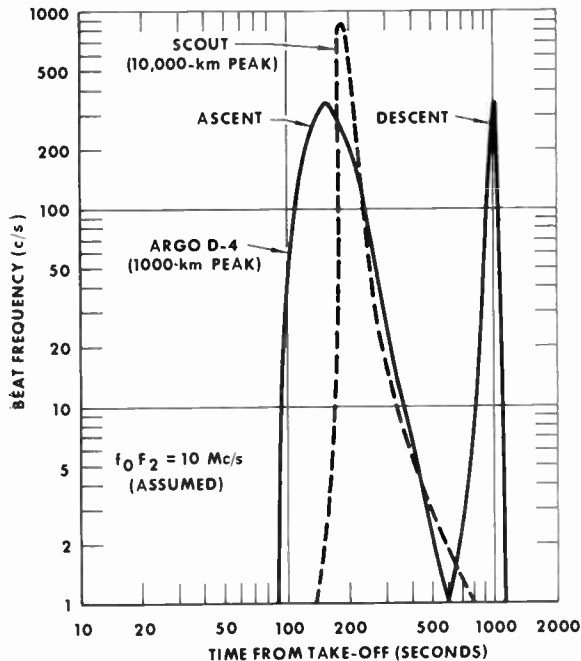

Fig. 5. Expected beat frequency with time.

used for the c.w. propagation experiment—as in satellite propagation work. If the need arises, the more complicated situation can be considered by ray tracing procedures using electronic computers as has been shown for satellite propagation studies.<sup>4</sup> A detailed theoretical discussion of propagation phenomena in a time-varying inhomogeneous ionosphere applicable to rocket and satellite measurements, has recently been given by Kelso.<sup>5</sup>

The upper limit for the propagation experiment is mainly determined by the magnitude of the beat frequency and the applicability of the correction procedure. Theoretically derived beat-frequencies based on estimates of ionospheric structure and vehicle performance for the *Argo D-4* and the *Scout* vehicle are shown in Fig. 5. It can be seen that for the *Scout*, the beat frequency drops to 1 c/s at about 800 seconds after take-off, corresponding to an altitude of about 4000 km. (These values would have to be reduced by a factor of about 4 at the time of minimum solar activity.) However, it is possible to average the readings of beat frequency over longer time intervals, so that it appears feasible to make useful measurements to even greater altitudes. The time period over which the beat notes are read may be of the order of several seconds, corresponding to a height interval small compared to the local scale-height which is of the order of a few hundred kilometres due to the pre-

dominance of the light ionic constituents at altitudes above 1500 km.

The use of the *Scout* vehicle should make it possible to measure with good accuracy the electron density distribution in the uppermost portion of the ionosphere and with reasonable accuracy the electron densities within the protonosphere.

Measurements of the electron density distribution well above the F2 peak of the ionosphere should also permit the determination of other structural parameters of the upper atmosphere such as temperature, and the concentration of light ions ( $\text{He}^+$  and  $\text{H}^+$ ). To make full use of the rocket vehicle, a direct-measurement technique such as an r.f. impedance probe, is included in the payload. The r.f. probe measures electron density on the downward leg where the propagation experiment is handicapped because of the oblique propagation paths. The propagation experiment also provides in-flight calibration on the upward leg for the direct measuring technique, since the r.f. probe at the present time has not yet achieved the degree of measurement accuracy ( $\pm 2\%$ ) which can be realized with the propagation technique under undisturbed conditions.

The c.w. propagation technique, which has in the past proved itself a useful tool for ionospheric research, may also find application in the future exploration of planetary ionospheres.

### 5. Acknowledgments

The instrumentation for the c.w. propagation experiment has been designed by G. H. Spaid and J. R. Hagemeyer. The contributions of J. C. Seddon to the design of the system are gratefully acknowledged.

### 6. References

1. J. C. Seddon, "Propagation measurements in the ionosphere with the aid of rockets", *J. Geophys. Res.*, **58**, pp. 323–35, 1953. (Also published in "Rocket Exploration of the Upper Atmosphere", Pergamon Press, London, 1954.)
2. J. E. Jackson and S. J. Bauer, "Rocket measurement of a daytime electron density profile up to 620 km.", *J. Geophys. Res.*, **66**, pp. 3055–7, 1961.
3. J. M. Kelso, "Electromagnetic Wave Propagation", ed. by M. Desirant and J. L. Michiels (Academic Press, London and New York, 1960.)
4. C. G. Little and R. S. Lawrence, "The use of polarization fading of satellite signals to study the electron content and irregularities in the ionosphere", *J. Res. Nat. Bur. Stand., (Radio Propagation)*, **64D**, pp. 335–46, 1960.
5. J. M. Kelso, "Doppler shifts and Faraday rotation of radio signals in a time-varying, inhomogeneous ionosphere, part II", *J. Geophys. Res.*, **66**, pp. 1107–16, 1961.

Manuscript first received by the Institution on 5th July 1961 and in final form on 6th November 1961. (Paper No. 706.)

© The British Institution of Radio Engineers, 1962

## GRADUATESHIP EXAMINATION—NOVEMBER 1961—PASS LISTS

These lists contain the results of all successful candidates in the November, 1961, Graduateship Examination. A total of 523 candidates entered for the Examination, which was held at seventy-one centres.

### LIST 1: The following candidates have now completed the Graduateship Examination and thus qualify for transfer or election to Graduate or a higher grade of membership.

- AHERN, Brian Henry (S) *Portsmouth, Hants.*  
 ARNETT, Leslie Frederick (S) *Great Malvern, Worcs.*
- BALASUBRAMANIAN, Mallagi Ramanatha (S) *Poona, India.*  
 BANSTEAD, Edward James, *Wickford, Essex.*  
 BIRCHAM, John (S) *Bristol.*  
 BOWMAN, Alan Michael (S) *Dartford, Kent.*
- CALDICOTT, Jack Richard (S) *Coventry, Warwicks.*  
 CHARAN SINGH (S) *Delhi, India.*  
 CHILDE, Percy (S) *Hong Kong.*  
 CHOY, Wai Man (S) *Hong Kong.*  
 CHRISTIE, Stanley (S) *Melbourne, Australia.*  
 CRAMP, Donald Henry (S) *Mitcham, Surrey.*
- DAVIS, John Graham (S) *Bristol.*
- FISHER, Derek, *Harlow, Essex.*
- GOUGH, Kenneth Ernest (S) *Epping, Essex.*  
 GROVES, Arthur Derek George, *Knebworth, Herts.*
- HALE, Peter Edward, *Romford, Essex.*  
 HALL, Ernest Charles (S) *Basildon, Essex.*  
 HARRISON, William (S) *Oldham, Lancs.*  
 HARWOOD, Anthony James (S) *Reading, Berks.*  
 HENDY, Jeffrey Alan James (S) *Southampton, Hants.*  
 HILL, Denis Frank, *Edware, Middlesex.*  
 HUMPHREYS, Humphrey Ioan, *Stevenage, Herts.*
- IYER, Rama Padmanabha (S) *Delhi, India.*
- KEANE, John Richard (S) *Woodley, Berks.*  
 KORB, Hans Arno Fritz (S) *Ennetbaden, Switzerland.*
- McCONNELL, John Frank (S) *Cambridge.*  
 McKISSOCK, James Barr (S) *Catterick Camp, Yorks.*  
 MACLEAN, Alexander Murdo (S) *London, W.5.*  
 MATTHEWS, Hector Macdonald John, *Romford, Essex.*  
 MORGAN, David Sydney (S) *Bristol.*
- NOBLE, Peter John Wellesley, *Reading, Berks.*
- PALMER, Donald Valentine (S) *Winnipeg, Canada.*  
 PEARCE, Thomas Leslie, *Basingstoke, Hants.*
- RICHARDS, David John (S) *Salisbury, S. Rhodesia.*  
 RICHARDS, William Milner (S) *Weston-super-Mare, Somerset.*  
 ROBERTS, Brian Gordon, *Rayleigh, Essex.*
- SEENEY, Gordon William (S) *B.F.P.O. 10.*  
 SHAMBAVI DEVI, Miss P. S. (S) *Delhi, India.*  
 SHILLONG, Leo Andrew (S) *Newark N. J., U.S.A.*
- TAYLOR, Raymond Jack, *Reading, Berks.*  
 TIERNEY, James Clive Cameron (S) *Cambridge.*  
 TIN-TUN, Maung (S) *Rangoon, Burma.*
- VERMEULEN, Adrain Isaac, *Causeway, S. Rhodesia.*
- WATSON, Brian David (S) *Harlow, Essex.*  
 WEISSBERG, Ernest Michael (S) *Ramat Gan, Israel.*  
 WILLIAMS, Paul David (S) *Carlingford, N.S.W., Australia.*  
 WILLIAMS, Trevor, *Fareham, Hants.*  
 WILLIS, Roy Frederick (S) *Totton, Hants.*
- YASIN, Mohammad (S) *Kharian Cantt., Pakistan.*

### LIST 2: The following candidates have now satisfied the requirements of Section A.

- ANN, Rupert Ru-Pern (S) *London, S.W.7.*
- BATTY, Colin Edward (S) *Gosport, Hants.*  
 BENTLEY, John (S) *Stockport, Cheshire.*  
 BERMINGHAM, Alan Patrick (S) *Whitchurch, Salop.*  
 BHALLA, Bawa Guru Pratap Singh (S) *Bangalore, India.*  
 BHATIKAR, Savla Jayakrishna (S) *Goa, India.*  
 BILLINGTON, Paul Stuart (S) *Brunton, Somerset.*  
 BOGHOSSIAN, Garabad Hagop (S) *Stanmore, Middlesex.*  
 BRAHAM, Brenda (S) *London, E.5.*  
 BREACH, Frank Thomas (S) *East Molesey, Surrey.*  
 BURNS, Robert Francis (S) *London, S.E.19.*
- CARR, Philip Ernest (S) *Broxbourne, Herts.*  
 CHAN, Chee Koung (S) *Singapore.*  
 CHAWLA, Hari Mohan (S) *Naya Nangal, India.*  
 CHOO, Mun Ling (S) *Singapore.*  
 CORR, Patrick Joseph (S) *Belfast, N. Ireland.*
- DIVEKAR, Vinayak Rajaram (S) *Goppingen, Germany.*  
 DUNCAN, Alexander Ranbin (S) *Weston-super-Mare, Somerset.*
- EKWELIBE, Michael U. (S) *Lagos, Nigeria.*  
 EZEIBE, Michael Okoli (S) *Lagos, Nigeria.*  
 EZEILO, Godwin Ikechukwu (S) *Lagos, Nigeria.*
- FROST, Robert (S) *Wells, Somerset.*
- GRAVENEY, William (S) *London, S.E.23.*  
 GREEN, John Clifford, *B.F.P.O. 33.*  
 GUNARATNE, Waragoda Galakumbura (S) *Colombo, Ceylon.*
- HARRIS, James, *Surbiton, Surrey.*  
 HARRIS, Jeffery Stuart E. (S) *Chippenham, Wilts.*  
 HUNTINGFORD, Frank (S) *Worcester Park, Surrey.*
- INKPEN, Jack Dennis (S) *H.M.S. Undaunted, London.*  
 ITAMBO, Ani Ukut (S) *Lagos, Nigeria.*  
 IWUCHUKWA, John Chukadibia (S) *Lagos, Nigeria.*
- JAYAN, Narampurath Jalathil (S) *Bombay, India.*  
 JUSTER, Nelu (S) *Tel-Aviv, Israel.*
- KAPTUR, Zenon (S) *London, N.W.4.*  
 KAUL, Mohan Kishen (S) *Delhi, India.*  
 KENNEDY, Charles Ian (S) *Salisbury, S. Rhodesia.*  
 KIGHTLEY, Anthony John, *Northampton.*  
 KOHEN, Dan, *Givatayim, Israel.*  
 KULKARNI, Vilas Mahadeo (S) *Jamnagar, India.*
- LAKSHMINARAYAN, Narayana (S) *Bangalore, India.*  
 LARKIN, Derek Edward (S) *R.A.F. Changi, Singapore.*  
 LEE, John Henry (S) *London, N.7.*  
 LEWIS, John Trewartha (S) *Hayes, Middlesex.*  
 LONGSTAFF, Reginald Edward (S) *Newton Abbot, Devon*
- McGREAL, David Edgar (S) *Winnipeg, Canada.*  
 MARCHANT, Raymond Jack (S) *Southampton, Hants.*  
 MARR, Robert Whyte (S) *Chadwell Heath, Essex.*  
 MILES, Martin James (S) *B.F.P.O. 69.*  
 MORGAN, Hywel Gwyn, *Crawley, Sussex.*
- NAGABHUSHANA, Harnahalli Mylariah (S) *Bangalore, India.*  
 NAIDU, Mahandhata Hannmantu (S) *Srinagar, India.*  
 NDENECHO, Humphrey Asaanchiri (S) *London, S.E.3.*  
 NICHOLAS, Peter Chaston (S) *Cambridge.*  
 NWASOKWA, Joseph C. (S) *Lagos, Nigeria.*
- ONOZIE, Baldwin Onyenaucheya (S) *Lagos, Nigeria.*  
 ONWASIGWE, Michael Enuta (S) *Lagos, Nigeria.*
- PARKINS, Trevor Williams (S) *Birmingham.*  
 PILLAI, Rajagopal (S) *Delhi, India.*  
 PRICE, David Wilfred (S) *Southall, Middlesex.*  
 PURUSHOTHAMAN, M. (S) *Bangalore, India.*
- QUINN, Edward Ronald (S) *Plymouth, Devon.*
- RABINDRAM, Arulam Andram (S) *Bangalore, India.*  
 RAMACHANDRAN, Ramachandran Marimuthu M. (S) *Bangalore.*  
 RIDLEY, Peter (S) *Edinburgh.*  
 RIVERS, Colin Walter (S) *Plymouth, Devon.*  
 ROWE, John Albert (S) *Rochford, Essex.*  
 ROY, Debabrata (S) *Delhi, India.*
- SAKTHIKUMAR, Conjee Yasudeva (S) *Madras, India.*  
 SEAR, Mubarak (S) *London, N.10.*  
 SMITH, Anthony James (S) *Ilford, Essex.*  
 STEDMON, Roy Frank (S) *Harrow, Middlesex.*
- TAM, Shun Kwong (S) *Hong Kong.*  
 THOMPSON, Anthony Ben (S) *Bognor Regis, Sussex.*
- WELSH, Michael William (S) *Bracknell, Berks.*  
 WONG, Yiu Wah (S) *Hong Kong.*
- ZAMBRANO-PEREZ, Jose Alfonso (S) *London, W.2.*

(S) denotes a Registered Student



# The Reduction of Local Radio Interference Caused by H.F. Ionospheric Sounding Equipment

By

V. A. W. HARRISON†

**Summary:** Ionospheric measurements commonly involve the use of high-power pulse-modulated transmissions in the h.f. spectrum and can cause severe interference in nearby receivers. The use of short bursts of pulses instead of continuous transmissions has virtually eliminated interference caused during absorption measurements and the use of horizontal, terminated, folded dipoles with other precautions has minimized interference during vertical incidence soundings.

## 1. Introduction

Ionospheric characteristics such as absorption, critical frequencies and heights of reflection of ionized regions, are generally measured by the technique of vertical incidence sounding. This involves the radiation of short pulses of radio frequency energy vertically upwards over a wide frequency range. Transmissions of this nature, particularly when operated on a routine basis, can cause considerable interference in nearby receivers. The effect is minimized by the use of directive aerials such as vertical rhombics designed to concentrate the main energy upwards, but, even so, a considerable amount of energy is still radiated horizontally.

Such subjective interference was found to be very troublesome at Port Stanley, in the Falkland Islands, where the D.S.I.R. Radio Research Station operates an ionospheric observatory. There, the research programme of ionospheric observations consists of absorption measurements, made manually each day at noon, and ionosonde height-frequency recordings made automatically at hourly intervals throughout the 24 hours or, on occasions of unusual ionospheric activity, at quarter-hourly intervals. The peak power of the transmissions is a few kilowatts.

The resulting interference had a high nuisance value because, at Port Stanley, even domestic receivers rely upon the reception of fairly weak h.f. signals for normal listening. Methods of reducing this interference to acceptable levels were therefore developed and are described here as the techniques used are of a general nature and can be applied at almost any ionospheric observatory where a similar problem exists. The method of reducing interference is different for the absorption and the ionosonde transmissions and the two are therefore treated separately.

†Official communication from D.S.I.R. Radio Research Station, Slough.

## 2. Absorption Transmissions

### 2.1. Measurement Technique

To appreciate the reasons for the technique that was finally adopted it is necessary to explain the basic principles of the absorption measurements that were carried out by the D.S.I.R. station.

The usual D.S.I.R. method of making absorption measurements<sup>1, 2</sup> uses continuous pulse-modulated transmissions and a receiver with wide dynamic range and calibrated gain controls. The ground pulse and ionospheric echoes are displayed on a c.r.t. A-display and the amplitude of the echoes and any succeeding multiple echoes are recorded in terms of the gain setting required to produce a standard deflection on the c.r.t.

Each day, measurements are attempted on 4 or 5 frequencies in the range 2 to 5 Mc/s, where the effect of non-deviative absorption is greatest. From the successful measurements the most probable value of D-region absorption can be estimated each day throughout the year; this is of use to radio engineers for the calculation of the attenuation of radio waves in oblique incidence propagation by way of the ionosphere.

A pulse duration of about 200 microseconds is used and is normally sufficiently long to avoid errors in the measurements arising from ionospheric dispersion. When operating near a critical frequency in the presence of severe group retardation, a pulse-width of up to 500  $\mu$ s may have to be used. Minimization of errors due to short and long period ionospheric fading is effected by taking about 50 observations of the instantaneous amplitude of the echoes on each frequency and by spreading the observations over a period equal to the quasi-period of the fading, which is about 10 minutes at noon.

The sum total of the transmission requirements for a satisfactory series of measurements is that pulse-

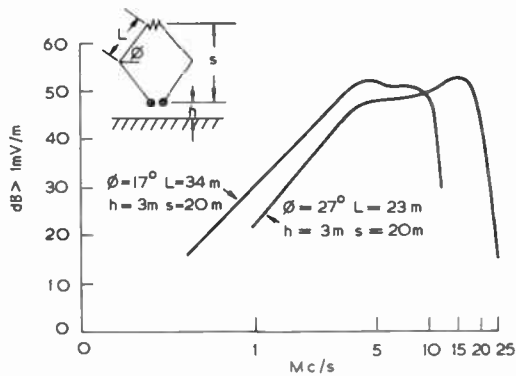

Fig. 2. Vertical rhombic aerial. Field strength at 1 km height with 1 ampere in aerial.

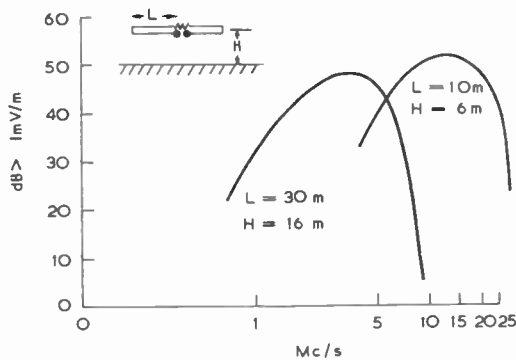

Fig. 3. Terminated folded dipole. Field strength at 1 km height with 1 ampere in aerial.

be required and with  $L = 10$  m and  $H = 6$  m, a frequency range of 5.5 to 25 Mc/s between 10 dB points could be obtained.

The combination of the two aerials would thus cover the frequency range of the ionosonde and the variations in field strength at 1 km above the aerials were calculated as for the rhombic aerials and the results shown in Fig. 3. It can be seen that their performance compares quite favourably with that of the rhombic aerials.

To minimize unwanted re-radiation, a 55-foot wooden lattice mast was used at the centre of the system. The top 12 feet of this mast are free of wire stays and split stays are used to support all masts. The transmitting aerials are terminated in 800-ohm carbon resistors in sealed tubes and fed by coaxial cables. Screened wide-band, balanced-to-unbalanced transformers are used to minimize radiation from the feeders and to match them to both transmitter and aerials. Separate transformers are necessary for the ranges 0.7 to 7 Mc/s and 7 to 25 Mc/s and details of their design are given in Fig. 4. As the ionosonde has

an aperiodic output stage the same type of transformer is used for both aerial and transmitter.

The receiving aerials are also fed by coaxial cables and screened transformers, the design of which has been previously described.<sup>5</sup>

The new aerial system is shown in Fig. 5. Experiments showed that a reduction of about 20 dB in the interference field compared with the rhombic aerials had been realized at short distances from the aerials and this proved sufficient to reduce the subjective effect of the interference in nearby receivers to an acceptably low level.

4. Conclusions

The development of the "intermittent pulse" technique for absorption measurements has virtually eliminated interference to local receivers caused by this work and has, in fact, introduced minor advantages in the control and accuracy of the observations.

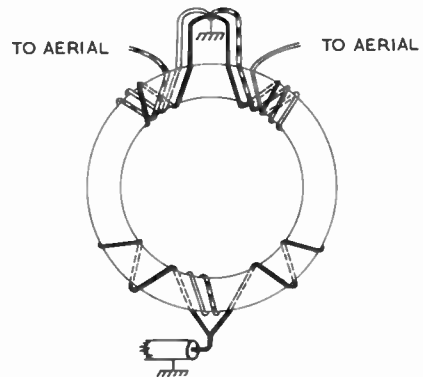
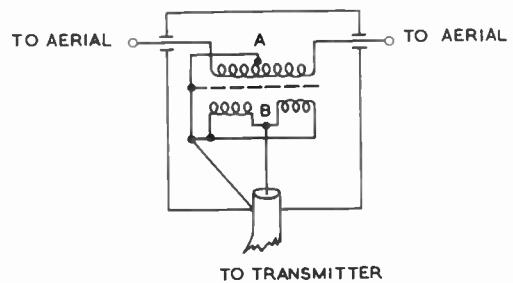

Winding Details.

- 0.7 — 15.0 Mc/s A 60 turns c.t. B 46 turns c.t.
- 15.0 — 25 Mc/s A 28 turns c.t. B 20 turns c.t.
- Wire A 20 s.w.g. enam. B 18
- Core: Two rings S.T.C. Permalloy WP 1008/9. (2.5" o.d., 1.7" i.d., 0.23" high)
- Feeder: Uniradio 1
- All windings in 2 mm polythene sleeving.

Fig. 4. Aerial transformers.

# The Reduction of Local Radio Interference Caused by H.F. Ionospheric Sounding Equipment

By

V. A. W. HARRISON†

**Summary:** Ionospheric measurements commonly involve the use of high-power pulse-modulated transmissions in the h.f. spectrum and can cause severe interference in nearby receivers. The use of short bursts of pulses instead of continuous transmissions has virtually eliminated interference caused during absorption measurements and the use of horizontal, terminated, folded dipoles with other precautions has minimized interference during vertical incidence soundings.

## 1. Introduction

Ionospheric characteristics such as absorption, critical frequencies and heights of reflection of ionized regions, are generally measured by the technique of vertical incidence sounding. This involves the radiation of short pulses of radio frequency energy vertically upwards over a wide frequency range. Transmissions of this nature, particularly when operated on a routine basis, can cause considerable interference in nearby receivers. The effect is minimized by the use of directive aerials such as vertical rhombics designed to concentrate the main energy upwards, but, even so, a considerable amount of energy is still radiated horizontally.

Such subjective interference was found to be very troublesome at Port Stanley, in the Falkland Islands, where the D.S.I.R. Radio Research Station operates an ionospheric observatory. There, the research programme of ionospheric observations consists of absorption measurements, made manually each day at noon, and ionosonde height-frequency recordings made automatically at hourly intervals throughout the 24 hours or, on occasions of unusual ionospheric activity, at quarter-hourly intervals. The peak power of the transmissions is a few kilowatts.

The resulting interference had a high nuisance value because, at Port Stanley, even domestic receivers rely upon the reception of fairly weak h.f. signals for normal listening. Methods of reducing this interference to acceptable levels were therefore developed and are described here as the techniques used are of a general nature and can be applied at almost any ionospheric observatory where a similar problem exists. The method of reducing interference is different for the absorption and the ionosonde transmissions and the two are therefore treated separately.

†Official communication from D.S.I.R. Radio Research Station, Slough.

## 2. Absorption Transmissions

### 2.1. Measurement Technique

To appreciate the reasons for the technique that was finally adopted it is necessary to explain the basic principles of the absorption measurements that were carried out by the D.S.I.R. station.

The usual D.S.I.R. method of making absorption measurements<sup>1, 2</sup> uses continuous pulse-modulated transmissions and a receiver with wide dynamic range and calibrated gain controls. The ground pulse and ionospheric echoes are displayed on a c.r.t. A-display and the amplitude of the echoes and any succeeding multiple echoes are recorded in terms of the gain setting required to produce a standard deflection on the c.r.t.

Each day, measurements are attempted on 4 or 5 frequencies in the range 2 to 5 Mc/s, where the effect of non-deviative absorption is greatest. From the successful measurements the most probable value of D-region absorption can be estimated each day throughout the year; this is of use to radio engineers for the calculation of the attenuation of radio waves in oblique incidence propagation by way of the ionosphere.

A pulse duration of about 200 microseconds is used and is normally sufficiently long to avoid errors in the measurements arising from ionospheric dispersion. When operating near a critical frequency in the presence of severe group retardation, a pulse-width of up to 500  $\mu$ s may have to be used. Minimization of errors due to short and long period ionospheric fading is effected by taking about 50 observations of the instantaneous amplitude of the echoes on each frequency and by spreading the observations over a period equal to the quasi-period of the fading, which is about 10 minutes at noon.

The sum total of the transmission requirements for a satisfactory series of measurements is that pulse-

modulated signals with a pulse-width of 200 to 500  $\mu$ s and a p.r.f. of 50 per second have to be radiated for about 10 minutes on each of 4 to 5 frequencies in the range 2 to 5 Mc/s. As the transmitters used have aperiodic output stages and the aerials are designed for wide-band performance, a considerable proportion of harmonics is also radiated. Thus, at noon at Port Stanley, intense local radio interference amounting at times to complete jamming was caused over a considerable part of the h.f. spectrum for about an hour.

2.2. Intermittent Pulse Method

By altering the method in the manner to be described it was found possible to radiate very short groups of pulses at intervals of about 8 seconds, when their effect on local radio reception became negligible. During the bursts the echoes are displayed on a c.r.t. with a long persistence screen and the amplitudes are scaled directly against a graticule. The impressive reduction in radio interference is accompanied by an increase in accuracy of the measurements, as with the method to be described, 50 observations can be automatically spaced over the period required to minimize errors due to fading effects, and errors due to the inability of an operator to adjust the receiver gain setting rapidly enough to obtain a standard deflection when fast fading is present are also eliminated.

A schematic diagram of a complete absorption equipment is shown in Fig. 1. For the intermittent

pulse method of making absorption measurements a Miller integrator is used to generate pulses which have a repetition frequency of 1 per 8 seconds and a duration, which can be pre-set, of up to 100 milliseconds. These pulses are used to control a gating valve to which a steady 50 c/s a.c. supply is applied. By these means groups of 50 c/s pulses having a group repetition frequency of one per 8 seconds are applied to the modulator of the transmitter. The width of the individual pulses transmitted can be varied in the range 150 to 500  $\mu$ s and, to reduce interference, the number of pulses in each group is reduced to a minimum consistent with the production of a satisfactory c.r.t. display. The Miller integrator may also be switched to generate pulses with a group repetition frequency of 2 per second to give a more "continuous" type of transmission which may be used for a few moments to facilitate accurate tuning of the receiver.

Each operation of the Miller integrator triggers the time-base of the display unit and also generates a pulse of controllable amplitude which is applied as a brightening pulse to the c.r.t. display. The c.r.t. is maintained at a low initial brilliance level and the brilliance modulator triggers only when the transmitter is pulsed.

The ionospheric echoes are displayed on a 12-inch c.r.t. with a green long-persistence screen and appear as vertical deflections against the horizontal time-base; blanking pulses are also applied to the c.r.t. to provide height marks at 25 km intervals along the time-base.

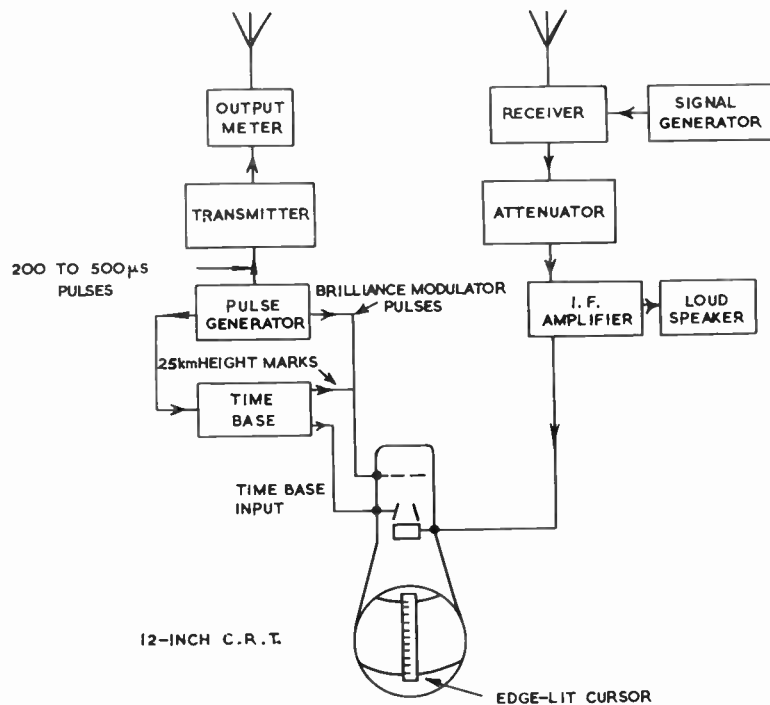

Fig. 1. Block schematic of equipment used for measuring ionospheric absorption.

### 2.2.1. Method of observation

Observations are made in a darkened room using an edge-lit transparent cursor on which is engraved a vertical line and amplitude scale. In use, the cursor is moved horizontally until the cursor line is set to a point on the leading edge of the echo to be measured. The vertical height of reflection is then read from the intersection of the vertical line with the height scale carried by the time-base. The echo amplitude is read against the scale on the cursor.

### 3. Ionosonde Transmissions

The standard equipment at all D.S.I.R. observatories and at a number of other ionospheric research stations is an automatic ionosonde<sup>3</sup> made to the design of the Radio Research Station. The ionosonde sweeps the frequency range 0.7 to 25 Mc/s and the total transmission time for each recording is about 5 minutes; the peak power of the transmitter is 2 kW, the pulse-width about 300  $\mu$ s and the p.r.f. 50 per second. Interference is caused in nearby receivers when the fundamental and harmonics of the transmitter output sweep through the frequency and the image of the frequency to which each receiver is tuned.

The intermittent pulse method described in Section 2 is not suitable for reducing interference from these transmissions since the smaller effective transmission time reduces the resolution of the ionogram below acceptable limits. Two other ways of reducing the interference were therefore considered, namely, to shape the pulses so that fewer side-band frequencies were produced and secondly, to redesign the transmitting aerials so that less ground wave was radiated.

By making the shape of the pulse triangular instead of rectangular, the time for which pulses were heard in a local receiver as the transmitter slowly swept through the frequency range was, in fact, reduced by about two thirds, but the idea was not pursued as the subjective improvement was not found to be very great, and some accuracy of height measurement was lost. Consequently the aerials were redesigned in the following manner.

The conventional aerial system used hitherto<sup>4</sup> for this work consists of four vertical rhombic aerials arranged to form two pairs of transmitting and receiving aerials for the ranges 0.7 to 7 Mc/s and 7 to 25 Mc/s. The transmitting aerials are fed by 600 ohm open-wire feeders and the receiving aerials by coaxial cables and wide-band matching transformers. This system is adequate for the production of satisfactory ionograms but it is capable of causing considerable local radio interference as it radiates an appreciable vertically polarized ground wave which decays approximately linearly with distance from the aerials. Re-radiation from metal masts and stays will also

add to the unwanted field. The horizontal radiation pattern of the vertical component of the electric field varies rapidly in shape with changes in frequency.

To minimize interference to nearby listeners at Port Stanley, a considerable reduction in the ground wave and unwanted re-radiation was required. To avoid the necessity of substantial modifications to the equipment it was also desirable that any new aerial system should have about the same gain and frequency characteristics in the vertical direction as the existing rhombic aerials. The upward radiation from a vertical rhombic aerial can be expressed by:

$$E = \frac{240I \cos \phi}{d} \left[ \frac{\sin^2 \frac{\pi L}{\lambda} (1 - \sin \phi)}{1 - \sin \phi} + \frac{\sin^2 \frac{\pi L}{\lambda} (1 + \sin \phi)}{1 + \sin \phi} \exp j \left\{ \frac{2\pi}{\lambda} (s + 2H) + \pi \right\} \right]$$

volts per metre

where  $d$ ,  $s$ ,  $H$ ,  $L$  and  $\lambda$  are in metres,  $I$  in amperes, and  $\phi$  is the included half-angle of the aerial. The two components of the radiated field in the expression are the field radiated vertically upwards and the field radiated downwards and reflected at the earth's surface.

The calculated variations of field strength with variation in frequency at 1 km above the aerials and with 1 ampere in the aerial are shown in Fig. 2.

The use of an alternative system of horizontal, terminated, folded dipoles which should neither radiate nor respond to vertically polarized ground radiation appeared promising. This type of aerial also has nulls in the end-on position and, at Port Stanley, orientation of the aerials for equal response to the ordinary and extraordinary modes of the ionospherically reflected signals fortunately placed the nulls in positions to reduce further any interference to some of the nearer receivers. In practice the horizontal terminated folded dipole does radiate a small proportion of horizontally polarized ground wave, but this decays rapidly with distance, approximately as an inverse square at short distances from the aerial.

The upward radiation of this type of aerial is expressed by

$$E = 480I \left( \sin \frac{2\pi L}{\lambda} \right) \left( \sin \frac{2\pi H}{\lambda} \right) / d \text{ volts per metre}$$

which, for  $L = 30$  m and  $H = 16$  m, gives an approximate frequency range of 1.4 to 6.5 Mc/s between 10 dB points, and would allow the aerial to be erected in place of the existing larger rhombic aerial. For higher frequencies, a second aerial would

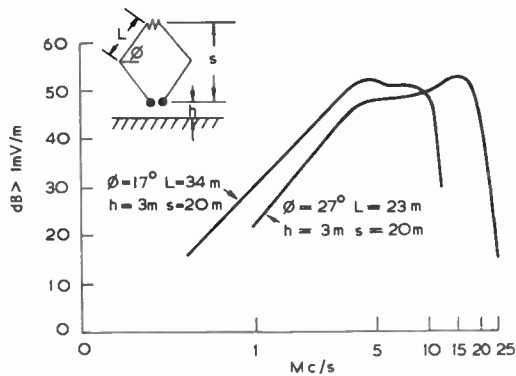

Fig. 2. Vertical rhombic aerial. Field strength at 1 km height with 1 ampere in aerial.

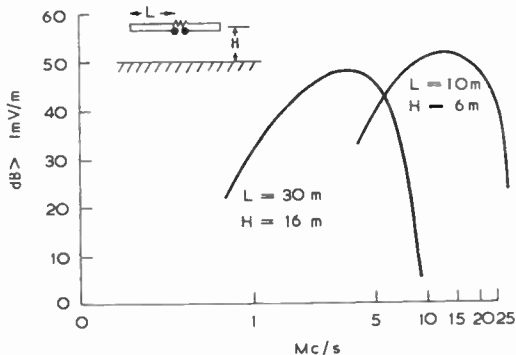

Fig. 3. Terminated folded dipole. Field strength at 1 km height with 1 ampere in aerial.

be required and with  $L = 10$  m and  $H = 6$  m, a frequency range of 5.5 to 25 Mc/s between 10 dB points could be obtained.

The combination of the two aerials would thus cover the frequency range of the ionosonde and the variations in field strength at 1 km above the aerials were calculated as for the rhombic aerials and the results shown in Fig. 3. It can be seen that their performance compares quite favourably with that of the rhombic aerials.

To minimize unwanted re-radiation, a 55-foot wooden lattice mast was used at the centre of the system. The top 12 feet of this mast are free of wire stays and split stays are used to support all masts. The transmitting aerials are terminated in 800-ohm carbon resistors in sealed tubes and fed by coaxial cables. Screened wide-band, balanced-to-unbalanced transformers are used to minimize radiation from the feeders and to match them to both transmitter and aerials. Separate transformers are necessary for the ranges 0.7 to 7 Mc/s and 7 to 25 Mc/s and details of their design are given in Fig. 4. As the ionosonde has

an aperiodic output stage the same type of transformer is used for both aerial and transmitter.

The receiving aerials are also fed by coaxial cables and screened transformers, the design of which has been previously described.<sup>5</sup>

The new aerial system is shown in Fig. 5. Experiments showed that a reduction of about 20 dB in the interference field compared with the rhombic aerials had been realized at short distances from the aerials and this proved sufficient to reduce the subjective effect of the interference in nearby receivers to an acceptably low level.

4. Conclusions

The development of the "intermittent pulse" technique for absorption measurements has virtually eliminated interference to local receivers caused by this work and has, in fact, introduced minor advantages in the control and accuracy of the observations.

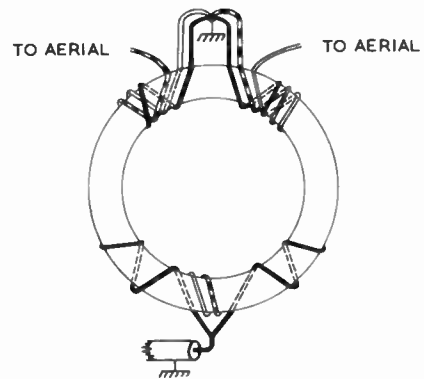
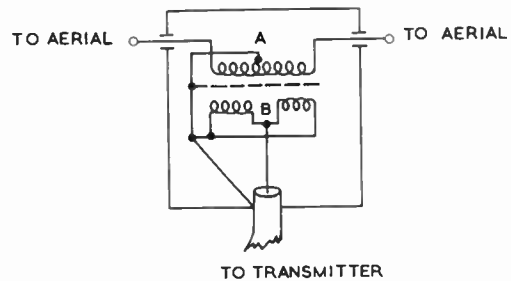

Winding Details.

- 0.7 - 15.0 Mc/s A 60 turns c.t. B 46
- 15.0 - 25 Mc/s A 28 turns c.t. B 20
- Wire A 20 B 18 s.w.g. enam.
- Core: Two rings S.T.C. Permalloy WP 1008/9. (2.5" o.d., 1.7" i.d., 0.23" high)
- Feeder: Uniradio 1
- All windings in 2 mm polythene sleeving.

Fig. 4. Aerial transformers.

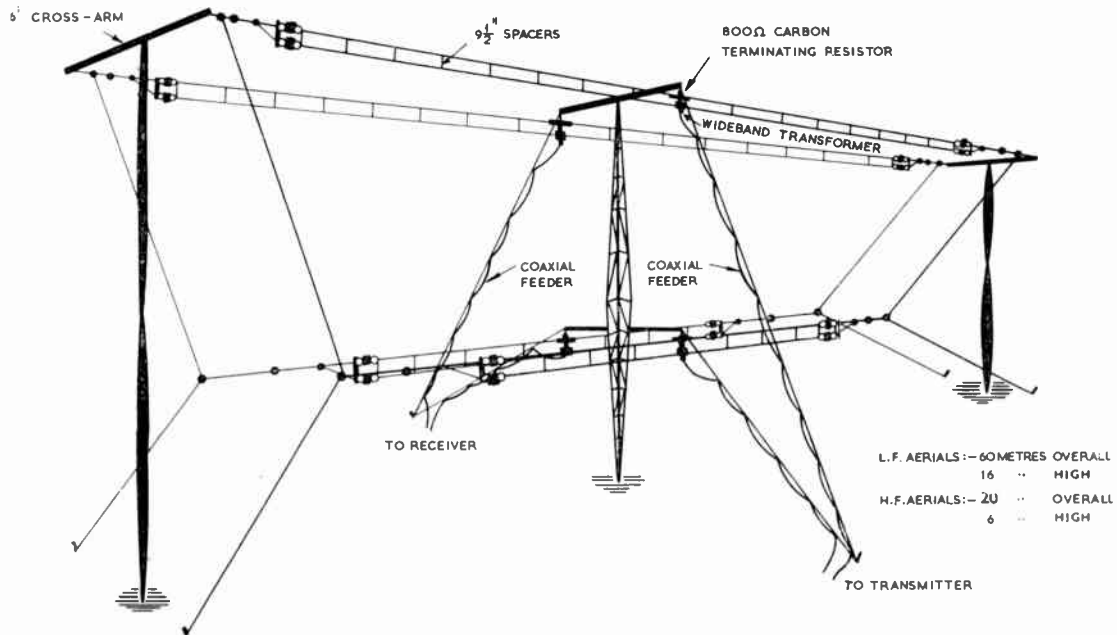

Fig. 5. Aerial system for modified ionosonde transmission.

The new aerial system has also greatly reduced interference caused by the ionosonde transmissions in the Falkland Islands and should enable other ionospheric observatories to be sited closer to built-up areas than might otherwise be possible.

### 5. Acknowledgments

The work described above was carried out as part of the programme of the Radio Research Board. This paper is published by permission of the Director of Radio Research of the Department of Scientific and Industrial Research. The author wishes to acknowledge the assistance of Messrs. R. J. B. Champion and W. Etheridge with the experimental work.

### 6. References

1. W. R. Piggott, "D.S.I.R. ionospheric absorption measuring equipment", *Wireless Engineer*, 32, p. 164, 1955.
2. W. R. Piggott, "The reflection and absorption of radio waves in the ionosphere", *Proc. Instn Elect. Engrs*, 100, Part III, p. 61, 1953.
3. C. Clarke and E. D. R. Shearman, "Automatic ionospheric recorder", *Wireless Engineer*, 30, p. 211, 1953.
4. R. Bailey, "Aperiodic aerials", *Wireless Engineer*, 28, p. 208, 1951.
5. D. Maurice and R. H. Minns, "Very wide-band radio-frequency transformers", *Wireless Engineer*, 24, p. 168, 1947.

Manuscript first received by the Institution on 28th October 1959 and in revised form on 3rd May 1961. (Paper No. 707).

© The British Institution of Radio Engineers 1962

## OBITUARY

The Council has learned with regret of the deaths of the following members:—

**Dr. Charles Cornfield Garrard**, the sixth President of the Institution, was born in London in 1877 and was educated at Finsbury Technical College and the University of Göttingen, Germany. He joined the Instruments Department of Ferranti Ltd. in 1901, and after seven years there joined Hugo Hirst (later Lord Hirst of Witton) at the General Electric Company Ltd. His association with the Company lasted for nearly fifty years.

During his career with the G.E.C., Dr. Garrard was Manager of the Switch Department at Salford and then of the main Switchgear and Transformer Works. It was, however, the development of the Telephone Works at Coventry, on which he had been consulted, that aroused his great interest in radio, and particularly the formation of the Institution in 1925. He sought membership in 1932 “. . . in order to assist in your work and demonstrate my hope that it will develop into one of our more important Institutions”. He was the first Chairman of the Midlands Section and was elected to the Council in 1937. He became a Vice-President in 1939 and was elected President in September 1941.

Dr. Garrard was particularly interested in establishing the true objects of the Institution, and in his

Presidential Address† he stressed the contributions which individual members should endeavour to make toward the advancement of the science and technology of radio engineering. It is interesting to note now one particular sentence from his Address: “True knowledge and its beneficent application can lead us to the stars.” He also recalled some interesting details about the early work of pioneers in radio communication, including the Russian scientists, Popov and Rybkin. His references to the possibilities of applying radio techniques to medicine were another instance of his forward looking approach.

Although Dr. Garrard's own professional work became concentrated in the field of electrical engineering, he maintained a lively interest in the welfare and policy of the Institution right up to the time of his retirement from active work in 1956. His advocacy of the purpose and need of the Institution was most valuable in the early days of its history. Many senior members will recall with affection not only the unfailing courtesy of Dr. Garrard in his personal contacts, but his ability to pass on the enthusiasm which he so obviously felt for the work of the Institution.

Dr. Garrard died in September 1961 at the age of 84 years.  
G. D. C.

The death occurred on 28th September last of **Charles Clayton Breakell**. Born in Preston in 1898, he was trained in Manchester as a dental surgeon and subsequently practised in Preston. From his student days he had taken a lively and active interest in radio and in World War II he was commissioned in the Royal Navy as a radar officer, eventually rising to the rank of Lieutenant-Commander. His appointments included that of officer in charge of technical training in H.M.S. *Valkyrie* and senior radar officer on the staffs of H.M. Signal School and later of H.M.S. *Collingwood*.

On being invalided out of the Navy Mr. Breakell returned to dental practice and was appointed full time Dental Officer at the Whittingham and Lancaster Moor Mental Hospitals, near Preston. His interests now turned to the application of electronics to medicine and in particular electro-encephalography. He constructed the Whittingham Hospital's first electro-encephalograph at a time when the techniques were still in the experimental stages, and this equipment was used to observe the brain patterns of mental disorders such as epilepsy. Mr. Breakell also designed a portable radio-electrophysiologram, which could

be worn by the subject during normal activity and while performing special tasks; this apparatus was described in the *Lancet* of 27th June 1953. He was elected an Associate Member of the Institution in 1946. Mr. Breakell suffered a breakdown in health in 1954 and subsequently retired from practice. He leaves a widow and a daughter.

**Sidney George Parnell**, who was born in 1910, was admitted to the Institution as an Associate Member in 1941. He first taught science at Raunds Senior School, Northamptonshire, and subsequently lectured on Radio at Wellingborough Technical Institute. During the war he gave instruction to R.A.F. units at Leicester College of Technology in radio and radar.

After the war he started a small manufacturing company in Raunds but from 1955 he suffered continuously from ill health and in 1957 had a severe heart attack. A recurrence of this condition in 1960 necessitated his giving up his business. He later returned to work for a short time but died in June last year.

† *J. Brit. I.R.E.*, 2, No. 3, pp. 67-71, September 1941.



# Microwave Thickness Measurement of Dielectric Materials

By

D. WHISTLECROFT, B.Sc.†

Presented at the South Western Section's Convention on "Aviation Electronics and its Industrial Applications" in Bristol on 7th-8th October, 1961.

**Summary:** This paper describes a mechanism which is sensitive to changes in electrical thickness of dielectric materials in the microwave region. The first part of the paper indicates qualitatively how the phase change produced by a radome affects its performance. The relevant properties of a waveguide hybrid-T junction are then briefly described with its application to the sensing head. The sensing head is then described and its performance discussed. A method of controlling electrical thickness using this device, as well as observing it, is finally mentioned.

## 1. Introduction

A radome is required when it is necessary to protect a radar or communication system from its environment while the system is in operation. For ground systems weather protection is needed, while in missile or aircraft systems protection is needed against the conditions produced by the movement through the air. In the case of a space station the isolation would be due to the pressure difference. Since the system is required by definition to operate through the radome, an electrical transparency condition is imposed as well as a structural one. The transparency condition is two-fold. Firstly, the power transfer through the radome must be a maximum so that the range decrease is a minimum. Secondly, the change in the apparent direction of the object viewed by the system must be a minimum. The second condition would not normally apply to a communication system, but it is important in any direction finding device. It will be shown qualitatively that both these conditions depend on the phase change produced by the radome on the radiation passing through it. Therefore the important electrical parameters of a radome are its insertion phase difference (i.p.d.) and the electrical thickness as a function of its shape.‡ A method of measuring variations in these quantities, and of controlling them during manufacture will also be described.

## 2. Importance of Electrical Thickness

Figure 1 (a) shows a beam of radiation incident at angle  $i$  on a homogeneous slab of material of dielectric constant  $k$  and negligible loss. The thickness of the

slab is  $d$  and the wavelength of the radiation  $\lambda$ . The phase difference between the ray reflected from the front surface and that reflected from the back surface is

$$\pi + \frac{4\pi d}{\lambda} \sqrt{(k - \sin^2 i)}$$

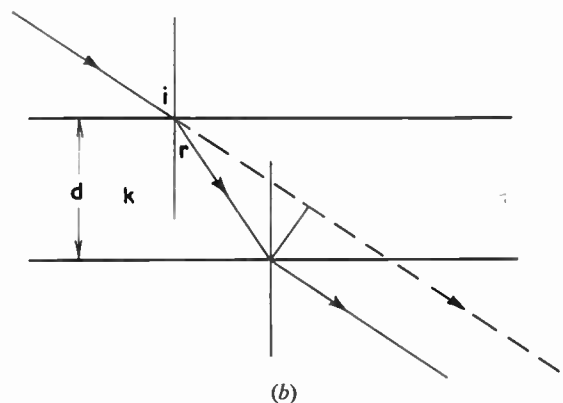
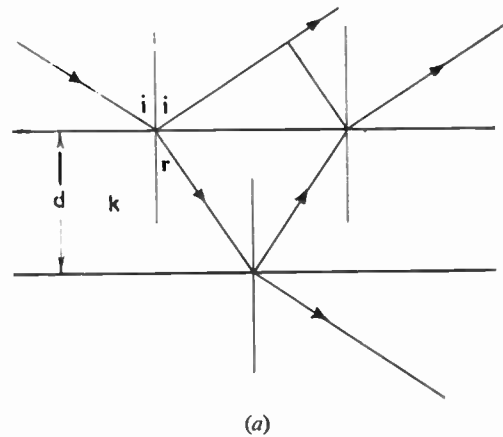

Fig. 1. Illustrating the reflection of a beam of radiation on a homogeneous slab of material.

† Bristol Aircraft Ltd., G. W. Engineering Dept., Bristol.

‡ I.p.d. is the difference in phase in the presence and absence of the radome sample. Electrical thickness is the phase change produced by the radome.

For maximum power transfer this phase difference is  $\pi$  or  $\lambda/2$  and therefore depends on  $d\sqrt{k}$  and  $i$ .

Figure 1 (b) shows the same state as in Fig. 1 but we now consider the phase difference between the radiation in the absence of the slab and that with it. This is given by

$$\frac{2\pi d}{\lambda} \left[ \sqrt{(k - \sin^2 i)} - \cos i \right]$$

This again is a function of  $d\sqrt{k}$  and the angle of incidence.

We now consider the effect of these phase changes on a direction indicating aerial. Figure 2 (a) shows a beam of radiation incident normally on an aerial aperture. (The aerial is shown as a paraboloid for simplicity.) The wave-fronts of the radiation are in the plane of the aperture and hence will converge in phase at the focus, by definition. The aerial can thus be said to be looking at the object, or source of the radiation. In Fig. 2 (b) a uniform parallel dielectric slab has been placed in the path of the radiation. There will be some loss due to the presence of this slab and the radiation will be delayed in phase. Because of the constancy of  $d$  and  $i$  across the aerial aperture this delay will be constant across the aperture and the aerial will still be looking at the object. In Fig. 2 (c)  $d\sqrt{k}$  is varied—this is shown as a variation in  $d$  but it could equally well be a variation in  $k$ . In Fig. 2 (d)  $i$  is varied. In both these cases the transmission loss and phase delay will not be constant over the paraboloid aperture. The phase delay will in the cases shown be greater over the right-hand side of the paraboloid. The effect therefore is to change the apparent direction of the radiation and in these cases the aerial would have to rotate in an anti-clockwise

direction to continue looking at the object, i.e. to keep the plane of the aerial in the plane of the radiation wavefronts. It is obvious that the total effect is a compound of the amplitude and phase distribution which makes this simple approach difficult to use as a design method. What is indicated however is that the aberration (defined as the angle through which the paraboloid must turn to continue looking at the object) and the loss are dependent on the i.p.d. and electrical thickness.

### 3. Application of Radomes

Most radomes must work with the paraboloid looking through various parts of the radome and the situations met can be considered as a sequence of the conditions shown in Figs. 2 (c) and (d) or a combination of both. Radome design becomes then a problem of relating angle of incidence, which is a function of the shape of the radome, to electrical thickness. From symmetry considerations it is obvious that the ideal arrangement is a spherical radome with an aerial at its centre. However as long as the aerial aperture is comparable with the radome diameter even this arrangement has finite loss and aberration. In general the shape of the radome in missile and aircraft work is determined by aerodynamic and structural considerations and is not generally spherical. Hence radome design consists (neglecting tuning ring techniques and electrical manipulation of the radome material) of choosing an electrical thickness distribution for the shape of radome. This design is done empirically using equipments which measure loss and aberration as a function of angle of look of paraboloid to radome. For efficient design however the process requires a method of measuring, and if possible controlling,

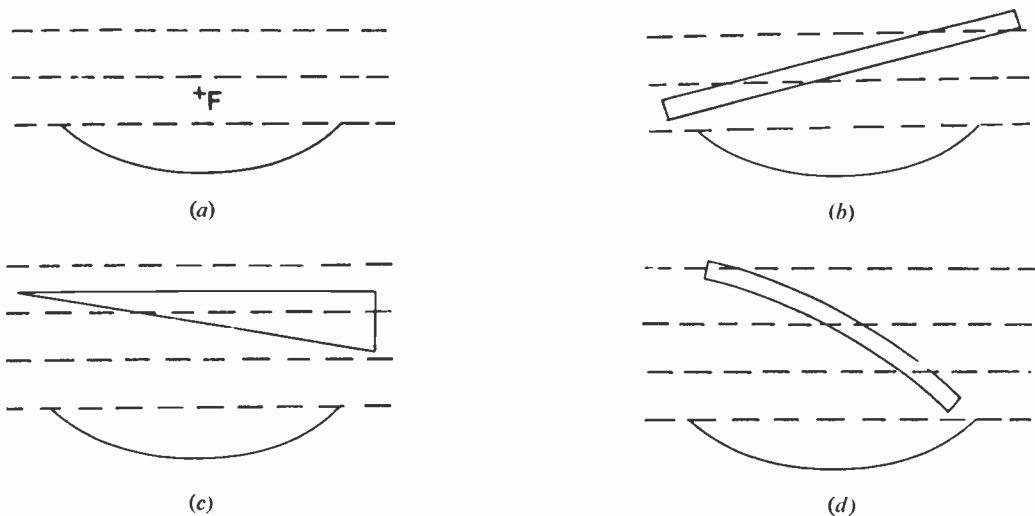

Fig. 2. The effect of phase changes on a direction indicating aerial.

electrical thickness. If  $k$  is known it is sufficient to measure  $d$  but with glass laminates the dielectric constant is difficult to control and varies over the radome. It was therefore decided to design a machine which would be sensitive to electrical thickness and, as a further development, control it. The basis of the system was chosen to be the hybrid or magic T.

4. The Magic T

As the problem is essentially one of phase measurement, the use of the hybrid or magic T was decided upon. The waveguide magic T consists of a combination of E plane junction (Fig. 3 (a)) and H plane junction (Fig. 3 (b)). The E plane junction has the property that power fed into arm 1 splits equally in arms 2 and 3 but in opposite phase. In reverse, power fed in arms 2 and 3 subtracts in arm 1. In the H plane junction power in arm 1 splits in phase in arms 2 and 3 and power in arms 2 and 3 adds in arm 1. When these are combined and the junction is tuned there results the hybrid T (Fig. 3 (c)). Its properties are as follows: equi-phase waves are set up in branches 1 and 2 by a wave in the H branch and opposite phase waves by a wave in the E branch. There is no coupling between the E and H branches. Therefore waves incident on arms 1 and 2 will add in the H arm and subtract in the E arm. Consider now the case when arms 1 and 2 are terminated so that the reflection coefficients viewed from the junction are  $\rho_1$  and  $\rho_2$ . These are in general complex:

$$\rho_1 = a + j b$$

and

$$\rho_2 = c + j d$$

Suppose now that a signal is fed into the E arm of the magic T, then: reflection coefficient in E arm is

$$\rho_E = \rho_1 + \rho_2$$

transmission coefficient to H arm is

$$\tau_{EH} = \rho_1 - \rho_2$$

The junction imperfections are ignored for the sake of clarity.

If  $\rho_1 = \rho_2$  which is the condition where the amplitude reflection coefficients are equal but the phases on reflection differ by  $\pi/2$  in the two cases then:

reflected wave from E arm = (i) =  $(jc - d) + (c + jd)$   
 $= c - d + j(c + d)$

transmitted wave from H arm = (ii) =  $(jc - d) - (c + jd)$   
 $= -(c + d) + j(c - d)$

reflected power in E arm = (i)<sup>2</sup> =  $(c - d)^2 + (c + d)^2$

transmitted power in H arm = (ii)<sup>2</sup> =  $(c + d)^2 + (c - d)^2$

which are equal.

It is in this condition that the magic T is operated in the sensing head with the signals arriving at the junction from arms (1) and (2)  $\pi/2$  out of phase.

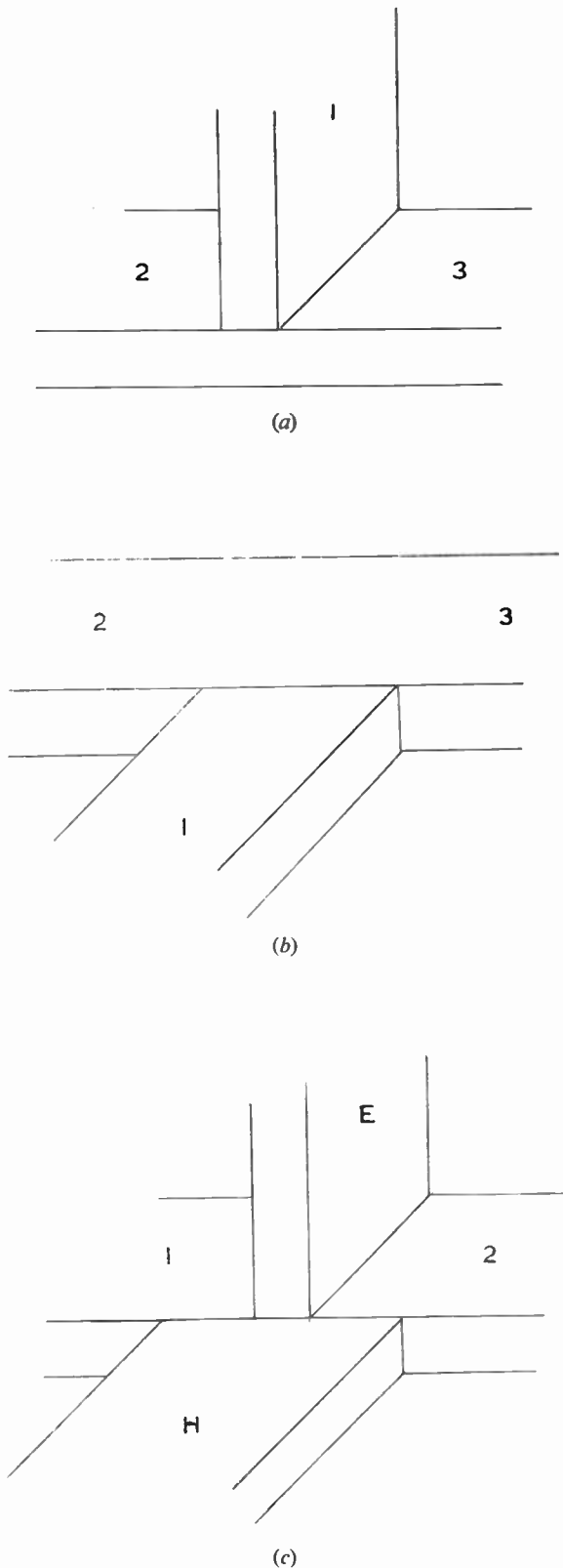
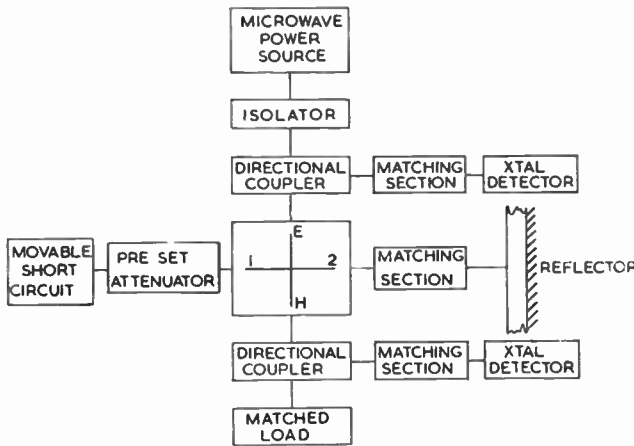
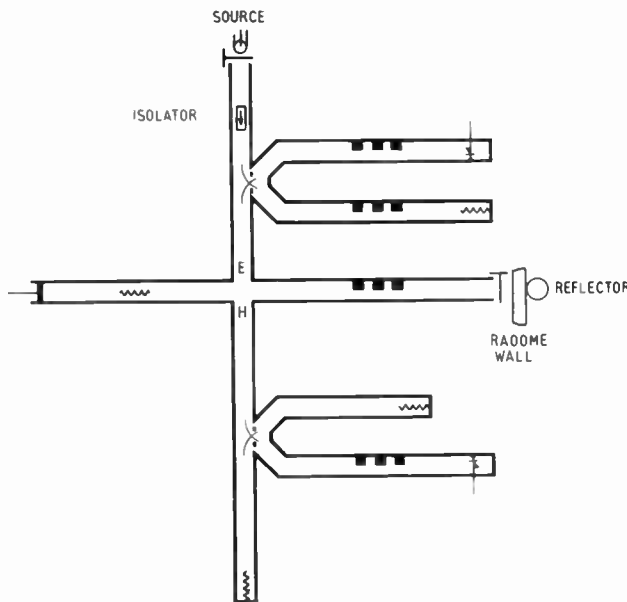

Fig. 3. The waveguide magic T.



(a) Block diagram.



(b) Waveguide circuit.

Fig. 4. The sensing head.

5. Sensing Head

We have seen that the magic T can be used to compare the values of the reflection coefficients of terminations and that if the amplitude reflection coefficients are equal, a balance condition occurs when the phases of the reflection coefficients differ by  $\pi/2$ . If the wave in one arm is reflected from a mismatch of controllable phase and the wave in the other arm is made to pass through the radome before being reflected, the phase delay introduced by the radome may be compared at the angle of incidence chosen. The system is considered to start with equal power in the E and H arms. A change in electrical thickness will upset this balance. If the calibrated mismatch is

adjusted to restore balance the amount of adjustment needed indicates the change in the electrical thickness.

The sensing head based on this principle is shown in Fig. 4. Power from a microwave oscillator is introduced into the E arm via an isolator. This splits into arms 1 and 2. Arm 2 is terminated by a matching section followed by the radome material pressed against the open end of the waveguide and followed by a reflector. The matching section is to minimize reflections from the front surface of the radome material. The amplitude reflection coefficient is determined by the loss in the radome (which is small) and the scattered radiation. The phase of the reflection coefficient is determined by the electrical thickness of the radome. Arm 1 is terminated in an attenuator and a variable waveguide short circuit. The attenuator can be adjusted to give the same amplitude reflection coefficient as in Arm 1. Then changes in the position of the short circuit to maintain equality in the E and H plane outputs indicate changes in electrical thickness.

The power in the E and H arms is sampled by directional couplers and fed via matching sections on to crystal detectors of different relative polarity. Fig. 5 shows variation in crystal output with changes in electrical thickness. A and B are balance points and with matched crystals are  $\pi/2$  apart. The difference between these outputs is the control parameter of the sensing head. It will be seen that the output is direction sensitive. This is a feature of the sensing head which permits it to be adapted for continuous operation as described below. It is required to monitor the whole of the radome surface and for this reason it was decided to record continuously the position of the short circuit at balance as the radome surface is made to track systematically between the end of the waveguide and the reflector. This is done by using a roller as reflector and simultaneously rotating and linearly tracking the radome so that a spiral path is covered over the whole radome. Continuous recording is achieved by servo-controlling the position of the

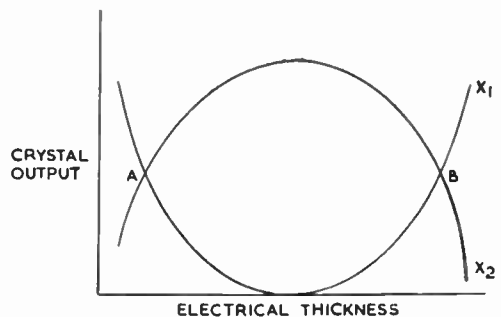

Fig. 5. Variation of crystal output with electrical thickness.

short circuit to maintain the balance condition, the short-circuit position being displayed. The system is shown schematically in Fig. 6. The servo used is an a.c. non-linear (or "bang-bang") type.

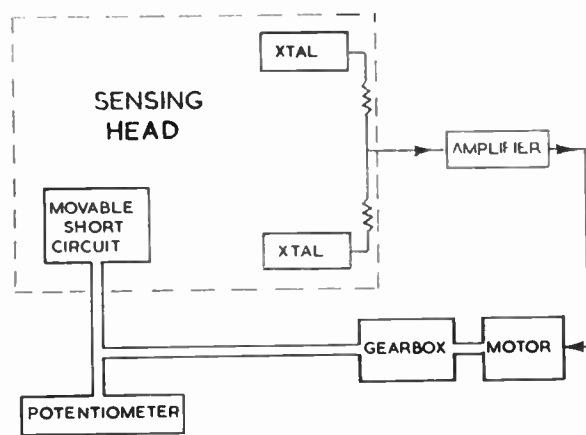

Fig. 6. The complete system.

### 6. Performance

It is emphasized that the instrument is essentially a comparator. It is controlled by electrical thickness but in its present form does not directly read this quantity. Since radome design is empirical it is sufficient to be able to reproduce changes known to have improved a radome. The sensing device here described can effect the comparison required for this purpose. It can also be used to control a machine varying electrical thickness to reproduce a radome shape known to be successful. Therefore the important parameters of the sensing head are its sensitivity and its stability.

The sensitivity is largely a question of servo design, particularly the choice of dead space with this type of servo. The sensitivity achieved is estimated to be  $\pm 0.00015$  in. of radome wall having a dielectric constant of approximately 4.

The stability of the sensing head has been measured with variations in oscillator frequency, oscillator output amplitude, and temperature variations both of the whole sensing-head and differentially across it. Of these factors the last is the most important. It is estimated that instability due to these causes will not exceed  $\pm 0.0001$  in. of radome wall of dielectric constant 4. This could be reduced by reducing temperature gradients across the head by the use of thermal shunts or by the construction of the head from temperature invariant metal.

Tests on a prototype model of the sensing head in a room without temperature or humidity control have shown a repeatability (which is a function of sensitivity and stability) of  $\pm 0.00014$  in.

The remaining obvious factor in stability is that of crystal sensitivity. Little as yet is known on the long term stability of this type of crystal, but it is planned to calibrate the head frequently using samples of high stability until experience is gained. Hence an accuracy of  $\pm 0.00025$  in. for radome wall having  $k=4$  is expected for the sensing head.

### 7. Further Developments

Immediate plans for the sensing head are to use it to control as well as measure electrical thickness. It is planned to do this by replacing the reflecting roller by a cutting tool. The position of the cutting tool will be varied as the radome tracks past thus producing a radome with an electrical thickness contour of a pre-determined type.

### 8. Conclusions

A device which senses changes in electrical thickness of dielectric material with an accuracy of  $\pm 0.00025$  in. equivalent wall thickness has been designed and constructed. The system can be used anywhere in the microwave region and the frequency of operation need not be that at which the material is used.

The quantity observed is of prime importance in radome design but it is also relevant in determining the performance of capacitors, and transmission lines.

If  $k$  is known accurately (and accurate methods exist for its measurement at these frequencies) the system measures  $d$ . In fabricating ceramics the process is to sample  $k$  continuously during mixing and hence in this case  $k$  is controlled and known accurately.

Conversely if  $d$  is known or measured separately the sensing head will give  $k$ . Because of the high dielectric constant of water the equipment can give an extremely sensitive indication of the amount of moisture in the material under test. An indication of physical or chemical composition of materials can also be obtained.

### 9. Acknowledgments

The author would like to thank Mr. G. B. Boulton, Mr. B. Pugh and Mr. C. Felix for their help and to thank Bristol Aircraft Ltd. for permission to publish this paper.

*Manuscript received by the Institution on 27th July 1961 and in final form on 24th November 1961. (Paper No. 708.)*

© The British Institution of Radio Engineers, 1962

# Electronics at the 1962 Physical Society Exhibition

For many years the Physical Society's Exhibition was held at Imperial College, London, and its emphasis was on experimental equipment devised within research laboratories for research; commercially available items were comparatively few. The scope of the Exhibition has, however, grown considerably and increasing emphasis seemed to be laid on the professionally made research tool. Transferring the Exhibition from the academic atmosphere to a medium-sized London hall perhaps encouraged this tendency.

Now, however, the Council of the combined body, the Institute of Physics and the Physical Society, have halted the trend by a specific pronouncement and this year's Exhibition bore witness

to the effectiveness of the decision. A far greater proportion of exhibits, notably those of an electronic nature which in the past had tended to include many commercially available instruments already shown in previous years, were working demonstrations of newly devised research experiments. A welcome increase in the number of stands from University departments underlined the return to the original purpose of the Exhibition, which indeed had the flavour of a *conversazione*.

Many organizations both large and small from the electronics industry, as well as from what may be termed the "user" industries, presented interesting exhibits and the following account gives necessarily brief details of a few items from both these categories.

## VALVES AND SEMICONDUCTORS

A demonstration of quick heating valves designed for mobile transmitters was given by the Mullard Radio Valve Company. The demonstration units all used valves with specially designed directly heated cathodes having a warm-up time of less than one second. This enabled the transmitter to be "on-the-air" within one second from cold, there being no necessity for "stand-by" operation; 70% of full output power was reached in approximately half a second. Apart from the obvious advantage of eliminating the drain on a vehicle battery during "stand-by", the transmitter runs cooler and can therefore be made smaller—the "transmit" time of a mobile communications transmitter is usually of short duration which helps in this respect.

Three types of cathode/filament have been developed for use in these valves.

The "harp" cathode consists of many strands of oxide coated tungsten wire in a "harp" type of construction, the tension being maintained by a system of rollers and springs at the ends. The effect of such construction is to produce a high emission cathode of low inductance which appears electrically similar to a solid surface cathode.

The nickel strip cathode consists of an oxide coated nickel strip tensioned by springs, also giving low inductance and high emission.

The four limbed or "M" type cathode is in the development stage and consists of oxide coated tungsten wire in an "M" configuration; it is designed mainly for use in an early stage valve for frequency multiplier stages.

An arrangement of semiconductor devices for generating microwaves was demonstrated by Ferranti's. A transistor oscillator operating at 166 Mc/s

passes its signal to four successive multiplying stages employing variable capacitance diodes. The frequency is increased by three doublers and one tripler to 3984 Mc/s. Advantages over the klystron are the possibility of low battery operation and relatively straightforward crystal control.

If greater bandwidths are required in amplification of r.f. signals to high power levels in the lower part of the u.h.f. band, it is necessary to make use of travelling wave interaction. A travelling wave tube was shown by the G.E.C. Hirst Research Centre which is intended to produce peak pulsed outputs of a few hundred kilowatts. Apart from its extraordinary size (measuring 8 ft in length by 11 in. in diameter, it is believed to be the largest travelling wave tube so far made), it is unusual in its use of a hollow cylindrical high-perveance electron beam and is expected to have a very wide bandwidth. Operation figures were not however divulged.

Semiconductor thermocouples performing the function of refrigerators and heat pumps which make use of the Peltier effect were shown by Semiconductor Thermoelements. The thermoelements of doped bismuth telluride are noiseless in operation and may be expected to have an indefinitely long life. The cooling elements are very small in size—they need not weigh more than 5 oz in a typical refrigerator—and their construction is essentially simple. The coefficient of performance of a thermoelectric refrigerator is of the order of 0.5, higher than that of the absorption unit, but lower than that of a compression unit. The freezer shown could be used to freeze and maintain specimens at temperatures down to  $-20^{\circ}\text{C}$ . A suitable control circuit enables it to be used as a low temperature thermostat.

## MICROWAVE EQUIPMENT

Dielectric line quasi-optical components for the millimetre wave region were shown by Mullard which incorporated a high  $Q$  resonator operating in a mode similar to the HE mode of a dielectric rod. Energy from a free wave is coupled in and out by a plane grid of thin dielectric threads and  $Q$  factors of 90 000 have been measured at wavelengths in the 4 mm region. The resonator can also be used for the measurement of wavelength, dielectric constant and loss factor of low loss materials, gases, liquids and solids. A standing wave indicator was also shown associated with the same system. The indicator is of the travelling probe type, consisting of two crosswise arranged grids of the form mentioned above. The energy of the travelling waves is coupled out and fed into a horn to be detected. The indicator can be used to measure standing waves on dielectric lines which employ polythene threads.

A model was displayed by A.E.I. (Manchester) of a linear accelerator which has been built to act as the injector for a 6 GeV electron synchrotron now under construction at Hamburg. Consisting of five sections of corrugated waveguide, each 1.5 m long, the accelerator is injected with electrons of an energy of 46 keV. Radio frequency power for each section is obtained from a conventional klystron amplifier run at its normal rating of 5 MV. Since it is desirable to have synchronism between the linear accelerator frequency of 2998 Mc/s and the synchrotron frequency of 499.67 Mc/s, a common crystal oscillator and frequency multiplier chain is used to drive both. The pulsed beam modulator employs a pulse-forming network which is charged up relatively slowly and then discharged rapidly through the primary of a pulse transformer by a hydrogen thyratron valve; the pulse duration is 1.6 microseconds.

## INDUSTRIAL MEASURING EQUIPMENT

A simple easily set up apparatus for measuring the stability of the rotational speed of a driving shaft to within 1 part in  $10^4$  of 1 rev/second was demonstrated by Mullard. It is based on the measurement of the time interval between a pulse obtained from a frequency standard and a pulse obtained by optically scanning a graduated disc on the shaft. Each pulse is repeated 100 times per second. In an ideal system the time interval would be constant, but in a practical system rotational errors in the drive will cause it to vary. In order to ensure that the two trains of pulses are coherent, the supply frequency to the hysteresis or synchronous motor is also obtained from the frequency standard. The interval is measured on an oscilloscope and an estimate can be made of its maximum rate of change at various instants. Knowing this, any variation in rotational speed can be calculated. Oscillation or hunting in the rotation can be detected and measured, and the effects of changes in the driving conditions can be assessed.

A torque meter shown by Dawe Instruments was claimed to represent an advance on existing equipment since it may be used to give measurements of torque to an accuracy frequently better than 0.25% over a wide range of shaft speeds. The digital presentation it uses gives a high order of reading accuracy and makes it possible for the instrument to be used by semi-skilled personnel in routine checks.

The equipment comprises two units, an electronic unit and torsionmeter. The torsionmeter consists of a shaft of accurately calibrated stiffness mounted between two lubricated bearings. At each end of the shaft is fitted a steel disc with twenty radial slots at its

periphery. Photo-diodes and lamps are rigidly mounted on each side of the two discs. The torsionmeter unit is readily coupled into the mechanical system under test, and gives rise to two sources of pulses from the photocells when it revolves.

The electronic unit, which may be connected to the torsionmeter unit with up to 50 ft of cable, consists of a 1 Mc/s crystal oscillator to provide pulses of accurate repetition rate, and a transistor crystal chronometer circuit which measures the delay between pulses from each of the photocells. This is then displayed digitally on four edgewise meters, thus giving a measurement of torque. In addition the period of one shaft revolution is measured on another chronometer circuit and displayed on a further four edgewise meters.

A "ferret" is a device which is inserted in a water or oil supply pipe and propelled along it by the fluid. Its purpose is to clean the pipe, but it is possible as well that it might be used to carry instruments. "Ferrets" used for cleaning may become lodged in the pipe and have to be found and recovered. "Ferrets" used for instrumentation would have to communicate with an observer, and any system for transmitting signals from the device might also be used to indicate its position in the pipe line.

The Water Research Association exhibited a method of communication which requires only simple and robust equipment on the "ferret" itself. A small magnet is mounted on the "ferret", the magnet axis being normal to that of the pipe. The magnet's field is insufficient to saturate the iron of the pipe, and

accordingly most of it is screened by the pipe walls. Despite this a leakage field escapes radially, but this is small compared to local variations in the Earth's magnetic field near iron pipes and so is not easily detected. The field is therefore modulated by making the magnet rotate and an alternating voltage is thus induced in a stationary coil outside the pipe, in the equipment used to locate the "ferret". This equipment enables a "ferret" in a pipeline to be located with accuracy, and thus overcomes one of the principal difficulties. The programme continues for the development of equipment in which signals are transmitted which indicate the position of leaks.

A prototype microwave moisture meter was displayed by the Building Research Station which depended on the principle that when radio waves are passed through a wet porous substance they are partially absorbed by the moisture and the intensity of

the emergent signal is thereby reduced. This reduction is a measure of the water content of the substance.

The demonstration illustrated this principle by comparing the transmission of radio waves of 10 cm wavelength through two brick walls of different moisture contents. The walls were supported on a motor-driven carriage such that they alternately intercepted the beam, the strength of the emergent signal being indicated electrically in each case. The demonstration served also to measure the water contents of the walls in pounds per square foot of the face, the meter having been calibrated for this purpose.

For determining moisture content in this way and for controlling the moisture content in many materials the instrument is used at low power, for example, about  $\frac{1}{2}$  watt. High power applications of microwaves are being investigated at B.R.S. and at a power about 2 kW output materials can be dried, wood-worm and dry rot destroyed, and concrete cracked.

#### COMPONENTS FOR COMPUTERS

An 8 × 8 memory store matrix was demonstrated by G. V. Planer comprising cylindrical, electro-plated film elements. The latter are in the form of bands, 0.4 mm in diameter × 2 mm length, of nickel-iron-cobalt alloy plated on to the external surfaces of non-magnetic steel tubes. These are woven into a conductor network which carries the "read" and "write" pulses. "Digit" and "sense" conductors thread the tubes.

The device has a high output—50 mV—with non-destructive read-out. Operating pulse amplitudes are typically 0.8 A "read" and "write" and 0.3 A "digit". A "read"/"write" cycle can be accomplished in durations as short as 15 nanoseconds.

For medium speed switching applications at frequencies up to 200 kc/s. Ferranti have introduced a range of encapsulated semiconductor logical circuit

modules, measuring less than 1 in. cube, which are capable of operating over a temperature range of approximately  $-40^{\circ}\text{C}$  to  $+120^{\circ}\text{C}$ . The modules are designed to operate on standard supply voltages of  $-12\text{ V}$  and  $+6\text{ V}$  nominal, accurate to within at least  $\pm 15\%$ . They use silicon semiconductors as the switching elements and, as a result, have a high degree of reliability. All modules are cast in epoxy resin and have extremely good mechanical properties.

Typical specifications for the modules are as follows:

(a) A flip-flop circuit giving d.c. outputs of  $-9\text{ V}$  at each collector.

(b) A dual inverter unit giving  $-12\text{ V}$  outputs. Other modules under development include diode AND, OR gates, buffer amplifiers, d.c. amplifiers, clock pulse generators, variable delay generators, and power supplies.

#### MASERS AND LASERS

The appearance of both microwave and optical masers attracted very considerable interest and it is obvious that much work is in progress. The National Physical Laboratory demonstrated the production of an intense flash of coherent light with its laser. A ruby "oscillator" feeds a ruby "amplifier" and a feature of the oscillator is a new type of spherical reflector designed to optimize the optical coupling between the ruby rod and the linear xenon flash-tube. The amplifier which uses two similar flash-tubes inside a double-cylinder reflector, is still in the

prototype stage. It has been designed to permit operation with a cooled crystal and with any number of similar units in cascade. The gain obtainable has not yet been assessed.

The Royal Radar Establishment's 9 Gc/s maser uses liquid nitrogen, which alleviates the cryogenic problem. The paramagnetic crystal is a rectangular block of ruby,  $\text{Cr}^{+++}$  in  $\text{Al}_2\text{O}_3$ , which has a metallic coating. This forms a microwave cavity resonant at two frequencies so chosen that they correspond to



transition frequencies in ruby at an angle of  $54^{\circ} 44'$  between the crystal C-axis and the magnetic field of about 3850 oersteds. The amplifier is quite compact and operates for several hours on one filling of liquid nitrogen. The pump oscillator has an available power of several watts and a power gain of 100 times (20 decibels) is possible with an amplifying bandwidth of 1.5 Mc/s, centred on a signal frequency of 9 Gc/s (a wavelength of 3.3 cm).

A proposed design of a 35 Gc/s maser was also shown by R.R.E. in which efficient operation can be obtained at a pump frequency of 70 Gc/s by use of a push-pull orientation of the crystal. One form of slow wave structure which avoids very fine mechanical tolerances is a dielectric filled waveguide propagating circularly polarized  $TE_{11}$  mode. The operating temperature will be in the liquid helium range, which also enables the required field of 10 000 oersteds to be provided by a solenoid of superconducting materials.

A portable maser frequency standard was shown by Glass Developments which used ammonia gas to generate oscillations in the microwave region (24 000 Mc/s). The higher energy molecules pass into a microwave cavity where they are stimulated to give up their excess energy. If sufficient power is emitted from the molecules to overcome losses in the cavity, oscillations will build up and be maintained. Since the frequency of oscillation depends on the inversion frequency of the molecule it will be essentially unaffected by outside conditions, such as temperature or pressure or variations due to ageing. The ammonia gas masers at present used as frequency standards are continuously pumped, when running, to maintain a high vacuum in the maser system. This confines their usefulness to laboratory working. The development of this portable instrument, for which a frequency stability of 1 in  $10^9$  is claimed, should prove of particular value in navigational aids for ships and aircraft.

#### NEW MEASUREMENT TECHNIQUES

The Atomic Weapons Research Establishment showed an automatic digital  $x$  and  $y$  co-ordinate graph analyser which provides precise information about the shape of waveforms, in the form of a punched tape record. Analysis of the record takes approximately 40 seconds and its accuracy is 2%. The waveform to be examined is scanned by a television camera using a raster of 156 lines, each 250 microseconds long. The video output from the camera is applied to seven gates. At the same time, the output from a seven stage line counter, synchronized with the scan, is applied to gates. An output appears at a gate when there is a video signal from the camera and a negative pulse from the counter. This corresponds to a "1" condition. If there is no video signal, or if there is a positive pulse from the counter a "0" condition will result. The "1" or "0" signals at the output of the gates are applied through amplifiers and monostable circuits to the coils of a seven digit punched tape recorder. The recorder binary number gives the position of a point on the curve on the  $x$  axis for this particular line scan. The scanning of one complete frame will provide 156 sets of punched holes, representing times from the edge of the graph at 156 uniformly spaced points on the  $y$  axis. The tape can be fed directly into a computer.

In the study of temperature discontinuities in the atmosphere by aircraft of the Meteorological Research Flight, it is required to record very rapid temperature changes by means of a thermometer with a lag coefficient of the order of 10 milliseconds. The

thermometer consists of a length of 48 s.w.g. (diameter 0.0016 in.) platinum wire exposed freely to the atmosphere and connected in a bridge circuit. The out-of-balance voltage is amplified and displayed on a recorder with a high natural frequency.

It is desirable at the same time to measure the associated change of humidity of the air and for this purpose a hygrometer with a similarly small lag coefficient is required. The refractive index of the air at radio frequencies is related to pressure, temperature and vapour pressure and thus with the use of a pressure recorder, a thermometer and a radio refractometer the vapour pressure can be obtained.

The radio refractometer demonstrated was made by the Radio Research Station, Slough, and has a lag coefficient of the same order as the high speed thermometer. It operates by comparing the resonant frequency of two microwave cavities, one of which is exposed to the atmosphere, and the other of which is sealed off at constant pressure and temperature inside the aircraft. It provides only relative values of refractive index and it must be calibrated at some point where conditions are steady by measuring pressure temperature and vapour pressure by standard instruments and calculating the value of refractive index at this point. Measurements can be made to an accuracy equivalent to  $\pm 0.1$  mb in vapour pressure. The instrument is therefore suitable for low level (below about 10 000 ft) only.

*A further report on the exhibition will be included in the next issue of the Journal.*

# Radio Engineering Overseas . . .

The following abstracts are taken from Commonwealth, European and Asian journals received by the Institution's Library. Abstracts of papers published in American journals are not included because they are available in many other publications. Members who wish to consult any of the papers quoted should apply to the Librarian, giving full bibliographical details, i.e. title, author, journal and date, of the paper required. All papers are in the language of the country of origin of the journal unless otherwise stated. Translations cannot be supplied. Information on translating services will be found in the Institution publication "Library Services and Technical Information".

## HIGH SPEED FACSIMILE SYSTEM

An experimental high-speed facsimile system with electronic horizontal scanning and mechanical vertical scanning has recently been described by Japanese engineers. A vidicon is used at the transmitting terminal while a flying-spot cathode-ray tube is used at the receiving terminal where the signal is recorded on electro-photographic paper. The transmitting speed of a facsimile system of this type is limited by the recording speed, which is dependent on the light sensitivity of the electro-photographic paper, the brightness of the flying-spot cathode-ray tube, etc. At present, the maximum transmitting speed is a horizontal repetition rate of 100 c/s with a vertical paper speed of 10 mm per second. In general, facsimile systems with electronic scanning are suitable for the high-speed transmission of small-size copy, and have the additional advantage that the pictures can be enlarged or contracted during reception.

"A high-speed facsimile system with electronic scanning", K. Kubota, K. Kobayashi, Y. Okajima and S. Nanbo. *Review of the Electrical Communication Laboratory, N.T.T.*, 9, No. 1-2, pp. 214-9, March-April 1961.

## A CROSS GUIDE COUPLER

The coupling of a cross-guide coupler with an aperture containing a ferrite is discussed in a recent paper by a Polish engineer. Calculations are based on Bethe's and Stinson's theories of a coupler with a smaller aperture. Comparison of theoretical computations with the results of the measurement for the aperture filled partially are presented. Applications of the coupler include measurement of the line width of ferromagnetic resonance and effective spectroscopical coefficient of ferrite cleavage.

"Cross-guide coupler with an aperture containing a ferrite", Z. Krzycki. *Rozprawy Elektrotechniczne*, 7, No. 3, pp. 355-64, 1961.

## SIGNAL LOSS IN MICROWAVE ANTENNAS DUE TO SNOW, ICE AND LEAVES

In a recent Canadian article the problem of the accumulation of foreign matter in horizontally mounted parabolic antennas, which produces serious signal loss in microwave relay systems, is discussed. Results with ice, snow and leaves are presented and the causes are analysed. In a typical case a build-up of 4 in. of solid ice and 4 in. of frozen snow lead to a loss in signal of 22 dB; with a radome fitted the loss was 6 dB but the ice and snow would soon have melted.

"Tests show how snow, ice and leaves in microwave antennas cause signal loss", F. R. Willis. *Canadian Electronic Engineering*, 5, pp. 45-47, December 1961.

## A TIME-CODE GENERATOR

A time code generator has been produced at the Weapons Research Establishment, Salisbury, South Australia for special application in data recording systems where a number of simultaneous records require accurate correlation and subsequent analysis. Four separate width modulated pulse trains are emitted continuously, each describing time but with differing pulse repetition frequencies. The unit employs etched foil circuit techniques. Continuous indication of time and date is given through slot windows in the door of the cabinet. The generator uses transistors and cold cathode switching tubes.

"A multiple output precision time-code generator", J. L. Harwood and F. A. Hinc. *Proceedings of the Institution of Radio Engineers Australia*, 22, No. 11, pp. 685-93, November 1961.

## RADAR CLUTTER

In a recent Polish paper some practical methods of determining the coefficients of a Hermitian quadratic-form are considered. The coefficients are necessary for giving an exact expression for the multi-dimensional normal probability density-function of a radar signal. They also give the optimal transfer-function of a pre-detection pulse filter for a coherent receiver. The method is based on the so-called "two-side Z-transform". The case of a multi-channel radar operating mode is considered as well as that of a variable repetition frequency. Practical examples are given to clarify the theoretical assumptions.

"On some problems concerning the determination of inverse covariance-matrix coefficients of radar signals in clutter". J. Kulikowski. *Rozprawy Elektrotechniczne*, 7, No. 3, pp. 315-33, 1961.

## HIGH-SPEED LOGIC CIRCUITS

In a recent paper a French engineer gives a brief account of binary variable functions, giving reasons for the choice of the function NOR to determine the single basic circuit in a system of logical circuits with modular elements. It is then shown how the calculation of logical functions is made easier by the use of a symbolic operator defining the NOR function. A description is given of the basic circuit and the results obtained. The author claims that this circuit shows how the rules for calculation make it possible to decide upon the grouping of logical circuits to be adopted and to set up the wiring information necessary for production of the device without reference to any diagram.

"System of logical circuits using as its basic elements the logical module", A. Pinet. *Onde Electriques*, 41, pp. 905-23, November 1961.