

# The Journal of THE BRITISH INSTITUTION OF RADIO ENGINEERS

FOUNDED 1925

INCORPORATED 1932

*"To promote the advancement of radio, electronics and kindred subjects  
by the exchange of information in these branches of engineering."*

VOLUME 19

OCTOBER 1959

NUMBER 10

## NOTICE OF THE THIRTY-FOURTH ANNUAL GENERAL MEETING

NOTICE IS HEREBY GIVEN that the THIRTY-FOURTH ANNUAL GENERAL MEETING (the twenty-sixth since Incorporation) of the Institution will be held on WEDNESDAY, 2nd DECEMBER, 1959, at 6 p.m. at the London School of Hygiene and Tropical Medicine, Keppel Street, Gower Street, London, W.C.1.

### AGENDA

1. **To confirm the Minutes of the 33rd Annual General Meeting held on 26th November, 1958.** (Reported on pages 693-695 of Volume 18 of *Journal* dated December 1958).
2. **To receive the Annual Report of the Council.** (Published on pages 594-613 of this *Journal*).
3. **To elect the President.**  
The Council is unanimous in recommending the re-election of Professor E. E. Zepler, PH.D., as President of the Institution for the year 1959-60.
4. **To elect the Vice-Presidents of the Institution.**  
The Council unanimously recommends the re-election of  
Air Vice-Marshal C. P. Brown, C.B., C.B.E., D.F.C.      Colonel G. W. Raby, C.B.E.  
John L. Thompson.      Professor Emrys Williams, PH.D., B.ENG.
5. **To elect the Ordinary Members of the Council.**  
The following members retire from Council in accordance with Article 28:  
A. D. Booth, D.S.C., PH.D. (*Member*).      F. G. Diver, M.B.E. (*Member*).  
Captain A. J. B. Naish, R.N., M.A. (*Member*).      E. W. Pulsford, B.SC. (*Associate Member*).  
A. H. Whiteley, M.B.E. (*Companion*).      Major P. A. Worsnop (*Associate Member*).  
Consequently, vacancies arise for ordinary members of Council as follows:—  
3 Members; 1 Honorary Member; 2 Associate Members; 1 Companion.  
In accordance with Article 30, the Council nominates:—
  - (a) Member for re-election; A. D. Booth, D.S.C., PH.D.
  - (b) Members for election: Air Marshal Sir Raymund G. Hart, K.B.E., C.B., M.C., A.R.C.S.;  
Ieuan Maddock, O.B.E., B.SC.
  - (c) Honorary Member for election: Eric K. Cole, C.B.E.
  - (d) Associate Members for election: D. L. Leete, B.SC.; Squadron Leader W. L. Price, O.B.E., M.SC.
  - (e) Companion for re-election: A. H. Whiteley, M.B.E.The above nominations for election to the General Council were circulated to corporate members on 16th September. There being no opposition, the above members will be elected to the Council at the Annual General Meeting.
6. **To elect the Honorary Treasurer.**  
The Council unanimously recommends the re-election of G. A. Taylor (*Member*).
7. **To receive the Auditors' Report, Accounts and Balance Sheets for the year ended 31st March, 1959.**  
The Accounts for the General and other Funds of the Institution are published on pages 611-612 of this *Journal*.
8. **To appoint Auditors and to agree their remuneration.**  
Council recommends the re-appointment of Gladstone, Jenkins & Co., 42 Bedford Avenue, London, W.C.1.
9. **To appoint Solicitors.**  
Council recommends the re-appointment of Braund & Hill, 6 Gray's Inn Square, London, W.C.1.
10. **Awards to Premium and Prize Winners.**
11. **Any other business.** (*Notice of any other business must reach the Secretary 40 days before the meeting.*)

## THE 33rd ANNUAL REPORT OF THE COUNCIL OF THE INSTITUTION

*The Council has pleasure in presenting the 33rd Annual Report of the Institution which reviews the proceedings for the twelve months ended 31st March, 1959. The Annual General Meeting will be held on Wednesday, 2nd December, 1959, at the London School of Hygiene and Tropical Medicine, Gower Street, London, W.C.1, commencing at 6 p.m.*

### INTRODUCTION

**A**N Annual Report is judged differently by different readers. It may provide evidence of progress but yet not be wholly satisfying to everyone. Some may find in it evidence of opportunities not taken, or even of bad management. In the latter event, an Annual General Meeting gives democratic opportunity for comment!

An Annual Report is sometimes the only means whereby the recipient may determine what personal advantage he derives from association with the company or society. The value of membership of a professional Institution certainly cannot be assessed wholly in terms of individual return. Nevertheless, in the corporate sense, the Institution must be judged by the way it fulfills its objects and at the same time serves the profession.

The formation of new Sections, both at home and overseas, the establishment of specialized Groups, expansion of the *Journal* content and of meeting arrangements, have all played their part in furthering the objects of the Institution and providing every possible service to members commensurate with the Institution's income.

Provision of working capital is a subject which commands attention in any Annual Report. An Institution cannot, of course, "raise" capital in the commercial sense, and the history of all learned societies shows that they tend to lean heavily upon a comparatively small band of men imbued with enthusiasm for the work of such Institutions as our own. In its 34th year, the Institution is increasingly able to show how well it is deserving of such support. The capital need now is for a building of our own and it is hoped that every member will do what he can to assist the Finance Committee in meeting this objective.

The Report shows not only how the Institution has discharged its responsibilities to the membership, but also the increasing opportunities for members to discharge their responsibilities to the Institution. Whilst there may be contention on how best to achieve our aims, the whole world is alive to the need for more widespread scientific and technical education. The Institution has shown its originality of outlook, as well as its preparedness to co-operate in the common good. Both as a "sounding board" and in its ability to initiate new ideas, the Institution provides opportunity for service to the community as a whole.

## PROFESSIONAL PURPOSES COMMITTEE

Three matters have dominated Committee proceedings during the year. Firstly, the strengthening of the Institution's relations with its overseas members; secondly, the establishment of specialized Groups; thirdly, consideration of Institution policy not only in the matter of Conventions, but in regard to participation in international and national meetings.

**Overseas Sections.**—During the year senior members of the Institution from Australia, Canada, East Africa, India, New Zealand, Pakistan and South Africa, visited 9 Bedford Square and discussed with Officers of the Institution membership activities in their various countries.

Senior members of the Institution also visited some of those countries and the Council is most grateful for the help given in promoting Institution activities outside Great Britain. In this connection, particular reference must be made to the joint endeavours of Mr. Leslie H. Paddle, a former Vice-President, and Mr. George Marriott, the Immediate Past President, who have done so much to promote Institution activity in Canada. Consequent upon the discussions which Mr. Paddle had with the Council during his visit to London in 1958, Mr. Marriott officially visited Canada on behalf of the Institution. Arrangements were made for him to meet members in Toronto and Montreal in May 1959, in order to examine the possibilities of establishing Sections in these cities and appointing a Canadian Advisory Committee.

As a result of such work the Council believes that there will be better opportunity in Canada for members to take part in the Institution's work. This follows the policy initiated some years ago to provide better contact between the Council and all members, irrespective of their place of residence.

Notices have appeared in the *Journal* regarding meetings of members in countries overseas, and the facilities which have been provided for banking arrangements—a service which has been much appreciated.

The Professional Purposes Committee continues to keep a close watch on the development of the Institution's membership and activities overseas and particularly in countries of the Commonwealth.

**Policy on Conventions.**—The Committee was consulted on arrangements for the 1959 Convention. Suggestions had been received advocating the holding of a commercial exhibition currently with the Institution's main Convention or in association with symposia organized by local Section Committees. Whilst these proposals had the merit of possibly helping to defray the cost of such Conventions, the Committee reiterated the view that it was not the function of the Institution to be concerned with the organization of trade shows. Council's policy in this matter has been stated in previous Annual Reports, and further consideration has not justified any change in that policy.

There are ample opportunities for the professional engineer in Great Britain to attend the exhibitions arranged by manufacturers, and the success of the Institution's Conventions appears fully to endorse Council policy.

These considerations do not, however, affect the arrangements which have always been made by the Institution for the demonstration of equipment or apparatus germane to papers presented at Institution meetings.

**International and national bodies.**—It has always been the policy of the Institution to afford co-operation with any other body or organization whose work impinges on the professional activity of the radio and electronics engineer—always provided that the purpose of the organization in question in no way conflicts with the objects of the Brit.I.R.E. In this wise, the Institution is represented on and actively supports a number of other bodies.

Radio and electronic engineering has an increasing impact on other fields of human activity. Outstanding examples in recent years have been the setting up of an International Medical Electronics Conference and a British Conference on Automation and Computation.

The Institution was one of the original supporters of the idea that an International Federation on Medical Electronics should be formed. In order that British participation should be truly representative of medical and engineering interests the Institution's delegates to the first International Congress were asked

to recommend that a British National Committee be established.\*

Subsequently the Institution suggested that a meeting be arranged between interested professional engineering Institutions; it was assumed that the medical interests would confer in a similar way and that there would accordingly be a firm basis for the establishment of a British National Committee on which the Institution would be represented.

The Council regrets that, despite the approval given at the International meeting, these eminently sensible proposals have been frustrated by an evasive, nonco-operative attitude on the part of another professional Institution concerned.

This has also been apparent in respect of the Institution's application for membership of Group B of the British Conference on Automation and Computation. Other professional bodies have shared the view that the Institution should have been invited to the original discussions which resulted in the formation of this British Conference. Despite this omission, the Institution made formal application for membership on 9th January 1958; an acknowledgment stated that the application would be considered by an Executive Committee who would report to the next General Meeting of the Group. Apparently a General Meeting of the Group was not held until September 1958, when the Institution was advised that its application had been deferred pending consideration of ". . . the principles which should underlie the consideration of applications for membership of the Group."

Meanwhile, Council had been informed by some existing members of the Group that they wished to see the Institution in membership. As no satisfactory answer to the Institution's application had been received by the end of November 1958, however, the Council decided to withdraw its original application.† It was understood that this withdrawal was to be referred to the Executive Committee and to the

General Meeting of the Group but at the end of the Institution's year no further communication had been received from the Group Secretariat.

The Council believes that only good can result from honest interchange of opinion between organizations having similar interests, and that no professional Institution need fear that its influence or standing would decline as a result of such co-operation. There are many fields, beginning with education, in which failure to co-operate with kindred societies can postpone developments which are greatly in the national interest.

The Institution firmly believes that little good will ever be achieved by attempts to create monopoly of thought and influence. Such an attitude is not likely to encourage technical progress which is, after all, a declared object of every professional body, and a fundamental point of a Royal Charter—a subject to which the Professional Purposes Committee has given much time.

In happier terms there will be found elsewhere in this Report‡ references to the mutually useful collaboration between the Institution and group associations which are not wholly controlled by an individual organization.

**The Institution's Building.**—During the year the continued growth of the Institution has emphasized the inadequacy of the present headquarters. As will be seen from the report of the Finance Committee, members and industrial organizations have appreciated the urgency of giving support to the appeal for funds adequate to provide the building necessary for the expansion of the Institution's activities.

This support encouraged the Professional Purposes Committee in recommending to Council that a suitable site be acquired and that an architect be engaged to interpret the requirements of the Institution. Council therefore appointed Mr. Darcy Braddell, F.R.I.B.A., as consulting architect. It is anticipated that before the next Annual Report members will be advised of developments regarding the purchase of a site and plans for the erection of the building.

In the meantime, the architect's report and

\* See *J. Brit.I.R.E.*, 18, p. 505, August 1958.

† Much support for the Institution's decision has been received from members of the Group. Their views have been summarized most admirably in the editorial to *Control*, September 1959, page 79.

‡ See the Appendices.

plans are available to any member who is anxious to further the Council's endeavours to see the Institution suitably housed. Indeed, the enthusiasm and support so far exhibited has encouraged the Council to produce a booklet outlining the reasons for the building appeal, detailing the support received, and incorporating an interpretation of the architect's drawings. Obviously this booklet cannot be sent to all members but it is available to all those who

wish to make a direct contribution or who are interested in completing a deed of covenant.

**Appreciation.**—The Council and the senior Committee of the Institution continue to express their appreciation of the work done on behalf of the Institution by all those members who serve on Committees, whether local or standing, and who otherwise assist in the attainment of the Institution's objects.

### MEMBERSHIP COMMITTEE

In nearly every country of the Commonwealth the Institution is represented either by a Section Committee or by a local corresponding member. Over 1,000 enquiries a year from prospective members in those countries are now handled by such Institution representatives.

Enquiries from Great Britain and countries outside the Commonwealth are dealt with by the Institution's secretariat in London, who last year handled 2,067 enquiries. With this evidence of continuing interest in the Institution, it is regretted that only a comparatively small percentage of enquirers are able to qualify for membership. Nevertheless, as shown in the following table, the year ended with a further

increase in Graduate and higher grade membership as a result of the Committee's consideration of 863 proposals.

The table does *not* include Studentship Registrations. This year there has been a most heartening increase in the number of approved studentship registrations—429 in 1958, compared with 336 in 1957. The number of Students qualifying for transfer to Graduate or higher grade of membership also increased from 116 in 1957 to 126 in 1958. The loss due to wastage was 348, and the combined result was a net loss over the year of 45 registered students. This compares with a loss of 156 in the previous year. There are now 1,857

#### Elections and Transfers for the year ended 31st March, 1959

(Excluding Studentship Registrations)

	Total considered	Approved						Total
		Honorary Member	Member	Associate Member	Companion	Associate	Graduate	
Direct Elections	453	1	11	95	2	87	150	346
Proposals for Transfer	405	—	20	126	—	9	103	258
Proposals for Reinstatements	5	—	—	3	—	2	—	5
<i>Totals</i>	863	1	31	224	2	98	253	609
<b>Losses during the year</b>								
Resignation, Removal or Decease		1	8	34	—	44	54	141
Transfers to other grades		—	—	19	—	24	89	132
<i>Totals</i>		1	8	53	—	68	143	273
<b>Net gain in membership</b>		—	23	171	2	30	110	336

**On 31st March, 1959, the Institution had a total effective membership of 5,913.**



registered students and the Committee feels confident that the decline in registrations has been arrested and that in future new entries will at least balance losses.

In the corporate and graduate classes the average yearly increase has been more than maintained. Over the past four years the corporate membership has increased by 42 per cent., whilst Graduate membership has increased by 60 per cent. net. The number of elections and transfers to the grade of Associate has, however, *decreased* in recent years. As indicated by its name, the class of Associateship affords opportunity for association with the Institution's work to those engineers who are unable to qualify for immediate election to corporate membership. Associates can and do make a useful contribution to the Institution's work as well as benefiting from its proceedings. Senior members could greatly help the Institution by drawing the attention of their staff to the regulations governing the election of Associates.

**Future membership.** — The Institution's strength is largely derived from the quality of its membership which must in turn start with the encouragement, and indeed the recruitment of the right type of student.

In the last Annual Report the Education Committee referred to the impending dissolution of the Engineering Joint Examinations Board which has conducted the Common Preliminary Examination for the last 12 years. There is every reason to believe that when this examination ceases in 1960 there will be ample opportunity in Great Britain for engineering students to qualify for Studentship by succeeding in the appropriate subjects of the General Certificate of Education. The same condition does not apply, however, to students in most other countries and in consultation with the Education Committee new regulations are being framed to cover the registration of students resident outside Great Britain.

**Honours.**—Once more the Council has particular pleasure in referring to the fact that members of the Institution were included in Her Majesty's Birthday and New Year's Honours Lists. Notices have already appeared in the July 1958 and February 1959 *Journals*.

**Honorary Members.**—Members will be aware that the Institution had not made any elections to Honorary Membership since 1956. In November 1958, the Council adopted a resolution that Mr. Eric Kirkham Cole, C.B.E., be elected an Honorary Member in recognition of his outstanding services to the radio industry.\*

**List of Members.**—The last *List of Members* was issued in November 1957 (7th edition). The costs involved in compiling and publishing this reference book are high but its value in promoting contact between members, as well as in assisting applicants who wish to approach members for support in sponsoring their proposals, demands regular publication.

To enable the *List of Members* to be published regularly each year, the Council has entered into arrangements whereby commencing with the next edition, the cost to the Institution will be considerably reduced. It will still not be possible, however, to include registered Students of the Institution, or to circulate the Year Book free of charge to Students. It is hoped to circulate the 8th edition to all other grades of membership at the end of November 1959.

In order to maintain the usefulness of this publication, the Membership Committee especially urges members to ensure that the Institution is advised of any change in address and other relevant particulars. It is also helpful for internal records if members will advise the Institution of any change or promotion in employment although these details are not published.

**Acknowledgments.**— In some parts of the Commonwealth engineers are required to be registered by a central authority. Where this applies the Council is negotiating with the appropriate body for recognition of the Institution's examination and membership. In general, these negotiations are proceeding satisfactorily.

Such registration is not, however, required in Great Britain, and membership of the Institution, as with all similar bodies, is a voluntary and personal matter. There is, of course, an

\* This nomination was subsequently confirmed by the membership, and Honorary Membership was conferred on Mr. Cole during the course of the 1959 Convention.

increasing awareness among engineers of the desirability and advantages of being members of their appropriate professional body. The effectiveness and value of an Institution is largely determined by its strength in membership and the Committee wishes to record its thanks to all those members who have assisted by recommending suitable applicants. Many members have also kindly collaborated by giving frank and confidential references in respect of new proposals.

### The Appointments Registers

For 21 years the Institution has operated an appointments service, although its effectiveness in being of service to the membership has decreased over the years! This is explained by

the continued demand for the qualified radio and electronics engineer; in most parts of the Commonwealth the tremendous unsatisfied demand for such engineers is shown by the expenditure on advertisements in the technical and general press. In an advisory capacity the Institution has, however, been of service to a number of firms on the matter of promoting recruitment, especially of the trainee and student. The problem of helping the older member to secure employment, particularly the man retired from the Services, was not so difficult as originally envisaged.

During the year, 189 vacancies were referred to the Institution, but it was only possible to introduce some 54 members who were free for new employment.

## EDUCATION AND EXAMINATIONS COMMITTEE

Twelve months ago Council gave notice of its intention to divide the work of the Education and Examinations Committee.\* In future the separate Examinations Committee will be concerned only with the holding of the Institution's Graduateship Examination, the assessment of courses and examinations qualifying for exemption, and like matters.

The new Education Committee will be more concerned with the Institution's policy on education and training and its first year's operation will be included in the next Annual Report.

The Committee comprises:—

R. H. Garner, B.Sc. (*Member*), (*Chairman*).  
Principal, Coatbridge Technical College.

Brig. L. H. Atkinson, O.B.E., B.Sc. (*Member*).  
Commandant, R.E.M.E. Training Centre, Arborfield.

A. P. J. Edwards, B.Sc. (*Associate Member*).  
Principal Scientific Officer, D.S.I.R.

W. A. Gambling, Ph.D., B.Sc. (*Associate Member*).  
Lecturer in Electronics, University of Southampton.

B. F. Gray, B.Sc. (*Member*).  
Head of Electrical Engineering Dept., Hatfield Technical College.

W. K. Newson (*Associate Member*).  
Engineering Recruitment Officer, B.B.C.

E. W. Pulsford, B.Sc. (*Associate Member*).  
Training Officer, A.E.R.E., Harwell

Group Captain J. H. Stevens (*Associate Member*).  
Director of Studies, R.A.F. Technical College, Henlow.

Prof. D. G. Tucker, D.Sc., Ph.D. (*Member*).  
Professor of Electrical Engineering, University of Birmingham.

The terms of reference of the Committee are:—

- (a) To make recommendations on the academic and practical training of professional radio and electronics engineers.
- (b) To keep under review the syllabus of the Institution's Graduateship Examination, the entry requirements and the exempting qualifications.
- (c) To make recommendations on long term education policy.
- (d) To consider the training requirements of the technician and mechanic in relation to the needs of the professional radio and electronics engineer.
- (e) To organize meetings of the Institution on education and training of radio and electronics engineers and to encourage the publication of papers in the *Journal* on this subject.

As this report is the last which will be given by the joint Committee, it is opportune to recall that the Education and Examinations Committees were merged in May 1943.

The last report of the independent Education Committee was "Post War Education and Training." It was one of the most forward looking reports ever published by the Institu-

\* See Introduction to Annual Report, *J. Brit.I.R.E.*, 18, p. 565, October 1958.

tion, anticipating many of the schemes, as well as curricula of training, now accepted as commonplace. It reiterated the need for establishing a Higher National Certificate in Radio Engineering. The report quoted from a memorandum lodged by the Institution in August 1935 with the Ministry (then *Board*) of Education!

A joint Education and Examinations Committee has enabled the Institution to implement fully the recommendations contained in that post war report. The Committee's constant attention to the syllabus of the Institution's examination, and to assessing examinations which might be accepted as an exempting qualification, has resulted in authoritative recognition of the Institution's contribution to the development of education and training schemes suitable for the radio and electronic engineering profession.

Inevitably the joint Committee has had to deal with much of its work through Panels. Whether they have served on a Panel or on the main Committee, the Institution is indebted to all those members drawn from the Universities, Technical Colleges and industry, who have given so much of their time to work which will benefit the radio and electronics engineer of the future.

In all these matters the Council wishes to emphasize that the Institution's own Graduateship Examination fulfils two purposes: firstly, the syllabus and actual examination papers indicate the minimum requirements for admission as a Graduate of the Institution; secondly, it affords a means of qualification to those who for one reason or another are not able to enjoy the advantage of a University course or appropriate courses in an approved Technical College. The Institution has played a not inconsiderable part in stimulating the demand for amendment to the National Certificate schemes, and for the provision of suitable courses in Technical Colleges. It is hoped and expected that there will in future be an increasing proportion of applicants able to secure exemption from the Institution's Graduateship Examination.

**Examination entries and results.**—As members will be aware, some changes were

made to the structure of the Graduateship Examination as from November 1956. As from May 1959 a further requirement is that candidates must take *all* parts of *either* Section A or Section B of the examination at one sitting. For these reasons there has been a slight decrease in the number of candidates taking the examinations since 1955, when 1,217 candidates were admitted to the Graduateship Examination.

The statistics for the May and November 1958 examinations are given below. These show that the number of passes has been maintained, but that the pass percentage is at a much higher level than it was when entries exceeded 1,100 per year. The introduction of the new syllabus has therefore achieved its purpose of ensuring that candidates are far better prepared. To enable a comparison to be made, the figures for 1957 are given in brackets.

	<i>May</i>	<i>November</i>
Entries received ... ..	425 (509)	392 (385)
Candidates appearing ...	322 (329)	285 (284)
Candidates succeeding in parts of Examination ...	105 (88)	105 (95)
Candidates who by their success completed the Graduateship Examination	58 (58)	33 (30)

It has always been difficult to present the examination statistics simply and at the same time show the actual achievement of candidates. This is because the regulations have hitherto permitted candidates to take individual parts of the examination although they had to take them in the correct order. With the introduction of the regulation requiring candidates to take a complete Section at one sitting, or those parts required to complete the Section, it will be possible in the next Annual Report to give a clearer picture of the examination results and candidates' progress.

**Exemptions.**—535 applications for exemption from the Graduateship Examination were considered during the year. Only 170 were granted entire exemption, but 302 were given partial exemption.

The Committee has been much concerned in the past few years with the consideration of



courses for inclusion in the schedule of exempting qualifications. In order to assess the training facilities and the laboratory equipment available, representatives of the Institution have visited various Colleges. The Council is most appreciative of the help given by Institution representatives who undertake often long journeys to visit Technical Colleges, Universities and industrial training establishments.

The Diploma Course of the Automatic Telephone and Electric Company's School of Electronics was also approved for exemption. This Diploma is not included in the published schedule of exempting qualifications, however, as the School is open only to employees of a group of companies. Nevertheless, the Committee wishes to take this opportunity of congratulating the company on the post graduate diploma course which they have introduced. The conception of the course and its high standard impressed the representatives of the Institution who visited the college.

Institution representatives also visited the R.A.F. Technical College at Henlow in order to assess the Engineering Cadet Course which qualifies for the Higher National Diploma award. In view of the standard of the Course, it has been agreed that candidates securing the Higher National Diploma will be granted full exemption from the Institution's examination.

In the last Annual Report the Council paid tribute to the City and Guilds of London Institute for the pioneer work it did in encouraging the study of radio engineering. Notice was then given that with the revision to the City and Guilds scheme of radio examinations, the Institution would no longer be able to afford the same degree of exemption as was given to candidates who passed the advanced examinations of the old scheme.

The first part of the new scheme of examination is designed for the technician; it is a little early to assess the new City and Guilds scheme from the viewpoint of determining whether any exemption can be granted from the Institution's examination.

The difficulty of considering exemption based on success in the new City and Guilds examinations will be appreciated when it is realized that

the new scheme up to the 4th year is only broadly equivalent to the Ordinary National Certificate standard. Because of the lower standard of these new examinations, it appears that the more capable candidates will prefer to take the National Certificate courses.

There is, however, an increasing demand for courses of a higher standard. For this reason, more Colleges are considering alternative examinations to those of the City and Guilds of London Institute as the objective of their internal courses.

The first college to approach the Institution with such a proposal was the Southampton Technical College. The College has proposed a full-time course with entry at "O" level in Physics and Mathematics which aims to reach the Institution's Graduateship Examination standard in three years. The Institution has agreed to assess the final examination papers of this Course as a basis for admitting successful students to Graduateship without further examination.

The Institution is continuing to enjoy co-operation with an increasing number of technical colleges; the idea of having full time courses designed specifically to cover the Graduateship Examination will no doubt be extended, at least until there is wider satisfaction with the Higher National Certificate scheme insofar as it may apply to students of radio and electronic engineering.

**National Certificates.**—The Institution has for many years favoured the establishment of an Ordinary and Higher National Certificate scheme in Radio and Electronic Engineering. It is realised however, that there is a genuine reluctance on the part of the Ministry of Education to allow a multiplicity of courses. The Ministry would prefer to see an assimilation of these courses, particularly in the earlier years, to reduce the number of classes.

The Council of the Institution has appreciated this point of view and has not wished to force the issue with regard to the economics of establishing specialized courses. Thus, the Council has always pressed for a minimum of adjustment at the Ordinary level and has emphasized the importance of an earlier introduction of radio and electronics subjects and for a greater

total electronic content. The regulations governing the curriculum of the Electrical Engineering National Certificate scheme have now been amended, thus enabling colleges to introduce electronics at the S3 year to the extent of 45 per cent. of the electrical content. Provided that the right emphasis is placed upon other subjects in the early years, the Examinations Committee is of the opinion that the present scheme would satisfy the requirements of the industry and profession.

The content of the Higher National Certificate in Electrical Engineering originally consisted of general and power subjects. In 1941 Telecommunications was introduced and since that time radio and electronics subjects have been included which meet the Institution's proposals of 1945. The Institution can certainly take much credit for this development in the Higher National Certificate scheme.

**Examination Prize Winners.**—Council has confirmed the award of Examination Prizes to the following candidates who were successful in the 1958 examinations:—

President's Prize: K. H. Green (*Associate Member*).

S. R. Walker Prize: D. G. Skinner (*Student*).

Electronics Measurements Prize: I. F. H. Goult (*Associate Member*).

The Committee was unable to make any recommendation for two further awards—the Mountbatten Medal and the Audio Frequency Engineering Prize—since no candidates in 1958 were eligible for consideration.

**Relations with the Armed Services.**—The Council of the Institution wishes to express appreciation of the co-operation afforded by Major General L. N. Tyler, C.B., O.B.E.,

Director of Electrical and Mechanical Engineering, War Office. Consequent upon preliminary discussions which took place between Major General Tyler and Officers of the Institution, a Working Party has been formed to enquire into the relationship between the Institution's Graduateship Examination and the qualifications required by R.E.M.E. for a permanent commission.

The Working Party, which comprises representatives of the Brit.I.R.E. and R.E.M.E., has made an interim report to the Council of the Institution and to the Director of R.E.M.E. and a full report on the final agreement will be given to members in the next Annual Report.

**Representation on Advisory Committees.**—Appendix 1 to this Report (page 613) gives a list of the members of the Institution who serve on Advisory Committees of Technical Colleges and Local Education Authorities. Council wishes to record appreciation of the service given to the Institution by these members.

**Radio Trades Examination Board.**—The Institution has continued its representation on the Board's Council and standing Committees in addition to providing secretarial facilities for the Board's activities.

A report on the method of conducting examinations has already been published in the *Journal*\* and it is hoped that in the near future the Board will be able to extend its scheme of examinations into the field of industrial electronics.

Now that the Board is well established, the Council of the Institution is considering whether it is necessary for the Institution to continue its financial subsidy. This matter is at present being discussed with the other members of the Board.

## TECHNICAL COMMITTEE

During the last few years the work of the Technical Committee has been divided into four distinct sections: preparation of reports; arrangement of visits; standardization; arrangements for special meetings.

**Reports.**—The main work of the Committee is the preparation of technical reports. Such has been the value of these reports that the Com-

mittee has been encouraged to extend the two series which are at present being prepared: (1) Materials Used in Radio and Electronic Engineering; (2) Recommended Method of Expressing Electronic Measuring Instrument Characteristics

During the year under review one further report from each of these two series was

\* See *J. Brit.I.R.E.*, 19, pp. 189-194, March 1959.

published; Magnetic Materials—August 1958, and Cathode Ray Oscilloscopes—January 1959. Six reports have thus now been published under the series “Materials used in Radio and Electronic Engineering” and two sections of the “Method of Expressing Characteristics of Electronic Instruments” series. Other reports planned under the first series are:—

No. 7 Insulators other than Plastics and Ceramics.

No. 8 Paints, Varnishes and Finishes.

No. 9 Wires and Coverings.

and the second series will include the following subjects:—

No. 3 Valve Voltmeters.

No. 4 Low Frequency Generators.

No. 5 A.F. and R.F. Bridges.

No. 6 Stabilized Power Supplies

No. 7 Wave or Distortion Analysers.

Work is proceeding on six of these reports, two of which have reached the final draft stage, and are now being circulated to other interested organizations for comment before publication.

The Committee takes this opportunity of thanking the many members who have given their time to the preparation of initial drafts, and the manufacturers who supplied and checked much of the information contained in the series on Materials.

**Visits.**—A regular feature of the Committee’s activities and one that is welcomed by members is the arrangement of visits of technical interest. The scope of these visits was extended considerably during the year and included the Radio Research Station, Slough; Southern Air Traffic Control Centre and London Airport; Vauxhall Motors; National Physical Laboratory; and the B.B.C. Technical Receiving and Measurements Station at Tatsfield. The Committee is at present arranging a series of visits to transistor factories.

One of the difficulties in arranging these visits is the limitation on the number of members who can usefully take part. The establishments appropriate for visits do not always lend themselves to large numbers; the type of visits that the Committee always has in mind is the well organized, small party visit, provided with a technical guide, so that members attending can derive the maximum professional benefit.

**The British Standards Institution.**—Any member who has had direct connection with B.S.I. Standards Committees and with Standards work in general, will know of the arduous nature of this work and the attention to detail which has to be given. Standards and specifications play an important part in the life of the professional engineer. It is often difficult to get agreement, but when agreement is reached and support obtained, the Standard is of vital concern to all members engaged in the industry. The Council is therefore, particularly grateful to those members who accept nomination to serve as Institution representatives on B.S.I. Committees. A list of representative members is given in Appendix 2 to this report.

There have been developments in the fields which are of particular interest to members. One is the consideration by the International Electrotechnical Commission of the Institution’s recommendations on Methods of Expressing the Characteristics of Signal Generators.† These recommendations are now before the B.S.I. Sub-Committee concerned with preparing standards.

In connection with the general subject of contemplated international Standards for Electronic Measuring Instruments is to be noted the setting up of two new B.S.I. Sub-Committees. These Sub-Committees (TLE/8/3 and TLE/8/4) will prepare draft Standards on Signal Generators and on Valve Voltmeters; the Institution is represented on both sub-committees.

Action is also being taken by the British Standards Institution to prepare one single Standard of graphical symbols to cover both electrical and telecommunications work, namely, to reconcile and combine B.S.108 and B.S.530. Many members who have had experience in both these fields will know of the contradictory symbols which exist. This effort by B.S.I. to produce a unified set of symbols has the full and active support of the Institution.

**Technical Meetings.**—In previous years the Technical Committee has co-operated with the Programme and Papers Committee in arranging some meetings of the Institution. With the formation of the Specialized Groups the Com-

† *J. Brit.I.R.E.*, 18, pp. 7-16, January 1958.

mittee is no longer required to give so much assistance in this direction. Consequently more time can be given to its main work in standards preparation, etc.

The Committee continues, however, to help any other Committee which requires specialized advice. For example, it co-operates with the Examinations Committee in the setting of the

Students Essay, with the Convention Committee when the occasion demands, and with the Group Committees when their work touches upon Standards and related topics. Through all these activities it is the aim of the Committee to ensure that the technical standards at both institutional and national level are continuously under constructive review.

### LIBRARY COMMITTEE

**Library Handbook.**—All members, both at home and overseas, received a copy of the handbook, "Library Services and Technical Information for the Radio and Electronics Engineer," which was published in November. This proved to be a useful reference and has been much appreciated by members, libraries, professional associations, industrial organizations, and other interested bodies. Although it was anticipated that the handbook would lead to a very much wider use of the Library, the increased interest surpassed expectations. Many members who had not previously used the Library now borrow books regularly and use the information service. Several enquiries have been received from overseas members. Although members outside the United Kingdom are not able to borrow books, all other library services are at their disposal.

There has also been an appreciable increase in postal loans; during the year 364 books were loaned, compared with 165 in the previous year.

The section of the handbook dealing with accessions to the Library will be kept up to date by the regular publication of supplements, two of which have already been issued.

The Library Committee wishes to record thanks to all who assisted in the compilation of the handbook, in particular, Messrs. L. W. Meyer and F. G. Diver (Members), Mr. S. G. Willby (Press Officer, B.S.I.), the Ministry of Supply (R.C.S.C.), and the Secretaries of the international organizations and committees, who supplied information on the "aims, objects and functions" of the groups in their own particular spheres.

**Translation Service.**—As a result of a notice which appeared in a library supplement, a list of technical translators has been compiled.

Several members have offered their services and translating facilities are available in six languages (German, Dutch, French, Russian, Hungarian and Spanish).

**Radio Engineering Overseas.**—Through this regular feature in the *Journal* members are kept informed of papers appearing in overseas periodicals which are received in the Library. Whilst the abstracts are translated, the papers themselves are in the language of the country of origin. Many requests for the loan of such journals are received, however, and if required, the Translation Service referred to is available.

**Co-operation with other Libraries.**—A large number of enquiries are received from libraries in industry, public libraries, and other information organizations, in this country and overseas.

**Library Fines.**—In an effort to ensure the prompt return of books, a system of fines was started in December 1958. A charge of 1s. is made for each week a book is overdue. This step has resulted in a greater turnover of books and consequently more members are able to borrow the books which are in greatest demand.

**Accessions.**—The problem of housing the books and periodicals persists and the Council is anxious to provide more spacious reference and reading sections for the visitors to the Library. The re-organization of the Library in 1957 however, enabled space to be found for the acquisition of 133 new books as well as additional periodicals.

The Library now regularly receives 161 periodicals originating from 25 countries. Additional periodicals taken during the year included *Transactions* of all the Professional Groups of the Institute of Radio Engineers of



America. Previously requests for these *Transactions* had to be passed on to other libraries, very few of which subscribe to all parts.

Other new subscriptions or exchanges arranged during the year were for 12 periodicals from the following countries: Czechoslovakia, Great Britain, Holland, Roumania, Japan, Pakistan, and Scandinavia.

**Acknowledgments.**—The Committee wishes to thank members who have presented books

and periodicals to the Library. The contributions from Messrs. M. T. Mason (Associate Member), W. K. Newson (Associate Member), N. S. Bakhshi (Graduate), and E. T. Mallory (Student), were especially welcome.

Thanks are also due to publishers in this country and abroad who have supplied new technical books which have been reviewed in the *Journal* and placed in the Institution's Library.

### PROGRAMME AND PAPERS COMMITTEE

Although mainly concerned with arrangements for the general meetings of the Institution and the examination of papers submitted for publication, the Committee also submitted proposals for the 1959 Convention and made recommendations to the Council on the formation of Specialized Groups.

During the year the detailed arrangements for the 1959 Convention were handled by a specially appointed Convention Committee under the Chairmanship of Mr. V. J. Cooper, B.Sc. (Member). Since this Report is circulated after the 1959 Convention, Council feels sure that the entire membership will wish to thank the Convention Committee for the work done in ensuring such a successful Convention, the results of which properly fall into next year's Report.

The activities of the Specialized Group Committees are reviewed separately in this Annual Report.

**Section Activity.**—The youngest of the Institution's Sections—the South Western Section—has now had its first full session of meetings and the five meetings held in Bristol were exceedingly well supported. Altogether, forty-nine meetings were held by the eight Sections in twelve different centres.

Further expansion of the Institution's activities throughout the country is planned; it is particularly hoped that a Section will be formed in Southern England, based on Southampton and Portsmouth. Council is also considering arranging occasional meetings in areas where the general concentration of members does not justify the establishment of a permanent Sec-

tion. In general, the Council only favours such arrangements where the area in question is adjacent to an existing and established Section.

Further afield the Sections in India, New Zealand, Pakistan and South Africa are to be congratulated on the way they continue to hold meetings which attract engineers from long distances. The full benefit of such activities both to the Institution generally and to the local members will depend on the increasing extent of the electronics industry in those countries. The extension of the Institution's activities to another country of the Commonwealth by the establishment of a Canadian Advisory Committee, is especially welcomed since one of its main objects will be the arrangement of meetings in Toronto and Montreal.

In London, 17 meetings were held during the 1958/9 session. An innovation was the inclusion of two half-day Symposiums, the first of which dealt with Radio Telemetry, and the second covering Large Capacity Storage Devices. Both these meetings attracted an attendance of over 180; all other meetings had an average attendance of 103.

**Conference of Local Section Chairmen.**—Although the Chairman of local Sections are *ex-officio* members of the Council, it is considered advantageous to continue holding a special meeting of Section representatives at least once a year. This not only provides opportunity for the full ventilation of Section views and activities, but also ensures that local Committees are familiar with Institution policy on a wide variety of subjects.

In addition, such conferences enable the



maximum help to be given to local Sections in arranging meetings best suited to the needs of the Section membership.

**The Journal.**—Both in content and in circulation the *Journal* continues to grow. The 1958 Volume contained 748 pages and included papers covering nearly all branches of radio and electronic engineering.

From notices which have appeared in the *Journal* members will know that in order to provide an authentic figure of circulation the Institution subscribes to the Audit Bureau of Circulation. By the end of the year, the Bureau Certificate confirmed that the circulation was in excess of 7,000 copies per month. This is not, of course, the final circulation figure of every issue, but is based on the A.B.C. formula as applied to newspapers and other journals.

Members have responded well to the suggestion made in the last annual report that those in a position to do so should recommend to their companies that the *Brit.I.R.E. Journal* be used as an advertising medium. More assistance is necessary, however, if the increase in publishing costs which will inevitably result from the settlement of the recent printing dispute, are to be met without reducing the size of the *Journal*.

**Consideration of Papers.**—A record number of papers was submitted during the year. Even more satisfactory is the fact that the standard of papers has not fallen with the increasing number submitted. It can fairly be claimed that this high standard of papers is due to one or both of two factors. Firstly, the *Journal* has become widely known among engineers in Great Britain and overseas as one of the most appropriate media for the publication of original papers on radio and electronics. Secondly, the Institution's leaflet "Guidance for authors of *Journal* papers" has been of great help to both experienced and novice authors in the preparation of their manuscripts in a form suitable to the *Journal*.

In the last Annual Report, it was forecast that Volume 18 of the *Journal* would contain a record number of papers from radio and electronics engineers overseas. Approximately 25 per cent. of the papers published were by overseas authors, the countries of origin including

Canada, Holland, India, United States of America, and Western Germany.

**Institution Premiums.**—At the request of Council the Committee has been considering the terms of reference of present Institution Premiums, and of four new Premiums which will be awarded annually from 1959.

Three of these new Premiums—the Charles Babbage, Lord Rutherford, and Arthur Gay Premiums—have been endowed to cover the increasing scope of the papers published in the *Journal*. The fourth—the Hugh Brennan Premium—has been endowed by a former Chairman of the North Eastern Section for an outstanding paper published in the *Journal* by a member of that Section. Details of these Premiums and the terms of reference were published in the February 1959 *Journal*.

Council approved the award of six of the existing nine Premiums for 1958 and details have been given in the July 1959 *Journal*.

**Co-operation with the Australian I.R.E.**—The Council of the Institution was again asked by the Australian Institution to adjudicate on the award of the Norman W. V. Hayes Memorial Medal. The paper by W. D. Meeuwen on "Some Aspects of Permeability Tuning," which was published in the August 1957 issue of the *Proceedings of the I.R.E. Aust.* was selected for the Award. Under the mutual arrangements which exist between the two Institutions, the paper was reprinted in the January 1959 issue of the *Brit.I.R.E. Journal*.

**The Christopher Columbus Prize.**—Members will recall the establishment of the Christopher Columbus Prize by the City of Genoa.\* This year the Prize is to be awarded in recognition of the most outstanding work in the field of communications.

Once again the Council of the Institution has been invited by the City of Genoa to make nominations for the award. The Council has unanimously recommended that the award should be given to those chiefly responsible for the initiation of Eurovision.†

\* The terms of reference of this international award were published in *J. Brit.I.R.E.*, 15, p. 334, July 1955.

† The last award in telecommunications was to British and American engineers responsible for the Transatlantic Telephone Project, *J. Brit.I.R.E.*, 16, p. 63, July 1956.

**Selected Abstracts.**—A revised edition of "Selected Abstracts from the *Journal* of the Brit.I.R.E. 1946-1958" was produced during the year. Once again this reference book has proved of great value to members, libraries, and to other readers of the *Journal*. It is intended that these Abstracts will be kept up-to-date by the issue of supplements at approximately half yearly intervals.

**Acknowledgments.**—The Council records thanks to the authorities of Universities, Tech-

nical Colleges, etc., who have provided facilities for Institution meetings. Particular appreciation is expressed to authors who have presented papers, to the organizations who have provided demonstration and other equipment, and to members who have given opinions on the suitability of manuscripts for publication.

The Council is also appreciative of the co-operation afforded by the editors of many technical and scientific journals who have included in their publications notices and reports of Institution meetings and other activities.

### REPORT OF GROUP ACTIVITIES

For the first time an Annual Report of the Institution deals separately with the activities of the Specialized Groups.\* Three of these Groups have been active during the year and Council will be reporting to the membership at a later date on the appointment of further Groups.

**Medical Electronics Group.**—The reference work "*J. Brit.I.R.E. Abstracts*" shows that the Institution had promoted a number of useful meetings and papers dealing with the application of electronics to biological research. Under the stimulus of the proposal made in 1958 to form an International Conference on Medical Electronics, it became obvious that a specialized Group of the Institution would provide the best means of covering the interests of many members of the Institution engaged in this particular branch of radio and electronics, as well as providing a specialized Committee which would advise in the matter of international and national representation.

The first meeting of the Medical Electronics Group was held in January 1959, and the Institution was honoured by Professor A. V. Hill, O.M., F.R.S., giving the Inaugural Address.

The Group Committee has since suggested proposals for a discussion on standardization which may be particularly applicable to this new and growing field. The Committee also

devoted time to suggesting papers which would be of particular interest in the programme of the 1959 Convention.

One of the purposes of the establishment of this Group Committee is to render every possible assistance to the Institution in the formation of a National Committee in Great Britain which will adequately represent medical, biological, scientific and engineering interests. It has been proposed that, under the aegis of the international body, a Conference shall be held in London in 1960. Through the Medical Electronics Group of the Institution, the Council is anxious to ensure that the Conference shall be successful and worthy of Great Britain as hosts.

**Computer Group.**—Computer technology has formed an integral part of the Institution post-war activity and was a feature, of course, in the 1954 Convention. Here again, the growing interest of the membership in this field is best served by the establishment of a specialist Group. The formation of this Group was largely inspired by a member of the Council, Dr. A. D. Booth, and his Inaugural Address as Chairman of the Group attracted wide attention. A subsequent symposium arranged by the Group Committee attracted an audience of well over 180.

Arrangements for holding meetings have obviously necessitated co-operation with the main Programme and Papers Committee, of which Dr. Booth is also Chairman. From the programme of meetings already arranged for the 1959/60 session, it is apparent that the Computer Group will certainly be most active.

\* Full details and terms of reference of these Groups, together with the membership of the Group Committees, will be included in the next issue of the List of Members to which reference has already been made.

**Radar and Navigational Aids Group.**—Here again Institution activity is reflected in the composition of a Committee responsible for ensuring that the interests of members engaged in this particular field are met.

The Group Committee has been concerned with arranging a programme of meetings and has also discussed with other Committees the matter of standards and the training required for technicians employed in the manufacture and maintenance of radar and navigational aids equipment. Due to the crowded programme at the end of the 1958-9 session, it was not possible to include the inaugural meeting of this Group; this will be held in October 1959.

**General.**—As a professional Institution develops and the engineering applications in which its members are engaged increase, it becomes very necessary to ensure that there should be sufficient opportunity for members with specialized interests to meet on common ground. As indicated in the last Annual Report,

### FINANCE COMMITTEE

The year's work for the Institution, in the financial sense, is shown by the audited Revenue Account and Balance Sheet appended to this Report.

**Income.**—Whilst all sources of income increased, it will be obvious that the *rate* of increase of revenue is the main concern of the Committee. It has inevitably led to a review of the present rates of subscription in relation to the services provided for members.

Members will be pleased to note the increased allocation to the Building Appeal as a result of further industrial donations.

All other items of revenue show an increase, with the exception of life subscriptions. In this connection, members are reminded that they may compound their annual subscriptions in one single payment, which can be used by the Institution for capital investment.

Whilst it is not the intention of the Council to call an immediate Extraordinary General Meeting for the purpose of revising the Articles, some comments from the membership on the

the Council intends to extend the establishment of specialized Groups. Meanwhile, it has been agreed that for the present time the idea of forming a Group on Missile Technology and a request for a platform for discussion on the "promotion of new music" shall be abandoned. The Council does intend, however, to establish a Group interested in Audio Engineering which may possibly consider it worth while to hold a special meeting to discuss "new music."

There is also a proposal that the Institution might devote more attention to the subject of "Quality Control." For the present, it is felt that meetings on this subject might well be the subject of a joint arrangement with other Institutions, as for example with the Institution of Production Engineers. The Programme and Papers Committee has been asked to examine this suggestion.

Finally, the Council wishes to emphasize that whilst Groups are obviously established primarily for the participation of members engaged in that particular branch of science, all members are welcomed at Group meetings.

question of increasing subscriptions would be welcomed. The Council would not favour, for obvious reasons, any increase in the subscriptions paid by registered Students and Graduates.

Members have, of course, already benefited by the decision of the Chancellor of the Exchequer to allow subscriptions to the Institution as a deduction from emoluments assessable to income tax.\*

In matters necessitating direct discussions between the Government and scientific bodies, the Parliamentary and Scientific Committee, of which the Institution is a founder member, is always helpful. The Council is grateful, therefore, to the Parliamentary and Scientific Committee for the representations made to the Chancellor of the Exchequer in regard to tax relief on professional subscriptions.

**Expenditure.**—The full impact of the October 1957 increase in postal charges became effective during the past year. Additional postage,

\* See *J. Brit.I.R.E.*, 18, p. 581, October, 1958.

including the despatch of Journals, List of Members, etc., added nearly £900 to the Institution's costs on this item alone.

The Parliamentary and Scientific Committee has again been most active in presenting to the Postmaster General the views of many professional bodies that postal rates on scientific Journals should be reviewed. There are obvious difficulties, however, and for the present it is unlikely that there will be any abatement of these heavy costs.

The percentage increase in administration expenses is low, bearing in mind the growth of the Institution and the fact that costs coming under this heading mainly reflect increases which in general are beyond the control of the Committee.

The largest increase in expenditure has been incurred in connection with Institution publications. Some part of this increase is due to a rise in printing costs, but the main reason lies in the considerable increase in the quantity of printed information circulated to members, including the expansion of *Journal* content. In comparing these costs with those of the previous year, it must also be borne in mind that a revised issue of the "List of Members" and "Technical Information and Library Catalogue" were published and despatched without charge to all members other than registered Students.

**Institution Headquarters.**—Although the Institution has many problems, none exceeds in difficulty that of headquarters accommodation. The lesser difficulty—acute though it may be—is that of adequately accommodating the staff necessary for the maintenance and expansion of Institution activities. The greater problem is the limitation imposed on the holding of members' meetings because of the lack of adequate facilities, principally that of a lecture theatre. The solution of this problem holds the key to future Institution expansion and usefulness to its members and to the profession. As already reported, therefore, the Council has decided to commence negotiations for a building site.

The acquisition of the capital necessary to purchase a site and building, however, is a slow process. The Council is indebted to those members who have given their support to the project and to the following companies who have

helped to launch the Building Appeal with donations of £500 or more:—

Associated Television Ltd.  
Broadcast Relay Services Ltd.  
E. K. Cole Ltd.  
A. C. Cossor Ltd.  
Curry's Ltd.  
Decca Record Company Ltd.  
Electric & Musical Industries Ltd.  
Erie Resistor Ltd.  
A. H. Hunt (Capacitors) Ltd.  
Marrison and Catherall Ltd.  
Mullard Ltd.  
Pye Ltd.  
Radio and Allied Industries Ltd.  
Tannoy Products Ltd.  
J. Langham Thompson Ltd.  
Whiteley Electrical Radio Co. Ltd.

Members who can contribute, or influence contributions to the building project are invited to give it their urgent attention and support.

Meanwhile, the cost of maintaining the present Institution building is increasing; here again the Finance Committee wishes to place on record appreciation of the efforts being made by the Parliamentary and Scientific Committee to secure a reduction in the rating assessment on premises used by scientific associations.

**Balance Sheet.**—The Institution's liquid Assets show a considerable increase, largely due to the extra monies now scheduled (2) as investment against the future purchase of a building. For this purpose it is considered expedient to have money on short call.

The Accounts show that cash donations to the Building Appeal now total £20,664. This does not, of course, include the amount outstanding under deeds of covenant and which, as at the 31st March 1959, brought the total donations to over £40,000.

**Overseas Accounts.**—It will also be seen that the financing of the Institution's operations overseas is facilitated by having overseas banking accounts; in subsequent years it is anticipated that the credits in those bank accounts will be substantially increased. Whenever necessary, however, such monies may be recalled for reduction of the liability with the Institution's main bankers.

**Library Account.**—Comment has been made in earlier years on the desirability of the re-valuation of the Institution's Library which, together with other equipment owned by the Institution, has always been subjected to an annual depreciation charge. The Library figure does not, therefore, truly represent the cost of replacement or indeed the value of the Library, and the Finance Committee believes that an early opportunity must be made for providing members with some factual report on the Library Asset.

**General.**—The Finance Committee is pleased to issue this report and Accounts which show continued progress, and believes that the membership as a whole will appreciate the importance of the points which have been made. The Council asks for co-operation in the efforts

designed to place the Institution's finances on a basis which will enable planned developments to be made in the near future.

### CONCLUSION

An Annual Report of an Institution must necessarily survey all the activities which come under the heading of the various standing Committees. The Council believes that the foregoing Report is evidence of the enthusiasm which attends the continued progress of the Institution.

All this work would be incapable of accomplishment were it not for the confidence which the Council is able to place in the permanent staff of the Institution. The Council feels sure that it reflects the view of the membership in expressing appreciation of the staff's implementation of Council policy.

### INVESTMENTS AT COST 31st MARCH, 1959

SCHEDULE (1)	<i>INVESTMENTS—GENERAL FUND</i>	£ s. d.	£ s. d.
£200 3% Savings Bonds 1960/70	... ..	200 0 0	
£800 4% Consolidated Stock	... ..	712 15 6	
£600 4% British Transport Guaranteed Stock 1972/77	... ..	544 1 4	
		£1,456 16 10	
(Market Value 31st March 1959, £1,278 0s. 0d.)			

SCHEDULE (2)	<i>INVESTMENTS—BUILDING APPEAL</i>	£ s. d.	£ s. d.
£1,400 4% Consolidated Stock	... ..	1,219 3 0	
£1,700 3½% War Loan	... ..	1,274 7 3	
£800 3% British Electricity Guaranteed Stock	... ..	597 6 0	
£2,900 4% British Transport Guaranteed Stock 1972/77	... ..	2,641 12 5	
£100 6% Associated Electrical Industries Debenture Stock 1978/83	... ..	98 10 0	
1,000 Units Orthodox Unit Trust	... ..	574 18 6	
250 Units A.E.G. Unit Trust	... ..	136 19 0	
£1,000 3% Exchequer Stock 1962/63	... ..	947 17 11	
£1,000 3% Exchequer Stock 1960	... ..	1,001 6 3	
£1,000 Government of the Federation of Rhodesia and Nyasaland 6% Stock 1978/81	... ..	988 0 1	
		9,480 0 5	
(Market Value 31st March 1959, £8,988 16s. 2d.)			
Halifax Building Society	... ..	4,208 2 3	
Balance at Bank	... ..	7,178 14 2	
		£20,866 16 10	

*The General Account and Balance Sheet is shown on pages 611-612*







## Appendix 1. Institution Members who serve on Advisory and Further Education Committees of Technical Colleges

- Birmingham College of Advanced Technology:  
Governor and Member of Engineering Advisory Committee  
PROFESSOR D. G. TUCKER, D.SC. (*Member*).  
Borough Polytechnic, London: Governor  
D. TAYLOR, M.SC., PH.D. (*Member*).  
City of Birmingham Further Education Sub-Committee:  
Electrical Engineering Advisory Committee  
R. A. LAMPITT (*Member*).  
City of Nottingham Education Committee  
F. W. HOPWOOD (*Associate Member*).  
Croydon Technical College:  
Electrical Engineering Advisory Committee  
G. A. TAYLOR (*Member*).  
East Berkshire Technical College:  
Electrical Engineering Advisory Committee  
F. G. DIVER, M.B.E. (*Member*).  
Erith Technical College: Governor  
R. G. D. HOLMES (*Member*).  
Flintshire Technical College:  
Engineering Advisory Committee  
PROFESSOR M. R. GAVIN, M.B.E., D.SC. (*Member*).  
Loughborough College of Technology: Governor  
AIR COM. W. C. COOPER, C.B.E., M.A. (*Member*).  
North Gloucestershire Technical College,  
Cheltenham: Science Advisory Committee  
F. BUTLER, B.SC. (*Member*).  
North West Wiltshire Technical College, Swindon:  
Engineering Advisory Committee  
H. HUNT (*Member*).  
Norwood Technical College:  
Advisory Committee Physics  
E. D. HART, M.A. (*Associate Member*).  
Norwood Technical College:  
Advisory Committee Telecommunications Engineering  
E. M. LEE, B.SC. (*Member*);  
D. A. E. BARNES (*Associate Member*).  
Nottingham and District Technical College:  
Joint Education Committee  
AIR COM. W. C. COOPER, C.B.E., M.A. (*Member*),  
(*Chairman*).  
Oxford College of Technology and Commerce:  
Science Advisory Committee  
E. W. PULSFORD, B.SC. (*Associate Member*).  
Redhill Technical College: Governor  
G. A. TAYLOR (*Member*).  
Rugby College of Engineering and Technology:  
Governor  
PROFESSOR D. G. TUCKER, D.SC., PH.D. (*Member*).  
Rutherford College of Technology,  
Newcastle-upon-Tyne:  
Electrical Engineering Advisory Committee  
PROFESSOR E. WILLIAMS, PH.D., B.(ENG.), (*Member*);  
J. BILBROUGH (*Associate Member*).  
Southampton Technical College: Governor  
PROFESSOR E. E. ZEPLER, PH.D. (*President*).  
South East London Technical College:  
Electrical Engineering and Applied Physics  
Consultative Committee  
S. R. WILKINS (*Member*).

## Appendix 2. Institution Representatives on Technical Committees of the B.S.I.

- ELE/TLE/2 Graphical Symbols for Electrical Engineering and Telecommunications.  
F. G. Diver, M.B.E. (*Member*).  
TLE/1 Terminology and Symbols for Telecommunications.  
F. G. Diver, M.B.E. (*Member*).  
TLE/1/1 Nomenclature and Letter Symbols for Telecommunications.  
To be appointed.  
TLE/2 Radio (including Television) Receivers.  
F. T. Lett (*Associate Member*).  
TLE/2/3 Receiving Aerials.  
A. Brown (*Associate Member*).  
TLE/3 Radio (including Television) Transmitters.  
J. R. Brinkley (*Member*).  
TLE/4 Components for Telecommunications Equipment.  
M. H. Evans (*Associate Member*).  
TLE/5 Electronic Tubes.  
G. R. Jessop (*Associate Member*).  
TLE/8 Instrument and Test Equipment for Telecommunication.  
S. R. Wilkins (*Member*).  
TLE/8/3 Signal Generators.  
R. A. H. Gooday (*Associate Member*).  
TLE/8/4 Electronic Instruments for Voltage Measurement.  
D. L. A. Smith (*Associate Member*).  
TLE/9 Aircraft Radio Equipment.  
J. D. O'Hanlon (*Associate Member*).  
TLE/11 Piezo-Electric Crystals.  
To be appointed.  
TLE/12 Transistors.  
B. R. A. Bettridge (*Member*).  
ELE/32 Radio Interference.  
O. E. Trivett (*Member*).  
ELE/66 R.F. Heating Equipment.  
R. E. Bazin (*Member*).  
ACM/8 Electro-Acoustic Transducers.  
H. J. Leak (*Member*).

## INSTITUTION NOTICES

### **Brit.I.R.E. Group with British United Provident Association**

As an additional service to members, who may prefer that they and their dependants should have private treatment for serious illness, including surgical operations, the Institution operates a Group with the British United Provident Association.

B.U.P.A. was formed in 1947 under the presidency of the Rt. Hon. Viscount Nuffield. It supplements the National Health Service by helping subscribers and their families with the cost of private treatment for illness or accident. Thus, registration with B.U.P.A. relieves anxiety by providing the means to have treatment under the most favourable conditions. During the past twelve years the Association has expanded rapidly and now covers over 750,000 people in the United Kingdom. By joining B.U.P.A. through the Brit.I.R.E. Group, the subscription is reduced and there is immediate entitlement to benefit without any waiting period. Subscriptions are payable annually in advance by Bankers Order.

Many members of the Institution have already joined or transferred to the Group. There are three age groups and five scales of benefit designed to give adequate cover throughout the United Kingdom. For example, a man between the ages of 30 and 49, by paying an annual subscription of £9 16s. can obtain grants of up to 24 guineas a week for private accommodation in a hospital or nursing home, 80 guineas for each operation (irrespective of number) and many other benefits, up to a maximum in any one year of £600. A feature of B.U.P.A. is that it provides a family service. The same man can include his wife in the registration for a further £4 17s. per annum and she will then be entitled in her own right to exactly similar benefits. He can also include all his children under 18 years of age for an additional total cost of £3 5s. per annum and each of them will receive the full scale of benefits. The other scales provide for higher or lower benefits at appropriate rates of subscription.

Existing members of the Association may apply to transfer to the Institution's Group, provided they are under 65 years of age, and that they enrol in Scales 6-10. A refund will be

made of any balance of the current individual subscription. In order that the transfer may be effected a Group application form should be completed quoting the subscriber's existing registration number.

Although the Group is open to members living in the United Kingdom, the benefits are available whilst a subscriber or his dependants are temporarily abroad on business or holiday. If treatment is received in hospital under the National Health Service, the subscriber is eligible for a special grant for other expenses connected with the illness, such as convalescence. Cover against the fee of a private general practitioner can be secured by the payment of an additional subscription.

Full details of the Group, with an application form, can be obtained from the Honorary Group Secretary, Brit.I.R.E., 9 Bedford Square, London, W.C.1.

### **Associated Television Grants**

The four main Independent Television Companies now distribute over £100,000 in grants to the arts and sciences each year. Recently Associated Television Ltd. announced grants for the year 1959 totalling £26,000.

As far as the sciences are concerned, £7,000 has been donated to Birmingham University for the founding of one Research Fellowship and two Research Scholarships in the Department of Electrical Engineering. In addition £2,000 has been made available for Commonwealth Scholarships to this country.

The Institution received the second of the covenant payments of £230, and also £52 10s. for the setting up of an annual prize of five guineas for the most outstanding candidate passing in the specialist subject of Television in the Graduateship Examination.

### **The Institution Tie**

Members are asked to note that owing to the continuing demand for the Institution Tie, it is now possible to reduce the prices as follows:—

Silk, 24s. 0d.; Terylene, 21s. 0d.

These prices include postage and packing.

Orders should be sent, with remittance, to the Institution at 9 Bedford Square, London, W.C.1.

# An X-ray Image Amplifier Using an Image Orthicon Camera Tube†

by

E. GARTHWAITE, M.B.E.‡, and D. G. HALEY‡

*A paper read on 4th July 1959 during the Institution's Convention in Cambridge.*

**Summary:** Special requirements of a television camera for use as an X-ray image amplifier are outlined. In television, illumination can be controlled, whereas in this X-ray application illumination is controlled by the thickness of the subject under examination. Details are given of the special camera tube which has been developed to operate under these conditions and also of the ancillary apparatus required to obtain maximum sensitivity and definition from such a tube. The reason for adopting a scanning system not compatible with any of the accepted standards is also discussed.

## 1. Introduction

The possibility of providing a brighter image, and, if possible, a lower dose rate for X-ray fluoroscopy, has received much attention in recent years.

Prior to the introduction of electronic devices to help solve this problem, much attention had been given to improving the fluorescent screens and these have been developed over the years to such an extent that one could not look forward to any major improvement in the future, and even if all the energy in the X-ray beam were converted to light the theoretical limit would represent only a 20 times improvement. The efficiency of the visual process involved in fluoroscopy is illustrated in Fig. 1.

It was suggested by Chamberlain in 1942§ that perhaps an electronic device could give a significant advantage, and a number of years later the static type X-ray image amplifier was introduced in America, followed by a similar device of European origin. A number of articles describing these devices can be found in the literature||. The introduction of these devices made possible, for the first time, X-ray cinematography at doses tolerable to the patient.

Much work has been done using static type

image amplifiers, but it soon became apparent that the size of the field, which is limited by the diameter of the image intensifier tube, was inadequate for some purposes and that an intensifier which was at least large enough to

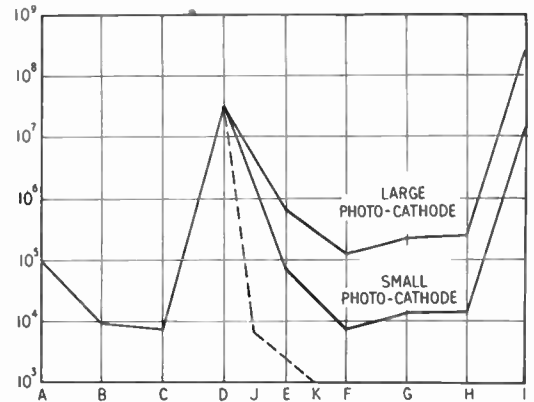
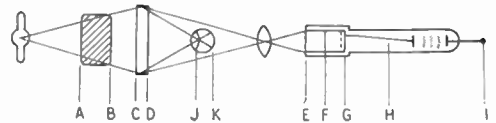

- A—Average number of X-ray quanta per elementary area in 1/2 c
- B—As above, less 90% absorbed by patient.
- C—Value at fluoroscopic screen.
- D—Average number of photons produced at screen.
- E—Photon value at photo cathode.
- F—Photo electrons.
- G—Value at target.
- H—Scanning beam modulation.
- I—Average value at output.
- J—Average number entering pupil.
- K—Effective at retina.

**Fig. 1.** Quantum value for visual and image orthicon fluoroscopy of an average chest with standard conditions of exposure.

† Manuscript received 30th April 1959. (Paper No. 521.)

‡ Marconi Instruments Ltd., St. Albans, Hertfordshire.

§ W. E. Chamberlain, "Fluoroscopes and fluoroscopy", *Radiology*, **38**, pp. 383-413, April 1942.

|| G. B. Banks, "Television pick-up tubes for X-ray screen intensification", *Brit. J. Radiology*, **31**, pp. 619-625, November 1958.

U.D.C. No. 621.397.331.21: 621.386.842



include an adult heart was a vital necessity for the further development of this new diagnostic tool.

Because of the difficulty of increasing the size of the image tube, the desire to increase the field size has led to an alternative method of image intensification by the introduction of optical coupling between the fluorescent screen and the photo-cathode, using the sensitive image orthicon as a light pick-up device.

A close analysis of the quantum efficiency at each of the stages shows that complete success could not be achieved unless the losses of the optical coupling could be considerably reduced. Figure 1 illustrates this problem: it will be seen that if the quantum efficiency at any point is allowed to drop below that which is necessary to provide the information in the final picture, this cannot in any way be restored in a later stage by amplification. In this connection it should be noted that there is a clear distinction between brightness gain and sensitivity gain.

The image amplifier to be described uses a mirror optical system in conjunction with a special image orthicon so that the losses in the optical coupling are reduced to a level where their effect upon the signal-to-noise ratio and, incidentally, definition, is not the limiting factor of the system.

From initial experiments, using refractive optics, it was decided that merely increasing the aperture of the lens would not give the gain in sensitivity and signal-to-noise ratio required. However, by using the largest possible photo-cathode area in combination with the widest aperture lens available, there was a possibility that a satisfactory image intensifier covering a large field could be produced.

## 2. Definition and Sensitivity

Before the problem is examined closely, it might appear that the definition requirements of an X-ray image intensifier will be lower than usual in standard television systems. Although this is indeed the case when viewing extremely thick parts, there are many requirements where the definition, if it is to compare with existing equipments, will have to be better than that considered satisfactory for television purposes.

The definition is limited, firstly by the screen converting X-rays into a visual image, secondly

by the optical system, and thirdly by the resolution of the target of the image orthicon. The scanning process which takes place at the target of the image orthicon is not, in this case, limited by bandwidth considerations as in television and therefore can be ruled out as a limit to the ultimate definition which may be achieved.

Present day X-ray screens of high efficiency have a circle of confusion which is smaller than  $\frac{1}{2}$  mm and at high brightness levels, where the losses in the optical system are unimportant, it is possible to maintain this definition throughout the whole system. This resolution, although better than present-day fluoroscopy is still below that which is obtained from radiographic films.

The reasons for this are obvious when one examines the detail of the various processes. In the case of films taken either direct from the patient or via a fluoroscopic screen, the film acts as a perfect integrator and collects all the information from the X-ray beam. This information can then be assimilated over a much longer interval of time when the film is viewed for diagnostic purposes. In fluoroscopic examinations it is necessary to have the X-rays on for the whole of the assimilation time. It is therefore necessary to reduce the intensity of the X-rays so that the dose to the patient is kept within tolerable limits. Methods to overcome this limitation will be discussed in the latter part of this paper.

The information in an X-ray image, either on film, or fluoroscopic screen, is proportional to the number of quanta per unit area. These events occur in a random fashion and it is necessary to have a ratio of at least 3 to 5 times between the detail to be perceived and the relative fluctuations of the surrounding area. Therefore, at lower light levels at the screen, proportional to less radiation to the patient, the detail will be less because then it will be necessary for the area to be increased so that the above ratio can be maintained†.

There are further factors limiting the resolution of the system which are not concerned with the quantum nature of the X-ray beam or the efficiency of the various processes, such as the fluorescent screen, the lens aperture and the photo-cathode efficiency. These are con-

† G. B. Banks, *loc. cit.*

cerned with the size of the focal spot of the X-ray tube in use and the efficiency of the anti-scatter device, which has to be used when thick sections are under examination.

There is a further factor concerning resolution which has to be taken into account when using an image orthicon tube. This concerns the signal-to-noise ratio of the scanning process. It has been discovered that by varying the distance between the target-to-mesh spacing, better signal-to-noise ratio can be obtained at

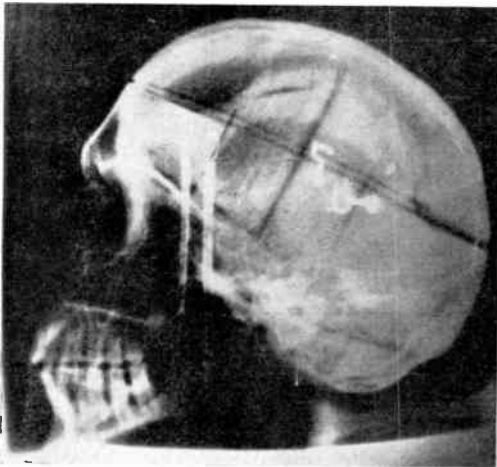

(a)

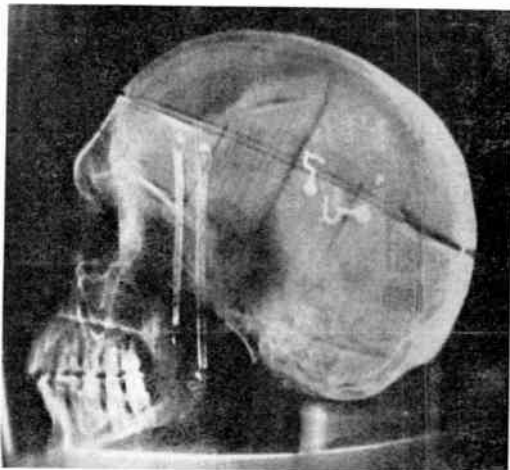

(b)

Fig. 2. Comparison negative photographs between (a) close and, (b) wide spaced tubes, using a skull phantom. The greater sensitivity and gamma compression of the wide spaced tube is apparent. (70 kV,  $7\frac{1}{2}$  mA. sec. 0.5 sec.)

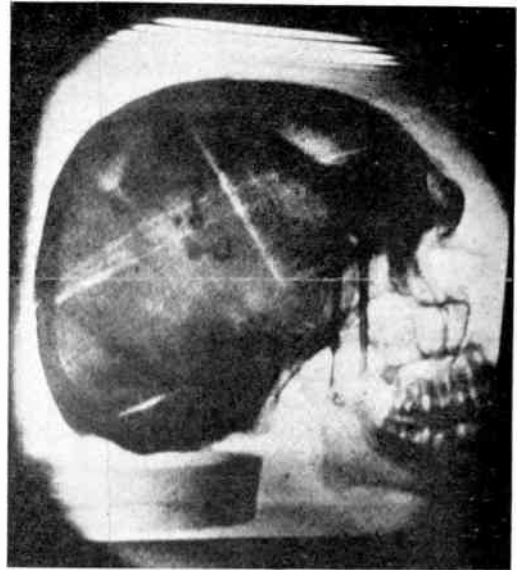

Fig. 3. Positive photograph of stored image using a direct view storage tube.

extremely low light levels than with conventional spacings. There is considerable gamma compression when using image orthicons with a wide target-to-mesh spacing and it is this property which no doubt contributes considerably to the additional sensitivity which can be obtained with tubes of this type (Fig. 2†).

It is fairly obvious that although the image orthicon image intensifier compares favourably with conventional screening and the static type intensifier, it is not likely that any significant reduction in the patient dose will be achieved. There is, of course, the reduction due to better perception and the improvement in fine detail, and also the very great advantage that cine and miniature still pictures can be made of all sections of the patient at tolerable doses. By using X-rays only to form the image and storing this image while it is assimilated, a great reduction in patient dose will be possible, and it is in this direction that it is believed that the ultimate reduction of dose will have to be sought.

Experiments have already been made using a direct view storage tube and the results of these at the moment rather crude experiments are

† A. A. Rotow, "Image orthicon for pick-up at low light levels", *R.C.A. Review*, 17, No. 3, p. 425, September 1956.

shown in Fig. 3. The resolution and transfer characteristics are not at present satisfactory, but it is quite conceivable that this or other schemes will be evolved so that the image can be written in the same fashion as it is in conventional radiography, and thereafter continuously displayed without further radiation to the patient. Images at one per second would give a dose reduction of 25 : 1. Further experiments are continuing on these lines with other forms of storage devices.

It is agreed that the movement of such organs as the heart will have to be displayed stroboscopically but the detail to be displayed in fluoroscopic examination can obviously be much greater than has to be accepted using conventional screening and continuous radiation of the patient.

With conventional fluoroscopy, in the past, it has been usual to operate at fixed X-ray conditions which are just tolerable to the patient for a reasonable time and to use the great range of human visual perception to discern detail in various parts of the anatomy, regardless of the fact that the amount of X-ray arriving at the screen to form the image varies considerably over different parts of the subject. At the chest 1 per cent of the X-ray arrives at the viewing screen, at the abdomen 0.1 per cent and a lateral view of the abdomen 0.01 per cent. There is also the fact that an increase in the patient thickness of 2 : 1 decreases the X-ray at the screen by a factor of 10, and hence the total range that has to be accommodated is in the region of 1000 : 1. Using radiographic films this range is reduced to that which can be accepted by the film by altering the kilovolts, milliamps and time to get a satisfactory exposure.

To enable the television image intensifier to be used for fluoroscopic examination it has been necessary to provide flexible controls that can accommodate the great change in levels when scanning across the patient. This has been achieved by using a number of push buttons to select pre-set settings of the camera. Further settings are provided for fluoro-photography. For cine work the conditions apply as for screening, but for miniature stills of the full-size image the conditions are more related to conventional radiography, where the conditions can be pre-set and there is no difficulty of having

to accommodate large changes in light levels at the screen.

To improve definition when less than the full size images are employed, as is usual when investigating thicker parts of the abdomen, provision is made to alter the field of view so that the smaller image will include the whole of the television scan. This is accomplished by altering the magnification between the photo-cathode and the target.

Cine-recording is very akin to telerecording in television, except that there are no limitations concerning the reproduction. It has therefore been possible to record at 16 frames per second, losing only one field in every three to cover the film movement. For faster speeds it is thought that it will be necessary to use a continuously moving film, so that all the fields are recorded. This may be specially important for certain medical applications.

Although it has been possible to specify the performance of this instrument in respect of such matters as field size and resolution, it is difficult to find any parameter for clearly defining the sensitivity as compared with other systems. The usual definition of sensitivity, as applied to X-ray images or films, is a graph showing the relationship between detail size and contrast and bears no relation to brightness gain. The brightness gain of the present system, measured photographically, is greater than 500 times.

To make a statement on the sensitivity in terms of the ability to provide a satisfactory image at stated X-ray factors, such as milliamps and kVp, is extremely difficult because this depends upon the initial calibration of the X-ray source. A better assessment can be made by quoting the X-ray dose at the patient's skin in terms of roentgens per minute. Initial experiments in this direction show that there is a substantial gain over the conventional fluoroscopic examination in sensitivity as expressed in these terms. These remarks refer to an average size patient.

### 3. Description

The apparatus consists in the main essentials of a camera unit, control unit, electronic rack and the radiologist's viewing monitor, plus an additional recording camera when this is required (Fig. 4).

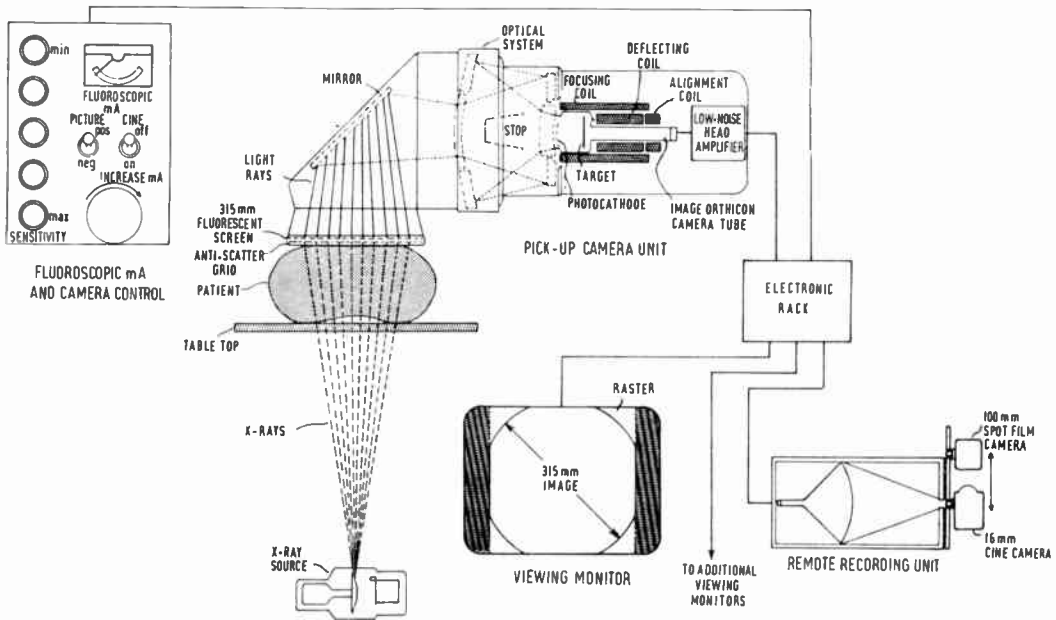

Fig. 4. Marconi 12-inch image amplifier schematic.

Although this is a closed-circuit television channel, certain differences will be noted. The first is that the large aperture lens is of considerable size and is working at a fixed focus. The control of the camera has been simplified to allow the camera to be adjusted to the screen illumination, which is dictated by the part of the patient to be investigated. This is, of course, different from the usual television camera operation where the studio lighting is modified to suit optimum camera conditions.

The scanning system does not conform to any of the published standards, as experience with the earlier models indicated that viewing distance to the monitor for X-rays will be only a matter of 6 to 9 inches and at this distance the lines of the picture are very apparent. Therefore, to increase the number of lines without using excessive bandwidths, it was decided to use triple interlace giving essentially 16 complete pictures per second and approximately 1000 lines.

The use of the image orthicon television camera as an X-ray image intensifier has been investigated by Strum and Morgan, in America, using the 3-inch image orthicon. In this country the 4½-inch image orthicon has been developed for broadcast purposes by the English Electric

Valve Company and since this tube is superior to the 3-inch version as regards signal-to-noise ratio, its use at the very low light levels encountered in diagnostic X-ray seemed to merit investigation.

The range of high-light levels produced by X-ray screens, using normal screening doses, is from  $10^{-4}$  to  $10^{-1}$  foot-lambert, compared with about 30-40 foot-lambert in a broadcast studio. This latter figure will fully charge an average standard 4½-inch image orthicon (P811) with a lens aperture of approximately  $f/8$ . Since the X-ray image is produced on a flat screen, there is no depth of focus problem, so that the widest aperture lens obtainable may be used. However, even if a lens aperture of  $f/0.7$  is used, the peak high-light required to charge the target to the knee of its characteristic curve will be about 0.25 foot-lambert, which is still well above the level which can be expected from an X-ray screen.

Figure 5 shows the standard image orthicon characteristic of signal output against photocathode illumination on arbitrary logarithmic scales. Below the knee the curve has a slope or gamma of unity. Also shown on the same scales is a curve of beam noise, which theoret-



cally has a slope of  $\frac{1}{2}$ , since beam noise is proportional to  $\sqrt{\text{(beam current)}}$ . The signal-noise ratio would therefore be expected to decrease as the square root of the light level. In practice, the signal/noise ratio decreases more rapidly at low light levels, due to the decrease in the beam modulation. Beam modulation is

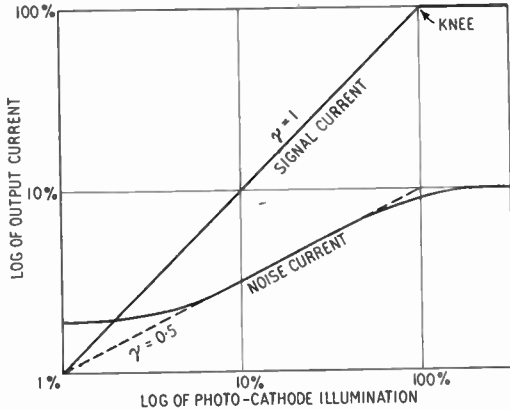

Fig. 5. Image orthicon transfer characteristic.

a function of the voltage to which the target is charged, and this is proportional to light input when working below the knee. The beam has a certain velocity spread, and at low target potentials only the very fastest beam electrons will land on the target. Another effect due to the very low target potential and low beam efficiency, is that the target is not completely discharged in one scan; the target must be scanned several times to take off most of the charge. The result of this is serious lag on moving objects. These effects limit the lowest light level at which the standard 4½-inch image orthicon can be used, when the signal/noise ratio becomes so poor that the signal is of no practical use.

There is another ill-effect of the standard tube used near the limit of its sensitivity which should be mentioned. If a reasonable signal-to-noise ratio is to be obtained, the beam current must be set very critically at just sufficient to discharge completely the high-lights of the picture. When the beam is so set, the tube is very susceptible to changes in light level, a slight increase causing an objectionable peel-off due to incomplete discharge of the target. For these reasons the standard broadcast image orthicon is unsuitable for use at very low light levels.

The total light which is collected is proportional to the brightness of the image and also to its size. The 4½-inch image orthicon bulb will accommodate a larger diameter photo-cathode than is normally used and in the P825 a photo-cathode of over 3½ inches diameter is used. A lens to cover this large photo-cathode and have an aperture of  $f/1$  or less is both rather bulky and expensive. Lenses of this type, using reflective optics, have fortunately already been developed by Dr. Bouwers for his Odelca X-ray cameras, and the lens used produces an image of 80 mm and has an effective aperture of approximately  $f/0.7$ . The image produced by this lens is spherical, necessitating a spherical face-plate to the image orthicon. This is an advantage, however, as far as the tube is concerned, since it makes easier the reduction of a 3.2-inch image onto a 2-inch target. The material used for the photo-cathode has been chosen to have a colour response which matches as nearly as possible the colour characteristic of the X-ray screens used.

The photo-electrons are accelerated and focused onto the glass target, where they produce a charge pattern of the image by secondary emission, the secondary electrons being collected by the target mesh. The spacing of this mesh from the glass target has a very considerable effect on the characteristics and behaviour of the image orthicon. It has been shown† that for very low light level work with image orthicons, a large target to mesh spacing, of the order of  $\frac{1}{4}$  in. is desirable.

Figure 6 shows the signal/light characteristics of a close and a wide spaced tube. These show clearly the reason for the choice of wide spaced target. The close-spaced tube (A) has gamma of unity and hence a much shorter grey scale than the wide-spaced tube (B), which compresses the grey scale, and has no well-defined knee, but a long, gradually changing slope. Although the absolute noise level is higher in the case of the wide spaced, the range of half-tones which produce a signal level above the noise level is seen to be much greater. Also due to the flattening off in the highlight region, beam setting is far less critical of changes in highlight brightness.

† A. A. Rotow, *loc. cit.*



The television scanning system used is 1024 line, 50-field, interlaced 3:1. This non-standard system was chosen to meet the requirements for definition and lack of line structure while still enabling standard components to be used. The definition obtainable on other types of X-ray image intensifier is at least 30 mesh/inch, i.e. 60 television lines/inch and this is the minimum definition aimed at in the central 60 per cent of the picture area. Since we are providing a field of view of 12 in. diameter, this means a definition of  $12 \times 60 = 720$  lines in each direction. A square raster has been adopted to make best use of lens, target and amplifier bandwidth. 1024 is  $2^{10}$ , which means that ten binary counters can be used in the synchronizing generator divider chain, without feedback. Also by closing feedback loops, the same binary chain can be made to divide by 675, giving a 2:1 interlace. The latter system is provided in case the  $16\frac{2}{3}$  pictures/sec should be too slow for some faster movements. The basic line frequencies of the two systems work out to be  $17,066\frac{2}{3}$  and 16,875 respectively. Since these are less than 200 c/s apart it is possible to switch from one to the other without any readjustments. Also, they are near enough to the 625-lines standard to enable standard parts, such as scan coils and transformers, to be used. The synchronizing pulse generator has been built using transistors throughout. In order to simplify the circuitry and ensure good interlace, particularly on the 3:1 system, the monitors are driven by line and field pulses direct.

As well as obtaining the desired results, it was essential to design the equipment to be capable of operation with the minimum of controls by personnel who are unskilled in the operation of television cameras. This problem is increased by the fact that, at low light levels, the settings of some tube controls become more critical. To meet this requirement a set of five buttons has been provided which operates relays to bring into circuit different sets of those controls which need readjustment on changes of light level. Each position is preset for different light levels, and the technique is to work on the lowest light level which will give a satisfactory picture. The X-ray milliamp control is on the same panel and may be used as a fine adjustment on light level.

A sixth relay and set of variable controls is set up for best possible picture under optimum light conditions. This relay is brought into operation by the Spot Film button on the X-ray table. When this button is pressed, as well as resetting the image orthicon, a fairly large pulse of X-rays is provided for a short period (0.04

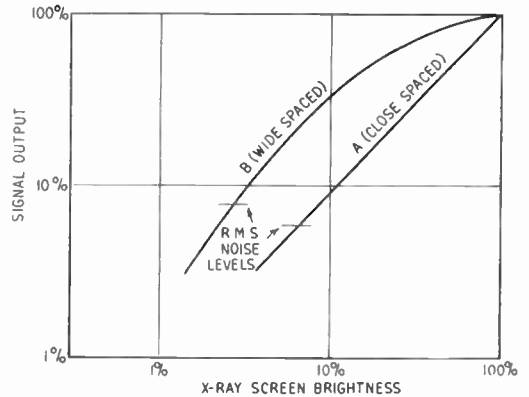

Fig. 6. Comparison of close and wide spaced targets.

to 0.25 sec), thus giving an optimum light level picture. This picture is recorded on 70 mm film off a remote recording monitor, so that a small X-ray film of high definition can be obtained.

Alternatively, cine-film can be taken of an examination on a separate recording monitor while the examination is being carried out, using only the X-ray dose necessary for normal screening. This represents a considerable advance on static image amplifiers which must have an increased X-ray dose sufficient to expose cine film; with a television system, the brightness of the recording monitor is under control.

In order that the cine camera pull-down and the television fly-back shall not strobe and produce an interference bar, the cine camera and the television system must be locked together. A simple 16 mm recording unit has been built using a comparatively inexpensive camera and a standard monitor. The shutter was removed from the camera to ensure that the whole of the stationary period of the film was used. The camera was driven by a synchronous motor and a blanking pulse applied to the monitor to suppress every third field, the two being phased

so that pull down takes place during this field. Since the television picture is square and the film format is  $4 \times 3$ , only the central 75 per cent of the picture was recorded, leaving  $12\frac{1}{2}$  per cent of the picture at top and bottom to cover overlap of the pull-down. This system proved quite satisfactory for the recording of  $16\frac{2}{3}$  pictures/sec.

The telerecording systems used on normal broadcast television can also, of course, be used for X-ray cine recording.

The 100 mm spot film camera is also exposed in the same way, i.e. by pulsing the monitor, the monitor, X-rays and image orthicon all being set by the operation of the spot film button. In order to obtain higher definition than is normally available over a smaller area, it is proposed to change the area covered from 12 in. diameter to about 8 in. diameter by altering the magnetic image reducing field in the image orthicon. Unfortunately, this can only be done at the expense of sensitivity, since less total charge will reach the target and therefore it is only useful for spot film technique, where the X-ray current may be increased to compensate and the dose kept down by reducing time.

However, when large direct view storage tubes become available, this higher definition will be available for instantaneous viewing, since these tubes will enable a short X-ray exposure to be viewed for up to several minutes without any further dose to the patient.

The electronic circuitry is similar to that used for broadcast cameras and is based on the Marconi Mk. IV  $4\frac{1}{2}$ -inch television camera. All controls are preset and are contained in one of the three cases which house the main circuitry. These cases contain the power supply, the signal processing circuitry, and the synchronizing generator and preset controls.

#### 4. Conclusions

The advantages of a television type image intensifier over the conventional static types may

be summarized as follows:

- (1) The ability to change the field size at will and the possibility of large field sizes from the same equipment.
- (2) The adaptability of the scanning system which allows devices such as direct view storage monitors to be used, with the possibility of great reduction in patient dose.
- (3) The substantial increase in brilliance of the monitor pictures over any other image intensifier, allows photographic work with fine grain film.
- (4) No dark adaptation of the eye is necessary.
- (5) Screening currents can be reduced so that fine focus X-ray tubes can be used with the consequent great improvement in definition of those parts where this is required.
- (6) All wet processes for X-ray diagnosis are eliminated and information is immediately available with its consequent advantage both to the doctor and to the patient.

The disadvantages compared with the conventional static type image intensifier are as follows:

- (1) Poorer signal-to-noise ratio when viewing thicker parts. This is somewhat offset by the fact that fast films with coarse grain normally have to be used with the conventional image intensifier.
- (2) Possibly higher costs of installation, due to the larger bulk of the optical system necessary.
- (3) The necessity for close control of the camera to meet the changing light conditions. This is not necessary during fluoroscopy, using a static type image intensifier, but is necessary when cine radiography is attempted. This disadvantage is therefore only apparent during fluoroscopy, and not during the interesting field of cine radiography.

## DISCUSSION

**T. E. Ivall:** Can Mr. Garthwaite say anything about the electro-luminescent amplifier and whether it is likely to prove a competitor to the television system for image intensification.

**E. Garthwaite (in reply):** We have a recent report on this light panel which shows that unfortunately it has a very long time constant. It needs a considerable amount of X-rays either

in a tremendous initial dose or over a long time in order to excite it. The panel can then be used very much like a conventional storage tube. Unfortunately, the signal/noise ratio, which one would expect to be near perfection is in fact quite poor. This is said to be due to manufacturing difficulties of the photo-conductor.

**A delegate :** Fig. 2(b) seems to have a three-dimensional quality which must have been an artefact introduced by the equipment. Is there any way in which the physician or radiologist can check the actual optical image to make sure that what he may see is in fact an artefact and not the real thing. For example, a certain type of noise might lead to a diagnosis of tuberculosis in the lung.

**E. Garthwaite (in reply):** The images shown are those which we use to guide ourselves. If we were taking pictures for X-ray diagnosis these would be taken at a level where the noise was not apparent. The effect of the gamma compression which you describe as an artefact can be an advantage in X-ray diagnosis.

**A delegate :** I would like to ask Mr. Garthwaite whether one can actually improve the appreciation contrast for the picture by adjusting the transfer characteristic of the system.

**E. Garthwaite (in reply):** The gamma compression, as it may be termed, means that in a small range of light and dark we can include more steps of grey. The greater number of grey scales is obtained not by any trick of the circuitry, but through the tube itself having a wide distance between the target and the mesh: it is a phenomena of the tube.

**M. F. Osmaston :** It occurred to me that in many X-ray pictures there would be considerable advantages in stereoscopic views of the patient. Perhaps this could be achieved by using rotating anode tubes with the two surfaces constituting the respective points of origin for the X-rays. The pictures could then be displayed on two tubes and viewed stereoscopically.

**E. Garthwaite (in reply):** We have already talked to the medical profession on this point. At the moment they use mostly a two-plane technique with the planes at right angles. We

have asked radiologists if they would accept a stereoscopic picture instead which would be based on very much the same system as Mr. Osmaston has just suggested, but we are unlikely to get their opinion until we are able to demonstrate stereoscopic equipment.

**R. A. Chippendale :** Could Mr. Garthwaite explain how the thick part is also affected by regions of low contrast? With wide spaced mesh and low gamma one can also resolve very satisfactory these low contrasting variations in gamma. The skull is of course a nice contrasty specimen.

**E. Garthwaite (in reply):** We have no difficulty at all with this tube in doing this. As with other television equipments we can increase contrast by using more gain.

**A delegate** asked if the device had been applied to the radiography of castings and forgings.

**E. Garthwaite (in reply):** We have made a few initial experiments but have not gone very far. In the industrial field it is sensitivity that is important, that is, being able to discriminate between small difference in thicknesses. In the case of aluminium the intensifier would be quite practical today. In the case of steel, however, it is not practicable yet because of the short integrating time of 1/25 sec compared with film exposure of up to 20 minutes or so. By employing some form of storage system we believe that a satisfactory system may be developed in the future.

**M. H. Cox :** Has any work been done on a suitable device which would convert the X-rays directly into a television type image? This would mean that it was not necessary to go through the fluorescent screen and then onto the photo-cathode and then onto the target.

**E. Garthwaite (in reply):** There are two possibilities. First of all a vidicon can be made directly sensitive to X-rays, but of course it suffers from the usual problems that the time of storing the image and releasing it is too long. Secondly, there is the same principle used in the panel type amplifier which is a sandwich of an electrical luminant and a photo-conductor, the latter being directly sensitive to X-rays.

## NOMINATED FOR ELECTION TO THE COUNCIL

**Air Marshal Sir Raymund George Hart** was born in Merton, Surrey, in 1899, and educated at the Simon Langton School, Canterbury. During the first world war he served in the Royal Flying Corps, and in 1918 was awarded the Military Cross for a combat victory over four enemy fighters while piloting an artillery observation aircraft.



After the end of hostilities he studied at the Royal College of Science, gaining his A.R.C.S., and later at the Ecole Supérieure d'Electricité, Paris, where he received the diploma of Ingenieur Radio-Electricien. Between 1930 and 1933, while Signals Staff Officer at R.A.F. Headquarters in India, he re-designed and rebuilt the Internal and Inter-Command R.A.F. Radio Communications Systems in that country. From 1936 to 1938 he served at the research station at Bawdsey, where he was closely associated with the pioneer development of radar, and subsequently was responsible for the introduction and application of ground based and airborne radar throughout the war.

Air Marshal Hart was appointed Chief Air Signals Officer, S.H.A.E.F. in 1944, and in this capacity was responsible for the planning and control of radio, radar and radio counter measures for the Allied Air Forces in the invasion of Europe. After the war his appointments included that of Air Officer Commanding No. 90 Signals Group, and Director General of Engineering. From 1956 to his retirement at the beginning of this year he was Controller of Engineering and Equipment at the Air Ministry.

For his services during the war Air Marshal Hart was appointed a Companion of the Most Honourable Order of the Bath, and in the Birthday Honours List of 1957 his promotion to Knight Commander of the Military Division of the Most Excellent Order of the British Empire was announced. Sir Raymund is now Director of the Radio Industry Council.

Sir Raymund was elected a Member of the Institution in 1957. Many members will recall that as Air Vice-Marshal Hart he proposed the toast of "The Institution" at the 1954 Convention Banquet at Christ Church, Oxford (published in the August 1954 *Journal*), and Sir Raymund has on numerous occasions advised the Council on matters affecting members serving in the R.A.F. His account of the history of radio and radar navigation for aircraft, given at the inaugural meeting of the Radar and Navigational Aids Group, is clearly based on first hand experience and will certainly be read with great interest by all radio engineers.

**David Latcham Leete**, who is nominated for election to Council as one of the Associate Members, is engaged in research at Manchester University in the Faculty of Technology. Here his work includes fundamental investigation into the design of machine tools to meet the increased accuracy in machining operations made possible by fully automatic electronic control. He was seconded to this appointment in 1957 from the Radar Research Establishment (now Royal Radar Establishment) where he had been concerned for the previous twelve years on such problems as airborne radio counter measures and high power radar transmitter design. From 1941 to 1944 he worked on counter measures at the Royal Aircraft Establishment.



Mr. Leete who was born in London in 1918 and educated at King's School, Ely, received his technical education at King's College, University of London, where he obtained a B.Sc. degree in 1941.

Elected an Associate of the Institution in 1941, Mr. Leete was transferred to Associate Membership in 1944. He took a leading part in the formation of the South Midlands Section based on Malvern and Cheltenham, and served as its first Chairman in 1956.



# The Problems of Reliability and Maintenance in Very Large Electronic Systems for Shipboard Use†

by

Captain G. C. F. WHITAKER, R.N. (RETD.), MEMBER‡

**Summary:** Current naval technical development is leading to the development of electronic systems for weapon control, air direction and guided missiles characterized by "size" and "complexity" of a different order of magnitude to anything hitherto met with at sea. Such very large systems, built up, in the main, of essentially commercial quality valves, resistors, capacitors and other electronic components, clearly present special problems if a high order of reliability is to be achieved. The special hazards of service at sea and the particular problems imposed by great size are considered. At the detailed design level the author suggests a number of possible approaches for the achievement of high reliability. Considering such systems as a whole the statistical pattern of component failure is discussed and taking practical examples the probable period of fault-free operation is derived. Typical figures are cited. The importance of rapid repair under battle conditions is stressed. Monitoring methods are critically reviewed.

## 1. Introduction and Historical

*"In an age of swift invention it is frequently believed  
That the pushing of a button is as good as work  
achieved.*

*But the optimist inventor should remember if he can  
Though the instrument be perfect there are limits to  
the man."*

The above lines were written by Admiral Hopwood at a time in the history of the Navy (1904), somewhat similar to the present, when great technical advances were imminent and are typical of the concern of the conservative present for the implications of the (always alarmingly complex) future.

Technical advance in the Naval sphere appears, as in other fields, to proceed in a series of random steps of major development separated by long periods of stagnation, or to put it more euphemistically, consolidation. Sir Francis Drake, Admiral Blake, and Lord Nelson, to name three successful Admirals widely separated in time, fought their battles with, broadly speaking, very similar ships

† Reprinted from *The Proceedings of the Institution of Radio Engineers, Australia*, 19, No. 12, December 1958. (Paper No. 522.)

‡ Formerly Director of Electrical Engineering, Department of the Navy, Melbourne, Victoria; now with Central Rediffusion Services Ltd., London, W.C.2.

U.D.C. No. 621.37/9.004.5

and remarkably similar weapons. The ship's company of the *Golden Hind* could have commissioned and fought the *Victory* with very little difficulty though a considerable increase in required numbers.

Major changes set in at the close of the nineteenth century with the coming of steam, the screw propeller, iron and later steel hulls and, somewhat later the advent of the breech loading gun. There followed a period of consolidation until roughly 1904 when a second wave of progress set in. The submarine emerged as a practical proposition, the torpedo was well established, the steam turbine appeared as the essential prime mover while the introduction of both wireless telegraphy and of the first rational fire control arrangements involved a marked extension of the uses of electricity in warships. All these things tended to make the warship of the period a very much more complicated unit, in the technical sense, than it had been in the past and provoked, amongst other reactions, the heart cry from one of England's most distinguished sailors quoted above. World War I was fought with the developed products of this particular period of evolution.

Between wars it can be said broadly that the accent in weapon development was on surface action and anti-submarine warfare. The offen-



sive weapons were the gun and the torpedo (delivered by ship, submarine or aircraft) while defensive weapons, other than the above, were limited to mines and depth charges. Anti-aircraft guns and fire control systems remained in their infancy and were more than a little primitive. The bomb was not very seriously considered as an anti-ship weapon.

Technically, inter-ship gunnery actions and anti-submarine warfare are characterized by the very low relative rates of change of the relevant parameters—essentially range and bearing for the gunnery case—and by the fact that in the case of the gun and, to a slightly lesser extent the torpedo, the velocity of the “missile” is extremely high in relation to the speed of both the target and the firing ship.

Prediction methods, if used at all, were therefore limited to simple velocity resolving systems, “rates” were derived directly from the slope of a distance/time plot and initial inaccuracies in range finding were corrected, along with misinformation on gun ballistics and meteorological data, by range spotting based on visual observation of fall of shot. Tachometric fire control systems were neither attempted nor necessary for the purpose then in hand. Due to the low relative rates, open loop, non-synchronous, hand followed, data transmission systems met all needs.

The main developments of World War II were, perhaps, the discovery and application of radio location providing a highly accurate measurement of both range and angular data, independent of visual aid, and the mass exploitation of air attack using the bomb rather than the torpedo.

The submarine remained much as in the past during the greater part of the war until German developments in new propulsion systems and underwater streamlining threatened to extend its speed and potency immeasurably. The war, perhaps fortunately, ended at this stage.

The point to be noted is that, to a large degree, most of the complications in warships at the close of the war lay in ancillary devices which had been added on to relatively simple primary systems. These devices were most useful aids but were not absolutely essential to fighting the ship with some reasonable prospect

of success. An echo sounder is convenient and useful but one can, at a pinch, use a sounding machine or lead and line.

The immense potency of air attack made it immediately necessary to evolve very much more sophisticated Fire Control methods. The field of operations was transferred from a two-dimensional plane to three-dimensional space and, with the tremendous development of aircraft in all respects, but especially in range, speed and ceiling, the gun began to lose its velocity advantage over the target. This trend has persisted since the war at an ever-increasing pace and it is now true to say that the chances of shooting down a modern aircraft at the desired range with an unguided missile are unacceptably small.

We are, in short, once again moving into a period of intensive technical development involving an immense increase in the technical complication of shipborne weapons and having implications which have yet to be fully resolved.

So far as Fire Control is concerned it is now no longer in any way acceptable that guns (or similar weapons) should be aimed, fused, or fired with the intervention of a series of human links and it is essential that all these functions, including, of course, the prediction, should be carried out automatically. This in its broadest terms involves the use of a large number of high grade servo systems, the practicalities of the case being such that their performance and speed of response must be of an order not normally necessary in the industrial world.

In naval parlance the fire control element in a ship's Electrical Department has traditionally always been known as the “Low Power Section.” It is an interesting commentary on the trends of the times to note that in the *Tiger* class cruisers, now building in the United Kingdom, the largest motors in the ship are the turret training motors which lie at the actuating end of the turret training servo loop. Properly enough they continue to be operated by the “Low Power Section.”

The essential point to be noted at the conclusion of this brief review of historical trends is that under modern conditions a ship cannot be fought at all unless a very large quantity of

electrical equipment, largely, "electronic," is functioning to rated performance. It must furthermore, work at any time required.

2. Naval Systems and Requirements

In discussing Naval systems it becomes, unfortunately, necessary to steer a careful course between the Scylla of total "Security" and the Charybdis of total "Obscurity." The observations which follow are therefore, necessarily, somewhat general. It is hoped, however, that they may, yet, serve to make clear the essentials which are, indeed, matters of general knowledge.

2.1. A "series" system

Considering, first, weapon control, a typical fire control system of the general type fitted in modern warships might take a form somewhat as indicated in Fig. 1. The essential functions carried out are the continuous measurement of the space co-ordinates of the target, the computation of the required path of the "missile" making allowance for all known variables, and the orientation of the mountings to achieve this path. Additional to the above requirements fundamental to any fire control system, we may add in the Naval case, a stabilizing system to remove the effects of roll, pitch and yaw to which ships are subject. This system will, ideally, have to work to a higher order of accuracy than the Fire Control system itself.

Something of a somewhat similar nature would clearly be also required for the control of a guided missile.

It will at once be noted that this is essentially a "series" system, in that the whole of the assembled apparatus is necessary for the achievement of the desired end and, in that, the failure of any single part of the gear will cause the "wrong answer" to be given and incapacitate the whole system.

2.2. A "parallel" system

An alternative type of system in common use is that required to "direct" fighter aircraft. A possible air direction system is shown in outline in Fig. 2. The basic desiderata for determining the instantaneous position of the target remain the same but in this case the required accuracy is very much lower since the aircraft being directed is, in effect, a manned "guided missile" and within limits can be "directed" on to its target even if the initial data are in error.

On the other hand since the "missile" velocity is of the same order as that of its target and because the process of "directing" takes time such a system calls for determination of the target co-ordinates at very much greater ranges than in the gun or guided weapon case. Such systems are, therefore, characterized by complex and high power associated radars and the maximum that can be accepted in aerial sizes and gains.

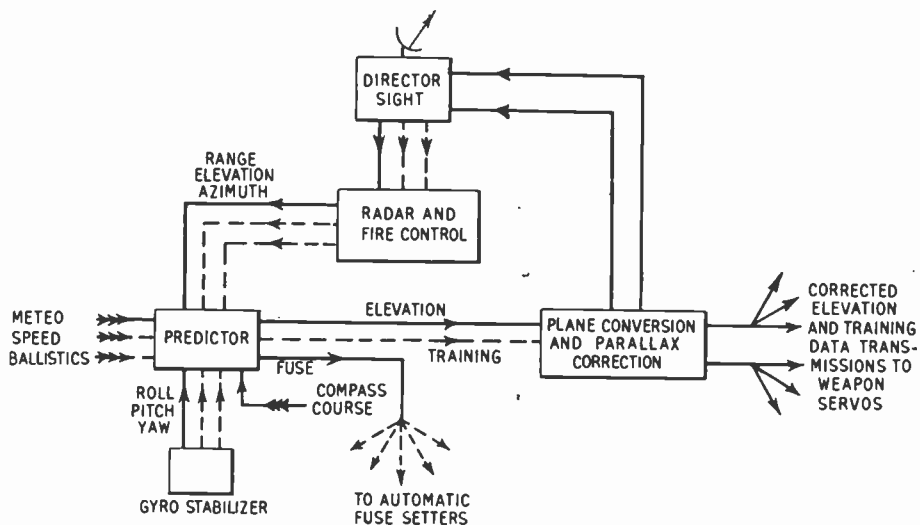

Fig. 1. Elements of a Weapon Control system. A "series" system.

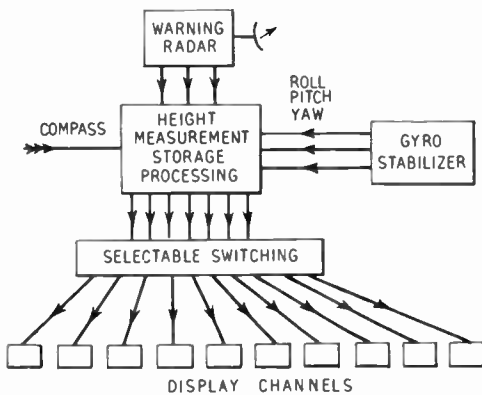

Fig. 2. Elements of an Air Direction system. A "parallel" system.

The position is further complicated by the fact that because Aircraft Direction is, at the moment, conducted by human intervention and as aircraft tend to attack in very large formations it becomes necessary for the system to have a very high data rate probably implying a measure of storage somewhere in the system and all manner of complexity in the display arrangements. Finally, it is implicit in any such scheme that, if it is to be capable of handling a large number of targets simultaneously, it must be split into a correspondingly large number of channels. All of which makes for greater complexity.

In contrast to the weapon control type of gear it will be seen that this type of system is, in terms of its overall complication, largely a "parallel" system in that failure in any particular "block" will not necessarily incapacitate the entire system. While a reduction in the overall handling capacity is evidently undesirable it is not necessarily disastrous.

2.3. Number of components

Considering now the practical realization of systems of the broad types discussed above we may note that a practical system shortly to be fitted in ships contains 7,000 valves and some 60,000 components. As a comparison with the commercial field we may note that a medium size digital computer (the LEO machine of Messrs. Lyons & Co.) contains some 3,000 valves while a modern monochrome television set has perhaps 20 valves and some 500 com-

ponents. It is with the intrinsic reliability of such very large concatenations of electronic gear that we shall be concerned.

3. A Specification for Operational Availability

At the end of Section 1 it was emphasized that, under present day conditions, it is essential that the whole of the armament of a ship should be available at all times. While this might be said to be a self-evident generality it will be useful, at this stage, to review its implications in terms of the task set to the designer.

In the Naval hierarchy ships, weapons, and other appurtenances of war are designed to meet Staff Requirements. The Naval Staff, basically responsible for the conduct of war, decide on the types of ship or weapon they consider will be necessary and lay down performance requirements which the Research and Development Establishments then endeavour to meet or improve on.

In the post-war epoch the emphasis on high performance and infallible operation has become so high that an attempt has been made to state the requirements in a more specific and quantitative form. For a particular system, therefore, the operational availability required was explicitly stated. It took a form somewhat as follows:

- (i) To be capable of operating under Admiralty standards of weather and temperature conditions for a two-week operational period during which time, except as indicated in (ii) below, the equipment must not be at greater notice for action than two minutes.
- (ii) During the operational period, as defined above, the notice may be extended to 10 minutes for maintenance purposes for one hour every day.
- (iii) An uninterrupted period of 12 hours for servicing will be given as often as operational requirements permit. This servicing period will occur at least once every fortnight.

This, it will be seen, is a fair and clear statement of the requirement. In the light of the current reliability of electronic equipment in general it is also an exceedingly difficult requirement for an engineer to meet.

#### 4. The Special Problems of a Naval Environment

The experiences of World War II, notably in the air and in the tropics, quickly established that for Service use a marked improvement on commercial electronic practice was required if equipment was to meet field conditions. The practical embodiment of the large amount of work which was done on this problem is to be seen in the ultimate Test Specification K.114 to which all British Service equipment is produced.

The hazards which the respective Services have to meet appear, in fact, to be somewhat different. The Air Force have to contend with high frequency vibration, rapid changes of temperature, rapid changes of air pressure and lowered air-breakdown potentials due to altitude. The Army seems to be more concerned with vibration, of a somewhat different nature to the airborne case, and with rough handling, and tropicalization problems. The Naval case seems, in general, to be rather less stringent and, apart from the special problem of underwater shock, it may be said that shipborne equipment has a rather easier time than that of either of the other two services.

Naval difficulties appear to be less fundamental and to be conspicuous for their "nuisance value" rather than as representing unsolved technical problems. There never seems, in general, to be enough room to fit equipment comfortably, while the nature of Naval systems is such that vital parts of the equipment (microwave heads and the like) tend to be mounted on the least accessible parts of remote, damp, and draughty structures. Broadly speaking, however, it can be said that the difficulties experienced at sea are less due to the fitting of equipment in a ship than due to the great complexity of the equipment which has to be fitted. It would be (and is) almost equally troublesome when mounted on dry land.

There is one aspect of the Naval environment in which the Navy is at a distinct disadvantage compared to its sister services. The nature of ship requirements is such that, firstly, an extremely wide range of equipment is fitted in almost all warships and secondly that, unlike the Army or the Air Force it is not normally possible to rely on "Base" or "Second Echelon" maintenance between "Missions."

A particular squadron of aircraft or unit of armour has, it is thought, a relatively limited amount of fitted equipment. Though the quantities may be relatively high, considered overall, the range of equipment is limited, it can be removed easily and comfortably for servicing and it is possible to divide the talents of the technical effort available conveniently.

Any ship larger than a frigate, on the other hand, seems to be fitted with at least one example of almost every manifestation of the electronic designers' art over a long period of years. The result is that a large range of techniques have to be mastered and met by a small number of technical staff in *every* ship and since technical complements are of necessity limited, it is quite impossible to handle simultaneous breakdown in a number of equipments. This leads to the conception of "queuing" for maintenance which, as will be shown subsequently, has a considerable effect on design desiderata and, ultimately, on the effectiveness of the ship considered as an integrated fighting unit.

#### 5. Some Design Approaches to High Reliability

While it is undoubtedly true that the ultimate reliability of any system is dependent upon the intrinsic reliability of the components from which is assembled, this aspect is most profitably considered on a statistical basis. There remain a number of generalized approaches to the design of highly reliable equipment some of which will be discussed briefly.

##### 5.1. *The use of components of the very highest quality and conservative rating*

The value of this approach may be said to be self evident. In the practical case, however, so far as Service equipment is concerned it is of somewhat limited application. Service equipment has, perforce, to be produced in quantity by semi-mass production methods, and beyond establishing high standards for Services preferred components, a matter constantly under review, and, it may be added, constantly under fire from the industry, there is not too much that can be done to exploit this approach.

The ultimate application of this line of attack has been seen in the design of the sub-ocean repeaters for the Key West and Trans-Atlantic telephone cables where the resultant product is



expected to have a life of 25 years in continuous operation.

All components used are of the ultimate in quality, hand selected from large trial batches and installed under conditions of advanced industrial hygiene. The valves used in the American designed repeaters are of low mutual conductance having wide inter-electrode spacings and with special attention given to heater/cathode design with a view to the avoidance of performance drop due to interface formation in the cathode structure.

5.2. Design for rated performance in the presence of drift of component values

Two possible approaches present themselves. In the first, the design is made such that the essential performance characteristic required is made dependent upon the smallest number of components which can then be especially selected, leaving the remainder of the associated parts of "normal" quality.

In the second, an extension to the first, the approach is to make the fullest possible use of heavy negative feedback so confining the variables of performance criteria to the limited number of components determining the feedback factor.

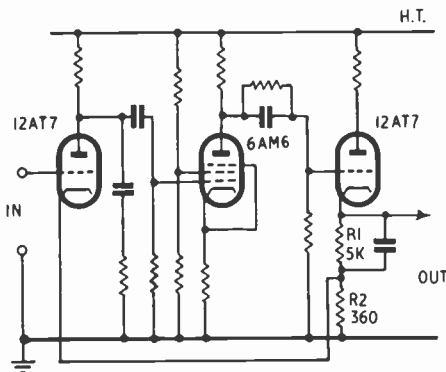

Fig. 3. High-stability feedback amplifier.

Figure 3 illustrates a highly-stable feedback amplifier used in a valve voltmeter<sup>1</sup> having a large loop gain and very modest overall gain. Clearly the variations of the gain characteristic with time and ageing depend, almost entirely, on the stability of the two resistors R1 and R2.

A recent exploitation of this approach has been seen in the design of the sub-ocean telephone repeaters designed also for the Trans-Atlantic telephone service, by the British Post Office. While conventional valves of high performance are used to provide high loop gain, long term performance is assured by the use of two paralleled amplifiers with a single stage feedback loop around the paralleled pair.

This approach does not seem to have been used, as yet, in any Naval equipment though the writer has noted its application in line amplifiers designed for military use.

5.3. Design for continued operation at reduced performance in the presence of total failure of sections of the equipment

With some types of equipment, notably radio transmitter systems, it is possible to assure high availability of service by arranging to split the equipment into a number of chains of reduced power which are effectively "paralleled" at some stage, usually the output, to provide the total power required. The complete failure of one chain does not, therefore, result in a complete loss of facilities but, in the case of a twin chain radio transmitter, merely results in a drop of 3 db in radiated power.

The method has been largely exploited in the post-war sound and vision transmitter designs of the British Broadcasting Corporation and in its latest application has been applied to the recently installed range of television transmitters.

This type of approach has been applied in somewhat different form in the early years of Naval Wireless but has had no recent application. In the case of radio equipments the method depends essentially upon the maintenance of an accurate phase balance between the two paralleled chains and is therefore not very suitable for equipments which have to operate over a wide frequency spectrum. Nor would it be easy to apply in the microwave region.

5.4. Provision of arrangements for the detection of incipient faults before they occur

The essence of any scheme of this nature is the detection of incipient breakdown, or of a falling off of performance, of some component before



it endangers the overall operation of the system as a whole. Unfortunately, as is shown later, the statistical nature of component failure in well designed systems tends to be entirely random and "catastrophic," while components subject to this type of failure seldom give any prior indication. The method is therefore more applicable to slow deterioration and in particular to the slow deterioration of the mutual conductance of valves.

An excellent example of the application of this technique is to be seen in the monitoring arrangements for the LEO Computer<sup>2</sup>. In this equipment means are provided for the selective application of a 50 c/s metered waveform to the grids of all valves so swinging their grids and mutual conductances over a range determined by its amplitude. Valves having sub-standard performance will "fail" (to function in their respective associated circuitry) at impressed amplitude levels below that which "fails" standard valves and so can be replaced before failure occurs under working conditions.

The method is elegant and is said to be most successful. It seems, however, to be applicable, in the main, to the type of circuitry, common, of course, in computers, where valves are used in the role of binary "on/off" switches and are normally operated in a fully conducting or fully cut-off state.

#### 5.5. *Design for the speedy diagnosis of an overall system failure.*

A major difficulty in very large systems is to discover, quickly, precisely what has failed. The problems of logical monitoring, with the minimum number of steps, form an extensive study in themselves and cannot be explored at length in this general review.

Suffice it to say that, for the reasons to be discussed further below, it is of the greatest significance to the overall efficiency of a ship that fault diagnosis and the subsequent repair should be conducted with the minimum of delay and that failure to do so has repercussions on the ship, considered as an integrated weapon, far more serious than might be, intrinsically, expected.

This leads, immediately, to the use of extensive monitoring and metering systems which

are, in fact, widely exploited in the latest designs. The practical difficulty, at the design level, lies in keeping them within practicable and inherently reliable bounds, and arranging them with a degree of circuit logic which leads the maintainer to the fault with the minimum of technical detour and waste of time.

#### 5.6. *Design for rapid repair of faults once located*

While it may be self evident that any fault should be rapidly repairable the point has a special significance in the Naval case where the number of maintenance staff is necessarily limited, and where, inherently, it is necessary either to postulate a fair measure of diversity in failure or for equipments to "queue for maintenance."

The current catchword is "repair by replacement" but in a ship carrying a very wide range of equipments and an even wider range of component sub-assemblies this is very much more easily said than applied in practice.

#### 5.7. *The provision of immediately available replacement units*

The statistical probability of component failure with currently available components, and their observed failure probabilities, is such that it is exceedingly difficult to meet a requirement of the nature of that postulated in Section 3, where a "large" equipment is concerned.

It will be shown, subsequently, that by suitable sub-division of the equipment and by the provision, at each sub-divisional level of two, or even three, replacements, instantly available, and switched by manual or automatic means, the overall reliability of an equipment built up of currently available components can be markedly increased and can, in fact, be brought within the required limits. This is an important approach and is discussed further in subsequent sections of this paper. It is, of course, "uneconomic" and, in fact, is an exploitation of the principle of redundancy. It is also not very easy to carry out in practice.

## 6. The Pattern of System Failure

### 6.1. *Component failure pattern*

The final product may be truly said to be no better than its most unreliable component element while the failure resistance of components

themselves, may be said to rest, firstly, on the success of the design and manufacture of the component (contributing to the pattern of random failure) and secondly on the stresses applied to it in a specific application (contributing to the pattern of "wear out" failure).

As an initial step to considering system failures it will therefore be as well to examine the statistical pattern of component failure and its underlying causes. This can be considered under four main headings.

6.1.1. Initial failures

These are caused by some positive defect at the time the component is first put into service and, generally speaking, are the result of some event in the earlier life history of the component. Such an event might be an error in its inherent design, or in its manufacture or a mishap during its subsequent storage, transportation or installation.

Such failures occur in the very early life of the completed equipment and are entirely random. Their incidence is unconnected with time and, statistically their occurrence pattern follows a Poisson distribution. They should normally be eliminated during the tuning, testing and setting to work of the equipment, and given also a reasonable "soak" period before the equipment is turned over to the ultimate user, they should not affect subsequent reliability to any great degree.

6.1.2. Failures due to poor equipment design

If, due to poor design of an equipment, the components are subjected to excessive ratings, are in an unsuitable temperature environment,

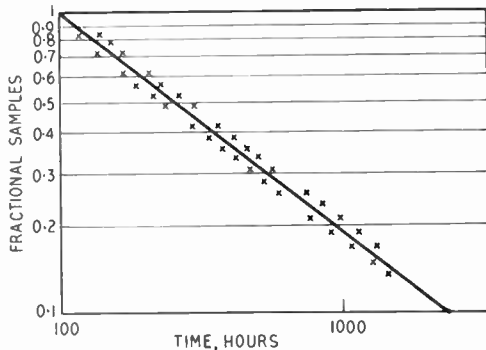
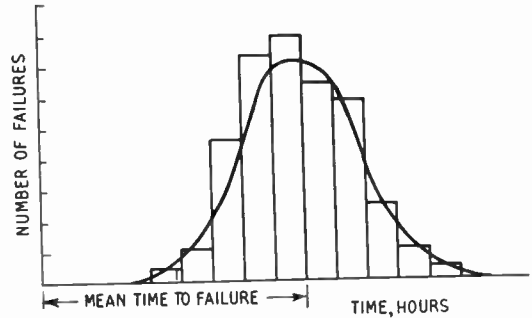

Fig. 4. Exponential (Poisson) failure distribution curves of receiving valves.



Normal Error Curves  $y = \frac{1}{\sigma \sqrt{2\pi}} \cdot \exp \frac{-(t - T)^2}{2\sigma^2}$   
 where  $t$  = Elapsed Time  
 $T$  = Mean Time to Failure  
 $\sigma$  = Standard Deviation

Fig. 5. Gaussian (wear out) failure distribution curves for incandescent lamps.

or are asked in some other way to handle stresses beyond their designed capacity, failures will clearly occur.

They are inherent to the design of the particular equipment and are predictable insofar as they will tend to recur in all similar equipments. Statistically speaking the failure distribution is Gaussian with a short term mean time to failure. They are subject to eventual eradication by either modification of the overall design to give improved working conditions, or by substitution of a more robustly rated component.

6.1.3. Random failure

A considerable and most important class of failures are entirely random, the moment of failure being a matter of pure chance entirely unrelated to time in service. Statistically a Poisson's distribution is shown, the failure rate being a constant with time and at a level determined by the "goodness" of the component. Figure 4 shows such a distribution in the case of a particular type of receiving valve.

This type of failure is typical of "good" designs and is to be expected with well designed equipment built up of suitable components, during its expected working life.

6.1.4. "Wear out" failures

All man-made objects have a finite life and eventually fail from deterioration of material or of some property necessary for their proper

functioning. The statistical pattern of this type of failure is well established and is Gaussian. Figure 5 which illustrates the type is a histogram and associated normal error curve covering the wear out failure of incandescent lamps.

6.2. *Equipment failure pattern*

The overall failure pattern of an equipment or system comprising a large number of components will, therefore, be a combination of these four types of failure and, over the whole life of an equipment will have a general form somewhat as shown in Fig. 6. The solid curve shows the life characteristics of an equipment made up of "good" components, the dashed curve the characteristics of a similar equipment using "poor" quality component parts.

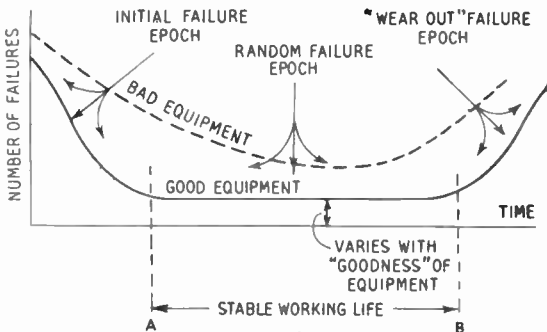

Fig. 6. Equipment overall failure pattern.

Considering this curve it will be seen to exemplify the four types of component failure discussed in the preceding paragraphs. The initial failure rate up to point "A" is high and is attributable to the types of failure considered in section 6.1.1 and to some extent section 6.1.2. This is followed by a period of low failure rate and highest reliability making the minimum demands upon maintenance attention. Failures during this phase are random and follow the pattern indicated in section 6.1.3. The stabilized plateau varies in height and length for different types of equipment. In a large-scale production run, as production proceeds and the product becomes more reliable, the point "A" moves to the left and downwards and less factory testing time is necessary to eliminate initial failures.

At point "B" reliability again begins to decrease as we move into the domain of wear

out failures, and, at some point beyond "B," depending, again, on the type of equipment and the circumstances, further maintenance of the gear becomes uneconomic and either large numbers of worn out parts should be replaced or, more probably, the whole equipment should be scrapped.

Considering, now, the dashed curve, we see that due to the use of poor quality components the plateau region of stability is never reached and, as a result it is quite impossible to reach a measure of stable reliability by factory testing.

6.3. *Equipment test programme*

It will be evident from the above that the final user should not get the equipment until point "A" has been passed and it is operating on the stable plateau with a random fault incidence. Scheer<sup>3</sup> has discussed this issue and concludes that for a certain (airborne) equipment containing some 2,000 component parts the required period of factory running, to reach point "A" was some 200 hours. His analysis in detail, indicating the nature of the test programme and the incidence of the faults thrown up at the various stages, is given in Table 1.

Table 1

Typical % failures during test programme

Test	Percentage faulty
48 hour shock test on bump table	49.2
18 hour tuning up to rated performance	11.1
3 hour overall system test	15.9
3 hour quality control test	6.4
1 hour climatic (cold) test	7.9
125 hour soak test	9.5

These results indicate clearly the progress towards failure stability over a particular factory testing cycle, and, in particular, emphasize the importance of the initial shock test. It may be remarked that in the U.K. such a test programme, except for prototypes, is believed to be the exception rather than the rule.

6.4. *Component reliability*

Considering, now, the relative reliability of differing component classes, an analysis from American sources based on 79 equipment failures arising in 33 similar airborne equip-

ments over an operating epoch of 2,800 hours showed a breakdown as in Table 2.

**Table 2**

Number of equipment failures due to different components

Component	Type	Number of failures
Valves	All types	45
Relays	Sealed (Design fault revealed)	11
	Unsealed	1
Capacitors	Tantalum	5
	Paper	1
	Vacuum	1
Switches	Stepping	2
	Wafer	12
	Input	1
	Aneroid	1
Resistors	Wire wound variable	1
Filters	Chokes	2
Miscellaneous	Plugs	3
	Solenoids	1
	Clutches	1
	Gears	1
	Dials	1
Total		79

Valves are seen to form by far the most unreliable individual group. In the particular equipment cited the population was 93 valves per equipment of which 67 were of the sub-miniature type. Considering the remaining components, the order, in terms of numbers fitted, was capacitors followed by resistors and relays. It will be noted that resistors showed up remarkably well.

An analysis of the actual nature of the individual component failures also showed that most of them were quite fundamental and would never have occurred if the components had been subjected to (by modern standards) adequate life tests before going into production. They were, in fact, entirely avoidable by up to date methods of life testing and subsequent quality control.

6.5. *Equipment reliability*

Turning now to somewhat larger systems working in the rather easier environment of Naval service, extensive analyses have been carried out in both the U.S.A. (U.S.N. Bureau of Ships) and in the United Kingdom on Naval equipments actually in use.

In both countries (but not at present in Australia) a system of 100 per cent. reporting of electronic component failure has been introduced. Every component which fails is reported back to headquarters with appropriate details as to its location in the equipment, attendant circumstances and other relevant data. The degree to which 100 per cent. reporting is in fact achieved is, no doubt, open to some conjecture. The writer's impression has been that in the Royal Navy the real figure was somewhere around 80 per cent. U.S.N. estimates, based on control checks carried out on certain specific equipments are somewhat less sanguine and point to a total figure of about 43 per cent.

The fact, however, remains that there is available a very large amount of field data on which statistical processing can be carried out with some conviction. U.S.N. figures quote 45,000 reports per annum on some 6,000 equipments covering 22,000 equipment failure incidents. These should be adequate data on which to base statistical opinions.

Harris and Tall<sup>4</sup> have attempted this task. An initial attempt was made to correlate the observed equipment failure rate with the number of components in an equipment, that is to

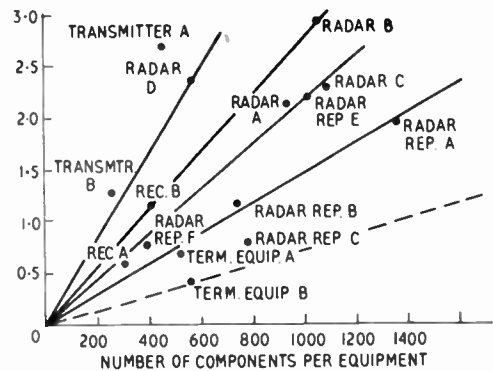

Fig. 7. Correlation of failure rate with number of components.

say with its "size." Figure 7 shows the number of equipment failures per 1,000 hours of operation for a number of shipborne electronic equipments plotted against the number of components fitted in each equipment. Radial lines drawn through the origin represent therefore equal levels of failure rate per component. The

fact that several equipments group themselves along a particular radial indicates the strong influence of the number of components on equipment reliability. The fact, however, that all equipment failures do not, in fact, fall along a single radial indicates that other important factors are present.

The equipments selected for this examination were widely in use and in all cases subject to the full hazards of Naval usage. It is noteworthy that no evidence was found that age had any influence on the failure rate indicating that the equipments were working within their expected useful life epoch and had not yet reached the wear out point.

Radar "C" was an improved version of Radar "B" while similarly Radar Repeater "C" was an improved version of Radar Repeater "B." In each case initial design mistakes had been eliminated (see section 5.2) with a marked improvement in reliability.

Terminal Equipment "A" and Terminal Equipment "B" were with one exception identical equipments. The exception lay in the fact that Terminal Equipment "B" was fitted with blower cooling while Terminal Equipment "A" was not. The improvement of almost 2:1 in the reliability of an already reliable equipment is clear evidence of the great effect of temperature conditions on overall reliability.

**7. The Pattern of Component Failure**

It is clear that, to draw any conclusions as to the reliability of any design using a large number of components, some knowledge of the statistical reliability of components, both considered in the mass and under appropriate sub-divisions, is essential.

Considering first the overall picture, the task of obtaining reliable figures of component failure from the field is, clearly, far from easy. A number of major studies have, however been made, notably in the U.S.A. from which some indication of the pattern can be derived.

In 1950 the U.S.N. had in service some 165,000 individual electronic equipments comprising some 2,600 individual types<sup>5</sup>. Broad classifications of components (excluding valves) considered amounted to 50 classifications and broke down to some 23,503 individual pattern

numbers, the whole having a statistical population of about 20 million individual items. Experience showed that about one million individual component failures occurred during a year's working giving an annual failure rate of about 5 per cent. per annum or, in terms of time at the 1,000 hr. rate, 0.57 per cent. The latter figure is quoted as a rough basis of comparison with figures that follow. It will be apparent that on block figures of the type quoted above, the real duty cycle of operating/ idle time is unknown. On a "per equipment" basis this amounts to somewhere around 6-8 failures per equipment per annum. While this may, at first sight, appear to be a not unreasonable figure it none the less represents an immense annual maintenance effort.

A parallel study at about the same time<sup>5</sup>, by the Bell Telephone Laboratories involved, *inter alia*, a detailed examination into the reasons for the failure of a very large number of individual components. The results of this are given in Table 3.

**Table 3**

Cause	Percentage
Manufacturing defects	28
Design deficiencies	26
Operating conditions	31
Undetermined causes	15

From the above it is seen that 54 per cent. of the troubles encountered could be imputed to poor design or manufacture, most of which could have been obviated by better quality control methods both in the manufacturing plant and in the works where components were being assembled into equipments. Very similar figures can be quoted from U.K. sources. For example, in Table 4 are shown annual failure rates for the extensive electronic instrumentation used by the Atomic Energy Research Establishments of the United Kingdom<sup>5</sup>. When considering this, it must be borne in mind that the working environment was, probably, highly favourable.

Table 4, which is based on a very large statistical population, gives a clear enough pattern of the overall component failure pattern. It is particularly noticeable that even at present



valves have a failure rate about 12 times in excess of other components. Similar ratios quoted elsewhere for the U.S.N. show this ratio to be somewhat lower (around 4-6) while figures quoted by the R.N. and R.A.F. show a ratio respectively of 20-25 and 15. Discounting any discrepancies in detail it remains abundantly clear that valves, considered as a group, constitute by far the most unreliable single group of components. (See also section 6.4.)

**Table 4**

Failure rates in A.E.R.E. electronic instruments

Component	% Failure Rate	% Failures per 1,000 hr. Working	% Un-weighted Av. / Group per 1,000 hr.	% Fractional Failure Rate per Component per 1,000 hr.
<i>Valves</i>				
Rectifiers	9.1	1.02		
Double Diodes	1.66	0.19		
Double Triodes	6.8	0.77	0.35	0.0035
Pentodes	2.67	0.3		
Stabilizers	4.18	0.48		
<i>Resistors</i>				
High Stability	0.73	0.08		
Carbon	0.25	0.03		
Wire Wound	0.30	0.03	0.04	0.0004
Pots-composition	0.24	0.03		
Pots-wire	0.21	0.02		
<i>Capacitors</i>				
Paper	0.22	0.02		
Visconol	0.29	0.03		
Nitrogel	0.15	0.01		
Mica	0.18	0.01	0.03	0.0003
Ceramic	0.15	0.01		
Electrolytic	0.95	0.10		
<i>Inductors</i>				
Transformers	2.06	0.20	0.10	0.0001
Chokes	0.17	0.01		
<i>Miscellaneous</i>				
Relays (P.O.)	0.29	0.03		
Relays (high speed)	0.85	0.09		
Meters	1.28	0.14	0.21	0.002
Registers	6.32	0.72		
Selenium				
Rectifiers	0.61	0.07		

Considering figures such as the above it further becomes clear that, whereas, at present, component quality is evaluated in terms of characteristics, performance and so forth at, in terms of ultimate usage, a time "t=0" it would, in principle, be most desirable to rate components after very extensive life tests on the basis of life expectancy and average failure rate. A possible approach might be to rate

them on the basis of percentage failure per 1,000 hours operating time (Note that 1 year = 8760 hours). This has been attempted in the U.S.A. and Fig. 8 represents a plot due to the Radio Corporation of America.

This diagram represents an attempt to indicate the component reliabilities required for various Equipment Life Expectancies considered in the light of the number of components fitted. Thus the failure rate/1,000

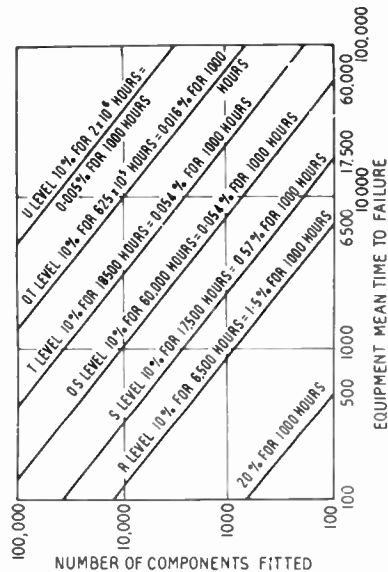

**Fig. 8.** Correlation of failure rate of components fitted and equipment mean time to failure.

hours of submarine cable repeater components subjected to stringent manufacturing conditions and 100 per cent. quality control selection, was found to be of the order of 0.002% per 1,000 hr. while the corresponding figure for the components in general use in domestic radio was 0.5 per cent. Between these two extremes the chart shows the Equipment Life, per number of components fitted, to be expected for a number of discrete component failure rates.

The basic levels of "reliability" plotted increase in each case by a factor of  $10 \times \log_{10} 10$  since, given a particular component this order of increase can usually be attained without further ado by merely working it under de-rated conditions.

It is of some interest to note that the overall

failure rate of the very "modern" equipment referred to at the end of section 2 is approximately at the "S" level being some 0.65% / 1,000 hours. Analysis showed that this, somewhat high, figure was largely attributable to valve failure (valves were all of "normal" quality) which averaged 3.3% / 1,000 hours (see also next section). Resistors and capacitors, constituting some 78 per cent. of the total component population, had failure rates of 0.126% / 1,000 hours and 0.094% / 1,000 hours respectively. These results are somewhat worse than the figures shown by A.E.R.E. in Table 4. The discrepancy is, probably, due to the invalidity of a direct comparison of uncorrelated statistics. The broad picture, however, is again clear.

**8. Reliability of Valves**

It is not intended to explore the details of component reliability in any detail since it is felt that this aspect is amply covered by other papers. A word must, however, be said on the subject of valves since, as has been shown, as a group, they have an order of reliability far less than any other major group of components.

A study<sup>5</sup> of 45,013, allegedly, defective valves from 44 types of airborne radio equipment having a total socket population of 489,049 showed the results given in Table 5.

**Table 5**  
Percentage defects in discarded valves.

Defects	Per cent.
None found	31.8
Electrical	28.7
Mechanical	21.0
Miscellaneous	18.5

A typical fault pattern of a very widely used high performance valve available in both "normal" and "reliable" guise (6AK5/5654) showed<sup>6</sup>, in the "reliable" form a failure pattern in terms of types of defect, as given in Table 6.

The current attack on the matter of improving the reliability of valves may be summarized and commented on under the following headings:

(i) "Burn out" the initial failure component (see section 6.1.1.) by an initial factory ageing

**Table 6**

Percentage of different faults in 6AK5/5654 valves.

Faults	Per cent.
Low mutual conductance	31
Gassy	2
Open circuited heater	4
Intermittent shorts	17
Permanent shorts	13
Noisy	12½
Broken bases	½
Broken envelope	4
Miscellaneous	16

run for *all* valves. On the basis of a 20-hour run this is said<sup>6</sup> to reduce output by 30 per cent. and double the cost as compared with "normal" valves.

(ii) Minor detailed improvements, mostly of a mechanical nature, to existing valve types together with production under a "hygienic" rigidly controlled regime resulting in "reliable" valves in the current classes. This approach is being widely followed in addition to the procedure outlined in (i) above. In its own right it is said to reduce output by 30 per cent. and increase cost by 75 per cent.

(iii) Design, *ab initio*, of "reliable" valve types outside the current ranges (section 5.1) and produce valves with the main accent on reliability—probably at the expense of performance. This is said to reduce mass production capacity by 75 per cent. and to increase costs by 200-900 per cent.

(iv) Eliminate the base and use permanently connected flying leads. This is being widely exploited, in particular in the U.K. It seems to the writer to be largely dependent for its success on increasing the reliability of valves *per se* and the stress laid by the valve manufacturers on socket difficulties (though they no doubt exist), could possibly be exaggerated. Suffice it to say that some "modern" multi-valve, r.f. designs (i.f. strips) using wired-in sub-miniature valves, though elegant and neat to see, have aroused, at least, some measure of doubt as to their real practicability. The conception of "remove the whole unit and repair at leisure" is not in fact too easy to apply in the Naval Service.

(v) Close attention to circuit and environmental application. In the writer's experience, apart from a not inconsiderable tendency to use "uncontrolled" valve characteristics (cf. "transistrons") as part of essential circuitry, on the whole, it is not generally true to say that valve circuit application as a whole causes wide overloading of valves. It would be truer to say that valves are frequently fitted in sockets where they get far too hot and it is perhaps necessary to point out that most of the modern miniature and sub-miniature range have characteristics comparable or better than the conventional ranges but involve the dissipation of identical or more heat in a much smaller envelope.

No one who has worked for any period of time in a Research and Development Establishment dealing with modern weapons can let one major hazard of the valve world pass without comment. Designers are supposed to work to a Services Preferred List of Valves and to use other valves, only, when some electrical characteristics, not available therein, become essential. Valve types and characteristics suffer unfortunately from wide and cyclic changes most of which can be only ascribed to, at best, fashion, or at worst more sinister influences. It takes from initial conception to production *at least ten years* to produce a really large, advanced, modern equipment. The alarming conclusion is reached that, in practice, the Preferred Valves of the earlier stages of design have regressed to the "obsolete" list by the time the equipment comes into service. This is a very real problem and in the Navy at least, where quantities involved are not very great constitutes a real practical difficulty.

Valve manufacturers are most reluctant to produce short production runs of what are to them "obsolete" types. Such runs also tend to make for very unsatisfactory valves (see also section 5.7).

It may be useful at this stage to tabulate<sup>7</sup> the life, and failure rates necessary to attain it, for a wide cross-section of applications using valves (Table 7).

Finally, since no discussion of valves can, nowadays, be conducted without consideration of the possible ultimate advantages of transistors it will be well to see how they are in fact, performing in practice. The dubious qualities are of course, their temperature dependency and as yet uncertain ageing characteristics<sup>7</sup>. Enough have however been employed in commercial service, notably in the U.S.A. to enable some broad conclusions to be drawn (Table 8). Some interesting figures as to valve performance are, incidentally, included.

It is apparent from the above that, in appropriate utilization, existing transistors show markedly lower failure rates than normal quality valves.

## 9. Component Reliability — The Benefits of De-Rating

Before leaving the generalized topic of components it is desirable to consider, briefly, the benefits to be obtained by operating them under de-rated conditions. This, in general results in a marked reduction in the heat dissipation the benefits of which have already been instanced in Section 6.5. Alternatively other characteristics may benefit.

**Table 7**  
Failure rates for valve applications.

Service	No. of valves	Permissible system failure interval (hr.)	% Time on duty	Unit hours before failure	Failure Rate % / 1,000 hr.
Domestic Radio	6	4,500	10	2,700	37
Submarine Repeater (Key West)	18	175,000	100	3.2 × 106	0.031
Telephone Switching Centre	8,000	4,500	100	3.6 × 106	0.028
Shipboard Communication (1)	23	2,160	65	32,000	3.1
Shipboard Communication (2)	48	2,160	87	90,000	1.1

Figures 9, 10 and 11 show graphs of the percentage failure rate/5,000 hours operation of resistors, capacitors and valves under various degrees of application severity<sup>4</sup>. They speak for themselves and indicate clearly the very considerable gain in reliability which can be achieved if it is possible to arrange for de-rated working.

With the first two classes of component this should not present too difficult a problem though the question of size in an age of miniaturization is always with us. In the case of valves a considerable number of applications call, unfortunately, for the extraction of the maximum gain/bandwidth product and in such instances de-rated working is less easy to achieve.

**10. Increases in Reliability due to Equipment Sub-division**

From Fig. 7 the relationship between component reliability, number of components fitted and mean time to equipment failure has been approximately indicated. The possibility of increasing equipment reliability, with a given quality of available components, by sub-division will now be examined in detail.

It will be assumed that the equipment has been properly installed, that initial component

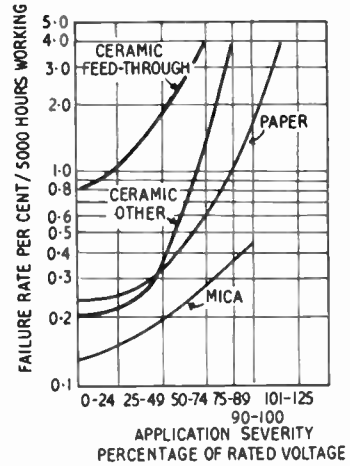

Fig. 10. Curves of failure rate versus application severity for capacitors.

difficulties have been rectified and that it is working on the flat "plateau" of the working hours/failure rate curve of Fig. 6<sup>8</sup>. The component failure distribution will therefore be of Poisson type and the failure probability will be a fraction *a*, less than unity, which will be a constant with time. It will, further, be assumed that *a* is the weighted mean failure probability for all types of component in the equipment that is to say that if *N*<sub>1</sub> components have a failure

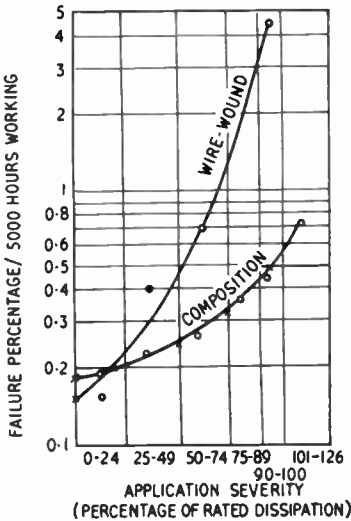

Fig. 9. Curves of failure rate versus application severity for resistors.

**Table 8**

Failure rates for valve and transistor applications.

Class of Service	"Transductor" Valve/Transistor	Failure Rate %/1,000 hr.	Required Failure Rate
Computer (1)	6SN7/6J6	1-2	—
Computer (2)	I.B.M. special valve	0.14-0.7	—
Carrier Phone	Special valve	0.2-0.1	0.028
Submarine Phone	Special valve	0.006	0.031
Carrier Phone	130 junction transistors	0.6	—
Card Translator	—	0.1	—
Computer (1)	700 point contact transistors	0.1	—
Computer (2)	615 junction transistors	0.1	—
Hearing Aid	Junction transistor	0.2-0.5	—

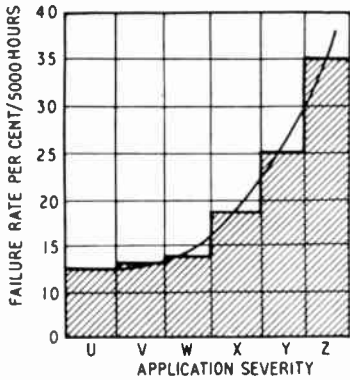

Fig. 11. Curves of failure rate versus application severity for valves. Classes of application severity—

	Voltage/Current	Dissipation
U	<50%	<25%
V	<75%	<50%
W	<90%	<75%
X	<90%	<90%
Y	>90-100%	
Z	>100%	

probability  $a_1, N_2 \dots a_2$  and so on then

$$Na = N_1a_1 + N_2a_2 + \dots + \dots + N_r a_r$$

where  $N = N_1 + N_2 + \dots + \dots + N_r \dots(1)$

With an exponential life distribution, such as has been assumed, given a total number of components  $N$  the number which will be working after a time  $T$  is

$$N_w = N \exp(-kT) \dots\dots\dots(2)$$

where  $k$  represents the mean probability of component failure and may be expressed as the failure rate per given epoch.

The equipment availability for service, probability of success, or "reliability" is, clearly, the probability of working which will be designated  $P_s$  giving a probability of failure  $(1 - P_s)$ . Assuming that amongst the number of components embodied in the equipment,  $N$  there are  $N_1$  having a probability of failure  $a_1$ , then the probability that all of these work during a stated interval of time is  $(1 - a_1)^{N_1}$  and similarly for further groups.

Applying the laws of "parallel" (AND/OR) probability it follows then that

$$P_s = (1 - a_1)^{N_1} \cdot (1 - a_2)^{N_2} \cdot \dots \cdot (1 - a_r)^{N_r} \dots(3)$$

$$= (1 - N_1a_1/N_1)^{N_1} \cdot (1 - N_2a_2/N_2)^{N_2} \cdot \dots$$

$$\dots (1 - N_r a_r / N_r)^{N_r}$$

$$= \exp [(- N_1a_1) \cdot \exp (- N_2a_2) \dots \exp (- N_r a_r)]$$

$$= \exp [(- (N_1a_1 + N_2a_2 + \dots + N_r a_r)]$$

Or  $P_s = \exp (- Na) = \text{Equipment Reliability}$  .....(4)

Considering a particular equipment for which the total number of components  $N$  amounted to 10,000 and assuming a working interval  $t$  of 10 minutes since this is directly related to the availability specification of Section 3 the reliability will vary with the component probability of failure, over a ten-minute epoch, as shown in Table 9.

Table 9

Equipment reliability ( $P_s$ ) for different values of component reliability  $a$ .

$a$	$P_s$	Remarks
0.01	0.00005	Totally unacceptable
0.0001	0.37	Unacceptable
0.00001	0.91	Acceptable

It is apparent that a system is unlikely to be acceptable unless  $Na$  is less than 0.1 implying in this specific case that  $a$  should not exceed 0.00001.

Unfortunately evidence on the broad reliability of components as available in quantity at present, suggests that the failure probability is around 0.0001 in actual practice (Fig. 6) whence the prospects of producing a reliable system containing 10,000 components do not seem to be too promising.

If, however, we consider the same equipment containing  $N$  components and sub-divide it into a number of sub-sections  $n$  which, for purposes of this broad argument, we will assume contain an equal number of components (though they would evidently differ in electrical function) then each sub-section will contain  $N/n$  components. The probability that any *one* of these sub-sections will be working over a stated interval of time now becomes

$$P_s = 1 - [1 - (1 - a)^{N/n}]^n \dots\dots\dots(6)$$

The probability that *at least one* of the  $n$  types of sub-section will be at all times working, i.e. that the equipment as a whole is working



becomes, in the case of duplication of sub-sections

$$P_s = \{1 - [1 - (1 - a)^{N/n}]^r\}^n \dots\dots(7)$$

Or, in the general case where we put no limit on the number of sub-sections to be used, or the degree to which they, themselves, may be "multiplied"

$$P_s = \{1 - [1 - (1 - a)^{N/n}]^r\}^n \dots\dots(8)$$

where  $r$  is the number of alternatives available. The physical picture is presented in block form in Fig. 12. Many important deductions can be made from these formulae.

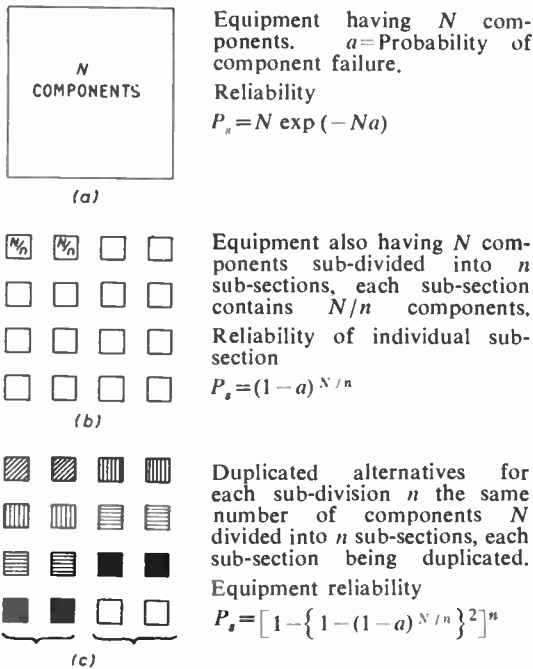

Fig. 12. Diagram explaining sub-division of equipment.

The curves of Fig. 13 are based on the assumptions that  $N=10,000$  and that  $r=2$ , that is to say, that the sub-sections are duplicated. In Fig. 14 the curves are repeated using logarithmic ordinates on both axes to bring out the detail for the low values of failure probability in which we are interested. It is seen at once that where  $a=0.001$ , i.e.  $Na=10$ , duplication of equipment is entirely inadequate since to attain a reasonable probability of failure, say

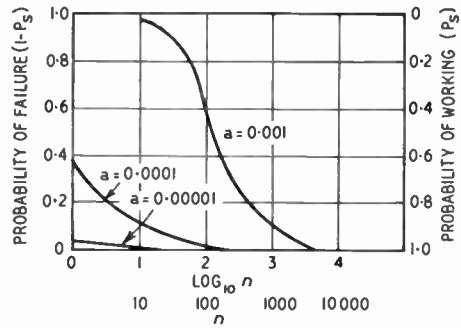

Fig. 13. Failure probability versus sub-division for duplicated equipment.

0.05 (probability of success=0.95) requires a value of  $n$  of about 1,600 which is clearly a totally impracticable degree of sub-division.

If, however, we assume a value for  $a$  of about 0.0001, thought to be a currently attainable figure, then, with duplication,  $n$  becomes 30 not, perhaps, an impossible degree of sub-division in the case of the very large equipments now under consideration.

If, by any chance, it were possible to reduce  $a$  to 0.000001 a state of affairs far from being realized as yet, i.e.  $Na=0.1$ , then a single equipment ( $N=1$ ) would have a probability of working of 0.91 without any sub-division at all, which might well be acceptable.

For the extreme case where  $a=0.001$  the only possible alternative would be to resort to a higher degree of multiplying which would probably be impracticable on other grounds. While the curves for this have not been plotted, the effect is to shift the present plots bodily to the left indicating that a high degree of reliability can be attained with a much lower value of  $n$ .

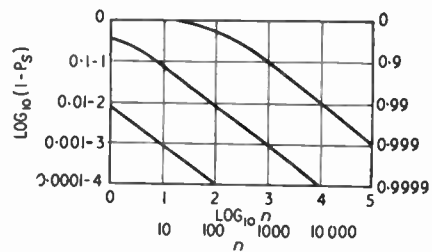

Fig. 14. Failure probability versus sub-division for duplicated equipment at low values of  $(1 - P_s)$ .

Summarizing, and stating the figures in terms of probability of working, the position for an equipment having 10,000 components sub-divided into 30 sub-sections and considering a failure probability over a ten minute epoch is shown in Table 10.

**Table 10**

Probability of sub-divided equipment working for different values of component reliability  $a$ .

$a$	Single set	Duplicate sets	Triplicate sets
0.001	0.00005	0.09	0.98
0.0001	0.37	0.97	0.99
0.00001	0.91	0.99	Infallible

The conclusions of this study indicate that the behaviour of a "large" equipment depends upon the value of the product  $Na$  where  $N$  is the total number of components and  $a$  is the weighted, average, probability of failure of components.

If  $Na < 1$  the reliability of a single equipment will be high.

If  $Na = 1$  the performance of a "single" equipment will be unsatisfactory but sub-division into a practical number of sub-sections and duplication of those sub-sections will provide adequate reliability.

If  $Na > 1$  duplication of the equipment will not provide adequate reliability and triplication will have to be adopted. In general, this is unlikely to be practicable and unless a higher component reliability can be achieved the project is probably impracticable.

These conclusions are not thought to be widely known. The gap between the processes of deductive statistical logic and what actually happens is, however, also at times considerable<sup>9</sup> (see also Section 12).

### 11. The Fighting Capacity of a Warship

For the purposes of discussion of this aspect of electronic reliability and maintenance it will be assumed that the fighting capacity of a ship

can, broadly speaking, be assessed as the percentage of its total "armament," using the term in its widest sense, which is in full operational condition at any time.

It is clear that to detect diagnose, and repair faults in armament systems takes time and in Section 5.5 it has been suggested that the time taken to rectify faults may have repercussions on the fighting efficiency of a ship far beyond what might at first sight have been expected. This suggestion will, now be examined further.

In general the "armament" of a warship consists of a relatively large number of complex systems. The armament of H.M.A.S. *Voyager*, a *Daring* class Destroyer, includes, *inter alia*,  
 9 weapon control/weapon systems,  
 7 radar equipments,  
 11 radio transmitters,  
 18 radio receivers.

It includes, in addition, a large number of essential ancillary devices such as gyro compasses, electric logs, navigational aids, de-gaussing equipment, inter-communication and ship broadcast equipment, alternator voltage regulators, and so forth, all of which depend, to a greater or lesser extent, on the applications of electronics for their functioning. For the ship to be fully effective all of these systems must be working to full rated standards.

For the reasons indicated in Sections 4 and 5.6 the available maintenance complement borne is, and inherently always will be, insufficient to handle the simultaneous failure of more than a very small percentage of the total armament. It follows, therefore, that should such failures occur sets that become defective will have to wait their turn for maintenance. The effect of this potential delay on the overall fighting capacity of a ship as defined at the start of this section will now be considered.

For the purposes of the argument that follows it will be assumed that a number of discrete systems  $N$  are fitted and that they are all of equal complexity. If they are not a "weighting" factor can be readily introduced.

The following terms will be defined:

Reliability  $R$  is the average time that an equipment is in a fully operational state, the working interval ready/not ready including stand-by periods.

Ease of serviceability ( $S$ ) is the average time taken to find and rectify a fault.

Availability ( $R/(R+S)$ ) is the fractional time that an equipment would be available if no delay was incurred in repairing faults due to waiting time.

As has been said, H.M. Ships are so manned that there is always a strong chance that equipments may have to "queue" for maintenance in the event of any serious simultaneous breakdowns; while the number of major equipments fitted is such that the possibility of this occurring is, at least, quite probable. Let  $Q$  be the average "queueing" time, that is to say the time that an equipment must remain out of service before receiving attention simply due to lack of available maintenance personnel.

Under these conditions it follows that the "Availability" in which we are primarily interested, is not  $R/(R+S)$  but

$$A = R/(R+Q+S) \quad \dots\dots(9)$$

If, therefore, a ship has  $N$  equipments in her armament and is subject to the conditions postulated above, the fighting capacity becomes

$$F = \frac{NR}{R+Q+S} \cdot 100\% \quad \dots\dots(10)$$

Now this can be written

$$F = \frac{NS}{R+Q+S} \cdot \frac{R}{S} \cdot 100\% \quad \dots\dots(11)$$

The fraction  $NS/(R+Q+S)$  is clearly the total proportion of time devoted to maintenance or in terms of "unit" maintenance staff, the man hours required for maintenance.

Since, in fact, not one man but several will be available and since, also, they work something less than a 24-hour day the available man hours can be expressed more succinctly as

$$\text{Man hours} = M \times W \quad \dots\dots(12)$$

where  $M$  is the number of maintenance ratings borne and  $W$  is the practical average working hours per diem. It follows, then, that

$$\begin{aligned} &\text{Percentage fighting capacity of a warship} \\ &= (MWR/S) 100\% \quad \dots(13) \end{aligned}$$

This seems to be an important conclusion.

While it is admittedly fully effective only when the maintenance staff of a ship is "over-worked," since this state of affairs is the rule

rather than the exception, the broad principles implicit in this conclusion may well be of wide application and certainly demand more consideration.

It is first of all clear that so long as this state of affairs obtains and equipments have to "queue" for maintenance the fighting capacity of a ship is in no way dependent on the number of systems fitted until it is reduced to the point where the need to "queue" ceases.

*Adding further armament without correspondingly increasing the maintenance complement merely reduces the availability of the equipment already installed and leaves the percentage effectiveness unchanged.* It will, of course, be understood that this statement is subject to the definition of fighting capacity given at the beginning of this section.

In actual practice the various systems fitted differ considerably in their relative importance and the effect of failure on the real fighting capacity of the ship in which they are fitted. If, however, the larger view is taken and it is assumed that all equipment installed in a warship is expected to work at all times then the above argument holds.

The second important point revealed by this "law" is that the fighting capacity can just as well be increased by reducing  $S$  the difficulty of maintenance, as it can by increasing  $M$  (the maintenance complement),  $W$  (the percentage hours worked per diem) or  $R$  (the reliability). Consider these four variables briefly.

While every effort is made to increase  $M$ , in actual practice, the bearing of technical ratings is already relatively high in proportion to ratings of other categories and for accommodation and other reasons it is extremely difficult to achieve any great improvement in this direction.

The factor  $W$  is clearly limited by man's endurance and the decencies of life, and there are, clearly, limits beyond which the very willing horses available cannot properly be spurred.

Factor  $R$  has already been discussed at great length and it will have become apparent that, while it is under continuous study, any radical improvement presents considerable problems. It increases very slowly with progress in the overall art.

We are left with variable *S* and it is suggested that *not nearly enough* serious attention has been paid to this aspect.

It is, in short, felt that the fighting efficiency of a ship could be appreciably increased if a great deal more attention were paid to simplifying fault detection and repair.

An elementary and highly hypothetical example may serve to emphasize the point. Consider two warships each of which has 10 discrete "armament" systems all of which are required to be simultaneously and continuously available. It will be assumed that each of these systems is of equal reliability and that experience shows that each of the systems shows one stoppage every  $9\frac{1}{2}$  hours operation. To simplify the argument it will, further, be assumed that, conveniently enough, the systems fail in exact sequence one at a time, every  $9\frac{1}{2}$  hours.

The ships are, as is normal, assumed to be rather undermanned with technical ratings in relation to the gear fitted and in this case the tendency is taken to the limit in that each ship has *one* technical rating, who, hard pressed, might work a 12 hour day.

In ship "A" the equipments are very well designed. Faults were easy to trace and repair and any foreseeable failure could be traced and rectified in 30 minutes. As a result, applying formula (13),

*The fighting capacity of ship "A" was 95%.*

In ship "B" the equipments though equally reliable were not nearly so well thought out from the maintenance standpoint and, consequently, it took twice as long to trace and rectify faults. As a result

*The fighting capacity of ship "B" was 47½%.*

The lesson of this simple example is that a 30-minute difference in servicing time between two equally reliable equipment systems has made the difference between a very reasonably effective fighting unit and one having more than 50 per cent. of its armament out of action. The argument has, of course, been over simplified. The implications remain true.

## 12. Monitoring and Maintenance

It will have become clear from the foregoing and in particular from Sections 10 and 11 that

speed in fault detection and repair is of the essence. This leads directly to the consideration of performance monitoring, fault detection and repair philosophy. These are large subjects<sup>11</sup> and it is intended here to give, only, a brief review of the issues involved and the decisions which have to be taken when working on a design.

Considering monitoring and measurement, decisions have to be made at a very early stage in a design on the extent to which the following choices will be utilized:

- (i) Continuous, intermittent, or sequential?
- (ii) Quantitative or qualitative?
- (iii) Centralized or distributed?
- (iv) Built-in or external (portable)?
- (v) Static or dynamic?
- (vi) Manual or automatic?

The selection made will obviously depend on the nature of the equipment. It would, however, be fairly accurate to say that for the very large systems now under discussion no general and widely accepted philosophy on such issues has as yet emerged. The remarks which follow will therefore serve only to outline the nature of the problems and to indicate the writer's personal prejudices and views.

### 12.1. *Continuous monitoring?*

The question of whether monitoring should be continuous or intermittent depends to some extent on practical politics<sup>10</sup>. If too many factors are monitored continuously the whole supervisory equipment becomes impracticably bulky. The line, in short, has to be drawn somewhere. In general this type of monitoring is best confined to important parameters which are likely to change slowly without immediate impact on the gear or, alternatively, are absolutely key factors in its overall functioning. Examples of factors usefully subjected to continuous or immediately available monitoring might be:

- (i) Radar transmitter power output and (possibly) frequency spectrum.
- (ii) Receiver noise factor and possibly gain.
- (iii) Functioning of receiver a.f.c. circuits.
- (iv) Transmitter modulation (if any).
- (v) Target range, bearing and elevation.
- (vi) R.m.s. error signal in servo links.

The list could be added to or pruned. Enough has been said to illustrate the principles.



12.2. *Qualitative or quantitative monitoring?*

Considering the question of whether supervisory schemes should present their findings in qualitative or quantitative terms there are at present two strong and opposed schools of thought. The first takes the view that the personnel recruited are inherently not too bright and feels that the whole onus of making a binary YES/NO choice should be made automatic and that the resultant increase in circuit complication must be accepted. The indications then appear as Red/Green lamp signals, meters without scales but with Red/Green sectors and the like. The working of such devices calls for comparison of signals with built-in standards of one kind or another and involves quite a lot of additional, and possibly rather dubious, circuitry.

The second school suggests that when dealing with immensely complicated equipments of the type we are now considering, unless men of considerable technical competence are somehow made available, there is little chance of their functioning satisfactorily at all. If such men are available then, in general, they prefer to have indications in quantitative terms so that the extent of any malfunctioning can also be approximately assessed. This school is opposed to any further circuit complication and is mistrustful of the validity of GO/NO-GO indications.

The writer belongs, firmly, to the second school.

12.3. *Centralized or distributed monitoring?*

The choice of whether monitoring arrangements should be concentrated at a central "monitoring desk" or should be distributed around the instrument racks, with perhaps a minimum of centralized supervision depends to some extent on the nature of the system.

Series systems such as those discussed in Section 2.1 have, inherently very few operators along the chain and there is little opportunity for what might be termed "incidental" monitoring by personnel who in any case have to be present to carry out some operational function, but who, with suitable training, might be expected to detect incipient or actual faults at the technical level.

Parallel systems of the type discussed in Section 2.2 on the other hand usually also necessitate the employment of a considerable

number of men and, in these cases, some use can be made of them for fault detection.

It is entirely possible to provide full centralized monitoring and indeed systems of this nature have been fully engineered and subjected to trial.

The general conclusion, however, is that this approach leads to too much complication together with resultant vulnerability. It involves inherently a mass of circuitry, display oscilloscopes, impedance changers, uni-selectors, a multitude of switches and miles of wire to an extent that, in a warship, the supervisory system tends to become so complex that its own reliability becomes questionable.

In practice some form of compromise is clearly called for and, in the writer's view, centralized monitoring should be confined to the parameters which are selected for continuous monitoring and to a few others of key importance which, in terms of system logic, give an immediate indication of the general location of a fault area.

12.4. *Built-in or external test facilities?*

Considering the question of whether test facilities should be fully built-in or, to some extent, external and portable the answer, in the writer's view, is quite definite (though it must be admitted that this view is not universally held).

It is felt that a firm line must be drawn between "monitoring," a process designed to ensure that an equipment is working to full performance or to locate a "stoppage" in some particular section, and "repair," which is the act of, by some means or another, of putting it right.

It is suggested that all monitoring equipment should be built-in as an integral part of the main equipment and that portable test gear should be limited in its use to fault finding on a panel after the faulty panel has been located.

12.5. *Static or dynamic monitoring?*

The choice between "static" (voltages, currents, etc.) or "dynamic" (amplitude and characteristics of input and output) measurements also seems to be, in principle, clear. In general it is most desirable that, at the "panel" level the input being received and the output being delivered should be readily ascertainable.



This calls for some sort of metering arrangements and possibly the provision of some sort of standard, built-in, signal source. Generally speaking, as always, a quantitative measurement is preferred. There is, however, a large generic class of equipment notably that essentially concerned with pulsed waveforms, such as display type units, where an alternative, quantitative form of continuous monitoring can be most usefully employed. The essence of this scheme is, simply, clear indication that the whole circuit is functioning properly.

Low voltage, self-focusing, miniature cathode-ray tubes are now readily available and can be satisfactorily operated from the standard voltages normally available in the type of gear under discussion. It is possible by their use by a judicious combination of the input and output signals with, possibly, the addition of a third parameter, injected as a blanking pulse, to produce a "cyclogram" type of display without the necessity for time bases or any other complication. Such a display gives, when all is well, a distinctive and known pattern which is immediately affected by any change in the signals producing it. This type of indication is simple, cheap, continuous, and sure, and seems to have considerable merit.

#### 12.6. Manual or automatic monitoring?

Finally if it is decided to follow the dictates of the "automation" school of Section 12.2, the possibility, evidently, exists of further complicating the circuitry by arranging that any deterioration to a NO-GO condition not only gives an indication, but also switches in the alternative unit (Section 10).

This approach has of course been exploited outside the Services (the monitoring and change-over arrangements for certain B.B.C. transmitters spring to mind) but so far has had no naval application in the field now under discussion.

### 13. Conclusion

The general problems entailed in the production of very large electronic systems have been broadly surveyed. They are of course, under continual review in the Research and Development Establishments. It may be appropriate to conclude with a statement indicating the current state of the art. In a very

large and complex equipment currently under late development the "Transmitter" included 470 valves while the "receiver" contained 1,040 valves.

The combined transmitter/receiver unit comprised 14,831 discrete components and some 46,000 soldered joints and was designed with particular attention to the question of reliability. Its design may be said to be representative of advanced modern practice.

Operated by its design staff over a 1,000 hours period, in approximately 8 hour daily shifts, the reliabilities realized amounted to 92 per cent. for the transmitter and 76 per cent. for the receiver. The former is probably fully acceptable operationally. The latter is not.

### 14. Acknowledgments

Acknowledgments are gratefully tendered to the Chief Scientist of the Admiralty, brother officers, and colleagues from Admiralty Signals and Radar Establishment Portsdown, Cosham whose past work and views have been freely drawn on. In particular to Com. J. C. G. Field, Lieut. Com. A. H. Miller, Lieut. Com. J. M. Hough of the Royal Navy, and H. W. Pout and P. R. Dax of the Royal Naval Scientific Service.

### 15. References

1. D. L. Davies, "Valve-voltmeter for synchro testing," *Electronic Engineering*, **29**, pp. 52-57, February 1957.
2. J. M. Pinkerton, E. J. Kaye, E. H. Lenaerts and G. R. Gibbs, "LEO (Lyons Electronic Office)," (Parts 1, 2 and 3), *Electronic Engineering*, **26**, pp. 284-91, 335-41, 386-92, July-September 1954.
3. G. H. Scheer, "Reliability in complex electronic equipment," *Electronic Engineering*, **27**, pp. December 1955.
4. V. Harris and M. M. Tall, "Prediction of electronic equipment reliability," *Electrical Engineering*, **74**, pp. 994-997, November 1955.
5. K. Henney, "Reliability Factors for Ground Electronic Equipment" (McGraw-Hill, New York, 1956).
6. Unpublished R.A.E. Report based on Aeronautical Radio Inc. figures.
7. D. E. Barnes, "A review of transistor reliability," *Bureau of Ships Journal*, November 1956.
8. H. W. Pout, "The Increase in Reliability of Complex Radar and Radio Systems resulting from Replication." Unpublished A.S.R.E. report.
9. D. Huff, "How to Lie with Statistics," W. W. Norton & Co., 1954.
10. G. Whitaker, "Maintenance Arrangements in Large and Complex Systems." Unpublished A.S.R.E. Memorandum.

# APPLICANTS FOR ELECTION AND TRANSFER

As a result of its September meeting the Membership Committee recommended to the Council the following elections and transfers.

In accordance with a resolution of Council, and in the absence of any objections, the election and transfer of the candidates to the class indicated will be confirmed fourteen days after the date of circulation of this list. Any objections or communications concerning these elections should be addressed to the General Secretary for submission to the Council.

## Transfer from Associate Member to Member

COTTRELL, John Gilmour. *Hornchurch.*  
McEWEN, Lt.-Col. John Alastair Douglas. R.A. (Retd.). *Cheltenham.*

## Direct Election to Associate Member

ASHWORTH, John Vernon. *Norwich.*  
COCKHILL, Thomas Derek. B.Sc. *Kenton.*  
COLLINS, Percy. *Malvern.*  
FIDDICK, Wg. Cdr. Ronald Victor, R.A.F. *Ewell.*  
†GROVER, Wg. Cdr. Leslie Alfred, R.A.F. (Retd.). *Harrow.*  
HODKINSON, Gordon Lambert. *Manchester.*  
\*JACKSON, Col. Brian Bannister, O.B.E. *Camberley.*  
JOANNOU, Andreas, B.Sc. *London, S.W.17.*  
MIFSUD, Lewis Joseph. *Hayes, Middlesex.*  
NURTHEN, Alan Edgar. *Chelmsford.*  
STEVENSON, William James. *Bury St. Edmunds.*  
TAYLOR, Sqdn. Ldr. Oliver Geoffrey, M.A.(Cantab.), R.A.F. *Moscow.*  
WILLIAMS, Sqdn. Ldr. John Newall, O.B.E., R.A.F. *Washington.*

## Transfer from Associate to Associate Member

BRODIE, Robert George. *Horley.*  
CLARK, Robert Richard. *Kenton.*  
GANDHI, Flt. Lt. Jai Krishan, M.Sc., B.Sc., B.A., I.A.F. *Bangalore.*  
NAMBUDIRIPAD, Moothiringot Narayan, B.Sc. *Ernakulam.*  
PICHAL, Henri Thomas. *Rochester, U.S.A.*  
PONTZEN, George Raoul. *Little Chalfont.*

## Transfer from Graduate to Associate Member

BARRS, Ronald Albert. *Crawley.*  
GREENWOOD, John Russell, B.Sc.(Eng.). *Evesham.*  
ISLAM, Capt. Sayed Sultan-ul. Pakistan Corps of Signals. *Rawalpindi.*  
JAROSZ, Jerzy Jan. *Burnham.*  
KETTLEBY, Arthur. *Derby.*  
MARTINEZ-PEREZ, Antonio. *Chelmsford.*  
MARTINEZ-PEREZ, Pedro. *Walton-on-Thames.*  
PACKER, Flt.-Lt. David Geoffrey L., B.Sc., Dip.El., R.A.F. *Chippenham.*  
PARSONS, Ronald. *Bexleyheath.*  
UBAID UR-RAHMAN. *Karachi.*  
RICHARDSON, Colin Charles. *Markyate.*  
SAWANT, Vasant Narayan. *Coventry.*  
SEN GUPTA, Ranjit Kumar, M.Sc. *New Delhi.*  
SINHA, Suransu, B.Sc. *London, S.W.2.*  
STATT, Stanley. *Stevenage.*  
TAYLOR, Denis Frederick. *Lagos.*  
WOOD, Captain Leslie Gilbert, R.E.M.E. *Salisbury.*  
YAM YAU BAN. *Hong Kong.*

## Direct Election to Associate

BAMPFIELD, Geoffrey. *Huddersfield.*  
BEGENT, Gilbert Samuel. *Rugeley.*  
FISK, Basil Clifford. *Hong Kong.*  
FOYSTER, William Francis. *Harefield.*  
GIBBONS, Gordon Henry Thomas. *Chippenham.*  
HUCKIN, Wallace. *Wolverhampton.*  
JOHNSON, Sqdn. Ldr. Richard Thomas, R.A.F. *Warwick.*  
NEWALL, Lionel Maurice, B.Sc. *London, S.E.20.*  
ROBINSON, Christopher Richard, B.Sc. *Stafford.*  
\*WILSON, George Raymond Briscoe. *Whitehaven, Cumberland.*

## Transfer from Student to Associate

TAYLOR, William John. *Hitchin.*

## Transfer from Associate to Graduate

CLARKE, Capt. George David, R.E.M.E. *Hitchin.*

## Direct Election to Graduate

AMIS, Major Bruce Gordon, R.A. *Singapore.*  
BAKER, Leonard George. *Welwyn Garden City.*  
BARBER, Charles Ronald. *Harrow.*  
BARGH, Frank Garnett. *Leeds.*  
BEARD, Robert Victor. *London, S.W.1*  
BENNETT, Louis William. *Chislehurst.*  
BENNEWITZ, Fritz Otto Max. *Bradford.*  
BOYCE, Kenneth Ronald. *East Barnet.*  
BRAUDE, Bernard, B.Sc. *London, N.W.11.*  
CALLENDAR, Michael Hugh, B.Sc. *London W.3.*  
CHAPPELL, Edgar Raymond Reginald. *Cardiff.*  
CLARKE, John Lawton. *Leubury.*  
CLIFTON, Donald Charles. *Malvern.*  
COOK, Maurice Edgar. *Weybridge.*  
CONWAY, Derck. *Bristol.*  
CURTIS, Thomas Anthony. *Bournemouth.*  
DINEEN, Bryan Ernest. *London, S.W.16.*  
DRAKE, Paul Stockton. *Basingstoke.*  
FILES, William Henry. *Liverpool.*  
GEALER, Brian John. *Evesham.*  
GREEN, Douglas Edward. *Farnborough, Kent.*  
HARMER, Daniel Sidney, B.Sc. *Norwich.*  
HARRIS, Robert. *London, S.E.26.*  
\*HERSH, Jack. *London, N.6.*  
HOWARD, Alwyn George. *Stafford.*  
JONES, William Owen. *Newport, Mon.*  
McINTOSH, John. *Malvern.*  
MOORE, Bryan. *Haywards Heath.*  
REES, Flt. Lt. Gareth Huw, B.Sc., Dip.El., R.A.F. *Henlow.*  
REYNOLDS, John Frederick, Lieut. B.A.(Cantab.), R.N. *Cardiff.*  
SHARPE, Terence Clifford. *London, S.W.19.*  
†SOLMAN, Stanley Jack. *Liverpool.*  
SWAINSON, Brian John. *Southport.*  
TAN, Chew Kim. *Brighton.*  
TAYLOR, Flt. Lt. Stanley Alfred Robert, R.A.F. *Chilpenham.*  
YAPP, Allan Robert Edward. *Hereford.*

## Transfer from Student to Graduate

CRIDLAND, William Wyndham. *Rochester, U.S.A.*  
DOBLE, Reginald George. *London, N.20.*  
ELSTEIN, Moses Herbert. *Haila.*  
FEEK, Derrick Townley. *Wick.*  
FRENCH, William Robert. *Nottingham.*  
GOVINDARAPURAM, R. Gayatri-Vallabham. B.E. *Bombay.*  
HALLEGU, Isaac Abraham, B.E. *Southall.*  
HARPER, Terence William. *Reading.*  
HARVEY, Edwin. *Cheltenham.*  
HODSON, Derrick Frank. *Stevenage.*  
JINADU, Saula Aremu. *London, N.7.*  
LAM, Chun Ming. *London, W.2.*  
LEONG, Kok Hung. *London, S.W.9.*  
LEVY, Monty. *London, N.1.*  
OLSEN, George Henry, B.Sc. *Newcastle-on-Tyne.*  
†SAYWELL, John Stephen. *Elizabeth East, South Australia.*  
†SHIPGOOD, Frederick John. *Farnborough, Hants.*  
STEELE, Capt. Peter Michael, B.Sc.(Eng.), R. Sigs. *Lechlade.*  
TARLOCHAN SINGH. *Jhansi.*

The names of 57 Students registered at this meeting will be published later.

\* Reinstatements.

† Omitted from list of elections in April.

## 1959 S.B.A.C. EXHIBITION

THE number of exhibits directly of interest to the radio and electronics engineer at the Farnborough Exhibition of the Society of British Aircraft Constructors was fully maintained this year. Apart from radar and communications, the aircraft industry uses electronic techniques to a very great extent, and in many cases aircraft manufacturers have set up their own large electronics departments who exhibit at this Show, often on a commercial basis. Guided weapons were this year much more in evidence, but as far as the associated electronics was concerned the information given seldom arose above the "black box" level.

In 1958 two companies exhibited guided weapons intended for use by troops against ground targets; in both cases directional information was passed along a trailing wire. A third weapon of this type has now appeared, the Australian Malkara anti-tank guided weapon, but this missile, which is launched from an armoured vehicle, is radio controlled by line-of-sight command guidance, the operator viewing target and missile through an optical sight and guiding the missile with a joystick control.

The use of a radio interferometer for satellite tracking has been very effectively developed by the Royal Aircraft Establishment, and an exhibit showed the manner of measuring r.f. phase differences of satellite transmissions by monitoring the standing wave pattern along the transmission lines joining diagonal pairs of four widely spaced aeriels. Demodulation of the amplitude modulated carrier wave gives voltages directly proportional to the sine and cosine of the phase differences. The equipment enables measurements to be made to a bearing accuracy of six seconds of arc.

Telemetry equipment has been shown at previous exhibitions, but this year it was interesting to see some of the means which have been devised to deal with the often overwhelming amount of data which is produced. The Bristol Aircraft Company has developed data processing equipment for dealing with time multiplex telemetered signals which are recorded on magnetic tape. The outputs of up to six of the twenty-four data channels can be presented on a 6-in. wide sensitized paper record during one

playback cycle, and the information of one data channel can be digitized and punched on cards, together with timing information. (The described before a meeting of the South Western equipment, which is known as TIMTAPE, will be Section at Bristol in January next).

Airborne navigation devices were well represented by the Marconi Company's exhibits of different types of Doppler navigator equipments. The emphasis is on weight reduction and a fully transistorized navigation computer weighing less than 25 lb was shown.

Probably the most significant advance in aircraft navigation during the past year has been the development of the automatic landing system by the Blind Landing Experimental Unit of R.A.E., Bedford, in conjunction with industry. Known as the "Autoland" system, this enables a fully automatic approach and landing to be made, first using the well known Instrument Landing System (I.L.S.) down to a height of about 300 ft., then magnetic fields set up by magnetic leader cables, and finally the height readings (below about 100 ft.) received from a radio altimeter of the frequency modulated type accurate to within about two feet. The signals received from these three successive aids are fed into an auto pilot which controls attitude, azimuth and speed. All stages of the landing are entirely automatic, the pilot observing the monitoring signals displayed on his normal flight instruments. (The Institution's Radar and Navigational Aids Group is sponsoring a paper on the equipment in London in May.)

While the Radio Components Exhibition is the usual place where engineers expect to see the latest advances in component design, special component development is often carried out by organizations producing complete equipments, and several instances of this were seen at Farnborough. A notable example was the miniature sealed two compartment relay developed by Smiths Aircraft Instruments, having dimensions of 0.3 in. diameter by 0.47 in. long. The input required for this relay was between 0.5 and 0.9 watts at up to 50 volts, and it has an operating time of less than 5 millise; at the rated load of 0.5 amps 30 volts (non-inductive) its rated life is greater than a million operations.

# Gap Filling Translators and Transmitters †

by

W. J. MORCOM, B.SC.(ENG.), A.C.G.I., WHIT.SCH.‡

*A paper read on 4th July 1959 during the Institution's Convention in Cambridge*

**Summary:** Due to topographical conditions areas often exist inside the service area of a television station where the field strength is inadequate for normal domestic receivers to operate. Apparatus is described which, mounted on high ground, can receive the programme and convert it to another frequency and re-radiate it into these areas. Regions beyond the service area of the television transmitter can be served by using a combination of a link system and a booster transmitter. For those areas where locally generated programmes are required for certain periods, apparatus for feeding in video and audio signals is described.

## 1. Introduction

The basic requirements of gap filling television equipment are that it shall work unattended and give acceptable picture and sound quality together with a constant output level over a wide range of signal fading at the receiver aerial terminal.

For reliability under conditions of unattended operation the circuit complexity must be reduced to a minimum. This in turn means that the fewest number of valve stages, all with non-critical controls, shall be used. Bearing in mind that the intention is that the equipment shall be mounted in a position where the received field strength is reasonable, the simplest solution to the problem appears to have an equipment comprising a receiving aerial, an aerial filter, an r.f. amplifier, a frequency changer, an i.f. stage, an a.g.c. stage, a second frequency changer followed by linear amplifier stages feeding to the transmitting aerial. This arrangement turns out to be quite satisfactory when f.m. sound is used; however, when the sound is amplitude modulated, tests have shown that it is quite difficult to achieve linearity good enough to avoid "sound on vision" interference and it has been found necessary to provide two separate i.f. amplifiers, one for vision and one for sound, each with their own a.g.c. circuits. These must be followed by separate second frequency changers and linear amplifiers for the vision and sound channels,

thence feeding either into a combining unit or into separate vision and sound aeriels. Figures 1 and 2 show the arrangement for the f.m. sound and a.m. sound systems respectively.

When the region of poor service area lies outside the service area of a transmitting station, it would be possible to use the arrangement shown in Fig. 3 whereby the aerial and receiver portion of the equipment already described reproduces the signal at i.f. frequency and feeds it into the transmitting end of a radio link. At the receiving end of this link the combined vision and sound signal on the i.f. frequency is then fed into the second frequency changer and hence via the linear amplifier to the aerial. With the a.m. sound service, of course, a pair of frequency changers and linear amplifiers would be required. A variant of this is to replace the radio link by a land line operating at the intermediate frequency.

For locally generated programmes additional units in the form of complete vision and sound modulated stages, both having their outputs at intermediate frequencies, spaced of course by the normal sound/vision frequency separation, are necessary. The outputs of these two equipments are combined in a resistance hybrid network and are fed via a changeover switch into the second frequency changer stage (Fig. 4). Omission of the early stages of the translator leaves a complete low power television transmitter, should this be required.

The reasoning behind the adoption of this combination of circuitry is that for the translator it is undesirable to demodulate to video and audio

† Manuscript received 11th May, 1959. (Paper No. 523.)

‡ Marconi's Wireless Telegraph Co. Ltd., Chelmsford, Essex.

U.D.C. No. 621.397.61/2

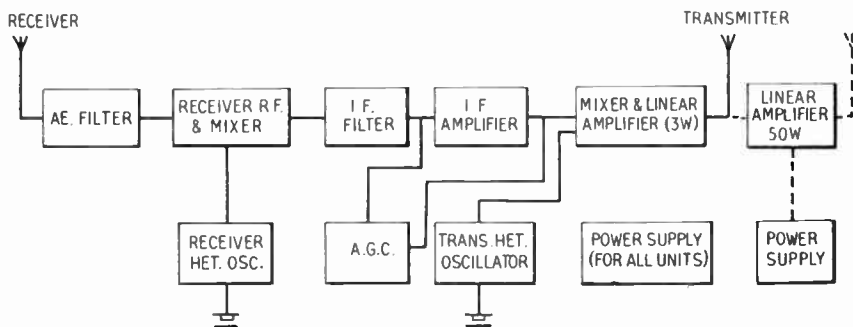

Fig. 1. Block diagram of low power television repeaters (F.M. sound).

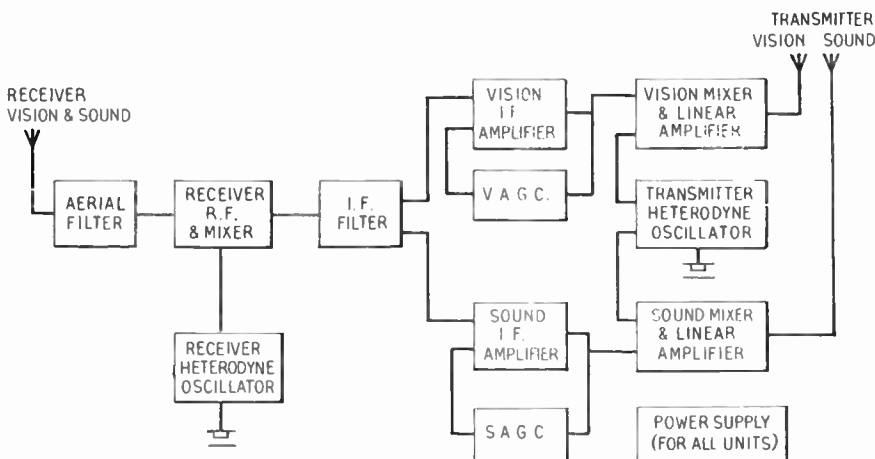

Fig. 2. Block diagram of low power television repeaters (A.M. sound).

frequencies. To have done so would have meant considerably more valve stages with their attendant risk of failure. Of course, this prevents the possibility of reshaping synchronizing pulses, but it is considered that the receiving aerials can be sited in regions where the field strength is sufficiently high that the picture quality is perfectly acceptable, and further waveform correction thus unnecessary.

The use of the double frequency-changing technique permits much closer spacing of the received and transmitted channels than would otherwise be possible. Furthermore it facilitates the interconnection of the various combinations of units which make up the various systems which have already been described. The intermediate frequencies adopted are those standardized in Europe for the C.C.I.R. systems

and in Great Britain for the United Kingdom standards (Table 1).

Table 1

	Vision I.F.	Sound I.F.
C.C.I.R. (7 Mc/s Channel)	38.9 Mc/s	33.4 Mc/s
U.K. (5 Mc/s Channel)	34.65 Mc/s	38.15 Mc/s

The lowest power version of the C.C.I.R. translator is 3-watts for vision and  $\frac{3}{4}$ -watt for sound; photographs are shown in Fig. 5. An additional amplifier with its associated power unit will raise this power to 50-watts vision and  $12\frac{1}{2}$ -watts sound. For the U.K. version the use of separate amplifiers for vision and sound gives vision power of 10-watts with the peak sound power also of 10 watts. Further stages of linear amplification can be added. Details of the



specifications of the various equipments are summarized in the Appendix.

All the units making up the various combinations have been designed for 19-in. rack mounting, the exact housing depending entirely on local circumstances. A single translator could be mounted in an outdoor waterproof kiosk provided it is fitted with standard 19-in. panel accommodation or on standard racking in larger kiosks or in small buildings.

## 2. Description of Equipment

### 2.1. Aerial Filters

The receiving aerial will have induced into it two signals, one from the parent station and the other at the re-radiated frequency from the translator transmitting aerial. Even with the specified attenuation between aerials of 40 db, the re-radiated signal at the receiver input is very much larger than the wanted signal. As a result, a very high unwanted signal will appear at the grid of the mixer stage causing considerable cross modulation. To reduce this effect, a filter is inserted between the aerial feeder and the receiver input. The aerial filter has seven synchronously tuned sections and is based on the work of J. Zdunek† and S. B. Cohn‡. The response is maximally flat within 0.1 db over a

† J. Zdunek, "The network synthesis on the insertion loss basis," I.E.E. Monograph No. 278R, January, 1958. (*Proc. Instn Elect. Engrs*, 105 C, pp. 259-291.)

‡ S. B. Cohn, "Direct coupled resonator filters," (*Proc. Inst. Radio Engrs*, 45, pp. 187-196, February, 1957.)

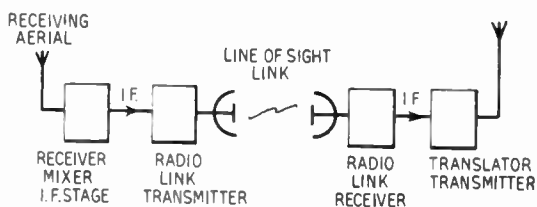

Fig. 3. Use of microwave link to feed translator transmitter.

bandwidth equal to the U.K., F.C.C. or C.C.I.R. channel bandwidths of 5, 6, or 7 Mc/s, respectively, and provides an attenuation of 40 db to the next but one channel on either side.

Two filters, one for Band I and the other for Band III, both of which are adjustable in frequency and bandwidth, cover all requirements for the three major systems. Both vision and sound signals are passed through a common aerial filter.

### 2.2. Receiver R.F. Input and Mixer

The two tunable versions of this unit, one for Band I and one for Band III, comprise a cascode R.F. amplifier followed by a pentode mixer. The input from the aerial filter is to a double tuned mutually coupled circuit in the input grid of the cascode amplifier. The amplifier output circuit is also double tuned but is top capacitance coupled. Both the double-tuned circuits can be adjusted in frequency and bandwidth to accept the various systems. The pentode mixer stage has the radio frequency signal applied to the

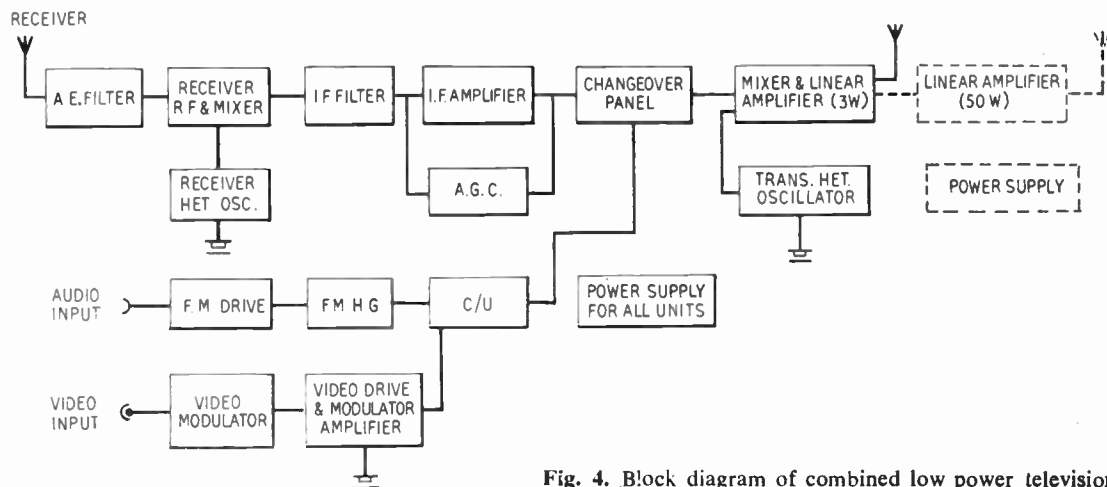

Fig. 4. Block diagram of combined low power television repeaters and transmitters (F.M. sound).

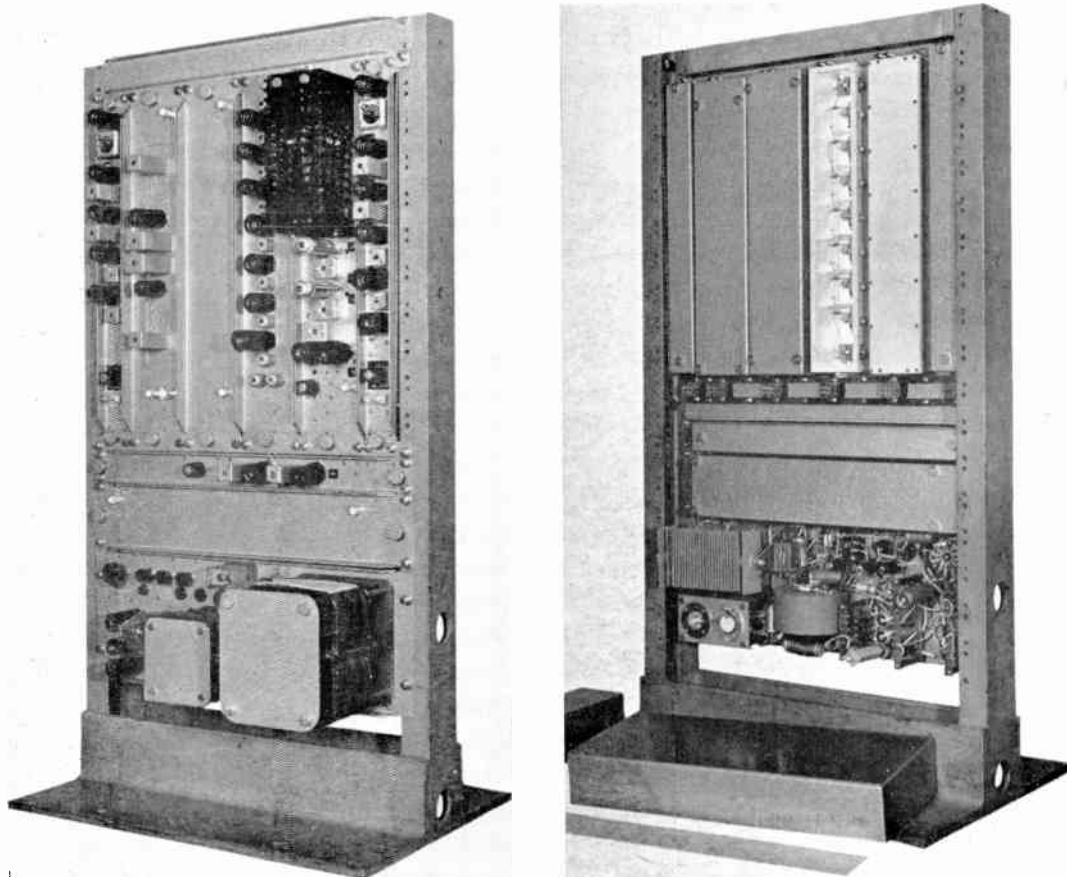

Fig. 5. Front and rear views of low power translator for C.C.I.R. standards.

control grid. On Band I the heterodyne signal, which is higher in frequency than the incoming signal, is capacitance coupled to the mixer cathode but on Band III it is mutually coupled into the control grid circuit to avoid spurious resonance in the cathode lead. The output circuit at intermediate frequency is double tuned and mutually coupled with load impedance of 75 ohms. The gain of the cascode amplifier is of the order of 12 db and the overall gain from the 50 ohms input to the 75 ohms output is approximately 11 db. Both the vision and sound signals pass through a common r.f. input and mixer unit.

### 2.3. Heterodyne Oscillators

To provide the heterodyne signal for both first and second mixers, identical heterodyne oscillators (working to different frequencies) are

used. The crystal oscillators are temperature compensated and operated in parallel resonance at fundamental frequency.

The crystals used are in the 8–14 Mc/s range and are AT cut. The crystal oscillator stage provides harmonic multiplication of the crystal frequency and is followed by a buffer stage, operating in class A, with a high  $Q$  anode circuit to suppress all unwanted crystal harmonic frequencies. Voltage control takes place in the cathode circuit of the buffer stage. Further harmonic generation takes place in the third valve stage which again operates with a high  $Q$  anode circuit.

On Band I a single amplifier stage, with twin outputs, is used, whereas on Band III an extra stage is employed for further harmonic generation.

#### 2.4. I.F. Filter (C.C.I.R. and F.C.C. standards)

The i.f. filter precedes the vision and sound i.f. amplifier and provides all the selectivity at intermediate frequencies. The filter can be adjusted to provide a maximally flat response with a passband between 0.1 db points, of either 6 or 7 Mc/s, as required for either F.C.C. or C.C.I.R. standards. The design is essentially the same as used for the aerial filters, and consists of seven synchronously tuned sections. In the channels to be protected (i.e. next but one channels) the attenuation exceeds 40 db.

Input and load impedances are both 75 ohms.

#### 2.5. I.F. Filter (U.K. standards) (See Fig. 6)

As the phase linear i.f. amplifier subsequently described is used to amplify the positive modulation vision signal, selectivity against unwanted

Amplitude response is flat within 0.1 db over the vision passband of 3.75 Mc/s with a rejection of 32 db or greater at half a megacycle outside the passband. The filter, with its two valve amplifiers provides an overall gain of 14 db.

#### 2.6. I.F. Amplifier (Vision and Sound)

The i.f. amplifier is the unit in which most of the translator gain is obtained. When used on negative modulation and f.m. sound systems, (i.e. C.C.I.R. and F.C.C.) a common amplifier amplifies both vision and sound signals. In the U.K. system, where positive modulation and amplitude modulated sound are employed, the vision signal only is passed through this amplifier, whilst the sound signal is amplified by a separate, narrow band i.f. amplifier. The reasons for this are twofold. Firstly, extremely accurate alignment is required to obtain the

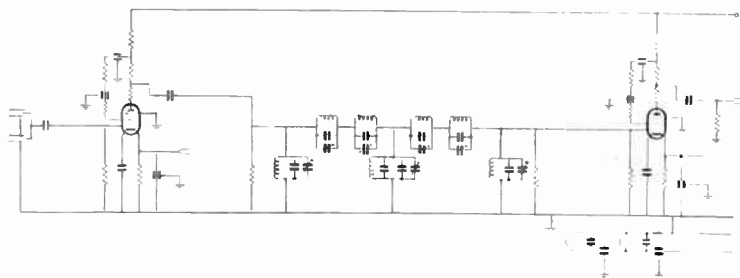

Fig. 6. Circuit diagram of the i.f. filter for U.K. Standards.

signals and against the accompanying sound signal must be provided by the i.f. filter. This filter differs from the one used on C.C.I.R. and F.C.C. systems because the sound signal has to be rejected, there being no "sound traps" in the vision i.f. amplifier. The steep sided response curve is obtained with a two-stage Darlington type filter.† Because the elements forming the filter are impracticable when designed with an input and output impedance of 75 ohms, this filter has a characteristic impedance of 500 ohms, and is placed between two valves. A bridging input is used to the first valve, and the termination is in the sound i.f. amplifier unit. The second valve operates into a load impedance of 75 ohms.

† J. K. Skwirzynski and J. Zdunek, "Design data for symmetrical Darlington filters," I.E.E. Monograph No. 227 R, March, 1957. (*Proc. Instn Elect. Engrs.*, 104, C, pp. 366-380.)

amplitude linearity of the amplifier necessary when two amplitude modulated signals are being passed through a common amplifier. Although the linearity required to reduce cross modulation between the vision and sound signals to an acceptable level can be obtained, thermal drift and valve ageing will increase the non-linearity, which makes this practice unacceptable for unattended and infrequently maintained systems. Secondly, a.g.c. is more readily applied to separate amplifiers, and will not cause cross modulation.

The amplifier consists of two triple stagger-tuned circuits, followed by a single valve wideband amplifier. A.g.c. control voltage is applied to each valve of the first triple stagger-tuned amplifier. The broad-band output circuit is a double-tuned auto-transformer, with a load impedance of 75 ohms.

The amplifier response is substantially phase linear. The resulting amplitude response is such that little selectivity is obtained within the amplifier. All of the i.f. selectivity is obtained in the i.f. filter which precedes the i.f. amplifier. The overall gain of the amplifier is 80 db, when the a.g.c. control voltage is zero.

The maximum output power is 50 mW peak vision plus 25 mW or 12.5 mW f.m. sound.

2.7. *I.F. Amplifier (A.M. Sound)*

The narrow band i.f. amplifier is used only for systems employing amplitude modulated sound channels. It consists of a four stage amplifier with single-tuned circuits between each valve stage. The coupling to the amplifier grids is taken from a tap on the anode coil, rather than from the anode itself, to ensure low damping of the tuned circuits due to the input conductance of the valve. With this controlled amount of circuit damping, an amplitude response which has little attenuation within the pass-band, but very steep flanks can be obtained. The attenuation at 0.5 Mc/s from the centre of the pass-band, i.e. at the edge of the vision band, is 25 db with respect to the amplitude at centre frequency. The amplifier output is inductively coupled to the anode tuned circuit of the last valve, and has an impedance of 75 ohms.

The anode of the last amplifier valve is connected to the input of the a.g.c. amplifier valve, amplifying at intermediate frequency. A germanium diode rectifier provides the a.g.c. control

voltage from the a.g.c. amplifier output signal. The gain of the i.f. amplifier is controlled by applying a variable d.c. potential in opposition to the a.g.c. control voltage, a "catch" diode being included to prevent the application of a positive voltage to the amplifier grids when no signal is being received. A.g.c. is applied to the first three amplifier valves, and maintains the output level constant within  $\pm 1$  db for an input change of 26 db. The manual gain control permits the carrier output level to be varied from 5mW to 30 mW.

2.8. *Positive Modulation Vision A.G.C. (See Fig. 7)*

To provide an a.g.c. control voltage from a positive modulated vision carrier, a reference point on the waveform which is subject to carrier level variations, but is free from picture signal variations, must be chosen. The "back porch" portion of the waveform fulfils these requirements, but as this is only present from 5 to 10 microsec per line, a gating system must be employed to sample its level.

In this a.g.c. unit the input, at intermediate frequency, is first amplified, and then detected using a voltage doubler detector. The demodulated video signal is first passed through a low-pass filter to remove the residual intermediate frequency, and then through a diode sync. pulse separator. The sync. separator is adjusted to remove all but 10 per cent of the picture signal. The signal, now comprising sync.

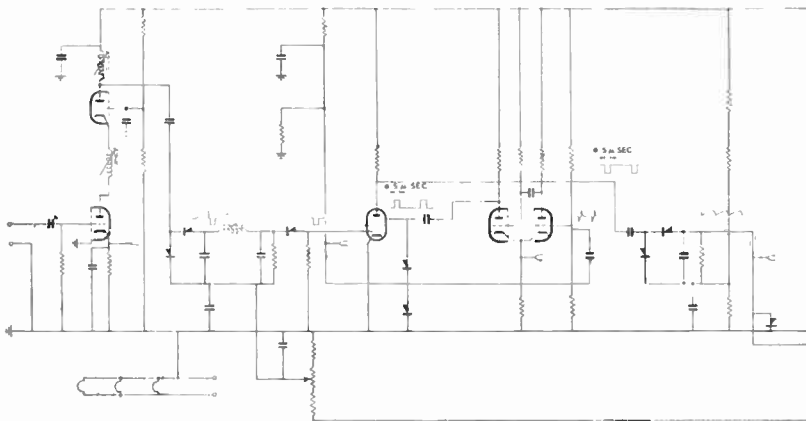

Fig. 7. Circuit diagram of positive modulation a.g.c. unit.

pulses plus 10 per cent of picture amplitude, is then applied to the control grid of the a.g.c. gated amplifier and also, via a differentiating network, to the trigger input of a cathode-coupled monostable multivibrator. On receipt of a trigger pulse, co-incident with the trailing edge of the sync. pulse, the multivibrator produces a positive-going output pulse of 4.5 microsec duration, i.e. for the minimum duration of the back porch period. These pulses are applied to the suppressor grid of the a.g.c. gated amplifier, and are d.c.-restored (using crystal diodes) to earth potential. Thus, during all parts of the waveform excepting the back porch region, a large negative voltage, due to d.c. restoration of the multivibrator pulses, will be present at the suppressor grid of the gated amplifier, driving the valve to cut off. During the back porch period, the suppressor grid will rise to earth (cathode) potential, and anode current will flow, the magnitude of the anode current being determined by amplitude of the back porch waveform applied to the control grid. Anode current pulses, and hence anode voltage pulses, will therefore be produced, the pulse amplitude being dependent upon the back porch—or blanking level—of the video signal, which in turn is dependent upon the amplitude of the intermediate frequency signal. The voltage pulses at the anode of the gated amplifier are rectified to produce an a.g.c. control voltage, which is applied to the i.f. amplifier.

To obtain large variations in a.g.c. control voltage, for small changes in i.f. signal level, it is necessary to produce an inconveniently large negative control voltage. This is “backed off” by a positive voltage derived from the h.t. line, with a diode to prevent the a.g.c. line from becoming positive with respect to earth in the absence of an i.f. signal. A control is fitted which enables the output of the i.f. amplifier to be varied from 5 mW to 50 mW.

### 2.9. Combined Sound and Vision (negative modulation) A.G.C. (See Fig. 8)

Vision and sound signals are passed through the common intermediate frequency amplifier, to which a.g.c. is applied. The amplitude of the a.g.c. control voltage is determined by the combined amplitudes of peak vision (i.e. tip of sync. pulses), and the f.m. sound signals.

To provide the control voltage, the output signal from the i.f. amplifier is amplified further by a two-stage wide-band amplifier. The output signal from the second valve is rectified to provide a large negative d.c. potential. Large variations of this negative voltage are obtained for small changes in i.f. level. To offset the large negative d.c. component, another detector provides a “backing off” voltage, of positive polarity, from the anode of the first a.g.c. amplifying stage. In the absence of signal, neither negative and positive potentials are generated, and so the i.f. amplifier controlled valve grids return to earth potential, and are therefore in the maximum gain condition.

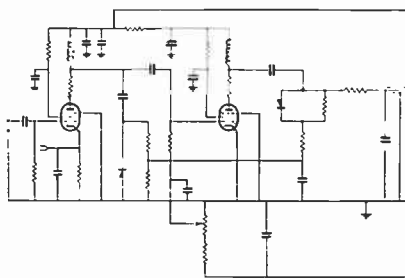

Fig. 8. Circuit diagram of negative modulation a.g.c. unit.

A control is fitted on this unit which enables the output of the i.f. amplifier to be varied from 5 mW to 50 mW.

### 2.10. Mixer and Linear Amplifier

The mixer and linear amplifier units perform the dual functions of second mixer and power amplifier stages. When used for C.C.I.R. and F.C.C. systems, both vision and sound signals are passed through the same mixer and amplifying stages, but for the U.K. system, using separate sound and vision channels, only the vision signal is passed through this unit.

A balanced mixer is employed with the signal being applied to the mixer valves in push-pull, and the heterodyne signal in parallel. The input signal is passed to the two mixer valve grids via a fixed tuned wide band transformer which has an unbalanced primary and a balanced secondary winding.

The push-pull output signal from the anode circuit of the mixer valves is amplified by a



three stage push-pull linear amplifier. For operation on Band III all intervalve circuits and the output circuit are double tuned, and all couplings and tuned circuits can be adjusted to cover all the television channels in Band III. The unit used for Band I frequencies has a double tuned circuit coupling the mixer valves to the first amplifier stage, with the coupling between the first, second and third amplifier stages forming a single stagger-tuned pair. The output coupling is double tuned.

When used for C.C.I.R. and F.C.C. transmissions, a vision output power of 3 watts, together with an f.m. sound carrier output of 1.5 W or 0.75 W is obtained for an input signal at i.f. frequency of approximately 20 mW vision power and the corresponding sound carrier level. For the U.K. system (vision signal only) an output power of 10 W is obtained.

All stages are operated under class A conditions, with the valves working at less than maximum anode dissipation to ensure long valve life for unattended operation.

#### 2.11. *Sound Mixer and Linear Amplifier*

The unit is essentially a narrow band equivalent of the vision mixer and linear amplifier. The balanced mixer is similar to the one previously described, the main differences being that controls are provided to adjust both the i.f. input and the heterodyne signal levels for optimum mixer linearity.

The balanced mixer output is coupled to a two-stage push-pull linear amplifier, single tuned circuits being used for intervalve couplings. A double tuned output circuit is employed, from the secondary of which a rectified (audio) signal provides a negative feedback voltage, which is applied to the mixer input.

### 3. Equipment for Locally Generated Programmes

For services which originate local programmes at audio and video frequencies, the sound transmitter and the vision drive and modulated amplifier, with its associated vision modulator, provide modulated carriers at intermediate frequencies. The vision carrier is capable of either positive or negative modulation for U.K., or C.C.I.R. and F.C.C. systems, whilst the sound carrier may be either amplitude or frequency modulated.

#### 3.1. *Vision Modulator (See Fig. 9)*

The vision modulator provides all the facilities normally found on larger vision modulating equipments. Black level clamping is employed to maintain black level at a constant amplitude, the clamp pulses being derived from the video signal via a noise immune clamp pulse generator. Synchronizing pulses are stretched and limited to remove up to 10 db of amplitude variation of the incoming synchronizing pulses, and pre-distortion can be applied to the white portion of the picture to improve the transmitter overall amplitude linearity.

Of the eleven valves used, three pentodes provide all of the modulation gain. Approximately 20 db of negative feedback is applied to the amplifier, providing good gain stability and a bandwidth level within 0.5 db to 10 Mc/s without the use of peaking circuits. The fourth valve has two outputs of equal amplitude but of opposite phase. One output is selected for positive modulation and the other for negative modulation. The final valve in the signal chain is a cathode follower of low output impedance. The frequency response of the complete amplifier is level to within  $\pm 0.25$  db to 8 Mc/s, falling to -2 db at 10 Mc/s. Black level clamping operative during the back porch period of the waveform is applied to the control grids of the third amplifier valve and the output cathode follower.

Stretching of the synchronizing pulse is achieved in the "triple" amplifier by reducing the negative feedback and hence increasing the amplifier gain during sync. pulses. The gating circuit which reduces the negative feedback is adjustable, and is normally sited at approximately 5 per cent below black level. The increase in gain is 8 times and so, even when the input sync pulses are reduced in amplitude by 10 db, large sync. pulses are available at the anode of the third amplifier valve. Here an adjustable amplitude limiter reduces the sync. pulse to the amplitude required to produce the correct transmitted picture/sync. ratio.

Pre-distortion of the white portion of the signal is also obtained in the "triple" amplifier by decreasing the negative feedback. Two pairs of controls, each pair varying the slope and the amplitude of stretched white signal, can be adjusted to provide a smooth curve, the inverse

of the modulated grid non-linearity curve. Both the sync. pulse stretch and the picture pre-distortion circuits require reference potentials of low source impedance. These are obtained from two triode cathode followers (a double triode valve) connected across the h.t. supply.

for the U.K. system, and 6.483333 Mc/s for both C.C.I.R. and F.C.C. systems. A multiplication of 6 times is used for all systems, providing vision intermediate frequencies of 34.65 and 38.9 Mc/s. Drive level is varied by adjusting the screen grid potential of the drive output stage.

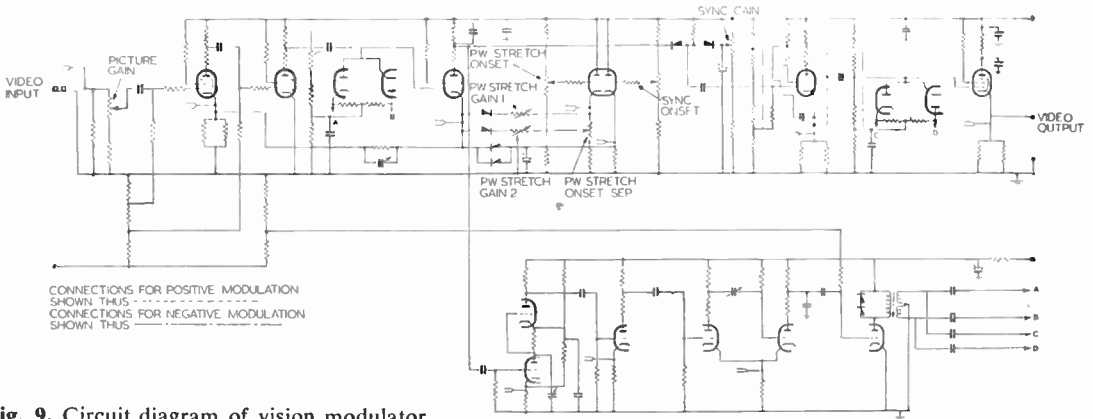

Fig. 9. Circuit diagram of vision modulator.

The clamp pulse generator employs a cathode-coupled monostable multivibrator to produce pulses 1.5 microsec wide. The multivibrator is triggered via a pulse inverter from a double triode valve which combines the functions of sync. pulse separation and pulse delay. The double triode generates its trigger pulse from the edge of the sync. pulse, and a control is provided to enable the delay time between the trigger pulse and the trailing edge of the sync. pulse to be varied. This stage will not produce false trigger pulses when noise pulses 1.0 microsec (C.C.I.R. systems) or 1.5 microsec (U.K. systems) wide, of any amplitude up to 6 db greater than picture amplitude, and of either polarity are superimposed upon any part of the waveform.

The output from the multivibrator is passed to a pulse amplifier in the anode circuit of which is a pulse transformer which delivers push-pull clamp pulses of equal amplitude to the two black level clamping circuits.

### 3.2. Vision Drive and Modulated Amplifier

The vision drive comprises a crystal oscillator followed by buffer and multiplier stages, using similar circuitry to that used in the heterodyne oscillators. The crystal frequency is 5.775 Mc/s

The modulated amplifier employs two pentodes connected as a long-tailed pair, the modulating video signal being applied to one control grid, and a variable d.c. potential to the other. The variable d.c. potential is adjusted by the black level control. The use of a long-tailed pair enables the modulated control grid to be sited at a potential positive with respect to earth, and thus makes direct connection from the modulator cathode follower possible without resorting to negative supplies. A variable "test bias" voltage is incorporated to facilitate amplifier adjustments. The anode circuit of the modulated pentode contains a "Darlington" type filter, which provides a maximally flat response of 4, 5 or 6 Mc/s as required, together with the shaping required for vestigial sideband transmission.

### 3.3. Amplitude-modulated Sound Transmitter

The drive circuitry used for the a.m. sound transmitter is identical to that used for the vision drive, and employs a crystal oscillating at 6.358333 Mc/s. With a multiplication factor of 6 times, this produces an intermediate frequency of 38.15 Mc/s.

The final stage is grid modulated. Envelope negative feedback to the modulator input is

employed to reduce the harmonic distortion of the r.f. envelope to 1 per cent at a modulation depth of 80 per cent and to 2 per cent at 90 per cent modulation. The double triode modulator employs one triode as an amplifier and the other as an output cathode follower, which is capacitance coupled to the grid of the modulated amplifier.

For 100 per cent modulation, the minimum audio frequency input level is -12 dbm, the transmitter modulation depth being controlled at the secondary of the input balance-to-unbalance transformer.

### 3.4. Frequency-modulated Sound Transmitter

The frequency modulated sound transmitter employs the "frequency modulated quartz" principle.†

In this system a specially manufactured crystal is directly modulated via a quarter wave circuit by a susceptance modulator and the resulting frequencies are harmonically multiplied twelve times to give the required centre frequency of 33.4 Mc/s.

### 4. Acknowledgments

The author wishes to thank the Engineer in Chief, Marconi's Wireless Telegraph Co. Ltd., for permission to publish this paper; also Messrs. J. Sutton and K. Baker who designed the equipment described and who assisted in compiling this paper.

† W. S. Mortley, "Frequency modulated quartz oscillators for broadcasting equipment," (*Proc. Instn Elect. Engrs*, 104, B, No. 15, pp. 239-248, May, 1957.)

## 5. Appendix : Performance Specifications

### (a) Translator for Vision and F.M. Sound

Power output (without amplifier)	Vision: 3 watts peak; Sound: 0.75/1.5 watts as required.
Power output (with amplifier)	Vision: 50 watts peak; Sound: 12.5/25 watts as required.
Frequency range	41-88 Mc/s; 174-216 Mc/s.
Frequency separation-receiver/transmitter	At least one channel.
Modulation system	C.C.I.R. or F.C.C. as desired.
Receiver input level	500 $\mu$ V (-6 db+20 db) (peak vision).
Auto gain control	+ 1 db for 500 $\mu$ V signal.
Time constant a.g.c.	20 milliseconds.
Frequency response relation to vision carrier	+0.5 db from -0.75 to 5.5 Mc/s; -0.5 db from 1 to 4 Mc/s; -1 db at 5 Mc/s; -2 db at -0.75 and 5.5 Mc/s.
Cross modulation	I.P's less than -40 db within the channel (relative to picture amplitude).
Separation between aerials	At least 40 db.

### (b) Low-power Transmitter with F.M. Sound

Power output	Same as for translator.
Frequency range	41-88 Mc/s; 174-216 Mc/s.
Modulation system	C.C.I.R. or F.C.C.
Input level	Vision: 1 volt peak to peak composite; Sound: 0 dbm.
Frequency response vision	As C.C.I.R.
Linearity, vision	Better than 4% non-linearity.
Noise level, vision	-50 db below peak output.
Blanking level stability	Less than $\pm$ 2% of peak output level over the full range of picture signal amplitude.
Frequency response (sound)	$\pm$ 1 db from 30 to 15,000 c/s.
Harmonic distortion (sound)	Less than 1% from 100-10,000 c/s. Less than 1.5% from 30-15,000 c/s.
Noise level (sound)	F.M. noise 60 db below $\pm$ 50 kc/s deviation. A.M. noise 50 db below carrier level.
Pre-emphasis	25, 50 or 75 microsec.

(c) *Translator for Vision and A.M. Sound*

Power output	Vision: 10 watts peak; Sound: 2.5 watts carrier.
Frequency range	41-88 Mc/s; 174-216 Mc/s.
Frequency separation receiver/transmitter	At least one channel.
Modulation system	U.K. (405 line) standards.
Receiver input level	500 $\mu$ V (-6 db +20 db) (peak vision).
Auto gain control	$\pm$ 1 db for 500 $\mu$ V signal.
Time constant a.g.c.	20 millisecc.
Frequency response (relative to vision carrier)	+0.5 db from -3.5 to +0.75 Mc/s; -0.5 db from -3 to -0.5 Mc/s; -1 db at -3.5 and +.75 Mc/s.

(d) *Low-power Transmitter with A.M. Sound*

Power output	Vision: 10 watts peak; Sound: 2.5 watts carrier.
Frequency range	41-88 Mc/s; 174-216 Mc/s.
Type of transmission	U.K. (405 line) system.
Input level	Vision: 1 volt peak-to-peak composite); Sound: 0 dbm.
Frequency response vision	To B.B.C. specification.
Linearity (vision)	Less than 4% non-linearity.
Noise (vision)	-50 db referred to peak outputs.
Blanking level stability	Less than $\pm$ 2% of peak output level over the full range of picture signal amplitude.
Frequency response (sound)	$\pm$ 2 db from 30 to 10,000 c/s; $\pm$ 0.5 db from 100 to 5,000 c/s.
Harmonic distortion (sound)	Less than 1% for 30% to 50% modn. Less than 1.5% for 70% modn. Less than 3% for 90% modn.
Noise level (sound)	-60 db.

## DISCUSSION

**W. N. Anderson :** Could Mr. Morcom tell us why his translator will not work with inputs of less than 250 microvolts. This seems rather different from the equipment which Mr. Kirilloff has described† which apparently works with an input of 36 microvolts. Secondly, I would like to know whether it would be possible, with more development, for the translator to work without an intervening channel.

**W. J. Morcom (in reply) :** The requirements specified were for operation with a minimum of 250 microvolts input and we have worked to that specification. There is no technical limit from that point of view.

The siting and spacing of the transmitters covering the British Isles are such that adjacent areas are spaced with at least one guard channel between. This is done because the design of

modern receivers makes it desirable to do so to give proper protection. I think you will find that in no case do we get adjacent service areas on adjacent channels.

**W. N. Anderson :** I am not very happy about that because there are many adjacent areas in this country where the channels are adjacent and the service areas overlap. There is also likely to be a requirement in the future where, in areas which are very well screened from other surrounding high-field areas, adjacent channel translation would be extremely valuable.

**W. J. Morcom (in reply) :** On the first point there are undoubtedly areas where by accident this happens. It is due to the fact that a third station happens to have a good strength in that area. Secondly, such translation could be carried out but it would mean more complexity of the design of the equipment and the main aim is for reliability with realistic requirements.

---

† P. K. Kirilloff, "Sync signal regeneration system for low power translators," 1959 Convention paper. To be published.

**A delegate :** Could Mr. Morcom confirm that if we need a 40 db separation at the aerial filter then we need the same at the receiving end? Secondly, in the absence of it being mentioned in the formal specification can we take it that the transient response linearity and noise are more or less equivalent to that of the signal received. Thirdly, has Mr. Morcom any experience as to how long the unattended transmitters can be run before noticeable deterioration takes place?

**W. J. Morcom (in reply):** Calculation and tests show that with any less attenuation than a total of 80 db one does get interference break through on the i.f. mixing channels. Secondly, the signal out of the translator is practically as good as that going in. Thirdly, on how long the translator can run unattended we are pretty sure that it is many months. This is a question of design, one must not overrun any valves or components and so keep a factor of safety in hand.

**R. E. Young :** The acceptable signal surely depends to some extent to the signal/noise ratio of the receiver. What is considered to be an acceptable signal/noise ratio on peak white modulation to give these signal input figures?

**W. J. Morcom (in reply) :** Put non-technically if the picture is good enough to view on a normal receiver it is perfectly good for the translator. The actual noise figure is 46 db.

**S. N. Watson :** When looking at a map of the distribution of television stations in Italy, it struck me that what we would describe as the main transmitters have the main function of sending signals to translators, for there seemed to be altogether hundreds of translators. Italy seems to be rather well provided for in this way for the people live on the tops of the hills and accessible sites are accordingly available. On the map of Great Britain, if we wished to achieve 100 per cent. coverage with this technique we should have to find high places in Scotland and Wales where nobody would dream of living. I would like to ask Mr. Morcom if he could devise something very much more simple than this translator equipment since his present

type of equipment would hardly work on the tops of mountains and remote places. I have heard that transistors have been used.

**W. J. Morcom (in reply):** I certainly think there is a market for completely transistorized gap fillers.

We could conceivably contemplate covering a country with a number of high powered transmitters in, say, Band IV or Band V, which are used purely to energize the translators which would be locally situated. It is a distinct possibility, however, that having a large number of translators in a country like England might cause difficulties since it would not be possible to use below about 55 Mc/s for local transmissions because of interference from distant transmissions under abnormal propagation conditions.

Very simple translators have, incidentally, been developed in Italy which have only one stage of frequency changing. Similarly in Germany a translator has been produced which is only about ten inches square and about six inches deep, and can be mounted on the side of a telegraph post. While these have been successful under limited circumstances, the difficulty has been that the frequencies they can use to transmit and receive are extremely restricted. I think that the value of the scheme depends upon the terrain of the country concerned.

**H. V. Sims (Member):** I would like more information on the switching on and off of the translator.

**W. J. Morcom (in reply):** As far as switching on and off is concerned there are two schools of thought. One is that small receiving valves of the kind that we have here should be left on continuously as they will have a longer life. The other school of thought says that it has been proved conclusively that if you switch them on and off they have a longer life! Both are very strong in their opinions and have a lot of evidence behind them but we feel personally that equipment of this sort should be kept continuously running. It is considered that it is at switching on and off times that equipment fails.



## of current interest . . .

### **The N.I.R.N.S. 50-MeV Proton Linear Accelerator**

The 50 million electron volt proton linear accelerator at the Rutherford High Energy Laboratory, Harwell, accelerated protons to an energy of 50 MeV for the first time on 12th July last. This is the first accelerator at the National Institute for Research in Nuclear Science to come into operation. It will be used for nuclear research by physicists from universities, the Atomic Energy Authority and a resident team based at the Rutherford Laboratory. When in full operation it is expected to have a proton beam intensity many times greater than other accelerators of this kind.

Protons are accelerated in the machine by applying r.f. voltage across successive gaps along a path in an evacuated chamber. There are three such chambers which accelerate the protons successively to energies of 10, 30 and 50 MeV, each structure being a cavity resonator at a frequency of 202.5 Mc/s. Pulsed operation is employed because of the very high radio frequency power required. One advantage of the linear accelerator over circular machines is that the energy can be increased by the addition of further units if so desired. Extraction of the proton beam is also simpler.

### **U.K. Delegation to Geneva Radio Conference**

A delegation of 45, led by Capt. C. F. Booth, C.B.E., an Assistant Engineer-in-Chief of the General Post Office, represents the United Kingdom at the Administrative Radio Conference which opened in Geneva on August 17th. The delegation includes representatives of various Government Departments and the armed forces as well as a number of advisers from operating agencies and other organizations. Captain F. J. Wylie, R.N.(Retd.) (*Member*), is representing marine radio interests.

The Conference is expected to last four months. Its main task will be to revise the Radio Regulations and Additional Radio Regulations adopted by the Atlantic City Radio Conference in 1947, and to deal with all other matters deemed necessary within the terms of the International Telecommunication Convention.

### **Television and Sound Developments in Eastern England**

The B.B.C.'s new Peterborough television and v.h.f. sound broadcasting station came into regular programme service on 5th October. It is situated at Morborne Hill, six miles south of Peterborough; the single-storey building provides accommodation for the vision and sound transmitters for the television service, the f.m. transmitters for the sound broadcasting service, of which there are six arranged in three groups of two, and the Post Office vision link equipment. A 560-ft. lattice steel mast carries two aerial systems, one for television and one for the v.h.f. sound service. Peterborough will radiate the B.B.C.'s television service in Channel 5 (vision 66.75 Mc/s, sound 63.25 Mc/s) using horizontal polarization. The aerial has an effective radiated power of 1 kW in all directions. The sound services on v.h.f. are transmitted with an effective radiated power between 1 kW and 22 kW depending on direction, and are horizontally polarized.

A Mesny type system has been installed on the 1,000 ft. mast—tallest in the Commonwealth—at Mendlesham, Suffolk, to carry East Anglia transmissions of the Independent Television Authority. It is designed to provide the unsymmetrical radiation pattern needed to meet the requirements of the area, namely the maximum signal in the directions of Norwich, Peterborough, Cambridge and Colchester, and the minimum towards London, the South Coast and Amiens areas, in fulfilling international requirements. This radiation system provides very high aerial-gain, enabling a comparatively low input of 8 kW from the transmitters to give an effective radiated power of 200 kW in the desired directions.

### **Changes at M.I.T.**

The Servomechanisms Laboratory, a leading research centre at the Massachusetts Institute of Technology since 1940, has changed its name to Electronic Systems Laboratory. The new name reflects the importance of systems concepts in modern engineering and the inter-relationship in many complex systems among control technology, data processing and electronic measuring devices and systems.

# Radio Engineering Overseas . . .

The following abstracts are taken from European and Commonwealth journals received in the Library of the Institution. Members who wish to borrow any of these journals should apply to the Librarian, stating full bibliographical details, i.e. title, author, journal and date, of the paper required. All papers are in the language of the country of origin of the journal unless otherwise stated. The Institution regrets that translations cannot be supplied.

## RADIO "TELESCOPES"

A useful survey of the principles underlying the design of existing and proposed directive aerials for radio astronomy is given in a paper by a radio astronomer with the Australian C.S.I.R.O. Structural considerations indicate that the design of highly directive aerials should change with size, and for diameters up to a few hundred feet, steerable paraboloids have many advantages. Fixed structures which can be supported from the earth at many points are necessary for larger sizes. For extremely large aerials the new types developed by radio astronomers provide high directivity in a very economical way. The feature of these new aerials is that they are "skeleton" aerials, since they provide a directivity which corresponds to a much greater surface area than they possess.

"Development of highly directive aerials in radio astronomy." W. N. Christiansen. *Proceedings of the Institution of Radio Engineers Australia*, **20**, pp. 519-528, September 1959.

## ATTENUATORS

A Czech paper describes a method of calibration of attenuators for the microwave range using a simple thermistor bridge. A simplification is brought about by using a stabilized voltage supply which makes possible the determination of the attenuation by determining the magnitude of a single series resistor when the bridge is balanced. Temperature stabilization of the thermistor holder is required during measurement. Measurements are carried out in the X band.

"Calibration of microwave attenuators by means of thermistor bridges." J. Hosek. *Slaboproudý Obzor (Prague)*, **7**, pp. 419-422, 1959.

## VARIABLE REACTANCE CIRCUITS

The quadripole equations and simple equivalent circuits for variable-reactance amplifiers, which consist of two parallel resonant circuits coupled by way of a semiconductor diode, have been derived in a paper by engineers from Telefunken. With their aid the transducer characteristics of the variable-reactance amplifier types are investigated, which are classified as mixers of the frequency non-inverting case and frequency inverting case, respectively, and as straight amplifiers; the charac-

teristic parameters of transducer gain, amplifier bandwidth, stability, noise figure and efficiency are calculated from the given data of the circuits and the diode. Design rules are determined for amplifiers with minimum noise figure, which furnish the required data of the diode and the circuits as a function of the demanded electrical amplifier performance data. The principal transducer and design parameters of the three amplifier types are finally compiled in a table, intercompared, and the characteristic parameters required for the assessing of diodes are explained. Because of the negative diode conductances appearing in the circuits of the frequency inverting case, these circuits allow a remarkable reduction of the contribution of the following amplifier to the overall noise figure.

"Theory of parallel circuit diode reactance amplifiers." W. Dahlke, R. Maurer and J. Schubert. *Archiv der Elektrischen Übertragung*, **13**, pp. 321-340, August 1959.

## PULSE AMPLIFIERS

Work has been undertaken at the Indian Institute of Technology, Kharagpur, on a new approach to the design of a pulse amplifier which is based on its transient response characteristics. Such an amplifier is characterized by its gain, rise-time and overshoot, and its design is dependent upon the relation between these parameters and the circuit constants. Analytical relations between overshoot and rise-time (defined as the time for 10 per cent. to 90 per cent. of the final value) cannot be obtained. A relation between gain, overshoot and the time to rise from zero to peak value has, however been determined, and the method of designing an actual pulse amplifier from a knowledge of these parameters shown. Results are compared with an actual pulse amplifier designed from the data obtained theoretically.

"The design of pulse amplifiers." R. C. Ganguli. *Indian Journal of Physics*, **33**, pp. 263-275, June 1959.

## HALL GENERATORS

The behaviour of Hall generators in an r.f. magnetic alternating field has been subjected to analytical and experimental investigation by Siemens-Schuckert. The eddy currents induced by the r.f. alternating field in the semi-conductor plate

effect an increase in the Hall voltage with increasing frequency and a phase lead of the Hall voltage with respect to the applied magnetic alternating field takes place as well. Amplitude increase and phase lead occur only if the semi-conductor layer of the Hall generator is embedded into ferrite at either side, i.e. the air gap height  $\delta$  equals the thickness  $d$  of the semi-conductor layer. The power dissipated by the eddy currents in the semi-conductor layer is calculated; its influence on the maximum permissible control power is discussed.

"On the frequency characteristics of Hall generators." F. Kuhrt, H.-J. Lippmann and K. Wiehl. *Archiv der Elektrischen Uebertragung*, 13, pp. 341-347, August 1959.

### TRANSISTOR OSCILLATORS

The behaviour of a junction transistor blocking oscillator during the various stages of its function are discussed in a recent Czech paper. The analysis is based on the linearized characteristics of the transistor. In the derivation of the formula for pulse duration the author considers both the primary inductance of the pulse transformer and the associated capacitances. Experimental results with various types of transistors do not differ by more than 30 per cent. from calculated values over a wide range of circuit parameter values. A possibility of eliminating the oscillatory overshoots is also indicated. In conclusion the author points out the influence of the magnetization current on the fall-time of the generated pulse.

"A new, approximate approach to the design of a junction transistor blocking oscillator." V. Spány. *Slaboproudý Obzor (Prague)*, 7, pp. 429-435, 1959.

### DISTORTION IN TRANSISTOR AMPLIFIERS

In a communication from the Zurich Technical Institute, a non-linear fourpole with parameters which are dependent on frequency is considered as a prelude to the calculation of non-linear distortions in h.f. transistor amplifiers. The output is short-circuited for h.f. currents, and the case of a quasi-linear fourpole is under these conditions reduced to a twopole circuit. A special twopole, consisting of a non-linear resistance in parallel to a non-linear capacitance is then treated mathematically. It appears that a frequency-modulated output signal arises together with an amplitude-modulated one, when cross-modulation is calculated. With a transistor-fourpole the grounded base connection at short-circuited output is considered as a first case, neglecting extrinsic elements. Carrier transport in the transistor is assumed to be uniquely due to diffusion. Thus, the calculations are restricted to small current densities, being based on the differential equations of diffusion.

By extensions of the boundary conditions and of the solutions, the non-linear effects may be readily expressed. Under specified conditions and at relatively low frequencies (with respect to the cut-off frequency) the non-linear solutions may be simplified considerably. These solutions are then applied to the grounded emitter connection, which is in preponderant practical use. By including the most important extrinsic element, i.e. the base resistance, the calculations lead to expressions for non-linear effects of grounded emitter h.f. amplifiers. These expressions are tested experimentally by measurements of cross-modulation and of third harmonic distortion of several types of h.f. transistors, applied in grounded emitter amplifiers. The tests show that the theory is valuable up to relatively high collector currents. Coincidence between theory and experiments is very satisfactory. An interesting feature is the presence of a pronounced minimum in each curve, representing cross-modulation as dependent on collector current at fixed voltages. It is shown that this minimum may be explained quantitatively by the presence of a modulation, the sign of which is opposite to the cross-modulation. It is caused by series resistances which are blocked at h.f., but not at l.f. By insertion of such resistances into the emitter lead or into the base lead or into both, the current values, at which such minima occur, may be shifted.

"Non-linear distortions and cross-modulation in h.f. transistors." M. Akgun and M. J. O. Strutt. *Archiv der Elektrischen Uebertragung*, 13, pp. 227-242, June 1959.

### BACKWARD-WAVE TUBES

A backward-wave tube with a periodic slow-wave structure for the generation of millimetric waves is described in a recent German paper. The electron gun produces a circular beam with a diameter of 0.25 to 0.3 mm and a current density of 15 to 20 A/cm<sup>2</sup>. The beam is focused through the interaction space of the slow-wave structure by a longitudinal permanent magnetic field. The rugged slow-wave structure is stacked from punched molybdenum or copper disks. It has a wide tuning range, low line-losses, and a fairly high coupling impedance. The element for coupling the r.f. power out of the slow-wave circuit and the vacuum window are designed for a large bandwidth. For line voltages between 550 and 3600 V the oscillator covers a tuning range from 26.5 to 48 kMc/s and supplies within this band a mean c.w. power of better than 40 mW.

"A backward-wave oscillator with periodic slow-wave structure for the frequency range 27-48 kMc/s. F. Gross. *Archiv der Elektrischen Uebertragung*, 13, pp. 356-362, August 1959.

### MICROPHONE EFFICIENCY

When a microphone is applied to the external auditory canal of the ear the character of the speech is changed in comparison with the reception of sound from the air. The transmission properties of the path from the organ of speech to the auditory canal have been measured by a German worker for various transducers and various sounds. Preliminary results for intelligibility are recorded; the ear microphone in single channel and double channel applications (one transducer in each auditory canal) was compared with a pressure gradient microphone as well as a throat microphone as far as suitability for the transmission of speech in the presence of strong background noise is concerned.

"Transmission of speech with the aid of an ear microphone." J. Naujoks. *Nachrichtentechnische Zeitschrift*, **12**, pp. 400-402, September 1959.

### TIME SIGNAL RECORDER

A frequency selective amplifier employed in registering radio time signals automatically on autographic records has recently been constructed at the Department of Mathematics and Geophysics, Bengal Engineering College, Howrah, and its design and operation is described in the College's journal. The amplifier possesses a peak gain of 60 db at an audio frequency of 1000 c/s falling to about 30 db within  $\pm 5$  c/s of the central frequency. The use of this apparatus takes advantage of the facts that—(i) broadcast carrier waves have a greater depth of modulation during transmission of time signal pips than during regular broadcast programmes, and (ii) 1000 c/s pips repeat at regular intervals over the duration of the radio time signals. The apparatus also incorporates a highly sensitive band-spread receiver whose output operates the time registering relay through the frequency selective amplifier during radio time signals.

"An automatic time signal recording device for autographic recorders." G. C. Choudhury. *Journal of Technology*, **3**, pp. 109-117, December 1958.

### TELEVISION TRANSMITTERS

When two or more television transmitters operate in the same channel, it is common practice, in order to reduce the mutual interference, to offset their respective carrier frequencies by a small amount. The improvement so obtained is greatest when the amount of this offset is close to one-half of the line-repetition frequency or to an odd multiple of that "half-line-frequency." However, in order to apply the principle to more than two transmitters, offsets approximating to one-

third or to two-thirds of the line frequency are usually adopted. It is possible to obtain even better results if, in addition, the offset is maintained very close to an integral multiple of the field frequency. Operation under such conditions is known as "precision offset." In certain circumstances its achievement presents no special difficulty. A method developed by Radiotelevisione Italiana for obtaining "precision offset" in the very difficult—but nonetheless not uncommon—case where the field frequency is not constant has recently been described. It employs a 250 kc/s crystal oscillator stable to within  $\pm 1$  in  $10^8$  to control the main oscillator to give an offset of  $\frac{1}{3} \times$  line frequency + 33 c/s.

"Precision offset of television transmitters with varying field frequency." R. Busi. *E.B.U. Review*, No. 56, pp. 2-5, August 1959.

### TELEVISION PICTURE TUBES

An Australian paper discusses the need, during manufacture of controlling the final colour of c.r.t. screens by measurement to a tolerance corresponding to the critical nature of human colour perception. The screen of a black and white picture tube is composed of two or more phosphors, chemical materials capable of giving coloured luminescence when excited by an electron beam. By suitable choice of phosphors a screen colour is achieved which can be closely duplicated from batch to batch. The C.I.E. system of colour specification and the black body curve on the C.I.E. diagram are used extensively in phosphor blending. Several aspects of actual screen application such as body colour of the phosphor, thickness of the screen and impurities in the settling water, can cause colour shifts.

"The synthesis of black and white television images from coloured picture tube phosphors." C. H. Laurence. *Proceedings of the Institution of Radio Engineers Australia*, **20**, pp. 463-471, August 1959.

### PROTON SYNCHROTRON

The June issue of the French journal *L'Onde Electrique* is completely given over to the publication of 35 papers describing the proton synchrotron SATURNE, which has been built at the Centre d'Etudes Nucleaires at Saclay. The machine, which can accelerate protons to about 3 GeV, is similar in mode of operation and performance to the Brookhaven Cosmotron. The accelerating path through electromagnets energized by an alternating field of about 8.7 Mc/s is about 68m in length. A Van de Graaff generator is used as injector.

*L'Onde Electrique*, **39**, No. 387, pp. 421-634.